

TM 9-1240-408-13&P

**OPERATOR'S, UNIT, AND DIRECT SUPPORT MAINTENANCE MANUAL
for
BINOCULAR: STABILIZED, M25
(NSN 1240-01-410-7418)**

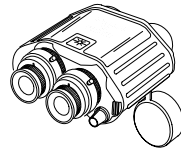

Distribution Statement A: Approved for public release; distribution is unlimited.

HEADQUARTERS, DEPARTMENT OF THE ARMY

31 MARCH 2000

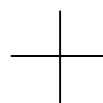
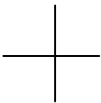

TM 9-1240-408-13&P

WARNING SUMMARY

Never point the M25 Stabilized Binocular directly at the sun. Heat generated by the sun's focused rays may cause serious damage to eyes of operator.

The M25 Stabilized Binocular is provided with internal laser protection filters. The laser protection filters are contained inside the body of the binocular and in the eyepiece assemblies. If the lens(es) or eyepiece(s) are damaged, the M25 Stabilized Binocular system is to be considered non-operational and must be turned in. Use of the M25 Stabilized Binocular with a faulty coated lens may result in irreparable damage to the eye if laser light is viewed through the binocular.

When using night vision eyepiece, eyepiece cup must be used to prevent detection.

a

TM 9-1240-408-13&P

WARNING SUMMARY (cont)

The M25 binocular may cause motion sickness or intensify disorientation or nausea in some users. If this occurs, discontinue use for a few minutes. Should the condition continue, seek medical attention.

The neck strap of the binocular may become tangled during an emergency exit from a vehicle; to facilitate quick removal, the neck strap incorporates a quick disconnect feature, activated by a pull release system.

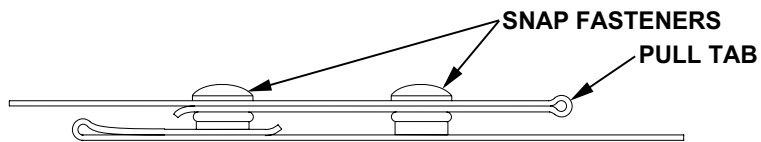

For first aid data, refer to FM 21-11.

b

TM 9-1240-408-13&P

LIST OF EFFECTIVE PAGES/WORK PACKAGES

Dates of issue for original and changed pages/work packages are:

Original... 0 .. 31 March 2000

**TOTAL NUMBER OF PAGES FOR FRONT AND REAR MATTER IS 24 AND
TOTAL NUMBER OF WORK PACKAGES IS 47 CONSISTING OF THE
FOLLOWING:**

Page/WP No.	*Change No.	Page/WP No.	*Change No.
Title	0	i-x	0
a-b	0	WP 0001 00 – 0047 00	0
A	0	Index 1-9	0
B Blank	0	Index 10 Blank	0

*Zero in this column indicates an original page or work package.

A/B blank

TM 9-1240-408-13&P

HEADQUARTERS
DEPARTMENT OF THE ARMY
WASHINGTON, D.C., 31 MARCH 2000

TECHNICAL MANUAL
OPERATOR'S, UNIT, AND DIRECT SUPPORT
MAINTENANCE MANUAL
for
BINOCULAR: STABILIZED, M25
(NSN 1240-01-410-7418)

TM 9-1240-408-13&P

REPORTING ERRORS AND RECOMMENDING IMPROVEMENTS

You can help improve this publication. If you find any mistakes or if you know of a way to improve the procedures, please let us know. Submit your DA Form 2028-2 (Recommended Changes to Equipment Technical Publications), through the Internet, on the Army Electronic Product Support (AEPS) website. The Internet address is <http://aeps.ria.army.mil>. If you need a password, scroll down and click on "ACCESS REQUEST FORM". The DA Form 2028 is located in the ONLINE FORMS PROCESSING section of the AEPS. Fill out the form and click on SUBMIT. Using this form on the AEPS will enable us to respond quicker to your comments and better manage the DA Form 2028 program. You may also mail, fax, or email your letter, DA Form 2028, or DA Form 2028-2 direct to: Commander, U.S. Army Tank-automotive and Armaments Command, ATTN: AMSTA-LC-CIP-WT, Rock Island, IL 61299-7630. The email address is TACOM-TECH-PUBS@ria.army.mil. The fax number is DSN 793-0726 or Commercial (309) 782-0726.

DISTRIBUTION STATEMENT A - Approved for public release; distribution is unlimited.

TM 9-1240-408-13&P
TABLE OF CONTENTS

	<u>WP Sequence No.</u>
WARNING SUMMARY	
HOW TO USE THIS MANUAL	
GENERAL INFORMATION.....	0001 00
CHAPTER 1 – DESCRIPTION AND THEORY OF OPERATION	
Equipment Description and Data	0002 00
Theory of Operation	0003 00

TM 9-1240-408-13&P

CHAPTER 2 – OPERATOR INSTRUCTIONS

Description and Use of Operator Controls and Indicators.....	0004 00
Assembly and Preparation for Use.....	0005 00
Operation Under Usual Conditions	0006 00
Night Mode Operation	0007 00
Operation Under Unusual Conditions	0008 00

**CHAPTER 3 – OPERATOR MAINTENANCE INSTRUCTIONS FOR THE
M25 STABILIZED BINOCULAR**

Operational Checkout	0009 00
Preventive Maintenance Checks and Services (PMCS) Introduction	0010 00
Preventive Maintenance Checks and Services (PMCS), Including Lubrication Instructions	0011 00
Battery Replacement	0012 00
Cleaning	0013 00

TM 9-1240-408-13&P

**CHAPTER 4 – UNIT MAINTENANCE INSTRUCTIONS FOR THE
M25 STABILIZED BINOCULAR**

Service Upon Receipt	0014 00
Hand Strap Assembly Maintenance	0015 00
Neck Strap Assembly Maintenance	0016 00
Transportation Case Maintenance.....	0017 00
Pouch Maintenance.....	0018 00
Arctic Pack (Optional) Maintenance	0019 00
Protective Covers Maintenance.....	0020 00
Daytime Eyepiece Maintenance	0021 00
Night Eyepiece (Optional) Maintenance.....	0022 00
Preparation for Shipment or Turn-In	0023 00

CHAPTER 5 – DIRECT SUPPORT TROUBLESHOOTING

Troubleshooting	0024 00
-----------------------	---------

TM 9-1240-408-13&P

**CHAPTER 6 – DIRECT SUPPORT MAINTENANCE INSTRUCTIONS FOR
THE M25 STABILIZED BINOCULAR**

Binocular Cover Maintenance	0025 00
Battery Cap Assembly Maintenance.....	0026 00
Power Control Knob Maintenance	0027 00
Eyepiece Lock Maintenance	0028 00

CHAPTER 7 – SUPPORTING INFORMATION

References	0029 00
Introduction for the Maintenance Allocation Chart (MAC)	0030 00
Maintenance Allocation Chart (MAC).....	0031 00
RPSTL Introduction.....	0032 00
Group 00 M25 Stabilized Binocular	0033 00
Group 01 Stabilized Binocular	0034 00
Group 0101 Optical Eyepiece Assembly.....	0035 00
Group 010101 Eyepiece Lock Kit	0036 00
Group 0103 Battery Cap Assembly.....	0037 00
Group 02 Optical Case	0038 00
Group 03 Textile Bag.....	0039 00
Group 04 Optional Battery Power Supply	0040 00

TM 9-1240-408-13&P

CHAPTER 7 – SUPPORTING INFORMATION – Continued

Group 05 Optional Optical Eyepiece Assembly (Night Vision)	0041 00
National Stock Number Index.....	0042 00
Part Number Index.....	0043 00
Components of End Item (COEI) and Basic Issue Items (BII) Lists	0044 00
Additional Authorization List (AAL)	0045 00
Expendable and Durable Items List	0046 00
Stabilization	0047 00

INDEX

TM 9-1240-408-13&P

HOW TO USE THIS MANUAL

The safest, easiest, and best way to operate and maintain the M25 Stabilized Binocular is to use this manual. Learning to use this TM is as easy as reading through the next few pages of this section. Knowing what is in this manual and how to use it will save you time and work and will help you avoid exposing yourself to unnecessary hazards while performing your job.

So where do you start?

Right here, if this is the first time you are using this TM. Be sure to completely read this section on how to use this manual first. There's a lot of information here that you need to know.

TM 9-1240-408-13&P

Organization

This manual covers the operation and maintenance of the M25 Stabilized Binocular. The manual itself is divided into seven chapters, including supporting information. The seven chapters, and what they contain, are found in the Table of Contents in the front of this manual. For example, to learn about operating the M25 Stabilized Binocular, you would look in the table of contents and discover that Chapter 2 provides all pertinent information about the operation of the binocular. Since Chapter 2 covers a great deal of information, you will have to scan the chapter to find the specific information you will need.

In Chapter 7, you will find the supporting information. Each work package provides specific information that will assist you in performing the various operational and maintenance tasks. The work packages provide such information as additional references (i.e. other TMs or FMs), as in WP 0029 00, and Expendable and Durable Items List, as in WP 0046 00. Become familiar with all supporting information work packages and what they contain before beginning any operational or maintenance task.

TM 9-1240-408-13&P

HOW TO USE THIS MANUAL - Continued

Am I ready to use the TM?

If you've taken the time necessary to read this section, and are sure of the location and arrangement of the different sections of this TM, you are ready to begin. Remember, this TM has been arranged with you, the user, in mind. Your safety and ability to perform the operational and maintenance tasks in the most efficient manner possible hinge on your ability to perform and understand the information contained in this manual. If you fully understand the arrangement and purpose of this TM, and have taken the time to read through this section, you will have no trouble operating and maintaining the binocular in the manner for which it was designed.

OPERATOR, UNIT, AND DIRECT SUPPORT

BINOCULAR: STABILIZED, M25

GENERAL INFORMATION

SCOPE

Type of Manual

Operator's, Unit, and Direct Support Maintenance, including Repair Parts and Special Tools List (RPSTL).

Model Number and Equipment Name

BINOCULAR: stabilized, M25.

Purpose of Equipment

The M25 Stabilized Binocular is designed to allow target detection, recognition, and identification at approximately twice the range of standard binoculars. It can also be used for observation from rotary or fixed wing aircraft and tracked or wheeled land vehicles.

MAINTENANCE FORMS, RECORDS, AND REPORTS

Department of the Army forms and procedures used for equipment maintenance will be those prescribed by DA PAM 738-750, Functional User's Manual for the Army Maintenance Management System (TAMMS).

REPORTING EQUIPMENT IMPROVEMENT RECOMMENDATIONS (EIR)

If your binocular needs improvement, let us know. Send us an EIR. You, the user, are the only one who can tell us what you don't like about your equipment. Let us know why you don't like the design or performance. Put it on an SF 368 (Product Quality Deficiency Report). Mail it to us at Commander, U.S. Army Armament Research, Development and Engineering Center, ATTN: AMSTA-AR-QAW-A, Rock Island, IL 61299-7630 (Fax: DSN 793-6653, Commercial (309) 782-6653) (E-mail: qawqdrs@ria.army.mil). We'll send you a reply.

CORROSION PREVENTION AND CONTROL (CPC)

Corrosion Prevention and Control (CPC) of Army materiel is a continuing concern. It is important that any corrosion problems with this item be reported so that the problem can be corrected and improvements can be made to prevent the problem in future items.

CORROSION PREVENTION AND CONTROL (CPC) - Continued

While corrosion is typically associated with rusting of metals, it can also include deterioration of other materials, such as rubber and plastic. Unusual cracking, softening, swelling, or breaking of these materials may be a corrosion problem.

If a corrosion problem is identified, it can be reported using SF 368, Product Quality Deficiency Report. Use of key words such as "corrosion", "rust", "deterioration", or "cracking" will ensure that the information is identified as a CPC problem.

The form should be submitted to:

Commander

U.S. Army Armament Research, Development and Engineering Center

ATTN: AMSTA-AR-QAW-A (R)/Customer Feedback Center

Rock Island, IL 61299-7300

Fax: DSN 793-6653, Commercial (309) 782-6653

E-Mail: qawqdrs@ria.army.mil

DESTRUCTION OF ARMY MATERIEL TO PREVENT ENEMY USE

Smash all optical elements to prevent enemy use.

PREPARATION FOR SHIPMENT OR TURN IN

Refer to WP 0023 00 for instructions on preparation for storage or turn-in.

WARRANTY

The M25 Binocular is under Fraser-Volpe Corporation warranty for one year. Report all defects in material or workmanship on a Quality Deficiency Report (QDR) utilizing the Army Electronic Product Support (AEPS) web site: <http://aeps.ria.army.mil>. If assistance is needed in submitting the QDR in AEPS, contact (309) 782-6764 or 7698 (DSN 793-6764 or 7698). Alternately, QDRs may also be recorded on a SF 368 and submitted to: QAWQDRS@ria.army.mil; faxed to (309) 782-6653 or 7609 (DSN 793-6653 or 7609); or mailed to Cdr, TACOM-ARDEC, ATTN: AMSTA-AR-QAW-C, Rock Island, IL 61299-7300.

NOMENCLATURE CROSS REFERENCE LIST

Common Name	Official Nomenclature
Arctic Pack	Battery Power Supply
Eyecup	Eyeshield, Optical Instrument
Hand Strap	Webbing Strap
Neck Strap	Webbing Strap
Optical Case	Transportation Case

LIST OF ABBREVIATIONS/ACRONYMS

Abbreviation	Acronym
Hz	Hertz
SB	Stabilized Binocular
VDC	Volts Direct Current

SAFETY, CARE, AND HANDLING

Handle the M25 Stabilized Binocular and its accessories with care. Dropping the binocular can damage or misalign the optics. Keep the binocular clean and dry. Store all components in the hard transportation case when not in use or when transporting to other locations. Follow the instructions outlined in this TM to ensure the best usage and service for the binocular.

DO NOT use a dry cloth to clean the glass lenses of the binocular. Specific cleaning instructions are given in WP 0013 00.

DO NOT disassemble the binocular beyond that authorized by this TM. They are purged and sealed units.

DO NOT attempt to force the binocular focus adjustments beyond their stop limits, as this will damage internal and external parts.

DO NOT unnecessarily expose the binocular to severe weather elements.

**SUPPORTING INFORMATION FOR REPAIR PARTS, SPECIAL TOOLS,
TMDE, AND SUPPORT EQUIPMENT****Common Tools and Equipment**

For authorized common tools and equipment, refer to the Modified Table of Organization and Equipment (MTOE), CTA 50-970, Expendable/Durable Items (Except: Medical, Class V, Repair Parts, and Heraldic Items), or CTA 8-100, Army Medical Department Expendable/Durable Items, as applicable to your unit.

Special Tools, TMDE, and Support Equipment

Refer to WP0031 00 for a list of special tools that are used on this equipment. Also, refer to WP 0031 00 for the Maintenance Allocation Chart.

Repair Parts

Repair parts are listed and illustrated in supporting information work packages 0033 00 through 0041 00.

END OF WORK PACKAGE

TM 9-1240-408-13&P

CHAPTER 1

**DESCRIPTION AND THEORY
OF OPERATION**

OPERATOR'S, UNIT, AND DIRECT SUPPORT

**BINOCULAR: STABILIZED, M25
(NSN 1240-01-410-7418)**

EQUIPMENT DESCRIPTION AND DATA

**EQUIPMENT CHARACTERISTICS, CAPABILITIES, AND FEATURES;
LOCATION AND DESCRIPTION OF MAJOR COMPONENTS;
EQUIPMENT DATA**

EQUIPMENT CHARACTERISTICS, CAPABILITIES, AND FEATURES

The M25 Binocular is a 14X Binocular with a built-in gyroscopically controlled optical stabilizer, minimizing effects of hand tremor and platform vibration.

**EQUIPMENT CHARACTERISTICS, CAPABILITIES, AND FEATURES -
Continued**

The M25 binocular has user removable day eyepieces that can be replaced with optional eyepieces containing GEN III Image Intensifier Tubes, to provide for night vision capability.

The binocular operates either from internal batteries (2 "AA" cell), or from 6-30 volts direct current (VDC) applied through a connector. The unit comes with a neck strap and is supplied with the following: technical manual, hand strap, special purpose cable assembly, hard transportation case, and soft carrying pouch. The performance of correct and timely maintenance will ensure continued serviceability.

TM 9-1240-408-13&P

0002 00

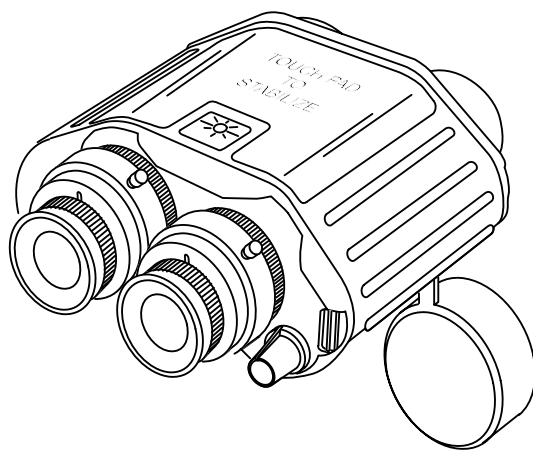

0002 00-3

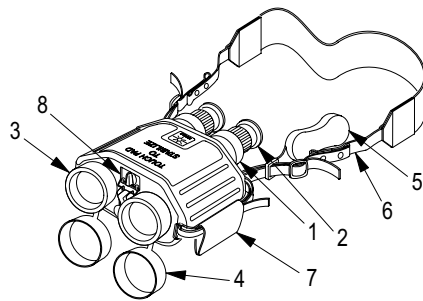
LOCATION AND DESCRIPTION OF MAJOR COMPONENTS

EYEPiece (1). Two detachable pieces used to look through binocular. They adjust for focus and individual eye spacing.

EYECUP (2). Rubber end on eyepiece. Folds back for viewing with eyeglasses.

OBJECTIVE LENS (3). Located on each side of battery box.

LENS CAP (4). Rubber cover for protection of objective lens when Stabilized Binocular is not in use.

LENS CAP (5). Rubber cover for protection of eyepiece lenses when Stabilized Binocular is not in use.

NECK STRAP (6). Allows operator to carry binocular around neck.

HAND STRAP (7). When adjusted properly, allows for easy operation with one hand.

BATTERY BOX (8). Houses two "AA" batteries required to supply power to Stabilized Binocular.

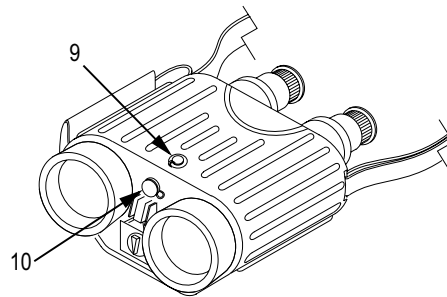
LOCATION AND DESCRIPTION OF MAJOR COMPONENTS - Continued

TRIPOD MOUNTING HOLE (9). Hole located on the bottom of binocular for securing binocular to a tripod.

VEHICLE POWER PLUG (10). Connects special purpose cable assembly to binocular for use with external power source.

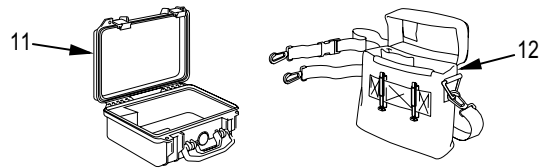

TRANSPORTATION CASE (11). Stores and carries Stabilized Binocular when not in use.

POUCH (12). Soft case for carrying binocular, coil cord, spare batteries, and optional night eyepiece. Strap assembly adjusts to carry pouch around waist or neck.

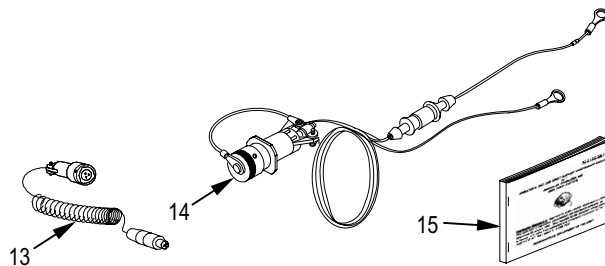

SPECIAL PURPOSE CABLE ASSEMBLY (13). Provides power from vehicle or arctic battery pack to Stabilized Binocular. Connects to binocular at plug between objective lenses.

HMMWV VEHICLE CONNECTOR ADAPTER (14). Supplies vehicle power from HMMWV through special purpose cable assembly to Stabilized Binocular.

TECHNICAL MANUAL (15). An operator's, unit, and direct support maintenance manual for the M25 Stabilized Binocular.

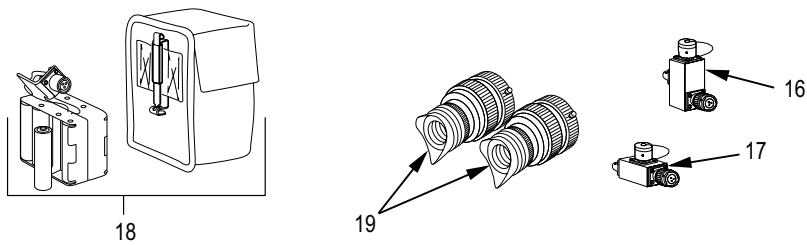
OPTIONAL ACCESSORIES

M1A1/A2 TANK VEHICLE CONNECTOR ADAPTER (16). Supplies vehicle power from M1A1/A2 Tank through special purpose cable assembly to Stabilized Binocular.

BRADLEY FIGHTING VEHICLE CONNECTOR ADAPTER (17). Supplies vehicle power from Bradley Fighting Vehicle through special purpose cable assembly to Stabilized Binocular.

LOCATION AND DESCRIPTION OF MAJOR COMPONENTS - Continued

ARCTIC PACK (18). Supplies power to Stabilized Binocular in extreme cold temperatures.

NOTE

The optional night eyepiece assembly may be used in pairs or singularly as a monocular.

NIGHT EYEPIECE ASSEMBLY (19). Optional eyepieces that provide for night vision capability.

EQUIPMENT DATA

	DAY	NIGHT (Optional)
Magnification	14X	14X
Objective Dia	41mm	41mm
Exit Pupil	3mm	3mm
Field of View	4.3 Degrees	4.4 Degrees
Resolution	4.3 Seconds	35LP/MM
Stabilization Freedom	±8 Degrees	±8 Degrees
Focus Adjust	±5 Diopters	±5 Diopters
Max Scan Rate	5-10 Deg/Sec	5-10 Deg/Sec
Interpupillary Adj	60-72mm	60-72mm
Internal Power	2 "AA" Cells	2 "AA" Cells

EQUIPMENT DATA - Continued

	DAY	NIGHT (Optional)
External Power	6-30 VDC at 0.5 amps	6-30 VDC at 0.5 amps
Optional Power (Arctic Pack)	8 "AA" Cells	8 "AA" Cells
Weight	2.1 kg (4.6 lb)	2.6 kg (5.8 lb)
Dimensions:		
Length	216mm (5.5 in.)	241mm (9.5 in.)
Width	191mm (7.5 in.)	191mm (7.5 in.)
Height	89mm (3.5 in.)	89mm (3.5 in.)

	OPERATE	STORAGE
Environmental Characteristics:		
High Temperature	+49 °C (120 °F)	+71 °C (160 °F)
Low Temperature	-32 °C (25.6 °F)	-46 °C (-50.8 °F)
Waterproof	1m depth	N/A
Stabilization Curve	(See WP 0047 00)	

END OF WORK PACKAGE

OPERATOR'S, UNIT, AND DIRECT SUPPORT

**BINOCULAR: STABILIZED, M25
(NSN 1240-01-410-7418)**

THEORY OF OPERATION

OPTICS, STABILIZATION

OPTICS

The Stabilized Binocular (SB), except for design details, has optical components that are identical to those found in conventional binoculars and that consist of an objective lens, prism erecting system, and eyepiece. All optical components are fully coated for optimum light transmission.

STABILIZATION

When a person holds a binocular in their hands they cannot hold it perfectly still. This small amount of movement, called, "jitter," is magnified by the optics. If the magnification of the binocular is high enough, as is the case with the M25 Stabilized Binocular, this blurring can degrade the image. It has been found that by stabilizing the prisms inside the binocular, the image is also stabilized and the clarity retained.

The prisms inside the M25 Stabilized Binocular are mounted on a platform that can swivel independently of the rest of the binocular. A tiny motor driven gyroscope also sits on the platform. The gyroscope helps to remove the hand jitter that would otherwise degrade the image.

The gyro-stabilization inside the M25 Stabilized Binocular will also remove some of the jitter introduced by vehicles. The M25 Stabilized Binocular is best at compensating for high frequency/low amplitude vibrations (see Figure 1, WP 0047 00). Depending on the type of vehicle and the terrain, the M25 Stabilized Binocular may be found to be very useful. The M25 Stabilized Binocular has been found to be highly effective in aircraft, including helicopters.

The M25 Stabilized Binocular also has a mechanism to lock the prism platform and keep it from swiveling. This helps to protect the prisms and gyroscope during transportation, and makes certain functions, such as acquiring or tracking a target easier. A touch pad located on top of the M25 Stabilized Binocular controls the locking mechanism.

END OF WORK PACKAGE

0003 00-3/4 blank

TM 9-1240-408-13&P

CHAPTER 2

OPERATOR INSTRUCTIONS

TM 9-1240-408-13&P

0004 00

OPERATOR

**BINOCULAR: STABILIZED, M25
(NSN 1240-01-410-7418)**

DESCRIPTION AND USE OF OPERATOR CONTROLS AND INDICATORS

CONTROLS AND INDICATORS

0004 00-1

CONTROLS AND INDICATORS

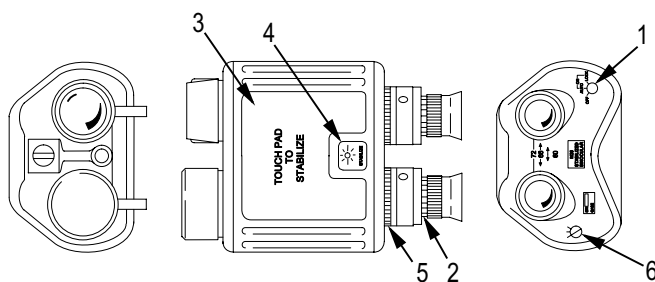

ITEM NO.	CONTROL OR INDICATOR	FUNCTION OR USE
1	Power Switch OFF ON/AUTO ON/LOCK	Turns OFF and ON power in three modes: Turns off power to Gyro Motor, Reticle, and Night Eyepiece. Turns on power to Gyro Motor, Reticle, and Night EyePiece, and provides for stabilization. Touch Pad is activated. Turns on power to Reticle and Night Eyepiece. Locks Gimbal and provides no stabilization.
2	Eyepiece Focus	Adjusts eyepiece to accommodate for differences in eyesight.

CONTROLS AND INDICATORS - Continued

ITEM NO.	CONTROL OR INDICATOR	FUNCTION OR USE
3	Stabilization Touch Pad	Activates stabilization of gimbal by touching; release activates caging mechanism.
4	Reticle Illumination	Provides adjustment of reticle illumination level.
5	Interpupillary Adjustment	Adjusts for individual eye spacing.
6	Battery State Indicator	Indicates battery status.

END OF WORK PACKAGE

OPERATOR

**BINOCULAR: STABILIZED, M25
(NSN 1240-01-410-7418)**

ASSEMBLY AND PREPARATION FOR USE

INITIAL ADJUSTMENTS

INITIAL ADJUSTMENTS

1. Remove the Stabilized Binocular from its carrying case. Place the neck strap over the operator's head with the unit in front of the operator. Adjust the neck strap so the unit hangs approximately halfway between the shoulders and waist. In a sitting position, the unit should not rest on the lap. Adjust hand strap to comfortably fit operator's hand. Fold the outer edge of the eyecups back for use with eyeglasses.
2. Ensure the unit is in the power OFF mode.

0005 00-1

INITIAL ADJUSTMENTS - Continued

3. Select a prominent target that is as distant as possible.
4. Rotate the focus adjustments (1) on the eyepieces fully counter-clockwise.

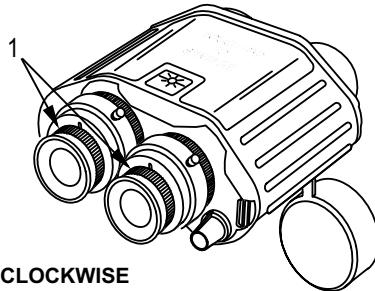

**ROTATE
COUNTERCLOCKWISE**

5. Remove the right lens cap, leaving the left one on.

NOTE

Rotating the eyepiece further than necessary in the clockwise direction could reduce the depth of field that can be achieved without refocusing.

6. Using the right eye, view through the right eyepiece (2) at the distant target. Slowly rotate the right eyepiece clockwise until the target is brought into sharp focus. Note the setting.
7. Replace the right lens cap and remove the left one.
8. Using the left eye, view through the left eyepiece (3) at the same distant target. Slowly rotate the left eyepiece clockwise until the target is brought into sharp focus. Note the setting.
9. Remove the right lens cap.

INITIAL ADJUSTMENTS - Continued

10. The stabilized binocular is now focused for your eyes. Set the Interpupillary Adjustment by moving the eyepieces (2 and 3) toward the center or outward, to accommodate the spacing of your eyes. Note the setting. No further eye adjustments should be needed during use of the device and the noted settings may be used for future initialization.

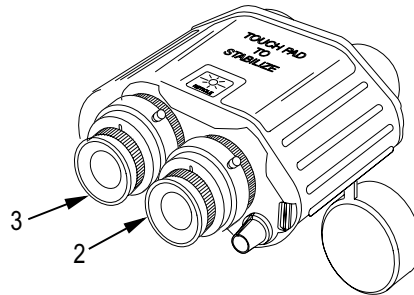
**END OF WORK PACKAGE**

TM 9-1240-408-13&P

0006 00

OPERATOR

**BINOCULAR: STABILIZED, M25
(NSN 1240-01-410-7418)**

OPERATION UNDER USUAL CONDITIONS

**NORMAL STABILIZED OPERATION; ACQUIRING AND
OBSERVING THE TARGET; USE OF RETICLE**

INITIAL SETUP:

References:

WP 0012 00, Battery Replacement

Materials/Parts:

Batteries (item 3, WP 0046 00)

0006 00-1

NORMAL STABILIZED OPERATION

1. The Stabilized Binocular is gyroscopically stabilized. The gyro is driven electrically by a small motor, powered by two "AA" batteries or external power in the range of 6 to 30 VDC.
2. External power is supplied via cable and connector from vehicle or from the optional arctic pack, and is connected on the objective lens and battery compartment end plate.
3. Open battery cover (1) on the front of the stabilized binocular.

NOTE

The battery cover face plate indicates proper installation of batteries.

4. Insert new batteries (2) (item 3, WP 0046 00) as indicated on inside of battery cover (1).

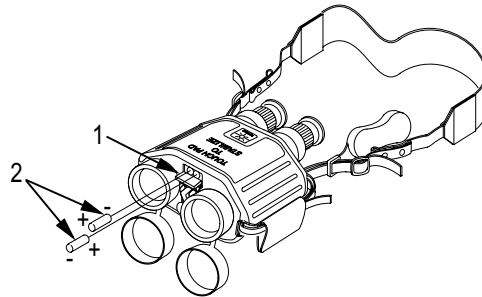

5. Turn the power ON by turning the power switch (3) to ON/AUTO.
6. Confirm power is ON by viewing the battery state indicator (4). Power is on when the indicator is in the green range. If the indicator is in the red range, battery replacement is necessary (see WP 0012 00).

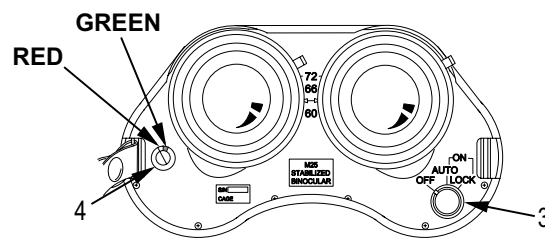
NORMAL STABILIZED OPERATION - Continued

7. When the indicator is at the green/red border, the unit will continue to run but will require new batteries shortly. Store spare batteries in the M25 Stabilized Binocular carrying case.
8. Verify the gyro is spinning up by listening for a slight humming sound.

NOTE

When the M25 Stabilized Binocular unit is to be used intermittently, it will be desirable to leave the power ON since the stabilization is not fully effective until the gyro reaches full speed.

9. When the gyro has reached full speed, hold the M25 Stabilized Binocular applying slight pressure to the stabilization touch pad (5). In the ON/AUTO mode, image stabilization will occur as long as there is pressure on the stabilization touch pad. Releasing pressure will unstabilize the binocular preventing potential damage.

NORMAL STABILIZED OPERATION - Continued

10. To illuminate the reticle, momentarily depress the reticle illumination switch (6) located on the top rear center of the M25 Stabilized Binocular. The switch can be stepped through six levels of increasing brightness and then returns to normal (non-illuminated). This is beneficial during low light level situations (dusk, dawn, overcast) when the reticle may be difficult to see against the background.

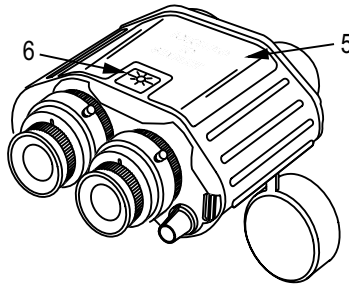

0006 00-6

ACQUIRING AND OBSERVING THE TARGET

The Stabilized Binocular is operated in a similar manner to a conventional binocular. The difference is the ability to switch from an unstabilized to a stabilized mode.

WARNING

Never point the M25 Stabilized Binocular directly at the sun. Heat generated by the sun's focused rays may cause serious damage to eyes of operator.

The M25 Stabilized Binocular may cause motion sickness or intensify disorientation or nausea in some users. If this occurs, discontinue use for a few minutes. Should the condition continue, seek medical attention.

NOTE

Smooth motion is important to tracking.

ACQUIRING AND OBSERVING THE TARGET - Continued

1. To observe a distant target more closely, raise the M25 Stabilized Binocular and hold it just below eye level, sighting the target across the top of the binocular.

WARNING

The M25 Stabilized Binocular is provided with internal laser protection filters. The laser protection filters are contained inside the body of the binocular and in the eyepiece assemblies. If the lens(es) or eyepiece(s) are damaged, the M25 Stabilized Binocular system is to be considered non-operational and must be turned in. Use of the M25 Stabilized Binocular with a faulty coated lens may result in irreparable damage to the eye if laser light is viewed through the binocular.

WARNING

When viewing targets in the general area of the sun, the laser filters may produce a sparkle or glint visible from the general area under view.

NOTE

It takes a short time for the moving internal prism elements to "catch up" to the target. Do not jerk the device around even faster. Relax and maintain smooth and even tracking.

2. Finish raising the M25 Binocular to the eyes, sight the target through it, and apply slight pressure to the stabilization touch pad.
3. Scan, acquire, or track a target in the unstabilized mode; then switch to the stabilized mode to identify or monitor the target.

PRACTICAL EXERCISES

It is important to practice using the M25 Stabilized Binocular prior to bringing it on a mission. The operator must be convinced the M25 Stabilized Binocular is the right tool for the mission as well as know how and when to use it. The M25 Stabilized Binocular provides a combination of increased standoff ranges, better target identification, and the ability to be used on some moving platforms, it does however, weigh more than a standard binocular. Perform the following exercises to become familiar with the advantages of the M25 Stabilized Binocular and to learn what it can do.

Learn the Advantages of High Power Combined with Stabilization

1. Take the M25 Stabilized Binocular outdoors and prepare it as instructed in work package pages 0005 00-1 through 0006 00-6.
2. Locate a target with some fine detail. A good target, for example purposes, is a vehicle license plate. Select a target at a distance so that when viewed in the unstabilized mode, it is very difficult to read the letters or numbers (the blurring due to hand jitter should be obvious).

3. Squeeze the stabilization touch pad on top of the binocular to engage the stabilization mechanism, note the improved clarity of the image.
4. Practice with different targets at different ranges to learn how the M25 Stabilized Binocular can be of benefit.

Learn How to Scan a Scene with a Stabilized Binocular

1. Take the M25 Stabilized Binocular outdoors and prepare it as instructed in work package pages 0005 00-1 through 0006 00-6
2. Locate a scene that covers a wide angle from side to side (e.g., a tree line or the horizon).
3. Start by viewing one edge of the scene through the M25 Stabilized Binocular and squeeze the stabilization touch pad to engage the stabilization mechanism.
4. Very slowly turn to scan across the scene.

PRACTICAL EXERCISES - Continued

5. Continue to repeat steps 3 and 4 slightly increasing the rate of turn until a bouncing or unstable image is noticed during scanning.
6. At this point the maximum scan rate of the binocular has been reached. To turn faster than this, perform the following steps:
 - a. View one edge of the scene through the M25 Stabilized Binocular.
 - b. Release the stabilization touch pad to disengage the stabilization.
 - c. Turn as quickly as wanted to the other side of the scene and stop.
 - d. Engage the stabilization touch pad to regain stabilization.
 - e. Practice this with moving targets also, learning when to disengage the stabilization mechanism to scan and when to engage it to identify a target.

USE OF RETICLE

NOTE

Eyepieces are interchangeable.

One binocular eyepiece has a horizontal and vertical scale reticle graduated in 10-mil major (5-mil minor) increment unit markings (1 major unit = 10 mils, 2 major units = 20 mils, etc.).

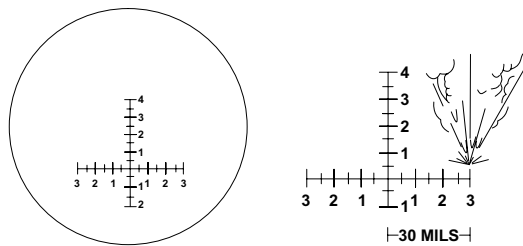
USE OF RETICLE - Continued

Fire corrections can be made by viewing the impact area and determining angular corrections by use of the left or right horizontal reticle scale.

In determining range, if an object fills one 10-mil unit marking on the horizontal reticle scale and is known to be 10 meters wide, the object is 1000 meters away. If the same size object fills two unit markings (20 mils), it would be 500 meters away. When this formula is used, the distance will be given in the same units of measurement (feet, meters, etc.) as is used in estimating the known size of the object.

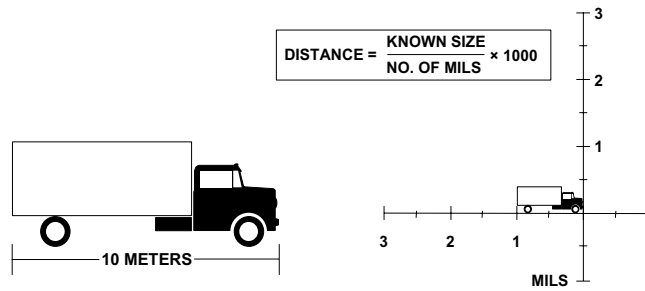

USE OF RETICLE - Continued

The same formula can be used to determine range with the vertical reticle scale when the height of an object is known. Use of the vertical scale is preferred (especially on level terrain), since objects are often viewed obliquely along the horizontal axis.

END OF WORK PACKAGE

TM 9-1240-408-13&P

0007 00

OPERATOR

**BINOCULAR, STABILIZED: M25
(NSN 1240-01-410-7418)**

NIGHT MODE OPERATION

INITIAL SETUP:

References:

WP 0006 00, Operation Under Usual Conditions

0007 00-1

NIGHT MODE OPERATION**CAUTION**

The night eyepiece(s) must not be installed when operating the binocular during daylight to protect the image intensifier tube from damage.

1. Ensure the unit is in the power OFF mode.
2. While depressing eyepiece lock (1), rotate daytime eyepiece (2) counter-clockwise to unlock and remove.

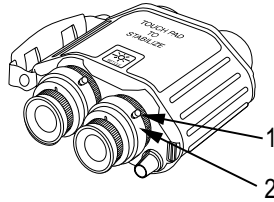
**0007 00-2**

3. Orient night eyepiece (3) so that the eyepiece lock (4) is aligned with the mark (5) on the binocular (approximately in the 12 o'clock position).
4. Depress eyepiece lock (4) and push eyepiece into bayonet ring.

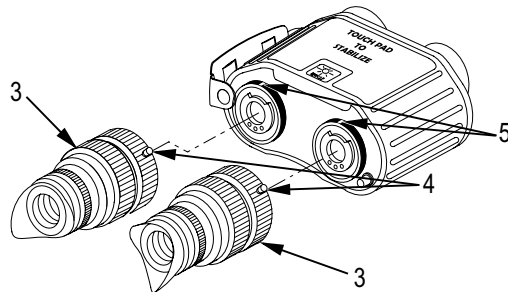

NIGHT MODE OPERATION - Continued**NOTE**

If eyepiece is not properly aligned, it will not lock into binocular.

5. Once in the binocular, rotate the night eyepiece (3) clockwise and release the eyepiece lock (4). Continue rotating until the lock snaps into the locking detent. A firm "click" will be discerned when eyepiece locks.
6. Turn power on.
7. Verify the battery state indicator needle is in the green area.

WARNING

When using night vision eyepiece, eyepiece cup must be used to prevent detection.

NOTE

The sharpest image will be observed only when the course and diopter adjustments are properly focused. The course adjustment ring (6) is used to focus on the target at varying distances. The diopter adjustment ring (7) is used to focus your eye (with or without glasses) on the image intensifier screen. These adjustments operate independently and must be made separately.

8. With the M25 Stabilized Binocular to the operator's eyes, adjust the focus as follows:

NIGHT MODE OPERATION - Continued

- a. Close left eye and make adjustments to right eyepiece by adjusting the diopter adjustment ring (7) for the clearest view on the image intensifier screen.

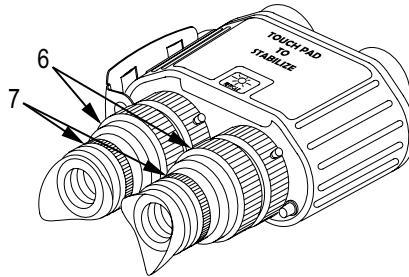

- b. With left eye still closed, make adjustment to right eyepiece by adjusting the course adjustment ring (6) on the individual eyepiece until a reasonably sharp image is formed of a target.
 - c. Repeat steps a and b until the best focus is obtained.
 - d. Open left eye, close right eye and repeat steps a and b for the left eyepiece until the best focus is obtained.
9. The unit is now ready for night operation. Refer to WP 0006 00 for stabilization use.

END OF WORK PACKAGE

0007 00-7/8 blank

OPERATOR

**BINOCULAR, STABILIZED: M25
(NSN 1240-01-410-7418)**

OPERATION UNDER UNUSUAL CONDITIONS

EXTERNAL POWER ADAPTERS, ARCTIC BATTERY PACK

EXTERNAL POWER ADAPTERS

The M25 Stabilized Binocular can operate from external DC power, 6 to 30 volts at 0.5 amps or from the arctic battery pack. Three adapters are available for use on three vehicles: the HMMWV, the Bradley Fighting Vehicle, and the M1A1/A2 Tank. The HMMWV adapter is supplied with the binocular, the remaining adapters and arctic battery pack are available as Additional Authorization List (WP 0045 00) items. The external power input is polarity protected. Internal batteries are automatically disconnected when external power is being used.

EXTERNAL POWER ADAPTERS - Continued

HMMWV

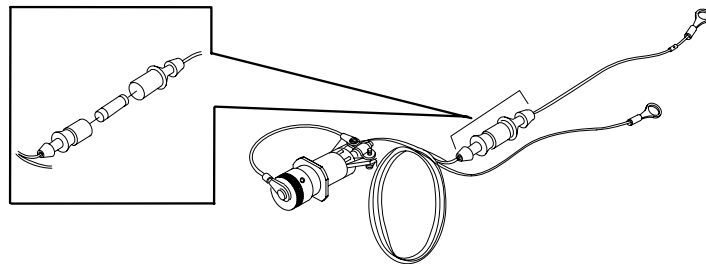

Perform the following steps to connect the HMMWV connector adapter to the vehicle battery under the commander's (curb side, front) seat.

CAUTION

Ensure the red wire with the fuse assembly is connected to the positive (+) battery terminal.

1. Fasten the two wires from the connector adapter, terminated in 3/8 in. lugs, to the bolts securing the vehicle power cables to the battery terminals.

EXTERNAL POWER ADAPTERS - Continued

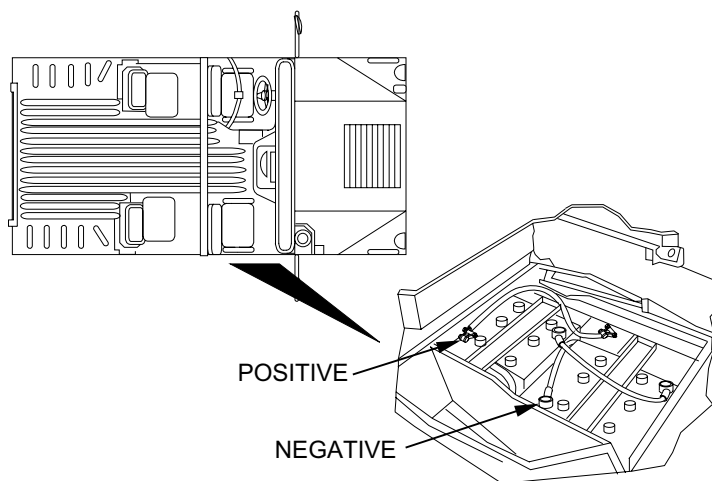

0008 00-4

2. Route the adapter end of the connector adapter wire out of the battery compartment through any convenient hole. Tape the wire and any sharp edges of the hole to prevent damage and possible shorting of the wire.
3. Run the connector adapter wire from the battery compartment to the left of the foot well, forward along the foot well, then up to the mounting plate. Secure adapter connector wire in place with tape, nylon cable ties, or similar materials.
4. Coil excess wire near adapter and secure with tape, nylon cable ties, or similar materials. Ensure an adequate length of wire is left to allow for free range of motion with binocular.
5. Attach the special purpose cable assembly to the connector on the Objective Lens and Battery Compartment End Plate.
6. Connect the special purpose cable assembly of the M25 Stabilized Binocular to the connector adapter.

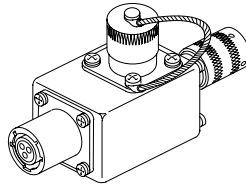
EXTERNAL POWER ADAPTERS - Continued**M3A2 Bradley Fighting Vehicle****NOTE**

In the absence of the M3A2 Bradley Fighting Vehicle adapter, the special purpose cable assembly may be plugged directly into the bulkhead connector. This will however sacrifice the operation of the service light.

1. Disconnect the power cord for the service light at the bulkhead.
2. Connect the connector adapter to the bulkhead connector and connect the service light cord to the connector adapter.
3. Attach the special purpose cable assembly to the connector on the Objective Lens and Battery Compartment End Plate.
4. Connect the special purpose cable assembly of the M25 Stabilized Binocular to the third connector.

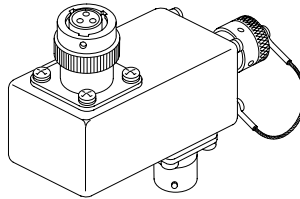
EXTERNAL POWER ADAPTERS - Continued**M1A1/A2 Tank**

1. Disconnect the power cord for the Commander's Dome Light and connect the connector adapter to the Dome Light.
2. Connect the Commander's Dome Light power cord to the connector adapter.
3. Attach the special purpose cable assembly to the connector on the Objective Lens and Battery Compartment End Plate.

-
4. Connect the special purpose cable assembly of the M25 Stabilized Binocular to the third connector.

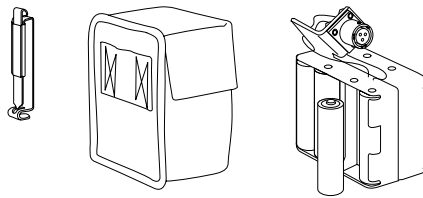
ARCTIC BATTERY PACK (OPTIONAL)**NOTE**

In extreme cold temperatures use the arctic battery pack.

1. Attach the special purpose cable assembly to the connector on the Objective Lens and Battery Compartment End Plate.

ARCTIC BATTERY PACK (OPTIONAL) - Continued

2. Attach the special purpose cable assembly to the arctic battery pack battery holder.
3. Place arctic battery pack inside coat to keep batteries warm.

END OF WORK PACKAGE

TM 9-1240-408-13&P

CHAPTER 3

**OPERATOR MAINTENANCE INSTRUCTIONS
FOR THE
M25 STABILIZED BINOCULAR**

TM 9-1240-408-13&P

0009 00

OPERATOR

**BINOCULAR: STABILIZED, M25
(NSN 1240-01-410-7418)**

EYEPIECE OPERATIONAL CHECKOUT

INITIAL SETUP:

References

WP 0012 00, Battery Replacement

EYEPIECE OPERATIONAL CHECKOUT

Perform the following operational checkout on the reticle eyepiece and optional night vision eyepiece prior to operating the binocular.

0009 00-1

EYEPIECE OPERATIONAL CHECKOUT - Continued

1. Install fresh batteries (WP 0012 00) and ensure eyepieces are locked in place.
2. Install lens covers on binocular.
3. Turn power switch to ON/LOCK position.
4. DAY RETICLE EYEPIECE – Look for different light levels while depressing reticle touch pad.
5. NIGHT VISION EYEPIECE(S) (OPTIONAL) – Look for green glow in eyepiece.

END OF WORK PACKAGE

TM 9-1240-408-13&P

0010 00

OPERATOR

**BINOCULAR: STABILIZED, M25
(NSN 1240-01-410-7418)**

**PREVENTIVE MAINTENANCE CHECKS AND SERVICES (PMCS)
INTRODUCTION**

GENERAL

GENERAL

Preventive Maintenance Checks and Services (PMCS) are performed to keep the equipment in operating condition. The checks are used to find, correct, or report problems. Operator members are to do the PMCS jobs as shown in WP 0011 00. PMCS are done every day the equipment is used, using WP 0011 00. Pay attention to WARNING and CAUTION statements. A WARNING means someone could be hurt. A CAUTION means equipment could be damaged.

0010 00-1

GENERAL - Continued

1. **BEFORE YOU OPERATE.** Perform your Before PMCS prior to the equipment performing its intended mission; if you are the assigned operator and the Binocular has been stored and not used for a period of 90 days; or if you have been issued the Binocular for the first time.
2. **WHILE YOU OPERATE.** Perform your During PMCS when the equipment is being used in its intended mission.
3. **AFTER YOU OPERATE.** Be sure to perform your After PMCS after the equipment has performed its mission.

Explanation of Columns

1. **ITEM NUMBER column:** Is to be used for reference. When completing DA Form 2404, Equipment Inspection and Maintenance Worksheet, include the item number for the check/service indicating a fault.

2. INTERVAL column: Tells you when to do a certain check or service.
3. MAN-HOUR column: Tells you how much time should be required for the procedure.
4. ITEM TO BE CHECKED OR SERVICED column: Identifies the item to be checked or serviced.
5. PROCEDURE column: Tells you how to do required checks and services.
6. EQUIPMENT NOT READY/AVAILABLE IF column: Tells you when and why your equipment cannot be used.

END OF WORK PACKAGE

0010 00-3/4 blank

TM 9-1240-408-13&P

0011 00

OPERATOR

**BINOCULAR: STABILIZED, M25
(NSN 1240-01-410-7418)**

**PREVENTIVE MAINTENANCE CHECKS AND SERVICES (PMCS),
INCLUDING LUBRICATION INSTRUCTIONS**

PMCS PROCEDURES

INITIAL SETUP:

References

WP 0034 00, Stabilized Binocular with Eyepiece
WP 0035 00, Optical Eyepiece Assembly

0011 00-1

PMCS PROCEDURES
**Table 1. Preventive Maintenance Checks and Services for M25
Stabilized Binocular**

ITEM NO.	INTERVAL	MAN-HOUR	ITEM TO BE CHECKED OR SERVICED	PROCEDURE	EQUIPMENT NOT READY/ AVAILABLE IF:
1	Before, After	0.1	Battery Cover	Check battery cover for corrosion; bent, broken, or missing contacts; and damaged gasket.	Battery cover is corroded; contacts are bent, broken, or missing; or gasket is damaged.
2	Before, During	0.1	Batteries	Turn power on and check battery status indicator to ensure the unit is equipped with batteries of sufficient power.	Batteries of sufficient power are not installed.

**Table 1. Preventive Maintenance Checks and Services for M25
Stabilized Binocular - Continued**

ITEM NO.	INTERVAL	MAN-HOUR	ITEM TO BE CHECKED OR SERVICED	PROCEDURE	EQUIPMENT NOT READY/ AVAILABLE IF:
3	Before	0.1	Gyro	Check to see that gyro spins up.	Gyro does not spin up.
4	Before, After	0.1	Eyepieces	Ensure eyepieces and all other components of eyepieces are present. Inventory to parts list for completeness (WP 0035 00).	Eyepiece is missing or components are missing.
5	Before, After	0.1	Eyepiece Lock	Visually inspect eyepieces for loose, missing, or damaged eyepiece lock.	Eyepiece lock is not functional.

PMCS PROCEDURES – Continued

**Table 1. Preventive Maintenance Checks and Services for M25
Stabilized Binocular – Continued**

ITEM NO.	INTERVAL	MAN-HOUR	ITEM TO BE CHECKED OR SERVICED	PROCEDURE	EQUIPMENT NOT READY/ AVAILABLE IF:
6	Before, During, After	0.2	Optic	Sight through the optic, inspect for visual obstruction of the target image; degradation of reticle; dust, dirt, cracks, scratches, or moisture on optical surface; loose or broken optical elements.	These conditions are present and cannot be corrected through cleaning procedures.
7	Before, After	0.1	Focus Adjustments	Ensure focus adjustments turn freely and are operable.	Focus adjustments do not turn freely or are not operable.

**Table 1. Preventive Maintenance Checks and Services for M25
Stabilized Binocular - Continued**

ITEM NO.	INTERVAL	MAN-HOUR	ITEM TO BE CHECKED OR SERVICED	PROCEDURE	EQUIPMENT NOT READY/ AVAILABLE IF:
8	Before	0.2	Power Source (Alternate)	Remove two "AA" batteries. Verify that Binocular works with vehicle power and optional arctic pack.	Binocular is nonfunctional.
9	Before	0.1	Special Purpose Cable Assembly	Check that special purpose cable assembly connectors and pins are not missing or bent.	Special purpose cable assembly connector or pins is missing or bent.
10	Before	0.1	Transportation Case, Pouch	Check transportation case and pouch for visible damage and ensure they close or latch securely.	Transportation case or pouch will not close or latch securely.

PMCS PROCEDURES – Continued

**Table 1. Preventive Maintenance Checks and Services for M25
Stabilized Binocular - Continued**

ITEM NO.	INTERVAL	MAN-HOUR	ITEM TO BE CHECKED OR SERVICED	PROCEDURE	EQUIPMENT NOT READY/ AVAILABLE IF:
11	Before, After	0.1	Accessories	Ensure straps, lens covers, and all components are present and secure. Inventory to parts list for completeness (WP 0034 00).	Straps and lens covers are missing or will not fasten securely.
12	Before, During, After	0.1	Rubber Components	Inspect all rubber components ensuring they are not worn, torn, or cracked.	Rubber components are worn, torn, or cracked.

END OF WORK PACKAGE

OPERATOR

**BINOCULAR: STABILIZED, M25
(NSN 1240-01-410-7418)**

BATTERY REPLACEMENT

INITIAL SETUP:

Materials/Parts

Batteries (Item 3, WP 0046 00)

BATTERY REPLACEMENT

1. Open battery cover (1) on the front of the stabilized Binocular.
2. Remove used batteries.

BATTERY REPLACEMENT - Continued

NOTE

The battery cover face plate indicates proper installation of batteries.

3. Insert new batteries (2) (item 3, WP 0046 00) as indicated on inside of battery cover (1).
4. Dispose of used batteries in accordance with local procedures.

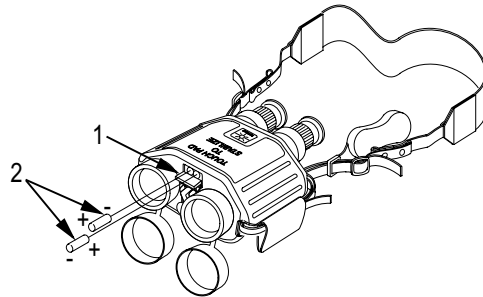

END OF WORK PACKAGE

0012 00-3/4 blank

TM 9-1240-408-13&P

0013 00

OPERATOR

**BINOCULAR: STABILIZED, M25
(NSN 1240-01-410-7418)**

CLEANING

CASE AND BINOCULAR EXTERIOR, OPTICAL SURFACES

INITIAL SETUP:

Materials/Parts

Artist's brush (Item 6, WP 0046 00)
Lens cleaner (Item 7, WP 0046 00)
Lens type paper (Item 10, WP 0046 00)
Watchmaker's blower (Item 4, WP 0046 00)

0013 00-1

CLEANING

Case and Binocular Exterior

Clean the exterior of the transportation case and the Binocular (not the lenses) with a clean lint-free cloth. Remove grease and soil with soap and water and a damp clean cloth. Dry with a clean, lint free cloth. Blow dirt and lint from case interiors.

Optical Surfaces

CAUTION

Never wipe dry or dirty lenses with a dry cloth.

Using watchmaker's blower (item 4, WP 0046 00), blow as much dust and dirt as possible from the exposed lens surface. Using artist's brush (item 6, WP 0046 00), brush across the surface with light, quick strokes, flicking after each stroke to dislodge the dust it has picked up. When all visible particles of dust and dirt have been removed, moisten a piece of lens type paper (item 10, WP 0046 00) with lens cleaner (item 7, WP 0046 00) and gently wipe over the surface.

END OF WORK PACKAGE

0013 00-3/4 blank

TM 9-1240-408-13&P

CHAPTER 4

**UNIT MAINTENANCE INSTRUCTIONS
FOR THE
M25 STABILIZED BINOCULAR**

TM 9-1240-408-13&P

0014 00

UNIT

**BINOCULAR: STABILIZED, M25
(NSN 1240-01-410-7418)**

SERVICE UPON RECEIPT

SERVICE UPON RECEIPT

Inspect the equipment for damage incurred during shipment. If the equipment has been damaged, report the damage on an SF 361, Transportation Discrepancy Report.

Check the equipment against WP 0002 00 to see if the shipment is complete. Report all discrepancies in accordance with applicable service instructions (e.g. Army instructions, see DA PAM 738-750).

END OF WORK PACKAGE

0014 00-1/2 blank

UNIT

**BINOCULAR: STABILIZED, M25
(NSN 1240-01-410-7418)**

HAND STRAP ASSEMBLY MAINTENANCE

REMOVAL, INSTALLATION

REMOVAL

1. Open Velcro fastener on hand pad (1).
2. Unbuckle webbing strap (2) from fastener (3).
3. Remove webbing strap (2) from objective lens strap hook (4).

REMOVAL - Continued

4. Remove hand pad (1) from webbing strap (2).
5. Remove webbing strap (2) from eyepiece strap hook (5).

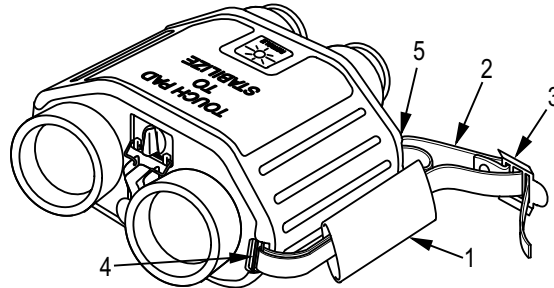

INSTALLATION

1. Slide plain end of webbing strap (1) through eyepiece strap hook (2).

NOTE

Hand strap may be installed on opposite side of the binocular for a left handed user.

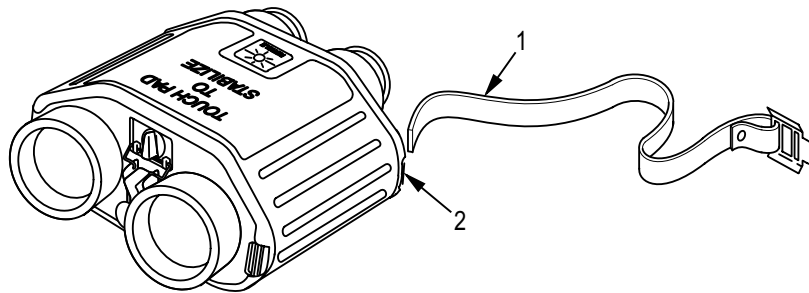

0015 00-3

INSTALLATION - Continued

2. With exterior side of pad facing binocular, lace webbing strap (1) through hand pad (3).
3. Insert webbing strap (1) under objective lens strap hook (4) and pull webbing strap through strap hook. Webbing strap should not be pulled tight against binocular.

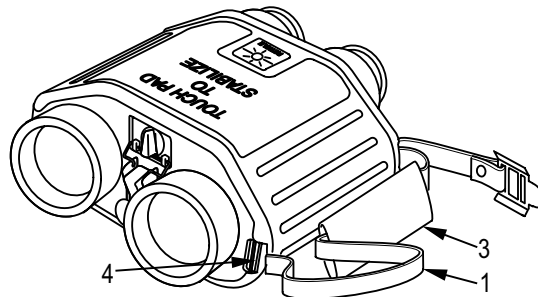

0015 00-4

-
4. Lace end of webbing strap (1) securely through fastener (5).
 5. With webbing strap (1) inside hand pad (3), fasten Velcro closure.

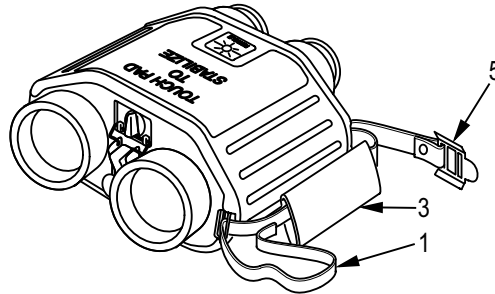

END OF WORK PACKAGE

0015 00-5/6 blank

TM 9-1240-408-13&P

0016 00

UNIT

**BINOCULAR: STABILIZED, M25
(NSN 1240-01-410-7418)**

NECK STRAP ASSEMBLY MAINTENANCE

REMOVAL, INSTALLATION

REMOVAL

1. Unfasten webbing strap (1) on each side.
2. Pull webbing strap (1) from strap hooks (2) on each side of Binocular.

0016 00-1

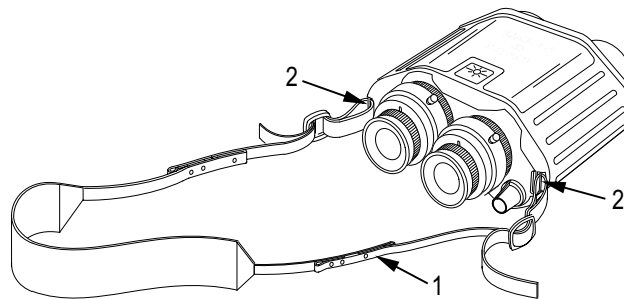
**INSTALLATION**

1. Slide webbing strap (1) through strap hooks (2) by power switch and battery indicator.
2. Secure ends of webbing strap (1) with fasteners on webbing strap.

WARNING

The neck strap of the binocular may become tangled during an emergency exit from the vehicle. To facilitate quick removal the neck strap incorporates a quick disconnect feature, activated by a pull release system.

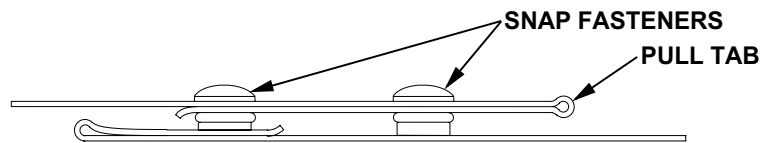

3. Using fasteners on webbing strap (1), adjust neck strap length so binocular hangs halfway between shoulders and waist.

END OF WORK PACKAGE

TM 9-1240-408-13&P

0017 00

UNIT

**BINOCULAR: STABILIZED, M25
(NSN 1240-01-410-7418)**

**TRANSPORTATION CASE MAINTENANCE
REMOVAL, INSTALLATION**

INITIAL SETUP:

Materials/Parts

Adhesive (item 1, WP 0046 00)

0017 00-1

REMOVAL

NOTE

Ensure contents of transportation case are removed.

1. Remove cushioning material (1) from lid of transportation case (2).
2. Pull cushioning material (3) from side of transportation case (2).
3. Lift cushioning material (4) from bottom of transportation case (2).

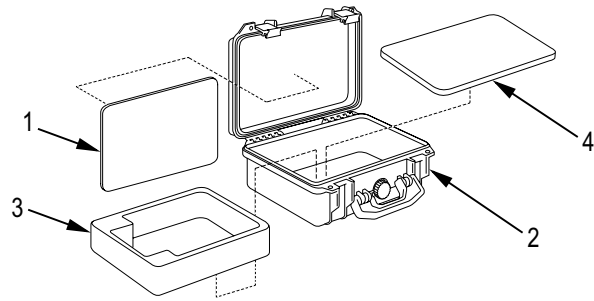

REMOVAL - Continued

4. Pull gasket (5) from groove in lid of transportation case (2) until completely removed.

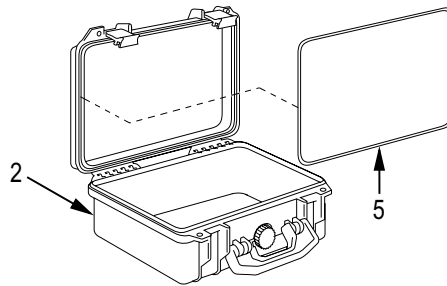

0017 00-4

5. Turn purge valve (6) counterclockwise until removed.

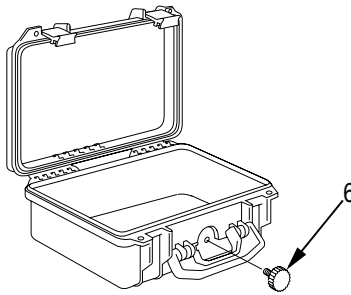

INSTALLATION

1. Insert threaded end of purge valve (1) into purge valve hole (2) in transportation case. Turn purge valve clockwise until secured.

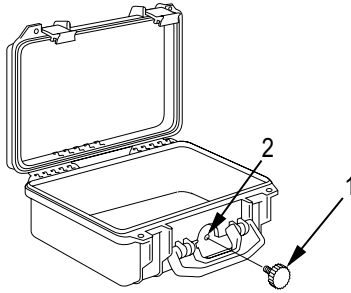

0017 00-6

2. Apply adhesive (item 2, WP 0046 00) to groove in lid of transportation case (3). Wipe off excess adhesive.
3. Press gasket (4) into groove in lid of transportation case (3). Channel in gasket should face outwards to form tight seal with base of transportation case.

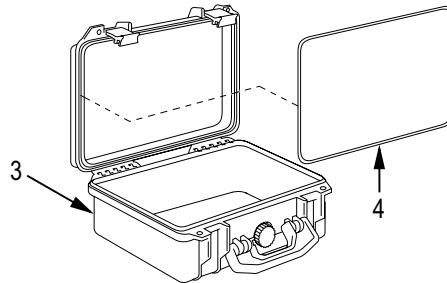

0017 00-7

INSTALLATION - Continued

4. Press bottom cushioning material (5) into transportation case (3).
5. Insert side cushioning material (6) into transportation case (3).
6. Press top cushioning material (7) into lid of transportation case (3).

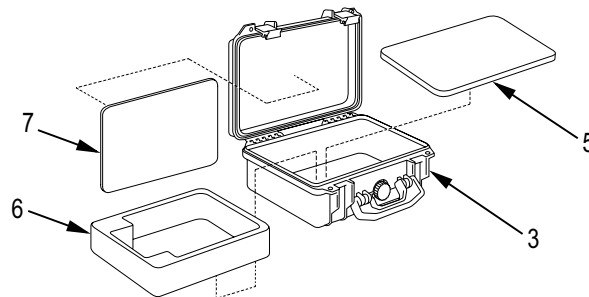
**END OF WORK PACKAGE****0017 00-8**

TM 9-1240-408-13&P

0018 00

UNIT

**BINOCULAR: STABILIZED, M25
(NSN 1240-01-410-7418)**

POUCH MAINTENANCE

REMOVAL, INSTALLATION

REMOVAL

NOTE

The two identical webbing straps are supplied to wear around the neck and chest.

0018 00-1

REMOVAL - Continued

1. Unfasten webbing straps (1 and 2) from two triangular latches (3) on pouch (4).
2. Store webbing straps (1 and 2) in pouch (4) when not in use.

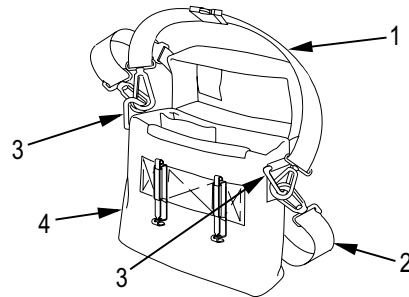

3. Firmly grasp bottom of belt strap keeper (5) while pulling up on top part of belt strap keeper.
4. Slide belt strap keeper (5) from strap (6) on pouch (4).
5. Repeat steps 3 and 4 for second belt strap keeper.

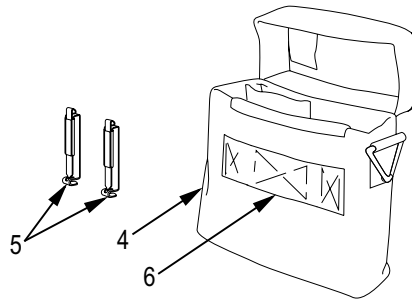

INSTALLATION

1. With belt strap keeper (1) in open position, slide belt strap keeper between strap (2) and pouch (3), until belt strap keeper is in place on strap.
2. Press firmly down on top of belt strap keeper (1) while holding bottom of belt strap keeper.

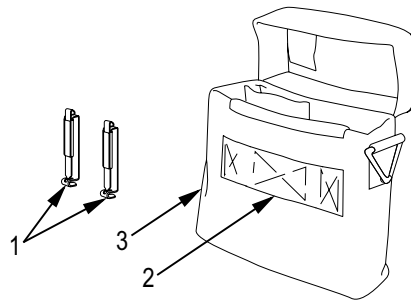

0018 00-4

3. Attach hooks on webbing straps (4 and 5) to two triangular latches (6) on pouch (3).
4. Adjust length of neck and chest straps by pulling webbing straps (4 and 5) through snap fasteners.

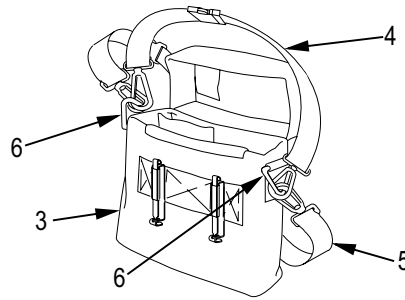

END OF WORK PACKAGE

0018 00-5/6 blank

TM 9-1240-408-13&P

0019 00

UNIT

**BINOCULAR: STABILIZED, M25
(NSN 1240-01-410-7418)**

ARCTIC PACK (OPTIONAL) MAINTENANCE

REMOVAL, INSTALLATION

REMOVAL

NOTE

Ensure special purpose cable assembly is disconnected from battery holder before performing maintenance.

0019 00-1

REMOVAL - Continued

1. Unfasten velcro closure on textile bag (1).
2. Remove battery holder (2), with batteries (3), from textile bag (1).
3. Remove batteries (3) from battery holder (2).
4. Dispose of batteries in accordance with local procedures.

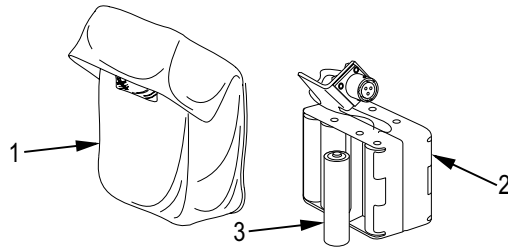

-
5. Firmly grasp bottom of belt strap keeper (4) while pulling up on top of belt strap keeper.
 6. Slide belt strap keeper (4) from strap (5) on textile bag (1).

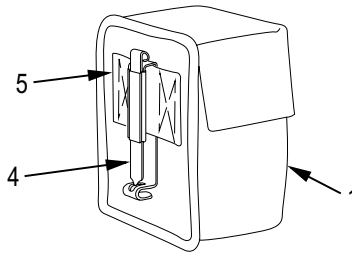

INSTALLATION

1. Insert new batteries (1) into battery holder (2), following diagram on holder for correct positioning of batteries.
2. Place battery holder (2) into textile bag (3) with adapter at opening of bag.
3. If arctic pack is to be used, connect coil cord to adapter.
4. Fasten velcro closure.

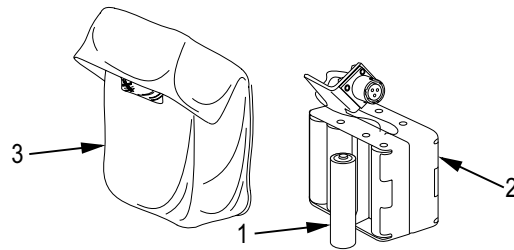

0019 00-4

-
5. With belt strap keeper (4) in open position, insert belt strap keeper between strap (5) and textile bag (3), until belt strap keeper is in place on strap.
 6. Firmly press down on top of belt strap keeper (4) while holding bottom of belt strap keeper.

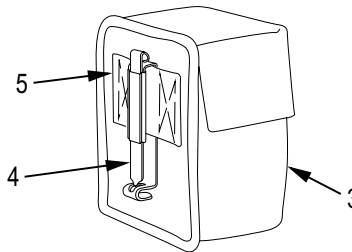

END OF WORK PACKAGE

0019 00-5/6 blank

UNIT**BINOCULAR: STABILIZED, M25
(NSN 1240-01-410-7418)****PROTECTIVE COVERS MAINTENANCE****REMOVAL, INSTALLATION**

REMOVAL

1. Remove lens cap (1) from eyecups (2).
2. Unfasten webbing strap (3).
3. Slide lens cap (1) from webbing strap (3).

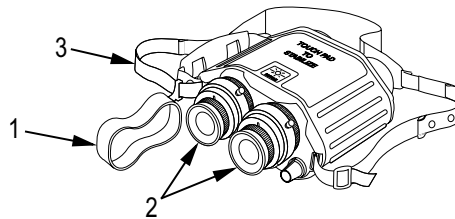
**0020 00-1**

TM 9-1240-408-13&P

0020 00

0020 00-1

REMOVAL - Continued

4. With lens cap covers in place or loose, slide lens cap (4) from objective lens (5).

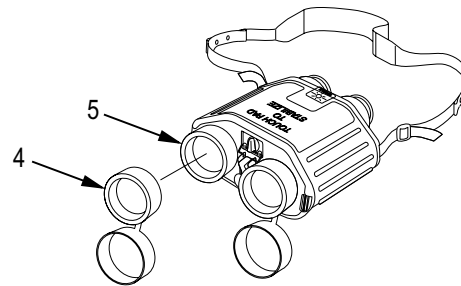

INSTALLATION

1. Slide lens cap (1) onto webbing strap (2) ensuring lens cap is in proper position to fit on eyecups (3).
2. Fasten webbing strap (2).
3. Install lens cap (1) on eyecups (3).

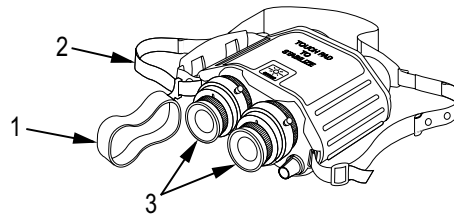

INSTALLATION - Continued**NOTE**

Battery cap assembly may be opened to aid in lens cap installation.

4. Press lens cap (4) over objective lens (5), ensuring lens cap fits into groove around objective lens.

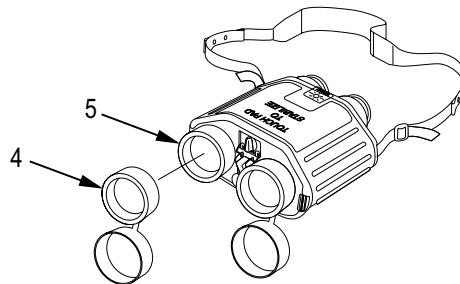
**END OF WORK PACKAGE**

TM 9-1240-408-13&P

0021 00

UNIT

**BINOCULAR: STABILIZED, M25
(NSN 1240-01-410-7418)**

**DAYTIME EYEPIECE MAINTENANCE
REMOVAL, INSTALLATION**

INITIAL SETUP:

Materials/Parts

Adhesive (item 1, WP 0046 00)

Aircraft grease (item 9, WP 0046 00)

0021 00-1

REMOVAL

1. Ensure the unit is in the power OFF mode.
2. While depressing eyepiece lock (1), rotate eyepiece (2) counterclockwise to unlock.

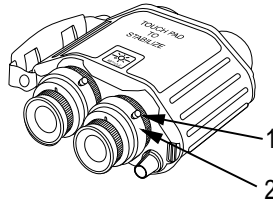

NOTE

Eyecup is adhered to eyepiece. Do not remove eyecup unless damaged.

3. Remove eyecup (3) from eyepiece (2).

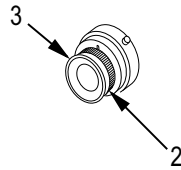

REMOVAL - Continued

4. Lift protective sleeve (4) from eyepiece (2) and over eyepiece lock (1).

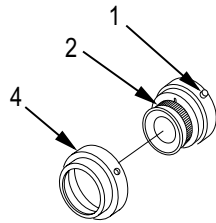

5. Lift O-ring (5) from outer edge of bayonet ring on binocular.

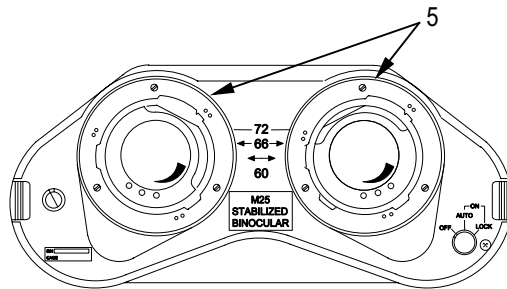

INSTALLATION

1. Apply adhesive (item 2, WP 0046 00) to O-ring (1).
2. Place O-ring (1) into groove on outer edge of bayonet ring on binocular.
3. Apply aircraft grease (item 9, WP 0046 00) to O-ring (1).

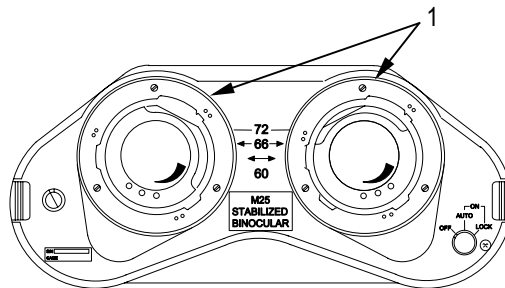

0021 00-6

4. Apply adhesive (item 1, WP 0046 00) to protective sleeve (2).
5. Place hole in protective sleeve (2) over eyepiece lock (3) and slide protective sleeve over eyepiece (4), ensuring protective sleeve is securely in place.

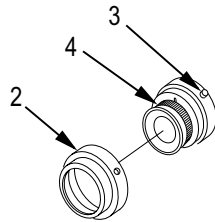

INSTALLATION - Continued

6. Apply adhesive (item 2, WP 0046 00) to eyecup (5).
7. Install eyecup (5) on eyepiece (4) ensuring eyecup securely fits groove around eyepiece.

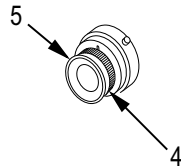

8. Orient eyepiece (4) so the eyepiece lock (3) is aligned with the mark (6) on the binocular (approximately in the 12 o'clock position).
9. Press the eyepiece lock (3) and push eyepiece onto bayonet ring.

NOTE

If eyepiece is not properly aligned, it will not lock into binocular.

10. Once in the binocular, rotate the eyepiece (4) clockwise and release the eyepiece lock (3). Continue rotating until the lock snaps into the locking detent. A firm click will be discerned when eyepiece locks.

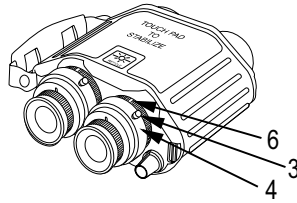

END OF WORK PACKAGE

0021 00-9/10 blank

TM 9-1240-408-13&P

0022 00

UNIT

**BINOCULAR: STABILIZED, M25
(NSN 1240-01-410-7418)**

**NIGHT EYEPIECE (OPTIONAL) MAINTENANCE
REMOVAL, INSTALLATION**

INITIAL SETUP:

References

WP 0021 00, Daytime Eyepiece Maintenance

0022 00-1

REMOVAL

NOTE

Optional night eyepieces required.

1. Ensure the unit is in the POWER OFF mode.
2. While depressing the eyepiece lock (1), rotate night eyepiece (2) counterclockwise to unlock.
3. Remove the night eyepiece (2) from the binocular.

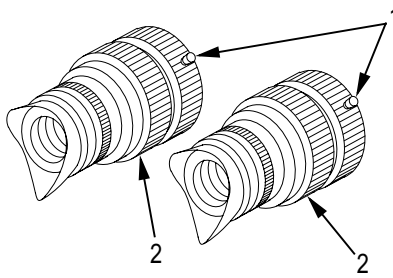

REMOVAL - Continued

4. Pull night vision eyepiece cup (3) from night eyepiece (2).

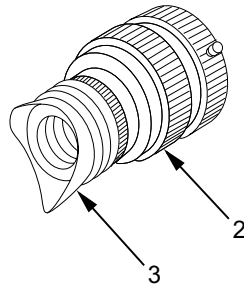

INSTALLATION

1. Install night vision eyepiece cup (1) onto night eyepiece (2), ensuring eyepiece cup fits securely over rim on eyepiece.

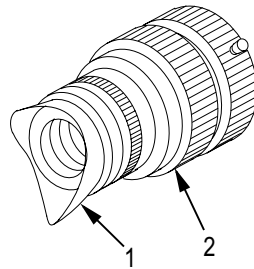

2. Remove daytime eyepiece from binocular (see WP 0021 00).

INSTALLATION - Continued

3. To install the night eyepiece(s) (2), orient eyepiece so that the eyepiece lock (3) is aligned with the mark (4) on the binocular (approximately in the 12 o'clock position).
4. Depress eyepiece lock (3) and push eyepiece (2) into bayonet ring.

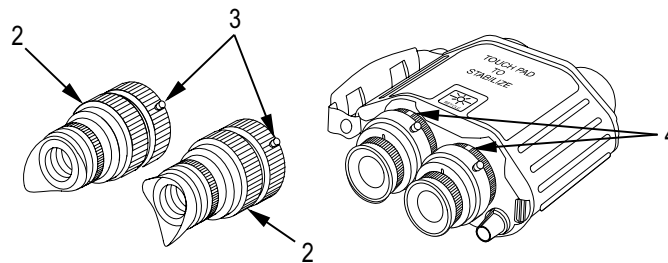

NOTE

If eyepiece is not properly aligned, it will not lock into binocular.

5. Once in the binocular, rotate the night eyepiece (2) clockwise and release the eyepiece lock (3). Continue rotating until the lock snaps into the locking detent. A firm click will be discerned when eyepiece locks.

END OF WORK PACKAGE

TM 9-1240-408-13&P

0023 00

UNIT

BINOCULAR: STABILIZED, M25
(NSN 1240-01-410-7418)

PREPARATION FOR SHIPMENT OR TURN-IN

DOCUMENTATION FOR TURN-IN, PREPARATION FOR SHIPMENT

INITIAL SETUP:

Materials/Parts

Shipping box (item 5, WP 0046 00)
Pressure sensitive tape (item 12, WP 0046 00)

References

WP 0012 00, Battery Replacement

0023 00-1

DOCUMENTATION FOR TURN-IN

1. For CONUS units and those OCONUS units with access to U.S. Registered Mail/FED EX/UPS for both shipping and receiving:
 - a. When it is determined an M25 SB or night eyepiece requires repair above direct support level, notify the installation accountable property officer.
 - b. The installation accountable property officer will process an FTE (Report of Excess) and an AOE (Requisition with Exception Data), in accordance with the Materiel Returns Program as detailed in the Requisition Receipt and Issue System, Chapter 7, AR 725-50, 19 Oct 90. Exception data for AOE is serial number of M25 SB and document number of FTE in the clear address and point of contact with phone number.
 - c. TACOM-RI will respond with an FTR (Reply to Report of Excess), directing shipment to the repair contractor.

- d. Ship per directions on FTR.
 - e. After the repair is completed, the items will be returned to the originating unit using the document number from the AOE.
2. For OCONUS units without access to US Registered Mail, FED EX, or UPS for both shipping and receiving:
- a. The procedure for FTE and AOE are the same as CONUS units.
 - b. TACOM-RI will respond with an FTR directing shipment of the M25 SB or night eyepiece using the Defense Transportation Service (DTS).
 - c. Ship per directions on FTR.
 - d. Repaired M25 SB will be returned using DTS.

DOCUMENTATION FOR TURN-IN - Continued

3. For urgent repair requirements, the following procedure must be used:
 - a. The FTE and AOE may be phoned into TACOM-RI, DSN 793-4377 or commercial (309) 782-4377.
 - b. Fax the above transactions to DSN 793-4485.
4. The above procedures will transfer accountability of the M25 SB from the unit to the wholesale system. The M25 SB will not be repaired and returned to the unit unless the above procedures are followed. The Provost Marshal will be notified that the unit has lost control of a property book item.

PREPARATION FOR SHIPMENT

NOTE

Remove all batteries before shipping.

1. Remove batteries from binocular (WP 0012 00).

NOTE

It is very important to complete and send DA Form 2407, Maintenance Request according to instructions.

2. Completely fill in DA Form 2407 in accordance with the instructions provided in DA PAM 738-750, Functional Users Manual for the Army Maintenance Management System (TAMMS). Describe the required maintenance action (what does not work) as thoroughly as possible in block 15 of the form.

PREPARATION FOR SHIPMENT - Continued

NOTE

Copies two through five of DA Form 2407 will be placed inside the shipping box (see step 7).

3. Send one copy of "Receipt Copy 1" of DA Form 2407 and one copy of shipment tracking document (US Registered Mail, Return Receipt Requested, Federal Express Tracking Number, United Parcel Service Return Receipt, etc.). The return receipt should contain the description "M25 Stabilized Binocular (SB)" and the system serial number.

Mail to:

Commander
US Army Tank-automotive and Armaments Command
ATTN: AMSTA-LC-CSIL
Rock Island, IL 61299-7630

NOTE

Ensure all lens caps are installed.

Do not send night eyepieces, arctic pack, M1 Tank adapter, or M2 Bradley FV adapter with shipment. These items are Additional Authorization List items and are owned by the unit. These items will not be returned if shipped. Night eyepieces can be shipped separately for contractor repair.

4. Place the M25 SB in pouch.
5. Place pouch in transportation case.
6. Place transportation case in a shipping box (item 5, WP 0046 00).

PREPARATION FOR SHIPMENT - Continued**NOTE**

Ensure that the four remaining copies of DA Form 2407 are inside the shipping box before closing and sealing the box. Repairs cannot be made unless the deficiency is identified on DA Form 2407.

7. Place copies two through five of DA Form 2407 in shipping box. Enclose Packing List, DD Form 1750, in the box.
8. Close the shipping box and seal all seams and joints with pressure sensitive tape (item 12, WP 0046 00).

END OF WORK PACKAGE

TM 9-1240-408-13&P

CHAPTER 5

**DIRECT SUPPORT
TROUBLESHOOTING**

DIRECT SUPPORT

BINOCULAR: STABILIZED, M25
(NSN 1240-01-410-7418)

TROUBLESHOOTING

GENERAL, TROUBLESHOOTING PROCEDURES

INITIAL SETUP:

Test Equipment

Multimeter (Item 1, WP 0031 00)

References

WP 0006 00, Operation Under
Usual Conditions
WP 0012 00, Battery Replacement
WP 0021 00, Daytime
Eyepiece Maintenance

References - Cont

WP 0022 00, Night Eyepiece
Maintenance
WP 0023 00, Preparation for
Shipment and Turn-In
WP 0026 00, Battery Cap
Assembly Maintenance

GENERAL

All internal maintenance on the M25 Stabilized Binocular (SB) is depot (contractor). If, after troubleshooting, there are deficiencies that cannot be corrected, the Binocular must be turned in to the proper maintenance/supply channel for return to the contractor or depot (WP 0023 00).

TROUBLESHOOTING PROCEDURES**Table 1. Direct Support Troubleshooting Procedures.**

MALFUNCTION	TEST OR INSPECTION	CORRECTIVE ACTION
1. BINOCULAR IS NOT FUNCTIONAL.	<ol style="list-style-type: none">1. Check to see if power switch is in ON position.2. Inspect battery power indicator.	<p>Turn on power switch (WP 0006 00).</p> <p>If battery power indicator shows red, replace batteries (WP 0012 00).</p>

TROUBLESHOOTING PROCEDURES – Continued

Table 1. Direct Support Troubleshooting Procedures - Continued.

MALFUNCTION	TEST OR INSPECTION	CORRECTIVE ACTION
2. NO BATTERY POWER.	<ol style="list-style-type: none"> 1. Check to see if batteries are present. 2. Check for low or dead batteries. 3. Check to see that batteries are properly installed. 4. Check to see if battery cap contact is bent, broken, or corroded. 5. Failure to respond to items 1 through 4 above. 	<p>If batteries are missing, install batteries (WP 0012 00).</p> <p>Install new batteries (WP 0012 00).</p> <p>Install batteries properly (WP 0012 00).</p> <p>Straighten contact or replace battery cap (WP 0026 00).</p> <p>Evacuate to depot (WP 0023 00).</p>

Table 1. Direct Support Troubleshooting Procedures - Continued.

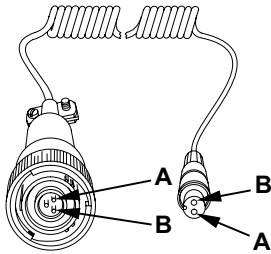
MALFUNCTION	TEST OR INSPECTION	CORRECTIVE ACTION
<p>3. NO REMOTE POWER.</p>	<p>1. Check special purpose cable assembly. Conduct pin to pin continuity check.</p> 	<p>Replace special purpose cable assembly if faulty.</p>

TROUBLESHOOTING PROCEDURES – Continued

Table 1. Direct Support Troubleshooting Procedures - Continued.

MALFUNCTION	TEST OR INSPECTION	CORRECTIVE ACTION
3. NO REMOTE POWER - Continued	2. Check vehicle adapter fuse. 3. Check voltage. 4. Check vehicle adapter. Conduct lug to pin continuity check. Ensure voltage output is 6 to 30 volts direct current.	Replace vehicle adapter fuse (item 8, WP 0046 00) if faulty. Check vehicle batteries. Replace vehicle adapter if faulty.
4. RETICLE DOES NOT ILLUMINATE.	1. Check contact points. 2. Check eyepieces.	Clean contact points. Ensure eyepieces are locked in position.

Table 1. Direct Support Troubleshooting Procedures - Continued.

MALFUNCTION	TEST OR INSPECTION	CORRECTIVE ACTION
4. RETICLE DOES NOT ILLUMINATE - Continued.	3. Ensure battery state indicator is in green level.	If not in green level, go to Malfunction 2, No Battery Power.
NOTE		
Reticle terminal voltage should increase very slightly each time reticle pad is pressed. After six levels it should return to zero.		
	4. With Binocular power switch in ON/LOCK position, verify Binocular output voltage is present at reticle terminals and is present at night vision terminals.	If voltage is present, verify reticle eyepiece and/or night vision eyepiece. If voltage is not present, evacuate to depot maintenance (WP 0023 00).

TROUBLESHOOTING PROCEDURES – Continued

Table 1. Direct Support Troubleshooting Procedures - Continued.

MALFUNCTION	TEST OR INSPECTION	CORRECTIVE ACTION
<p>GROUND</p> <p>NIGHT VISION VOLTAGE</p> <p>RETICLE VOLTAGE</p>		<p>RETICLE VOLTAGE</p> <p>NIGHT VISION VOLTAGE</p> <p>GROUND</p>

Table 1. Direct Support Troubleshooting Procedures - Continued.

MALFUNCTION	TEST OR INSPECTION	CORRECTIVE ACTION
5. VERIFY EYEPIECE RETICLE.	1. Inspect that contacts are present and not corroded.	Replace if readings are not met (WP 0021 00).

The diagram shows a cross-sectional view of an eyepiece reticle assembly. It features a central circular lens area surrounded by a reticle. A circuit board is attached to the side of the assembly. Three specific points are labeled with arrows: 'CIRCUIT BOARD' points to the side of the assembly; 'POSITIVE VOLTAGE POINT (RETICLE)' points to a contact point on the reticle; and 'GROUND POINT' points to another contact point on the reticle.

TROUBLESHOOTING PROCEDURES – Continued

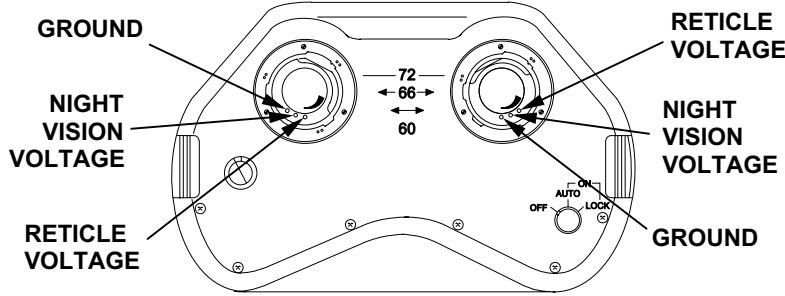
Table 1. Direct Support Troubleshooting Procedures - Continued.

MALFUNCTION	TEST OR INSPECTION	CORRECTIVE ACTION
6. BINOCULAR DOES NOT STABILIZE.	1. Verify battery state indicator is in green level. Turn Binocular power switch to ON/AUTO position. Gyro should spin up. Press stabilization touch pad and listen for click.	Evacuate to depot if inoperable (WP 0023 00).
7. VERIFY NIGHT VISION EYEPIECE.	1. Inspect contacts are present and not corroded.	Replace if reading is not met (WP 0022 00).

Table 1. Direct Support Troubleshooting Procedures - Continued.

MALFUNCTION	TEST OR INSPECTION	CORRECTIVE ACTION
<p>The diagram shows a cross-section of a night vision device. On the left, a 'CIRCUIT BOARD' is connected to the device. A 'POSITIVE VOLTAGE POINT (NIGHT VISION)' is indicated by an arrow pointing to a specific contact on the device's internal assembly. A 'GROUND POINT' is indicated by an arrow pointing to another contact on the assembly.</p>		

END OF WORK PACKAGE

TM 9-1240-408-13&P

CHAPTER 6

**DIRECT SUPPORT MAINTENANCE INSTRUCTIONS
FOR THE
M25 STABILIZED BINOCULAR**

TM 9-1240-408-13&P

0025 00

DIRECT SUPPORT

**BINOCULAR: STABILIZED, M25
(NSN 1240-01-410-7418)**

**BINOCULAR COVER MAINTENANCE
REMOVAL, INSTALLATION**

INITIAL SETUP:

Materials/Parts

Adhesive (Item 2, WP 0046 00)

0025 00-1

REMOVAL

NOTE

It may be necessary to remove optical lens cap and battery cover to aid in removal and installation of binocular cover.

1. Remove damaged binocular cover (1) from binocular (2).
2. Remove adhesive residue from binocular surface.

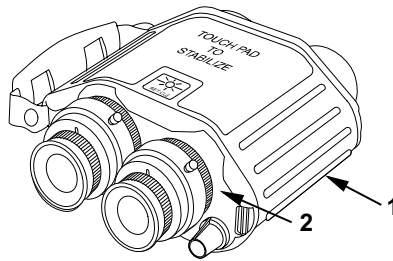

INSTALLATION

CAUTION

Do not apply adhesive to touch pad.

1. Apply adhesive (item 2, WP 0046 00) to binocular surface.

INSTALLATION - Continued

2. Install new binocular cover (1). Ensure curved end of cover folds over the edge of the binocular (2).

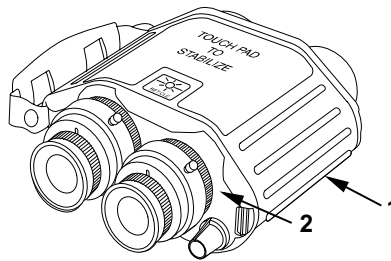
**END OF WORK PACKAGE**

TM 9-1240-408-13&P

0026 00

DIRECT SUPPORT

**BINOCULAR: STABILIZED, M25
(NSN 1240-01-410-7418)**

BATTERY CAP ASSEMBLY MAINTENANCE

REMOVAL, INSTALLATION

INITIAL SETUP:

Tools and Special Tools

Shop Set, Small Arms: Field Maintenance (Item 2, WP 0031 00)

0026 00-1

REMOVAL

NOTE

It may be necessary to remove optical lens cap to aid in removal and installation of battery cover.

1. Unlock and remove battery cover (1).
2. Remove gasket (2) from battery cover (1).

CAUTION

Do not unscrew connecting nut to power adapter. Do not remove screw under mounting bracket. Doing so will cause loss of nitrogen purge and potential damage to binocular.

3. Using 5/64 in. key wrench, remove hexagon screw (3) that secures mounting brackets (4 and 5) to binocular (6).

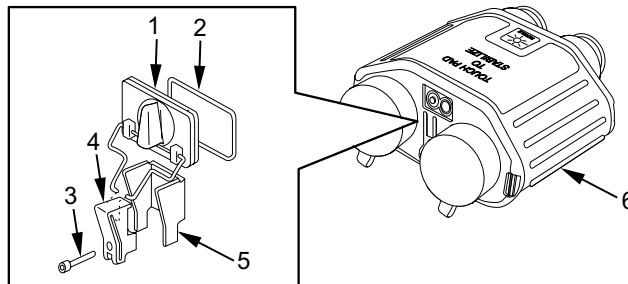

0026 00-3

INSTALLATION

1. Using 5/64 in. key wrench, install hexagon screw (1) to secure mounting brackets (2 and 3) to binocular (4).
2. Install gasket (5) on battery cover (6).
3. Install and lock battery cover (6).

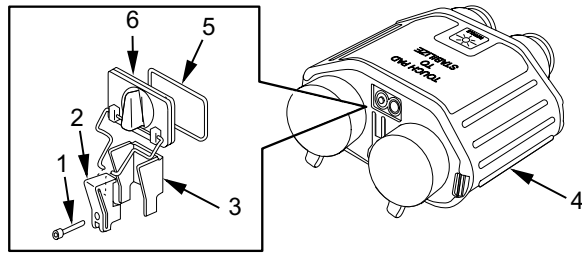

END OF WORK PACKAGE

0026 00-5/6 blank

TM 9-1240-408-13&P

0027 00

DIRECT SUPPORT

**BINOCULAR: STABILIZED, M25
(NSN 1240-01-410-7418)**

**POWER CONTROL KNOB MAINTENANCE
REMOVAL, INSTALLATION**

INITIAL SETUP:

Tools and Special Tools

Shop Set, Small Arms: Field Maintenance (Item 2, WP 0031 00)

Materials/Parts

Sealing Compound (item 11, WP 0046 00)

0027 00-1

REMOVAL

1. Using .050 in. key wrench, remove set screw (1) on side of knob (2).
2. Remove knob (2) from binocular.

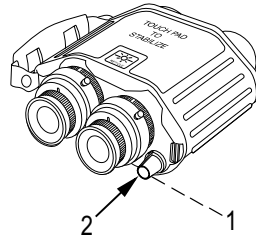

INSTALLATION

1. Apply Sealing Compound (item 11, WP 0046 00) to set screw (1).
2. Place knob (2) on binocular.
3. Using .050 in. key wrench, install set screw (1) on side of knob (2) and tighten until knob is secure.

END OF WORK PACKAGE

TM 9-1240-408-13&P

0028 00

DIRECT SUPPORT

**BINOCULAR: STABILIZED, M25
(NSN 1240-01-410-7418)**

EYEPIECE LOCK MAINTENANCE

REMOVAL, INSTALLATION

0028 00-1

NOTE

The following procedure is applicable to both daytime and night eyepieces. Both configurations are illustrated in this work package.

REMOVAL

1. Remove eyepiece (1) from binocular (2) by depressing button (3) and rotating counterclockwise.
2. Unscrew button (3).
3. Remove O-ring (4), washer (5), and spring (6) from button (3).
4. Remove lock (7) from inside of eyepiece (1).

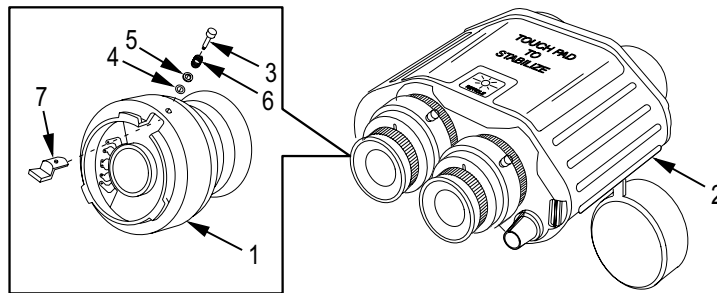

DAYTIME EYEPIECE LOCK REMOVAL

REMOVAL - Continued

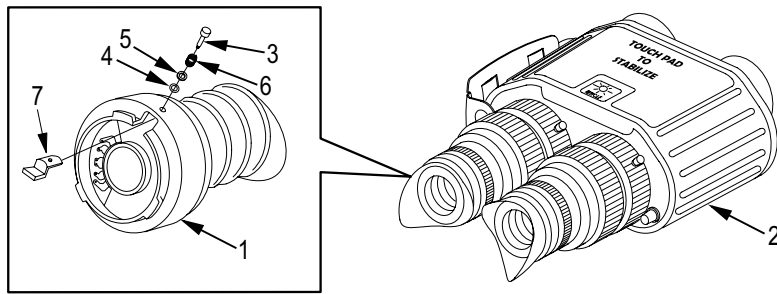

NIGHT EYEPiece LOCK REMOVAL

INSTALLATION

1. Place spring (1), washer (2), and O-ring (3) on button (4).
2. Insert button (4) with assembled parts into hole (5) on eyepiece.
3. Depress button (4) while placing lock (6) onto threaded end of button.
4. Screw button (4) into lock (6).
5. Install eyepiece on binocular (7).

INSTALLATION - Continued

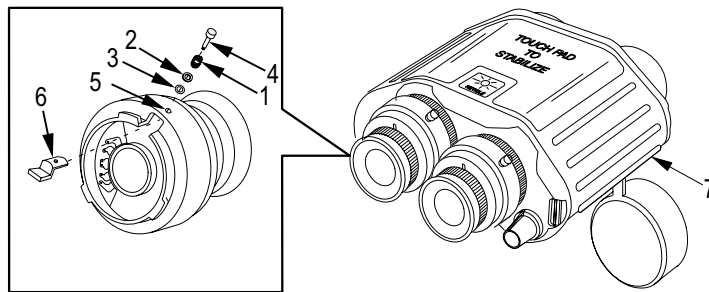

DAYTIME EYEPIECE LOCK INSTALLATION

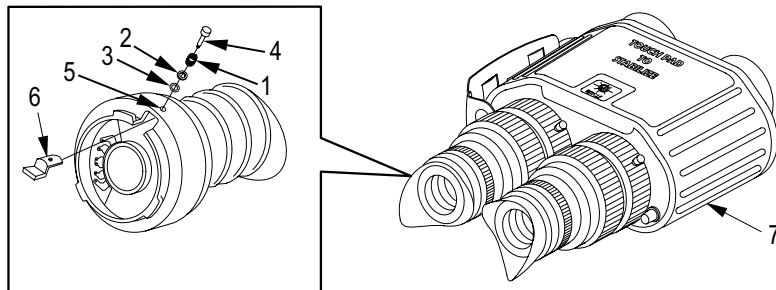

NIGHT EYEPiece LOCK INSTALLATION

END OF WORK PACKAGE

0028 00-7/8 blank

TM 9-1240-408-13&P

CHAPTER 7

SUPPORTING INFORMATION

OPERATOR, UNIT, AND DIRECT SUPPORT

**BINOCULAR: STABILIZED, M25
(NSN 1240-01-410-7418)**

REFERENCES

SCOPE

This work package lists all field manuals, forms, and miscellaneous publications referenced in this manual.

FIELD MANUALS

FM 21-11 First Aid for Soldiers

FORMS

DA Form 2404	Equipment Inspection and Maintenance Worksheet
DA Form 2407	Maintenance Request
DD Form 1750	Packing List
SF 361	Transportation Discrepancy Report
SF 368	Product Quality Deficiency Report

MISCELLANEOUS PUBLICATIONS

AR 725-50	Requisition Receipt and Issue System
CTA 8-100	Army Medical Department Expendable/Durable Items

TM 9-1240-408-13&P

0029 00

CTA 50-970	Expendable/Durable Items (Except: Medical, Class V, Repair Parts, and Heraldic Items)
DA PAM 738-750	Functional User's Manual for the Army Maintenance Management System (TAMMS)

END OF WORK PACKAGE

0029 00-3/4 blank

OPERATOR, UNIT, AND DIRECT SUPPORT

**BINOCULAR: STABILIZED, M25
(NSN 1240-01-410-7418)**

INTRODUCTION FOR MAINTENANCE ALLOCATION CHART (MAC)

INTRODUCTION

The Army Maintenance System MAC

This introduction provides a general explanation of all maintenance and repair functions authorized at various maintenance levels under the standard Army Maintenance System concept.

The MAC (immediately following the introduction) designates overall authority and responsibility for the performance of maintenance functions on the identified end item of component. The application of the maintenance functions to the end item or component shall be consistent with the capacities and capabilities of the designated maintenance levels, which are shown on the MAC in column (4) as:

Unit – includes two subcolumns, C (operator/crew) and O (unit) maintenance.

Direct Support – includes an F subcolumn.

General Support – includes an H subcolumn.

Depot – includes a D subcolumn.

The tools and test equipment requirements (immediately following the MAC) list the tools and test equipment (both special tools and common tool sets) required for each maintenance function as referenced from the MAC.

The remarks (immediately following the tools and test equipment requirements) contain supplemental instructions and explanatory notes for a particular maintenance function.

Maintenance Functions

Maintenance functions are limited to and defined as follows:

1. **Inspect.** To determine the serviceability of an item by comparing its physical, mechanical, and/or electrical characteristics with established standards through examination (e.g., by sight, sound, or feel). This includes scheduled inspection and gagings and evaluation of cannon tubes.
2. **Test.** To verify serviceability by measuring the mechanical, pneumatic, hydraulic, or electrical characteristics of an item and comparing those characteristics with prescribed standards on a scheduled basis, i.e., load testing of lift devices and hydrostatic testing of pressure hoses.

3. Service. Operations required periodically to keep an item in proper operating condition; e.g., to clean (includes decontaminate, when required), to preserve, to drain, to paint, or to replenish fuel, lubricants, chemical fluids, or gases. This includes scheduled exercising and purging of recoil mechanisms.
4. Adjust. To maintain or regulate, within prescribed limits, by bringing into proper position, or by setting the operating characteristics to specified parameters.
5. Align. To adjust specified variable elements of an item to bring about optimum or desired performance.
6. Calibrate. To determine and cause corrections to be made or to be adjusted on instruments of test, measuring, and diagnostic equipment used in precision measurement. Consists of comparisons of two instruments, one of which is a certified standard of known accuracy, to detect and adjust any discrepancy in the accuracy of the instrument being compared.

7. Remove/Install. To remove and install the same item when required to perform service or other maintenance functions. Install may be the act of emplacing, seating, or fixing into position a spare, repair part, or module (component or assembly) in a manner to allow the proper functioning of an equipment or system.
8. Replace. To remove an unserviceable item and install a serviceable counterpart in its place. "Replace" is authorized by the MAC and assigned maintenance level is shown as the third position code of the Source, Maintenance and Recoverability (SMR) code.
9. Repair. The application of maintenance services, including fault location/troubleshooting, removal/installation, disassembly/assembly procedures, and maintenance actions to identify troubles and restore serviceability to an item by correcting specific damage, fault, malfunction, or failure in a part, subassembly, module (component or assembly), end item, or system.

NOTE

The following definitions are applicable to the "Repair" maintenance function:

Services – Inspect, test, service, adjust, align, calibrate, and/or replace.

Fault location/troubleshooting – The process of investigating and detecting the cause of equipment malfunctioning; the act of isolating a fault within a system or Unit Under Test (UUT).

Disassembly/assembly – The step-by-step breakdown (taking apart) of a spare/functional group coded item to the level of its least component, that is assigned an SMR code for the level of maintenance under consideration (i.e., identified as maintenance significant).

NOTE -- CONTINUED

Actions – Welding, grinding, riveting, straightening, facing, machining, and/or resurfacing.

10. Overhaul. That maintenance effort (service/action) prescribed to restore an item to a completely serviceable/operational condition as required by maintenance standards in appropriate technical publications. Overhaul is normally the highest degree of maintenance performed by the Army. Overhaul does not normally return an item to like new condition.
11. Rebuild. Consists of those services/actions necessary for the restoration of unserviceable equipment to a like new condition in accordance with original manufacturing standards. Rebuild is the highest degree of materiel maintenance applied to Army equipment. The rebuild operation includes the act of returning to zero those age measurements (e.g. hours/miles) considered in classifying Army equipment/components.

Explanation of Columns in the MAC

Column (1) – Group Number. Column (1) lists the FGC numbers, the purpose of which is to identify maintenance significant components, assemblies, subassemblies, and modules with the Next Higher Assembly (NHA).

Column (2) – Component/Assembly. Column (2) contains the item names of components, assemblies, subassemblies, and modules for which maintenance is authorized.

Column (3) – Maintenance Function. Column (3) lists the functions to be performed on the item listed in column (2). (For a detailed explanation of these functions refer to "Maintenance Functions" outlined above.)

Column (4) – Maintenance Level. Column (4) specifies each level of maintenance authorized to perform each function listed in column (3), by indicating work time required (expressed as manhours in whole hours or decimals) in the appropriate subcolumn. This work time figure represents the active time required to perform that maintenance function at the indicated level of maintenance. If the number or complexity of the tasks within the listed maintenance function varies at different maintenance levels, appropriate work time figures are to be shown for each level. The work time figure represents the average time required to restore an item (assembly, subassembly, component, module, end item, or system) to a serviceable condition under typical field operating conditions. This time includes preparation time (including any necessary disassembly/assembly time), troubleshooting/fault location time, and quality assurance time in addition to the time required to perform the specific tasks identified for the maintenance functions authorized in the MAC. The symbol designations for the various maintenance levels are as follows:

- C – Operator or crew maintenance
- O – Unit maintenance

F – Direct support maintenance
L – Specialized repair activity (SRA)
H – General support maintenance
D – Depot maintenance

NOTE

The "L" maintenance level is not included in column (4) of the MAC. Functions to this level of maintenance are identified by a work time figure in the "H" column of column (4), and an associated reference code is used in the REMARKS column (6). This code is keyed to the remarks and the SRA complete repair application is explained there.

Column (5) – Tools and Equipment Reference Code. Column (5) specifies, by code, those common tool sets (not individual tools), common Test, Measurement, and Diagnostic Equipment (TMDE), and special tools, special TMDE and special support equipment required to perform the designated function. Codes are keyed to the entries in the tools and test equipment table.

Column (6) – Remarks Code. When applicable, this column contains a letter code, in alphabetical order, which is keyed to the remarks table entries.

Explanation of Columns in the Tools and Test Equipment Requirements

Column (1) – Tool or Test Equipment Reference Code. The tool or test equipment reference code correlates with a code used in column (5) of the MAC.

Column (2) – Maintenance Level. The lowest level or maintenance authorized to use the tool or test equipment.

Column (3) – Nomenclature. Name or identification of the tool or test equipment.

Column (4) – National Stock Number (NSN). The NSN of the tool or test equipment.

Column (5) – Tool Number. The manufacturer's part number, model number, or type number.

Explanation of Columns in the Remarks

Column (1) – Remarks Code. The code recorded in column (6) of the MAC.

Column (2) – Remarks. This column lists information pertinent to the maintenance function being performed as indicated in the MAC.

END OF WORK PACKAGE

TM 9-1240-408-13&P

0031 00

OPERATOR, UNIT, AND DIRECT SUPPORT

BINOCULAR: STABILIZED, M25
(NSN 1240-01-410-7418)

MAINTENANCE ALLOCATION CHART (MAC)

0031 00-1

Table 1. Maintenance Allocation Chart for M25 Stabilized Binocular

(1) GROUP NUMBER	(2) COMPONENT/ ASSEMBLY	(3) MAINTENANCE FUNCTION	(4) MAINTENANCE LEVEL				(5) TOOLS AND EQUIP- MENT REF CODE	(6) REMARKS CODE
			UNIT		DS	GS		
			C	O	F	H		
00	M25 STABILIZED BINOCULAR	Inspect	.1	.2				
		Remove			.5			
		Repair			.5			
		Replace			.5			
01	STABILIZED BINOCULAR	Inspect	.1	.1			A	
		Remove		.1				
		Replace		.1				
0101	OPTICAL EYEPIECE ASSEMBLY	Inspect	.1					
		Remove		.1				
		Repair		.1				
		Replace		.1				

TM 9-1240-408-13&P

0031 00

(1) GROUP NUMBER	(2) COMPONENT/ ASSEMBLY	(3) MAINTENANCE FUNCTION	(4) MAINTENANCE LEVEL				(5) TOOLS AND EQUIP- MENT REF CODE	(6) REMARKS CODE
			UNIT		DS	GS		
			C	O	F	H		
010101	EYEPIECE LOCK KIT	Inspect	.1	.1				
		Remove		.1				
		Repair		.1				
		Replace		.1				
0102	OPTICAL EYEPIECE ASSEMBLY	Inspect	.1	.1				
		Remove		.1				
		Repair		.1				
		Replace		.1				
010201	EYEPIECE LOCK KIT	Inspect	.1	.1				
		Remove		.1				
		Repair		.1				
		Replace		.1				
0103	BATTERY CAP ASSEMBLY	Inspect	.1					
		Remove			.2			
		Repair			.2			
		Replace			.2			

0031 00-3

Table 1. Maintenance Allocation Chart for M25 Stabilized Binocular

(1) GROUP NUMBER	(2) COMPONENT/ ASSEMBLY	(3) MAINTENANCE FUNCTION	(4) MAINTENANCE LEVEL				(5) TOOLS AND EQUIP- MENT REF CODE	(6) REMARKS CODE
			UNIT		DS	GS		
			C	O	F	H		
02	CASE, OPTICAL	Inspect Remove Repair Replace	.1	.1 .1 .1				A
03	TEXTILE BAG	Inspect Remove Repair Replace	.1	.1 .1 .1				
04	BATTERY POWER SUPPLY	Inspect Remove Repair Replace	.1	.1 .1 .1				

TM 9-1240-408-13&P

0031 00

(1) GROUP NUMBER	(2) COMPONENT/ ASSEMBLY	(3) MAINTENANCE FUNCTION	(4) MAINTENANCE LEVEL				(5) TOOLS AND EQUIP MENT REF CODE	(6) REMARKS CODE
			UNIT		DS	GS		
			C	O	F	H		
05	OPTICAL EYEPIECE ASSEMBLY (NIGHT VISION)	Inspect Remove Repair Replace	.1	.1 .1 .1				
0501	EYEPIECE LOCK KIT (NIGHT VISION)	Inspect Remove Repair Replace	.1	.1 .1 .2				A

0031 00-5

Table 2. Tools and Test Equipment for M25 Stabilized Binocular

TOOL OR TEST EQUIPMENT REF CODE	MAINTENANCE LEVEL	NOMENCLATURE	NATIONAL STOCK NUMBER	TOOL NUMBER
1	F	Multimeter	6685-01-265-6000	LIN M60449
2	F	Shop Set, Small Arms: Field Maintenance	4933-00-754-0664	SC 4933-95-A11

Table 3. Remarks for M25 Stabilized Binocular

REMARKS CODE	REMARKS
A	Preventive maintenance checks and services (PMCS)

END OF WORK PACKAGE

UNIT AND DIRECT SUPPORT MAINTENANCE**BINOCULAR: STABILIZED, M25
(NSN 1240-01-410-7418)****REPAIR PARTS AND SPECIAL TOOLS LIST INTRODUCTION**

SCOPE

This Repair Parts and Special Tools List (RPSTL) lists and authorizes spares and repair parts; special tools; special test, measurement, and diagnostic equipment (TMDE); and other special support equipment required for performance of Unit/Direct Support maintenance of the M25 Stabilized Binocular. It authorizes the requisitioning, issue, and disposition of spares, repair parts, and special tools as indicated by the source, maintenance and recoverability (SMR) codes.

GENERAL

In addition to the Introduction work package, this RPSTL is divided into the following work packages:

1. **Repair Parts List Work Packages.** Work packages containing lists of spares and repair parts authorized by this RPSTL for use in the performance of maintenance. These work packages also include parts which must be removed for replacement of the authorized parts. Parts lists are composed of functional groups in ascending alphanumeric sequence, with the parts in each group listed in ascending figure and item number sequence. Sending units, brackets, filters, and bolts are listed with the component they mount on. Bulk materials are listed by item name in FIG. BULK at the end of the work packages. Repair parts kits are listed separately in their own functional group and work package. Repair parts for reparable special tools are also listed in a separate work package. Items listed are shown on the associated illustrations.

2. Special Tools List Work Packages. Work packages containing lists of special tools, special TMDE, and special support equipment authorized by this RPSTL (as indicated by Basis of Issue (BOI) information in DESCRIPTION AND USABLE ON CODE (UOC) column). Tools that are components of common tool sets and/or Class VII are not listed.

3. Cross-Reference Indexes Work Packages. There are two cross-reference indexes work packages in this RPSTL: the National Stock Number (NSN) Index Work package and the Part Number (P/N) Index Work Package. The National Stock Number Index work package refers you to the figure and item number. The Part Number Index work package refers you to the figure and item number.

EXPLANATION OF COLUMNS IN THE REPAIR PARTS LIST AND SPECIAL TOOLS LIST WORK PACKAGES

ITEM NO. (Column (1)). Indicates the number used to identify items called out in the illustration.

SMR CODE (Column (2)). The SMR code containing supply/requisitioning information, maintenance level authorization criteria, and disposition instruction, as shown in the following breakout:

<u>Source Code</u>	<u>Maintenance Code</u>	<u>Recoverability Code</u>
<u>XX</u>	<u>XX</u>	<u>X</u>
First two positions: How to get an item.	Third position: Who can install, replace, or use the item.	Fourth position: Who can do complete repair* on the item.
		Fifth position: Who determines disposition action on unserviceable items.

*Complete Repair: Maintenance capacity, capability, and authority to perform all corrective maintenance tasks of the "Repair" function in a use/user environment in order to restore serviceability to a failed item.

Source Code. The source code tells you how to get an item needed for maintenance, repair, or overhaul of an end item/equipment. Explanations of source codes follow:

Source Code**Application/Explanation**

PA
PB
PC
PD
PE
PF
PG

Stock items; use the applicable NSN to requisition/request items with these source codes. They are authorized to the level indicated by the code entered in the third position of the SMR code.

NOTE

Items coded PC are subject to deterioration.

<u>Source Code</u>	<u>Application/Explanation</u>
KD KF KB	Items with these codes are not to be requested/requisitioned individually. They are part of a kit which is authorized to the maintenance level indicated in the third position of the SMR code. The complete kit must be requisitioned and applied.
MO - Made at unit/ AVUM level MF - Made at DS/ AVIM level MH - Made at GS level ML - Made at SRA MD - Made at depot	Items with these codes are not to be requisitioned/requested individually. They must be made from bulk material which is identified by the P/N in the DESCRIPTION AND USABLE ON CODE (UOC) column and listed in the bulk material group work package of the RPSTL. If the item is authorized to you by the third position code of the SMR code, but the source code indicates it is made at a higher level, order the item from the higher level of maintenance.

<u>Source Code</u>	<u>Application/Explanation</u>
AO - Assembled by unit/AVUM level	Items with these codes are not to be requisitioned/requested individually. The parts that make up the assembled item must be requisitioned or fabricated and assembled at the level of maintenance indicated by the source code. If the third position of the SMR code authorizes you to replace the item, but the source code indicates the item is assembled at a higher level, order the item from the higher level of maintenance.
AF - Assembled by DS/AVIM level	
AH - Assembled by GS level	
AL - Assembled by SRA	
AD - Assembled by depot	
XA	Do not requisition an "XA" coded item. Order the higher assembly. (Refer to NOTE below.)
XB	If an item is not available from salvage, order it using the CAGEC and P/N.

<u>Source Code</u>	<u>Application/Explanation</u>
XC	Installation drawings, diagrams, instruction sheets, field service drawings; identified by manufacturer's P/N.
XD	Item is not stocked. Order an XD-coded item through normal supply channels using the CAGEC and P/N given, if no NSN is available.

NOTE

Cannibalization or controlled exchange, when authorized, may be used as a source of supply for items with the above source codes, except for those items source coded "XA" or those aircraft support items restricted by requirements of AR 750-1.

Maintenance Code. Maintenance codes tell you the level(s) of maintenance authorized to use and repair support items. The maintenance codes are entered in the third and fourth positions of the SMR code as follows:

Third Position. The maintenance code entered in the third position tells you the lowest maintenance level authorized to remove, replace, and use the item. The maintenance code entered in the third position will indicate authorization to one of the following levels of maintenance:

<u>Maintenance Code</u>	<u>Application/Explanation</u>
C	— Crew or operator maintenance done within unit/AVUM maintenance.
O	— Unit level/AVUM maintenance can remove, replace, and use the item.
F	— Direct support/AVIM maintenance can remove, replace, and use the item.

Maintenance Code	<u>Application/Explanation</u>
-------------------------	---------------------------------------

H	— General support maintenance can remove, replace, and use the item.
L	— Specialized repair activity can remove, replace, and use the item.
D	— Depot can remove, replace, and use the item.

Fourth Position. The maintenance code entered in the fourth position tells you whether or not the item is to be repaired and identifies the lowest maintenance level with the capability to do complete repair (perform all authorized repair functions).

NOTE

Some limited repair may be done on the item at a lower level of maintenance, if authorized by the Maintenance Allocation Chart (MAC) and SMR codes.

Maintenance Code **Application/Explanation**

- | | | |
|----------|---|--|
| O | — | Unit/AVUM is the lowest level that can do complete repair of the item. |
| F | — | Direct support/AVIM is the lowest level that can do complete repair of the item. |
| H | — | General support is the lowest level that can do complete repair of the item. |
| L | — | Specialized repair activity is the lowest level that can do complete repair of the item. |
| D | — | Depot is the lowest level that can do complete repair of the item. |

<u>Maintenance Code</u>		<u>Application/Explanation</u>
Z	—	Nonreparable. No repair is authorized.
B	—	No repair is authorized. No parts or special tools are authorized for the maintenance of a "B" coded item. However, the item may be reconditioned by adjusting, lubricating, etc., at the user level.

Recoverability Code. Recoverability codes are assigned to items to indicate the disposition action on unserviceable items. The recoverability code is shown in the fifth position of the SMR code as follows:

<u>Recoverability Code</u>		<u>Application/Explanation</u>
Z	—	Nonreparable item. When unserviceable, condemn and dispose of the item at the level of maintenance shown in the third position of the SMR code.

<u>Recoverability Code</u>		<u>Application/Explanation</u>
O	—	Reparable item. When uneconomically reparable, condemn and dispose of the item at the unit level.
F	—	Reparable item. When uneconomically reparable, condemn and dispose of the item at the direct support level.
H	—	Reparable item. When uneconomically reparable, condemn and dispose of the item at the general support level.
D	—	Reparable item. When beyond lower level repair capability, return to depot. Condemnation and disposal of item are not authorized below depot level.
L	—	Reparable item. Condemnation and disposal not authorized below Specialized Repair Activity (SRA).
A	—	Item requires special handling or condemnation procedures because of specific reasons (such as precious metal content, high dollar value, critical material, or hazardous material). Refer to appropriate manuals/directives for specific instructions.

NSN (Column (3)). The NSN of the item is listed in this column.

CAGEC (Column (4)). The Contractor and Government Entity Code (CAGEC) is a five-digit code which is used to identify the manufacturer, distributor, or Government agency/activity that supplies the item.

PART NUMBER (Column (5)). Indicates the primary number used by the manufacturer (individual, company, firm, corporation, or Government activity), which controls the design and characteristics of the item by means of its engineering drawings, specifications, standards, and inspection requirements to identify an item or range of items.

NOTE

When you use an NSN to requisition an item, the item you receive may have a different P/N from the number listed.

DESCRIPTION AND USABLE ON CODE (UOC) (Column (6)). This column includes the following information:

1. The federal item name, and when required, a minimum description to identify the item.
2. P/Ns of bulk materials are referenced in this column in the line entry to be manufactured or fabricated.
3. Hardness Critical Item (HCI). A support item that provides the equipment with special protection from electromagnetic pulse (EMP) damage during a nuclear attack.
4. The statement END OF FIGURE appears just below the last item description in column (6) for a given figure in both the repair parts list and special tools list work packages.

QTY (Column (7)). The QTY (quantity per figure) column indicates the quantity of the item used in the breakout shown on the illustration/figure, which is prepared for a functional group, subfunctional group, or an assembly. A "V" appearing in this column instead of a quantity indicates that the quantity is variable and quantity may change from application to application.

EXPLANATION OF CROSS-REFERENCE INDEXES WORK PACKAGES FORMAT AND COLUMNS

1. National Stock Number (NSN) Index Work Package.

STOCK NUMBER Column. This column lists the NSN in National item identification number (NIIN) sequence. The NIIN consists of the last nine digits of the NSN.

NSN _____ (e.g., 5385-01-574-1476)	When using this column to locate an item, ignore the first four digits of the NSN. However, the complete NSN should be used when ordering items by stock number.
NIIN	

FIG. Column. This column lists the number of the figure where the item is identified/located. The figures are in numerical order in the repair parts list and special tools list work packages.

ITEM Column. The item number identifies the item associated with the figure listed in the adjacent FIG. column. This item is also identified by the NSN listed on the same line.

2. Part Number (P/N) Index Work Package. P/Ns in this index are listed in ascending alphanumeric sequence (vertical arrangement of letter and number combinations which places the first letter or digit of each group in order A through Z, followed by the numbers 0 through 9 and each following letter or digit in like order).

PART NUMBER column. Indicates the P/N assigned to the item.

FIG. Column. This column lists the number of the figure where the item is identified/located in the repair parts and special tools list work packages.

ITEM Column. The item number is the number assigned to the item as it appears in the figure referenced in the adjacent figure number column.

SPECIAL INFORMATION

USABLE ON CODE (UOC). The UOC appears in the lower left corner of the Description Column heading. Usable on codes are shown as "UOC: ..." in the Description Column (justified left) on the first line under the applicable item/nomenclature. Uncoded items are applicable to all models.

Fabrication Instructions. Bulk materials required to manufacture items are listed in the bulk material functional group of this RPSTL. Part numbers for bulk material are also referenced in the Description Column of the line item entry for the item to be manufactured/fabricated.

Index Numbers. Items which have the word BULK in the figure column will have an index number shown in the item number column. This index number is cross-referenced between the NSN/ P/N index work packages and the bulk material list in the repair parts list work package.

HOW TO LOCATE REPAIR PARTS

1. When NSNs or P/Ns Are Not Known.

First. Using the table of contents, determine the assembly group which the item belongs. This is necessary since figures are prepared for assembly groups and subassembly groups, and lists are divided into the same groups.

Second. Find the figure covering the functional group or the subfunctional group to which the item belongs.

Third. Identify the item on the figure and note the number(s).

Fourth. Look in the repair parts list work packages for the figure and item numbers. The NSNs and part numbers are on the same line as the associated item numbers.

2. When NSN Is Known.

First. If you have the NSN, look in the STOCK NUMBER column of the NSN index work package. The NSN is arranged in NIIN sequence. Note the figure and item number next to the NSN.

Second. Turn to the figure and locate the item number. Verify that the item is the one you are looking for.

3. When P/N Is Known.

First. If you have the P/N and not the NSN, look in the PART NUMBER column of the P/N index work package. Identify the figure and item number.

Second. Look up the item on the figure in the applicable repair parts list work package.

ABBREVIATIONS

Not applicable.

END OF WORK PACKAGE

TM 9-1240-408-13&P

0033 00

UNIT AND DIRECT SUPPORT MAINTENANCE

**BINOCULAR: STABILIZED, M25
(NSN 1240-01-410-7418)**

M25 STABILIZED BINOCULAR

REPAIR PARTS LIST

0033 00-1

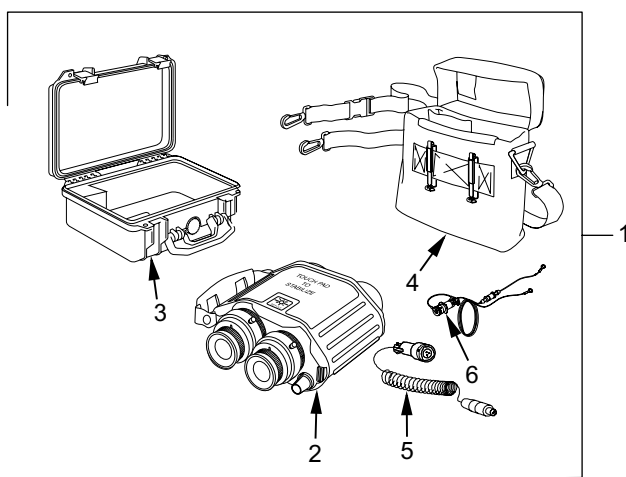

Figure 1. M25 Stabilized Binocular, 129613237.

TM 9-1240-408-13&P

0033 00

(1) ITEM NO.	(2) SMR CODE	(3) NSN	(4) CAGEC	(5) PART NUMBER	(6) DESCRIPTION AND USABLE ON CODE (UOC)	(7) QTY
					GROUP 00 FIG. 1 BINOCULAR, STABILIZED M25, 12961237	
1	PAODD	1240-01-410-7418	19200	12961237	BINOCULAR, STABILIZED M25 W/LASER FILTER	1
2	XAODD		55096	93143-400-14	BINOCULAR, STABILIZED (for item breakdown, see Figure 2)	1
3	PAOOO	1240-01-467-7442	55096	93143-121-2	CASE, OPTICAL (for assembly breakdown, see Figure 6).....	1
4	PAOOO	8105-01-467-7450	55096	93143-122B	BAG, TEXTILE (for assembly breakdown, see Figure 7).....	1
5	PAOZZ	6150-01-468-6060	55096	93143-126	CABLE ASSEMBLY, SPECIAL PURPOSE...	1

0033 00-3

TM 9-1240-408-13&P

0033 00

(1) ITEM NO.	(2) SMR CODE	(3) NSN	(4) CAGEC	(5) PART NUMBER	(6) DESCRIPTION AND USABLE ON CODE (UOC)	(7) QTY
6	PAOZZ	5935-01-467-7451	55096	96043-104	ADAPTER, CONNECTOR (HMMWV)	1

END OF FIGURE

0033 00-4

TM 9-1240-408-13&P

0034 00

UNIT AND DIRECT SUPPORT MAINTENANCE

BINOCULAR: STABILIZED, M25

STABILIZED BINOCULAR, PN 93143-400-14

REPAIR PARTS LIST

0034 00-1

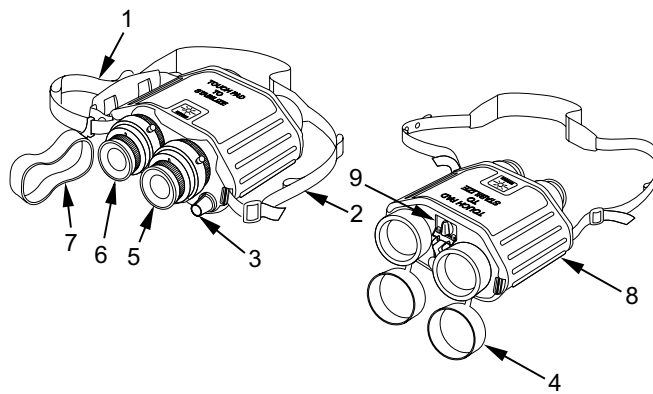

Figure 2. Stabilized Binocular, 93143-400-14.

TM 9-1240-408-13&P

0034 00

(1) ITEM NO.	(2) SMR CODE	(3) NSN	(4) CAGEC	(5) PART NUMBER	(6) DESCRIPTION AND USABLE ON CODE (UOC)	(7) QTY
					GROUP 01 FIG. 2 STABILIZED BINOCULAR, 93143-400-14	
1	PAOZZ	5340-01-467-7438	55096	93143-124	STRAP, WEBBING	1
2	PAOZZ	5340-01-467-7439	55096	93143-125	STRAP, WEBBING	1
3	PAFZZ	5355-01-467-7453	55096	93143-170	KNOB	1
4	PAOZZ	6650-01-467-7454	55096	93143-141	CAP, LENS	2
5	PAODD	1240-01-468-6060	55096	93143-108-1	EYEPIECE ASSEMBLY, OPTICAL (with reticle) (for assembly breakdown see Figure 3)	1
6	PAOOO	1240-01-467-7455	55096	93143-108-2	EYEPIECE ASSEMBLY, OPTICAL (for assembly breakdown see Figure 3)	1

0034 00-3

TM 9-1240-408-13&P

0034 00

(1) ITEM NO.	(2) SMR CODE	(3) NSN	(4) CAGEC	(5) PART NUMBER	(6) DESCRIPTION AND USABLE ON CODE (UOC)	(7) QTY
7	PAOZZ	6650-01-467-7447	55096	93143-143	LENS CAP	1
8	PAFZZ	1240-01-467-7751	55096	93143-140	COVER (1), BINOCULAR	1
9	PAFFF	6160-01-468-8248	55096	93143-127	BATTERY CAP ASSY (See Figure 5 for assembly breakdown)..	1

END OF FIGURE

0034 00-4

TM 9-1240-408-13&P

0035 00

UNIT AND DIRECT SUPPORT MAINTENANCE

**BINOCULAR: STABILIZED, M25
(NSN 1240-01-410-7418)**

OPTICAL EYEPIECE ASSEMBLY, PN 94143-108-1

REPAIR PARTS LIST

0035 00-1

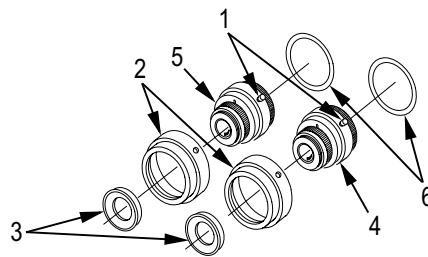

Figure 3. Optical Eyepiece Assembly, 93143-108-1.

TM 9-1240-408-13&P

0035 00

(1) ITEM NO.	(2) SMR CODE	(3) NSN	(4) CAGEC	(5) PART NUMBER	(6) DESCRIPTION AND USABLE ON CODE (UOC)	(7) QTY
					GROUP 0101 FIG. 3 OPTICAL EYEPIECE ASSEMBLY, 93143-108-1	
1	PAFZZ	1240-01-467-7748	55096	93143-108- KIT	EYEPIECE, LOCK KIT (See Figure 4 for assembly breakdown) ..	1
2	PAOZZ	1240-01-467-7749	55096	93143-144	SLEEVE, PROTECTIVE.....	1
3	PAOZZ	1240-01-467-7750	55096	84025-199	EYECUP.....	1
4	XAOZZ		55096	93143-070-1	EYEPIECE.....	1
5	XAOZZ		55096	93143-070-2	EYEPIECE.....	1
6	PAFZZ	5331-00-702-4725	81343	AS3578-033	O-RING.....	1

END OF FIGURE

0035 00-3/4 blank

TM 9-1240-408-13&P

0036 00

UNIT AND DIRECT SUPPORT MAINTENANCE

**BINOCULAR: STABILIZED, M25
(NSN 1240-01-410-7418)**

EYEPIECE LOCK KIT, PN 93143-108-KIT

REPAIR PARTS LIST

0036 00-1

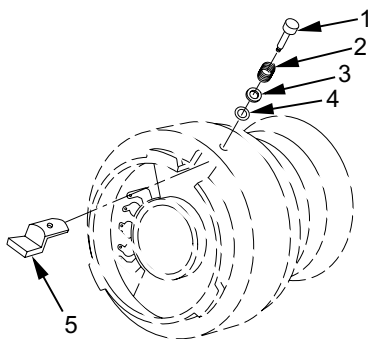

Figure 4. Eyepiece Lock Kit, 93143-108-KIT.

TM 9-1240-408-13&P

0036 00

(1) ITEM NO.	(2) SMR CODE	(3) NSN	(4) CAGEC	(5) PART NUMBER	(6) DESCRIPTION AND USABLE ON CODE	(7) QTY
					GROUP 010101 FIG. 4 EYEPIECE LOCK KIT, 93143-108-KIT	
1	KFFZZ		55096	93143-075	BUTTON	1
2	KFFZZ		55096	LC-022B-3	SPRING.....	1
3	KFFZZ		55096	68F-030-D2	WASHER.....	1
4	KFFZZ		55096	AS3578-005	O-RING.....	1
5	KFFZZ		55096	93143-008	LOCK.....	1

END OF FIGURE

0036 00-3/4 blank

TM 9-1240-408-13&P

0037 00

UNIT AND DIRECT SUPPORT MAINTENANCE

**BINOCULAR: STABILIZED, M25
(NSN 1240-01-410-7418)**

BATTERY CAP ASSEMBLY, PN 93143-127

REPAIR PARTS LIST

0037 00-1

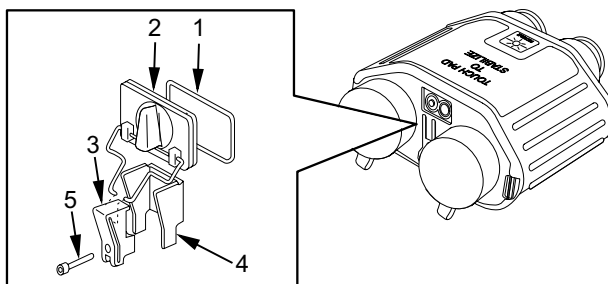

Figure 5. Battery Cap Assembly, 93143-127.

TM 9-1240-408-13&P

0037 00

(1) ITEM NO.	(2) SMR CODE	(3) NSN	(4) CAGEC	(5) PART NUMBER	(6) DESCRIPTION AND USABLE ON CODE	(7) QTY
					GROUP 0103 FIG. 5 BATTERY CAP ASSEMBLY, 93143-127	
1	PAOZZ	5330-01-467-7448	55096	93143-127-1	GASKET.....	1
2	XAFZZ		55096	93143-127-3	COVER, BATTERY	1
3	PAFFF	5340-01-467-7449	55096	93143-147-1	BRACKET, MOUNTING.....	1
4	PAFFF	5340-01-467-7440	55096	93143-147-2	BRACKET, MOUNTING.....	1
5	PAFZZ	5305-00-470-5988	80205	MS16995-3B	SCREW, CAP, SOCKET, HEAD.....	1

END OF FIGURE

0037 00-3/4 blank

TM 9-1240-408-13&P

0038 00

UNIT AND DIRECT SUPPORT MAINTENANCE

**BINOCULAR: STABILIZED, M25
(NSN 1240-01-410-7418)**

OPTICAL CASE, PN 93143-121-2

REPAIR PARTS LIST

0038 00-1

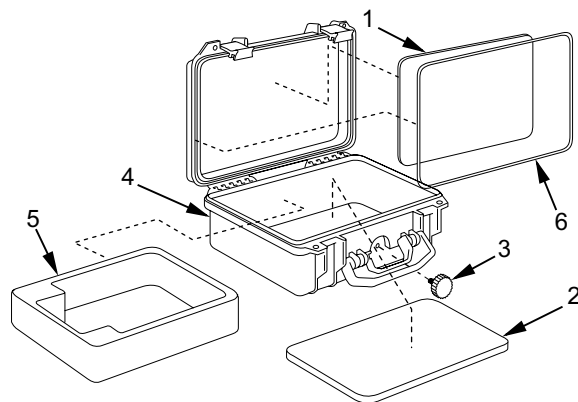

Figure 6. Optical Case, 93143-121-2.

TM 9-1240-408-13&P

0038 00

(1) ITEM NO.	(2) SMR CODE	(3) NSN	(4) CAGEC	(5) PART NUMBER	(6) DESCRIPTION AND USABLE ON CODE (UOC)	(7) QTY
					GROUP 02 FIG. 6 CASE, OPTICAL, 93143-121-2	
1	PAOZZ	8145-01-467-7444	55096	93143-242-2-2	CUSHIONING MATERIAL.....	1
2	PAOZZ	8145-01-467-7443	55096	93143-242-2-3	CUSHIONING MATERIAL.....	1
3	PAOZZ	4820-01-467-7458	55096	93143-242-2-5	PURGE VALVE.....	1
4	XAOZZ		55096	93143-242-6	CASE.....	1
5	PAOZZ	8145-01-467-7457	55096	93143-242-2-1	CUSHIONING MATERIAL.....	1
6	PAOZZ	5330-01-467-7456	55096	93143-242-2-4	GASKET.....	1

END OF FIGURE

0038 00-3/4 blank

TM 9-1240-408-13&P

0039 00

UNIT AND DIRECT SUPPORT MAINTENANCE

**BINOCULAR: STABILIZED, M25
(NSN 1240-01-410-7418)**

TEXTILE BAG, PN 93143-122B

REPAIR PARTS LIST

0039 00-1

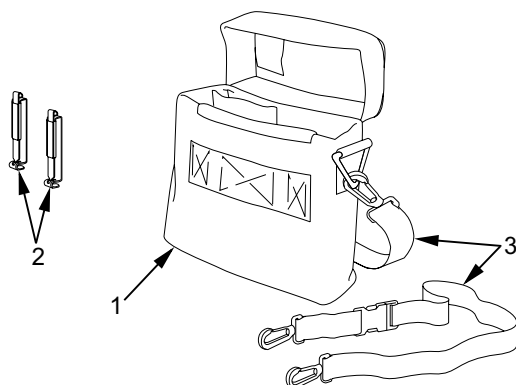

Figure 7. Textile Bag, 93143-122B.

TM 9-1240-408-13&P

0039 00

(1) ITEM NO.	(2) SMR CODE	(3) NSN	(4) CAGEC	(5) PART NUMBER	(6) DESCRIPTION AND USABLE ON CODE (UOC)	(7) QTY
					GROUP 03 FIG. 7 TEXTILE BAG, 93143-122B	
1	XAOZZ		55096	93143-122A	POUCH.....	1
2	PAOZZ	5340-00-753-5580	81349	MIL-H-9890 TYPE X	KEEPER, BELT- STRAP.....	2
3	PAOZZ	5340-01-468-8250	55096	93143-155	STRAP, WEBBING	2

END OF FIGURE

0039 00-3/4 blank

TM 9-1240-408-13&P

0040 00

UNIT AND DIRECT SUPPORT MAINTENANCE

**BINOCULAR: STABILIZED, M25
(NSN 1240-01-410-7418)**

**OPTIONAL BATTERY POWER SUPPLY, PN 93143-123-3
(SEE AAL, WP 0045 00)**

REPAIR PARTS LIST

0040 00-1

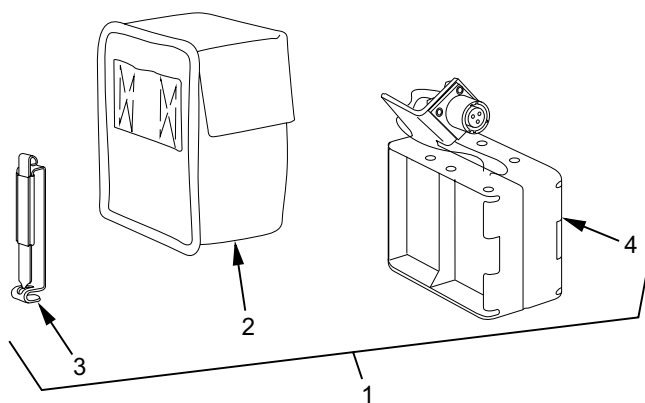

Figure 8. Battery Power Supply, 93143-134-B.

TM 9-1240-408-13&P

0040 00

(1) ITEM NO.	(2) SMR CODE	(3) NSN	(4) CAGEC	(5) PART NUMBER	(6) DESCRIPTION AND USABLE ON CODE (UOC)	(7) QTY
					GROUP 04 FIG. 8 BATTERY POWER SUPPLY, 93143-134-B	
1	PAOZZ	6130-01-467-7445	55096	93143-134-B	BATTERY POWER SUPPLY	1
2	XAOZZ		55096	93143-134-A	BAG, TEXTILE.....	1
3	PAOZZ	5340-00-753-5580	81349	MIL-H-9890 TYPE X	KEEPER, BELT- STRAP	1
4	XAOZZ		55096	RS270-391	BATTERY HOLDER...	1

END OF FIGURE

0040 00-3/4 blank

TM 9-1240-408-13&P

0041 00

UNIT AND DIRECT SUPPORT MAINTENANCE

**BINOCULAR: STABILIZED, M25
(NSN 1240-01-410-7418)**

OPTIONAL OPTICAL EYEPIECE ASSEMBLY (NIGHT VISION), PN 93143-300

REPAIR PARTS LIST

0041 00-1

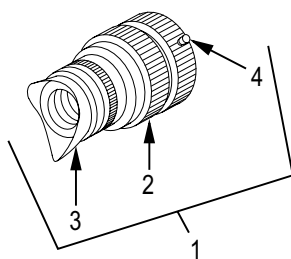

Figure 9. Optical Eyepiece Assembly (Night Vision), 93143-300.

TM 9-1240-408-13&P

0041 00

(1) ITEM NO.	(2) SMR CODE	(3) NSN	(4) CAGEC	(5) PART NUMBER	(6) DESCRIPTION AND USABLE ON CODE (UOC)	(7) QTY
					GROUP 05 FIG. 9 OPTICAL EYEPIECE ASSEMBLY (NIGHT VISION), 93143-300	
1	PAODD	5855-01-469-6123	55096	93143-300	OPTICAL EYEPIECE ASSEMBLY (NIGHT VISION)	2
2	XAFZZ		55096	93143-300A	NIGHT EYEPIECE	1
3	PAOZZ	5855-01-250-2356	80063	A3140632	EYEPIECE, CUP.....	1
4	PAFZZ	1240-01-467-7748	55096	93143-108- KIT	KIT, EYEPIECE LOCK (See Figure 4 for assembly breakdown) ..	1

END OF FIGURE

0041 00-3/4 blank

TM 9-1240-408-13&P

0042 00

UNIT AND DIRECT SUPPORT MAINTENANCE

BINOCULAR: STABILIZED, M25
(NSN 1240-01-410-7418)

NATIONAL STOCK NUMBER INDEX

<u>STOCK NUMBER</u>	<u>FIG.</u>	<u>ITEM</u>	<u>STOCK NUMBER</u>	<u>FIG.</u>	<u>ITEM</u>
5305-00-470-5988	5	5	5935-01-467-7451	1	6
5331-00-702-4725	3	6	5355-01-467-7453	2	3
5340-00-753-5580	7	2	6650-01-467-7454	2	4
	8	3	1240-01-467-7455	2	6
5855-01-250-2356	9	2		8	1
5855-01-380-5098	9	4	5330-01-467-7456	6	6
1240-01-410-7418	1	1	8145-01-467-7457	6	5
5340-01-467-7438	2	1	4820-01-467-7458	6	3
5340-01-467-7439	2	2	1240-01-467-7748	3	1
5340-01-467-7440	5	4		9	3
1240-01-467-7442	1	3	1240-01-467-7749	3	2
8145-01-467-7443	6	2	1240-01-467-7750	3	3
8145-01-467-7444	6	1	1240-01-467-7751	2	8
6650-01-467-7447	2	7	1240-01-468-6060	2	5
5330-01-467-7448	5	1	6150-01-468-6060	1	5
5340-01-467-7449	5	3	6160-01-468-8248	2	9
8105-01-467-7450	1	4	5340-01-468-8250	7	3

0042 00-1

TM 9-1240-408-13&P

0042 00

<u>STOCK NUMBER</u>	<u>FIG.</u>	<u>ITEM</u>
5855-01-469-6123	9	1

END OF WORK PACKAGE

0042 00-2

TM 9-1240-408-13&P

0043-00

UNIT AND DIRECT SUPPORT MAINTENANCE

BINOCULAR: STABILIZED, M25
(NSN 1240-01-410-7418)

PART NUMBER INDEX

<u>PART NUMBER</u>	<u>FIG.</u>	<u>ITEM</u>	<u>PART NUMBER</u>	<u>FIG.</u>	<u>ITEM</u>
AS3578-005	4	4	93143-075	4	1
AS3578-033	3	6	93143-108-1	2	5
A3140632	9	3	93143-108-2	2	6
A3187450	9	4	93143-108-KIT	3	1
LC-022B-3	4	2		9	4
MIL-H-9890 TYPE X	7	3	93143-121-2	1	3
	8	3	93143-122A	7	1
MS16995-3B	5	5	93143-122B	1	4
RS270-391	8	4	93143-124	2	1
12961237	1	1	93143-125	2	2
68F-030-D2	4	3	93143-126	1	5
84025-199	3	3	93143-127	2	9
93143-008	4	5	93143-127-1	5	1
93143-070-1	3	4	93143-127-3	5	2
93143-070-2	3	5	93143-134-A	8	2

0043 00-1

TM 9-1240-408-13&P

0043-00

<u>PART NUMBER</u>	<u>FIG</u>	<u>ITEM</u>
93143-140	2	8
93143-141	2	4
93143-143	2	7
93143-144	3	2
93143-147-1	5	3
93143-147-2	5	4
93143-155	7	3
93143-170	2	3
93143-242-2-1	6	5
93143-242-2-2	6	1
93143-242-2-3	6	2
93143-242-2-4	6	6
93143-242-2-5	6	3
93143-242-6	6	4
93143-300	9	1
93143-300A	9	2
93143-400-14	1	2
96043-104	1	6

END OF WORK PACKAGE

0043 00-2

UNIT AND DIRECT SUPPORT MAINTENANCE

**BINOCULAR: STABILIZED M25
(NSN 1240-01-410-7418)**

COMPONENTS OF END ITEM (COEI) AND BASIC ISSUE ITEMS (BII) LISTS

COMPONENTS OF END ITEM (COEI) AND BASIC ISSUE ITEMS (BII) LISTS

This work package lists COEI and BII for the M25 Stabilized Binocular to help you inventory items for safe and efficient operation of the equipment.

General

The COEI and BII information is divided into the following lists:

Components of End Item (COEI). There are no COEI for the M25 Stabilized Binocular.

COMPONENTS OF END ITEM (COEI) AND BASIC ISSUE ITEMS (BII) LISTS - Continued

Basic Issue Items (BII). These essential items are required to place the M25 binocular in operation, operate it, and to do emergency repairs. BII must be with the M25 binocular during operation and when it is transferred between property accounts. Listing these items is your authority to request/requisition them for replacement based on authorization of the end item by the TOE/MTOE. Illustrations are furnished to help you find and identify the items.

Explanation of Columns in the BII List

Column (1) — Illus Number. Gives you the number of the item illustrated.

Column (2) — National Stock Number (NSN). Identifies the stock number of the item to be used for requisitioning purposes.

Column (3) — Description, CAGEC, and Part Number. Identifies the Federal item name (in all capital letters) followed by a minimum description when needed. The stowage location of COEI and BII is also included in this column. The last line below the description is the CAGEC (Commercial and Government Entity Code) (in parentheses) and the part number.

Column (4) — Usable On Code. When applicable, gives you a code if the item you need is not the same for different models of equipment.

Column (5) — Unit of Measure (U/M). Indicates how the item is issued for the National Stock Number shown in column (2).

Column (6) — Qty Rqr. Indicates the quantity required.

**COMPONENTS OF END ITEM (COEI) AND BASIC ISSUE ITEMS (BII) LISTS -
Continued**



Table 1. Basic Issue Items List.

(1) ILLUS NUMBER	(2) NATIONAL STOCK NUMBER	(3) DESCRIPTION, CAGEC, AND PART NUMBER	(4) USABLE ON CODE	(5) U/M	(6) QTY RQR
1	N/A	MANUAL, TECHNICAL, OPERATOR'S, UNIT, AND DIRECT SUPPORT MAINTENANCE		EA	1

END OF WORK PACKAGE

UNIT AND DIRECT SUPPORT MAINTENANCE

**BINOCULAR: STABILIZED, M25
(NSN 1240-01-410-7418)**

ADDITIONAL AUTHORIZATION LIST (AAL)

INTRODUCTION

Scope

This work package lists additional items you are authorized for the support of the M25 Stabilized Binocular.

General

This list identifies items that do not have to accompany the M25 Stabilized Binocular and that do not have to be turned in with it. These items are all authorized to you by CTA, MTOE, TDA, or JTA.

INTRODUCTION - Continued**Explanation of Columns in the AAL**

Column (1) – National Stock Number (NSN). Identifies the stock number of the item to be used for requisitioning purposes.

Column (2) – Description, Commercial and Government Entity Code (CAGEC), and Part Number (P/N). Identifies the Federal item name (in all capital letters) followed by a minimum description when needed. The last line below the description is the CAGEC (in parentheses) and the part number.

Column (3) – Usable On Code. When applicable, gives you a code if the item you need is not the same for different models of equipment.

Column (4) – Unit of Measure (U/M). Indicates the physical measurement or count of the time as issued per the National Stock Number shown in column (1).

Column (5) – Qty Recm. Indicates the quantity recommended.

ADDITIONAL AUTHORIZED LIST ITEMS**Table 1. Additional Authorization List.**

(1) NATIONAL STOCK NUMBER	(2) DESCRIPTION, CAGEC, AND PART NUMBER	(3) USABLE ON CODE	(4) U/M	(5) QTY RECM
5935-01-467-7452	ADAPTER, CONNECTOR (M1 TANK) (55096) 96043-106		EA	1
5395-01-467-7446	ADAPTER, CONNECTOR, (BRADLEY FV) (55096) 96043-101		EA	1

ADDITIONAL AUTHORIZED LIST ITEMS - Continued**Table 1. Additional Authorization List - Continued.**

(1) NATIONAL STOCK NUMBER	(2) DESCRIPTION, CAGEC, AND PART NUMBER	(3) USABLE ON CODE	(4) U/M	(5) QTY RECM
6130-01-467-7445	BATTERY POWER SUPPLY (ARCTIC PACK) (55096) 93143-134-B		EA	1
5855-01-469-6123	NIGHT EYEPIECE (55096) 93143-300A		EA	2

END OF WORK PACKAGE

UNIT AND DIRECT SUPPORT MAINTENANCE**BINOCULAR: STABILIZED, M25
(NSN 1240-01-410-7418)****EXPENDABLE AND DURABLE ITEMS LIST**

INTRODUCTION**Scope**

This work package lists expendable and durable items that you will need to operate and maintain the M25 Stabilized Binocular. This list is for information only and is not authority to requisition the listed items. These items are authorized to you by CTA 50-970, Expendable/Durable Items (Except Medical, Class V Repair Parts, and Heraldic Items), or CTA 8-100, Army Medical Department Expendable/Durable Items.

Explanation of Columns in the Expendable/Durable Items List

Column (1) – Item Number. This number is assigned to the entry in the list and is referenced in the narrative instructions to identify the item (e.g., Use adhesive (item 1, WP 0046 00)).

Column (2) – Level. This column identifies the lowest level of maintenance that requires the listed item (C = Operator/Crew, O = Unit, F = Direct Support).

Column (3) – National Stock Number (NSN). This is the NSN assigned to the item which you can use to requisition it.

Column (4) – Item Name, Description, Commercial and Government Entity Code (CAGEC), and Part Number (P/N). This column provides the other information you need to identify the item.

Column (5) – Unit of Measure (U/M). This code shows the physical measurement or count of an item, such as gallon, dozen, gross, etc.

EXPENDABLE AND DURABLE ITEMS LIST**Table 1. Expendable and Durable Items List**

(1) ITEM NUMBER	(2) LEVEL	(3) NATIONAL STOCK NUMBER	(4) ITEM NAME, DESCRIPTION, CAGEC, PART NUMBER	(5) U/M
1	O	8040-01-233-0057	Adhesive, 3 oz Bottle (cyanoacrylate) (80244) A-A 3097 TY2CL1	OZ
2	F	8040-00-221-3811	Adhesive, 2 oz Bottle (rubber cement) (81348) MMM-A-1617	EA

Table 1. Expendable and Durable Items List - Continued

(1) ITEM NUMBER	(2) LEVEL	(3) NATIONAL STOCK NUMBER	(4) ITEM NAME, DESCRIPTION, CAGEC, PART NUMBER	(5) U/M
3	C	6135-00-985-7845	Battery, Nonrechargeable (80204) C18.1 "AA"	PG
4	C	5120-00-254-4612	Blower, Watchmaker's (19200) 8284021	EA

Table 1. Expendable and Durable Items List - Continued

(1) ITEM NUMBER	(2) LEVEL	(3) NATIONAL STOCK NUMBER	(4) ITEM NAME, DESCRIPTION, CAGEC, PART NUMBER	(5) U/M
5	F	8115-00-174-2349	Box, Shipping, 16 in. X 16 in. X 8 in., 25 each (81346) ASTM-D1974	BL
6	C	8020-00-240-6361	Brush, Artist's (80244) GSAPD	EA
7	C	6850-00-392-9751	Cleaner, Lens (58536) A-A-59199	BT

Table 1. Expendable and Durable Items List - Continued

(1) ITEM NUMBER	(2) LEVEL	(3) NATIONAL STOCK NUMBER	(4) ITEM NAME, DESCRIPTION, CAGEC, PART NUMBER	(5) U/M
8	O	5920-00-280-8342	Fuse, Cartridge (81349) F02A250V1A	EA
9	O	9150-00-119-9291	Grease, Aircraft, 2 oz. bottle (81343) AMS-G-4343	TU
10	C	6640-00-663-0832	Paper, Lens, Type (81348) NNP40	BK

Table 1. Expendable and Durable Items List - Continued

(1) ITEM NUMBER	(2) LEVEL	(3) NATIONAL STOCK NUMBER	(4) ITEM NAME, DESCRIPTION, CAGEC, PART NUMBER	(5) U/M
11	C	8030-01-014-5869	Sealing Compound (0ZDS4) MILS46163AT2GN	PK
12	F	7510-00-297-6655	Tape, Pressure Sensitive Paperback, Water- Resistant, 2 in. wide, 120 yd roll (58536) ASTM D5486	YD

END OF WORK PACKAGE

0046 00-7/8 blank

OPERATOR'S, UNIT, AND DIRECT SUPPORT

**BINOCULAR, STABILIZED: M25
(NSN 1240-01-410-7418)**

STABILIZATION

STABILIZATION

The unique optical feature of the M25 SB is that it requires no additional optical components to provide the stabilization function; the erecting prism itself is stabilized.

The erecting prisms are mounted on a gimbal, which allows them to move freely in two axes – up and down and left to right – as you look through it. When the stabilized binocular is moved, the prisms stay where they were and then slowly come around to the new alignment.

STABILIZATION - Continued

All stabilization systems utilize a property called inertia in order to work. The SB takes advantage of the augmented inertia of the gyroscope. The erecting prism gimbal described above is mechanically linked to a second small gimbal which carries the gyroscope. In the presence of vibration inputs, which would ordinarily blur the image seen by the observer, the gyroscope controls the motions of the prisms to remove this blur and stabilize the image. Over the long term, the gyro and prism gimbals are returned to their center position.

The results of this stabilization technique in removing unwanted image motion are shown in the compensation curve of Figure 1. The curve plots percentage compensation as a function of the input motion frequency. For example, at two per revolution of the OH-58 helicopter, approximately 11 Hertz (Hz), the percentage compensation is 98 percent. This means that 98 percent of the input motion at 11 Hz is removed and only 2 percent remains. If the input motion amplitude is 10 milliradians only 0.2 milliradians blur will be left in the image observed through the device.

When the SB is unstabilized, the prisms and gyroscope are locked to the case and, therefore, cannot stabilize the image. When the SB is stabilized, the prisms and gyroscope operate as described above.

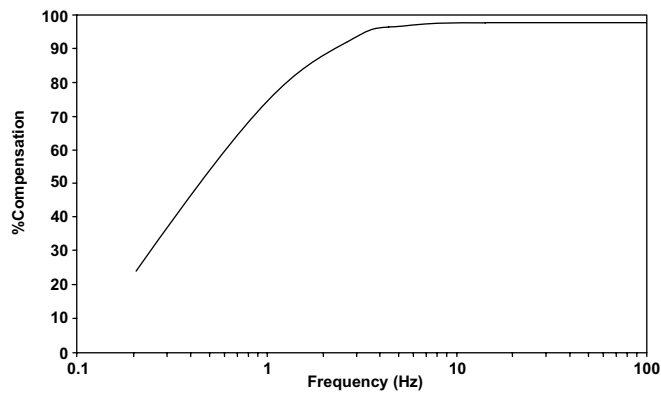

STABILIZED BINOCULAR COMPENSATION CURVE

END OF WORK PACKAGE

0047 00-3/4 blank

TM 9-1240-408-13&P

INDEX

Subject WP Sequence No. - Page No.

A

Acquiring and Observing the Target	0006 00-7
Additional Authorization List (AAL)	0045 00-1
Arctic Battery Pack	0008 00-9
Arctic Pack Maintenance	0019 00-1
Assembly and Preparation for Use	0005 00-1

B

Basic Issue Items (BII)	0044 00-1
Battery Cap Assembly Maintenance	0026 00-1
Battery Replacement	0012 00-1
Binocular Cover Maintenance	0025 00-1

TM 9-1240-408-13&P

INDEX

Subject WP Sequence No. - Page No.

C

Cleaning	
Case and Binocular Exterior	0013 00-1
Optical Surfaces	0013 00-3
Components of End Item (COEI)	0044 00-1
Controls and Indicators, Operator	0004 00-1
Corrosion Prevention and Control (CPC)	0001 00-3

D

Description and Use of Operator	
Controls and Indicators	0004 00-1
Daytime Eyepiece Maintenance.....	0021 00-1
Destruction of Army Materiel to Prevent	
Enemy Use	0001 00-5
Documentation for Turn - In	0023 00-2

TM 9-1240-408-13&P

INDEX - Continued

<u>Subject</u>	<u>WP Sequence No. - Page No.</u>
E	
Equipment Characteristics, Capabilities, and Features	0002 00-1
Equipment Data	0002 00-11
Expendable and Durable Items List	0046 00-1
External Power Adapters	0008 00-1
Eyepiece Lock Maintenance	0028 00-1
G	
General Information - Scope	0001 00-1

TM 9-1240-408-13&P

INDEX - Continued

<u>Subject</u>	<u>WP Sequence No. - Page No.</u>
H	
Hand Strap Assembly Maintenance	0015 00-1
I	
Initial Adjustments	0005 00-1
L	
List of Abbreviations/Acronyms	0001 00-6
Location and Description of Major Components	0002 00-4

TM 9-1240-408-13&P

INDEX - Continued

Subject WP Sequence No. - Page No.

M

Maintenance Allocation Chart	
Introduction	0030 00-1
Table	0031 00-1
Maintenance Forms, Records, and Reports	0001 00-2

N

National Stock Number (NSN) Index	0042 00-1
Neck Strap Assembly Maintenance	0016 00-1
Night Eyepiece (Optional) Maintenance	0022 00-1
Night Mode Operation	0007 00-1
Nomenclature Cross-Reference List	0001 00-6
Normal Stabilized Operation	0006 00-2

TM 9-1240-408-13&P

INDEX - Continued

Subject WP Sequence No. - Page No.

O

Operation Under Usual Conditions	0006 00-1
Operation Under Unusual Conditions	0008 00-1
Operational Checkout	0009 00-1
Operator Controls and Indicators	0004 00-1
Optics	0003 00-1

P

Part Number Index	0043 00-1
Pouch Maintenance	0018 00-1
Power Control Knob Maintenance	0027 00-1
Practical Exercises	0006 00-10
Preparation for Shipment or Turn-In	0001 00-5, 0023 00-5

TM 9-1240-408-13&P

INDEX - Continued

Subject WP Sequence No. - Page No.

P

Preventive Maintenance Checks and Services (PMCS)	
Introduction, Operator	0010 00-1
PMCS Procedures, Operator	0011 00-1
Protective Covers Maintenance	0020 00-1

R

References	0029 00-1
Repair Parts and Special Tools List	
Introduction	0032 00-1
Parts Lists	0033 00 thru 0041 00
Reporting Equipment Improvement	
Recommendations (EIR)	0001 00-3

TM 9-1240-408-13&P

INDEX - Continued

<u>Subject</u>	<u>WP Sequence No. - Page No.</u>
S	
Safety, Care, and Handling	0001 00-7
Service Upon Receipt	0014 00-1
Stabilization	0047 00-1
Supporting Information for Repair Parts, Special Tools, TMDE, and Support Equipment	0001 00-8

TM 9-1240-408-13&P

INDEX - Continued

<u>Subject</u>	<u>WP Sequence No. - Page No.</u>
T	
Theory of Operation	0003 00-1
Transportation Case Maintenance	0017 00-1
Troubleshooting Procedures	0024 00-1
U	
Use of Reticle	0006 00-13
W	
Warning Summary	a
Warranty	0001 00-5

9/10 blank

By Order of the Secretary of the Army:

ERIC K. SHINSEKI
General, United States Army
Chief of Staff

Official:

JOEL B. HUDSON
Administrative Assistant to the
Secretary of the Army

0008002

DISTRIBUTION:

To be distributed in accordance with initial distribution number (IDN) 410465 requirements for TM 9-1240-408-13&P.

RECOMMENDED CHANGES TO EQUIPMENT TECHNICAL PUBLICATIONS



THEN...JOT DOWN THE DOPE ABOUT IT ON THIS FORM. CAREFULLY TEAR IT OUT, FOLD IT AND DROP IT IN THE MAIL.

SOMETHING WRONG WITH PUBLICATION

FROM: (PRINT YOUR UNIT'S COMPLETE ADDRESS)

DATE SENT

PUBLICATION NUMBER

PUBLICATION DATE

PUBLICATION TITLE

BE EXACT PIN-POINT WHERE IT IS

PAGE NO.

PARA-GRAPH

FIGURE NO.

TABLE NO.

IN THIS SPACE, TELL WHAT IS WRONG AND WHAT SHOULD BE DONE ABOUT IT.

TEAR ALONG PERFORATED LINE

PRINTED NAME, GRADE OR TITLE AND TELEPHONE NUMBER

SIGN HERE

The Metric System and Equivalents

Linear Measure

1 centimeter = 10 millimeters = .39 inch
 1 decimeter = 10 centimeters = 3.94 inches
 1 meter = 10 decimeters = 39.37 inches
 1 dekameter = 10 meters = 32.8 feet
 1 hectometer = 10 dekameters = 328.08 feet
 1 kilometer = 10 hectometers = 3,280.8 feet

Weights

1 centigram = 10 milligrams = .15 grain
 1 decigram = 10 centigrams = 1.54 grains
 1 gram = 10 decigrams = .035 ounce
 1 dekagram = 10 grams = .35 ounce
 1 hectogram = 10 dekagrams = 3.52 ounces
 1 kilogram = 10 hectograms = 2.2 pounds
 1 quintal = 100 kilograms = 220.46 pounds
 1 metric ton = 10 quintals = 1.1 short tons

Liquid Measure

1 centiliter = 10 milliliters = .34 fl. ounce
 1 deciliter = 10 centiliters = 3.38 fl. ounces
 1 liter = 10 deciliters = 33.81 fl. ounces
 1 dekaliter = 10 liters = 2.64 gallons
 1 hectoliter = 10 dekaliters = 26.42 gallons
 1 kiloliter = 10 hectoliters = 264.18 gallons

Square Measure

1 sq. centimeter = 100 sq. millimeters = .155 sq. inch
 1 sq. decimeter = 100 sq. centimeters = 15.5 sq. inches
 1 sq. meter (centare) = 100 sq. decimeters = 10.76 sq. feet
 1 sq. dekameter (are) = 100 sq. meters = 1,076.4 sq. feet
 1 sq. hectometer (hectare) = 100 sq. dekameters = 2.47 acres
 1 sq. kilometer = 100 sq. hectometers = .386 sq. mile

Cubic Measure

1 cu. centimeter = 1000 cu. millimeters = .06 cu. inch
 1 cu. decimeter = 1000 cu. centimeters = 61.02 cu. inches
 1 cu. meter = 1000 cu. decimeters = 35.31 cu. feet

Approximate Conversion Factors

To change	To	Multiply by	To change	To	Multiply by
inches	centimeters	2.540	ounce-inches	newton-meters	.007062
feet	meters	.305	centimeters	inches	.394
yards	meters	.914	meters	feet	3.280
miles	kilometers	1.609	meters	yards	1.094
square inches	square centimeters	6.451	kilometers	miles	.621
square feet	square meters	.093	square centimeters	square inches	.155
square yards	square meters	.836	square meters	square feet	10.764
square miles	square kilometers	2.590	square meters	square yards	1.196
acres	square hectometers	.405	square kilometers	square miles	.386
cubic feet	cubic meters	.028	square hectometers	acres	2.471
cubic yards	cubic meters	.765	cubic meters	cubic feet	35.315
fluid ounces	milliliters	29.573	cubic meters	cubic yards	1.308
pints	liters	.473	milliliters	fluid ounces	.034
quarts	liters	.946	liters	pints	2.113
gallons	liters	3.785	liters	quarts	1.057
ounces	grams	28.349	liters	gallons	.264
pounds	kilograms	.454	grams	ounces	.035
short tons	metric tons	.907	kilograms	pounds	2.205
pound-feet	newton-meters	1.356	metric tons	short tons	1.102
pound-inches	newton-meters	.11296			

Temperature (Exact)

°F Fahrenheit temperature 5/9 (after subtracting 32) Celsius temperature °C

PIN: 078619-000

This fine document...

Was brought to you by me:



[Liberated Manuals -- free army and government manuals](#)

Why do I do it? I am tired of sleazy CD-ROM sellers, who take publicly available information, slap “watermarks” and other junk on it, and sell it. Those masters of search engine manipulation make sure that their sites that sell free information, come up first in search engines. They did not create it... They did not even scan it... Why should they get your money? Why are not letting you give those free manuals to your friends?

I am setting this document FREE. This document was made by the US Government and is NOT protected by Copyright. Feel free to share, republish, sell and so on.

I am not asking you for donations, fees or handouts. If you can, please provide a link to liberatedmanuals.com, so that free manuals come up first in search engines:

<A HREF=<http://www.liberatedmanuals.com/>>Free Military and Government Manuals

- Sincerely
Igor Chudov
<http://igor.chudov.com/>
- [Chicago Machinery Movers](#)