

\* TM 55-1520-244-PMD

---

TECHNICAL MANUAL  
PREVENTIVE MAINTENANCE  
DAILY

AH-1E/F/P/S HELICOPTER

DISTRIBUTION STATEMENT A: Approved for public release; distribution is unlimited.

---

\* This manual supersedes TM 55-1520-244-PMD, 30 April 1990, including changes.

HEADQUARTERS, DEPARTMENT OF THE ARMY  
30 April 1992



**CHANGE**  
**NO.4**

HEADQUARTERS  
DEPARTMENT OF THE ARMY  
WASHINGTON, D.C., 31 October 1995

PREVENTIVE MAINTENANCE  
DAILY

**AH-1E/F/P/HELICOPTER**

DISTRIBUTION STATEMENT A: Approved for public release; distribution is unlimited

TM 55-1520-244-PMD, 30 April 1992, is changed as follows:

1. Remove and insert pages as indicated below. New or changed text material is indicated by a vertical bar in the margin. An illustration change is indicated by a miniature pointing hand.

Remove pages

13 and 14

17 and 18

19 and 20

Insert pages

13 and 14

17 and 18

19 and 20

2. Retain this sheet in front of manual for reference purposes.

**By Order of the Secretary the Army:**

Official:

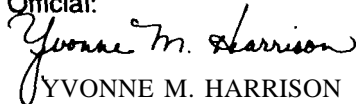

YVONNE M. HARRISON  
*Administrative Assistant to the  
Secretary of the Army*

00994

DENNIS J. REIMER  
*General, United States Army  
Chief of Staff*

**DISTRIBUTION:**

**To be distributed in accordance with DA Form 12-31-E, block no. 1311, requirements for TM 55-1520-244-PMD.**

**CHANGE**

**No. 3**

**HEADQUARTERS  
DEPARTMENT OF THE ARMY  
WASHINGTON, D.C., 31 August 1994**

**TECHNICAL MANUAL**

**PHASED MAINTENANCE DAILY**

**AH-1E/F/P/S HELICOPTER**

**DISTRIBUTION STATEMENT A: Approved for public release; distribution is unlimited**

**TM 55-1520-244-PMD, 30 April 1992, is changed as follows:**

- 1. Publication date of 30 April 1990 on banner page of change 2 should be changed to read 30 April 1992..**
- 2. Remove and insert pages as indicated below. New or changed text material is indicated by a vertical bar in the margin. An illustration change is indicated by a miniature pointing hand.**

**Remove pages**

**9 and 10**

**13 and 14**

**25 and 26**

**Insert pages**

**9 and 10**

**13 and 14**

**25 and 26**

**TM 55-1520-244-PMD**  
**C 6**

3. Retain this sheet in front of manual for reference purposes.

By Order of the Secretary of the Army

Official:

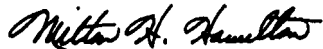

MILTON H. HAMILTON  
*Administrative Assistant to the  
Secretary of the Army*

07465

GORDON R. SULLIVAN  
*General, United States Army  
Chief of Staff*

**DISTRIBUTION:**

To be distributed in accordance with DA Form 12-31-E, block no. 1311, requirements for  
TM 55-1520-244-PMD.

# URGENT

TM 55-1520-244-PMD

C 2

CHANGE

HEADQUARTERS

DEPARTMENT OF THE ARMY

WASHINGTON, D.C., 15 December 1992

NO. 2

PREVENTIVE MAINTENANCE DAILY

AH-1E/F/P/S HELICOPTER

DISTRIBUTION STATEMENT A: Approved for public release; distribution is unlimited.

TM 55-1520-244-PMD, 30 April 1990<sup>2</sup>, is changed as follows:

1. Remove and insert pages as indicated below. New or changed text material is indicated by a vertical bar in the margin. An illustration change is indicated by a miniature pointing hand.

Remove pages

Insert pages

15 and 16

15 and 16

2. Retain this sheet in front of manual for reference purposes.

# URGENT

TM 55-1520-244-PMD  
C 2

By Order of the Secretary of the Army:

Official:

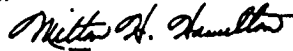

MILTON H. HAMILTON  
*Administrative Assistant to the  
Secretary of the Army*

02995

GORDON R. SULLIVAN  
*General, United States Army  
Chief of Staff*

**DISTRIBUTION:**

To be distributed in accordance with DA Form 12-31-E, block no. 1311, distribution for TM 55-1520-244-PMD.



# URGENT

TM 55-1520-244-PMD  
C 1

CHANGE }  
NO. 1 }

HEADQUARTERS  
DEPARTMENT OF THE ARMY  
WASHINGTON, D.C., 27 July 1992

TECHNICAL MANUAL  
PREVENTIVE MAINTENANCE  
DAILY

AH-1E/F/P/S HELICOPTER

TM 55-1520-244-PMD, 30 April 1992, is changed as follows:

1. Remove and insert pages as indicated below. New or changed text material is indicated by a vertical bar in the margin. An illustration change is indicated by a miniature pointing hand.

Remove pages

1 and 2  
7 through 10  
17 and 18  
- - - -  
27 and 28

Insert pages

1 and 2  
7 through 10  
17 and 18  
18.1/18.2  
27 and 28

2. Retain this sheet in front of manual for reference purposes.

# URGENT

TM 55-1520-244-PMD  
C 1

By Order of the Secretary of the Army:

Official:

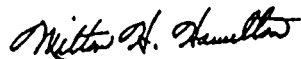

MILTON H. HAMILTON  
*Administrative Assistant to the  
Secretary of the Army*

GORDON R. SULLIVAN  
*General, United States Army  
Chief of Staff*

DISTRIBUTION

To be distributed in accordance with DA Form 12-31-E, block no. 1311, PM maintenance requirements for  
TM 55-1520-244-PMD.

**HEADQUARTERS  
DEPARTMENT OF THE ARMY  
WASHINGTON, D. C., 30 April 1992**

**PREVENTIVE MAINTENANCE DAILY  
AH-1E/F/P/S HELICOPTER**

**GENERAL INFORMATION AND SCOPE**

**WARNING:** CERTAIN INSPECTIONS ARE MANDATORY SAFETY-OF-FLIGHT REQUIREMENTS, AND THE INSPECTION INTERVALS CANNOT BE EXCEEDED. IN THE EVENT THESE INSPECTIONS CANNOT BE ACCOMPLISHED AT THE SPECIFIED INTERVAL, THE AIRCRAFT CONDITION STATUS SYMBOL WILL BE IMMEDIATELY CHANGED TO A RED "X". THESE TYPE INSPECTION ITEMS ARE PRECEDED BY "MANDATORY SAFETY-OF-FLIGHT INSPECTION ITEM".

**NOTE:** INSPECTION ITEMS CONTAINED IN THIS MANUAL ARE CONSIDERED THE MINIMUM REQUIREMENTS FOR PERFORMING A DAILY INSPECTION AND MUST BE PERFORMED. THE CUMULATIVE EFFECTS OF INSPECTION DEFERRALS ARE UNKNOWN AND COULD RESULT IN CATASTROPHIC FAILURE OR INCREASED MAINTENANCE AT A LATER DATE. THEREFORE, THE USE OF SPECIAL LETTERING TO EMPHASIZE MANDATORY SAFETY-OF-FLIGHT INSPECTION ITEMS IS NOT TO BE CONSTRUED AS AUTHORITY FOR DEFERRAL OF OTHER INSPECTIONS.

THIS MANUAL MAY DUPLICATE INSPECTION DATA CONTAINED IN THE PREVENTIVE MAINTENANCE CHECKS AND SERVICES (PMCS) TABLES IN THE SUBSYSTEM TMs OR THE INSPECTION CRITERIA INCLUDED IN THE PM AND PMD MAY DIFFER FROM THAT INCLUDED IN THE SUBSYSTEM TMs. WHEN A DIFFERENT INSPECTION INTERVAL IS SPECIFIED IN THE PMCS, THE PM AND PMD WILL TAKE PRECEDENCE. THE PM AND PMD SHALL BE USED TO PERFORM ALL DAILY AND/OR PHASE INSPECTIONS EXCEPT WHERE THE INSPECTION IS REFERENCED TO THE APPROPRIATE SUBSYSTEM TM. IN THIS CASE THE PMCS TABLES IN THE SUBSYSTEM TMs SHALL BE USED.

★ This manual supersedes TM-55-1520-244-PMD, 30 April 1990, including changes.

## C1

**1. Inspection Requirements.** This manual contains complete requirements for daily inspection for AH-1 E/F/P/S helicopters. It does not contain instructions for repair, adjustment, or other means of rectifying conditions, nor does it contain instructions for troubleshooting to find causes for malfunctioning. Specific tolerances, limits, etc, can be found in the applicable maintenance manuals. Use of the alphabetical index or table of contents in the applicable manuals will facilitate locating the required information.

### NOTE

Many procedures in this manual begin with a command such as check, inspect, or clean, etc. Where a specific command is not given, inspect, is implied.

**2. Maintenance Activities.** The inspections prescribed by this manual will be performed at specific periods by Aviation Unit Maintenance (AVUM) activities with assistance of Aviation Intermediate Maintenance (AVIM) and depot Maintenance activities when required.

### 3. General Information.

a. The inspection requirements contained herein are stated in such a manner as to establish when certain equipment is to be inspected and what conditions are desired/undesired. Compliance with the provisions outlined herein is required in order to assure that proper servicing has been accomplished and latent defects are discovered and corrected before malfunctioning or serious trouble results. Inspection requirements are arranged, as nearly as possible, according to the manner in which they will be performed. The requirements are divided into groups listed under area headings.

b. The inspection intervals designated herein will not be exceeded except in actual operational emergencies as explained herein. It is the commander's responsibility to determine (on an individual aircraft basis) when inspection intervals may be exceeded. For this purpose, operational emergencies are conditions of combat or conditions of disaster which necessitate flight to evacuate aircraft or personnel.

When aircraft are operated beyond the normal inspection due-time because of such emergency situations, a circled red X status symbol and an appropriate statement (to include authority) must be entered in blocks 16 and 17 of DA Form 2408-13 (Aircraft Inspection and Maintenance Record) until such time as the inspection is complete. Since safety may be jeopardized when inspections are delayed to meet emergency requirements, commanders will ensure that the aircraft status symbol reverts to a red "X" and that delayed inspections are accomplished immediately upon termination of the actual emergency. When unusual local conditions of environment, utilization, mission, experience of flight crew and maintenance personnel, periods of inactivity, etc., are encountered, the Maintenance Officer will, at his discretion, increase the scope and/or frequency of maintenance or inspections as necessary to ensure safe flight.

c. This manual may contain inspection requirements applicable to specific equipment not installed on helicopter. Those requirements that are not applicable should be disregarded.

d. DA Form 2408-13 shall be used to record all deficiencies or shortcomings discovered during the inspection to insure the current status of the aircraft is recorded.

e. A one and one-half inch space between each area of inspection is being provided to allow insertion of additional inspection items as required by local command inspection procedures.

f. Panels, fairings, and/or cowlings that are removed to facilitate this inspection do not require separate DA Form 2408-13 entries.

### 4. Special instructions.

a. A Preventive Maintenance Daily inspection is accomplished after the last flight of the mission day, or prior to the first flight on the next mission day on which the aircraft is flown. The inspection consists of visual examination and operational checks to determine that the aircraft can safely and efficiently perform the assigned mission.

b. Requirements to accomplish each inspection are stated at top of the checklist.

**5. Reporting of Errors and Recommending improvements.** You can help improve this manual. If you find any mistakes or if you know of a way to improve the procedures, please let us know. Mail your letter, DA form 2028 (Recommended Changes to Publications and

Blank Forms) or DA Form 2028-2 located in the back of the applicable aircraft maintenance manual (when using the 2028-2 from the maintenance manual, insure that the publication number and title refer to this **PMD**) directly to Commander, U.S. Army Aviation Systems Command, ATTN: AMSAV-MC, 4300 Goodfellow Blvd., St. Louis, MO 63120. A reply will be furnished to you.

**6. Inspection Areas.** Inspection areas are shown in figure 1.

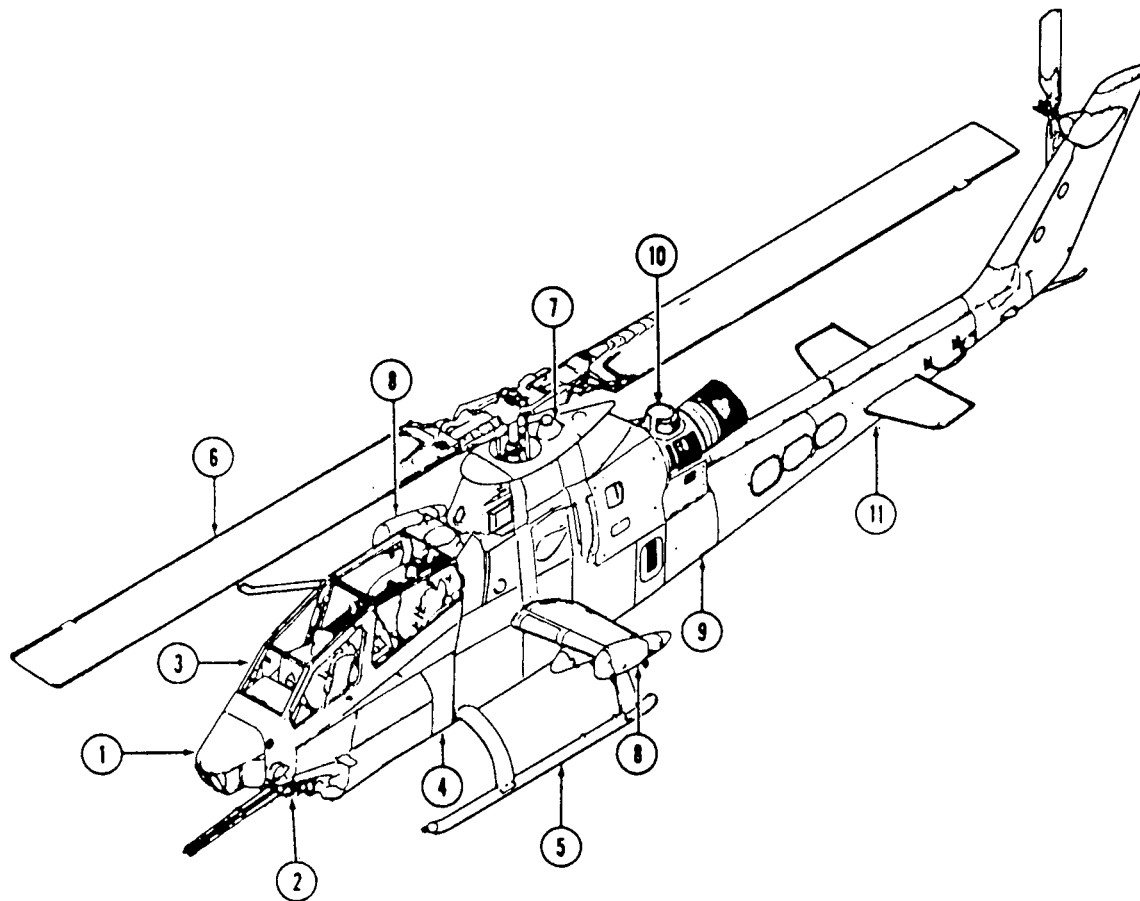

**NOTE**

AH-1F shown, typical areas apply to AH-1P, E, and S.

Figure 1. Area Diagram

Area No. 1	Nose Area	All surfaces, components and equipment in nose compartment and on exterior ahead of forward edge of gunner door.
Area No. 2	Turret Area	All surfaces, components and equipment inside and outside of armament turret and ammunition compartment.
Area No. 3	Gunner and Pilot Area	All surfaces, components and equipment inside and outside the gunner-pilot compartment Includes items stowed in cabin aft of pilot seat.
Area No. 4	Lower Forward Fuselage Area	All surfaces, components and equipment contained in, and on exterior of, lower forward portion of fuselage between ammunition compartment and aft cabin bulkhead (Sta 186.25) except forward fuel cell.
Area No. 5	Landing Gear Area	All surfaces, components and equipment which constitute the landing gear and attachments.
Area No. 6	Main Rotor Area	All components of the main rotor hub and blade. Does not include the mast.
Area No. 7	Pylon Area	All surfaces, components and equipment contained in, and on the exterior of, the hydraulic and transmission compartments to the bottom of the transmission, compartments to the bottom of the transmission. Includes transmission cowling, mast, mounts, rotating and fixed controls, and main (input) driveshaft.
Area No. 8	Wing Area	All surfaces, components and equipment contained in and on the wings. Includes all external fittings and attachments.
Area No. 9	Center Fuselage Area	All surfaces, components and equipment in and on the fuselage below the engine deck (WL 65.00) and between the cabin area (Sta 186.25) and tailboom attachment bulkhead (Sta 299.57). Includes forward and aft fuel cells, compartment below transmission, oil cooler and compartments accessible through side doors and panels on fuselage.

Area No. 10	Engine Area	All surfaces, components and equipment associated with engine installation located above engine work deck (WL 65.00) and within engine cowling, tailpipe fairing, countermeasure set cover and aft fairing.
Area No. 11	Tailboom Area	All surfaces, components and equipment located in and on the tailboom and vertical fin. Includes tail rotor, synchronized elevator, control linkages, and drive train of shafts and gearboxes mounted on the tailboom.



## DAILY INSPECTION CHECKLIST TM 55-1520-244-PMD

The preventive maintenance daily inspection is accomplished after the last flight of the mission day or prior to the first flight on the next mission day on which the aircraft is flown. The inspection consists of visual examination and operational checks to determine that the aircraft can safely and efficiently perform its assigned mission.

### WARNING

Insure that all weapons are CLEARED AND SAFED  
prior to inspection IAW TM 55-1520-236-10 or TM 55-1520-234-10.

DAILY INSPECTION TOTAL WORK TIME:

AH-1E/F/P/S

2.5 Hours

SEQ NO.	Item and Procedure	SEQ NO.	Item and Procedure
	<b>NOSE AREA LEFT SIDE</b>		<b>TURRET AREA LEFT SIDE</b>
1.1	Inspect helicopter forms and records for recorded discrepancies (DA PAM 738-751.	2.1	Ammunition compartment door for damage, interior for cleanliness and condition. Electrical receptacles for damage and corrosion.
1.2	Nose section exterior for visible damage.	2.2	GRENADE LAUNCHER, M129(P/S) Check grenade launcher and gun cradle for secure mounting in turret. Bolts securing launcher to cradle should be tight and safety wired. Feed tray, ammunition chute, ejection chute, and gun drive shaft should be securely attached. Check barrel for obstructions and remove excess oil by running a dry patch through the bore. Check launcher for proper lubrication with drive cable disconnected; the launcher cycles freely by moving rear gear until barrel in rear position begins cocking action. With drive cable connected the launcher functional movement is noticeably restricted. (TM 9-1090-203 Series)
1.3	Telescopic sight unit (TSU). Check azimuth indicator for damage and security. Check TSU window for cleanliness and excessive scratches. (TM 9-1 425-473-20)		
1.4	Check windshield and rain removal nozzles for damage, security and obstruction.		

"FOD REMINDER"

CHECK WORK AREA FOR TOOLS AND PARTS AFTER COMPLETION OF MAINTENANCE AND INSPECTION.

SEQ NO.	Item and Procedure
2.3	<p>GUN DRIVE ASSEMBLY (40-MM) (P/S)            Check drive assembly for secure mounting on weapon saddle. Flexible drive shaft should be securely connected to gun drive assembly. Inspect electrical cable for cuts or fraying. Check drive assembly electrical cable for secure connection at rear of weapon saddle. (TM 9-1090-203 Series)</p>
2.4	<p>FLEXIBLE DRIVE SHAFT (40-MM) (P/S)            Inspect shaft assembly for evidence of wear, binding, or twisting. Check that the drive shaft is routed through the web strap at the rear of the saddle and connects securely to the gun drive assembly and launcher. (TM 9-1090-203 Series)</p>
2.5	<p>DYNAMIC BRAKE TRANSDUCER MODULE (P/S)            Check electrical connector for secure connection to transducer module. Transducer module, mounting plate and gun cradle cam bracket should be securely installed. Check cam bracket on gun cradle for bent, broken, loose, or cracked arm. (TM 9-1090-203 Series)</p>

SEQ NO.	Item and Procedure
	<p style="text-align: center;"><b>NOTE</b></p> <p style="text-align: center;">Dampness due to slight seepage is allowable not to exceed two drops in 10 minutes from any given point.</p> <p>2.6 HYDRAULIC COMPONENTS (P/S)            Check for visible leakage of hydraulic fluid from hydraulic components in turret and ammunition compartment. (TM 9-1090-203 Series)</p> <p>2.7 ELECTRICAL CABLE ASSEMBLIES (TURRET AREA, AMMUNITION COMPARTMENT AREAS.)            Check cable assemblies for secure connections. Inspect connectors for evidence of cross-threading or damage. Wires and insulation should not be cut or frayed. (TM 9-1090-203/206 Series)</p> <p>2.8 Inspect turret for cleanliness, visible damage, and security of mounting hardware. (TM 9-1090-203/206 Series)</p>

**“FOD REMINDER”**

**CHECK WORK AREA FOR TOOLS AND PARTS AFTER COMPLETION OF MAINTENANCE AND INSPECTION.**

C3

SEQ NO.	Item and Procedure
2.9	FAIRINGS (P/S) Check fairings for secure attachment. Turret access doors should be securely locked in place. Inspect fairings for cracks or breaks. (TM 9-1090-203 Series)
2.10	AMMUNITION MAGAZINES AND CHUTING (AMMUNITION COMPARTMENT AREA) Inspect magazine assemblies for dented, cracked, or loose parts. Check electrical cables and chutes for secure attachment and proper routing. (TM 9-1090-203/206 Series)
2.11	AIM-1/EXL AIMING LIGHT Inspect mounting for security and damage and front window for cleanliness, scratches, and cracks.
<b>GUNNER AREA</b>	
3.1	All windows for damage and cleanliness.
3.2	Gunner door for positive latching, struts for operation and security, linear explosive for breaks; activation handle for installed safety pin.

SEQ NO.	Item and Procedure
3.3	Cabin interior gunner area clean and clear of loose objects.
3.4	Fire extinguisher for broken or missing seal, safety pin installed, bracket for serviceability, inspection tag for date.
3.5	Magnetic compass for security of mounting, broken glass, fluid for proper level, discoloration, and current correction card.
3.6	Gunner safety belt and shoulder harness for damage and security. Inertia reel for positive lock and unlock.
3.7	Gunner seat for damage and security.
3.8	Armor panels for security of attachment and damage.
3.9	Check gunner helmet sight rails for security and cleanliness (TM 9-1270-212-14&P)
3.10	All instruments on gunners panel for cleanliness and visible damage. Instrument range markings for accuracy and legibility. All gage lenses for looseness, cracks. Check spillage marks, if applicable.

**“FOD REMINDER”**

**CHECK WORK AREA FOR TOOLS AND PARTS AFTER COMPLETION OF MAINTENANCE AND INSPECTION.**

SEQ NO.	Item and Procedure
3.11	TELESCOPIC SIGHTING UNIT (TSU) Ensure that controls and switches are free from binding. Check optical elements for cleanliness and rendition. Ensure no moisture is visible on optics, refer to AVIM. (TM 9-1425-473-20)
3.12	GUNNER CONTROL PANELS Check control panels for secure installation. Electrical cables should be securely connected. Check that indicator lamps are serviceable and all switches are in normal or off positions. (TM 9-1090-203/206 Series)
	<b>LOWER FORWARD FUSELAGE AREA LEFT SIDE</b>
4.1	Exterior surfaces for visible damage, loose or missing access plates, chipping or peeling paint, and legibility of decals. Steps for condition.
4.2	Drains for cleanliness and obstructions.

SEQ NO.	Item and Procedure
4.3	Fuel tank sump drains for water or other contamination, (use sample jar.) Fuel supply lines and fuel cell cavity drain for damage and evidence of leakage.
4.4	Static port for cleanliness and obstructions.
4.5	Cross tube mounted fight for security, wires for chafing, mount for cracks (none allowed)
	<b>LANDING GEAR AREA (Left Side)</b>
5.1	Landing gear and cross tube fakings for damage and security.
5.2	Cross tubes for visible indications of excessive spread.
5.3	Skid shoes for condition and security.

**“FOD REMINDER”**

**CHECK WORK AREA FOR TOOLS AND PARTS AFTER COMPLETION OF MAINTENANCE AND INSPECTION.**

SEQ NO.	Item and Procedure
	<b>WING AREA (Left Side)</b>
	<b>WARNING</b>
	Do not work on wings or ejectors unless safety pins are installed. Accidental jettison of launchers can cause injury or death.
8.1	Exterior surfaces of wings for damage, chipped or peeling paint, and legibility of decals. Condition of ejector rack fairing.
8.2	Access doors for damage and security.
8.3	Stores ejector racks for damage, security, corrosion and distortion of any parts.
	<b>NOTE</b>
	Clean ejector rack daily when in use.
8.4	Stores ejector for adjustment and seating on external stores; safety pins installed.
8.5	External stores for looseness in stores rack.

SEQ NO.	Item and Procedure
8.6	Check wing area for evidence of hydraulic leaks.
8.7	<b>ROCKET LAUNCHERS</b> Visual Inspection-check for wear, cracks, deterioration, bends, and dents in tubes. Check connectors for wear or broken pins. Check detent spring in launcher tubes for wear, cracks, and deterioration. Check condition of suspension lugs on launcher. Check for broken or cut wires (M158A1 and M200 Series Launchers). Ensure that contacts are not bent, loose, broken, or damaged. Check to see if igniter arm is broken or worn. Check spring in igniter arm assembly for wear or damage. Check to see if igniter head is bent, loose, broken, or damaged. Check to see if retaining ring is broken or missing. Check system for moisture, corrosion, and cleanliness. (TM 9-1055-460-13&P)
8.8	<b>M65 LAUNCHER MOUNTING</b> Upper launcher aft and forward adjustable bomb lugs secure to helicopter ejector racks and rack sway brace bolts firmly against launcher sway brace pads. Lower launcher aft and forward attaching points secure to upper launcher aft and forward attaching points. (TM 9-1 425-473-20)

**“FOD REMINDER”**

**CHECK WORK AREA FOR TOOLS AND PARTS AFTER COMPLETION OF MAINTENANCE AND INSPECTION.**

SEQ NO.	Item and Procedure
8.9	<p>M65 ELECTRICAL CONNECTOR Upper launcher harness connected to helicopter receptacle and jettison quick disconnect lanyard attached to harness and launcher. Quick disconnect lanyard not twisted. Lower launcher harness connected to upper launcher harness receptacle. (TM 9-1425-473-20)</p>
<p><b>CENTER FUSELAGE AREA (Left Side)</b></p>	
9.1	<p>All exterior surfaces for damage, chipped or peeling paint and legibility of decals.</p>
9.2	<p>Inspection plate for damage, missing fasteners and positive latching.</p>

SEQ NO.	Item and Procedure
9.3	<p>INTERVALOMETER (P/S) Check intervalometer for secure mounting. Check electrical cables for damage and secure connection. Wipe intervalometer dry to remove dirt, grease, and oil. (TM 9-1090-203 Series)</p> <p><b>MANDATORY SAFETY OF FLIGHT INSPECTION ITEM</b></p>
9.4	<p>Hydraulic cylinders and lines for damage, evidence of leakage and security. Reposition hoses, if necessary to prevent chafing. Wiping down exposed control rods with clean soft cloth.</p>
9.5	<p>Check #3 emergency hydraulics system fluid level. (E/F/P)</p>
9.6	<p>Check control linkage for bolt wear and elongation of bolt holes. Check for excessive play in bearings and bushings. Check for cracked washers.</p>

**“FOD REMINDER”**

**CHECK WORK AREA FOR TOOLS AND PARTS AFTER COMPLETION OF MAINTENANCE AND INSPECTION.**

SEQ No.	Item and Procedure
	<b>PYLON AREA (Left Side)</b>
7.1	All cowling, accessdoors, and inspection plates for damage, missing fasteners, positive latching and unlatching, condition of hinges.
7.2	Inspect laser sensor fairing and housing for damage, security, and missing screws.
7.3	Check laser sensor units for condition, if installed. Refer to TM 11-1520-236-23.
	<b>MANDATORY SAFETY OF FLIGHT INSPECTION</b>
7.4	Hydraulic reservoir, module, lines and hoses in hydraulic compartment for evidence of damage, security, leakage and chafing.
7.5	Hydraulic reservoir for correct fluid level.
7.6	Environmental control system (ECS) for damage, security and evidence of leakage.
7.7	Check cylinder mount nuts (4) for condition and security. Retorque nuts and repaint slippage marks if necessary.
7.8	Visually check 10KVA alternator for evidence of overheating, wiring for chafing, and loose or corroded connections, and security.

SEQ No.	Item and Procedure
7.9	Transmission and connections for damage and oil leakage. Lift link for security. Lift link lugs for cracks.
7.10	Main (input drive shaft couplings for evidence of grease leakage. Clamps for damage and security. (Kaflex Drive Shaft) Inspect for loose bolts, cracks scratches, and proper installation.
7.11	Check control linkage for bolt wear and elongation of bolt holes. Check for excessive play in bearings and bushings. Check for cracked washers.
7.12	Scissors and sleeve for visible damage and security. Scissors drive link bearings for looseness or excessive play, slippage marks, and alignment. Swashplate for visible damage, security and for evidence of contact between outer ring or drive link and stationary swashplate. Minimum vertical clearance between drive links and all three horns must not be less than 0.035.

**“FOD REMINDER”**

**CHECK WORK AREA FOR TOOLS AND PARTS AFTER COMPLETION OF MAINTENANCE AND INSPECTION.**

SEQ No.	Item and Procedure
7.13	Scissors hub assembly and lower dust boot for evidence of overheating (discoloration of cadmium plating or distortion of boot.)
7.14	Pitot tube for damage, cleanliness, obstructions and security.
7.15	Engine oil tank, lines and hoses for evidence of damage, leakage and chafing.
7.16	Check engine oil tank for correct oil level.
7.16.1	Aircraft equipped with ODDS, check external engine oil filter bypass button for extended indicator.
7.17	Upper faking for damage and security.
7.18	Check Anti-collision light for damage and security.
7.19	Mast and boot for visible damage, corrosion and security
7.20	Exposed part of mast for visible damage and cleanliness.
7.21	Inspect pitch change tubes, bearings, nuts, bolts, and trunnion housing for excessive radial and axial play and any other damage. If any play is observed in elastomeric bearings, perform serviceability check.

SEQ No.	Item and Procedure
	<b>NOTE</b>
	<b>Cracks in elastomer are acceptable as long as the requirements of the serviceability check are met.</b>
	<b>NOTE</b>
	<b>Metal shims form the circular ridges found in the elastomer of the rod end bearing.</b>
	Visually inspect elastomeric bearings for evidence of broken/cracked shims or gross elastomer degradation or separation.
7.22	Visually inspect tube for straightness. If tube appears to be bent, have TIR check accomplished.
7.23	Inspect upper bearing housing and bearing outer race or marks (located in approximately 12 and 6 o'clock position on race) caused by contact of pitch horn. If such new marks are observed, perform a TIR check of pitch change tube.

**“FOD REMINDER”**

**CHECK WORK AREA FOR TOOLS AND PARTS AFTER COMPLETION OF MAINTENANCE AND INSPECTION.**



C2

SEQ NO.	Item and Procedure
	<b>MAIN ROTOR AREA (Left Side)</b> <b>MANDATORY SAFETY-OF-FLIGHT ITEM</b>
	<b>NOTE</b>
	Actual hands on verification of the pitch horn bolts and nuts for installation/security is required.
6.1	Inspect hub, blade grips, pitch horns, bolts, nuts, dust shields, yoke, and drag braces for visible damage end security. Pitch change tube bearings for axial looseness. Pitch horn inner bushing at pitch link attachment for cracks on flange area.
6.2	Inspect trunnion housings (P/N 540-011-101-5/9 hubs only) and inboard feathering bearing housings for protruding teflon, teflon residue, evidence of overheating and security of extension sleeve.
6.3	Inspect outboard feathering beatings for evidence of overheating and teflon residue.
6.4	Inspect elastomeric trunnion bearings for damage and security.
6.5	Sand deflectors for cracks and damage, if installed.
6.6	Inspect for slipped inboard extension sleeve.

SEQ NO.	Item and Procedure
	<b>ENGINE AREA (Left Side)</b>
10.1	Visually check FOD screen for security, FOD, grass leaves or other debris.
10.2	Aircraft modified per MWO 55-1520-236-50-12. Inspect particle separator left screen and right side bypass door for foreign objects. Remove all foreign objects. Loosen two studs from screen, P/N CC-00158-2D217A and remove screen. Check and remove foreign objects from left bypass door, replace screen.
10.3	Inspect cowl intake ramp for cleanliness, damage, obstructions and loose or missing fasteners.
10.4	Visually inspect engine accessories and connections, for damage, security and loose bolts.
10.5	Visually inspect engine compressor housing for security, cracks, scratches, and corrosion.
10.6	Visually inspect engine mounts for security, cracks, loose bolts, and damage.

**“FOD REMINDER”**

**CHECK WORK AREA FOR TOOLS AND PARTS AFTER COMPLETION OF MAINTENANCE AND INSPECTION.**

SEQ NO.	Item and Procedure
10.7	Inspect engine control linkage, actuator, and cambox for condition and security.
10.8	Visually inspect engine combustion chamber housing exhaust diffuser, support cone, fireshield, and tailpipe or exhaust duct for cracks, dents, and burned or buckled areas and missing blades.
10.9	Cowling, latches, and fire detector elements for damage and security.
10.10	IR duct, countermeasure cover (AH-IF), tailpipe fairing and ejector for damage and security.
<b>CENTER FUSELAGE AREA (Left Side)</b>	
9.1	External power receptacle and access door for security and condition.
9.2	External drains for damage, corrosion and obstructions.

SEQ NO.	Item and Procedure
9.3	Oil cooler (and duct screen) for damage, obstructions, and security. Oil cooler blower for visible damage and evidence of grease leakage. Check turbine for rough or binding bearings by turning turbine by hand.
<b>TAILBOOM AREA</b>	
11.1	Tailboom exterior for evidence of damage; elevators for damage and security.
11.2	Tail rotor drive shaft installation for damage and security shafts, hangers, couplings, and clamps. Visually inspect clamps for cracks. Visually examine hanger bearings and couplings for evidence of overheating. Inspect tail rotor drive shaft couplings for grease leakage and protruding seals.

**“FOD REMINDER”**

**CHECK WORK AREA FOR TOOLS AND PARTS AFTER COMPLETION OF MAINTENANCE AND INSPECTION.**

SEQ No.	Item and Procedure
11.3	Tail rotor (90°) gearbox for security, correct oil level, and leakage. Sight gage for cracks, security and stains that might give a false indication of the oil level. Check chip detector for physical security and damage (i.e. broken tires). Check filler cap for security and dogged vent.  <b>NOTE</b>  <b>Position tail rotor blades at the 6 and 12 o'clock positions. Check tail rotor blade pitch change bearings for looseness by holding one blade Inboard so that the hub is against the stop. Inboard/outboard movement of the opposite blade shall not exceed one-half (1/2) inch at the blade tip. Rotate blades and repeat procedure for the opposite blade.</b>
11.4	Tail rotor hub and blade assembly for security and visible damage. Check bearings for deterioration, damage, or excessive play.
11.5	Tail rotor control installation for security.
11.6	Visually inspect tail rotor crosshead retaining nuts and bolts ensure cotter pins are installed and are securing nuts to blots.

SEQ NO.	Item and Procedure
11.7	90° gearbox support fitting (casting) for evidence of chafing by vertical fin door.
11.8	Intermediate (42°) gearbox for security, correct oil level, and leakage. Sight gage for cracks, security and stains that might give a fake indication of the oil level. Check chip detector for physical security and damage (i.e. broken wires). Check filler cap for security and clogged vent.
11.9	Tailboom exterior for evidence of damage; elevators and tail skid for damage and security.
11.10	Tailboom attaching fittings for security and cracks.
11.11	Tailboom attaching bolts for proper torque by checking slippage marks.
11.12	Inspect tailboom skid tube, support block and packing for cracks or excessive wear.  <b>CENTER FUSELAGE AREA (Right Side)</b>
9.1	Electrical compartment for security of components and condition of wiring.
9.2	Tail rotor boost cylinder and hoses for evidence of damage, security, leakage and chafing.

**“FOD REMINDER”****CHECK WORK AREA FOR TOOLS AND PARTS AFTER COMPLETION OF MAINTENANCE AND INSPECTION.**

SEQ No.	Item and Procedure
9.3	Battery compartment interior for cleanliness and corrosion. Battery and connections for security, presence of safety wire, cleanliness and corrosion. Battery vent for obstructions and proper positioning. Battery connector for arching and corrosion.
	<b>ENGINE AREA (Right Side)</b>
10.1	IR duct, countermeasure cover (AH-1F), tailpipe fairing and ejector for damage and security.
10.2	All cowlings, access doors, and inspection plates for damage, security, and loose or faulty latches.
10.3	Cowling, latches, and fire detector elements for damage and security.
10.4	Engine combustion chamber housing exhaust diffuser, support done, fireshield, and tailpipe or exhaust duct for cracks, dents, and burned or buckled areas and missing blades.
10.5	Engine mount for security, cracks, and damage; trunnion at mid-points or underside for cracks.
10.6	Engine accessories, connections, and bipod mounts visually for damage, security, loose bolts and cracks.
10.7	Engine compressor housing visually for security, cracks, scratches, and corrosion.

SEQ No.	Item and Procedure
10.8	Oil lines and hoses for evidence of damage, leakage and chafing.
10.8.1	Check oil bypass indicator buttons for extended condition.
10.9	VIGV linkage for condition and security.
10.10	Inspect cowl intake ramp for cleanliness, damage, obstructions, loose or missing fasteners.
10.11	Visually check FOD screen for security, FOD, grass, leaves or other debris.
10.12	Aircraft modified per MWO 55-1520-236-50-12. Inspect particle separator left screen and right side bypass door for foreign objects. Remove all foreign objects. Loosen two studs from screen, P/N CC-00158-2D217A and remove screen. Check and remove foreign objects from surface of left bypass door, replace screen.

**“FOD REMINDER”**

**CHECK WORK AREA FOR TOOLS AND PARTS AFTER COMPLETION OF MAINTENANCE AND INSPECTION.**

C1

SEQ NO.	Item and Procedure
10.13	Aircraft modified per MWO 55-1520-236-50-12. Inspect the eight scavenge ejectors for blockage and restrictions, P/N CD-00158-1D293A, TM 55-1520-236-23P-1 Figure 52A, Item 74. This can be accomplished by opening the check valve (doors) in scavenge connector assembly, P/N CD-00158-1D295A, Item 70.
10.13.1	If blockage or accumulation of dirt or oil is not found the inspection is complete.
10.13.2	Scavenge ejectors found blocked and/or with an accumulation of dirt and oil are to be cleaned per TM 55-1520-236-23, Page 4-22.1, Paragraph 4-29.

SEQ NO.	Item and Procedure

**"FOD" REMINDER"**

**CHECK WORK AREA FOR TOOLS AND PARTS AFTER COMPLETION OF MAINTENANCE AND INSPECTION.**



**C 4**

SEQ No.	Item and Procedure
<b>PYLON AREA (Right Side)</b>	
7.1	All cowling, access doors, and inspection plates for damage, missing fasteners, positive latching and unlatching, condition of hinges.
7.2	inspect laser sensor fairing and housing for damage, security, and missing screws.
7.3	Check laser sensor units for condition, if installed. Refer to TM 11-1520-236-23.
<b>MANDATORY SAFETY OF FLIGHT INSPECTION</b>	
7.4	Hydraulic reservoir, module, lines and hoses in hydraulic compartment for evidence of damage, security, leakage and chafing.
7.5	Hydraulic reservoir for correct fluid level. Check module filter for extended indicators.
7.6	Environmental control system (ECS) for damage, security and evidence of leakage.
7.7	Check cylinder mount nuts (4) for condition and security. Retorque nuts and repaint slippage marks if necessary.
7.8	Transmission and connections for damage and oil leakage. Sight gage for cracks, security and stains that might give a false indication of the oil level.

SEQ NO.	Item and Procedure
7.8 Cont	Transmission sump for water contamination and correct oil level. Aircraft equipped with ODDS, check physical security of debris monitor electrical connector and condition of wires. Lift link for security. Lift link lugs for cracks with particular attention to right lift link lug in area of bushing.
7.9	Transmission external oil filter bypass indicator for condition of filter element.
7.10	Check control leakage for bolt wear and elongation of bolt holes. Check for excessive play in beatings and bushings. Check for cracked washers.
7.11	Scissors and sleeve for visible damage and security. scissors drive link bearings for looseness or excessive play, slippage marks, and alignment. Swashplate for visible damage, security and for evidence of contact between outer ring or drive link and stationary swashplate. Minimum vertical clearance between drive links and all three horns must not be less than 0.035.
7.12	Scissors hub assembly and lower dust boot for evidence of overheating (discoloration of cadmium plating or distortion of boot.)
7.13	Mast and boot for visible damage, corrosion and security.

**“FOD REMINDER”**

CHECK WORK AREA FOR TOOLS AND PARTS AFTER COMPLETION OF MAINTENANCE AND INSPECTION.

iSEQ No.	Item and Procedure
7.14	Exposed part of mast for visible damage and cleanliness.
7.15	Inspect pitch change tubes, bearings, nuts, bolts, and trunnion housing for excessive radial and axial play and other damage. If any play is observed in elastomeric bearings, perform serviceability check.
<b>NOTE</b>	
<b>Cracks In elastomer are acceptable as long as the requirements of the serviceability check are met.</b>	
<b>NOTE</b>	
<b>Metal shims form the circular ridges found In the elastomer of the rod end bearing.</b>	
Visually inspect elastomeric bearings for evidence of broken/cracked shims or gross elastomer degradation or separation.	
7.16	Visually inspect tube for straightness. If tube appears to be bent, have TIR check accomplished.
7.17	Inspect upper bearing housing and bearing outer race for marks (located in approximately 12 and 6 o'clock position on race) caused by contact of pitch horn. If such new marks are observed, perform a TIR check of pitch change tube.

SEQ NO.	Item and Procedure
7.18	Upper fairing for damage and security.
<b>MAIN ROTOR AREA (Right Side) MANDATORY SAFETY-OF-FLIGHT ITEM</b>	
<b>NOTE</b>	
<b>Actual hands on verification of the pitch horn bolts and nuts for installation/security is required.</b>	
6.1	Inspect hub, blade grips, pitch horns, bolts, nuts, dust shields, yoke, and drag braces for visible damage and security. Pitch change tube bearings for axial looseness.
6.2	Inspect trunnion housings (P/N 540-011-101-5/9 hubs only) and inboard feathering bearing housings for protruding teflon, teflon residue, evidence of overheating and security of extension sleeve.
6.3	Inspect outboard feathering bearings for evidence of overheating and teflon residue.
6.4	Inspect elastomeric trunnion bearings for damage and security.
6.5	Sand deflectors for cracks and damage, if installed.
6.6	Inspect for slipped inboard extension sleeve.

**“FOD REMINDER”**

CHECK WORK AREA FOR TOOLS AND PARTS AFTER COMPLETION OF MAINTENANCE AND INSPECTION.



SEQ NO.	Item and Procedure
<b>WING AREA (Right Side)</b>	
<b>WARNING</b>	
Do not work on wings ejectors unless safety pins have been installed. Accidental jettison of launchers can cause injury or death.	
8.1	Exterior surfaces of wings for damage, chipped or peeling paint, and legibility of decals. Condition of ejector rack fairing.
8.2	Access doors for damage and security.
8.3	Stores ejector racks for damage, security, corrosion and distortion of any parts.
<b>NOTE</b>	
Clean ejector rack daily when in use.	
8.4	Stores ejector for adjustment and seating on external stores; safety pins installed.
8.5	External stores for looseness in stores rack.

SEQ NO.	Item and Procedure
8.6	Check wing area for evidence of hydraulic leaks.
8.7	<b>ROCKET LAUNCHERS</b> Visual Inspection--check for wear, cracks, deterioration, bends, and dents in tubes. Check connectors for wear or broken pins. Check detent spring in launcher tubes for wear, cracks, and deterioration. Check condition of suspension lugs on launcher. Check for broken or cut wires (M158A1 and M200 Series Launchers). Ensure that contacts are not bent, loose, broken, or damaged. Check to see if igniter arm is broken or worn. Check spring in igniter arm assembly for wear or damage. Check to see if igniter head is bent, loose, broken, or damaged. Check to see if retaining ring is broken or missing. Check system for moisture, corrosion, and cleanliness. (TM 9-1055 -460-13&P)
8.8	<b>M65 LAUNCHER MOUNTING</b> Upper launcher aft and forward adjustable bomb lugs secure to helicopter ejector racks and rack swaybrace bolts firmly against launcher swaybrace pads. Lower launcher aft and forward attaching points secure to upper launcher aft and forward attaching points. (TM 9-1425-473-20)

**"FOD REMINDER"**

**CHECK WORK AREA FOR TOOLS AND PARTS AFTER COMPLETION OF MAINTENANCE AND INSPECTION.**

SEQ NO.	Item and Procedure
8.9	<p>M65 ELECTRICAL CONNECTOR Upper launcher harness connected to helicopter receptacle and jettison quick disconnect lanyard attached to harness and launcher. Quick disconnect lanyard not twisted. Lower launcher harness connected to upper launcher harness receptacle. (TM 9-1425-473-20)</p>
<b>CENTER FUSELAGE AREA (Right Side)</b>	
9.1	<p>INTERVALOMETERS (Right Side) (P/S) Check intervalometers for secure mounting. Check electrical cables for damage and secure connection. Wipe intervalometers dry to remove dirt, grease, and oil. (TM 9-1090-203 Series)</p>
<b>MANDATORY SAFETY OF FLIGHT INSPECTION ITEM</b>	
9.2	<p>Hydraulic cylinders and lines for damage, evidence of leakage and security. Reposition hoses, if necessary to prevent chafing. Wipe down exposed control rods with clean soft cloth.</p>

SEQ NO.	Item and Procedure
<b>MANDATORY SAFETY OF FLIGHT INSPECTION ITEM</b>	
9.3	<p>Emergency hydraulic pump motor package for damage, security and evidence of leaks. (E/F/P)</p>
<b>MANDATORY SAFETY OF FLIGHT INSPECTION ITEM</b>	
9.4	<p>Hydraulic accumulator for precharge. Discharge hydraulic pressure for check. (S)</p>
9.5	<p>Emergency hydraulic reservoir for correct fluid level. Check module filter for extended indicator. (E/F/P)</p>
<b>LOWER FORWARD FUSELAGE AREA (Right Side)</b>	
4.1	<p>Exterior surfaces for visible damage, loose or missing access plates, chipping or peeling paint, and legibility of decals. Steps for condition.</p>
4.2	<p>Drains for cleanliness and obstructions.</p>

**"FOD REMINDER"**

**CHECK WORK AREA FOR TOOLS AND PARTS AFTER COMPLETION OF MAINTENANCE AND INSPECTION.**

SEQ NO.	Item and Procedure
<b>LANDING GEAR AREA (Right Side)</b>	
5.1	Landing gear and cross tube fairings for damage and security.
5.2	Cross tubes for visible indications of excessive spread.
5.3	Skid shoes for condition and security.
<b>TURRET AREA (Right Side)</b>	
2.1	<p>MACHINE GUN M134 (P/S)  Check machine gun for secure mounting in turret. Support extension should be tight and recoil adapters should not have excessive free play. Housing cover and safing sector should be securely attached. Rotate gun barrel and inspect moving parts for freedom of movement and proper lubrication. Check total rounds fired and compare to round dependent parts replacement and maintenance. (TM 9-1090-203 Series)</p>

SEQ NO.	Item and Procedure
2.2	<p>DELINKING FEEDER MAU-56/A (P/S)  Check feeder for secure attachment to machine gun. Chutes should be securely attached to feeder. Electrical cable connection to feeder gate solenoid should be secure. Inspect feeder for proper lubrication. Check timing by rotating gun barrels until timing pins depress simultaneously. When timing is incorrect before operation, re-time feeder and gun. (TM 9-1090-203 Series)</p>
2.3	<p>MACHINE GUN DRIVE ASSEMBLY (P/S)  Check drive assembly for secure attachment to machine gun. Flexible shaft should be securely connected to drive assembly. Check drive assembly electrical cable for secure connection at rear of weapon saddle. Inspect drive assembly for dents, cracks, or loose parts. Check gears for chipped or missing teeth and electrical cable for cuts or fraying. (TM 9-1090-203 Series)</p>

**"FOD REMINDER"**

**CHECK WORK AREA FOR TOOLS AND PARTS AFTER COMPLETION OF MAINTENANCE AND INSPECTION.**

SEQ NO.	Item and Procedure
2.4	<p>FLEXIBLE SHAFT ASSEMBLY (P/S)            Check to see that flexible shaft is properly routed through the chute separator (above the electrical cables and hydraulic hoses). Check for secure connections at ammunition magazine and machine gun drive assembly. Check that the ammunition magazine functions when gun barrels are rotated. Inspect shaft assembly for evidence of wear, binding, or twisting. Check shaft housing for cuts and possible separation at connectors. (TM 9-1090-203 Series)</p>
2.5	<p>All hydraulic lines, hoses, and hydraulic components in the turret for evidence of damage, and chafing. (P/S)</p>
2.6	<p>FAIRINGS (P/S)            Check fairings for secure attachment. Turret access doors should be securely locked in place. Inspect fairings for cracks or breaks. (TM 9-1090-203 Series)</p> <p style="text-align: center;"><b>NOTE</b></p> <p>Dampness due to slight seepage is allowable not to exceed two drops in 10 minutes from any given point.</p>

SEQ NO.	Item and Procedure
2.7	<p>HYDRAULIC COMPONENTS (TURRET AREA AND AMMUNITION COMPONENTS AREA), (Right Side) (P/S)            Check for visible leakage of hydraulic fluid from hydraulic components in turret and ammunition compartment. (TM 9-1090-203 Series)</p>
2.8	<p>MACHINE GUN M197 (E/F)            Check machine gun for secure mounting in turret. Rotate gun barrel and inspect moving parts for freedom of movement and proper lubrication. Check total rounds fired and compare to round dependent parts replacement and maintenance. (TM 9-1090-206 Series)</p>
2.9	<p>M89 FEEDER (E/F)            Check feeder for secure attachment to machine gun. Chutes should be securely attached to feeder. Electrical cable connection to feeder gate solenoid should be secure. Ensure security of drive motor. Inspect feeder for proper lubrication. Check timing by rotating gun barrels until timing pins depress simultaneously. When timing is incorrect before operation, re-time feeder and gun (TM 9-1090-206 Series).</p>

**"FOD REMINDER"**

**CHECK WORK AREA FOR TOOLS AND PARTS AFTER COMPLETION OF MAINTENANCE AND INSPECTION.**

SEQ NO.	Item and Procedure
2.10	Ammunition compartment door for damage, interior for cleanliness and condition. Electrical receptacles for damage, corrosion and security.
2.11	Check electrical cable assemblies for secure connections. Inspect connectors for evidence of cross-threading or damage. Wires and insulation should not be cut or frayed. (TM 9-1090-203/206 Series)
2.12	Inspect magazine assemblies for dented, cracked, or loose parts. Check electrical cables and chutes for secure attachment and proper routing. (TM 9-1090-203/206 Series)
PILOT AREA	
3.1	Static port for cleanliness and obstructions.
3.2	Check air data system pilot tube for proper movement and unobstructed. (F)

SEQ NO.	Item and Procedure
3.3	Pilot door for positive latching. Struts for operation and security. Linear explosive for breaks; activation handle for installed safety pin.
3.4	Cabin interior pilot area clean and clear of loose objects and tools.
3.5	First aid kit, presence of inspection dale tags, broken or missing seal, and security.
3.6	Storage compartment above and aft of pilot for secure stowage of required items.
3.7	Check pilot helmet sight rails for security and cleanliness (TM 9-1270-212 Series).
3.8	All instruments on pilot panel for cleanliness and visible damage. instrument range markings for accuracy and legibility. All gage lenses for looseness, cracks, and slippage marks.
3.9	Pilot safety belt and shoulder harness for damage and security. Inertia reel for positive lock and unlock.

**"FOD REMINDER"**

**CHECK WORK AREA FOR TOOLS AND PARTS AFTER COMPLETION OF MAINTENANCE AND INSPECTION.**

C3

SEQ NO.	Item and Procedure	SEQ NO.	Item and Procedure
3.10	Pilot seat for damage and security positive movement and locking in all positions.	3.14	XM-76 HEAD-UP SYSTEM (F) Check for broken, chipped or cracked glass. Check desiccant color (should be bright blue). Check edgelit panels for illumination. (TM 9-1270-219 Series)
3.11	Pilot armor panels for security of attachment and damage.		
3.12	REFLEX SIGHT M73 (PILOT COCKPIT AREA) (E/P/S) Check reflex sight for secure installation. Electrical cables should be securely connected. Check optical elements for cleanliness. Check that both filaments of reticle lamp are serviceable. Rotate elevation/depression knob and check that beamsplitter elevates and depresses without binding or catching. (TM 9-1090-203/206 Series)	3.15	GLOBAL POSITIONING SYSTEM Check that receiver, mounted on glareshield, connectors and switches are secure and undamaged. Check that display screen is clean and undamaged. Check that antenna, mounted on cockpit roof, and its connector are undamaged.
3.13	PILOT ARMAMENT CONTROL PANELS Check control panels for secure installation. Electrical cables should be securely connected. Check that indicator lamps are serviceable and all switches are in normal or off positions. (TM 9-1090-203/206 Series)	ALL AREAS	Wipe up all POL leaks, seeps, and drips.
		ALL AREAS	<p style="text-align: center;"><b>LUBRICATION</b></p> Lubricate in accordance with lubrication chart contained in applicable maintenance manual.

**"FOD REMINDER"**

**CHECK WORK AREA FOR TOOLS AND PARTS AFTER COMPLETION OF MAINTENANCE AND INSPECTION.**

C1

SEQ NO.	Item and Procedure
<b>POWER ON</b>	
1.1	Pilot heater for operation.
3.2	Caution panel lights for illumination.
3.3	Interior lights (cockpit, instrument, console, and panel lights) for proper operation.
3.4	Exterior lights (navigation, anticollision, and search lights) for proper operation.
3.5	Fuel quantity indicator checked with test switch.
10.6	Engine controls for free action through full range, idle stop release and governor rpm actuator functionally check.

SEQ NO.	Item and Procedure
10.7	Main fuel filter for caution panel indication of clogged element condition, evidence of water in filter drain sample, leakage from lines. (Fuel boost pumps on.)
<b>MAIN ROTOR AREA</b>	
<b>NOTE</b>	
Aircraft operation in areas of salt laden air and high humidity will be washed daily with fresh water to prevent corrosion.	

**"FOD REMINDER"**

CHECK WORK AREA FOR TOOLS AND PARTS AFTER COMPLETION OF MAINTENANCE AND INSPECTION.

SEQ NO.	Item and Procedure
6.9	<p><b>MANDATORY SAFETY OF FLIGHT INSPECTION ITEM</b></p> <p>Wipe blades upper and lower surfaces with clean soft cloth and inspect both surfaces and blade tip for damage, cracks and visible indications of voids and bond separation. Inspect for nicks and dents in trailing edge. On other than K747 blades, inspect scarf joints for erosion and corrosion. On K747 blades, inspect leading edge erosion guard for delamination, cuts and tears, and excessive erosion. Pay particular attention to any separations or delaminations of the erosion guard's spanwise seam between blade stations 75 and 260 and the chordwise seam at station 75 (and at approximately 213 to 215 if appropriate) on both top and bottom surfaces of blade. Inspect leading edge erosion guard for circular delamination or raised areas in the blade weight retention area (Station 224.4 to Station 238.0)</p>
3.10	Clean windscreen IAW TM 55-1520-236-23.

SEQ NO.	Item and Procedure
	<p><b>FORMS AND RECORDS COMPLETION</b></p> <p>Ensure that all entries on forms, records, and worksheets have been completed or updated and new forms initiated as required (DA PAM 738-751).</p> <p>Check separator overboard vent during engine operation, or prior to engine shutdown for air stream flow. Smooth flow indicates sand ejector operating satisfactorily.</p>

**"FOD REMINDER"**

**CHECK WORK AREA FOR TOOLS AND PARTS AFTER COMPLETION OF MAINTENANCE AND INSPECTION.**



By Order of the Secretary of the Army:

Official:

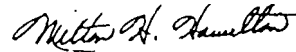

MILTON H. HAMILTON  
*Administrative Assistant to the  
Secretary of the Army*

01296

GORDON R. SULLIVAN  
*General, United States Army  
Chief of Staff*

DISTRIBUTION:

To be distributed in accordance with DA Form 12-31-E, block no. 1311, PM maintenance requirements for TM 55-1520-244-PMD.

PIN: 067714-004

This fine document...

Was brought to you by me:



## [Liberated Manuals -- free army and government manuals](#)

Why do I do it? I am tired of sleazy CD-ROM sellers, who take publicly available information, slap “watermarks” and other junk on it, and sell it. Those masters of search engine manipulation make sure that their sites that sell free information, come up first in search engines. They did not create it... They did not even scan it... Why should they get your money? Why are not letting you give those free manuals to your friends?

I am setting this document FREE. This document was made by the US Government and is NOT protected by Copyright. Feel free to share, republish, sell and so on.

I am not asking you for donations, fees or handouts. If you can, please provide a link to [liberatedmanuals.com](http://liberatedmanuals.com), so that free manuals come up first in search engines:

<A HREF=<http://www.liberatedmanuals.com/>>Free Military and Government Manuals</A>

- Sincerely  
Igor Chudov  
<http://igor.chudov.com/>
- [Chicago Machinery Movers](#)