

TECHNICAL MANUAL

OPERATOR, ORGANIZATIONAL AND  
DIRECT SUPPORT MAINTENANCE MANUAL  
INCLUDING REPAIR PARTS AND  
SPECIAL TOOLS LIST

TEST SET, ELECTRICAL  
(0-33 KW LOAD BANK)  
MODEL 1057  
NSN 6625-01-108-3651

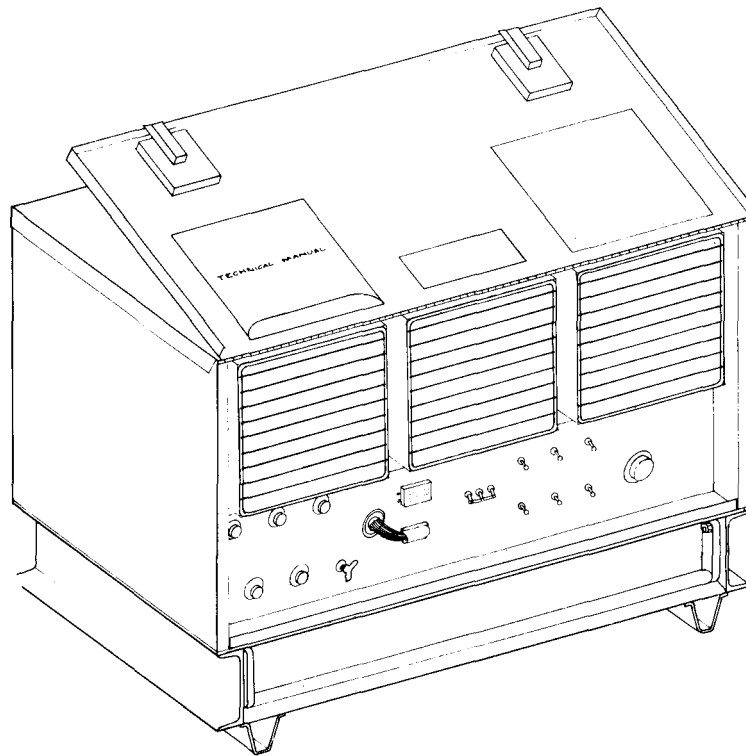

---

HEADQUARTERS, DEPARTMENT OF THE ARMY

10 May 83



CHANGE

NO. 1

HEADQUARTERS  
DEPARTMENT OF THE ARMY  
WASHINGTON, D.C., 6 May 1987

Operator, Organizational and Direct Support Maintenance Manual  
Including Repair Parts and Special Tools List

TEST SET, ELECTRICAL  
(0-33 KW LOAD BANK)  
MODEL 1057  
NSN 6625-01-108-3651

TM 5-6625-2694-13&P, 10 May 1983, is changed as follows:

1. Remove and insert pages as indicated below. New or changed text material is indicated by a vertical bar in the margin. An illustration change is indicated by a miniature pointing hand.

Remove pages	Insert pages
i and ii	i and ii
iii and 1-0	iii and 1-0
1-1 through 1-4	1-1 through 1-4
2-3 through 2-6	2-3 through 2-6
3-1 through 3-3/3-4	3-1 through 3-3/3-4
5-1 through 5-10	5-1 through 5-10
5-17 through 5-20	5-17 through 5-20
5-25 and 5-26	5-25 and 5-26
B-1 through B-6	B-1 through B-6
C-7 through C-10	C-7 through C-10
C-15 and C-16	C-15 and C-16
c-21/c-22	C-21/C-22
F0-1	FO-1
F0-2	FO-2

2. Retain this sheet in front of manual for reference purposes.

By Order of the Secretary of the Army:

**JOHN A. WICKHAM, JR.**  
*General, United States Army*  
*Chief of Staff*

Official:

**R.L. DILWORTH**  
*Brigadier General, United States Army*  
*The Adjutant General*

DISTRIBUTION:

To be distributed in accordance with DA Form 12-25A, Operator, Organizational, Direct Support and General Support Maintenance Requirements for Test Set, Electric, Load Bank, 0-33KW (1057).



**W A R N I N G**

**H I G H V O L T A G E**

is handled by this equipment.

**D E A T H O N C O N T A C T**

may result if personnel fail to observe safety precautions.

Make sure the test set is properly grounded before starting.

Do not attempt to connect or disconnect load cable while test set is operating or connected to a generator.

**N O I S E H A Z A R D**

Operation of this equipment presents a noise hazard to personnel in the area. The noise level exceeds the allowable limits for unprotected personnel. Wear ear muffs or ear plugs which were fitted by a trained professional.

**W E I G H T H A Z A R D**

Test Set weighs approximately 225 pounds. Use suitable number of personnel or available lifting equipment.

**F I R S T A I D**

FOR FIRST AID INSTRUCTIONS, REFER TO FM 21-11



TECHNICAL MANUAL }  
 NO. 5-6625-2694-13&P }

HEADQUARTERS  
 DEPARTMENT OF THE ARMY  
 WASHINGTON, D.C., 10 May 1983

OPERATOR, ORGANIZATIONAL AND DIRECT SUPPORT MAINTENANCE MANUAL  
 INCLUDING REPAIR PARTS AND SPECIAL TOOLS LIST

TEST SET, ELECTRICAL (0-33 KW LOAD BANK)  
 NSN 6625-01-108-3651

REPORTING ERRORS AND RECOMMENDING IMPROVEMENTS

You can help improve this manual. If you find any mistake or if you know of a way to improve the procedures, please let us know. Mail your letter, DA Form 2028 (Recommended Changes to Publications and Blank Forms), or DA Form 2028-2 located in the back of this manual direct to: Commander, US Army Troop Support Command, ATTN: AMSTR-MCTS, 4300 Goodfellow Blvd., St. Louis, MO 63120-1798. A reply will be furnished directly to you.

TABLE OF CONTENTS

	Page
CHAPTER 1. INTRODUCTION	
Section I. General . . . . .	1-1
II. Equipment Description . . . . .	1-2
III. Technical Principles of Operation. . . . .	1-4
CHAPTER 2. OPERATING INSTRUCTIONS	
Section I. Description and Use of Operator's Controls and Indicators. . .	2-1
II. Operator Preventive Maintenance Checks and Services (PMCS) . . . . .	2-2
III. Operation Under Usual Conditions . . . . .	2-4
IV. Operation Under Unusual Conditions. . . . .	2-6
CHAPTER 3. OPERATOR'S MAINTENANCE INSTRUCTIONS	
Section I. Lubrication Instructions . . . . .	3-1
II. Troubleshooting. . . . .	3-1
III. Maintenance Procedures . . . . .	3-3
CHAPTER 4. ORGANIZATIONAL MAINTENANCE INSTRUCTIONS . .	4-1
CHAPTER 5. DIRECT SUPPORT MAINTENANCE INSTRUCTIONS	
Section I. Repair Parts, Special Tools, TMDE and Support Equipment .	5-1
II. Troubleshooting. . . . .	5-1
III. Maintenance of Main Housing Assembly . . . . .	5-8
IV. Maintenance of Power Absorber. . . . .	5-10
v. Maintenance of Chassis Assembly. . . . .	5-18

APPENDIX A. References . . . . . A-1  
B. Maintenance Allocation Chart. . . . . B-1  
C. Repair Parts and Special Tools List . . . . . C-1  
    Group 01 Main Housing (Fig. 1) . . . . . C-8  
    Group 02 Base Assembly (Fig. 2) . . . . . C-10  
    Group 03 Power Absorber (Fig. 3) . . . . . C-12  
    Group 04 Chassis Assembly (Fig. 4)..... . . . . C-15  
    Group 05 Control Panel Assembly (fig. 5) . . . . . C-17  
    Group 06 Bulk Material . . . . . C-19  
National Stock Number and Part Number Index. . . . . C-20

I N D E X



## LIST OF ILLUSTRATIONS

Figure	Title	Page
1-1	Test Set, Electrical	1-0
1-2	Location of Major Components	1-3
2-1	Operator Control Panel	2-1
2-2	Test Set, Electrical	2-5
5-1	Control Circuit Components	5-2
5-2	Test Set, Louver Removal	5-9
5-3	Wind Switch Replacement	5-11
5-4	Fan Motor Replacement	5-13
5-5	Resistor Replacement	5-15
5-6	Chassis Assembly	5-20
F0-1	Schematic Diagram	F0-1
F0-2	Wiring Diagram	F0-2

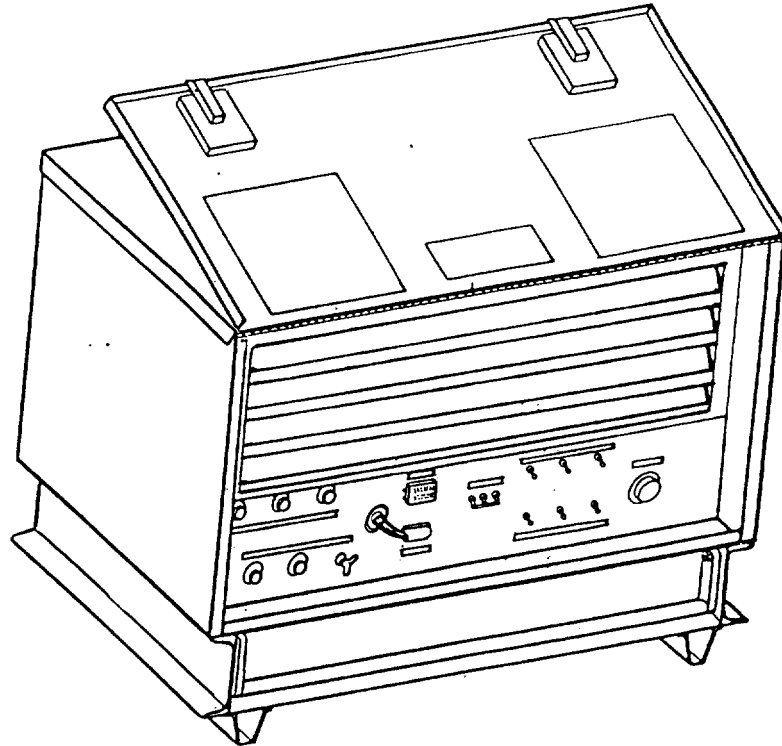

Figure 1-1. Test Set, Electrical

# CHAPTER 1

## INTRODUCTION

### Section I. GENERAL

1-1. Scope. This manual is for use by operator and direct support personnel for operation and maintenance of the Model 1057 Electrical Test Set. The Model 1057 Electrical Test Set (Figure 1-1) is a 0-33 KW load bank used for presenting dummy loads to engine driven single phase and three phase generators. Chapters 2 and 3 provide information on operation, preventative maintenance services, and operator's maintenance of the equipment. Chapter 4 is not applicable and Chapter 5 details direct support maintenance instructions.

1-2. Maintenance Forms and Records. Department of the Army forms and procedures used for equipment maintenance will be those prescribed by DA Pam 738-750, The Army Maintenance Management System (TAMMS).

1-3. Reporting Equipment Improvement Recommendations (EIR's). If your Test Set needs improvement, let us know. Send us an EIR. You, the user, are the only one who can tell us what you do not like about your equipment. Let us know why you do not like the design. Tell us why a procedure is hard to perform. Put it on a SF 368 (Quality Deficiency Report). Mail it to Commander, U.S. Army Troop Support Command, ATTN: AMSTR-QX, 4300 Goodfellow Blvd., St. Louis, MO 63120-1798. We'll send you a reply.

1-4. Destruction of Army Material to Prevent Enemy Use. (Refer to TM 750-244-3.)

1-5. Preparation for Shipment and Storage. (Refer to TM 750-90-1.)

## Section II. EQUIPMENT DESCRIPTION

1-6. Equipment purpose, Capabilities and Features. A portable, skid mounted, 0-33 KW load bank for loading engine driven generators. Provides variable loads for 120, 120/208, 240, or 240/416 VAC single phase or three phase. Features include automatic sensing of input voltage to prevent damage and automatic disconnect from loss of air flow or overheating.

1-7. Location and Description of Major Components (Figure 1-2).

- a. The Skid Base(1) provides for handling and mounting.
- b. The Power Input Terminals (2) provide connections to generator.
- c. The Voltage Selector Plug (3) allows selection of HI or LO voltage input.
- d. The Master On Switch(4) applies generator output to selected load.
- e. The Load Selector Switches (5) select 3 KW or 6 KW load increments.
- f. The Variable Load Control(6) applies 0-3 KW variable load.
- g. The Air Exhaust Grills (7) provide operator protection of load ducts.
- h. The Access Door(8) provides access to operator control panel and power input terminals.

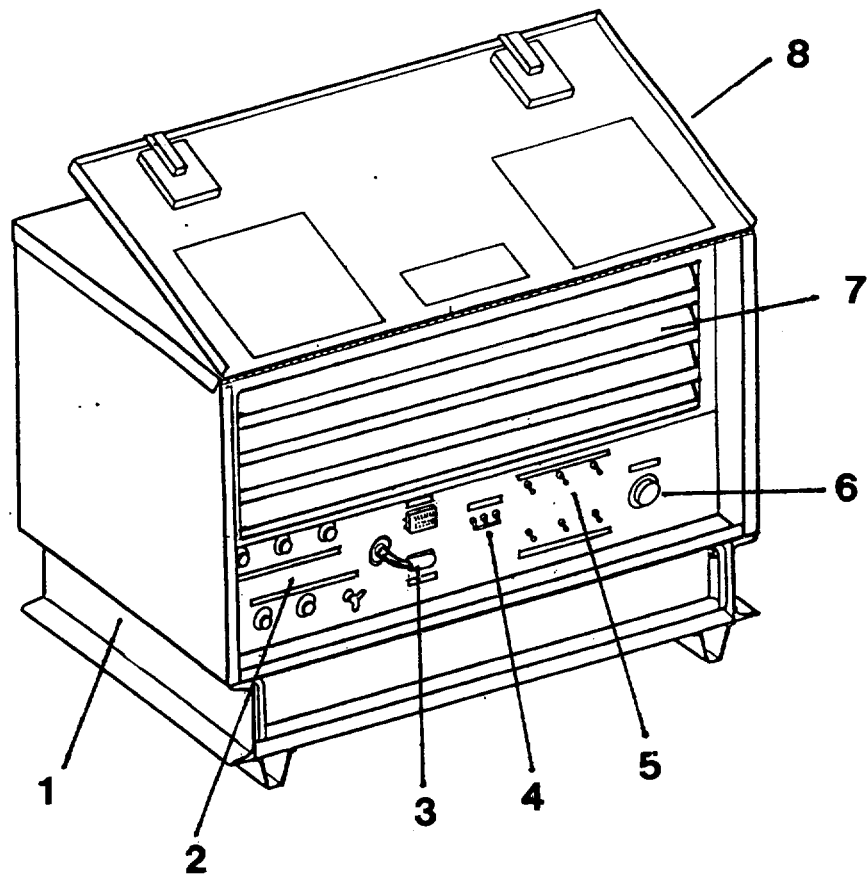

- |                          |                           |
|--------------------------|---------------------------|
| 1. Skid Base             | 5. Load Selector Switches |
| 2. Power Input Terminals | 6. Variable Load Control  |
| 3. Voltage Selector      | 7. Air Intake Louvers     |
| 4. Master On Switch      | 8. Access Door            |

Figure 1-2. Location of Major Components

1-8. Equipment Data.

Manufacturer . . . . . Technical Services Laboratory, Inc.

Dimensions . . . . . 22.5" W, 24" H, 36" L

W e i g h t . . . . . 225 lbs.

Model No . . . . . Model 1057

Operating Modes . . . . . 120/208 4W  
240/416 4W  
120/240 3W (Note 1)  
120/2w (Note 2)  
240/2W (Note 3)

Operating Temperatures . . . . . 0 - 50 Degrees Centigrade

NOTES :

- (1) 120/240 Neutral not used - high power.
- (2) Phase shorting link - neutral return.
- (3) Phase shorting link - neutral return.

**Section III. TECHNICAL PRINCIPLES OF OPERATION**

1-9. The Model 1057 Test Set utilizes switchable fixed air-cooled resistors to present various loads from 0-33 KW to the generator. The resistor loads are arranged in groups of three, thereby allowing the Test Set to present balanced loads to three phase generators. A shorting link connects the three groups of resistors in parallel for loading single phase generators. A voltage sensing module monitors the input, automatically determining whether the control circuits are configured for HI or LO input voltage. This module works in conjunction with the Voltage Input Selector (P1) to prevent damage to the Test Set should improper voltage be applied to the input terminals.

CHAPTER 2

OPERATING INSTRUCTIONS

Section I. DESCRIPTION AND USE OF OPERATOR'S CONTROLS AND INDICATORS

2-1. General. Figure 2-1 shows the controls you will need to operate the Test Set.

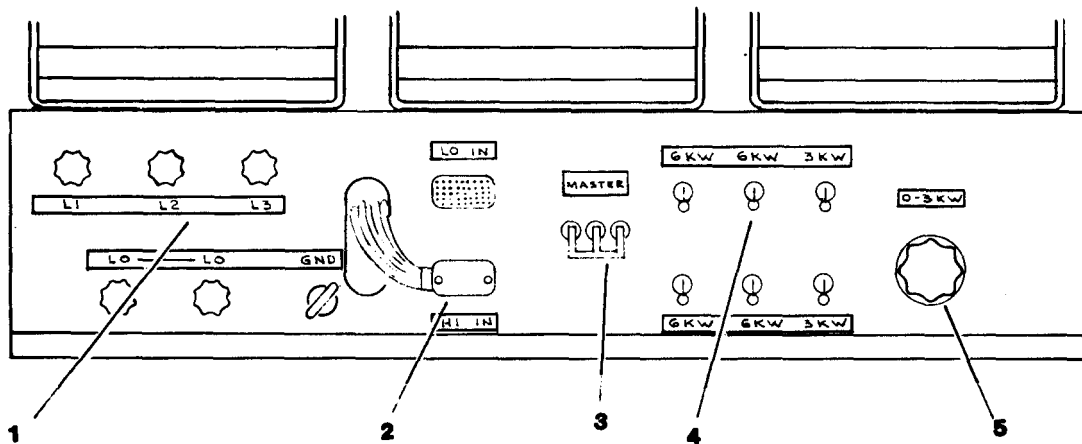

Figure 2-1. Operator Control Panel

KEY	CONTROL	FUNCTION
1	Input Terminals	Connect Generator Output To Test Set
2	Hi-Lo Selector	Selects Test Set For Hi Or Lo Voltage Input
3	Master Switch	Applies Power From Generator to Test Set
4	Load Selector	Applies 0-30 KW Load To Generator In 3 KW or 6 KW Steps
5	Variable Selector	Applies 0-3 KW Load To Generator.

**Section II. OPERATOR PREVENTIVE MAINTENANCE  
CHECKS AND SERVICES (PMCS)**

2-2. General. Even though the Test Set has been designed to include certain safety and protective features, periodic inspection must be performed so that any defects will be discovered and corrected before they result in serious damage. When performing your Before Operation (B) PMCS, always keep in mind the CAUTIONS and WARNINGS. If your equipment fails to operate, troubleshoot with proper equipment. Report any deficiencies using the proper forms, see TM 38-750.

2-3. Operator Preventative Maintenance Checks and Services. Refer to Table 2-1 for Operator PMCS.

a. Item Number Column. Checks and services are numbered in chronological order regardless of interval. This column will be used as a source of item numbers for the "TM Item Number" column on DA Form 2404 in recording results on PMCS.

b. Interval Columns. The column headed by B will contain a dot opposite the appropriate check indicating it is to be performed Before Operation.

c. Item To Be Inspected Column. The items listed in this column are divided into groups and identify the items to be inspected.

d. Procedures Column. This column contains a brief description of the procedure by which the check is to be performed.

e. Equipment Will Be Reported Not Ready/Available If Column. This column will contain the criteria which will cause the equipment to be classified as Not Ready/Available because of inability to perform its primary mission.



Table 2-1. Operator Preventative Maintenance Checks and Services

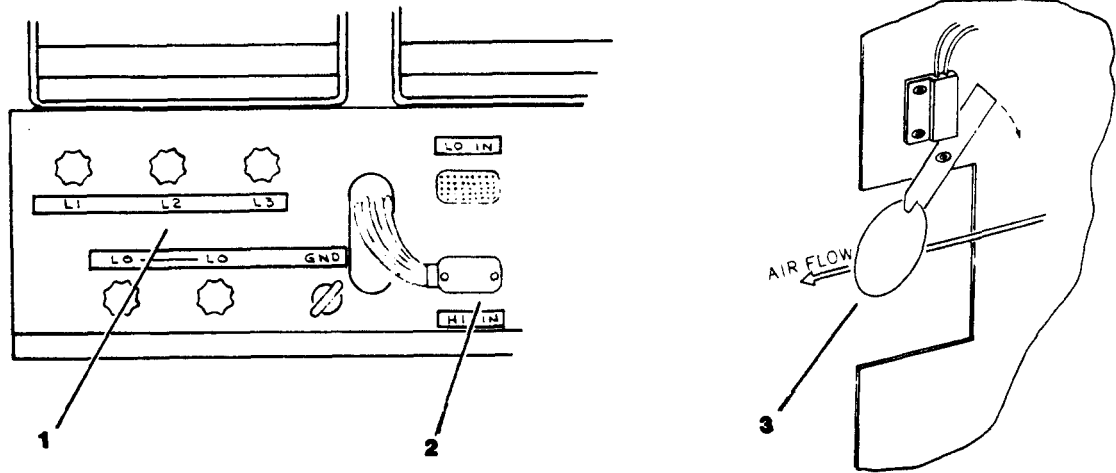

1. Power Input Terminals      2. Voltage Selector  
 3. Wind Switch

B-Before

Item No	Interval		Item To Be Inspected Procedures	Equipment Will Be Reported Not Ready/ Available If:
	B			
1	●		INPUT TERMINALS. Inspect for hardware tightness and security of cables.	Input Cables remain loose.
2	●		VOLTAGE SELECTOR (P1). Check that screws securing P1 are tight and connector is properly seated.	P1 is not seated
3	●		WIND SWITCH. Check for complete freedom of movement of vane.	Any jamming of vane.

### Section III. OPERATION UNDER USUAL CONDITIONS

#### 2-4. Operating Procedure (Figure 2-2).

a. General. The operator must know how to perform every operation of which the Test Set is capable. This section gives instructions on starting and stopping the Test Set, and adjusting the Test Set to the desired load.

**WARNING**

#### HIGH VOLTAGE IS PRESENT

DEATH ON CONTACT may result if personnel fail to observe safety precautions

b. Preparation for Starting. Perform the PMCS as indicated in Table 2-1. Make sure that the top rear panel is removed so that air can be exhausted from the load bank.

c. Starting (Figure 2-2).

(1) Open Access Door (1).

(2) Selection of high or low voltage loading is made by inserting Voltage Selector Plug (2) into the appropriate receptacle. This must be considered for single and three-phase operation.

(a) The Voltage Selector Plug (2) should be inserted in the LO receptacle when operating with generators of the following ratings:

120/208 volts, three-phase, 4-wire  
120 volts, single-phase  
240 volts, three-phase 3-wire

(b) The Voltage Selector Plug (2) should be inserted in the HI receptacle when operating with generators of the following ratings:

240/416 volts, three-phase, 4-wire  
240 volts, single-phase

(3) Input power from the generator is connected by way of the knob-type terminals (3) L1, L2, L3 and LO on the block located on the control panel. The input wires should be terminated with flat lugs suitable for a 3/8 inch diameter stud.

(a) When connecting a single phase load, the two input wires are connected to L1 and LO, without concern for polarity. The brass jumper link, stored on the control panel, is installed between L1-L2 and L2-L3.

**WARNING**

Brass link is NOT installed during 3 phase operation.  
Injury to personnel or damage to equipment may result.

(b) On a three-phase, 3-wire connection, the input wires are connected to L1, L2 and L3 without concern for polarity or phase sequence. LO is not used.

(4) Turn Master Switch (4) ON and apply desired Load Switches (5).

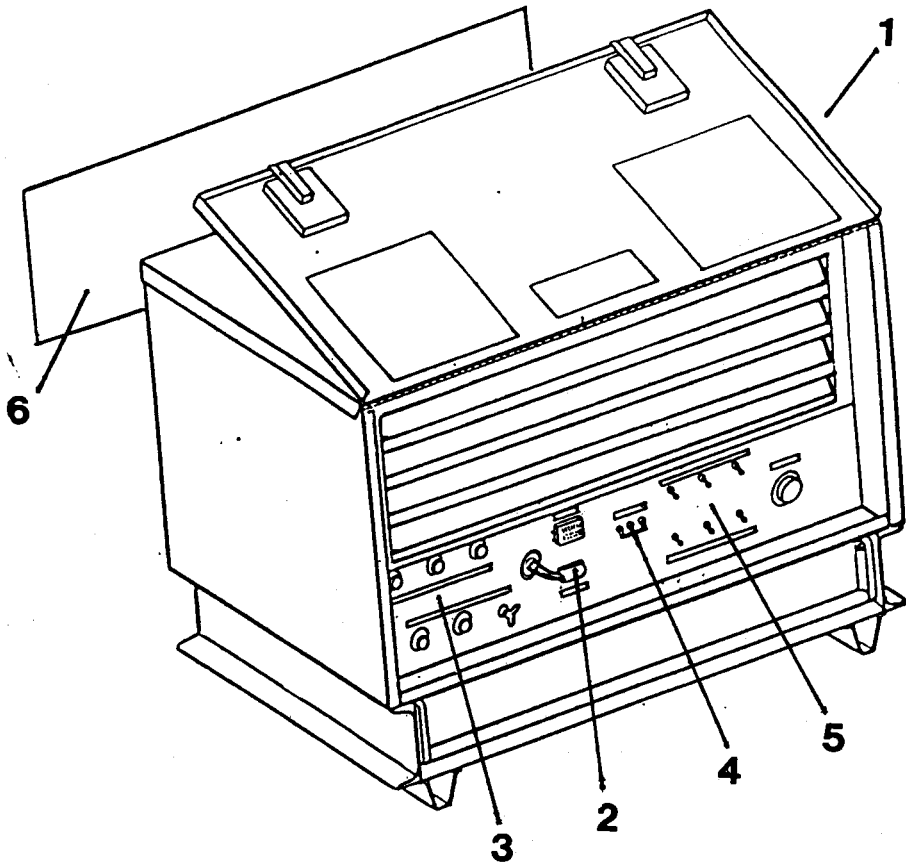

1. Access Door
2. Voltage Selector Plug
3. Power Input Terminals
4. Master On Switch
5. Load Switches
6. Rear Panel

Figure 2-2. Test Set, Electrical

d. Stopping.

(1) Turn all Load Switches (5) OFF and allow Test Set to cool down for 10 minutes.

(2) Turn Master On Switch (4) OFF.

(3) Turn input power OFF.

**Section IV. OPERATION UNDER UNUSUAL CONDITIONS**

2-5. Operation in Extreme Cold (Below Zero C). There are no particular safeguards to be taken at temperatures below zero centigrade. If the Test Set has been stored at extremely low temperatures for an extended length of time, allow the Test Set to stabilize at the new ambient environment for a minimum of 8 hours before performing the operating procedures of paragraph 2-4.

2-6. Operation in Extreme Heat. The Test Set has been designed for continuous, full load duty at temperatures up to 50 degrees centigrade. Should it be necessary to operate in a higher ambient temperature, the total load dissipation must be restricted to a maximum of 50% of full load (15 KW).

2-7. Operation in Dusty or Sandy Areas. Care should be taken to prevent sand or dust from entering the Test Set through the air intake louvers during operation. If foreign matter collects in the Test Set during shutdown, a thorough cleaning is required before the Test Set may be operated.

2-8. Operation Under Rainy or Humid Conditions. The Test Set has been designed to operate in a light (1 inch per hour) rain without harm, if the wind does not blow the rain onto components. Should the Test Set be exposed to heavy, blowing rain, shut it down and thoroughly dry it out before attempting to operate.

2-9. Operation at High Altitudes. Operation of the Test Set at an elevation above 8000 feet and at ambient temperatures above 35 degrees C. must be accomplished with a maximum loading of 50% of full load (15 KW).

2-10. Operation Under Sea Spray or Salt Air Conditions. The Test Set has been designed so that moderate salt spray is not harmful. However, should a buildup of salt scum or corrosion become apparent, the Test Set should be thoroughly cleaned before using.

**CHAPTER 3****OPERATOR'S MAINTENANCE INSTRUCTIONS****Section I. LUBRICATION INSTRUCTIONS**

3-1. General. There are no lubrication requirements for the Test Set.

**Section II. TROUBLESHOOTING**

3-2. General. This section contains troubleshooting information for locating and correcting most of the operating troubles which may develop in the Test Set. Each malfunction is followed by a list of tests or inspections which will help you to determine corrective actions to take. You should perform the tests/inspections and corrective actions in the order listed. This TM cannot list all malfunctions that may occur, nor all tests or inspections and corrective actions. If a malfunction is not listed or is not corrected by the listed corrective actions, notify your supervisor.

3-3. Operator Troubleshooting. Perform troubleshooting functions in accordance with Table 3-1.

**WARNING****HIGH VOLTAGE IS PRESENT**

DEATH ON CONTACT may result if personnel fail to observe safety precautions.

Table 3-1. Operator Troubleshooting

MALFUNCTION	TEST OR INSPECTION	CORRECTIVE ACTION
-------------	--------------------	-------------------

1. Test Set fails to start.

- Step 1. Check for proper input connections (1).  
Connect properly.
- Step 2. Inspect for proper voltage selection (2).  
Connect Voltage Selector (2) to correct receptacle.
- Step 3. Check master circuit breaker (3).  
Place master circuit breaker to "ON" position.

2. Test Set starts but presents no load to generator.

- Step 1. Inspect load switches (4) for proper selection.  
Switch on proper load switches.
- Step 2. Check wind switches (6) for proper operation.  
Free wind vane.
- Step 3. Inspect air intake louver (5) for obstructions.  
Clean louver.

- |                          |                     |
|--------------------------|---------------------|
| 1. Power Input Terminals | 3. Master On Switch |
| 2. Voltage Selector Plug | 4. Load Switches    |

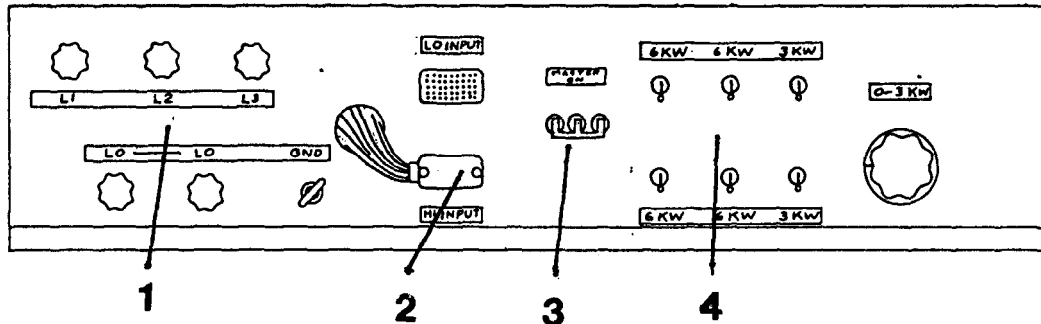

Section III. MAINTENANCE PROCEDURES

3-4. General. Instructions in this section are published for the information and guidance of tile operator in maintaining the Test Set.

3-5. Main Housing Assembly. Inspect exterior of housing for dents, cracks or chipped paint.

3-6. Air Intake Louver (5). Check air intake louver for any foreign material that might impair airflow and clean louver accordingly.

3-7. Deleted.

3-8. Wind Switches (6). Manually operate the airflow vanes to ensure proper mechanical operation.

3-9. Voltage selector Plug (2). Inspect the selector for bent pins, loose screws or dirt.

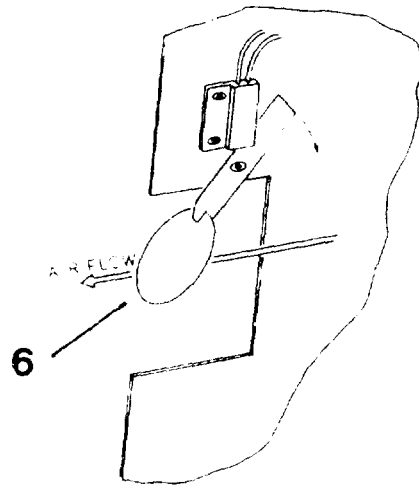
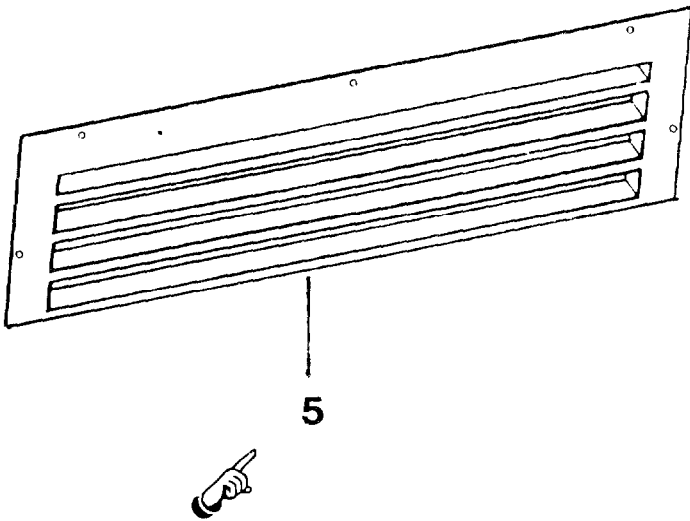

- 5. Air Intake Louver
- 6. Wind Switch





CHAPTER 4

ORGANIZATIONAL MAINTENANCE INSTRUCTIONS

Not Applicable



## CHAPTER 5

## DIRECT SUPPORT MAINTENANCE INSTRUCTIONS

## Section I. REPAIR PARTS, SPECIAL TOOLS, TMDE AND SUPPORT EQUIPMENT

5-1. Common Tools and Equipment. For authorized common tools and equipment refer to the Modified Table of Organization and Equipment (MTOE) applicable to your unit.

5-2. Special Tools, TMDE and Support Equipment. None required.

5-3. Repair Parts and Special Tools List. Repair parts and the special tools are listed and illustrated in Appendix C.

## Section II. TROUBLESHOOTING

5-4. Troubleshooting. Refer to Table 5-1 for troubleshooting information.

**WARNING****HIGH VOLTAGE IS PRESENT**

DEATH ON CONTACT may result if personnel fail to observe safety precautions.

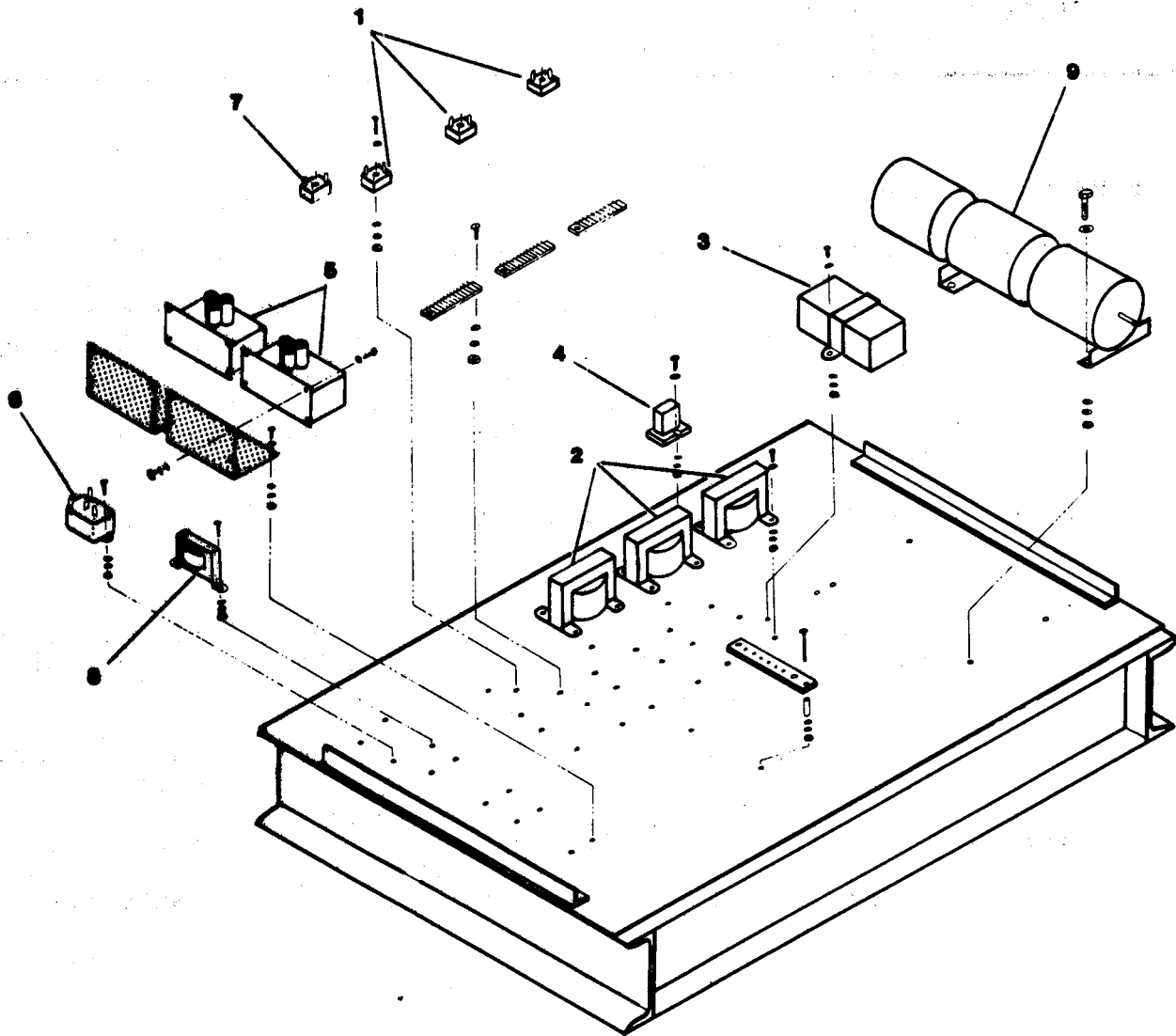

- |                                     |                         |
|-------------------------------------|-------------------------|
| 1. Bridge Rectifier (CR1, CR2, CR3) | 6. Contactor Relay (K4) |
| 2. 24 V. Transformer (T1, T2, T3)   | 7. Not Used             |
| 3. Voltage Sensor (A1)              | 8. Not Used             |
| 4. Control Relay (K3)               | 9. Variable Transformer |
| 5. Contactor (K1, K2)               |                         |

Figure 5-1. Control Circuit Components

Table 5-1. Direct Support Troubleshooting

MALFUNCTION	TEST OR INSPECTION	CORRECTIVE ACTION
1. FANS DO NOT RUN.	Step 1. No power applied to Test Set.	<ul style="list-style-type: none"> <li>a. Check for power applied to Test Set. Voltage at load terminals L1, L2, L3 to LO should equal voltage at generator terminals L1, L2, L3 to LO.</li> <li>b. If voltage is incorrect check generator and connections</li> </ul>
	Step 2. Circuit Breaker CB1 turned off or faulty.	<ul style="list-style-type: none"> <li>a. Turn Circuit Breaker on.</li> <li>b. Measure voltage from input terminals of CB1 to LO. Measure voltage from output terminals of CB1 to LO. Voltage measurements should be equal.</li> </ul> <p>Refer to paragraph 5-20 and replace Circuit Breaker if voltage measurements are NOT equal.</p>
	Step 3. Voltage Selector Plug in improper position.	Refer to paragraph 2-4 for proper voltage selector plug positioning.
	Step 4. Voltage Sensor A1 defective.	<ul style="list-style-type: none"> <li>a. Check voltage sensor for proper input voltage across terminal 1 to terminal 2. If voltage is 150 VAC or higher, voltage across terminal 3 (-) to terminal 4 (+) should be 28 VDC.</li> <li>b. Refer to paragraph 5-18 and replace voltage sensor if voltage across terminal 1 and terminal 2 is 150 VAC or higher and voltage across terminal 3 and terminal 4 is 0 VDC.</li> </ul>

Table 5-1. Direct Support Troubleshooting (cont'd.)

---

MALFUNCTION

TEST OR INSPECTION

CORRECTIVE ACTION

---

2. ONE OR TWO FAN MOTORS DO NOT RUN.

Step 1. Check Fan Motor(s) that does not run and associated components.

a. Check voltage across leads to Fan Motor at terminal strip. Terminal 15 (+) to terminal 16 (-) should be 24 VDC.

b. Refer to paragraph 5-7 and replace Fan Motor(s) if 24 VDC is present and Fan Motor(s) does not run.

Step 2. Check Rectifier Bridge(s) associated with Fan Motor(s) that does not run.

a. Measure voltage across + terminal and - terminal on Rectifier Bridge; should be 24 VDC. Measure voltage across AC terminals; should be 24 VAC.

b. Refer to paragraph 5-19 and replace Rectifier(s) if 24 VAC is present across AC terminals and 0 VDC is present across + terminal and - terminal.

Step 3. Check 24 V. Transformer(s) associated with Fan Motor(s).

a. Measure output voltage terminal 5 and terminal 6 of associated Transformer(s); should be 24 VAC.

b. Measure input voltage across terminal 1 and terminal 4 of associated Transformer(s). With Voltage Selector Plug in LO input position measurement should be 120 VAC. With Voltage Selector Plug in HI input position, measurement should be 240 VAC.

c. Refer to paragraph 5-15 and replace Transformer(s) if input voltage is correct and output is NOT 24 VAC.

Table 5-1. Direct Support Troubleshooting (cont'd.)

MALFUNCTION	TEST OR INSPECTION	CORRECTIVE ACTION
-------------	--------------------	-------------------

3. NO LOAD APPLIED TO GENERATOR, ALL FANS RUNNING.

Step 1. Visually check all wind switches for full forward movement.

a. Check voltage across terminals 24 and 25 of each Load Duct terminal strip. Measurement should be 0 VDC.

b. If measurement is 0 VDC on all three terminal strips, proceed to Step 3.

If measurement is 24 VDC, disconnect power from Test Set. Disconnect and tag leads from terminals 24 and 25 to terminal strip. Remove Exhaust Guard and connect ohmmeter leads across Wind Switch terminals. Ohmmeter should read infinite. Manually move wind switch vane forward. Ohmmeter should read 0 Ohms.

d. Refer to paragraph 5-6 and replace Wind Switch if ohmmeter does not read 0 Ohms.

Step 2. Attach ohmmeter leads across terminal of Thermal Switch. Ohmmeter should read 0 Ohms.

Refer to paragraph 5-9 and replace Thermal Switch if ohmmeter does not read 0 Ohms.

TEXT DELETED

Table 5-1. Direct Support Troubleshooting (cont'd)

MALFUNCTION	TEST OR INSPECTION	CORRECTIVE ACTION
Step 3 Check Contactor Relay K4.	Measure voltage across terminals 1 (-) to 3 (+); should be 24 VDC.	b. Measure voltage across terminals 5 (+) to 4 (-); should be 0 VDC.
	c. Refer to paragraph 5-13 and replace Contactor Relay if measurement across terminal 1 to terminal 3 is 24 VDC and measurement across terminal 4 to terminal 5 is NOT 0 VDC.	
4. PARTIAL LOAD APPLIED TO GENERATOR.	Step 1. Check Contractors K1 and K2.	a. Measure voltage across terminal X1 and terminal X2 of each contactor. Should read 24 VDC.
		b. With 24 VDC applied to terminals X1 and X2, measure voltage from input terminals of Contactor to L0 and from output terminals of Contactor to L0. Measurements should be equal.
		c. Refer to paragraph 5-12 and replace Contactor if measurements from input and output terminals to L0 are NOT equal.



Table 5-1. Direct Support Troubleshooting (cont'd.)

MALFUNCTION	TEST OR INSPECTION	CORRECTIVE ACTION
-------------	--------------------	-------------------

Step 2. Load Selector Switch(s) defective.

a. Disconnect power from Test Set.

b. Remove and tag leads from switch terminals. Attach ohmmeter leads across switch terminals top to bottom.

c. With Switch in on (up) position, ohmmeter should read 0 Ohms. With Switch in off (down) position, ohmmeter should read infinite.

d. Refer to paragraph 5-21 and replace defective Switch(s).

Step 3. Check Load Resistors.

a. Disconnect and tag lead from one end of Resistor.

b. Attach ohmmeter leads to Resistor terminals.

c. Ohmmeter should read 15 Ohms for 1 KW Resistors and 30 Ohms for 500 W Resistors.

d. Refer to paragraph 5-8 and replace defective Resistors.

5. VARIABLE LOAD CONTROL HAS NO EFFECT ON LOADING.

Step 1. Measure AC voltage on TB1-1, TB2-1 and TB3-1 with respect to LO while varying the load control. AC Voltage should vary in direct proportion to load control.

If any phase exhibits no variation remove and replace T4. Refer to paragraph 5-17

Section III. MAINTENANCE OF MAIN HOUSING ASSEMBLY

5-5. Test Set Louver (Figure 5-2).

- a. Remove
- b. Inspect
- c. Repair
- d. Install

INITIAL SET-UP

Tools and Equipment:	personnel Required: MOS 52D10 MOS 44B
Electrical Repair Tool Kit (4940-00-294-9517) Rivet Kit (5120-00-017-2849)	Equipment Condition: Power Off

LOCATION	ITEM	ACTION	REMARKS
 REMOVE			
1. Louver (2)	Four screws (1)	Loosen	Remove Louver
 INSPECT			
2. Louver (2)		Inspect For:  Cracked Welds, Louver Damage, Air Blockage, Faulty Fasteners.	
 REPAIR			
3. Louver (2)		Weld Cracks, Straight- en Louvers, Remove Air Blockage, Repair Faulty Fasteners	If Beyond Repair, Re- place Louver
 INSTALL			
4. Louver (2)	a. Louver	Install	
	b. Four screws (1)	Tighten	

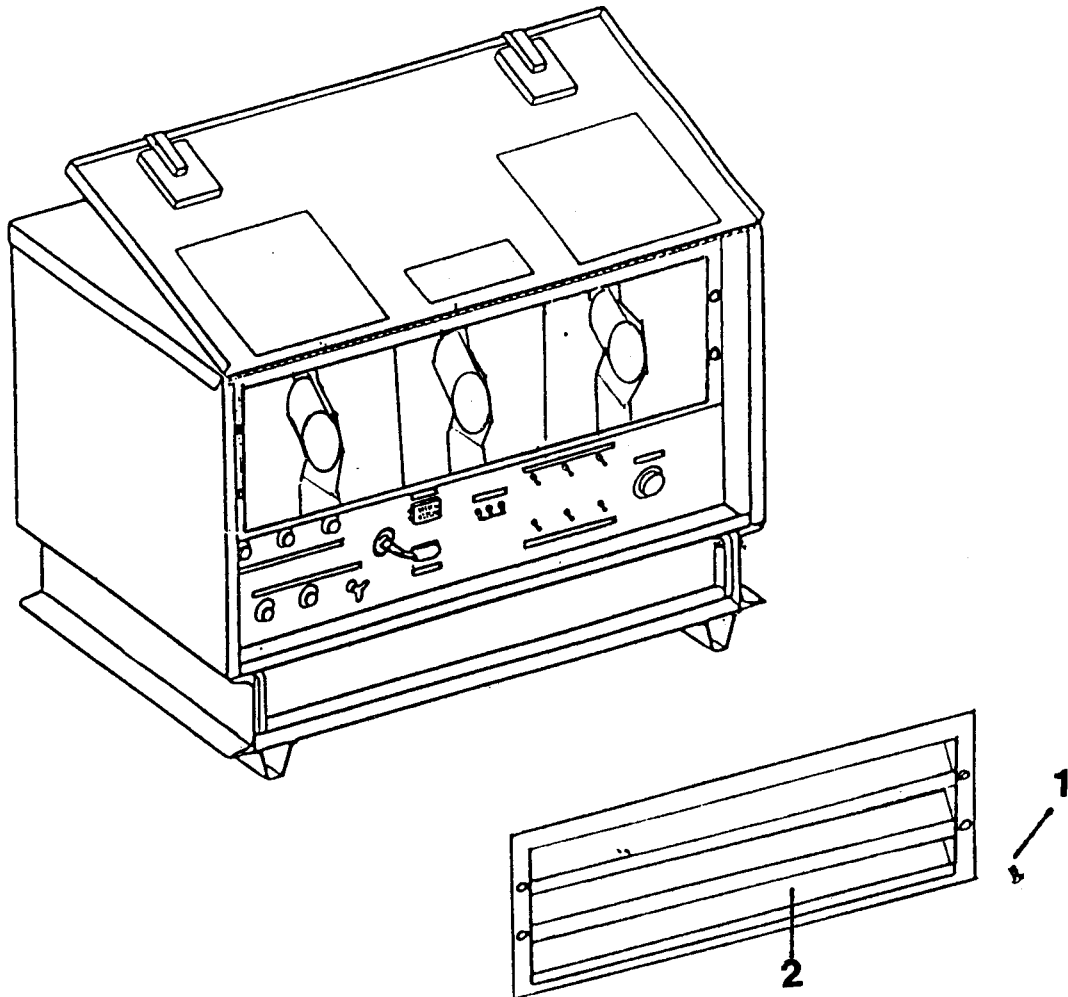

- 1. Screws
- 2. Air Intake Louver

Figure 5-2. Test Set, Louver Removal

Section IV. MAINTENANCE OF POWER ABSORBER

5-6. Wind Switch (Figure 5-3).

- a. Inspect
- b. Test
- c. Replace

INITIAL SET-UP

Tools and Equipment:

Personnel Required: MOS 52D10

Electrical Repair Kit  
(4940-00-294-9517)

Equipment Condition: Power Off

LOCATION	ITEM	ACTION	REMARKS
INSPECT			
1.	Wind Switch (1)	Inspect For:  Damaged Components Frayed or Damaged Wire  Replace Switch	
TEST			
2.	TB1, TB2 or TB3 On Air Inlet Side	Terminals 24 & 25	Test for continuity between terminals, switch activated
REPLACE			
3.	Wind Switch (1)	a. Six Nuts(5), Two Lock Wash- ers(4), Eight Flat Washers(3) Two Screws(2)	Remove
		b. Switch Elements(6)	Remove and Replace  Cut Wires
		c. Two Screws (2), Eight Flat Washers(3), Two Lock Washers(4) Six Nuts(5)	Install & Tighten  Splice By Crimping Butt Splice
4.	Perform Operational Check. Refer to Chapter 2.		

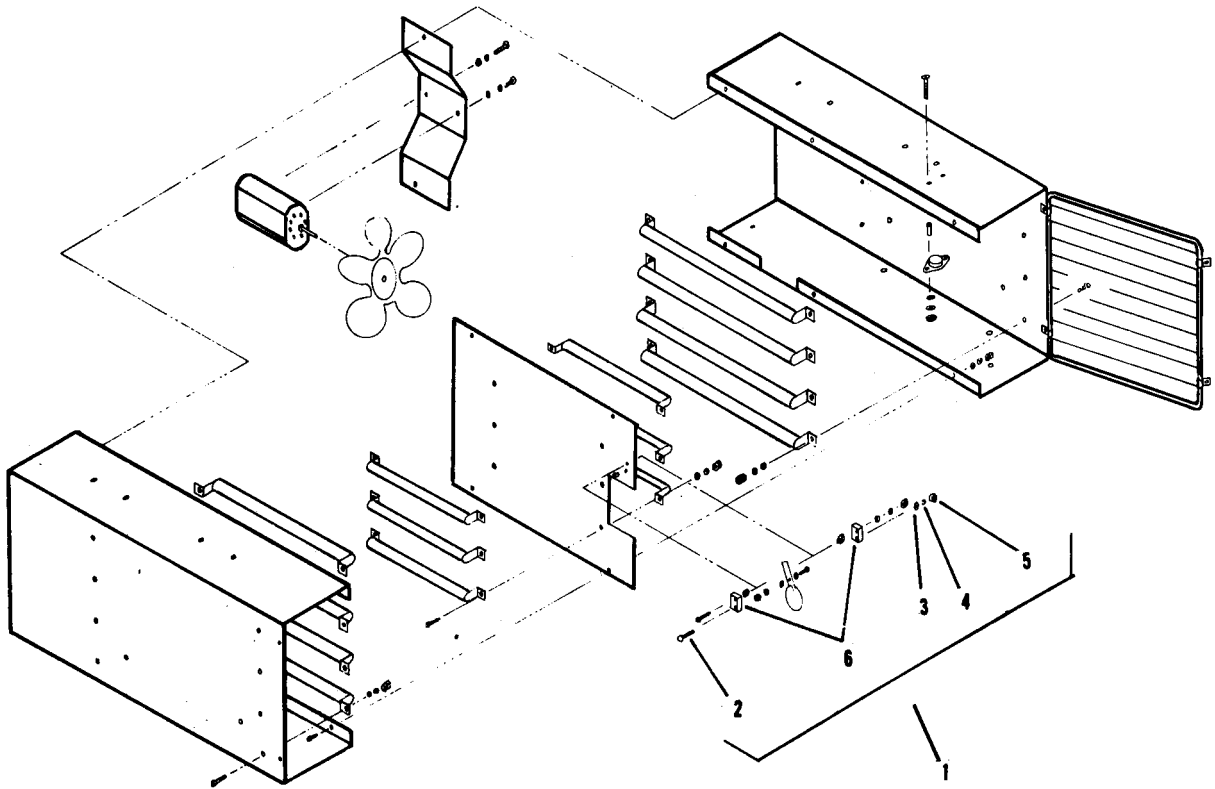

- 1. Wind Switch
- 2. Screw
- 3. Flat Washer
- 4. Lock Washer
- 5. Nut
- 6. Switch Elements

Figure 5-3. Wind Switch Replacement

5-7. Fan Motor and Blade (Figure 5-4).

- a. Inspect
- b. Test
- c. Replace

INITIAL SET-UP

Tools and Equipment:

Personnel Required: MOS 52D10

Electrical Repair Kit  
(4940-00-294-9517)

Equipment Condition: Power Off

LOCATION	ITEM	ACTION	REMARKS
INSPECTION			
1.	Fan Motor (1)	Inspect for: Bent or Cracked Blades Noisy Bearings Shaft Play	
		Replace Fan Motor or Blade	
TEST			
2.	TB1, TB2 or TB3 On Air Inlet	Terminals 15 and 16	Measure 20 to 50 Ohms If In Error Replace Motor
REPLACE			
3.	Fan Motor(1)	a. Two Nuts(5), Two Lock Washers(4), two Flat Washers(3) Two Screws(2)	Remove
		b. Motor(1) & Bkt. (10)	Remove
		c. Set Screw(6)	Loosen
		d. Fan Blade(7)	Remove
		e. Two Screws(8), Two Lock Washers(9)	Remove
		f. Fan Motor(1)	Remove and Replace
		g. Bracket (10), Two Screws (8), Two Lock Washers (9)	Install and Tighten on Motor(1)
			Note Orientation For Air Flow

LOCATION	ITEM	ACTION	REMARKS
	h. Fan Blade(7)	Install	Note Orientation For Air Flow
	i. Set Screw(6)	Tighten	
	j. Motor(1) & Bkt. (10)	Install	
	k. Two Screws(2), Two Flat Washers(3), Two Lock Washers(4), Two Nuts(5)	Install and Tighten	

4. Perform Operational Check. Refer to Chapter 2.

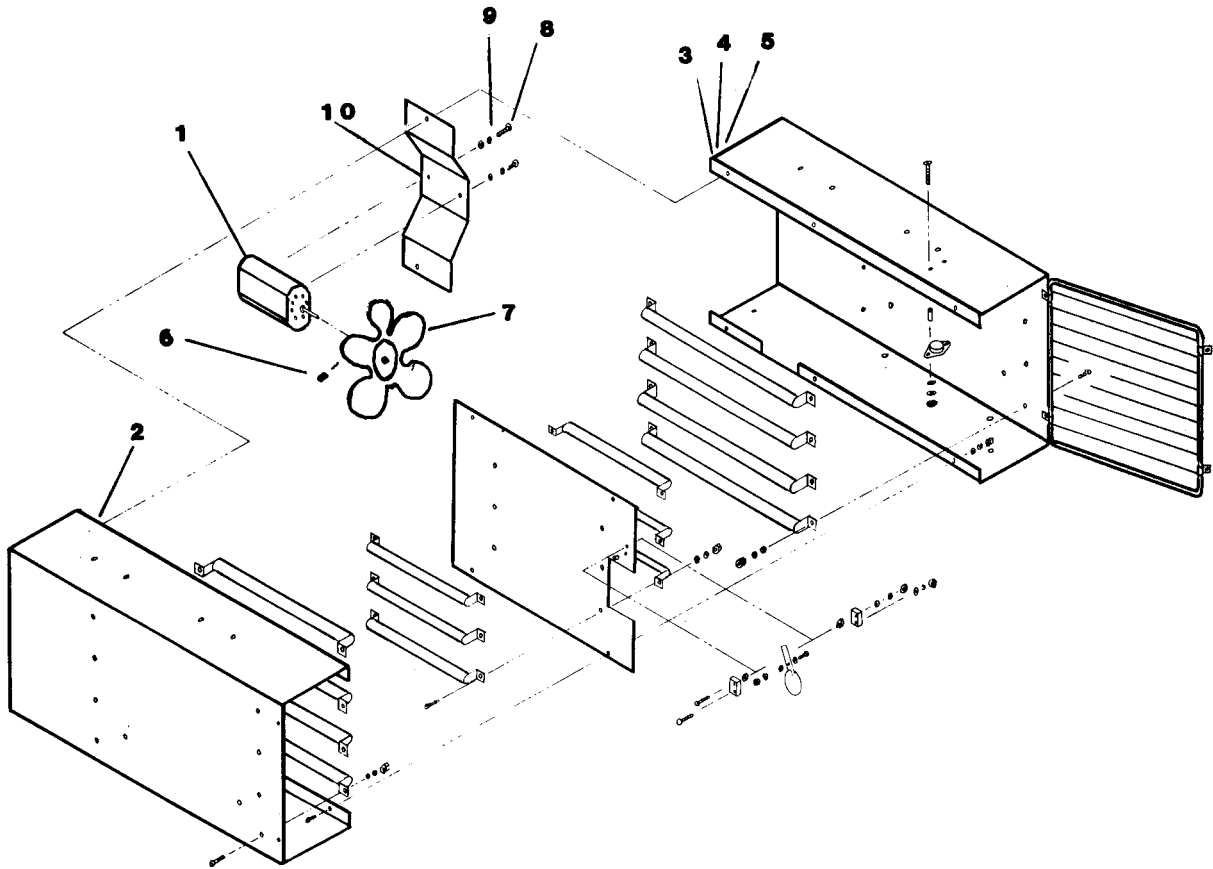

- |                |                |
|----------------|----------------|
| 1. Fan Motor   | 6. Set Screw   |
| 2. Screws      | 7. Fan Blade   |
| 3. Flat Washer | 8. Screw       |
| 4. Lock Washer | 9. Lock Washer |
| 5. Nut         | 10. Bracket    |

Figure 5-4. Fan Motor Replacement

**5-8. Load Resistors (Figure 5-5).**

- a. Inspect
- b. Test
- c. Replace

INITIAL SET-UP

Tools and Equipment:

Personnel Required: MOS 52D10

Electrical Repair Tool Kit  
(4940-00-294-9517)

Equipment Condition: Power Off

LOCATION	ITEM	ACTION
INSPECT		
1. Guard(2)	a. Four Nuts(6), Four Lock Washers(4), Four Flat Washers Four Screws(3)	Remove
	b. Guard(2)	Remove
2. Load Resistors		Inspect For: Cracked Insulation Broken Terminals  Replace Faulty Load
TEST		
3. Load Resistors	Terminals	Remove Wires and Measure; 15 Ohms For 1 KW Load and 30 Ohms For 0.5 KW
REPLACE		
4. Resistor(1)	a. Nut(10), Lock Washer(8), Flat Washer(9), Thru-Bolt(7)	Remove
	b. Load Resistor(1)	Remove and Replace
	c. Thru-Bolt(7), Flat Washer(9), Lock Washer(8), Nut(10)	Install and Tighten
	d. Terminals	Install Wires



LOCATION	ITEM	ACTION
5. Guard	Four Screws(3), Four Flat Washers(5), Four Lock Washers(4), Four Nuts(6)	Install and Tighten
6.	Perform Operational Check. Refer to Chapter 2.	

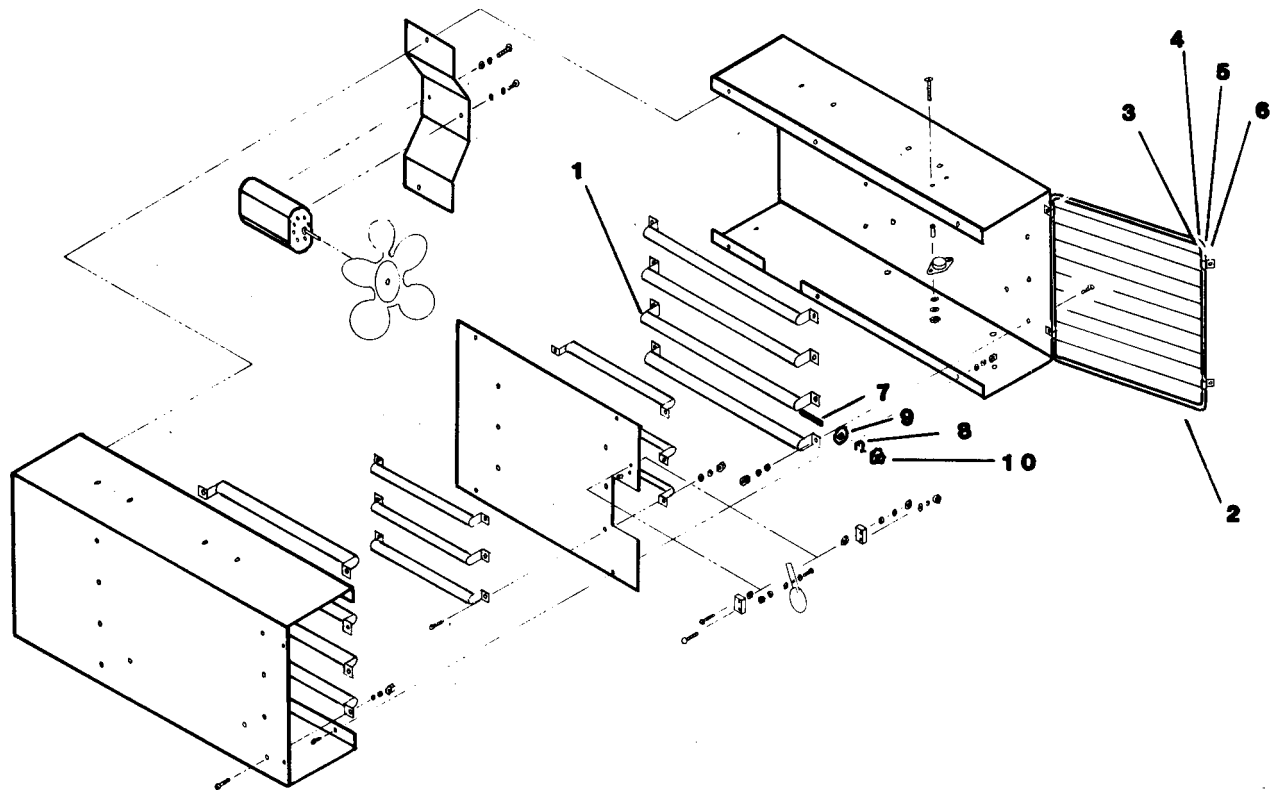

- |                  |                |
|------------------|----------------|
| 1. Load Resistor | 6. Nut         |
| 2. Finger Guard  | 7. Thru-bolt   |
| 3. Screw         | 8. Lock Washer |
| 4. Lock Washer   | 9. Flat Washer |
| 5. Flat Washer   | 10. Nut        |

Figure 5-5. Resistor Replacement

**5-9. Thermal Switch.**

- a. Test
- b. Replace

INITIAL SET-UP

Tools and Equipment:

Personnel Required: MOS 52D10

Electrical Repair Tool Kit  
(4949-00-294-9517)

Equipment Condition: Power Off

LOCATION	ITEM	ACTION
TEST		
1. Guard(2)	Two Nuts(6), Two Lock Washers(5), Two Flat Washers(4), Two Screws(3)	Remove
2. Thermal Switch(1)	Terminals	Measure for 0 Ohms Replace if defective

- 1. Thermal Switch
- 2. Finger Guard
- 3. Screws
- 4. Screws
- 5. Lock Washer
- 6. Nut
- 7. Nut
- 8. Lock Washer
- 9. Flat Washer

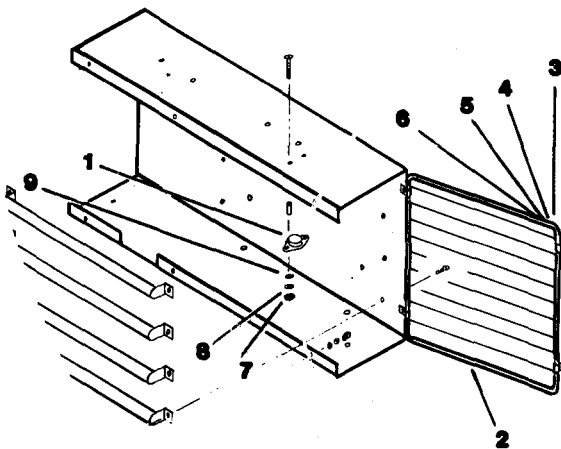

LOCATION	ITEM	ACTION
REPLACE		
3. Thermal Switch(1)	a. Two Nuts(7), Two Lock Washers(8), Two Flat Washers(9)	Remove
	b. Two Wires	Unsolder
	c. Thermal Switch(1)	Remove and Replace
	d. Two Wires	Solder to Switch
	e. Two Flat Washers(9), Two Lock Washers, Two Nuts (7)	Install and Tighten
4. Guard(2)	a. Guard(2)	Swing Closed
	b. two Screws(3), Two Flat Washers(4), Two Lock Washers(5), Two Nuts(6)	Install and Tighten
5.	Perform Operational Check. Refer to Chapter 2.	

Section V. MAINTENANCE OF CHASSIS ASSEMBLY

5-10. General Removal of the rear panel and main housing is necessary before maintenance on the chassis assembly can be performed.

5-11. Rear Panel and Main Housing.

a. Removal

b. Install

INITIAL SET-UP

Tools and Equipment:

Personnel Required: MOS 52D10

Electrical Repair Tool Kit  
(4940-00-294-9517)

Equipment Condition: Power Off

LOCATION	ITEM	ACTION	REMARKS
REMOVAL			
1. Panel(1)	Thirteen Captive Screws(2)	Loosen 1/4 Turn	Remove Panel
2. Housing(3)	Fourteen Screws(4), Fourteen Flat Washers(5)	Remove	Remove Housing

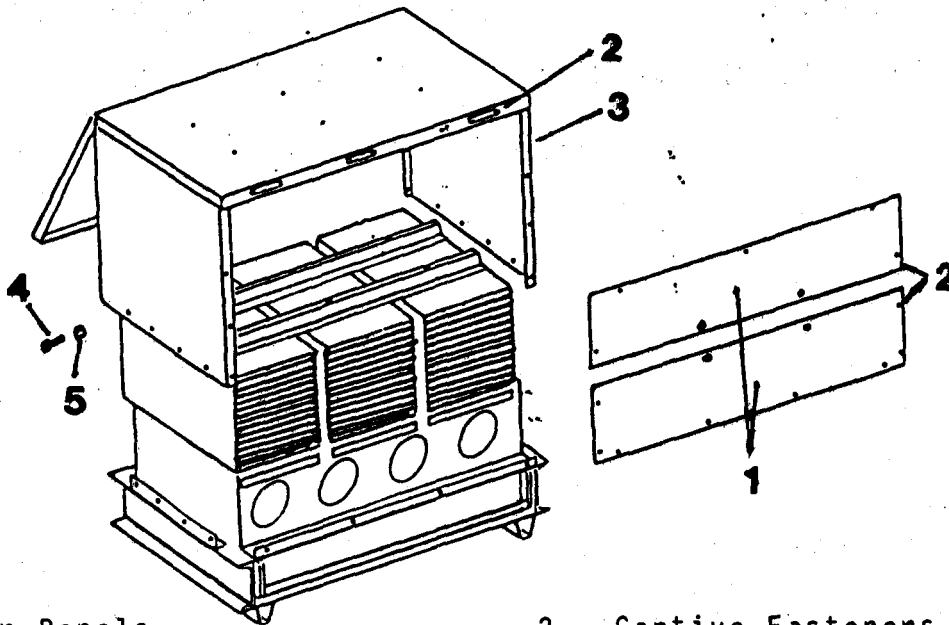

- 1. Rear Panels
- 3. Housing
- 5. Flat Washer

- 2. Captive Fasteners
- 4. Screw

LOCATION	ITEM	ACTION	REMARKS
----------	------	--------	---------

NOTE

Do not install until all required maintenance steps have been performed.

INSTALL

3. Perform Operational Check. Refer to Chapter 2.

4. Housing(3)	a. Housing	Install	
	b. Fourteen Flat Wash- ers(5, Fourteen Screws(4)	Install and Tighten	

5. Panel(1)	a. Panel	Install	
	b. Thirteen Captive Screws(2)	Tighten 1/4 Turn	

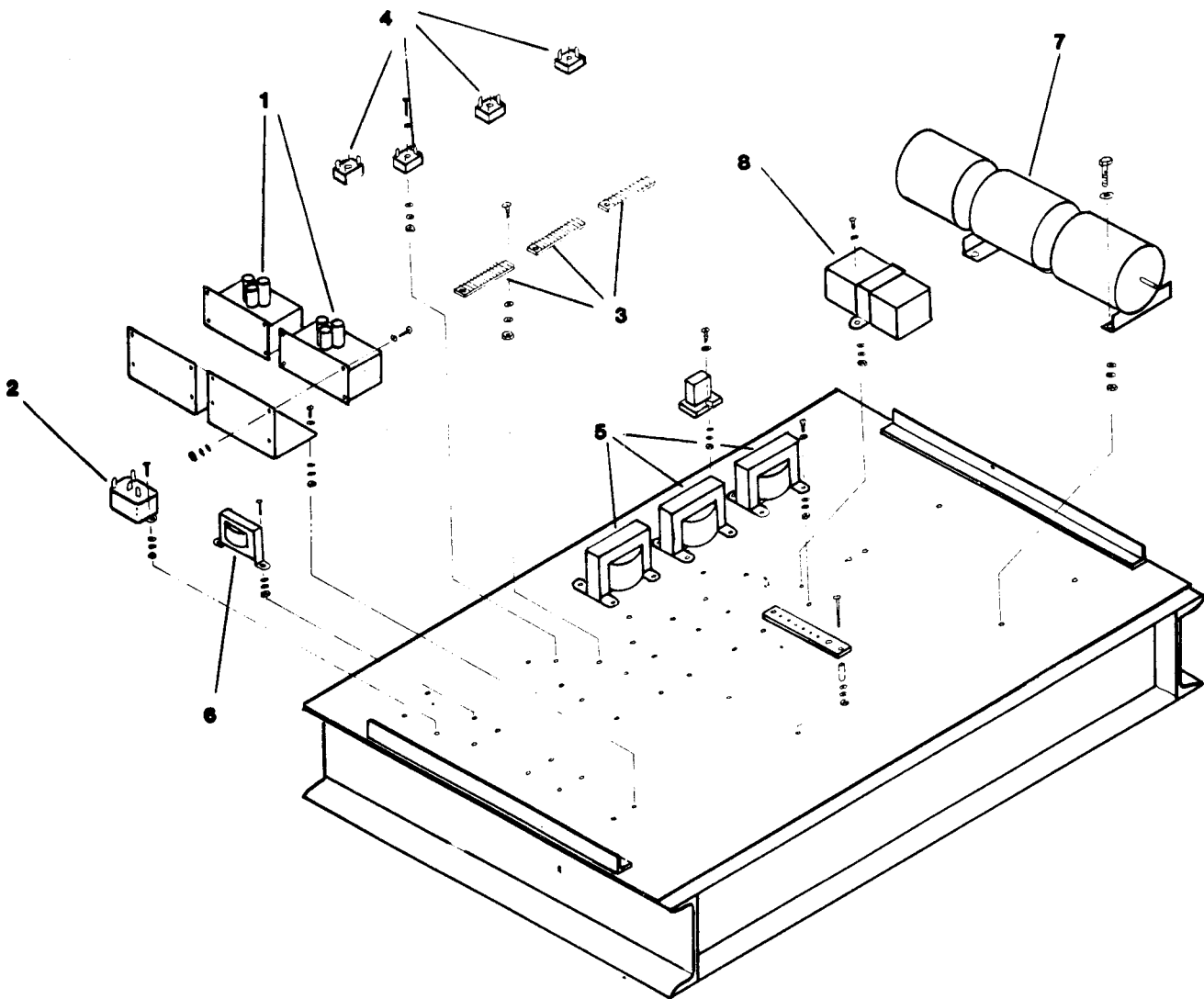

- 1. Contactor
- 2. Contactor Relay
- 3. Terminal Blocks
- 4. Rectifier Bridge

- 5. 24 V. Transformer
- 6. Not Used
- 7. Variable Transformer
- 8. Voltage Sensor

Figure 5-6. Chassis Assembly

**5-12. Contactor.**

Replace

INITIAL SET-UP

Tools and Equipment:

Electrical Repair Tool Kit  
(4940-00-294-9517)

Personnel Required: MOS 52D10

Equipment Condition: Power Off  
Housing Removed (Para. 5-11)

LOCATION	ITEM	ACTION
REPLACE		
Contractor(1)	a. Four Nuts(5), Four Lock Washers(4), Four Flat Washers(3), Four Screws(2)	Remove
	b. Six Set Screws and Wires(6)	Loosen and Tag Wires
	c. Contractor(1)	Remove and Replace
	d. Six Wires and Set Screws(6)	Remove Tags, Install and Tighten
	e. Four Screws(2), Four Flat Washers(3), Four Lock Washers(4), Four Nuts(5)	Install and Tighten
	f. Housing	Install (Para. 5-11)

1. Contactor
2. Screw
3. Flat Washer
4. Lock Washer
5. Nut
6. Set Screw

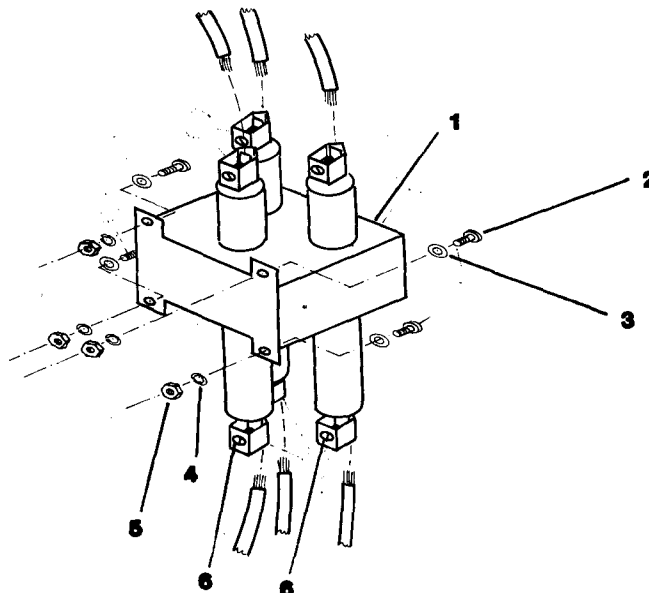

**5-13. Contactor Relay.**

Replace

INITIAL SET-UP

Tools and Equipment:

Electrical Repair Tool Kit  
(4940-00-294-9517)

Personnel Required: MOS 52D10

Equipment Condition: Power Off  
Housing Removed (Para. 5-11)

LOCATION	ITEM	ACTION
REPLACE		
RELAY(1)	a. Four Screws(2) Four Wires(7)	Remove and Tag Wires
	b. TWO Nuts(6), Two Lock Washers(5), Four Flat Washers(4), Two Screws(3)	Remove
	c. Relay(1)	Remove and Replace
	d. Two Screws(3), Four Flat Washers(4), Two Lock Washers(5), Two Nuts(6)	Install and Tighten
	e. Four Screws(2) Four Wires(7)	Remove Tags, Install and Tighten
	f. Housing	Install (Para. 5-11)

- 1. Relay
- 2. Screw
- 3. Screw
- 4. Flat Washer
- 5. Lock Washer
- 6. Nut
- 7. Wire

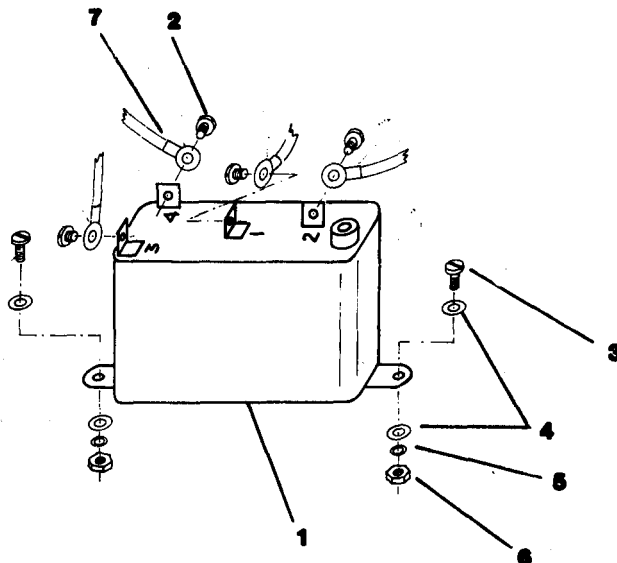



**5-14. Control Relay.**

Replace

INITIAL SET-UP

Tools and Equipment:

Electrical Repair Tool Kit  
(4940-00-294-9517)

Personnel Required: MOS 52D10

Equipment Condition: Power Off  
Housing Removed (Para. 5-11)

LOCATION	ITEM	ACTION
REPLACE		
Relay(1)	a. Control Relay	Remove By Pulling Relay Up
	b. Control Relay	Replace By Aligning Pins and Inserting
	c. Panel	Install (Para. 5-11)

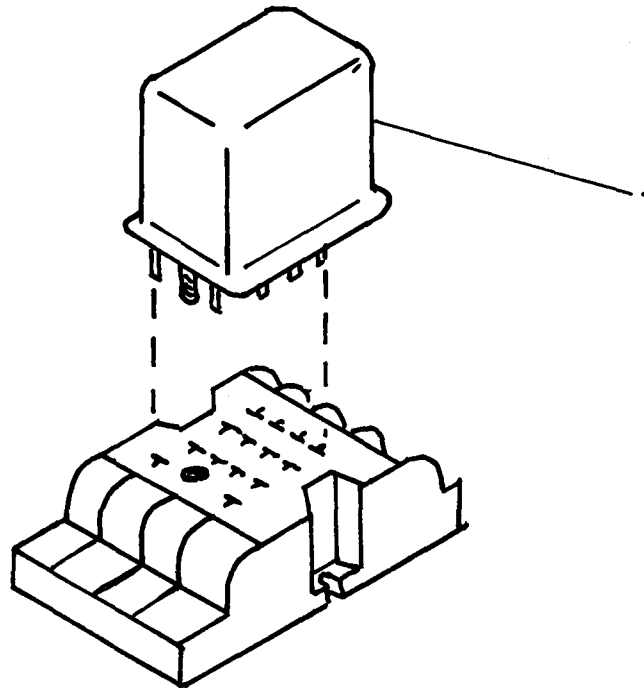

5-15 Control Transformer, 90 V.

Replace

INITIAL SET-UP

Tools and Equipment:

Personnel Required: MOS 52D10

Electrical Repair Tool Kit  
(4940-00-294-9517)

Equipment Condition: Power Off.  
Housing Removed (Para. 5-11)

LOCATION	ITEM	ACTION
REPLACE		
1. TB Strip(9)	Four Screws(2), Four Wires(3)	Disconnect and Tag Wires
2. Bridge(10)	Two Wires(4)	Disconnect and Tag, Wires Pull Off
3. Transformer (1)	a. Four Nuts(8), Four Lock Washers(7), Four Flat Washers(6), Four Screws(5)	Remove
	b. Transformer(1)	Remove and Replace
4. Transformer	Four Screws(5), Four Flat Washers(6), Four Lock Washers(7), Four Nuts(8)	Install and Tighten
5. TB Strip(9)	Four Wires(3), Four Screws(2)	Remove Tags Install and Tighten
6. Bridge	a. Two Wires(4)	Push On
	b. Housing	Install (Para. 5-11)

- 1. Transformer
- 2. Screw
- 3. Four Wires
- 4. Two Wires
- 5. Screw
- 6. Flat Washer
- 7. Lock Washer
- 8. Nut
- 9. TB Strip
- 10. Bridge

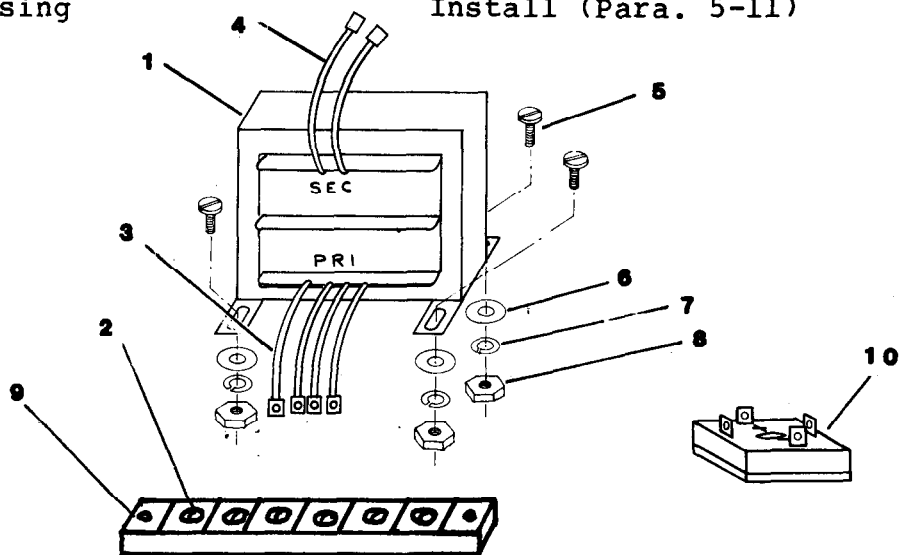

5 - 1 6 . DELETED

THIS PAGE INTENTIONALLY LEFT BLANK

**5-17. Variable Transformer.**

Replace

INITIAL SET-UP

Tools and Equipment:

Personnel Required: MOS 52D10

Electrical Repair Tool Kit  
(4940-00-294-9517)

Equipment Condition: Power Off  
Housing Removed (Para. 5-11)

LOCATION	ITEM	ACTION
REPLACE		
Transformer(1)	a. Set Screw (2) Knob (8)	Loosen & Remove
	b. Eleven Wires(3)	Disconnect and Tag Wires
	c. Four Nuts(7), Four Lock Washers(6) Eight Flat Washers(5) Four Bolts(4)	Remove
	d. Transformer(1)	Remove and Replace
	e. Four Bolts(4) Eight Flat Washers(5) Four Lock Washers(6) Four Nuts(7)	Install and Tighten
	f. Eleven Wires(3)	Remove Tags and Connect
	g. Knob (8) Set Screw (2)	Replace & tighten
	h. Housing	Install (Para. 5-11)

- 1. Transformer
- 2. Set Screw
- 3. Wire
- 4. Bolt
- 5. Flat Washer
- 6. Lock Washer
- 7. Nut
- 8. Knob

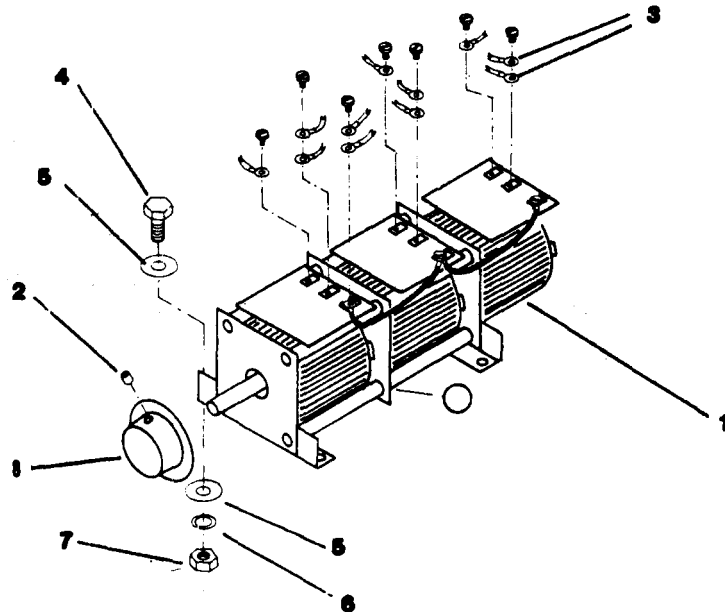

**5-18. Voltage Sensor.**

Replace

INITIAL SET-UP

Tools and Equipment:

Personnel Required: MOS 52D10

Electrical Repair Tool Kit  
(4940-00-294-9517)

Equipment Condition: Power Off  
Housing Removed (Para. 5-11)

LOCATION	ITEM	ACTION
REPLACE		
Sensor(1)	a. Four Nuts(2), Four Lock Washers(8), Four Flat Washers(9), Four Wires(3)	Disconnect and Tag Wires
	b. Two Nuts(7), Two Lock Washers(6), Two Flat Washers(5), Two Screws(4)	Remove
	c. Sensor(1)	Remove and Replace
	d. Two Screws(4), Two Flat Washers(5), Two Lock Washers(6), Two Nuts(7)	Install and Tighten
	e. Four Wires(3), Four Flat Washers(9), Four Lock Washers(8), Four Nuts(2)	Remove Tags and Connect
	f. Housing	Install (Para. 5-11)

- Sensor
- Nut
- Wire
- Screw
- Flat Washer
- Lock Washer
- Nut
- Lock Washer
- Flat Washer

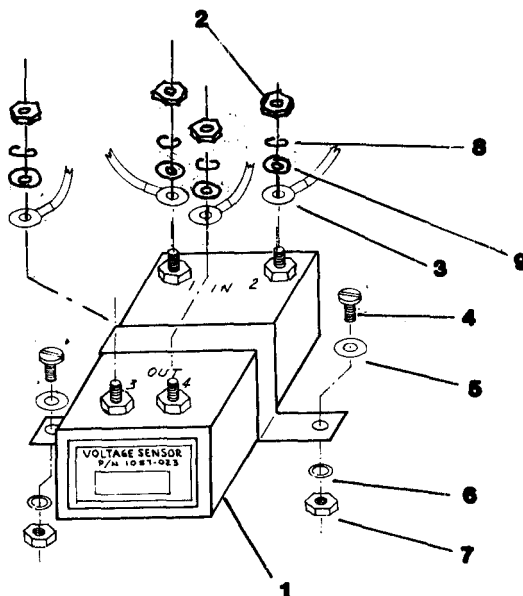

**5-19. Rectifier Bridge.**

Replace

INITIAL SET-UP

Tools and Equipment:

Electrical Repair Tool Kit  
(4940-00-294-9517)

Personnel Required: MOS 52D10

Equipment Condition: Power Off  
Housing Removed (Para. 5-11)

LOCATION	ITEM	ACTION
REPLACE		
Bridge(1)	a. Four Terminals(2)	Disconnect and Tag, Wires Pull Off
	b. Nut(6), Lock Washer(5), Flat Washer(4) Screw(3)	Remove
	c. Bridge(1)	Remove and Replace
	d. Screw(3), Flat Washer(4), Lock Washer(5), Nut(6)	Install and Tighten
	e. Four Terminals(2)	Remove Tags and Connect
	f. Housing	Install (Para. 5-11)

1. Bridge
2. Terminals
3. Screw
4. Flat Washer
5. Lock Washer
6. Nut

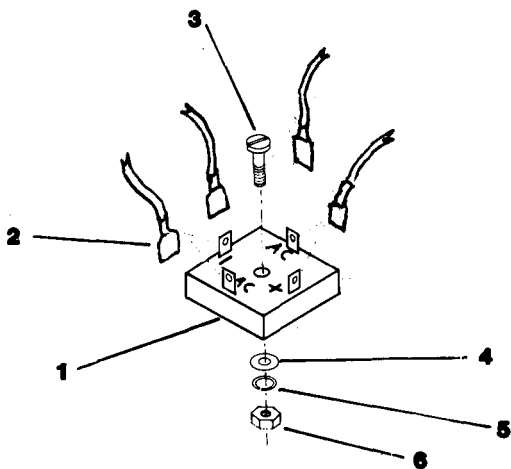

**5-20. Circuit Breaker.**

Replace

INITIAL SET-UP

Tools and Equipment:

Personnel Required: MOS 52D10

Electrical Repair Tool Kit  
(4940-00-294-9517)

Equipment Condition: Power Off  
Housing Removed (Para. 5-11)

LOCATION	ITEM	ACTION
REPLACE		
Breaker(1)	a. Six Terminals(2)	Disconnect and Tag, Wires Pull Off
	b. Rod(3), Spacer(7)	Remove With Pin Punch
	c. Six Screws(4), Six Lock Washers(5), Six Flat Washers(6)	Remove
	d. Breaker(1)	Remove and Replace
	e. Six Flat Washers(6), Six Lock Washers(5) Six Screws(4)	Install and Tighten
	f. Rod(3), Spacers(7)	Insert
	g. Six Terminals(2)	Remove Tags and Connect
	h. Housing	Install (Para. 5-11)

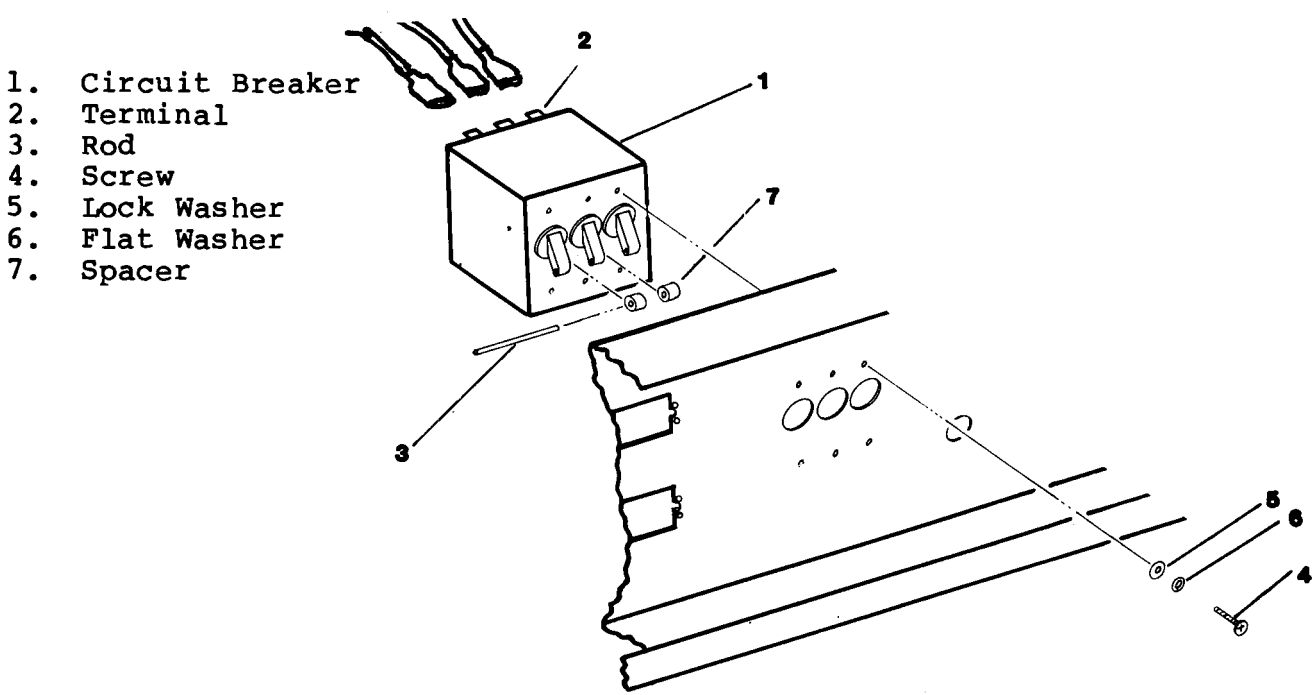

**5-21. Load Switch.**

Replace

INITIAL SET-UP

Tools and Equipment:

Electrical Repair Tool Kit  
(4940-00-294-9517)

Personnel Required: MOS 52D10

Equipment Condition: Power Off  
Housing Removed (Para. 5-11)

LOCATION	ITEM	ACTION
REPLACE		
Switch(1)	a. Six Screws(4), Six Terminals(2)	Disconnect and Tag, Wires Pull Off
	b. Nut(3),	Remove
	c. Switch(1)	Remove and Replace
	d. Nut(3),	Install and Tighten
	e. Six Terminals(2), Six Screws(4)	Remove Tags and Connect Wires
	f. Housing	Install (Para. 5-11)

- 1. Load Switch
- 2. Terminal
- 3. Nut
- 4. Screw

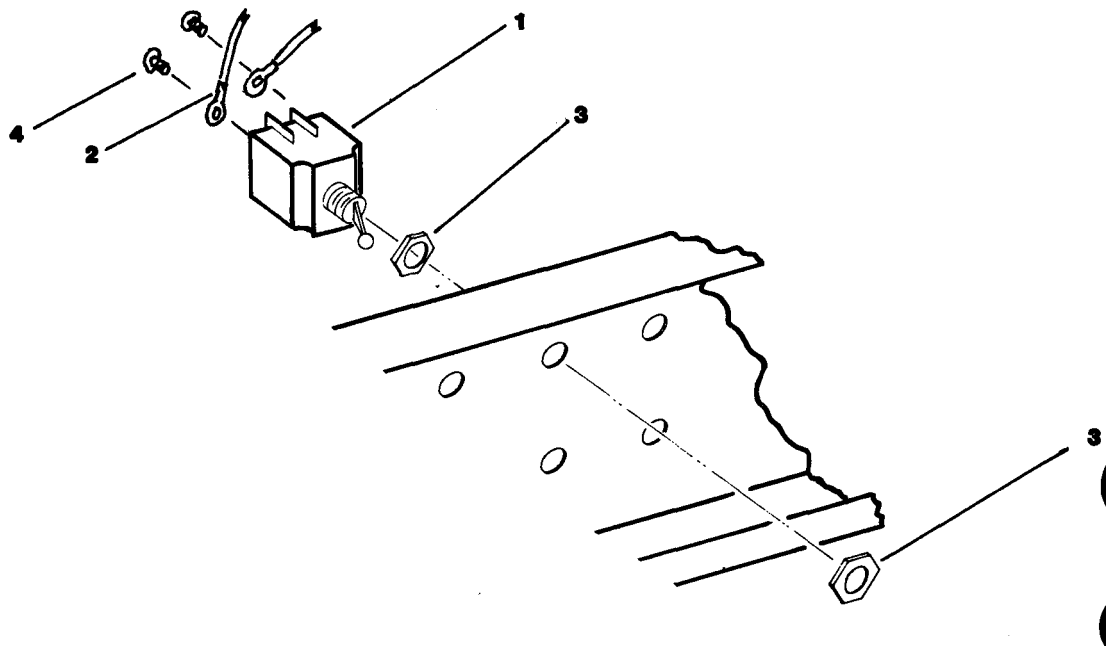



5-22. Wire Harness.

Repair

Tools and Equipment:

Electrical Repair Tool Kit  
(4940-00-294-9517)  
Crimping Tool 5120-00-165-3912  
Extraction Tool 5120-00-930-7503  
Insertion Tool 5120-00-930-7504

Personnel Required: MOS 52D10

Equipment Condition: Power Off  
Housing Removed (Para. 5-11)

REPAIR

For repair procedures refer to TM55-1500-323-25



## APPENDIX A

## REFERENCES

- A - 1 . TB 5-4200-200-10 Hand Portable Fire Extinguishers for Army Users
- A - 2 . TM 43-0139 Painting Instructions for Field Use
- A - 3 . TM 11-483 Radio Interference Suppression
- A - 4 . TM 38-750 The Army Maintenance Management System(TAMMS)
- A - 5 . TM 9-237 Welding Theory and Application
- A - 6 . TB 740-97-2 Preservation of USAMECOM Mechanical Equipment for Shipment and Storage
- A - 7 . TM 750-90-1 Administrative Storage of Equipment
- A - 8 . TM 38-230 Preservation, Packaging, and Packing of Military Supplies and Equipment
- A - 9 . TM 750-244-3 Procedures for Destruction of Equipment to Prevent Enemy Use
- A-10. TB MED 251 Noise and Conservation of Hearing
- A-11. SC4940-95-CL-B05 Shop Equipment, Electrical Repair
- A-12. MIL-STD-12 Abbreviations for Use on Drawings, Specifications, Standards and in Technical Documents
- A-13. TM 55-1500-323-25 Installation Practice For Aircraft Electrical Wiring
- A - 14 . FM 21-11 First Aid For Soldiers



## APPENDIX B

## MAINTENANCE ALLOCATION CHART

## Section I. INTRODUCTION

## B-1 General

a. This section provides a general explanation of all maintenance and repair functions authorized at various maintenance levels.

b. The Maintenance Allocation Chart (MAC) in Section II designates overall responsibility for the performance of maintenance functions on the identified end item or component. The implementation of the maintenance functions upon the end item or component will be consistent with the assigned maintenance functions.

c. Section III lists the special tools and test equipment required for each maintenance function as referenced from Section II.

## B-2 Maintenance Functions

a. Inspect. To determine the serviceability of an item by comparing its physical, mechanical and/or electrical characteristics with established standards through examination.

b. Test. To verify serviceability and detect incipient failure by measuring the mechanical or electrical characteristics of an item and comparing those characteristics with prescribed standards.

c. Service. Operations required periodically to keep an item in proper operating condition, i.e., to clean (decontaminate), to preserve, to drain, to paint, or to replenish fuel, lubricants, hydraulic fluids, or compressed air supplies.

d. Adjust. To maintain, within prescribed limits, by bringing into proper or exact position, or by setting the operating characteristics to specified parameters.

e. Align. To adjust specified variable elements of an item to bring about optimum or desired performance.

f. Calibrate. To determine and cause corrections to be made or to be adjusted on instruments or test measuring and diagnostic equipments used in precision measurements. Consists of comparisons of two instruments, one of which is a certified standard of known accuracy, to detect and adjust any discrepancy in the accuracy of the instrument being compared.

g. Install. The act of emplacing, seating, or fixing into position an item, part, or module (component or assembly) in a manner to allow the proper functioning of an equipment or system.

h. Replace. The act of substituting a serviceable like type part, subassembly, or module (component or assembly) for an unserviceable counterpart.

i. Repair. The application of maintenance services (inspect, test, service, adjust, align, calibrate or replace) or other maintenance actions (welding, grinding, riveting, straightening, facing, remachining or resurfacing) to restore serviceability to an item by correcting specific damage, fault, malfunction, or failure in a part, subassembly, module (component or assembly), end item, or system.

j. Overhaul. That maintenance effort (services/actions) necessary to restore an item to a completely serviceable/operational condition as prescribed by maintenance standards (i.e., DMWR) in appropriate technical publications. Overhaul is normally the highest degree of maintenance performed by the Army. Overhaul does not normally return an item to like new condition.

k. Rebuild. Consists of those services/actions necessary for the restoration of unserviceable equipment to a like new condition in accordance with original manufacturing standards. Rebuild is the highest degree of material maintenance applied to Army equipment. The rebuild operation includes the act of returning to zero those age measurements (hours/miles, etc.) considered in classifying Army equipments/components.

#### B-3 Column Entries Used in the MAC

a. Column 1, Group Number. Column 1 lists group numbers, the purpose of which is to identify components, assemblies, subassemblies, and modules with the next higher assembly.

b. Column 2, Component/Assembly. Column 2 contains the names of components, assemblies, subassemblies, and modules for which maintenance is authorized.

c. Column 3, Maintenance Functions. Column 3 lists the functions to be performed on the item listed in Column 2. (For detailed explanations of these functions, see paragraph B-2).

d. Column 4, Maintenance Level. Column 4 specified, by the listing of a "work time" figure in the appropriate subcolumn(s), the lowest level of maintenance authorized to perform the function listed in Column 3. This figure represents the active time required to perform the maintenance function at the indicated level of maintenance. If the number or complexity of the tasks within the listed maintenance function vary at different maintenance levels, the

appropriate work time figures will be shown for each level. The number of man-hours specified by the work time figure represents the average time required to restore an item (assembly, subassembly, component, module, end item, or system) to a serviceable condition under typical field operating conditions. This time includes preparation time, troubleshooting time, and quality assurance/quality control time, in addition to the time required to perform the specific tasks identified for the maintenance functions authorized in the maintenance allocation chart. The symbol designations for the various maintenance levels are as follows:

C-----Operator or Crew  
 O-----Organizational Maintenance  
 F-----Direct Support Maintenance  
 H-----General Support Maintenance  
 D-----Depot Maintenance

e. Column 5, Tools and Equipment. Column 5 specified, by code, those common tool sets (not individual tools) and special tools, test and support equipment required to perform the designated function.

f. Column 6, Remarks. This column contains a letter code in alphabetical order which is keyed to the remarks contained in Section IV.

#### B-4 Column Entries Used in Tool and Test Equipment Requirements.

a. Column 1, Tool or Test Equipment Reference Code. The tool and test equipment reference code correlates with a maintenance function on the identified end item or component.

b. Column 2, Maintenance Level. The lowest level of maintenance authorized to use the tool or test equipment.

c. Column 3, Nomenclature. Name or identification of the tool or test equipment.

d. Column 4, National\NATO Stock Number. The National or NATO stock number of the tool or test equipment.

e. column 5, Tool Number. The manufacturer's part number.

Section II. MAINTENANCE ALLOCATION CHART

(1) Group Number	(2) Component/Assembly	(3) Maintenance Function	(4) Maintenance Level					(5) Tools and Equipment	(6) Remarks
			C	O	F	H	D		
01	Main Housing	Inspect Replace	0.1		0.6			T1	
0101	Rear Panel	Inspect Replace Repair	0.1		0.1 0.4 0.6			T1 T2	
02	Base Assembly								
0201	Guard, Exhaust	Inspect Clean	0.1 0.1					T1	
03	Power Absorber								
0301	Switch Wind	Inspect Test Replace	0.1		0.1 0.1 0.8			T1	
0302	Motor & Blade	Inspect Test Replace			0.1 0.2 1.1			T1	
0303	Resistors, Load	Inspect Test Replace			0.1 0.2 1.5			T1	
0304	Switch Thermal	Test Replace			0.2 1.5			T1	
04	Chassis Assembly								
0401	Contacto	Replace			1.3			T1	
0402	Relay, Contacto	Replace			0.6			T1	



(1) Group Number	(2) Component/Assembly	(3) Maintenance Function	(4) Maintenance Level					(5) Tools and Equipment	(6) Remarks
			C	O	F	H	D		
0403	Relay Control	Replace			0.1			T1	
0404	Transformer,	Replace			0.6			T1	
0405	Not Used							T1	
0406	Transformer, Var.	Replace			1.2			T1	
0407	Sensor, Voltage	Replace			0.6			T1	
0408	Bridge, Rectifier	Replace			0.4			T1	
05	Control Panel								
0501	Breaker, Circuit	Replace			0.6			T1	
0502	Switch, Load	Replace			0.8			T1	
0503	Harness, Wire	Repair			2.0			T1,T3,T4,T5	

SECTION III. TOOL AND TEST EQUIPMENT REQUIREMENTS				
(1) REFERENCE CODE	(2) MAINTENANCE LEVEL	(3) NOMENCLATURE	(4) NATIONAL/NATO STOCK NUMBER	(5) TOOL NUMBER
T1	C,F	SHOP EQUIPMENT, ELECTRICAL REPAIR TOOL KIT	4940-00-294-9517	
T2	F	KIT RIVET	5120-00-017-2849	
T3	F	TOOL, INSERTION	5120-00-930-7504	
T4	F	TOOL, EXTRACTION	5120-00-930-7503	
T5	F	TOOL, CRIMPING	5120-00-165-3912	

## APPENDIX C

## REPAIR PARTS AND SPECIAL TOOLS LIST

## Section I. INTRODUCTION

## C-1 Scope

This manual lists spares and repair parts; special tools; special test, measurement, and diagnostic equipment (TMDE), and other special support equipment required for performance of direct support maintenance of the Test Set. It authorizes the requisitioning and issue of spares and repair parts as indicated by the source and maintenance codes.

## C-2 General

This Repair Parts and Special Tools List is divided into the following sections:

a. Section II. Repair Parts List. A list of spares and repair parts authorized for use in the performance of maintenance. The list also includes parts which must be removed for replacement of the authorized parts. Parts lists are composed of functional groups in numeric sequence, with the parts in each group listed in figure and item number sequence.

b. Section III. Special Tools List. A list of special tools, special TMDE, and other special support equipment authorized for the performance of maintenance.

c. Section IV. National Stock Number and Part Number Index. A list, in National item identification number (NIIN) sequence, of all National stock numbers (NSN) appearing in the listings, followed by a list in alphabetic sequence of all part numbers appearing in the listings. National stock numbers and part numbers are cross-referenced to each illustration figure and item number appearance. This index is followed by a cross-reference list of reference designators to figure and item numbers.

## C-3 Explanation of Columns.

a. Illustration. This column is divided as follows:

(1) Figure Number. Indicates the figure number of the illustration on which the item is shown.

(2) Item Number. The number used to identify item called out in the illustration.

b. Source, Maintenance, and Recoverability (SMR) Codes.

(1) Source Code. Source codes indicate the manner of acquiring support items for maintenance, repair, or overhaul of end items. Source codes are entered in the first and second positions of the Uniform SMR Code format as follows:

CODE	DEFINITION
PA	-Item procured and stocked for anticipated or known usage.
PB	-Item procured and stocked for insurance purpose because essentiality dictates that a minimum quantity be available in the supply system.
PC	-Item procured and stocked and which otherwise would be coded PA except that it is deteriorative in nature.
PD	-Support item, excluding support equipment, procured for initial issue or outfitting and stocked only for subsequent or additional initial issues or outfittings. Not subject to automatic replenishment.
PE	-Support equipment procured and stocked for initial issue or outfitting to specified maintenance repair activities.
PF	-Support equipment which will not be stocked but which will be centrally procured on demand.
PG	-Item procured and stocked to provide for sustained support for the life of the equipment. It is applied to an item peculiar to the equipment which, because of probable discontinuance or shutdown of production facilities, would prove uneconomical to reproduce at a later time.
KD	-An item of a depot overhaul/repair kit and not purchased separately. Depot kit defined as a kit that provides items required at the time of overhaul or repair.
KF	-An item of a maintenance kit and not purchased separately. Maintenance kit defined as a kit that provides an item that can be replaced at organizational or intermediate levels of maintenance.
KB	-Item included in both a depot overhaul/repair kit and a maintenance kit.
MO	-Item to be manufactured or fabricated at organizational level.
MF	-Item to be manufactured or fabricated at the direct support maintenance level.
MH	-Item to be manufactured or fabricated at the general support maintenance level.

- MD -Item to be manufactured or fabricated at the depot maintenance level.
- AO -Item to be assembled at organizational level.
- AF -Item to be assembled at direct support maintenance level.
- AH -Item to be assembled at general support maintenance level.
- AD -Item to be assembled at depot maintenance level.
- XA -Item is not procured or stocked because the requirements for the item will result in the replacement of the next higher assembly.
- XB -Item is not procured or stocked. If not available through salvage, requisition.
- XC -Installation drawing, diagram, instruction sheet, field service drawing, that is identified by manufacturer's part number.
- XD -A support item that is not stocked. When required, item will be procured through normal supply channels.

NOTE

Cannibalization or salvage may be used as a source of supply for any items coded above except those coded XA and aircraft support items as restricted by AR 700-42

(2) Maintenance Code. Maintenance codes are assigned to indicate the levels of maintenance authorized to USE and REPAIR support items. The maintenance codes are entered in the third and fourth positions of the Uniform SMR Code format as follows:

(a) The maintenance code entered in the third position will indicate the lowest maintenance level authorized to remove, replace, and use the support item. The maintenance code entered in the third position will indicate one of the following levels of maintenance:

CODE	APPLICATION/EXPLANATION
C	-Crew or operator maintenance performed within organizational maintenance.
O	-Support item is removed, replaced, used at the organizational level.
F	-Support item is removed, replaced, used at the direct support level.
H	-Support item is removed, replaced, used at the general support level.
D	-Support items that are removed, replaced, used at depot, mobile depot, or specialized repair activity only.

(b) The maintenance code entered in the fourth position indicates whether the item is to be repaired and identifies the lowest maintenance level with the capability to perform complete repair (i.e., all authorized maintenance functions). This position will contain one of the following maintenance codes.

CODE	APPLICATION/EXPLANATION
O	-The lowest maintenance level capable of complete repair of the support item is the organizational level.
F	-The lowest maintenance level capable of complete repair of the support item is the direct support level.
H	-The lowest maintenance level capable of complete repair of the support item is the general support level.
D	-The lowest maintenance level capable of complete repair of the support item is the depot level.
L	-Repair restricted to equipment manufacturer.
Z	-Nonrepairable. No repair is authorized.
B	-No repair is authorized. The item may be reconditioned by adjusting, lubricating, etc., at the user level. No parts or special tools are procured for the maintenance of this item.

(3) Recoverability Code. Recoverability codes are assigned to support items to indicate the disposition action on unserviceable items. The recoverability code is entered in the fifth position of the Uniform SMR Code format as follows:

RECOVERABILITY CODES	APPLICATION/EXPLANATION
Z	-Nonrepairable item. When unserviceable, condemn and dispose at the level indicated in position 3.
0	-Repairable item. When uneconomically repairable, condemn and dispose at organizational level.
F	-Repairable item. When uneconomically repairable, condemn and dispose at the direct support level.
H	-Repairable item. When uneconomically repairable, condemn and dispose at the general support level.
D	-Repairable item. When beyond lower level repair capability, return to depot. Condemnation and disposal not authorized below depot level.

- L -Reparable item. Repair, condemnation, and disposal not authorized below depot/specialized repair activity level.
- A -Item requires special handling or condemnation procedures because of specific reasons (i.e., precious metal content, high dollar value, critical material or hazardous material). Refer to appropriate manuals/directives for specific instructions.

c. National Stock Number. Indicates the National stock number assigned to the item and which will be used for requisitioning.

d. Part Number. Indicates the primary number used by the manufacturer (individual, company, firm, corporation, or Government activity), which controls the design and characteristics of the item by means of its engineering drawings, specifications, standards, and inspection requirements to identify an item or range of items.

#### NOTE

When a stock numbered item is requisitioned, the item received may have a different part number than the part being replaced.

e. Federal Supply Code for Manufacturer (FSCM). The FSCM is a 5-digit numeric code listed in SB 708-42 which is used to identify the manufacturer, distributor, or Government agency, etc.

f. Description. Indicates the Federal item name and, if required, a minimum description to identify the item. The physical security classification of the item is indicated by the parenthetical entry (insert applicable physical security classification abbreviation, e.g. Phy Sec C1 (C)-Confidential, Phy Sec C1 (S)-Secret, Phy Sec C1 (T)-Top Secret). Items that are included in kits and sets are listed below the name of the kit or set with the quantity of each item in the kit or set indicated in the quantity incorporated in unit column. When the part to be used differs between serial numbers of the same model, the effective serial numbers are shown as the last line of the description. In the Special Tools List, the initial basis of issue (BOI) appears as the last line in the entry for each special tool, special TMDE, and other special support equipment. When density of equipments supported exceeds density spread indicated in the basis of issue, the total authorization is increased accordingly.

g. Unit of Measure (U/M). Indicates the standard of the basic quantity of the listed item as used in performing the actual maintenance function. This measure is expressed by a two-character alphabetical abbreviation (e.g., ea, in, pr, etc.). When the unit of measure differs from the unit of issue, the lowest unit of issue that will satisfy the required units of measure will be requisitioned.

h. Quantity Incorporated in Unit. Indicates the quantity of the item used in the breakout shown on the illustration figure, which is prepared for a functional group, subfunctional group, or an assembly. A "V" appearing in this column in lieu of a quantity indicates that no specific quantity is applicable, (e.g., shims, spacers, etc.).

#### C-4 Special Information

a. Action Change Codes indicated in the left-hand margin of the listing page denote the following:

N-Indicates an added item.

C-Indicates a change in data

R-Indicates a change in NSN only



## C-5 How to Locate Repair Parts

## a. When National Stock Number or Part Number is Unknown:

(1) First. Using the table of contents, determine the subgroup within which the item belongs. This is necessary since illustrations are prepared for subgroups, and listings are divided into the same groups.

(2) Second. Find the illustration covering the subgroup to which the item belongs.

(3) Third. Identify the item on the illustration and note the illustration figure and item number of the item.

(4) Fourth. Using the Repair Parts Listing, find the figure and item number noted on the illustration.

## b. When National Stock Number or Part Number is Known:

(1) First. Using the Index of National Stock Numbers and Part Numbers, find the pertinent National stock number or part number. This index is in NIIN sequence followed by a list of part numbers in alphameric sequence, cross-referenced to the illustration figure number and item number.

(2) Second. After finding the figure and item number, locate the figure and item number in the repair parts list.

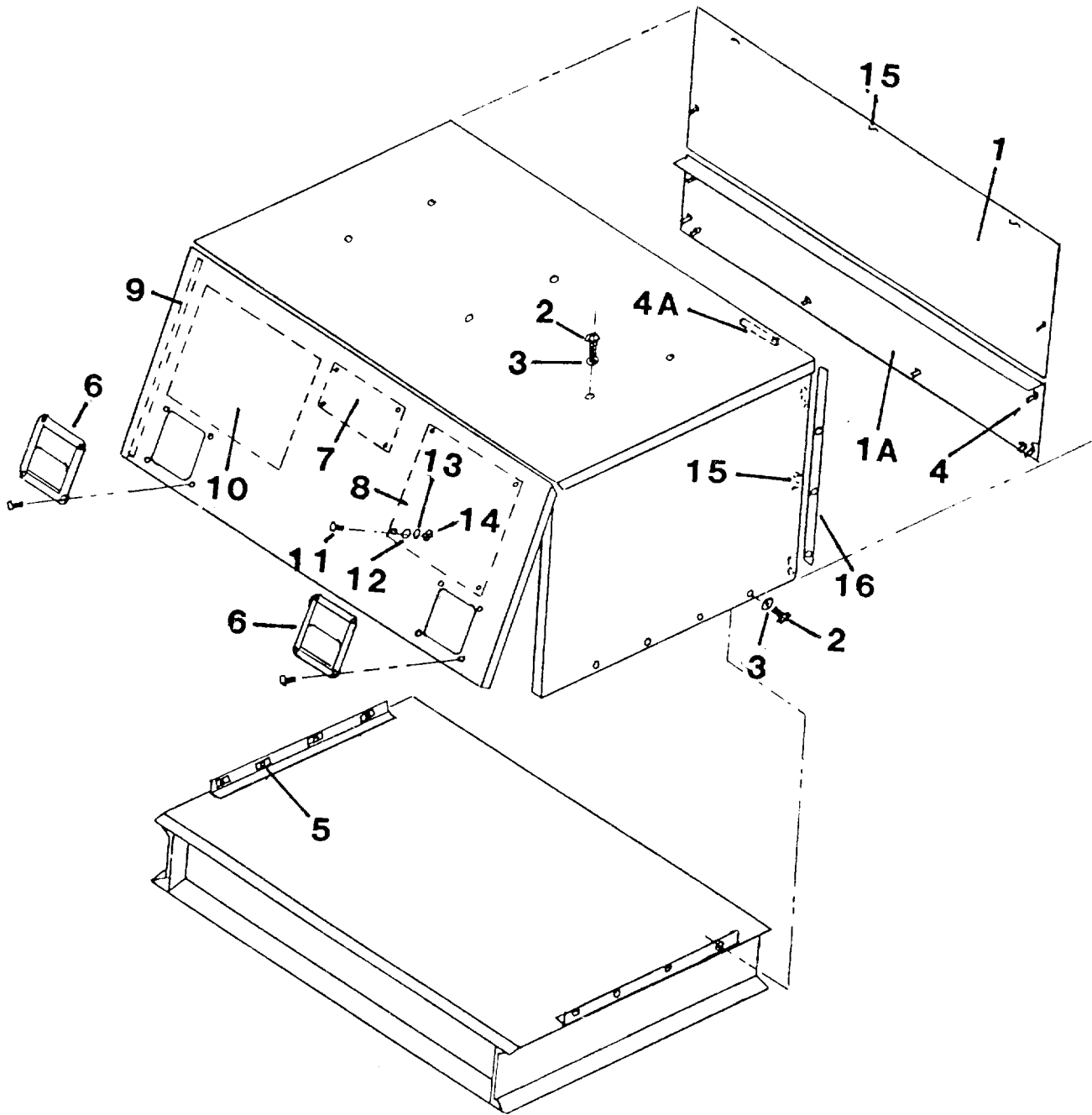

Figure 1. Main Housing Assembly

(1) ILLUSTRATION (a) FIG NO	(2) (b) ITEM NO	(3) SMR CODE	(4) NATIONAL STOCK NUMBER	(5) FSCM	(6) PART NUMBER	TM5-6625-2694-13&P (6) DESCRIPTION	(7) USABLE ON CODE U/M	(8) QTY INC IN UNIT
GROUP 01: MAIN HOUSING								
1	1	XBFFF		51283	1057-006A	PANEL	EA	1
1	1A	XBFFF		51283	1057-006B	PANEL	EA	1
1	2	PAFZZ	5305-00-059-3661	96906	MS51958-65	SCREW, MACHINE	EA	14
1	3	PAFZZ	5310-00-883-9384	96906	MS15795-842	WASHER, FLAT	EA	14
1	4	PAFZZ		72794	AJ5-45	FASTENER, CAPTIVE	EA	10
1	4A	PAFZZ		72794	A5-50	FASTENER, CAPTIVE	EA	3
1	5	PAFZZ	5310-00-778-2655	96906	MS21059-3	NUT, SELF LOCKING, PLATE, FLOATING	EA	14
1	6	XBFFZ		19220	62-4905SS	LATCH, PADDLE LOCK	EA	2
1	7	XCPFF		51283	1057T-1	PLATE, IDENTIFICATION	EA	1
1	8	XCFZZ		51283	1057D	PLATE, WIRING DIAGRAM	EA	1
1	9	PAFZZ		39428	1117A18	WEATHERSTRIPPING	FT	7
1	10	PAFZZ	7520-00-559-9618	81348	MIL-C-11743	CASE, MANUAL	EA	1
1	11	PAFZZ	5305-00-054-5649	96906	MS51957-15	SCREW, MACHINE	EA	10
1	12	PAFZZ	5310-00-595-6211	96906	MS15795-803	WASHER, FLAT	EA	10
1	13	PAFZZ	5310-00-933-8118	96906	MS35338-135	WASHER, LOCK	EA	10
1	14	PAFZZ	5310-00-934-9748	96906	MS35649-244	NUT, PLAIN, HEXAGON	EA	10
1	15	PAFZZ	5325-00-285-3374	72794	S5A-225	LOCKSPRING, TURNLOCK	EA	9
1	16	PAFZZ		39428	1117A12	WEATHERSTRIPPING	FT	6

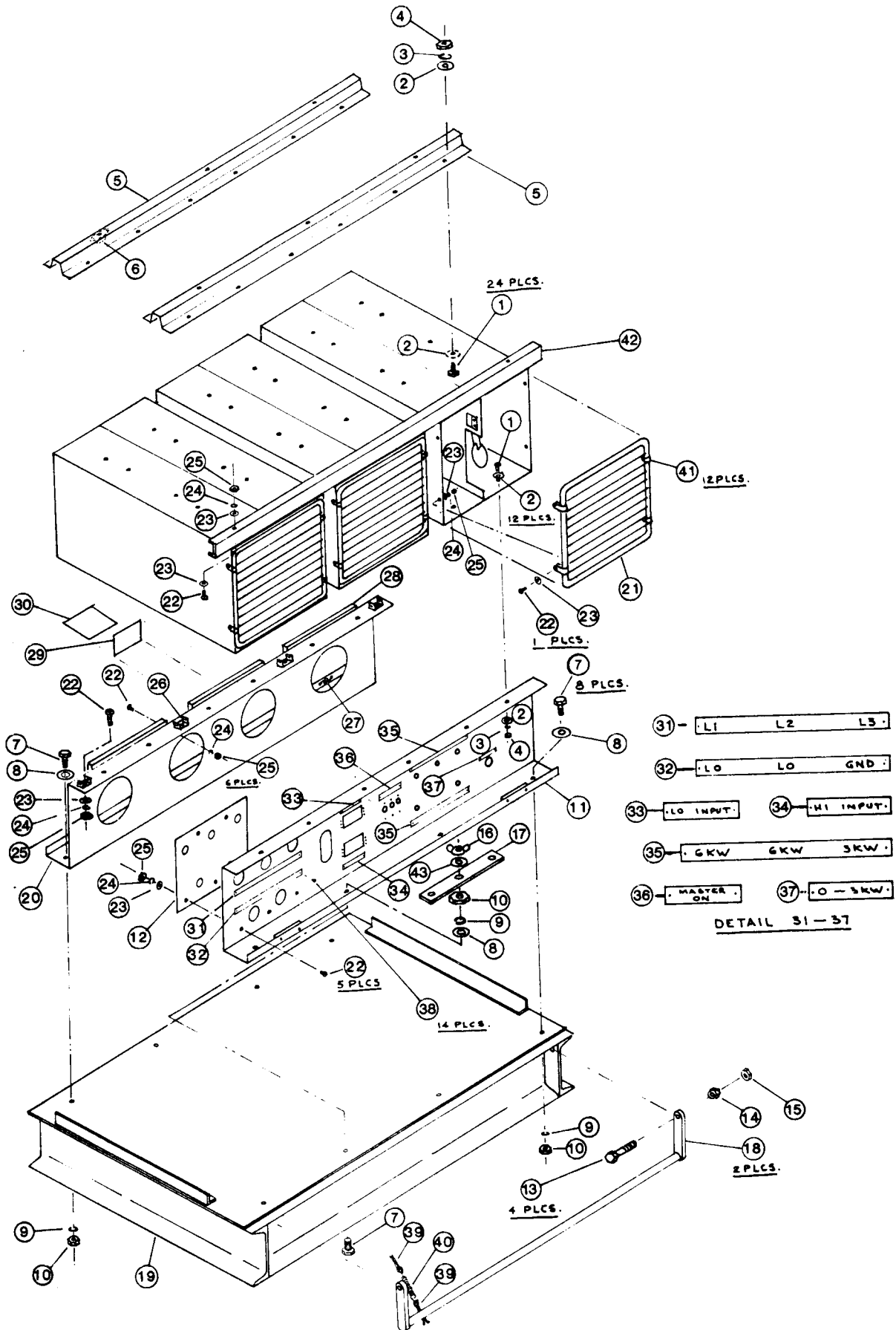

Figure 2. Base Assembly

(1) ILLUSTRATION (a) FIG NO	(2) (b) ITEM NO	(3) SMR CODE	(4) NATIONAL STOCK NUMBER	(5) FSCM	(6) PART NUMBER	TM5-6625-2694-13&P (6) DESCRIPTION	(7) USABLE ON CODE U/M	(8) QTY INC IN UNIT
GROUP 02: BASE ASSEMBLY								
2	1	PAFZZ	5305-00-701-5061	96906	MS51958-45	SCREW, MACHINE	EA	41
2	2	PAFZZ	5310-00-880-5978	96906	MS15795-807	WASHER, FLAT	EA	41
2	3	PAFZZ	5310-00-933-8119	96906	MS35338-137	WASHER, LOCK	EA	41
2	4	PAFZZ	5310-00-934-9759	96906	MS35649-284	NUT, PLAIN, HEXAGON	EA	41
2	5	XBFZZ		51283	1057-007	SUPPORT, TOP	EA	2
2	6	PAFZZ	5310-00-778-2655	96906	MS21059-3	NUT, SELF-LOCKING, PLATE, FLOATING	EA	6
2	7	PAFZZ		96906	MS35307-308	BOLT, MAHCINE	EA	8
2	8	PAFZZ	5310-00-582-5677	96906	MS15795-810	WASHER, FLAT	EA	8
2	9	PAFZZ	5310-00-933-8121	96906	MS35338-139	WASHER, LOCK	EA	8
2	10	PAFZZ	5310-00-903-5966	96906	MS51971-1	NUT, PLAIN, HEXAGON	EA	8
2	11	XBFZZ		51283	1057-008A	SUPPORT, FRONT	EA	1
2	12	XBFZZ		51283	1057-012	INSULATOR	EA	1
2	13	PAFZZ	5305-00-701-7628	96906	MS35307-415	SCREW, CAP, HEXAGON	EA	4
2	14	PAFZZ	5310-00-989-5945	96906	MS35691-35	NUT, PLAIN, HEXAGON	EA	4
2	15	PAFZZ	5310-00-411-4385	96906	MS17830-8C	NUT, SELF-LOCKING, HEXAGON	EA	8
2	16	PAOZZ	5310-00-933-8778	96906	MS35425-71	NUT, PLAIN, WING, BRASS	EA	8
2	17	PAOZZ	5310-00-768-0321	51283	1057-017	SHORTING BAR	EA	1
2	18	XBFZZ		51283	1057-003	BAR, LIFTING	EA	2
2	19	XBFFF		51283	1057-002	BASE	EA	1
2	20	XBFZZ		51283	1057-008B	SUPPORT, REAR	EA	1
2	21	XBFZZ		51283	1057-050	GUARD, EXHAUST	EA	3
2	22	PAFZZ	5305-00-054-6654	96906	MS51957-30	SCREW, MACHINE	EA	17
2	23	PAFZZ	5310-00-722-5998	96906	MS15795-805	WASHER, FLAT	EA	33
2	24	PAFZZ	5310-00-929-6395	96906	MS35338-136	WASHER, LOCK	EA	33
2	25	PAFZZ		96906	MS35649-264	NUT, PLAIN, HEXAGON	EA	21
2	26	PAFZZ		06383	TM2S8-C	MOUNT, WIRE TIE	EA	4
2	27	PAFZZ	5325-00-285-3374	72794	S5A-225	LOCKSPRING, TURNLOCK	EA	4
2	28	PAFZZ		13150	7605	TERMINAL STRIP, 25 TERMINALS	EA	3
2	29	XCFZZ		51283	1057T-11	DECAL, FRONT PANEL	EA	1
2	30	XCFZZ		51283	1057T-12	DECAL, CHASSIS COMPONENT LOCATOR	EA	1
2	31	XCFZZ		51283	1057T-7	PLATE, IDENTIFICATION, L1, L2, L3	EA	1
2	32	XCFZZ		51283	1057T-6	PLATE, IDENTIFICATION, LO, LO, GRD	EA	1
2	33	XCFZZ		51283	1057T-9	PLATE, IDENTIFICATION, LOW, INPUT	EA	1
2	34	XCFZZ		51283	1057T-8	PLATE, IDENTIFICATION, HI, INPUT	EA	1
2	35	XCFZZ		51283	1057T-3	PLATE, IDENTIFICATION, 6KW, 6KW, 3KW	EA	1
2	36	XCFZZ		51283	1057T-10	PLATE, IDENTIFICATION, MASTER ON	EA	1
2	37	XCFZZ		51283	1057T-5	PLATE, IDENTIFICATION, O - 3KW	EA	1
2	38	PAFZZ	5305-00-253-5606	96906	MS21318-7	SCREW, DRIVE, SIZE 0	EA	2
2	39	PAFZZ		96906	MS24655-372	PIN, COTTER	EA	2
2	40	PAFZZ		39428	9533K	SPRING, LIFTING HAND	EA	2
2	41	PAFZZ	5340-00-471-1913	96906	MS21103-4	CLAMP, LOOP, EXHAUST GUARD MOUNTING	EA	4
2	42	XBFZZ		51283	1057-016	SUPPORT, HOUSING FRONT	EA	1
2	43	PAFZZ	5310-00-045-5210	96906	MS15795-910	WASHER, FLAT, BRASS	EA	1

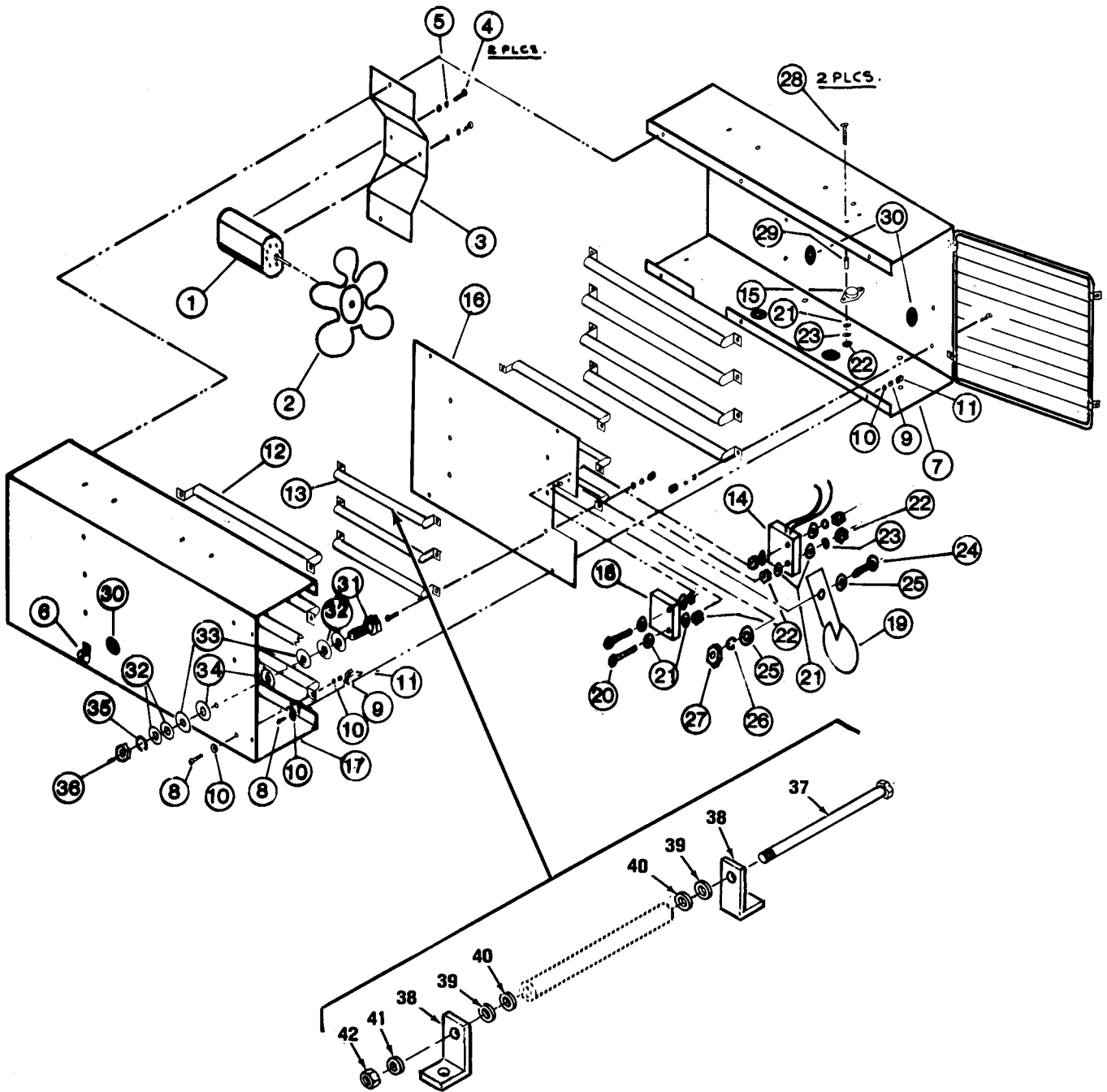

Figure 3. Power Absorber Assembly

(1) ILLUSTRATION (a) FIG NO	(2) (b) ITEM NO	(3) SMR CODE	(4) NATIONAL STOCK NUMBER	(5) FSCM PART NUMBER	TM5-6625-2694-13&P (6) DESCRIPTION	(7) USABLE ON CODE U/M	(8) QTY INC IN UNIT
GROUP 03: POWER ABSORBER							
3		XBFFF		51283 1057-Q-05	LOAD DUCT ASSEMBLY	EA	3
3	1	PAFZZ		51283 1057-020	MOTOR, UNIVERSAL	EA	3
3	2	PAFZZ		51283 1057-021	IMPELLER, FA, AXIAL	EA	3
3	3	XBFZZ		51283 1057-013	MOUNT, MOTOR	EA	1
3	4	PAFZZ	5305-00-059-3655	96906 MS51958-59	SCREW, MACHINE	EA	6
3	5	PAFZZ	5310-00-933-8120	96906 MS35338-138	WASHER, LOCK	EA	6
3	6	PAFZZ		83330 8944	CLAMP, LOOP, NYLON	EA	3
3	7	XBFZZ		51283 1057-010AD	DUCT, LEFT	EA	1
3	8	PAFZZ	5305-00-701-5061	96906 MS51958-8	SCREW, MACHINE	EA	90
3	9	PAFZZ	5310-00-933-8119	96906 MS35338-137	WASHER, LOCK	EA	90
3	10	PAFZZ	5310-00-880-5978	96906 MS15795-807	WASHER, FLAT	EA	90
3	11	PAFZZ	5310-00-934-9750	96906 MS35649-384	NUT, PLAIN, HEXAGON	EA	90
3	12	PAFZZ		82807 18-168-15R	RESISTOR, FIXED, 1K WATT, 15 OHM	EA	24
3	13	PAFZZ		82807 12-104-30R	RESISTOR, FIXED, 500 WATT, 30 OHM	EA	18
3	14	PAFZZ		12617 5801	SWITCH, MAGNETIC	EA	1
3	15	PAFZZ		14640 S0-250	SWITCH, THERMOSTATIC	EA	3
3	16	XFBZZ		51283 1057-010AS	SUPPORT, CENTER	EA	1
3	17	XBFZZ		51283 1057-010B	DUCT, RIGHT	EA	1
3	18	PAFZZ		12617 5701	ACTUATOR, MAGNETIC	EA	3
3	19	PAFZZ		51283 1057-015	VANE, WIND SWITCH	EA	3
3	20	PAFZZ	5305-00-054-5654	96906 MS51957-20	SCREW, MACHINE	EA	2
3	21	PAFZZ	5310-00-595-6211	96906 MS15795-803	WASHER, FLAT	EA	10
3	22	PAFZZ	5310-00-934-9748	96906 MS35649-244	NUT, PLAIN, HEXAGON	EA	8
3	23	PAFZZ	5310-00-933-8118	96906 MS35338-135	WASHER, LOCK	EA	4
3	24	PAFZZ	5305-00-054-6656	96906 MS51957-32	SCREW, MACHINE	EA	1
3	25	PAFZZ	5310-00-722-5998	96906 MS15795-805	WASHER, FLAT	EA	2
3	26	PAFZZ	5310-00-929-6395	96906 MS35338-136	WASHER, LOCK	EA	1
3	27	PAFZZ	5310-00-934-9761	96906 MS35649-264	NUT, PLAIN, HEXAGON	EA	1
3	28	PAFZZ	5305-00-054-5655	96906 MS51957-21	SCREW, MACHINE	EA	2
3	29	PAFZZ		83330 8483	SPACER	EA	2
3	30	PAFZZ		83330 2170	GROMMET, RUBBER	EA	7
3	31	PAFZZ	5305-00-550-3934	96906 MS35309-308	SCREW, CAP, HEXAGON HEAD, BRASS	EA	1
3	32	PAFZZ	5310-00-045-5210	96906 MS15795-910	WASHER, FLAT, BRASS	EA	4
3	33	PAFZZ		91833 3217	WASHER, INSULATOR	EA	2
3	34	PAFZZ		91833 3240	WASHER, STEPPED, INSULATOR	EA	2
3	35	PAFZZ	5310-00-187-2425	96906 MS35338-120	WASHER, LOCK, BRASS	EA	1
3	36	PAFZZ	5310-00-939-2653	96906 MS51969-1	NUT, PLAIN, HEXAGON, BRASS	EA	1
3	37	PAFZZ		82807 11-206	BOLT, RESISTOR, MTG 500 WATT	EA	1
3	37	PAFZZ		82807 11-208	BOLT, RESISTOR, MTG 1K WATT	EA	1
3	38	PAFZZ		82807 22-112-100	BRACKET, RESISTOR, MOUNTING, 500 WATT	EA	2
3	38	PAFZZ		82807 22-114-100	BRACKET, RESISTOR, MOUNTING, 1K WATT	EA	1

(1) ILLUSTRATION		(2)	(3)	(4)	(5)	TM5-6625-2694-13&P (6) DESCRIPTION	(7)	(8)
(a) FIG NO	(b) ITEM NO	SMR CODE	NATIONAL STOCK NUMBER	FSCM	PART NUMBER		USABLE ON CODE	QTY IN UNIT
3	39	PAFZZ		82807	12-700-004	DIMPLE WASHER, RESISTOR MOUNTING, 500 WATT	EA	2
3	39	PAFZZ		82807	12-700-007	DIMPLE WASHER, RESISTOR MOUNTING, 1K WATT	EA	2
3	40	PAFZZ		82807	12-800-003	MICA WASHER, RESISTOR MOUNTING, 500 WATT	EA	2
3	40	PAFZZ		82807	12-800-006	MICA WASHER, RESISTOR MOUNTING, 1K WATT	EA	2
3	41	PAFZZ	5310-00-019-0672	96906	MS35333-107	WASHER, LOCK, INTERNAL TOOTH, RESISTOR MOUNTING, 500 WATT	EA	1
3	41	PAFZZ	5310-00-543-2740	96906	MS35333-74	WASHER, LOCK, INTERNAL TOOTH, RESISTOR MOUNTING, 1K WATT	EA	1
3	42	PAFZZ		96906	MS36650-302	NUT, PLAIN HEXAGON, RESISTOR MOUNTING, 500 WATT	EA	1
3	42	PAFZZ	5310-00-997-1888	96906	MS35649-2252	NUT, PLAIN, HEXAGON, RESISTOR MOUNTING, 1K WATT	EA	1



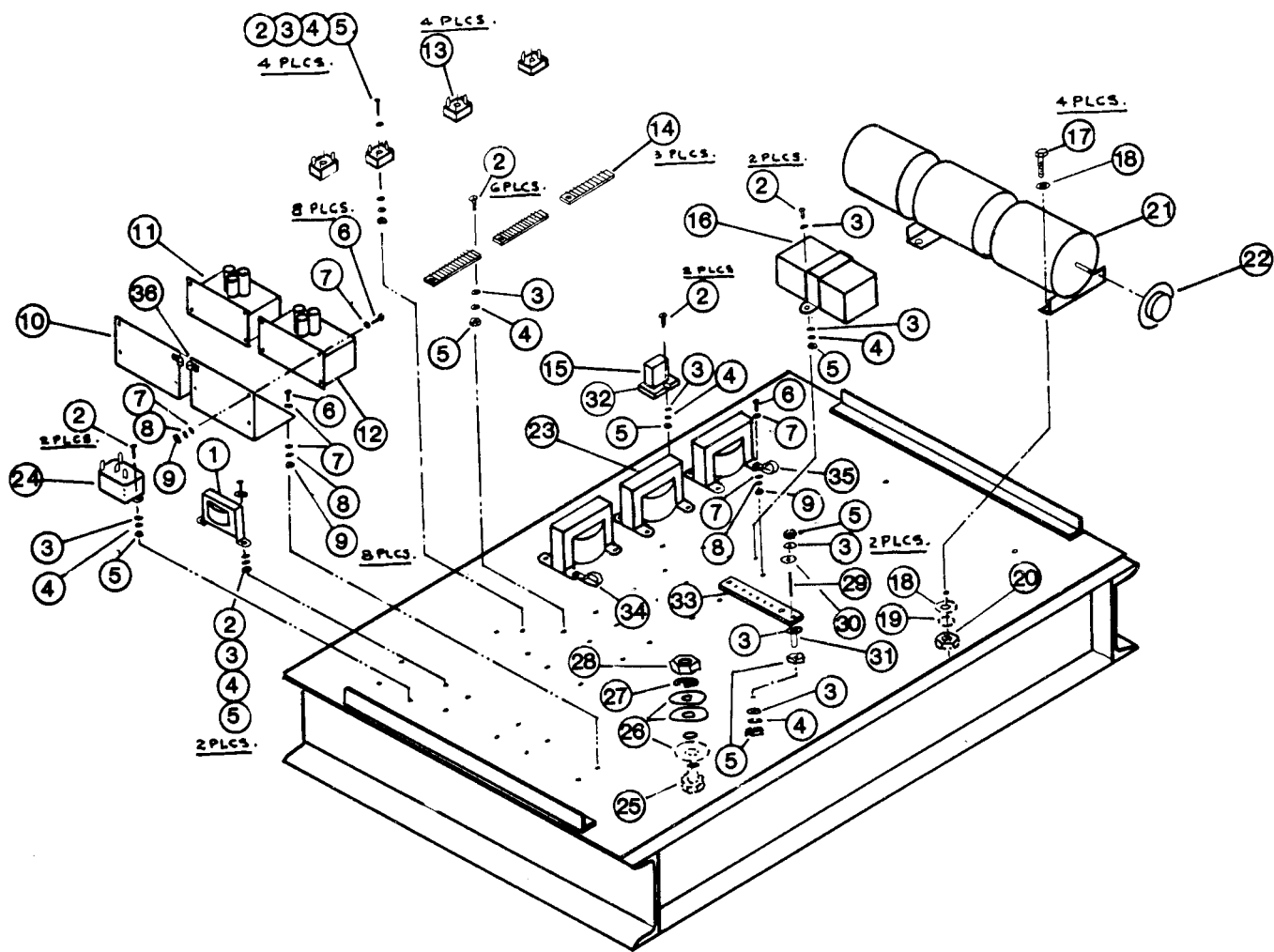

Figure 4. Chassis Assembly

(1) ILLUSTRATION (a) FIG NO	(2) (b) ITEM NO	(3) SMR CODE	(4) NATIONAL STOCK NUMBER	(5) FSCM	(6) PART NUMBER	TM5-6625-2694-13&P (6) DESCRIPTION	(7) USABLE ON CODE U/M	(8) QTY INC IN UNIT
GROUP 04: CHASSIS ASSEMBLY								
4	1					NOT USED		
4	2	PAFZZ	5305-00-054-6656	96906	MS51957-32	SCREW, MACHINE	EA	13
4	3	PAFZZ	5310-00-880-5976	96906	MS15795-305	WASHER, FLAT	EA	19
4	4	PAFZZ	5310-00-929-6395	96906	MS35338-136	WASHER, LOCK	EA	13
4	5	PAFZZ	5310-00-934-9761	96906	MS35649-264	NUT, PLAIN, HEXAGON	EA	13
4	6	PAFZZ	5305-00-054-6672	96906	MS51957-47	SCREW, MACHINE	EA	30
4	7	PAFZZ	5310-00-722-5998	96906	MS15795-805	WASHER, FLAT	EA	30
4	8	PAFZZ	5310-00-929-6395	96906	MS35338-136	WASHER, LOCK	EA	30
4	9	PAFZZ	5310-00-934-9761	96906	MS35649-264	NUT, PLAIN, HEXAGON	EA	30
4	10	XBFZZ		51283	1057-011	SUPPORT, CONTRACTOR	EA	2
4	11	PAFZZ		94696	WM60AAA-24D	CONTACTOR, 60A	EA	1
4	12	PAFZZ		94696	WM35AAA-24D	RELAY, ELECTROMAGNETIC	EA	1
4	13	PAFZZ	6130-01-091-3775	77638	KBPC10-02	RECTIFIER BRIDGE	EA	3
4	14	PAFZZ		13150	72106	TERMINAL STRIP	EA	3
4	15	PAFZZ		77342	KHS17D11-24VDC	RELAY, ELECTROMAGNETIC, 4 PDT, 24 VDC	EA	1
4	16	PAFZZ		51283	1057-023	SENSOR, VOLTAGE	EA	1
4	17	PAFZZ	5305-00-207-8253	96906	MS35307-308	SCREW, CAP, HEXAGON HEAD	EA	4
4	18	PAFZZ	5310-00-582-5677	96906	MS15795-811	WASHER, FLAT	EA	8
4	19	PAFZZ	5310-00-933-8121	96906	MS35338-139	WASHER, LOCK	EA	4
4	20	PAFZZ	5310-00-903-5966	96906	MS51971-1	NUT, PLAIN, HEXAGON	EA	4
4	21	PAFZZ		83008	1220-3	TRANSFORMER, VARIABLE	EA	1
4	22	PAFZZ		83008	399-0001	KNOB, VARIABLE, RESISTOR	EA	1
4	23	PAFZZ		51283	1057-1324	TRANSFORMER, CONTROL,	EA	3
4	24	PAFZZ		80089	84-902	RELAY, SPDT	EA	1
4	25	PAFZZ	5305-00-550-3934	96906	MS35309-308	SCREW, CAP, HEXAGON HEAD, BRASS	EA	1
4	26	PAFZZ	5310-00-045-5210	96906	MS15795-910	WASHER, FLAT, BRASS	EA	3
4	27	PAFZZ	5310-00-187-2425	96906	MS35338-120	WASHER, LOCK, BRASS	EA	1
4	28	PAFZZ	5310-00-939-2653	96906	MS51969-1	NUT, PLAIN, HEXAGON, BRASS	EA	1
4	29	PAFZZ		39428	98812A007	ROD, THREADED, BRASS	EA	2
4	30	PAFZZ		83330	2662	WASHER, SHOULDER, NYLON	EA	4
4	31	PAFZZ	5340-00-737-6389	83330	8503	SPACER, SPECIAL	EA	2
4	32	PAFZZ		77342	27E166	SOCKET, RELAY	EA	1
4	33	XBFZZ		51283	1057-024	BAR, TERMINAL	EA	1
4	34	PAFZZ		83330	8952	CLAMP, LOOP, NYLON	EA	1
4	35	PAFZZ		83330	785	CLAMP, LOOP, NYLON	EA	1
4	36	PAFZZ		83330	8951	CLAMP, LOOP, NYLON	EA	3

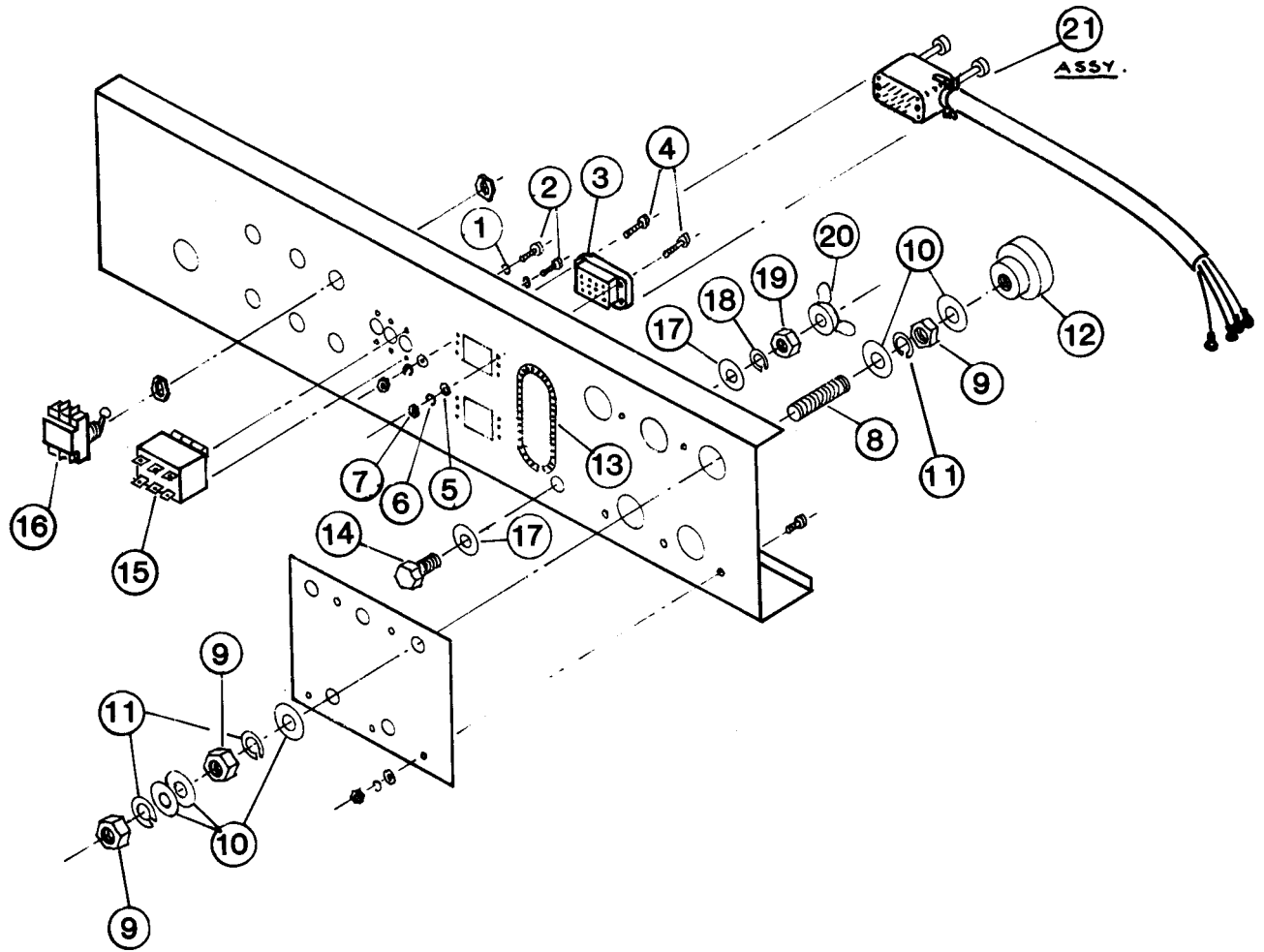

Figure 5. Control Panel Assembly

(1) ILLUSTRATION (a) FIG NO	(b) ITEM NO	(2) SMR CODE	(3) NATIONAL STOCK NUMBER	(4) FSCM	(5) PART NUMBER	TM5-6625-2694-13&P (6) DESCRIPTION	USABLE ON CODE	(7) U/M	(8) QTY INC IN UNIT
GROUP 05: CONTROL PANEL									
5	1	PAFZZ	5310-00-929-6395	96906	MS35338-136	WASHER, LOCK		EA	6
5	2	PAFZZ	5305-00-054-6650	96906	MS51957-26	SCREW, MACHINE		EA	6
5	3	PAFZZ	5935-00-995-0025	81312	MRAC66SJ	CONNECTOR BODY, RECEPTACLE		EA	2
5	4	PAFZZ	5305-00-054-5653	96906	MS51957-19	SCREW, MACHINE		EA	8
5	5	PAFZZ	5310-00-595-6761	96906	MS15795-802	WASHER, FLAT		EA	8
5	6	PAFZZ	5310-00-933-8118	96906	MS35338-135	WASHER, LOCK		EA	8
5	7	PAFZZ	5310-00-934-9748	96906	MS35649-244	NUT, PLAIN, HEXAGON		EA	8
5	8	PAFZZ		39428	98812031	ROD, THREADED, BRASS		EA	5
5	9	PAFZZ	5310-00-903-3994	96906	MS51969-3	NUT, PLAIN, HEXAGON BRASS		EA	15
5	10	PAOZZ	5310-00-045-5214	96906	MS15795-914	WASHER, FLAT, BRASS		EA	10
5	11	PAFZZ	5310-00-984-7042	96906	MS35338-122	WASHER, LOCK BRASS		EA	5
5	12	PAOZZ		75376	385-64-B-536	KNOB, LOAD TERMINAL		EA	5
5	13	PAFZZ		02929	23N3660	GROMMET		FT	1
5	14	PAFZZ	5305-00-550-3934	96906	MS35309-308	SCREW, CAP, HEXAGON, BRASS		EA	1
5	15	PAFZZ		77342	W69X2Q1-2-5	CIRCUIT BREAKER		EA	1
5	16	PAFZZ	5930-00-504-6068	27193	8320K1	SWITCH, TOGGLE, 3 PST, 20 AMP		EA	6
5	17	PAFZZ	5310-00-045-5210	96906	MS15795-910	WASHER, FLAT, BRASS		EA	3
5	18	PAFZZ	5310-00-187-2425	96906	MS35338-120	WASHER, LOCK, BRASS		EA	1
5	19	PAFZZ	5310-00-939-2653	96906	MS51969-1	NUT, PLAIN, HEXAGON, BRASS		EA	1
5	20	PAOZZ		96906	MS35425-71	NUT, PLAIN, WING, BRASS		EA	1
5	21	PAFZZ		81312	MRAC66PJTCH9	PLUG, 26 PIN		EA	1

(1) ILLUSTRATION (a) FIG NO	(b) ITEM NO	(2) SMR CODE	(3) NATIONAL STOCK NUMBER	(4) FSCM	(5) PART NUMBER	TM5-6625-2694-13&P (6) DESCRIPTION	(7) USABLE ON CODE U/M	(8) QTY INC IN UNIT
GROUP 06: BULK MATERIAL								
BULK		PAFZZ	5975-00-727-5153	96906	MS3367-4-9	STRAP, TIEDOWN, ELECTRICAL, 3/32 IN WIDE, 3 IN. LG.	EA	V
BULK		PAFZZ	5940-00-113-9826	96906	MS25036-114	TERMINAL,LUG INSULATED 10 GAUGE WIRE, 3/8 INCH STUD	EA	V
BULK		PAFZZ	5975-00-074-2072	96906	MS3367-1-9	STRAP,TIEDOWN,ELECT, 3/16 IN. WIDE,8 IN. LG	EA	V
BULK		PAFZZ	5940-00-143-4777	96906	MS25036-157	TERMINAL,LUG,INSULATED 10 GAUGE WIRE,1/4 INCH STUD	EA	V
BULK		PAFZZ	5940-00-143-4793	96906	MS25036-110	TERMINAL,LUG,INSULATED 16 GAUGE WIRE,3/8 INCH STUD	EA	V
BULK		PAFZZ	5940-00-204-8990	96906	MS25036-111	TERMINAL,LUG,INSULATED 10 GAUGE WIRE,#6 STUD	EA	V
BULK		PAFZZ	5940-00-230-0515	96906	MS25036-154	TERMINAL,LUG,INSULATED 16 GAUGE WIRE,1/4 INCH STUD	EA	V
BULK		PAFZZ	5940-00-282-5280	96906	MS25036-106	TERMINAL,LUG,INSULATED 16 GAUGE WIRE,#6 STUD	EA	V
BULK		PAFZZ	6145-00-532-6342	92194	2858-1	WIRE,ELECTRICAL, 16 GAUGE, 19 STRAND, HIGH TEMP	FT	V
BULK		PAFZZ	5940-00-557-4344	96906	MS25036-120	TERMINAL,INSULATED,6 GAUGE WIRE,1/4 IN. STUD	EA	V
BULK		PAFZZ	6145-00-578-6594	81349	M5086/2-6-9	WIRE,ELECTRICAL 6 GAUGE	FT	V
BULK		PAFZZ	6145-00-578-6605	81349	M5086/2-16-9	WIRE,ELECTRICAL 16 GAUGE	FT	V
BULK		PAFZZ	6145-00-578-7513	81349	M5086/2-10-9	WIRE,ELECTRICAL 10 GAUGE	FT	V
BULK		PAFZZ	5970-00-812-2969	81349	M23053/5-104-0	INSULATION SLEEVING,ELECTRICAL,HEAT SHRINKABLE,1/8 IN. ID	FT	V
BULK		PAFZZ	5970-00-815-1300	81349	M23053/5-110-0	INSULATION SLEEVING,ELECTRICAL,HEAT SHRINKABLE,1 IN. ID	FT	V
BULK		PAFZZ		52760	5081	ADAPTER, TERMINAL, QUICK, DISCONNECT	EA	V
BULK		PAFZZ		96906	MS25036-122	TERMINAL,INSULATED,6 GAUGE WIRE,3/8 IN. STUD	EA	V
BULK		PAFZZ		92219	2626	TERMINAL,PUSH,ON,1/4 INCH	EA	V
BULK		PAFZZ		96906	MS21003-19	TERMINAL,INSULATED,16 GAUGE WIRE,1/4 INCH STUD	EA	V
BULK		PAFZZ		96906	MS21003-13	TERMINAL,UNINSULATED,16 GAUGE WIRE,#6 STUD	EA	V
BULK		PAFZZ		81349	MILW16878-4	WIRE,ELECTRICAL,20 GAUGE,19 STRAND,HIGH TEMP	FT	V

NATIONAL STOCK NUMBER AND PART NUMBER INDEX

STOCK NUMBER	FIG NO	ITEM NO	STOCK NUMBER	FIG NO	ITEM NO
5310-00-019-0672	3	41	5305-00-701-7628	2	13
9905-00-027-4577	BULK		5310-00-722-5998	2	23
5310-00-045-5210	2	43	5310-00-722-5998	3	25
5310-00-045-5210	4	26	5310-00-722-5998	4	7
5310-00-045-5214	5	10	5340-00-737-6389	4	31
5305-00-054-5649	1	11	5310-00-768-0321	2	17
5305-00-054-5653	5	4	5310-00-778-2655	1	5
5305-00-054-5654	3	20	5310-00-778-2655	2	6
5305-00-054-5655	3	28	5970-00-812-2969	BULK	
5305-00-054-6650	5	2	5975-00-727-5153	BULK	
5305-00-054-6654	2	22	5310-00-880-5976	4	3
5305-00-054-6656	3	24	5310-00-880-5977	4	18
5305-00-054-6656	4	2	5310-00-880-5978	2	2
5305-00-054-6672	4	6	5310-00-880-5978	3	10
5305-00-059-3655	3	4	5310-00-883-9384	1	3
5305-00-059-3661	1	2	5310-00-903-3994	5	9
5975-00-074-2072	BULK		5310-00-903-5966	2	10
5940-00-113-9826	BULK		5310-00-903-5966	4	20
5940-00-143-4777	BULK		5310-00-929-6395	2	24
5940-00-143-4793	BULK		5310-00-929-6395	4	4
5310-00-187-2425	3	35	5310-00-929-6395	4	8
5310-00-187-2425	4	27	5310-00-929-6395	5	1
5310-00-187-2425	5	18	5310-00-933-8118	1	13
5940-00-204-8990	BULK		5310-00-933-8118	3	23
5305-00-207-8253	4	17	5310-00-933-8118	5	6
5940-00-230-0515	BULK		5310-00-933-8119	2	3
5305-00-253-5606	2	38	5310-00-933-8119	3	9
5940-00-283-5280	BULK		5310-00-933-8120	3	5
5325-00-285-3374	1	15	5310-00-933-8121	2	9
5325-00-285-3374	2	27	5310-00-933-8121	4	19
5310-00-411-4385	2	15	5310-00-933-8778	2	16
5340-00-471-1913	2	41	5310-00-934-9748	1	14
5930-00-504-6068	5	16	5310-00-934-9748	3	22
6145-00-532-6342	BULK		5310-00-934-9748	5	7
5310-00-543-2740	3	41	5310-00-934-9750	3	11
5305-00-550-3934	3	31	5310-00-934-9759	2	4
5305-00-550-3934	4	25	5310-00-934-9761	3	27
5305-00-550-3934	5	14	5310-00-934-9761	4	5
6145-00-578-6594	BULK		5310-00-934-9761	4	9
6145-00-578-6605	BULK		5310-00-939-2653	3	36
6145-00-578-7513	BULK		5310-00-939-2653	4	28
5310-00-582-5677	2	8	5310-00-939-2653	5	19
5310-00-595-6211	1	12	5310-00-984-7042	5	11
5310-00-595-6211	3	21	5310-00-989-5945	2	14
5310-00-595-6761	5	5	5935-00-995-0025	5	3
5305-00-701-5061	2	1	5310-00-997-1888	3	42
5305-00-701-5061	3	8	6130-01-091-3775	4	13
5310-00-045-5210	3	32	5310-00-582-5677	4	18
5310-00-045-5210	5	17	5310-00-929-6395	3	26
7520-00-559-9618	1	10			

FSCM	PART NUMBER	FIGURE NO.	ITEM NO.	FSCM	PART NUMBER	FIGURE NO.	ITEM NO.
72794	AJ5-45	1	4	96906	MS25036-106	BULK	
72794	A5-50	1	4A	96906	MS25036-110	BULK	
77638	KBPC10-02	4	13	96906	MS25036-111	BULK	
77342	KHS17D11-24VDC	4	15	96906	MS25036-114	BULK	
81348	MIL-C-11743	1	10	96906	MS25036-154	BULK	
81349	MILW16878-4	BULK		96906	MS25036-157	BULK	
81312	MRAC66PJTCH9	5	21	96906	MS3367-4-9	BULK	
81312	MRAC66SJ	5	3	96906	MS3367-1-9	BULK	
96906	MS15795-305	4	3	96906	MS35307-308	4	17
96906	MS15795-802	5	5	96906	MS35307-415	2	13
96906	MS15795-803	1	12	96906	MS35309-308	3	31
96906	MS15795-803	3	21	96906	MS35309-308	4	25
96906	MS15795-805	2	23	96906	MS35309-308	5	14
96906	MS15795-805	3	25	96906	MS35333-107	3	41
96906	MS15795-805	4	7	96906	MS35333-74	3	41
96906	MS15795-807	2	2	96906	MS35338-120	3	35
96906	MS15795-807	3	10	96906	MS35338-120	4	27
96906	MS15795-810	2	8	96906	MS35338-120	5	18
96906	MS15795-811	4	18	96906	MS35338-122	5	11
96906	MS15795-842	1	3	96906	MS35338-135	1	13
96906	MS15795-910	2	43	96906	MS35338-135	3	23
96906	MS15795-910	4	26	96906	MS35338-135	5	6
96906	MS15795-914	5	10	96906	MS35338-136	2	24
96906	MS17830-8C	2	15	96906	MS35338-136	4	4
96906	MS21003-19	BULK		96906	MS35338-136	4	8
96906	MS21059-3	1	5	96906	MS35338-136	5	1
96906	MS21059-3	2	6	96906	MS35338-137	2	3
96906	MS21103-4	2	41	96906	MS35338-137	3	9
96906	MS21318-7	2	38	96906	MS35338-138	3	5
96906	MS24655-372	2	39	96906	MS35338-139	2	9

NATIONAL STOCK NUMBER AND PART NUMBER INDEX

FSCM	PART NUMBER	FIGURE NO.	ITEM NO.	FSCM	PART NUMBER	FIGURE NO.	ITEM NO.
96906	MS35338-139	4	19	51283	1057-008A	2	11
96906	MS35425-71	2	16	51283	1057-008B	2	20
96906	MS35425-71	5	20	51283	1057-010AD	3	7
96906	MS35649-2252	3	42	51283	1057-010AS	3	16
96906	MS35649-244	1	14	51283	1057-010B	3	17
96906	MS35649-244	3	22	51283	1057-011	4	10
96906	MS35649-244	5	7	51283	1057-012	2	12
96906	MS35649-264	3	27	51283	1057-013	3	3
96906	MS35649-264	4	5	51283	1057-016	2	42
96906	MS35649-264	4	9	51283	1057-017	2	17
96906	MS35649-284	2	4	51283	1057-020	3	1
96906	MS35649-384	3	11	51283	1057-021	3	2
96906	MS35691-35	2	14	51283	1057-023	4	16
96906	MS36650-302	3	42	51283	1057-024	4	33
96906	MS51957-15	1	11	51283	1057-050	2	21
96906	MS51957-19	5	4	51283	1057-1324	4	23
96906	MS51957-20	3	20	82807	11-206	3	37
96906	MS51957-21	3	28	82807	11-208	3	37
96906	MS51957-26	5	2	39428	1117A12	1	16
96906	MS51957-30	2	22	39428	1117A18	1	9
96906	MS51957-32	3	24	82807	12-104-30R	3	13
96906	MS51957-32	4	2	82807	12-700-004	3	39
96906	MS51957-47	4	6	82807	12-700-007	3	39
96906	MS51958-45	2	1	82807	12-800-003	3	40
96906	MS51958-59	3	4	82807	12-800-006	3	40
96906	MS51958-65	1	2	83008	1220-3	4	21
96906	MS51958-8	3	8	82807	18-168-15R	3	12
96906	MS51969-1	3	36	82807	22-112-100	3	38
96906	MS51969-1	4	28	82807	22-114-100	3	38
96906	MS51969-1	5	19	02929	23N3660	5	13
96906	MS51969-3	5	9	92219	2626	BULK	
96906	MS51971-1	2	10	83330	2662	4	30
96906	MS51971-1	4	20	77342	27E166	4	32
81349	M23053/5-104-0	BULK		92194	2853-1	BULK	
81349	M23053/5-110-0	BULK		96906	35307-308	2	7
81349	M5086/2-10-9	BULK		75376	385-64-B-536	5	12
81349	M5086/2-16-9	BULK		83008	399-0001	4	22
81349	M5086/2-6-9	BULK		52760	5081	BULK	
94696	WM60AAA-24D	4	11	12617	5801	3	14
14640	SO-250	3	15	19220	62-4905SS	1	6
72794	S5A-225	1	15	13150	72106	4	14
72794	S5A-225	2	27	13150	7605	2	28
06383	TM2S8-C	2	26	27193	8320K1	5	16
94696	WM35AAA-24D	4	12	80089	84-902	4	24
77342	W69X2Q1-2-5	5	15	83330	8483	3	29
51283	1057-Q-05	3		8330	8503	4	31
51283	1057-002	2	19	83330	8951	4	36
51283	1057-003	2	18	83330	8952	4	34
51283	1057-006	1	1	39428	98812A007	4	29
51283	1057-007	2	5	39428	98812A031	5	8





**A P P E N D I X D**

**A D D I T I O N A L A U T H O R I Z A T I O N L I S T**

**Section I. INTRODUCTION**

D-1 Scope: This appendix lists additional items that are authorized for the support of the Test Set.

D-2 Explanation of Listing: National stock numbers, descriptions and quantities are provided to help you identify and request the additional items you require to support this equipment.

**Section II. ADDITIONAL AUTHORIZATION LIST**

NSN	P/N & FSCM	Description	Useable U/M On Code	Qty. Auth.
4949-00-294-9517		Shop Equipment, Electrical, Repair Tool Kit	ea	1
5120-00-017-2849		Kit, Rivet	ea	1
5120-00-930-7504		Tool, Insertion	ea	1
5120-00-930-7503		Tool, Extraction	ea	1
5120-00-165-3912		Tool, Crimping	ea	1



	I N D E X	Paragraph	Page
	A		
Air Exhaust Grills		3 - 7	3 - 3
Air Intake Louver (Rear Panel)		3 - 6	3 - 3
Air Intake Louver (Rear Panel)		5 - 5	5 - 8
	C		
Circuit Breaker		5 - 20	5 - 27
Contacto r		5 - 12	5 - 19
Contacto r Relay		5 - 13	5 - 20
Control Relay		5 - 14	5 - 21
Control Transformer, 36 V.		5 - 16	5 - 23
Control Transformer, 90 V.		5 - 15	5 - 22
	D		
Destruction of Army Material		1 - 4	1 - 1
Direct Support Troubleshooting		5 - 4	5 - 1
	E		
Equipment Purpose		1 - 6	1 - 2
Equipment Data		1 - 8	1 - 4
	F		
Fan Motor and Blade		5 - 7	5 - 12
	G		
General		2 - 1	2 - 1
General		3 - 1	3 - 1
	L		
Load Resistor		5 - 8	5 - 14
Load Switch		5 - 21	5 - 28
Location and Description of Major Components		1 - 7	1 - 2
	M		
Main Housing Assembly		3 - 5	3 - 2
Main Housing and Rear Panel Assembly		5 - 11	5 - 17
Maintenance Forms and Records		1 - 2	1 - 1

	Paragraph	Page
O		
Operating Procedure	2 - 4	2 - 4
Operation At High Altitudes	2 - 9	2 - 6
Operation In Dusty or Sandy Areas	2 - 7	2 - 6
Operation In Extreme Cold	2 - 5	2 - 6
Operation In Extreme Heat	2 - 6	2 - 6
Operation Under Rainy or Humid Conditions	2 - 8	2 - 6
Operation Under Sea Spray or Salt Air	2 - 10	2 - 6
Operator Preventative Maintenance Checks And Services	2 - 3	2 - 2
Operator Troubleshooting	3 - 3	3 - 1
P		
Preparation for Shipment and Storage	1 - 5	1 - 1
R		
Rear Panel (Air Intake Louver)	3 - 6	3 - 3
Rear Panel (Air Intake Louver)	5 - 5	5 - 8
Rear Panel and Main Housing	5 - 11	5 - 17
Rectifier Bridge	5 - 19	5 - 26
Repair Parts and Special Tools List	5 - 3	5 - 1
Reporting Equipment Improvement Recommendations	1 - 3	1 - 1
S		
Scope	1 - 1	1 - 1
Special Tools and Equipment	5 - 2	5 - 1
T		
Thermal Switch	5 - 9	5 - 16
Troubleshooting	5 - 4	5 - 1
V		
Variable Transformer	5 - 17	5 - 24
Voltage Selector Plug	3 - 9	3 - 3
Voltage Sensor	5 - 18	5 - 25
W		
Wind Switch	3 - 8	3 - 3
Wind Switch	5 - 6	5 - 10
Wire Harness	5 - 22	5 - 29

By Order of the Secretary of the Army:

Official:

**ROBERT M. JOYCE**  
*Major General, United States Army*  
*The Adjutant General*

**E. C. MEYER**  
*General, United States Army*  
*Chief of Staff*

DISTRIBUTION:

To be distributed in accordance with DA Form 12-25D, Operator Maintenance requirements for Motor Generators: Generator Test Equipment.



RECOMMENDED CHANGES TO EQUIPMENT TECHNICAL PUBLICATIONS



THEN... JOT DOWN THE DOPE ABOUT IT ON THIS FORM, CAREFULLY TEAR IT OUT, FOLD IT AND DROP IT IN THE MAIL!

SOMETHING WRONG WITH THIS PUBLICATION?

FROM: (PRINT YOUR UNIT'S COMPLETE ADDRESS)  
**PFC JOHN DOE**  
**COA, 3d ENGINEER BN**  
**FT. LEONARDWOOD, MA 63108**  
 DATE SENT

PUBLICATION NUMBER: **TM 5-6625-2694-13&P**  
 PUBLICATION DATE: **10 May 83**  
 PUBLICATION TITLE: **Test Set, Electrical (0-33 KW Load Bank) Model 1057**

BE EXACT... PIN-POINT WHERE IT IS				IN THIS SPACE TELL WHAT IS WRONG AND WHAT SHOULD BE DONE ABOUT IT:
PAGE NO.	PARA-GRAPH	FIGURE NO.	TABLE NO.	
<b>6</b>	<b>2-1 a</b>			<i>In line 6 of paragraph 2-1a the manual states the engine has <u>6</u> cylinders. The engine on my set only has <u>4</u> cylinders. Change the manual to show <u>4</u> cylinders.</i>
<b>B1</b>		<b>4-3</b>		<i>Callout 16 on figure 4-3 is pointing at a <u>bolt</u>. In key to figure 4-3, item 16 is called a <u>shim</u> - Please correct one or the other.</i>
<b>125</b>	<b>line 20</b>			<i>I ordered a gasket, item 19 on figure B-16 by NSN 2 910-00-762-3001. I got a gasket but it doesn't fit. Supply says I got what I ordered, so the NSN is wrong. Please give me a good NSN</i>

PRINTED NAME, GRADE OR TITLE, AND TELEPHONE NUMBER: **JOHN DOE, PFC (268) 317-7111**  
 SIGN HERE: **JOHN DOE**

DA FORM 2028-2 1 JUL 79

PREVIOUS EDITIONS ARE OBSOLETE.  
 DRSTS-M Overprint 1, 1 Nov 80

PS.--IF YOUR OUTFIT WANTS TO KNOW ABOUT YOUR RECOMMENDATION MAKE A CARBON COPY OF THIS AND GIVE IT TO YOUR HEADQUARTERS.

TEAR ALONG PERFORATED LINE

FILL IN YOUR  
UNIT'S ADDRESS

FOLD BACK

DEPARTMENT OF THE ARMY

OFFICIAL BUSINESS  
PENALTY FOR PRIVATE USE \$300

POSTAGE AND FEES PAID  
DEPARTMENT OF THE ARMY  
DOD 314



TEAR ALONG PERFORATED LINE

COMMANDER  
U S ARMY SUPPORT AND AVIATION MATERIEL READINESS COMMAND  
ATTN: DRSTS-MPSD  
4300 GOODFELLOW BOULEVARD  
ST. LOUIS, MO 63120



RECOMMENDED CHANGES TO EQUIPMENT TECHNICAL PUBLICATIONS



THEN... JOT DOWN THE DOPE ABOUT IT ON THIS FORM. CAREFULLY TEAR IT OUT. FOLD IT AND DROP IT IN THE MAIL!

**SOMETHING WRONG WITH THIS PUBLICATION?**

FROM: (PRINT YOUR UNIT'S COMPLETE ADDRESS)

DATE SENT

PUBLICATION NUMBER

TM 5-6625-2694-13&P

PUBLICATION DATE

10 May 83

PUBLICATION TITLE Test Set, Electrical  
(0-33 Kw Load Bank) Model 1057

BE EXACT... PIN-POINT WHERE IT IS

PAGE NO.	PARA-GRAPH	FIGURE NO.	TABLE NO.

IN THIS SPACE TELL WHAT IS WRONG AND WHAT SHOULD BE DONE ABOUT IT:

TEAR ALONG PERFORATED LINE

PRINTED NAME, GRADE OR TITLE, AND TELEPHONE NUMBER

SIGN HERE:

DA FORM 2028-2  
1 JUL 79

PREVIOUS EDITIONS ARE OBSOLETE.  
DRSTS-M Overprint 2, 1 Nov 80.

P.S.--IF YOUR OUTFIT WANTS TO KNOW ABOUT YOUR RECOMMENDATION MAKE A CARBON COPY OF THIS AND GIVE IT TO YOUR HEADQUARTERS.

FILL IN YOUR  
UNIT'S ADDRESS

FOLD BACK

DEPARTMENT OF THE ARMY

\_\_\_\_\_  
\_\_\_\_\_

OFFICIAL BUSINESS  
PENALTY FOR PRIVATE USE \$300

POSTAGE AND FEES PAID  
DEPARTMENT OF THE ARMY  
DOD 314



TEAR ALONG PERFORATED LINE

COMMANDER  
U S ARMY SUPPORT AND AVIATION MATERIEL READINESS COMMAND  
ATTN: DRSTS-MPSD  
4300 GOODFELLOW BOULEVARD  
ST. LOUIS, MO 63120

RECOMMENDED CHANGES TO EQUIPMENT TECHNICAL PUBLICATIONS



THEN... JOT DOWN THE DOPE ABOUT IT ON THIS FORM. CAREFULLY TEAR IT OUT, FOLD IT AND DROP IT IN THE MAIL!

**SOMETHING WRONG WITH THIS PUBLICATION?**

FROM: (PRINT YOUR UNIT'S COMPLETE ADDRESS)

DATE SENT

PUBLICATION NUMBER

TM 5-6625-2694-13&P

PUBLICATION DATE

10 May 83

PUBLICATION TITLE Test Set, Electrical  
(0-33 KW Load Bank) Model 1057

BE EXACT... PIN-POINT WHERE IT IS

PAGE NO.	PARA-GRAPH	FIGURE NO.	TABLE NO.

IN THIS SPACE TELL WHAT IS WRONG AND WHAT SHOULD BE DONE ABOUT IT:

TEAR ALONG PERFORATED LINE

PRINTED NAME, GRADE OR TITLE, AND TELEPHONE NUMBER

SIGN HERE:

DA FORM 2028-2  
1 JUL 79

PREVIOUS EDITIONS ARE OBSOLETE.  
DRSTS-M Overprint 2, 1 Nov 80.

P.S.--IF YOUR OUTFIT WANTS TO KNOW ABOUT YOUR RECOMMENDATION MAKE A CARBON COPY OF THIS AND GIVE IT TO YOUR HEADQUARTERS.

FILL IN YOUR  
UNIT'S ADDRESS

FOLD BACK

DEPARTMENT OF THE ARMY

OFFICIAL BUSINESS  
PENALTY FOR PRIVATE USE \$300

POSTAGE AND FEES PAID  
DEPARTMENT OF THE ARMY  
DOD 314



COMMANDER  
U S ARMY SUPPORT AND AVIATION MATERIEL READINESS COMMAND  
ATTN: DRSTS-MPSD  
4300 GOODFELLOW BOULEVARD  
ST. LOUIS, MO 63120

TEAR ALONG PERFORATED LINE

RECOMMENDED CHANGES TO EQUIPMENT TECHNICAL PUBLICATIONS



THEN... JOT DOWN THE DOPE ABOUT IT ON THIS FORM. CAREFULLY TEAR IT OUT. FOLD IT AND DROP IT IN THE MAIL!

SOMETHING WRONG WITH THIS PUBLICATION?

FROM: (PRINT YOUR UNIT'S COMPLETE ADDRESS)

DATE SENT

PUBLICATION NUMBER

TM 5-6625-2694-13&P

PUBLICATION DATE

10 May 83

PUBLICATION TITLE Test Set, Electrical  
(0-33 KW Load Bank) Model 1057

BE EXACT... PIN-POINT WHERE IT IS

PAGE NO.	PARA-GRAPH	FIGURE NO.	TABLE NO.
----------	------------	------------	-----------

IN THIS SPACE TELL WHAT IS WRONG AND WHAT SHOULD BE DONE ABOUT IT:

TEAR ALONG PERFORATED LINE

PRINTED NAME, GRADE OR TITLE, AND TELEPHONE NUMBER

SIGN HERE:

DA FORM 2028-2  
1 JUL 79

PREVIOUS EDITIONS ARE OBSOLETE.  
DRSTS-M Overprint 2, 1 Nov 80.

P.S.--IF YOUR OUTFIT WANTS TO KNOW ABOUT YOUR RECOMMENDATION MAKE A CARBON COPY OF THIS AND GIVE IT TO YOUR HEADQUARTERS.

FILL IN YOUR  
UNIT'S ADDRESS

FOLD BACK

DEPARTMENT OF THE ARMY

OFFICIAL BUSINESS  
PENALTY FOR PRIVATE USE \$300

POSTAGE AND FEES PAID  
DEPARTMENT OF THE ARMY  
DOD 314



COMMANDER  
U S ARMY SUPPORT AND AVIATION MATERIEL READINESS COMMAND  
ATTN: DRSTS-MPSD  
4300 GOODFELLOW BOULEVARD  
ST. LOUIS, MO 63120

TEAR ALONG PERFORATED LINE

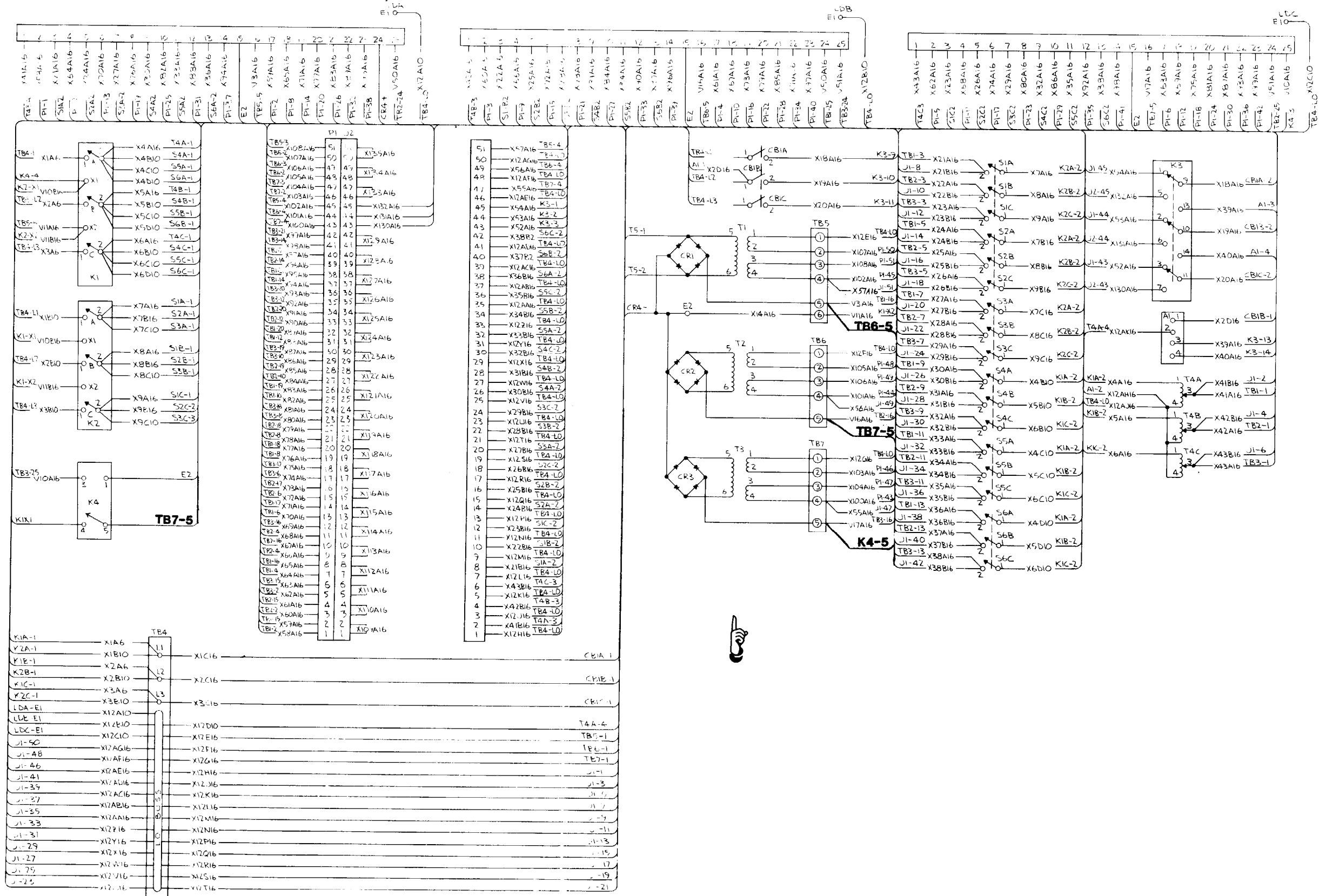

FO-1. Schematic.

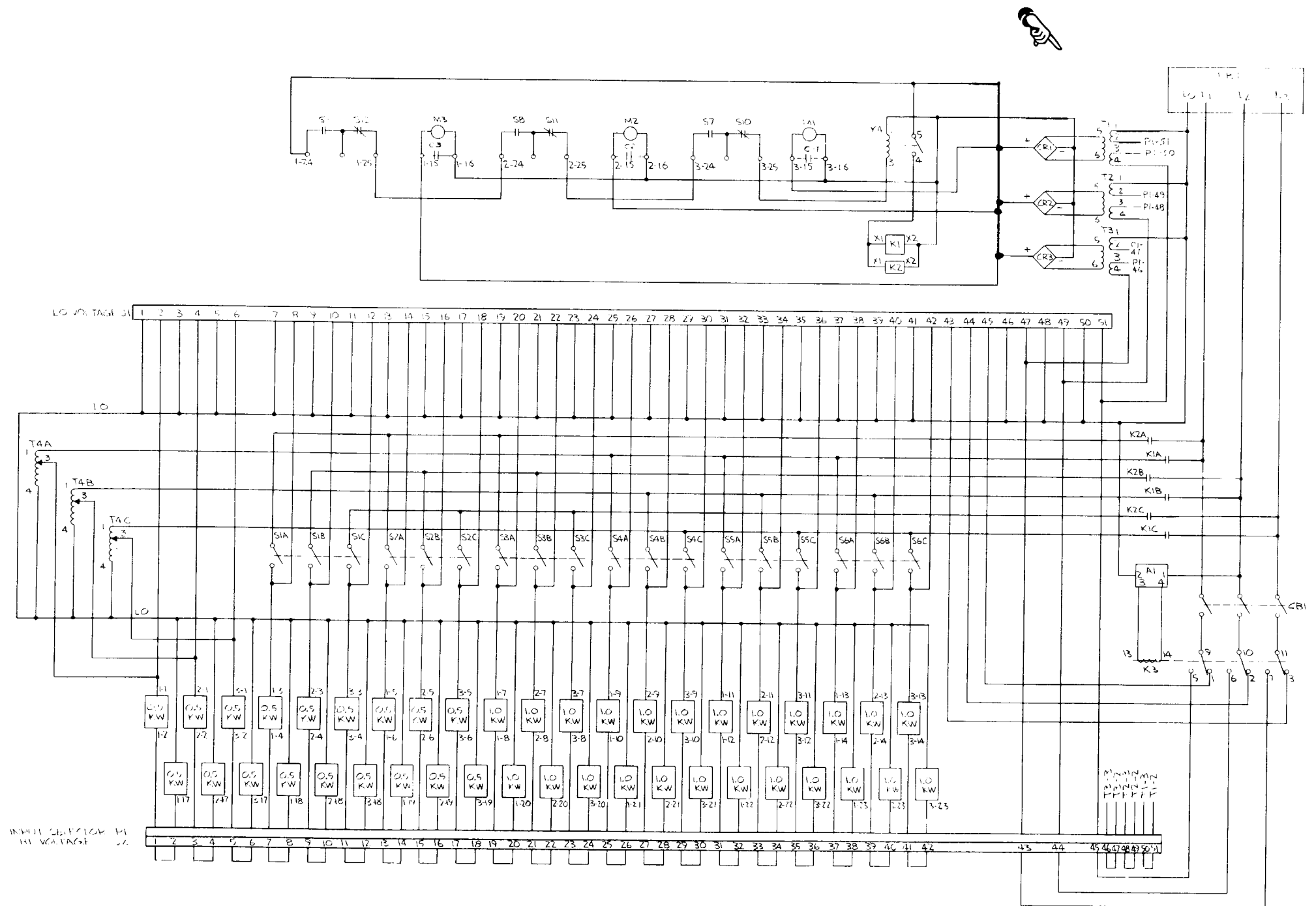

FO-2. Wiring Diagram.



# The Metric System and Equivalents

## Linear Measure

1 centimeter = 10 millimeters = .39 inch  
 1 decimeter = 10 centimeters = 3.94 inches  
 1 meter = 10 decimeters = 39.37 inches  
 1 dekameter = 10 meters = 32.8 feet  
 1 hectometer = 10 dekameters = 328.08 feet  
 1 kilometer = 10 hectometers = 3,280.8 feet

## Weights

1 centigram = 10 milligrams = .15 grain  
 1 decigram = 10 centigrams = 1.54 grains  
 1 gram = 10 decigrams = .035 ounce  
 1 dekagram = 10 grams = .35 ounce  
 1 hectogram = 10 dekagrams = 3.52 ounces  
 1 kilogram = 10 hectograms = 2.2 pounds  
 1 quintal = 100 kilograms = 220.46 pounds  
 1 metric ton = 10 quintals = 1.1 short tons

## Liquid Measure

1 centiliter = 10 milliliters = .34 fl. ounce  
 1 deciliter = 10 centiliters = 3.38 fl. ounces  
 1 liter = 10 deciliters = 33.81 fl. ounces  
 1 dekaliter = 10 liters = 2.64 gallons  
 1 hectoliter = 10 dekaliters = 26.42 gallons  
 1 kiloliter = 10 hectoliters = 264.18 gallons

## Square Measure

1 sq. centimeter = 100 sq. millimeters = .155 sq. inch  
 1 sq. decimeter = 100 sq. centimeters = 15.5 sq. inches  
 1 sq. meter (centare) = 100 sq. decimeters = 10.76 sq. feet  
 1 sq. dekameter (are) = 100 sq. meters = 1,076.4 sq. feet  
 1 sq. hectometer (hectare) = 100 sq. dekameters = 2.47 acres  
 1 sq. kilometer = 100 sq. hectometers = .386 sq. mile

## Cubic Measure

1 cu. centimeter = 1000 cu. millimeters = .06 cu. inch  
 1 cu. decimeter = 1000 cu. centimeters = 61.02 cu. inches  
 1 cu. meter = 1000 cu. decimeters = 35.31 cu. feet

## Approximate Conversion Factors

To change	To	Multiply by	To change	To	Multiply by
inches	centimeters	2.540	ounce-inches	newton-meters	.007062
feet	meters	.305	centimeters	inches	.394
yards	meters	.914	meters	feet	3.280
miles	kilometers	1.609	meters	yards	1.094
square inches	square centimeters	6.451	kilometers	miles	.621
square feet	square meters	.093	square centimeters	square inches	.155
square yards	square meters	.836	square meters	square feet	10.764
square miles	square kilometers	2.590	square meters	square yards	1.196
acres	square hectometers	.405	square kilometers	square miles	.386
cubic feet	cubic meters	.028	square hectometers	acres	2.471
cubic yards	cubic meters	.765	cubic meters	cubic feet	35.315
fluid ounces	milliliters	29.573	cubic meters	cubic yards	1.308
pints	liters	.473	milliliters	fluid ounces	.034
quarts	liters	.946	liters	pints	2.113
gallons	liters	3.785	liters	quarts	1.057
ounces	grams	28.349	liters	gallons	.264
pounds	kilograms	.454	grams	ounces	.035
short tons	metric tons	.907	kilograms	pounds	2.205
pound-feet	newton-meters	1.356	metric tons	short tons	1.102
pound-inches	newton-meters	.11296			

## Temperature (Exact)

°F	Fahrenheit	5/9 (after	Celsius	°C
	temperature	subtracting 32)	temperature	



This fine document...

Was brought to you by me:



## [Liberated Manuals -- free army and government manuals](#)

Why do I do it? I am tired of sleazy CD-ROM sellers, who take publicly available information, slap “watermarks” and other junk on it, and sell it. Those masters of search engine manipulation make sure that their sites that sell free information, come up first in search engines. They did not create it... They did not even scan it... Why should they get your money? Why are not letting you give those free manuals to your friends?

I am setting this document FREE. This document was made by the US Government and is NOT protected by Copyright. Feel free to share, republish, sell and so on.

I am not asking you for donations, fees or handouts. If you can, please provide a link to [liberatedmanuals.com](http://liberatedmanuals.com), so that free manuals come up first in search engines:

<A HREF=<http://www.liberatedmanuals.com/>>Free Military and Government Manuals</A>

- Sincerely  
Igor Chudov  
<http://igor.chudov.com/>
- [Chicago Machinery Movers](#)