

This copy is a reprint which includes current pages from changes 1 and 2.

**TECHNICAL MANUAL
UNIT, INTERMEDIATE DIRECT
SUPPORT
AND INTERMEDIATE GENERAL
SUPPORT
MAINTENANCE INSTRUCTIONS
GYRO AND MAGNETIC
COMPASS SYSTEMS
FOR
LANDING CRAFT UTILITY (LCU)
NSN 1905-01-154-1191**

INTRODUCTION	1-1	
UNIT MAINTENANCE INSTRUCTIONS	2-1	
INTERMEDIATE DIRECT SUPPORT MAINTENANCE INSTRUCTIONS	3-1	
INTERMEDIATE GENERAL SUPPORT MAINTENANCE INSTRUCTIONS	4-1	
APPENDIXES	A-1	
ALPHABETICAL INDEX	Index-1	

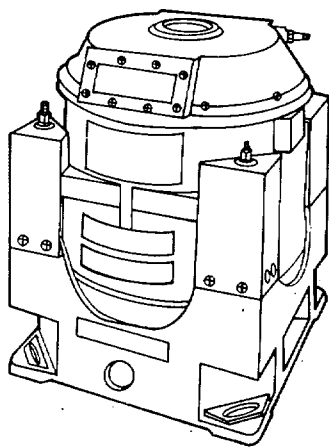

GYRO COMPASS

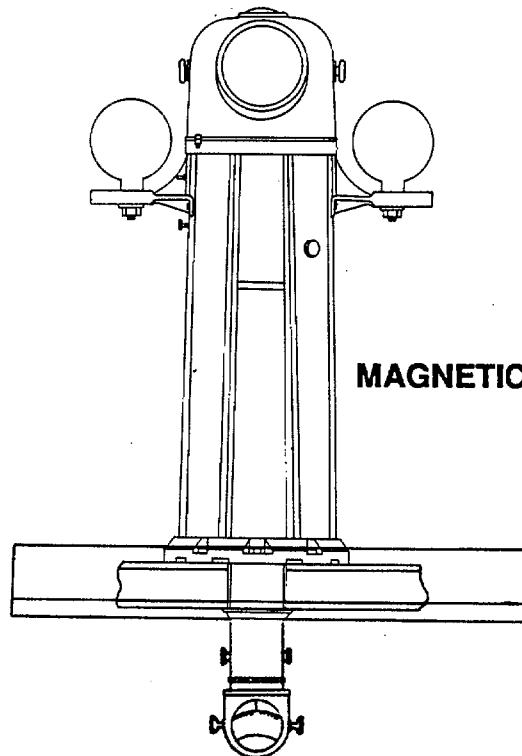

MAGNETIC COMPASS

Approved for public release; distribution is unlimited.

CHANGE

NO. 2

HEADQUARTERS
DEPARTMENT OF THE ARMY
WASHINGTON, D.C., 9 NOVEMBER 1992

**Unit, Intermediate Direct Support and Intermediate General Support
Maintenance Instructions**

**GYRO AND MAGNETIC COMPASS SYSTEMS
FOR
LANDING CRAFT UTILITY (LCU)
NSN 1905-01-154-1191**

Approved for public release; distribution is unlimited

TM 55-1905-223-24-14, 17 January 1989, is changed as follows:

1. Remove and insert pages as indicated below. New or changed text material is indicated by a vertical bar in the margin. An illustration change is indicated by a miniature pointing hand.

Remove pages

Insert pages

C-1 and C-2

C-1 and C-2

2. Retain this sheet in front of manual for reference purposes.

By Order of the Secretary of the Army:

Official:

GORDON R. SULLIVAN
*General, United States Army
Chief of Staff*

MILTON H. HAMILTON
*Administrative Assistant to the
Secretary of the Army*

03005

DISTRIBUTION:

To be distributed in accordance with DA Form 12-25-E, block no. 481 0, requirements for TM 55-1905-223-24-14.

CHANGE

NO. 1

HEADQUARTERS
DEPARTMENT OF THE ARMY
WASHINGTON, D.C., 30 SEPTEMBER 1991

**Unit, Intermediate Direct Support and Intermediate General Support
Maintenance Instructions**

**GYRO AND MAGNETIC COMPASS SYSTEMS
FOR
LANDING CRAFT UTILITY (LCU)
NSN 1905-01-154-1191**

Approved for public release; distribution is unlimited

TM 55-1905-223-24-14, 17 January 1989, is changed as follows:

1. Remove and insert pages as indicated below. New or changed text material is indicated by a vertical bar in the margin. An illustration change is indicated by a miniature pointing hand.

Remove pages

Insert pages

2-17 and 2-18

2-17 and 2-18

2-61 and 2-62

2-61 and 2-62

B-5 through B-8

B-5 through B-8

2. Retain this sheet in front of manual for reference purposes.

By Order of the Secretary of the Army:

GORDON R. SULLIVAN
*General, United States Army
Chief of Staff*

Official:

PATRICIA P. HICKERSON
Brigadier General, United States Army
The Adjutant General

DISTRIBUTION:

To be distributed in accordance with DA Form 1 2-25E, (qty rqr block no. 4810)

WARNING

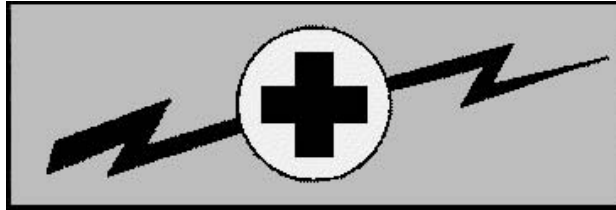

HIGH VOLTAGE

**is used in the operation of this equipment.
DEATH ON CONTACT
may result if personnel fail to observe safety precautions.**

Never work on electronic equipment unless there is another person nearby who is familiar with the operation and hazards of the equipment, and who is competent in administering first aid. When the technicians are aided by the operators, the operators must be warned about dangerous areas.

Whenever possible, the power supply to the equipment must be shut off before beginning work on the equipment. Take particular care to ground every capacitor likely to hold a dangerous potential. When working inside the equipment, after the power has been turned off, always ground every part of the equipment before touching it.

Be careful not to contact high-voltage connections or 115-Vac input connections when installing or operating this equipment.

Whenever the nature of the operation permits, keep one hand away from the equipment to reduce the hazard of current flowing through the body.

WARNING

Do not be misled by the term "low voltage. " Potentials as low as 50 volts may cause death under adverse conditions.

WARNING

DANGEROUS CHEMICALS are used for cleaning this equipment. DEATH or severe breathing difficulties may result if personnel do not observe safety precautions.

For Artificial Respiration, refer to FM 21-1 1.

a/(b blank)

**UNIT, INTERMEDIATE DIRECT SUPPORT,
AND INTERMEDIATE GENERAL SUPPORT
MAINTENANCE INSTRUCTIONS
FOR THE
GYRO AND MAGNETIC COMPASS SYSTEM
FOR LANDING CRAFT UTILITY (LCU) NSN 1905-01-154-1191
REPORTING ERRORS AND RECOMMENDING IMPROVEMENTS**

You can help improve this manual. If you find any mistakes, or if you know of a way to improve the procedures, please let us know. Mail your letter, DA Form 2028 (Recommended Changes to Publications and Blank Forms), or DA Form 2028-2 located in the back of this manual, directly to: Commander, U S. Army Troop Support Command; Attention: AMSTR-MCTS; 4300 Goodfellow Blvd.; St. Louis, Missouri 63120-1798. A reply will be sent directly to you.

Approved for public release; distribution is unlimited

TABLE OF CONTENTS

		<u>PAGE</u>
CHAPTER 1	INTRODUCTION	1-1
Section I	General Information	1-1
Section II	Equipment Description and Data	1-4
Section III	Principles of Operation	1-28
CHAPTER 2	UNIT MAINTENANCE INSTRUCTIONS	2-1
Section I	Repair Parts, Special Tools; Test, Measurement, and Diagnostic Equipment (TMDE); and Support Equipment	2-1
Section II	Service Upon Receipt	2-1
Section III	Unit Preventive Maintenance Checks and Services (PMCS)	2-2
Section IV	Unit Maintenance Troubleshooting	2-8
Section V	Unit Maintenance Procedures	2-16
Section VI	Preparation for Storage or Shipment	2-82
CHAPTER 3	INTERMEDIATE DIRECT SUPPORT MAINTENANCE INSTRUCTIONS	3-1
CHAPTER 4	INTERMEDIATE GENERAL SUPPORT MAINTENANCE INSTRUCTIONS	4-1

TABLE OF CONTENTS - CONT

		<u>PAGE</u>
APPENDIX A	REFERENCES	A-1
APPENDIX B	MAINTENANCE ALLOCATION CHART	B-1
APPENDIX C	EXPENDABLE/DURABLE SUPPLIES AND MATERIALS LIST	C-1
APPENDIX D	TORQUE VALUES	D-1
GLOSSARY	ABBREVIATIONS AND DEFINITIONS	Glossary-1
ALPHABETICAL INDEX.....		Index-1

CHAPTER 1

INTRODUCTION

Section I.	General Information	1-1
Section II.	Equipment Description and Data	1-4
	Gyro Compass System.....	1-4
	Magnetic Compass System	1-23
Section III.	Principles of Operation.....	1-28
	Gyro Compass System.....	1-28
	Magnetic Compass System	1-30

Section I. GENERAL INFORMATION

1-1. Scope. The scope of this manual is as follows:

a. Type of Manual. Unit, intermediate direct support, and intermediate general support maintenance manual.

b. Model Number and Equipment Name. Gyro Compass System MK 27 Mod 1 (FIGURE 1-1) and Magnetic Compass System (FIGURE 1-2).

c. Purpose of Equipment. The Gyro Compass System provides data for navigating the Landing Craft Utility (LCU) 2000 Class watercraft. The Magnetic Compass System provides backup navigation data.

1-2. Maintenance Forms, Records, and Reports. Department of the Army forms and procedures used for equipment maintenance are those prescribed by DA Pam 738-750, the Army Maintenance Management System.

1-3. Destruction of Army Materiel. Refer to TM 750-244-3 for instructions covering the destruction of Army materiel to prevent enemy use.

1-4. Reporting Equipment Improvement Recommendations (EIR). If your equipment needs improvement, let us know. Sent us an EIR. You, the user, are the only one who can tell us what you don't like about your equipment. Let us know why you don't like the design. Put it on an SF 368 (Quality Deficiency Report). Mail it to: Commander, U.S. Army Troop Support Command; ATTM: AMSTR-QX; 4300 Goodfellow Blvd.; St., Louis, Missouri 63120-1798. We'll send you a reply.

1-5. Preparation for Storage or Shipment. Administrative storage of equipment issued to and used by Army activities will have preventive maintenance performed in accordance with the Preventive Maintenance Checks and Services (PMCS) charts before storing. When removing the equipment from administrative storage, the PMCS should be performed to assure operational readiness. Repacking of equipment for shipment or short term storage, are covered in paragraph 2-22.

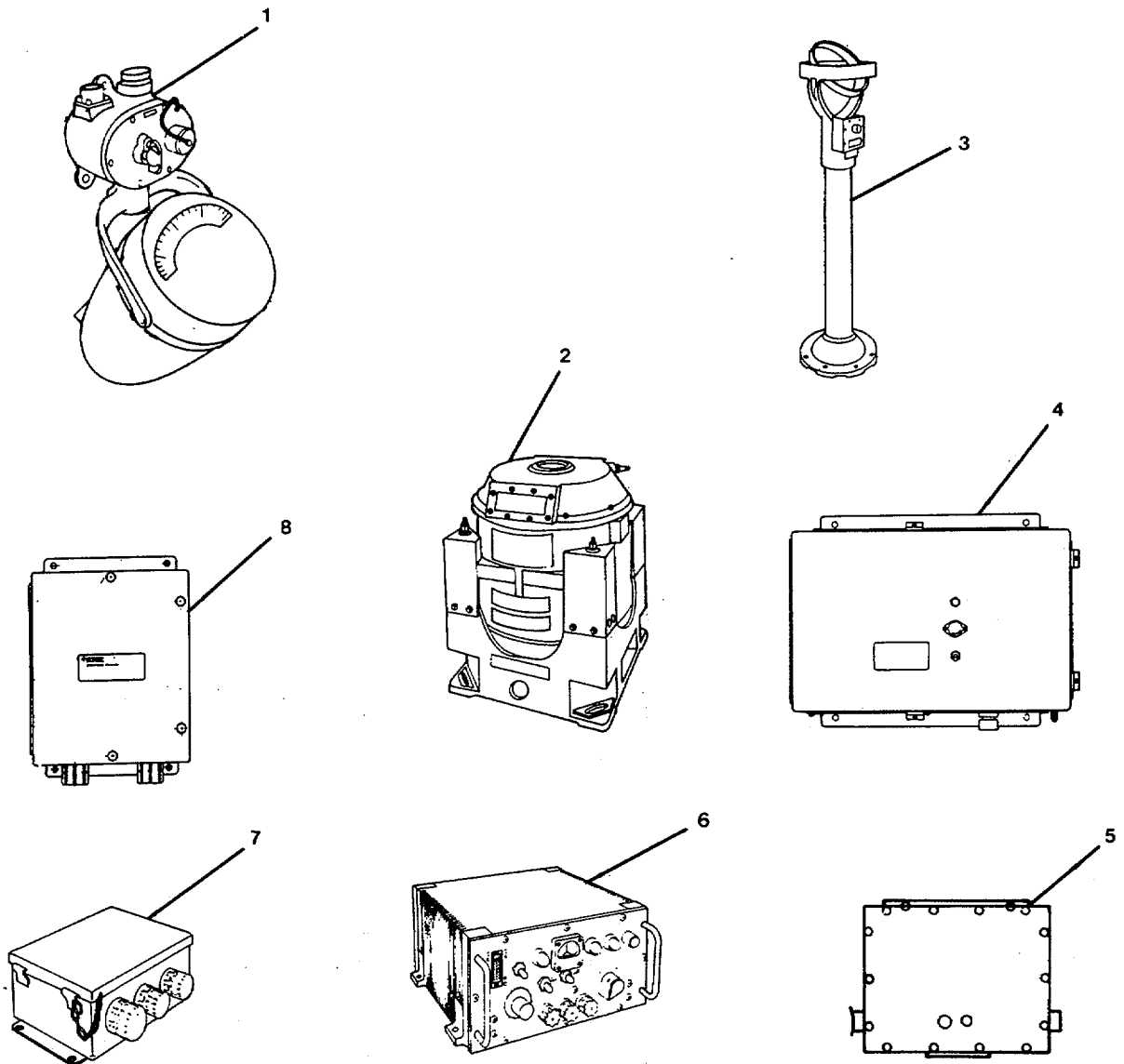

LEGEND

1. OPEN SCALE REPEATER AND BULKHEAD MOUNTING BRACKET
2. GYRO COMPASS
3. BEARING REPEATER AND PELORUS STAND
4. RELAY TRANSMITTER
5. POWER CONVERTER UNIT
6. GYRO CONTROL AND POWER ASSEMBLY
7. SWITCH UNIT
8. POWER TRANSFER UNIT

FIGURE 1-1. Gyro Compass System Equipment.

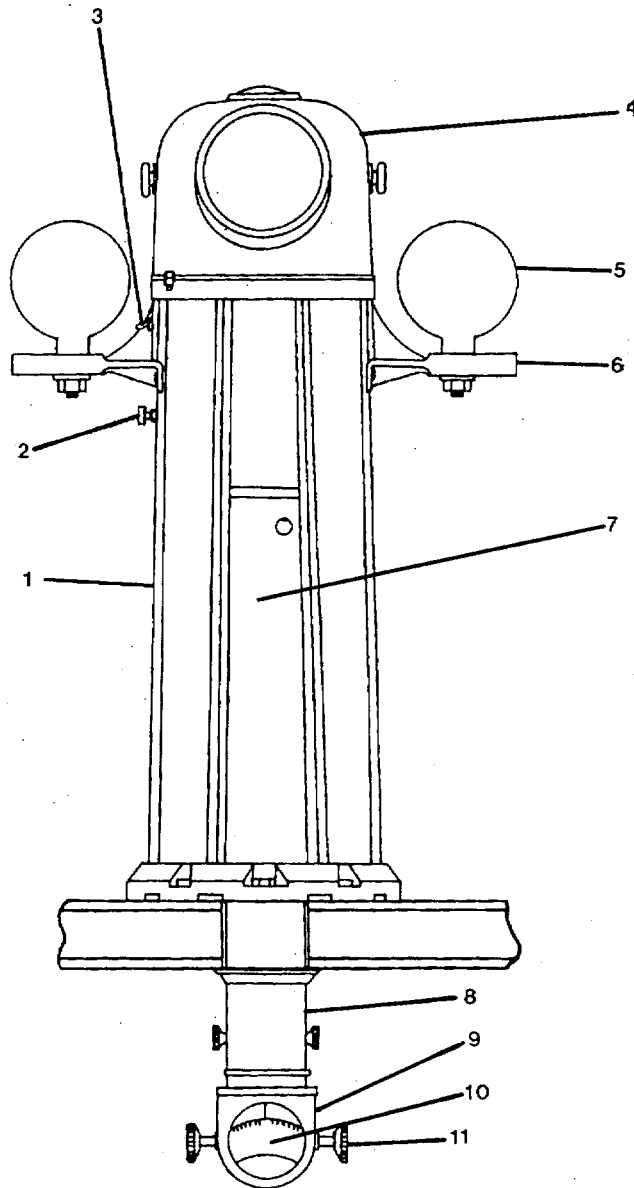

LEGEND

- 1. PEDASTAL
- 2. RHEOSTAT KNOB
- 3. TOGGLE SWITCH
- 4. HOOD
- 5. QUADRANTAL SPHERES
- 6. BRACKETS
- 7. ACCESS DOOR
- 8. REFLECTOR TUBE ASSEMBLY
- 9. REFLECTOR
- 10. REFLECTOR MIRROR
- 11. ADJUSTING KNOB

FIGURE 1-2. Magnetic Compass System Equipment.

Section II. EQUIPMENT DESCRIPTION AND DATA

1-6. Gyro Compass.

a. Equipment Characteristics, Capabilities, and Features. These are very broad points about the Gyro Compass System.

(1) Characteristics:

- o Gyro compass can give true north.
- o Gyro compass electronics compensate for earth's magnetic fields.
- o Gyro compass is an electric compass.
- o Ship's emergency power source provides 24 Vdc backup capability.

(2) Capabilities and features:

- o Gyro compass transmits the ship's heading to external repeaters.

b. Location And Description Of Major Components. The basic MK 27 Mod 1 Gyro Compass System consists of the gyro compass, gyro control and power assembly, power converter, and switch unit. In addition to the basic equipment, the system also utilizes a power transfer unit, a relay transmitter (MK 37 Mod E transmission unit), three bearing repeaters mounted in pelorus stands, two open scale repeaters mounted in bulkhead mounting brackets, a standard Navy type azimuth circle, and three bearing repeater covers to be placed over the bearing repeaters to protect the repeaters when not in use. Ship's cabling connects the system. The major components of the system are illustrated in FIGURE 1-1.

(1) Gyro Compass. The gyro compass is located in the pilothouse, FIGURES 1-3 and 1-4. The gyro compass (FIGURE 1-5) consists of a shock-mounted, fluid-filled binnacle which houses the gyroscope (sensitive element). The unit is sealed and is mounted on top of the gyro control and power assembly. The gyroscope can be caged (suspended from operation) by pressing a button on the top of the unit to prevent damage when not in use. The viewing window for the compass card is on the aft end of the compass. The dial is red lighted and its brightness is adjusted at the gyro control and power assembly.

(2) Gyro Control and Power Assembly. The gyro control and power assembly is located in the pilot house, as shown in FIGURE 1-3. The gyro control and power assembly (FIGURE 1-6) is a watertight, deck-mounted unit which houses the control panel, power supply, servoamplifier, latitude compensation circuit, and alarm circuit. Power amplifier transistors are attached to the cabinet frame for adequate heat dissipation. The unit is mounted directly under the gyro compass to permit ease of operation when starting or adjusting dial illumination.

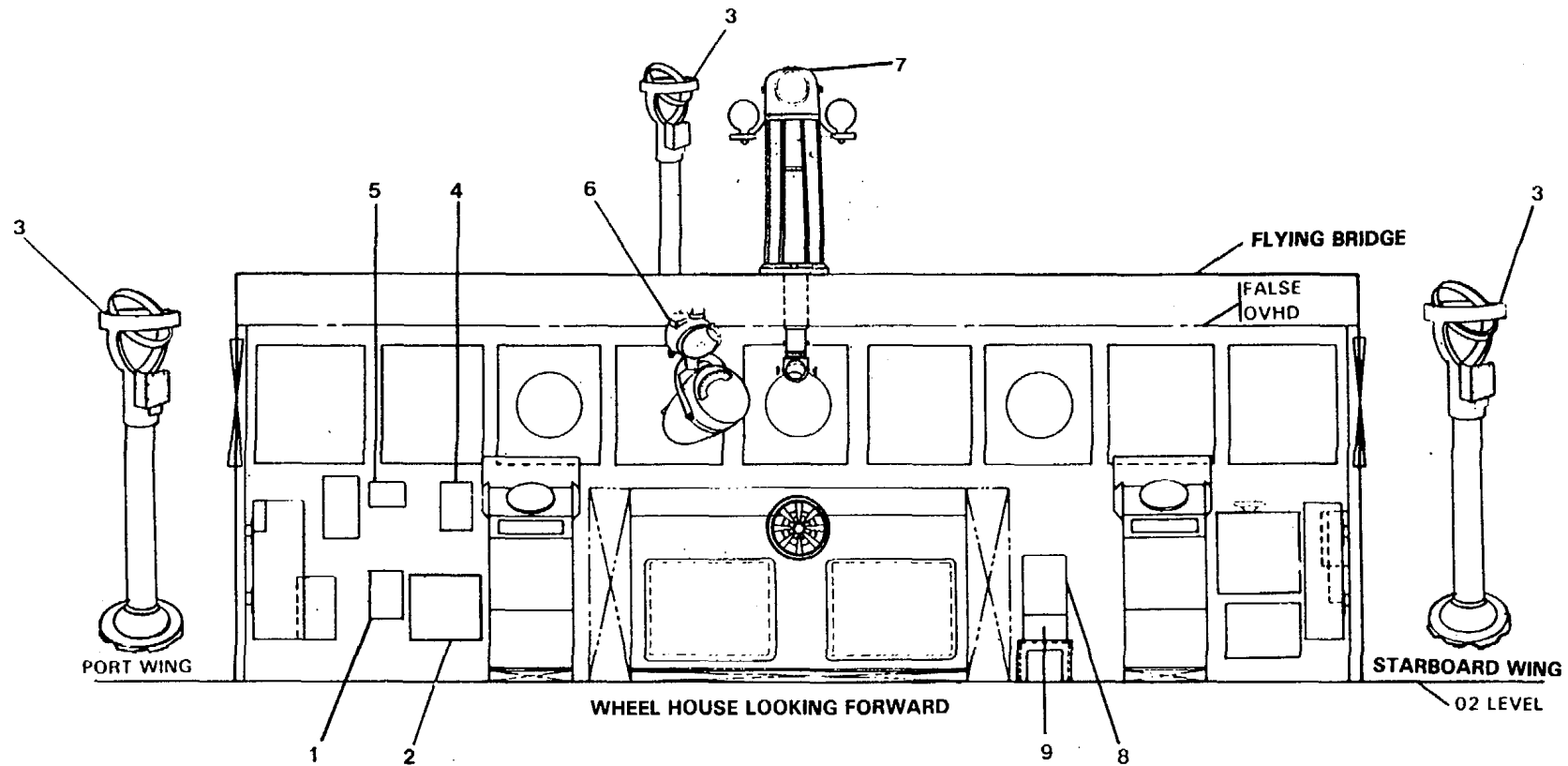

LEGEND

- | | |
|---|---|
| <ul style="list-style-type: none"> 1. POWER TRANSFER UNIT 2. RELAY TRANSMITTER (MK 37 MOD E) 3. BEARING REPEATER AND PELORUS STAND 4. POWER CONVERTER | <ul style="list-style-type: none"> 5. SWITCH UNIT 6. OPEN SCALE REPEATER AND BULKHEAD MOUNTING BRACKET 7. BINNACLE AND MAGNETIC COMPASS 8. GYRO COMPASS 9. GYRO CONTROL AND POWER ASSEMBLY |
|---|---|

FIGURE 1-3. Gyro and Magnetic Compass Equipment Location (Pilothouse).

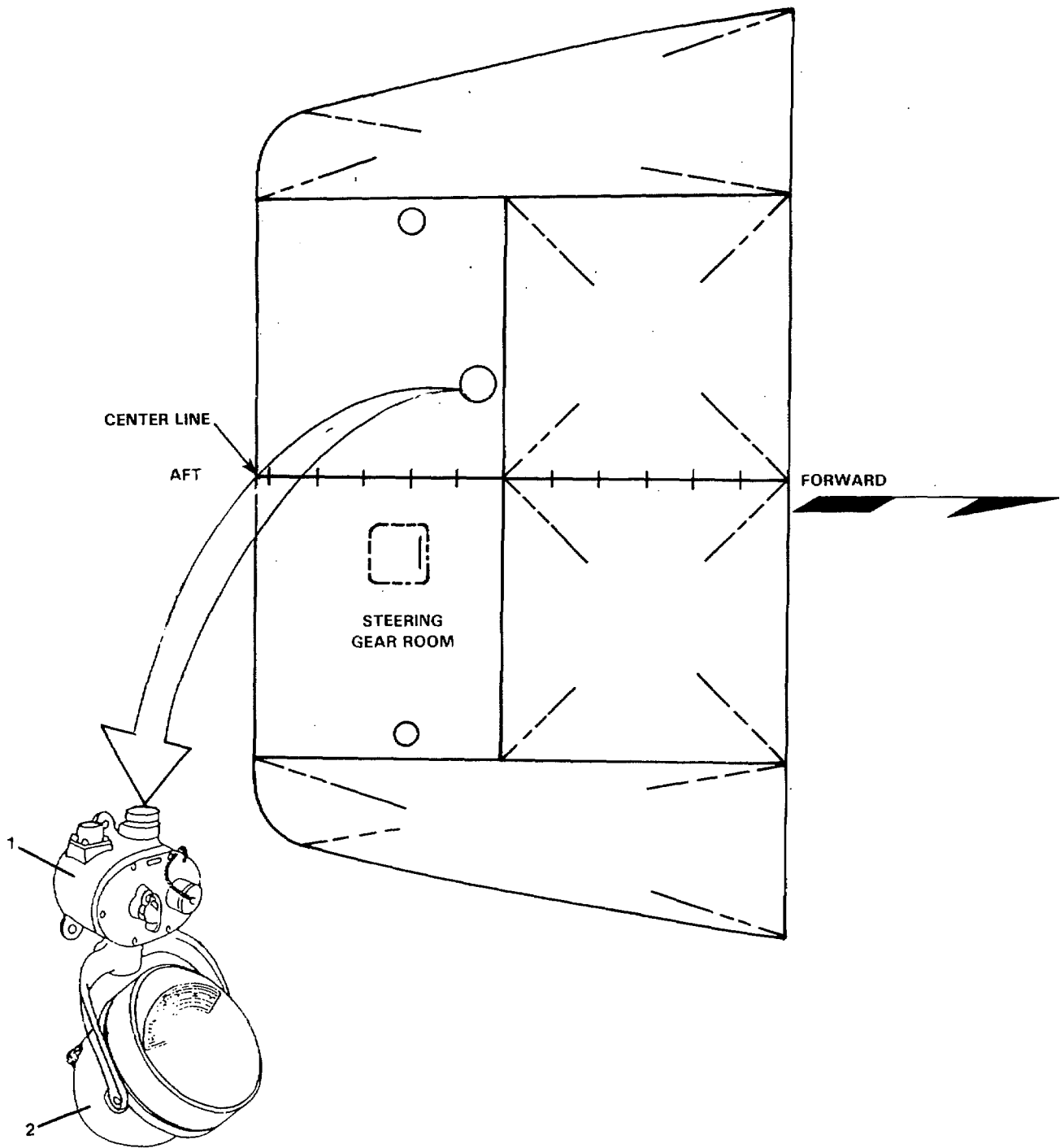

- LEGEND
- 1. BULKHEAD MOUNTING BRACKET
 - 2. OPEN SCALE REPEATER

FIGURE 1-4. Gyro Compass Equipment Location (Below Decks - AFT).

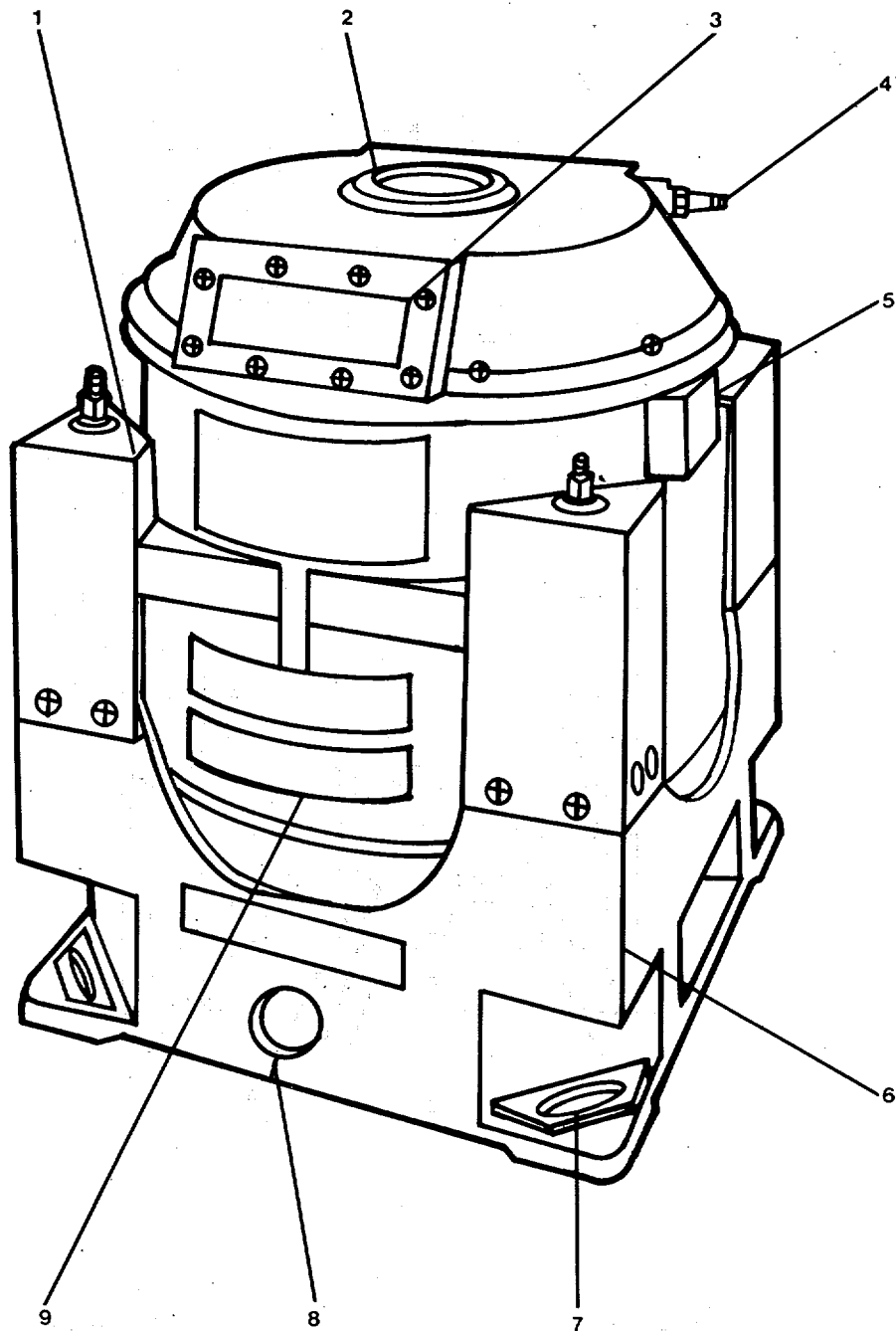

LEGEND

- 1. VIBRATION SHOCK MOUNTS
- 2. CAGER BUTTON
- 3. VIEWING WINDOW
- 4. FILL AND DRAIN VALVE (COVER REMOVED)

- 5. JACK (J1)
- 6. MOUNTING BASE
- 7. MOUNTING BOLT HOLES
- 8. ALIGNMENT MARK
- 9. BINNACLE

FIGURE 1-5. Gyro Compass.

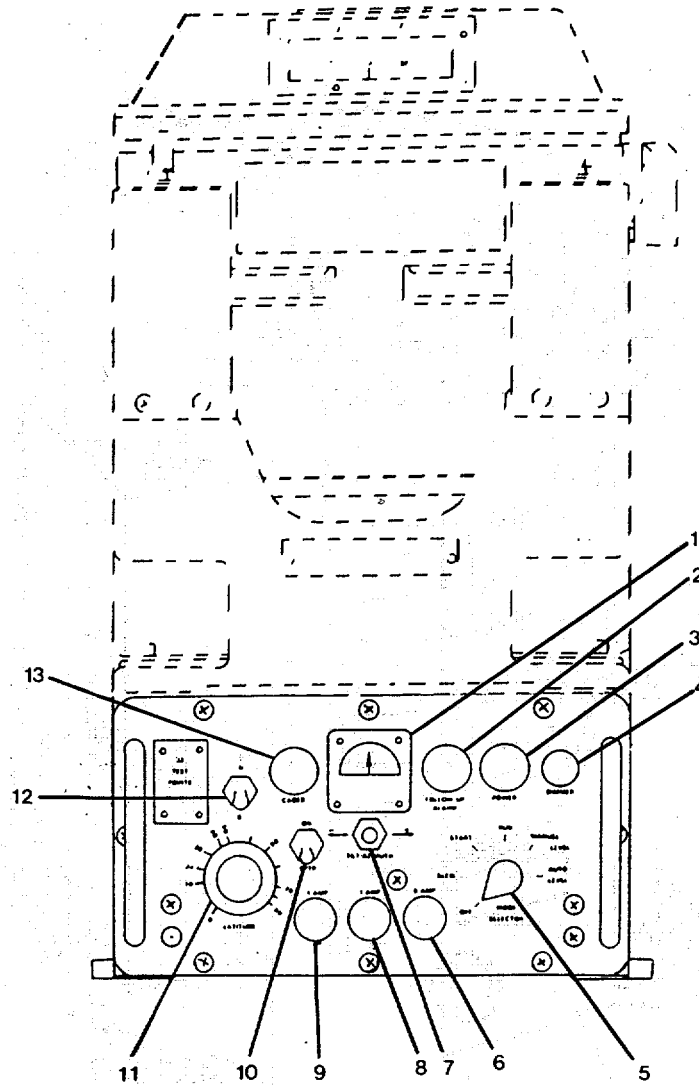

- | | |
|-------------------------|-------------------------|
| LEGEND | |
| 1. LEVEL METER | 7. TILT/AZIMUTH CONTROL |
| 2. FOLLOW-UP ALARM LAMP | 8. FUSE 1 AMP AC |
| 3. POWER LAMP | 9. FUSE 1 AMP RPTR |
| 4. DIMMER CONTROL | 10. RPTR SWITCH |
| 5. MODE SELECTOR SWITCH | 11. LATITUDE CONTROL |
| 6. FUSE 8 AMP DC | 12. N-S SWITCH |
| | 13. CAGES LAMP |

FIGURE 1-6. Gyro Control and Power Assembly.

(3) Power Converter. The power converter is located in the pilot house, as shown in FIGURE 1-3. The power converter (FIGURE 1-7) adapts the gyro compass equipment to the ship's single phase 120 Vac, 60 Hz power source. The converter is housed in a watertight enclosure and is bulkhead mounted. The cover contains a lamp holder and fuse holder. Two stuffing tube assemblies are affixed to the enclosure on either end, for power cable attachment. The unit converts the ship's ac input power to 24 Vdc for use by the gyro compass equipment and provides 120 Vac, 60 Hz power to the gyro control and power assembly.

(4) Switch Unit. The switch unit is located in the pilot house, as shown in FIGURE 1-3. The switch unit (FIGURE 1-8) is contained in a drip-proof enclosure with a cover secured with fasteners and attached to the enclosure with a chain. Three stuffing tubes are affixed to the underside of the enclosure for cable access. The unit is bulkhead mounted with four bolts. The switch unit controls the power delivered to the coils of two remote steering repeaters and will drive two 70 Vdc step motors. The switch unit is a component of the gyro compass system transmission circuit.

(5) Relay Transmitter. The relay transmitter is located as shown in FIGURE 1-3. The relay transmitter (FIGURE 1-9, Sheet 1) is a MK 37 Mod E type transmission unit. The unit consists of a drip-proof enclosure which contains two subassemblies: repeater circuit card assembly A1 and transmission terminal circuit board A2. Front cover and chassis mounted components are used for input power regulation, protection, and control circuits. The unit operates from ship's ac power. Terminal board connections match input power to an internal transformer for different ac input power. The main power switch, power fuse F1, and power indicator lampholder are mounted on the front of the hinged cabinet cover. Switches and fuses for each transmission output channel are located inside the enclosure on transmission terminal circuit board A2 (FIGURE 1-9, Sheet 3).

(a) Repeater Circuit Card Assembly A1. The repeater circuit card assembly A1 (FIGURE 1-9, Sheet 2) is mounted on the rear of the enclosure cover. This assembly amplifies the signal from the step transmitter (in the gyro compass) to provide enough power to drive up to 12 repeaters with 70 Vdc coils. This assembly also converts the ship's ac input to 70 Vdc output for the repeaters.

(b) Transmission Terminal Circuit Board A2. The transmission terminal circuit board A2 is mounted in the rear of the enclosure (FIGURE 1-9, Sheet 3). The board contains 12 identical output control and switch circuits. Each circuit contains an On/Off toggle switch and a series fuse.

(6) Power Transfer Unit. The power transfer unit is located as shown in FIGURE 1-3. The power transfer unit (FIGURE 1-10) is bulkhead mounted with four bolts. The unit is housed in a drip-proof electrical equipment cabinet. Two stuffing tube assemblies are affixed to the underside for cable access. The unit contains no external controls. Four thumbscrews on the cover allow for cover opening for access to the inside. The power transfer unit transfers the gyro compass equipment from normal input dc power from the power converter to the ship's emergency dc supply in the event of normal supply failure.

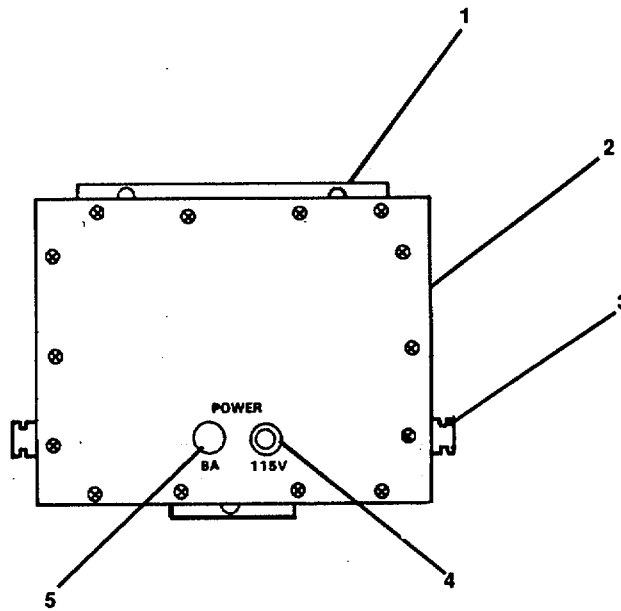

LEGEND

- 1. WATERTIGHT ENCLOSURE
- 2. COVER
- 3. STUFFING TUBE ASSEMBLY
- 4. LAMPHOLDER
- 5. FUSEHOLDER

FIGURE 1-7. Power Converter.

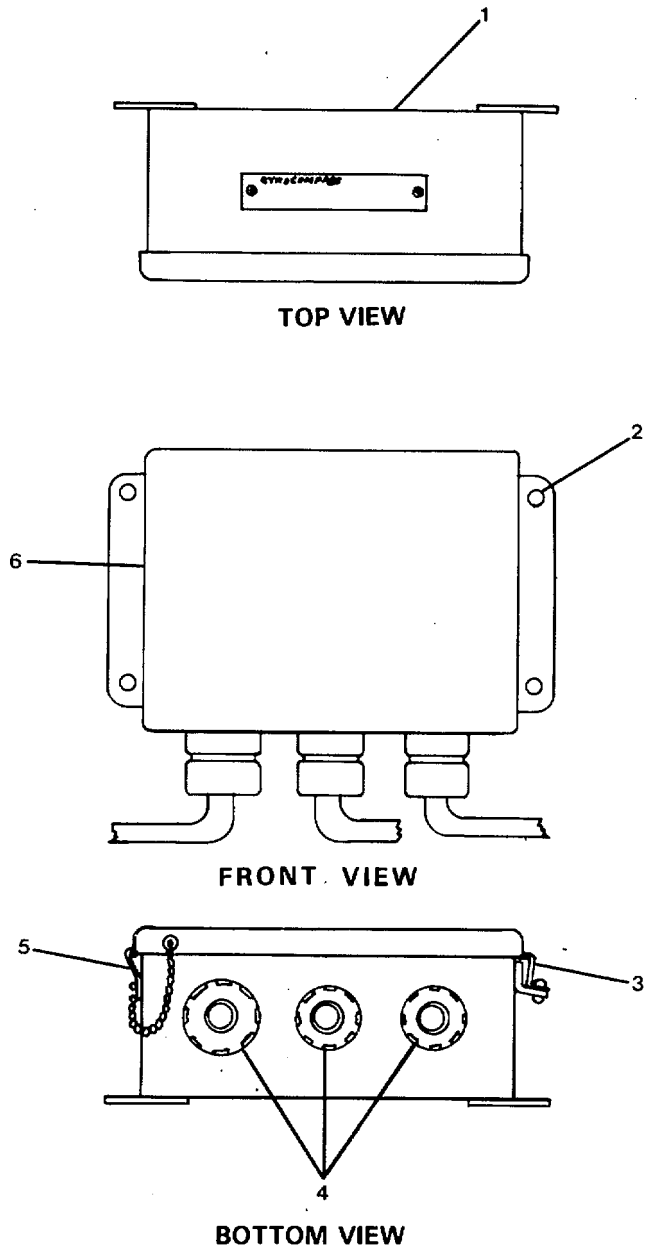

LEGEND

- | | |
|----------------------------|-----------------------------|
| 1. WATERTIGHT ENCLOSURE | 4. STUFFING TUB ASSEMBLY |
| 2. BULKHEAD MOUNTING HOLES | 5. COVER RETAINER AND CHAIN |
| 3. COVER RETAINER | 6. COVER |

FIGURE 1-8. Switch Unit.

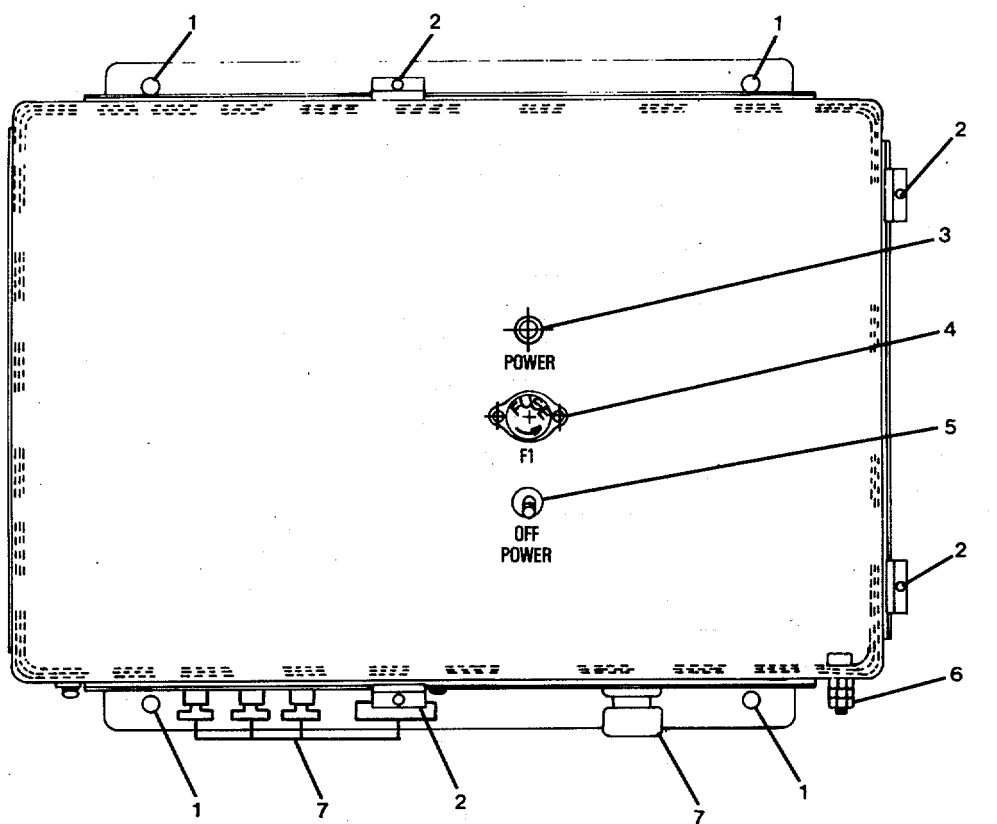

FRONT VIEW

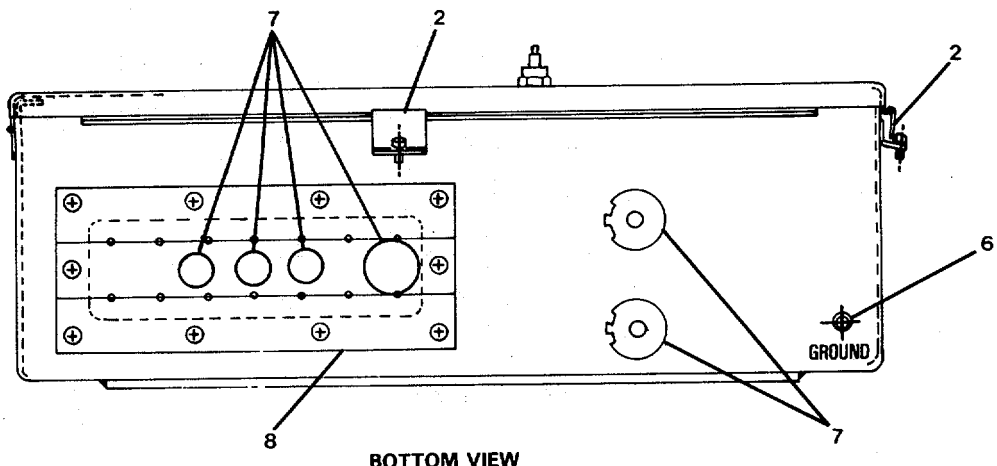

BOTTOM VIEW

LEGEND

- | | |
|-------------------------|---------------------------|
| 1. MOUNTING HOLES | 5. OFF POWER SWITCH |
| 2. COVER REATINING CLIP | 6. GROUND TERMINAL |
| 3. POWER INDICATOR | 7. STUFFING TUBE ASSEMBLY |
| 4. FUSE HOLDER | 8. CABLE ENTRANCE PLATE |

FIGURE 1-9. Relay Transmitter (Sheet 1 of 3).

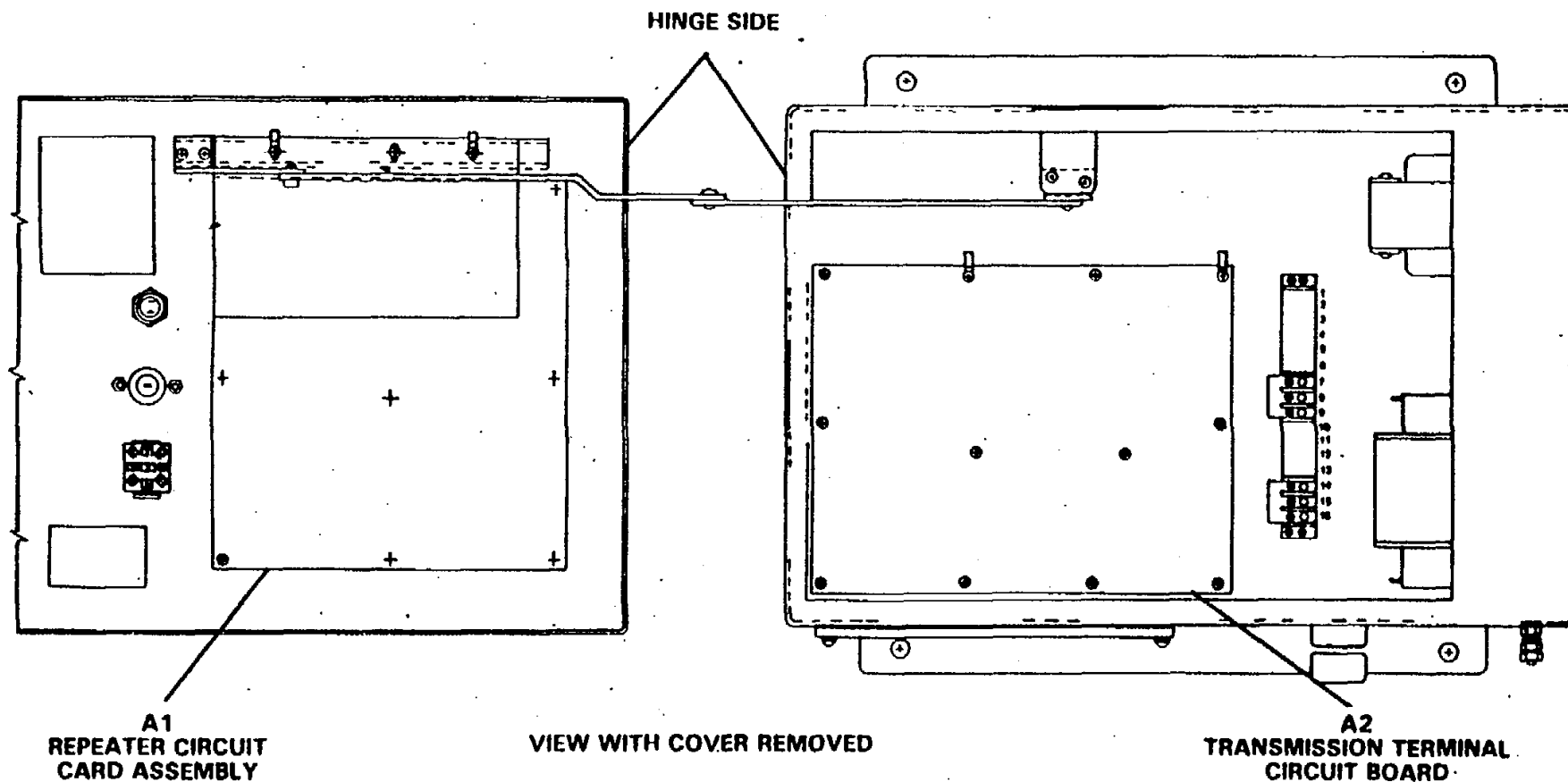
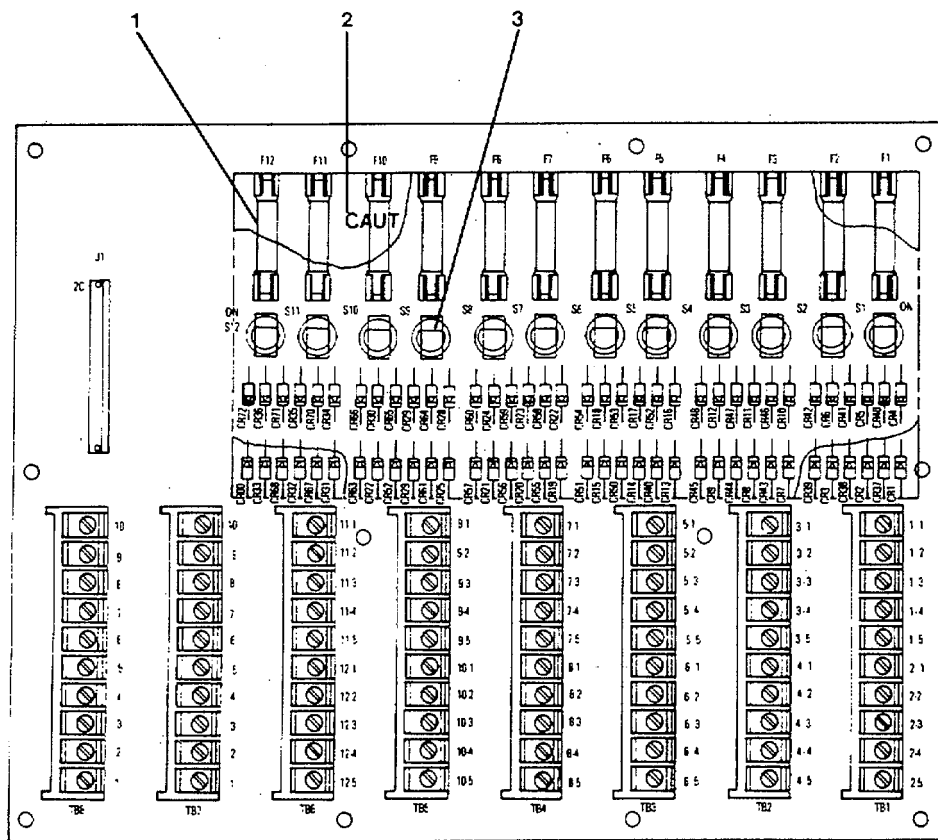

FIGURE 1-9. Relay Transmitter (Sheet 2 of 3).



A2
TRANSMISSION TERMINAL CIRCUIT BOARD

LEGEND

- 1. FUSE CARTRIDGE
- 2. SEE-THROUGH PROTECTIVE COVER
- 3. TOGGLE SWITCH

FIGURE 1-9. Relay Transmitter (Sheet 3 of 3).

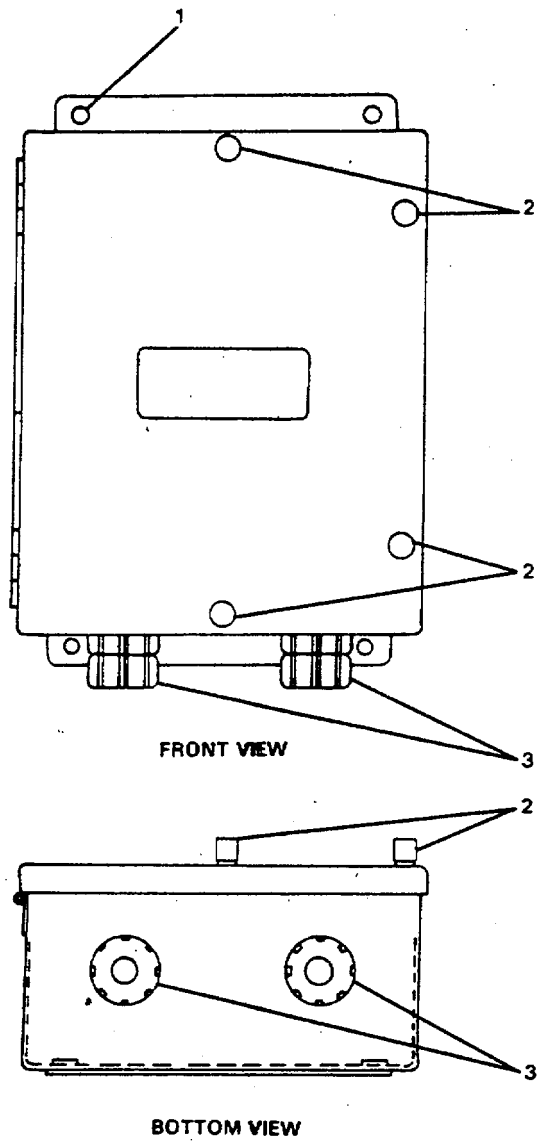

LEGEND

- 1. MOUNTING HOLES
- 2. THUMBSCREWS

- 3. STUFFING TUBE ASSEMBLY

FIGURE 1-10. Power Transfer Unit.

(7) Bearing Repeater. Three bearing repeaters mounted in pelorus stands are located as shown in FIGURE 1-3. One repeater is located on each bridge wing of the ship (port and starboard) and one repeater is located on top of the pilot house to the port side of the binnacle. The bearing repeater (FIGURE 1-11) consists of a step motor geared to a compass card and contained in a watertight case. The repeater is gimbal-ring-mounted on a pelorus stand. An integral cable is provided for interface to the gyro compass transmission system at the pelorus stand. A synchronizing knob is located on the side of the repeater to synchronize the repeater with the gyro compass.

(8) Pelorus Stand. Three pelorus stands are located as shown in FIGURE 1-3. Each pelorus stand (FIGURE 1-12) is deck-mounted with eight bolts. The stand consists of the repeater support and column assembly. The repeater support provides mounting for the bearing repeater. The column assembly contains a cover plate and gasket for access to internal wiring for the repeater lighting dimmer circuit. The rheostat is mounted on the cover plate with a knob secured to the rheostat shaft on the outside. A stuffing tube is provided for cable access to the stand.

(9) Open Scale Repeater. One open scale repeater is located as shown in FIGURE 1-3, mounted in a bulkhead mounting bracket. Another open scale repeater is located as shown in FIGURE 1-4, Steering Gear Room. Each open scale repeater (FIGURE 1-13) consists of a step motor geared to a compass card and a mask. The heading is read from the exposed numeral and the number of graduations from the numeral to the rubber line. The repeater is red-lighted by three incandescent lamps with red lens covers. The lamp intensity is varied by the internal dimmer circuit controlled from a rheostat on the bulkhead mounting bracket. The repeater is yoke-mounted and can be adjusted for ease of viewing from the helm or at the emergency steering station. The enclosure is splashproof but not watertight. It is not designed to be mounted in a pelorus stand. A synchronizing knob is provided on the enclosure for synchronizing the repeater with the gyro compass. An integral cable is provided with stuffing tube to interface the repeater with a terminal board located in the bulkhead mounting bracket.

(10) Bulkhead Mounting Bracket. The bulkhead mounting bracket (FIGURE 1-14) consists of a yoke and housing assembly. The yoke supports an open scale repeater. The housing assembly contains internal circuitry for power and compass data for the repeater. External controls on the housing assembly include a power toggle switch with cover and a knob for the internal rheostat to control repeater lamp intensity. Three holes are provided for mounting bolts. A stuffing tube assembly and cable receptacle are located on the upper end of the housing assembly for gyro compass data and for power cable and repeater cable access.

(11) Azimuth Circle. The azimuth circle (2, FIGURE 1-15) is a Navy standard type that is kept in a wooden box (1) for protection when not being used. The azimuth circle (2) is an instrument used for determining both bearings of terrestrial objects and azimuths of celestial objects. It consists of a non-magnetic ring formed to fit snugly over the top of a compass bowl (magnetic compass) or onto the top of a gyro compass bearing repeater, about which it can be turned to any desired direction. The azimuth circle inner lip (8) is graduated from 0 degrees to 360 degrees, counterclockwise, for measuring relative bearings. On one diameter of this lip is mounted a pair of sighting vanes, consisting of a peep vane (3) and a far vane (6) with a vertical wire mounted in its frame.

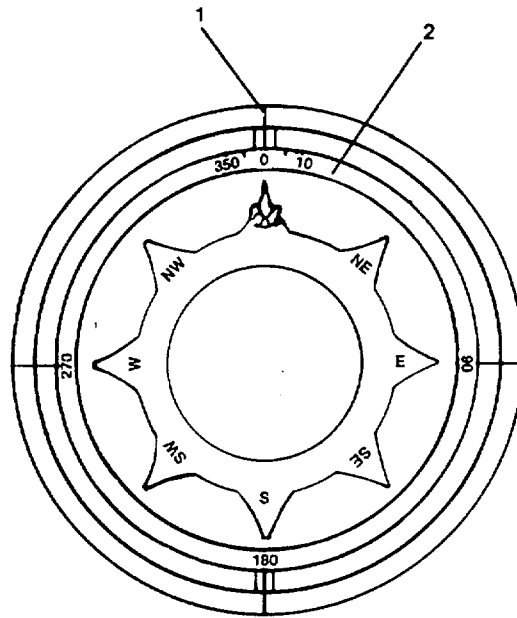

TOP VIEW

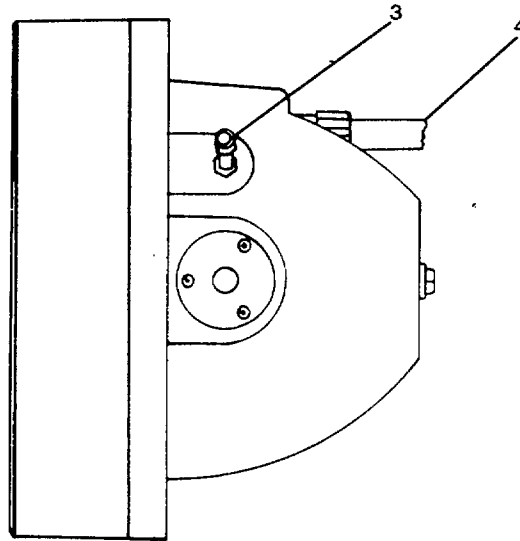

SIDE VIEW

LEGEND

- 1. LUBBER LINE
- 2. COMPASS CARD

- 3. SYNCHRONIZING KNOB
- 4. CABLE ASSEMBLY

FIGURE 1-11. Bearing Repeater.

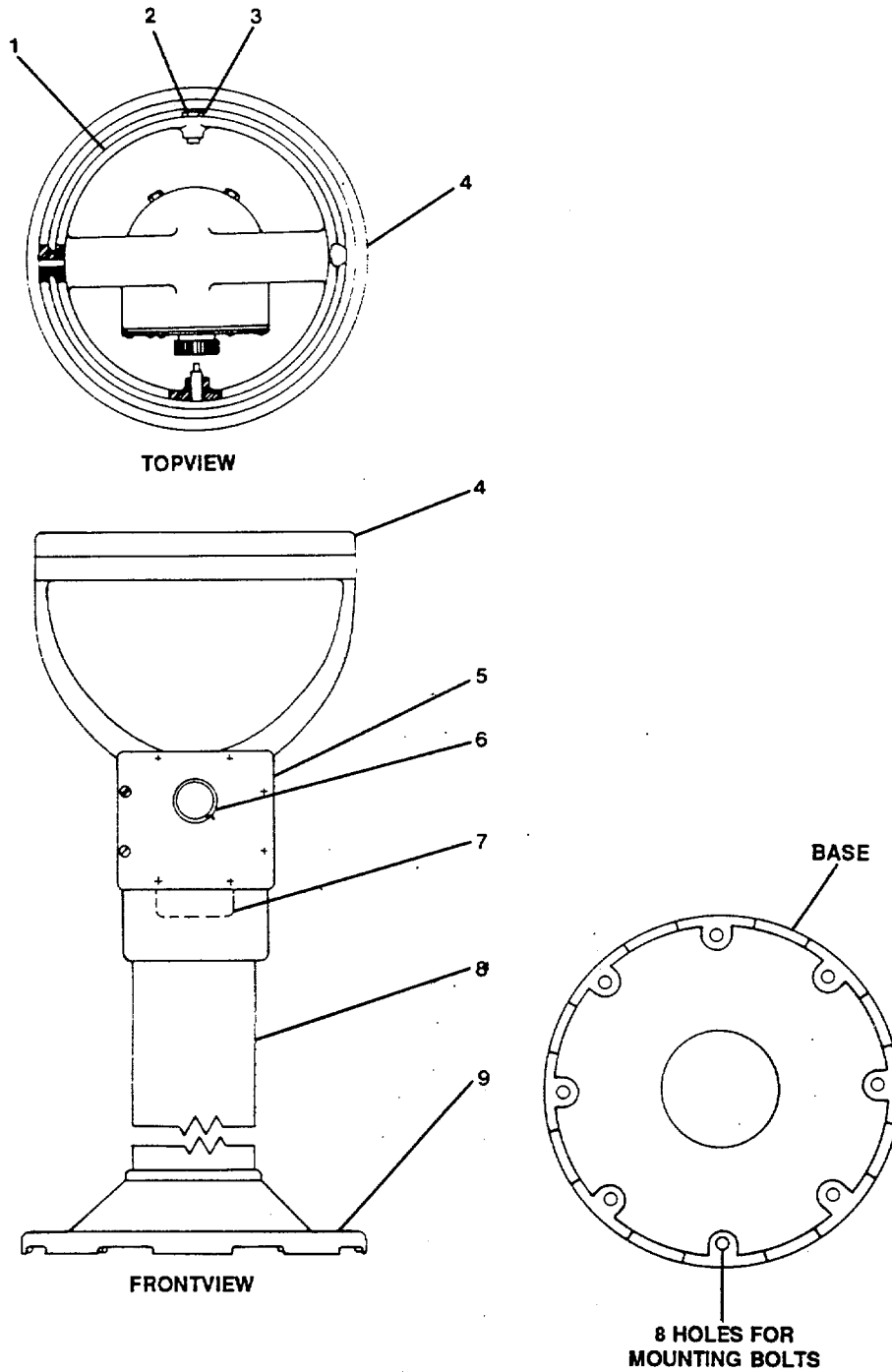

LEGEND

- 1. GIMBAL RING
- 2. PIVOT SCREW
- 3. PIVOT SCREW
- 5. COVER PLATE

- 6. KNOB (RHEOSTAT)
- 7. STUFFING TUBE ASSEMBLY (INTERNAL)
- 8. COLUMN ASSEMBLY
- 9. BASE

FIGURE 1-12. Pelorus Stand.

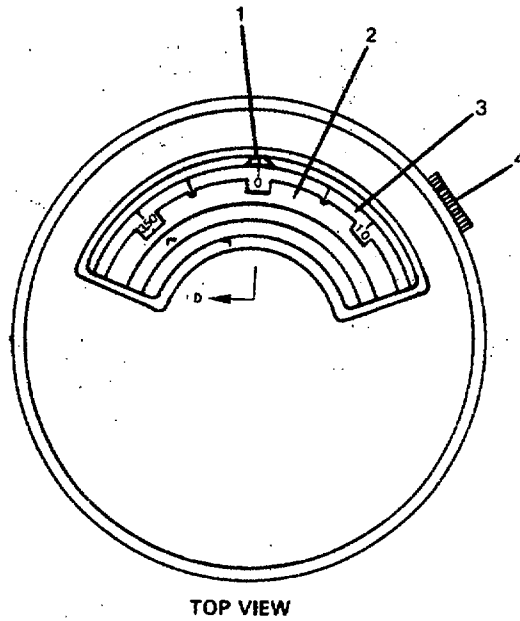

TOP VIEW

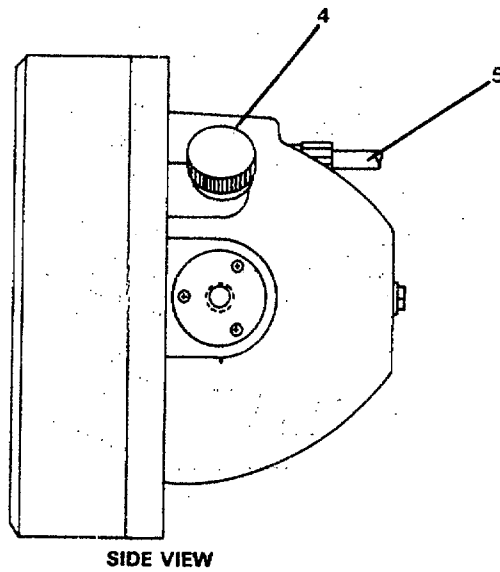

SIDE VIEW

LEGEND

1. LUBBER LINE

2. MASK

3. COMPASS CARD

4..SYNCHRONIZING KNOB

5. CABLE ASSEMBLY

FIGURE 1-13. Open Scale, Repeater.

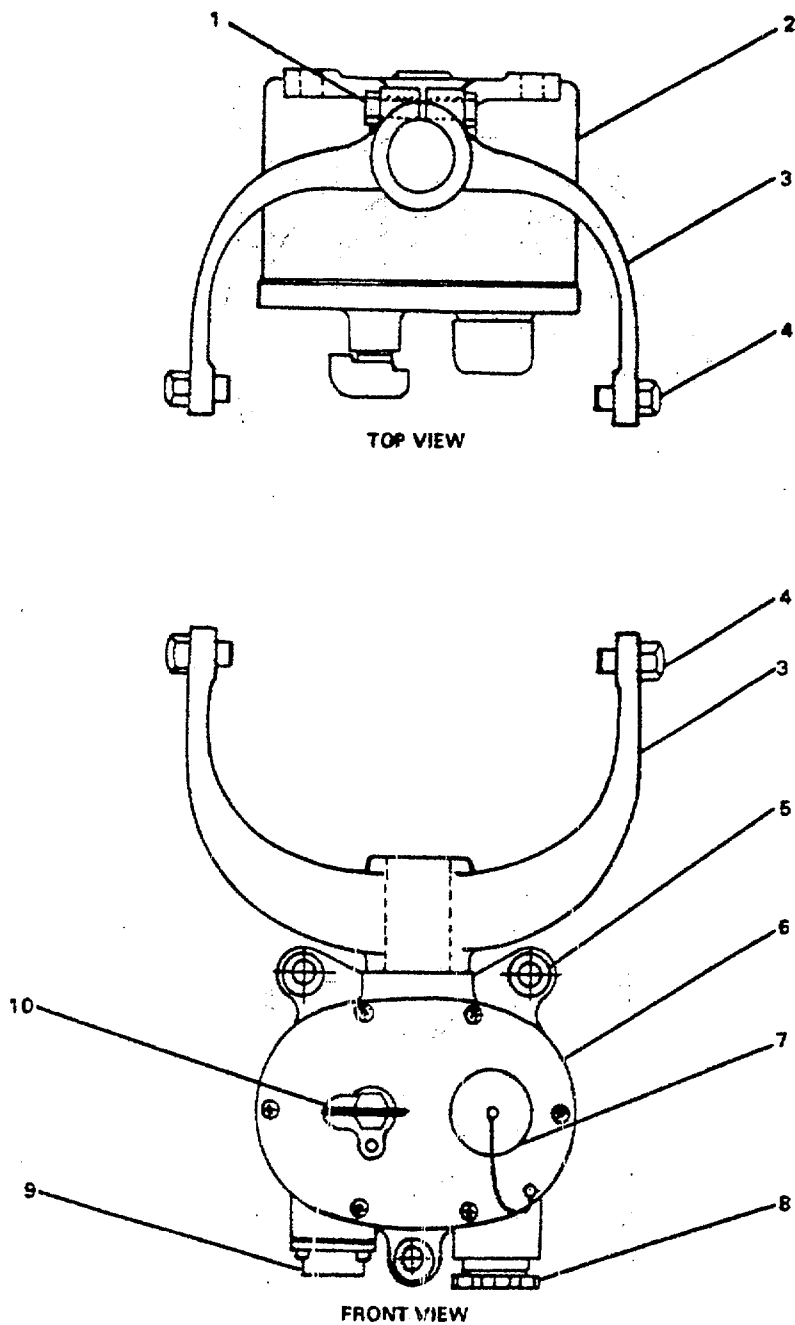

LEGEND

- | | |
|--------------------------|-----------------------------------|
| 1. BASE BOLT | 6. FRONT COVER |
| 2. HOUSING | 7. TOGGLE SWITCH COVER WITH CHAIN |
| 3. MOUNTING BRACKET ARMS | 8. CABLE GLAND (INCOMING) |
| 4. HOLDING SCREWS | 9. CABLE GLAND (TO REPEATER) |
| 5. MOUNTING HOLES (3) | 10. KNOB (RHEOSTAT) |

FIGURE 1-14. Bulkhead Mounting Bracket.

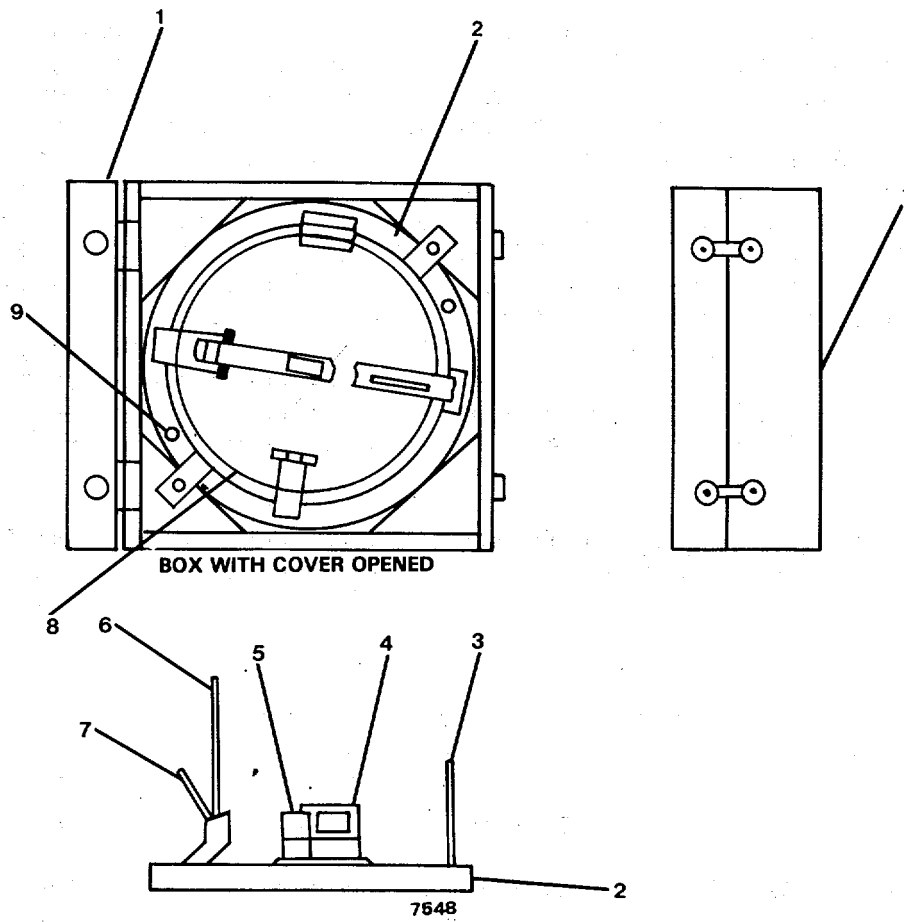

LEGEND

- | | |
|-------------------|----------------------|
| 1. WOODEN BOX | 6. FAR VANE |
| 2. AZIMUTH CIRCLE | 7. REFLECTING MIRROR |
| 3. PEEP VANE | 8. INNER LIP |
| 4. CONCAVE MIRROR | 9. FINGER LUGS |
| 5. PRISM HOUSING | |

FIGURE 1-15. Azimuth Circle and Box.

(a) Terrestrial Bearings. To observe the bearing of a terrestrial object, the observer looks through the peep vane (3) in the direction of the object and by means of finger lugs (9) provided on the circle, turns the circle until the object appears on the vertical wire of the far vane (6). At the base of the far vane (6) is a mirror marked with a center line agreeing with the vertical wire of the far vane (6). The mirror (7) reflects the compass card (of the bearing repeater or magnetic compass) into the view of the observer to see the observed object and the compass card at the same time. The compass bearing of the observed object can then be read by the vertical wire on the compass card.

(b) Celestial Azimuths. A dark glass reflector (7) is attached to the far vane (6), movable about a horizontal axis, enabling the observer to adjust it so that the reflected image of a celestial body can be brought to the observer's eye, and a compass azimuth can be read from the compass card as was described for a terrestrial object. At right angles to the line of sight of the pair of vanes (3 and 6) is another set of observing devices for obtaining the compass azimuth of the sun. Light is reflected by 45 degree reflecting prism encased in a metal housing (5) provided with a slit in which light is received from a concave mirror (4) diametrically opposite, with the slit being in the focus of the concave mirror. Light is reflected downward by the prism and appears on the graduations of the compass card as a bright narrow band or line. To observe the compass bearings of the sun with this arrangement, the observer turns the-azimuth circle until the sun's rays are reflected by the mirror across the card to the prism, where the bearing can be read on the compass card by means of the narrow band of light.

c. Gyro Compass Equipment Data. Reference data for the Gyro Compass System is provided in Table 1-1. Also see the equipment data given in the operator's manual, TM 55-1905-223-10.

Table 1-1. Equipment Data

Characteristic	Reference Data
Gyro Compass Power Input	24 Vdc from gyro control and power assembly
gyro Control and Power Assembly Power Input	24 Vdc from power converter or from power transfer unit (normal power failure)
Power Converter Power Input power source	120 Vac, single phase, 60 Hz, from ship's
Switch Unit Power Input	70 Vdc from gyro control and power assembly
Relay Transmitter Power Input power source	120 Vac, single phase, 60 Hz, from ship's
Power Transfer Unit Power Input	24 Vdc from ship's emergency 24 Vdc source 24 Vdc from power converter (sensing voltage)

Table 1-1. Equipment Data - CONT

Characteristic	Reference Data
Bearing Repeater Power Input	70 Vdc step voltage 24 Vdc lamp voltage
Pelorus Stand Power Input	70 Vdc step voltage 24 Vdc lamp voltage
Open Scale Repeater Power Input	70 Vdc step voltage 24 Vdc lamp voltage
Bulkhead Mounting Bracket Power Input	70 Vdc step voltage 24 Vdc lamp voltage

d. Safety, Care and Handling. Safety precautions must be observed at all times while performing maintenance. General WARNINGS and first-aid data appear in front of this manual. Review all safety information before starting any task. Carefully read through an entire maintenance procedure before performing any maintenance function. Make sure the task can be done safely. All WARNINGS, CAUTIONS, and NOTES are of great importance to your safety and the safety of the equipment.

(1) Keep Away From Live Circuits. The soldier must at all times observe all safety regulations. Do not replace components inside the equipment with power turned on. Under certain conditions, dangerous potentials may exist when power is turned off. Always remove power at its source, and discharge or ground a circuit before touching it.

(2) Do Not Service Alone. Under no circumstances should any soldier reach into or enter an enclosure for the purpose of maintenance or service of the equipment except in the presence of another soldier who is capable of rendering aid and assistance.

(3) Resuscitation. Soldiers working with or near energized equipment should be familiar with modern methods of resuscitation.

1-7. Magnetic Compass.

a. Equipment Characteristics, Capabilities, and Features. These are broad points about the magnetic compass.

(1) Characteristics:

o Magnets align themselves with the magnetic field in which they exist.

- o Magnetic compasses are important because they do not require power.

(2) Capabilities and Features.

- o 0° on the compass card, attached to the magnets, always points to magnetic north.
- o The vessel's heading is indicated by the alignment of the compass card and the lubber's line.

b. Location and Description of Major Components. The Magnetic Compass System equipment (FIGURE 1-2) consists of a binnacle containing a 7-1/2 inch Navy standard type reflector compass. The binnacle is located on top of the wheel house (FIGURE 1-3) with the reflector tube assembly extending down through the pilot house overhead for viewing by the soldier at the helm.

(1) Binnacle. The binnacle (FIGURE 1-16, Sheet 1) consists of a pedestal mounted to the pilothouse top by eight bolts through a bottom ring. Also included in the binnacle are the hood, quadrantal spheres and brackets, rheostat, toggle switch, and access door. Located in the pilot house is the reflector tube assembly secured to the overhead by a ceiling flange. Also in the pilot house is the reflector mirror housing containing the reflector mirror and mirror adjusting knobs. FIGURE 1-16, Sheet 2 shows the flinders bar tube attached to the pedestal by two brackets and with a cap. The pedestal houses the heeling magnet assembly and lens assembly. The hood houses the hood lamp and covers the magnetic compass.

(2) Magnetic Compass. The magnetic compass (FIGURE 1-17) is a 7-1/2 inch reduced diameter dead beat card in Navy standard type, silvered bowl graduated 0-360 degrees, under lighted. The compass is suspended by bronze bearings in a gimbal ring mounted on spring suspension to reduce vibration.

c. Magnetic Compass Equipment Data. The following reference data applies to the magnetic compass system:

Binnacle Power Input: 24 Vdc, single phase, 60 Hz.

d. Safety, Care and Handling. Safety precautions must be observed at all times while performing maintenance. General WARNINGS and first-aid data appear in front of this manual. Review all safety information before starting any task. Carefully read through an entire maintenance procedure before performing any maintenance function. Make sure the task can be done safely. All WARNINGS, CAUTIONS, and NOTES are of great importance to your safety and the safety of the equipment.

(1) Keep Away From Live Circuits. Soldiers must at all times observe all safety regulations. Do not replace components inside the equipment with power turned on. Under certain conditions, dangerous potentials may exist when power is turned off. Always remove power at the source, and discharge or ground a circuit before touching it.

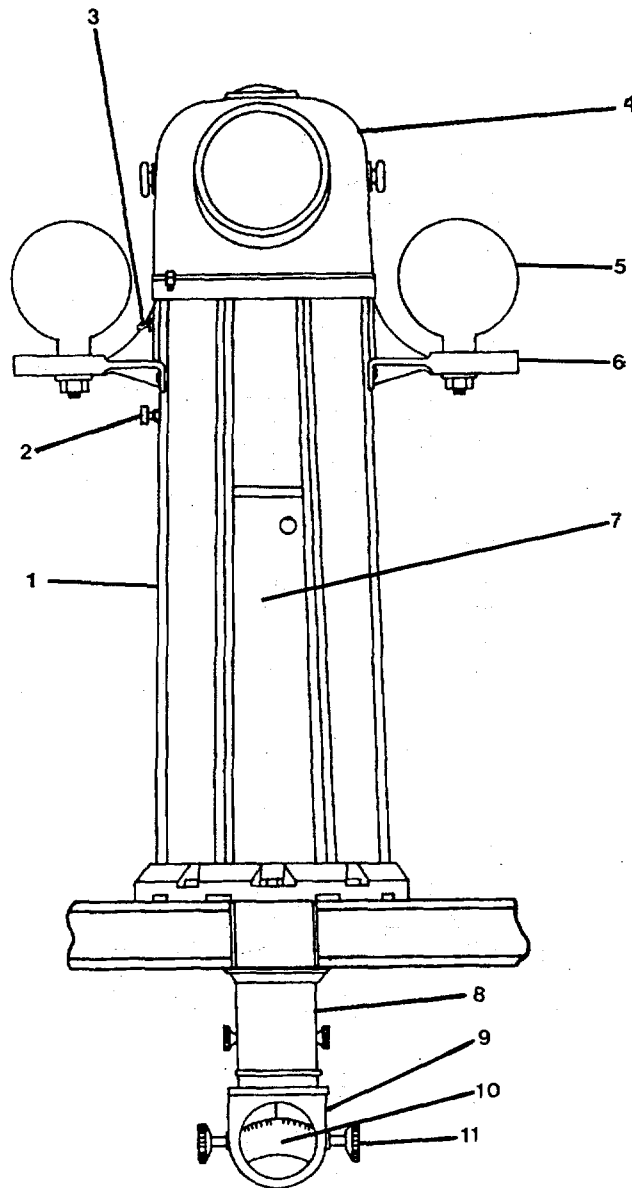

LENGEND

- 1. PEDASTAL
- 2. RHEOSTAT KNOB
- 3. TOGGLE SWITCH
- 4. HOOD
- 5. QUADRANTAL SPHERES
- 6. BRACKETS
- 7. ACCESS DOOR
- 8. REFLECTOR TUBE ASSEMBLY
- 9. REFLECTOR MIRROR HOUSING
- 10. REFLECTOR MIRROR
- 11. ADJUSTING KNOB

FIGURE 1-16. Binnacle (Sheet 1 of 2).
1-25

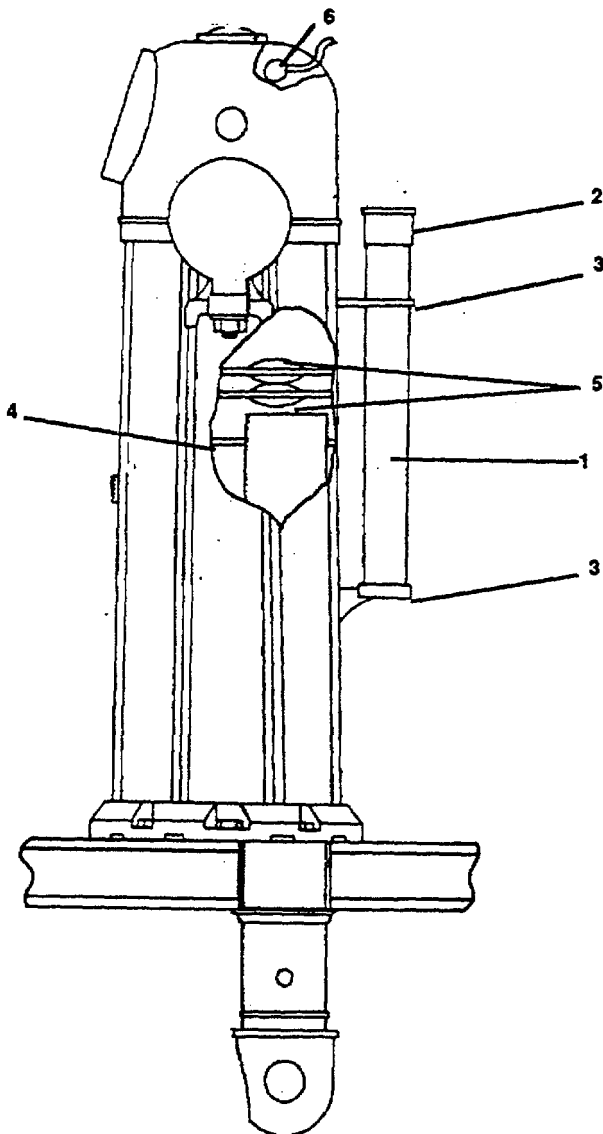

LENGEND:

- 1. FLINDERS BAR TUBE
- 2. CAP
- 3. BRACKETS

- 4. HEELING MAGNET ASEMBLY
- 5. LENS ASSEMBLY
- 6. HOOD LAMP

FIGURE 1-16. Binnacle (Sheet 2 of 2).

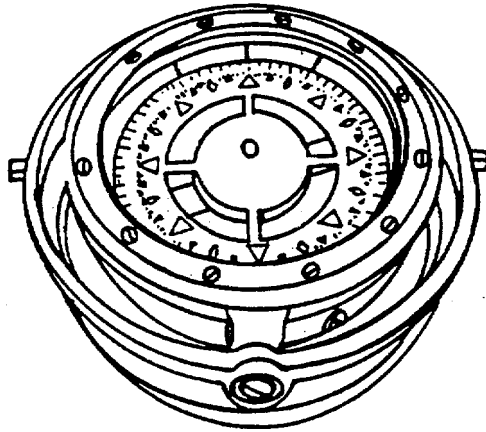

FIGURE 1-17. Magnetic Compass.

(2) Do Not Service Alone. Under no circumstances should any soldier work on energized equipment alone, except in the presence of another soldier who is capable of rendering aid and assistance.

(3) Resuscitation. Soldiers working with or near energized equipment should be familiar with modern methods of resuscitation.

Section III. PRINCIPLES OF OPERATION

Overview of Gyro and Magnetic Compass Systems

The Principles of Operation section will tell you basic information about how these two compass systems work.

1-8. **Gyro Compass.**

a. Power Distribution. Gyro compass system (Sheet 1, FIGURE 2-18) power (FIGURE 1-18) is supplied from 120 Vac, single phase, 60 Hz input from the pilothouse IC/ELEX (interior communications/electronics) panel to the power converter (Sheet 2). The power converter converts the 120 Vac input to 24 Vdc. This normal operating power of 24 Vdc is supplied to the power transfer unit. The power converter also supplies 120 Vac to the gyro control and power assembly. The power transfer unit transfers the gyro compass equipment from the normal 24 Vdc input power to the emergency 24 Vdc supply in the event of normal supply failure.

The gyro control and power assembly receives its operating 24 Vdc normally from the power converter through the power transfer unit and in an emergency, from the ship's 24 Vdc source. The switch unit (Sheet 3) receives dc power from the gyro control and power assembly. It amplifies the power to the two open scale repeaters. Another output from the switch unit is applied to the relay transmitter (Sheet 4). The relay transmitter receives 120 Vac, single phase, 60 Hz power from the pilothouse IC/ELEX panel. This assembly converts the ship's ac input power to +70 Vdc output for the repeaters. The unit also provides dc output distribution for the amplified compass step data. In the event of an overload on any channel output, the data for that particular channel is turned off automatically by internal circuitry-and the alarm lamp on circuit card A1 lights. When the overload has been removed, such as by turning off the defective channel, the overload circuit automatically resets itself with the next change in input data. However, the overload lamp will remain on until the reset switch A1S1 is depressed. This will alert maintenance personnel to momentary overloads which might otherwise go unnoticed. The open scale repeaters (Sheet 5) receive step data power and 70 Vdc supply from the switch unit through the bulkhead mounting bracket. The bearing repeaters (Sheet 6) receive step data, power, and 70 Vdc from the relay transmitter through the pelorus stand. The stand contains a rheostat for controlling the 70 Vdc lamp power.

b. Slew Mode. The SLEW position of the mode selector switch gives the operator manual control of the gyro compass. The compass card can be slewed in either direction using the tilt/azimuth switch. The slew signal is routed to the servoamplifier for amplification to drive the azimuth motor. The gyro does not run, the CAGED lamp is illuminated, and the, cager is engaged in the slew mode. Resistor R10 develops the input voltage for slewing and sets the rate at which the compass slews.

WARNING

To prevent personal injury, the gyro must be caged to prevent tilt while the gyro comes up to speed. Use caution when leveling the gyro since uncaging enables it to tilt.

c. Start Mode. With the mode selector switch in START position, power is applied to the gyro motor. Once the wheel is brought up to speed, the gyro is uncaged and manually leveled using the level meter. A special start circuit establishes a three-phase voltage sequence when the gyro is starting, because impedance of the motor windings when the gyro is starting and accelerating is appreciably different from impedance of the motor when the gyro is up to speed. The 120 volt, 60 Hz winding of transformer T2 in the power supply is the source of power for the start circuit and gyro motor. While the gyro motor is coming up to speed, the vertical ring and sphere are caged to prevent tilt and the compass is slewed to heading. Once the gyro has developed sufficient momentum it is uncaged.

d. Run Mode. Normal operation of the gyro compass takes place when the mode selector switch is at RUN position. All circuits operate the same as in start mode except any output from the tilt/azimuth switch is shorted to ground. This protects the compass against being upset by accidental operation-of the switch after the compass has started to settle. The pickoff signal is coupled to the servoamplifier, and the amplifier increases the signal and drives the azimuth motor. Output of the servoamplifier is also fed to the alarm circuit to provide an indication if follow-up system failure should occur.

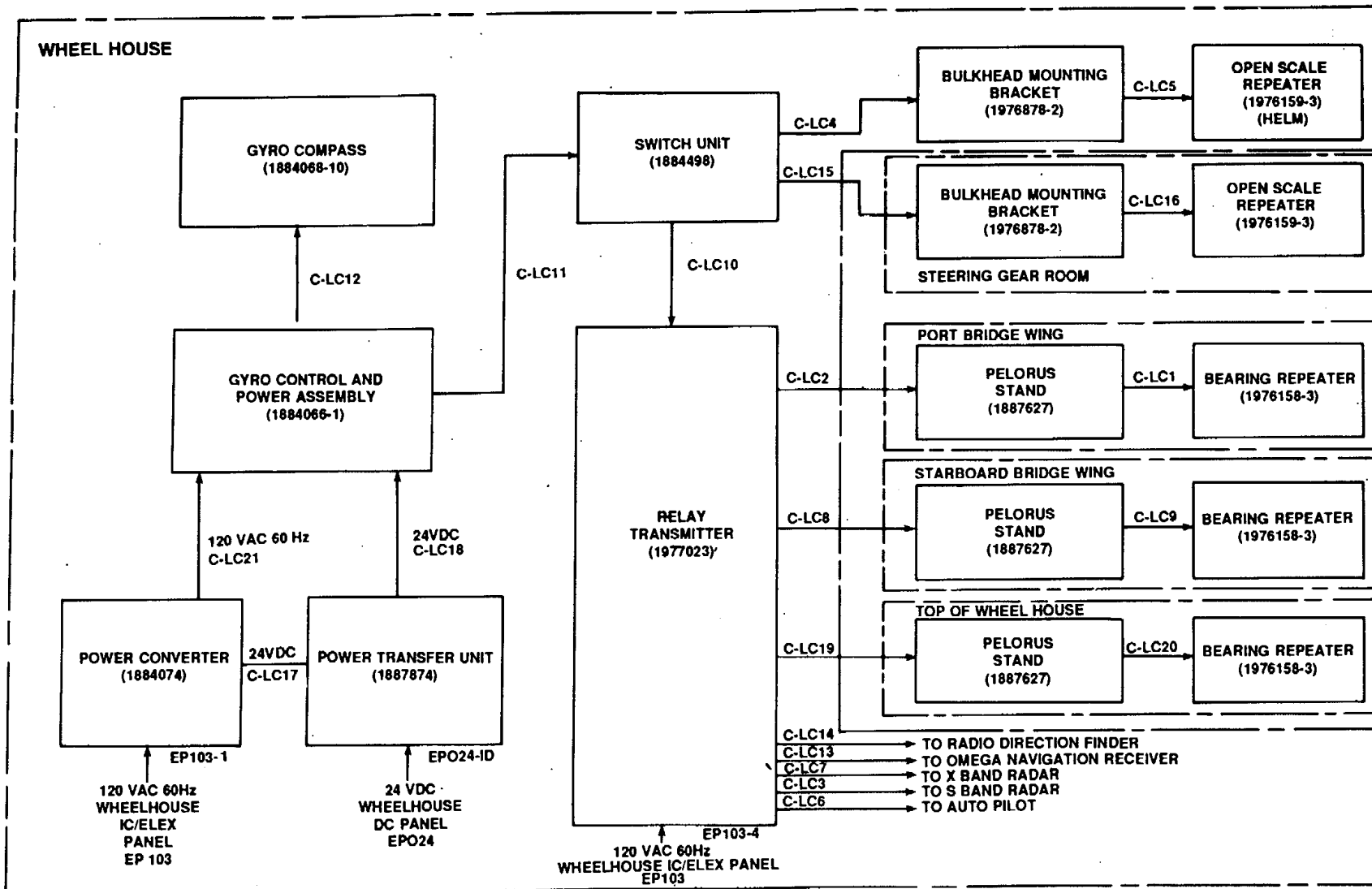

FIGURE 1-18. Gyro Compass System (Sheet 1 of 6).

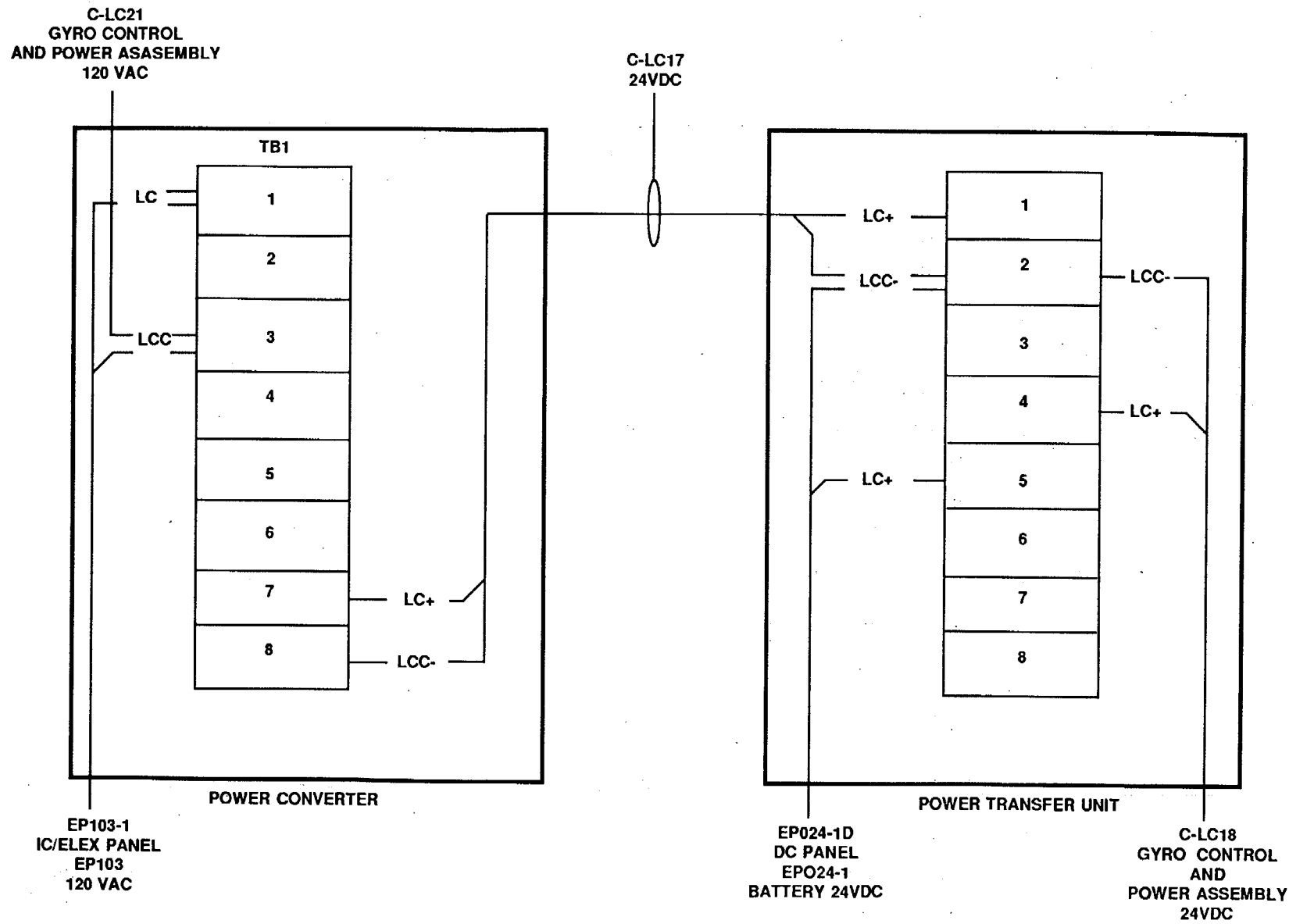

FIGURE 1-18. Gyro Compass System (Sheet 2-of 6).

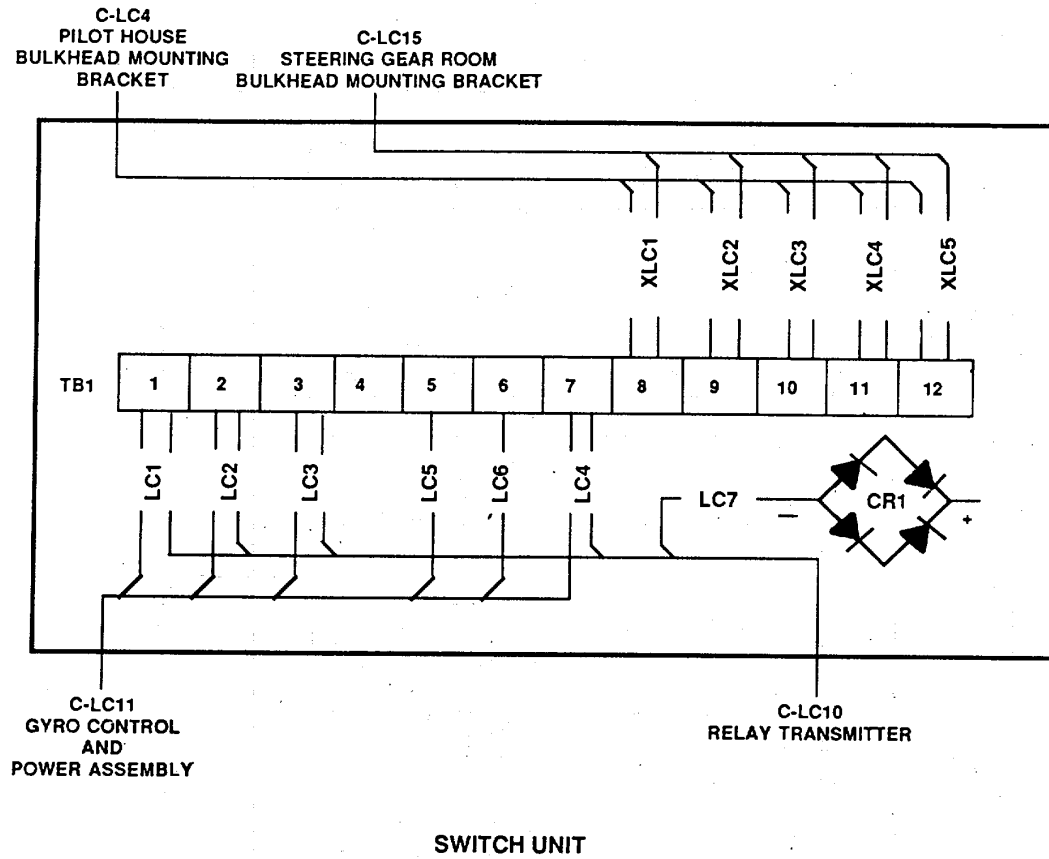

FIGURE 1-18. Gyro Compass System (Sheet 3 of 6).

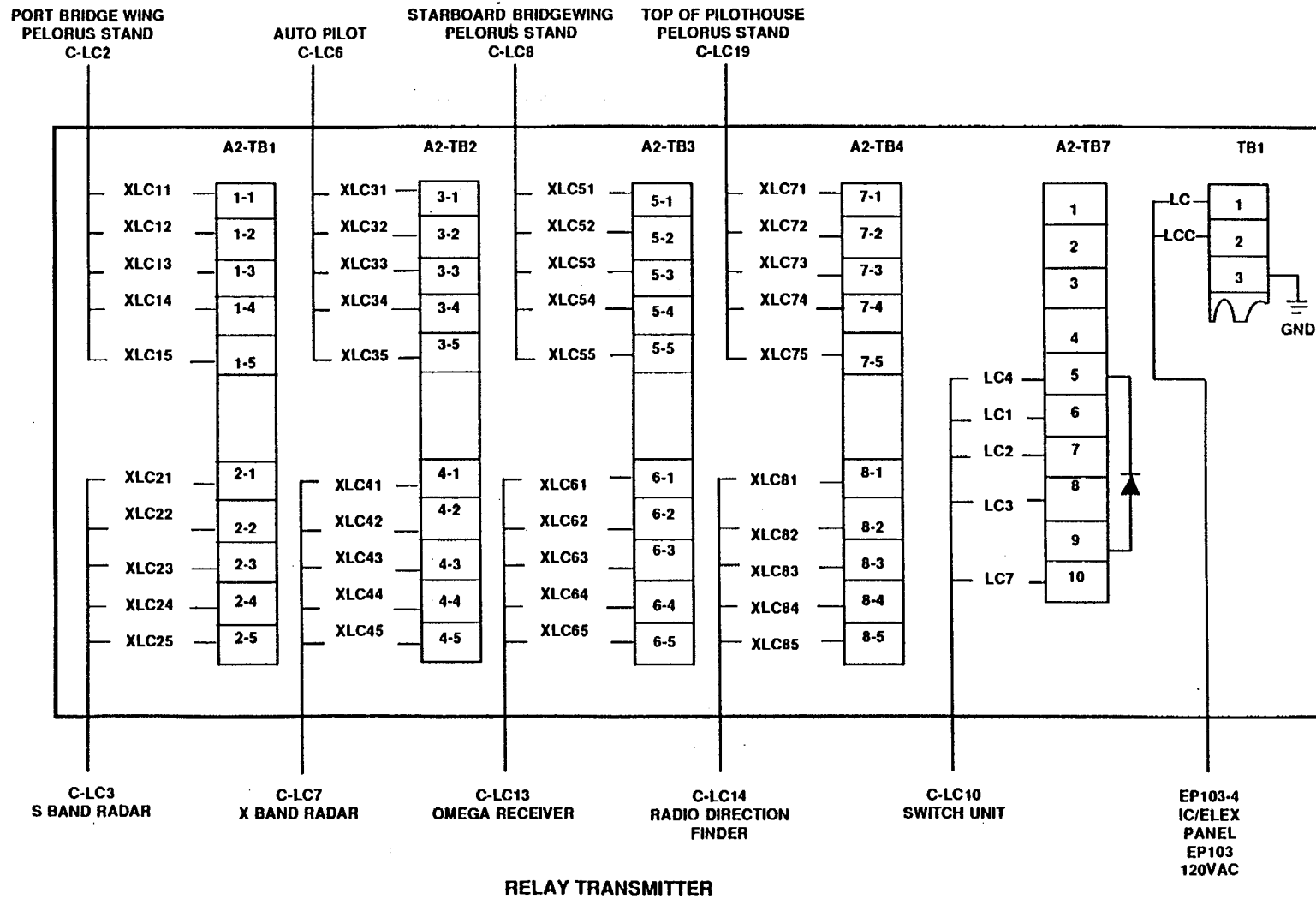

FIGURE 1-18. Gyro Compass System (Sheet 4 of 6).

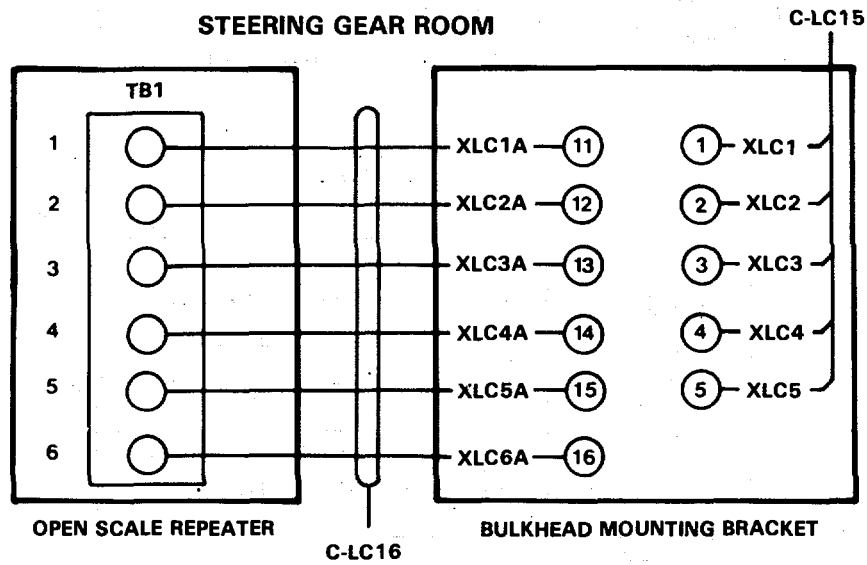
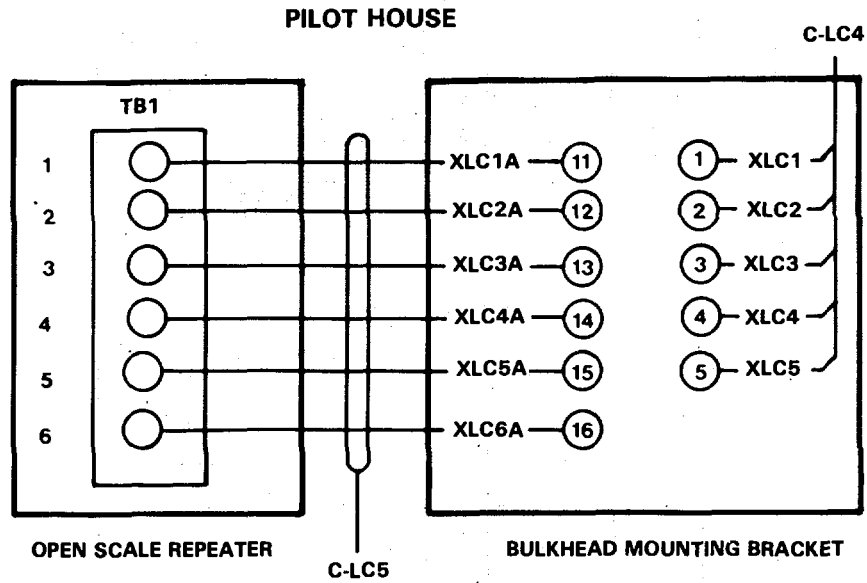

FIGURE 1-18. Gyro Compass System (Sheet 5 of 6).

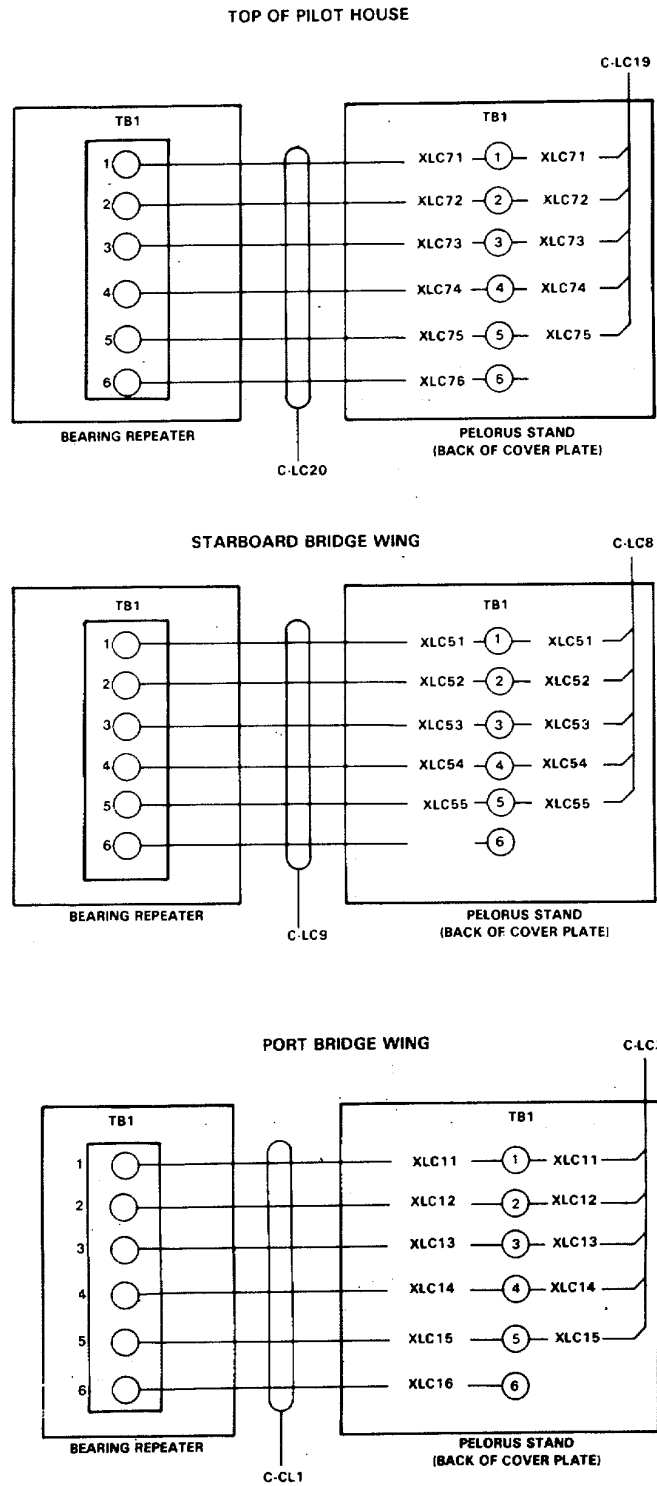

FIGURE 1-18. Gyro Compass System (Sheet 6 of 6).

e. Manual Level Mode. The manual level position of the mode selector switch connects the output of the tilt/azimuth switch to the input of the servoamplifier. Leveling is done in the manner described in the start mode. Leveling is accomplished by offsetting the phantom fork and vertical ring in azimuth with respect to the rigid gyrosphere, thereby forcing the stops on the vertical ring to deflect the springs attached to the gyrosphere. The pressure of the springs creates a vertical torque which causes the gyro to precess about the horizontal axis. When the gyro is caged in this mode and the tilt/azimuth switch is used to introduce a large tilt, the horizontal torque developed by the pressure of the cager spring precesses the compass in azimuth. This is used to slew the compass to a desired heading when the gyro is up to speed.

f. Automatic Level Mode. This mode is used to rapidly level the gyro while it is still running after being dumped or heavily tilted. Tilt of the gyro axis is detected by an electrolytic level located on top of the vertical ring which contains electrodes immersed in an electrolytic fluid. Leveling is accomplished by using the signal output of the level to offset the phantom fork and apply a torque to the gyro in the same manner as that described in the manual level mode for the tilt/azimuth signal. The level signal is routed to the tilt indicating circuit to provide a visual display of gyro tilt on the level meter. The automatic leveling system provides a course level only to within 4 to 5 minutes because the clearance between the stops on the vertical ring and the springs on the gyrosphere allows a $\pm \frac{1}{2}$ degree dead spot to exist with no torque developed. The manual level mode must be used for precise leveling.

g. Transmission System. The gyro compass, primarily a direct reading compass, is also equipped with synchro transmitters and step transmitters to transmit the compass heading indication to external repeaters.

1-9. **Magnetic Compass**. When a compass is mounted on a vessel, its magnets align themselves with the magnetic field in which they exist. If there are no local influences (objects of magnetic material or electrical currents), this alignment will be parallel to the horizontal component of the earth's magnetic field. The compass card will maintain this alignment regardless of the vessel's heading.

a. Compass Card. As the compass card is attached to the magnets, the 0° mark on the card always points in the direction of magnetic north, and the vessel's compass heading is indicated by the alignment of the compass card and the lubber's line. If there are no local disturbing influences and no deviation, then this is also the magnetic heading. When a compass is installed, great care must be taken to align the lubber's line exactly parallel to the center line of the vessel. The compass bowl and lubber's line are constrained to turn with the vessel; thus, the direction of the lubber's line from the center of the compass always represents the direction of the vessel's head. Since the 0° mark on the card is always toward the magnetic north, the direction indicated on the compass card opposite the lubber's line is the vessel's heading. As the vessel turns, the lubber's line turns with it, while the compass card remains aligned with north, so that the heading at any moment is indicated at the lubber's line. The lubber's line, not the compass card, turns.

(1) Deviation. The compass needle, free to turn horizontally, tends to align itself with the earth's magnetic lines of force. It is not free to do so in a steel vessel; such vessels have marked magnetic properties of their own, and these tend to deflect the compass from the magnetic meridian. The divergence caused between the north-south axis of the compass card and the magnetic meridian is called deviation. Even in a vessel made of wood or fiberglass there is enough magnetic material on board (engines, fuel and water tanks, and rigging) to cause deviation.

(a) Electrical. The possibility of deviation from electrical circuits cannot be overlooked. Direct currents (dc) flowing in straight wires establish magnetic fields. Care must be taken that all wiring in the vicinity of a magnetic compass is properly installed to eliminate or reduce any effect on the compass.

(b) Variation. Although deviation differs from variation in that variation is caused by the earth's magnetism, the two are designated in the same manner. If no deviation is present, the compass card lies with its axis in the magnetic meridian and its north point indicates the direction-of magnetic north. If deviation is present and the north point of the compass points eastward of magnetic north, the deviation is named easterly and marked E. If it points westward of magnetic north, the deviation is named westerly and marked W. The navigator can easily find the correct variation by referring to the compass rose on the chart of the vessel's position. Deviation, however, is not as easy to recognize. It varies not only on different vessels, but on any particular ship it varies with changes in the vessel's heading. It also changes with large changes in the vessel's magnetic latitude.

(2) Compass Error. The algebraic sum of variation and deviation is compass error. The navigator must understand thoroughly how to apply variation, deviation, and compass error, in order to use them in converting one kind of direction to another. There are three ways in which a direction can be expressed:

(a) As true, when the true (geographic) meridian is the reference of measurement.

(b) As magnetic, when the magnetic meridian is the reference of measurement.

(c) As compass, when the axis of the compass card is the reference of measurement.

(d) Any given direction may be expressed in all three of these ways, if it is understood that true differs from magnetic by variation, magnetic differs from compass by deviation, and compass differs from true by compass error.

b. Coefficients of Deviation. The total local magnetic effects which cause deviation of a vessel's compass can be broken down into a series of components termed coefficients. Soft iron is material in which magnetism is induced by the earth's magnetic field. This magnetism changes as its orientation with respect to the earth's magnetic field changes. On the other hand, the vessel's hard iron has the relative permanent magnetism acquired during construction and fitting-out. Soft and hard iron are also classified as horizontal or vertical, according to the orientation of their magnetic axes when induced by components of the earth's field.

(1) Coefficient A is constant on all headings and may be a combination of other parameters or may be mechanical, as from an incorrectly placed lubber's line (binnacle misaligned).

(2) Coefficient B is maximum on compass headings east or west and zero on compass headings north or south.

(3) Coefficient C is maximum on compass headings north or south and zero on east or west.

(4) Coefficient D is quadrantal deviation. It is maximum on intercardinal headings (0450-1350-2250-3150), and zero on cardinal headings (North-South-East-West).

(5) Coefficient E is quadrantal deviation, which is maximum on the cardinal compass headings and zero on the intercardinal headings.

(6) Coefficients D and E are caused by induced magnetism in horizontal soft iron, and are compensated for by the use of the soft iron quadrantal spheres mounted on brackets athwartships on the binnacle.

c. Heeling Error. Coefficient J is defined as the change of deviation for a heel of 1° while the vessel is on compass 0° . It is, in effect, the error caused because the compass, with its gimbaling arrangement, remains in a horizontal plane while the vessel, with its magnetic field, rolls and pitches. A slight change in the relative positions of the compass and vessel is therefore introduced. This change in deviation caused by the motion of the vessel can cause the compass card to oscillate. Coefficient J is compensated for by a heeling magnet placed in a vertical tube directly below the center of the compass.

d. Flinders Bar. On the magnetic equator, there is no vertical component of the earth's magnetic field, and therefore no induced magnetism in vertical soft iron. At other locations, such as at higher latitudes, the vertical component can cause the compass to become more unreliable than if the force is neutralized. To compensate for or neutralize any induced magnetism in vertical soft iron, a flinders bar is used. This consists of sections of soft iron having no permanent magnetism; as many sections as required are installed vertically in a tube on the side of the compass opposite to the effective pole of the vessel's field.

e. Periscopic Reflection. The periscopic reflection compass and binnacle can be used as a combined steering and bearing compass. It permits installing the compass on the level above the pilothouse or wheelhouse. The image of the compass card is reflected down periscopically and presented in the field of view of the soldier at the helm. The compass itself is removed from the enclosed pilothouse, where it would be surrounded by metal and much electrical and electronic equipment. On the open deck above, bearings and azimuths may be obtained directly on the compass itself, either for navigation or for checking the compass.

1-10. **Power Distribution.** The binnacle (FIGURE 1-19) receives 24 Vdc from the pilothouse dc panel via ship's cable. The cable is routed in the pilothouse top, up through the deck and pedestal to an internal terminal block. The terminal block connections supply power to the hood lamp through a toggle switch and rheostat. The internal wiring is terminated on the hood plug. The hood lamp cable runs out of the hood on the forward side and connects to the hood plug.

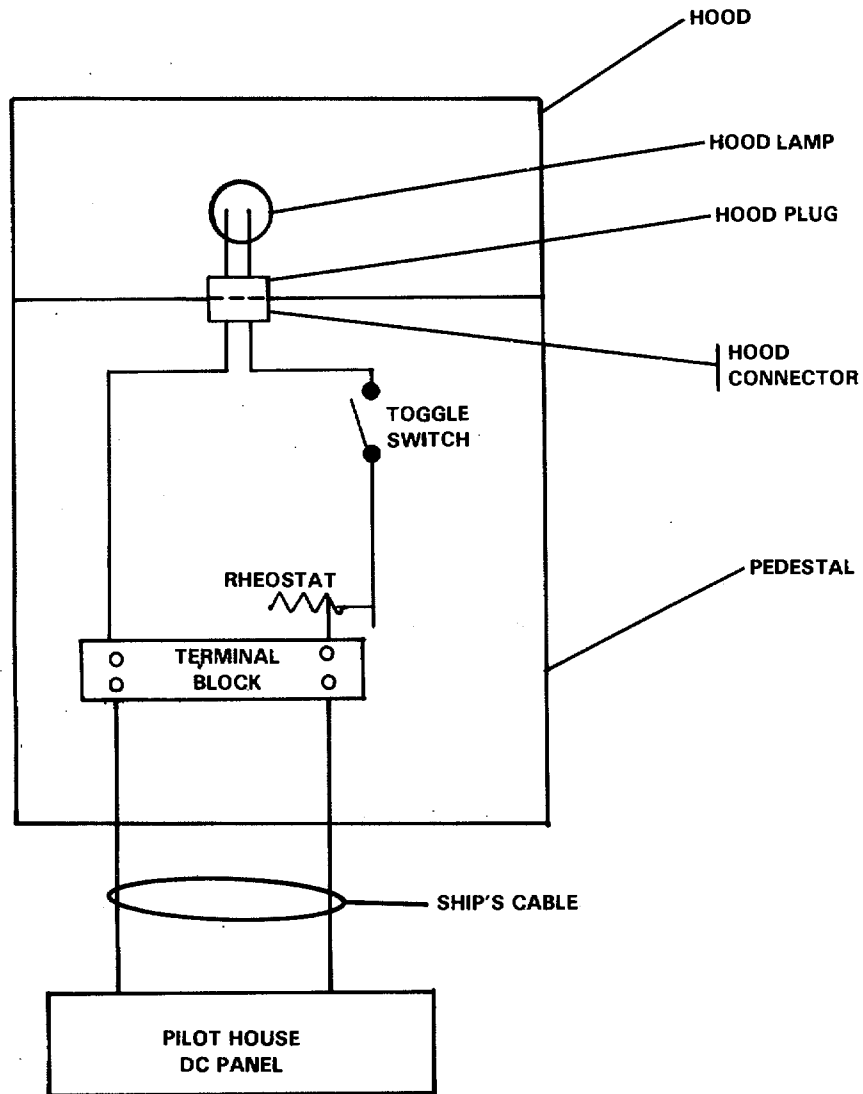

FIGURE 1-19. Binnacle Power Distribution.

CHAPTER 2

UNIT MAINTENANCE INSTRUCTIONS

	<u>Page</u>
Section I. Repair Parts, Special Tools; Test, Measurement, and Diagnostic Equipment (TMDE); and Support Equipment	2-1
Section II. Service Upon Receipt	2-1
Section III. Unit Preventive Maintenance Checks and Services (PMCS)	2-2
Section IV. Unit Maintenance Troubleshooting.	2-8
Section V. Unit Maintenance Procedures	2-16
Section VI. Preparation for Storage or Shipment	2-82

Section I. REPAIR PARTS, SPECIAL TOOLS; TEST, MEASUREMENT, AND DIAGNOSTIC EQUIPMENT (TMDE); AND SUPPORT EQUIPMENT

2-1. **Common Tools and Equipment** . For authorized common tools and equipment, refer to the Modified Table of Organization and Equipment (MTOE) applicable to your organization.

2-2. **Special Tools, TNDE, and Support Equipment** . Special tools; test, measurement, and diagnostic equipment; and support equipment requirements are listed and illustrated in the Repair Parts and Special Tools List (RPSTL), TM 55-1905-223-24P. These items are also listed in the Maintenance Allocation Chart (MAC), Appendix B of this manual.

2-3. **Repair Parts**. Repair parts are listed and illustrated in the Repair Parts and Special Tools list (RPSTL), TM 55-1905-223-24P.

Section II. SERVICE UPON RECEIPT

2-4. **Checking Unpacked Equipment**.

- a. Inspect the equipment for damage incurred during shipment. If the equipment has been damaged, report the damage in accordance with the instructions of DA Pam 738-750.
- b. Check the equipment against the packing slip to see if the shipment is complete. Report all discrepancies in accordance with the instructions of DA Pam 738-750.
- c. Check to see whether the equipment has been modified.
- d. Remove protective caps, plugs, inserts, wrappings, and tape when inspection/inventory is completed. Inspect piping openings for damage. Wipe off dirt, grease, or protective films at time of installation.

e. Remove chocks from resilient mounted components.

2-5. **Initial Setup Procedure.** Includes operations checks and inspections that are not performed for a routine startup. Direct support maintenance personnel will perform initial setup in accordance with the operator's manual TM 55-1905-223-10.

2-6. **Normal Startup.** Refer to operator's manual TM 55-1905-223-10.

2-7. **Shutdown Procedure (Usual or Unusual).** Refer to operator's manual TM 55-1905-223-10.

Section III. UNIT PREVENTIVE MAINTENANCE CHECKS AND SERVICES (PMCS)

2-8. **Explanation of PMCS Table.** PMCS is designed to keep the equipment in good working condition. This is accomplished by performing certain tests, inspections, and services. Tables 2-1 and 2-2 list items to be serviced and the procedures needed to accomplish the PMCS. The "Interval" column tells you when to perform a check or service. If needed, PMCS may be performed more frequently than the indicated interval. The "Procedures" column tells you how to perform the required checks and services. If your equipment does not perform as required, see Table 2-3, Troubleshooting. Report any malfunctions or failures on DA Form 2404. In the "TM" Number column on DA Form 2404, record the appropriate Item Number from the PMCS table.

Table 2-1. Unit Preventive Maintenance Checks and Services (PMCS) for the Gyro Compass System

E - Each Watch

W - Weekly

M - Monthly

Item No.	Interval			Items To Be Inspected	Procedures
	E	W	M		
1		•		Compass binnacle	<p>Check for indications of oil seepage around binnacle seams. If seepage is noted, notify your supervisor.</p> <p>Check that binnacle is free in its shock mounts. If not, check for dirt and obstruction. Make sure cable to binnacle is free and flexible.</p> <p>Clean with soft rag (Appendix C, Item 6) and mild soapy water (Appendix C, Item 4).</p> <p>Check for accumulated dirt and oil. Remove dirt with a dusting cloth (Appendix C, Item 2). Remove oil deposits with soft cloth (Appendix C, Item 2) and cleaning solvent (Appendix C, Item 1).</p> <p>Check for operation of lamp prior to sailing of vessel.</p>
2		•		Compass shock mounts	
3		•		Compass viewing window	
4			•	Compass exterior surfaces	
5	•			Gyro control and power assembly FOLLOW-UP ALARM LAMP	
6	•			Gyro control and power assembly CAGED lamp	

Table 2-1. Preventive Maintenance Checks and Services (PMCS) for the Gyro Compass System - CONT

Item No.	Interval			Items To Be Inspected	Procedures
	E	W	M		
7	•			Gyro control and power assembly LATITUDE control	Make sure this is set at local latitude. If not, reset to local latitude (TM 55-1905-223-10).
8	•			Gyro control and power assembly N-S switch proper latitude.	Make sure this switch is set at proper latitude position (TM 55-1905-223-10).
9	•			Gyro control and power assembly level meter	Record average reading of needle oscillations when compass is settled; abnormal deviations in average values indicate a malfunction. Notify your supervisor.
10		•		Gyro control and power assembly cable connections	Make sure cable connections and stuffing tubes are secure with no crimps or breaks.
11			•	Gyro control and power assembly exterior surfaces	Check for any accumulated dirt and oil. Remove dirt with a dusting cloth (Appendix C, Item 2). Remove oil deposits with soft cloth (Appendix C, Item 2) and cleaning solvent (Appendix C, Item 1).
12			•	Switch unit exterior surfaces	Clean with damp soft cloth (Appendix C, Item 2).

Table 2-1. Preventive Maintenance Checks and Services (PMCS) for the Gyro Compass System - CONT

Item No.	E - Each Watch			Items To Be Inspected	W - Weekly	M - Monthly	Procedures
	Interval	W	E				
13			•	Switch unit retaining			Check for looseness and secure. chain/bolt, stuffing tubes, mounting bolts, and fasteners.
14			•	Relay transmitter stuffing tubes, mounting bolts, and fasteners			Check for looseness and secure.
15				• Relay transmitter exterior surfaces			Clean with damp soft cloth (Appendix C, Item 2).
16	•			Bearing repeater lamp			Check illumination by rotating dimmer knob.
17			•	Bearing repeater support			Make sure there is free movement of repeater in support.
18			•	Bearing repeater cable assembly			Make sure there is free movement of repeater in support. Check for kinks or breaks.
19			•	Bearing repeater and pelorus stand exterior surfaces (pilot house top, bridge wings)			Clean with damp soft cloth (Appendix C, Item 2). Check for rust and corrosion.
20	•			Open scale repeater lamp			Check illumination by rotating dimmer knob.
21			•	Open scale repeater mounting bolts and cable assembly			Check for security, crimps, breaks, and condition of cable.
22			•	Open scale repeater and bulkhead mounting bracket exterior surfaces			Clean with damp soft cloth (Appendix C, Item 2). Check for rust and corrosion.

Table 2-1. Preventive Maintenance Checks and Services (PMCS) for the Gyro Compass System - CONT

E - Each Watch

W - Weekly

M - Monthly

Item No.	Interval			Items To Be Inspected	Procedures
	E	W	M		
23		•		Power converter stuffing tubes and mounting bolts	Check for looseness and secure.
24			•	Power converter exterior surfaces	Clean with damp soft cloth (Appendix C, Item 2). Check for rust and corrosion.
25		•		Power transfer unit cover, stuffing tubes, and mounting bolts	Check for looseness and secure.
26			•	Power transfer unit exterior surfaces	Clean with damp soft cloth (Appendix C, Item 2). Check for rust and corrosion.

Table 2-2. Unit Preventive Maintenance Checks and Services (PMCS) for Magnetic Compass System

W - Weekly

M - Monthly

Item No.	Interval		Items To Be Inspected	Procedures
	W	M		
1	•		Binnacle and compass Assembly window	Clean exterior window with damp soft cloth (Appendix C, Item 2).
2	•		Binnacle and compass assembly lenses	Wipe clean with soft cloth (Appendix, Item 2).
3	•		Binnacle and compass assembly mirror	Wipe clean with soft cloth (Appendix, Item 2).
4		•	Binnacle and compass assembly lighting fixture	Check lamp illumination by rotating dimmer knob. Make sure knob functions freely. Inspect lighting fixture for looseness or corrosion. If fixture is loose or corrosion exists, notify your supervisor.
5	• •		Binnacle and compass assembly pedestal (pilot house top)	Make sure toggle switch functions freely. Clean surface with a damp soft cloth (Appendix C, Item 2).

SYMPTOM INDEX - CONT

GYROCOMPASS

Does not offset	Item 17
Does not slew correctly	Item 11
Fails to slew	Item 10
Slews erratically	Item 19
Slews rapidly	Item 9,18
Slews when compass is caged	Item 8

OPEN SCALE REPEATER

Does not track gryocompass	Item 22, 24, 25
Lamps do not dim	Item 26
Lamps not lit	Item 23

PANEL LAMPS

Not lit	Item 1, 2, 3
---------	--------------

POWER LAMP

Not lit	Item 4, 7, 20, 21
---------	-------------------

MAGNETIC COMPASS SYSTEM

BINNACLE HOOD LAMP

Not lit	Item 1
---------	--------

MAGNETIC COMPASS

Bubbles	Item 2
Erratic	Item 3

Table 2-3 lists the common fault conditions that may be found during operation or maintenance of the equipment. Look for causes and do corrective actions in the order listed. This manual cannot list every symptom that may show up, and it cannot list all the possible causes and corrective actions. If a symptom is not listed, or if it keeps up after you have performed the corrective actions, notify your supervisor.

Table 2-3. Unit Maintenance Troubleshooting

Malfunction	Test or Inspection	Corrective Action
-------------	--------------------	-------------------

GYRO COMPASS SYSTEM

1. No panel lamps lit on gyro control and power assembly.
 - STEP 1. Check to see if 8 AMP dc fuse blown.
Replace 8 AMP dc fuse (para. 2-14c).
 - STEP 2. Check to see if 1 AMP ac fuse is blown.
Replace 1 AMP ac fuse (para. 2-14b).
2. No panel lamps lit, 8 AMP dc fuse good on gyro control and power assembly.
 - STEP 1. Check to see if POWER lamp is defective.
Replace POWER lamp (para. 2-14a).
3. No panel lamps lit; 8 AMP dc fuse, 1 AMP ac fuse and POWER lamp good on gyro control and power assembly.
 - STEP 1. Check to see if input power to gyro control and power assembly is defective.
Reset pilothouse IC/ELEX panel circuit breaker No. 1.
4. POWER lamp not lit, CAGED lamp lit on gyro control and power assembly.
 - STEP 1. Check to see if POWER lamp is defective.
Replace power lamp (para. 2-13a).
5. 8 AMP dc fuse continually blows on gyro control and power assembly.
 - STEP 1. Check to see if gyro control and power assembly is defective.
Replace gyro control and power assembly (para. 2-13).
 - STEP 2. Check cable C-LC12 for security, kinks, breaks, etc.
Replace cable C-LC12 (para. 2-14d.).
6. FOLLOW-UP ALARM lamp lit on gyro control and power assembly.
 - STEP 1. Verify that system is not on backup power.
Notify supervisor.
7. POWER lamp not lit on gyro control and power assembly.
 - STEP 1. Check to see if 1 AMP ac fuse is blown.
Replace 1 amp ac fuse (para. 2-14b).

Table 2-3. Unit Maintenance Troubleshooting - CONT

Malfunction	Test or Inspection	Corrective Action
-------------	--------------------	-------------------

GYRO COMPASS SYSTEM - Continued

- STEP 2. Check to see if POWER lamp is defective.
Replace POWER lamp (para. 2-14a).
- STEP 3. Check for power to gyro control and power assembly.
Check IC/ELEX power panel circuit breaker No. 1. Reset.
- STEP 4. Check cables and connections for security, kinks, or breaks.
Replace cables. Refer to TM 55-1905-223-24-18.
- 8. Gyro compass slews when compass caged; CAGED lamp is lit.
 - STEP 1. Check to see if gyro compass is defective.
Replace gyro compass (para. 2-12).
 - STEP 2. Check to see if gyro control and power assembly is defective.
Replace gyro control and power assembly (para 2-13).
- 9. FOLLOW-UP ALARM lamp lit, slews rapidly when TILT/AZIMUTH switch is operated.
 - STEP 1. Check to see if gyro control and power assembly is defective.
Replace gyro control and power assembly (para. 2-13).
- 10. Compass fails to slew when using TILT/AZIMUTH switch; FOLLOWUP ALARM lamp not lit.
 - STEP 1. Check to see if 8 AMP dc fuse is blown.
Replace 8 AMP dc fuse (para. 2-14c).
 - STEP 3. Check to see if gyro control and power assembly is defective.
Replace gyro control and power assembly (para. 2-13).
- 11. FOLLOW-UP ALARM lamp lit, compass does not slew correctly when TILT/AZIMUTH switch operated.
 - STEP 1. Check to see if gyro control and power assembly is defective.
Replace gyro control and power assembly (para. 2-13).
- 12. CAGED lamp does not light when compass caged.
 - STEP 1. Check to see if CAGED lamp is defective.
Replace CAGED lamp (para. 2-14).

Table 2-3. Unit Maintenance Troubleshooting - CONT

Malfunction	Test or Inspection	Corrective Action
-------------	--------------------	-------------------

GYRO COMPASS SYSTEM - Continued

13. Gyro motor will not start.
 - STEP 1. Check cable C-LC12 for security and condition.
Replace cable (para. 2-14d).
 - STEP 2. Check to see if gyro control and power assembly is defective.
Replace gyro control and power assembly (para. 2-13).

14. Gyro motor does not come up to full speed.
 - STEP 1. Check to see if gyro compass is defective.
Replace gyro compass (para. 2-12).
 - STEP 2. Check to see if gyro control and power assembly is defective.
Replace gyro control and power assembly (para. 2-13).

15. Gyro control and power assembly level meter does not indicate level.
 - STEP 1. Check to see if gyro control and power assembly is defective.
Replace gyro control and power assembly (para. 2-13).
 - STEP 2. Check to see if gyro compass is defective.
Replace gyro compass (para. 2-12).

16. Gyro control and power assembly level meter does not change when TILT/AZIMUTH switch is operated (maintains fixed deflection).
 - STEP 1. Check to see if gyro control and power assembly is defective.
Replace gyro control and power assembly (para. 2-13).
 - STEP 2. Check to see if gyro compass is defective.
Replace gyro compass (para. 2-12).

17. Compass does not offset when TILT/AZIMUTH switch is operated; follow-up normal. I
 - STEP 1. Check to see if gyro control and power assembly is defective.
Replace gyro control and power assembly (para. 2-13).

18. Compass slews rapidly when uncaged; level meter full scale.
 - STEP 1. Check to see if gyro compass is defective.
Replace gyro compass (para. 2-12).

Table 2-3. Unit Maintenance Troubleshooting - CONT

Malfunction	Test or Inspection	Corrective Action
GYRO COMPASS SYSTEM - Continued		
19.	Compass slews erratically when uncaged; level meter erratic.	<p>STEP 1. Check to see if gyro compass is defective. Replace gyro compass (para. 2-12).</p>
20.	Relay transmitter POWER lamp not lit when POWER switch is ON.	<p>STEP 1. Check to see if fuse F1 is defective. Replace fuse F1 (para. 2-17).</p> <p>STEP 2. Check to see if POWER lamp is defective. a. Replace POWER lamp (para. 2-17). b. If FUSE F1 and POWER lamp are good, check pilothouse IC/ELEX panel circuit breaker No. 1. Reset.</p> <p>STEP 3. Check cable EP103-4 for security and condition. Replace cable. Refer to TM 55-1905-223-24-18.</p>
21.	Relay transmitter POWER lamp not lit when POWER switch is ON; FUSE F1 good, POWER lamp good, input power good.	<p>STEP 1. Check to see if relay transmitter is defective. Replace relay transmitter (para. 2-16).</p>
22.	Open scale repeater does not track gyro compass.	<p>STEP 1. Check to see if bulkhead mounting bracket power switch is OFF. On bulkhead mounting bracket, set power switch (under cover) to ON position.</p> <p>STEP 2. Check to see if open scale repeater is defective. Replace open scale repeater (para. 2-18).</p>
23.	Open scale repeater lamp(s) not lit.	<p>STEP 1. Check to see if bulkhead mounting bracket power switch is OFF. On bulkhead mounting bracket, set power switch (under cover) to ON position.</p> <p>STEP 2. Check to see if open scale repeater lamps are defective. Replace open scale repeater lamp(s) (para. 2-19).</p>

Table 2-3. Unit Maintenance Troubleshooting - CONT

Malfunction	Test or Inspection	Corrective Action
-------------	--------------------	-------------------

GYRO COMPASS SYSTEM - Continued

- 24. Open scale repeater does not track gyro compass and lamps are lit.
 STEP 1. Check to see if switch unit is defective.
 Replace switch unit (para. 2-15).
- 25. Both open scale repeaters (pilothouse and steering gear compartment) do not track gyro compass and lamps are not lit.
 STEP 1. Check to see if switch unit is defective.
 Replace switch unit (para. 2-15).
- 26. Open scale repeater lamps do not dim when bulkhead mounting bracket dimmer control is operated.
 STEP 1. Check to see if bulkhead mounting bracket dimmer circuit is defective.
 Replace bulkhead mounting bracket (para. 2-22).
- 27. All bearing repeater lamps not lit.
 STEP 1. Check to see if relay transmitter is defective.
 Replace relay transmitter (para. 2-16).
- 28. Bearing repeater lamp(s) not lit, repeater operates normally.
 STEP 1. Check for defective lamp(s).
 Replace bearing repeater lamp(s) (para. 2-21).
- 29. Bearing repeater lamps do not dim when dimmer control on pelorus stand operated.
 STEP 1. Check to see if pelorus stand dimmer circuit is defective.
 Replace pelorus stand (para. 2-23).
- 30. Bearing repeater does not track gyro compass, lamps lit.
 STEP 1. Check to see if relay transmitter is defective.
 Replace relay transmitter (para. 2-16).

Table 2-3. Unit Maintenance Troubleshooting - CONT

Malfunction
Test or Inspection
Corrective Action

GYRO COMPASS SYSTEM - Continued

31. Loss of all auxiliary gyro compass outputs; direction finder, omega receiver, 3CM radar, 10CM radar, auto pilot and all bearing repeater lamps not lit and repeaters inoperative.
- STEP 1. Check to see if relay transmitter is defective.
 Replace relay transmitter (para. 2-16).

MAGNETIC COMPASS SYSTEM

1. Binnacle hood lamp not lit.
- STEP 1. Check to see if input power 24 Vdc from pilothouse dc panel is defective.
- a. Check dc panel circuit breaker No. 1F. Reset.
 - b. If hood lamp does not light, replace lamp (para. 2-28a.).
 - c. If hood lamp still does not light, internal wiring is defective.
 Replace binnacle (para. 2-27).
2. Magnetic compass erratic.
- STEP 1. Check for defective compass (needles sluggish or not moving).
 Replace magnetic compass (para. 2-27).
- STEP 2. Check for low fluid level.
 Replace/add compass fluid (para. 2-28).
3. Bubbles in magnetic compass.
- STEP 1. Check for loss of compass fluid.
 Replace compass fluid (para. 2-28).
-

Section V. UNIT MAINTENANCE PROCEDURES

2-10. Introduction. This section contains information to perform unit maintenance tasks directed by the Maintenance Allocation Chart (MAC).

MAINTENANCE OF GYRO AND MAGNETIC COMPASS SYSTEM

2-11. Replace/Repair Gyro Compass System MK 27 MOD 1.

This task covers: a. Replace, b. Repair.

INITIAL SETUP

Tools

Tool kit, general mechanics
5180-00-699-5273
Tool kit, electrician's,
5180-00-391-1087

Equipment Condition

TM 55-1905-223-10, compass
secured.

Materials/Parts

Gyro compass system, Mk 27 Mod 1,
P/N 1883956-120

REPLACEMENT

Replace gyro compass system equipment in accordance with paragraphs 2-12 (gyro compass), 2-13 (gyro control and power assembly), and 2-15 (switch unit).

REPAIR

Repair of gyro compass system (lamps, fuses and cable C-LC12) is-covered in paragraph 2-14.

2-12. Replace Gyro Compass. (FIGURE 2-1)

This task covers: a. Remove, b. Replace

INITIAL SETUPTools

Tool kit, general mechanic's,
5180-00-699-5273
Tool kit, electrician's,
5180-00-391-1087

Equipment Condition

TM 55-1905-223-10, compass
secured.

Materials/Parts

Gyro compass P/N 1884068-10

REMOVAL

- a. Disconnect cable C-LC12 (4) from binnacle (1) by removing four pan head screws (2) and lockwashers (3) from cable connector.
- b. Remove four captive socket head screws (5), lock washers (6), and flat washers (7) securing gyro compass (9) to gyro control and power assembly (8).

CAUTION

The following step requires two soldiers because of the weight (66 pounds) of gyro compass.

- c. Lift gyro compass (9) off gyro control and power assembly (8).

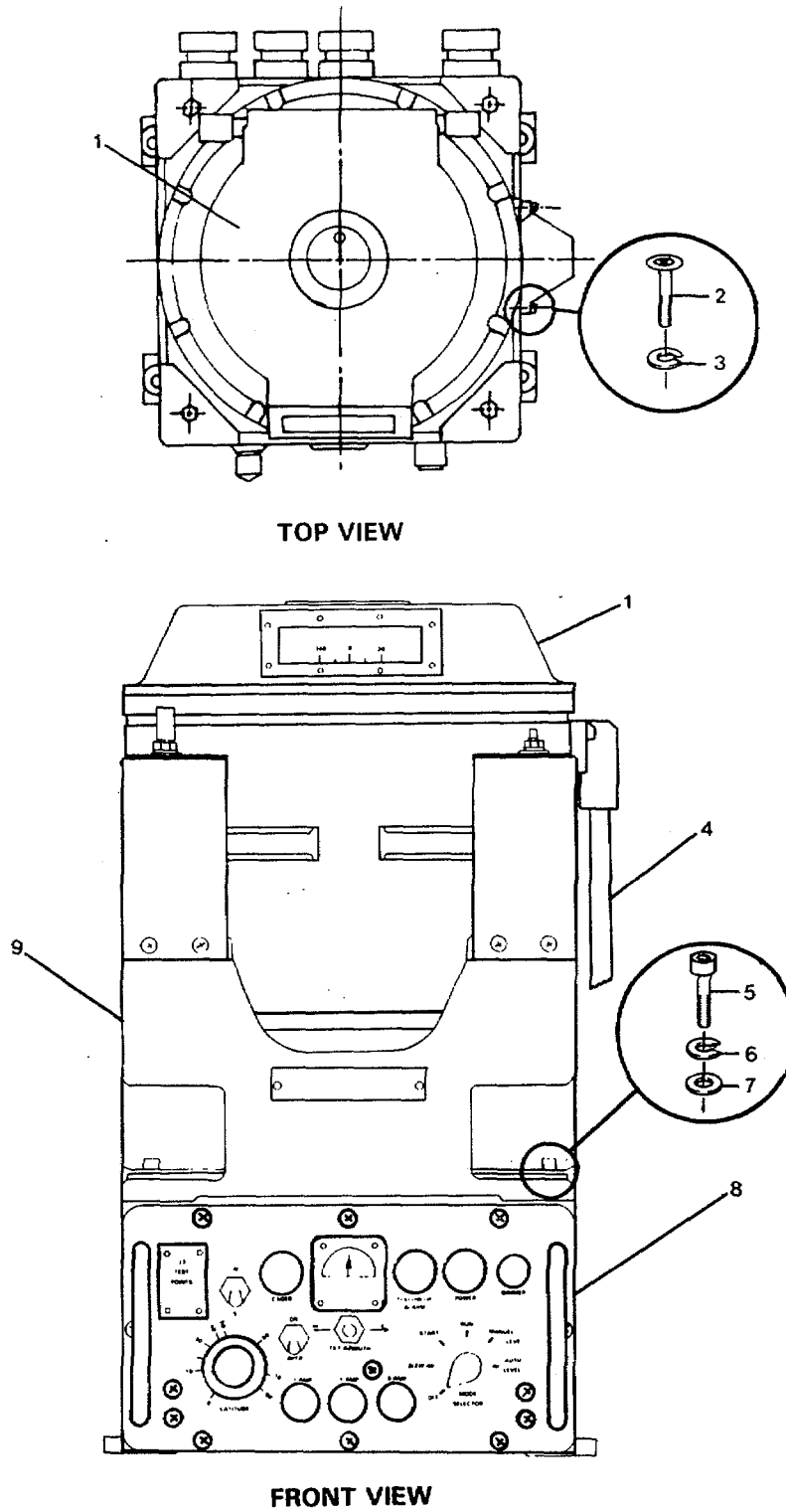

FIGURE 2-1. Gyro Compass Replacement.

REPLACEMENTCAUTION

The following step requires two soldiers because of the weight (66 pounds) of gyro compass.

- a. Position gyro compass (9) on gyro control and power assembly (8) and secure with four flat washers (7), lock washers (6), and captive socket head screws (5), loosely.
- b. Align gyro compass (9) on gyro control and power assembly (8) with scribed fore and aft centerline marks on gyro compass (9) base.
- c. Secure four captive socket head screws (5), lockwashers (6), and flat flat washers (7), being careful not to disturb alignment.
- d. Connect cable C-LC12 (4) to binnacle (1) and secure with four lockwashers (3) and pan head screws (2).
- e. Start compass (TM 55-1905-223-10).

2-13. Replace Gyro Control And Power Assembly. (FIGURE 2-2)

This task covers: a. Remove, b. Replace.

INITIAL SETUPTools

Tool kit, general mechanic's,
5180-00-699-5273

Tool kit, Electrician's,
5180-00-391-1087

Equipment Condition

TM 55-1905-223-10, gyro compass
secured.

Gyro compass removed (para. 2-12).

Materials/Parts

Gyro control and power assembly,
P/N 1884066-1

Warning tags, Item 8, Appendix C

REMOVAL

- a. On pilothouse dc panel, set circuit breaker No. 1F (MK 27 GYRO PWR XFR UNIT) to OFF. Tag "Out of Service, Do Not Operate."
- b. On pilothouse IC/ELEX panel, set circuit breaker No. 1 (MK 27 GYRO PWR CONV UNIT) to OFF. Tag "Out of Service, Do Not Operate."
- c. Remove four bolts (6) that mount gyro control and power assembly (13).
- d. Remove eight screws (8) securing rear panel (7) to cabinet and pull panel back for access to inside of cabinet.
- e. Disassemble stuffing tube assemblies (4) on cabling.
- f. Tag and remove leads of cables (1, 2, 3 and 5) from terminal board TB-1 inside of cabinet.
- g. Remove four screws (11) and lockwashers (12) from plate (10) that secures cable (3) and jack (9) J1 to rear cabinet frame member, then remove J1 (9) and plate (10) from cabinet.
- h. Lift gyro control and power assembly (13) from mounting foundation.

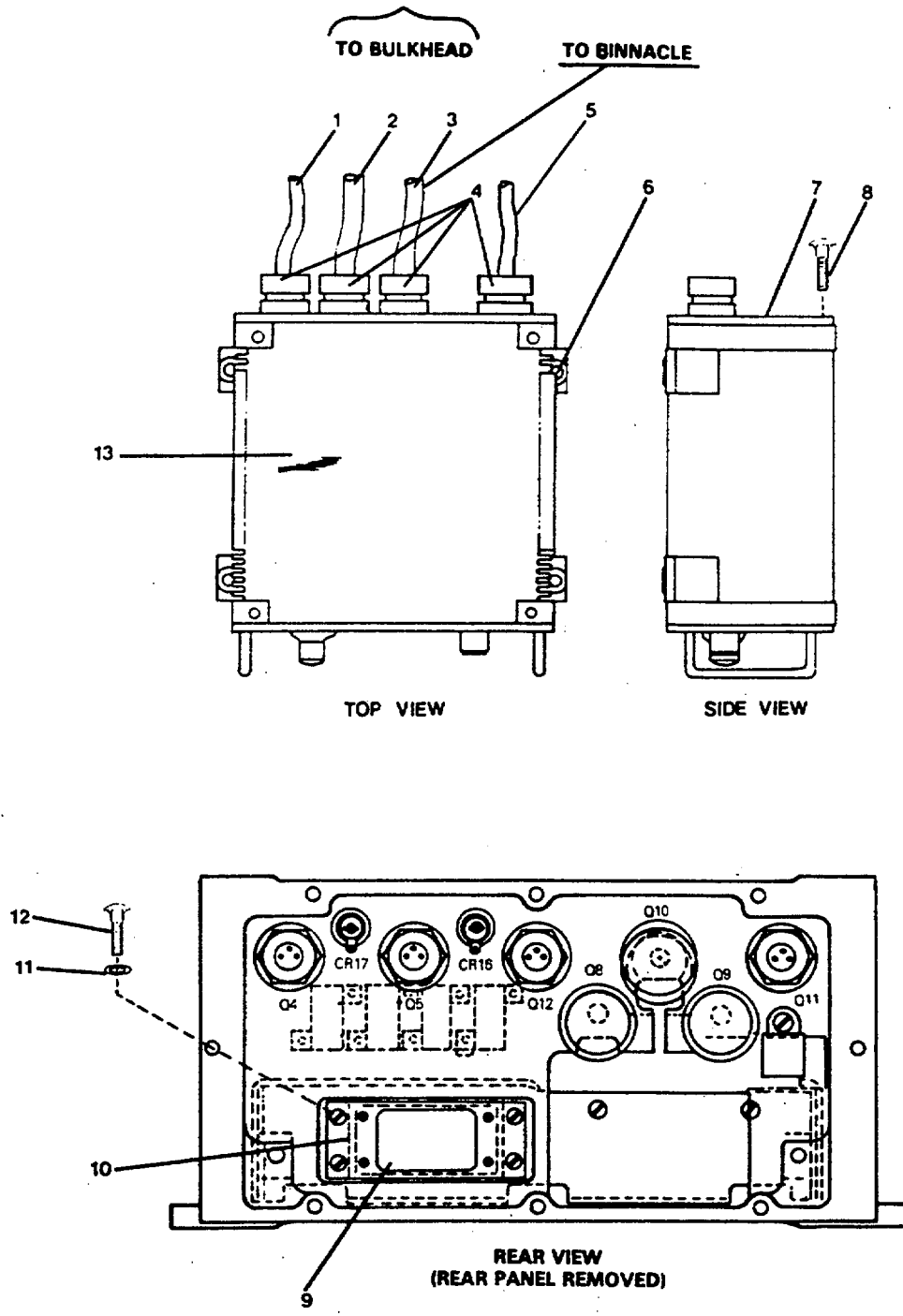

FIGURE 2-2. Gyro Control and Power Assembly Replacement.

REPLACEMENT

- a. Position gyro control and power assembly (13) on mounting foundation.
- b. Remove eight screws (8) securing rear panel (7) to cabinet (13) and pull panel back for access to inside of cabinet.
- c. Assemble stuffing tubes (4) on cables (1, 2, 3 and 5).
- d. Route cables (1, 2, 3 and 5) inside cabinet and connect leads to terminal board TB-1. Remove tags.
- e. Dress slack leads of cables inside cabinet.
- f. Replace plate (10) holding cable (3) and jack (9) J1 to rear cabinet frame member and secure with four screws (12) and lockwashers (11).
- g. Secure rear panel (7) to gyro control and power assembly (13) with eight screws (8).
- h. Align gyro control and power assembly (13) mounting holes on mounting foundation and secure with four bolts (6) through cabinet base.
- i. Replace gyro compass (paragraph 2-12).
- j. On pilothouse IC/ELEX panel, set circuit breaker No. 1 (MK 27 GYRO PWR CONV UNIT) to ON. Remove OUT OF SERVICE tag.
- k. On pilothouse dc panel, set circuit breaker No. 1F (MK 27 CYRO PWR XFR UNIT) to ON. Remove OUT OF SERVICE tag.
- l. Start compass (TM 55-1905-223-10).

2-14. Repair Gyro Control And Power Assembly. (FIGURES 2-3, 2-4, and 2-5)

This task covers: Repair.

INITIAL SETUPTools

Tool kit, general mechanic's,
5180-00-699-5273
Tool kit, electrician's,
5180-00-391-1087

Equipment Condition

TM 55-1905-223-10, compass
secured.

Materials/Parts

Special purpose electrical cable assembly
P/N T961101
Glow lamp, P/N 632234-6
Cartridge fuse, (1 amp), P/N F03A25VIAS
Cartridge fuse, (8 amp), P/N F03A25OVIAS
Warning tags, Item 8, Appendix C

REPAIR

Repair of the gyro control and power assembly is limited to lamp replacement and fuse replacement.

a. Lamp Replacement.

- (1) On gyro control and power assembly (1, FIGURE 2-3), remove appropriate lampholder lens (3) by turning counterclockwise.
- (2) Push in on appropriate lamp (2) and turn counterclockwise and remove.
- (3) Position replacement lamp (2) in appropriate lampholder, push in and turn clockwise.
- (4) Thread lens to appropriate lampholder and secure by turning clockwise.
- (5) Start compass (TM 55-1905-223-10).

b. AC or RPTR Fuse Replacement.

- (1) On gyro control and power assembly (1, FIGURE 2-4), push in on appropriate fuseholder cap (AC or RPTR), turn counterclockwise, and remove fuse (3).

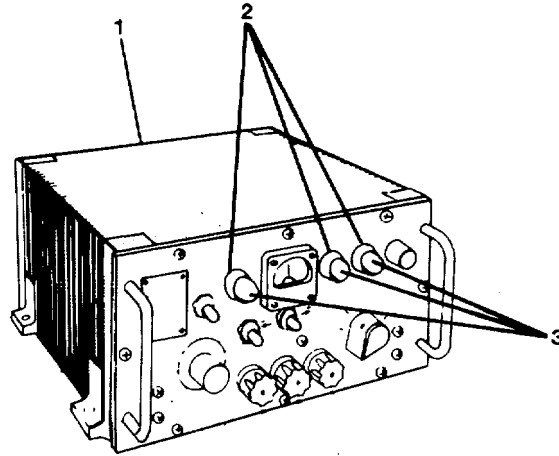

FIGURE 2-3. Gyro Control and Power Assembly Lamp Replacement.

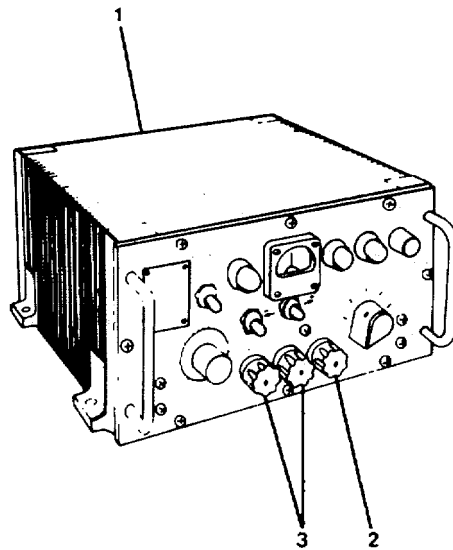

FIGURE 2-4. Gyro Control and Power Assembly Fuse Replacement.

- (2) Remove fuse (3) from fuseholder cap.
- (3) Place replacement fuse (3) in fuseholder cap.
- (4) Insert fuse (3) into appropriate fuseholder (ac or RPTR) on gyro control and power assembly (1), push in and turn clockwise to secure.
- (5) Start compass (TM 55-1905-223-10).

c. DC Fuse Replacement.

- (1) On pilothouse IC/ELEX panel, set circuit breaker No. 1 (MK 27 GYRO PWR CONV UNIT) to OFF. Tag "Out of Service, Do Not Operate."
- (2) On pilothouse dc panel, set circuit breaker No. 1F (MK 27 GYRO PWR XFR UNIT) to OFF. Tag "Out of Service, Do Not Operate."
- (3) On gyro control and power assembly (1, FIGURE 2-4), push in on DC 8 AMP fuseholder cap and turn counterclockwise and remove fuse with fuseholder cap.
- (4) Remove fuse (2) from fuseholder cap.
- (5) Place replacement fuse into fuseholder cap (2).
- (6) Insert fuseholder cap on gyro control and power assembly (1), push in and turn clockwise.
- (7) On pilothouse IC/ELEX panel, set circuit breaker No. 1 (MK 27 GYRO PWR CONV UNIT) to ON. Remove "Out of Service - Do Not Operate" tag.
- (8) On pilothouse dc panel, set circuit breaker No. 1F (MK 27 GYRO PWR XFR UNIT) to ON. Remove "Out of Service - Do Not Operate" tag.
- (9) Start compass (TM 55-1905-223-10).

d. Cable (C-LC12) Replacement.

- (1) On pilothouse IC/ELEX panel, set circuit breaker No. 1 (MK 27 GYRO PWR XFR CONV UNIT) to OFF. Tag "Out of Service, Do Not Operate."
- (2) On pilothouse dc panel, set circuit breaker No. 1F (MK 27 GYRO PWR XFR UNIT) to OFF. Tag "Out of Service, Do Not Operate."
- (3) Remove gyro compass (para. 2-12).
- (4) Remove four bolts (6, FIGURE 2-5) that mount gyro control and power assembly (13).
- (5) Position gyro control and power assembly (13) for access to rear of assembly.

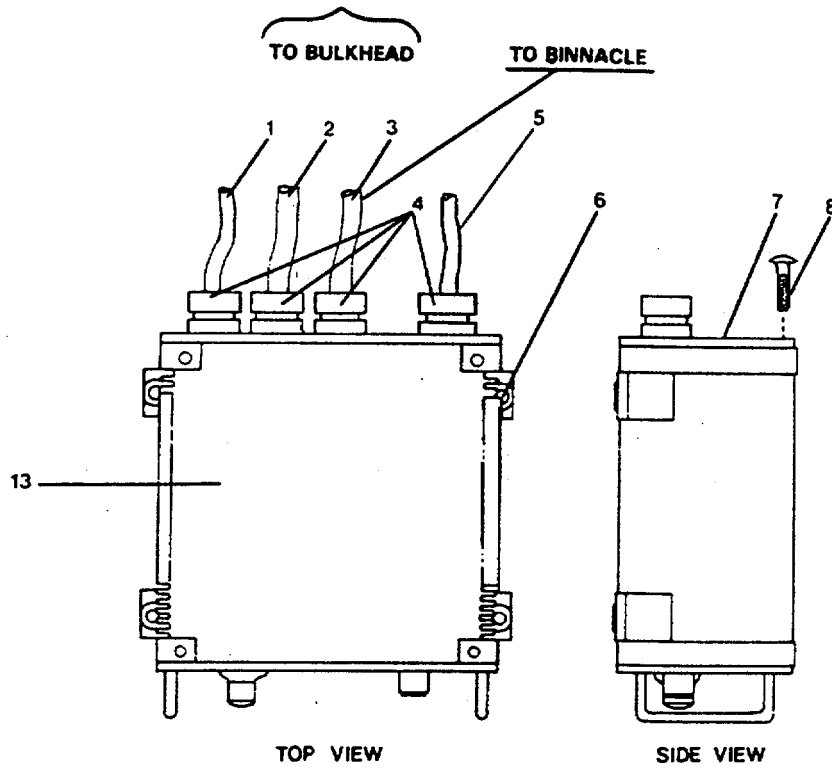

7744

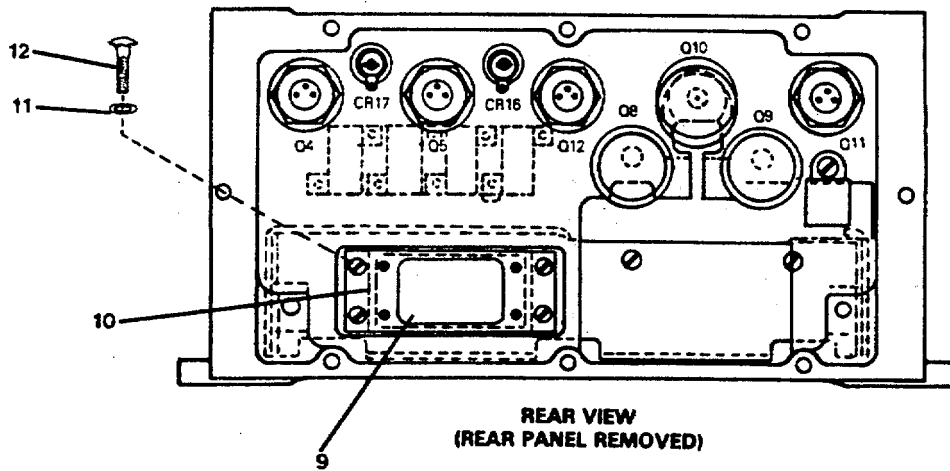

FIGURE 2-5. Cable (C-LC12) Replacement.

- (6) Remove eight screws (8) securing rear panel (7) to assembly and pull rear panel back as far as cabling will allow for access to inside of assembly.
- (7) Remove four screws (11) and lockwashers (12) from plate (10) securing cable (3) and jack (9) J1 to rear cabinet frame member.
- (8) Tag and remove cable (3) wiring from terminal board TB1 (located internally).
- (9) Remove cable (3) with jack (9) J1 and leads from cabinet.
- (10) Disassemble stuffing tube (4) from cable (3) and remove cable from rear panel (7).
- (11) On replacement cable (3), assemble stuffing tube (4) to cable and rear panel (7).
- (12) Route cable (3) with jack (9) J1 and leads inside of cabinet.
- (13) Connect cable (3) leads to terminal board TB1 (located internally). Remove tags.
- (14) Connect jack (9) J1 to plug P1 (internal) and secure jack (9) J1 to rear cabinet member with plate (10) and four lockwashers (12) and screws (11).
- (15) Dress cables (1, 2, 3, and 5) inside of cabinet and secure stuffing tube (4) assembled on cable (3) and rear panel (7).
- (16) Position rear panel (7) on gyro control and power assembly (13) and secure with eight screws (8).
- (17) Position gyro control and power assembly (13) on mounting surface.
- (18) Secure gyro control and power assembly (13) to mounting surface with four bolts (6).
- (19) Replace gyro compass (para. 2-12).
- (20) On pilot house dc panel, set circuit breaker No. 1F (MK 27 GYRO PWR XFR UNIT) to ON. Remove "Out of Service, Do Not Operate" tag.
- (21) On pilot house IC/ELEX panel, set circuit breaker No. 1F (MK 27 GYRO PWR CONV UNIT) to ON. Remove "Out of Service, Do Not Operate" tag.
- (22) Start compass. Refer to TM 55-1905-223-10.

2-15. Replace Switch Unit. (FIGURE 2-6)

This task covers: a. Removal, b. Replacement

INITIAL SETUPTools

Tool kit, general mechanic's,
5180-00-699-5273
Tool kit, electrician's,
5180-00-391-1087

Equipment Condition

TM 55-1905-223-10, compass
secured.

Materials/Parts

Switch unit, P/N 1884498
Warning tags, Item 8, Appendix C

REMOVAL

- a. On pilothouse IC/ELEX panel, set circuit breaker No. 1 (MK 27 CYRO PWR CONV UNIT) to OFF. Tag "Out of Service, Do Not Operate."
- b. On pilothouse dc panel, set circuit breaker No. 1F (MK 27 GYRO PWR XFR UNIT) to OFF. Tag "Out of Service, Do Not Operate."
- c. On switch unit (1), loosen two fasteners (6) by loosening retaining screws (7).
- d. Remove enclosure cover (12) and let cover suspend on retaining chain (9).
- e. Tag and disconnect four cables (3, 4, 5 and 10) wiring from terminal board TB1 (11).
- f. Disconnect wire from cable (4) C-LC1O to CR1 from CR1 negative (-) terminal.
- g. Disassemble stuffing tubes (8) and pull cables (3, 4, 5 and 10) from switch unit (1). Remove stuffing tubes and retain.
- h. Remove switch unit (1) from bulkhead by removing four mounting bolts (2) from mounting holes.

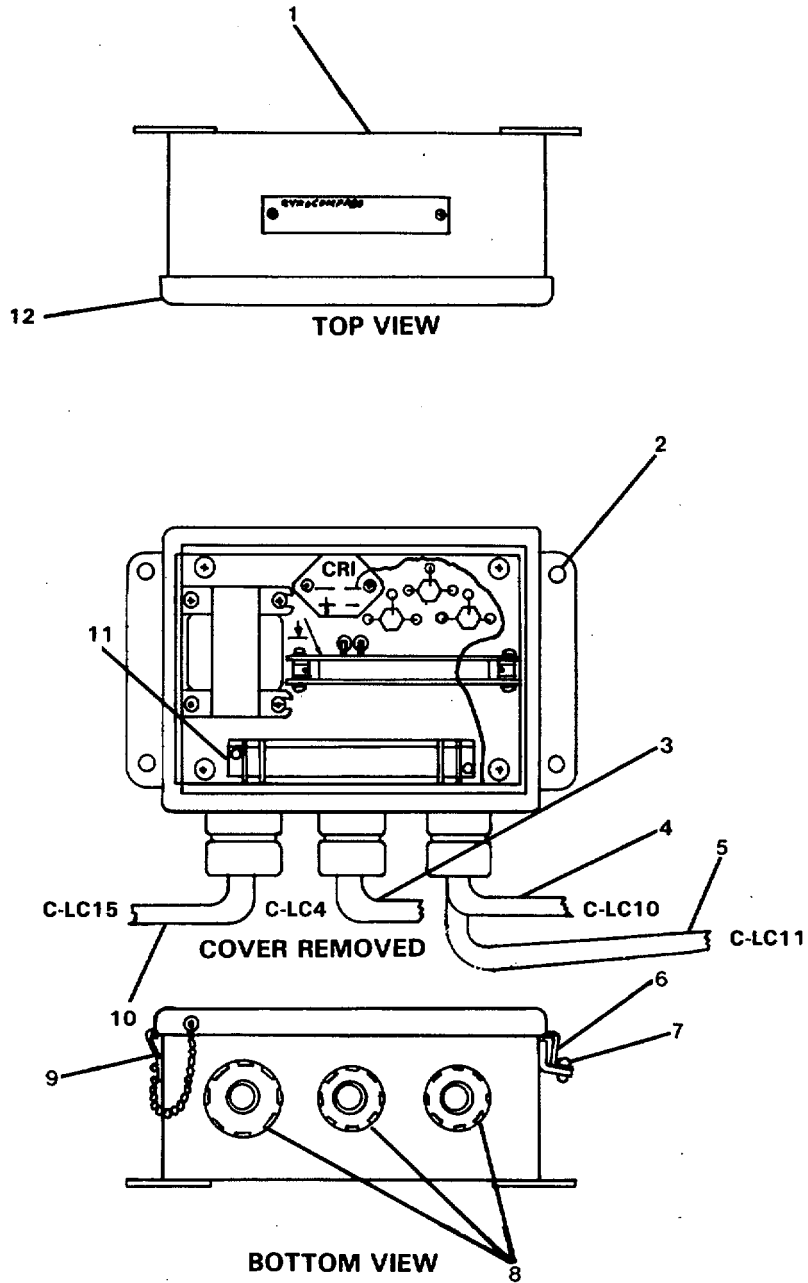

FIGURE 2-6. Switch Unit Replacement.

REPLACEMENT

- a. Position replacement switch unit (1) on bulkhead mounting holes and secure with four bolts (2) through unit mounting holes.
- b. Remove enclosure cover (12) from replacement switch unit (1) by loosening two retaining screws (7) on fasteners (6).
- c. Assemble stuffing tube caps to cables (3, 4, 5 and 10) and route cables into enclosure through holes in bottom of switch unit.
- d. Assemble stuffing tube bodies to cables inside of enclosure, do not secure.
- e. Connect cables (3, 4, 5 and 10) wiring to terminal board TB1 (11) and remove tags.
- f. Connect cable C-LC10 lead to CR1 negative (-) terminal.
- g. Dress cables inside of enclosure and secure stuffing tube (8) assemblies.
- h. Position enclosure cover (12) on switch unit (1).
- i. Secure cover with fasteners (6) and retaining screws (7).
- j. On pilothouse IC/ELEX panel, set circuit breaker No. 1 (MK 27 GYRO PWR CONV UNIT) to ON. Remove "Out of Service, Do Not Operate" tag.
- k. On pilothouse dc panel, set circuit breaker No. 1F (MK 27 GYRO PWR XFR UNIT) to ON. Remove "Out of Service, Do Not Operate" tag.
- l. Start compass (TM 55-1905-223-10).

2-16. Replace Relay Transmitter. (FIGURE 2-7)

This task covers: a. Removal, b. Replacement.

INITIAL SETUPTools

Tool kit, general mechanic's,
5180-00-699-5273
Tool kit, electrician's,
5180-00-391-1087

Equipment Condition

TM 55-1905-223-10, compass
secured.

Materials/Parts

Relay transmitter MK 37 Mod E
P/N 1977023
Warning tags, Item 8, Appendix C

REMOVAL

- a. On relay transmitter (1, Sheet 1) set POWER switch (4) to OFF.
- b. On pilothouse IC/ELEX panel, set circuit breaker No. 4 (MK 37 HEADING XMTR) to OFF. Tag "Out of Service, Do Not Operate."
- c. On relay transmitter (1, Sheet 1, FIGURE 2-7) remove ground cable (6) by removing hexagon nut (8) and lockwasher (7) from ground terminal (5).
- d. Loosen four fasteners (2) by loosening four pan head screws (12) and open cabinet on hinges as indicated on FIGURE 2-7, Sheet 2.
- e. Tag and disconnect cable (9, Sheet 2) EP103-4 from terminal board (22) TB1.
- f. Tag and disconnect cable (10) C-LC10 from terminal board (27) A2TB7.
- g. Disassemble two stuffing tubes (11) and pull cables (9 and 10) from cabinet.
- h. Tag and disconnect repeater cables (13, 14, 15, 16, 17, 18, 19, and 20, Sheet 1) from terminal board (23, Sheet 2) A2TB1, (24) A2TB2, (25) A2TB3 and (26) A2TB4.

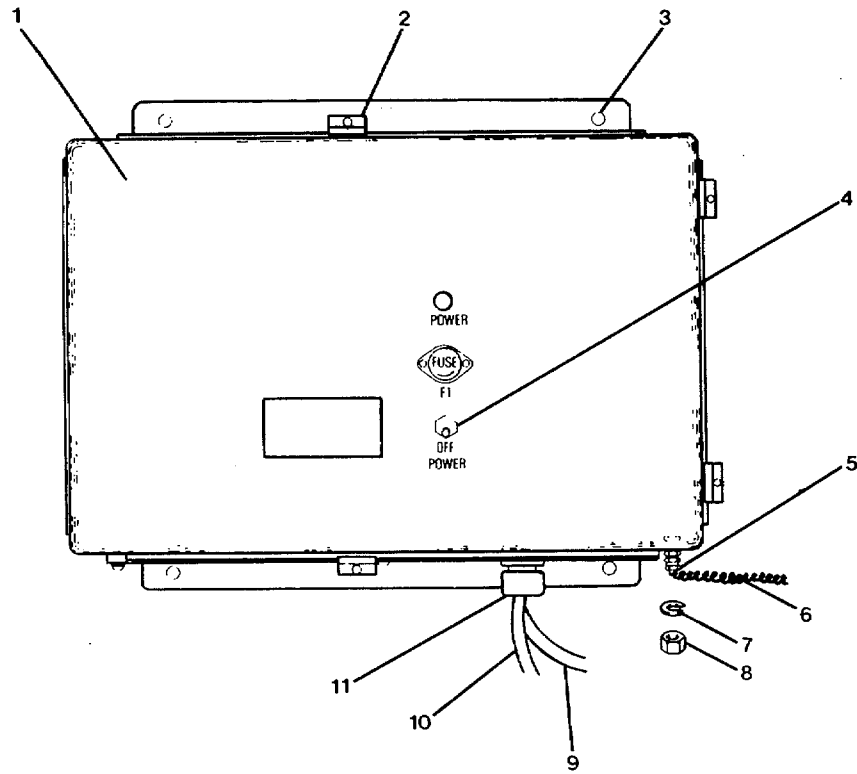

FRONT VIEW

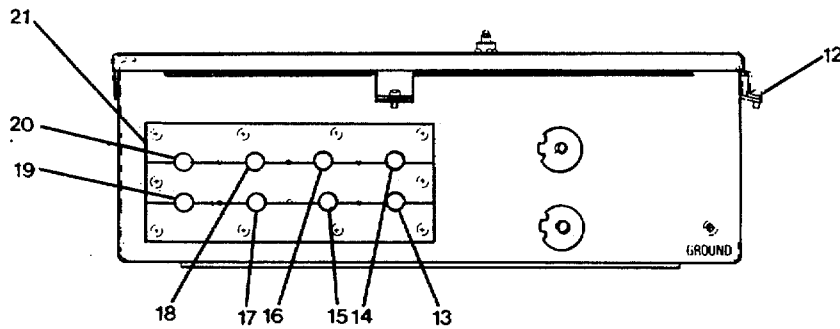

BOTTOM VIEW

FIGURE 2-7. Relay Transmitter Replacement (Sheet 1 of 2).

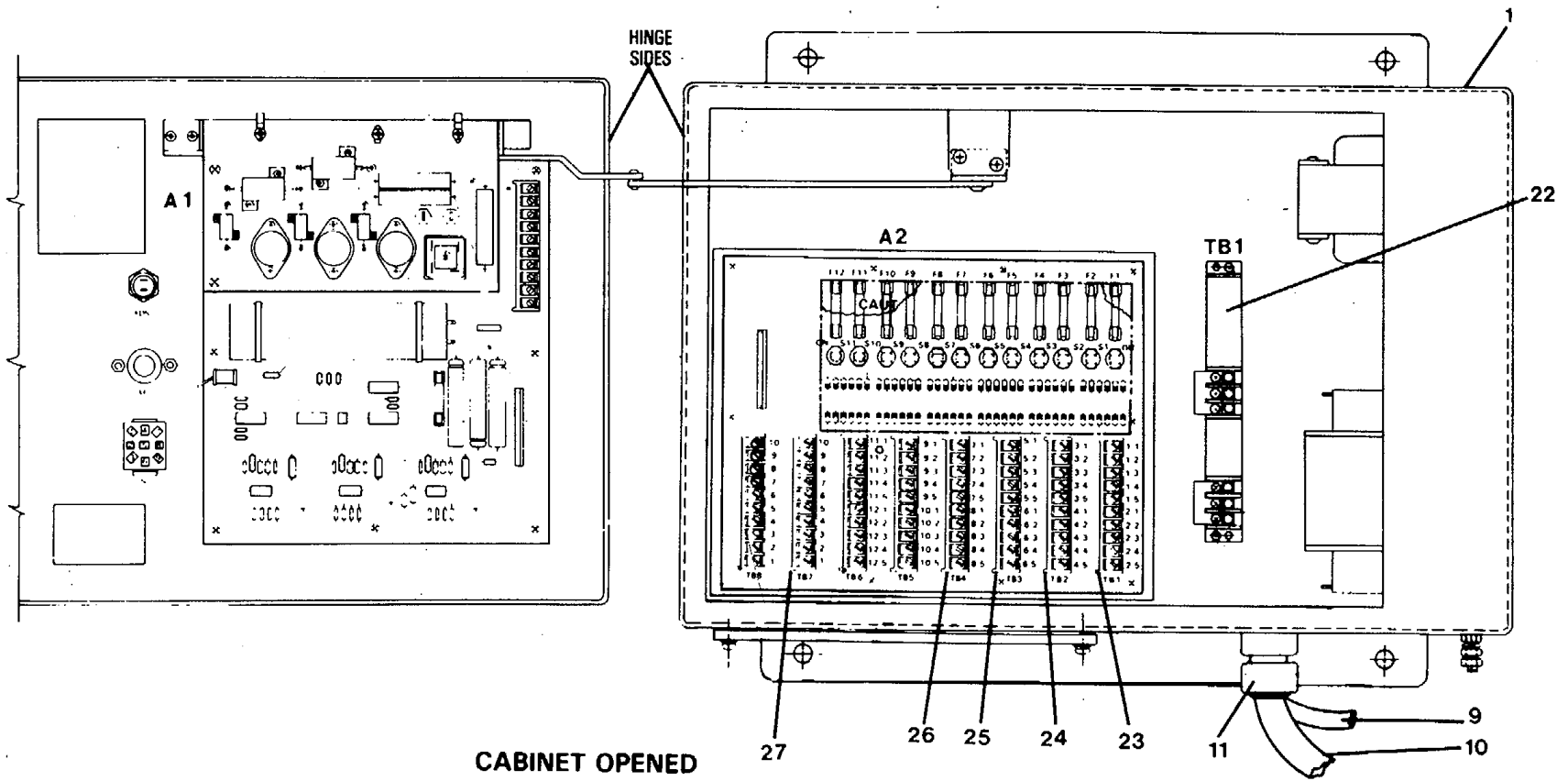

FIGURE 2-7. Relay Transmitter Replacement (Sheet 2 of 2).

- i. Remove repeater cables (13, 14, 15, 16, 17, 18, 19, and 20, Sheet 1) by pulling each from the cabinet through cable entrance plate (21).
- j. Close cabinet and secure four fasteners (2) by securing four pan head screws (12).

CAUTION

Two soldiers are required for the following step because of relay transmitter weight (60 pounds).

- k. Support relay transmitter (1, Sheet 1) and remove four mounting bolts (3) from bulkhead through mounting holes, and remove relay transmitter.

REPLACEMENT

CAUTION

Two soldiers are required for the following step because of relay transmitter weight (60 pounds).

- a. Position replacement relay transmitter (1, Sheet 1) by aligning bulkhead mounting holes on bulkhead and secure with four mounting bolts (3).
- b. Open cabinet of relay transmitter (1) to position indicated in FIGURE 2-7, Sheet 2.
- c. Route repeater cables (13, 14, 15, 16, 17, 18, 19, and 20, Sheet 1) through appropriate holes on cable entrance plate (21). Cables should fit snugly.
- d. Connect cables (13, 14, 15, 16, 17, 18, 19, and 20, Sheet 1) to terminal boards (26, Sheet 2) A2TB4, (25) A2TB3, (24) A2TB2, and (23) A2TB1. Remove tags.
- e. Assemble stuffing tubes (11) on cables (9 and 10).
- f. Route cable (9) through appropriate hole in bottom of relay transmitter (1).
- g. Connect cable (9) leads to terminal board (22) TB1. Remove tags.
- h. Dress cable (9) inside of cabinet and secure stuffing tube (11).
- i. Route cable (10) through appropriate hole in bottom of relay transmitter (1).
- j. Connect cable (10) leads to terminal board (27) A2TB7. Remove tags.
- k. Dress cable (10) inside of cabinet and secure stuffing tube (11).

- l. Set repeater switches A2S1 through A2S8 to ON.
- m. Close cabinet door and secure four fasteners (2, Sheet 1) by securing four pan head screws (12).
- n. Connect ground cable (6) to ground terminal (5) and secure with lockwasher (7) and hex nut (8).
- o. On pilothouse PANEL, set circuit breaker No. 4 (MK 27 HEADING XMTR) to ON. Remove "Out of Service, Do Not Operate" tag.
- p. On relay transmitter (1), set POWER OFF switch (4) to up position. POWER lamp should light red.
- q. Start compass (TM 55-1905-223-10).

2-17. Repair Relay Transmitter. (FIGURE 2-8)

This task covers: a. Disassembly, b. Repair, c. Assembly.

INITIAL SETUP

Tools

Tool kit, general mechanic's,
5180-00-699-5273
Tool kit, electrician's,
5180-00-391-1087

Equipment Condition

TM 55-1905-223-10, compass
secured.

Materials/Parts

Glow lamp, P/N M15098/10-001
Fuse cartridge (3 amp) P/N F60C500V34
Warning tags, Item 8, Appendix C

Repair of the relay transmitter includes lamp replacement and fuse replacement.

DISASSEMBLY

a. Lamp.

- (1) On relay transmitter (1, FIGURE 2-8), set POWER switch (4) to OFF.
- (2) Remove lampholder lens by turning lens counterclockwise.

b. Fuse.

- (1) On relay transmitter (1), set POWER switch (4) to OFF.
- (2) On pilothouse IC/ELEX PANEL, set circuit breaker No. 4 (MK 27 HEADING XMTR) to OFF. Tag "Out of Service - Do Not Operate."
- (3) On relay transmitter (1), push in on FUSE F1 fuseholder cap (3) and turn counterclockwise and remove.

REPAIR

a. Lamp.

- (1) Push in on glow lamp (2), and turn counterclockwise, and remove.

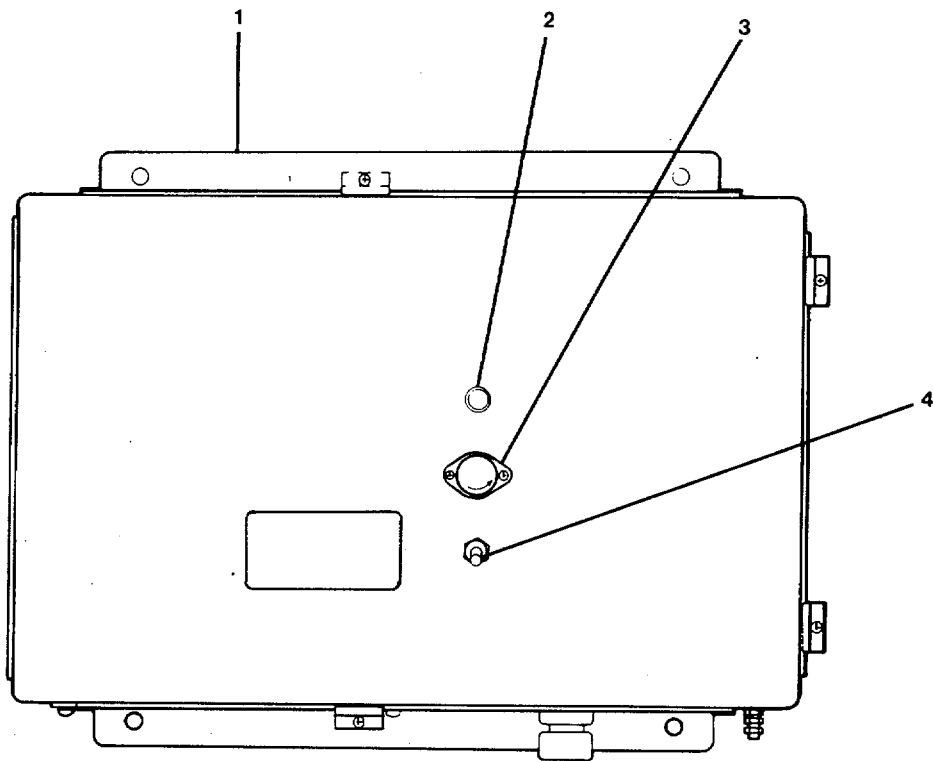

FIGURE 2-8. Relay Transmitter Lamp and Fuse Replacement.

(2) Position replacement lamp (2) in lampholder, push in, and turn clockwise to secure.

b. Fuse.

(1) Remove fuse cartridge from fuseholder cap (3) and discard.

(2) Insert replacement fuse cartridge into fuseholder cap.

ASSEMBLY

a. Lamp.

(1) Thread lampholder lens on lampholder and secure by turning clockwise.

(2) Set POWER switch (4) to up position. POWER lamp (2) should light red.

b. Fuse.

(1) Position fuseholder cap with fuse cartridge into fuseholder on relay transmitter (1), push in and turn clockwise to secure.

(2) On pilothouse IC/ELEX PANEL, set circuit breaker No. 4 (MK 27 HEADING XMTR) to ON. Remove "Out of Service, Do Not Operate" tag.

(3) On relay transmitter (1) set POWER switch (4) to on (up). POWER lamp (2) should light red.

2-18. Replace Open Scale Repeater. (FIGURE 2-9)

This task covers: a. Removal, b. Replacement.

INITIAL SETUPTools

Tool kit, general mechanic's,
5180-00-699-5273
Tool kit, electrician's,
5180-00-391-1087

Equipment Condition

TM 55-1905-223-1O, compass
secured.

Materials/Parts

Open scale repeater, P/N 1976159-3

REMOVAL

- a. On bulkhead mounting bracket arms (4), loosen two bolts (1) and rotate open scale repeater (5) to ROTATED position and secure bolts (1).
- b. Remove eight screws (10), lockwashers (9), and flat washers (8) from cover (7).
- c. Remove cover (7) from open scale repeater (5) as far as cabling will allow.
- d. Tag and disconnect cable (3) wiring from terminal board (6).
- e. Disassemble stuffing tube (2) from cable (3) and pull cable (3) from open scale repeater (5).
- f. Supporting open scale repeater (5), remove two mounting bolts (1) from end of mounting bracket arms (4) and remove open scale repeater (5).

REPLACEMENT

- a. Position replacement open scale repeater (5) between mounting bracket arms (4) and install two mounting bolts (1).
- b. Rotate open scale repeater (5) to ROTATED position and secure two mounting bolts (1).
- c. Remove eight screws (10), lockwashers (9), and flat washers (8) from cover (7).

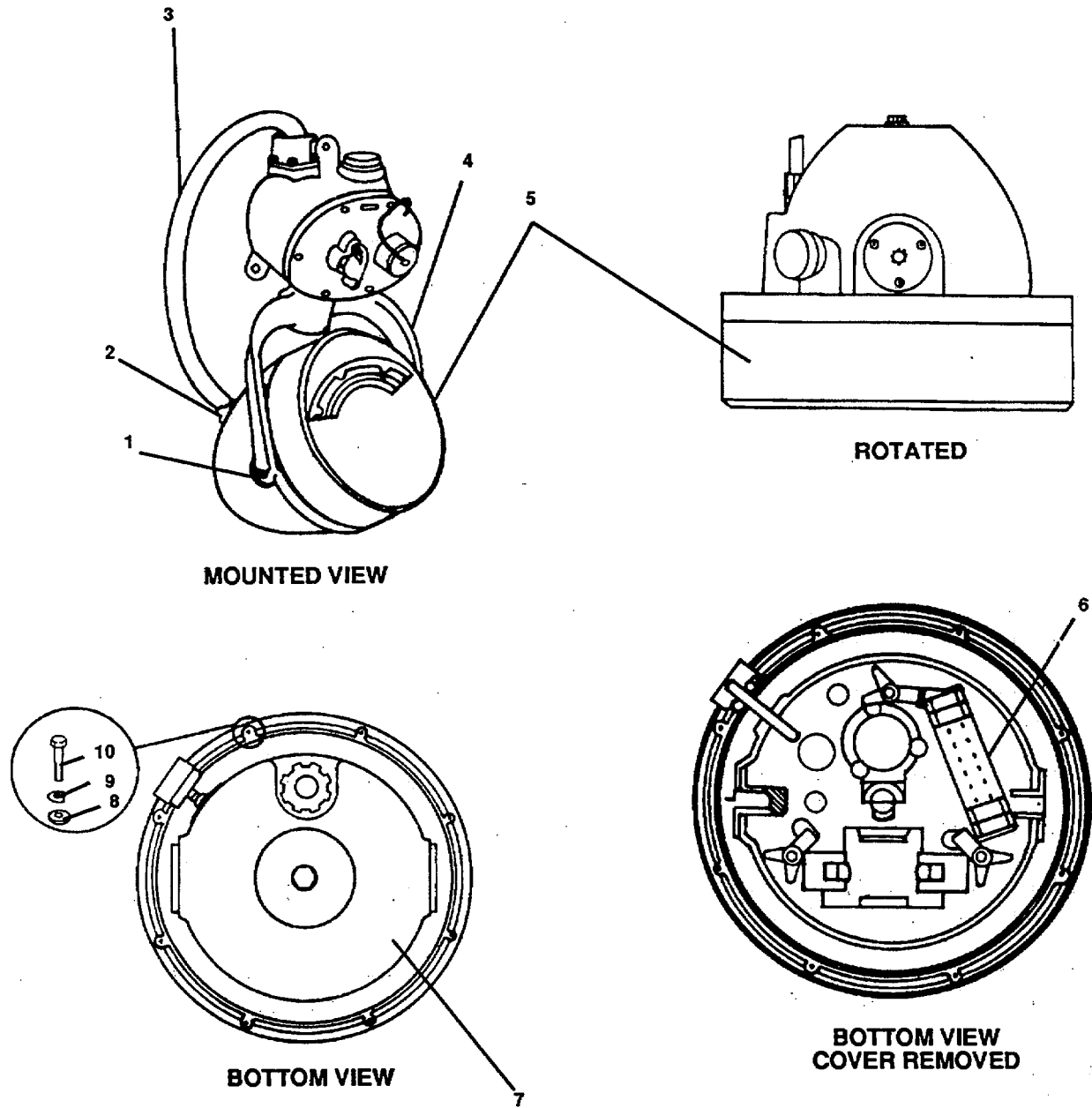

FIGURE 2-9. Open Scale Repeater Replacement.

- d. Remove cover (7) from open scale repeater (5) as far as cabling will allow.
- e. Route cable (3) through stuffing tube (2) and cover (7).
- f. Connect cable (3) wiring to terminal board (6). Remove tags.
- g. Dress cable (3) wiring inside of open scale repeater (5) and secure stuffing tube (2).
- h. Position cover (7) on open scale repeater (5) and secure with eight flat washers (8), lockwashers (9), and screws (10).
- i. Loosen two mounting bolts (1) and rotate open scale repeater (5) to MOUNTED VIEW and secure two mounting bolts (1).
- j. Start compass (TM 55-1905-223-10).

2-19. Repair Open Scale Repeater. (FIGURES 2-10 and 2-11)

This task covers: Repair.

INITIAL SETUPTools Equipment Condition

Tool kit, general mechanic's,
5180-00-699-5273

TM 55-1905-223-10, compass
secured.

Tool kit, electrician's,
5180-00-391-1087

Materials/Parts

Incandescent lamp, P/N MS25231-1819
Special purpose electrical cable assembly
(6 ft.) P/N T966063-2

REPAIR

- a. Lamp replacement. (FIGURE 2-10).
 - (1) On bulkhead mounting bracket arms (2), loosen two mounting bolts (1) and rotate repeater (3) to ROTATED position and secure bolts (1).
 - (2) Remove eight screws (4), lockwashers (5) and flat washers (6) from cover (7).
 - (3) Remove cover (7) from repeater (3) as far as cabling will allow.
 - (4) Locate lamp assemblies (8, 9, and 10).
 - (5) On appropriate lamp assembly (8, 9, or 10), remove screw (11), lockwasher (12) and flat washer (13).
 - (6) Remove lampholder (14) and remove lamp (15).
 - (7) Install replacement lamp (15) into lampholder (14).
 - (8) Position lampholder (14) and secure with washer (13), lockwasher (12), and screw (11).
 - (9) Position cover (7) on repeater (3) and secure with eight flat washers (6), lockwashers (5), and screws (4).

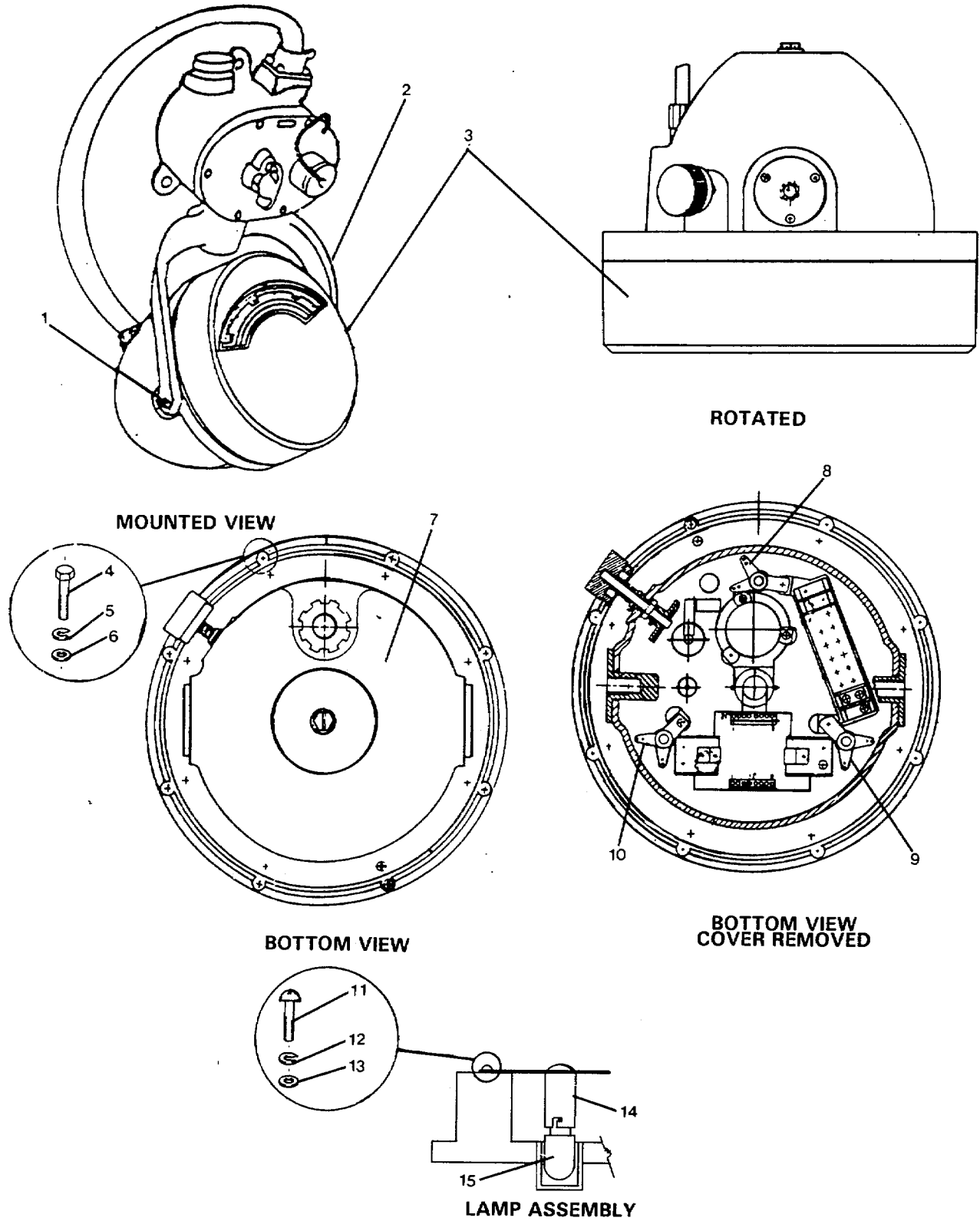

FIGURE 2-10. Open Scale Repeater Lamp Replacement.

- (10) Loosen two bolts (1) on mounting bracket arms (2) and rotate repeater (3) to desired viewing position.
- (11) Secure repeater (3) by securing two bolts (1).
- (12) Start compass (TM 55-1905-223-10).
- (13) Verify operation of lamps.

b. Special purpose electrical cable (6 ft) replacement. (FIGURE 2-11).

- (1) On bulkhead mounting bracket arms (8), loosen two mounting bolts (1) and rotate open scale repeater (9) to ROTATED position and secure mounting bolts (1).
- (2) Remove eight screws (14), lockwashers (13), and flat washers (12) from cover (11).
- (3) Remove cover (11) from open scale repeater (9) as far as cabling will allow.
- (4) Tag and disconnect cable (5) wiring from terminal board (10).
- (5) Disassemble stuffing tube (2) from cable (5) and pull cable (5) from open scale repeater (9).
- (6) On bulkhead mounting bracket cover (6), remove six screws (3) and washers (4) and remove cover (6) as far as cabling inside will allow.
- (7) Tag and disconnect cable (5) wiring from terminal board (7) inside of junction box.
- (8) Disconnect cable (5) connector from junction box and connector adapter pull cable (5) from junction box.
- (9) Route replacement cable (5) into junction box through junction box connector adapter. Secure connector to connector adapter.
- (10) Connect cable (5) wiring to junction box terminal board (7). Remove tags.
- (11) Dress cable (5) wiring inside of junction box and position cover (6) and secure with six washers (4) and screws (3).
- (12) Assemble cable (5) and stuffing tube (2) into open scale repeater (9) cover (11).
- (13) Connect cable (5) wiring to open scale repeater (9) terminal board (10). Remove tags.
- (14) Secure stuffing tube (2) and dress cable (5) wiring inside of open scale repeater (9).

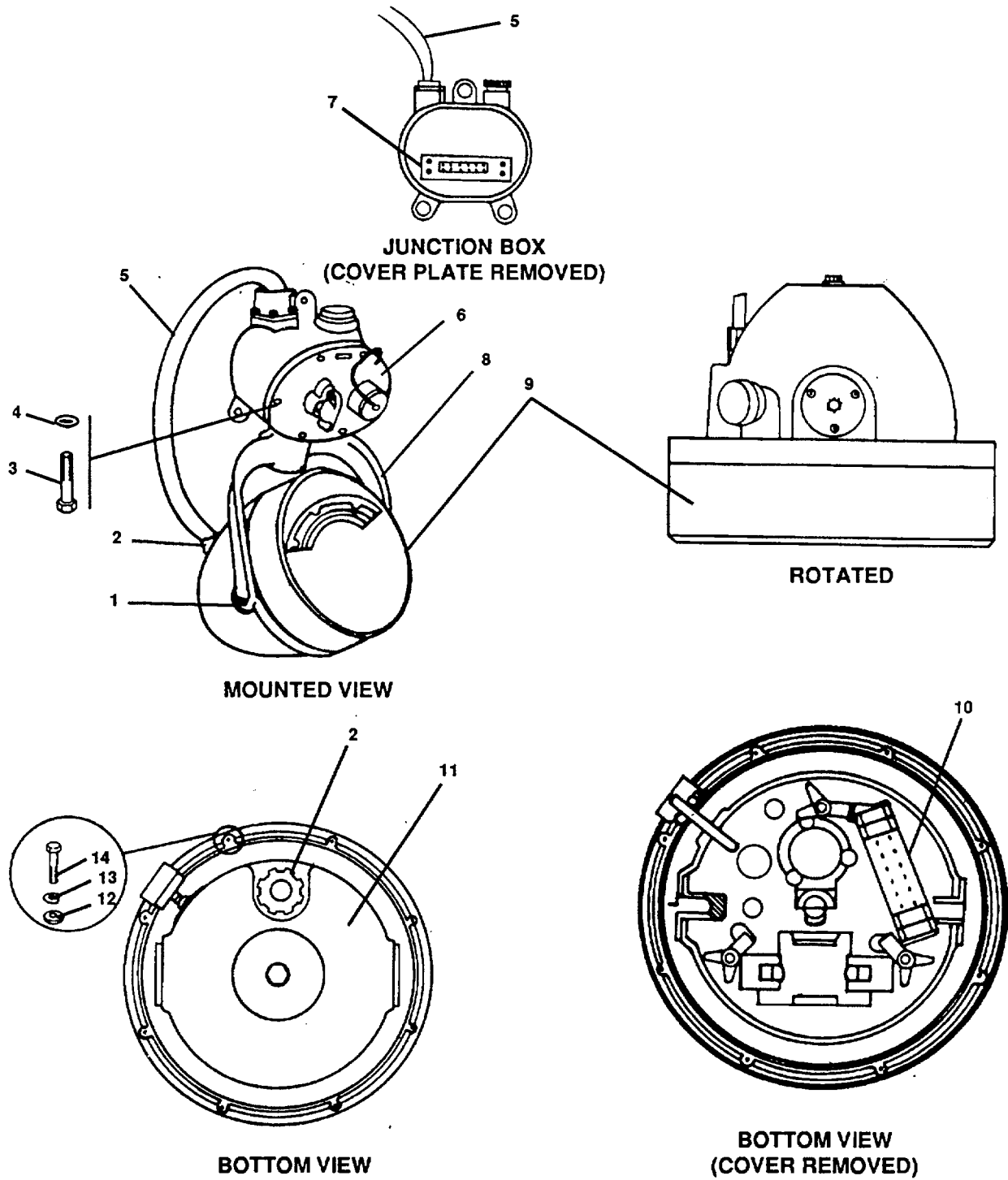

FIGURE 2-11. Open Scale Repeater Cable Replacement.

- (15) Position cover (11) on open scale repeater (9) and secure with eight flat washers (12), lockwashers (13), and screws (14).
- (16) Rotate open scale repeater (9) to viewing position and secure bolts (1)
- (17) Start compass (TM 55-1905-223-10).

2-20. Replace Bearing Repeater. (FIGURES 2-12 and 2-13)

This task covers: a. Removal, b. Replacement.

INITIAL SETUP
Tools

Tool kit, general mechanic's,
5180-00-699-5273
Tool kit, electrician's,
5180-00-391-1087

Materials/Parts

Bearing repeater, P/N 1976158-3
Thread compound, (Appendix C, Item 3)
Warning tags, Appendix C, Item 8

General Instructions

There are three bearing repeaters: (1) port bridge wing, (2) starboard bridge wing and (3) top of pilothouse. Transmission power to each bearing repeater is controlled by switches in relay transmitter. These switches are labeled S1 (port bridge wing), S5 (starboard bridge wing), and S7 (top of pilot-house).

REMOVAL

- a. On relay, transmitter (1, FIGURE 2-12), loosen four retaining clips (2) and open cabinet cover (3).

WARNING

Ship's ac power is present at FUSE F1 and POWER switch S1 terminals on the inside of the cabinet cover. THESE VOLTAGES ARE DANGEROUS. Use extreme care when working inside of cabinet.

- b. On A2 circuit card assembly (4) set appropriate repeater switch (5) to the down position and close cover (3). Secure four retaining clips (2).
- c. Tag relay transmitter to indicator bearing repeater Out of Service.
- d. On appropriate pelorus stand (4, FIGURE 2-13) loosen two pivot nuts (12) pivot screws (11) on support plate (3).
- e. Rotate bearing repeater (2) on pivot screws to BOTTOM VIEW position. Secure pivot nuts (12), holding bearing repeater (2-) in this position.
- f. Remove eight screws (6), lockwashers (7), and flat washers (8) from cover (9).

- g. Remove cover (9) from bearing repeater (2) as far as cabling will allow.
- h. Tag and disconnect cable (1) wiring connections from terminal board (10).
- i. Disassemble stuffing tube (5) from cable (1) and pull cable (1) from bearing repeater and cover (9).
- j. Replace cover (9) and secure with eight flat washers (8), lockwashers (7), and screws (6).
- k. Loosen pivot nuts (12) and rotate bearing repeater (2) in support plate (3) to upright position.

CAUTION

The following step requires two soldiers to support removal of bearing repeater, to prevent dropping and damaging the unit.

- l. While supporting bearing repeater (2), loosen two pivot nuts (12), back out two pivot screws (11), and remove bearing repeater (2) from pelorus stand repeater support (3).

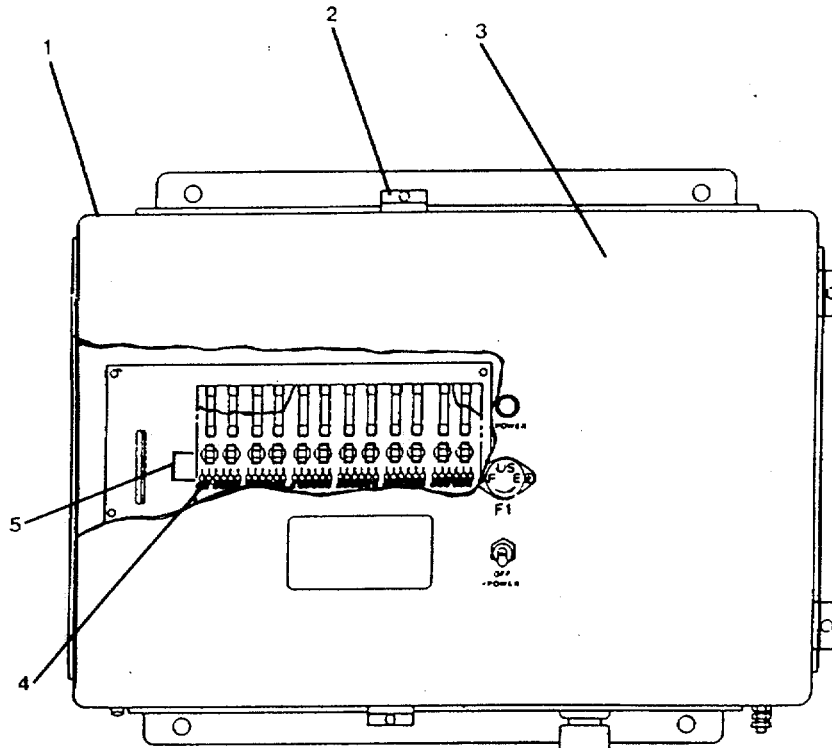

FIGURE 2-12. Relay Transmitter.

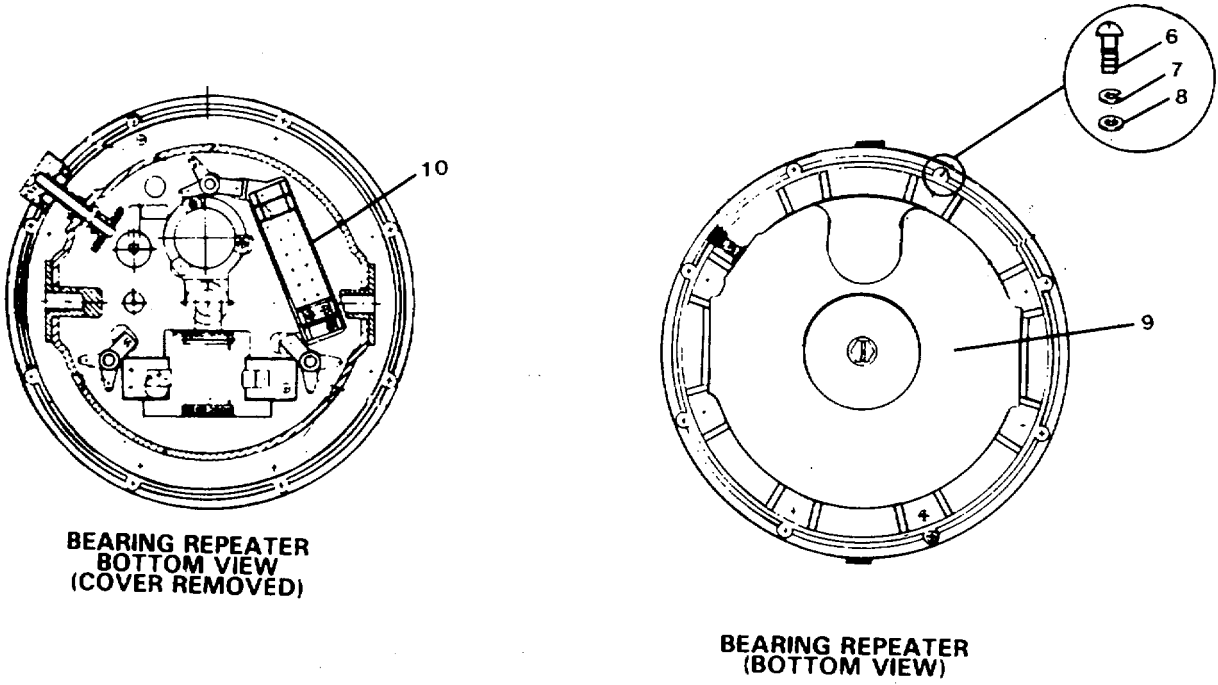
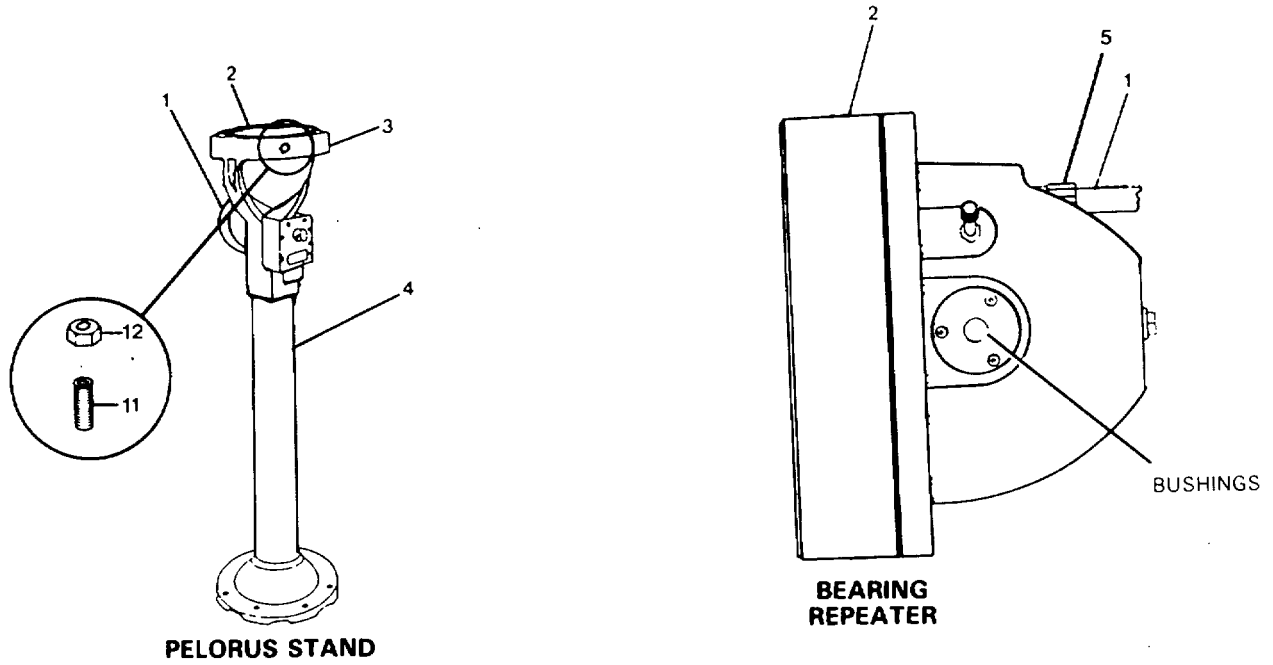

FIGURE 2-13. Bearing Repeater Replacement.

REPLACEMENTCAUTION

The following step requires two soldiers to support installation of bearing repeater to prevent dropping and damaging the unit.

- a. Position replacement bearing repeater (2, FIGURE 2-13) inside pelorus stand bearing repeater support (13) in line with bushings on repeater bezel assembly.
- b. Apply thread compound (Item 3, Appendix C) to pivot screws (11).
- c. Secure two pivot screws (11) into repeater bezel assembly bushings and lock screws (11) by securing two pivot nuts (12).
- d. Loosen two pivot nuts (12) and rotate bearing repeater (2) in pelorus stand support plate (3) to BOTTOM VIEW position.
- e. Remove eight screws (6), lockwashers (7), and flat washers (8).
- f. Remove cover (9).
- g. Route cable (1) with stuffing tube (5) into bearing repeater (2)-;
- h. Connect cable (1) wiring connection to terminal board (10). Remove tags.
- i. Dress cable (1) wiring inside of bearing repeater (2) and secure stuffing tube (5) to cover (9).
- j. Position cover (9) on bearing repeater (2) and secure with eight flat washers (8), lockwashers (7), and screws (6).
- k. Loosen two pivot nuts (12) and rotate bearing repeater (2) in pelorus stand support plate (3) to normal viewing position. Secure two pivot nuts (12).
- l. Synchronize bearing repeater with gyro compass. Refer to TM 55-1905-223-10.

WARNING

Ship's ac power is present at FUSE F1 and POWER switch S1 terminals on inside of cabinet cover. THESE VOLTAGES ARE DANGEROUS. Use extreme care when working inside of cabinet.

- m. On relay transmitter (1, FIGURE 2-12), loosen four retaining clips (2) and open cabinet cover.
- n. On A2 circuit card assembly (4), set appropriate repeater switch (5) to ON.
- o. Close cabinet cover (3) and secure four retaining clips (2).
- p. Remove "Out of Service" tags.

2-21. Repair Bearing Repeater.

This task covers: Repair.

INITIAL SETUP

Tools

Tool kit, general mechanic's,
5180-00-699-5273
Tool kit, electrician's,
5180-00-391-1087

Materials/Parts

Incandescent lamp, P/N MS25231-1819
Special purpose electrical cable
assembly (4 ft.) P/N T966063
Warning tags, Appendix C, Item 8

Equipment Condition

There are three bearing repeaters: (1) port bridge wing, (2) starboard bridge wing and (3) top of pilothouse. Transmission power to each bearing repeater is controlled by switches in relay transmitter. These switches are labeled S1 (port bridge wing), S5 (starboard bridge wing), and S7 (top of pilothouse).

REPAIR

- a. Lamp replacement. (FIGURE 2-14).

WARNING

Ship's ac power is present at FUSE F1 and POWER switch S1 terminals on inside of cabinet cover. THESE VOLTAGES ARE DANGEROUS. Use extreme care when working inside of cabinet.

- (1) On relay transmitter (1, FIGURE 2-12), loosen four retaining clips (2) and open cabinet cover (3).
- (2) On A2 circuit card assembly (4), set appropriate repeater toggle switch (5) to the down position.
- (3) Close cabinet cover (3) and secure with four retaining clips (2).
- (4) Tag relay transmitter to indicate appropriate bearing repeater "Out of Service."
- (5) On appropriate pelorus stand (FIGURE 2-14) loosen two pivot nuts (2) and two pivot screws (3) on stand support plate (1).

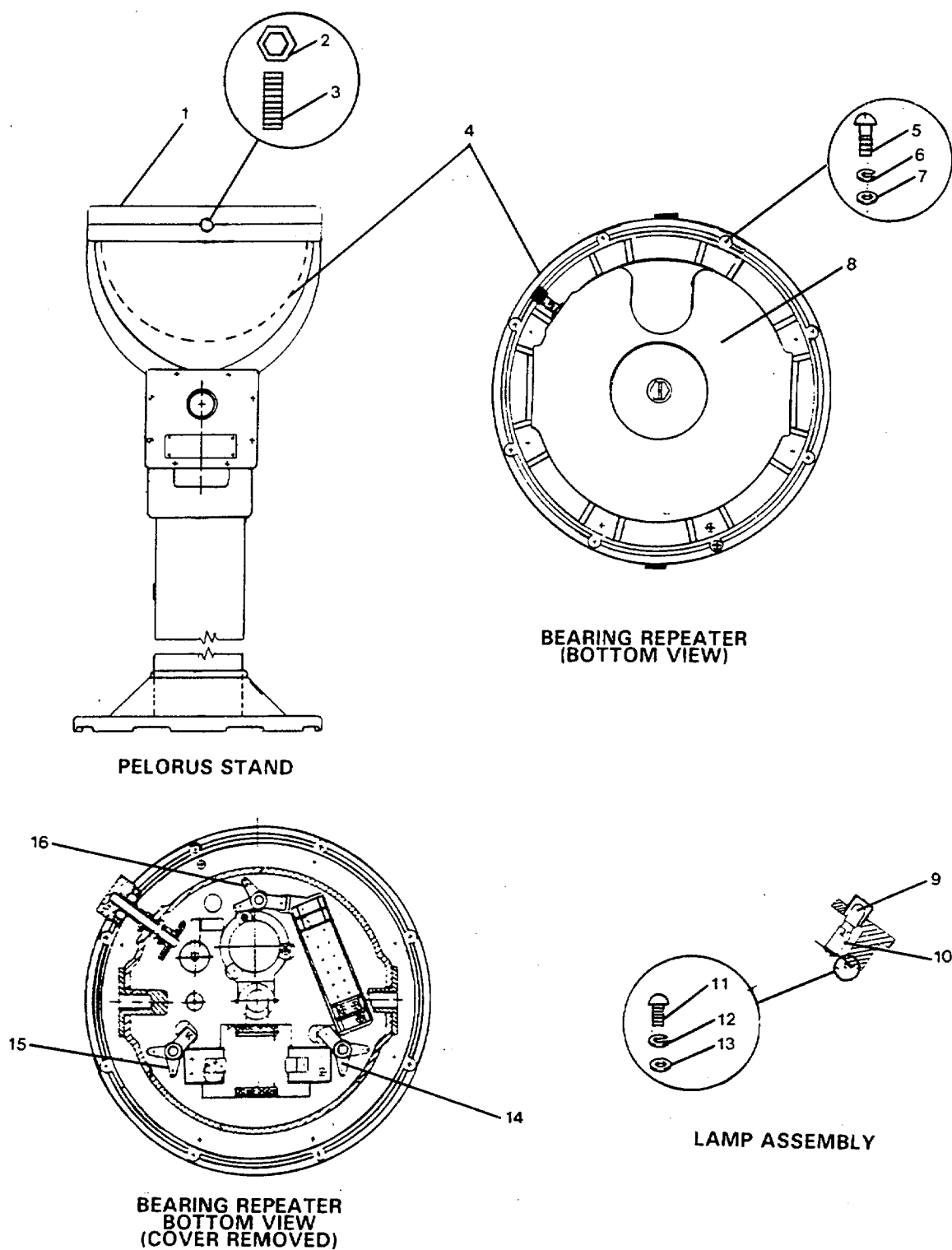

FIGURE 2-14. Bearing Repeater Lamp Replacement.

- (6) Rotate bearing repeater (4) on pivot screws (3) to BOTTOM VIEW position. Secure pivot nuts (2) holding repeater in this position.
- (7) Remove eight screws (5), lockwashers (6) and flat washers (7) from cover (8).
- (8) Remove cover (8) from repeater (4) as far as cabling will allow.
- (9) Locate lamp assemblies (14) DS1, (15) DS2, and (16) DS3.
- (10) On appropriate lamp assembly (14, 15, or 16) remove screw (11), lockwasher (12), and washer (13).
- (11) Remove lampholder (10) and remove incandescent lamp (9) from lampholder.
- (12) Insert replacement lamp (9) into lampholder (10).
- (13) Position lampholder and secure with washer (13), lockwasher (12), and screw (11).
- (14) Position cover (8) on repeater (4) and secure with eight flat washers (7), lockwashers (6), and screws (5).
- (15) Loosen two pivot nuts (2) and pivot screws (3) on support plate (1) and rotate repeater (4) to normal position.
- (16) Secure repeater by tightening two pivot screws (3) and two pivot nuts (2).
- (17) Synchronize bearing repeater with gyro compass. Refer to TM 55-1905-223-10.

WARNING

Ship's ac power is present at FUSE F1 and POWER switch S1 terminals on inside of cabinet cover. THESE VOLTAGES ARE DANGEROUS. Use extreme care when working-inside of cabinet.

- (18) On relay transmitter (1, FIGURE 2-12) loosen four retaining clips (2) and open cabinet cover (3).
- (19) On A2 circuit card assembly (4), set appropriate repeater toggle switch (5) to ON.
- (20) Close cabinet cover (3) and secure four retaining clips (2).
- (21) Remove "Out of Service" tag.

- b. Special purpose electrical cable (4 ft) replacement. (FIGURE 2-15).

WARNING

Ship's ac power is present at FUSE F1 and POWER switch S1 terminals on inside of cabinet cover. THESE VOLTAGES ARE DANGEROUS. Use extreme care when working inside of cabinet.

- (1) On relay transmitter (1, FIGURE 2-12), loosen four retaining clips (2) and open cabinet cover (3).
- (2) On A2 circuit card assembly (4), set appropriate repeater toggle switch (5) to the down position.
- (3) Close cabinet cover (3) and secure with four retaining clips (2).
- (4) Tag relay transmitter to indicate appropriate bearing repeater "Out of Service."
- (5) Loosen two pivot nuts (16, FIGURE 2-15) and rotate bearing repeater (2) in pelorus stand support plate (3) to BOTTOM VIEW position.
- (6) Remove eight screws (9), lockwashers (10), and flat washers (11) securing cover (12) to bearing repeater.
- (7) Remove bearing repeater cover (12) as far as cabling will allow.
- (8) Tag and disconnect cable (1) wiring from bearing repeater terminal board (13).
- (9) Disassemble stuffing tube (5) from cable (1) and pull cable (1) from bearing repeater.
- (10) On pelorus stand (4) remove eight pan head screws (7) and lockwashers (8), and remove cover plate (6) as far as cabling will allow.
- (11) On terminal board (14), tag and disconnect cable (1) wiring.
- (12) On rear of pelorus stand, disconnect cable gland on cable (1) from pelorus stand and route cable (1) from stand. Remove cable gland from cable.
- (13) Install cable gland on replacement cable (1).
- (14) Route cable (1) into pelorus stand at rear.
- (15) Connect cable (1) wiring to terminal board (14). Remove tags.

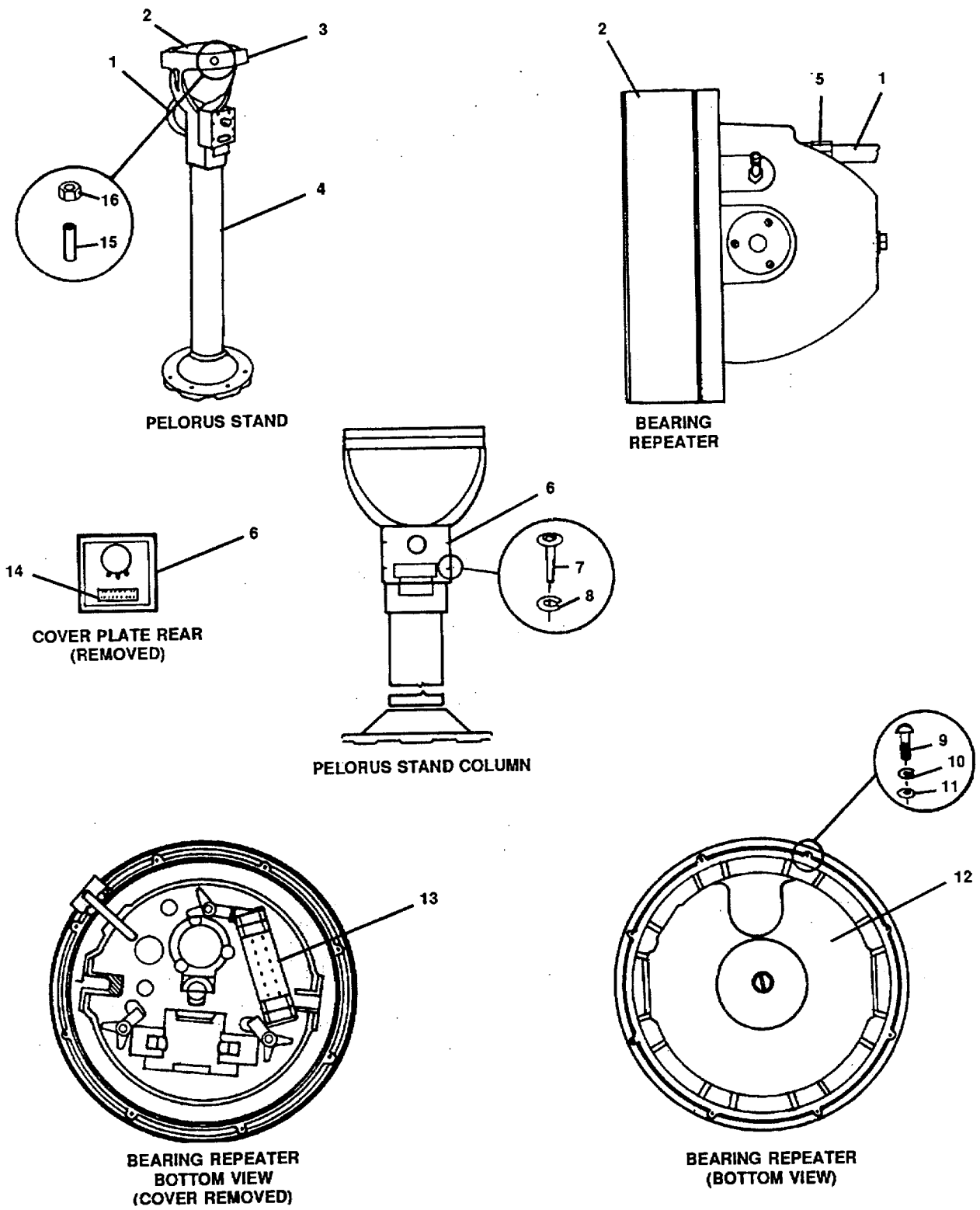

FIGURE 2-15. Bearing Repeater Cable Replacement.

- (16) Dress cable (1) inside of pelorus stand.
- (17) Position cover plate (6) on pelorus stand (4) and secure with eight lockwashers (8) and pan head screws (7).
- (18) Secure cable (1) cable gland to pelorus stand (4).
- (19) Assemble stuffing tube (5) to other end of cable (1) and route cable into bearing repeater (2).
- (20) Connect cable (1) wiring to terminal board (13). Remove tags.
- (21) Dress cable (1) inside of bearing repeater (2) and secure stuffing tube (5).
- (22) Position cover (12) on bearing repeater (2) and secure with eight flat washers (11), lockwashers (10), and screws (9).
- (23) Loosen two pivot nuts (16) and rotate bearing repeater (2) in pelorus stand support plate (3) to normal viewing position. Secure pivot nuts (16).
- (24) Synchronize bearing repeater with gyro compass. Refer to TM 55-1905-223-10.

WARNING

Ship's ac power is present at FUSE F1 and POWER switch S1 terminals on inside of cabinet cover. THESE VOLTAGES ARE DANGEROUS. Use extreme care when working inside of cabinet.

- (25) On relay transmitter (1, FIGURE 2-12) loosen four retaining clips (2) and open cabinet cover (3).
- (26) On A2 circuit card assembly (4), set appropriate repeater toggle switch (5) to ON.
- (27) Close cabinet cover (3) and secure four retaining clips (2).
- (28) Remove "Out of Service" tag.

2-22. Replace Bulkhead Mounting Bracket. (FIGURE 2-16)

This task covers: a. Removal, b. Replacement.

INITIAL SETUP**Tools**

Tool kit, general mechanic's,
5180-00-699-5273
Tool kit, electrician's,
5180-00-391-1087

Equipment Condition

Compass secured. TM 55-1905-223-10.
Appropriate open scale repeater
removed, para. 2-18.

Materials/Parts

Bulkhead mounting, bracket
P/N 1976878-2

REMOVAL

- a. On appropriate bulkhead mounting bracket (FIGURE 2-16), remove six screws (8) and washers (9) and remove covet (5) from junction box (7) as far as cabling will allow.
- b. On inside of junction box (7), tag and disconnect cable (1) from terminal board (6) TBI.
- c. Tag and disconnect system cable (3) connections from terminal board (6) TBI.
- d. On top of junction box (7), remove cable (1) connector (10) from connector adapter and pull cable (1) out of junction box.
- e. On top of junction box (7), remove cable (3) cable gland (4) and pull cable (3) out of junction box.

CAUTION

The next step requires two soldiers to support bulkhead mounting bracket while removing mounting hardware.

- f. Support bulkhead mounting bracket and removing three mounting bolts (2) from mounting holes and remove bulkhead mounting bracket.

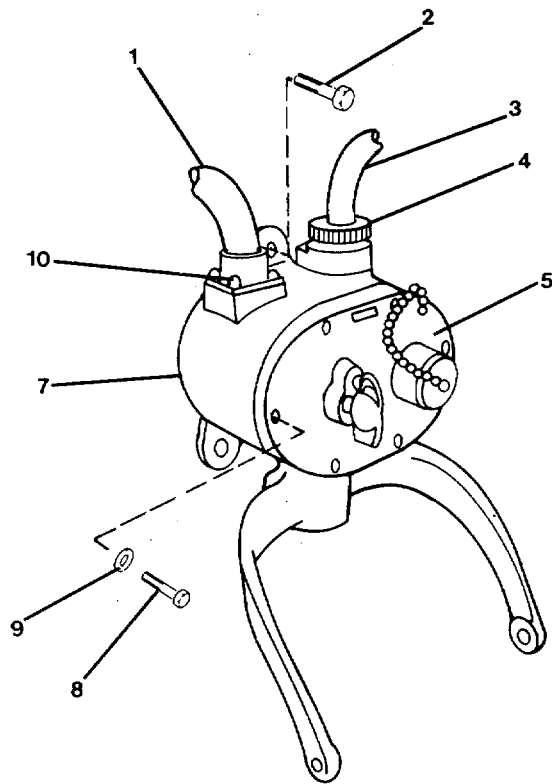

BULKHEAD MOUNTING BRACKET

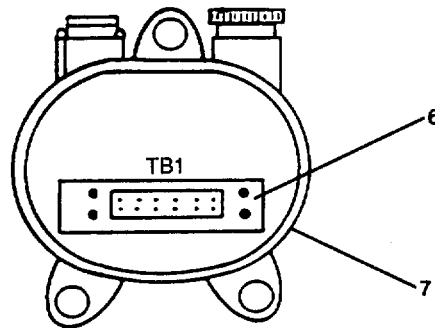

FIGURE 2-16. Bulkhead Mounting Bracket Replacement.

REPLACEMENT**NOTE**

Verify that replacement bulkhead mounting bracket rheostat is 25K ohm, 2 watt, for 70 Vdc circuitry. If not, notify manufacturer.

CAUTION

The next step requires two soldiers to support bulkhead mounting bracket while mounting to bulkhead.

- a. Position and support replacement bulkhead mounting bracket (FIGURE 2-16) aligning mounting bracket mounting holes to bulkhead mounting holes. Secure with three bolts (2).
- b. Route system cable (3) into junction box (7) and secure cable gland (4).
- c. Route cable (1) into junction box (7) and secure cable (1) connector (10) to connector adapter.
- d. On inside of junction box (7) connect system cable (3) connections to terminal board (6) TB1. Remove tags.
- e. On inside of junction box (7) connect cable (1) connections to terminal board (6) TB1. Remove tags.
- f. Dress cable (1 and 3) inside of junction box.
- g. Position cover (5) on junction box (7) and secure with six washers (9) and screws (8).
- h. Replace appropriate open scale repeater. Refer to paragraph 2-18.

2-23. Replace Pelorus Stand. (FIGURE 2-17)

This task covers: a. Removal, b. Replacement.

INITIAL SETUP**Tools**

Tool kit, general mechanic's,
5180-00-699-5273
Tool kit, electrician's,
5180-00-391-1087
Electrical drill, portable 3/8-inch
Cap. Class C, Style 1
5130-00-473-6224
Screw threading set, 1/4-inch
2 to 1 inch - 8NC type 1
5180-00-448-2362
Drill bit (.375), 3/8-inch
5133-00-277-9666

Equipment Condition

Bearing repeater removed (para. 2-20).

General Information

There are three pelorous stands: (1) port bridge wing, (2) starboard bridge wing, and (3) top of pilothouse. Each stand is supplied transmission data and lamp power by system cables up through the base of the stand and column assembly into the junction box terminal board. Power to the stand is removed in bearing repeater removal.

Materials/Parts

Pelorus stand, P/N 1887627
Threaded compound, P/N MIL-T-22361

NOTE

Manufacturer assistance is needed to align pelorus stand to vessel centerline.

REMOVAL

- a. Remove eight pan head screws (13, FIGURE 2-16) and lockwashers (12) securing cover plate (15) to housing (2).
- b. Remove cover plate (15) and gasket (17) from housing (2) as far as cabling will allow.
- c. On rear of cover plate (15), tag and disconnect repeater cable (3) connections from terminal board (16).
- d. On rear of cover plate (15), tag and disconnect system cable (8) connections from terminal board (16).
- e. On rear of housing (2) remove repeater cable (3) and cable gland.
- f. Remove fillister head screw (7) and lockwasher (6) securing housing (2) to column (10) at point (9).

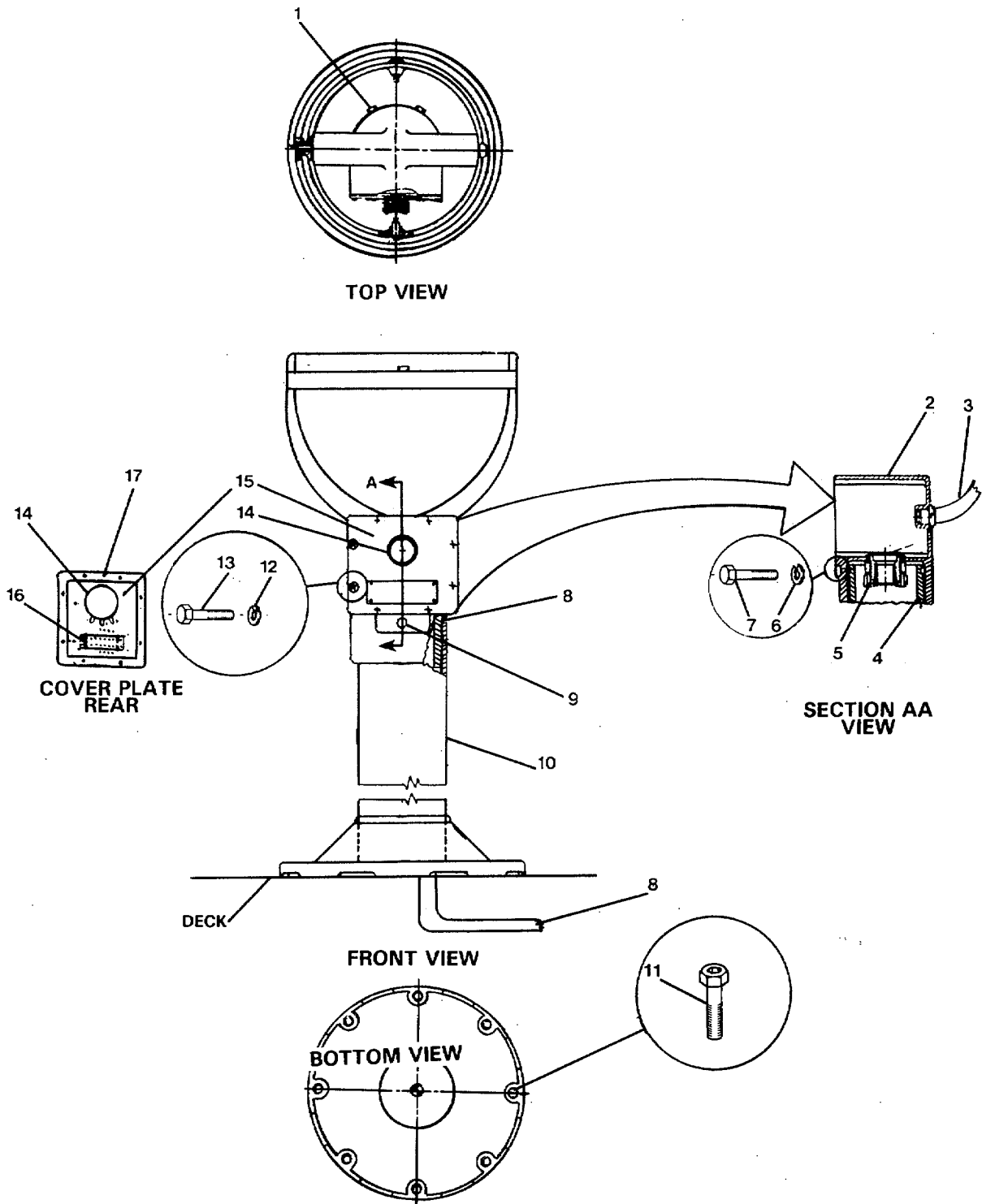

FIGURE 2-17. Pelorus Stand Replacement.

- g. Loosen two locking bolts (1) on housing (2).
- h. Lift bearing repeater support housing (2) up and off column (10)
- i. On column (10), disassemble stuffing tube (5) and let system cable (8) fall down into column (10).
- j. Re-assemble stuffing tube (5) to column (10).
- k. Remove eight deck mounting bolts (11) from base of pelorus stand.

CAUTION

The next step requires two soldiers because of the weight (66 pounds) of the pelorus stand.

- l. Lift pelorus stand column (10) from deck mounting and set aside.
- m. Position bearing repeater support housing (2) over column (10).
- n. Secure two locking bolts (1).
- o. Place fillister head screw (7) and lockwasher (5) in bag and tie bag to dimmer (rheostat) knob (14).
- p. Position cover plate (15) with gasket (17) on bearing support plate housing (2) and secure with eight lockwashers (12) and pan head screws (13).

CAUTION

If this replacement is the top of pilot house pelorus stand, action should be taken at this time to remove the pelorus stand from the pilot house top, to prevent injury to personnel or damage to the LCU from pelorus stand falling.

REPLACEMENT

CAUTION

Two soldiers are required to lift the pelorus stand when handling because of its weight (66 pounds).

- a. Position replacement pelorus stand (FIGURE 2-16) next to deck mounting area.
- b. Remove bearing support plate housing (2) from column (10) and set aside.
- c. Lay column (10) with base on deck.

- d. Remove stuffing tube (5) from column (10).
- e. Route system cable (8) through column (10) and up through stuffing tube (5) body.
- f. Assemble stuffing tube (5) on cable (8) and column (10) but do not secure.
- g. Lift column (6) and base up and align base mounting holes with deck mounting holes, being careful not to damage cable (8), and set on deck.
- h. Secure column (6) and base to deck with eight deck mounting bolts (11).
- i. Lift bearing support plate housing (2) up and place on column (10) being careful not to damage cable (8).
- j. Remove cover plate (15) by removing eight pan head screws (13) and lockwashers (12).
- k. Connect system cable (8) connections to terminal board (16) TB1. Remove tags.
- l. Secure cable (8) and stuffing tube (5).
- m. Route repeater cable (3) into housing (2) and secure cable gland.
- n. Connect repeater cable (3) connections to terminal board (16). Remove tags.
- o. Position cover plate (15) on housing (2) and secure with eight lockwashers (12) and pan head screws (13).
- p. Remove bag from dimmer (rheostat) knob (14) containing fillister head screw (7) and lockwasher (6).
- q. Replace bearing repeater. Refer to paragraph 2-20.
- r. Loosen two locking bolts (1, FIGURE 2-17).
- s. Align bearing repeater with the ship's center line. (Manufacturer's assistance is needed.)
- t. Secure locking bolts (1).
- u. Drill a number 6 drill-size hole through both the column (10) and bearing repeater support housing (2) at point indicated by callout (9).
- v. Tap 1/4-20 threads through both bearing support plate housing (2) and column (10).
- w. Drill with an "F" drill (.257) through bearing support plate housing (2) only.
- x. Install lockwasher (6) and fillister head screw (7) and secure.
- y. Start compass. Refer to TM 55-1905-223-10.

2-24. Replace Power Converter. (FIGURE 2-18)

This task covers: a. Removal, b. Replacement.

INITIAL SETUP

Tools

Tool kit, general mechanic's,
5180-00-699-5273
Tool kit, electrician's,
5180-00-391-1087

Equipment Condition

TM 55-1905-223-10, compass
secured.

Materials/Parts

Power converter P/N 1884074
Warning tags, Item 8, Appendix C

REMOVAL

- a. On pilothouse IC/ELEX, set circuit breaker No. 1 (MK 27 GYRO PWR CONV UNIT) to OFF. Tag "Out of Service, Do Not Operate."
- b. On pilothouse dc panel, set circuit breaker No. 1F (GYRO PWR TRANSF UNIT) to OFF. Tag "Out of Service, Do Not Operate."
- c. On power converter, remove cover (1) by removing fourteen hex head screws (5), lockwashers (4), and flat washers (3).
- d. Tag and disconnect cables (8), (9), and (10) from terminal board (11) TB1.
- e. Disassemble two stuffing tubes (7).
- f. Pull cables (8, 9, and 10) from enclosure and remove stuffing tubes.

CAUTION

The next step requires two soldiers because of the weight (26.5 pounds) of the power converter.

- g. Support power converter and remove three mounting bolts (2) and remove unit from bulkhead.

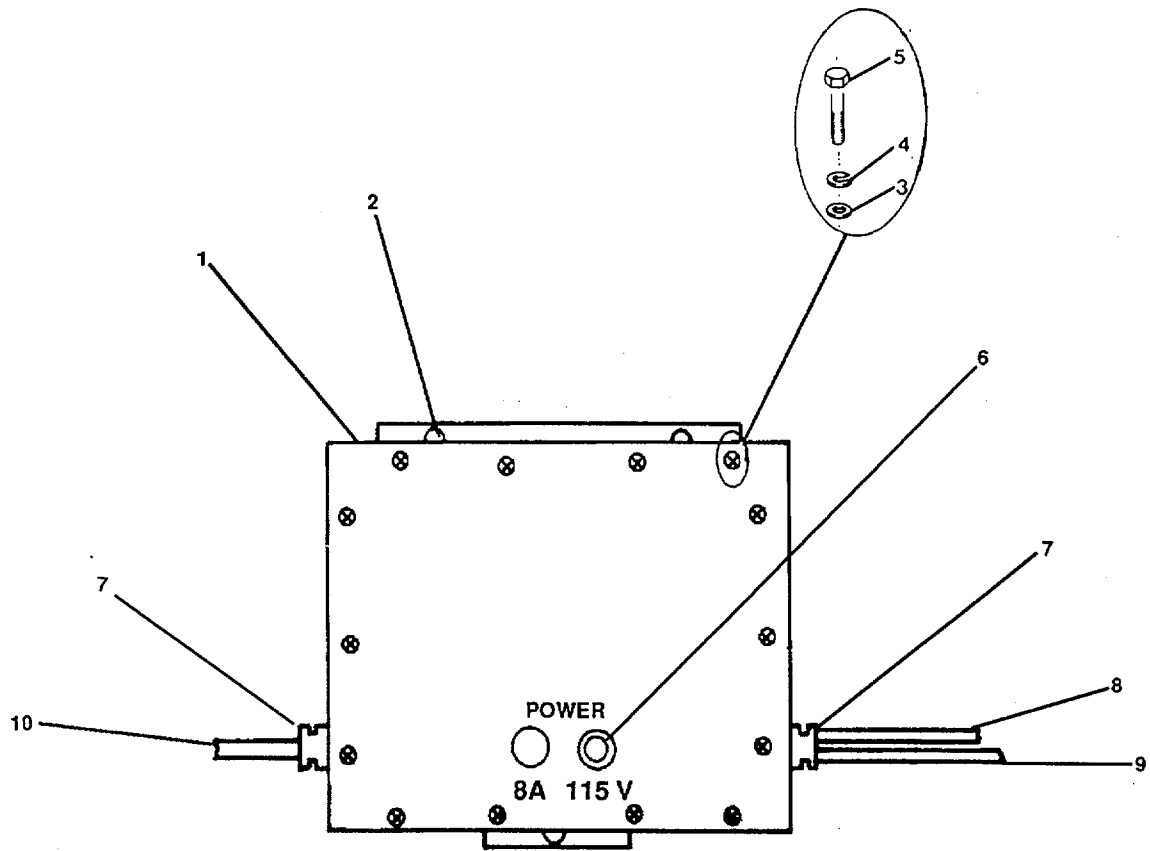

FRONT VIEW

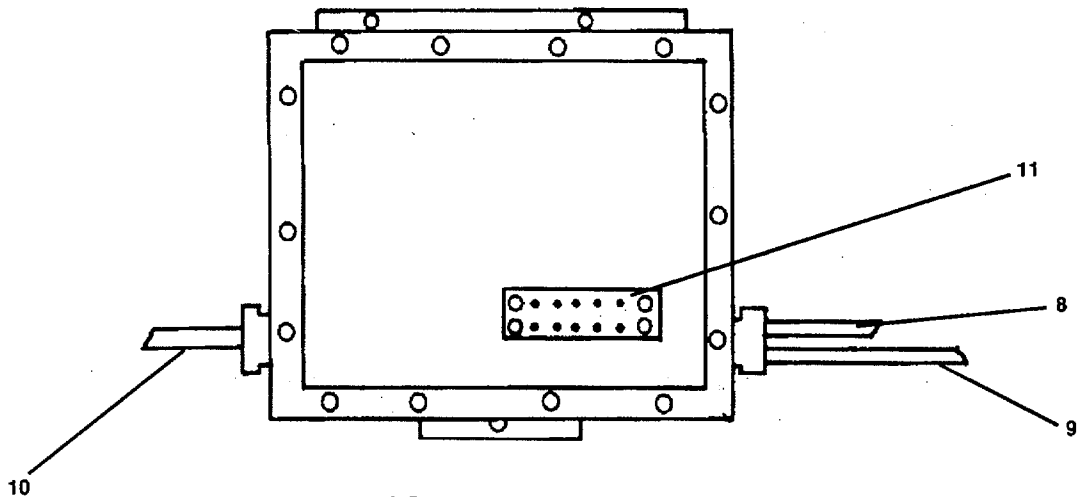

COVER REMOVED

FIGURE 2-18. Power Converter Replacement.

REPLACEMENT**CAUTION**

The next step requires two soldiers because of the weight (26.5 pounds) of the power converter.

- a. Position replacement power converter (FIGURE 2-18) on bulkhead, aligning mounting holes on unit to bulkhead mounting holes, and secure with three mounting bolts (2).
- b. Remove cover (1) by removing fourteen hex head screws (5), lockwashers (4), and flat washers (3).
- c. Assemble two stuffing tubes (7) to unit and cables (8, 9, and 10).
- d. Route cables (8, 9, and 10) into unit through stuffing tubes (7) and connect to terminal board (11) TB1 and remove tags. Secure stuffing tubes (7).
- e. Replace cover (1) and secure with fourteen flat washers (3), lockwashers (4), and hex head screws (5).
- f. On pilothouse IC/ELEX panel, set circuit breaker No. 1 (MK 27 GYRO PWR CONV UNIT) to ON. Remove "Out of Service, Do Not Operate" tag. POWER lamp (6) should light red.
- g. On pilothouse dc panel, set circuit breaker No. 1F (GYRO PWR TRANSF UNIT) to ON. Remove "Out of Service, Do Not Operate" tag.
- h. Start compass (TM 55-1905-223-10).

2-25. Repair Power Converter. (FIGURE 2-19)

This task covers: a. Disassembly, b. Repair, c. Assembly.

INITIAL SETUP**Tools**

Tool kit, general mechanic's,
5180-00-699-5273
Tool kit, electrician's,
5180-00-391-1087

Equipment Condition

TM 55-1905-223-10, compass
secured.

Materials/Parts

Glow lamp P/N 632234-6
Cartridge fuse (8 amp) P/N F03A250V8AS
Warning Tags, Item 8, Appendix C

Repair of the power converter consists of lamp replacement and fuse replacement.

DISASSEMBLY**a. Lamp.**

- (1) On pilothouse IC/ELEX panel, set circuit breaker No. 1 (MK 27 GYRO PWR CONV UNIT) to OFF. Tag "Out of Service, Do Not Operate."
- (2) On pilothouse dc panel, set circuit breaker No. 1F (GYRO PWR TRANSF UNIT) to OFF. Tag "Out of Service, Do Not Operate."
- (3) On power converter (1, FIGURE 2-19) remove lampholder lens (3) by turning counterclockwise.

b. Fuse.

- (1) On pilothouse IC/ELEX panel, set circuit breaker No. 1 (MK 27 GYRO PWR CONV UNIT) to OFF. Tag "Out of Service, Do Not Operate."
- (2) On pilothouse dc panel, set circuit breaker No. 1F (GYRO PWR TRANSF UNIT) to OFF. Tag "Out of Service, Do Not Operate."
- (3) On power converter (1, FIGURE 2-19) remove 8A fuse cartridge by pushing in on fuseholder cap (2) and turning counterclockwise.

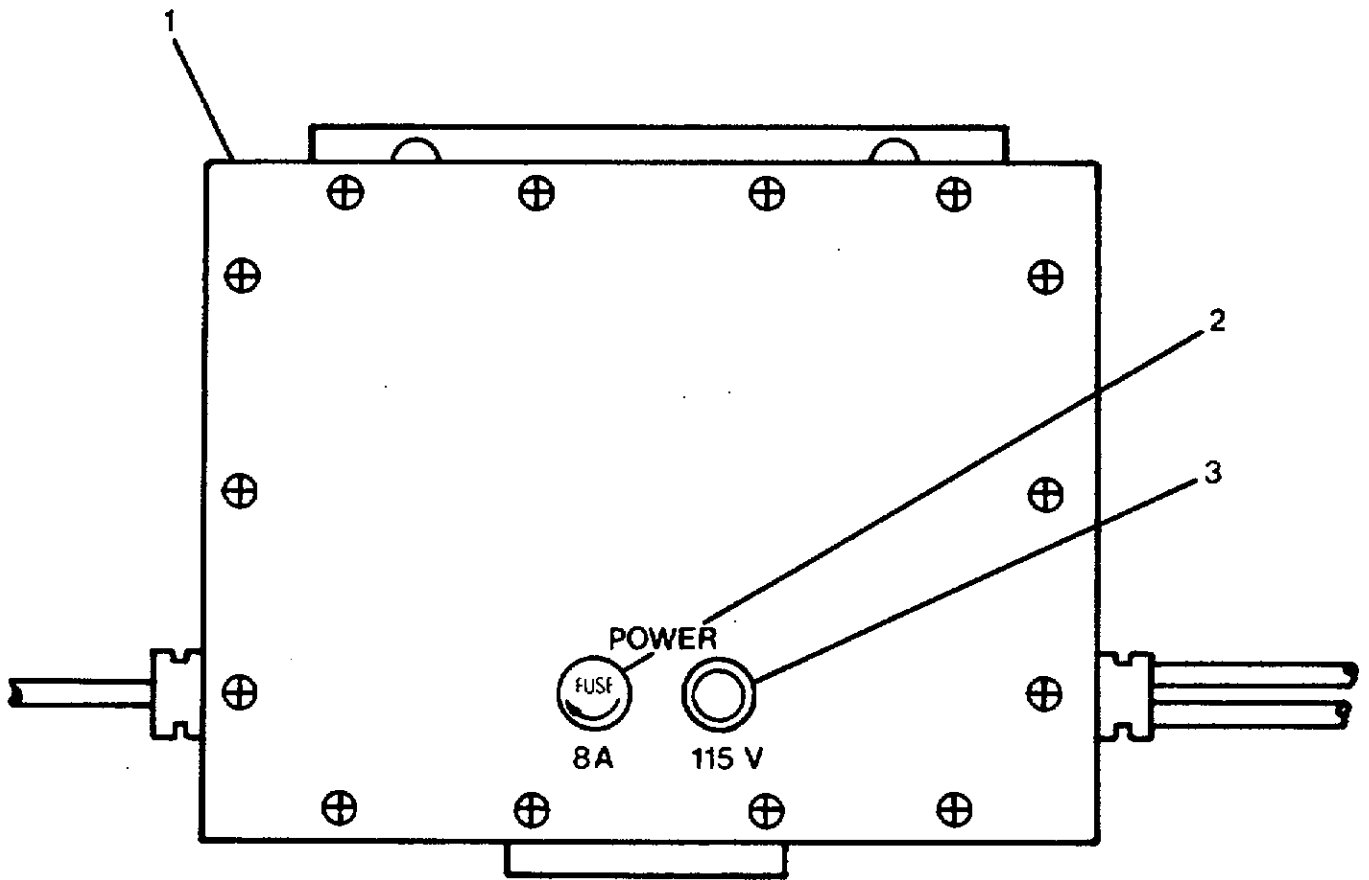

FIGURE 2-19. Power Converter Lamp and Fuse Replacement.

REPAIRa. Lamp.

- (1) Grasp glow lamp (3) with fingers and remove by pushing in and turning counterclockwise.
- (2) Insert replacement glow lamp (3) into lampholder, push in and turn clockwise to secure.

b. Fuse.

- (1) Remove fuse cartridge from fuseholder cap (2) and discard.
- (2) Insert replacement fuse cartridge into fuseholder cap (2).

ASSEMBLYa. Lamp.

- (1) Replace lampholder lens (3) by threading onto lampholder clockwise.
- (2) On pilothouse IC/ELEX panel, set circuit breaker No. 1 (MK 27 GYRO PWR CONV UNIT) to ON. Remove "Out of Service, Do Not Operate" tag. POWER lamp (3, FIGURE 2-16) should light red.
- (3) On pilothouse dc panel, set circuit breaker No. 1F (GYRO PWR TRANSF UNIT) to ON. Remove "Out of Service - Do Not Operate" tag.
- (4) Verify operation of lamp.
- (5) Start compass (TM 55-1905-223-10).

b. Fuse.

- (1) Insert fuseholder cap (2) and fuse cartridge into fuseholder, push in and turn clockwise to secure.
- (2) On pilothouse IC/ELEX panel, set circuit breaker No. 1 (MK 27 GYRO PWR CONV UNIT) to ON. POWER lamp (3, FIGURE 2-16) should light red.
- (3) On pilothouse dc panel, set circuit breaker No. 1F to ON. Remove "Out of Service, Do Not Operate" tag.
- (4) Start compass (TM 55-1905-223-10).

2-26. Replace Power Transfer Unit. (FIGURE 2-20)

This task covers: a. Removal, b. Replacement.

INITIAL SETUP**Tools**

Tool kit, general mechanic's,
5180-00-699-5273
Tool kit, electrician's,
5180-00-391-1087

Equipment Condition

TM 55-1905-223-10, compass
secured.

Materials/Parts

Power transfer unit P/N 1887874
Warning Tags, Item 8, Appendix C

REMOVAL

- a. On pilothouse IC/ELEX panel, set circuit breaker No. 1 (MK 27 GYRO PWR CONV UNIT) to OFF. Tag "Out of Service, Do Not Operate."
- b. On pilothouse dc panel, set circuit breaker No. 1F (GYRO PWR TRANSF UNIT) to OFF. Tag "Out of Service - Do Not Operate."
- c. On power transfer unit (1), open cover (2) by loosening four captive thumbscrews (3).
- d. Tag and disconnect cables (6), (7), and (8) from terminal board (4) TB1.
- e. Disassemble stuffing tubes (5) and pull cables (6, 7, and 8) out of electrical equipment cabinet.
- f. Support power transfer unit (1) and remove four bolts (9) from mounting holes and remove power transfer unit (1) from bulkhead.

REPLACEMENT

- a. Position replacement power transfer unit (1), on bulkhead aligning mounting holes on unit with mounting holes on bulkhead, secure with four bolts (9).
- b. Open cover (2) by loosening four captive thumbscrews (3).

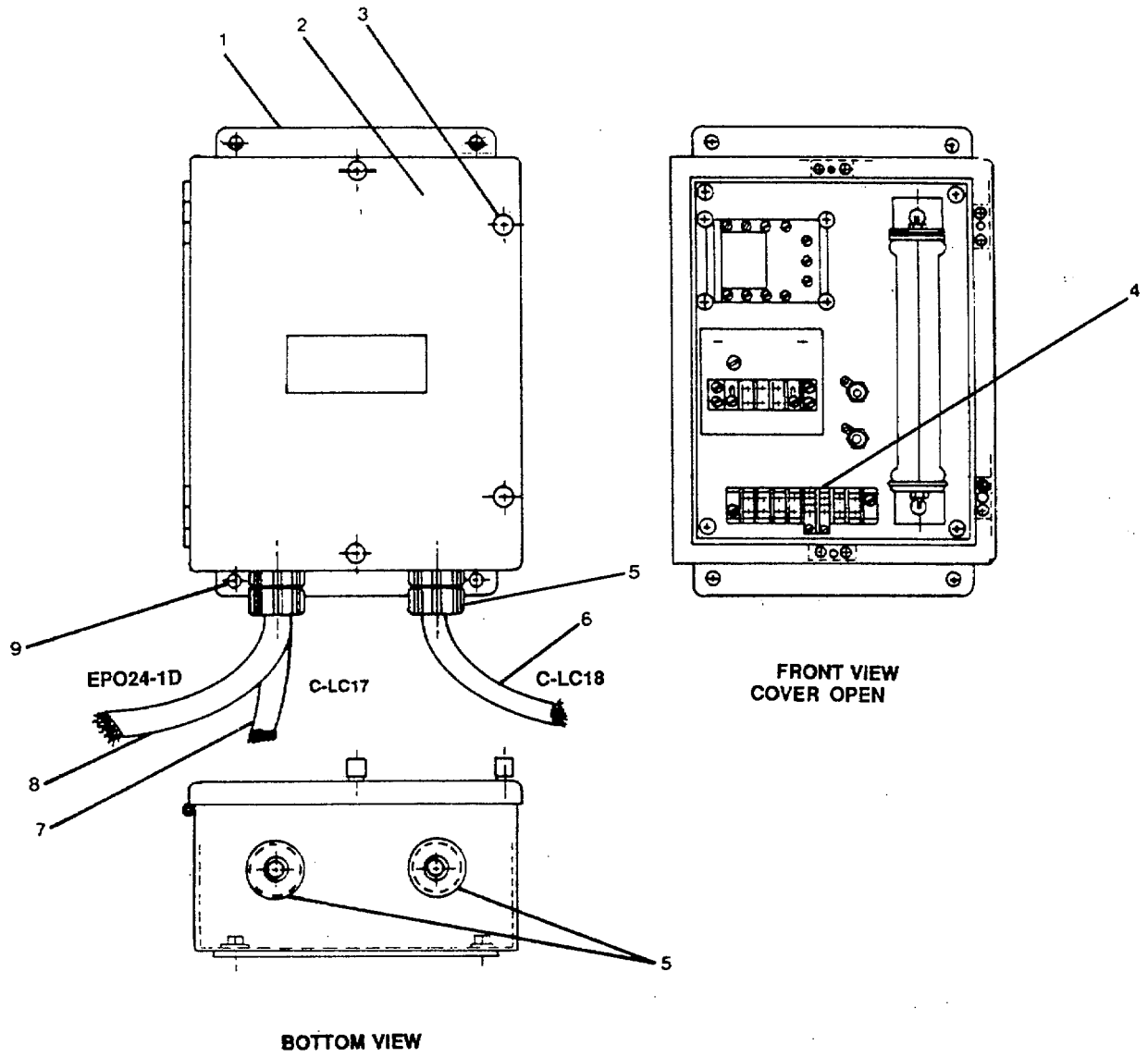

FIGURE 2-20. Power Transfer Unit Replacement.

- c. Assemble stuffing tubes (5) on electrical equipment cabinet and cables (6), (7), and (8).
- d. Route cables (6, 7, and 8) into electrical equipment cabinet and connect to terminal board (4) TB1. Remove tags.
- e. Dress cables inside electrical equipment cabinet and secure stuffing tubes (5).
- f. Close cover (2) and secure with four captive thumbscrews (3).
- g. On pilothouse IC/ELEX panel, set circuit breaker No. 1 (MK 27 GYRO PWR CONV UNIT) to ON. Remove "Out of Service, Do Not Operate" tag.
- h. On pilothouse dc panel, set circuit breaker No. 1F (GYRO PWR TRANSF UNIT) to ON. Remove "Out of Service, Do Not Operate" tag.
- i. Start compass (TM 55-1905-223-10).

 MAINTENANCE OF MAGNETIC COMPASS BINNACLE

2-27. Replace Binnacle. (FIGURE 2-21)

This task covers: a. Removal, b. Replacement.

INITIAL SETUP

Tools

Tool kit, general mechanic's,
5180-00-699-5273
Tool kit, electrician's,
5180-00-391-1087

Equipment Condition

Pilothouse IC/ELEX panel circuit breaker
No. 1F to OFF.

Materials/Parts

Binnacle, P/N BL101
Warning tags, Item 8, Appendix C

REMOVAL

- a. On binnacle (FIGURE 2-21), set lighting toggle switch (6) to OFF.
- b. On pilothouse IC/ELEX panel, set circuit breaker No. 1F (MAGNETIC COMPASS LT) to OFF. Tag "Out of Service, Do Not Operate."
- c. Unlock door lock (3).
- d. Open door (4) by pulling on knob (5).
- e. On inside of pedestal (6), tag and disconnect ship's electrical cable from terminal block (14).
- f. Remove any clamps on cable inside of pedestal (6).
- g. Close door (4) and secure door lock (3).
- h. Remove eight bolts (7), lockwashers (8), and flat washers (9) from bottom ring (10).
- i. In pilothouse, remove ceiling flange (12) and remove reflector tube assembly (13) by pulling down through pilot house overhead.

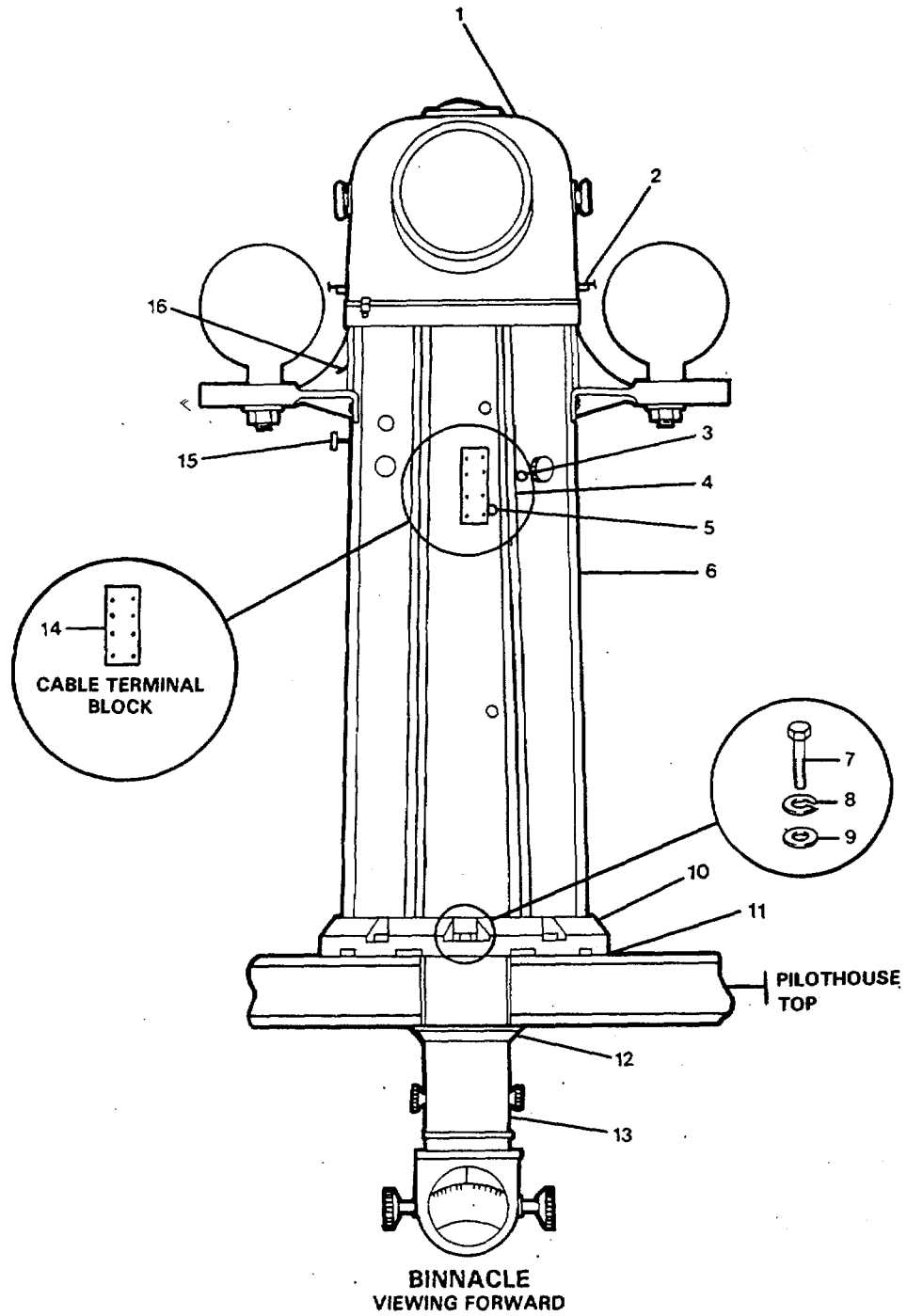

FIGURE 2-21. Binnacle Replacement.

CAUTION

The next step requires two soldiers because of the weight (117 pounds) of the binnacle.

- j. On pilot house top, lift binnacle and gasket (11) up and off deck mounting surface being careful not to damage electrical cable.

REPLACEMENT

- a. Ensure gasket (11) is aligned with deck mounting holes.

CAUTION

The next step requires two soldiers because of the weight (117 pounds) of the binnacle.

- b. Route electrical cable into pedestal (6) and lift binnacle and align bottom ring (10) mounting holes to deck mounting holes and place into mounting position.
- c. Secure binnacle with eight flat washers (9), lockwashers (8), and bolts (7) through bottom ring (10).
- d. In pilothouse, install reflector tube assembly (13) and secure with ceiling flange (12).
- e. On top of pilothouse, insert key into door locks (3) and unlock door (4).
- f. Open door (4) by pulling on knob (5).
- g. On inside of pedestal (6), locate ship's electrical cable and connect to terminal block (14). Remove tags.
- h. Dress cable inside of pedestal (6) and replace any cable clamps.
- i. Close door (4) and insert key into door locks (3) and secure.
- j. On pilothouse dc panel, set circuit breaker No. 1F (Magnetic Compass LT) to ON. Remove "Out of Service, Do Not Operate" tag.
- k. On binnacle (FIGURE 2-21), set lighting toggle switch (16) to ON. Verify hood lamp lights.
- 1. Vary setting of dimmer (rheostat) knob (15) and verify that lamp varies in illumination.

NOTE

The magnetic compass must be aligned after replacing the binnacle. See your supervisor.

2-28. Repair Binnacle. (FIGURES 2-22 and 2-23)

This task covers: Repair.

INITIAL SETUP

Tools

Tool kit, general mechanic's,
5180-00-699-5273
Tool kit, electrician's,
5180-00-391-1087

Materials/Parts

Incandescent lamp P/N BL1O1ITEM23
Compass oil (Varsol), Appendix C, Item 5
Distilled water, Appendix C, Item 7
Warning tags, Item 8, Appendix C

REPAIR

Repair of binnacle is limited to lamp replacement and compass fluid replacement.

a. Lamp replacement.

- (1) On binnacle (FIGURE 2-22), set lighting toggle switch (5) to OFF.
- (2) On pilothouse dc panel, set circuit breaker No. 1F (MAGNETIC COMPASS LT) to OFF. Tag "Out of Service, Do Not Operate."
- (3) On top of wheel house, release two hood,(l, FIGURE 2-22) clamps (2) and remove hood (1) from binnacle. (Hood lamp cabling is attached to binnacle.)
- (4) While holding hood (1), reach inside and remove incandescent lamp (3) from lampholder (4).
- (5) Install replacement incandescent lamp (3) in lampholder (4).
- (6) Install hood (1) on binnacle and secure with two clamps (2).
- (7) On pilothouse dc panel, set circuit breaker No. 1F (MAGNETIC COMPASS LT) to ON. Remove "1Out of Service, Do Not Operate" tag.

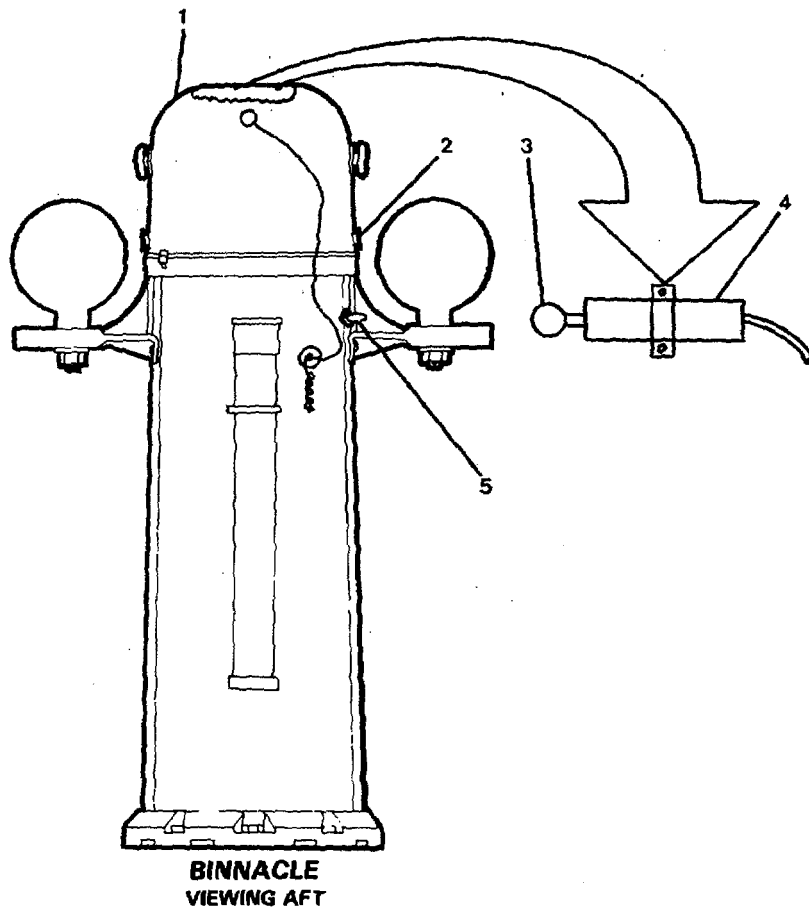

FIGURE 2-22. Binnacle Lamp Replacement.

(8) On binnacle (FIGURE 2-22), set lighting toggle switch (5) to ON.

(9) Verify binnacle lamp lights.

b. Compass fluid replacement.

(1) On binnacle (FIGURE 2-22) set lighting toggle switch (5) to OFF.

(2) On pilothouse dc panel, set circuit breaker No. 1F (Magnetic Compass LT) to OFF. Tag "Out of Service, Do Not Operate".

(3) On binnacle (FIGURE 2-23), release two clamps (1) and remove hood (2).

(4) Tip magnetic compass (3) upright in gimbal ring (4) so that filler plug screw (5) is at top.

(5) Back filler plug screw (5) out SLOWLY. If fluid should start to leak out, secure filler plug screw (5) to prevent any further fluid loss.

(6) Reposition magnetic compass (3) until bubble is directly beneath filler plug screw (5).

(7) Back out filler plug screw (5) SLOWLY and remove.

(8) Fill magnetic compass (3) with compass oil if compass was manufactured after 1970 (see data plate); use distilled water if compass was manufactured before 1970.

(9) Secure filler plug screw (5) into magnetic compass (3) bowl.

(10) Replace hood (2) on binnacle and secure with two clamps (1).

(11) On pilothouse dc panel, set circuit breaker No. 1F (Magnetic Compass LT) to ON. Remove "Out of Service, Do Not Operate" tag.

(12) On binnacle (FIGURE 2-22) set lighting toggle switch (5) to ON.

(13) Verify that hood lamp lights.

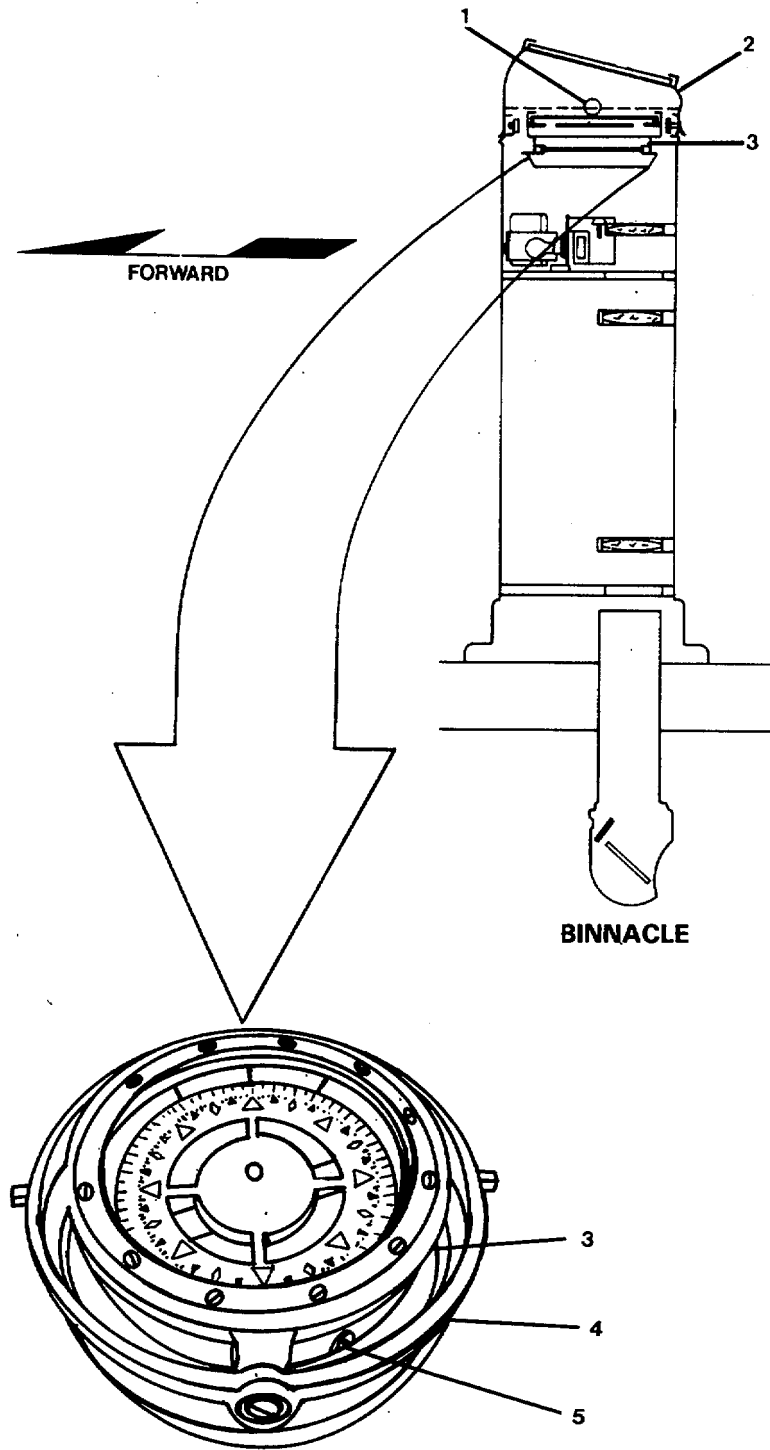

FIGURE 2-23. Magnetic Compass Fluid Replacement.

Section VI. PREPARATION FOR STORAGE OR SHIPMENT

2-29. Administrative Storage. Administrative storage of equipment issued to and used by Army activities will have preventive maintenance performed in accordance with the Preventive Maintenance Checks and Services (PMCS) tables before storing. When removing the equipment from administrative storage, the PMCS should be performed to ensure operational readiness. Removal of components for shipment or limited storage is covered in paragraphs 2-11 through 2-28. Use the following steps for repacking for shipment or short term storage.

- a. Place all loose components in a plastic bag and secure the bag to the unit.
- b. Pack the unit in a box using suitable protection.
- c. Seal the box containing the unit and mark appropriately.
- d. Do not store the unit in a place where moisture is present.

CHAPTER 3

INTMRMEDIATE DIRECT SUPPORT MAINTENANCE INSTRUCTIONS

There are no intermediate direct support maintenance procedures authorized by the Maintenance Allocation Chart (MAC). Refer to MAC Section IV, Remarks.

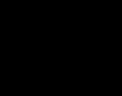

CHAPTER 4

INTERMEDIATE GENERAL SUPPORT MAINTENANCE INSTRUCTIONS

There are no intermediate general support maintenance procedures authorized by the Maintenance Allocation Chart (MAC). Refer to MAC Section IV, Remarks.



APPENDIX A

REFERENCES

A-1. Scope. This paragraph lists the manuals, bulletins, specifications, and miscellaneous publications referenced in this manual or required for maintenance activities.

A-2. Field Manuals.

FM 21-11	First Aid for Soldiers
FM 31-70	Basic Cold Weather Manual
FM 55-501	Marine Crewman's Handbook

A-3. Technical Manuals.

TM 43-0139	Painting Instructions for Field Use
TM 43-0144	Painting of Vessels
TM 55-1905-223-10	Operator's Manual for Landing Craft, Utility (LCU) -
TM 55-1905-223-24-18	LCU 2000 Class Basic Craft Maintenance Manual
TM 55-1905-223-24P	Repair Parts and Special Tools List for the LCU 2000 Class Watercraft
TM 750-244-3	Destruction of Army Materiel to Prevent Enemy Use

A-4. Technical Bulletins.

TB 55-1900-207-24	Treatment of Cooling Water in Marine Diesel Engines
TB 740-97-4	Preservation of Vessels for Storage

A-5. Military Specifications.

MIL-C-16173C	Rust Preventive, Type P-1
MIL-L-644	Preservative Oil, Type P-9
MIL-L-21260	Preservative Oil, Type P-10

A-6. Miscellaneous Publications.

DA Pam 738-750	The Army Maintenance Management System
LO 55-1905-223-12	Lubrication Order for the LCU 2000 Class Watercraft
*AMC-R 750-11	Use of Lubricants, Fluids, and Associated Products

A-7. Forms.

DA Form 2028 and 2028-2	Recommended Changes to Publications and Blank Forms
DA Form 2404	Equipment Maintenance and Inspection Worksheet
DA Form 2408-16	Logsheet
DA Form 2410	Logsheet
SF Form 368	Quality Deficiency Report

*Supercedes Darcom-R 750-11

APPENDIX B**MAINTENANCE ALLOCATION CHART****Section I. INTRODUCTION****B-1. General.**

a. This section provides a general explanation of all maintenance and repair functions authorized at various maintenance categories (levels).

b. The Maintenance Allocation Chart (MAC) in Section II designates overall authority and responsibility for the performance of maintenance functions on the identified end item or component. The application of the maintenance functions to the end item or component will be consistent with the capacities and capabilities of the designated maintenance categories.

c. Section III lists the tools and test equipment (both special tools and common tool sets) required for each maintenance function as referenced from Section II.

d. Section IV contains supplemental instructions and explanatory notes for a particular maintenance function.

B-2. Maintenance Functions. Maintenance functions will be limited to and defined as follows:

a. Inspect. To determine the serviceability of an item by comparing its physical, mechanical, and/or electrical characteristics with established standards through examination (for example, by sight, sound, or feel).

b. Test. To verify serviceability by measuring the mechanical, pneumatic, hydraulic, or electrical characteristics of an item and comparing those characteristics with prescribed standards.

c. Service. Operations required periodically to keep an item in proper operating condition, that is, to clean (includes decontaminate, when required), to preserve, to drain, to paint, or to replenish fuel, lubricants, chemical fluids, or gases.

d. Adjust. To maintain or regulate, within prescribed limits, by bringing into proper or exact position, or by setting the operating characteristics to specified parameters.

e. Align. To adjust specified variable elements of an item to bring about optimum or desired performance.

f. Calibrate. To determine and cause corrections to be made or to be adjusted on instruments or test, measuring, and diagnostic equipments used in precision measurement. Consists of comparisons of two instruments, one of which is a certified standard of known accuracy, to detect and adjust any discrepancy in the accuracy of the instrument being compared.

g. Remove/Install. To remove and install the same item when required to perform service or other maintenance functions. Install may be the act of emplacing, seating, or fixing into position a spare, repair part, or module (component or assembly) in a manner to allow the proper functioning of an equipment or system.

h. Replace. To remove an unserviceable item and install a serviceable counterpart in its place. "Replace" is authorized by the MAC and is shown as the third position code of the SMR code.

i. Repair. The application of maintenance services¹, including fault location/troubleshooting², removal/installation, and disassembly/assembly³ procedures, and maintenance actions to identify troubles and restore serviceability to an item by correcting specific damage, fault, malfunction, or failure in a part, subassembly, module (component or assembly), end item, or system.

j. Overhaul. That maintenance effort-(service/action) necessary to restore an item to a completely serviceable/operational condition as required by maintenance standards in appropriate technical publications [i.e., Depot Maintenance Work Requirements (DMWR)]. Overhaul is normally the highest degree of maintenance performed by the Army. Overhaul does not normally return an item to like-new condition.

k. Rebuild. Consists of those services/actions necessary for the restoration of unserviceable equipment to a like-new condition in accordance with original manufacturing standards. Rebuild is the highest degree of materiel maintenance applied to Army equipment. The rebuild operation includes the act of returning to zero those age measurements (hours, miles, etc.) considered in classifying Army equipments/components.

B-3. Explanation of Columns in the MAC, Section II.

a. Column 1, Group Number. Column 1 lists functional group code numbers, the purpose of which is to identify maintenance-significant components, assemblies, subassemblies, and modules with the next higher assembly. End item-group number shall be "00."

¹Services - inspect, test, service, adjust, align, calibrate, and/or replace.

²Fault locate/troubleshoot - The process of investigating and detecting the cause of equipment malfunctioning; the act of isolating a fault within a system or unit under test (UUT).

³Disassemble/assemble - encompasses the step-by-step taking apart (or breakdown) of a spare/functional group coded item to the level of its least component identified as maintenance significant (that is, assigned an SMR code) for the category of maintenance under consideration.

⁴Actions - welding, grinding, riveting, straightening, facing, remachinery, and/or resurfacing.

b. Column 2, Component/Assembly. Column 2 contains the noun names of components, assemblies, subassemblies, and modules for which maintenance is authorized.

c. Column 3, Maintenance Function. Column 3 lists the functions to be performed on the item listed in Column 2. (For detailed explanation of these functions, see paragraph B-2.)

d. Column 4, Maintenance Category. Column 4 specifies, by the listing of a work time figure in the appropriate subcolumn(s), the category of maintenance authorized to perform the function listed in Column 3. This figure represents the active time required to perform that maintenance function at the indicated category of maintenance. If the number or complexity of the tasks within the listed maintenance function vary at different maintenance categories, appropriate work time figures will be shown for each category. The work time figure represents the average time required to restore an item (assembly, subassembly, component, module, end item or system) to a serviceable condition under typical field operating conditions. This time includes preparation time (including any necessary disassembly/assembly time), troubleshooting/fault location time, and quality assurance/quality control time in addition to the time required to perform the specific tasks identified for the maintenance functions authorized in the maintenance allocation chart. The symbol designations for the various maintenance categories are as follows:

<u>UNIT</u>	C - Operator or Crew O - Organizational Maintenance
<u>INTERMEDIATE</u>	F - Direct Support Maintenance H - General Support Maintenance
<u>DEPOT</u>	D - Depot

e. Column 5, Tools and Equipment. Column 5 specifies, by code, those common tool sets (not individual tools) and special tools, TMDE, and support equipment required to perform the designated function.

f. Column 6, Remarks. This column shall, when applicable, contain a letter code, in alphabetic order, which shall be keyed to the remarks contained in Section IV.

B-4. Explanation of Columns in Tool and Test Equipment Requirements, Section III.

a. Column 1, Reference Code. The tool and test equipment reference code correlates with a code used in the MAC, Section II, Column 5.

b. Column 2, Maintenance Category. The lowest category of maintenance authorized to use the tool or test equipment.

c. Column 3, Nomenclature. Name or identification of the tool or test equipment.

d. Column 4, National Stock Number. The National stock number of the tool or test equipment.

e. Column 5, Tool Number. The manufacturer's part number.

B-5. Explanation of Columns in Remarks, Section IV.

a. Column 1, Reference Code. This code recorded in Column 6, Section II.

b. Column 2, Remarks. This column lists information pertinent to the maintenance function being performed as indicated in the MAC, Section II.

SECTION II MAINTENANCE ALLOCATION CHART
FOR
GYRO AND MAGNETIC COMPASS ASSEMBLY

(1) GROUP NUMBER	(2) COMPONENT/ASSEMBLY	(3) MAINTENANCE FUNCTION	(4) MAINTENANCE LEVEL					(5) TOOLS & EQPT.	(6) REMARKS
			UNIT		INTERMED.		DE PO T		
			C	O	F	H	D		
14	GYRO AND MAGNETIC COMPASS SYSTEM	INSPECT SERVICE REPLACE REPAIR	2.0 1.0 10.0					1 1,2 1-5	A,B
1401	COMPASS, GYRO SYSTEM, MK 27 MOD 1	INSPECT REPLACE REPAIR	1.5 8.0	1.0 0.5				1,2 1,2	A,E
140101	COMPASS, GYRO	REPLACE	2.0					1,2	
140102	GYRO CONTROL AND POWER ASSEMBLY	REPLACE REPAIR	1.0	0.3				1,2 1,2	B,E
140103	SWITCH UNIT	INSPECT REPLACE	0.5	1.0				1,2	B,D
1402	TRANSMITTER, RELAY	INSPECT REPLACE REPAIR	0.5 1.0	0.3				1,2 1,2	B,E
1403	REPEATER, OPEN SCALE	INSPECT REPLACE REPAIR	0.5 2.0	0.3				1,2 1,2	B,E
1404	REPEATER, BEARING	INSPECT REPLACE REPAIR	0.5 2.0	0.3				1,2 1,2	B,E
1405	BRACKET, BULKHEAD MOUNTING	INSPECT REPLACE	0.5 1.0					1,2	D
1406	PELORUS STAND	INSPECT REPLACE	0.5 1.0					1-5	D
1407	POWER CONVERTER	INSPECT REPLACE REPAIR	0.5 1.0	0.3				1,2 1,2	B,E

SECTION II MAINTENANCE ALLOCATION CHART
FOR
GYRO AND MAGNETIC COMPASS ASSEMBLY

(1) GROUP NUMBER	(2) COMPONENT/ASSEMBLY	(3) MAINTENANCE FUNCTION	(4) MAINTENANCE LEVEL					(5) TOOLS & EQPT.	(6) REMARKS
			UNIT		INTERMED.		DE PO T		
			C	O	F	H	D		
1408	POWER TRANSFER UNIT	INSPECT REPLACE	0.5 1.0					1,2	B,D
1409	BINNACLE	INSPECT REPLACE REPAIR	0.5 2.0	1.5				1,2 1,2	B,C

SECTION III TOOL AND TEST EQUIPMENT REQUIREMENTS
FOR
GYRO AND MAGNETIC COMPASS SYSTEM

TOOL OR TEST EQPT REF CODE	MAINT. LEVEL	NOMENCLATURE	NATIONAL,NATO STOCK NUMBER	TOOL NUMBER
1	C,O	Tool kit, general mechanics	5180-00-699-5273	(50980) SC-5180-90-CL-N05
2	C,O	Tool kit, electricians	5180-00-391-1087	(80064) 9000S6202-73125ALT2
3	C,O	Electric drill, portable 3/8-inch cap, Class C, style 1	5130-00-473-6224	
4	C,O	Screw threading set 1/4-inch,	5130-00448-2362	
5	C,O	2-1 inch-8NC type 1 Drill bit (.375), 3/8-inch	5133-00-227-9666	

**SECTION IV REMARKS
GYRO AND MAGNETIC COMPASS SYSTEM**

REFERNCE CODE	REMARKS
A.	LIMITED REPAIR AT DS/GS LEVEL. WHEN COMPLETE REPAIR/IN-DEPTH EPAIR IS REQUIRED, REFER TO THE NICP FOR INSTRUCTIONS/APPROVAL.
B.	COMPLETE REPAIR/IN-DEPTH REPAIR IS TO BE PERFORMED BY MANUFACTURER.
C.	EXCEPT FOR FLUID LOSS (BUBBLES) IN COMPASS, THERE SHOULD BE NO REPAIRS ATTEMPTED ABOARD SHIP. REPLACE FLUID AND AT FIRST PORT OF CALL EVACUATE TO FACILITY THAT HAS A VACUUM CHAMBER TO CORRECT CAUSE OF FIUID LOSS.
D.	REPAIR FOR THIS ITEM IS BY REPLACEMENT.
E.	UNIT REPAIR IS LIMITED TO LAMPS AND FUSES ONLY.

APPENDIX C

EXPENDABLE/DURABLE SUPPLIES AND MATERIALS LIST

Section I. INTRODUCTION

C-1. Scope. This appendix lists expendable/durable supplies and materials you will need to operate and maintain the Gyro and Magnetic Compass System. This list is for informational purposes only and is not authority to requisition the listed items. These items are authorized to you by CTA 50-970, Expendable/Durable Items (Except Medical, Class V, Repair Parts, Heraldic Items), or CTA 8-100, Army Medical Department Expendable/Durable Items. Adjust when higher category maintenance requirements are involved.

C-2. Explanation of Columns .

a. Column (1) - Item number. This number is assigned to the entry in the listing and is referenced in the narrative instructions to identify the material (e.g., "Use cleaning compound, Item 5, App. C").

b. Column (2) - Level. This column identifies the lowest level of maintenance that requires the listed item.

C - Operator/Crew

O - Organizational Maintenance

F - Direct Support Maintenance

H - General Support Maintenance

c. Column (3) - National Stock Number. This is the National stock number assigned to the item; use it to request or requisition the item.

d. Column (4) - Description. Indicates the Federal item name and, if required, a description to identify the item. The last line for each item indicates the Federal Supply Code for Manufacturer (FSCM) in parentheses followed by the part number.

e. Column (5) - Unit of Measure (U/M). Indicates the measure used in performing the actual maintenance function. This measure is expressed by a two-character alphabetical abbreviation (e.g., ea, in, pr). If the unit of measure differs from the unit of issue, requisition the lowest unit of issue that will satisfy your requirements.

SECTION II. EXPENDABLE/DURABLE SUPPLIES AND MATERIALS LIST

(1) ITEM NUMBER	(2) LEVEL	(3) NATIONAL STOCK NUMBER	(4) DESCRIPTION	(5) U/M
1	C	6850-00-110-4498	Cleaning Solvent	CN
2	C	7920-00-044-9281	Cloth, Dusting	BX
3	C	5305-00-357-3477	Compound, Thread	CN
4	C	6508-00-727-2941	Detergent, Mild	GL
5	H	9150-00-851-4257	Oil, Compass (Damping Fluid)	CN
6	C	7920-00-212-8543	Rag, Cleaning	BL
7	H	6810-00-107-1510	Water, Distilled	DR
8	C	2995-00-868-2735	Tag, Warning	EA
9	C	6850-00-880-7616	Grease	TU

APPENDIX D

TORQUE VALUES

D-1. Scope. SAE capscrews are graded according to the strength of the capscrew. They are marked on the head so the correct strength and torque value are known. The tables in this appendix will list the capscrew markings with correct torque values as well as values for pipe plugs and metric bolts.

CAUTION

When replacing capscrews, always use a capscrew of the same measurement and strength as the capscrew being replaced. Using incorrect capscrews can result in equipment damage. Bolts threaded into aluminum require much less torque.

NOTE

Always use torque values listed in the tables when specific torque values are unknown. The torque -values listed in the tables are based on the use of lubricated threads.

Table D-1. Capscrew Markings and Torque Values

Capacity Body Size		SAE Grade #5 Cast Iron or Steel			SAE Grade #6 or #7 Cast Iron or Steel			SAE Grade #8 Cast Iron or Steel		
Inches-Thread		ft-lb	Torque		ft-lb	Torque		ft-lb	Torque	
			kgm	N•m		kgm	N•m		kgm	N•m
1/4	-20	8	1.1064	10.8465	10	1.3630	13.5582	12	1.6596	16.2698
	-28	10	1.3830	13.5582				14	1.9362	18.9815
5/16	-18	17	2.3511	23.0489	19	2.6277	25.7605	24	3.3192	32.5396
	-24	19	2.6277	25.7605				27	3.7341	36.6071
3/8	-16	31	4.2873	42.0304	34	4.7022	46.0978	44	6.0852	59.6560
	-24	35	4.8405	47.4536				49	6.7767	66.4351
7/16	-14	49	6.7767	66.4351	55	7.6065	74.5700	70	9.6810	94.9073
	-20	55	7.6065	74.5700				78	10.7874	105.7538
1/2	-13	75	10.3725	101.6863	85	11.7555	115.2445	105	14.5215	142.3609
	-20	85	11.7555	115.2445				120	16.5860	162.6960
9/16	-12	110	15.2130	149.1380	120	16.5960	162.6960	155	21.4365	210.1490
	-18	120	16.5960	162.6960				170	23.5110	230.4860
5/8	-11	150	20.7450	203.3700	167	23.0961	226.4186	210	29.0430	284.7180
	-18	170	23.5110	230.4860				240	33.1920	325.3920
3/4	-10	270	37.3410	366.0660	280	38.7240	379.6240	375	51.8625	508.4250
1/2	-16	295	40.7985	399.9610				420	58.0860	568.4360
7/8	-9	395	54.6285	535.5410	440	60.8520	596.5520	605	83.6715	820.2590
	-14	435	60.1605	589.7730				675	93.3525	915.1650
1.0	-8	590	81.5970	799.9220	660	91.2780	894.8280	910	125.8530	1233.7780
	-14	660	91.2780	849.8280				990	136.9170	1342.2420

Table D-1. Capscrew Markings and Torque Values - CONT

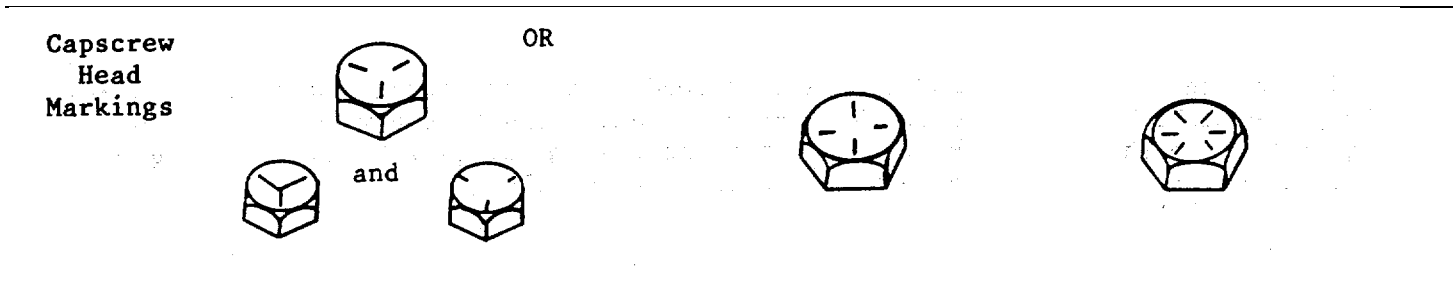

Table D-2. Pipe Plug Torque Values

Thread	Size Actual	Thread O.D.	In Aluminum Components			In Cast Iron or Steel Components	
			(in)	Torque N•m	(ft-lb)	Torque N•m	(ft-lb)
1/16	8.1	(0.32)	5	(45 in-lb)	15	(10)	
1/8	10.4	(0.41)	15	(10)	20	(15)	
1/4	13.7	(0.54)	20	(15)	25	(20)	
3/8	17.3	(0.68)	25	(20)	35	(25)	
1/2	21.6	(0.85)	35	(25)	55	(40)	
3/4	26.7	(1.05)	45	(35)	75	(55)	
1	33.5	(1.32)	60	(45)	95	(70)	
1-1/4	42.2	(1.66)	75	(55)	115	(85)	
1-1/2	48.3	(1.90)	85	(65)	135	(100)	

Table D-3. Metric Bolt Torque Values

Thread for general purposes (size x pitch (mm))	Cast Iron or Steel			
	Head Mark 4		Head Mark 7	
	ft-lb	Torque (N•m)	ft-lb	Torque (N•m)
6 x 1.0	2.2 to 2.9	(3.0 to 3.9)	3.6 to 5.8	(4.9 to 7.8)
8 x 1.25	5.8 to 8.7	(7.9 to 12)	9.4 to 14	(13 to 19)
10 x 1.25	12 to 17	(16 to 23)	20 to 29	(27 to 39)
12 x 1.25	21 to 32	(29 to 43)	35 to 53	(47 to 72)
14 x 1.5	35 to 52	(48 to 70)	57 to 85	(77 to 110)
16 x 1.5	51 to 77	(67 to 100)	90 to 120	(130 to 160)
18 x 1.5	74 to 110	(100 to 150)	130 to 170	(180 to 230)
20 x 1.5	110 to 140	(150 to 190)	190 to 240	(160 to 320)
22 x 1.5	150 to 190	(200 to 260)	250 to 320	(340 to 430)
24 x 1.5	190 to 240	(260 to 320)	310 to 410	(420 to 550)

GLOSSARY

Section I. ABBREVIATIONS

A.....	Ampere
AC (ac).....	Alternating Current
A1, A2.....	Reference Designators
DC (dc).....	Direct Current
DS.....	Incandescent Lamp
F.....	Fuse
Hz.....	Hertz
LCU.....	Landing Craft Utility
S.....	Switch
TB.....	Terminal Board
V.....	Volt(s)

Section II. DEFINITION OF UNUSUAL TERMS

Aft or After	-	At, near, or toward the stern.
Azimuth Circle	-	Device that can be fitted to the Bearing Repeater to take terrestrial or celestial bearings.
Binnacle	-	Compass stand made of nonmagnetic material, serving to house, illuminate and protect the Magnetic Compass. Component of the Gyro Compass, serving to house, illuminate and protect the gyro element.
Bulkhead	-	Partition dividing the interior of a vessel into compartments.
Caged	-	Spring loaded action like a ball point pen, suspending Gyro from operation.
Gimbal Ring	-	Device consisting of two rings mounted on axes at right angles to each other so that an object, such as a compass, will remain suspended in a horizontal plane between them, regardless of the motion of the vessel.
Heel	-	To list over or lean to one side.
Helm	-	Mechanism by which a vessel is steered.
List	-	Inclination of a vessel to one side; as a list to port or a list to starboard.
Lubber's Line	-	Line on a compass that is exactly parallel to the vessel's centerline.

GLOSSARY - CONT

- Pelorus Stand - Device serving to mount and provide power and data to Bearing Repeater.
- Port - Left side of vessel looking forward.
- Slew - To twist around on an axis.
- Starboard - Right side of vessel looking forward.
- Stern - After end of a vessel.
- Trim - Difference in draft at the bow and stern of a vessel in the water.
- Wing - Platform on either side of the bridge.

ALPHABETICAL INDEX

Subject; Paragraph

A

Administrative Storage; 2-29

B

Bearing Repeater Repair; 2-21
 Bearing Repeater Replacement; 2-20
 Binnacle Repair; 2-28
 Binnacle Replacement; 2-27
 Bulkhead Mounting Bracket Replacement;
 2-22

C

Common Tools and Equipment; 2-1
 Checking Unpacked Equipment; 2-4

D

Destruction of Army Materiel; 1-3

G

Gyro Compass Equipment Characteristics,
 Capabilities and Features; 1-6a
 Gyro Compass Equipment Data; 1-6c
 Gyro Compass Equipment Location and
 Description of Major Components; 1-6b
 Gyro Compass Principles of Operation;
 1-8
 Gyro Compass Replacement; 2-12
 Gyro Compass Safety, Care, and Handling;
 1-6d
 Gyro Compass System Replace/Repair;
 2-11
 Gyro Control and Power Assembly
 Repair; 2-14
 Gyro Control and Power Assembly
 Replacement; 2-13

I

Initial Setup Procedure; 2-5

M

Magnetic Compass Equipment
 Characteristics, Capabilities and
 Features; 1-7a

Subject; Paragraph

M - CONT

Magnetic Compass Equipment Data;
 1-7c
 Magnetic Compass Equipment Safety,
 Care and Handling; 1-7d
 Magnetic Compass Location and
 Description of Major Components;
 1-7b
 Magnetic Compass Principles of
 Operation; 1-9
 Maintenance Forms and Records; 1-2

N

Normal Startup; 2-6

O

Open Scale Repeater Repair; 2-19
 Open Scale Repeater Replacement; 2-18

P

Pelorus Stand Replacement; 2-23
 PMCS; 2-8
 Power Converter Fuse Replacement; 2-24
 Power Converter Lamp Replacement; 2-24
 Power Converter Repair; 2-25
 Power Converter Replacement; 2-24
 Power Distribution; 1-10
 Power Transfer Unit Replacement; 2-26
 Preparation for Storage or Shipment;
 1-5, 2-29

R

Relay Transmitter Repair; 2-17
 Relay Transmitter Replacement; 2-16
 Repair Parts; 2-3
 Reporting Equipment Improvement
 Recommendations (EIRs); 1-4

S

Scope; 1-1
 Shutdown Procedure; 2-7
 Special Tools; 2-2
 Support Equipment; 2-2
 Switch Unit Replacement; 2-15

ALPHABETICAL-INDEX - CONT

Subject; Paragraph

Subject; Paragraph

T

TMDE; 2-2

Troubleshooting; 2-9

By Order of the Secretary of the Army:

CARL E. VUONO
General, United States Army
Chief of Staff

Official:

WILLIAM J. MEEHAN, II
Brigadier General, United States Army
The Adjutant General

DISTRIBUTION:

To be distributed in accordance with DA Form 12-25A, Unit, Direct Support and General Support Maintenance requirements for Landing Craft, Utility, LUC-1466, Type III.

The Metric System and Equivalents

Linear Measure

1 centimeter = 10 millimeters = .39 inch
 1 decimeter = 10 centimeters = 3.94 inches
 1 meter = 10 decimeters = 39.37 inches
 1 dekameter = 10 meters = 32.8 feet
 1 hectometer = 10 dekameters = 328.08 feet
 1 kilometer = 10 hectometers = 3,280.8 feet

Weights

1 centigram = 10 milligrams = .15 grain
 1 decigram = 10 centigrams = 1.54 grains
 1 gram = 10 decigram = .035 ounce
 1 dekagram = 10 grams = .35 ounce
 1 hectogram = 10 dekagrams = 3.52 ounces
 1 kilogram = 10 hectograms = 2.2 pounds
 1 quintal = 100 kilograms = 220.46 pounds
 1 metric ton = 10 quintals = 1.1 short tons

Liquid Measure

1 centiliter = 10 milliliters = .34 fl. ounce
 1 deciliter = 10 centiliters = 3.38 fl. ounces
 1 liter = 10 deciliters = 33.81 fl. ounces
 1 dekaliter = 10 liters = 2.64 gallons
 1 hectoliter = 10 dekaliters = 26.42 gallons
 1 kiloliter = 10 hectoliters = 264.18 gallons

Square Measure

1 sq. centimeter = 100 sq. millimeters = .155 sq. inch
 1 sq. decimeter = 100 sq. centimeters = 15.5 sq. inches
 1 sq. meter (centare) = 100 sq. decimeters = 10.76 sq. feet
 1 sq. dekameter (are) = 100 sq. meters = 1,076.4 sq. feet
 1 sq. hectometer (hectare) = 100 sq. dekameters = 2.47 acres
 1 sq. kilometer = 100 sq. hectometers = .386 sq. mile

Cubic Measure

1 cu. centimeter = 1000 cu. millimeters = .06 cu. inch
 1 cu. decimeter = 1000 cu. centimeters = 61.02 cu. inches
 1 cu. meter = 1000 cu. decimeters = 35.31 cu. feet

Approximate Conversion Factors

To change	To	Multiply by	To change	To	Multiply by
inches	centimeters	2.540	ounce-inches	newton meters	.007062
feet	meters	.305	centimeters	inches	.394
yards	meters	.914	meters	feet	3.280
miles	kilometers	1.609	meters	yards	1.094
square inches	square centimeters	6.451	kilometers	miles	.621
square feet	square meters	.093	square centimeters	square inches	.155
square yards	square meters	.836	square meters	square feet	10.764
square miles	square kilometers	2.590	square meters	square yards	1.196
acres	square hectometers	.405	square kilometers	square miles	.386
cubic feet	cubic meters	.028	square hectometers	acres	2.471
cubic yards	cubic meters	.765	cubic meters	cubic feet	35.315
fluid ounces	milliliters	29.573	cubic meters	cubic yards	1.308
pints	liters	.473	milliliters	fluid ounces	.034
quarts	liters	.946	liters	pints	2.113
gallons	liters	3.785	liters	quarts	1.057
ounces	grams	28.349	liters	gallons	.264
pounds	kilograms	.454	grams	ounces	.035
short tons	metric tons	.907	kilograms	pounds	2.205
pound-feet	newton meters	1.356	metric tons	short tons	1.102
pound-inches	newton meters	.11296			

Temperature (Exact)

°F	Fahrenheit temperature	5/9 (after subtracting 32)	Celsius temperature	°C
----	------------------------	----------------------------	---------------------	----

This fine document...

Was brought to you by me:



[Liberated Manuals -- free army and government manuals](#)

Why do I do it? I am tired of sleazy CD-ROM sellers, who take publicly available information, slap “watermarks” and other junk on it, and sell it. Those masters of search engine manipulation make sure that their sites that sell free information, come up first in search engines. They did not create it... They did not even scan it... Why should they get your money? Why are not letting you give those free manuals to your friends?

I am setting this document FREE. This document was made by the US Government and is NOT protected by Copyright. Feel free to share, republish, sell and so on.

I am not asking you for donations, fees or handouts. If you can, please provide a link to liberatedmanuals.com, so that free manuals come up first in search engines:

<A HREF=<http://www.liberatedmanuals.com/>>Free Military and Government Manuals

- Sincerely
Igor Chudov
<http://igor.chudov.com/>
- [Chicago Machinery Movers](#)