

**TECHNICAL MANUAL**

**UNIT AND INTERMEDIATE DIRECT SUPPORT  
MAINTENANCE REPAIR PARTS AND SPECIAL TOOLS LIST**

**COMPRESSOR UNIT, RECIPROCATING,  
25 CFM, 175 PSI,  
ELECTRIC MOTOR DRIVEN,  
MODEL 10HT8G,  
NSN 4310-01-198-9365**

**Approved for public release; distribution is unlimited.**

**\*This manual supersedes TM 5-4310-380-23P, 15 September 1986, including all changes.**

---

**HEADQUARTERS, DEPARTMENT OF THE ARMY  
10 OCTOBER 1989**

CHANGE  
NO. 1

HEADQUARTERS  
DEPARTMENT OF THE ARMY  
WASHINGTON, D.C., 30 JUNE 1993

Unit and Direct Support Maintenance  
Repair Parts and Special Tools List  
For  
COMPRESSOR UNIT, RECIPROCATING  
25 CFM, 175 PSI  
ELECTRIC MOTOR DRIVEN  
MODEL: 10HT8G  
NSN: 4310-01-198-9365

DISTRIBUTION STATEMENT A: Approved for public release; distribution is unlimited.

TM 5-4310-380-23P, 10 October 1989, is changed as follows:

1. Title is changed as indicated above.
2. Remove and insert pages as indicated below. New or changed text material is indicated by a vertical bar in the margin. An illustration change is indicated by a miniature pointing hand.

Remove pages

i and ii  
1 through 6  
13-1 and Figure 14  
I-3 and I-4  
I-7 and I-8  
I-11 and I-12

Insert pages

i and ii  
1 through 6  
13-1 and Figure 14  
I-3 and I-4  
I-7 and I-8  
I-11 and I-12

3. Retain this sheet in front of manual for reference purposes.

**By Order of the Secretary of the Army:**

Official:

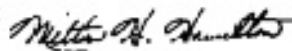

MILTON H. HAMILTON  
Administrative Assistant to the  
Secretary of the Army  
04490

GORDON R. SULLIVAN  
General, United States Army  
Chief of Staff

DISTRIBUTION:

To be distributed in accordance with DA Form 12-25-E, block no. 2444, requirements for TM 5-4310-380-23P.

TECHNICAL MANUAL  
No. 5-4310-380-23P

HEADQUARTERS  
DEPARTMENT OF THE ARMY  
WASHINGTON, D.C, 10 October 1989

Unit and Direct Support  
Maintenance Repair Parts  
and Special Tools List  
For  
COMPRESSOR UNIT, RECIPROCATING  
25 CFM, 175 PSI, ELECTRIC  
MOTOR DRIVEN  
MODEL: 10HT8G  
NSN: 4310-01-198-9365

Current as of 3 June 1989

**DISTRIBUTION STATEMENT A: Approved for public release; distribution is unlimited.**

REPORTING ERRORS AND RECOMMENDING IMPROVEMENTS

You can help improve this manual. If you find any mistakes or if you know of a way to improve the procedures, please let us know. Mail your letter, DA Form 2028 (Recommended Changes to Publications and Blank Forms), or DA Form 2028-2 located in the back of this manual direct to: Commander, U.S. Army Aviation and Troop Command, ATTN: AMSAT-I-MP, 4300 Goodfellow Boulevard, St. Louis, MO 63120-1798. A reply will be furnished directly to you.

TABLE OF CONTENTS

		Page	Illus. Figure
Section I.	INTRODUCTION		
Section II.	REPAIR PARTS LIST		
Group 00	Reciprocating Compressor Unit		
Group 01	Electric Motor Starter and Wiring	1-1	1
	Pressure Switch	2-1	2
Group 02	Belt Guard Assembly	3-1	3
	V Belts and Drive Pulley	4-1	4
Group 03	Compressor Assembly	5-1	5
	Air Cleaner	6-1	6
	Oil Filler Cap, Plugs, Fan and Pulley	7-1	7
	Tube Assemblies	8-1	8
	Cylinder Head Assembly, 1st Stage	9-1	9
	Cylinder Head Assembly, 2nd Stage	10-1	10
	Pistons, Connecting Rods and Cylinders	11-1	11
	Crankshaft, Bearings and Oil Seals	12-1	12
Group 04	Electric Motor, 10HP	13-1	13

\*This manual supersedes TM 5-4310-380-23P, 15 September 1986, including all changes.

## TABLE OF CONTENTS - Continued

		Page	Illus. Figure
Group 05	Receiver System	14-1	14
Group 06	Air Discharge System	15-1	15
Section III.	SPECIAL TOOLS LIST (Not applicable)		
Section IV.	CROSS-REFERENCE INDEXES	I-1	
	National Stock Number Index	I-1	
	Part Number Index	I-3	
	Figure & Item Number Index	I-8	

UNIT AND DIRECT SUPPORT  
MAINTENANCE REPAIR PARTS AND SPECIAL TOOLS LIST

COMPRESSOR UNIT, RECIPROCATING,  
25 CFM, 175 PSI,  
ELECTRIC MOTOR DRIVEN,  
MODEL 10HT8G,  
NSN 4310-01-1989365

**SECTION I. INTRODUCTION**

**1. SCOPE.** This RPSTL lists and authorizes spares and repair parts; special tools; special test, measurement, and diagnostic equipment (TMDE); and other special support equipment required for performance of unit and direct support maintenance of the Compressor Unit, Reciprocating. It authorizes the requisitioning, issue, and disposition of spares, repair parts and special tools as indicated by the source, maintenance and recoverability (SMR) codes

**2. GENERAL.** In addition to this section, Introduction, this Repair Parts and Special Tools List is divided into the following sections:

**a. Section II. Repair Parts List.** A list of spares and repair parts authorized by this RPSTL for use in the performance of maintenance. The list also includes parts which must be removed for replacement of the authorized parts. Parts lists are composed of functional groups in ascending alphanumeric sequence, with the parts in each group listed in ascending figure and item number sequence. Bulk materials are listed in item name sequence. Repair parts kits are listed separately in their own functional group within Section II. Repair parts for repairable special tools are also listed in this section. Items listed are shown on the associated illustration(s)/figure(s).

**b. Section III. Special Tools List.** A list of special tools, special TMDE, and other special support equipment authorized by this RPSTL (as indicated by Basis of Issue (BOI) information in DESCRIPTION AND USABLE ON CODE column) for the performance of maintenance.

**c. Section IV. Cross-references Indexes.** A list, in National Item Identification Number (NIIN) sequence, of all National stock numbered items appearing in the listing, followed by a list in alphanumeric sequence of all part numbers appearing in the listings. National stock numbers and part numbers are cross referenced to each illustration figure and item number appearance. The figure and item number index lists figure and item number in alphanumeric sequence and cross references NSN, FSCM and part number.

**3. EXPLANATION OF COLUMNS (SECTIONS II AND III).**

**a. ITEM NO. (Column (1)).** Indicates the number used to identify items called out in the illustration.

**b. SMR Code (Column (2)).** The Source, Maintenance, and Recoverability (SMR) code is a S-position code containing supply/requisitioning information, maintenance category authorization criteria, and disposition instruction, as shown in the following breakout

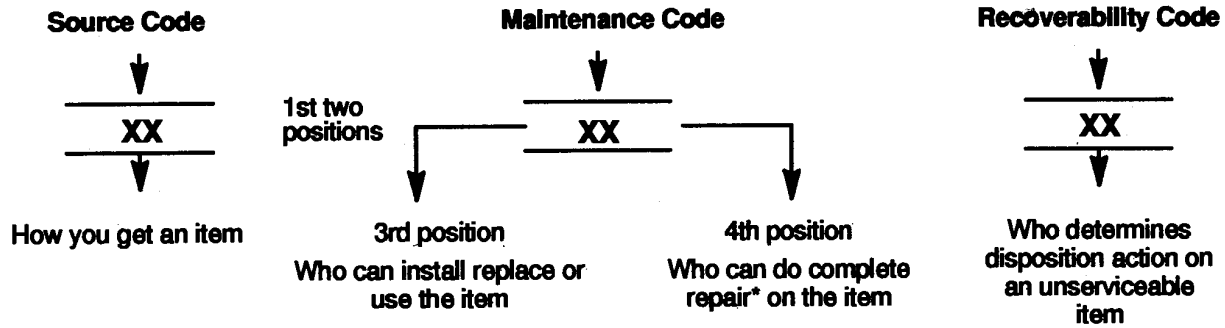

**NOTE**

\*Complete Rear: Maintenance capacity, capability, and authority to perform all corrective maintenance tasks of the "Repair" function in a use/user environment in order to restore serviceability to a failed item.

\*

(1) **Source Code.** The source code tells you how to get an item needed for maintenance, repair, or overhaul of an end item/equipment. Explanations of source codes follows:

Code	Explanation
PA PB PC** PD PE PF PG	} Stocked items; use the applicable NSN to request/requisition items with these source codes. They are authorized to the category indicated by the code entered in the 3rd position of the SMR code.  **NOTE : Items coded PC are subject to deterioration.
KD KF KB	} Items with these codes are not to be requested/requisitioned individually. They are part of a kit which is authorized to the maintenance category indicated in the 3rd position of the SMR code. The complete kit must be requisitioned and applied.
MO (Made at org AVUM level) MF (Made at DS/AVUM level) MH (Made at GS level) ML (Made at Specialized Repair Activity (SRA)) MD (Made at Depot)	} Items with these codes are not to be requested/requisitioned individually. They must be made from bulk material which is identified by the part number in the DESCRIPTION and USABLE ON CODE (UOC) column and listed in the Bulk Material group of the repair parts list in the RPSTL. If the item is authorized to you by the 3rd position code of the SMR code, but the source code indicates it is made at a higher level, order the item from the higher level of maintenance.

Explanation

<p>AO (Assembled by org AVUM Level)</p> <p>AF (Assembled by DS/AVUM Level)</p> <p>AH (Assembled by GS Category)</p> <p>AL (Assembled by SRA)</p> <p>AD (Assembled by Depot)</p>	}	<p>Items with these codes are not to be requested/requisitioned individually. The parts that make up the assembled item must be requisitioned or fabricated and assembled at the level of maintenance indicated by the source code. If the 3rd position code of the SMR code, authorizes you to replace the item, but the source code indicates the items are assembled at a higher level, order the item from the higher level of maintenance.</p>
---	---	---

Code	Explanation
------	-------------

- XA - - Do not requisition an "XA"-coded item. Order its next higher assembly. (Also, refer to the NOTE below.)
- XB - - If an "XB" item is not available from salvage, order it using the CAGE Code and part number given.
- XC - - Installation drawing, diagram, instruction sheet, field service drawing, that is identified by manufacturer's part number.
- XD - - Item is not stocked. Order an "XD"-coded item through normal supply channels using the CAGE Code and part number given, if no NSN is available.

**NOTE**

Cannibalization or controlled exchange, when authorized, may be used as a source of supply for items with the above source codes, except for those source coded "XA" or those aircraft support items restricted by requirements of AR 750-1.

(2) **Maintenance Code.** Maintenance codes tells you the level(s) of maintenance authorized to USE and REPAIR support items. The maintenance codes are entered in the third and fourth positions of the SMR code as follows:

- (a) The maintenance code entered in the third position tells you the lowest maintenance level authorized to remove, replace, and use an item. The maintenance code entered in the third position will indicate authorization to one of the following levels of maintenance.

Code	Application/Explanation
C	Crew or operator maintenance done within unit or aviation unit maintenance.
O	Unit or aviation unit category can remove, replace, and use the item.

F - Direct support or aviation intermediate level can remove, replace, and use the item.

H - General support level can remove, replace, and use the item.

L - Specialized repair activity can remove, replace, and use the item.

D - Depot level can remove, replace, and use the item.

- (b) The maintenance code entered in the fourth position tells whether or not the item is to be repaired and identifies the lowest maintenance level with the capability to do complete repair (i.e., perform all authorized repair functions.) NOTE: Some limited repair may be done on the item at a lower level of maintenance, if authorized by the Maintenance Allocation Chart (MAC) and SMR codes. This position will contain one of the following maintenance codes.

Code	Application/Explanation
------	-------------------------

O	Unit or (aviation unit) is the lowest level that can do complete repair of the item.
---	--

F	Direct support or aviation intermediate is the lowest level that can do complete repair of the item.
---	--

H	General Support is the lowest level that can do complete repair of the item.
---	--

L	Specialized repair activity is the lowest level that can do complete repair of the item.
---	--

D	Depot is the lowest level that can do complete repair of the item.
---	--

Z	Nonreparable No repair is authorized.
---	---------------------------------------

B	No repair is authorized. (No parts or special tools are authorized for the maintenance of a "B" coded item). However, the item may be reconditioned by adjusting, lubricating, etc., at the user level.
---	---

- (3) Recoverability Code.** Recoverability codes are assigned to items to indicate the disposition action on unserviceable items. The recoverability code is entered in the fifth position of the SMR Code as follows:

Recoverability Codes	Application/Explanation
-------------------------	-------------------------

Z	Nonreparable item. When unserviceable, condemn and dispose of the item at the level of maintenance shown in 3d position of SMR Code.
---	--



Recoverability  
Codes

Application/Explanation

- O - Repairable item. When uneconomically repairable, condemn and dispose of the item at unit or aviation unit level
- F - Repairable item. When uneconomically repairable, condemn and dispose of the item at the direct support or aviation intermediate level
- H - Repairable item. When uneconomically repairable, condemn and dispose of the item at the general support level.
- D - Repairable item. When beyond lower level repair capability, return to depot Condemnation and disposal of item not authorized below depot level.
- L - Repairable item. Condemnation and disposal not authorized below specialized repair activity (SRA).
- A - Item requires special handling or condemnation procedures because of specific reasons (e.g., precious metal content, high dollar value, critical material, or hazardous material). Refer to appropriate manuals/directives for specific instructions.

**c. FSCM (Column (3)).** The Federal Supply Code for Manufacturer (FSCM) is a S-digit numeric code which is used to identify the manufacturer, distributor, or Government agency, etc, that supplies the item.

**d. PART NUMBER (Column (4)).** Indicates the primary number used by the manufacturer, (individual company, firm, corporation, or Government activity), which controls the design and characteristics of the item by means of its engineering drawings, specification standards, and inspection requirements to identify an item or range of items.

**NOTE**

**When you use an NSN to requisition an item, the item you receive may have a different part number from the part ordered.**

**e. DESCRIPTION AND USABLE ON CODE (UOC) (Column (5)).** This column includes the following information:

- (1) The Federal item name and, when required, a minimum description to identify the item.
- (2) The physical security classification of the item is indicated by the parenthetical entry. e.g., Phy Sec CI - Confidential, Phy Sec CI (S) - Secret, Phy Sec CI (T) - Top Secret.
- (3) Items that are included in kits and sets are listed below the name of the kit or set.
- (4) Spare/repair parts that make up an assembled item are listed immediately following the assembled item line entry.
- (5) Part numbers for bulk materials are referenced in this column in the line item entry for the item to be manufactured/fabricated.
- (6) When the item is not used with all serial numbers of the same model, the effective serial numbers are shown on the last line(s) of the description (before UOC).

- (7) The usable on code, when applicable (see paragraph 5, Special Information).
- (8) In the Special Tools List section, the basis of issue (BOI) appears as the last line(s) in the entry for each special tool, special TMDE, and other special support equipment. When density of equipments supported exceeds density spread indicated in the basis of issue, the total authorization is increased proportionately.
- (9) The statement "END OF FIGURE" appears just below the last item description in Column 5 for a given figure in both Section II and Section III.
- (10) The indenture, shown as dots appearing before the repair part, indicates that the item is a repair part of the next higher assembly.

f. **QTY (Column (6)).** The QTY (quantity per figure column) indicates the quantity of the item used in the breakout shown on the illustration figure, which is prepared for a functional group, subfunctional group, or an assembly. A 'V' appearing in this column in lieu of a quantity indicates that the quantity is variable and may vary from application to application.

**4. EXPLANATION OF COLUMNS (SECTION IV).**

**a. NATIONAL STOCK NUMBER (NSN) INDEX.**

(1) **STOCK NUMBER column.** This column lists the NSN by National item identification number (NIIN) sequence. The NIIN consists of the last nine digits of the NSN

NSN
NSN, i.e.5305-01-574-1467
NIIN

When using this column to locate an item, ignore the first 4 digits of the NSN. However, the complete NSN should be used when ordering items by stock number.

- (2) **FIG. column.** This column lists the number of the figure where the item is identified/located. The figures are in numerical order in Section II and Section III.
- (3) **ITEM column.** The item number identifies the item associated with the figure listed in the adjacent FIG. column. This item is also identified by the NSN listed on the same line.

**b. PART NUMBER INDEX.** Part numbers in this index are listed by part number in ascending alphanumeric sequence (i.e., vertical arrangement of letter and number combination which places the first letter or digit of each group in order A through Z, followed by the numbers 0 through 9 and each following letter or digit in like order).

- (1) **FSCM column.** The Federal Supply Code for Manufacturer (FSCM) is a 5-igit numeric code used to identify the manufacturer, distributor, or Government agency, etc., that supplies the item.
- (2) **PART NUMBER column.** Indicates the primary number used by the manufacturer (individual, firm, corporation, or Government activity), which controls the design and characteristics of the item by means of its engineering drawings, specifications standards, and inspection requirements to identify an item or range of items.
- (3) **STOCK NUMBER column.** This column lists the NSN for the associated part number and manufacturer identified in the PART NUMBER and FSCM columns to the left.

- (4) **FIG. column.** This column lists the number of the figure where the item is identified/located in Sections II and III.
- (5) **ITEM column.** The item number is that number assigned to the item as it appears in the figure referenced in adjacent figure number column.

**c. FIGURE AND ITEM NUMBER INDEX.**

- (1) **FIG. column.** This column lists the number of the figure where the item is identified/located in Section II and III.
- (2) **ITEM column.** The item number is that number assigned to the item as it appears in the figure referenced in the adjacent figure number column.
- (3) **STOCK NUMBER column.** This column lists the NSN for the item.
- (4) **FSCM column.** The Federal Supply Code for Manufacturer (FSCM) is a 5-digit numeric code used to identify the manufacturer, distributor, or Government agency, etc., that supplies the item.
- (5) **PART NUMBER column.** Indicates the primary number used by the manufacturer (individual, firm, corporation, or Government activity), which controls the design and characteristics of the item by means of its engineering drawings, specifications standards, and inspection requirements to identify an item or range of items.

**5. SPECIAL INFORMATION.**

**a. USABLE ON CODE.** The usable on code appears in the lower left corner of the Description column heading. Usable on codes are shown as "UOC: ....." in the Description Column (justified left) on the last line applicable item description/nomenclature. Uncoded items are applicable to all models.

**b. ASSOCIATED PUBLICATIONS.** The publications listed below pertains to the Compressor Unit, Reciprocating and its components.

Publication	Short Title
TM 5-4310-380-13	Compressor Unit, Reciprocating

**6. HOW TO LOCATE REPAIR PARTS.**

**a. When National Stock Number or Part Number Is NOT known.**

- (1) **First.** Using the table of contents, determine the assembly group or subassembly group to which the item belongs. This is necessary since figures are prepared for assembly groups and subassembly groups, and listings are divided into the same groups.
- (2) **Second.** Find the figure covering the assembly group or subassembly group to which the item belongs.
- (3) **Third.** Identify the item on the figure and note the item number.
- (4) **Fourth.** Refer to the Repair Parts List for the figure to find the part number for the item number noted on the figure.

(5) **Fifth.** Refer to the Part Number Index to find the NSN, if assigned.

**b. When National Stock Number or Part Number Is Known:**

- (1) **First.** Using the Index of National Stock Numbers and Part Numbers, find the pertinent National Stock Number or Part Number. The NSN index is in National Item Identification Number (NIIN) sequence (see c-4a.(1)). The part numbers in the Part Number index are listed in ascending alphanumeric sequence (see paragraph c-4.b). Both indexes cross-reference you to the illustration figure and item number of the item you are looking for.
- (2) **Second.** After finding the figure and item number, verify that the item is the one you are looking for, then locate the item number in the repair parts list for the figure.

**7. ABBREVIATIONS.** Abbreviations used in this manual are listed in MIL-STD-12.



## SECTION II

TM 5-4310-380-23P

(1) ITEM NO	(2) SMR CODE	(3) FSCM	(4) PART NUMBER	(5) DESCRIPTION AND USABLE ON CODES (UOC)	(6) QTY
GROUP 01 MOTOR CONTROLS					
FIG. 1 ELECTRIC MOTOR STARTER AND WIRING					
1	XBOOO	55921	OF608	WIRE ASSY, MOTOR.....	1
2	PBOZZ	78229	NC-011	.BOX CONNECTOR, ELECT 3/4 IN X 3/4 .....	2
3	XBOZZ	59730	394	IN 90 ELBOW CONNECTOR (WITH NUT) .....	2
4	XBOZZ	55921	VE1034-14	.ANTI-SHORT 3/4 IN CONDUIT ANTI-.....	2
5	PAOZZ	55921	VE1036-32	SHORT.....	1
6	XBOOO	55921	OF609	.CONDUIT, FLEX 3/4 IN X 14 IN LG.....	3
7	PBOZZ	03743	7380V	STEEL GALVANIZED FLEXIBLE .....	3
8	XBOZZ	59730	391	.WIRE, ELECTRICAL MFR FROM P/N J-C-.....	1
9	XBOZZ	55921	VE1015-13	30THW06CG1/8TUJO;32IN.REQ.....	1
10	PAOZZ	55921	VE1004-30	WIRE ASSY, PRESSURE SWITCH.....	1
11	XBOZZ	03743	7245V	.BOX CONNECTOR, ELECT 1/2 IN X 3/8 .....	1
12	PAOZZ	96906	M590728-6	IN FLEX CONDUIT 90 DEGREE ELBOW (WITH NUT) .....	2
13	PAOZZ	96906	M535338-44	.ANTI-SHORT 3/8 IN CONDUIT ANTI-.....	2
14	PBOOD	61802	100C-KBL	SHORT.....	1
15	PAOZZ	01121	800T-H2A	.CONDUIT, FLEX 3/8 IN FLEX CONDUIT .....	1
16	PBOZZ	89946	RSK-12	13 IN LG.....	2
17	PAOZZ	71400	HRC-1-KTK-R-20	.WIRE, ELECTRICAL MFR FROM P/N J-C-.....	2
18	PAOZZ	96906	MS24625-31	30THW06CEI/18TUJ0 ; 30 IN.REQ .....	1
19	PAOZZ	96906	MS35338-42	.BOX CONNECTOR, ELECT 1/2 IN K/O X.....	1
20	XBOZZ	71400	2079-30A-600V	3/8 IN FLEX CONDUIT 45 DEGREES.....	4
21	PAOZZ	96906	MS24629-48	.SCREW, CAP, HEXAGON H.....	4
22	PAOZZ	96906	MS35338-43	.WASHER, LOCK.....	4
23	PAOZZ	96906	MS27183-42	STARTER, MOTOR FOR 10 HP, 3 PH, 60 HZ, .....	1
24	PBOZZ	61802	R-35E-28	230 V MOTOR IN NEMA 12 ENCLOSURE.....	1
25	PBOZZ	61802	C-35E-B	.SWITCH, ROTARY .....	1
26	PAOZZ	96906	MS24629-50	.PLUNGER, DETENT.....	1
27	PAOZZ	96906	MS24629-47	.FUSE CLASS CC , CURRENT LIMITING.....	2
28	PAOZZ	61802	24193-3	200 KA .....	2
29	KFOZZ	61802	CMK-35E-A	.SCREW, TAPPING, THREA .....	2
30	KFOZZ	61802	CMK-35E-C	.WASHER, LOCK.....	2
31	KFOZZ	61802	CMK-35E-B	.HOLDER, FUSE.....	1
32	PBOZZ	61802	CC-50-B-SZ1-230V	.SCREW, TAPPING, THREA .....	4
33	XBOZZ	00843	A16P14	.WASHER, LOCK.....	8
34	XBOZZ	00843	A1614CH	.WASHER, FLAT.....	8
	PAOZZ	61802	CMK-35	.RELAY, OVERLOAD 28 AMPS .....	1
				.CONTACTOR, MAGNETIC 240 VAC .....	1
				..SCREW, TAPPING, THREA .....	2
				..SCREW, TAPPING, THREA .....	2
				..SCREW, CONTACT.....	6
				..CONTACT PART OF KIT P/N CMK-35.....	6
				..SPRING PART OF KIT P/N CMK-35.....	3
				..CONTACT PART OF KIT P/N CMK-35.....	3
				..COIL.....	1
				.PANEL, BOX 14-3/4 IN.X 12-7/8 IN .....	1
				.BOX, STARTER BOX SIZE 16X14X6.....	1
				CONTACT KIT, MAIN.....	1

SECTION II

TM 5-4310-380-23P

(1) ITEM NO	(2) SMR CODE	(3) FSCM	(4) PART NUMBER	(5) DESCRIPTION AND USABLE ON CODES (UOC)	(6) QTY
				CONTACT ( 6)	1-29
				CONTACT ( 3)	1-31
				SPRING ( 3)	1-30

END OF FIGURE

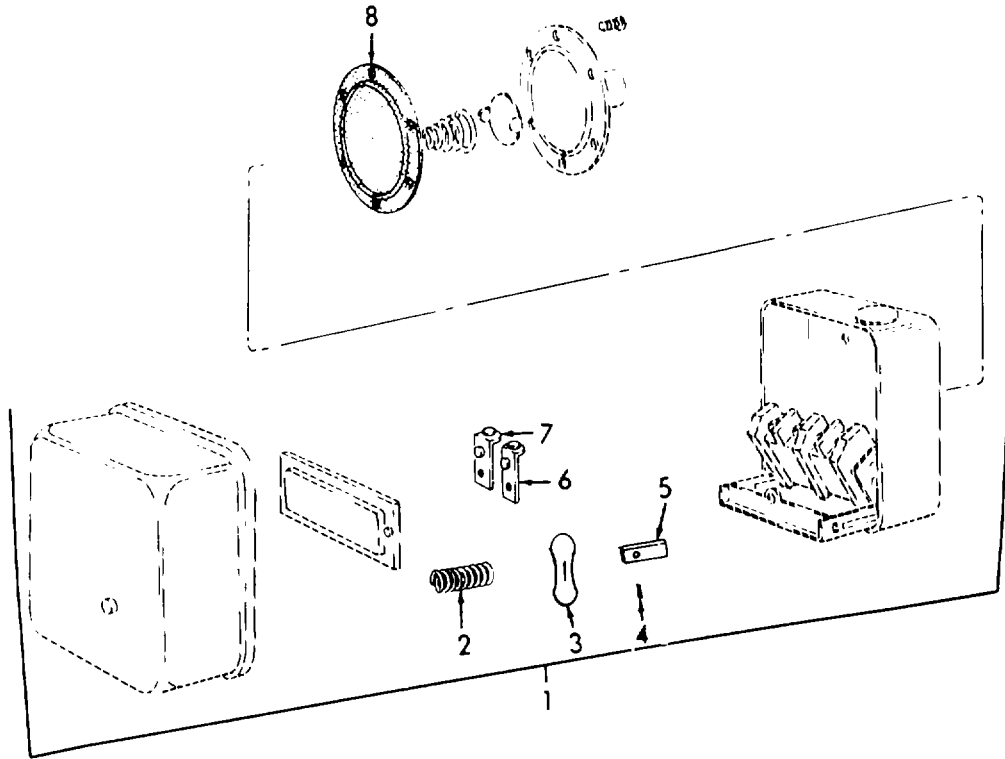

Figure 2. Pressure Switch.



SECTION II

TM 5-4310-380-23P

(1) ITEM NO	(2) SMR CODE	(3) FSCM	(4) PART NUMBER	(5) DESCRIPTION AND USABLE ON CODES (UOC)	(6) QTY
GROUP 01 MOTOR CONTROLS					
FIG. 2 PRESSURE SWITCH					
1	PBOOD	23826	69HAUL	SWITCH, PRESSURE 165 PSI CUT IN - ..... 195 PSI CUT OUT.....	1
2	KFOZZ	23826	D27257-1	.SPRING PART OF KIT P/N 75HA69 .....	2
3	KFOZZ	23826	D817-2	.CONTACT, MOVEABLE PART OF KIT P/N..... 75HA69 .....	2
4	KFOZZ	23826	D354-1	.PIN PART OF KIT P/N 75HA69.....	2
5	KFOZZ	23826	D334-1	.ROD, PUSH PART OF KIT P/N 75HA69 .....	2
6	KFOZZ	23826	D661-0-8	.CONTACT, STAIONARY PART OF KIT P/N..... 75HA69 .....	4
7	KFOZZ	23826	D661-0-7	.CONTACT, STATIONARY PART OF KIT P/N..... 75HA69 .....	4
8	XDOZZ	23826	D274-1	.DIAPHRAGM, ELECTRICA PART OF KIT P/N .....	1
	PAOZZ	23826	75HA69	REPAIR KIT, PRESSURE .....	1
				CONTACT,MOVEABLE ( 2) 2-3	
				CONTACT,STAIONARY ( 4) 2-6	
				CONTACT,STATIONARY ( 4) 2-7	
				DIAPHRAGM,ELECTRICA ( 1) 2-8	
				PIN ( 2) 2-4	
				ROD,PUSH ( 2) 2-5	
				SPRING ( 2) 2-2	

END OF FIGURE

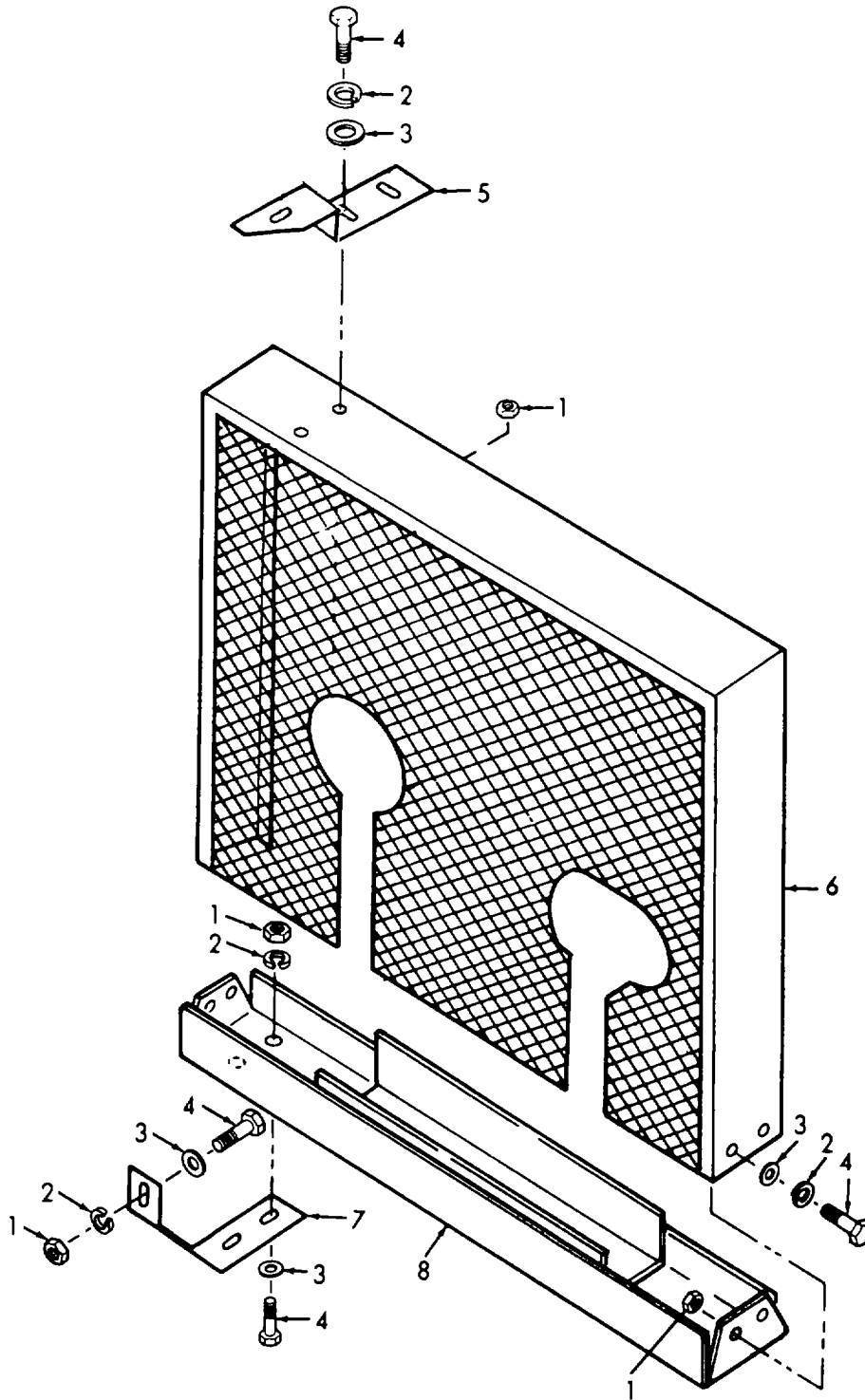

Figure 3. Belt Guard Assembly.

SECTION II

TM 5-4310-380-23P

(1) ITEM NO	(2) SMR CODE	(3) FSCM	(4) PART NUMBER	(5) DESCRIPTION AND USABLE ON CODES (UOC)	(6) QTY
GROUP 02 COMPRESSOR DRIVE					
FIG. 3 BELT GUARD ASSEMBLY					
1	PAOZZ	96906	M535690-604	NUT, PLAIN, HEXAGON .....	12
2	PAOZZ	96906	MS35338-46	WASHER, LOCK.....	12
3	PAOZZ	96906	MS27183-15	WASHER, FLAT.....	12
4	PAOZZ	96906	MS90725-53	SCREW, CAP, HEXAGON H.....	12
5	XBOZZ	55921	CAC2203	BRACE, TOP.....	1
6	PBOZZ	55921	CAC2202	GUARD, MECHANICAL DR .....	1
7	XBOZZ	55921	CAC2207	BRACE, BOTTOM.....	2
8	XBOZZ	55921	CAC2203	PANEL, BOTTOM GUARD.....	1

END OF FIGURE

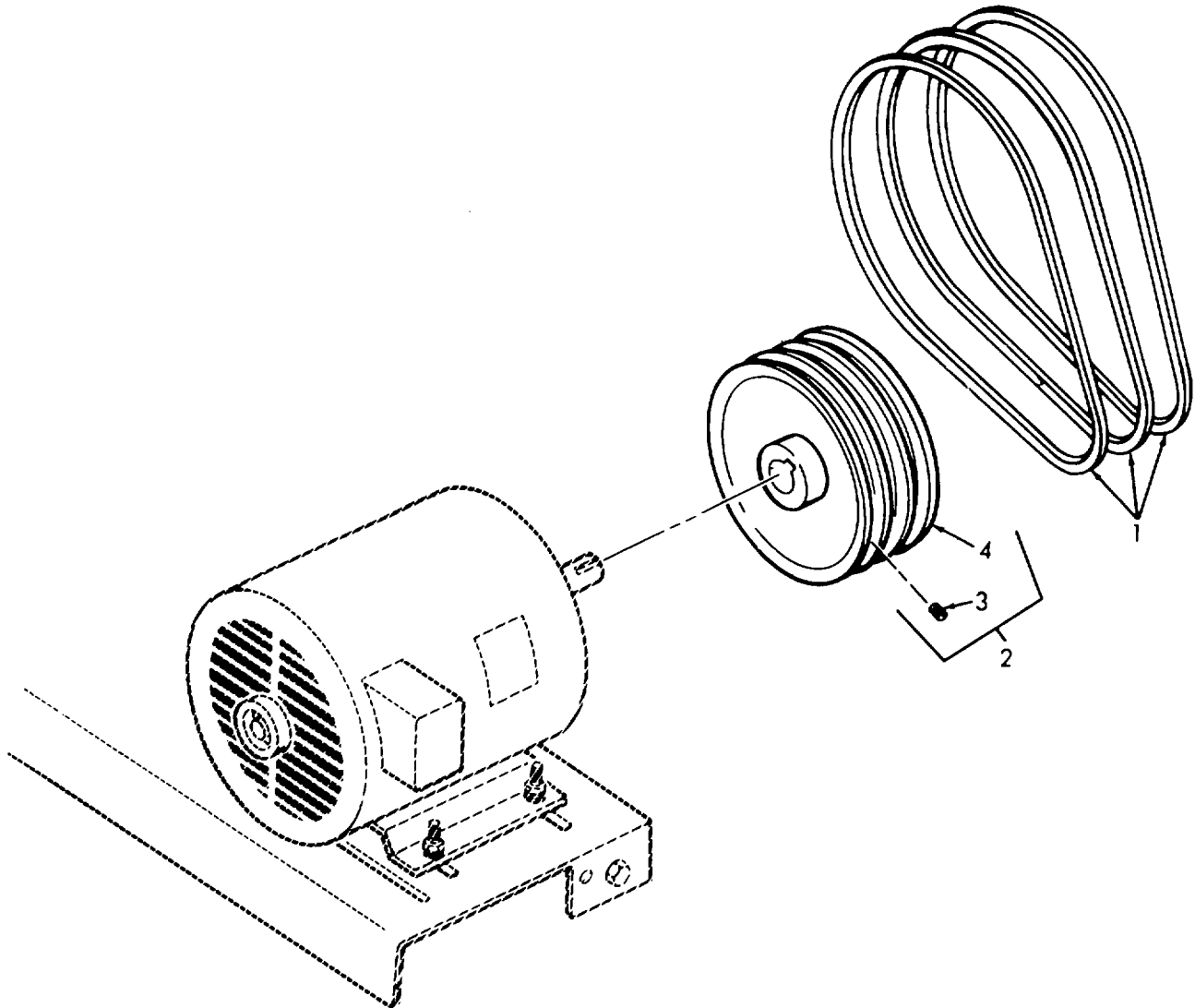

Figure 4. V Belts and Drive Pulley.

SECTION II

TM 5-4310-380-23P

(1) ITEM NO	(2) SMR CODE	(3) FSCM	(4) PART NUMBER	(5) DESCRIPTION AND USABLE ON CODES (UOC)	(6) QTY
GROUP 02 COMPRESSOR DRIVE					
FIG. 4 BELTS AND DRIVE PULLEY					
1	PAOZZ	96906	MS51067C68B3	BELTS, V, MATCHED SET .....	3
2	XBOZZ	55921	VDA246	PULLEY ASSY 165 MM DIA-162 MM PD .....	1
3	PAOZZ	55921	VH1421	.SETSCREW HEX SOC SET SCR, SIZE .....	2
				M10X1.5X25LG .....	
4	XBOZZ	55921	VDA246A	.PULLEY .....	1

END OF FIGURE

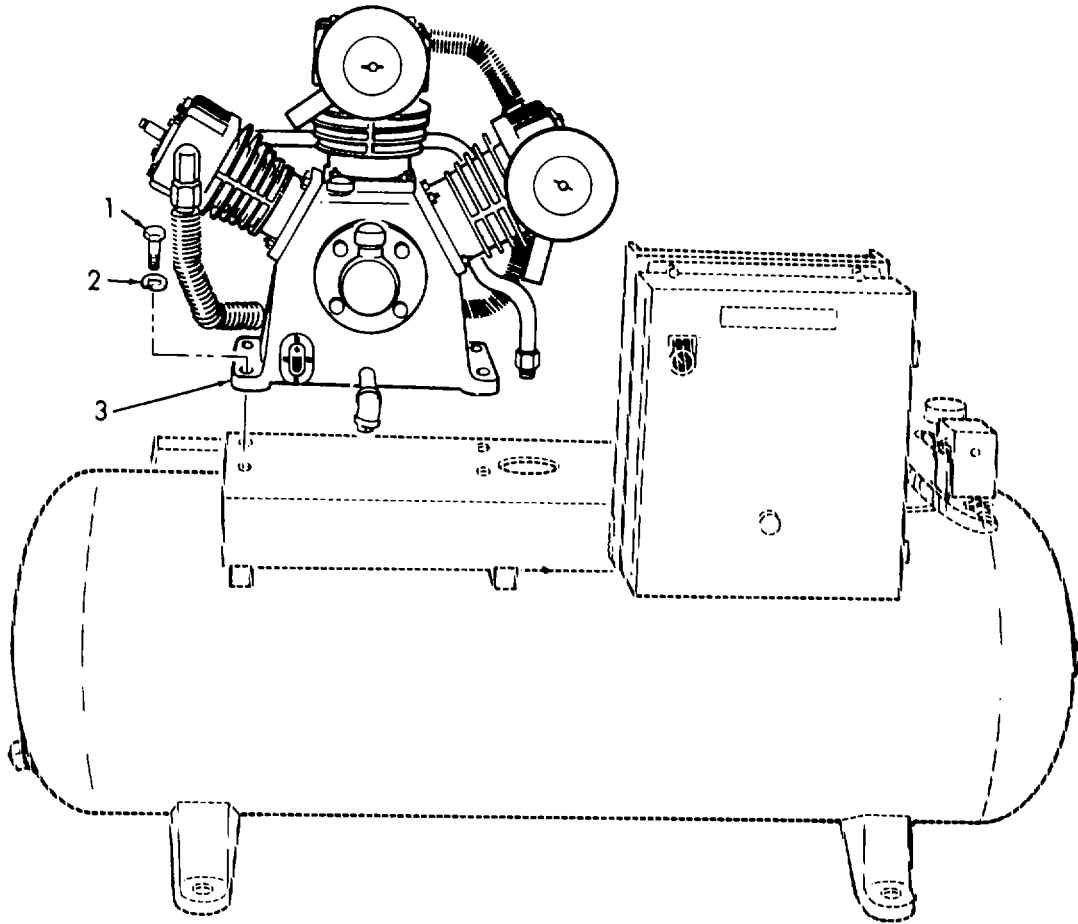

Figure 5. Compressor Assembly.

SECTION II

TM 5-4310-380-23P

(1) ITEM NO	(2) SMR CODE	(3) FSCM	(4) PART NUMBER	(5) DESCRIPTION AND USABLE ON CODES (UOC)	(6) QTY
				GROUP 03 COMPRESSOR ASSEMBLY FIG. 5 COMPRESSOR ASSEMBLY	
1	PAOZZ	96906	MS90728-110	SCREW, CAP, HEXAGON H.....	4
2	PAOZZ	96906	MS35338-48	WASHER, LOCK.....	4
3	PBOFF	55921	C70174-00000	COMPRESSOR, RECIPROC.....	1

END OF FIGURE

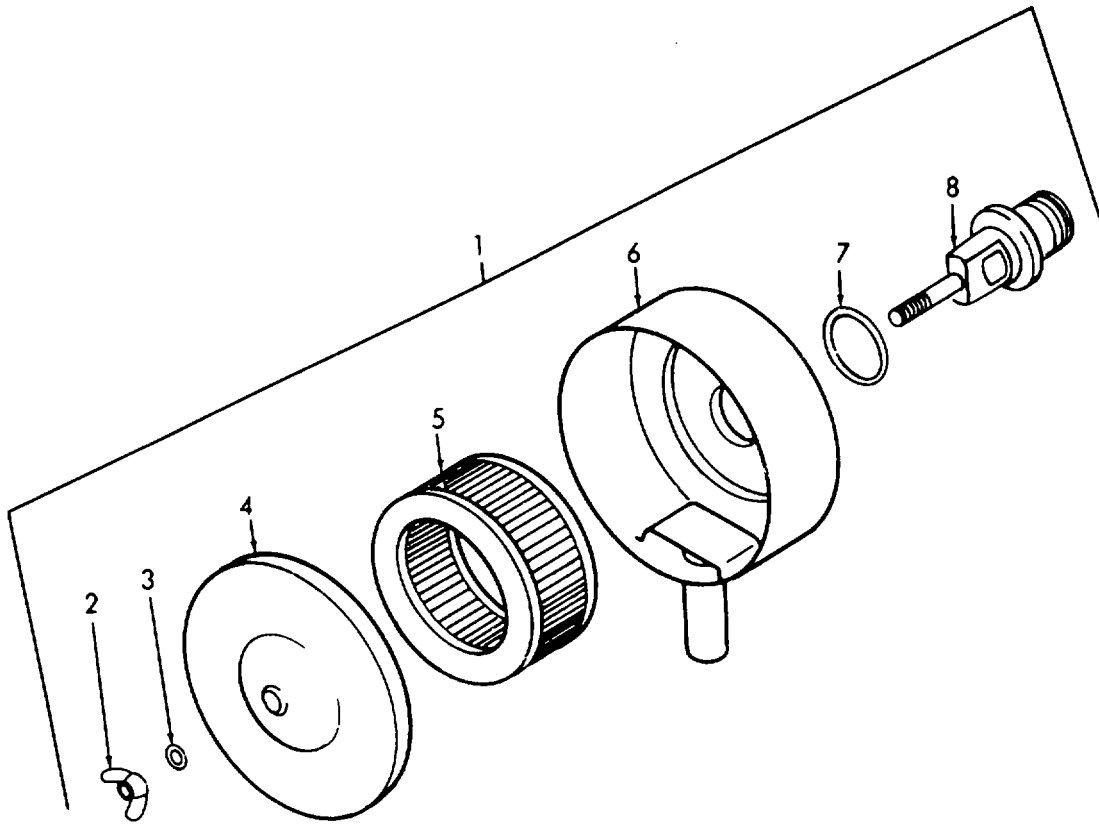

Figure 6. Air Cleaner.



SECTION II

TM 5-4310-380-23P

(1) ITEM NO	(2) SMR CODE	(3) FSCM	(4) PART NUMBER	(5) DESCRIPTION AND USABLE ON CODES (UOC)	(6) QTY
GROUP 03 COMPRESSOR ASSEMBLY					
FIG. 6 AIR CLEANER					
1	PBOOD	55921	C70123-66000	AIR CLEANER, INTAKE.....	2
2	PAOZZ	55921	C92513-150600	.NUT, PLAIN, WING.....	1
3	PAOZZ	55921	C92521-110600	.WASHER, FLAT.....	1
4	XBOZZ	55921	C70123-66170	.COVER, AIR STRAINER.....	1
5	PAOZZ	55921	C70123-66140	.FILTER ELEMENT, INTA.....	1
6	XBOZZ	55921	C70123-66010	.BODY, AIR STRAINER.....	1
7	PAOZZ	55921	C70123-66130	.PACKING, PREFORMED.....	1
8	XBOZZ	55921	C70123-66030	.JOINT, AIR STRAINER.....	1

END OF FIGURE

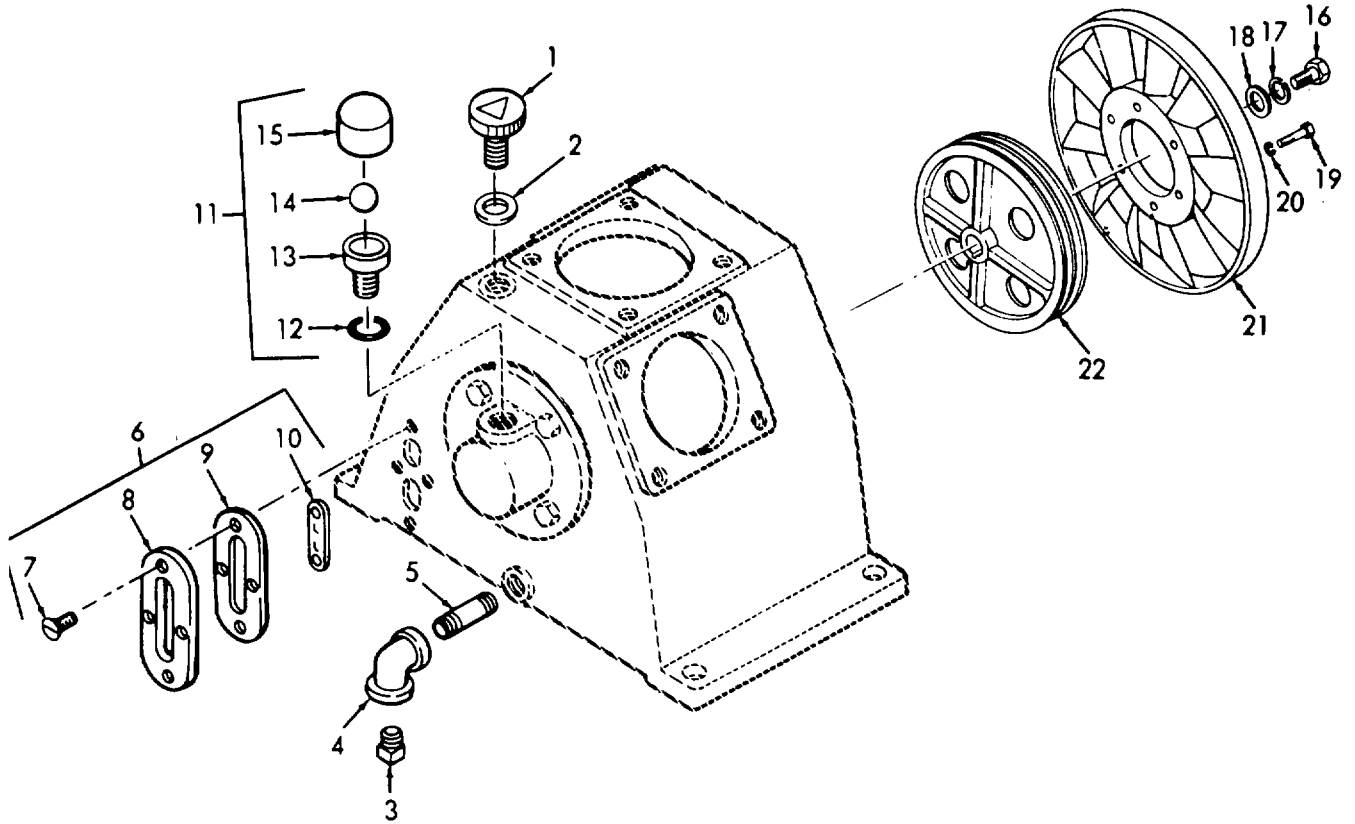

Figure 7. Oil Filler Cap, Plugs, Fan and Pulley.

## SECTION II

TM 5-4310-380-23P

(1) ITEM NO	(2) SMR CODE	(3) FSCM	(4) PART NUMBER	(5) DESCRIPTION AND USABLE ON CODES (UOC)	(6) QTY
GROUP 03 COMPRESSOR ASSEMBLY FIG. 7 OIL FILTER CAP, PLUGS, FAN, AND PULLEY					
1	PAOZZ	55921	C70123-57190	CAP, FILLER OPENING.....	1
2	PAOZZ	55921	C93601-810018	PACKING, PREFORMED.....	1
3	PAOZZ	96906	MS51884-7	PLUG, PIPE 1/2 INCH.....	1
4	PAOZZ	88044	AN916-4J	ELBOW, PIPE 90 DEGREE, 1/2 IN.....	1
5	PAOZZ	55921	VA13DLA	NIPPLE, PIPE 6IN LG X 1/2 IN N.....	1
6	PAOOO	55921	C70124-57700	INDICATOR, SIGHT, LIQ.....	1
7	PAOZZ	55921	C71505-1305012	.SCREW, MACHINE.....	4
8	XAOZZ	55921	C70124-57720	.COVER, GAUGE PLASTIC.....	1
9	PAOZZ	55921	C70124-57730	.GASKET ASTM NBR SYNTHETIC RUBBER.....	1
10	XAOZZ	55921	C70124-57710	.GAUGE, OIL.....	1
11	PAOOO	55921	C70124-57600	BREATHER.....	1
12	XAOZZ	55921	C93601-810020	.O-RING.....	1
13	XAOZZ	55921	C70124-57670	.BODY, BREATHER.....	1
14	XAOZZ	55921	C93601-890700	.BALL, GLASS GLASS BALL 7/8 INCH.....	1
15	XAOZZ	55921	C70124-57610	.CAP, BREATHER.....	1
16	PAOZZ	55921	C91501-2312040	SCREW, CAP, HEXAGON H.....	1
17	PAOZZ	55921	VH2406	WASHER, LOCK.....	1
18	PAOZZ	55921	C70124-76210	BEARING, WASHER, THRU.....	1
19	PAOZZ	55921	VH2404	SCREW, CAP, HEXAGON H.....	6
20	PAOZZ	96906	MS35338-45	WASHER, LOCK.....	6
21	PAOZZ	55921	C70124-76310	IMPELLER, FAN, AXIAL.....	1
22	PAOZZ	55921	C70134-76010	PULLEY, GROOVE GRAY IRON ASTM CLASS 35, 300MM DIA.....	1

END OF FIGURE

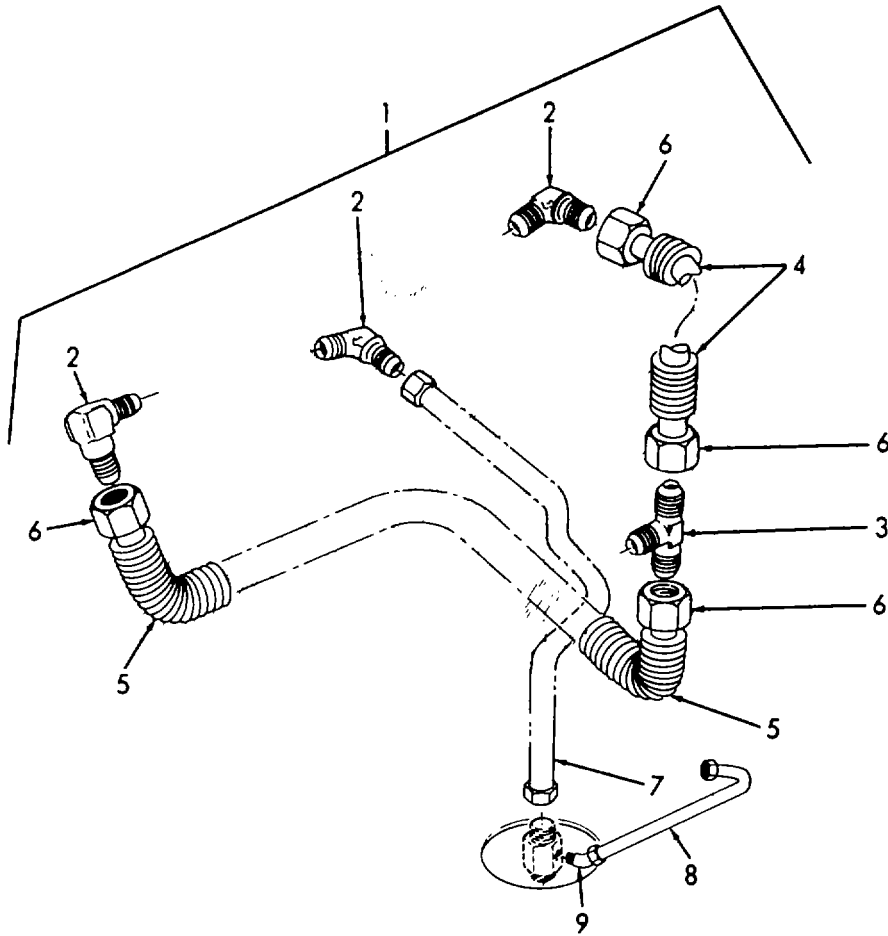

Figure 8. Tube Assemblies.

## SECTION II

TM 5-4310-380-23P

(1) ITEM NO	(2) SMR CODE	(3) FSCM	(4) PART NUMBER	(5) DESCRIPTION AND USABLE ON CODES (UOC)	(6) QTY
GROUP 03 COMPRESSOR ASSEMBLY					
FIG. 8 TUBE ASSEMBLIES					
1	XBOZZ	55921	C70174-87001	PIPE ASSEMBLY .....	1
2	PAOZZ	55921	C70124-87010	.ELBOW, PIPE .....	3
3	PAOZZ	55921	C70174-87020	.TEE, PIPE .....	1
4	PAOZZ	55921	C70134-87100	.TUBE ASSEMBLY, METAL RIGID FINNED .....	1
COPPER TUBE.....					
5	PAOZZ	55921	C70174-87300	.TUBE ASSEMBLY, METAL.....	1
6	PAOZZ	55921	C79922-130707	.NUT, TUBE COUPLING .....	5
7	PAOZZ	55921	OFB859	.TUBE, BENT, METALLIC 7/8 INCH.....	1
COPPER TUBE.....					
8	PAOZZ	55921	VA1602A	.TUBE, BENT, METALLIC 1/4 INCH O.D. ....	1
COPPER X .030WALL, TYPE L 50FT 23					
INCH LG.....					
9	PAOZZ	81343	4-2 120202BA	.ELBOW, PIPE TO TUBE.....	1

END OF FIGURE

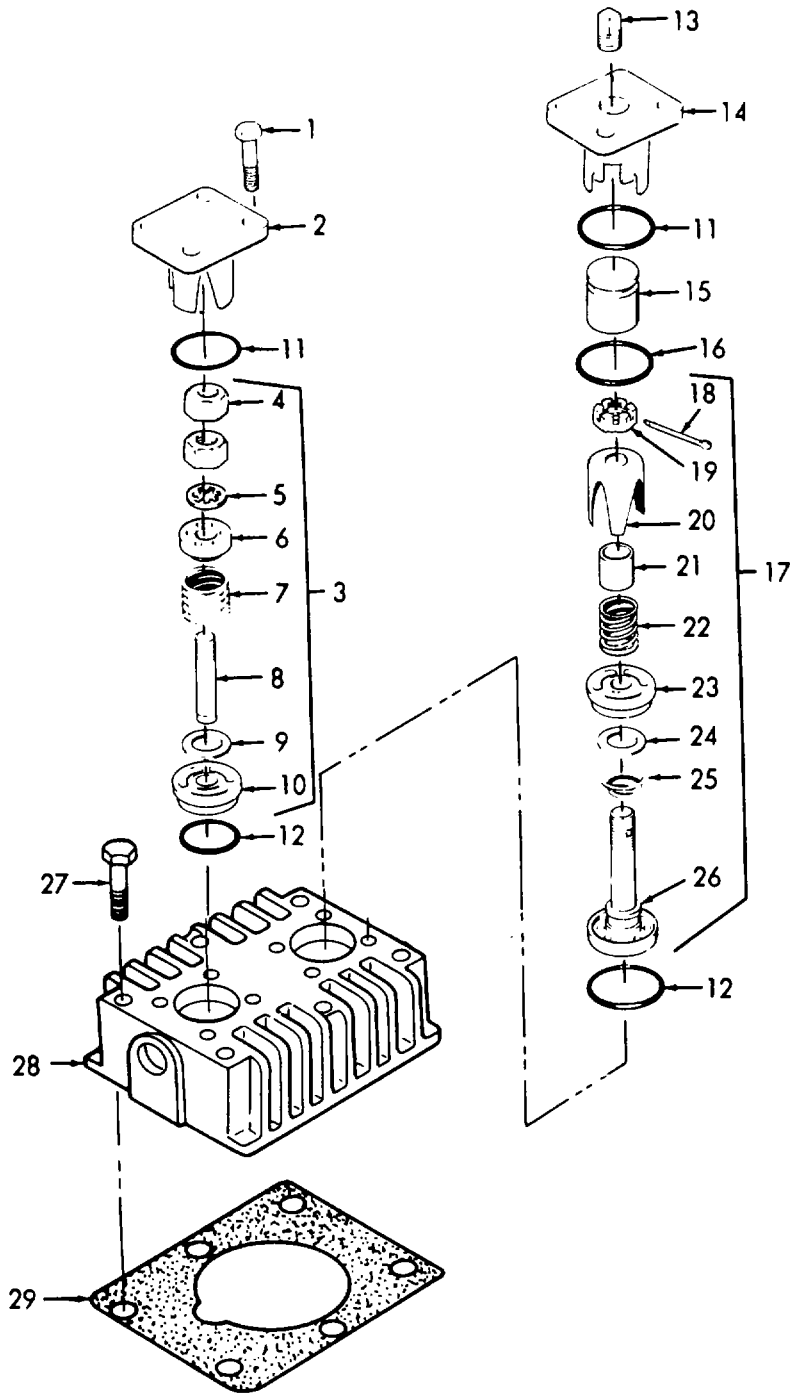

Figure 9. Cylinder Head Assembly, 1st Stage.

## SECTION II

TM 5-4310-380-23P

(1) ITEM NO	(2) SMR CODE	(3) FSCM	(4) PART NUMBER	(5) DESCRIPTION AND USABLE ON CODES (UOC)	(6) QTY
GROUP 03 COMPRESSOR ASSEMBLY					
FIG. 9 CYLINDER HEAD ASSEMBLY, 1ST STAGE					
	XBFFF	55921	C70124-11000	CYLINDER HEAD ASSY .....	2
1	PAFZZ	55921	C91501-1308025	..SCREW,CAP,HEXAGON H .....	8
2	XBFZZ	55921	C70124-11450	..COVER NODULAR IRON ASTM 60-40-18 .....	1
3	PAFZF	55921	C70124-41000	..VALVE,REGULATING,FL FIRST STAGE,..... LOW PRESS .....	1
4	XAFZZ	55921	C92501-131000	..NUT .....	2
5	XAFZZ	55921	C92521-151000	..WASHER SPRING .....	1
6	XAFZZ	55921	C70124-41020	..RECEIVER .....	1
7	XAFZZ	55921	C70124-41070	..SPRING,OUTLET VALVE .....	1
8	XAFZZ	55921	C70124-41810	..STUD,OUTLET VALVE .....	1
9	XAFZZ	55921	C70124-31030	..PLATE,VALVE .....	2
10	XAFZZ	55921	C70124-41010	..SEAT,VALVE OUTLET .....	1
11	PAFZZ	55921	C93602-870055	..PACKING,PREFORMED .....	2
12	PAFZZ	55921	C70124-11110	..GASKET .....	2
13	PAFZZ	81348	WW-P-471AASBCA	..PLUG,PIPE .....	2
14	XBFZZ	55921	C70124-11150	..COVER .....	2
15	XBFZZ	55921	C70124-11220	..PISTON .....	1
16	XBFZZ	55921	C93601-810020	..O-RING .....	1
17	PAFZF	55921	C70124-31000	..VALVE,REGULATING,FL FIRST STAGE,..... LOW PRESSURE .....	2
18	XAFZZ	55921	C93701-232018	..PIN,COTTER .....	1
19	XAFZZ	55921	C92517-231000	..NUT .....	2
20	XAFZZ	55921	C70124-31080	..FORK,UNLOADING .....	1
21	XAFZZ	55921	C70124-31090	..GUIDE,FORK .....	1
22	XAFZZ	55921	C70124-11230	..SPRING,UNLOADER .....	1
23	XAFZZ	55921	C70124-31010	..SEAT,VALVE INLET .....	1
24	XAFZZ	55921	C70124-31030	..PLATE,VALVE .....	1
25	XAFZZ	55921	C70124-31070	..SPRING,STEEL .....	1
26	XAFZZ	55921	C70124-31020	..RECEIVER,INLETVALVE .....	1
27	PAFZZ	55921	C91501-1310080	SCREW,CAP,HEXAGON H .....	12
28	XBFZZ	55921	C70124-11010	..CYLINDER HEAD .....	1
29	PAFZZ	55921	C70124-11020	GASKET ASBESTOS NO. 1500 .....	1

END OF FIGURE

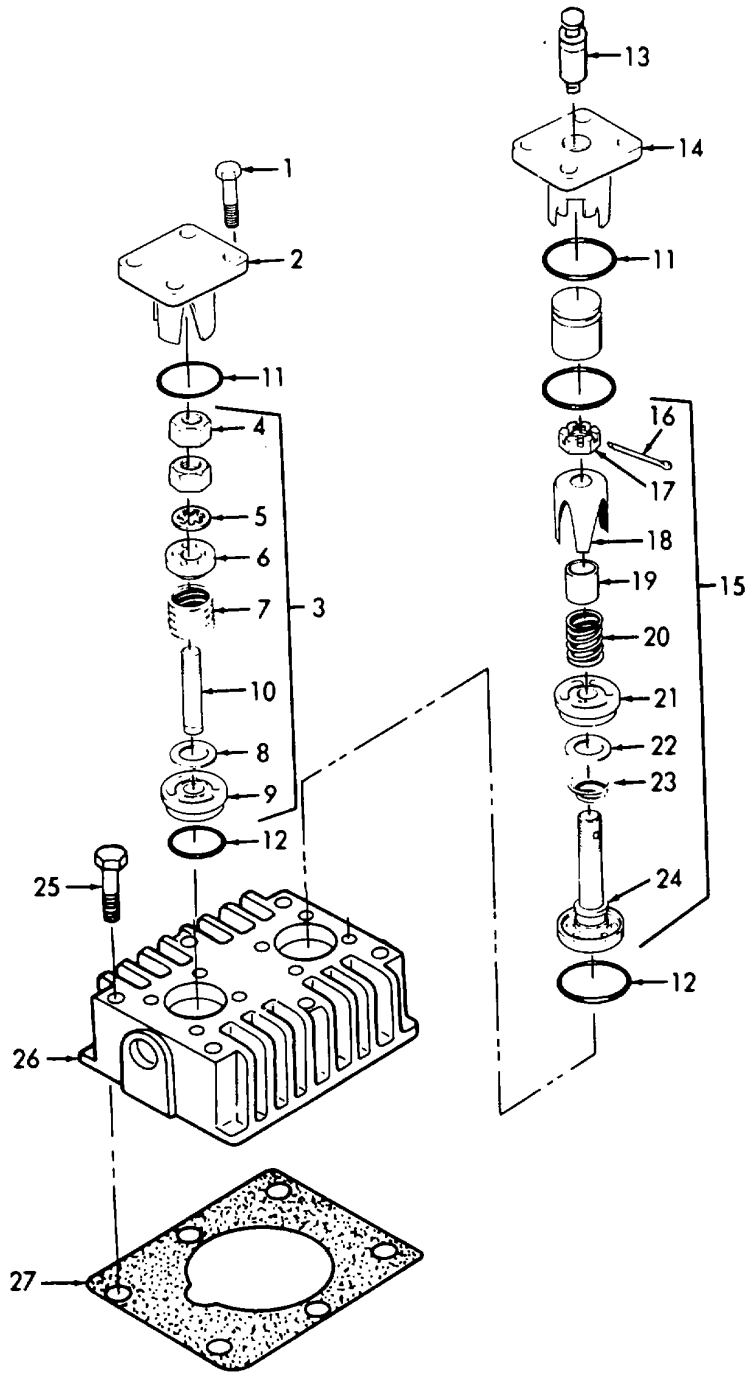

Figure 10. Cylinder Head Assembly, 2nd Stage.



## SECTION II

TM 5-4310-380-23P

(1) ITEM NO	(2) SMR CODE	(3) FSCM	(4) PART NUMBER	(5) DESCRIPTION AND USABLE ON CODES (UOC)	(6) QTY
GROUP 03 COMPRESSOR ASSEMBLY					
FIG. 10 CYLINDER HEAD ASSEMBLY, 2ND STAGE					
				CYLINDER HEAD ASSY .....	1
1	XBFFF	55921	C70174-12000	..BOLT,MACHINE .....	8
2	PAFZZ	80204	B18231A08020N	..COVER,OUTLET VALVE .....	1
3	XBFFF	55921	C70123-11450	..VALVE,REGULATING,FL SECOND STAGE,.....	1
	PAFFF	55921	C70123-41000	HIGH PRESSURE .....	
4	XAFZZ	55921	C92502-130800	..NUT .....	2
5	PAOZZ	96906	MS35338-45	..WASHER,LOCK .....	1
6	XAFZZ	55921	C70123-41020	..RECEIVER,OUTLET VAL VALVE .....	1
7	XAFZZ	55921	C70123-41070	..SPRING,VALVE OUTLET .....	1
8	XAFZZ	55921	C70123-31030	..PLATE,VALVE ASSAB-928 .....	1
9	XAFZZ	55921	C70123-41010	..SEAT,VALVE OUTLET .....	1
10	XAFZZ	55921	C70123-41811	..BOLT,VALVE OUTLET .....	1
11	PAFZZ	55921	C93601-870040	..PACKING,PREFORMED .....	1
12	PAFZZ	55921	C70123-11110	..GASKET COPPER .....	1
13	PAFZZ	58818	NC25-70	..VALVE,SAFETY RELIEF 1/4 MPT- .....	1
				70PSUG,BRASS .....	
14	XBFFF	55921	C70123-11150A	..COVER,INLET VALVE .....	1
15	PAFFF	55921	C70123-31000	..VALVE,REGULATING,FL .....	1
16	XAFZZ	55921	C93701-232018	..PIN,COTTER .....	1
17	XAFZZ	55921	C92106-131001	..NUT .....	1
18	XAFZZ	55921	C70123-31080	..GUIDE,FORK .....	1
19	XAFZZ	55921	C70123-31090	..GUIDE,FORK .....	1
20	XAFZZ	55921	C70123-11230	..SPRING .....	1
21	XAFZZ	55921	C70123-31010	..SEAT,VALVE INLET .....	1
22	XAFZZ	55921	C70123-31030	..PLATE .....	1
23	XAFZZ	55921	C70123-31070	..SPRING,VALVE INLET .....	1
24	XAFZZ	55921	C70123-31020	..RECEIVER,VALVE .....	1
25	PAFZZ	55921	C91501-1310070	SCREW,CAP,HEXAGON H .....	4
26	XBFFF	55921	C70174-12010	..HEAD,CYLINDER .....	1
27	PAFZZ	55921	C70123-11020	GASKET ASBESTOS NO.1500-.8MM THICK- .....	1
				139MM X 139MM .....	

END OF FIGURE

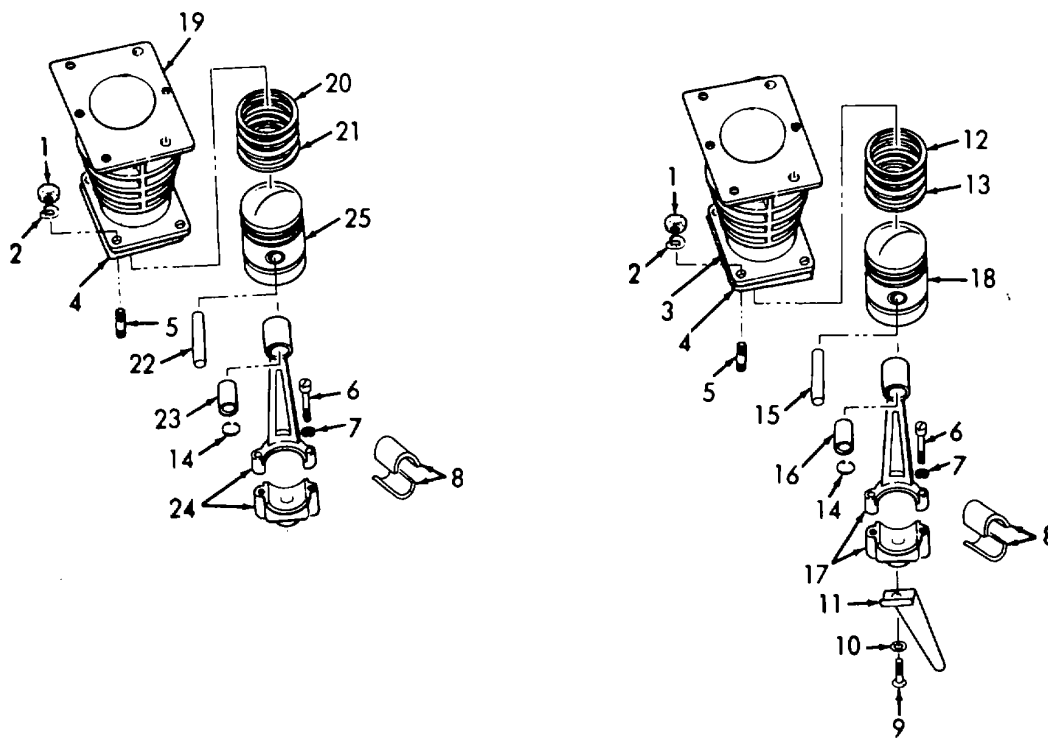

Figure 11. Pistons, Connecting Rods and Cylinders.

## SECTION II

TM 5-4310-380-23P

(1) ITEM NO	(2) SMR CODE	(3) FSCM	(4) PART NUMBER	(5) DESCRIPTION AND USABLE ON CODES (UOC)	(6) QTY
GROUP 03 COMPRESSOR ASSEMBLY					
FIG. 11 PISTONS, CONNECTING RODS, AND CYLINDERS					
1	PAFZZ	55921	VH2402	NUT,PLAIN,HEXAGON .....	12
2	PAFZZ	55921	VH2403	WASHER,LOCK .....	12
3	XBFZZ	55921	C70124-51010	CYLINDER .....	2
4	PAFZZ	55921	C70124-51030	GASKET .....	3
5	PAFZZ	55921	C70123-51810	STUD,PLAIN .....	12
6	PAFZZ	55921	C70123-61250	BOLT,MACHINE .....	6
7	PAFZZ	55921	VH2403	WASHER,LOCK .....	6
8	PAFZZ	55921	C70124-61090	BEARING,PLAIN,ROD E .....	6
9	PAFZZ	55921	C91501-1306020	SCREW,CAP,HEXAGON H .....	2
10	PAFZZ	55921	VH35D	WASHER,LOCK .....	2
11	XBFZZ	55921	C70124-61281	DIPPER,OIL SPLASH .....	2
12	PAFZZ	55921	C70124-61030	RING,PISTON LOW PRESSURE,FIRST .....	6
				STAGE .....	
13	PAFZZ	55921	C70124-61050	RING,PISTON LOW PRESSURE,FIRST .....	2
				STAGE .....	
14	PAFZZ	55921	C70124-61070	RING,RETAINING .....	6
15	XBFZZ	55921	C70124-61120	PIN PISTON LOW PRESSURE,FIRST STAGE .....	2
16	PAFZZ	55921	C70124-61080	BUSHING,SLEEVE LOW PRESSURE,FIRST .....	2
				STAGE .....	
17	XBFZZ	55921	C70124-61210	ROD,CONNECTING LOW PRESSURE,FIRST .....	2
				STAGE .....	
18	XBFZZ	55921	C70124-61010	PISTON LOW PRESSURE,FIRST STAGE .....	2
19	XBFZZ	55921	C70174-52010	CYLINDER HIGH PRESSURE,SECOND STAGE .....	1
20	PAFZZ	55921	C70123-61030	RING,PISTON INSTALL WITH SIDE .....	3
				MARKER R TOWARD HEAD OF PISTON HIGH PRESSURE,SECOND STAGE .....	
21	PAFZZ	55921	C70123-61050	RING,PISTON HIGH PRESSURE,SECOND .....	2
				STAGE .....	
22	XBFZZ	55921	C70174-62120	PIN,PISTON HIGH PRESSURE,SECOND .....	1
				STAGE .....	
23	PAFZZ	55921	C70174-62080	BUSHING,SLEEVE HIGH PRESSURE, .....	1
				SECOND STAGE .....	
24	XBFZZ	55921	C70174-61210	ROD,CONNECTING HIGH PRESSURE, .....	1
				SECOND STAGE .....	
25	XBFZZ	55921	C70174-62010	PISTON HIGH PRESSURE,SECOND STAGE .....	1

END OF FIGURE

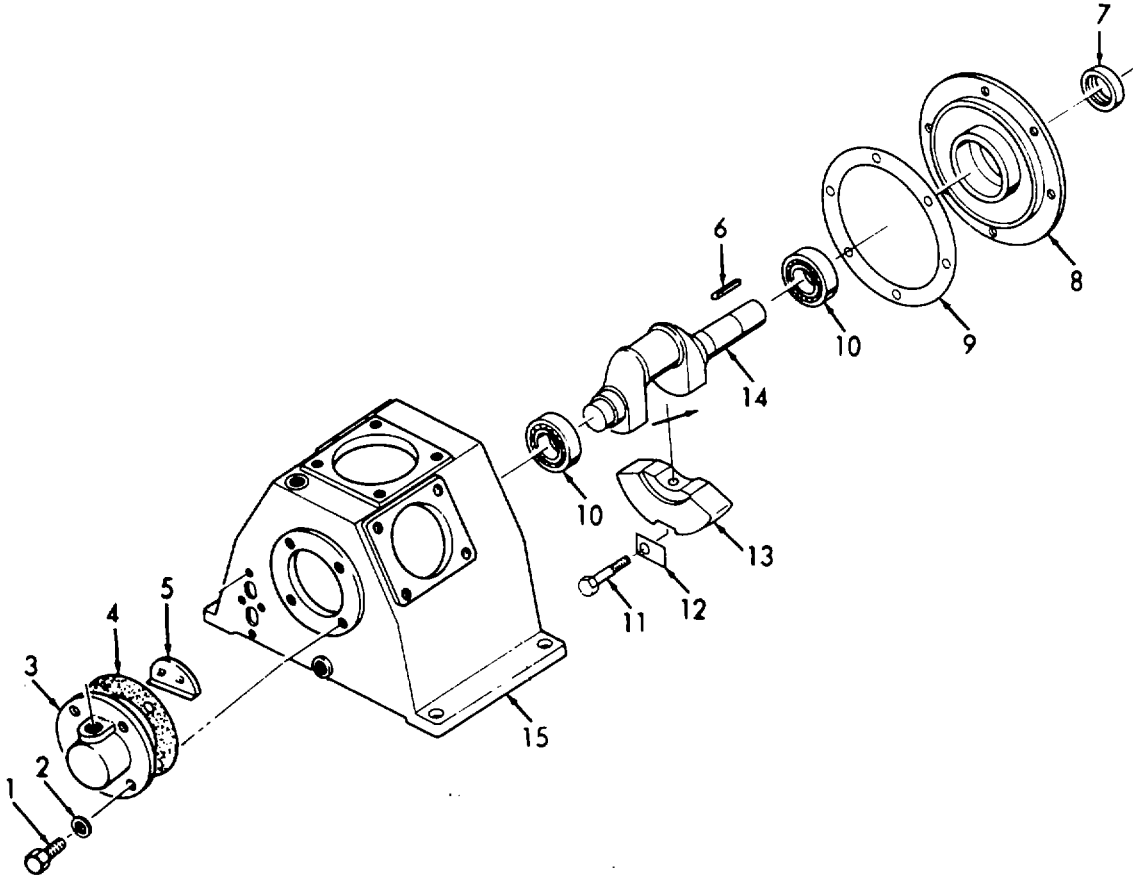

Figure 12. Crankshaft, Bearings and Oil Seals.

## SECTION II

TM 5-4310-380-23P

(1) ITEM NO	(2) SMR CODE	(3) FSCM	(4) PART NUMBER	(5) DESCRIPTION AND USABLE ON CODES (UOC)	(6) QTY
GROUP 03 COMPRESSOR ASSEMBLY					
FIG. 12 CRANKSHAFT, BEARINGS, AND OIL SEALS					
1	PAFZZ	55921	C91501-1310025	SCREW,CAP,HEXAGON H .....	10
2	PAFZZ	55921	VH2407	WASHER,FLAT .....	10
3	XBFZZ	55921	C70134-57060	COVER,REAR .....	1
4	PAFZZ	55921	C70134-57070	GASKET ASBESTOS NO. 1500 8MM .....	1
5	XBFZZ	55921	C70134-57590	BAFFLE,REAR COVER .....	1
6	PAFZZ	55921	C70134-56060	KEY,MACHINE CRS AISI 1020 .....	1
7	PAFZZ	55921	C70134-57080	10MMX8MMX45MM LG .....	1
8	XBFZZ	55921	C70134-57030	SEAL,PLAIN ENCASED MATL IS NBR .....	1
9	PAFZZ	55921	C70124-57040	NITRILE AND STEEL 18MM THICK 77MM DIA 49.5 SHAFT .....	1
10	PAFZZ	55921	E32210J	COVER,FRONT .....	1
11	PAFZZ	55921	C70125-56810	GASKET ASBESTOS NO.1500 5MM THICK .....	1
12	XBFZZ	55921	C70124-56830	BEARING,ROLLER,TAPE CRNKSHT .....	2
13	XBFZZ	55921	C70134-56030	SCREW,CAP,HEXAGON H .....	2
14	XBFZZ	55921	C70134-56010	WASHER,LOCK COUNTERWEIGHT 52MM X .....	1
15	XBFZZ	55921	C70134-57011	25MM .....	1
				WEIGHT,COUNTER .....	2
				CRANKSHAFT .....	1
				CRANKCASE .....	1

END OF FIGURE

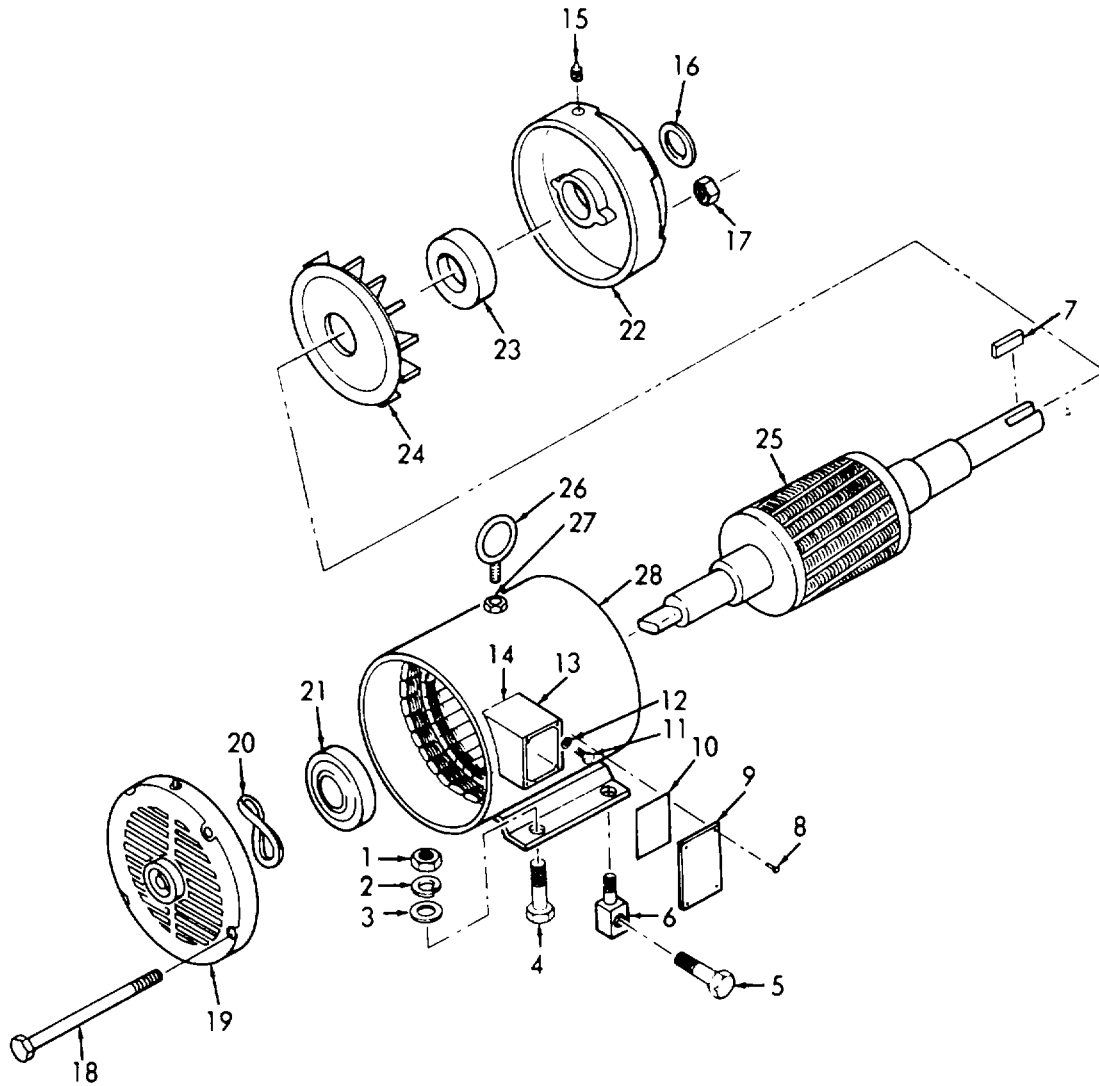

Figure 13. Electric Motor, 10HP.

## SECTION II

TM 5-4310-380-23P

(1) ITEM NO	(2) SMR CODE	(3) FSCM	(4) PART NUMBER	(5) DESCRIPTION AND USABLE ON CODES (UOC)	(6) QTY
				GROUP 04 ELECTRIC MOTOR	
				FIG. 13 ELECTRIC MOTOR, 10HP	
	PBOFF	05472	37B01X33	MOTOR, ALTERNATING C IOHP, 3PH, 60HZ ..... 230-460V, 1740RPM, DRIPPROOF RIGID MT, 215TFRAME.....	1
1	PAOZZ	96906	MS35690-604	.NUT, PLAIN, HEXAGON .....	4
2	PAOZZ	96906	MS35338-46	.WASHER, LOCK.....	4
3	PAOZZ	96906	MS27183-15	.WASHER, FLAT.....	4
4	PAOZZ	96906	MS35751-71	BOLT, SQUARE NECK .....	3
5	PAOZZ	55921	OF269	.BOLT, MACHINE 112 IN NC X 6 1/2 IN..... LG, STEEL .....	1
6	PAOZZ	55921	OFA299	BOLT, MOTOR 7/8 IN SQ-2 1/8 IN LG 112 1 N- 13NC-2B THREADS .....	
7	PAOZZ	05472	HW2501F21	.KEY, MACHINE MANUFACTURER FROM PIN ..... OO-K-220A; 2 3/8 IN. LG. REQUIRED .....	1
8	PAOZZ	05472	51X70832A07	.SCREW .....	4
9	XBOZZ	05472	37CB4500	.LID .....	1
10	PAOZZ	05472	37GS1000	.GASKET .....	1
11	XBOZZ	05472	10XN2520A10	.SCREW.....	2
12	XBOZZ	05472	HW10011A25	.WASHER .....	2
13	XBOZZ	05472	37CB1001A01	.BOX, CONDUIT .....	1
14	PAOZZ	05472	37GS1000	.GASKET .....	
15	PAOZZ	05472	HW4500A011	.FITTING, LUBRICATION.....	
16	XBOZZ	05472	HACB1001A01	.SLINGER .....	
17	PAFZZ	96906	MS51967-35	.NUT, PLAIN, HEXAGON .....	4
18	XBFZZ	05472	HA3104A14	.BOLT, MACHINE.....	4
19	XBFZZ	05472	37EP3200A01	.PLATE, END .....	1
20	PAFZZ	05472	HWS100A06	.BEARING, WASHER, THRU .....	1
21	PAFZZ	59690	A26836	.BEARING, BALL, ANNULA .....	1
22	XBFZZ	05472	37EP3201A01	.END BELL ELECTRICAL .....	1
23	PAFZZ	8E499	A26836	.BEARING, BALL, ANNULA .....	1
24	XBFZZ	05472	37FN5000A02	.FAN .....	1
25	XAFZZ	05472	37RAB001X033	.ROTOR ASSY.....	1
26	XBOZZ	05472	HW3200A01	.BOLT, EYE .....	1
27	XBOZZ	05472	HA3200A01	.NUT .....	1
28	XAFZZ	05472	37SAB001X033	.STATOR ASSY .....	1

END OF FIGURE

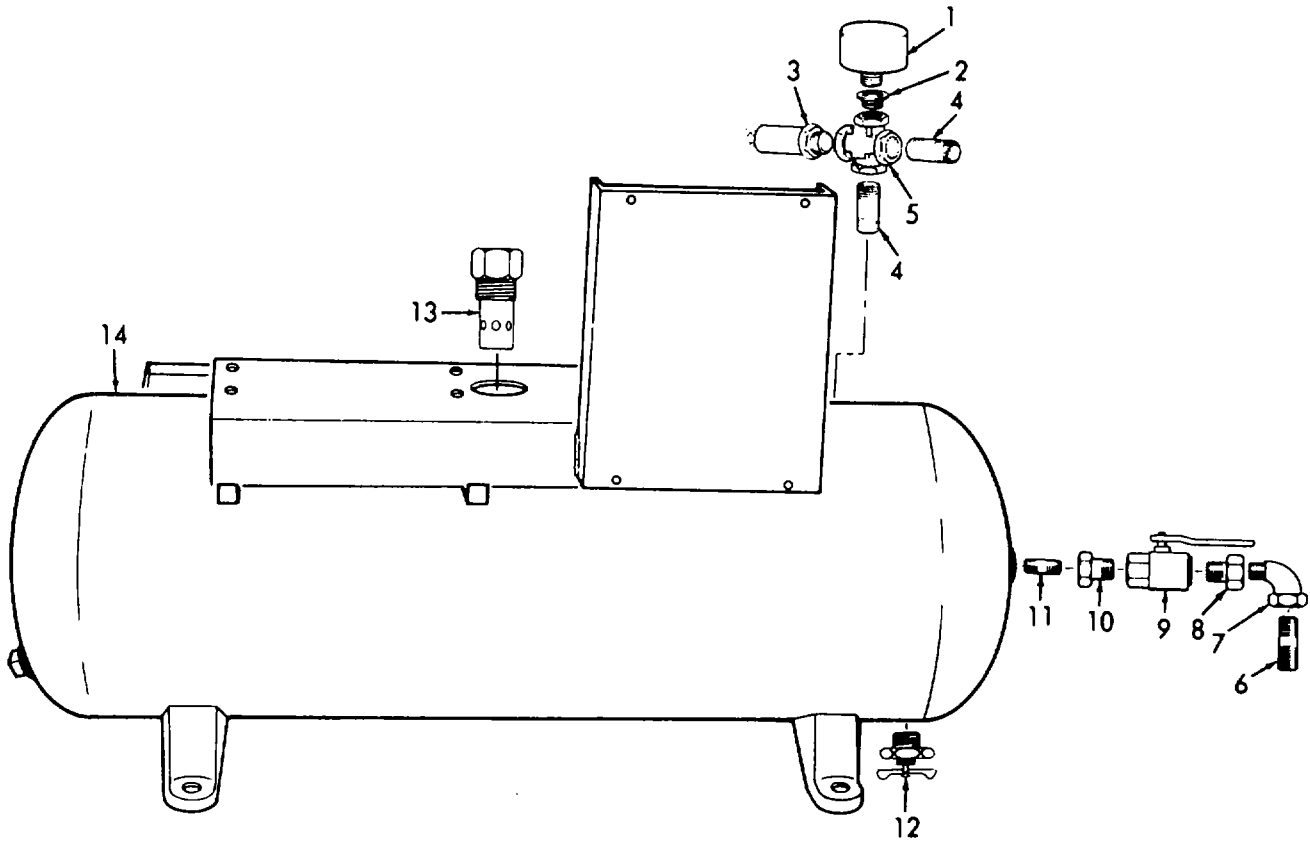

Figure 14. Air Receiver System.



## SECTION II

TM 5-4310-380-23P

(1) ITEM NO	(2) SMR CODE	(3) FSCM	(4) PART NUMBER	(5) DESCRIPTION AND USABLE ON CODES (UOC) GROUP 05 AIR RECEIVER SYSTEM  FIG. 14 AIR RECEIVER SYSTEM	(6) QTY
1	PAOZZ	55921	VA316	GAGE,PRESSURE,DIAL 2INCH DIA. ¼.....	1
				IN MPT,0-300PSI .....	
2	PAOZZ	19422	BM11352-77	BUSHING,PIPE .....	1
3	PAOZZ	58818	SV-33-3/8-200	VALVE, SAFETY RELIEF 3/8MPT-200PSI .....	1
				ASME RATED 152 CFM, BRASS .....	
4	XBOZZ	96906	MS51953-52	NIPPLE, PIPE .....	2
5	XBOZZ	97403	13218E0056-3	CROSS .....	1
6	PAOZZ	96906	MS51953-25B	NIPPLE, PIPE .....	1
7	PAOZZ	96906	MS39230-2	ELBOW, PIPE .....	1
8	PAOZZ	96906	MS51887-10	BUSHING, PIPE .....	1
9	PAOZZ	19243	3500-1/2	VALVE, BALL BALL TYPE,1/2 IN FPT .....	1
				BRASS .....	
10	PAOZZ	81348	WW-P-471BDQAAED	BUSHING,PIPE .....	1
11	PAOZZ	96906	MS51953-60	NIPPLE,PIPE .....	1
12	PAOZZ	96906	MS35784-2	COCK,DRAIN .....	1
13	PAOZZ	58818	P7510S	VALVE,CHECK 3/4 FPT INLET X 1 INCH .....	1
				MPT OUTLET WITH 1/8 FPT SIDE PORT .....	
14	XBOZZ	55921	OFC252	TANK AIR .....	1

END OF FIGURE

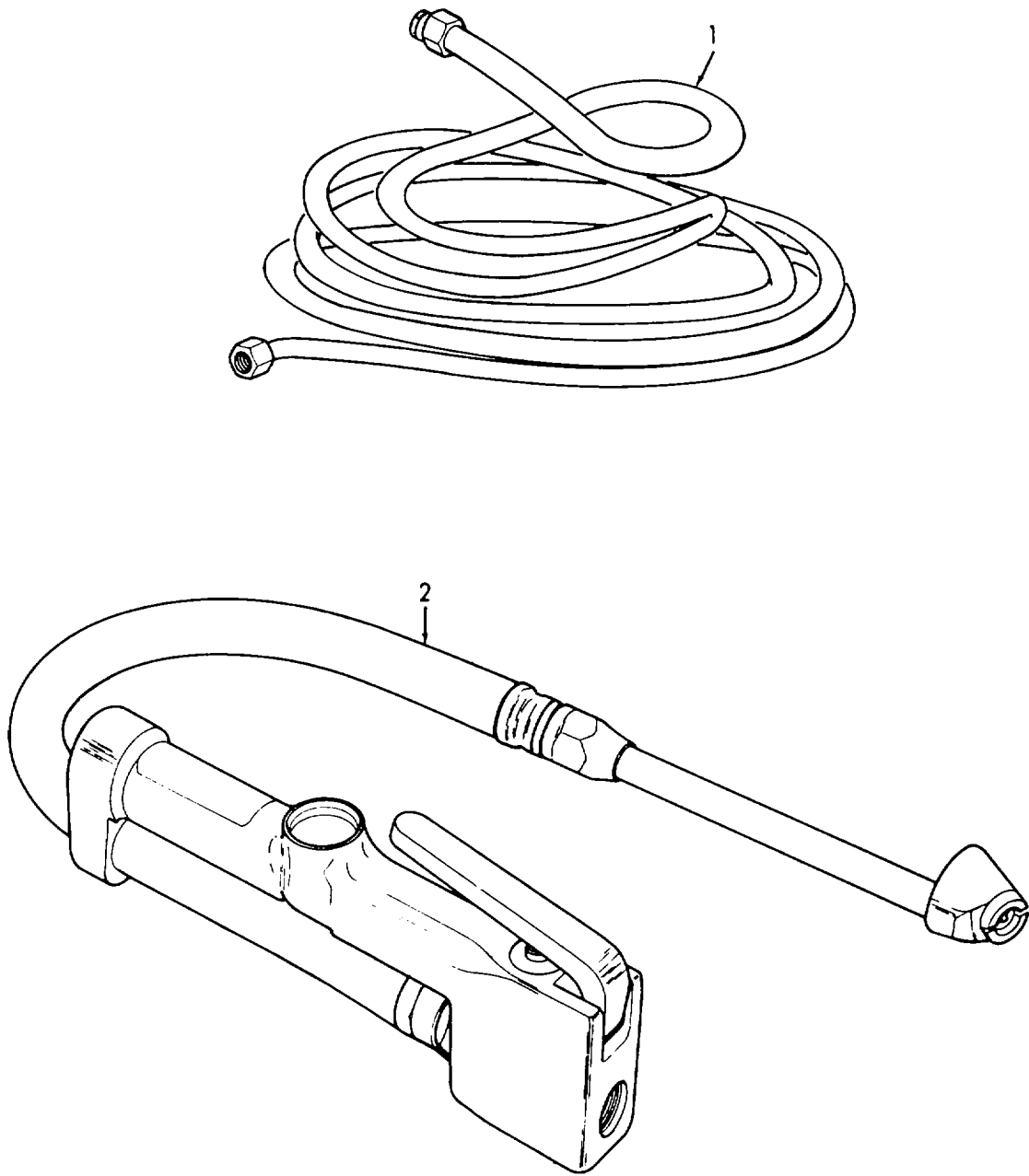

Figure 15. Air Discharge System.

SECTION II

TM 5-4310-380-23P

(1) ITEM NO	(2) SMR CODE	(3) FSCM	(4) PART NUMBER	(5) DESCRIPTION AND USABLE ON CODES (UOC)	(6) QTY
GROUP 06 AIR DISCHARGE SYSTEM					
FIG. 15 AIR DISCHARGE SYSTEM					
1	PAOZZ	55921	VR318	HOSE ASSEMBLY, NONME 5/16 IN. ID. X 50.0 FT. LG. WITH 1/4 IN. STD. ONE END, 1/4 IN. MPT. OTHER END	1
2	PAOZZ	81348	GG-G-91TYPE3STYL E2	INFLATOR-GAGE, PNEUM 1/4 IN FPT	1

END OF FIGURE

**SECTION III**

**Not Applicable**

**CROSS-REFERENCE INDEXES**  
**NATIONAL STOCK NUMBER INDEX**

STOCK NUMBER	FIG.	ITEM	STOCK NUMBER	FIG.	ITEM
5310-00-014-5850	1	23	5930-01-225-8490	2	1
4730-00-044-4587	7	3	6110-01-225-8540	1	14
5310-00-045-3296	1	22	5310-01-225-8541	11	1
5310-00-045-3299	1	19	5310-01-225-8542	6	2
5305-00-052-6917	1	26	5315-01-225-8544	12	6
5305-00-068-0508	1	12	4730-01-225-8551	8	2
5975-00-152-1046	1	2	4730-01-225-8552	7	5
5975-00-152-1127	1	7	4310-01-225-8554	5	3
4820-00-165-0579	10	13	4730-01-225-8555	8	6
4730-00-193-0869	14	2	5330-01-225-8557	12	7
4730-00-196-1543	14	11	5330-01-225-8559	6	7
4730-00-196-2055	14	6	5330-01-225-8560	7	2
4730-00-253-4412	14	7	5330-01-225-8561	9	11
5305-00-269-3204	3	4	5330-01-225-8562	10	11
4820-00-287-4268	14	12	5330-01-225-8564	9	12
4730-00-288-8055	9	13	5330-01-225-8565	9	29
5310-00-407-9566	7	20	5330-01-225-8566	10	12
	10	5	5330-01-225-8567	10	27
5305-00-472-5276	1	18	5330-01-225-8568	11	4
5930-00-521-8471	2		5330-01-225-8569	12	4
3110-00-554-3197	13	21	5330-01-225-8570	12	9
3110-00-555-5207	13	23	5305-01-225-8590	7	7
5310-00-582-5965	1	13	6685-01-225-8594	14	1
5310-00-584-5272	5	2	5365-01-225-8595	11	14
5930-00-631-7542	1	15	3020-01-225-8597	7	22
5310-00-637-9541	3	2	4140-01-225-8599	7	21
	13	2	4310-01-225-8600	6	1
5310-00-655-9544	3	1	4310-01-225-8601	7	11
	13	1	4310-01-225-8603	11	12
5305-00-732-0511	5	1	4310-01-225-8604	11	13
5310-00-762-6241	13	17	4310-01-225-8605	11	20
5310-00-809-4061	3	3	4310-01-225-8606	11	21
	13	3	3120-01-225-8609	11	16
5306-00-816-2441	13	4	3120-01-225-8610	11	23
5305-00-855-0956	1	27	3120-01-225-8612	11	8
5305-00-855-0964	1	21	5310-01-225-8617	6	3
4730-00-921-3240	8	9	5310-01-225-8618	12	2
4730-01-122-9150	7	4	5310-01-225-8623	11	2
5330-01-124-6430	13	10		11	7
	13	14	5310-01-225-8624	11	10
5306-01-174-8741	10	1	5307-01-225-8633	11	5
3120-01-185-2800	13	20	5305-01-225-8641	7	16
5340-01-196-2729	1	16	5305-01-225-8642	7	19
4730-01-198-0569	13	15	5305-01-225-8643	9	27
4720-01-204-8374	15	1	5305-01-225-8644	11	9
4730-01-223-3756	14	10	5305-01-225-8645	12	1
4820-01-225-8254	14	13	5305-01-225-8646	12	11
4820-01-225-8255	14	3	4710-01-225-8679	8	4
4820-01-225-8260	14	9	4710-01-225-8680	8	5
3110-01-225-8471	12	10	4820-01-225-8693	9	3

**SECTION IV**

TM 5-4310-380-23P

**CROSS-REFERENCE INDEXES  
NATIONAL STOCK NUMBER INDEX**

<b>STOCK NUMBER</b>	<b>FIG.</b>	<b>ITEM</b>	<b>STOCK NUMBER</b>	<b>FIG.</b>	<b>ITEM</b>
4820-01-225-8694	9	17			
4820-01-225-8695	10	3			
4820-01-225-8696	10	15			
2805-01-225-8702	7	1			
4710-01-225-8786	8	7			
4710-01-225-8787	8	8			
4310-01-225-8812	6	5			
3020-01-225-8830	3	6			
5945-01-226-7505	1	24			
6105-01-226-7599	13				
5315-01-226-7607	13	7			
4730-01-226-7613	8	3			
3120-01-226-7637	7	18			
5305-01-226-7664	9	1			
6110-01-226-7687	1	25			
5999-01-227-7967	1				
5306-01-227-7975	11	6			
2920-01-229-1140	1	32			
5306-01-229-6068	13	6			
5306-01-229-6201	13	5			
5330-01-229-6218	7	9			
5305-01-229-6244	4	3			
5305-01-229-6272	10	25			
4730-01-235-5781	14	8			
5310-01-235-5889	7	17			
5920-01-237-0607	1	17			
5305-01-237-0608	1	28			
5305-01-237-0609	13	8			
6680-01-237-8126	7	6			
3030-01-247-2616	4	1			

## CROSS-REFERENCE INDEXES

## PART NUMBER INDEX

FSCM	PART NUMBER	STOCK NUMBER	FIG.	ITEM
88044	AN916-4J	4730-01-122-9150	7	4
00843	A16P14		1	33
00843	A1614CH		1	34
59690	A26836	3110-00-554-3197	13	21
8E499	A26836	3110-00-555-5207	13	23
19422	BM11352-77	4730-00-193-0869	14	2
80204	B1823 11A08020N	5306-01-174-8741	10	1
61802	C-35E-B	6110-01-226-7687	1	25
55921	CAC2202	3020-01-225-8830	3	6
55921	CAC2203		3	8
55921	CAC2207		3	7
55921	CAC2208		3	5
61802	CC-50-BSZ 1-230V	2920-01-229-1140	1	32
61802	CMK-35	5999-01-227-7967	1	
61802	CMK-35E-A		1	29
61802	CMK-35E-B		1	31
61802	CMK-35E-C		1	30
55921	C70123-11020	5330-01-225-8567	10	27
55921	C70123-1110	5330-01-225-8566	10	12
55921	C70123-11150A		10	14
55921	C70123-11230		10	20
55921	C70123-11450		10	2
55921	C70123-31000	4820-01-225-8696	10	15
55921	C70123-31010		10	21
55921	C70123-31020		10	24
55921	C70123-31030		10	8
			10	22
55921	C70123-31070		10	23
55921	C70123-31080		10	18
55921	C70123-31090		10	19
55921	C70123-41000	4820-01-225-8695	10	3
55921	C70123-41010		10	9
55921	C70123-41020		10	6
55921	C70123-41070		10	7
55921	C70123-41811		10	10
55921	C70123-51810	5307-01-225-8633	11	5
55921	C70123-57190	2805-01-225-8702	7	1
55921	C70123-61030	4310-01-225-8605	11	20
55921	C70123-61050	4310-01-225-8606	11	21
55921	C70123-61250	5306-01-227-7975	11	6
55921	C70123-66000	4310-01-225-8600	6	1
55921	C70123-66010		6	6
55921	C70123-66030		6	8
55921	C70123-66130	5330-01-225-8559	6	7
55921	C70123-66140	4310-01-225-8812	6	5
55921	C70123-66170		6	4
55921	C70124-11000		9	
55921	C70124-11010		9	28
55921	C70124-11020	5330-01-225-8565	9	29
55921	C70124-11110	5330-01-225-8564	9	12
55921	C70124-11150		9	14
55921	C70124-11220		9	15

## CROSS-REFERENCE INDEXES

FSCM	PART NUMBER	PART NUMBER INDEX STOCK NUMBER	FIG.	ITEM
55921	C70124-11230		9	22
55921	C70124-11450		9	2
55921	C70124-31000	4820-01-225-8694	9	17
55921	C70124-31010		9	23
55921	C70124-31020		9	26
55921	C70124-31030		9	9
			9	24
55921	C70124-31070		9	25
55921	C70124-31080		9	20
55921	C70124-31090		9	21
55921	C70124-41000	4820-01-225-8693	9	3
55921	C70124-41010		9	10
55921	C70124-41020		9	6
55921	C70124-41070		9	7
55921	C70124-41810		9	8
55921	C70124-51010		11	3
55921	C70124-51030	5330-01-225-8568	11	4
55921	C70124-56830		12	12
55921	C70124-57040	5330-01-225-8570	12	9
55921	C70124-57600	4310-01-225-8601	7	11
55921	C70124-57610		7	15
55921	C70124-57670		7	13
55921	C70124-57700	6680-01-237-8126	7	6
55921	C70124-57710		7	10
55921	C70124-57720		7	8
55921-	C70124-57730	5330-01-229-6218	7	9
55921	C70124-61010		11	18
55921	C70124-61030	4310-01-225-8603	11	12
55921	C70124-61050	4310-01-225-8604	11	13
55921	C70124-61070	5365-01-225-8595	11	14
55921	C70124-61080	3120-01-225-8609	11	16
55921	C70124-61090	3120-01-225-8612	11	8
55921	C70124-61120		11	15
55921	C70124-61210		11	17
55921	C70124-61281		11	11
55921	C70124-76210	3120-01-226-7637	7	18
55921	C70124-76310	4140-01-225-8599	7	21
55921	C70124-87010	4730-01-225-8551	8	2
55921	C70125-56810	5305-01-225-8646	12	11
55921	C70134-56010		12	14
55921	C70134-56030		12	13
55921	C70134-56060	5315-01-225-8544	12	6
55921	C70134-57011		12	15
55921	C70134-57030		12	8
55921	C70134-57060		12	3
55921	C70134-57070	5330-01-225-8569	12	4
55921	C70134-57080	5330-01-225-8557	12	7
55921	C70134-57590		12	5
55921	C70134-76010	3020-01-225-8597	7	22
55921	C70134-87100	4710-01-225-8679	8	4
55921	C70174-00000	4310-01-225-8554	5	3



## CROSS-REFERENCE INDEXES

FSCM	PART NUMBER	PART NUMBER INDEX		FIG.	ITEM
			STOCK NUMBER		
55921	C70174-12000			10	
55921	C70174-12010			10	26
55921	C70174-52010			11	19
55921	C70174-61210			11	24
55921	C70174-62010			11	25
55921	C70174-62080	3120-01-225-8610		11	23
55921	C70174-62120			11	22
55921	C70174-87001			8	1
55921	C70174-87020	4730-01-226-7613		8	3
55921	C70174-87300	4710-01-225-8680		8	5
55921	C71505-1305012	5305-01-225-8590		7	7
55921	C79922-130707	4730-01-225-8555		8	6
55921	C91501-1306020	5305-01-225-8644		11	9
55921	C91501-1308025	5305-01-226-7664		9	1
55921	C91501-1310025	5305-01-225-8645		12	1
55921	C91501-1310070	5305-01-229-6272		10	25
55921	C91501-1310080	5305-01-225-8643		9	27
55921	C91501-2312040	5305-01-225-8641		7	16
55921	C92106-131001			10	17
55921	C92501-131000			9	4
55921	C92502-130800			10	4
55921	C92513-150600	5310-01-225-8542		6	2
55921	C92517-231000			9	19
55921	C92521-110600	5310-01-225-8617		6	3
55921	C92521-151000			9	5
55921	C93601-810018	5330-01-225-8560		7	2
55921	C93601-810020			7	12
				9	16
55921	C93601-870040	5330-01-225-8562		10	11
55921	C93601-890700			7	14
55921	C93602-870055	5330-01-225-8561		9	11
55921	C93701-232018			9	18
				10	16
23826	D27257-1			2	2
23826	D274-1			2	8
23826	D334-1			2	5
23826	D354-1			2	4
23826	D661-0-7			2	7
23826	D661-0-8			2	6
23326	D817-2			2	3
55921	E32210J	3110-01-225-8471		12	10
81348	GG-G-91TYPE3STYL E2			15	2
05472	HACB1001A01			13	16
05472	HA3104A14			13	18
05472	HA3200A01			13	27
71400	HRC-1-KTK-R-20	5920-01-237-0607		1	17
05472	HW1001A25			13	12
05472	HW2501F21	5315-01-226-7607		13	7
05472	HW3200A01			13	26
05472	HW4500A01	4730-01-198-0569		13	15

## CROSS-REFERENCE INDEXES

FSCM	PART NUMBER	PART NUMBER INDEX		FIG.	ITEM
			STOCK NUMBER		
05472	HW5100A06		3120-01-185-2800	13	20
96906	MS24625-31		5305-00-472-5276	1	18
96906	MS24629-47		5305-00-855-0956	1	27
96906	MS24629-48		5305-00-855-0964	1	21
96906	MS24629-50		5305-00-052-6917	1	26
96906	MS27183-15		5310-00-809-4061	3	3
				13	3
96906	MS27183-42		5310-00-014-5850	1	23
96906	MS35338-42		5310-00-045-3299	1	19
96906	MS35338-43		5310-00-045-3296	1	22
96906	MS35338-44		5310-00-582-5965	1	13
96906	MS35338-45		5310-00-407-9566	7	20
				10	5
96906	MS35338-46		5310-00-637-9541	3	2
				13	2
96906	MS35338-48		5310-00-584-5272	5	2
96906	M535690-604		5310-00-655-9544	3	1
				13	1
96906	MS35751-71		5306-00-816-2441	13	4
96906	M535784-2		4820-00-287-4268	14	12
96906	M539230-2		4730-00-253-4412	14	7
96906	MS51067C68B3		3030-01-247-2616	4	1
96906	MS51884-7		4730-00-044-4587	7	3
96906	M551887-10		4730-01-235-5781	14	8
96906	MS51953-25B		4730-00-196-2055	14	6
96906	M551953-52			14	4
96906	M551953-60		4730-00-196-1543	14	11
96906	M551967-35		5310-00-762-6241	13	17
96906	MS90725-53		5305-00-269-3204	3	4
96906	MS90728-110		5305-00-732-0511	5	1
96906	M590728-6		5305-00-068-0508	1	12
78229	NC-011		5975-00-152-1046	1	2
58818	NC25-70		4820-00-165-0579	10	13
55921	OFA299		5306-01-229-6068	13	6
55921	OFB859		4710-01-225-8786	8	7
55921	OFC252			14	14
55921	OF269		5306-01-229-6201	13	5
55921	OF608			1	1
55921	OF609			1	6
58818	P7510S		4820-01-225-8254	14	13
61802	R-35E-28		5945-01-226-7505	1	24
89946	RSK-12		5340-01-196-2729	1	16
58818	SV-33-3/8-200		4820-01-225-8255	14	3
55921	VA13DLA		4730-01-225-8552	7	5
55921	VA1602A		4710-01-225-8787	8	8
55921	VA316		6685-01-225-8594	14	1
55921	VDA246			4	2
55921	VDA246A			4	4
55921	VE1004-30			1	10
55921	VE1015-13			1	9
55921	VE1034-14			1	4

## CROSS-REFERENCE INDEXES

FSCM	PART NUMBER	PART NUMBER INDEX		FIG.	ITEM
			STOCK NUMBER		
55921	VE1036-32			1	5
55921	VH1421		5305-01-229-6244	4	3
55921	VH2402		5310-01-225-8541	11	1
55921	VH2403		5310-01-225-8623	11	2
				11	7
55921	VH2404		5305-01-2258642	7	19
55921	VH2406		5310-01-235-5889	7	17
55921	VH2407		5310-01-225-8618	12	2
55921	VH35D		5310-01-225-8624	11	10
55921	VR318		4720-01-204-8374	15	1
81348	WW-P-471AASBCA		4730-00-288-8055	9	13
81348	WW-P-471BDQAAED		4730-01-223-3756	14	10
05472	10XN2520A10			13	11
61802	100C-KBL		6110-01-225-8540	1	14
97403	13218E0056-3			14	5
71400	2079-30A-600V			1	20
61802	24193-3		5305-01-237-0608	1	28
19243	3500-1/2		4820-01-225-8260	14	9
05472	37B01X33		6105-01-226-7599	13	
05472	37CB1001A01			13	13
05472	37CB4500			13	9
05472	37EP3200A01			13	19
05472	37EP3201A01			13	22
05472	37FN5000A02			13	24
05472	37GS1000		5330-01-124-6430	13	10
				13	14
05472	37RAB001X033			13	25
05472	37SAB001X033			13	28
59730	391			1	8
59730	394			1	3
81343	4-2120202BA		4730-00-921-3240	8	9
05472	51X70832A07		5305-01-237-0609	13	8
23826	69HAUL		5930-01-225-8490	2	1
03743	7245V			1	11
03743	7380V		5975-00-152-1127	1	7
23826	75HA69		5930-00-521-8471	2	
01121	800T-H2A		5930-00-631-7542	1	15

## CROSS-REFERENCE INDEXES

## FIGURE AND ITEM NUMBER INDEX

FIG.	ITEM	STOCK NUMBER	FSCM	PART NUMBER
1		5999-01-227-7967	61802	CMK-35
1	1		55921	OF608
1	2	5975-00-152-1046	78229	NC-011
1	3		59730	394
1	4		55921	VE1034-14
1	5		55921	VE1036-32
1	6		55921	OF609
1	7	5975-00-152-1127	03743	7380V
1	8		59730	391
1	9		55921	VE1015-13
1	10		55921	VE1004-30
1	11		03743	7245V
1	12	5305-00-068-0508	96906	MS90728-6
1	13	5310-00-582-5965	96906	MS35338-44
1	14	6110-01-225-8540	61802	100C-KBL
1	15	5930-00-631-7542	01121	800T-H2A
1	16	5340-01-196-2729	89946	RSK-12
1	17	5920-01-237-0607	71400	HRC-1-KTK-R-20
1	18	5305-00-472-5276	96906	MS24625-31
1	19	5310-00-045-3299	96906	MS35338-42
1	20		71400	2079-30A-600V
1	21	5305-00-855-0964	96906	MS24629-48
1	22	5310-00-045-3296	96906	MS35338-43
1	23	5310-00-014-5850	96906	MS27183-42
1	24	5945-01-226-7505	61802	R-35E-28
1	25	6110-01-226-7687	61802	C-35E-B
1	26	5305-00-052-6917	96906	MS24629-50
1	27	5305-00-855-0956	96906	MS24629-47
1	28	5305-01-237-0608	61802	24193-3
1	29		61802	CMK-35E-A
1	30		61802	CMK-35E-C
1	31		61802	CMK-35E-B
1	32	2920-01-229-1140	61802	CC-50-B-SZ1-230V
1	33		00843	A16P14
1	34		00843	A1614CH
2		5930-00-521-8471	23826	75HA69
2	1	5930-01-225-8490	23826	69HAUL
2	2		23826	D27257-1
2	3		23826	D817-2
2	4		23826	D354-1
2	5		23826	D334-1
2	6		23826	D661-0-8
2	7		23826	D661-0-7
2	8		23826	D274-1
3	1	5310-00-655-9544	96906	MS35690-604
3	2	5310-00-637-9541	96906	MS35338-46
3	3	5310-00-809-4061	96906	MS27183-15
3	4	5305-00-269-3204	96906	MS90725-53
3	5		55921	CAC2208
3	6	3020-01-225-8830	55921	CAC2202
3	7		55921	CAC2207

## CROSS-REFERENCE INDEXES

## FIGURE AND ITEM NUMBER INDEX

FIG.	ITEM	STOCK NUMBER	FSCM	PART NUMBER
3	8		55921	CAC2203
4	1	3030-01-247-2616	96906	MS51067C68B3
4	2		55921	VDA246
4	3	5305-01-229-6244	55921	VH1421
4	4		55921	VDA246A
5	1	5305-00-732-0511	96906	MS90728-110
5	2	5310-00-584-5272	96906	MS35338-48
5	3	4310-01-225-8554	55921	C70174-00000
6	1	4310-01-225-8600	55921	C70123-66000
6	2	5310-01-225-8542	55921	C92513-150600
6	3	5310-01-225-8617	55921	C92521-110600
6	4		55921	C70123-66170
6	5	4310-01-225-8812	55921	C70123-66140
6	6		55921	C70123-66010
6	7	5330-01-225-8559	55921	C70123-66130
6	8		55921	C70123-66030
7	1	2805-01-225-8702	55921	C70123-57190
7	2	5330-01-225-8560	55921	C93601-810018
7	3	4730-00-044-4587	96906	MS51884-7
7	4	4730-01-122-9150	88044	AN916-4J
7	5	4730-01-225-8552	55921	VA13DLA
7	6	6680-01-237-8126	55921	C70124-57700
7	7	5305-01-225-8590	55921	C71505-1305012
7	8		55921	C70124-57720
7	9	5330-01-229-6218	55921	C70124-57730
7	10		55921	C70124-57710
7	11	4310-01-225-8601	55921	C70124-57600
7	12		55921	C93601-810020
7	13		55921	C70124-57670
7	14		55921	C93601-890700
7	15		55921	C70124-57610
7	16	5305-01-225-8641	55921	C91501-2312040
7	17	5310-01-235-5889	55921	VH2406
7	18	3120-01-226-7637	55921	C70124-76210
7	19	5305-01-225-8642	55921	VH2404
7	20	5310-00-407-9566	96906	MS35338-45
7	21	4140-01-225-8599	55921	C70124-76310
7	22	3020-01-225-8597	55921	C70134-76010
8	1		55921	C70174-87001
8	2	4730-01-225-8551	55921	C70124-87010
8	3	4730-01-226-7613	55921	C70174-87020
8	4	4710-01-225-8679	55921	C70134-87100
8	5	4710-01-225-8680	55921	C70174-87300
8	6	4730-01-225-8555	55921	C79922-130707
8	7	4710-01-225-8786	55921	OFB859
8	8	4710-01-225-8787	55921	VA1602A
8	9	4730-00-921-3240	81343	4-2 120202BA
9			55921	C70124-11000
9	1	5305-01-226-7664	55921	C91501-1308025
9	2		55921	C70124-11450
9	3	4820-01-225-8693	55921	C70124-41000

## CROSS-REFERENCE INDEXES

## FIGURE AND ITEM NUMBER INDEX

FIG.	ITEM	STOCK NUMBER	FSCM	PART NUMBER
9	4		55921	C92501-131000
9	5		55921	C92521-151000
9	6		55921	C70124-41020
9	7		55921	C70124-41070
9	8		55921	C70124-41810
9	9		55921	C70124-31030
9	10		55921	C70124-41010
9	11	5330-01-225-8561	55921	C93602-870055
9	12	5330-01-225-8564	55921	C70124-11110
9	13	4730-00-288-8055	81348	WW-P-471AASBCA
9	14		55921	C70124-11150
9	15		55921	C70124-11220
9	16		55921	C93601-810020
9	17	4820-01-225-8694	55921	C70124-31000
9	18		55921	C93701-232018
9	19		55921	C92517-231000
9	20		55921	C70124-31080
9	21		55921	C70124-31090
9	22		55921	C70124-11230
9	23		55921	C70124-31010
9	24		55921	C70124-31030
9	25		55921	C70124-31070
9	26		55921	C70124-31020
9	27	5305-01-225-8643	55921	C91501-1310080
9	28		55921	C70124-11010
9	29	5330-01-225-8565	55921	C70124-11020
10			55921	C70174-12000
10	1	5306-01-174-8741	80204	B18231A08020N
10	2		55921	C70123-11450
10	3	4820-01-225-8695	55921	C70123-41000
10	4		55921	C92502-130800
10	5	5310-00-407-9566	96906	MS35338-45
10	6		55921	C70123-41020
10	7		55921	C70123-41070
10	8		55921	C70123-31030
10	9		55921	C70123-41010
10	10		55921	C70123-41811
10	11	5330-01-225-8562	55921	C93601-870040
10	12	5330-01-225-8566	55921	C70123-11110
10	13	4820-00-165-0579	58818	NC25-70
10	14		55921	C70123-11150A
10	15	4820-01-225-8696	55921	C70123-31000
10	16		55921	C93701-232018
10	17		55921	C92106-131001
10	18		55921	C70123-31080
10	19		55921	C70123-31090
10	20		55921	C70123-11230
10	21		55921	C70123-31010
10	22		55921	C70123-31030
10	23		55921	C70123-31070
10	24		55921	C70123-31020

## CROSS-REFERENCE INDEXES

## FIGURE AND ITEM NUMBER INDEX

FIG.	ITEM	STOCK NUMBER	FSCM	PART NUMBER
10	25	5305-01-229-6272	55921	C91501-1310070
10	26		55921	C70174-12010
10	27	5330-01-225-8567	55921	C70123-11020
11	1	5310-01-225-8541	55921	VH2402
11	2	5310-01-225-8623	55921	VH2403
11	3		55921	C70124-51010
11	4	5330-01-225-8568	55921	C70124-51030
11	5	5307-01-225-8633	55921	C70123-51810
11	6	5306-01-227-7975	55921	C70123-61250
11	7	5310-01-225-8623	55921	VH2403
11	8	3120-01-225-8612	55921	C70124-61090
11	9	5305-01-225-8644	55921	C91501-1306020
11	10	5310-01-225-8624	55921	VH35D
11	11		55921	C70124-61281
11	12	4310-01-225-8603	55921	C70124-61030
11	13	4310-01-225-8604	55921	C70124-61050
11	14	5365-01-225-8595	55921	C70124-61070
11	15		55921	C70124-61120
11	16	3120-01-225-8609	55921	C70124-61080
11	17		55921	C70124-61210
11	18		55921	C70124-61010
11	19		55921	C70174-52010
11	20	4310-01-225-8605	55921	C70123-61030
11	21	4310-01-225-8606	55921	C70123-61050
11	22		55921	C70174-62120
11	23	3120-01-225-8610	55921	C70174-62080
11	24		55921	C70174-61210
11	25		55921	C70174-62010
12	1	5305-01-225-8645	55921	C91501-1310025
12	2	5310-01-225-8618	55921	VH2407
12	3		55921	C70134-57060
12	4	5330-01-225-8569	55921	C70134-57070
12	5		55921	C70134-57590
12	6	5315-01-225-8544	55921	C70134-56060
12	7	5330-01-225-8557	55921	C70134-57080
12	8		55921	C70134-57030
12	9	5330-01-225-8570	55921	C70124-57040
12	10	3110-01-225-8471	55921	E32210J
12	11	5305-01-225-8646	55921	C70125-56810
12	12		55921	C70124-56830
12	13		55921	C70134-56030
12	14		55921	C70134-56010
12	15		55921	C70134-57011
13		6105-01-226-7599	05472	37B01X33
13	1	5310-00-655-9544	96906	MS35690-604
13	2	5310-00-637-9541	96906	MS35338-46
13	3	5310-00-809-4061	96906	MS27183-15
13	4	5306-00-816-2441	96906	MS35751-71
13	5	5306-01-229-6201	55921	OF269
13	6	5306-01-229-6068	55921	OFA299
13	7	5315-01-226-7607	05472	HW2501F21

## CROSS-REFERENCE INDEXES

## FIGURE AND ITEM NUMBER INDEX

FIG.	ITEM	STOCK NUMBER	FSCM	PART NUMBER
13	8	5305-01-237-0609	05472	51X70832A07
13	9		05472	37CB4500
13	10	5330-01-124-6430	05472	37GS1000
13	11		05472	10XN2520A10
13	12		05472	HW10001A25
13	13		05472	37CB1001A01
13	14	5330-01-124-6430	05472	37GS1000
13	15	4730-01-198-0569	05472	HW4500A01
13	16		05472	HACB1001A01
13	17	5310-00-762-6241	96906	MS5 1967-35
13	18		05472	HA3104A14
13	19		05472	37EP3200A0 1
13	20	3120-01-185-2800	05472	HW5 100A06
13	21	3110-00-554-3197	59690	A26836
13	22		05472	37EP3201A01
13	23	3110-00-555-5207	8E499	A26836
13	24		05472	37FNS000A02
13	25		05472	37RAB001X033
13	26		05472	HW3200A01
13	27		05472	HA3200A01
13	28		05472	37SAB001X033
14	1	6685-01-225-8594	55921	VA316
14	2	4730-00-193-0869	19422	BM 11352-77
14	3	4820-01-225-8255	58818	SV-33-3/8-200
14	4		96906	MS5 1953-52
14	5		97403	13218E0056-3
14	6	4730-00-196-2055	96906	MS5 1953-25B
14	7	4730-00-253-4412	96906	MS39230-2
14	8	4730-01-235-5781	96906	MS5 1887-10
14	9	4820-01-225-8260	19243	3500-1/2
14	10	4730-01-223-3756	81348	WW-P-471 BDQAAED
14	11	4730-00-196-1543	96906	MS5 1953-60
14	12	4820-00-287-4268	96906	MS35784-2
14	13	4820-01-225-8254	58818	P7510S
14	14		55921	OFC252
15	1	4720-01-204-8374	55921	VR318
15	2		81348	GG-G-91TYPE3STYL E2

\*U.S. GOVERNMENT PRINTING OFFICE: 1993 - 755-028/80293



By Order of the Secretary of the Army:

**CARL E. VUONO**  
*General, United States Army*  
*Chief of Staff*

OFFICIAL:

**WILLIAM J. MEEHAN, II**  
*Brigadier General, United States Army*  
*The Adjutant General*

DISTRIBUTION:

To be printed in accordance with DA Form 12-25A, Unit, Intermediate Direct Support and Intermediate General Support Maintenance requirements for Compressor Unit, Model E23CV.

RECOMMENDED CHANGES TO EQUIPMENT TECHNICAL PUBLICATIONS

 <p style="text-align: center;"><i>THEN...JOT DOWN THE DOPE ABOUT IT ON THIS FORM. CAREFULLY TEAR IT OUT, FOLD IT AND DROP IT IN THE MAIL.</i></p>		SOMETHING WRONG WITH PUBLICATION		
		FROM: (PRINT YOUR UNIT'S COMPLETE ADDRESS)		
PUBLICATION NUMBER		DATE SENT		
PUBLICATION DATE		PUBLICATION TITLE		
BE EXACT PIN-POINT WHERE IT IS				
PAGE NO.	PARA-GRAPH	FIGURE NO.	TABLE NO.	<p style="text-align: center; font-weight: bold;">IN THIS SPACE, TELL WHAT IS WRONG AND WHAT SHOULD BE DONE ABOUT IT.</p>
PRINTED NAME, GRADE OR TITLE AND TELEPHONE NUMBER			SIGN HERE	

# The Metric System and Equivalents

## Linear Measure

1 centimeter = 10 millimeters = .39 inch  
 1 decimeter = 10 centimeters = 3.94 inches  
 1 meter = 10 decimeters = 39.37 inches  
 1 dekameter = 10 meters = 32.8 feet  
 1 hectometer = 10 dekameters = 328.08 feet

1 centiliter = 10 milliliters = .34 fl. ounce  
 1 deciliter = 10 centiliters = 3.38 fl. ounces  
 1 liter = 10 deciliters = 33.81 fl. ounces  
 1 dekaliter = 10 liters = 2.64 gallons  
 1 hectoliter = 10 dekaliters = 26.42 gallons  
 1 kiloliter = 10 hectoliters = 264.18 gallons  
 1 kilometer = 10 hectometers = 3,280.8 feet

## Square Measure

1 centigram = 10 milligrams = .15 grain  
 1 decigram = 10 centigrams = 1.54 grains  
 1 gram = 10 decigrams = .035 ounce  
 1 decagram = 10 grams = .35 ounce  
 1 hectogram = 10 decagrams = 3.52 ounces

1 sq. centimeter = 100 sq. millimeters = .155 sq. inch  
 1 sq. decimeter = 100 sq. centimeters = 15.5 sq. inches  
 1 sq. meter (centare) = 100 sq. decimeters = 10.76 sq. feet  
 1 sq. dekameter (are) = 100 sq. meters = 1,076.4 sq. feet  
 1 sq. hectometer (hectare) = 100 sq. dekameters = 2.47 acres  
 1 sq. kilometer = 100 sq. hectometers = .386 sq. mile  
 1 kilogram = 10 hectograms = 2.2 pounds

## Cubic Measure

1 quintal = 100 kilograms = 220.46 pounds

1 metric ton = 10 quintals = 1.1 short tons  
 1 cu. centimeter = 1000 cu. millimeters = .06 cu. inch  
 1 cu. decimeter = 1000 cu. centimeters = 61.02 cu. inches  
 1 cu. meter = 1000 cu. decimeters = 35.31 cu. feet

## Approximate Conversion Factors

To change	To	Multiply by	To change	To	Multiply by
inches	centimeters	2.540	ounce-inches	Newton-meters	
feet	meters		.305 centimeters	inches	
yards	meters		.914 meters	feet	
miles	kilometers		1.609 meters	yards	
square inches	square centimeters		6.451 kilometers	miles	
square feet	square meters	.093	square centimeters	square inches	
square yards	square meters	.836	square meters	square feet	
square miles	square kilometers	2.590	square meters	square yards	
acres	square hectometers	.405	square kilometers	square miles	
cubic feet	cubic meters	.028	square hectometers	acres	
cubic yards	cubic meters	.765	cubic meters	cubic feet	
fluid ounces	milliliters	29,573	cubic meters	cubic yards	
pints	liters	.473	milliliters	fluid ounces	
quarts	liters	.946	liters	pints	
gallons	liters	3.785	liters	quarts	
ounces	grams	28.349	liters	gallons	
pounds	kilograms	.454	grams	ounces	
short tons	metric tons	.907	kilograms	pounds	
pound-feet	Newton-meters	1.356	metric tons	short tons	
			pound-inches	Newton-meters	

## Temperature (Exact)

°F Fahrenheit temperature  $\frac{5}{9}$  (after subtracting 32) Celsius temperature °C

**PIN: 060431-001**

This fine document...

Was brought to you by me:



## [Liberated Manuals -- free army and government manuals](#)

Why do I do it? I am tired of sleazy CD-ROM sellers, who take publicly available information, slap “watermarks” and other junk on it, and sell it. Those masters of search engine manipulation make sure that their sites that sell free information, come up first in search engines. They did not create it... They did not even scan it... Why should they get your money? Why are not letting you give those free manuals to your friends?

I am setting this document FREE. This document was made by the US Government and is NOT protected by Copyright. Feel free to share, republish, sell and so on.

I am not asking you for donations, fees or handouts. If you can, please provide a link to [liberatedmanuals.com](http://liberatedmanuals.com), so that free manuals come up first in search engines:

<A HREF=<http://www.liberatedmanuals.com/>>Free Military and Government Manuals</A>

- Sincerely  
Igor Chudov  
<http://igor.chudov.com/>
- [Chicago Machinery Movers](#)