

**OPERATOR'S, ORGANIZATIONAL,
DIRECT SUPPORT AND GENERAL
SUPPORT MAINTENANCE MANUAL**

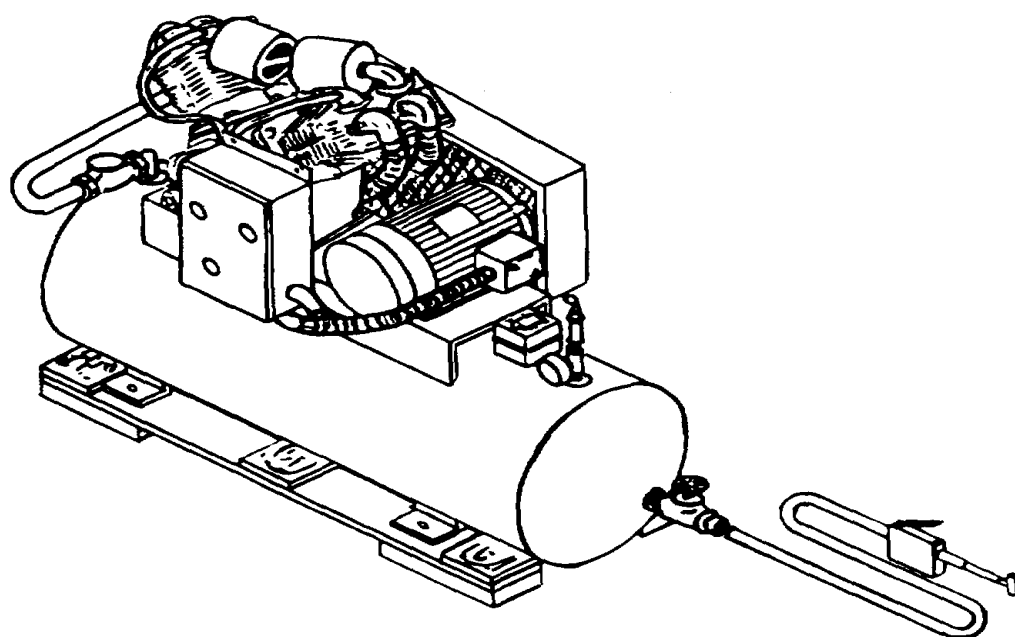

**COMPRESSOR UNIT,
RECIPROCATING
ELECTRIC
25 CFM, 175 PSI
(4310-01-090-5911)**

INTRODUCTION

**OPERATING
INSTRUCTIONS**

**OPERATION
MAINTENANCE
INSTRUCTIONS**

**ORGANIZATIONAL
MAINTENANCE**

**DIRECT AND
GENERAL
SUPPORT
MAINTENANCE**

**MAINTENANCE
PROCEDURES**

REFERENCE

INDEX

HEADQUARTERS, DEPARTMENT OF THE ARMY

11 MAY 1981

WARNING

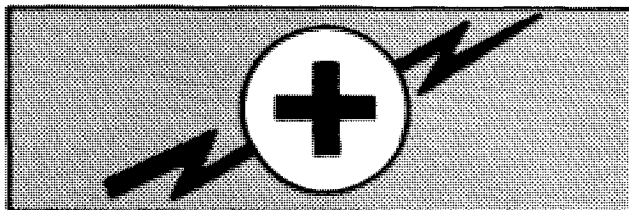

WARNING

Release pressure from air receiver and compressor pump before inspection, performing procedures, or disassembly of equipment to avoid personal injury.

WARNING

Disconnect compressor unit from main power supply before servicing, replacing or repairing parts of equipment, to avoid personal injury.

WARNING

Do not start or operate compressor unit with belt guard off, to avoid personal injury.

WARNING

Dry cleaning solvent, P-D-680, used to clean parts, is potentially dangerous to personnel and property. Use in a well ventilated area as the fumes are dangerous if inhaled. Avoid repeated and prolonged skin contact. Do not use near open flame or excessive heat. Flash point of solvent is 100°F 138°F. (38°C 59°C).

WARNING

Close globe valve tightly to avoid personal injury.

WARNING

Disconnect compressor unit from main power supply before performing check(s) or inspection, to avoid personal injury.

WARNING

Before you use this table, be sure that compressor unit has been disconnected from main power supply, to avoid personal injury.

WARNING

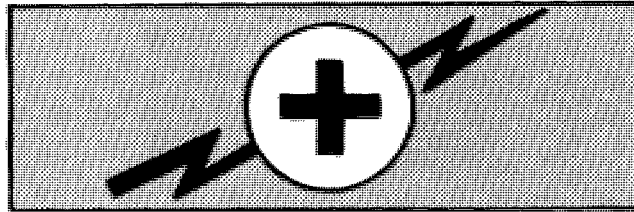

WARNING

Disconnect compressor unit from main power supply before moving compressor unit, to avoid personal injury.

WARNING

Use extreme caution during the following procedures as pressure switch carries an electrical charge which will cause personal injury.

WARNING

Use extreme caution during the following procedures, as adjusting of pressure switch will cause compressor unit to start up to pressurize air receiver.

WARNING

Power supply voltage, wire size, and fuses must meet specifications.

**OPERATOR, ORGANIZATIONAL, DIRECT SUPPORT
AND GENERAL SUPPORT MAINTENANCE MANUAL**

Compressor Unit, Reciprocating Electric
25 CFM 175 PSI Model 50-6717
NSN 4310-01-090-5911

REPORTING OF ERRORS

You can help improve this manual by calling attention to errors and by recommending improvements and stating your reasons for the recommendations. Your letter or DA Form 2028, Recommended Changes to Publications, should be mailed directly to US Army Troop Support and Aviation Material Readiness Command, Attn: DRSTS-MTT, 4300 Goodfellow Boulevard, St. Louis, MO 63120. A reply will be furnished to you.

TABLE OF CONTENTS

			Page(s)
CHAPTER	1	INTRODUCTION	1-1
Section	I	General Information	1-1
	II	Equipment Description	1-1
	III	Technical Principles of Operation.....	1-4
CHAPTER	2	OPERATING INSTRUCTIONS	2-1
Section	I	Description and Use of Operator's Controls and Indicators	2-1
	II	<u>Operator/Crew Preventive Maintenance Checks and Services (PMCS)</u>	2-1
	III	Operation under Usual Conditions.....	2-4
	IV	Operation under Unusual Conditions	2-5
CHAPTER	3	<u>OPERATION MAINTENANCE INSTRUCTIONS</u>	3-1
Section	I	Lubrication Instructions	3-1
	II	Operator/Crew Troubleshooting.....	3-3
	III	Maintenance Procedures.....	3-8

TABLE OF CONTENTS (Cont'd)

		Page(s)
CHAPTER	4	<u>ORGANIZATIONAL MAINTENANCE</u> 4-1
Section	I	Preparation for Storage or Shipment 4-1
	II	Organizational Troubleshooting..... 4-2
	III	Maintenance Procedures..... 4-7
CHAPTER	5	<u>DIRECT AND GENERAL SUPPORT MAINTENANCE</u> 5-1
Section	I	Direct and General Support Troubleshooting 5-1
	II	<u>Maintenance Procedures</u> 5-10
APPENDIX	A	REFERENCES A-1
	B	MAINTENANCE ALLOCATION CHART..... B-1
	C	COMPONENTS OF END ITEMS LIST..... C-1
	D	ADDITIONAL AUTHORIZATION LIST..... D-1
	E	EXPENDABLE SUPPLIES AND MATERIALS LIST..... E-1
INDEX		I-1

CHAPTER 1

INTRODUCTION

Section I. GENERAL INFORMATION

1-1. SCOPE. Type of Manual: Operator's, Organizational, Direct and General Support Maintenance for Eclipse Reciprocating Compressor Unit Model 50-6717.

1-2. MAINTENANCE FORMS AND RECORDS. The Department of the Army forms and procedures used for equipment maintenance will be those prescribed by TM 38-750, the Army Maintenance Management System (TAMMS).

1-3. REPORTING EQUIPMENT IMPROVEMENT RECOMMENDATIONS (EIR'S). The EIR'S can and must be submitted by anyone who is aware of an unsatisfactory condition with equipment design or use. It is not necessary to show a new design or list a better way to perform a procedure, just simply tell why the design is unfavorable or why a procedure is difficult. EIR's may be submitted on SF 368 (Quality Deficiency Report). Mail EIR's directly to: Commander, USATSARCOM, ATTN: DRSTS-MEM, 4300 Goodfellow Boulevard, St. Louis, MO 63120. A reply will be furnished to you.

1-4. DESTRUCTION OF ARMY MATERIAL TO PREVENT ENEMY USE. For general destruction procedures for the compressor, refer to TM 750-244-3 (Procedures for Destruction of Equipment to Prevent Enemy Use).

1-5. HAND RECEIPT MANUAL. Hand receipts for the End Item/Components of End Item (COEI), Basic Issue Items (BII), and Additional Authorization List (AAL) items are published in a Hand Receipt Manual. The Hand Receipt Manual numerical designation is the same as the related Technical Manual with letters HR added to the number. These manuals are published to aid in property accountability and are available through: Commander, US Army Adjutant General Publication Center, ATTN: AGDL-OD, 1665 Woodson Road, St. Louis, MO 63114.

1-6. PREPARATION FOR STORAGE AND SHIPMENT. Administrative storage of the Air Compressor shall conform generally with the provisions of TM 740-90-1, Administrative Storage of Equipment.

Section II. EQUIPMENT DESCRIPTION

1-7. DESCRIPTION. The Eclipse Reciprocating Compressor Unit, Model 50-6717 is a stationary compressor unit intended for use as a source of compressed air in the normal operations conducted at filling stations and vehicle maintenance shops. The major components, indicators, safety apparatus, and essential operating items are shown in Figure 1-1.

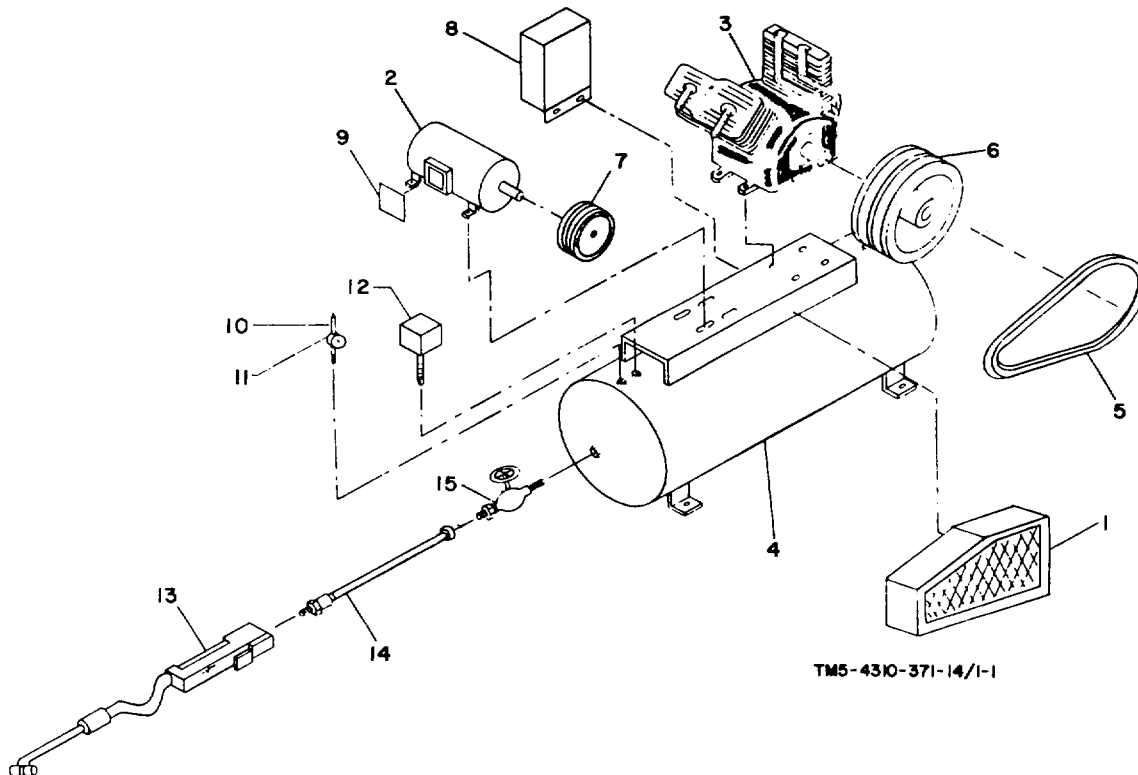

TM5-4310-371-14/1-1

- | | | |
|--------------------|-----------------------|------------------------|
| 1. Belt Guard | 6. Flywheel | 11. Pressure Gage |
| 2. Motor | 7. Motor Pulley | 12. Pressure Switch |
| 3. Compressor Pump | 8. Starter Switch | 13. Inflator Gage |
| 4. Air Receiver | 9. Junction Box Cover | 14. Inflator Gage Hose |
| 5. "V" Belts | 10. Safety Valve | 15. Globe Valve |

FIGURE 1-1. COMPONENT IDENTIFICATION

1-8. PERFORMANCE DATA.

a. Major Identification Plates

- (1) The manufacturer's plate(s) located on the rear of the air receiver mounting bracket below compressor pump and includes serial number, contract number, type of compressor, CFM/PSI, manufacturer FSCM, model number, and date of manufacture, and National Stock Number.
- (2) The motor plate located on the side of body of the motor denotes make, model, frame size, h.p., rpm., ft. lbs. of torque, full load current and serial #.

(3) The Air Receiver Plate is located on the air receiver and lists manufacturer's name, National Board Number, model number, year of manufacture, and working pressure.

b. Tabulated Data, Operator Maintenance

WEIGHTS AND DIMENSIONS

Weight	830 lbs. (376 kg)
Length, Overall	66 in. (167.6 cm)
Width, Overall.....	23 in. (58.4 cm)
Height, Overall.....	46 in. (116.8 cm)

CAPACITIES, OIL/GREASE

Compressor Crankcase.....	4 qts. (3.781 l)
Motor Crankcase	as required

c. Tabulated Data, Organizational Maintenance

COMPONENT WEIGHTS

Motor	120 lbs. (54.3 kg)
Compressor Pump	248 lbs. (112.4 kg)
Air Receiver.....	462 lbs. (209.3 kg)
Air Receiver Capacity.....	80 gal. (302.4 l)

d. Tabulated Data, Direct and General Support Maintenance Compressor Nut and Bolt Torque Data

Cylinder	470 in. lbs. (83,842 gr. cm)
Cylinder Stud Bolts	470 in. lbs. (83,942 gr. cm)
Connecting Rod Bolts	230 in. lbs. (41,078 gr. cm)
Bearing Housing Bolts.....	550 in. lbs. (98,230 gr. cm)
Flywheel to Crankshaft.....	600 in. lbs.(107,160 gr. cm)

e. Compressor Data

Manufacturer.....	Champion Pneumatic Machinery Co.
Model.....	R-30B
Type	Two Stage, Two Stroke
Capacity Free Air	34.40 cfm (0.974 m ³ /m)
Speed.....	765 rpm
Displacement.....	44.6 cfm (1.263 m ³ /m)
Number of Cylinders	4
Bore and Stroke.....	4 5/8 in. (2) & 2 1/2 in. (2) x 3 in. (11.75mm & 6.35mm x 7.62mm)
Maximum Working Pressure.....	200 PSI (1380 KPa)
Rotation	Counter Clockwise

Section III. TECHNICAL PRINCIPLES OF OPERATION

1-9. MAJOR COMPONENTS (Figure 1-1)

- a. Belt Guard (Item 1) Protects operator from flywheel and motor pulley and from V belts if they should break.
- b. Motor (Item 2) Drives compressor pump.
- c. Compressor Pump (Item 3) Pumps air into air receiver at required pressure.
- d. Air Receiver (Item 4) Receives and stores air at required pressure for use with shop equipment.

1-10. MINOR COMPONENTS AND ACCESSORIES (Figure 1-1).

- e. "V" Belts (Item 5) Connects motor to compressor pump to drive same.
- f. Flywheel (Item 6) Receives belts from motor to drive compressor pump.
- g. Motor Pulley (Item 7) Receives V belts from compressor pump to drive same.
- h. Starter Switch (Item 8) Starts and stops unit.
- j. Junction Box Cover (Item 9) Covers motor electrical leads.
- k. Safety Valve (Item 10) Releases air from air receiver when there is too much pressure in air receiver.
- l. Pressure Gage (Item 11) Indicates air pressure in air receiver.
- m. Pressure Switch (Item 12) Activates motor to drive compressor pump when air pressure is required in air receiver.
- n. Inflator Gage (Item 13) Indicates level of air pressure contained in air inflatable item.
- o. Inflator Gage Hose (Item 14) Connects inflator gage to globe valve.
- p. Globe Valve (Item 15) Closes off air supply to inflator gage.

CHAPTER 2
OPERATING INSTRUCTIONS

Section I. DESCRIPTION AND USE OF OPERATOR'S CONTROLS AND INDICATORS

2-1. OPERATOR CONTROLS:

- a. Air Receiver Drain - Screw type valve located on the bottom of air receiver, used to drain condensation build-up from air receiver. (See figure 2-1, item 1.)
- b. Globe Valve - Screw type valve with handle located at motor end of air receiver, which turns air flow on and off to inflator gage. (See figure 2-1, item 2.)
- c. Starter Switch - Push button type mounted to the air receiver mounting bracket, used to stop and start motor. (See figure 2-1, item 5.)

2-2. OPERATOR INDICATORS:

- a. Visible Sight Oil Level Gage - Small round clear disc with oil level line on the face. It is located on the rear of compressor pump body near the bottom and indicates oil level. (See figure 2-1, item 6.)
- b. Pressure Gage - Clear face dial on air receiver next to motor. It indicates air pressure in the air receiver. (See figure 2-1, item 3.)
- c. Safety Valve - A brass pressure release valve located on the air receiver next to the compressor pump. Its function is to allow air pressure to escape from the air receiver, i.e., unit malfunctions. (See figure 2-1, item 4.)

Section II. OPERATOR/CREW PREVENTIVE MAINTENANCE CHECKS AND SERVICES (PMCS).

2-3. SCOPE.

- a. This section contains preventive checks and services for the safe and efficient use of the compressor unit. Each item to be inspected is followed by a check(s) which should be performed prior to the starting and use of the compressor unit. The interval required for said check(s) is also indicated. The compressor unit will be reported not ready/available when any check has found any of the inspected items to be loose, damaged, or missing.

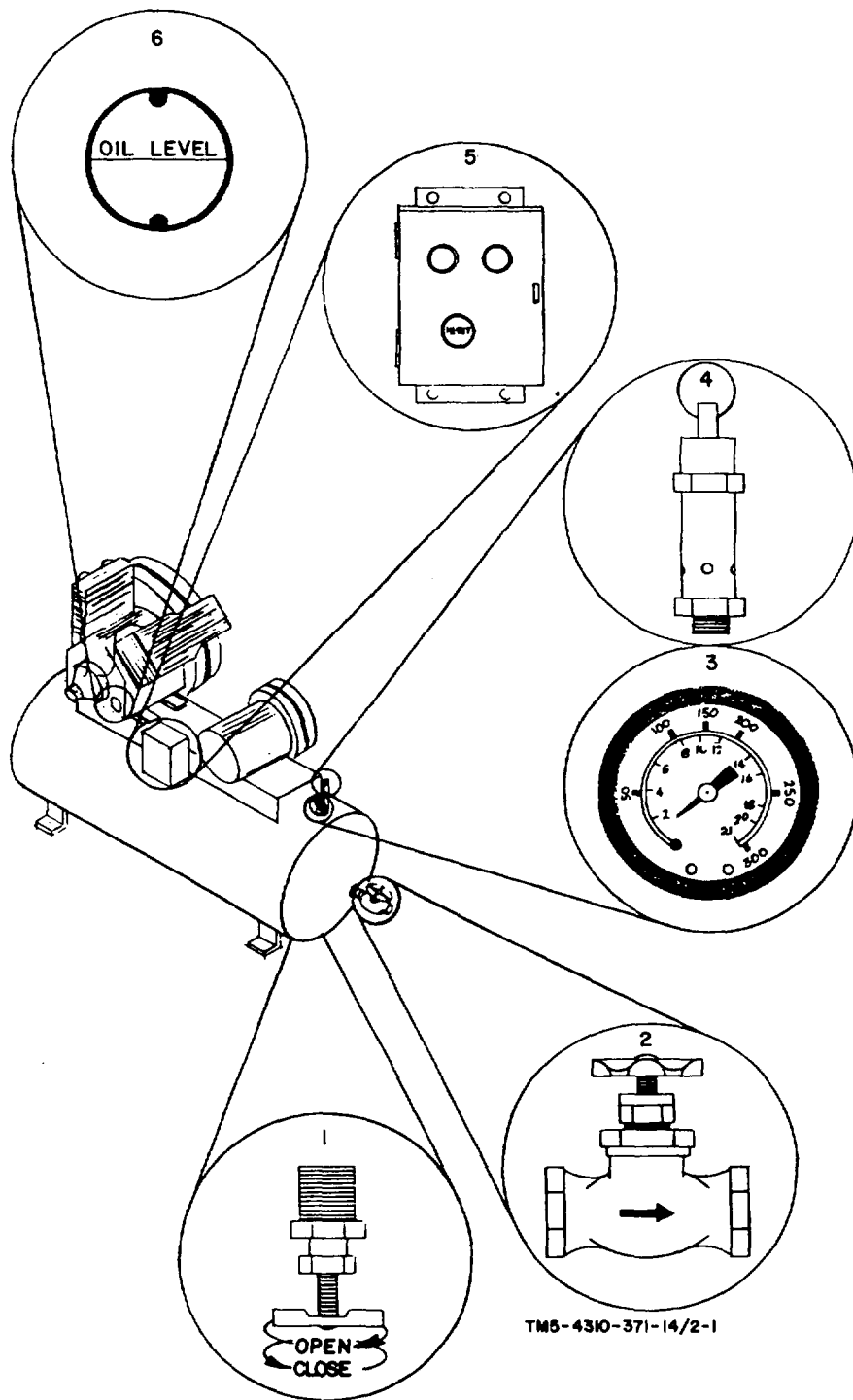

TM5-4310-371-14/2-1

- | | | |
|-----------------------|------------------|---------------------------------|
| 1. Air Receiver Drain | 3. Pressure Gage | 5. Starter Switch |
| 2. Globe Valve | 4. Safety Valve | 6. Visible Sight Oil Level Gage |

FIGURE 2-1. OPERATORS CONTROLS AND INDICATORS

- b. This manual cannot list all possible items to be checked. If any other item appears to be in a not ready condition, refer same to next higher level of maintenance (see APP. B) for servicing.
- c. Table 2-1 lists the common items and checks you will need to operate compressor unit. You should perform these checks and/or services in the order listed.

WARNING

Before you use this table, be sure that compressor unit has been disconnected from main power supply, to avoid personal injury.

TABLE 2-1. OPERATOR/CREW PREVENTIVE CHECKS AND SERVICES

B-Before D-During A-After W-Weekly M-Monthly

Item	Interval					Item to be Inspected	Procedures: Check for and have repaired, or adjusted, as necessary	For readiness reporting, equipment is not ready/available if:
	B	D	A	W	M			
1	•			•		V belts.	There should be no more than 1/2" of play in the V belts. To tighten, loosen four (4) motor mount nuts and slide motor back until V belts are taut.	
2	•					Starter Switch	Check for any loose wires or nuts and bolts. Check to see if switch is loose.	Check finds any loose hardware or wires.
3	•	•				Compressor Pump	Check for any loose connections or nuts and bolts.	Check finds any loose connections.
4	•			•		Air Receiver	Check for any damage to Air Receiver or its components.	If any damage found creates an air leak.
5	•		•			Globe Valve	Check to see that globe valve turns freely.	
6		•				Inflator Gage Hose	Check for air leaks in inflator gage hose or its connections.	Large air leak is found.

TABLE 2-1. OPERATOR/CREW PREVENTIVE CHECKS AND SERVICES (Cont'd)

Item	Interval					Item to be Inspected	Procedures: Check for and have repaired, or adjusted, as necessary	For readiness reporting, equipment is not ready/available if:
	B	D	A	W	M			
7	•	•				Inflator Gage	Check for damage to inflator gage.	If damage is such that it interferes with the proper working or measuring of air.
8		•				Pressure Gage	Check air pressure. Pressure should not exceed 195 PSI (1350 KPa).	Pressure exceeds 195 PSI (1350 KPa).
9	•					Air Receiver Drain	Check to make sure air receiver drain is tightly closed.	Air receiver drain is missing or drain will not close.
10	•		•	•		Visible Sight Oil Level Gage	Check to see that oil has been filled to level shown on visible sight oil level gage.	Oil is below proper level.
11		•				Safety Valve	Check to make sure safety valve is tight and is not releasing air constantly.	Safety valve is not functioning properly.

Section III. OPERATION UNDER USUAL CONDITIONS

2-4. INSPECTION AND SERVICING PRIOR TO OPERATION.

- a. Inspection. You should inspect the entire compressor unit for signs of damage, missing, or loose hardware, or any faults that may have occurred during shipment. Report all faults to your supervisor.
- b. Servicing. Perform all the preventive maintenance services listed in Table 2-1, fill compressor pump with oil as described in Chapter 3, Section I.
- c. Check oil level in compressor pump at visible sight oil level gage to make sure compressor pump will have proper lubrication during operation.
- d. Test all inflator gage hose connections to prevent air leaks during operation.
- e. Check all pipe connections by twisting and shaking with hands to check for any looseness which could cause air leaks.
- f. Check for any loose screws, nuts, or bolts, as they may present hazards during operation.

2-5. COMPRESSOR UNIT PREPARATION PRIOR TO OPERATION.

- a. Release all the air receiver pressure by first turning the globe valve, counter clockwise, to the open position (see figure 2-1, item 2) and then depressing the inflator gage handle.
- b. Drain the air receiver of all its water by turning the air receiver drain counter clockwise, to the open position (see figure 2-1, item 1). When all the water has drained out, close air receiver drain clockwise, until air receiver drain is in the closed position (see figure 2-1, item 1).

2-6. OPERATION OF COMPRESSOR UNIT.

- a. To start compressor unit, press the black button on the starter switch marked "START". As the air receiver pressure increases, check for air leaks. An air leak can be found by a hissing sound which is the air escaping rapidly from a malfunctioning joint or part. In case of such a leak, immediately shut compressor unit off by pressing the red button marked "STOP" on the starter switch and advise next higher level of maintenance.
- b. Note, that once compressor unit has pumped air pressure up to maximum operating pressure of 195 PSI (1350 KPa), compressor unit will shut off until operating point of falling pressure reaches 175 PSI (1210 KPa) when compressor unit will again begin pumping air.
- c. To stop compressor unit for total shutdown or repairs, press red button on starter switch marked "STOP".

Section IV. OPERATION UNDER UNUSUAL CONDITIONS

2-7. OPERATION in EXTREME COLD (0°F - 18°F).

- a. Select the correct lubricants for the expected air temperatures as indicated on the lubricant chart.
- b. Drain condensation from air receiver prior to shutdown while unit is still warm.
- c. When possible, install the compressor unit in a properly protected shelter. Protect motor and magnetic starter from ice and snow.

2-8. OPERATION in EXTREME HEAT.

- a. Locate the compressor unit in a well ventilated area that will allow maximum amount of air to circulate through motor and compressor.
- b. Check oil levels frequently. Fill if necessary.
- c. Keep outside of motor and compressor clean. Dirt acts as an insulator which prevents heat from escaping into the air.

2-9. OPERATION IN DUSTY OR SANDY AREAS.

- a. Protect the compressor unit from dust and sand as much as possible. Cleanliness is important to proper cooling.
- b. Check air cleaners on the compressor frequently; clean or replace as required.
- c. When adding or changing oil, remove dirt from around openings. Keep oil containers covered, dust-free and tight.

2-10. OPERATION UNDER RAINY OR MOIST CONDITIONS.

- a. High humidity and rainy weather conditions can cause deterioration of exposed metal parts.
- b. Do not operate compressor unit outside while it is raining. Make every effort to protect the motor and magnetic starter from the elements.
- c. Drain air receiver frequently of all condensation.
- d. If the compressor is not to be used for a period of time, either move it to a shelter or protect it by covering with a tarpaulin.

2-11. OPERATION in SALT WATER AREAS.

- a. The deterioration and corrosion of exposed metal is greatly accelerated in salt water areas. All parts of the unit should be wiped dry whenever the unit is shutdown.
- b. If the compressor unit is not to be used a long period of time, apply an approved preservative to all exposed metal parts.

2-12. OPERATION AT HIGH ALTITUDES.

- a. A decrease in compressor efficiency will be observed at high altitudes. Less air is drawn into the cylinders.
- b. Service the air filters on compressor daily to assure maximum air intake.
- c. Check belt tension daily to assure maximum transfer of power from electric motor to compressor.

CHAPTER 3
OPERATION MAINTENANCE INSTRUCTIONS

Section I. LUBRICATION INSTRUCTIONS

WARNING

Disconnect compressor unit from main power supply before servicing, replacing, or repairing parts of equipment, to avoid personal injury.

NOTE

Drain compressor pump oil only when compressor unit has operated for an hour or more.

3-1. COMPRESSOR PUMP LUBRICATION.

- a. Remove oil drain cap by turning it counter clockwise. (See figure 3-1.)
- b. When oil stops running out, oil has been drained.
- c. Replace oil drain cap and tighten. (See figure 3-1.)
- d. Remove oil filler plug by turning it counter clockwise. (See figure 3-1.)
- e. Fill crankcase until oil level reaches proper level as shown on the Visible Sight Oil Level Gage in Figure 3-1. (Do not overfill.)
- f. Use MIL-L-12104, single weight oil-(See figure 3-1 (Lubrication Chart) for proper grade of oil.)
- g. Replace oil filler plug and tighten. (Figure 3-1.)

3-2. MOTOR LUBRICATION WARNING

WARNING

Disconnect compressor unit from main power supply before servicing, replacing, or repairing parts of equipment, to avoid personal injury.

- a. The motor has sufficient grease to last indefinitely under usual operating conditions.

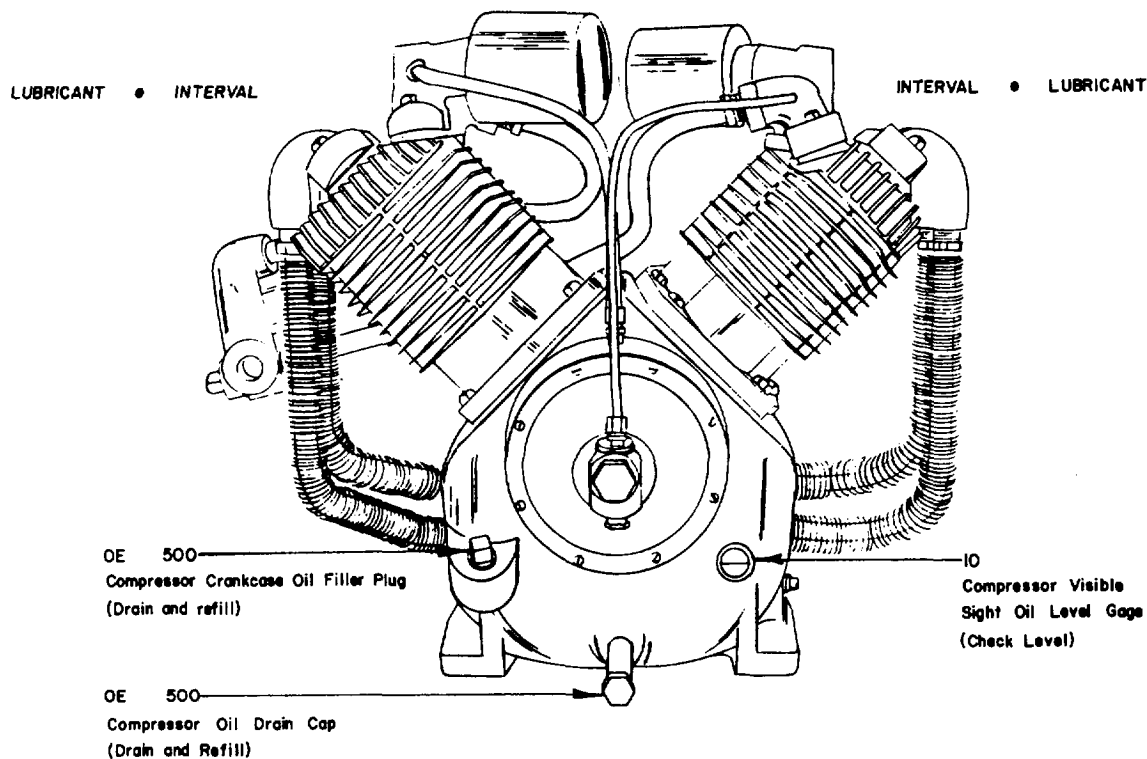

KEY

LUBRICANTS	CAPACITY	EXPECTED TEMPERATURES			INTERVAL
		Above =+ 32° F	+ 40°F to -10° F	0°F to -65° F	
Compressor, Crankcase	4 qts	OE 30	OE 10	OES	Intervals given are in hrs. of normal operation

NOTES:

1. For Operation in Protracted Cold Temperatures Below -- 10°F. Remove lubricants prescribed in the key for temperatures above -- 10°F. Relubricate with lubricants specified in the key for temperatures below -- 10°F.
2. Lubricants. The following is a list of lubricants with the Military Symbols and applicable specification numbers.

TM 5-4310-371-14/3-1

OE MIL-L-2104
 OES MIL-L-10295

FIGURE 3-1. LUBRICATION CHART

- b. Where motor is used constantly in very dirty, wet, or corrosive atmospheres, add one quarter ounce of grease for each of two bearings every three months.
- c. To grease motor, use standard grease gun, and grease at points shown in Figure 3-2.

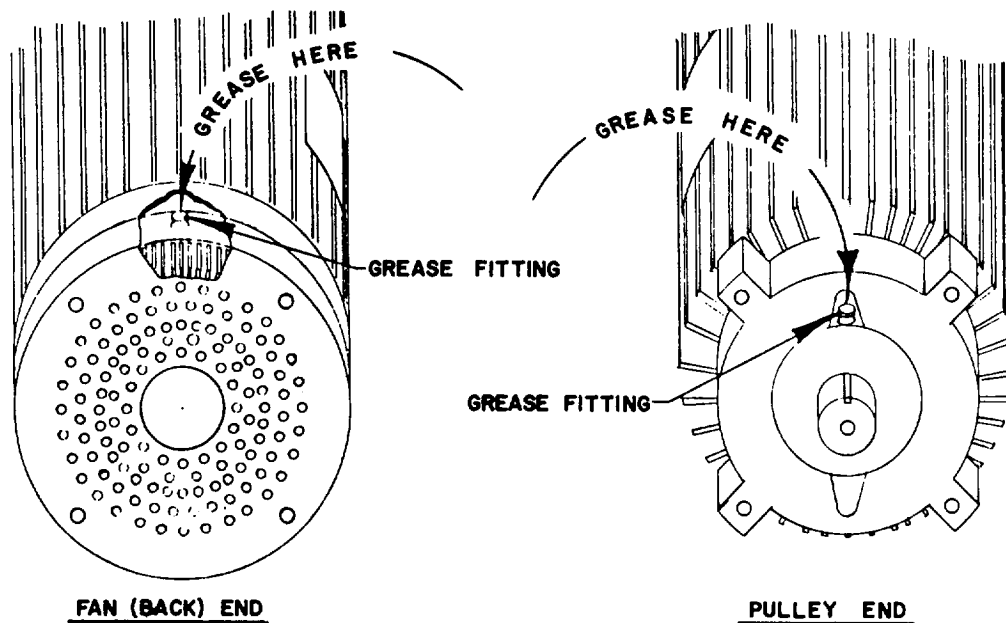

TM 5-4310-371-14/3-2

FIGURE 3-2. MOTOR LUBRICATION

Section II. OPERATOR/CREW TROUBLESHOOTING

3-3. SCOPE.

- a. This section contains troubleshooting or malfunction information and tests for locating and correcting most of the troubles which may develop in the compressor unit. Each malfunction or trouble symptom for an individual component, unit, or system is followed by a list of test or inspections necessary for you to determine probable causes and suggested corrective actions for you to remedy the malfunction.
- b. This manual cannot list all possible malfunctions that may occur or all tests or inspections, and corrective actions. If a malfunction is not listed or is not corrected by listed corrective actions, you should notify higher level maintenance.
- c. Table 3-1. Lists the common malfunctions that you may find during the operation or maintenance of compressor unit or its components. You should perform the test, inspections and corrective actions in the order listed.

NOTE

Before you use this table, be sure you have performed all applicable operating checks.

TABLE 3-1. OPERATOR/CREW TROUBLESHOOTING

MALFUNCTION

TEST OR INSPECTION

CORRECTIVE ACTION

1. NO AIR COMING OUT OF INFLATOR GAGE

WARNING

Disconnect compressor unit from main power supply before servicing, replacing or repairing parts of equipment, to avoid personal injury.

Step 1. Check to be sure inflator gage hose is connected to globe valve.

Refer problems to higher level of maintenance. (See Appendix B)

Step 2. Make sure globe valve is opened.

Turn globe valve to open position by turning handle counter clockwise until it stops.

2. NO PRESSURE IN AIR RECEIVER

Step 1. Check level of air pressure in air receiver on pressure gage, it should not be less than 175 PSI (1210 KPa).

If air pressure is less than 175 PSI, (1210 KPa) tighten all connections.

Step 2. Check connections and safety valve for air leaks.

Tighten any leaking connections and safety valve.

Step 3. Check air receiver drain to make sure it is closed.

Close air receiver drain tightly. If open, a loud noise from air escaping will be heard.

3. WATER IN INFLATOR GAGE HOSE OR INFLATOR GAGE.

Step 1. Check to see if there are any loose hose connections and if inflator gage hose or inflator gage are lying in water.

Drain air receiver of water as described in Chapter 3, Section III, Para 3-5, and remove inflator gage hose or inflator gage from water.

TABLE 3-1. OPERATOR/CREW TROUBLESHOOTING (Cont'd)

MALFUNCTION	TEST OR INSPECTION	CORRECTIVE ACTION
-------------	--------------------	-------------------

4. COMPRESSOR UNIT WILL NOT START

WARNING

Disconnect compressor unit from main power supply before servicing, replacing or repairing parts of equipment, to avoid personal injury.

Step 1. Check pressure gage for amount of pressure in air receiver as compressor unit will not come on until pressure is below 175 PSI (1210 KPa).

Tighten all electrical connections.

WARNING

Disconnect compressor unit from main power supply before performing check(s) or inspection, to avoid personal injury.

Step 2. If pressure is below 175 PSI (1210 KPa), check to make sure all wiring connections are tight.

Tighten pressure switch, located next to motor.

Step 3. Check to see that pressure switch is tight to air receiver.

If unit does not start, refer further service to higher level of maintenance. (See Appendix B)

5. MOTOR IS RUNNING, BUT COMPRESSOR PUMP IS NOT

WARNING

Disconnect compressor unit from main power supply before performing check(s) or inspection, to avoid personal injury.

Step 1. Check V Belts for slippage or looseness.

Tighten belts as described in Chapter 3, Section III, Para 3-4.

6. MOTOR OVERHEATS

Step 1. If compressor unit shuts down and motor is very hot to the touch of the hand.

TABLE 3-1. OPERATOR/CREW TROUBLESHOOTING (Cont'd)

MALFUNCTION	TEST OR INSPECTION	CORRECTIVE ACTION
-------------	--------------------	-------------------

Allow motor to cool until it is cool to the touch of the hand.

After motor has cooled, it will automatically reset itself and begin to operate again.

If cooled motor does not reset and operate, refer further service to higher level of maintenance. (See Appendix B)

7. V BELT BREAKAGE

WARNING

Disconnect compressor unit from main power supply before performing check(s) or inspection, to avoid personal injury.

Step 1. Check for frayed or broken V belts.

For V belt replacement, refer service to next higher level of maintenance. (See Appendix B)

Step 2. Check both flywheel and motor pulley to make sure they are secure to shafts and in line.

Step 3. Any misalignment of motor pulley and flywheel will cause excessive V belt wear and breakage.

8. OIL LEAKAGE

WARNING

Disconnect compressor unit from main power supply before performing check(s) or inspection, to avoid personal injury.

WARNING

Disconnect compressor unit from main power supply before servicing, replacing or repairing parts of equipment, to avoid personal injury.

Step 1. Check to see that oil filler plug and oil drain cap are in place and secure.

Wipe oil filler plug and oil drain cap areas clean of dirt and oil.

TABLE 3-1. OPERATOR/CREW TROUBLESHOOTING (Cont'd)

MALFUNCTION	TEST OR INSPECTION	CORRECTIVE ACTION
-------------	--------------------	-------------------

Tighten oil filler plug and oil drain cap.

Begin normal operation and check to see if leak persists. If it does, refer malfunction to higher level of maintenance. (See Appendix B)

9. AIR LEAKAGE

WARNING

Disconnect compressor unit from main power supply before performing check(s) or inspection, to avoid personal injury.

WARNING

Disconnect compressor unit from main power supply before servicing, replacing or repairing parts of equipment, to avoid personal injury.

Step 1. Check for and note location of leak.

If leak is present, refer malfunction to higher level of maintenance. (See Appendix B)

10. RESTRICTED AIR FLOW THROUGH AIR INLET FILTERS AND/OR PARTICLES IN INFLATOR GAGE HOSE OR INFLATOR GAGE

WARNING

Disconnect compressor unit from main power supply before performing check(s) or inspection, to avoid personal injury.

WARNING

Disconnect compressor unit from main power supply before servicing, replacing or repairing parts of equipment, to avoid personal injury.

Step 1. If compressor pump is running, but air receiver is receiving air slowly, check air inlet filters for build-up of dirt.

Step 2. If there is dirt or particles in inflator gage.

Refer malfunction to higher level of maintenance. (See Appendix B)

Section III. MAINTENANCE PROCEDURES

3-4. V BELTS ADJUSTMENT.

WARNING

Release pressure from air receiver and compressor pump before inspection, performing procedures, or disassembly of equipment to avoid personal injury.

- a. Remove belt guard front by turning belt guard fasteners one quarter turn (figure 3-3).
- b. Loosen motor mounting nuts and pull motor back until V belts become taut, as shown in figure 3-3. Proper V belt tension is when V belts can be deflected 3/8" to 1/2" midway between pulleys.
- c. With one hand holding motor in position, tighten motor mounting nuts, shown in figure 3-3.
- d. Replace belt guard front and tighten belt guard fasteners.

WARNING

Do not start or operate compressor unit with belt guard off, to avoid personal injury.

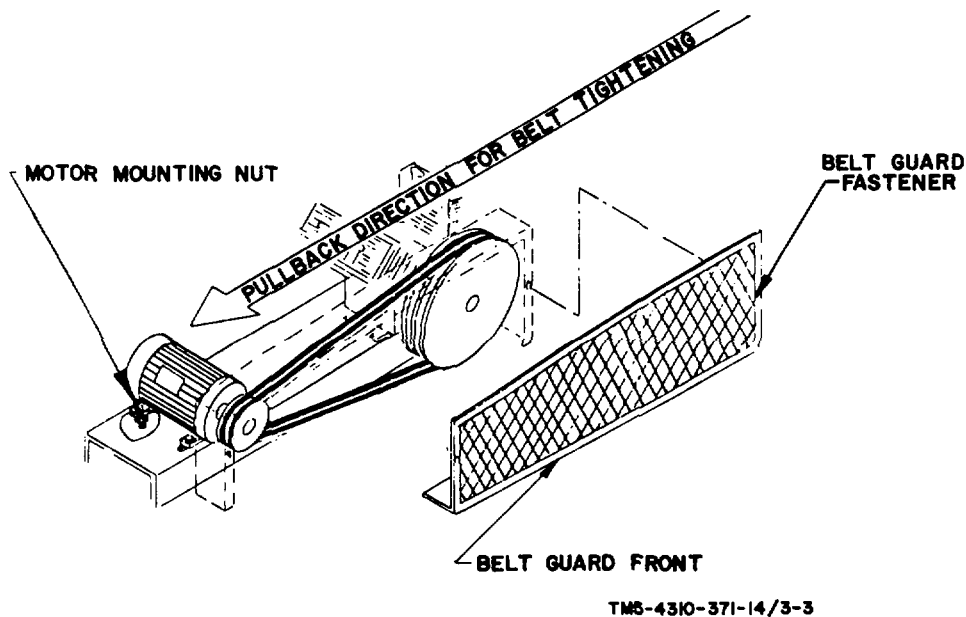

FIGURE 3-3. V BELT ADJUSTMENT

3-5. DAILY DRAINING OF AIR RECEIVER

WARNING

Disconnect compressor unit from main power supply before servicing, replacing, or repairing parts of equipment, to avoid personal injury.

WARNING

Release pressure from air receiver and compressor pump before inspection, performing procedures, or disassembly of equipment to avoid personal injury.

- a. To release the air receiver pressure, depress handle on inflator gage until all air is drained or pull safety pin ring on safety valve until all air escapes. See figure 3-4.
- b. Then turn air receiver drain counter clockwise until it stops. See figure 3-5.
- c. Water will then drain out of air receiver drain.
- d. When water is no longer running out, turn air receiver drain clockwise until it is tight.

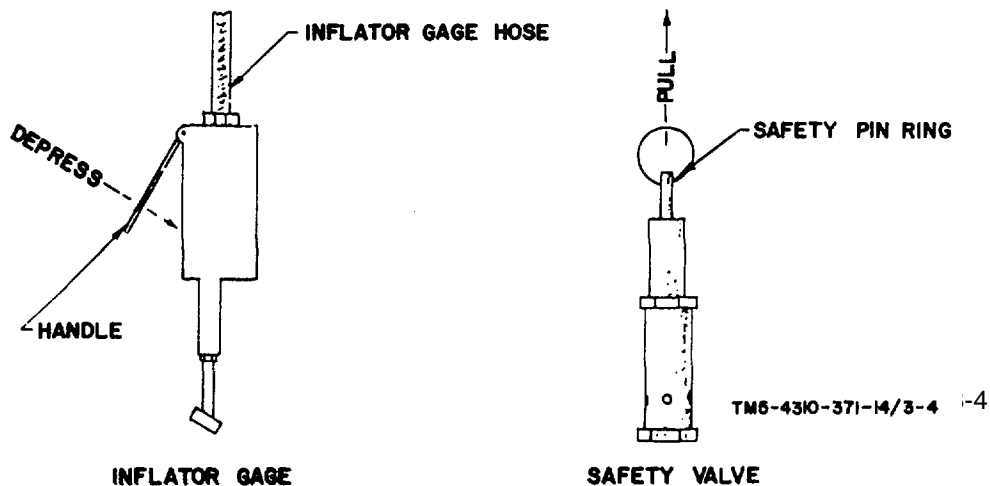

FIGURE 3-4. AIR RECEIVER AIR RELEASE

3-6. GLOBE VALVE USE

- a. Turns the air supply to inflator gage and inflator gage hose on and off.
- b. To turn globe valve ON, turn valve handle counter clockwise.
- c. To turn globe valve OFF, turn valve handle clockwise.
- d. See figure 3-6.

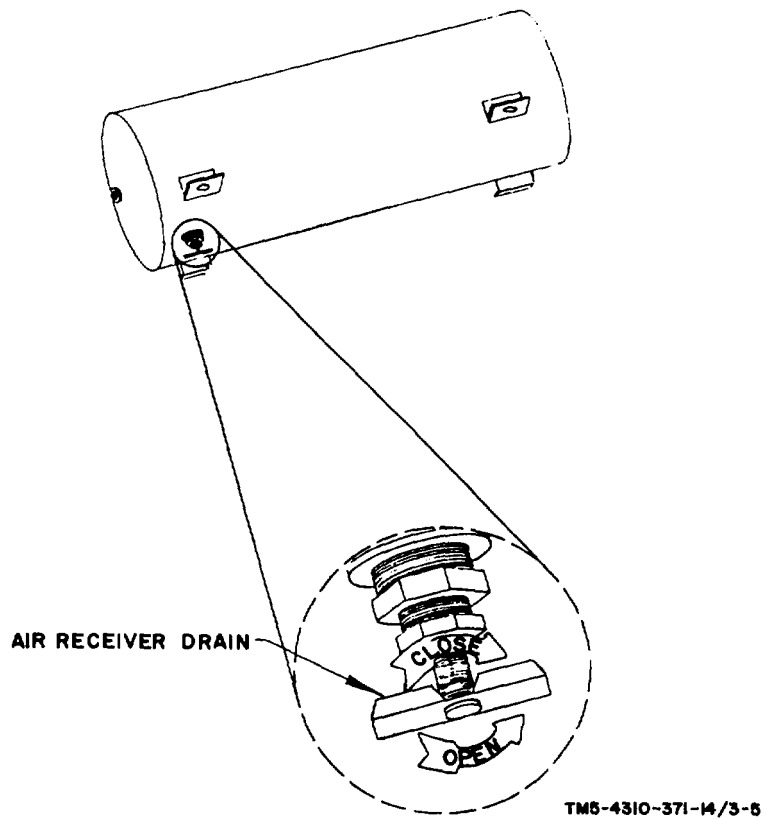

FIGURE 3-5. AIR RECEIVER DRAINING

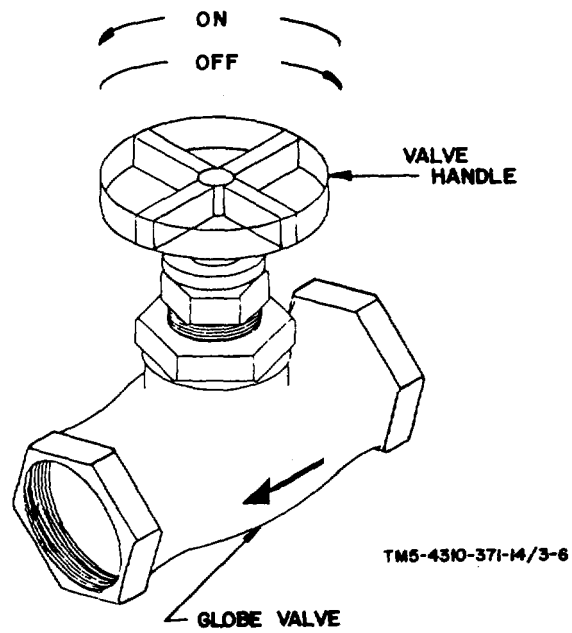

FIGURE 3-6. GLOBE VALVE USE

3-7. TIGHTENING OF INFLATOR GAGE HOSE CONNECTIONS.

- a. Turn globe valve OFF.
- b. Refer to higher level of maintenance. (See Appendix B)
- c. Turn globe valve ON.
- d. See figure 3-7.

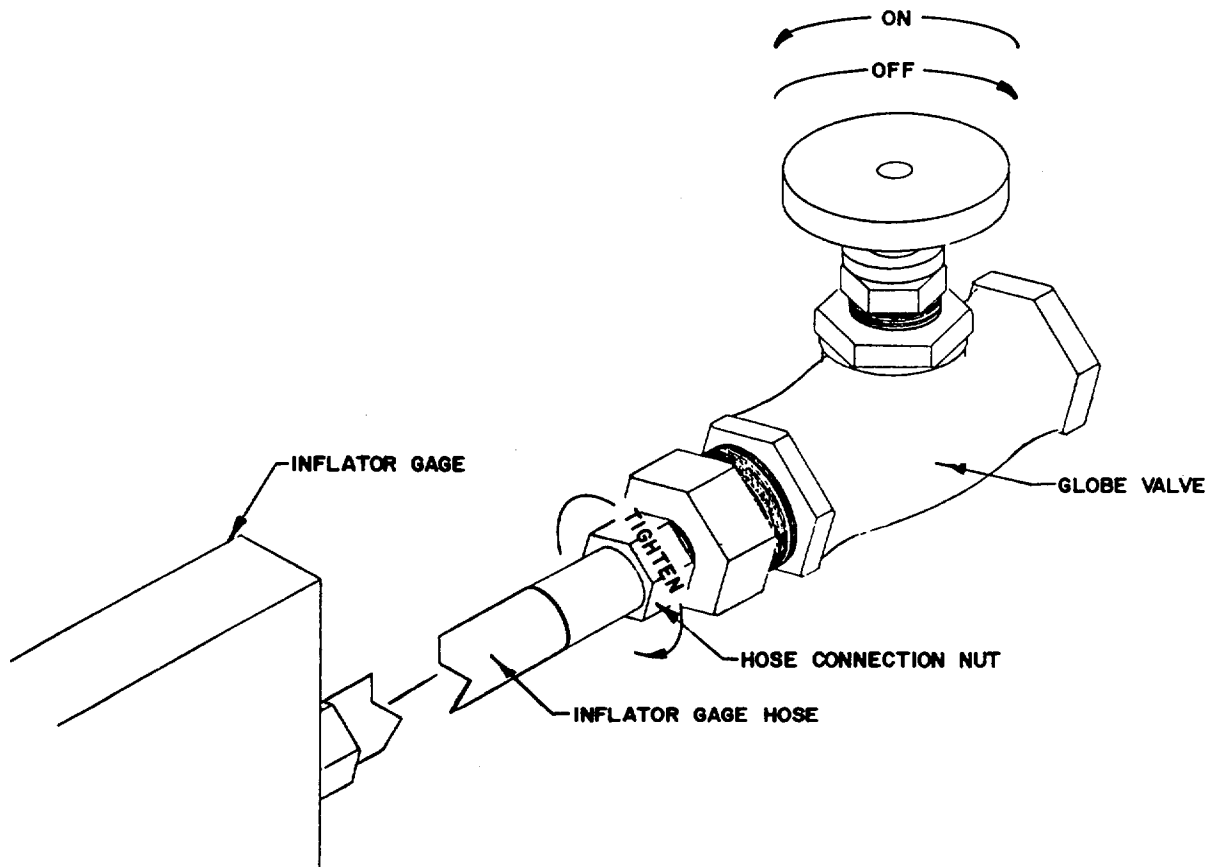

FIGURE 3-7. INFLATOR GAGE HOSE CONNECTION

3-8. CLEANING OR REPLACING OF AIR INLET FILTERS.

WARNING

Disconnect compressor unit from main power supply before servicing, replacing, or repairing parts of equipment, to avoid personal injury.

- a. Loosen slotted set screw, as shown in figure 3-8 and remove air inlet filter assembly.
- b. Open air inlet filter housing by removing housing screw and nut shown in figure 3-8.
- c. Remove foam filters and wash in warm water with ordinary soap.

CAUTION

Do not use any caustic cleaners as they may damage the foam filters.

- d. If filters will not get clean, become brittle or damaged, replace them.
- e. When filters are clean, remove excess water by using low pressure compressed air.
- f. Install filters into housing and screw housing back together.
- g. Place air inlet filters assembly back in intake manifold and tighten down the slotted set screw until muffler is secured firmly.

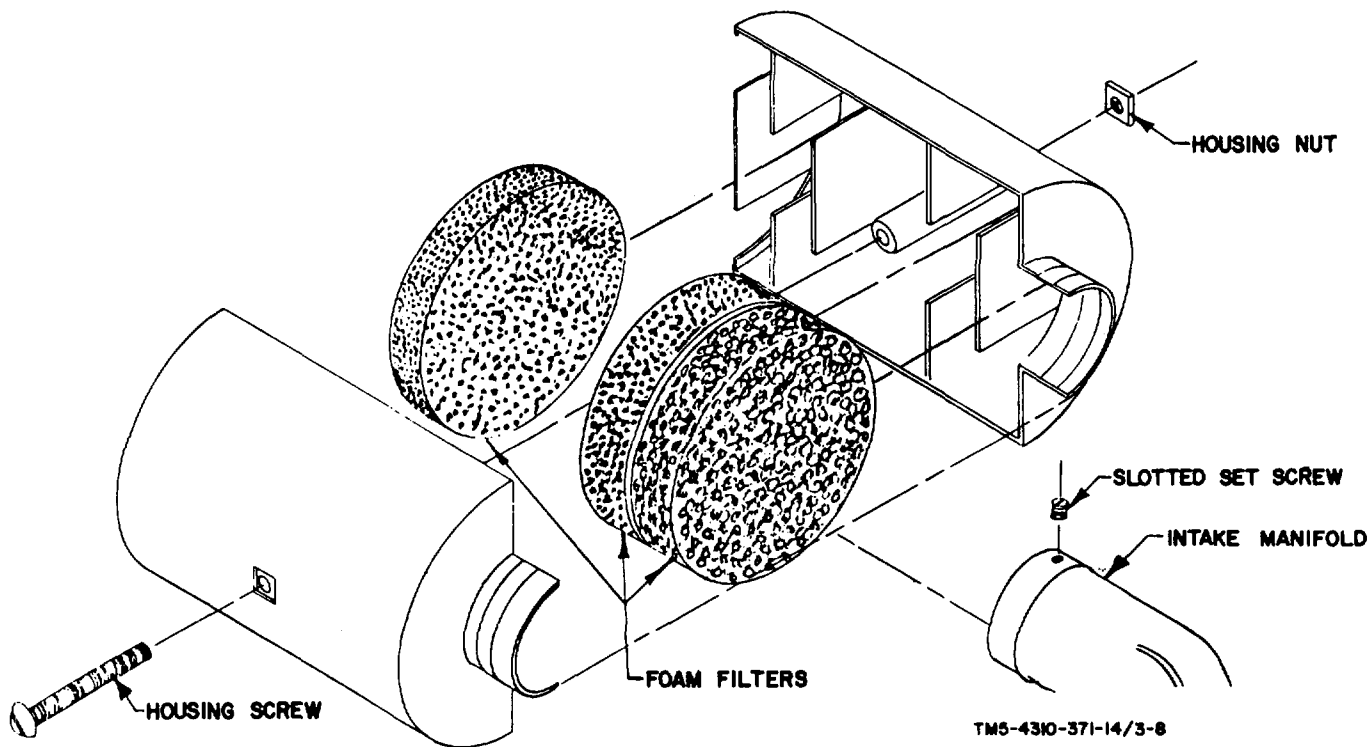

FIGURE 3-8. AIR INLET FILTER REPLACEMENT

CHAPTER 4
 ORGANIZATIONAL MAINTENANCE

Section I. PREPARATION FOR STORAGE OR SHIPMENT

4-1. UNLOADING AND UNPACKAGING. The total weight of the compressor unit is 830 pounds (376 kg). You must use a fork lift of 1000 pounds (453 kg) capacity to unload compressor unit. Keep compressor unit flat during the unloading operation. Before unpacking, place compressor unit in the location where it is to be installed. Remove the packaging material carefully so you do not damage the contents with the tools used for unpackaging.

4-2. INSTALLATION.

- a. Place in desired position, making sure to keep compressor unit level.
- b. For wiring instructions of starter switch and main power supply disconnect, see Figure 4-1. Wiring must be installed by a qualified electrician.

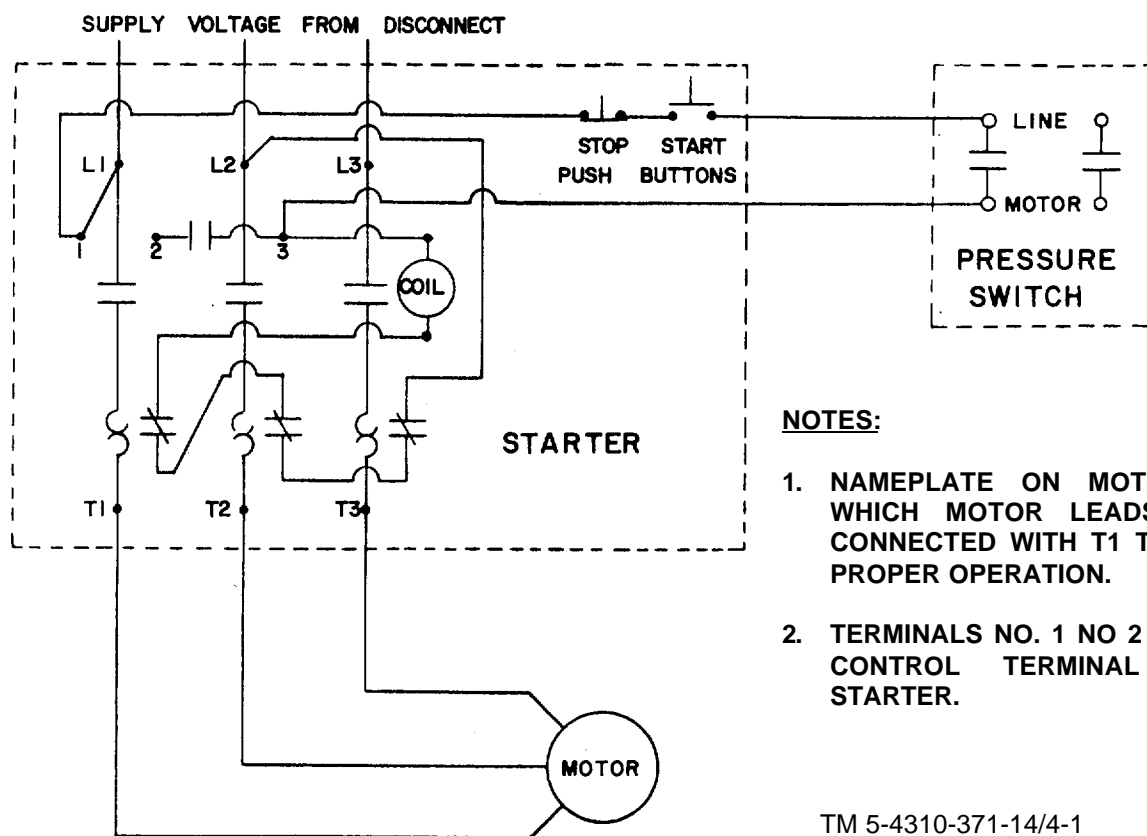

TM 5-4310-371-14/4-1

FIGURE 4-1. WIRING DIAGRAM

4-3. SHIPMENT AND/OR STORAGE PROCEDURES.

a. Shipment of Reciprocating Compressor Unit Procedures.**WARNING**

Release pressure from air receiver and compressor pump before disassembly of equipment, to avoid personal injury.

WARNING

Disconnect compressor unit from main power supply before moving of unit, to avoid personal injury.

- (1) Open air receiver drain and leave open after air receiver has been drained of water.
- (2) Disconnect inflator gage and inflator gage hose. Package in same manner as received.
- (3) Loosen V belts by loosening motor mounting nuts and slide motor towards compressor pump and tighten motor mounting nuts.
- (4) Pick up compressor unit with forklift of 1000 lbs. minimum capacity. Be sure to keep compressor unit level while moving it.
- (5) After compressor unit is placed on vehicle, which is to move it, tie compressor unit down securely and cover it with a tarpaulin to protect it from elements.

b. Storage of Reciprocating Compressor Unit

- (1) Release air pressure from air receiver and compressor pump before storage of equipment.
- (2) Disconnect inflator gage and inflator gage hose and package in same manner as received.
- (3) Open air receiver drain and leave it open.
- (4) Loosen V belts by loosening motor mounting nuts and push motor towards compressor pump and tighten motor mounting nuts.
- (5) Package compressor unit in same manner as received and be sure to store compressor unit in enclosed, dry area. Compressor unit should not, under any condition, be allowed to stand in or be submerged in water.

Section II. ORGANIZATIONAL TROUBLESHOOTING

4-4. SCOPE.

- a. This section contains troubleshooting or malfunction information and tests for locating and correcting most of the troubles which may develop in the

compressor unit. Each malfunction or trouble symptom for an individual component, unit, or system is followed by a list of tests or inspections necessary for you to determine probable causes and suggested correction actions for you to remedy the malfunction.

- b. This manual cannot list all possible malfunctions that may occur or all tests or inspections, and corrective actions. If a malfunction is not listed or is not corrected by listed corrective actions, you should notify higher level maintenance.
- c. Table 4-1, lists the common malfunctions that you may find during the operation or maintenance of compressor unit or its components. You should perform the test, inspections and corrective actions in the order listed.

NOTE

Before you use this table, be sure you have performed all applicable operating checks.

TABLE 4-1. ORGANIZATIONAL TROUBLESHOOTING

MALFUNCTION	TEST OR INSPECTION	CORRECTIVE ACTION
-------------	--------------------	-------------------

1. BROKEN V BELT

WARNING

Disconnect compressor unit from main power supply before performing check(s) or inspection, to avoid personal injury.

WARNING

Disconnect compressor unit from main power supply before servicing, replacing or repairing parts of equipment, to avoid personal injury.

Step 1. Check to see if one or both V belts are broken.

Install both V belts with new set of V belts even if only one V belt has broken as described in 4-4.

2. MOTOR INOPERATIVE

WARNING

Disconnect compressor unit from main power supply before performing check(s) or inspection, to avoid personal injury.

TABLE 4-1. ORGANIZATIONAL TROUBLESHOOTING (Cont'd)

MALFUNCTION	TEST OR INSPECTION	CORRECTIVE ACTION
-------------	--------------------	-------------------

WARNING

Disconnect compressor unit from main power supply before servicing, replacing or repairing parts of equipment, to avoid personal injury.

Step 1. Check to see if motor is hot to the hand.

If motor is hot to the hand, it has over-heated. Allow motor to cool.

Step 2. Check motor wiring connections.

If after motor has cooled and will not start, tighten motor wiring connections.

Step 3. Make sure that motor shaft is still capable of turning.

If motor shaft will not turn, install motor as described in paragraph 4-5, Section V. Maintenance Procedures.

3. COMPRESSOR UNIT RUNS ABOVE SHUT OFF PRESSURE (195 PSI 1350 KPa)

WARNING

Release pressure from air receiver and compressor pump before inspection, performing procedures or disassembly of equipment to avoid personal injury.

WARNING

Disconnect compressor unit from main power supply before performing check(s) or inspection, to avoid personal injury.

WARNING

Disconnect compressor unit from main power supply before servicing, replacing or repairing parts of equipment, to avoid personal injury.

Step 1. Remove pressure switch cover and check for loose wire connections.

Tighten any loose wire connections.

TABLE 4-1. ORGANIZATIONAL TROUBLESHOOTING (Cont'd)

MALFUNCTION	TEST OR INSPECTION	CORRECTIVE ACTION
	Step 2.	<p>Check setting of pressure switch.</p> <p>Adjust pressure switch settings as described in paragraph 4-7, figure 4-4.</p>
4. KNOCKING OR RATTLE DEVELOPS IN COMPRESSOR PUMP		
WARNING		
<p>Disconnect compressor unit from main power supply before performing check(s) or inspection, to avoid personal injury.</p>		
WARNING		
<p>Disconnect compressor unit from main power supply before servicing, replacing or repairing parts of equipment, to avoid personal injury.</p>		
	Step 1.	<p>Check for loose motor pulley or flywheel.</p> <p>Tighten motor pulley and flywheel.</p>
	Step 2.	<p>Check for loose V belts.</p> <p>Tighten V belts as described in Chapter 3, Section III, paragraph 3-3.</p>
	Step 3.	<p>Listen for squeaky V belts.</p> <p>If V belts squeak, then they have been glazed and should be replaced as described in Chapter 4, Section III, paragraph 4-4.</p>
	Step 4.	<p>Check for loose compressor pump mounting nuts and bolts.</p> <p>Tighten any loose mountings.</p>
	Step 5.	<p>Check oil level in compressor pump.</p> <p>If oil level is low, fill to correct level as described in Chapter 3, Section I, paragraph 3-1.</p>
	Step 6.	<p>Check to make sure oil in compressor pump is correct weight.</p>

TABLE 4-1. ORGANIZATIONAL TROUBLESHOOTING (Cont'd)

MALFUNCTION	TEST OR INSPECTION	CORRECTIVE ACTION
-------------	--------------------	-------------------

If oil weight is incorrect, change oil in compressor pump as described in Chapter 3, Section I, paragraph 3-1.

Step 7. Check for any loose connections in tubing, compression fittings, etc.

If any loose connections are found, tighten them.

5. EXCESSIVE OIL CONSUMPTION

WARNING

Disconnect compressor unit from main power supply before performing check(s) or inspection, to avoid personal injury.

WARNING

Disconnect compressor unit from main power supply before servicing, replacing or repairing parts of equipment, to avoid personal injury.

Step 1. Check for oil leak.

If oil leak is external, tighten connection from where oil is leaking. If oil leak is internal, such as if there is oil in the discharge air, remove compressor pump as described in Chapter 4, Section III, paragraph 4-6, and refer to next higher level of maintenance. (See Appendix B)

Step 2. Check for proper level of oil.

If oil level is low, fill to correct level as described in Chapter 3, Section I, paragraph 3-1.

Step 3. Check for proper weight of oil.

If oil weight is incorrect, change oil in compressor pump as described in Chapter 3, Section I, paragraph 3-1.

6. COMPRESSOR PUMP OVERHEATS

WARNING

Disconnect compressor unit from main power supply before performing check(s) or inspection, to avoid personal injury.

TABLE 4-1. ORGANIZATIONAL TROUBLESHOOTING (Cont'd)

MALFUNCTION	TEST OR INSPECTION	CORRECTIVE ACTION
-------------	--------------------	-------------------

WARNING

Disconnect compressor unit from main power supply before servicing, replacing or repairing parts of equipment, to avoid personal injury.

Step 1. If compressor pump over-heats (hot to the touch of hand) shut compressor unit off.

Allow compressor pump to cool until it is cool to touch of the hand.

Step 2. Check V belts to see if they are too loose or too tight.

Adjust as described in Chapter 3, Section III, paragraph 3-3.

Step 3. Check oil level to see if it is low.

If oil level is low, fill to correct level as described in Chapter 3, Section I, paragraph 3-1.

Step 4. Check oil to make sure correct weight oil is being used.

If improper oil weight is found, change oil as described in Chapter 3, Section I, paragraph 3-1.

Section III. MAINTENANCE PROCEDURES

4-5. V BELT REPLACEMENT.

WARNING

Disconnect compressor unit from main power supply before servicing, replacing or repairing parts of equipment, to avoid personal injury.

- a. Loosen belt guard fasteners. (Figure 4-2)
- b. Remove belt guard front. (Figure 4-2)
- c. Loosen motor mounting nuts and move motor towards compressor pump until V belts can be removed easily. (Figure 4-2)

- d. Remove old V belts and replace with new set (both V belts must be replaced).
- e. Move motor away from compressor pump, tightening V belts (figure 4-2). Play in fully tightened V belts should be no more than 1/2".
- f. Tighten motor mounting nuts.
- g. Install belt guard front. (Figure 4-2)
- h. Tighten belt guard fasteners. (Figure 4-2)

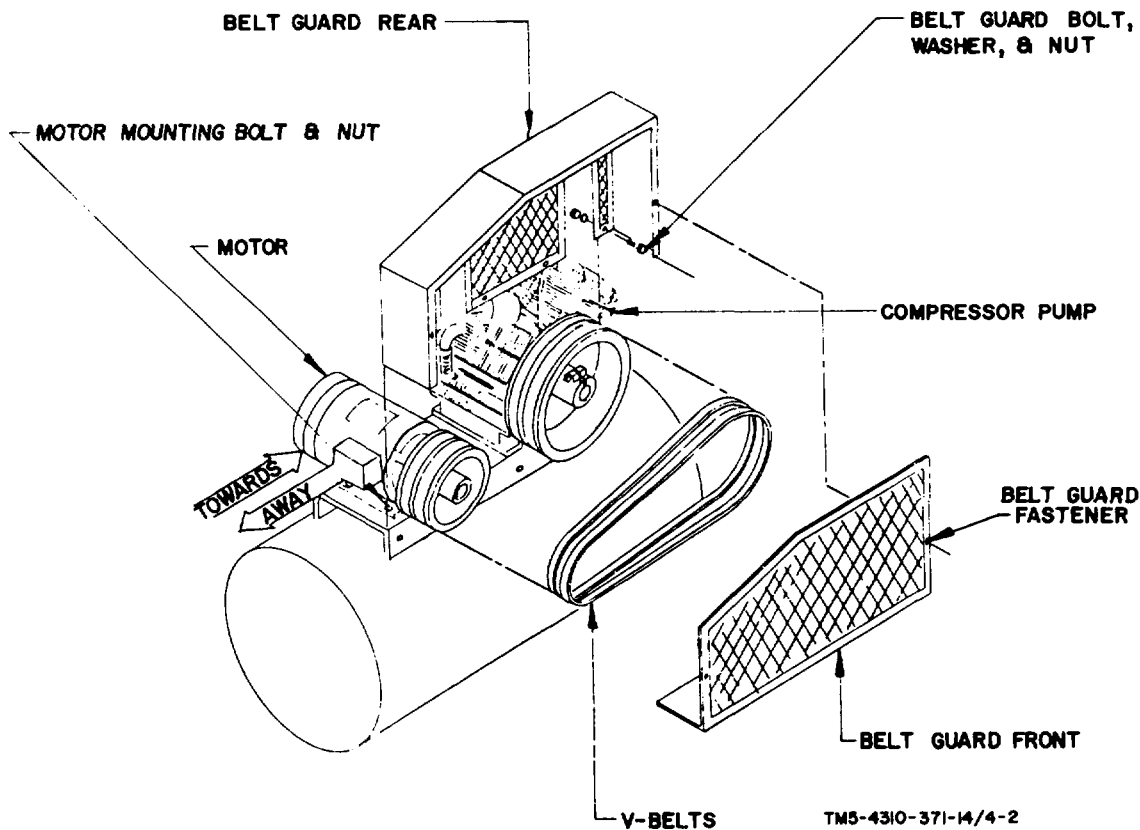

FIGURE 4-2. V BELT REPLACEMENT

4-6. STARTER SWITCH - MOTOR DISCONNECT.

WARNING

Disconnect compressor unit from main power supply before servicing, replacing or repairing parts of equipment, to avoid personal injury.

WARNING

Depress starter switch STOP button and leave it depressed, to avoid personal injury.

NOTE

The following steps must be performed by a utilities repairer:

- a. Remove junction box acorn nuts by turning them counter clockwise and remove junction box cover and junction box gasket. (Figure 4-2)
- b. Disconnect starter switch and motor leads by removing tape, screws and nuts from wire lugs. (Figure 4-3)
- c. Disconnect motor cable from junction box by removing cable connection nuts as shown in figure 4-3.
- d. Install motor cable to junction box and replace cable connection nut.
- e. Install starter switch and motor leads by replacing screws and nuts through wire lugs and tightening, then taping wire lugs (Figure 4-3).
- f. Install junction box gasket, junction box cover, and replace junction box acorn nuts by turning them clockwise. (Figure 4-3)

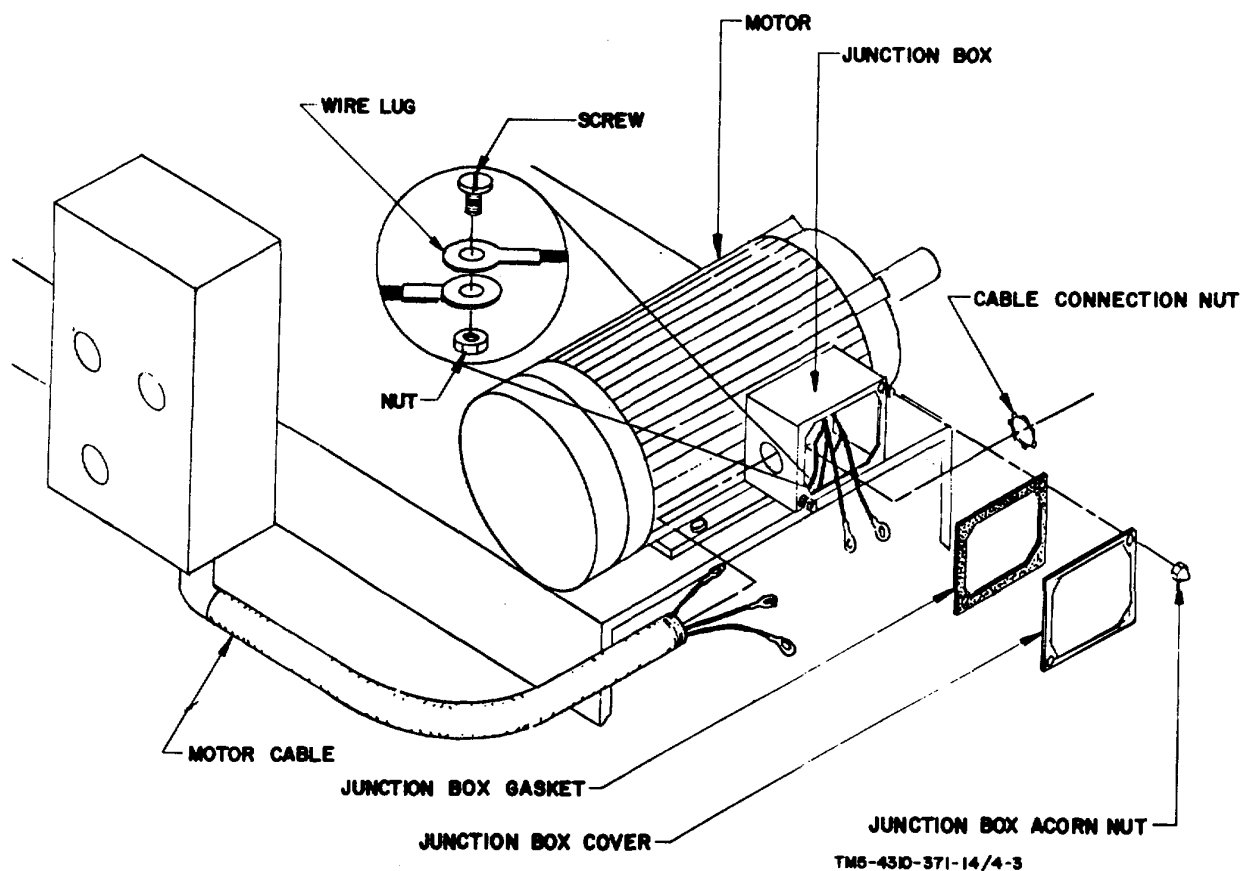

FIGURE 4-3. STARTER SWITCH-MOTOR DISCONNECT

4-7. MOTOR REPLACEMENT.

WARNING

Disconnect compressor unit from main power supply before servicing, replacing or repairing parts of equipment, to avoid personal injury.

- a. Remove belt guard front and V belts as described in paragraph 4-4.
- b. Remove motor cable by removing junction box cover. Untap and remove screws and nuts from wire lugs as shown in figure 4-3. This step must be performed by a qualified electrician.
- c. Remove motor pulley and motor pulley key from motor shaft by turning motor pulley set screw counter clockwise as shown in figure 4-4.
- d. Remove motor mounting nuts, lockwashers, and bolts as shown in figure 4-4.
- e. Lift motor from air receiver mounting bracket. (Figure 4-4)
- f. Install motor on to air receiver mounting bracket. (Figure 4-4)
- g. Install motor mounting bolts, lockwashers and nuts, figure 4-4, but do not tighten.
- h. Install motor pulley and motor pulley key on to motor shaft (figure 4-4) and tighten with set screw. Be sure motor pulley is aligned with flywheel to avoid excessive V belt wear or breakage.
- j. Install motor cable by connecting wire lugs with screws and nuts together and tapping same as shown in figure 4-3. This step must be performed by a qualified electrician.
- k. Install V belts and belt guard as described in paragraph 4-3.

4-8. PRESSURE SWITCH ADJUSTMENT.

WARNING

Use extreme caution during the following procedures as pressure switch carries electrical charge which will cause personal injury.

WARNING

Use extreme caution during the following procedures, as adjusting of pressure switch will cause unit to start up to pressurize air receiver.

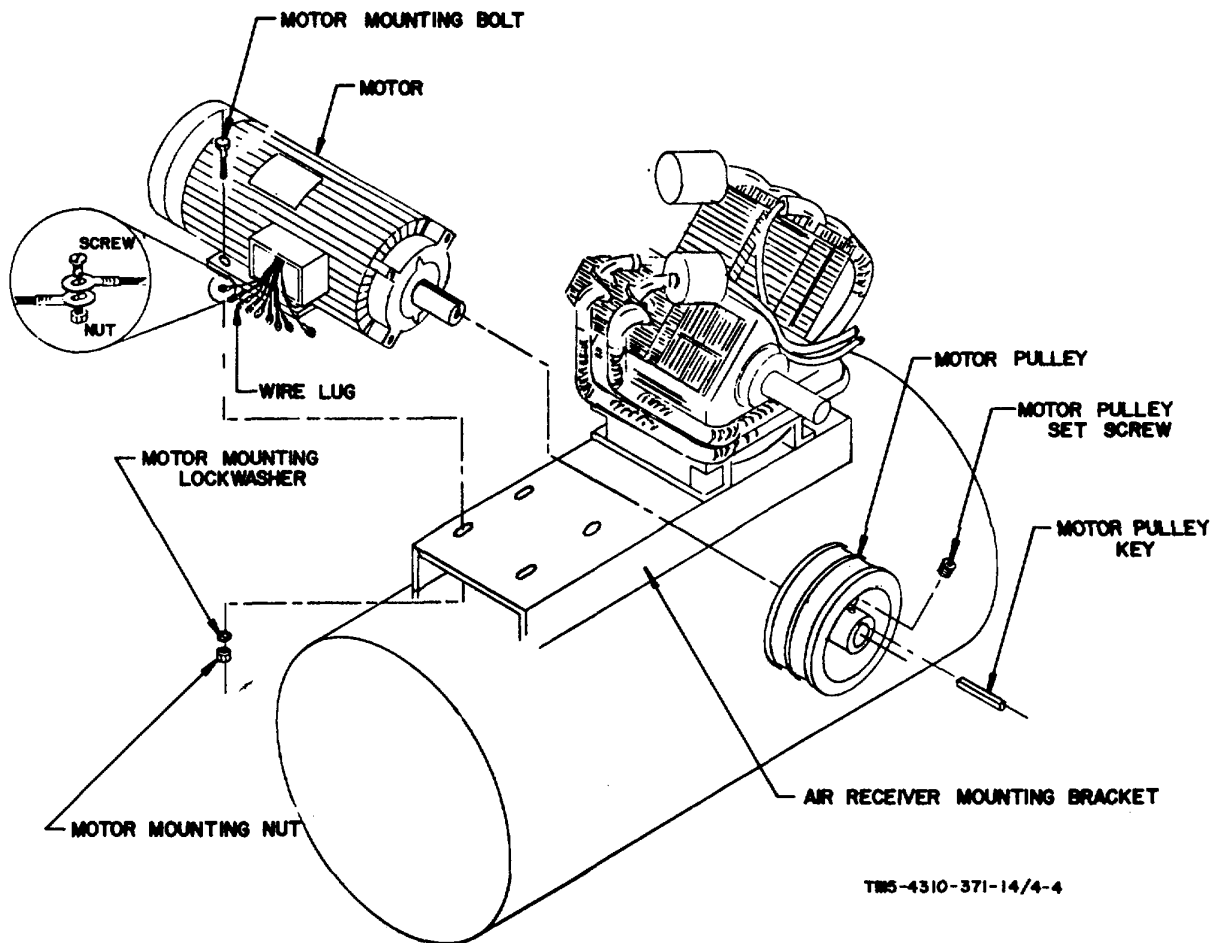

TM5-4310-371-14/4-4

FIGURE 4-4. MOTOR REMOVAL AND REPLACEMENT

- a. Remove pressure switch cover by turning pressure switch cover nut counter clockwise and lifting cover off. (Figure 4-5)
- b. Always adjust the range spring nut (A) first, until the operating point on falling pressure is 175 PSI (1210 KPa).
- c. Turning nut (A) clockwise will increase setting. Turning it counter clockwise will decrease setting. This adjustment changes both high and low operating points.
- d. To adjust operating point on rising pressure, turn differential spring nut (B) clockwise to increase the pressure difference between high and low operating points and counter clockwise to decrease pressure difference.
- e. Begin adjustments by first turning compressor unit off by pushing STOP button on starter switch.

- f. Adjust nut (A) to increase or decrease low operating point as required, to set low operating point at 175 PSI (1210 KPa). This should be done by increments of a half turn at a time.
- g. After each half turn, start compressor unit and allow compressor unit to pressurize to high operating point when it will shut off. Then slowly bleed off air by depressing inflator gage handle. As air escapes and air pressure in air receiver decreases, note at what pressure the compressor unit begins operation to repressurize air receiver. If this does not occur at 175 PSI (1210 KPa), repeat step "f" until low operating point of 175 PSI (1210 KPa) is attained.
- h. After low operating point is attained, again turn compressor unit off and begin to adjust high operating point, nut (B), in half turn increments. High operating point should be 195 PSI (1350 KPa) maximum.
- j. After high operating point has been attained, replace pressure switch cover and secure it in place with pressure switch cover nut.

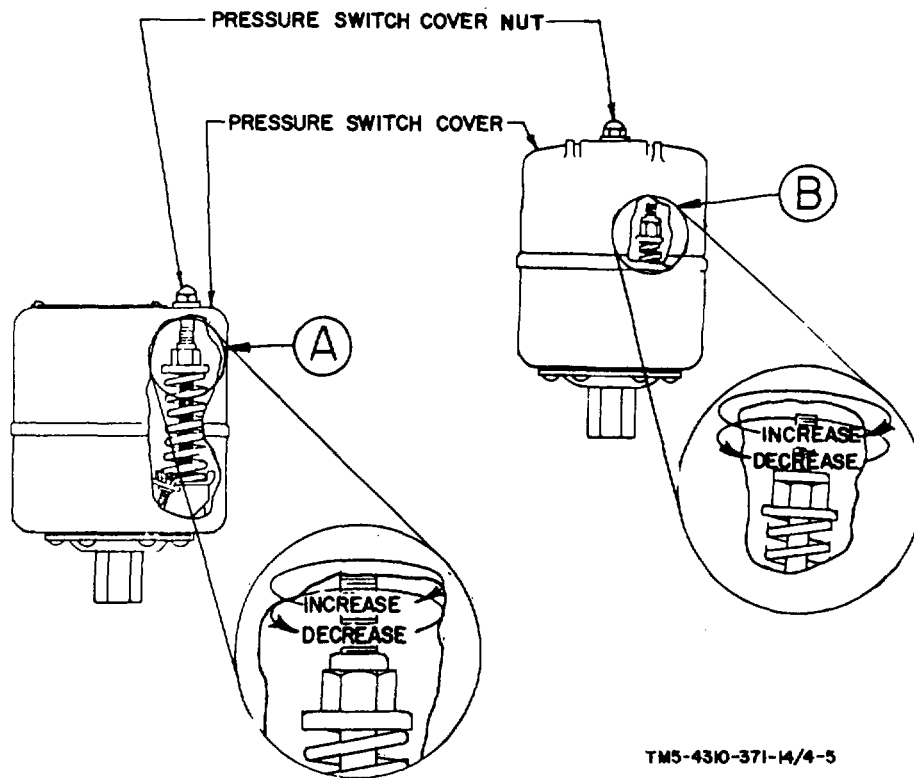

FIGURE 4-5. PRESSURE SWITCH ADJUSTMENT

4-9. COMPRESSOR PUMP REPLACEMENT.

WARNING

Disconnect compressor unit from main power supply before servicing replacing or repairing parts of equipment, to avoid personal injury.

WARNING

Release pressure from air receiver and compressor pump before inspection, performing procedures, or disassembly of equipment to avoid personal injury.

- a. Remove belt guard front and V belts as described in paragraph 4-4.
- b. Remove flywheel and flywheel key by removing flywheel bolt and nut. Then pull off flywheel and flywheel key from compressor pump shaft (figure 4-6).
- c. Disconnect exhaust tube from aftercooler manifold as shown in figure 4-7.
- d. Remove compressor pump mounting nuts, lockwashers and bolts (4) as shown in figure 4-6.
- e. Lift compressor pump off air receiver mounting bracket.
- f. Install compressor pump on to air receiver mounting bracket so that compressor pump and air receiver mounting bracket holes are aligned.
- g. Install compressor pump mounting bolts, lockwashers and nuts (4). (Figure 4-6)
- h. Reconnect exhaust tube to aftercooler manifold (figure 4-7).
- j. Install flywheel and flywheel key by pushing them back on to compressor pump shaft and installing flywheel bolt and nut. Be sure that flywheel is aligned with motor pulley to prevent excessive V belt wear or V belt breakage.
- k. Install V belts and then belt guard front as described in paragraph 4-4.

4-10. REMOVAL AND REPLACEMENT OF PRESSURE GAGE.

WARNING

Disconnect compressor unit from main power supply before servicing, replacing or repairing parts of equipment, to avoid personal injury.

WARNING

Release pressure from air receiver and compressor pump before inspection, performing procedures, or disassembly of equipment to avoid personal injury.

- a. To test suspect pressure gage, remove by turning pressure gage counter clockwise as shown in figure 4-8.
- b. Perform a comparison test with known good gage.
- c. To install serviceable pressure gage, apply thread tape or thread compound to threads and turn pressure gage clockwise into side of mounting tee located next to pressure switch until tight.

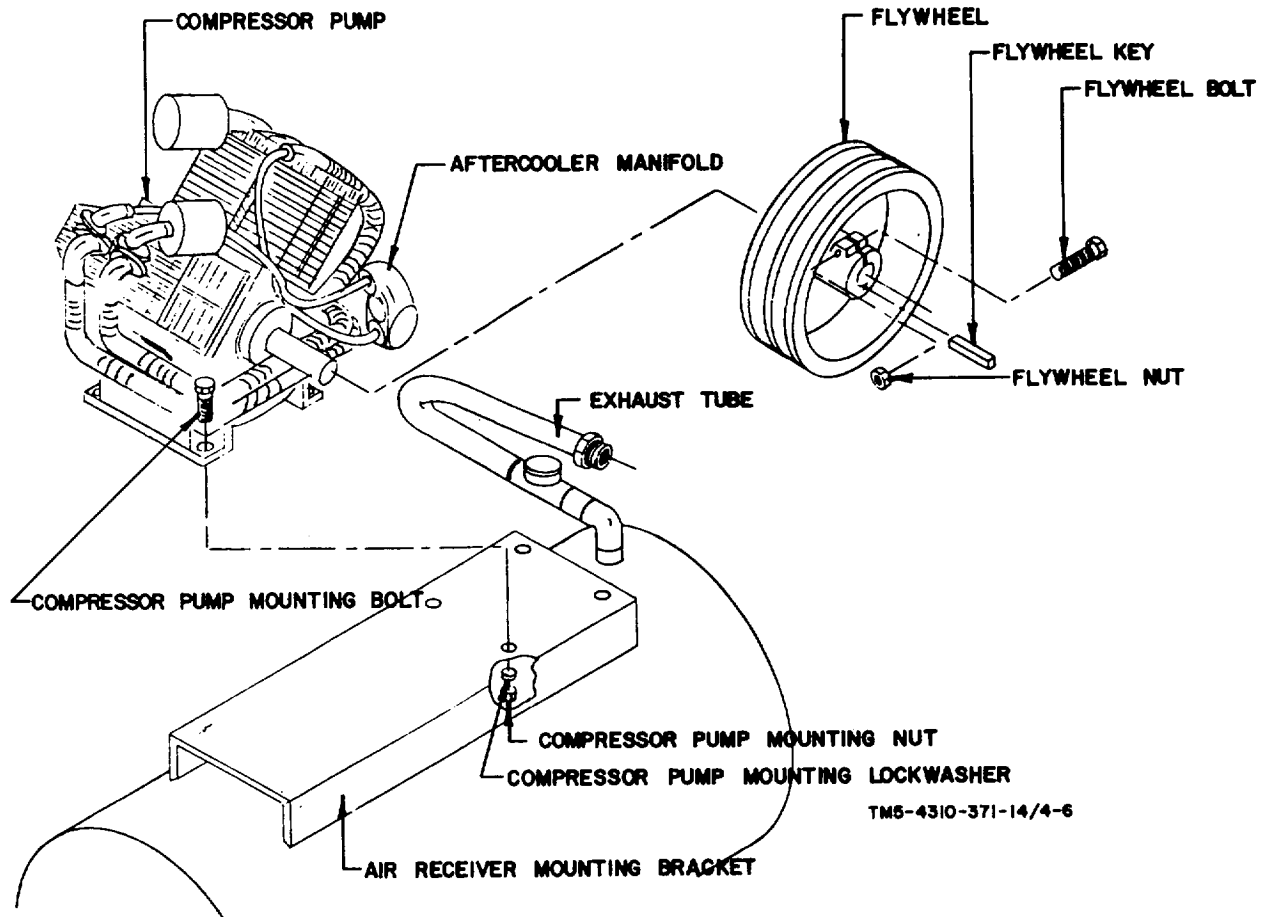
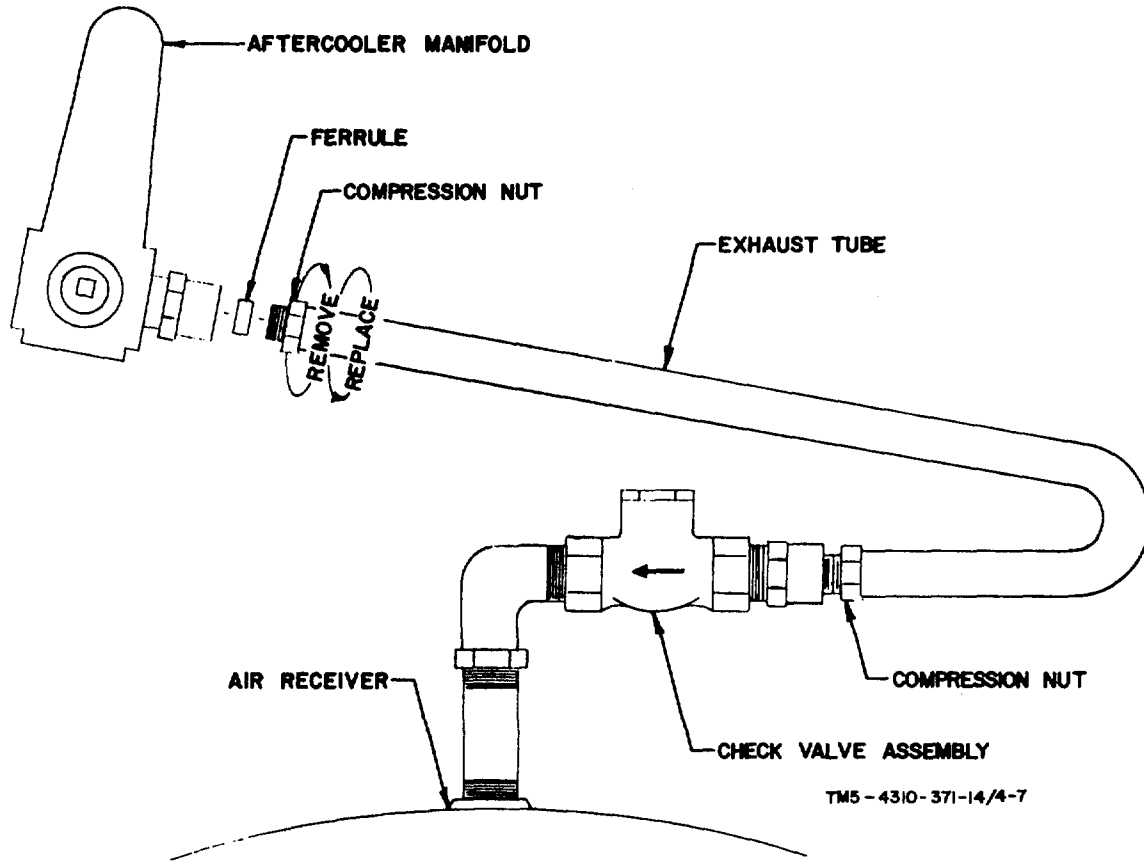

FIGURE 4-6. COMPRESSOR PUMP REMOVAL AND REPLACEMENT



TM5 - 4310 - 371 - 14 / 4 - 7

FIGURE 4-7. EXHAUST TUBE DISCONNECT

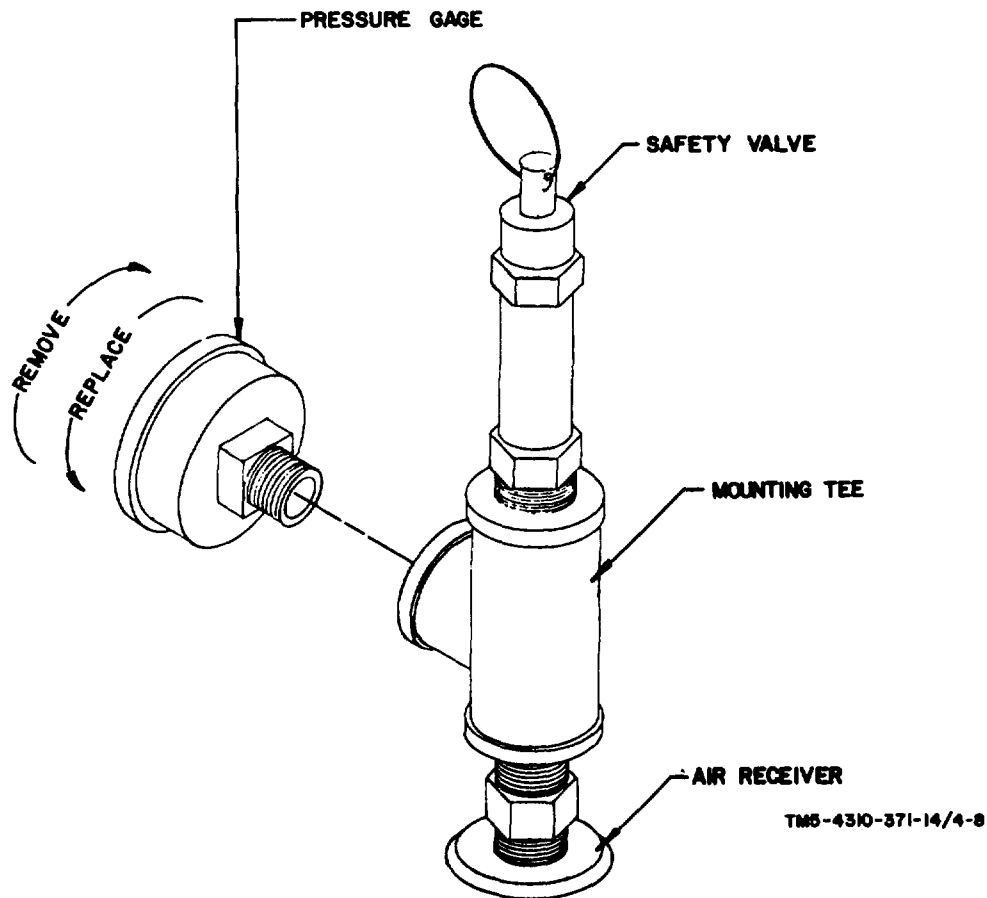

FIGURE 4-8. PRESSURE GAGE REMOVAL AND REPLACEMENT

4-11. CHECK VALVE REPLACEMENT.

WARNING

Disconnect compressor unit from main power supply before servicing, replacing or repairing parts of equipment, to avoid personal injury.

WARNING

Release pressure from air receiver and compressor pump before inspection, performing procedures, or disassembly of equipment to avoid personal injury.

- a. Disconnect compression body from check valve (figure 4-9).
- b. Remove check valve by turning counter clockwise until disconnected from street elbow (figure 4-8).

- c. To replace check valve, apply thread tape or thread compound to street elbow. With check valve arrow pointing toward street elbow, turn check valve clockwise until tight (figure 4-8). Turn check valve until cap is on top.

CAUTION

Arrow on check valve body must be pointing towards street elbow in order for unit to work properly. Failure to do this will cause compressor unit to malfunction.

- d. Apply thread tape or thread compound to compression body threads before installing check valve and tighten (figure 4-8).

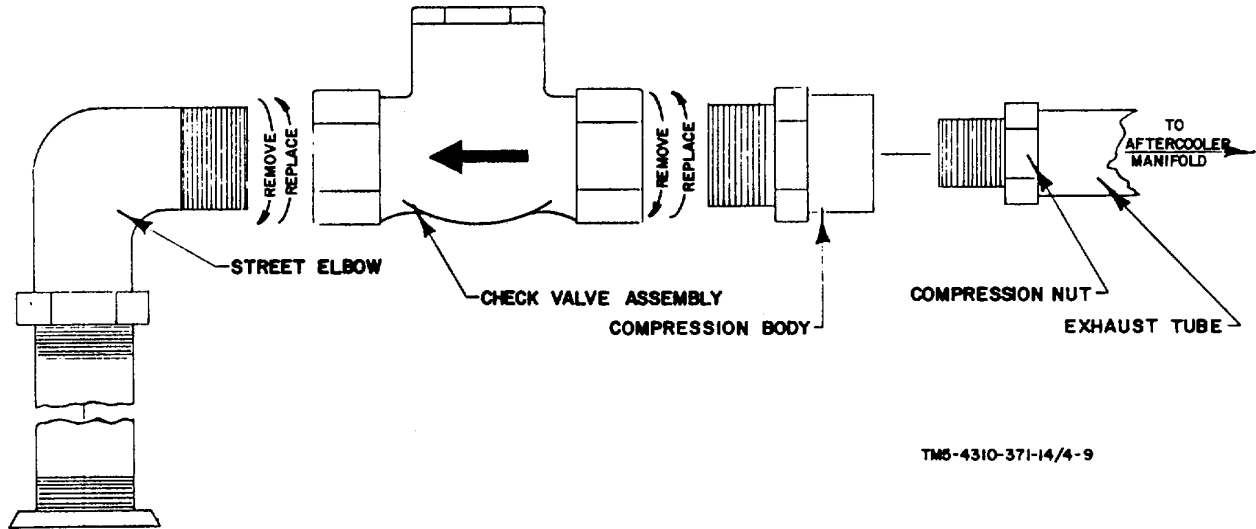

FIGURE 4-9. CHECK VALVE REMOVAL AND REPLACEMENT

4-12. GLOBE VALVE REPLACEMENT.

WARNING

Disconnect compressor unit from main power supply before servicing, replacing or repairing parts of equipment, to avoid personal injury.

WARNING

Release pressure from air receiver and compressor pump before inspection, performing procedures, or disassembly of equipment to avoid personal injury.

- a. Disconnect inflator gage hose from globe valve by turning bushing counter clockwise (figure 4-10).

- b. Remove globe valve from air receiver by turning it counter clockwise from air receiver nipple (figure 4-10).
- c. To replace globe valve apply thread tape or thread compound to threads of bushing, and with arrow on globe valve pointing away from air receiver, turn globe valve clockwise into air receiver nipple until tight. Turn globe valve until handle is up.
- d. Install the inflator gage hose by turning the bushing clockwise into the globe valve.
- e. Check packing of globe valve for leak around packing nut with valve open and pressure in air receiver. Use soap and water applied at top of nut, look for bubbles.
- f. Tighten packing nut.

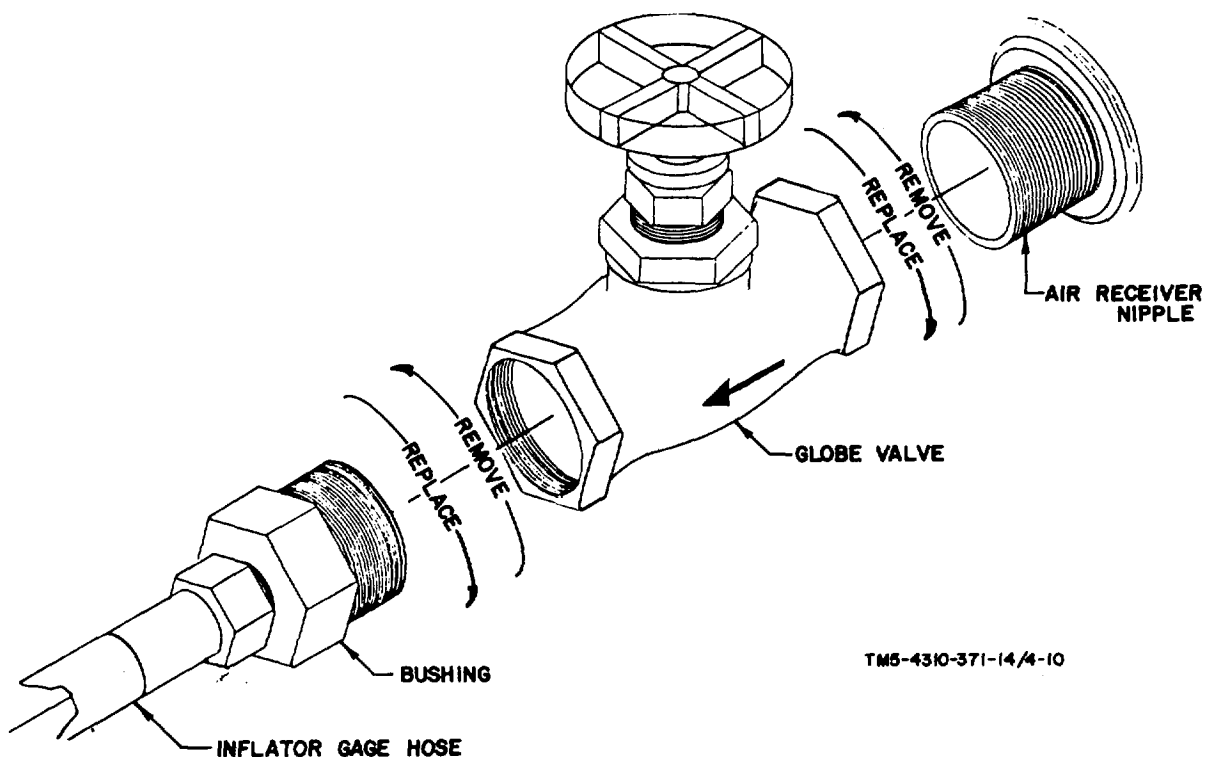

TM5-4310-371-14/4-10

FIGURE 4-10. GLOBE VALVE REMOVAL AND REPLACEMENT

4-13. INFLATOR GAGE HOSE REPLACEMENT.

WARNING

Close globe valve tightly to avoid personal injury.

- a. Disconnect inflator gage hose from globe valve by turning hose connection nut counter clockwise (figure 4-11).
- b. Disconnect inflator gage hose from inflator gage by turning inflator gage counter clockwise until disconnected (figure 4-11).
- c. Leave globe valve closed.
- d. Use thread tape or thread compound on globe valve bushing and install inflator gage hose into globe valve by turning hose connection nut clockwise until tight (figure 4-11).
- e. Use thread tape or thread compound on inflator gage hose and install in inflator gage by turning hose connection nut clockwise until tight (figure 4-11).
- f. Open globe valve and check connections for air leaks.

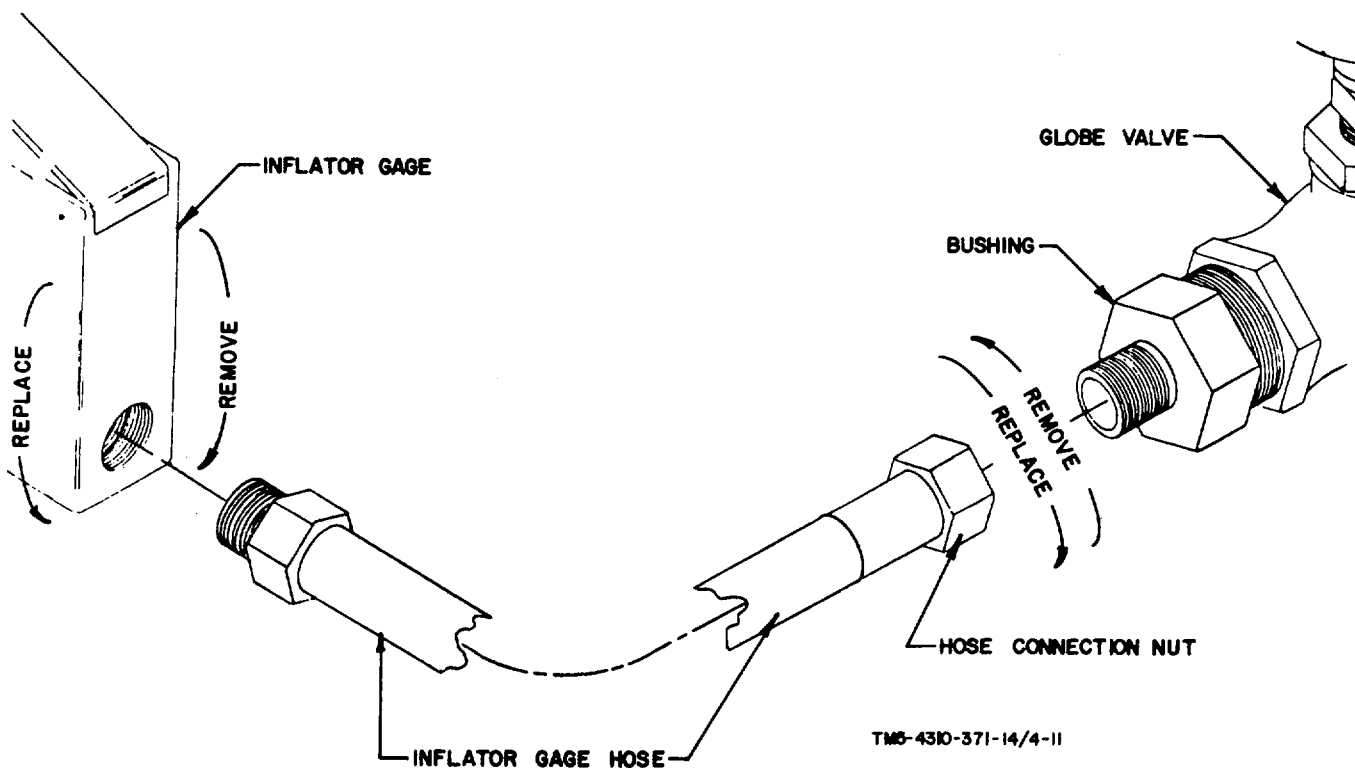

FIGURE 4-11. INFLATOR GAGE HOSE REPLACEMENT

4-14. INFLATOR GAGE REPLACEMENT.

WARNING

Close globe valve tightly to avoid personal injury.

- a. Disconnect inflator gage from inflator gage hose by turning inflator gage counter clockwise as viewed from end of inflator gage hose (figure 4-12).
- b. Leave globe valve closed.
- c. To reconnect inflator gage, turn it clockwise as viewed from end of inflator gage hose on to inflator gage hose until tight.
- d. Open globe valve and check connection for air leak.

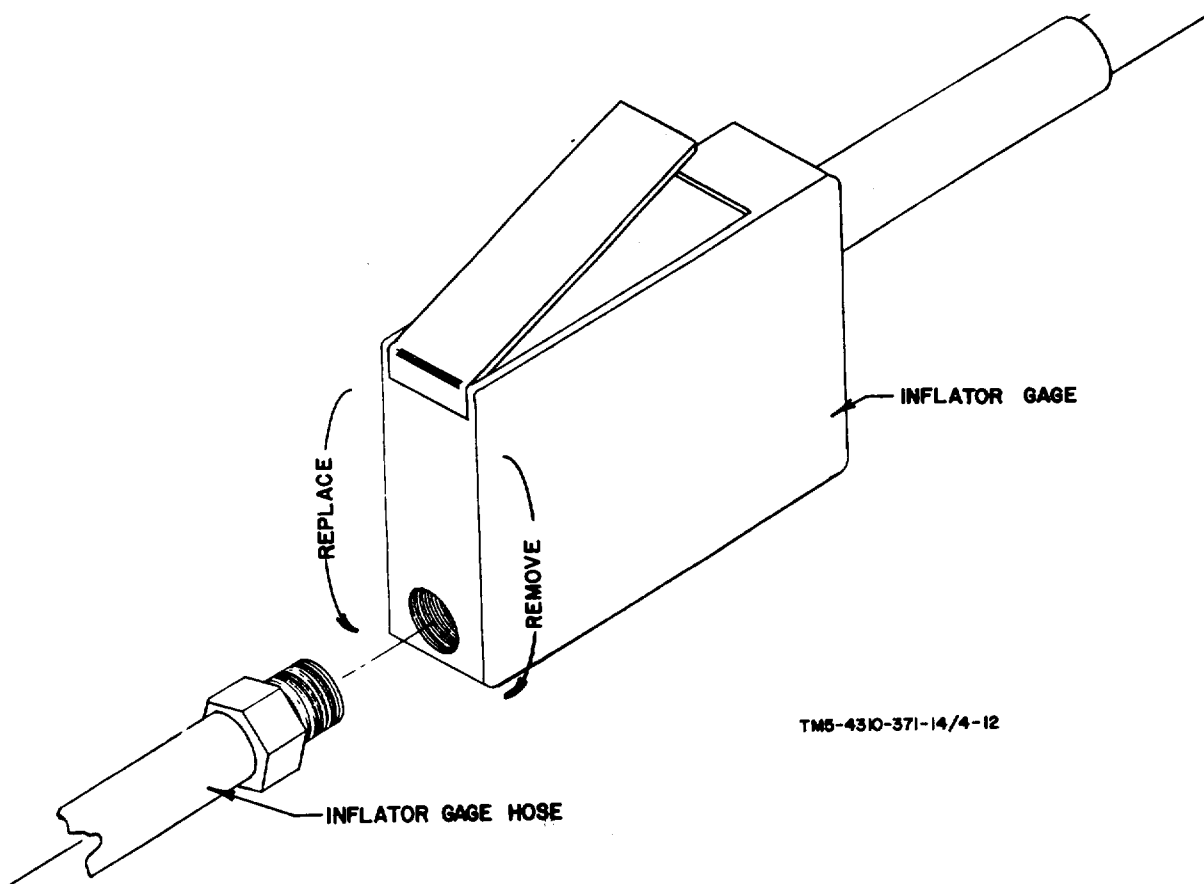

FIGURE 4-12. INFLATOR GAGE REPLACEMENT

CHAPTER 5

DIRECT AND GENERAL SUPPORT MAINTENANCE

Section I. DIRECT AND GENERAL SUPPORT TROUBLESHOOTING

5-1. SCOPE.

- a. This section contains troubleshooting or malfunction information and tests for locating and correcting most of the troubles which may develop in the compressor unit. Each malfunction or trouble symptom for an individual component, unit, or system is followed by a list of tests or inspections necessary for you to determine probable causes and suggested corrective actions for you to remedy the malfunction.
- b. This manual cannot list all possible malfunctions that may occur or all tests or inspections, and corrective actions. If a malfunction is not listed or is not corrected by listed corrective actions, you should notify higher level maintenance.
- c. Table 5-1. lists the common malfunctions that you may find during the operation or maintenance of compressor unit or its components. You should perform the test, inspections and corrective actions in the order listed.

NOTE

Before you use this table, be sure you have performed all applicable operating checks.

TABLE 5-1. DIRECT AND GENERAL SUPPORT TROUBLESHOOTING

MALFUNCTION	TEST OR INSPECTION	CORRECTIVE ACTION
-------------	--------------------	-------------------

1. MOTOR RUNNING ERRATICALLY

WARNING

Disconnect compressor unit from main power supply before performing check(s) or inspection, to avoid personal injury.

TABLE 5-1. DIRECT AND GENERAL SUPPORT TROUBLESHOOTING (Cont'd)

MALFUNCTION	TEST OR INSPECTION	CORRECTIVE ACTION
-------------	--------------------	-------------------

WARNING

Disconnect compressor unit from main power supply before servicing, replacing or repairing parts of equipment, to avoid personal injury.

Step 1. Check rotor assembly rings to see if they are spotted, rough or eccentric.

If rotor assembly rings are spotted, rough or eccentric, remove assembly and replace. Send assembly to next higher level of maintenance. (See Appendix B)

2. LOSS OF, OR NO MOTOR OUTPUT

WARNING

Disconnect compressor unit from main power supply before performing check(s) or inspection, to avoid personal injury.

WARNING

Disconnect compressor unit from main power supply before servicing, replacing or repairing parts of equipment, to avoid personal injury.

Step 1. Check wire connections to stator to see if they are loose or frayed.

If wire connections are loose or frayed, replace stator. Send stator to next higher level of maintenance. (See Appendix B)

Step 2. Check windings to see if they have dried out and are loose.

If windings are loose, replace stator and send suspect stator to next higher level of maintenance. (See Appendix B)

3. MOTOR WILL NOT START UP

WARNING

Disconnect compressor unit from main power supply before performing check(s) or inspection, to avoid personal injury.

TABLE 5-1. DIRECT AND GENERAL SUPPORT TROUBLESHOOTING (Cont'd)

MALFUNCTION	TEST OR INSPECTION	CORRECTIVE ACTION
-------------	--------------------	-------------------

WARNING

Disconnect compressor unit from main power supply before servicing, replacing or repairing parts of equipment, to avoid personal injury.

- Step 1. Check starter switch to see if all wires are tight to terminal base.

If there are wires which are not tight to terminal blocks, tighten terminal screws.
- Step 2. Check to see that switch mechanism of starter switch assembly works smoothly without sticking.

If starter switch mechanism sticks or jams, replace starter switch assembly.

4. MOTOR DOES NOT START AT LOW OPERATING POINT OR DOES NOT STOP AT HIGH OPERATING POINT

WARNING

Disconnect compressor unit from main power supply before performing check(s) or inspection, to avoid personal injury.

WARNING

Disconnect compressor unit from main power supply before servicing, replacing or repairing parts of equipment, to avoid personal injury.

- Step 1. Check pressure switch to see if any leads are loose or disconnected at terminals.

If pressure switch leads are loose or are not connected, reconnect leads and/or tighten leads.
- Step 2. Check to see if pressure switch can still be adjusted.

If pressure switch adjustment mechanism can not be adjusted any further replace pressure switch.
- Step 3. Check to see if pressure switch still fails after above inspection and/or corrective actions.

TABLE 5-1. DIRECT AND GENERAL SUPPORT TROUBLESHOOTING (Cont'd)

MALFUNCTION	TEST OR INSPECTION	CORRECTIVE ACTION
-------------	--------------------	-------------------

In after above inspections and/or corrective actions, the pressure switch still malfunctions, replace it.

5. INTAKE OR EXHAUST VALVE TAP OR STICKING

WARNING

Disconnect compressor unit from main power supply before performing check(s) or inspection, to avoid personal injury.

WARNING

Disconnect compressor unit from main power supply before servicing, replacing or repairing parts of equipment, to avoid personal injury.

WARNING

Release pressure from air receiver and compressor pump before inspection, performing procedures or disassembly of equipment to avoid personal injury.

- Step 1. Listen for valve(s) tapping.
If valve(s) is tapping, remove and replace valve(s).
- Step 2. Check to see if valve(s) is sticking.
If valve(s) is sticking, remove and replace valve(s).
- Step 3. Inspect valve(s) for wear including gasket(s).
If valve(s) is worn, remove and replace.

6. LOW DISCHARGE PRESSURE

WARNING

Disconnect compressor unit from main power supply before performing check(s) or inspection, to avoid personal injury.

WARNING

Disconnect compressor unit from main power supply before servicing, replacing or repairing parts of equipment, to avoid personal injury.

TABLE 5-1. DIRECT AND GENERAL SUPPORT TROUBLESHOOTING (Cont'd)

MALFUNCTION	TEST OR INSPECTION	CORRECTIVE ACTION
-------------	--------------------	-------------------

WARNING

Release pressure from air receiver and compressor pump before inspection, performing procedures or disassembly of equipment to avoid personal injury.

- Step 1. Check to see if valve(s) is leaking.
If valve(s) is leaking, remove and replace.
- Step 2. Check to see if piston rings are worn or defective.
If piston rings are worn or defective, remove and replace.

7. COMPRESSOR PUMP KNOCKING

WARNING

Disconnect compressor unit from main power supply before performing check(s) or inspection, to avoid personal injury.

WARNING

Disconnect compressor unit from main power supply before servicing, replacing or repairing parts of equipment, to avoid personal injury.

- Step 1. Check for worn connecting rod bearings.
If connecting rod bearings are worn, remove and replace connecting rod assembly.
- Step 2. Check for worn piston pin bearing.
If piston pin bearing is worn, remove and replace connecting rod assembly.
- Step 3. Check for worn main bearings.
If main bearings are worn, remove and replace main bearing assemblies.
- Step 4. Check to see if piston(s) is loose.

TABLE 5-1. DIRECT AND GENERAL SUPPORT TROUBLESHOOTING (Cont'd)

MALFUNCTION	TEST OR INSPECTION	CORRECTIVE ACTION
		If piston(s) is loose, tighten down connecting rod bolts or replace piston.
	Step 5. Check to see if piston(s) is hitting head(s).	
		If piston(s) is hitting head(s), remove any foreign matter found and/or replace piston(s).
	Step 6. Check to see if there is excessive crankshaft end play. (See Table 5-2)	
		If there is excessive crankshaft end play, replace crankshaft and also any other worn mating parts.

8. COMPRESSOR PUMP OVERHEATING

WARNING

Disconnect compressor unit from main power supply before performing check(s) or inspection, to avoid personal injury.

WARNING

Disconnect compressor unit from main power supply before servicing, replacing or repairing parts of equipment, to avoid personal injury.

WARNING

Release pressure from air receiver and compressor pump before inspection, performing procedures or disassembly of equipment to avoid personal injury.

Step 1. Check for defective or worn valve(s).

If valve(s) is defective or worn, remove and replace.

9. OIL IN DISCHARGE AIR

WARNING

Disconnect compressor unit from main power supply before performing check(s) or inspection, to avoid personal injury.

TABLE 5-1. DIRECT AND GENERAL SUPPORT TROUBLESHOOTING (Cont'd)

MALFUNCTION	TEST OR INSPECTION	CORRECTIVE ACTION
-------------	--------------------	-------------------

WARNING

Disconnect compressor unit from main power supply before servicing, replacing or repairing parts of equipment, to avoid personal injury.

WARNING

Release pressure from air receiver and compressor pump before inspection, performing procedures or disassembly of equipment to avoid personal injury.

Step 1. Check for worn piston rings.

If piston rings are worn, remove and replace.

Step 2. Check for defective breather tube or breather tube release valve.

If breather tube or breather tube release valve are defective, remove and replace.

10. SAFETY VALVE RELEASES AIR BELOW WORKING PRESSURE OF 195 PSI (1350 KPa)

WARNING

Disconnect compressor unit from main power supply before performing check(s) or inspection, to avoid personal injury.

WARNING

Disconnect compressor unit from main power supply before servicing, replacing or repairing parts of equipment to avoid personal injury.

WARNING

Release pressure from air receiver and compressor pump before inspection, performing procedures or disassembly of equipment to avoid personal injury.

Step 1. Check to see that safety valve has been mounted to air receiver properly.

If safety valve has not been mounted properly, or if connection is loose, remount and tighten.

TABLE 5-1. DIRECT AND GENERAL SUPPORT TROUBLESHOOTING (Cont'd)

MALFUNCTION	TEST OR INSPECTION	CORRECTIVE ACTION
-------------	--------------------	-------------------

Step 2. Check to see if safety valve is malfunctioning.

If safety valve is malfunctioning constantly, remove and replace.

11. MOTOR INCAPABLE OF TURNING COMPRESSOR PUMP

WARNING

Disconnect compressor unit from main power supply before performing check(s) or inspection, to avoid personal injury.

WARNING

Disconnect compressor unit from main power supply before servicing, replacing or repairing parts of equipment, to avoid personal injury.

WARNING

Release pressure from air receiver and compressor pump before inspection, performing procedures or disassembly of equipment to avoid personal injury.

Step 1. Check to see that compressor pump can be turned by hand.

If compressor pump cannot be turned by hand, it may be due to back pressure leaking through check valve from air receiver. Remove and replace check valve.

TABLE 5-2. COMPRESSOR PUMP OVERHAUL REPLACEMENT STANDARDS

ITEM	Manufacturer's Dimensions and Tolerance in inches		Desired Clearance		Maximum allowable wear and clearance
	MIN.	MAX.	MIN.	MAX.	
Cylinders					
Bore, low-pressure	4.6245	4.6255	0.004
Bore, high-pressure	2.4995	2.5005	0.002
Out-of-round	0.001
Taper	0.001
Crankshaft					
Rod size	1.623	1.625	
Taper	0.001
Out-of-round	0.005
End Play	0.000	0.002	
Pistons and Pins					
Piston, low-pressure	4.619	4.620	0.003	0.005	0.005
Piston, high-pressure	2.4965	2.4975	0.0015	0.0035	0.003
Pin, low-pressure	2.125	2.135	0.0001	0.0005	
Pin, high-pressure	2.125	2.135	0.0001	0.0005	
Connecting rod bearings					
Bearing, I.D.	0.8125	. . .	0.001	. . .	
Bearing, side clearance	0.010	. . .	

Section II. MAINTENANCE PROCEDURES

5-2. MOTOR REPAIR.

a. Motor Disassembly (Figure 5-1).

- (1) Remove front housing slinger (figure 5-1, item 1).
- (2) Remove housing nuts (figure 5-1, item 2) by turning them counter clockwise.
- (3) Remove front housing (figure 5-1, item 3) and rear housing (figure 5-1, item 4).
- (4) Remove tension clip (figure 5-1, item 5) from rear end of shaft, and then remove fan (figure 5-1, item 6) with suitable puller.
- (5) Remove sleeve bolts (figure 5-1, item 7).
- (6) Remove bell housing slinger (figure 5-1, item 8) from shaft.
- (7) Remove bell housing (figure 5-1, item 9) from shaft.
- (8) Remove front bearing (figure 5-1, item 10) from front housing (figure 5-1, item 3).
- (9) Remove spring washer (figure 5-1, item 11) from rear of shaft.
- (10) Remove rotor assembly (figure 5-1, item 12) from inside stator (figure 5-1, item 13).
- (11) Remove rear bearing (figure 5-1, item 14) from rear of shaft.
- (12) Remove stator (figure 5-1, item 13) if necessary. (See Chapter 5, Section I, Para 5-1b.), and refer it to next level of maintenance, (See Appendix B).

b. Cleaning, Inspection, Repair or Replacement of Parts

WARNING

Dry cleaning solvent, P-D-680, used to clean parts is potentially dangerous to personnel and property. Use in well ventilated area as the fumes are dangerous if inhaled. Avoid repeated and prolonged skin contact. Do not use near open flame or excessive heat. Flash point of solvent is 100°F 138°F (38°C 59°C).

- (1) All parts to be thoroughly cleaned with P-D-680 solvent, and then air dried.
- (2) Inspect all parts for cracks, breaks, fissures, scores, distortions or any other applicable damage.

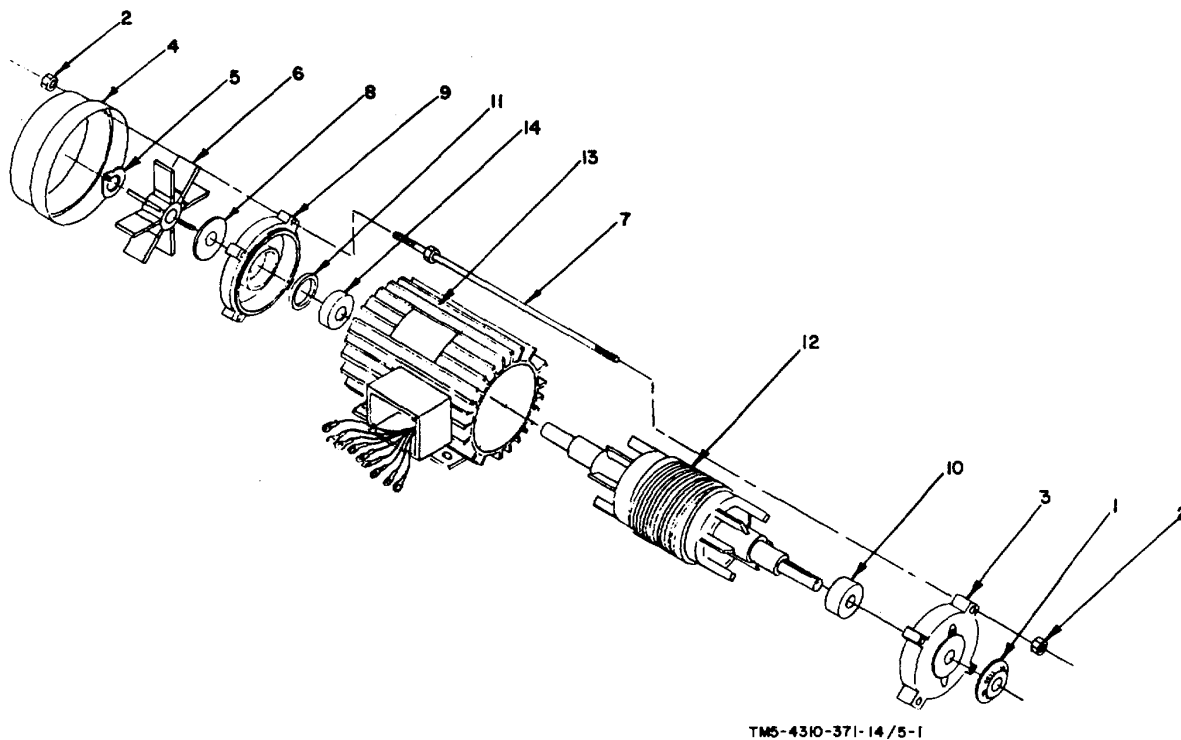

TMS-4310-371-14/5-1

- | | |
|--------------------------|-------------------------|
| 1. Front Housing Slinger | 8. Bell Housing Slinger |
| 2. Housing Nut | 9. Bell Housing |
| 3. Front Housing | 10. Front Bearing |
| 4. Rear Housing | 11. Spring Washer |
| 5. Tension Clip | 12. Rotor Assembly |
| 6. Fan | 13. Stator |
| 7. Sleeve Bolts | 14. Rear Bearing |

FIGURE 5-1. MOTOR (EXPLODED VIEW)

(3) Repair or replace any unserviceable parts.

c. Motor, Reassembly

- (1) Install rear bearing (figure 5-1, item 14) onto rear of shaft of rotor assembly (figure 5-1, item 12).
- (2) Install rotor assembly (figure 5-1, item 12) back into stator (figure 5-1, item 13).
- (3) Install spring washer (figure 5-1, item 11) onto rear of shaft of rotor assembly (figure 5-1, item 12) so that it is flush against rear bearing.

- (4) Press front bearing (figure 5-1, item 10) back into front housing (figure 5-1, item 3).
 - (5) Install bell housing (figure 5-1, item 9) back onto rotor assembly shaft (figure 5-1, item 12).
 - (6) Install bell housing slinger (figure 5-1, item 8) onto rear of shaft so that it is flush with bell housing.
 - (7) Install sleeve bolts (figure 5-1, item 7) back into position on stator (figure 5-1, item 13).
 - (8) Install fan (figure 5-1, item 6) back onto shaft as far as it will go and in line with key, and then immediately replace tension clip (figure 5-1, item 5) onto shaft.
 - (9) Install rear housing (figure 5-1, item 4) and front housing (figure 5-1, item 3).
 - (10) Install housing nuts (figure 5-1, item 2) onto sleeve bolts (figure 5-1, item 7) and tighten down securely.
 - (11) Install front housing slinger (figure 5-1, item 1) onto shaft so that it is flush with outside of front housing (figure 5-1, item 3).
- d. Rotor Assembly Inspection and Replacement
- (1) Inspection check to see if rotor rings (windings) are spotted, rough, eccentric, or broken. If any of these conditions exist, the rotor assembly must be replaced.
 - (2) Replacement replace rotor assembly in accordance with procedures described in paragraph 5-1a.
- e. Stator Assembly Inspection and Replacement
- (1) Inspection check to see if stator assembly windings are dried out and/ or cracked and if stator assembly cables are loose, frayed, split or disconnected. If any of these conditions exist, the stator assembly should be removed and sent to the next level of maintenance to be repaired.
 - (2) Replacement replace stator assembly in accordance with procedures described in paragraph 5-2a.
- f. Starter Switch Replacement
- (1) If starter switch malfunctions, check all terminals to see that starter switch has been wired properly (figure 2-2) and that connections are tight. Loose connections will cause starter switch to work improperly or not at all.
 - (2) Starter switch wiring procedures (figure 2-2).

WARNING

Disconnect unit from main power supply before servicing, replacing or repairing parts of equipment, to avoid personal injury.

WARNING

Push STOP button on starter switch and leave depressed, to avoid personal injury.

NOTE

All following procedures must be performed by a utilities equipment repairer:

- (a) Open front of starter switch (figure 5-2, item 1) and disconnect all electrical leads. Unscrew connection screws (figure 5-2, item 2) off wire leads (figure 5-2, item 3).
 - (b) Remove cable connection nuts (figure 5-2, item 4) from motor cable (figure 5-2, item 5), pressure switch cable (figure 5-2, item 6) and main power supply cable (figure 5-2, item 7). Pull all cables from starter switch (figure 5-2, item 1).
 - (c) Remove starter switch (figure 5-2, item 1). Turn mounting bolts (figure 5-2, item 8) and mounting nuts (figure 5-2, item 9) counter clockwise. Remove them from the mounting lockwashers (figure 5-2, item 10) and from air receiver mounting bracket (figure 5-2, item 11).
 - (d) For wiring schematic, see paragraph 2-4, figure 2-2.
 - (e) Install starter switch (figure 5-2, item 1) on to air receiver mounting bracket. Replace mounting bolts (figure 5-2, item 8) mounting nuts (figure 5-2, item 9) turning them clockwise.
 - (f) Install cable connection nuts (figure 5-2, item 4) on to motor cable (figure 5-2, item 5). Install cable connection nut (figure 5-2, item 4) on to pressure switch cable (figure 5-2, item 6). Install cable connection nuts (figure 5-2, item 4) on to main power supply cable (figure 5-2, item 7).
 - (g) Install all electrical leads from pressure switch and motor. Screw connection screws (figure 5-2, item 2) down on to wire leads (figure 5-2, item 3) by turning them clockwise.
- g. Pressure Switch Replacement (figure 5-3).

WARNING

Disconnect unit from main power supply before servicing, replacing or repairing parts of equipment, to avoid personal injury.

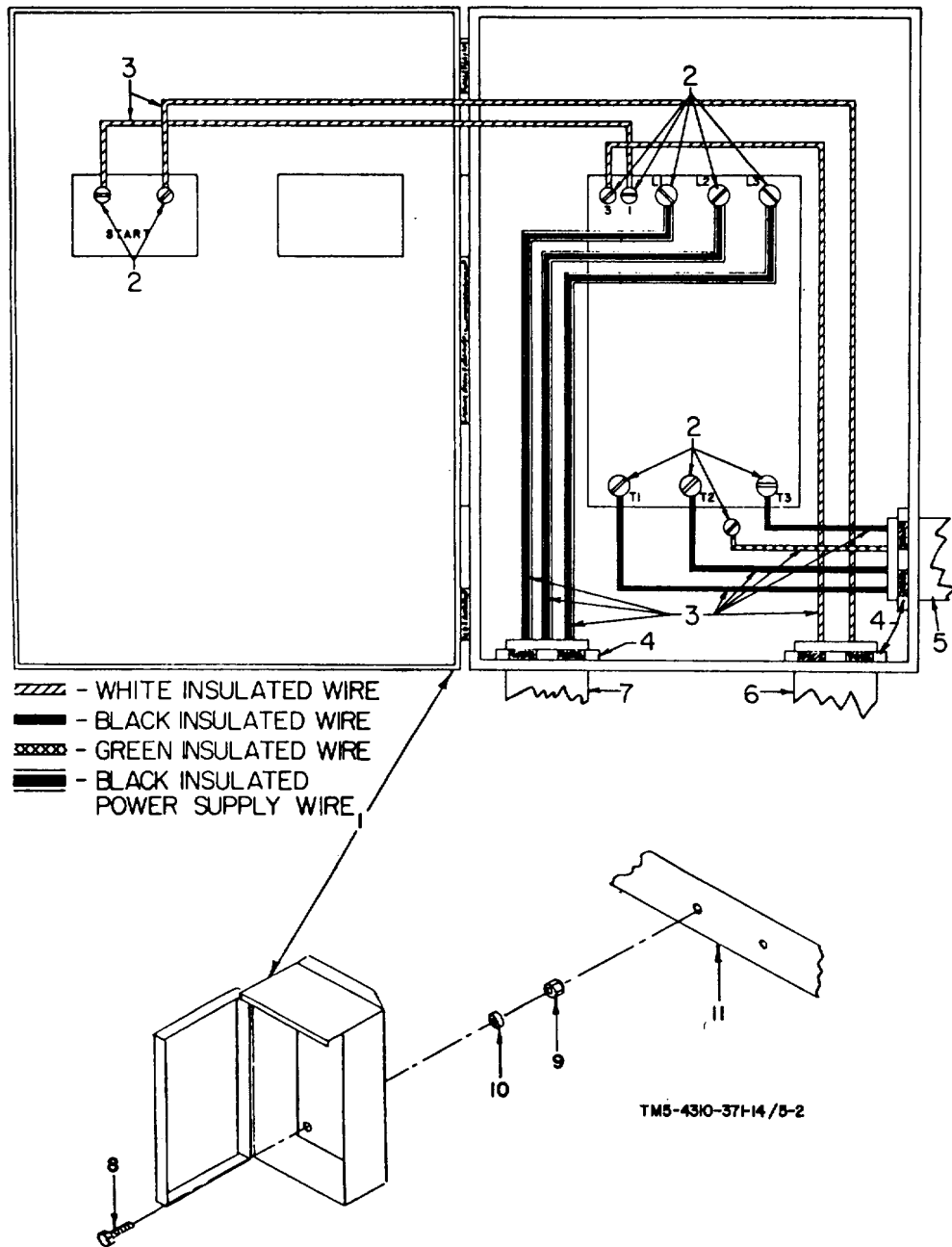

FIGURE 5-2. STARTER SWITCH REPLACEMENT

WARNING

Release pressure from air receiver and compressor pump before inspection, performing procedures, or disassembly of equipment to avoid personal injury.

- (1) Remove pressure switch cover by removing pressure switch cover nut. Disconnect wire lugs (figure 5-3).
- (2) Remove pressure switch cable by removing cable connection nut. (Figure 5-3).
- (3) To remove pressure switch, turn hex fitting at bottom of switch counter clockwise until disconnected from air receiver (figure 5-3).
- (4) To install pressure switch onto air receiver nipple, apply thread tape or thread compound and tighten hex fitting at bottom of switch clockwise (figure 5-3).
- (5) Reconnect wire lugs and replace switch cover (figure 5-3).
- (6) Connect to power supply, start compressor and check pressure switch for proper adjustment. (Paragraph 4-8 and Figure 4-5)

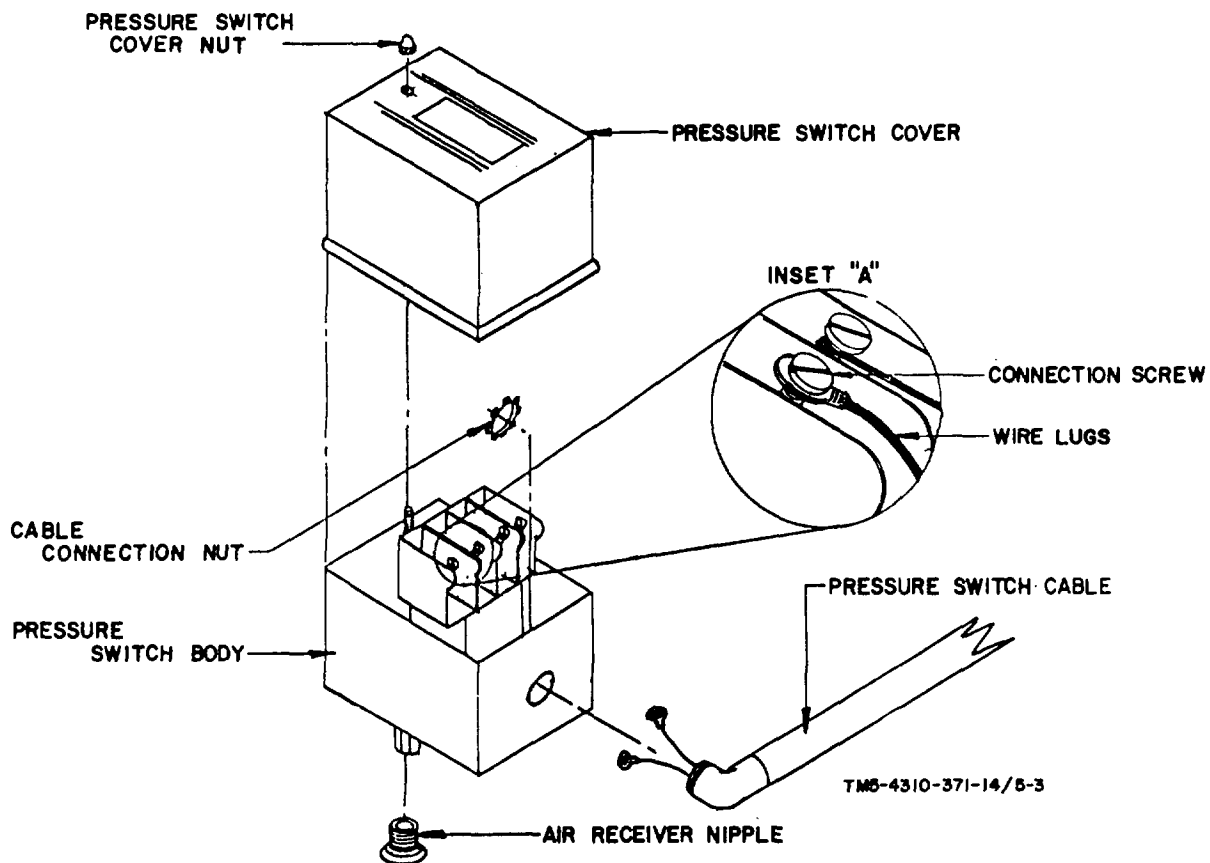

FIGURE 5-3. PRESSURE SWITCH REPLACEMENT

5-3. MANIFOLD AND TUBING ASSEMBLIES.

WARNING

Disconnect compressor unit from main power supply before servicing, replacing or repairing parts of equipment, to avoid personal injury.

WARNING

Release air pressure from air receiver and compressor pump before inspection, performing procedures or disassembly of equipment to avoid personal injury.

a. Disassembly

(1) Air Inlet Filters and Tubing

- (a) Remove air inlet filters (figure 5-4, item 1) by turning slotted set screw (figure 5-4, item 2) counter clockwise.
- (b) Remove breather tube assembly (figure 5-5, item 1) by removing compression nuts (figure 5-5, item 2). Remove breather tube (figure 5-5, item 3) from left low pressure intake manifold (figure 5-5, item 4) and straight compression body (figure 5-5, item 5).
- (c) Remove release valve tube assembly (figure 5-5, item 6) by removing compression nuts (figure 5-5, item 2). Remove release valve tube (figure 5-5, item 8) from right high pressure exhaust manifold (figure 5-5, item 9) and compression body (figure 5-5, item 10).
- (d) Remove intercooler tube #1 (figure 5-4, item 3) from left low pressure exhaust manifold (figure 5-4, item 15) and from right high pressure intake manifold (figure 5-5, item 13). Turn compression nuts (figure 5-4, item 8) counter clockwise. Also, remove ferrules (figure 5-4, item 9) at this time.
- (e) Remove intercooler tube #2 (figure 5-4, item 4) from left high pressure intake manifold (figure 5-4, item 16) and right low pressure exhaust manifold (figure 5-5, item 14). Turn compression nuts (figure 5-4, item 8) counter clockwise. Also remove ferrules (figure 5-4, item 9) at this time.
- (f) Remove right aftercooler tube (figure 5-4, item 5) from right high pressure exhaust manifold (figure 5-4, item 17). Turn compression nut (figure 5-4, item 8) counter clockwise. Remove ferrules (figure 5-4, item 9).
- (g) Remove left aftercooler tube (figure 5-4, item 6) from left high pressure exhaust manifold (figure 5-4, item 14). Turn compression nut (figure 5-4, item 8) counter clockwise and also remove ferrule (figure 5-4, item 9).

- (h) Disconnect aftercooler tubes (figure 5-4, items 5 and 6) from aftercooler manifold (figure 5-4, item 7). Turn compression nuts (figure 5-4, item 8) counter clockwise. Remove ferrules (figure 5-4, item 9).

(2) Manifold Assemblies

- (a) Remove pipe plug (figure 5-4, item 10) from aftercooler manifold (figure 5-4, item 7), if aftercooler manifold is blocked or has particles in it.
- (b) Remove safety valves (figure 5-4, item 11 and figure 5-5, item 12) from left high pressure intake manifold (figure 5-4, item 16) and from right high pressure intake manifold (figure 5-5, item 13) by turning them counter clockwise.
- (c) Remove left low pressure intake manifold (figure 5-4, item 13 and figure 5-5, item 4). Turn manifold screws (figure 5-4, item 12 and figure 5-5, item 11) counter clockwise.
- (d) Remove left high pressure exhaust manifold (figure 5-4, item 14 and figure 5-5, item 15). Turn manifold screws (figure 5-4, item 12 and figure 5-5, item 11) counter clockwise.
- (e) Remove left low pressure exhaust manifold (figure 5-4, item 15) by turning manifold screws (figure 5-4, item 12) counter clockwise.
- (f) Remove left high pressure intake manifold (figure 5-4, item 16) by turning manifold screws (figure 5-4, item 12) counter clockwise.
- (g) Remove right high pressure exhaust manifold (figure 5-4, item 17) by turning manifold screws (figure 5-4, item 12) counter clockwise.
- (h) Remove right low pressure intake manifold (figure 5-4, item 18) by turning manifold screws (figure 5-4, item 12) counter clockwise.
- (j) Remove right high pressure intake manifold (figure 5-5, item 14) by turning manifold screws (figure 5-5, item 11) counter clockwise.
- (k) Remove right low pressure exhaust manifold (figure 5-5, item 14) by turning manifold screws (figure 5-5, item 11) counter clockwise.

(3) Unloader Muffler Assembly

- (a) Remove unloader muffler assembly (figure 5-5, item 16).
- (b) Unloader muffler disassembly order.
 - 1 Unloader muffler body (figure 5-5, item 17).
 - 2 Screen (figure 5-5, item 18).
 - 3 Felt filter (figure 5-5, item 19).

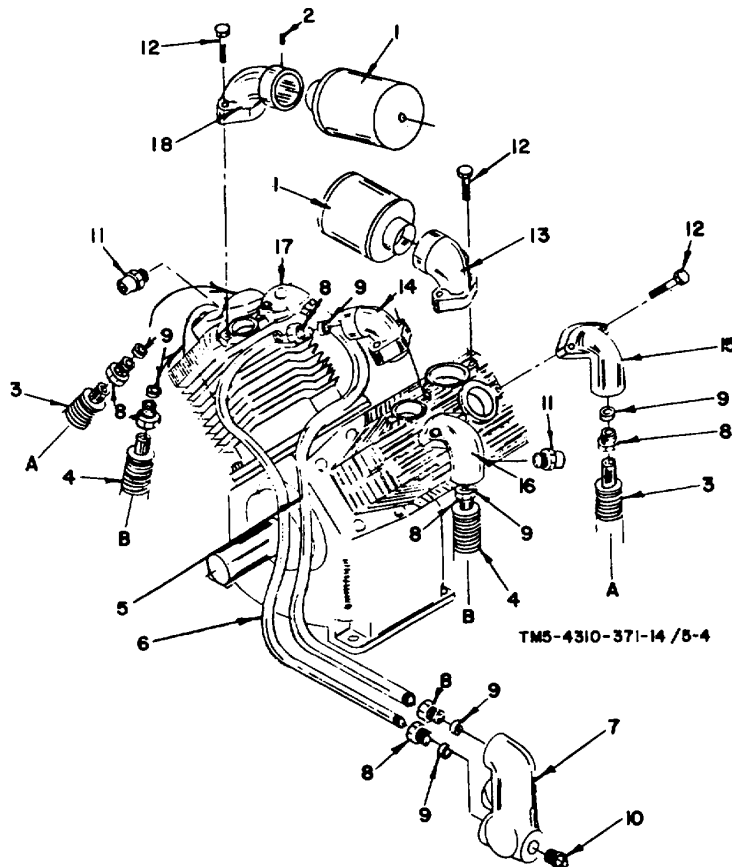

- | | |
|--|---|
| <ul style="list-style-type: none"> 1. Air Inlet Filter 2. Slotted Set Screw 3. Intercooler Tube #1 4. Intercooler Tube #2 5. Right Aftercooler Tube 6. Left Aftercooler Tube 7. Aftercooler Manifolds 8. Compression Nuts 9. Ferrules | <ul style="list-style-type: none"> 10. Pipe Plug 11. Safety Valve 12. Manifold Screws 13. Left L.P. Intake Manifold 14. Left H.P. Exhaust Manifold 15. Left L.P. Exhaust Manifold 16. Left H.P. Intake Manifold 17. Right H.P. Exhaust Manifold 18. Right L.P. Intake Manifold |
|--|---|

FIGURE 5-4. MANIFOLD AND TUBING ASSEMBLIES

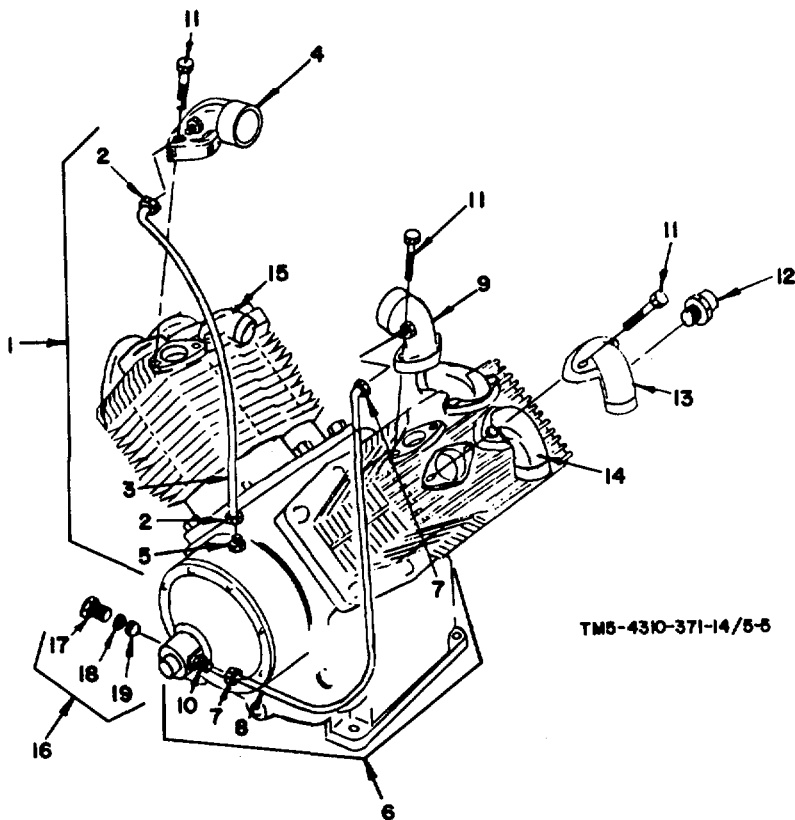

- | | |
|--------------------------------|---------------------------------|
| 1. Breather Tube Assembly | 10. Compression Body |
| 2. Compression Nuts | 11. Manifold Screws |
| 3. Breather Tube | 12. Safety Valves |
| 4. Left L.P. Intake Manifold | 13. Right H.P. Intake Manifold |
| 5. Straight Compression Body | 14. Right L.P. Exhaust Manifold |
| 6. Release Valve Tube Assembly | 15. Left H.P. Exhaust Manifold |
| 7. Right H.P. Exhaust Manifold | 16. Unloader Muffler Assembly |
| 8. Release Valve Tube | 17. Unloader Muffler Body |
| 9. Right H.P. Exhaust Manifold | 18. Screen |
| | 19. Felt Filter |

FIGURE 5-5. MANIFOLD AND TUBING ASSEMBLIES

b. Cleaning, Inspection, Repair or Replacement of Parts

WARNING

Dry cleaning solvent, P-D-680, used to clean parts is potentially dangerous to personnel and property. Use in well ventilated area as the fumes are dangerous if inhaled. Avoid repeated and prolonged skin contact. Do not use near open flame or excessive heat. Flash point of solvent is 100°F 138°F (38°C 59°C).

- (1) All parts to be thoroughly cleaned with P-D-680 solvent, and then air dried.

- (2) Inspect all parts for cracks, breaks, fissures, scores, distortions or any other damage.
- (3) Repair or replace any damaged parts.

c. Reassembly

(1) Unloader Muffler Assembly

(a) Unloader Muffler Reassembly Order

- 1 Felt filter (figure 5-5, item 19)
- 2 Screen (figure 5-5, item 18)
- 3 Unloader muffler body (figure 5-5, item 17)

(b) Install unloader muffler assembly (figure 5-5, item 16)

(2) Manifold Assemblies

- (a) Install right low pressure exhaust manifold (figure 5-5, item 14) by turning manifold screws (figure 5-5, item 11) clockwise.
- (b) Install right high pressure intake manifold (figure 5-5, item 13) by turning manifold screws (figure 5-5, item 11) clockwise.
- (c) Install right low pressure intake manifold (figure 5-4, item 18) by turning manifold screws (figure 5-4, item 12) clockwise.
- (d) Install right high pressure exhaust manifold (figure 5-4, item 17) by turning manifold screws (figure 5-4, item 12) clockwise.
- (e) Install left high pressure intake manifold (figure 5-4, item 16) by turning manifold screws (figure 5-4, item 12) clockwise.
- (f) Install left low pressure exhaust manifold (figure 5-4, item 15) by turning manifold screws (figure 5-4, item 12) clockwise.
- (g) Install left high pressure exhaust manifold (figure 5-4, item 14 and figure 5-5, item 15). Turn manifold screws (figure 5-4, item 12 and figure 5-5, item 11) clockwise.
- (h) Install left low pressure intake manifold (figure 5-4, item 13 and figure 5-5, item 4). Turn manifold screws (figure 5-4, item 12 and figure 5-5, item 11) clockwise.
- (j) Install safety valves (figure 5-4, item 11 and figure 5-5, item 11) on to right high pressure intake manifold (figure 5-5, item 7) and left high pressure intake manifold (figure 5-4, item 16).
- (k) Install pipe plug (figure 5-4, item 10) into aftercooler manifold (figure 5-4, item 7) if aftercooler manifold has been disassembled for cleaning.

(3) Air Inlet Filters and Tubing

- (a) Install aftercooler tubes (figure 5-4, item 5 and 6) to aftercooler manifold (figure 5-4, item 7). Turn compression nuts (figure 5-4, item 8) counter clockwise. Also replace ferrules (figure 5-4, item 9) if necessary.
- (b) Install left aftercooler tube (figure 5-4, item 6) to left high pressure exhaust manifold (figure 5-4, item 14). Turn compression nut (figure 5-4, item 8) clockwise. Also replace ferrules (figure 5-4, item 9) if necessary.
- (c) Install right aftercooler tube (figure 5-4, item 5) to right high pressure exhaust manifold (figure 5-4, item 17). Turn compression nut (figure 5-4, item 8) clockwise. Also, replace ferrules (figure 5-4, item 9) if necessary.
- (d) Install intercooler tube #2 (figure 5-4, item 4) to left high pressure intake manifold (figure 5-4, item 16) and right low pressure exhaust manifold (figure 5-5, item 14). Turn compression nuts (figure 5-4, item 8) clockwise. Also replace ferrules (figure 5-4, item 9) if necessary.
- (e) Install intercooler tube #1 (figure 5-4, item 3) to left low pressure exhaust manifold (figure 5-4, item 15) and to right high pressure intake manifold (figure 5-5, item 13). Turn compression nuts (figure 5-4, item 9).
- (f) Install release valve tube (figure 5-5, item 8) to right high pressure exhaust manifold (figure 5-5, item 9). Reconnect compression body (figure 5-5, item 9). Reconnect compression body (figure 5-5, item 10). Install compression nuts (figure 5-5, item 7).
- (g) Install breather tube (figure 5-5, item 3) to left low pressure intake manifold (figure 5-5, item 4) and straight compression body (figure 5-5, item 5). Install compression nuts (figure 5-5, item 2).
- (h) Install air inlet filters (figure 5-4, item 1). Turn slotted set screws (figure 5-4, item 2) counter clockwise. One air inlet filter must be placed in left low pressure intake manifold (figure 5-4, item 13). The other in the right low pressure intake manifold (figure 5-4, item 18).

5-4. VALVE ASSEMBLIES.

WARNING

Disconnect compressor unit from main power supply before servicing, replacing or repairing parts of equipment, to avoid personal injury.

WARNING

Release air pressure from air receiver and compressor pump before inspection, performing procedures or disassembly of equipment, to avoid personal injury.

a. Disassembly

- (1) Remove right and left low pressure intake valve assemblies (figure 5-6, item 1) and disassemble for inspection.
- (2) Low pressure intake valve disassembly order.
 - (a) Fillister head steel machine screw with washer (figure 5-6, item 2)
 - (b) Intake valve seat (figure 5-6, item 3)
 - (c) Valve disc (figure 5-6, item 4)
 - (d) Valve spring (figure 5-6, item 5)
 - (e) Intake valve cage (figure 5-6, item 6)
 - (f) Valve gasket (figure 5-6, item 7)
- (3) Remove right and left low pressure exhaust valve assemblies (figure 5-6, item 8) and disassemble for inspection.
- (4) Low pressure intake valve disassembly order.
 - (a) Fillister head steel machine screw with washer (figure 5-6, item 9)
 - (b) Valve gasket (figure 5-6, item 10)
 - (c) Exhaust valve cage (figure 5-6, item 11)
 - (d) Valve spring (figure 5-6, item 12)
 - (e) Valve disc (figure 5-6, item 13)
 - (f) Exhaust valve seat (figure 5-6, item 14)
 - (g) Valve gasket (figure 5-6, item 15)
- (5) Remove right and left high pressure intake valve assemblies (figure 5-6, item 16) and disassemble for inspection.
- (6) High pressure intake valve disassembly order.
 - (a) Fillister head steel machine screw with washer (figure 5-6, item 17)
 - (b) Valve gasket (figure 5-6, item 18)

- (c) Intake valve seat (figure 5-6, item 19)
 - (d) Valve disc (figure 5-6, item 20)
 - (e) Valve spring (figure 5-6, item 21)
 - (f) Intake valve cage (figure 5-6, item 22)
 - (g) Valve gasket (figure 5-6, item 23)
- (7) Remove high pressure exhaust valve assemblies (figure 5-6, item 24) and disassemble for inspection.
- (8) High pressure exhaust valve disassembly order.
- (a) Fillister head steel machine screw with washer (figure 5-6, item 25)
 - (b) Valve gasket (figure 5-6, item 26)
 - (c) Exhaust valve cage (figure 5-6, item 27)
 - (d) Valve spring (figure 5-6, item 28)
 - (e) Valve disc (figure 5-6, item 29)
 - (f) Exhaust valve seat (figure 5-6, item 30)
 - (g) Valve gasket (figure 5-6, item 31)

b. Cleaning, Inspection, Repair or Replacement of Parts

WARNING

Dry cleaning solvent, P-D-680, used to clean parts is potentially dangerous to personnel and property. Use in a well ventilated area as the fumes are dangerous if inhaled. Avoid repeated and prolonged skin contact. Do not use near open flame or excessive heat. Flash point of solvent is 100°F 138°F (38°C 59°C).

- (1) All parts to be thoroughly cleaned with P-D-680 solvent, and then air dried.
- (2) Inspect all parts for cracks, breaks, fissures, scores, distortions or any other damage.
- (3) Replace any damaged parts.

c. Reassembly

- (1) High pressured exhaust valve reassembly.
 - (a) Valve gasket (figure 5-6, item 31)

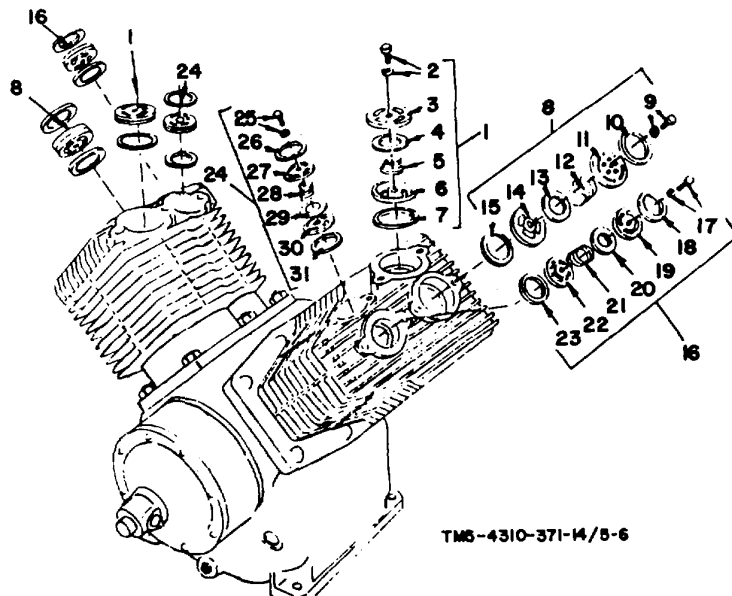

TMS-4310-371-14/5-6

- | | |
|---|---|
| <ol style="list-style-type: none"> 1. Right and left low pressure intake valve assembly. 2. Fillister head steel machine screw with washer 3. Intake valve seat 4. Valve disc 5. Valve spring 6. Intake valve cage 7. Valve gasket 8. Right and left low pressure exhaust valve assembly 9. Fillister head steel machine screw with washer 10. Valve gasket 11. Exhaust valve cage 12. Valve spring 13. Valve disc 14. Exhaust valve seat 15. Valve gasket | <ol style="list-style-type: none"> 16. Right and left high pressure intake valve assembly 17. Fillister head steel machine screw with washer 18. Valve gasket 19. Intake valve seat 20. Valve disc 21. Valve spring 22. Intake valve cage 23. Valve gasket 24. Right and left high pressure exhaust valve assembly 25. Fillister head steel machine screw with washer 26. Valve gasket 27. Exhaust valve cage 28. Valve spring 29. Valve disc 30. Exhaust valve seat 31. Valve gasket |
|---|---|

FIGURE 5-6. VALVE ASSEMBLY

- (b) Exhaust valve seat (figure 5-6, item 30)
- (c) Valve disc (figure 5-6, item 29)
- (d) Valve spring (figure 5-6, item 28)
- (e) Exhaust valve cage (figure 5-6, item 27)

- (f) Valve gasket (figure 5-6, item 26)
- (g) Fillister head steel machine screw with washer (figure 5-6, item 25)
- (2) Install high pressure exhaust valve assembly (figure 5-6, item 24)
- (3) High pressure intake valve reassembly
 - (a) Valve gasket (figure 5-6, item 23)
 - (b) Intake valve cage (figure 5-6, item 22)
 - (c) Valve spring (figure 5-6, item 21)
 - (d) Valve disc (figure 5-6, item 20)
 - (e) Intake valve seat (figure 5-6, item 19)
 - (f) Valve gasket (figure 5-6, item 18)
 - (g) Fillister head steel machine screw with washer (figure 5-6, item 17)
- (4) Install high pressure intake valve assembly (figure 5-6, item 16)
- (5) Low pressure exhaust valve reassembly
 - (a) Valve gasket (figure 5-6, item 15)
 - (b) Exhaust valve seat (figure 5-6, item 14)
 - (c) Valve disc (figure 5-6, item 13)
 - (d) Valve spring (figure 5-6, item 12)
 - (e) Exhaust valve gasket (figure 5-6, item 11)
 - (f) Valve gasket (figure 5-6, item 10)
 - (g) Fillister head steel machine screw with washer (figure 5-6, item 9)
- (6) Install low pressure exhaust valve assembly (figure 5-6, item 8)
- (7) Low pressure intake valve reassembly
 - (a) Valve gasket (figure 5-6, item 7)
 - (b) Intake valve cage (figure 5-6, item 6)
 - (c) Valve spring (figure 5-6, item 5)
 - (d) Valve disc (figure 5-6, item 4)
 - (e) Intake valve seat (figure 5-6, item 3)

(f) Fillister head steel machine screw with washer (figure 5-6, item 2)

(8) Install low pressure intake valve assembly (figure 5-6, item 1)

5-5. CYLINDER, PISTON AND CONNECTING ROD ASSEMBLIES.

a. Disassembly

(1) Cylinders

(a) Remove hex steel cap screws (figure 5-7, item 1) by turning them counter clockwise.

(b) Remove cylinders (figure 5-7, item 2) and cylinder flange gasket (figure 5-7, item 3).

(2) Pistons

(a) Remove piston pin retaining rings (figure 5-7, item 4)

(b) Remove piston pin (figure 5-7, item 5)

(c) Remove high pressure piston (figure 5-7, item 6) and low pressure piston (figure 5-7, item 7)

(3) Connecting Rods

(a) Remove connecting rod bolts (figure 5-7, item 8) by turning them counter clockwise.

(b) Remove connecting rods (figure 5-7, item 9)

(c) Remove piston pin bearing (figure 5-7, item 10)

(d) Remove oil dippers (figure 5-7, item 11)

(e) Remove high pressure piston ring set(s) (figure 5-7, item 12)

(f) Remove low pressure piston ring set(s) (figure 5-7, item 13)

b. Cleaning, Inspection, Repair or Replacement of Parts

WARNING

Dry cleaning solvent, P-D-680, used to clean parts is potentially dangerous to personnel and property. Use in a well ventilated area as the fumes are dangerous if inhaled. Avoid repeated and prolonged contact. Do not use near open flame or excessive heat. Flash point of solvent is 100°F 138°F (38°C 59°C).

(1) All parts to be thoroughly cleaned with P-D-680 solvent, and then air dried.

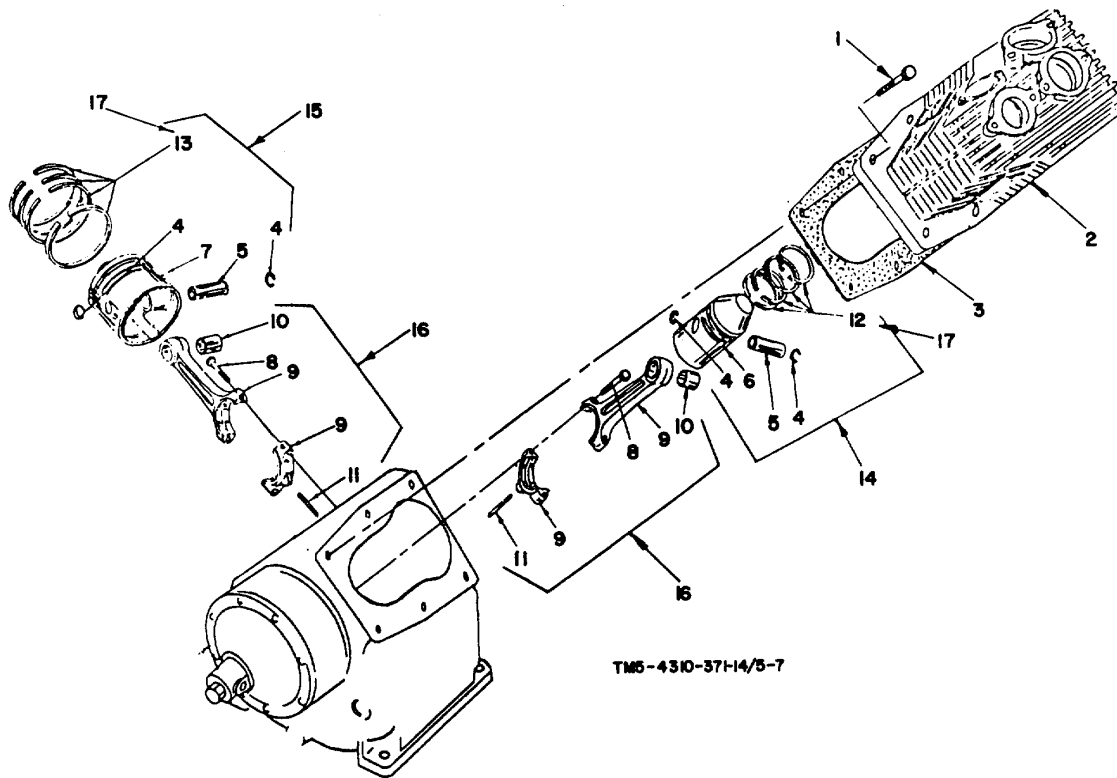

- | | |
|-------------------------------|---------------------------------|
| 1. Hex steel cap screw | 10. Piston pin bearing |
| 2. Cylinder | 11. Oil dippers |
| 3. Cylinder flange gasket | 12. H.P. Piston ring set |
| 4. Piston Pin Retaining rings | 13. L.P. Piston ring set |
| 5. Piston Pin | 14. H.P. Piston assembly kit |
| 6. High pressure piston | 15. L.P. Piston assembly kit |
| 7. Low pressure piston | 16. Connecting rod assembly kit |
| 8. Connecting rod bolts | 17. Complete pump ring set |
| 9. Connecting rods | |

FIGURE 5-7. CYLINDER, PISTON AND CONNECTING ROD ASSEMBLY

- (2) Inspect all parts for cracks, breaks, fissures, scores, distortions or any other damage.
- (3) Inspect all parts for serviceable tolerance. (see Table 5-2)
- (4) Repair or replace any damaged parts.

c. Reassembly

- (1) Connecting Rods

- (a) Install low pressure piston ring set(s) (figure 5-7, item 13)
- (b) Install high pressure piston ring set(s) (figure 5-7, item 12)
- (c) Install oil dippers (figure 5-7, item 11) by pressing them into bottom of connecting rods (figure 5-7, item 9)
- (d) Install piston pin bearing (figure 5-7, item 10)
- (e) Install connecting rods (figure 5-7, item 9) by bolting them together around crankshaft using connecting rod bolts (figure 5-7, item 8) tightened each to 230 in. lbs. (41,078 gr. cm).

(2) Pistons

- (a) Install on to connecting rods low pressure piston (figure 5-7, item 7) and high pressure piston (figure 5-7, item 6).
- (b) Install piston pin (figure 5-7, item 5).
- (c) Install piston pin retaining rings (figure 5-7, item 4).

(3) Cylinders

- (a) Replace cylinder flange gasket (figure 5-7, item 3), and install gasket and cylinder (figure 5-7, item 2).
- (b) Install hex steel cap screws (figure 5-7, item 1) and tighten to 470 in. lbs. (83,942 gr. cm).

5-6. GOVERNOR AND RELEASE VALVE ASSEMBLY

a. Disassembly

(1) Release Valve Assembly

- (a) Turn release valve cap (figure 5-7, item 7) until it is removed.
- (b) Remove release valve spring (figure 5-8, item 2).
- (c) Remove release valve ball (figure 5-8, item 3).
- (d) Remove release valve body (figure 5-8, item 4).
- (e) Remove release valve body gasket (figure 5-8, item 5).
- (f) Remove release valve plunger sleeve (figure 5-8, item 6).
- (g) Remove release valve plunger (figure 5-8, item 7).

(2) Governor

- (a) Turn fillister head machine screws (8) (figure 5-8, item 8) counter clockwise until removed.

- (b) Remove governor housing cover (figure 5-8, item 9).
- (c) Remove governor cover gasket (figure 5-8, item 10).
- (d) Remove spring sleeve (figure 5-8, item 11).
- (e) Remove governor main spring (figure 5-8, item 12).
- (f) Remove flat steel washer (figure 5-8, item 13).
- (g) Remove hex steel cap screw (figure 5-8, item 14).
- (h) Remove spring lockwasher (figure 5-8, item 15).
- (j) Remove governor weight pins (figure 5-8, item 16).
- (k) Remove governor weight (figure 5-8, item 17).
- (l) Remove governor weight spindle (figure 5-8, item 18).

(3) Upper Governor Housing

- (a) Remove hex steel cap screws (4) (figure 5-8, item 19).
- (b) Remove governor baffle plate (figure 5-8, item 20).
- (c) Remove upper governor housing (figure 5-8, item 21).
- (d) Remove governor housing gasket set (figure 5-8, item 22).

b. Cleaning, Inspection, Repair or Replacement of Parts

WARNING

Dry cleaning solvent, P-D-680, used to clean parts is potentially dangerous to personnel and property. Use in a well ventilated area as the fumes are dangerous if inhaled. Avoid repeated and prolonged skin contact. Do not use near open flame or excessive heat. Flash point of solvent is 100° F 138° F (38° C 59° C).

- (1) All parts to be thoroughly cleaned with P-D-680 solvent, and then air dried.
- (2) Inspect all parts for cracks, breaks, fissures, scores, distortions or any other damage.
- (3) Repair or replace any damaged parts.

c. Reassembly

- (1) Upper Governor Housing

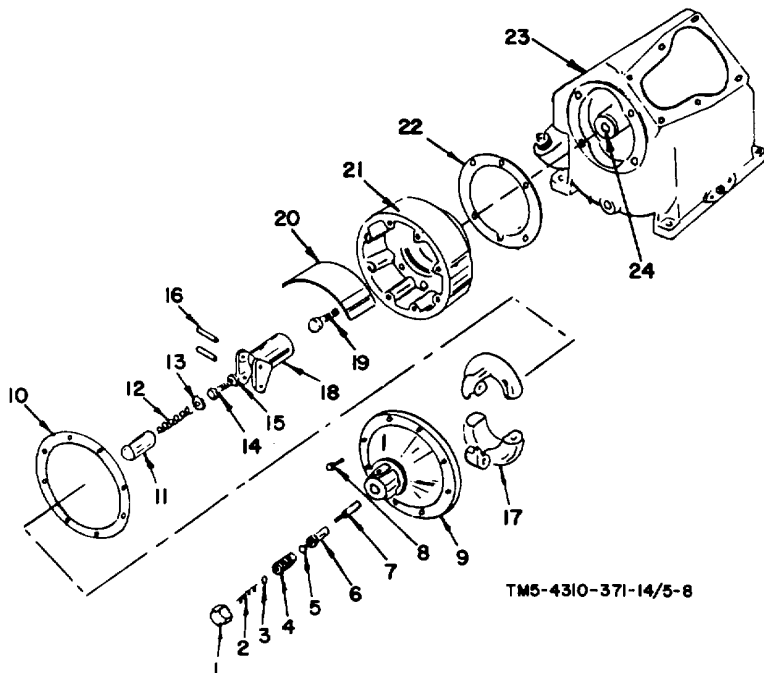

- | | |
|----------------------------------|---------------------------------|
| 1. Release valve cap | 13. Flat steel washer |
| 2. Release valve spring | 14. Hex steel cap screws |
| 3. Release valve ball | 15. Spring lockwasher |
| 4. Release valve body | 16. Governor weight pins |
| 5. Release valve body gasket | 17. Governor weight |
| 6. Release valve plunger sleeve | 18. Governor weight spindle |
| 7. Release valve plunger | 19. Hex steel cap screws |
| 8. Fillister head machine screws | 20. Governor baffle plate |
| 9. Governor housing cover | 21. Upper governor housing |
| 10. Governor cover gasket | 22. Governor housing gasket set |
| 11. Spring sleeve | 23. Crankcase |
| 12. Governor main spring | 24. Main bearing |

FIGURE 5-8. RELEASE VALVE ASSEMBLY AND GOVERNOR

- (a) Install upper governor housing (figure 5-8, item 21) to crankcase (figure 5-8, item 23) leaving out the governor housing gasket set (figure 5-8, item 22). Attach the housing to the crankcase with one hex steel cap screw (figure 5-8, item 19) at the top and one at the bottom. Be sure the main bearing (figure 5-8, item 24) fits properly in the housing (figure 5-8, item 21). Set the two attaching screws finger tight. Use a feeler gage, measure the gap between the housing (figure 5-8, item 21) and crankcase (figure 5-8, item 23) at the top and bottom of the housing (figure 5-8, item 21). Average the two dimensions and add 0.005 inch (0.0127 cm). This will determine the selection of gaskets (figure 5-8, item 22) to use. A combination of gaskets should equal the total dimension above. Proper adherence to this procedure will minimize crankshaft end play.

- (b) Install new governor housing gasket set (figure 5-8, item 22) and reinstall upper governor housing (figure 5-8, item 21).
- (c) Install hex steel cap screws (4) (figure 5-8, item 19) and torque to 550 in. lbs. (98,23 gr. cm). Install governor baffle plate (figure 5-8, item 20) at this time.

(2) Release Valve Assembly

- (a) Install release valve plunger (figure 5-8, item 7).
- (b) Install release valve plunger sleeve (figure 5-8, item 7).
- (c) Install release valve body gasket (figure 5-8, item 5).
- (d) Install release valve body (figure 5-8, item 4).
- (e) Install release valve ball (figure 5-8, item 3).
- (f) Install release valve spring (figure 5-8, item 2).
- (g) Install release valve cap (figure 5-8, item 1).

(3) Governor

- (a) Install governor weight spindle (figure 5-8, item 18).
- (b) Install governor weight (figure 5-8, item 17).
- (c) Install governor weight pins (figure 5-8, item 16).
- (d) Install spring lockwasher (figure 5-8, item 15).
- (e) Install hex steel cap screw (figure 5-8, item 14).
- (f) Install flat steel washer (figure 5-8, item 13).
- (g) Install governor main spring (figure 5-8, item 12).
- (h) Install spring sleeve (figure 5-8, item 11)
- (j) Install governor cover gasket (figure 5-8, item 10).
- (k) Install governor housing cover (figure 5-8, item 9).
- (l) Install fillister head machine screws (8) (figure 5-8, item 8).

5-7. CRANKCASE ASSEMBLY.

a. Disassembly

- (1) If visible sight oil level gage (figure 5-9, item 1) is damaged in any way, remove by prying it out.

- (2) Remove oil filler pipe plug (figure 5-9, item 2) by turning it counter clockwise.
- (3) Removal of oil drain cap (figure 5-9, item 3) and oil drain pipe (figure 5-9, item 4). To remove, turn items counter clockwise.
- (4) Remove crankcase pipe plug (figure 5-9, item 5) by turning it counter clockwise.
- (5) Remove crankshaft assembly (figure 5-9, item 6).
- (6) Remove oil seal (figure 5-9, item 8) from crankcase (figure 5-9, item 7).
- (7) Remove flywheel end main bearing cup (figure 5-9, item 9).
- (8) Remove flywheel end main bearing cone and roller (figure 5-9, item 10).
- (9) Remove governor end main bearing cup (figure 5-9, item 11).
- (10) Remove governor end main bearing cone and roller (figure 5-9, item 12).

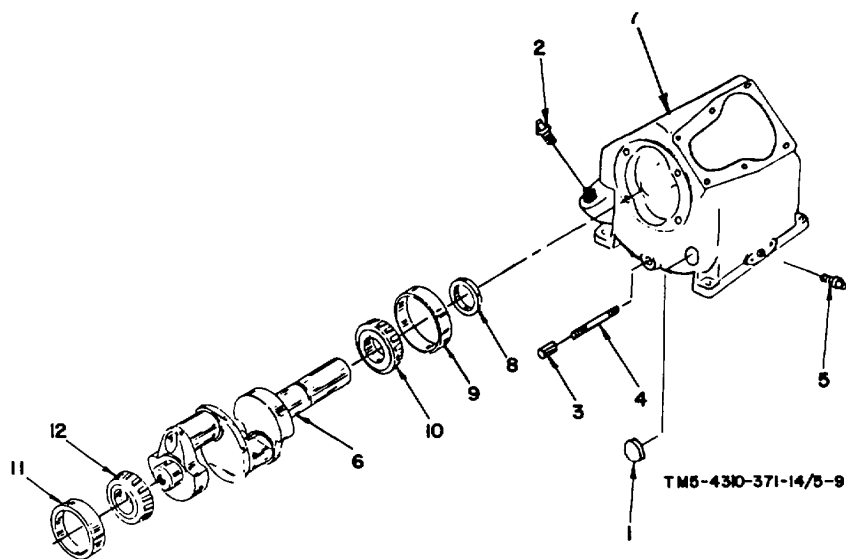

- | | |
|---------------------------------|---|
| 1. Visible sight oil level gage | 7. Crankcase |
| 2. Oil filler pipe plug | 8. Oil seal |
| 3. Oil drain cap | 9. Flywheel end main bearing cup |
| 4. Oil drain pipe | 10. Flywheel end main bearing cone & roller |
| 5. Crankcase pipe plug | 11. Governor end main bearing cup |
| 6. Crankshaft Assembly | 12. Governor end main bearing cone & roller |

FIGURE 5-9. CRANKCASE ASSEMBLY

b. Cleaning, Inspection, Repair or Replacement of Parts

WARNING

Dry cleaning solvent, P-D-680, used to clean parts is potentially dangerous to personnel and property. Use in a well ventilated area as the fumes are dangerous if inhaled. Avoid repeated and prolonged skin contact. Do not use near open flame or excessive heat. Flash point of solvent is 100°F - 138°F (38°C - 59°C).

- (1) All parts to be thoroughly cleaned with P-D-680 solvent, and then air dried.
- (2) Inspect all parts for cracks, breaks, fissures, scores, distortions or any other damage.
- (3) Inspect all parts for serviceable tolerances. (see Table 5-2.)
- (4) Repair or replace any damaged parts.

c. Reassembly

- (1) Install governor end main bearing cone and roller (figure 5-9, item 12).
- (2) Install governor end main bearing cup (figure 5-9, item 11).
- (3) Install flywheel end main bearing cone and roller (figure 5-9, item 10).
- (4) Install flywheel end main bearing cup (figure 5-9, item 9).
- (5) Install oil seal (figure 5-9, item 8) into crankcase (figure 5-9, item 7).
- (6) Install crankshaft assembly (figure 5-9, item 6) in crankcase (figure 5-9, item 7).
- (7) Install crankcase pipe plug (figure 5-9, item 5) by turning it clockwise and tighten.
- (8) Install oil drain cap (figure 5-9, item 3) and oil drain pipe (figure 5-9, item 4). Turn items clockwise and tighten.
- (9) Install oil filler pipe plug (figure 5-9, item 2) by turning it clockwise and tighten.
- (10) Install new visible sight oil level gage (figure 5-9, item 1) into mounting hole on crankcase (figure 5-9, item 7) by pressing visible sight oil level gage (figure 5-9, item 1) firmly.

5-8. SAFETY VALVE TESTING AND REPLACEMENT.

WARNING

Disconnect compressor unit from main power supply before servicing, replacing or repairing parts of equipment, to avoid personal injury.

WARNING

Release air pressure from air receiver and compressor pump before inspection, performing procedures or disassembly of equipment, to avoid personal injury.

- a. To remove safety valve, turn valve at base counter clockwise (figure 5-10, item 1) until free.
- b. To test, connect safety valve to a test unit. Valve must allow air to escape at 200 PSI (1380 KPa) to be properly working.
- c. To install, turn safety valve at base clockwise and tighten (figure 5-10, item 1), into mounting tee (figure 5-10, item 2) atop of air receiver (figure 5-10, item 3).

5-9. CHECK VALVE TESTING AND REPAIR

WARNING

Disconnect compressor unit from main power supply before servicing, replacing or repairing parts of equipment, to avoid personal injury.

WARNING

Release air pressure from air receiver and compressor pump before inspection, performing procedures, or disassembly of equipment to avoid personal injury.

- a. To test check valve, remove valve and connect to test unit to see if valve (figure 5-11) is closing off after air passes through it or if air is backing through valve under pressure.
- b. Disassembly
 - (1) Remove cap (figure 5-11, item 1) by turning it counter clockwise off of body (figure 5-11, item 7).
 - (2) Remove gasket (figure 5-11, item 2) from inside body (figure 5-11, item 7).
 - (3) Remove spring (figure 5-11, item 3) from inside body (figure 5-11, item 7).
 - (4) Remove disc (figure 5-11, item 4) from inside body (figure 5-11, item 7).

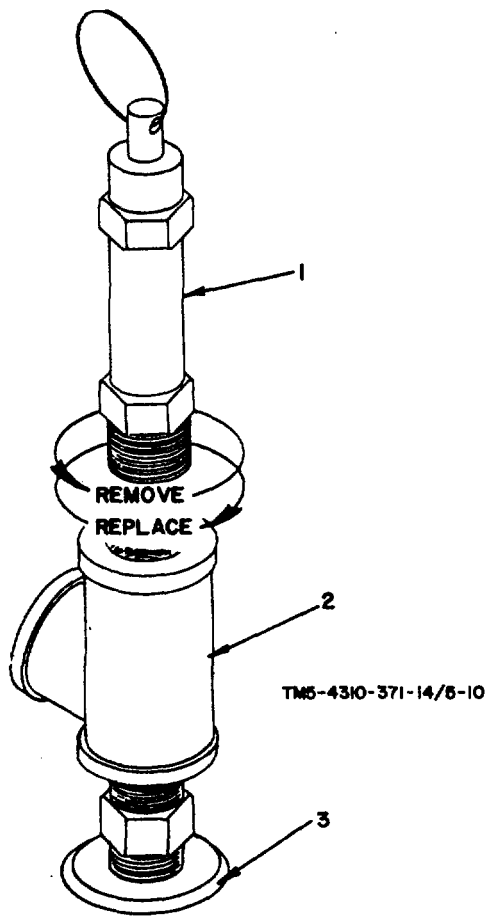

- 1. Safety Valve
- 2. Mounting Tee
- 3. Air Receiver

FIGURE 5-10. SAFETY VALVE REMOVAL AND REPLACEMENT

- (5) Remove seat (figure 5-11, item 5) from inside body (figure 5-11, item 7).
- (6) Remove guide (figure 5-11, item 6) from inside body (figure 5-11, item 7).

c. Cleaning, Inspection, Repair or Replacement of Parts

WARNING

Dry cleaning solvent, P-D-680, used to clean parts is potentially dangerous to personnel and property. Use in a well ventilated area as the fumes are dangerous if inhaled. Avoid repeated and prolonged skin contact. Do not use near open flame or excessive heat. Flash point of solvent is 100°F 138°F (38°C 59°C).

- (1) All parts to be thoroughly cleaned with P-D-680 solvent, and then air dried.

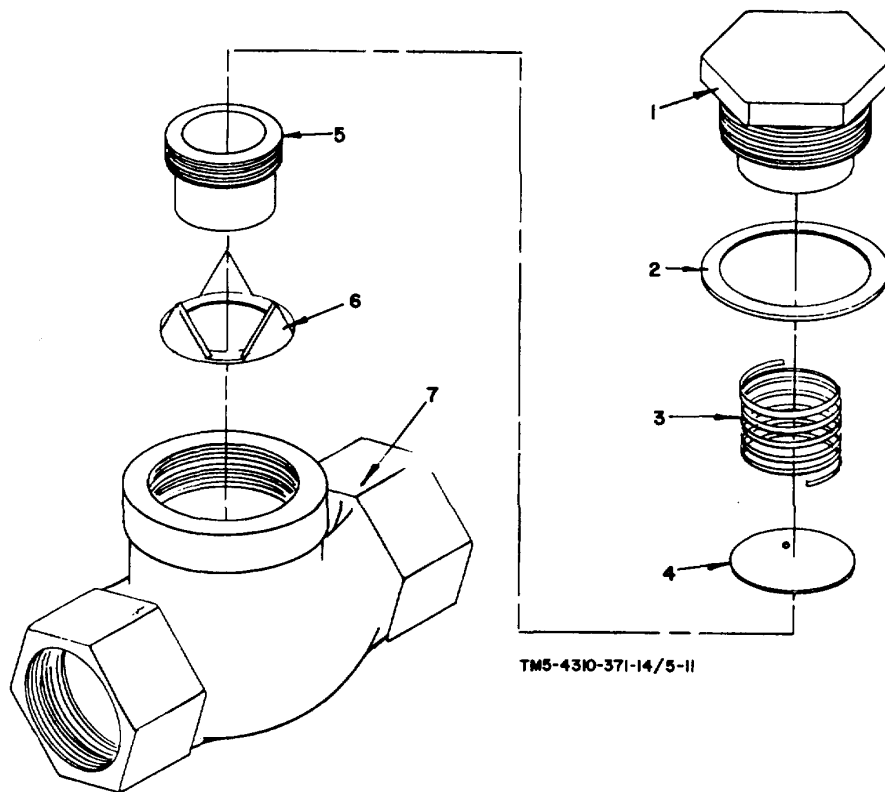

- | | |
|---|--|
| <ul style="list-style-type: none"> 1. Check valve cap 2. Check valve gasket 3. Check valve spring 4. Check valve disc | <ul style="list-style-type: none"> 5. Check valve seat 6. Check valve guide 7. Check valve body |
|---|--|

FIGURE 5-11. CHECK VALVE REPAIR

- (2) Inspect all parts for cracks, breaks, fissures, scores, distortions or any other damage.
- (3) Replace check valve if any parts are found to be unserviceable.

d. Reassembly

- (1) Install guide (figure 5-11, item 6) into body (figure 5-11, item 7).
- (2) Install seat (figure 5-11, item 5) into body (figure 5-11, item 7).
- (3) Install disc (figure 5-11, item 4) into body (figure 5-11, item 7).
- (4) Install spring (figure 5-11, item 3) into body (figure 5-11, item 7).

- (5) Install gasket (figure 5-11, item 2) on to body top (figure 5-11, item 7).
 - (6) Install cap (figure 5-11, item 1) by turning cap clockwise down in body (figure 5-11, item 7).
- e. Install check valve (figure 5-11) in accordance with paragraph 4-11 and figure 4-8.

APPENDIX A
REFERENCES

A-1. Fire Protection and Safety

TB4-4200-200-10

Hand Portable Fire Extinguishers approved for Army Users

A-2. Lubrication

C91001L

Fuel, Lubricants, Oils and Waxes

A-3. Painting

TM43-0139

Painting Instructions for Field Use

A-4. Maintenance

TM-38-750

The Army Maintenance Management Systems (TAMMS)

TB-742-93-1

Inspection and Test of Air and Other Gas Compressors

TM5-4310-371-24P

Organizational, Direct Support and General Support Maintenance Repair Parts List for Compressor Unit, Reciprocating, Electric, 25 CFM, 195 PSI (Eclipse Systems, Inc. Model 50-6717) NSN 4310-00-204-2595

A-5. Shipment Storage

TM-740-90-1

Administrative Storage of Equipment

A-6. Destruction of Army Material

TM-750-244-3

The Destruction of Army Material to Prevent Enemy Use

A-7. Radio Interference Suppression

TM11-483

Radio Interference Suppression

APPENDIX B

MAINTENANCE ALLOCATION CHART

Section I. INTRODUCTION

B-1. GENERAL.

a. This section provides a general explanation of all maintenance and repair functions authorized at various maintenance levels.

b. The Maintenance Allocation Chart (MAC) in Section II designates overall responsibility for the performance of maintenance functions on the identified end item or component. The implementation of the maintenance functions upon the end item or component will be consistent with the assigned maintenance functions.

c. Section III lists the special tools and test equipment required for each maintenance function as referenced from Section II.

d. Section IV contains supplemental instructions on explanatory notes for a particular maintenance function.

B-2. MAINTENANCE FUNCTIONS.

a. Inspect. To determine the serviceability of an item by comparing its physical, mechanical and/or electrical characteristics with established standards through examination.

b. Test. To verify serviceability and detect incipient failure by measuring the mechanical or electrical characteristics of an item and comparing those characteristics with prescribed standards.

c. Service. Operations required periodically to keep an item in proper operating condition, i.e., to clean (decontaminate), to preserve, to drain, to paint or to replenish fuel, lubricants, hydraulic fluids, or compressed air supplies.

d. Adjust. To maintain, within prescribed limits, by bringing into proper or exact position, or by setting the operating characteristics to specified parameters.

e. Align. To adjust specified variable elements of an item to bring about optimum or desired performance.

f. Calibrate. To determine and cause corrections to be made or to be adjusted on instruments or test measuring and diagnostic equipments used in precision measurement. Consists of comparisons of two instruments, one of which is a certified standard of known accuracy, to detect and adjust any discrepancy in the accuracy of the instrument being compared.

g. Install. The act of emplacing, seating, or fixing into position an item, part, or module (component or assembly) in a manner to allow the proper functioning of an equipment or system.

h. Replace. The act of substituting a serviceable like type part, subassembly, or module (component or assembly) for an unserviceable counterpart.

i. Repair. The application of maintenance services (inspect, test, service, adjust, align, calibrate, or replace) or other maintenance actions (welding, grinding, riveting, straightening, facing, remachining, or resurfacing) to restore serviceability to an item by correcting specific damage, fault, malfunction, or failure in a part, subassembly, module (component or assembly), and item, or system.

j. Overhaul. That maintenance effort (services/actions) necessary to restore an item to a completely serviceable/operational condition as prescribed by maintenance standards (i.e., DMWR) in appropriate technical publications. Overhaul is normally the highest degree of maintenance performed by the Army. Overhaul does not normally return an item to like new condition.

k. Rebuild. Consists of those services/actions necessary for the restoration of unserviceable equipment to a like new condition in accordance with original manufacturing standards. Rebuild is the highest degree of material maintenance applied to Army equipment. The rebuild operation includes the act of returning to zero those age measurements (hours/miles, etc.) considered in classifying Army equipments/components.

B-3. COLUMN ENTRIES USED IN THE MAC.

a. Column 1, Group Number. Column 1 lists group numbers, the purpose of which is to identify components, assemblies, subassemblies, and modules with the next higher assembly.

b. Column 2, Component/Assembly. Column 2 contains the names of components, assemblies, subassemblies, and modules for which maintenance is authorized.

c. Column 3, Maintenance Functions. Column 3 lists the functions to be performed on the item listed in Column 2. (For detailed explanation of these functions, see paragraph B-2.)

Section II. MAINTENANCE ALLOCATION CHART (MAC)

(1) Group Number	(2) Component/Assembly 01 Group Guard	(3) Maintenance function	(4) Maintenance level					(5) Tools and Equipment	(6) Remarks
			C	O	F	H	D		
0101	Belt Guard	Inspect Replace	0.1 0.5						
	V Belts	Inspect Adjust Replace	0.1 0.8	0.9					
<u>02 Group, Electric Motor & Related Parts</u>									
0201	Electric Motor	Service Replace Repair Inspect	0.3	1.0 0.1	4.0				
0202	Rotor Assy	Inspect Replace	0.1		2.0				
0203	Stator Assy	Inspect Repair			0.1	12.0			
		Replace			2.0				
0204	Motor Starter Assy	Inspect Repair	0.1		1.0				
		Replace			2.0				
0205	Pressure Switch Assy	Adjust Replace		0.5	0.8				
		Repair			1.0				
<u>03 Group, Air Compressor Assy</u>									
0301	Air Compressor	Inspect Replace	0.3	1.5	4.0	8.0			
		Repair Overhaul							
0302	Unloader Assy	Inspect Repair		0.2	1.0				
		Replace		1.0					
0303	Inlet Filter	Service Replace	0.2 0.3						

Section II. MAINTENANCE ALLOCATION CHART (MAC) (Cont'd)

(1) Group Number	(2) Component/Assembly 01 Group Guard	(3) Maintenance function	(4) Maintenance level					(5) Tools and Equipment	(6) Remarks
			C	O	F	H	D		
			0304	Valve Assemblies, Intake & Exhaust	Inspect Repair Replace		0.5		
0305	Pistons & Connecting Rod Assemblies	Inspect Replace			0.3 3.0				
0306	Crankshaft Assy	Inspect Replace			0.3 3.0				
<u>04 Group, Air Receiver</u>									
0401	Air Receiver Assy	Inspect Test Replace Repair	0.2		1.0 4.0 1.0				
0402	Air Pressure Gauge	Inspect Test Replace	0.1	0.3 0.5					
0403	Valve, Safety Relief	Test Replace			0.1 0.3				
0404	Valve, Check Assy	Test Repair Replace		0.1	0.3 0.5				
0405	Valve, Globe	Inspect Replace	0.1	0.5					
0406	Hose, Air, Assy	Inspect Repair Replace	0.1	0.5 0.3					
0407	Inflator Gauge	Inspect Replace	0.1	0.3					

APPENDIX C**COMPONENTS OF END ITEMS LIST****Section I. INTRODUCTION****C-1. SCOPE.**

This appendix lists integral components of and Basic Issue Items (BII) for Air Compressor to help you inventory items required for safe and efficient operation.

C-2. GENERAL.

The components of end item list are divided into the following sections:

- a. Section II. Integral Components of the End Item. These items, when assembled, comprise the Air Compressor and must accompany it whenever it is transferred or turned in. The illustrations will help you identify these items.
- b. Section III. Basic Issue Items. These are minimum essential items required to place the Air Compressor in operation, to operate it, and to perform emergency repairs. Although shipped separately packed, they must accompany the Compressor during operation and whenever it is transferred between accountable officers. The illustration will assist you with hard-to-identify items. This manual is your authority to requisition replacement BII, based on TOE/MTOE authorization of the end item.

C-3. EXPLANATION OF COLUMNS.

- a. Illustration: This column is divided as follows:
 - (1) Figure Number: Indicates the figure number of the illustration.
 - (2) Item Number: The number used to identify item called out in the illustration.
- b. National Stock Number (NSN) : Indicates the national stock number assigned to the end item which will be used for requisitioning.
- c. Part Number (P/N) : Indicates the primary number used by the manufacturer which controls the design and characteristics of the item by means of its engineering drawings, specifications, standards and inspection requirements to identify an item or range of items.
- d. Description. Indicates the federal item name and, if required, a minimum description to identify the item.
- e. Location. The physical location of each item listed is given in this column. The lists are designed to inventory all items in one area of the major item before moving on to an adjacent area.
- f. Usable on Code. (Not applicable)

- g. Quantity Required (Qty Reqd). This column lists the quantity of each item required for a complete major item.
- h. Quantity. This column is left blank for use during an inventory. Under the received column, list the quantity you actually receive on your major item. The date columns are for use when you inventory the major item at a later date, such as for shipment to another site.

Section II. INTEGRAL COMPONENTS OF END ITEM

(1) ILLUSTRATION (a) FIGURE No.	(2) ITEM (b) No.	(3) NSN	(4) PART NO. & FSCM	(5) DESCRIPTION	(6) LOCATION	(7) USABLE ON CODE	(7) QTY RQD	(8) QUANTITY			
								Recd	Date	Date	Date
			61-JS-1506 94894	INFLATOR ASSEMBLY			1				
			50-6741 19272	HOSE ASSEMBLY			1				

Section III. BASIC ISSUE ITEMS

		19272	TM 5-4310-371-14				1				
--	--	-------	------------------	--	--	--	---	--	--	--	--

APPENDIX D

ADDITIONAL AUTHORIZATION LIST

Section I. INTRODUCTION

D-1. SCOPE.

This appendix lists additional items you are authorized for the support of the Air Compressor.

D-2. GENERAL.

This list identifies items that do not have to accompany the Air Compressor and that do not have to be turned in with it. These items are authorized to you by CTA, MTOE, TDA or JTA.

D-3. EXPLANATION OF LISTING.

(Not applicable)

Section II. ADDITIONAL AUTHORIZATION LIST

(1) NATIONAL STOCK NUMBER	(2) PART NO. DESCRIPTION & FSCM USABLE ON CODE	(3) U/M	(4) QTY AUTH
4210-00-555-8837	EXTINGUISHER, FIRE		1

APPENDIX E

EXPENDABLE SUPPLIES AND MATERIALS LIST

Section I. INTRODUCTION

E-1. SCOPE.

This appendix lists expendable supplies and materials you will need to operate and maintain the Air Compressor.

These items are authorized to you by CTA 50-970, Expendable Items (Except Medical, Class V, Repair Parts, and Heraldic Items).

E-2. EXPLANATION OF COLUMNS.

a. Column 1 Item number. This number is assigned to the entry in the listing and is referenced in the narrative instructions to identify the material (e.g., "Use cleaning compound, item 5, Appendix D").

b. Column 2 Level. This column identifies the lowest level of maintenance that requires the listed item.

(enter as applicable)

- C Operator/Crew
- O Organizational Maintenance
- F Direct Support Maintenance
- H General Support Maintenance

c. Column 3 National Stock Number. This is the National Stock Number assigned to the item; use it to request or requisition the item.

d. Column 4 Description. Indicates the Federal item name and, if required, a description to identify the item. The last line for each item indicates the part number followed by the Federal Supply Code for Manufacturer (FSCM) in parentheses, if applicable.

e. Column 5 Unit of Measure (U/M). Indicates the measure used in performing the actual maintenance function. This measure is expressed by a two-character alphabetical abbreviation (e.g., ea, in, pr). If the unit of measure differs from the unit of issue, requisition the lowest unit of issue that will satisfy your requirements.

Section II. EXPENDABLE SUPPLIES AND MATERIALS LIST

(1) ITEM NUMBER	(2) LEVEL	(3) NATIONAL STOCK NUMBER	(4) DESCRIPTION	(5) U/M
	O, F, & H	6850-00-274-5421	Drycleaning Solvent P-D-680	gal.

INDEX

Subject	Paragraph
A	
Adjustments	
Belts	3-4
Pressure Switch	4-8
Administrative Storage	4-3
Air Inlet Filters	
Replacement	3-8
Air Receiver	
Draining of	3-5
Army Material, Destruction of	1-4
B	
Belts	
Adjustment	3-4
Replacement	4-5
Belt Guard	
Replacement	4-5
C	
Check Valve	
Replacement	4-11
Repair	5-9
Compressor Pump	
Repair	5-3
Replacement	4-9
Compressor Unit	
Inspection	2-4
Preparation	2-5
Controls, Operator	2-1
Crankcase	
Replacement	5-7
Specifications	Table 5-2
D	
Data Tabulated	1-8
Description, Equipment	1-7
Destruction of Army Material	1-4

INDEX

Subject		Paragraph
	E	
Errors, Improvements, Reporting of		1-3
	F	
Flywheel		1-10f.
Forms and Records, Maintenance of		1-2
	G	
Globe Valve		
Use		3-6
Replacement		4-12
	I	
Identification		1-8a.
Inflator Gage		
Replacement		4-14
Inflator Gage Hose		
Replacement		4-13
	L	
Lubrication		
Compressor Pump		3-1
Motor		3-2
	M	
Maintenance Forms and Records		1-2
Maintenance Procedures		
Operator		3-3
Organizational		4-4
Support, Direct and General		5-2

INDEX

Subject	Paragraph
Motor	
Repair	5-2
Replacement	4-7
	0
Operation	2-4
	P
Piston, Piston Rings & Connecting Rods	5-5
Pressure Gage	
Replacement	4-10
Testing	4-10a.
Pressure Switch	
Adjustment	4-8
Replacement	5-2g.
Preventive Maintenance Checks and Services	2-3
	R
Rotor Assembly	
Replacement	5-1d.
	S
Safety Valve	
Testing and Replacement	5-8
Scope	1-1
Starter Switch	
Operation	2-1c.
Replacement	5-1f.
Starting	2-6a.
	T
Tabulated Data	1-8
Troubleshooting, Tables	

INDEX

Subject	Paragraph
Operator Organizational Support, Direct and General	Chapter 3, Sec. II Chapter 4, Sec. II Chapter 5, Sec. I
U	
Unloading Unpacking	4-1 4-1
W	
Wiring Instructions	4-2b.
"THE END"	

By Order of the Secretary of the Army:

Official:

J. C. PENNINGTON
Major General, United States Army
The Adjutant General

E. C. MEYER
General, United States Army
Chief of Staff

DISTRIBUTION:

To be distributed in accordance with DA Form 12-25A, Operator Maintenance requirements for Air Compressors: 25 CFM.

RECOMMENDED CHANGES TO EQUIPMENT TECHNICAL PUBLICATIONS



THEN... JOT DOWN THE DOPE ABOUT IT ON THIS FORM. CAREFULLY TEAR IT OUT, FOLD IT AND DROP IT IN THE MAIL!

SOMETHING WRONG WITH THIS PUBLICATION?

FROM: (PRINT YOUR UNIT'S COMPLETE ADDRESS)

PFC JOHN DOE
COA, 3d ENGINEER BN
FT. LEONARDWOOD, MD 63108

DATE SENT

PUBLICATION NUMBER

TM 5-4310-371-14

PUBLICATION DATE

PUBLICATION TITLE COMPRESSOR UNIT,
RECIPROCATING ELECTRIC 25 CFM,
175 PSI

BE EXACT... PIN-POINT WHERE IT IS

PAGE NO.	PARA-GRAPH	FIGURE NO.	TABLE NO.
6	2-1 a		
B1		4-3	
125	line 20		

IN THIS SPACE TELL WHAT IS WRONG AND WHAT SHOULD BE DONE ABOUT IT:

In line 6 of paragraph 2-1a the manual states the engine has 6 cylinders. The engine on my set only has 4 cylinders. Change the manual to show 4 cylinders.

Callout 16 on figure 4-3 is pointing at a bolt. In key to figure 4-3, item 16 is called a shim - Please correct one or the other.

I ordered a gasket, item 19 on figure B-16 by NSN 2 910-00-762-3001. I got a gasket but it doesn't fit. Supply says I got what I ordered, so the NSN is wrong. Please give me a good NSN

PRINTED NAME, GRADE OR TITLE, AND TELEPHONE NUMBER

JOHN DOE, PFC (268) 317-7111

SIGN HERE:

JOHN DOE

DA FORM 2028-2
1 JUL 79

PREVIOUS EDITIONS ARE OBSOLETE.

DRSTS-M Overprint 1, 1 Nov 80

P.S.-IF YOUR OUTFIT WANTS TO KNOW ABOUT YOUR RECOMMENDATION MAKE A CARBON COPY OF THIS AND GIVE IT TO YOUR HEADQUARTERS.

TEAR ALONG PERFORATED LINE

FILL IN YOUR
UNIT'S ADDRESS

FOLD BACK

DEPARTMENT OF THE ARMY

OFFICIAL BUSINESS
PENALTY FOR PRIVATE USE \$300

POSTAGE AND FEES PAID
DEPARTMENT OF THE ARMY
DOD 314



TEAR ALONG PERFORATED LINE

COMMANDER
U S ARMY SUPPORT AND AVIATION MATERIEL READINESS COMMAND
ATTN: DRSTS-MTT
4300 GOODFELLOW BOULEVARD
ST. LOUIS, MO 63120

RECOMMENDED CHANGES TO EQUIPMENT TECHNICAL PUBLICATIONS



THEN... JOT DOWN THE DOPE ABOUT IT ON THIS FORM, CAREFULLY TEAR IT OUT, FOLD IT AND DROP IT IN THE MAIL!

SOMETHING WRONG WITH THIS PUBLICATION?

FROM: (PRINT YOUR UNIT'S COMPLETE ADDRESS)

DATE SENT

PUBLICATION NUMBER

TM 5-4310-371-14

PUBLICATION DATE

PUBLICATION TITLE COMPRESSOR UNIT, RECIPROCATING ELECTRIC 25 CFM, 175 PSI

BE EXACT... PIN-POINT WHERE IT IS

PAGE NO

PARA-GRAPH

FIGURE NO

TABLE NO

IN THIS SPACE TELL WHAT IS WRONG AND WHAT SHOULD BE DONE ABOUT IT:

TEAR ALONG PERFORATED LINE

PRINTED NAME, GRADE OR TITLE, AND TELEPHONE NUMBER

SIGN HERE:

DA FORM 2028-2
1 JUL 79

PREVIOUS EDITIONS ARE OBSOLETE.
DRSTS-M Overprint 2, 1 Nov 80.

P.S.--IF YOUR OUTFIT WANTS TO KNOW ABOUT YOUR RECOMMENDATION MAKE A CARBON COPY OF THIS AND GIVE IT TO YOUR HEADQUARTERS.

REVERSE OF DA FORM 2028-2

Reverse of DRSTS-M Overprint 1,
1 Nov 80

FILL IN YOUR
UNIT'S ADDRESS

FOLD BACK

DEPARTMENT OF THE ARMY

OFFICIAL BUSINESS
PENALTY FOR PRIVATE USE \$300

POSTAGE AND FEES PAID
DEPARTMENT OF THE ARMY
DOD 314



TEAR ALONG PERFORATED LINE

COMMANDER
U S ARMY SUPPORT AND AVIATION MATERIEL READINESS COMMAND
ATTN: DRSTS-MTT
4300 GOODFELLOW BOULEVARD
ST. LOUIS, MO 63120

The Metric System and Equivalents

Linear Measure

1 centimeter = 10 millimeters = .39 inch
 1 decimeter = 10 centimeters = 3.94 inches
 1 meter = 10 decimeters = 39.37 inches
 1 dekameter = 10 meters = 32.8 feet
 1 hectometer = 10 dekameters = 328.08 feet
 1 kilometer = 10 hectometers = 3,280.8 feet

Weights

1 centigram = 10 milligrams = .15 grain
 1 decigram = 10 centigrams = 1.54 grains
 1 gram = 10 decigram = .035 ounce
 1 dekagram = 10 grams = .35 ounce
 1 hectogram = 10 dekagrams = 3.52 ounces
 1 kilogram = 10. hectograms = 2.2 pounds
 1 quintal, = 10 kilograms = 220.46 pounds
 1 metra = 10 quintals = 1.1 short tons

Liquid Measure

1 centiliter = 10 milliliters = .34 fl. ounce
 1 deciliter = 10 centiliters = 3.38 fl. ounces
 1 liter = 10 deciliters = 33.81 fl. ounces
 1 dekaliter = 10 liters = 2.64 gallons
 1 hectoliter = 10 dekaliters = 26.42 gallons
 1 kiloliter = 10 hectoliters = 264.18 gallons

Square Measure

1 sq. centimeter = 100 sq. millimeters = .155 sq. inch
 1 sq. decimeter = 100 sq. centimeters = 15.5 sq. inches
 1 sq. meter (centare) = 100 sq. decimeters = 10.76 sq. feet
 1 sq. dekameter (are) = 100 sq. meters = 1,076.4 sq. feet
 1 sq. hectometer (hectare) = 100 sq. dekameters = 2.47 acres
 1 sq. kilometer = 100 sq. hectometers = .386 sq. mile

Cubic Measure

1 cu. centimeter = 1000 cu. millimeters = .06 cu. inch
 1 cu. decimeter = 1000 cu. centimeters = 61.02 cu. inches
 1 cu. meter = 1000 cu. decimeters = 35.31 cu. feet

Approximate Conversion Factors

<i>To change</i>	<i>To</i>	<i>Multiply by</i>	<i>To change</i>	<i>To</i>	<i>Multiply by</i>
inches	centimeters	2.540	ounce-inches	newton-meters	.007062
feet	meters	.305	centimeters	inches	.394
yards	meters	.914	meters	feet	3.280
miles	kilometers	1.609	meters	yards	1.094
square inches	square centimeters	6.451	kilometers	miles	.621
square feet	square meters	.093	square centimeters	square inches	.155
square yards	square meters	.836	square meters	square feet	10.764
square miles	square kilometers	2.590	square meters	square yards	1.196
acres	square hectometers	.405	square kilometers	square miles	.386
cubic feet	cubic meters	.028	square hectometers	acres	2.471
cubic yards	cubic meters	.765	cubic meters	cubic feet	35.315
fluid ounces	milliliters	29.573	cubic meters	cubic yards	1.308
pints	liters	.473	milliliters	fluid ounces	.034
quarts	liters	.946	liters	pints	2.113
gallons	liters	3.785	liters	quarts	1.057
ounces	grams	28.349	liters	gallons	.264
pounds	kilograms	.454	grams	ounces	.035
short tons	metric tons	.907	kilograms	pounds	2.205
pound-feet	newton-meters	1.365	metric tons	short tons	1.102
pound-inches	newton-meters	11375			

Temperature (Exact)

	°F Fahrenheit temperature	5/9 (after subtracting 32)	Celsius temperature °C
--	---------------------------	----------------------------	------------------------

This fine document...

Was brought to you by me:



[Liberated Manuals -- free army and government manuals](#)

Why do I do it? I am tired of sleazy CD-ROM sellers, who take publicly available information, slap “watermarks” and other junk on it, and sell it. Those masters of search engine manipulation make sure that their sites that sell free information, come up first in search engines. They did not create it... They did not even scan it... Why should they get your money? Why are not letting you give those free manuals to your friends?

I am setting this document FREE. This document was made by the US Government and is NOT protected by Copyright. Feel free to share, republish, sell and so on.

I am not asking you for donations, fees or handouts. If you can, please provide a link to liberatedmanuals.com, so that free manuals come up first in search engines:

<A HREF=<http://www.liberatedmanuals.com/>>Free Military and Government Manuals

- Sincerely
Igor Chudov
<http://igor.chudov.com/>
- [Chicago Machinery Movers](#)