

TM11-6625-3087-24P

TECHNICAL MANUAL

**ORGANIZATIONAL, DIRECT SUPPORT AND
GENERAL SUPPORT MAINTENANCE
REPAIR PARTS AND SPECIAL TOOLS LIST**

FOR

**FREQUENCY SELECTIVE LEVEL
METER, AN/USM-490**

(NSN 6625-01-138-3351)

**HEADQUARTERS, DEPARTMENT OF THE ARMY
27 DECEMBER 1985**

Technical Manual

No. 11-6625-3087-24P

HEADQUARTERS
DEPARTMENT OF THE ARMY
Washington, DC, 27 December 1985

ORGANIZATIONAL, DIRECT SUPPORT, AND GENERAL SUPPORT

MAINTENANCE REPAIR PARTS AND SPECIAL TOOLS LIST

FOR

FREQUENCY SELECTIVE LEVEL METER

(AN/USM-490)

(6625-01-138-3351)

Current as of 15 August 1985

REPORTING ERRORS AND RECOMMENDING IMPROVEMENTS

You can help improve this manual. If you find any mistakes or if you know of a way to improve the procedures, please let us know. Mail your letter, DA Form 2028 (Recommended Changes to Publications and Blank Forms), or DA Form 2028-2 located in the back of this manual direct to: Commander, U.S. Army Communications-Electronics Command and Fort Monmouth, ATTN: AMSEL-ME-MP, Fort Monmouth, New Jersey 07703-5007.

In either case, a reply will be furnished direct to you.

Table of Contents

		Page	Illus Figure
Section I.	Introduction	1	
II.	Repair Parts List	1-1	
Group 00	Frequency Selective Level Meter, AN/USM-490	1-1	1
01	Input Multiplexer Circuit Card Assembly (A1)	2-1	2
02	Input Amplifier Circuit Card Assembly (A2)	3-1	3
03	Broadband Power/CAL/Overload Circuit Card Assembly	4-1	4
04	Input Mixer Circuit Card Assembly (A5)	5-1	5
05	Second Mixer Circuit Card Assembly (A10)	6-1	6
06	Second LO Circuit Card Assembly (A11)	7-1	7
07	Tracking Output Circuit Card Assembly (A15)	8-1	8

Table of Contents-Continued

		Page	Illus Figure
Group	08	10 MHz Frequency REF Circuit Card Assembly (A16)	9-1 9
	09	IF Filter Circuit Card Assembly (A20)	10-1 10
	10	IF Gain/DET Circuit Card Assembly (A21)	11-1 11
	11	Analog to Digital Converter Circuit Card Assembly (A22)	12-1 12
	12	Frequency Reference Circuit Card Assembly (A40)	13-1 13
	13	Step Loop Circuit Card Assembly (A50)	14-1 14
	14	Controller Circuit Card Assembly (A60)	15-1 15
	15	Impairments B Circuit Card Assembly (A70)	16-1 16
	16	Switch/Display Circuit Card Assembly (A98)	17-1 17
	17	Motherboard Circuit Card Assembly (A99)	18-1 18
Section III.		Special Tools List (Not Applicable)	
IV.		National Stock Number and Part Number Index	I-1

SECTION I
INTRODUCTION

1. Scope

This manual lists and authorizes spares and repair parts; special tools; special test, measurement, and diagnostic equipment (TMDE); and other special support equipment required for performance of organizational, direct support, and general support of the AN/USM-490. It authorizes the requisitioning, issue, and disposition of spares and repair parts, and special tools as indicated by the Source, Maintenance and Recoverability (SMR) codes.

2. General

This Repair Parts and Special Tools list is divided into the following sections:

a. Section II. Repair Parts List. A list of spares and repair parts authorized by this RPSTL for use in the performance of maintenance. The list also includes parts which must be removed for replacement of the authorized parts. Parts lists are composed of functional groups in ascending numeric sequence, with the parts in each group listed in ascending item number sequence. Figure numbers are listed directly beneath the group header. Bulk materials are listed in item name sequence. Repair part kits are listed separately in their own functional group within section II. Repair parts for reparable special tools are also listed in this section. Items listed are shown on the associated illustration.

b. Section III. Special Tools List. Not applicable.

NOTE

*Complete Repair: Maintenance capacity, capability, and authority to perform all the corrective maintenance tasks of the "Repair" function in a use/user environment in order to restore serviceability to a failed item.

(1) Source Code. The source codes tells you how to get an item needed for maintenance, repair, or overhaul of an end item/equipment. Explanations of source codes follow:

<u>Code</u>	<u>Defi ni ti on</u>
PA	--Stocked items: use the applicable NSN to request/requisition items with these source codes. They are authorized to the category indicated by the code entered in the 3rd position of the SMR code.
PC	--Stocked items: use the applicable NSN to request/requisition items with these source codes. They are authorized to the category indicated by the code entered in the 3rd position of the SMR code.

NOTE

Items coded PC are subject to deterioration.

- XB --If an "XB" item is not available from salvage, order it using the FSCM and part number given.
- XA --Do not request an "XA" coded item. Order its next higher assembly.
- XD --Item is not stocked. Order an "XD" coded item through normal supply channels using the FSCM and part number given, if no NSN is available.

NOTE

Cannibalization or controlled exchange, when authorized, may be used as a source of supply for items with the above source codes, except those source coded XA or those aircraft support items as restricted by requirements of AR 750-1.

(2) Maintenance Code. Maintenance codes tell you the category of maintenance authorized to USE and REPAIR support items. The maintenance codes are entered in the third and fourth positions of the SMR Code as follows:

(a) The maintenance code entered in the third position tells you the lowest maintenance category authorized to remove, replace, and use an item. The maintenance code entered in the third position will indicate authorization to one of the following categories of maintenance:

<u>Code</u>	<u>Application/Explanation</u>
H	--General support category can remove, replace, and use the item.
0	--Organizational or aviation unit category can remove, replace, and use the item.

(b) The maintenance code entered in the fourth position tells you whether or not the item is to be repaired and identifies the lowest maintenance category with the capability to do complete repair (i.e., perform all authorized functions). This position will contain one of the following maintenance codes.

NOTE

Some limited repair may be performed on the item at a lower category of maintenance, if authorized by the Maintenance Allocation Chart (MAC) and SMR codes).

<u>Code</u>	<u>Application/Explanation</u>
H	--General support is the lowest category that can do complete repair of the item.
	--Nonrepairable. No repair is authorized.

(3) Recoverability Code. Recoverability codes are assigned to items to indicate the disposition action on unserviceable items. The recoverability code is entered in the fifth position of the SMR Code as follows:

Recoverability

Codes

Definition

- A --Item requires special handling or condemnation procedures because of specific reasons (e.g., precious metal content, high dollar value, critical material, or hazardous material). Refer to appropriate manuals/directives for specific instructions.
- H --Repairable item. When uneconomically repairable, condemn and dispose of the item at the general support category.
- Z --Nonrepairable item. When unserviceable, condemn and dispose of the item at the category of maintenance shown in third position of SMR Code.

c. FSCM (Column (3)). The Federal Supply Code for Manufacturer (FSCM) is a 5-digit numeric code which is used to identify the manufacturer, distributor, or Government agency, etc., that supplies the item.

d. Part Number (Column (4)). Indicates the primary number used by the manufacturer (individual, company, firm, corporation, or Government activity), which controls the design and characteristics of the item by means of its engineering drawings, specifications, standards, and inspection requirements to identify an item or range of items.

NOTE

When you use an NSN to requisition an item, the item you receive may have a different part number than the part ordered.

e. Description and Usable on Code (UOC) (Column (5)). This column includes the following information.

(1) The Federal item name and, when required, a minimum description to identify the item.

(2) The physical security classification of the item is indicated by the parenthetical entry Phy Sec C1 (U) - Unclassified.

(3) Items that are included in kits and sets are listed below the name of the kit or set.

(4) Spare/repair parts that make up an assembled item are listed immediately following the assembled item line entry.

(5) Part numbers for bulk materials are referenced in this column in the line item entry for the item to be manufactured/fabricated.

(6) When the item is not used with all serial numbers of the same model, the effective serial numbers are shown as the last line of the description (before UOC).

(7) The USABLE ON CODE, when applicable (see paragraph 5).

(8) In the Special Tools List section, the basis of issue (BOI) appears as the last line(s) in the entry for each special tool, Special TMDE, and other special support equipment. When density of equipments supported exceeds density spread indicated in the basis of issue, the total authorization is increased proportionately.

(9) The statement "END OF FIGURE" appears just below the last item description in Column (5) for a given figure in both section II and section III.

f. QTY (Column (6)). Indicates the quantity of the item used in the breakout shown on the illustration figure, which is prepared for a functional group, subfunctional group, or an assembly. A "V" appearing in this column in lieu of a quantity indicates that the quantity is variable and the quantity may vary from application to application.

4. Explanation of Columns (Section IV)

a. National Stock Number (NSN) Index.

(1) Stock number column. This column lists the NSN by National item identification number (NIIN) sequence. The NIIN consists of the last nine digits of the NSN. When using this column to locate an item, ignore the first four digits of the NSN. When requisitioning items, use the complete NSN (13 digits).

(2) Fig. column. This column lists the number of the figure where the item is identified/located. The illustrations are in numerical sequence in sections II and III.

(3) Item column. The item number identifies the item associated with the figure listed in the adjacent Fig. column. This item is also identified by the NSN listed on the same line.

b. Part Number Index. Part numbers in this index are listed by part number in ascending alphmeric sequence.

(1) FSCM column. This column lists the Federal supply code for manufacturer (FSCM).

(2) Part number column. This column indicates the part number assigned to the item.

(3) Stock number column. This column lists the National stock number for the associated part number and manufacturer identified in the part number and FSCM columns to the left.

(4) Fig. column. This column lists the number of the figure where the item is identified/located in sections II and III.

(5) Item column. The item number is that number assigned to the item as it appears in the figure referenced in the adjacent figure number column.

5. Special Information

The following publications pertain to the AN/USM-490 and its components:

TM 11-6625-3087-12, Frequency Selective Level Meter AN/USM-490.

TM 11-6625-3087-40, Frequency Selective Sevel Meter AN/USM-490.

6. How to locate repair parts

a. When National Stock Number or Part Number is Not Known:

(1) First. Using the table of contents, determine the assembly group or subassembly group to which the item belongs. This is necessary since figures are prepared for assembly groups and subassembly groups, and listings are divided into the same groups.

(2) Second. Find the illustration covering the assembly group or subassembly group to which the item belongs.

(3) Third. Identify the item on the figure and note the item number of the item.

(4) Fourth. Refer to the Repair Parts List for the figure to find the part number for the item number noted on the figure.

(5) Fifth. Refer to the Part Number Index to find the NSN, is assigned.

b. When National Stock Number or Part Number is Known:

(1) First. Using the Index of National Stock Numbers and Part Numbers, find the pertinent National Stock Number or part number. The NSN index is in National Item Identification Number (NIIN) sequence. The part numbers in the Part Number index are listed in ascending alphanumeric sequence. Both indexes cross-reference you to the illustration figure and item number of the item you are looking for.

(2) Second. After finding the figure and item number, verify that the item is the one you're looking for, then locate the item number in the repair parts list for the figure.

7. Abbreviations.

Not applicable.

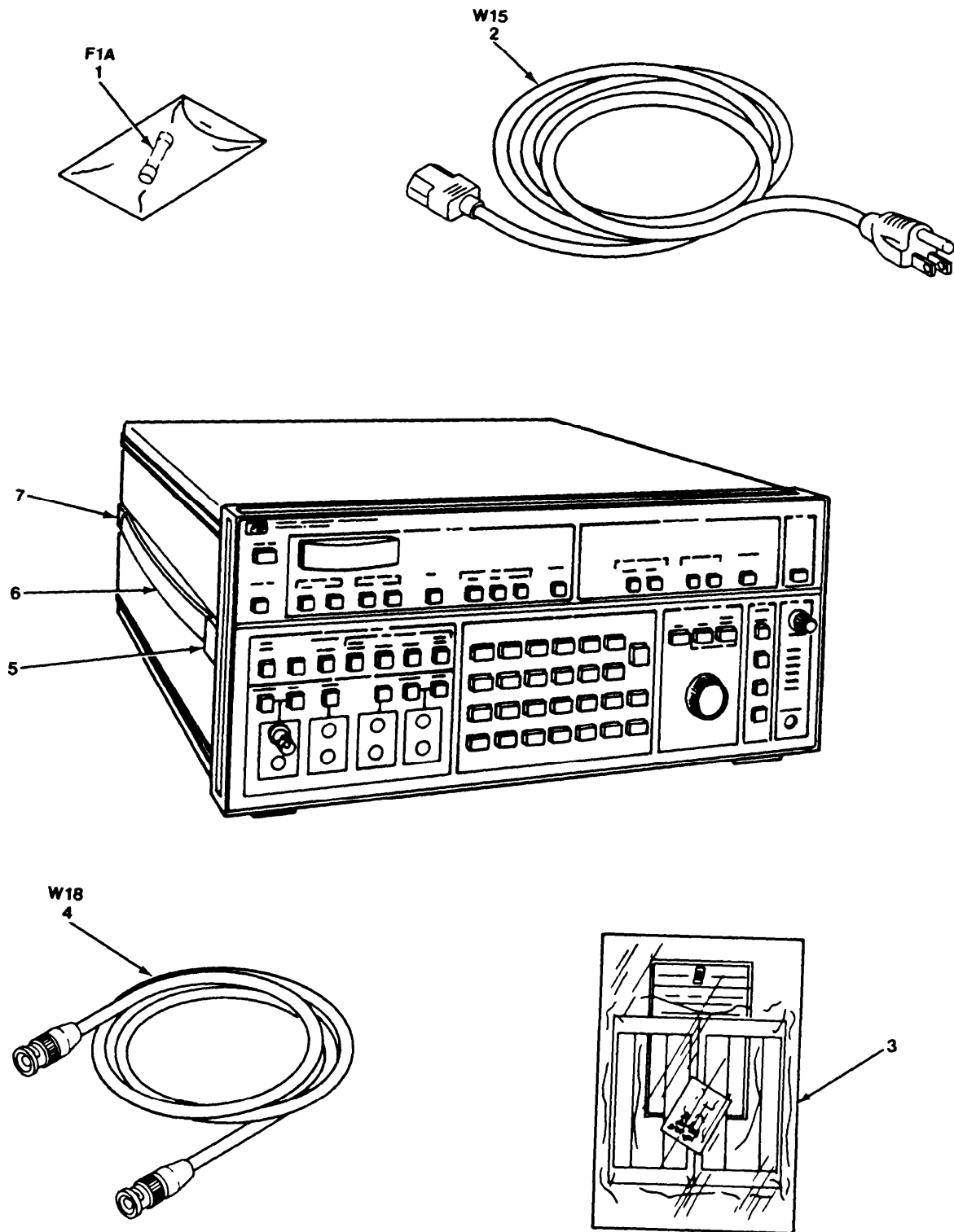

Figure 1. Frequency Selective Level Meter, AN/USM-490 (Sheet 1 of 11).

EL9NV001

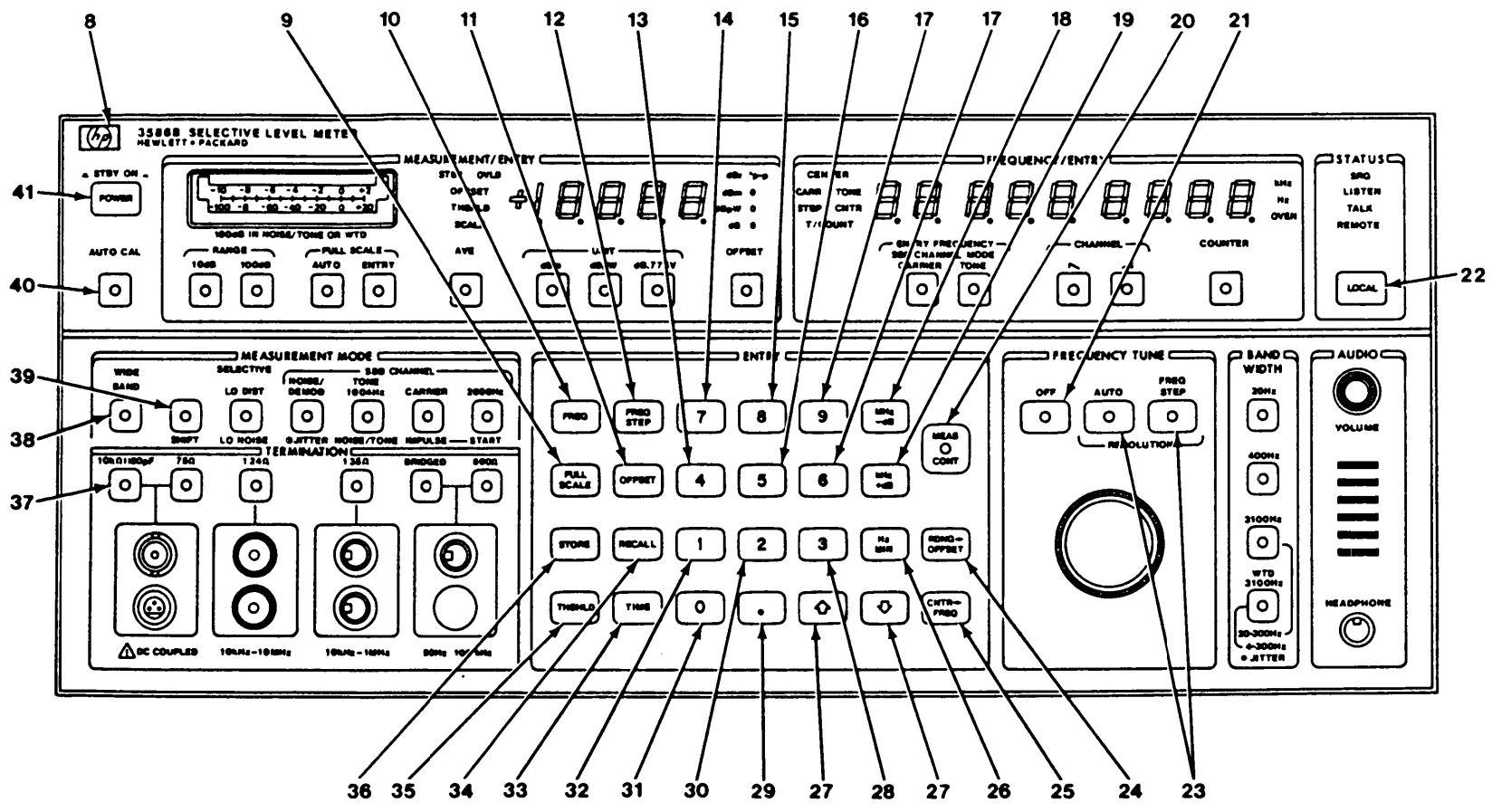
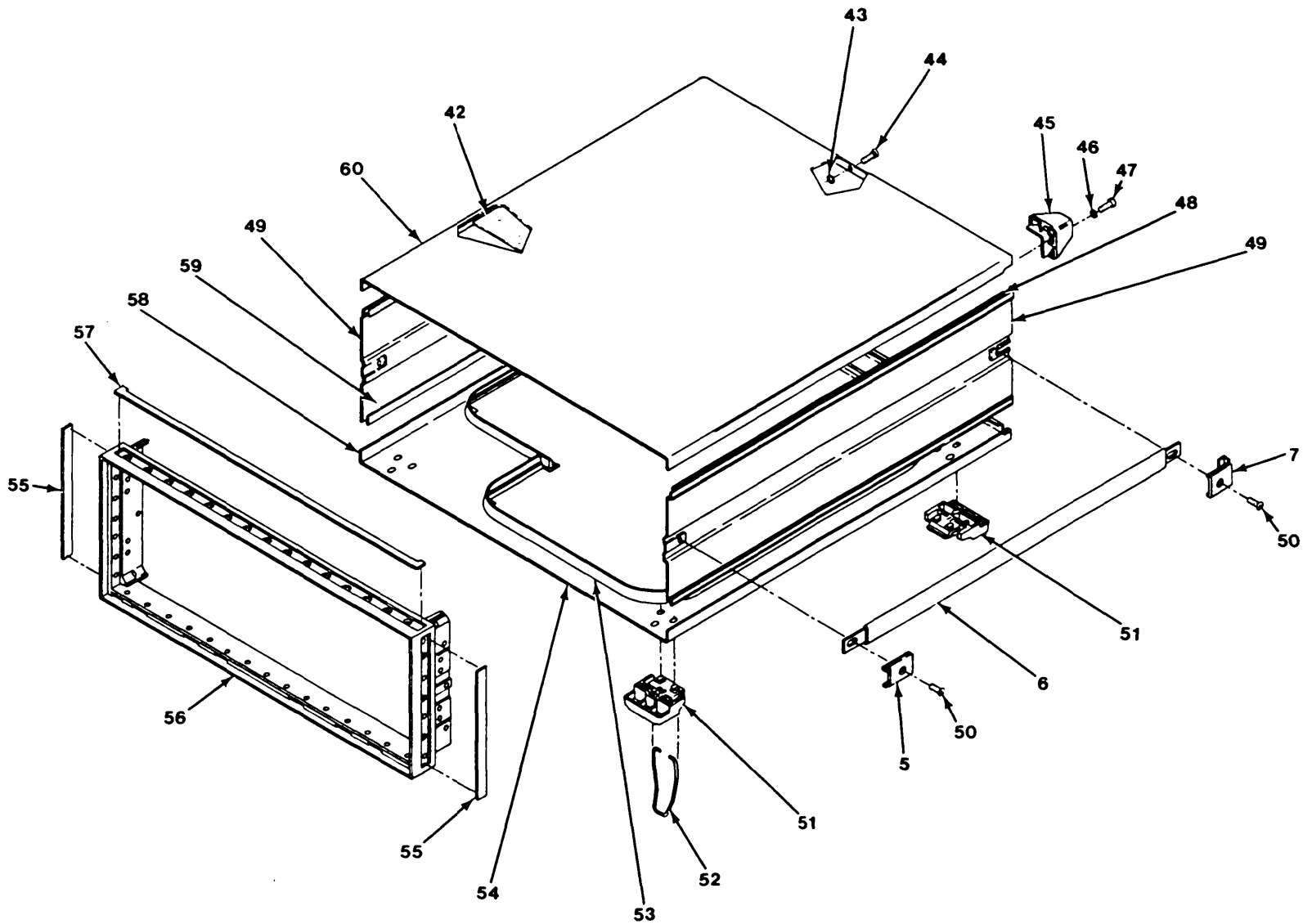

Figure 1. Frequency Selective Level Meter, AN/USM-490 (Sheet 2 of 11).

EL9NV002



TM11-6625-3087-24P

Figure 1. Frequency Selective Level Meter, AN/USM-490 (Sheet 3 of 11).

EL9NV003

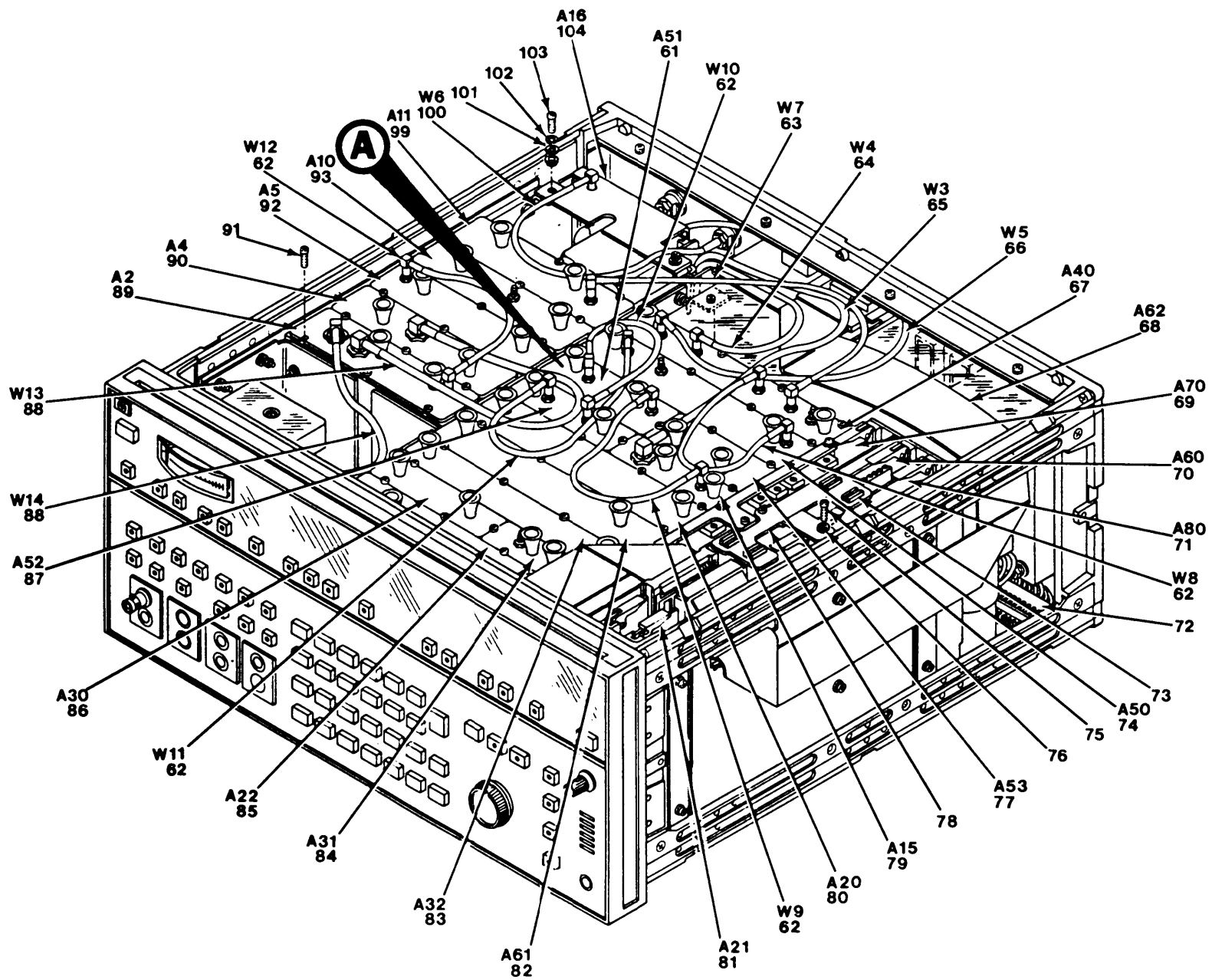

TM11-6625-3087-24P

Figure 1. Frequency Selective Level Meter, AN/USM-490 (Sheet 4 of 11).

EL9NV004

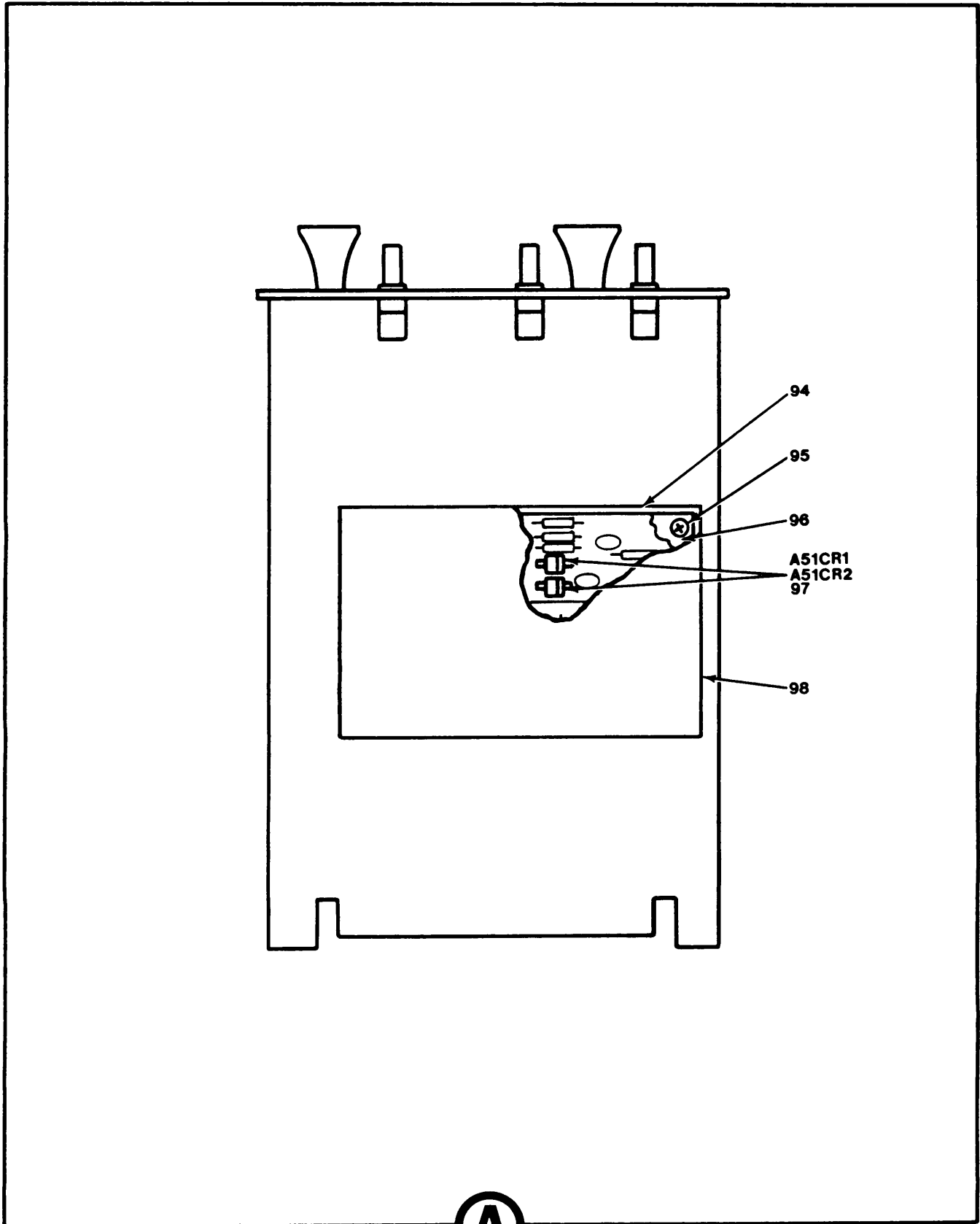

EL9NV005

Figure 1. Frequency Selective Level Meter, AN/USM-490 (Sheet 5 of 11).

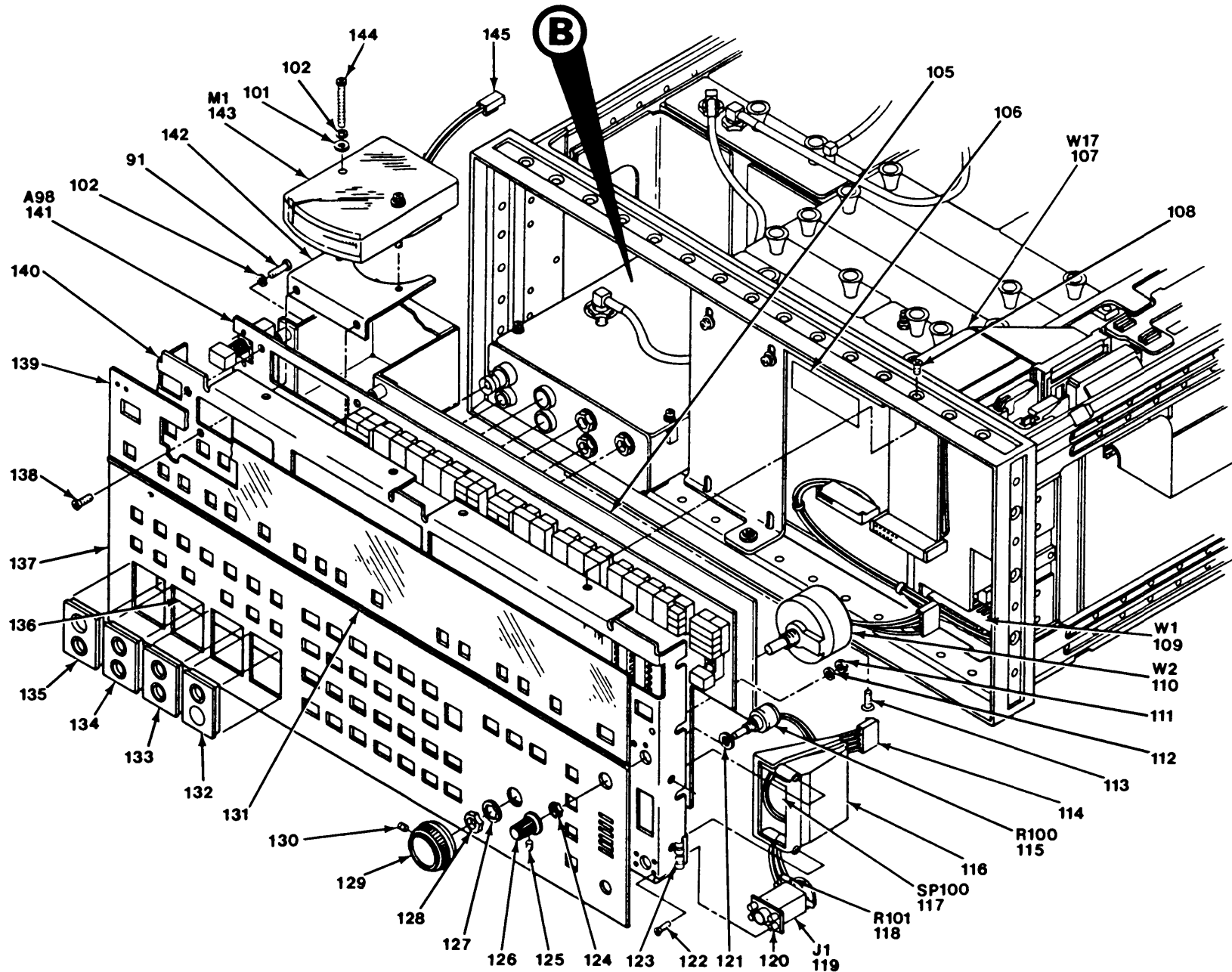
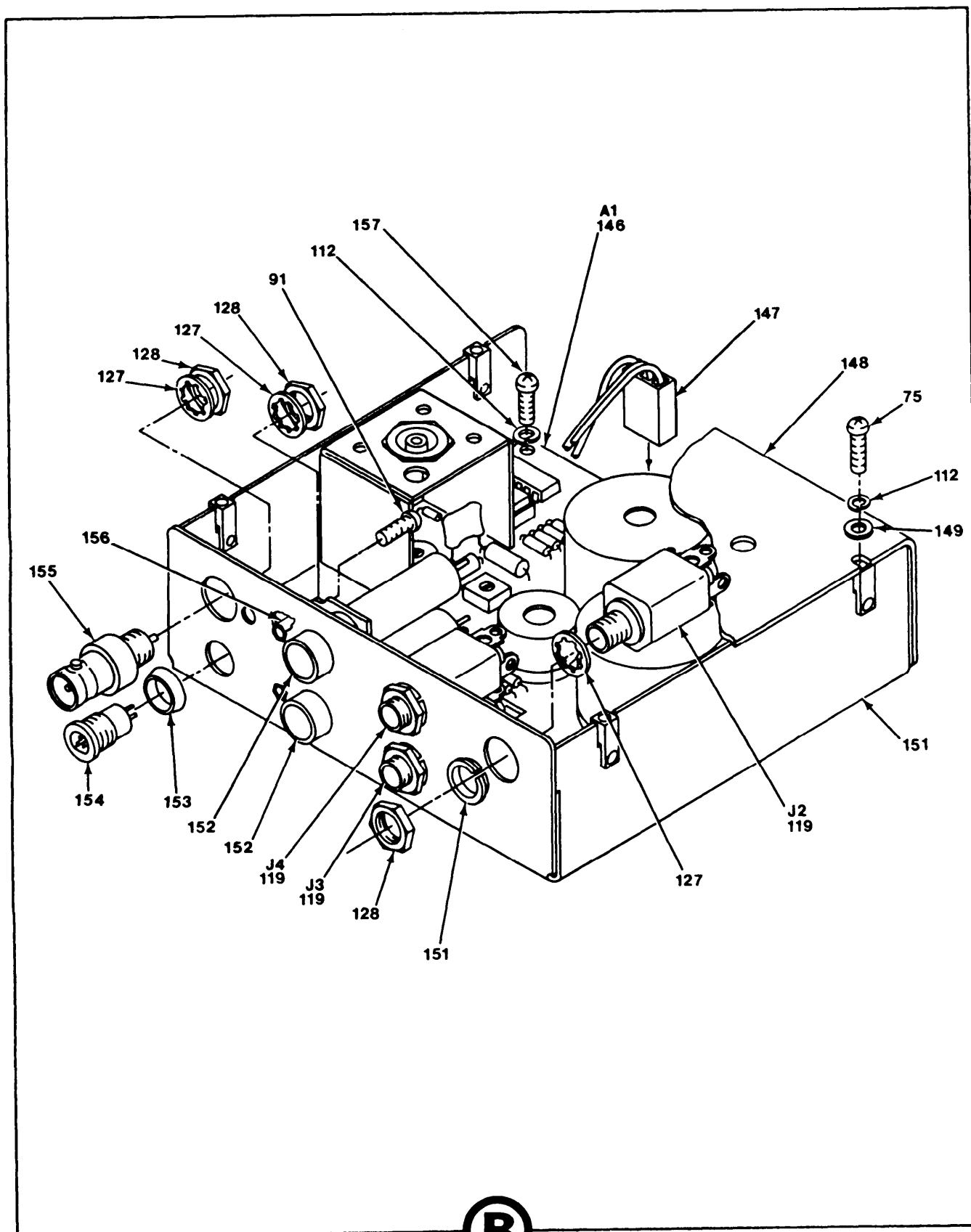

Figure 1. Frequency Selective Level Meter, AN/USM-490 (Sheet 6 of 11).

EL9NV006



EL9NV007

Figure 1. Frequency Selective Level Meter, AN/USM-490 (Sheet 7 of 11).

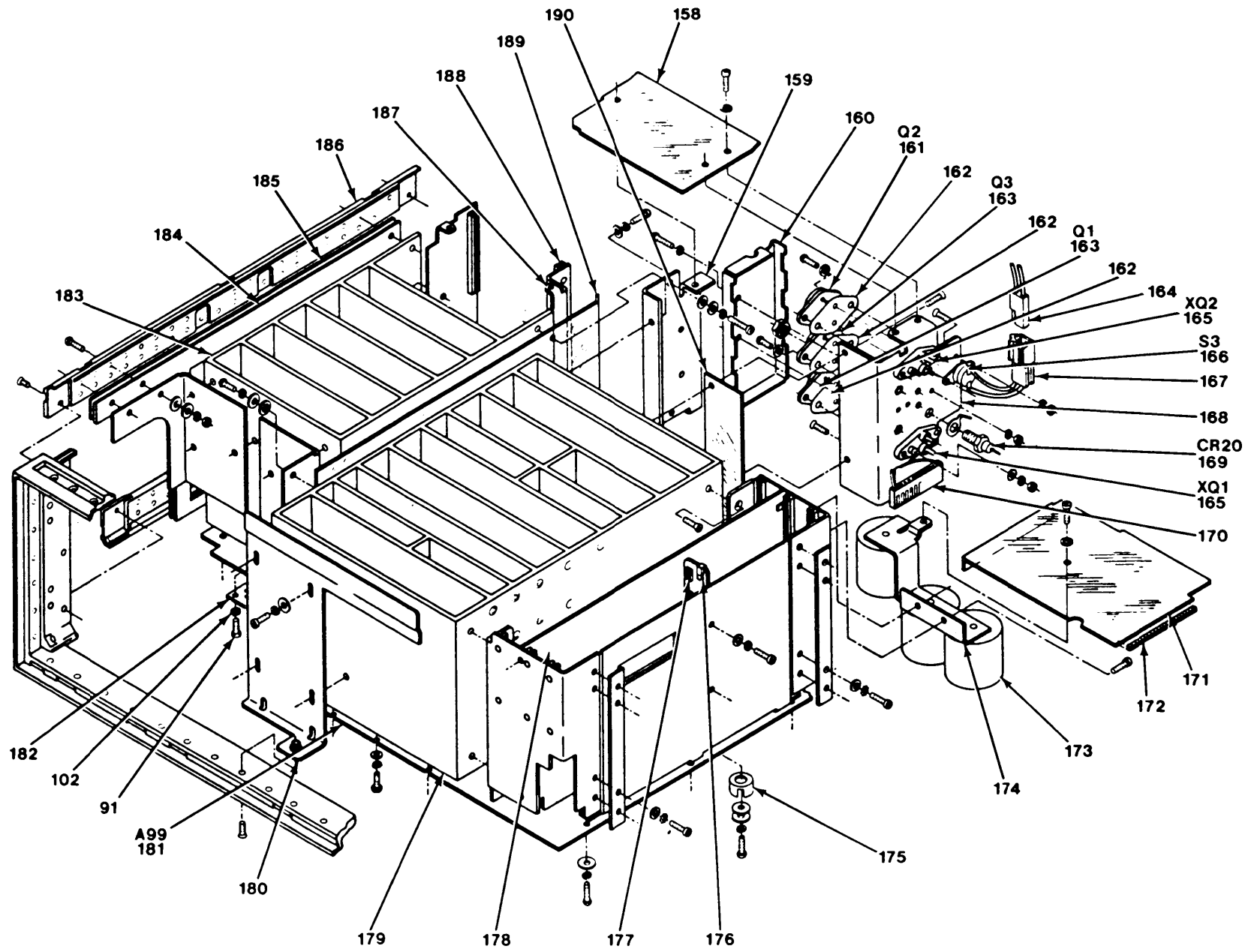

Figure 1. Frequency Selective Level Meter, AN/USM-490 (Sheet 8 of 11).

EL9NV008

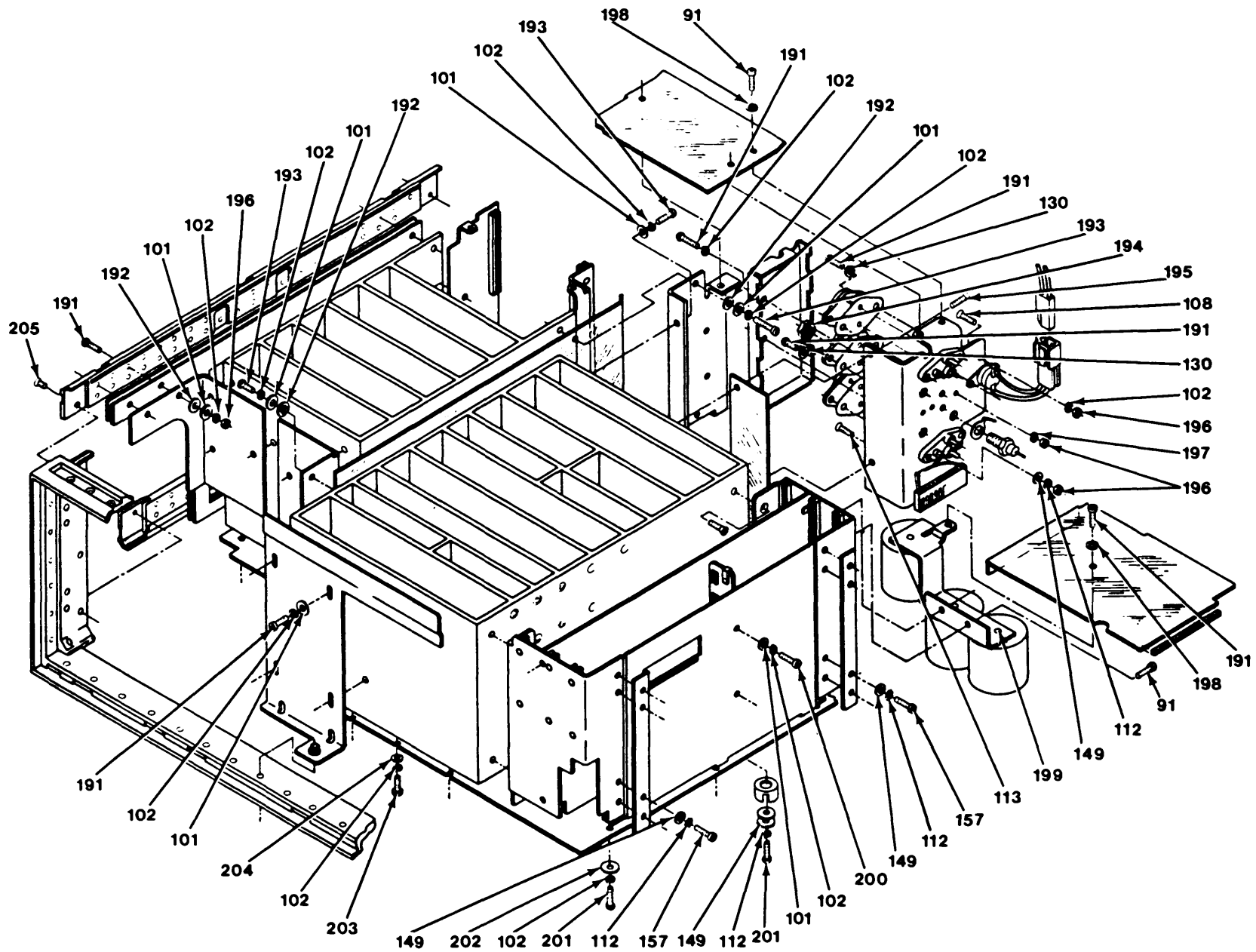

Figure 1. Frequency Selective Level Meter, AN/USM-490 (Sheet 9 of 11).

EL9NV009

TM11-6625-3087-24P

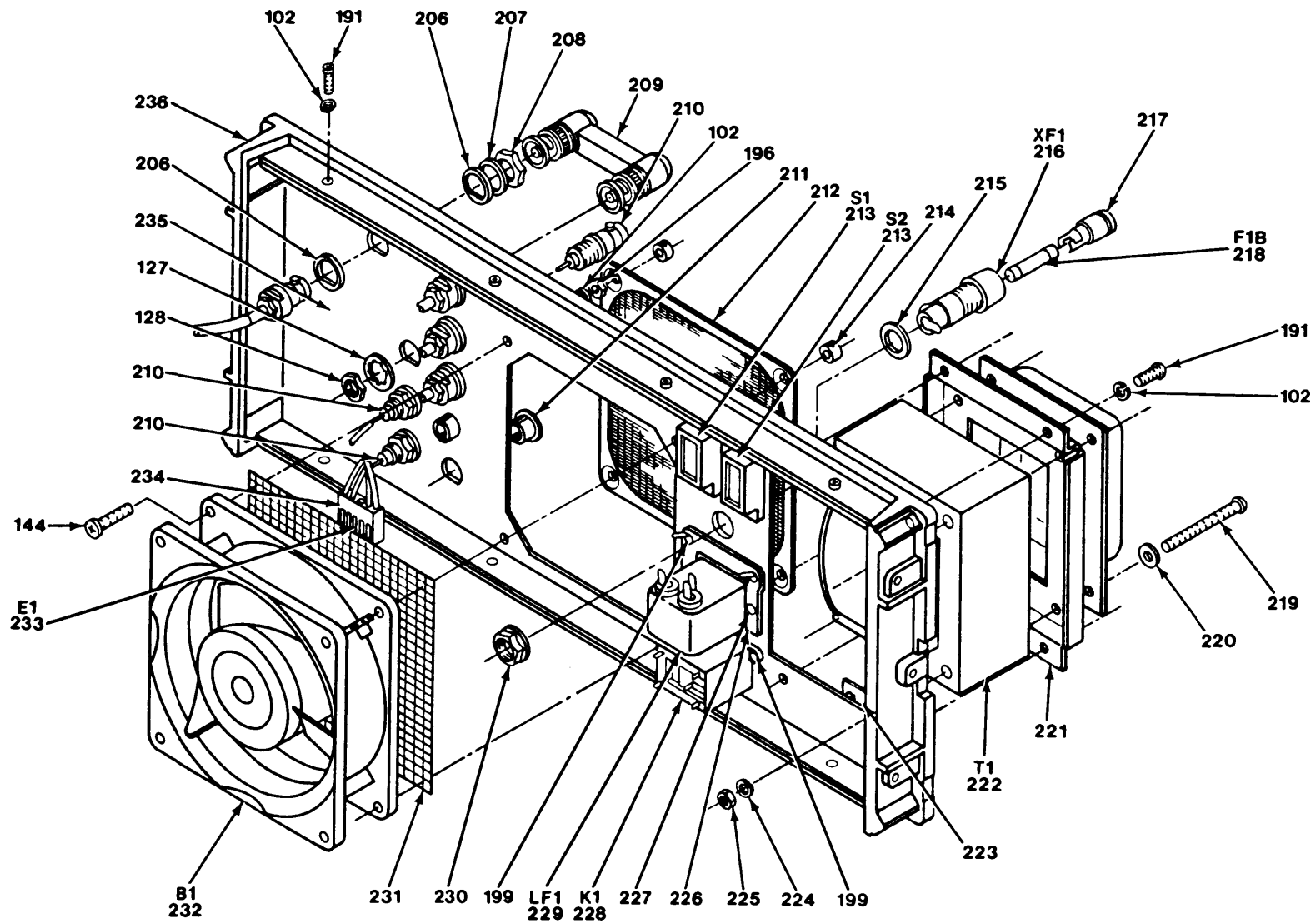

Figure 1. Frequency Selective Level Meter, AN/USM-490 (Sheet 10 of 11).

EL9NV010

REF DES	ITEM NO	REF DES	ITEM NO	REF DES	ITEM NO	REF DES	ITEM NO	REF DES	ITEM NO	REF DES	ITEM NO
A1	146	W2	110								
A2	89	W3	65								
A4	90	W4	64								
A5	92	W5	66								
A10	93	W6	100								
A11	99	W7	63								
A15	79	W8	62								
A16	104	W9	62								
A20	80	W10	62								
A21	81	W11	62								
A22	85	W12	62								
A30	86	W13	88								
A31	84	W14	88								
A32	83	W15	2								
A40	67	W17	107								
A50	74	W18	4								
A51	61	XF1	216								
A52	87	XQ1	165								
A53	77	XQ2	165								
A60	70										
A61	82										
A62	68										
A70	69										
A80	71										
A98	141										
A99	181										
B1	232										
CR1-2	97										
CR20	169										
E1	233										
F1A	1										
F1B	218										
J1	119										
J2	119										
J3	119										
J4	119										
K1	228										
LF1	229										
M1	143										
Q1	163										
Q2	161										
Q3	163										
R100	115										
R101	118										
S1	213										
S2	213										
S3	166										
SP100	117										
T1	222										
W1	109										

Figure 1. Frequency Selective Level Meter, AN/USM-490 (Sheet 11 of 11).

SECTION II

TM11-6625-3087-24P

(1) ITEM NO	(2) SMR CODE	(3) FSCM	(4) PART NUMBER	(5) DESCRIPTION AND USABLE ON CODE (UOC)	(6) QTY
GROUP 00 FREQUENCY SELECTIVE LEVEL METER, AN/USM-490					
FIG. 1					
1	PAOZZ	81349	F02A250B1A	FUSE, CARTRIDGE	1
2	PAOZZ	16428	KH7147	CABLE ASSEMBLY, POWE	1
3	PAOZZ	28480	5061-0090	HANDLE KIT	1
4	PAOZZ	28480	8120-0688	CABLE ASSEMBLY	1
5	PAOZZ	28480	5040-7219	CAP STRAP HANDLE	2
6	PAOZZ	28480	5060-9803	HANDLE, LUGGAGE	2
7	PAOZZ	28480	5040-7220	CAP, HANDLE STRAP	2
8	XBHZZ	28480	7120-1254	PLATE, IDENT	1
9	PAOZZ	28480	5041-1752	PUSH BUTTON	1
10	PAOZZ	28480	5041-1749	PUSH BUTTON	1
11	PAOZZ	28480	5041-1750	PUSH BUTTON	1
12	PAOZZ	28480	5041-1753	PUSH BUTTON	1
13	PAOZZ	28480	5041-0814	PUSH BUTTON	1
14	PAOZZ	28480	5041-0817	PUSH BUTTON	1
15	PAOZZ	28480	5041-0818	PUSH BUTTON	1
16	PAOZZ	28480	5041-0815	PUSH BUTTON	1
17	PAOZZ	28480	5041-0816	PUSH BUTTON	2
18	PAOZZ	28480	5041-1745	PUSH BUTTON	1
19	PAOZZ	28480	5041-1744	PUSH BUTTON	1
20	PAOZZ	28480	5041-1754	PUSH BUTTON	1
21	PAOZZ	28480	5041-0343	PUSH BUTTON	1
22	PAOZZ	28480	5041-0943	PUSH BUTTON	1
23	PAOZZ	28480	5041-0352	PUSH BUTTON	2
24	PAOZZ	28480	5041-1746	PUSH BUTTON	1
25	PAOZZ	28480	5041-1747	PUSH BUTTON	1
26	PAOZZ	28480	5041-1743	PUSH BUTTON	1
27	PAOZZ	28480	5041-0855	PUSH BUTTON	2
28	PAOZZ	28480	5041-0813	PUSH BUTTON	1
29	PAOZZ	28480	5041-0808	PUSH BUTTON	1
30	PAOZZ	28480	5041-0812	PUSH BUTTON	1
31	PAOZZ	28480	5041-0819	PUSH BUTTON	1
32	PAOZZ	28480	5041-0811	PUSH BUTTON	1
33	PAOZZ	28480	5041-1751	PUSH BUTTON	1
34	PAOZZ	28480	5041-0775	PUSH BUTTON	1
35	PAOZZ	28480	5041-1748	PUSH BUTTON	1
36	PAOZZ	28480	5041-0774	PUSH BUTTON	1
37	PAOZZ	28480	5041-0285	PUSH BUTTON	10
38	PAOZZ	28480	5041-0384	PUSH BUTTON	6
39	PAOZZ	28480	5041-0450	QUARTER KEY PUSHBUT	1
40	PAOZZ	28480	5041-0417	PUSH BUTTON	15
41	PAOZZ	28480	5041-0031	PUSH BUTTON	1
42	PAHZZ	28480	0340-0618	INSULATOR, PLATE	1
43	XBHZZ	79136	5133-14SZDR	RING, RETAINING	2
44	PAHZZ	28480	0570-1171	SCREW, MACHINE	2
45	PAOZZ	28480	5061-2009	BRACKET, ANGLE	1
46	PAHZZ	96906	MS35335-29	WASHER, LOCK	4
47	PAHZZ	96906	MS51957-28	SCREW, MACHINE	4

SECTION II

TM11-6625-3087-24P

(1) ITEM NO	(2) SMR CODE	(3) FSCM	(4) PART NUMBER	(5) DESCRIPTION AND USABLE ON CODE (UOC)	(6) QTY
48	XBHZZ	28480	8160-0360	SHIELD,RFI	16
49	XBHZZ	28480	5060-9941	COVER,SIDE	2
50	PAHZZ	96906	MS24693C48	SCREW,MACHINE	4
51	PAOZZ	28480	5040-7201	BUMPER,PLASTIC	4
52	PAOZZ	28480	1460-1345	CLIP,RETAINING	2
53	PAHZZ	28480	4320-0324	NONMETALLIC SPECIL	60
54	XBHZZ	28480	8160-0507	SHIELD,RFI	8
55	XBHZZ	28480	5001-0440	TRIM,CABINET	2
56	XBHZZ	28480	5021-4712	FRAME,FRONT	1
57	PAOZZ	28480	5040-7202	TRIM TOP	1
58	XBHZZ	28480	03586-64101	COVER,BOTTOM	1
59	XBHZZ	28480	8160-0498	SHIELD,RFI	16
60	XBHZZ	28480	5060-9834	COVER,TOP	1
61	PAHZZ	28480	03586-66551	CIRCUIT CARD ASSEMB	1
62	PAHZZ	28480	03586-61678	CABLE ASSEMBLY,RADI	5
63	PAHZZ	28480	03586-61677	CABLE ASSEMBLY,RADI	1
64	PAHZZ	28480	03586-61674	CABLE ASSEMBLY,RADI	1
65	PAHZZ	28480	03586-61671	CABLE ASSEMBLY,RADI	1
66	PAHZZ	28480	03586-61675	CABLE ASSEMBLY,RADI	1
67	PAHHH	28480	03586-66540	CIRCUIT CARD ASSEMB	1
68	PAHZZ	28480	03586-66562	CIRCUIT CARD ASSEMB	1
69	PAHHH	28480	03586-66570	CIRCUIT CARD ASSEMB	1
70	PAHHH	28480	03586-66560	CIRCUIT CARD ASSEMB	1
71	PAHZZ	28480	03586-66580	CIRCUIT CARD ASSEMB	1
72	PAHZZ	27264	09-50-7141	CONNECTOR,PLUG,ELEC	1
73	XBHZZ	28480	0403-0132	GUIDE,CKT CARD	4
74	PAHHH	28480	03586-66550	CIRCUIT CARD ASSEMB	1
75	XBHZZ	28480	0515-0055	SCREW,MACHINE	9
76	PAHZZ	96906	MS35340-40	WASHER,LOCK	2
77	PAHZZ	28480	03586-66553	CIRCUIT CARD ASSEMB	1
78	XBHZZ	28480	03586-04704	BRKT,MOUNTING	1
79	PAHHH	28480	03586-66515	CIRCUIT CARD ASSEMB	1
80	PAHHH	28480	03586-66523	CIRCUIT CARD ASSEMB	1
81	PAHHH	28480	03586-66521	CIRCUIT CARD ASSEMB	1
82	PAHZZ	28480	03586-66561	CIRCUIT CARD ASSEMB	1
83	PAHZZ	28480	03586-66532	CIRCUIT CARD ASSEMB	1
84	PAHZZ	28480	03586-66531	CIRCUIT CARD ASSEMB	1
85	PAHHH	28480	03586-66522	CIRCUIT CARD ASSEMB	1
86	PAHZZ	28480	03586-66530	CIRCUIT CARD ASSEMB	1
87	PAHZZ	28480	03586-66552	CIRCUIT CARD ASSEMB	1
88	PAHZZ	28480	03586-61691	CABLE ASSEMBLY,RADI	2
89	PAHHH	28480	03586-66502	CIRCUIT CARD ASSEMB	1
90	PAHHH	28480	03586-66504	CIRCUIT CARD ASSEMB	1
91	XBHZZ	28480	0515-0169	SCREW,MACHINE	83
92	PAHHH	28480	03586-66505	CIRCUIT CARD ASSEMB	1
93	PAHHH	28480	03586-66510	CIRCUIT CARD ASSEMB	1
94	XBHZZ	28480	03586-20614	SHIELD,ELEC	2
95	XBHZZ	28480	0515-0158	SCREW,MACHINE	8
96	XBHZZ	28480	03586-00603	PLATE,ELEC SHLD	2
97	PAHZZ	04713	MV109	SEMICONDUCTOR DEVIC	1
98	XBHZZ	28480	03586-00604	PLATE,ELEC SHLD	2
99	PAHHH	28480	03586-66511	CIRCUIT CARD ASSEMB	1

SECTION II

TM11-6625-3087-24P

(1) ITEM NO	(2) SMR CODE	(3) FSCM	(4) PART NUMBER	(5) DESCRIPTION AND USABLE ON CODE (UOC)	(6) QTY
100	PAHZZ	28480	03586-61676	CABLE ASSEMBLY, RADI	1
101	XBHZZ	28480	3050-0010	WASHER, FLAT	13
102	PAHZZ	96906	MS35338-136	WASHER, LOCK	56
103	XBHZZ	28480	0515-0165	SCREW, MACHINE	2
104	PAHHH	28480	03586-66516	CIRCUIT CARD ASSEMB	1
105	XBHZZ	28480	03586-60603	SHIELD, FRONT PANEL	1
106	XBHZZ	28480	7120-8607	PLATE, INSTR	3
107	PAHZZ	28480	8120-2888	CABLE ASSEMBLY	1
108	XBHZZ	28480	0515-0080	SCREW, MACHINE	9
109	PAHZZ	28480	03586-61612	CABLE ASSEMBLY, SPEC	1
110	PAHZZ	28480	03586-61615	GENERATOR, PULSE	1
111	XBHZZ	28480	0535-0004	NUT, PLAIN, HEX	8
112	PAHZZ	96906	MS35338-40	WASHER, LOCK	31
113	XBHZZ	28480	0515-0082	SCREW, MACHINE	3
114	PAHZZ	27264	22-01-2055	CONNECTOR BODY, PLUG	1
115	PAHZZ	28480	2100-0669	RESISTOR, VARIABLE, N	1
116	XBHZZ	28480	5040-7695	MOUNT, SPEAKER	1
117	PAHZZ	73445	50P01-8	SPEAKER	1
118	PAHZZ	81349	RCR07G101JS	RESISTOR, FIXED, COMP	1
119	PAHZZ	82389	M114B	JACK, TELEPHONE	4
120	XBHZZ	28480	03586-04702	BRKT, MTG, JACK	1
121	PAHZZ	96906	MS35333-108	WASHER, LOCK	1
122	XBHZZ	28480	0515-0223	SCREW, MACHINE	4
123	XBHZZ	28480	8160-0506	SHIELD, RFI	16
124	PAHZZ	82389	410C507	NUT, PLAIN, HEXAGON	1
125	PAHZZ	96906	MS51963-9	SETSCREW	2
126	PAOZZ	28480	0370-1001	KNOB	1
127	PAHZZ	78189	1920-02	WASHER, LOCK	10
128	XBHZZ	73743	28200-10-101	NUT, PLAIN, HEX	10
129	PAOZZ	28480	0370-1303	KNOB	1
130	PAHZZ	96906	MS51963-21	SETSCREW	2
131	XBHZZ	28480	5040-6928	STRIP, DIVIDER	1
132	PAHZZ	28480	5041-1600	INSULATOR, INPUT	1
133	PAHZZ	28480	5041-1467	INSULATOR, INPUT	1
134	PAHZZ	28480	5041-1466	INSULATOR, INPUT	1
135	PAHZZ	28480	5041-1470	INSULATOR INPUT	1
136	PAHZZ	22670	8035-112	INSULATOR, PLATE	1
137	XBHZZ	28480	03586-00203	PANEL, FRONT	1
138	XBHZZ	28480	0515-0076	SCREW, MACHINE	2
139	XBHZZ	28480	03586-20202	PANEL, FRONT	1
140	XBHZZ	28480	03586-00201	PANEL, FRONT	1
141	PAHHH	28480	03586-66598	CIRCUIT CARD ASSEMB	1
142	XBHZZ	28480	03586-01209	BRKT, MTG, METER	1
143	PAHZZ	28480	1120-0692	METER, ARBITRARY SCA	1
144	XBHZZ	28480	0515-0069	SCREW, MACHINE	6
145	PAHZZ	27264	22-01-1023	CONNECTOR BODY, PLUG	1
146	PAHHH	28480	03586-66501	CIRCUIT CARD ASSEMB	1
147	PAHZZ	27264	09-50-7031	CONNECTOR BODY, RECE	1
148	XBHZZ	28480	03586-04101	COVER, ACCESS	1
149	PAHZZ	96906	MS27183-4	WASHER, FLAT	14
150	XBHZZ	28480	03586-00106	CHASSIS, ELEC EQPT	1
151	XBHZZ	28480	1531-0160	BUSHING, RTNR	3

SECTION II

TM11-6625-3087-24P

(1) ITEM NO	(2) SMR CODE	(3) FSCM	(4) PART NUMBER	(5) DESCRIPTION AND USABLE ON CODE (UOC)	(6) QTY
152	PAHZZ	00144	CJ1010	CONNECTOR, RECEPTACL	2
153	XBHZZ	28480	03586-24702	SPACER, CONNECTOR	1
154	PAHZZ	28480	5060-0467	CONNECTOR, PLUG, ELEC	1
155	PAHZZ	24931	28JR318-1	CONNECTOR, RECEPTICA	1
156	XBHZZ	28480	03586-24701	SPACER, CONNECTOR	2
157	XBHZZ	28480	0515-0104	SCREW, MACHINE	12
158	PAHZZ	28480	03586-04185	COVER, ACCESS	1
159	XBHZZ	28480	03586-01211	BRKT, MOUNTING	1
160	XBHZZ	28480	03586-04197	COVER, ACCESS	1
161	PAHZZ	09966	M235A147-1	SEMICONDUCTOR DEVIC	1
162	PAHZZ	55285	7403-10-02	INSULATOR, PLATE	3
163	PAHZZ	08742	61-687-003	TRANSISTOR	2
164	PAHZZ	27264	03-09-1028	CONNECTOR BODY, PLUG	1
165	PAHZA	28480	1200-0819	SOCKET, PLUG-IN ELEC	2
166	PAHZZ	28480	3103-0020	SWITCH, THERMOSTATIC	1
167	PAHZZ	27264	03-09-2028	CONNECTOR, PLUG, ELEC	1
168	XBHZZ	28480	03586-01208	BRKT, REGULATOR	1
169	PAHZZ	28480	1902-1217	SEMICONDUCTOR DEVIC	1
170	PAHZZ	27264	09-50-7131	CONNECTOR, RECEPTACL	1
171	PAHZZ	28480	03586-04198	COVER, ACCESS	1
172	PAHZZ	96906	MS21266-1N	GROMMET, NONMETALLIC	6
173	PAHZZ	28480	4040-0707	BUMPER, PLASTIC	3
174	XBHZZ	28480	03586-04703	BRKT, MTG, CAP	1
175	XBHZZ	28480	00312-20067	SPACER, FILTER	2
176	XBHZZ	28480	03586-01214	BRKT, GUIDE	1
177	XBHZZ	28480	0403-0133	GUIDE, CKT CARD	2
178	XBHZZ	28480	03586-00601	PLATE, ELEC SHLD	1
179	XBHZZ	28480	03586-40101	CHASSIS, ELEC EQPT	1
180	XBHZZ	28480	03586-01202	BRKT, FRONT	1
181	PAHHH	28480	03586-66599	CIRCUIT CARD ASSEMB	1
182	XBHZZ	28480	03586-60604	SHIELD, CKT CARD	1
183	XBHZZ	28480	03586-40102	CHASSIS, ELEC EQPT	1
184	PAHZZ	28480	0340-0918	INSULATOR, PLATE	1
185	XBHZZ	28480	03586-04186	PLATE, ELEC SHLD	1
186	XBHZZ	28480	5020-8836	STRUT, CORNER	4
188	XBHZZ	28480	0403-0147	GUIDE, CKT CARD	1
189	XBHZZ	28480	03586-04187	PLATE, INSULATOR	1
190	XBHZZ	28480	03586-04195	PLATE, INSULATOR	1
191	XBHZZ	28480	0515-0067	SCREW, MACHINE	28
192	XBHZZ	28480	3050-0427	WASHER, INSULATOR	4
193	XBHZZ	28480	0515-0068	SCREW, MACHINE	4
194	XBHZZ	78189	5111018005002802 580	NUT, SELF LOCKING	1
195	XBHZZ	28480	0515-0166	SCREW, MACHINE	2
196	XBHZZ	28480	0535-0007	NUT, PLAIN, HEX	12
197	PAHZZ	96906	MS35333-71	WASHER, LOCK	6
198	PAHZZ	96906	MS27183-3	WASHER, FLAT	4
199	PAHZZ	96906	MS16535-156	RIVET, TUBULAR	11
200	XBHZZ	28480	0515-0066	SCREW, MACHINE	2
201	XBHZZ	28480	0515-0054	SCREW, MACHINE	7
202	PAHZZ	96906	MS15795-806	WASHER, FLAT	5
203	XBHZZ	28480	0515-0239	SCREW, MACHINE	65

SECTION II

TM11-6625-3087-24P

(1) ITEM NO	(2) SMR CODE	(3) FSCM	(4) PART NUMBER	(5) DESCRIPTION AND USABLE ON CODE (UOC)	(6) QTY
204	PAHZZ	96906	MS27183-5	WASHER, FLAT	4
205	PAHZZ	96906	MS24693C46	SCREW, MACHINE	16
206	PAHZZ	28480	5040-7624	INSULATOR, WASHER	8
207	PAHZZ	96906	MS35333-113	WASHER, LOCK	4
208	PAHZZ	53655	11-341LN	NUT, PLAIN, HEXAGON	4
209	PAHZZ	94375	RF-03152M	ADAPTER, CONNECTOR	1
210	PAHZZ	81349	M39012/21-0002	CONNECTOR, RECEPTACL	3
211	PAHZZ	28520	DP562	BUTTON, PLUG	2
212	PAHZZ	82877	5502	FILTER ELEMENT, AIR	1
213	PAHZZ	28480	3101-2298	SWITCH, SLIDE	2
214	PAOZZ	28480	0515-0099	NUT, THUMB	1
215	PAHZZ	75915	901-129	INSULATOR, WASHER	1
216	PAHZZ	28480	A-2110-0564-1	FUSEHOLDER, EXTR	1
217	PAOZZ	28480	2110-0565	FUSEHOLDER CAP	1
218	PAOZZ	81349	F02A250V2A	FUSE, CARTRIDGE	1
219	XBHZZ	28480	0515-0156	SCREW, MACHINE	4
220	PAHZZ	88044	AN960C8	WASHER, FLAT	4
221	XBHZZ	28480	03586-01216	BRKT, MTG, XFMR	1
222	PAHZZ	28480	9100-0440	TRANSFORMER, POWER	1
223	XBHZZ	28480	7122-0058	PLATE, IDENT	1
224	PAHZZ	96906	MS35338-42	WASHER, LOCK	4
225	XBHZZ	28480	0535-0006	NUT, PLAIN, HEX	4
226	XBHZZ	28480	03585-01215	BRKT, FILTER	1
227	PAHZZ	96906	MS16535-160	RIVET, TUBULAR	2
228	PAHZZ	28480	0490-1222	RELAY, ELECTROMAGNET	1
229	PAHZZ	05245	3EF2	FILTER, RADIO FREQUE	1
230	PAHZZ	28480	2110-0569	NUT, PLAIN, EXTENDED	1
231	XBHZZ	28480	03582-04104	GUARD, FAN	1
232	PAHZZ	23936	4800X	FAN, TUBEAXIAL	1
233	XDHZZ	27264	15-04-0219	POLARIZING KEY, ELEC	3
234	PAHZZ	27264	09-50-7051	CONNECTOR, PLUG, ELEC	1
235	XBHZZ	28480	03586-00202	PANEL, REAR	1
236	XBHZZ	28480	5020-8806	FRAME, REAR	1

END OF FIGURE

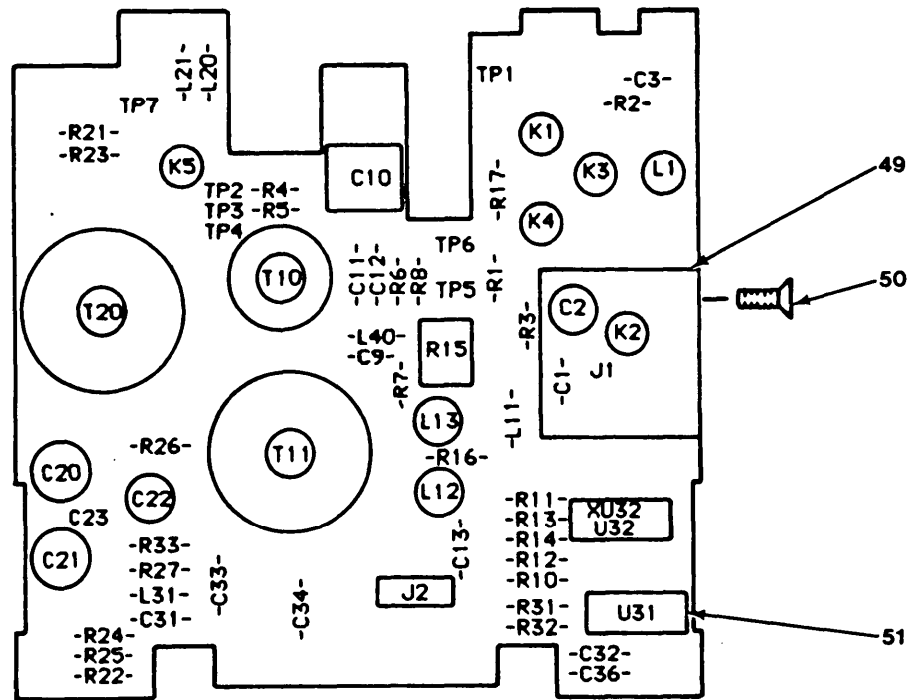

NOTE: PREFIX ALL REFERENCE
DESIGNATORS WITH 1A1

EL9NV011

Figure 2. Input Multiplexer Circuit Card Assembly (Sheet 1 of 2).

REF DES	ITEM NO	REF DES	ITEM NO	REF DES	ITEM NO	REF DES	ITEM NO	REF DES	ITEM NO	REF DES	ITEM NO
C1	1	R21	35								
C2	2	R22	36								
C3	1	R23	35								
C9	3	R24	36								
C10	4	R25	36								
C11	3	R26	37								
C12	3	R27	38								
C13	5	R31	39								
C20	6	R32	40								
C21	6	R33	41								
C22	7	T10	42								
C23	8	T11	43								
C31	9	T20	44								
C32	10	TP1	45								
C33	3	TP2	45								
C34	11	TP3	45								
C36	12	TP4	45								
J1	13	TP5	45								
J2	14	TP6	45								
K1	15	TP7	45								
K2	15	U31	46								
K3	15	U32	47								
K4	15	XU32	48								
K5	16										
L1	17										
L11	18										
L12	19										
L13	20										
L20	21										
L21	21										
L31	22										
L40	23										
L40	23										
L40	23										
R1	24										
R2	25										
R3	26										
R4	27										
R5	27										
R6	28										
R7	29										
R8	28										
R10	30										
R11	30										
R12	30										
R13	30										
R14	31										
R15	32										
R16	33										
R17	34										

Figure 2. Input Multiplexer Circuit Card Assembly (Sheet 2 of 2).

(1) ITEM NO	(2) SMR CODE	(3) FSCM	(4) PART NUMBER	(5) DESCRIPTION AND USABLE ON CODE (UOC)	(6) QTY
GROUP 01 INPUT MULTIPLEXER CIRCUIT CARD ASSEMBLY (A1)					
FIG. 2					
1	PAHZZ	81349	CM10ED300G03	CAPACITOR, FIXED, MIC	2
2	PAHZZ	28480	0121-0114	CAPACITOR, VARIABLE	1
3	PAHZZ	56289	5CZ5U225X0050C5C	CAPACITOR, FIXED, CER	4
4	PAHZZ	28480	0121-0162	CAPACITOR, VARIABLE	1
5	PAHZZ	28480	0160-0938	CAPACITOR, FIXED, MIC	1
6	PCHZZ	28480	0180-2735	CAPACITOR, FIXED, ELE	2
7	PAHZZ	52763	30432215-60PFN15	CAPACITOR, VARIABLE	1
8	PAHZZ	81349	CM10FD201G03	CAPACITOR, FIXED, MIC	1
9	PAHZZ	81349	M39003/01-2991	CAPACITOR, FIXED, ELE	1
10	PAHZZ	28480	0160-0570	CAPACITOR, FIXED, CER	1
11	PAHZZ	28480	0160-0576	CAPACITOR, FIXED, CER	1
12	PAHZZ	72982	8121M112X7R0103M	CAPACITOR, FIXED, CER	1
13	PAHZZ	98291	51-149-0000	CONNECTOR, RECEPTACL	1
14	PAHZZ	27264	09-60-1031	CONNECTOR, PLUG, ELEC	1
15	PAHZZ	11532	412YM0060	RELAY, ELECTROMAGNET	4
16	PAHZZ	28480	0490-1405	RELAY	1
17	PAHZZ	28480	9140-0422	COIL, ELECTRICAL	1
18	PAHZZ	28480	9100-1625	COIL, RADIO FREQUEN	1
19	PAHZZ	28480	9100-3294	COIL, RADIO FREQUENC	1
20	PAHZZ	28480	9140-0421	REACTOR	1
21	PAHZZ	96906	MS90538-01	COIL, RADIO FREQUENC	2
22	PAHZZ	96906	MS90538-12	COIL, RADIO FREQUENC	1
23	PAHZZ	10001	2270098-28	CHOKE, RAD FREQ	1
23	PAHZZ	24226	15M151J	COIL, RADIO FREQUENC	1
23	PAHZZ	28480	9140-0266	COIL, RADIO FREQUENC	1
24	PAHZZ	28480	0698-7363	RESISTOR, FIXED FILM	1
25	PAHZZ	19647	MS210N	RESISTOR, FIXED, FILM	1
26	PAHZZ	81349	RNC60K1002FS	RESISTOR, FIXED, FILM	1
27	PAHZZ	81349	RNC60K10R5FS	RESISTOR, FIXED, FILM	2
28	PAHZZ	81349	RNC60K10R2FS	RESISTOR, FIXED, FILM	2
29	PAHZZ	81349	RNC60K4530FS	RESISTOR, FIXED, FILM	1
30	PAHZZ	81349	RNC60K15R0FS	RESISTOR, FIXED, FILM	4
31	PAHZZ	81349	RNC60K1211FS	RESISTOR, FIXED, FILM	1
32	PAHZZ	28480	2100-3211	RESISTOR, VARIABLE, N	1
33	PAHZZ	81349	RNC70K1500FS	RESISTOR, FIXED, FILM	1
34	PAHZZ	81349	RNC60K75R0FS	RESISTOR, FIXED, FILM	1
35	PAHZZ	81349	RNC60K3240FS	RESISTOR, FIXED, FILM	2
36	PAHZZ	81349	RCR07G105JS	RESISTOR, FIXED, COMP	3
37	PAHZZ	81349	RNC60K6491FS	RESISTOR, FIXED, FILM	1
38	PAHZZ	81349	RNC60J5491FS	RESISTOR, FIXED, FILM	1
39	PAHZZ	81349	RCR07G472JS	RESISTOR, FIXED, COMP	1
40	PAHZZ	81349	RCR07G101JS	RESISTOR, FIXED, COMP	1
41	PAHZZ	81349	RWR89SR511FS	RESISTOR, FIXED, WIRE	1
42	PAHZZ	28480	9100-0471	TRANSFORMER	1
43	PAHZZ	28480	9100-0473	TRANSFORMER	1
44	PAHZZ	28480	9100-0459	TRANSFORMER, AUDIO F	1
45	PAHZZ	28480	1251-0600	CONNECTOR, RECEPTACL	7

SECTION II

TM11-6625-3087-24P

(1) ITEM NO	(2) SMR CODE	(3) FSCM	(4) PART NUMBER	(5) DESCRIPTION AND USABLE ON CODE (UOC)	(6) QTY
46	PAHZZ	81349	M38510/30605BCB	MICROCIRCUIT, DIGITA	1
47	PAHZZ	28480	1858-0047	MICROCIRCUIT, DIGITA	1
48	PAHZZ	09922	DILB16P108	SOCKET, PLUG-IN ELEC	1
49	XBHZZ	28480	03586-01201	BRKT, MTG, CONN	1
50	XBHZZ	28480	0515-0076	SCREW, MACHINE	1
51	PAHZZ	80009	136-0269-02	SOCKET, PLUG-IN ELEC	1

END OF FIGURE

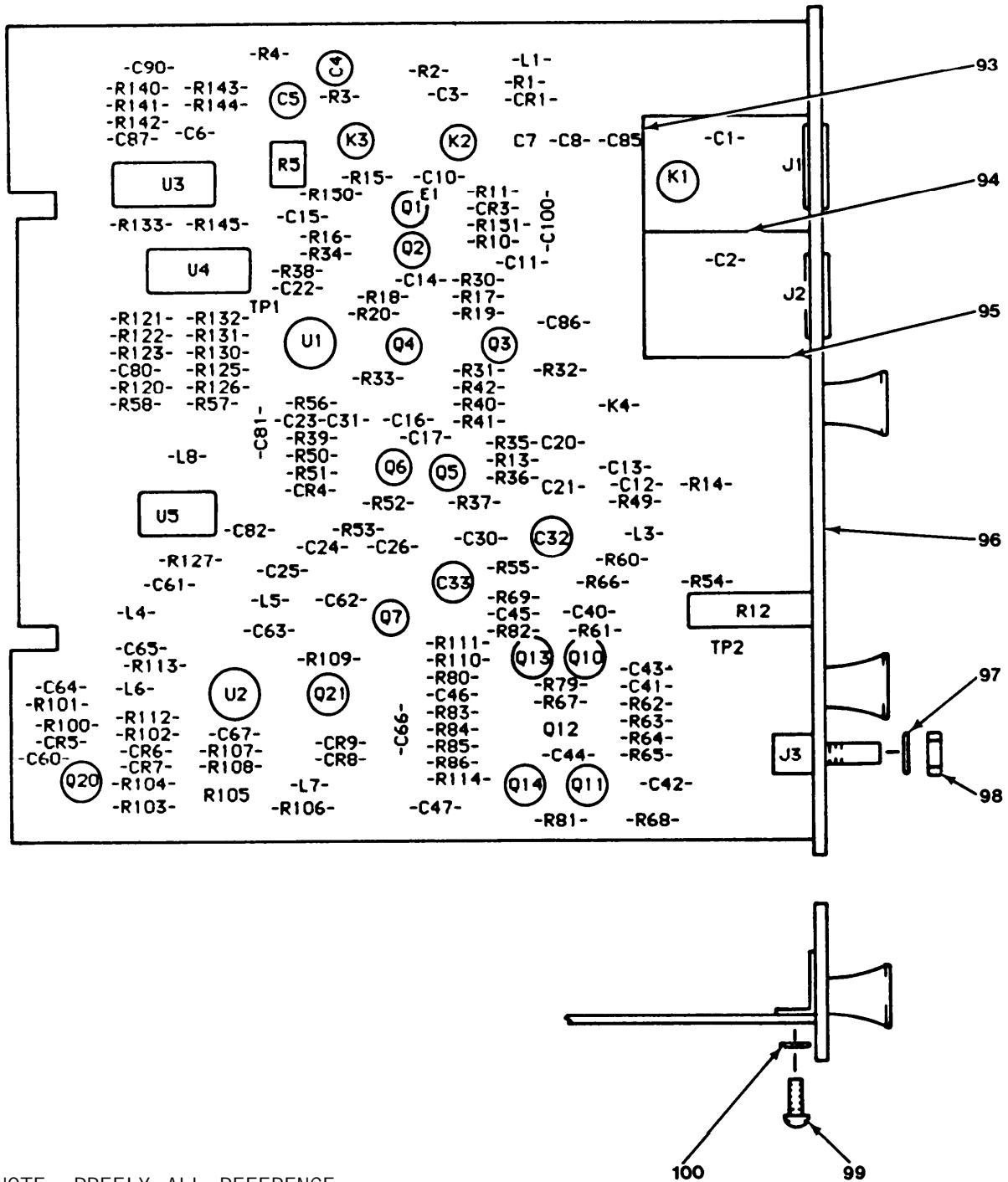

NOTE: PREFIX ALL REFERENCE DESIGNATORS WITH 1A2

EL9NV012

Figure 3. Input Amplifier Circuit Card Assembly (Sheet 1 of 2).

REF DES	ITEM NO	REF DES	ITEM NO	REF DES	ITEM NO	REF DES	ITEM NO	REF DES	ITEM NO	REF DES	ITEM NO
C1	1	C100	7	R17	50	R105	79				
C2	1	CR1	21	R18	50	R106	80				
C3	2	CR3	21	R19	51	R107	51				
C4	3	CR4	21	R20	51	R108	51				
C5	4	CR5	21	R30	52	R109	81				
C6	5	CR6	21	R31	53	R110	74				
C7	6	CR7	22	R32	54	R111	76				
C8	7	CR8	21	R33	53	R112	82				
C10	7	CR9	21	R34	52	R113	81				
C11	8	E1	23	R35	52	R114	81				
C12	7	J1	24	R36	52	R120	83				
C13	9	J2	24	R37	55	R121	83				
C14	7	J3	25	R38	56	R122	83				
C15	10	K1	26	R39	52	R123	83				
C16	11	K2	26	R40	57	R125	84				
C17	12	K3	26	R41	58	R126	84				
C20	13	K4	27	R42	57	R127	67				
C21	14	L1	28	R49	59	R130	84				
C22	1	L3	29	R50	46	R131	84				
C23	13	L4	30	R51	52	R132	84				
C24	7	L5	30	R52	60	R133	85				
C25	9	L6	30	R53	47	R140	82				
C26	14	L7	30	R54	61	R141	82				
C30	10	L8	30	R55	62	R142	86				
C31	7	Q1	31	R56	63	R143	86				
C32	3	Q2	32	R57	64	R144	86				
C33	6	Q3	33	R58	65	R145	86				
C40	1	Q4	32	R60	52	R150	87				
C41	1	Q5	32	R61	66	R151	57				
C42	15	Q6	33	R62	63	TP1	88				
C43	1	Q7	34	R63	67	TP2	88				
C44	16	Q10	35	R64	52	U1	89				
C45	1	Q11	35	R65	68	U2	89				
C46	1	Q12	35	R66	69	U3	90				
C47	15	Q13	32	R67	70	U4	91				
C60	7	Q14	32	R68	71	U5	92				
C61	17	Q20	36	R69	69						
C62	7	Q21	37	R79	70						
C63	17	R1	38	R80	72						
C64	1	R2	39	R81	71						
C65	15	R3	40	R82	66						
C66	15	R4	41	R83	63						
C67	1	R5	42	R84	67						
C80	18	R10	43	R85	73						
C81	7	R11	44	R86	68						
C82	19	R12	45	R100	74						
C85	7	R13	46	R101	75						
C86	7	R14	47	R102	76						
C87	20	R15	48	R103	77						
C90	18	R16	49	R104	78						

Figure 3. Input Amplifier Circuit Card Assembly (Sheet 2 of 2).

(1) ITEM NO	(2) SMR CODE	(3) FSCM	(4) PART NUMBER	(5) DESCRIPTION AND USABLE ON CODE (UOC)	(6) QTY
GROUP 02 INPUT AMPLIFIER CIRCUIT CARD ASSEMBLY (A2)					
FIG. 3					
1	PAHZZ	56289	5CZ5U225X0050C5C	CAPACITOR, FIXED, CER	10
2	PAHZZ	28480	0160-2241	CAPACITOR, FIXED, CER	1
3	PAHZZ	74970	187-0106-005	CAPACITOR, VARIABLE	2
4	PAHZZ	52763	30432215-60PFN15	CAPACITOR, VARIABLE	1
5	PAHZZ	04222	MA101A820JAA	CAPACITOR, FIXED, CER	1
6	PAHZZ	28480	0121-0455	CAPACITOR VARIABLE	2
7	PAHZZ	28480	0160-0576	CAPACITOR, FIXED, CER	12
8	PAHZZ	56289	292CC0G510J100B	CAPACITOR, FIXED, CER	1
9	PAHZZ	81349	M39003/01-2977	CAPACITOR, FIXED, ELE	2
10	PAHZZ	81349	M39003/01-2966	CAPACITOR, FIXED, ELE	2
11	PAHZZ	56289	292CC0G301J100B	CAPACITOR FIXED CAP	1
12	PAHZZ	04222	MA201A821JAA	CAPACITOR, FIXED, CER	1
13	PAHZZ	28480	0160-3874	CAPACITOR, FIXED, CER	2
14	PAHZZ	72982	8121B227C0J0229C	CAPACITOR, FIXED, CER	2
15	PAHZZ	81349	M39003/01-2991	CAPACITOR, FIXED, ELE	4
16	PAHZZ	72982	8121M112X7R0103M	CAPACITOR, FIXED, CER	1
17	PAHZZ	81349	M39003/01-3009	CAPACITOR, FIXED, ELE	2
18	PAHZZ	28480	0160-4557	CAPACITOR, FIXED, CER	2
19	PAHZZ	56289	292CC0G201J100B	CAPACITOR, FIXED, CER	1
20	PAHZZ	16546	C31A103K	CAPACITOR, FIXED, CER	1
21	PAHZZ	81349	JAN1N485B	SEMICONDUCTOR DEVIC	7
22	PAHZZ	81349	JAN1N825	SEMICONDUCTOR DEVIC	1
23	PAHZZ	28480	9170-0894	CORE, ELECTROMAGNET	1
24	PAHZZ	98291	51-149-0000	CONNECTOR, RECEPTACL	2
25	PAHZZ	28480	1250-1512	CONNECTOR RECEPTACL	1
26	PAHZZ	11532	412YM0060	RELAY, ELECTROMAGNET	3
27	PAHZZ	21317	RX1-12	RELAY, REED	1
28	PAHZZ	28480	9100-2486	COIL, RADIO FREQUENC	1
29	PAHZZ	24226	15M161J1	COIL, RADIO FREQUENC	1
30	PAHZZ	96906	MS14046-1	COIL, RADIO FREQUENC	5
31	PAHZZ	28480	A-1855-0410-1	TRANSISTOR	1
32	PAHZZ	28480	1853-0354	TRANSISTOR	5
33	PAHZZ	28480	1854-0305	TRANSISTOR	2
34	PAHZZ	28480	1854-0092	TRANSISTOR	1
35	PAHZZ	04713	MPSH10	TRANSISTOR	3
36	PAHZZ	80131	2N4037	TRANSISTOR	1
37	PAHZZ	28480	1854-0039	TRANSISTOR	1
38	PAHZZ	81349	RNC60H1470FS	RESISTOR, FIXED, FILM	1
39	PAHZZ	91637	PTF55-9001B	RESISTOR FIXED FILM	1
40	PAHZZ	81349	RNC55H9000BS	RESISTOR, FIXED, FILM	1
41	PAHZZ	81349	RNC65J1000BS	RESISTOR, FIXED, FILM	1
42	PAHZZ	28480	2100-3212	RESISTOR, VARIABLE, N	1
43	PAHZZ	81349	RCR07G100JS	RESISTOR, FIXED, COMP	1
44	PAHZZ	81349	RNC60K1130FS	RESISTOR, FIXED, FILM	1
45	PAHZZ	80294	3006P1-103	RESISTOR, VARIABLE, N	1
46	PAHZZ	81349	RNC60K2490FS	RESISTOR, FIXED, FILM	2
47	PAHZZ	81349	RNC60K6811FS	RESISTOR, FIXED, FILM	2

SECTION II

TM11-6625-3087-24P

(1) ITEM NO	(2) SMR CODE	(3) FSCM	(4) PART NUMBER	(5) DESCRIPTION AND USABLE ON CODE (UOC)	(6) QTY
48	PAHZZ	81349	RCR07G305JS	RESISTOR, FIXED, COMP	1
49	PAHZZ	81349	RNC60K1100FS	RESISTOR, FIXED, FILM	1
50	PAHZZ	81349	RNC60K1003FS	RESISTOR, FIXED, FILM	2
51	PAHZZ	81349	RNC60K5111FS	RESISTOR, FIXED, FILM	4
52	PAHZZ	81349	RCR07G470JS	RESISTOR, FIXED, COMP	8
53	PAHZZ	81349	RNC60K29R4FS	RESISTORFIXEDWIRE	2
54	PAHZZ	81349	RNC60K59R0FS	RESISTOR, FIXED, FILM	1
55	PAHZZ	81349	RNR60K4751FM	RESISTOR, FIXED FILM	1
56	PAHZZ	81349	RNC60K4870FS	RESISTOR, FIXED, FILM	1
57	PAHZZ	81349	RNC60K10R0BS	RESISTOR, FIXED, FILM	3
58	PAHZZ	81349	RNC60K1210FS	RESISTOR, FIXED, FILM	1
59	PAHZZ	81349	RNC60K1101FS	RESISTOR, FIXED, FILM	1
60	PAHZZ	81349	RNC60K5761FS	RESISTOR, FIXED, FILM	1
61	PAHZZ	81349	RNC60K4120FS	RESISTOR, FIXED, FILM	1
62	PAHZZ	81349	RNC60K4420FS	RESISTOR, FIXED, FILM	1
63	PAHZZ	81349	RNC60K1001FS	RESISTOR, FIXED, FILM	3
64	PAHZZ	81349	RCR07G362JS	RESISTOR, FIXED, COMP	1
65	PAHZZ	81349	RCR07G152JS	RESISTOR, FIXED, COMP	1
66	PAHZZ	81349	RNC60K1912FS	RESISTOR, FIXED, FILM	2
67	PAHZZ	81349	RCR07G101JS	RESISTOR, FIXED, COMP	3
68	PAHZZ	81349	RNC60K3240FS	RESISTOR, FIXED, FILM	2
69	PAHZZ	81349	RNC60K7321FS	RESISTOR, FIXED, FILM	2
70	PAHZZ	81349	RNC60K8250FS	RESISTOR, FIXED, FILM	2
71	PAHZZ	81349	RNC60K97R6FS	RESISTOR, FIXED, FILM	2
72	PAHZZ	81349	RNC60K48R7FS	RESISTOR, FIXED, FILM	1
73	PAHZZ	81349	RCR07G242JS	RESISTOR, FIXED, COMP	1
74	PAHZZ	81349	RCR07G511JS	RESISTOR, FIXED, COMP	2
75	PAHZZ	81349	RCR07G4R7JS	RESISTOR, FIXED, COMP	1
76	PAHZZ	81349	RCR07G202JS	RESISTOR, FIXED, COMP	2
77	PAHZZ	81349	RNC60K7500FS	RESISTOR, FIXED, FILM	1
78	PAHZZ	81349	RNC60K5110FS	RESISTOR, FIXED, FILM	1
79	PAHZZ	32997	3386XY46-201	RESISTOR, VARIABLE, N	1
80	PAHZZ	81349	RNC60K1241FS	RESISTOR, FIXED, FILM	1
81	PAHZZ	81349	RCR07G6R2JS	RESISTOR, FIXED, COMP	3
82	PAHZZ	81349	RCR07G103JS	RESISTOR, FIXED, COMP	3
83	PAHZZ	81349	RCR07G471JS	RESISTOR, FIXED, COMP	4
84	PAHZZ	81349	RCR07G472JS	RESISTOR, FIXED, COMP	5
85	PAHZZ	81349	RCR07G102JS	RESISTOR, FIXED, COMP	1
86	PAHZZ	81349	RCR07G3R3JS	RESISTOR, FIXED, COMP	4
87	PAHZZ	81349	RNC60K49R9FS	RESISTOR, FIXED, FILM	1
88	PAHZZ	28480	0360-0077	TERMINAL, STUD	2
89	PAHZZ	28480	1826-0111	MICROCIRCUIT, LINEAR	2
90	PAHZZ	28480	1858-0047	MICROCIRCUIT, DIGITA	1
91	PAHZZ	01295	SN74LS273N	MICROCIRCUIT, DIGITA	1
92	PAHZZ	81349	M38510/30605BCB	MICROCIRCUIT, DIGITA	1
93	XBHZZ	28480	1600-0839	PLATE, ELEC SHLD	1
94	XBHZZ	28480	1600-0838	PLATE, ELEC SHLD	1
95	XBHZZ	28480	1600-0840	PLATE, ELEC SHLD	1
96	XBHZZ	28480	03586-04102	COVER, CKT CD	1
97	PAHZZ	98291	3002-26	WASHER, LOCK	1
98	PAHZZ	98291	3002-18	NUT, PLAIN, HEXAGON	1
99	XBHZZ	28480	0515-0150	SCREW, MACHINE	2

SECTION II

TM11-6625-3087-24P

(1) ITEM NO	(2) SMR CODE	(3) FSCM	(4) PART NUMBER	(5) DESCRIPTION AND USABLE ON CODE (UOC)	(6) QTY
100	XBHZZ	73734	99401	WASHER, LOCK	2

END OF FIGURE

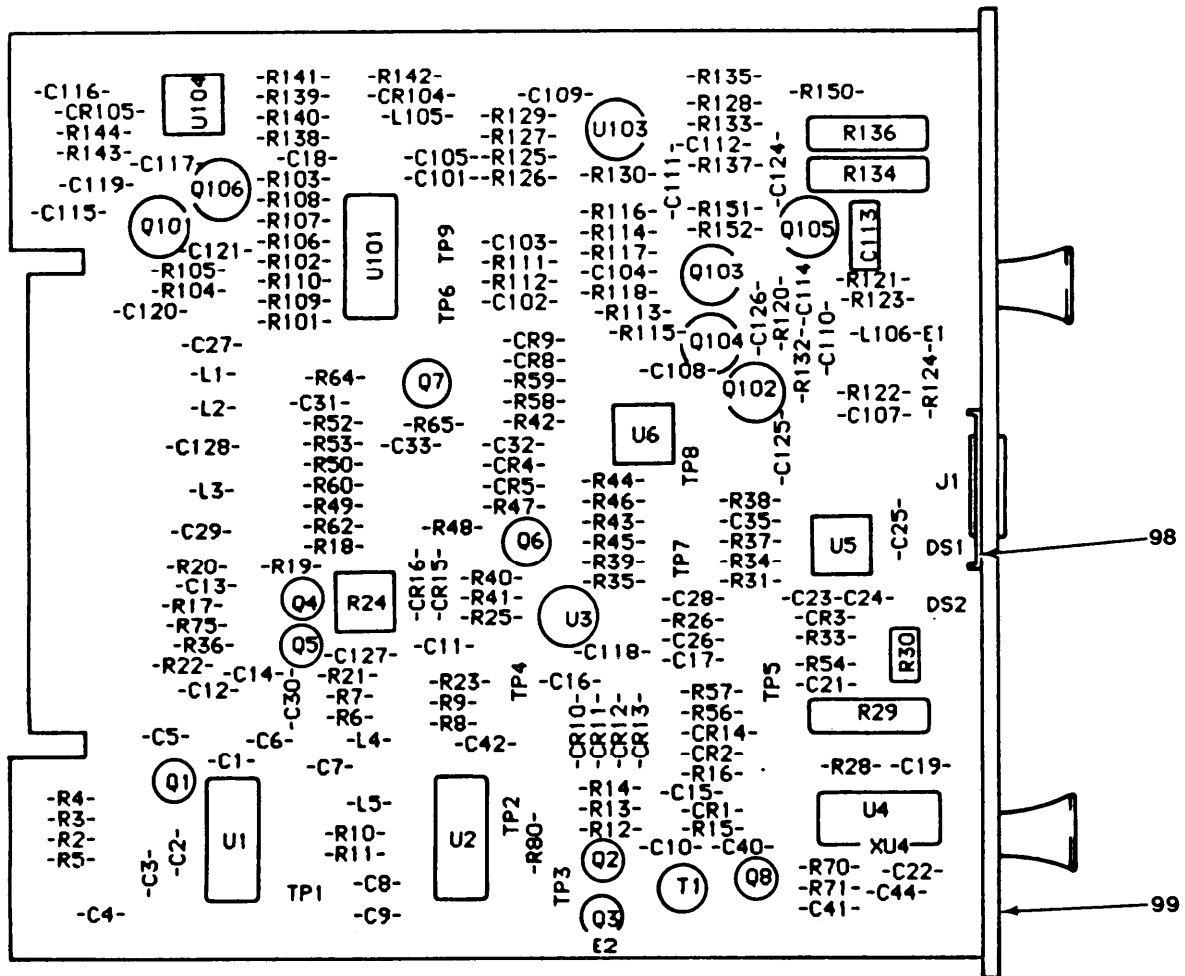

NOTE: PREFIX ALL REFERENCE DESIGNATORS WITH 1A4

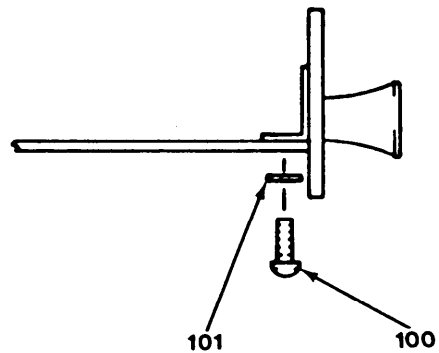

EL9NV013

Figure 4. Broadband Power/CAL/Overload Circuit Card Assembly (Sheet 1 of 2).

REF DES	ITEM NO	REF DES	ITEM NO	REF DES	ITEM NO	REF DES	ITEM NO	REF DES	ITEM NO	REF DES	ITEM NO
C1	1	C111	3	Q7	36	R44	56	R130	76		
C2	2	C112	3	Q8	36	R45	67	R132	76		
C3	3	C113	15	Q101	36	R46	52	R133	84		
C4	4	C114	16	Q102	37	R47	68	R134	85		
C5	5	C115	3	Q103	37	R48	68	R135	55		
C6	3	C116	3	Q104	37	R49	40	R136	86		
C7	6	C117	1	Q105	37	R50	40	R137	38		
C8	7	C118	1	Q106	36	R52	69	R138	52		
C9	7	C119	17	R2	38	R53	70	R139	52		
C10	3	C120	1	R3	38	R54	71	R140	38		
C11	7	C121	1	R4	39	R56	56	R141	52		
C12	4	C124	1	R5	40	R57	72	R142	74		
C13	4	C125	3	R6	41	R58	73	R143	74		
C14	3	C126	18	R7	42	R59	73	R144	87		
C15	3	C127	19	R8	43	R60	52	R150	68		
C16	8	C128	20	R9	43	R62	52	R151	52		
C17	1	CR1	21	R10	44	R64	52	R152	76		
C18	1	CR2	21	R11	44	R65	52	T1	88		
C19	3	CR3	21	R12	45	R70	47	TP1	89		
C21	3	CR4	22	R13	46	R71	74	TP2	89		
C22	3	CR5	22	R14	45	R75	44	TP3	89		
C23	3	CR8	22	R15	47	R80	75	TP4	89		
C24	9	CR9	22	R16	47	R101	76	TP5	89		
C25	3	CR10	23	R17	48	R102	63	TP6	89		
C26	10	CR11	23	R18	49	R103	63	TP7	89		
C27	11	CR12	23	R19	44	R104	77	TP8	89		
C28	11	CR13	23	R20	50	R105	52	TP9	89		
C29	4	CR14	22	R21	51	R106	63	U1	90		
C30	1	CR15	21	R22	42	R107	78	U2	91		
C31	1	CR16	21	R23	52	R108	78	U3	92		
C32	1	CR104	22	R24	53	R109	78	U4	93		
C33	1	CR105	24	R25	54	R110	78	U5	94		
C35	12	DS1	25	R26	55	R111	79	U6	94		
C40	2	DS2	26	R28	56	R112	79	U101	95		
C41	13	E1	27	R29	57	R113	80	U103	96		
C42	1	E2	28	R30	58	R114	80	U104	94		
C44	1	J1	29	R31	59	R115	45	XU4	97		
C101	3	L1	30	R33	60	R116	45				
C102	10	L2	30	R34	61	R117	78				
C103	10	L3	30	R35	62	R118	78				
C104	7	L4	31	R36	63	R120	81				
C105	3	L5	31	R37	64	R121	82				
C107	10	L105	30	R37	61	R122	81				
C108	1	L106	32	R37	64	R123	83				
C109	3	Q1	33	R38	56	R124	83				
C110	14	Q2	34	R39	65	R125	80				
C110	14	Q3	34	R40	65	R126	74				
C110	14	Q4	35	R41	52	R127	52				
C110	14	Q5	35	R42	52	R128	78				
C110	14	Q6	36	R43	66	R129	76				

Figure 4. Broadband Power/CAL/Overload Circuit Card Assembly (Sheet 2 of 2).

(1) ITEM NO	(2) SMR CODE	(3) FSCM	(4) PART NUMBER	(5) DESCRIPTION AND USABLE ON CODE (UOC)	(6) QTY
GROUP 03 BROADBAND POWER/CAL/OVER- LOAD CIRCUIT CARD ASSEMBLY (A4)					
FIG. 4					
1	PAHZZ	72982	8121M112X7R0103M	CAPACITOR, FIXED, CER	15
2	PAHZZ	28480	1854-0305	TRANSISTOR	2
3	PAHZZ	28480	0160-0576	CAPACITOR, FIXED, CER	18
4	PAHZZ	81349	M39003/01-2991	CAPACITOR, FIXED, ELE	4
5	PAHZZ	81349	CFR02AQC562GM	CAPACITOR, FIXED, PLA	1
6	PAHZZ	81349	CMR06F621G0DR	CAPACITOR, FIXED, MIC	1
7	PAHZZ	18876	10018712-022	CAPACITOR, FIXED, ELE	4
8	PAHZZ	28480	0140-0193-PS	CAPACITOR, FIXED, MIC	1
9	PAHZZ	81349	CM10FD101G03	CAPACITOR, FIXED, MIC	1
10	PAHZZ	56289	5CZ5U225X0050C5C	CAPACITOR, FIXED, CER	4
11	PAHZZ	81349	M39003/01-3009	CAPACITOR, FIXED, ELE	2
12	PAHZZ	81349	M39003/01-2964	CAPACITOR, FIXED, ELE	1
13	PAHZZ	12954	ST513B106K020N	CAPACITOR, FIXED, ELE	1
14	PAHZZ	81349	CM10ED390G03	CAPACITOR, FIXED, MIC	1
14	PAHZZ	81349	CMR05E240J0DR	CAPACITOR, FIXED, MIC	1
14	PAHZZ	72136	RDM15C200J3C	CAPACITOR, FIXED, MIC	1
14	PAHZZ	81349	CM10ED300G03	CAPACITOR, FIXED, MIC	1
14	PAHZZ	28480	0160-2308	CAPACITOR, FIXED, MIC	1
15	PAHZZ	28480	0121-0036	CAPACITOR, VARIABLE	1
16	PAHZZ	16546	C31A103K	CAPACITOR, FIXED, CER	1
17	PAHZZ	81349	M39003/01-3088	CAPACITOR, FIXED, ELE	1
18	PAHZZ	59660	8121B227C0J339C	CAPACITOR, FIXED, CER	1
19	PAHZZ	28480	0160-3874	CAPACITOR, FIXED, CER	1
20	PAHZZ	00853	RDM15F471J3C	CAPACITOR, FIXED, MIC	1
21	PAHZZ	28480	5082-5511	SEMICONDUCTOR, DEVIC	5
22	PAHZZ	81349	JAN1N4150	SEMICONDUCTOR, DEVIC	6
23	PAHZZ	30890	40-001020-02	SEMICONDUCTOR, DEVIC	4
24	PAHZZ	81349	JAN1N825	SEMICONDUCTOR, DEVIC	1
25	PAHZZ	28480	1990-0487	LIGHT EMITTING DIOD	1
26	PAHZZ	28480	1990-0486	LIGHT EMITTING DIOD	1
27	PAHZZ	28480	0360-1716	TERMINAL, FEEDTHRU	1
28	PAHZZ	28480	9170-0894	CORE, ELECTROMAGNET	2
29	PAHZZ	98291	51-149-0000	CONNECTOR, RECEPTACL	1
30	PAHZZ	24226	15M102J	COIL, RADIO FREQUENC	4
31	PAHZZ	24226	15M470J	COIL, RADIO FREQUENC	2
32	PAHZZ	28480	9140-0411	REACTOR	1
33	PAHZZ	28480	1853-0010	TRANSISTOR	1
34	PAHZZ	28480	1853-0354	TRANSISTOR	2
35	PAHZZ	28480	1854-0485	TRANSISTOR	2
36	PAHZZ	04713	SPS5103	TRANSISTOR	5
37	PAHZZ	04713	MPSH10	TRANSISTOR	4
38	PAHZZ	81349	RCR07G563JS	RESISTOR, FIXED, COMP	4
39	PAHZZ	81349	RCR07G512JS	RESISTOR, FIXED, COMP	1
40	PAHZZ	81349	RCR07G332JS	RESISTOR, FIXED, COMP	3
41	PAHZZ	81349	RCR07G752JS	RESISTOR, FIXED, COMP	1
42	PAHZZ	81349	RCR07G202JS	RESISTOR, FIXED, COMP	2

SECTION II

TM11-6625-3087-24P

(1) ITEM NO	(2) SMR CODE	(3) FSCM	(4) PART NUMBER	(5) DESCRIPTION AND USABLE ON CODE (UOC)	(6) QTY
43	PAHZZ	81349	RCR07G430JS	RESISTOR, FIXED, COMP	2
44	PAHZZ	81349	RCR07G510JS	RESISTOR, FIXED, COMP	4
45	PAHZZ	81349	RCR07G270JS	RESISTOR, FIXED, COMP	4
46	PAHZZ	81349	RCR07G301JS	RESISTOR, FIXED, COMP	1
47	PAHZZ	81349	RCR07G243JS	RESISTOR, FIXED, COMP	3
48	PAHZZ	81349	RNC60K3010FS	RESISTOR, FIXED, FILM	1
49	PAHZZ	81349	RCR07G203JS	RESISTOR, FIXED, COMP	1
50	PAHZZ	81349	RCR07G362JS	RESISTOR, FIXED, COMP	1
51	PAHZZ	81349	RNC60K200FS	RESISTOR, FIXED, FILM	1
52	PAHZZ	81349	RCR07G103JS	RESISTOR, FIXED, COMP	14
53	PAHZZ	32997	3386XY46-500	RESISTOR, VARIABLE, N	1
54	PAHZZ	81349	RNC60K4530FS	RESISTOR, FIXED, FILM	1
55	PAHZZ	81349	RNC60K6041FS	RESISTOR, FIXED, FILM	2
56	PAHZZ	81349	RNC60K2002FS	RESISTOR, FIXED, FILM	4
57	PAHZZ	28480	2100-3054	RESISTOR, VARIABLE, N	1
58	PAHZZ	32997	3386XY46-201	RESISTOR, VARIABLE, N	1
59	PAHZZ	81349	RNC60K8250FS	RESISTOR, FIXED, FILM	1
60	PAHZZ	81349	RNC60K3572FS	RESISTOR, FIXED, FILM	1
61	PAHZZ	81349	RNC60K1022FS	RESISTOR, FIXED, FILM	2
62	PAHZZ	81349	RNC60K1131FS	RESISTOR, FIXED, FILM	1
63	PAHZZ	81349	RNC60K1001FS	RESISTOR, FIXED, FILM	4
64	PAHZZ	81349	RNC60K9761FS	RESISTOR, FIXED, FILM	1
64	PAHZZ	81349	RNC60K1002FS	RESISTOR, FIXED, FILM	1
65	PAHZZ	28480	0757-0467	RESISTOR, FIXED, FILM	2
66	PAHZZ	81349	RNC60K5622FS	RESISTOR, FIXED, FILM	1
67	PAHZZ	81349	RNC60J6192FS	RESISTOR, FIXED, FILM	1
68	PAHZZ	81349	RCR07G105JS	RESISTOR, FIXED, COMP	3
69	PAHZZ	81349	RNC60K1003FS	RESISTOR, FIXED, FILM	1
70	PAHZZ	81349	RNC60K8061FS	RESISTOR, FIXED, FILM	1
71	PAHZZ	28480	0811-1780	RESISTOR, FIXED, WIRE	1
72	PAHZZ	81349	RNC60K1152FS	RESISTOR, FIXED, FILM	1
73	PAHZZ	81349	RNC60H6042FS	RESISTOR, FIXED, FILM	2
74	PAHZZ	81349	RCR07G472JS	RESISTOR, FIXED, COMP	4
75	PAHZZ	56289	203C75	RESISTOR ASSEMBLY	1
76	PAHZZ	81349	RCR07G101JS	RESISTOR, FIXED, COMP	5
77	PAHZZ	81349	RCR07G303JS	RESISTOR, FIXED, COMP	1
78	PAHZZ	81349	RCR07G102JS	RESISTOR, FIXED, COMP	7
79	PAHZZ	81349	RCR07G471JS	RESISTOR, FIXED, COMP	2
80	PAHZZ	81349	RCR07G470JS	RESISTOR, FIXED, COMP	3
81	PAHZZ	81349	RNC60K88R7FS	RESISTOR, FIXED, FILM	2
82	PAHZZ	81349	RNC60K4020FS	RESISTOR, FIXED, FILM	1
83	PAHZZ	28480	0698-7363	RESISTOR, FIXED FILM	2
84	PAHZZ	81349	RNC60K6490FS	RESISTOR, FIXED, FILM	1
85	PAHZZ	80294	3006P-1-501	RESISTOR, VARIABLE, N	1
86	PAHZZ	80294	3006P1-101	RESISTOR, VARIABLE, N	1
87	PAHZZ	81349	RNC60K7320FS	RESISTOR, FIXED, FILM	1
88	PAHZZ	28480	08552-6044	TRANSFORMER, RADIO F	1
89	PAHZZ	28480	1251-0600	CONNECTOR, RECEPTCL	9
90	PAHZZ	01295	SN74LS625N	MICROCIRCUIT, DIGITA	1
91	PAHZZ	81349	M38510/06003BEB	MICROCIRCUIT, DIGITA	1
92	PAHZZ	96214	808052-3	MICROCIRCUIT, LINEAR	1
93	PAHZZ	51870	AD536AJD	MICROCIRCUIT, ANALOG	1

SECTION II

TM11-6625-3087-24P

(1) ITEM NO	(2) SMR CODE	(3) FSCM	(4) PART NUMBER	(5) DESCRIPTION AND USABLE ON CODE (UOC)	(6) QTY
94	PAHZZ	28480	1826-0111	MICROCIRCUIT, LINEAR	3
95	PAHZZ	14933	7800901EB	MICROCIRCUIT, LINEAR	1
96	PAHZZ	12040	LM307H	MICROCIRCUIT, LINEAR	1
97	PAHZZ	80009	136-0269-02	SOCKET, PLUG-IN ELEC	1
98	PAHZZ	28480	1600-0904	TERMINAL, LUG	1
99	XBHZZ	28480	03586-04104	COVER, CKT CD	1
100	XBHZZ	28480	0515-0150	SCREW, MACHINE	2
101	XBHZZ	73734	99401	WASHER, LOCK	2

END OF FIGURE

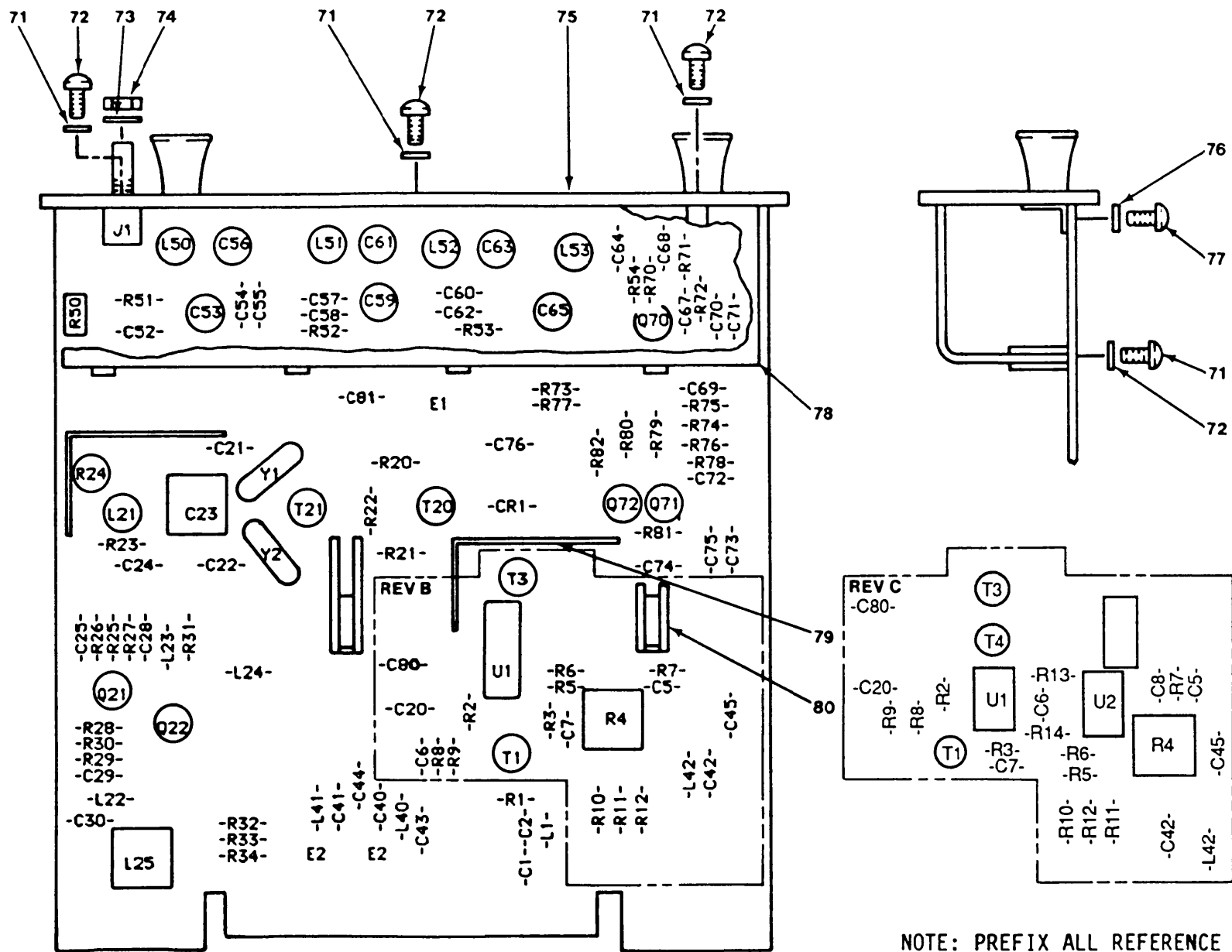

NOTE: PREFIX ALL REFERENCE DESIGNATORS WITH 1A5

Figure 5. Input Mixer Circuit Card Assembly (Sheet 1 of 2).

EL9NV014

TM11-6625-3087-24P

REF DES	ITEM NO	REF DES	ITEM NO	REF DES	ITEM NO	REF DES	ITEM NO	REF DES	ITEM NO	REF DES	ITEM NO
C1	1	E1	22	R25	45						
C2	1	E2	23	R26	46						
C5	2	J1	24	R27	47						
C6	2	L1	25	R28	48						
C6	81	L21	26	R29	47						
C7	2	L22	27	R30	49						
C8	2	L23	27	R31	50						
C20	3	L24	27	R32	51						
C21	4	L25	28	R33	52						
C22	4	L40	29	R34	51						
C23	5	L41	29	R50	53						
C24	6	L42	29	R51	54						
C25	2	L50	30	R52	54						
C28	2	L51	31	R53	55						
C29	2	L52	31	R54	56						
C30	7	L53	32	R70	57						
C40	8	Q21	33	R71	58						
C41	8	Q22	33	R72	59						
C42	8	Q70	34	R73	60						
C43	2	Q71	34	R74	61						
C44	2	Q72	35	R75	62						
C45	2	R1	36	R76	61						
C52	9	R2	37	R77	63						
C53	10	R2	82	R78	64						
C54	11	R3	37	R79	65						
C55	12	R3	82	R80	65						
C56	10	R4	38	R81	64						
C57	13	R5	39	R82	66						
C58	12	R6	39	T1	67						
C59	10	R7	40	T3	68						
C60	14	R8	39	T4	83						
C61	10	R9	36	T20	67						
C62	15	R10	37	T21	67						
C63	10	R11	40	U1	69						
C64	16	R12	36	U1	84						
C65	10	R13	82	U2	84						
C67	17	R14	82	Y1-2	70						
C68	2	R20	41								
C69	2	R21	41								
C70	18	R22	42								
C71	18	R23	43								
C72	2	R23	43								
C73	8	R23	43								
C74	2	R23	43								
C75	8	R23	43								
C76	19	R23	43								
C80	20	R23	43								
C81	20	R23	43								
CR1	21	R24	44								

Figure 5. Input Mixer Circuit Card Assembly (Sheet 2 of 2).

(1) ITEM NO	(2) SMR CODE	(3) FSCM	(4) PART NUMBER	(5) DESCRIPTION AND USABLE ON CODE (UOC)	(6) QTY
GROUP 04 INPUT MIXER CIRCUIT CARD ASSEMBLY (A5)					
FIG. 5					
1	PAHZZ	81349	CCR19CG150GM	CAPACITOR, FIXED, CER	2
2	PAHZZ	16546	C31A103K	CAPACITOR, FIXED, CER DELETE C6, ADD C8 FOR REV C	13
3	PAHZZ	51642	150-100NP0-101J	CAPACITOR, FIXED, CER	1
4	PAHZZ	28480	0160-2249	CAPACITOR, FIXED, CER	2
5	PAHZZ	28480	0121-0162	CAPACITOR, VARIABLE	1
6	PAHZZ	71590	TCZ-18	CAPACITOR, FIXED, CER	1
7	PAHZZ	28480	0160-2306	CAPACITOR, FIXED, MIC	1
8	PAHZZ	81349	M39003/01-2991	CAPACITOR, FIXED, ELE	5
9	PAHZZ	59660	301-000-C0H0-829	CAPACITOR, FIXED, CER	1
10	PAHZZ	74970	187-0106-005	CAPACITOR, VARIABLE	6
11	PAHZZ	28480	0160-2241	CAPACITOR, FIXED, CER	1
12	PAHZZ	81349	CMR05E510G0DR	CAPACITOR, FIXED, MIC	2
13	PAHZZ	81349	CC22CH100C	CAPACITOR, FIXED, CER	1
14	PAHZZ	81349	CC22CH6R8C	CAPACITOR, FIXED, CER	1
15	PAHZZ	81349	CM10ED560G03	CAPACITOR, FIXED, MIC	1
16	PAHZZ	80009	281-0564-00	CAPACITOR, FIXED, CER	1
17	PAHZZ	72982	8121M112X7R0103M	CAPACITOR, FIXED, CER	1
18	PAHZZ	81349	M39003/01-2962	CAPACITOR, FIXED, ELE	2
19	PAHZZ	81349	M39003/01-2983	CAPACITOR, FIXED, ELE	1
20	04222	04222	SR205C102KAA	CAPACITOR, FIXED, CER	2
21	04222	28480	1906-0211	SEMICONDUCTOR DEVIC	1
22	04222	00779	50462-8	CONTACT, ELECTRICAL	2
23	04222	28480	9170-0894	CORE, ELECTROMAGNET	3
24	PAHZZ	28480	1250-1512	CONNECTOR, RECEPTACL	1
25	PAHZZ	28480	9100-2249	COIL, RADIO FREQUENC	1
26	PAHZZ	28480	9100-1379	COIL, ELECTRICAL	1
27	PAHZZ	24226	15M471J	COIL, RADIO FREQUENC	3
28	PAHZZ	55940	Q2-33TAPPED	COIL, RADIO FREQUENC	1
29	PAHZZ	24226	15M680J	COIL, RADIO FREQUENC	3
30	PAHZZ	28480	9140-0384	COIL, RADIO FREQUENC	1
31	PAHZZ	28480	9140-0386	COIL, RADIO FREQUENC	2
32	PAHZZ	28480	9140-0385	TRANSFORMER, RADIO F	1
33	PAHZZ	81349	2N5179	TRANSISTOR	2
34	PAHZZ	04713	MPSH10	TRANSISTOR	2
35	PAHZZ	28480	1853-0354	TRANSISTOR	1
36	PAHZZ	81349	RNC60H2210FS	RESISTOR, FIXED, FILM	3
37	PAHZZ	81349	RNC60K49R9FS	RESISTOR, FIXED, FILM QUANTITY IS 3 FOR REV B (R2,R3,R10), 1 FOR REV C (R10)	3
38	PAHZZ	28480	2100-3383	RESISTOR, VARIABLE, N	1
39	PAHZZ	81349	RNC60H1000FS	RESISTOR, FIXED, FILM	3
40	PAHZZ	81349	RNC60K1500FS	RESISTOR, FIXED, FILM	2
41	PAHZZ	81349	RNC60K11R8FS	RES, FXD, FILM	2
42	PAHZZ	81349	RNC60K59R0FS	RESISTOR, FIXED, FILM	1
43	PAHZZ	81349	RNC60K3480FS	RESISTOR, FIXED, FILM	1
43	PAHZZ	81349	RNC60K4220FS	RESISTOR, FIXED, FILM	1

SECTION II

TM11-6625-3087-24P

(1) ITEM NO	(2) SMR CODE	(3) FSCM	(4) PART NUMBER	(5) DESCRIPTION AND USABLE ON CODE (UOC)	(6) QTY
43	PAHZZ	81349	RNC60K4530FS	RESISTOR, FIXED, FILM	1
43	PAHZZ	81349	RNC60K4990FS	RESISTOR, FIXED, FILM	1
43	PAHZZ	81349	RNC60K3240FS	RESISTOR, FIXED, FILM	1
43	PAHZZ	81349	RNC60K3740FS	RESISTOR, FIXED, FILM	1
43	PAHZZ	81349	RNC60K4020FS	RESISTOR, FIXED, FILM	1
43	PAHZZ	81349	RNC60K5230FS	RESISTOR, FIXED, FILM	1
44	PAHZZ	28480	2100-1984	RESISTOR, VARIABLE, N	1
45	PAHZZ	81349	RCR07G622JS	RESISTOR, FIXED, COMP	1
46	PAHZZ	81349	RCR07G272JS	RESISTOR, FIXED, COMP	1
47	PAHZZ	81349	RCR07G750JS	RESISTOR, FIXED, COMP	2
48	PAHZZ	81349	RCR07G181JS	RESISTOR, FIXED, COMP	1
49	PAHZZ	81349	RNC60K75R0FS	RESISTOR, FIXED, FILM	1
50	PAHZZ	81349	RCR07G101JS	RESISTOR, FIXED, COMP	1
51	PAHZZ	81349	RNC60K2940FS	RESISTORFIXEDWIRE	2
52	PAHZZ	81349	RNC60K17R8FS	RESISTOR, FIXED, FILM	1
53	PAHZZ	28480	2100-3349	RESISTOR, VARIABLE, N	1
54	PAHZZ	81349	RNC60K4991FS	RESISTOR, FIXED, FILM	2
55	PAHZZ	81349	RNC60K4421FS	RESISTOR, FIXED, FILM	1
56	PAHZZ	81349	RNC60K8870FS	RESISTOR, FIXED, FILM	1
57	PAHZZ	81349	RCR07G240JS	RESISTOR, FIXED, COMP	1
58	PAHZZ	81349	RCR07G511JS	RESISTOR, FIXED, COMP	1
59	PAHZZ	81349	RCR07G102JS	RESISTOR, FIXED, COMP	1
60	PAHZZ	81349	RNC60H3320FS	RESISTOR, FIXED, FILM	1
61	PAHZZ	28480	0698-0063	RESISTOR, FIXED, FILM	2
62	PAHZZ	81349	RNC60K1501FS	RESISTOR, FIXED, FILM	1
63	PAHZZ	81349	RNC60H4750FS	RESISTOR, FIXED, FILM	1
64	PAHZZ	81349	RNC60K15R0FS	RESISTOR, FIXED, FILM	2
65	PAHZZ	81349	RCR07G510JS	RESISTOR, FIXED, COMP	2
66	PAHZZ	81349	RNC60K73R2FS	RESISTOR, FIXED, FILM	1
67	PAHZZ	28480	08552-6044	TRANSFORMER, RADIO F	3
68	PAHZZ	28480	9100-4038	TRANSFORMER ASSEMBL	1
69	PAHZZ	28480	1858-0015	MICROCIRCUIT, LINEAR ONLY (U1)	1 USED FOR REV B
70	PAHZZ	28480	0410-0753	CRYSTAL UNIT, QUARTZ	1
71	XBHZZ	78189	SF1904-00	WASHER, LOCK	7
72	XBHZZ	28480	0515-0055	SCREW, MACHINE	7
73	PAHZZ	98291	3002-26	WASHER, LOCK	1
74	PAHZZ	98291	3002-18	NUT, PLAIN, HEXAGON	1
75	XBHZZ	28480	03586-04105	COVER, CKT CD	1
76	XBHZZ	73734	99401	WASHER, LOCK	2
77	XBHZZ	28480	0515-0150	SCREW, MACHINE	2
78	XBHZZ	28480	03586-00602	SHIELD, ELEC	1
79	XBHZZ	28480	8160-0289	SHIELD, RFI	2
80	XBHZZ	28480	03577-00901	SPRING, GROUND	2
81	PAHZZ	04222	SR205C102KAA	CAPACITOR, FIXED, CER ONLY (C6)	1 USED FOR REV C
82	PAHZZ	28480	0699-1183	RESISTOR, FIXED, FILM ONLY (R2, R3, R13, R14)	4 USED FOR REV C
83	PAHZZ	28480	08552-6024	TRANSFORMER, RADIO F ONLY (T4)	1 USED FOR REV C
84	PAHZZ	28480	1858-0059	SEMICONDUCTOR DEVIC ONLY (U1, U2)	2 USED FOR REV C

END OF FIGURE

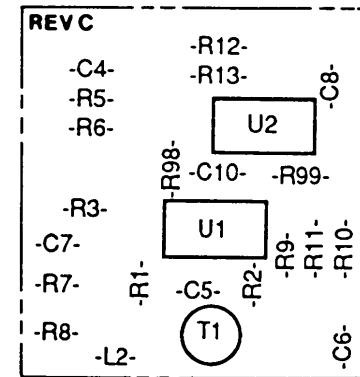
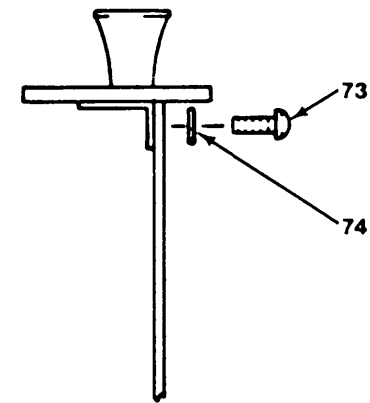
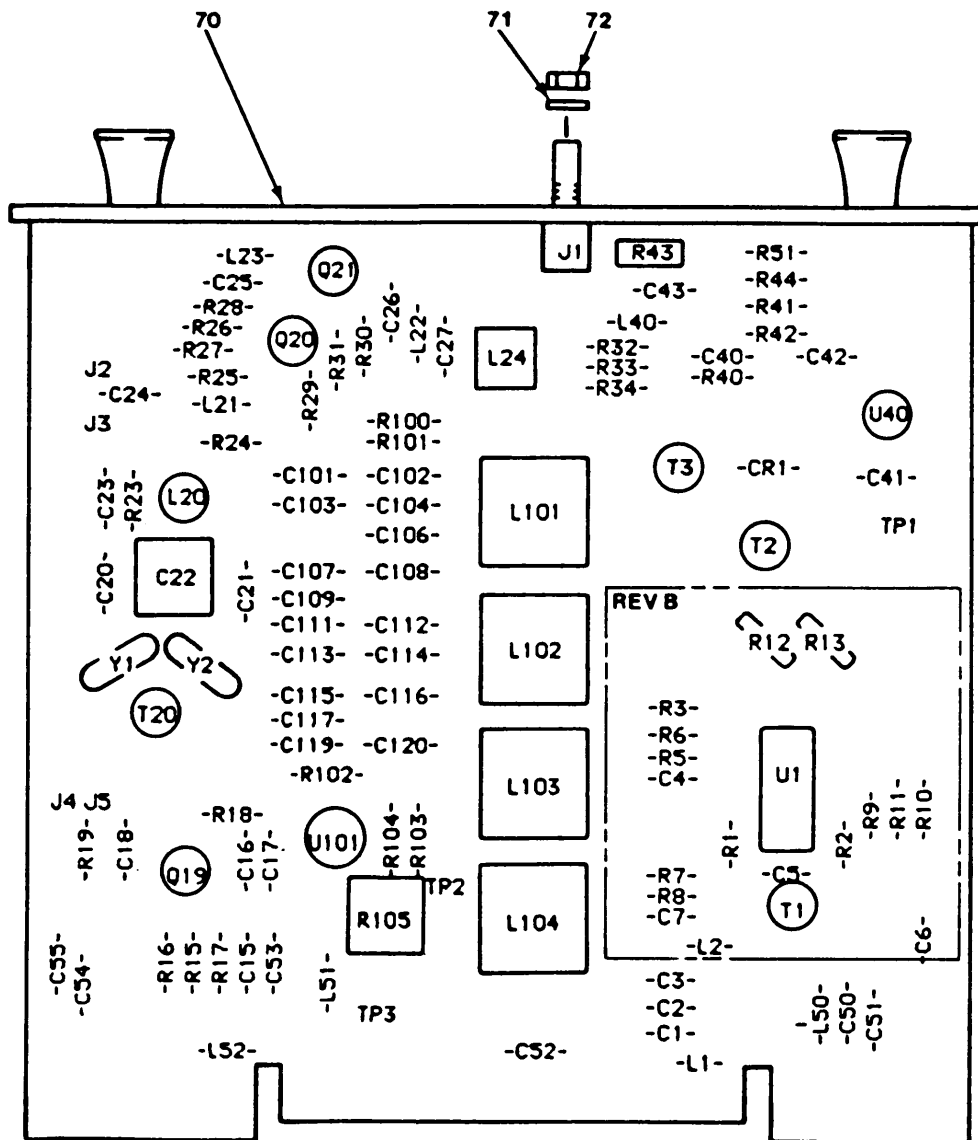

NOTE: PREFIX ALL REFERENCE DESIGNATORS WITH 1A10

Figure 6. Second Mixer Circuit Card Assembly (Sheet 1 of 2).

EL9NV015

TM11-6625-3087-24P

REF DES	ITEM NO	REF DES	ITEM NO	REF DES	ITEM NO	REF DES	ITEM NO	REF DES	ITEM NO	REF DES	ITEM NO
C1	1	31	27	R25	41						
C2	2	J2	28	R26	50						
C3	1	J3	28	R27	51						
C4	3	J4	28	R28	52						
C5	3	J5	28	R29	53						
C6	3	L1	29	R30	52						
C7	3	L2	29	R31	52						
C8	3	L20	30	R32	54						
C10	75	L21	31	R33	55						
C15	3	L22	31	R34	54						
C16	3	L23	31	R40	52						
C17	3	L24	32	R41	52						
C18	3	L40	33	R42	52						
C20	4	L50	34	R43	56						
C21	4	L51	34	R44	57						
C22	5	L52	34	R51	58						
C23	6	L101	35	R98	76						
C24	3	L102	36	R99	76						
C25	3	L103	35	R100	59						
C26	3	L104	35	R101	60						
C27	7	Q19	37	R102	61						
C40	8	Q20	37	R103	57						
C41	9	Q21	37	R104	62						
C42	3	R1	38	R105	63						
C43	3	R2	38	T1	64						
C50	10	R3	39	T2	65						
C51	3	R5	40	T3	64						
C52	10	R6	39	T20	64						
C53	3	R7	41	TP1	66						
C54	10	R8	42	TP2	66						
C55	3	R9	38	TP3	66						
C101	11	R10	40	U1	67						
C102	12	R11	42	U1	77						
C103	13	R12	43	U2	77						
C104	14	R13	43	U40	68						
C106	15	R15	38	U101	68						
C107	7	R16	44	Y1-2	69						
C108	16	R17	45								
C109	17	R18	46								
C111	18	R19	47								
C112	14	R23	48								
C113	19	R23	48								
C114	20	R23	48								
C115	21	R23	48								
C116	22	R23	48								
C117	23	R23	48								
C119	24	R23	48								
C120	25	R23	48								
CR1	26	R24	49								

Figure 6. Second Mixer Circuit Card Assembly (Sheet 2 of 2).

(1) ITEM NO	(2) SMR CODE	(3) FSCM	(4) PART NUMBER	(5) DESCRIPTION AND USABLE ON CODE (UOC)	(6) QTY
GROUP 05 SECOND MIXER CIRCUIT CARD ASSEMBLY (A10)					
FIG. 6					
1	PAHZZ	81349	CM10FD121G03	CAPACITOR, FIXED, MIC	2
2	PAHZZ	28480	0160-2202	CAPACITOR, FIXED, MIC	1
3	PAHZZ	16546	C31A103K	CAPACITOR, FIXED, CER	16
				QUANTITY IS 16 FOR REV B, 17 FOR REV C (ADD C8)	
4	PAHZZ	72982	301-000C0H0-479C	CAPACITOR, FIXED, CER	2
5	PAHZZ	28480	0121-0162	CAPACITOR, VARIABLE	1
6	PAHZZ	71590	TCZ-18	CAPACITOR, FIXED, CER	1
7	PAHZZ	28480	0160-2306	CAPACITOR, FIXED, MIC	2
8	PAHZZ	81349	CMR06F332G0DR	CAPACITOR, FIXED, MIC	1
9	PAHZZ	28480	1854-0305	TRANSISTOR	1
10	PAHZZ	81349	M39003/01-2991	CAPACITOR, FIXED, ELE	3
11	PAHZZ	81349	CMR05E620G0DR	CAPACITOR, FIXED, MIC	1
12	PAHZZ	81349	CMR06F122F0DR	CAPACITOR, FIXED, MIC	1
13	PAHZZ	81349	CMR05F131G0DR	CAPACITOR, FIXED, MIC	1
14	PAHZZ	81349	CMR06F102F0DR	CAPACITOR, FIXED, MIC	2
15	PAHZZ	81349	CMR06F472G0DR	CAPACITOR, FIXED, MIC	1
16	PAHZZ	28480	0140-0223	CAPACITOR, FIXED, MIC	1
17	PAHZZ	28480	0160-3084	CAPACITOR, FIXED, MIC	1
18	PAHZZ	81349	CMR05F910G0DR	CAPACITOR, FIXED, MIC	1
19	PAHZZ	28480	0140-0178	CAPACITOR, FIXED, MIC	1
20	PAHZZ	72136	DM19F622G0300WV4	CAPACITOR, FIXED, MIC	1
21	PAHZZ	28480	0160-2307	CAPACITOR, FIXED, MIC	1
22	PAHZZ	28480	0160-3156	CAPACITOR, FIXED, MIC	1
23	PAHZZ	28480	0140-0217	CAPACITOR, FIXED, MIC	1
24	PAHZZ	81349	CM10CD050D03	CAPACITOR, FIXED, MIC	1
25	PAHZZ	28480	0140-0228	CAPACITOR, FIXED, MIC	1
26	PAHZZ	28480	1906-0210	SEMICONDUCTOR DEVIC	1
27	PAHZZ	28480	1250-1512	CONNECTOR, RECEPTACL	1
28	PAHZZ	00779	50462-8	CONTACT, ELECTRICAL	4
29	PAHZZ	24226	15M047M1	COIL, RADIO FREQUENC	2
30	PAHZZ	28480	9100-1379	COIL, ELECTRICAL	1
31	PAHZZ	24226	15M471J	COIL, RADIO FREQUENC	3
32	PAHZZ	55940	Q2-33TAPPED	COIL, RADIO FREQUENC	1
33	PAHZZ	24226	15M202J1	COIL, RADIO FREQUENC	1
34	PAHZZ	24226	15M680J	COIL, RADIO FREQUENC	3
35	PAHZZ	28480	9140-0376	REACTOR	3
36	PAHZZ	28480	9140-0377	REACTOR	1
37	PAHZZ	81349	2N5179	TRANSISTOR	3
38	PAHZZ	81349	RNC60K49R9FS	RESISTOR, FIXED, FILM	4
39	PAHZZ	81349	RNC60K1100FS	RESISTOR, FIXED, FILM	2
40	PAHZZ	81349	RNC60K1500FS	RESISTOR, FIXED, FILM	2
41	PAHZZ	81349	RCR07G101JS	RESISTOR, FIXED, COMP	2
42	PAHZZ	81349	RNC60H2210FS	RESISTOR, FIXED, FILM	2
43	PAHZZ	81349	RNC60K22R1FS	RESISTOR, FIXED, FILM	2
44	PAHZZ	81349	RNC55K24R9FS	RESISTOR, FIXED, FILM	1
45	PAHZZ	81349	RNC60H1000FS	RESISTOR, FIXED, FILM	1
46	PAHZZ	81349	RNR60K6340FS	RESISTOR, FIXED, FILM	1

SECTION II

TM11-6625-3087-24P

(1) ITEM NO	(2) SMR CODE	(3) FSCM	(4) PART NUMBER	(5) DESCRIPTION AND USABLE ON CODE (UOC)	(6) QTY
47	PAHZZ	81349	RCR07G100JS	RESISTOR, FIXED, COMP	1
48	PAHZZ	81349	RNC60K3480FS	RESISTOR, FIXED, FILM	1
48	PAHZZ	81349	RNC60K4220FS	RESISTOR, FIXED, FILM	1
48	PAHZZ	81349	RNC60K4530FS	RESISTOR, FIXED, FILM	1
48	PAHZZ	81349	RNC60K4990FS	RESISTOR, FIXED, FILM	1
48	PAHZZ	81349	RNC60K3240FS	RESISTOR, FIXED, FILM	1
48	PAHZZ	81349	RNC60K3740FS	RESISTOR, FIXED, FILM	1
48	PAHZZ	81349	RNC60K4020FS	RESISTOR, FIXED, FILM	1
48	PAHZZ	81349	RNC60K5230FS	RESISTOR, FIXED, FILM	1
49	PAHZZ	28480	2100-0568	RESISTOR, VARIABLE, N	1
50	PAHZZ	81349	RCR07G622JS	RESISTOR, FIXED, COMP	1
51	PAHZZ	81349	RCR07G272JS	RESISTOR, FIXED, COMP	1
52	PAHZZ	81349	RNC60K75R0FS	RESISTOR, FIXED, FILM	6
53	PAHZZ	81349	RCR07G181JS	RESISTOR, FIXED, COMP	1
54	PAHZZ	81349	RNC60K4420FS	RESISTOR, FIXED, FILM	2
55	PAHZZ	81349	RNC60K26R7FS	RESISTOR, FIXED, FILM	1
56	PAHZZ	28480	2100-3352	RESISTOR, VARIABLE, N	1
57	PAHZZ	81349	RNC60K1001FS	RESISTOR, FIXED, FILM	2
58	PAHZZ	81349	RCR07G102JS	RESISTOR, FIXED, COMP	1
59	PAHZZ	81349	RNC60K3162FS	RESISTOR, FIXED, FILM	1
60	PAHZZ	81349	RNC60K1472FS	RESISTOR, FIXED, FILM	1
61	PAHZZ	81349	RNC60K2052FS	RESISTOR, FIXED, FILM	1
62	PAHZZ	81349	RNC60K4021FS	RESISTOR, FIXED, FILM	1
63	PAHZZ	28480	2100-0567	RESISTOR, VARIABLE, N	1
64	PAHZZ	28480	08552-6044	TRANSFORMER, RADIO F	3
65	PAHZZ	28480	9100-4038	TRANSFORMER ASSEMBL	1
66	PAHZZ	28480	1251-0600	CONNECTOR, RECEPTAC	3
67	PAHZZ	28480	1858-0015	MICROCIRCUIT, LINEAR ONLY (U1)	1
68	PAHZZ	18324	NE5534AN	MICROCIRCUIT, LINEAR	2
69	PAHZZ	28480	0410-0753	CRYSTAL UNIT, QUARTZ	1
70	XBHZZ	28480	03586-04110	COVER, CKT CD	1
71	PAHZZ	98291	3002-26	WASHER, LOCK	1
72	PAHZZ	98291	3002-18	NUT, PLAIN, HEXAGON	1
73	XBHZZ	28480	0515-0150	SCREW, MACHINE	2
74	XBHZZ	73734	99401	WASHER, LOCK	2
75	PAHZZ	04222	SR205C102KAA	CAPACITOR, FIXED, CER ONLY (C10)	1
76	PAHZZ	28480	0699-1183	RESISTOR, FIXED, FILM ONLY (R98, R99)	2
77	PAHZZ	28480	1858-0059	SEMICONDUCTOR DEVIC ONLY (U1, U2)	2

END OF FIGURE

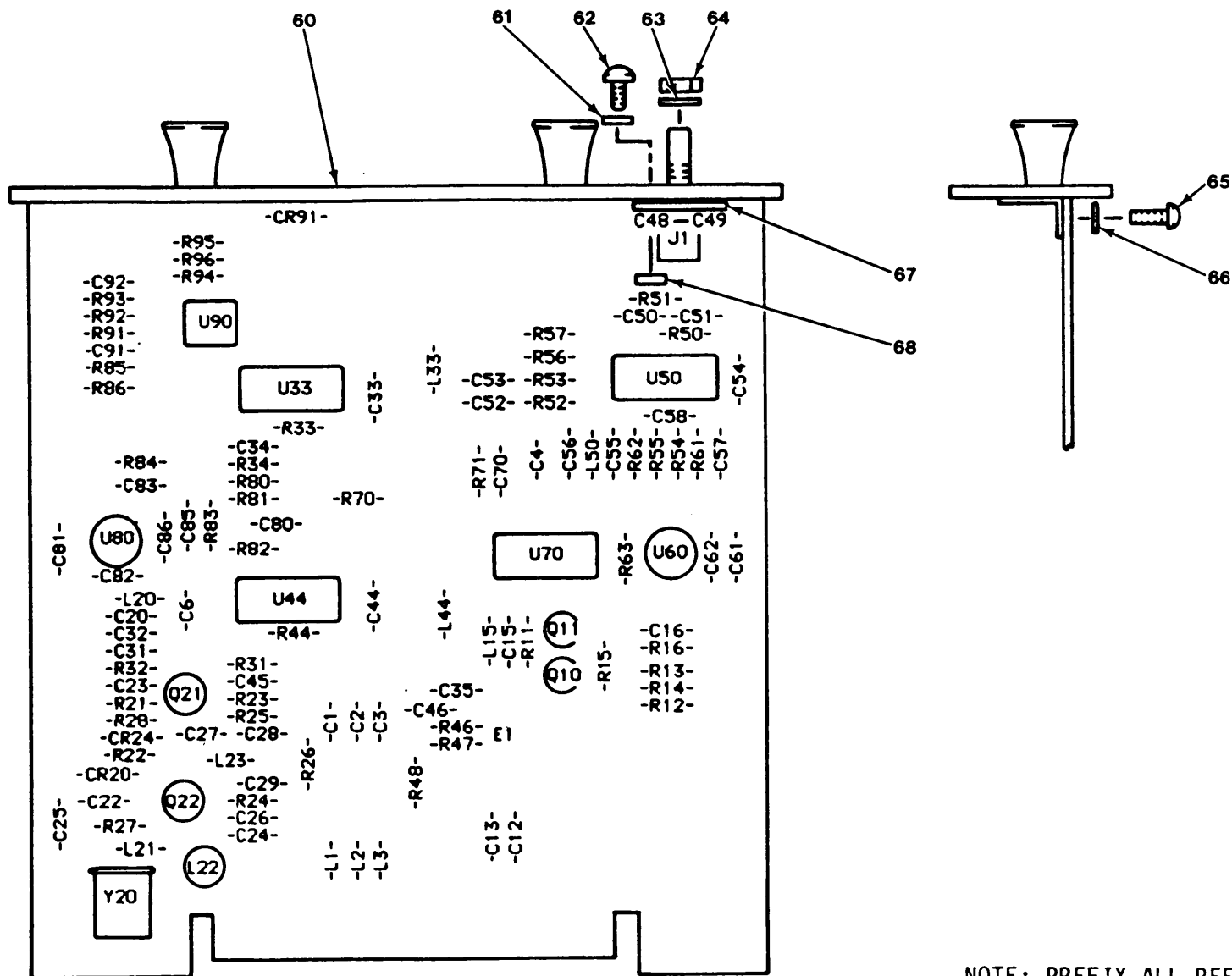

NOTE: PREFIX ALL REFERENCE DESIGNATORS WITH 1A11

Figure 7. Second LO Circuit Card Assembly (Sheet 1 of 2).

EL9NV016

REF DES	ITEM NO	REF DES	ITEM NO	REF DES	ITEM NO	REF DES	ITEM NO	REF DES	ITEM NO	REF DES	ITEM NO
C1	1	CR91	18	R63	45						
C2	1	E1	19	R70	46						
C3	2	J1	20	R71	47						
C4	3	L1	21	R80	48						
C6	3	L2	21	R81	48						
C12	4	L3	22	R82	49						
C13	5	L15	23	R83	50						
C15	5	L20	24	R84	50						
C16	5	L21	25	R85	51						
C20	5	L22	26	R86	51						
C22	6	L23	27	R91	51						
C23	5	L33	24	R92	32						
C24	5	L44	24	R93	51						
C25	3	L50	23	R94	51						
C26	5	Q10	28	R95	52						
C27	7	Q11	28	R96	32						
C28	8	Q21	29	U33	53						
C29	9	Q22	29	U44	53						
C31	5	R11	30	U50	54						
C32	10	R12	31	U60	55						
C33	5	R13	32	U70	56						
C34	5	R14	33	U80	57						
C35	5	R15	34	U90	58						
C44	5	R16	33	Y20	59						
C45	5	R21	35								
C46	11	R22	35								
C48	12	R23	36								
C49	12	R24	36								
C50	13	R25	35								
C51	13	R26	33								
C52	3	R27	35								
C53	3	R28	36								
C54	5	R31	37								
C55	5	R32	35								
C56	5	R33	38								
C57	5	R34	39								
C58	12	R44	38								
C61	4	R46	40								
C62	4	R47	41								
C70	4	R48	42								
C80	14	R50	43								
C81	15	R51	36								
C82	4	R52	36								
C83	4	R53	36								
C85	5	R54	44								
C86	13	R55	44								
C91	4	R56	43								
C92	4	R57	43								
CR20	16	R61	35								
CR24	17	R62	35								

Figure 7. Second LO Circuit Card Assembly (Sheet 2 of 2).

(1) ITEM NO	(2) SMR CODE	(3) FSCM	(4) PART NUMBER	(5) DESCRIPTION AND USABLE ON CODE (UOC)	(6) QTY
GROUP 06 SECOND LO CIRCUIT CARD ASSEMBLY (All)					
FIG. 7					
1	PAHZZ	81349	M39003/01-3009	CAPACITOR, FIXED, ELE	2
2	PAHZZ	81349	M39003/01-2977	CAPACITOR, FIXED, ELE	1
3	PAHZZ	72982	8121M112X7R0103M	CAPACITOR, FIXED, CER	5
4	PAHZZ	16546	C31C104K	CAPACITOR, FIXED, CER	8
5	PAHZZ	16546	C31A103K	CAPACITOR, FIXED, CER	18
6	PAHZZ	72982	301NP0-2-4PF+-0. 25PF	CAPACITOR, FIXED, CER	1
7	PAHZZ	28480	0140-0193-PS	CAPACITOR, FIXED, MIC	1
8	PAHZZ	81349	CM10FD101G03	CAPACITOR, FIXED, MIC	1
9	PAHZZ	72136	RDM15F221J3C	CAPACITOR, FIXED, MIC	1
10	PAHZZ	81349	M39003/01-2988	CAPACITOR, FIXED, ELE	1
11	PAHZZ	81349	CCR09CG470GR	CAPACITOR, FIXED, CER	1
12	PAHZZ	04222	SR205C102KAA	CAPACITOR, FIXED, CER	3
13	PAHZZ	28480	0160-3877	CAPACITOR, FIXED, CER	3
14	PAHZZ	81349	M39003/01-2966	CAPACITOR, FIXED, ELE	1
15	PAHZZ	28480	0160-2611	CAPACITOR, FIXED, MET	1
16	PAHZZ	04713	MV109	SEMICONDUCTOR DEVIC	1
17	PAHZZ	80131	1N3956	SEMICONDUCTOR DEVIC	1
18	PAHZZ	28480	1990-0486	LIGHT EMITTING DIOD	1
19	PAHZZ	28480	9170-0894	CORE, ELECTROMAGNET	1
20	PAHZZ	28480	1250-1512	CONNECTOR RECEPTACL	1
21	PAHZZ	96906	MS90538-20	COIL, RADIO FREQUENC	2
22	PAHZZ	24226	15M561J	COIL, RADIO FREQUENC	1
23	PAHZZ	96906	MS75084-8	COIL, RADIO FREQUENC	2
24	PAHZZ	24226	15M431J1	COIL, RADIO FREQUENC	3
25	PAHZZ	10001	2270098-28	COIL, RADIO FREQUENC	1
26	PAHZZ	28480	9100-1379	COIL, ELECTRICAL	1
27	PAHZZ	24226	15M220J	COIL, RADIO FREQUENC	1
28	PAHZZ	04713	SPS5103	TRANSISTOR	2
29	PAHZZ	28480	1853-0405	TRANSISTOR	2
30	PAHZZ	81349	RCR07G152JS	RESISTOR, FIXED, COMP	1
31	PAHZZ	81349	RCR07G222JS	RESISTOR, FIXED, COMP	1
32	PAHZZ	81349	RCR07G103JS	RESISTOR, FIXED, COMP	3
33	PAHZZ	81349	RCR07G332JS	RESISTOR, FIXED, COMP	3
34	PAHZZ	81349	RCR07G112JS	RESISTOR, FIXED, COMP	1
35	PAHZZ	81349	RCR07G102JS	RESISTOR, FIXED, COMP	7
36	PAHZZ	81349	RCR07G470JS	RESISTOR, FIXED, COMP	6
37	PAHZZ	81349	RCR07G104JS	RESISTOR, FIXED, COMP	1
38	PAHZZ	28480	1810-0229	RESISTOR NETWORK, FI	2
39	PAHZZ	81349	RCR07G271JS	RESISTOR, FIXED, COMP	1
40	PAHZZ	81349	RCR07G560JS	RESISTOR, FIXED, COMP	1
41	PAHZZ	81349	RCR07G121JS	RESISTOR, FIXED, COMP	1
42	PAHZZ	81349	RCR07G100JS	RESISTOR, FIXED, COMP	1
43	PAHZZ	81349	RCR07G101JS	RESISTOR, FIXED, COMP	3
44	PAHZZ	81349	RCR07G681JS	RESISTOR, FIXED, COMP	2
45	PAHZZ	81349	RCR07G513JS	RESISTOR, FIXED, COMP	1
46	PAHZZ	81349	RCR07G105JS	RESISTOR, FIXED, COMP	1

SECTION II

TM11-6625-3087-24P

(1) ITEM NO	(2) SMR CODE	(3) FSCM	(4) PART NUMBER	(5) DESCRIPTION AND USABLE ON CODE (UOC)	(6) QTY
47	PAHZZ	81349	RCR07G301JS	RESISTOR, FIXED, COMP	1
48	PAHZZ	81349	RNC60K2002FS	RESISTOR, FIXED, FILM	2
49	PAHZZ	81349	RCR07G823JS	RESISTOR, FIXED, COMP	1
50	PAHZZ	81349	RCR07G303JS	RESISTOR, FIXED, COMP	2
51	PAHZZ	81349	RCR07G182JS	RESISTOR, FIXED, COMP	5
52	PAHZZ	81349	RCR07G471JS	RESISTOR, FIXED, COMP	1
53	PAHZZ	14933	7800901EB	MICROCIRCUIT, LINEAR	2
54	PAHZZ	04713	MC12002P	MICROCIRCUIT, DIGITA	1
55	PAHZZ	81349	M38510/10304BGC	MICROCIRCUIT, LINEAR	1
56	PAHZZ	04713	MC14568BCP	MICROCIRCUIT, LINEAR	1
57	PAHZZ	81349	M38510/10104BGC	MICROCIRCUIT, LINEAR	1
58	PAHZZ	80009	156-1225-00	MICROCIRCUIT, LINEAR	1
59	PAHZZ	28480	0410-0759	CRYSTAL UNIT, QUARTZ	1
60	XBHZZ	28480	03586-04111	COVER, CKT CD	1
61	XBHZZ	78189	SF1904-00	WASHER, LOCK	2
62	XBHZZ	28480	0515-0055	SCREW, MACHINE	2
63	PAHZZ	98291	3002-26	WASHER, LOCK	1
64	PAHZZ	98291	3002-18	NUT, PLAIN, HEXAGON	1
65	XBHZZ	28480	0515-0150	SCREW, MACHINE	2
66	XBHZZ	73734	99401	WASHER, LOCK	2
67	XBHZZ	28480	03586-26512	PRINTED WIRG BD	1
68	XBHZZ	46384	KF2M3ZI	NUT, THREADED INSERT	2

END OF FIGURE

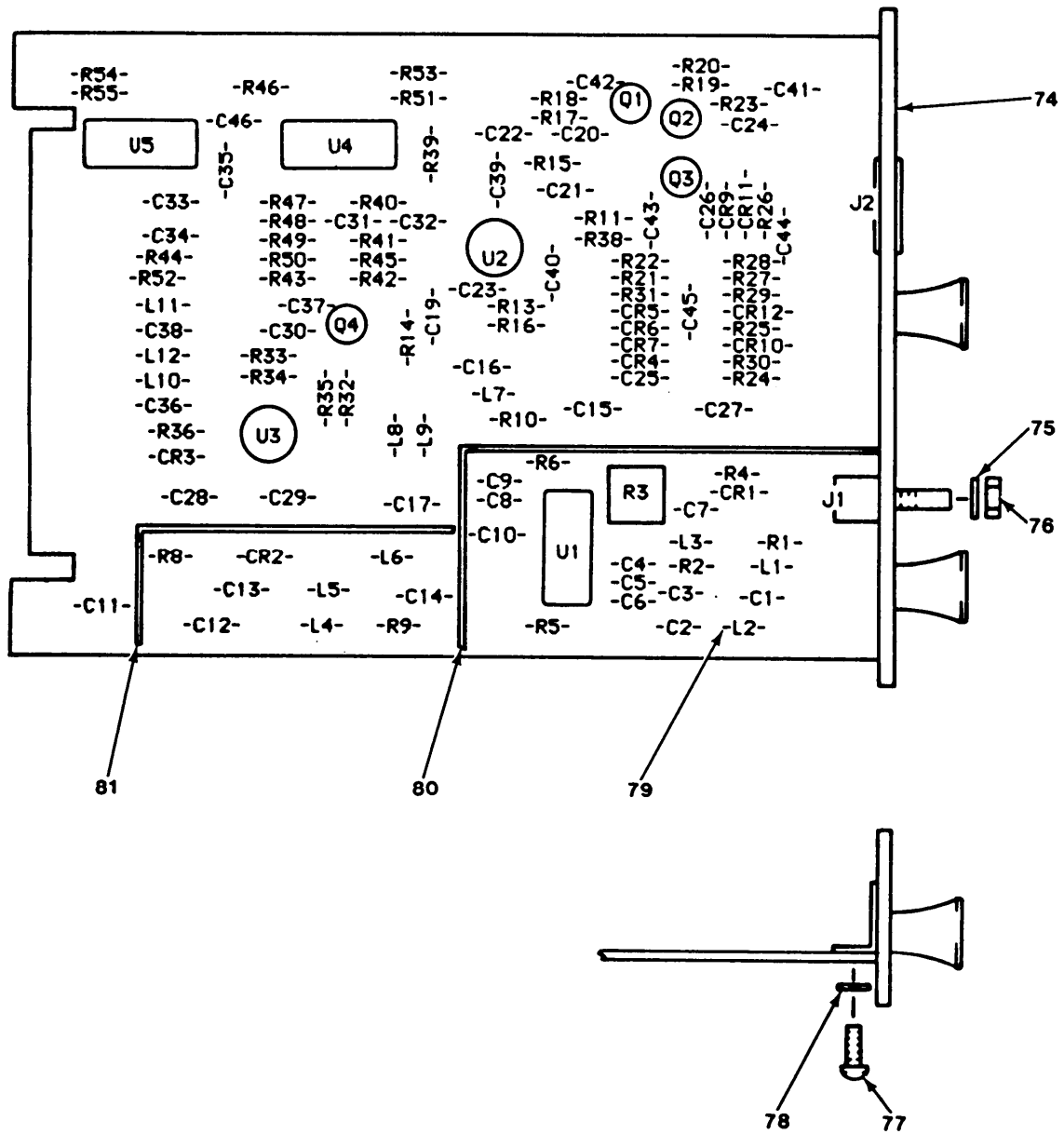

NOTE: PREFIX ALL REFERENCE
DESIGNATORS WITH 1A15

EL9NVO17

Figure 8. Tracking Output Circuit Card Assembly (Sheet 1 of 2).

REF DES	ITEM NO	REF DES	ITEM NO	REF DES	ITEM NO	REF DES	ITEM NO	REF DES	ITEM NO	REF DES	ITEM NO
C1	1	CR6	21	R29	53						
C2	2	CR7	21	R30	51						
C3	1	CR9	20	R31	49						
C4	3	CR10	19	R32	55						
C5	3	CR11	20	R32	55						
C6	3	CR12	19	R32	55						
C7	3	J1	22	R32	55						
C8	3	J2	23	R32	55						
C9	3	L1	24	R33	56						
C10	3	L2	25	R34	57						
C11	3	L3	24	R35	50						
C12	4	L4	24	R36	58						
C13	5	L5	26	R38	41						
C14	6	L6	24	R39	59						
C15	7	L7	27	R40	60						
C16	8	L8	27	R41	60						
C17	9	L9	28	R42	61						
C19	10	L10	29	R43	62						
C20	11	L11	29	R44	62						
C21	12	L12	29	R45	63						
C22	12	Q1	30	R46	64						
C23	11	Q2	31	R47	65						
C24	13	Q3	31	R48	66						
C25	13	Q4	32	R49	65						
C26	14	R1	33	R50	66						
C27	15	R2	34	R51	67						
C28	16	R3	35	R52	46						
C29	8	R4	36	R53	67						
C30	11	R5	37	R54	68						
C31	11	R6	37	R55	62						
C32	11	R8	38	U1	69						
C33	15	R9	39	U2	70						
C34	15	R10	40	U3	71						
C35	11	R11	41	U4	72						
C36	12	R13	42	U5	73						
C37	17	R14	39								
C38	17	R15	43								
C39	11	R16	43								
C40	11	R17	44								
C41	11	R18	45								
C42	11	R19	46								
C43	11	R20	36								
C44	18	R21	47								
C45	3	R22	48								
C46	3	R23	49								
CR1	19	R24	50								
CR2	20	R25	51								
CR3	20	R26	52								
CR4	21	R27	53								
CR5	21	R28	54								

Figure 8. Tracking Output Circuit Card Assembly (Sheet 2 of 2).

(1) ITEM NO	(2) SMR CODE	(3) FSCM	(4) PART NUMBER	(5) DESCRIPTION AND USABLE ON CODE (UOC)	(6) QTY
GROUP 07 TRACKING OUTPUT CIRCUIT CARD ASSEMBLY (A15)					
FIG. 8					
1	PAHZZ	81349	CMR05E620GODR	CAPACITOR, FIXED, MIC	2
2	PAHZZ	72982	301000C0G0110J	CAPACITOR, FIXED, CER	1
3	PAHZZ	72982	8121M112X7R0103M	CAPACITOR, FIXED, CER	20
4	PAHZZ	81349	CM10FD101G03	CAPACITOR, FIXED, MIC	1
5	PAHZZ	81349	CC22CK1R5C	CAPACITOR, FIXED, CER	1
6	PAHZZ	81349	CMR05F910G0DR	CAPACITOR, FIXED, MIC	1
7	PAHZZ	81349	CC22CH100C	CAPACITOR, FIXED, CER	1
8	PAHZZ	81349	CM10ED300G03	CAPACITOR, FIXED, MIC	2
9	PAHZZ	80009	281-0564-00	CAPACITOR, FIXED, CER	1
10	PAHZZ	81349	M39003/01-2966	CAPACITOR, FIXED, ELE	1
11	PAHZZ	28480	0160-0576	CAPACITOR, FIXED, CER	11
12	PAHZZ	18876	10018712-022	CAPACITOR, FIXED, ELE	3
13	PAHZZ	81349	M39003/01-3003	CAPACITOR, FIXED, ELE	2
14	PAHZZ	28480	1854-0305	TRANSISTOR	1
15	PAHZZ	81349	M39003/01-2962	CAPACITOR, FIXED, ELE	3
16	PAHZZ	56289	292P22352	CAPACITOR, FIXED, PLA	1
17	PAHZZ	81349	M39003/01-2991	CAPACITOR, FIXED, ELE	2
18	PAHZZ	28480	0160-3874	CAPACITOR, FIXED, CER	1
19	PAHZZ	04713	SZ30016-98	SEMICONDUCTOR, DEVIC	3
20	PAHZZ	81349	JAN1N4150	SEMICONDUCTOR DEVIC	4
21	PAHZZ	28480	5082-5511	SEMICONDUCTOR DEVIC	4
22	PAHZZ	28480	1250-1512	CONNECTOR RECEPTACL	1
23	PAHZZ	98291	51-149-0000	CONNECTOR, RECEPTACL	1
24	PAHZZ	24226	15M100J2	COIL, RADIO FREQUENC	4
25	PAHZZ	24226	15M560J	COIL, RADIO FREQUENC	1
26	PAHZZ	24226	15M431J1	COIL, RADIO FREQUENC	1
27	PAHZZ	10001	2270098-28	COIL, RADIO FREQUENC	2
28	PAHZZ	24226	15M151J	COIL, RADIO FREQUENC	1
29	PAHZZ	96906	MS90538-12	COIL, RADIO FREQUENC	3
30	PAHZZ	28480	1853-0354	TRANSISTOR	1
31	PAHZZ	28480	1854-0354	TRANSISTOR	2
32	PAHZZ	04713	SPS5103	TRANSISTOR	1
33	PAHZZ	81349	RNC60K18R2FS	RESISTOR, FIXED, FILM	1
34	PAHZZ	81349	RCR07G131JS	RESISTOR, FIXED, COMP	1
35	PAHZZ	28480	2100-3383	RESISTOR, VARIABLE, N	1
36	PAHZZ	81349	RCR07G331JS	RESISTOR, FIXED, COMP	2
37	PAHZZ	81349	RCR07G470JS	RESISTOR, FIXED, COMP	2
38	PAHZZ	81349	RCR07G472JS	RESISTOR, FIXED, COMP	1
39	PAHZZ	81349	RCR07G102JS	RESISTOR, FIXED, COMP	2
40	PAHZZ	81349	RCR07G271JS	RESISTOR, FIXED, COMP	1
41	PAHZZ	81349	RNC60H1000FS	RESISTOR, FIXED, FILM	2
42	PAHZZ	81349	RNC60K2000FS	RESISTOR, FIXED, FILM	1
43	PAHZZ	81349	RNC60K3400FS	RESISTOR, FIXED, FILM	2
44	PAHZZ	81349	RCR07G202JS	RESISTOR, FIXED, COMP	1
45	PAHZZ	81349	RCR07G101JS	RESISTOR, FIXED, COMP	1
46	PAHZZ	81349	RCR07G152JS	RESISTOR, FIXED, COMP	2
47	PAHZZ	81349	RNC60K3091FS	RESISTOR, FIXED, FILM	1

SECTION II

TM11-6625-3087-24P

(1) ITEM NO	(2) SMR CODE	(3) FSCM	(4) PART NUMBER	(5) DESCRIPTION AND USABLE ON CODE (UOC)	(6) QTY
48	PAHZZ	81349	RNC60K3921FS	RESISTOR, FIXED, FILM	1
49	PAHZZ	81349	RNC60K4020FS	RESISTOR, FIXED, FILM	2
50	PAHZZ	81349	RNC60K1004FS	RESISTOR, FIXED, FILM	2
51	PAHZZ	81349	RCR07G104JS	RESISTOR, FIXED, COMP	2
52	PAHZZ	81349	RNC60K75R0FS	RESISTOR, FIXED, FILM	1
53	PAHZZ	81349	RNC60K4420FS	RESISTOR, FIXED, FILM	2
54	PAHZZ	81349	RNC60K26R1FS	RESISTOR, FIXED, FILM	1
55	PAHZZ	81349	RNC60K9312FS	RESISTOR, FIXED, FILM	1
55	PAHZZ	81349	RNC60K9762FS	RESISTOR, FIXED, FILM	1
55	PAHZZ	81349	RNC60J9092FS	RESISTOR, FIXED, FILM	1
55	PAHZZ	81349	RNC60K1003FS	RESISTOR, FIXED, FILM	1
55	PAHZZ	81349	RNC60K9532FS	RESISTOR, FIXED, FILM	1
56	PAHZZ	81349	RNC60K2102FS	RESISTOR, FIXED, FILM	1
57	PAHZZ	81349	RNC60K9763FS	RESISTOR, FIXED, FILM	1
58	PAHZZ	81349	RNC60K4993FS	RESISTOR, FIXED, FILM	1
59	PAHZZ	81349	RCR07G201JS	RESISTOR, FIXED, COMP	1
60	PAHZZ	81349	RNC60K1001FS	RESISTOR, FIXED, FILM	2
61	PAHZZ	81349	RCR07G513JS	RESISTOR, FIXED, COMP	1
62	PAHZZ	81349	RCR07G752JS	RESISTOR, FIXED, COMP	3
63	PAHZZ	81349	RNC60K2001FS	RESISTOR, FIXED, FILM	1
64	PAHZZ	28480	1810-0076	RESISTOR NETWORK, FI	1
65	PAHZZ	81349	RNC60K1580FS	RESISTOR, FIXED, FILM	2
66	PAHZZ	81349	RNC60K73R2FS	RESISTOR, FIXED, FILM	2
67	PAHZZ	81349	RCR07G471JS	RESISTOR, FIXED, COMP	2
68	PAHZZ	81349	RCR07G242JS	RESISTOR, FIXED, COMP	1
69	PAHZZ	04713	MC12002P	MICROCIRCUIT, DIGITA	1
70	PAHZZ	96214	531932-2	MICROCIRCUIT, LINEAR	1
71	PAHZZ	81349	M38510/10104BGC	MICROCIRCUIT, LINEAR	1
72	PAHZZ	14933	7800901EB	MICROCIRCUIT, LINEAR	1
73	PAHZZ	80009	156-0205-00	MICROCIRCUIT, DIGITA	1
74	XBHZZ	28480	03586-04115	COVER, CKT CD	1
75	PAHZZ	98291	3002-26	WASHER, LOCK	1
76	PAHZZ	98291	3002-18	NUT, PLAIN, HEXAGON	1
77	XBHZZ	28480	0515-0150	SCREW, MACHINE	2
78	XBHZZ	73734	99401	WASHER, LOCK	2
79	PAHZZ	98291	013-2046-00-0-68 9	TERMINAL, STUD	2
80	XBHZZ	28480	1600-0836	PLATE, ELEC SHLD	1
81	XBHZZ	28480	1600-0837	PLATE, ELEC SHLD	1

END OF FIGURE

NOTE: PREFIX ALL REFERENCE
DESIGNATORS WITH 1A16

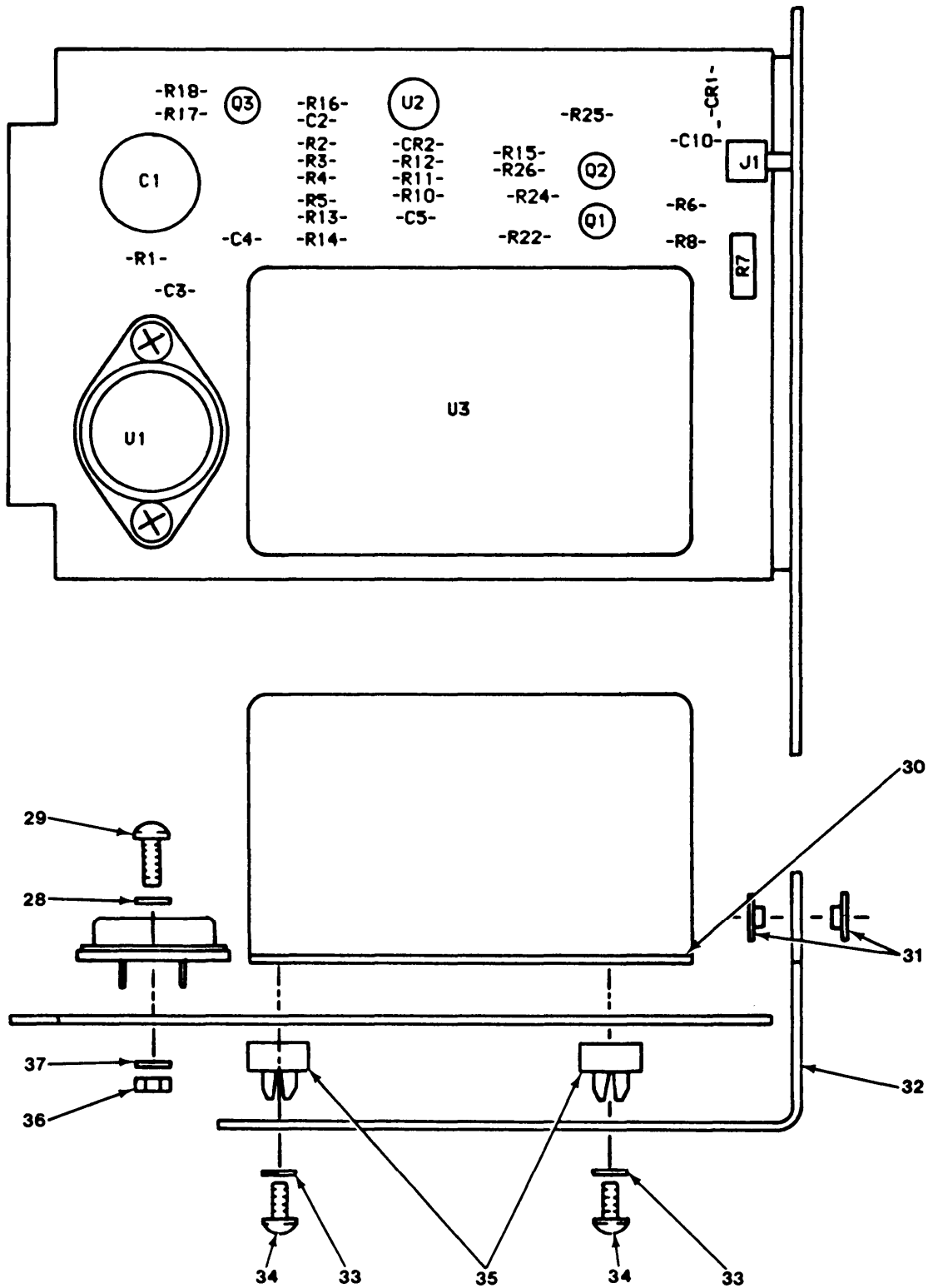

EL9NV018

Figure 9. 10 MHz Frequency REF Circuit Card Assembly (Sheet 1 of 2).

REF DES	ITEM NO	REF DES	ITEM NO	REF DES	ITEM NO	REF DES	ITEM NO	REF DES	ITEM NO	REF DES	ITEM NO
C1	1										
C2	2										
C3	2										
C4	2										
C5	3										
C10	4										
CR1	5										
CR2	6										
J1	7										
Q1	8										
Q2	9										
Q3	9										
R1	10										
R2	11										
R3	12										
R4	11										
R5	13										
R6	14										
R7	15										
R8	16										
R10	17										
R11	18										
R12	14										
R13	19										
R14	20										
R15	16										
R16	16										
R17	21										
R18	17										
R22	22										
R24	23										
R25	22										
R26	24										
U1	25										
U2	26										
U3	27										

Figure 9. 10 MHz Frequency REF Circuit Card Assembly (Sheet 2 of 2).

(1) ITEM NO	(2) SMR CODE	(3) FSCM	(4) PART NUMBER	(5) DESCRIPTION AND USABLE ON CODE (UOC)	(6) QTY
GROUP 08 10 MHZ FREQUENCY REF CIRCUIT CARD ASSEMBLY (A16)					
FIG. 9					
1	PCHZZ	28480	0180-2635	CAPACITOR, FIXED, ELE	1
2	PAHZZ	16546	C31C104K	CAPACITOR, FIXED, CER	3
3	PAHZZ	16546	C31A103K	CAPACITOR, FIXED, CER	1
4	PAHZZ	18876	8193477	CAPACITOR, FIXED, CER	1
5	PAHZZ	28480	50824655	LIGHT EMITTING DIOD	1
6	PAHZZ	81349	JAN1N965B	SEMICONDUCTOR DEVIC	1
7	PAHZZ	17773	11263624	CONNECTOR, RECEPACL	1
8	PAHZZ	28480	1853-0020	TRANSISTOR	1
9	PAHZZ	81349	2N3646	TRANSISTOR	2
10	PAHZZ	81349	RWR80S1R00FS	RESISTOR, FIXED, WIRE	1
11	PAHZZ	81349	RNC60K5901FS	RESISTOR, FIXED, FILM	2
12	PAHZZ	81349	RNC60K3162FS	RESISTOR, FIXED, FILM	1
13	PAHZZ	81349	RNC60K3242FS	RESISTOR, FIXED, FILM	1
14	PAHZZ	81349	RCR07G102JS	RESISTOR, FIXED, COMP	2
15	PAHZZ	28480	2100-3351	RESISTOR, VARIABLE, N	1
16	PAHZZ	81349	RCR07G202JS	RESISTOR, FIXED, COMP	3
17	PAHZZ	81349	RCR07G472JS	RESISTOR, FIXED, COMP	2
18	PAHZZ	81349	RCR07G164JS	RESISTOR, FIXED, COMP	1
19	PAHZZ	81349	RNC60K6981FS	RESISTOR, FIXED, FILM	1
20	PAHZZ	81349	RNC60K8061FS	RESISTOR, FIXED, FILM	1
21	PAHZZ	81349	RCR07G103JS	RESISTOR, FIXED, COMP	1
22	PAHZZ	81349	RCR07G101JS	RESISTOR, FIXED, COMP	2
23	PAHZZ	81349	RCR20G821JS	RESISTOR, FIXED, COMP	1
24	PAHZZ	81349	RCR07G391JS	RESISTOR, FIXED, COMP	1
25	PAHZZ	10001	3167520	MICROCIRCUIT, LINEAR	1
26	PAHZZ	28480	1826-0678	MICROCIRCUIT, LINEAR	1
27	PAHZZ	28480	0960-0568	OSCILLATOR, CRYSTAL	1
28	PAHZZ	96906	MS35333-105	WASHER, LOCK	2
29	XBHZZ	28480	0515-0067	SCREW, MACHINE	2
30	XBHZZ	28480	03585-04132	INSULATOR, OVEN	1
31	XBHZZ	73734	1461	WASHER, SHOULDER	4
32	XBHZZ	28480	03586-04116	COVER, CKT CD	1
33	PAHZZ	96906	MS35335-57	WASHER, LOCK	2
34	PAHZZ	96906	MS51957-17	SCREW, MACHINE	2
35	PAHZZ	28480	5040-4527	INSULATOR, BUSHING	2
36	XBHZZ	28480	0535-0007	NUT, PLAIN, HEX	2
37	XBHZZ	28480	2190-0918	WASHER, LOCK	2

END OF FIGURE

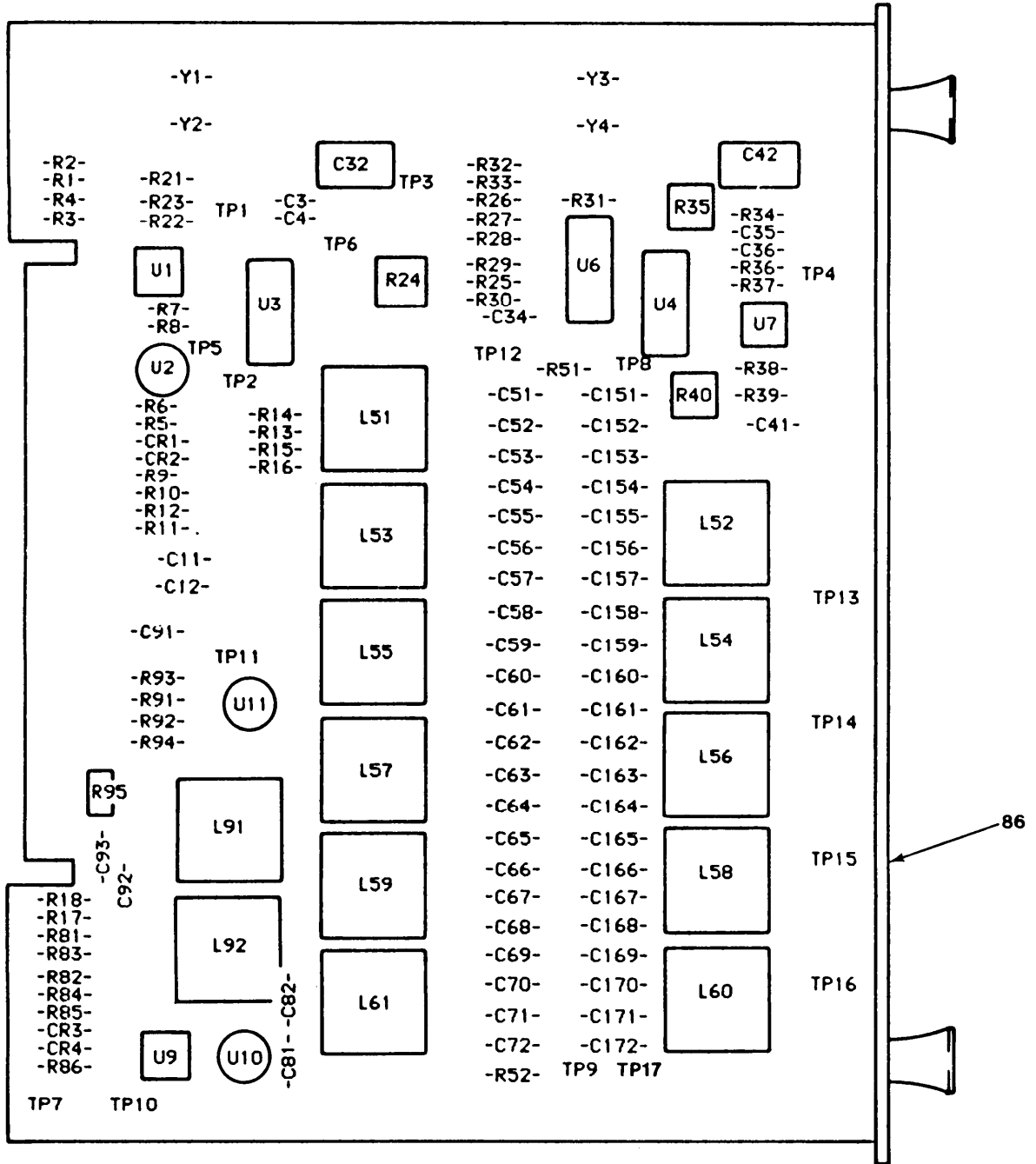

NOTE: PREFIX ALL REFERENCE DESIGNATORS WITH 1A20

Figure 10. IF Filter Circuit Card Assembly (Sheet 1 of 2).

EL9NV019

REF DES	ITEM NO	REF DES	ITEM NO	REF DES	ITEM NO	REF DES	ITEM NO	REF DES	ITEM NO	REF DES	ITEM NO
C3	1	C164	35	R21	60	TP11	77				
C4	1	C165	26	R21	60	TP12	77				
C11	2	C166	29	R22	61	TP13	77				
C12	2	C167	34	R23	61	TP14	77				
C32	3	C168	34	R24	62	TP15	77				
C34	4	C169	28	R25	63	TP16	77				
C35	1	C170	36	R26	64	TP17	77				
C36	1	C171	37	R27	65	U1	78				
C41	4	C172	38	R28	66	U2	79				
C42	3	CR1	39	R29	66	U3	80				
C51	5	CR2	39	R30	67	U4	80				
C52	6	CR3	40	R31	60	U6	81				
C53	7	CR4	40	R31	60	U7	78				
C54	8	L51	41	R31	60	U9	82				
C55	9	L52	42	R31	60	U10	83				
C56	10	L53	42	R32	61	U11	84				
C57	11	L54	43	R33	61	Y1-2	85				
C58	12	L55	44	R34	65	Y3-4	85				
C59	13	L56	45	R35	68						
C60	9	L57	46	R36	65						
C61	14	L58	41	R37	66						
C62	15	L59	47	R38	66						
C63	10	L60	48	R39	69						
C64	16	L61	49	R40	70						
C65	8	L91	50	R51	66						
C66	17	L92	51	R52	71						
C67	8	R1	52	R81	72						
C68	18	R2	52	R82	73						
C69	14	R3	53	R83	53						
C70	9	R4	53	R84	74						
C71	19	R5	54	R85	75						
C72	20	R6	53	R86	55						
C81	21	R7	52	R86	55						
C82	21	R8	52	R86	55						
C91	22	R9	55	R86	55						
C92	22	R9	55	R91	69						
C93	23	R9	55	R92	69						
C151	24	R9	55	R93	65						
C152	25	R9	76	R94	76						
C153	26	R10	56	R95	62						
C154	27	R11	57	TP1	77						
C155	28	R12	57	TP2	77						
C156	26	R13	58	TP3	77						
C157	29	R14	59	TP4	77						
C158	30	R15	58	TP5	77						
C159	31	R16	59	TP6	77						
C160	32	R17	58	TP7	77						
C161	26	R18	59	TP8	77						
C162	33	R21	60	TP9	77						
C163	34	R21	60	TP10	77						

Figure 10. IF Filter Circuit Card Assembly (Sheet 2 of 2).

(1) ITEM NO	(2) SMR CODE	(3) FSCM	(4) PART NUMBER	(5) DESCRIPTION AND USABLE ON CODE (UOC)	(6) QTY
GROUP 09 IF FILTER CIRCUIT CARD ASSEMBLY (A20)					
FIG. 10					
1	PAHZZ	16546	C31A103K	CAPACITOR, FIXED, CER	4
2	PAHZZ	81349	M39003/01-3006	CAPACITOR, FIXED, ELE	2
3	PAHZZ	28480	0121-0162	CAPACITOR, VARIABLE	2
4	PAHZZ	00853	RDM15F471J3C	CAPACITOR, FIXED, MIC	2
5	PAHZZ	81349	CMR06F472GODR	CAPACITOR, FIXED, MIC	1
6	PAHZZ	28480	0140-0231	CAPACITOR, FIXED, MIC	1
7	PAHZZ	28480	0140-0226	CAPACITOR, FIXED, MIC	1
8	PAHZZ	81349	CMR06F102FODR	CAPACITOR, FIXED, MIC	3
9	XDHZZ	72136	RDM20F252F5C	CAPACITOR, FIXED, MIC	3
10	PAHZZ	28480	0140-0155	CAPACITOR, FIXED, MIC	2
11	PAHZZ	28480	0160-3288	CAPACITOR, FIXED, MIC	1
12	PAHZZ	00853	RDM15E561F1S	CAPACITOR, FIXED, MIC	1
13	PAHZZ	28480	0160-3024	CAPACITOR, FIXED, MIC	1
14	PAHZZ	28480	0160-3156	CAPACITOR, FIXED, MIC	2
15	PAHZZ	72136	RDM15F361F3C	CAPACITOR, FIXED, MIC	1
16	PAHZZ	81349	CMR06F302FODR	CAPACITOR, FIXED, MIC	1
17	PAHZZ	28480	0160-0952	CAPACITOR, FIXED, MIC	1
18	PAHZZ	00853	RDM19E782F1S	CAPACITOR, FIXED, MIC	1
19	PAHZZ	00853	RDM19F122F1S	CAPACITOR, FIXED, MIC	1
20	PAHZZ	28480	0140-0184	CAPACITOR, FIXED, MIC	1
21	PAHZZ	72982	8121M112X7R0103M	CAPACITOR, FIXED, CER	2
22	PAHZZ	28480	0160-3548	CAPACITOR	2
23	PAHZZ	28480	0160-0576	CAPACITOR, FIXED, CER	1
24	PAHZZ	81349	CM10FD121G03	CAPACITOR, FIXED, MIC	1
25	PAHZZ	81349	CMR05E240J0DR	CAPACITOR, FIXED, MIC	1
26	PAHZZ	81349	CMR05E330GODR	CAPACITOR, FIXED, MIC	4
27	PAHZZ	28480	0140-0197	CAPACITOR, FIXED, MIC	1
28	PAHZZ	28480	0140-0220	CAPACITOR, FIXED, MIC	2
29	PAHZZ	81349	CMR05C150J0DR	CAPACITOR, FIXED, MIC	2
30	PAHZZ	72136	RDM15C200J3C	CAPACITOR, FIXED, MIC	1
31	PAHZZ	28480	0140-0196	CAPACITOR, FIXED, MIC	1
32	PAHZZ	72136	RDM15E560J3C	CAPACITOR, FIXED, MIC	1
33	PAHZZ	28480	0160-2197	CAPACITOR, FIXED, MIC	1
34	PAHZZ	28480	0160-2307	CAPACITOR, FIXED, PAP	3
35	PAHZZ	72136	DM15FA911G0	CAPACITOR, FIXED, MIC	1
36	PAHZZ	00853	RDM15F221J5S	CAPACITOR, FIXED, MIC	1
37	PAHZZ	28480	0140-0194	CAPACITOR, FIXED, MIC	1
38	PAHZZ	81349	CMR06F621G0DR	CAPACITOR, FIXED, MIC	1
39	PAHZZ	28480	5082-5511	SEMICONDUCTOR DEVIC	2
40	PAHZZ	80131	1N3956	SEMICONDUCTOR DEVIC	2
41	PAHZZ	28480	9140-0354	COIL, RADIO FREQUENC	2
42	PAHZZ	28480	9140-0355	COIL, RADIO FREQUENC	2
43	PAHZZ	28480	9140-0356	COIL, RADIO FREQUENC	1
44	PAHZZ	28480	9140-0357	COIL, RADIO FREQUENC	1
45	PAHZZ	28480	9140-0358	COIL, RADIO FREQUENC	1
46	PAHZZ	28480	9140-0359	COIL, RADIO FREQUENC	1
47	PAHZZ	28480	9140-0360	COIL, RADIO FREQUENC	1

SECTION II

TM11-6625-3087-24P

(1) ITEM NO	(2) SMR CODE	(3) FSCM	(4) PART NUMBER	(5) DESCRIPTION AND USABLE ON CODE (UOC)	(6) QTY
48	PAHZZ	28480	9140-0361	COIL,RADIO FREQUENC	1
49	PAHZZ	28480	9140-0362	COIL,RADIO FREQUENC	1
50	PAHZZ	28480	9140-0378	COIL,RADIO FREQUENC	1
51	PAHZZ	28480	9140-0379	COIL,RADIO FREQUENC	1
52	PAHZZ	19701	5033R1/8T9-1000B	RESISTOR,FIXED,FILM	4
53	PAHZZ	19701	5033R1/8T9-4321B	RESISTOR,FIXED,FILM	4
54	PAHZZ	81349	RNC60K2261FS	RESISTOR,FIXED,FILM	1
55	PAHZZ	81349	RNC60K3162FS	RESISTOR,FIXED,FILM	2
55	PAHZZ	81349	RNC60K4642FS	RESISTOR,FIXED,FILM	2
55	PAHZZ	81349	RNC60K8662FS	RESISTOR,FIXED,FILM	2
55	PAHZZ	81349	RNC60K2432FS	RESISTOR,FIXED,FILM	1
55	PAHZZ	81349	RNC60K1503FS	RESISTOR,FIXED,FILM	1
56	PAHZZ	81349	RNC60K2051FS	RESISTOR,FIXED,FILM	1
57	PAHZZ	81349	RNC60K10R0BS	RESISTOR,FIXED,FILM	2
58	PAHZZ	81349	RCR07G683JS	RESISTOR,FIXED,COMP	3
59	PAHZZ	81349	RCR07G513JS	RESISTOR,FIXED,COMP	3
60	PAHZZ	81349	RNC60K1240FS	RESISTOR,FIXED,FILM	2
60	PAHZZ	81349	RNC60K1500FS	RESISTOR,FIXED,FILM	2
60	PAHZZ	81349	RNC60K75R0FS	RESISTOR,FIXED,FILM	2
60	PAHZZ	81349	RNC60H1000FS	RESISTOR,FIXED,FILM	2
61	PAHZZ	81349	RNC60K4991FS	RESISTOR,FIXED,FILM	4
62	PAHZZ	73138	72-111-0	RESISTOR,VARIABLE N	2
63	PAHZZ	81349	RNC60H7502FS	RESISTOR,FIXED,FILM	1
64	PAHZZ	81349	RNC60K5492FS	RESISTOR,FIXED,FILM	1
65	PAHZZ	81349	RNC60K1003FS	RESISTOR,FIXED,FILM	4
66	PAHZZ	81349	RNC60K1002FS	RESISTOR,FIXED,FILM	5
67	PAHZZ	81349	RNC60K3482FS	RESISTOR,FIXED,FILM	1
68	XDHZZ	28480	2100-3214	RESISTOR,VARIABLE,N	1
69	PAHZZ	81349	RNC60K3012FS	RESISTOR,FIXED,FILM	3
70	PAHZZ	28480	2100-3210	RESISTOR,VARIABLE,N	1
71	PAHZZ	81349	RNC60K1542FS	RESISTOR,FIXED,FILM	1
72	PAHZZ	18701	5033R1/8T9-11050 ORB	RES,FXD,FILM	1
73	PAHZZ	28480	0698-6624	RESISTOR,FIXED,FILM	1
74	PAHZZ	81349	RNC60K3160FS	RESISTOR,FIXED,FILM	1
75	PAHZZ	81349	RNC60K1691FS	RESISTOR,FIXED,FILM	1
76	PAHZZ	81349	RNC60K4022FS	RESISTOR,FIXED,FILM	2
77	PAHZZ	28480	1251-0600	CONNECTOR,RECEPTACL	17
78	PAHZZ	04713	MC4558CG	MICROCIRCUIT,LINEAR	2
79	PAHZZ	12040	LM307H	MICROCIRCUIT,LINEAR	1
80	PAHZZ	19645	SC8431	MICROCIRCUIT,LINEAR	2
81	PAHZZ	81349	M38510/11004BCC	MICROCIRCUIT,LINEAR	1
82	PAHZZ	28480	1826-0476	MICROCIRCUIT,LINEAR	1
83	PAHZZ	18324	NE5534AN	MICROCIRCUIT,LINEAR	1
84	PAHZZ	81349	M38510/10107BGC	MIRCROCIRCUIT,LINEAR	1
85	PAHZZ	28480	0410-0765	CRYSTAL UNIT SET,QU	2
86	XBHZZ	28480	03586-04120	COVER,CKT CD	1
87	XBHZZ	73734	99401	WASHER,LOCK	3
88	XBHZZ	28480	0515-0150	SCREW,MACHINE	3

END OF FIGURE

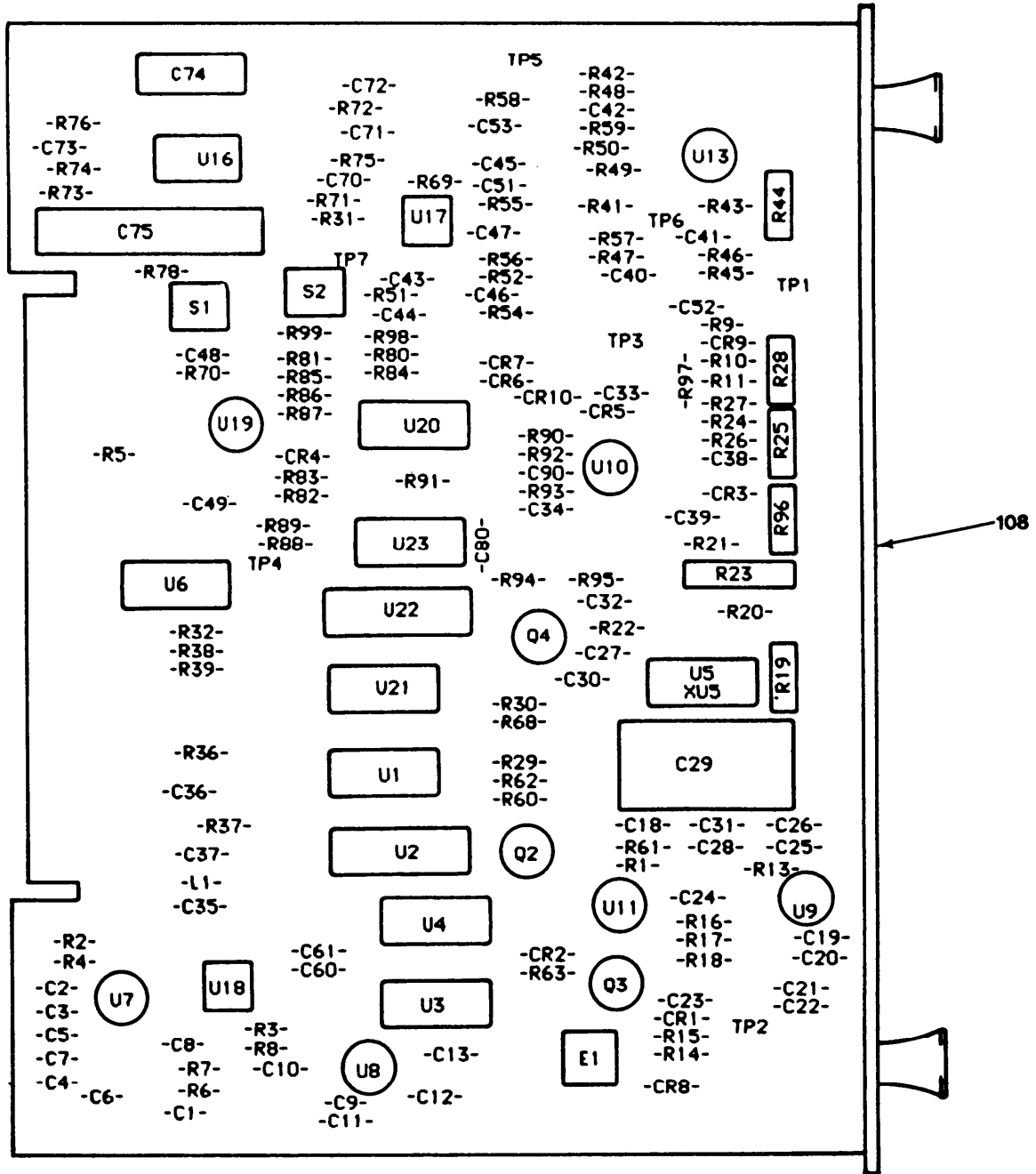

NOTE: PREFIX ALL REFERENCE DESIGNATORS WITH 1A21

EL9NV020

Figure 11. IF Gain/DET Circuit Card Assembly (Sheet 1 of 2).

REF DES	ITEM NO	REF DES	ITEM NO	REF DES	ITEM NO	REF DES	ITEM NO	REF DES	ITEM NO	REF DES	ITEM NO
C1	1	C51	8	R16	45	R73	74	U20	105		
C1	1	C52	14	R17	46	R74	75	U21	91		
C1	1	C53	14	R18	47	R75	34	U22	92		
C1	1	C60	1	R19	48	R76	59	U23	106		
C1	9	C60	1	R20	49	R78	76	XU5	107		
C1	20	C60	20	R21	50	R80	33				
C2	2	C60	20	R22	51	R81	77				
C3	3	C60	20	R23	52	R82	46				
C4	3	C60	20	R24	53	R83	78				
C5	3	C61	1	R25	54	R84	79				
C6	4	C61	4	R26	55	R85	79				
C7	5	C61	21	R27	56	R86	79				
C8	3	C61	21	R27	56	R87	79				
C9	3	C70	3	R27	56	R88	80				
C10	3	C71	12	R28	57	R89	81				
C11	4	C72	22	R29	58	R90	82				
C12	5	C73	22	R30	58	R91	83				
C13	6	C74	23	R31	34	R92	33				
C18	7	C75	24	R32	59	R93	84				
C19	3	C80	3	R36	60	R94	85				
C20	3	C90	25	R37	60	R95	86				
C21	4	CR1	26	R38	34	R96	87				
C22	5	CR2	27	R39	34	R97	34				
C23	6	CR3	27	R41	61	R98	78				
C24	8	CR4	26	R42	62	R99	88				
C25	9	CR5	28	R43	63	S1	89				
C26	3	CR6	26	R44	64	S2	89				
C27	3	CR7	26	R45	46	TP1	90				
C28	3	CR8	26	R46	46	TP2	90				
C29	10	CR9	26	R47	46	TP3	90				
C30	11	CR10	29	R48	65	TP4	90				
C31	3	E1	30	R49	46	TP5	90				
C32	12	L1	31	R50	46	TP6	90				
C33	3	Q2	32	R51	66	TP7	90				
C34	3	Q3	32	R52	66	U1	91				
C35	13	Q4	32	R54	66	U2	92				
C36	13	R1	33	R55	66	U3	93				
C37	13	R2	34	R56	36	U4	94				
C38	12	R3	35	R57	67	U5	95				
C39	14	R4	36	R58	68	U6	96				
C40	3	R5	37	R59	59	U7	97				
C41	3	R6	38	R60	61	U8	97				
C42	6	R7	39	R61	69	U9	97				
C43	15	R8	40	R62	70	U10	98				
C44	16	R9	41	R63	33	U11	99				
C45	17	R10	42	R68	71	U13	100				
C46	15	R11	43	R69	72	U16	101				
C47	16	R13	34	R70	36	U17	102				
C48	18	R14	44	R71	73	U18	103				
C49	19	R15	36	R72	36	U19	104				

Figure 11. IF Gain/DET Circuit Card Assembly (Sheet 2 of 2).

(1) ITEM NO	(2) SMR CODE	(3) FSCM	(4) PART NUMBER	(5) DESCRIPTION AND USABLE ON CODE (UOC)	(6) QTY
GROUP 10 IF GAIN/DET CIRCUIT CARD ASSEMBLY (A21)					
FIG. 11					
1	PAHZZ	28480	0140-0193-PS	CAPACITOR, FIXED, MIC	2
1	PAHZZ	28480	0140-0194	CAPACITOR, FIXED, MIC	1
1	PAHZZ	28480	0140-0196	CAPACITOR, FIXED, MIC	2
1	PAHZZ	81349	CM10FD121G03	CAPACITOR, FIXED, MIC	2
2	PAHZZ	28480	0140-0208	CAPACITOR, FIXED, MIC	1
3	PAHZZ	56289	562CZ5UBA501AG10 3M	CAPACITOR, FIXED, CER	18
4	PAHZZ	28480	0160-2306	CAPACITOR, FIXED, MIC	4
5	PAHZZ	72136	RDM15E560J3C	CAPACITOR, FIXED, MIC	3
6	PAHZZ	16546	C31C104K	CAPACITOR, FIXED, CER	3
7	PAHZZ	28480	1854-0305	TRANSISTOR	1
8	PAHZZ	16546	C31A103K	CAPACITOR, FIXED, CER	2
9	PAHZZ	81349	CM10FD101G03	CAPACITOR, FIXED, MIC	2
10	PAHZZ	84411	HEW249-10UF10PCT 50V	CAPACITOR, FIXED, PLA	1
11	PAHZZ	56289	5C11B7S	CAPACITOR, FIXED, CER	1
12	PAHZZ	56289	192P10292	CAPACITOR, FIXED, PLA	3
13	PAHZZ	81349	M39003/01-3006	CAPACITOR, FIXED, ELE	3
14	PAHZZ	81349	M39003/01-3088	CAPACITOR, FIXED, ELE	3
15	PAHZZ	28480	0140-0222	CAPACITOR, FIXED, MIC	2
16	PAHZZ	81349	CMR06F102FODR	CAPACITOR, FIXED, MIC	2
17	PAHZZ	28480	0160-3548	CAPACITOR	1
18	PAHZZ	18876	8193477	CAPACITOR, FIXED, CER	1
19	PAHZZ	56289	5CZ5U225X0050C5C	CAPACITOR, FIXED, CER	1
20	PAHZZ	81349	CMR05F131GODR	CAPACITOR, FIXED, MIC	2
20	PAHZZ	28480	0140-0197	CAPACITOR, FIXED, MIC	1
20	PAHZZ	81349	CM10FD201G03	CAPACITOR, FIXED, MIC	1
20	PAHZZ	81349	CM10FD161G03	CAPACITOR, FIXED, MIC	1
21	PAHZZ	81349	CMR05E680GODR	CAPACITOR, FIXED, MIC	1
21	PAHZZ	28480	0160-2307	CAPACITOR, FIXED, PAP	1
22	PAHZZ	18876	10018712-022	CAPACITOR, FIXED, ELE	2
23	PAHZZ	81349	M39003/01-3005	CAPACITOR, FIXED, ELE	1
24	PAHZZ	55680	16ELA2200T	CAPACITOR, FIXED, ELE	1
25	PAHZZ	81349	M39014/05-2237	CAPACITOR, FIXED, CER	1
26	PAHZZ	80131	1N3956	SEMICONDUCTOR DEVIC	6
27	PAHZZ	81349	JAN1N645	SEMICONDUCTOR DEVIC	2
28	PAHZZ	81349	JAN1N754A	SEMICONDUCTOR DEVIC	1
29	PAHZZ	28480	1902-0945	SEMICONDUCTOR DEVIC	1
30	PAHZZ	18178	VTL5C3/2	COUPLER, OPTOELECTRO	1
31	PAHZZ	24226	15M102J	COIL, RADIO FREQUENC	1
32	PAHZZ	04713	SPS5103	TRANSISTOR	3
33	PAHZZ	81349	RCR07G103JS	RESISTOR, FIXED, COMP	4
34	PAHZZ	81349	RCR07G102JS	RESISTOR, FIXED, COMP	7
35	PAHZZ	81349	RNC60K3921FS	RESISTOR, FIXED, FILM	1
36	PAHZZ	81349	RCR07G104JS	RESISTOR, FIXED, COMP	5
37	PAHZZ	81349	RCR07G473JS	RESISTOR, FIXED, COMP	1
38	PAHZZ	28480	0698-6624	RESISTOR, FIXED, FILM	1

SECTION II

TM11-6625-3087-24P

(1) ITEM NO	(2) SMR CODE	(3) FSCM	(4) PART NUMBER	(5) DESCRIPTION AND USABLE ON CODE (UOC)	(6) QTY
39	PAHZZ	18701	5033R1/8T9-11050 ORB	RES,FXD,FILM	1
40	PAHZZ	81349	RNC60K4991FS	RESISTOR,FIXED,FILM	1
41	PAHZZ	81349	RNC60K1152FS	RESISTOR,FIXED,FILM	1
42	PAHZZ	81349	RNC60K3572FS	RESISTOR,FIXED,FILM	1
43	PAHZZ	81349	RNC60K6043FS	RESISTOR,FIXED,FILM	1
44	PAHZZ	81349	RNC60K3012FS	RESISTOR,FIXED,FILM	1
45	PAHZZ	81349	RNC60K1003FS	RESISTOR,FIXED,FILM	1
46	PAHZZ	81349	RNC60K1002FS	RESISTOR,FIXED,FILM	7
47	PAHZZ	81349	RCR07G271JS	RESISTOR,FIXED,COMP	1
48	PAHZZ	32997	3386XY46-201	RESISTOR,VARIABLE,N	1
49	PAHZZ	28480	0811-1780	RESISTOR,FIXED,WIRE	1
50	PAHZZ	81349	RNC60K2492FS	RESISTOR,FIXED,FILM	1
51	PAHZZ	81349	RNC60K1503FS	RESISTOR,FIXED,FILM	1
52	PAHZZ	28480	2100-3054	RESISTOR,VARIABLE,N	1
53	PAHZZ	81349	RNC60K2263FS	RESISTOR,FIXED,FILM	1
54	PAHZZ	28480	2100-3274	RESISTOR,VARIABLE,N	1
55	PAHZZ	81349	RNC60K7322FS	RESISTOR,FIXED,FILM	1
56	PAHZZ	81349	RNC60K7321FS	RESISTOR,FIXED,FILM	1
56	PAHZZ	81349	RNC60K7681FS	RESISTOR,FIXED,FILM	1
56	PAHZZ	81349	RNC60K8061FS	RESISTOR,FIXED,FILM	1
57	PAHZZ	28480	2100-3351	RESISTOR,VARIABLE,N	1
58	PAHZZ	81349	RCR07G472JS	RESISTOR,FIXED,COMP	2
59	PAHZZ	81349	RCR07G101JS	RESISTOR,FIXED,COMP	3
60	PAHZZ	81349	RCR07G100JS	RESISTOR,FIXED,COMP	2
61	PAHZZ	81349	RNC60K4021FS	RESISTOR,FIXED,FILM	2
62	PAHZZ	81349	RNR60K4751FM	RESISTOR,FIXED FILM	1
63	PAHZZ	81349	RNC60J9091FS	RESISTOR,FIXED,FILM	1
64	PAHZZ	28480	2100-3273	RESISTOR,VARIABLE,N	1
65	PAHZZ	81349	RNC60K1102FS	RESISTOR,FIXED,FILM	1
66	PAHZZ	81349	RNC60K6342FS	RESISTOR,FIXED,FILM	4
67	PAHZZ	81349	RCR07G471JS	RESISTOR,FIXED,COMP	1
68	PAHZZ	81349	RCR07G302JS	RESISTOR,FIXED,COMP	1
69	PAHZZ	81349	RNC60K1001FS	RESISTOR,FIXED,FILM	1
70	PAHZZ	81349	RNC60K3740FS	RESISTOR,FIXED,FILM	1
71	PAHZZ	81349	RCR07G243JS	RESISTOR,FIXED,COMP	1
72	PAHZZ	81349	RCR07G203JS	RESISTOR,FIXED,COMP	1
73	PAHZZ	81349	RCR07G152JS	RESISTOR,FIXED,COMP	1
74	PAHZZ	81349	RCR07G513JS	RESISTOR,FIXED,COMP	1
75	PAHZZ	81349	RCR07G202JS	RESISTOR,FIXED,COMP	1
76	PAHZZ	28480	0811-3070	RESISTOR,FIXED,FILM	1
77	PAHZZ	81349	RNC60K1211FS	RESISTOR,FIXED,FILM	1
78	PAHZZ	81349	RNC60K1103FS	RESISTOR,FIXED,FILM	2
79	PAHZZ	28480	0698-6360	RESISTOR,FIXED,FILM	4
80	PAHZZ	81349	RNC60H3320FS	RESISTOR,FIXED,FILM	1
81	PAHZZ	81349	RNC60K2212FS	RESISTOR,FIXED,FILM	1
82	PAHZZ	81349	RNC60K1004FS	RESISTOR,FIXED,FILM	1
83	PAHZZ	81349	RNC60K3321FS	RESISTOR,FIXED,FILM	1
84	PAHZZ	81349	RCR07G753JS	RESISTOR,FIXED,COMP	1
85	PAHZZ	81349	RNC60J5491FS	RESISTOR,FIXED,FILM	1
86	PAHZZ	81349	RNC60K6041FS	RESISTOR,FIXED,FILM	1
87	PAHZZ	28480	2100-3352	RESISTOR,VARIABLE,N	1

SECTION II

TM11-6625-3087-24P

(1) ITEM NO	(2) SMR CODE	(3) FSCM	(4) PART NUMBER	(5) DESCRIPTION AND USABLE ON CODE (UOC)	(6) QTY
88	PAHZZ	81349	RNC60K9531FS	RESISTOR, FIXED, FILM	1
89	PAHZZ	79727	G111-0004	SWITCH, SLIDE	2
90	PAHZZ	28480	1251-0600	CONNECTOR, RECEPTACL	7
91	PAHZZ	81349	M38510/30605BCB	MICROCIRCUIT, DIGITA	2
92	PAHZZ	01295	SN74LS273N	MIRCROCIRCUIT, DIGITA	2
93	PAHZZ	28480	5061-0795	MICROCIRCUIT	1
94	PAHZZ	27014	LF13508D	MICROCIRCUIT, LINEAR	1
95	PAHZZ	51870	AD536AJD	MICROCIRCUIT, ANALOG	1
96	PAHZZ	19645	SC8431	MICROCIRCUIT, LINEAR	1
97	PAHZZ	28480	1826-0109	MICROCIRCUIT, LINEAR	3
98	PAHZZ	81349	M38510/10101BGC	MICROCIRCUIT, LINEAR	1
99	PAHZZ	12040	LM307H	MICROCIRCUIT, LINEAR	1
100	PAHZZ	96214	536958-1	MICROCIRCUIT, LINEAR	1
101	PAHZZ	27014	LM377N	MICROCIRCUIT, LINEAR	1
102	PAHZZ	28480	1826-0111	MICROCIRCUIT, LINEAR	1
103	PAHZZ	28480	1826-0476	MICROCIRCUIT, LINEAR	1
104	PAHZZ	89536	3140-288365	MICROCIRCUIT, LINEAR	1
105	PAHZZ	27014	LM348J	MICROCIRCUIT, LINEAR	1
106	PAHZZ	81349	M38510/11301BEC	MICROCIRCUIT, LINEAR	1
107	PAHZZ	80009	136-0269-02	SOCKET, PLUG-IN ELEC	1
108	XBHZZ	28480	03586-04121	COVER, CKT CD	1
109	XBHZZ	73734	99401	WASHER, LOCK	2
110	XBHZZ	28480	0515-0150	SCREW, MACHINE	2

END OF FIGURE

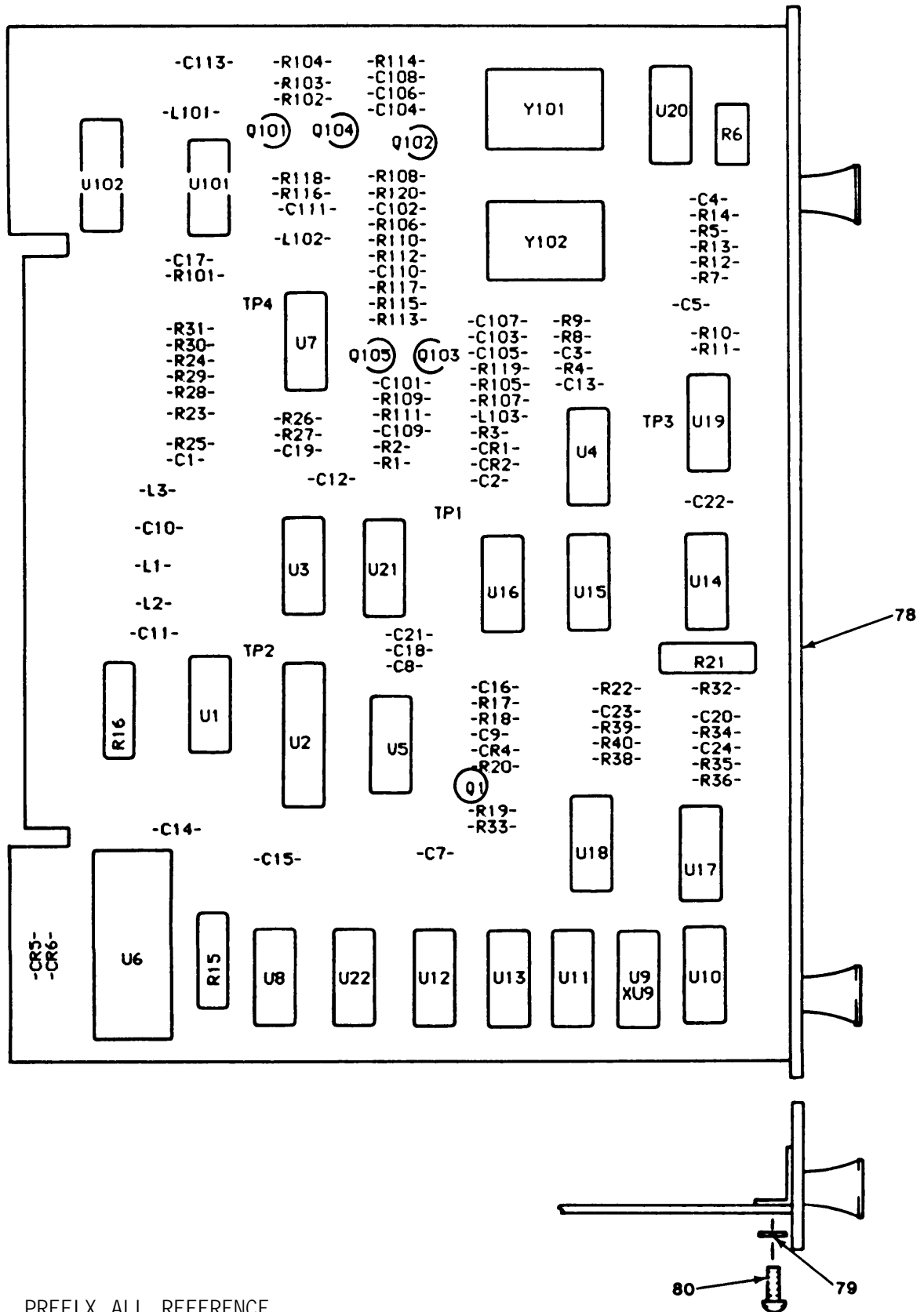

NOTE: PREFIX ALL REFERENCE DESIGNAORS WITH 1A22

EL9NV021

Figure 12. Analog to Digital Converter Circuit Card Assembly (Sheet 1 of 2).

REF DES	ITEM NO	REF DES	ITEM NO	REF DES	ITEM NO	REF DES	ITEM NO	REF DES	ITEM NO	REF DES	ITEM NO
C1	1	Q104	24	R110	52						
C2	2	Q105	24	R111	53						
C3	1	R1	25	R112	53						
C4	3	R2	26	R113	52						
C5	4	R3	27	R114	52						
C7	5	R4	26	R115	54						
C8	6	R5	28	R116	54						
C9	6	R6	29	R117	55						
C10	7	R7	30	R118	55						
C11	7	R8	31	R119	56						
C12	7	R9	31	R120	56						
C13	6	R10	27	TP1	57						
C14	6	R11	32	TP2	57						
C15	6	R12	27	TP3	57						
C16	6	R13	33	TP4	57						
C17	6	R14	31	U1	58						
C18	6	R15	34	U2	59						
C19	6	R16	35	U3	60						
C20	8	R17	31	U4	61						
C21	6	R18	36	U5	62						
C22	6	R19	36	U6	63						
C23	6	R20	37	U7	60						
C24	6	R21	38	U8	64						
C101	9	R22	39	U9	65						
C102	10	R23	40	U10	66						
C103	11	R24	41	U11	66						
C104	12	R25	31	U12	67						
C105	8	R26	42	U13	66						
C106	13	R27	43	U14	68						
C107	14	R28	43	U15	68						
C108	14	R29	43	U16	68						
C109	6	R30	44	U17	69						
C110	6	R31	44	U18	70						
C111	6	R32	45	U19	71						
C113	15	R33	46	U20	72						
CR1	16	R34	46	U21	61						
CR2	16	R35	47	U22	73						
CR4	17	R36	46	U101	74						
CR5	16	R38	46	U102	68						
CR6	16	R39	46	XU9	75						
L1	18	R40	48	Y101	76						
L2	18	R101	49	Y102	77						
L3	18	R102	50								
L101	19	R103	50								
L102	20	R104	50								
L103	21	R105	51								
Q1	22	R106	51								
Q101	23	R107	51								
Q102	24	R108	51								
Q103	24	R109	52								

Figure 12. Analog to Digital Converter Circuit Card Assembly (Sheet 2 of 2).

(1) ITEM NO	(2) SMR CODE	(3) FSCM	(4) PART NUMBER	(5) DESCRIPTION AND USABLE ON CODE (UOC)	(6) QTY
GROUP 11 ANALOG TO DIGITAL CONVERTER CIRCUIT CARD ASSEMBLY (A22)					
FIG. 12					
1	PAHZZ	16546	C31A103K	CAPACITOR, FIXED, CER	2
2	PAHZZ	81349	M39003/01-2988	CAPACITOR, FIXED, ELE	1
3	PAHZZ	28480	0160-4812	CAPACITOR, FIXED, CER	1
4	PAHZZ	56289	292P47352	CAPACITOR, FIXED, PLA	1
5	PAHZZ	28480	0160-3405	CAPACITOR, FIXED, PLA	1
6	PAHZZ	16546	C31C104K	CAPACITOR, FIXED, CER	16
7	PAHZZ	81349	M39003/01-2991	CAPACITOR, FIXED, ELE	3
8	PAHZZ	56289	292CC0G201J100B	CAPACITOR, FIXED, CER	2
9	PAHZZ	56289	292CC0G181J100B	CAPACITOR, FIXED CER	1
10	PAHZZ	04222	MA101A101JAA	CAPACITOR, FIXED, CER	1
11	PAHZZ	28480	0140-0194	CAPACITOR, FIXED, MIC	1
12	PAHZZ	72136	RDM15E750J3C	CAPACITOR, FIXED, MIC	1
13	PAHZZ	81349	CM10FD241G03	CAPACITOR, FIXED, MIC	1
14	PAHZZ	81349	CCR77CG102GR	CAPACITOR, FIXED, CER	2
15	PAHZZ	81349	M39003/01-2977	CAPACITOR, FIXED, ELE	1
16	PAHZZ	80131	1N3956	SEMICONDUCTOR DEVIC	4
17	PAHZZ	81349	JAN1N825	SEMICONDUCTOR, DEVIC	1
18	PAHZZ	59474	30134-3K	COIL, RADIO FREQUENC	3
19	PAHZZ	96906	MS90539-15	COIL, ELECTRICAL	1
20	PAHZZ	96906	MS90538-14	COIL, RADIO FREQUENC	1
21	PAHZZ	96906	MS90538-09	COIL, RADIO FREQUENC	1
22	PAHZZ	80131	2N4917	TRANSISTOR	1
23	PAHZZ	04713	SPS5103	TRANSISTOR	1
24	PAHZZ	13499	352-0722-020	TRANSISTOR	4
25	PAHZZ	81349	RCR07G222JS	RESISTOR, FIXED, COMP	1
26	PAHZZ	81349	RCR07G224JS	RESISTOR, FIXED, COMP	2
27	PAHZZ	81349	RCR07G223JS	RESISTOR, FIXED, COMP	3
28	PAHZZ	81349	RCR07G183JS	RESISTOR, FIXED, COMP	1
29	PAHZZ	28480	2100-3356	RESISTOR, VARIABLE, N	1
30	PAHZZ	81349	RCR07G753JS	RESISTOR, FIXED, COMP	1
31	PAHZZ	81349	RCR07G103JS	RESISTOR, FIXED, COMP	5
32	PAHZZ	81349	RCR07G683JS	RESISTOR, FIXED, COMP	1
33	PAHZZ	81349	RCR07G333JS	RESISTOR, FIXED, COMP	1
34	PAHZZ	28480	1810-0231	RESISTOR NETWORK, FI	1
35	PAHZZ	56289	256CH102X2PD	RESISTOR NETWORK, FI	1
36	PAHZZ	81349	RCR07G512JS	RESISTOR, FIXED, COMP	2
37	PAHZZ	81349	RNC60H5421DS	RESISTOR, FIXED, FILM	1
38	PAHZZ	28480	2100-3095	RESISTOR, VARIABLE, N	1
39	PAHZZ	81349	RNC60J1001FS	RESISTOR, FIXED, FILM	1
40	PAHZZ	81349	RNC60K3481FS	RESISTOR, FIXED, FILM	1
41	PAHZZ	81349	RNC60K1501FS	RESISTOR, FIXED, FILM	1
42	PAHZZ	81349	RNC60K1001FS	RESISTOR, FIXED, FILM	1
43	PAHZZ	81349	RNC60K1002FS	RESISTOR, FIXED, FILM	3
44	PAHZZ	81349	RNC60K1302FS	RESISTOR, FIXED, FILM	2
45	PAHZZ	81349	RNC60K8060FS	RESISTOR, FIXED, FILM	1
46	PAHZZ	81349	RNC60K5111FS	RESISTOR, FIXED, FILM	5
47	PAHZZ	81349	RNC60K3012FS	RESISTOR, FIXED, FILM	1

SECTION II

TM11-6625-3087-24P

(1) ITEM NO	(2) SMR CODE	(3) FSCM	(4) PART NUMBER	(5) DESCRIPTION AND USABLE ON CODE (UOC)	(6) QTY
48	PAHZZ	81349	RCR07G100JS	RESISTOR, FIXED, COMP	1
49	PAHZZ	81349	RCR07G104JS	RESISTOR, FIXED, COMP	1
50	PAHZZ	81349	RCR07G203JS	RESISTOR, FIXED, COMP	3
51	PAHZZ	81349	RNC60K4222FS	RESISTOR, FIXED, FILM	4
52	PAHZZ	81349	RNC60K6040FS	RESISTOR, FIXED, FILM	4
53	PAHZZ	81349	RNC60K4121FS	RESISTOR, FIXED, FILM	2
54	PAHZZ	81349	RNC60K1912FS	RESISTOR, FIXED, FILM	2
55	PAHZZ	81349	RNC60K4990FS	RESISTOR, FIXED, FILM	2
56	PAHZZ	81349	RNC60K49R9FS	RESISTOR, FIXED, FILM	2
57	PAHZZ	28480	1251-0600	CONNECTOR, RECEPTACL	4
58	PAHZZ	81349	M38510/30605BCB	MICROCIRCUIT, DIGITA	1
59	PAHZZ	01295	SN74LS273N	MICROCIRCUIT, DIGITA	1
60	PAHZZ	27014	LF13508D	MICROCIRCUIT, LINEAR	2
61	PAHZZ	81349	M38510/11004BCC	MICROCIRCUIT, LINEAR	2
62	PAHZZ	04713	MC1405L	MICROCIRCUIT, LINEAR	1
63	PAHZZ	28480	1820-2310	MICROCIRCUIT, DIGITA	1
64	PAHZZ	81349	M38510/00803BCB	MICROCIRCUIT, DIGITA	1
65	PAHZZ	81349	M38510/31302BCB	MICROCIRCUIT, DIGITA	1
66	PAHZZ	01295	8N74LS00N	MICROCIRCUIT, DIGITA	3
67	PAHZZ	81349	M38510/31004BCB	MICROCIRCUIT, DIGITA	1
68	PAHZZ	81349	M38510/32701BEB	MICROCIRCUIT, DIGITA	4
69	PAHZZ	81349	M38510/11201BCB	MICROCIRCUIT, LINEAR	1
70	PAHZZ	81349	M38510/31602BEB	MICROCIRCUIT, DIGITA	1
71	PAHZZ	55973	279390-1	MICROCIRCUIT, DIGITA	1
72	PAHZZ	27014	CD4046BMJ/883B	MICROCIRCUIT, DIGITA	1
73	PAHZZ	28480	1820-1112	MICROCIRCUIT, DIGITA	1
74	PAHZZ	81349	M38510-30005BCX	MICROCIRCUIT, DIGITA	1
75	PAHZZ	80009	136-0269-02	SOCKET, PLUG-IN ELEC	1
76	PAHZZ	28480	0410-1209	CRYSTAL UNIT, QUARTZ	1
77	PAHZZ	28480	0410-1214	CRYSTAL UNIT, QUARTZ	1
78	XBHZZ	28480	03586-04122	COVER, CKT CD	1
79	XBHZZ	73734	99401	WASHER, LOCK	2
80	XBHZZ	28480	0515-0150	SCREW, MACHINE	2

END OF FIGURE

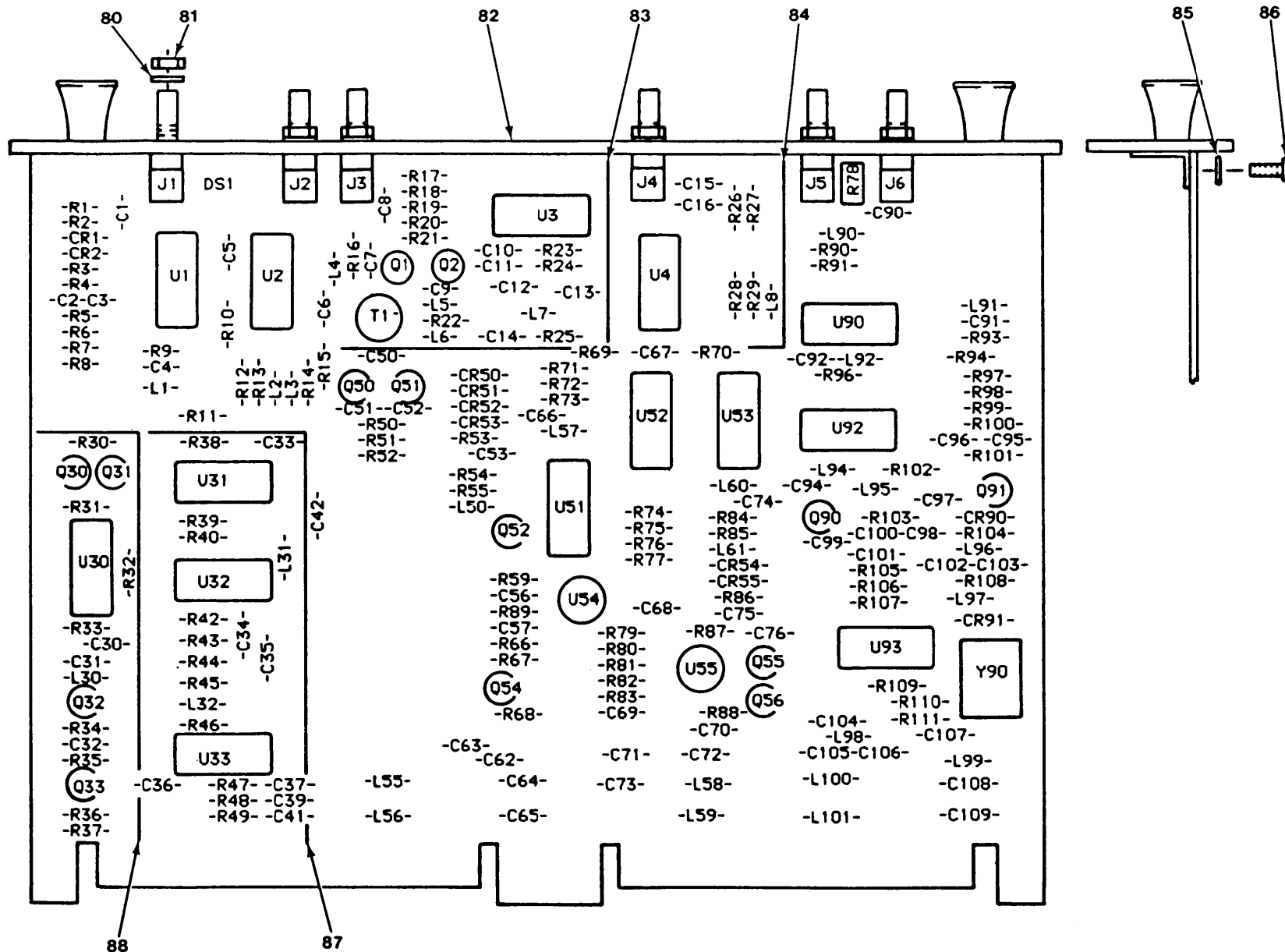

NOTE: PREFIX ALL REFERENCE DESIGNATORS WITH 1A40

Figure 13. Frequency Reference Circuit Card Assembly (Sheet 1 of 2).

TM11-6625-3087-24P

EL9NV022

REF DES	ITEM NO	REF DES	ITEM NO	REF DES	ITEM NO	REF DES	ITEM NO	REF DES	ITEM NO	REF DES	ITEM NO
C1	1	C92	6	L59	30	R23	50	R83	65		
C2	2	C94	6	L60	25	R24	51	R84	44		
C3	2	C95	6	L61	25	R25	42	R85	52		
C4	3	C96	18	L90	31	R26	49	R86	64		
C5	1	C97	19	L91	31	R27	43	R87	50		
C6	4	C98	2	L92	25	R28	52	R88	66		
C7	5	C99	6	L94	25	R29	44	R89	67		
C8	6	C100	6	L95	32	R30	44	R90	68		
C9	5	C101	16	L96	25	R31	49	R91	69		
C10	2	C102	6	L97	33	R32	44	R93	43		
C11	6	C103	6	L98	25	R33	44	R94	49		
C12	7	C104	4	L99	31	R34	53	R96	52		
C13	8	C105	4	L100	29	R35	41	R97	52		
C14	2	C106	6	L101	29	R36	41	R98	52		
C15	6	C107	10	Q1	34	R37	46	R99	52		
C16	6	C108	13	Q2	34	R38	50	R100	41		
C30	4	C109	13	Q30	35	R39	44	R101	44		
C31	9	CR1	20	Q31	36	R40	44	R102	41		
C32	3	CR2	20	Q32	35	R42	50	R103	48		
C33	6	CR50	20	Q33	37	R43	50	R104	48		
C34	2	CR51	20	Q50	34	R44	50	R105	60		
C35	1	CR52	20	Q51	34	R45	50	R106	50		
C36	10	CR53	20	Q52	34	R46	54	R107	52		
C37	11	CR54	20	Q54	38	R47	55	R108	50		
C39	11	CR55	20	Q55	39	R48	55	R109	52		
C41	11	CR90	20	Q56	39	R49	56	R110	69		
C42	1	CR91	21	Q90	40	R50	57	R111	68		
C50	2	DS1	22	Q91	40	R51	46	T1	70		
C51	10	J1	23	R1	41	R52	46	U1	71		
C52	10	J2	23	R2	42	R53	58	U2	72		
C53	12	J3	23	R3	43	R54	49	U3	72		
C56	7	J4	23	R4	43	R55	45	U4	72		
C57	4	J5	23	R5	44	R59	59	U30	73		
C62	4	J6	23	R6	43	R66	60	U31	74		
C63	4	L1	24	R7	43	R67	50	U32	75		
C64	13	L2	25	R8	45	R68	54	U33	76		
C65	13	L3	25	R9	46	R69	44	U51	72		
C66	6	L4	26	R10	47	R70	52	U52	75		
C67	6	L5	25	R11	44	R71	44	U53	74		
C68	14	L6	25	R12	43	R72	50	U54	77		
C69	15	L7	27	R13	43	R73	50	U55	78		
C70	16	L8	25	R14	48	R74	50	U90	72		
C71	4	L30	25	R15	49	R75	60	U92	71		
C72	16	L31	25	R16	42	R76	46	U93	72		
C73	4	L32	25	R17	50	R77	61	Y90	79		
C74	6	L50	28	R18	43	R78	62				
C75	14	L55	29	R19	49	R79	63				
C76	11	L56	29	R20	43	R80	50				
C90	17	L57	25	R21	49	R81	64				
C91	17	L58	30	R22	49	R82	55				

Figure 13. Frequency Reference Circuit Card Assembly (Sheet 2 of 2).

(1) ITEM NO	(2) SMR CODE	(3) FSCM	(4) PART NUMBER	(5) DESCRIPTION AND USABLE ON CODE (UOC)	(6) QTY
GROUP 12 FREQUENCY REFERENCE CIRCUIT CARD ASSEMBLY (A40)					
FIG. 13					
1	PAHZZ	28480	1854-0305	TRANSISTOR	4
2	PAHZZ	28480	0160-0576	CAPACITOR, FIXED, CER	7
3	PAHZZ	04222	MA101A560JAA	CAPACITOR, FIXED, CER	2
4	PAHZZ	16546	C31A103K	CAPACITOR, FIXED, CER	9
5	PAHZZ	28480	0160-0939	CAPACITOR, FIXED, MIC	2
6	PAHZZ	72982	8121M112X7R0103M	CAPACITOR, FIXED, CER	16
7	PAHZZ	81349	CM10FD161G03	CAPACITOR, FIXED, MIC	2
8	PAHZZ	28480	0140-0207	CAPACITOR, FIXED, MIC	1
9	PAHZZ	18876	10018712-022	CAPACITOR, FIXED, ELE	1
10	PAHZZ	28480	0160-3875	CAPACITOR, FIXED, CER	4
11	PAHZZ	28480	0160-3877	CAPACITOR, FIXED, CER	4
12	PAHZZ	81349	CM10FD241G03	CAPACITOR, FIXED, MIC	1
13	PAHZZ	81349	M39003/01-2991	CAPACITOR, FIXED, ELE	4
14	PAHZZ	56289	5C11B7S	CAPACITOR, FIXED, CER	2
15	PAHZZ	56289	5CZ5U225X0050C5C	CAPACITOR, FIXED, CER	1
16	PAHZZ	81349	M39003/01-3009	CAPACITOR, FIXED, ELE	3
17	PAHZZ	81349	CCR75CG220GR	CAPACITOR, FIXED, CER	2
18	PAHZZ	81349	CMR05E680GODR	CAPACITOR, FIXED, MIC	1
19	PAHZZ	72136	RDM15E750J3C	CAPACITOR, FIXED, MIC	1
20	PAHZZ	80131	1N3956	SEMICONDUCTOR DEVIC	9
21	PAHZZ	04713	MV109	SEMICONDUCTOR DEVIC	1
22	PAHZZ	28480	1990-0486	LIGHT EMITTING DIOD	1
23	PAHZZ	28480	1250-1512	CONNECTOR RECEPTACL	6
24	PAHZZ	24226	15M121J	COIL, RADIO FREQUENC	1
25	PAHZZ	96906	MS75084-8	COIL, RADIO FREQUENC	15
26	PAHZZ	24226	15M750J1	COIL, RADIO FREQUENC	1
27	PAHZZ	24226	15M221J	COIL, RADIO FREQUENC	1
28	PAHZZ	24226	15M101J	COIL, RADIO FREQUENC	1
29	PAHZZ	59474	30134-3K	COIL, RADIO FREQUENC	4
30	PAHZZ	59474	15-1315-13J	COIL, RADIO FREQUENC	2
31	PAHZZ	24226	15M470J	COIL, RADIO FREQUENCY	3
32	PAHZZ	24226	15M220J	COIL, RADIO FREQUENC	1
33	PAHZZ	10001	2270098-28	COIL, RADIO FREQUENC	1
34	PAHZZ	81349	2N3906	TRANSISTOR	5
35	PAHZZ	81349	JAN2N2369A	TRANSISTOR	2
36	PAHZZ	80131	2N4917	TRANSISTOR	1
37	PAHZZ	04713	MPSH81	TRANSISTOR	1
38	PAHZZ	13499	352-0722-020	TRANSISTOR	1
39	PAHZZ	28480	1855-0386	TRANSISTOR	2
40	PAHZZ	28480	1853-0405	TRANSISTOR	2
41	PAHZZ	81349	RNC60K49R9FS	RESISTOR, FIXED, FILM	5
42	PAHZZ	81349	RNC60H1000FS	RESISTOR, FIXED, FILM	3
43	PAHZZ	81349	RCR07G331JS	RESISTOR, FIXED, COMP	10
44	PAHZZ	81349	RCR07G471JS	RESISTOR, FIXED, COMP	12
45	PAHZZ	81349	RNC60K1500FS	RESISTOR, FIXED, FILM	2
46	PAHZZ	81349	RNC60K1001FS	RESISTOR, FIXED, FILM	5
47	PAHZZ	81349	RNC60K2740FS	RESISTOR, FIXED, FILM	1

SECTION II

TM11-6625-3087-24P

(1) ITEM NO	(2) SMR CODE	(3) FSCM	(4) PART NUMBER	(5) DESCRIPTION AND USABLE ON CODE (UOC)	(6) QTY
48	PAHZZ	81349	RNC55K82R5FS	RESISTOR, FIXED, FILM	3
49	PAHZZ	81349	RCR07G430JS	RESISTOR, FIXED, COMP	8
50	PAHZZ	81349	RCR07G102JS	RESISTOR, FIXED, COMP	15
51	PAHZZ	81349	RCR07G202JS	RESISTOR, FIXED, COMP	1
52	PAHZZ	81349	RCR07G681JS	RESISTOR, FIXED, COMP	9
53	PAHZZ	81349	RNC60K4870FS	RESISTOR, FIXED, FILM	1
54	PAHZZ	81349	RCR07G203JS	RESISTOR, FIXED, COMP	2
55	PAHZZ	81349	RCR07G512JS	RESISTOR, FIXED, COMP	3
56	PAHZZ	81349	RCR07G220JS	RESISTOR, FIXED, COMP	1
57	PAHZZ	81349	RNC60K2213FS	RESISTOR, FIXED, FILM	1
58	PAHZZ	81349	RNC60K3240FS	RESISTOR, FIXED, FILM	1
59	PAHZZ	81349	RNC60K1003FS	RESISTOR, FIXED, FILM	1
60	PAHZZ	81349	RNC60K1002FS	RESISTOR, FIXED, FILM	3
61	PAHZZ	81349	RNC60K1622FS	RESISTOR, FIXED, FILM	1
62	PAHZZ	80294	3299X1-502	RESISTOR, VARIABLE, N	1
63	PAHZZ	81349	RNC60K4993FS	RESISTOR, FIXED, FILM	1
64	PAHZZ	81349	RNC60K1004FS	RESISTOR, FIXED, FILM	2
65	PAHZZ	81349	RNC60J1242FS	RESISTOR, FIXED, FILM	1
66	PAHZZ	81349	RCR07G515JS	RESISTOR, FIXED, COMP	1
67	PAHZZ	81349	RNC60K2671FS	RESISTOR, FIXED, FILM	1
68	PAHZZ	81349	RNC60K59R0FS	RESISTOR, FIXED, FILM	2
69	PAHZZ	81349	RNC60K3570FS	RESISTOR, FIXED, FILM	2
70	PAHZZ	28480	08552-6044	TRANSFORMER, RADIO F	1
71	PAHZZ	14933	7800901EB	MICROCIRCUIT, LINEAR	2
72	PAHZZ	81349	M38510/06006BEB	MICROCIRCUIT, DIGITA	6
73	PAHZZ	14933	7701001CB	MICROCIRCUIT, DIGITA	1
74	PAHZZ	04713	MC10138L	MICROCIRCUIT, DIGITA	2
75	PAHZZ	81349	M38510/06003BEB	MICROCIRCUIT, DIGITA	2
76	PAHZZ	14933	7901401EB	MICROCIRCUIT, DIGITA	1
77	PAHZZ	12040	LM307H	MICROCIRCUIT, LINEAR	1
78	PAHZZ	81349	M38510/10104BGC	MICROCIRCUIT, LINEAR	1
79	PAHZZ	28480	0410-0751	CRYSTAL UNIT, QUARTZ	1
80	PAHZZ	98291	3002-26	WASHER, LOCK	6
81	PAHZZ	98291	3002-18	NUT, PLAIN, HEXAGON	6
82	XBHZZ	28480	03586-04171	COVER, ACCESS	1
83	XBHZZ	28480	1600-0841	PLATE, ELEC SHLD	1
84	XBHZZ	28480	1600-0842	PLATE, ELEC SHLD	1
85	XBHZZ	73734	99401	WASHER, LOCK	2
86	XBHZZ	28480	0515-0150	SCREW, MACHINE	2
87	XBHZZ	28480	1600-0835	PLATE, ELEC SHLD	1
88	XBHZZ	28480	1600-0843	PLATE, ELEC SHLD	1

END OF FIGURE

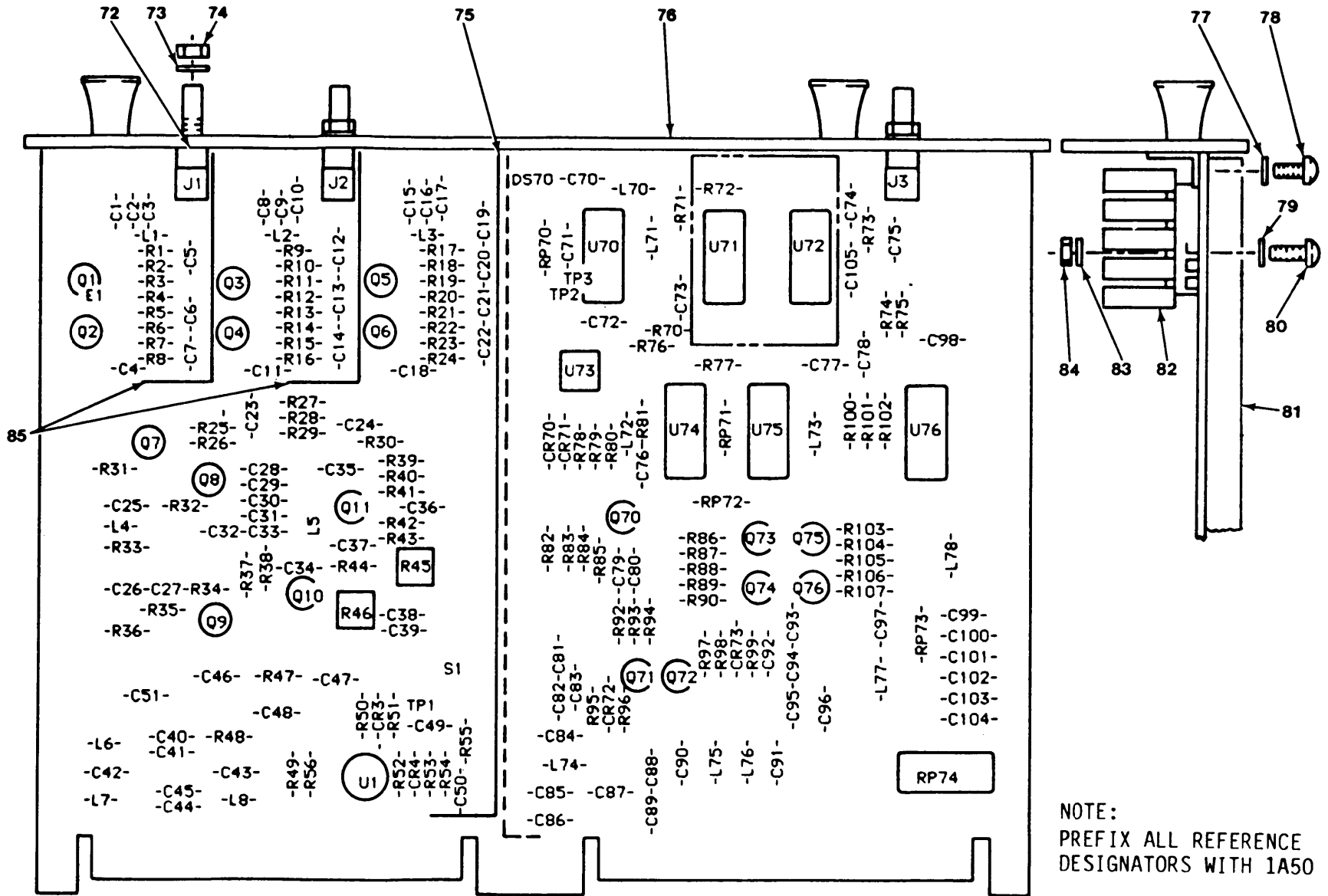

TM11-6625-3087-24P

Figure 14. Step Loop Circuit Card Assembly (Sheet 1 of 2).

EL9NV023

REF DES	ITEM NO	REF DES	ITEM NO	REF DES	ITEM NO	REF DES	ITEM NO	REF DES	ITEM NO	REF DES	ITEM NO
C1	1	C51	10	L3	21	R18	31	R81	31		
C2	2	C70	2	L4	22	R19	32	R82	55		
C3	1	C71	2	L5	23	R20	31	R83	31		
C4	2	C72	2	L6	22	R21	33	R84	31		
C5	2	C73	2	L7	24	R22	32	R85	43		
C6	2	C74	2	L8	24	R23	34	R86	32		
C7	2	C75	2	L70	22	R24	35	R87	57		
C8	1	C76	2	L71	22	R25	36	R88	57		
C9	2	C77	5	L72	22	R26	37	R89	32		
C10	1	C78	2	L73	22	R27	38	R90	58		
C11	2	C79	2	L74	25	R28	31	R92	31		
C12	2	C80	2	L75	24	R29	36	R93	35		
C13	2	C81	2	L76	24	R30	39	R94	35		
C14	2	C82	2	L77	26	R31	40	R95	43		
C15	1	C83	11	L78	22	R32	41	R96	32		
C16	2	C84	12	Q1	27	R33	42	R97	32		
C17	1	C85	13	Q2	27	R34	32	R98	43		
C18	2	C86	9	Q3	27	R35	43	R99	31		
C19	2	C87	14	Q4	27	R36	44	R100	55		
C20	2	C88	2	Q5	27	R37	44	R101	44		
C21	2	C89	9	Q6	27	R38	33	R102	55		
C22	2	C90	6	Q7	27	R39	45	R103	32		
C23	2	C91	6	Q8	27	R40	46	R104	32		
C24	2	C92	11	Q9	28	R41	36	R105	57		
C25	2	C93	2	Q10	27	R42	43	R106	57		
C26	2	C94	2	Q11	27	R43	43	R107	59		
C27	2	C95	2	Q70	28	R44	47	RP70	60		
C28	3	C96	15	Q71	28	R45	48	RP71	60		
C29	4	C97	2	Q72	29	R46	48	RP72	60		
C30	4	C98	2	Q73	29	R47	49	RP73	61		
C31	4	C99	2	Q74	29	R48	50	RP74	62		
C32	2	C100	2	Q75	28	R49	51	S1	63		
C33	4	C101	2	Q76	28	R50	33	TP1	64		
C34	4	C102	2	R1	30	R51	52	TP2	64		
C35	2	C103	2	R2	31	R52	52	TP3	64		
C36	2	C104	2	R3	32	R53	52	U1	65		
C37	5	C105	2	R4	31	R54	32	U70	66		
C38	2	CR3	16	R5	33	R55	52	U71	67		
C39	2	CR4	17	R6	32	R56	38	U72	67		
C40	2	CR70	16	R7	34	R70	53	U73	68		
C41	2	CR71	16	R8	35	R71	53	U74	69		
C42	6	CR72	16	R9	30	R72	53	U75	70		
C43	6	CR73	16	R10	31	R73	31	U76	71		
C44	7	DS70	18	R11	32	R74	54				
C45	7	E1	19	R12	31	R75	31				
C46	5	J1	20	R13	33	R76	55				
C47	5	J2	20	R14	32	R77	53				
C48	8	J3	20	R15	34	R78	43				
C49	9	L1	21	R16	35	R79	56				
C50	5	L2	21	R17	30	R80	43				

Figure 14. Step Loop Circuit Card Assembly (Sheet 2 of 2).

(1) ITEM NO	(2) SMR CODE	(3) FSCM	(4) PART NUMBER	(5) DESCRIPTION AND USABLE ON CODE (UOC)	(6) QTY
GROUP 13 STEP LOOP CIRCUIT CARD ASSEMBLY (A50)					
FIG. 14					
1	PAHZZ	81349	CCR09CG330GR	CAPACITOR, FIXED, CER	6
2	PAHZZ	72982	8121M112X7R0103M	CAPACITOR, FIXED, CER	53
3	PAHZZ	81349	CCR19CG150GM	CAPACITOR, FIXED, CER	1
4	PAHZZ	59660	8121B227C0G680J	CAPACITOR, FIXED, CER	5
5	PAHZZ	81349	CCR05CG101GR	CAPACITOR, FIXED, CER	5
6	PAHZZ	81349	M39003/01-3009	CAPACITOR, FIXED, ELE	4
7	PAHZZ	28480	0160-0570	CAPACITOR, FIXED, CER	2
8	PAHZZ	56289	292P39352	CAPACITOR, FIXED, PLA	1
9	PAHZZ	28480	0160-0571	CAPACITOR, FIXED, CER	3
10	PAHZZ	56289	150D566X9015R2	CAPACITOR, FIXED, ELE	1
11	PAHZZ	28480	1854-0305	TRANSISTOR	2
12	PAHZZ	28480	0160-2306	CAPACITOR, FIXED, MIC	1
13	PAHZZ	81349	CM10FD121G03	CAPACITOR, FIXED, MIC	1
14	PAHZZ	00853	RDM15F471J3C	CAPACITOR, FIXED, MIC	1
15	PAHZZ	56289	500D477H016DF7	CAPACITOR, FIXED, ELE	1
16	PAHZZ	80131	1N3956	SEMICONDUCTOR DEVIC	5
17	PAHZZ	04713	SZ30016-170	SEMICONDUCTOR DEVIC	1
18	PAHZZ	28480	1990-0486	LIGHT EMITTING DIOD	1
19	PAHZZ	28480	9170-0894	CORE, ELECTROMAGNET	4
20	PAHZZ	28480	1250-1512	CONNECTOR RECEPTACL	3
21	PAHZZ	28480	9100-2249	COIL, RADIO FREQUENC	3
22	PAHZZ	24226	15M561J	COIL, RADIO FREQUENC	7
23	PAHZZ	55940	Q2V-15T	COIL, RADIO FREQUENC	1
24	PAHZZ	59474	15-1315-13J	COIL, RADIO FREQUENC	4
25	PAHZZ	28480	9100-1641	COIL, RADIO FREQUENC	1
26	PAHZZ	59474	30134-3K	COIL, RADIO FREQUENC	1
27	PAHZZ	81349	2N5179	TRANSISTOR	10
28	PAHZZ	13499	352-0722-020	TRANSISTOR	5
29	PAHZZ	81349	2N3906	TRANSISTOR	3
30	PAHZZ	81349	RNC60K75R0FS	RESISTOR, FIXED, FILM	3
31	PAHZZ	81349	RNC60K1001FS	RESISTOR, FIXED, FILM	14
32	PAHZZ	81349	RCR07G470JS	RESISTOR, FIXED, COMP	14
33	PAHZZ	81349	RNC60K7500FS	RESISTOR, FIXED, FILM	5
34	PAHZZ	81349	RNC60K21R5FS	RESISTOR, FIXED, FILM	3
35	PAHZZ	81349	RNC60K2000FS	RESISTOR, FIXED, FILM	5
36	PAHZZ	81349	RNC55K24R9FS	RESISTOR, FIXED, FILM	3
37	PAHZZ	81349	RNC60K5110FS	RESISTOR, FIXED, FILM	1
38	PAHZZ	81349	RNC60K3161FS	RESISTOR, FIXED, FILM	2
39	PAHZZ	81349	RNC60K4531FS	RESISTOR, FIXED, FILM	1
40	PAHZZ	81349	RNC60K3570FS	RESISTOR, FIXED, FILM	1
41	PAHZZ	81349	RNC60K1241FS	RESISTOR, FIXED, FILM	1
42	PAHZZ	81349	RNC60J9092FS	RESISTOR, FIXED, FILM	1
43	PAHZZ	81349	RNC60K1002FS	RESISTOR, FIXED, FILM	8
44	PAHZZ	81349	RNC60K49R9FS	RESISTOR, FIXED, FILM	3
45	PAHZZ	81349	RNC60K1212FS	RESISTOR, FIXED, FILM	1
46	PAHZZ	81349	RNC60K8061FS	RESISTOR, FIXED, FILM	1
47	PAHZZ	81349	RNC60J5621FS	RESISTOR, FIXED, FILM	1

SECTION II

TM11-6625-3087-24P

(1) ITEM NO	(2) SMR CODE	(3) FSCM	(4) PART NUMBER	(5) DESCRIPTION AND USABLE ON CODE (UOC)	(6) QTY
48	PAHZZ	73138	72-111-0	RESISTOR,VARIABLE N	2
49	PAHZZ	81349	RNC60H1000FS	RESISTOR,FIXED,FILM	1
50	PAHZZ	81349	RNC60H7502FS	RESISTOR,FIXED,FILM	1
51	PAHZZ	81349	RNC60K4532FS	RESISTOR,FIXED,FILM	1
52	PAHZZ	81349	RCR07G202JS	RESISTOR,FIXED,COMP	4
53	PAHZZ	81349	RNC60K2610FS	RESISTOR,FIXED,FILM	4
54	PAHZZ	81349	RNC60K5111FS	RESISTOR,FIXED,FILM	1
55	PAHZZ	81349	RCR07G471JS	RESISTOR,FIXED,COMP	4
56	PAHZZ	81349	RNC60J6192FS	RESISTOR,FIXED,FILM	1
57	PAHZZ	81349	RNC60K10R0BS	RESISTOR,FIXED,FILM	4
58	PAHZZ	81349	RNC60K8060FS	RESISTOR,FIXED,FILM	1
59	PAHZZ	81349	RNC60H3320FS	RESISTOR,FIXED,FILM	1
60	PAHZZ	01121	208B331	RESISTOR NETWORK,FI	3
61	PAHZZ	28480	1810-0121	RESISTOR NETWORK,FI	1
62	PAHZZ	56289	916C102X2SR	RESISTOR NETWORK,FI	1
63	XDHZZ	22753	MA012-4CEP2W	SWITCH,SLIDE	1
64	PAHZZ	28480	1251-0600	CONNECTOR,RECEPTACL	3
65	PAHZZ	12040	LM307H	MICROCIRCUIT,LINEAR	1
66	PAHZZ	14933	7800901EB	MICROCIRCUIT,LINEAR	1
67	PAHZZ	34148	F10016DC	MICROCIRCUIT,DIGITA	2
68	PAHZZ	28480	1826-0678	MICROCIRCUIT,LINEAR	1
69	PAHZZ	81349	M38510/06101BEB	MICROCIRCUIT,DIGITIA	1
70	PAHZZ	80009	156-0205-00	MICROCIRCUIT,DIGITA	1
71	PAHZZ	04713	MC10138L	MICROCIRCUIT,DIGITA	1
72	PAHZZ	76854	8942-3	INSULATOR,WASHER	5
73	PAHZZ	98291	3002-26	WASHER,LOCK	3
74	PAHZZ	98291	3002-18	NUT,PLAIN,HEXAGON	3
75	XBHZZ	28480	1600-0846	PLATE,ELEC SHLD	1
76	XBHZZ	28480	03586-04150	COVER,CKT CD	1
77	XBHZZ	73734	99401	WASHER,LOCK	2
78	XBHZZ	28480	0515-0150	SCREW,MACHINE	2
79	XBHZZ	76854	3482-4	WASHER,INSULATOR	1
80	XBHZZ	28480	0515-0063	SCREW,MACHINE	1
81	XBHZZ	28480	1600-0845	PLATE,ELEC SHLD	1
82	PAHZZ	13499	352-9638-050	HEAT SINK,ELECTRICA	1
83	XBHZZ	76854	2-1185108	WASHER,INSULATOR	1
84	XBHZZ	28480	0535-0008	NUT,PLAIN,HEX	1
85	XBHZZ	28480	1600-0844	PLATE,ELEC SHLD	2

END OF FIGURE

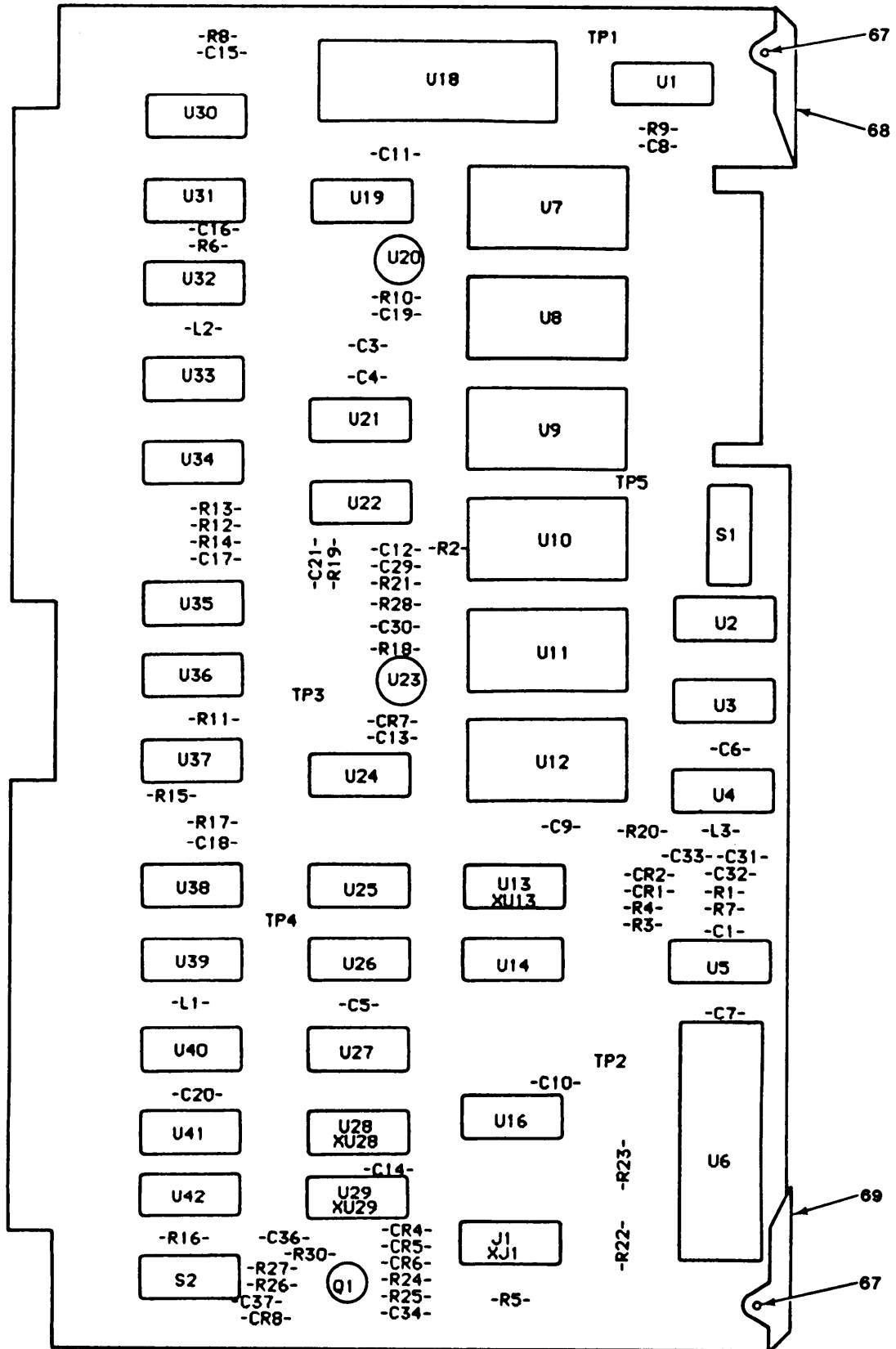

NOTE : PREFIX ALL REFERENCE
DESIGNATORS WITH 1A60

EL9NV024

Figure 15. Controller Circuit Card Assembly (Sheet 1 of 2).

REF DES	ITEM NO	REF DES	ITEM NO	REF DES	ITEM NO	REF DES	ITEM NO	REF DES	ITEM NO	REF DES	ITEM NO
C1	1	R11	24	U21	54						
C3	2	R12	18	U22	54						
C4	3	R13	25	U23	55						
C5	3	R14	25	U24	56						
C6	4	R15	26	U25	57						
C7	4	R16	21	U26	56						
C8	4	R17	27	U27	41						
C9	4	R18	28	U28	58						
C10	4	R19	29	U29	58						
C11	4	R20	30	U30	56						
C12	4	R21	31	U31	56						
C13	4	R22	21	U32	41						
C14	4	R23	21	U33	59						
C15	4	R24	32	U34	60						
C16	4	R25	32	U35	59						
C17	4	R26	28	U36	61						
C18	4	R27	33	U37	62						
C19	5	R28	29	U38	61						
C20	4	R30	34	U39	63						
C21	5	S1	35	U40	63						
C29	6	S2	36	U41	63						
C30	7	TP1	37	U42	63						
C31	8	TP2	37	XJ1	64						
C32	7	TP3	37	XU13	65						
C33	9	TP4	37	XU28	66						
C34	7	TP5	37								
C36	3	U1	38								
C37	10	U2	39								
CR1	11	U3	40								
CR2	11	U4	41								
CR4	12	U5	42								
CR5	12	U6	43								
CR6	11	U7	44								
CR7	13	U7	44								
CR8	11	U8	45								
J1	14	U8	45								
L1	15	U9	46								
L2	15	U9	46								
L3	16	U10	47								
Q1	17	U10	47								
R1	18	U11	48								
R2	19	U11	48								
R3	20	U12	49								
R4	20	U12	49								
R5	21	U13	38								
R6	22	U14	50								
R7	18	U16	50								
R8	20	U18	51								
R9	20	U19	52								
R10	23	U20	53								

Figure 15. Controller Circuit Card Assembly (Sheet 2 of 2).

(1) ITEM NO	(2) SMR CODE	(3) FSCM	(4) PART NUMBER	(5) DESCRIPTION AND USABLE ON CODE (UOC)	(6) QTY
GROUP 14 CONTROLLER CIRCUIT CARD ASSEMBLY (A60)					
FIG. 15					
1	PAHZZ	81349	M39003/01-2988	CAPACITOR, FIXED, ELE	1
2	PAHZZ	28480	0160-3165	CAPACITOR, FIXED, PLA	1
3	PAHZZ	81349	M39003/01-2991	CAPACITOR, FIXED, ELE	3
4	PAHZZ	16546	C31C104K	CAPACITOR, FIXED, CER	24
5	PAHZZ	16546	C31A103K	CAPACITOR, FIXED, CER	2
6	PAHZZ	18876	10018712-022	CAPACITOR, FIXED, ELE	1
7	PAHZZ	28480	1854-0305	TRANSISTOR	3
8	PAHZZ	28480	0160-2307	CAPACITOR, FIXED, PAP	1
9	PAHZZ	81349	CM10FD391G03	CAPACITOR, FIXED, MIC	1
10	PAHZZ	81349	CMR06F621G0DR	CAPACITOR, FIXED, MIC	1
11	PAHZZ	80131	1N3956	SEMICONDUCTOR DEVIC	4
12	PAHZZ	81349	JAN1N5711	SEMICONDUCTOR DEVIC	2
13	PAHZZ	28480	5082-5511	SEMICONDUCTOR DEVIC	1
14	PAHZZ	01121	316X101	NETWORK, INTERCONN	1
15	PAHZZ	59474	30134-3K	COIL, RADIO FREQUENC	2
16	PAHZZ	96906	MS90538-03	COIL, RADIO FREQUENC	1
17	PAHZZ	28480	1853-0020	TRANSISTOR	1
18	PAHZZ	81349	RCR07G201JS	RESISTOR, FIXED, COMP	3
19	PAHZZ	81349	RNC60K1003FS	RESISTOR, FIXED, FILM	1
20	PAHZZ	81349	RCR07G302JS	RESISTOR, FIXED, COMP	4
21	PAHZZ	56289	216CJ104	RESISTOR NETWORK, FI	4
22	PAHZZ	81349	RCR07G241JS	RESISTOR, FIXED, COMP	1
23	PAHZZ	81349	RNC60J9091FS	RESISTOR, FIXED, FILM	1
24	PAHZZ	81349	RCR07G105JS	RESISTOR, FIXED, COMP	1
25	PAHZZ	81349	RCR07G471JS	RESISTOR, FIXED, COMP	2
26	PAHZZ	80294	4308R-101-103S	RESISTOR NETWORK, FI	1
27	PAHZZ	81349	RNC60K2552FS	RESISTOR, FIXED, FILM	1
28	PAHZZ	81349	RCR07G202JS	RESISTOR, FIXED, COMP	2
29	PAHZZ	81349	RNC60K2492FS	RESISTOR, FIXED, FILM	2
30	PAHZZ	81349	RCR07G391JS	RESISTOR, FIXED, COMP	1
31	PAHZZ	81349	RNC60J9092FS	RESISTOR, FIXED, FILM	1
32	PAHZZ	81349	RCR07G513JS	RESISTOR, FIXED, COMP	2
33	PAHZZ	81349	RCR07G101JS	RESISTOR, FIXED, COMP	1
34	PAHZZ	81349	RCR07G510JS	RESISTOR, FIXED, COMP	1
35	PAHZZ	28480	3101-1860	SWITCH ASSEMBLY	1
36	PAHZA	81073	76SB08S	SWITCH ASSEMBLY	1
37	PAHZZ	28480	1251-0600	CONNECTOR, RECEPTAC	5
38	PAHZZ	27014	DM81LS97AN	MICROCIRCUIT, DIGITA	2
39	PAHZZ	81349	M38510/30007BCB	MICROCIRCUIT, DIGITA	1
40	PAHZZ	28480	1820-1112	MICROCIRCUIT, DIGITA	1
41	PAHZZ	81349	M38510-30003BCB	MICROCIRCUIT, DIGITA	3
42	PAHZZ	04713	MC6875L	MICROCIRCUIT, DIGITA	1
43	PAHZZ	04713	MC6800S	MICROCIRCUIT, DIGITA	1
44	PAHZZ	28480	1818-1159	MICROCIRCUIT, DIGITA	1
44	PAHZZ	28480	1818-1515	MICROCIRCUIT, DIGITA	1
45	PAHZZ	28480	1818-1158	MICROCIRCUIT, DIGITAL	1
45	PAHZZ	28480	1818-1514	MICROCIRCUIT, DIGITA	1

SECTION II

TM11-6625-3087-24P

(1) ITEM NO	(2) SMR CODE	(3) FSCM	(4) PART NUMBER	(5) DESCRIPTION AND USABLE ON CODE (UOC)	(6) QTY
46	PAHZZ	28480	1818-1157	MICROCIRCUIT,DIGITA	1
46	PAHZZ	28480	1818-1513	MICROCIRCUIT,DIGITA	1
47	PAHZZ	28480	1818-1156	MICROCIRCUIT,DIGITA	1
47	PAHZZ	28480	1818-1512	MICROCIRCUIT,DIGITA	1
48	PAHZZ	28480	1818-1155	MICROCIRCUIT,DIGITA	1
48	PAHZZ	28480	1818-1511	MICROCIRCUIT,DIGITA	1
49	PAHZZ	28480	1818-1154	MICROCIRCUIT,DIGITA	1
49	PAHZZ	28480	1818-1510	MICROCIRCUIT,DIGITA	1
50	PAHZZ	01295	TMS2114-45NL	MICROCIRCUIT,DIGITA	2
51	PAHZZ	04713	MC6821S	MICROCIRCUIT,DIGITA	1
52	PAHZZ	81349	M38510/30608BEB	MICROCIRCUIT,DIGITA	1
53	PAHZZ	81349	M38510/10901BGC	MICROCIRCUIT,LINEAR	1
54	PAHZZ	01295	SN74LS273N	MICROCIRCUIT,DIGITA	2
55	PAHZZ	81349	M38510/10304BGC	MICROCIRCUIT,LINEAR	1
56	PAHZZ	81349	M38510/30701BEB	MICROCIRCUIT,DIGITA	4
57	PAHZZ	81349	M38510/30501BCB	MICROCIRCUIT/DIGITA	1
58	PAHZZ	32293	IM65X61AMJN/883B	MICROCIRCUIT,DIGITA	2
59	PAHZZ	81349	M38510/31004BCB	MICROCIRCUIT,DIGITA	2
60	PAHZZ	28480	1820-1367	MICROCIRCUIT,DIGITA	1
61	PAHZZ	81349	M38510/30908BEB	MICROCIRCUIT,DIGITA	2
62	PAHZZ	81349	M38510/11201BCB	MICROCIRCUIT,LINEAR	1
63	PAHZZ	81349	M3851030905BCB	MICROCIRCUIT,DIGITA	4
64	PAHZZ	09922	DILB16P108	SOCKET,PLUG-IN ELEC	1
65	PAHZZ	06776	0002984	SOCKET,PLUG-IN ELEC	1
66	PAHZZ	00779	641601-1	SOCKET,PLUG-IN ELEC	2
67	XBHZZ	73957	GP24-063X250-14	PIN,GRVD,HDL5	2
68	PAHZZ	28480	5040-5112	EXTRACTOR,ELECTRICA	1
69	PAHZZ	28480	5040-4529	EXTRACTOR,ELECTRICA	1

END OF FIGURE

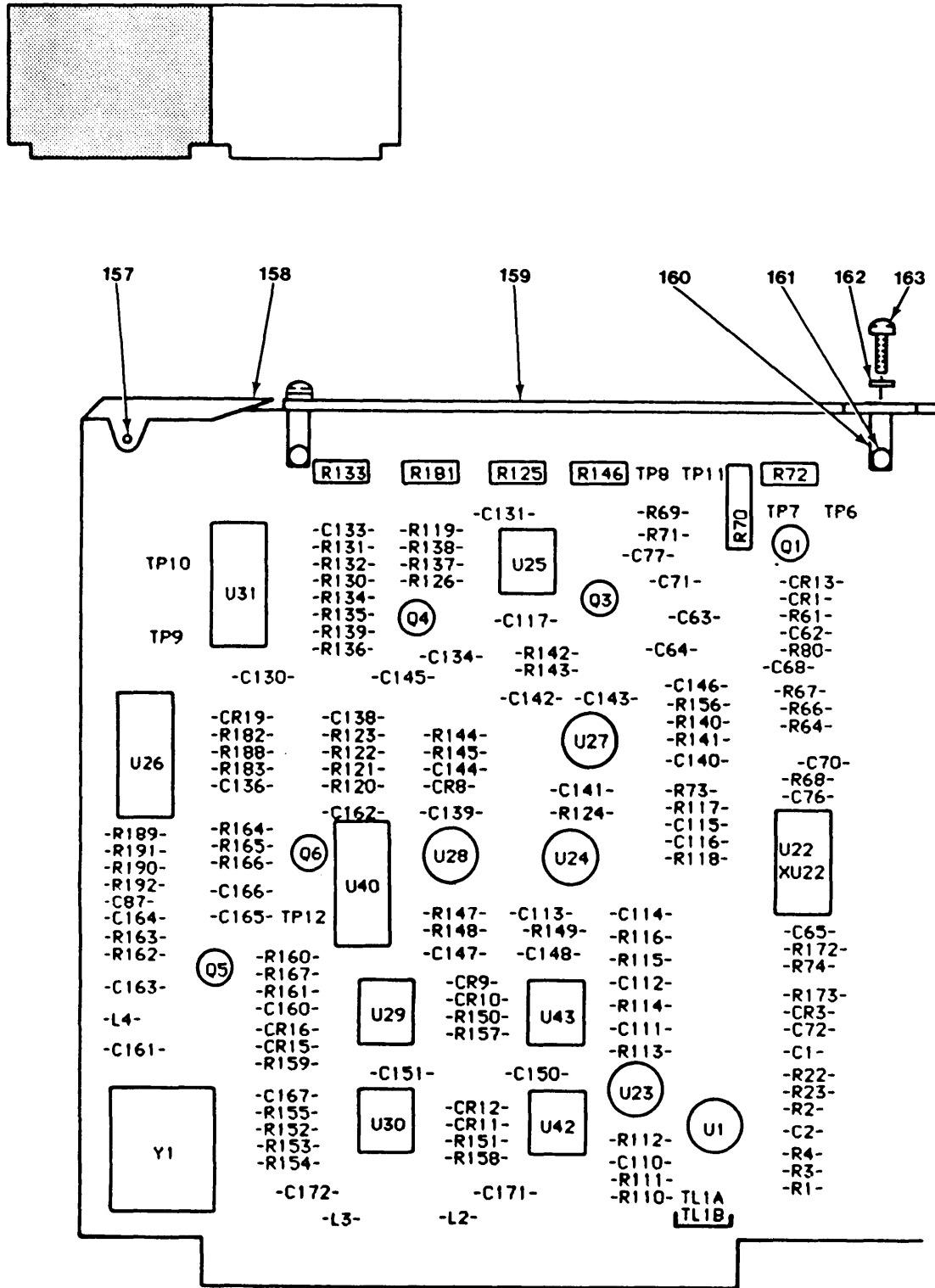

NOTE: PREFIX ALL REFERENCE
DESIGNATORS WITH 1A70

EL9NV025

Figure 16. Impairments B Circuit Card Assembly (Sheet 1 of 4).

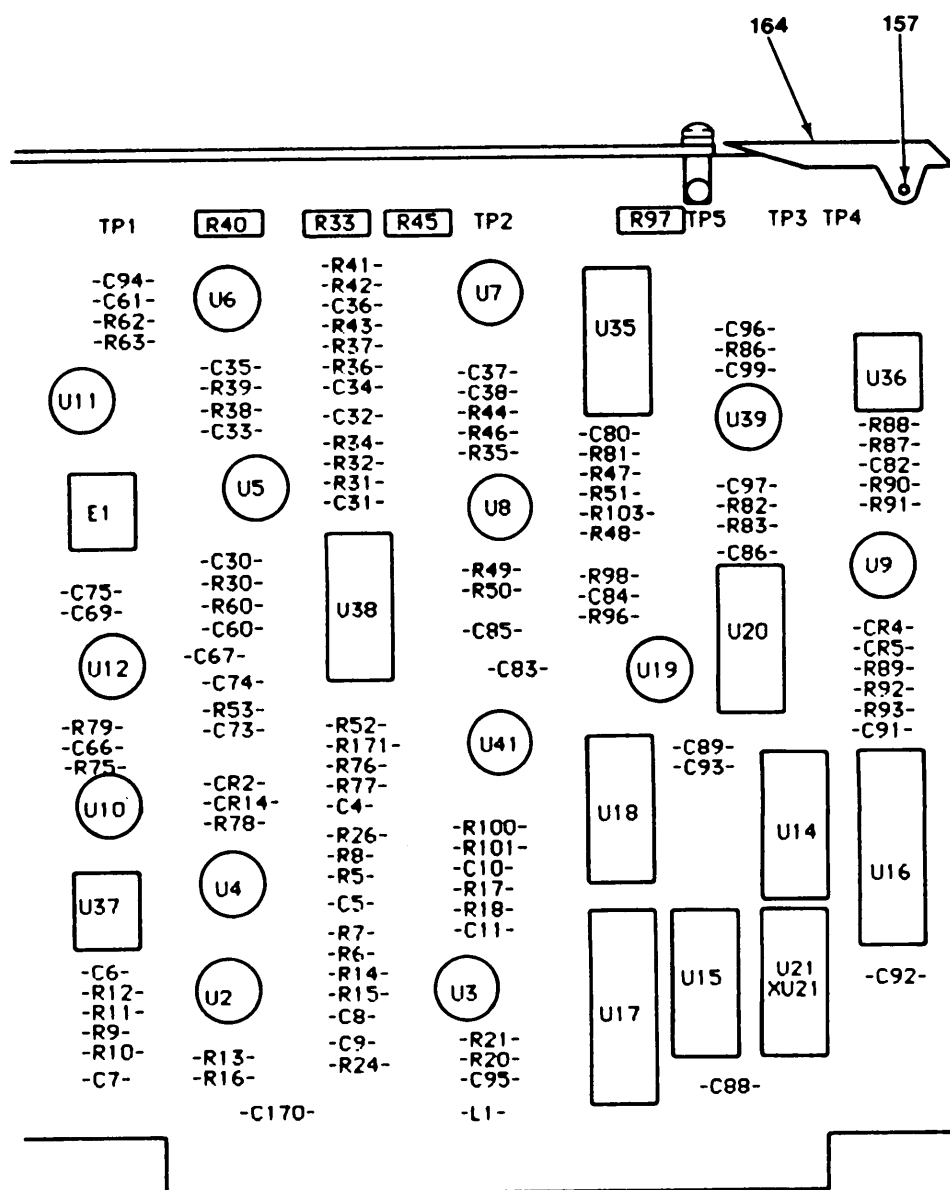
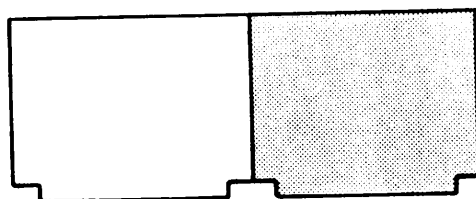

NOTE: PREFIX ALL REFERENCE DESIGNATORS WITH 1A70

EL9NV026

Figure 16. Impairments B Circuit Card Assembly (Sheet 2 of 4).

REF DES	ITEM NO	REF DES	ITEM NO	REF DES	ITEM NO	REF DES	ITEM NO	REF DES	ITEM NO	REF DES	ITEM NO
C1	1	C95	10	CR12	33	R40	62	R103	94	R160	122
C2	1	C96	10	CR13	33	R41	54	R110	95	R161	122
C4	2	C97	10	CR14	33	R42	56	R111	95	R162	123
C5	2	C99	16	CR15	33	R43	54	R112	96	R163	124
C6	3	C110	19	CR16	33	R44	58	R113	97	R164	123
C7	3	C111	19	CR19	37	R45	57	R114	98	R165	125
C8	3	C112	20	E1	38	R46	59	R115	99	R166	126
C9	3	C113	21	L1	39	R47	54	R116	100	R167	127
C10	1	C114	4	L2	39	R48	54	R117	101	R171	60
C11	1	C115	22	L3	39	R49	54	R118	102	R172	128
C30	4	C116	22	L4	40	R50	54	R119	103	R173	129
C31	5	C117	17	Q1	41	R51	63	R120	99	R181	76
C32	4	C130	23	Q3	41	R52	64	R121	104	R182	105
C33	6	C131	23	Q4	41	R53	65	R122	105	R183	130
C34	5	C133	10	Q5	42	R60	66	R123	79	R188	131
C35	4	C134	24	Q6	42	R61	67	R124	75	R189	75
C36	5	C136	10	R1	43	R62	54	R125	106	R190	75
C37	4	C138	10	R2	43	R63	68	R126	107	R191	89
C38	4	C139	10	R3	44	R64	69	R130	108	R192	79
C60	7	C140	4	R4	45	R66	70	R131	109	TL1A	132
C61	8	C141	25	R5	46	R67	71	R132	110	TL1B	133
C62	8	C142	4	R6	47	R68	72	R133	111	TP1	134
C63	7	C143	26	R7	45	R69	73	R134	112	TP2	134
C64	9	C144	27	R8	46	R70	74	R135	113	TP3	134
C65	8	C145	28	R9	48	R71	75	R136	84	TP4	134
C66	10	C146	15	R10	48	R72	76	R137	89	TP5	134
C67	11	C147	4	R11	49	R73	77	R138	79	TP6	134
C68	12	C148	15	R12	45	R74	78	R139	84	TP7	134
C69	13	C150	15	R13	50	R75	79	R140	114	TP8	134
C70	14	C151	15	R14	51	R76	80	R141	115	TP9	134
C71	8	C160	29	R15	45	R77	81	R142	116	TP10	134
C72	10	C161	29	R16	50	R78	82	R143	117	TP11	134
C73	10	C162	10	R17	52	R79	83	R144	97	TP12	134
C74	10	C163	16	R18	52	R80	84	R144	97	U1	135
C75	10	C164	16	R20	53	R81	85	R144	97	U2	135
C76	10	C165	30	R21	45	R82	86	R145	118	U3	135
C77	15	C166	31	R22	54	R83	65	R146	62	U4	135
C80	16	C167	10	R23	54	R86	85	R147	71	U5	136
C82	17	C170	32	R24	55	RS7	87	R148	119	U6	136
C83	18	C171	32	R26	46	R88	88	R149	84	U7	136
C84	8	C172	32	R30	54	R89	54	R150	68	U8	135
C85	8	CR1	33	R31	54	R90	54	R151	68	U9	136
C86	10	CR2	34	R32	56	R91	54	R152	120	U10	136
C87	10	CR3	35	R33	57	R92	54	R153	121	U11	137
C88	10	CR4	33	R34	58	R93	54	R154	120	U12	138
C89	10	CR5	33	R35	59	R96	89	R155	121	U14	139
C91	10	CR8	36	R36	54	R97	90	R156	84	U15	139
C92	10	CR9	33	R37	56	R98	91	R157	72	U16	140
C93	10	CR10	33	R38	60	R100	92	R158	72	U17	140
C94	10	CR11	33	R39	61	R101	93	R159	79	U18	141

Figure 16. Impairments B Circuit Card Assembly (Sheet 3 of 4).

REF DES	ITEM NO	REF DES	ITEM NO	REF DES	ITEM NO	REF DES	ITEM NO	REF DES	ITEM NO	REF DES	ITEM NO
U19	142										
U20	143										
U21	144										
U22	145										
U23	136										
U24	136										
U25	146										
U26	147										
U27	136										
U28	136										
U29	148										
U30	148										
U31	149										
U35	150										
U36	146										
U37	146										
U38	151										
U39	135										
U40	152										
U41	137										
U42	153										
U43	153										
XU21	154										
XU22	155										
Y1	156										

Figure 16. Impairments B Circuit Card Assembly (Sheet 4 of 4).

(1) ITEM NO	(2) SMR CODE	(3) FSCM	(4) PART NUMBER	(5) DESCRIPTION AND USABLE ON CODE (UOC)	(6) QTY
GROUP 15 IMPAIRMENTS B CIRCUIT CARD ASSEMBLY (70)					
FIG. 16					
1	PAHZZ	28480	0160-3024	CAPACITOR, FIXED, MIC	4
2	PAHZZ	28480	0160-2130	CAPACITOR, FIXED, MIC	2
3	PAHZZ	28480	0170-0163	CAPACITOR, FIXED, MIC	4
4	PAHZZ	28480	0160-3548	CAPACITOR	9
5	PAHZZ	56289	292CC0G100K050B	CAPACITOR, FIXED, MIC	3
6	PAHZZ	81349	CMR06F202F0DR	CAPACITOR, FIXED, MIC	1
7	PAHZZ	18876	10018712-022	CAPACITOR, FIXED, ELE	2
8	PAHZZ	16546	C31C104K	CAPACITOR, FIXED, CER	6
9	PAHZZ	81349	M39003/01-2991	CAPACITOR, FIXED, ELE	1
10	PAHZZ	16546	C31A103K	CAPACITOR, FIXED, CER	23
11	PAHZZ	28480	0160-2306	CAPACITOR, FIXED, MIC	1
12	PAHZZ	72136	RDM15E560J3C	CAPACITOR, FIXED, MIC	1
13	PAHZZ	28480	1854-0305	TRANSISTOR	1
14	PAHZZ	81349	CM10FD101G03	CAPACITOR, FIXED, MIC	1
15	PAHZZ	81349	M39003/01-3006	CAPACITOR, FIXED, ELE	5
16	PAHZZ	28480	0160-4557	CAPACITOR, FIXED, CER	4
17	PAHZZ	81349	M39003/01-3003	CAPACITOR, FIXED, ELE	2
18	PAHZZ	28480	0160-3787	CAPACITOR, FIXED, MET	1
19	PAHZZ	28480	0160-2587	CAPACITOR, FIXED, MIC	2
20	PAHZZ	28480	0160-3939	CAPACITOR, FIXED, MIC	1
21	PAHZZ	28480	0160-3046	CAPACITOR, FIXED, MIC	1
22	PAHZZ	16299	CAC04X7R104K050A	CAPACITOR, FIXED, CER	2
23	PAHZZ	28480	0160-2671	CAPACITOR, FIXED, PLA	2
24	PAHZZ	81349	M39003/01-3076	CAPACITOR, FIXED, ELE	1
25	PAHZZ	81349	CMR06F302F0DR	CAPACITOR, FIXED, MIC	1
26	PAHZZ	28480	0160-3936	CAPACITOR, FIXED, MIC	1
27	PAHZZ	28480	0160-0341	CAPACITOR, FIXED, MIC	1
28	PAHZZ	28480	0160-4463	CAPACITOR, FIXED, MET	1
29	PAHZZ	04222	MA101A101JAA	CAPACITOR, FIXED, CER	2
30	PAHZZ	56289	292CC0G151J100B	CAPACITOR, FIXED, CER	1
31	PAHZZ	81349	CCR77CG102GR	CAPACITOR, FIXED, CER	1
32	PAHZZ	81349	M39003/01-3018	CAPACITOR, FIXED, ELE	3
33	PAHZZ	81349	JAN1N4150	SEMICONDUCTOR DEVIC	11
34	PAHZZ	81349	JAN1N754A	SEMICONDUCTOR DEVIC	1
35	PAHZZ	81349	JAN1N645	SEMICONDUCTOR DEVIC	1
36	PAHZZ	81349	JAN1N5711	SEMICONDUCTOR DEVIC	1
37	PAHZZ	81349	JAN1N752A	SEMICONDUCTOR DEVIC	1
38	PAHZZ	18178	VTL5C3/2	COUPLER, OPTOELECTRO	1
39	PAHZZ	28480	9100-1631	COIL, RADIO FREQUENC	3
40	PAHZZ	96906	MS90538-14	COIL, RADIO FREQUENC	1
41	PAHZZ	04713	SPS5103	TRANSISTOR	3
42	PAHZZ	13499	352-0722-020	TRANSISTOR	2
43	PAHZZ	19701	5033R1/8T2-20605 RB	RESISTOR FIXED FILM	2
44	PAHZZ	19701	5033R1/8T2-13394 RB	RESISTOR FIXED FILM	1
45	PAHZZ	81349	RNC60K2002FS	RESISTOR, FIXED, FILM	5

SECTION II

TM11-6625-3087-24P

(1) ITEM NO	(2) SMR CODE	(3) FSCM	(4) PART NUMBER	(5) DESCRIPTION AND USABLE ON CODE (UOC)	(6) QTY
46	PAHZZ	28480	0698-7372	RESISTOR FIXED FILM	3
47	PAHZZ	19701	5033R1/8T2-11397 RB	RESISTOR, FIXED FILM	1
48	PAHZZ	19701	5033R1/8T2-10964 1B	RESISTOR FIXED FILM	2
49	PAHZZ	19701	5033R1/8T2-78028 RB	RESISTOR FIXED FILM	1
50	PAHZZ	19701	5033R1/8T2-36901 RB	RESISTOR FIXED FILM	2
51	PAHZZ	28480	0698-7370	RESISTOR, FIXED, FILM	1
52	PAHZZ	28480	0698-7375	RESISTOR, FIXED FILM	2
53	PAHZZ	81349	RNC60J1242FS	RESISTOR, FIXED, FILM	1
54	PAHZZ	81349	RNC60K1002FS	RESISTOR, FIXED, FILM	17
55	PAHZZ	81349	RNC60K2212FS	RESISTOR, FIXED, FILM	1
56	PAHZZ	81349	RNC60J1582FS	RESISTOR, FIXED, FILM	3
57	PAHZZ	28480	2100-3273	RESISTOR, VARIABLE, N	2
58	PAHZZ	81349	RNC60K1472FS	RESISTOR, FIXED, FILM	2
59	PAHZZ	81349	RNC60K3742FS	RESISTOR, FIXED, FILM	2
60	PAHZZ	81349	RNC60K1152FS	RESISTOR, FIXED, FILM	2
61	PAHZZ	81349	RNC60K6652FS	RESISTOR, FIXED, FILM	1
62	PAHZZ	28480	2100-3207	RESISTOR, VARIABLE, N	2
63	PAHZZ	81349	RNC60K2432FS	RESISTOR, FIXED, FILM	1
64	PAHZZ	28480	0757-0434	RESISTOR, FIXED, FILM	1
65	PAHZZ	81349	RNC60K1001FS	RESISTOR, FIXED, FILM	2
66	PAHZZ	81349	RNC60K1622FS	RESISTOR, FIXED, FILM	1
67	PAHZZ	81349	RCR07G271JS	RESISTOR, FIXED, COMP	1
68	PAHZZ	81349	RNC60K1003FS	RESISTOR, FIXED, FILM	3
69	PAHZZ	81349	RNC60K3012FS	RESISTOR, FIXED, FILM	1
70	PAHZZ	81349	RCR07G472JS	RESISTOR, FIXED, COMP	1
71	PAHZZ	81349	RCR07G243JS	RESISTOR, FIXED, COMP	2
72	PAHZZ	81349	RCR07G102JS	RESISTOR, FIXED, COMP	3
73	PAHZZ	81349	RNC60K2492FS	RESISTOR, FIXED, FILM	1
74	PAHZZ	28480	2100-3054	RESISTOR, VARIABLE, N	1
75	PAHZZ	81349	RCR07G203JS	RESISTOR, FIXED, COMP	4
76	PAHZZ	32997	3386XY46-201	RESISTOR, VARIABLE, N	2
77	PAHZZ	28480	0811-1780	RESISTOR, FIXED, WIRE	1
78	PAHZZ	81349	RNC60K7321FS	RESISTOR, FIXED, FILM	1
79	PAHZZ	81349	RCR07G103JS	RESISTOR, FIXED, COMP	5
80	PAHZZ	81349	RNC60K1004FS	RESISTOR, FIXED, FILM	1
81	PAHZZ	81349	RNC60K3321FS	RESISTOR, FIXED, FILM	1
82	PAHZZ	81349	RCR07G202JS	RESISTOR, FIXED, COMP	1
83	PAHZZ	81349	RCR07G100JS	RESISTOR, FIXED, COMP	1
84	PAHZZ	81349	RCR07G104JS	RESISTOR, FIXED, COMP	5
85	PAHZZ	81349	RCR07G154JS	RESISTOR, FIXED, COMP	2
86	PAHZZ	81349	RNC55K4641FS	RESISTOR, FIXED, FILM	1
87	PAHZZ	81349	RNC55K2802FS	RESISTOR, FIXED, FILM	1
88	PAHZZ	81349	RNC60H9090FS	RESISTOR, FIXED, FILM	1
89	PAHZZ	81349	RCR07G512JS	RESISTOR, FIXED, COMP	3
90	PAHZZ	28480	2100-3356	RESISTOR, VARIABLE, N	1
91	PAHZZ	81349	RNC60K3573FS	RESISTOR, FIXED, FILM	1
92	PAHZZ	81349	RNC60K3011FS	RESISTOR, FIXED, FILM	1
93	PAHZZ	81349	RNC60K6041FS	RESISTOR, FIXED, FILM	1

SECTION II

TM11-6625-3087-24P

(1) ITEM NO	(2) SMR CODE	(3) FSCM	(4) PART NUMBER	(5) DESCRIPTION AND USABLE ON CODE (UOC)	(6) QTY
94	PAHZZ	81349	RCR07G751JS	RESISTOR, FIXED, COMP	1
95	PAHZZ	81349	RNC60K8451FS	RESISTOR, FIXED, FILM	2
96	PAHZZ	81349	RNC60K5232FS	RESISTOR, FIXED, FILM	1
97	PAHZZ	81349	RNC60K6982FS	RESISTOR, FIXED, FILM	2
97	PAHZZ	81349	RNC60K7152FS	RESISTOR, FIXED, FILM	1
97	PAHZZ	81349	RNC60K6812FS	RESISTOR, FIXED, FILM	1
98	PAHZZ	81349	RNC60K5902FS	RESISTOR, FIXED, FILM	1
99	PAHZZ	81349	RNC60K1103FS	RESISTOR, FIXED, FILM	2
100	PAHZZ	81349	RNC60K4872FS	RESISTOR, FIXED, FILM	1
101	PAHZZ	81349	RNC60K6651FS	RESISTOR, FIXED, FILM	1
102	PAHZZ	81349	RNC60K2672FS	RESISTOR, FIXED, FILM	1
103	PAHZZ	81349	RNC70K1244FS	RESISTOR, FIXED, FILM	1
104	PAHZZ	81349	RNC60H1000FS	RESISTOR, FIXED, FILM	1
105	PAHZZ	81349	RNC60K4992FS	RESISTOR, FIXED, FILM	2
106	PAHZZ	28480	2100-3358	RESISTOR, VARIABLE, N	1
107	PAHZZ	81349	RNC60K3482FS	RESISTOR, FIXED, FILM	1
108	PAHZZ	81349	RCR07G155JS	RESISTOR, FIXED, COMP	1
109	PAHZZ	81349	RNC60K1403FS	RESISTOR, FIXED, FILM	1
110	PAHZZ	81349	RNC60K7503FS	RESISTOR, FIXED, FILM	1
111	PAHZZ	28480	2100-3357	RESISTOR, VARIABLE, N	1
112	PAHZZ	81349	RNC55K3922FS	RESISTOR, FIXED, FILM	1
113	PAHZZ	81349	RNC60K2262FS	RESISTOR, FIXED, FILM	1
114	PAHZZ	81349	RNC60K2493FS	RESISTOR, FIXED, FILM	1
115	PAHZZ	81349	RNC60K1023FS	RESISTOR, FIXED, FILM	1
116	PAHZZ	81349	RNC60J2873BS	RESISTOR, FIXED, FILM	1
117	PAHZZ	81349	RNC60K1693FS	RESISTOR, FIXED, FILM	1
118	PAHZZ	81349	RNC60K5362FS	RESISTOR, FIXED, FILM	1
119	PAHZZ	81349	RNC60K1373FS	RESISTOR, FIXED, FILM	1
120	PAHZZ	81349	RNC60K8063FS	RESISTOR, FIXED, FILM	2
121	PAHZZ	81349	RNC60K4023FS	RESISTOR, FIXED, FILM	2
122	PAHZZ	81349	RNC60K4222FS	RESISTOR, FIXED, FILM	2
123	PAHZZ	81349	RNC60K6040FS	RESISTOR, FIXED, FILM	2
124	PAHZZ	81349	RNC60K4121FS	RESISTOR, FIXED, FILM	1
125	PAHZZ	81349	RNC60K1912FS	RESISTOR, FIXED, FILM	1
126	PAHZZ	81349	RNC60K4990FS	RESISTOR, FIXED, FILM	1
127	PAHZZ	81349	RNC60K49R9FS	RESISTOR, FIXED, FILM	1
128	PAHZZ	81349	RNC60K3572FS	RESISTOR, FIXED, FILM	1
129	PAHZZ	81349	RNC60K6043FS	RESISTOR, FIXED, FILM	1
130	PAHZZ	81349	RNC60K1212FS	RESISTOR, FIXED, FILM	1
131	PAHZZ	81349	RNC60K1210FS	RESISTOR, FIXED, FILM	1
132	PAHZZ	27264	22-03-2031	CONNECTOR, RECEPTACL	1
133	PAHZA	00779	530153-2	CONNECTOR, PLUG, ELE	1
134	PAHZZ	28480	1251-0600	CONNECTOR, RECEPTACL	12
135	PAHZZ	04713	MC4558CG	MICROCIRCUIT, LINEAR	6
136	PAHZZ	28480	1826-0111	MICROCIRCUIT, LINEAR	9
137	PAHZZ	12040	LM307H	MICROCIRCUIT, LINEAR	2
138	PAHZZ	28480	1826-0109	MICROCIRCUIT, LINEAR	1
139	PAHZZ	81349	M38510/30605BCB	MICROCIRCUIT, DIGITA	2
140	PAHZZ	01295	SN74LS273N	MICROCIRCUIT, DIGITA	2
141	PAHZZ	81349	M38510/11301BEC	MICROCIRCUIT, LINEAR	1
142	PAHZZ	81349	M38510/10304BGC	MICROCIRCUIT, LINEAR	1
143	PAHZZ	81349	M38510/31403BCB	MICROCIRCUIT, DIGITA	1

SECTION II

TM11-6625-3087-24P

(1) ITEM NO	(2) SMR CODE	(3) FSCM	(4) PART NUMBER	(5) DESCRIPTION AND USABLE ON CODE (UOC)	(6) QTY
144	PAHZZ	28480	1820-1194	MICROCIRCUIT, DIGITA	1
145	PAHZZ	51870	AD536AJD	MICROCIRCUIT, ANALOG	1
146	PAHZZ	28480	1826-0476	MICROCIRCUIT, LINEAR	3
147	PAHZZ	81349	M38510/11201BCB	MICROCIRCUIT, LINEAR	1
148	PAHZZ	14933	8102305PB	MICROCIRCUIT, LINEAR	2
149	PAHZZ	27014	CD4046BMJ/883B	MICROCIRCUIT, DIGITA	1
150	PAHZZ	28480	1826-0416	MICROCIRCUIT, LINEAR	1
151	PAHZZ	19645	SC8431	MICROCIRCUIT, LINEAR	1
152	PAHZZ	81349	M38510-30005BCX	MICROCIRCUIT, DIGITA	1
153	PAHZZ	01295	TL610CP	MICROCIRCUIT, LINEAR	2
154	PAHZZ	09922	DILB16P108	SOCKET, PLUG-IN ELEC	1
155	PAHZZ	80009	136-0269-02	SOCKET, PLUG-IN ELEC	1
156	PAHZZ	28480	0410-1212	CRYSTAL UNIT, QUARTZ	1
157	XBHZZ	73957	GP24-063X250-14	PIN, GRVD, HDLS	2
158	PAHZZ	28480	5040-5112	EXTRACTOR, ELECTRICA	1
159	XBHZZ	28480	03586-04170	COVER, CKT CD	1
160	XBHZZ	83058	BS10370	CLEVIS, ROD END	3
161	PAHZZ	96906	MS16535-79	RIVET, TUBULAR	3
162	PAHZZ	73734	99401	WASHER, LOCK	3
163	XBHZZ	28480	0515-0055	SCREW, MACHINE	3
164	PAHZZ	28480	4040-0756	EXTRACTOR, ELECTRICA	1

END OF FIGURE

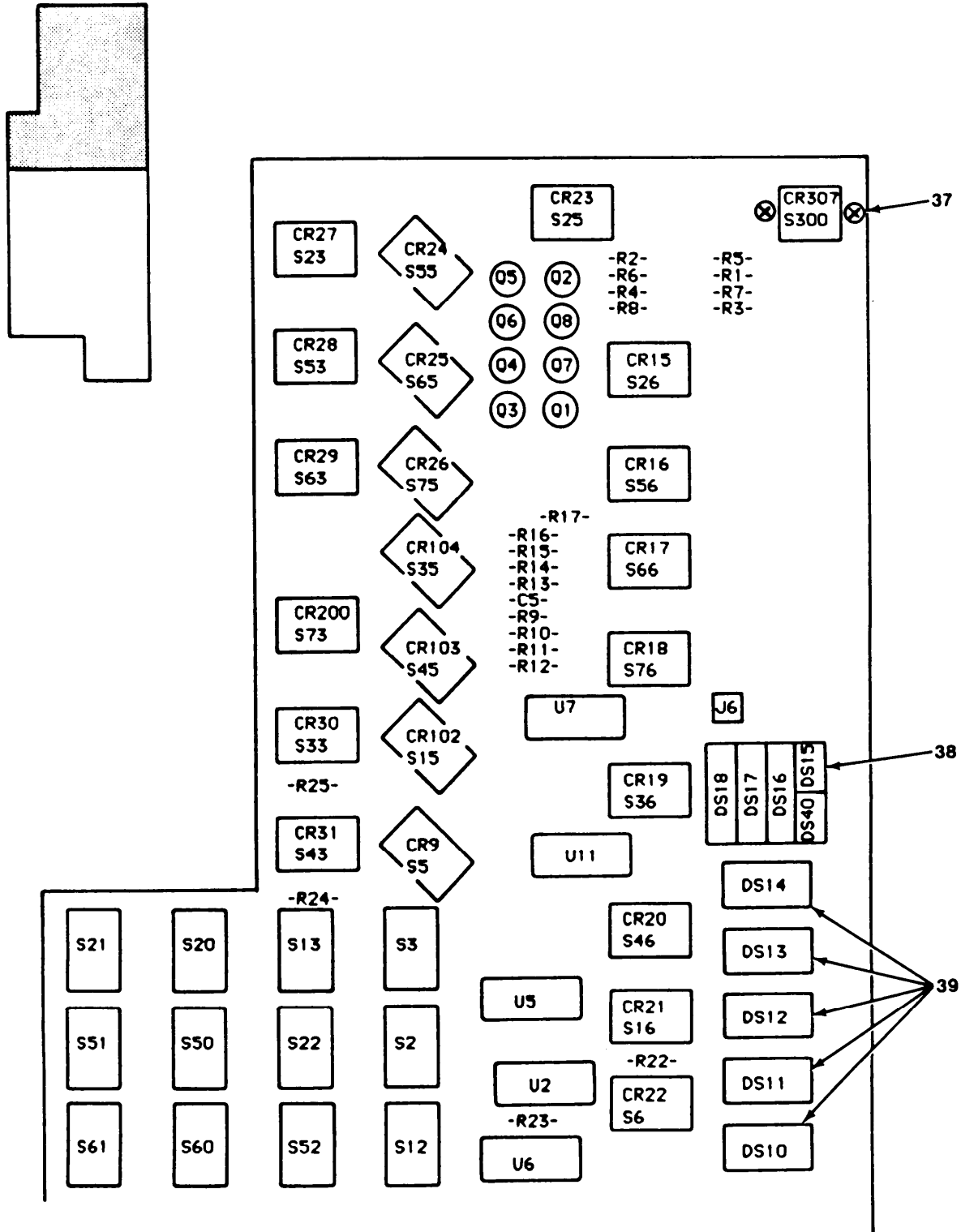

NOTE: PREFIX ALL REFERENCE DESIGNATORS WITH 1A98

EL9NV027

Figure 17. Switch/Display Circuit Card Assembly (Sheet 1 of 3).

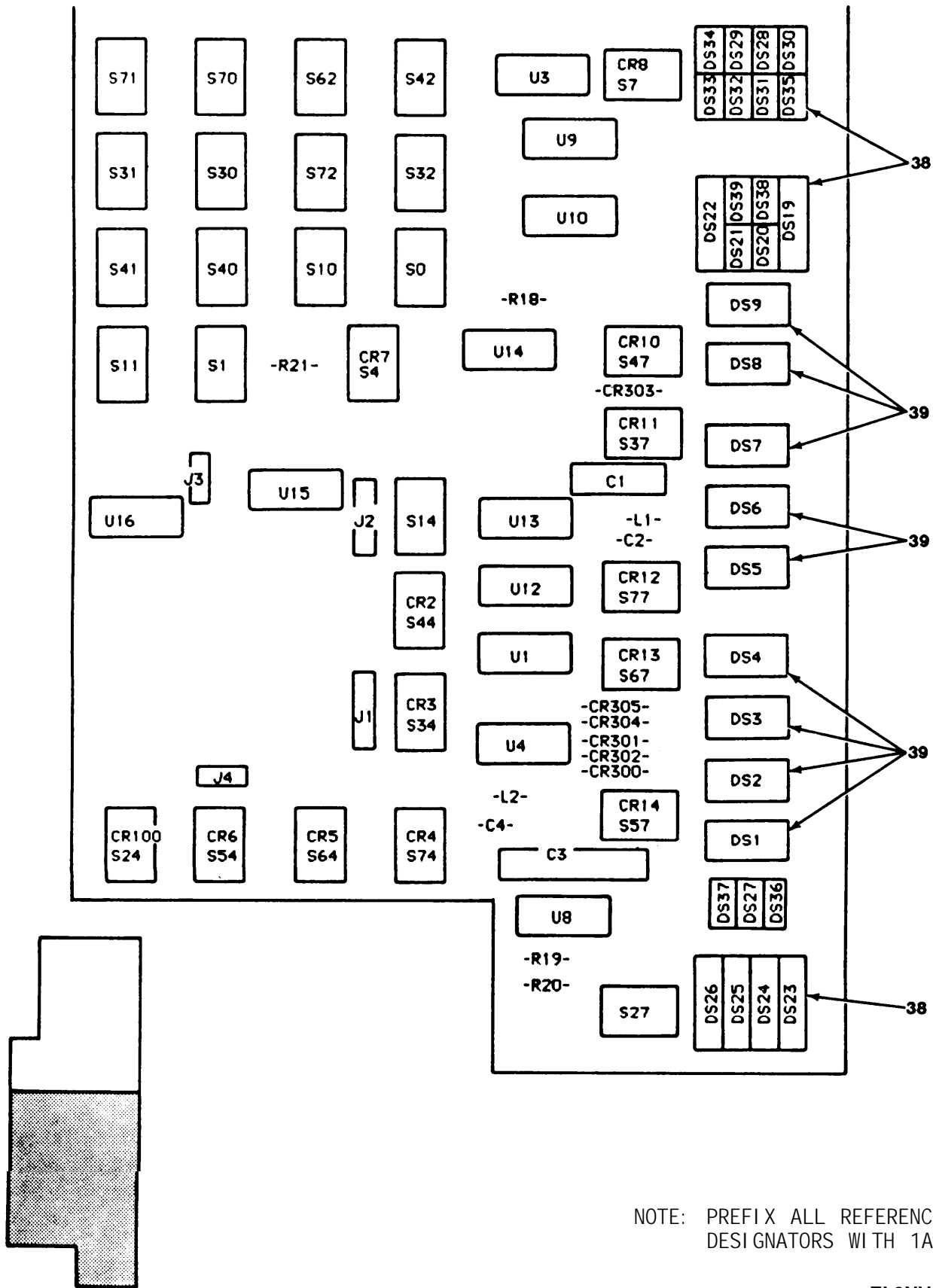

NOTE: PREFIX ALL REFERENCE DESIGNATORS WITH 1A98

EL9NV028

Figure 17. Switch/Display Circuit Card Assembly (Sheet 2 of 3).

REF DES	ITEM NO	REF DES	ITEM NO	REF DES	ITEM NO	REF DES	ITEM NO	REF DES	ITEM NO	REF DES	ITEM NO
C1	1	DS4	9	Q7	18	S30	27	U10	32		
C2	2	DS5	9	Q8	18	S31	27	U11	32		
C3	3	DS6	9	R1	19	S32	27	U12	33		
C4	2	DS7	9	R2	19	S33	27	U13	33		
C5	2	DS8	9	R3	19	S34	27	U14	34		
CR2	4	DS9	9	R4	19	S35	27	U15	35		
CR3	4	DS10	9	R5	19	S36	27	U16	36		
CR4	4	DS11	9	R6	19	S37	27				
CR5	4	DS12	9	R7	19	S40	27				
CR6	4	DS13	9	R8	19	S41	27				
CR7	4	DS14	10	R9	20	S42	27				
CR8	4	DS15	11	R10	20	S43	27				
CR9	4	DS16	12	R11	20	S44	27				
CR10	4	DS17	12	R12	20	S45	27				
CR11	4	DS18	12	R13	20	S46	27				
CR12	4	DS19	12	R14	20	S47	27				
CR13	4	DS20	11	R15	20	S50	27				
CR14	4	DS21	11	R16	20	S51	27				
CR15	4	DS22	12	R17	21	S52	27				
CR16	4	DS23	12	R18	22	S53	27				
CR17	4	DS24	12	R19	23	S54	27				
CR18	4	DS25	12	R20	24	S55	27				
CR19	4	DS26	12	R21	25	S56	27				
CR20	4	DS27	11	R22	25	S57	27				
CR21	4	DS28	11	R23	25	S60	27				
CR22	4	DS29	11	R24	25	S61	27				
CR23	4	DS30	11	R25	26	S62	27				
CR24	4	DS31	11	S0	27	S63	27				
CR25	4	DS32	11	S1	27	S64	27				
CR26	4	DS33	11	S2	27	S65	27				
CR27	4	DS34	11	S3	27	S66	27				
CR28	4	DS35	11	S4	27	S67	27				
CR29	4	DS36	11	S5	27	S70	27				
CR30	4	DS37	11	S6	27	S71	27				
CR31	4	DS38	11	S7	27	S72	27				
CR100	4	DS39	11	S10	27	S73	27				
CR102	4	DS40	11	S11	27	S74	27				
CR103	4	J1	13	S12	27	S75	27				
CR104	4	J2	14	S13	27	S76	27				
CR200	4	J3	15	S14	27	S77	27				
CR300	5	J4	15	S15	27	S300	28				
CR301	6	J6	16	S16	27	U1	29				
CR302	7	L1	17	S20	27	U2	29				
CR303	5	L2	17	S21	27	U3	29				
CR304	6	Q1	18	S22	27	U4	30				
CR305	7	Q2	18	S23	27	U5	30				
CR307	8	Q3	18	S24	27	U6	30				
DS1	9	Q4	18	S25	27	U7	31				
DS2	9	Q5	18	S26	27	U8	32				
DS3	9	Q6	18	S27	27	U9	32				

Figure 17. Switch/Display Circuit Card Assembly (Sheet 3 of 3).

(1) ITEM NO	(2) SMR CODE	(3) FSCM	(4) PART NUMBER	(5) DESCRIPTION AND USABLE ON CODE (UOC)	(6) QTY
GROUP 16 SWITCH/DISPLAY CIRCUIT CARD ASSEMBLY (A98)					
FIG. 17					
1	PCHZZ	56289	30D207F016DF2	CAPACITOR, FIXED, ELE	1
2	PAHZZ	16546	C31A103K	CAPACITOR, FIXED, CER	3
3	PAHZZ	56289	500D477H016DF7	CAPACITOR, FIXED, ELE	1
4	PAHZZ	28480	1990-0665	LIGHT EMITTING DIOD	35
5	PAHZZ	81349	JAN1N485B	SEMICONDUCTOR DEVIC	2
6	PAHZZ	81349	JAN1N4370A	SEMICONDUCTOR DEVIC	2
7	PAHZZ	28480	1902-0126	SEMICONDUCTOR DEVIC	2
8	PAHZZ	04713	SZ40145-017	SMCND DVC, DIODE	1
9	PAHZZ	28480	1990-0592	LIGHT EMITTING DIOD	13
10	XDHZZ	28480	1990-0681	DISPLAY, OPTOELECTRO	1
11	PAHZZ	28480	1990-0696	LIGHT EMITTING DIOD	17
12	PAHZZ	28480	1990-0699	SEMICONDUCTOR DEVIC	9
13	PAHZZ	22526	65692-019	CONNECTOR, RECEPTACL	1
14	PAHZZ	27264	22-27-2141	HEADEN, STRAIGHT	1
15	PAHZZ	27264	22-27-2051	CONNECTOR, PLUG, ELEC	2
16	PAHZZ	27264	22-29-2021	CONNECTOR, PLUG, ELEC	1
17	PAHZZ	59474	30134-3K	COIL, RADIO FREQUENC	2
18	PAHZZ	81349	JAN2N3638A	TRANSISTOR	8
19	PAHZZ	81349	RCR07G270JS	RESISTOR, FIXED, COMP	8
20	PAHZZ	81349	RCR07G182JS	RESISTOR, FIXED, COMP	8
21	PAHZZ	91637	CSP09C07-472J	RESISTOR NETWORK	1
22	PAHZZ	56289	216CJ104	RESISTOR NETWORK, FI	1
23	PAHZZ	81349	RNC60K1822FS	RESISTOR, FIXED, FILM	1
24	PAHZZ	81349	RNC60K1301FS	RESISTOR, FIXED, FILM	1
25	PAHZZ	81349	RCR07G200JS	RESISTOR, FIXED, COMP	4
26	PAHZZ	81349	RCR07G100JS	RESISTOR, FIXED, COMP	1
27	PAHZZ	28480	5060-9436	SWITCH, PUSH	63
28	PAHZZ	28480	3101-2441	SWITCH, PUSH	1
29	PAHZZ	81349	M38510/30605BCB	MICROCIRCUIT, DIGITA	3
30	PAHZZ	28480	1820-1740	MICROCIRCUIT, LINEAR	3
31	PAHZZ	01295	SN74LS273N	MICROCIRCUIT, DIGITA	1
32	PAHZZ	28480	1820-1587	MICROCIRCUIT, DIGITA	4
33	PAHZZ	28480	1820-1200	MICROCIRCUIT	2
34	PAHZZ	28480	1820-1873	MICROCIRCUIT, DIGITA	1
35	PAHZZ	81349	M3851032204BEB	MICROCIRCUIT, DIGITA	1
36	PAHZZ	28480	1820-1112	MICROCIRCUIT, DIGITA	1
37	XBHZZ	28480	0624-0333	SCR, TPG, THD FMG	2
38	PAHZZ	52072	CA28SD10SD	SOCKET, PLUG-IN ELEC	9
39	PAHZZ	80009	136-0269-02	SOCKET, PLUG-IN ELEC	14

END OF FIGURE

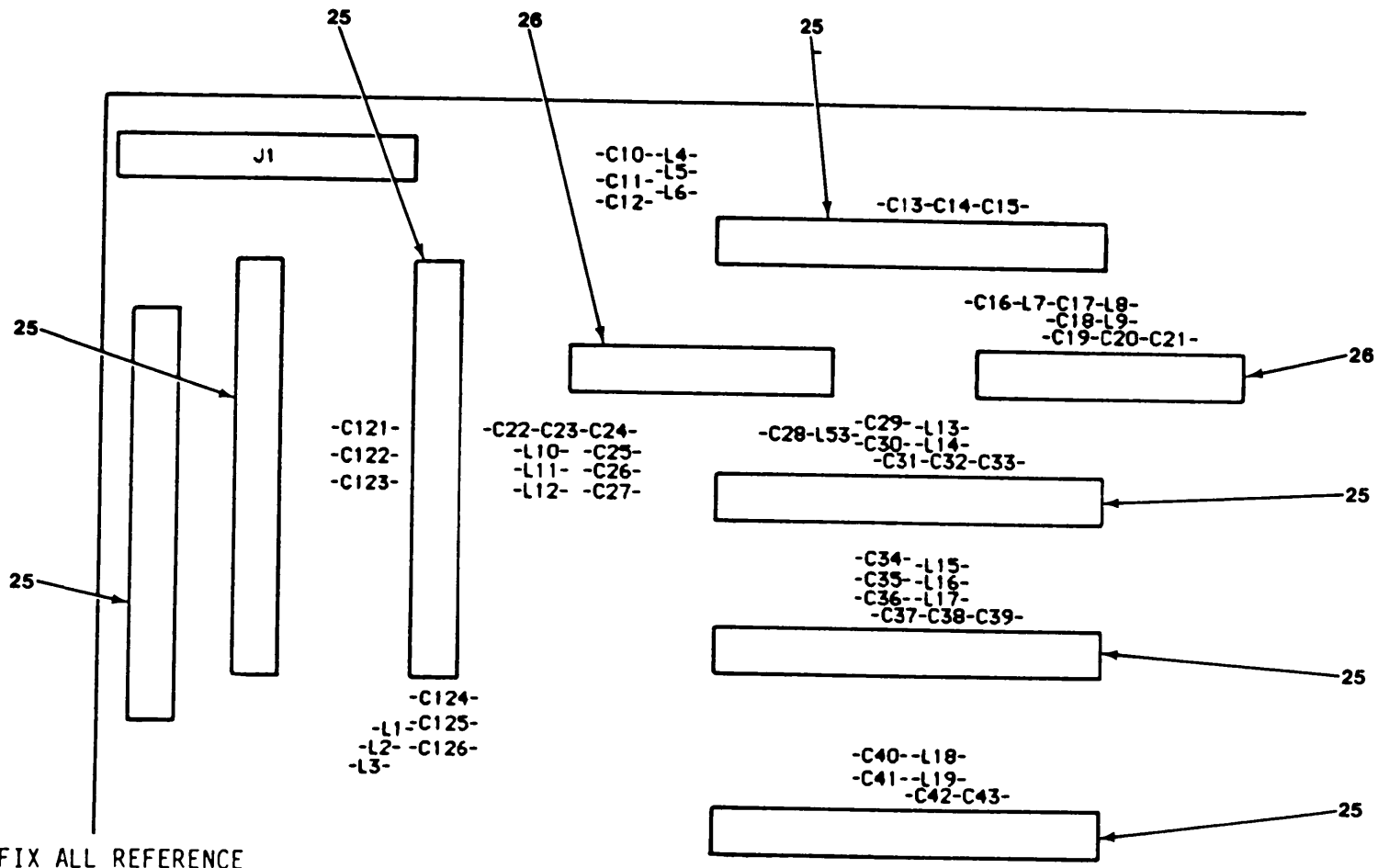

NOTE: PREFIX ALL REFERENCE DESIGNATORS WITH 1A99

Figure 18. Motherboard Circuit Card Assembly (Sheet 1 of 5).

EL9NV029

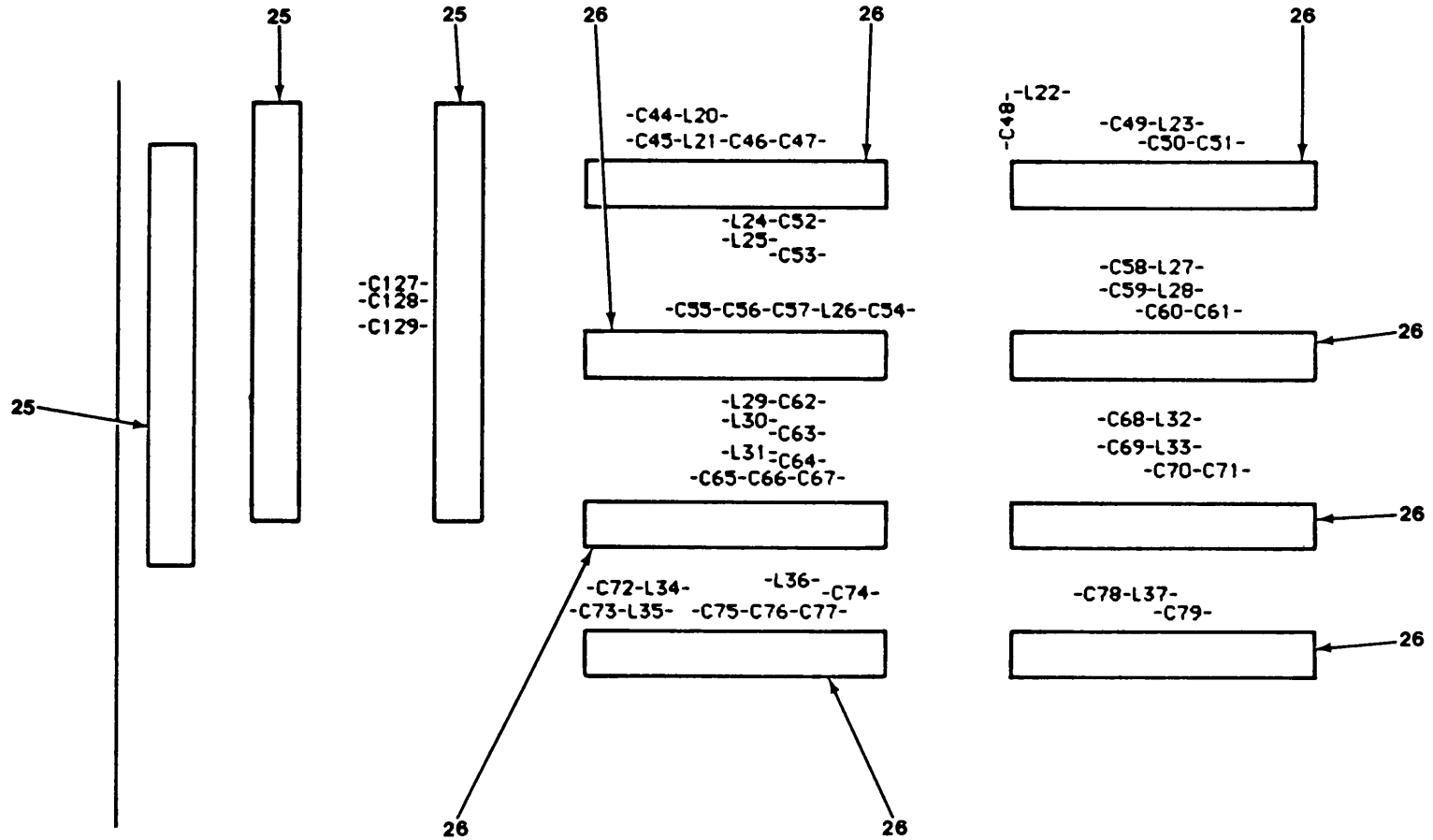
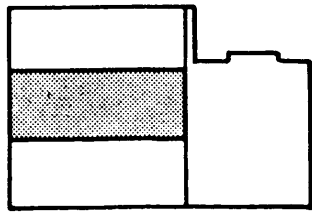

NOTE: PREFIX ALL REFERENCE DESIGNATORS WITH 1A99

Figure 18. Motherboard Circuit Card Assembly (Sheet 2 of 5).

EL9NV030

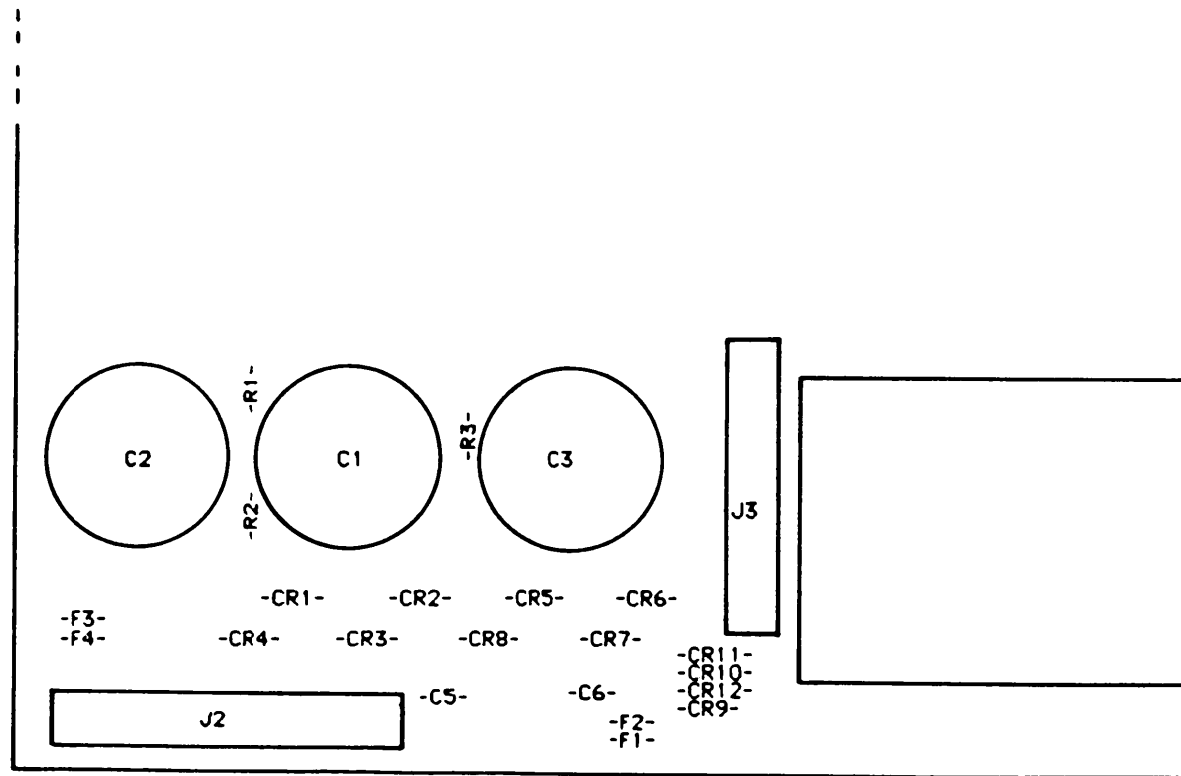
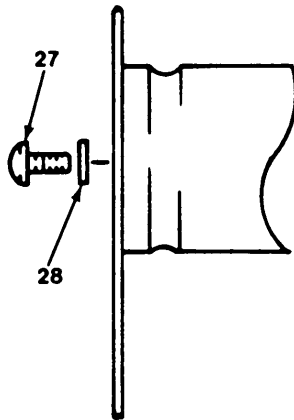
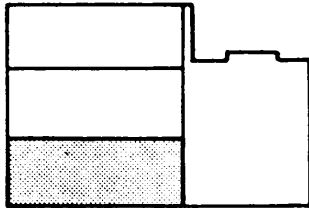

NOTE: PREFIX ALL REFERENCE
DESIGNATORS WITH 1A99

Figure 18. Motherboard Circuit Card Assembly (Sheet 3 of 5).

EL9NV031

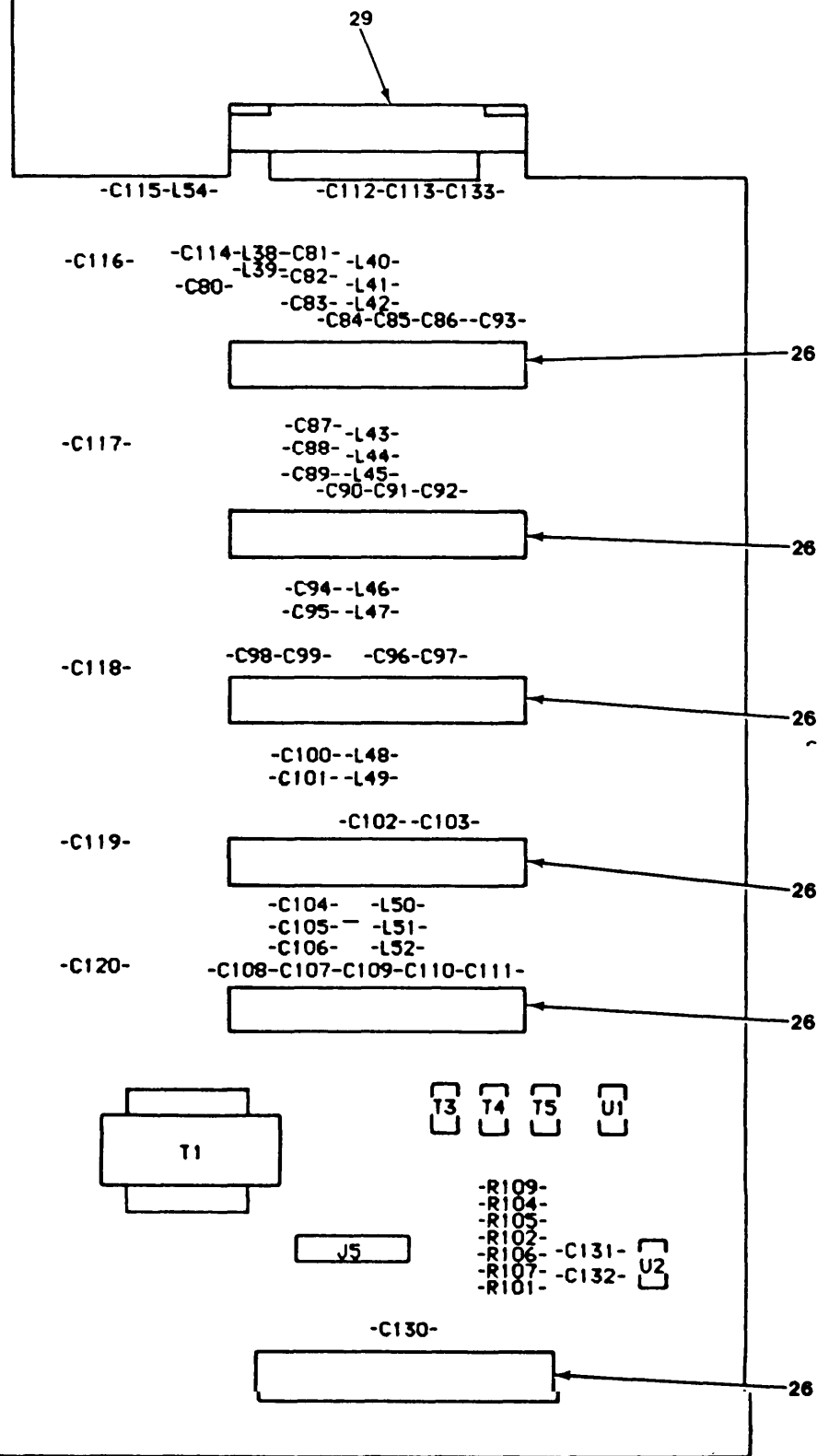
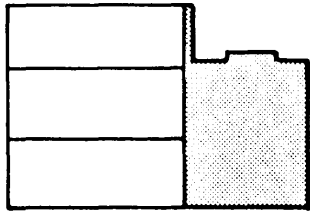

NOTE:
 PREFIX ALL REFERENCE
 DESIGNATORS WITH 1A99

EL9NV032

Figure 18. Motherboard Circuit Card Assembly (Sheet 4 of 5).

REF DES	ITEM NO	REF DES	ITEM NO	REF DES	ITEM NO	REF DES	ITEM NO	REF DES	ITEM NO	REF DES	ITEM NO
C1	1	C55	5	C105	5	L2	15	L52	15		
C2	1	C56	5	C106	5	L3	15	L53	14		
C3	2	C57	5	C107	5	L4	15	L54	15		
C5	3	C58	5	C108	5	L5	15	R1	16		
C6	4	C59	5	C109	5	L6	14	R2	16		
C10	5	C60	5	C110	5	L7	14	R3	17		
C11	5	C61	5	C111	5	L8	15	R101	18		
C12	5	C62	5	C112	5	L9	15	R102	18		
C13	5	C63	5	C113	5	L10	14	R104	19		
C14	5	C64	5	C114	5	L11	15	R105	19		
C15	5	C65	5	C115	5	L12	15	R106	18		
C16	5	C66	5	C116	5	L13	15	R107	18		
C17	5	C67	5	C117	5	L14	15	R109	20		
C18	5	C68	5	C118	5	L15	14	T1	21		
C19	5	C69	5	C119	5	L16	15	T3	22		
C20	5	C70	5	C120	5	L17	15	T4	22		
C21	5	C71	5	C121	5	L18	15	T5	22		
C22	5	C72	5	C122	5	L19	15	U1	23		
C23	5	C73	5	C123	5	L20	15	U2	24		
C24	5	C74	5	C124	5	L21	15				
C25	5	C75	5	C125	5	L22	14				
C26	5	C76	5	C126	5	L23	15				
C27	5	C77	5	C127	5	L24	15				
C28	5	C78	5	C128	5	L25	15				
C29	5	C79	5	C129	5	L26	14				
C30	5	C80	5	C130	6	L27	15				
C31	5	C81	5	C131	7	L28	15				
C32	5	C82	5	C132	7	L29	15				
C33	5	C83	5	C133	7	L30	15				
C34	5	C84	5	CR1	8	L31	14				
C35	5	C85	5	CR2	8	L32	15				
C36	5	C86	5	CR3	8	L33	15				
C37	5	C87	5	CR4	8	L34	15				
C38	5	C88	5	CR5	8	L35	15				
C39	5	C89	5	CR6	8	L36	14				
C40	5	C90	5	CR7	8	L37	14				
C41	5	C91	5	CR8	8	L38	15				
C42	5	C92	5	CR9	9	L39	15				
C43	5	C93	5	CR10	9	L40	14				
C44	5	C94	5	CR11	9	L41	15				
C45	5	C95	5	CR12	9	L42	15				
C46	5	C96	5	F1	10	L43	14				
C47	5	C97	5	F2	10	L44	15				
C48	5	C98	5	F3	10	L45	15				
C49	5	C99	5	F4	10	L46	15				
C50	5	C100	5	J1	11	L47	15				
C51	5	C101	5	J2	11	L48	15				
C52	5	C102	5	J3	12	L49	15				
C53	5	C103	5	J5	13	L50	14				
C54	5	C104	5	L1	14	L51	15				

Figure 18. Motherboard Circuit Card Assembly (Sheet 5 of 5).

(1) ITEM NO	(2) SMR CODE	(3) FSCM	(4) PART NUMBER	(5) DESCRIPTION AND USABLE ON CODE (UOC)	(6) QTY
GROUP 17 MOTHERBOARD CIRCUIT CARD ASSEMBLY (A99)					
FIG. 18					
1	PAHZZ	28480	0180-0677	CAPACITOR	2
2	PAHZZ	81349	M39018/06-0044M	CAPACITOR, FIXED, ELE	1
3	PAHZZ	56289	292P10452	CAPACITOR, FIXED, PLA	1
4	PAHZZ	28480	0160-3787	CAPACITOR, FIXED, MET	1
5	PAHZZ	72982	8121M112X7R0103M	CAPACITOR, FIXED, CER	120
6	PAHZZ	28480	0180-2779	CAPACITOR, FIXED, ELE	1
7	PAHZZ	28480	0160-0576	CAPACITOR, FIXED, CER	3
8	PAHZZ	98380	116057	SEMICONDUCTOR DEVIC	8
9	PAHZZ	04713	SR1358-8B	SEMICONDUCTOR DEVIC	4
10	PAHZZ	99971	7527486P110	FUSE, CARTRIDGE	4
11	PAHZZ	27264	09-88-2141	CONNECTOR, RECEPTACL	2
12	PAHZZ	27264	09-60-1131	CONNECTOR, PLUG, ELEC	1
13	PAHZZ	27264	09-60-1051	CONNECTOR, PLUG, ELEC	1
14	PAHZZ	28480	9100-1791	COIL, RADIO, FREQUENC	14
15	PAHZZ	24226	15M470J	COIL, RADIO FREQUENC	40
16	PAHZZ	81349	RCR20G202JS	RESISTOR, FIXED, COMP	2
17	PAHZZ	81349	RCR20G471JS	RESISTOR, FIXED, COMP	1
18	PAHZZ	81349	RCR07G103JS	RESISTOR, FIXED, COMP	4
19	PAHZZ	81349	RNC60K2001FS	RESISTOR, FIXED, FILM	2
20	PAHZZ	81349	RCR20G102JS	RESISTOR, FIXED, COMP	1
21	PAHZZ	28480	9100-0447	TRANSFORMER, POWER	1
22	PAHZZ	01961	PE8117	TRANSFORMER, PULSE	3
23	PAHZZ	28480	1990-0444	COUPLER, OPTOELECTRO	1
24	PAHZZ	34148	UA7815UC	MICROCIRCUIT, LINEAR	1
25	PAHZZ	71785	252-22-30-300	CONNECTOR, RECEPTACL	10
26	PAHZZ	71785	252-15-30-300	CONNECTOR, RECEPTACL	16
27	PAHZZ	96906	MS51958-60	SCREW, MACHINE	6
28	PAHZZ	96906	MS35333-35	WASHER, LOCK	6
29	PAHZZ	28480	1251-5566	CONNECTOR, RECEPTACL	1

END OF FIGURE

NATIONAL STOCK NUMBER AND PART NUMBER INDEX

STOCK NUMBER	NATIONAL STOCK NUMBER INDEX		STOCK NUMBER	NATIONAL STOCK NUMBER INDEX	
	FIG.	ITEM		FIG.	ITEM
5905-00-001-5835	6	55	5905-00-028-1832	17	24
5910-00-001-7244	16	2	5950-00-031-4571	7	23
5905-00-006-5576	12	44		13	25
5905-00-006-5578	4	70	6150-00-041-5038	1	2
	9	20	5310-00-042-4229	1	207
	11	56	5935-00-043-3914	2	13
	14	46		3	24
5905-00-006-6981	5	36		4	29
	6	42		8	23
5905-00-006-6985	16	59	5310-00-045-3299	1	224
5905-00-006-6987	3	60	5910-00-054-0761	10	35
5910-00-007-2000	5	18	5305-00-054-5651	9	34
	8	15	5305-00-054-6652	1	47
5910-00-007-2001	3	10	5910-00-057-3934	2	3
	7	14		3	1
	8	10		4	10
5910-00-007-2002	8	13		11	19
	16	17		13	15
5910-00-007-2003	3	17	5310-00-058-3599	9	33
	4	11	5305-00-059-3656	18	27
	7	1	5961-00-062-3133	9	9
	13	16	5935-00-064-3037	1	152
	14	6	5910-00-068-3898	6	1
5910-00-007-2004	4	17		10	24
	11	14		11	1
5910-00-007-3974	2	9		14	13
	3	15	5950-00-075-9144	2	22
	4	4		8	29
	5	8	5910-00-075-9238	4	14
	6	10	5910-00-085-0438	5	15
	8	17		10	32
	12	7		11	5
	12	8		16	12
	12	9	5961-00-087-6047	11	27
	13	13		16	35
	15	3	5910-00-098-9281	11	25
	16	9	5905-00-101-2325	8	56
5910-00-007-7471	5	19	5905-00-104-8368	3	52
5910-00-010-8159	7	10		4	80
	12	2		7	36
	15	1		8	37
5910-00-010-8422	4	12		14	32
5910-00-012-3433	5	9	5905-00-104-8369	3	64
5910-00-018-0918	15	9		4	50
5310-00-019-0669	9	28	5910-00-105-5486	10	10
5310-00-022-8834	1	121	5905-00-105-7764	7	31
5905-00-024-0598	3	41		12	25
5905-00-025-5988	11	83	5905-00-105-7765	12	26
	16	81	5905-00-106-1249	4	44
5905-00-026-9341	8	54		5	65

NATIONAL STOCK NUMBER AND PART NUMBER INDEX

STOCK NUMBER	NATIONAL STOCK NUMBER INDEX		STOCK NUMBER	FIG.	ITEM
	FIG.	ITEM			
5905-00-106-1249	15	34	5905-00-110-7620	16	72
5905-00-106-1356	3	65	4130-00-111-0397	1	212
	7	30	5905-00-111-1679	4	39
	8	46		12	36
	11	73		13	55
5905-00-106-1357	4	38		16	89
5910-00-106-3615	7	9	5905-00-111-1684	16	108
5905-00-106-3666	3	82	5905-00-111-4727	5	46
	4	52		6	51
	7	32	5905-00-111-4750	4	46
	9	21		7	47
	11	33	5905-00-111-4845	8	59
	12	31		15	18
	16	79	5905-00-111-4858	18	17
	18	18	5905-00-112-1026	3	87
5905-00-106-3668	13	56		5	37
5910-00-106-6977	2	1		6	38
	4	14		12	56
	8	8		13	41
5905-00-106-9356	4	49		14	44
	11	72		16	127
	12	50	5905-00-112-1502	8	55
	13	54	5905-00-112-7039	10	75
	16	75	5905-00-112-9215	16	117
5905-00-106-9357	5	47	5905-00-113-4860	4	45
5905-00-107-0656	3	43		17	19
	6	47	5910-00-113-5475	4	13
	7	42		10	2
	11	60		11	13
	12	48		16	15
	16	83	5910-00-113-5610	16	22
	17	26	5910-00-114-0221	16	32
5910-00-107-2540	11	20	5905-00-114-0708	3	76
	13	7		4	42
5935-00-107-2601	9	7		8	44
5905-00-110-0196	18	20		9	16
5905-00-110-0388	7	37		11	75
	8	51		13	51
	11	36		14	52
	12	49		15	28
	16	84		16	82
5905-00-110-7620	3	85	5905-00-114-0710	8	36
	4	78		13	43
	5	59	5905-00-114-0711	2	39
	6	58		3	84
	7	35		4	74
	8	39		8	38
	9	14		9	17
	11	34		11	58
	13	50		16	70

NATIONAL STOCK NUMBER AND PART NUMBER INDEX

STOCK NUMBER	NATIONAL STOCK NUMBER INDEX		STOCK NUMBER	FIG.	ITEM
	FIG.	ITEM			
5905-00-114-5339	16	85	5905-00-121-9938	11	84
5905-00-114-5343	7	51		12	30
	17	20	5905-00-126-6683	4	40
5905-00-115-2223	4	43		7	33
	13	49	5905-00-126-6690	9	18
5905-00-115-3560	12	28	5905-00-126-6696	16	94
5905-00-116-2394	3	74	5905-00-128-6237	3	86
	5	58	5905-00-131-5877	5	56
5910-00-116-8239	3	20	5905-00-131-9729	11	68
	4	16		15	20
	5	2	5905-00-133-0440	7	40
	6	3	5910-00-134-0621	2	8
	7	5		11	20
	9	3	5905-00-135-3972	17	25
	10	1	5905-00-135-6046	7	44
	11	8		13	52
	12	1	5905-00-136-3890	7	45
	13	4		8	61
	15	5		10	59
	16	10		11	74
	17	2		15	32
5905-00-116-8554	2	36	5905-00-136-8405	8	34
	4	68	5905-00-136-8406	3	73
	7	46		8	68
	15	24	5905-00-137-0804	3	50
5905-00-116-8556	12	27		4	69
5905-00-116-8569	9	23		8	55
5905-00-118-4559	12	33		10	65
5910-00-118-7902	6	24		11	45
5905-00-119-3503	7	39		13	59
	8	40		15	19
	11	47		16	68
	16	67	5961-00-137-4608	4	36
5905-00-119-3505	10	58		7	28
	12	32		8	32
5905-00-119-8812	7	41		11	32
5905-00-119-8855	7	34		12	23
5905-00-120-9154	3	83		16	41
	4	79	5905-00-138-1285	8	63
	7	52		18	19
	8	67	5910-00-138-1320	2	5
	11	67	5910-00-138-1324	16	23
	13	44	5910-00-138-1328	15	2
	14	55	5950-00-138-1334	5	83
	15	25	5910-00-138-5048	16	21
5905-00-121-9920	4	77	5905-00-139-2305	5	44
	7	50	5905-00-140-7037	8	55
5905-00-121-9921	3	48	5905-00-140-7142	3	66
5905-00-121-9932	9	24		12	54
	15	30		16	125

NATIONAL STOCK NUMBER AND PART NUMBER INDEX

STOCK NUMBER	NATIONAL STOCK NUMBER INDEX		STOCK NUMBER	FIG.	ITEM
	FIG.	ITEM			
5905-00-140-7159	16	110	5905-00-154-7029	10	63
5905-00-140-7233	2	29		14	50
	4	54	5905-00-160-4905	4	60
	5	43		11	42
	6	48		16	128
5905-00-141-0717	11	37	5962-00-167-6330	11	98
5905-00-141-0742	5	48	5962-00-172-8261	11	100
	6	53	5905-00-173-1622	3	59
5905-00-141-1132	4	41	5961-00-173-9932	1	163
	8	62	5910-00-175-3687	6	22
5905-00-141-1183	1	118		10	14
	2	40	5961-00-175-8467	4	22
	3	67		8	20
	4	76		16	33
	5	50	5961-00-179-8478	12	22
	6	41		13	36
	7	43	5935-00-180-4186	1	154
	8	45	5905-00-189-2454	8	50
	9	22		11	82
	11	59		13	64
	15	33		16	80
5905-00-141-1295	4	47	5905-00-189-2456	11	78
	11	71		16	99
	16	71	5905-00-189-2467	16	92
5905-00-142-0901	4	51	5905-00-189-2468	10	67
	8	42		16	107
	14	35	5905-00-189-2477	16	105
5905-00-142-0902	14	51	5905-00-189-2478	16	118
5905-00-142-0903	11	65	5905-00-189-2479	4	66
5905-00-142-0931	3	51	5905-00-189-2481	9	19
	12	46	5905-00-189-2482	16	97
	14	54	5905-00-189-2483	3	69
5905-00-146-4165	4	73		11	56
5905-00-147-2042	8	57		16	78
5905-00-147-2062	11	81	5905-00-189-2487	10	55
	16	55	5910-00-189-4248	3	9
5310-00-151-8865	3	97		7	2
	5	73		12	15
	6	71	5905-00-192-3434	4	55
	7	63		11	86
	8	75		16	93
	13	80	5905-00-192-3458	16	97
	14	73	5905-00-192-3876	10	55
5310-00-151-8877	3	98		11	51
	5	74	5905-00-192-3877	16	113
	6	72	5905-00-192-3880	11	50
	7	64		15	29
	8	76		16	73
	13	81	5905-00-192-3882	16	114
	14	74	5905-00-192-3883	16	98

NATIONAL STOCK NUMBER AND PART NUMBER INDEX

STOCK NUMBER	NATIONAL STOCK NUMBER INDEX		STOCK NUMBER	FIG.	ITEM
	FIG.	ITEM			
5905-00-194-1691	16	102	5962-00-252-4926	16	137
5905-00-194-2324	13	57	5962-00-256-0340	8	70
5905-00-195-6379	17	23	5905-00-257-9411	2	33
5905-00-195-6384	10	69	5905-00-259-4626	13	61
	11	44		16	66
	12	47	5905-00-259-4627	8	48
	16	69		11	35
5905-00-199-6290	16	109	5905-00-259-4629	4	72
5905-00-200-9602	6	62		11	41
	11	61		16	60
5905-00-214-1136	13	67	5905-00-261-7051	14	39
5905-00-214-2927	3	78	5905-00-261-7689	10	71
	14	37	5905-00-264-3431	16	97
5961-00-222-1541	18	8	5910-00-264-5596	6	17
5905-00-228-5506	5	45	5905-00-267-1662	16	101
	6	50	5950-00-269-2978	12	21
5999-00-230-8833	15	69	5310-00-269-6498	1	208
5999-00-230-8834	15	68	5905-00-270-1403	16	86
	16	158	5905-00-270-4960	16	112
5961-00-232-3279	15	12	5905-00-273-9608	12	52
	16	36		16	123
5905-00-232-7791	5	40	5905-00-273-9666	16	121
	6	40	5905-00-273-9687	6	60
	10	60		16	58
	13	45	5905-00-273-9761	12	53
5905-00-232-9912	6	44		16	124
	14	36	5905-00-279-6491	4	82
5905-00-233-7145	16	100		5	43
5910-00-234-9817	11	11		6	48
	13	14		8	49
5905-00-243-1778	3	45	5920-00-280-4960	1	218
5905-00-243-5622	4	48	5905-00-284-7841	10	60
5905-00-246-9393	3	75	5905-00-284-7852	16	120
5910-00-247-8626	4	20	5905-00-284-8262	14	53
	10	4	5905-00-285-0423	10	64
	14	14	5905-00-285-0546	16	96
5961-00-250-8132	3	33	5905-00-286-4543	10	74
	4	2	5905-00-289-3532	5	43
	6	9		6	48
	8	14		12	55
	11	7		16	126
	13	1	5905-00-295-4769	3	56
	14	11		13	53
	15	7	5905-00-308-7594	14	45
	16	13		16	130
5962-00-252-4926	4	96	5950-00-308-7930	3	30
	10	79	5905-00-311-2116	16	61
	11	99	5905-00-311-2131	11	66
	13	77	5905-00-312-3513	11	88
	14	65	5905-00-317-8960	8	55

NATIONAL STOCK NUMBER AND PART NUMBER INDEX

STOCK NUMBER	NATIONAL STOCK NUMBER INDEX		STOCK NUMBER	INDEX	
	FIG.	ITEM		FIG.	ITEM
5905-00-317-9668	6	61	5905-00-426-7095	16	54
5915-00-318-3246	1	229	5905-00-426-7096	5	43
5905-00-320-6506	11	55		6	48
5905-00-320-6545	4	62	5905-00-426-7098	2	37
5905-00-321-7850	15	27	5905-00-426-7120	2	31
5905-00-325-6796	3	44		11	77
5905-00-325-7686	4	64	5905-00-426-7121	4	56
5905-00-339-7599	11	53		7	48
5905-00-340-9798	4	84		16	45
5905-00-344-1720	2	35	5905-00-426-7144	2	34
	3	68		5	49
	5	43		6	52
	6	48		8	52
	13	58		10	60
5905-00-348-2710	16	91		14	30
5905-00-359-5408	4	57	5905-00-428-2017	13	47
	11	52	5905-00-428-5335	4	85
	16	74	5905-00-428-8317	13	69
5905-00-359-5434	4	86		14	40
5905-00-361-8419	4	61	5905-00-429-3096	9	11
5905-00-365-5560	11	43	5905-00-429-9726	16	103
	16	129	5905-00-430-1637	8	65
5962-00-369-9839	12	64	5910-00-430-5647	4	14
5935-00-372-1963	18	25		10	30
4140-00-372-2947	1	232	5910-00-430-5715	5	4
5962-00-378-0077	18	24		6	4
5961-00-401-0507	5	33	5910-00-430-6138	10	13
	6	37		16	1
	14	27	5905-00-430-6486	13	65
5905-00-402-1185	16	116		16	53
5961-00-402-1654	7	29	5950-00-430-6882	5	25
	13	40		14	21
5905-00-404-8782	10	55	5950-00-431-3175	4	88
	16	63		5	67
5935-00-405-7720	18	26		6	64
5910-00-406-9675	6	21		13	70
	10	34	5950-00-431-3203	14	25
	11	21	5905-00-431-3914	4	71
	15	8		11	49
5905-00-408-9105	8	55		16	77
	14	42	5905-00-431-9764	11	63
	15	31		15	23
5910-00-422-0502	2	2	5905-00-432-0469	3	62
5905-00-426-7095	2	26		6	54
	4	64		8	53
	10	66	5905-00-432-5846	4	67
	11	46		14	56
	12	43	5905-00-432-6410	3	63
	13	60		4	63
	14	43		6	57

NATIONAL STOCK NUMBER AND PART NUMBER INDEX

STOCK NUMBER	NATIONAL STOCK NUMBER INDEX		STOCK NUMBER	FIG.	ITEM
	FIG.	ITEM			
5905-00-432-6410	8	60	5905-00-462-5669	3	38
	11	69	5920-00-462-6897	18	10
	12	42	5910-00-463-2715	17	1
	13	46	5905-00-465-0335	3	81
	14	31	5910-00-469-2823	6	25
	16	65		10	15
5905-00-432-6412	8	58	5910-00-469-2932	4	14
	13	63	5905-00-469-7380	11	79
5905-00-432-8648	16	56	5905-00-469-7382	10	73
5905-00-432-8956	2	38		11	38
	11	85	5910-00-470-2671	16	18
5905-00-435-1718	15	22		18	4
5905-00-435-6374	7	49	5950-00-470-9400	12	20
5905-00-435-6432	13	66		16	40
5905-00-442-9356	5	57	5905-00-471-2259	5	39
5950-00-443-9512	3	23		6	45
	4	28		8	41
	5	23		10	60
	7	19		13	42
	14	19		14	49
	2	19		16	104
	14	38	5905-00-471-2261	16	88
5950-00-444-0492	2	19	5905-00-472-3471	6	59
5905-00-451-7528	14	38		9	12
5905-00-451-7531	10	55		10	55
5905-00-451-7532	5	54		16	39
	10	61	5950-00-472-4985	10	33
5905-00-451-7533	11	40	5910-00-472-5027	8	31
5905-00-451-7534	3	47	5961-00-472-5039	13	62
	3	77	5905-00-474-8810	3	6
5961-00-451-8685	14	33	5910-00-476-5685	2	12
	4	21	5910-00-477-8011	3	16
	8	21		4	1
	10	39		5	17
	15	13		7	3
5905-00-452-0736	13	48		8	3
5905-00-452-0742	3	49		10	21
	6	39		13	6
5905-00-452-0743	3	58		14	2
	16	131		18	5
5905-00-452-0753	5	43		11	23
	6	48	5910-00-481-0470	5	63
5905-00-452-0754	12	40	5905-00-481-6111	16	20
5905-00-452-0761	12	51	5910-00-488-3049	11	89
	16	122	5910-00-492-2561	16	24
5905-00-452-0773	3	70	5910-00-495-0042	16	26
	4	59	5910-00-500-9092	16	119
5905-00-452-0774	16	95	5905-00-506-6415	3	61
5910-00-455-0119	13	5	5905-00-506-6563	8	16
5950-00-455-0156	18	14	5910-00-506-7014	14	8
5910-00-456-0235	14	10	5910-00-506-7031		
5310-00-460-3056	1	124			

NATIONAL STOCK NUMBER AND PART NUMBER INDEX

STOCK NUMBER	NATIONAL STOCK NUMBER INDEX		STOCK NUMBER	FIG.	ITEM
	FIG.	ITEM			
5910-00-506-7036	11	12	5905-00-758-4811	5	60
5910-00-511-2717	12	4		11	80
5905-00-517-9352	5	43		14	59
	6	48	5905-00-758-4840	5	62
	11	70		12	41
5905-00-521-2506	16	115	5961-00-762-3115	7	17
5935-00-534-8481	2	14		10	40
5935-00-534-8486	18	13		11	26
5961-00-540-9621	1	161		12	16
5910-00-543-0506	8	5		13	20
5310-00-543-2410	1	112		14	16
5961-00-544-5753	3	35		15	11
	4	37	5905-00-767-0978	3	46
	5	34	5905-00-767-0983	9	13
5910-00-544-6742	10	27	5910-00-772-6726	10	28
	11	20	5910-00-772-6734	11	15
5355-00-548-4866	1	129	5910-00-774-7294	10	31
5905-00-552-5208	3	53		11	1
5905-00-552-5219	5	51	5910-00-774-7319	4	8
5961-00-577-0558	4	23		7	7
5310-00-579-5554	18	28		11	1
5905-00-588-8342	5	43	5910-00-776-4174	16	27
	6	48	5961-00-780-8330	17	7
5962-00-615-6101	11	104	5910-00-787-5261	3	3
5310-00-616-3554	1	46		5	10
5310-00-616-3555	1	197	5910-00-788-0328	11	3
5905-00-628-4661	3	80	5910-00-806-1269	5	6
	14	41		6	6
5999-00-631-2891	5	22	5961-00-824-5202	13	39
	6	28	5320-00-826-0329	1	199
5310-00-655-9505	1	76	5950-00-827-5209	2	21
5310-00-685-3744	1	220	5905-00-828-0409	5	61
5905-00-689-4720	14	47	5950-00-828-1305	15	16
5305-00-717-6950	1	125	5950-00-828-1742	2	23
5305-00-719-5330	1	130		7	25
5910-00-719-9879	6	2		8	27
	12	12		13	33
	13	19	5910-00-831-8690	10	7
5905-00-721-2353	12	39	5320-00-837-4067	16	161
5905-00-721-2381	8	47	5961-00-840-5466	3	21
5910-00-726-8695	5	13		17	5
	8	7	5961-00-852-7549	11	28
5910-00-728-4973	10	6		16	34
5961-00-752-6163	9	6	5935-00-853-7596	1	210
5905-00-758-3406	10	56	5910-00-854-3157	8	2
5905-00-758-3436	10	76	5910-00-855-2389	5	14
5905-00-758-3444	5	55	5905-00-858-8868	4	65
5905-00-758-3447	12	45	5910-00-866-2952	10	20
	14	58	5910-00-866-3123	4	9
5905-00-758-4792	16	87		7	8

NATIONAL STOCK NUMBER AND PART NUMBER INDEX

STOCK NUMBER	NATIONAL STOCK NUMBER INDEX		STOCK NUMBER	FIG.	ITEM
	FIG.	ITEM			
5910-00-866-3123	8	4	5325-00-960-2410	1	172
	11	9	5961-00-979-0108	3	36
	16	14	5310-00-983-8483	1	204
5910-00-879-6053	4	15	5961-00-985-9073	3	37
5320-00-879-6604	1	227	5910-00-988-1572	16	3
5910-00-879-6852	5	16	5950-00-994-6600	7	21
	8	9	5961-00-995-2310	16	37
5310-00-880-5976	1	202	5905-00-998-1793	16	64
5910-00-883-6281	5	7	5910-00-998-5447	12	13
	6	7		13	12
	11	4	5935-01-005-0016	1	234
	14	12	5935-01-005-0017	1	147
	16	11	5970-01-005-2884	1	215
5305-00-889-2991	1	50	5961-01-005-5155	1	97
5961-00-892-8706	12	24		7	16
	13	38		13	21
	14	28	5910-01-006-8551	2	11
	16	42		3	7
		19		4	3
5950-00-893-8650	12	19		4	3
5305-00-902-2136	1	205		8	11
5910-00-902-2577	6	23		10	23
5910-00-903-8325	3	2		13	2
	5	11		18	7
5961-00-904-2540	9	8	5905-01-007-1444	6	56
	15	17		11	87
5961-00-912-9008	17	18	5905-01-007-5603	3	54
5910-00-914-2623	11	2		5	42
5961-00-923-3940	3	22		13	68
	4	24	5910-01-010-7561	5	12
	12	17	5962-01-010-7808	7	57
5910-00-924-9758	6	19		8	71
5961-00-926-0237	13	35		13	78
5310-00-929-6395	1	102	5905-01-012-1096	11	56
5961-00-931-0372	13	34	5962-01-012-1460	16	144
	14	29	5905-01-013-3179	4	87
5961-00-931-6998	4	33	5905-01-013-4348	3	40
5910-00-933-7537	6	16	5905-01-017-0083	11	54
5905-00-935-8539	18	16	5910-01-022-1966	7	4
5961-00-939-4263	17	6		9	2
5910-00-940-3184	13	8		11	6
5310-00-950-1310	1	149		12	6
5910-00-950-2368	4	7		15	4
	8	12		16	8
	11	22	5905-01-023-1731	3	71
	13	9	5905-01-023-6161	10	54
	15	6	5961-01-024-3683	18	23
	16	7	5910-01-024-4140	7	15
5310-00-951-4679	1	198	5910-01-024-4141	12	5
5940-00-957-2683	8	79	5961-01-025-1105	4	35
5910-00-957-2765	7	6	5961-01-025-4605	4	26

NATIONAL STOCK NUMBER AND PART NUMBER INDEX

STOCK NUMBER	NATIONAL STOCK NUMBER INDEX		STOCK NUMBER	FIG.	ITEM
	FIG.	ITEM			
5961-01-025-4605	7	18	5910-01-044-3580	10	8
	13	22		11	16
	14	18	5910-01-044-5615	11	21
5962-01-026-2493	15	39		13	18
5962-01-027-6863	15	41	5910-01-044-8563	10	36
5910-01-028-0196	16	19	5961-01-045-9170	13	37
5905-01-029-7979	5	66	5962-01-046-9457	15	43
	8	66	5962-01-048-5850	15	51
5962-01-030-6352	12	74	5962-01-048-7767	7	55
	16	152		15	55
5905-01-030-7963	14	62		16	142
5910-01-030-9211	6	15	5962-01-049-0349	15	53
	10	5	5905-01-049-4709	4	81
5962-01-031-1918	15	57	5961-01-049-6786	4	25
5962-01-031-7030	12	66	5962-01-050-0918	15	56
5910-01-032-1819	18	3	5355-01-050-5041	1	126
5905-01-032-6417	6	43		1	127
5905-01-032-9758	8	43	5905-01-051-1211	9	15
5962-01-033-2285	12	71		11	57
5940-01-033-4629	3	88	5905-01-051-1219	6	49
5910-01-034-9281	10	16	5962-01-051-2606	2	47
	16	25		3	90
5962-01-034-9832	12	67	5905-01-051-3945	2	30
	15	59		5	64
5935-01-035-1138	16	133	5905-01-051-5484	3	42
5910-01-035-6720	7	13	5905-01-051-5485	10	70
	13	11	5962-01-051-6527	14	67
5905-01-038-1324	3	72	5999-01-051-8488	16	164
5905-01-038-5364	16	62	5910-01-052-2963	6	8
5905-01-038-5365	16	111	5961-01-052-3895	1	169
5905-01-038-5366	5	53	5905-01-052-5802	2	32
5910-01-038-5394	4	6	5905-01-052-9092	12	38
	10	38	5962-01-053-2508	11	101
	15	10	5905-01-053-7972	14	34
5910-01-038-6392	4	14	5962-01-054-1412	8	73
	10	25		14	70
5910-01-038-7913	10	17	5961-01-054-2140	3	31
5905-01-039-3758	11	64	5905-01-055-9198	12	29
	16	57		16	90
5910-01-039-8150	18	1	5910-01-056-2163	13	10
5962-01-040-6377	10	84	5905-01-056-3498	16	106
5905-01-042-5044	14	61	5910-01-056-5015	6	18
5962-01-042-5709	5	69		8	6
	6	67	5999-01-057-4610	14	82
5910-01-043-6897	6	13	5961-01-057-6119	3	32
	11	20		4	34
5910-01-043-6898	6	11		5	35
	8	1		8	30
5910-01-043-8883	10	26	5910-01-057-8163	3	13
5910-01-044-3580	6	14		4	19

NATIONAL STOCK NUMBER AND PART NUMBER INDEX

STOCK NUMBER	NATIONAL STOCK NUMBER INDEX		STOCK NUMBER	FIG.	ITEM
	FIG.	ITEM			
5910-01-057-8163	8	18	5905-01-079-9580	3	79
5962-01-058-1539	12	73		4	58
	15	40		11	48
	17	36		16	76
	15	61	5935-01-081-0156	2	51
5910-01-058-6456	14	5		4	97
5962-01-058-6767	15	38		11	107
5910-01-058-9579	16	6		12	75
5910-01-058-9584	10	12		16	155
5910-01-058-9983	6	12		17	39
5962-01-059-2590	13	74	5962-01-081-5414	3	89
	14	71		4	94
5961-01-060-4624	11	30		11	102
	16	38		16	136
5962-01-061-2207	3	91	5962-01-081-8324	4	92
	11	92	5970-01-081-8530	1	162
	12	59	5962-01-082-0083	17	30
	15	54	5935-01-082-1966	2	45
	16	140		4	89
	17	31		6	66
5962-01-061-6583	12	65		10	77
5340-01-062-6736	1	52		11	90
5340-01-063-2862	1	51		12	57
5905-01-065-6081	2	27		14	64
5905-01-066-6251	9	10		15	37
5935-01-067-1246	2	48		16	134
	15	64	5930-01-082-4289	17	27
	16	154	5905-01-082-5270	12	34
5910-01-067-5391	10	29	5962-01-082-9854	4	91
5910-01-067-7323	16	5		13	75
5905-01-068-2221	2	28	5962-01-083-3609	12	62
5905-01-068-2223	5	52	5905-01-084-2216	8	33
5962-01-068-9593	2	46	5962-01-084-6425	14	69
	3	92	5962-01-084-6427	16	143
	11	91	5935-01-084-6543	16	132
	12	58	5962-01-085-0603	12	70
	16	139	5905-01-085-9871	17	21
	17	29	5920-01-087-0836	1	217
5910-01-069-9715	13	17	5920-01-087-1951	1	216
5910-01-069-9721	12	14	5905-01-087-3163	4	75
	16	31	5905-01-087-5720	5	38
5305-01-072-9124	1	44		8	35
5962-01-073-7152	10	80	5962-01-088-3862	12	69
	11	96		15	62
	16	151		16	147
5905-01-075-2884	6	63	5910-01-089-8745	7	11
5962-01-077-2495	9	25	5910-01-089-9537	14	4
5910-01-077-8290	3	5	5905-01-090-2994	7	38
5962-01-078-7027	13	72	5962-01-091-0555	12	68
5910-01-079-2399	14	9	5930-01-091-3651	15	35

NATIONAL STOCK NUMBER AND PART NUMBER INDEX

STOCK NUMBER	NATIONAL STOCK NUMBER INDEX		STOCK NUMBER	FIG.	ITEM
	FIG.	ITEM			
5935-01-096-0010	1	167	5910-01-124-1749	11	17
5905-01-096-1764	12	37		16	4
5962-01-096-2147	15	60	5962-01-129-1152	11	106
6625-01-096-5940	15	14		16	141
6625-01-096-5943	1	5	5930-01-129-4714	15	36
6625-01-096-8911	1	7	5905-01-129-4905	14	60
5930-01-097-4308	1	213	5970-01-130-9035	1	42
5910-01-097-6584	4	5	5975-01-130-9306	1	41
5310-01-097-7987	1	230	5975-01-130-9307	1	23
5905-01-098-8545	15	26	5975-01-130-9308	1	40
5962-01-099-8505	12	72	5975-01-130-9309	1	36
	16	149	5975-01-130-9310	1	34
5962-01-101-7968	13	73	5975-01-130-9311	1	29
5962-01-102-4233	15	58	5975-01-130-9312	1	32
5962-01-103-0540	10	81	5975-01-130-9313	1	30
	12	61	5975-01-130-9314	1	28
6625-01-103-4901	1	39	5975-01-130-9315	1	13
5962-01-103-6124	11	97	5975-01-130-9316	1	16
	16	138	5975-01-130-9317	1	17
5905-01-104-0985	2	24	5975-01-130-9318	1	14
	4	83	5975-01-130-9319	1	15
5905-01-105-8049	8	64	5975-01-130-9320	1	31
5962-01-106-7727	15	52	5975-01-130-9321	1	27
5961-01-106-8189	17	4	5975-01-130-9322	1	22
5962-01-108-1966	13	76	5975-01-130-9323	1	26
5961-01-108-9528	14	17	5975-01-130-9324	1	19
5962-01-109-9745	17	33	5975-01-130-9325	1	18
5910-01-110-5809	2	4	5975-01-130-9326	1	24
	5	5	5975-01-130-9327	1	10
	6	5	5975-01-130-9328	1	11
	10	3	5975-01-130-9329	1	9
5962-01-110-7284	4	95	5975-01-130-9330	1	12
	7	53	5975-01-130-9331	1	20
	8	72	5975-01-130-9332	1	37
	13	71	5975-01-130-9333	1	38
	14	66	5970-01-131-8053	1	184
5962-01-111-1025	15	42	5970-01-131-8054	1	136
5910-01-111-1289	2	10	5945-01-131-9889	3	27
	14	7	5950-01-131-9958	4	32
5935-01-116-3591	17	38	5950-01-131-9959	6	35
6625-01-118-8222	1	57	5950-01-131-9960	6	36
5962-01-119-4692	16	148	5950-01-131-9962	5	30
5935-01-119-6840	1	164	5950-01-131-9963	5	31
5950-01-121-9464	13	30	5950-01-131-9965	2	44
	14	24	5950-01-131-9966	4	30
5945-01-122-9077	2	15		11	31
	3	26	5950-01-131-9967	5	28
5910-01-123-0742	14	1		6	32
5962-01-123-8136	7	58	5950-01-131-9969	3	29
5910-01-124-1749	10	22	5950-01-131-9970	4	31

NATIONAL STOCK NUMBER AND PART NUMBER INDEX

STOCK NUMBER	NATIONAL STOCK NUMBER INDEX		STOCK NUMBER	FIG.	ITEM
	FIG.	ITEM			
5950-01-131-9970	13	31	6625-01-132-3757	1	85
	18	15	6625-01-132-3758	1	86
5950-01-131-9971	5	27	6625-01-132-3759	1	84
	6	31	5905-01-132-4351	4	53
5950-01-131-9972	5	29	5950-01-132-4481	7	27
	6	34		13	32
5950-01-131-9973	6	29	5955-01-132-4484	12	76
5950-01-131-9974	6	33	5955-01-132-4485	13	79
5950-01-131-9975	7	22	5955-01-132-4559	10	85
	14	22	6625-01-132-4606	1	143
5950-01-131-9976	10	41	6625-01-132-4625	1	83
5950-01-131-9977	10	44	6625-01-132-4626	1	68
5950-01-131-9978	10	46	6625-01-132-4627	1	71
5950-01-131-9979	10	47	6625-01-132-4629	1	181
5950-01-131-9980	10	48	5955-01-132-5349	12	77
5950-01-131-9981	10	49	6625-01-132-5399	1	93
5950-01-131-9982	10	50	6625-01-132-5400	1	82
5950-01-131-9983	10	51	5975-01-132-8840	1	25
5950-01-131-9984	13	24	5910-01-133-1077	10	11
5950-01-131-9985	13	26	5910-01-133-1078	10	18
5950-01-131-9986	13	27	5910-01-133-1080	4	18
5950-01-131-9987	13	28	5910-01-133-1081	5	3
5950-01-131-9988	14	23	5910-01-133-1082	14	15
5950-01-131-9991	5	26		17	3
	6	30	5910-01-133-1092	2	6
	7	26	5935-01-133-1110	15	65
5950-01-131-9993	2	17	5935-01-133-1112	1	165
5950-01-131-9994	1	222	5935-01-133-1125	17	15
5950-01-132-0161	5	68	5935-01-133-1126	17	16
	6	65	5935-01-133-1127	18	12
5950-01-132-1611	18	22	5935-01-133-1131	1	72
5950-01-132-1613	7	24	5935-01-133-1135	17	13
	8	26	5935-01-133-1136	18	11
5950-01-132-1614	2	23	5935-01-133-1137	18	29
	8	28	5935-01-133-1161	3	25
5950-01-132-1617	18	21		5	24
6625-01-132-1728	1	99		6	27
6625-01-132-1729	1	79		7	20
6625-01-132-1730	1	80		8	22
6625-01-132-1731	1	81		13	23
6625-01-132-1732	1	67		14	20
6625-01-132-1733	1	87	5935-01-133-1166	1	114
6625-01-132-1734	1	77	5935-01-133-1167	1	145
6625-01-132-1735	1	70	5930-01-133-1199	17	28
5950-01-132-3513	5	32	5961-01-133-1250	17	12
5950-01-132-3514	8	24	5961-01-133-1253	5	21
5950-01-132-3515	8	25	5961-01-133-1254	6	26
5950-01-132-3516	10	42	5905-01-133-3394	11	76
5950-01-132-3517	10	43	5905-01-133-3423	15	21
5950-01-132-3518	10	45		17	22

NATIONAL STOCK NUMBER AND PART NUMBER INDEX

STOCK NUMBER	NATIONAL STOCK NUMBER INDEX		STOCK NUMBER	FIG.	ITEM
	FIG.	ITEM			
5962-01-133-3639	11	93	5910-01-142-2914	14	3
5935-01-133-3938	1	170	5910-01-142-3370	11	24
5995-01-133-4007	1	109	6625-01-142-6723	1	110
5995-01-133-4010	1	88	6625-01-142-6762	1	74
5962-01-133-4160	7	54	6625-01-143-5841	1	104
	8	69	5950-01-143-6768	2	23
5995-01-133-4274	1	65	5910-01-145-0421	3	8
5995-01-133-4275	1	64	5955-01-147-1555	16	156
5995-01-133-4276	1	66	5961-01-147-2405	17	9
5995-01-133-4277	1	63	5962-01-147-5791	16	150
5995-01-133-4278	1	62	5950-01-147-8806	2	42
5975-01-133-4291	1	21	5950-01-147-8807	2	43
5940-01-133-5441	4	98	5961-01-148-3336	11	29
5955-01-133-5472	7	59	5910-01-148-4858	18	6
5962-01-133-6737	11	94	5962-01-148-4962	16	153
	12	60	5950-01-148-6121	2	20
5962-01-133-6738	11	105	5905-01-148-6750	16	51
5962-01-133-6744	12	63	5905-01-148-6751	16	52
5962-01-133-6745	15	44	5910-01-148-6774	16	28
5962-01-133-6746	15	45	5905-01-148-7722	16	46
5962-01-133-6747	15	46	5945-01-149-1160	1	228
5962-01-133-6748	15	47	5935-01-149-2471	1	209
5962-01-133-7147	17	34	5961-01-150-5508	5	84
5962-01-133-7563	15	48		6	77
5962-01-133-7564	15	49	5910-01-153-9284	12	3
5962-01-133-7565	15	50	5950-01-155-4796	3	28
5962-01-133-7566	17	32	5962-01-157-3646	6	68
5962-01-133-9397	10	82		10	83
	11	103	5962-01-158-5204	4	90
	16	146	5955-01-159-2393	5	70
5910-01-133-9459	9	1		6	69
5995-01-134-3763	1	107	5955-01-159-2499	9	27
5340-01-135-3719	1	211	5910-01-161-4712	3	18
5340-01-135-3725	1	173		3	19
5340-01-135-4194	1	45		16	16
5340-01-135-9591	1	6	6625-01-163-9024	1	158
5961-01-136-6853	3	34	5950-01-170-6392	2	18
5340-01-136-7384	1	171	5905-01-171-5662	12	35
5905-01-137-0081	2	41	6625-01-174-0496	1	141
5935-01-138-6074	1	119	5961-01-174-6427	17	11
5975-01-141-0577	1	35	6625-01-175-4906	1	61
5975-01-141-0578	1	33	5935-01-181-0024	15	66
6625-01-141-8859	1	100	5910-01-186-6789	18	2
5930-01-141-9419	1	166	5962-01-199-6736	7	56
6625-01-142-0903	1	146	5970-01-214-6485	1	132
6625-01-142-0904	1	89	5970-01-214-6490	9	35
6625-01-142-0905	1	90	5970-01-214-6491	1	206
6625-01-142-0906	1	92	5950-01-214-8399	12	18
6625-01-142-0907	1	69		13	29
5910-01-142-2914	5	1		14	26

NATIONAL STOCK NUMBER AND PART NUMBER INDEX

STOCK NUMBER	NATIONAL STOCK NUMBER INDEX		FIG.	ITEM
	FIG.	ITEM		
5950-01-214-8399	15	15		
	17	17		
5935-01-215-1415	1	155		
5962-01-215-1751	15	46		
5962-01-215-1752	15	44		
5970-01-215-2105	1	134		
5970-01-215-2106	1	133		
5970-01-215-2107	1	135		
5962-01-215-4360	15	49		
5962-01-215-4361	15	45		
5945-01-215-4649	2	16		
5905-01-216-0998	2	25		
5905-01-216-0999	16	48		
5905-01-216-1000	16	49		
5905-01-216-1001	16	50		
5965-01-216-1992	1	117		
5905-01-216-2107	10	52		
5905-01-216-2108	10	53		
5905-01-216-2109	16	47		
5310-01-216-3680	1	214		
5905-01-216-4338	16	43		
5905-01-216-6447	16	44		
5962-01-216-6942	10	78		
	16	135		
5340-01-218-1582	1	3		

NATIONAL STOCK NUMBER AND PART NUMBER INDEX

FSCM	PART NUMBER	PART NUMBER INDEX STOCK NUMBER	FIG.	ITEM
28480	A-1855-0410-1	5961-01-054-2140	3	31
28480	A-2110-0564-1	5920-01-087-1951	1	216
51870	AD536AJD		4	93
			11	95
			16	145
88044	AN960C8	5310-00-685-3744	1	220
83058	BS10370		16	160
52072	CA28SD10SD	5935-01-116-3591	17	38
81349	CCR05CG101GR	5910-01-058-6456	14	5
81349	CCR09CG330GR	5910-01-123-0742	14	1
81349	CCR09CG470GR	5910-01-089-8745	7	11
81349	CCR09CH2R2CR		3	14
81349	CCR19CG150GM	5910-01-142-2914	5	1
			14	3
81349	CCR75CG100GR	5910-01-067-7323	16	5
81349	CCR75CG220GR	5910-01-069-9715	13	17
81349	CCR75CG510GR	5910-01-145-0421	3	8
81349	CCR75CG820GR	5910-01-077-8290	3	5
81349	CCR77CG102GR	5910-01-069-9721	12	14
			16	31
81349	CC22CH100C	5910-00-726-8695	5	13
			8	7
81349	CC22CH6R8C	5910-00-855-2389	5	14
81349	CC22CK1R5C	5910-00-543-0506	8	5
27014	CD4046BMJ/883B	5962-01-099-8505	12	72
			16	149
81349	CFR02AQC562GM	5910-01-097-6584	4	5
00144	CJ1010	5935-00-064-3037	1	152
81349	CMR05C150J0DR	5910-01-067-5391	10	29
81349	CMR05E240J0DR	5910-01-038-6392	4	14
			10	25
81349	CMR05E330G0DR	5910-01-043-8883	10	26
81349	CMR05E510G0DR	5910-01-010-7561	5	12
81349	CMR05E620G0DR	5910-01-043-6898	6	11
			8	1
81349	CMR05E680G0DR	5910-01-044-5615	11	21
			13	18
81349	CMR05F131G0DR	5910-01-043-6897	6	13
			11	20
81349	CMR05F221G0DR	5910-01-044-8563	10	36
81349	CMR05F910G0DR	5910-01-056-5015	6	18
			8	6
81349	CMR06F102F0DR	5910-01-044-3580	6	14
			10	8
			11	16
81349	CMR06F122F0DR	5910-01-058-9983	6	12
81349	CMR06F202F0DR	5910-01-058-9579	16	6
81349	CMR06F302F0DR	5910-01-034-9281	10	16
			16	25
81349	CMR06F332G0DR	5910-01-052-2963	6	8
81349	CMR06F472G0DR	5910-01-030-9211	6	15

NATIONAL STOCK NUMBER AND PART NUMBER INDEX

FSCM	PART NUMBER	PART NUMBER INDEX		FIG.	ITEM
		STOCK NUMBER			
81349	CMR06F472GODR	5910-01-030-9211		10	5
81349	CMR06F561F0DR	5910-01-058-9584		10	12
81349	CMR06F621G0DR	5910-01-038-5394		4	6
				10	38
				15	10
81349	CM10CD050D03	5910-00-118-7902		6	24
81349	CM10ED300G03	5910-00-106-6977		2	1
				4	14
				8	8
81349	CM10ED390G03	5910-00-075-9238		4	14
81349	CM10ED560G03	5910-00-085-0438		5	15
81349	CM10FD101G03	5910-00-866-3123		4	9
				7	8
				8	4
				11	9
				16	14
81349	CM10FD121G03	5910-00-068-3898		6	1
				10	24
				11	1
				14	13
81349	CM10FD161G03	5910-00-107-2540		11	20
				13	7
81349	CM10FD201G03	5910-00-134-0621		2	8
				11	20
81349	CM10FD221G03	5910-00-106-3615		7	9
81349	CM10FD241G03	5910-00-998-5447		12	13
				13	12
81349	CM10FD391G03	5910-00-018-0918		15	9
81349	CM11FD471G03	5910-00-247-8626		4	20
91637	CSP09C07-472J	5905-01-085-9871		17	21
16546	C31A103K	5910-00-116-8239		3	20
				4	16
				5	2
				6	3
				7	5
				9	3
				10	1
				11	8
				12	1
				13	4
				15	5
				16	10
				17	2
16546	C31C104K	5910-01-022-1966		7	4
				9	2
				11	6
				12	6
				15	4
				16	8
09922	DILB16P108	5935-01-067-1246		2	48
				15	64

NATIONAL STOCK NUMBER AND PART NUMBER INDEX

FSCM	PART NUMBER	PART NUMBER INDEX		FIG.	ITEM
		STOCK NUMBER			
09922	DILB16P108	5935-01-067-1246		16	154
72136	DM15FA911G0	5910-00-054-0761		10	35
72136	DM19F622G0300WV4			6	20
27014	DM81LS97AN	5962-01-058-6767		15	38
28520	DP562	5340-01-135-3719		1	211
81349	F02A250B1A			1	1
81349	F02A250V2A	5920-00-280-4960		1	218
34148	F10016DC	5962-01-051-6527		14	67
73957	GP24-063X250-14			15	67
				16	157
79727	G111-0004	5930-00-492-2561		11	89
84411	HEW249-10UF10PCT 50V			11	10
32293	IM65X61AMJN/883B	5962-01-102-4233		15	58
81349	JAN1N4150	5961-00-175-8467		4	22
				8	20
				16	33
81349	JAN1N4370A	5961-00-939-4263		17	6
81349	JAN1N485B	5961-00-840-5466		3	21
				17	5
81349	JAN1N5711	5961-00-232-3279		15	12
				16	36
81349	JAN1N645	5961-00-087-6047		11	27
				16	35
81349	JAN1N752A	5961-00-995-2310		16	37
81349	JAN1N754A	5961-00-852-7549		11	28
				16	34
81349	JAN1N825	5961-00-923-3940		3	22
				4	24
				12	17
81349	JAN1N965B	5961-00-752-6163		9	6
81349	JAN2N2369A	5961-00-926-0237		13	35
81349	JAN2N3638A	5961-00-912-9008		17	18
46384	KF2M3ZI			7	68
16428	KH7147	6150-00-041-5038		1	2
27014	LF13508D	5962-01-133-6737		11	94
				12	60
12040	LM307H	5962-00-252-4926		4	96
				10	79
				11	99
				13	77
				14	65
				16	137
27014	LM348J	5962-01-133-6738		11	105
27014	LM377N	5962-01-053-2508		11	101
22753	MA012-4CEP2W			14	63
04222	MA101A101JAA			12	10
				16	29
04222	MA101A560JAA			13	3
04222	MA201A821JAA			3	12
04713	MC10138L	5962-01-059-2590		13	74

NATIONAL STOCK NUMBER AND PART NUMBER INDEX

FSCM	PART NUMBER	PART NUMBER INDEX	
		STOCK NUMBER	FIG. ITEM
04713	MC10138L	5962-01-059-2590	14 71
04713	MC12002P	5962-01-133-4160	7 54
			8 69
04713	MC1405L	5962-01-083-3609	12 62
04713	MC14568BCP	5962-01-199-6736	7 56
04713	MC4558CG	5962-01-216-6942	10 78
			16 135
04713	MC6800S	5962-01-046-9457	15 43
04713	MC6821S	5962-01-048-5850	15 51
04713	MC6875L	5962-01-111-1025	15 42
04713	MPSH10	5961-00-544-5753	3 35
			4 37
			5 34
04713	MPSH81	5961-01-045-9170	13 37
96906	MS14046-1	5950-00-308-7930	3 30
96906	MS15795-806	5310-00-880-5976	1 202
96906	MS16535-156	5320-00-826-0329	1 199
96906	MS16535-160	5320-00-879-6604	1 227
96906	MS16535-79	5320-00-837-4067	16 161
19647	MS210N	5905-01-216-0998	2 25
96906	MS21266-1N	5325-00-960-2410	1 172
96906	MS24693C46	5305-00-902-2136	1 205
96906	MS24693C48	5305-00-889-2991	1 50
96906	MS27183-3	5310-00-951-4679	1 198
96906	MS27183-4	5310-00-950-1310	1 149
96906	MS27183-5	5310-00-983-8483	1 204
96906	MS35333-105	5310-00-019-0669	9 28
96906	MS35333-108	5310-00-022-8834	1 121
96906	MS35333-113	5310-00-042-4229	1 207
96906	MS35333-35	5310-00-579-5554	18 28
96906	MS35333-71	5310-00-616-3555	1 197
96906	MS35335-29	5310-00-616-3554	1 46
96906	MS35335-57	5310-00-058-3599	9 33
96906	MS35338-136	5310-00-929-6395	1 102
96906	MS35338-40	5310-00-543-2410	1 112
96906	MS35338-42	5310-00-045-3299	1 224
96906	MS35340-40	5310-00-655-9505	1 76
96906	MS51957-17	5305-00-054-5651	9 34
96906	MS51957-28	5305-00-054-6652	1 47
96906	MS51958-60	5305-00-059-3656	18 27
96906	MS51963-21	5305-00-719-5330	1 130
96906	MS51963-9	5305-00-717-6950	1 125
96906	MS75084-8	5950-00-031-4571	7 23
			13 25
96906	MS90538-01	5950-00-827-5209	2 21
96906	MS90538-03	5950-00-828-1305	15 16
96906	MS90538-09	5950-00-269-2978	12 21
96906	MS90538-12	5950-00-075-9144	2 22
			8 29
96906	MS90538-14	5950-00-470-9400	12 20
			16 40

NATIONAL STOCK NUMBER AND PART NUMBER INDEX

FSCM	PART NUMBER	PART NUMBER INDEX		FIG.	ITEM
		STOCK NUMBER			
96906	MS90538-20	5950-00-994-6600		7	21
96906	MS90539-15	5950-00-893-8650		12	19
04713	MV109	5961-01-005-5155		1	97
				7	16
				13	21
82389	M114B	5935-01-138-6074		1	119
09966	M235A147-1	5961-00-540-9621		1	161
81349	M38510-30003BCB	5962-01-027-6863		15	41
81349	M38510-30005BCX	5962-01-030-6352		12	74
				16	152
81349	M38510/00803BCB	5962-00-369-9839		12	64
81349	M38510/06003BEB	5962-01-082-9854		4	91
				13	75
81349	M38510/06006BEB	5962-01-078-7027		13	72
81349	M38510/06101BEB	5962-01-084-6425		14	69
81349	M38510/10101BGC	5962-00-167-6330		11	98
81349	M38510/10104BGC	5962-01-010-7808		7	57
				8	71
				13	78
81349	M38510/10107BGC	5962-01-040-6377		10	84
81349	M38510/10304BGC	5962-01-048-7767		7	55
				15	55
				16	142
81349	M38510/10901BGC	5962-01-049-0349		15	53
81349	M38510/11004BCC	5962-01-103-0540		10	81
				12	61
81349	M38510/11201BCB	5962-01-088-3862		12	69
				15	62
				16	147
81349	M38510/11301BEC	5962-01-129-1152		11	106
				16	141
81349	M38510/30007BCB	5962-01-026-2493		15	39
81349	M38510/30501BCB	5962-01-031-1918		15	57
81349	M38510/30605BCB	5962-01-068-9593		2	46
				3	92
				11	91
				12	58
				16	139
				17	29
81349	M38510/30608BEB	5962-01-106-7727		15	52
81349	M38510/30701BEB	5962-01-050-0918		15	56
81349	M38510/30908BEB	5962-01-058-4868		15	61
81349	M38510/31004BCB	5962-01-034-9832		12	67
				15	59
81349	M38510/31302BCB	5962-01-061-6583		12	65
81349	M38510/31403BCB	5962-01-084-6427		16	143
81349	M38510/31602BEB	5962-01-085-0603		12	70
81349	M38510/32701BEB	5962-01-091-0555		12	68
81349	M3851030905BCB			15	63
81349	M3851032204BEB			17	35
81349	M39003/01-2962	5910-00-007-2000		5	18

NATIONAL STOCK NUMBER AND PART NUMBER INDEX

FSCM	PART NUMBER	PART NUMBER INDEX	
		STOCK NUMBER	FIG. ITEM
81349	M39003/01-2962	5910-00-007-2000	8 15
81349	M39003/01-2964	5910-00-010-8422	4 12
81349	M39003/01-2966	5910-00-007-2001	3 10
			7 14
			8 10
81349	M39003/01-2977	5910-00-189-4248	3 9
			7 2
			12 15
81349	M39003/01-2983	5910-00-007-7471	5 19
81349	M39003/01-2988	5910-00-010-8159	7 10
			12 2
			15 1
81349	M39003/01-2991	5910-00-007-3974	2 9
			3 15
			4 4
			5 8
			6 10
			8 17
			12 7
			13 13
			15 3
			16
81349	M39003/01-3003	5910-00-007-2002	8 13
			16 17
81349	M39003/01-3005	5910-00-481-0470	11 23
81349	M39003/01-3006	5910-00-113-5475	4 13
			10 2
			11 13
			16 15
81349	M39003/01-3009	5910-00-007-2003	3 17
			4 11
			7 1
			13 16
			14 6
81349	M39003/01-3018	5910-00-114-0221	16 32
81349	M39003/01-3076	5910-00-495-0042	16 24
81349	M39003/01-3088	5910-00-007-2004	4 17
			11 14
81349	M39012/21-0002	5935-00-853-7596	1 210
81349	M39014/05-2237	5910-00-098-9281	11 25
81349	M39014/05-2291	5910-00-113-5610	16 22
81349	M39018/06-0044M	5910-01-186-6789	18 2
18324	NE5534AN	5962-01-157-3646	6 68
			10 83
01961	PE8117	5950-01-132-1611	18 22
91637	PTF55-9001B		3 39
55940	Q2-33TAPPED	5950-01-131-9967	5 28
			6 32
55940	Q2V-15T	5950-01-131-9988	14 23
81349	RCR07G100JS	5905-00-107-0656	3 43
			6 47

NATIONAL STOCK NUMBER AND PART NUMBER INDEX

FSCM	PART NUMBER	PART NUMBER INDEX		FIG.	ITEM
		STOCK NUMBER			
81349	RCR07G100JS	5905-00-107-0656		7	42
				11	60
				12	48
				16	83
				17	26
81349	RCR07G101JS	5905-00-141-1183		1	118
				2	40
				3	67
				4	76
				5	50
				6	41
				7	43
				8	45
				9	22
				11	59
				15	33
81349	RCR07G102JS	5905-00-110-7620		3	85
				4	78
				5	59
				6	58
				7	35
				8	39
				9	14
				11	34
				13	50
				16	72
81349	RCR07G103JS	5905-00-106-3666		3	82
				4	52
				7	32
				9	21
				11	33
				12	31
				16	79
				18	18
				7	37
				8	51
81349	RCR07G104JS	5905-00-110-0388		11	36
				12	49
				16	84
				2	36
				4	68
81349	RCR07G105JS	5905-00-116-8554		7	46
				15	24
				7	34
				7	41
				8	34
81349	RCR07G112JS	5905-00-119-8855		3	65
				7	30
				8	46
				11	73
				16	85
81349	RCR07G121JS	5905-00-119-8812		7	34
				7	41
				8	34
				3	65
				7	30
81349	RCR07G131JS	5905-00-136-8405		8	46
				8	46
				11	73
				11	73
				16	85
81349	RCR07G152JS	5905-00-106-1356		3	65
				7	30
				8	46
				11	73
				16	85
81349	RCR07G154JS	5905-00-114-5339		7	34
				7	41
				8	34
				3	65
				7	30

NATIONAL STOCK NUMBER AND PART NUMBER INDEX

FSCM	PART NUMBER	PART NUMBER INDEX	
		STOCK NUMBER	FIG. ITEM
81349	RCR07G155JS	5905-00-111-1684	16 108
81349	RCR07G164JS	5905-00-126-6690	9 18
81349	RCR07G181JS	5905-00-141-0742	5 48
			6 53
81349	RCR07G182JS	5905-00-114-5343	7 51
			17 20
81349	RCR07G183JS	5905-00-115-3560	12 28
81349	RCR07G200JS	5905-00-135-3972	17 25
81349	RCR07G201JS	5905-00-111-4845	8 59
			15 18
81349	RCR07G202JS	5905-00-114-0708	3 76
			4 42
			8 44
			9 16
			11 75
			13 51
			14 52
			15 28
			16 82
81349	RCR07G203JS	5905-00-106-9356	4 49
			11 72
			12 50
			13 54
			16 75
81349	RCR07G220JS	5905-00-106-3668	13 56
81349	RCR07G222JS	5905-00-105-7764	7 31
			12 25
81349	RCR07G223JS	5905-00-116-8556	12 27
81349	RCR07G224JS	5905-00-105-7765	12 26
81349	RCR07G240JS	5905-00-442-9356	5 57
81349	RCR07G241JS	5905-00-435-1718	15 22
81349	RCR07G242JS	5905-00-136-8406	3 73
			8 68
81349	RCR07G243JS	5905-00-141-1295	4 47
			11 71
			16 71
81349	RCR07G270JS	5905-00-113-4860	4 45
			17 19
81349	RCR07G271JS	5905-00-119-3503	7 39
			8 40
			11 47
			16 67
81349	RCR07G272JS	5905-00-111-4727	5 46
			6 51
81349	RCR07G3R3JS	5905-00-128-6237	3 86
81349	RCR07G301JS	5905-00-111-4750	4 46
			7 47
81349	RCR07G302JS	5905-00-131-9729	11 68
			15 20
81349	RCR07G303JS	5905-00-121-9920	4 77
			7 50

NATIONAL STOCK NUMBER AND PART NUMBER INDEX

FSCM	PART NUMBER	PART NUMBER INDEX		FIG.	ITEM
		STOCK NUMBER			
81349	RCR07G305JS	5905-00-121-9921		3	48
81349	RCR07G331JS	5905-00-114-0710		8	36
				13	43
81349	RCR07G332JS	5905-00-126-6683		4	40
				7	33
81349	RCR07G333JS	5905-00-118-4559		12	33
81349	RCR07G362JS	5905-00-104-8369		3	64
				4	50
81349	RCR07G391JS	5905-00-121-9932		9	24
				15	30
81349	RCR07G4R7JS	5905-00-246-9393		3	75
81349	RCR07G430JS	5905-00-115-2223		4	43
				13	49
81349	RCR07G470JS	5905-00-104-8368		3	52
				4	80
				7	36
				8	37
				14	32
81349	RCR07G471JS	5905-00-120-9154		3	83
				4	79
				7	52
				8	67
				11	67
				13	44
				14	55
				15	25
81349	RCR07G472JS	5905-00-114-0711		2	39
				3	84
				4	74
				8	38
				9	17
				11	58
				16	70
81349	RCR07G473JS	5905-00-141-0717		11	37
81349	RCR07G510JS	5905-00-106-1249		4	44
				5	65
				15	34
81349	RCR07G511JS	5905-00-116-2394		3	74
				5	58
81349	RCR07G512JS	5905-00-111-1679		4	39
				12	36
				13	55
				16	89
81349	RCR07G513JS	5905-00-136-3890		7	45
				8	61
				10	59
				11	74
				15	32
81349	RCR07G515JS	5905-00-435-6432		13	66
81349	RCR07G515JS	5905-00-435-6432		13	66
81349	RCR07G560JS	5905-00-133-0440		7	40
81349	RCR07G563JS	5905-00-106-1357		4	38

NATIONAL STOCK NUMBER AND PART NUMBER INDEX

FSCM	PART NUMBER	PART NUMBER INDEX		FIG.	ITEM
		STOCK NUMBER			
81349	RCR07G6R2JS	5905-00-465-0335		3	81
81349	RCR07G622JS	5905-00-228-5506		5	45
				6	50
81349	RCR07G681JS	5905-00-135-6046		7	44
				13	52
81349	RCR07G683JS	5905-00-119-3505		10	58
				12	32
81349	RCR07G750JS	5905-00-106-9357		5	47
81349	RCR07G751JS	5905-00-126-6696		16	94
81349	RCR07G752JS	5905-00-141-1132		4	41
				8	62
81349	RCR07G753JS	5905-00-121-9938		11	84
				12	30
81349	RCR07G823JS	5905-00-435-6374		7	49
81349	RCR20G102JS	5905-00-110-0196		18	20
81349	RCR20G202JS	5905-00-935-8539		18	16
81349	RCR20G471JS	5905-00-111-4858		18	17
81349	RCR20G821JS	5905-00-116-8569		9	23
72136	RDM15C200J3C	5910-00-430-5647		4	14
				10	30
72136	RDM15E560J3C	5910-00-085-0438		10	32
				11	5
				16	12
72136	RDM15E750J3C	5910-00-719-9879		12	12
				13	19
72136	RDM15F361F3C	5910-00-469-2823		10	15
00853	RDM15F471J3C	5910-00-247-8626		10	4
				14	14
00853	RDM19E782F1S	5910-01-133-1078		10	18
00853	RDM19F122F1S			10	19
72136	RDM20F252F5C			10	9
94375	RF-03152M	5935-01-149-2471		1	209
81349	RNC55H9000BS	5905-01-013-4348		3	40
81349	RNC55K24R9FS	5905-00-232-9912		6	44
				14	36
81349	RNC55K2802FS	5905-00-758-4792		16	87
81349	RNC55K3922FS	5905-00-270-4960		16	112
81349	RNC55K4641FS	5905-00-270-1403		16	86
81349	RNC55K82R5FS	5905-00-452-0736		13	48
81349	RNC60H1000FS	5905-00-471-2259		5	39
				6	45
				8	41
				10	60
				13	42
				14	49
				16	104
81349	RNC60H1470FS	5905-00-462-5669		3	38
81349	RNC60H2210FS	5905-00-006-6981		5	36
				6	42
81349	RNC60H3320FS	5905-00-758-4811		5	60
				11	80

NATIONAL STOCK NUMBER AND PART NUMBER INDEX

FSCM	PART NUMBER	PART NUMBER INDEX		FIG.	ITEM
		STOCK NUMBER			
81349	RNC60H3320FS	5905-00-758-4811		14	59
81349	RNC60H4750FS	5905-00-481-6111		5	63
81349	RNC60H5421DS	5905-01-096-1764		12	37
81349	RNC60H6042FS	5905-00-146-4165		4	73
81349	RNC60H7502FS	5905-00-154-7029		10	63
				14	50
81349	RNC60H9090FS	5905-00-471-2261		16	88
81349	RNC60J1001FS	5905-00-721-2353		12	39
81349	RNC60J1242FS	5905-00-430-6486		13	65
				16	53
81349	RNC60J1582FS	5905-00-432-8648		16	56
81349	RNC60J2873BS	5905-00-402-1185		16	116
81349	RNC60J5491FS	5905-00-432-8956		2	38
				11	85
81349	RNC60J5621FS	5905-00-689-4720		14	47
81349	RNC60J6192FS	5905-00-432-5846		4	67
				14	56
81349	RNC60J9091FS	5905-00-431-9764		11	63
				15	23
81349	RNC60J9092FS	5905-00-408-9105		8	55
				14	42
				15	31
81349	RNC60K10R0BS			3	57
				10	57
				14	57
81349	RNC60K10R2FS	5905-01-068-2221		2	28
81349	RNC60K10R5FS	5905-01-065-6081		2	27
81349	RNC60K1001FS	5905-00-432-6410		3	63
				4	63
				6	57
				8	60
				11	69
				12	42
				13	46
				14	31
				16	65
81349	RNC60K1002FS	5905-00-426-7095		2	26
				4	64
				10	66
				11	46
				12	43
				13	60
				14	43
				16	54
81349	RNC60K1003FS	5905-00-137-0804		3	50
				4	69
				8	55
				10	65
				11	45
				13	59
				15	19

NATIONAL STOCK NUMBER AND PART NUMBER INDEX

FSCM	PART NUMBER	PART NUMBER INDEX STOCK NUMBER	FIG.	ITEM
81349	RNC60K1003FS	5905-00-137-0804	16	68
81349	RNC60K1004FS	5905-00-189-2454	8	50
			11	82
			13	64
			16	80
81349	RNC60K1022FS	5905-00-361-8419	4	61
81349	RNC60K1023FS	5905-00-521-2506	16	115
81349	RNC60K11R8FS		5	41
81349	RNC60K1100FS	5905-00-452-0742	3	49
			6	39
81349	RNC60K1101FS	5905-00-173-1622	3	59
81349	RNC60K1102FS	5905-00-142-0903	11	65
81349	RNC60K1103FS	5905-00-189-2456	11	78
			16	99
81349	RNC60K1130FS	5905-00-325-6796	3	44
81349	RNC60K1131FS	5905-00-320-6545	4	62
81349	RNC60K1152FS	5905-00-259-4629	4	72
			11	41
			16	60
81349	RNC60K1210FS	5905-00-452-0743	3	58
			16	131
81349	RNC60K1211FS	5905-00-426-7120	2	31
			11	77
81349	RNC60K1212FS	5905-00-308-7594	14	45
			16	130
81349	RNC60K1240FS	5905-00-284-7841	10	60
81349	RNC60K1241FS	5905-00-628-4661	3	80
			14	41
81349	RNC60K1301FS	5905-00-028-1832	17	24
81349	RNC60K1302FS	5905-00-006-5576	12	44
81349	RNC60K1373FS	5905-00-506-6415	16	119
81349	RNC60K1403FS	5905-00-199-6290	16	109
81349	RNC60K1472FS	5905-00-273-9687	6	60
			16	58
81349	RNC60K15R0FS	5905-01-051-3945	2	30
			5	64
81349	RNC60K1500FS	5905-00-232-7791	5	40
			6	40
			10	60
			13	45
81349	RNC60K1501FS	5905-00-758-4840	5	62
			12	41
81349	RNC60K1503FS	5905-00-192-3876	10	55
			11	51
81349	RNC60K1542FS	5905-00-261-7689	10	71
81349	RNC60K1580FS	5905-00-430-1637	8	65
81349	RNC60K1622FS	5905-00-259-4626	13	61
			16	66
81349	RNC60K1691FS	5905-00-112-7039	10	75
81349	RNC60K1693FS	5905-00-112-9215	16	117
81349	RNC60K17R8FS	5905-01-068-2223	5	52

NATIONAL STOCK NUMBER AND PART NUMBER INDEX

FSCM	PART NUMBER	PART NUMBER INDEX		FIG.	ITEM
		STOCK NUMBER			
81349	RNC60K18R2FS	5905-01-084-2216		8	33
81349	RNC60K1822FS	5905-00-195-6379		17	23
81349	RNC60K1912FS	5905-00-140-7142		3	66
				12	54
				16	125
81349	RNC60K2000FS	5905-00-142-0901		4	51
				8	42
				14	35
81349	RNC60K2001FS	5905-00-138-1285		8	63
				18	19
81349	RNC60K2002FS	5905-00-426-7121		4	56
				7	48
				16	45
81349	RNC60K2051FS	5905-00-758-3406		10	56
81349	RNC60K2052FS	5905-00-317-9668		6	61
81349	RNC60K21R5FS	5905-01-053-7972		14	34
81349	RNC60K2102FS	5905-00-101-2325		8	56
81349	RNC60K22R1FS	5905-01-032-6417		6	43
81349	RNC60K2212FS	5905-00-147-2062		11	81
				16	55
81349	RNC60K2213FS	5905-00-194-2324		13	57
81349	RNC60K2261FS	5905-01-023-6161		10	54
81349	RNC60K2262FS	5905-00-192-3877		16	113
81349	RNC60K2263FS	5905-00-339-7599		11	53
81349	RNC60K2432FS	5905-00-404-8782		10	55
				16	63
81349	RNC60K2490FS	5905-00-767-0978		3	46
81349	RNC60K2492FS	5905-00-192-3880		11	50
				15	29
				16	73
81349	RNC60K2493FS	5905-00-192-3882		16	114
81349	RNC60K2552FS	5905-00-321-7850		15	27
81349	RNC60K26R1FS	5905-00-026-9341		8	54
81349	RNC60K26R7FS	5905-00-001-5835		6	55
81349	RNC60K2610FS	5905-00-284-8262		14	53
81349	RNC60K2671FS	5905-00-214-1136		13	67
81349	RNC60K2672FS	5905-00-194-1691		16	102
81349	RNC60K2740FS	5905-00-428-2017		13	47
81349	RNC60K29R4FS	5905-00-552-5208		3	53
81349	RNC60K2940FS	5905-00-552-5219		5	51
81349	RNC60K3010FS	5905-00-243-5622		4	48
81349	RNC60K3011FS	5905-00-189-2467		16	92
81349	RNC60K3012FS	5905-00-195-6384		10	69
				11	44
				12	47
				16	69
81349	RNC60K3091FS	5905-00-721-2381		8	47
81349	RNC60K3160FS	5905-00-286-4543		10	74
81349	RNC60K3161FS	5905-00-451-7528		14	38
81349	RNC60K3162FS	5905-00-472-3471		6	59
				9	12

NATIONAL STOCK NUMBER AND PART NUMBER INDEX

FSCM	PART NUMBER	PART NUMBER INDEX		FIG.	ITEM
		STOCK NUMBER			
81349	RNC60K3162FS	5905-00-472-3471		10	55
81349	RNC60K3240FS	5905-00-344-1720		2	35
				3	68
				5	43
				6	48
				13	58
81349	RNC60K3242FS	5905-00-767-0983		9	13
81349	RNC60K3321FS	5905-00-025-5988		11	83
				16	81
81349	RNC60K3400FS	5905-01-032-9758		8	43
81349	RNC60K3480FS	5905-00-452-0753		5	43
				6	48
81349	RNC60K3481FS	5905-00-452-0754		12	40
81349	RNC60K3482FS	5905-00-189-2468		10	67
				16	107
81349	RNC60K3570FS	5905-00-428-8317		13	69
				14	40
81349	RNC60K3572FS	5905-00-160-4905		4	60
				11	42
				16	128
81349	RNC60K3573FS	5905-00-348-2710		16	91
81349	RNC60K3740FS	5905-00-517-9352		5	43
				6	48
				11	70
81349	RNC60K3742FS	5905-00-006-6985		16	59
81349	RNC60K3921FS	5905-00-259-4627		8	48
				11	35
81349	RNC60K4020FS	5905-00-279-6491		4	82
				5	43
				6	48
				8	49
81349	RNC60K4021FS	5905-00-200-9602		6	62
				11	61
81349	RNC60K4022FS	5905-00-758-3436		10	76
81349	RNC60K4023FS	5905-00-273-9666		16	121
81349	RNC60K4120FS	5905-00-506-6563		3	61
81349	RNC60K4121FS	5905-00-273-9761		12	53
				16	124
81349	RNC60K4220FS	5905-00-426-7096		5	43
				6	48
81349	RNC60K4222FS	5905-00-452-0761		12	51
				16	122
81349	RNC60K4420FS	5905-00-432-0469		3	62
				6	54
				8	53
81349	RNC60K4421FS	5905-00-758-3444		5	55
81349	RNC60K4530FS	5905-00-140-7233		2	29
				4	54
				5	43
				6	48
81349	RNC60K4531FS	5905-00-261-7051		14	39

NATIONAL STOCK NUMBER AND PART NUMBER INDEX

FSCM	PART NUMBER	PART NUMBER INDEX		FIG.	ITEM
		STOCK NUMBER			
81349	RNC60K4532FS	5905-00-142-0902		14	51
81349	RNC60K4642FS	5905-00-451-7531		10	55
81349	RNC60K48R7FS	5905-01-038-1324		3	72
81349	RNC60K4870FS	5905-00-295-4769		3	56
				13	53
81349	RNC60K4872FS	5905-00-233-7145		16	100
81349	RNC60K49R9FS	5905-00-112-1026		3	87
				5	37
				6	38
				12	56
				13	41
				14	44
				16	127
81349	RNC60K4990FS	5905-00-289-3532		5	43
				6	48
				12	55
				16	126
81349	RNC60K4991FS	5905-00-451-7532		5	54
				10	61
				11	40
81349	RNC60K4992FS	5905-00-189-2477		16	105
81349	RNC60K4993FS	5905-00-432-6412		8	58
				13	63
81349	RNC60K5110FS	5905-00-214-2927		3	78
				14	37
81349	RNC60K5111FS	5905-00-142-0931		3	51
				12	46
				14	54
81349	RNC60K5230FS	5905-00-588-8342		5	43
				6	48
81349	RNC60K5232FS	5905-00-285-0546		16	96
81349	RNC60K5362FS	5905-00-189-2478		16	118
81349	RNC60K5492FS	5905-00-285-0423		10	64
81349	RNC60K5622FS	5905-00-189-2479		4	66
81349	RNC60K5761FS	5905-00-006-6987		3	60
81349	RNC60K59R0FS	5905-01-007-5603		3	54
				5	42
				13	68
81349	RNC60K5901FS	5905-00-429-3096		9	11
81349	RNC60K5902FS	5905-00-192-3883		16	98
81349	RNC60K6040FS	5905-00-273-9608		12	52
				16	123
81349	RNC60K6041FS	5905-00-192-3434		4	55
				11	86
				16	93
81349	RNC60K6043FS	5905-00-365-5560		11	43
				16	129
81349	RNC60K6342FS	5905-00-311-2131		11	66
81349	RNC60K6490FS	5905-00-340-9798		4	84
81349	RNC60K6491FS	5905-00-426-7098		2	37
81349	RNC60K6651FS	5905-00-267-1662		16	101

NATIONAL STOCK NUMBER AND PART NUMBER INDEX

FSCM	PART NUMBER	PART NUMBER INDEX		FIG.	ITEM
		STOCK NUMBER			
81349	RNC60K6652FS	5905-00-311-2116		16	61
81349	RNC60K6811FS	5905-00-451-7533		3	47
81349	RNC60K6812FS	5905-00-192-3458		16	97
81349	RNC60K6981FS	5905-00-189-2481		9	19
81349	RNC60K6982FS	5905-00-189-2482		16	97
81349	RNC60K7152FS	5905-00-264-3431		16	97
81349	RNC60K73R2FS	5905-01-029-7979		5	66
				8	66
81349	RNC60K7320FS	5905-01-013-3179		4	87
81349	RNC60K7321FS	5905-00-189-2483		3	69
				11	56
				16	78
81349	RNC60K7322FS	5905-00-320-6506		11	55
81349	RNC60K75R0FS	5905-00-426-7144		2	34
				5	49
				6	52
				8	52
				10	60
				14	30
81349	RNC60K7500FS	5905-00-451-7534		3	77
				14	33
81349	RNC60K7503FS	5905-00-140-7159		16	110
81349	RNC60K7681FS	5905-01-012-1096		11	56
81349	RNC60K8060FS	5905-00-758-3447		12	45
				14	58
81349	RNC60K8061FS	5905-00-006-5578		4	70
				9	20
				11	56
				14	46
81349	RNC60K8063FS	5905-00-284-7852		16	120
81349	RNC60K8250FS	5905-00-452-0773		3	70
				4	59
81349	RNC60K8451FS	5905-00-452-0774		16	95
81349	RNC60K8662FS	5905-00-189-2487		10	55
81349	RNC60K88R7FS	5905-01-049-4709		4	81
81349	RNC60K8870FS	5905-00-131-5877		5	56
81349	RNC60K9312FS	5905-00-140-7037		8	55
81349	RNC60K9531FS	5905-00-312-3513		11	88
81349	RNC60K9532FS	5905-00-317-8960		8	55
81349	RNC60K97R6FS	5905-01-023-1731		3	71
81349	RNC60K9761FS	5905-00-325-7686		4	64
81349	RNC60K9762FS	5905-00-112-1502		8	55
81349	RNC60K9763FS	5905-00-147-2042		8	57
81349	RNC65J1000BS	5905-00-024-0598		3	41
81349	RNC70K1244FS	5905-00-429-9726		16	103
81349	RNC70K1500FS	5905-00-257-9411		2	33
81349	RNR60K4751FM			3	55
				11	62
81349	RNR60K6340FS			6	46
81349	RWR80S1R00FS	5905-01-066-6251		9	10
81349	RWR89SR511FS	5905-01-137-0081		2	41

NATIONAL STOCK NUMBER AND PART NUMBER INDEX

FSCM	PART NUMBER	PART NUMBER INDEX		FIG.	ITEM
		STOCK NUMBER			
21317	RX1-12	5945-01-131-9889		3	27
19645	SC8431	5962-01-073-7152		10	80
				11	96
				16	151
78189	SF1904-00			5	71
				7	61
01295	SN74LS273N	5962-01-061-2207		3	91
				11	92
				12	59
				15	54
				16	140
				17	31
01295	SN74LS625N	5962-01-158-5204		4	90
04713	SPS5103	5961-00-137-4608		4	36
				7	28
				8	32
				11	32
				12	23
				16	41
04713	SR1358-8B			18	9
04222	SR205C102KAA			5	20
				5	81
				6	75
				7	12
04713	SZ30016-70	5961-01-108-9528		14	17
04713	SZ30016-98			8	19
04713	SZ40145-017			17	8
71590	TCZ-18	5910-00-806-1269		5	6
				6	6
01295	TL610CP	5962-01-148-4962		16	153
01295	TMS2114-45NL	5962-01-133-7565		15	50
34148	UA7815UC	5962-00-378-0077		18	24
18178	VTL5C3/2	5961-01-060-4624		11	30
				16	38
06776	0002984	5935-01-133-1110		15	65
28480	00312-20067			1	175
28480	0121-0036	5910-00-879-6053		4	15
28480	0121-0114	5910-00-422-0502		2	2
28480	0121-0162	5910-01-110-5809		2	4
				5	5
				6	5
				10	3
28480	0121-0455	5910-00-476-5685		3	6
98291	013-2046-00-0-68	5940-00-957-2683		8	79
	9				
28480	0140-0155	5910-00-105-5486		10	10
28480	0140-0178	5910-00-924-9758		6	19
28480	0140-0184	5910-00-866-2952		10	20
28480	0140-0193-PS	5910-00-774-7319		4	8
				7	7
				11	1

NATIONAL STOCK NUMBER AND PART NUMBER INDEX

FSCM	PART NUMBER	PART NUMBER INDEX		
		STOCK NUMBER	FIG. ITEM	
28480	0140-0194		10 37	
			11 1	
			12 11	
28480	0140-0196	5910-00-774-7294	10 31	
				11 1
28480	0140-0197	5910-00-544-6742	10 27	
				11 20
				13 8
28480	0140-0207	5910-00-940-3184	11 2	
28480	0140-0208	5910-00-914-2623	6 23	
28480	0140-0217	5910-00-902-2577	10 28	
28480	0140-0220	5910-00-772-6726	11 15	
28480	0140-0222	5910-00-772-6734	6 16	
28480	0140-0223	5910-00-933-7537	10 7	
28480	0140-0226	5910-00-831-8690	6 25	
28480	0140-0228	5910-00-469-2823	10 6	
28480	0140-0231	5910-00-728-4973	16 27	
28480	0160-0341	5910-00-776-4174	2 10	
28480	0160-0570	5910-01-111-1289	14 7	
28480	0160-0571	5910-01-079-2399	14 9	
28480	0160-0576	5910-01-006-8551	2 11	
			3 7	
			4 3	
			8 11	
			10 23	
			13 2	
			18 7	
28480	0160-0938	5910-00-138-1320	2 5	
28480	0160-0939	5910-00-455-0119	13 5	
28480	0160-0952	5910-01-038-7913	10 17	
28480	0160-2130	5910-00-001-7244	16 2	
28480	0160-2197	5910-00-472-5027	10 33	
28480	0160-2202	5910-00-719-9879	6 2	
28480	0160-2241	5910-00-903-8325	3 2	
			5 11	
28480	0160-2242	5910-00-957-2765	7 6	
28480	0160-2249	5910-00-430-5715	5 4	
28480	0160-2306	5910-00-883-6281	5 7	
			6 7	
			11 4	
			14 12	
			16 11	
28480	0160-2307	5910-00-406-9675	6 21	
			10 34	
			11 21	
			15 8	
28480	0160-2308	5910-00-469-2932	4 14	
28480	0160-2587	5910-01-028-0196	16 19	
28480	0160-2611	5910-01-024-4140	7 15	
28480	0160-2671	5910-00-138-1324	16 23	
28480	0160-3024	5910-00-430-6138	10 13	

NATIONAL STOCK NUMBER AND PART NUMBER INDEX

FSCM	PART NUMBER	PART NUMBER INDEX	
		STOCK NUMBER	FIG. ITEM
28480	0160-3024	5910-00-430-6138	16 1
28480	0160-3046	5910-00-138-5048	16 21
28480	0160-3084	5910-00-264-5596	6 17
28480	0160-3156	5910-00-175-3687	6 22
			10 14
28480	0160-3165	5910-00-138-1328	15 2
28480	0160-3288	5910-01-133-1077	10 11
28480	0160-3405	5910-01-024-4141	12 5
28480	0160-3548	5910-01-124-1749	10 22
			11 17
			16 4
28480	0160-3787	5910-00-470-2671	16 18
			18 4
28480	0160-3874	5910-01-057-8163	3 13
			4 19
			8 18
28480	0160-3875	5910-01-056-2163	13 10
28480	0160-3877	5910-01-035-6720	7 13
			13 11
28480	0160-3936	5910-00-500-9092	16 26
28480	0160-3939	5910-00-488-3049	16 20
28480	0160-4463	5910-01-148-6774	16 28
28480	0160-4557	5910-01-161-4712	3 18
			16 16
28480	0160-4812	5910-01-153-9284	12 3
28480	0170-0163	5910-00-988-1572	16 3
28480	0180-0677	5910-01-039-8150	18 1
28480	0180-2635	5910-01-133-9459	9 1
28480	0180-2735	5910-01-133-1092	2 6
28480	0180-2779	5910-01-148-4858	18 6
27264	03-09-1028	5935-01-119-6840	1 164
27264	03-09-2028	5935-01-096-0010	1 167
28480	0340-0618	5970-01-130-9035	1 42
28480	0340-0918	5970-01-131-8053	1 184
28480	03577-00901		5 80
28480	03582-04104		1 231
28480	03585-01215		1 226
28480	03585-04132		9 30
28480	03586-00106		1 150
28480	03586-00201		1 140
28480	03586-00202		1 235
28480	03586-00203		1 137
28480	03586-00601		1 178
28480	03586-00602		5 78
28480	03586-00603		1 96
28480	03586-00604		1 98
28480	03586-01201		2 49
28480	03586-01202		1 180
28480	03586-01208		1 168
28480	03586-01209		1 142
28480	03586-01211		1 159

NATIONAL STOCK NUMBER AND PART NUMBER INDEX

FSCM	PART NUMBER	PART NUMBER INDEX	
		STOCK NUMBER	FIG. ITEM
28480	03586-01214		1 176
28480	03586-01216		1 221
28480	03586-04101		1 148
28480	03586-04102		3 96
28480	03586-04104		4 99
28480	03586-04105		5 75
28480	03586-04110		6 70
28480	03586-04111		7 60
28480	03586-04115		8 74
28480	03586-04116		9 32
28480	03586-04120		10 86
28480	03586-04121		11 108
28480	03586-04122		12 78
28480	03586-04150		14 76
28480	03586-04170		16 159
28480	03586-04171		13 82
28480	03586-04185	6625-01-163-9024	1 158
28480	03586-04186		1 185
28480	03586-04187		1 189
28480	03586-04195		1 190
28480	03586-04197		1 160
28480	03586-04198	5340-01-136-7384	1 171
28480	03586-04702		1 120
28480	03586-04703		1 174
28480	03586-04704		1 78
28480	03586-20202		1 139
28480	03586-20614		1 94
28480	03586-24701		1 156
28480	03586-24702		1 153
28480	03586-26512		7 67
28480	03586-40101		1 179
28480	03586-40102		1 183
28480	03586-60603		1 105
28480	03586-60604		1 182
28480	03586-61612	5995-01-133-4007	1 109
28480	03586-61615	6625-01-142-6723	1 110
28480	03586-61671	5995-01-133-4274	1 65
28480	03586-61674	5995-01-133-4275	1 64
28480	03586-61675	5995-01-133-4276	1 66
28480	03586-61676	6625-01-141-8859	1 100
28480	03586-61677	5995-01-133-4277	1 63
28480	03586-61678	5995-01-133-4278	1 62
28480	03586-61691	5995-01-133-4010	1 88
28480	03586-64101		1 58
28480	03586-66501	6625-01-142-0903	1 146
28480	03586-66502	6625-01-142-0904	1 89
28480	03586-66504	6625-01-142-0905	1 90
28480	03586-66505	6625-01-142-0906	1 92
28480	03586-66510	6625-01-132-5399	1 93
28480	03586-66511	6625-01-132-1728	1 99
28480	03586-66515	6625-01-132-1729	1 79

NATIONAL STOCK NUMBER AND PART NUMBER INDEX

FSCM	PART NUMBER	PART NUMBER INDEX	
		STOCK NUMBER	FIG. ITEM
28480	03586-66516	6625-01-143-5841	1 104
28480	03586-66521	6625-01-132-1731	1 81
28480	03586-66522	6625-01-132-3757	1 85
28480	03586-66523	6625-01-132-1730	1 80
28480	03586-66530	6625-01-132-3758	1 86
28480	03586-66531	6625-01-132-3759	1 84
28480	03586-66532	6625-01-132-4625	1 83
28480	03586-66540	6625-01-132-1732	1 67
28480	03586-66550	6625-01-142-6762	1 74
28480	03586-66551	6625-01-175-4906	1 61
28480	03586-66552	6625-01-132-1733	1 87
28480	03586-66553	6625-01-132-1734	1 77
28480	03586-66560	6625-01-132-1735	1 70
28480	03586-66561	6625-01-132-5400	1 82
28480	03586-66562	6625-01-132-4626	1 68
28480	03586-66570	6625-01-142-0907	1 69
28480	03586-66580	6625-01-132-4627	1 71
28480	03586-66598	6625-01-174-0496	1 141
28480	03586-66599	6625-01-132-4629	1 181
28480	0360-0077	5940-01-033-4629	3 88
28480	0360-1716		4 27
28480	0370-1001	5355-01-050-5041	1 126
28480	0370-1303	5355-00-548-4866	1 129
28480	0403-0132		1 73
28480	0403-0133		1 177
28480	0403-0147		1 188
28480	0410-0751	5955-01-132-4485	13 79
28480	0410-0753	5955-01-159-2393	5 70
			6 69
28480	0410-0759	5955-01-133-5472	7 59
28480	0410-0765	5955-01-132-4559	10 85
28480	0410-1209	5955-01-132-4484	12 76
28480	0410-1212	5955-01-147-1555	16 156
28480	0410-1214	5955-01-132-5349	12 77
28480	0490-1222	5945-01-149-1160	1 228
28480	0490-1405	5945-01-215-4649	2 16
28480	0515-0054		1 201
28480	0515-0055		1 75
			5 72
			7 62
			16 163
28480	0515-0063		14 80
28480	0515-0066		1 200
28480	0515-0067		1 191
			9 29
28480	0515-0068		1 193
28480	0515-0069		1 144
28480	0515-0076		1 138
			2 50
28480	0515-0080		1 108
28480	0515-0082		1 113

NATIONAL STOCK NUMBER AND PART NUMBER INDEX

FSCM	PART NUMBER	PART NUMBER INDEX STOCK NUMBER	FIG.	ITEM
28480	0515-0099	5310-01-216-3680	1	214
28480	0515-0104		1	157
28480	0515-0150		3	99
			4	100
			5	77
			6	73
			7	65
			8	77
			10	88
			11	110
			12	80
			13	86
			14	78
28480	0515-0156		1	219
28480	0515-0158		1	95
28480	0515-0165		1	103
28480	0515-0166		1	195
28480	0515-0169		1	91
28480	0515-0223		1	122
28480	0515-0239		1	203
28480	0535-0004		1	111
28480	0535-0006		1	225
28480	0535-0007		1	196
			9	36
28480	0535-0008		14	84
28480	0570-1171	5305-01-072-9124	1	44
28480	0624-0333		17	37
28480	0698-0063	5905-00-828-0409	5	61
28480	0698-6360	5905-00-469-7380	11	79
28480	0698-6624	5905-00-469-7382	10	73
			11	38
28480	0698-7363	5905-01-104-0985	2	24
			4	83
28480	0698-7370	5905-01-148-6750	16	51
28480	0698-7372	5905-01-148-7722	16	46
28480	0698-7375	5905-01-148-6751	16	52
28480	0699-1183		5	82
			6	76
28480	0757-0434	5905-00-998-1793	16	64
28480	0757-0467	5905-00-858-8868	4	65
28480	0811-1780	5905-00-431-3914	4	71
			11	49
			16	77
28480	0811-3070	5905-01-133-3394	11	76
28480	08552-6024	5950-00-138-1334	5	83
28480	08552-6044	5950-00-431-3175	4	88
			5	67
			6	64
			13	70
27264	09-50-7031	5935-01-005-0017	1	147
27264	09-50-7051	5935-01-005-0016	1	234

NATIONAL STOCK NUMBER AND PART NUMBER INDEX

FSCM	PART NUMBER	PART NUMBER INDEX		FIG.	ITEM
		STOCK NUMBER			
27264	09-50-7131	5935-01-133-3938		1	170
27264	09-50-7141	5935-01-133-1131		1	72
27264	09-60-1031	5935-00-534-8481		2	14
27264	09-60-1051	5935-00-534-8486		18	13
27264	09-60-1131	5935-01-133-1127		18	12
27264	09-88-2141	5935-01-133-1136		18	11
28480	0960-0568	5955-01-159-2499		9	27
28480	1250-1512	5935-01-133-1161		3	25
80131	1N3956	5961-00-762-3115		7	17
				10	40
				11	26
				12	16
				13	20
				14	16
				15	11
18876	10018712-022	5910-00-950-2368		4	7
				8	12
				11	22
				13	9
				15	6
				16	7
53655	11-341LN	5310-00-269-6498		1	208
28480	1120-0692	6625-01-132-4606		1	143
17773	11263624	5935-00-107-2601		9	7
98380	116057	5961-00-222-1541		18	8
28480	1200-0819	5935-01-133-1112		1	165
				5	24
				6	27
				7	20
				8	22
				13	23
				14	20
28480	1251-0600	5935-01-082-1966		2	45
				4	89
				6	66
				10	77
				11	90
				12	57
				14	64
				15	37
				16	134
28480	1251-5566	5935-01-133-1137		18	29
80009	136-0269-02	5935-01-081-0156		2	51
				4	97
				11	107
				12	75
				16	155
				17	39
28480	1460-1345	5340-01-062-6736		1	52
73734	1461			9	31
27264	15-04-0219			1	233

NATIONAL STOCK NUMBER AND PART NUMBER INDEX

FSCM	PART NUMBER	PART NUMBER INDEX		ITEM
		STOCK NUMBER	FIG.	
59474	15-1315-13J	5950-01-121-9464	13	30
			14	24
24226	15M047M1	5950-01-131-9973	6	29
24226	15M100J2	5950-01-132-3514	8	24
24226	15M101J	5950-01-131-9987	13	28
24226	15M102J	5950-01-131-9966	4	30
			11	31
24226	15M121J	5950-01-131-9984	13	24
24226	15M151J	5950-01-132-1614	2	23
			8	28
24226	15M161J1	5950-01-131-9969	3	29
24226	15M202J1	5950-01-131-9974	6	33
24226	15M220J	5950-01-132-4481	7	27
			13	32
24226	15M221J	5950-01-131-9986	13	27
24226	15M431J1	5950-01-132-1613	7	24
			8	26
24226	15M470J	5950-01-131-9970	4	31
			13	31
			18	15
24226	15M471J	5950-01-131-9971	5	27
			6	31
24226	15M560J	5950-01-132-3515	8	25
24226	15M561J	5950-01-131-9975	7	22
			14	22
24226	15M680J	5950-01-131-9972	5	29
			6	34
24226	15M750J1	5950-01-131-9985	13	26
51642	150-100NP0-101J	5910-01-133-1081	5	3
56289	150D566X9015R2	5910-00-456-0235	14	10
28480	1531-0160		1	151
80009	156-0205-00	5962-01-054-1412	8	73
			14	70
80009	156-1225-00	5962-01-123-8136	7	58
55680	16ELA2200T	5910-01-142-3370	11	24
28480	1600-0835		13	87
28480	1600-0836		8	80
28480	1600-0837		8	81
28480	1600-0838		3	94
28480	1600-0839		3	93
28480	1600-0840		3	95
28480	1600-0841		13	83
28480	1600-0842		13	84
28480	1600-0843		13	88
28480	1600-0844		14	85
28480	1600-0845		14	81
28480	1600-0846		14	75
28480	1600-0904	5940-01-133-5441	4	98
28480	1810-0076	5905-01-105-8049	8	64
28480	1810-0121	5905-01-042-5044	14	61
28480	1810-0229	5905-01-090-2994	7	38

NATIONAL STOCK NUMBER AND PART NUMBER INDEX

FSCM	PART NUMBER	PART NUMBER INDEX	
		STOCK NUMBER	FIG. ITEM
28480	1810-0231	5905-01-082-5270	12 34
28480	1818-1154	5962-01-215-4360	15 49
28480	1818-1155		15 48
28480	1818-1156		15 47
28480	1818-1157	5962-01-215-1751	15 46
28480	1818-1158	5962-01-215-4361	15 45
28480	1818-1159	5962-01-215-1752	15 44
28480	1818-1510	5962-01-133-7564	15 49
28480	1818-1511	5962-01-133-7563	15 48
28480	1818-1512	5962-01-133-6748	15 47
28480	1818-1513	5962-01-133-6747	15 46
28480	1818-1514	5962-01-133-6746	15 45
28480	1818-1515	5962-01-133-6745	15 44
28480	1820-1112	5962-01-058-1539	12 73
			15 40
			17 36
28480	1820-1194	5962-01-012-1460	16 144
28480	1820-1200	5962-01-109-9745	17 33
28480	1820-1367	5962-01-096-2147	15 60
28480	1820-1587	5962-01-133-7566	17 32
28480	1820-1740	5962-01-082-0083	17 30
28480	1820-1873	5962-01-133-7147	17 34
28480	1820-2310	5962-01-133-6744	12 63
28480	1826-0109	5962-01-103-6124	11 97
			16 138
28480	1826-0111	5962-01-081-5414	3 89
			4 94
			11 102
			16 136
28480	1826-0416	5962-01-147-5791	16 150
28480	1826-0476	5962-01-133-9397	10 82
			11 103
			16 146
28480	1826-0678		9 26
			14 68
28480	1853-0010	5961-00-931-6998	4 33
28480	1853-0020	5961-00-904-2540	9 8
			15 17
28480	1853-0354	5961-01-057-6119	3 32
			4 34
			5 35
			8 30
28480	1853-0405	5961-00-402-1654	7 29
			13 40
28480	1854-0039	5961-00-985-9073	3 37
28480	1854-0092	5961-01-136-6853	3 34
28480	1854-0305	5961-00-250-8132	3 33
			4 2
			6 9
			8 14
			11 7

NATIONAL STOCK NUMBER AND PART NUMBER INDEX

FSCM	PART NUMBER	PART NUMBER INDEX STOCK NUMBER	FIG.	ITEM
28480	1854-0305	5961-00-250-8132	13	1
			14	11
			15	7
			16	13
28480	1854-0354	5961-00-472-5039	8	31
28480	1854-0485	5961-01-025-1105	4	35
28480	1855-0386	5961-00-824-5202	13	39
28480	1858-0015	5962-01-042-5709	5	69
			6	67
28480	1858-0047	5962-01-051-2606	2	47
			3	90
28480	1858-0059	5961-01-150-5508	5	84
			6	77
74970	187-0106-005	5910-00-787-5261	3	3
			5	10
28480	1902-0126	5961-00-780-8330	17	7
28480	1902-0945	5961-01-148-3336	11	29
28480	1902-1217	5961-01-052-3895	1	169
28480	1906-0210	5961-01-133-1254	6	26
28480	1906-0211	5961-01-133-1253	5	21
56289	192P10292	5910-00-506-7036	11	12
78189	1920-02	5310-01-G04-0710	1	127
28480	1990-0444	5961-01-024-3683	18	23
28480	1990-0486	5961-01-025-4605	4	26
			7	18
			13	22
			14	18
28480	1990-0487	5961-01-049-6786	4	25
28480	1990-0592	5961-01-147-2405	17	9
28480	1990-0665	5961-01-106-8189	17	4
28480	1990-0681		17	10
28480	1990-0696	5961-01-174-6427	17	11
28480	1990-0699	5961-01-133-1250	17	12
76854	2-1185108		14	83
81349	2N3646	5961-00-062-3133	9	9
81349	2N3906	5961-00-931-0372	13	34
			14	29
80131	2N4037	5961-00-979-0108	3	36
80131	2N4917	5961-00-179-8478	12	22
			13	34
81349	2N5179	5961-00-401-0507	5	33
			6	37
			14	27
56289	203C75	5905-01-087-3163	4	75
01121	208B331	5905-01-129-4905	14	60
28480	2100-0567	5905-01-075-2884	6	63
28480	2100-0568	5905-01-051-1219	6	49
28480	2100-0669		1	115
28480	2100-1984	5905-00-139-2305	5	44
28480	2100-3054	5905-00-359-5408	4	57
			11	52

NATIONAL STOCK NUMBER AND PART NUMBER INDEX

FSCM	PART NUMBER	PART NUMBER INDEX	
		STOCK NUMBER	FIG. ITEM
28480	2100-3054	5905-00-359-5408	16 74
28480	2100-3095	5905-01-052-9092	12 38
28480	2100-3207	5905-01-038-5364	16 62
28480	2100-3210	5905-01-051-5485	10 70
28480	2100-3211	5905-01-052-5802	2 32
28480	2100-3212	5905-01-051-5484	3 42
28480	2100-3214		10 68
28480	2100-3273	5905-01-039-3758	11 64
			16 57
28480	2100-3274	5905-01-017-0083	11 54
28480	2100-3349	5905-01-038-5366	5 53
28480	2100-3351	5905-01-051-1211	9 15
			11 57
28480	2100-3352	5905-01-007-1444	6 56
			11 87
28480	2100-3356	5905-01-055-9198	12 29
			16 90
28480	2100-3357	5905-01-038-5365	16 111
28480	2100-3358	5905-01-056-3498	16 106
28480	2100-3383	5905-01-087-5720	5 38
			8 35
28480	2110-0565	5920-01-087-0836	1 217
28480	2110-0569	5310-01-097-7987	1 230
56289	216CJ104	5905-01-133-3423	15 21
			17 22
28480	2190-0918		9 37
27264	22-01-1023	5935-01-133-1167	1 145
27264	22-01-2055	5935-01-133-1166	1 114
27264	22-03-2031	5935-01-084-6543	16 132
27264	22-27-2051	5935-01-133-1125	17 15
27264	22-27-2141		17 14
27264	22-29-2021	5935-01-133-1126	17 16
10001	2270098-28	5950-00-828-1742	2 23
			7 25
			8 27
			13 33
71785	252-15-30-300	5935-00-405-7720	18 26
71785	252-22-30-300	5935-00-372-1963	18 25
56289	256CH102X2PD	5905-01-171-5662	12 35
55973	279390-1	5962-01-033-2285	12 71
24931	28JR318-1	5935-01-215-1415	1 155
80009	281-0564-00	5910-00-879-6852	5 16
			8 9
73743	28200-10-101		1 128
56289	292CC0G151J100B		16 30
56289	292CC0G181J100B	5910-01-G40-3110	12 9
56289	292CC0G201J100B	5910-01-G40-3036	3 19
			12 8
56289	292P10452	5910-01-032-1819	18 3
56289	292P22352	5910-00-506-7014	8 16
56289	292P39352	5910-00-506-7031	14 8

NATIONAL STOCK NUMBER AND PART NUMBER INDEX

FSCM	PART NUMBER	PART NUMBER INDEX	
		STOCK NUMBER	FIG. ITEM
56289	292P47352	5910-00-511-2717	12 4
05245	3EF2	5915-00-318-3246	1 229
56289	30D207F016DF2	5910-00-463-2715	17 1
98291	3002-18	5310-00-151-8877	3 98
			5 74
			6 72
			7 64
			8 76
			13 81
			14 74
98291	3002-26	5310-00-151-8865	3 97
			5 73
			6 71
			7 63
			8 75
			13 80
			14 73
80294	3006P-1-501	5905-00-428-5335	4 85
80294	3006P1-101	5905-00-359-5434	4 86
80294	3006P1-103	5905-00-243-1778	3 45
59660	301-000-C0H0-829	5910-00-012-3433	5 9
72982	301-000C0H0-479C	5910-00-430-5715	6 4
72982	301000C0G0110J	5910-00-854-3157	8 2
59474	30134-3K	5950-01-214-8399	12 18
			13 29
			14 26
			15 15
			17 17
52763	304322-664		2 7
52763	30432215-60PFN15		3 4
28480	3050-0010		1 101
28480	3050-0427		1 192
28480	3101-1860	5930-01-091-3651	15 35
28480	3101-2298	5930-01-097-4308	1 213
28480	3101-2441	5930-01-133-1199	17 28
28480	3103-0020	5930-01-141-9419	1 166
89536	3140-288365	5962-00-615-6101	11 104
01121	316X101	6625-01-096-5940	15 14
10001	3167520	5962-01-077-2495	9 25
80294	3299X1-502	5905-00-474-8810	13 62
32997	3386XY46-201	5905-01-079-9580	3 79
			4 58
			11 48
			16 76
32997	3386XY46-500	5905-01-132-4351	4 53
76854	3482-4		14 79
13499	352-0722-020	5961-00-892-8706	12 24
			13 38
			14 28
			16 42
13499	352-9638-050	5999-01-057-4610	14 82

NATIONAL STOCK NUMBER AND PART NUMBER INDEX

FSCM	PART NUMBER	PART NUMBER INDEX		FIG.	ITEM
		STOCK NUMBER			
30890	40-001020-02	5961-00-577-0558		4	23
28480	4040-0707	5340-01-135-3725		1	173
28480	4040-0756	5999-01-051-8488		16	164
82389	410C507	5310-00-460-3056		1	124
11532	412YM0060	5945-01-122-9077		2	15
				3	26
80294	4308R-101-103S	5905-01-098-8545		15	26
28480	4320-0324			1	53
23936	4800X	4140-00-372-2947		1	232
56289	5CZ5U225X0050C5C	5910-00-057-3934		2	3
				3	1
				4	10
				11	19
				13	15
56289	5C11B7S	5910-00-234-9817		11	11
				13	14
73445	50P01-8	5965-01-216-1992		1	117
56289	500D477H016DF7	5910-01-133-1082		14	15
				17	3
28480	5001-0440			1	55
28480	5020-8806			1	236
28480	5020-8836			1	186
28480	5021-4712			1	56
19701	5033R1/8T2-10964	5905-01-216-0999		16	48
	1B				
19701	5033R1/8T2-11397	5905-01-216-2109		16	47
	RB				
19701	5033R1/8T2-13394	5905-01-216-6447		16	44
	RB				
19701	5033R1/8T2-20605	5905-01-216-4338		16	43
	RB				
19701	5033R1/8T2-36901	5905-01-216-1001		16	50
	RB				
19701	5033R1/8T2-78028	5905-01-216-1000		16	49
	RB				
19701	5033R1/8T9-1000B	5905-01-216-2107		10	52
18701	5033R1/8T9-11050			10	72
	ORB				
				11	39
19701	5033R1/8T9-4321B	5905-01-216-2108		10	53
28480	5040-4527	5970-01-214-6490		9	35
28480	5040-4529	5999-00-230-8833		15	69
28480	5040-5112	5999-00-230-8834		15	68
				16	158
28480	5040-6928			1	131
28480	5040-7201	5340-01-063-2862		1	51
28480	5040-7202	6625-01-118-8222		1	57
28480	5040-7219	6625-01-096-5943		1	5
28480	5040-7220	6625-01-096-8911		1	7
28480	5040-7624	5970-01-214-6491		1	206
28480	5040-7695			1	116

NATIONAL STOCK NUMBER AND PART NUMBER INDEX

FSCM	PART NUMBER	PART NUMBER INDEX	
		STOCK NUMBER	FIG. ITEM
28480	5041-0031	5975-01-130-9306	1 41
28480	5041-0285	5975-01-130-9332	1 37
28480	5041-0343	5975-01-133-4291	1 21
28480	5041-0352	5975-01-130-9307	1 23
28480	5041-0384	5975-01-130-9333	1 38
28480	5041-0417	5975-01-130-9308	1 40
28480	5041-0450	6625-01-103-4901	1 39
28480	5041-0774	5975-01-130-9309	1 36
28480	5041-0775	5975-01-130-9310	1 34
28480	5041-0808	5975-01-130-9311	1 29
28480	5041-0811	5975-01-130-9312	1 32
28480	5041-0812	5975-01-130-9313	1 30
28480	5041-0813	5975-01-130-9314	1 28
28480	5041-0814	5975-01-130-9315	1 13
28480	5041-0815	5975-01-130-9316	1 16
28480	5041-0816	5975-01-130-9317	1 17
28480	5041-0817	5975-01-130-9318	1 14
28480	5041-0818	5975-01-130-9319	1 15
28480	5041-0819	5975-01-130-9320	1 31
28480	5041-0855	5975-01-130-9321	1 27
28480	5041-0943	5975-01-130-9322	1 22
28480	5041-1466	5970-01-215-2105	1 134
28480	5041-1467	5970-01-215-2106	1 133
28480	5041-1470	5970-01-215-2107	1 135
28480	5041-1600	5970-01-214-6485	1 132
28480	5041-1743	5975-01-130-9323	1 26
28480	5041-1744	5975-01-130-9324	1 19
28480	5041-1745	5975-01-130-9325	1 18
28480	5041-1746	5975-01-130-9326	1 24
28480	5041-1747	5975-01-132-8840	1 25
28480	5041-1748	5975-01-141-0577	1 35
28480	5041-1749	5975-01-130-9327	1 10
28480	5041-1750	5975-01-130-9328	1 11
28480	5041-1751	5975-01-141-0578	1 33
28480	5041-1752	5975-01-130-9329	1 9
28480	5041-1753	5975-01-130-9330	1 12
28480	5041-1754	5975-01-130-9331	1 20
00779	50462-8	5999-00-631-2891	5 22
			6 28
28480	5060-0467	5935-00-180-4186	1 154
28480	5060-9436	5930-01-082-4289	17 27
28480	5060-9803	5340-01-135-9591	1 6
28480	5060-9834		1 60
28480	5060-9941		1 49
28480	5061-0090	5340-01-218-1582	1 3
28480	5061-0795	5962-01-133-3639	11 93
28480	5061-2009	5340-01-135-4194	1 45
28480	5082-5511	5961-00-451-8685	4 21
			8 21
			10 39
			15 13

NATIONAL STOCK NUMBER AND PART NUMBER INDEX

FSCM	PART NUMBER	PART NUMBER INDEX STOCK NUMBER	FIG.	ITEM
28480	50824655		9	5
98291	51-149-0000	5935-00-043-3914	2	13
			3	24
			4	29
			8	23
78189	5111018005002802		1	194
	580			
79136	5133-14SZDR		1	43
00779	530153-2	5935-01-035-1138	16	133
96214	531932-2	5962-00-256-0340	8	70
96214	536958-1	5962-00-172-8261	11	100
82877	5502	4130-00-111-0397	1	212
56289	562CZ5UBA501AG10	5910-00-788-0328	11	3
	3M			
56289	592CC0G301J100B		3	11
08742	61-687-003	5961-00-173-9932	1	163
00779	641601-1	5935-01-181-0024	15	66
22526	65692-019	5935-01-133-1135	17	13
28480	7120-1254		1	8
28480	7120-8607		1	106
28480	7122-0058		1	223
73138	72-111-0		10	62
			14	48
55285	7403-10-02	5970-01-081-8530	1	162
99971	7527486P110	5920-00-462-6897	18	10
81073	76SB08S	5930-01-129-4714	15	36
14933	7701001CB	5962-01-101-7968	13	73
14933	7800901EB	5962-01-110-7284	4	95
			7	53
			8	72
			13	71
			14	66
14933	7901401EB	5962-01-108-1966	13	76
01295	8N74LS00N	5962-01-031-7030	12	66
22670	8035-112	5970-01-131-8054	1	136
96214	808052-3	5962-01-081-8324	4	92
14933	8102305PB	5962-01-119-4692	16	148
28480	8120-0688		1	4
28480	8120-2888	5995-01-134-3763	1	107
59660	8121B227C0G680J	5910-01-089-9537	14	4
59660	8121B227C0J339C	5910-01-133-1080	4	18
72982	8121M112X7R0103M	5910-00-477-8011	2	12
			3	16
			4	1
			5	17
			7	3
			8	3
			10	21
			13	6
			14	2
			18	5

NATIONAL STOCK NUMBER AND PART NUMBER INDEX

FSCM	PART NUMBER	PART NUMBER INDEX	
		STOCK NUMBER	FIG. ITEM
28480	8160-0289		5 79
28480	8160-0360		1 48
28480	8160-0498		1 59
28480	8160-0506		1 123
28480	8160-0507		1 54
18876	8193477		9 4
			11 18
76854	8942-3		14 72
75915	901-129	5970-01-005-2884	1 215
28480	9100-0440	5950-01-131-9994	1 222
28480	9100-0447	5950-01-132-1617	18 21
28480	9100-0459	5950-01-131-9965	2 44
28480	9100-0471	5950-01-147-8806	2 42
28480	9100-0473	5950-01-147-8807	2 43
28480	9100-1379	5950-01-131-9991	5 26
			6 30
			7 26
28480	9100-1625	5950-01-170-6392	2 18
28480	9100-1631	5950-00-472-4985	16 39
28480	9100-1641	5950-00-431-3203	14 25
28480	9100-1791	5950-00-455-0156	18 14
28480	9100-2249	5950-00-430-6882	5 25
			14 21
28480	9100-2486	5950-01-155-4796	3 28
28480	9100-3294	5950-00-444-0492	2 19
28480	9100-4038	5950-01-132-0161	5 68
			6 65
28480	9140-0266	5950-01-143-6768	2 23
28480	9140-0354	5950-01-131-9976	10 41
28480	9140-0355	5950-01-132-3516	10 42
28480	9140-0356	5950-01-132-3517	10 43
28480	9140-0357	5950-01-131-9977	10 44
28480	9140-0358	5950-01-132-3518	10 45
28480	9140-0359	5950-01-131-9978	10 46
28480	9140-0360	5950-01-131-9979	10 47
28480	9140-0361	5950-01-131-9980	10 48
28480	9140-0362	5950-01-131-9981	10 49
28480	9140-0376	5950-01-131-9959	6 35
28480	9140-0377	5950-01-131-9960	6 36
28480	9140-0378	5950-01-131-9982	10 50
28480	9140-0379	5950-01-131-9983	10 51
28480	9140-0384	5950-01-131-9962	5 30
28480	9140-0385	5950-01-132-3513	5 32
28480	9140-0386	5950-01-131-9963	5 31
28480	9140-0411	5950-01-131-9958	4 32
28480	9140-0421	5950-01-148-6121	2 20
28480	9140-0422	5950-01-131-9993	2 17
56289	916C102X2SR	5905-01-030-7963	14 62
28480	9170-0894	5950-00-443-9512	3 23
			4 28
			5 23

NATIONAL STOCK NUMBER AND PART NUMBER INDEX

FSCM	PART NUMBER	PART NUMBER INDEX STOCK NUMBER	FIG.	ITEM
28480	9170-0894	5950-00-443-9512	7	19
			14	19
73734	99401		3	100
			4	101
			5	76
			6	74
			7	66
			8	78
			10	87
			11	109
			12	79
			13	85
			14	77
			16	162

RECOMMENDED CHANGES TO EQUIPMENT TECHNICAL PUBLICATIONS



THEN... JOT DOWN THE DOPE ABOUT IT ON THIS FORM. CAREFULLY TEAR IT OUT. FOLD IT AND DROP IT IN THE MAIL!

SOMETHING WRONG WITH THIS PUBLICATION?

FROM (PRINT YOUR UNIT'S COMPLETE ADDRESS)
 Commander
 Stateside Army Depot
 ATTN: AMSTA-US
 Stateside, N.J. 07703-5007

DATE SENT
 10 July 1975

PUBLICATION NUMBER
 TM 11-5840-340-20P

PUBLICATION DATE
 23 Jan 78

PUBLICATION TITLE
 Radar Set AN/PRC-76

BE EXACT PIN-POINT WHERE IT IS

PAGE NO	PARA-GRAPH	FIGURE NO	TABLE NO
33			
44		19	
45			

IN THIS SPACE TELL WHAT IS WRONG AND WHAT SHOULD BE DONE ABOUT IT:

For item 2, change the NSN to read: 5835-00-134-9186.
Reason: Accuracy.

Identify the cover on the junction box (item no. 5).
Reason: It is a separate item and is not called out on figure 19.

Add the cover of the junction box as an item in the listing for figure 19.
Reason: Same as above

SAMPLE

PRINTED NAME GRADE OR TITLE AND TELEPHONE NUMBER
 SSG I. M. DeSpirit of 999-1776

SIGN HERE

TEAR ALONG PERFORATED LINE

FILL IN YOUR
UNIT'S ADDRESS

FOLD BACK

DEPARTMENT OF THE ARMY

POSTAGE AND FEES PAID
DEPARTMENT OF THE ARMY
DOD 314



OFFICIAL BUSINESS
PENALTY FOR PRIVATE USE \$300

SAMPLE

Commander
US Army Communications-Electronics Command
and Fort Monmouth
ATTN: AMSEL-ME-MP
Fort Monmouth, New Jersey 07703-5007

TEAR ALONG PERFORATED LINE

FILL IN YOUR
UNIT'S ADDRESS

FOLD BACK

DEPARTMENT OF THE ARMY

OFFICIAL BUSINESS
PENALTY FOR PRIVATE USE \$300

POSTAGE AND FEES PAID
DEPARTMENT OF THE ARMY
DOD 314



TEAR ALONG PERFORATED LINE

Commander
US Army Communications-Electronics Command
and Fort Monmouth
ATTN: AMSEL-ME-MP
Fort Monmouth, New Jersey 07703-5007

RECOMMENDED CHANGES TO EQUIPMENT TECHNICAL PUBLICATIONS



THEN...JOT DOWN THE DOPE ABOUT IT ON THIS FORM. CAREFULLY TEAR IT OUT, FOLD IT AND DROP IT IN THE MAIL.

SOMETHING WRONG WITH THIS PUBLICATION?

FROM: (PRINT YOUR UNIT'S COMPLETE ADDRESS)

DATE SENT

PUBLICATION NUMBER

TM 11-6625-3087-24P

PUBLICATION DATE

27 Dec 1985

PUBLICATION TITLE

Frequency Selective Level Meter
AN/USM-490

BE EXACT PIN-POINT WHERE IT IS

PAGE
NO.

PARA-
GRAPH

FIGURE
NO.

TABLE
NO.

IN THIS SPACE TELL WHAT IS WRONG
AND WHAT SHOULD BE DONE ABOUT IT:

U R URG PRIORITY

PRINTED NAME GRADE OR TITLE AND TELEPHONE NUMBER

SIGN HERE

DA FORM 2028-2
1 JUL 79

PREVIOUS EDITIONS
ARE OBSOLETE

P.S. IF YOUR OUTFIT WANTS TO KNOW ABOUT YOUR
RECOMMENDATION MAKE A CARBON COPE OF THIS
AND GIVE IT TO YOUR HEADQUARTERS.

FILL IN YOUR
UNIT'S ADDRESS

FOLD BACK

DEPARTMENT OF THE ARMY

OFFICIAL BUSINESS
PENALTY FOR PRIVATE USE \$300

POSTAGE AND FEES PAID
DEPARTMENT OF THE ARMY
DOD 314



TEAR ALONG
SEPARATED LINE

Commander
US Army Communications-Electronics Command
and Fort Monmouth
ATTN: AMSEL-ME-MP
Fort Monmouth, New Jersey 07703-5007

RECOMMENDED CHANGES TO EQUIPMENT TECHNICAL PUBLICATIONS



SOMETHING WRONG WITH THIS PUBLICATION?

THEN...JOT DOWN THE DOPE ABOUT IT ON THIS FORM. CAREFULLY TEAR IT OUT, FOLD IT AND DROP IT IN THE MAIL.

FROM: (PRINT YOUR UNIT'S COMPLETE ADDRESS)

DATE SENT

PUBLICATION NUMBER

TM 11-6625-3087-24P

PUBLICATION DATE

27 Dec 1985

PUBLICATION TITLE

Frequency Selective Level Meter
AN/USM-490

BE EXACT PIN-POINT WHERE IT IS

PAGE NO.

PARA-GRAPH

FIGURE NO.

TABLE NO.

IN THIS SPACE TELL WHAT IS WRONG AND WHAT SHOULD BE DONE ABOUT IT:

IF IT IS LONG PREFER TO USE

PRINTED NAME GRADE OR TITLE AND TELEPHONE NUMBER

SIGN HERE

DA FORM 2028-2
1 JUL 79

PREVIOUS EDITIONS ARE OBSOLETE

P.S. IF YOUR OUTFIT WANTS TO KNOW ABOUT YOUR RECOMMENDATION MAKE A CARBON COPE OF THIS AND GIVE IT TO YOUR HEADQUARTERS.

FILL IN YOUR
UNIT'S ADDRESS

FOLD BACK

DEPARTMENT OF THE ARMY

OFFICIAL BUSINESS
PENALTY FOR PRIVATE USE \$300

POSTAGE AND FEES PAID
DEPARTMENT OF THE ARMY
DOD 314



TEAR ALONG PERFORATED LINE

Commander
US Army Communications-Electronics Command
and Fort Monmouth
ATTN: AMSEL-ME-MP
Fort Monmouth, New Jersey 07703-5007

By Order of the Secretary of the Army:

JOHN A. WICKHAM JR.
General, United States Army
Chief of Staff

Official:

MILDRED E. HEDBERG
Brigadier General, United States Army
The Adjutant General

DISTRIBUTION:

To be distributed in accordance with DA Form 12-36 literature requirements for SG-1170/U.

This fine document...

Was brought to you by me:



[Liberated Manuals -- free army and government manuals](#)

Why do I do it? I am tired of sleazy CD-ROM sellers, who take publicly available information, slap “watermarks” and other junk on it, and sell it. Those masters of search engine manipulation make sure that their sites that sell free information, come up first in search engines. They did not create it... They did not even scan it... Why should they get your money? Why are not letting you give those free manuals to your friends?

I am setting this document FREE. This document was made by the US Government and is NOT protected by Copyright. Feel free to share, republish, sell and so on.

I am not asking you for donations, fees or handouts. If you can, please provide a link to liberatedmanuals.com, so that free manuals come up first in search engines:

<A HREF=<http://www.liberatedmanuals.com/>>Free Military and Government Manuals

- Sincerely
Igor Chudov
<http://igor.chudov.com/>
- [Chicago Machinery Movers](#)