

TECHNICAL MANUAL

GENERAL SUPPORT MAINTENANCE MANUAL

CHARGER BATTERY

PP-1660/G

PP-1660A/G, AND PP-1660B/G

(NSN 6130-00-669-6659)

WARNING

HIGH VOLTAGE

is used in this equipment

DEATH ON CONTACT

may result if safety precaution
are not observed.

Be careful when working on the 115-volt ac input circuit. Use insulated test probes when making voltage measurements. When working inside the equipment, be extremely careful not to touch any internal parts while the battery charger is energized. Disconnect the ac input cable before performing routine maintenance or attempting to remove any part. Some models of the PP-1660/G and PP-1660A/G contain selenium rectifiers. The failure of selenium rectifiers can result in the liberation of poisonous fumes and the deposit of poisonous selenium compounds. When a rectifier burns out or arcs over, the odor is strong. Provide maximum ventilation immediately. AVOID INHALING THE FUMES. Do not touch the damaged rectifier until it has cooled.

DON'T TAKE CHANCES!!



5

SAFETY STEPS TO FOLLOW IF SOMEONE IS THE VICTIM OF ELECTRICAL SHOCK

1

DO NOT TRY TO PULL OR GRAB THE INDIVIDUAL

2

IF POSSIBLE , TURN OFF THE ELECTRICAL POWER

3

IF YOU CANNOT TURN OFF THE ELECTRICAL POWER, PULL, PUSH, OR LIFT THE PERSON TO SAFETY USING A WOODEN POLE OR A ROPE OR SOME OTHER INSULATING MATERIAL

4

SEND FOR HELP AS SOON AS POSSIBLE

5

AFTER THE INJURED PERSON IS FREE OF CONTACT WITH THE SOURCE OF ELECTRICAL SHOCK, MOVE THE PERSON A SHORT DISTANCE AWAY AND IMMEDIATELY START ARTIFICIAL RESUSCITATION

TECHNICAL MANUAL }
 No. 11-6130-227-40 }

HEADQUARTERS
 DEPARTMENT OF THE ARMY
 WASHINGTON, DC, 14 January 1983

GENERAL SUPPORT
 MAINTENANCE MANUAL
 CHARGER, BATTERY PP-1660/G, PP-1660A/G
 AND PP-1660B/G
 (NSN 6130-00-669-6659)

REPORTING ERRORS AND RECOMMENDING IMPROVEMENTS

You can help improve this manual. If you find any mistakes or if you know of a way to improve the procedures, please let us know. Mail your letter, DA Form 2028 (Recommended Changes to Publications and Blank Forms), or DA Form 2028-2 located in the back of this manual direct to Commander, US Army Communications-Electronics Command and Fort Monmouth, ATTN: DRSEL-ME-MP, Fort Monmouth, NJ 07703.

In either case, a reply will be furnished direct to you.

		Paragraph	Page
CHAPTER	1. INTRODUCTION		
	Scope	1-1	1-1
	Consolidated Index of Army Publications and Blank Forms.	1-2	1-1
	Reporting Equipment Improvement Recommendations (EIR)	1-3	1-1
	Administrative Storage	1-4	1-1
	Destruction of Army Electronics Materiel.	1-5	1-1
	Associated Publications	1-6	1-1
	2. THEORY		
	Block Diagram Analysis	2-1	2-1
	Circuit Analysis.	2-2	2-1
	Circuit Analysis(PP-1660B/G)	2-3	2-5
	3. MAINTENANCE INSTRUCTIONS		
SECTION I.	General		
	Scope of Maintenance	3-1	3-1
	Tools, Materials, and Test Equipment.	3-2	3-1
	II. Routine Maintenance		
	Scope of Routine Maintenance	3-3	3-1
	Routine Maintenance Procedures.	3-4	3-1
	III. Troubleshooting		
	Scope of Troubleshooting	3-5	3-2
	Troubleshooting Procedures.	3-6	3-2
	Troubleshooting Chart	3-7	3-3

*This manual supersedes TM 11-6130-227-40,16 March 1977.

	Paragraph	Page
Troubleshooting Chart (PP-1660B/G)	3-8	3-4
Voltage Measurements	3-9	3-4
Resistance Measurements	3-10	3-5
IV. Removal and Replacement of Parts and Testing After Repair General Procedures.	3-11	3-5
Remove and Replacement of Parts.	3-12	3-5
Removal and Replacement of Parts (PP-1660B/G).	3-13	3-6
Testing After Repair	3-14	3-6
APPENDIX A . REFERENCES		A-1

CHAPTER 1

INTRODUCTION

1-1. Scope

a. This manual covers general support maintenance of Battery Charger PP-1660/G, PP-1660A/G, and PP-1660B/G. It includes instructions appropriate to general support for routine maintenance of the same for troubleshooting, testing, and repairing this equipment, and for replacing maintenance parts. The electrical functions of the equipment are described in paragraphs 2-1 and 2-2. Unless otherwise specified herein, all references to PP-1660/G apply equally to the PP-1660A/G and PP-1660B/G.

b. The PP-1660/G and PP-1660A/G, except for reference designations, are identical in internal circuit design. The PP-1660B/G uses the same reference designations as PP-1660A/G, in addition, PP-1660B/G has a POWER switch, fan safety interlock switch, and an ac input indicator.

1-2. Consolidated Index of Army Publications and Blank Forms

Refer to the latest issue of DA Pam 310-1 to determine whether there are new editions, changes, or additional publications pertaining to the equipment.

NOTE

For applicable forms and records, see TM 11-6130-227-12.

1-3. Reporting Equipment Improvement Recommendations (EIR)

If your PP-1660(*)/G needs improvement, let us know. Send us an EIR. You, the user, are the only

one who can tell us what you don't like about your equipment. Let us know why you don't like the design. Put it on an SF 368 (Quality Deficiency Report). Mail it to Commander, US Army Communications-Electronics Command and Fort Monmouth, ATTN: DRSEL-ME-MP, Fort Monmouth, New Jersey 07703. We'll send you a reply.

1-4. Administrative Storage

Administrative storage of equipment issued to and used by Army activities shall be in accordance with TM 740-90-1.

1-5. Destruction of Army Electronics Materiel

Destruction of Army electronics materiel to prevent enemy use shall be in accordance with TM 750-244-2.

1-6. Associated Publications

The operating instructions and operator's and organizational maintenance instructions for PP-1660/G are contained in TM 11-6130-227-12. TM 11-6130-227-12 also covers maintenance allocation for this equipment. TM 11-6130-227-20P contains the organizational maintenance repair parts and special tools list for PP-1660/G. TM 11-6130-227-20P-1 contains the organizational maintenance repair parts and special tools list for PP-1660A/G and PP-1660B/G. TM 11-6130-227-40P contains the general support and depot repair parts and special tools list for PP-1660/G. TM 11-6130-227-40P-1 contains the general support and depot repair parts and special tools list for PP-1660A/G and PP-1660B/G.

CHAPTER 2

THEORY

2-1. Block Diagram Analysis (Fig. 2-1)

NOTE

All reference designations within () pertain to the components of the PP-1660A/G and PP-1660B/G.

During fast charging, the contacts of TIME SWITCH M1 are closed and the alternating-current ac input is applied directly to the primary winding of transformer T1. During slow charging, the contacts of TIME SWITCH M1 are open and the

115-volt ac input is connected through current-limiting reactor L1 to the primary winding of transformer T1. Transformer T1 has two separate secondary windings. The output of one is connected to rectifier CR1, and the output of the other is connected to rectifier CR2. The fullwave direct-current (dc) outputs of rectifiers CR1 and CR2 are switched by relays K2-K6 (K1-K5) into series or parallel combinations to provide the proper dc output voltages and currents for fast or slow-charging 6-, 12-, or 24-volt storage batteries.

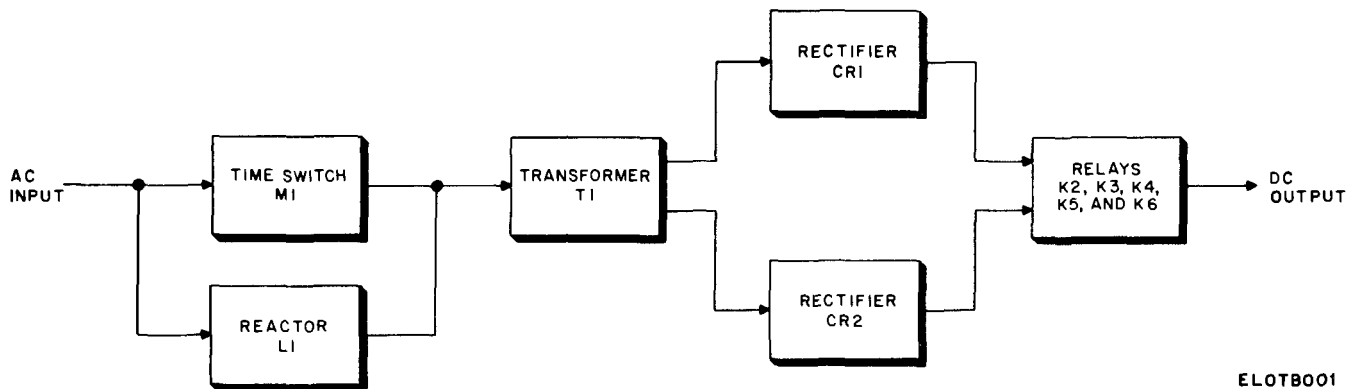

ELOTB001

Figure 2-1. Charger, Battery PP-1660/G, Block Diagram.

2-2. Circuit Analysis

a. Ac Input Circuit. One side of the 105 to 125-volt ac input is connected, by means of plug connector P1 and the ac input cable, through either TIME SWITCH M1 or reactor L1 to CHARGE SWITCH S1; the other side of the ac input is connected to terminal 5 of transformer T1. TIME SWITCH M1 is a mechanically operated clock with a normally open electrical contact.

(1) When TIME SWITCH M1 is in the SLOW CHARGE position, its electrical contact is open. The ac input then is connected through reactor L1 and circuit breaker CB1 to the rotor of CHARGE SWITCH S1 and the ac input circuit is completed through the selected contact of CHARGE SWITCH S1 and the associated tap of the primary winding of transformer T1 (*b*) below). Reactor L1 is a choke that limits the input current applied to transformer

T1. Circuit breaker CB1 is a thermal type, automatic reset circuit breaker rated at 5 amperes. Connected in series with reactor L1, it opens the input circuit to protect reactor L1 from overload when the input current exceeds this value. After a cooling period, circuit breaker CB1 recloses the input circuit automatically.

(2) Setting TIME SWITCH M1 to any time interval between 1 and 55 minutes closes its electrical contact and winds the clock mechanism, which holds the contact closed until the expiration of the time interval for which TIME SWITCH M1 is set. When the contact of TIME SWITCH M1 is closed, the ac input is connected directly to the rotor of CHARGE SWITCH S1 and the input circuit is completed through the selected contact of CHARGE SWITCH S1 and the associated tap of the primary winding of transformer T1 (*b*) below).

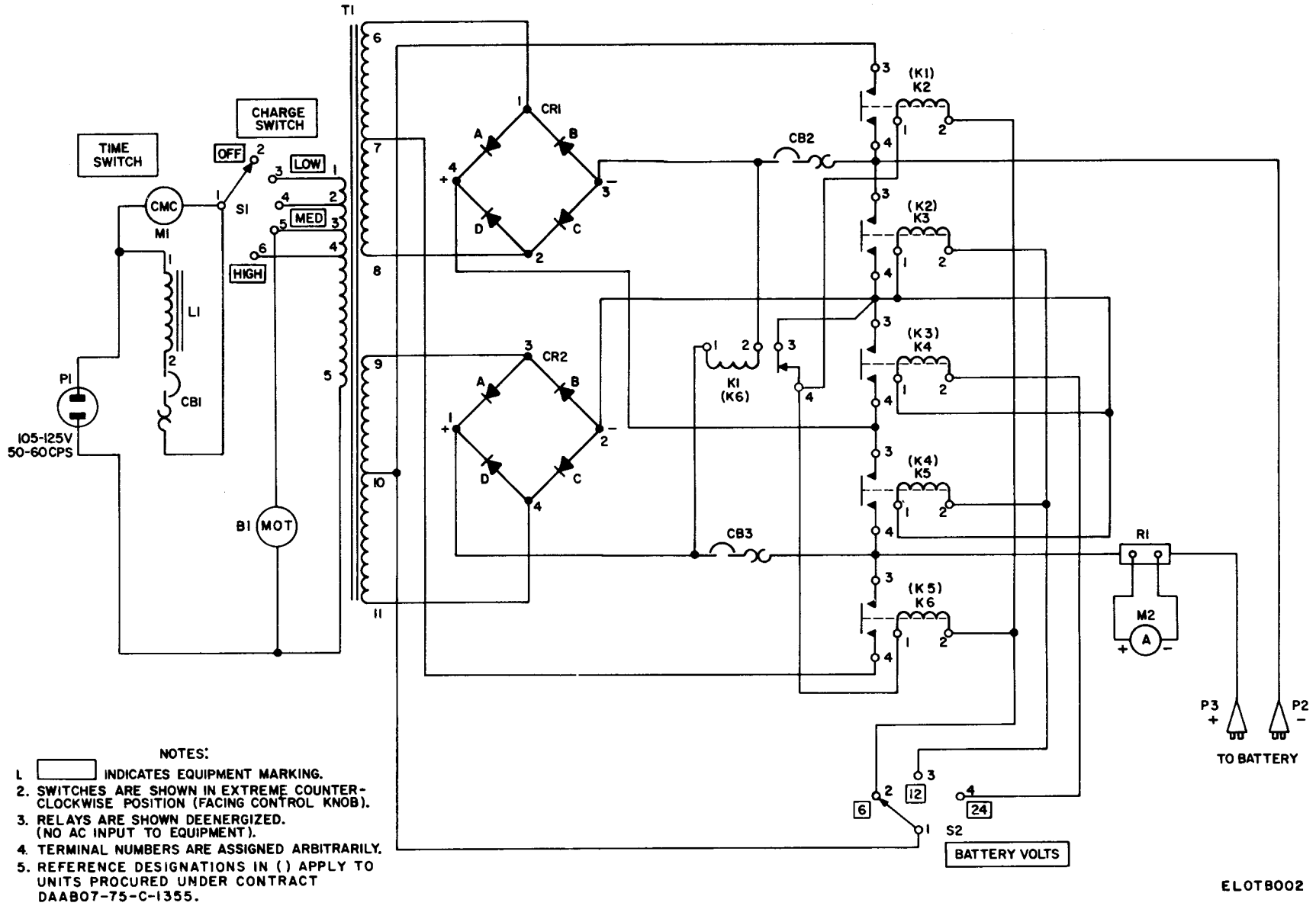

Figure 2-2. Charger, Battery PP-1660/G, Schematic Diagram.

ELOTB002

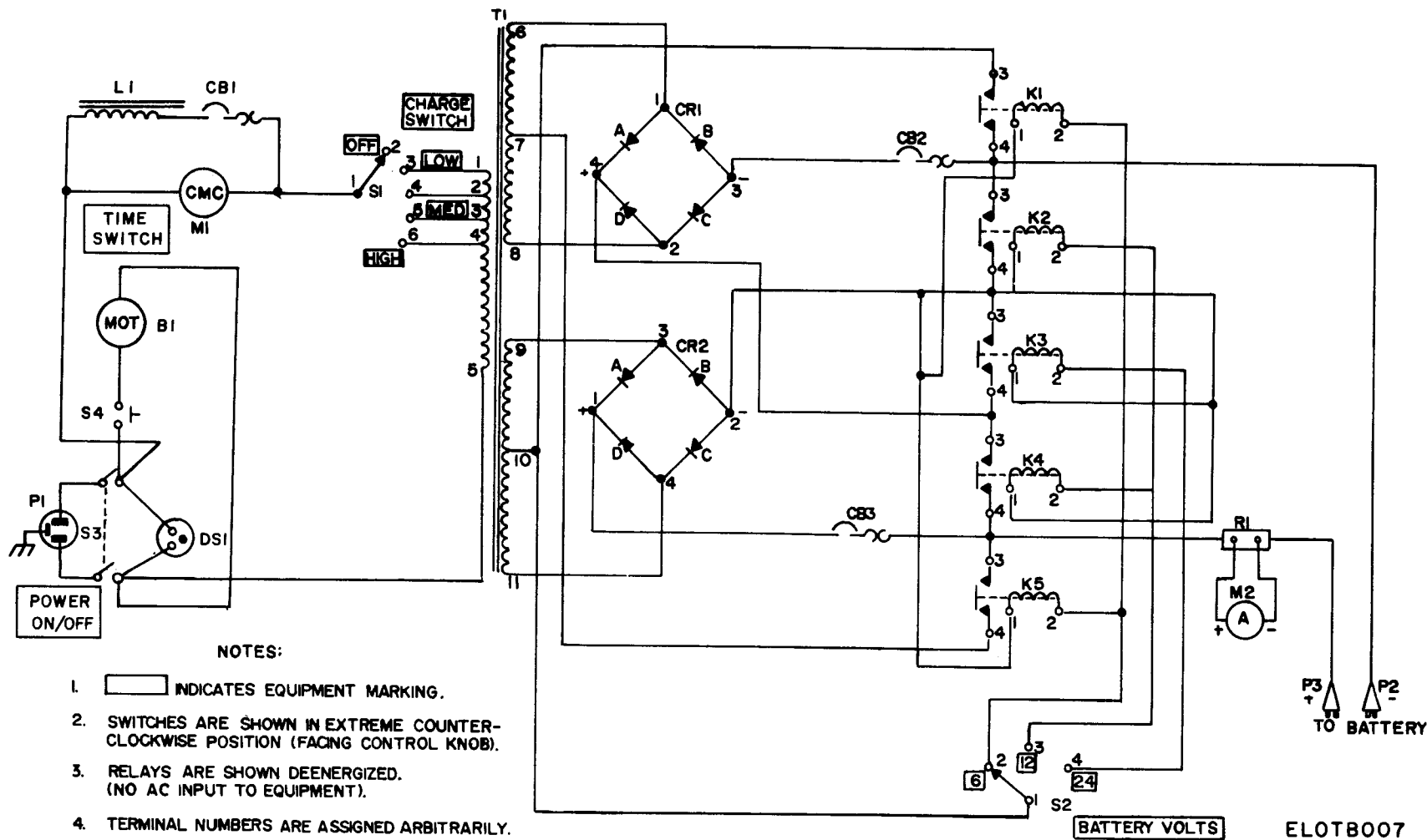

Figure 2-3. Charger, Battery PP-1660B/G, Schematic Diagram.

ELOTB007

b. Transformer T1 Circuits. Transformer T1 has a multiple-tapped primary winding and two separate, identical, center-tapped secondary windings. Primary taps 1, 2, 3, and 4 are connected to contacts 3, 4, 5, and 6, respectively, of CHARGE SWITCH S1. Thus the setting of CHARGE SWITCH S1 determines the number of effective turns of the primary winding of transformer T1 and consequently the voltage and current of the outputs of the two secondary windings. This arrangement provides a range of transformer outputs that permits the selection of a high, medium, or low charging rate (c below). Blower motor B1 is connected across the ac input between contact 5 of CHARGE SWITCH S1 and terminal 5 of the primary winding of transformer T1. The primary winding of transformer T1 acts as an autotransformer so that the voltage applied to blower motor B1 increases as CHARGE SWITCH S1 is advanced from LOW to MED to HIGH and consequently the speed of blower motor B1 increases proportionally. Thus, a larger amount of cooling air is drawn in and expelled by the blower as the charging rate is increased.

c. Rectifier Circuits. Transformer T1 has two separate, identical secondary windings whose output voltage is controlled by the position of CHARGE SWITCH S1 (b above). The output of secondary winding 6-8 is connected to rectifier CR1, and the output of secondary winding 9-11 is connected to rectifier CR2. Each rectifier is a full-wave, bridge rectifier; this arrangement provides two separate full-wave rectifier circuits. Each rectifier circuit has a maximum output of approximately 12.6 volts at 40 amperes. These outputs are connected to five solenoid relays K2-K6 (K1-K5) in such a manner that they can be switched into series and parallel combination (d below) to provide proper dc voltages and currents for fast- or slow- charging 6-, 12-, or 24-volt storage batteries. Circuit breakers CB2 and CB3 are connected into the output circuits of rectifiers CR1 and CR2, respectively, to protect the rectifiers from overload when the battery charger is operated in the fast-charge range. Circuit breakers CB2 and CB3 are thermal type, automatic reset circuit breakers. Each is rated at 40 amperes and will open its rectifier circuit when the dc output current of that circuit exceeds this value. After a cooling period, the circuit breaker will reclose the rectifier circuit automatically. Ammeter M2 is a dc ammeter inserted in one side of the dc output circuit. It indicates the dc output of the battery charger (charging rate) in amperes. Resistor R1 is a meter shunt for ammeter M2.

d. Switching Circuits. The switching circuits consists of BATTERY VOLTS switch S2 and

solenoid relays K2-K6 (K1-K5) which are energized in various combinations, depending on the position of BATTERY VOLTS switch S2. The 6-volt dc required to energize the coils of the relays is taken from legs B and C of rectifier CR2.

(1) *6-volt charging.* When BATTERY VOLTS switch S2 is in the 6 position, relays K2-K6 (K1-K5) are energized. The energizing circuit is from center tap 10 of winding 9-11 of transformer T1, through BATTERY VOLTS switch S2 in the 6 position, through the coils of relays K2(K1) and K6(K5) in parallel, through normally closed contacts 3-4 of relay K1(K6), to the Negative (−) terminal of rectifier CR2. When relays K2(K1) and K6(K5) are operated, two parallel circuits, using legs B and C of rectifier CR1 and legs A and D of rectifier CR2 as a full-wave, center-tap rectifier, are established. This arrangement produces a dc output of approximately 6.5 volts at 75 amperes maximum. One circuit is from center tap 7 of winding 6-8 of transformer T1, through contacts 4-3 of relay K6(K5) through ammeter M2 to positive (+) battery connector P3, through circuit breaker CB2 to the negative (−) battery connector P2, and through circuit breaker CB2 to the negative terminal of rectifier CR1. The other circuit is from the positive (+) terminal of rectifier CR2, through circuit breaker CB3 and ammeter M2 to positive battery connector P3, through the battery under charge to negative battery connector P2, through contacts 4-3 of relay K2(K1), to center tap 10 of winding 9-11 of transformer T1. The coil of relay K1(K6) is connected directly across the dc output of the rectifiers and controls the operation of relays K2(K1) and K6(K5). Relay K1(K6) will operate (open its contacts) when a voltage of 16 to 18 volts passes through its coil. This deenergizes relays K2(K1) and K6(K5) and opens the dc output circuit to prevent damage to the rectifiers in case of overload.

(2) *12-volt charging.* When BATTERY VOLTS switch S2 is in the 12 position, relays K3(K2) and K5(K4) are energized. The energizing circuit is from center tap 10 of winding 9-11 of transformer T1, through BATTERY VOLTS switch S2 in the 12 position, through the coils of relays K3(K2) and K5(K4) in parallel, to the negative terminal of rectifier CR2. When relays K3(K2) and K5(K4) are operated, two full-wave rectifier circuits, using rectifiers CR1 and CR2 connected in parallel, are established. This arrangement produces a dc output of approximately 12.6 volts at 75 amperes maximum. One circuit is from the positive terminal of rectifier CR2, through circuit breaker CB3 and ammeter M2 to positive battery connector P3, through the battery under charge to negative battery connector P2, through contacts 3-4 of relay

K3(K2) to the negative terminal of rectifier CR2. the other circuit is from the positive terminal of rectifier CR1, through contacts 3-4 of relay K5(K4) and ammeter M2 to positive battery connector P3, through the battery under charge to negative battery connector P2, and through circuit breaker CB2 to the negative terminal of rectifier CR1.

(3) *24-volt charging.* When BATTERY VOLTS switch S2 is in the 24 position, relay K4(K3) is energized. The energizing circuit is from center tap 10 of winding 9-11 of transformer T1, through BATTERY VOLTS switch S2 in the 24 position, through the coil of relay K4(K3) to the negative terminal of rectifier CR2. When relay K4(K3) is operated, a full-wave rectifier circuit, using rectifiers CR1 and CR2 connected in series, is established. This arrangement provides a dc output of approximately 26 volts at 40 amperes maximum. This circuit is from the positive terminal of rectifier CR1, through contacts 4-3 of relay K4(K3) to the negative terminal of rectifier CR2, through rectifier CR2 to its positive terminal, through circuit breaker CB3 and ammeter M2 to positive battery connector P3, through the battery under charge to negative battery connector P2, through circuit breaker CB2

to the negative terminal of rectifier CR1.

2-3. Circuit Analysis (PP-1660B/G)

a. AC Input Circuit. One side of the nominal 115 volt ac input is connected by means of plug connector P1 and the ac input cable, through POWER SWITCH S3 and either TIME SWITCH M1 or reactor L1 to CHARGE SWITCH S1; the other side of the ac input is connected through POWER SWITCH S3 to terminal 5 of transformer T1. DS1 is a green neon lamp used to monitor the ac input. TIME SWITCH M1 and CHARGE SWITCH S1 operation is the same as described for PP-1660/G.

b. Transformer T1 Circuits. Except for the blower circuits transformer T1 circuits are the same as described for PP-1660/G. Blower motor B1 is connected directly across the ac input. Power is applied through POWER SWITCH S3 and an interlock FAN SAFETY SWITCH S4.

c. Rectifier Circuits. Same as described for PP-1660/G.

d. Switching Circuits. 6 volt charging circuit does not use relay K1, (K6), all other functions are as described for PP-1660/G.

CHAPTER 3

MAINTENANCE INSTRUCTIONS

Section I. GENERAL

3-1. Scope of Maintenance

General support maintenance of the PP-1660/G consists of the following.

- a. Routine maintenance (para 3-3 and 3-4).
- b. Troubleshooting (para 3-5 through 3-10).
- c. Replacement of authorized maintenance parts (para 3-11, 3-12 and 3-13).
- d. Testing performance for return to service (para 3-14).

3-2. Tools, Materials, and Test Equipment

The following tools, materials, and test equipment are required for routine maintenance, troubleshooting, and repair:

- a. Tool Kit, Electronic Equipment TK-105/G.
- b. Trichlorotrifluoroethane.
- c. Multimeter AN/USM-223 or TS-352/U.

Section II. ROUTING MAINTENANCE

3-3. Scope of Routine Maintenance

a. *Duties.* Routine maintenance of the PP-1660/G consists of the following

- (1) Cleaning the interior of the equipment (para 3-4a).
- (2) Inspecting interior parts and wiring (para 3-4 b).
- (3) Tightening loose connections and mounting hardware (para 3-4b).

b. *Intervals.* Perform routine maintenance regularly in accordance with a schedule established on the basis of days or months of use, with consideration for the conditions under which the equipment is operated. For maintenance purposes, a day consists of 8 hours of operation and a month consists of 30 days of 8-hour operation. It is recommended that routine maintenance of the PP-166/G be performed monthly, or more frequently under adverse operating conditions, such as exist in very hot, humid, or dusty areas.

3-4. Routine Maintenance Procedures

WARNING

Turn the equipment OFF and disconnect the ac input cable from the ac supply before servicing the Battery Charger. Never perform routine maintenance with the power on, shock hazard exists, death on contact may result, don't take chances.

a. *Cleaning.* Remove the cover of the battery charger (para 3-12) and clean the interior of the equipment. Use a clean, dry cloth to remove dust and dirt. If necessary, use a cloth dampened (not wet) with trichlorotrifluoroethane and wipe thoroughly dry with a clean, dry cloth. If available, cleaning equipment or dry compressed air may be used to remove loose dust and dirt. If compressed air is used, the pressure must be low enough to prevent damage to the equipment. Be sure ventilating grilles are thoroughly clean and free of foreign matter that might obstruct the free circulation of air.

WARNING

Adequate ventilation should be provided while using TRICHLOROTRIFLUOROETHANE. Prolonged breathing of vapor should be avoided. The solvent should not be used near heat or open flame, the products of decomposition are toxic and irritating. Since TRICHLOROTRIFLUOROETHANE dissolves natural oils, prolonged contact with skin should be avoided. When necessary use gloves which the solvent cannot penetrate. If the solvent is taken internally, consult a physician.

b. *Inspection.* Inspect all interior parts and wiring for evidence of incipient malfunction or failure.

(1) See that all parts are mounted securely. Tighten loose mounting hardware and replace all missing parts.

(2) Insure that all switch contacts are clean and tight clean and tighten, if necessary.

(3) Inspect the transformer, reactor, and rectifier for evidence of overheating.

(4) See that the impeller is mounted securely on the hub of the lower motor and that it rotates freely and has adequate clearance.

(5) Assure that all wiring is in good condition and that connections are clean and tight. If necessary, clean and tighten connections; replace wiring that shows evidence of deterioration.

Section III. TROUBLESHOOTING

WARNING

Be extremely careful when performing troubleshooting with the power on. Use insulated test probes when making voltage measurements. Always disconnect the ac input cable before touching any internal part.

3-5. Scope of Troubleshooting

Troubleshooting at general support includes all the techniques outlined for operator's and organizational maintenance and all additional techniques required to isolate a defective part. The maintenance procedure is not complete in itself, but supplements the procedures described in TM 11-6130-227-12.

3-6. Troubleshooting Procedures

The first step in servicing the defective battery charger is to sectionalize the fault to a major circuit group. The second step is to localize the trouble to an individual circuit that is not functioning properly, and the final step is to isolate the defective part.

a. Operational Checks. Most trouble in PP-1660/G can be sectionalized to the ac input circuits, the transforming circuits, the rectifying circuits, or the switching circuits by systematic checks of the performance of the equipment. Examine the repair tag to see whether the trouble has been sectionalized and localized by operator organizational maintenance. If the trouble has not

been localized, check the performance of the equipment in accordance with the equipment performance checklist and the troubleshooting instructions in TM 11-6130-227-12.

b. Visual Inspection. Before disassembling the equipment, inspect it. Many defective parts can be identified by sight, touch, or smell. Remove the cover of the case (para 3-12) and inspect all internal parts and wiring carefully for evidence of damage such as the following

(1) Loose or broken connections and defective wiring.

(2) Loose or missing mounting hardware and broken or otherwise physically damaged parts.

(3) Blistered, buckled, or discolored rectifier plates.

(4) Evidence of overheated transformer, reactor, or blower motor.

c. Troubleshooting Chart. Use the troubleshooting chart (para 3-7 as an aid in determining the probable causes of the symptoms of faulty operation and the corrective measures required.

d. Tests. Use Multimeter AN/USM-223 or TS-352/U to perform point-to-point continuity tests and to make voltage and resistance measurements (para 3-9 and 3-10) to determine the condition of individual parts. Refer to the schematic diagram (fig. 2-2 and 2-3) to identify circuit components and test point and to the wiring diagram (fig. 3-6 and 3-7) for point-to-point wiring and connection points.

3-7. Troubleshooting Chart

Symptom	Probable cause	Corrective measure
No dc output in either slow- or fast-charge ranges and blower does not operate.	No ac input	Check continuity of ac input cable; repair or replace (para 3- 12) if defective.
	CHARGE SWITCH S1 defective.	Replace CHARGE SWITCH S1 (para 3-12).
	Primary winding of transformer T1 open.	Check primary winding of transformer T1 (para 3-9a); if open, replace transformer T1 (para 3-12).
No dc output in either slow- or fast-charge ranges but blower operates with CHARGE SWITCH S1 in one MED position.	Primary winding of transformer T1 open.	Check primary winding of transformer T1 (para 3-9a); if open, replace transformer T1 (para 3-12).
	Rectifier L1 defective	Check reactor L1 (para 3-10); replace defective (para 3- 12).
Dc outputs in fast-charge range satisfactory but no dc output in slow-charge range.	Circuit breaker CB1 defective.	Check circuit breaker CB1; replace if defective (para 3- 12).
	TIME SWITCH M1 defective.	Replace TIME SWITCH M1 (para 3-12).
Dc outputs in slow-charge range satisfactory but no dc output in fast charge range.	Blower motor B1 defective	Check continuity of motor winding and check rotor for binding, replace blower motor B 1 (para 3-12) if defective.
	Transformer T1 defective	Check secondary windings of transformer T1 (para 3-9a); if unsatisfactory, replace transformer T1 (para 3- 12).
Dc output in both fast- and slow-charge ranges satisfactory but blower does not operate.	Rectifier CR2 defective	Check rectifier CR2 (para 3-9b); re- place rectifier assembly (para 3-12) if defective.
	BATTERY VOLTS switch S2 defective.	Replace BATTERY VOLTS switch S2 (para 3-12).
	Dc output cable defective	Check continuity of both dc output cables; repair or replace defective dc output cable (para 3-12).
Blower operates with TIME SWITCH M1 and CHARGE SWITCH S1 in any position (except OFF) but no dc output at any setting of BATTERY VOLTS switch S2.	Relays K2(K1) and K6(K5) defective	Check relays K2 (K1) and K6 (K5) (para 3-9d and 3-10); replace (para 3-12) if defective.
	Relay K1(K6) defective	Check relay K1(K6) (para 3-9c and 3-10); replace (para 3-12) if defective.
	BATTERY VOLTS switch S2 defective.	Replace BATTERY VOLTS switch S2 (para 3-12h).
No dc output with BATTERY VOLTS switch S2 in 6 position; outputs with BATTERY VOLTS switch S2 in 12 24 position satisfactory.	Rectifier CR1 defective	Check rectifier CR1 (para 3-9 b); re- place (para 3- 12) if defective.
	Transformer T1 defective	Check transformer T1 winding 6-8 (para 3-9a); if defective replace transformer T1 (para 3-12).
	Relay K6(K1) defective	Check relay K6 (K1) (para 3-9d and 3-10); replace (para 3-12) if defective.
Charging rate higher than 40 amperes cannot be obtained in 6-volt fast charging.	Relays K3(K2) and K3(K4) defective.	Check relays K3(K2) and K5(K4) (para 3-9d and 3-10); replace (para 3-12) if defective.
	BATTERY VOLTS switch S2 defective.	Replace (para 3-12) BATTERY VOLTS switch S2.
	Rectifier CR1 defective	Check rectifier CR1 (para 3-9b; re- place rectifier assembly (para 3-12) if defective.
No dc output with BATTERY VOLTS switch S2 in 12 position, outputs with BATTERY VOLTS switch S2 in 6 or 24 position satisfactory.	Transformer T1 defective	Check transformer T1 winding 6-8 (para 3-9a), if defective, replace transformer T1 (para 3-12).
	Circuit breaker CB2 defective	Replace circuit breaker CB2 (para 3-12).
	Relay K5(K4)defective	Check relay K5(K4) (para 3-9d and 3-10); (para 3-12) if defective.

Symptom	Probable cause	Corrective measure
No dc output with BATTERY VOLTS switch S2 in 24 position; output with BATTERY VOLTS switch S2 in 6 or 12 position satisfactory.	Relay K4(K3) defective BATTERY VOLTS switch S2 defective.	Check Relay K4(K3) (para 3-9d and 3-10); (para 3- 12) if defective. Replace BATTERY VOLTS switch S2 (para 3-12).
Charging rate does not increase when CHARGE SWITCH S1 is advanced to Med and HIGH.	CHARGE SWITCH S1 defective.	Replace CHARGE SWITCH S1 (para 3-12).
Battery charger operating but ammeter M2 does not indicate any dc output.	Ammeter M2 disconnected or defective.	Check connections of ammeter M2 to shunt resistor R1; replace ammeter M2 (para 3-12) if defective.
Battery charger stops whenever 40-ampere charging rate is exceeded during 6- or 12-volt charging.	Circuit breaker CB2 or CB3 defective.	Check circuit breakers CB2 and CB3; replace defective circuit breaker (para 3-12).
TIME SWITCH M1 does not return to SLOW CHARGE position	Clock of TIME SWITCH M1 defective	Replace TIME SWITCH M1 (para 3- 12).
Charging rate does not drop into slow-charge range where TIME SWITCH M1 returns to SLOW CHARGE position.	TIME SWITCH M1 defective. Reactor L1 defective	Replace TIME SWITCH M1 (para 3-12). Check reactor L1 (para 3-10); replace (para 3-12) if defective.
Maximum charging rate in fast-charge range cannot be obtained.	Rectifiers CR1 and CR2 aged for defective	Check rectifiers CR1 and CR2 (para 3-9b); replace rectifier assembly (para 3-12) if unsatisfactory.

3-8. Troubleshooting Chart (PP-1660B/G)

procedures are the same as described for PP-1660/G.

Other than the ac input circuits, troubleshooting

Symptom	Probable cause	Corrective measure
Blower does not operate, indicator lamp not lighted, no output.	POWER SWITCH S3 defective	Replace POWER SWITCH S3.
Blower does not operate, indicator lamp lighted, output satisfactory.	Interlock safety switch S4 defective.	Replace safety switch S4.
Output satisfactory, blower operates, indicator lamp not lighted.	Neon lamp DS1 defective.	Replace neon lamp.

3-9. Voltage Measurements

WARNING

Be extremely careful when making voltage measurements. Use insulated test probes and do not touch any internal part of the battery charger while it is energized,

a. *Transformer T1.* With the battery charger operating in the fast-charge range and the CHARGE SWITCH at LOW (the BATTERY VOLTS switch may be in any position), the voltages shown in the chart below should be obtained at the terminals indicated.

Winding	Terminals	volts
Primary	1 - 5	115
	2 - 5	106.5
	3 - 5	99.0
	4 - 5	93.0

Winding	Terminals	volts
Secondary	6 - 8	15.0
	6 - 7	7.5
	9 - 11	15.0
	9 - 10	7.5

NOTE

The voltage values given in the chart above and based on a 115-volt ac input. If the ac input voltage is above or below this value, the voltages across the several windings of transformer T1 will vary proportionally.

b. *Rectifiers CR1 and CR2.* With the battery charger operating in the fast-charge range, the BATTERY VOLTS switch at 12, and the charging rate adjusted to 75 amperes, measure the voltage across each leg of rectifiers CR1 and CR2. The difference between the highest and the lowest voltage reading obtained should not exceed 0.3 volt.

c. *Relay K1(K6)*. Relay K1(K6) should operate when 16 to 18 volts is applied to its coil (across terminals 1-2) and should release when the voltage is reduced to approximately 13 volts.

d. *Relays K2-K6(L1-K5)*. Relay K2-K6(K1-K5) each should operate when a voltage of 4.8 volts (maximum) is applied to its coil (across terminals 1-2).

3-10. Resistance Measurements

Make all resistance measurements with the

equipment deenergized and with the part disconnected from the remainder of the circuit. The approximate resistances of the winding of reactor L1 and of the coils of relays K1 through K6 are given in the chart below.

<i>Item</i>	<i>Terminals</i>	<i>Resistance (ohms)</i>
Reactor L1	1-2	0.412
Relay K1(K6)	1-2	400
Relays K2 through K6 (K1 through K5)	1-2	8.0

Section IV. REMOVAL AND REPLACEMENT OF PARTS AND TESTING AFTER REPAIR

NOTE

All maintenance parts for Charter Battery PP-1660()/G (TM 11-6130-227-40P) are replaceable at general support.

3-11. General Procedures

All parts of the PP-1660()/G, except transformer T1, are readily accessible when the cover of the case is removed and can be removed and replaced individually without first removing any other parts. Instructions for the removal and replacement of all functional parts are provided in paragraph 3-12. When removing parts or repairing wiring, tag leads and mark terminals for positive indication before disconnecting any wiring to assure correct reconnection. When wiring is replaced, use wire that conforms with that specified in figure 3-6.

3-12. Removal and Replacement of Parts

NOTE

Most parts can be reinstalled by remounting them in their original locations with the original hardware and reconnecting the leads. Replacement instructions are given only when special procedures or precautions are required.

a. *Cover (1, fig. 3-1)*. Remove four screws from the top and three screws from each side of the cover and carefully lift off the cover.

b. *Blower Assembly (5 and 6, fig. 3-4)*. Remove the two hexagonal nuts that fasten blower motor B1 (6) to the bracket. Disconnect the leads at blower motor B1 and lift out the blower assembly. To remove impeller MP4 (5, fig. 3-4) loosen the set-screw in the hub and pull impeller MP4 off the shaft of the motor B1.

c. *Ac Input Cable (4, fig. 3-1)*. Disconnect one cable lead from TIME SWITCH M1 (19, fig. 3-3)

and unsolder and disconnect the other cable lead from the solder connection (fig. 3-6). Release the strain relief bushing (9, fig. 3-3) in the back of the case (12, fig. 3-1) and pull out the ac input cable. When reinstalling the ac input cable, connect the cable lead with a lug to TIME SWITCH M1 (19, fig. 3-3). Splice the other cable lead to one lead of blower motor B1 (6 fig. 3-4) and the black lead from the primary winding of transformer T1 (4, fig. 3-3). Solder the connector and tape securely.

d. *Dc Output Cables (5, fig. 3-1)*. The positive (red connector) dc output cable is connected to resistor R1 (12, fig. 3-3) and the negative (black connector) dc output cable is connectd to circuit breaker CB2 (13, fig. 3-3). To remove either dc output cable, disconnect it, release the strain relief bushing (10 or 11, fig. 3-3) in the back of the case (12, fig. 3-1), and pull out the cable.

e. *Ammeter M2 (1, fig. 3-3)*. Disconnect the leads, remove the mounting screws and nuts, and carefully remove ammeter M2 from the front panel from the front. When reconnecting the ammeter leads, be sure to observe correct polarity (fig. 3-6).

f. *TIME SWITCH M1 (19, fig. 3-3)*. Loosen the two setscrews that secure TIME SWITCH knob MP12A (6, fig. 3-1) and pull the knob off the shaft. Disconnect the leads, remove the locknut, and remove TIME SWITCH M1 from the front panel from the rear. When reinstalling TIME SWITCH M1, rotate the shaft fully counterclockwise and install TIME SWITCH knob MP12A (6, fig. 3-1) so that the pointer is at SLOW CHARGE. Be sure to tighten both setscrews.

g. *CHARGE SWITCH S1 (2, fig. 3-3)*. Loosen the two setscrews that secure CHARGE SWITCH knob MP12B (9, fig. 3-1) and pull the knob off the shaft. Disconnect the leads, remove the locknut, and remove CHARGE SWITCH S1 from the front panel from the rear. When reinstalling CHARGE

SWITCH S1, rotate the shaft fully counterclockwise and reinstall CHARGE SWITCH knob MP12B (9) so that the pointer is at OFF. Be sure to tighten both setscrews.

h. BATTERY VOLTS SWITCH S2 (7, fig. 3-1). Pull BATTERY VOLTS switch knob MP11 (8, fig. 3-1) straight forward off the shaft. Disconnect the leads, remove the locknut, and remove BATTERY VOLTS switch S2 from the front panel from the rear. When reinstalling BATTERY VOLTS switch S2, rotate the shaft fully counterclockwise and reinstall BATTERY VOLTS switch knob MP11(8) so that the engraved pointer is at 6.

i. Circuit Breaker CB1 (18, fig. 3-3). Circuit breaker CB1 is mounted on a bracket fastened to the top flange of transformer T1 (4, fig. 3-3). To remove circuit breaker CB1, disconnect the leads and remove the nuts, lockwashers, and screws that fasten circuit breaker CB1 to its bracket.

j. Rectifiers CR1 and CR2. Rectifiers CR1 and CR2 (2, fig. 3-4) are connected together and are removed as an assembly. The rectifier assembly is mounted on top of transformer T1 (4, fig. 3-3). To remove the rectifier assembly, take out the four screws that secure it to transformer T1 (4), disconnect all leads, and lift the rectifier assembly out of the case. The four screws (3, fig. 3-1) also must be removed prior to removal of the rectifier assembly.

k. Reactor L1 (3, fig. 3-3). Reactor L1 is mounted in front of transformer T1 (4, fig. 3-3). To remove reactor L1, disconnect the two pigtail leads from TIME SWITCH M1 (19, fig. 3-3) and circuit breaker CB1 (18, fig. 3-3), remove the two mounting screws, accessible from the bottom of the case, and lift out reactor L1.

l. Transformer T1 (4, fig. 3-3). Remove rectifiers CR1 and CR2 (*j* above) and circuit breaker CB1 (*i* above); it is not necessary to disconnect circuit breaker CB1. Disconnect the 11 pigtail leads of transformer T1, remove the four mounting screws, and lift transformer T1 out of the case. When reinstalling transformer T1, be sure to solder and tape the connection to the ac input cable lead and the blower motor lead (fig. 3-6) securely.

m. Subpanel (16, fig. 3-3). The subpanel is a U-shaped, sheet-metal chassis on which are mounted relay K1(K6) (17, fig. 3-3) relays K2-K6(K1-K5) (5, 6, 7, 14, 15, fig. 3-3), and circuit

breakers CB2 (13, fig. 3-3) and CB3 (8, fig. 3-3). The subpanel is located behind transformer T1 (4, fig. 3-3) and is fastened to the case by three screws. Parts mounted on the subpanel can be removed individual (without removing the subpanel) by disconnecting their leads and removing the mounting hardware. To remove the subpanel as an assembly, it is necessary first to disconnect all leads connected to parts not mounted on the subpanel.

n. Resistor R1 (12, fig. 3-3). Resistor R1 is mounted on the inside of the back of the case by means of the same screw and nut that secure the lower hanger of the ac input cable to the outside of the case. To remove resistor R1, disconnect the leads from its terminals and remove the nut and the screw.

3-13. Removal and Replacement of Parts (PP-1660B/G)

NOTE

Most parts can be reinstalled by remounting them in their original locations with the original hardware and reconnecting the leads. Replacement instructions are given only when special procedures or precautions are required.

a. POWER Switch S3. Disconnect the leads, remove the locknut, and remove POWER switch S3 from the front panel from the rear.

b. FAN SAFETY Switch S4. Disconnect the leads, remove two screws from front panel, and remove SAFETY switch S4 from the front panel from the rear.

c. Circuit Breaker CB1. Circuit Breaker CB1 is mounted on a bracket fastened to the mounting bracket of the rectifier assembly. To remove circuit breaker CB1, disconnect the leads and remove the nuts, lockwashers, and screws that fasten circuit breaker CB1 to its bracket.

d. Neon Lamp DS1. Disconnect the leads and remove lamp assembly from front panel from the rear, snap in, snap out.

3-14. Testing After Repair

Whenever the battery charger has been repaired, check the overall, operation of the equipment. Follow the procedure outlined in the equipment performance checklist (TM 11-6130-227-12).

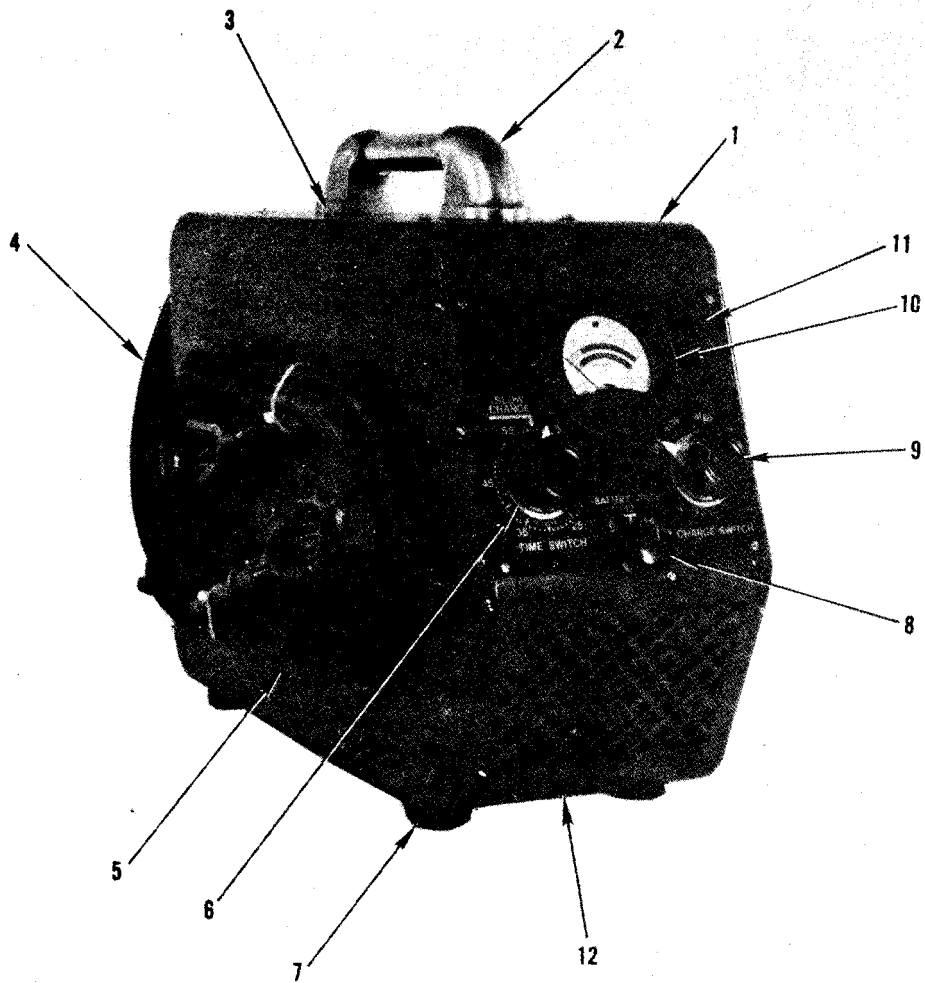

ELOTB003

1. Cover
2. Handle
3. Rectifier mounting screws (4)
4. Ac input cable
5. Dc output cables
6. TIME SWITCH Knob MP12A
7. Bumpers, rubber (4)
8. BATTERY VOLTS switch knob MP11
9. CHARGER SWITCH knob MP12B
10. Ammeter M2
11. Front panel
12. Case

Figure 3-1. Charger, Battery PP-1660()/G.

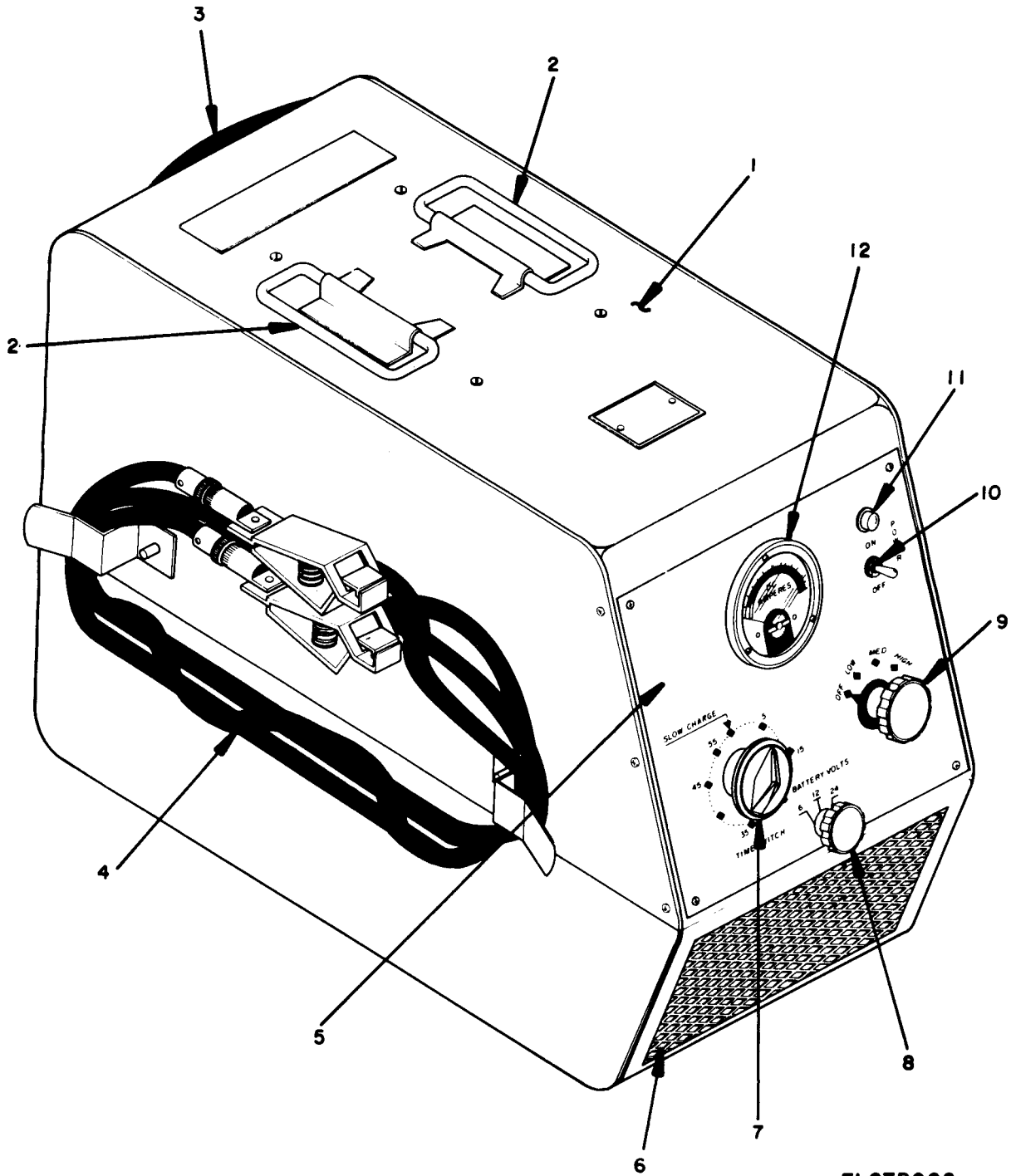

ELOTB008

- | | |
|---------------------|-------------------------------|
| 1. Cover | 7. TIME SWITCH Knob |
| 2. Handle | 8. BATTERY VOLTS switch Knob |
| 3. Ac input cable | 9. CHARGER SWITCH Knob |
| 4. Dc output cables | 10. POWER SWITCH (toggle) |
| 5. Front panel | 11. Indicator DS1 (neon lamp) |
| 6. Case | 12. Ammeter M2 |

Figure 3-2. Charger, Battery PP-1660B/G

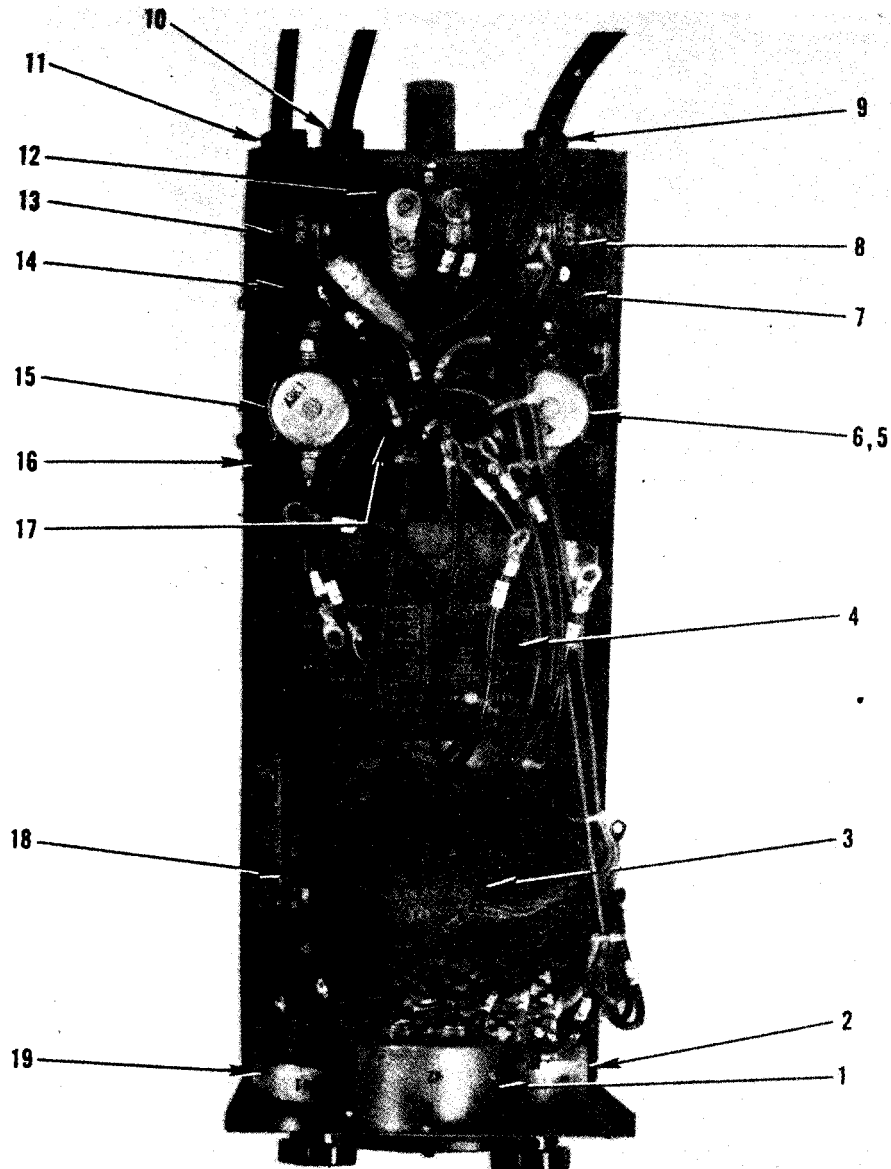

ELOTBOO4

- | | | |
|-----------------------|----------------------------|-------------------------|
| 1. Ammeter | 8. Circuit breaker CB3 | 14. Relay, Solenoid K3 |
| 2. CHARGE SWITCH S1 | 9. Bushing, strain relief | 15. Relay, Solenoid K2 |
| 3. REACTOR L1 | 10. Bushing, strain relief | 16. Sub panel |
| 4. Transformer T1 | 11. Bushing, strain relief | 17. Relay, K1 |
| 5. Relay, Solenoid K5 | 12. Shunt R1 | 18. Circuit breaker CB1 |
| 6. Relay, Solenoid K6 | 13. Circuit breaker CB2 | 19. TIME SWITCH S2 |
| 7. Relay, Solenoid K4 | | |

Figure 3-3. Charger, Battery PP-1660()/G, Internal Parts.

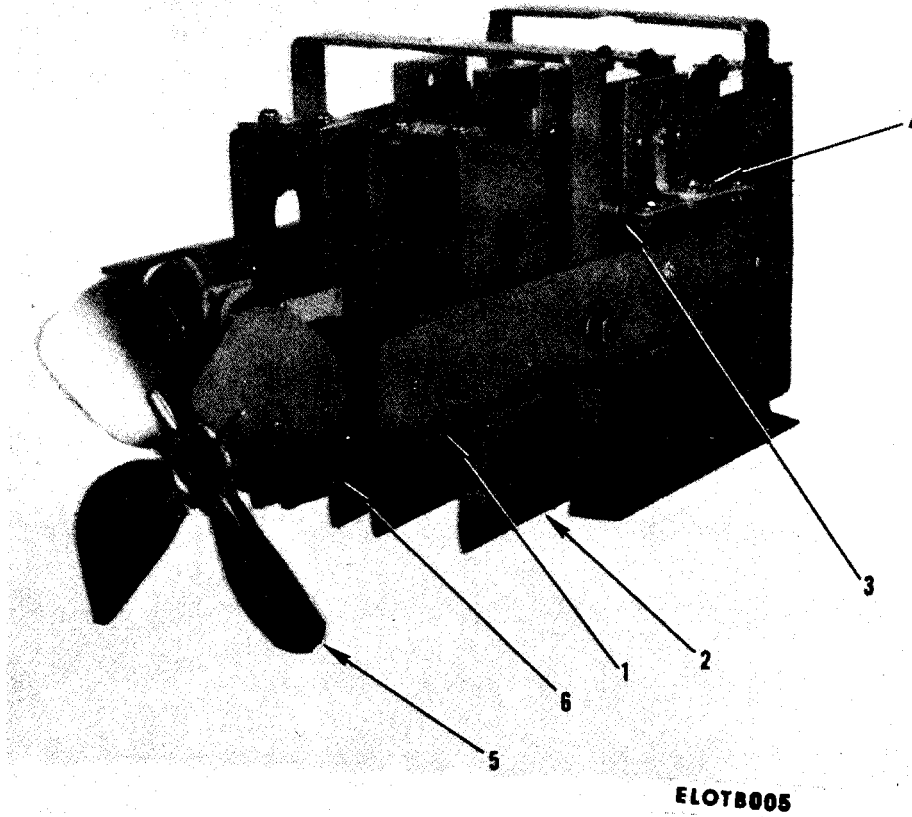

- | | |
|---|--------------------------------|
| 1. Rectifier assembly CR1 and CR2 | 4. Rectifier, silicon, reverse |
| 2. Half of rectifier assembly CR1 and CR2 | 5. Impeller MP4 |
| 3. Rectifier, silicon, forward | 6. Blower Motor B1 |

Figure 3-4. Charger, Battery PP-1660A (Contract DAAB07-75-C-1355), Rectifier Assembly.

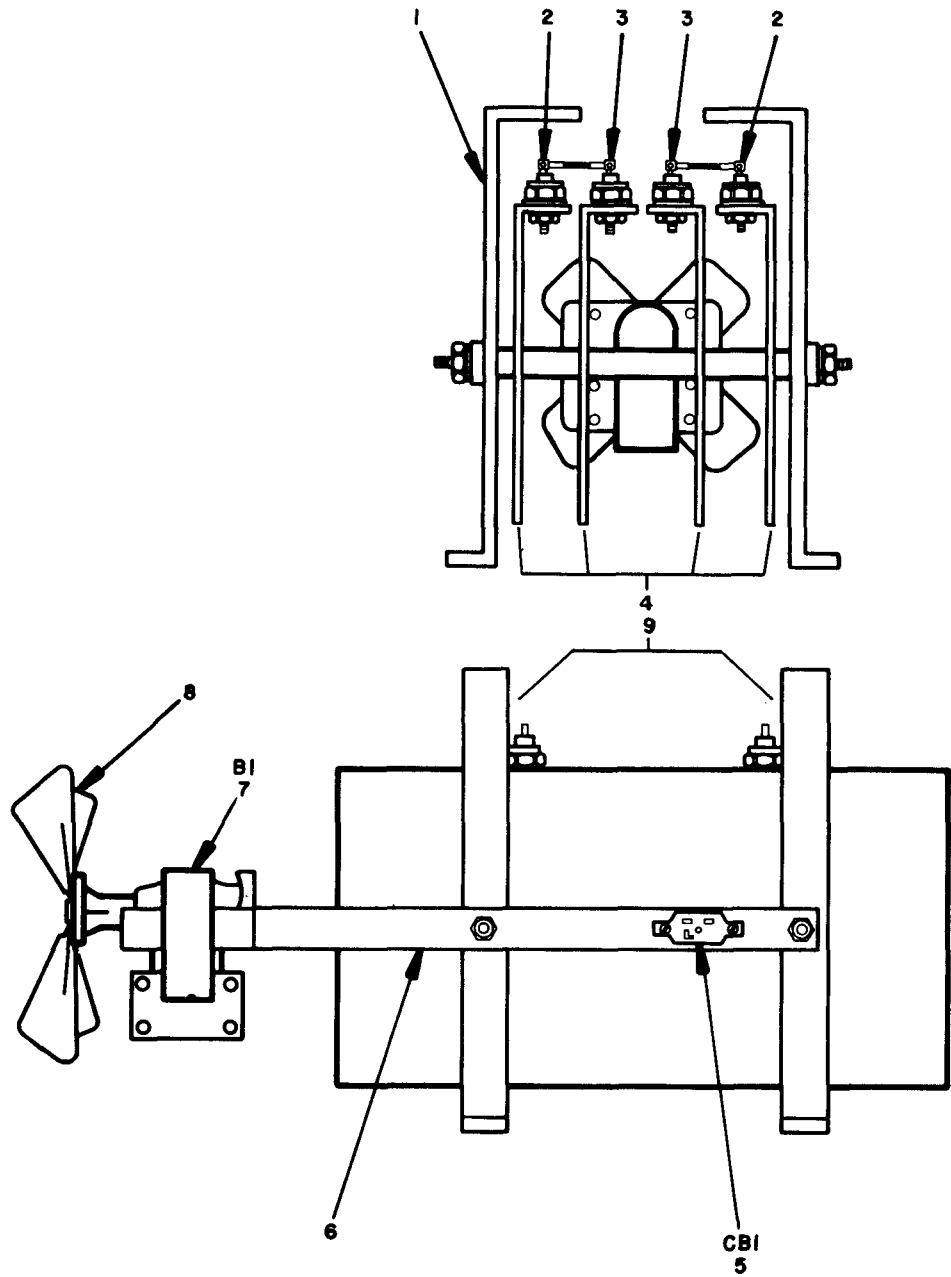

ELOTB009

- | | |
|---------------------------------|-------------------------|
| 1. Rectifier Assembly | 6. Fan bracket |
| 2. Rectifier, selenium, forward | 7. Blower Motor B1 |
| 3. Rectifier, selenium, reverse | 8. Impeller MP4 |
| 4. Heatsinks | 9. Transformer brackets |
| 5. Circuit breaker CB1 | |

Figure 3-5. Charger, Battery PP-1660B/G, Rectifier Assembly.

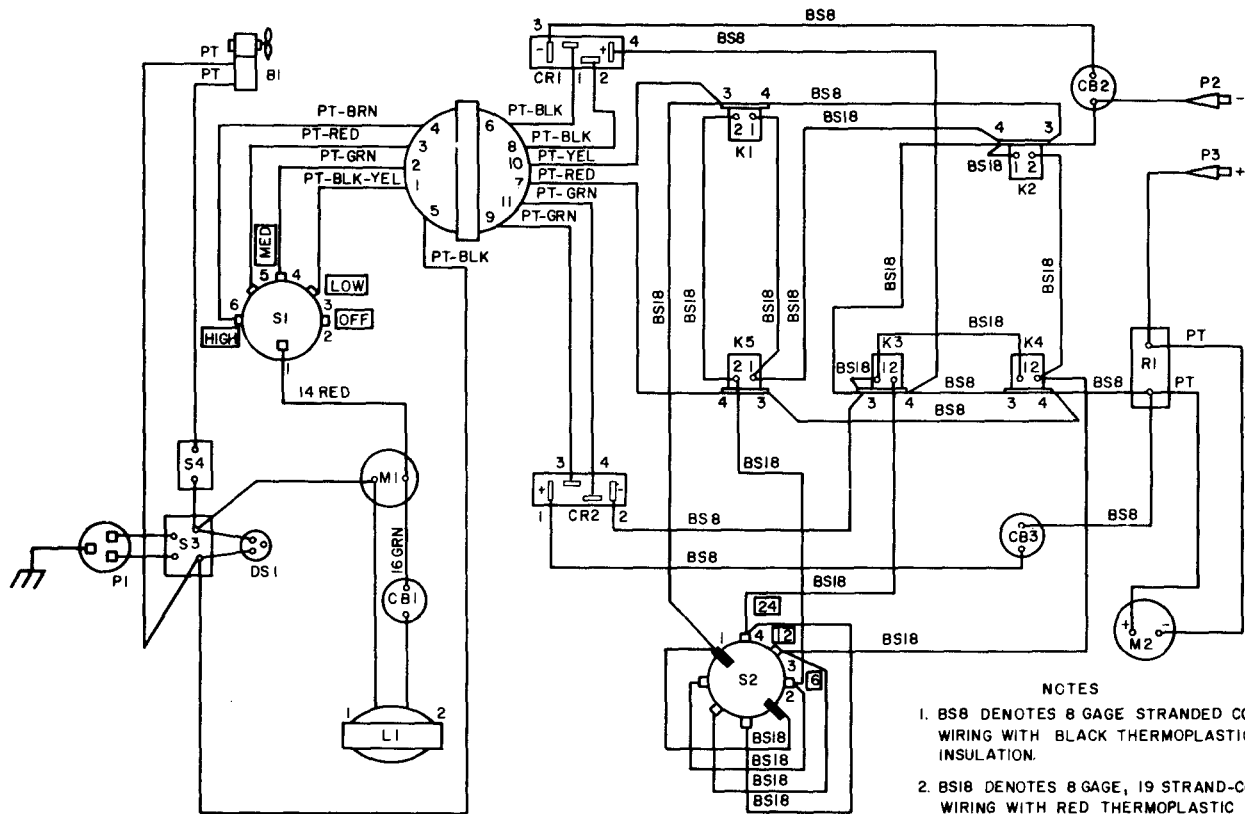

- NOTES
1. BS8 DENOTES 8 GAGE STRANDED COPPER WIRING WITH BLACK THERMOPLASTIC INSULATION.
 2. BS18 DENOTES 8 GAGE, 19 STRAND-COPPER WIRING WITH RED THERMOPLASTIC INSULATION.
 - 3 PT DENOTES PIGTAIL LEAD.

ELOTBOIO

Figure 3-7. Charges, Battery PP-1660B/G Wiring Diagram.

APPENDIX A

REFERENCES

DA Pam 310-1	Consolidated Index of Army Publications and Blank Forms.
TM 11-6130-227-12	Operator and Organizational Maintenance Manual: Charger, Battery PP-1660/G and PP-1660A/G (NSN6130-00-669-6659).
TM 11-6130-227-20P	Organizational Maintenance Repair Parts and Special Tools Lists: Chargers, Battery PP-1660/G and PP-1660A/G(FSN 6130-669-6659).
TM 11-6130-227-20P-1	Organizational Maintenance Repair Parts and Special Tools List for Charger, Battery PP-1660A/G(NSN6130-00-669-6659).
TM 11-6130-227-40P	General Support Maintenance Repair Parts and Special Tools List (Including Depot Maintenance Repair Parts and Special Tools) Chargers, Battery PP-1660/G and PP-1660A/G (FSN 6130-669-6659).
TM 11-6130-227-40P-1	General Support Maintenance Repair Parts and Special Tools Lists for Charger, Battery PP-1660A/G (NSN 6130-00-669-6659).
TM 11-6625-298-24P	Organizational, Direct Support, and General Support Maintenance Repair Parts and Special Tools Lists (Including Depot Maintenance Repair Parts and Special Tools) for Ohmmeter ZM-21A/U (NSN 6625-00-643-1030) and ZM-21B/U (6625-00-643-1030).
TM 11-6625-366-15	Operator's, Organizational, Direct Support, General Support, and Depot Maintenance Manual: Multimeter TS-352B/U (NSN 6625-00-553-0142).
TM 11-6625-654-14	Operator's Organizational, Direct Support, and General Support Maintenance Repair Parts and Special Tools List (Including Depot Maintenance Repair Parts and Special Tools List) for Multimeter AN/USM-223.
TM38-750	The Army Maintenance Management System (TAMMS).
TM740-90-1	Administrative Storage of Equipment.
TM750-244-2	Procedures for Destruction of Electronics Materiel to Prevent Enemy Use (Electronic Command).

By Order of the Secretary of the Army:

E. C. MEYER
General, United States Army
Chief of Staff

Official:

ROBERT M. JOYCE
Major General, United States Army
The Adjutant General

Distribution:

To be distributed in accordance with Special Mailing List.

RECOMMENDED CHANGES TO EQUIPMENT TECHNICAL PUBLICATIONS



THEN... JOT DOWN THE DOPE ABOUT IT ON THIS FORM. CAREFULLY TEAR IT OUT. FOLD IT AND DROP IT IN THE MAIL!

SOMETHING WRONG WITH THIS PUBLICATION?

FROM: (PRINT YOUR UNIT'S COMPLETE ADDRESS)
 Commander
 Stateside Army Depot
 ATTN: AMSTA-US
 Stateside, N.J. 07703

DATE SENT
 10 July 1975

PUBLICATION NUMBER
 TM 11-5840-340-12

PUBLICATION DATE
 23 Jan 74

PUBLICATION TITLE
 Radar Set AN/PRC-76

BE EXACT... PIN-POINT WHERE IT IS

PAGE NO	PARA-GRAPH	FIGURE NO	TABLE NO
2-25	2-28		
3-10	3-3		3-1
5-6	5-8		
		F03	

IN THIS SPACE TELL WHAT IS WRONG AND WHAT SHOULD BE DONE ABOUT IT:

Recommend that the installation antenna alignment procedure be changed throughout to specify a 2° IFF antenna lag rather than 1°.

REASON: Experience has shown that with only a 1° lag, the antenna servo system is too sensitive to wind gusting in excess of 25 knots, and has a tendency to rapidly accelerate and decelerate as it hunts, causing strain to the drive train. Hunting is minimized by adjusting the lag to 2° without degradation of operation.

Item 5, Function column. Change "2 db" to "3db."

REASON: The adjustment procedure the the TRANS POWER FAULT indicator calls for a 3 db (500 watts) adjustment to light the TRANS POWER FAULT indicator.

Add new step f.1 to read, "Replace cover plate removed in step e.1, above."

REASON: To replace the cover plate.

Zone C 3. On J1-2, change "+24 VDC to "+5 VDC."

REASON: This is the output line of the 5 VDC power supply. +24 VDC is the input voltage.

TEAR ALONG PERFORATED LINE

PRINTED NAME, GRADE OR TITLE, AND TELEPHONE NUMBER
 SSG I. M. DeSpirito 999-1776

SIGN HERE

FILL IN YOUR
UNIT'S ADDRESS

FOLD BACK

DEPARTMENT OF THE ARMY

OFFICIAL BUSINESS
PENALTY FOR PRIVATE USE \$300

POSTAGE AND FEES PAID
DEPARTMENT OF THE ARMY
DOD 314



TEAR ALONG PERFORATED LINE

Commander
US Army Communications-Electronics Command
and Fort Monmouth
ATTN: DRSEL-ME-MP
Fort Monmouth, New Jersey 07703

This fine document...

Was brought to you by me:



[Liberated Manuals -- free army and government manuals](#)

Why do I do it? I am tired of sleazy CD-ROM sellers, who take publicly available information, slap “watermarks” and other junk on it, and sell it. Those masters of search engine manipulation make sure that their sites that sell free information, come up first in search engines. They did not create it... They did not even scan it... Why should they get your money? Why are not letting you give those free manuals to your friends?

I am setting this document FREE. This document was made by the US Government and is NOT protected by Copyright. Feel free to share, republish, sell and so on.

I am not asking you for donations, fees or handouts. If you can, please provide a link to liberatedmanuals.com, so that free manuals come up first in search engines:

<A HREF=<http://www.liberatedmanuals.com/>>Free Military and Government Manuals

- Sincerely
Igor Chudov
<http://igor.chudov.com/>
- [Chicago Machinery Movers](#)