

ARMY  
NAVY  
AIR FORCE

TM 11-5895-833-34P-7  
NAVELEX 0967-LP-550-1 164  
TO 31RS-2MSC46-4

---

**DIRECT SUPPORT AND GENERAL SUPPORT  
MAINTENANCE REPAIR PARTS AND SPECIAL TOOLS  
LISTS (INCLUDING DEPOT MAINTENANCE REPAIR  
PARTS AND SPECIAL TOOLS)**

**FOR**

**CONVERTERS, FREQUENCY, ELECTRONIC  
CV-3085/MSC-46(V) (NSN 5895-00-100-4311)  
AND  
CV-3085A/MSC-46(V) (NSN 5895-00-614-9575)**

---

**DEPARTMENTS OF THE ARMY, THE NAVY AND THE AIR FORCE  
21 DECEMBER 1984**

Technical Manual  
 No. 11-5895-833-34P-7  
 Technical Manual  
 NAVEX 0967-LP-550-1164  
 Technical Order  
 TO 31R5-2MSC46-4

DEPARTMENTS OF THE ARMY,  
 THE NAVY, AND THE AIR FORCE  
 Washington, DC, 21 December 1984

**DIRECT SUPPORT AND GENERAL SUPPORT MAINTENANCE REPAIR PARTS AND SPECIAL TOOLS  
 LISTS (INCLUDING DEPOT MAINTENANCE REPAIR PARTS FOR SPECIAL TOOLS)  
 FOR  
 CONVERTORS, FREQUENCY, ELECTRONIC  
 CV-3085/MSC-46(V) (NSN 5895-00-100-4311)  
 AND  
 CV-3085A/MSC-46(V) (NSN 5895-00-614-9575)**

*Current as of 27 September 1984*

**REPORTING ERRORS AND RECOMMENDING IMPROVEMENTS**

You can help improve this manual if you find any mistakes or if you know of a way to improve the procedures, please let us know. Mail your letter, DA Form 2028 (Recommended Changes to Publications and Blank Forms), or DA Form 2028-2 located in back of this manual direct to Commander, US Army Communications-Electronics Command and Fort Monmouth, ATTN AMSEL-ME-MP, Fort Monmouth, New Jersey 07703-5007.

For Air Force, submit AFTO Form 22 (Technical Order System Publication Improvement Report and Reply) in accordance with paragraph 6-5, Section VI, T.O 00-5-1 Forward direct to prime ALC/MST

For Navy, mail comments to the Commander, Naval Electronic Systems Command, ATTN ELEX 8122, Washington, DC 20360

In either case a reply will be furnished direct to you.

**TABLE OF CONTENTS**

		Page	Illus Figure
Section I.	Introduction .....	1	
Section II.	Repair Parts .....	5	
Group 02	Converter, Electronic Frequency CV-3085/MSC-46(V), CV-3085A/MSC-46(V).....	5	1
	Converter, Electronic Frequency CV-3085/MSC-46(V), CV-3085A/MSC-46(V).....	5	2
	Converter, Electronic Frequency CV-3085/MSC-46(V), CV-3085A/MSC-46(V).....	15	3
	Converter, Electronic Frequency CV-3085/MSC-46(V), CV-3085A/MSC-46(V).....	19	4
	Converter, Electronic Frequency CV-3085/MSC-46(V), CV-3085A/MSC-46(V).....	23	5
	Converter, Electronic Frequency CV-3085/MSC-46(V), CV-3085A/MSC-46(V).....	25	6
	Converter, Electronic Frequency CV-3085/MSC-46(V), CV-3085A/MSC-46(V).....	29	7
	0201 70-MHZ IF. Amp (1A2AR2) and (1A2AR3) (No Parts Authorized)		
	0202 Wiring Harness, Interlock (1A2W31) .....	31	8
	0203 Cable Assembly, RF (1A2W9) .....	33	9
	0204 Cable Assembly, RF (1A2W8) .....	35	10
	0205 Cable Assembly, RF (1A2W13) .....	37	11

\*This manual supersedes TM 11-5895-833-34P-7, 26 September 1977, including all changes

Group	Page	Illus Figure
0206 Cable Assembly, RF (1A2W16) .....	39	12
0207 Cable Assembly, RF (1A2W17) .....	41	13
0208 IF Phase-Locked Oscillator (1A2Y2) (No Parts Authorized)		
0209 Filter Bandpass FL3 (No Parts Authorized)		
0210 700-MHZ Amp (1A2AR1) (No Parts Authorized)		
0211 RF Conversion Stripline Assembly (1A2CR1) (No Parts Authorized)		
0212 IF Conversion Stripline Assembly (1A2CRC) (No Parts Authorized)		
0213 Phase Equalizer (1A2EQ1) (No Parts Authorized)		
0214 RF-Input Stripline Assembly (1A2DC1) (No Parts Authorized)		
0215 Wiring Harness, Interconnection (1A2W29) .....	43	14
0216 Wiring Harness, AC Prime Power (1A2W30) .....	45	15
0217 Amplitude Step Attenuator(1A2AT5).....	49	16
021701 Circuit Card Assembly (1A2AT5A1).....	49	16
021702 Circuit Card Assembly (1A2AT5A4) .....	49	16
021703 Circuit Card Assembly(1A2AT5A3).....	49	16
021704 Circuit Card Assembly (1A2AT5A2).....	49	16
0218 Out-of-Lock Detector (1A2A4) (Circuit Card Assembly) .....	53	17
0219 Status Indicator Calibration (1A2A3) (Circuit Card Assembly).....	57	18
0220 Bandpass Filter Assembly (1A2A7).....	59	19
02201 Bandpass Filter (1A2A7FL1) (No Parts Authorized).....	59	19
0221 Wiring Harness, Frequency Control (1A2W26).....	61	20
0222 Front Panel Assembly (1A2A2) .....	63	21
022201 Tuning Shunt .....	63	21
022202 RF Power Monitor (1A2A2CR4) (No Parts Authorized)		
0223 Power Supply Assembly (1A2A1).....	67	22
022301 Power Supply (1A2A1 PSI) (No Parts Authorized)		
0224 Cable Assembly, RF (1A2W24) .....	69	23
0225 Cable Assembly, RF (1A2W25). .....	71	24
0226 Cable Assembly, RF (1A2W22) .....	73	25
0227 RF Phase-Locked Oscillator(1A2Y1) . .....	75	26
022701 RF Control Assembly (1A2Y1A1).....	75	26
022702 Filter Network Circuit Card Assembly (1AY2Y1A5) (No Parts Authorized).....	75	26
022703 Phase Lock Control Circuit Card Assembly (No Parts Authorized) .....	75	26
022704 L-Band Oscillator (1A2Y1A3) (Radio Frequency Oscillator) (No Parts Authorized) .....	75	26
022705 Frequency Multiplier Assembly (1A2Y1A4) (No Parts Authorized).....	75	26
0228 Wiring Harness, Oscillator (1A2W35) .....	77	27
0229 Cable Assembly, RF (1A2W12) . .....	79	28
0230 Cable Assembly, RF (1A2W18) .....	81	29
0231 Cable Assembly, RF (1A2W20) .....	83	30
0232 Wiring Harness, Oscillator (1A2W36) .....	85	31
0233 700 MHZ Amp (1A2AR4) (No Parts Authorized)		

		Page	Illus Figure
Group	0234 Directional Coupler (1A2DC3) (No Parts Authorized)		
	0235 Cable Assembly, RF(1A2W32) .....	87	32
	0236 Bandpass Filter (1A2FL4) (No Parts Authorized)		
	0237 Wiring Harness (1A2W37) . .....	89	33
Section III.	Special Tools List .....	91	
Group 30	Special Tools.....	91	34
Section IV.	National Stock Number and Part Number Index .....	93	

iii/(iv blank)

SECTION I

INTRODUCTION

**1. Scope**

This manual lists spares and repair parts, special tools; special test, measurement, and diagnostic equipment (TMDE), and other special support equipment required for performance of Direct Support and General Support maintenance of the CV-3085/MS-46(V) and CV-3085A/MS-46(V). It authorizes requisitioning and Issue of spares and repair parts as indicated by the source and maintenance codes

**2. General**

This Repair Parts and Special Tools List is divided into the following sections:

*a. Section II. Repair Parts List.* A list of spares and repair parts authorized for use in the performance of maintenance. The list also includes parts which must be removed for replacement of the authorized parts. Parts lists are composed of functional groups in numeric sequence, with the parts in each group listed in figure and item number sequence

*b. Section III. Special Tools List.* A list of special tools, special TMDE, and other special support equipment authorized by this RPSTL for the performance of maintenance

*c. Section IV. National Stock Number and Part Number Index.* A list, in National item identification number (NIIN) sequence, of all National stock numbers (NSN) appearing in the listings, followed by a list, in alphanumeric sequence, of all part numbers appearing in the listings. National stock numbers and part numbers are cross-referenced to each illustration figure and item number appearance

**3. Explanation of Columns**

*a. Illustration.* This column is divided as follows

(1) *Figure number.* Indicates the figure number of the illustration on which the item is shown

(2) *Item number.* The number used to identify item called out in the illustration

*b. Source, Maintenance, and Recoverability (SMR) Codes*

(1) *Source code.* Source codes indicate the manner of acquiring support items for maintenance, repair, or overhaul of end items. Source codes are entered in the first and second positions of the Uniform SMR Code format as follows.

<i>Code</i>	<i>Definition</i>
PA —	Item procured and stocked for anticipated or known usage.
PE —	Support equipment procured and stocked for initial issue or outfitting to specified maintenance repair activities.
XA —	Item is not procured or stocked because the requirements for the item will result in the replacement of the next higher assembly.
XB —	Item is not procured or stocked if not available through salvage, requisition.

**NOTE**

Cannibalization or salvage may be used as a source of supply for any items source coded above except those coded XA and aircraft support items as restricted by AR 750-1

(2) *Maintenance code.* Maintenance codes are assigned to indicate the levels of maintenance authorized to USE and REPAIR support items. The maintenance codes are entered in the third and fourth positions of the Uniform SMR Code format as follows.

(a) The maintenance code entered in the third position will indicate the lowest maintenance level authorized to remove, replace, and use the support item. The maintenance code

entered in the third position will indicate one of the following levels of maintenance:

<i>Code</i>	<i>Application/Explanation</i>
O —	Support Item is removed, replaced, used at the organizational level
F —	Support item is removed, replaced, used at the direct support level.
D —	Support Items that are removed, replaced, used at depot, mobile depot, specialized repair activity only

(b) The maintenance code entered in the fourth position indicates whether the item is to be repaired and identifies the lowest maintenance level with the capability to perform complete repair (i.e., all authorized maintenance functions). This position will contain one of the following maintenance codes:

<i>Code</i>	<i>Application/Explanation</i>
-------------	--------------------------------

- F - The lowest maintenance level capable of complete repair of the support item is the direct support level.
- D - The lowest maintenance level capable of complete repair of the support item is the depot level
- Z - Nonreparable. No repair is authorized

(3) Recoverability code. Recoverability codes are assigned to support items to indicate the disposition action on unserviceable items. The recoverability code is entered in the fifth position of the Uniform SMR Code format as follows:

<i>Recoverability Code</i>	<i>Definition</i>
Z —	Nonreparable. Item When unserviceable, condemn and dispose at the level indicated in position 3
F —	Reparable item When uneconomically repairable condemn and dispose at the direct support level.
D —	Reparable item When beyond lower level repair capability, return to depot. Condemnation and disposal not authorized below depot level
L —	Reparable item Repair, condemnation, and disposal not authorized below depot/specialized repair activity level

A — Item requires special handling or condemnation procedures because of specific reasons (i.e., precious metal content, high dollar value, critical material or hazardous material). Refer to appropriate manuals/directives for specific instructions

c. National Stock Number. Indicates the National stock number assigned to the item and will be used for requisitioning purposes

d. Federal Supply Code for Manufacturer (FSCM). The FSCM is a 5-digit numeric code listed in SB 708-41/42 which is used to identify the manufacturer, distributor, or Government agency, etc.

e. Part Number. Indicates the primary number used by the manufacturer (individual, company, firm, corporation, or Government activity), which controls the design and characteristics of the item by means of its engineering drawings, specifications, standards, and inspection requirements to identify an item or range of items

**NOTE**

When a stock numbered item is requisitioned, the repair part received may have a different part number than the part being replaced.

f. Description. Indicates the Federal item name and, if required, a minimum description to identify the item. In the Special Tools List, the initial basis of Issue (BOI) appears as the last line in the entry for each special tool, special TMDE, and other special support equipment. When density of equipments supported exceeds density spread indicated in the basis of Issue, the total authorization is increased accordingly

g. Unit of Measure (U/M). Indicates the standard of the basic quantity of the listed item as used in performing the actual maintenance function. This measure is expressed by a two-character alphabetical abbreviation (e.g., ea, in, pr, etc). When the unit of measure differs from the unit of Issue, the lowest unit of Issue that will satisfy the required units of measure will be requisitioned

h. Quantity Incorporated in Unit. Indicates the quantity of the item used in the breakout shown on the illustration figure, which is prepared for a

functional group, subfunctional group, or an assembly. A "V" appearing in this column in lieu of a quantity indicates that no specific quantity is applicable, (e.g., shims, spacers, etc).

4. Special Information

a. Usable on codes are shown in the description column. Uncoded items are applicable to all models. Identification of the usable on codes used in this publication are:

<i>Code</i>	<i>Used On</i>
CEQ	CV-3085/MSC-46(V)
DND	CV-3085A/MSC-46(V)

b. The following publications pertain to the CV-3085/MSC-46(V) and CV-3085A/MSC-46(V) and their components

- TM 11-5895-833-12, Frequency Conversion Subsystem.
- TM 11-5895-833-20P, Frequency Conversion Subsystem.
- TM 11-5895-833-34P-1, Frequency Conversion Subsystem
- TM 11-5895-833-34-7, Converter, Frequency, Electronic

c. National stock numbers (NSN's) that are missing from P source coded items have been applied for and will be added to this TM by future change/revision when they are entered in the Army Master Data File (AMDF). Until the NSN's are established and published, submit exception requisitions to Commander, US Army Communications-Electronics Command, ATTN: AMSEL-MM, Fort Monmouth, NJ 07703-5006 for the part required to support your equipment.

5. How to Locate Repair Parts

a. When National stock number or part number is unknown

(1) First. Using the table of contents, determine the functional group within which the item belongs. This is necessary since illustrations are prepared for functional groups and listings and divided into the same groups.

(2) Second. Find the illustration covering the functional group to which the item belongs.

(3) Third. Identify the item on the illustration and note the illustration figure and item number of the item.

(4) Fourth. Using the Repair Parts Listing, find the figure and item number noted on the illustration.

b. When National stock number or part number is known

(1) First. Using the Index of National Stock Numbers and Part Numbers, find the pertinent National stock number or part number. This index is in NIIN sequence followed by a list of part numbers in alphanumeric sequence, cross-referenced to the illustration figure number and item number.

(2) Second. After finding the figure and item number, locate the figure and item number in the repair parts list.

6. Abbreviations

Not applicable

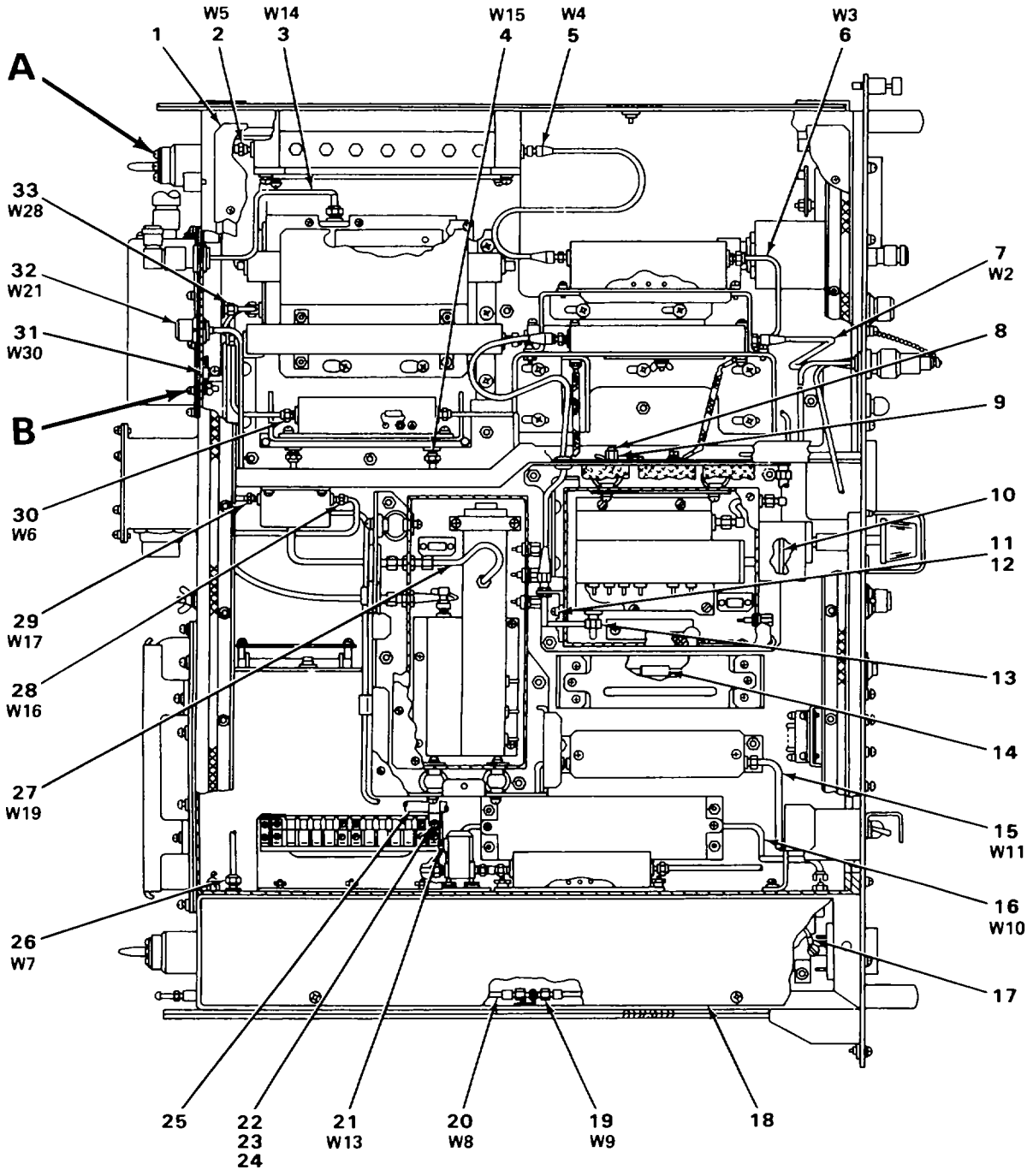

NOTE:  
 PREFIX ALL REFERENCE DESIGNATIONS WITH  
 UNIT NUMBER AND SUBASSEMBLY DESIGNATION

ELOJT001

FIGURE 1. CONVERTER, ELECTRONIC FREQUENCY CV-3085/MSC-46(V) AND CV-3085A/MSC-46(V)  
 (SHEET 1 OF 2)



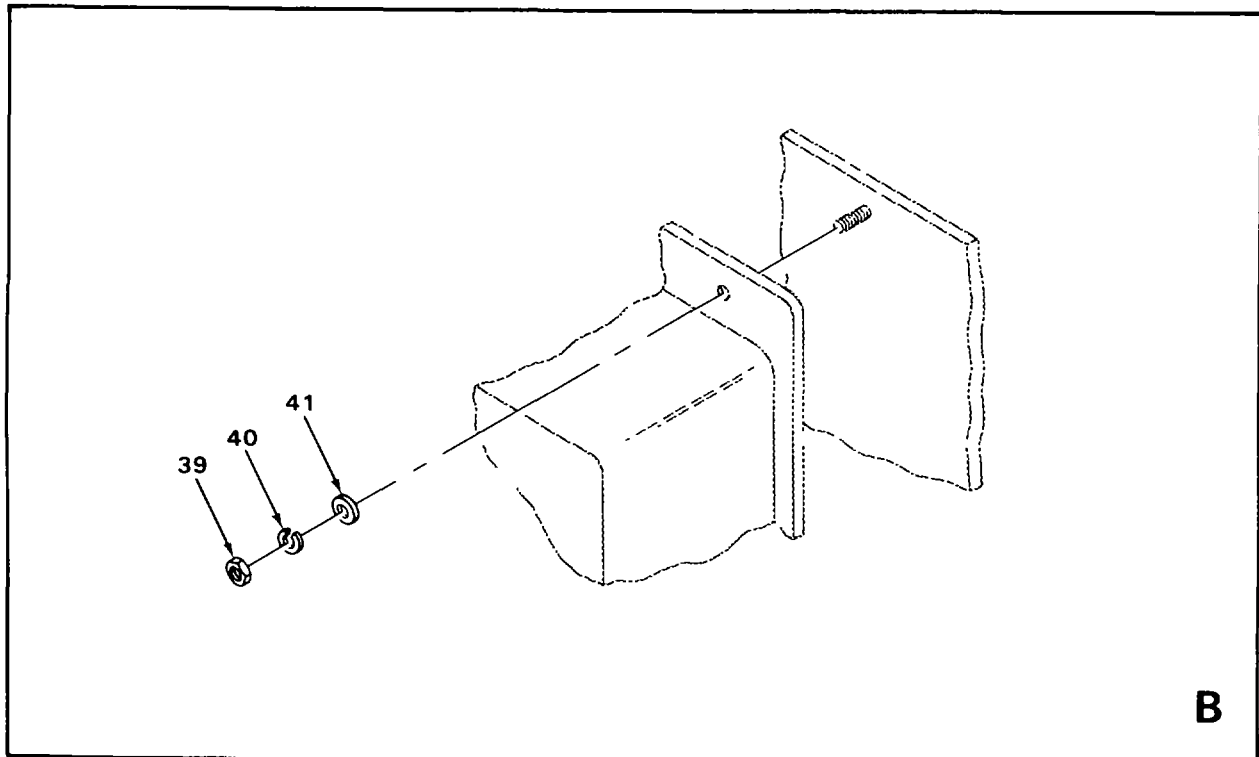
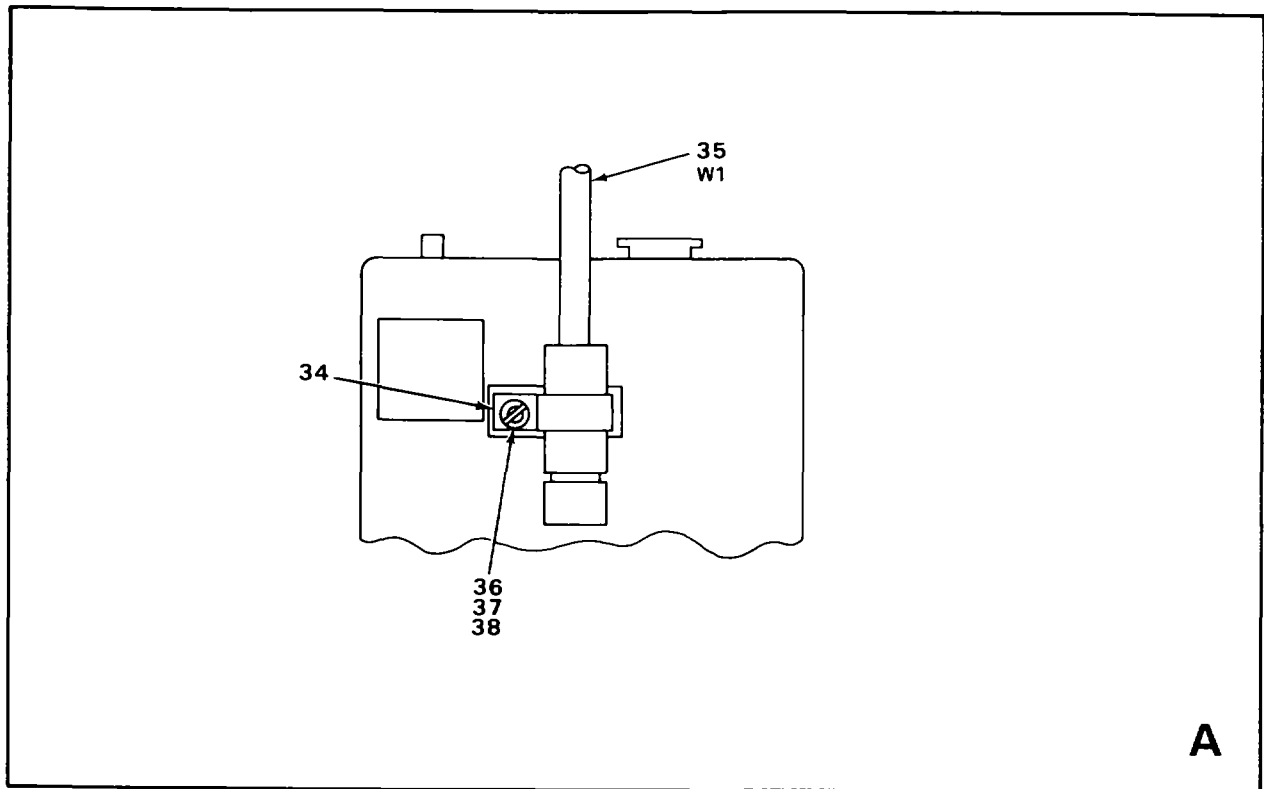

EL0JT035

FIGURE 1 CONVERTER, ELECTRONIC FREQUENCY CV-3085/MSC-46(V) AND CV-3085A/MSC-46(V)  
(SHEET 2 OF 2)

SECTION II

(1) ILLUSTRATION		(2)	(3)	(4)	(5)	(6) DESCRIPTION	(7)	(8)
(a) FIG NO.	(b) ITEM NO.	SMR CODE	NATIONAL STOCK NUMBER	FSCM	PART NUMBER	USABLE ON CODE	U/M	QTY INC IN UNIT
						GROUP 02 CONVERTER, ELECTRONIC FREQUENCY CV-3085/MSC-46(V) AND CV-3085A/MSC-46(V)		
1	1	XBFZZ		31196	4350000624	COVER,ACCESS,TOP .....	EA	1
1	2	PAFZZ	5995-01-009-5460	31196	3120001627	CABLE ASSEMBLY,RADI .....	EA	1
1	3	PAFZZ	5995-01-017-7137	31196	4120001636	CABLE ASSEMBLY,RADI .....	CEQ	EA 1
1	4	PAFZZ	5995-01-017-7138	31196	4120001637	CABLE ASSEMBLY,RADI .....	EA	1
1	5	PAFZZ	5995-01-017-7128	34677	S01SOID000-09-05	CABLE ASSEMBLY,RADI .....	CEQ	EA 1
1	6	PAFZZ	5995-01-017-7134	31196	3120001626	CABLE ASSEMBLY,RADI .....	EA	1
1	7	XBFZZ		31196	2120008768	CABLE ASSEMBLY,RADI .....	EA	1
1	8	PAFZZ	5305-00-922-8778	96906	MS35275-203	SCREW,MACHINE .....	EA	1
1	9	PAFZZ	5340-00-793-0543	06992	CONO	CLIP .....	EA	1
1	10	PAFZZ	4010-01-020-8884	29440	3CCF24E	CHAIN .....	EA	1
1	11	PAFZZ	5305-00-054-5648	96906	MS51957-14	SCREW,MACHINE .....	EA	7
1	12	PAFZZ	5310-00-595-6211	96906	MS15795-803	WASHER,FLAT .....	EA	17
1	13	PAFZZ	5995-01-012-3638	31196	3120005378	CABLE ASSEMBLY,RADI .....	EA	1
1	14	XBFFF		31196	6240001379-1	WIRING HARNESS, INTC (SEE FIGURE 14 FOR BREAKDOWN)	EA	1
1	15	PAFZZ	5995-01-009-5461	31196	3120001633	CABLE ASSEMBLY,RADI .....	EA	1
1	16	PAFZZ	5995-01-017-7135	31196	3120001632	CABLE ASSEMBLY,RADI .....	EA	1
1	17	PAFFF	5995-01-140-0963	31196	4240004811	WIRING HARNESS,INTE (SEE FIGURE 8 FOR BREAKDOWN)	EA	1
1	18	XBFZZ		31196	4040000736	COVER,ACCESS .....	EA	1
1	19	PAFFF	5995-01-146-1401	31196	2120001631	CABLE ASSEMBLY,RADI(SEE FIGURE 9 FOR BREAKDOWN)	EA	1
1	20	PAFFF	5995-01-146-1399	31196	2120001630	CABLE ASSEMBLY,RADI(SEE FIGURE 10 FOR BREAKDOWN)	EA	1
1	21	PAFFF	5895-01-131-3819	31196	2120001635	CABLE ASSEMBLY,RADI(SEE FIGURE 11 FOR BREAKDOWN)	EA	1
1	22	PAFZZ	5305-00-054-6657	96906	MS51957-33	SCREW,MACHINE .....	EA	4
1	23	PAFZZ	5310-00-929-6395	96906	MS35338-136	WASHER,LOCK .....	EA	4
1	24	PAFZZ	5310-00-973-8660	80063	SM-B-416109-1	WASHER,FLAT .....	EA	4
1	25	PAFZZ	5340-00-721-5315	96906	MS25281R5	CLAMP,LOOP .....	EA	1
1	26	PAFZZ	5995-01-095-5462	31196	4120001629	CABLE ASSEMBLY,RADI .....	EA	1
1	27	PAFZZ	5995-01-023-2334	31196	3120005396	CABLE ASSEMBLY,RADI .....	EA	1

SECTION II

TM 11-5895-833-34P-7/0967-LP-550-1164/TO 31R5-2MSC46-4

(1) ILLUSTRATION		(2)	(3)	(4)	(5)	(6)	(7)	(8)
(a) FIG NO.	(b) ITEM NO.	SMR CODE	NATIONAL STOCK NUMBER	FSCM	PART NUMBER	DESCRIPTION  USABLE ON CODE	U/M	QTY INC IN UNIT
1	28	PAFFF	5995-01-146-1400	31196	2120001638	CABLE ASSEMBLY,RADI(SEE FIGURE 12 FOR BREAKDOWN)	EA	1
1	29	PAFFF	5995-01-146-1397	31196	2120001639	CABLE ASSEMBLY,RADI(SEE FIGURE 13 FOR BREAKDOWN)	EA	1
1	30	PAFZZ	5995-01-009-5463	31196	3120001628	CABLE ASSEMBLY,RADI .....	EA	1
1	31	PAFFF	5995-01-140-0962	31196	4240001617	WIRING HARNESS,POWE (SEE FIGURE 15 FOR BREAKDOWN)	EA	1
1	32	PAFZZ	5995-01-009-5464	31196	4120001643	CABLE ASSEMBLY,RADI .....	EA	1
1	33	PAFZZ	5995-01-017-7136	31196	4120001625	CABLE ASSEMBLY,RADI .....	EA	1
1	34	PAFZZ	5340-00-820-1789	96906	MS25281R13	CLAMP,LOOP ..... CEQ	EA	1
1	34	PAFZZ	5340-00-051-6819	96906	MS25281R-14	CLAMP,LOOP ..... DND	EA	1
1	35	XBFZZ		52214	F345AA0223A02	CABLE ASSEMBLY,RADI .....	EA	1
1	36	PAFZZ	5305-00-837-9739	96906	MS21316-13	THUMBSCREW .....	EA	1
1	37	PAFZZ	5310-00-933-8119	96906	MS35338-137	WASHER,LOCK .....	EA	1
1	38	PAFZZ	5310-00-880-5978	96906	MS15795-807	WASHER,FLAT .....	EA	1
1	39	PAFZZ	5310-00-934-9765	96906	M5S35650-304	NUT,PLAIN,HEXAGON .....	EA	6
1	40	PAFZZ	5310-00-933-8120	96906	MS35338-138	WASHER,LOCK .....	EA	6
1	41	PAFZZ	5310-00-595-6772	96906	M5S15795-808	WASHER,FLAT .....	EA	6

6/(7 blank)

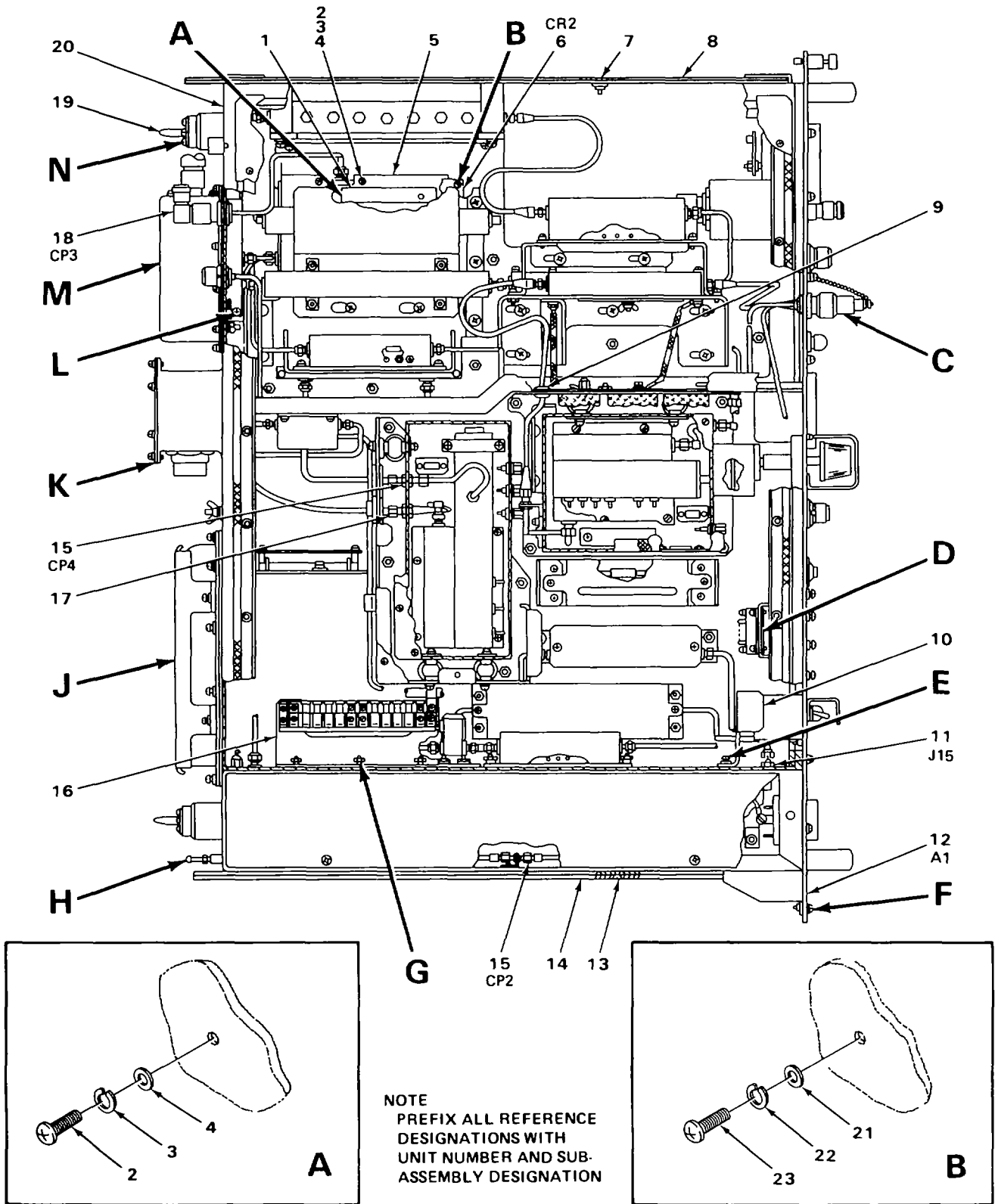

ELOJT005

FIGURE 2. CONVERTER, ELECTRONIC FREQUENCY CV-3085/MSC-46(V) AND CV-3085A/MSC-46(V)  
(SHEET 1 OF 3)

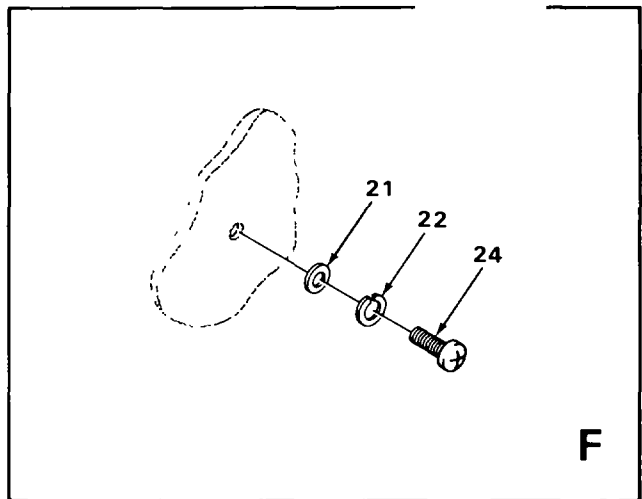
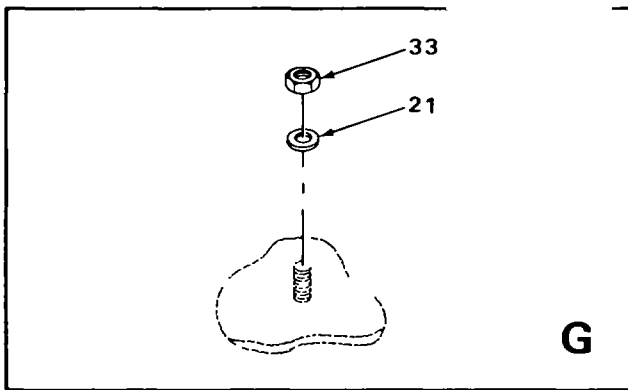
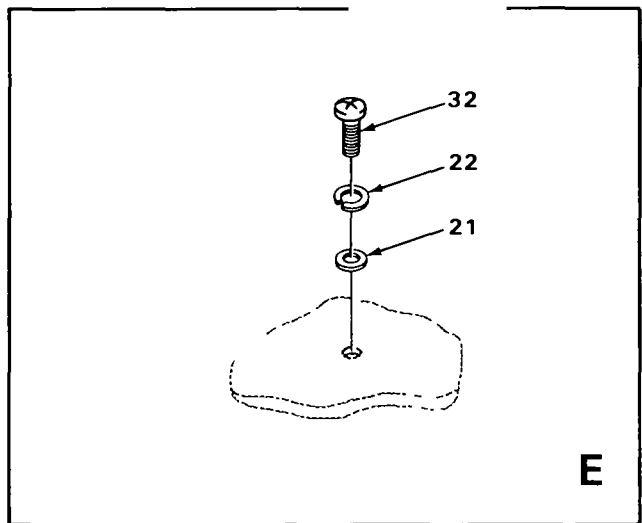
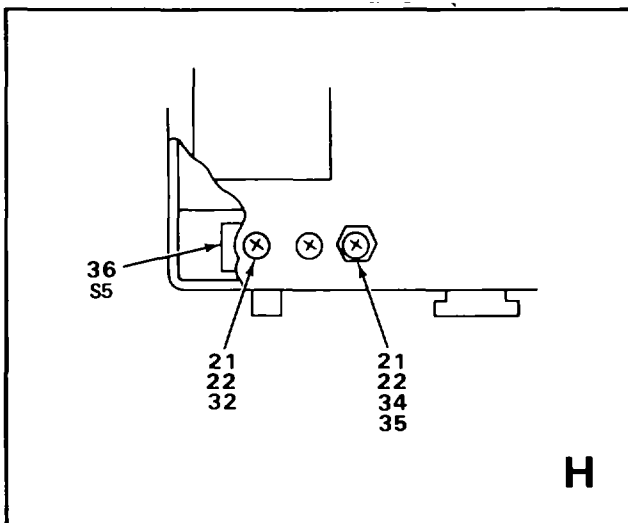
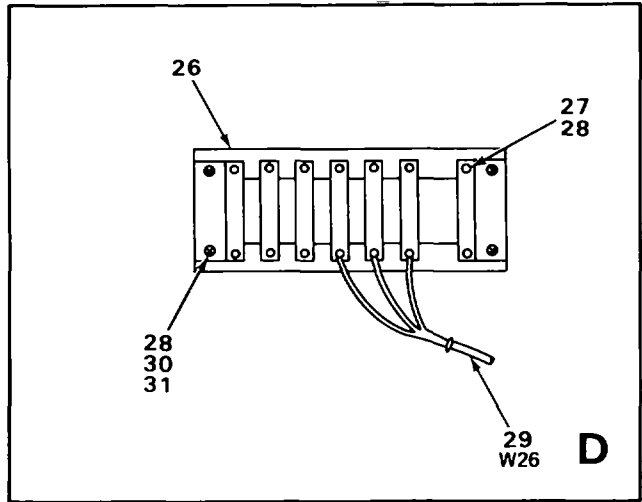
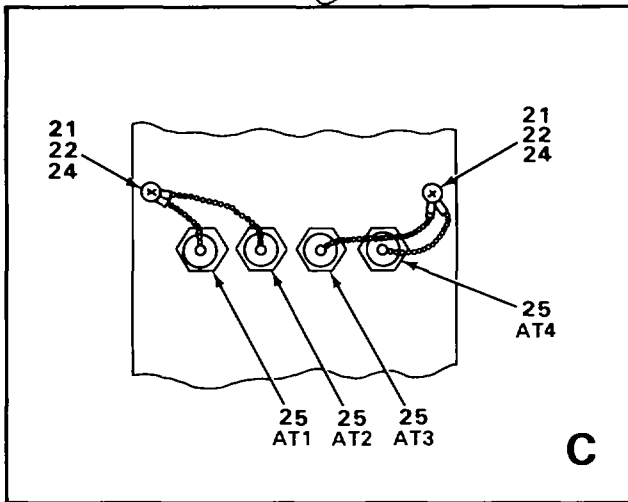

NOTE  
PREFIX ALL REFERENCE DESIGNATIONS WITH  
UNIT NUMBER AND SUBASSEMBLY DESIGNATION

ELOJT006

FIGURE 2. CONVERTER, ELECTRONIC FREQUENCY CV-3085/MSC-46(V) AND CV-3085A/MSC-46(V)  
(SHEET 2 OF 3)

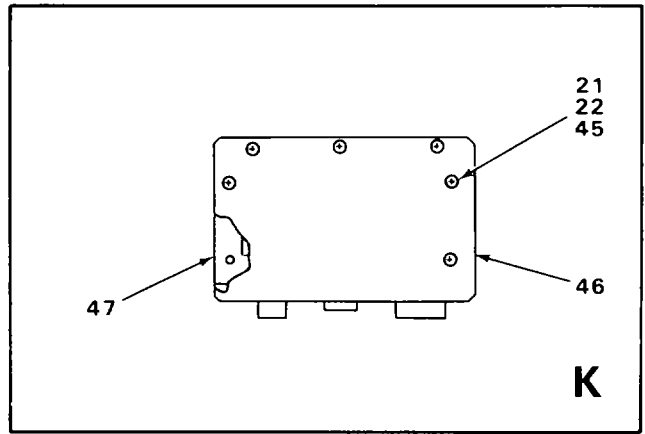
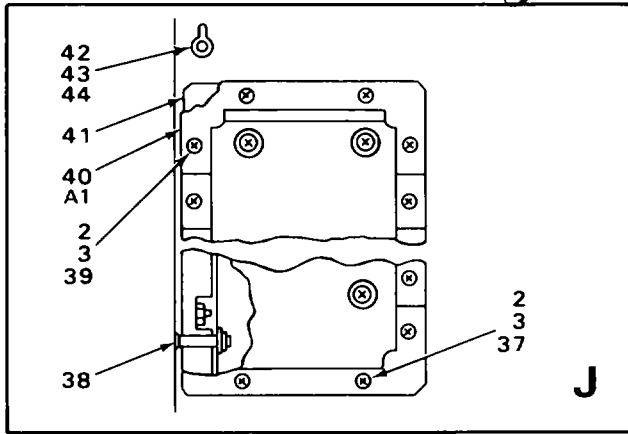

NOTE  
 PREFIX ALL REFERENCE DESIGNATIONS WITH  
 UNIT NUMBER AND SUBASSEMBLY DESIGNATION

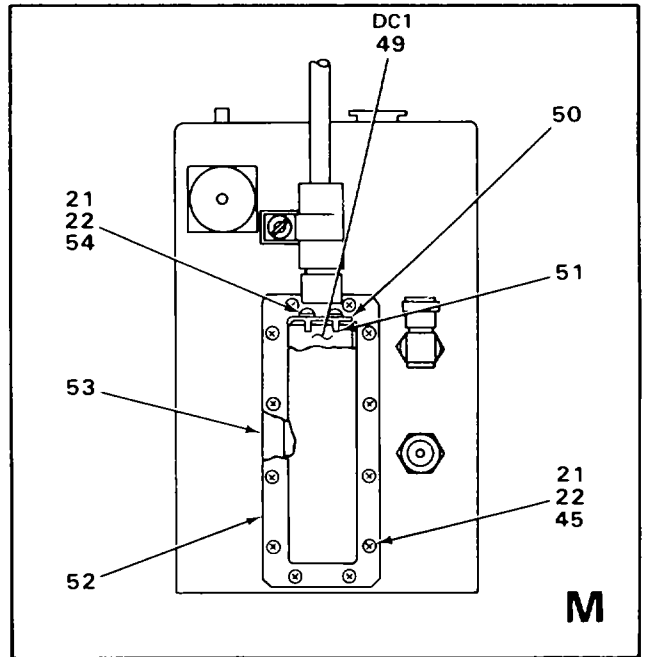
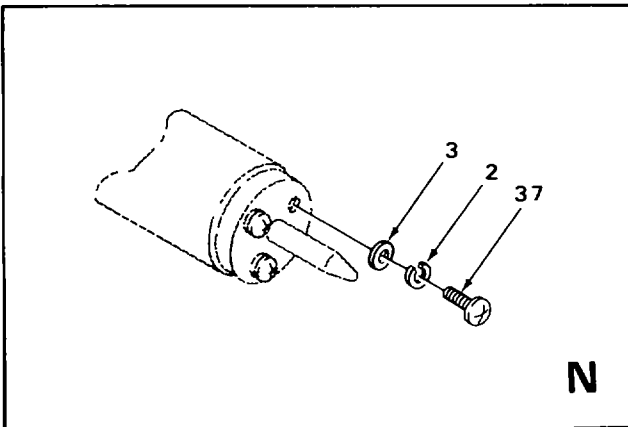
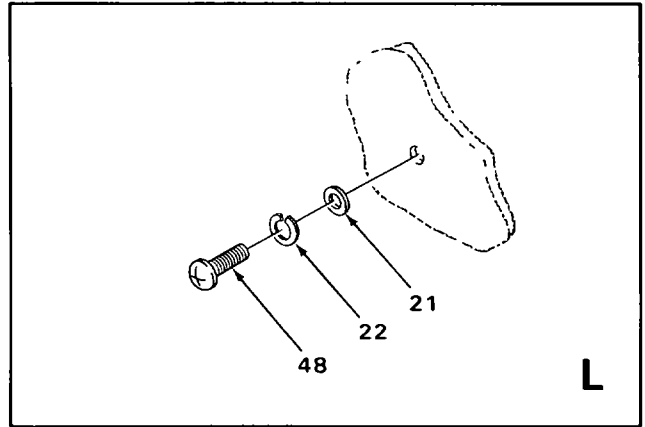

EL0JT034

FIGURE 2. CONVERTER, ELECTRONIC FREQUENCY CV-3085/MSC-46(V) AND CV-3085/MSC-46(V)  
 (SHEET 3 OF 3)

SECTION II

TM 11-5895-833-34P-7/0967-LP-550-1164/TO 31R5-2MSC46-4

(1) ILLUSTRATION		(2)	(3)	(4)	(5)	(6) DESCRIPTION	(7)	(8)
(a) FIG NO.	(b) ITEM NO.	SMR CODE	NATIONAL STOCK NUMBER	FSCM	PART NUMBER	USABLE ON CODE	U/M	QTY INC IN UNIT
2	1	XBFZZ		31196	2090000516	SPACER, PLATE .....	EA	1
2	2	PAFZZ	5305-00-054-6668	96906	MS51957-43	SCREW, MACHINE .....	EA	4
2	3	PAFZZ	5310-00-933-8119	96906	MS35338-137	WASHER, LOCK .....	EA	4
2	4	PAFZZ	5310-00-880-5978	96906	MS15795-807	WASHER, FLAT .....	EA	4
2	5	XBDZZ		31196	404000574	BRACKET, ELECT COMP .....	EA	1
2	6	PAFDA	5895-00-014-8318	31196	1130000011	STRIPLINE ASSEMBLY .....	EA	1
2	7	PAFZZ	5305-00-088-9671	96906	MS24693C52	SCREW, MACHINE .....	EA	4
2	8	XBFZZ		05236	1301542B	SLIDE, DRAWER, EXT .....	EA	1
2	9	PAFZZ	5325-00-185-0012	96906	MS35489-35	GROMMET, NONMETALLIC .....	EA	1
2	10	XBFZZ		31196	3090000726	GUARD, SAFETY .....	EA	1
2	11	PAFZZ	5915-01-004-9318	26805	2056-6200-02	FILTER, RADIO FREQUE .....	EA	1
2	12	XBDDO		31196	5040000757	PANEL ASSEMBLY .....	EA	1
2	13	PAFZZ	5305-00-043-0267	96906	MS24693C274	SCREW, MACHINE .....	EA	4
2	14	XBFZZ		05236	300293B	SLIDE, DRAWER .....	EA	1
2	15	PAFZZ	5935-00-337-6770	26805	2084-0000-02	ADAPTER, CONNECTOR .....	EA	2
2	16	XBDZZ		31196	3090000741	BRACKET, TERMINAL .....	EA	1
2	17	PAFZZ	5325-00-185-0001	96906	MS35489-46	GROMMET, NONMETALLIC .....	EA	2
2	18	PAFZZ	5935-00-904-4050	80058	UG27D/U	ADAPTER, CONNECTOR .....	EA	1
2	19	XBFZZ		31196	2090000746	PIN, FLANGED, SHOCK .....	EA	2
2	20	XBDZZ		31196	5040001356	CHASSIS, ELECTRICAL .....	EA	1
2	21	PAFZZ	5310-00-973-8660	80063	SM-B-416109-1	WASHER, FLAT .....	EA	36
2	22	PAFZZ	5310-00-929-6395	96906	MS35338-136	WASHER, LOCK .....	EA	33
2	23	PAFZZ	5305-00-411-0682	96906	M5S51957-124	SCREW, MACHINE .....	EA	4
2	24	PAFZZ	5305-00-054-6654	96906	MS51957-30	SCREW, MACHINE .....	EA	7
2	25	PAOZZ	5940-01-004-1893	31196	1130000018	TERMINATION .....	EA	4
2	26	XBDZZ		31196	3090000500	BRACKET, CONNECTOR .....	EA	1
2	27	PAFZZ	5305-00-054-5642	96906	MS51957-8	SCREW, MACHINE .....	EA	14
2	28	PAFZZ	5310-00-595-6761	96906	M5S15795-802	WASHER, FLAT .....	EA	18

SECTION II

TM 11-5895-833-34P-7/0967-LP-550-1164/TO 31R5-2MSC46-4

(1) ILLUSTRATION		(2)	(3)	(4)	(5)	(6) DESCRIPTION	(7)	(8)
(a) FIG NO.	(b) ITEM NO.	SMR CODE	NATIONAL STOCK NUMBER	FSCM	PART NUMBER	USABLE ON CODE	U/M	QTY INC IN UNIT
2	29	XBFFF		31196	6240001647	WIRING HARNESS FREQ(SEE FIGURE 20 FOR BREAKDOWN)	EA	1
2	30	PAFZZ	5305-00-054-5638	96906	MS51957-4	SCREW,MACHINE .....	EA	4
2	31	PAFZZ	5310-00-928-2690	96906	MS35338-134	WASHER,LOCK .....	EA	4
2	32	PAFZZ	5305-00-054-6650	96906	MS51957-26	SCREW,MACHINE .....	EA	3
2	33	PAFZZ	5310-00-801-4420	56878	58FK632	NUT,SELF-LOCKING HE .....	EA	1
2	34	PAFZZ	5305-00-221-6116	96906	MS51957-125	SCREW,MACHINE .....	EA	1
2	35	PAFZZ	5310-00-934-9761	96906	MS35649-264	NUT,PLAIN,HEXAGON .....	EA	1
2	36	PAFZZ	5930-00-519-8144	96906	MS16106-1	SWITCH,SENSITIVE .....	EA	1
2	37	PAFZZ	5305-00-054-6671	96906	MS51957-46	SCREW,MACHINE .....	EA	15
2	38	PAFZZ	5305-00-088-9668	96906	MS24693C54	SCREW,MACHINE .....	EA	5
2	39	PAFZZ	5305-00-054-6670	96906	MS51957-45	SCREW,MACHINE .....	EA	15
2	40	XBFDL		31196	40000781	POWER SUPPLY ASSY(SEE FIGURE 22 FOR BREAKDOWN)	EA	1
2	41	XBFZZ		31196	3090000733	SHIELDING GASKET .....	EA	1
2	42	PAFZZ	5310-00-933-8120	96906	MS35338-138	WASHER,LOCK .....	EA	1
2	43	PAFZZ	5310-00-595-6772	96906	MS15795-808	WASHER,FLAT .....	EA	1
2	44	PAFZZ	5310-00-720-8549	96906	MS35426-13	NUT,PLAIN,WING .....	EA	1
2	45	PAFZZ	5305-00-054-6651	96906	MS51957-27	SCREW,MACHINE .....	EA	19
2	46	XBFZZ		31196	3090000732	SHIELDING COVER,REA .....	EA	1
2	47	XBFZZ		31196	3090000729	SHIELDING GASKET,R .....	EA	1
2	48	PAFZZ	5305-00-054-6659	96906	MS51957-35	SCREW,MACHINE .....	EA	4
2	49	PAFDA	5895-00-014-7848	31196	1130000010	COUPLER,DIRECTIONAL .....	EA	1
2	50	XBFZZ		31196	2090000543	SHIELDING GASKET .....	EA	1
2	51	XBFZZ		70472	W0855-OIOS	WASHER,WAVE SPRING .....	EA	1
2	52	XBFZZ		31196	3090000706	SHIELDING ENCLOSURE .....	EA	1
2	53	XBFZZ		31196	2090000707	SHIELDING GASKET .....	EA	1
2	54	PAFZZ	5305-00-054-6652	96906	MS51957-28	SCREW,MACHINE .....	EA	2



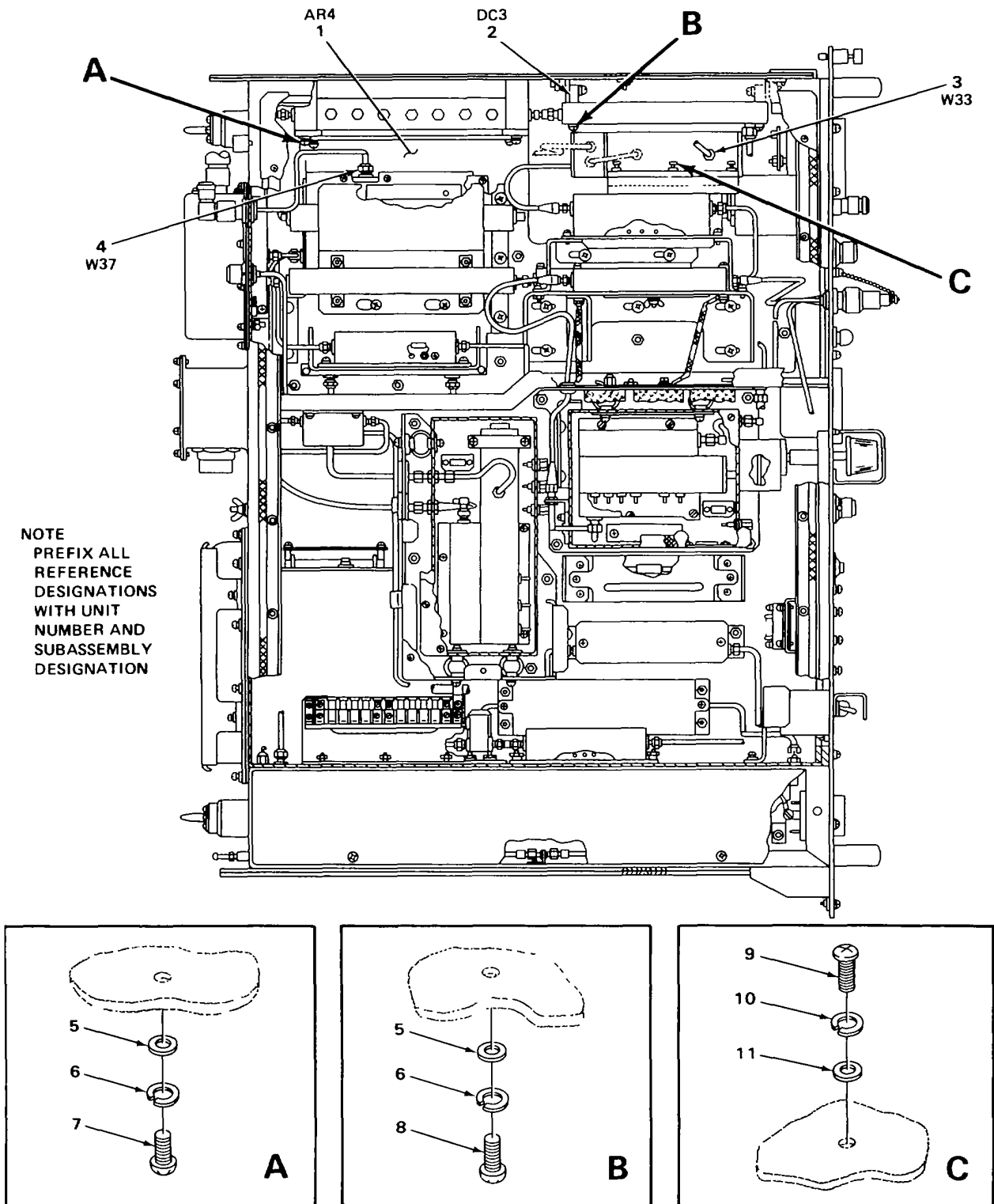

ELOJT008

FIGURE 3. CONVERTER, ELECTRONIC FREQUENCY CV-3085/MSC-46(V) AND CV-3085/MSC-46(V)

SECTION II

TM 11-5895-833-34P-7/0967-LP-550-1164/TO 31R5-2MSC46-4

(1) ILLUSTRATION		(2)	(3)	(4)	(5)	(6)	(7)	(8)
(a) FIG NO.	(b) ITEM NO.	SMR CODE	NATIONAL STOCK NUMBER	FSCM	PART NUMBER	DESCRIPTION  USABLE ON CODE	U/M	QTY INC IN UNIT
3	1	PAFDA	5895-01-016-8419	34874	LNA700/2276	AMPLIFIER,RAOIO FRE..... DND	EA	1
3	2	PAFDA	5985-01-022-9708	31196	1130004195	COUPLER,DIRECTIONAL ..... DND	EA	1
3	3	PAFZZ	5995-01-012-3639	31196	3120006353	CABLE ASSEMBLY,RADI ..... DND	EA	1
3	4	XBFFF		31196	4240006383	WIRING HARNESS (SEE FIGURE 33 FOR BREAKDOWN) ...	EA	1
3	5	PAFZZ	5310-00-722-5998	96906	MS15795-805	WASHER,FLAT .....	EA	8
3	6	PAFZZ	5310-00-929-6395	96906	MS35338-136	WASHER,LOCK .....	EA	8
3	7	PAFZZ	5305-00-054-6651	96906	MS51957-27	SCREW,MACHINE .....	EA	4
3	8	PAFZZ	5305-00-411-0682	96906	MS51957-124	SCREW,MACHINE .....	EA	4
3	9	PAFZZ	5305-00-054-5648	96906	MS51957-14	SCREW,MACHINE .....	EA	3
3	10	PAFZZ	5310-00-933-8118	96906	MS35338-135	WASHER,LOCK .....	EA	3
3	11	PAFZZ	5310-00-595-6211	96906	MS15795-803	WASHER,FLAT .....	EA	3

15/(16 blank)

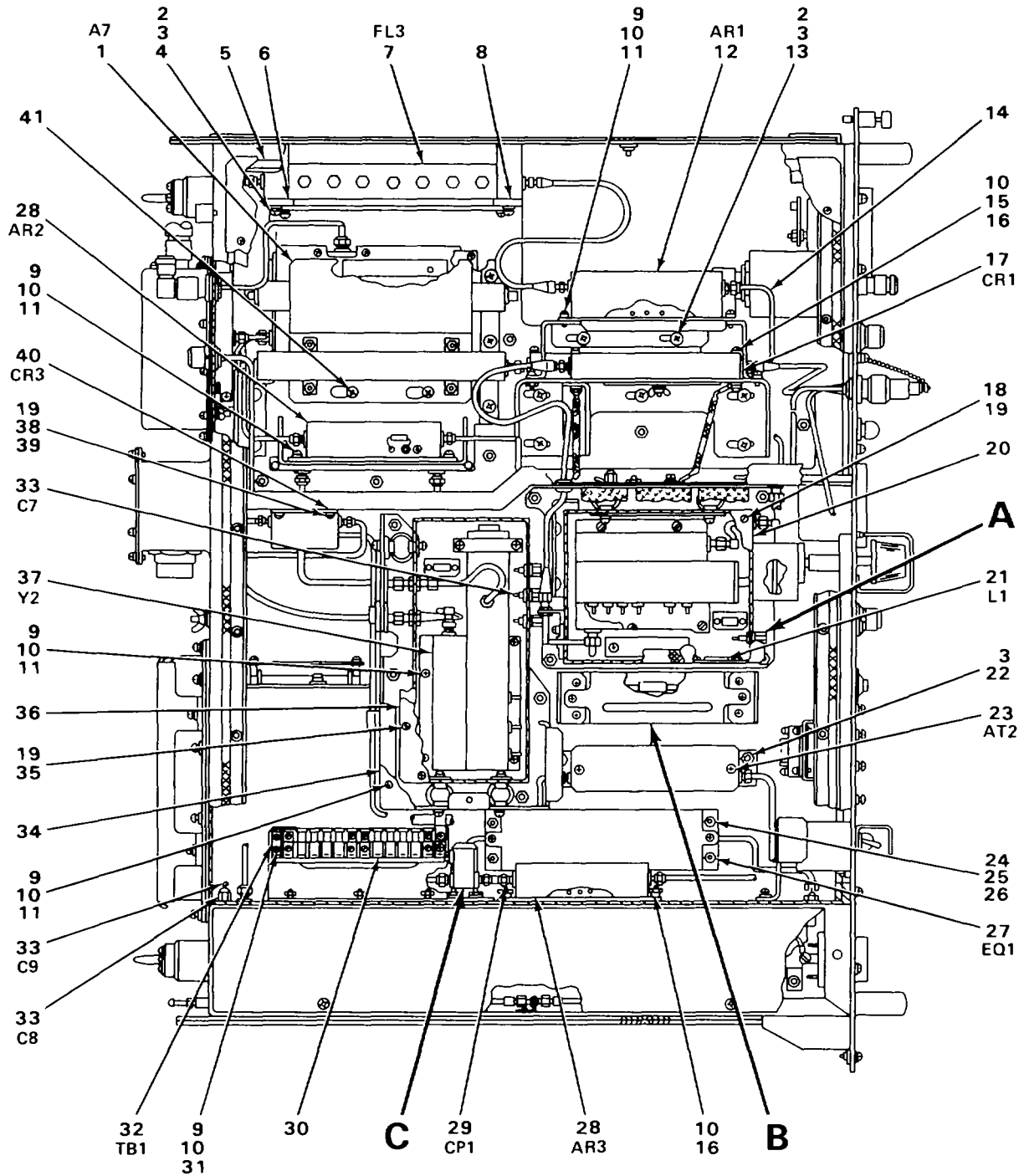

NOTE  
 PREFIX ALL REFERENCE DESIGNATIONS WITH  
 UNIT NUMBER AND SUBASSEMBLY DESIGNATION

FIGURE 4. CONVERTER, ELECTRONIC FREQUENCY CV-3085/MSC-46(V) AND CV-3085A/MSC-46(V)  
 (SHEET 1 OF 2)

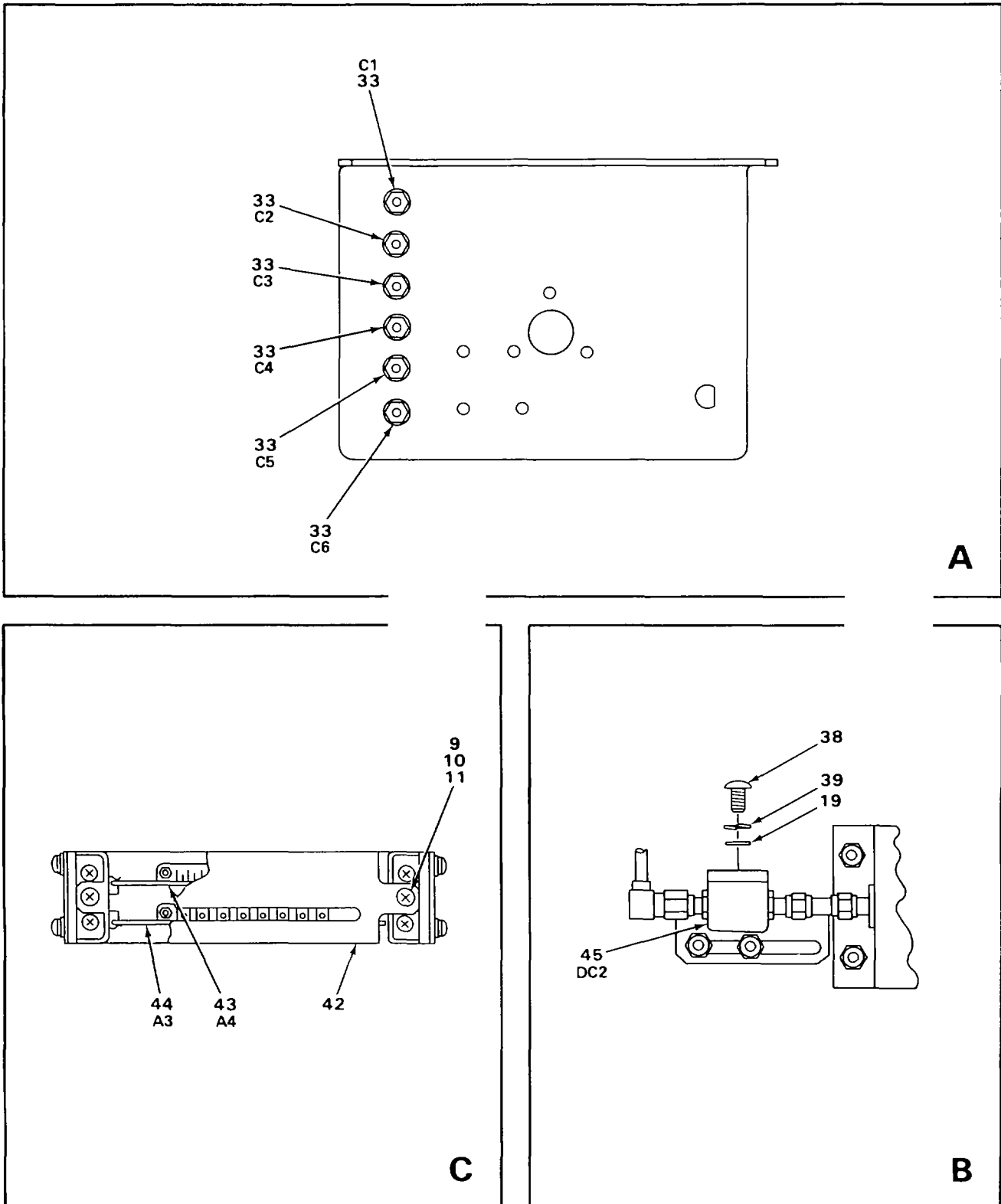

ELQJT004

FIGURE 4. CONVERTER, ELECTRONIC FREQUENCY CV-3085/MSC-46(V) AND CV-3085A/MSC-46(V)  
(SHEET 2 OF 2)

SECTION II

(1) ILLUSTRATION		(2)	(3)	(4)	(5)	(6) DESCRIPTION	(7)	(8)
(a) FIG NO.	(b) ITEM NO.	SMR CODE	NATIONAL STOCK NUMBER	FSCM	PART NUMBER	USABLE ON CODE	U/M	QTY INC IN UNIT
4	1	XBFDA		31196	3040000762	FILTER ASSY,BANDPAS(SEE FIGURE 19 FOR BREAKDOWN)	EA	1
4	2	PAFZZ	5310-00-933-8119	96906	MS35338-137	WASHER,LOCK .....	EA	6
4	3	PAFZZ	5310-00-880-5978	96906	MS15795-807	WASHER,FLAT .....	EA	6
4	4	PAFZZ	5305-00-054-6651	96906	MS51957-27	SCREW,MACHINE .....	EA	4
4	5	XBFZZ		31196	2090000621	RETAINER,FILTER..... CEQ	EA	2
4	6	XBFZZ		31196	2359005960-2	RETAINER,FILTER..... DND	EA	1
4	7	PAFDA	5915-01-150-0757	31196	1130000041	FILTER,BANDPASS .....	EA	1
4	8	XBFZZ		31196	62359005960-1	RETAINER,FILTER..... DND	EA	1
4	9	PAFZZ	5310-00-929-6395	96906	MS35338-136	WASHER,LOCK .....	EA	18
4	10	PAFZZ	5310-00-722-5998	96906	MS15795-805	WASHER,FLAT .....	EA	28
4	11	PAFZZ	5305-00-054-6652	96906	MS51957-28	SCREW,MACHINE .....	EA	12
4	12	PAFDD	5895-00-140-8635	31091	AL1076	AMPLIFIER, IF .....	EA	1
4	13	PAFZZ	5305-00-054-6668	96906	MS51957-43	SCREW,MACHINE .....	EA	2
4	14	XBFZZ		31196	4040000613	BRACKET,AMPLIFIER .....	EA	1
4	15	PAFZZ	5305-00-054-6659	96906	MS51957-35	SCREW,MACHINE .....	EA	2
4	16	PAFZZ	5310-00-801-4420	56878	58FK632	NUT,SELF-LOCKING,HE .....	EA	6
4	17	XBFDA		31196	1130000011	MIXER,STAGE.....	EA	1
4	18	PAFZZ	5305-00-054-5650	96906	MS51957-16	SCREW,MACHINE .....	EA	8
4	19	PAFZZ	5310-00-595-6211	96906	M5S15795-803	WASHER,FLAT .....	EA	8
4	20	XBFZZ		31196	3350006329	COVER,OSCILLATOR .....	EA	1
4	21	PAFZZ	5950-00-645-3771	76493	4624	COIL,RADIO FREQ .....	EA	1
4	22	PAFZZ	5310-00-801-4420	80205	NAS679C06M	NUT,SELF-LOCKING,HE .....	EA	2
4	23	PAFOD	5895-00-124-8709	31196	4040000790	ATTENUATOR STEP ..(SEE FIGURE 16 FOR BREAKDOWN)	EA	1
4	24	PAFZZ	5310-00-146-7102	96906	MS25082C1	NUT,PLAIN,HEXAGON .....	EA	4
4	25	PAFZZ	5310-00-616-3555	96906	MS35333-71	WASHER,LOCK .....	EA	4
4	26	PAFZZ	5310-00-531-9514	80044	AN960C6	WASHER,FLAT .....	EA	4
4	27	XBFDA		31196	1130000796	FILTER,PHASE.....	EA	1
4	28	XBFDO		34874	IFA70-1258	AMPLIFIER,IF .....	EA	2

SECTION II

TM 11-5895-833-34P-7/0967-LP-550-1164/TO 31R5-2MSC46-4

(1) ILLUSTRATION		(2)	(3)	(4)	(5)	(6) DESCRIPTION	(7)	(8)
(a) FIG NO.	(b) ITEM NO.	SMR CODE	NATIONAL STOCK NUMBER	FSCM	PART NUMBER	USABLE ON CODE	U/M	QTY INC IN UNIT
4	29	PAFZZ	5935-00-394-1018	26805	2081-0000-02	ADAPTER,CONNECTOR.....	EA	1
4	30	XBFZZ		75382	6001	STRAP,JUMPER.....	EA	10
4	31	PAFZZ	5305-00-054-6655	96906	MS51957-31	SCREW,MACHINE.....	EA	4
4	32	XBFZZ		75382	37TB12	TERMINAL BOARD.....	EA	1
4	33	PAFZZ	5310-00-852-7099	81349	CK70AX471K	CAPACITOR,FIXED,CER.....	EA	9
4	34	XBFZZ		31196	3090004785	COVER,OSCILLATOR FL.....	EA	1
4	35	PAFZZ	5305-00-054-5649	96906	MS51957-15	SCREW,MACHINE.....	EA	10
4	36	XBFZZ		31196	3090004778	COVER,OSCILLATOR.....	EA	1
4	37	PAFDD	5895-00-014-7845	31196	3040005493	OSCILLATOR,RADIO FR.....	EA	1
4	38	PAFZZ	5305-00-054-5648	96906	MS51957-14	SCREW,MACHINE.....	EA	1
4	39	PAFZZ	5310-00-933-8118	96906	MS35338-135	WASHER,LOCK.....	EA	1
4	40	PAFZZ	6625-00-124-5269	12598	M2158	MONITOR,RADIO FREQ.....	EA	1
4	41	PAFZZ	5305-00-054-6669	96906	MS51957-44	SCREW,MACHINE.....	EA	4
4	42	XBFZZ		31196	3040000719	COVER,CKT CD.....	EA	1
4	43	XBFDA		80063	SM952556-1	CIRCUIT CARD ASSY.(SEE FIGURE 17 FOR BREAKDOWN)	EA	1
4	44	PAFDA	5999-00-124-5264	31196	4040000436	CIRCUIT CARD ASSY.(SEE FIGURE 18 FOR BREAKDOWN)	EA	1
4	45	PAFZZ	5985-00-124-5119	32252	0-D3-10-137	COUPLER,DIRECTIONAL.....	EA	1

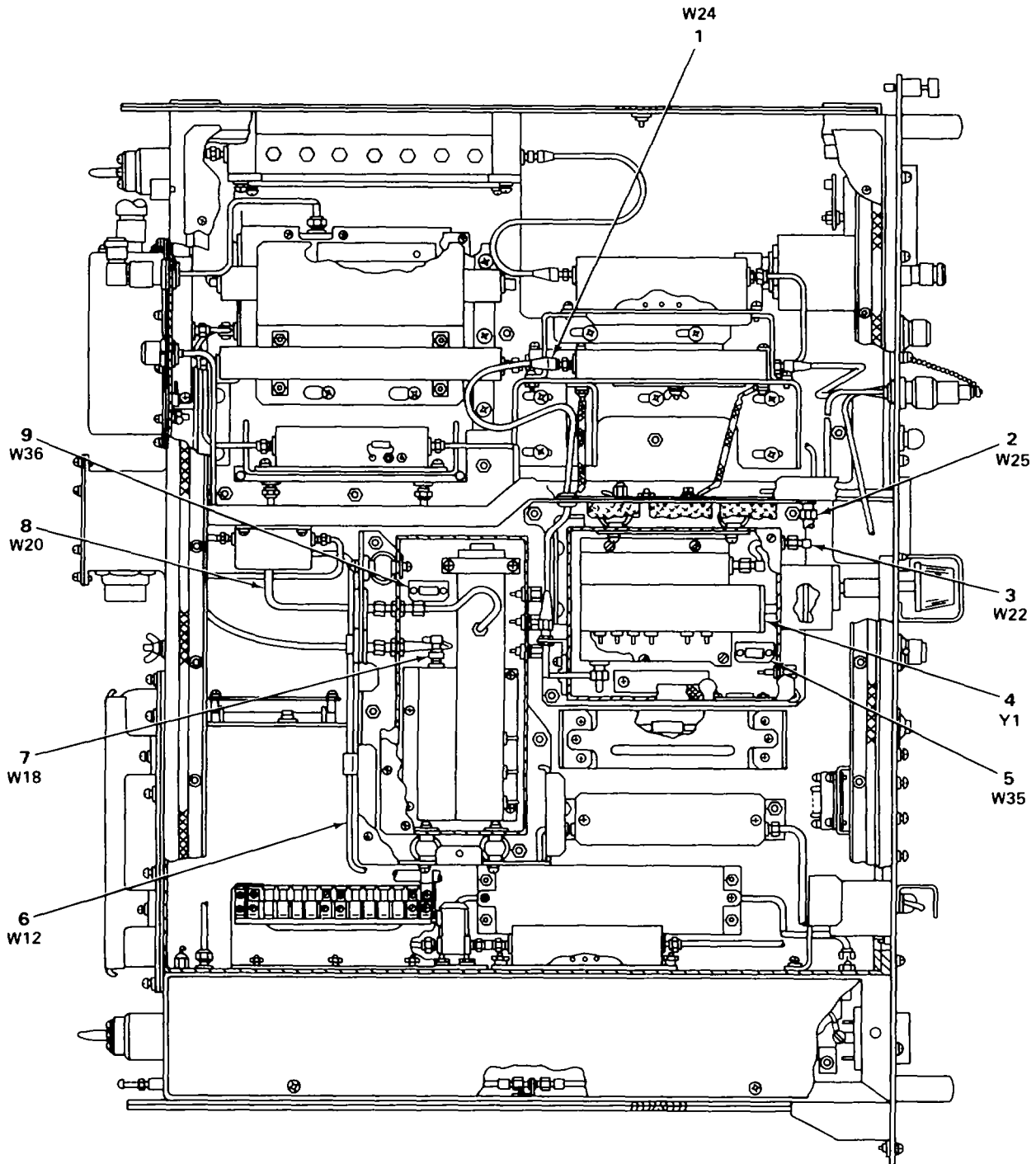

NOTE  
PREFIX ALL REFERENCE DESIGNATIONS WITH  
UNIT NUMBER AND SUBASSEMBLY DESIGNATION

FIGURE 5. CONVERTER, ELECTRONIC FREQUENCY CV-3085/MSC-46(V) AND CV-3085A/MSC-46(V)

SECTION II

TM 11-5895-833-34P-7/0967-LP-550-1164/TO 31R5-2MSC46-4

(1) ILLUSTRATION		(2)	(3)	(4)	(5)	(6)	(7)	(8)
(a) FIG NO.	(b) ITEM NO.	SMR CODE	NATIONAL STOCK NUMBER	FSCM	PART NUMBER	DESCRIPTION  USABLE ON CODE	U/M	QTY INC IN UNIT
5	1	PAFFF	5995-01-140-1142	31196	3120006332	CABLE ASSEMBLY,RADI(SEE FIGURE 23 FOR BREAKDOWN)	EA	1
5	2	XBFFF		31196	3129005393-3	CABLE ASSEMBLY,RADI(SEE FIGURE 24 FOR BREAKDOWN)	EA	1
5	3	PAFFF	5995-01-140-1144	31196	3129005393-2	CABLE ASSEMBLY,RADI(SEE FIGURE 25 FOR BREAKDOWN)	EA	1
5	4	PAFFF	5895-00-014-7845	31196	3040005493	OSCILLATOR,RADIO FR(SEE FIGURE 26 FOR BREAKDOWN)	EA	1
5	5	PAFFF	5995-01-140-0964	31196	4240005468	WIRING HARNESS,OSCI(SEE FIGURE 27 FOR BREAKDOWN)	EA	1
5	6	PAFFF	5995-01-140-1141	31196	3120005409	CABLE ASSEMBLY,RADI(SEE FIGURE 28 FOR BREAKDOWN)	EA	1
5	7	PAFFF	5895-01-140-1143	31196	3129005393-1	CABLE ASSEMBLY,RADI(SEE FIGURE 29 FOR BREAKDOWN)	EA	1
5	8	PAFFF	5995-01-1401140	31196	3120005404	CABLE ASSEMBLY,RADI(SEE FIGURE 30 FOR BREAKDOWN)	EA	1
5	9	XBFFF		80063	SM-D-754369	WIRING HARNESS,OSCI(SEE FIGURE 31 FOR BREAKDOWN)	EA	1



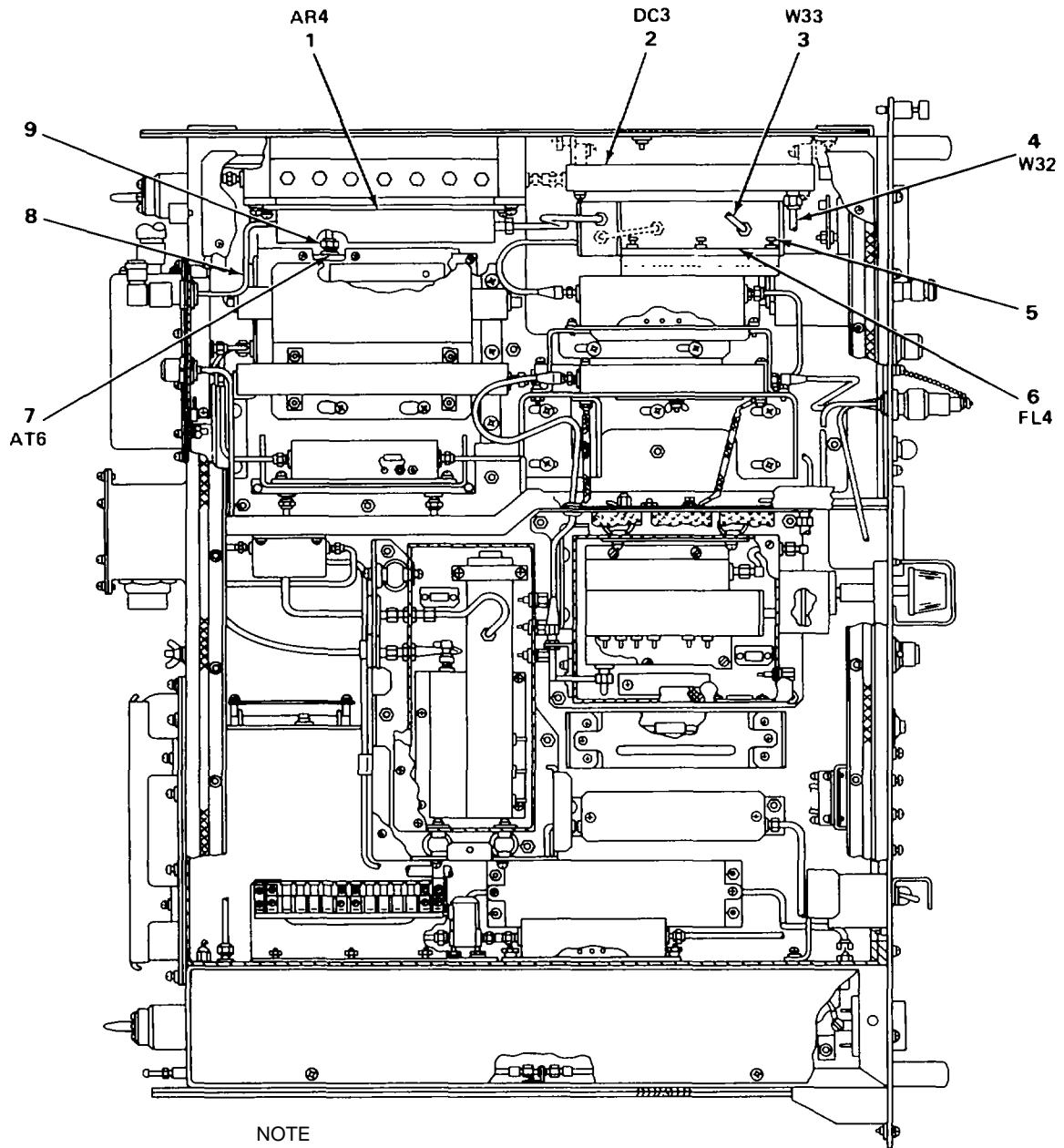

NOTE  
PREFIX ALL REFERENCE DESIGNATIONS WITH  
UNIT NUMBER AND SUBASSEMBLY DESIGNATION

ELOJT028

FIGURE 6. CONVERTER, ELECTRONIC FREQUENCY CV-3085/MSC-46(V) AND CV-3085A/MSC-46(V)

SECTION II

TM 11-5895-833-34P-7/0967-LP-550-1164/TO 31R5-2MSC46-4

(1) ILLUSTRATION		(2)	(3)	(4)	(5)	(6) DESCRIPTION	(7)	(8)
(a) FIG NO.	(b) ITEM NO.	SMR CODE	NATIONAL STOCK NUMBER	FSCM	PART NUMBER	USABLE ON CODE	U/M	QTY INC IN UNIT
6	1	PAFDA	5895-01-016-8419	34874	LNA700/2276	AMPLIFIER,RADIO FRE.....EA	1	
6	2	PAFDA	5985-01-022-9708	31196	1130004195	COUPLER,DIRECTIONAL .....EA	1	
6	3	PAFZZ	5995-01-012-3639	31196	3120006353	CABLE ASSEMBLY,RADI .....EA	1	
6	4	PAFFF	5995-01-146-1402	31196	2120006351	CABLE ASSEMBLY,RADI(SEE FIGURE 32 FOR BREAKDOWN)DND	EA	1
6	5	PAFZZ	5305-00-068-5414	96906	MS16995-11	SCREW,CAP,SOCKET HE .....EA	1	
6	6	PAFDA	5895-01-024-0393	31196	1130005788	FILTER,EQUALIZER .....EA	1	
6	7	XBFZZ		52335	8018-6005	TERMINATION .....EA	1	
6	8	XBFZZ		34677	SOIB25D00-07-5	CABLE ASSEMBLY,RADI .....EA	1	
6	9	XBFZZ		31196	4240006383	WIRING HARNESS .....EA	1	

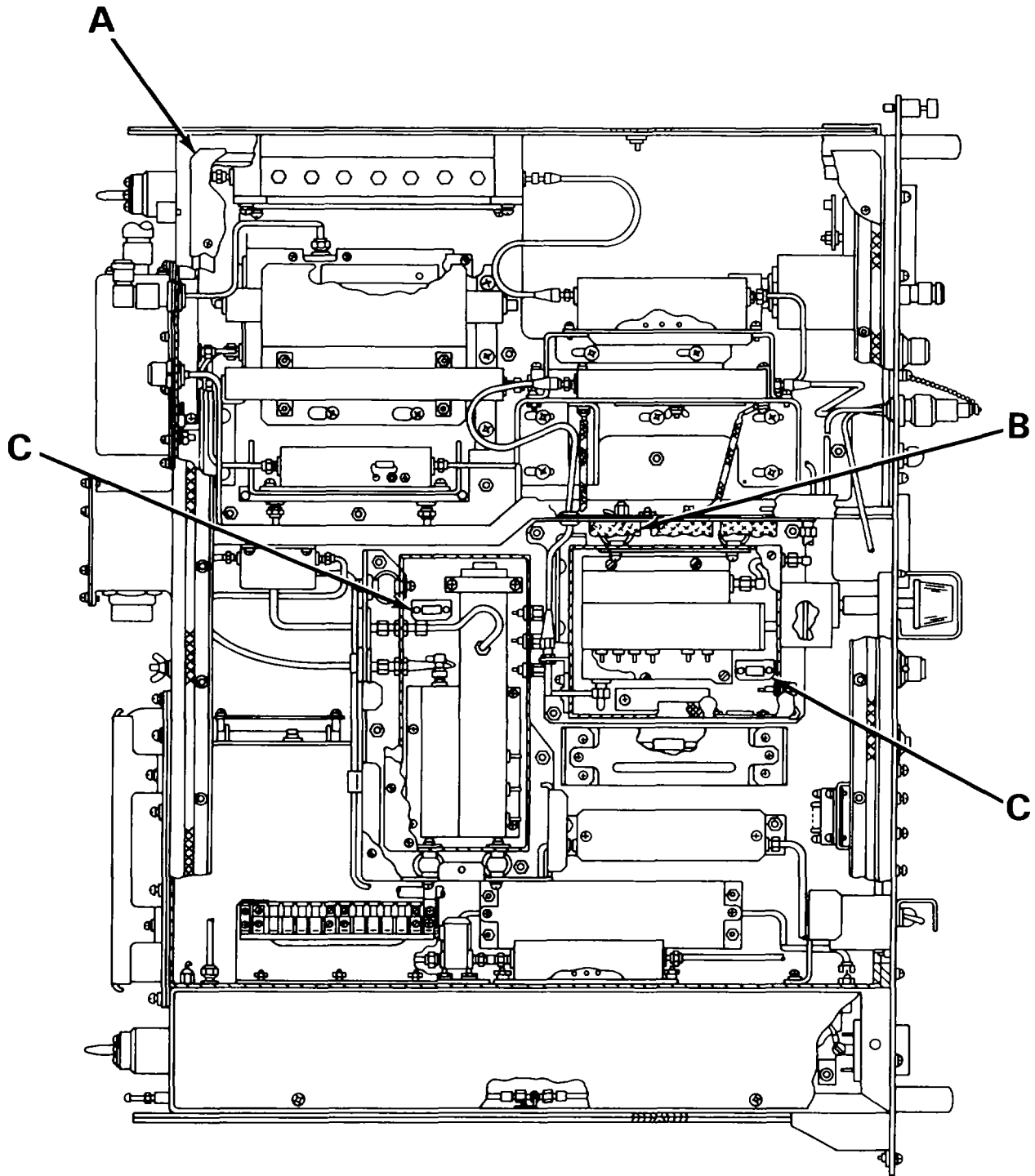
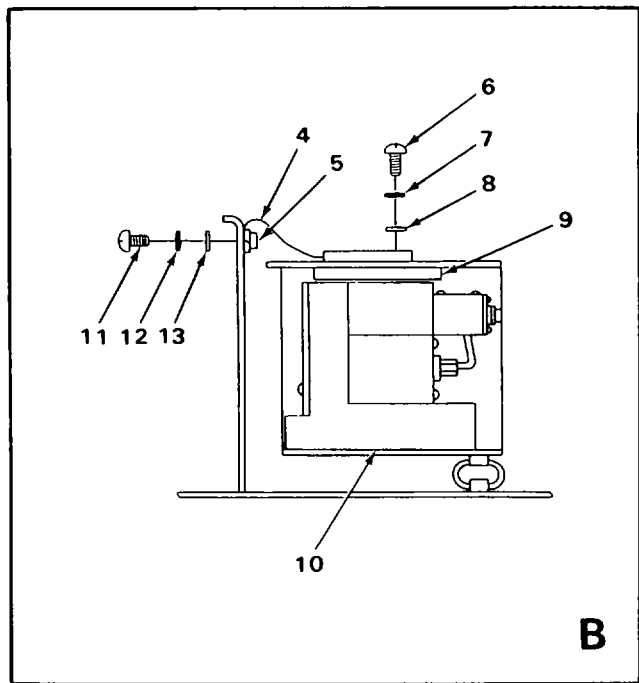
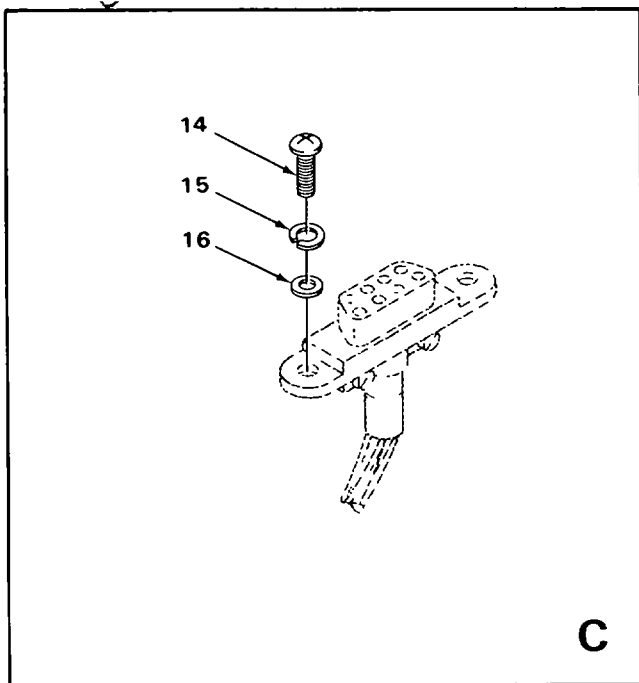
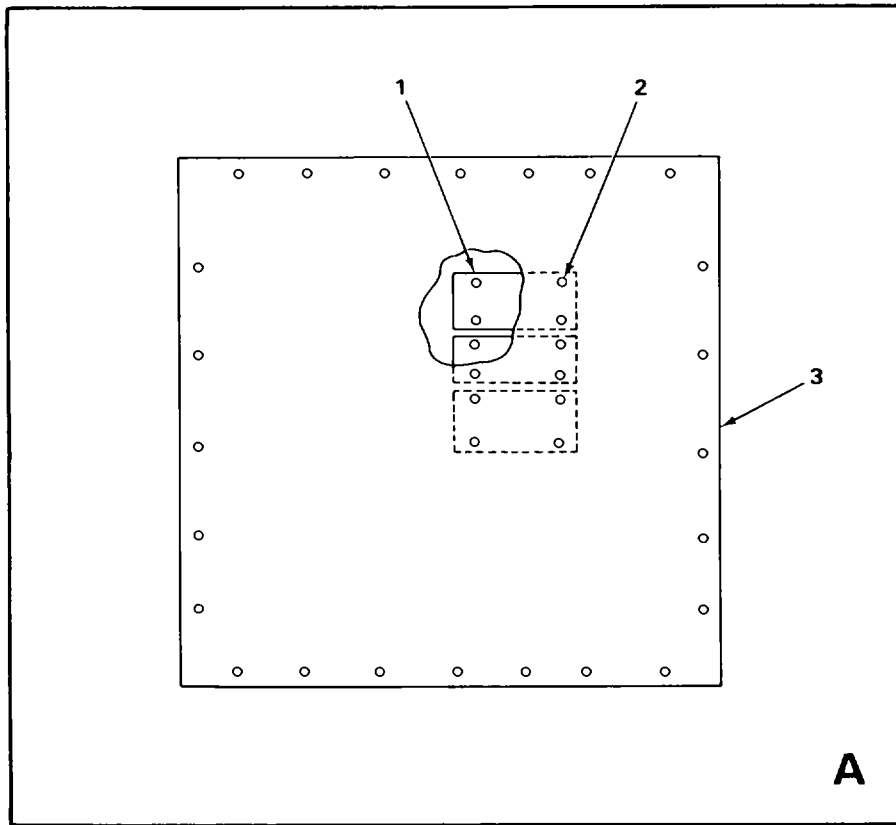

FIGURE 7. CONVERTER, ELECTRONIC FREQUENCY CV-3085/MSC-46(V) AND CV-3085A/MSC-46(V)  
(SHEET 1 OF 2)

ELOJT007



ELOJT030

FIGURE 7. CONVERTER, ELECTRONIC FREQUENCY CV-3085/MSC-46(V) AND CV-3085A/MSC-46(V)  
(SHEET 2 OF 2)

SECTION II

TM 11-5895-833-34P-7/0967-LP-550-1164/TO 31R5-2MSC46-4

(1) ILLUSTRATION		(2)	(3)	(4)	(5)	(6) DESCRIPTION	(7)	(8)
(a) FIG NO.	(b) ITEM NO.	SMR CODE	NATIONAL STOCK NUMBER	FSCM	PART NUMBER	USABLE ON CODE	U/M	QTY INC IN UNIT
7	1	XBFZZ		31196	3350012223	HEAT SINK,ELECT .....	EA	3
7	2	PAFZZ	5305-00-0667328	96906	MS24693C27	SCREW,MACHINE .....	EA	12
7	3	XBFZZ		80063	SM-D-753571-11	COVER .....	EA	1
7	4	XBFZZ		31196	3350012226	CONDUCTOR,THRM .....	EA	1
7	5	XBFZZ		31196	3090012228	NUT,STRIP .....	EA	1
7	6	PAFZZ	5305-00-054-6653	96906	MS51957-29	SCREW,MACHINE .....	EA	1
7	7	PAFZZ	531-00-929-6395	96906	1S35338-136	WASHER,LOCK .....	EA	1
7	8	PAFZZ	5310-00-722-5998	96906	MS15795-805	WASHER,FLAT .....	EA	1
7	9	XBFZZ		31196	3090000712	PLATE,HEAT SINK.....	EA	1
7	10	PAFZZ	5365-01-112-6399	31196	3090012229	SHIM .....	EA	1
7	11	PAFZZ	5305-00-054-5651	96906	MS51957-17	SCREW,MACHINE .....	EA	1
7	12	PAFZZ	5310-00-933-8118	96906	MS35338-135	WASHER,LOCK .....	EA	1
7	13	PAFZZ	5310-00-595-6211	96906	MS15795-803	WASHER,FLAT .....	EA	1
7	14	PAFZZ	5305-00-054-5638	96906	MS51957-4	SCREW,MACHINE .....	EA	4
7	15	PAFZZ	5310-00-928-2690	96906	MS35338-134	WASHER,LOCK .....	EA	4
7	16	PAFZZ	5310-00-595-6761	96906	MS15795-802	WASHER,FLAT .....	EA	4

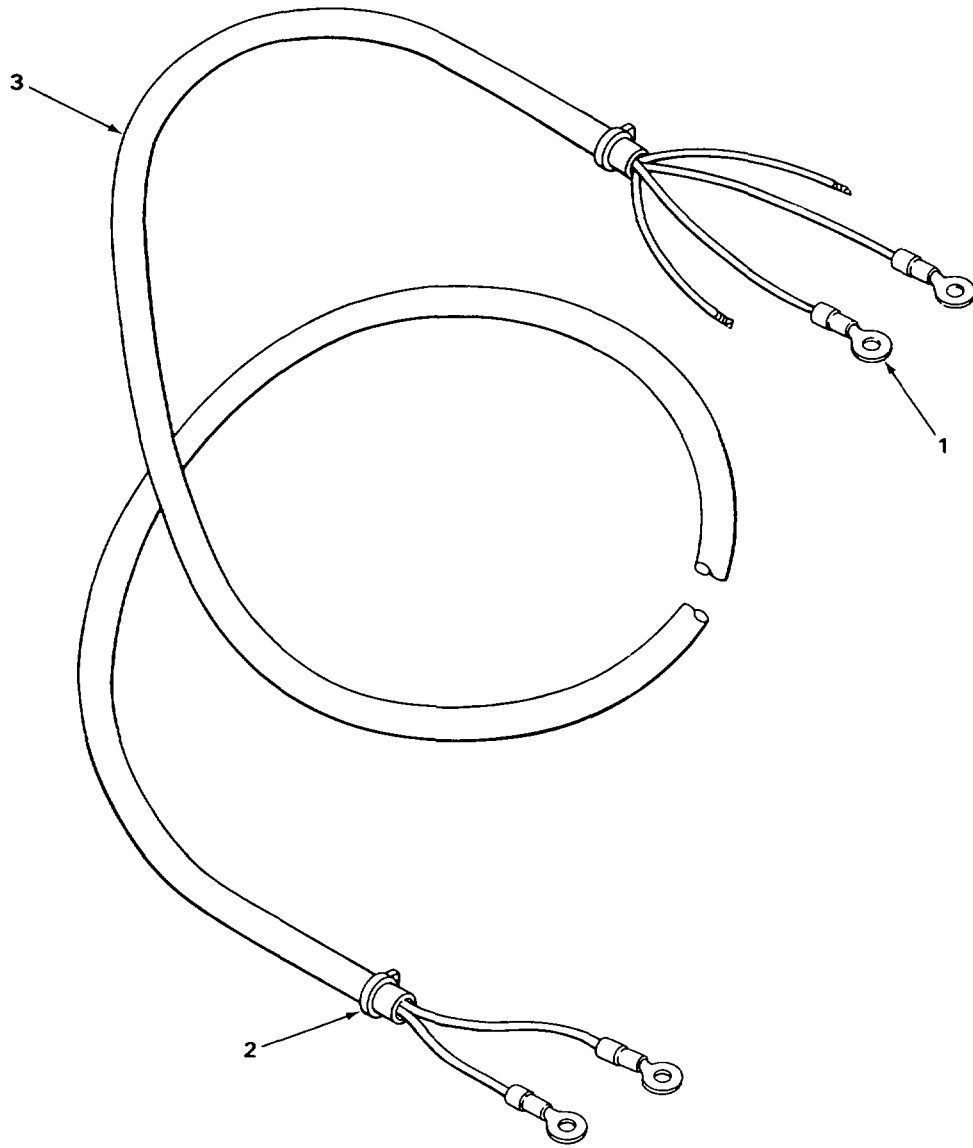

FIGURE 8. WIRING HARNESS, INTERLOCK (1A2W31)

ELOJT036

SECTION II

TM 11-5895-833-34P-7/0967-LP-550-1164/TO 31R5-2MSC46-4

(1) ILLUSTRATION		(2)	(3)	(4)	(5)	(6)	(7)	(8)
(a) FIG NO.	(b) ITEM NO.	SMR CODE	NATIONAL STOCK NUMBER	FSCM	PART NUMBER	DESCRIPTION  USABLE ON CODE	U/M	QTY INC IN UNIT
8	1	PAFZZ	5940-00-204-8966	96906	MS25036-102	GROUP 0202 WIRING HARNESS, INTERLOCK	EA	4
8	2	PADZZ	5975-00-727-5153	96906	MS3367-9	TERMINAL,LUG.....	EA	2
8	3	PAFZZ	5970-00-052-3297	81349	MIL-1-23053/5	STRAP,TIEDOWN,ELECT .....	IN	5
						INSULATION,SLEEVING.....		

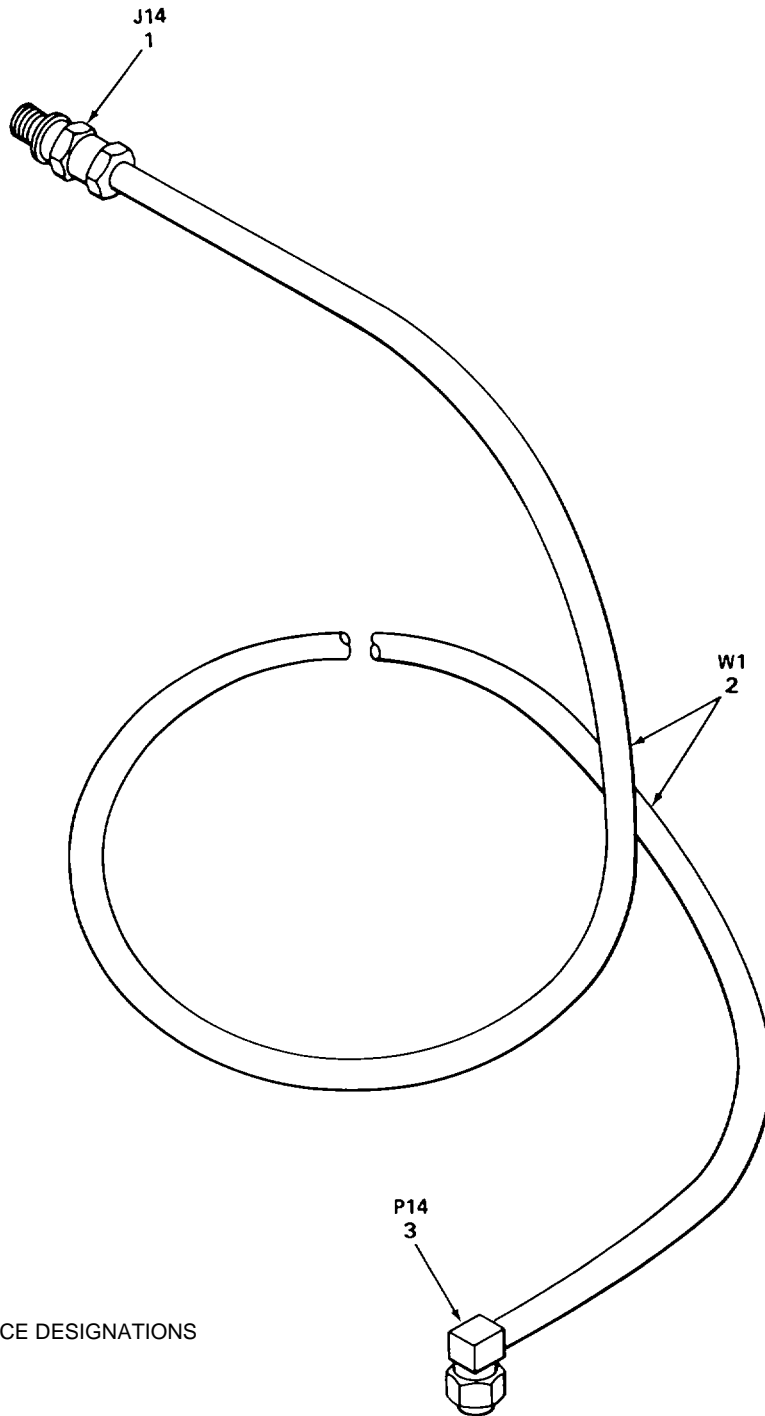

NOTE  
PREFIX ALL REFERENCE DESIGNATIONS  
WITH 1A2W9

EL0JT037

FIGURE 9. CABLE ASSEMBLY, RF (1A2W9)



SECTION II

TM 11-5895-833-34P-7/0967-LP-550-1164/TO 31R5-2MSC46-4

(1) ILLUSTRATION		(2)	(3)	(4)	(5)	(6) DESCRIPTION	(7)	(8)
(a) FIG NO.	(b) ITEM NO.	SMR CODE	NATIONAL STOCK NUMBER	FSCM	PART NUMBER	USABLE ON CODE	U/M	QTY INC IN UNIT
9	1	PAFZZ	5935-01-005-0024	26805	2034-7188-02	GROUP 0203 CABLE ASSEMBLY, RF		
9	2	PAFZZ	6145-00-918-9494	81349	M17/113-RG316	CONNECTOR, RECEPTACL .....	EA	1
9	3	PAFZZ	5935-01-120-5144	26805	2037-5008-02	CABLE, RADIO FREQUEN .....	FT	5
						CONNECTOR, PLUG, ELEC.....	EA	1

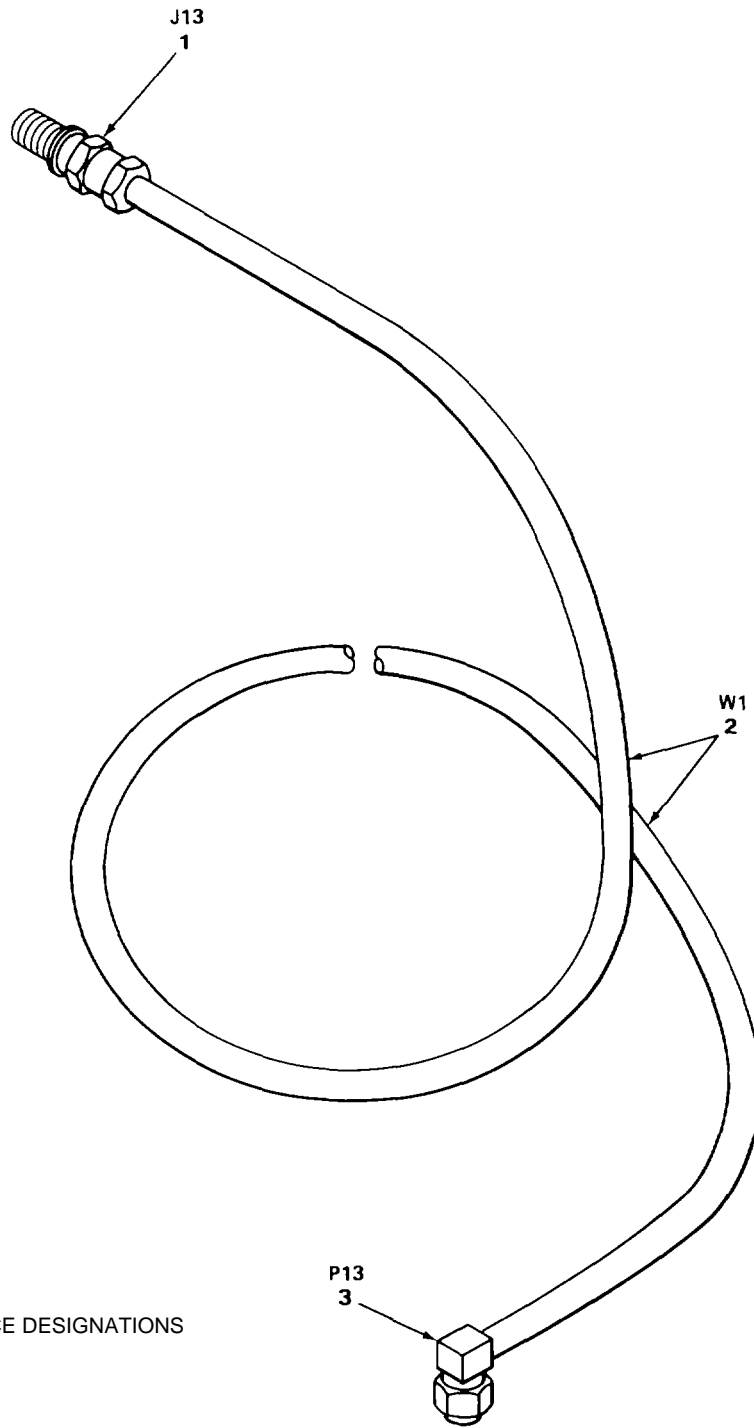

NOTE  
PREFIX ALL REFERENCE DESIGNATIONS  
WITH 1A2W8

ELOJT038

FIGURE 10. CABLE ASSEMBLY, RF (1A2W8)

SECTION II

TM 11-5895-833-34P-7/0967-LP-550-1164/TO 31R5-2MSC46-4

(1) ILLUSTRATION		(2)	(3)	(4)	(5)	(6)	(7)	(8)
(a) FIG NO.	(b) ITEM NO.	SMR CODE	NATIONAL STOCK NUMBER	FSCM	PART NUMBER	DESCRIPTION  USABLE ON CODE	U/M	QTY INC IN UNIT
10	1	PAFZZ	5935-01-005-0024	26805	2034-7188-02	GROUP 0204 CABLE ASSEMBLY, RF	EA	1
10	2	PAFZZ	6145-00-918-9494	81349	M17/113-RG316	CONNECTOR, RECEPTACL .....	FT	5
10	3	XBFZZ		26805	2056-0000-02	CABLE, RADIO FREQUEN .....	EA	1
						CONNECTOR, PLUG, ELEC.....		

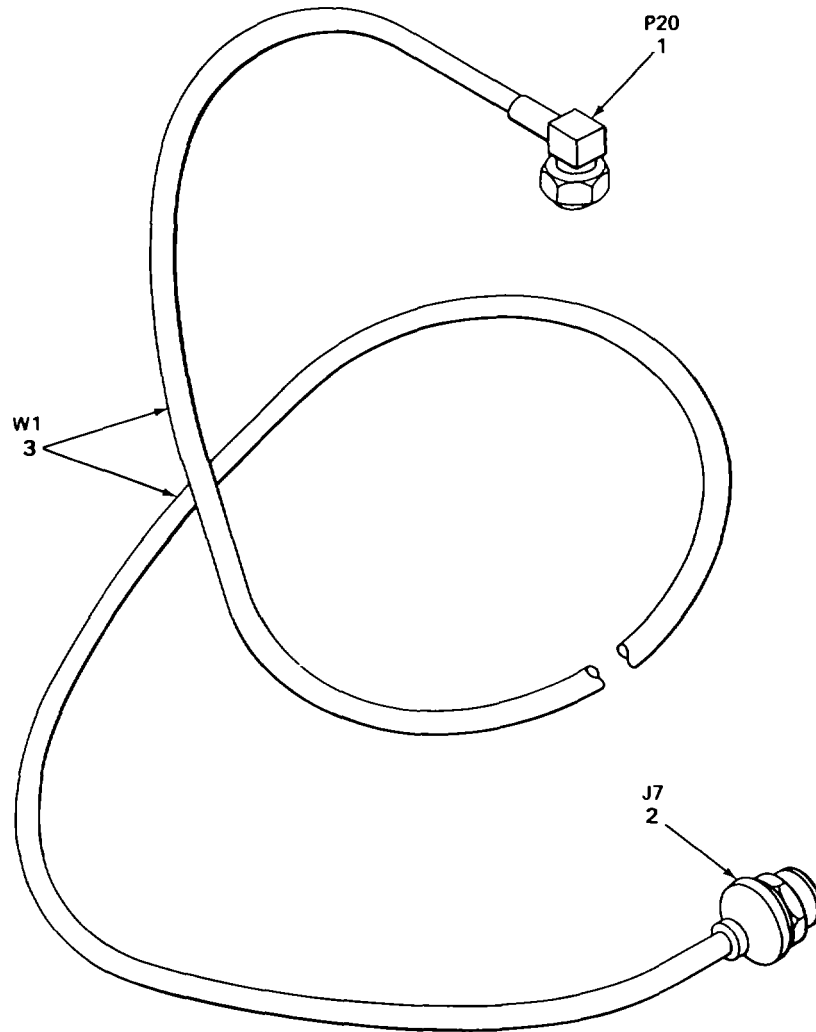

NOTE  
PREFIX ALL REFERENCE DESIGNATIONS  
WITH 1A2W13

FIGURE 11. CABLE ASSEMBLY, RF (1A2W13)

EL0JTO39

SECTION II

TM 11-5895-833-34P-7/0967-LP-550-1164/TO 31R5-2MSC46-4

(1) ILLUSTRATION		(2)	(3)	(4)	(5)	(6)	(7)	(8)
(a) FIG NO.	(b) ITEM NO.	SMR CODE	NATIONAL STOCK NUMBER	FSCM	PART NUMBER	DESCRIPTION  USABLE ON CODE	U/M	QTY INC IN UNIT
11	1	XBZZ		26805	2052-1303	GROUP 0205 CABLE ASSEMBLY, RF		
11	2	PAZZ	5935-01-007-8810	26805	3034-7188-02	CONNECTOR, PLUG, ELEC.....	EA	1
11	3	PAZZ	6145-00-918-9494	81349	M17/113-RG316	CONNECTOR, RECEPTACL.....	EA	1
						CABLE, RADIO FREQUEN .....	FT	5

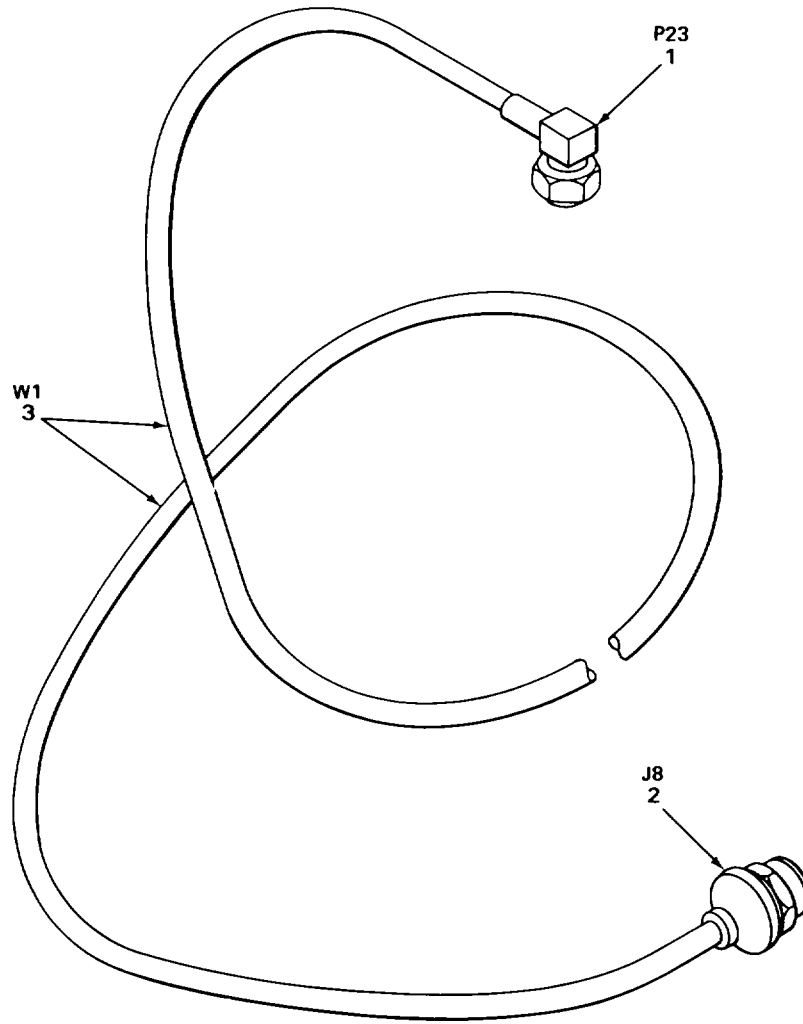

NOTE  
PREFIX ALL REFERENCE DESIGNATIONS  
WITH 1A2W16

FIGURE 12. CABLE ASSEMBLY, RF (1A2W16)

ELOJT040

SECTION II

TM 11-5895-833-34P-7/0967-LP-550-1164/TO 31R5-2MSC46-4

(1) ILLUSTRATION		(2)	(3)	(4)	(5)	(6)	(7)	(8)
(a) FIG NO.	(b) ITEM NO.	SMR CODE	NATIONAL STOCK NUMBER	FSCM	PART NUMBER	DESCRIPTION  USABLE ON CODE	U/M	QTY INC IN UNIT
12	1	PAFZZ	5935-00-470-8995	95077	2913-6001	GROUP 0206 CABLE ASSEMBLY, RF		
12	2	XBZZ		31196	3090005148	CONNECTOR, PLLG, ELEC .....	EA	1
12	3	PAFZZ	6145-00-918-9494	81349	M17/113-RG316	CONNECTOR, RECEPTACL .....	EA	1
						CABLE, RADIO FREQUEN .....	FT	5

NOTE  
PREFIX ALL REFERENCE DESIGNATIONS  
WITH 1A2W17

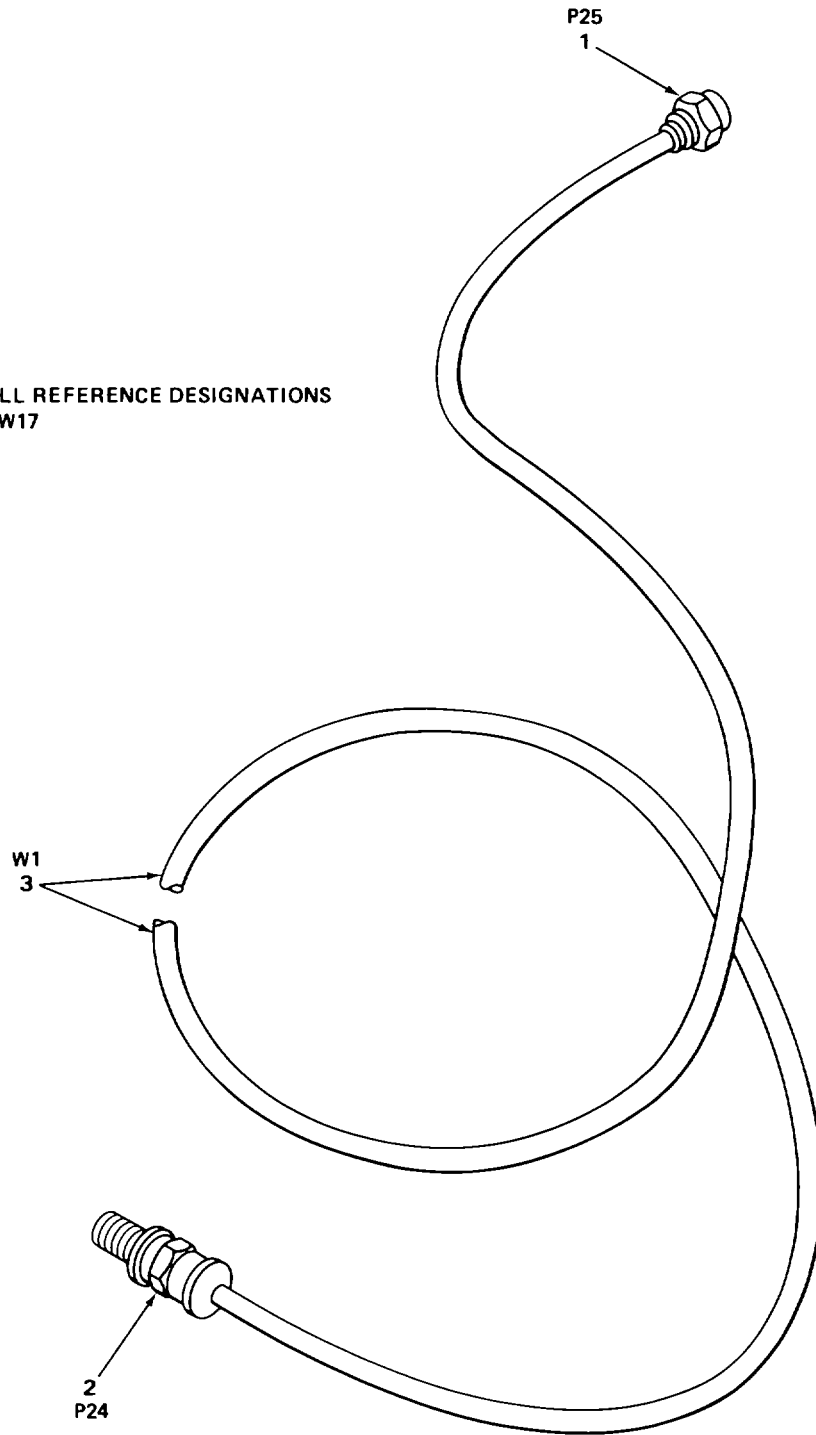

FIGURE 13. CABLE ASSEMBLY, RF (1A2W17)

EL0JT041



SECTION II

TM 11-5895-833-34P-7/0967-LP-550-1164/TO 31R5-2MSC46-4

(1) ILLUSTRATION		(2)	(3)	(4)	(5)	(6)	(7)	(8)
(a) FIG NO.	(b) ITEM NO.	SMR CODE	NATIONAL STOCK NUMBER	FSCM	PART NUMBER	DESCRIPTION  USABLE ON CODE	U/M	QTY INC IN UNIT
13	1	PAFZZ	5935-01-009-2960	26805	2031-7188-02	GROUP 0207 CABLE ASSEMBLY, RF		
13	2	XBZZ		26805	2056-5006	CONNECTOR, PLUG, ELEC.....	EA	1
13	3	PAFZZ	6145-00-722-5932	81349	M17/113-RG316	CONNECTOR, RECEPTACL.....	EA	1
						CABLE, RADIO FREQUEN .....	FT	5

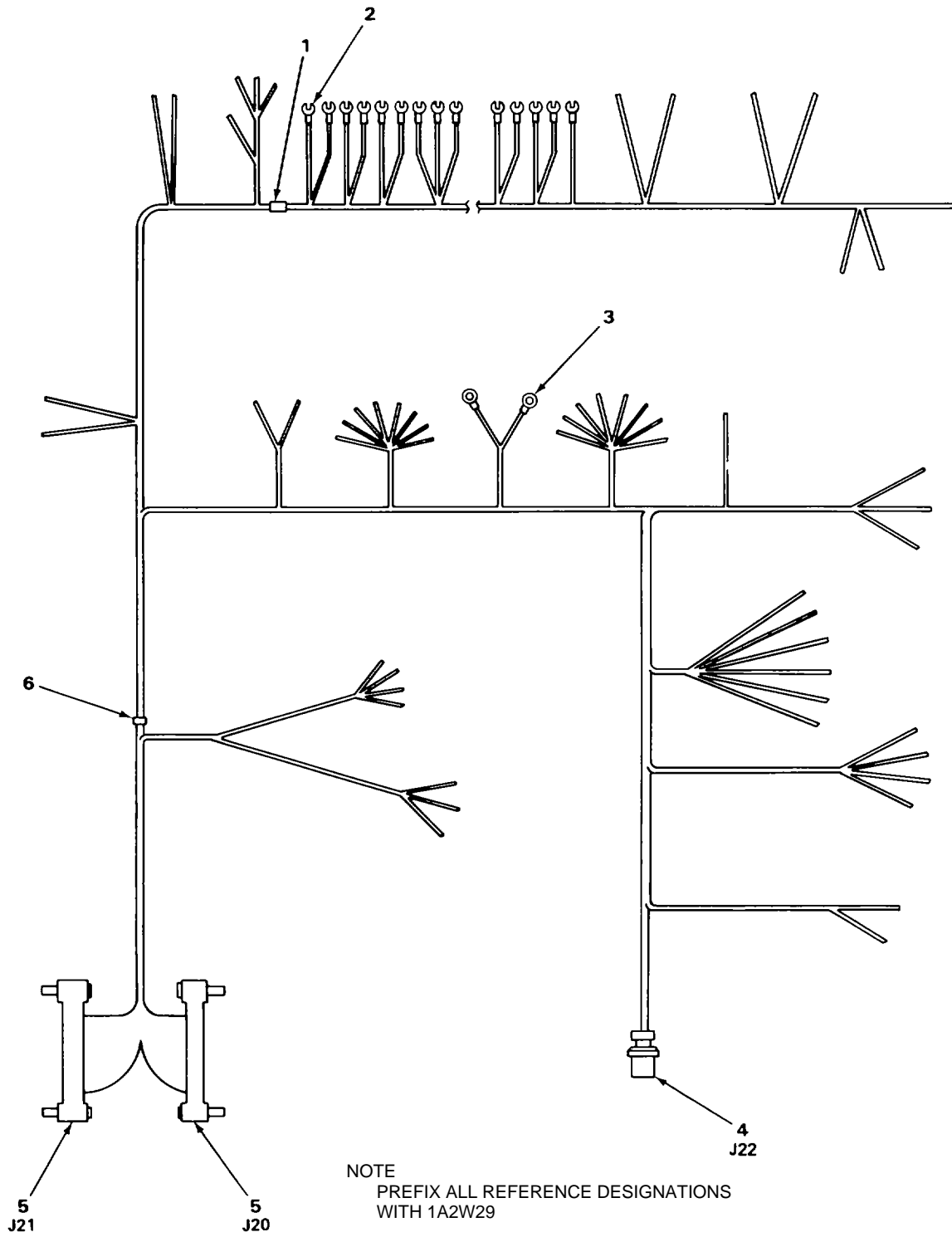

NOTE  
PREFIX ALL REFERENCE DESIGNATIONS  
WITH 1A2W29

EL0JT009

FIGURE 14. WIRING HARNESS, INTERCONNECTION (1A2W29)

SECTION II

TM 11-5895-833-34P-7/0967-LP-550-1164/TO 31R5-2MSC46-4

(1) ILLUSTRATION		(2)	(3)	(4)	(5)	(6)	(7)	(8)
(a) FIG NO.	(b) ITEM NO.	SMR CODE	NATIONAL STOCK NUMBER	FSCM	PART NUMBER	DESCRIPTION  USABLE ON CODE	U/M	QTY INC IN UNIT
14	1	PAFZZ	5975-00-482-3954	96906	MS3368-5-9E	GROUP 0215 WIRING HARNESS, INTERCONNECTION		
14	2	PAFZZ	5940-00-983-7091	88779	323011	STRAP,TIEDOWN,ELECT .....	EA	2
14	3	PAFZZ	5940-00-804-0365	96906	MS25036-146	TERMINAL,LUG .....	EA	14
14	4	PAFZZ	5935-00-783-2071	96906	MS3116E14-15S	TERMINAL,LUG .....	EA	2
14	5	XBFZZ		97954	M1G23F	CONNECTOR,PLUG,ELEC.....	EA	1
14	6	PAFZZ	5975-00-727-5153	96906	MS3367-4-9	CONNECTOR,RECEPTACL .....	EA	2
						STRAP,TIEDOWN,ELECT .....	EA	1

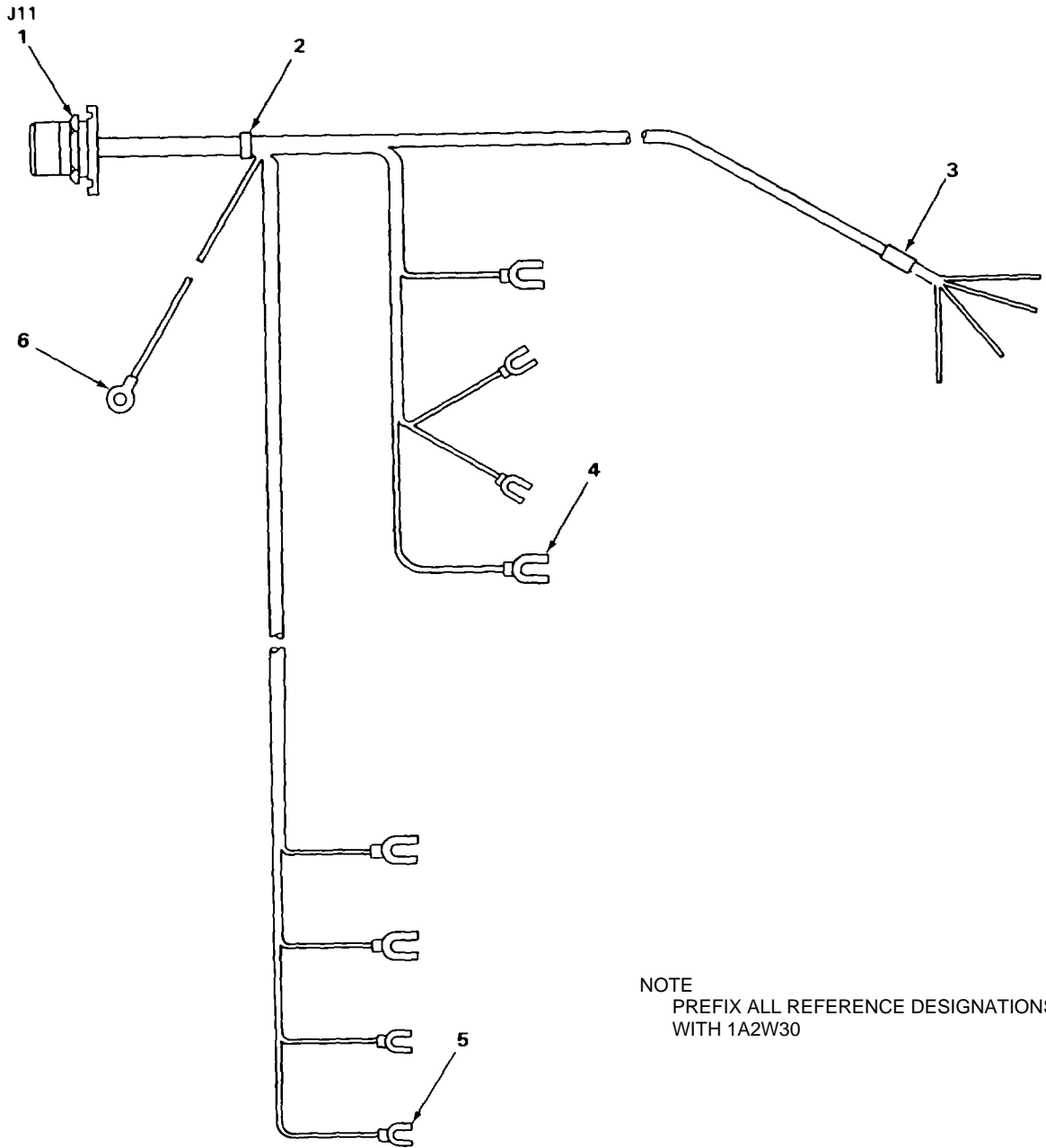

FIGURE 15. WIRING HARNESS, AC PRIME POWER (1A2W30)

EL0JTO10

SECTION II

TM 11-5895-833-34P-7/0967-LP-550-1164/TO 31R5-2MSC46-4

(1) ILLUSTRATION		(2)	(3)	(4)	(5)	(6) DESCRIPTION	(7)	(8)
(a) FIG NO.	(b) ITEM NO.	SMR CODE	NATIONAL STOCK NUMBER	FSCM	PART NUMBER	USABLE ON CODE	U/M	QTY INC IN UNIT
15	1	PAFZZ	5935-00-845-2537	96906	MS3114E12-3P	GROUP 0216 WIRING HARNESS, AC PRIME POWER	EA	1
15	2	PAFZZ	5975-00-727-5153	96906	MS3367-4-9	CONNECTOR, RECEPTACL .....	EA	15
15	3	XSFZZ		96906	MS3368-5-9A	STRAP, TIEDOWN, ELECT .....	EA	2
15	4	PAFZZ	5940-01-138-2996	00779	328281	STRAP, TIEDOWN .....	EA	4
15	5	PAFZZ	5940-00-636-5593	18876	9100471	TERMINAL, LUG .....	EA	4
15	6	PAFZZ	5940-00-143-4780	96906	MS25036-108	TERMINAL, LUG .....	EA	1

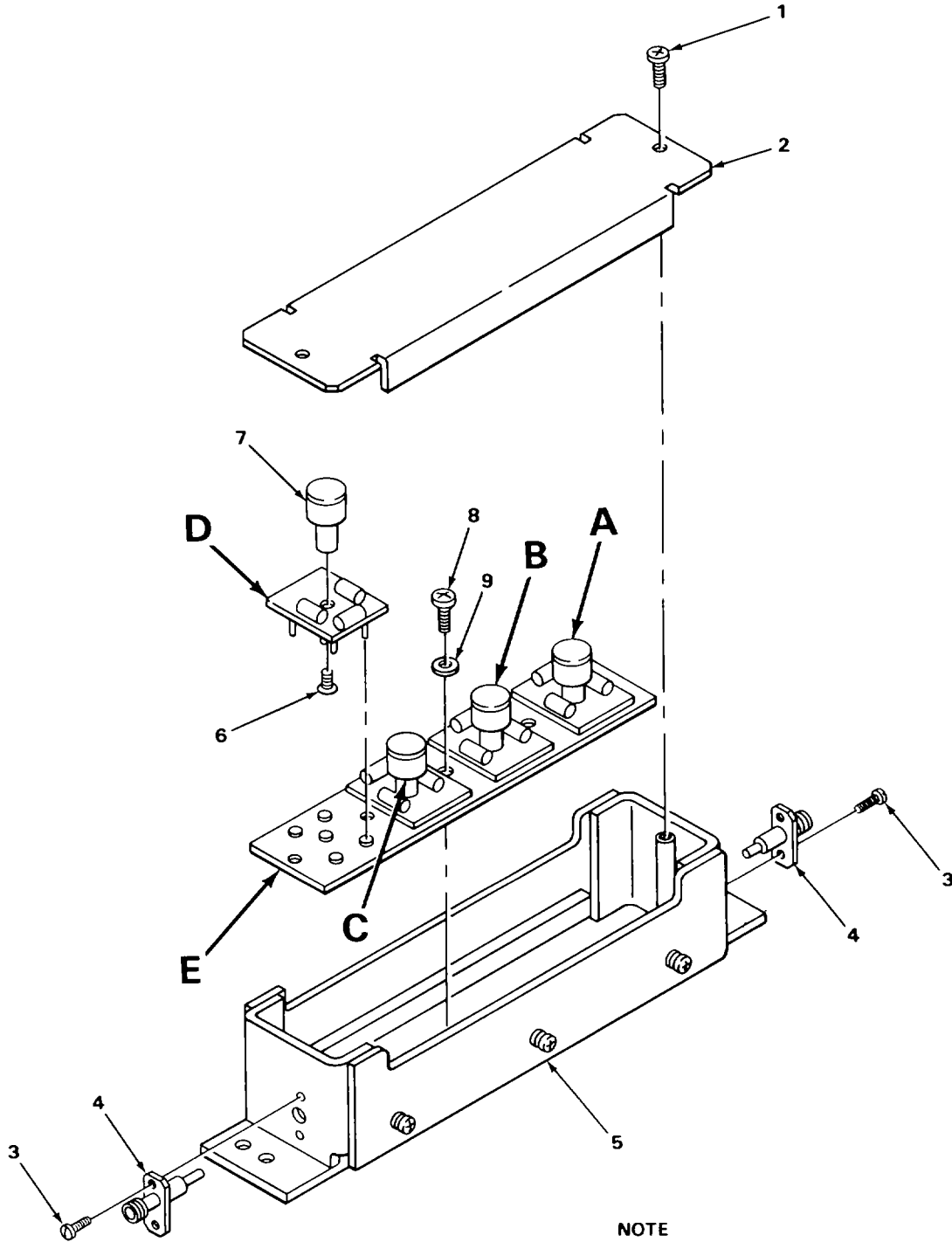

NOTE  
PREFIX ALL REFERENCE DESIGNATIONS  
WITH 1A2AT5

EL0JT011

FIGURE 16. AMPLITUDE STEP ATTENUATOR (1A2AT5) (SHEET 1 OF 2)

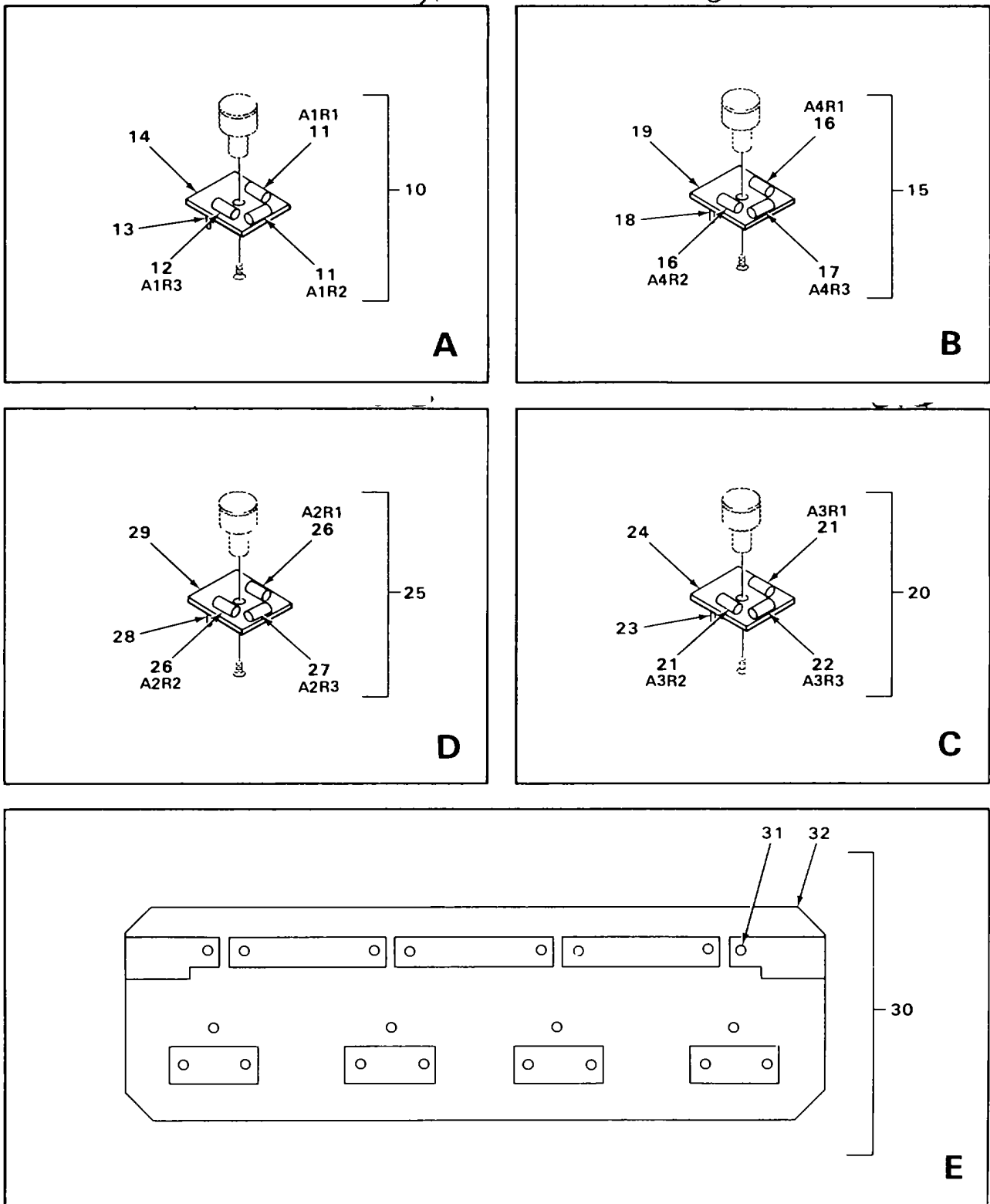

EL0JT051

FIGURE 16. AMPLITUDE STEP ATTENUATOR (1A2AT5) (SHEET 2 OF 2)

SECTION II

TM 11-5895-833-34P-7/0967-LP-550-1164/TO 31R5-2MSC46-4

(1) ILLUSTRATION		(2)	(3)	(4)	(5)	(6) DESCRIPTION	(7)	(8)
(a) FIG NO.	(b) ITEM NO.	SMR CODE	NATIONAL STOCK NUMBER	FSCM	PART NUMBER	USABLE ON CODE	U/M	QTY INC IN UNIT
GROUP 0217 AMPLITUDE STEP ATTENUATOR								
16	1	PADZZ	5305-00-056-9961	96906	MS24693C4	SCREW,MACHINE .....	EA	2
16	2	XBDZZ		31196	3090000788	COVER,ATTENUATOR .....	EA	1
16	3	PADZZ	5305-00-054-5637	96906	MS51957-3	SCREW,MACHINE .....	EA	4
16	4	XBDZZ		31196	2239000794	CONN,RCPT,ELEC MOD .....	EA	2
16	5	XBDZZ		31196	4040000787	ENCLOSURE,ATTENUAT .....	EA	1
16	6	PADZZ	5305-00-833-8624	96906	MS18212-13	SCREW,MACHINE .....	EA	4
16	7	XBDZZ		31196	2090001377	KNOB,PC EXTRACTOR .....	EA	4
16	8	PADZZ	5305-00-054-5653	96906	MS51957-19	SCREW,MACHINE .....	EA	5
16	9	PADZZ	5310-00-595-6211	96906	MS15795-803	WASHER,FLAT .....	EA	5
16	10	XBDDDO		31196	2049000792-1	CKT CARD ASSY .....	EA	1
GROUP 021701 CIRCUIT CARD ASSEMBLY								
16	11	XBDZZ		81349	RN55D1150F	RESISTOR,FIXED,FILM .....	EA	2
16	12	PADZZ	5905-00-138-4918	81349	RNC55K52R3FS	RESISTOR,FIXED FILM .....	EA	1
16	13	PADZZ	5999-00-061-3276	02660	220-S02	CONTACT,ELECTRICAL .....	EA	4
16	14	XBDZZ		31196	2069000792-1	PRINTED WRG BD .....	EA	1
16	15	XBDDD		31196	20490000792-4	CKT CARD ASSY .....	EA	1
GROUP 021702 CIRCUIT CARD ASSEMBLY								
16	16	PADZZ	5905-00-238-3831	81349	RNC55K23R7FS	RESISTOR,FIXED,FILM .....	EA	1
16	17	PADZZ	5905-00-163-7092	81349	RNC55K2210FS	RESISTOR,FIXED FILM .....	EA	2
16	18	PADZZ	5999-00-061-3276	02660	220-S02	CONTACT,ELECTRICAL .....	EA	4
16	19	XBDZZ		31196	2069000792-4	PRINTED WRG BD .....	EA	1
16	20	XBDDO		31196	204000792-3	CKT CARD ASSY .....	EA	1
GROUP 021703 CIRCUIT CARD ASSEMBLY								
16	21	PADZZ	5905-00-758-4802	81349	RNC55K4320FS	RESISTOR,FIXED,FILM .....	EA	2
16	22	PADZZ	5905-00-232-9350	81349	RN55DIIR5F	RESISTOR,FIXED FILM .....	EA	1
16	23	PADZZ	5999-00-061-3276	02660	220-S02	CONTACT,ELECTRICAL .....	EA	4
16	24	XBDZZ		31196	2069000792-3	PRINTED WRG BD .....	EA	1
16	25	XBDDD		31196	2049000792-2	CKT CARD ASSY .....	EA	1



SECTION II

TM 11-5895-833-34P-7/0967-LP-550-1164/TO 31R5-2MSC46-4

(1) ILLUSTRATION		(2)	(3)	(4)	(5)	(6)	(7)	(8)
(a) FIG NO.	(b) ITEM NO.	SMR CODE	NATIONAL STOCK NUMBER	FSCM	PART NUMBER	DESCRIPTION  USABLE ON CODE	U/M	QTY INC IN UNIT
16	26	XBDZZ		81349	RN55D8660F	GROUP 021704 CIRCUIT CARD ASSEMBLY RESISTOR, FIXED, FILM .....	EA	2
16	27	PADZZ	5905-00-121-9863	81349	RCR07G5R6JS	RESISTOR, FIXED, COMP .....	EA	1
16	28	PADZZ	5999-00-061-3276	02660	220-S02	CONTACT, ELECTRICAL .....	EA	4
16	29	XBDZZ		31196	2069000792-2	PRINTED WRG 8D .....	EA	1
16	30	XBDDD		31196	3040001340	CKT CARD ASSY .....	EA	1
16	31	PADZZ	5935-00-191-5434	71279	450-3388-01-03	JACK, TIP .....	EA	20
16	32	XBDZZ		31196	3060001340	PRINTED WRG BD .....	EA	1

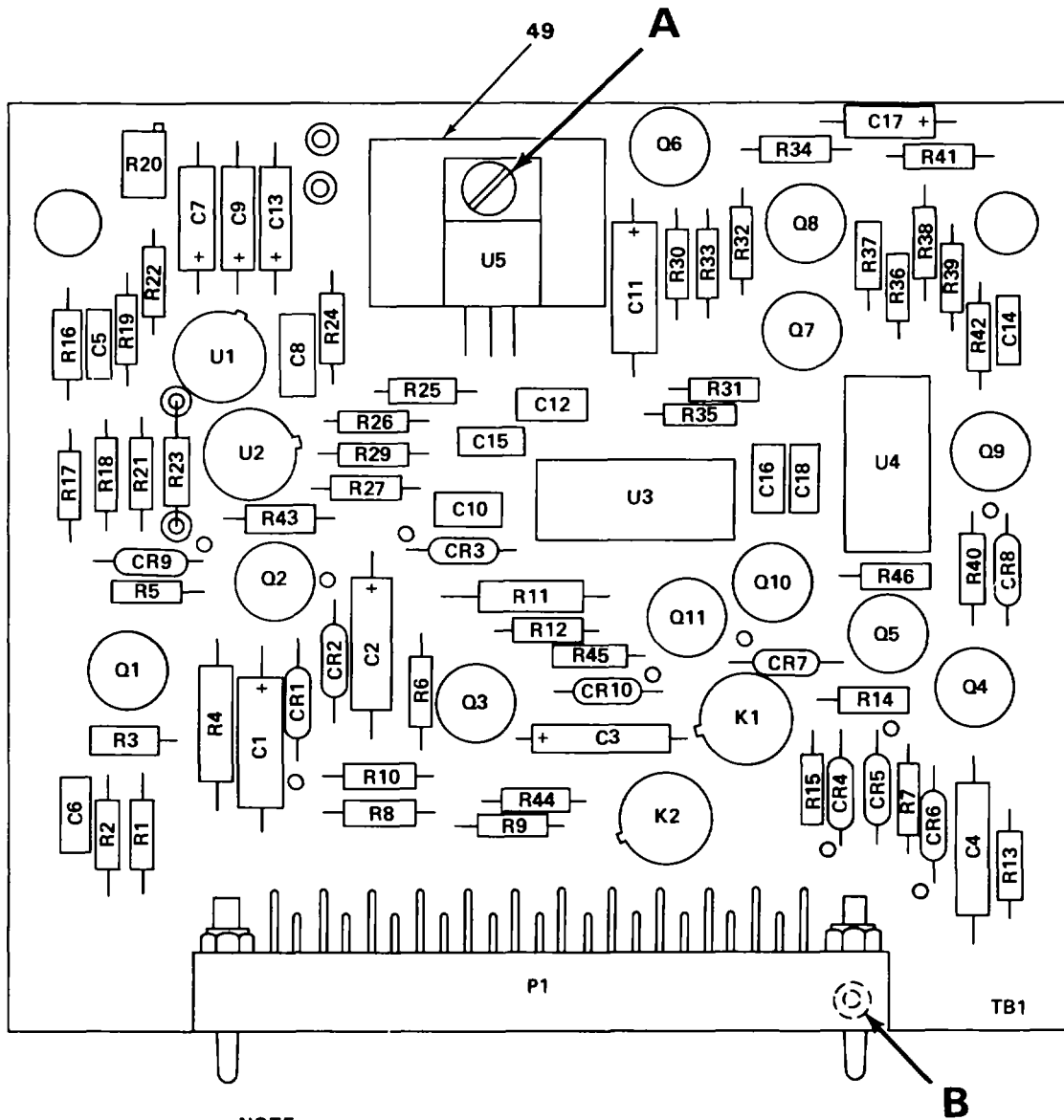

NOTE:  
 PREFIX ALL REFERENCE DESIGNATIONS  
 WITH 1A2A4

EL0JT012

FIGURE 17. OUT-OF-LOCK DETECTOR (1A2A4) (CIRCUIT CARD ASSEMBLY) (SHEET 1 OF 2)

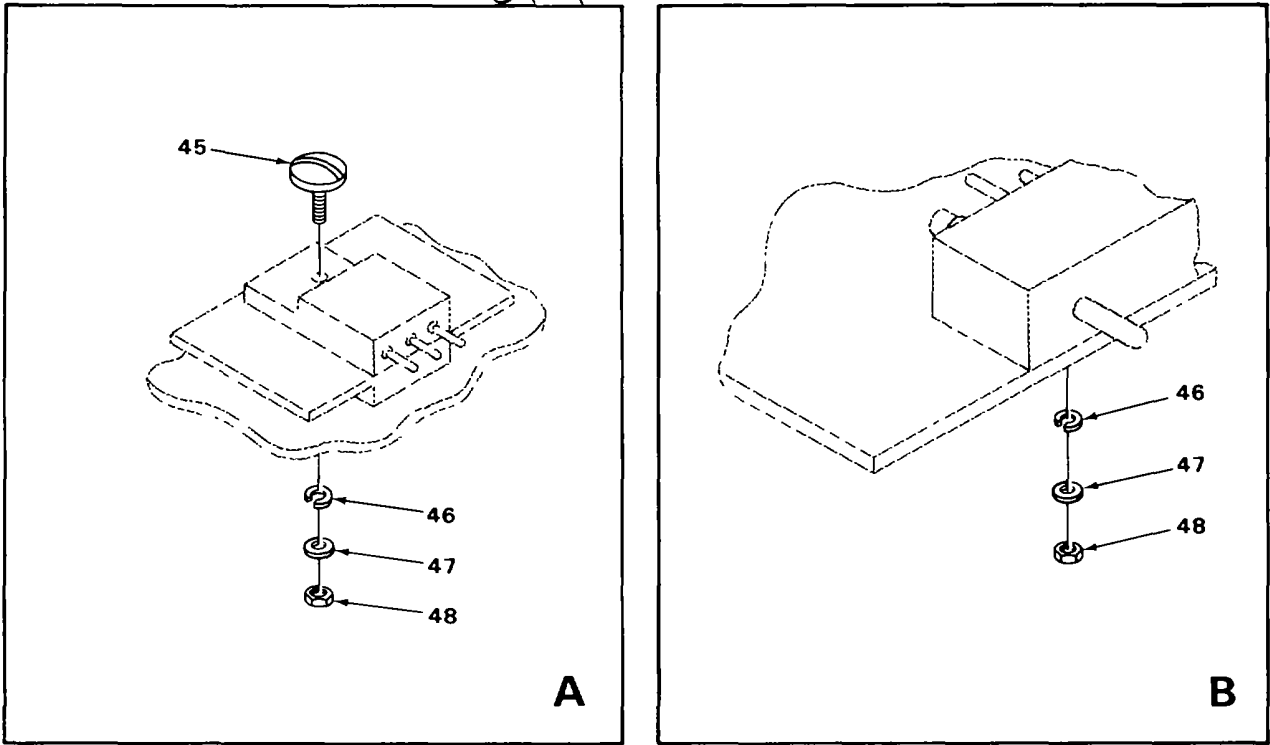

NOTE  
 PREFIX ALL REFERENCE DESIGNATIONS  
 WITH 1A2A4

REF DES	FIND NO	REF DES	FIND NO	REF DES	FIND NO	REF DES	FIND NO
CR1	1	C15	9	R6	20	R30	33
CR2	1	C16	10	R7	21	R31	22
CR3	2	C17	11	R8	16	R32	20
CR4	1	C18	10	R9	16	R33	34
CR5	1	K1	12	R10	17	R34	16
CR6	2	K2	12	R11	18	R35	35
CR7	1	P1	13	R12	19	R36	22
CR8	1	Q1	14	R13	20	R37	32
CR9	2	Q2	14	R14	22	R38	36
CR10	1	Q3	14	R15	23	R39	37
C1	3	Q4	14	R16	24	R40	32
C2	3	Q5	14	R17	25	R41	37
C3	3	Q6	15	R18	25	R42	22
C4	3	Q7	14	R19	26	R43	38
C5	4	Q8	14	R20	27	R44	23
C6	4	Q9	14	R21	28	R45	21
C7	5	Q10	14	R22	20	R46	20
C8	6	Q11	14	R23	29	TB1	39
C9	5	R1	16	R24	30	U1	40
C10	7	R2	16	R25	31	U2	41
C11	8	R3	17	R26	16	U3	42
C12	9	R4	18	R27	32	U4	43
C13	5	R5	19	R29	19	U5	44
C14	4						

ELOJT013

FIGURE 17. OUT-OF-LOCK DETECTOR (1A2A4) (CIRCUIT CARD ASSEMBLY) (SHEET 2 OF 2)

SECTION II

TM 11-5895-833-34P-7/0967-LP-550-1164/TO 31R5-2MSC46-4

(1) ILLUSTRATION		(2)	(3)	(4)	(5)	(6) DESCRIPTION	(7)	(8)
(a) FIG NO.	(b) ITEM NO.	SMR CODE	NATIONAL STOCK NUMBER	FSCM	PART NUMBER	USABLE ON CODE	U/M	QTY INC IN UNIT
GROUP 0218 OUT-OF-LOCK DETECTOR								
17	1	PADZZ	5961-00-985-4900	81349	JANIN647	SEMICONDUCTOR DEVIC.....	EA	7
17	2	PADZZ	5961-00-232-3279	81349	JANIN5711	SEMICONDUCTOR DEVIC.....	EA	3
17	3	XBDZZ		34303	35V47PORMIOPCT	CAPACITOR,FXD,ELECT.....	EA	4
17	4	PADZZ	5910-00-113-9453	81349	M39014/02-1417	CAPACITOR,FIXED,CER.....	EA	3
17	5	XBDZZ		34303	35V22PORM20PCT	CAPACITOR,FXD,ELECT.....	EA	3
17	6	PADZZ	5910-01-054-6159	81349	CMR04C3R0D00DR	CAPACITOR,FIXED,MIC.....	EA	1
17	7	PADZZ	5910-00-113-5445	81349	M39014/01-1339	CAPACITOR,FIXED,CER.....	EA	1
17	8	XBDZZ		34303	SWT4CIOV100J	CAPACITOR,FXD,ELECT.....	EA	1
17	9	PADZZ	5910-00-010-8717	81349	M39014/01-1593	CAPACITOR,FIXED,CER.....	EA	2
17	10	PADZZ	5910-00-124-0659	81349	M39014/01-1575	CAPACITOR,FIXED,CER.....	EA	2
17	11	XBDZZ		34303	SWT3C35VIOJ	CAPACITOR,FXD,ELECT.....	EA	1
17	12	XBDZZ		81349	JM39016/9-005L	RELAY,ARMATURE.....	EA	2
17	13	PADZZ	5935-01-006-7791	80063	SM-A-754194	CONNECTOR,RECEPTACL.....	EA	1
17	14	PADZZ	5961-00-951-8757	81349	JAN2N2222A	TRANSISTOR.....	EA	10
17	15	PADZZ	5961-00-137-0813	81349	JAN2N5431	TRANSISTOR.....	EA	1
17	16	PADZZ	5905-00-111-1679	81349	RCR07G512JS	RESISTOR,FIXED,COMP.....	EA	6
17	17	PADZZ	5905-00-104-8368	81349	RCR07G470JS	RESISTOR,FIXED,COMP.....	EA	2
17	18	PADZZ	5905-00-104-8349	81349	RCR20GS11JS	RESISTOR,FIXED,COMP.....	EA	2
17	19	PADZZ	5905-00-141-1183	81349	RCR07G10IJS	RESISTOR,FIXED,COMP.....	EA	3
17	20	PADZZ	5905-00-105-7764	81349	RCR07G222JS	RESISTOR,FIXED,COMP.....	EA	5
17	21	PADZZ	5905-00-141-0717	81349	RCR07G473JS	RESISTOR,FIXED,COMP.....	EA	2
17	22	PADZZ	5905-00-114-0711	81349	RCR07G472JS	RESISTOR,FIXED,COMP.....	EA	4
17	23	PADZZ	5905-00-111-4750	81349	RCR07G301JS	RESISTOR,FIXED,COMP.....	EA	2
17	24	PADZZ	5905-00-104-8369	81349	RCR07G362JS	RESISTOR,FIXED,COMP.....	EA	1
17	25	PADZZ	5905-00-435-1718	81349	RCR07G241JS	RESISTOR,FIXED,COMP.....	EA	2
17	26	PADZZ	5905-00-119-8768	81349	RCR07G821JS	RESISTOR,FIXED,COMP.....	EA	1
17	27	PADZZ	5905-01-057-4386	81349	RJR26FX501P	RESISTOR,VARIABLE,N.....	EA	1
17	28	PADZZ	5905-00-419-5258	81349	RNR55C2211FS	RESISTOR,FIXED,FILM.....	EA	1

SECTION II

TM 11-5895-833-34P-7/0967-LP-550-1164/TO 31R5-2MSC46-4

(1) ILLUSTRATION		(2)	(3)	(4)	(5)	(6)	(7)	(8)
(a) FIG NO.	(b) ITEM NO.	SMR CODE	NATIONAL STOCK NUMBER	FSCM	PART NUMBER	DESCRIPTION  USABLE ON CODE	U/M	QTY INC IN UNIT
17	29	PADZZ	5905-00-240-2012	81349	RNR55C1003FS	RESISTOR, FIXED, FILM .....	EA	1
17	29	PADZZ	5905-00-264-4066	81349	RNR55C1103FS	RESISTOR, FIXED, FILM .....	EA	1
17	29	XBDZZ		81349	RNR55C1213FS	RESISTOR, FIXED, FILM .....	EA	1
17	29	PADZZ	5905-00-456-3852	81349	RNR55C1333FS	RESISTOR, FIXED, FILM .....	EA	1
17	29	PADZZ	5905-00-456-3874	81349	RNR55C1403FS	RESISTOR, FIXED, FILM .....	EA	1
17	29	PADZZ	5905-00-430-3626	81349	RNR55C1543FS	RESISTOR, FIXED, FILM .....	EA	1
17	29	PADZZ	5905-00-456-3875	81349	RNR55C1623FS	RESISTOR, FIXED, FILM .....	EA	1
17	29	PADZZ	5905-00-456-3887	81349	RNR55C1693FS	RESISTOR, FIXED, FILM .....	EA	1
17	30	PADZZ	5905-00-116-8556	81349	RCR07G223JS	RESISTOR, FIXED, COMP .....	EA	1
17	31	PADZZ	5905-00-104-8362	81349	RCR07G132JS	RESISTOR, FIXED, COMP .....	EA	1
17	32	PADZZ	5905-00-136-8406	81349	RCR07G242JS	RESISTOR, FIXED, COMP .....	EA	3
17	33	PADZZ	5905-00-104-8360	81349	RCRO7G623JS	RESISTOR, FIXED, COMP .....	EA	1
17	34	PADZZ	5905-00-106-3668	81349	RCR07G220JS	RESISTOR, FIXED, COMP .....	EA	1
17	35	PADZZ	5905-00-120-9154	81349	RCR07G471JS	RESISTOR, FIXED, COMP .....	EA	1
17	36	PADZZ	5905-00-121-9919	81349	RCR07G106JS	RESISTOR, FIXED, COMP .....	EA	1
17	37	PADZZ	5905-00-485-4545	81349	RCR07G334JS	RESISTOR, FIXED, COMP .....	EA	2
17	38	PADZZ	5905-00-110-7620	81349	RCR07G102JS	RESISTOR, FIXED, COMP .....	EA	1
17	39	XADZZ		80063	SM-D-952557-1	PRINTED WRG BOARD .....	EA	1
17	40	XBDZZ		81349	JANM38510/10103B A2	MICROCIRCUIT, LINEAR.....	EA	1
17	41	PADZZ	5962-01-077-6116	27014	LM193AH/883B	MICROCIRCUIT, LINEAR.....	EA	1
17	42	XBDZZ		81349	JANM38510/01309B A2	MICROCIRCUIT, LINEAR.....	EA	1
17	43	PADZZ	5962-01-102-5022	18324	SE556-IF/883B	MICROCIRCUIT, LINEAR.....	EA	1
17	44	XBDZZ		18324	SA78MO5CU	MICROCIRCUIT, LINEAR.....	EA	1
17	45	PADZZ	5305-00-054-5649	96906	MS51957-15	SCREW, MACHINE .....	EA	1
17	46	PADZZ	5310-00-933-8118	96906	MS35338-135	WASHER, LOCK .....	EA	3
17	47	PADZZ	5310-00-595-6211	96906	MS15795-803	WASHER, FLAT .....	EA	3
17	48	PADZZ	5310-00-934-9748	96906	MS35649-244	NUT, PLAIN, HEXAGON .....	EA	3
17	49	XBDZZ		80063	SM-B-952492	HEATSINK .....	EA	1

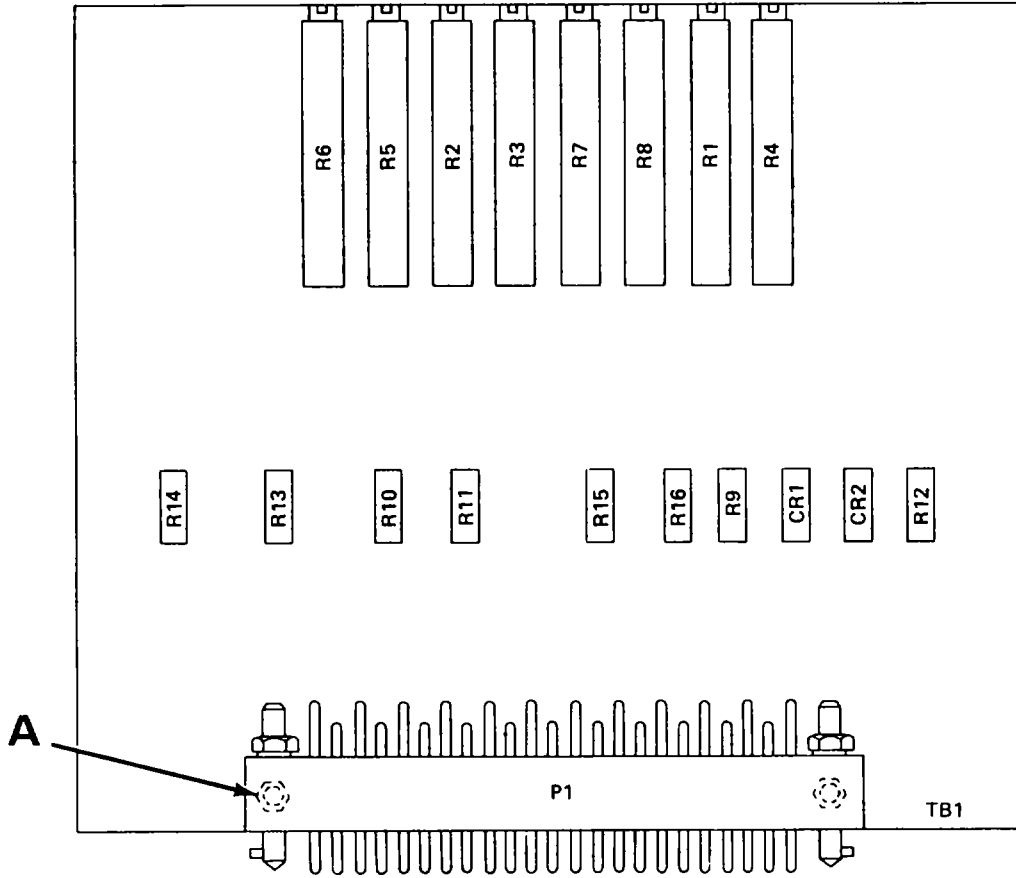

REF DES	INDEX NO
CR1	1
CR2	1
P1	2
R1	3
R2	3
R3	3
R4	3
R5	3
R6	3
R7	3
R8	3
R9	4
R10	5
R11	6
R12	7
R13	8
R14	9
R15	4
R16	9
TB1	10

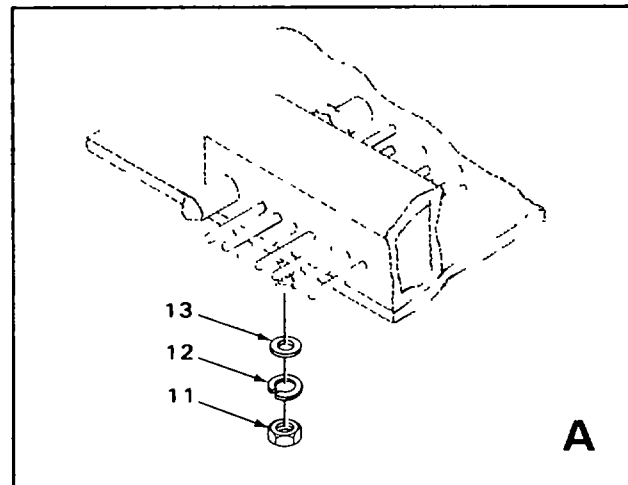

NOTE  
PREFIX ALL REFERENCE DESIGNATIONS  
WITH 1A2A3

EL0JT015

FIGURE 18. STATUS INDICATOR CALIBRATION (1A2A3) (CIRCUIT CARD ASSEMBLY)

SECTION II

TM 11-5895-833-34P-7/0967-LP-550-1164/TO 31R5-2MSC46-4

(1) ILLUSTRATION		(2)	(3)	(4)	(5)	(6) DESCRIPTION	(7)	(8)
(a) FIG NO.	(b) ITEM NO.	SMR CODE	NATIONAL STOCK NUMBER	FSCM	PART NUMBER	USABLE ON CODE	U/M	QTY INC IN UNIT
						GROUP 0219 STATUS INDICATOR CALIBRATION		
18	1	XBDZZ		13715	IN914A	SEMICONDUCTOR .....	EA	2
18	2	PADZZ	5935-01-006-7791	80063	SM-A-754194	CONNECTOR,RECEPTACL .....	EA	1
18	3	PADZZ	5905-00-483-4284	81349	RJ12CY103	RESISTOR,VARIABLE .....	EA	8
18	4	PADZZ	5905-00-105-7767	81349	RNC55H8252FS	RESISTOR,FIXED,COMP .....	EA	2
18	5	PADZZ	5905-00-110-7620	81349	RCR07G102JS	RESISTOR,FIXED,COMP .....	EA	1
18	6	PADZZ	5905-00-141-1183	81349	RCR07G10IJS	RESISTOR,FIXED,COMP .....	EA	1
18	7	PADZZ	5905-00-435-6414	81349	RCR07G114JS	RESISTOR,FIXED,COMP .....	EA	1
18	8	PADZZ	5905-00-110-0388	81349	RCR07G104JS	RESISTOR,FIXED,COMP .....	EA	1
18	9	PADZZ	5905-00-106-3666	81349	RCR07G103JS	RESISTOR,FIXED,COMP .....	EA	2
18	10	XADZZ		31196	4060000436	PRINTED WRG BD .....	EA	1
18	11	PADZZ	5310-00-934-9748	96906	MS35649-244	NUT,PLAIN,HEXAGON .....	EA	2
18	12	PADZZ	5310-00-933-8118	96906	MS35338-135	WASHER,LOCK .....	EA	2
18	13	PADZZ	5310-00-595-6211	96906	MS15795-803	WASHER,FLAT .....	EA	2

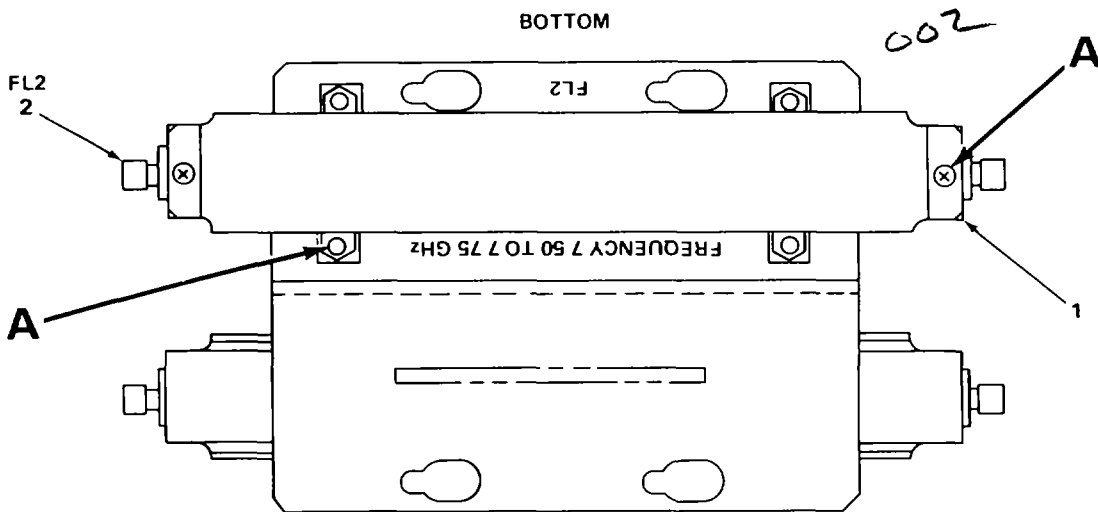
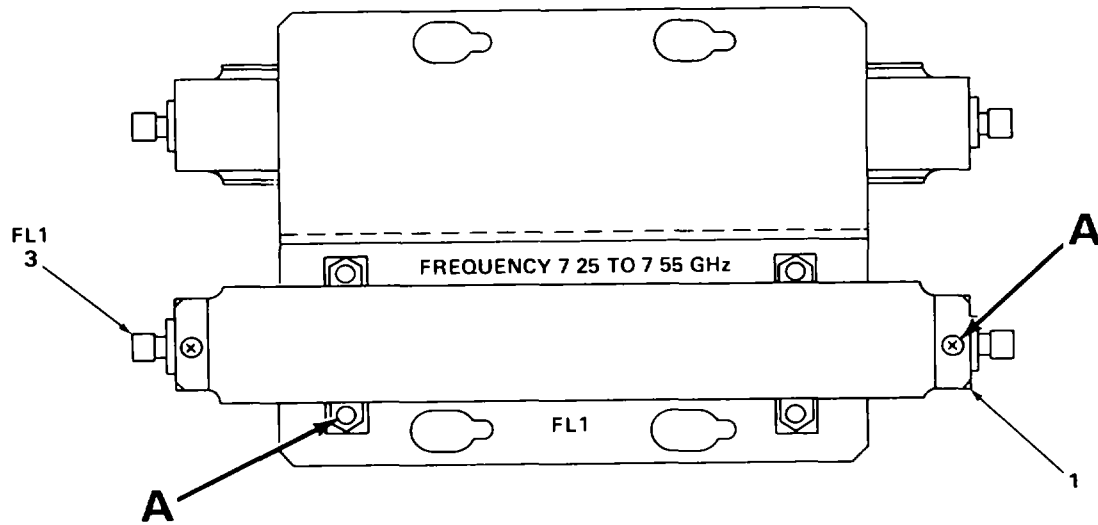

NOTE  
 PREFIX ALL REFERENCE DESIGNATIONS  
 WITH 1A2A7

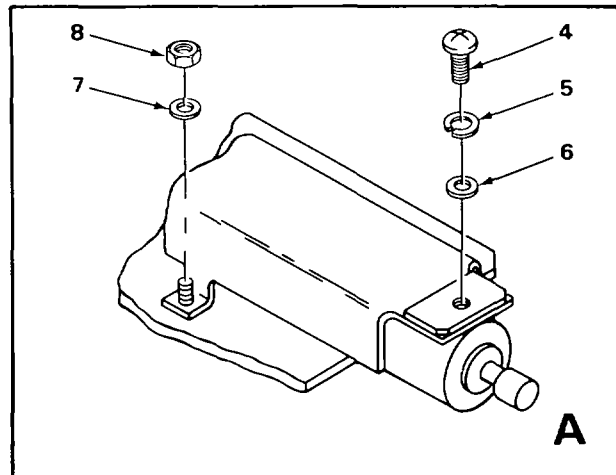

ELOJT017

FIGURE 19. BANDPASS FILTER ASSEMBLY (1A2A7)



SECTION II

TM 11-5895-833-34P-7/0967-LP-550-1164/TO 31R5-2MSC46-4

(1) ILLUSTRATION		(2)	(3)	(4)	(5)	(6) DESCRIPTION	(7)	(8)
(a) FIG NO.	(b) ITEM NO.	SMR CODE	NATIONAL STOCK NUMBER	FSCM	PART NUMBER	USABLE ON CODE	U/M	QTY INC IN UNIT
19	1	XBDZZ		31196	3090001341	GROUP 0220 BANDPASS FILTER ASSEMBLY		
19	2	XBFDA		31196	1130000040	COVER,FILTER .....	EA	2
19	3	PAFDA	5915-00-124-4714	31196	1130000039	FILTER,BANDPASS .....	EA	1
19	4	PAFZZ	5305-00-054-5648	96906	MS51957-14	FILTER,BANDPASS .....	EA	1
19	5	PAFZZ	5310-00-933-8118	96906	MS35338-135	SCREW,MACHINE .....	EA	4
19	6	PAFZZ	5310-00-595-6211	96906	MS15795-803	WASHER,LOCK .....	EA	4
19	7	PAFZZ	5310-00-973-8660	80063	SM--416109-1	WASHER,FLAT .....	EA	4
19	8	PAFZZ	5310-00-801-4420	80205	NAS679CO6M	WASHER,FLAT .....	EA	8
						NUT,SELF-LOCKING,HE .....	EA	8

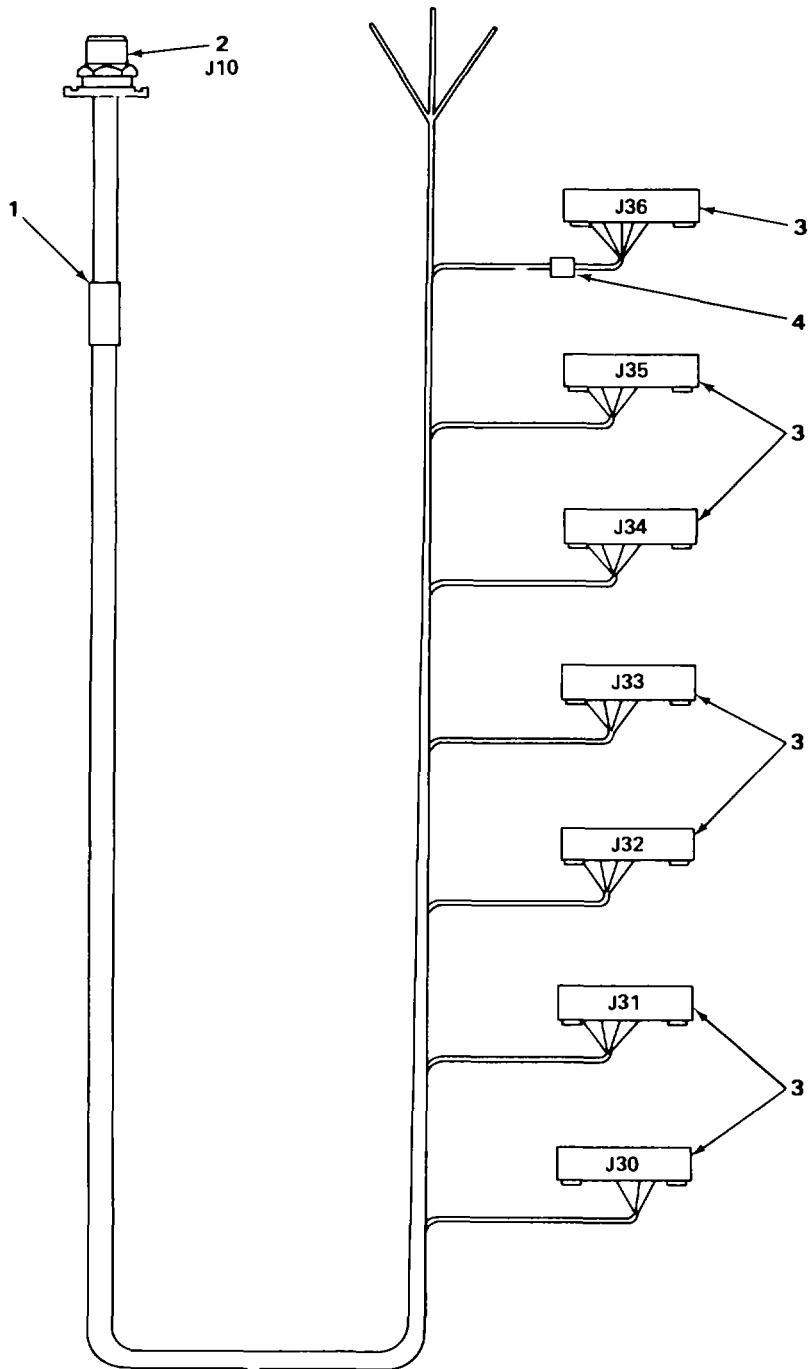

NOTE  
PREFIX ALL REFERENCE DESIGNATIONS WITH 1A2W26

FIGURE 20. WIRING HARNESS, FREQUENCY CONTROL (1A2W26)

SECTION II

TM 11-5895-833-34P-7/0967-LP-550-1164/TO 31R5-2MSC46-4

(1) ILLUSTRATION		(2)	(3)	(4)	(5)	(6) DESCRIPTION	(7)	(8)
(a) FIG NO.	(b) ITEM NO.	SMR CODE	NATIONAL STOCK NUMBER	FSCM	PART NUMBER	USABLE ON CODE	U/M	QTY INC IN UNIT
						GROUP 0221 WIRING HARNESS, FREQUENCY CONTROL		
20	1	PAFZZ	5975-00-482-3954	96906	MS3368-5-9E	STRAP,TIEDOWN,ELECT .....	EA	1
20	2	PAFZZ	5935-00-913-4462	96906	MS3114E20-39S	CONNECTOR,RECEPTACL .....	EA	1
20	3	XBFZZ		95238	600-4PCGDF7-50	CONN,RECP,ELEC .....	EA	7
20	4	PAFZZ	5975-00-727-5153	96906	MS3367-4-9	STRAP,TIEDOWN,ELECT .....	EA	7

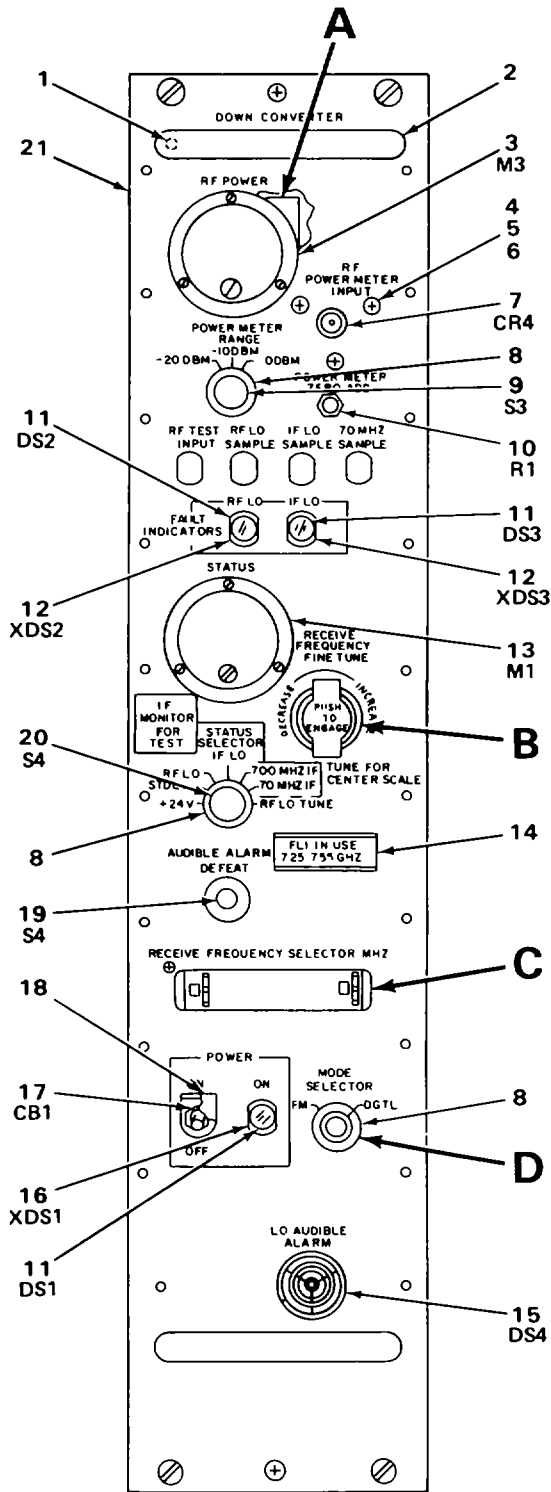

NOTE  
 PREFIX ALL REFERENCE DESIGNATIONS  
 WITH 1A2A2

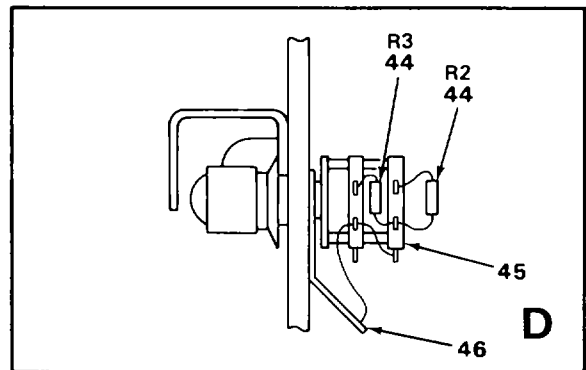
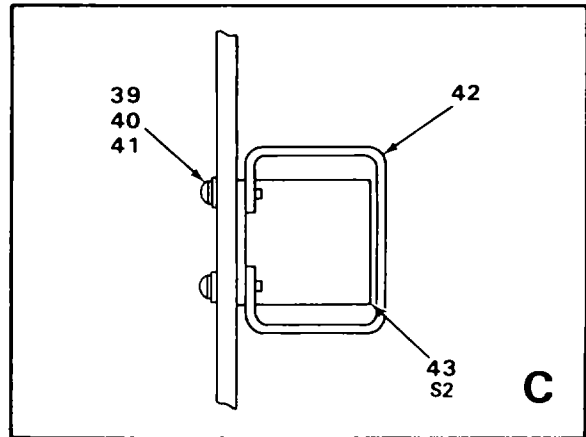
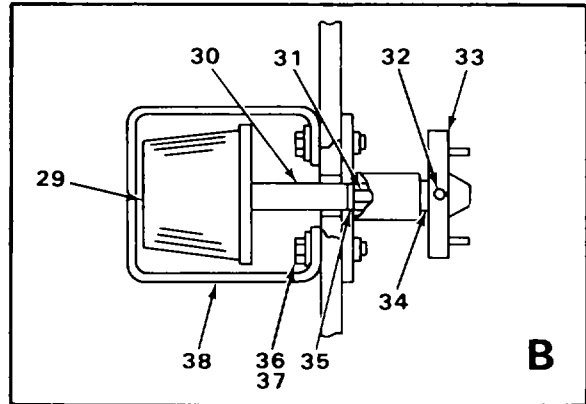
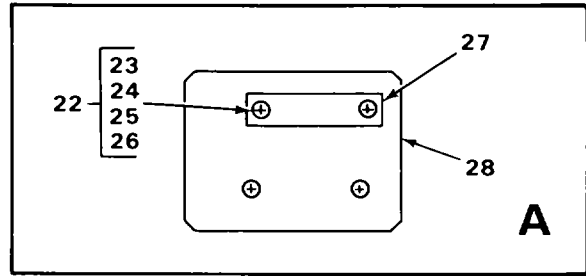

EL0JT020

FIGURE 21. FRONT PANEL ASSEMBLY (1A2A2)

SECTION II

TM 11-5895-833-34P-7/0967-LP-550-1164/TO 31R5-2MSC46-4

(1) ILLUSTRATION		(2)	(3)	(4)	(5)	(6) DESCRIPTION	(7)	(8)
(a) FIG NO.	(b) ITEM NO.	SMR CODE	NATIONAL STOCK NUMBER	FSCM	PART NUMBER	USABLE ON CODE	U/M	QTY INC IN UNIT
GROUP 0222 FRONT PANEL ASSEMBLY								
21	1	PAFZZ	5305-00-071-1322	96906	MS51960-65	SCREW,MACHINE .....	EA	4
21	2	XBFZZ		71279	2112-2-02	HANDLE,BOW .....	EA	2
21	3	XBFZZ		77221	621-16814	METER,SPECIAL SCALE .....	EA	1
21	4	PAFZZ	5305-00-054-5650	96906	MS51957-16	SCREW,MACHINE .....	EA	3
21	5	PAFZZ	5310-00-933-8118	96906	MS35338-135	WASHER,LOCK .....	EA	3
21	6	PAFZZ	5310-00-595-6211	96906	MS15795-803	WASHER,FLAT .....	EA	3
21	7	PAFDA	6625-00-140-9318	11332	N427-2	MONITOR RADIO FREQ.....	EA	1
21	8	PAOZZ	5355-00-680-1357	96906	MS91528-IF2B	KNOB .....	EA	1
21	9	PAFZZ	5930-00-124-4985	80063	SM-A-753398	SWITCH,ROTARY .....	EA	1
21	10	PAFZZ	5905-00-632-9515	34263	VA45-25K	RESISTOR,VARIABLE,N .....	EA	1
21	11	PAOZZ	6240-00-155-7836	96906	MS25237-327	LAMP, INCANDESCENT .....	EA	2
21	12	PAFZZ	6210-00-840-0850	72619	812-1030-0971-50 A	LIGHT, INDICATOR.....	EA	2
21	13	PAFZZ	6625-00-G90-5339	77221	1621-16815	AMMETER .....	EA	1
21	14	XBDZZ		31196	2090001390	PLATE INSTRUCTION .....	EA	1
21	15	PAFZZ	6350-00-102-4210	90201	SC628	BUZZER.....	EA	1
21	16	PAFZZ	6210-00-892-4468	72619	812-1030-0975-50 A	LIGHT, INDICATOR.....	EA	1
21	17	XBFZZ		81349	M39019-4-38	CIRCUIT BREAKER .....	EA	1
21	18	XBFZZ		31196	2090000727-1	SHIELD,CIRCUIT.....	EA	1
21	19	PAFZZ	5930-00-501-1749	96906	MS25089-3C	SWITCH,PUSH.....	EA	1
21	20	PAFZZ	5930-00-626-2917	76854	5-17351-411	SWITCH,ROTARY .....	EA	1
21	21	XBDZZ		31196	5040000580	PANEL,FRONT .....	EA	1
21	22	PAFFF	5895-01-021-3286	31196	2040000742	SHUNT,TUNING .....	EA	1
GROUP 022201 TUNING SHUNT								
21	23	PAFZZ	5305-00-054-5640	96906	MS51957-6	SCREW,MACHINE .....	EA	4
21	24	PAFZZ	5310-00-928-2690	96906	MS35338-134	WASHER,LOCK .....	EA	4
21	25	PAFZZ	5310-00-595-6761	96906	MS15795-802	WASHER,FLAT .....	EA	4
21	26	PAFZZ	5310-00-934-9748	96906	MS35649-244	NUT,PLAIN,HEXAGON .....	EA	4
21	27	XBFZZ		81348	RJ12L501	RESISTOR VARIABLE .....	EA	1

SECTION II

TM 11-5895-833-34P-7/0967-LP-550-1164/TO 31R5-2MSC46-4

(1) ILLUSTRATION		(2)	(3)	(4)	(5)	(6) DESCRIPTION	(7)	(8)
(a) FIG NO.	(b) ITEM NO.	SMR CODE	NATIONAL STOCK NUMBER	FSCM	PART NUMBER	USABLE ON CODE	U/M	QTY INC IN UNIT
21	28	XBFZZ		31196	2090000728	TERMINAL BOARD .....	EA	1
21	29	PAOZZ	5355-01-020-3111	99813	101357	KNOB .....	EA	1
21	30	XBFZZ		31196	2099005384-1	SHAFT, SHOULDERED .....	EA	1
21	31	PAFZZ	5360-00-517-6225	84830	LC024C5SS	SPRING, HELICAL, COMP .....	EA	1
21	32	PAFZZ	5305-00-045-1684	96906	MS51021-9	SETSCREW .....	EA	2
21	33	XBDZZ		31196	3350005413	DRIVER, TUNING .....	EA	1
21	34	PAFZZ	5365-00-432-3584	96906	MS16624-5018-1	RING, RETAINING .....	EA	1
21	35	PAFZZ	3120-01-024-0434	80063	SM-B-754330	BEARING, WASHER, THRU .....	EA	1
21	36	XBFZZ		70318	6-32X3-4	SCREW, MACHINE .....	EA	2
21	37	PAFZZ	5310-00-880-5978	96906	MS15795-807	WASHER, FLAT .....	EA	2
21	38	XBDZZ		31196	3090005381	GUARD, KNOB, TUNING .....	EA	1
21	39	PAFZZ	5310-00-928-2690	96906	MS35338-134	WASHER, LOCK .....	EA	4
21	40	PAFZZ	5310-00-595-6761	96906	MS15795-802	WASHER, FLAT .....	EA	4
21	41	PAFZZ	5305-00-054-5641	96906	MS51957-7	SCREW, MACHINE .....	EA	4
21	42	XBFZZ		31196	3090000486	BRACKET, SWITCH .....	EA	1
21	43	XBFZZ		07126	7C83C	SWITCH, RECEIVE .....	EA	1
21	44	PAFZZ	5905-00-110-0196	81349	RCR20G102JS	RESISTOR, FIXED, COMP .....	EA	2
21	45	XBFZZ		31336	1090F-202-2NP	SWITCH, ROTARY .....	EA	1
21	46	XBFZZ		78189	2440-20-03	TERMINAL, LUG .....	EA	1

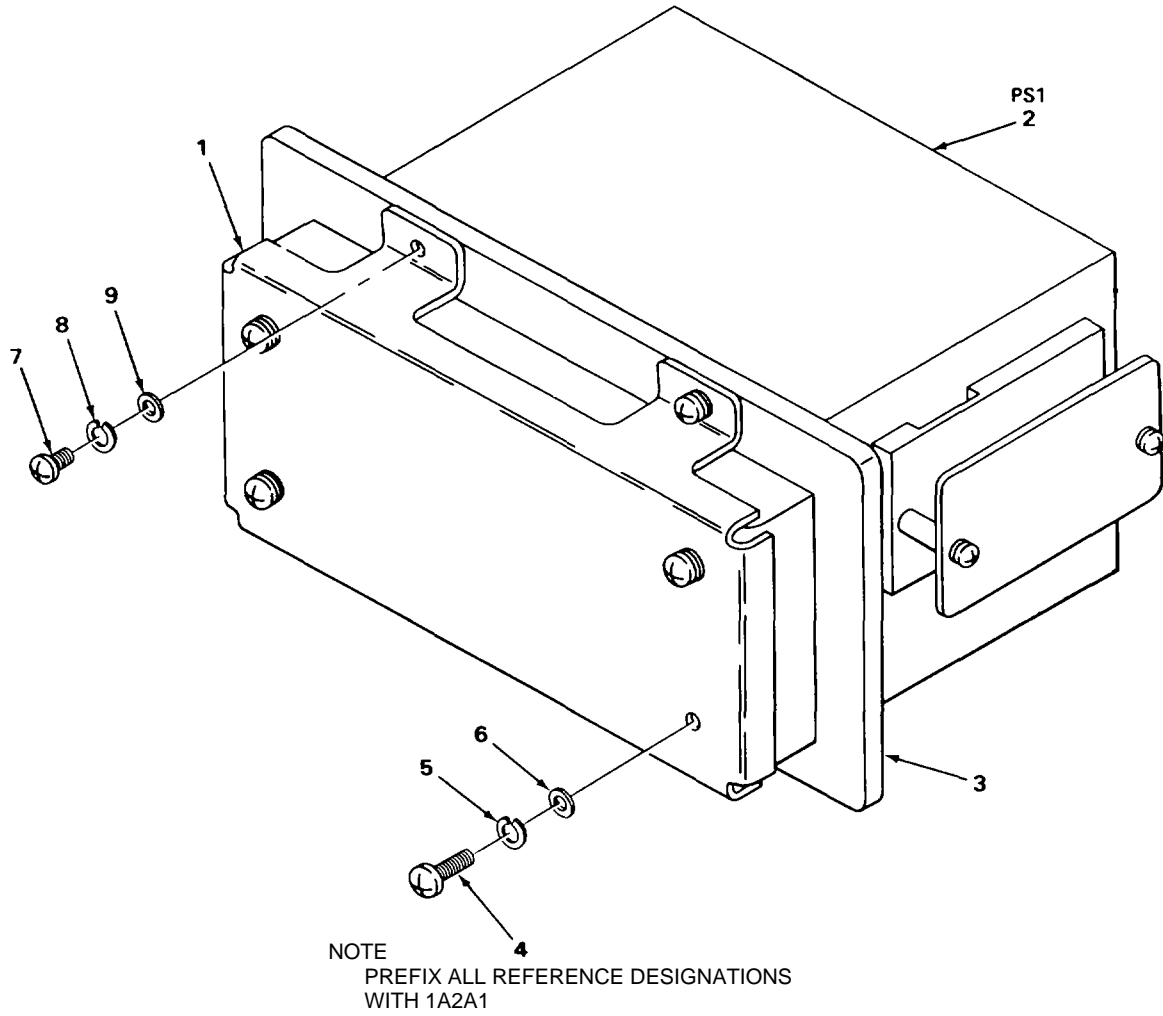

FIGURE 22. POWER SUPPLY ASSEMBLY (1A2A1).

EL0JT021

SECTION II

TM 11-5895-833-34P-7/0967-LP-550-1164/TO 31R5-2MSC46-4

(1) ILLUSTRATION		(2)	(3)	(4)	(5)	(6)	(7)	(8)
(a) FIG NO.	(b) ITEM NO.	SMR CODE	NATIONAL STOCK NUMBER	FSCM	PART NUMBER	DESCRIPTION  USABLE ON CODE	U/M	QTY INC IN UNIT
22	1	XBFZZ		31196	4090000748	GROUP 0223 POWER SUPPLY ASSEMBLY		
22	2	PAFZZ	6130-00-124-4986	31196	1130000097	SHIELD,HEATSINK .....	EA	1
22	3	XBFZZ		31196	3040000711	POWER SUPPLY .....	EA	1
22	4	PAFZZ	5305-00-054-6673	96906	MS51957-48	HEATSINK,ELEC-ELEC .....	EA	1
22	5	PAFZZ	5310-00-933-8119	96906	MS35338-137	SCREW,MACHINE .....	EA	4
22	6	PAFZZ	5310-00-880-5978	96906	MS15795-807	WASHER,LOCK .....	EA	4
22	7	PAFZZ	5305-00-054-6652	96906	MS51957-28	WASHER,FLAT .....	EA	4
22	8	PAFZZ	5310-00-929-6395	96906	MS35338-136	SCREW,MACHINE .....	EA	4
22	9	PAFZZ	5310-00-973-8660	80063	SM-B-416109-1	WASHER,LOCK .....	EA	4
						WASHER,FLAT .....	EA	4



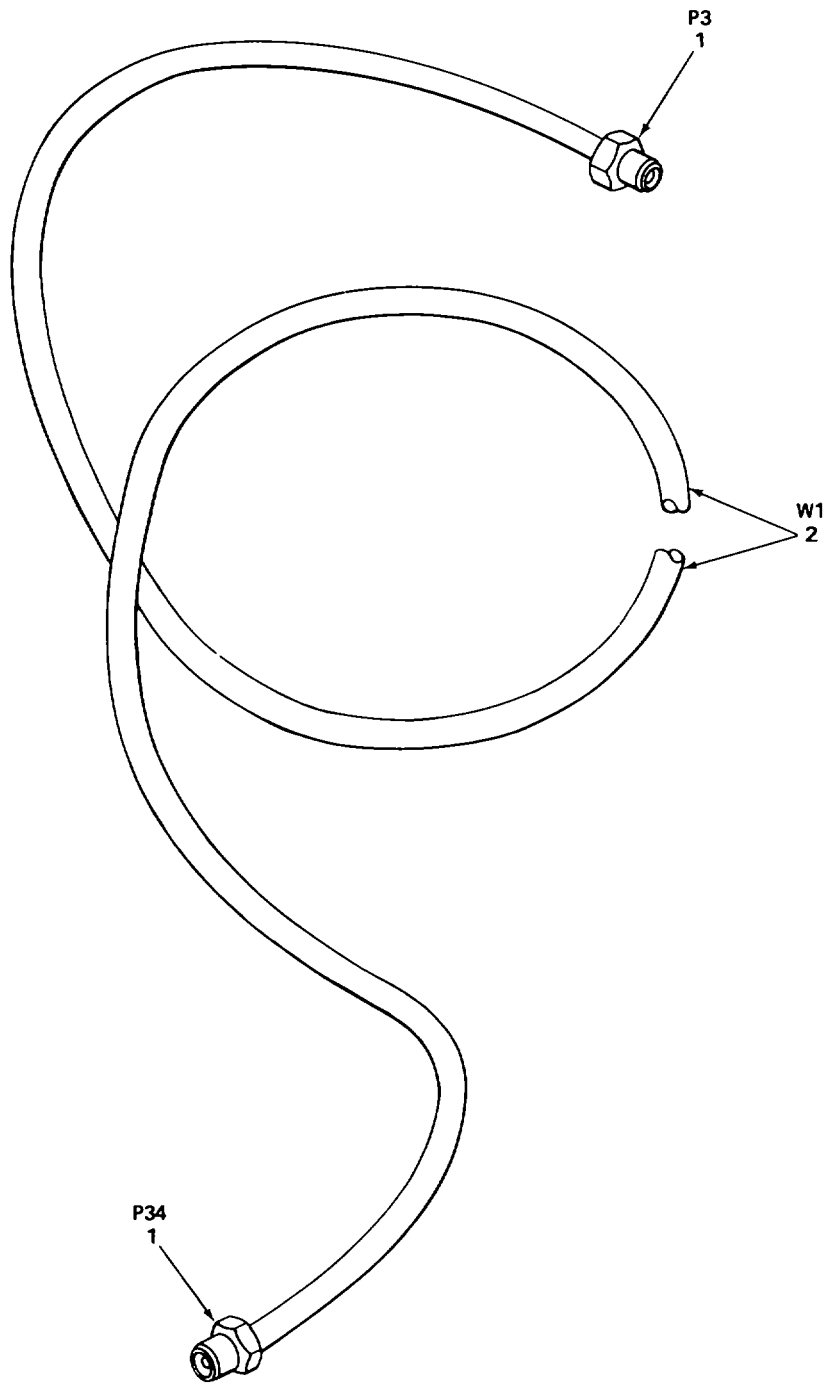

NOTE  
PREFIX ALL REFERENCE DESIGNATIONS  
WITH 1A2W24

FIGURE 23. CABLE ASSEMBLY, RF (1A2W24)

EL0JT042

SECTION II

TM 11-5895-833-34P-7/0967-LP-550-1164/TO 31R5-2MSC46-4

(1) ILLUSTRATION		(2)	(3)	(4)	(5)	(6) DESCRIPTION	(7)	(8)
(a) FIG NO.	(b) ITEM NO.	SMR CODE	NATIONAL STOCK NUMBER	FSCM	PART NUMBER	GROUP0224  USABLE ON CODE	U M	QTY INC IN UNIT
23 23	1 2	PAFZZ PAFZZ	5935-00-426-9453 6145-00-823-2544	95077 81349	2900-6001 RG142BU	CONNECTOR,PLUG,ELEC..... CABLE,RADIO,FREQUEN .....	EA FT	2 5

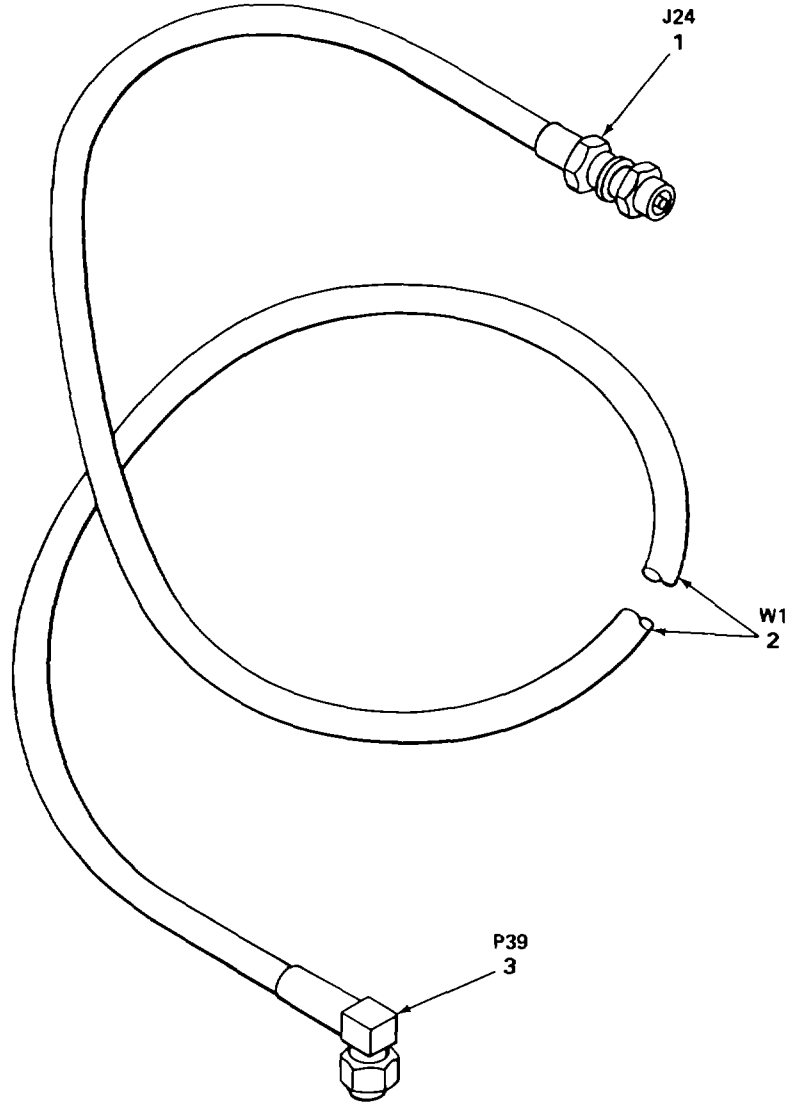

NOTE  
PREFIX ALL REFERENCE DESIGNATIONS  
WITH 1A2W25

ELOJT043

FIGURE 24. CABLE ASSEMBLY, RF (1A2W25)

SECTION II

TM 11-5895-833-34P-7/0967-LP-550-1164/TO 31R5-2MSC46-4

(1) ILLUSTRATION		(2)	(3)	(4)	(5)	(6)	(7)	(8)
(a) FIG NO.	(b) ITEM NO.	SMR CODE	NATIONAL STOCK NUMBER	FSCM	PART NUMBER	DESCRIPTION  USABLE ON CODE	U/M	QTY INC IN UNIT
24	1	PAFZZ	5935-01-005-0024	95077	2943-6001P	GROUP 0225 CABLE ASSEMBLY, RF		
24	2	PAFZZ	6145-00-918-9494	81349	M17/113-RG316	CONNECTOR, RECEPTACL .....	EA	1
24	3	PAFZZ	5935-00-470-8995	95077	2913-6001	CABLE, RADIO FREQUEN .....	FT	5
						CONNECTOR, PLUG, ELEC.....	EA	1

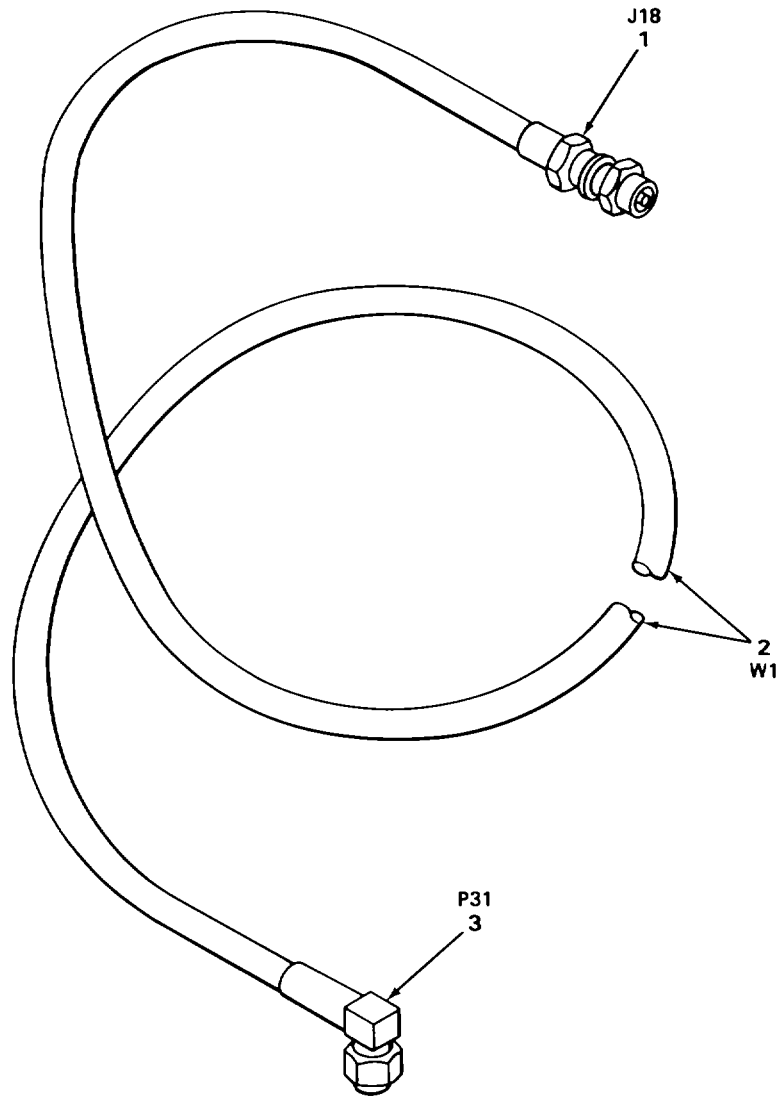

NOTE  
PREFIX ALL REFERENCE DESIGNATIONS  
WITH 1A2W22

FIGURE 25. CABLE ASSEMBLY, RF (1A2W22)

EL0JT044

SECTION II

TM 11-5895-833-34P-7/0967-LP-550-1164/TO 31R5-2MSC46-4

(1) ILLUSTRATION		(2)	(3)	(4)	(5)	(6) DESCRIPTION	(7)	(8)
(a) FIG NO.	(b) ITEM NO.	SMR CODE	NATIONAL STOCK NUMBER	FSCM	PART NUMBER	USABLE ON CODE	U/M	QTY INC IN UNIT
25	1	PAFZZ	5935-01-005-0024	95077	2943-6001P	GROUP 0226 CABLE ASSEMBLY, RF		
25	2	PAFZZ	6145-00-918-9494	81349	M17/113-RG316	CONNECTOR, RECEPTACL .....	EA	1
25	3	PAFZZ	5935-00-470-8995	95077	2913-6001	CABLE, RADIO FREQUEN .....	FT	5
						CONNECTOR, PLUG, ELEC.....	EA	1

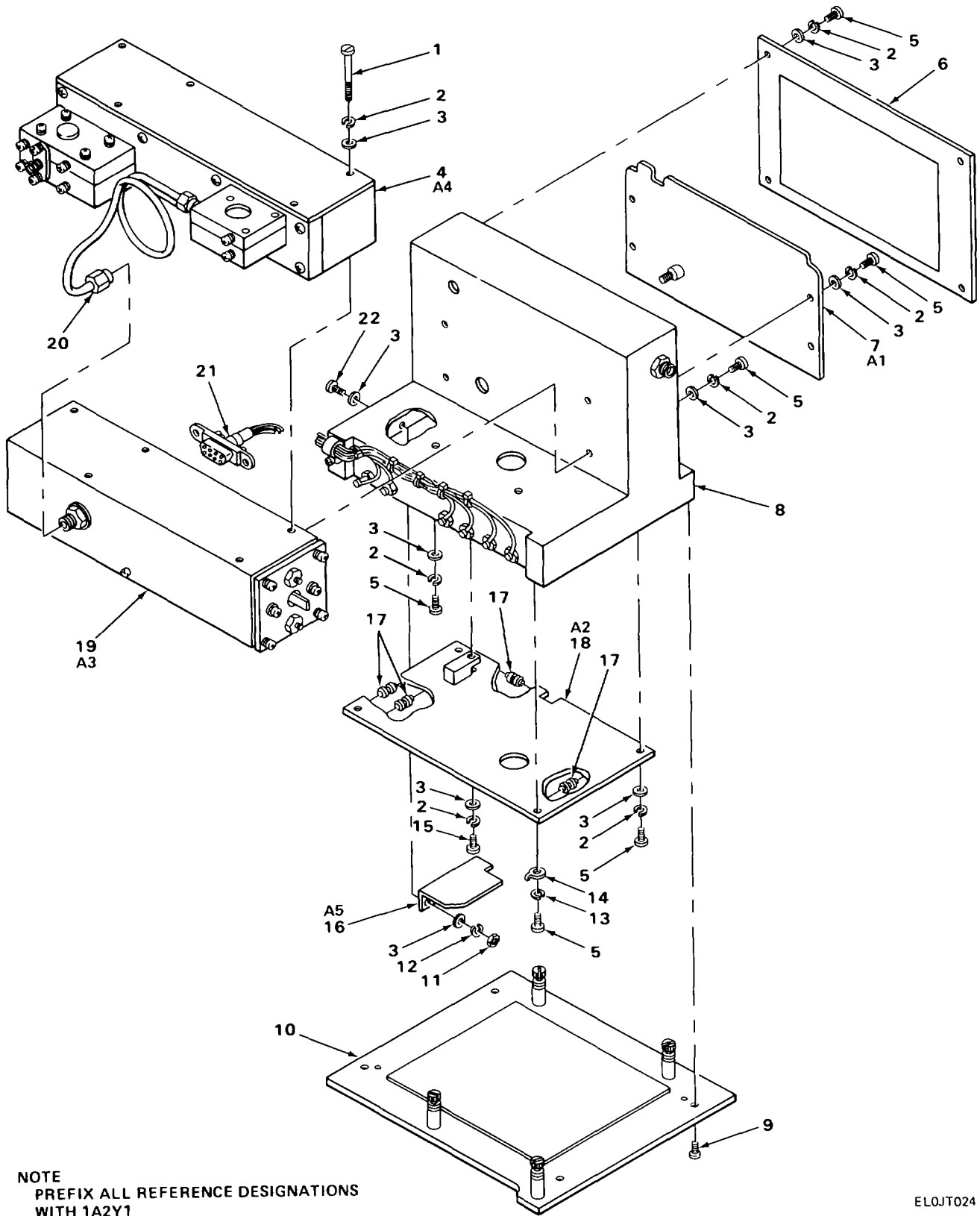

FIGURE 26. RF PHASE-LOCKED OSCILLATOR (1A2Y1)

SECTION II

TM 11-5895-833-34P-7/0967-LP-550-1164/TO 31R5-2MSC46-4

(1) ILLUSTRATION		(2)	(3)	(4)	(5)	(6) DESCRIPTION	(7)	(8)
(a) FIG NO.	(b) ITEM NO.	SMR CODE	NATIONAL STOCK NUMBER	FSCM	PART NUMBER	USABLE ON CODE	U/M	QTY INC IN UNIT
						GROUP 0227 RF PHASE-LOCKED OSCILLATOR		
26	1	XBDZZ		70318	2-56UNC2AX13-16	SCREW,MACHINE .....	EA	5
26	2	PADZZ	5310-00-928-2690	96906	MS35338-134	WASHER,LOCK .....	EA	24
26	3	PADZZ	5310-00-043-4708	13499	310-0470-080	WASHER,FLAT .....	EA	28
26	4	PADOA	5895-01-008-8164	31196	4049005321-2	MULTIPLIER ASSEMBLY.....	EA	1
26	5	PADZZ	5305-00-054-5637	96906	MS51957-3	SCREW,MACHINE .....	EA	19
26	6	XBDZZ		31196	2090005074	COVER,RF CAVITY.....	EA	1
26	7	PADDA		31196	4049005326-2	CIRCUIT CARD ASSEMB .....	EA	1
26	8	XBDZZ		80063	SM-D-754272	HOUSING,ELEC,OSC .....	EA	1
26	9	PADZZ	5305-00-054-5636	96906	MS51957-2	SCREW,MACHINE .....	EA	4
26	10	XBDZZ		31196	3040005173	PLATE,BASE .....	EA	1
26	11	XBDZZ		70318	1-64UNC2B	NUT,PLAIN,HEXAGON .....	EA	2
26	12	XBDZZ		70318	N01	WASHER,LOCK .....	EA	2
26	13	PADZZ	5310-00-543-4652	96906	MS35333-69	WASHER,LOCK .....	EA	1
26	14	PADZZ	5940-00-581-7899	79963	263	TERMINAL,LUG.....	EA	1
26	15	PADZZ	5305-00-054-5635	96906	MS51957-1	SCREW,MACHINE .....	EA	1
26	16	XBDZZ		31196	3040005961	CIRCUIT CARD ASSEMB .....	EA	1
26	17	XBDZZ		31196	359005369-2	BEAD,FERRITE .....	EA	4
26	18	PADDA	5895-01-007-9484	31196	4040005307	CKT CARD ASSY,PHASE .....	EA	1
26	19	PADDA	5895-00-014-7826	80063	SM-754367-1	OSCILLATOR RADIO FR .....	EA	1
26	20	XBDZZ		31196	2350005444	CABLE ASSY,RF .....	EA	1
26	21	XBDZZ		80063	SM-754486	WIRING HARNESS,OSC .....	EA	1
26	22	XBDZZ		70318	1-64UNC2AX1-4	SCREW,MACHINE .....	EA	2



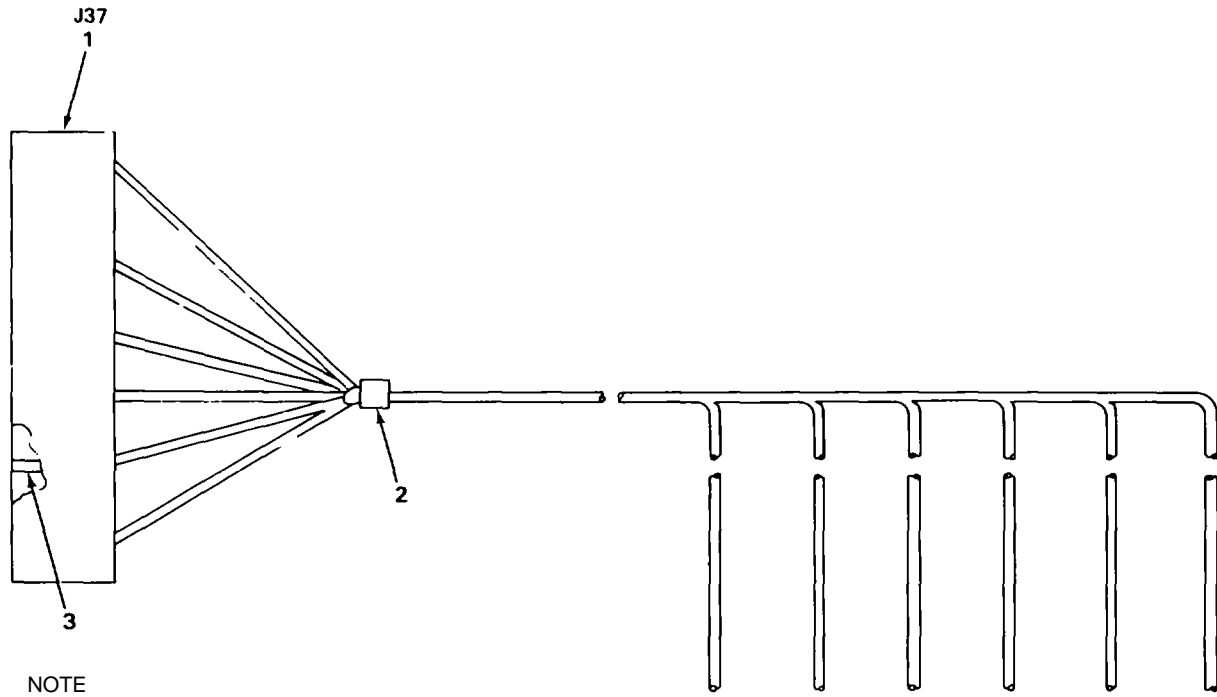

NOTE  
PREFIX ALL REFERENCE DESIGNATIONS  
WITH 1A2W35

FIGURE 27. WIRING HARNESS, OSCILLATOR (1A2W35)

EL0JT025

SECTION II

TM 11-5895-833-34P-7/0967-LP-550-1164/TO 31R5-2MSC46-4

(1) ILLUSTRATION		(2)	(3)	(4)	(5)	(6)	(7)	(8)
(a) FIG NO.	(b) ITEM NO.	SMR CODE	NATIONAL STOCK NUMBER	FSCM	PART NUMBER	DESCRIPTION  USABLE ON CODE	U/M	QTY INC IN UNIT
27	1	PAFZZ	5935-00-763-0858	81349	223-1109	GROUP 0228 WIRING HARNESS, OSCILLATOR	EA	1
27	2	PAFZZ	5975-00-727-5153	96906	MS3367-4-9	CONNECTOR BODY, RECE.....	EA	7
27	3	PAFZZ	5990-00-062-1608	02660	220P02	STRAP, TIEDOWN, ELECT .....	EA	6
						CONTACT, ELECTRICAL .....		

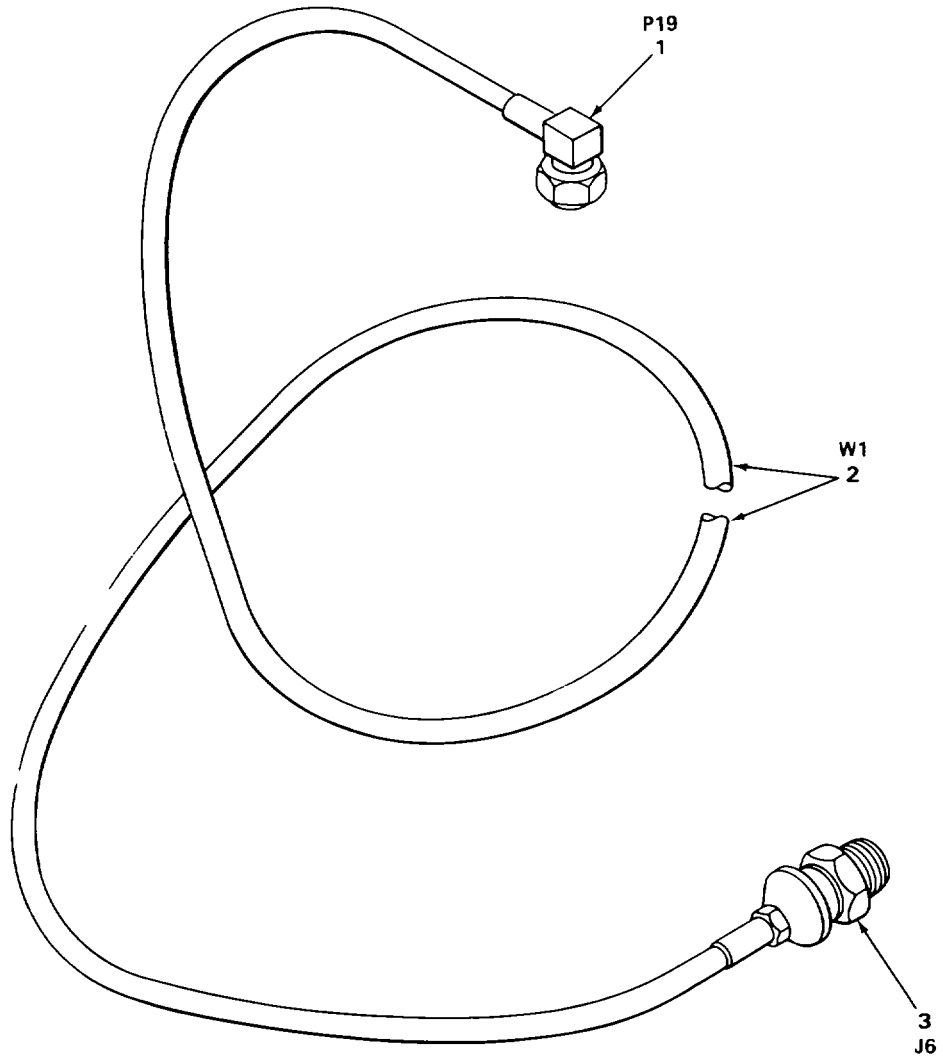

NOTE  
PREFIX ALL REFERENCE DESIGNATIONS  
WITH 1A2W12

FIGURE 28. CABLE ASSEMBLY, RF (1A2W12)

ELOJT045

SECTION II

TM 11-5895-833-34P-7/0967-LP-550-1164/TO 31R5-2MSC46-4

(1) ILLUSTRATION		(2)	(3)	(4)	(5)	(6) DESCRIPTION	(7)	(8)
(a) FIG NO.	(b) ITEM NO.	SMR CODE	NATIONAL STOCK NUMBER	FSCM	PART NUMBER	USABLE ON CODE	U/M	QTY INC IN UNIT
28	1	XBFZZ		95077	2910-6001	GROUP 0229 CABLE ASSEMBLY, RF		
28	2	PAFZZ	6145-00-823-2544	81349	RG142BU	CONNECTOR, PLUG .....	EA	1
28	3	PAFZZ	5935-00-426-9453	95077	2900-6001	CABLE, RADIO FREQUEN .....	FT	5
						CONNECTOR, PLUG, ELEC .....	EA	1

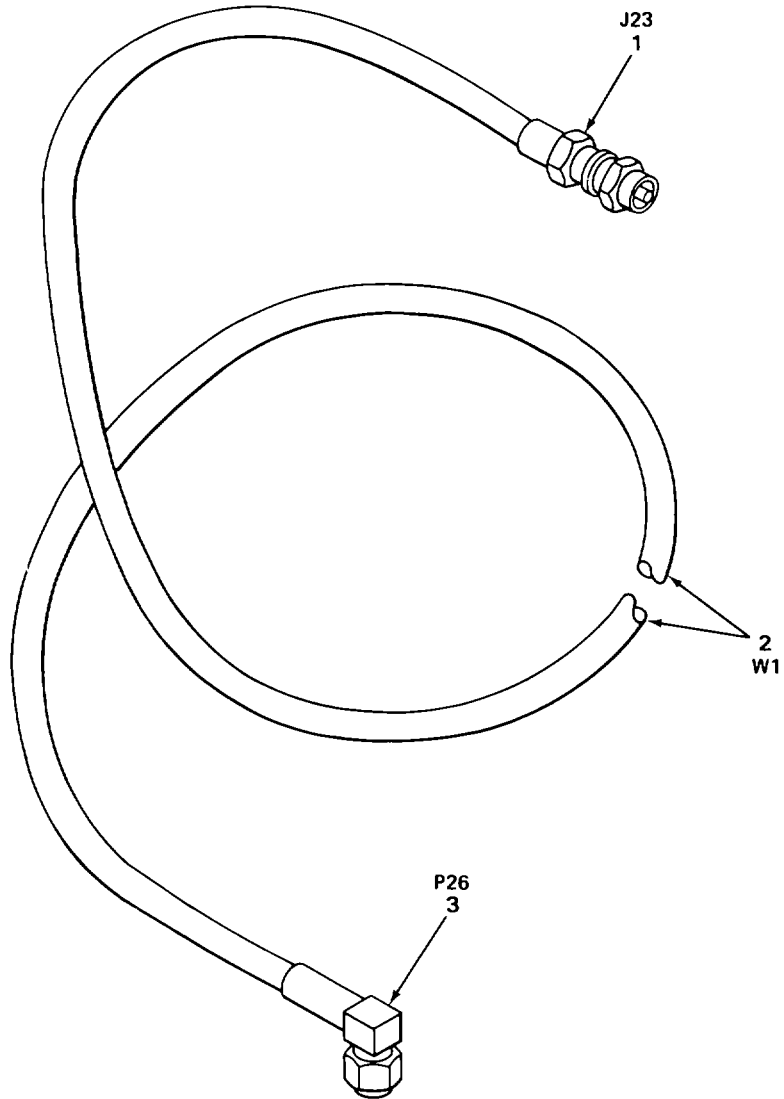

NOTE  
PREFIX ALL REFERENCE DESIGNATIONS  
WITH 1A2W18

ELOJT046

FIGURE 29. CABLE ASSEMBLY, RF (1A2W18)

SECTION II

TM 11-5895-833-34P-7/0967-LP-550-1164/TO 31R5-2MSC46-4

(1) ILLUSTRATION		(2)	(3)	(4)	(5)	(6) DESCRIPTION	(7)	(8)
(a) FIG NO.	(b) ITEM NO.	SMR CODE	NATIONAL STOCK NUMBER	FSCM	PART NUMBER	USABLE ON CODE	U/M	QTY INC IN UNIT
29	1	XBFZZ	95077	2943-6001		GROUP 0230 CABLE ASSEMBLY, RF		
29	2	PAFZZ	6145-00-918-9494	81349	M17/113-RG316	CONNECTOR .....	EA	1
29	3	PAFZZ	5935-00-470-8995	95077	2913-6001	CABLE,RADIO FREQUEN .....	FT	5
						CONNECTOR,PLUG,ELEC.....	EA	1

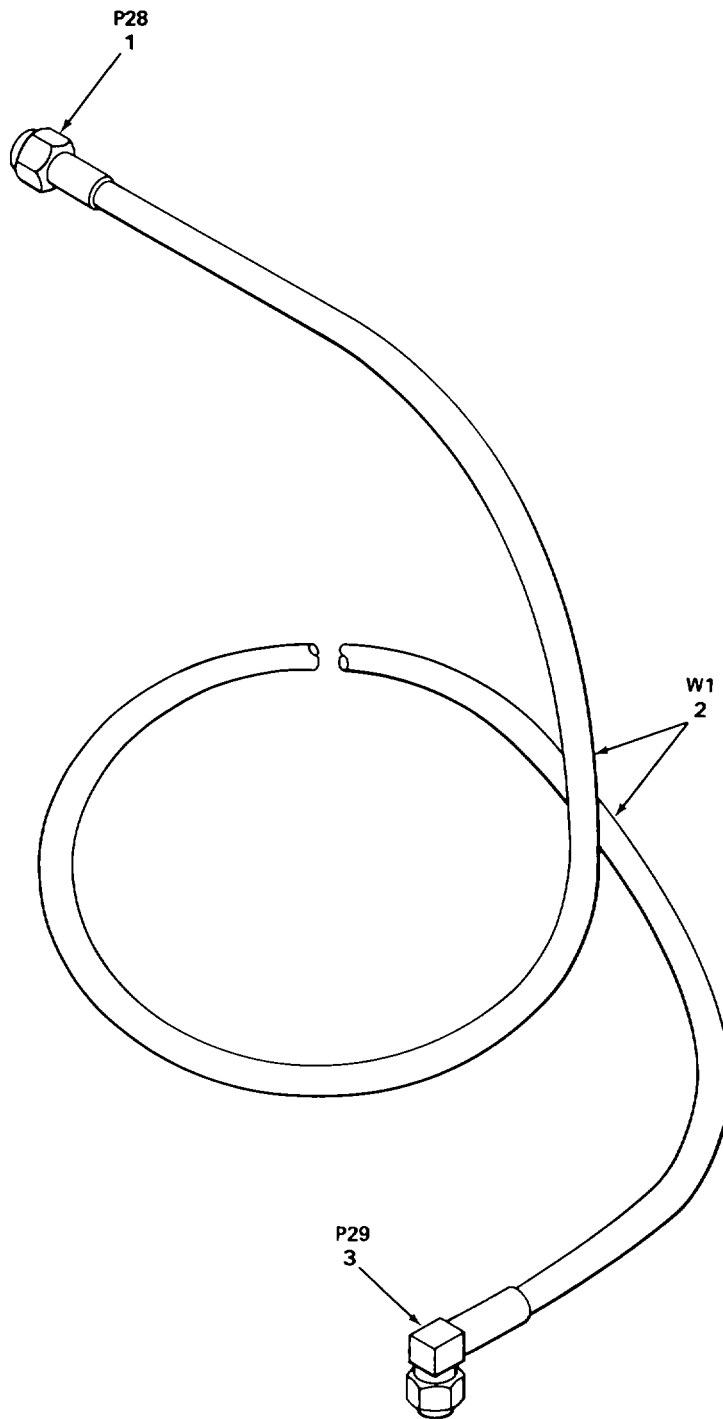

NOTE  
PREFIX ALL REFERENCE DESIGNATIONS  
WITH 1A2W20

EL0JT47

FIGURE 30. CABLE ASSEMBLY, RF (1A2W20).

SECTION II

TM 11-5895-833-34P-7/0967-LP-550-1164/TO 31R5-2MSC46-4

(1) ILLUSTRATION		(2)	(3)	(4)	(5)	(6) DESCRIPTION	(7)	(8)
(a) FIG NO.	(b) ITEM NO.	SMR CODE	NATIONAL STOCK NUMBER	FSCM	PART NUMBER	USABLE ON CODE	U/M	QTY INC IN UNIT
30	1	PAFZZ	5935-01-019-8481	26805	3034-7141-02	GROUP 0231 CABLE ASSEMBLY, RF		
30	2	PAFZZ	6145-00-823-2544	81349	RG142BU	CONNECTOR, RECEPTACL .....	EA	1
30	3	XBFZZ	95077	2910-6001		CABLE, RADIO FREQUEN .....	FT	5
						CONNECTOR, PLUG .....	EA	1



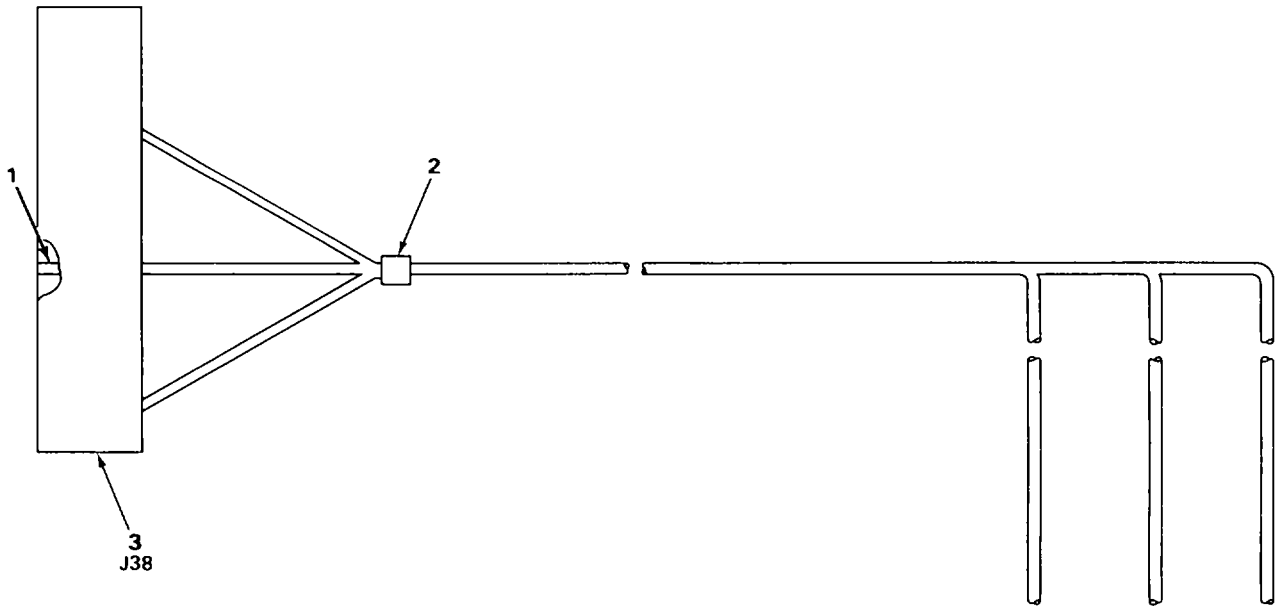

NOTE  
PREFIX ALL REFERENCE DESIGNATIONS  
WITH 1A2W36

FIGURE 31. WIRING HARNESS, OSCILLATOR (1A2W36)

ELOJT048

SECTION II

TM 11-5895-833-34P-7/0967-LP-550-1164/TO 31R5-2MSC46-4

(1) ILLUSTRATION		(2)	(3)	(4)	(5)	(6)	(7)	(8)
(a) FIG NO.	(b) ITEM NO.	SMR CODE	NATIONAL STOCK NUMBER	FSCM	PART NUMBER	DESCRIPTION  USABLE ON CODE	U/M	QTY INC IN UNIT
31	1	PAFZZ	5999-00-062-1608	02660	220P02	GROUP 0232 WIRING HARNESS, OSCILLATOR	EA	3
31	2	PAFZZ	5975-00-727-5153	96906	MS3367-4-9	CONTACT,ELECTRICAL .....	EA	8
31	3	PAFZZ	5935-00-114-8767	29587	223-1209	STRAP,TIEDOWN .....	EA	1
						INSERT,ELECTRICAL.....		

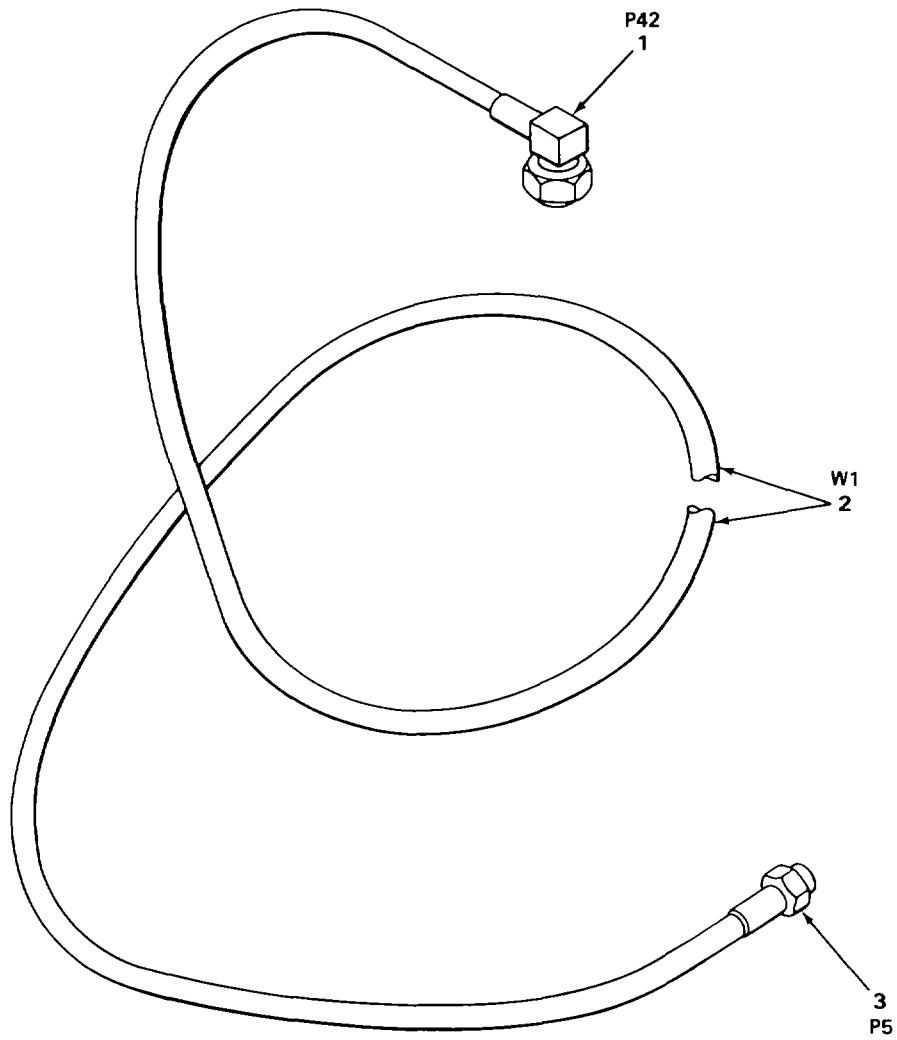

NOTE  
PREFIX ALL REFERENCE DESIGNATIONS  
WITH 1A2W32

ELOJT049

FIGURE 32. CABLE ASSEMBLY, RF (1A2W32)

SECTION II

TM 11-5895-833-34P-7/0967-LP-550-1164/TO 31R5-2MSC46-4

(1) ILLUSTRATION		(2)	(3)	(4)	(5)	(6)	(7)	(8)
(a) FIG NO.	(b) ITEM NO.	SMR CODE	NATIONAL STOCK NUMBER	FSCM	PART NUMBER	DESCRIPTION  USABLE ON CODE	U/M	QTY INC IN UNIT
32	1	PAFZZ	5935-00-426-9453	95077	2900-6001	GROUP 0235 CABLE ASSEMBLY, RF		
32	2	PAFZZ	6145-00-823-2544	81349	RG142BU	CONNECTOR, PLUG, ELEC..... DND	EA	1
32	3	PAFZZ	5935-00-426-9453	95077	2910-6001	CABLE RADIO FREQUEN ..... DND	FT	5
						CONNECTOR, PLUG, ELEC..... DND	EA	1

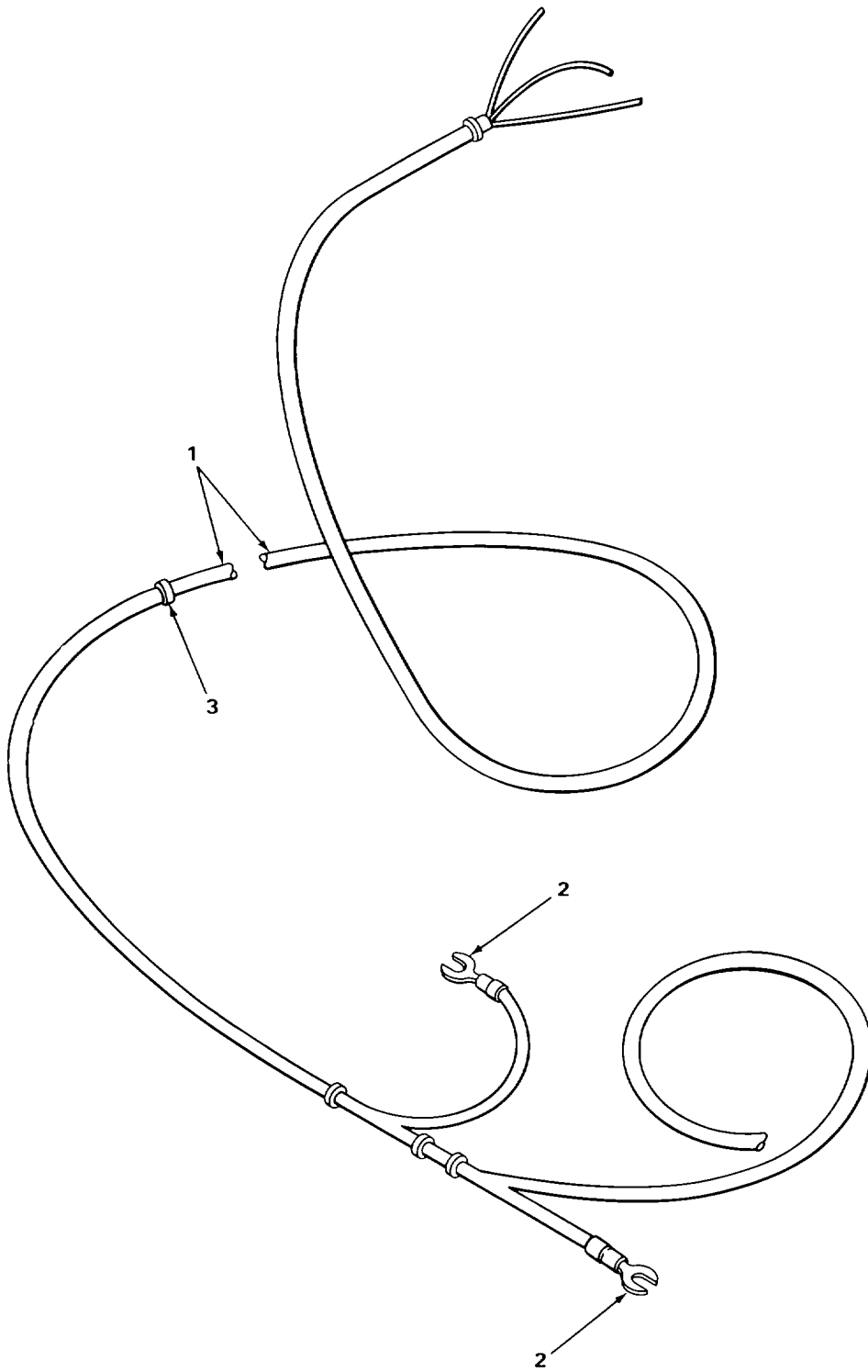

ELOJT050

FIGURE 33 .WIRING HARNESS (1A2W37)

SECTION III

TM 11-5895-833-34P-7/0967-LP-550-1164/TO 31R5-2MSC46-4

(1) ILLUSTRATION		(2)	(3)	(4)	(5)	(6) DESCRIPTION	(7)	(8)
(a) FIG NO.	(b) ITEM NO.	SMR CODE	NATIONAL STOCK NUMBER	FSCM	PART NUMBER	USABLE ON CODE	U/M	QTY INC IN UNIT
33	1	PAFZZ	6145-00-062-6684	81349	MIL-W-16878/4	GROUP 0237 WIRING HARNESS		
33	2	PAFZZ	5940-00-983-7091	00779	323011	WIRE,ELECTRICAL .....	IN	125
33	3	PAFZZ	5975-00-727-5153	96906	MS3367-4-9	TERMINAL,LUG.....	EA	2
						STRAP,TIEDOWN ELECT .....	EA	18

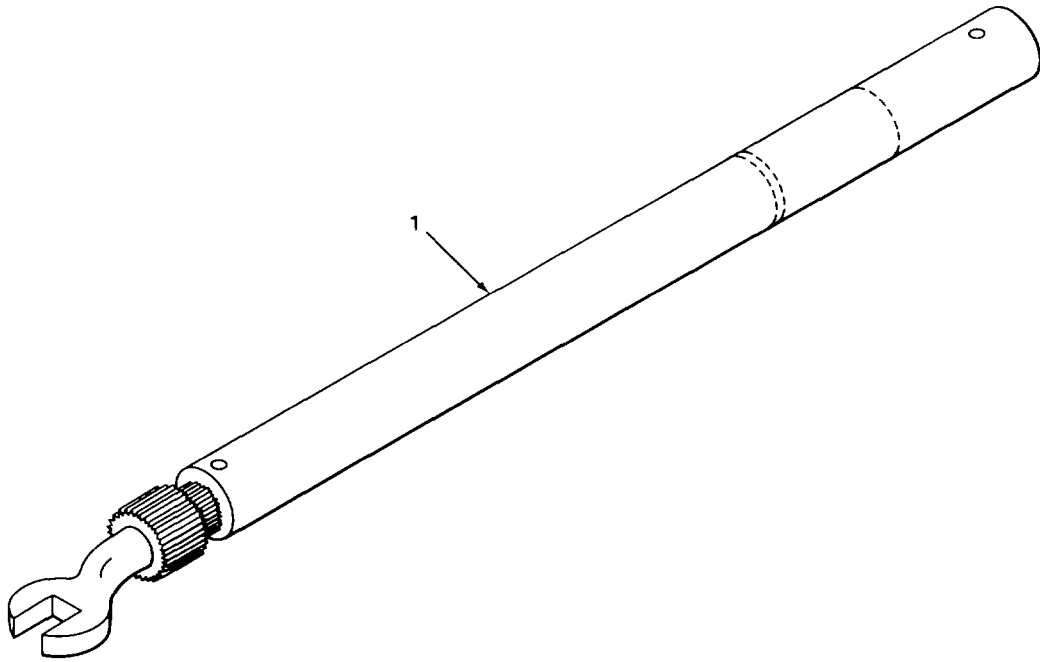

FIGURE 34. SPECIAL TOOLS

EL0JT029

SECTION III

TM 11-5895-833-34P-7/0967-LP-550-1164/TO 31R5-2MSC46-4  
SPECIAL TOOLS LIST

(1) ILLUSTRATION		(2)	(3)	(4)	(5)	(6)	(7)	(8)
(a) FIG NO.	(b) ITEM NO.	SMR CODE	NATIONAL STOCK NUMBER	FSCM	PART NUMBER	DESCRIPTION  USABLE ON CODE	U/M	QTY INC IN UNIT
34	1	PEFZZ	5120-00-169-5776	26805	T8438	GROUP 30 SPECIAL TOOLS TORQUE WRENCH BOI: 1 AUTH FOR EACH EQUIP .....	EA	1



## NATIONAL STOCK NUMBER AND PART NUMBER INDEX

NATIONAL STOCK NUMBER	FIGURE NO.	ITEM NO.	NATIONAL STOCK NUMBER	FIGURE NO.	ITEM NO.
5910-00-010-8717	17	9	5305-00-071-1322	21	1
5895-00-014-7826	26	19	5305-00-088-9668	2	38
5895-00-014-7845	4	37	5305-00-088-9671	2	7
5895-00-014-7845	5	4	6350-00-102-4210	21	15
5895-00-014-7848	2	49	5905-00-104-8349	17	18
5895-00-014-8318	2	6	5905-00-104-8360	17	33
5305-00-043-0267	2	13	5905-00-104-8362	17	31
5310-00-043-4708	26	3	5905-00-104-8368	17	17
5305-00-045-1684	21	32	5905-00-104-8369	17	24
5340-00-051-6819	1	34	5905-00-105-7764	17	20
5970-00-052-3297	8	3	5905-00-105-7767	18	4
5305-00-054-5635	26	15	5905-00-106-3666	18	9
5305-00-054-5636	26	9	5905-00-106-3668	17	34
5305-00-054-5637	16	3	5905-00-110-0196	21	44
5305-00-054-5637	26	5	5905-00-110-0388	18	8
5305-00-054-5638	2	30	5905-00-110-7620	17	38
5305-00-054-5638	7	14	5905-00-110-7620	18	5
5305-00-054-5640	21	23	5905-00-111-1679	17	16
5305-00-054-5641	21	41	5905-00-111-4750	17	23
5305-00-054-5642	2	27	5910-00-113-5445	17	7
5305-00-054-5648	1	11	5910-00-113-9453	17	4
5305-00-054-5648	3	9	5905-00-114-0711	17	22
5305-00-054-5648	4	38	5935-00-114-8767	31	3
5305-00-054-5648	19	4	5905-00-116-8556	17	30
5305-00-054-5649	4	35	5905-00-119-8768	17	26
5305-00-054-5649	17	45	5905-00-120-9154	17	35
5305-00-054-5650	4	18	5905-00-121-9863	16	27
5305-00-054-5650	21	4	5905-00-121-9919	17	36
5305-00-054-5651	7	11	5910-00-124-0659	17	10
5305-00-054-5653	16	8	5915-00-124-4714	19	3
5305-00-054-6650	2	32	5930-00-124-4985	21	9
5305-00-054-6651	2	45	6130-00-124-4986	22	2
5305-00-054-6651	3	7	5985-00-124-5119	4	45
5305-00-054-6651	4	4	5999-00-124-5264	4	44
5305-00-054-6652	2	54	6625-00-124-5269	4	40
5305-00-054-6652	4	11	5895-00-124-8709	4	23
5305-00-054-6652	22	7	5905-00-136-8406	17	32
5305-00-054-6653	7	6	5961-00-137-0813	17	15
5305-00-054-6654	2	24	5905-00-138-4918	16	12
5305-00-054-6655	4	31	5895-00-140-8635	4	12
5305-00-054-6657	1	22	6625-00-140-9318	21	7
5305-00-054-6659	2	48	5905-00-141-0717	17	21
5305-00-054-6659	4	15	5905-00-141-1183	17	19
5305-00-054-6668	2	2	5905-00-141-1183	18	6
5305-00-054-6668	4	13	5940-00-143-4780	15	6
5305-00-054-6669	4	41	5310-00-146-7102	4	24
5305-00-054-6670	2	39	6240-00-155-7836	21	11
5305-00-054-6671	2	37	5905-00-163-7092	16	17
5305-00-054-6673	22	4	5120-00-169-5776	34	1
5305-00-056-9961	16	1	5325-00-185-0001	2	17
5999-00-061-3276	16	13	5325-00-185-0012	2	9
5999-00-061-3276	16	18	5935-00-191-5434	16	31
5999-00-061-3276	16	23	5940-00-204-8966	8	1
5999-00-061-3276	16	28	5305-00-221-6116	2	34
5990-00-062-1608	27	3	5961-00-232-3279	17	2
5999-00-062-1608	31	1	5905-00-232-9350	16	22
6145-00-062-6684	33	1	5905-00-238-3831	16	16
5305-00-066-7328	7	2	5905-00-240-2012	17	29
5305-00-068-5414	6	5	5905-00-264-4066	17	29
			5935-00-337-6770	2	15

## NATIONAL STOCK NUMBER AND PART NUMBER INDEX

NATIONAL STOCK NUMBER	FIGURE NO.	ITEM NO.	NATIONAL STOCK NUMBER	FIGURE NO.	ITEM NO.
5935-00-394-1018	4	29	5975-00-727-5153	20	4
5305-00-411-0682	2	23	5975-00-727-5153	27	2
5305-00-411-0682	3	8	5975-00-727-5153	31	2
5905-00-419-5258	17	28	5975-00-727-5153	33	3
5935-00-426-9453	23	1	5905-00-758-4802	16	21
5935-00-426-9453	28	3	5935-00-763-0858	27	1
5935-00-426-9453	32	1	5935-00-783-2071	14	4
5935-00-426-9453	32	3	5340-00-793-0543	1	9
5905-00-430-3626	17	29	5310-00-801-4420	2	33
5365-00-432-3584	21	34	5310-00-801-4420	4	16
5905-00-435-1718	17	25	5310-00-801-4420	4	22
5905-00-435-6414	18	7	5310-00-801-4420	19	8
5905-00-456-3852	17	29	5940-00-804-0365	14	3
5905-00-456-3874	17	29	5340-00-820-1789	1	34
5905-00-456-3875	17	29	6145-00-823-2544	23	2
5905-00-456-3887	17	29	6145-00-823-2544	28	2
5935-00-470-8995	12	1	6145-00-823-2544	30	2
5935-00-470-8995	24	3	6145-00-823-2544	32	2
5935-00-470-8995	25	3	5305-00-833-8624	16	6
5935-00-470-8995	29	3	5305-00-837-9739	1	36
5975-00-482-3954	14	1	6210-00-840-0850	21	12
5975-00-482-3954	20	1	5935-00-845-2537	15	1
5905-00-483-4284	18	3	5310-00-852-7099	4	33
5905-00-485-4545	17	37	5310-00-880-5978	1	38
5930-00-501-1749	21	19	5310-00-880-5978	2	4
5360-00-517-6225	21	31	5310-00-880-5978	4	3
5930-00-519-8144	2	36	5310-00-880-5978	21	37
5310-00-531-9514	4	26	5310-00-880-5978	22	6
5310-00-543-4652	26	13	6210-00-892-4468	21	16
5940-00-581-7899	26	14	5935-00-904-4050	2	18
5310-00-595-6211	1	12	5935-00-913-4462	20	2
5310-00-595-6211	3	11	6145-00-918-9494	9	2
5310-00-595-6211	4	19	6145-00-918-9494	10	2
5310-00-595-6211	7	13	6145-00-918-9494	11	3
5310-00-595-6211	16	9	6145-00-918-9494	12	3
5310-00-595-6211	17	47	6145-00-918-9494	24	2
5310-00-595-6211	18	13	6145-00-918-9494	25	2
5310-00-595-6211	19	6	6145-00-918-9494	29	2
5310-00-595-6211	21	6	5305-00-922-8778	1	8
5310-00-595-6761	2	28	5310-00-928-2690	2	31
5310-00-595-6761	7	16	5310-00-928-2690	7	15
5310-00-595-6761	21	25	5310-00-928-2690	21	24
5310-00-595-6761	21	40	5310-00-928-2690	21	39
5310-00-595-6772	1	41	5310-00-928-2690	26	2
5310-00-595-6772	2	43	5310-00-929-6395	1	23
5310-00-616-3555	4	25	5310-00-929-6395	2	22
5930-00-626-2917	21	20	5310-00-929-6395	3	6
5905-00-632-9515	21	10	5310-00-929-6395	4	9
5940-00-636-5593	15	5	5310-00-929-6395	7	7
5950-00-645-3771	4	21	5310-00-929-6395	22	8
5355-00-680-1357	21	8	5310-00-933-8118	3	10
5310-00-720-8549	2	44	5310-00-933-8118	4	39
5340-00-721-5315	1	25	5310-00-933-8118	7	12
6145-00-722-5932	13	3	5310-00-933-8118	17	46
5310-00-722-5998	3	5	5310-00-933-8118	18	12
5310-00-722-5998	4	10	5310-00-933-8118	19	5
5310-00-722-5998	7	8	5310-00-933-8118	21	5
5975-00-727-5153	8	2	5310-00-933-8119	1	37
5975-00-727-5153	14	6	5310-00-933-8119	2	3
5975-00-727-5153	15	2	5310-00-933-8119	4	2

## NATIONAL STOCK NUMBER AND PART NUMBER INDEX

NATIONAL STOCK NUMBER	FIGURE NO.	ITEM NO.	NATIONAL STOCK NUMBER	FIGURE NO.	ITEM NO.
5310-00-933-8119	22	5	5940-01-138-2996	15	4
5310-00-933-8120	1	40	5995-01-140-0962	1	31
5310-00-933-8120	2	42	5995-01-140-0963	1	17
5310-00-934-9748	17	48	5995-01-140-0964	5	5
5310-00-934-9748	18	11	5995-01-140-1140	5	8
5310-00-934-9748	21	26	5995-01-140-1141	5	6
5310-00-934-9761	2	35	5995-01-140-1142	5	1
5310-00-934-9765	1	39	5895-01-140-1143	5	7
5961-00-951-8757	17	14	5995-01-140-1144	5	3
5310-00-973-8660	1	24	5995-01-146-1397	1	29
5310-00-973-8660	2	21	5995-01-146-1399	1	20
5310-00-973-8660	19	7	5995-01-146-1400	1	28
5310-00-973-8660	22	9	5995-01-146-1401	1	19
5940-00-983-7091	14	2	5995-01-146-1402	6	4
5940-00-983-7091	33	2	5915-01-150-0757	4	7
5961-00-985-4900	17	1			
5940-01-004-1893	2	25			
5915-01-004-9318	2	11			
5935-01-005-0024	9	1			
5935-01-005-0024	10	1			
5935-01-005-0024	24	1			
5935-01-005-0024	25	1			
5935-01-006-7791	17	13			
5935-01-006-7791	18	2			
5935-01-007-8810	11	2			
5895-01-007-9484	26	18			
5895-01-008-8164	26	4			
5935-01-009-2960	13	1			
5995-01-009-5460	1	2			
5995-01-009-5461	1	15			
5995-01-009-5463	1	30			
5995-01-009-5464	1	32			
5995-01-012-3638	1	13			
5995-01-012-3639	3	3			
5995-01-012-3639	6	3			
5895-01-016-8419	3	1			
5895-01-016-8419	6	1			
5995-01-017-7128	1	5			
5995-01-017-7134	1	6			
5995-01-017-7135	1	16			
5995-01-017-7136	1	33			
5995-01-017-7137	1	3			
5995-01-017-7138	1	4			
5935-01-019-8481	30	1			
5355-01-020-3111	21	29			
4010-01-020-8884	1	10			
5895-01-021-3286	21	22			
5985-01-022-9708	3	2			
5985-01-022-9708	6	2			
5995-01-023-2334	1	27			
5895-01-024-0393	6	6			
3120-01-024-0434	21	35			
5910-01-054-6159	17	6			
5905-01-057-4386	17	27			
5962-01-077-6116	17	41			
5995-01-095-5462	1	26			
5962-01-102-5022	17	43			
5365-01-112-6399	7	10			
5935-01-120-5144	9	3			
5895-01-131-3819	1	21			

## SECTION IV

TM 11-5895-833-34P-7/0967-LP-550-1164/TO 31R5-2MSC46-4

## NATIONAL STOCK NUMBER AND PART NUMBER INDEX

FSCM	PART NUMBER	NATIONAL STOCK NUMBER	FIGURE NO.	ITEM NO.	FSCM	PART NUMBER	NATIONAL STOCK NUMBER	FIGURE NO.	ITEM NO.
31091	AL1076	5895-00-140-8635	4	12	96906	MS25089-3C	5930-00-501-1749	21	19
80044	AN960C6	5310-00-531-9514	4	26	96906	MS25237-327	6240-00-155-7836	21	11
81349	CK70AX471K	5310-00-852-7099	4	33	96906	MS25281R-14	5340-00-051-6819	1	34
81349	CMR04C3R0D00DR	5910-01-054-6159	17	6	96906	MS25281R13	5340-00-820-1789	1	34
06992	CONO	5340-00-793-0543	1	9	96906	MS25281R5	5340-00-721-5315	1	25
52214	F345AA0223A02		1	35	96906	MS3114E12-3P	5935-00-845-2537	15	1
34874	IFA70-1258		4	28	96906	MS3114E20-39S	5935-00-913-4462	20	2
13715	IN914A		18	1	96906	MS3116E14-15S	5935-00-783-2071	14	4
81349	JANM38510/01309B		17	42	96906	MS3367-4-9	5975-00-727-5153	8	2
	A2				96906	MS3367-4-9	5975-00-727-5153	14	6
81349	JANM38510/10103B		17	40	96906	MS3367-4-9	5975-00-727-5153	15	2
	A2				96906	MS3367-4-9	5975-00-727-5153	20	4
81349	JANIN5711	5961-00-232-3279	17	2	96906	MS3367-4-9	5975-00-727-5153	27	2
81349	JAN1N647	5961-00-985-4900	17	1	96906	MS3367-4-9	5975-00-727-5153	31	2
81349	JAN2N2222A	5961-00-951-8757	17	14	96906	MS3367-4-9	5975-00-727-5153	33	3
81349	JAN2N5431	5961-00-137-0813	17	15	96906	MS3368-5-9A		15	3
81349	JM39016/9-005L		17	12	96906	MS3368-5-9E	5975-00-482-3954	14	1
84830	LC024C5SS	5360-00-517-6225	21	31	96906	MS3368-5-9E	5975-00-482-3954	20	1
27014	LM193AH/883B	5962-01-077-6116	17	41	96906	MS35275-203	5305-00-922-8778	1	8
34874	LNA700/2276	5895-01-016-8419	3	1	96906	MS35333-69	5310-00-543-4652	26	13
34874	LNA700/2276	5895-01-016-8419	6	1	96906	MS35333-71	5310-00-616-3555	4	25
81349	MIL-I-23053/5	5970-00-052-3297	8	3	96906	MS35338-134	5310-00-928-2690	2	31
81349	MIL-W-16878/4	6145-00-062-6684	33	1	96906	MS35338-134	5310-00-928-2690	7	15
96906	MS15795-802	5310-00-595-6761	2	28	96906	MS35338-134	5310-00-928-2690	21	24
96906	MS15795-802	5310-00-595-6761	7	16	96906	MS35338-134	5310-00-928-2690	21	39
96906	MS15795-802	5310-00-595-6761	21	25	96906	MS35338-134	5310-00-928-2690	26	2
96906	MS15795-802	5310-00-595-6761	21	40	96906	MS35338-135	5310-00-933-8118	3	10
96906	MS15795-803	5310-00-595-6211	1	12	96906	MS35338-135	5310-00-933-8118	4	39
96906	MS15795-803	5310-00-595-6211	3	11	96906	MS35338-135	5310-00-933-8118	7	12
96906	MS15795-803	5310-00-595-6211	4	19	96906	MS35338-135	5310-00-933-8118	17	46
96906	MS15795-803	5310-00-595-6211	7	13	96906	MS35338-135	5310-00-933-8118	18	12
96906	MS15795-803	5310-00-595-6211	16	9	96906	MS35338-135	5310-00-933-8118	19	5
96906	MS15795-803	5310-00-595-6211	17	47	96906	MS35338-135	5310-00-933-8118	21	5
96906	MS15795-803	5310-00-595-6211	18	13	96906	MS35338-136	5310-00-929-6395	1	23
96906	MS15795-803	5310-00-595-6211	19	6	96906	MS35338-136	5310-00-929-6395	2	22
96906	MS15795-803	5310-00-595-6211	21	6	96906	MS35338-136	5310-00-929-6395	3	6
96906	MS15795-805	5310-00-722-5998	3	5	96906	MS35338-136	5310-00-929-6395	4	9
96906	MS15795-805	5310-00-722-5998	4	10	96906	MS35338-136	5310-00-929-6395	7	7
96906	MS15795-805	5310-00-722-5998	7	8	96906	MS35338-136	5310-00-929-6395	22	8
96906	MS15795-807	5310-00-880-5978	1	38	96906	MS35338-137	5310-00-933-8119	1	37
96906	MS15795-807	5310-00-880-5978	2	4	96906	MS35338-137	5310-00-933-8119	2	3
96906	MS15795-807	5310-00-880-5978	4	3	96906	MS35338-137	5310-00-933-8119	4	2
96906	MS15795-807	5310-00-880-5978	21	37	96906	MS35338-137	5310-00-933-8119	22	5
96906	MS15795-807	5310-00-880-5978	22	6	96906	MS35338-138	5310-00-933-8120	1	40
96906	MS15795-808	5310-00-595-6772	1	41	96906	MS35338-138	5310-00-933-8120	2	42
96906	MS15795-808	5310-00-595-6772	2	43	96906	MS35426-13	5310-00-720-8549	2	44
96906	MS16106-1	5930-00-519-8144	2	36	96906	MS35489-35	5325-00-185-0012	2	9
96906	MS16624-5018-1	5365-00-432-3584	21	34	96906	MS35489-46	5325-00-185-0001	2	17
96906	MS16995-11	5305-00-068-5414	6	5	96906	MS35649-244	5310-00-934-9748	17	48
96906	MS18212-13	5305-00-833-8624	16	6	96906	MS35649-244	5310-00-934-9748	18	11
96906	MS21316-13	5305-00-837-9739	1	36	96906	MS35649-244	5310-00-934-9748	21	26
96906	MS24693C27	5305-00-066-7328	7	2	96906	MS35649-264	5310-00-934-9761	2	35
96906	MS24693C274	5305-00-043-0267	2	13	96906	MS35650-304	5310-00-934-9765	1	39
96906	MS24693C4	5305-00-056-9961	16	1	96906	MS51021-9	5305-00-045-1684	21	32
96906	MS24693C52	5305-00-088-9671	2	7	96906	MS51957-1	5305-00-054-5635	26	15
96906	MS24693C54	5305-00-088-9668	2	38	96906	MS51957-124	5305-00-411-0682	2	23
96906	MS25036-102	5940-00-204-8966	8	1	96906	MS51957-124	5305-00-411-0682	3	8
96906	MS25036-108	5940-00-143-4780	15	6	96906	MS51957-125	5305-00-221-6116	2	34
96906	MS25036-146	5940-00-804-0365	14	3	96906	MS51957-14	5305-00-054-5648	1	11
96906	MS25082C1	5310-00-146-7102	4	24	96906	MS51957-14	5305-00-054-5648	3	9

## SECTION IV

TM 11-5895-833-34P-7/0967-LP-550-1164/TO 31R5-2MSC46-4

## NATIONAL STOCK NUMBER AND PART NUMBER INDEX

FSCM	PART NUMBER	NATIONAL STOCK NUMBER	FIGURE NO.	ITEM NO.	FSCM	PART NUMBER	NATIONAL STOCK NUMBER	FIGURE NO.	ITEM NO.
96906	MS51957-14	5305-00-054-5648	4	38	81349	RCR07G103JS	5905-00-106-3666	18	9
96906	MS51957-14	5305-00-054-5648	19	4	81349	RCR07G104JS	5905-00-110-0388	18	8
96906	MS51957-15	5305-00-054-5649	4	35	81349	RCR07G106JS	5905-00-121-9919	17	36
96906	MS51957-15	5305-00-054-5649	17	45	81349	RCR07G114JS	5905-00-435-6414	18	7
96906	MS51957-16	5305-00-054-5650	4	18	81349	RCR07G132JS	5905-00-104-8362	17	31
96906	MS51957-16	5305-00-054-5650	21	4	81349	RCR07G220JS	5905-00-106-3668	17	34
96906	MS51957-17	5305-00-054-5651	7	11	81349	RCR07G222JS	5905-00-105-7764	17	20
96906	MS51957-19	5305-00-054-5653	16	8	81349	RCR07G223JS	5905-00-116-8556	17	30
96906	MS51957-2	5305-00-054-5636	26	9	81349	RCR07G241JS	5905-00-435-1718	17	25
96906	MS51957-26	5305-00-054-6650	2	32	81349	RCR07G242JS	5905-00-136-8406	17	32
96906	MS51957-27	5305-00-054-6651	2	45	81349	RCR07G301JS	5905-00-111-4750	17	23
96906	MS51957-27	5305-00-054-6651	3	7	81349	RCR07G334JS	5905-00-485-4545	17	37
96906	MS51957-27	5305-00-054-6651	4	4	81349	RCR07G362JS	5905-00-104-8369	17	24
96906	MS51957-28	5305-00-054-6652	2	54	81349	RCR07G470JS	5905-00-104-8368	17	17
96906	MS51957-28	5305-00-054-6652	4	11	81349	RCR07G471JS	5905-00-120-9154	17	35
96906	MS51957-28	5305-00-054-6652	22	7	81349	RCR07G472JS	5905-00-114-0711	17	22
96906	MS51957-29	5305-00-054-6653	7	6	81349	RCR07G473JS	5905-00-141-0717	17	21
96906	MS51957-3	5305-00-054-5637	16	3	81349	RCR07G5R6JS	5905-00-121-9863	16	27
96906	MS51957-3	5305-00-054-5637	26	5	81349	RCR07G512JS	5905-00-111-1679	17	16
96906	MS51957-30	5305-00-054-6654	2	24	81349	RCR07G623JS	5905-00-104-8360	17	33
96906	MS51957-31	5305-00-054-6655	4	31	81349	RCR07G821JS	5905-00-119-8768	17	26
96906	MS51957-33	5305-00-054-6657	1	22	81349	RCR20G102JS	5905-00-110-0196	21	44
96906	MS51957-35	5305-00-054-6659	2	48	81349	RCR20G511JS	5905-00-104-8349	17	18
96906	MS51957-35	5305-00-054-6659	4	15	81349	RG142BU	6145-00-823-2544	23	2
96906	MS51957-4	5305-00-054-5638	2	30	81349	RG142BU	6145-00-823-2544	28	2
96906	MS51957-4	5305-00-054-5638	7	14	81349	RG142BU	6145-00-823-2544	30	2
96906	MS51957-43	5305-00-054-6668	2	2	81349	RG142BU	6145-00-823-2544	32	2
96906	MS51957-43	5305-00-054-6668	4	13	81349	RJR26FX501P	5905-01-057-4386	17	27
96906	MS51957-44	5305-00-054-6669	4	41	81349	RJ12CY103	5905-00-483-4284	18	3
96906	MS51957-45	5305-00-054-6670	2	39	81348	RJ12L501		21	27
96906	MS51957-46	5305-00-054-6671	2	37	81349	RNC55H8252FS	5905-00-105-7767	18	4
96906	MS51957-48	5305-00-054-6673	22	4	81349	RNC55K2210FS	5905-00-163-7092	16	17
96906	MS51957-6	5305-00-054-5640	21	23	81349	RNC55K23R7FS	5905-00-238-3831	16	16
96906	MS51957-7	5305-00-054-5641	21	41	81349	RNC55K4320FS	5905-00-758-4802	16	21
96906	MS51957-8	5305-00-054-5642	2	27	81349	RNC55K52R3FS	5905-00-138-4918	16	12
96906	MS51960-65	5305-00-071-1322	21	1	81349	RNR55C10O3FS	5905-00-240-2012	17	29
96906	MS91528-1F2B	5355-00-680-1357	21	8	81349	RNR55C11O3FS	5905-00-264-4066	17	29
97954	M1G23F		14	5	81349	RNR55C1213FS		17	29
81349	M17/113-RG316	6145-00-918-9494	9	2	81349	RNR55C1333FS	5905-00-456-3852	17	29
81349	M17/113-RG316	6145-00-918-9494	10	2	81349	RNR55C1403FS	5905-00-456-3874	17	29
81349	M17/113-RG316	6145-00-918-9494	11	3	81349	RNR55C1543FS	5905-00-430-3626	17	29
81349	M17/113-RG316	6145-00-918-9494	12	3	81349	RNR55C1623FS	5905-00-456-3875	17	29
81349	M17/113-RG316	6145-00-722-5932	13	3	81349	RNR55C1693FS	5905-00-456-3887	17	29
81349	M17/113-RG316	6145-00-918-9494	24	2	81349	RNR55C2211FS	5905-00-419-5258	17	28
81349	M17/113-RG316	6145-00-918-9494	25	2	81349	RN55D11R5F	5905-00-232-9350	16	22
81349	M17/113-RG316	6145-00-918-9494	29	2	81349	RN55D1150F		16	11
12598	M2158	6625-00-124-5269	4	40	81349	RN55D8660F		16	26
81349	M39014/01-1339	5910-00-113-5445	17	7	18324	SA78MO5CU		17	44
81349	M39014/01-1575	5910-00-124-0659	17	10	90201	SC628	6350-00-102-4210	21	15
81349	M39014/01-1593	5910-00-010-8717	17	9	18324	SE556-1F/883B	5962-01-102-5022	17	43
81349	M39014/02-1417	5910-00-113-9453	17	4	80063	SM-A-753398	5930-00-124-4985	21	9
81349	M39019-4-38		21	17	80063	SM-A-754194	5935-01-006-7791	17	13
80205	NAS679CO6M	5310-00-801-4420	4	22	80063	SM-A-754194	5935-01-006-7791	18	2
80205	NAS679CO6M	5310-00-801-4420	19	8	80063	SM-B-416109-1	5310-00-973-8660	1	24
70318	NO1		26	12	80063	SM-B-416109-1	5310-00-973-8660	2	21
11332	N427-2	6625-00-140-9318	21	7	80063	SM-B-416109-1	5310-00-973-8660	19	7
81349	RCR07G101JS	5905-00-141-1183	17	19	80063	SM-B-416109-1	5310-00-973-8660	22	9
81349	RCR07G101JS	5905-00-141-1183	18	6	80063	SM-B-754330	3120-01-024-0434	21	35
81349	RCR07G102JS	5905-00-110-7620	17	38	80063	SM-B-952492		17	49
81349	RCR07G1002JS	5905-00-110-7620	18	5					

## SECTION IV

TM 11-5895-833-34P-7/0967-LP-550-1164/TO 31R5-2MSC46-4

## NATIONAL STOCK NUMBER AND PART NUMBER INDEX

FSCM	PART NUMBER	NATIONAL STOCK NUMBER	FIGURE NO.	ITEM NO.	FSCM	PART NUMBER	NATIONAL STOCK NUMBER	FIGURE NO.	ITEM NO.
80063	SM-D-753571-11		7	3	31196	2090001377		16	7
80063	SM-D-754272		26	8	31196	2090001390		21	14
80063	SM-D-754367-1	5895-00-014-7826	26	19	31196	2090005074		26	6
80063	SM-D-754369		5	9	31196	2099005384-1		21	30
80063	SM-D-754486		26	21	71279	2112-2-02		21	2
80063	SM-D-952556-1		4	43	31196	2120001630	5995-01-146-1399	1	20
80063	SM-D-952557-1		17	39	31196	2120001631	5995-01-146-1401	1	19
34303	SWT3C35V100J		17	11	31196	2120001635	5895-01-131-3819	1	21
34303	SWT4CIOVIOOJ		17	8	31196	2120001638	5995-01-146-1400	1	28
34677	S01B25D00-07-5		6	8	31196	2120001639	5995-01-146-1397	1	29
34677	S01S01D000-09-05	5995-01-017-7128	1	5	31196	2120006351	5995-01-146-1402	6	4
26805	T8438	5120-00-169-5776	34	1	31196	2120008768		1	7
80058	UG-27D/U	5935-00-904-4050	2	18	02660	220-S02	5999-00-061-3276	16	13
34263	VA45-25K	5905-00-632-9515	21	10	02660	220-S02	5999-00-061-3276	16	18
70472	W0855-010S		2	51	02660	220-S02	5999-00-061-3276	16	23
32252	0-D3-10-137	5985-00-124-5119	4	45	02660	220-S02	5999-00-061-3276	16	28
70318	1-64UNC2AXI-4		26	22	02660	220P02	5990-00-062-1608	27	3
70318	1-64UNC2B		26	11	02660	220P02	5999-00-062-1608	31	1
99813	101357	5355-01-020-3111	21	29	81349	223-1109	5935-00-763-0858	27	1
31336	1090F-202-2NP		21	45	29587	223-1209	5935-00-114-8767	31	3
31196	1130000010	5895-00-014-7848	2	49	31196	2239000794		16	4
31196	1130000011	5895-00-014-8318	2	6	31196	2350005444		26	20
31196	1130000011		4	17	31196	2359005960-2		4	6
31196	1130000018	5940-01-004-1893	2	25	78189	2440-20-03		21	46
31196	1130000039	5915-00-124-4714	19	3	79963	263	5940-00-581-7899	26	14
31196	1130000040		19	2	95077	2900-6001	5935-00-426-9453	23	1
31196	1130000041	5915-01-150-0757	4	7	95077	2900-6001	5935-00-426-9453	28	3
31196	1130000097	6130-00-124-4986	22	2	95077	2900-6001	5935-00-426-9453	32	1
31196	1130000796		4	27	95077	2910-6001		28	1
31196	1130004195	5985-01-022-9708	3	2	95077	2910-6001		30	3
31196	1130004195	5985-01-022-9708	6	2	95077	2910-6001	5935-00-426-9453	32	3
31196	1130005788	5895-01-024-0393	6	6	95077	2913-6001	5935-00-470-8995	12	1
05236	13015428		2	8	95077	2913-6001	5935-00-470-8995	24	3
77221	1621-16815		21	13	95077	2913-6001	5935-00-470-8995	25	3
70318	2-56UNC2AX13-16		26	1	95077	2913-6001	5935-00-470-8995	29	3
26805	2031-7188-02	5935-01-009-2960	13	1	95077	2943-6001		29	1
26805	2034-7188-02	5935-01-005-0024	9	1	95077	2943-6001P	5935-01-005-0024	24	1
26805	2034-7188-02	5935-01-005-0024	10	1	95077	2943-6001P	5935-01-005-0024	25	1
26805	2037-5008-02	5935-01-120-5144	9		329440	3CCF24E	4010-01-020-8884	1	10
31196	2040000742	5895-01-021-3286	21	22	05236	3002938		2	14
31196	204000792-3		16		2026805	3034-7141-02	5935-01-019-8481	30	1
31196	20490000792-4		16		1526805	3034-7188-02	5935-01-007-8810	11	2
31196	2049000792-1		16	10	31196	3040000711		22	3
31196	2049000792-2		16	25	31196	3040000719		4	42
26805	2052-1303		11	1	31196	3040000762		4	1
26805	2056-0000-02		10	3	31196	3040001340		16	30
26805	2056-5006		13	2	31196	3040005173		26	10
26805	2056-6200-02	5915-01-004-9318	2	11	31196	3040005493	5895-00-014-7845	4	37
31196	2069000792-1		16	14	31196	3040005493	5895-00-014-7845	5	4
31196	2069000792-2		16	29	31196	3040005961		26	16
31196	2069000792-3	-	16	24	31196	3060001340		16	32
31196	2069000792-4		16	19	31196	3090000486		21	42
26805	2081-0000-02	5935-00-394-1018	4	29	31196	3090000500		2	26
26805	2084-0000-02	5935-00-337-6770	2	15	31196	3090000706		2	52
31196	2090000516		2	1	31196	3090000712		7	9
31196	2090000543		2	50	31196	3090000726		2	10
31196	2090000621		4	5	31196	3090000729		2	47
31196	2090000707		2	53	31196	3090000732		2	46
31196	2090000727-1		21	18	31196	3090000733		2	41
31196	2090000728		21	28	31196	3090000741		2	16
31196	2090000746		2	19					

## SECTION IV

TM 11-5895-833-34P-7/0967-LP-550-1164/TO 31R5-2MSC46-4

## NATIONAL STOCK NUMBER AND PART NUMBER INDEX

FSCM	PART NUMBER	NATIONAL STOCK NUMBER	FIGURE NO	ITEM NO.	FSCM	PART NUMBER	NATIONAL STOCK NUMBER	FIGURE NO.	ITEM NO.
31196	3090000788		16	2	76854	5-17351-411	5930-00-626-2917	21	20
31196	3090001341		19	1	31196	5040000580		21	21
31196	3090004778		4	36	31196	5040000757		2	12
31196	3090004785		4	34	31196	5040001356		2	20
31196	3090005148		12	2	56878	58FK632	5310-00-801-4420	2	33
31196	3090005381		21	38	56878	58FK632	5310-00-801-4420	4	16
31196	3090012228		7	5	70318	6-32X3-4		21	36
31196	3090012229	5365-01-112-6399	7	10	95238	600-4PCGDF7-50		20	3
13499	310-0470-080	5310-00-043-4708	26	3	75382	6001		4	30
31196	3120001626	5995-01-017-7134	1	6	77221	621-16814		21	3
31196	3120001627	5995-01-009-5460	1	2	31196	62359005960-1		4	8
31196	3120001628	5995-01-009-5463	1	30	31196	6240001379-1		1	14
31196	3120001632	5995-01-017-7135	1	16	31196	6240001647		2	29
31196	3120001633	5995-01-009-5461	1	15	07126	7C83C		21	43
31196	3120005378	5995-01-012-3638	1	13	52335	8018-6005		6	7
31196	3120005396	5995-01-023-2334	1	27	72619	812-1030-0971-50	6210-00-840-0850	21	12
31196	3120005404	5995-01-140-1140	5	8		A			
31196	3120005409	5995-01-140-1141	5	6	72619	812-1030-0975-50	6210-00-892-4468	21	16
31196	3120006332	5995-01-140-1142	5	1		A			
31196	3120006353	5995-01-012-3639	3	3	18876	9100471	5940-00-636-5593	15	5
31196	3120006353	5995-01-012-3639	6	3					
31196	3129005393-1	5895-01-140-1143	5	7					
31196	3129005393-2	5995-01-140-1144	5	3					
31196	3129005393-3		5	2					
88779	323011	5940-00-983-7091	14	2					
00779	323011	5940-00-983-7091	33	2					
00779	328281	5940-01-138-2996	15	4					
31196	3350005413		21	33					
31196	3350006329		4	20					
31196	3350012223		7	1					
31196	3350012226		7	4					
34303	35V22PORM20PCT		17	5					
34303	35V47PORM10PCT		17	3					
31196	359005369-2		26	17					
75382	37TB12		4	32					
31196	40000781		2	40					
31196	4040000436	5999-00-124-5264	4	44					
31196	4040000613		4	14					
31196	4040000736		1	18					
31196	4040000787		16	5					
31196	4040000790	5895-00-124-8709	4	23					
31196	4040005307	5895-01-007-9484	26	18					
31196	404000574		2	5					
31196	4049005321-2	5895-01-008-8164	26	4					
31196	4049005326-2		26	7					
31196	4060000436		18	10					
31196	4090000748		22	1					
31196	4120001625	5995-01-017-7136	1	33					
31196	4120001629	5995-01-095-5462	1	26					
31196	4120001636	5995-01-017-7137	1	3					
31196	4120001637	5995-01-017-7138	1	4					
31196	4120001643	5995-01-009-5464	1	32					
31196	4240001617	5995-01-140-0962	1	31					
31196	4240004811	5995-01-140-0963	1	17					
31196	4240005468	5995-01-140-0964	5	5					
31196	4240006383		3	4					
31196	4240006383		6	9					
31196	4350000624		1	1					
71279	450-3388-01-03	5935-00-191-5434	16	31					
76493	4624	5950-00-645-3771	4	21					

By Order of the Secretaries of the Army, the Navy and the Air Force-

Official:

**JOHN A. WICKHAM JR.**  
*General, United States Army*  
*Chief of Staff*

**ROBERT M. JOYCE**  
*Major General, United States Army*  
*The Adjutant General*

Official:

**G. B. SCHICK, JR.**  
*Rear Admiral, United States Navy*  
*Commander, Naval Electronic*  
*Systems Command*

**JAMES P MULLINS**  
*General, USAF, Commander, Air Force*  
*Logistics Command*

**CHARLES A. GABRIEL**  
*General, USAF*  
*Chief of Staff*

DISTRIBUTION;

To be distributed in accordance with DA Form 12-51B literature requirements for CV-3085 & A/MS-46(V).



RECOMMENDED CHANGES TO EQUIPMENT TECHNICAL PUBLICATIONS



THEN... JOT DOWN THE DOPE ABOUT IT ON THIS FORM, CAREFULLY TEAR IT OUT, FOLD IT AND DROP IT IN THE MAIL!

**SOMETHING WRONG WITH THIS PUBLICATION?**

FROM: (PRINT YOUR UNIT'S COMPLETE ADDRESS)

DATE SENT

PUBLICATION NUMBER

PUBLICATION DATE

PUBLICATION TITLE

BE EXACT... PIN-POINT WHERE IT IS

IN THIS SPACE TELL WHAT IS WRONG AND WHAT SHOULD BE DONE ABOUT IT:

PAGE NO.	PARA-GRAPH	FIGURE NO.	TABLE NO.
----------	------------	------------	-----------

TEAR ALONG PERFORATED LINE

PRINTED NAME, GRADE OR TITLE, AND TELEPHONE NUMBER

SIGN HERE:

DA FORM 2028-2 JUL 79

PREVIOUS EDITIONS ARE OBSOLETE.

P.S.—IF YOUR OUTFIT WANTS TO KNOW ABOUT YOUR RECOMMENDATION MAKE A CARBON COPY OF THIS AND GIVE IT TO YOUR HEADQUARTERS.



This fine document...

Was brought to you by me:



## [Liberated Manuals -- free army and government manuals](#)

Why do I do it? I am tired of sleazy CD-ROM sellers, who take publicly available information, slap “watermarks” and other junk on it, and sell it. Those masters of search engine manipulation make sure that their sites that sell free information, come up first in search engines. They did not create it... They did not even scan it... Why should they get your money? Why are not letting you give those free manuals to your friends?

I am setting this document FREE. This document was made by the US Government and is NOT protected by Copyright. Feel free to share, republish, sell and so on.

I am not asking you for donations, fees or handouts. If you can, please provide a link to [liberatedmanuals.com](http://liberatedmanuals.com), so that free manuals come up first in search engines:

<A HREF=<http://www.liberatedmanuals.com/>>Free Military and Government Manuals</A>

- Sincerely  
Igor Chudov  
<http://igor.chudov.com/>
- [Chicago Machinery Movers](#)