

TECHNICAL MANUAL

**DIRECT SUPPORT AND GENERAL SUPPORT MAINTENANCE
REPAIR PARTS AND SPECIAL TOOLS LISTS
(INCLUDING DEPOT MAINTENANCE REPAIR PARTS AND SPECIAL TOOLS)
FOR
AIR TRAFFIC CONTROL FACILITY AN/TSQ-97
(NSN 5895-00-137-8548)**

HEADQUARTERS, DEPARTMENT OF THE ARMY

23 NOVEMBER 1983

Technical Manual
 No. 11-5895-800-34P

HEADQUARTERS
 DEPARTMENT OF THE ARMY
 Washington, DC, 23 November 1983

**DIRECT SUPPORT AND GENERAL SUPPORT MAINTENANCE
 REPAIR PARTS AND SPECIAL TOOLS LIST
 (INCLUDING DEPOT MAINTENANCE REPAIR PARTS AND SPECIAL TOOLS)
 for
 AIR TRAFFIC CONTROL FACILITY AN/TSQ-97
 (NSN 5895-00-137-8548)**

Current as of 27 June 1983

REPORTING ERRORS AND RECOMMENDING IMPROVEMENTS

You can help improve this manual. If you find any mistakes or if you know of a way to improve the procedures, please let us know. Mail your letter, DA Form 2028 Recommended Changes to Publications and Blank Forms), or DA Form 2028-2 located in back of this manual direct to: Commander, US Army Communications-Electronics Command and Fort Monmouth, ATTN: DRSEIME-MP, Forth Monmouth, NJ 07703.

In either case, a reply will be furnished direct to you.

Table of Contents

	Page	Illus. Figure
Section I. Introduction	1	
II. Repair Parts List	5	
Group 00 Air Traffic Control Facility AN/TSQ-97	5	1
01 Radio Set AN/ARC-114 and AN/ARC-114A (See TM 11-5821-259-24P for parts)		
02 Radio Set AN/ARC-115 (See TM 11-5821 260-24P for parts) and Radio Set AN/ARC-115A(V)1 (See TM 11-5821-260-34P-1 for parts)		
03 Radio Receiver-Transmitter RT-1167/ARC-164 (V) (See TM 11-5821-311-34P for parts)		
04 Air Traffic Control Facility, Group Assembly OA-8879/TSQ-97 (No parts authorized)		
0401 Case Assembly	9	2
0402 Control-Monitor	13	3
040201 Front Panel Assembly	19	4
04020101 Wind Direction Indicator ID-637/ARN (No parts authorized)		
04020102 Altimeter AAO-8/A (No parts authorized)		
040202 Rear Panel Assembly	23	5
04020201 Interface Circuit Board	27	6
04020202 Relay, Board Assembly (See Group 040201 for parts)		
040203 Control Circuit Board Assembly	29	7
040204 Microphone Amplifier Printed Circuit Board Assembly	31	8
040205 Headset Amplifier Printed Circuit Board Assembly	33	9
040206 Lamp Indicator Printed Circuit Board Assembly	35	10
040207 Card Enclosure Assembly	37	11
04020701 Mother Printed Circuit Card Assembly (No parts authorized)		

* This manual supersedes TM 11-5895-800-34P, 29 July 1980

Table of Contents

Group		Page Figure	Illus.
0403	Mast Assembly	41	12
0404	Coupler Assembly (See Group 00 for parts)		
0405	UHF/VHF Antenna Assembly AT-1108/ARC	45	13
0406	Detector, Wind Direction and Speed ML-653-TSQ97	47	14
0407	Headset/Microphone H-337/U	51	15
0408	Antennas AS- 1703/ARC (No parts authorized)		
0409	Adapter Battery No parts authorized)		
0410	Cable Assembly, Secure Signal	55	16
0411	Cable Assembly, Secure Control.....	55	16
0412	Cable Assembly, Radio Control.....	55	16
0413	Cable Assembly W401	55	16
0414	Cable Assembly W402	55	16
0415	Cable Assembly W701	55	16
0416	Cable Assembly W702	55	16
0417	Cable Assembly W201	55	16
0418	Cable Assembly W202	56	16
0419	Cable Assembly W203	56	16
0420	Cable Assembly W301	56	16
0421	Cable Assembly W302	56	16
0422	Cable Assembly W303	56	16
Section III.	Special Tools List (Not applicable)		
IV.	National Stock Number and Part Number Index	57	

SECTION I INTRODUCTION

1. Scope

This manual lists spares and repair parts; special tools; special test, measurement, and diagnostic equipment(TMDE), and other special support equipment required for performance of direct support and general support maintenance of the AN/TSQ-97. It authorizes the requisitioning and issue of spares and repair parts as indicated by the source and maintenance codes.

2. General

This Repair Parts and Special Tools List is divided into the following sections:

a. Section II. Repair Parts List. A list of spares and repair parts authorized for use in the performance of maintenance. The list also includes parts which must be removed for replacement of the authorized parts. Parts lists are composed of functional groups in numeric sequence, with the parts in each group listed in figure and item number sequence

b. Section III. Special Tools List. Not applicable.

c. Section IV. National Stock Number and Part Number Index. A list, in National item identification number (NIIN) sequence, of all National stock numbers (NSN) appearing in the listings, followed by a list, in alphanumeric sequence, of all part numbers appearing in the listings. National stock numbers and part numbers are cross-referenced to each illustration figure and item number appearance.

3. Explanation of Columns

a. Illustration. This column is divided as follows:

(1) *Figure number.* Indicates the figure number of the illustration on which the item is shown.

(2) *Item number.* The number used to identify item called out in the illustration.

b. Source, Maintenance, and Recoverability (SMR) Codes

(1) *Source code.* Source codes indicate the manner of acquiring support items for maintenance, repair, or overhaul of end items. Source codes are entered in the first and second positions of the Uniform SMR Code format as follows:

<i>Code</i>	<i>Definition</i>
PA -	Item procured and stocked for anticipated or known usage.
PC -	Item procured and stocked and which otherwise would be coded
PA -	except that it is deteriorative in nature.
PD -	Support item, excluding support equipment procured for initial issue or outfitting and stocked only for subsequent or additional initial issues or outfitting. Not subject to automatic replenishment.
PF -	Support equipment which will not be stocked but which will be centrally procured on demand.
PG -	Item procured and stocked to provide for sustained support for the life of the equipment.. It is applied to an item peculiar to the equipment which, because of probable discontinuance or shutdown of production facilities, would prove uneconomical to reproduce at a later time.
XA -	Item is not procured or stocked because the requirements for the item will result in the replacement of the next higher assembly.
XB -	Item is not procured or stocked. If not available through salvage, requisition.
XD -	A support item that is not stocked. When required, item will be procured through normal supply channels.

NOTE

Cannibalization or salvage may be used as a source of supply for any items source coded above except those coded XA and aircraft support items as restricted by AR 750-1.

(2) *Maintenance code.* Maintenance codes are assigned to indicate the levels of maintenance authorized to USE and REPAIR support items. The maintenance codes are entered in the third and fourth positions of the Uniform SMR Code format as follows:

(a) The maintenance code entered in the third position will indicate the lowest maintenance level authorized to remove, replace, and use the support item. The maintenance code entered in the third position will indicate one of the following levels of maintenance:

Code Application Explanation

- O - Support item is removed, replaced, used at the organizational level.
- F - Support item is removed, replaced, used at the direct support level.
- H - Support item is removed, replaced, used at the general support level.
- D - Support items that are removed, replaced, used at depot, mobile depot, specialized repair activity only.

(b) The maintenance code entered in the fourth position indicates whether the item is to be repaired and identifies the lowest maintenance level with the capability to perform complete repair (i.e., all authorized maintenance functions). This position will contain one of the following maintenance codes:

Code Application Explanation

- O- The lowest maintenance level capable of complete repair of the support item is the organizational level.
- F - The lowest maintenance level capable of complete repair of the support item is the direct support level.
- H - The lowest maintenance level capable of complete repair of the support item is the general support level.
- D - The lowest maintenance level capable of complete repair of the support item is the depot level.

L - Repair restricted to designated specialized repair activity.

Z - Nonreparable. No repair is authorized.

(3) *Recoverability code.* Recoverability codes are assigned to support items to indicate the disposition action on unserviceable items. The recoverability code is entered in the fifth position of the Uniform SMR Code format as follows:

Codes Recoverability Definition

Z - Nonreparable item. When unserviceable, condemn and dispose at the level indicated in position 3.

O - Repairable item. When uneconomically repairable, condemn and dispose at organizational level.

F - Repairable item. When uneconomically repairable, condemn and dispose at the direct support level.

H - Repairable item. When uneconomically repairable, condemn and dispose at the general support level.

D - Repairable item. When beyond lower level repair capability, return to depot. Condemnation and disposal not authorized below depot level

L - Repairable item. Repair, condemnation, and disposal not authorized below depot/specialized repair activity level.

c. *National Stock Number.* Indicates the National stock number assigned to the item and will be used for requisitioning purposes.

d. *Federal Supply Code for Manufacturer (FSCM).* The FSCM is a 5-digit numeric code listed in SB 708-41/42 which is used to identify the manufacturer, distributor, or Government agency, etc.

e. *Part Number.* Indicates the primary number used by the manufacturer (individual, company, firm, corporation, or Government activity), which controls the design and characteristics of the item by means of its engineering drawings, specifications, standards, and inspection requirements to identify an item or range of items.

NOTE

When a stock numbered item is requisitioned, the repair part received may have a different part number than the part being replaced.

f *Description.* Indicates the Federal item name and, if required, a minimum description to identify the item.

g. *Unit of Measure (U/M).* Indicates the standard of the basic quantity of the listed item as used in performing the actual maintenance function. This measure is expressed by a two-character alphabetical abbreviation (e.g., ea, in, pr, etc). When the unit of measure differs from the unit of issue, the lowest unit of issue that will satisfy the required units of measure will be requisitioned.

h. *Quantity Incorporated in Unit.* Indicates the quantity of the item used in the breakout shown on the illustration figure, which is prepared for a functional group, subfunctional group, or an assembly.

4. Special Information

- a. The following publications pertain to the AN/TSQ-97 and its components:

TM 11-5821-259-20, Radio Sets AN/ARC-114 and AN/ARC-114A, Network Impedance Matching CU-1794/ARC-114; Network, Impedance Matching-Quadrature Hybrid CU-1796/ARC114
TM 11-5821-259-24P, Radio Set AN/ARC-114 and AN/ARC-114A
TM 11-5821-260-35, Radio Set AN/ARC 114 and AN/ARC-114A
TM 11-5821-260-20, Radio Set AN/ARC-115
TM 11-5821-20P-1, Radio Set AN/ARC-115A(V)1
TM 11-5821-260-24P, Radio Set AN/ARC-115
TM 11-5821-260-34P-1, Radio Set AN/ARC-115A(V)1
TM 11-5821-260-35, Radio Set AN/ARC-115
TM 11-5821-311-12, Receiver-Transmitter, Radio RT-1167/ARC-164(V)
TM 11-5821-311-20, Receiver-Transmitter, Radio RT-1167ARC-164(V)
TM 11-5821-311-34, Receiver-Transmitter, Radio RT-1167/ARC-164(V)
TM 11-5895-800-12, Air Traffic Control Facility AN/TSQ-97
TM 11-5895-800-20P, Air Traffic Control Facility AN/TSQ-97
TM 11-5895-800-34, Air Traffic Control Facility AN/TSQ-97

b. National stock number (NSN's) that are missing from P source coded items have been applied for and will be added to the TM by future change/revision when they are entered in the Army Master Data File (AMDF). Until the NSN's are established and published, submit exception requisitions to: Commander, US Army Communications - Electronics Command and Fort Monmouth, ATTN: DRSEL-MM, Fort Monmouth, NJ 07703 for the part required to support your equipment.

5. How to Locate Repair Parts

- a. When National stock number or part number is unknown.

(1) *First.* Using the table of contents, determine the functional group within which the item belongs. This is necessary since illustrations are prepared for functional groups and listings are divided into the same groups.

(2) *Second.* Find the illustration covering the functional group to which the item belongs.

(3) *Third.* Identify the item on the illustration and note the illustration figure and item number of the time.

(4) *Fourth.* Using the Repair Parts Listing, find the figure and item number noted on the illustration.

- b. When National stock number or part number is known.

(1) *First.* Using the Index of National Stock Numbers and Part Number4s, find the pertinent National stock number of part number. This index is in NIIN sequence followed by a list of part numbers in alphameric sequence, cross-referenced to the illustration figure number and item number.

(2) *Second.* After finding the figure and item number, locate the figure and item number in the repair parts list.

6. Abbreviations

Not applicable.

(Next printed page is 4.1)

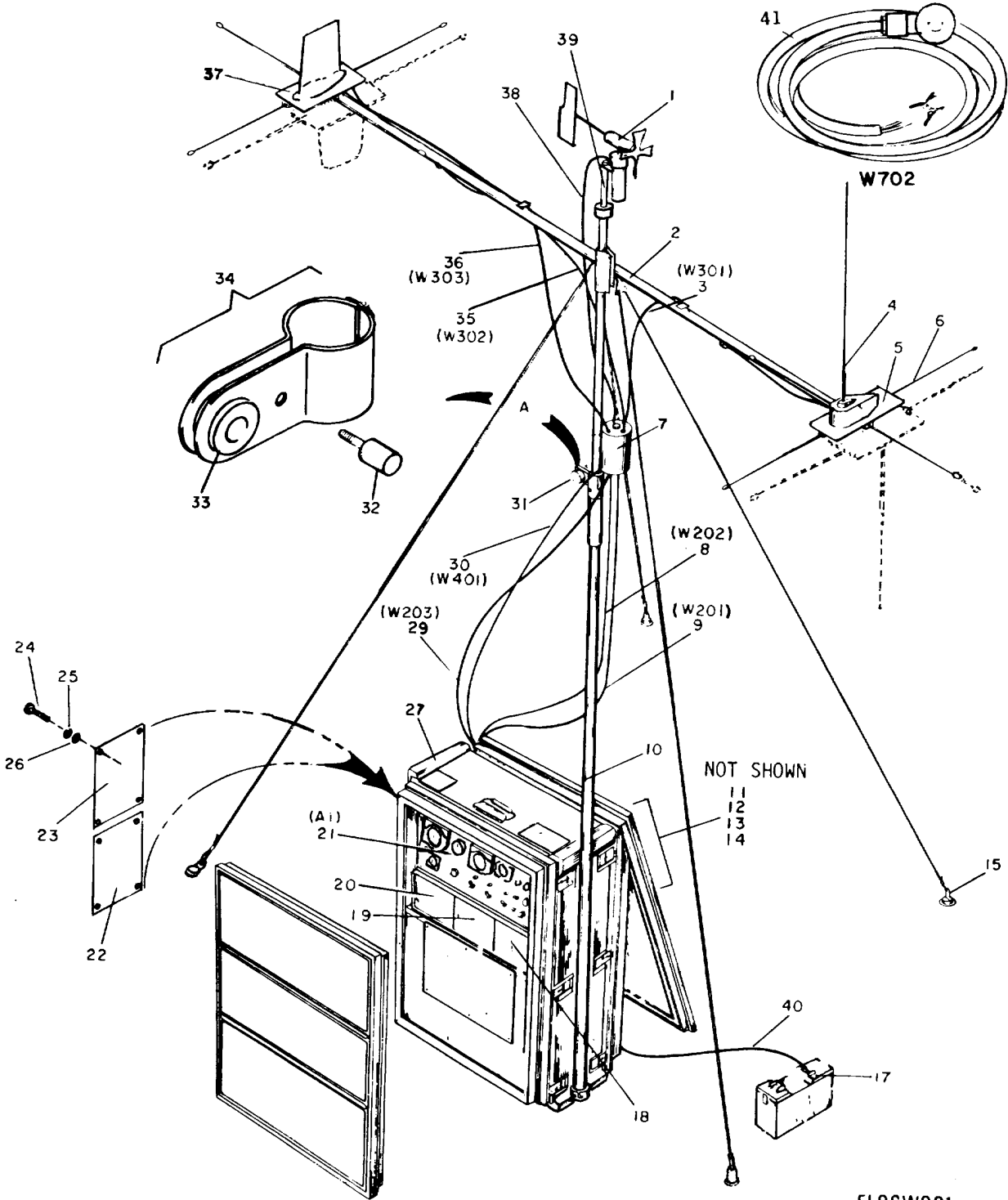
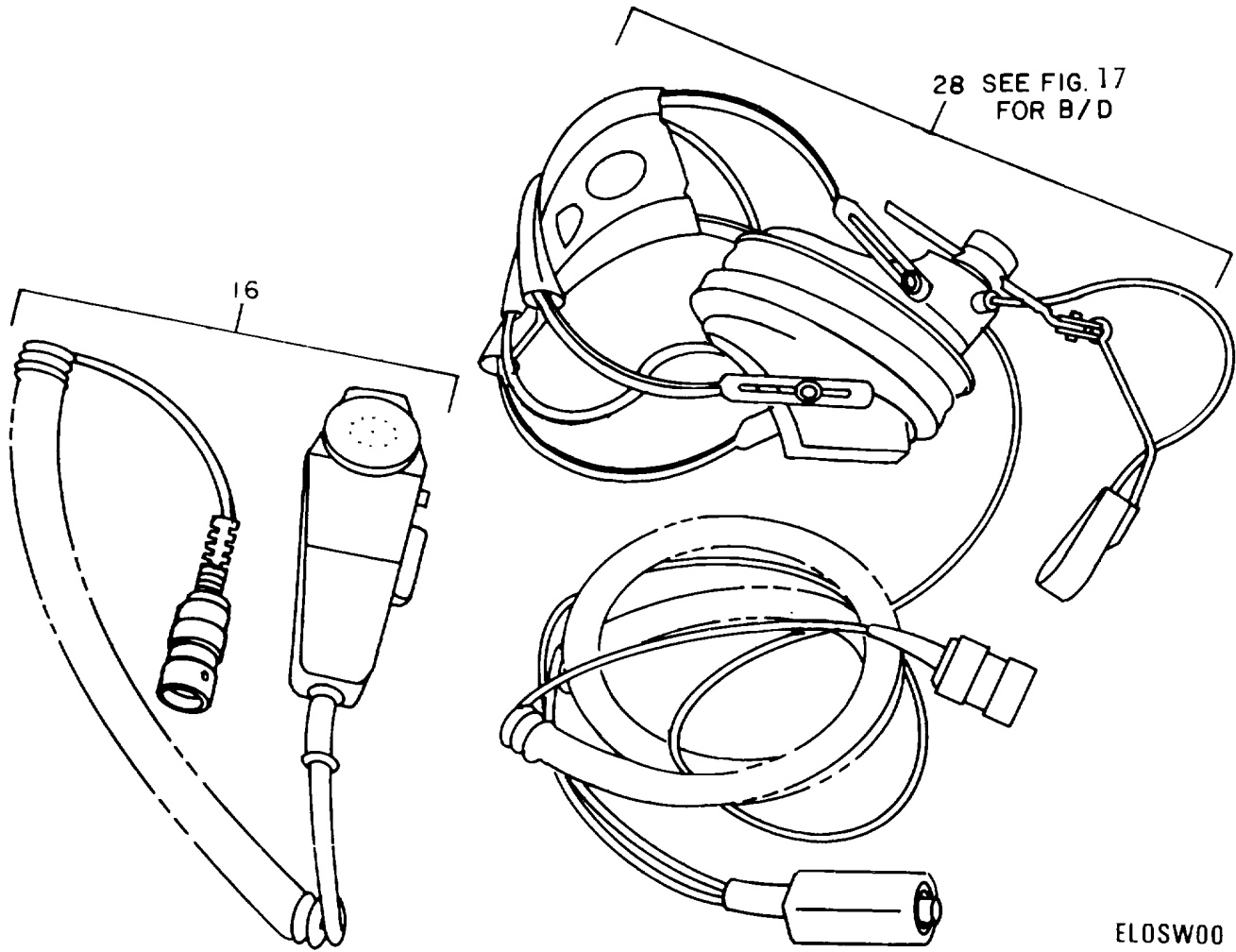

Figure 1. Air Traffic Control Facility AN/TSQ-97 (Sheet 1 of 2).

ELOS001



ELOSW00 2

TM 11-5895-800-34P

Figure 1. Air Traffic Control Facility AN/TSQ-97 (Sheet 2 of 2).

SECTION II

TM 11-5895-800-34P

(1) ILLUSTRATION		(2)	(3)	(4)	(5)	(6)	(7)	(8)
(a) FIG NO	(b) ITEM NO	SMR CODE	NATIONAL STOCK NUMBER	FSCM	PART NUMBER	DESCRIPTION <i>USABLE ON CODE</i>	U/M	QTY INC IN UNIT
						GROUP 00 AIR TRAFFIC CONTROL FACILITY AN/TSQ-97		
1	1	PAOHH	6660-01-009-4369	80058	ML-653/TSQ-97	DETECTOR.WIND DIREC	EA	1
1	2	PAOZZ	5895-01-093-0591	80063	SC-0-706037	BOOM	EA	1
1	3	PFFFF		80063	SC-D-706109	CABLE ASSEMBLY.RADI	EA	1
1	4	PAOZZ	5985-00-082-3991	80058	AS-1703/AR	ANTENNA	EA	2
1	5	PAOOO	5895-01-087-3059	80063	SC-D-706027	COUPLER ASSEMBLY	EA	2
1	6	PAOZZ	5895-01-025-8899	80058	AS-4034/TSQ-97	ANTENNA ELEMENT	EA	12
1	7	PAOZZ	5950-01-025-6732	80058	MX-9713/TSQ-97	CHOKE.ASSEMBLY RF	EA	1
1	8	PFFFF		80063	SC-D-706261	CABLE ASSEMBLY, RADI	EA	1
1	9	XBFFF		80063	SC-D-706113	CABLE ASSEMBLY.RADI	EA	1
1	10	PAOZZ	5985-81-091-9654	80063	SC-D-706006	MAST	EA	1
1	11	PAFZZ	5895-01-088-1788	80063	SC-C-706243	SUPPRESSOR. TRANSIEN	EA	1
1	12	PFFFF		80063	SC-D-706265	CABLE AY,RADIO CONT	EA	3
1	13	PFFFF		80063	SC-D-706259	CABLE AY,SECURE SIG	EA	3
1	14	PFFFF		80063	SC-D-706262	CABLE AY, SECURE CON	EA	3
1	15	PAFZZ		81349	MIL-P-501TYPE2	PIN, TENT	EA	4
1	16	PAOZZ	5965-00-179-7762	81349	M-80C/U	MICROPHONE, DYNAMIC	EA	1
1	17	PAOZZ	6135-00-087-2301	80058	MX-4430/PRC-47	COVER,BATTERY BOX	EA	1
1	18	PDODD	5821-00-138-7990	80058	RT-1167/ARC-164 (V)	RECEIVER-TRANSMITTE	EA	1
1	19	PDODD	5821-01-057-4037	80058	AN/ARC-115A	RADIO SET	EA	1
1	20	PDODD	5821-00-165-2970	80058	AN/ARC-114A	RAOIO SET	EA	1
1	21	PAFFF	5895-01-088-1789	80058	C-9921/TSQ--97	CONTROL-MONITOR	EA	1
1	22	XBFZZ		80063	SC-C-706005	PLATE,IDENTIFICATION	EA	1
1	23	XBFZZ		80063	SC-C-706002	PLATE,IDENTIFICATION	EA	1
1	24	PAFZZ	5305-00-439-2737	96906	MS51957-128	SCREW,MACHINE	EA	4
1	25	PAFZZ	5310-00-224-0746	96906	MS35338-135B	WASHCR.LOCK.	EA	4
1	26	PAFZZ	5310-00-194-3647	96906	MS15795-8038	WASHER.FLAT	EA	4
1	27	XAFFF		80063	SC-D-706362	CASE ASSEMBLY	EA	1
1	28	PAOFF	5965-01-089-7678	83058	H-337/TSQ-97	HUCADSCT-MHICRO PHO NE	EA	1
1	29	PFFFF		80063	SC-D-706264	CABLE ASSEMBLY,RADI	EA	1
1	30	PFFFF		80063	SC-D-706115	CABLE AY, POWER,ELEC	EA	1
1	31	PAOZZ	6685-00-557-5316	96906	MS28028-1	THERMOMETER. SELF-IN	EA	1
1	32	XAFZZ		80063	SC-B-61162	THUMBSR EWI	EA	1
1	33	PAFZZ	5325-00-290-6163	96906	MS35489-13	GROMMET,NON-METALLIC	EA	2
1	34	PAFZZ	5895-01-087-3061	80063	SC-C-I06057	BRACKET,THERMOME..	EA	1
1	35	PFFFF		80063	SC-D-706320	CABLE ASSEMBLY,RADI	EA	1
1	36	PFFFF		80063	SC-D-706321	CABLE ASSEMBLY,RADI	EA	1
1	37	PAODD	5985-01-088-1896	80063	SC-D-706059	ANTENNA ASSEMBLY	EA	2

SECTION II

TM 11-5895-800-4P

(1) ILLUSTRATION		(2)	(3)	(4)	(5)	(6)	(7)	(8)
(a) FIG NO	(b) ITEM NO	SMR CODE	NATIONAL STOCK NUMBER	FSCM	PART NUMBER	DESCRIPTION <i>USABLE ON CODE</i>	U/M	QTY INC IN UNIT
1	38	XBFFF		80063	SC-D-706112	Cable AY POWER	EA	1
1	39	XDFZZ		80063	SC-C-7J6031	STANDOFF	EA	1
1	40	XBFFF		83063	SC-D-706253	CABLE AY,POWER,ELEC	EA	1
1	41	XBFFF		80063	SC-D-706256	CABLE AY,POWER,ELEC	EA	1
						6		

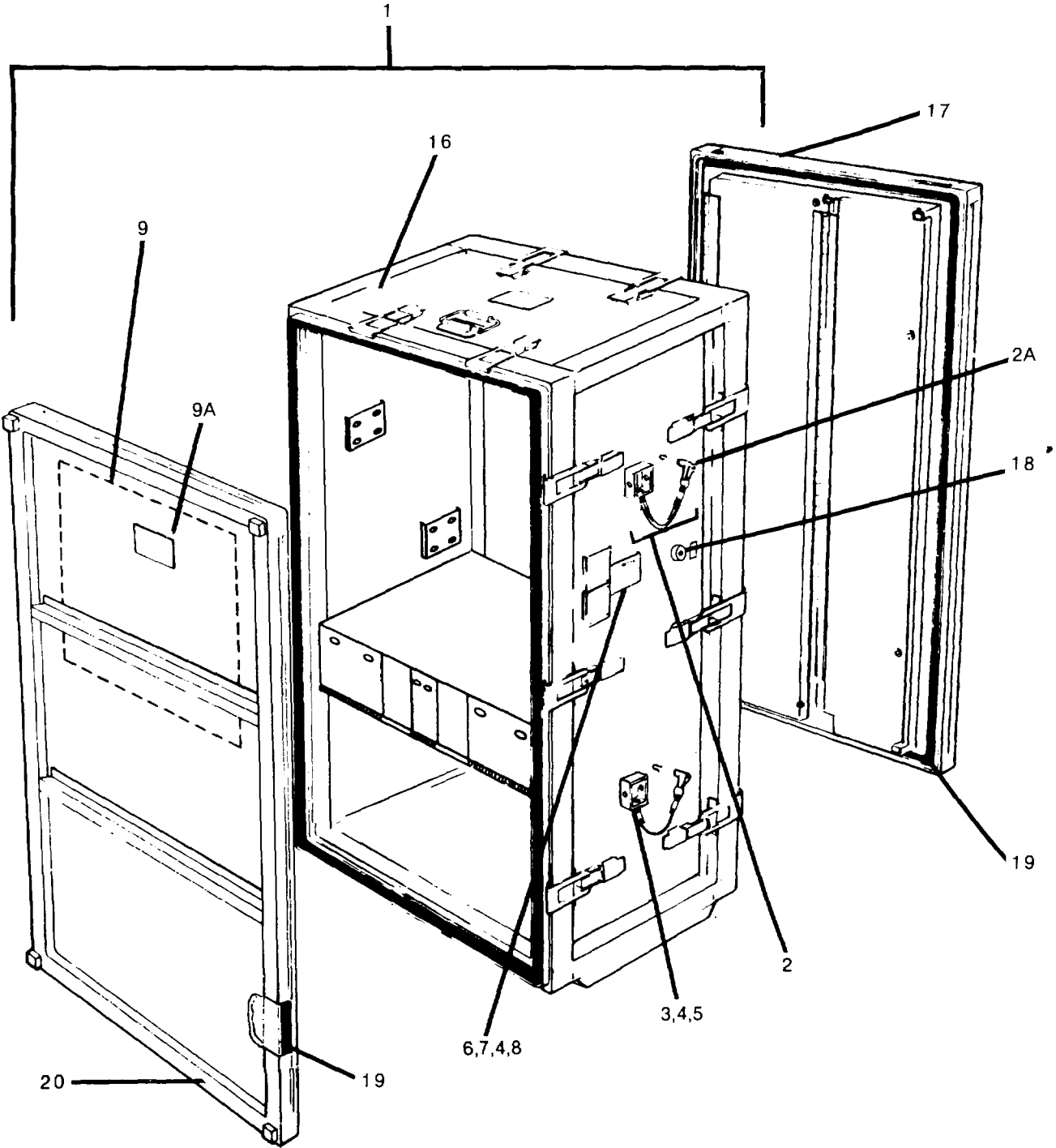

EL0SW00 3

Figure 2. Case Assembly (Sheet 1 of 2).

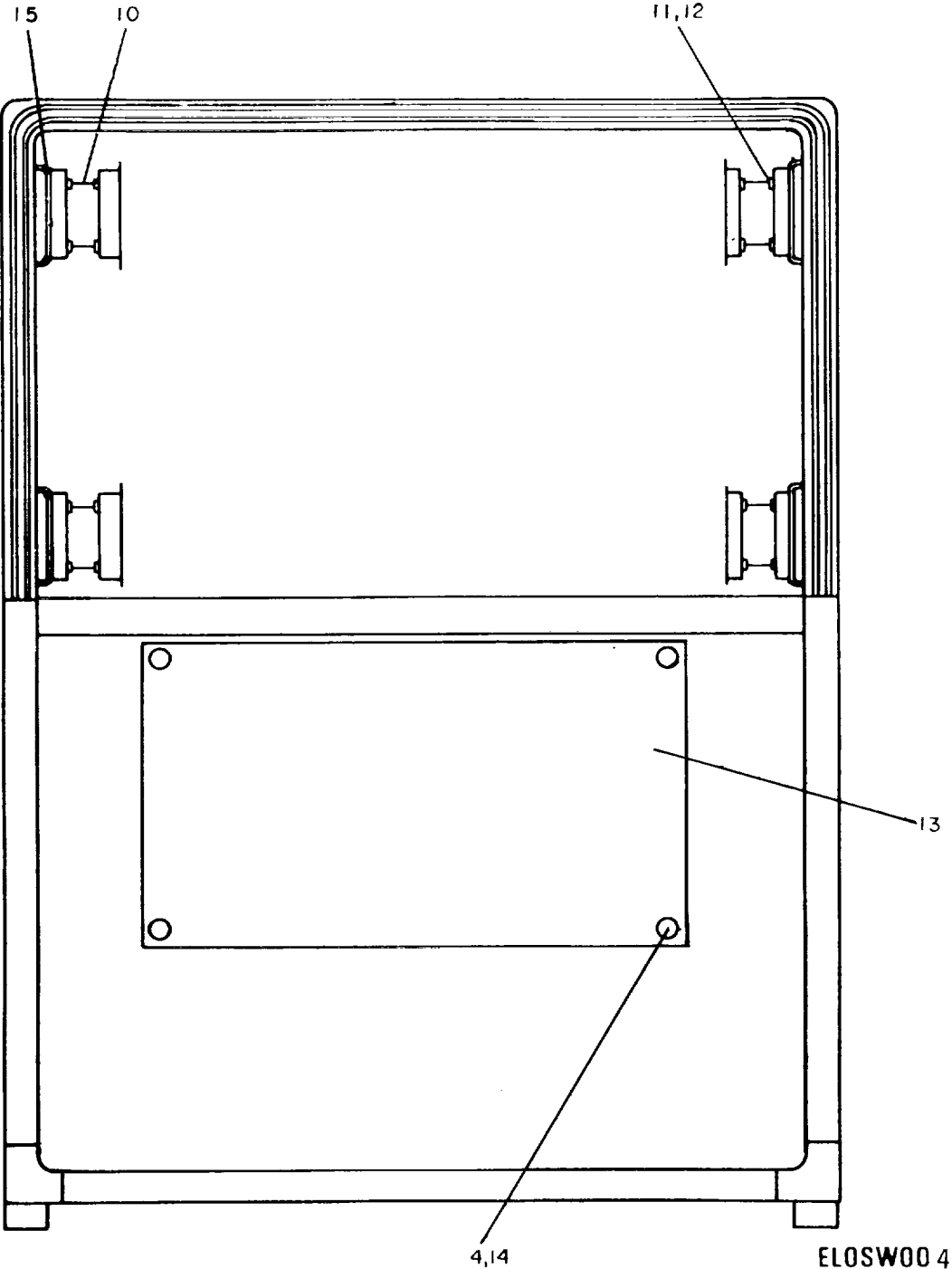
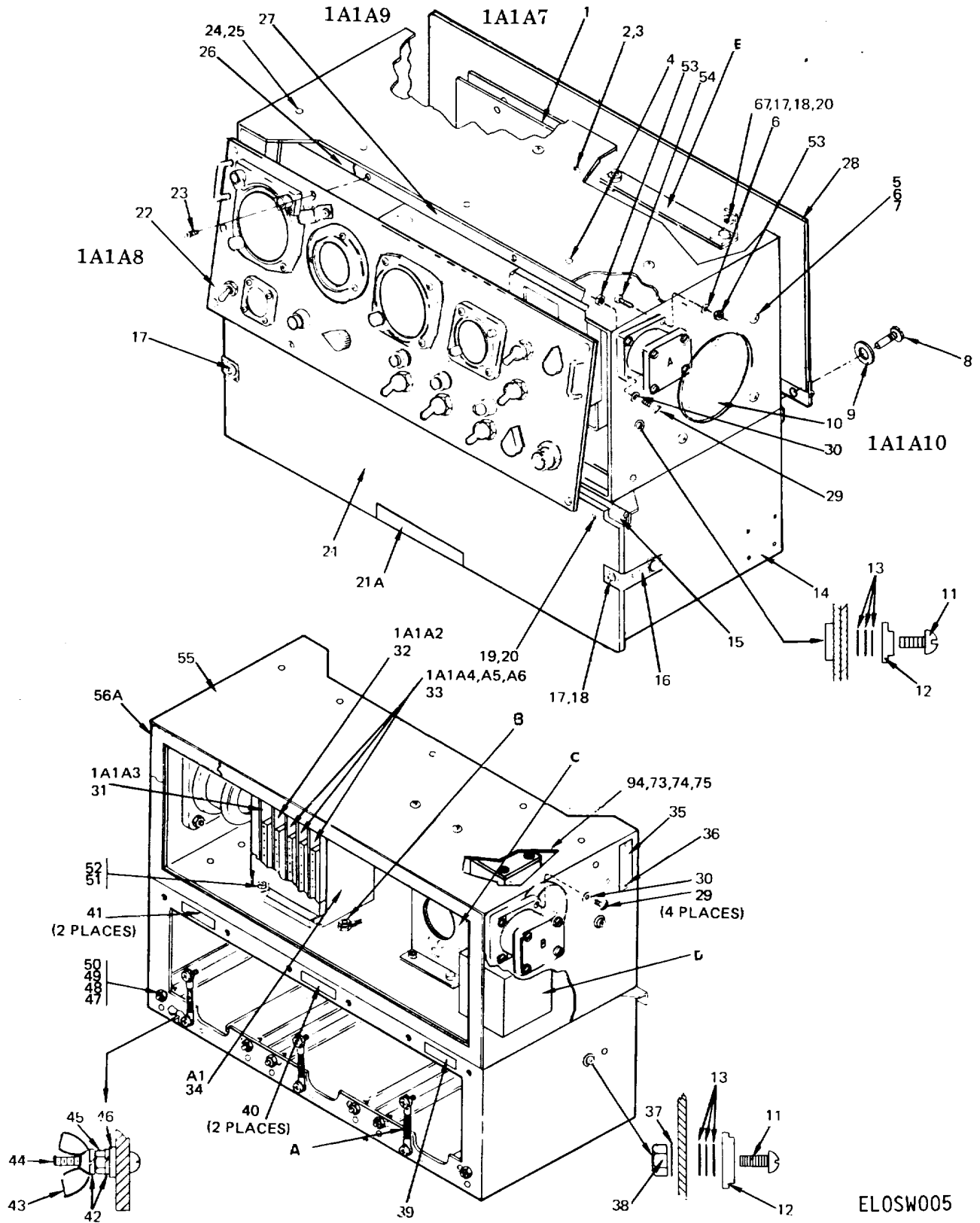

Figure 2. Case Assembly (Sheet 2 of 2).

SECTION II

TM 11-5895-800-34P

(1) ILLUSTRATION		(2)	(3)	(4)	(5)	(6)	(7)	(8)
(a) FIG NO	(b) ITEM NO	SMR CODE	NATIONAL STOCK NUMBER	FSCM	PART NUMBER	DESCRIPTION <i>USABLE ON CODE</i>	U/M	QTY INC IN UNIT
						GROUP 0401 CASE ASSEMBLY		
2	I	XAFDD		80063	SC-D-706399	CONTAINER,MODULAR	EA	1
2	2	PAFZZ	5895-01-092-3078	80063	SC-C-706392	LANYARD ASSEMBLY	EA	4
2	2A	PAFZZ	5340-00-915-4847	96906	MS17987C418	PIN,QUICK RELEASE.....	EA	1
2	3	PAFZZ	5305-00-770-2580	96906	MS51959-16	SCREW,MACHINE	EA	1
2	4	PAFZZ	5310-90-595-6211	96906	MS15195-803	WASHER.FLAT.....	EA	11
2	5	PAFZZ	5310-00-811-6419	96906	MS21042-04	NUT,SELE-LOCKING,EX.....	EA	1
2	6	XBFZZ		80063	SC-C-706360	PLATE,INFORMATION.....	EA	1
2	7	PAFZZ	5305-00-439-2737	96906	MS51957-128	SCREW,MACHINE.....	EA	4
2	8	PAFZZ	5310-00-933-8118	96906	NS35338-135	WASHER,LOCK.....	EA	4
2	9	XBFZZ		80063	SC-D-706361	PLATE,INFORMATION.....	EA	1
2	9A	XBFZZ		80063	SC-C-706389	PLATE,INFORMATION.....	EA	3
2	10	PCFZZ	1440-01-029-3260	81860	21271-5	SHOCK MOUNT	EA	4
2	11	PAFZZ	5305-01-087-4481	96906	MS51849-57	SCREW,MACHINE	EA	4
2	12	PAFZZ	5310-00-880-5978	96906	MS15795-807	WASHER.FLAT.....	EA	4
2	13	XBFZZ		80063	SC-D-706163	PLATE,INFORMATION.....	EA	1
2	14	PAFZZ	5305-00-459-4687	96906	MS51957-148	SCREW,MACHINE	EA	6
2	15	PAFZZ		80063	SC-B-706388	SHIM SHOCKMOUNT	EA	8
2	16	XBFZZ		80063	SC-D-706095	CASE ASSEMBLY	EA	1
2	17	XBFZZ		80063	SC-D-706093	COVER ASSY,REAR.....	EA	1
2	18	XBFZZ		19178	ZSP-6-037-4	VALVE.PRESS RELEIF.....	EA	1
2	19	XBFZZ		80063	SC-D-706153	GASKET ASSEMBLY.....	EA	2
2	20	XAFZZ		80063	SC-D-706090	COVER ASSY.FRONT.....	EA	1
						9		



ELOS005

Figure 3. Control Monitor (Sheet 1 of 3).

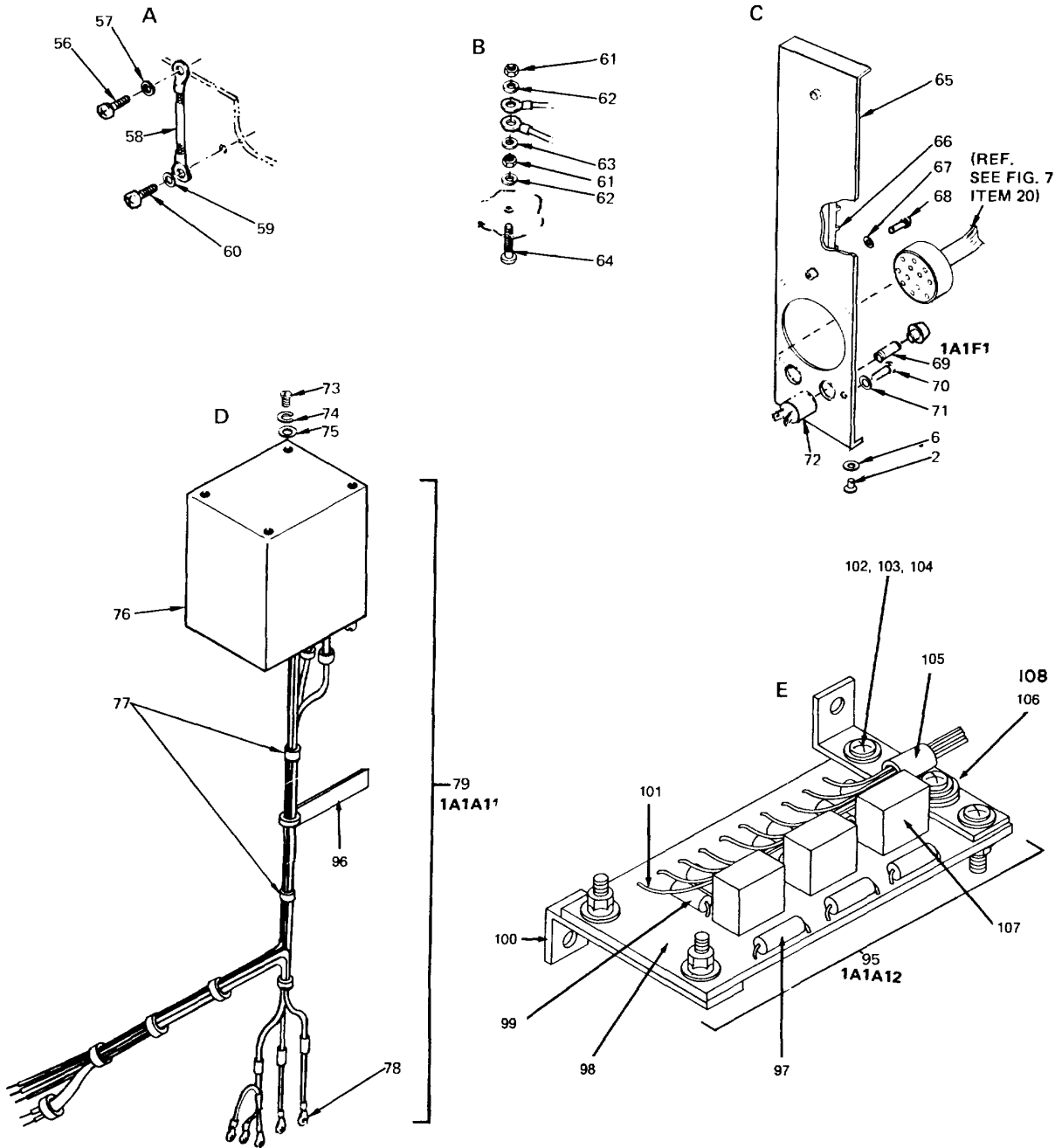

ELOS006

Figure 3. Control Monitor (Sheet 2 of 3)

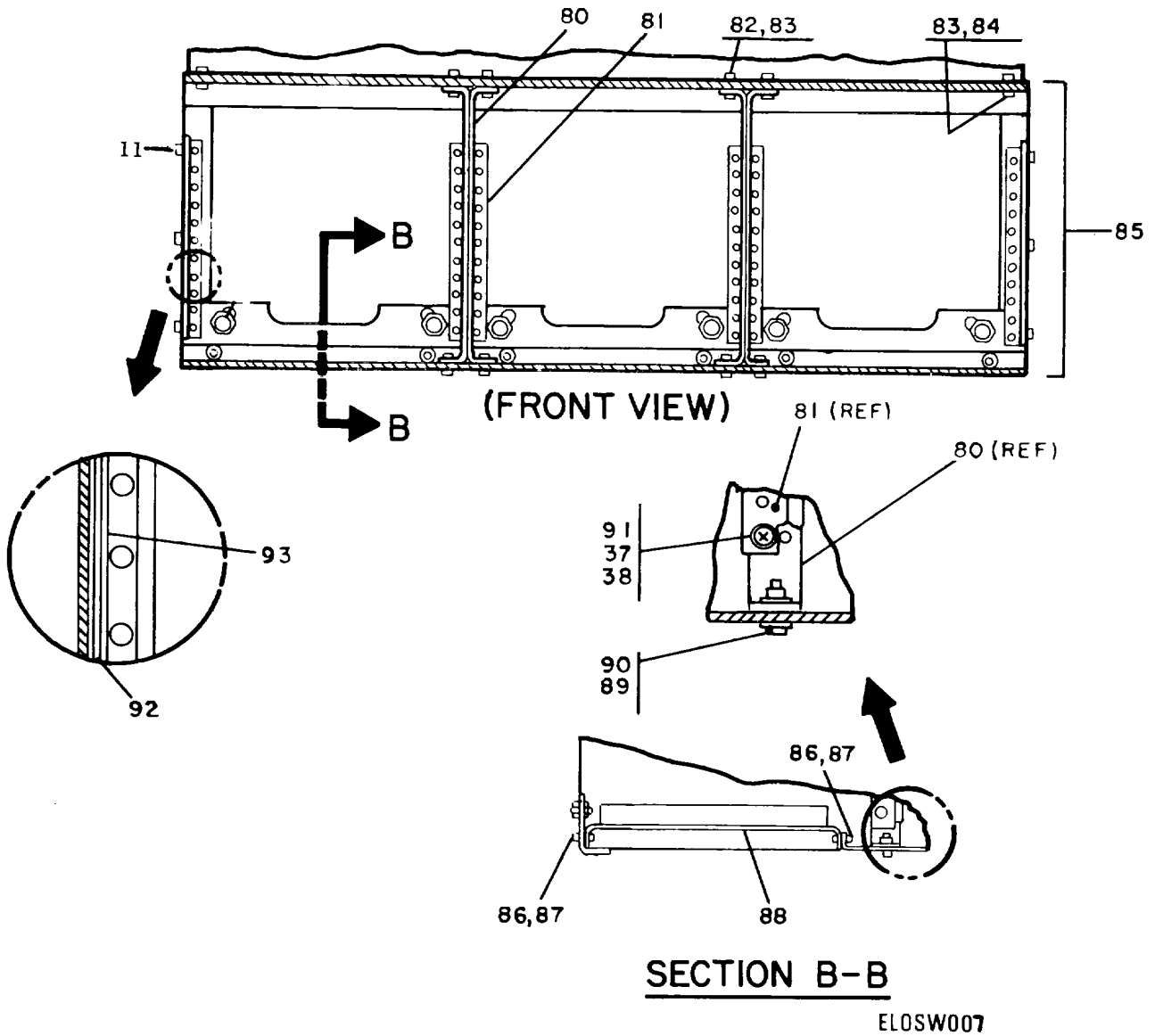

Figure 3. Control Monitor (Sheet 3 of 3).

SECTION II

TM 11-5895-800-34P

(1) ILLUSTRATION		(2)	(3)	(4)	(5)	(6)	(7)	(8)
(a) FIG NO.	(b) ITEM NO.	SMR CODE	NATIONAL STOCK NUMBER	FSCM	PART NUMBER	DESCRIPTION <i>USABLE ON CODE</i>	U/M	QTY INC IN UNIT
GROUP 0402 CONTROL MONITOR								
3	1	PAFLL	5895-01-038-6799	80063	SC-C-706228	CIRCUIT CARD ASSEMB	EA	1
3	2	PAFZZ	5305-00-448-6500	96906	MS51957-288	SCREW,MACHINE	EA	4
3	3	PAFZZ	5310-00-409-1763	96906	MS15795-805B	WASHER,FLAT	EA	4
3	4	PAFZZ	5305-00-770-2579	96906	MS51959-15	SCREW,MACHINE	EA	2
3	5	PAFZZ	5305-00-470-5602	96906	MS51957-32B	SCREW,MACHINE	EA	4
3	6	PAFZZ	5310-00-409-1763	96906	MS15795-805B	WASHER,FLAT	EA	8
3	7	PAFZZ	5310-00-807-1465	96906	MS21042-06	NUT SELF-LOCKING	EA	4
3	8	PAFZZ	5305-00-054-6654	96906	MS51957-30	SCREW,MACHINE.	EA	7
3	9	XDFZZ	5310-00-722-5998	96906	MS15795-805	WASHER,FLAT	EA	7
3	10	PAFZZ		80063	SC-C-706188	SPFAKER ASSEMBLY	EA	A
3	11	PAFZZ	5305-00-465-6745	96906	MS51957-16B	SCREW,MACHINE	EA	2
3	12	PAFZZ	5325-00-842-1879	96906	MS27980-7B	STUD.SNAP FASTENER	EA	2
3	13	PAFZZ	5310-00-782-1349	96906	MS15795-804	WASHER.FLAT	EA	6
3	14	XDFFF		80063	5C-D-706167	CONSOLE ASSEMBLY	EA	1
3	15	PAFZZ	5340-01-088-1923	80063	SC-D-706185	HINGE,BUTT.	EA	1
3	16	XDFFF		80063	SC-C-706356	STRAP ASSEMBLY.RAIN	A8	2
3	17	PAFZZ		96906	MS51957-8048	WASHER	EA	2
3	18	PAFZZ	5305-00-465-6745	96906	MS51957-168	SCRE W.MACHINE	EA	2
3	19	PAFZZ	5305-00-455-2516	96906	MS51959-158	SCREW,MACHINE	EA	6
3	20	PAFZZ	5310-00-811-6419	96906	MS21042-04	NUT,SELF-LOCKING,EX	EA	6
3	21	XBFZZ		80063	SC-D-706184	COVER,RAINSHLELD	EA	1
3	21A	XBFZZ		80063	SC-C-706384	PLATE,INFORMATION.....	EA	1
3	22	XAFZZ		80063	SC-D-706214	FRONT PANEL ASSEMBL	EA	1
3	23	PAFZZ	5305-00-764-0068	96906	MS5159-45	SCREW,MACHINE	EA	12
3	24	PAFZZ	5305-00-242-7275	96906	MS51957-158	SCREW,MACHINE	EA	10
3	25	PAF8Z	5310-00-194-3647	96906	MS151795-8036	WASHER,FLAT	EA	10
3	26	PA8ZZ		80063	SC-D-706238	GASKET	EA	1
3	27	XAFFF		80063	SC-D-706342	FRAME ASSEMBLY,FRON	EA	1
3	28	XAFFF		80063	SC-D-706223	REAR PANEL ASSEMBLY	EA	1
3	29	PAFZZ	5305-01-087-4481	96906	MS51849-57	SCREW,MACHINE	EA	12
3	30	PAFZZ	5310-00-880-5978	96906	MS15795-807	WASHER,FLAT	EA	16
3	31	PAFLL	5895-01-024-7841	21617	DL-SC-R-706195	CIRCUIT CARD ASSEMB	EA	1
3	32	PAFLL	5895-01-021-5923	21617	DL-SC-B-706200	CIRCUIT CARD ASSEMB	EA	1
3	33	PAFLL	5895-01-027-0296	21617	DL-SC-B-706205	CIRCUIT CARD ASSEM	EA	3
3	34	XDFFF		80063	SC-D-706186	CARD ENCLOSURE ASSE	EA	1
3	35	XBFZZ		80063	SC-C-706166	IDENTIFICATION PLAT	EA	1
3	36	PAFZZ	5320-00-117-6010	88044	AN426AD2-3	RIVET,SOLID	EA	2
3	37	PAFZZ	5310-00-595-6211	96906	MS15795-803	WASHER,FLAT	EA	2
3	38	PAFZZ	5310-00-811-6419	96906	MS21042-04	NUT SELF-LOCKING.EX	EA	2

SECTION II

TM 11-5895-800-34P

(1) ILLUSTRATION		(2)	(3)	(4)	(5)	(6)	(7)	(8)
(a) FIG NO.	(b) ITEM NO.	SMR CODE	NATIONAL STOCK NUMBER	FSCM	PART NUMBER	DESCRIPTION <i>USABLE ON CODE</i>	U/M	QTY INC IN UNIT
3	39	XBFZZ		80063	SC-C-706373-1	PLATE,INFORMATION	EA	2
3	40	XBFZZ		80063	SC-C-706373-2	PLATE,INFORMATION	EA	2
3	41	XBFZZ		80063	SC-C-706373-3	PLATE,INFORMATION	EA	2
3	42	PAFZZ	5310-00-933-8120	96906	MS35338-138	WASHER,LOCK	EA	2
3	43	PAFZZ	5310-01-077-1016	96906	MS35426-25	NUT,PLAIN	EA	1
3	44	PAFZZ	5305-00-059-3662	96906	MS51958-66	SCREW,MACHINE	EA	1
3	45	PAFZZ	5310-00-934-9765	96906	M35650-304	NUT,PLAIN HEXAGON	EA	1
3	46	PAFZZ	5310-00-619-1148	96906	MSI579 808	WASHER,FLAT	EA	1
3	47	PAFZZ	5310-00-412-9825	96906	MS35650-3048	NUT,PLAIN,HEXAGON	EA	1
3	48	PAFZZ	5310-00-224-0749	96906	MS35338-138B	WASHER,LOCK	EA	1
3	49	PAFZZ	5310-00-194-3649	96906	MS15795-8088	WASHER FLAT	EA	1
3	50	XAFZZ		80063	SC-C-706245	GUIDE PIN,RADIO	EA	6
3	51	PAFZZ	5310-00-722-5998	96906	MS15795-805	WASHER,FLAT	EA	4
3	52	PAFZZ	5305-00-054-6652	96906	MS51957-28	SCREW,MACHINE	EA	4
3	53	PAFZZ	5310-00-807-1466	96906	MS21042-08	NUT,SELF-LOCKING,EX	EA	4
3	54	PAFZZ	5335-01-052-3709	96906	MS24693-53	SCREW,MACHINE	EA	4
3	55	XDFFF		80063	SC-D-706173	CONSOLE ASSEMBLY,UP	EA	1
3	56	XDFZZ		80063	SC-B-706374	SCREW,GROUNDING	EA	1
3	56A	PAFZZ		80063	SC-D-706218	GASKET	EA	1
3	57	PAFZZ	5310-00-933-8120	96906	MS35338-138	WASHER,LOCK	EA	1
3	58	PAFZZ	5895-01-092-3079	80063	SC-C-706247	GROUND STRAP ASSEMB	EA	3
3	59	PAFZZ	5310-00-619-1148	96906	MS15795-808	WASHER FLAT	EA	1
3	60	PAPZZ	5305-00-059-3657	96906	MS51958-61	SCREW,MACHINE	EA	1
3	61	PAFZZ	5310-00-934-9761	96906	MS35649-264	NUT,PLAIN,HEXAGON	EA	2
3	62	PAFZZ	5310-00-929-6395	96906	MS35338-136	WASHER,LOCK	EA	1
3	63	PAFZZ	5310-00-722-5998	96906	MS15795-805	WASHER,FLAT	EA	2
3	64	PAFZZ	5310-00-933-8120	96906	MS35338-138	WASHER,LOCK.	EA	1
3	65	XAFZZ		80063	SC-C-706282	BRACKET ASSMBLY.CO	EA	1
3	66	PAFZZ	5940-00-836-7402	81349	26TB8	TERMINAL BOARD	EA	1
3	67	PAFZZ	5310-00-595-6211	96906	MS15795-803	WASHER,FLAT	EA	2
3	68	PAFZZ	5305-00-054-5652	96906	MS51957-18	SCREW,MACHINE	EA	2
3	69	PAOZZ	5920-00-929-7899	81349	FM02-125V-1-1/2A	FUSE,CARTRIDGE	EA	1
3	70	PAFZZ	5305-00-054-5651	96906	MS51957-17	SCREW,MACHINE	EA	1
3	71	PAFZZ	5310-00-595-6211	96906	MS15795-803	WASHER,FLAT	EA	6
3	72	PAFZZ	5310-00-785-5471	81349	FHN42W	FUSEHOLDER, EXTRACTO	EA	1
3	73	PAFZZ	5305-00-165-8019	96906	MS51958-608	SCREW, MACHINE	EA	4
3	74	PAFZZ	5310-00-224-0749	96906	MS35338-1388	WASHER,LOCK	EA	4
3	75	PAFZZ	5310-00-194-3649	96906	MS15795-8088	WASHER,FLAT	EA	4
3	76	XAFZZ		80063	SC-A-706171	POWER SUPPLY	EA	1
3	77	PAFZZ	5975-00-727-5153	96906	MS3367-4-9	STRAP,TIEDOWN,ELECT	EA	3

SECTION II

TM 11-5805-693-34P

(1) ILLUSTRATION		(2)	(3)	(4)	(5)	(6)	(7)	(8)
(a) FIG NO	(b) ITEM NO	SMR CODE	NATIONAL STOCK NUMBER	FSCM	PART NUMBER	DESCRIPTION <i>USABLE ON CODE</i>	U/M	QTY INC IN UNIT
3	78	PAFZZ	5940-00-113-9828	96906	MS25036-148	TERMINAL,LUG	EA	5
3	79	PAFZZ	6130-01-088-1856	80063	SC-D-706279	POWER SUPPLY	EA	1
3	80	XAFFF		80063	SC-B-706180	BRACKET ASSEMBLY,FA	EA	4
3	81	PAFZZ	5895-01-088-1790	80063	SC-B-706182	RECEPTACLE,CONTROL	EA	4
3	82	PAFZZ	5305-00-054-6654	96906	MS51957-30	SCREW,MACHINE	EA	1
3	83	PAFZZ	5310-00-722-5998	96906	MS15795-805	WASHER,FLAT	EA	4
3	84	PAFZZ	5305-00-054-6652	96906	MS51957-28	SCREW,MACHINE	EA	4
3	85	XAFFF		80063	SC-D-706168	CONSOLE ASSEMBLY,LO	EA	1
3	86	PAFZZ	5310-01-053-7003	96906	MS51338-135	NUT,SELF-LOCKING.CL	EA	2
3	87	PAFZZ	5310-00-194-3647	96906	MS15795-803B	WASHER,FLAT	EA	2
3	88	XDFZZ		80063	SC-D-706339	SLIDE ASSY	EA	6
3	89	PAFZZ	5310-00-409-1763	96906	MS15795-8058	WASHER,FLAT	EA	1
3	90	PAFZZ	5305-00-448-6500	96906	MS51957-288	SCREW,MACHINE	EA	1
3	91	PAFZZ	5305-00-054-5652	96906	MS51957-18	SCREW,MACHINE	EA	2
3	92	XDFZZ		80063	SC-C-706183-1	SPACER,RECEPTACLE	EA	8
3	93	XDFZZ		80063	SC-C-706183-2	SPACER,RECEPTACLE	EA	4
3	94	PAHZZ	5915-01-112-9672	80063	SC-A-706170	FILTER.	EA	1
3	95	PAFLL	5945-01-108-9215	80063	SC-C-706050	RELAY BOARD ASSEMBL	EA	1
3	96	PAFZZ	5975-00-043-3403	96906	MS3368-1-9-B	STRAP,TIE,ELECT	EA	1
3	97	PAHZZ	5910-00-189-3178	81349	M39003/01-3058	CAPACITOR.FIXED,ELE	EA	3
3	98	XAHZZ		80063	SC-C-706052	PRINTED WIRING BOAR	EA	
3	99	PAHZZ	5961-00-087-6047	81349	JAN1N645	SEMICONDUCTOR DEVICE	EA	6
3	100	XAHZZ		80063	SC-C-706053	BRACKET, PWB	EA	2
3	101	PAFZZ	6145-00-681-8517	81349	LW-C22(7)U9	WIRE,ELECTRICAL	FT	332
3	102	PAHZZ	5305-00-054-5650	96906	MS51957-16	SCREW,MACHINE	EA	2
3	103	PAHZZ	5310-00-782-1349	96906	MS15795-804	WASHER.FLAT	EA	4
3	104	PAHZZ	5310-00-811-6419	96906	MS21042-04	NUT,SELF-LOCKING,EX	EA	2
3	105	PAHZZ	5975-00-074-2072	96906	MS3367-1-9	STRAP.TIEDOWN,,ELECT	EA	1
3	106	XDHZZ		89536	104406	TIE ANCHOR	EA	1
3	107	PAHZZ	5945-01-065-3969	81349	M39016/34-008L	RELAY,ELECTROMAGNET	EA	3
3	108	PAHZZ	5310-00-782-1349	96906	MS15795-804	WASHER.FLAT	EA	2
15/(16 blank)								

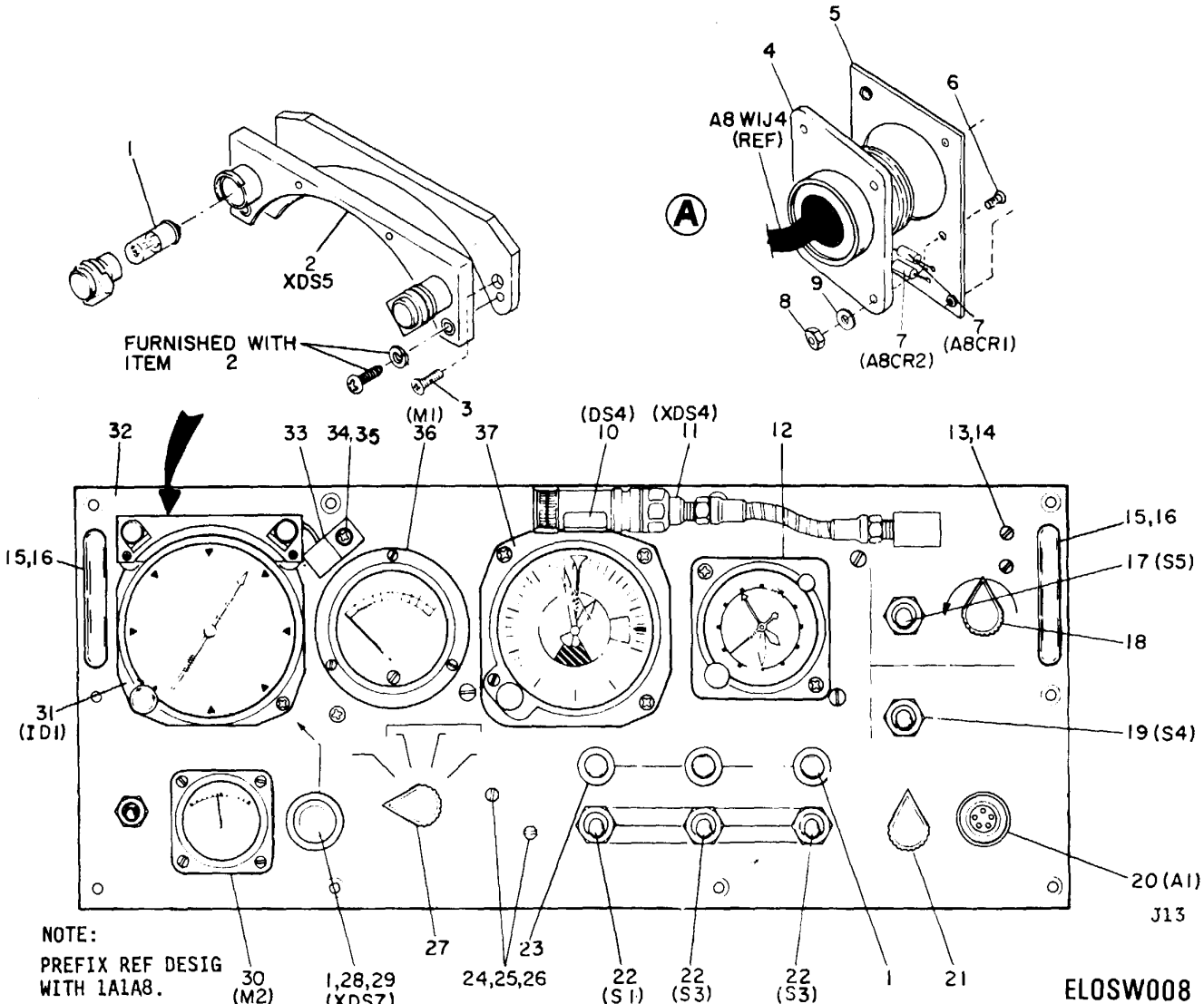

Figure 4. Front Panel Assembly (Sheet 1 of 2).

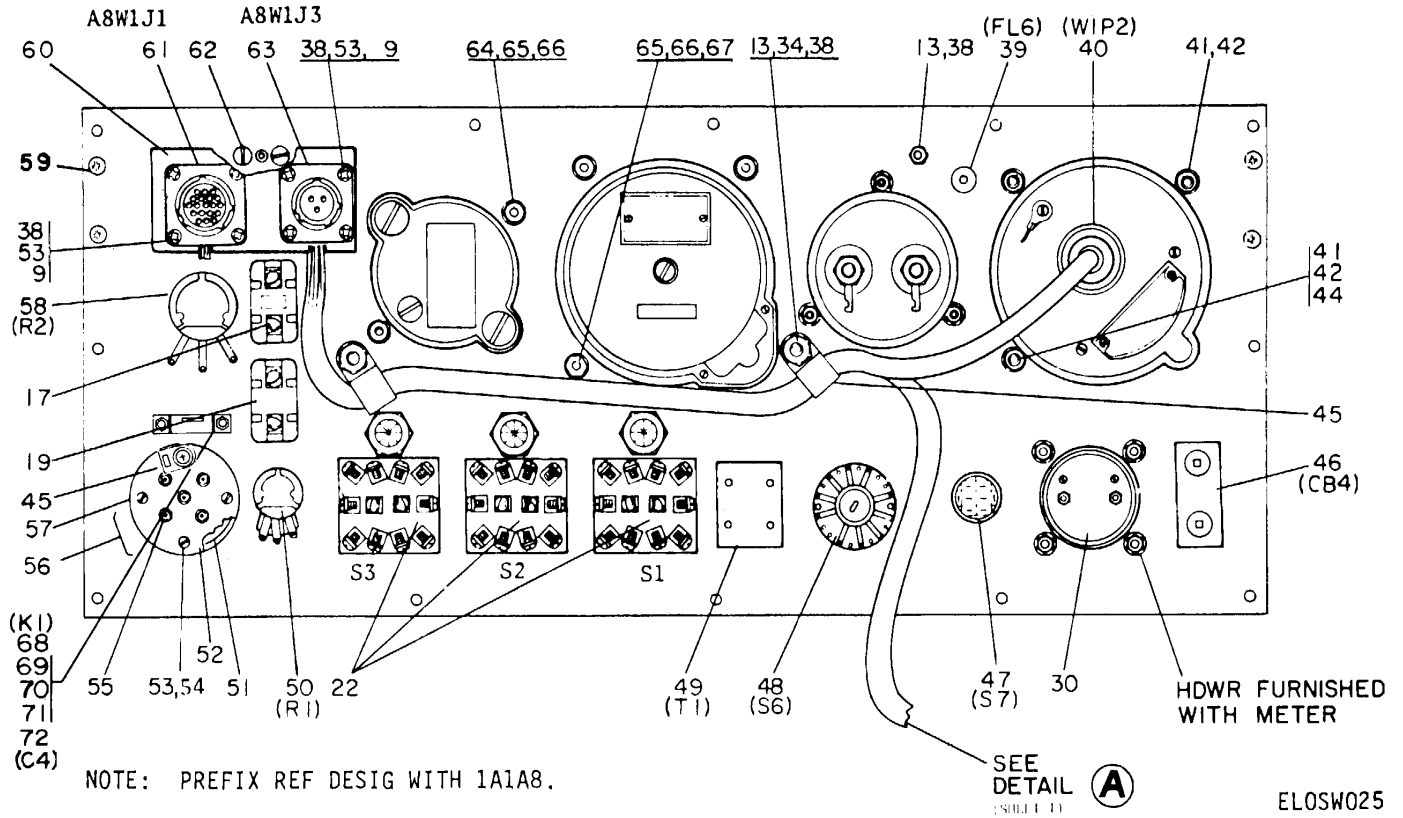

Figure 4. Front Panel Assembly (Sheet 2 of 2).

SECTION II

TM 11-5895-800-34P

(1) ILLUSTRATION (a) FIG NO.		(2) SMR CODE	(3) NATIONAL STOCK NUMBER	(4) FSCM	(5) PART NUMBER	(6) DESCRIPTION USABLE ON CODE	(7) U/M	(8) QTY INC IN UNIT
GROUP 040201 FRONT PANEL ASSEMBLY								
4	1	PAOZZ	6240-00-763-7744	81348	W-L-00111/7	LAMP, INCANDESCENT	EA	6
4	2	PAFZZ	6210-00-548-0196	72914	A167451RY24	LIGHT, PANEL.....	EA	1
4	3	PAFZZ	5305-00-777-5984	96906	MS24693C32	SCREW, MACHINE.....	EA	1
4	4	PAHZZ	5935-00-827-1547	96906	MS3112E22-55S	CONNECTOR RECEPTACL.....	EA	1
4	5	XDFZZ		80063	SC-C-706357	BRACKET ASSSEMBY, CON.....	EA	1
4	6	PAFZZ	5305-00-770-2579	96906	MS51959-15	SCREW, MACHINE.....	EA	16
4	7	PAFZZ	5961-00-087-6047	81349	JAN1N645	SEMICONDUCTOR DEVIC.....	EA	2
4	8	PAFZZ	5310-00-811-6419	96906	MS21042-04	NUT, SELF-LOCKING.EX.....	EA	16
4	9	PAFZZ	5310-00-595-6211	96906	MS15795-803	WASHER.FLAT.....	EA	16
4	10	PAOZZ	6240-00-155-8714	96906	MS25231-313	LAMP, INCANDESCENT.....	EA	1
4	11	PAFZZ	6220-01-092-8817	72914	B-5645-1	LIGHT, PANEL.....	EA	1
4	12	PAFZZ	6645-00-950-8599	81349	MILC6499ATYPEA13 A	CLOCK, AIRCRAFT, MECH.....	EA	1
4	13	PAFZZ	5310-00-194-3647	96906	MS15795-803B	WASHER, FLAT.....	EA	4
4	14	PAFZZ	5305-00-465-6745	96906	MS51957-168	SCREW, MACHINE.....	EA	4
4	15	PAFZZ	5340-00-021-3426	71219	1290-1	HANDLE, BOW.....	EA	2
4	16	PAFZZ	5305-00-455-6927	96906	MS21093-0835	SCREW, SELF-LOCKING.....	EA	2
4	17	PAFZZ	5930-00-683-1625	96906	MS24523-31	SWITCH, TOGGLE.....	EA	1
4	18	PAOZZ	5355-00-556-0145	96906	MS91528-1K2B	KNOB.....	EA	1
4	19	PAFZZ	5930-00-683-1628	96906	MS24523-22	SWITCH, TOGGLE.....	EA	1
4	20	PAFZZ	5935-00-823-0667	80058	U-183/U	CONNECTOR, RECEPTACL.....	EA	1
4	21	PAOZZ	5355-00-552-1810	96906	MS91528-1KID	KNOB.....	EA	1
4	22	PAFZZ	5930-00-660-3952	96906	MS24525-21	SWITCH, TOGGLE.....	EA	3
4	23	PAFZZ	6210-00-538-8770	96906	MS25041-3	LIGHT, INDICATOR.....	EA	3
4	24	PAFZZ	5305-00-242-7275	96906	MS51957-158	SCREW, MACHINE.....	EA	2
4	25	PAFZZ	5310-00-194-3647	96906	MS15795-803B	WASHER, FLAT.....	EA	4
4	26	PAFZZ	5310-00-224-0746	96906	MS35338-135B	WASHER, LOCK.....	EA	2
4	27	PAOZZ	5355-00-881-0722	96906	MS91528-1K4B	KNOB.....	EA	1
4	28	PAFZZ		97539	4086(ENGR, N01223 /6)	SEAL.SWITCH.....	EA	1
4	29	PAFZZ	5310-01-092-5340	97539	10	NUT.....	EA	1
4	30	PAFZZ	6625-01-114-3545	81349	MRI3B050CVVR	VOLTMETER.....	EA	1
4	31	PAFZZ	5826-00-553-5926	80058	ID-637/ARN	INDICATOR AZIMUTH.....	EA	1
4	32	PAFZZ		80063	SC-D-0706213	PANEL, FRONT.....	EA	1
4	33	XAFZZ		80063	SC-C-706216	COVER, FILTER.....	EA	1
4	34	PAFZZ	5305-00-182-9459	96906	MS51957-17B	SCREW, MACHINE.....	EA	4
4	36	PAFZZ	6625-00-894-2821	81349	MR26B050DCUAR	AMMETER.....	EA	1
4	37	PAFDD		81996	1845X4-030F	ALTIMETER, PRESSURE.....	EA	1
4	38	PAFZZ	5310-00-811-6419	96906	MS21042-04	NUT SELF-LOCKING.....	EA	1
4	39	PAFZZ	5915-01-094-1876	81349	M15733/24-0002	FILTER, RADIO FREQUE.....	EA	1

SECTION II

TM 11-5895-800-34P

(1) ILLUSTRATION		(2)	(3)	(4)	(5)	(6)	(7)	(8)
(a) FIG NO.	(b) ITEM NO.	SMR CODE	NATIONAL STOCK NUMBER	FSCM	PART NUMBER	DESCRIPTION USABLE ON CODE	U/M	QTY INC IN UNIT
4	40	PAHZZ	5935-00-642-2656	00781	14491	CONNECTOR, PLUG, ELEC	EA	1
4	41	PAFZZ	5310-00-807-1465	96906	MS21042-06	NUT, SELF-LOCKING, EX	EA	2
4	42	PAFZZ	5310-00-722-5998	96906	MS15795-805	WASHER FLAT	EA	2
4	44	PAFZZ	5305-00-150-3426	96906	MS51957-338	SCREW, MACHINE	EA	1
4	45	XDFZZ		89536	104406	TIE ANCHOR	EA	4
4	46	PAFZZ	5925-01-047-1458	81349	M39019/01-25	CIRCUIT BREAKER.....	EA	1
4	47	PAFZZ		81349	M22885/47-26	SWITCH	EA	1
4	48	PAFZZ		81349	M3786104-5058	SWITCH,ROTARY	EA	1
4	49	PAFZZ	5950-01-094-1717	98675	51-24-0	TRANSFORMER,AUDIO F.....	EA	1
4	50	PAFZZ	5905-00-851-9227	81349	RA10NASD501A	RESISTOR,VARIABLE,W	EA	1
4	51	PAFZZ	5999-01-119-9154	80063	SC-C-706255	GASKET	EA	1
4	52	XDFZZ		80063	SC-C-706222	PLATE,CONNECTOR COV.....	EA	1
4	53	PAFZZ	5310-00-595-6211	96906	MS15795-803	WASHER,FLAT	EA	4
4	54	PAFZZ	5305-00-054-5649	96906	51957-15	SCREW.MACHINE.....	EA	4
4	55	PAFZZ	5915-01-093-0799	81349	M15733/61-0011	FILTER,RADIO FREQUE	EA	5
4	56	XDFFF		80063	SC-C-706326	CONNECTOR ASSEMBL	EA	1
4	57	XAFFF		80063	SC-C-706220	COVER ASSEMBLY.CONN	EA	1
4	58	PAFZZ	5905-00-186-3125	81349	M22/03-00111SD	RESISTOR,VARIABLE,W	EA	1
4	59	PAFZZ	5305-00-770-2579	96906	MS51959-15	SCREW, MACHINE	EA	12
4	60	XDFFF		80063	SC-C-706343	BRACKET ASSEMBLY,CO	EA	1
4	61	PAHZZ	5935-00-825-8862	96906	MS3112E14-195	CONNECTOR,RECEPTACL	EA	1
4	62	PAFZZ	5105-00-455-9971	96906	MS21093-0831	SCREW,SELF-LOCKING.....	EA	2
4	63	PAFZZ	5935-30-995-5782	96906	MS3112E12-3P	CONNECTOR,RECEPTACL	EA	1
4	64	PAFZZ	5305-00-470-5602	96906	MS51957-32B	SCREW MACHINE	EA	2
4	65	PAFZZ	5310-00-807-1465	96906	MS521042-06	NUT,SELF-LOCKING,EX.....	EA	3
4	66	PAFZZ	5310-00-722-5998	96906	MS15795-805	WASHER,FLAT.....	EA	3
4	67	PAFZZ	5305-00-428-0732	96906	M551957-34B	SCREW.MACHINE.....	EA	3
4	68	PAFZZ		81349	MS39016/13-060L	RELAY,K1.....	EA	1
4	69	PAFZZ		96906	MS1957-4B	SCREW	EA	2
4	70	PAFZZ	5310-00-433-3599	96906	MS15795-802B	WASHER.FLAT	EA	2
4	71	PAFZZ	5310-00-05-1823	96906	MS21042-02	NUT.SELF-LOCKING, EX	EA	1
4	72	PAFZZ	5910-00-469-5622	81349	M39003/01-2579	CAPACITOR.....	EA	1

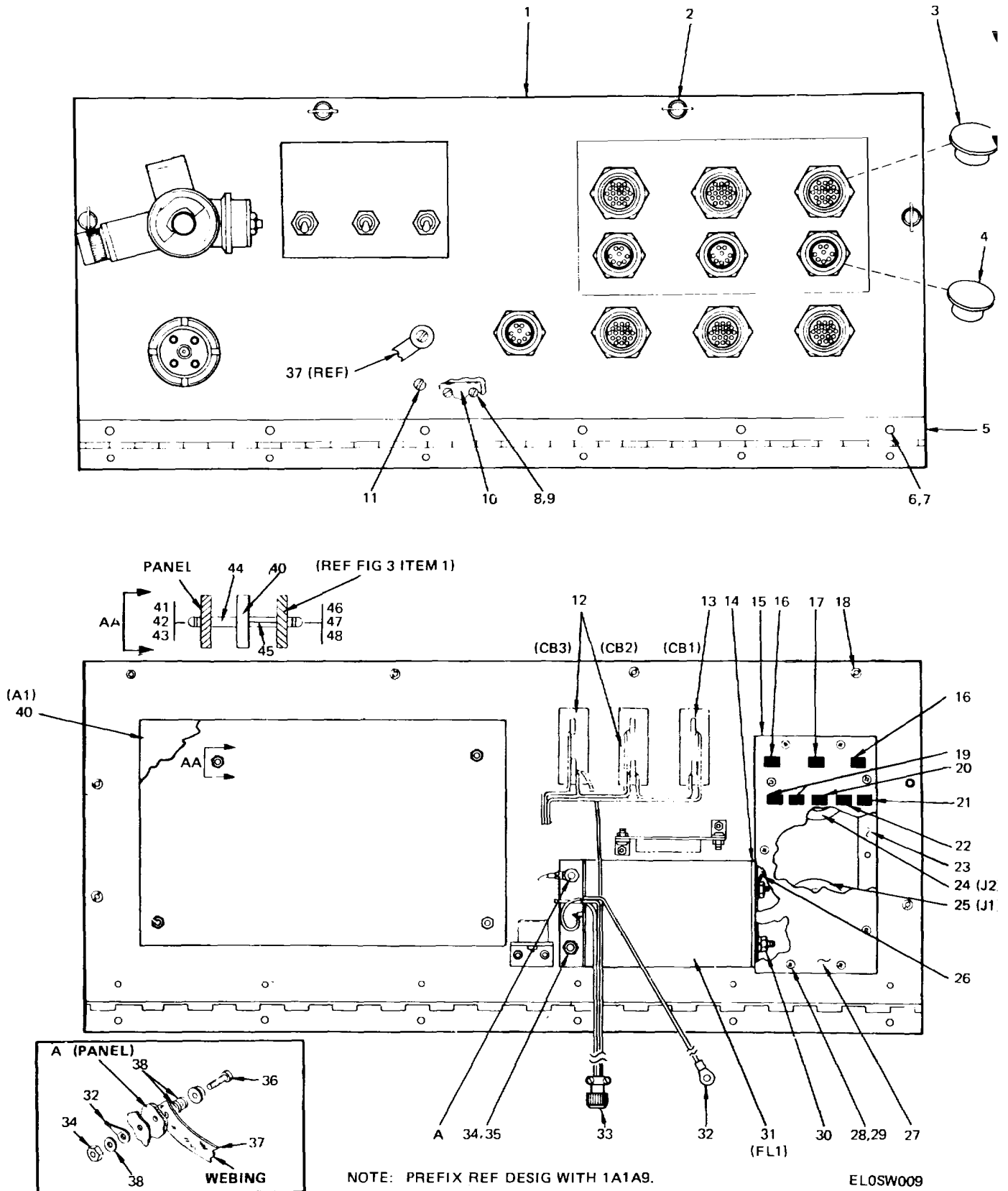

NOTE: item 39 not used.

Figure 5. Rear Panel Assembly

SECTION II

TM 11-5895-800-34P

(1) ILLUSTRATION		(2)	(3)	(4)	(5)	(6)	(7)	(8)
(a) FIG NO.	(b) ITEM NO.	SMR CODE	NATIONAL STOCK NUMBER	FSCM	PART NUMBER	DESCRIPTION USABLE ON CODE	U/M	QTY INC IN UNIT
						GROUP 040202		
5	1	XAFHH		80061	SC-D-706224	REAR PANEL ASSEMBLY	EA	1
5	2	PAFZZ	5325-01-093-0818	71186	5S10-19	STUD,TURNBUTTON FAS	EA	8
5	3	PAHZZ	5935-00-990-5580	96906	MS3181-14N	COVER,ELECTRICAL CO	EA	3
5	4	PAHZZ	5935-00-913-1823	96906	MS3181-12N	COVER,ELECTRICAL CU	EA	3
5	5	XAFZZ		80063	SC-D-7062Z6	HINGE,REAR PANEL	EA	1
5	6	PAFZZ	5305-00-494-7333	96906	MS51957-13B	SCREW, MACHINE	EA	7
5	71	PAFZZ	5310-00-224-0746	96906	MS35338-135B	WASHER,LOCK	EA	7
5	8	PAFZZ	5305-00-490-4581	96906	MS51957-298	SCREW.MACHINE	EA	2
5	9	PAFZZ	5310-00-409-1763	96906	MS15795-805B	WASHER.FLAT	EA	2
5	10	XAFZZ		89063	SC-C-706359	BRACKET ASSEMBLY,CA	EA	1
5	11	PAHZZ	5305-00-182-9459	96906	MS51957-17B	SCREW,MACHINE	EA	2
5	12	PAFZZ	5925-01-019-9703	81349	M39019/01-2Z34	CIRCUIT BREAKER	EA	2
5	13	PAHZZ	5925-01-038-1352	81349	M39019/01-231	CIRCUIT BREAKER	EA	1
5	14	PAHZZ		80063	SC-C-706351	GASKET	EA	1
5	15	XAFHH		80063	SC-C-706273	BOX ASSEMBLY,POWER	EA	1
5	16	PAOZZ	6240-00-763-7744	81348	W-L-00111/7	LAMP,INCANDESCENT.....	EA	2
5	17	PAOZZ	6240-00-155-8714	96906	MS25231-313	LAMP,INCANDESCENT.....	EA	1
5	18	PAFZZ	5310-00-849-1984	73342	6862093	WASHER,SPLIT	EA	8
5	19	PAOZZ	5920-00-782-6179	81349	FM02-125V5A	FUSE CARTRIDGE	EA	2
5	20	PAOZZ		81349	FM2A125V1 1/2A	FUSE,CARTRIDGE	EA	1
5	21	PAOZZ	5920-00-901-9938	81349	FM01-125V5A	FUSE.CARTRIDGE	EA	1
5	22	PACZZ		81349	FMO1125VSA	FUSE,CARTRIDGE	EA	1
5	23	PAFZZ		80063	SC-C-706276	GASKET	EA	1
5	24	PAHZZ	5935-00-071-1235	81349	MW20F(M)A00	CONNECTOR,RECEPTACL.....	EA	1
5	25	PAHZZ	5935-00-227-8818	81349	MW20(MM)A00	CONNECTOR,RECEPTACL.....	EA	1
5	26	PAHZZ	5940-00-143-4774	96906	MS25036-153	TERMINAL LUG	EA	2
5	27	XAFZZ		80063	SC-C-706358	COVER ASSEMBLY,POWE.....	EA	1
5	28	PAFZZ	5305-00-054-5650	96906	MS51957-16	SCREW,MACHINE.....	EA	10
5	29	PAFZZ	5310-00-595-6211	96906	MS15795-803	WASHER.FLAT.....	EA	10
5	30	PAFZZ	5310-00-934-9761	96906	MS35649-264	NUT,PLAIN,HEXAGON.....	EA	4
5	31	PAHZZ	5915-01-094-1715	13619	RF8053A	FILTER,RADIO FREOUE	EA	1
5	32	PAHZZ	5940-00-143-4774	96906	MS25036-153	TERMINAL,LUG	EA	1
5	33	PAHZZ	5935-00-901-8871	96906	MS31116F12-3S	CONECTUR,PLUG,ELEC	EA	1
5	34	PAHZZ	5310-00-811-6419	96906	MS21042-04	NUT,SELF-LOCKING.EX	EA	2
5	35	PAHZZ	5310-00-687-6664	96906	MS15195-804B	WASHER,FLAT	EA	1
5	36	PAHZZ	5305-00-433-3744	96906	MS51951-18B	SCREW.MACHINE.....	EA	1
5	37	PAHZZ		80063	SC-C-706355	STRAP ASSEMBLY CABL	EA	1
5	38	PAHZZ	5310-00-782-1349	96906	MS15795-804	WASHER,FLAT	EA	5
5	40	PAFLL	5895-01-021-5924	21671	DL-SC-B-706233	CIRCUIT CARD ASSEMB.....	EA	1

SECTION II

TM 11-5895-800-34P

(1) ILLUSTRATION		(2)	(3)	(4)	(5)	(6)	(7)	(8)
(a) FIG NO.	(b) ITEM NO.	SMR CODE	NATIONAL STOCK NUMBER	FSCM	PART NUMBER	DESCRIPTION USABLE ON CODE	U/M	QTY INC IN UNIT
5	41	PAFZZ	5305-00-231-9808	96906	MSS1957-19B	SCREW,MACHINE	EA	4
5	42	PAFZZ	5310-00-194-3647	96906	MS15795-803B	WASHER,FLAT	EA	4
5	43	PAFZZ	5310-00-Z24-0746	96906	MS35338-135B	WASHER,LOCK	EA	4
5	44	PAFZZ	5365-01-092-9076	80063	SC-B-706379	SPACER, RING	EA	4
5	45	PAFZZ		80063	SC-C-706240	SPACER,PLATE	EA	4
5	46	PAFZZ	5305-00-054-5649	96906	MSS1957-1S	SCEW MACHINE	EA	4
5	47	PAFZZ	5310-00-933-8118	96906	MSI5338-135	WASHER,LOCK	EA	4
5	48	PAFZZ	5310-00-595-6211	96906	MS15795-803	WASHER,FLAT	EA	4

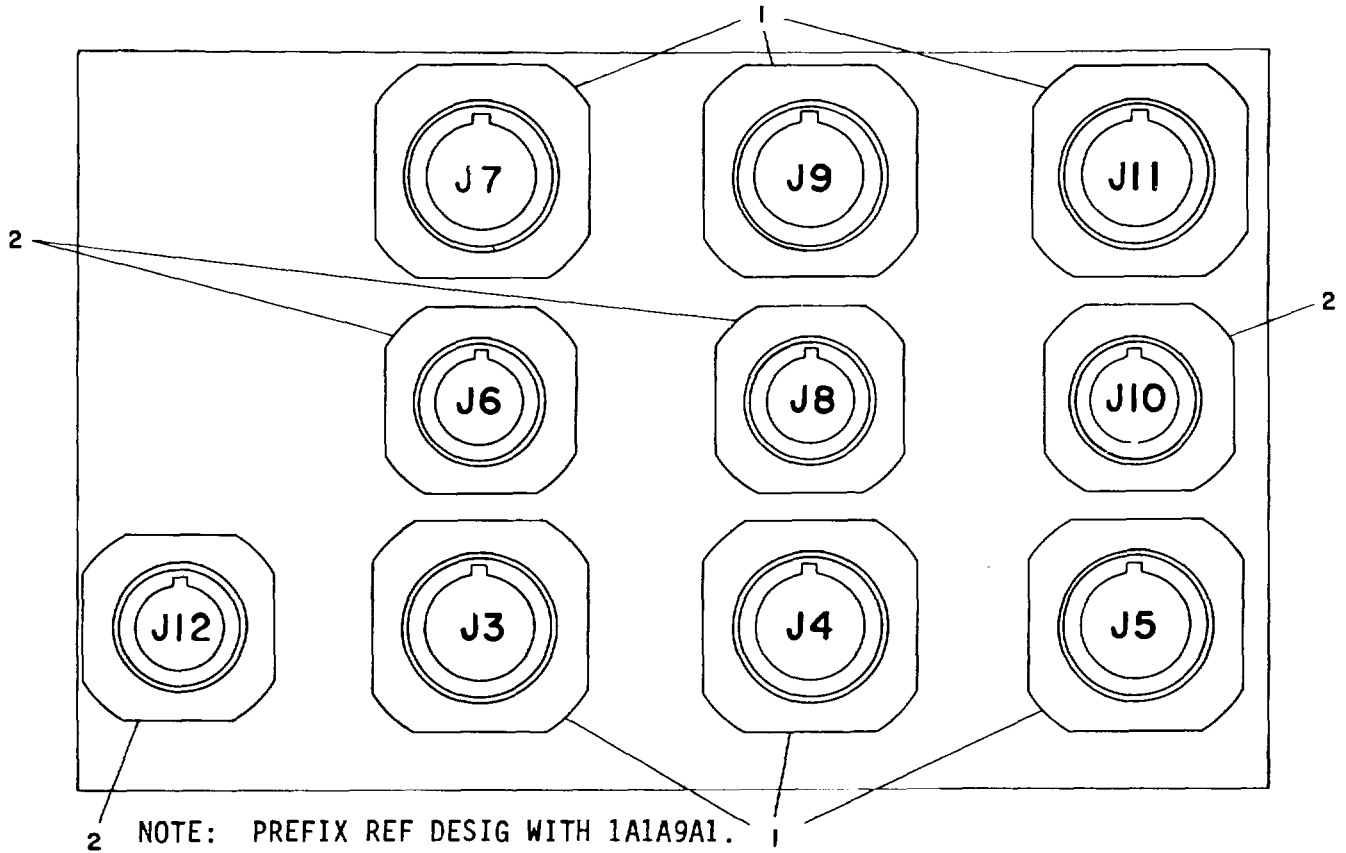

ELOSW010

Figure 6. Interface Circuit Board (Sheet 1 of 2).

REF DES	ITEM NO.	REF DES	ITEM NO.
C1	5	C23	5
C2		C24	
C3		C25	
C4		C26	
C5		C27	
C6		C28	
C7		C29	
C8		C30	
C9		C31	
C10		C32	
C11		C33	
C12		C34	
C13		C35	
C14		C36	
C15		C37	
C16		C38	
C17		C39	
C18		C40	
C19		C41	
C20		C42	
C21		C43	
C22		C44	

REF DES	ITEM NO.	REF DES	ITEM NO.
C45	5	C67	5
C46		C68	
C47		C69	
C48		C70	
C49		C71	
C50		C72	
C51		C73	
C52		C74	
C53		C75	
C54		C76	
C55		C77	
C56		C78	
C57		C79	
C58		C80	
C59		C81	
C60		C82	
C61		C83	
C62		C84	5
C63		CR1	11
C64		CR2	
C65		CR3	
C66		CR4	
		CR5	
		CR6	11

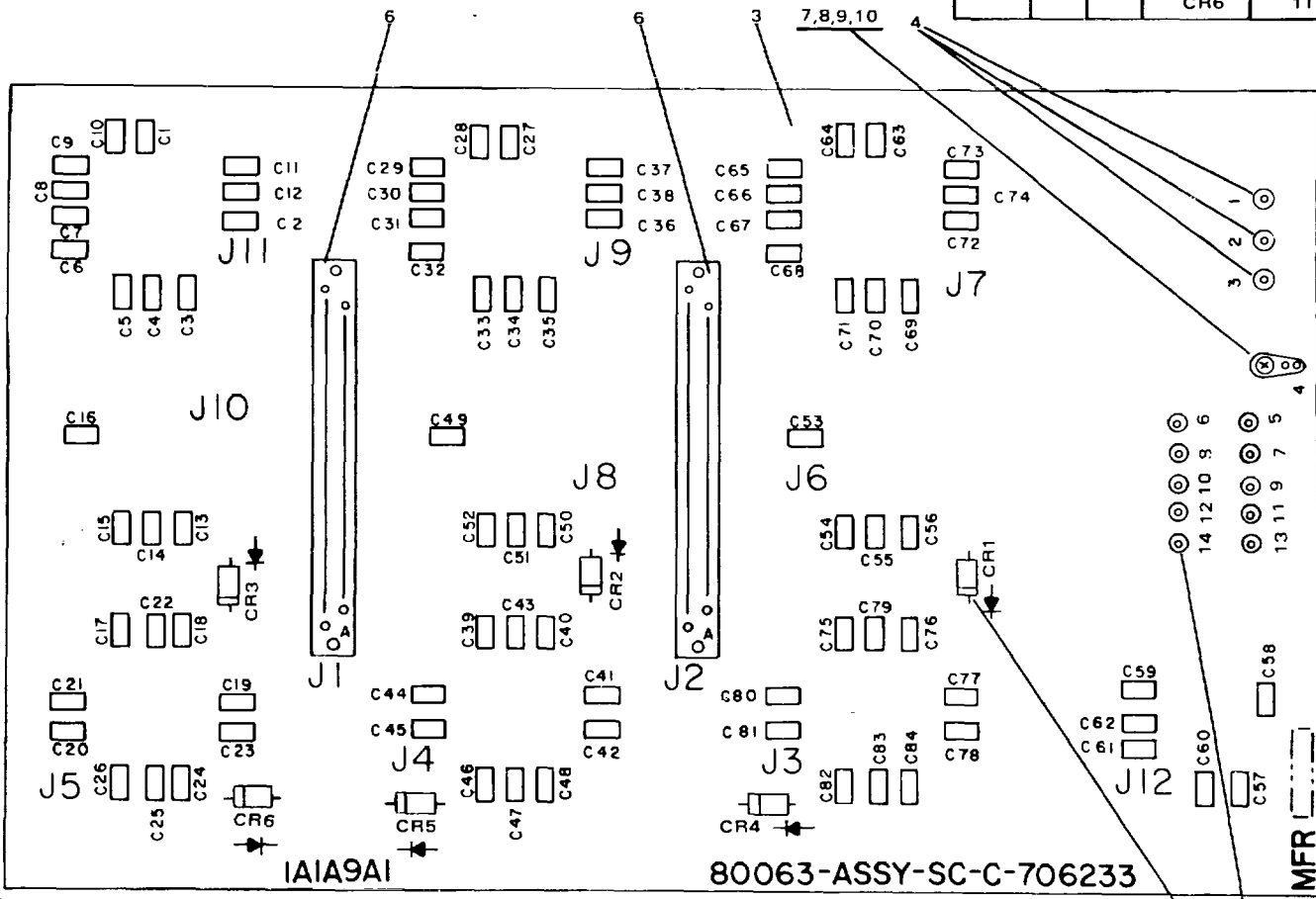

NOTE: ALL CAPACITORS C1-C84 ARE IDENTICAL
 PREFIX REF DESIG WITH 1A1A9A1.

* TERMINAL STUD SHOWN 10 EACH ON EARLIER
 REVISIONS ARE ITEM 12

** CR1-6 ON EARLIER MODELS WILL HAVE
 DIFFERENT PHYSICAL LOCATION

ELOSWO11

Figure 6. Interface Circuit Board (Sheet 2 of 2)

SECTION II

TM 11-5895-800-34P

(1) ILLUSTRATION		(2)	(3)	(4)	(5)	(6)	(7)	(8)
(a) FIG NO.	(b) ITEM NO.	SMR CODE	NATIONAL STOCK NUMBER	FSCM	PART NUMBER	DESCRIPTION USABLE ON CODE	U/M	QTY INC IN UNIT
						GROUP 04020201 INTERFACE CIRCUIT BOARD		
6	1	PAHZZ		17820	71 252714-19S	CONNECTOR,RECEPTACL.....	EA	6
6;	2	PAHZZ	5935-01-113-4488	77820	71-252712-8S	CONNECTOR, RECEPTACL	EA	4
6	3	XAHZZ		80063	SC-C-706235	PRINTED WIRING BOAR	EA	1
6	4	PAHZZ	5940-00-915-6128	81349	SE25XC02	TERMINALSUTD.....	EA	4
6	5	PAHZZ		81349	M39014/01-1447	CAPACITOR.FIXED,CER	EA	84
6	6	PAHZZ	5935-00-162-1543	31349	M55302/6-05	CONNECTOR ,RECEPTACL.....	EA	2
6	7	PAHZZ	5940-00-682-2477	96906	MS77068-1	TERMINAL.LUG	EA	1
6	8	PADZZ	505-00-054-5653	96906	MS51957-19	SCREW,MACHINE.....	EA	1
6	9	PAHZZ	5310-00-595-6211	96906	MS15795-803	WASHER,FLAT	EA	1
6	10	PAHZZ	5310-00-811-6419	96906	MS21042-04	NUT,SELF-LOCKING,EX	EA	1
6	11	PADZZ	5961-00-087-6047	R1349	JAN1N645	SEMICONDUCTCR DEVIC.....	EA	6
6	12	PADZZ	5940-00-915-6128	81349	SE25XC02	TERMINAL,STUD	EA	1

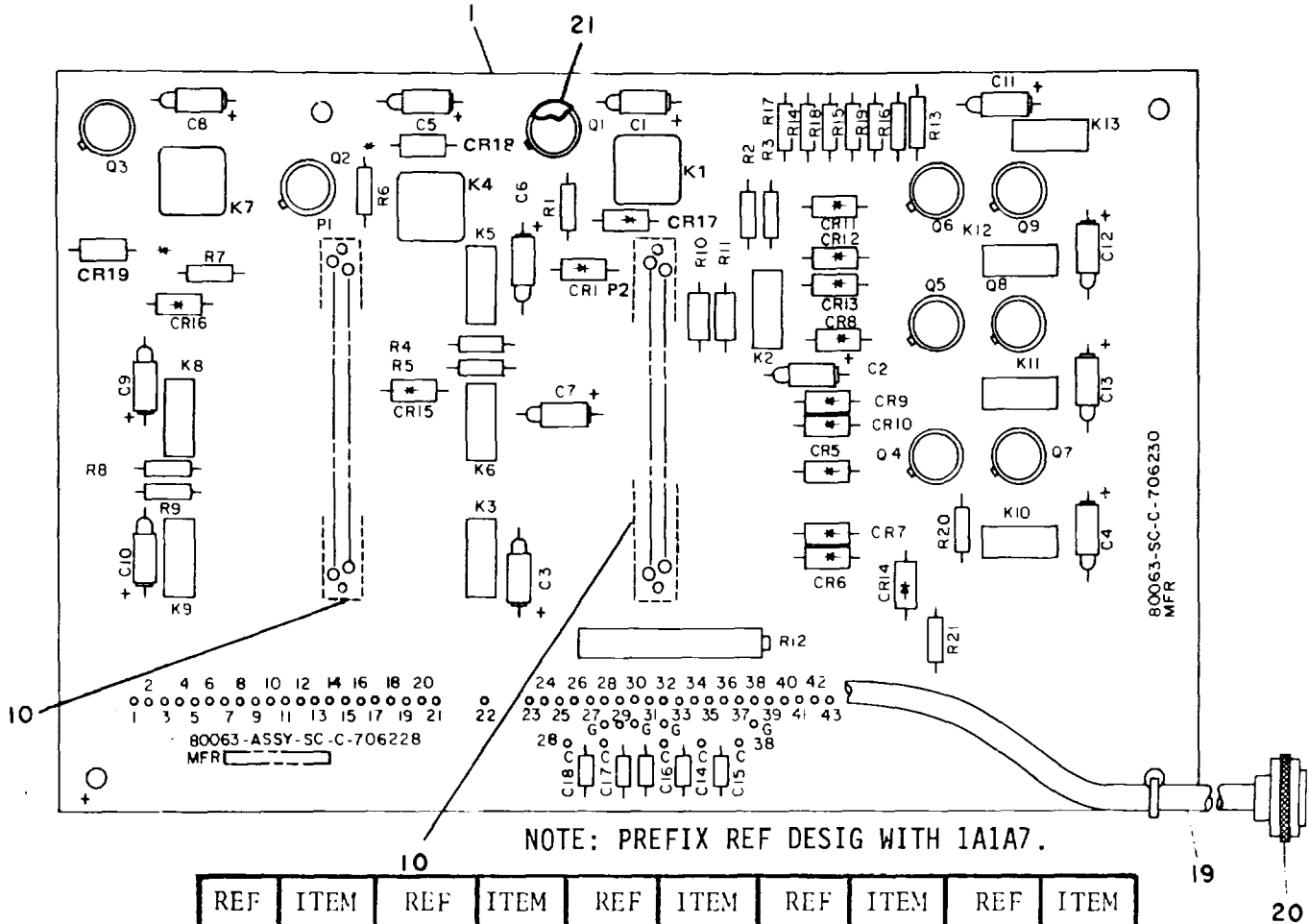

REF DES	ITEM NO.	REF DES	ITEM NO.	REF DES	ITEM NO.	REF DES	ITEM NO.	REF DES	ITEM NO.
C1	2	CR1	6	K1	3	Q1	4	R8	8
C2	2	CR5	6	K2	7	Q2	4	R9	9
C3	2	CR6	6	K3	7	Q3	4	R10	14
C4	2	CR7	6	K4	3	Q4	4	R11	15
C5	2	CR8	6	K5	7	Q5	4	R12	13
C6	2	CR9	6	K6	7	Q6	4	R13	18
C7	2	CR10	6	K7	3	Q7	4	R14	17
C8	2	CR11	6	K8	7	Q8	4	R15	17
C9	2	CR12	6	K9	7	Q9	4	R16	17
C10	2	CR13	6	K10	7			R17	17
C11	2	CR14	12	K11	7			R18	17
C12	2	CR15	6	K12	7	R1	5	R19	17
C13	2	CR16	6	K13	7	R2	8	R20	9
C14	11	CR17	6			R3	9		
C15	11	CR18	6			R4	8	R21	16
C16	11	CR19	6	P1		R5	9		
C17	11			P2		R6	5		
C18	11					R7	5		

ITEM NO. NOT USED, 22

ELOSW012

Figure 7. Control Circuit Board Assembly.

SECTION II

TM 11-5895-800-34P

(1) ILLUSTRATION		(2)	(3)	(4)	(5)	(6)	(7)	(8)
(a) FIG NO.	(b) ITEM NO.	SMR CODE	NATIONAL STOCK NUMBER	FSCM	PART NUMBER	DESCRIPTION USABLE ON CODE	U/M	QTY INC IN UNIT
						GROUP 040203 CONTROL CIRCUIT BOARD ASSY		
7	1	XDHZZ		80063	SC-C-706230	PRINTED WIRING BOAR	EA	1
7	2	PAHZZ	5910-00-189-3178	81349	M39003/01-3058	CAPACITOR FIXED, ELE	EA	13
7	3	PAHZZ		99928	JRA-4C-24B	RELAY,ELFCTRCMAGNET WHEN DEFECTED REPLACE 80063 SL-C-706228..	EA	3
7	3	PAFZZ		81349	M939016114-0021	ON LATER PRUCJCTION CARDS USE 81349 M39016114-0021..... RELAY	EA	3
7	4	PAHZZ	5961-00-054-0046	81349	JAN2N1711	TRANSISTOR	EA	9
7	5	PAHZZ	5905-00-141-0743	81349	RCR07G392JS	RESISTOR.FIXED,COMP	EA	3
7	6	PAHZZ	5961-00-087-6047	81349	JAN1N645	SEMICONDUCTOR DEVIC.....	EA	15
7	7	PAHZZ	5945-01-065-3969	81349	M39016/34-008L	RELAY, ELECTROMAGNET.....	EA	10
7	8	PAHZZ	5905-00-105-7168	81349	RCR07G561JS	RESISTOR.FIXED,COMP	EA	3
7	9	PAHZZ	5905-00-119-8811	81349	RCR07151JS	RESISTOR,FIXED,COMP	EA	4
7	11	PAHZZ	5935-01-094-3686	813491	M55302/5-05	CONNECTOR.RECEPTACL.....	EA	2
7	11	PAHZ7	5910-00-098-9281	81349	M39014/05-2237	CAPACITER,FIXED,CER.....	EA	5
7	12	PAHZZ	5961-00-903-2990	81349	JAN1N4372A	SEMICONDUCTR DEVIC	EA	1
7	13	PAHZZ	5905-00-593-5037	81349	M39015/1-006YP	RESISTOR,VARIABLE,W.....	EA	1
7	14	PAHZZ	5905-00-235-8959	81349	RNR55CS111FS	RESISTOR,,FIXED,FILM	EA	1
7	15	PAHZZ	5905-00-419-5257	81349	RNR55C2210FS	RESISTOR,FIXED,FILM.....	EA	1
7	16	PAHMZ	5905-00-116-8556	81349	RCRO7G223JS	RESISTOR,FIXED,COMP.....	EA	1
7	17	PAHZZ	5905-00-106-3666	81349	RCR07G103JS	RESISTOR,FIXED,COMP	EA	6
7	18	PAHZZ		81349	RWR82S1211FM	RESISTOR,FIXED.FILM	EA	1
7	19	XDHHH		80063	SC-D-706314	WIRE HARNESS,CONTRO	EA	1
7	20	PAHZZ	5935-00-892-9329	96906	MS3116F22-55P	CONNECTOR,PLUG,ELEC	EA	1
7	21	PAHZZ	5999-01-072-8616	81349	M38527/2-04N	MOUNTING PAD,ELECTR	EA	9

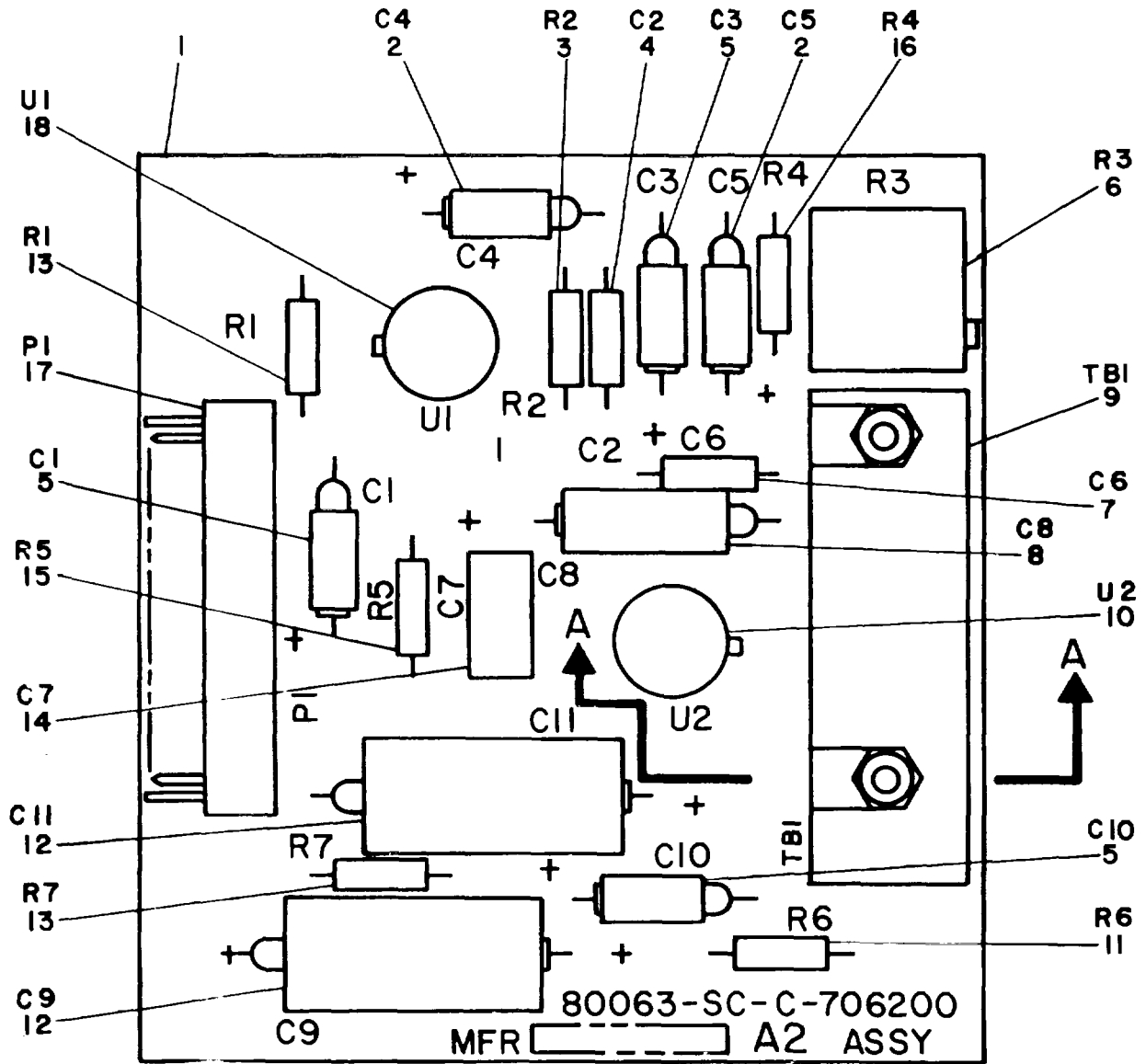

NOTE: PREFIX REF DESIG WITH 1A1A2.

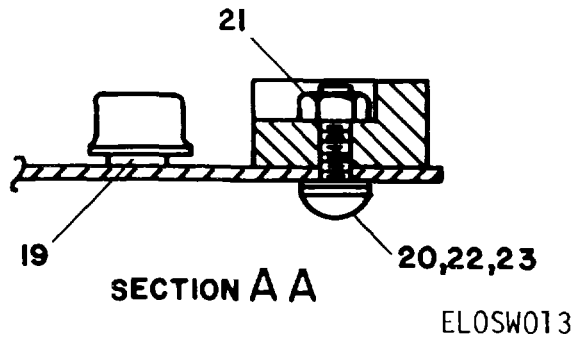
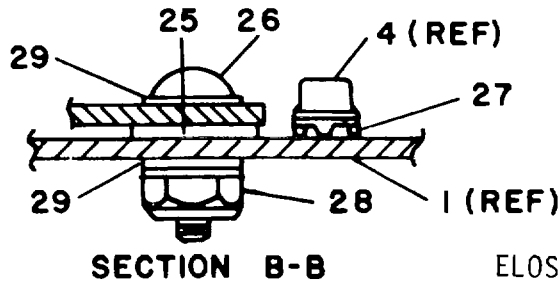
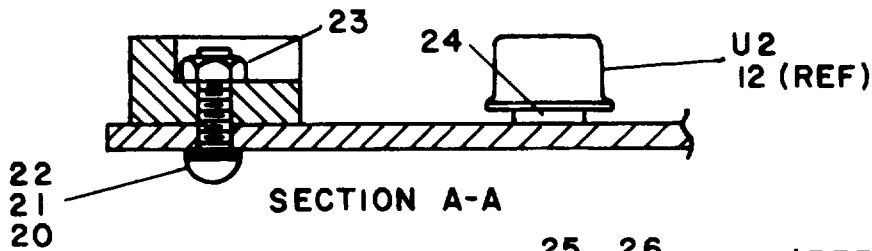
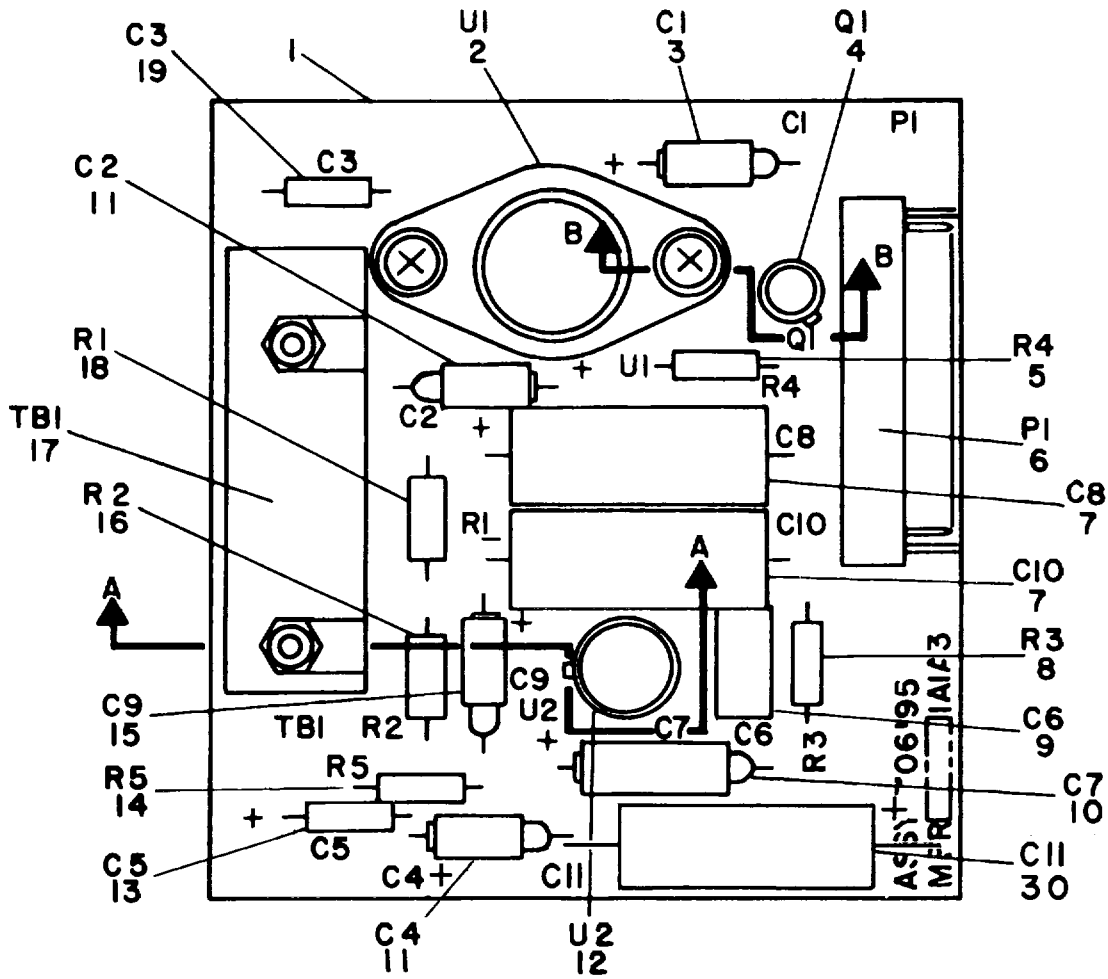

Figure 8. Microphone Amplifier Printed Circuit Board Assembly.

SECTION II

TM 11-5895-800-34P

(1) ILLUSTRATION		(2)	(3)	(4)	(5)	(6)	(7)	(8)
(a) FIG NO.	(b) ITEM NO.	SMR CODE	NATIONAL STOCK NUMBER	FSCM	PART NUMBER	DESCRIPTION USABLE ON CODE	U/M	QTY INC IN UNIT
						GROUP 040204 MICROPHONE AMPLIFIER PRINTED CIRCUIT BOARD ASSY		
8	1	XAHZZ		30363	SC-C-706202	PRINTED WIRING BOAR	EA.	1
8	2	PAHZZ	5910-00-217-1228	81349	M39003/01-3063	CAPACITOR, FIXED, ELE.....	EA	2
8	3	PAHZZ	5905-00-116-8556	81349	RCR07G223JS	RESISTOR, FIXED. COMP	EA	1
8	4	PAHZZ		81349	M39014/13-0515	CAPACITOR, FIXED, CER.....	EA	1
8	5	PAHZZ	5910-00-495-0042	81349	M39003/01-3076	CAPACITOR, ELECTRICA.....	EA	3
8	6	PAHZZ	5905-01-011-7614	81349	M39015/2-006PR	RESISTOR, VARIABLE, W.....	EA	1
8	7	PAHZZ		81349	M39014/13-0515	CAPACITOR, FIXED, CER.....	EA	1
8	8	PAHZZ	5910-00-113-5475	81349	M39003/01-3006	CAPACITOR, FIXED, ELE	EA	1
8	9	XAHZZ		81349	M39024/6-03	CONNECTOR, PLUG, ELEC.	EA	1
8	10	PGHZZ		04713	MC1554D8XS	MICROCIRCUIT, LINEAR	EA	1
8	11	PAHZZ	5905-00-107-0656	81349	RCR07G100JS	RESISTOR. FIXED. COMP	EA	1
8	12	PAHZZ	5910-00-236-8745	81349	M39003/01-3021	CAPACITOR. FIXED, ELE	EA	2
8	13	PAHZZ	5905-00-119-8811	81349	RCR07G151JS	RESISTOR, FIXED. COMP	EA	2
8	14	PAHZZ	5910-01-049-5675	81349	CMR04E390GODM	CAPACITOR, F IXED, MIC.....	EA	1
8	15	PAHZZ	5905-00-120-9154	81349	RCR07G471JS	RESISTOR, FIXED, COMP	EA	1
8	16	PAHZZ	5905-00-106-3666	8149	RCR07G103JS	RESISTOR, FIXED, COMP	EA	1
8	17	PAHZZ	5935-00-400-1714	81349	M5530211-03	CONNECTOR RECEPTACL.....	EA	1
8	18	PGHZZ	5962-01-093-0947	80063	SC-A-706206	MICROCIRCUIT, LINEAR	EA	1
8	19	PAHZZ	5310-00-716-5618	96906	MS51859-1	WASHER, FLAT.....	EA	2
8	20	PAHZZ	5305-00-054-5639	96906	MS51957-5	SCREW, MACHINE.....	EA	2
8	21	PAHZZ	5310-00-938-2013	96906	MS35649-224	NUT, PLAIN, HEXAGON	EA	2
8	22	PAHZZ	5310-00-928-2690	96906	MS35338-134	WASHER, LOCK	EA	2
8	23	PAHZZ	5310-00-595-6761	96906	MS15795-802	WASHER. FLAT	EA	2



NOTES:

1. PREFIX REFERENCE DESIGNATIONS WITH 1A1A3.
2. PRODUCTION UNITS REWORKED BY MOUNTING CAPACITOR C11 ON CIRCUIT SIDE.

ELOSW014

Figure 9. Headset Amplifier Printed Circuit Board Assembly.

SECTION II

TM 11-5895-800-34P

(1) ILLUSTRATION		(2)	(3)	(4)	(5)	(6)	(7)	(8)
(a) FIG NO.	(b) ITEM NO.	SMR CODE	NATIONAL STOCK NUMBER	FSCM	PART NUMBER	DESCRIPTION USABLE ON CODE	U/M	QTY INC IN UNIT
						GROUP 040205 HEADSET AMPLIFIER PAINTED CIRCUIT BOARD ASSEMBLY		
9	1	XAHZZ		80063	SC-C-706197	PRINTED WIRING; BOAR	EA	1
9	2	PGHZZ	5962-00-361-8672	45413	134511-1	MICROCIRCUIT LINEAR	EA	1
9	3	PAHZZ	5910-00-455-4304	813491	M39003/0-367	CAPACITOR.FIXED,ELE	EA	1
9	4	PAHZZ	5961-00-842-6937	81349	JAN2N706	TRANSISTOR.....	EA	1
9	5	PAHZZ	5905-00-402-7134	81349	RWR81SIR50FR	RESISTOR,FIXED, WIRE.....	EA	1
9	6	PAHZZ	5935-00-40-1714	81349	M5530211-03	CONNECTOR.RECEPTACL.....	EA	1
9	7	PAHZZ	5910-00-236-8745	81349	M39003/1-3021	CAPACITOR,FIXED,ELE.....	EA	2
9	8	PAHZZ	5905-00-106-3666	81349	RCR07GI03JS	RESISTOR,FIXED.COMP.....	EA	1
9	9	PAHZZ	5910-01-049-5675	81349	CMR04E390GODM	CAPACITOR,FIXED.MIC	EA	1
9	10	PAHZZ	5910-00-113-5475	81349	M39003/01-3006	CAPACITOR.FIXED,ELE	EA	1
9	11	PAHZZ	5910-00-217-1228	81349	M39003/01-3063	CAPACITOR,FIXED,ELE.....	EA	2
9	12	PAHZZ		04713	MC1554D8XS	MICROCIRCUIT,LINEAR	EA	1
9	13	PAHZZ		81349	M39014/13-0515	CAPACITOR.FIXED,CER	EA	1
9	14	PAHZZ	5905-00-107-0656	81349	RCR07G100JS	RESISTOR,FIXED,COMP.....	EA	1
9	15	PAHZZ	5910-00-495-0042	81349	M39003/01-3076	CAPACITOR.ELECTRCA	EA	1
9	16	PAHZZ	5905-00-444-0291	81349	RNR55C6811FS	RESISTOR,FIXED.FILM	EA	1
9	17	PAHZZ		81349	M39024/6-03	CONNECTOR,PLUG,ELEC.....	EA	1
9	18	PAHZM	5905-00-523-8750	81349	RN855CI782FS	RESISTOR,FIXED.FILM	EA	1
9	19	PAHZZ		81349	M39014/13-0505	CAPACITOR,FIXED,CER.....	EA	1
9	20	PAHZZ	5305-00-054-5639	96906	MS51957-5	SCREW,MACHINE.....	EA	2
9	21	PAHZZ	5310-00-978-2690	96906	MS35338-134	WASHER.LOCK	EA	2
9	22	PAHZZ	5310-00-595-6761	96906	MS15795-802	WASHER.FLAT.....	EA	2
9	23	PAHZZ	5310-00-938-2013	96906	MS35649-224	NUT,PLAIN.HEXAGON.....	EA	2
9	24	PAHZZ	5310-00-716-5618	96906	MS51859-1	WASHER.FLAT.....	EA	1
9	25	PAHZZ	5310-00-716-5612	96906	MS51859-2	WASHER.FLAT	EA	2
9	26	PAHZZ	5305-00-054-5649	96906	MS51957-15	SCREW,MACHINE	EA	2
9	27	PAHZZ	5965-00-179-7762	81349	M80CU	MOUNTING PAD,ELECTR.....	EA	1
9	28	PAHZZ	5310-00-811-6419	96906	MS21042-04	NUT.SELF-LOCKING.EX.....	EA	2
9	29	PAHZZ	5310-00-595-6211	96906	MS15795-803	WASHER,FLAT	EA	2
9	30	PAHZZ	5910-00-601-5624	81349	M39006121-0148	CAPACITOR.FIXED,ELE.....	EA	1

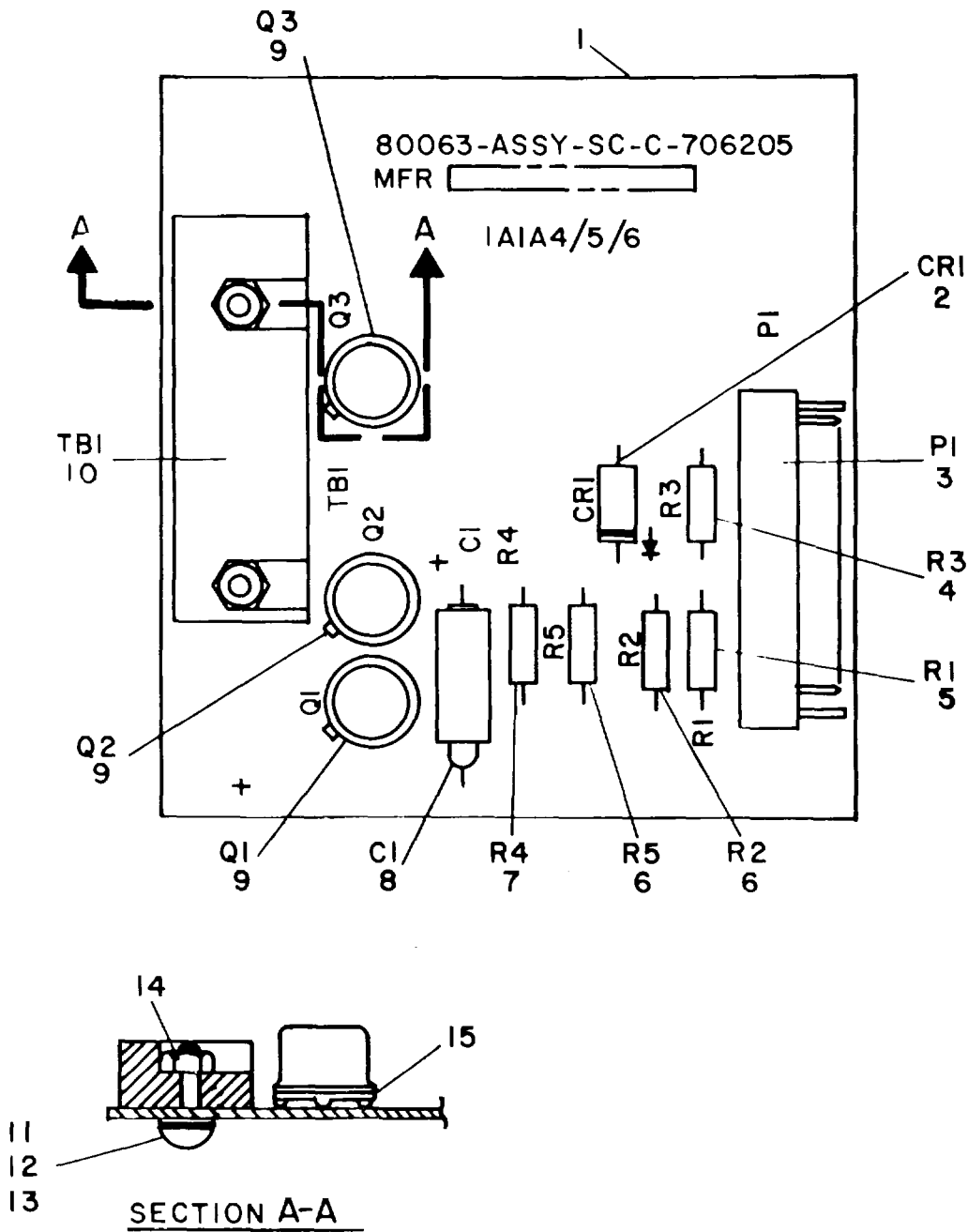

NOTE: PREFIX REF DESIG WITH 1A1A4,
1A1A5, OR 1A1A6.

Figure 10. Lamp Indicator Printed Circuit Board Assembly.

SECTION II

TM 11-5895-800-34P

(1) ILLUSTRATION		(2)	(3)	(4)	(5)	(6) DESCRIPTION	(7)	(8)
(a) FIG NO.	(b) ITEM NO.	SMR CODE	NATIONAL STOCK NUMBER	FSCM	PART NUMBER	USABLE ON CODE	U/M	QTY INC IN UNIT
						GROUP 040206 LAMP INDICATOR PRINTED CIRCUIT BOARD ASSEMBLY		
10	1	XDHZZ		80063	SC-C-0620	PRINTED WIRING, BOAR	EA	1
10	2	PAHZZ	5961-00-995-2310	81349	JANIN752A	SEMICONDUCTOR DEVIC	EA	1
10	3	PAHZZ	5935-00-400-1714	81349	M55302/1-03	CONNECTOR,RECEPTACL	EA	1
10	4	PAHZZ	5905-00-114-0711	81349	RCR07G472JS	RESISTOR,FIXED,COMP	EA	1
10	5	PAHZZ	5905-00-131-1255	81349	RCR07G122JS	RESISTOR,FIXED,COMP	EA	1
10	6	PAHZZ	5905-00-106-3666	81349	RCR07G103JS	RESISTOR,FIXED,COMP	EA	2
10	7	PAHZZ	5905-00-485-4545	81349	RCR07G334JS	RESISTOR.FIXED,COMP.	EA	1
10	8	PAHZZ	5910-00-007-3974	81349	M39003/01-2991	CAPACITOR,FIXED,ELE	EA	1
10	9	PAHZZ	5961-00-853-2601	81349	JAN2N1893	TRANSISTOR	EA	3
10	10	PADZZ		81349	M39024/6-03	CONNECTOR,PLUG.ELEC	EA	1
10	11	PAHZZ	5305-00-054-5639	96906	MS51957-5	SCREW.MACHNE	EA	2
10	12	PAHZZ	5310-00-928-2690	96906	MS35338-134	WASHER,LOCK	EA	2
10	13	PAHZZ	5310-00-595-6761	96906	MS15795-802	WASHER,FLAT	EA	2
10	14	PAHZZ	5310-00-938-2013	96906	MS35649-224	NUT,PLAIN,HEXAGON	EA	2
10	15	PAHZZ	5999-01-072-8616	81349	M38527/2-04N	MOUNTING PAD,ELECTR.....	EA	3

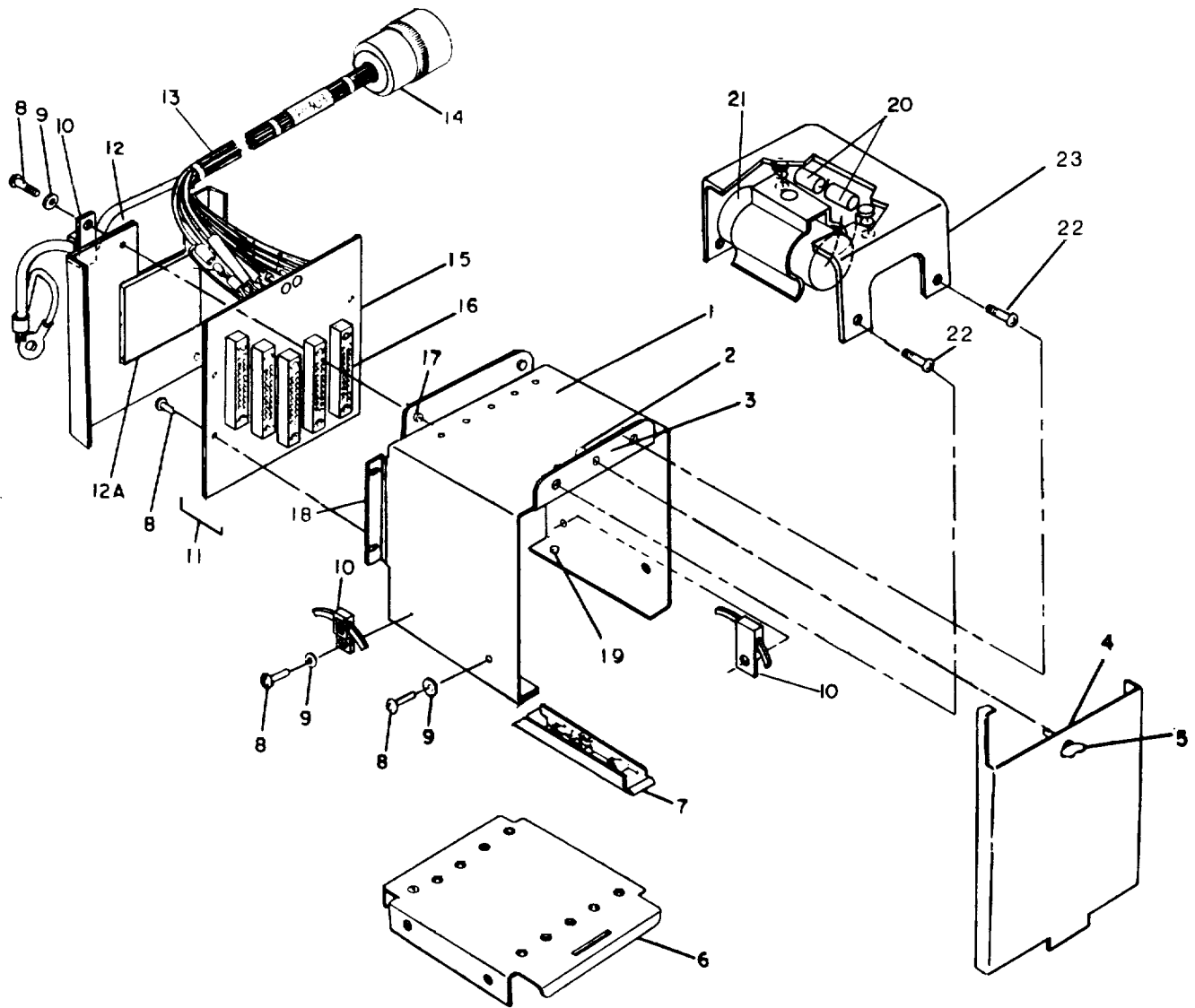

ELOS016

Figure 11 . Card Enclosure Assembly.

SECTION II

TM 11-5895-800-34P

(1) ILLUSTRATION		(2)	(3)	(4)	(5)	(6)	(7)	(8)
(a) FIG NO.	(b) ITEM NO.	SMR CODE	NATIONAL STOCK NUMBER	FSCM	PART NUMBER	DESCRIPTION USABLE ON CODE	U/M	QTY INC IN UNIT
						GROUP 040207 CARD ENCLOSURE ASSEMBLY		
11	1	XAFFF		80063	SC-C-706289	FRAME ASSEMBLY.....	EA	1
11	2	PAFZZ	5325-00-758-0113	71286	5R2-3	RECEPTACLE,TURNLOCK.....	EA	1
11	3	PAFZZ	5320-00-117-6937	96906	MS20426AD3-3	RIVET,SOLID.....	EA	2
11	4	XAFZZ		80063	SC-C-706210	COVER,FRONT.....	EA	1
11	5	PAFZZ	5325-00-808-1023	71286	5510-16	STUD,TURNLOCK FASTE.....	EA	1
11	6	XAFZZ		80063	SC-C-706189	BASE.....	EA	1
11	7	PAFZZ	5999-00-506-6746	32559	E-250	HOLDER,ELECTRICAL C.....	EA	10
11	8	PAFZZ	5305-00-054-5649	96906	MS51957-15	SCREW,MACHINE.....	EA	4
11	9	PAFZZ	5310-00-595-6211	96906	MS15795-803	WASHER,FLAT.....	EA	4
11	10	XDFZZ		89536	104406	TIE ANCHOR.....	EA	3
11	11	XDFFF		80063	SC-D-706191	MOTHER BOARD ASSEMB.....	EA	1
11	12	XAFZZ		80063	SC-C-706211	COVER,BACK.....	EA	1
11	12A	XDFZZ		80063	SC-B-706349-1	CUSHION,CIRCUIT BOA.....	EA	1
11	13	XDFZZ		80063	SC-D-706316	WIRING HARNESS ASSE.....	EA	1
11	14	PAFZZ	5935-00-779-8294	96906	MS3116F14-19P	CONNECTOR,PLUG,ELEC.....	EA	1
11	15	XAFZZ		80063	SC-C-706192	PRINTED WIRING BOAR.....	EA	1
11	16	PAFZZ	5935-00-241-2746	81349	M55302/2-03	CONNECTOR,RECEPTACLE.....	EA	5
11	17	PAFZZ	5310-01-053-7003	81349	M45938/3-4L	NUT,SELF-LOCKING,CL.....	EA	6
11	18	XDFZZ		80063	SC-8-706354	SPACER,CIRCUIT BOAR.....	EA	2
11	19	PAFZZ	5310-01-057-9348	81349	M45938/3-6L	NUT,SELF-LOCKING,CL.....	EA	4
11	20	PAFZZ	5910-00-601-5624	81349	M39006/21-0148	CAPACITOR,FIXED,ELE.....	EA	2
11	21	PAFZZ		80063	SC-A-706198	CHOKE.....	EA	1
11	22	PAFZZ	5305-00-763-7822	96906	MS51959-14	SCREW,MACHINE.....	EA	2
11	23	PAFZZ		80063	SC-C-706176	BRACKET ASSY,FILTER.....	EA	1

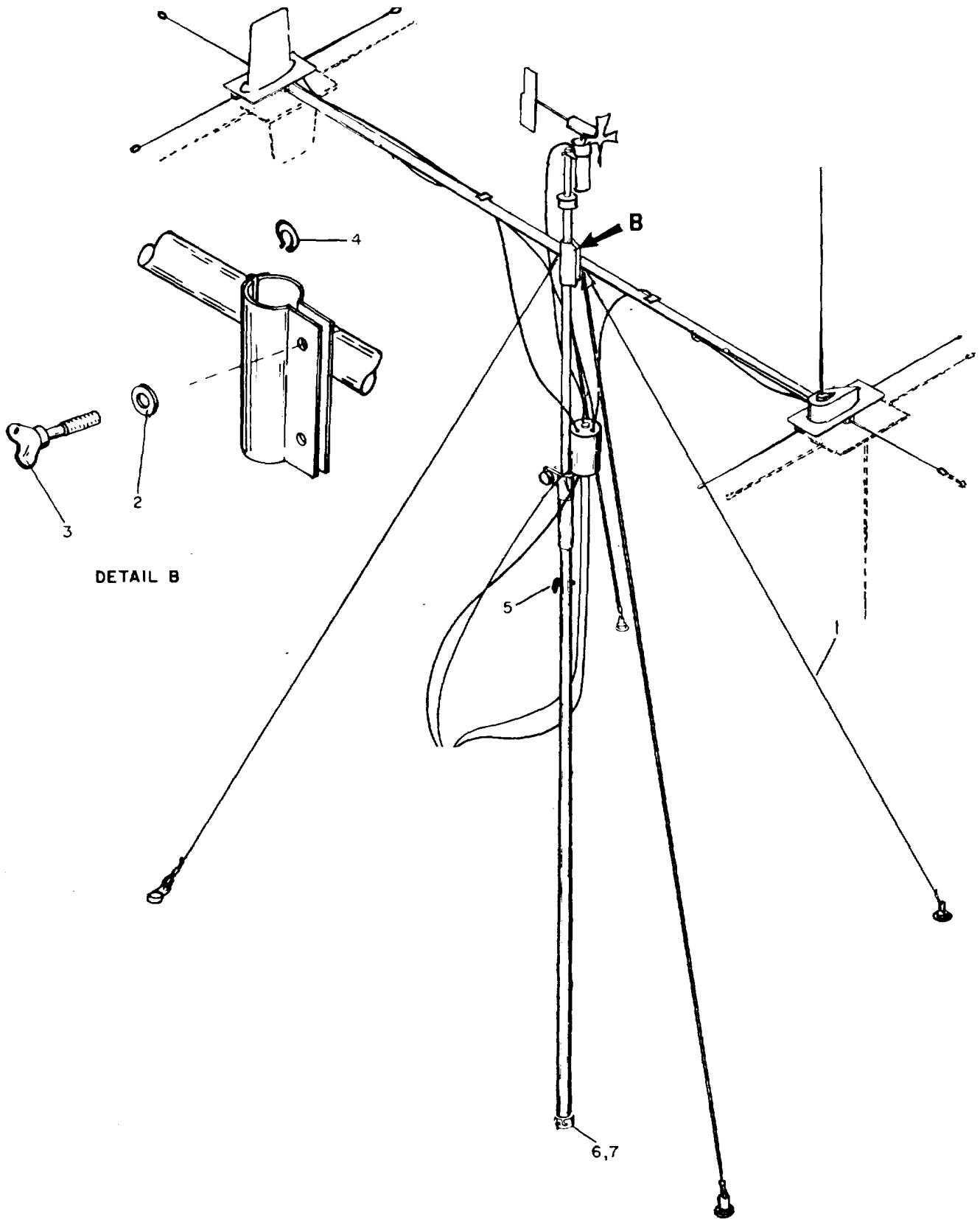

Figure 12. Mast Assembly.

ILLUSTRATION		SMR CODE	NATIONAL STOCK NUMBER	FSCM	PART NUMBER	DESCRIPTION	USABLE ON CODE	U/M	QTY INC IN UNIT
(a) FIG NO.	(b) ITEM NO.								
						GROUP 0403 MAST ASSEMBLY			
12	1	XADZZ		80063	SC-C-706040	GUY,ASSEMBLY,ANTENN.....		EA	2
12	2	PADZZ	5310-00-470-3000	96906	MS15795-8108	WASHER,FLAT.....		EA	1
12	3	PADZZ	5310-01-087-3102	80063	SC-C-706141	NUT,PLAIN,WING.....		EA	2
12	4	PADZZ	5365-01-121-8093	96906	MS3215-4025	RING,RETAINING.....		EA	1
12	5	PADZZ	5895-01-088-1792	80063	SC-C-706138	LANYARD ASSEMBLY.....		EA	1
12	6	XDOOO		80063	SC-C-706121	CAP ASSEMBLY,MAST.....		EA	1
12	7	PADZZ	5895-01-088-1791	80063	SC-C-706017	LANYARD ASSEMBLY.....		EA	1

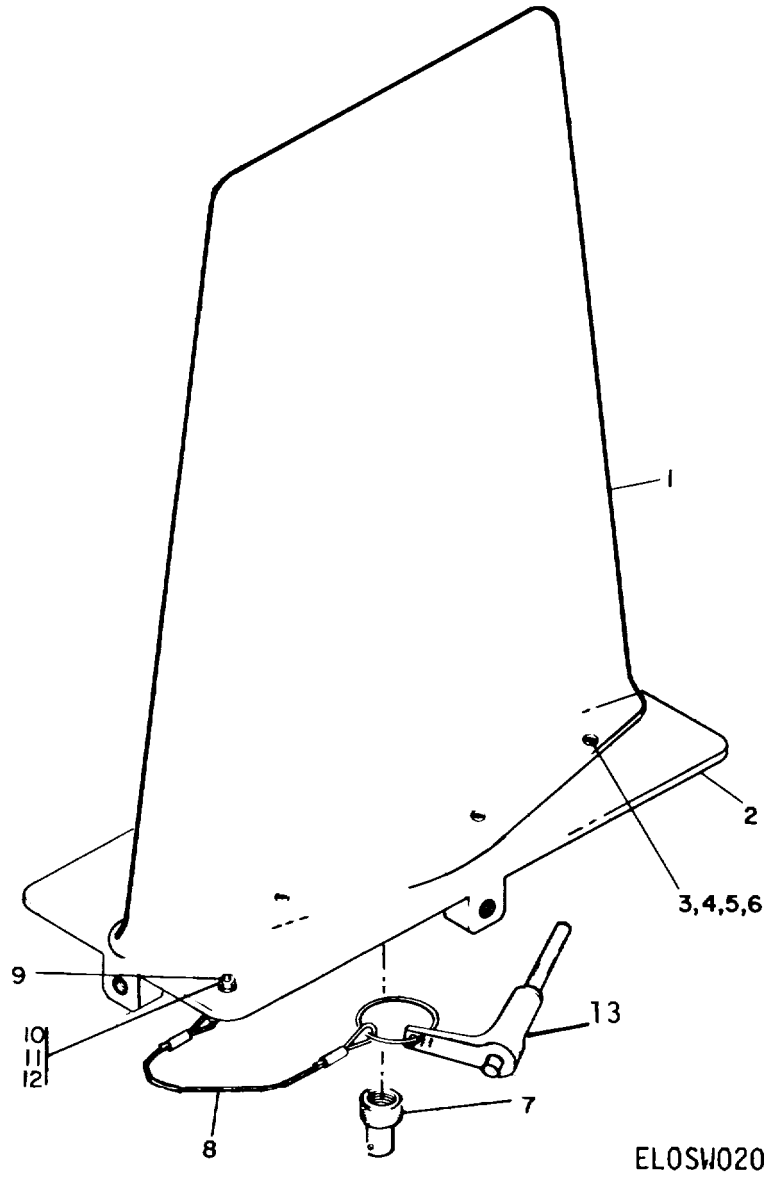

Figure 13. UHF/VHF Antenna Assembly (AT-1108/ARC).

SECTION II

TM 11-5895-800-34P

(1) ILLUSTRATION		(2)	(3)	(4)	(5)	(6)	(7)	(8)
(a) FIG NO.	(b) ITEM NO.	SMR CODE	NATIONAL STOCK NUMBER	FSCM	PART NUMBER	DESCRIPTION USABLE ON CODE	U/M	QTY INC IN UNIT
						GROUP 0405 UHF/VHF ANTENNA ASSEMBLY		
13	1	PDOHH	5985-00-892-0895	80058	AT-1108/ARC	ANTENNA	EA	1
13	2	XDFZZ		80063	SC-D-706032	MOUNTING PLATE ASSE	EA	1
13	3	PDHZZ	5305-00-151-6208	96906	MS51957-49B	SCREW,MACHINE	EA	6
13	4	PDHZZ	5310-00-420-0737	96906	MS35649-2848	NUT,PLAIN,HEXAGON	EA	6
13	5	PDHZZ	5310-00-880-5978	96906	MS15795-807	WASHER,FLAT	EA	6
13	6	PDHZZ	5310-00-933-8119	96906	MS35338-137	WASHER,LOCK	EA	6
13	7	PDHZZ	5935-00-701-2215	74868	79675	ADAPTER,CONNECTOR.....	EA	1
13	8	PDHZZ	5895-01-087-3060	80063	SC-C-706038	LANYARD ASSEMBLY	EA	1
13	9	PDHZZ	5305-00-490-4581	96906	MS51957-29B	SCREW,MACHINE	EA	1
13	10	PDHZZ	5310-00-689-3772	96906	MS35649-264B	NUT,PLAIN,HEXAGON	EA	1
13	11	PDHZZ	5310-00-224-0747	96906	MS35338-136B	WASHER,LOCK	EA	1
13	12	PDHZZ	5310-00-722-5998	96906	MS15795-805	WASHER,FLAT	EA	1
13	13	PDHZZ	5340-00-369-0077	96906	MS17986C415	PIN,QUICK RELEASE	EA	1

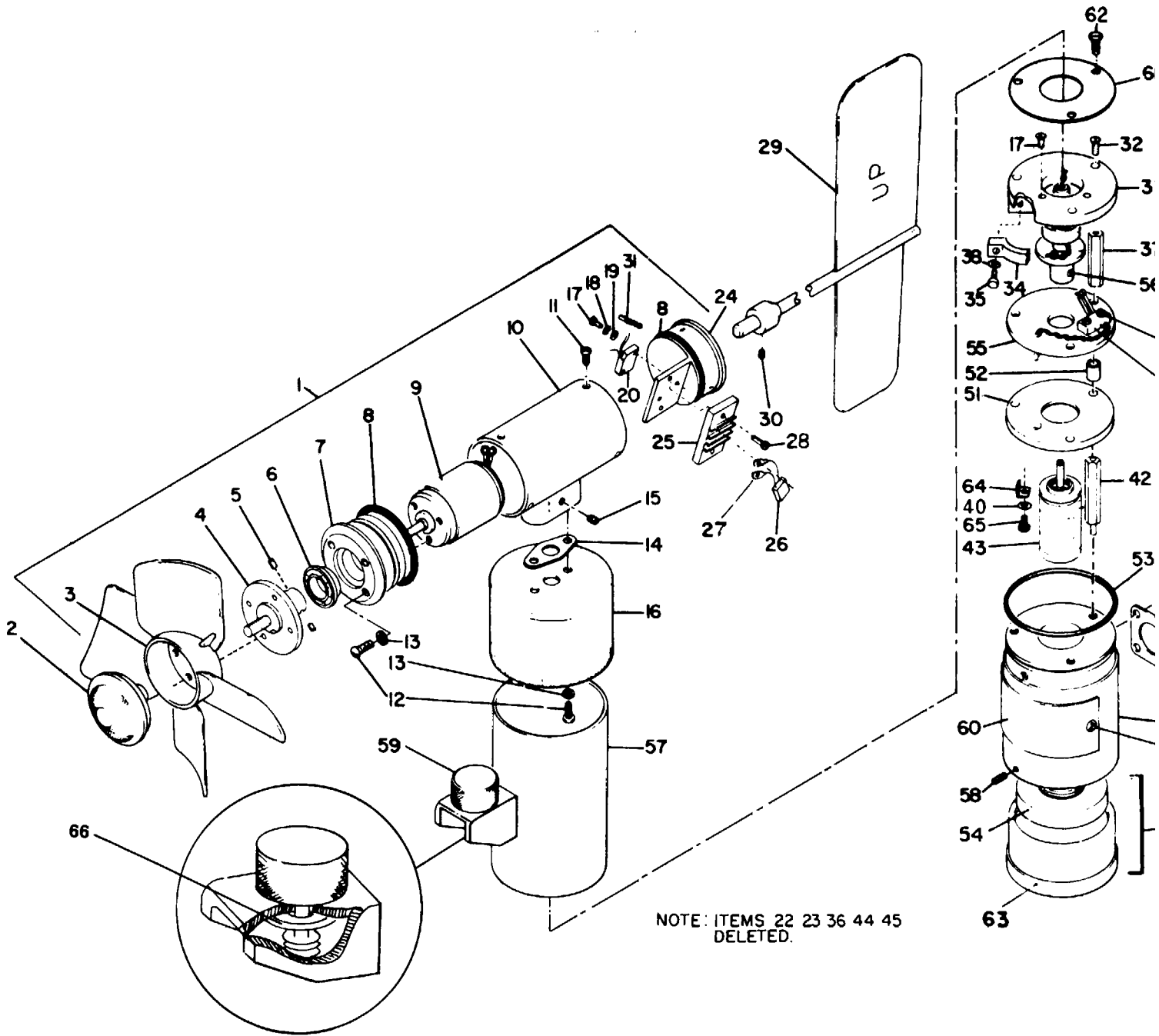

Figure 14. Detector, Wind Direction and Speed ML-653/TSQ-97.

SECTION II

TM 11-5895-800-34P

(1) ILLUSTRATION		(2)	(3)	(4)	(5)	(6)	(7)	(8)
(a) FIG NO.	(b) ITEM NO.	SMR CODE	NATIONAL STOCK NUMBER	FSCM	PART NUMBER	DESCRIPTION USABLE ON CODE	U/M	QTY INC IN UNIT
						GROUP 0406 DETECTOR,WIND DIRECTION AND SPEED ML-653/TSQ-97		
14	1	PAOHH	5895-01-088-1766	80063	SC-D-706070	GENERATOR,WIND DIRE.....	EA	1
14	2	XDHZZ		80063	SC-C706078	HUB,IMPELLER	EA	1
14	3	PAHZZ	4140-01-088-1898	80063	SC-C-706111	IMPELLER,FAN,AXIAL	EA	1
14	4	XDHZZ		80063	SC-C-706071	SHAFT,GENERATOR	EA	1
14	5	PAHZZ	5305-00-843-2841	96906	MS51021-1	SETSCREW	EA	1
14	6	PAHZZ	3110-01-092-8781	80063	SC-A-706391	BEARING,BALL,ANNULA	EA	1
14	7	XDHZZ		80063	SC-D-706072	CAP,GENERATOR.....	EA	1
14	8	PAHZZ	5330-00-250-0236	96906	MS29513-024	PACKING,PREFORMED.....	EA	2
14	9	PAHZZ	6105-00-306-9501	50778	26PC11-213-8	MOTOR,DIRECT CURREN.....	EA	1
14	10	XAHHH		80063	SC-D-706074	HOUSING,GENERATOR	EA	1
14	11	PAHZZ	5305-00-490-4580	96906	MS51957-3B	SCREW,MACHINE.....	EA	3
14	12	PAHZZ	5305-00-054-5648	96906	MS51957-14	SCREW,MACHINE.....	EA	3
14	13	PAHZZ	5310-00-933-8118	96906	MS35338-135	WASHER,LOCK	EA	3
14	14	XDHZZ		80063	SC-B-706367	GASKET,GENERATOR AS.....	EA	1
14	15	PAHZZ	5305-00-058-9367	96906	MS51977-29	SETSCREW	EA	2
14	16	XAHZZ		80063	SC-C-706076	DIAL,INDICATOR.....	EA	1
14	17	PAHZZ	5305-00-054-5638	96906	MS51957-4	SCREW,MACHINE.....	EA	2
14	18	PAHZZ	5310-00-928-2690	96906	MS35338-134	WASHER,LOCK	EA	2
14	19	PAHZZ	5310-00-595-6761	96906	MS15795-802	WASHER,FLAT	EA	2
14	20	PAHZZ	5909-00-271-7421	81349	M39015-2-006LP	RESISTOR, VARIABLE,W	EA	1
14	21	PAHHH	5895-01-088-1769	80063	SC-D-706370	SYNCHRONIZER,WIND D.....	EA	1
14	24	XDHHH		80063	SC-D-706067	CAP,RUDDER.....	EA	1
14	25	XDHHH		80063	SC-B-706068	TERMINAL BOARD.....	EA	1
14	26	PAHZZ	5910-00-010-8721	81349	M03014/02-1419	CAPACITOR,FIXED,CER.....	EA	1
14	27	XDHZZ		79963	690	TERMINAL,LUG	EA	7
14	28	PAHZZ	5305-00-054-5638	96906	MS51957-4	SCREW,MACHINE.....	EA	2
14	29	XDHHH		80063	SC-C-706064	RUDDER ASSEMBLY	EA	1
14	30	PAHZZ	5305-00-655-9246	96906	MS51029-10	SETSCREW	EA	2
14	31	PAHZZ	5340-00-075-0530	01226	SSB-50N	PLUNGER,QUICK RELEA	EA	1
14	32	PAHZZ	5305-00-763-7822	96906	MS51959-14	SCREW,MACHINE.....	EA	3
14	33	XAHZZ		80063	SC-C-706092	BEARING PLATE	EA	1
14	34	XDHZZ		80063	SC-B-706365	CLAMP,BEARING	EA	1
14	35	PAHZZ	5305-00-242-7275	96906	MS51957-15B	SCREW,MACHINE.....	EA	6
14	37	XAHZZ		80063	SC-B-706083-1	STANDOFF,PLATE	EA	3
14	38	PAHZZ	5310-00-933-8118	96906	MS35338-135	WASHER,LOCK	EA	6
14	39	PAHZZ	5305-00-054-5639	96906	MS51957-5	SCREW,MACHINE.....	EA	2
14	40	PAHZZ	5310-00-595-6211	96906	MS15795-803	WASHER,FLAT	EA	5
14	41	PAHZZ	5895-01-091-7737	80063	SC-B-706117	BRUSH ASSEMBLY.....	EA	1

SECTION II

TM 11-5895-800-34P

(1) ILLUSTRATION		(2)	(3)	(4)	(5)	(6) DESCRIPTION	(7)	(8)
(a) FIG NO.	(b) ITEM NO.	SMR CODE	NATIONAL STOCK NUMBER	FSCM	PART NUMBER	USABLE ON CODE	U/M	QTY INC IN UNIT
14	42	XAHZZ		80063	SC-B-706083-2	STANDOFF,PLATE	EA	3
14	43	PAHZZ	5990-00-465-4829	81349	M20708-78D001	SYNCHRO,TRANSMITTER	EA	1
14	46	PAHZZ	5935-00-901-5782	96906	MS3112E10-6P	CONNECTOR,RECEPTACLE.....	EA	1
14	47	PAHZZ	5330-01-092-5517	80063	SC-C-706098	GASKET	EA	1
14	48	PAHHH	5895-01-091-7736	80063	SC-D-706080	BASE,SYNCHRONIZER	EA	1
14	49	PAHZZ	5305-00-494-7333	96906	MS51957-13B	SCREW,MACHINE.....	EA	2
14	50	XDHHH		80063	SC-C-706381	COMPASS ASSEMBLY	EA	1
14	51	XAHHH		80063	SC-C706082	PLATE,MOUNTING,SYNC.....	EA	1
14	52	XDHZZ		80063	SC-B-706-081	SPACER,PLATE	EA	3
14	53	PAHZZ	5330-00-841-2366	96906	MS29513-030	PACKING,PREFORMED.....	EA	1
14	54	XAHZZ		80063	SC-C-706097	MOUNTING PLATE,COMP	EA	1
14	55	XDHHH		80063	SC-C-706084	BRUSH HOLDER ASSEMB	EA	1
14	56	XDHHH		80063	SC-C-706087	SHAFT ASSEMBLY	EA	1
14	57	XDHHH		80063	SC-D-706094	HOUSING,SYNCHRO ASS.....	EA	1
14	58	PAHZZ	5305-00-655-9246	96906	MS51029-10	SETSCREW	EA	2
14	59	XDHZZ		80069	SC-C-706105	THUMBSCREW	EA	1
14	60	XBHZZ		80063	SC-C-706063	PLATE,IDENTIFICATION.....	EA	1
14	61	XDHZZ		80063	SC-B-706369	GASKET,MOUNTING PLA.....	EA	1
14	62	PAHZZ	5305-00-770-2533	96906	MS51959-13	SCREW,MACHINE.....	EA	3
14	63	PAHZZ		61349	AW231	COMPASS,MAGNETIC,UN.....	EA	1
14	64	XDHZZ		80063	SC-B-706368	CLAMP,SYNCHRO	EA	3
14	65	PAHZZ	5305-00-959-0379	96906	MS16995-10	SCREW,CAP,SOCKET HE	EA	1
14	66	PAFZZ		80063	SC-B-706108	WASHER.....	EA	1

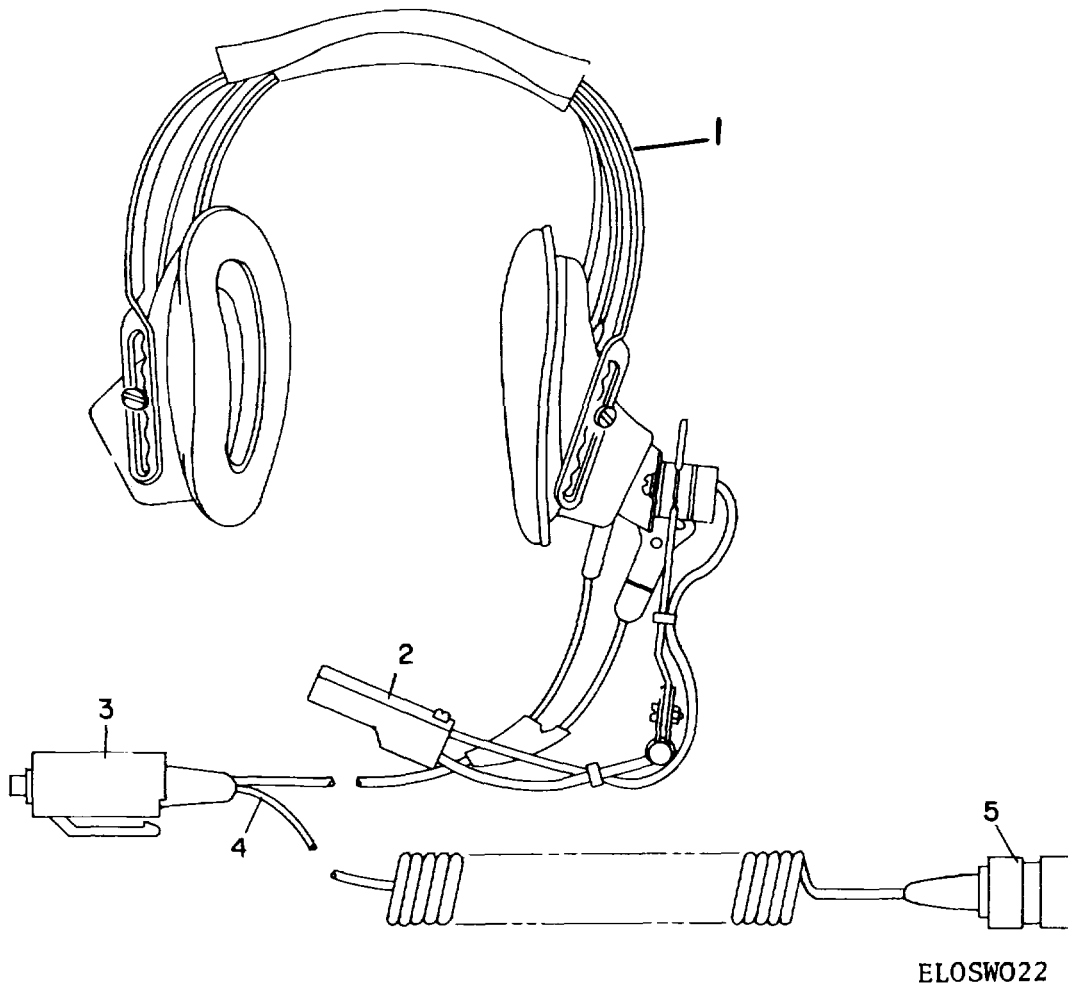
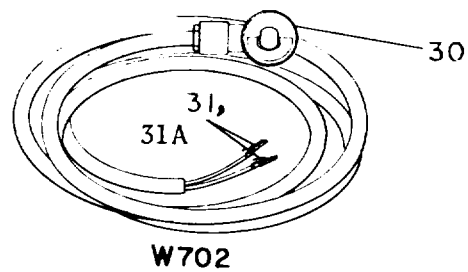
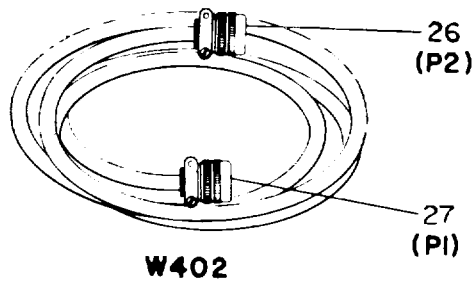
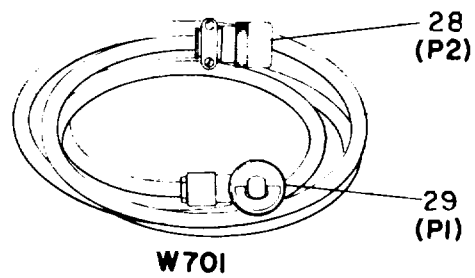
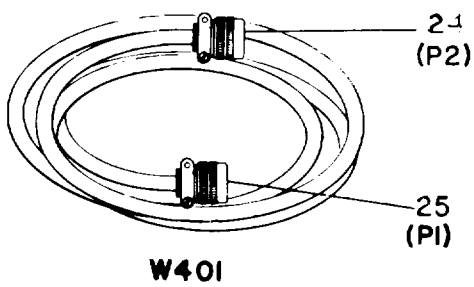
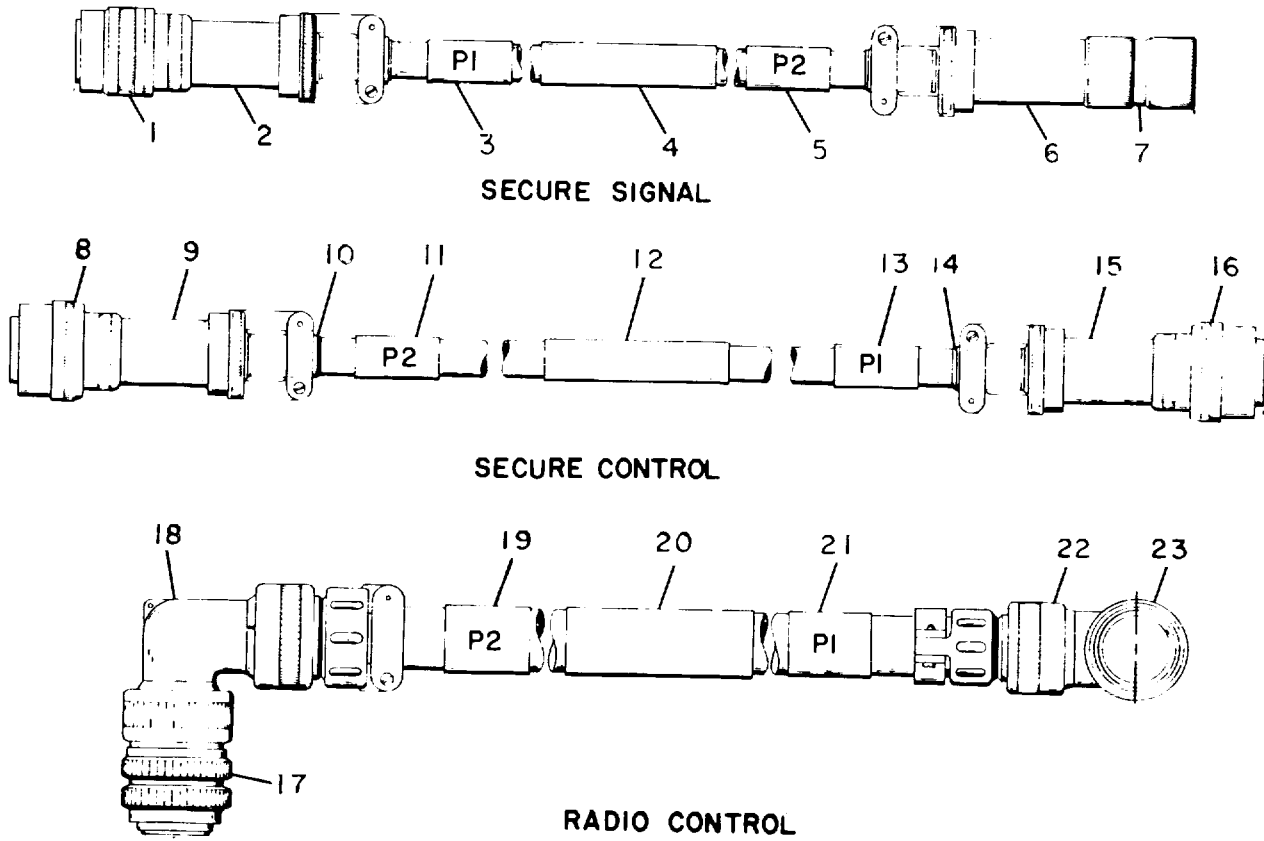

Figure 15. Headset/Microphone H-337/TSQ-97.

SECTION II

TM 11-5895-800-34P

(1) ILLUSTRATION		(2)	(3)	(4)	(5)	(6)	(7)	(8)
(a) FIG NO.	(b) ITEM NO.	SMR CODE	NATIONAL STOCK NUMBER	FSCM	PART NUMBER	DESCRIPTION USABLE ON CODE	U/M	QTY INC IN UNIT
						GROUP 0407 HEADSET/MICROPHONE H-337/0		
15	1	XDFZZ		80063	SC-C-706299ITEM1	HEADSET.....	EA	1
15	2	PAFZZ	5965-00-937-1851	80058	M-138/G	MICROPHONE, DYNAMIC	EA	1
15	3	PAFZZ			M8805/3-MS25089-	SWITCH ASSEMBLY	EA	1
				81349	1E			
15	4	XDFFF		80063	SC-C706299ITEM2	CABLE ASSEMBLY	EA	1
15	5	PAFZZ	5935-00-992-2035	80058	U-182/0	CONNECTOR,PLUG,ELEC	EA	1
47/(48 blank)								



ELOSW023

Figure 16. Cable Assemblies (Sheet 1 of 2).

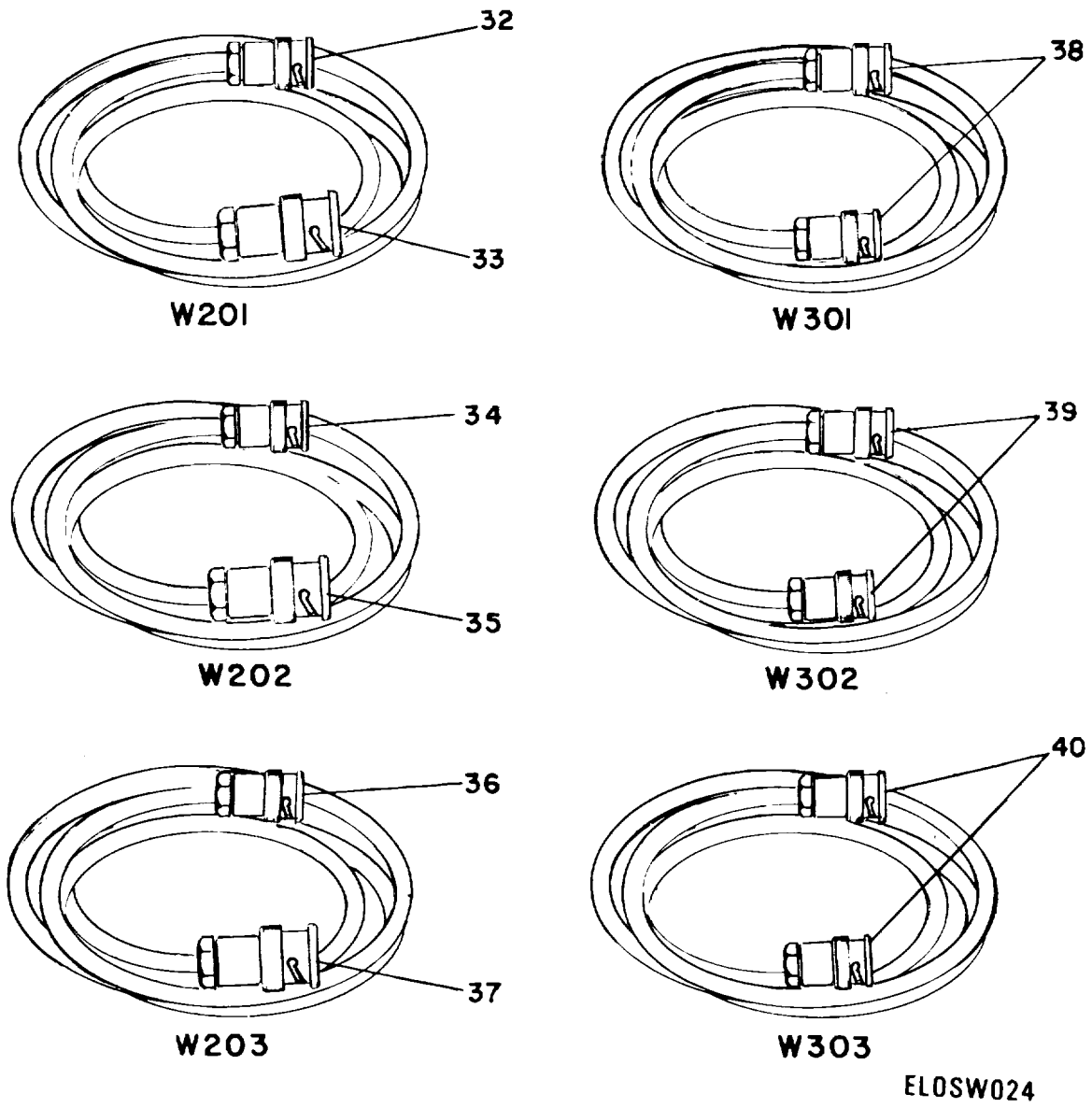

Figure 16. Cable Assemblies (Sheet 2 of 2).

SECTION II

TM 11-5895-800-34P

(1) ILLUSTRATION		(2)	(3)	(4)	(5)	(6) DESCRIPTION	(7)	(8)
(a) FIG NO.	(b) ITEM NO.	SMR CODE	NATIONAL STOCK NUMBER	FSCM	PART NUMBER	USABLE ON CODE	U/M	QTY INC IN UNIT
GROUP 0410 CABLE ASSY, SECURE SIGNAL								
16	1	PAFZZ	5935-01-006-8163	96906	MS3476L12-8P	CONNECTOR, PLUG, ELEC	EA	1
16	2	PAFZZ	5935-01-094-7478	06324	G3702-124-2.0B	ADAPTER, CONNECTOR	EA	1
16	3	XBFZZ		80063	SC-D-706110-42	BAND, IDENTIFICATION	EA	1
16	4	XBFZZ		80063	SC-D-706110-41	BAND, IDENTIFICATION	EA	1
16	5	XBFZZ		80063	SC-D-706110-43	BAND, IDENTIFICATION	EA	1
16	6	PAFZZ	5935-01-094-5856	06324	G62951	ADAPTER, CABLE CLAMP	EA	1
16	7	PAFZZ	5935-00-992-2035	80058	U-229/U	CONNECTOR, PLUG, ELEC	EA	1
16	8	PAFZZ	5935-00-172-1008	96906	MS3476L16-26S	CONNECTOR, PLUG, ELEC	EA	1
16	9	PAFZZ	5935-01-094-7480	06324	G3702-164-2B	ADAPTER, CONNECTOR	EA	1
16	10	PAFZZ	5940-00-578-2317	96906	MS21981-287	FERRULE, METALLIC SH	EA	2
16	11	XBFZZ		80063	SC-D-706110-46	BAND, IDENTIFICATION	EA	1
16	12	XBFZZ		80063	SC-D-706110-44	BAND, IDENTIFICATION	EA	1
16	13	XBFZZ		80063	SC-D-706110-45	BAND, IDENTIFICATION	EA	1
16	14	PAFZZ	5940-01-008-7727	96906	MS18121-375	FERRULE, METALLIC SH	EA	2
16	15	PAFZZ	5935-01-094-7479	06324	G3702-144-2B	ADAPTOR, CONNECTOR	EA	1
16	16	PAFZZ	5935-00-408-4455	96906	MS3476L14-19P	CONNECTOR, PLUG, ELEC	EA	1
GROUP 0412 CABLE ASSY, RADIO CONTROL								
16	17	PAFZZ	5935-01-088-1875	80063	SC-C-706309	CONNECTOR, PLUG, EL	EA	1
16	18	PAFZZ	5935-01-114-0702	06324	G8560-184-B	ADAPTER, CONNECTOR	EA	1
16	19	XBFZZ		80063	SC-D-706110-46	BAND, IDENTIFICATION	EA	1
16	20	XBFZZ		80063	SC-D-706110-47	BAND, IDENTIFICATION	EA	1
16	21	XDFZZ		80063	SC-D-706110-45	BAND, IDENTIFICATION	EA	1
16	22	PAFZZ		96906	M53188A100	BACKSHELL, 90 DEG	EA	1
16	23	PAFZZ	5935-00-408-4455	96906	MS3476L14-19P	CONNECTOR, PLUG, ELEC	EA	1
GROUP 0413 CABLE ASSY, W-401								
16	24	PAFZZ	5935-01-009-9809	96906	MS3116E12-8P	CONNECTOR, PLUG, ELEC	EA	1
16	25	PAFZZ	5935-00-958-8462	96906	MS3116E10-6S	CONNECTOR, PLUG, ELEC	EA	1
GROUP 0414 CABLE ASSY, W-402								
16	26	PAFZZ	5935-00-089-6878	96906	MS3116E10-6P	CONNECTOR, PLUG, ELEC	EA	1
16	27	PAFZZ	5935-00-958-8462	96906	MS3116E10-6S	CONNECTOR, PLUG, ELEC	EA	1
GROUP 0415 CABLE ASSY, W-701							EA	1
16	28	PAFZZ	5935-00-632-7314	96906	MS3116J14-5P	CONNECTOR, PLUG, ELEC	EA	1
16	29	PAFZZ	5935-00-921-3399	81349	MW1 OF (M)A17	CONNECTOR, PLUG, ELEC	EA	1
GROUP 0416 CABLE ASSY, W-702								
16	30	PAFZZ	5935-00-921-3399	81349	MW1 OF (M)A17	CONNECTOR, PLUG, ELEC	EA	1
16	31	PAFZZ	5999-01-094-1905	76545	46-CRED	CLIP, ELECTRICAL	EA	1
16	31A	PAFZZ	5999-01-094-1906	76545	46-CBLACK	CLIP, ELECTRICAL	EA	1
GROUP 0417 CABLE ASSY, W-201								

SECTION II

TM 11-5895-800-34P

(1) ILLUSTRATION		(2)	(3)	(4)	(5)	(6)	(7)	(8)
(a) FIG NO.	(b) ITEM NO.	SMR CODE	NATIONAL STOCK NUMBER	FSCM	PART NUMBER	DESCRIPTION USABLE ON CODE	U/M	QTY INC IN UNIT
16	32	PAFZZ	5935-00-177-2712	95712	UG13660	CONNECTOR,PLUG,ELEC	EA	1
16	33	PAFZZ	5935-01-043-0629	81349	M39012/16-0101	CONNECTOR,PLUG,ELEC	EA	1
						GROUP 0418 CABLE ASSY, W-202		
16	34	PAFZZ	5935-00-812-8779	81349	UG-1366/U	CONNECTOR,PLUG,ELEC	EA	1
16	35	PAFZZ	5935-01-043-0629	81349	M39012/16-0101	CONNECTOR,PLUG,ELEC	EA	1
						GROUP 0419 CABLE ASSY,W-203		
16	36	PAFZZ	5935-00-812-8779	81349	UG-1366/U	CONNECTOR,PLUG,ELEC	EA	1
16	37	PAFZZ	5935-01-043-0629	81349	M39012/16-0101	CONNECTOR,PLUG,ELEC	EA	1
						GROUP 0420 CABLE ASSY,W-301		
16	38	PAFZZ	5935-01-043-0629	81349	M39012/16-0101	CONNECTOR,PLUG,ELEC	EA	2
						GROUP 0421 CABLE ASSY,W-302		
16	39	PAFZZ	5935-01-043-0629	81349	M39012/16-0101	CONNECTOR,PLUG,ELEC	EA	2
						GROUP 0422 CABLE ASSY,W-303		
16	40	PAFZZ	5935-01-043-0629	81349	M39012/16-0101	CONNECTOR,PLUG,ELEC	EA	2

NATIONAL STOCK NUMBER AND PART NUMBER INDEX

NATIONAL STOCK NUMBER INDEX					
STOCK NUMBER	FIGURE NO.	ITEM NO.	STOCK NUMBER	FIGURE NO.	ITEM NO.
5910-00-007-3974	10	8	5310-00-194-3647	1	26
5910-00-010-8721	14	26	5310-00-194-3647	3	25
5340-00-021-3426	4	15	5310-00-194-3647	3	87
5975-00-043-3403	3	96	5310-00-194-3647	4	13
5961-00-054-0046	7	4	5310-00-194-3647	4	25
5305-00-054-5638	14	17	5310-00-194-3647	5	42
5305-00-054-5638	14	28	5310-00-194-3649	3	49
5305-00-054-5639	8	20	5310-00-194-3649	3	75
5305-00-054-5639	9	20	5910-00-217-1228	8	2
5305-00-054-5639	10	11	5910-00-217-1228	9	11
5305-00-054-5639	14	39	5310-00-224-0746	1	25
5305-00-054-5648	14	12	5310-00-224-0746	4	26
5305-00-054-5649	4	54	5310-00-224-0746	5	7
5305-00-054-5649	5	46	5310-00-224-0746	5	43
5305-00-054-5649	9	26	5310-00-224-0747	13	11
5305-00-054-5649	11	8	5310-00-224-0749	3	48
5305-00-054-5650	3	102	5310-00-224-0749	3	74
5305-00-054-5650	5	28	5935-00-227-8818	5	25
5305-00-054-5651	3	70	5305-00-231-9808	5	41
5305-00-054-5652	3	68	5905-00-235-8959	7	14
5305-00-054-5652	3	91	5910-00-236-8745	8	12
5305-00-054-5653	6	8	5910-00-236-8745	9	7
5305-00-054-6652	3	52	5935-00-241-2746	11	16
5305-00-054-6652	3	84	5305-00-242-7275	3	24
5305-00-054-6654	3	82	5305-00-242-7275	14	35
5310-00-058-1823	4	71	5330-00-250-0236	14	8
5305-00-058-9367	14	15	5905-00-271-7421	14	20
5305-00-058-9367	14	15	5905-00-271-7421	14	20
5305-00-059-3657	3	60	5325-00-290-6163	1	33
5305-00-059-3662	3	44	6105-00-306-9501	14	9
5935-00-071-1235	5	24	5962-00-361-8672	9	2
5975-00-074-2072	3	105	5340-00-369-0077	13	13
5340-00-075-0530	14	31	5935-00-400-1714	8	17
5985-00-082-3991	1	4	5935-00-400-1714	9	6
6135-00-087-2301	1	17	5935-00-400-1714	10	3
5961-00-087-6047	3	99	5905-00-402-7134	9	5
5961-00-087-6047	4	7	5935-00-408-4455	16	16
5961-00-087-6047	6	11	5935-00-408-4455	16	23
5961-00-081-6047	7	6	5310-00-409-1763	3	3
5935-00-089-6878	16	26	5310-00-409-1763	3	6
5910-00-098-9281	7	11	5310-00-409-1763	3	89
5905-00-105-7768	7	8	5310-00-409-1763	5	9
5905-00-106-3666	7	17	5310-00-412-9825	3	47
5905-00-106-3666	8	16	5905-00-419-5257	7	15
5905-00-106-3666	9	8	5310-30-420-0737	13	4
5905-00-106-3666	10	6	5305-00-428-0732	4	67
5905-00-107-0656	8	11	5310-00-433-3599	4	70
5905-00-107-0656	9	14	5305-00-433-3744	5	36
5910-00-113-5475	8	8	5305-00-439-2737	1	24
5910-00-113-5475	9	10	5305-00-439-2737	2	7
5940-00-113-9828	3	78	5905-00-444-0291	9	16
5905-00-114-0711	10	4	5305-00-448-6500	3	2
5905-00-116-8556	7	16	5305-00-448-6500	3	90
5905-00-116-8556	8	3	5305-30-455-2516	3	19
5320-00-117-6010	3	36	5910-00-455-4304	9	3
5320-00-117-6937	11	3	5305-00-455-6927	4	16
5905-00-119-8811	7	9	5305-00-455-9971	4	62
5905-00-119-8811	8	13	5305-00-459-4687	2	14
5905-00-120-9154	8	15	5990-00-465-4829	14	43
5905-00-131-1255	10	5	5305-00-465-6745	3	11
5821-00-138-7990	1	18	5305-00-465-6745	3	18
5905-00-141-0743	7	5	5305-00-465-6745	4	14
5940-00-143-4774	5	26	5910-00-469-5622	4	72
5940-00-143-4774	5	32	5310-00-470-3000	12	2
5305-00-150-3426	4	44	5305-00-470-5602	3	5
5305-00-151-6208	13	3	5305-00-470-5602	4	64
6240-00-155-8714	4	10	5905-00-485-4545	10	7
6240-00-155-8714	5	17	5305-00-490-4580	14	11
5935-00-162-1543	6	6	5305-00-490-4581	5	8
5821-00-165-2970	1	20	5305-00-490-4581	13	9
5305-00-165-8019	3	73	5305-00-494-7333	5	6
5935-00-172-1008	16	8	5305-00-494-7333	14	49
5935-00-177-2712	16	32	5910-00-495-0042	8	5
5965-00-179-7762	1	16	5910-00-495-0042	9	15
5965-00-179-7762	9	27	5999-00-506-6747	11	7
5305-00-182-9459	4	34	5905-00-523-8750	9	18
5305-00-182-9459	5	11	6210-00-538-8770	4	23
5905-00-186-3125	4	58	6210-00-548-0196	4	2
5910-00-189-3178	3	97	5355-00-552-1810	4	21
5910-00-189-3178	7	2	5826-00-553-5926	4	31

NATIONAL STOCK NUMBER AND PART NUMBER INDEX

NATIONAL STOCK NUMBER INDEX			NATIONAL STOCK NUMBER INDEX		
STOCK NUMBER	FIGURE	ITEM	STOCK NUMBER	FIGURE	ITEM
	No.	No.		No.	No.
5355-00-556-0145	4	18	5935-00-812-8779	16	34
6685-00-557-5316	1	31	5935-00-812-8779	16	36
5940-00-578-2317	16	10	5935-00-823-0667	4	20
5905-00-593-5037	7	13	5935-00-825-8862	4	61
5310-00-595-6211	2	4	5935-00-827-1547	4	4
5310-00-595-6211	3	37	5940-00-836-7402	3	66
5310-00-595-6211	3	67	5330-00-841-2366	14	53
5310-00-595-6211	3	71	5325-00-842-1879	3	12
5310-00-595-6211	4	9	5961-00-842-6937	9	4
5310-00-595-6211	4	53	5305-00-843-2841	14	5
5310-00-595-6211	5	29	5310-00-849-1984	5	18
5310-00-595-6211	5	48	5905-30-851-9227	4	50
5310-00-595-6211	6	9	5961-00-853-2601	10	9
5310-00-595-6211	9	29	5310-00-880-5978	2	12
5310-00-595-6211	11	9	5313-00-880-5978	3	30
5310-00-595-6211	14	40	5310-00-880-5978	13	5
5310-00-595-6761	8	23	5355-00-881-0722	4	27
5310-00-595-6761	9	22	5985-00-892-0895	13	1
5310-00-595-6761	10	13	5935-00-892-9329	7	20
5310-00-595-6761	14	19	6625-00-894-2827	4	36
5910-00-601-5624	9	30	5935-00-901-5782	14	46
5910-00-601-5624	11	20	5935-00-901-8871	5	33
5310-00-619-1148	3	46	5920-00-901-9938	5	21
5310-00-619-1148	3	59	5961-00-903-2990	7	12
5935-00-632-7314	16	28	5935-00-913-1823	5	4
5935-00-642-2656	4	40	5340-00-915-4847	2	2A
5305-00-655-9246	14	30	5940-00-915-6128	6	4
5305-00-655-9246	14	58	5940-00-915-6128	6	12
5930-00-660-3952	4	22	5935-00-921-3399	16	29
6145-00-681-8517	3	101	5935-00-921-3399	16	30
5940-00-682-2477	6	7	5310-00-928-2690	8	22
5930-00-683-1625	4	17	5310-00-928-2690	9	21
5930-00-683-1628	4	19	5310-00-928-2690	10	12
5310-00-687-6664	5	35	5310-00-928-2690	14	18
5310-00-689-3772	13	10	5310-00-929-6395	3	62
5935-00-701-2215	13	7	5920-00-929-7899	3	69
5310-00-716-5612	9	25	5310-00-933-8118	2	8
5310-00-716-5618	8	19	5310-00-933-8118	5	47
5310-00-716-5618	9	24	5310-00-933-8118	14	13
5310-00-722-5998	3	9	5310-00-933-8118	14	38
5310-00-722-5998	3	51	5310-00-933-8119	13	6
5310-00-722-5998	3	63	5310-00-933-8120	3	42
5310-00-722-5998	3	83	5310-00-933-8120	3	57
5310-00-722-5998	4	42	5310-00-933-8120	3	64
5310-00-722-5998	4	66	5310-00-934-9761	3	61
5310-00-722-5998	13	12	5310-00-934-9761	5	30
5975-00-727-5153	3	77	5310-00-934-9765	3	45
5325-00-758-0113	11	2	5965-00-937-1851	15	2
6240-00-763-7744	4	1	5310-00-938-2013	8	21
6240-00-763-7744	5	16	5310-00-938-2013	9	23
5305-00-763-7822	11	22	5310-00-938-2013	10	14
5305-00-763-7822	14	32	6645-00-950-8599	4	12
5305-00-764-0068	3	23	5935-00-958-8462	16	25
5305-00-770-2533	14	62	5935-00-958-8462	16	27
5305-00-770-2579	3	4	5305-00-959-0379	14	65
5305-00-770-2579	4	6	5935-00-990-5580	5	3
5305-00-770-2579	4	59	5935-00-992-2035	15	5
5305-00-770-2580	2	3	5935-00-992-2035	16	7
5305-00-777-5984	4	3	5961-00-995-2310	10	2
5935-00-779-8294	11	14	5935-00-995-5782	4	63
5310-00-782-1349	3	13	5935-01-006-8163	16	1
5310-00-782-1349	3	103	5940-01-008-7727	16	14
5310-00-782-1349	3	108	6660-01-009-4369	1	1
5310-00-782-1349	5	38	5935-01-039-9809	16	24
5920-00-782-6179	5	19	5905-01-011-7614	8	6
5920-00-785-5471	3	72	5925-01-019-9703	5	12
5310-00-807-1465	3	7	5895-01-021-5923	3	32
5310-00-807-1465	4	41	5895-01-021-5924	5	40
5310-00-807-1465	4	65	5895-01-024-7841	3	31
5310-00-807-1466	3	53	5950-01-025-6732	1	7
5325-00-808-1023	11	5	5895-01-025-8899	1	6
5310-00-811-6419	2	5	5895-01-027-0296	3	33
5310-00-811-6419	3	20	1440-01-029-3260	2	10
5310-00-811-6419	3	38	5925-01-038-1352	5	13
5310-00-811-6419	3	104	5935-01-043-0629	16	33
5310-00-811-6419	4	8	5935-01-043-0629	16	35
5310-00-811-6419	4	38	5935-01-043-0629	16	37
5310-00-811-6419	5	34	5935-01-043-0629	16	38
5310-00-811-6419	6	10	5935-01-043-0629	16	39
5310-00-811-6419	9	28	5935-01-043-0629	16	40

SECTION IV

TM 11-5895-800-34P

NATIONAL STOCK NUMBER AND PART NUMBER INDEX

STOCK NUMBER	FIGURE		ITEM	STOCK NUMBER	FIGURE		ITEM
	No.	No.			No.	No.	
5925-01-047-1458	4		46	5965-01-089-7678	1		28
5910-01-049-5675	8		14	5895-01-091-7736	14		48
5910-01-049-5675	9		9	5895-01-091-7737	14		41
5305-01-052-3709	3		54	5985-01-091-9654	1		10
5310-01-053-7003	3		86	5895-01-092-3078	2		2
5310-01-053-7003	11		17	5895-01-092-3079	3		58
5821-01-057-4037	1		19	5310-01-092-5340	4		29
5310-01-057-9348	11		19	5330-01-092-5517	14		47
5945-01-065-3969	3		107	3110-01-092-8781	14		6
5945-01-065-3969	7		7	6220-01-092-8817	4		11
5999-01-072-8616	7		21	5365-01-092-9076	5		44
5999-01-072-8616	10		15	5895-01-093-0591	1		2
5310-01-077-1016	3		43	5915-01-093-0799	4		55
5895-01-087-3059	1		5	5325-01-093-0818	5		2
5895-01-087-3060	13		8	5962-01-093-0947	8		18
5895-01-087-3061	1		34	5915-01-094-1775	5		31
5310-01-087-3102	12		3	5950-01-094-1777	4		49
5305-01-087-4481	2		11	5915-01-094-1876	4		39
5305-01-087-4481	3		29	5999-01-094-1905	16		31
5895-01-088-1766	14		1	5999-01-094-1906	16		31A
5895-01-088-1769	14		21	5935-01-094-3686	7		10
5895-01-088-1788	1		11	5935-01-094-5856	16		6
5895-01-088-1789	1		21	5935-01-094-7478	16		2
5895-01-088-1790	3		81	5935-01-094-7479	16		15
5895-01-088-1791	12		7	5935-01-094-7480	16		9
5895-01-088-1792	12		5	5945-01-108-9215	3		95
6130-01-088-1856	3		79	5915-01-112-9672	3		94
5935-01-088-1875	16		17	5935-01-113-4488	6		2
5985-01-088-1896	1		37	5935-01-114-0702	16		18
4140-01-088-1898	14		3	6625-01-114-3545	4		30
5340-01-088-1923	3		15	5999-01-119-9154	4		51
5895-01-088-6799	3		1	5365-01-121-8093	12		4

FSCM	PART NUMBER	FIGURE NO.	ITEM NO.	FSCM	PART NUMBER	FIGURE NO.	ITEM NO.
80058	AN/ARC-114A	1	20	04713	MC1554D8XS	8	10
80058	AN/ARC-115A	1	19	04713	MC1554D8XS	9	12
88044	AN426AD2-3	3	36	81349	MIL-P-501TYPE2	1	15
80058	AS-1703/AR	1	4	81349	MILC6499ATYPEEA13A	4	12
80058	AS-4034/TSQ-97	1	6	80058	ML-653/TSQ-97	1	1
80058	AT-1108/ARC	13	1	81349	MR13B050DCVVR	4	30
61349	AW231	14	63	81349	MR26B050DCUAR	4	36
72914	A67451RY24	4	2	96906	MS15795-802	8	23
72914	B-5645-1	4	11	96906	MS15795-802	9	22
80058	C-9921/TSQ-97	1	21	96906	MS15795-802	10	13
81349	CMR04E390G0DM	8	14	96906	MS15795-802	14	19
81349	CMR04E390G0DM	9	9	96906	MS15795-802B	4	70
21617	DL-SC-B-706195	3	31	96906	MS15795-803	2	4
21617	DL-SC-B-706200	3	32	96906	MS15795-803	3	37
21617	DL-SC-B-706205	3	33	96906	MS15795-803	3	67
21617	DL-SC-B-706233	5	40	96906	MS15795-803	3	71
32559	E-250	11	7	96906	MS15795-803	4	9
81349	FHN42W	3	72	96906	MS15795-803	4	53
81349	FM02A125V1 1/2A	5	20	96906	MS15795-803	5	29
81349	FM01-125V1A	5	21	96906	MS15795-803	5	48
81349	FM01 125V5A	5	22	96906	MS15795-803	6	9
81349	FM02-125V-1-1/2A	3	69	96906	MS15795-803	9	29
81349	FM02-125V5A	5	19	96906	MS15795-803	11	9
06324	G3702-124-2.08	16	2	96906	MS15795-803	14	40
06324	G3702-144-2B	16	15	96906	MS15795-803B	1	26
06324	G3702-164-2B	16	9	96906	MS15795-803B	3	25
06324	G62951	16	6	96906	MS15795-803B	3	87
06324	G8560-184-B	16	18	96906	MS15795-803B	4	13
80058	H-337/TSQ-97	1	28	96906	MS15795-803B	4	25
80058	ID-637ARN	4	31	96906	MS15795-803B	5	42
81349	JAN1N4372A	7	12	96906	MS15795-804	3	13
81349	JAN1N645	3	99	96906	MS15795-804	3	103
81349	JAN1N645	4	7	96906	MS15795-804	3	108
81349	JAN1N645	6	11	96906	MS15795-804	5	38
81349	JAN1N645	7	6	96906	MS15795-804B	5	35
81349	JAN1N752A	10	2	96906	MS15795-805	3	9
81349	JAN2N1711	7	4	96906	MS15795-805	3	51
81349	JAN2N1893	10	9	96906	MS15795-805	3	63
81349	JAN2N706	9	4	96906	MS15795-805	3	83
99928	JRA-4C-24B	7	3	96906	MS15795-805	4	42
81349	LW-C22(7)09	3	101	96906	MS15795-805	4	66
80058	M-138/G	15	2	96906	MS15795-805	13	12
81349	M-80C/U	1	16	96906	MS15795-805B	3	3

NATIONAL STOCK NUMBER AND PART NUMBER INDEX

FSCM	PART NUMBER	FIGURE NO.	ITEM NO.	FSCM	PART NUMBER	FIGURE NO.	ITEM NO.
96906	MS15795-8058B	3	6	96906	MS35338-135B	4	26
96906	MS15795-805B	3	89	96906	MS35338-135B	5	7
96906	MS15795-805B	5	9	96906	MS35338-135B	5	43
96906	MS15795-807	2	12	96906	MS35338-136	3	62
96906	MS15795-807	3	30	96906	MS35338-136B	13	11
96906	MS15795-807	13	5	96906	MS35338-137	13	6
96906	MS15795-808	3	46	96906	MS35338-138	3	42
96906	MS15795-808	3	59	96906	MS35338-138	3	57
96906	MS15795-808B	3	49	96906	MS35338-138	3	64
96906	MS15795-808B	3	75	969096	MS35338-138B	3	48
96906	MS15795-810B	12	2	96906	MS35338-138B	3	74
96906	MS16995-10	14	65	96906	MS35426-25	3	43
96906	MS17986C415	13	13	96906	MS35489-13	1	33
96906	MS17987C418	2	2A	96906	MS35649-224	8	21
96906	MS18121-375	16	14	96906	MS35649-224	9	23
96906	MS1957-4B	4	69	96906	MS35649-224	10	14
96906	MS20426AD3-3	11	3	96906	MS35649-264	3	61
96906	MS21042-02	4	71	96906	MS35649-264	5	30
96906	MS21042-04	2	5	96906	MS35649-264B	13	10
96906	MS21042-04	3	20	96906	MS35649-284B	13	4
96906	MS21042-04	3	38	96906	MS35650-304	3	45
96906	MS21042-04	3	104	96906	MS35650-304B	3	47
96906	MS21042-04	4	8	81349	MS39016/13-060L	4	68
96906	MS21042-04	4	38	96906	MS51021-1	14	5
96906	MS21042-04	5	34	96906	MS51029-10	14	30
96906	MS21042-04	6	10	96906	MS51029-10	14	58
96906	MS21042-04	9	28	96906	MS51338-135	3	86
96906	MS21042-06	3	7	96906	MS5159-45	3	23
96906	MS21042-06	4	41	96906	MS51849-57	2	11
96906	MS21042-06	4	65	96906	MS51849-57	3	29
96906	MS21042-08	3	53	96906	MS51859-1	8	19
96906	MS21093-0831	4	62	96906	MS51859-1	9	24
96906	MS21093-0835	4	16	96906	MS51859-2	9	25
96906	MS21981-287	16	10	96906	MS51957-12B	1	24
96906	MS2453-22	4	19	96906	MS51957-12B	2	7
96906	MS24523-31	4	17	96906	MS51957-13B	5	6
96906	MS24525-21	4	22	96906	MS1957-13B	14	49
96906	MS24693-53	3	54	96906	MS51957-14	14	12
96906	MS24693C32	4	3	96906	MS51957-14B	2	14
96906	MS25036-148	3	78	96906	MS51957-15	4	54
96906	MS25036-153	5	26	96906	MS51957-15	5	46
96906	MS25036-153	5	32	96906	MS51957-15	9	26
96906	MS25041-3	4	23	96906	MS51957-15	11	8
96906	MS25231-313	4	10	96906	MS51957-15B	3	24
96906	MS25231-313	5	17	96906	MS51957-15B	4	24
96906	MS27980-7B	3	12	96906	MS51957-15B	14	35
96906	MS28028-1	1	31	96906	MS51957-16	3	102
96906	MS29513-024	14	8	96906	MS51957-16	5	28
96906	MS29513-030	14	53	96906	MS51957-16B	3	11
96906	MS3112E10-6P	14	46	96906	MS51957-16B	3	18
96906	MS3112E12-3P	4	63	96906	MS51957-16B	4	14
96906	MS3112E14-19S	4	61	96906	MS51957-17	3	70
96906	MS3112E22-55S	4	4	96906	MS51957-17B	4	34
96906	MS3116E10-6P	16	26	96906	MS51957-17B	5	11
96906	MS3116E10-6S	16	25	96906	MS51957-18	3	68
96906	MS3116E10-6S	16	27	96906	MS51957-18	3	91
96906	MS3116E12-8P	16	24	96906	MS51957-18B	5	36
96906	MS3116F12-3S	5	33	96906	MS51957-19	6	8
96906	MS3116F14-19[11	14	96906	MS51957-19B	5	41
96906	MS3116F22-55P	7	20	96906	MS51957-28	3	52
96906	MS3116J14-5P	16	28	96906	MS51957-28	3	84
96906	MS3181-12N	5	4	96906	MS51957-28B	3	2
96906	MS3181-14N	5	3	96906	MS51957-28B	3	90
96906	MS3215-4025	12	4	96906	MS51957-29B	5	8
96906	MS3367-1-9	3	105	96906	MS51957-29B	13	9
96906	MS3367-4-9	3	77	96906	MS51957-3B	14	11
96906	MS3368-1-9-B	3	96	96906	MS51957-30	3	8
96906	MS3476L12-8P	16	1	96906	MS51957-30	3	82
96906	MS3476L14-19P	16	16	96906	MS51957-32B	3	5
96906	MS3476L14-19P	16	23	96906	MS51957-32B	4	64
96906	MS3476L16-26S	16	8	96906	MS51957-33B	4	44
96906	MS35338-134	8	22	96906	MS51957-34B	4	67
96906	MS35338-134	9	21	96906	MS51957-4	14	17
96906	MS35338-134	10	12	96906	MS51957-4	14	28
96906	MS35338-134	14	18	96906	MS51957-49B	13	3
96906	MS35338-135	2	8	96906	MS51957-5	8	20
96906	MS35338-135	5	47	96906	MS51957-5	9	20
96906	MS35338-135	14	13	96906	MS51957-5	10	11
96906	MS35338-135	14	38	96906	MS51957-5	14	39
96906	MS35338-135B	1	25	96906	MS51957-804B	3	17

NATIONAL STOCK NUMBER AND PART NUMBER INDEX

FSCM	PART NUMBER	FIGURE NO.	ITEM NO.	FSCM	PART NUMBER	FIGURE NO.	ITEM NO.
99096	NS51958-60B	3	73	81349	M8805/3-MS25089-1E	15	3
96900	MS51958-61	3	60	81349	RA10NASD501A	4	50
96906	MS51958-66	3	44	81349	RCR07G100JS	8	11
96906	MS51959-13	14	62	81349	RCR07G100JS	9	14
96906	MS51959-14	11	22	81349	RCR07G103JS	7	17
96906	MS51959-14	14	32	81349	RCR07G103JS	8	16
96906	MS51959-15	3	4	81349	RCR07G103JS	9	8
96906	MS51959-15	4	6	81349	RCR07G103JS	10	6
96906	MS51959-15	4	59	81349	RCR07G122JS	10	5
96906	MS51959-15B	3	19	81349	RCR07G151JS	7	9
96906	MS51959-16	2	3	81349	RCR07G151JS	8	13
96906	MS51977-29	14	15	81349	RCR07G223JS	7	16
96906	MS77068-1	6	7	81349	RCR07G223JS	8	3
96906	MS91528-1KID	4	21	81349	RCR0G334JS	10	7
96906	MS91528-1K2B	4	18	81349	RCR07G392JS	7	5
96906	MS91528-1K4B	4	27	81349	RCR07G471JS	8	15
81349	MW10F(M)A17	16	29	81349	RCR07G472JS	10	4
81349	MW10F(M)A17	16	30	81349	RCR07G561JS	7	8
81349	MW20(MM)A00	5	25	13619	RF8053A	5	31
81349	MW20F(M)A00	5	24	81349	RNR55C1782FS	9	18
80058	MX-4430/PRC-47	1	17	81349	RNR55C221OFS	7	15
80058	MX-9713/TSQ-97	1	7	81349	RNR55C5111FS	7	14
81349	M03014/02-1419	14	26	81349	RNR55C6811FS	9	16
81349	M15733/24-0002	4	39	80058	RT-1167/ARC-164(V)	1	18
81349	M15733/61-0011	4	55	81349	RWR81S1R5OFR	9	5
81349	M20708-78D001	14	43	81349	RWR82S1211FM	7	18
81349	M22/03-00111SD	4	58	80063	SC-A-706170	3	94
81349	M22885/47-26	4	47	80063	SC-A-706171	3	76
81349	M3786/04-5058	4	48	80063	SC-A-706198	11	21
81349	M38527/2-04N	7	21	80063	SC-A-706206	8	18
81349	M38527/2-04N	10	15	80063	SC-A-706391	14	6
81349	M39003/01-2579	4	72	80063	SC-B-706068	14	25
81349	M39003/01-2991	10	8	80063	SC-B-706081	14	52
81349	M39003/01-3006	8	8	80063	SC-B-706083-1	14	37
81349	M39003/01-3006	9	10	80063	SC-B-706083-2	14	42
81349	M39003/01-3021	8	12	80063	SC-B-706108	14	66
81349	M39003/01-3021	9	7	80063	SC-B-706117	14	41
81349	M39003/01-3058	3	97	80063	SC-B-706162	1	32
81349	M39003/01-3058	7	2	80063	SC-B-706180	3	80
81349	M39003/01-3063	8	2	80063	SC-B-706182	3	81
81349	M39003/01-3063	9	11	80063	SC-B-706349-1	11	12A
81349	M39003/01-3067	9	3	80063	SC-B-706354	11	18
81349	M39003/01-3076	8	5	80063	SC-B-706365	14	34
81349	M39003/01-3076	9	15	80063	SC-B-706367	14	14
81349	M39006/21-0148	9	30	80063	SC-B-706368	14	64
81349	M39006/21-0148	11	20	80063	SC-B-706369	14	61
81349	M39012/16-0101	16	33	80063	SC-B-706374	3	56
81349	M39012/16-0101	16	35	80063	SC-B-706379	5	44
81349	M39012/16-0101	16	37	80063	SC-B-706388	2	15
81349	M39012/16-0101	16	38	80063	SC-C-706002	1	23
81349	M39012/16-0101	16	39	80063	SC-C-706005	1	22
81349	M39012/16-0101	16	40	80063	SC-C-706017	12	7
81349	M39014/01-1447	6	5	80063	SC-C-706031	1	39
81349	M39014/05-2237	7	11	80063	SC-C-706038	13	8
81349	M39014/13-0505	9	19	80063	SC-C-706040	12	1
81349	M39014/13-0515	8	4	80063	SC-C-706050	3	95
81349	M39014/13-0515	8	7	80063	SC-C-706052	3	98
81349	M39014/13-0515	9	13	80063	SC-C-706053	3	100
81349	M39015-2-006LP	14	20	80063	SC-C-706057	1	34
81349	M39015/1-006YP	7	13	80063	SC-C-706063	14	60
81349	M39015/2-006PR	8	6	80063	SC-C-706064	14	29
81349	M39016/34-008L	3	107	80063	SC-C-706071	14	4
81349	M39016/34-008L	7	7	80063	SC-C-706076	14	16
81349	M39016114-0021	7	3	80063	SC-C-706078	14	2
81349	M39019/01-231	5	13	80063	SC-C-706082	14	51
81349	M3901/01-234	5	12	80063	SC-C-706084	14	55
81349	M39019/01-254	4	46	80063	SC-C-706087	14	56
81349	M39024/6-03	8	9	80063	SC-C-706092	14	33
81349	M39024/6-03	9	17	80063	SC-C-706097	14	54
81349	M39024/6-03	10	10	80063	SC-C-706098	14	47
81349	M45938/3-4L	11	17	80063	SC-C-706105	14	59
81349	M45938/3-6L	11	19	80063	SC-C-706111	14	3
96906	M53188A100	16	22	80063	SC-C-706121	12	6
81349	M55302/1-03	8	17	80063	SC-C-706138	12	5
81349	M55302/1-03	9	6	80063	SC-C-706141	12	3
81349	M55302/1-03	10	3	80063	SC-C-706166	3	35
81349	M55302/2-03	11	16	80063	SC-C-706176	11	23
81349	M55302/5-05	7	10	80063	SC-C-706183-1	3	92
81349	M55302/6-05	6	6	80063	SC-C-706183-2	3	93
81349	M80CU	9	27	80063	SC-C-706188	3	10

NATIONAL STOCK NUMBER AND PART NUMBER INDEX

FSCM	PART NUMBER	FIGURE NO.	ITEM NO.	FSCM	PART NUMBER	FIGURE NO.	ITEM NO.
80063	SC-C-706189	11	6	80063	SC-D-706163	2	13
80063	SC-C-706192	11	15	80063	SC-D-706167	3	14
80063	SC-C-706197	9	1	80063	SC-D-706197	3	85
80063	SC-C-706202	8	1	80063	SC-D-706173	3	55
80063	SC-C-706207	10	1	80063	SC-D-706184	3	21
80063	SC-C-706210	11	4	80063	SC-D-706185	3	15
80063	SC-C-706211	11	12	80063	SC-D-706186	3	34
80063	SC-C-706216	4	33	80063	SC-D-706191	11	11
80063	SC-C-706220	4	57	80063	SC-D-706213	4	32
80063	SC-C-706222	4	52	80363	SC-D-706214	3	22
80063	SC-C-706228	3	1	80063	SC-D-706218	3	56A
80063	SC-C-706230	7	1	80063	SC-D-706223	3	28
80063	SC-C-706235	6	3	80063	SC-D-706224	5	1
80063	SC-C-706240	5	45	80063	SC-D-706226	5	5
80063	SC-C-706243	1	11	80063	SC-D-706238	3	26
80063	SC-C-706245	3	50	80063	SC-D-706253	1	40
80063	SC-C-706247	3	58	80063	SC-D-706256	1	41
80063	SC-C-706255	4	51	80063	SC-D-706259	1	13
80063	SC-C-706273	5	15	80063	SC-D-706261	1	8
80063	SC-C-706276	5	23	80063	SC-D-706262	1	14
80063	SC-C-706282	3	65	80063	SC-D-706264	1	29
80063	SC-C-706289	11	1	80063	SC-D-706265	1	12
80063	SC-C-706299ITEM2	15	4	80063	SC-D-706314	7	19
80063	SC-C-706299ITEM1	15	1	80063	SC-D-706279	3	79
80063	SC-C-706309	16	17	80063	SC-D-706316	11	13
80063	SC-C-706326	4	56	80063	SC-D-706320	1	35
80063	SC-C-706343	4	60	80063	SC-D-706321	1	36
80063	SC-C-706351	5	14	80063	SC-D-706339	3	88
80063	SC-C-706355	5	37	80063	SC-D-706342	3	27
80063	SC-C-706356	3	16	80063	SC-D-706361	2	9
80063	SC-C-706357	4	5	80063	SC-D-706362	1	27
80063	SC-C-706358	5	27	80063	SC-D-706370	14	21
80063	SC-C-706359	5	10	80063	SC-D-706399	2	1
80063	SC-C-706360	2	6	81349	SE25XC02	6	4
80063	SC-C-706373-1	3	39	81349	SE25XC02	6	12
80063	SC-C-706373-2	3	40	98675	SI-24-0	4	49
80063	SC-C-706373-3	3	41	01226	SSB-50N	14	31
80063	SC-C-706381	14	50	80058	U-182/U	15	5
80063	SC-C-706384	3	21A	80058	U-183/U	4	20
80063	SC-C-706389	2	9A	80058	U-229/U	16	7
80063	SC-C-706392	2	2	81349	UG-1366/U	16	34
80063	SC-D-706006	1	10	81349	UG-1366/U	16	36
80063	SC-D-706027	1	5	95712	UG1366U	16	32
80063	SC-D-706032	13	2	81348	W-L-00111/7	4	1
80063	SC-D-706037	1	2	81348	W-L-00111/7	5	16
80063	SC-D-706059	1	37	19178	ZSP-6-037-4	2	18
80063	SC-D-706067	14	24	97539	10	4	29
80063	SC-D-706070	14	1	89536	104406	3	106
80063	SC-D-706072	14	7	89536	104406	4	45
80063	SC-D-706074	14	10	89536	104406	11	10
80063	SC-D-706080	14	48	71279	1290-1	4	15
80063	SC-D-706090	2	20	45413	134511-1	9	2
80063	SC-D-706093	2	17	00781	14491	4	40
80063	SC-D-706094	14	57	81996	1845X4-03DF	4	37
80063	SC-D-706095	2	16	81860	21271-5	2	10
80063	SC-D-706190	1	3	50778	26PC11-213-8	14	9
80063	SC-D-706110-41	16	4	81349	26TB8	3	66
80063	SC-D-706110-42	16	3	97539	4086(ENGR,NO1223/6)	4	28
80063	SC-D-706110-43	16	5	76545	46-CBLACK	16	31A
80063	SC-D-706110-44	16	12	76545	46-CRED	16	31
80063	SC-D-706110-45	16	13	71286	5R2-3	11	2
80063	SC-D-706110-45	16	21	71286	5S10-16	11	5
80063	SC-D-706110-46	16	11	71286	5S10-19	5	2
80063	SC-D-706110-46	16	19	73342	6862093	5	18
80063	SC-D-706110-47	16	20	79963	690	14	27
80063	SC-D-706112	1	38	77820	71-252714-19S	6	1
80063	SC-D-706113	1	9	77820	71-252712-8S	6	2
80063	SC-D-706115	1	30	74868	79675	13	7
80063	SC-D-706153	2	19				

By Order of the Secretary of the Army:

Official:

JOHN A. WICKHAM JR.
General, United States Army
Chief of Staff

ROBERT M. JOYCE
Major General, United States Army
The Adjutant General

DISTRIBUTION:

To be distributed in accordance with DA Form 12-36B, Direct and General Support Maintenance requirements for AN/TSQ97.

PIN: 046121-000

This fine document...

Was brought to you by me:



[Liberated Manuals -- free army and government manuals](#)

Why do I do it? I am tired of sleazy CD-ROM sellers, who take publicly available information, slap “watermarks” and other junk on it, and sell it. Those masters of search engine manipulation make sure that their sites that sell free information, come up first in search engines. They did not create it... They did not even scan it... Why should they get your money? Why are not letting you give those free manuals to your friends?

I am setting this document FREE. This document was made by the US Government and is NOT protected by Copyright. Feel free to share, republish, sell and so on.

I am not asking you for donations, fees or handouts. If you can, please provide a link to liberatedmanuals.com, so that free manuals come up first in search engines:

<A HREF=<http://www.liberatedmanuals.com/>>Free Military and Government Manuals

- Sincerely
Igor Chudov
<http://igor.chudov.com/>
- [Chicago Machinery Movers](#)