

DEPARTMENT OF THE NAVY TECHNICAL MANUAL

NAVSHIPS 0967-217-4010

DEPARTMENT OF THE ARMY TECHNICAL MANUAL

TM 11-5895-490-20

ORGANIZATIONAL MAINTENANCE MANUAL

RECEIVER-TRANSMITTERS, RADIO
RT-859/APX-72 (NSN 5895-00-089-7179)
RT-859A/APX-72 (NSN 5895-00-160-2198)
AND
MOUNTINGS
MT-3809/APX-72 (NSN 5895-00-063-9498)
MT-3948/APX-72 (NSN 5895-00-089-9202)

This copy is a reprint which includes current
pages from Changes 1 and 2.

PUBLISHED UNDER AUTHORITY OF THE COMMANDER, NAVAL
SHIP-SYSTEMS COMMAND AND HEADQUARTERS, DEPARTMENT
OF THE ARMY.

JUNE 1967

WARNING

DANGEROUS VOLTAGES EXIST IN THIS EQUIPMENT

DON'T TAKE CHANCES!

DANGEROUS VOLTAGES EXIST IN—

Receiver-Transmitter, Radio RT-859/APX-72

Technical Manual No. }
NAVELEX 0967-217-4010 }
TM 11-5895-490-20 }

DEPARTMENTS OF THE NAVY
AND THE ARMY
WASHINGTON, DC, 1 June 1967

**ORGANIZATIONAL MAINTENANCE MANUAL
RECEIVER-TRANSMITTERS, RADIO
RT-859/APX-72 (NSN 5895-00-089-7179)
RT-859A/APX-72 (NSN 5895-00-160-2198)
AND
MOUNTINGS
MT-3809/APX-72 (NSN 5895-00-063-9498)
MT-3948/APX-72 (NSN 5895-00-089-9202)**

REPORTING ERRORS AND RECOMMENDING IMPROVEMENTS
You can help improve this manual. If you find any mistakes or if you know of a way to improve the procedures, please let us know. Mail your letter or DA Form 2028 (Recommended Changes to Publications and Blank Forms) direct to Commmdr, US Army Communications and Electronics Materiel Readiness Command, Attn: DRSEL-ME-MQ Fort Monmouth, NJ 07703.
For Navy, mail comments to the Commander, Naval Electronics Systems Command, Training and Publications Management Office, ELEX 04F3, P.O. Box 80337, San Diego, CA 92138.
In either case, a reply will be furnished direct to you.

	Paragraph	Page
CHAPTER 1. INTRODUCTION		
Section I. General		
Scope of manual	1-1	1-1
Indexes of publications	1-2	1-1
Maintenance forms, records, and reports	1-3	1-1
Section II. Description and data		
Purpose and use	1-4	1-1
Technical characteristics	1-5	1-3
Table of components	1-6	1-4
Description of Receiver-Transmitter, Radio RT-859/APX-72 and Mountings MT-3809/APX-72 and MT-3498/APX-72	1-7	1-4
Additional equipment required	1-8	1-7
Section III. System analysis		
General	1-9	1-8
System analysis	1-10	1-9
Section IV. Service upon receipt of equipment		
Unpacking	1-11	1-11
Checking unpacked equipment	1-12	1-13
CHAPTER 2. OPERATING INSTRUCTIONS		
Section I. Controls and indicators		
General	2-1	2-1
Operating controls and indicators	2-2	2-1
Section II. Operation		
Types of operation	2-3	2-5
Starting Procedure	2-4	2-5
Operating procedures	2-5	2-6
Stopping procedure	2-6	2-7
CHAPTER 3. ORGANIZATIONAL MAINTENANCE		
Section I. General		
Scope of maintenance	3-1	3-1
Tools, test equipment, and materials	3-2	3-1

	Paragraph	Page
Section II. Preventive maintenance checks and services		
Preventive maintenance	3-3	3-1
Intermediate preventive maintenance checks and services	3-4	3-2
Intermediate preventive maintenance checks and services chart	3-5	3-2
Pressurization	3-6	3-3
Cleaning	3-7	3-3
Power-On inspection.....	3-9	3-3
Preliminary procedures.....	3-10	3-3
Starting procedure	3-11	3-8
Receiver-Transmitter, Radio RT-859/APX-72 tests.....	3-12	3-8
Stopping procedure.....	3-13	3-11
Alternate performance check.....	3-14	3-11
Periodic preventive maintenance checks and services	3-15	3-11
Periodic preventive maintenance checks and services chart	3-16	3-12
Section III. Troubleshooting		
General troubleshooting.....	3-17	3-12
Troubleshooting chart.....	3-18	3-13
Removal and replacement	3-19	3-13
APPENDIX A. REFERENCES	A-1	A-1
B. MAINTENANCE ALLOCATION	B-1	B-1
C. EXPENDABLE SUPPLIES AND MATERIALS LIST (Not applicable)		

LIST OF ILLUSTRATIONS

Figure No.	Title	Page
1-1	Receiver-Transmitter, Radio RT-859/APX-72 and Mountings MT-3809/APX-72 and MT-3948/APX-72 -----	iv
1-2	Receiver-Transmitter, Radio RT-859/APX-72 functional block diagram -----	1-2
1-3	Receiver-Transmitter, Radio RT-859/APX-72 -----	1-4
1-4	Mounting MT-3809/APX-72 -----	1-5
1-5	Mounting MT-3948/APX-72 -----	1-6
1-6	Antenna AT-884A/APX -----	1-6
1-7	Control, Transponder Set C-6280(P)/APX -----	1-7
1-8	Test Set, Transponder Set TS-1843/APX -----	1-8
1-9	System analysis, block diagram -----	1-9
1-10	Typical packaging, Receiver Transmitter, Radio RT-859/APX-72 -----	1-10
1-11	Typical packaging, Mountings MT-3809/APX-72 and MT-3948/APX-72 -----	1-12
2-1	Control, Transponder Set C-6280(P)/APX, controls and indicators -----	2-3
2-2	Receiver-Transmitter, Radio RT-859/APX-72, controls and indicators -----	2-4
3-1	Test setup for radiation operation -----	3-4
3-2	Antenna positioning for vertical and horizontal polarization -----	3-5
3-3	Test Set, Transponder AN/APM-123A(V)1, controls and indicators -----	3-6
3-4	Test setup for nonradiation operation -----	3-7

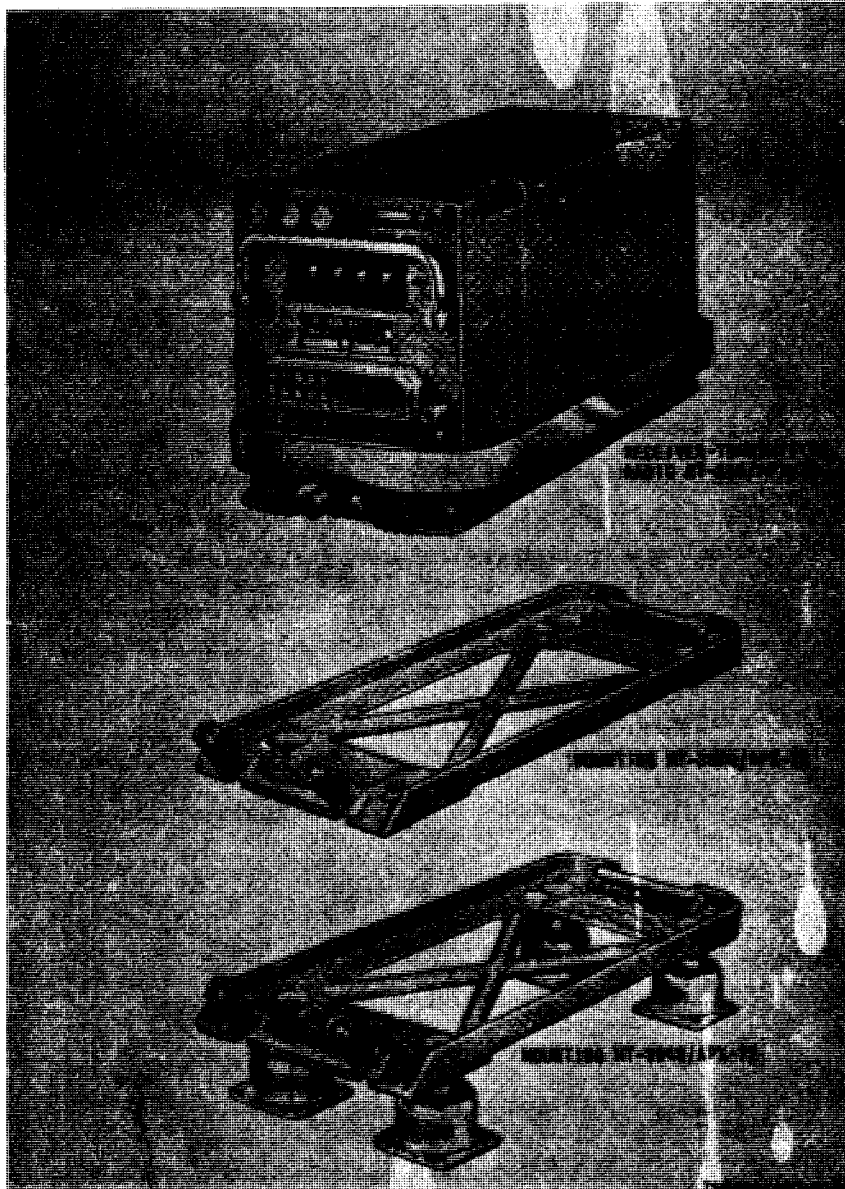

*Figure 1-1. Receiver-Transmitter, Radio RT-859/APX-72
and Mountings MT-3809/APX-72 and MT-3948/APX-72.*

CHAPTER 1 INTRODUCTION

Section I. General

1-1. Scope of Manual

This manual describes Receiver-Transmitters, Radio RT-859/APX-72 and RT-859/APX-72 and Mountings MT-3809/APX-72 and MT-3948/APX-72 (fig. 1-1) and covers their operation and organizational maintenance. It includes instructions for operation, inspection, and preventive maintenance of the equipment. All descriptions and instructions for the RT-859/APX-72 contained in this manual also apply to the RT-859A/APX-72. Also included in this manual is a *maintenance allocation chart* (app B.)

1-2. Indexes of Publications

a. DA Pam 310-4. Refer to the latest issue of DA Pam 310-4 or NAVSUP 2002 Section viii (Navy) to determine whether there are new editions, changes, or additional publications pertaining to the equipment.

b. DA Pam 310-7. Refer to DA Pam 310-7 to determine whether there are modification work orders (MWO's) pertaining to the equipment.

1-3. Maintenance Forms, Records, and Reports

a. Reports of Maintenance and Unsatisfactory Equipment. Department of the Army forms and procedures used for equipment maintenance will be those prescribed by TM 38-750, The Army Maintenance Management System (Army). Navy personnel will report maintenance performed utilizing the Maintenance Data Collection Sub-system (MDCS) IAW OPNAVINST 4790.2, Vol 3 and unsatisfactory material/conditions (UR submissions) IAW OPNAVINST 4790.2, Vol 2, chapter 17.

b. Report of Packaging and Handling Deficiencies. Fill out and forward DD Form 6 (Packaging Improvement Report) as prescribed in AR 735-11-2/NAVSUPINST 4440.127E/AFR 400-54/MCO 4430.3E and DSAR 4140.55.

c. Discrepancy in Shipment Report (DISREP) (SF 361). Fill out forward Discrepancy in Shipment Report (DISREP) (SF 361). Fill out and forward Discrepancy in Shipment Report (DISREP) (SF 361) as prescribed in AR 55-38/

NAVSUPINST 4610.33B/AFR 75-18/MCO P4610.19C and D LAR 4500.15.

d. Reporting Equipment Improvement Recommendations (EIR).

(1) *Army.* If your equipment needs improvement, let us know. Send us an EIR. You, the user, are the only one who can tell us what you don't like about your equipment. Let us know why you don't like the design. Tell us why a procedure is hard to perform. Put it on an SF 368 (Quality Deficiency Report). Mail it to Commander, US Army Communication and Electronics Materiel Readiness command, ATTN: DRSEL-ME-MQ, Fort Monmouth, 07703. We'll send you a reply.

(2) *Navy.* Navy personnel are encouraged to submit EIR's through their local Beneficial Suggestion Program.

e. (Army Only) Destruction of Army Materiel to Prevent Enemy Use. Demolition of the test set will be accomplished only upon the order of the Commander. Refer to TM 750-244-2 for procedures to prevent the enemy from using or salvaging this equipment.

f. (Army Only) Administrative Storage. Administrative storage of equipment issued to and used by Army activities shall be maintained in a maximum Readiness Condition (REDCON). Equipment placed in administrative storage should be capable of being readied to perform its mission within a 24 hour period or as otherwise prescribed by the approving authority. Before equipment is placed in administrative storage, current maintenance service should be performed; shortcomings and deficiencies should be corrected; and all modification work orders (MWO's) as listed in DA Pam 310-7 should be applied. Particular attention is directed to security and calibration of installed electronic equipments in or out of aircraft or surface equipment prior and during administrative storage. Special procedures include protection from dust and humidity and the cleanliness and inspection of the electronic equipments. Upon removal from storage, the electronic equipments must be prepared for operation and tested in accordance with the PMCS charts and procedures in pertinent technical manuals.

Section II. DESCRIPTION AND DATA

1-4. Purpose and Use

a. Receiver-Transmitter, Radio RT-859/APX-72 or RT-859A/APX-72 (RT-859/APX-72) when used with auxillary equipment described in paragraph 1-8, provides automatic radar identification of aircraft or surface vessel to all suitably equipped challenging aircraft, surface ships, and ground facilities within the operational range of the

system. The RT-859/APX-72 receives, decodes, and responds to the characteristic interrogations of operational modes 1, 2, 3/A, C and 4. The receiver section operates on a frequency of 1080 megahertz (MHz) and the transmitter section operates on a frequency of 1090 MHz. Specially coded identification of position (1P) and emergency.

signals may be transmitted to interrogating stations when conditions warrant.

b. Figure 1-2 is a functional block diagram showing the interrogation and response of the RT-859/APX-72. Signals, consisting of pairs of pulses spaced to form a code, are transmitted to the RT-859/APX-72 which receives the coded signal and transfers it to the decoder. The decoder checks the incoming signal for valid code and proper mode (except for mode 4 interrogations which are sent directly to the mode 4 board). If valid, the decoded signal is sent to the encoder board which prepares the coded reply. The coded reply is sent through the transmitter and antenna to the interrogating source.

c. The RT-859/APX-72 can be operated in any one of the following categories, each of which may be selected by the operator at Control, Transponder Set C-6280(P)/APX.

- (1) Low (sensitivity) operation
- (2) Normal (sensitivity) operation

- (3) Identification of position (IDENT-MIC)
- (4) Emergency

d. Five independent coding modes are available to the operator. The first three modes may be used independently or in combination. Mode 1 provides 32 possible code combinations, any one of which may be selected in flight. Mode 2 provides 4,096 possible code combinations but only one is available since the selection dials are not normally available in flight and must be preset before flight. Mode 3/A provides 4,096 possible codes any one of which may be selected in flight. Mode C, when connected to Pressure Altitude Digitizer CPU-66/A (or equivalent), will indicate pressure altitude of aircraft when interrogated. Mode 4, which is connected to an external computer, can be selected to display any one of many classified operational codes for security identification.

e. The range of the RT-859/APX-72 is limited to line-of-sight transmission since its

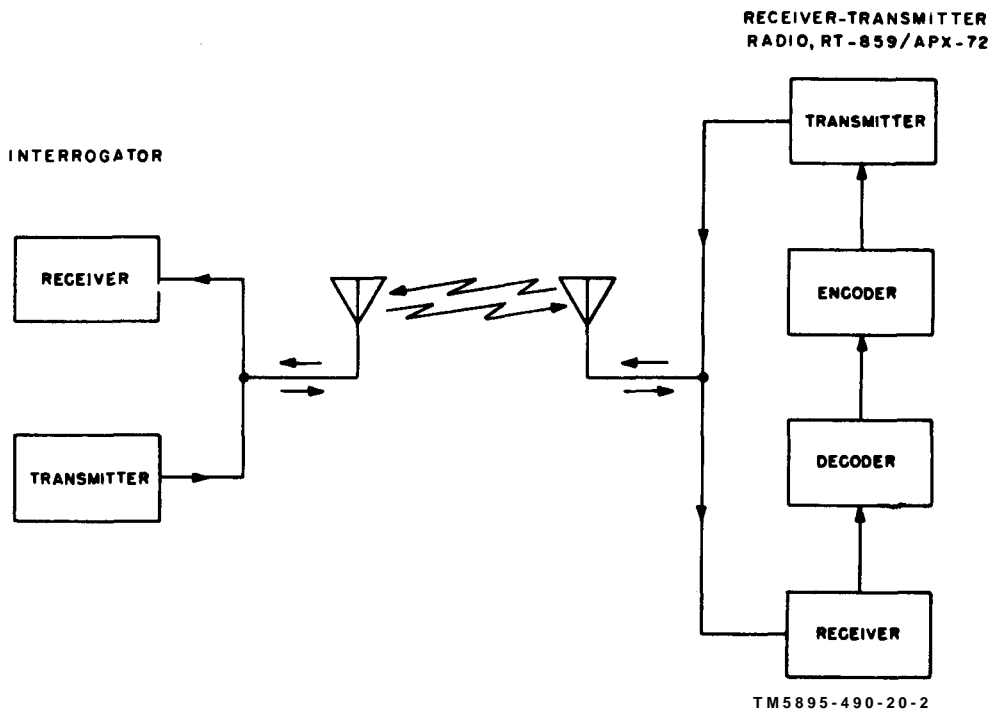

Figure 1-2 Receiver-Transmitter, Radio RT-859/APX-72 functional block diagram.

frequency of operation is in the uhf band making range dependent on altitude of aircraft. 3948/APX-72 provide a frame for mounting the RT-859/APX-72 in the aircraft or surface vessel.
 f. Mountings MT-3809/APX-72 and MT-

1-5. Technical Characteristics

a. Receiver-Transmitter, Radio RT-859/APX-72.

- Number of modules ----- 26
- Number of silicon diodes ----- 311
- Number of transistors -----196
- Range-----Line-of-sight.
- Response-----Limited by interrogation rate and internal limiting action.
- Power requirements ----- 28 vdc, 70 watts maximum or 28 vdc, 8.4 watts and 115 vac, 95 va maximum, 360-440 cps.
- Power source -----28 vdc source or 28 vdc and 115 vac source.
- Operating temperature range --- 54° (-65°F) to + 95°C (203°F).
- Warmup time ----- 1 minute maximum standard condition.
 2 minute maximum extreme service conditions.
- Pressurization -----5 psig at sea level (can operate unpressurized to 30,000 feet).

(1) *Receiver:*

- Type of signal received ----- Pulsed radio frequency.
- Frequency -----1030 ± 0.5mc.
- Bandwidth -----Minimum 7 mc at 6 db point.
 Maximum ±25 mc at 60 db point.
- Frequency stability ----- ±1.5 mc maximum for a period of at least 500 hours.
- Sensitivity:
 - Normal triggering level --- Between 69 and 77 db below 1 milliwatt.
 - Low triggering level ----- Between 52 and 67 db below 1 milliwatt.
- Random triggering rate ----- Maximum of five replies per second averaged over a one-minute period.
- Triggering bandwidth ----- ±2.5 mc at 3 db points.

(2) *Transmitter:*

- Type of signal transmitted -- Pulsed radio frequency.
- Frequency ----- 1090 ±0.5mc.
- Frequency stability ----- ±3 mc maximum drift.
- Peak power output ----- 500w ±3 db.
- Duty cycle ----- 1.1 percent maximum.
- Delay ----- 3.5 ±5 µsec between the leading edge of the second interrogation pulse to the leading edge of the first reply pulse.
- Spurious responses ----- Maximum of 60 db down from the amplitude of transmitted pulse.

1-6. Table of Components

(fig. 1-1)

a. Components. This listing is based on original shipment of contract No. NOW 66-0637. For a current official listing, see the *basic issue items list* (appx B, section II).

b. Running Spare. A 5-ampere fuse is the only running spare. It is stored in the fuseholder labeled SPARE 5A, located on the front panel of Receiver-Transmitter, Radio RT-859/APX-72.

Quantity	Item	Height (in.)	Depth (in.)	Width (in.)	Weight (lb)
1	Receiver-Transmitter, Radio RT-859/APX-72	6.06	12.25	5.76	15.00
1	Mounting MT-3809/APX-72 or Mounting MT-3948 /APX-72	0.81	12.4	5.06	1.50
1	Running spare (b. below)	2.50	12.4	5.06	2.10

1-7. Description of Receiver-Transmitter, Radio RT-859/APX-72 and Mountings MT-3809/APX-72 and MT-3948/APX-72

a. The RT-859/APX-72 (fig.1-3) is encased in a two-sectioned housing suitable for pressurizing. A silicon rubber O-ring serves as a pressure seal between the two sections which are joined together by an encircling flange coupler with clamp. The lower section of the housing is provided with extrusions which mate with cavities on the mounting frame. The upper section of the housing contains a chassis with compartments for seven digital circuitry printed circuit boards and a plug-in power supply. A frontal panel, containing three fuseholders, an elapsed time meter, the MODE 2 switch assembly, the power control connector, and a folding handle, is fastened to the upper section of the case. The lower section of the housing contains the rf and video circuit com-

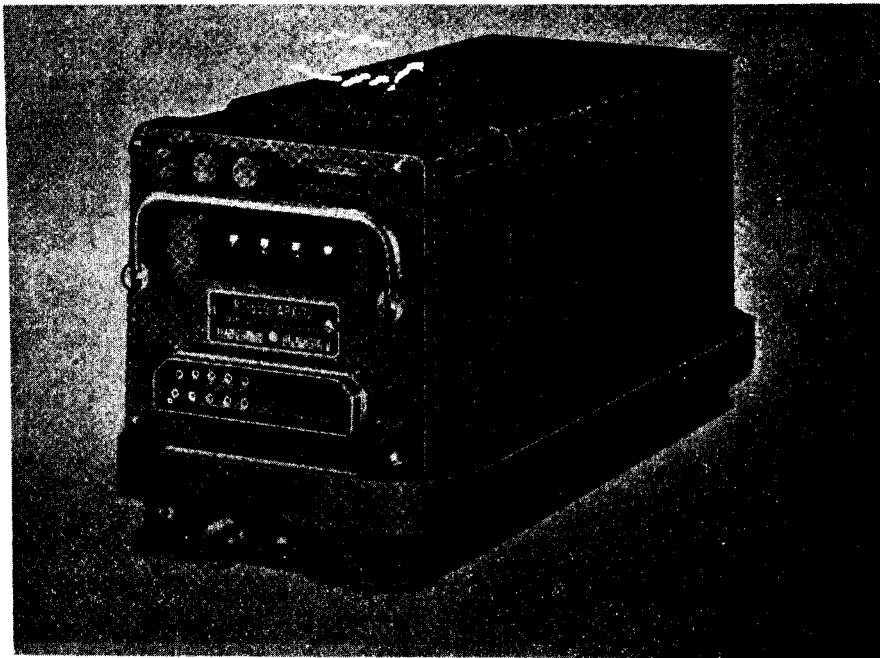

Figure 1-3. Receiver-Transmitter, Radio RT-859/APX-72.

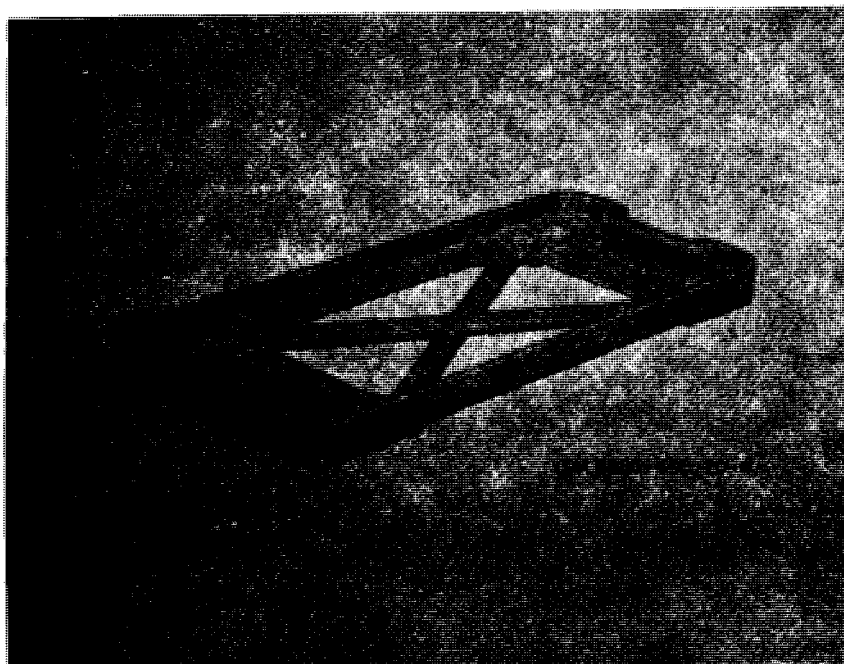

Figure 1-4. Mounting MT-3809/APX-72.

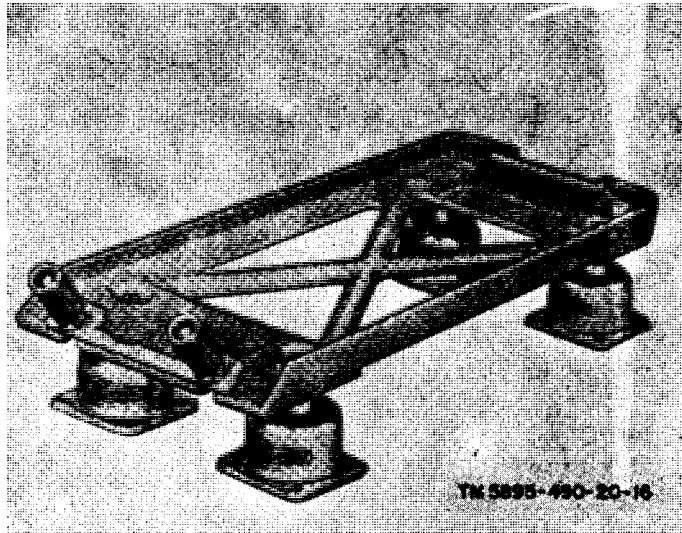

Figure 1-5. Mounting MT-3948/Apx-72.

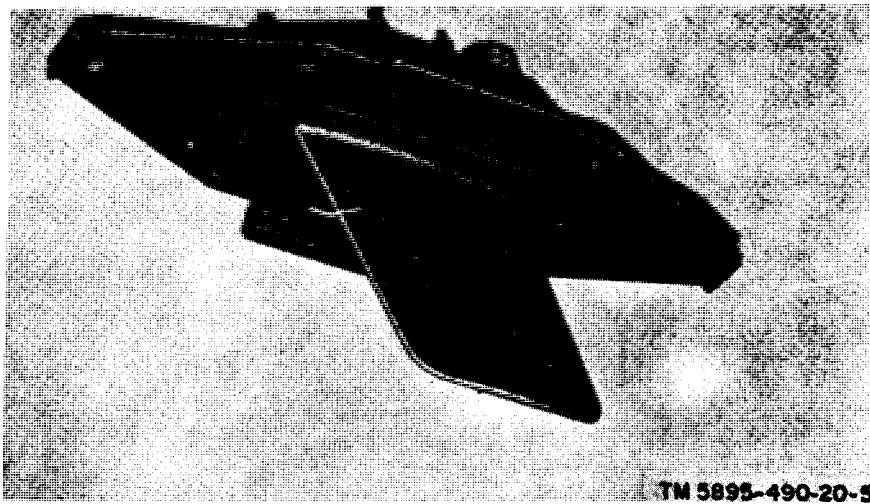

Figure 1-6. Antenna AT-884A/APX

ponents, the antenna connector, and the pressurization valve.

b. The MT-3809/APX-72 (fig. 1-4) is a hard-type mount. It has a recess at the rear into which a protruding lip on the RT-859/APX-72 lower case is placed. Two swivel operating nut and bolt combinations at the front fasten down on two protruding feet on the front of the RT-859/APX-72. The MT-3809/APX-72 is constructed of cast aluminum.

c. The MT-3948/APX-72 (fig. 1-5) is identical to the MT-3908/APX-72 except for the addition of four isolators which are connected to the four corners of the mount.

1-8. Additional Equipment Required

The following equipment is not supplied as part of the RT-859/APX-72 and MT-3809/APX-72 and MT-3948/APX-72 but is needed for partial or full operation of the set:

a. *Antenna AT-884A/APX.* The AT-884A/

APX (fig. 1-6), or equivalent, (one required) is needed to receive the signal of the interrogating station and to radiate the reply signal.

b. *Control, Transponder Set C-6280(P)/APX.* The C-6280(P)/APX (fig. 1-7) (one required) is needed for operation of the RT-859/APX-72. The C-6280(P)/APX applies power to the RT-859/APX-72, determines the modes and categories of operation, and selects the mode code settings except for mode 2. Refer to manual NAVWEPS 16-35C6280-1/T.O. 12P4-2APX-142 (Navy/Air Force) or TM 11-5841-268-25 (Army).

c. *Computer KIT-1A/TSEC.* The KIT-1A/TSEC (classified), or equivalent, is required for mode 4 operation of the RT-859/APX-72. The KIT-1A/TSEC processes mode 4 interrogations and prepares the coded reply for transmission.

d. *Pressure Altitude Digitizer CPU-66/A.* The CPU-66/A, or equivalent, is used in mode

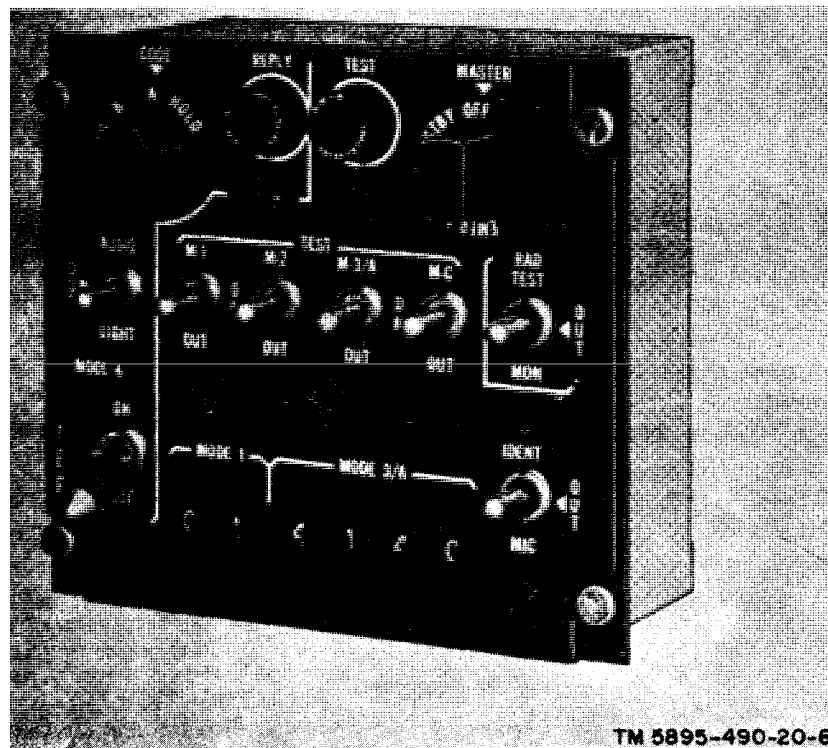

Figure 1-7. Control, Transponder Set C-6280(P)/Apx.

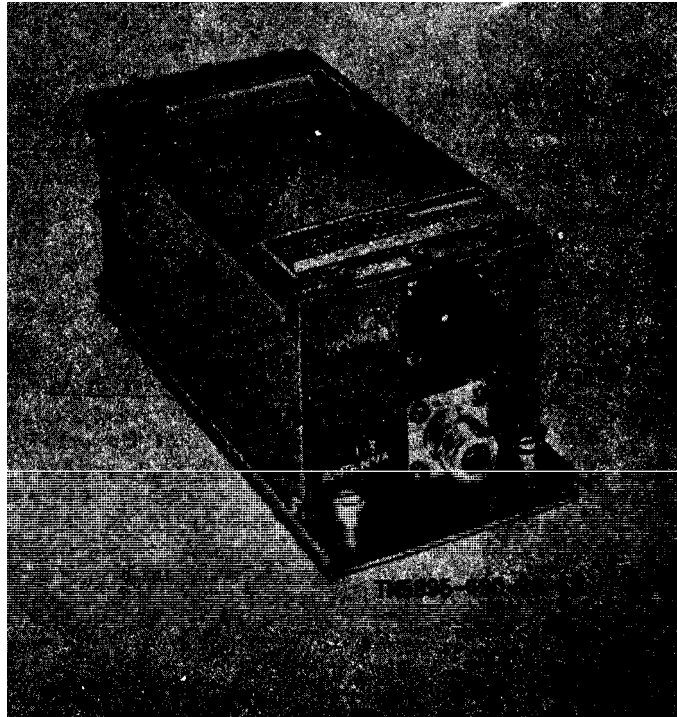

Figure 1-8, Test Set, Transponder Set TS-1843/APX.

C operation to prepare coded signals, indicating aircraft pressure altitude in hundreds of feet, for transmission.

e. *Power Supply.* A source of primary power capable of supplying 27.5 vdc at 2.5 amperes or 27.5 vdc at 2.5 amperes and 115 vac at 90 va, 400 \pm 10% cps is required to operate the power supply in the RT-859/APX-72. The power is obtained from the aircraft or surface vessel electrical system.

f. *Test Set, Transponder Set TS-1843/APX.*

The TS-1843/APX (fig. 1-8) is an in-flight test set that is used to indicate either satisfactory or unsatisfactory performance of the overall transponder system on a go, no-go basis. Refer to manual NAVWEPS 16-35TS1843-1/T.O.12P4-2APX-152.

g. *Interconnecting Cables.* Interconnecting cables with connectors to mate with the multi-pin connector and the rf coaxial connector on the RT-859/APX-72 are required. These cables are installed as part of the aircraft.

Section III. SYSTEM ANALYSIS

1-9. General

The RT-859/APX-72 is an integral part of a transponder system which is used to present

positive identification, position, altitude, and emergency conditions (if they exist) of an aircraft or surface vessel to an interrogating sta-

tion. The auxiliary equipment required for limited operation of the RT-859/APX-72 consists of Antenna AT-884A/APX (or equivalent), Control, Transponder Set C-6280(P)/APX and a 28 vdc or 28 vdc and 115 vac power source. Additional auxiliary equipment required for complete operation consists of Computer KIT-1A/TSEC, Pressure Altitude Digitizer CPU-66/A (or equivalent) and Test Set, Transponder Set TS-1843/APX.

1-10. System Analysis

Refer to block diagram (fig. 1-9) for this discussion of system analysis.

a. Antenna AT-884A/APX (or equivalent). The mode 1, 2, 3/A, C, or 4 coded interrogating pulse is received at the AT-884A/APX and fed directly to the RT-859/APX-72. If the interrogating signal is determined to be valid, a coded

reply pulse will be transmitted through the AT-884A/APX to the interrogating station.

b. Receiver-Transmitter, Radio RT-859/APX-72. The coded interrogating pulse input to the RT-859/APX-72 is tested for validity and, if it conforms to the mode and code preset in the RT-859/APX-72, a coded reply pulse will be generated and fed to the AT-884A/APX for transmission, Modes 1, 2, and 3/A interrogations are processed within the RT-859/APX-72, but modes C and 4 interrogations are applied to external equipment which generates the coded reply pulse for transmission through the RT-859/APX-72. The RT-859/APX-72 contains only the MODE 2 code setting switch; all other controls including source power switch are on the C-6280(P)/APX. Additional reply responses for identification of position and emergency are available for trans-

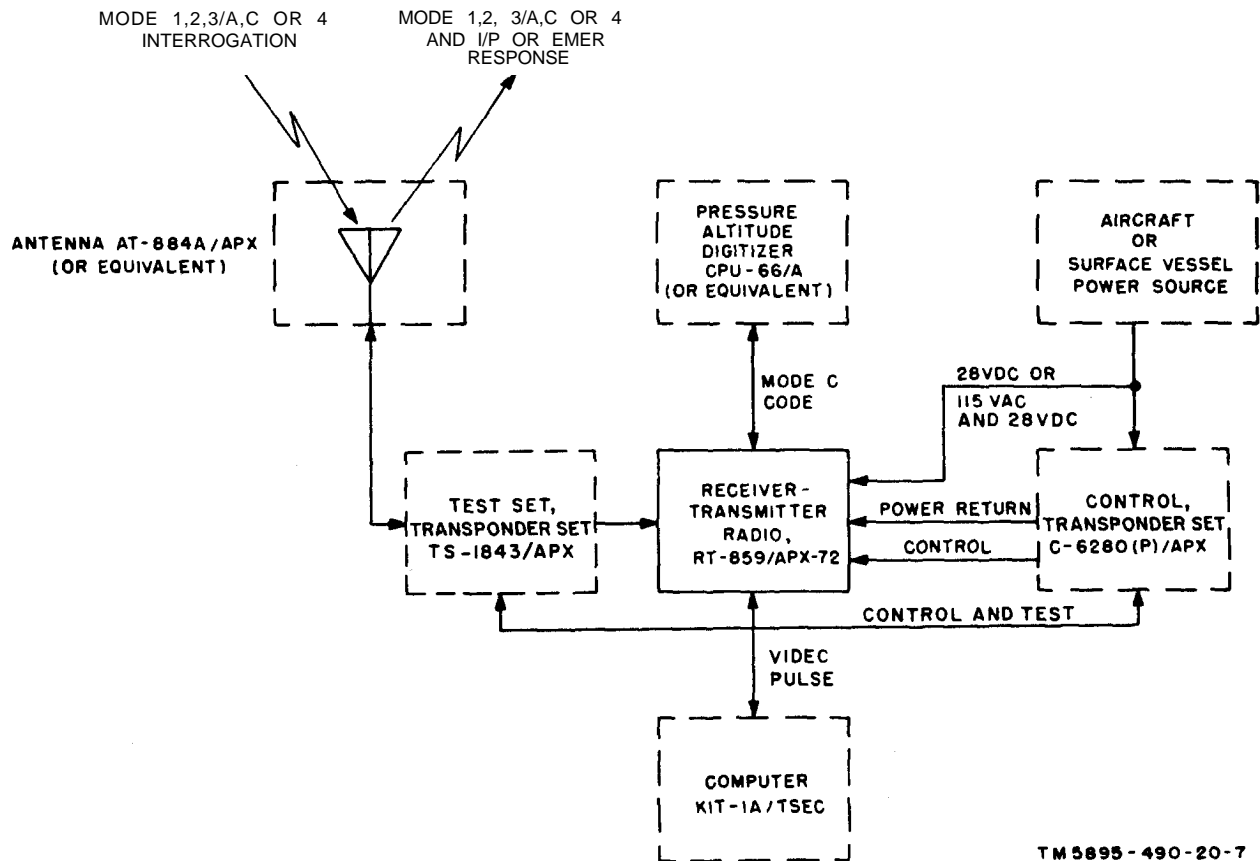

TM 5895-490-20-7

Figure 1-9. System analysis, block diagram.

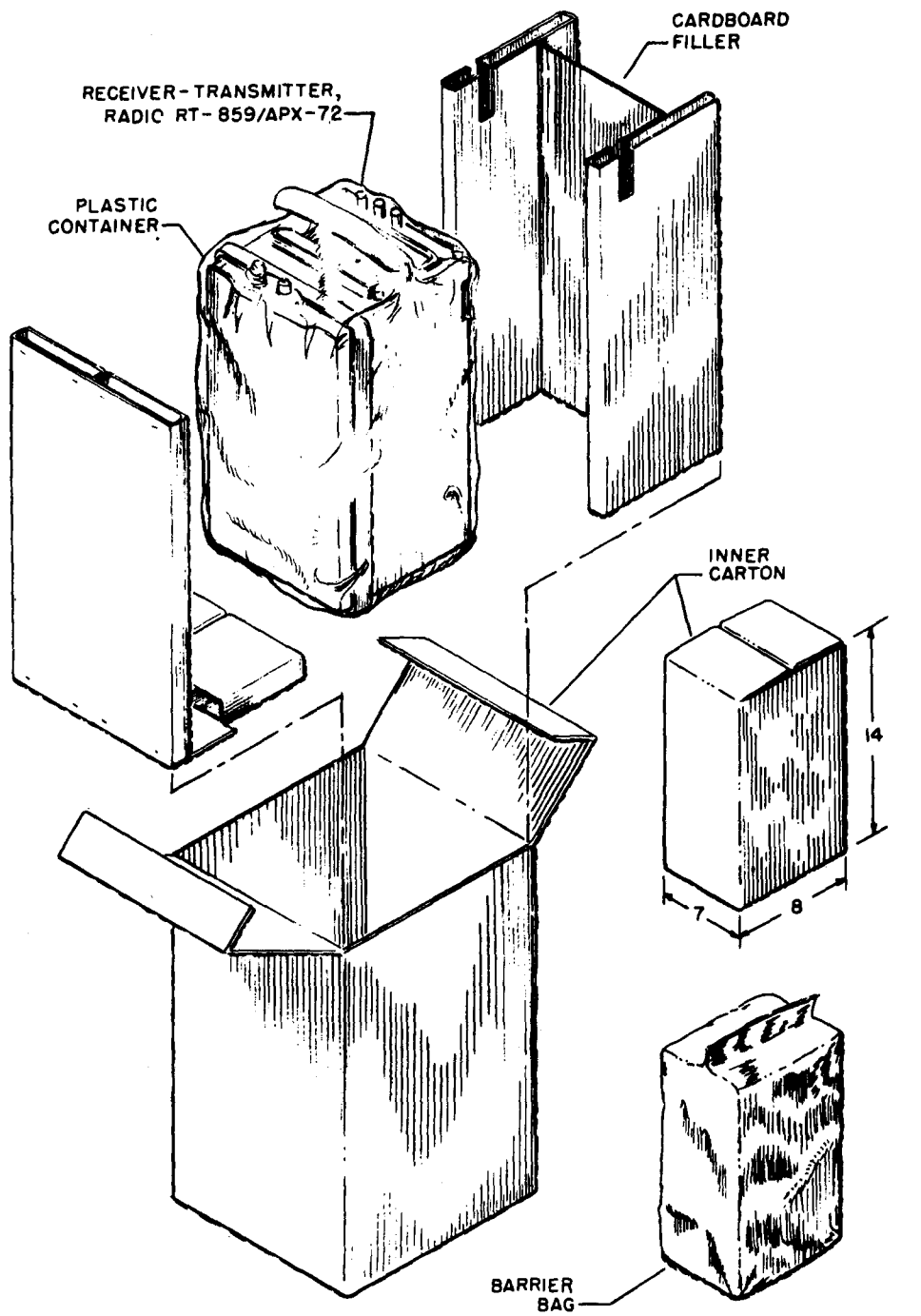

Figure 1-10. Typical packaging Receiver-transmitter, Radio RT-859/APX-72.

mission by the RT-859/APX-72 when so selected at the C-6280(P)/APX.

c. Control, Transponder Set C-6280(P)/APX. The C-6280(P)/APX provides the control functions for the RT-859/APX-72. It controls the application of source power, pre-sets the modes and codes (except mode 2 code setting), and selects the enabling switches which determine the modes of operation for which the RT-859/APX-72 will function. The C-6280(P)/APX also selects the degree of RT-859/APX-72 sensitivity and the identification of position and emergency output functions.

d. Computer KIT-1A/TSEC. The RT-859/APX-72 can be operated without the KIT-1A/TSEC. When the KIT-1A/TSEC is connected, mode 4 interrogations bypass the decoder in the RT-859/APX-72 and are applied directly to the KIT-1A/TSEC. The coded interrogation pulse is decoded in the KIT-1A/TSEC and a coded reply pulse generated which

is returned to the RT-859/APX-72 for transmission to the interrogating source. The operation of the KIT-1A/TSEC is classified.

e. Pressure Altitude Digitizer CPU-66/A (or equivalent). The RT-859/APX-72 can be operated without the CPU-66/A. When used, the CPU-66/A receives mode C interrogations from the RT-859/APX-72, generates a coded reply pulse (indicating aircraft pressure altitude in hundreds of feet), and returns this code reply pulse to the RT-859/APX-72 for transmission to the interrogating source.

f. Test Set, Transponder Set TS-18.43/APX. The RT-859/APX-72 can be operated without the TS-1843/APX. When used, the TS-1843/APX is activated by controls on the C-6280(P)/APX and provides signals for processing by the RT-859/APX-72. The processed signals are returned to the TS-1843/APX which then activates a test light on the C-6280(P)/APX if the proper response has occurred.

Section IV. SERVICE UPON RECEIPT OF EQUIPMENT

1-11. Unpacking

a. Packaging Data. The RT-859/APX-72, MT-3809/APX-72, and MT-3948/APX-72 are packaged individually for shipment.

- (1) The RT-859/APX-72 is enclosed in a plastic bag, surrounded by contoured corrugated cardboard filler, placed in an inner packing carton, and then sealed in a barrier bag. The barrier bag and contents are placed in a shipping carton approximately 10 inches high, 16 inches deep, and 8½ inches wide. The volume of the complete package is 0.7 cubic feet and the gross weight approximately 22 pounds. A typical shipping configuration and its contents is shown in figure 1-10.
- (2) MT-3809/APX-72 and MT-3948/APX-72 are packaged and shipped individually in contoured corrugated cardboard as illustrated in figure

1-11. The gross weight of the packaged mountings is approximately ½ pound for the MT-3809/APX-72, and 5/8 pound for the MT-3948/APX-72.

b. Removing RT-859/APX-72.

- (1) Place the outer container in a location that provides vertical clearance of at least twice the container height when standing upright.
- (2) Keep the container upright and open the top of the container.
- (3) Remove the contents of the container, and remove the barrier bag from around the inner packing carton.
- (4) Place the inner packing carton in an upright position, and open the top of the carton.
- (5) Remove the contents of the carton, and then remove the cardboard filler

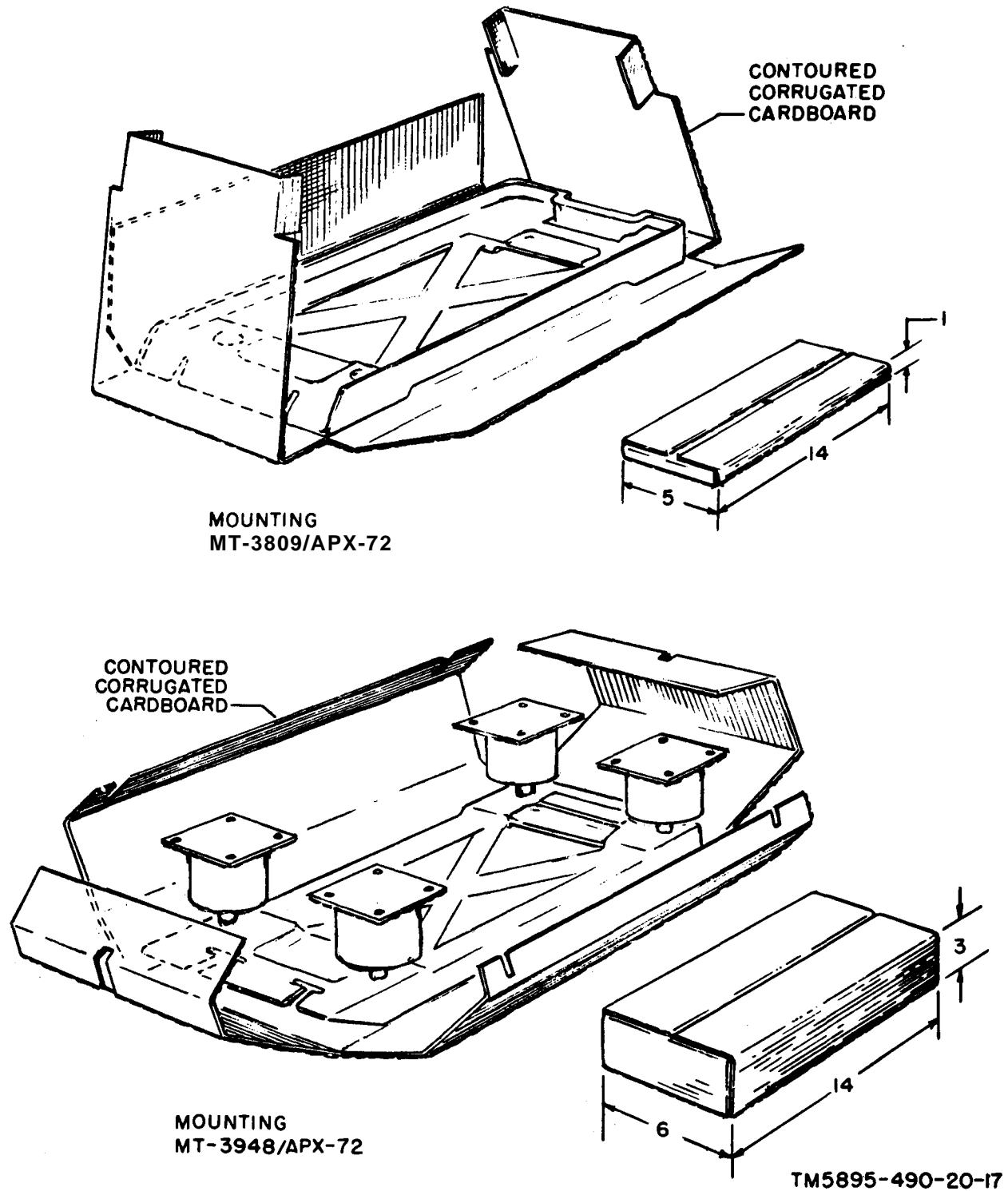

Figure 1-11. Typical packaging Mountings MT-3809/APX-72 and MT-3948/APX-72.

and plastic bag encasing the RT-859/APX-72.

c. Removing MT-3809/APX-72 or MT-3948/APX-72. Place the container on a flat surface, unseal, and remove the contoured corrugated cardboard.

1-12. Checking Unpacked Equipment

a. Inspect the equipment for damage incurred during shipment. If the equipment has been damaged, report the damage on DD Form 6 (para 1-3b).

b. See that the equipment is complete as listed on the packing slip. If a packing slip is not available, check the equipment against the

basic issue items list (appx B). Report all discrepancies in accordance with paragraph 1-3c. Shortage of a minor assembly or part that does not affect proper functioning of the equipment should not prevent use of the equipment.

c. If the equipment has been used or reconditioned, see whether it has been changed by a modification work order (MWO). If the equipment has been modified, the MWO number will appear on the front panel near the nomenclature plate, and the technical manual should reflect the modification.

Note: Current MWO'S applicable to the equipment are listed in DA PAM 310-4 (Army), T.O. 0-1-12 (Air Force); or NAVSUP 2002, section viii (Navy).

CHAPTER 2

OPERATING INSTRUCTIONS

Section I. CONTROLS AND INDICATORS

2-1. General

All operating and mode code select switches for Receiver-Transmitter, Radio RT-859/APX-27 are located on Control, Transponder Set C-6280(P)/APX, except for the MODE 2 code select switch which is on the front panel of the RT-859/APX-72.

2-2. Operating Controls and Indicators

a. Control, Transponder Set C-8280(P)/APX. (fig. 2-1) The following chart lists the controls and their function in each position.

Control	Position	Function
MASTER control	OFF	Turns RT-859/APX-72 off.
	STBY	Places RT-859/APX-72 in warmup (standby) condition.
	LOW	Applies power to operate RT-859/APX-72, but at reduced receiver sensitivity.
	NORM	Applies power to operate RT-859/APX-72 at normal receiver sensitivity.
	EMER	Transmits emergency reply signals to mode 1, 2, or 3/A interrogations regardless of mode control settings.
IDENT-MIC switch	IDENT	When momentarily actuated (switch has spring-loaded return) initiates identification of position reply for approximately 25 seconds.
	QUT	Prevents triggering of identification of position reply.
	MIC	Not used.
M-1 switch	ON	Enables the RT-859/APX-72 to reply to mode 1 interrogations.
	OUT	Disables the reply to mode 1 interrogations.
	TEST	Enables the TS-1843/APX to locally interrogate the RT-859/APX-72 mode 1.
M-2 switch	ON	Enables the RT-859/APX-72 to reply to mode 2 interrogations.

a. Control, Transponder Set C-6280(P)/APX. (cont)

Control	Position	Function
	OUT	Disables the reply to mode 2 interrogations.
	TEST	Enables the TS-1843/APX to locally interrogate the RT-859/APX-72 in mode 2,
M-3/A switch	ON	Enables the RT-859/APX-72 to reply to mode 3/A interrogations.
	OUT	Disables the reply to mode 3/A interrogations.
	TEST	Enables the TS-1843/APX to locally interrogate the RT-859/APX-72 in mode 3/A.
M-C switch	ON	Enables the RT-859/APX-72 to reply to mode C interrogations.
	OUT	Disables the reply to mode C interrogations.
	TEST	Enables the TS-1843/APX to locally interrogate the RT-859/APX-72 in mode C.
MODE 1 code select switches		Selects and indicates the mode 1 two-digit reply code number.
MODE 3/A code select switches		Selects and indicates the mode 3/A four-digit reply code number.
TEST indicator		Lights when the RT-859/APX-72 responds properly to a mode 1,2, 3/A, or C test, or when depressed.
MODE 4 switch	ON	Enables the RT-859/APX-72 to reply to mode 4 interrogations.
	OUT	Disables the reply to mode 4 interrogations.
CODE control		Functions of this switch are operationally classified.
AUDIO-LIGHT switch	AUDIO	Enables aural and REPLY light monitoring of valid mode 4 interrogations and replies.
	LIGHT	Enables REPLY light only monitoring of valid mode 4 interrogations and replies.
	OUT	Disables aural and REPLY light monitoring of valid mode 4 interrogations and replies.
REPLY indicator		Lights when valid mode 4 replies are present, or when depressed.

a. Control, Transponder Set C-6280(P)/APX. (cont)

Control	Position	Function
RAD TEST-MON switch	RAD TEST	Enables RT-859/APX-72 to reply to TEST mode interrogations from an AN/APM-123A(V), or equivalent. Other functions of this switch position are classified.
	MON	Enables the monitor circuits of the TS-1843/APX.
	OUT	Disables the RAD TEST and MON features of the C-6280(P)/APX.

b. Receiver-Transmitter, Radio RT-859/APX-72. (fig. 2-2) The MODE 2 code select switch on the front panel of the RT-859/APX-72 selects and indicates the mode 2 four-digit

reply code number. The elapsed time meter indicates the time the equipment has been in operation.

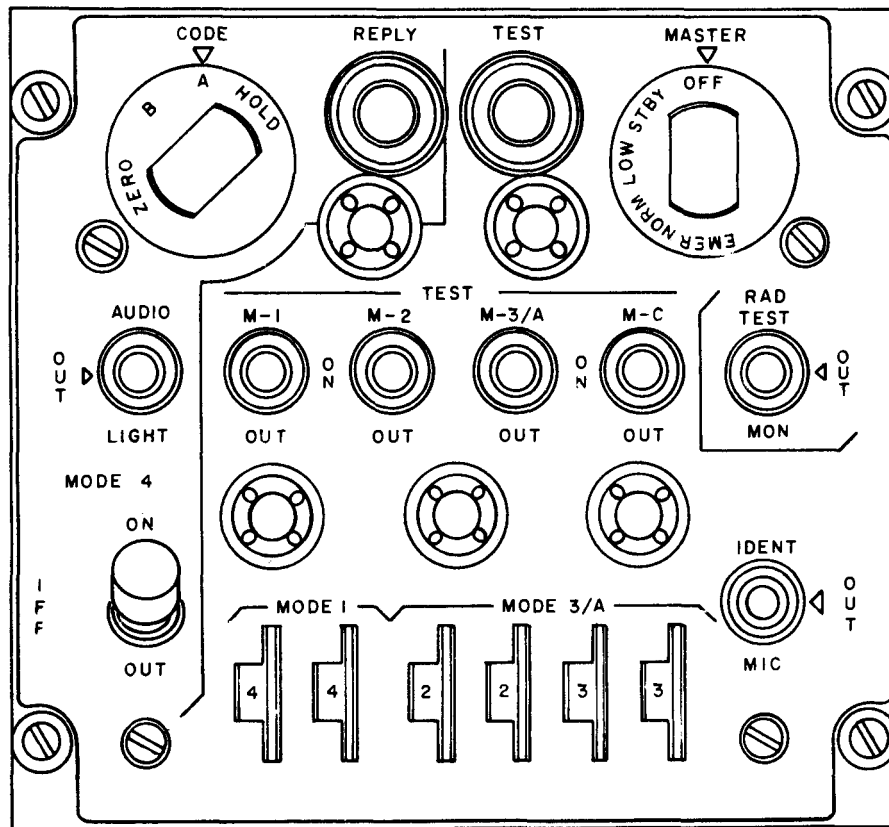

TM 5895-490-20-9

Figure 2-1. Control, Transponder Set C-6280(P)APX, controls and indicators.

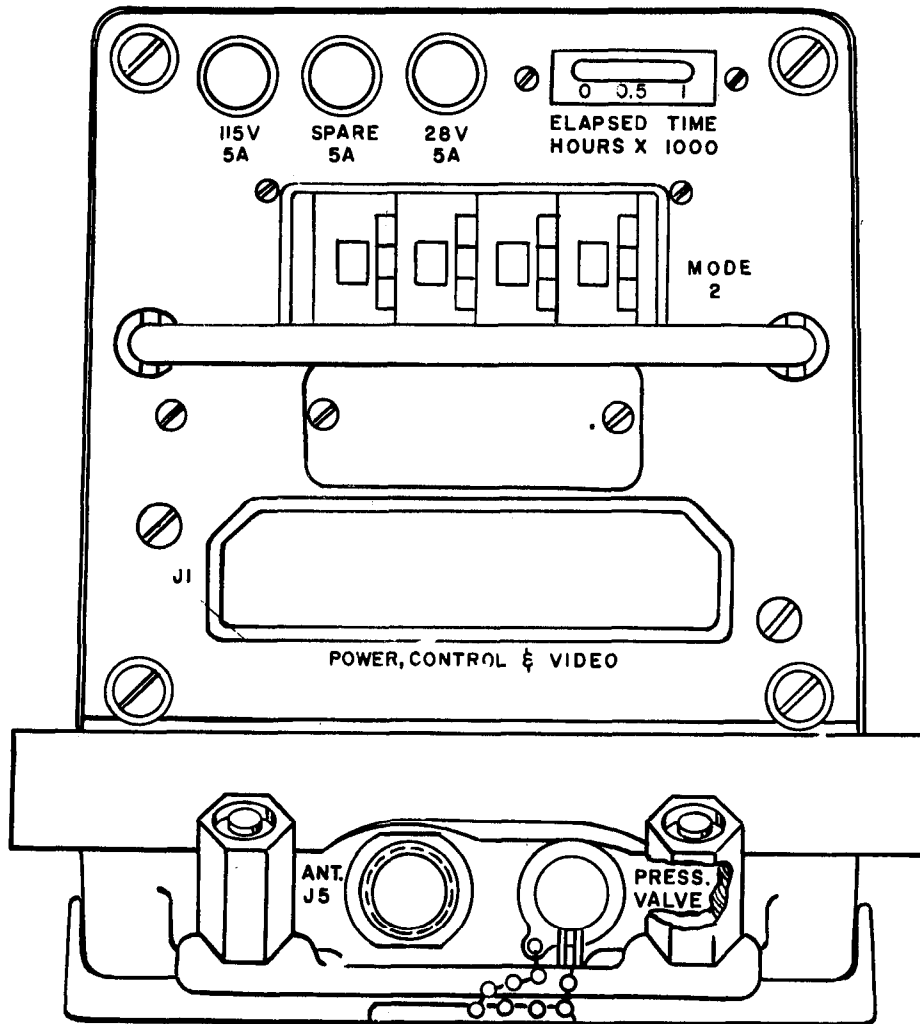

TM5895-490-20-10

Figure 2-2. Receiver-Transmitter, Radio RT-859/APX-72,
controls and indicators

Section II. OPERATION

2-3. Types of Operation

Receiver-Transmitter, Radio RT-859/APX-72 operates as an active receiver-transmitter unit which will respond only to an interrogating signal from an external source corresponding to the modes and codes preset in the C-6280(P)/APX and the RT-859/APX-72.

a. The RT-859/APX-72 is capable of responding in nine coded modes of operation to six coded modes of interrogation. The coded interrogation inputs are classified as modes 1, 2, 3/A, C, 4, and test. The normal coded output responses are classified as modes 1, 2, 3/A, C, and 4. Modes 1, 2, 3/A can be modified for special responses, designated identification of

position, emergency, and X pulse. Mode C can be modified for special pulse indications.

b. To operate the RT-859/APX-72 in any of the modes described above, perform the following procedures:

- (1) Starting procedure (para 2-4).
- (2) Operating procedure (para 2-5).
- (3) Stopping procedure (para 2-6).

2-4. Starting Procedure

Perform the preliminary and starting procedures (*a* and *b*, below) before performing the operating procedures (para 2-5).

a. Preliminary.

Control	Location (fig. No.)	Position
Master power	(See note)	OFF
MASTER control	C-6280(P)/APX (fig. 2-1)	OFF
IDENT-MIC switch	C-6280(P)/APX (fig. 2-1)	OUT
M-1, M-2, M-3/A, M-C and MODE 4 switches	C-6280(P)/APX (fig. 2-1)	OUT
AUDIO-LIGHT switch	C-6280(P)/APX (fig. 2-1)	OUT
RAD TEST-MON switch	C-6280(P)/APX (fig. 2-1)	OUT
MODE 1, 3/A, and 4 code select switches	C-6280(P)/APX (fig. 2-1)	Set to operational code required.
MODE 2 code select switch	RT-859/APX-72 (fig. 2-2)	Set to operational code required.

Note: The master power control is part of the aircraft equipment and will vary in position between types of aircraft. Refer to applicable aircraft technical manual for location details.

b. Starting. Check preliminary control settings (*a*, above) for proper position, then perform the following starting procedures:

Control	Location (fig. No.)	Position
Master power	(See note in <i>a</i> , above)	ON
MASTER control	C-6280(P)/APX (fig. 2-1)	STBY—one minute for standard temperature conditions and two minutes under extreme ranges of operating temperature. LOW—low receiver sensitivity for receiving high energy

b. Starting. (cont)

Control	Location (fig. No.)	Position
		NORM—normal receiver sensitivity.
		EMER—refer to para 2-5c.
M-1, M-2, M-3/A, M-C and MODE 4 switches	C-6280(P)/APX (fig. 2-1)	ON—as required, refer to para 2-5a.
AUDIO-LIGHT switch	C-6280(P)/APX (fig. 2-1)	LIGHT—refer to para 2-5d.
IDENT-MIC switch	C-6280(P)/APX (fig. 2-1)	OUT—refer to para 2-5b.
RAD TEST-MON switch	C-6280(P)/APX (fig. 2-1)	MON

2-5. Operating Procedures of the RT-859/APX-72, set controls of the
a. Normal Operation. For normal operation C-6280(P)/APX (fig. 2-1) as follows:

Control	Position
MASTER control	LOW or NORM as required.
M-1, M-2, M-3/A, M-C, and MODE 4 switches	ON—unless operational requirements indicate that only specific modes are to be used, then all other mode switches will be OUT.
AUDIO-LIGHT switch	LIGHT—refer to para 2-5d.
IDENT-MIC switch	OUT—refer to para 2-5b.
RAD TEST-MON switch	OUT

d. Identification of Position (I/P) Operation.
 The RT-859/APX-72 will transmit position identifying signals to all interrogating stations on modes 1, 2, and 3/A when the IDENT-MIC switch on the C-6280(P)/APX is set to IDENT. Transmission of the I/P signal will occur in these modes even if the mode enable switches are in the OUT position. The I/P operation is as follows:

Momentarily hold the IDENT-MIC switch in the IDENT position (spring-loaded return) and then release it. This action will cause the RT-859/APX-72 to transmit the I/P signal for a period of approximately 30 seconds to all interrogating stations on modes 1, 2, and 3/A. Repeat as required.

c. Emergency Operation. During an aircraft emergency or distress condition, the RT-859/

APX-72 may be used to transmit specially coded emergency signals on modes 1, 2, and 3/A to all interrogating stations. These emergency signals will be transmitted as long as the MASTER control on the C-6280(P)/APX remains in the EMER position. For emergency operation, set the C-6280(P)/APX control as follows:

- (1) Pull the MASTER control knob outward and rotate to the EMER position.
- (2) Let the MASTER control remain in the EMER position for the duration of the emergency.
- (3) When the emergency is over, return the MASTER control to the NORM or LOW position.

d. Monitoring Operation. Valid mode 4 interrogations and replies can be monitored either aurally and visually or visually by placement

of the AUDIO-LIGHT switch on the C-6280 (P) /APX as follows:

- (1) Place the AUDIO-LIGHT switch in AUDIO. Mode 4 interrogating and reply pulses will be audible in the pilot's headset and visible on the REPLY light.
- (2) Place the AUDIO-LIGHT switch in LIGHT. Indication of mode 4 interrogating and reply pulses will be visible on the REPLY light.

2-6. Stopping Procedure

Set the controls on the C-6280 (P) /APX as follows:

Control	Position
MASTER control	OFF
IDENT-MIC switch	OUT
M-1, M-2, M-3/A, M-C, and MODE 4 switches	OUT
AUDIO-LIGHT switch	OUT

CHAPTER 3

ORGANIZATIONAL MAINTENANCE

Section I. GENERAL

3-1. Scope of Maintenance

The maintenance duties assigned to the organizational maintenance repairman of Receiver-Transmitter, Radio RT-859/APX-72 and Mountings MT-3809/APX-72 and MT-3948/APX-72 are listed below together with a reference to the paragraphs covering the specific maintenance function. The duties include inspection, testing, and servicing instructions for performing preventive maintenance services, GO/NO-GO performance tests, and replacement of entire unit if found defective. These procedures do not require special tools or test equipment other than those allocated in paragraph 3-2.

- a. Intermediate preventive maintenance checks and services (para 3-4).
- b. Cleaning (para 3-7).
- c. Touchup painting instructions (para 3-8).
- d. Power-on inspection (para 3-9).
- e. Periodic preventive maintenance checks and services (para 3-15).
- f. General troubleshooting (para 3-17).
- g. Removal and replacement (para 3-19).

3-2. Tools, Test Equipment, and Materials

The parts authorized for organizational maintenance are listed in TM 11-5895-490-20P, Repair Parts and Special Tools List (Army only). The tools, test equipment, and materials required for organizational maintenance are listed below.

- a. *Tools.*
 - Tool Kit, Electronic Equipment TK-105/G.
- b. *Test Equipment.*
 - (1) Multimeter AN/USM-223, or equivalent.
 - (2) Test Set, Transponder AN/APM-123A(V).
 - (3) Adapter, UG-1108/U.
 - (4) Pump, Dehydrator, Manual MK-20A/UP (if required).
- c. *Materials.*
 - (1) Fine sandpaper No. 000.
 - (2) Clean, dry, lint-free cloth.
 - (3) Soft bristle brush.
 - (4) Cleaning compound, FSN 7930-395-9542.
 - (5) Paint, enamel, lusterless gray, Federal Standard 595, color 36231.

Section II. PREVENTIVE MAINTENANCE CHECKS AND SERVICES

3-3. Preventive Maintenance

Preventive maintenance is the systematic care, inspection, and servicing of equipment to maintain it in a serviceable condition, prevent breakdown, and assure maximum operational capability. Preventive maintenance is the responsibility of all categories of maintenance concerned with the equipment and includes the inspection, testing, and replacement of parts or units that inspection and checks indicate

would probably fail before the next scheduled periodic service. Preventive maintenance checks and services of the RT-859/APX-72, MT-3809/APX-72, and MT-3948/APX-72 at the organizational maintenance level, are made at intermediate and periodic intervals unless otherwise directed by the commanding officer. The maintenance services should be performed concurrently with the inspection schedules of the aircraft.

a. *Systematic Care.* The procedures in paragraphs 3-5 through 3-8 cover the routine systematic care and cleaning essential to proper upkeep and operation of the equipment.

b. *Maintenance Checks and Services.* The maintenance checks and services charts (para 3-5 and 3-16) outline functions to be performed at specific intervals. These checks and services are performed to determine that the equipment is in good general (physical) condition, and good operating condition, and likely to remain combat serviceable. To assist the organizational maintenance repairman in determining and maintaining combat serviceability, the charts indicate what to inspect, how to inspect, and what the normal conditions are; the *Reference* column lists the appropriate references and also contains corrective data information. If the defect cannot be remedied by the organizational maintenance repairman, a higher category of maintenance or repair is required. Records and reports of these inspections must be made in accordance with NAVWEPS Form

13070/5 (Navy), TM 38-750 (Army), and AFTO Form 29/29A (Air Force).

3-4. Intermediate Preventive Maintenance Checks and Services

The intermediate preventive maintenance checks and services chart (para 3-5) provides verification of satisfactory operation at intervals between the periodic inspections. The interval at which the intermediate maintenance will be accomplished is 25 flying hours. The intermediate maintenance should be performed concurrently with the intermediate maintenance performed on the aircraft in which the equipment is installed. Adjustments of the maintenance interval should be made to components for any unusual operating conditions. Equipment maintained in a standby (ready for immediate operation) condition must have intermediate maintenance performed on aircraft that is in a standby condition. Equipment in limited storage (requires service before inspection) does not require intermediate maintenance.

3-5. Intermediate Preventive Maintenance Checks and Services Chart

Sequence No.	Item to be inspected	Procedure	Reference
1	Cable connectors	Check all connections to the RT-859/APX-72 and allied components ensuring that they are all clean, intact, and not loose fitting.	
2*	Pressurization	Check for 5 psig pressure.	Para 3-6
3	Exterior surfaces	Remove all dirt, grease, and moisture from all external surfaces as required. Check general condition of RT-859/APX-72 and MT-3809/APX-72 and MT-3948/APX-72. Inspect for scratched paint, missing screws, and bent or broken hardware. Repair as necessary.	Para 3-7 and 3-8
4	Indicators	Check to see that the indicators are in good condition and that their glass surfaces are clean and not cracked or damaged.	Para 3-7
5	Fuses	Check all operating fuses for condition and correct values. Check spare fuses for proper value and quantity.	
6	Knobs, dials, and switches	Check each control for proper mechanical action. Observe that the mechanical action is without backlash, binding or scraping.	
7	Mountings	Inspect seating and stability of MT-3809/APX-72 or MT-3948/-APX-72. Check for loose or missing hardware and tighten or replace as necessary.	
8	Power-on inspection	Check to see that, the RT-859/APX-72 operates in accordance with the power-on inspection procedures.	Para 3-9

If required.

3-6. Pressurization

The RT-859/APX-72 requires a pressurization of 5 psig when aircraft is operating at altitudes in excess of 30,000 feet. Apply a pressure gage to valve on front of RT-859/APX-72 (fig. 2-2) and read value of pressure. If value of pressure exceeds 5 psig, bleed pressure until proper value is reached. If value of pressure is less than 5 psig, apply air pressure until proper value is obtained. Ensure that air is free of moisture and contaminants.

3-7. Cleaning

Inspect the exterior of the RT-859/APX-72 and MT-3809/APX-72 or MT-3849/APX-72. The exterior surfaces should be free from moisture, dirt, grease, and fungus.

a. Remove dust and loose dirt with a clean, soft cloth.

Warning: Cleaning compound is flammable and its fumes are toxic. Provide adequate ventilation; do not use near a flame.

b. Remove dirt from the connectors with a soft bristled brush.

c. Remove grease, fungus, and ground-in dirt from cases; use a cloth dampened (not wet) with cleaning compound.

3-8. Touchup Painting Instructions

Note: Refer to the cleaning and refinishing practices specified in applicable manual (appx A).

a. Remove rust and corrosion from metal surfaces by lightly sanding them with No. 000 sandpaper.

b. Brush two thin coats of paint (enamel, lusterless gray, Federal Standard 595, color 36231) on the bare metal to protect it from further corrosion.

3-9. Power-On Inspection

Note: All references to the AN/APM-123A(V) apply to the AN/APM-123A(V) 1, 2, or 3, as applicable.

a. *Performance Checks.* The performance checks listed below are performed with ex-

ternal power connected to the aircraft and using Test Set, Transponder AN/APM-123A(V). For external power, refer to the applicable manual covering the aircraft. Perform the following procedures and checks in the order given. If the correct response is not obtained in any of the checks, refer to the troubleshooting chart (para 3-18) for corrective action.

- (1) Preliminary procedures (para 3-10).
- (2) Starting procedure (para 3-11).
- (3) Receiver-Transmitter, Radio RT-859/APX-72 tests (para 3-12).
- (4) Stopping procedure (para 3-13).

b. *Alternate Performance Check.* If the test equipment called for in the performance checks above is not available, an alternate performance check, using the local transponder interrogation equipment, can be made. To carry out this alternate performance check, follow the procedures given in paragraph 3-14. If the correct responses are not obtained, refer to the troubleshooting chart (para 3-18) for corrective action.

3-10. Preliminary Procedures

The AN/APM-123A(V) can be operated to perform either radiation or nonradiation tests. Refer to instruction manual with the AN/APM-123A(V) (appx A). The difference between the operations for the radiation and nonradiation test is the means of coupling RF energy between the AN/APM-123A(V) and Antenna AT-884A/APX (or equivalent). °Free-space coupling for radiation tests are performed using an adjustable antenna mounted on the front panel of the AN/APM-123A(V). Nonradiation tests are performed either by direct cable-attenuator coupling to the RT-859/APX-72 ANT. J5 connector or by an antenna test hood provided for the AT-884/APX44 (or equivalent) type antennas.

a. *Test Setup for Radiation Operation.* (fig. 3-1)

- (1) Unscrew the relief valve of the AN/APM-123A(V) two turns to release any internal pressure.

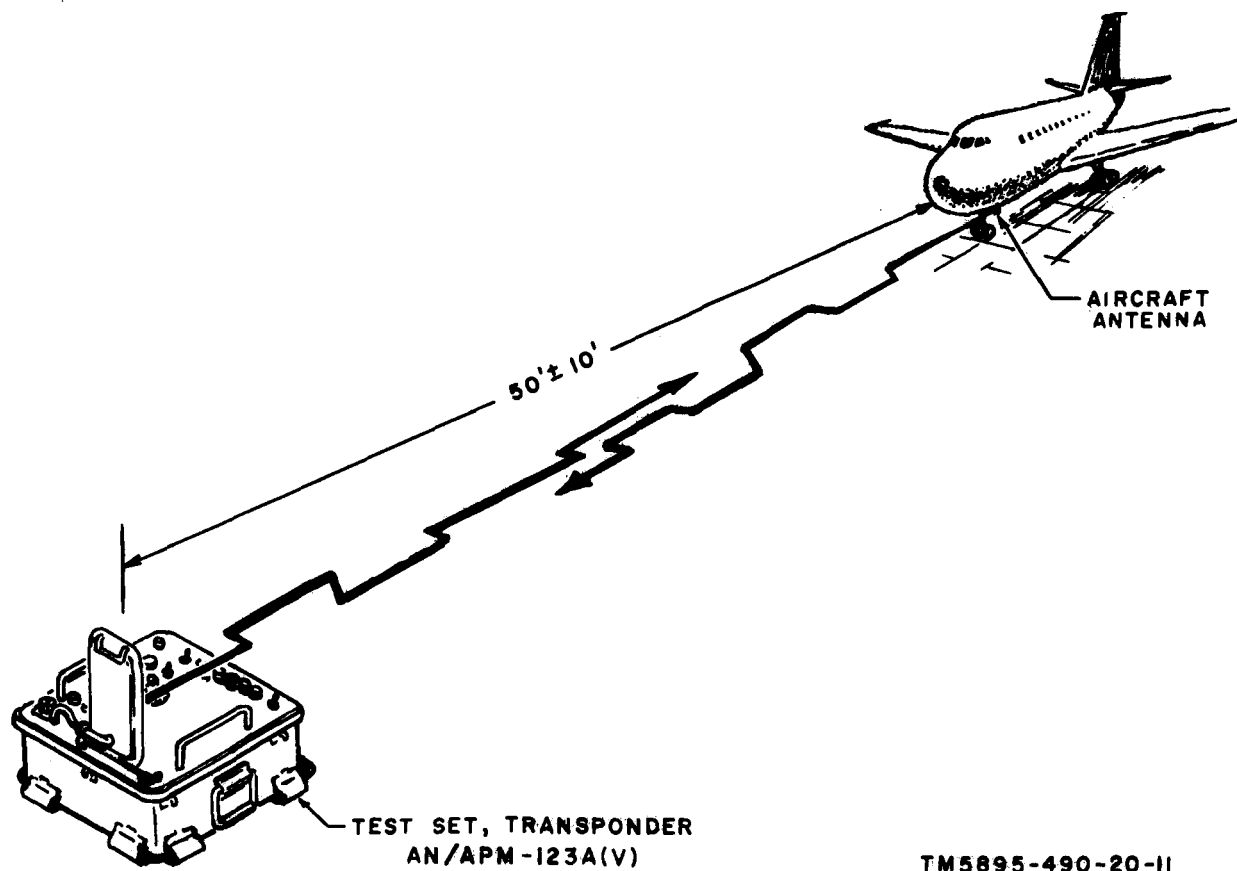

TM5895-490-20-II

Figure 3-1. Test setup for radiation operation.

Warning: Pressure must be released before the cover is removed from the AN/APM-123A(V) because the cover may spring up forcibly and cause serious injury.

- (2) Place the AN/APM-123A(V) 50 ±10 feet from the AT-84A/APX (or equivalent) avoiding obstructions in the path between the AN/APM-123A(V) and the aircraft antenna.
- (3) Remove the AN/APM-123A(V) cover by releasing its latches.
- (4) Position the AN/APM-123A(V) so that the front panel faces the sky and the arrow on the adjustable antenna is directed toward the aircraft transponder antenna.
- (5) To position the AN/APM-123A(V) for horizontally polarized aircraft transponder antennas, grasp the antenna handle (fig. 3-2) and gently pull up the antenna to disengage it from a snap latch. Swing the antenna up until a vertical detent locking pin locks the antenna. Pull the antenna up at the right-hand corner to unlock it from the vertical detent locking pin. Lift the antenna up until a horizontal detent pin locks the antenna,
- (6) To position the antenna for vertical polarization, grasp the antenna handle (fig. 3-2) and gently pull up the antenna to disengage it from a snap

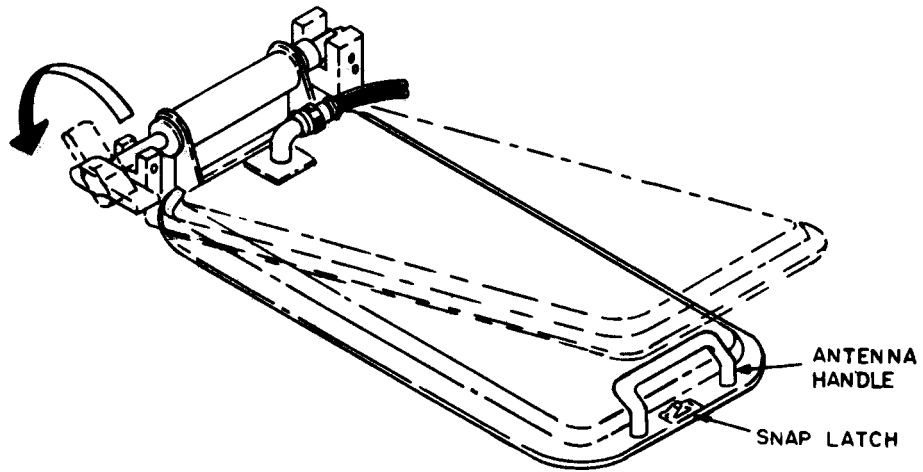

A. VERTICAL ANTENNA POLARIZATION

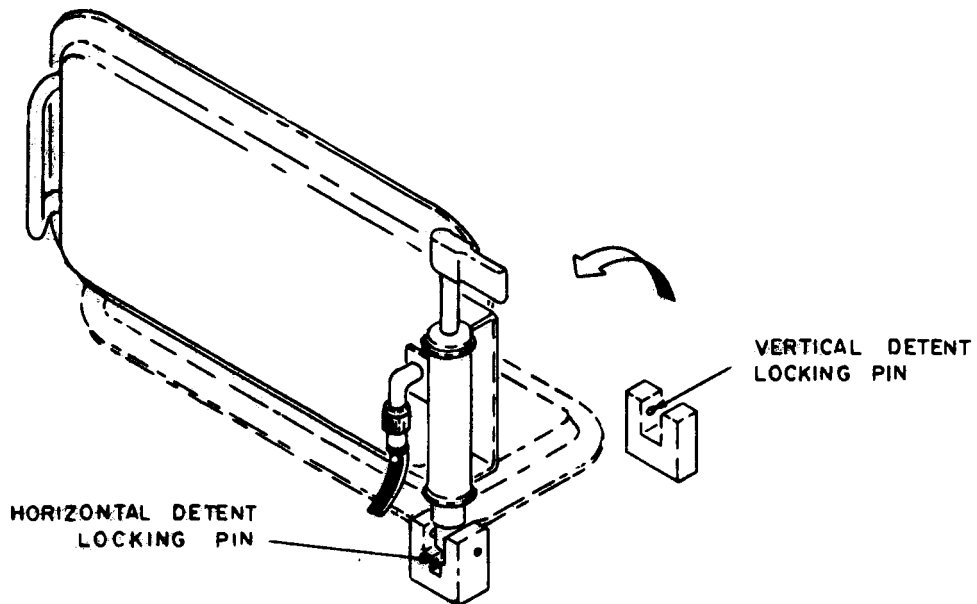

B. HORIZONTAL ANTENNA POLARIZATION

TM5895-490-20-12

Figure 3-2. Antenna positioning for vertical and horizontal polarization.

latch. Swing the antenna up until a vertical detent locking pin locks the antenna.

b. Test Setup for Nonradiation Operation, Direct Coupling. (fig. 3-3)

(1) Place the AN/APM-123A(V) near

the ANT. J5 connector on the RT-859/APX-72.

(2) Release the AN/APM-123A(V) cover latches and remove the cover. Remove the CG-409G/U rf cable and the CN-1088A/U fixed attenuator from the cover.

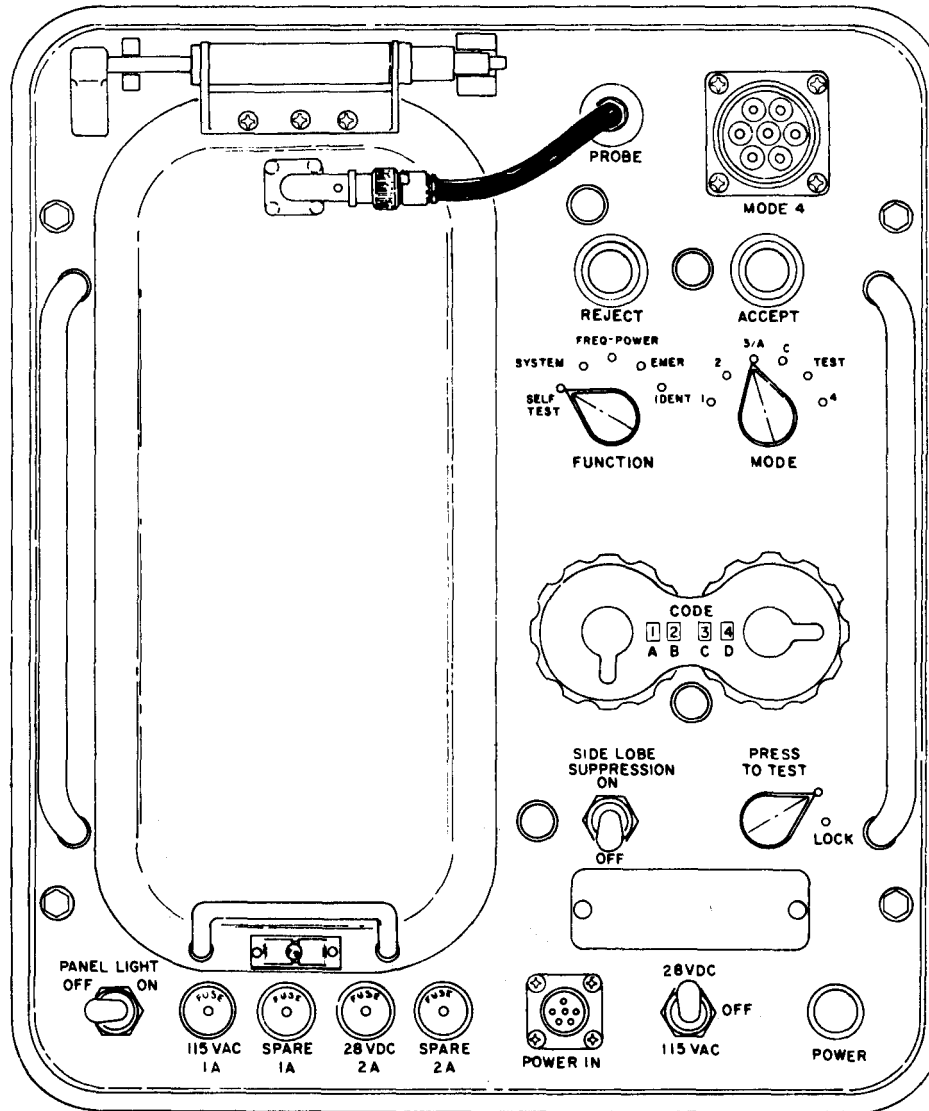

TM 5895-490-20-13

Figure 3-3. Test Set, Transponder AN/APM-1234(V)1, controls and indicators.

- (3) Disconnect the AN/APM-123A(V) antenna rf cable from the PROBE jack (fig. 3-3) and connect this cable to one end of the CG-409G/U rf cable.
- (4) Connect one end of the CN-1088/U fixed attenuator through a UG-1108/U adapter to the ANT. J5 input of the RT-859/APX-72. Connect the other end to the CG-409G/U rf cable.

c. Test Setup for Nonradiation Operation, Antenna Hood Coupling. (fig. 3-4)

Note: The antenna test hood is to be used only for the specific type antenna for which it is designated.

- (1) Release the AN/APM-123A(V) cover latches and remove the cover.
- (2) Remove the CG-409G/U rf cable and antenna test hood from the cover and connect one end of the rf cable to the test hood using attenuator
- (3) Disconnect the AN/APM-123A(V) antenna rf cable from the PROBE jack (fig. 3-3) and connect this cable to the other end of the CG-409G/U rf cable.

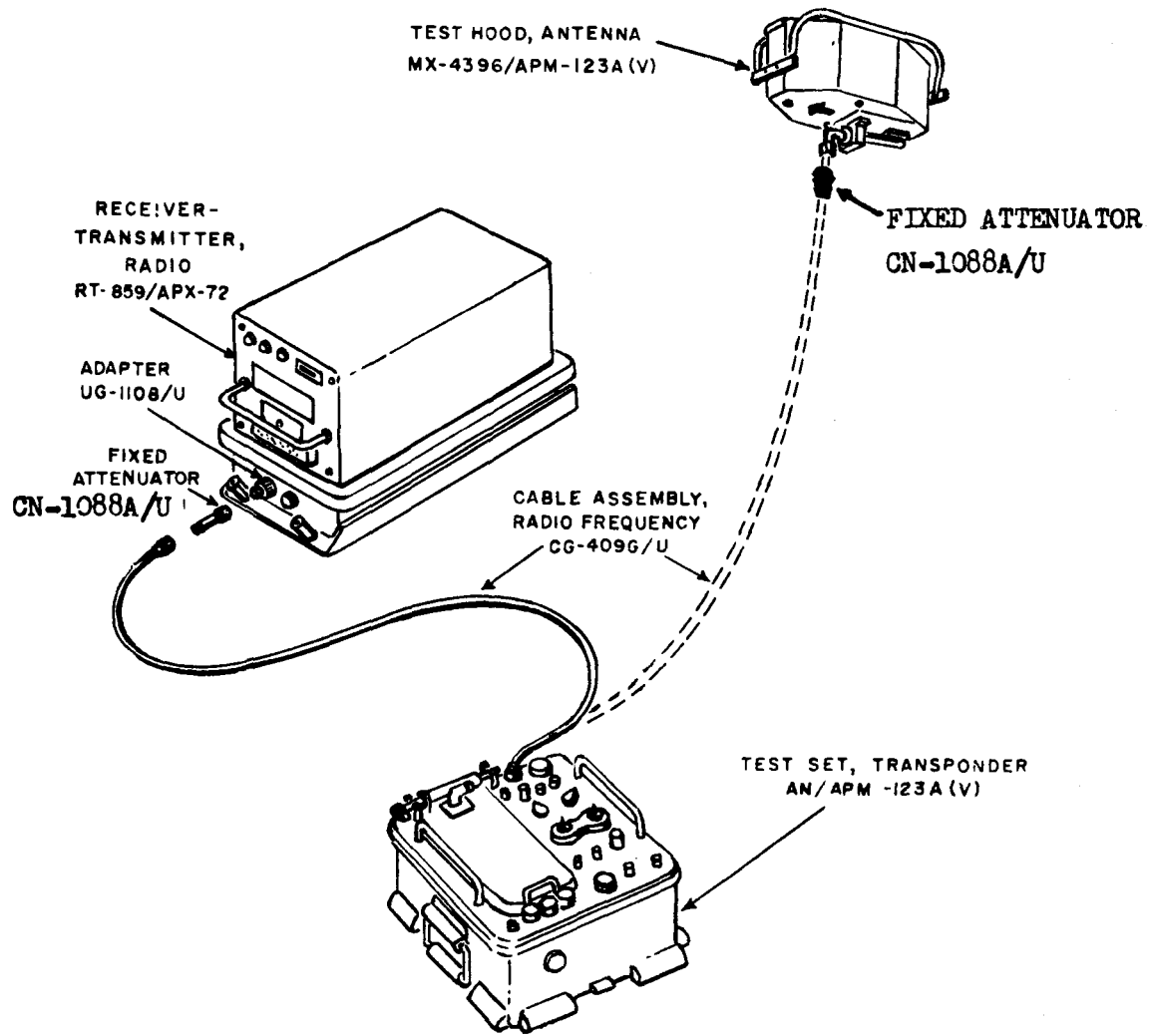

Figure 3-4. Test setup for nonradiation operation.

3-11. Starting Procedure

Set up the equipment for one of the applicable operations as instructed in paragraph 3-10 and proceed as follows to start the equipment:

a. Set the AN/APM-123A (V) controls as follows: (fig. 3-3)

Control	Position
28 VDC-115 VAC-OFF power switch	OFF
MODE switch	Any mode except mode 4.
SIDELOBE SUPPRESSION ON-OFF switch	OFF
FUNCTION switch	SELF TEST
AB-CD CODE controls	0000

b. Remove the power cable from the cover of the AN/APM-123A (V).

c. Connect the power cable between the power source and AN/APM-123A (V) POWER IN connector.

Caution: When connecting dc power cables supplied with battery clips to a dc power source, be sure the battery clip with a red insulator is connected to the positive (+) side of the battery terminal. Improper connection will damage the equipment.

d. Set the 28 VDC-115 VAC-OFF power switch to 115 VAC if an ac power source is used or to 28 VDC if a dc power source is used. The POWER indicator should light. Allow the AN/APM-123A (V) to warm up for approximately two minutes.

e. Press the PRESS TO TEST switch. The ACCEPT indicator should light. If the REJECT indicator lights, the AN/APM-123.4 (V) requires higher level maintenance.

f. Set the SIDELOBE SUPPRESSION ON-OFF switch to ON. The ACCEPT indicator should remain lighted.

g. Release the PRESS TO TEST switch.

3-12. Receiver-Transmitter, Radio
 RT-859/APX-72 Tests

The operating control positions (code, mode, etc.) of the AN/APM-123.4 (V) must agree

with the operating control positions of the RT-859/APX-72 and the C-6280(P) /APX. Perform the preliminary test setup previously described in paragraph 3-10 and proceed as follows:

a. *Preliminary Panel Control Settings.* Set the RT-859,/APX-72 MODE 2 code selector switches to a four-digit code. Set the C-6280 (P) /APX controls as outlined in the chart below.

Control	Position
MASTER control	STBY for one minute, then set to NORM.
IDENT-MIC switch	OUT
M-1 switch	ON
M-2 switch	OUT
M-3/A switch	OUT
M-C switch	OUT
MODE 4 switch	OUT
MODE 1 code selector	00
MODE 3/A code selector	0000

b. *Systems Test.* Set the AN/APM-123A (V) FUNCTION switch to SYSTEM and proceed as follows:

- (1) Use the chart below to set the mode switches of the AN/APM-123A (V) and the C-6280 (P) /APX for the desired mode.

Mode selected	AN/APM-123A(v) MODE switch position	C-6280 (P) /APX	
		Switch	Position
1	1	M-1	ON
		M-2, M-3/A, M-C	OUT
		MODE 4	OUT
2	2	M-2	ON
		M-1, M-3/A, M-C	OUT
		MODE 4	OUT
3/A	3/A	M-3/A	ON
		M-1, M-2, M-C	OUT
		MODE 4	OUT

- (2) Use the chart below to set the code selector switches of the AN/APM-123A(V), C - 6280(P)/APX, and RT-859/APX-72 for the desired code.

Mode selected	AN/APM-123A (V) MODE switch position	C-6280 (P) / APX	RT-859 / APX-72	Setting
1	0000-7300 (CD always 00)	MODE 1		00-73
2	0000-7777		MODE 2	0000-7777
3/A	0000-7777	MODE 3/A		0000-7777

- (3) Press the AN/APM - 123A(V) PRESS TO TEST switch. The ACCEPT indicator should light. If the REJECT indicator lights, perform the procedure, given in (4) below and then perform the procedures given in (5) and (6) below as applicable.
- (4) Press and turn the AN/APM-123A (V) PRESS TO TEST switch to LOCK and set the AN/APM-123A (V) FUNCTION switch to FREQ-POWER. If the ACCEPT indicator lights, the RT-859/APX-72 power output is abnormal, the coder operation is abnormal, or the antenna system (except when using direct coupling) is defective. To determine if the RT-859/APX-72 power output or coder operation is abnormal, perform the procedure in (5) below. To determine if the transponder antenna system is defective, perform the procedure in (6) below.
- (5) If using the radiation test setup of

paragraph 3-10a, move the AN/APM-123A (V) 10 feet closer to the aircraft transponder antenna. Set the FUNCTION switch to SYSTEM. If the ACCEPT indicator lights, the RT-859/APX-72 power output is abnormal. If the REJECT indicator lights, the coder operation is abnormal.

- (6) Connect the AN/APM-123A (V) for nonradiation operation, direct coupling (para 3-10b). Press the PRESS TO TEST switch. If the ACCEPT indicator lights, the antenna system is defective. If the REJECT indicator lights, the RT-859/APX-72 is defective.

c. Emergency Tests (Military and Civil).

- (1) Military emergency tests can be performed in modes 1, 2, and 3/A. Civil emergency tests can be performed in mode 3/A only. Set the C-6280 (P) /APX MASTER control to EMER and the AN/APM-123A (V) FUNCTION switch to EMER. Use the chart below to set the mode and code switches of the AN/APM - 123A(V), C - 6280(P)/APX, and RT-859/APX-72.

Note: Emergency operation may interfere with distress signals. Perform the tests as quickly as possible.

Mode selected	AN/APM-123A (V) switches		C-6280 (P) /APX	RT-859/APX-72	Setting
	MODE	CODE			
1	1	0000-7300 (CD always 00)	M-1 to ON, all others to OUT		00-73
2	2	0000-7777	M-2 to ON, all others to OUT	MODE 2 code	0000-7777
3/A	3/A	7700 (for normal use) 7600 (for communication failure)	M-3/A to ON, all others to OUT		7700 7600

- (2) Press the AN/APM-123A(v) PRESS TO TEST switch. The ACCEPT indicator should light.
- (3) Set the C-6280(P)/APX MASTER control to NORM.

d. Identification of Position Test.

- (1) Set the C-6280 (P)/APX IDENT-MIC switch to IDENT.

- (2) Set the AN/APM-123A(V) and C-6280(P)/APX code and mode switches in accordance with the instructions in b (1) and b (2), above.
- (3) Set the AN/APM-123A (V) FUNCTION switch to IDENT and press the AN/APM-123A (V) PRESS TO TEST switch. The ACCEPT indicator should light.

e. Mode C (Altitude) Tests. Mode C tests are performed with the RT-859/APX-72 connected to an auxiliary Pressure Altitude Digitizer CPU-66/A, or equivalent.

- (1) Set the AN/APM-123A (V) MODE switch to C and FUNCTION switch to SYSTEM.
- (2) Set the C-6280 (P)/APX M-C switch to ON and all other mode switches to OUT.

- (3) Obtain the local barometric altitude from the operations group and refer to the chart below for the AN/APM-123A (V) code control settings to be used. Preset this code in the AN/APM-123A(V).

Note: The chart provides altitudes in increments of 100-foot values. The code settings shown for each value should be used for altitudes 50 feet below and above that shown. For example, when the local barometric altitude is between 50 and 150 feet, use 100 feet, etc.

Altitude	Reply code				Altitude	Reply code			
	A	B	C	D		A	B	C	D
-1,000	0	0	2	0	2,600	0	1	6	0
-900	0	0	3	0	2,700	0	1	4	0
-800	0	0	1	0	2,800	4	1	4	0
-700	0	4	1	0	2,900	4	1	6	0
-600	0	4	3	0	3,000	4	1	2	0
-500	0	4	2	0	3,100	4	1	3	0
-400	0	4	6	0	3,200	4	1	1	0
-300	0	4	4	0	3,300	4	5	1	0
-200	0	6	4	0	3,400	4	5	3	0
-100	0	6	6	0	3,500	4	5	2	0
000	0	6	2	0	3,600	4	5	6	0
100	0	6	3	0	3,700	4	5	4	0
200	0	6	1	0	3,800	4	7	4	0
300	0	2	1	0	3,900	4	7	6	0
400	0	2	3	0	4,000	4	7	2	0
500	0	2	2	0	4,100	4	7	3	0
600	0	2	6	0	4,200	4	7	1	0
700	0	2	4	0	4,300	4	3	1	0
800	0	3	4	0	4,400	4	3	3	0
900	0	3	6	0	4,500	4	3	2	0
1,000	0	3	2	0	4,600	4	3	6	0
1,100	0	3	3	0	4,700	4	3	4	0
1,200	0	3	1	0	4,800	4	2	4	0
1,300	0	7	1	0	4,900	4	2	6	0
1,400	0	7	3	0	5,000	4	2	2	0
1,500	0	7	2	0	5,100	4	2	3	0
1,600	0	7	6	0	5,200	4	2	1	0
1,700	0	7	4	0	5,300	4	6	1	0
1,800	0	5	4	0	5,400	4	6	3	0
1,900	0	5	6	0	5,500	4	6	2	0
2,000	0	5	2	0	5,600	4	6	6	0
2,100	0	5	3	0	5,700	4	6	4	0
2,200	0	5	1	0	5,800	4	4	4	0
2,300	0	1	1	0	5,900	4	4	6	0
2,400	0	1	3	0	6,000	4	4	2	0
2,500	0	1	2	0					

(4) Press the AN/APM-123A(V) PRESS TO TEST switch. The ACCEPT indicator should light. If the REJECT indicator lights, set in the altitude code for one increment (100 feet) above or below the test setting. Press the AN/APM-123A(V) PRESS TO TEST switch. An ACCEPT condition indicates the RT-859/APX-72 reply is normal; this action accounts for the normal deviations of the CPU-66/A.

f. Mode 4 Tests.

(1) Prepare equipment for nonradiation operation (direct coupling) in accordance with instructions in paragraph 3-10b.

(2) Connect Interrogator Computer KIR-1A/TSEC to test set MODE 4 connector using cable CX-12216/APM-123(V). The ZEROIZE light on the test set should light.

(3) Using Code Changer Key KIK-18/TSEC, key the KIR-1A and close the access door. ZEROIZE light on the test set should go out.

(4) Install Computer KIT-1A/TSEC in the aircraft.

(5) Turn the MASTER switch on Transponder Set Control C-6280A(P)/APX to STBY.

(6) Connect headset to aircraft intercom system.

(7) Set the controls on the C-6280A(P)/APX as follows

<i>Control</i>	<i>Position</i>
MASTER	NORM
TEST M-1/OUT	OUT
TEST M-2/OUT	OUT
TEST M-3/OUT	OUT
TEST MC/OUT	OUT
AUDIO/OUT/LIGHT	AUDIO
CODE	A
MODE 4 ON/OUT	OUT

(8) On the test set, place the FUNCTION switch to SYSTEM, the MODE 4 DIR/RAD switch to DIR, the MODE switch to 4, the MODE 4 Code A/B switch to A and the PUSH TO TEST switch to the LOCK position, and (when operating test set) observe the following

(a) On the test set, the REJECT light should light.

(b) Audio tone should be heard in headset.

(c) IFF CAUTION light located on aircraft instrument panel should light.

(9) Using KIK-18/TSEC, key the KIT-1A/TSEC and close access door. Observe same indications listed in (8) above. Release PUSH TO TEST switch.

(10) On C-62110A(P)/APX, place the MODE 4 switch to ON.

(11) On the test set, briefly depress the PUSH TO TEST switch and observe the following:

(a) On the test set, the ACCEPT light should light.

(b) On the C-6280A(P)/APX, the REPLY light should light.

(c) Audio tone should be heard in headset.

(12) On the C-6280A(P)/APX, place the AUDIO/LIGHT switch to the LIGHT position, and repeat the above test. Audio tone should not be heard, but REPLY light should light.

(13) On the test set, place the MODE 4 CODE A/B switch to B and briefly depress the PUSH TO TEST switch. The REJECT light should light. Return MODE 4 CODE A/B switch to A.

(14) On the test set, place the MODE 4 VER BIT 1 switch to 1 and briefly depress the PUSH TO TEST switch. The REJECT light should light. Return MODE 4 VER BIT 1 switch to OFF.

(15) On the test set, place the MODE 4 VER BIT 2 switch to 2 and briefly depress the PUSH TO TEST switch. The REJECT light should light. Return MODE 4 VER BIT 2 switch to OFF.

(16) On the test set, place the ISLS switch to ON and briefly depress PUSH TO TEST switch. The REJECT light should light. Return ISLS switch to OFF.

(17) On aircraft with rigid landing gear, set IFF CODE HOLD switch located on aircraft instrument panel to ON. IFF CODE HOLD light located on aircraft instrument panel should light. On aircraft with compression or retractable landing gear, make certain landing gear is in a stable condition so that the automatic IFF CODE HOLD switch on landing gear is activated and remains so.

(18) On C-6280A(P)/APX, place CODE switch to HOLD, then return to A.

(19) Wait at least 15 seconds and then on the C-6280A(P)/APX turn MASTER switch to OFF.

(20) Wait at least 15 seconds and then on the C-6280A(P)/APX turn MASTER switch to STBY for a warmup of about 30 seconds; then turn MASTER switch to NORM.

(21) On the test set, briefly depress PUSH TO TEST switch. ACCEPT light should light.

(22) On the C-6280A(P)/APX pull out CODE switch and turn to ZERO, and place AUDIO/LIGHT switch to AUDIO position.

(23) On the test set, place PUSH TO TEST switch to LOCK position, and observe the following:

(a) On the test set the REJECT light should light.

(b) Audio tone shall be heard in headset.

(c) IFF CAUTION light located on aircraft instrument panel should light.

3-13. Stopping Procedure

To stop the AN/APM-123A (V), release the PRESS TO TEST switch if it is in LOCK position and set the 28 VDC-115 VAC-OFF power switch to OFF.

3-14. Alternate Performance Check

To perform the alternate performance check, proceed as follows.

a. Preliminary Procedures.

(1) Apply external power to aircraft (para 3-9a).

(2) Energize aircraft radio and contact local GCA facility or organization having an RT-859/APX-72 interrogation capability. Use locally assigned and approved frequency channel.

(3) Set the RT-859/APX-72 and C-6280 (P)/APX switches in accordance with table of paragraph 3-12a.

NOTE

Due to close proximity of local interrogation facility, it would be advisable to place MASTER control of C-6280(P) /APX on LOW rather than NORM to reduce the RT-859/APX-72 sensitivity.

b. Systems Tests.

NOTE

Code settings used for these tests should be standard, prearranged codes, known to both maintenance personnel and operators of the transponder system interrogation equipment.

(1) Set prearranged mode 1 code settings into C-6280(P) /APX.

(2) Request interrogation of RT-859/APX-72 by local interrogating facility on mode 1 using same code.

(3) Request results of interrogation. Positive results indicate equipment is operating normally. If results are negative, recheck mode and code switches and if found correct, refer to troubleshoot-

ing chart (para 3-18).

(4) Set mode and prearranged code settings for modes 2 and 3/A and test as above.

(5) Preset equipment as described in paragraph 3-12c, 3-12d, and 3-12e. Request interrogations in each mode of operation and obtain results from interrogation facility. Positive results indicate equipment is operating normally. If results are negative, recheck switch settings and if found correct, refer to troubleshooting chart (para 3-18).

3-15. Periodic Preventive Maintenance Checks and Services

In addition to the intermediate preventive maintenance checks and services, periodic preventive maintenance checks and services will be scheduled in accordance with the requirements of MIL-M-23618 (WEP) (Navy), TM 38-750 (Army), and AFR-66-12 (Air Force). The RT-859/APX-72 will normally be part of an aircraft installation. The periodic preventive maintenance checks and services should be scheduled concurrently with the periodic maintenance service schedule of the aircraft in which the equipment is installed to reduce out-of-service time to a minimum. Refer to the applicable aircraft technical manual for the hours between service periods. All deficiencies or shortcomings will be immediately reported to higher category of maintenance by use of NAV WEPS Form 13070/5 (Navy), TM 38-750 (Army), an AFTO Form 29/29A (Air Force). Equipment that cannot be corrected by organizational maintenance should be deadlined in accordance with applicable directives. Perform all checks and services listed in the periodic preventive maintenance checks and services chart (para 3-16) in addition to the intermediate preventive maintenance checks and services chart (para 3-5).

3-16. Periodic Preventive Maintenance Checks and Services Chart

Sequence No.	Item	Procedure	Reference
1	Installation	Check the installation of the RT-859/APX-72 and MT-3809/APX-72 or MT-3948/APX-72 for conformity with the instructions contained in aircraft configuration manual.	Configuration manual of applicable aircraft.
2	Publications	a. Check to see that pertinent publications are on hand and that there are no missing pages. Requisition pertinent publications not on hand. b. Check index of changes for applicable service to see whether all changes to pertinent publications covering the equipment are on hand.	a. (App A.) b. NAVSUP-2002, section viii (Navy), DA PAM 310-4 (Army), T.O. 0-1-12 (Air Force)
3	Modification work orders	a. Check applicable publications to determine whether new applicable MWO's have been published. b. Insure that all URGENT MWO's have been applied to the equipment. c. Insure that all NORMAL MWO's have been scheduled.	a. NAVSUP-2002, section viii (Navy), DA Pam 310-4 (Army), T.O. 0-1-12 (Air Force) b. NAVSUP-2002, section viii (Navy), DA PAM 310-4 (Army), T.O. 0-1-12 (Air Force) c. NAVSUP-2002, section viii (Navy), DA PAM 310-4 (Army), T.O. 0-1-12 (Air Force)

Section III. TROUBLESHOOTING

3-17. General Troubleshooting

General troubleshooting of the RT-859/APX-72 is based on the Powers performance checks contained in paragraphs 3-9 through 3-13, and the alternate

performance checks given in paragraph 3-14. When an abnormal condition or result is observed, refer to the troubleshooting chart (para 3-18). Perform

the checks and corrective actions indicated in the troubleshooting chart. If the corrective measures indicated do not result in correction of the trouble, higher category of maintenance is required.

3-18. Troubleshooting Chart

When a fault has been detected within the RT-859/APX-72, refer to the troubleshooting chart below to correct the malfunction. The paragraph references given in the *Ref para No.*

column of the troubleshooting chart correspond to the paragraph numbers of the performance checks and the alternate performance checks. When a malfunction has been detected, all electrical connections, fuses, mode settings, and code settings should be checked. The corrective action, other than for the replacement of fuses, calls for the replacement of the complete RT-859/APX-72. Paragraph 3-19 details the component removal and replacement procedures.

Item No.	Ref para No.	Trouble symptom	Probable fault	Checks and corrective measures
1	3-12b	No output in any mode of operation.	a. No aircraft power.	a. Check that C-6280 (P)/APX panel is lighted. Apply aircraft power.
			b. MASTER control C-6280 (P)/APX set to OFF or STDBY.	b. Check MASTER control position. Place in LOW or NORM.
			c. Defective cable or loose connections.	c. Check cable and connections. Replace or tighten as applicable.
			d. Defective fuse in RT-859/APX-72.	d. Check and replace defective fuse.
			e. Defective antenna.	e. Check, using AN/APM-123A (V). If ACCEPT indicator lights, replace antenna.
			f. Defective RT-859/APX-72.	f. Check using set AN/APM-123A (V). Replace RT-859/APX-72.
	3-12b (6)			
	3-12b (5), (6)			
2	3-12b (5)	Output low or intermittent in any or all modes of operation.	a. Power supply in RT-859/APX-72 abnormal.	a. Check using AN/APM-123A (V). Replace RT-859/APX-72.
			b. RT-859/APX-72 coder operations abnormal.	b. Check using AN/APM-123A (V). Replace RT-859/APX-72.
3	3-12b	No output from a single mode. All others normal.	a. Applicable mode enable switch (C-6280 (P)/APX) in OUT or TEST position.	a. Check that applicable mode enable switch is set to ON.
			b. Improper code setting in applicable mode switch.	b. Check for proper code setting.

3-19. Removal and Replacement

a. To remove the RT-859/APX-72 from the MT-3809/APX-72, or MT-3948/APX-72, proceed as follows:

- (1) Remove the power and control cable connector.
- (2) Remove the antenna cable connector.
- (3) Disengage the two screw clamps on

the front of the RT-859/APX-72 by turning the knurled nuts counterclockwise.

- (4) Using the handle on the front of the RT-859/APX-72, pull forward and away from the MT-3809/APX-72 or MT-3948/APX-72.

b. To remove the MT-3809/APX-72 or MT-3948/APX-72, refer to instructions contained in the applicable aircraft technical manual.

c. To replace the RT-859/APX-72, perform the removal procedures in reverse sequence to the order of removal.

APPENDIX A

REFERENCES

Following is a list of applicable references available to the operator and organizational repairman of Receiver-Transmitter, Radio RT-859/APX-72 and Mounting MT-3809/APX-72:

NAVSUP-2002, section viii (Navy)	Index of Technical Bulletins, Technical Manuals, Technical Orders, Illustrated Parts Breakdown, Supply Bulletins, Supply Manuals, Lubrication Orders, and Modification Work Orders.
DA PAM 310-4 (Army)	
T.O. 0-1-12 (Air Force)	
NAVWEPS Form 13070/5 (Navy)	Equipment Record Procedures
TM 38-750 (Army)	
AFTO Form 29/29A (Air Force)	
Publication 378 (Navy)	Report of Packaging and Handling Deficiencies (DD Form 6)
AFR 71-4 (Air Force)	
AR 700-58 (Army)	
NAVSUP Pub 459 (Navy)	Discrepancy in Shipment Report (SF 361)
AR 55-38 (Army)	
AFM 75-34 (Air Force)	
NAVWEPS 16-35C6280-1 (Navy)	Control, Transponder Set C-6280 (P) /APX
T.O. 12P4-2APX-142 (AirForce)	
TM 11-5841-268-25 (Army)	
NAVAIR 16-30APM123-() (Navy)	Test Set, Transponder AN/APM-123 (V) 2 Test Set, Transponder AN/APM-123 (V) 1 Test Set, Transponder AN/APM-123 (V) 3
TM 11-6625-667-12 (Army)	
T.O. 33A1-3-367-1 (Air Force)	
NAVAIR 16-35TS1843-1 (Navy)	Test Set, Transponder Set TS-1843/APX
T.O. 12P4-2APX-152 (Air Force)	
SB 38-100 (Army)	
TB SIG 364 (Army)	Preservation, Packaging and Packing Materials, Supplies, and Equipment Used by the Army.
TM 9-213 (Army)	
	Field Instructions for Painting and Preserving Electronics Command Equipment.
	Painting Instructions for Field Use.

APPENDIX B MAINTENANCE ALLOCATION

Section 1. INTRODUCTION

B-1. General

This appendix provides a summary of the maintenance operations covered in the equipment literature or Receiver-Transmitter, Radio RT-859/APX-72 md RT-859A/APX-72 and Mountings MT-3809/APX-72 and MT-3948/APX-72. It authorizes levels of maintenance of specific maintenance functions on repairable items and components and the tools and equipment required to perform each function. This appendix may be used as an aid in planning maintenance operations.

B-2. Explanation of Format

a. Group Number. Group numbers correspond to the reference designation prefix assigned in accordance with ASA Y32.16, Electrical and Electronic Reference Designations. They indicate the relation of listed items to the next higher assembly.

b. Component Assembly Nomenclature. This column lists the item names of component units, assemblies, subassemblies, and modules on which maintenance is authorized.

c. Maintenance Function. This column indicates the maintenance category at which performance of the specific maintenance function is authorized. Authorization to perform a function at higher categories. The codes used represent the various maintenance categories as follows:

<i>Code</i>	<i>Maintenance category</i>
C	Operator/crew
O	Organizational
F	Direct support
H	General support
D	Depot

d. Tools and Equipment. The numbers appearing in this column refer to specific tools and equipment which are identified by these numbers in Section III.

e. Remarks. Self-explanatory.

B-3. Explanation of Format for Tool and Test Equipment Requirements

The columns in the tool and test equipment requirements chart are as follows:

a. Tools or Test Equipment Reference Code. The numbers in this column coincide with the numbers used in the tools and equipment column of the Maintenance Allocation Chart (MAC). The numbers indicate the applicable tool for the maintenance function.

b. Maintenance Category. The codes in this column indicate the maintenance category normally allocated to the facility.

c. Nomenclature. This column lists tools, test, and maintenance equipment required to perform the maintenance functions.

d. Federal Stock Number. This column lists the Federal stock number.

e. Remarks. Self-explanatory.

Nomenclature of End Item or Component																
Receiver-Transmitter, Radio RT-859A/APX-72 AND MOUNTINGS MT-3809/APX-72 AND MT-3948/APX-72																
SECTION II - MAINTENANCE ASSIGNMENT																
a Group Number	b Component Assembly Nomenclature	c Maintenance Function										d Tools and Equipment	e Remarks			
		Inspect	Test	Service	Adjust	Align	Calibrate	Install	Replace	Repair	Overhaul			Rebuild		
	Receiver-Transmitter, Radio RT-859A/APX-72	0 .1	0 .3	0 .2					0 .1					11, 15, 17 14 14 1,2,4,5,6,8,9,12,22 4,5 4, 13, 16 1,2,3,4,5,8,9,10, 12, 19, 20, 21,22 1,2,5,6,8,9,12,22 7, 13, 16	Visual Inspection Verify Operation Clean dirt, grease & touchup paint Fuses, fuse cap & RT box Visual Inspection Test Operation Power Supply Replace assemblies, subassemblies, connectors & replace pluck-out boards Visual Inspection Assemblies, sub-assemblies, RT for bad pluck-out boards & RF section For optimum operating conditions and to meet system tolerances Assemblies, sub-assemblies	
		F .1	F .5			F .3			F .3							
		H .1	H .5				H .4		H .3							

SECTION II - MAINTENANCE ASSIGNMENT

a Group Number	b Component Assembly Nomenclature	c Maintenance Function										d Tools and Equipment	e Remarks	
		Inspect	Test	Service	Adjust	Align	Calibrate	Install	Replace	Repair	Overhaul			Rebuild
	Processor A1)) Decoder A2)) Mode 4 A3) Encoder Clock A4)) Encoder Control A5) Encoder Gating A6) Delay Line DL1) Mounting MT-3809/APX-72 or MT-3948/APX-72	D .1	D 1.0							D 3			18 7, 13 14 14	Visual Inspection Pluck-out boards to component level Pluck-out boards piece parts Visual Inspection Piece parts Mounting

Change 1 B-3

TM 11-5895-490-20

SECTION III - TOOL AND TEST EQUIPMENT REQUIREMENTS					
Tool or Test Equipment Reference Code	Maintenance Category	Nomenclature		FSN	Tool Number
1	F,H,D	Generator, Signal	AN/URM-64A	6625-553-0433	
2	F,H,D	Generator, Sweep Signal	AN/USM-203	6625-086-7165	
3	H,D	Electronic Voltmeter	ME-202()/U	6625-709-0288	
4	F,H,D	Multimeter	AN/USM-223	6625-999-7465	
5	F,H,D	Multimeter	ME-26B/U	6625-913-9781	
6	F,H,D	Oscilloscope	AN/USM-281A	6625-228-2201	
7	H,D	Repair Kit, Printed Circuit Board	MK-772/U	5999-757-7042	
8	F,H,D	Test Set, Radar	AN/UPM-98A	6625-912-0429	
9	F,H,D	Test Set, Simulator	AN/APM-245	6625-087-1227	
10	H,D	Test Set, Semiconductor Device	TS-1836/U	6625-893-2628	
11	O	Test Set, Transponder	AN/APM-123(V)	6625-948-0071	
12	F,H,D	Test Set, Transponier	AN/APM-239A	6625-802-7425	
13	F,H,D	Tool Kit, Electronic Equipment	TK-100/G	5180-605-0079	
14	O	Tool Kit, Electronic Equipment	TK-101/G	5180-064-5178	
15	O,F,H,D	Adapter	UG-564/U	5935-258-9891	
16	F,H,D	Maintenance Kit, Electronic Equipment	MK-693/A	5821-045-9695	
17	O	Multimeter	AN/URM-105C	6625-999-6282	
18	D	Test Set, Electronic Circuit Plug-in Unit	AN/APM-338		
19	H,D	Test Set, Crystal Unit Quartz	TS-268E/U	6625-669-1215	
20	H,D	Counter, Electronic Digital Readout	AN/USM-207	6625-911-6368	
21	H,D	Comparator, Frequency	CM-77()/USM	6625-080-7204	
22*	F,H,D	Test Set, Transponder	AN/APM-305A	6626-01-052-3881	
*Replaces items 1,2,8 and 9.					

By Order of the Secretaries of the Army and the Navy.

Official:
KENNETH G. WICKHAM,
Major General, United States Army.
The Adjutant General.

HAROLD K. JOHNSON,
General, United States Army,
Chief of Staff.

J. E. RICE,
Rear Admiral, US. Navy,
Commander, Naval Electronic Systems Command.

DEPARTMENT OF THE ARMY
US ARMY AG PUBLICATIONS CENTER
1655 WOODSON ROAD
ST. LOUIS, MISSOURI 63114

OFFICIAL BUSINESS
PENALTY FOR PRIVATE USE, \$300

POSTAGE AND FEES PAID
DEPARTMENT OF THE ARMY
DOD 314

FOURTH CLASS



This fine document...

Was brought to you by me:



[Liberated Manuals -- free army and government manuals](#)

Why do I do it? I am tired of sleazy CD-ROM sellers, who take publicly available information, slap “watermarks” and other junk on it, and sell it. Those masters of search engine manipulation make sure that their sites that sell free information, come up first in search engines. They did not create it... They did not even scan it... Why should they get your money? Why are not letting you give those free manuals to your friends?

I am setting this document FREE. This document was made by the US Government and is NOT protected by Copyright. Feel free to share, republish, sell and so on.

I am not asking you for donations, fees or handouts. If you can, please provide a link to liberatedmanuals.com, so that free manuals come up first in search engines:

<A HREF=<http://www.liberatedmanuals.com/>>Free Military and Government Manuals

- Sincerely
Igor Chudov
<http://igor.chudov.com/>
- [Chicago Machinery Movers](#)