

ARMY
NAVY
AIR FORCE

TM 11-5895-1179-23 P
EE132-EA-PLO-010-E106 KY883
TO 31S1-2GSC-164

ORGANIZATIONAL AND DIRECT SUPPORT
MAINTENANCE REPAIR PARTS AND
SPECIAL TOOLS LIST
(INCLUDING DEPOT MAINTENANCE REPAIR
PARTS AND SPECIAL TOOLS)
FOR
ENCODER-DECODER
KY-883/GSC
(NSN 5895-01-114-1358)

DEPARTMENTS OF THE ARMY, THE NAVY, AND THE AIR FORCE

16 JULY 1984

TECHNICAL MANUAL
 No. TM 11-5895-1179-23P
 TECHNICAL MANUAL
 NO. EE132-EA-PLO-010/E106 KY-883
 TECHNICAL ORDER
 No. TO 31S1-2GSC-164



DEPARTMENTS OF THE ARMY,
 THE NAVY, AND THE AIR FORCE

WASHINGTON, DC 16 July 1984

**ORGANIZATIONAL AND DIRECT SUPPORT MAINTENANCE
 REPAIR PARTS AND SPECIAL TOOLS LIST
 (INCLUDING DEPOT MAINTENANCE REPAIR PARTS
 AND SPECIAL TOOLS)
 FOR
 ENCODER-DECODER KY-883/GSC
 (NSN 5895-01-114-1358)**

Current as of 23 April, 1984

REPORTING ERRORS AND RECOMMENDING IMPROVEMENTS

You can help improve this manual. If you find any mistakes or if you know of a way to improve the procedures, please let us know. Mail your letter, DA Form 2028 (Recommended Changes to Publications and Blank Forms), or DA Form 2028-2 located in back of this manual direct to: Commander, US Army Communications-Electronics Command and Fort Monmouth, ATTN: DRSEL-ME-MP Fort Monmouth, NJ 07703.

For Air Force, submit AFTO Form 22 (Technical Order System Publication Improvement Report and Reply) in accordance with paragraph 6-5, Section VI, T.O. 00-5-1. Forward direct to prime ALCIMST.

For Navy, mail comments to the Commander, Naval Electronics Systems Command, ATTN: ELEX 8122, Washington, DC 20360.

In either case, a reply will be furnished direct to you.

Table of Contents

SECTION	I	Introduction	Page	Illus Figure
	II	Repair Parts List	1	
GROUP	00	Encoder-Decoder KY-883/GSC	5	
	01	Decoder Circuit Card Assembly	5	1
	02	Interleaver Circuit Card Assembly	9	2
	03	Input/Output Circuit Card Assembly	15	3
			21	4

		Page	Illus Figure
GROUP	04	Power Supply Circuit Card Assembly	29 5
		0401 Heat Sink Assembly.....	33 6
	05	Chassis Assembly	35 7
		0501 Front Panel Assembly.....	37 8
		050101 Display and Control Circuit Card Assembly.....	41 9
		050102 Front Panel Assembly (See Group 0501 for parts)	
		050103 Power Switch Assembly (See Group 0501 for parts)	
		050104 Fuseholder Assembly (See Group 0501 for parts)	
		0502 Bottom Panel Assembly.....	45 10
		0503 Rear Panel Assembly	49 11
		050301 Backplane Circuit Card Assembly	51 12
		050302 Rear Panel Subassembly (See Group 0503 for parts)	
		050303 Power Connector Assembly (See Group 0503 for parts)	
		050304 Fan Assembly (See Group 0503 for parts)	
		0504 Harness Assembly (See Group 05 for parts)	
		0505 Chassis Subassembly	53 13
III		Special Tools List (Not applicable)	
IV		National Stock Number and Part Number Index	54

**SECTION I
INTRODUCTION**

1. Scope

This manual lists spares and repair parts; special tools; special test, measurement, and diagnostic equipment (TMDE), and other special support equipment required for performance of organizational, direct support, and general support maintenance of the KY-883/GSC. It authorizes the requisitioning and issue of spares and repair parts as indicated by the source and maintenance codes.

2. General

This Repair Parts and Special Tools List is divided into the following sections:

a. Section II. Repair Parts List. A list of spares and repair parts authorized for use in the performance of maintenance. The list also includes parts which must be removed for replacement of the authorized parts. Parts lists are composed of functional groups in numeric sequence, with the parts in each group listed in figure and item number sequence.

b. Section III. Special Tools List. Not applicable.

c. Section IV National Stock Number and Part Number Index. A list, in National item identification number (NIIN) sequence, of all National stock numbers (NSN) appearing in the listings, followed by a list, in alphameric sequence, of all part numbers appearing in the listings. National stock numbers and part numbers are cross-referenced to each illustration figure and item number appearance.

3. Explanation of Columns

a. Illustration. This column is divided as follows:

(1) *Figure number.* Indicates the figure number of the illustration on which the item is shown.

(2) *Item number.* The number used to identify item called out in the illustration.

b. Source, Maintenance, and Recoverability (SMR) Codes.

(1) *Source code.* Source codes indicate the manner of acquiring support items for maintenance, repair, or overhaul of end items. Source codes are entered in the first and second positions of the Uniform SMR Code format as follows:

<i>Code</i>	<i>Definition</i>
PA -	Item procured and stocked for anticipated or known usage.
PB -	Item procured and stocked for insurance purpose because essentiality dictates that

<i>Code</i>	<i>Definition</i>
	a minimum quantity be available in the supply system.
PC -	Item procured and stocked and which otherwise would be coded PA except that it is deteriorative in nature.
PD -	Support item, excluding support equipment, procured for initial issue or outfitting and stocked only for subsequent or additional initial issues or outfittings. Not subject to automatic replenishment.
PE -	Support equipment procured and stocked for initial issue or outfitting to specified maintenance repair activities.
PF -	Support equipment which will not be stocked but which will be centrally procured on demand.
PG -	Item procured and stock to provide for sustained support for the life of the equipment. It is applied to an item peculiar to the equipment which, because of probable discontinuance or shutdown of production facilities, would prove uneconomical to reproduce at a later time.
KD -	An item of a depot overhaul/repair kit and not purchased separately. Depot kit defined as a kit that provides items required at the time of overhaul or repair.
KF -	An item of a maintenance kit and not purchased separately. Maintenance kit defined as a kit that provides an item that can be replaced at organizational or intermediate levels of maintenance.
KB -	Item included in both a depot overhaul/repair kit and a maintenance kit.
MO -	Item to be manufactured or fabricated at the organizational level.
MF -	Item to be manufactured or fabricated at the direct support maintenance level.
MH -	Item to be manufactured or fabricated at the general support maintenance level.
MD -	Item to be manufactured or fabricated at the depot maintenance level.
AO -	Item to be assembled at organization level.
AF -	Item to be assembled at direct support maintenance level.
AH -	Item to be assembled at general support maintenance level.

<i>Code</i>	<i>Definition</i>
AD -	Item to be assembled at depot maintenance level.
XA -	Item is not procured or stocked because the requirements for the item will result in the replacement of the next higher assembly.
XB -	Item is not procured or stocked. If not available through salvage, requisition.
XC -	Installation drawing, diagram, instruction sheet, field service drawing, that is identified by manufacturer's part number.
XD -	A support item that is not stocked. When required, item will be procured through normal supply channels.

NOTE

Cannibalization or salvage may be used as a source of supply for any items source coded above except those coded XA and aircraft support items as restricted by AR 750-1.

(2) *Maintenance code.* Maintenance codes are assigned to indicate the levels of maintenance authorized to USE and REPAIR support items. The maintenance codes are entered in the third and fourth positions of the Uniform SMR Code format as follows:

(a) The maintenance code entered in the third position will indicate the lowest maintenance level authorized to remove, replace, and use the support item. The maintenance code entered in the third position will indicate one of the following levels of maintenance:

<i>Code</i>	<i>Application/Explanation</i>
C -	Crew or operator maintenance performed within organizational maintenance.
O -	Support item is removed, replaced, used at the organizational level.
F -	Support item is removed, replaced, used at the direct support level.
H -	Support item is removed, replaced, used at the general support level.
D -	Support items that are removed, replaced, used at depot, -mobile depot, specialized repair activity only.

(b) The maintenance code entered in the fourth positions indicates whether the item is to be repaired and identifies the lowest maintenance level with the capability to perform complete repair (i.e., all authorized maintenance functions). This position will contain one of the following maintenance codes:

<i>Code</i>	<i>Application/Explanation</i>
O -	The lowest maintenance level capable of complete repair of the support item is the organizational level.
F -	The lowest maintenance level capable of complete repair of the support item is the direct support level.
H -	The lowest maintenance level capable of complete repair of the support item is the general support level.
D -	The lowest maintenance level capable of complete repair of the support item is the depot level.
L -	Repair restricted to designated specialized repair activity.
Z -	Nonreparable. No repair is authorized.
B -	No repair is authorized. The item may be reconditioned by adjusting, lubricating, etc., at the user level. No parts or special tools are procured for the maintenance of this item.

(3) *Recoverability code.* Recoverability codes are assigned to support items to indicate the disposition action on unserviceable items. The recoverability code is entered in the fifth position of the Uniform SMR Code format as follows:

Recoverability codes

<i>Code</i>	<i>Definition</i>
Z -	Nonreparable item. When unserviceable, condemn and dispose at the level indicated in position 3.
O -	Reparable item. When uneconomically repairable, condemn and dispose at organizational level.
F -	Reparable item. When uneconomically repairable, condemn and dispose at the direct support level.
H -	Reparable item. When uneconomically repairable, condemn and dispose at the general support level.
D -	Reparable item. When beyond lower level repair capability, return to depot. Condemnation and disposal not authorized below depot level.
L -	Reparable item. Repair, condemnation, and disposal not authorized below depot/specialized repair activity level.
A -	Item requires special handling or condemnation procedures because of specific reasons (i.e., precious metal content, high dollar value, critical material or hazardous material). Refer to appropriate manuals/directives for specific instructions.

c. *National Stock Number.* Indicates the National stock number assigned to the item and will be used for requisitioning purposes.

d. *Federal Supply Code for Manufacturer (FSCM).* The FSCM is a 5-digit numeric code listed in SB 708-41/42 which is used to identify the manufacturer, distributor, or Government agency, etc.

e. *Part Number.* Indicates the primary number used by the manufacturer (individual, company, firm, corporation, or Government activity), which controls the design and characteristics of the item by means of its engineering drawings, specifications, standards, and inspection requirements to identify an item or range of items.

NOTE

When a stock numbered item is requisitioned, the repair part received may have a different part number than the part being replaced.

f. *Description.* Indicates the Federal item name and, if required, a minimum description to identify the item.

g. *Unit of Measure (U/M).* Indicates the standard of the basic quantity of the listed item as used in performing the actual maintenance function. This measure is expressed by a two-character alphabetical abbreviation (e.g., ea, in, pr, etc). When the unit of measure differs from the unit of issue, the lowest unit of issue that will satisfy the required units of measure will be requisitioned.

h. *Quantity Incorporated in Unit.* Indicates the quantity of the item used in the breakout shown on the illustration figure, which is prepared for a functional group, subfunctional group, or an assembly.

4. Special Information

a. The following publications pertain to the KY-883/GSC and its components: TM 11-5895-1179-13, Encoder-Decoder KY-883/ GSC.

b. National stock numbers (NSN's) that are missing from P source coded items have been applied for and will be added to this TM by future change/revision when they are entered in the Army Master Data File (AMDF). Until the NSN's are established and published, submit exception requisitions to: Commander, US Army Communications-Electronics Command and Fort Monmouth, ATTN: DRSEL-MM, Fort Monmouth, NJ 07703 for the part required to support your equipment.

5. How to Locate Repair Parts

a. When National stock number or part number is unknown.

(1) *First.* Using the table of contents, determine the functional group within which the item belongs. This is necessary since illustrations are prepared for functional groups and listings are divided into the same groups.

(2) *Second.* Find the illustration covering the functional group to which the item belongs.

(3) *Third.* Identify the item on the illustration and note the illustration figure and item number of the item.

(4) *Fourth.* Using the Repair Parts Listing, find the figure and item number noted on the illustration.

b. When National stock number or part number is known.

(1) *First.* Using the index of National Stock Numbers and Part Numbers, find the pertinent National stock number or part number. This index is in NIIN sequence followed by a list of part numbers in alphameric sequence, cross-referenced to the illustration figure number and item number.

(2) *Second.* After finding the figure and item number, locate the figure and item number in the repair parts list.

6. Abbreviations

Not applicable.

(Next printed page is 4)

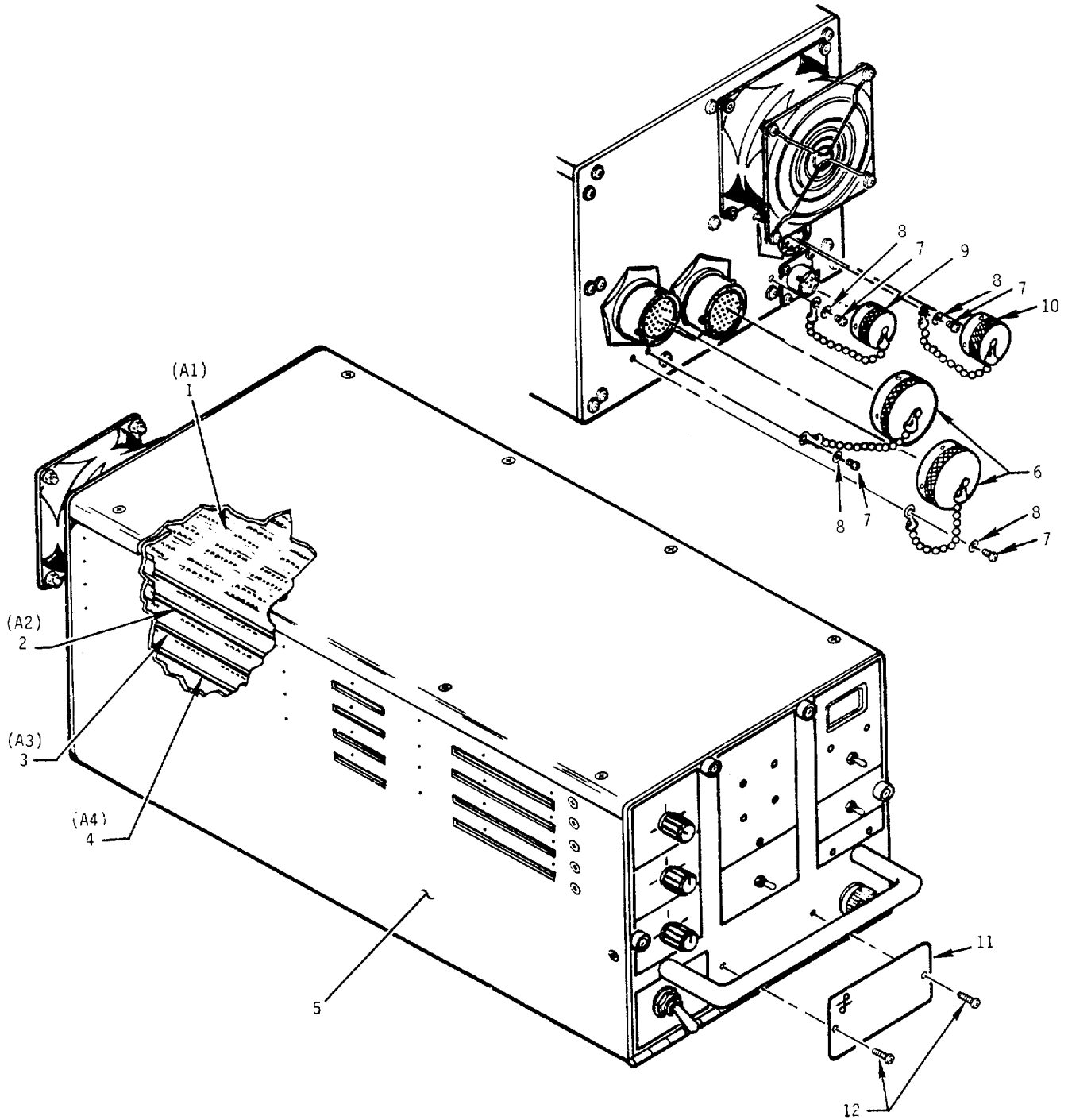

EL8XA001

Figure 1. Encoder/Decoder KY-883/GSC

SECTION II

TM 11-5895-1179-23P / EE132 - EA- PLO-010/E106 KY883 / TO 31S1-2GSC-164

(1) ILLUSTRATION		(2)	(3)	(4)	(5)	(6) DESCRIPTION	(7)	(8)
(a) FIG NO.	(b) ITEM NO.	SMR CODE	NATIONAL STOCK NUMBER	FSCM	PART NUMBER	USABLE ON CODE	U/M	QTY INC IN UNIT
						GROUP 00 ENCODER-DECODER KY-883		
1	1	PADDD	5999-01-129-1521	80063	SM-D-986495	CIRCUIT CARD ASSEMB	EA	1
1	2	PAODD	5999-01-129-1522	80063	SM-D-986498	CIRCUIT CARD ASSEMB	EA	1
1	3	PAODD	5999-00-129-1523	80063	SM-D-986492	CIRCUIT CARD ASSEMB	EA	1
1	4	PAODD	5820-01-045-3438	80063	SM-D-882477	CIRCUIT CARD ASSEMB	EA	1
1	5	XBDDD		80063	SH-D-986475	CHASSIS ASSEMBLY	EA	1
1	6	XBZZ		06324	G1109D24B3-15	COVER, PROTECTIVE	EA	2
1	7	PAFZZ	5305-00-054-5653	96906	MS51957-19	SCREW, MACHINE	EA	2
1	8	PAFZZ	5310-00-057-0573	88769	91921002	WASHERFLAT	EA	2
1	9	XBZZ		06324	G1109D12B2-15	COVER, PROTECTIVE	EA	1
1	10	XBZZ		06324	G1109D16B3-15	COVER, PROTECTIVE	EA	1
1	11	XBZZ		80063	SM-D-986479	PLATE, IDENT	EA	1
1	12	PAFZZ	5305-00-054-5636	96906	MS51957-2	SCREW, MACHINE	EA	2
5								

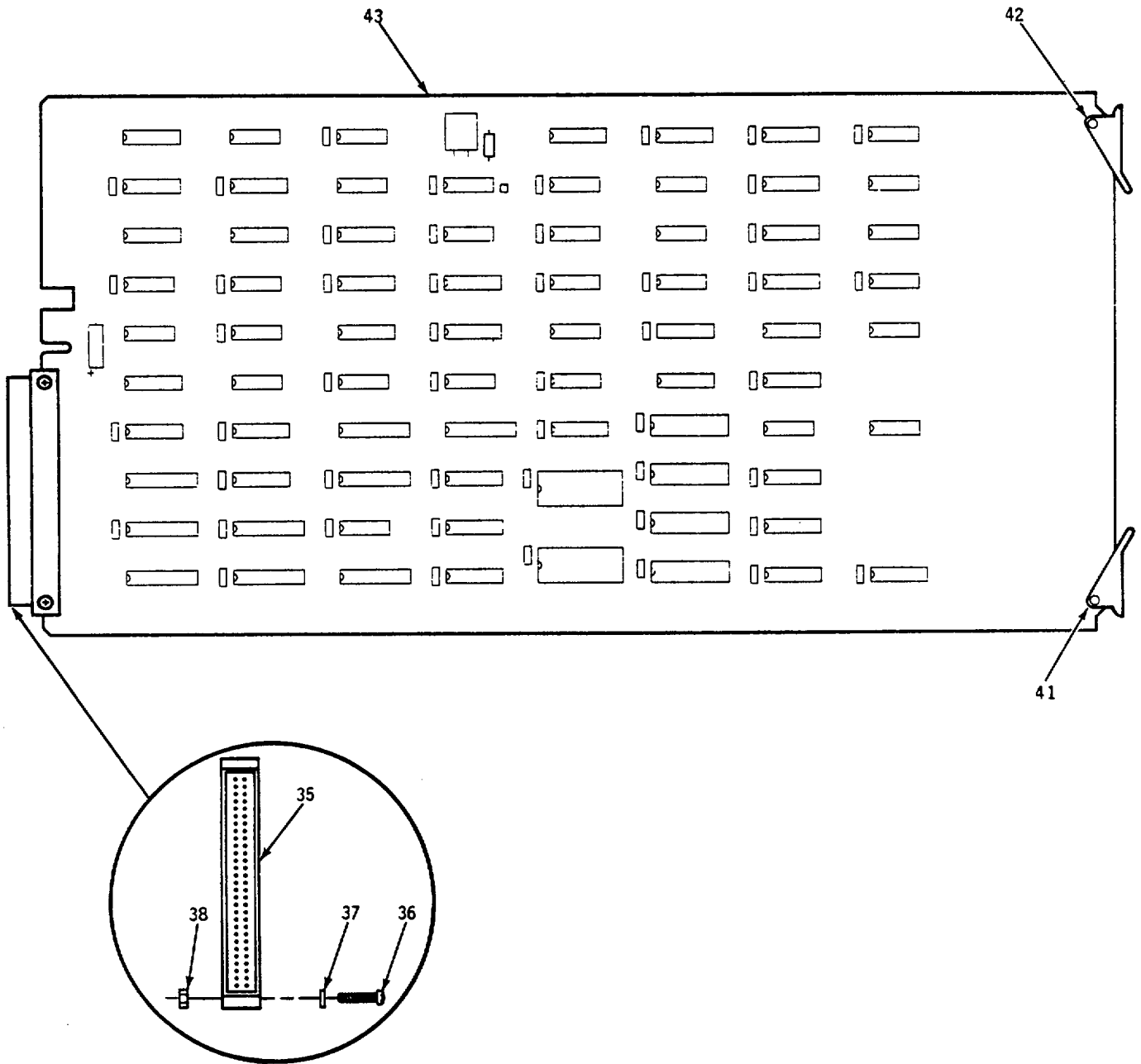

EL8XA002

Figure 2. Circuit Card Assembly, Decoder (A1) (Sheet 1 of 3)

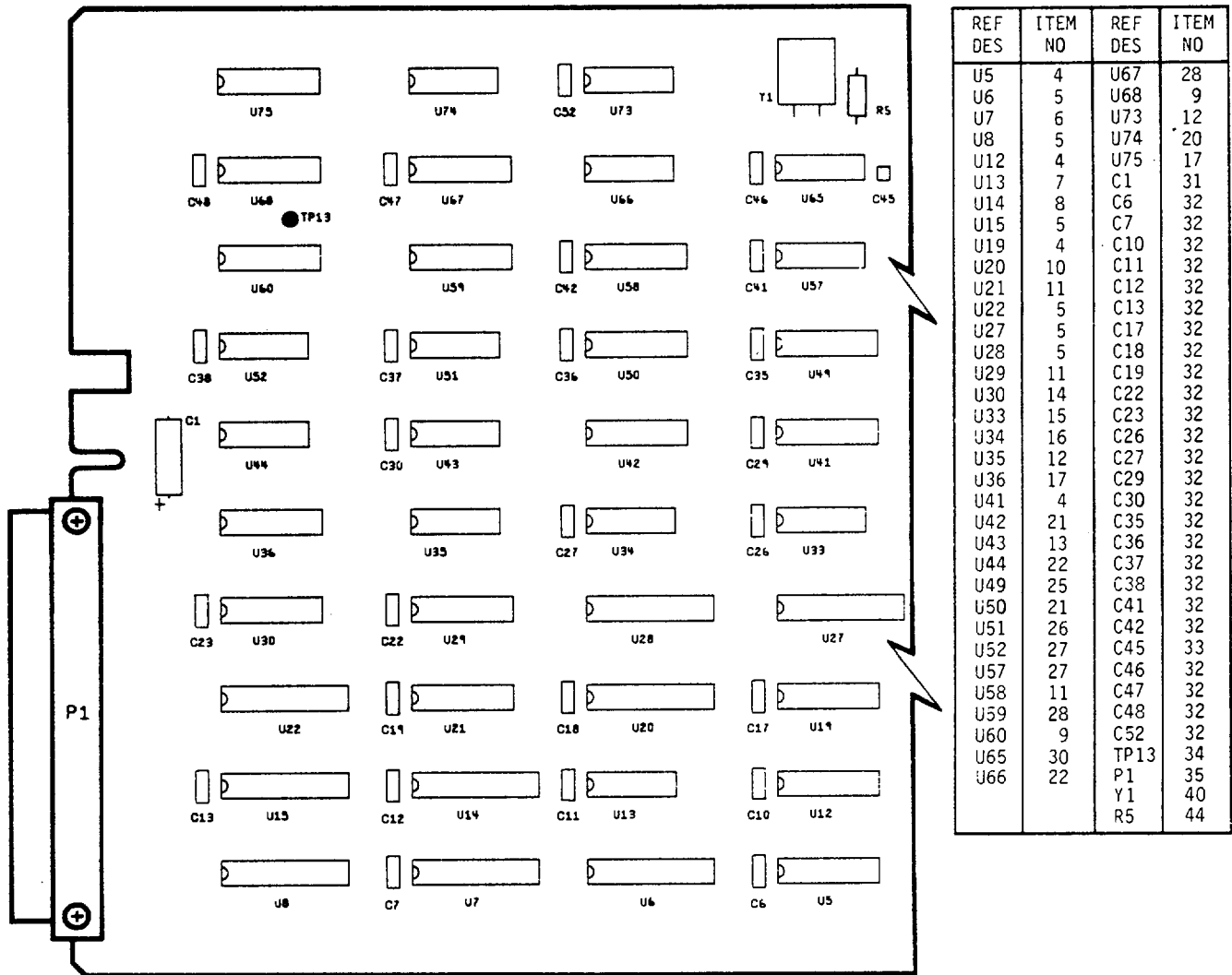

EL8XA025

Figure 2. Circuit Card Assembly, Decoder (A1) (Sheet 2 of 3)

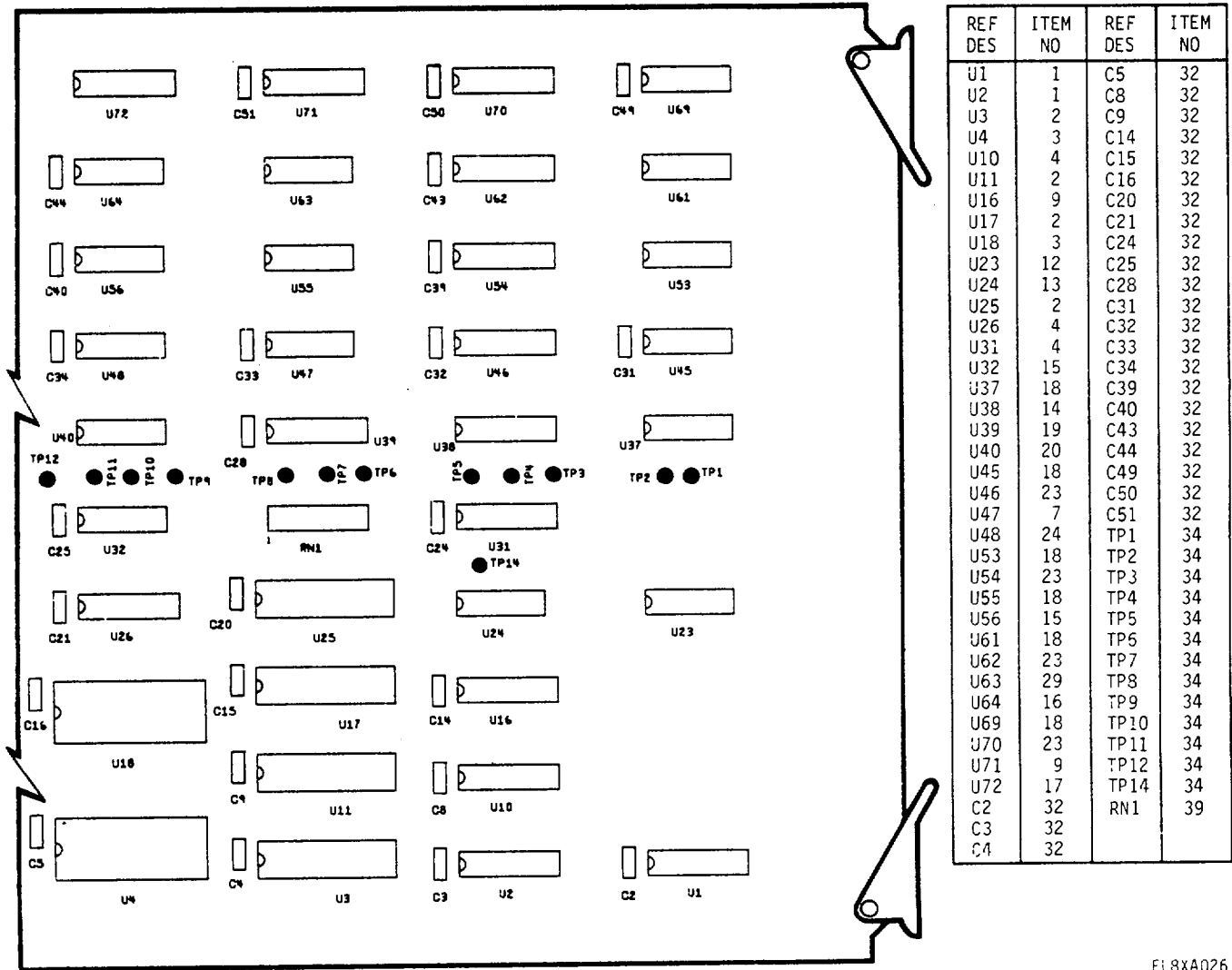

EL8XA026

Figure 2. Circuit Card Assembly, Decoder (A1) (Sheet 3 of 3)

(1) ILLUSTRATION		(2)	(3)	(4)	(5)	(6)	(7)	(8)
(a) FIG NO.	(b) ITEM NO.	SMR CODE	NATIONAL STOCK NUMBER	FSCM	PART NUMBER	DESCRIPTION USABLE ON CODE	U/M	QTY INC IN UNIT
						GROUP 01 DECODER CIRCUIT CARD ASSEMBLY		
2	1	PGDZZ	5962-01-077-0657	81349	M38510/08201BEB	MICROCIRCUIT, DIGITA.....	EA	2
2	2	PADZZ		07263	934220MQB	MICROCIRCUIT.....	EA	4
2	3	PADZZ	5962-01-041-3500	11627	1046B	MICROCIRCUIT, DIGITA.....	EA	2
2	4	PGDZZ	5962-01-054-3675	81349	M38510/07904BEB	MICROCIRCUIT, DIGITA.....	EA	7
2	5	PADZZ	5962-01-102-8671	81349	M38510/32504BRB	MICROCIRCUIT, DIGITA.....	EA	6
2	6	PAOZZ		80063	SM-A-986471-01	MICROCIRCUIT.....	EA	1
2	7	PGDZZ	5962-01-043-3941	81349	M38510/07501BCB	MICROCIRCUIT, DIGITA.....	EA	2
2	8	PADZZ		80063	SM-A-9864711-00	MICROCIRCUIT.....	EA	1
2	9	PADZZ	5962-01-069-2637	27014	M38510/315128BEB	MICROCIRCUIT, DIGITA.....	EA	4
2	10	PGDZZ	5967-01-104-6417	01295	SNJ54S374J	MICROCIRCUIT, DIGITA.....	EA	1
2	11	PGDZZ	5962-01-027-5649	01295	SNC54S163J	MICROCIRCUIT, DIGITA.....	EA	3
2	12	PGDZZ	5962-01-041-3214	81349	M38510/30502BCB	MICROCIRCUIT, DIGITA.....	EA	3
2	13	PGDZZ	5962-01-027-6863	81349	M38510130003BCB	MICROCIRCUIT, DIGITA.....	EA	2
2	14	PGDZZ	5962-01-084-7398	01295	SNC54LS378J	MICROCIRCUIT, DIGITA.....	EA	2
2	15	PGDZZ	5962-01-021-5875	81349	M38510/07001BCB	MICROCIRCUIT, DIGITA.....	EA	3
2	16	PGDZZ	5962-01-030-2118	81349	438510/07301BCB	MICROCIRCUIT, DIGITA.....	EA	2
2	17	PGDZZ	5962-01-086-0458	01295	SNC54LS669J	MICROCIRCUIT, DIGITA.....	EA	2
2	18	PGDZZ	5962-01-068-9593	81349	M38510/30605BCB	MICROCIRCUIT, DIGITA.....	EA	6
2	19	PGDZZ	5962-01-042-8072	81349	M38510107902BEB	MICROCIRCUIT, DIGITA.....	EA	1
2	20	PGDZZ	5962-01-034-9832	81349	M38510/31004BCB	MICROCIRCUIT, DIGITA.....	EA	1
2	21	PGDZZ	5962-01-057-7054	81349	M38510/30601BEB	MICROCIRCUIT, DIGITA.....	EA	2
2	22	PGDZZ	5962-01-031-7030	81349	M38510/30001BCB	MICROCIRCUIT, DIGITA.....	EA	2
2	23	PADZZ	5962-01-047-7408	07263	93425DM8B	MICROCIRCUIT, DIGITA.....	EA	4
2	24	PGDZZ	5962-01-026-2489	81349	M38510/07003BCB	MICROCIRCUIT, DIGITA.....	EA	1
2	25	PADZZ		01295	SNC54S283J	MICROCIRCUIT.....	EA	1
2	26	PGDZZ	5962-01-039-4752	81349	M38510/07401BCB	MICROCIRCUIT, DIGITA.....	EA	1
2	27	PGDZZ	5962-01-026-8818	81349	M38510/07101BCB	MICROCIRCUIT, LINEAR.....	EA	2
2	28	PGDZZ	5962-01-051-3402	81349	M38510/30109BEB	MICROCIRCUIT, DIGITA.....	EA	2
2	29	PGDZZ	5962-01-039-6395	81349	438510/30301BCB	MICROCIRCUIT, DIGITA.....	EA	
2	30	PGDZZ	5962-01-008-9563	04713	4324/BCBJC	MICROCIRCUIT, DIGITA.....	EA	1
2	31	PADZZ	5910-00-464-9812	81349	439003/01-2497	CAPACITOR, FIXED, ELE.....	EA	1
2	32	PADZZ	5910-00-113-5499	81349	M39014/02-1350	CAPACITOR, FIXED, CER.....	EA	50
2	33	PADZZ	5910-00-010-8666	81349	M39014/01-1357	CAPACITOR, FIXED, CER.....	EA	1
7	34	PADZZ	5940-00-082-5094	81349	M55155-30-5	TERMINAL, STUD.....	EA	15
2	35	PADZZ		91662	00-8257-064-000-900	CONNECTOR, PLUG.....	EA	1
2	36	PADZZ	5305-00-054-5640	96906	M551957-6	SCREW, MACHINE.....	EA	2
2	37	PADZZ	5310-00-043-4708	13499	310-0740-080	WASHER, FLAT.....	EA	2
2	38	PADZZ	5310-00-058-1823	96906	MS21042-02	NUT, SELF-LOCKING, EX.....	EA	2

SECTION II

TM 11-5895-1179-23P / EE132 - EA- PLO-010/E106 KY883 / TO 31S1-2GSC-164

(1) ILLUSTRATION		(2)	(3)	(4)	(5)	(6)	(7)	(8)
(a) FIG NO.	(b) ITEM NO.	SMR CODE	NATIONAL STOCK NUMBER	FSCM	PART NUMBER	DESCRIPTION USABLE ON CODE	U/M	QTY INC IN UNIT
						USABLE ON CODE		
2	39	PADZZ		81349	M8340102M1801GB	RESISTOR NETWORK	EA	1
2	40	PADZZ		81349	CR60AU13-450MHZ	OSCILLATOR, CRYSTAL.....	EA	1
2	41	PAFZZ	5999-01-092-9318	18677	5208	RETAINER-EJECTOR, EL	EA	1
2	42	PAFZZ		18677	S-208-1	RETAINER-EJECTOR, EL	EA	1
2	43	XADZZ		80063	SM-0-986494	PRINTED WIRING BD	EA	1
2	44	PADZZ	5905-00-458-9500	81349	RCR05G102JS	RESISTOR, FIXED, COMP	EA	1
2	45	PADZZ		01295	SNC54508J	MICROCIRCUIT	EA	1
2	46	PADZZ	5962-01-040-2979	01295	SNC54S169J	MICROCIRCUIT, DIGITA	EA	1
					10			

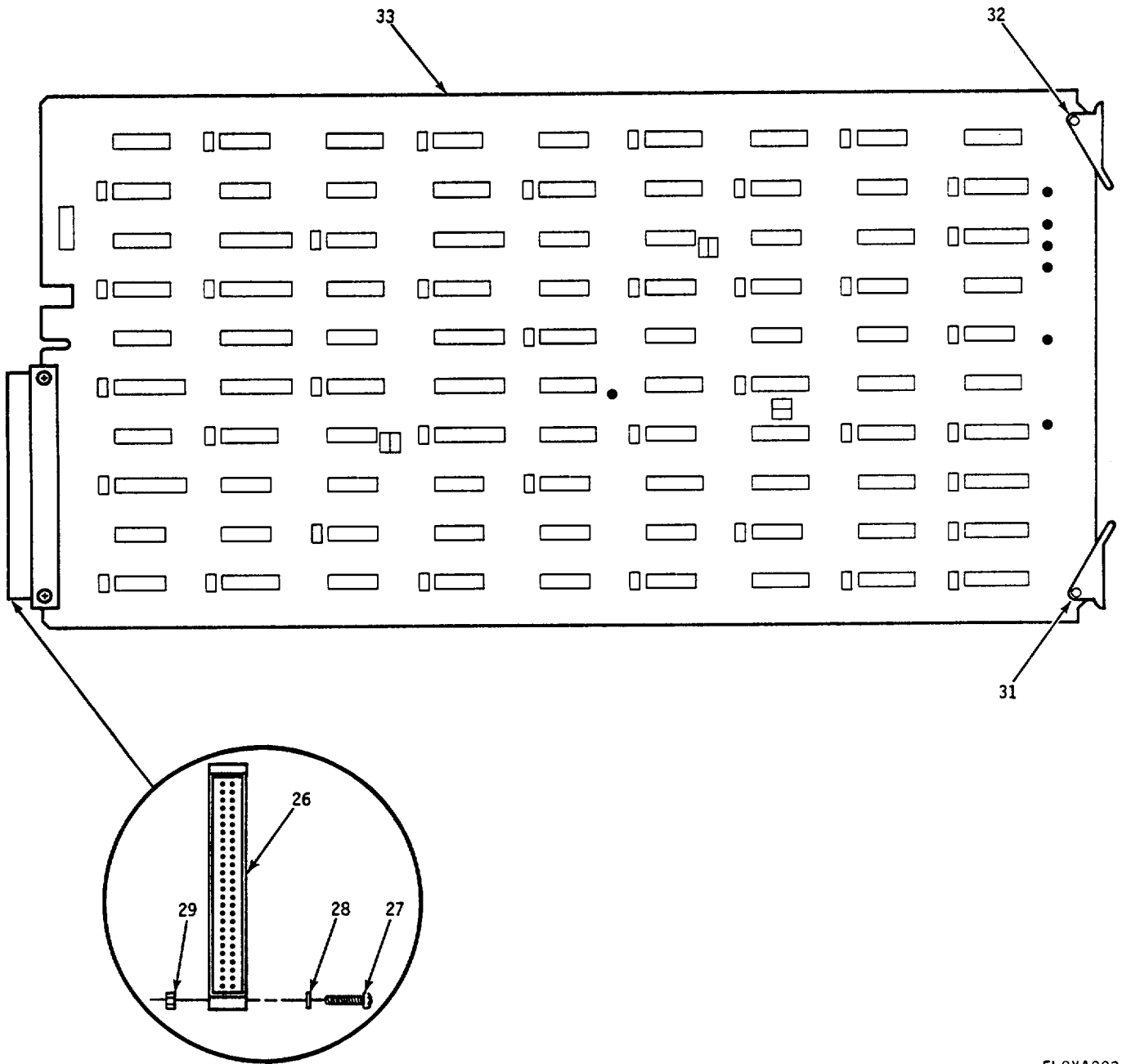

EL8XA003

Figure 3. Circuit Card Assembly, Interleaver (A2) (Sheet 1 of 4)

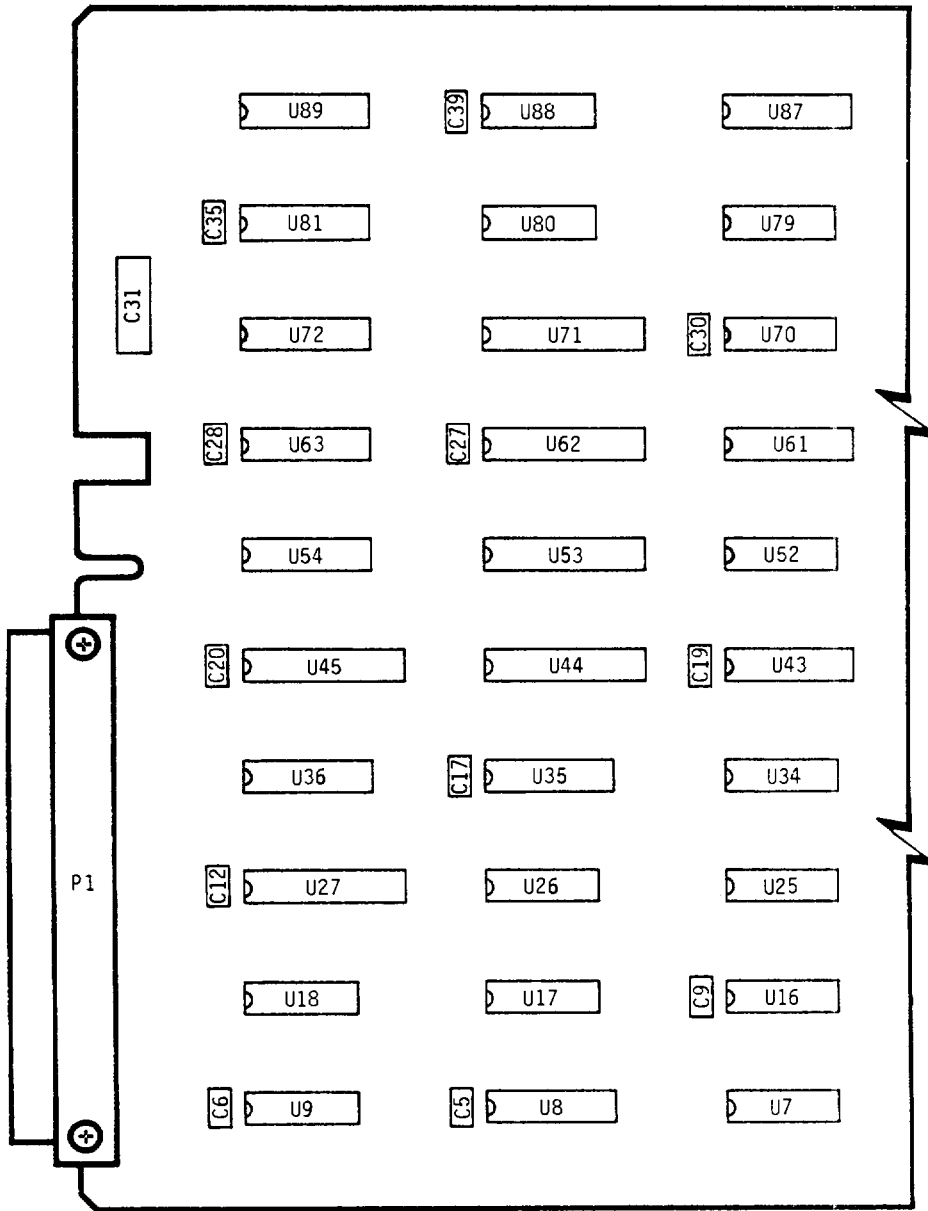

REF DES	ITEM NO	REF DES	ITEM NO
U7	6	U71	15
U8	7	U72	19
U9	5	U79	21
U16	5	U80	4
U17	5	U81	14
U18	10	U87	7
U25	6	U88	22
U26	8	U89	19
U27	12	C5	23
U34	5	C6	23
U35	16	C12	23
U36	17	C17	23
U43	14	C19	23
U44	15	C20	23
U45	18	C27	23
U52	5	C28	23
U53	15	C30	23
U54	19	C31	24
U61	14	C35	23
U62	15	C39	22
U63	14	P1	26
U70	21		

EL8XA018

Figure 3. Circuit Card Assembly, Interleaver (A2) (Sheet 2 of 4)

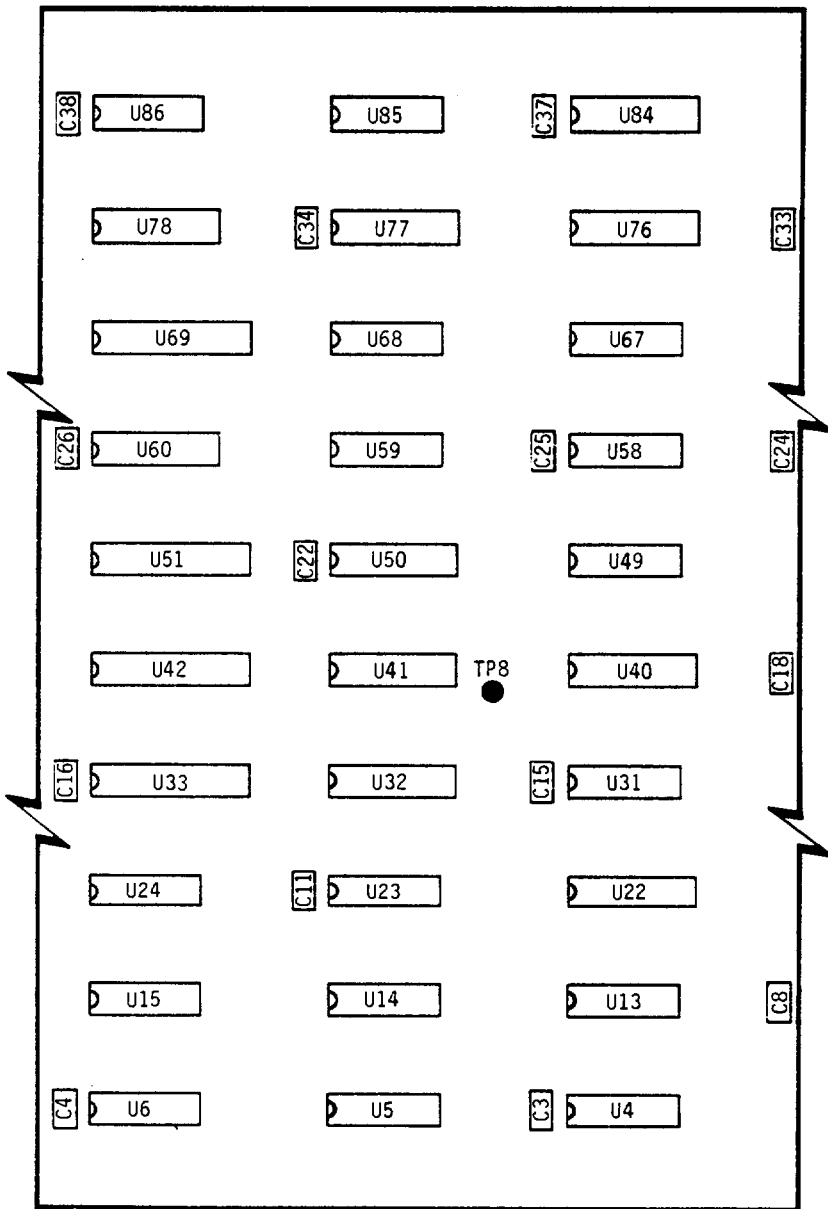

REF DES	ITEM NO	REF DES	ITEM NO
U4	4	U69	15
U5	5	U76	11
U6	5	U77	11
U13	8	U78	19
U14	8	U84	11
U15	9	U85	9
U22	11	U86	9
U23	9	C3	23
U24	5	C4	23
U31	9	C8	23
U32	14	C11	23
U33	15	C15	23
U40	3	C16	23
U41	14	C18	23
U42	15	C22	23
U49	9	C24	23
U50	3	C25	23
U51	15	C26	23
U58	6	C33	23
U59	8	C34	23
U60	3	C37	23
U67	4	C38	23
U68	9	TP8	25

EL8XA019

Figure 3. Circuit Card Assembly, Interleaver (A2) (Sheet 3 of 4)

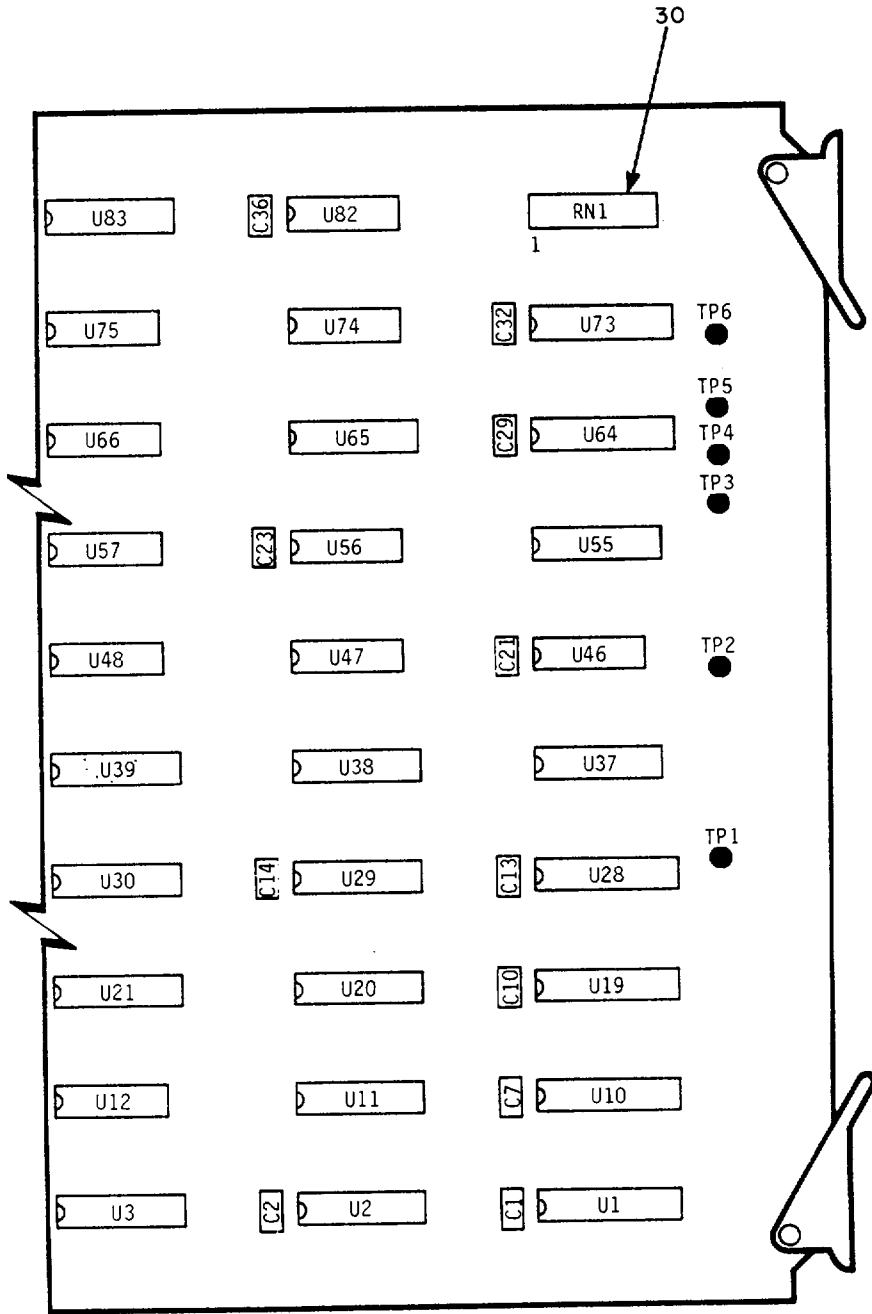

REF DES	ITEM NO	REF DES	ITEM NO
U1	1	U66	8
U2	2	U73	1
U3	3	U74	6
U10	1	U75	8
U11	3	U82	6
U12	4	U83	20
U19	1	C1	23
U20	3	C2	23
U21	7	C7	23
U28	1	C10	23
U29	13	C13	23
U30	11	C14	23
U37	13	C21	23
U38	13	C23	23
U39	11	C29	23
U46	6	C32	23
U47	8	C36	23
U48	8	TP1	25
U55	20	TP2	25
U56	6	TP3	25
U57	10	TP4	25
U64	1	TP5	25
U65	20	TP6	25
		RN1	30

EL8XA020

Figure 3. Circuit Card Assembly, Interleaver (A2) (Sheet 4 of 4)

SECTION II

(1) ILLUSTRATION		(2)	(3)	(4)	(5)	(6)	(7)	(8)
(a) FIG NO.	(b) ITEM NO.	SMR CODE	NATIONAL STOCK NUMBER	FSCM	PART NUMBER	DESCRIPTION USABLE ON CODE	U/M	QTY INC IN UNIT
GROUP 02 INTERLEAVER CIRCUIT CARD ASSEMBLY								
3	1	PADZZ		81349	M38510/238038VB	MICROCIRCUIT.....	EA	6
3	2	XDDZZ		07263	54LS133DMQB	MICROCIRCUIT, DIGITA.....	EA	1
3	3	PGDZZ	5962-01-058-4867	81349	M38510/31202BEB	MICROCIRCUIT, DIGITA.....	EA	6
3	4	PGDZZ	5962-01-027-6863	81349	M38510/30003BCB	MICROCIRCUIT, DIGITA.....	EA	4
3	5	PGDZZ	5962-01-039-6395	81349	M38510/30301BCB	MICROCIRCUIT, DIGITA.....	EA	8
3	6	PGDZZ	5962-01-098-5043	81349	M38510/32901BCB	MICROCIRCUIT, DIGITA.....	EA	7
3	7	PGDZZ	5962-01-084-7398	01295	SNC54LS378J	MICROCIRCUIT, DIGITA.....	EA	3
3	8	PGDZZ	5962-01-041-3214	81349	M38510/30502BCB	MICROCIRCUIT, DIGITA.....	EA	7
3	9	PGDZZ	5962-01-031-1918	81349	M38510/30501BCB	MICROCIRCUIT, DIGITA.....	EA	8
3	10	PGDZZ	5962-01-034-9832	81349	38510/3100C	MICROCIRCUIT, DIGITA.....	EA	2
3	11	PADZZ	5962-01-069-2637	27014	M38510/31512BEB	MICROCIRCUIT, DIGITA.....	EA	6
3	12	PGDZZ	5962-01-093-8823	81349	M38510/32401BRB	MICROCIRCUIT, DIGITA.....	EA	1
3	13	PGDZZ	5962-01-050-0921	81349	M38510/30903BEB	MICROCIRCUIT, DIGITA.....	EA	3
3	14	PGDZZ	5962-01-057-7054	81349	M3851013060BEB	MICROCIRCUIT, DIGITA.....	EA	6
3	15	PAOZZ	5962-01-102-8611	81349	M38510/32504BRB	MICROCIRCUIT, DIGITA.....	EA	8
3	16	PGDZZ	5962-01-092-6229	81349	N38510/32601BEB	MICROCIRCUIT, DIGITA.....	EA	1
3	17	PGDZZ	5962-00-074-8876	81349	N38510/32203BEB	MICROCIRCUIT, DIGITA.....	EA	1
3	18	PGDZZ	5962-01-080-6210	34335	SN54S240JB	INTEGRATED CIRCUIT.....	EA	1
3	19	PGDZZ	5962-01-051-3402	81349	M38510/30109BEB	MICROCIRCUIT, DIGITA.....	EA	4
3	20	PGDZZ	5962-01-069-2610	81349	M38510/30906BEB	MICROCIRCUIT, DIGITA.....	EA	3
3	21	PGDZZ	5962-01-031-7030	81349	M38510/30001BCB	MICROCIRCUIT, DIGITA.....	EA	2
3	22	PGDZZ	5962-01-035-7479	81349	M38510/30401BCB	MICROCIRCUIT, DIGITA.....	EA	1
3	23	PADZZ	5910-01-119-7435	81349	M39014-22-0494	CAPACITOR, FIXED, CER.....	EA	32
3	24	PADZZ	5910-00-464-9812	81349	M39003/01-2497	CAPACITOR, FIXED, ELE.....	EA	1
3	25	PADZZ	5943-00-082-5094	81349	MS5155-30-5	TERMINAL, STUD.....	EA	9
3	26	PADZZ			00-8257-064-000-900	CONNECTOR, PLUG.....	EA	1
3	21	PADZZ	5305-00-054-5640	96906	MS51957-6	SCREW, MACHINE.....EA	2	
3	28	PADZZ	5310-00-043-4708	13499	310-0740-080	WASHER, FLAT.....EA	2	
3	29	PADZZ	5310-00-058-1823	96906	MS21042-02	NUT SELF-LOCKING, EX.....EA	2	
3	30	PADZZ		81349	M8340102M1801GB	RESISITOR NETWORK.....EA	1	
3	31	PAFZZ	5999-01-092-9318	18677	S208	RETAINER-EJECTOR, EL.....EA	1	
3	32	PAFZZ	5999-01-163-9048	18677	S-208-2	RETAINER-EJECTOR, EL.....EA	1	
3	33	XADZZ		80063	SM-D-986497	PRINTED WIRING BD.....EA	1	

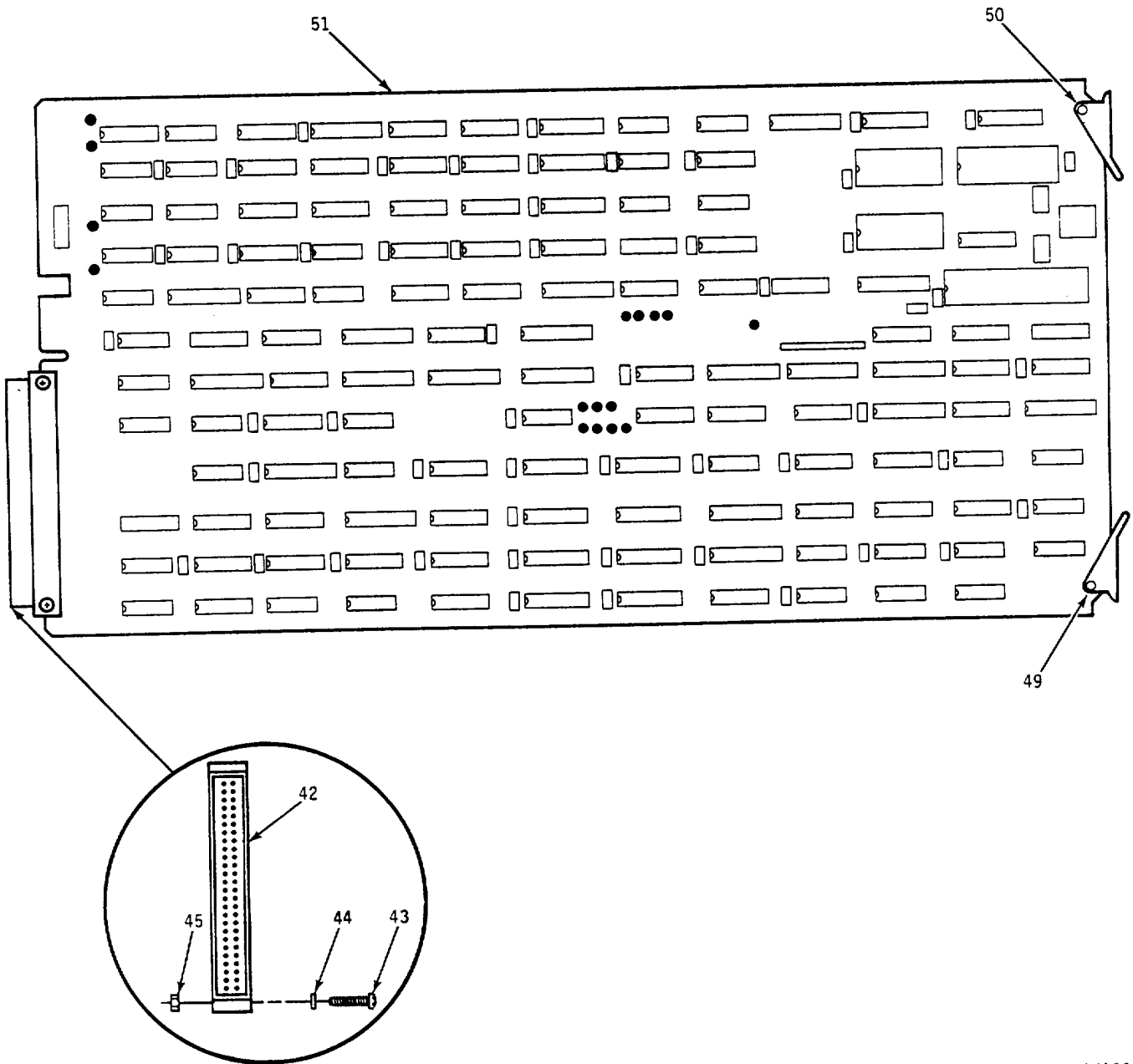

EL8XA004

Figure 4. Circuit Card Assembly, Input/Output (A3) (Sheet 1 of 5)

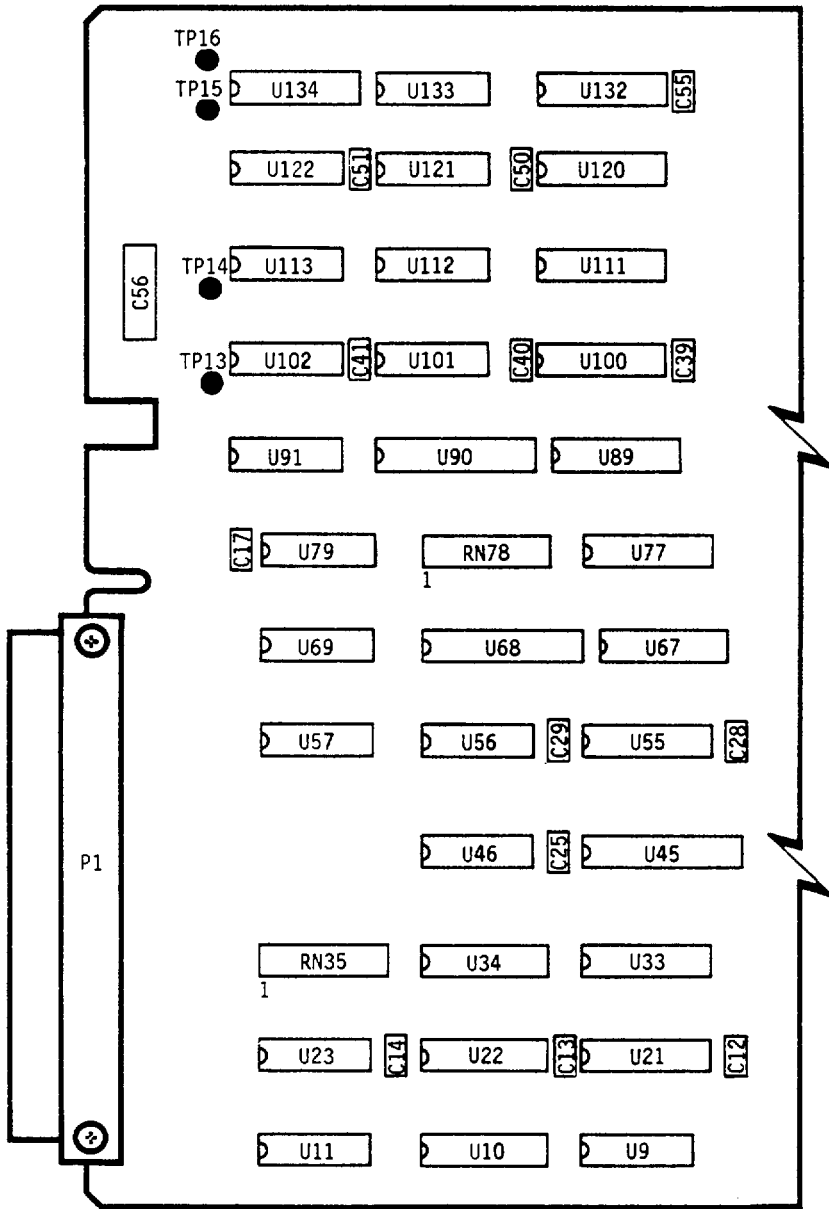

REF DES	ITEM NO	REF DES	ITEM NO
U9	1	U120	14
U10	7	U121	10
U11	8	U122	11
U21	13	U132	14
U22	14	U133	1
U23	8	U134	27
U33	14	C12	38
U34	14	C13	38
U45	19	C14	38
U46	20	C17	38
U55	7	C25	38
U56	20	C28	38
U57	20	C29	38
U67	22	C39	38
U68	25	C40	38
U69	8	C41	38
U77	7	C50	38
U79	8	C51	38
U89	13	C55	38
U90	15	C56	39
U91	28	TP13	40
U100	22	TP14	40
U101	11	TP15	40
U102	1	TP16	40
U111	7	P1	42
U112	3	RN35	46
U113	2	RN78	46

EL8XA014

Figure 4. Circuit Card Assembly, Input/Output (A3) (Sheet 2 of 5)

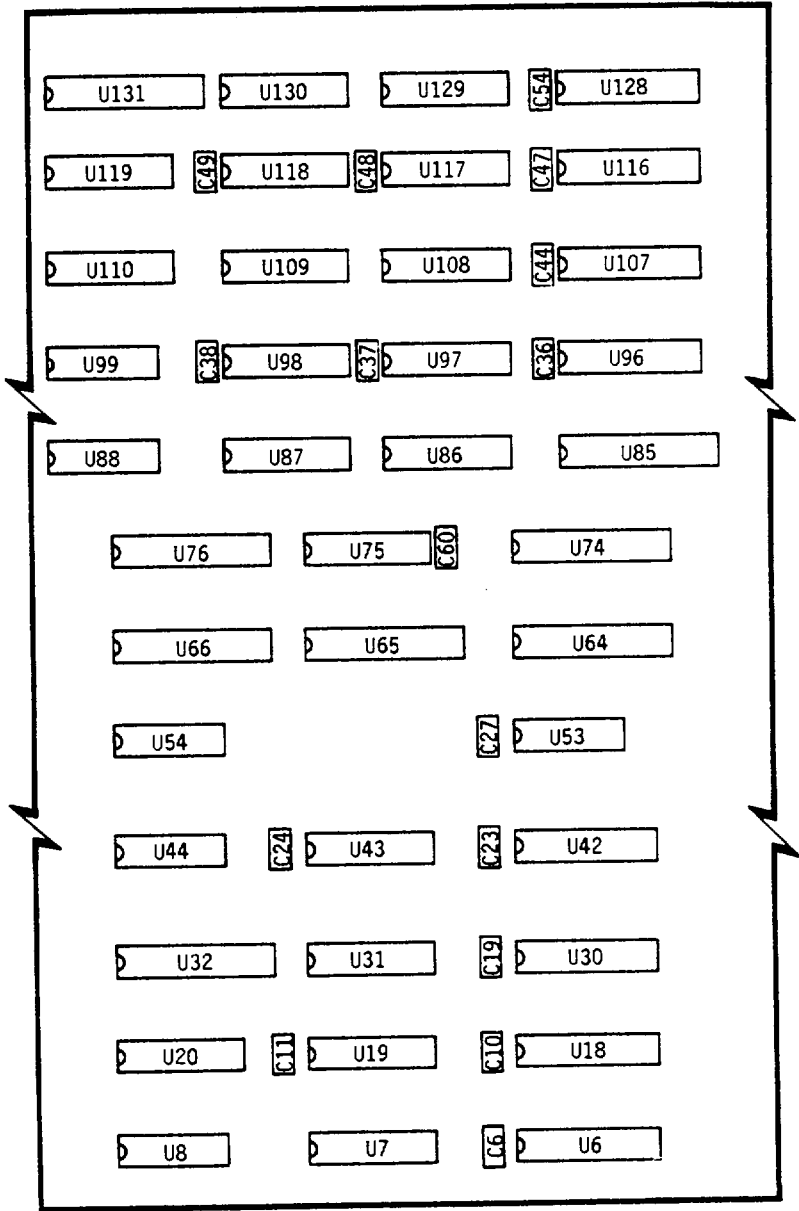

REF DES	ITEM NO	REF DES	ITEM NO
U6	6	U107	6
U7	7	U108	7
U8	2	U109	14
U18	6	U110	7
U19	7	U116	6
U20	7	U117	7
U30	6	U118	14
U31	7	U119	13
U32	15	U128	5
U42	6	U129	7
U43	7	U130	14
U44	18	U131	34
U53	23	C6	38
U54	23	C10	38
U64	21	C11	38
U65	15	C19	38
U66	21	C23	38
U74	15	C24	38
U75	22	C27	33
U76	21	C36	38
U85	15	C37	38
U86	22	C38	38
U87	7	C44	38
U88	18	C47	38
U96	6	C48	38
U97	7	C49	38
U98	14	C54	38
U99	1	C60	35

EL8XA015

Figure 4. Circuit Card Assembly, Input/Output (A3) (Sheet 3 of 5)

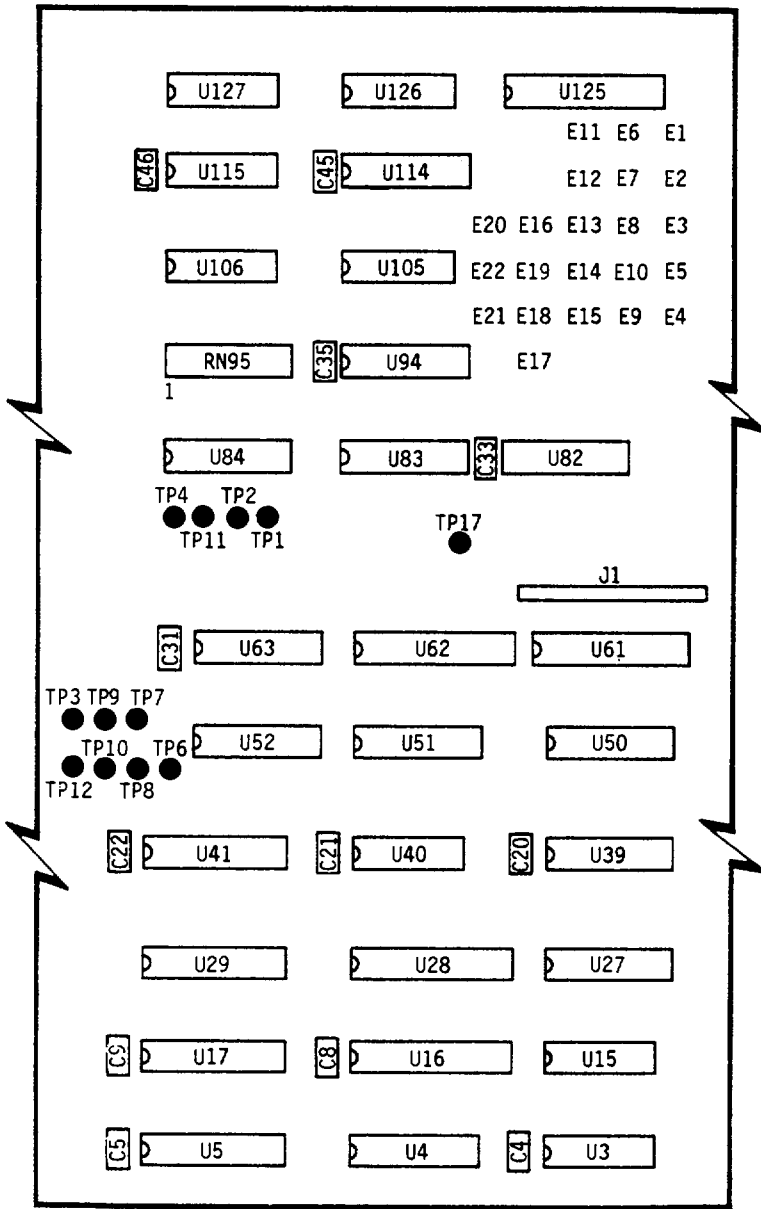

REF DES	ITEM NO	REF DES	ITEM NO
U3	3	U127	10
U4	4	C4	38
U5	5	C5	38
U15	10	C8	38
U16	12	C9	38
U17	5	C20	38
U27	7	C21	38
U28	15	C22	38
U29	6	C31	38
U39	7	C33	38
U40	10	C35	38
U41	6	C45	38
U50	7	C46	38
U51	7	TP1	40
U52	22	TP2	40
U61	15	TP3	40
U62	21	TP4	40
U63	4	TP6	40
U82	4	TP7	40
U83	27	TP8	40
U84	4	TP9	40
U94	27	TP10	40
U105	3	TP11	40
U106	3	TP12	40
U114	27	TP17	40
U115	2	J1	41
U125	33	RN95	47
U126	10		

EL8XA016

Figure 4. Circuit Card Assembly, Input/Output (A3) (Sheet 4 of 5)

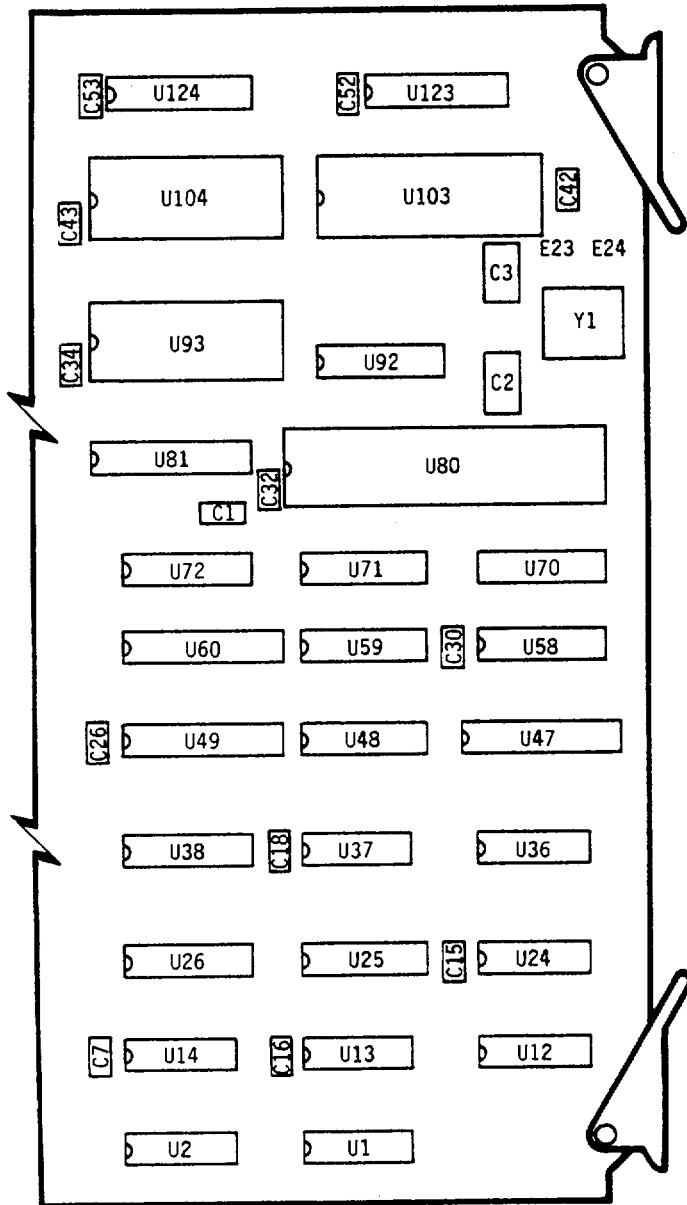

REF DES	ITEM NO	REF DES	ITEM NO
U1	1	U92	29
U2	2	U93	30
U12	9	U103	31
U13	10	U104	32
U14	11	U123	5
U24	3	U124	5
U25	14	C1	35
U26	7	C2	36
U36	11	C3	37
U37	16	C7	38
U38	17	C15	38
U47	15	C16	38
U48	7	C18	38
U49	21	C26	38
U58	7	C30	38
U59	24	C32	38
U60	15	C34	38
U70	7	C42	38
U71	14	C43	38
U72	17	C52	38
U80	26	C53	38
U81	25	Y1	48

EL8XA017

Figure 4. Circuit Card Assembly, Input/Output (A3) (Sheet 5 of 5)

(1) ILLUSTRATION		(2)	(3)	(4)	(5)	(6)	(7)	(8)
(a) FIG NO.	(b) ITEM NO.	SMR CODE	NATIONAL STOCK NUMBER	FSCM	PART NUMBER	DESCRIPTION USABLE ON CODE	U/M	QTY INC IN UNIT
						GROUP 03 INPUT-OUTPUT CIRCUIT CARD ASSEMBL		
4	1	PGDZZ	5962-01-041-3214	81349	M38510/30502BCB	MICROCIRCUIT, DIGITA.....	EA	5
4	2	PGDZZ	5962-01-027-6863	81349	M38510/30003BCB	MICROCIRCUIT, DIGITA.....	EA	4
4	3	PGDZZ	5962-01-031-1918	81349	M38510/30501BCB	MICROCIRCUIT, DIGITA.....	EA	5
4	4	PGDZZ	5962-01-074-8876	81349	M38510/32203BEB	MICROCIRCUIT, DIGITA.....	EA	4
4	5	PGDZZ	5962-01-129-1910	34649	MD2114A-5/8	MICROCIRCUIT, DIGITA.....	EA	5
4	6	PADZZ		81349	M38510/23803BCB	MICROCIRCUIT.....	EA	9
4	7	PADZZ	5962-01-069-2637	27014	M38510/31512BEB	MICROCIRCUIT, DIGITA.....	EA	23
4	8	PGDZZ	5962-00-621-7201	81349	938510/10401BEB	INTEGRATED CIRCUIT.....	EA	4
4	9	PGDZZ	5962-01-043-3941	81349	M38510/07501BCB	MICROCIRCUIT, DIGITA.....	EA	1
4	10	PGDZZ	5962-01-031-7030	81349	M38510130001BCB	MICROCIRCUIT, DIGITA.....	EA	6
4	11	PGDZZ	5962-01-034-9832	81349	M38510/31004BCB	MICROCIRCUIT, DIGITA.....	EA	4
4	12	PADZZ		80063	SM-A-986473-00	MICROCIRCUIT.....	EA	1
4	13	PGDZZ	5962-01-050-0921	81349	M38510/30903BE8	MICROCIRCUIT, DIGITA.....	EA	2
4	14	PGDZZ	5962-01-084-7398	01295	SNC54L5378J	MICROCIRCUIT, DIGITA.....	EA	11
4	15	PADZZ	5962-01-102-8671	81349	M38510/32504BRB	MICROCIRCUIT, DIGITA.....	EA	9
4	16	PGDZZ	5962-01-039-6395	81349	M38510/303018BCB	MICROCIRCUIT, DIGITA.....	EA	1
4	17	PGDZZ	5962-01-050-0920	81349	M38510/30901BEB	MICROCIRCUIT, DIGITA.....	EA	2
4	18	PGDZZ	5962-01-035-7479	81349	M38510/30401BCB	MICROCIRCUIT, DIGITA.....	EA	2
4	19	PGDZZ	5962-01-080-6210	34335	SN54S240J8	INTEGRATED CIRCUIT.....	EA	1
4	20	PGDZZ	5962-00-570-5909	01295	SNC55109AJ	MICROCIRCUIT, LINEAR.....	EA	3
4	21	PGDZZ	5962-01-093-8823	81349	M38510132401BRB	MICROCIRCUIT, DIGIT.....	EA	5
4	22	PGDZZ	5962-01-051-3402	81349	M38510130109BEB	MICROCIRCUIT, DIGITA.....	EA	5
4	23	PGDZZ	5962-01-091-0557	81349	M38510/32702BCB	MICROCIRCUIT, DIGITA.....	EA	2
4	24	PGDZZ	5962-01-086-0458	01295	SNC54LS669J	MICROCIRCUIT, DIGITA.....	EA	1
4	25	PGDZZ	5962-01-110-2679	81349	M38510/32803BRB	MICROCIRCUIT, DIGITA.....	EA	2
4	26	PADZZ		34649	MD8035L/B	MICROCIRCUIT.....	EA	1
4	27	PGDZZ	5962-01-092-6229	81349	M38510/32601BEB	MICROCIRCUIT, DIGITA.....	EA	4
4	28	PADZZ		32440	TTLDL-1000M	DELAY LINE, DIGITAL.....	EA	1
4	29	PGDZZ	5962-01-101-7969	81349	M38510/31604BEB	MICROCIRCUIT, DIGITA.....	EA	1
4	30	PADZZ		80063	SM-A-986461-00	MICROCIRCUIT.....	EA	1
4	31	PADZZ		80063	SM-A-986474-00	MICROCIRCUIT.....	EA	1
4	32	PADZZ		80063	SM-A-986474-01	MICROCIRCUIT.....	EA	1
4	33	PGDZZ	5962-01-107-6934	81349	M38510/32502BRB	MICROCIRCUIT, DIGITA.....	EA	1
4	34	PADZZ		80063	SM-A-986472-00	MICROCIRCUIT.....	EA	1
4	35	PADZZ	5910-00-007-2002	81349	M39003/01-3003	CAPACITOR, FIXED, ELE.....	EA	1
4	36	PADZZ	5910-01-047-7866	81349	CMR04CD50DDDP	CAPACITOR, FIXED, MIC.....	EA	1
4	37	PADZZ	5910-01-064-9674	81349	CMR04E200JDDR	CAPACITOR, FIXED, MIC.....	EA	1
4	38	PADZZ	5910-01-119-7435	81349	M39014-22-0494	CAPACITOR, FIXED, CER.....	EA	45
4	39	PADZZ	5910-00-464-9812	81349	M39003/01-2497	CAPACITOR, FIXED, ELE.....	EA	2

SECTION II

TM 11-5895-1179-23P / EE132 - EA- PLO-010/E106 KY883 / TO 31S1-2GSC-164

(1) ILLUSTRATION		(2)	(3)	(4)	(5)	(6)	(7)	(8)
(a) FIG NO.	(b) ITEM NO.	SMR CODE	NATIONAL STOCK NUMBER	FSCM	PART NUMBER	DESCRIPTION USABLE ON CODE	U/M	QTY INC IN UNIT
4	40	PADZZ	5940-00-082-5094	81349	M55155-30-5	TERMINAL, STUD	EA	16
4	41	PADZZ		95354	1100-1-112-02-09	CONNECTOR, HEADER	EA	1
4	42	PADZZ			00-8257-096-000-911	CONNECTOR, PLUG	EA	1
4	43	PADZZ	5305-00-054-5640	91662	96906 MS51957-6	SCREW, MACHINE	EA	2
4	44	PAOZZ	5310-00-043-4708	13499	310-0740-080	WASHER, FLAT	EA	2
4	45	PAOZZ	5310-00-058-1823	96906	MS21042-02	NUT, SELF-LOCKING, EX	EA	2
4	46	PADZZ	5905-01-122-4151	81349	M8340102M39R0GB	RESISTOR NETWORK, FI	EA	2
4	47	PADZZ		81349	M8340102M1801GB	RESISTOR NETWORK	EA	1
4	40	PADZZ		81349	CR64/U-6.000MHZ	OSCILLATOR, CRYSTAL	EA	1
4	49	PAFZZ	5999-01-092-9318	18677	2S08	RETAINER-EJECTOR, EL	EA	1
4	50	PAFZZ	5999-01-163-9049	18677	S-208-3	RETAINER-EJECTOR, EL	EA	1
4	51	XADZZ		80063	SN-D-986491	PRINTED WIRING BD	EA	1
22/(23 BLANK)								

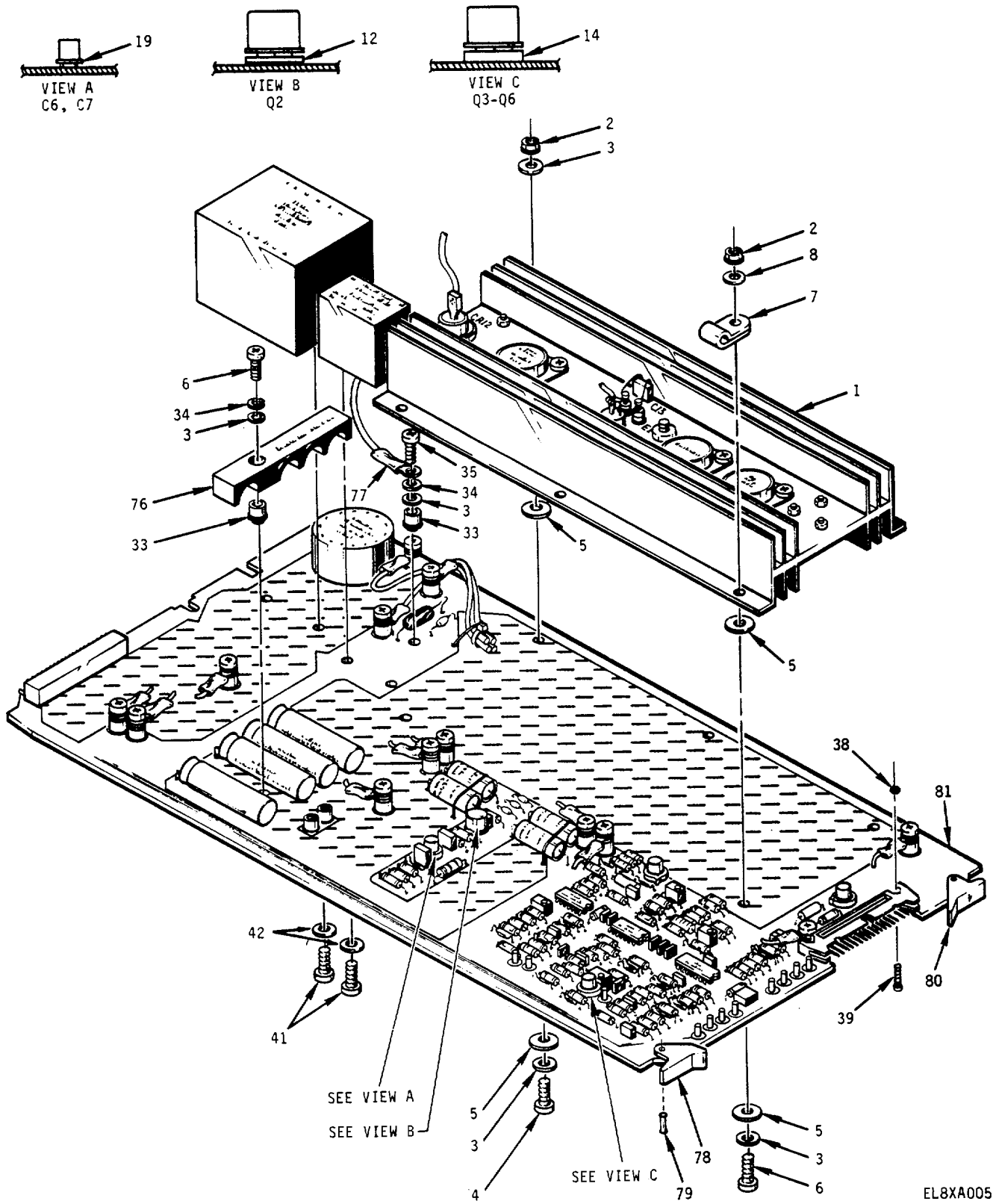
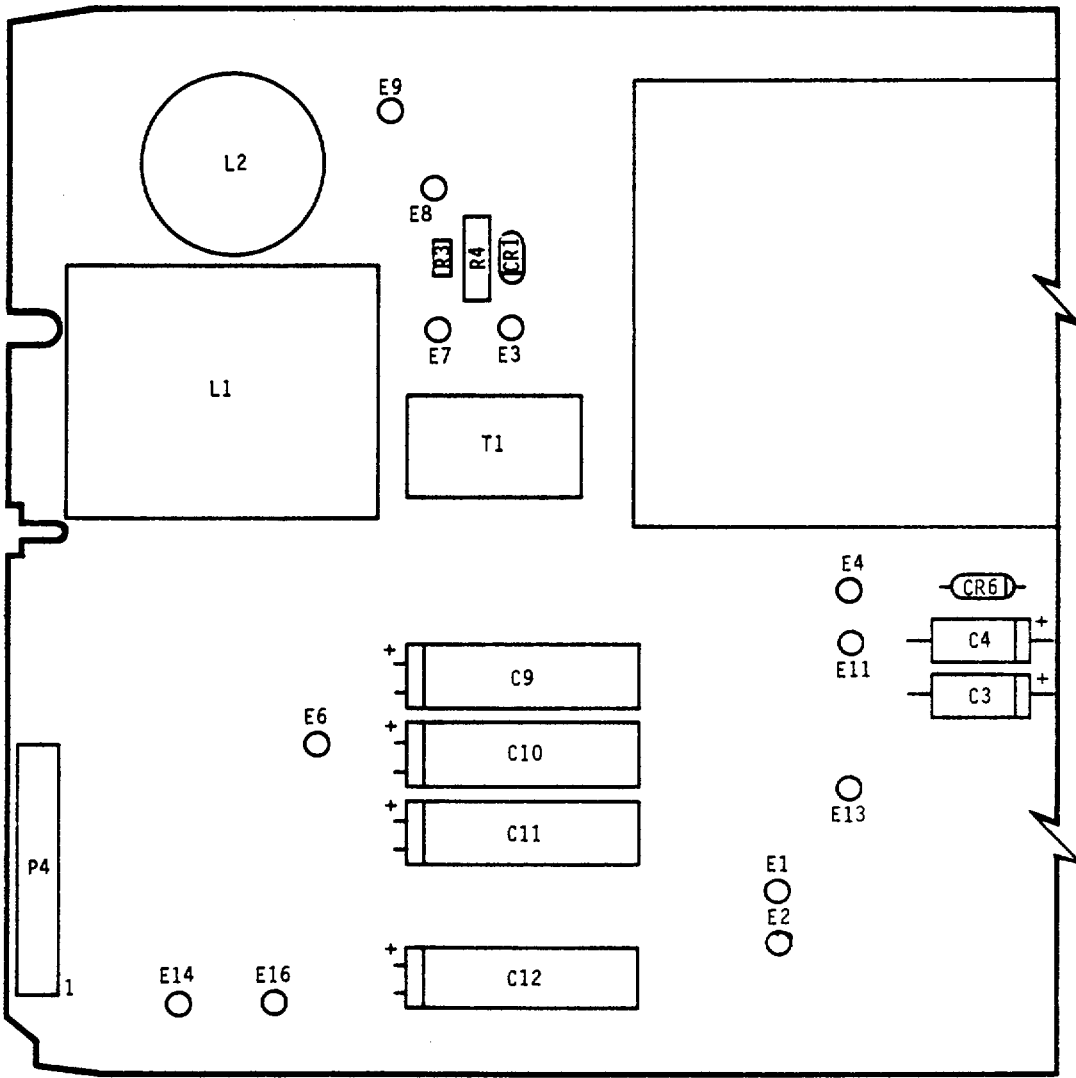

Figure 5. Circuit Card Assembly, Power Supply (A4) (Sheet 1 of 5)



REF DES	ITEM NO
C3	16
C4	16
C9	22
C10	22
C11	22
C12	22
CR1	28
CR6	30
E1	33
E2	33
E3	33
E4	33
E6	33
E7	33
E8	33
E9	33
E11	33
E13	33
E14	33
E16	33
L1	40
L2	43
P4	44
R3	46
R4	47
T1	75

EL8XA021

Figure 5. Circuit Card Assembly, Power Supply (A4) (Sheet 2 of 5)

REF DES	ITEM NO	REF DES	ITEM NO
U3	10	E10	33
Q2	11	E18	36
Q3	13	R2	45
C1	16	R5	48
C2	16	R6	49
C5	17	R7	50
C6	18	R8	51
C7	20	R9	52
C20	25	R10	53
CR4	29	R23	61
CR5	29	R24	50
CR7	29	R25	55
CR8	29	R33	65
CR9	29	R34	58
CR10	30	R35	50
CR11	30	R36	64
CR19	30	R37	66
CR30	30	R38	67
CR32	30	R53	58
CR42	30	R57	58
E5	33	R81	64

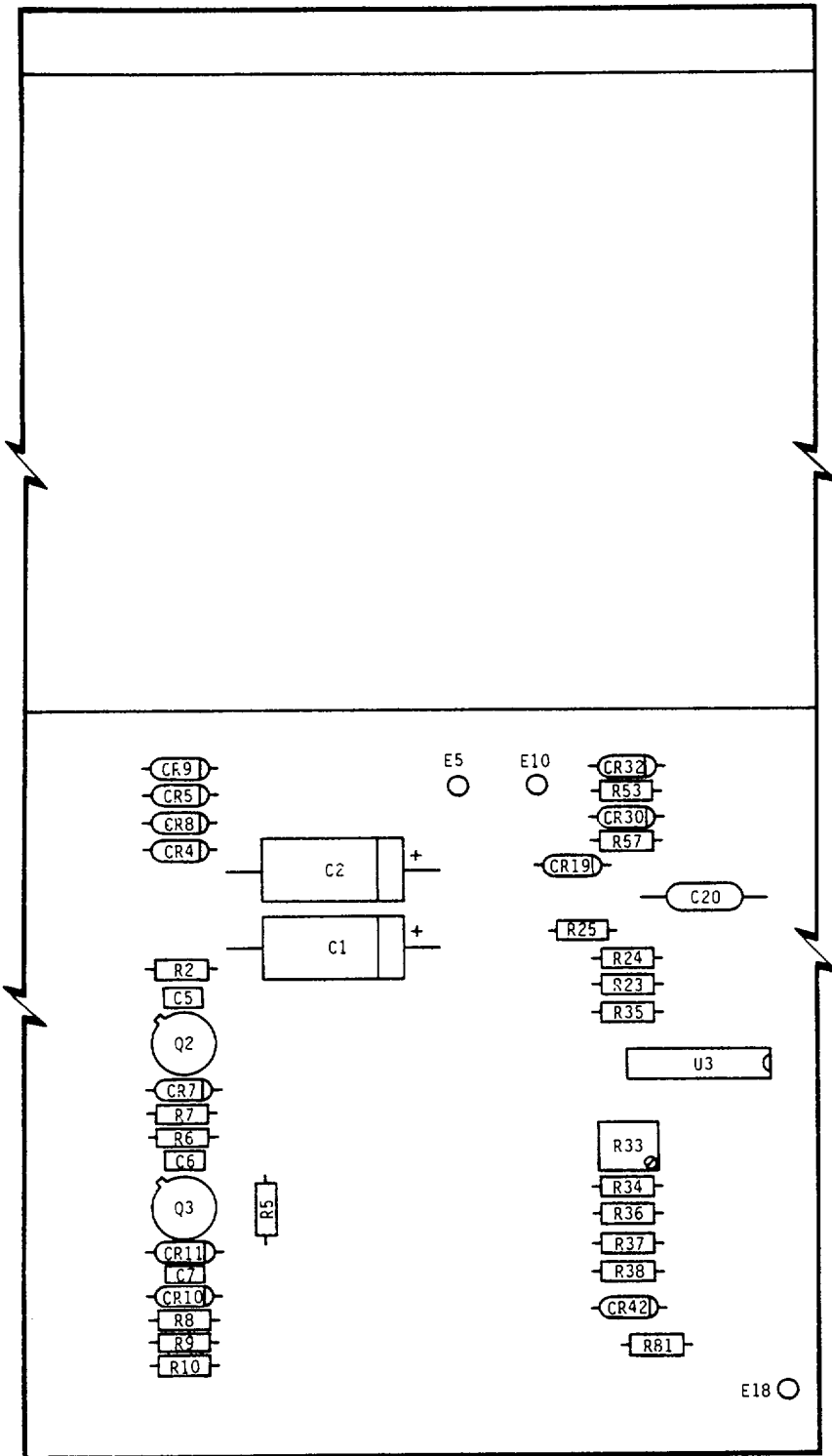

EL8XA022

Figure 5. Circuit Card Assembly, Power Supply (A4) (Sheet 3 of 5)

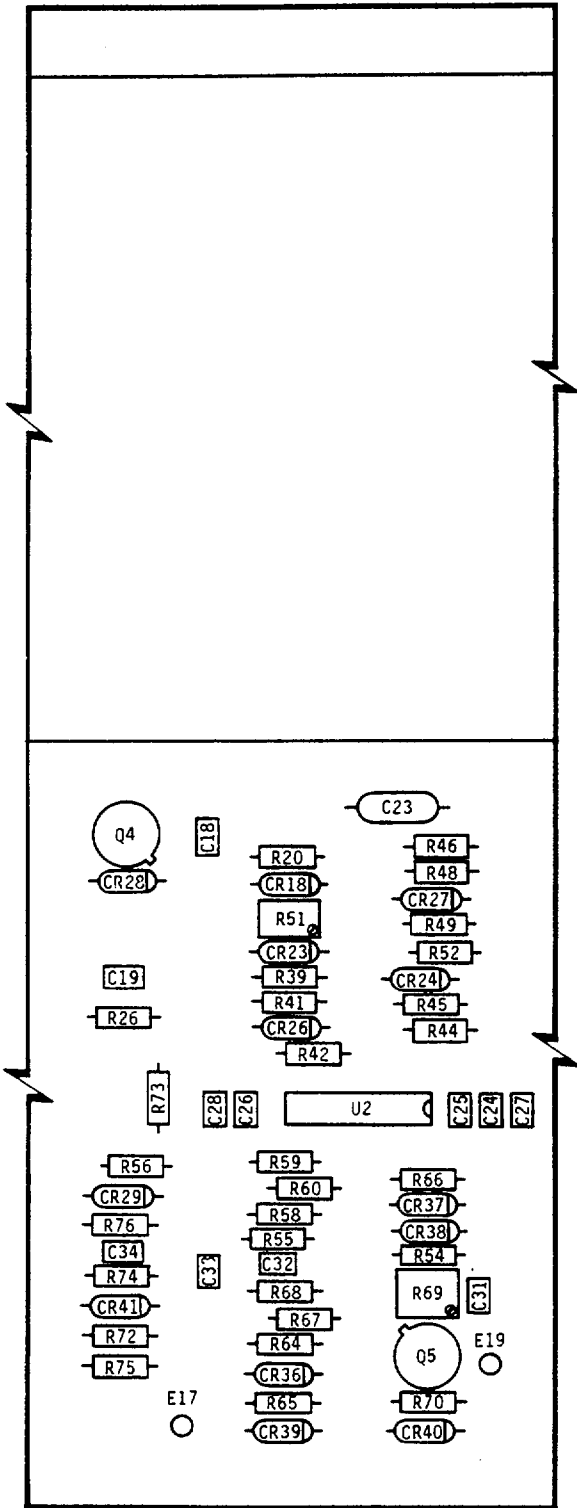

REF DES	ITEM NO	REF DES	ITEM NO
U2	9	R20	59
Q4	13	R26	62
Q5	15	R39	58
C18	17	R41	55
C19	17	R42	57
C23	25	R44	58
C24	23	R45	68
C25	26	R46	55
C26	26	R48	64
C27	27	R49	56
C28	17	R51	69
C31	23	R52	64
C32	17	R54	52
C33	23	R55	70
C34	17	R56	58
CR18	31	R58	71
CR23	30	R59	53
CR24	32	R60	72
CR26	30	R64	64
CR27	30	R65	64
CR28	30	R66	55
CR29	30	R67	50
CR36	30	R68	72
CR37	30	R69	73
CR38	30	R70	74
CR39	30	R72	70
CR40	30	R73	70
CR41	30	R74	55
E17	36	R75	46
E19	36	R76	71

EL8XA023

Figure 5. Circuit Card Assembly, Power Supply (A4) (Sheet 4 of 5)

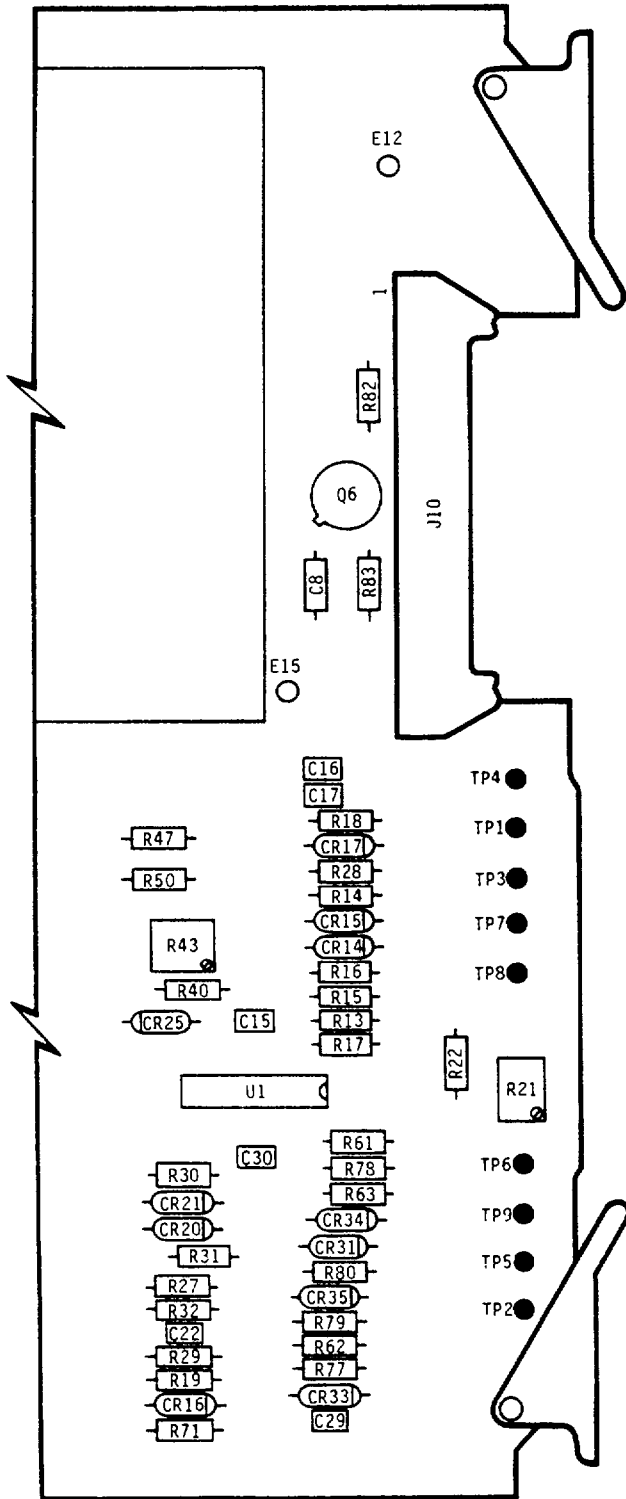

REF DES	ITEM NO	REF DES	ITEM NO
U1	9	R22	53
Q6	13	R27	63
C8	21	R28	64
C15	23	R29	64
C16	23	R30	64
C17	24	R31	55
C22	17	R32	52
C29	17	R40	58
C30	23	R43	65
CR14	30	R47	58
CR15	30	R50	52
CR16	30	R61	70
CR17	30	R62	70
CR20	30	R63	55
CR21	30	R71	64
CR25	30	R77	58
CR31	30	R78	70
CR33	30	R79	71
CR34	30	R80	64
CR35	30	R82	50
E12	33	R83	53
E15	33	TP1	36
J10	37	TP2	36
R13	54	TP3	36
R14	55	TP4	36
R15	56	TP5	36
R16	57	TP6	36
R17	54	TP7	36
R18	54	TP8	36
R19	58	TP9	36
R21	60		

EL8XA024

Figure 5. Circuit Card Assembly, Power Supply (A4) (Sheet 5 of 5)

(1) ILLUSTRATION		(2)	(3)	(4)	(5)	(6)	(7)	(8)
(a) FIG NO.	(b) ITEM NO.	SMR CODE	NATIONAL STOCK NUMBER	FSCM	PART NUMBER	DESCRIPTION USABLE ON CODE	U/M	QTY INC IN UNIT
						GROUP 04 POWER SUPPLY CIRCUIT CARD ASSEMBL		
5	1	PADZZ	5999-01-155-1422	80063	SH-0-882514	HEAT SINK ASSEMBLY.....	EA	1
5	2	PADZZ	5310-00-878-3291	96906	MS21043-06	NUT, SELF-LOCKING, EX.....	EA	6
5	3	PAFZZ	5310-00-773-7624	08226	REW620-6	WASHERFLAT	EA	4
5	4	PADZZ	5305-00-054-6653	96906	MS51957-29	SCREW, MACHINE	EA	5
5	5	PADZZ	5970-00-177-1405	80205	8AS549FL6	INSULATOR, WASHER	EA	12
5	6	PADZZ	5305-00-054-6655	96906	MS51957-31	SCREW, MACHINE	EA	1
5	7	PADZZ	5340-00-753-3456	96906	MS25281R2	CLAMP, LOOP	EA	1
5	8	PADZZ	5310-00-773-7624	08225	REW620-6	WASHER, FLAT	EA	11
5	9	PADZZ		34335	LM139D/883B	MICROCIRCUIT, LINEAR.....	EA	2
5	10	PADZZ	5962-01-086-6681	27014	LM747J/8838	MICROCIRCUIT, LINEAR.....	EA	1
5	11	PADZZ	5961-00-014-6458	81349	JAN2N3498	TRANSISTOR.....	EA	1
5	12	PADZZ	5999-00-349-7432	13103	7717-79N	MOUNTING PAD, ELECTR.....	EA	1
5	13	PADZZ	5961-00-951-8757	81349	JAN2N2222A	TRANSISTOR	EA	3
5	14	XDDZZ	5999-01-076-9605	13103	7717-139N	MOUNTING PAD, ELECTR.....	EA	4
5	15	PADZZ	5961-00-925-3777	81349	JAN2N2907A	TRANSISTOR	EA	1
5	16	PADZZ	5910-01-047-6273	56289	109D227X9060T2	CAPACITOR, FIXED, ELE.....	EA	4
5	17	PADZZ	5910-00-010-8666	81349	M39014/01-1357	CAPACITOR, FIXED, CER	EA	8
5	18	PADZZ	5910-00-113-5499	81349	439014/02-1350	CAPACITOR, FIXED, CER	EA	1
5	19	PADZZ	5999-00-138-1522	32559	302-200	MOUNTING PAD, ELECTR.....	EA	2
5	20	PADZZ	5910-00-115-8456	81349	M39014-02-1258	CAPACITOR, FIXED, CER	EA	1
5	21	PADZZ	5910-00-236-8740	81349	M39003/01-2974	CAPACITOR, FIXED, ELE.....	EA	1
5	22	PADZZ	5910-01-072-3855	56289	6720567H020055C	CAPACITOR, FIXED, ELE.....	EA	4
5	23	PADZZ	5910-00-096-4644	81349	439014/01-1330	CAPACITOR, FIXED, ECE.....	EA	6
5	24	PADZZ	5910-00-096-5160	81349	M39014/01-1359	CAPACITOR, FIXED, CER	EA	1
5	25	PADZZ	5910-00-420-8555	81349	M39003/01-3082	CAPACITOR, FIXED, ELE.....	EA	2
5	26	PADZZ	5910-00-112-433T	81349	M39014/01-1321	CAPACITOR, FIXED, CER	EA	2
5	27	PADZZ	5910-00-113-5445	81349	M39014/01-1339	CAPACITOR, FIXED, CER	EA	1
5	28	PADZZ	5961-01-006-0215	81349	JANIN817	SEMICONDUCTOR DEV	EA	1
5	29	PADZZ	5961-00-565-5092	81349	JANIN4942	SEMICONDUCTOR DEVIC.....	EA	5
5	30	PADZZ	5961-01-038-6918	81349	JANIN4148-1	SEMICONDUCTOR DEVIC.....	EA	29
5	31	PADZZ	5961-00-081-6103	81349	JANIN823	SEMICONDUCTOR	EA	1
5	32	PADZZ	5961-00-821-2309	81349	JANIN751A	SEMICONDUCTOR DEVI.....	EA	1
5	33	PADZZ		88245	81530-8-3/16-11	SPACER, SLEEVE	EA	17
5	34	PADZZ	5310-00-929-6395	96906	MS35338-136	WASHER, LOCK	EA	1
5	35	PADZZ	5305-00-054-6650	96906	MS55957-26	SCREW, MACHINE	EA	14
5	36	PADZZ	5940-00-901-2040	88245	4521C	TERMINAL, STUD	EA	12
5	37	PADZZ	5935-00-517-8520	30142	3431-1003	CONNECTOR, RECEPTACL	EA	1
5	38	PADZZ	5310-00-938-2013	96906	MS35649-224	NUT, PLAIN, HEXAGON	EA	2
5	39	PADZZ	5305-00-054-5639	96906	MS51957-5	SCREW, MACHINE	EA	2

(1) ILLUSTRATION		(2)	(3)	(4)	(5)	(6)	(7)	(8)
(a) FIG NO.	(b) ITEM NO.	SMR CODE	NATIONAL STOCK NUMBER	FSCM	PART NUMBER	DESCRIPTION USABLE ON CODE	U/M	QTY INC IN UNIT
5	40	PADZZ	5950-01-041-6787	11627	12123	CHOKE, RADIO FREQUEN	EA	1
5	41	PADZZ	5305-00-054-5653	96906	MS51957-19	SCREW, MACHINE	EA	2
5	42	PADZZ	5970-00-827-2110	80205	NAS549FL4	INSULATOR, WASHER	EA	4
5	43	PADZZ	5950-01-045-3441	11627	12122	REACTOR	EA	1
5	44	PADZZ	5935-00-177-2017	81349	M55302/7-04	ADAPTER, CONNECTOR	EA	1
5	45	PADZZ	5905-00-141-0598	81349	RCR20G561JS	RESISTOR, FIXED, COMP	EA	1
5	46	PADZZ	5961-01-148-8413	16845	1000-409-16	TRANSISTOR	EA	2
5	47	PADZZ		91637	NS28.05/3PCT	RESISTOR	EA	1
5	48	PADZZ	5905-00-111-4738	81349	RCR20GL52JS	RESISTOR, FIXED, COMP	EA	1
5	49	PADZZ	5905-00-119-8811	81349	M39016/9-013L	RESISTOR, FIXED, COMP	EA	1
5	50	PADZZ	5905-00-110-7620	81349	RCR07G102JS	RESISTOR, FIXED, COMP	EA	5
5	51	PADZZ	5905-00-106-1278	81349	RCR07G123JS	RESISTOR, FIXED, COMP	EA	1
5	52	PADZZ	5905-00-114-0711	81349	RCR07G472JS	RESISTOR, FIXED, COMP	EA	4
5	53	PADZZ	5905-00-105-7764	81349	RCR07G222JS	RESISTOR, FIXED, COMP	EA	4
5	54	PADZZ	5905-00-110-0388	81349	RCR07G104JS	RESISTOR, FIXED, COMP	EA	3
5	55	PADZZ	5905-00-116-8555	81349	RCR07G153JS	RESISTOR, FIXED, COMP	EA	8
5	56	PADZZ	5905-00-119-3504	81349	RCR07G273JS	RESISTOR, FIXED, COMP	EA	2
5	57	PADZZ	5905-00-115-3560	81349	RCR07G183JS	RESISTOR, FIXED, COMP	EA	2
5	58	PADZZ	5905-01-149-5107	16845	1000-483-23	RESISTOR, FIXED	EA	10
5	59	PADZZ	5905-00-141-0593	81349	RCR20G182JS	RESISTOR, FIXED, COMP	EA	1
5	60	PADZZ	5905-01-090-5259	81349	RJR26FP202P	RESISTOR, VARIABLE	EA	1
5	61	PADZZ	5905-00-111-4727	81349	RCR07G272JS	RESISTOR, FIXED, COMP	EA	1
5	62	PADZZ	5905-00-114-5344	81349	RCR0G184JS	RESISTOR, FIXED, COMP	EA	1
5	63	PADZZ	5905-00-136-8406	81349	RCR07G242JS	RESISTOR, FIXED, COMP	EA	1
5	64	PADZZ	5905-00-141-0717	81349	RCR07G473JS	RESISTOR, FIXED, COMP	EA	11
5	65	PADZZ	5905-01-047-5172	81349	RJR26FWI03P	RESISTOR, VARIABLE	EA	2
5	66	PADZZ	5905-00-116-8554	81349	RCR07G105JS	RESISTOR, FIXED, COMP	EA	1
5	67	PADZZ	5905-00-116-8556	81349	RCR07G223JS	RESISTOR, FIXED, COMP	EA	1
5	68	PADZZ	5905-00-104-8348	81349	RCR20G332JS	RESISTOR, FIXED, COMP	EA	1
5	69	PADZZ	5905-01-037-4171	81349	RJR26FW202P	RESISTOR, VARIABLE, N	EA	1
5	70	PADZZ	5905-00-110-7622	81349	RCR07G682JS	RESISTOR, FIXED, COMP	EA	6
5	71	PADZZ	5905-00-141-1132	81349	RCR01G752JS	RESISTOR, FIXED, CQMP	EA	3
5	72	PADZZ	5905-00-120-9154	81349	RCR0TG471JS	RESISTOR, FIXED, COMP	EA	2
5	73	PADZZ	5905-01-073-5732	81349	RJR26FW201P	RESISTOR, VARIABLE, N	EA	1
5	74	PADZZ	5961-01-148-8412	16845	1000-409-15	TRANSISTOR	EA	1
5	75	PADZZ	5950-01-046-3846	11627	12124	TRANSFORMER, PULSE	EA	1
5	76	PADZZ		80063	SM-D-882520	STRAP, RETAINING	EA	1
5	77	PADZZ	5940-00-283-5280	96906	MS25036-106	TERMINAL, LUG	EA	1
5	78	PAFZZ	5999-01-092-9318	18677	S208	RETAINER-EJECTOR, EL	EA	1
5	79	PAFZZ	5315-00-514-6944	96906	MS51923-312	PIN, SPRING	EA	1

SECTION II

TM 11-5895-1179-23P / EE132 - EA- PLO-010/E106 KY883 / TO 31S1-2GSC-164

(1) ILLUSTRATION		(2)	(3)	(4)	(5)	(6)	(7)	(8)
(a) FIG NO.	(b) ITEM NO.	SMR CODE	NATIONAL STOCK NUMBER	FSCM	PART NUMBER	DESCRIPTION USABLE ON CODE	U/M	QTY INC IN UNIT
5 5	80 81	PAFZZ XADZZ		18677 80063	S-208-4 SH-D-882478 31	RETAINER-EJECTOR, EL PRINTED CIRCUIT.....	EA EA	1 1

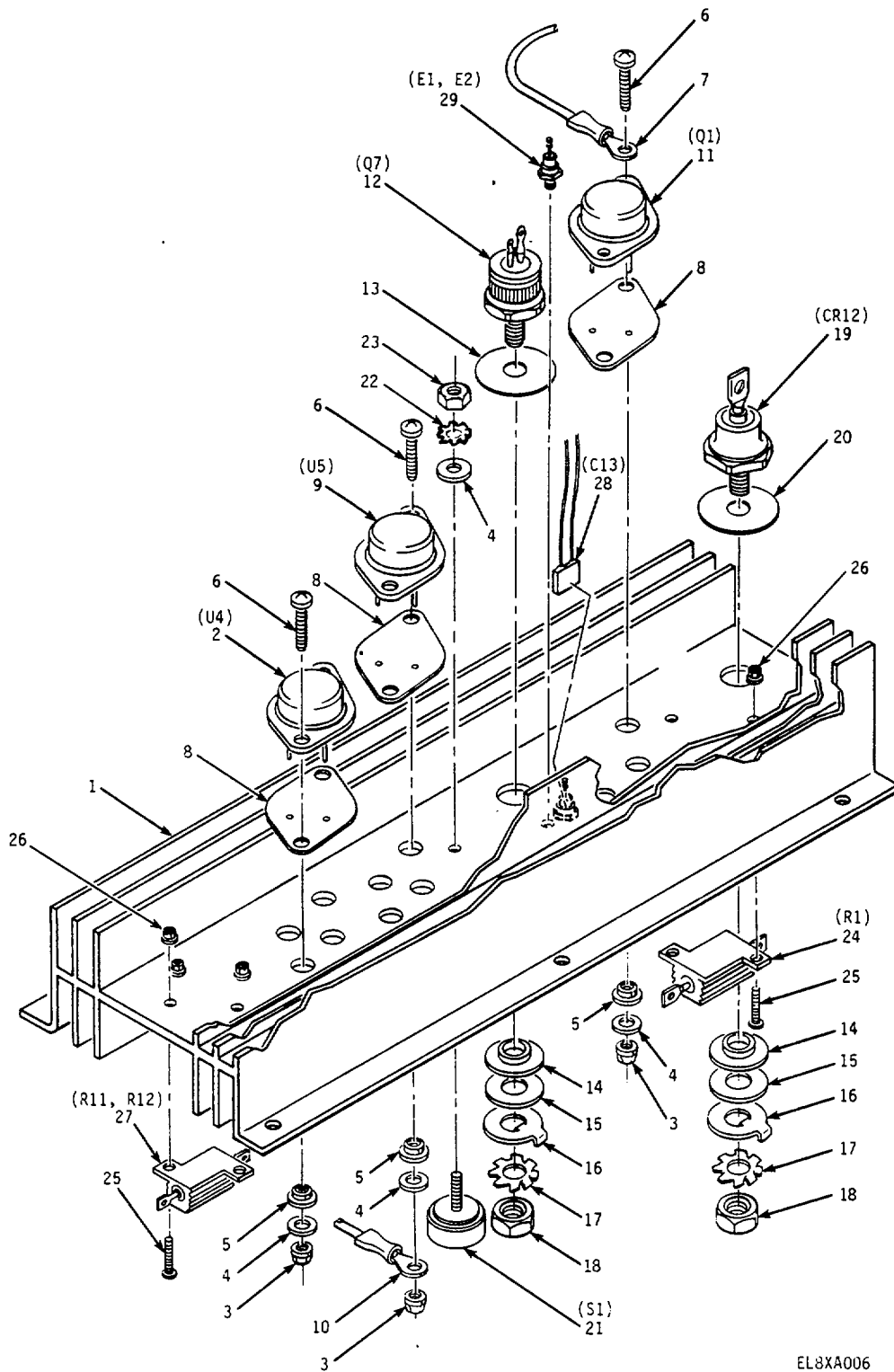
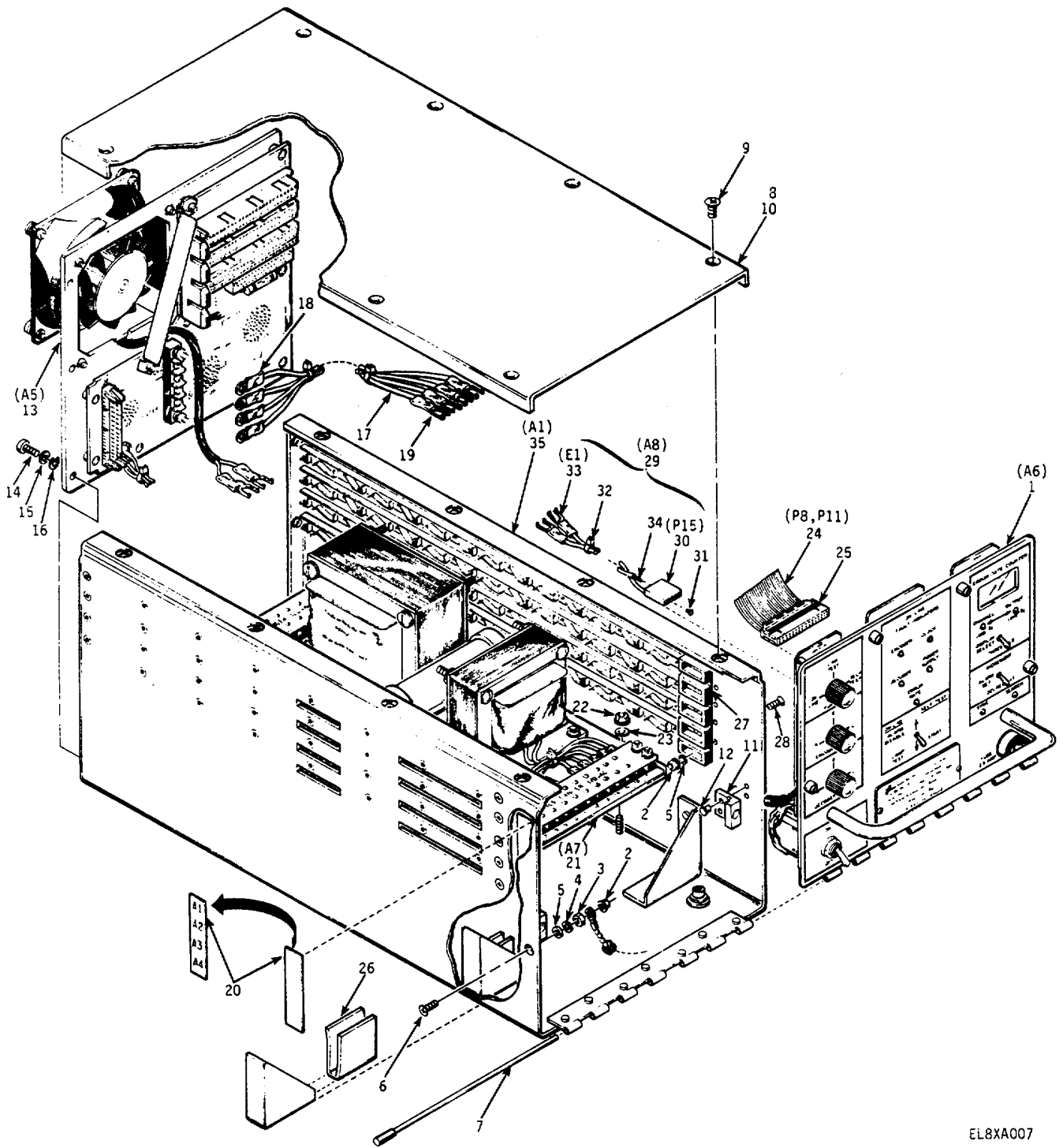

Figure 6. Heat Sink Assembly (A4A1)

SECTION II

(1) ILLUSTRATION		(2)	(3)	(4)	(5)	(6)	(7)	(8)
(a) FIG NO.	(b) ITEM NO.	SMR CODE	NATIONAL STOCK NUMBER	FSCM	PART NUMBER	DESCRIPTION USABLE ON CODE	U/M	QTY INC IN UNIT
						GROUP 0401 HEAT SINK ASSEMBLY		
6	1	XBDZZ		80063	SM-D-882515	HEATSINK SUBASSY	EA	1
6	2	PADZZ	5962-01-086-0286	27014	LM109K-883	MICPOCIRCUIT, LINEAR.....	EA	1
6	3	PAFZZ	5310-00-878-3291	96906	MS21043-06	NUT, SELF-LOCKING, EX.....	EA	2
6	4	PADZZ	5310-00-531-9514	81352	AN960C6	WASHER, FLAT	EA	2
6	5	PADZZ		13103	2660	INSULATOR, WASHER	EA	2
6	6	PADZZ	5305-00-054-6654	96906	MS51957-30	SCREW, MACHINE	EA	2
6	7	PADZZ	5940-00-283-5280	96906	MS25036-106	TERMINAL, LUG.....	EA	7
6	8	PADZZ		13103	43-03-02	INSULATOR, FLEXIBLE.....	EA	3
6	9	PADZZ		27014	LM120K-5.0/883	MICROCIRCUIT.....	EA	1
6	10	PADZZ	5940-00-204-8966	96906	MS25036-102	TERMINAL, LUG.....	EA	9
6	11	PADZZ	5961-00-220-6651	81349	JAN2N5685	TRANSISTOR	EA	1
6	12	PADZZ	5961-01-054-3758	10001	2880595	SEMICONDUCTOR DEVIC.....	EA	1
6	13	PADZZ		86928	5611-78-2	INSULATOR, WASHER	EA	1
6	14	PADZZ	5310-01-134-0759	86928	5607-121	WASHER, SHOULDERED	EA	1
6	15	PADZZ	5310-00-764-9564	80205	NAS620C416L	WASHER, FLAT	EA	1
6	16	PADZZ	5940-00-230-0515	96906	MS25036-154	TERMINAL, LUG.....	EA	2
6	17	PADZZ	5310-00-527-3634	96906	MS35335-61	WASHER, LOCK	EA	1
6	18	PADZZ	5310-00-131-3134	96906	MS25082C4	NUT, PLAIN, HEXAGON	EA	1
6	19	PADZZ	5961-01-055-4348	01281	1N6098	SEMICONDUCTOR DEVIC.....	EA	1
6	20	PADZZ		86928	5611-79-2	INSULATOR, WASHER	EA	1
6	21	PADZZ		14604	3150-23-103	THERMOSTAT	EA	1
6	22	PADZZ	5310-00-209-1366	96906	MS35335-58	WASHER, LOCK	EA	1
6	23	PADZZ	5310-00-934-9761	96906	MS35649-264	NUT, PLAIN, HEXAGON	EA	1
6	24	PADZZ	5905-00-330-0113	81349	RER45F1500R	RESISTOR, FIXED, WIRE.....	EA	1
6	25	PADZZ	5305-00-054-5639	96906	MS51957-5	SCREW, MACHINE	EA	4
6	26	PADZZ	5310-00-813-6950	80205	NAS1291C02M	NUTSELF-LOCKING, EX.....	EA	4
6	27	PADZZ	5905-00-905-7761	81349	RE60G1000	RESISTOR, FIXED, WIRE.....	EA	2
6	28	PADZZ	5910-00-010-8721	81349	M39014/02-1419	CAPACTOR, FIXED, CER.....	EA	1
6	29	PADZZ		88245	1480C-4-11	TERNINAL, FEEDTHRU, E	EA	2



EL8XA007

Figure 7. Chassis Assembly (A8)

SECTION II

TM 11-5895-1179-23P / EE132 - EA- PLO-010/E106 KY883 / TO 31S1-2GSC-164

(1) ILLUSTRATION		(2)	(3)	(4)	(5)	(6)	(7)	(8)
(a) FIG NO.	(b) ITEM NO.	SMR CODE	NATIONAL STOCK NUMBER	FSCM	PART NUMBER	DESCRIPTION USABLE ON CODE	U/M	QTY INC IN UNIT
						GROUP 05 CHASSIS ASSEMBLY		
7	1	XBFFD		80063	SM-D-986481	PANEL ASSY, FRONT	EA	1
7	2	PAFZZ	5310-00-878-3292	96906	MS21043-04	NUT, SELF-LOCKING, EX	EA	5
7	3	PAFZZ	5310-00-203-3786	80205	NAS671C4	NUT, PLAIN, HEXAGON	EA	1
7	4	PAFZZ	5310-00-933-8118	96906	MS35338-135	WASHER, LOCK	EA	1
7	5	PAFZZ	5310-00-057-0573	88769	91921002	WASHER, FLAT	EA	5
7	6	PAFZZ	5305-00-056-9961	96906	MS24693C4	SCREW, MACHINE X 3/8.....	EA	1
7	7	XBZZZ		80063	SM-D-882511	PIN ASSEMBLY, HINGE	EA	1
7	8	XBZZZ		80063	SM-D-882472	COVER ASSEMBLY	EA	1
7	9	PAFZZ	5305-00-066-7328	96906	MS24693C27	SCREW, MACHINE X 7/16.....	EA	8
7	10	XAFZZ		80063	SM-D-882472-1	COVER	EA	1
7	11	PAFZZ		72794	PRB3-1/2	RECEPTACLE, FASTENER	EA	2
7	12	PAFZZ	5320-00-117-6950	96906	MS20426AD4-5	RIVET,SOLID.....	EA	4
7	13	XBFFD		80063	SM-D-986483	PANEL ASSY, REAR.....	EA	1
7	14	PAFZZ	5305-00-054-6652	96906	MS51957-28	SCREW, MACHINE	EA	6
7	15	PAFZZ	5310-00-773-7624	08226	REW620-6	WASHER, FLAT	EA	8
7	16	PAFZZ	5310-00-929-6395	96906	MS35338-136	WASHER, LOCK	EA	14
7	17	XBFFF		80063	SM-D-882523	HARNES ASSEMBLY	EA	1
7	18	PAFZZ	5940-00-283-5280	96906	MS25036-106	TERMINAL, LUG.....	EA	4
7	19	PAFZZ		94983	4916	TERMINAL, LUG.....	EA	4
7	20	XBZZZ		80063	SM-C-882527	PLATE, DESIGNATION.....	EA	1
7	21	PAFDD	5975-01-129-9601	80063	SM-0-882483-1	BOTTOM PANEL ASSEMB.....	EA	1
7	22	PAFZZ	5310-00-167-0801	88044	AN960C10	WASHER, FLAT	EA	5
7	23	PAFZZ	5310-00-844-3302	96906	MS21043-3	NUT, PLAIN, EXTENDED.....	EA	5
7	24	PAFZZ	5995-01-043-9687	80063	SM-D-882521-1	CABLE ASSEMBLY, SPEC	EA	1
7	25	PAFZZ	5935-01-012-1298	75037	3414-6034	CONNECTOR, RECEPTACL	EA	2
7	26	PAFZZ	5340-01-035-4454	30142	3484-1000	CLIP, SPRING TENSION	EA	4
7	27	PAFZZ		80063	SM-D-882487	GUIDE BLOCK.....	EA	2
T	28	PAFZZ	5305-00-225-6400	96906	MS24693C3	SCREWMNACHINE 5/16	EA	5
7	29	PAFZZ	5995-01-042-0222	80063	SM-0-882506	CABLE ASSEMBLY, SPEC	EA	1
7	30	XAFZZ		27264	22-01-2051	CONNECTOR	EA	1
7	31	XAFZZ		27264	15-04-9209	KEY, POLARIZING, ELE	EA	1
7	32	PAFZZ	5975-00-727-5153	59130	TY-23M	STRAP, TIEDOWN, ELECT	EA	3
7	33	PAFZZ		00779	326881	TERMINAL, LUG.....	EA	2
7	34	XAFZZ		27264	08-56-0110	CONTACT, ELECTRICAL	EA	4
T	35	XAFZZ		80063	SM-D-88Z471	CHASSIS SUBASSEMBLY	EA	1

(1) ILLUSTRATION		(2)	(3)	(4)	(5)	(6)	(7)	(8)
(a) FIG NO.	(b) ITEM NO.	SMR CODE	NATIONAL STOCK NUMBER	FSCM	PART NUMBER	DESCRIPTION USABLE ON CODE	U/M	QTY INC IN UNIT
						GROUP 0501 FRONT PANEL ASSEMBLY		
8	1	PAFZZ	5340-01-092-4022	27193	49-4157	COVER	EA	3
8	2	PAOZZ	5355-00-871-6025	81073	33-128	KNOB	EA	3
8	3	PAOZZ	5305-00-576-7266	96906	MS51021-22	SETSCREW	EA	3
8	4	XBFZZ		80063	SM-D-882498	BLOCK ASSEMBLY.....	EA	1
8	5	XAFZZ		80063	SM-D-882498-1	BLOCK, CLAMPING	EA	1
8	6	XBFZZ		80063	SM-D-882498-2	PAD, CLAMPING BLOCK.....	EA	1
8	7	PAFZZ	5305-00-054-5649	96906	MS51957-15	SCREW.MACHINE	EA	2
8	8	PAFZZ	5310-00-057-0573	88769	91921002	WASHER, FLAT	EA	2
8	9	PAFZZ	5310-00-933-8118	96906	MS35338-135	WASHER, LOCK	EA	2
8	10	PAFZZ	5820-01-045-2202	80063	SM-D-882499	RESTRAINT ASSEMBLY	EA	1
8	11	PAFZZ	5310-00-878-3292	96906	MS21043-04	NUT, SELF-LOCKING, EX.....	EA	1
8	12	PAFDD	5999-01-129-1524	80063	SM-D-986489	CIRCUIT CARD ASSEMB.....	EA	1
8	13	PAFZZ	5305-00-054-6651	96906	MS51957-27	SCREW.MACHINE	EA	5
8	14	PAFZZ	5310-00-929-6395	96906	MS35338-136	WASHER, LOCK	EA	5
8	15	PAFZZ	5310-00-773-7624	08226	REW620-6	WASHER, FLAT	EA	5
8	16	PAFZZ	5970-00-177-1405	80205	NAS549FL6	INSULATOR, WASHER	EA	5
8	17	PADZZ		06540	8109-SS-0440-0	POST, ELECTRICAL	EA	2
8	18	XBFFF		80063	SM-D-882497	SWITCH ASSEMBLY	EA	1
8	19	PAFZZ	5930-00-655-4241	96906	MS24524-23	SWITCH, TOGGLE	EA	1
8	20	PAFZZ	5975-00-727-5153	59730	TY-23M	STRAP, TIEDOWN, ELECT	EA	3
8	21	PAFZZ		00779	326881	TERMINAL, LUG.....	EA	2
8	22	PAFZZ	5940-00-204-8966	96906	MS25036-102	TERMINAL, LUG.....	EA	2
8	23	PAFZZ	5940-00-632-7234	75382	600J	BUS, CONDUCTOR	EA	2
8	24	XBFFF		80063	SM-D-882496	FUSEHOLDER ASSEMBLY	EA	1
8	25	PAFZZ	5920-00-881-6584	81349	FHL17G2	FUSEHOLDER, EXTRACTO.....	EA	1
8	26	PAOZZ	5920-00-284-1079	75915	31202.5	FUSE, CARTRIDGE	EA	1
8	27	XRFZZ		06540	10531SS1032	HANDLE, LUGGAGE.....	EA	1
8	28	PAFZZ	5305-00-059-3659	96906	MS51958-63	SCREW, MACHINE	EA	2
8	29	PAFZZ	5310-00-933-8120	96906	MS35338-138	WASHER, LOCK	EA	2
8	30	PAFZZ	5310-00-989-0640	80205	NAS620C10	WASHER, FLAT	EA	2
8	31	XBFZZ		80063	SM-B-699758-L	FILTER ASSEMBLY	EA	1
8	32	XBFZZ		80063	SM-D-986480	PANEL SUBASSY, FRONT.....	EA	1
8	33	XAFZZ		80063	SM-D-986480-1	PANEL, FRONT	EA	1
8	34	PADZZ		96906	MS20257C2-750	HINGE, CONTINUOUS.....	EA	1
8	35	PADZZ	5320-00-117-6949	96906	MS20426AD4-4	RIVET, SOLID.....	EA	8
8	36	PADZZ	5310-01-168-5473	46384	CS0S632-9	NUT, PLAIN, CLINCH.....	EA	5
8	37	PADZZ		72794	PFSC3-1/2-44A	STUD ASSEMBLY	EA	4
8	38	PADZZ	5307-00-996-4438	46384	FHS440-8	STUD, SELF-LOCKING.....	EA	3
8	39	PAFZZ	5975-00-727-5153	59730	TY-23M	STRAP, TIEDOWN, ELECT	EA	3

SECTION II

TM 11-5895-1179-23P / EE132 - EA- PLO-010/E106 KY883 / TO 31S1-2GSC-164

(1) ILLUSTRATION		(2)	(3)	(4)	(5)	(6)	(7)	(8)
(a) FIG NO.	(b) ITEM NO.	SMR CODE	NATIONAL STOCK NUMBER	FSCM	PART NUMBER	USABLE ON CODE	U/M	QTY INC IN UNIT
8	40	PAFZZ		00779	326881	TERMINAL, LUG..... 38/(39 BLANK)	EA	2

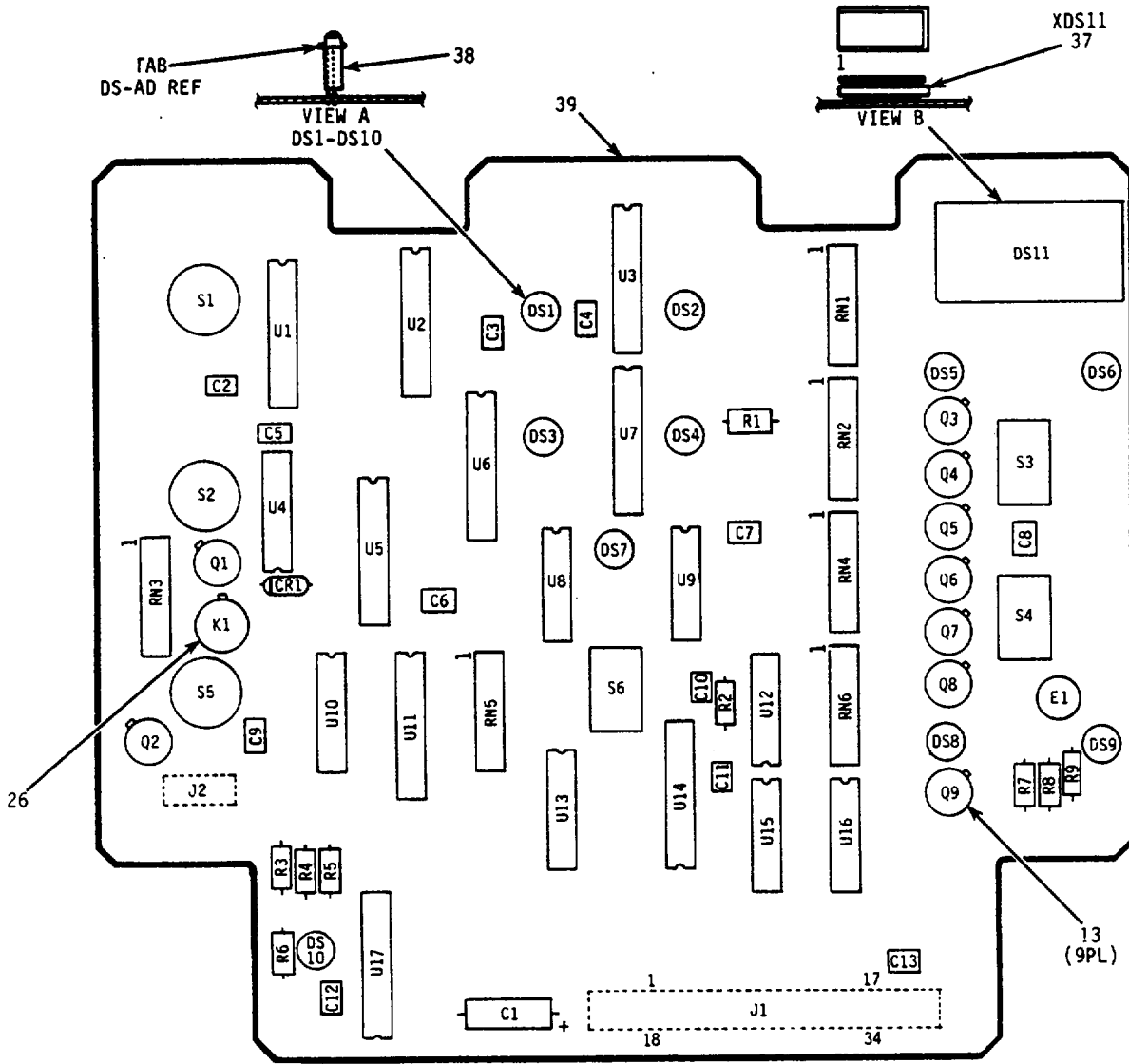

LEGEND

REF DES	ITEM NO	REF DES	ITEM NO	REF DES	ITEM NO	REF DES	ITEM NO	REF DES	ITEM NO	REF DES	ITEM NO	REF DES	ITEM NO
U1	1	U12	8	Q6	14	C8	16	DS5	19	R1	27	RN3	32
U2	2	U13	9	Q7	14	C9	16	DS6	19	R2	28	RN4	32
U3	3	U14	10	Q8	14	C10	16	DS7	18	R3	29	RN5	33
U4	4	U15	11	Q9	14	C11	16	DS8	19	R4	29	RN6	34
U5	2	U16	5	C1	15	C12	16	DS9	20	R5	30	S1	35
U6	2	U17	1	C2	16	C13	16	DS10	19	R6	29	S2	35
U7	3	Q1	12	C3	16	CR1	17	DS11	21	R7	30	S3	36
U8	5	Q2	12	C4	16	DS1	18	E1	22	R8	30	S4	36
U9	6	Q3	14	C5	16	DS2	18	J1	23	R9	30	S5	35
U10	7	Q4	14	C6	16	DS3	18	J2	24	RN1	31	S6	36
U11	3	Q5	14	C7	16	DS4	18	K1	25	RN2	31	XDS11	37

EL8XA009

Figure 9. Circuit Card Assembly, Display/Control (A6A1)

(1) ILLUSTRATION		(2)	(3)	(4)	(5)	(6)	(7)	(8)
(a) FIG NO.	(b) ITEM NO.	SMR CODE	NATIONAL STOCK NUMBER	FSCM	PART NUMBER	DESCRIPTION USABLE ON CODE	U/M	QTY INC IN UNIT
						GROUP 050101 DISPLAY AND CONTROL CIRCUIT CARD ASSEMBLY		
9	1	PGDZZ	5962-01-093-8823	81349	M38510/32401BRB	MICROCIRCUIT, DIGITA.....	EA	2
9	2	PADZZ	5962-01-102-8671	81349	M38510/32504BRB	MICROCIRCUIT, DIGITA.....	EA	3
9	3	PGDZZ	5962-01-080-6210	34335	SN545240JB	INTEGRATED CIRCUIT.....	EA	3
9	4	PGDZZ	5962-01-092-6229	81349	M38510/32601BEB	MICROCIRCUIT, DIGITA.....	EA	1
9	5	PGDZZ	5962-01-026-2489	81349	M38510/07003BCB	MICROCIRCUIT, DIGITA.....	EA	2
9	6	PGDZZ	5962-01-031-1918	81349	M38510/30501BCB	MICROCIRCUIT, DIGITA.....	EA	1
9	7	PGDZZ	5962-01-084-7398	01295	SNC54LS378J	MICROCIRCUIT, DIGITA.....	EA	1
9	8	PGDZZ	5962-01-084-6427	81349	M38510/31403BCB	MICROCIRCUIT, DIGITA.....	EA	1
9	9	PGDZZ	5962-01-069-2610	81349	M38510/30906BEB	MICROCIRCUIT, DIGITA.....	EA	1
9	10	PGDZZ	5962-00-110-2679	81349	M38510/32803BRB	MICROCIRCUIT, DIGITA.....	EA	1
9	11	PGDZZ	5962-01-068-9593	81349	M38510/30605BCB	MICROCIRCUIT, DIGITA.....	EA	1
9	12	PADZZ	5961-00-858-3826	81349	JANTX2N2222A	TRANSISTOR.....	EA	2
9	13	XDDZZ	5999-01-076-9605	13103	7717-139N	MOUNTING PAD, ELECTR.....	EA	9
9	14	PADZZ	5961-00-022-5666	81349	JANTX2N2907A	TRANSISTOR.....	EA	7
9	15	PADZZ	5910-00-464-9812	81349	M39003/01-2497	CAPACITOR, FIXED, ELE.....	EA	1
9	16	PADZZ	5910-00-113-5499	81349	M39014/02-1350	CAPACITOR, FIXED, CER.....	EA	12
9	17	PADZZ	5961-00-494-4915	81349	JANTX1N4148	SEMICONDUCTOR DEVIC.....	EA	1
9	18	PADZZ	5961-01-070-9490	81349	JANTX1N6092	LIGHT EMITTING DIOD.....	EA	5
9	19	PADZZ	5961-01-069-5766	81349	JANTX1N6094	LIGHT EMITTING DIOD.....	EA	4
9	20	PADZZ	5961-01-070-8972	81349	JANTX1N6093	LIGHT EMITTING DIOD.....	EA	1
9	21	PADZZ	6625-00-359-6769	28480	5082-7100	READOUT ASSEMBLY, DI.....	EA	1
9	22	PADZZ	5940-00-082-5094	81349	M55155-30-5	TERMINAL, STUD.....	EA	1
9	23	PADZZ	5935-00-605-6581	75037	3431-2003	CONNECTOR, RECEPTACL.....	EA	1
9	24	PADZZ	5935-01-047-4715	27264	22-11-2051	CONNECTOR, RECEPTACL.....	EA	1
9	25	PADZZ	5945-01-128-9948	81349	M39016/9-013L	RELAY.....	EA	1
9	26	PADZZ	5999-00-004-0088	11532	192-10	MOUNTING PA, ELECTR.....	EA	1
9	27	PADZZ	5905-00-114-0710	81349	RCR07G331JS	RESISTOR, FIXED, COMP.....	EA	1
9	28	PADZZ	5905-00-110-0388	81349	RCR07G104JS	RESISTOR, FIXED, COMP.....	EA	1
9	29	PADZZ	5905-00-110-7623	81349	RCR07G102JS	RESISTOR, FIXED, COMP.....	EA	3
9	30	PADZZ	5905-01-149-5107	16845	1000-483-23	RESISTOR, FIXED.....	EA	1
9	31	PADZZ	5905-01-040-0391	81349	M8340102M1000GA	RESISTOR NETWORK, FI.....	EA	2
9	32	PADZZ		81349	M8340102M1801GB	RESISTOR NETWORK.....	EA	2
9	33	PADZZ	5905-01-122-1472	81349	M8340102M3300GB	RESISTOR NETWORK, FI.....	EA	1
9	34	PADZZ	5905-01-128-8916	81349	M8340102M2000GA	RESISTOR NETWORK, FI.....	EA	1
9	35	PADZZ	5930-01-047-4754	81073	50MP90-01-1-03N	SWITCH, ROTARY.....	EA	3
9	36	PADZZ	5930-01-096-8083	96906	MS21354-271	SWITCH, TOGGLE.....	EA	3
9	37	PADZZ	5935-00-201-0024	01295	C912400	SOCKET, PLUG-IN ELEC.....	EA	1
9	38	XBDZZ		80063	SM-B-882503	SPACER, LED MTG.....	EA	10

SECTION II

TM 11-5895-1179-23P / EE132 - EA- PLO-010/E106 KY883 / TO 31S1-2GSC-164

(1) ILLUSTRATION		(2)	(3)	(4)	(5)	(6)	(7)	(8)
(a) FIG NO.	(b) ITEM NO.	SMR CODE	NATIONAL STOCK NUMBER	FSCM	PART NUMBER	USABLE ON CODE	U/M	QTY INC IN UNIT
9	39	XADZZ		80063	SM-D-986488	PRINTED WIRING BD	EA	1
					42/(43 BLANK)			

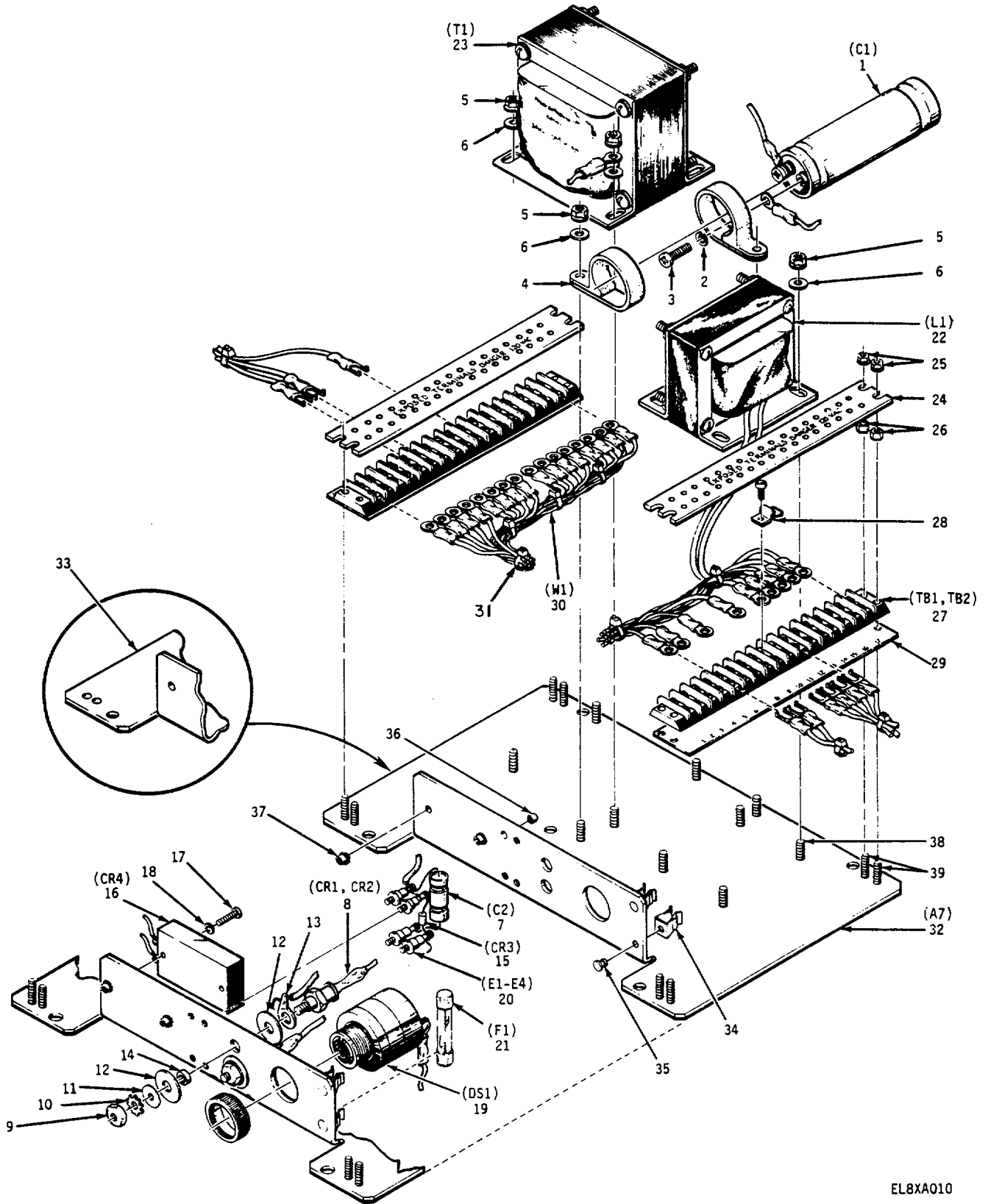

EL8XA010

Figure 10. Bottom Panel Assembly (A7)

(1) ILLUSTRATION		(2)	(3)	(4)	(5)	(6)	(7)	(8)
(a) FIG NO.	(b) ITEM NO.	SMR CODE	NATIONAL STOCK NUMBER	FSCM	PART NUMBER	DESCRIPTION USABLE ON CODE	U/M	QTY INC IN UNIT
						GROUP 0502 BOTTOM PANEL ASSEMBLY		
10	1	PAFZZ	5913-00-236-8740	81349	M39003/01-2974	CAPACITOR, FIXED, ELE.....	EA	1
10	2	PAFZZ	5305-00-993-1849	96906	MS35207-259	SCREW, MACHINE.....	EA	2
10	3	PAFZZ	5310-00-543-5933	96906	MS35333-73	WASHER, LOCK.....	EA	2
10	4	PAFZZ	5340-00-820-6093	96906	MS25281R22	CLAMP, LOOP.....	EA	2
10	5	PAFZZ	5310-00-878-7196	96906	MS21043-08	NUT, SELF-LOCKING, EX.....	EA	2
10	6	PAFZZ	5310-00-685-3744	88044	AN960C8	WASHER, FLAT.....	EA	2
10	7	PAFZZ	5910-01-047-6273	56289	109D227X9060T2	CAPACITOR, FIXED, ELE.....	EA	1
10	8	PAFZZ	5961-00-931-0437	81349	IN3B93	SEMICONDUCTOR DEVIC.....	EA	2
10	9	PAFZZ	5313-00-934-9765	96906	MS35650-304	NUT, PLAIN, HEXAGON.....	EA	2
10	10	PAFZZ	5310-00-209-1239	96906	MS35335-60	WASHER, LOCK.....	EA	2
10	11	PAFZZ	5310-00-167-0801	88044	AN96C10	WASHER, FLAT.....	EA	2
10	12	PAFZZ	5970-00-134-9073	86928	5624-17-3	INSULATOR, WASHER.....	EA	4
10	13	PADZZ	5940-00-283-5280	96906	MS25036-106	TERMINAL, LUG.....	EA	1
10	14	PAFZZ	5970-01-088-8939	04713	B51547F012	BUSHING TEFLON.....	EA	2
10	15	PAFZZ	5961-00-565-5092	81349	JANIN4942	SEMICONDUCTOR DEVI.....	EA	1
10	16	PAFZZ	5920-01-029-6626	06481	932183-1	ARRESTER, ELECTRICAL.....	EA	1
10	17	PAFZZ	5305-00-054-5653	96906	MS51957-19	SCREW, MACHINE.....	EA	2
10	18	PAFZZ	5310-00-057-0573	88769	91921002	WASHER FLAT.....	EA	2
10	19	XDFZZ	6350-00-412-8037	90201	SC628MP	BUZZER.....	EA	1
10	20	PAFZZ		88245	1480C-4-11	TERMINAL, FEEDTHRU, E.....	EA	4
10	21	PAOZZ	5920-00-284-7079	75915	31202.5	FUSE, CARTRIDGE.....	EA	1
10	22	PAFZZ	5950-01-041-6533	11627	12121	COIL, RADIO FREQUENC.....	EA	1
10	23	PAFZZ	5950-01-041-6517	11627	12120	TRANSFORMER, POWER.....	EA	1
10	24	XBFZZ		80063	SM-D-882510	COVER, TERMINAL BD.....	EA	2
10	25	PAFZZ	5310-00-878-3291	96906	MS21043-06	NUT, SELF-LOCKING, EX.....	EA	8
10	26	XBFZZ		83330	8824	NUT, PLAIN, HEXAGON.....	EA	8
10	27	PAFZZ	5940-00-983-6058	81349	37TB17	TERMINAL BOARD.....	EA	2
10	28	PAFZZ	5940-00-632-7234	75382	600J	BUS, CONDUCTOR.....	EA	13
10	29	XBFZZ			MS600-17			
				75382	GEE-STYL	MARKER STRIP.....	EA	2
					E1A			
10	30	XBFZZ		80063	SM-0-882513	HARNESS ASSEMBLY.....	EA	1
10	31	PAFZZ	5975-00-727-5153	59730	TY-23M	STRAP, TIEDOWN, ELECT.....	EA	3
10	32	XBFZZ		80063	SM-D-882484	PANEL SUBASSY.....	EA	1
10	33	XFFZZ		80063	SM-D-882484-1	PANEL, BOTTOM.....	EA	1
10	34	PAFZZ	5999-00-244-5391	75915	101001	CLIP, ELECTRICAL.....	EA	2
10	35	PAFZZ	5320-00-117-6949	96906	MS20426AD4-4	RIVET, SOLID.....	EA	2
10	36	PAFZZ	5340-00-631-7894	96906	MS21209C0415	INSERT, SCREW THREAD.....	EA	4
10	37	PAFZZ	5310-01-074-1495	81349	M45938/3-4CL	NUT, SELF-LOCKING, CL.....	EA	2
10	38	PAFZZ	5307-00-974-0535	46384	FHS832-8	STUD, SELF-LOCKING.....	EA	10

SECTION II

TM 11-5895-1179-23P / EE132 - EA- PLO-010/E106 KY883 / TO 31S1-2GSC-164

(1) ILLUSTRATION		(2)	(3)	(4)	(5)	(6)	(7)	(8)
(a) FIG NO.	(b) ITEM NO.	SMR CODE	NATIONAL STOCK NUMBER	FSCM	PART NUMBER	USABLE ON CODE	U/M	QTY INC IN UNIT
10	39	PAFZZ	5307-00-237-6092	46384	FHS632-14 46/(47 BLANK)	STUD, SELF-LOCKING.....	EA	8

SECTION II

(1) ILLUSTRATION		(2)	(3)	(4)	(5)	(6)	(7)	(8)
(a) FIG NO.	(b) ITEM NO.	SMR CODE	NATIONAL STOCK NUMBER	FSCM	PART NUMBER	DESCRIPTION USABLE ON CODE	U/M	QTY INC IN UNIT
						GROUP 0503 REAR PANEL ASSEMBLY		
11	1	PAFFF	5895-01-151-6035	80063	SH-D-882494	FAN ASSEMBLY.....	EA	1
11	2	XBFZZ		80063	SM-C-699765	GUARD, FAN.....	EA	1
11	3	PAFZZ	4140-00-456-2268	23936	5508	GUARD, FAN.....	EA	1
11	4	PAFZZ	5305-00-054-6653	96906	MS51957-29	SCREW, MACHINE.....	EA	4
11	5	PAFZZ	5310-00-773-7624	08226	REW620-6	WASHER, FLAT.....	EA	8
11	6	PAFZZ	5310-00-878-3291	96906	MS21043-06	NUT, SELF-LOCKING, EX.....	EA	4
11	7	PAOOO	4140-01-064-5526	23936	8124	FAN, TUBEAXIAL.....	EA	1
11	8	PAFZZ		00779	326881	TERMINAL, LUG.....	EA	2
11	9	PAFZZ	5305-00-788-8401	80205	NAS1352C06-6	SCREW, CAP, SOCKET HE.....	EA	4
11	10	PAFZZ	5975-00-727-5153	59730	TY-23M	STRAP, TIEDOWN, ELECT.....	EA	2
11	11	PAFZZ	53050-0-054-6655	96906	MS51957-31	SCREW, MACHINE.....	EA	2
11	12	XBFFF		80063	SM-0-882495	CONNECTOR ASSEMBLY.....	EA	1
11	13	PAFZZ	5305-00-054-5648	96906	MS51957-14	SCREW, MACHINE.....	EA	4
11	14	PAFZZ	5310-00-057-0573	88769	91921002	WASHER, FLAT.....	EA	4
11	15	PAFZZ	5935-00-995-5782	96906	MS31L2E12-3P	CONNECTOR, RECEPTACL.....	EA	1
11	16	PAFDD	5999-01-129-1525	80063	SM-D-986486	CIRCUIT CARD ASSEB.....	EA	1
11	17	PAFZZ	5305-00-054-6651	96906	MS51957-27	SCREW, MACHINE.....	EA	8
11	18	PAFZZ	5310-00-929-6395	96906	MS35338-136	WASHER, LOCK.....	EA	8
11	19	XBDZZ		80063	SK-0-882493	BRACKET ASSY.....	EA	1
11	20	XADZZ		80063	SM-0-882493-1	BRACKET.....	EA	1
11	21	PADZZ	5310-00-589-8028	46384	FE-632	NUT, SELF-LOCKING, CL.....	EA	4
11	22	XBFD		80063	SM-D-882480	PANEL SUBASSY, REAR.....	EA	1
11	23	XBFD		80063	SM-D-882480-1	PANEL, REAR.....	EA	1
11	24	PADZZ	5340-00-631-7894	96906	MS21209C0415	INSERT, SCREW THREAD.....	EA	4

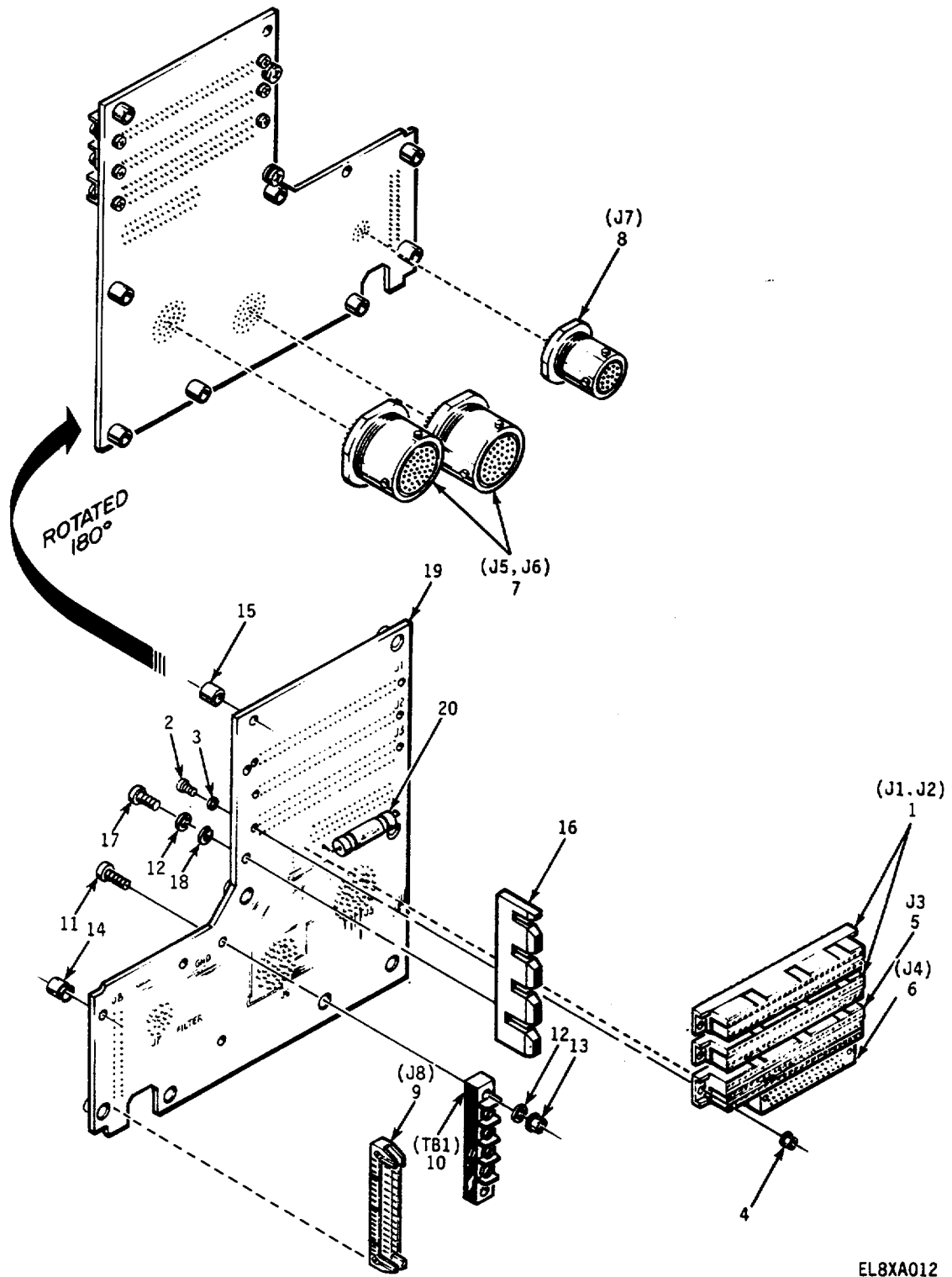

EL8XA012

Figure 12. Circuit Card Assembly, Backplane (A5A1)

SECTION II

TM 11-5895-1179-23P / EE132 - EA- PLO-010/E106 KY883 / TO 31S1-2GSC-164

(1) ILLUSTRATION		(2)	(3)	(4)	(5)	(6)	(7)	(8)
(a) FIG NO.	(b) ITEM NO.	SMR CODE	NATIONAL STOCK NUMBER	FSCM	PART NUMBER	DESCRIPTION USABLE ON CODE	U/M	QTY INC IN UNIT
						GROUP 050301 BACKPLANE CIRCUIT CARD ASSEMBLY		
12	1	PADZZ		91662	00-8257-064-649-900	CONNECTOR, RECEPTACL	EA	2
12	2	PADZZ	5305-00-054-5638	96906	NS51957-4	SCREW, MACHINE	EA	6
12	3	PADZZ	5310-00-043-4708	13499	310-01740-080	WASHER, FLAT	EA	12
12	4	PADZZ	5310-00-058-1823	96906	MS21042-02	NUT, SELF-LOCKING, EX.....	EA	6
12	5	PADZZ		91662	00-8257-096-649-907	CONNECTOR, RECEPTACL	EA	1
12	6	PADZZ	5935-00-425-6016	81349	M55302/8-04	CONNECTOR, RECEPTACL L, RECEPTACLE, 49 PIN.....	EA	1
12	7	PADZZ	5935-01-047-4718	11627	6893-2	CONNECTOR, RECEPTACL	EA	2
12	8	PADZZ	5935-01-047-4717	11627	6893-1	CONNECTOR, RECEPTACL	EA	1
12	9	PADZZ	5935-00-605-6581	75037	3431-2003	CONNECTOR, RECEPTACL	EA	1
12	10	PADZZ	5940-01-139-4809	71785	353-51-04-001	TERMINAL BOARD	EA	1
12	11	PADZZ	S305-00-054-6655	96906	MS51957-31	SCREW, MACHINE	EA	2
12	12	PAFZZ	5310-00-773-7624	08226	REW620-6	WASHER, FLAT	EA	4
12	13	PAFZZ	5310-00-878-3291	96906	MS21043-06	NUT, SELF-LOCKING, EX.....	EA	2
12	14	PADZZ	5310-01-141-1847	06540	95328-550632	NUT, PLAIN, CLINCH	EA	8
12	15	PADZZ		06540	95328-SS150	NUT, PLAIN, CLINCH	EA	2
12	16	XBDZZ		60063	51-D-882522-1	RETAINER	EA	1
12	17	PADZZ	5305-00-054-6656	96906	MS51957-30	SCREW, MACHINE	EA	2
12	16	PADZZ	5310-00-616-3555	96906	MS35333-71	WASHER, LOCK	EA	2
12	19	XADZZ		80063	SM-D-986485	PRINTED WIRING BD.....	EA	1
12	20	PAOZZ		56289	1350566X0075T2	CAPACITOR	EA	1
51								

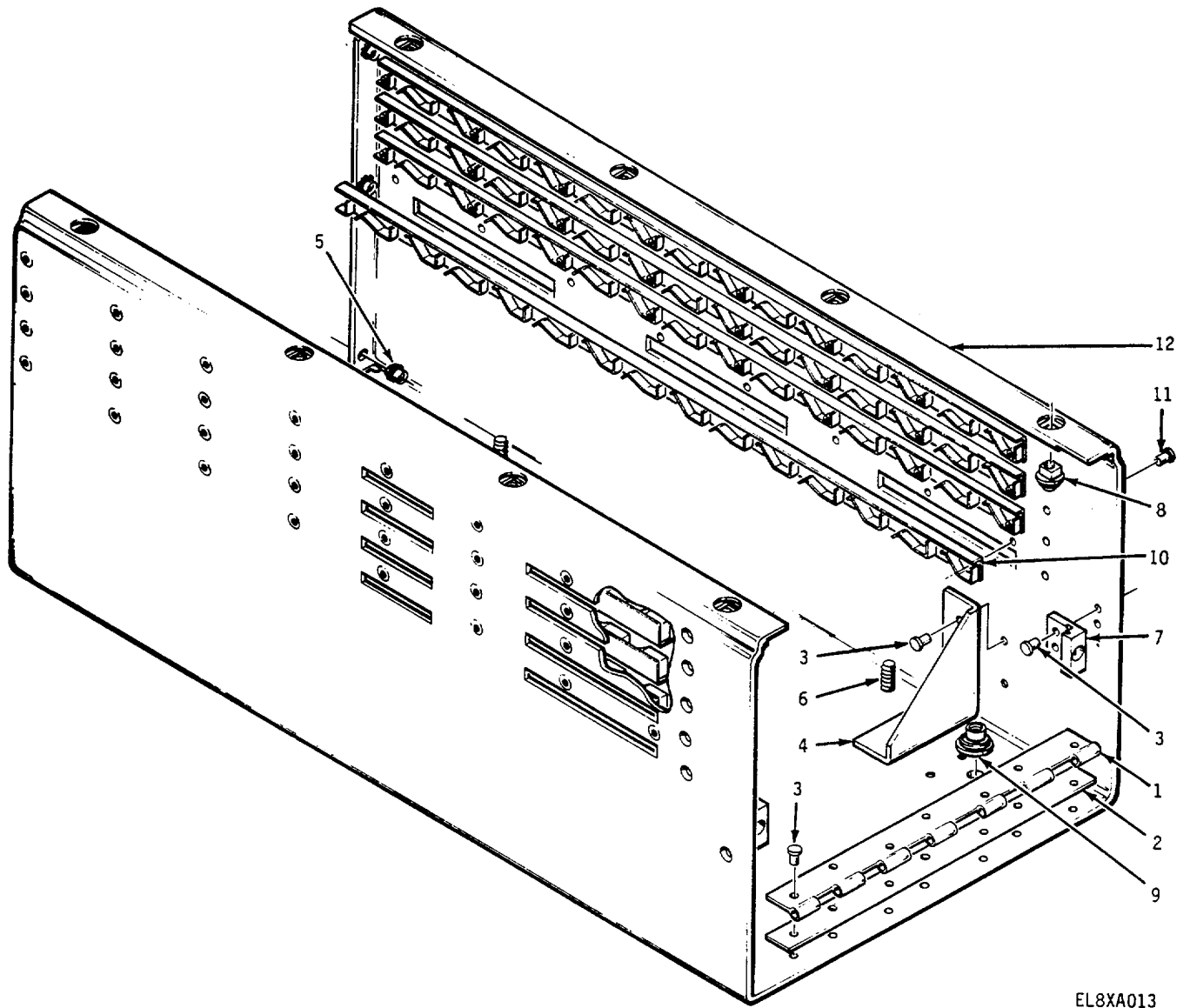

EL8XA013

Figure 13. Chassis, Sub-Assembly (A8A1)

SECTION II

TM 11-5895-1179-23P / EE132 - EA- PLO-010/E106 KY883 / TO 31S1-2GSC-164

(1) ILLUSTRATION		(2)	(3)	(4)	(5)	(6)	(7)	(8)
(a) FIG NO.	(b) ITEM NO.	SMR CODE	NATIONAL STOCK NUMBER	FSCM	PART NUMBER	DESCRIPTION USABLE ON CODE	U/M	QTY INC IN UNIT
						GROUP 0505 CHASSIS SUBASSEMBLY		
13	1	XAFZZ		96906	MS20257C2-650	HINGE, CONTINUOUS.....	EA	1
13	2	XAFZZ		80063	SM-D-882471-2	SPACER, PLATE, HINGE	EA	1
13	3	PAFZZ	5320-00-117-6950	96906	MS20426AD4-5	RIVET, SOLID.....	EA	15
13	4	XBDZZ		80063	SM-D-882492	GUSSET	EA	2
13	5	PAFZZ	5310-00-589-8028	46384	FE-632	NUT , SELF-LOCKING, CL.....	EA	6
13	6	PAFZZ	5307-00-075-2730	46384	FHS032-8	STUD, SELF-LOCKING.....	EA	5
13	7	PAFZZ		72794	PRB3-112	RECEPTACLE, FASTENER.....	EA	2
13	8	PAFZZ	5310-00-873-3195	46384	LAC632-2	NUT, SELF-LOCKING, CL.....	EA	8
13	9	PAFZZ	5310-00-873-3194	46384	LAC032-2	NUT, SELF-LOCKING, CL.....	EA	4
13	10	PAFZZ		02683	125-06-14.25	RETAINER	EA	8
13	11	PAFZZ	5320-00-811-7299	96906	MS20605AD3C2	RIVET, BLIND.....	EA	64
13	12	XAFZZ		80063	SM-D-882471-1	ENCLOSURE.....	EA	1
					53			

SECTION IV

TM 11-5895-1179-23P/EE132-EA-PLO-010-E106 KY883/TO 31S1-2GSC-165
 NATIONAL STOCK NUMBER AND PART NUMBER INDEX

STOCK NUMBER	FIG.	ITEM	STOCK NUMBER	FIG.	ITEM
5999-00-004-0088	9	26	5320-00-117-6950	13	3
5910-00-007-2002	4	35	5905-00-119-3504	5	56
5910-00-010-8666	2	33	5905-00-119-8811	5	49
5910-00-010-8666	5	17	5905-00-120-9154	5	72
5910-00-010-8721	6	28	5970-00-134-9073	10	12
5961-00-014-6458	5	11	5905-00-136-8406	5	63
5961-00-022-5666	9	14	5310-00-137-3134	6	18
5310-00-043-4708	2	37	5999-00-138-1522	5	19
5310-00-043-4708	3	28	5905-00-141-0593	5	59
5310-00-043-4708	4	44	5905-00-141-0598	5	45
5310-00-043-4708	12	3	5905-00-141-0717	5	64
5305-00-054-5636	1	12	5905-00-141-1132	5	71
5305-00-054-5638	12	2	5310-00-167-0801	7	22
5305-00-054-5639	5	39	5310-00-167-0801	10	11
5305-00-054-5639	6	25	5970-00-177-1405	5	5
5305-00-054-5640	2	36	5970-00-177-1405	8	16
5305-00-054-5640	3	21	5935-00-177-2017	5	44
5305-00-054-5640	4	43	5935-00-201-0024	9	37
5305-00-054-5648	11	13	5940-00-204-8966	6	10
5305-00-054-5649	8	7	5940-00-204-8966	8	22
5305-00-054-5653	1	7	5310-00-208-3786	7	3
5305-00-054-5653	5	41	5310-00-209-1239	10	10
5305-00-054-5653	10	17	5310-00-209-1366	6	22
5305-00-054-6650	5	35	5961-00-220-6651	6	11
5305-00-054-6651	8	13	5305-00-225-6400	7	28
5305-00-054-6651	11	17	5940-00-230-0515	6	16
5305-00-054-6652	7	14	5910-00-236-8740	5	21
5305-00-054-6653	5	4	5910-00-236-8740	10	1
5305-00-054-6653	11	4	5307-00-237-6092	10	39
5305-00-054-6654	6	6	5999-00-244-5391	10	34
5305-00-054-6654	12	17	5940-00-283-5280	5	77
5305-00-054-6655	5	6	5940-00-283-5280	6	7
5305-00-054-6655	11	11	5940-00-283-5280	7	18
5305-00-054-6655	12	11	5940-00-283-5280	10	13
5305-00-056-9961	7	6	5920-00-284-7079	8	26
5310-00-057-0573	1	8	5920-00-284-7079	10	21
5310-00-057-0573	7	5	5905-00-330-0113	6	24
5310-00-057-0573	8	8	5999-00-349-7432	5	12
5310-00-057-0573	10	18	6625-00-359-6769	9	21
5310-00-057-0573	11	14	6350-00-412-8037	10	19
5310-00-058-1823	2	38	5910-00-420-8555	5	25
5310-00-058-1823	3	29	5935-00-425-6016	12	6
5310-00-058-1823	4	5	4140-00-456-2268	11	3
5310-00-058-1823	12	4	5905-00-458-9500	2	44
5305-00-059-3659	8	28	5910-00-464-9812	2	31
5305-00-066-7328	7	9	5910-00-464-9812	3	24
5307-00-075-2730	13	6	5910-00-464-9812	4	39
5961-00-081-6103	5	31	5910-00-464-9812	9	15
5940-00-082-5094	2	34	5961-00-494-4915	9	17
5940-00-082-5094	3	25	5315-00-514-6944	5	79
5940-00-082-5094	4	40	5935-00-517-8520	5	37
5940-00-082-5094	9	22	5310-00-527-3634	6	17
5910-00-096-4644	5	23	5310-00-531-9514	6	4
5910-00-096-5160	5	24	5310-00-543-5933	10	3
5905-00-104-8348	5	68	5961-00-565-5092	5	29
5905-00-105-7764	5	53	5961-00-565-5092	10	15
5905-00-106-1278	5	51	5962-00-570-5909	4	20
5905-00-110-0388	5	54	5305-00-576-7266	8	3
5905-00-110-0388	9	28	5310-00-589-8028	11	21
5905-00-110-7620	5	50	5310-00-589-8028	13	5
5905-00-110-7620	9	29	5935-00-605-6581	9	23
5905-00-110-7622	5	70	5935-00-605-6581	12	9
5905-00-111-4727	5	61	5310-00-616-3555	12	18
5905-00-111-4738	5	48	5962-00-621-7201	4	8
5910-00-112-4337	5	26	5340-00-631-7894	10	36
5910-00-113-5445	5	27	5340-00-631-7894	11	24
5910-00-113-5499	2	32	5940-00-632-7234	8	23
5910-00-113-5499	5	18	5940-00-632-7234	10	28
5910-00-113-5499	9	16	5930-00-655-4241	8	19
5905-00-114-0110	9	27	5310-00-685-3744	10	6
5905-00-114-0711	5	52	5975-00-727-5153	7	32
5905-00-114-5344	5	62	5975-00-727-5153	8	20
5905-00-115-3560	5	57	5975-00-727-5153	8	39
5910-00-115-8456	5	20	5975-00-727-5153	10	31
5905-00-116-8554	5	66	5975-00-727-5153	11	10
5905-00-116-8555	5	55	5340-00-753-3456	5	7
5905-00-116-8556	5	67	5310-00-764-9564	6	15
5320-00-117-6949	8	35	5310-00-773-7624	5	3
5320-00-117-6949	10	35	5310-00-773-7624	5	8
5320-00-117-6950	7	12	5310-00-773-7624	7	15

SECTION IV

**TM 11-5895-1179-23P/EE132-EA-PLO-010-E106 KY883/TO 31S1-2GSC-165
NATIONAL STOCK NUMBER AND PART NUMBER INDEX**

STOCK NUMBER	FIG.	ITEM	STOCK NUMBER	FIG.	ITEM
5310-00-773-7624	8	15	5962-01-041-3500	2	3
5310-00-773-7624	11	5	5950-01-041-6517	10	23
5310-00-773-7624	12	12	5950-01-041-6533	10	22
5305-00-188-8401	11	9	5950-01-041-6787	5	40
5320-00-811-7299	13	11	5995-01-042-0222	7	29
5310-00-813-6950	6	26	5962-01-042-8072	2	19
5340-00-820-6093	10	4	5962-01-043-3941	2	7
5961-00-821-2309	5	32	5962-01-043-3941	4	9
5970-00-827-2110	5	42	5995-01-043-9687	7	24
5310-00-844-3302	7	23	5820-01-045-2202	8	10
5961-00-858-3826	9	12	5820-01-045-3438	1	4
5355-00-871-6025	8	2	5950-01-045-3441	5	43
5310-00-873-3194	13	9	5950-01-046-3846	5	75
5310-00-873-3195	13	8	5935-01-047-4715	9	24
5310-00-878-3291	5	2	5935-01-047-4717	12	8
5310-00-878-3291	6	3	5935-01-047-4718	12	7
5310-00-878-3291	10	25	5930-01-047-4754	9	35
5310-00-878-3291	11	6	5905-01-047-5172	5	65
5310-00-878-3291	12	13	5910-01-047-6273	5	16
5310-00-878-3292	7	2	5910-01-047-6273	10	7
5310-00-878-3292	8	11	5962-01-047-7408	2	23
5310-00-878-7196	10	5	5910-01-047-7866	4	36
5920-00-881-6584	8	25	5962-01-050-0920	4	17
5940-00-901-2040	5	36	5962-01-050-0921	3	13
5905-00-905-7761	6	27	5962-01-050-0921	4	13
5961-00-925-3177	5	15	5962-01-051-3402	2	28
5310-00-929-6395	5	34	5962-01-051-3402	3	19
5310-00-929-6395	7	16	5962-01-051-3402	4	22
5310-00-929-6395	8	14	5962-01-054-3675	2	4
5310-00-929-6395	11	18	5961-01-054-3758	6	12
5961-00-931-0437	10	8	5961-01-055-4348	6	19
5310-00-933-8118	7	4	5962-01-057-7054	2	21
5310-00-933-8118	8	9	5962-01-057-7054	3	14
5310-00-933-8120	8	29	5962-01-058-4867	3	3
5310-00-934-9761	6	23	4140-01-064-5526	11	7
5310-00-934-9765	10	9	5910-01-064-9674	4	37
5310-00-938-2013	5	38	5962-01-068-9593	2	18
5961-00-951-8757	5	13	5962-01-068-9593	9	11
5307-00-974-0535	10	38	5962-01-069-2610	3	20
5940-00-983-6058	10	27	5962-01-069-2610	9	9
5310-00-989-0640	8	30	5962-01-069-2637	2	9
5305-00-993-1849	10	2	5962-01-069-2637	3	11
5935-00-995-5782	11	15	5962-01-069-2637	4	7
5307-00-996-4438	8	38	5961-01-069-5766	9	19
5961-01-006-0215	5	28	5961-01-070-8972	9	20
5962-01-008-9563	2	30	5961-01-070-9490	9	18
5935-01-012-1298	7	25	5910-01-072-3855	5	22
5962-01-021-5875	2	15	5905-01-073-5732	5	73
5962-01-026-2489	2	24	5310-01-074-1495	10	37
5962-01-026-2489	9	5	5962-01-074-8876	3	17
5962-01-026-8818	2	27	5962-01-074-8876	4	4
5962-01-027-5649	2	11	5999-01-076-9605	5	14
5962-01-027-6863	2	13	5999-01-076-9605	9	13
5962-01-027-6863	3	4	5962-01-077-0657	2	1
5962-01-027-6863	4	2	5962-01-080-6210	3	18
5920-01-029-6626	10	16	5962-01-080-6210	4	19
5962-01-030-2118	2	16	5962-01-080-6210	9	3
5962-01-031-1918	3	9	5962-01-084-6427	9	8
5962-01-031-1918	4	3	5962-01-084-7398	2	14
5962-01-031-1918	9	6	5962-01-084-7398	3	7
5962-01-031-7030	2	22	5962-01-084-7398	4	14
5962-01-031-7030	3	21	5962-01-084-7398	9	7
5962-01-031-7030	4	10	5962-01-086-0286	6	2
5962-01-034-9832	2	20	5962-01-086-0458	2	17
5962-01-034-9832	3	10	5962-01-086-0458	4	24
5962-01-034-9832	4	11	5962-01-086-6681	5	10
5340-01-035-4454	7	26	5970-01-088-8939	10	14
5962-01-035-7479	3	22	5905-01-090-5259	5	60
5962-01-035-7419	4	18	5962-01-091-0557	4	23
5905-01-037-4171	5	69	5340-01-092-4022	8	1
5961-01-038-6918	5	30	5962-01-092-6229	3	16
5962-01-039-4752	2	26	5962-01-092-6229	4	27
5962-01-039-6395	2	29	5962-01-092-6229	9	4
5962-01-039-6395	3	5	5999-01-092-9318	2	41
5962-01-039-6395	4	16	5999-01-092-9318	3	31
5905-01-040-0391	9	31	5999-01-092-9318	4	49
5962-01-040-2979	2	46	5999-01-092-9318	5	78
5962-01-041-3214	2	12	5962-01-093-8823	3	12
5962-01-041-3214	3	8	5962-01-093-8823	4	21
5962-01-041-3214	4	1	5962-01-093-8823	9	1

SECTION IV

**TM 11-5895-1179-23P/EE132-EA-PLO-010-E106 KY883/TO 31S1-2GSC-165
NATIONAL STOCK NUMBER AND PART NUMBER INDEX**

STOCK NUMBER	FIG.	ITEM	STOCK NUMBER	FIG.	ITEM
5930-01-096-8083	9	36	5999-01-129-1523	1	3
5962-01-098-5043	3	6	5999-01-129-1524	8	12
5962-01-101-7969	4	29	5999-01-129-1525	11	16
5962-01-102-8671	2	5	5962-01-129-1910	4	5
5962-01-102-8671	3	15	5975-01-129-9601	7	21
5962-01-102-8671	4	15	5310-01-134-0759	6	14
5962-01-102-8671	9	2	5940-01-139-4809	12	10
5962-01-104-6417	2	10	5310-01-141-1847	12	14
5962-01-107-6934	4	33	5310-01-141-1847	12	15
5962-01-110-2679	4	25	5961-01-148-8412	5	74
5962-01-110-2679	9	10	5961-01-148-8413	5	46
5910-01-119-7435	3	23	5905-01-149-5107	5	58
5910-01-119-7435	4	38	5905-01-149-5107	9	30
5905-01-122-1472	9	33	5895-01-151-6035	11	1
5905-01-122-4151	4	46	5999-01-155-1422	5	1
5905-01-128-8916	9	34	5999-01-163-9048	3	32
5945-01-128-9948	9	25	5999-01-163-9049	4	50
5999-01-129-1521	1	1	5310-01-168-5473	8	36
5999-01-129-1522	1	2			

FSCM PART NUMBER	FIGURE NO.	ITEM NO.	FSCM PART NUMBER	FIGURE NO.	ITEM NO.
88044 AN960C10	7	22	96906 MS21042-02	12	4
88044 AN960C10	10	11	96906 MS21043-04	7	2
81352 AN960C6	6	4	96906 MS21043-04	8	11
88044 AN960C8	10	6	96906 MS21043-06	5	2
88245 81530-8-3/L6-11	5	33	96906 MS21043-06	6	3
04713 851547F012	10	14	96906 MS21043-06	10	25
81349 CMR04CO50DODP	4	36	96906 MS21043-06	11	6
81349 CMR04E200JODR	4	37	96906 MS21043-06	12	13
81349 CR60AU13-450MHZ	2	40	96906 MS21043-08	10	5
81349 CR64/U-6.000MHZ	4	48	96906 MS21043-3	7	23
46384 CSOS632-9	8	36	96906 MS21209C0415	10	36
01295 C912400	9	37	96906 MS21209C0415	11	24
46384 FE-632	11	21	96906 MS21354-271	9	36
46384 FE-632	13	5	96906 MS24524-23	8	19
81349 FHL17G2	8	25	96906 MS24693C27	7	9
46384 FHS032-8	13	6	96906 MS24693C3	7	28
46384 FHS440-8	8	38	96906 MS24693C4	7	6
46384 FHS632-14	10	39	96906 MS25036-102	6	10
46384 FHS832-8	10	38	96906 MS25036-102	8	22
06324 G110901282-1S	1	9	96906 MS25036-106	5	77
06324 G110901683-1S	1	10	96906 MS25036-106	6	7
06324 G1109024B3-1S	1	6	96906 MS25036-106	7	18
81349 JANTX1N4148	9	17	96906 MS25036-106	10	13
81349 JANTX1N6092	9	18	96906 MS25036-154	6	16
81349 JANTX1N6093	9	20	96906 MS25082C4	6	18
81349 JANTX1N6094	9	19	96906 MS25281R2	5	7
81349 JANTX2N2222A	9	12	96906 MS25281R22	10	4
81349 JANTX2N2907A	9	14	96906 MS3112E12-3P	11	15
81349 JAN1N4148-1	5	30	96906 MS35207-259	10	2
81349 JAN1N4942	5	29	96906 MS35333-71	12	18
81349 JAN1N4942	10	15	96906 MS35333-73	10	3
81349 JAN1N5187	5	28	96906 MS35335-58	6	22
81349 JAN1N751A	5	32	96906 MS35335-60	10	10
81349 JAN1N823	5	31	96906 MS35335-61	6	17
81349 JAN2N2222A	5	13	96906 MS35338-135	7	4
81349 JAN2N2907A	5	15	96906 MS35338-135	8	9
81349 JAN2N3498	5	11	96906 MS35338-136	5	34
81349 JAN2N5685	6	11	96906 MS35338-136	7	16
46384 LAC032-2	13	9	96906 MS35338-136	8	14
46384 LAC632-2	13	8	96906 MS35338-136	11	18
27014 LM109K-883	6	2	96906 MS35338-138	8	29
27014 LM120K-5.0/883	6	9	96906 MS35649-224	5	38
34335 LM139D/883B	5	9	96906 MS35649-264	6	23
27014 LM747J/8838	5	10	96906 MS35650-304	10	9
34649 MD2114A-5/B	4	5	96906 MS51021-22	8	3
34649 MD8035L/B	4	26	96906 MS51923-312	5	79
96906 MS20257C2-650	13	1	96906 MS51957-14	11	13
96906 MS20257C2-750	8	34	96906 MS51957-15	8	7
96906 MS20426AD4-4	8	35	96906 MS51957-19	1	7
96906 MS20426AD4-4	10	35	96906 MS51957-19	5	41
96906 MS20426AD4-5	7	12	96906 MS51957-19	10	17
96906 MS20426AD4-5	13	3	96906 MS51957-2	1	12
96906 MS20605AD3C2	13	11	96906 MS51957-26	5	35
96906 MS21042-02	2	38	96906 MS51957-27	8	13
96906 MS21042-02	3	29	96906 MS51957-27	11	17
96936 MS21042-02	4	45	96906 MS51957-28	7	14

SECTION IV

TM 11-5895-1179-23P/EE132-EA-PLO-010-E106 KY883/TO 31S1-2GSC-165
 NATIONAL STOCK NUMBER AND PART NUMBER INDEX

		FIGURE	ITEM			FIGURE	ITEM
FSCM	PART NUMBER	NO.	NO.	FSCM	PART NUMBER	NO.	NO.
96906	MS51957-29	5	4	81349	M38510/32702BCB	4	23
96906	MS51957-29	11	4	81349	M38510/32803BRB	4	25
96906	MS51957-30	6	6	81349	M38510/32803BRB	9	10
96906	MS51957-30	12	17	81349	M38510/32901BCB	3	6
96906	MS51957-31	5	6	81349	M39003/01-2497	2	31
96906	MS51957-31	11	11	81349	M39003/01-2497	3	24
96906	MS51957-31	12	11	81349	M39003/01-2497	4	39
96906	MS51957-4	12	2	81349	M39003/01-2497	9	15
96906	MS51957-5	5	39	81349	M39003/01-2974	5	21
96906	MS51957-5	6	25	81349	M39003/01-2974	10	1
96906	MS51957-6	2	36	81349	M39003/01-3003	4	35
96906	MS51957-6	3	27	81349	M39003/01-3082	5	25
96906	MS51957-6	4	43	81349	M39014-02-1258	5	20
96906	MS51958-63	8	28	81349	M39014-22-0494	3	23
75382	MS600-17GEE-STYLEIA	10	29	81349	M39014-22-0494	4	38
81349	M38510/07001BCB	2	15	81349	M39014/01-1321	5	26
81349	M38510/07003BCB	2	24	81349	M39014/01-1330	5	23
81349	M38510/07003BCB	9	5	81349	M39014/01-1339	5	27
81349	M38510/07101BCB	2	27	81349	M39014/01-1357	2	33
81349	M38510/07301BCB	2	16	81349	M39014/01-1357	5	17
81349	M38510/07401BCB	2	26	81349	M39014/01-1359	5	24
81349	M38510/07501BCB	2	7	81349	M39014/02-1350	2	32
81349	M38510/07501BCB	4	9	81349	M39014/02-1350	5	18
81349	M38510/07902BEB	2	19	81349	M39014/02-1350	9	16
81349	M38510/07904BEB	2	4	81349	M39014/02-1419	6	28
81349	M38510/08201BEB	2	1	81349	M39016/9-013L	5	49
81349	M38510/10401BCB	4	8	81349	M39016/9-013L	9	25
81349	M38510/23803BVB	3	1	81349	M45938/3-4CL	10	37
81349	M38510/23803BVB	4	6	81349	M55155-30-5	2	34
81349	M38510/30001BCB	2	22	81349	M55155-30-5	3	25
81349	M38510/30001BCB	3	21	81349	M55155-30-5	4	40
81349	M38510/30001BCB	4	10	81349	M55155-30-5	9	22
81349	M38510/30003BCB	2	13	81349	M55302/7-04	5	44
81349	M38510/30003BCB	3	4	81349	M55302/8-04	12	6
81349	M38510/30003BCB	4	2	81349	M8340102M1000GA	9	31
81349	M38510/30109BEB	2	28	81349	M8340102M1801GB	2	39
81349	M38510/30109BEB	3	19	81349	M8340102M1801GB	3	30
81349	M38510/30109BEB	4	22	81349	M8340102M1801G8	4	47
81349	M38510/30301BCB	2	29	81349	M8340102M1801GB	9	32
81349	M38510/30301BCB	3	5	81349	M8340102M2000GA	9	34
81349	M38510/30301BCB	4	16	81349	M8340102M3300GB	9	33
81349	M38510/30401BCB	3	22	81349	M8340102M39ROGB	4	46
81349	M38510/30401BCB	4	18	80205	NAS291C02M	6	26
81349	M38510/30501BCB	3	9	80205	NAS1352C06-6	11	9
81349	M38510/30501BCB	4	3	80205	NAS549FL4	5	42
81349	M38510/30501BCB	9	6	80205	NAS549FL6	5	5
81349	M38510/30502BCB	2	12	80205	NAS549FL6	8	16
81349	M38510/30502BCB	3	8	80205	NAS620C10	8	30
81349	M38510/30502BCB	4	1	80205	NAS620C416L	6	15
81349	M38510/30601BEB	2	21	80205	NAS671C4	7	3
81349	M38510/30601BEB	3	14	91637	NS28.05/3PCT	5	47
81349	M38510/30605BCB	2	18	72794	PFSC3-1/2-44A	8	37
81349	M38510/30605BCB	9	11	72794	PRB3-1/2	7	11
81349	M38510/30901BEB	4	17	72794	PRB3-1/2	13	7
81349	M38510/30903BEB	3	13	81349	RCR05G102JS	2	44
81349	M38510/30903BEB	4	13	81349	RCR07G102JS	5	50
81349	M38510/30906BEB	3	20	81349	RCR07G102JS	9	29
81349	M38510/30906BEB	9	9	81349	RCR07G104JS	5	54
81349	M38510/31004BCB	2	20	81349	RCR07S104JS	9	28
81349	M38510/31004BCB	3	10	81349	RCR07G105JS	5	66
81349	M38510/31004BCB	4	11	81349	RCR07G123JS	5	51
81349	M38510/31202BEB	3	3	81349	RCR07G153JS	5	55
81349	M38510/31403BCB	9	8	81349	RCR07G183JS	5	57
27014	M38510/31512BEB	2	9	81349	RCR07S184JS	5	62
27014	M38510/31512BEB	3	11	81349	RCR07G222JS	5	53
27014	M38510/31512BEB	4	7	81349	RCR07S223JS	5	67
81349	M38510/31604BEB	4	29	81349	RCR07G242JS	5	63
81349	M38510/32203BEB	3	17	81349	RCR07G272JS	5	61
81349	M38510/32203BEB	4	4	81349	RCR07G273JS	5	56
81349	M38510/32401BRB	3	12	81349	RCR07G331JS	9	27
81349	M38510/32401BRB	4	21	81349	RCR07G471JS	5	72
81349	M38510/32401BRB	9	1	81349	RCR07G472JS	5	52
81349	M38510/32502BRB	4	33	81349	RCR07G473JS	5	64
81349	M38510/32504BRB	2	5	81349	RCR07G682JS	5	70
81349	M38510/32504BRB	3	15	81349	RCR07S752JS	5	71
81349	M38510/32504BRB	4	15	81349	RCR20G152JS	5	48
81349	M38510/32504BRB	9	2	81349	RCR20G182JS	5	59
81349	M38510/32601BEB	3	16	81349	RCR20G332JS	5	68
81349	M38510/32601BEB	4	27	81349	RCR20S561JS	5	45
81349	M38510/32601BEB	9	4	81349	RE45F1500R	6	24

SECTION IV

TM 11-5895-1179-23P/EE132-EA-PLO-010-E106 KY883/TO 31S1-2GSC-165
 NATIONAL STOCK NUMBER AND PART NUMBER INDEX

FSCM PART NUMBER		FIGURE NO.	ITEM NO.	FSCM PART NUMBER		FIGURE NO.	ITEM NO.
08226	REW620-6	5	3	01295	SNC54LS378J	9	7
08226	REW620-6	5	8	01295	SNC54LS669J	2	17
08226	REW620-6	7	15	01295	SNC54LS669J	4	24
08226	REW620-6	8	15	01295	SNC54S08J	2	45
08226	REW620-6	11	5	01295	SNC54S163J	2	11
08226	REW620-6	12	12	01295	SNC54S169J	2	46
81349	RE60G1000	6	27	01295	SNC54S283J	2	25
81349	RJR26FP202P	5	60	01295	SNC55109AJ	4	20
81349	RJR26FW103P	5	65	01295	SNJ54S374J	2	10
81349	RJR26FW201P	5	73	34335	SN54S240JB	3	18
81349	RJR26FW202P	5	69	34335	SN54S240JB	4	19
18677	S-208-1	2	42	34335	SN54S240JB	9	3
18677	S-208-2	3	32	18677	S208	2	41
18677	S-208-3	4	50	18677	S208	3	31
18677	S-208-4	5	80	18677	S208	4	49
90201	SC628MP	10	19	18677	S208	5	78
80063	SM-A-986467-00	4	30	32440	TTLDL-1000M	4	28
80063	SM-A-986471-00	2	8	59730	TY-23M	7	32
80063	SM-A-986471-01	2	6	59730	TY-23M	8	20
80063	SM-A-986472-00	4	34	59730	TY-23M	8	39
80063	SM-A-986473-00	4	12	59730	TY-23M	10	31
80063	SM-A-986474-00	4	31	59730	TY-23M	11	10
80063	SM-A-986474-01	4	32	91662	00-8257-064-000-900	2	35
80063	SM-B-699758-1	8	31	91662	00-8257-064-000-900	3	26
80063	SM-B-882503	9	38	91662	00-8257-064-649-900	12	1
80063	SM-C-699765	11	2	91662	00-8257-096-000-911	4	42
80063	SM-C-882527	7	20	91662	00-8251-096-649-907	12	5
80063	SM-D-882471	7	35	27264	08-56-0110	7	34
80063	SM-D-882471-1	13	12	81349	1N3893	10	8
80063	SM-D-882471-2	13	2	01281	1N6098	6	19
80063	SM-D-882472	7	8	16845	1000-409-15	5	74
80063	SM-D-882472-1	7	10	16845	1000-409-16	5	46
80063	SM-D-882477	1	4	16845	1000-483-23	5	58
80063	SM-D-882478	5	81	16845	1000-483-23	9	30
80063	SM-D-882480	11	22	75915	101001	10	34
80063	SM-D-882480-1	11	23	11627	10468	2	3
80063	SM-D-882483-1	7	21	06540	10531SS1032	8	27
80063	SM-D-882484	10	32	56289	109D227X9060T2	5	16
80063	SM-D-882484-1	10	33	56289	109D227X9060T2	10	7
80063	SM-D-882487	7	27	95354	1100-1-112-02-09	4	41
80063	SM-D-882492	13	4	11627	12120	10	23
80063	SM-D-882493	11	19	11627	12121	10	22
80063	SM-D-882493-1	11	20	11627	12122	5	43
80063	SM-D-882494	11	1	11627	12123	5	40
80063	SM-D-882495	11	12	11627	12124	5	15
80063	SM-D-882496	8	24	02683	125-06-14.25	13	10
80063	SM-D-882497	8	18	56289	135D566X0075T2	12	20
80063	SM-D-882498	8	4	88245	1480C-4-11	6	29
80063	SM-D-882498-1	8	5	88245	1480C-4-11	10	20
80063	SM-D-882498-2	8	6	27264	15-04-9209	7	31
80063	SM-D-882499	8	10	11532	192-10	9	26
80063	SM-D-882506	7	29	27264	22-01-2051	7	30
80063	SM-D-882510	10	24	27264	22-11-2051	9	24
80063	SM-D-882511	7	7	13103	2660	6	5
80063	SM-D-882513	10	30	10001	2880595	6	12
80063	SM-D-882514	5	1	32559	302-200	5	19
80063	SM-D-882515	6	1	13499	310-0740-080	2	37
80063	SM-D-882520	5	16	13499	310-0740-080	3	28
80063	SM-D-882521-1	7	24	13499	310-0740-080	4	44
80063	SM-D-882522-1	12	16	13499	310-0740-080	12	3
80063	SM-D-882523	7	17	75915	31202.5	8	26
80063	SM-D-986475	1	5	75915	31202.5	10	21
80063	SM-D-986479	1	11	14604	3150-23-103	6	21
80063	SM-D-986480	8	32	00779	326881	7	33
80063	SM-D-986480-1	8	33	0079	326881	8	21
80063	SM-D-986481	7	1	00779	326881	8	40
80063	SM-D-986483	1	13	00779	326881	11	8
80063	SM-D-986485	12	19	81073	33-128	8	2
80063	SM-D-986486	11	16	75037	3414-6034	7	25
80063	SM-D-986488	9	39	30142	3431-1003	5	37
80063	SM-D-986489	8	12	75037	3431-2003	9	23
80063	SM-D-986491	4	51	75037	3431-2003	12	9
80063	SM-D-986492	1	3	30142	3484-1000	7	26
80063	SM-D-986494	2	43	71785	353-51-04-001	12	10
80063	SM-D-986495	1	1	81349	37TB17	10	27
80063	SM-D-986497	3	33	13103	43-03-02	6	8
80063	SM-D-986498	1	2	04713	4324/BCBJC	2	30
01295	SNC54LS378J	2	14	88245	4521C	5	36
01295	SNC54LS378J	3	7	27193	49-4157	8	1
01295	SNC54LS378J	4	14	94983	4916	7	19

SECTION IV

**TM 11-5895-1179-23P/EE132-EA-PLO-010-E106 KY883/TO 31S1-2GSC-165
NATIONAL STOCK NUMBER AND PART NUMBER INDEX**

FSCM	PART NUMBER	FIGURE NO.	ITEM NO.	FSCM	PART NUMBER	FIGURE NO.	ITEM NO.
81073	50MP90-01-1-03N	9	35	13103	7717-79N	5	12
28480	5082-7100	9	21	06540	8109-SS-0440-0	8	17
07263	54LS133DMQB	3	2	23936	8124	11	7
23936	5508	11	3	83330	8824	10	26
86928	5607-121	6	14	88769	91921002	1	8
86928	5611-78-2	6	13	88769	91921002	7	5
86928	5611-79-2	6	20	88769	91921002	8	8
86928	5624-17-3	10	12	88769	91921002	10	18
75382	600J	8	23	88769	91921002	11	14
75382	600J	10	28	06481	932183-1	10	16
56289	672D567H020DS5C	5	22	07263	93422DMQB	2	2
11627	6893-1	12	8	07263	93425DMQB	2	23
11627	6893-2	12	7	06540	95328-550632	12	14
13103	7717-139N	5	14	06540	95328-SS150	12	15
13103	7717-139N	9	13				

59/(60 BLANK)

By Order of the Secretaries of the Army, the Navy and the Air Force:

Official:

JOHN A. WICKHAM JR.
General, United States Army
Chief of Staff

ROBERT M. JOYCE
Major General, United States Army
The Adjutant General

G. B. SCHICK, JR.
Rear Admiral, United States Navy
Commander, Naval Electronic
Systems Command

Official:

JAMES P. MULLINS
General, USAF, Commander, Air Force
Logistics Command

CHARLES A. GABRIEL
General, USAF
Chief of Staff

Distribution:

To be distributed in accordance with special list.

*U.S. GOVERNMENT PRINTING OFFICE: 1994 -705-046/4191

RECOMMENDED CHANGES TO EQUIPMENT TECHNICAL PUBLICATIONS



THEN... JOT DOWN THE DOPE ABOUT IT ON THIS FORM, CAREFULLY TEAR IT OUT, FOLD IT AND DROP IT IN THE MAIL!

SOMETHING WRONG WITH THIS PUBLICATION?

FROM: (PRINT YOUR UNIT'S COMPLETE ADDRESS)

DATE SENT

PUBLICATION NUMBER

PUBLICATION DATE

PUBLICATION TITLE

BE EXACT... PIN-POINT WHERE IT IS

PAGE NO.

PARA-GRAPH

FIGURE NO.

TABLE NO.

IN THIS SPACE TELL WHAT IS WRONG AND WHAT SHOULD BE DONE ABOUT IT:

TEAR ALONG PERFORATED LINE

PRINTED NAME, GRADE OR TITLE, AND TELEPHONE NUMBER

SIGN HERE:

DA FORM 2028-2
1 JUL 79

PREVIOUS EDITIONS ARE OBSOLETE.

P.S.—IF YOUR OUTFIT WANTS TO KNOW ABOUT YOUR RECOMMENDATION MAKE A CARBON COPY OF THIS AND GIVE IT TO YOUR HEADQUARTERS.

PIN: 056008-000

This fine document...

Was brought to you by me:



[Liberated Manuals -- free army and government manuals](#)

Why do I do it? I am tired of sleazy CD-ROM sellers, who take publicly available information, slap “watermarks” and other junk on it, and sell it. Those masters of search engine manipulation make sure that their sites that sell free information, come up first in search engines. They did not create it... They did not even scan it... Why should they get your money? Why are not letting you give those free manuals to your friends?

I am setting this document FREE. This document was made by the US Government and is NOT protected by Copyright. Feel free to share, republish, sell and so on.

I am not asking you for donations, fees or handouts. If you can, please provide a link to liberatedmanuals.com, so that free manuals come up first in search engines:

<A HREF=<http://www.liberatedmanuals.com/>>Free Military and Government Manuals

- Sincerely
Igor Chudov
<http://igor.chudov.com/>
- [Chicago Machinery Movers](#)