

**TECHNICAL MANUAL
MAINTENANCE INSTRUCTIONS**

**RIGID SHELTER
S-611/T**

**TEXAS INSTRUMENTS INCORPORATED
F19628-77-C-0126**

Each transmittal of this document outside the Department of Defense must have approval of the issuing service.

Published Under Authority of the Secretary of the Air Force.

LIST OF EFFECTIVE PAGES

INSERT LATEST CHANGED PAGES. DESTROY SUPERSEDED PAGES.

NOTE: The portion of the text affected by the changes is indicated by a vertical line in the outer margins of the page. Changes to illustrations are indicated by miniature pointing hands. Changes to wiring diagrams are indicated by shaded areas.

Dates of issue for original and changed pages are:

Original 0 29 February 1980

TOTAL NUMBER OF PAGES IN THIS PUBLICATION IS 20 CONSISTING OF THE FOLLOWING:

Page No.	*Change No.
Title	0
A.....	0
i.....	0
ii Blank	0
1-1-1-4.....	0
2-1-2-7.....	0
2-8 Blank	0
3-1-3-4.....	0

*Zero in this column indicates an original page.

TABLE OF CONTENTS

<i>Section/Para</i>	<i>Title</i>	<i>Page</i>
I	GENERAL DESCRIPTION	1-1
1-1	INTRODUCTION.....	1-1
1-4	DESCRIPTION OF EQUIPMENT	1-1
II	INSTALLATION.....	2-1
2-1	PREPARATION FOR USE	2-1
2-2	Site Selection	2-1
2-3	Site Preparation.....	2-1
2-4	Inspection	2-1
2-5	Placement	2-1
2-6	Removing Mobilizer From Shelter	2-1
2-7	Leveling Jack Installation Procedure.....	2-2
2-8	Removable Access Panel	2-4
2-9	Air Conditioning Group (ACG)	2-4
2-10	PREPARATION FOR SHIPMENT	2-4
2-11	Preparation for Loading the Shelter	2-4
2-12	Attaching Mobilizer to Shelter	2-4
III	MAINTENANCE	3-1
3-1	CLEANING	3-1
3-2	PAINTING	3-1
3-5	SHELTER SKIN REPAIR.....	3-1
3-6	Repairing Delaminated Areas in Shelter Skin.....	3-1
3-9	Repairing Shelter Skin Punctures	3-3

LIST OF ILLUSTRATIONS

<i>Figure</i>	<i>Title</i>	<i>Page</i>
1-1	Rigid Shelter, S-61 I/T (Curbside View).....	1-2
1-2	Shelter With Lifting Sling and Jacks (Streetside View)	1-4
2-1	Shelter in Transport Configuration	2-2
2-2	Jack and Interface on Shelter	2-3
2-3	Lowered Mobilizer With Lockout Active	2-5
2-4	Mobilizer to Shelter Alignment	2-6
2-5	Mobilizer With Shelter Partially Raised	2-7
3-1	Delamination Repair	3-2

LIST OF TABLES

<i>Table</i>	<i>Title</i>	<i>Page</i>
1-1	Related Publications	1-1
1-2	Physical Characteristics	1-3
3-1	Shelter Repair Materials	3-4

SECTION I

GENERAL DESCRIPTION

1-1. INTRODUCTION.

1-2. This manual contains service and repair instructions for the Rigid Shelter S-611/T (shelter). This section contains descriptive type information, section II provides installation procedures, and section III provides maintenance instructions. Table 1-1 is a list of related publications that provide additional information about the shelter.

1-3. The purpose of the shelter is to provide an equipment enclosure that is transportable by air, water, road, and rail transport. The shelter is capable of transporting a 10,000-pound payload under worldwide conditions. Figure 1-1 is an illustration of the shelter.

1-4. DESCRIPTION OF EQUIPMENT.

1-5. The shelter (figure 1-1) is of aluminum welded and riveted construction. Panels are sandwich type utilizing foam and beam construction techniques. The side of the shelter (curbside) contains a primary personnel door (11), two power entry panels (12, 13), and an access panel (14) for use in moving equipment in and out of the shelter. Two skids (9) are bolted to the underside of the shelter. Table 1-2 gives the physical characteristics of the shelter.

1-6. The shelter is transportable by both mobilizers of the end mount type and of the van transporter type. Each end of the shelter contains brackets (4, 6) for mounting the end mount mobilizers. The underside of the shelter contains rails (8) for use in transporting the shelter using the van transporter. Lifting eyes (3) are provided at each upper corner of the shelter. Towing eyes (5) are provided at each lower corner of the shelter. A lifting sling is provided. Four demountable jacks are provided to level the shelter and for raising and lowering the shelter from the van transporter. The roof of the shelter contains the interface (2, 15) for mounting the air-conditioning group ducts. Refer to figure 1-2 for a lifting sling and leveling jacks configuration.

Table 1-1. Related Publications

Publication Title	Publication Number
Operations and Maintenance Instructions, Imagery Interpretation Segments AN/TYQ-I I(V) and AN/TYQ- 12(V)	T.O. 10M1-7-9-1-1 TM 11-5895-1021-14 TM 08045-15/1
Operations and Maintenance Instructions, Auxiliary Interpretation-Data Processing Group OL-80(V)/TYQ-I 1(V)	T.O. 10M1--7-7-1 TM 11-5895-1028-14
Operations and Maintenance Instructions, Interpretations-Data Processing Group OL-81(V)/TYQ-I I(V)	T.O. 10M1-7-6-1
Operations and Maintenance Instructions, Augmented Interpretation-Data Processing Group OL-87(V)/TYQ	T.O. 10M1-7-5-1 TM 11-5895-1029-14 TM 08045-15/11
Workcards, Periodic Inspection Requirements for Imagery Interpretation Segment	T.O. 10M1-7-9-6WC-I TM 11-5895-1021-14/2
Illustrated Parts Breakdown Rigid Shelter S-61 I/T	T.O. 10M -8-4-4 TM 11-5895-1044-24P TM 08045A

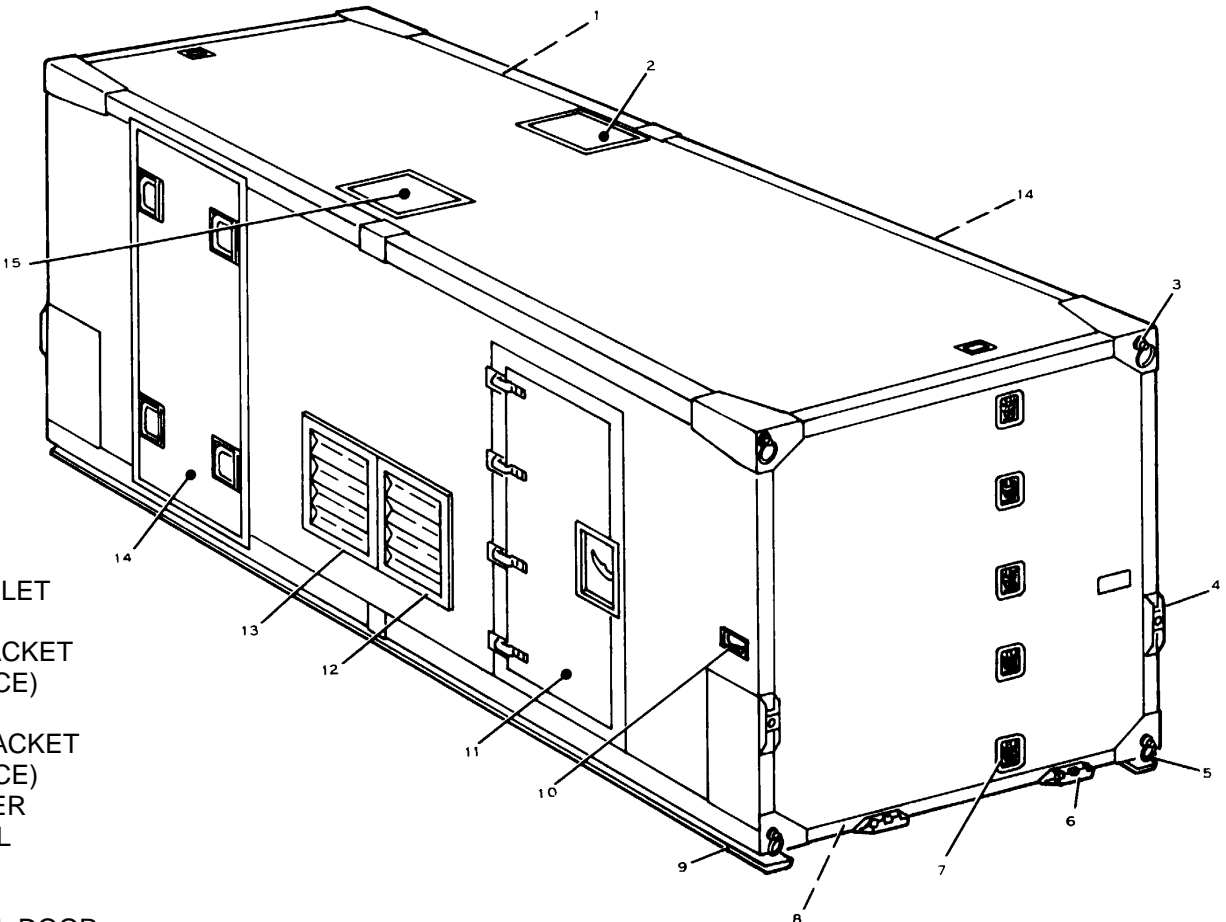

- 1. EMERGENCY DOOR
- 2. AIR CONDITIONING INLET
- 3. LIFTING EYES
- 4. UPPER SHELTER BRACKET (MOBILIZER INTERFACE)
- 5. TOWING EYES
- 6. SHELTER MOUNT BRACKET (MOBILIZER INTERFACE)
- 7. RETRACTABLE LADDER
- 8. VAN TRANSPORT RAIL
- 9. SKIDS
- 10. INCLINOMETER
- 11. PRIMARY PERSONNEL DOOR
- 12. POWER ENTRY PANEL
- 13. POWER ENTRY PANEL
- 14. ACCESS PANEL
- 15. AIR CONDITIONING OUTLET

Figure 1-1. Rigid Shelter, S-611/T (Curbside View)

Table 1-2. Physical Characteristics

Characteristics	Specification
Dimension (exterior)	
Height	97.3 inches maximum
Width	96.6 inches maximum
Length	240.6 inches maximum
Dimension (interior)	
Height	85.25 inches maximum
Width	91.25 inches maximum
Length	231.25 inches maximum
Weight	
Net (without payload)	4,200 pounds
Gross (with payload)	14,200 pounds

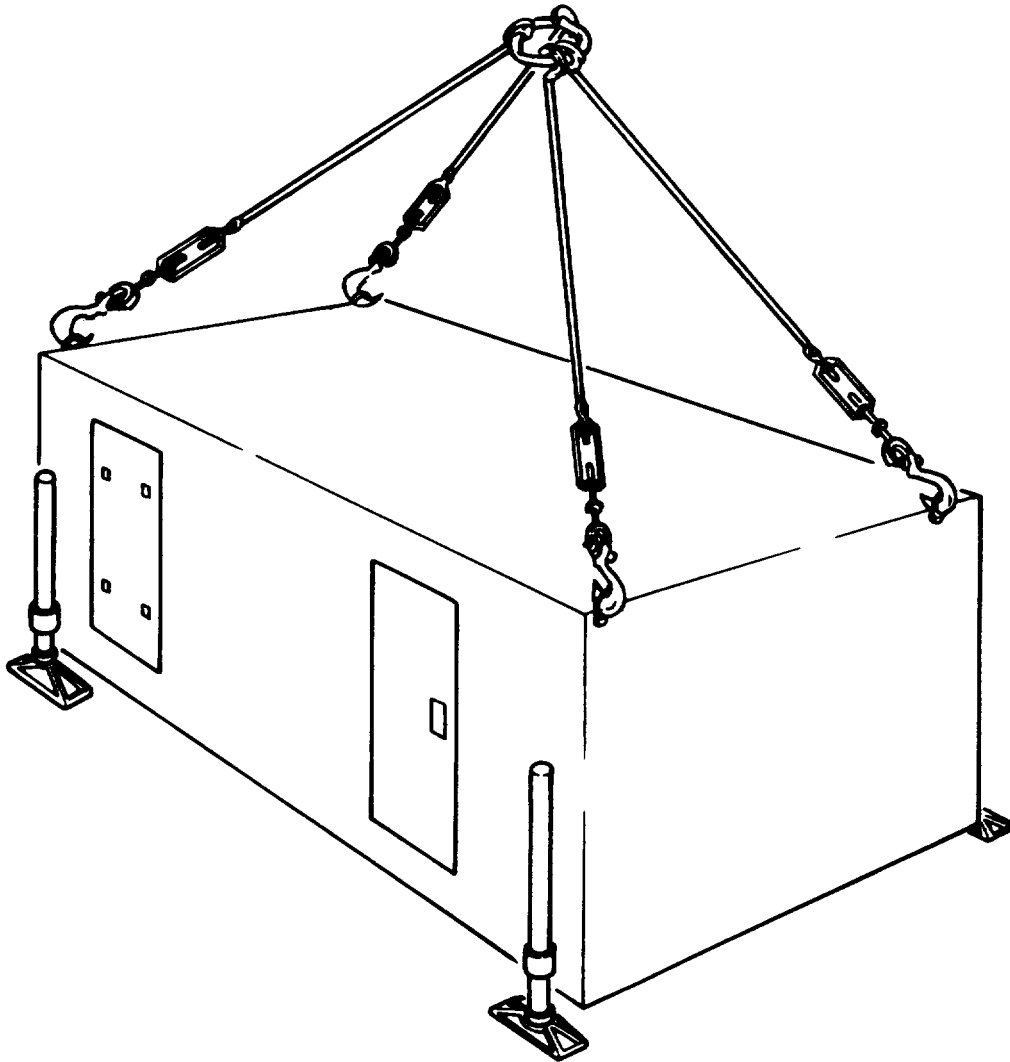

Figure 1-2. Shelter with Lifting Sling and Jacks (Streetside view)

SECTION II

INSTALLATION

2-1. PREPARATION FOR USE.

2-2. SITE SELECTION. It is desirable to select a suitable site for installation before the shelter arrives. The site should be reasonably flat with good drainage.

2-3. SITE PREPARATION. After the site has been selected and before the equipment arrives, the site should be prepared for the installation of the shelter. Perform the following steps to prepare the site:

- a. Survey and stake the site to establish the location of all units and cable runs.
- b. Clear foliage from unit locations, access routes and cable runs.

2-4. INSPECTION. Before accepting the shelter, perform a walkaround inspection. Report any visible shelter damage to supervisory personnel immediately.

2-5. PLACEMENT. When the shelter arrives, it should be positioned in accordance with the desired usage. The shelter can be installed with the Trailer, Transportable Shelter A/M 32U-17 (mobilizer) attached or removed. The shelter can be set up on jacks or it can be set up on the ground. Remove any packing materials or equipment stored in the walk area.

2-6. REMOVING MOBILIZER FROM SHELTER. A placard on the mobilizer provides instructions for operating the mobilizer and disengaging the mobilizer from the shelter. The instructions are repeated in case the placard is not readable. Refer to figure 2-1 for an illustration. Refer to Technical Manual, Operation and Maintenance, Trailer, Transportable Shelter A/M 32U-17 for mobilizer operation.

- a. Set rear mobilizer parking brake.
- b. Disconnect mobilizer from tow vehicle.
- c. Disconnect intervehicular hydraulic brake hose from rear mobilizer. Coil the hose and stow in strap mounted on front mobilizer adapter.
- d. Disconnect intervehicular electrical cable from front and rear mobilizer. Coil the cable and stow in the provided strap on the front mobilizer adapter.
- e. Set pump lever to PUMP position.
- f. Open valves at base of hydraulic cylinders (counterclockwise).
- g. Insert pump handle into pump and operate until hydraulic cylinders are extended on both front and rear mobilizers to relieve pressure on struts.
- h. Release the strut clamp on both front and rear mobilizer. Be sure the clamp is free of the upper strut arm.

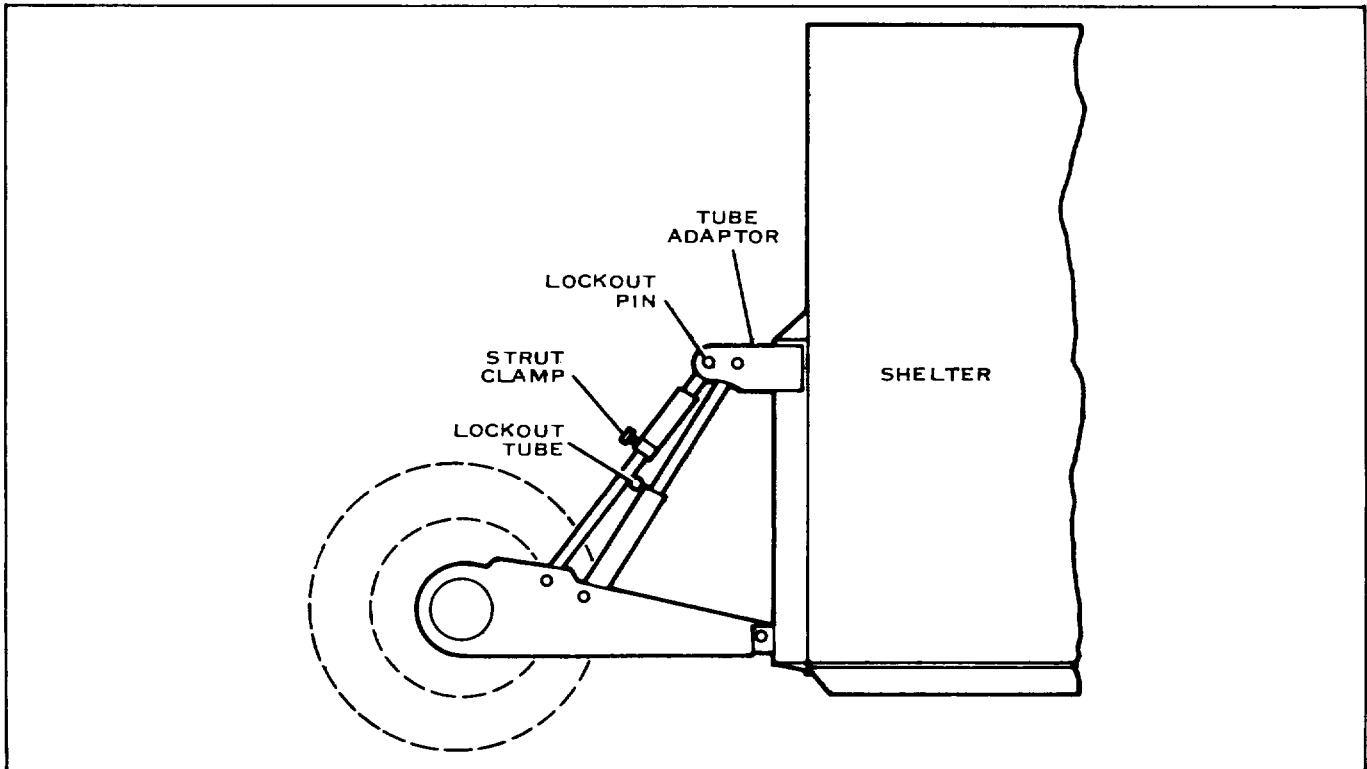

Figure 2-1. Shelter in Transport Configuration

WARNING

Releasing the pump too quickly will allow the payload to drop rapidly causing possible equipment damage and/or personnel injuries. Stand clear of the mobilizer and payload during lowering operation.

While lowering payload do not have tow bar in raised position as damage may occur to the payload front wall.

- i. Slowly position front and rear mobilizer pump control lever to release, easing the payload to approximately 1 inch from the ground.
- j. Remove the lockout pin from the strut assembly.
- k. Remove binder bolts from mobilizer shelter brackets.
- l. Lower payload to the ground, mobilizer should drop free of payload.
- m. Insert the lockout pin through the strut mounting hole and the lockout tube.
- n. Back the mobilizers away from the payload, utilizing tow bar and positioning bar.

2-7. LEVELING JACK INSTALLATION PROCEDURE. Leveling jacks are used when terrain conditions require leveling of the shelter. To install leveling jacks, proceed as follows:

- a. Attach jack to each corner of the shelter using interface provided. Refer to figure 2-2.
- b. Raise jack to allow insertion of the jack pad under the ball joint on the jack.

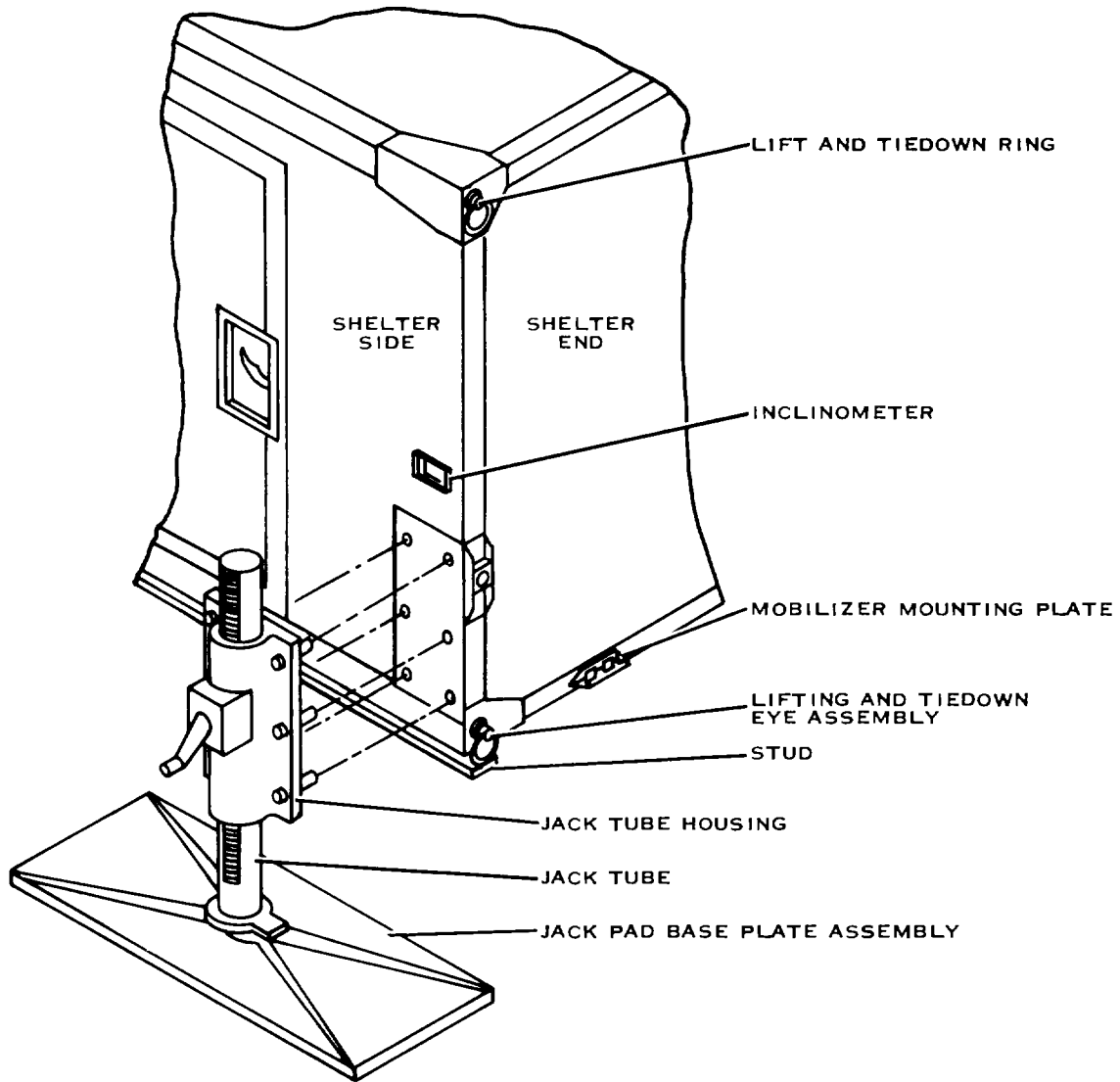

Figure 2-2. Jack and Interface on Shelter

NOTE

Orient jack pad so that the long dimension of the pad is parallel to the shelter sidewall. Lower jack until the ball joint on the jack engages the pocket on the jack pad.

c. To raise shelter, place ratchet wrench in straight down position, flip ratchet lever to right and rotate wrench counterclockwise using the handle provided.

WARNING

To prevent possible injury to personnel, damage to jack assembly or shelter, and for ease of operation, jacking must be done in unison, one man per jack, to allow equal weight distribution on all four jacks during raising and lowering of shelter.

2-8. REMOVABLE ACCESS PANEL. The access panels are removed when needed for installation and/or removal of equipment larger than the door opening will allow. To remove access panel, open slide bolts and remove screws.

2-9. AIR-CONDITIONING GROUP (ACG). Before installation of the ACG ducts, remove the cover plate by removing screws. Install the duct adapter to shelter using screws provided with the ACG cover.

2-10. PREPARATION FOR SHIPMENT.

2-11. PREPARATION FOR LOADING THE SHELTER. Before loading the shelter on the mobilizer for transport a thorough check of the exterior and interior is mandatory. Perform the following steps before moving the shelter.

WARNING

A heavy, movable object not secured in place could cause extensive damage during transit. Failure to disconnect a power line could prove fatal to personnel.

- a. Disconnect all telecommunication lines.
- b. Disconnect all air-conditioning ducts.
- c. Secure all loose gear within shelter.
- d. After loading procedure, remove corner jacks and stow.

2-12. ATTACHING MOBILIZER TO SHELTER. A placard on the mobilizer provides instructions for engaging and operating the mobilizer with the shelter. The instructions are repeated in case the placard is not readable.

- a. Both front and rear mobilizers must be uncoupled and in the down (lowered) position with the lockout pin inserted through the strut lockout tube and strut straight with clamp secure (figure 2-3).
- b. With the shelter in down position, position front and rear mobilizers at opposite ends of the shelter with rear mobilizer at the main door end of the shelter (figure 2-4).
- c. Align lifting lugs with the mount brackets at bottom of shelter. Slots located in the upper mount brackets on the mobilizer adapter should line up with the threaded holes located on the upper shelter bracket.
- d. Raise the adapter until the lower lugs are engaged with the shelter brackets.

NOTE

Lugs on the front mobilizer can be lifted into position by pushing down on the drawbar. Lugs on the rear mobilizer can usually be positioned as follows:

1. Position mobilizer tightly against shelter.
2. Set parking brake.
3. Telescoping bar on rear axle should be removed, extended, locked, inserted in tube on rear axle, and used in the same manner as for the front mobilizer.
 - e. Thread the binder bolts into each of the four (4) upper attachment points.
 - f. Set parking brake on rear mobilizer.
 - g. Loosen strut clamp. Remove lockout pin. Bend strut and align with lockout pin hole as shown in figure 2-5. Reinstall lockout pin.

CAUTION

Never lift the shelter until both mobilizers are attached.

- h. Raise shelter by applying air to hydraulic pump (from towing vehicle) or by pumping with handle.
- i. Lock the extended struts in place by using the strut clamp. Tighten the clamp screw with normal hand pressure.
- j. Close the valve at the base of the hydraulic cylinders (clockwise).

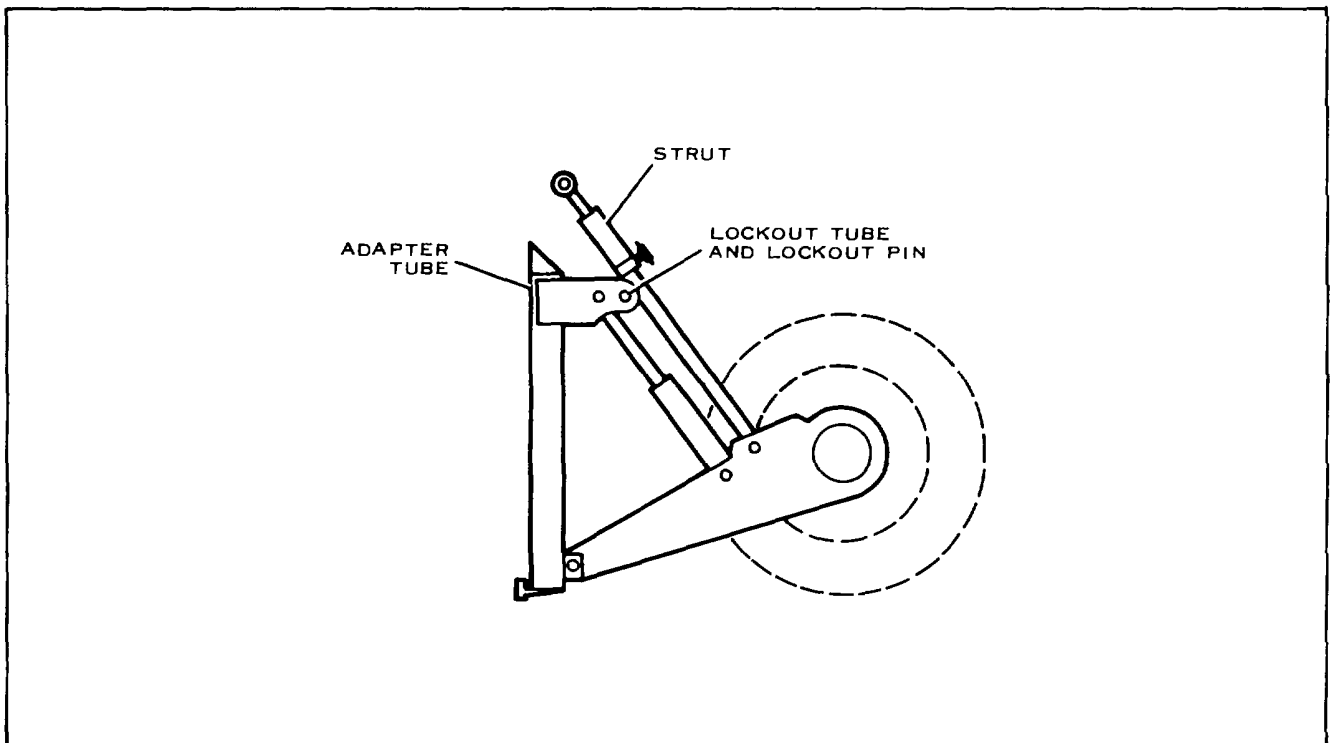

Figure 2-3. Lowered Mobilizer With Lockout Active

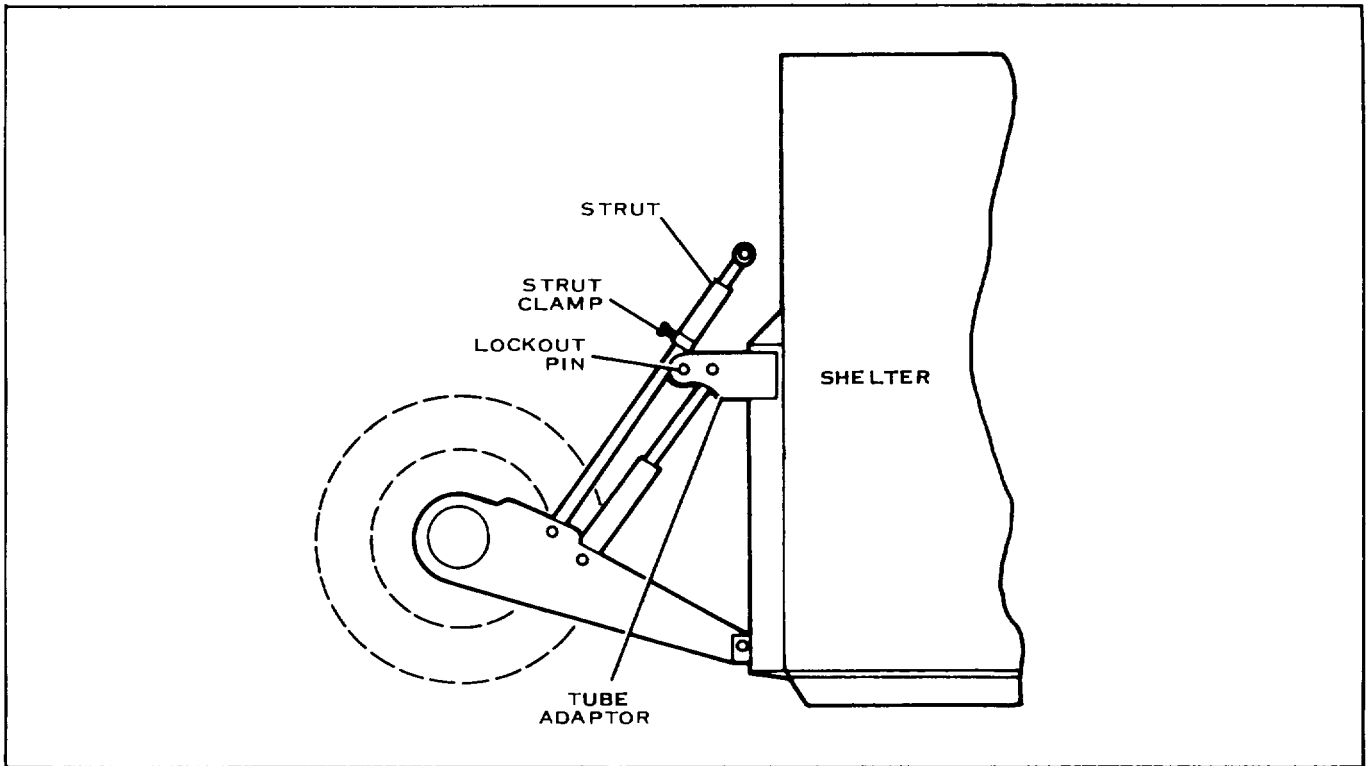

Figure 2-4. Mobilizer to Shelter Alignment

- k. Return the pump handles to the tool box, or air line to stowed position on front mobilizer adaptor.
- l. Connect intervehicular electrical cable and hydraulic brake line between front and rear mobilizers.

m. Before extensive transport, the mobilizer air springs, with payload in raised position, MUST be checked for proper "riding height." The mobilizer/shelter complex shall be parked on an even and level area. Each air spring height should be such that the lower edge of the shield on the shock absorber, adjacent to the air spring, aligns with the top of the white half moon painted on its body. Remove air from those air springs which require a reduction in air pressure first (shield above half moon); then, if necessary, add air to those requiring additional pressure to gain proper riding height (shield covers half moon). If an adjustment is made on any of the air springs, recheck the other air springs to determine its effect on them and readjust if required.

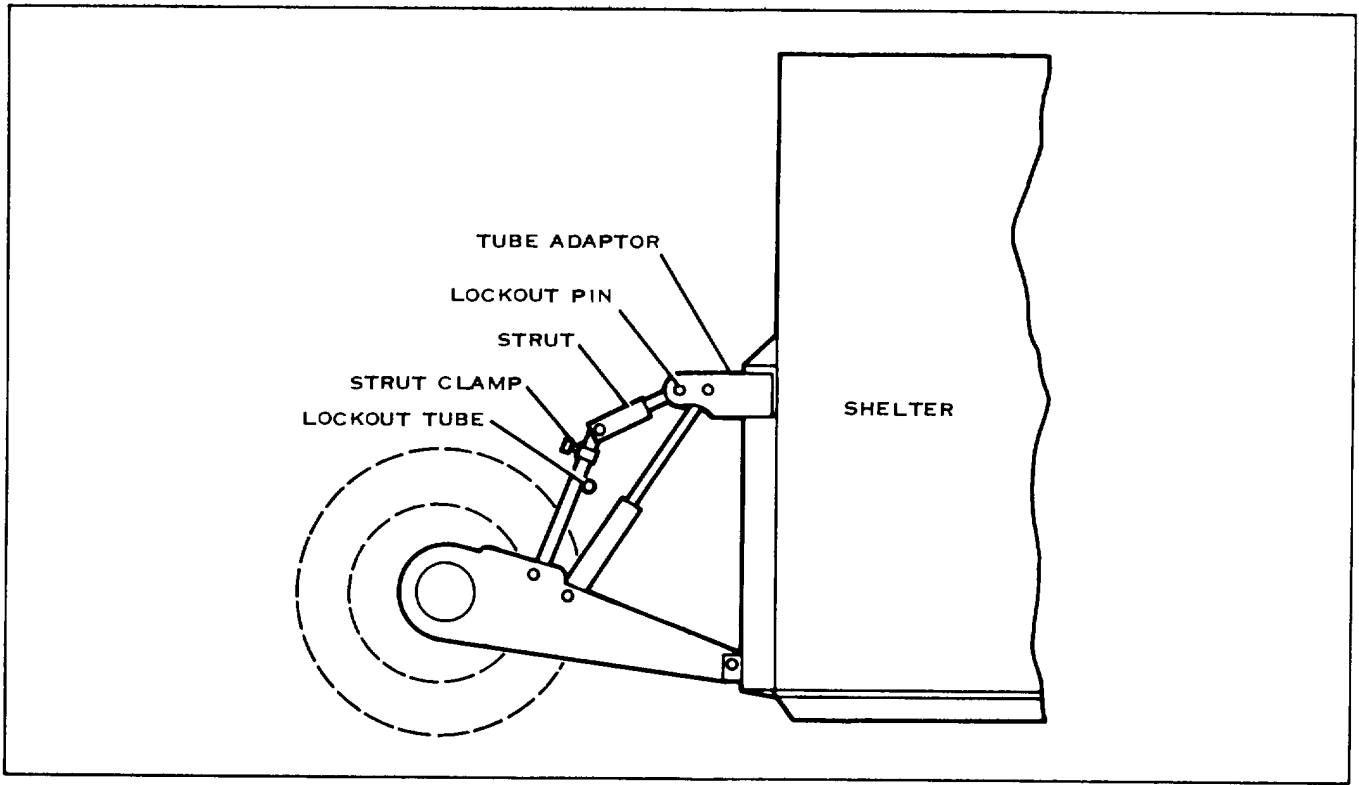

Figure 2-5. Mobilizer With Shelter Partially Raised

SECTION III
MAINTENANCE

3-1. CLEANING.

3-2. Instructions for cleaning the shelter are presented in the workcards listed in table 1-1.

3-3. PAINTING.

3-4. All exterior surfaces of the shelter shall be conversion coated per MIL-P-5541 followed by one coat of wash primer per MIL-P-15328, one coat of MIL-P-23377 class 1, epoxy primer and two coats of MIL-C-83286, type 1, class 3, color no. 24052 per FED-STD-595.

3-5. SHELTER SKIN REPAIR.

3-6. **REPAIRING DELAMINATED AREAS IN SHELTER SKIN.** Delaminated areas can be detected by movement of skin much like an oil-can effect. Large delaminations should be repaired to restore overall strength to shelters.

3-7. Materials necessary to repair delaminations are provided below:

- a. AK66H pop rivets
- b. Epic 794-1 adhesive
- c. Versamid 140 resin material
- d. Sealant cartridges
- e. Gloves, polyethylene
- f. Polyethylene film material approximately 7 to 10 mils thick
- g. J-7 body filler material (with instruction for use)
- h. Toluol solvent material and/or alcohol.

3-8. Determine delaminated area by tapping with a light, blunt instrument. A delaminated area will have a dull sound compared to undamaged areas. Sound will also change as tapping crosses mounting members.

CAUTION

Make sure drill bit has a drill stop attached which will prohibit the drill bit from exceeding a depth of 5/8 inch.

a. On completion of sounding, check the approximate center of the delaminated area and drill a 3/16-inch diameter hole through affected skin only. Refer to figure 3-1 as a visual guide. This hole will be used to pump epoxy into delaminated area.

b. Drill 3/6-inch diameter pressure release holes no closer than 1/2 inch from the edge of the delaminated surface.

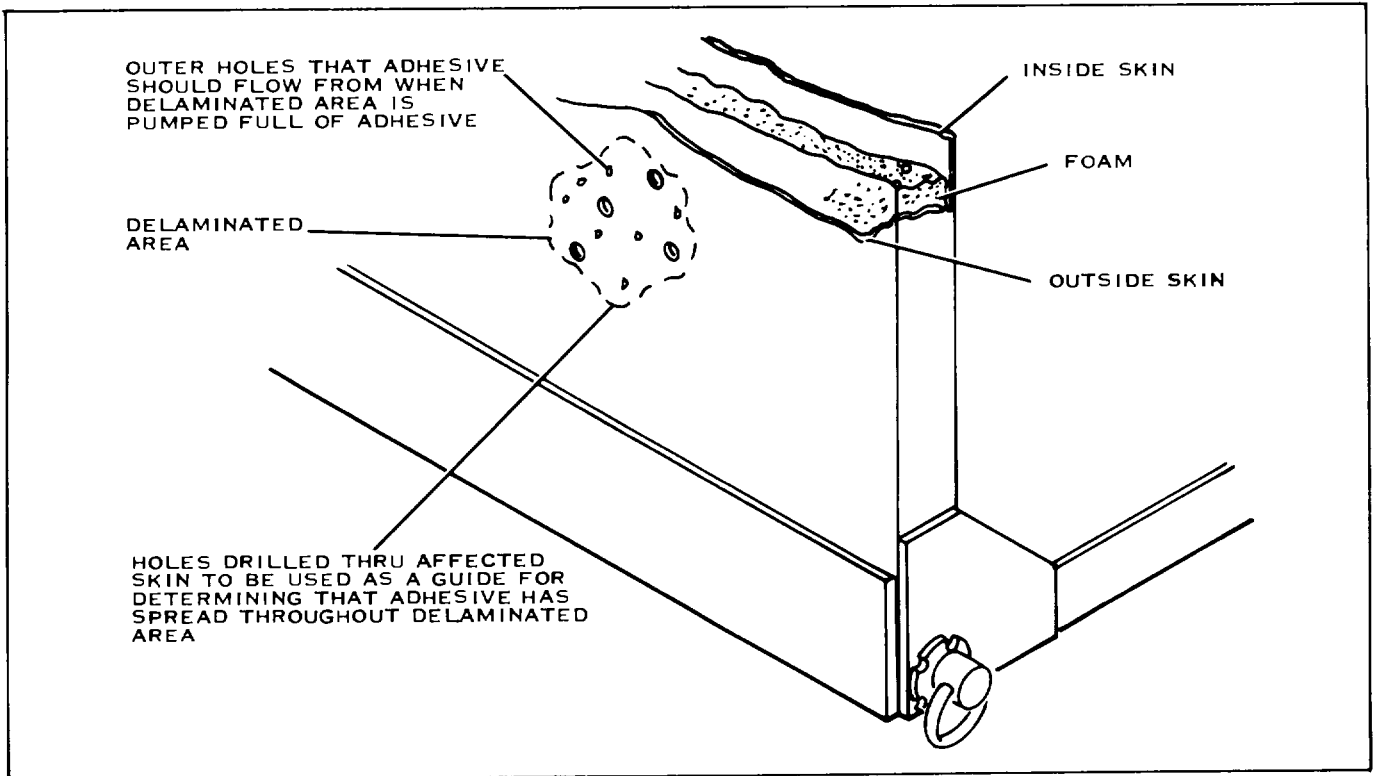

Figure 3-1. Delamination Repair

WARNING

Throwaway plastic gloves are to be worn when mixing and applying adhesive material because of possible skin irritation caused by adhesive coming into contact with the body skin surface. The Versamid material is extremely sensitive to moisture absorption. Therefore, make sure Versamid 140 container has lid firmly replaced after material has been removed from shipping or storage container. Both the Epic JS-794-1 and the Versamid 140 materials have a shelf life of 1 year.

c. Using the outline of the marked delaminated area, mask off the surrounding area approximately a width of 2 feet with Kraft wrapping paper or newspaper. Using unwaxed clean containers, mix the Epic Adhesive and Versamid material as follows:

- By weight-15 parts Epic JS-794-1 to 5 parts of Versamid 140
- By volume-2 parts of Epic JS-794-1 to 1 part of Versamid 140.

Utilizing a plastic cartridge similar to a caulking cartridge containing the mixed adhesive material, start at the center hole and inject the adhesive material into the void area. Remove cartridge and knead or roll lightly with a roller over the adhesive filled skin surface, making sure the adhesive fills evenly all void areas and that air entrapment and adhesive is moved out through outer holes. Tape center hole shut with masking tape after injecting with adhesive.

CAUTION

Do not saturate area with solvent. Use light cleaning strokes only.

WARNING

Toluol (toluene) and alcohol are airborne toxicants and are flammable. These materials should only be used for short duration and with good ventilation. Vapor should *not* be inhaled. Material should not be used if only one person is present. After use, the area should be vacated until the air turnover has reduced the vapor content.

- d. Clean off excess adhesive with toluol solvent (cloth lightly coated).
- e. Apply polyethylene sheet material over the delaminated skin area.
- f. Using the recommended flat surface of $\frac{1}{2}$ inch or heavier plywood sheeting placed against the polyethylene sheet material, apply an even surface pressure of approximately 1 pound per square inch to the repaired area for a period of not less than 12 hours.
- g. After the adhesive has been allowed to dry the required time, clean the surface area with Scotchbrite rubbing pad and wipe clean with toluol and/or alcohol. Proceed as follows before applying finish paint.
- h. Redrill a 0.190 diameter (#11 drill) x $\frac{1}{8}$ -inch deep hole at each of the holes previously provided in paragraphs 3-7(a) and 3-7(b). Slightly dimple the drilled hole interior skin area with a punch (0.062 X 120 degrees) and install a $\frac{3}{8}$ -inch diameter countersunk "pop" rivet AK66H.
- i. Fill the hollow core portion of the pop rivet and any surrounding uneven surface with J-7b body filler material. Allow to dry minimum of 1 hour. Grind surface smooth and complete finish paint cycle.

3-9. REPAIRING SHELTER SKIN PUNCTURES. Punctured areas of any size should be repaired to prevent moisture from entering shelter. Table 3-1 provides a list of materials necessary to perform maintenance on the shelter. Use the following procedure:

- a. Use aluminum sheet material of any alloy at least 0.032-inch thick and large enough to overlay punctured area by at least 1 inch on all sides to cover puncture.
- b. Drill $\frac{1}{8}$ -inch diameter holes around edges of patch.
- c. Center the patch over punctured area and mark holes on shelters.
- d. Pierce or drill small holes in shelter skin to attach patch. Use proper size punch or drill for screws or pop rivets to be used to attach patch. Mark around patch to indicate area to be cleaned.
- e. Remove patch and thoroughly clean marked area with emery cloth and wipe off residue with a clean cloth.
- f. Fill puncture cavity with shredded or block insulation such as polyurethane or polystyrene foam.
- g. Mix two part epoxy adhesive.
- h. Wipe off aluminum surface to be patched and clean patch.
- i. Apply epoxy adhesive to back of patch and cleaned shelter surface.
- j. Position the patch, dip fasteners in adhesive and apply fasteners, working from the center of each side to the corners.
- k. Smooth and taper adhesive (squeezed out during fastening process) along the edges of the patch and around the heads of each sheet metal screw. Clean off excess adhesive.
- l. After the adhesive has dried, clean and paint repaired area.

Table 3-1. Shelter Repair Material

Quantity	Name
3	Prepunched aluminum patches, 12 X 12 X 0.040 inches thick
2	Prepunched aluminum patches, 6 X 8 x 0.040 inches thick
2 sheets	Coarse grit
1	Awl
1	Plastic bag of shredded foam (approximately 5 H x 5 W x 12-inch L)
2	Maximum sticks (tongue depressors)
1	Adhesive kit (two-part epoxy)
4	Paint brush, 1 inch
1 gross	Phillips-head sheet metal screws (#6-X2-inch L)
1	Phillips screwdriver
1	Paint (1/2 pint can), color #23, Marine Corps green semi-gloss
1	Instruction sheet
1	Reusable container

RECOMMENDED CHANGES TO EQUIPMENT TECHNICAL PUBLICATIONS



SOMETHING WRONG WITH THIS PUBLICATION?

FROM: (PRINT YOUR UNIT'S COMPLETE ADDRESS)

DATE SENT

PUBLICATION NUMBER

PUBLICATION DATE

PUBLICATION TITLE

BE EXACT... PIN-POINT WHERE IT IS

PAGE
NO.

PARA-
GRAPH

FIGURE
NO.

TABLE
NO.

IN THIS SPACE TELL WHAT IS WRONG
AND WHAT SHOULD BE DONE ABOUT IT:

TEAR ALONG PERFORATED LINE

PRINTED NAME, GRADE OR TITLE, AND TELEPHONE NUMBER

SIGN HERE:

DA FORM 2028-2
1 JUL 79

PREVIOUS EDITIONS
• ARE OBSOLETE.

P.S.—IF YOUR OUTFIT WANTS TO KNOW ABOUT YOUR
RECOMMENDATION MAKE A CARBON COPY OF THIS
AND GIVE IT TO YOUR HEADQUARTERS.

PIN: 046584 - 000

This fine document...

Was brought to you by me:



[Liberated Manuals -- free army and government manuals](#)

Why do I do it? I am tired of sleazy CD-ROM sellers, who take publicly available information, slap “watermarks” and other junk on it, and sell it. Those masters of search engine manipulation make sure that their sites that sell free information, come up first in search engines. They did not create it... They did not even scan it... Why should they get your money? Why are not letting you give those free manuals to your friends?

I am setting this document FREE. This document was made by the US Government and is NOT protected by Copyright. Feel free to share, republish, sell and so on.

I am not asking you for donations, fees or handouts. If you can, please provide a link to liberatedmanuals.com, so that free manuals come up first in search engines:

<A HREF=<http://www.liberatedmanuals.com/>>Free Military and Government Manuals

- Sincerely
Igor Chudov
<http://igor.chudov.com/>
- [Chicago Machinery Movers](#)