

TECHNICAL MANUAL

DIRECT SUPPORT MAINTENANCE REPAIR

PARTS AND SPECIAL TOOLS LISTS

(INCLUDING DEPOT MAINTENANCE REPAIR

PARTS AND SPECIAL TOOLS)

FOR

RADAR TARGET SIMULATOR

GROUP OH-36/GPN

(NSN 5840-00-138-9974)

HEADQUARTERS, DEPARTMENT OF THE ARMY

15 DECEMBER 1981



DIRECT SUPPORT MAINTENANCE REPAIR PARTS

AND SPECIAL TOOLS LISTS

(INCLUDING DEPOT MAINTENANCE

REPAIR PARTS AND SPECIAL TOOLS)

FOR

RADAR TARGET SIMULATOR

GROUP OH-36/GPN

(NSN 5840-00-138-9974)

Current as of 29 June 1981

REPORTING ERRORS AND RECOMMENDING IMPROVEMENTS You can help improve this manual. If you find any mistakes or if you know of a way to improve the procedures, please let us know. Mail your letter, DA Form 2028 (Recommended Changes to Publications and Blank Forms), or DA Form 20282 located in back of this manual direct to: Commander, US Army Communications-Electronics Command, ATTN: DRSEL-ME-MQ, Fort Monmouth, NJ 07703.

In either case, a reply will be furnished direct to you

Table of Contents

			Page	Illus Figure
SECTION I	Introduction		1	
	II. Repair Parts List		5	
Group 00	Radar Target Simulator Group OH-36/GPN		5	1
01	Control Module.....		9	2
	0101 BCD and Rate Multiplexer (1A 1) (No parts authorized)			
	0102 Memory and Display Latch (1A2) (No parts authorized)			
	0103 Analog/Digital Converter (1A3) (No parts authorized)			
	0104 Range and Pulse Generator (1A4) (No parts authorized)			
	0105 Program Controller (1A5) (No parts authorized)			
	0106 Arithmetic Logic Unit (ALU) (1A6) (No parts authorized)			
	0107 Mother Board Assembly (1A8) 13.....		13	
	0108 Power Supply ± 15 VDC (1A9).....		17	4
	010801 Power Supply PCB (1A9A1) (No parts authorized)			
	0109 Power Supply +0.5 VDC (1PS1).....		19	5
	0110 Control Module Panel Assembly.....		21	6
	0111 Extender Card (1A7) (No parts authorized)			
02	Target Module Assembly		5	7
	0201 Display Module (2A1) (No parts authorized)			
	0202 Audio Amplifier Assembly (2A2) (No parts authorized)			
03	Target Module Assembly (Same as Group 02)			
	0301 Display Module (3A1) (Same as Group 0201)			

*This manual supersedes TM 11-5840-359-34P, 29 June 1979.

		Page	Illus Figure
Group	03 0302 Audio Amplifier Assembly (9A2) (Same as Group 0202)		
	04 Target Module Assembly (Same as Group 02)		
	0401 Display Module (4A1) (Same as Group 0201)		
	0402 Audio Amplifier Assembly (4A2) (Same as Group 0202)		
	05 Student Communication Station Assembly.....	29	8
	06 Student Communication Station Assembly (Same as Group 05)		
	0601 Audio Amplifier Assembly (17A1) (Same as Group 0501)		
	07 Student Communication Station Assembly (Same as Group 05)		
	0701 Audio Amplifier Assembly 18A1 (Same as Group 0501)		
	08 Headset and Microphone (No parts authorized)		
	09 Headset and Microphone Same as Group 08)		
	10 PAR/ASR Junction Box Assembly 535085E62005-1	31	9
	1001 Case E60019-8 (No parts authorized)		
	1002 Panel Assembly E60016-.....	35	10
	100201 PC Card Assembly E63127-1 (No parts authorized)		
	100202 PC Card Assembly E63117-1 (No parts authorized)		
	100203 PC Card Assembly E63122-3 (No parts authorized)		
	11 PAR/ASR Junction Box Assembly 535085E62006-1	37	11
	1101 Case E60019-9 (No parts authorized)		
	1102 Panel Assembly E60016-11.....	41	12
	110201 PC Card Assembly E63118-1 (No parts authorized)		
	110202 PC Card Assembly E63128-1 (No parts authorized)		
	110203 PC Card Assembly E63122-1 (No parts authorized)		
	12 Alignment Fixture	43	13
	Alignment Fixture, Switch Assembly	45	14
	13 Cable Assembly E64102-1	47	15
	14 Cable Assembly E64104-1	47	15
	15 Cable Assembly E64107-2	49	16
	16 Cable Assembly E64109-3	51	17
	17 Cable Assembly E64114-23	53	18
	18 Cable Assembly E64114-24 (Same as Group 17)		
	19 Cable Assembly E64114-25	53	18
	20 Cable Assembly E64114-26 (Same as Group 19)		
	21 Cable Assembly E64116-1	53	18
	22 Cable Assembly E64115-1		
	23 Cable Assembly E64115-3 (Same as Group 21)		
	24 Cable Assembly E64117-13	55	19
	26 Cable Assembly E64117-14 (Same as Group 24)		
	26 Cable Assembly E64117-15	55	19
	27 Cable Assembly E64117-16		
	28 Cable Assembly E64118-1	57	20
	29 Transit Case E60020-2 (No parts authorized)		
	30 Transit Case E60018-2 (No parts authorized)		
	31 Transit Case E60018-4 (No parts authorized)		
	32 Transit Case E60023-2 (No parts authorized)		
Section	III. Special Tools List (Not applicable)		
	IV. National Stock Number and Part Number Index.....	58	

SECTION I

INTRODUCTION

1.Scope

This manual lists spares and repair parts; special, tools; special test, measurement, and diagnostic other special support equipment required for performance of direct support maintenance of the OH-36/GPN. It authorizes the requisitioning and issue of spares and repair parts as indicated by the source and maintenance codes. normal supply channels.

Code

Definition

PD-Support item, excluding support equipment, procured for initial issue or outfitting and stocked only for subsequent or additional initial issues or outfitting. Not subject to automatic replenishment.
 XD-A support item that is not stocked. When required, item will be procured through normal supply channels.

2. General

This Repair Parts and Special Tools List is divided into the following section:

a Section II. Repair Parts List. A list of spares and repair parts authorized for use in the performance of maintenance. The list also includes parts which must be removed for replacement of the authorized parts. Parts list are composed of functional groups in numeric sequence, with the parts in each group listed in figure and time number sequence.

b Section III. Special Tools List. Not applicable. as follows:

c Section IV. National Stock Number and Part Number Index. A list in National item identification number (NIIN) sequence, of all National stock numbers (NSN) appearing in the listings, followed by a list, in alphanumeric sequence, of all part numbers sequence, of all part numbers appearing in the listings. National stock numbers and part numbers are cross referenced to each illustration figure and item number appearance.

3. Explanation of Columns

a Illustration. This column is divided as follows:

(1) *Figure number.* Indicates the figure number of the illustration on which the item is show.

(2) *Item number.* The number' used to identify item called out in the illustration.

b. Source, Maintenance, and Recoverability repaired (SMR) Codes.

(1) *Source code.* Source codes indicate the manner of acquiring support items for maintenance, repair, or overhaul of end items, Source codes are entered in the first and second positions of the Uniform SMR Code format as follows:

Code Definition

PA-Item procured and stocked for anticipated or.,

NOTE

Cannibalization or salvage may be used as a source of supply for any items source coded above except those coded XA and aircraft support items as restricted by AR 700-42.

(2) *Maintenance code.* Maintenance codes are assigned to indicate the levels of maintenance authorized to USE and REPAIR support items. The maintenance codes are entered in the third and fourth positions of the Uniform SMR Code format as follows:

(a) the maintenance code entered in the third position will indicate the lowest maintenance level authorized to remove, replace, and use the support item. The maintenance code entered in the third position will indicate one of the following levels of maintenance:

Code Application/Explanation

F-Support item is removed, replaced, used at the direct support level.
 D-Support items that are removed, replaced, used at depot, mobile depot, specialized repair activity only.
 (b) The maintenance code entered in the fourth position indicates whether the item is to be repaired and identifies the lowest maintenance level with the capability to perform complete repair(i.e., all authorized maintenance functions). This position will contain one of the following maintenance codes:

Code Application/Explanation

F-The lowest maintenance level capable of complete repair of the support item is the direct support level.
 D-The lowest maintenance level capable of complete repair of the support item is the depot level.

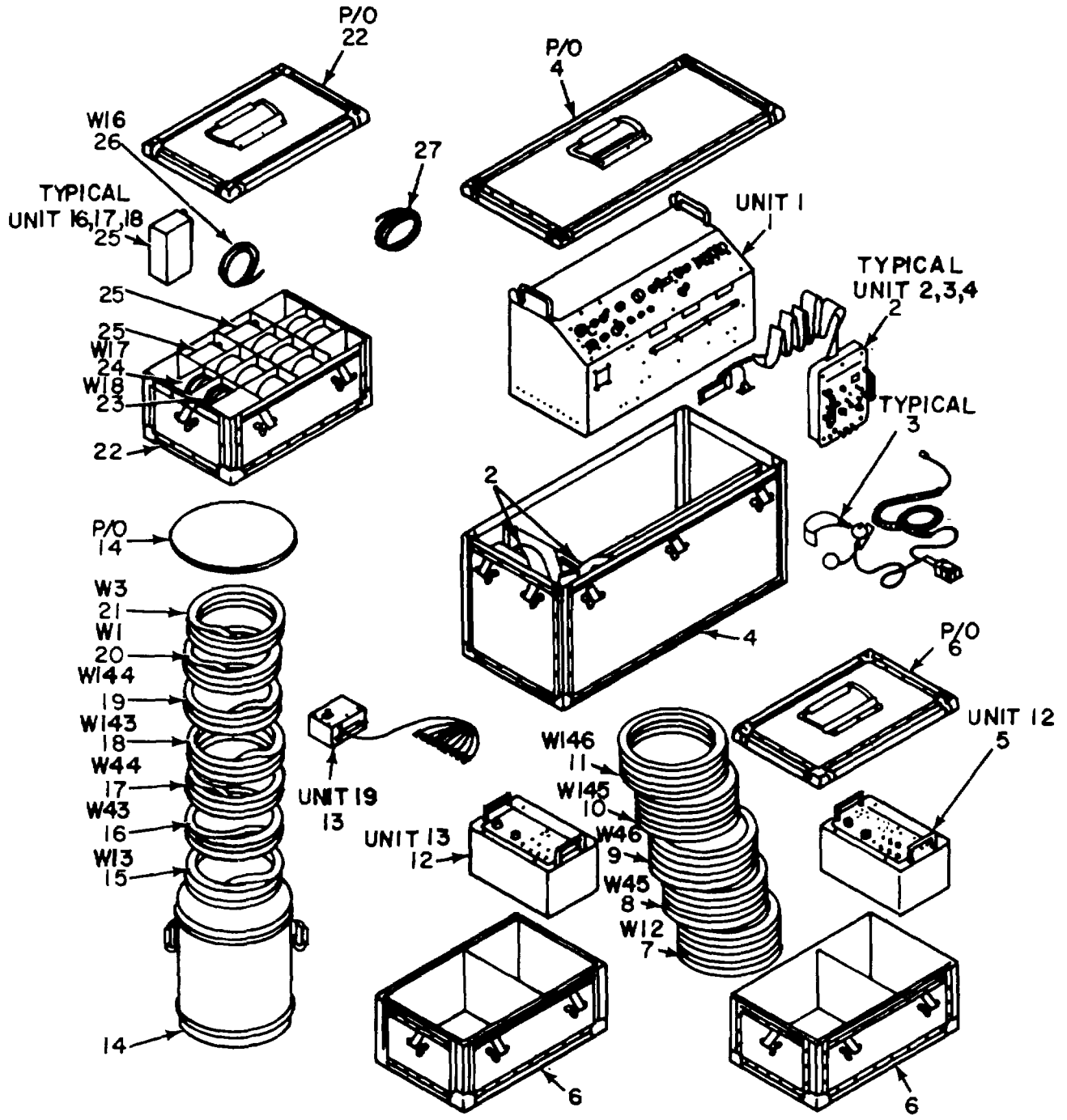

EL5WDO01

Figure 1. Radar Target Simulator Group OH-W/GPN.

SECTION II

TM 11-5840-359-30P

(1) ILLUSTRATION		(2)	(3)	(4)	(5)	(6)	(7)	(8)
(a) FIG NO.	(b) ITEM NO.	SMR CODE	NATIONAL STOCK NUMBER	FSCM	PART NUMBER	DESCRIPTION USABLE ON CODE	U/M	QTY INC IN UNIT
						GROUP 00 RADAR TARGET SIMULATOR GROUP OH- 36/GPN		
1	1	PDFFF	5840-01-017-7044	57230	35085E60010-2	CONTROL MODULE	EA	1
1	2	XDFFD	5840-01-017-6968	57230	535081E60011-2	TARGET MODULE	EA	1
1	3	KDFDL	5965-00-614-7280	80058	H-170/U	HEADSET-ICROPHNE	EA	1
1	4	XDDDL		23259	535085E60020-2	TRANSIT CASE.....	EA	1
1	5	PDFFF	5840-00-138-9976	23259	35085162005-1	J, BOX SPECIAL PPO.....	EA	1
1	6	XDDDL		23259	535085E60018-4	TRANSIT CASE.....	EA	2
1	7	XDFFF		23259	53508E64109-3	CABLE ASSEMBLY(SEE FIG-17 FOR PARTS BREAKDOWN)	EA	1
1	8	XDFFF		23259	535085E64114-25	CABLE ASSEMBLY(SEE FIG 18 FOR PARTS BREAKDOWN)	EA	1
1	9	XDFFF		23259	535085164114-26	CABLE ASSEMBLY(SEE FIG 18 FOR PARTS BREAKDOWN)	EA	10
1	10	XDFFF		23259	535085E64117-15	CABLE ASSEMBLY(SEE FIG 19 FOR PARTS BREAKDOWN)	EA	1
1	11	XDFFF		23259	535085E64117-16	CABLE ASSEMBLY(SEE FIG 19 FOR PARTS BREAKDOWN)	EA	1
1	12	PDFFF	5810-00-138-9975	23259	535085162006-1	J.BOX SPECIAL PURPO.....	EA	1
1	13	XDFDL		23259	535085E60026-1	ASSEMBLY.ALIGN FTR	EA	1
1	14	XDDDL		23259	35085E6023-2	TRANSIT CASE.....	EA	1
1	15	XDFF		23259	5350851E64107-2	CABLE ASSEMBLY(SEE FIG 16 FOR PARTS BREAKDOWN)	EA	1
1	16	XDFFF		23259	535085E64114-23	CABLE ASSEMBLY(SEE FIG 18 FOR PARTS BREAKDOWN)	EA	1
1	17	XDFFF		23259	535085E64114-24	CABLE ASSEMBLY(SEE FIG 18 FOR PARTS BREAKDOWN)	EA	1
1	18	XDFFF		23259	535085E64117-13	CABLE ASSEMBLY(SEE FIG 19 FOR PARTS BREAKDOWN)	EA	1
1	19	XDFFF		23259	535085E44117-14	CABLE ASSEMBLY(SEE FIG 19 FOR PARTS BREAKDOWN)	EA	1
1	20	XDFFF		23259	535085E64102-1	CABLE ASSEMBLY(SEE FIG 15 FOR PARTSBREAKDOWN)	EA	1
1	21	XDFFF		23259	535085E64104-1	CABLE ASSEMBLY(SEE FIG 15 FOR PARTS BREAKDOWN)	EA	1
1	22	XDDDL		23259	535085E101&2	TRANSIT CASE	EA	1
1	23	XDFFF		23259	535085E64115-3	CABLE ASSEMBLY(SEE FIG 18 FOR PARTS BREAKDOWN)	EA	1
1	24	XDFFF		23259	535085164115-2	CABLE ASSEMBLY(SEE FIG 18 FOR PARTS BREAKDOWN)	EA	1
1	25	PDFFF	5840-01-008-4110	57230	535085E60009-2	COMMUNICATIONS DEVI	EA	3
1	26	XDFFF		23259	535085E64115-1	CABLE ASSEMBLY(SEE FIG 18 FOR PARTS BREAKDOWN)	EA	1
1	27	XDFFF		23259	535085E64118-1	CABLE ASSEMBLY(SEE FIG 20 FOR PARTS BREAKDOWN)	EA	1

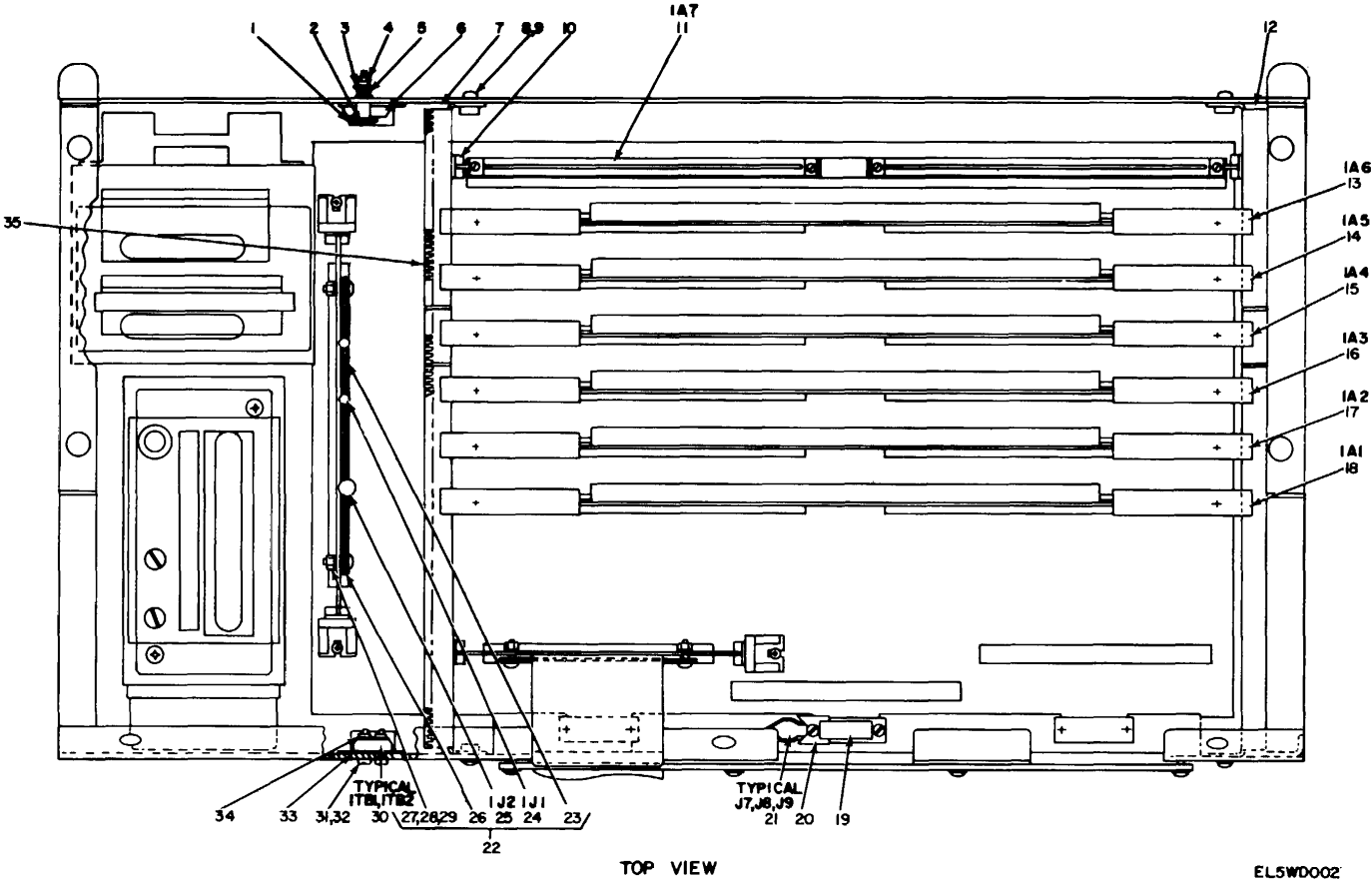

Figure 2. Control Module (Sheet 1 of 3)

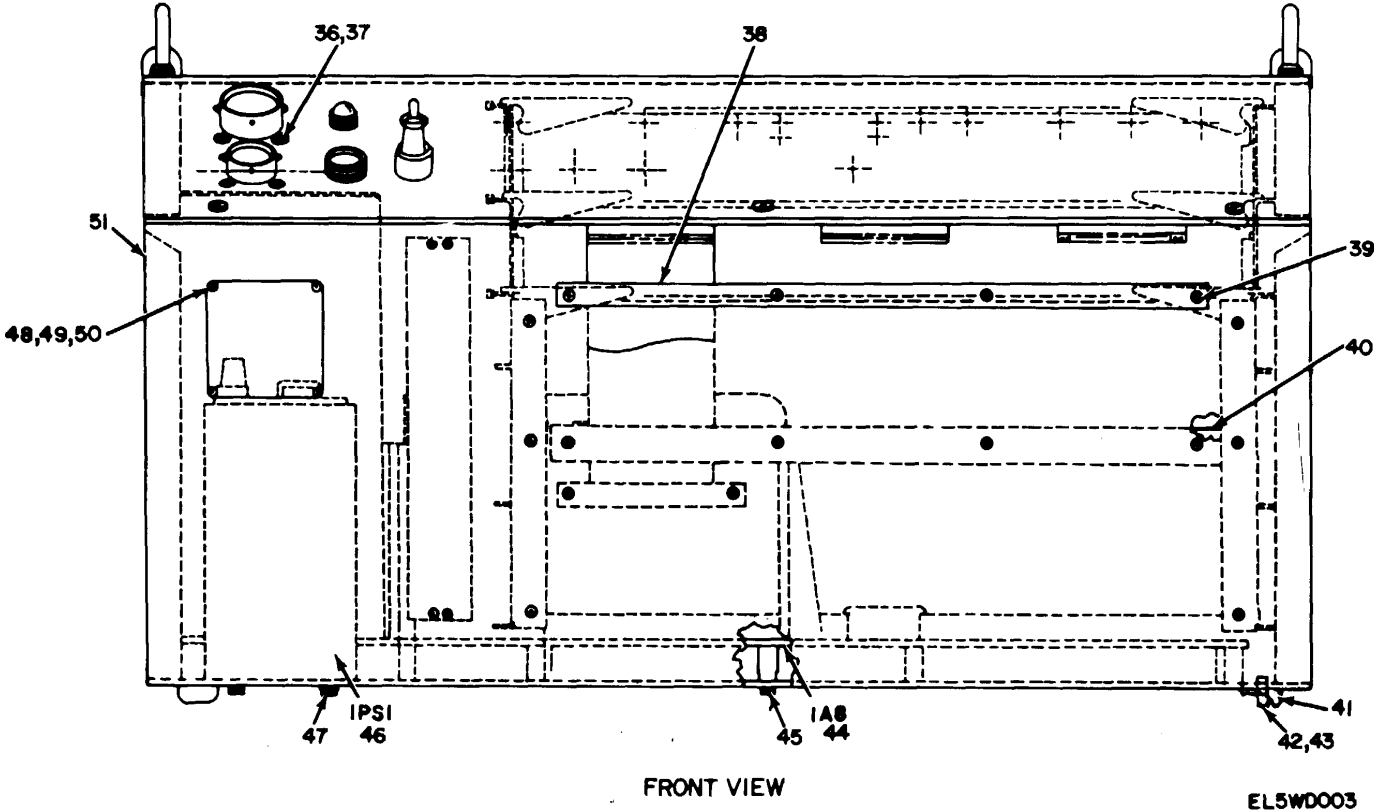
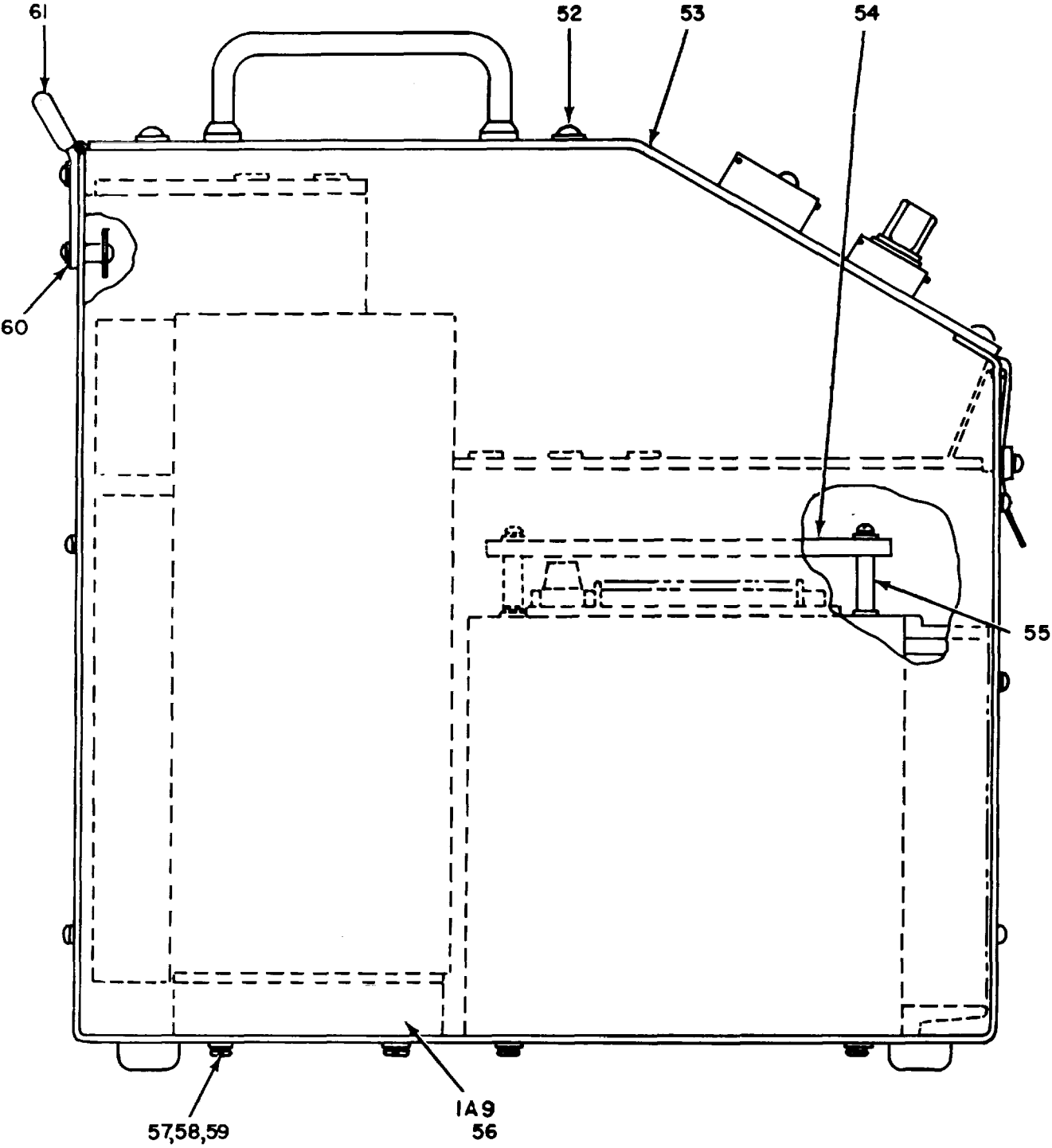

Figure 2. Control Module Sheet 2of3).

EL5W003



SIDE VIEW

EL5WD004

Figure 2 ③. Control Module (Sheet 3 of 3.)

SECTION II

TM 11-5840-359-30P

(1) ILLUSTRATION		(2)	(3)	(4)	(5)	(6)	(7)	(8)
(a) FIG NO.	(b) ITEM NO.	SMR CODE	NATIONAL STOCK NUMBER	FSCM	PART NUMBER	DESCRIPTION USABLE ON CODE	U/M	QTY INC IN UNIT
						GROUP 01 CONTROL MODULE		
2	1	PAFZZ	5940-00-839-0828	81349	SEZAXFOL	TERMINAL STUD.....	EA	1
2	2	PAFZZ	5305-00-984-6197	96906	MS35206-Z29	SCREW, MACHINE.....	EA	1
2	3	PAFZZ	5310-00-619-3847	96906	S795-707	WASHER FLAT.....	EA	1
2	4	PAFZZ	5310-00-045-3299	96906	MS35338-42	WASHER, LOCK.....	EA	10
2	5	PAFZZ	5310-00-934-9757	96906	S535649-212	NUT, PLAIN HEXAGON.....	EA	12
2	6	PAFZZ	5940-00-632-7234	75382	600J	BUS, CONDUCTOR.....	EA	17
2	7	XDFZZ		23259	535085E10007-4	BRACKET ASSEMBLY LH.....	EA	1
2	8	PAFZZ	5305-00-914-4989	96906	MS35206-229	SCREW.MACHINE.....	EA	12
2	9	PAFZZ	5310-00-595-6333	96906	MS15795-705	WASHER, FLAT.....	EA	29
2	10	XOFZZ	5999-00-843-0925	07556	RAD1125	GUIDE, PRINTER CIRCU.....	EA	24
2	11	XOFZZ		23259	535085F63107-1	EXTENDER ASSEMBLY.....	EA	1
2	12	XDFZZ		23259	535085E10007-5	BRACKET ASSEMBLY.RH.....	EA	1
2	13	XDFDL	6940-01-034-6421	57230	535085E63106-	CIRCUIT CARD ASSEMB.....	EA	1
2	14	XDFDL	6930-01-026-8420	89297	535085E63105-	CIRCUIT CARD ASSEMB.....	EA	1
2	15	XDFDL	6930-01-026-8066	89297	535085E63104-	CIRCUIT CARD ASSEMB.....	EA	1
2	16	XDFDL	6930-01-026-8065	89297	535085E63103-	CIRCUIT CARD ASSEMB.....	EA	1
2	17	XDFDL	6930-01-026-8064	89297	535085E63102-	CIRCUIT CARD ASSEMB.....	EA	1
2	18	XDFDL	6940-01-030-0953	57230	535085E63101-I	CIRCUIT CARD ASSEMB.....	EA	1
2	19	XDFZZ		71408	D110277	SPRING LATCH ASSY.....	EA	1
2	20	PAFZZ	5310-00-543-2410	96906	MS353380-40	WASHER.LOCK.....	EA	23
2	21	PAFZZ	5935-00-490-5220	81349	M24308-2-2	CONNECTOR, RECEPTAC.....	EA	3
2	22	XDFFF		23259	53505E64100-1	CABLE ASSEMBLY.....	EA	1
2	23	XDFZZ		23259	535085E13120-	PRINTED WIRING BD.....	EA	1
2	24	PAFZZ	5935-00-726-7075	96906	HS3122EZ2-55P	CONNECTOR.RECEPTAC.....	EA	1
2	25	PAFZZ	5935-00-990-4557	96906	NS3122E18-32P	CONNECTOR, RECEPTAC.....	EA	1
2	26	XDFZZ		23250	53508E11006-12	CLAM.....	EA	1
2	27	PAFZZ	5305-00-889-3000	96906	155206-230	SCREW.MACHINE.....	EA	6
2	28	PAFZZ	5310-00-807-1465	96906	MS21042-06	NUT.SELF-LOCKING, EX.....	EA	4
2	29	PAFZZ	5310-00-595-6333	96906	KS15795-705 H	WASHER.FLAT.....	EA	4
2	30	XDFZZ		75382	600-20	TERMINAL BOARD.....	EA	2
2	31	PAFZZ	5305-00-983-6730	96906	35218	SCREW MACHINE.....	EA	4
2	32	PAFZZ	5310-00-656-0111	96906	MSI5795-703	WASHER.FLAT.....	EA	25
2	33	XDFZZ		96906	MS60020-BE	MARKER STRIP.....	EA	2
2	34	PAFZZ	5310-00-811-6419	96906	MS21042-04	NUT.SELF-LOCKING.EX.....	EA	
2	35	PAFZZ	5325-00-074-3301	96906	MS21266-2	GROMET. NONMETALLIC.....	EA	1
2	36	XDFZZ		96906	NS24493BB5	SCREW, MACHINE.....	EA	4
2	37	PAFZZ	5310-00-934-9739	96906	MS35649-242	NUT.PLAIN, HEXAGON.....	EA	
2	38	XDFZZ		23259	53S505E10007-18	CLAMP ASSEMBLY.....	EA	1
2	39	PAFZZ	5305-00-984-4993	96906	MS35206-233	SCREW MACHINE.....	EA	4

SECTION II

TM 11-5840-359-30P

(1) ILLUSTRATION		(2)	(3)	(4)	(5)	(6)	(7)	(8)
(a) FIG NO.	(b) ITEM NO.	SMR CODE	NATIONAL STOCK NUMBER	FSCM	PART NUMBER	DESCRIPTION USABLE ON CODE	U/M	QTY INC IN UNIT
2	40	XDFZZ		23259	535085EI0007-28	BRACKET, CONECTOR.....	EA	1
2	41	PAFZZ	5340-00-915-4839	83330	2135	BUMPER, RUBBER.....	EA	4
2	42	PAFZZ	5305-00-984-6194	96906	MS35206-246	SCREW, MACHINE.....	EA	4
2	43	XDFZZ		96906	MS21042-03	NUT.....	EA	4
2	44	XDFDL	6940-01-046-8478	57230	535085E63108-3	CIRCUIT CARD ASSEMB.....	EA	1
2	45	PAFZZ	5305-00-889-2999	96906	MS35206-217	SCREW MACHINE.....	EA	4
2	46	XDFDL	6940-01-030-0983	57230	535085E90011-2	POWER SUPPLY.....	EA	1
2	47	PAFZZ	5305-00-984-6192	96906	MS35206-244	SCREW, MACHINE.....	EA	4
2	48	PAFZZ	5305-00-889-3118	96906	MS35206-203	SCREW, MACHINE.....	EA	4
2	49	PAFZZ	5310-00-543-5060	96906	MS35138-39	WASHER LOCK.....	EA	4
2	50	PAFZZ	5310-00-121-3674	96906	MNS15795-702	WASHER FLAT.....	EA	4
2	51	XDFZZ		23259	535085E10007-2	CHASSIS ASSEBL.....	EA	1
2	52	PAFZZ	5305-00-984-4988	96906	MS35206-228	SCREW.MACHINE.....	EA	7
2	53	XDFDL		23259	53508560013-2	PANEL ASSY.CONT MDL.....	EA	1
2	54	XDFZZ		23259	535085F10018-12	SHIELD.....	EA	1
2	55	XDFZZ		833301	8268	SPACER.....	EA	2
2	56	XDFDD		23259	15350BSF0017-1	POWER SUPPLY ASS.....	EA	1
2	57	XDFZZ		96906	5S25207-264	SCREW.....	EA	4
2	58	PAFZZ	5310-00-045-3296	96906	5K35338-43	WASH LOCK.....	EA	4
2	59	PAFZZ	5310-00-584-7800	96906	MS15795-708	WASHERFLAT.....	EA	4
2	60	XDFZZ		23259	5085E10007-8	BRACET STOP.....	EA	2
2	61	XDFZZ		15819	062x3-4x111	CLOSURE.....	EA	2
10/(11 BLANK)								

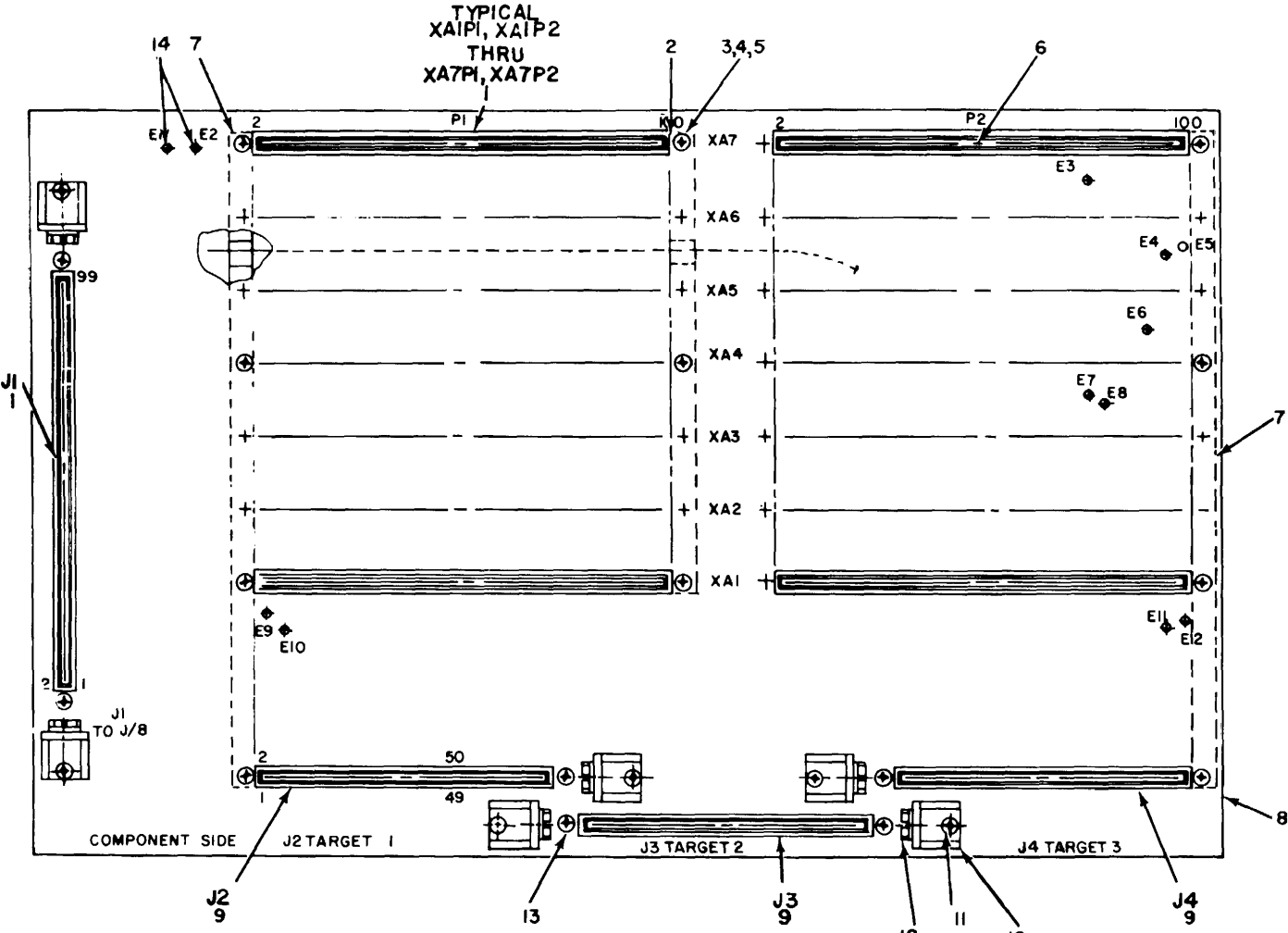

NOTE FOR COMPLETE REFERENCE DESIGNATION, PREFIX WITH 1A8

EL5WD005

Figure 3. Mother Board Assembly (1A8)..

SECTION II

TM 11-5840-359-30P

(1) ILLUSTRATION		(2)	(3)	(4)	(5)	(6)	(7)	(8)
(a) FIG NO.	(b) ITEM NO.	SMR CODE	NATIONAL STOCK NUMBER	FSCM	PART NUMBER	DESCRIPTION USABLE ON CODE	U/M	QTY INC IN UNIT
						GROUP 0107 MOTHER BOARD ASSEMBLY (1A8)		
3	1	XDDZZ		31529	EP1225-50PAIR	CONNECTOR.RCPT	EA	15
3	2	XDDZZ		23259	535085E10004-12	SPACE	EA	1
3	3	PADZZ	5305-00-889-2999	96906	MS35206-2117	SCREW, MACHINE	EA	17
3	4	PADZZ	5310-00-543-2410	96906	MS35338-0	WASHER.LOCK	EA	20
3	5	PADZZ	5310-00-595-6211	96906	MS15795-803	WASHERFLAT	EA	24
3	6	PADZZ		31529	EP1227	KEY	EA	11
3	7	XDDZZ		23254	53505E100G0-11	SPACER	EA	2
3	8	XDDDL		23259	535085E1310-1	FABRICATION.....	EA	1
3	9	XDDZZ		31529	EP1225	CONNECTOR, CPT.....	EA	3
3	10	XDDZZ	5999-01-046-9422	07556	VM7500	HOLDER.ELECTRICAL C	EA	6
3	11	PADZZ	5310-00-811-6419	96906	NS21042-04	WUT, SELF-LOCKING, EX.....	EA	6
3	12	XDDZZ	5999-00-843-0925	07556	RA04125	GUIDE.PRINTED CIRCU.....	EA	6
3	13	XDDZZ		83330	8684	SPACER.....	EA	6
3	14	PADZZ	5940-00-926-0021	81349	SE12XC03	TERMINAL, STUD.....	EA	12
13/(14 BLANK)								

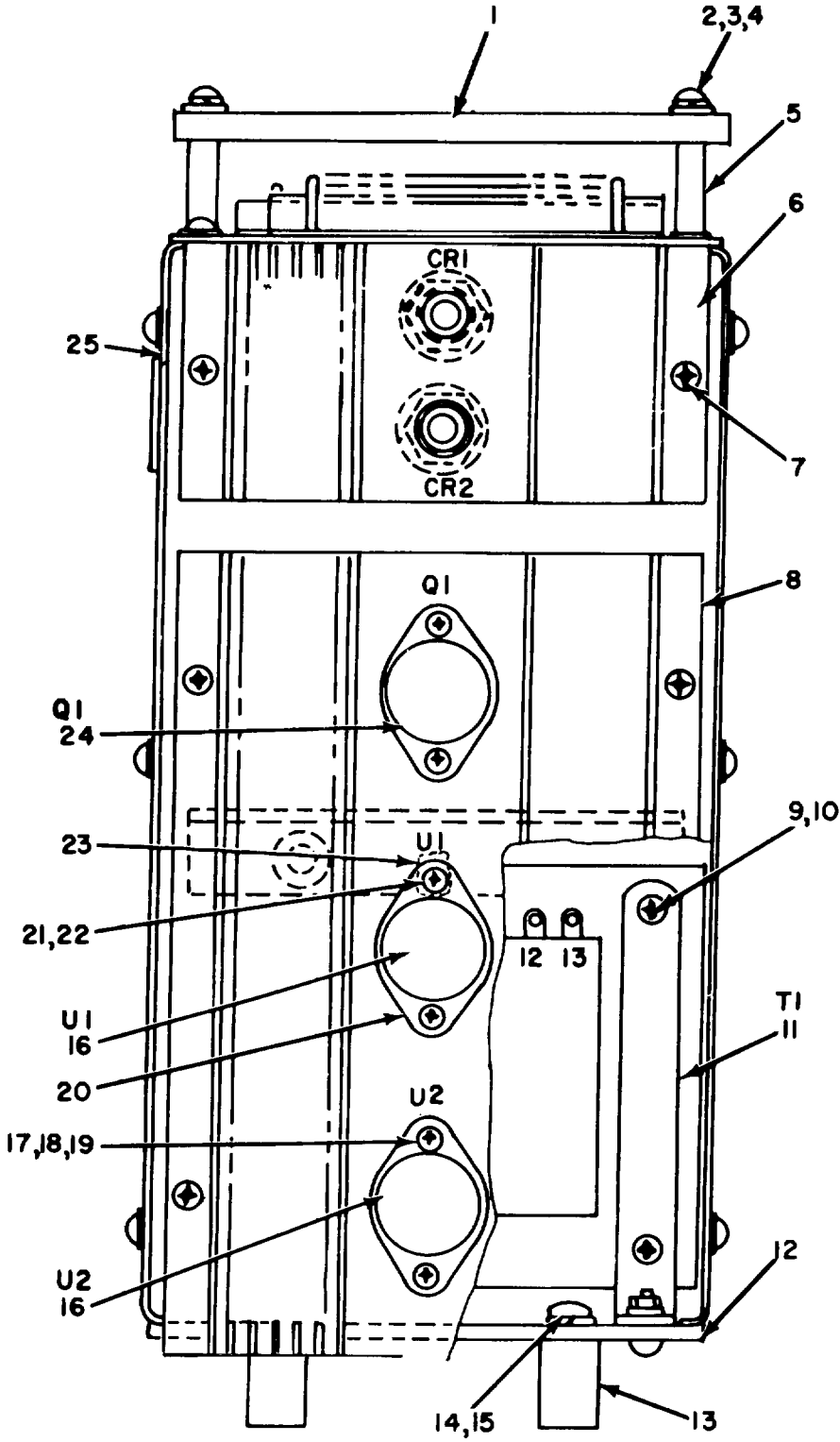

SIDE VIEW

NOTE: FOR COMPLETE REFERENCE DESIGNATION PREFIX WITH 1A9
EL5WD006

Figure 4 ①. Power Supply ± 15 VDC (1A9) (Sheet 1 of 2).

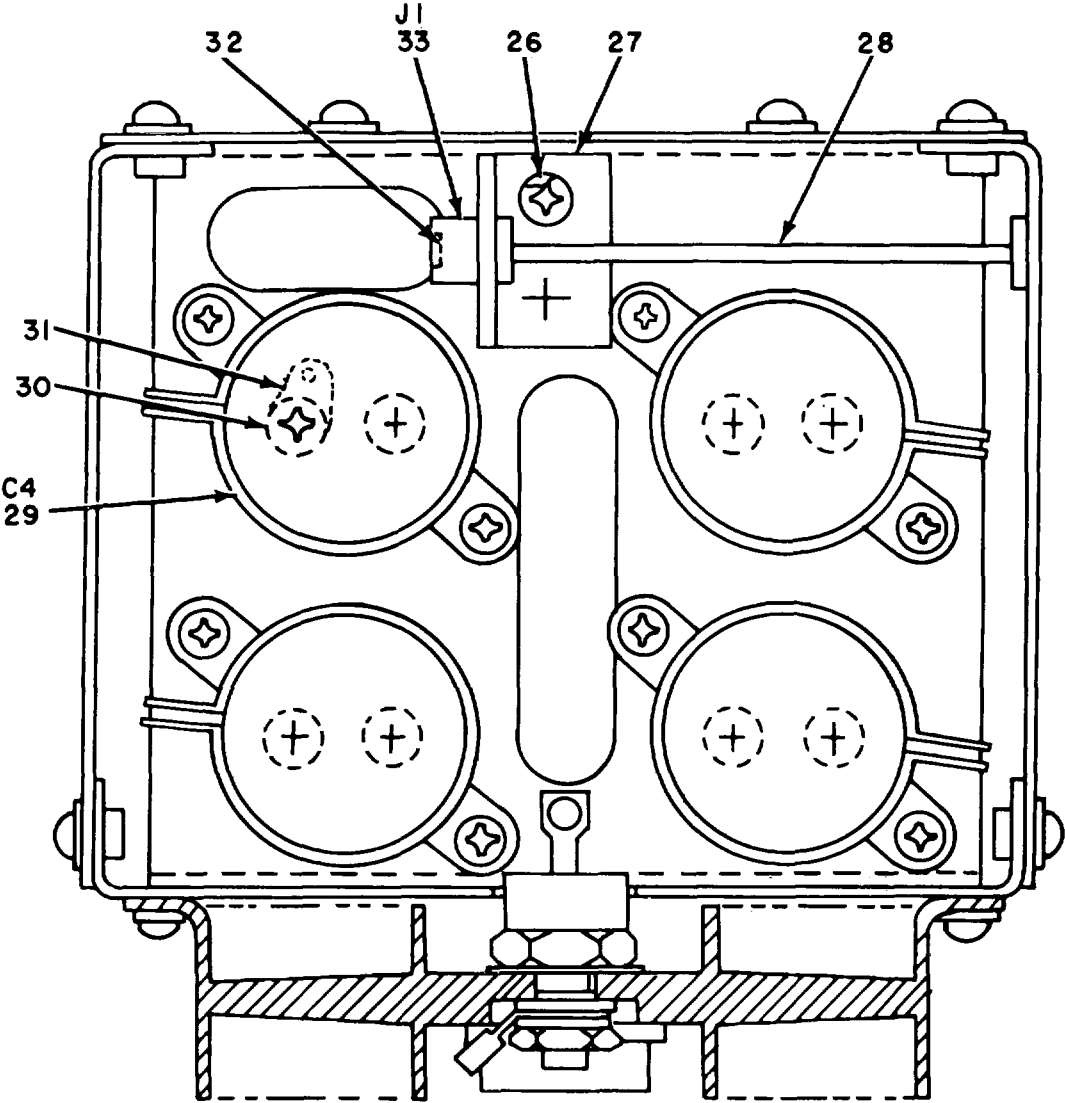

TOP VIEW

NOTE: FOR COMPLETE REFERENCE DESIGNATION PREFIX WITH 1A9.

EL5W0007

Figure 4. Power Supply +15 VDC(Sheet 2 of 2).

SECTION II

TM 11-5840-359-30P

(1) ILLUSTRATION		(2)	(3)	(4)	(5)	(6)	(7)	(8)
(a) FIG NO.	(b) ITEM NO.	SMR CODE	NATIONAL STOCK NUMBER	FSCM	PART NUMBER	DESCRIPTION USABLE ON CODE	U/M	QTY INC IN UNIT
						GROUP 0108 POWER SUPPLY 15 VDC (1A9)		
4	1	XDDZZ		23259	535085EI0011-L	SHIELD.....	EA	1
4	2	PADZZ	5305-00-889-3001	96906	HS35206-231	SCREW MACHINE.....	EA	
4	3	PADZZ	5310-00-045-4007	96906	5S35338-41	WASHER, LOCKE.....	EA	1
4	4	PADZZ	5310-00-595-6333	96906	MS15795-7105	WASHER, FLAT.....	EA	8
4	5	XDDZZ		83330	8236	SPACER, SLEEVE.....	EA	4
4	6	XDDZZ		23259	535085E10017-28	HEAT SINK.....	EA	1
4	7	PADZZ	5305-00-984-4988	96906	HS35206-228	SCREW, MACHINE.....	EA	13
4	8	XDDZZ		23259	535085E10017-29	HEATSINK.....	EA	1
4	9	PADZZ	5305-00-984-6192	96906	MS35206-244	SCREW, MACHINE.....	EA	4
4	10	PADZZ	5310-00-807-1466	96906	HS21042-08	NUT, SELF-LOCKING, EX.....	E.A	4
4	11	XDDZZ		10501	50894	TRANSFORMER.....	EA	1
4	12	XDDZZ		23259	535085E10017-22	PLATE, BOTTOM.....	EA	1
4	13	XDDZZ		23259	535085E10017-25	BAR, MOUNTNG.....	EA	2
4	14	PADZZ	5305-00-989-6265	96906	HS35207-262	SCREW, MACHINE.....	EA	4
4	15	PADZZ	5310-00-045-3296	96906	MS35338-43	WASHER, LOCK.....	EA	6
4	16	XDDZZ		07263	UA7815GJ393	INTEGRATED CIRCUIT.....	EA	2
4	17	PADZZ	5305-00-983-6730	96906	MS15206-&218	SCREW, MACHINE.....	EA	8
4	18	PADZZ	5310-00-656-0111	96906	MS1595-701	WASHER, FLAT.....	EA	11
4	19	PADZZ	5310-00-543-2410	96906	MS35338-40	WASHER, LOCK.....	EA	6
4	20	PADZZ	5970-00-840-5109	08530	734	INSULATOR, PLATE.....	EA	3
4	21	PADZZ	5310-00-579-3663	83330	2150	WASHER, SHOULDERED.....	E.A	6
4	22	XDDZZ	5310-00-934-9739	96906	NS2031-4S	NUT PLAIN, HEXAGON.....	EA	6
4	23	PADOZ	5940-00-113-9828	96906	MS250-46-148	TERNINAL LUG.....	EA	2
4	24	PADZZ	5961-00-712-5578	813491	JAN23442	TRANSISTOR.....	EA	1
4	25	XDOZZ		23259	535085510017-4	SIDESKIN ASSY, RH.....	EA	1
4	26	PADZZ	5310-00-807-1465	96906	MS21042-06	NUT, SELF-LOCKING, EX.....	EA	2
4	27	XDDZZ		23259	535085E63126-1	BRACKET, CONNECTOR.....	EA	1
4	28	XDFDL	6930-01-026-8376	89297	535085EG63126-1	BOARD ASSEKBLYP	EA	
4	29	XDDZZ		56289	36D273G10AC2A	CAPACITOR, FXD.....	EA	1
4	30	PADZZ	5305-00-990-6444	96906	207-261	SCREW, MACHINE.....	EA	2
4	31	PADZZ	5940-00-143-4771	969061	MS25036-103	TERHINAL LUG.....	EA	5
4	32	PADZZ	5310-00-811-6419	96906	MS21042-04	NUT, SELF-LCCKING, EX.....	EA	2
4	33	XDDZZ		81349	M21097-L-163	CONNECTOR, RECEPTACL.....	EA	1'

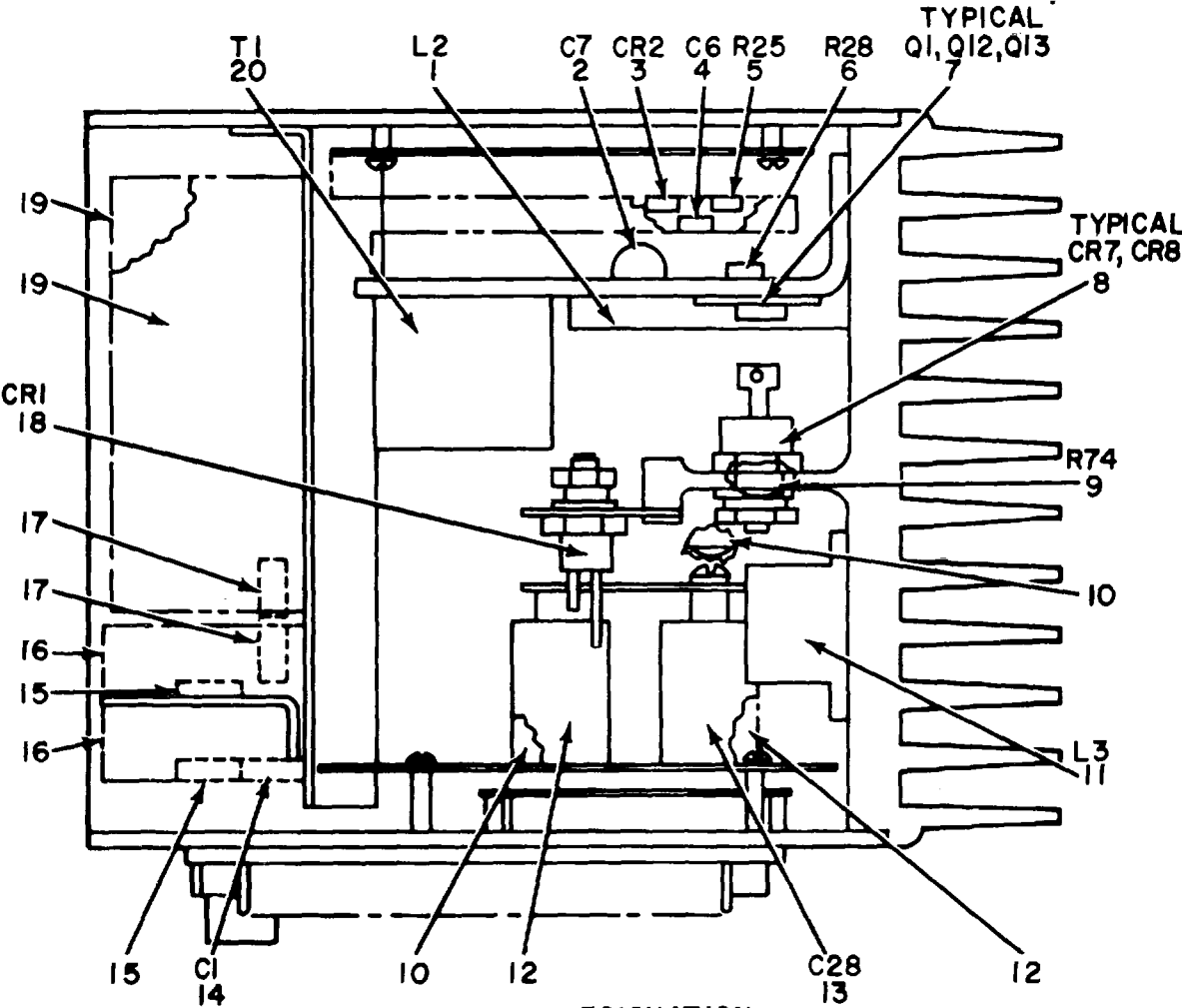

NOTE FOR COMPLETE REFERENCE DESIGNATION
PREFIX WITH IPSI.

EL5WD008

Figure 5. Power Supply +0.5 VDC (1PSI).

SECTION II

TM 11-5840-359-30P

(1) ILLUSTRATION		(2)	(3)	(4)	(5)	(6)	(7)	(8)
(a) FIG NO.	(b) ITEM NO.	SMR CODE	NATIONAL STOCK NUMBER	FSCM	PART NUMBER	DESCRIPTION USABLE ON CODE	U/M	QTY INC IN UNIT
						GROUP 0109 POSER SUPPLY +0.5 VDC (IPS1)		
5	1	XDDZZ		00630	50278	REACTOR	EA	1
5	2	XDDZZ		81349	CL13CN680-5R3	CAPACITOR, FXD, ELCT.....	EA	1
5	3	PADZZ	5961-00-005-2956	00638	24810-1	SEMICONDUCTOR DEVIC.....	EA	1
5	4	PADZZ	5910-00-825-1342	81349	CK62AX222K	CAPACITOR.FIXED.CER.....	EA	1
5	5	PADZZ	5905-00-107-0656	81349	RCR07G100KR	RESISTCR, FIXED.COMP.....	EA	1
5	6	PADZZ	5905-00-249-4233	81349	RC42GF223K	RESISTOR, FI TASK 4A.....	EA	1
5	7	XDDZZ		12965	YPI004	TRANSISTOR.....	EA	3
5	8	XDDZZ		04713	MR890	SEMICONDUCTOR DEVIC.....	EA	1
5	9	PADZZ	5905-00-106-3668	81349	RCR07G100KR	RESISTOR.FXD.CEPSI.....	EA	1
5	10	XDOZZ		89297	53508E3126-1	POWER SUPPLY	EA	2
5	11	XODZZ		00638	50274	REACTOR	EA	1
5	12	XDDZZ	5910-00-248-4905	56289	80P5	CAPACITOR.FIXED.PAP	EA	2
5	13	PADZZ	5910-00-144-4381	81349	CSRI3F6S5K	CAPACITOR, FIXD ELCTL.....	EA	1
5	14	PADZZ	5910-00-913-1097	56289	220P10494	CAPACITOR FIXED PLA.....	EA	1
5	15	PADZZ	5910-00-903-2950	56289	220P22494	CAPACITOR FIXED. PAP	EA	2
5	16	XDDZZ		00634	50275	REACTOR	EA	2
5	17	PADZZ	5905-00-978-7702	81399	RW69V2R0	RESISTOR, FIXED, WIRE. EA.....	EA	2
5	18	XDDZZ		81349	2N681	SEMICONDUCTOR DEVIC.....	EA	1
5	19	PADZZ	5910-00-431-4825	56289	36D431F200AB2	CAPACITOR.FIXED, ELE.....	EA	2
5	20	XDDZZ		00638	50401	TRANSFORMER, POWERS	EA	1

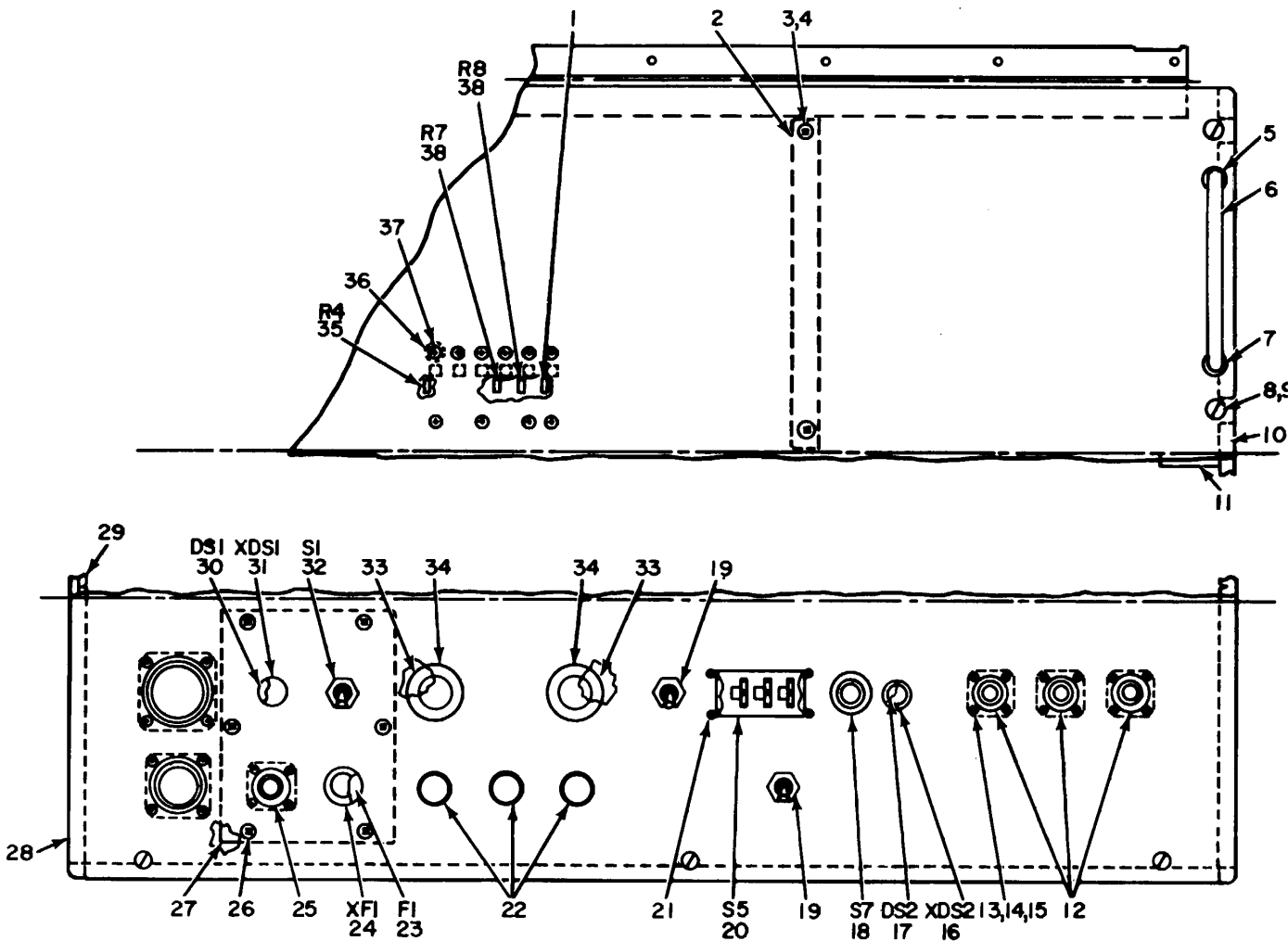

NOTE FOR COMPLETE REFERENCE DESIGNATION
PREFIX WITH I.

EL5WD009

Figure 6. Control Module Panel Assembly.

(1) ILLUSTRATION		(2)	(3)	(4)	(5)	(6)	(7)	(8)
(a) FIG NO.	(b) ITEM NO.	SMR CODE	NATIONAL STOCK NUMBER	FSCM	PART NUMBER	DESCRIPTION USABLE ON CODE	U/M	QTY INC IN UNIT
						GROUP 0110 CONTROL MODULE PANEL ASSEMBLY		
6	1	PADZZ	5905-00-106-3666	81349	RCROG 103KN	RESISTOR, FIXED.COP	EA	1
6	2	XDDZZ		3259	535085E10003-	RETAINERS	EA	1
6	3	PADZZ	5305-00-837-3343	96906	HS24693S28	SCREW .MACHINE	EA	2
6	4	PADZZ	5310-00-807-1465	96906	KS21042-06	NUT.SELF-LOCKING, EX.....	EA	2
6	5	PADZZ	5305-00-957-7086	96906	NS24693S273	SCREW .MACHINE	EA	4
6	6	PADZZ	5340-00-456-2611	88245	1064-30	HANDLEBOW.	EA	2
6	7	PADZZ	5340-00-976-4123	88245	901-30	FERRULE, GROOVED CLA.	EA	4
6	8	XDDZZ	5325-00-269-3747	94222	82-1L-260-16	STUD, TUNLOCK FASTEE	EA	7
6	9	XDDZZ	5330-00-876-0086	94222	82-46-101-41	PACKING, PREFOCREO.	EA	7
6	10	XDDZZ	5310-00-845-5472	94222	82-32-101-17	WASHER, SPLIT	EA	7
6	11	PADZZ	5360-00-9248167	94222	43-13-1-24	SPRING, HELICAL, COMP.....	EA	7
6	12	PADZZ	5935-00-988-5470	96906	S3122E10-65	CONNECTOR.RECEPTAC.....	EA	3
6	13	XDDZZ		96906	MS2469885	SCREW.	EA	16
6	14	XDDZZ	5310-00-934-9739	9690	MS20341-6S	NUT.PLAIN.HEXAGON.	EA	16
6	15	PADZZ	5310-00-543-2410	96906	MS35338-40	WASHER, LOCK.	EA	16
6	16	XDDZZ		81349	LH73-ILC29RT2	LIGHT, INDICATOR.....	EA	16
6	17	PADZZ	6240-00-683-0560	08806	345	LAMP, INCANDESCENT	EA	17
6	18	PADZZ	5930-00-462-1802	96906	MS250899-1CR	SWITCH.PUSH	EA	11
6	19	PLDZZ	5930-00-914-6458	96906	MS90310-231	SWITCH.TOGGLE	EA	2
6	20	XDDZZ		07126	8H195A	SWITCH ASSEMBLY	EA	1
6	21	PADZZ	5305-00-844-4371	80205	NAS662C2R6	SCREW MACHINE	EA	11
6	22	PADZZ	5905-00-051-1665	80Z94	3600S1-103	RESISTOR VARIABLE, W	EA	3
6	23	PADZZ	5920-00-284-6787	81349	F02A250V5A	FUSE, CARTRIDGE	EA	1
6	24	XDDZZ		81349	RHL17GI	FUSEHOLDER.	EA	1
6	25	XDDZZ		96906	MS3102EL0SL3P	CONNECTOR., RECEPTAC.....	EA	1
6	26	PADZZ	5305-00-957-7017	96906	MS24693S26	SCREW, MACHINE	EA	6
6	27	XDDZZ		23259	535085E90013-1	ENCLOSURE.RFI.....	EA	1
6	28	XDDZZ		23259	535085E10003-2	PANELS ASSEMBLY	EA	1
6	29	XDDZZ		36743	97-555A	FINGER CONTACT.RFI.	EA	4
6	30	PADZZ	6240-00-223-9100	08806	NE51	LAMP, GLO.	EA	1
6	31	XDDZZ		81349	LH6-1LC14RD3	LAP ASSEMBLY.....	EA	1
6	32	PADZZ	5930-00-655-1575	96906	1S35059-22	SWITCH TOGGLE	EA	1
6	33	PADZZ	5930-00-465-4348	81073	430-02-1-3N	SWITCH ROTARY.....	EA	2
6	34	PADZZ	5355-00-680-1357	96906	MS91528-1F28	KNOB	EA	2
6	35	PADZZ	5905-00-110-7620	81349	RCR07GI02KKN	RESISTOR FIXED COMP	EA	1
6	36	XDDZZ		23259	SE10-9001	INSULAOR, STANDOFF	EA	2
6	37	PADZZ	5305-00-901-5075	96906	MS24693BB1	SCREW MACHINE	EA	10
6	38	PADZZ	5905-00-105-7768	81349	RCR07G561KM	RESISTOR FIXED, CO,	EA	2

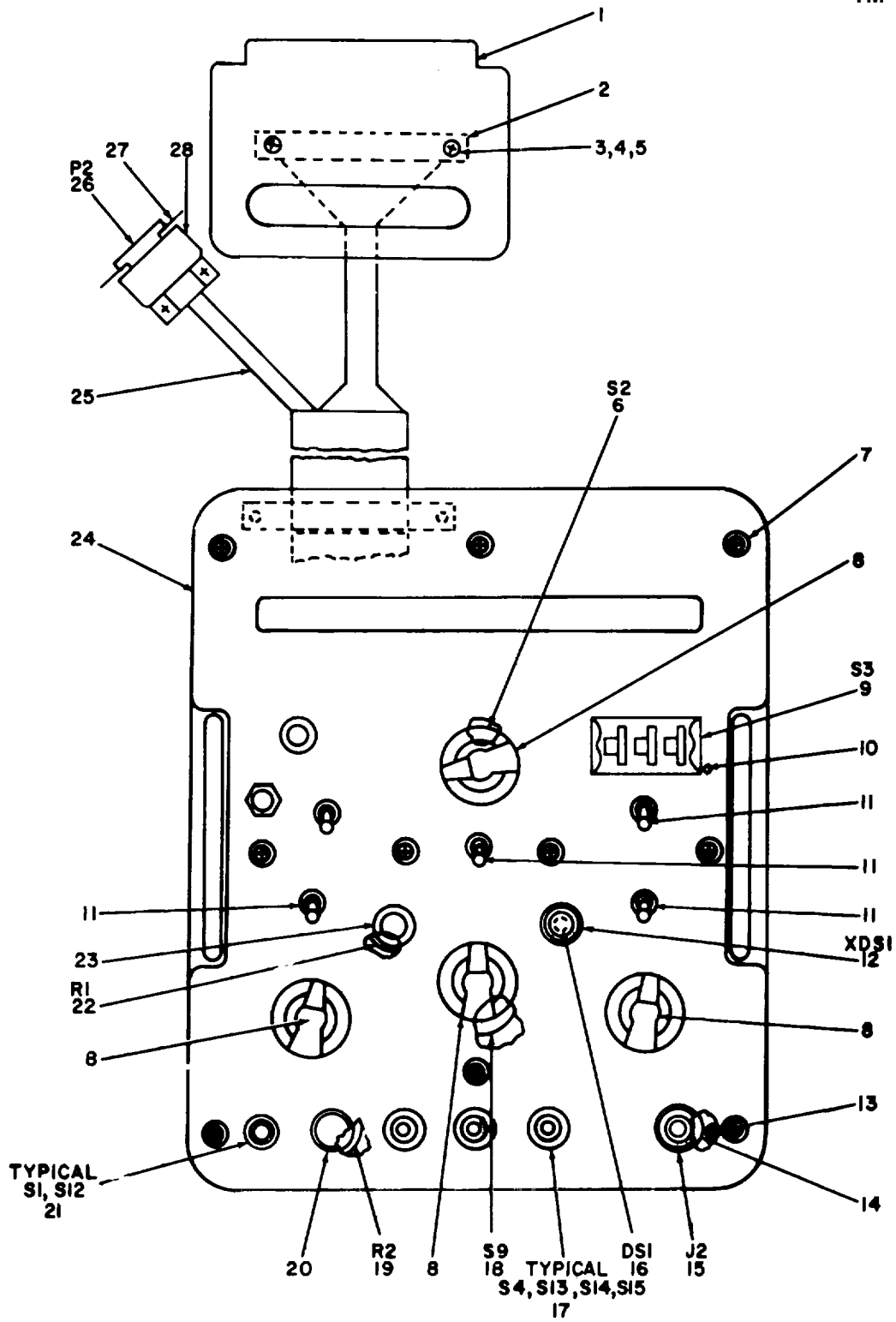

FRONT VIEW

NOTE FOR COMPLETE REFERENCE DESIGNATION,
PREFIX WITH 2.

EL5WDO10

Figure 7. ① Target Module Assembly (Sheet 1 of 1)

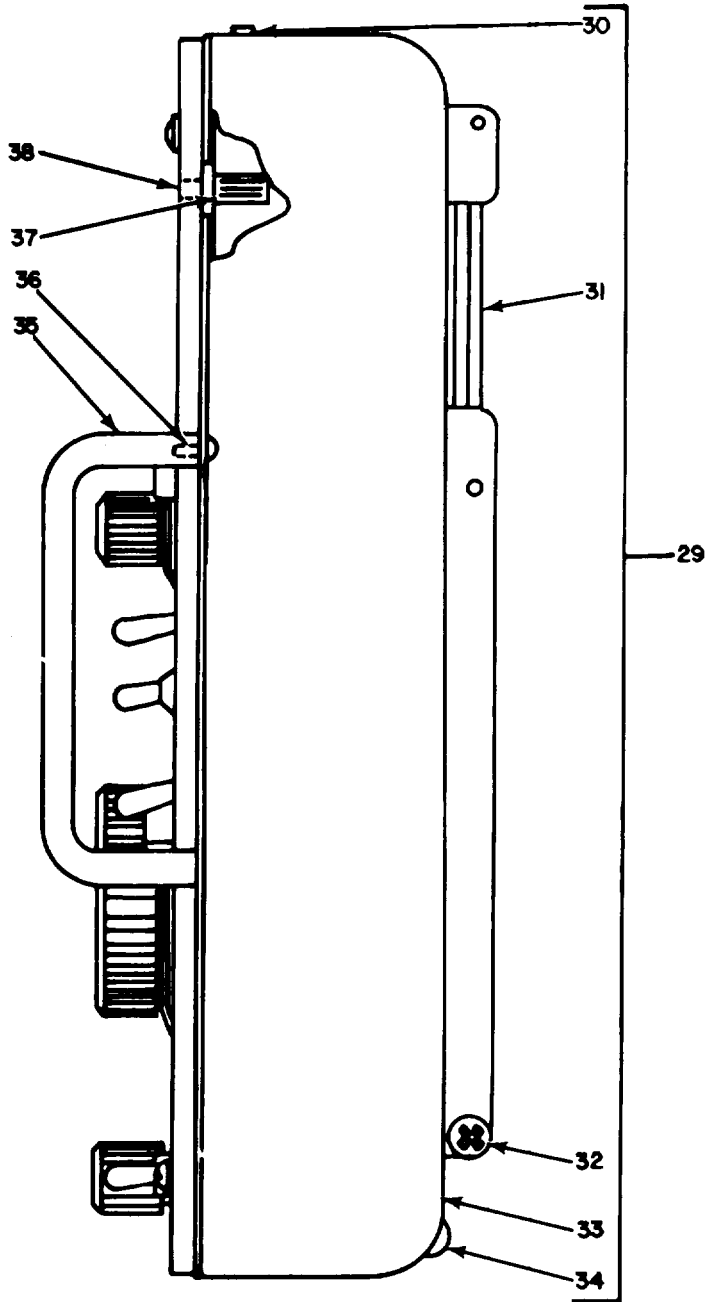

SIDE VIEW

EL5WDO11

Figure 7. 2 Target Module Assembly (Sheet 2 of 3)

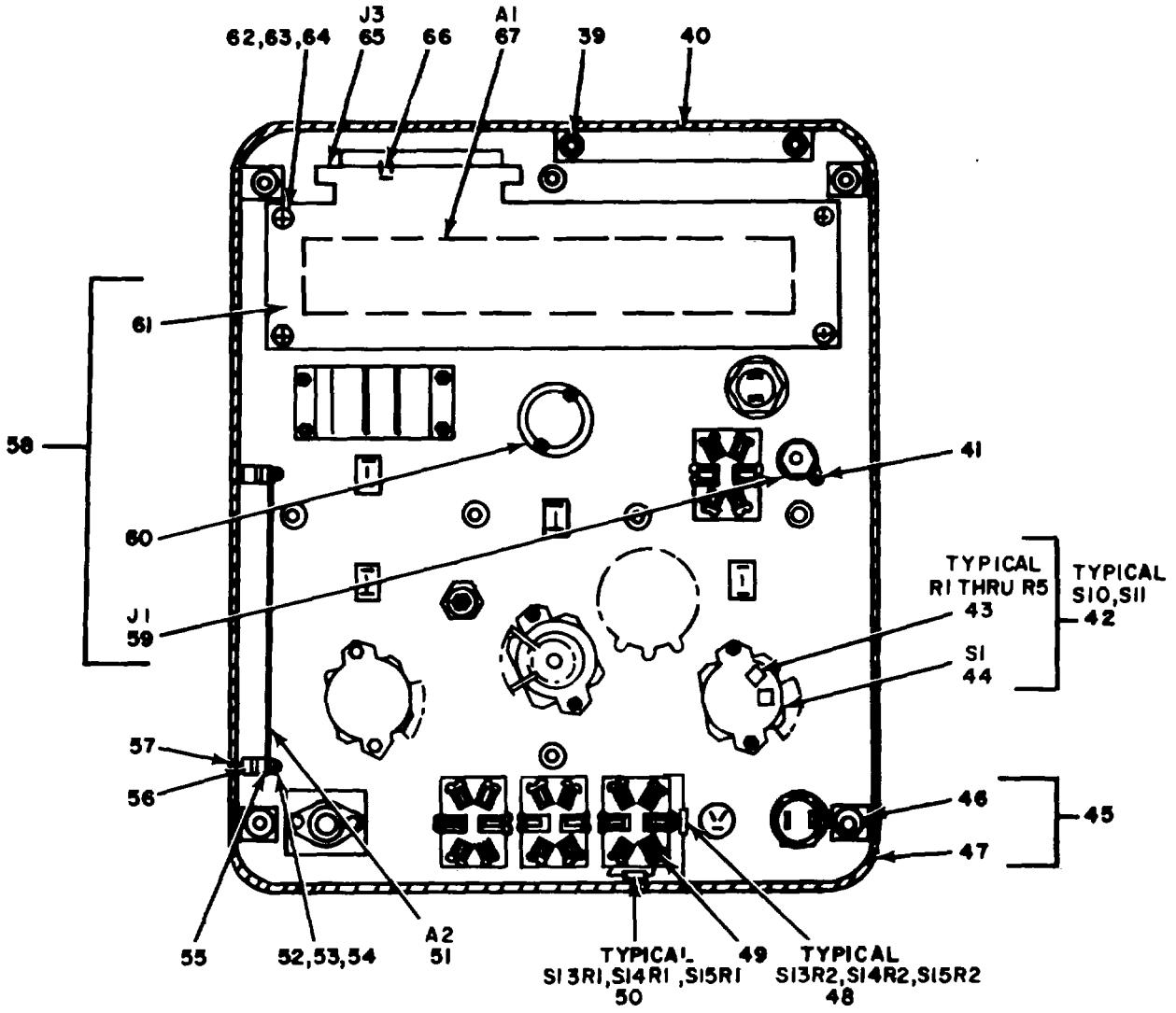

PANEL REAR VIEW

NOTE: FOR COMPLETE REFERENCE DESIGNATION PREFIX WITH 2.

EL5W0012

Figure 7. © Target Module Assembly (Sheet 3 of 3).

(1) ILLUSTRATION		(2)	(3)	(4)	(5)	(6)	(7)	(8)
(a) FIG NO.	(b) ITEM NO.	SMR CODE	NATIONAL STOCK NUMBER	FSCM	PART NUMBER	DESCRIPTION USABLE ON CODE	U/M	QTY INC IN UNIT
GROUP 02 TARGET MODULE ASSEMBLY								
7	1	XDFZZ		23259	535085E13121-1	BOARD, PTD WIRING	EA	1
7	2	XDFZZ		23259	535085E100011	CLAMP.....	EA	1
7	3	PAFZZ	5305-00-889-3000	96906	MS35206-230	SCREW, MACHINE.....	EA	2
7	4	PAFZZ	5310-00-595-6333	96906	S15795-705	WASHER FLAT.....	EA	4
7	5	PAFZZ	5310-00-807-1465	96906	MS21042-06	NUT, SELF-LOCKING.EX	EA	2
7	6	XDFZZ		81073	44M30-01-1-6	STITCH ROTARY.....	EA	1
7	7	XDFZZ		96906	K535306-231	SCREW	EA	10
7	8	XOFZZ		15084	533-051-19	KNOB	EA	4
7	9	XDFZZ		23259	535085E90005-2	SWITCH ASSEMBLY	EA	1
7	10	PAFZZ	5305-00-844-4371	80205	NAS662C2R6	SCREW MACHINE	EA	4
7	11	PAFFZ	5930-00-914-6458	96906	NS90310-231	SWITCH, TOGGLE.....	EA	4
7	12	XDFZZ		81349	LH73-2LC26GT2	LAMP ASSEMBLY.....	EA	1
7	13	XDFZZ		96906	MS2459388B	SCREW	EA	2
7	14	XDFZZ		23259	35085E60012-14	SPACER.....	EA	1
7	15	PAFZZ	5935-01-039-8378	28986	TJ120S	JACK, TELEPHONE	EA	1
7	16	PAFZZ	6240-00-6B3-0560	08806	345	LAMP, INCANDESCENT.....	EA	1
7	17	PAFZZ	593000-064-3511	96906	MS25201-4	SWITCH, TOGGLE.....	EA	4
7	18	XDFZZ		23259	535085E60022-1	SWITCH ASSEMBLY	EA	1
7	19	PAFZZ	5905-00-577-1759	81349	RV6NAYSD501A	RESISTOR, VARIABLE.N.	EA	1
7	20	PAFZZ	5355-00-685-4688	96906	MS91528-ODIB	KNOB	EA	1
7	21	PAFZZ	5930-00-110-1113	96906	MS25089-IGR	SWITCH.PUSH.	EA	2
7	22	XDFZZ		44655	OI40NGDE2H	RHEOSTAT	EA	1
7	23	PAFZZ	5355-00-556-0151	96906	MS91528-D2B	KNOB	EA	1
7	24	XDFZZ	5340-00-865-0220	83330	652	BUTTON.PLUG.	EA	4
7	25	XDFZZ		23259	535085E64101-5	CABLE	EA	1
7	26	PAFZZ	5935-00-490-3743	81349	M2430B-4-2	CONNECTOR, RECEPTACL.....	EA	1
7	27	XDFZZ	5340-00-139-7498	71468	D110278	LATCH, SPRING.	EA	2
7	28	PAFZZ	5935-00-783-9133	71468	0AI465B	SHIELD, ELECTRICAL C	EA	1
7	29	XDFZZ		23259	53508E10001-2	COVER ASSEMBLY.....	EA	7
7	30	XDFZZ		96906	MS21266-2	GROMMET	EA	1
7	31	XDFZZ		23259	535085E1000-9	STAND ASSEMBLY.....	EA	2
7	32	XDFZZ		79136	5115-12H	RIG, RETAINING.....	EA	2
7	33	XDFZZ		23259	535085E10001-6	COVER ASSEMBLY.....	EA	1
7	34	XDFZZ		23259	535005EU0001-1	CUSHION.....	EA	1
7	35	XDFZZ		88245	1064	HANDLE	EA	2
7	36	PAFZZ	5305-00-989-7434	96906	MS35207-263	SCREW, MACHINE	EA	4
7	37	XDFZZ		83330	8423	BUMPER, COMPUTER	EA	4
7	38	PAFZZ	5305-00-957-7818	96906	MS24693527	SCREW MACHINE	EA	4
7	39	PAFZZ	5305-00-957-7820	96906	MS24693531	SCREW MACHINE	EA	2

SECTION II

TM 11-5840-359-30P

(1) ILLUSTRATION		(2)	(3)	(4)	(5)	(6)	(7)	(8)
(a) FIG NO.	(b) ITEM NO.	SMR CODE	NATIONAL STOCK NUMBER	FSCM	PART NUMBER	DESCRIPTION USABLE ON CODE	U/M	QTY INC IN UNIT
7	40	XDFZZ		23259	535085E60012-2	CLAMP ASSEMBLY	EA	1
7	41	XDFZZ	5940-00-247-8217	79963	80	TERMINAL LUG	EA	2
7	42	XDFFF		23259	535085E6002Z-1	SWITCH ASSEMBLY	EA	2
7	43	PAFZZ	5905-00-106-3666	81349	RC017G103JN	RESISTOR FIXED	EA	1
7	44	XDFZZ		23259	53508590008-2	SWITCH, ROTARY	EA	1
7	45	XDFFF		23259	535085E60012-	PANEL	EA	1
7	46	PAFZZ	5310-00-813195	46384	LAC632'2	NUT, SELF-LOCKING, CL	EA	1
7	47	XDFZZ		23259	535085E0012-11	PANEL	EA	1
7	48	PAFZZ	5905-00-110-7620	81349	RCR07G102JM	RESISTOR, FIXED COMP	EA	2
7	49	PAFZZ	5940-00-204-8966	96906	MS25036-102	TERMINAL, LUG	EA	24
7	50	PAFZZ	5905-00-764-2773	81349	RCR07G202JM	RESISTOR, FIXED COP	EA	3
7	51	XDFDL		23259	535085E63110-1	AMPLIFIER ASSEMBLY	EA	1
7	52	PAFZZ	5305-00-889-2999	96906	MS35206-217	SCREW MACHINE	EA	1
7	53	PAFZZ	5310-00-543-2410	96906	1535338-40	WASHER LOCK	EA	4
7	54	PAFZZ	5310-00-595-6211	96906	MS15795-803	WASHER FLAT	EA	4
7	55	XDFZZ	5970-00-350-4800	81330	8880	INSULATOR, BUSHING	EA	4
7	56	XDFZZ		23250	53508E10001-18	SPACE	EA	2
7	57	PAFZZ	5305-00-958-9549	96906	MS24693B828	SCREW, MACHINE	EA	2
7	58	XDFFF		23259	535085E10038-1	SPACER	EA	1
7	59	PAFZZ	5935-00-909-1831	96906	MS90335-2	CONNECTOR, RECEPTACL	EA	1
7	60	PAFZZ	5325-00-817-0510	96906	MS25381-1	GROMMET, METALLIC	EA	10
7	61	XDFZZ		23259	53508581002-1	FILTER	EA	1
7	62	PAFZZ	5305-00-984-4984	96906	MS35206-227	SCREW, MACHINE	EA	4
7	63	PAFZZ	53100-045-4007	96906	MS35338-41	WASHER LOCK	EA	4
71	64	PAFZZ	5310-00-595-6333	96906	MS15795-705	WASHER FLAT	EA	4
71	65	PAFZZ	5935-00-938-468	81349	21097-1-091	CONNECTOR, RECEPTACL	EA	1
7	66	XDFZZ	5935-00-120-9209	02660	225-594	POLARIZING, KEY	EA	1
7	67	XDFDL	6940-01-030-0954	57230	535085E63109-1	CIRCUIT CARD ASSEMB	EA	1
26/(27 BLANK)								

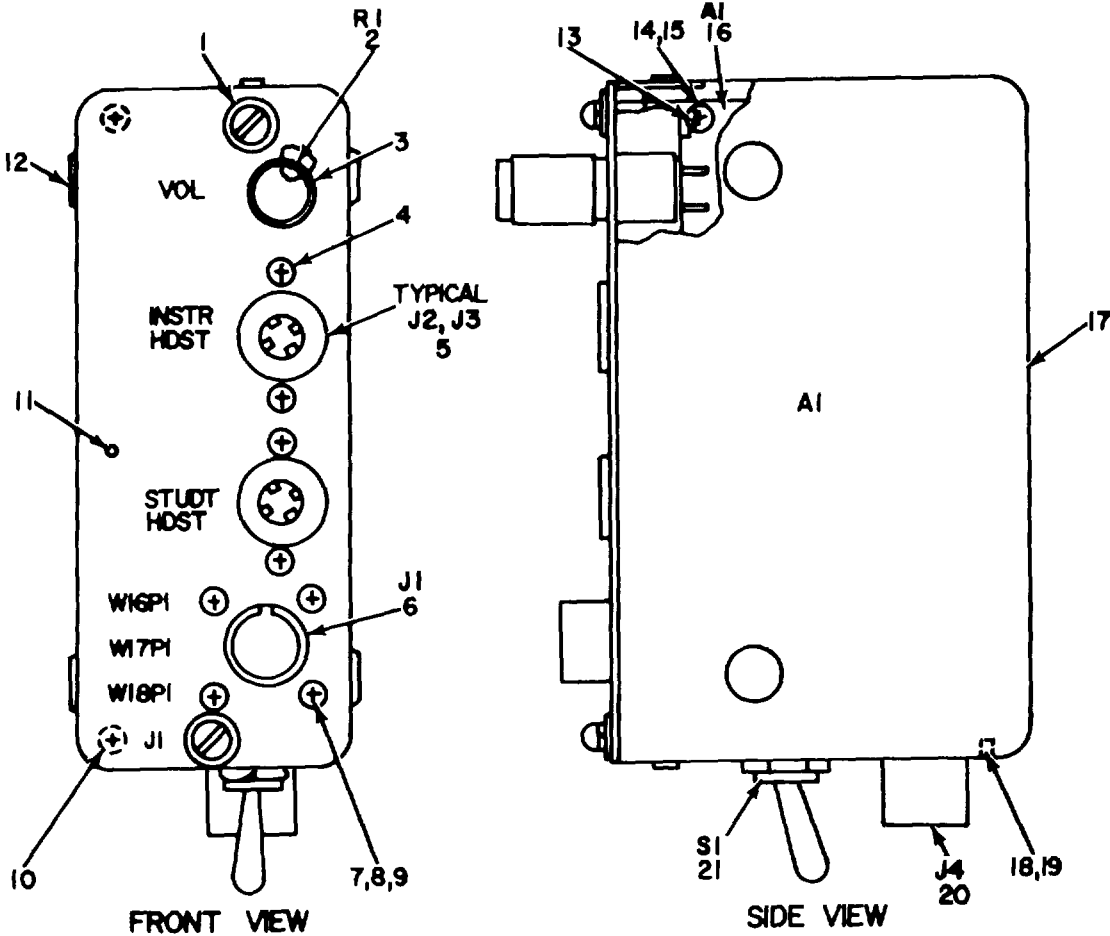

NOTE: FOR COMPLETE REFERENCE DESIGNATION
PREFIX WITH 16.

EL5WDC13

Figure 8. Student Communication Station Assembly.

SECTION II

TM 11-5840-359-30P

(1) ILLUSTRATION		(2)	(3)	(4)	(5)	(6)	(7)	(8)
(a) FIG NO.	(b) ITEM NO.	SMR CODE	NATIONAL STOCK NUMBER	FSCM	PART NUMBER	DESCRIPTION USABLE ON CODE	U/M	QTY INC IN UNIT
						GROUP 05 STUDENT COR/UNICATION STATION ASSEMBLY		
8	1	XDFZZ		98376	ZSP10-1003-1	SCREW EXTERNALLY RE EA	2
8	2	PAFZZ	5905-00-542-9605	81349	RV6NAYSO103A	RESISTOR.VARIABLE, N	EA	2
8	3	PAFZZ	5355-00-685-4688	96906	MS91528-DIB	KNOB	EA	1
8	4	PAFZZ	5305-00-958-9549	96906	NS246938828	SCREW, MACHNE.....	EA	2
8	5	PAFZZ	5935-0-039-8378	28986	TJIZO 1S	JACK, TELEPHCNE	EA	4
8	6	PAFZZ	5935-00988-4353	96906	MS3L22EO-6P	CONNECTOR, RECEPTACL	EA	1
8	7	PAFZZ	5305-00-282-5958	96906	S524693884	SCREW, MACHINE.....	EA	4
8	8	PAFZZ	5310-00-54-2410	96906	KS35338-40	WASHER.LOCK	EA	12
8	9	XDFZZL	5310-00-934-9739	96906	KS20341-45	NUT.PLAIN, HEXAGCN.....	EA	1
8	10	XDFZZ		23259	535085E10009-9	SPACER.....	EA	2
8	11	XDFZZ		23259	535085E10009-1	PANEL	EA	1
8	12	XDFZZ		83330	650	BUTTON, PLUG.....	EA	4
8	13	XDFZZ	5910-00-350-4800	83330	880	INSULATOR.BUSHING	EA	4
8	14	PAFZZ	5305-00-889-2999	96906	HS35206-217	SCREW, MACHINE.....	EA	4
8	15	PAFZZ	5310-00-595-6211	96906	KS1SZ95-803	WASHER, FLAT	EA	4
8	16	XDFDL	6930-01-026-8429	89297	535085E63119-1	CIRCUIT CARD ASSEK8	EA	1
8	17	XDFZZ		23259	535085E10090-13	ENCLOSURE	EA	1
8	18	PAFZZ	5305-00-889-2997	96906	MS35206-215	SCREW , MACHNE.....	EA	1
8	19	PAFZZ	5310-00-181-2397	8804	AN960D4L	WASHER, FLAT	EA	4
8	20	XDFZZ		96906	NS3102AIOSL3P	CONNECTOR, RCPT	EA	1
8	21	PAFZZ	5930-00-914-6458	96906	MS90310-231	SWITCH TOGGLE.....	EA	1
29								

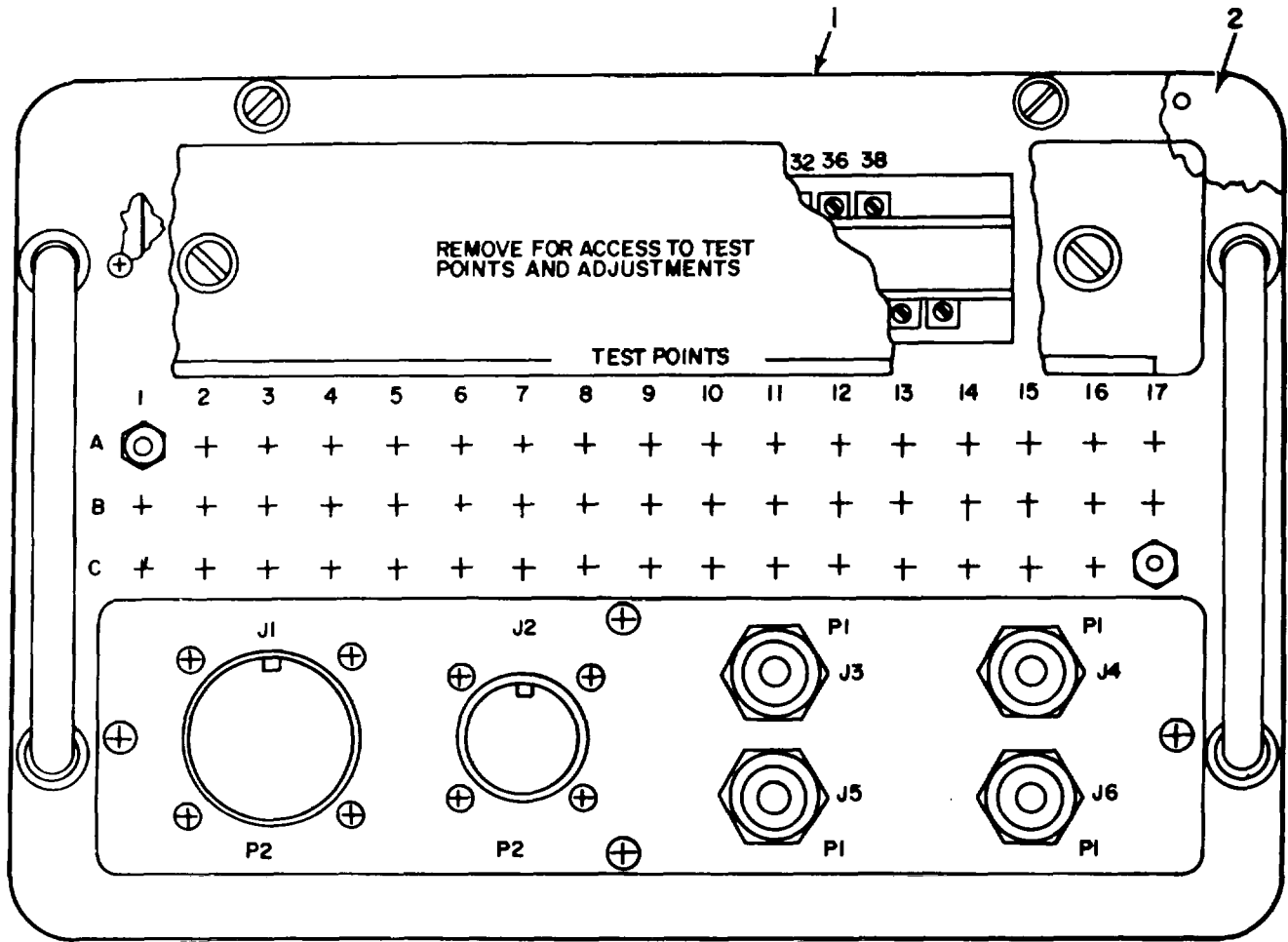

EL5WD014

Figure 9. PAR/ASR Junction Box Assembly 535085E62005-1.

SECTION II

TM 11-5840-359-30P

(1) ILLUSTRATION		(2)	(3)	(4)	(5)	(6)	(7)	(8)
(a) FIG NO.	(b) ITEM NO.	SMR CODE	NATIONAL STOCK NUMBER	FSCM	PART NUMBER	DESCRIPTION USABLE ON CODE	U/M	QTY INC IN UNIT
9	1	XDFDD		232529	535085E60016-10	GROUP 10 PAR/ASR JUNCTION BOX ASSEMBLY 535085E62005-1		
9	2	XDDDL		232529	53508E60019-8	PANEL ASSEMBLY..... CASE.....	EA EA	1 1
31/(32 BLANK)								

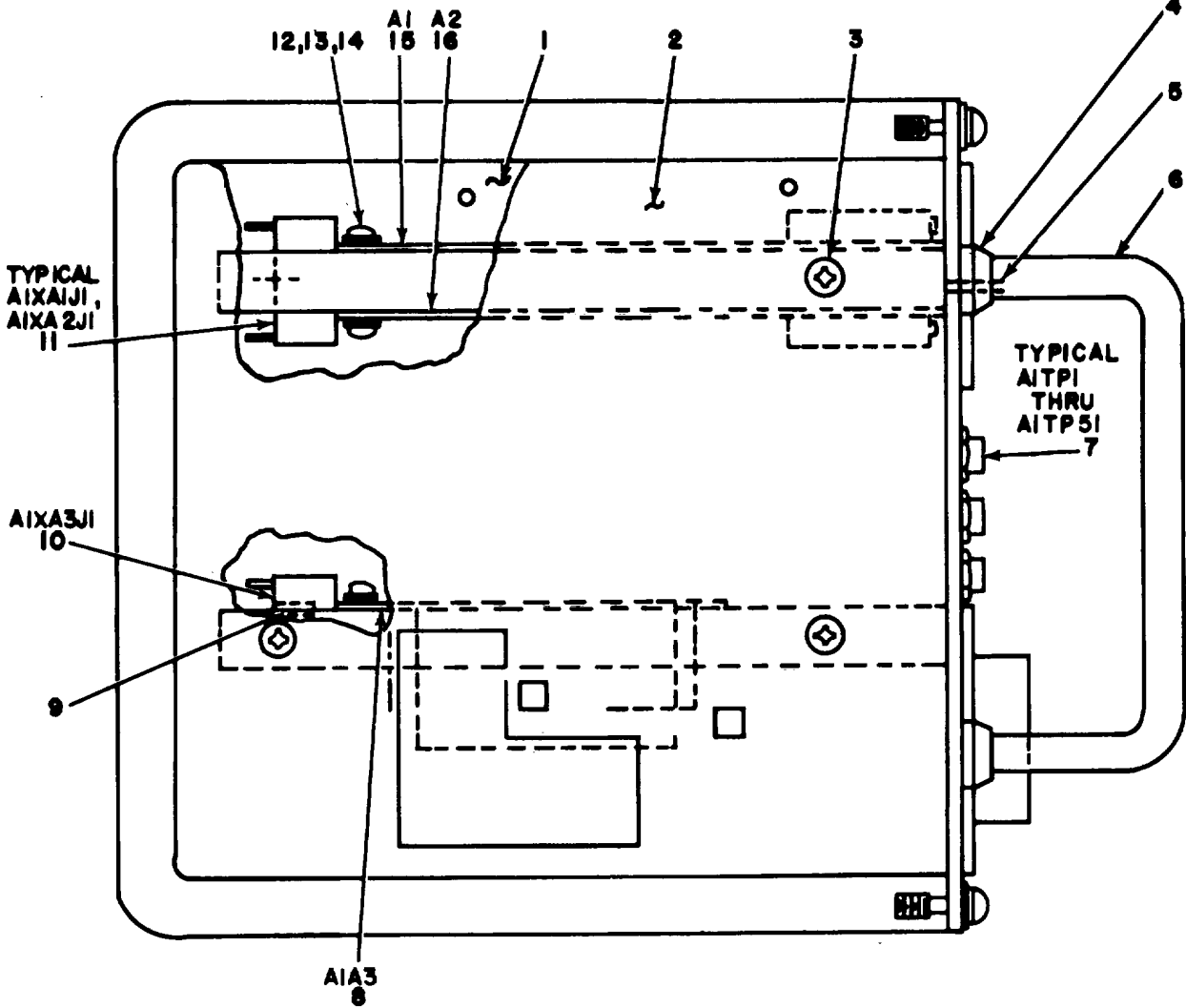

SIDE VIEW

NOTE: FOR COMPLETE REFERENCE DESIGNATION,
PREFIX WITH 12.

EL5W0015

Figure 10 . Panel Assembly E60016-10 (Sheet 1 of 2).

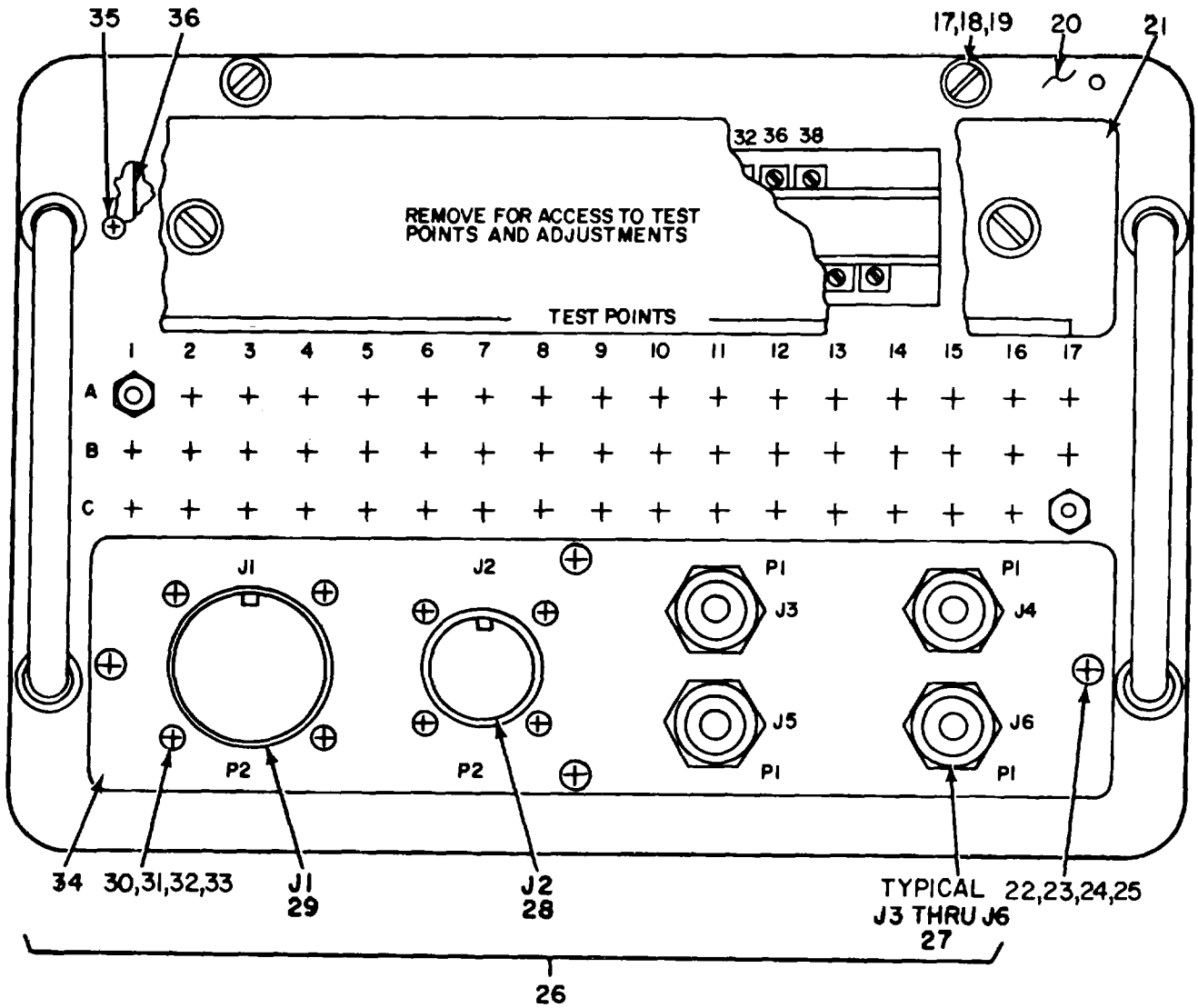

FRONT VIEW

NOTE: FOR COMPLETE REFERENCE DESIGNATION PREFIX WITH 12A1.

EL5WD016

Figure 10. Panel Assembly E60016-10 (Sheet 2 of 2).

(1) ILLUSTRATION		(2)	(3)	(4)	(5)	(6) DESCRIPTION	(7)	(8)
(a) FIG NO.	(b) ITEM NO.	SMR CODE	NATIONAL STOCK NUMBER	FSCM	PART NUMBER	USABLE ON CODE	U/M	QTY INC IN UNIT
					GROUP 1002 PANEL ASSEMBLY E60016-10			
10	1	XDDZZ		23259	53508SE10012-12	SIDE SKIN, RH.....	EA	1
10	2	XDDZZ		23259	535085E10012-11	SIDE SKIN.LH.....	EA	1
10	3	XOOZZ		96906	MS242693526	SCREW	EA	1
10	4	PADZZ	5340-00-976-4123	88245	901-30	FERRULE, GROOVED CLA	EA	4
10	5	PADZZ	5305-00-957-7086	96906	526935213	SCREW MACHINE	EA	4
10	6	PADZZ	5340-00-456-2611	88245	1064-30	HANDLE, BOW.....	EA	2
10	7	PADZZ	5935-00-113-4871	81349	M39024-10-11	JACK, TIP.....	EA	1
10	8	XDFDL	6930-01-028-3364	89297	535085E63122-3	CIRCUIT CARD ASSEN.....	EA	1
10	9	XDDZZ	5935-00-120-9209	02660	225-594	POLARIZING, KEY.....	EA	3
10	10	XDDZZ		02660	225-21851-101	CONNECTOR, RECEPTACL.....	EA	1
10	11	XDDZZ		81349	M21097-1-235	CONNECTOR, RECEPTACL.....	EA	2
10	12	PAFZZ	5305-00-993-0190	96906	MS35206-214	SCREW M.ACHINE	EA	12
10	13	PAFZZ	5310-00-543-2410	96906	MS35338-40	WASHER, LOCK.....	EA	20
10	14	PAFZZ	5310-00-656-0111	96906	MS15795-703	WASHER, FLAT.....	EA	12
10	15	PAFDL	5840-01-042-0026	89279	535085E63127-L	CIRCUIT CARD ASSEMS.....	EA	1
10	16	XDFDL		23359	535085E63117-1	PC CARD ASSEMBLY.....	EA	1
10	17	XDDZZ		96906	ZSPI0-L003-1	SCREW	EA	4
10	18	PADZZ	5310-00-167-0739	88044	AN96008	SCREW, FLAT.....	EA	4
10	19	PADDZ	5310-00-045-3299	96906	KS35338-42	WASHER, LOCK.....	EA	4
10	20	XDDZZ		32591	35085E10016-1	PANEL. JUNCTION BOX.....	EA	1
10	21	XDDZZ		23259	53508	E100016-2PANEL ACCESS	EA	1
10	22	PADZZ	5305-00-849-7034	96906	MS246938B27	SCREW, MACHINE	EA	4
10	23	PADZZ	5310-00-595-6333	96906	MS15795-705	WASHER, FLAT	EA	4
10	24	PADZZ	5310-00-045-4007	96906	MS35338-41	WASHER. LOCK	EA	4
10	25	PADZZ	5131-00-68-6627	96906	MS25082-1	NUT, PLAIN.HEXAGON.....	EA	4
10	26	XDDDL		23259	535085E60015	PANEL ASSEMBLY CONN.....	EA	1
10	27	XDDZZ	5935-00-724-3775	80058	UG556BU	CONNECTOR RECEPTACL.....	EA	4
10	28	PADZZ	5935-00-783-5402	96906	M3122E6-6P	CONNECTOR.RECEPTACL.....	EA	1
10	29	PADZZ	5935-00-726-7014	96906	MS3122E22-55S	CONNECTOR, RECEPTACL	EA	1
10	30	XDDZZ		96906	M1524693885	SCREW, MACHINE	EA	8
10	31	PADZZ	5310-00-656-0111	96906	M15795-703	WASH FLAT.....	EA	10
10	32	PADZZ	5310-00-543-2410	96906	MS35338-40	WASHER LOCK.....	EA	1
10	33	XDDZZ	5310-00-934-9739	96906	520341-45	NUT.PLAIN, HEXAGON.....	EA	8
10	34	XDDZZ		23259	35085E10015-19	PANEL. CONNECTOR.....	EA	1
10	35	PADZZ	5305-00-837-3343	96906	11524693528	SCREW, MACHINE	EA	4
10	36	XDDZZ		23259	535085F10012-13	BAR.MOUNTING.....	EA	4

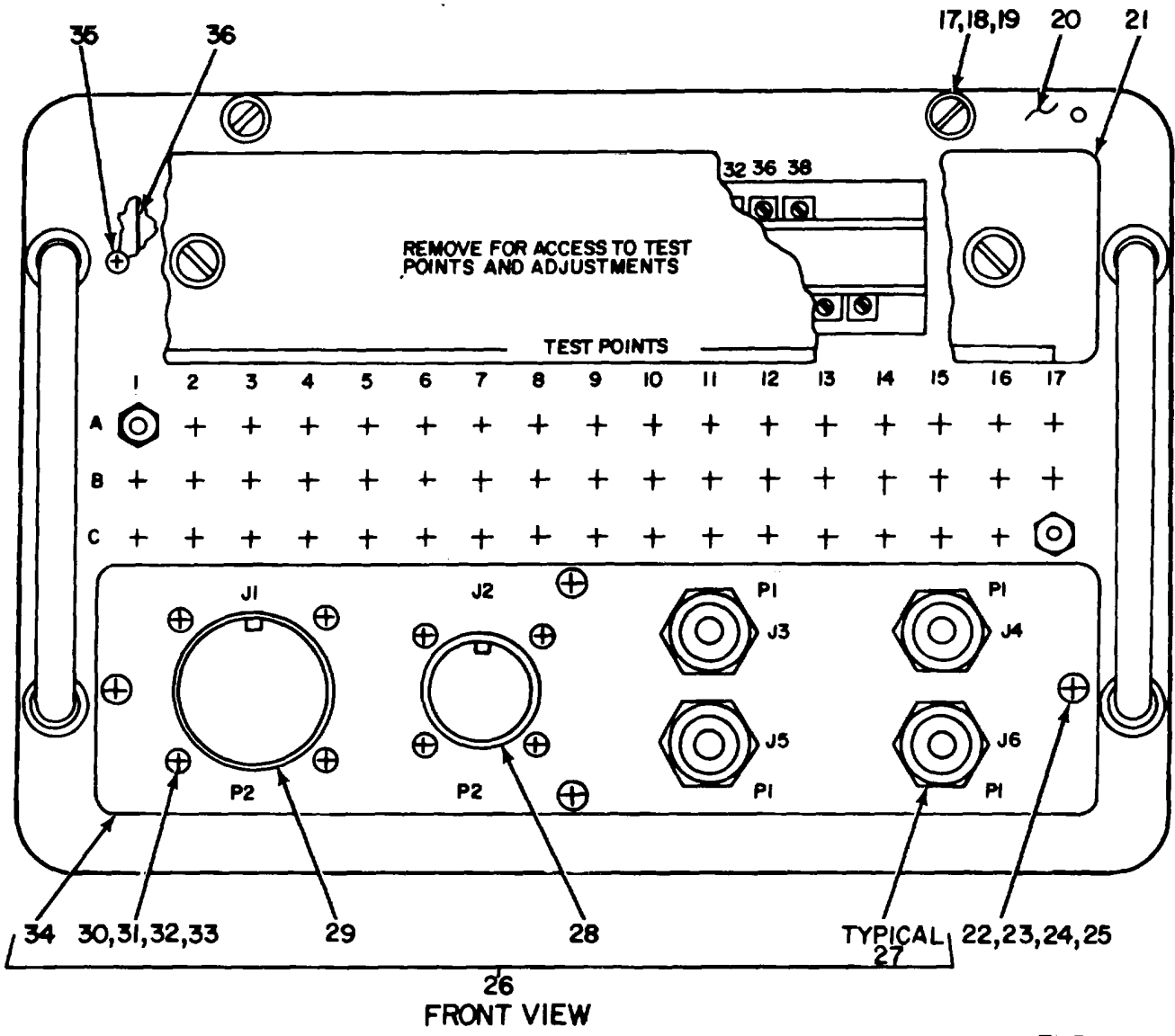

EL5WD019

Figure 11. PAR/ASR Junction Box Assembly 535085E62006-1.

(1) ILLUSTRATION		(2)	(3)	(4)	(5)	(6)	(7)	(8)
(a) FIG NO.	(b) ITEM NO.	SMR CODE	NATIONAL STOCK NUMBER	FSCM	PART NUMBER	DESCRIPTION USABLE ON CODE	U/M	QTY INC IN UNIT
11	1	XDDDL	23259	23259	535085E60019-11	GROUP 11 PAR/ASR JUNCTION BOX ASSEMBLY 535085E62006-1	EA	1
11	2	XDFDD	23259	23259	535085E60019-9	CASE PANEL ASSEMBLY.....	EA	1
37/(38 BLANK)								

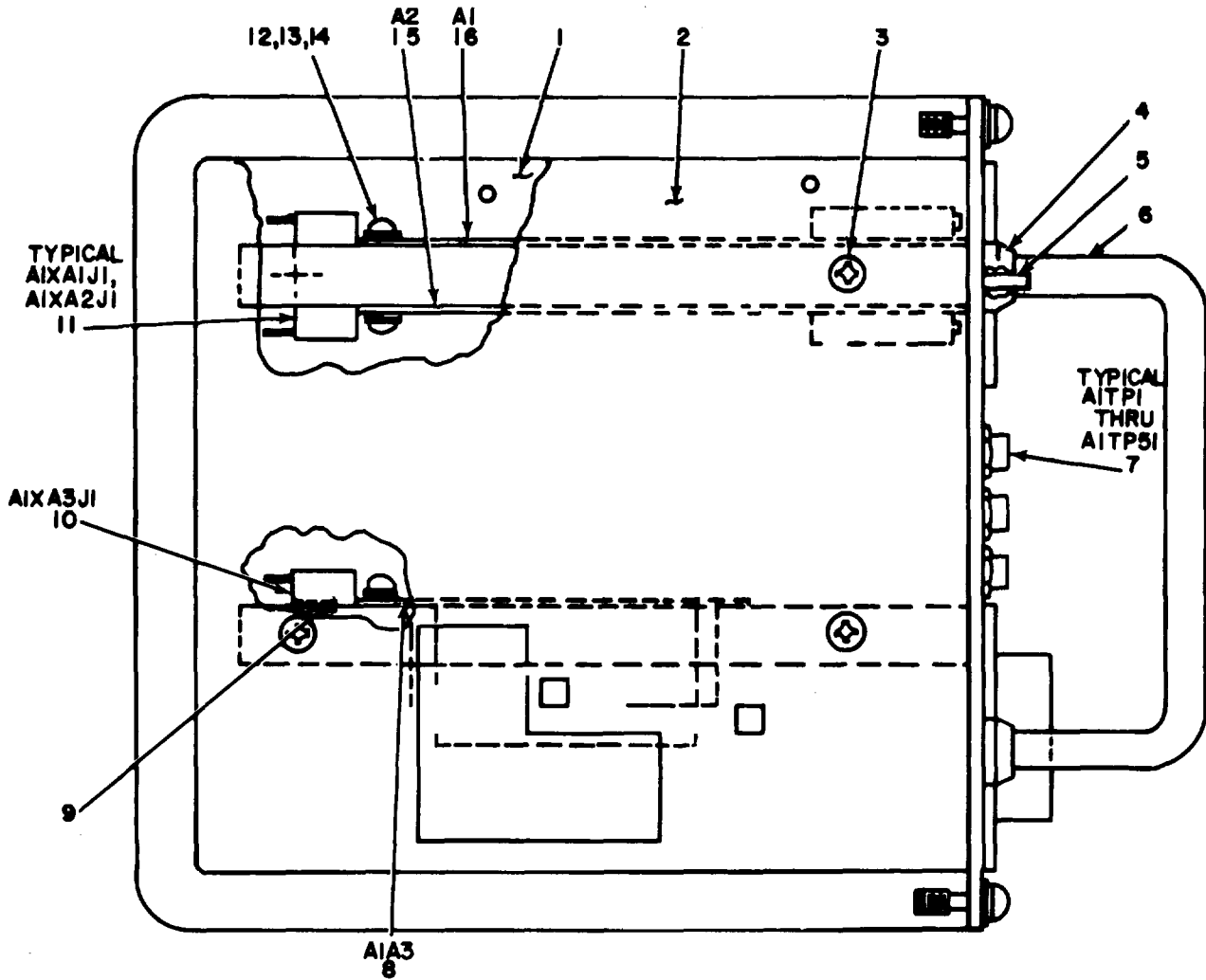

SIDE VIEW

NOTE FOR COMPLETE REFERENCE DESIGNATION
PREFIX WITH 13.

EL5WDO18

Figure 12. Ⓞ. Panel Assembly E60016-11 (Sheet 1 of 2).

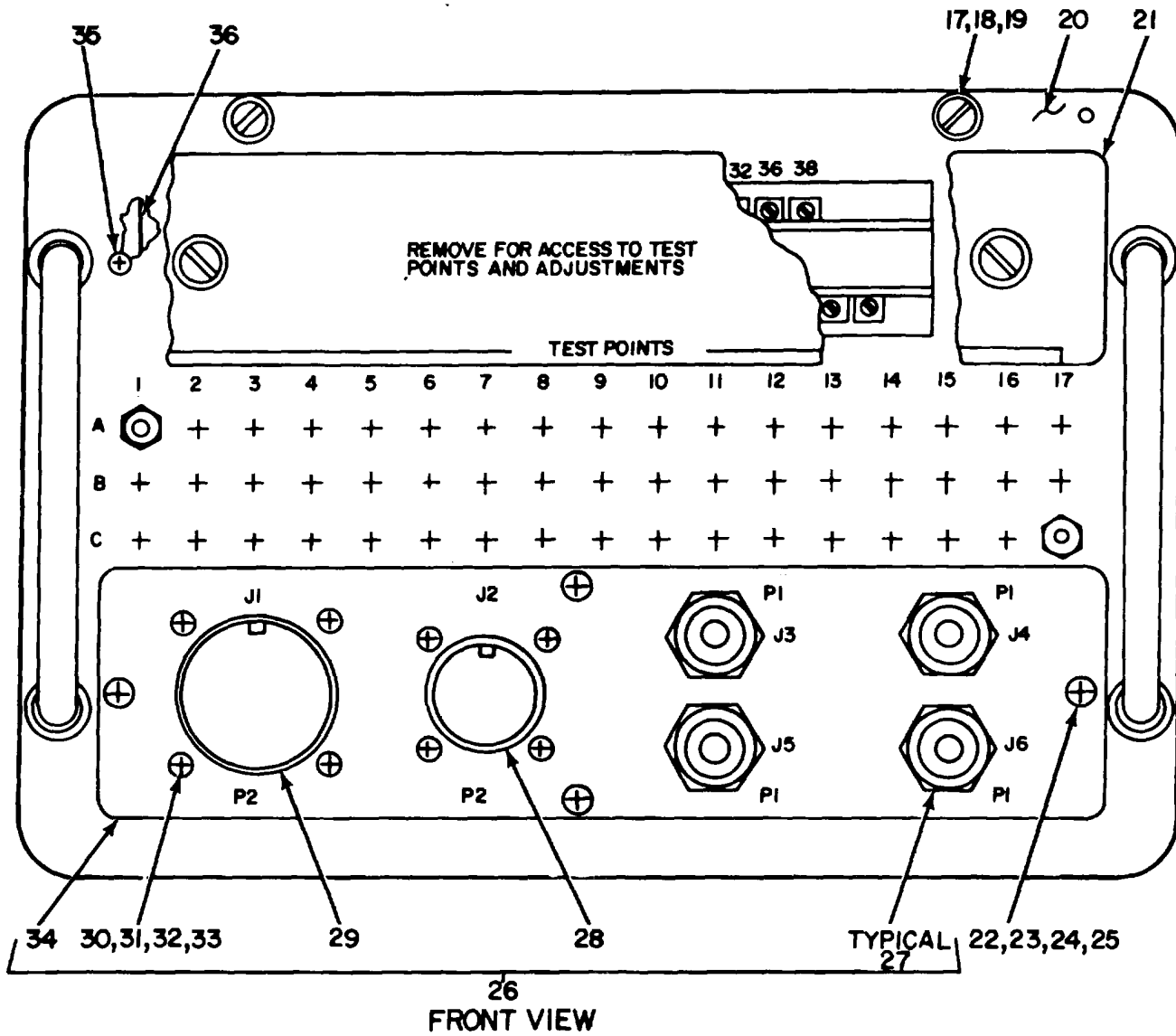

EL5WD019

Figure 12. © Panel Assembly E60016-11 (Sheet 2 of 2).

(1) ILLUSTRATION		(2)	(3)	(4)	(5)	(6) DESCRIPTION	(7)	(8)
(a) FIG NO.	(b) ITEM NO.	SMR CODE	NATIONAL STOCK NUMBER	FSCM	PART NUMBER	USABLE ON CODE	U/M	QTY INC IN UNIT
						GROUP 102 PANEL ASSEMBLY E6001-11		
12	1	XDDZZ		23259	535085E0012-1	2SIDE SKIN, RFI.....	EA	11
12	2	XDDZZ		23259	53508E110012-1	SIDE SKIN, LH.	EA	1
12	3	PADZZ	5305-00-957-7817	96906	MS24693526	SCREW. MACHINE.	EA	1
12	4	PADZZ	5340-00-976-4123	88245	901-30	FERRULE, GROOVED CLA.	EA	4
12	5	PADZZ	5305-00-957-7086	96906	MS24693S2Z3	SCREW. MACHINE.	EA	4
12	6	PADZZ	5340-00-456-2611	88245	064-30	HANDLE BOW.	EA	2
12	7	PADZZ	5935-00-113-4811	81349	M39024-10-11	JACK, TIP.	EA	51
12	8	PAFDL	5840-01-042-0024	89279	535085E63122-1	CIRCUIT CARD ASSEMBLY.	EA	1
12	9	XDDZZ		02660	225-534	INSERT, ELECTRICAL C.....	EA	3
12	10	XDDZZ		02660	225-2151-101	CONNECTOR, RECEPTACL.	EA	1
12	11	XDOZZ		81349	M21097-1-235	CONNECTOR, RECEPTACL.	EA	2
12	12	PAFFZ	5105-00-993-0190	96906	535206-214	SCREW. MACHINE.	EA	12
12	13	PAFZZ	5310-00-543-2410	96906	MS35338-0	WASHER, LOCK.....	EA	20
12	14	PAFZZ	5310-00-680-6745	96906	MS51795	WASHER.	EA	12
12	15	XDFDL	6930-01-026-8428	89297	535085E6311-1	CIRCUIT CARD ASSEMB.	EA	
12	16	PAFDL	5840-01-042-0025	92179	535085E63128-1	CIRCUIT CARD ASSEMB.	EA	1
12	17	XDDZZ		19173	ZSP1-1003-1	SCREW.	EA	4
12	18	PADZZ	5310-00-167-0739	88044	AN96OD8	WASHER. FLAT.	EA	4
12	19	PADZZ	5310-00-045-3299	96906	MS35338-42	WASER, LOCK.	EA	4
12	20	XDDZZ		23259	535085E10016-1	PANEL, JUNCTION BOX.	EA	1
12	21	XDDZZ		23259	535085E100L16-2	PANEL, ACCESS.	EA	1
12	22	PADZZ	5305-00-849-7034	96906	MS246938827	SCREW, MACHINE.	EA	4
12	23	PADZZ	5310-00-595-6333	96906	MS1595-705	WASER, FLAT.	EA	1
12	24	PADZZ	5310-00-045-4007	96906	MS35338-41	WASHER, LOCK.	EA	4
12	25	PADZZ	5310-00-680-6627	96906	MS25082-1	NUT, PLAIN, HEXAGON.	EA	4
12	26	XDDDL		23259	53505E60015-9	PANEL ASSEMBLY, CONN.	EA	1
12	27	XDDZZ	5935-00-124-3715	80058	UG556BU	CONNECTOR, RECEPTACL.	EA	4
12	28	PADZZ	5935-00-783-5402	96906	MS3122E16-26P	CONNECTOR, RECEPTACL.	EA	1
12	29	PADZZ	5935-00-726-707	96906	MS3122E22-555	CONNECTOR, RECEPTACL.	EA	1
12	30	XDDZZ		96906	MS24693885	SCREW, MACHINE.	EA	1
12	31	PADZZ	5310-00-656-0111	96906	MS15795-703	WASHER, FLAT.	EA	1
12	32	PADZZ	5310-00-543-2410	96906	S353538-40	WASHER, LOCK.	EA	12
12	33	XDDZZ	5310-00-934-9739	96906	MS20341-4S	NUT. PLAIN, HEXAGON.	EA	1
12	34	XDDZZ		23259	53508SEL6015-19	PANEL CONNECTOR.	EA	1
12	35	PADZZ	5305-00-837-3343	96906	MS24693528	SCREW MACHINE.	EA	4
12	36	XDDZZ		23259	535085010012-13	BAR, MOUNTING.	EA	4

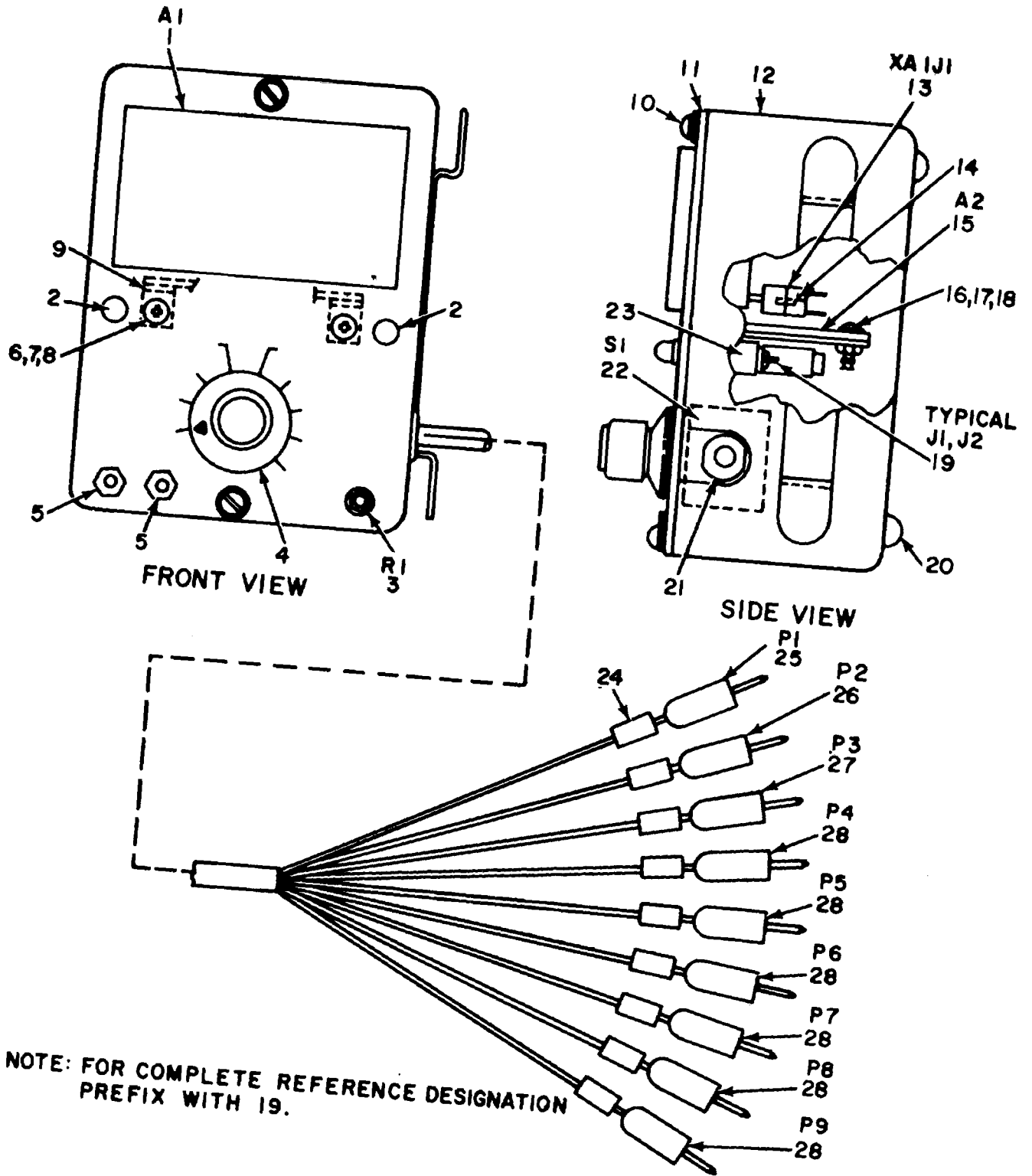

EL5WD020

Figure 13. Alignment Fixture.

(1) ILLUSTRATION		(2)	(3)	(4)	(5)	(6)	(7)	(8)
(a) FIG NO.	(b) ITEM NO.	SMR CODE	NATIONAL STOCK NUMBER	FSCM	PART NUMBER	DESCRIPTION USABLE ON CODE	U/M	QTY INC IN UNIT
						GROUP 12 ALIGNMENT FIXTURE		
13	1	XDDZZ		24355	ADZ102010	INDICATOR, DIGITAL T D	EA	1
13	2	XDDZZ		T2619	507-4764	DATA LAMP	EA	1
13	3	XDDZZ		80294	3059L1-200N	RESISTOR VARIABLE	EA	1
13	4	PADZZ	5355-00-680-1357	96190	S915211F2	KNOB	EA	1
13	5	PADLZ	5935-00-113-4871	81349	N39024-10-11	JACK, TIP	EA	2
13	6	PADZZ	5305-00-849-7034	96906	S24693127	SCREW, MACHNE	EA	2
13	7	PADZZ	5310-00-045-4001	96906	M3533-41	WASHERLOCK	EA	2
13	8	PADZZ	5310-00-934-9747	96906	MS35649-262	NUT, PLAIN, HEXAGON	EA	2
13	9	XDDZZ		91833	1567	JACKET	EA	1
13	10	XDDZZ		98376	ZSPI0-1003-1	SCREW EXTERNALLY RE	EA	2
13	11	XDDZZ		23259	535085E1002-4	PANEL ASSEMBLY	EA	1
13	12	XDDZZ		2329	53501SE10026-1	CASE ASSEMBLY	EA	1
13	13	PADZZ	5935-00-938-4761	81349	21091-1-091	CONNECTOR.RECEPTACL	EA	1
13	14	XDDZZ	5935-00-120-9209	02640	225-594	POLARIZING, KEY	EA	1
13	15	XDDZZ		23259	535085E60007-1	ASSEMBLY, CMPNT, BD.	EA	1
13	16	PADZZ	53058-00-899-2997	96906	S35206-215	SCREW MACHINE	EA	4
13	17	PADZZ	5310-00-656-0111	96906	S15795-103	WASHER, FLAT	EA	4
13	18	PADZZ	5310-00-11-6419	96901	5NS21042-04	NUT, SELF-LOCKING, EX	EA	4
13	19	PADZZ	6250-00-96-5260	72619	515-0012	LAMPHOLDER	EA	1
13	20	XDDZZ		76385	53221	BUMPER	EA	4
13	21	XDDZZ	5975-00-376-1585	28520	SR5N4	BUSHING, STRAIN RELI	EA	1
13	22	XDDDL		23259	5350ISEA0006-1	SWITCH ASSEMBLY	EA	1
13	23	XDDZZ		72019	515-0051	CLIP	EA	2
13	24	XDDZZ		23259	ES23	MARKER, CABLE	EA	9
13	25	PADZZ	5935-00-578-3494	83330	492-102	PLUG, TIP	EA	1
13	26	PADZZ	5935-00-720-6248	83330	492-103	PLUG, TIP	EA	1
13	27	XDDZZ		83330	492-104	PLUG, TIP	EA	1
13	28	XDDZZ		83330	492-101	PLUG TIP	EA	6

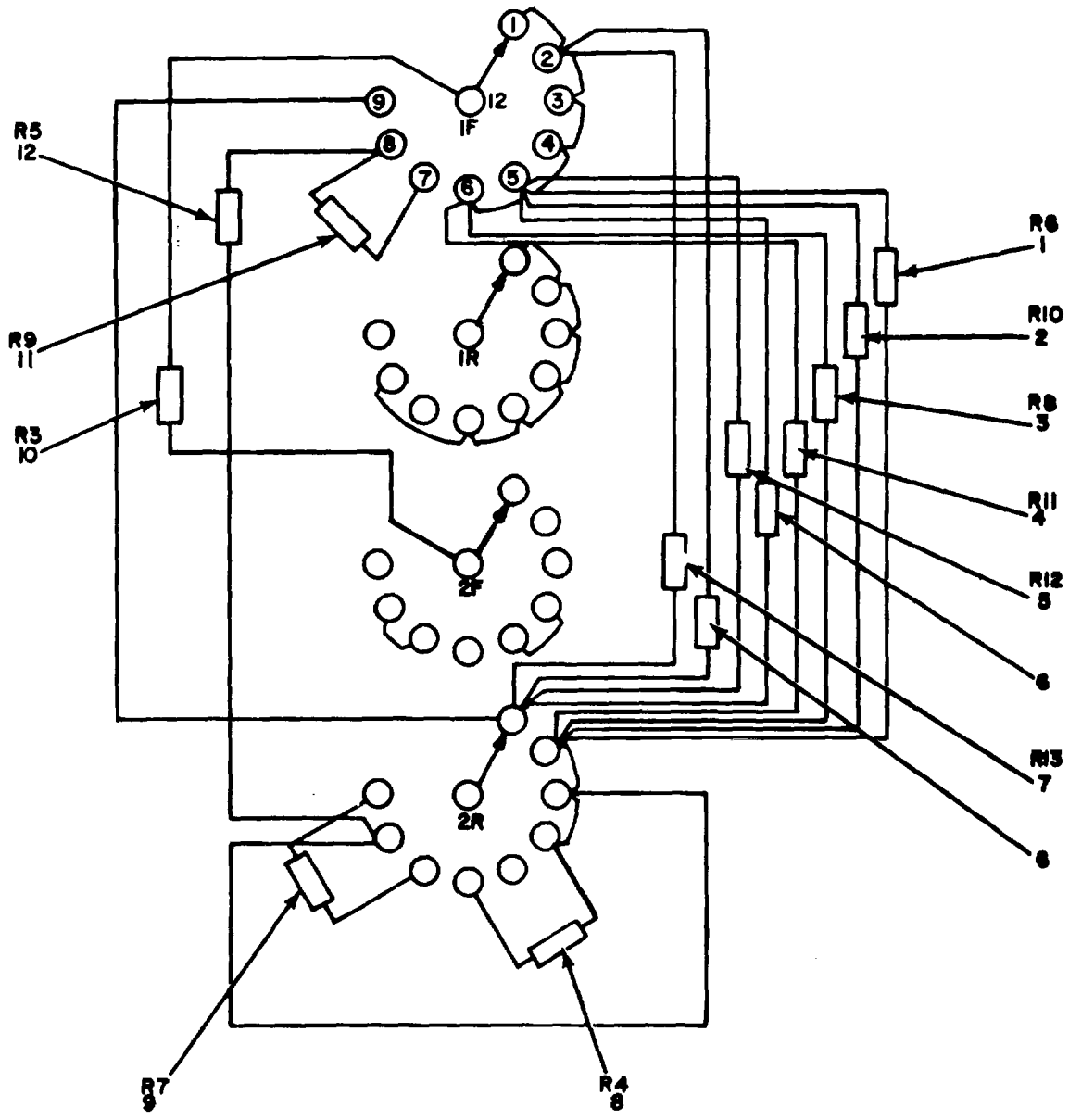

NOTE FOR COMPLETE REFERENCE DESIGNATION,
PREFIX WITH 1931.

EL5WD021

Figure 14. Alignment Fixture, Switch Assembly.

(1) ILLUSTRATION		(2)	(3)	(4)	(5)	(6)	(7)	(8)
(a) FIG NO.	(b) ITEM NO.	SMR CODE	NATIONAL STOCK NUMBER	FSCM	PART NUMBER	DESCRIPTION USABLE ON CODE	U/M	QTY INC IN UNIT
14	1	XDDZZ		81319	RNR55C1270BM	RESISTOR, FIXED, FILM	EA	1
14	2	XDDZZ		81319	RNR55C2492FM	RESISTOR, FIXED, FILM	EA	1
14	3	XDDZZ		81319	RNR55C8250BM	RESISTOR, FIXED, FILM	EA	1
14	4	XDDZZ		81319	RNR55C4422FM	RESISTOR, FIXED, FILM	EA	1
14	5	XDDZZ		81319	RNR55C2153FM	RESISTOR, FIXED, FILM	EA	1
14	6	XDDZZ	5905-00-509-3784	81319	RNR55C1001BM	RESISTOR, FIXED, FILM	EA	2
14	7	XDDZZ		81319	RNR55C5362FM	RESISTOR, FIXED, FILM	EA	1
14	8	XDDZZ	5905-01-029-4676	81319	RNR55C30R1FM	RESISTOR, FIXED, FILM	EA	1
14	9	XDDZZ		81319	RNR55C1961FM	RESISTOR, FIXED, FILM	EA	1
14	10	XDDZZ	5905-00-434-1869	81319	RNR55C1003BM	RESISTOR, FIXED, FILM	EA	1
14	11	XDDZZ		81319	RNR55C9090FM	RESISTOR, FIXED, FILM	EA	1
14	12	XDDZZ	5905-00-463-8149	81319	RNR55C1000FM	RESISTOR, FIXED, FILM	EA	1
					45			

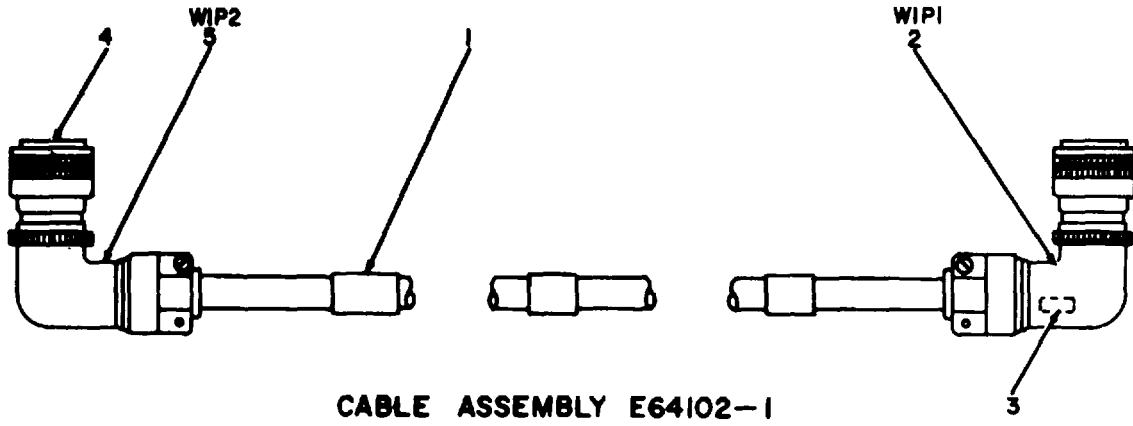

CABLE ASSEMBLY E64102-1

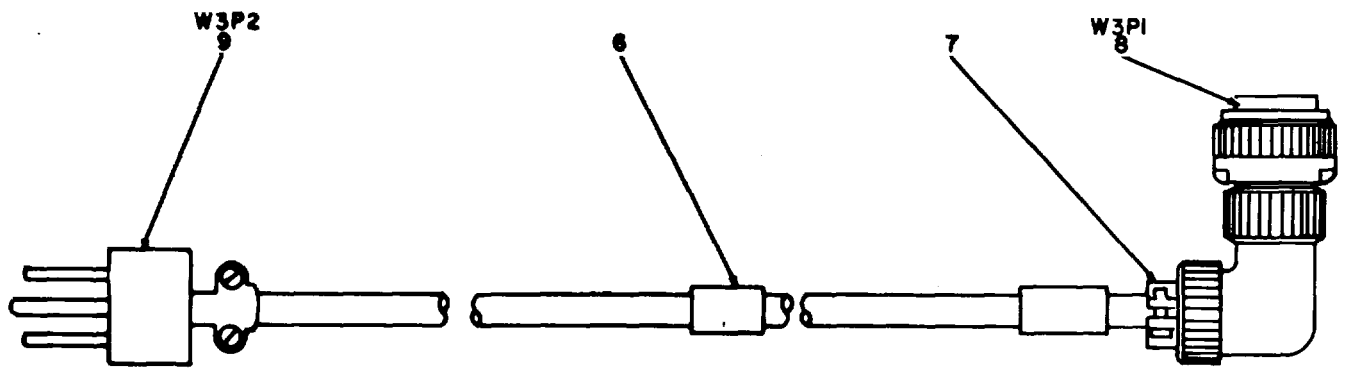

CABLE ASSEMBLY E64104-1

EL5WD022

Figure 15. Cable Assembly E6410-1 and E64104-1.

(1) ILLUSTRATION		(2)	(3)	(4)	(5)	(6)	(7)	(8)
(a) FIG NO.	(b) ITEM NO.	SMR CODE	NATIONAL STOCK NUMBER	FSCM	PART NUMBER	DESCRIPTION USABLE ON CODE	U/M	QTY INC IN UNIT
GROUP 13 CABLE ASSEMBLY E64102-4								
15	1	XDFZZ		23259	ES23	MARKER, CABLE	EA	3
15	2	PAFZZ	5935-00-765-6006	96906	MS3126E22-55S	CONNECTOR, PLUG, ELEC	EA	1
15	3	PAFZZ	5940-01-010-1571	06090	D142-51	SPLICE, CONDUCTOR	EA	1
15	4	XDFZZ		50619	CT0823622-20A	ADAPTER, CABLE CLAMP	EA	2
15	5	PAFZZ	5935-00-728-7793	96906	MS3126E22-55P	CONNECTOR, PLUG, ELEC	EA	1
GROUP 14 CABLE ASSEMBLY E64104-1								
15	6	XDFZZ		23259	ES23	MARKER, CABLE	EA	2
15	7	PAFZZ	5935-00-240-0173	96906	MS3057-4A	CLAMP, CABLE, ELECTRI	EA	1
15	8	XDFZZ		96906	MS3108A105L3S	CONNECTOR, PLUG.....	EA	1
15	9	PAFZZ	5935-00-539-2854	74545	5266	CONNECTOR, PLUG ELEC		
47								

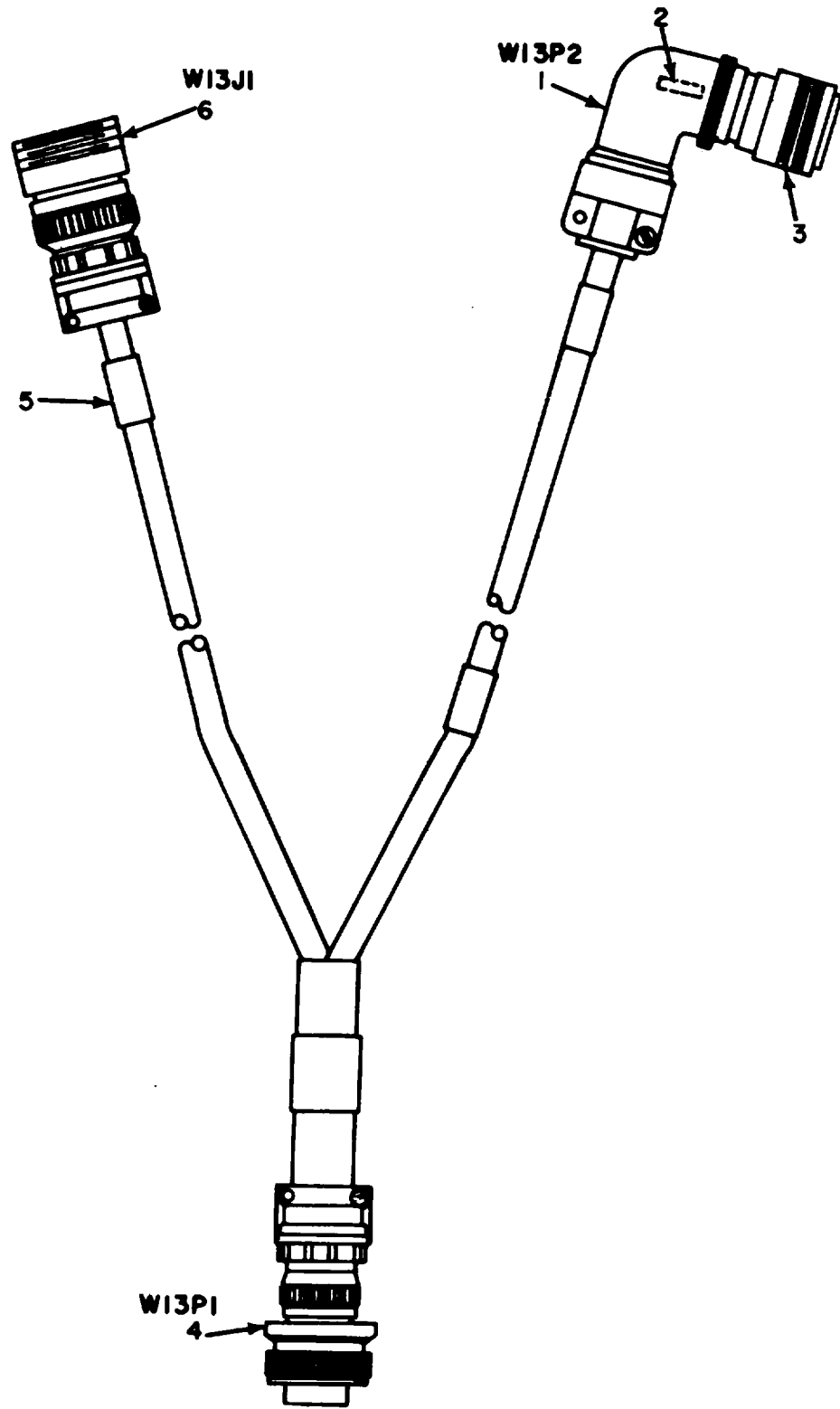

EL5WD023

Figure 16. Cable Assembly EB6107-1

(1) ILLUSTRATION		(2)	(3)	(4)	(5)	(6)	(7)	(8)
(a) FIG NO.	(b) ITEM NO.	SMR CODE	NATIONAL STOCK NUMBER	FSCM	PART NUMBER	DESCRIPTION USABLE ON CODE	U/M	QTY INC IN UNIT
						GROUP 15 CABLE ASSEMBLY E64107-2		
16	1	XDFZZ		96906	MS312GE16-26S	CONNECTOR, PLUG.....	EA	1
16	2	PAFZZ	5940-01-010-1571	06090	D142-51	SPLICE, CONDUCTOR	EA	1
16	3	XDFZZ		50619	CT0823E16-10A	ADAPTER	EA	1
16	4	PAFZZ	5935-00-256-8543	96906	MS3106F36-105	CONNECTOR, PLUG, ELEC	EA	11
16	5	XDFZZ		23259	ES23	MARKER, CABLE	EA	3
16	6	XDFZZ		96906	MS3101F36-10P	CONNECTOR, PLUG, ELEC	EA	1
						49		

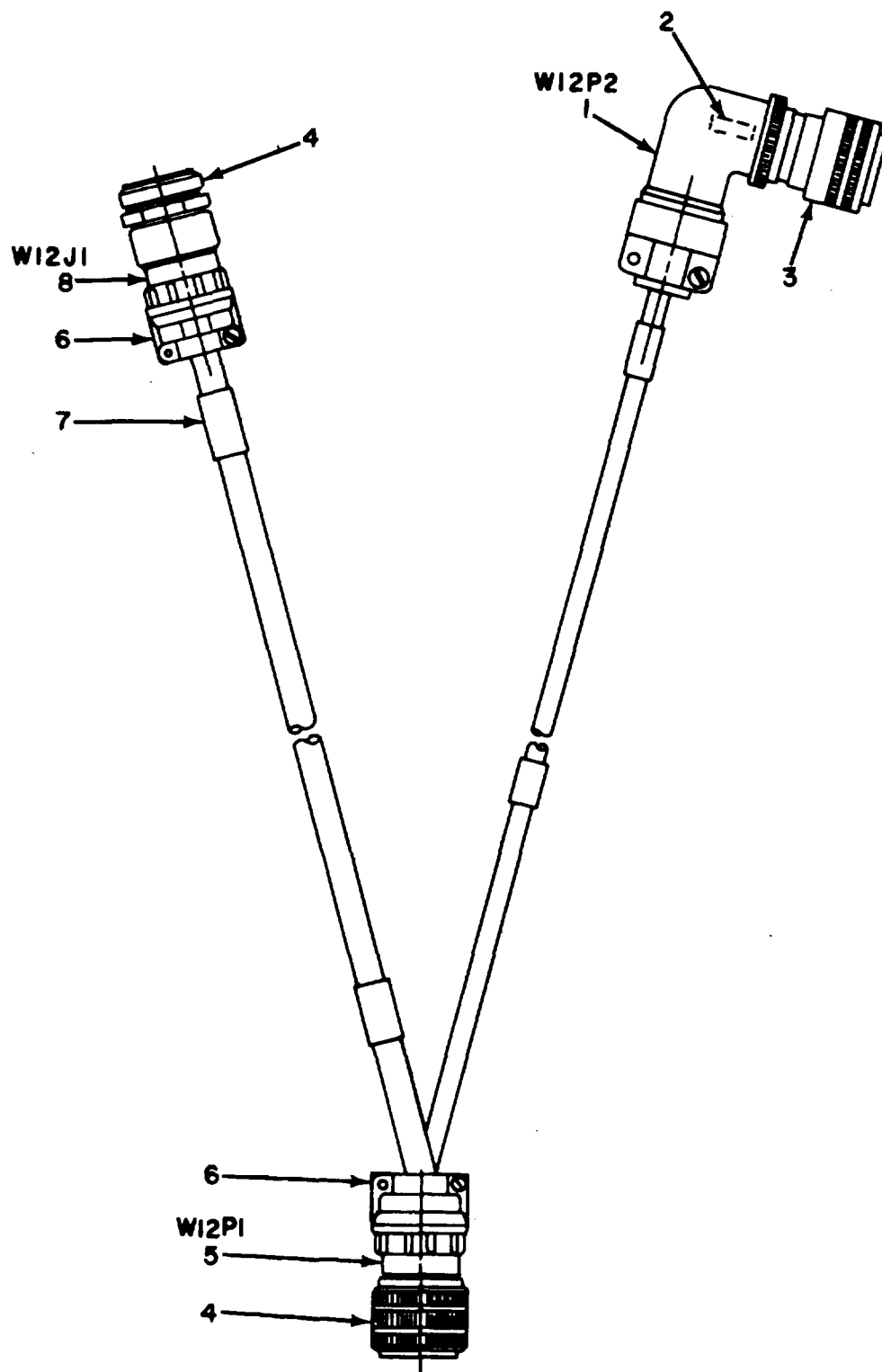

EL5WD024

Figure 17. Cable Assembly E64109-3

(1) ILLUSTRATION		(2)	(3)	(4)	(5)	(6)	(7)	(8)
(a) FIG NO.	(b) ITEM NO.	SMR CODE	NATIONAL STOCK NUMBER	FSCM	PART NUMBER	DESCRIPTION USABLE ON CODE	U/M	QTY INC IN UNIT
						GROUP 16 CABLE ASSEMBLY E64109-3		
17	1	XDFZZ		96906	MS312GE16-26S	CONNECTOR PLUG.....	EA	1
17	2	PAFZZ	5940-01-010-1S1 090 D1-51	50619	CT0823E16-10A	SPLICE, CODUCTO	EA	1
17	3	XDFZZ		77820	10-113138-36	ADAPTER, CABLE CLAMP	EA	1
17	4	PAFZZ	5935-00-648-2148	77820	10-10763152I	ADAPTER, CABLE CLAMP	EA	1
17	5	PAFZZ	5935-00-690-4665	77820	10-350349-363	CONNECTOR, PLUG.ELEC	EA	1
17	6	XDFZZ		23259	ES23	CLAMP CABLE, ELECTRI	EA	2
17	7	XDZZ		77120	10-107113-52P	MARKER, CABLE.....	EA	3
17	8	XDFZZ				CONNECTOR.PLU, ELEC	EA	1
51								

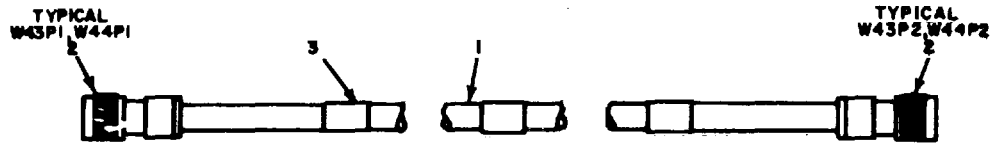

CABLE ASSEMBLIES E64114-23, E64114-24

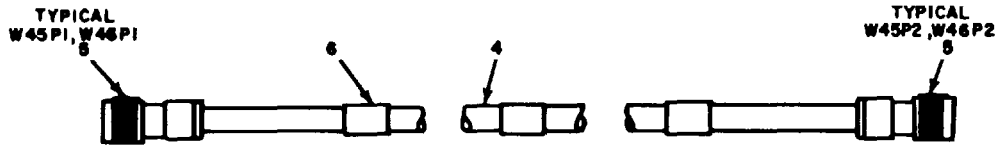

CABLE ASSEMBLIES E64114-25, E64114-26

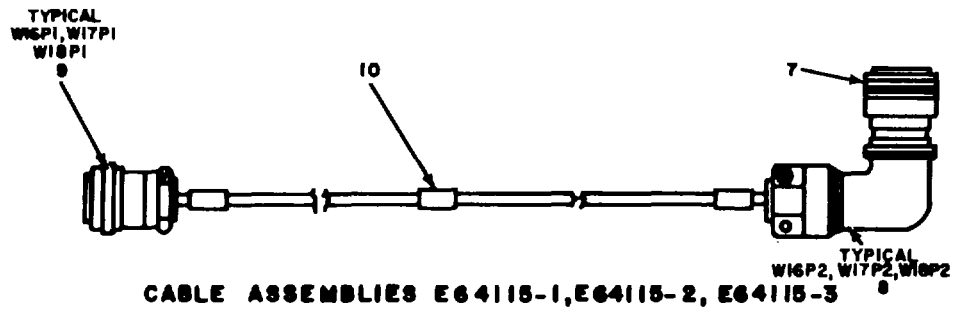

CABLE ASSEMBLIES E64115-1, E64115-2, E64115-3

EL 5W0025

Figure 18. Cable Assemblies E64114-23 Through E64114-26 and E64115-1 Through E64115-3

(1) ILLUSTRATION		(2)	(3)	(4)	(5)	(6)	(7)	(8)
(a) FIG NO.	(b) ITEM NO.	SMR CODE	NATIONAL STOCK NUMBER	FSCM	PART NUMBER	DESCRIPTION USABLE ON CODE	U/M	QTY INC IN UNIT
GROUP 17 CABLE ASSEMBLY E64114-23								
18	1	PAFZZ	6145-00542-6092	80058	RG58CU	CABLE, RADIO FREQUEN.....	FT	V
18	2	XDFZZ	5935-00-721-2675	80058	UG7099BU	CONNECTOR, PLUG, ELEC	EA	2
18	3	XDFZZ		23259	ES23	MARKE, CABLE.....	EA	1
GROUP 19 CABLE ASSEMBLY E64114-25								
18	4	PAFZZ	6145-00-542-6092	80058	RG58GU	CABLE, RADIO FREQUEN.....	FT	V
18	5	XDFZZ	5935-00-660-4296	80058	UG536CU	CONNECTOR, RF	EA	2
18	6	XDFZZ		23259	ES23	MARKER, CABLE	EA	1
GROUP 21 CABLE ASSEMBLY E64115-1								
18	7	XDFZZ		50619	CTO823E16-10	AADAPTER.....	EA	1
18	8	PAFZZ	5935-00-988-5461	96906	MS3126E10-6P	CONNECTOR, PLUG, ELEC	EA	1
18	9	PAFZZ	5935-00-988-3546	96096	MS3126E10-6S	CONNECTOR, PLUG, ELEC	EA	1
18	10	XDFZZ		23259	ES23	MARKER, CABLE	EA	1

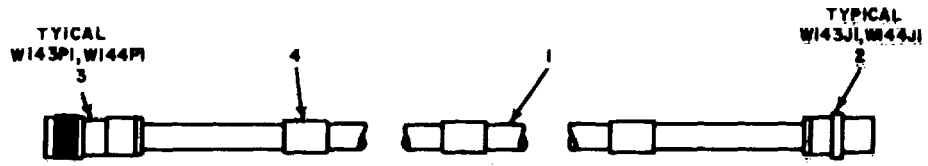

CABLE ASSEMBLIES E64117-13, E64117-14

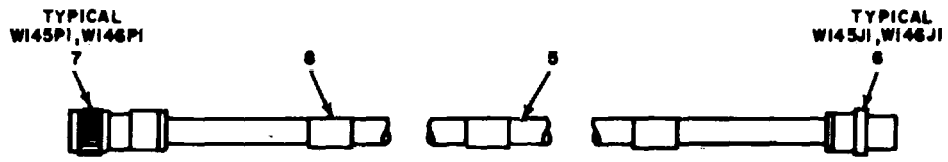

CABLE ASSEMBLIES E64117-15, E64117-16

EL5WD028

Figure 19. Cable Assemblies e64117-13 Through E64117-16

SECTION II

TM 11-5840-359-30P

(1) ILLUSTRATION		(2)	(3)	(4)	(5)	(6)	(7)	(8)
(a) FIG NO.	(b) ITEM NO.	SMR CODE	NATIONAL STOCK NUMBER	FSCM	PART NUMBER	DESCRIPTION USABLE ON CODE	U/M	QTY INC IN UNIT
						GROUP 24 CABLE ASSEMBLY E64117-13		
19	1	PAFZZ	6145-00-542-6092	80058	RG58CU	CABLE, RADIO FREQUEN	FT	V
19	2	XDFZZ		74868	81575	CONNECTOR, PLUG, ELEC.....	EA	1
19	3	XDFZZ	5935-00-721-2675	80058	UG709BU	CONNECTOR, PLUG, ELEC.....	EA	1
19	4	XDFZZ		23259	ES23	MARKER, CABLE.....	EA	3
						GROUP 26 CABLE ASSEMBLY E64117-15		
19	5	PAFZZ	6145-00-542-6092	80058	RG58CU	CABLE, RADIO FREQUEN	FT	V
19	6	PAFZZ	5935-00-781-2520	74868	3500	CONNECTOR, PLUG, ELEC.....	EA	1
19	7	XDFZZ	5935-00-660-4296	80058	UG536BU	CONNECTOR, RF	EA	1
19	8	XDFZZ		23259	ES23	MARKER, CABLE.....	EA	1
55								

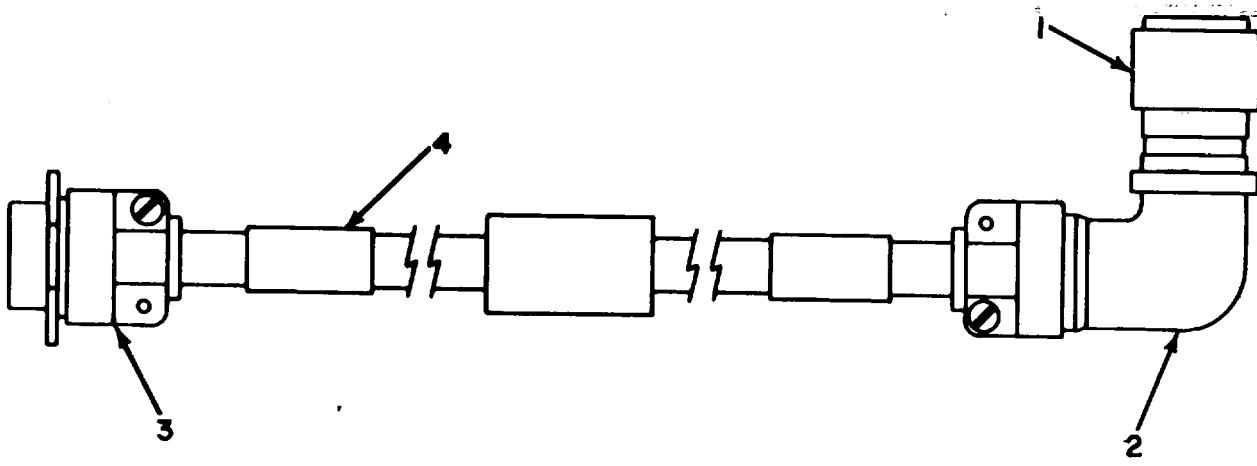

EL5WD027

Figure 20. Cable Assembly E64118-1.

(1) ILLUSTRATION		(2)	(3)	(4)	(5)	(6)	(7)	(8)
(a) FIG NO.	(b) ITEM NO.	SMR CODE	NATIONAL STOCK NUMBER	FSCM	PART NUMBER	DESCRIPTION USABLE ON CODE	U/M	QTY INC IN UNIT
						GROUP 28 CABLE ASSEMBLY E64118-1		
20	1	PAFZZ	5935-00-988-3540	96906	MS3126E18-32S	CONNECTOR, PLUG, ELEC	EA	1
20	2	XDFZZ		50619	CT0823L18-16A	ADAPTER, CABLE CLAMP	EA	1
20	3	PAFZZ	5935-00-103-5210	96906	MS3121F22-55P	CONNECTOR, PLUG, ELEC	EA	1
20	4	XDFZZ		23259	ES23	MARKER, CABLE	EA	1
57								

NATIONAL STOCK AND PART NUMBER INDEX

STOCK NUMBER	FIG. NO.	ITEM NO.	STOCK NUMBER	FIG. NO.	ITEM No.
5961-00-005-2956	5	3	5935-00-578-3494	13	25
5930-00-044-3511	7	17	5310-00-579-3663	4	21
5310-00-045-3296	2	58	5310-00-584-7800	2	59
5310-00-045-3296	4	15	5310-00-595-6211	3	5
5310-00-045-3299	2	4	5310-00-595-6211	7	54
5310-00-045-3299	10	19	5310-00-595-6211	8	15
5310-00-045-3299	12	19	5310-00-595-6333	2	9
5310-00-045-4007	4	3	5310-00-595-6333	2	29
5310-00-045-4007	7	61	5310-00-595-6333	4	4
5310-00-045-4007	10	24	5310-00-595-6333	1	4
5310-00-045-4007	12	24	5310-00-595-6333	7	64
5310-00-045-4007	13	7	5310-00-595-6333	10	23
5905-00-051-1665	6	22	5310-00-595-6333	12	23
5325-00-074-3301	2	35	5965-00-614-7280	1	3
5935-00-103-5210	20	3	5310-00-619-3847	2	3
5905-00-105-7768	6	38	5940-00-632-7234	2	6
5905-00-106-3666	6	1	5930-00-648-2148	17	4
5905-00-106-3666	7	43	5930-00-655-1575	6	32
5905-00-106-3668	5	9	5310-00-656-0111	2	32
5905-00-107-0656	5	5	5310-00-656-0111	4	18
5930-00-110-1113	7	21	5310-00-656-0111	10	14
5905-00-110-7620	6	35	5310-00-656-0111	10	31
5905-00-110-7620	T	48	5310-00-656-0111	12	31
5935-00-113-4871	10	7	5310-00-656-0111	13	18
5935-00-113-4871	12	7	5935-00-660-4296	1a	5
5935-00-113-4871	13	5	5935-00-660-4296	19	7
5940-00-113-9828	4	23	5355-00-680-1357	6	34
5935-00-120-9209	7	66	5355-00-680-1357	13	4
5935-00-120-9209	10	P	5310-00-680-6627	10	25
5935-00-120-9209	13	14	5310-00-680-6627	12	25
5840-00-138-9975	1	12	5310-00-680-6745	12	14
5840-00-138-9976	1	5	6240-00-683-0560	6	17
5340-00-139-7498	7	27	6240-00-683-0560	7	16
5940-00-143-4771	4	31	5355-00-685-4688	7	20
5910-00-144-4381	5	13	5355-00-685-4688	8	3
5310-00-167-0739	10	8	5935-00-690-4665	17	5
5310-00-167-0739	12	18	5961-00-712-5578	4	24
5310-00-187-2397	8	19	5935-00-721-2675	18	2
5940-00-204-8966	7	49	5935-00-721-2675	19	3
6240-00-223-9100	6	30	5310-00-721-3674	2	50
5905-00-235-8954	14	9	5935-00-724-3775	10	27
5935-00-240-0173	15	7	5935-00-724-3775	12	27
5940-00-247-8217	7	41	5935-00-726-7074	10	29
5910-00-248-4905	5	12	5935-00-726-7074	12	29
5935-00-256-8543	16	4	5935-00-726-7075	2	24
5325-00-269-3747	6	8	5935-00-728-6248	13	26
5305-00-282-5958	8	7	5935-00-728-7193	18	5
5920-00-284-6787	6	23	5905-00-764-2773	7	50
5970-00-350-4800	7	55	5935-00-765-6006	15	2
5970-00-350-4800	8	13	5935-00-781-2520	19	6
5975-00-376-1585	13	21	5935-00-783-5402	10	28
5910-00-431-4825	5	19	5935-00-783-5402	12	28
5905-00-434-1869	14	10	5935-00-783-9133	7	28
5340-00-456-2611	6	6	5310-00-807-1465	2	28
5340-00-456-2611	10	6	5310-00-807-1465	4	26
5340-00-456-2611	12	6	5310-00-807-1465	6	4
5930-00-462-1802	6	18	5310-00-807-1465	1	5
5905-00-463-8149	14	12	5310-00-807-1466	4	10
5930-00-465-4348	6	33	5310-00-811-6419	2	34
5935-00-490-3743	7	26	5310-00-811-6419	3	11
5935-00-490-5220	2	21	5310-00-811-6419	4	32
5905-00-509-3784	14	6	5310-00-811-6419	13	18
6145-00-542-6092	18	1	5325-00-817-0510	7	60
6145-00-542-6092	18	4	5910-00-825-7342	5	4
6145-00-542-6092	19	1	5305-00-837-3343	6	3
6145-00-542-6092	19	5	5305-00-837-3343	10	35
5905-00-542-9605	8	2	5305-00-837-3343	12	35
5310-00-543-2410	2	20	5940-00-839-0828	2	1
5310-00-543-2410	3	4	5917-00-840-5109	4	20
5310-00-543-2410	4	19	5999-00-430-0925	2	10
5310-00-543-2410	6	18	5999-00-843-0925	3	7
5310-00-543-2410	7	53	5305-00-844-4371	6	21
5310-00-543-2410	8	8	5305-00-844-4371	7	10
5310-00-543-2410	10	13	5310-00-845-5472	6	31
5310-00-543-2410	10	32	5305-00-849-7034	10	22
5310-00-543-2410	12	13	5305-00-849-7034	12	22
5310-00-543-2410	12	32	5305-00-849-7034	13	6
5310-00-543-5060	2	49	5340-00-865-0220	7	24
5355-00-556-0150	7	23	5310-00-873-3195	7	46
5905-00-577-1759	7	19	5330-00-876-0086	6	9

NATIONAL STOCK AND PART NUMBER INDEX

STOCK NUMBER	FIG. NO.	ITEM NO.	STOCK NUMBER	FIG. NO.	ITEM No.
5305-00-889-2997	8	18	5305-00-984-4988	2	52
5305-00-889-2997	13	16	5305-00-984-4988	6	52
5305-00-889-2999	2	45	5305-00-984-4989	2	8
5305-00-889-2999	3	3	5305-00-984-4993	2	39
5305-00-889-2999	7	52	5305-00-984-6192	2	47
5305-00-889-2999	8	14	5305-00-984-6192	4	9
5305-00-889-3000	2	27	5305-00-984-6194	2	42
5305-00-889-3000	7	3	5305-00-984-6197	2	2
5305-00-889-3001	4	2	5935-00-988-3540	20	1
5305-00-889-3118	2	48	5935-00-988-3566	18	9
5305-00-901-5075	6	37	5935-00-988-4353	8	6
5910-00-903-2950	5	165	5935-00-988-5461	18	8
5935-00-909-1831	7	59	5935-00-988-5470	6	12
5910-00-913-1097	5	14	5305-00-989-6265	4	4
5930-00-914-6458	6	19	5305-00-989-7434	7	36
5930-00-914-6458	7	11	5935-00-990-4557	2	25
5930-00-914-6458	8	21	5305-00-990-6444	4	30
5340-00-915-4839	2	41	5305-00-993-0190	10	12
5360-00-924-8167	6	11	5305-00-993-0190	12	12
5940-00-926-0021	3	14	6250-00-996-5260	13	19
5940-00-926-9739	2	37	5840-01-008-4110	1	25
5940-00-926-9739	4	22	5940-01-010-1571	15	3
5940-00-926-9739	6	14	5940-01-010-1571	16	2
5940-00-926-9739	8	9	5940-01-010-1571	17	2
5310-00-934-9739	10	33	5840-01-017-6968	1	2
5310-00-934-9739	12	33	5840-01-017-7044	1	1
5310-00-934-9747	13	8	6930-01-026-8064	2	17
5310-00-934-9757	2	5	6930-01-026-8065	5	16
5935-00-938-4768	7	65	6930-01-026-8066	2	15
5935-00-938-4768	13	13	6930-01-026-8066	2	15
5305-00-957-7086	6	5	6930-01-026-8428	12	15
5305-00-957-7086	10	5	6930-01026-8429	8	16
5305-00-957-7086	12	5	6930-01-028-3364	10	8
5305-00-957-7817	6	26	5905-01-029-4676	14	8
5305-00-957-7817	12	3	6940-01-030-0953	2	18
5305-00-957-7818	7	38	6940-01-030-0954	7	67
5305-00-957-7820	7	39	6940-01-030-0983	2	46
5305-00-958-9549	7	57	6940-01-034-6421	2	13
5305-00-958-9549	8	4	5935-01-039-8378	7	15
5340-00-976-4123	6	7	5935-01-039-8378	8	5
5340-00-976-4123	10	4	5840-01-042-0024	12	8
5340-00-976-4123	12	4	5840-01-042*0025	12	16
5905-00-978-7702	5	17	5840-01-042-0026	10	15
5305-00-983-6730	2	31	6940-01-046-8478	2	44
5305-00-983-6730	4	17	5999-01-046-9422	3	10
5305-00-984-4984	7	62			

SECTION IV

NATIONAL STOCK NUMBER AND PART NUMBER INDEX

FSCM	PART NUMBER	FIGURE NO.	ITEM NO.	FSCM	PART NUMBER	FIGURE NO.	ITEM NO.
24355	AD2010	13	1	23259	ES23	19	4
88044	AN960D4L	8	19	23259	ES23	19	8
88044	AN960D8	10	18	23259	ES23	20	4
88044	AN960D8	12	18	81349	F02A250V5A	6	23
81349	CK62AX222K	5	4	80058	H-170/U	1	3
81349	CL13CN680-5R3	5	2	81349	JAN2N3442	4	24
81349	CSR13F685K	5	13	46384	LAC632-2	7	46
50619	CT0823E16-10A	16	3	81349	LH73-1LC29RT2	6	16
50619	CT0823E16-10A	17	3	81349	LH73-2LC26GT2	7	12
50619	CT0823E16-10A	18	7	81349	LW76-1LC14RD3	6	31
50619	CT0823L18-16A	20	2	04713	MR890	5	8
50619	CT0823L22-20A	15	4	96906	MS15795	12	14
71468	DA24658	7	28	96906	MS15795-702	2	50
71408	D110277	2	19	96906	MS15795-703	2	32
71468	D110278	7	27	96906	MS15795-703	4	18
06090	D142-51	15	3	96906	MS15795-703	10	14
06090	D142-51	16	2	96906	MS15795-703	10	31
06090	D142-51	17	2	96906	MS15795-703	12	31
31529	EP1225-35PAIR	3	9	96906	MS15795703	13	17
31529	EP1225-50PAIR	3	1	96906	MS15795705	2	9
31529	EP1227	3	6	96906	MS15795705	2	29
23250	EP1227	18	6	96906	MS15795705	4	4
23259	ES23	13	24	96906	MS15795705	7	4
23259	ES23	15	1	96906	MS15795705	7	64
23259	ES23	15	6	96906	MS15795705	10	23
23259	ES23	16	5	96906	MS15795705	12	23
23259	ES23	17	7	96906	MS15795707	2	3
23259	ES23	18	3	96906	MS15795708	2	59
23259	ES23	18	10	96906	MS15795803	3	5

NATIONAL STOCK NUMBER AND PART NUMBER INDEX

FSCM	PART NUMBER	FIGURE NO.	ITEM NO.	FSCM	PART NUMBER	FIGURE NO.	ITEM NO.
96906	MS15795	7	54	96906	MS35206-217	2	45
96906	MS157-803	8	15	96906	MS35206-217	3	3
9690	MS20341-4S	4	22	96906	MS35206-217	1	52
96906	MS20341-4S	6	14	96906	MS35206-217	8	14
96906	MS20341-4S	8	9	96906	MS35206-218	2	31
96906	MS20341-45	10	33	96906	MS35206-218	4	17
96906	MS20341-45	12	33	96906	MS35206-227	7	62
96906	MS21042-03	2	43	96906	MS35206-228	2	52
96906	MS21042-04	2	34	96906	MS35206-228	4	7
96906	MS21042-04	3	11	96906	MS535206-229	a	8
96906	MS21042-04	4	32	96906	MS35206-230	2	27
96906	MS21042-04	13	18	96906	MS535206-230	7	3
96906	MS21042-06	2	28	96906	MS35206-231	4	2
96906	MS21042-06	4	26	96906	MS35206-233	2	39
96906	MS21042-06	6	4	96906	MS35206-244	2	47
96906	MS21042-06	7	5	96906	MS35206-244	4	9
96906	MS21042-08	4	10	96906	MS35206-246	2	42
96906	MS21266-2	7	30	96906	MS35206-249	2	2
96906	MS21266-2N	2	35	96906	MS535207-261	4	30
96906	MS242693526	10	3	96906	MS535207-262	4	14
96906	MS24593BB8	7	13	96906	MS535207-263	7	36
96906	MS24693BB1	6	37	96906	MS353506-231	7	7
96906	MS5246939827	10	22	96906	MS35338-39	2	49
96906	MS246938827	12	22	96906	MS35338-40	2	20
96906	MS246"38821	13	6	96906	MS35338-40	3	4
96906	MS246v38828	7	57	96906	MS35338-40	4	19
96906	MS246938828	8	4	96906	MS35338-40	6	15
96906	MS24693884	8	7	96906	MS35338-40	7	53
96906	MS24693885	2	36	96906	MS35338-40	8	8
96906	MS524693885	10	30	96906	MS35339-40	10	13
96906	MS24693885	12	30	96906	MS35338-40	10	32
96906	MS24693526	6	26	96906	MS35338-40	12	13
96906	MS24693526	12	3	96906	MS35338-40	12	32
96906	MS24693521	7	38	96906	MS35338-41	4	3
96906	MS5246935273	6	5	96906	MS35338-41	7	63
96906	MS246935273	10	5	96906	MS35338-41	10	24
96906	MS246935273	12	5	96906	MS35338-41	12	24
96906	MS24693528	6	3	96906	MS35338-41	13	7
96906	MS524693528	10	35	96906	MS35338-42	2	4
96906	MS24693MS28	12	35	96906	MS35338-42	10	19
96906	MS24693531	7	39	96906	MS35338-42	12	19
96906	MS24698895	6	13	96906	MS35338-43	2	58
96906	MS25036-102	7	49	96906	MS35338-43	4	15
96906	MS25036-103	4	31	96906	MS35649-242	2	37
96906	MS25036-148	4	23	96906	MS35649-262	13	8
96906	MS25082-1	10	25	96906	MS35649-282	2	5
96906	MS525082-1	12	25	96906	MS600Y20-8E	2	33
96906	MS25089-1CR	6	18	96906	MS90310-231	6	19
96906	MS25089-1GR	7	21	96906	MS90310-231	7	11
96906	MS525201-4	7	17	96906	MS90310-231	8	21
96906	MS525207-264	2	57	96906	MS90335-2	7	59
96906	MS25381-1	7	60	96906	MS91528-1D1B	7	20
96906	MS3051-4A	15	7	96906	MS91525-1D1B	8	3
96906	MS3101F36-IOP	16	6	96906	MS91528-1D2B	7	23
96906	MS3102A1LOSL3P	8	20	96906	MS91528-1NF2B	6	34
96906	MS3102EOSL3P	6	25	96906	MS91528-1F2B	13	4
96906	MS3106F36-IOS	16	4	81349	MS21097-1-091	7	65
96906	MS3108A1035	15	8	81349	M21097-1-091	13	13
96906	MS312GE16-265	17	1	81349	M21097-1-163	4	33
96906	MS312GE16-265	16	1	81349	M21097-1-235	10	11
96906	MS3121F22-MS5P	20	3	81349	210971-1-235	12	11
96906	MS3122E10-P	8	6	81349	N24308-2-2	2	21
96906	MS3122E10-65	6	12	81349	424308-4-2	7	26
96906	MS3L22E16-26P	10	28	81349	139024-10-11	10	7
96906	MS3122E16-26P	12	28	81349	M39024-10-11	12	7
96906	MS3122E18-32P	2	25	81349	139024-10-11	13	5
96906	MS3122E22-55P	2	24	80205	NAS662C2R6	6	21
96906	MS3122E22-55S	10	29	80205	NAS662C2R6	7	10
96906	MS3122E22-55S	12	29	08806	NE51	6	30
96906	MS3126E10-6P	18	8	07556	RAD4125	2	10
96906	MSMS126E10-65	18	9	017556	RAD4125	3	12
96906	MS3126E18-325	20	1	81349	RCR07G100KR	5	5
96906	MS3126E22-SSP	15	5	81349	RCR07G1002JM	7	48
96906	MS3126122-555	15	2	81349	RCR07G1002KM	6	35
96906	MS35059-22	6	32	81349	RCR07G103JM	7	43
96906	MS35206-203	2	48	81349	RCR07G103KM	6	1
96906	MS535206-214	10	12	81349	RCR07G202JM	7	50
96906	MS35206-214	12	12	81349	RCR07G220KR	5	9
96906	MS35206-215	8	18	81349	RCR07G561KM	6	38
96906	MS535206-215	13	16	81349	RC42GF223K	5	6

NATIONAL STOCK NUMBER AND PART NUMBER INDEX

FSCM	PART NUMBER	FIGURE NO.	ITEM NO.	FSCM	PART NUMBER	FIGURE NO.	ITEM NO.
80058	RG58CU	18	1	00638	50401	5	20
80058	RG58CU	18	4	72619	501-4764	13	2
80058	RG58CU	19	1	10581	50894	4	11
80058	RG58CU	19	5	79136	511S-12H	7	32
81349	RHL17G1	6	24	26119	515-0012	13	19
81349	RNR55C1000FM	14	12	2019	515-0051	13	23
81349	RNR55C1001B	14	6	74545	5266	15	9
81349	RNR55C1003BM	14	10	15084	533-051-19	7	8
81349	RNR55C1270BM	14	1	23259	53508E60019-0	9	2
81349	RNR55C1961FM	14	9	89297	53508E63126-1	5	10
81349	RNR55C2153FM	14	5	23259	53508581002-1	7	61
81349	RNR55C2492FM	14	2	23299	3508501L0012-13	12	36
81349	RNR55C30R1FM	14	8	89297	535085E663126-1	4	28
81349	RNR55C4422FM	14	4	2325	535085EU000-9	7	34
81349	RNR55C5362FM	14	7	23259	535085E100004-11	3	7
81349	RNR55C8250BM	14	3	23259	535015E100004-12	3	2
81349	RNR55C9090FM	14	11	23250	535085E10001-1S	7	56
81349	RV6NAYSD103A	8	2	23259	535085110001-2	7	29
81349	RV6NAYSD501A	7	19	2329	535085E100001-6	7	33
81349	RW69V2R0	5	17	23259	535085E10001-9	7	31
23259	SE10-9D01	6	36	23259	535085E100016-1	10	20
81349	SE12XC03	3	14	23259	535085E10016-2	10	21
81349	SE26XF01	2	1	23259	535085E10003-2	6	28
28520	SRSNI	13	21	23259	535085E10003-4	6	2
28986	TJ120MS	7	15	23259	535085E10006-11	7	2
28986	TJ120MS	8	5	23250	535085E10006-12	2	26
07263	UA7815GJ393	4	16	23259	935085E10007-14	2	7
80058	UG536BU	18	5	23259	5350851E1000-15	2	12
80058	UG536BU	19	1	23259	535085E100071-18	2	38
80058	UG556BU	10	27	23259	5350851E1000-2	2	51
80058	UG556BU	12	27	23259	535085E10007-28	2	40
80058	UG709BU	18	Z	23259	53508SE10001-8	2	60
80058	UG709BU	19	3	23259	535085E10009-11	8	11
07556	VM7500	3	10	23259	535085E10009-13	a	17
12965	YP1004	5	7	23259	535085E10009-9	8	10
76385	ZB3221	13	20	23259	535085E10012-11	10	2
19173	ZSP10-1003-1	12	17	23259	535085E10012-11	12	2
96906	ZSP10-1003-1	10	11	23259	535085E10012-12	10	1
98376	ZSP10-1003-1	8	1	23259	535085E10012-12	12	1
98376	ZSP10-1003-1	13	10	23259	S35085E10012-13	10	36
44655	0140MGDE2H	7	22	23259	535085E10015-19	10	34
15819	062X3-4X111	2	61	23259	535085E10016-1	12	20
77820	10-107136-52P	17	8	23259	535085E10016-2	12	21
77820	10-107636-52S	17	5	23259	535085EL0017-22	4	12
77820	10-113138-36	17	4	23259	535085E10017-25	4	13
77820	10-350349-363	17	6	23259	535085E10017-28	4	6
88245	1064	7	35	23259	535085E10017-29	4	8
88245	1064-30	6	6	23259	535085E10018-11	4	1
88245	1064-30	10	6	23259	535085E10026-1	13	12
88245	1064-30	12	6	23259	535085E10026-4	13	11
91833	1567	13	9	23259	535085E10038-1	7	58
81349	2N681	5	18	23259	535085E13108-1	3	8
83330	2135	2	41	23259	535085E13120-1	2	23
83330	2150	4	2L	23259	535085E13121-1	7	1
56289	220P10494	5	14	23259	535085E16015-19	12	34
56289	220P22494	5	15	23259	535085E60006-1	13	22
02660	225-21851-101	10	10	23259	535085E60007-1	13	15
02660	225-21851-101	12	10	57230	535085E60009-2	1	25
02660	225-534	12	9	57230	53508SE60010-2	1	1
02660	225-594	7	66	57230	535085E60011-2	1	2
02660	225-594	10	9	23259	535085E60012-1	7	45
02660	225-594	13	14	23259	535085E60012-11	7	47
00638	24870-1	5	3	23259	535085E60012-14	7	14
80294	3059L1-200M	13	3	23259	535085E60012-2	7	40
08806	345	6	17	23259	535085E60015-9	10	26
08806	345	7	16	23259	535085E60015-9	12	26
74868	35000	19	6	23259	535085E60016-10	9	1
56289	36D273G010AC2A	4	29	23259	535085E60018-2	1	22
56289	36D431F200AB2A	5	19	23259	5350851E60018-4	1	6
80294	3600S1-103	6	22	23259	535085160019-1	11	1
94222	43-13-1-24	6	11	23259	53508560019-9	11	2
81073	44M30-01-1-6N	7	6	23259	53508560020-2	1	4
81073	44M30-02-1-3N	6	33	23259	535085E60021-1	7	42
83330	492-101	13	28	23259	535085E60022-1	7	18
83330	492-102	13	25	23259	535085E60023-2	1	14
83330	492-103	13	26	23259	535085E60026-1	1	13
83330	492-104	13	27	23259	535085E62005-1	1	5
00638	50274	5	11	23259	535085E62006-1	1	12
00634	50275	5	16	57230	535085E63101-1	2	18
00638	50278	5	1	89297	535085E63102-1	2	17

NATIONAL STOCK NUMBER AND PART NUMBER INDEX

FSCM	PART NUMBER	FIGURE NO.	ITEM NO.	FSCM	PART NUMBER	FIGURE NO.	ITEM NO.
89297	535085E63103-1	2	16	23259	535085E64118-1	1	27
89297	535085E631041	2	15	23259	535085E90005-2	7	9
89297	535085E63105-1	2	14	23259	535085E90008-2	7	44
57230	535085E631061	2	13	57230	535085E90011-2	2	46
57230	535085E63108-3	2	4	23259	535085E90013-1	6	27
57230	535085E63109-1	7	67	23259	535085F10018-12	2	54
23259	535085E63110-1	7	51	23259	535085F60017-1	2	56
23359	535085E63117-1	10	16	23259	535085F63107-1	2	11
89297	535085E63118-1	12	15	23259	535085510017-4	4	25
89297	535085E63119-1	8	16	23259	53508560013-2	2	53
89279	535085E63122-1	12	8	75382	600-20	2	30
89297	535085E63122-3	10	8	75382	600J	2	6
23259	535085E63126-1	4	27	83330	650	8	12
89279	535085E63127-1	10	15	83330	652	7	24
89279	535085E63128-1	12	16	08530	734	4	20
23259	535085164100-1	2	22	07L26	8H195A	6	20
23259	535085E64101-5	7	25	79963	80	7	41
23259	535085E64102-1	1	20	56289	80P5	5	12
23259	535085E64104-1	1	21	74868	815715	19	2
23259	535085E64107-2	1	15	94222	82-11-260-16	6	8
23259	535085E64109-3	1	7	94222	82-32-101-17	6	10
23259	535085E64114-23	1	16	94222	82-46-101-41	6	9
23259	535085E6411424	1	17	83330	8236	4	5
23259	535085E64114-25	1	8	83330	8268	2	55
23259	535085E64114-26	1	9	83330	8423	7	37
23259	535085E64115-1	1	26	83330	8684	3	13
23259	535085E64115-2	1	24	83330	8880	7	55
23259	535085E64115-3	1	23	83330	8880	8	13
23259	535085E64117-13	1	18	88245	901-30	6	7
23259	535085E6411F14	1	19	88245	901-30	10	4
23259	535085E64117-15	1	10	88245	901-30	12	4
23259	535085E64117-16	1	11	36743	97-555A	6	29

LATEST NATIONAL STOCK NUMBER ASSIGNMENTS

STOCK NUMBER	FIGURE ITEM	
	NO.	NO.
5905-00-249-4233	5	6
5935-00-539-2854	15	9
6930-01-026-8376	4	28

By Order of the Secretary of the Army:

E. C. MEYER
General, United States Army
Chief of Staff

Official:

ROBERT M. JOYCE
Brigadier General, United States Army
The Adjutant General

DISTRIBUTION:

To be distributed in accordance with DA Form 12-36, Direct and General Support Maintenance requirements for AN/ FPN-40, and AN/TPN-18.

This fine document...

Was brought to you by me:



[Liberated Manuals -- free army and government manuals](#)

Why do I do it? I am tired of sleazy CD-ROM sellers, who take publicly available information, slap “watermarks” and other junk on it, and sell it. Those masters of search engine manipulation make sure that their sites that sell free information, come up first in search engines. They did not create it... They did not even scan it... Why should they get your money? Why are not letting you give those free manuals to your friends?

I am setting this document FREE. This document was made by the US Government and is NOT protected by Copyright. Feel free to share, republish, sell and so on.

I am not asking you for donations, fees or handouts. If you can, please provide a link to liberatedmanuals.com, so that free manuals come up first in search engines:

<A HREF=<http://www.liberatedmanuals.com/>>Free Military and Government Manuals

- Sincerely
Igor Chudov
<http://igor.chudov.com/>
- [Chicago Machinery Movers](#)