

**TECHNICAL MANUAL**

**DIRECT SUPPORT AND GENERAL SUPPORT  
MAINTENANCE MANUAL**

**TRANSMITTER, RADIO T-1428/FRN**

**(NSN 5895-01-099-3576)**

**TUNER, RADIO FREQUENCY**

**TN-588/F RN**

**(NSN 5895-01-107-2124)**

**SWITCHING UNIT, POWER**

**TRANSFER SA-2318/FRN**

**(NSN 6110-01-099-3573)**

---

**HEADQUARTERS, DEPARTMENT OF THE ARMY**

**20 SEPTEMBER 1983**

**WARNING**

HIGH VOLTAGE is used in the operation of this equipment. DEATH ON CONTACT may result if personnel fail to observe safety precautions. Learn the areas containing high voltage in each piece of equipment. Be careful not to contact high voltage connections when installing or operating this equipment.

**DON'T TAKE CHANCES!**

**WARNING**

Do not attempt internal service or adjustment unless another person, capable of rendering first aid and resuscitation, is present.

**WARNING**

A periodic review of safety precautions in TB 385-4, Safety Precautions for Maintenance of Electrical/Electronic Equipment, is recommended. When the equipment is operated with covers removed, DO NOT TOUCH exposed connections or components. MAKE CERTAIN you are not grounded when making connections or adjusting components inside the equipment.

**WARNING**

Adequate ventilation should be provided while using TRICHLOROTRIFLUOROETHANE. Prolonged breathing of vapor should be avoided. The solvent should not be used near heat or open flame; the products of decomposition are toxic and irritating. Since TRICHLOROTRIFLUOROETHANE dissolves natural oils, prolonged contact with skin should be avoided. When necessary, use gloves which the solvent cannot penetrate. If the solvent is taken internally, consult a physician immediately.

**DIRECT SUPPORT AND GENERAL SUPPORT  
MAINTENANCE MANUAL**

**TRANSMITTER, RADIO T-1428/FRN**

**(NSN 5895-01-099-3576)**

**TUNER, RADIO FREQUENCY TN-588/FRN**

**(NSN 5895-01-107-2124)**

**SWITCHING UNIT, POWER TRANSFER SA-2318/FRN**

**(NSN 6110-01-099-3573)**

**REPORTING ERRORS AND RECOMMENDING IMPROVEMENTS**

You can help improve this manual. If you find any mistakes or if you know of a way to improve the procedures, please let us know. Mail your letter, DA Form 2028 (Recommended Changes to Publications and Blank Forms), or DA Form 2028-2 located in the back of this manual direct to: Commander, US Army Communications-Electronics Command and Fort Monmouth, ATTN: DR-SEL-ME-MP, Fort Monmouth, New Jersey 07703.

In either case, a reply will be furnished direct to you.

	Paragraph	Page
CHAPTER 1. INTRODUCTION		
CHAPTER 2. FUNCTIONING OF EQUIPMENT		
SECTION I. General .....	2-1	2-1
II. Functional Description .....	2-3	2-3
III. Detailed Functional Description, NDB Transmitter .....	2-13	2-5
IV. Detailed Functional Description, ATU.....	2-21	2-11
V. Detailed Functional Description, Change-over Unit.....	2-26	2-12
CHAPTER 3. DIRECT SUPPORT MAINTENANCE INSTRUCTIONS		
SECTION I. General .....	3-1	3-1
II. Direct Support Maintenance of NDB Transmitter .....	3-5	3-1
III. Direct Support Maintenance of ATU .....	3-14	3-7
IV. Direct Support Testing Procedures		
CHAPTER 4. GENERAL SUPPORT MAINTENANCE INSTRUCTIONS		
SECTION I. General .....	4-1	4-1
II. General Support Maintenance of NDB Transmitter.....	4-5	4-1
III. General Support Maintenance of ATU .....	4-7	4-8
IV. General Support Testing Procedures		
APPENDIX A. REFERENCES		
INDEX		

## LIST OF ILLUSTRATIONS

<i>Figure</i>	<i>Title</i>	<i>Page</i>
2-1	Single NDB Transmitter System .....	2-1
2-2	Dual NDB Transmitter System.....	2-2
2-3	RF Filter Strapping.....	2-8
3-1	Removal and Replacement of Control Panel Assembly .....	3-2
3-2	Removal and Replacement of Resistor Bracket and Relay Bracket Assemblies .....	3-4
3-3	Removal and Replacement of Resistor Bracket Potentiometers.....	3-5
3-4	Removal and Replacement of Relay Bracket Components .....	3-6
3-5 (1)	Removal and Replacement of Core Assembly and Motor Tuning Assembly (Sheet 1 of 2)	3-9
3-5 (2)	Removal and Replacement of Core Assembly and Motor Tuning Assembly (Sheet 2 of 2)	3-10
4-1 (1)	Removal and Replacement of Board Chassis Assembly (Sheet 1 of 5) .....	4-3
4-1 (2)	Removal and Replacement of Board Chassis Assembly (Sheet 2 of 5) .....	4-4
4-1 (3)	Removal and Replacement of Board Chassis Assembly (Sheet 3 of 5) .....	4-5
4-1 (4)	Removal and Replacement of Board Chassis Assembly (Sheet 4 of 5) .....	4-6
4-1 (5)	Removal and Replacement of Board Chassis Assembly (Sheet 5 of 5) .....	4-7
4-2	Removal and Replacement of Electronic Assembly and Control Panel .....	4-9
FO-1	Single Transmitter Installation, Interconnection Diagram .....	Located in
FO-2	NDB Transmitter, Interconnection Diagram.....	back of
FO-3	Transformer Chassis Assembly, Schematic Diagram .....	manual
FO-4	Power Supply A1A1, Schematic Diagram.....	
FO-5 (1)	Exciter Assembly A1A2, Schematic Diagram (Sheet 1 of 2) .....	
FO-5 (2)	Exciter Assembly A1A2, Schematic Diagram (Sheet 2 of 2) .....	
FO-6	Switched Regulator Driver AiA3, Schematic Diagram .....	
FO-7	PA Module A1A4, Schematic Diagram .....	
FO-8	RF Filter A1A5, Schematic Diagram .....	
FO-9	Power Probe A1A6, Schematic Diagram.....	
FO-10	Monitor Assembly A1A7, Schematic Diagram .....	
FO-11	ATU, Schematic Diagram .....	
FO-12	Change-over Unit, Schematic Diagram .....	

## CHAPTER 1 INTRODUCTION

---

### 1-1. Scope

a. This technical manual contains functional theory and direct and general support maintenance procedures for:

(1) Transmitter, Radio T-1428/FRN (NDB transmitter).

(2) Tuner, Radio Frequency TN-588/FRN (ATU).

(3) Switching Unit, Power Transfer SA-2318/FRN (change-over unit).

b. In a dual transmitter configuration there is a Switching Unit, Power Transfer SA-2318/FRN (change-over unit). There are no direct or general support maintenance procedures for the change-over unit; the information on this unit IS provided for reference only.

c. Topics covered by this technical manual include functioning, troubleshooting, removing and replacing, assembling and disassembling, adjusting, and testing of the equipment

d. The other technical manual necessary for maintenance of the equipment is TM 11-5825-271-12.

### 1-2. Consolidated Index of Army Publications and Blank Forms

Refer to the latest issue of DA Pam 310-1 to determine whether there are new editions, changes or additional publications pertaining to the equipment.

### 1-3. Maintenance Forms, Records and Reports

a. *Reports of Maintenance and Unsatisfactory Equipment.* Department of the Army forms and procedures used for equipment maintenance will be those prescribed by TM 38-750, The Army Maintenance Management System (TAMMS).

b. *Report of Packaging and Handling Deficiencies.* Fill out and forward SF 364 (Report of Discrepancy (ROD)) as prescribed in AR 735-11-2/DLAR 4140.55/NAVMATINST 4355.73A/AFR 400-54/ MCO 4430 3F.

c. *Discrepancy in Shipment Report (DISREP) (SF 361).* Fill out and forward Discrepancy in Shipment Report (DISREP) (SF 361) as prescribed in AR 55-38/NAVSUPINST 4610.33C/AFR 75-18/MCO P4610.19D/DLAR 4500 15.

### 1-4. Administrative Storage

Administrative storage of the equipment is from 1 to 45 days and may be accomplished as follows:

a. *Storage Site.* The equipment should be stored in an area specifically marked Administrative Storage The area should be covered and protected from the elements

b. *Maintenance Services.* Before storage, perform the next scheduled major preventive maintenance service (monthly).

c. *Inspection.* Inspect the equipment for proper operation before storage. Do not store inoperable equipment

d. *Protection.* Protect the equipment by storing it in the boxes and packaging material in which it was shipped. Be sure to put a fresh desiccant bag in each package (NSN 6850-00-264-6572).

### 1-5. Destruction of Army Electronics Materiel

Destruction of Army electronics materiel to prevent enemy use shall be in accordance with TM 750-244-2

### 1-6. Reporting Equipment Improvement Recommendations (EIR)

If your NDB transmitter, ATU, or change-over unit needs improvement, let us know. Send us an EIR You, the user, are the only one who can tell us what you don't like about your equipment Let us know why you don't like the design. Put it on an SF 368 (Quality Deficiency Report). Mail It to Commander, US Army Communications-Electronics Command and Fort Monmouth, ATTN: DRSEL-ME-MP, Fort Monmouth, New Jersey, 07703. A reply will be furnished direct to you

CHAPTER 2  
FUNCTIONING OF EQUIPMENT

Section I. GENERAL

2-1. Introduction

The NDB transmitter is a 50-watt transmitter which, when used in conjunction with an ATU and a suitable antenna, serves as a nondirectional radio aid operating in the 190 kHz to 535 kHz frequency band. The system is designed for continuous operation.

2-2. System Description

a. The system can be configured as a single transmitter installation or as a dual transmitter

installation (figs. 2-1 and 2-2). When configured as a single transmitter installation, the system consists of an NDB transmitter and an ATU which connects to an antenna. When configured as a dual transmitter installation (with main and standby NDB transmitters), the change-over unit is used to connect the two NDB transmitters to the ATU and to provide switching in the event of a malfunction in the main NDB transmitter

SINGLE TRANSMITTER INSTALLATION

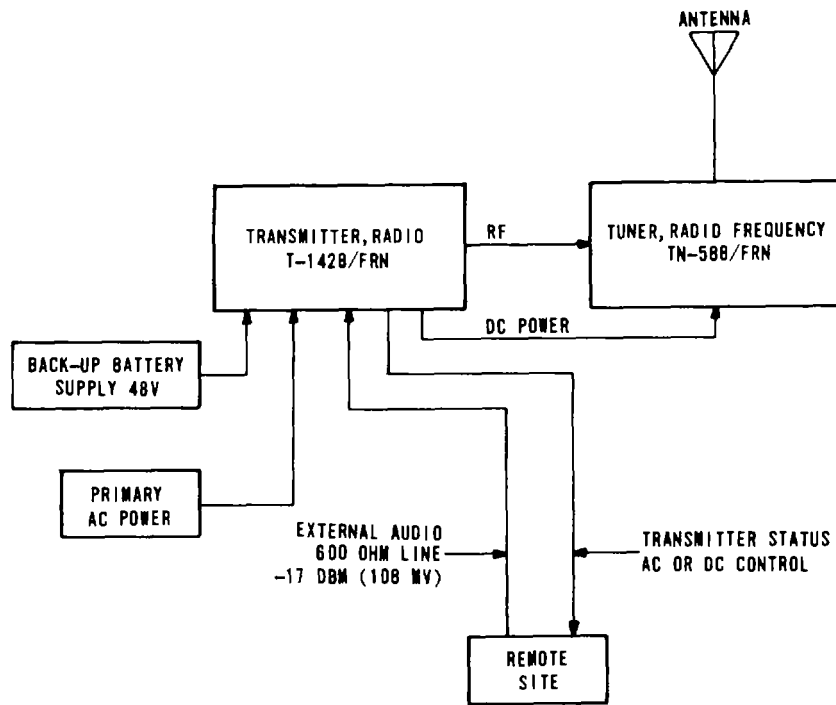

EL6ZF001

Figure 2-1. Single NDB Transmitter System

DUAL TRANSMITTER INSTALLATION

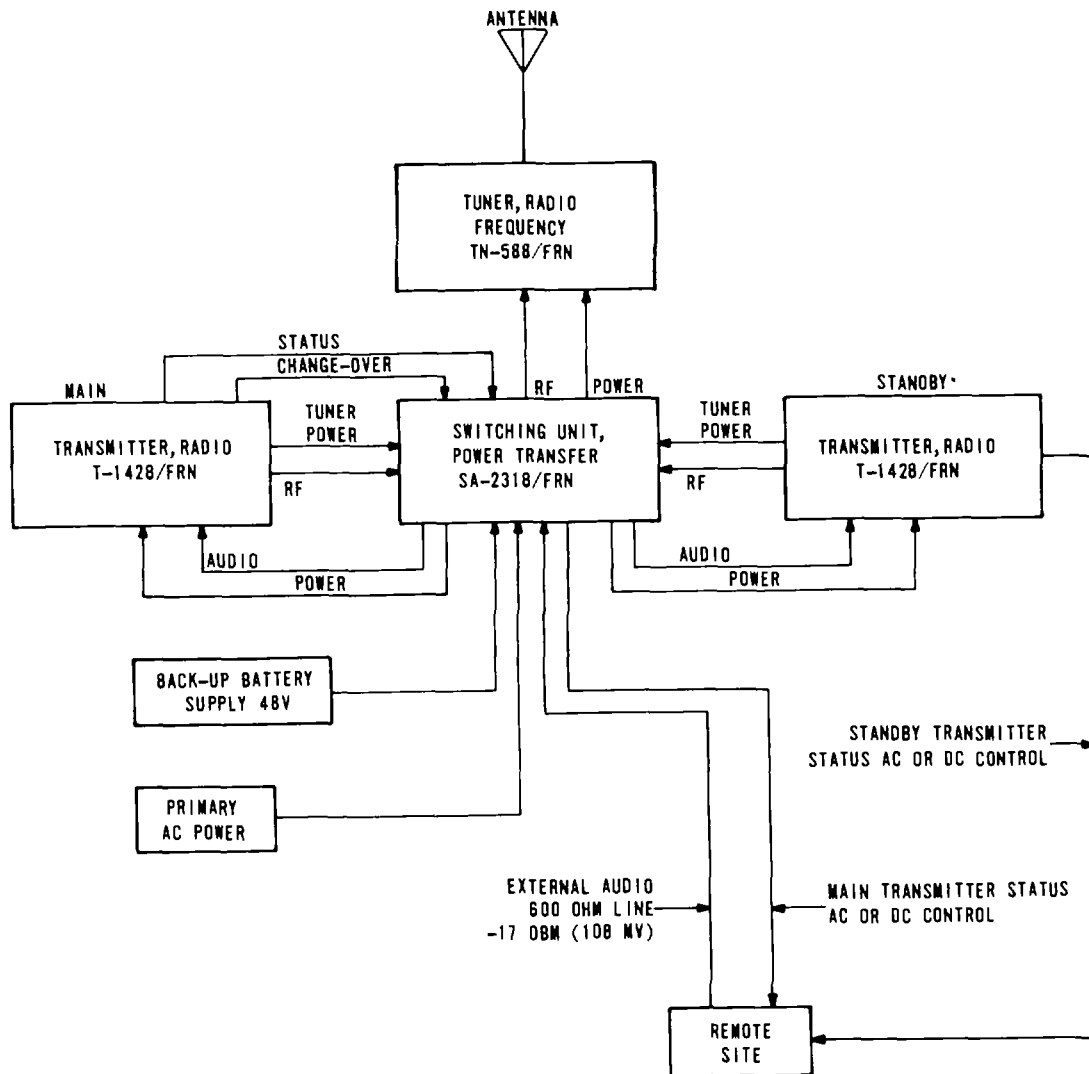

EL6ZF002

Figure 2-2. Dual NDB Transmitter System

b. The NDB transmitter is a crystal-controlled, fixed-tuned unit which operates within the frequency range of 190 kHz to 535 kHz, and provides a 50-watt (maximum) output. When in the beacon mode, the carrier frequency is amplitude modulated by an internally generated 1020 Hz or 400 Hz tone which is keyed on and off by a preprogrammed two or three

letter station identification code. The unit can also be operated with continuous tone or without a tone for maintenance. An external voice input can be used with any three of the aforementioned modes.

c. If an abnormal operating condition results in loss of keying or causes the carrier and/or modulation level to fall below preset threshold levels, automatic shutdown of

the NDB transmitter occurs and an alarm is generated. A visual alarm is provided on the control panel of the NDB transmitter and there are provisions to route the alarm condition to a remote site. In dual transmitter configuration, a shutdown of the main NDB transmitter causes the standby NDB transmitter to be switched on. Shutdown occurs 20 to 35 seconds after the abnormal operation condition is detected.

*d.* The ATU matches the antenna impedance to the 50-ohm output impedance of the NDB transmitter. While the system is operating, the ATU automatically compensates for the variations in antenna reactance caused by environmental changes. The power radiated from the antenna is dependent upon the relative values

of the antenna loss resistance, the ATU coil loss resistance, and the antenna radiation resistance.

*e.* The change-over unit is used only in dual transmitter systems. In the event of a shutdown of the main NDB transmitter, the change-over unit automatically switches on the standby NDB transmitter. The rf outputs of the two NDB transmitters are connected to the change-over unit and the switched rf output from the change-over unit is fed to the ATU.

*f.* The NDB transmitter operates from a 115/230 Vac, 60/50 Hz primary power source. Provisions are included for connecting a 48V backup battery supply, if required. Power for the ATU and the change-over unit is provided by the NDB transmitter.

## Section II. FUNCTIONAL DESCRIPTION

### 2-3. General

This section provides a functional description of the NDB transmitter and ATU. The description is supported by a block schematic diagram (fig. FO-1) which identifies all major assemblies within each unit and their interconnections. The overall functional description of the various assemblies is provided in the following paragraphs. For detailed functional description, refer to section III.

#### NOTE

Refer to figures FO-1 and FO-2 for the description that follows.

### 2-4. Power Supply A1A1 and Transformer Chassis Assembly

Although physically located on the transformer chassis assembly, the power transformer T1 and choke L1 are functionally an integral part of the power supply A1A1. Together, they provide the regulated and nonregulated dc voltages (+24 Vdc and +50 Vdc) for operation of all circuitry within the NDB transmitter, and the ATU. Power supply A1A1 contains the power switching arrangement and adjustment controls for the output voltage levels. An adjustable trickle charging circuit for an external 48V battery is also contained in the power supply A1A1.

### 2-5. Exciter Assembly A1A2

*a.* A keyer code matrix in the exciter assembly A1A2 contains solder-in type links to provide selection of any two or three letter sequence for the appropriate call sign (station identification code). The code length is 48 bits (dot lengths) for two letter codes or 64 bits for three letter codes. The dot length is adjustable from 100 to

150 milliseconds, normally set at 125 milliseconds.

*b.* The carrier frequency produced by exciter assembly A1A2 is derived from a crystal-controlled oscillator operating at 10 times the operating carrier frequency. The carrier can be produced without tone or voice modulation, with continuous tone modulation, or modulated with the keyed beacon signal. The external audio modulation input (TB2-5/6, fig. FO-1), if used, is unswitched and can be operated with or without the keyed beacon code.

### 2-6. Switched Regulator Driver A1A3

Switched regulator driver A1A3 is turned on and off by the input from exciter assembly A1A2. This arrangement prevents over-dissipation in the pa module A1A4, should a fault condition cause the mark/space signal (identification code) to assume a steady mark condition. If this occurs, the rf output remains off until the NDB transmitter is reset by switching the POWER switch S1 to OFF, then back to ON again.

### 2-7. Pa Module A1A4

The output transistors in the pa module A1A4 are hard-switched on/off by the rf drive signal from exciter assembly A1A2. The dc supply level for the pa module A1A4 is varied sinusoidally by the modulation signal and regulated by the negative feedback to the modulator.

### 2-8. Rf Filter A1A5

The rf output from the pa module A1A4 is fed to a tuned filter which removes harmonics resulting from the hard-switching action of pa module A1A4. The harmonic attenuation, relative to carrier level, is 60 dB. Five differ-



ent filter configurations, set up by installing appropriate links on terminal blocks on the rf filter A1A5, cover the complete operating frequency range of the NDB transmitter.

## 2-9. Power Probe A1A6

The power probe A1A6 detects the level of rf output and performs the following functions.

(1) Supplies a current limit signal to the monitor assembly A1A2 which keeps the rf current within safe limits in the event of a malfunction (e g, partial or complete short circuit) at the output of the NDB transmitter

(2) Supplies the rf level signal to the monitor assembly A1A7 for modulation and carrier detection circuitry

(3) Provides forward and reflected power signals for use by the metering circuits.

(4) Provides final output from the NDB transmitter (50 watts maximum) The output from the power probe A1A6 is fed to the ATU through TB1-2/3 and J3 using a 50 ohm coaxial cable.

## 2-10. Monitor Assembly A1A7

a. The monitor assembly A1A7 contains the normal/special shutdown control circuits. The rf level from the power probe A1A6 is routed to the monitor assembly A1A7 through R2 and R3, which set the threshold levels for the modulation and carrier respectively When the NDB transmitter is operating properly, shutdown relay K1 is energized, normal light DS1 is on, alarm light DS2 is off, and the transmitter status monitoring contacts are closed (K1 contacts 2-5) The shutdown circuits have a time delay which causes shutdown to occur 20 to 35 seconds after the out-of-tolerance condition is detected.

b. The normal shutdown control circuit deenergizes relay K1 if keying is lost, modulation falls below the threshold level set by R2, or if the carrier falls below the threshold level set by R3. When the normal shutdown circuit deenergizes K1, the rf oscillator in the exciter assembly A1A2 is turned off, the NORM light DS1 is turned off, the ALARM light DS2 is turned on, and the transmitter status monitoring contacts (K1 contacts 2-5) become open circuit. When NORM/BYP switch S1 is in the NORM position, the BPY light DS3 is normally off. When switch S1 is set to the BPY position, the normal shutdown circuit keeps the shutdown relay K1 in an energized state and prevents a shutdown, the BYP light DS3 comes on and the NORM light DS1 flashes at the keying rate.

c. The special shutdown circuit is similar to the normal shutdown circuit except that it causes shutdown only if keying is lost or if modulation falls

below the threshold level set by R2. Shutdown does not take place if the carrier level falls below the threshold setting of R3, however, the NORM light DS1 is turned off, the ALARM light DS2 is turned on, and the transmitter status monitoring contacts (K1 contacts 2-5) become open-circuit When the special shutdown circuit is used, the special link must be in, and the normal link must be out

d. The modulation detector monitors the rf level and provides the modulation reading for the metering circuit With the modulation removed, the zero set control R1 is adjusted to provide a meter reading of 0%. The tone level detector monitors the output of the one oscillator located in the exciter assembly A1A2. The output from the tone level detector is also fed to the metering circuit.

## 2-11. Metering

The TEST switch S2 and TEST meter M1 are used to monitor all pertinent parameters of the NDB transmitter Calibration controls R5 and R6 are provided to calibrate the meter for forward/reflected power and dc current respectively. The TEST switch S2 also permits checking of the modulation % (percentage), unregulated and regulated voltages, tone level, dc current and the rf drive level

## 2-12. ATU

a. The ATU matches the antenna impedance to the 50-ohm impedance of the NDB transmitter, automatically compensating for variations in the antenna reactance caused by environmental changes The power radiated by the antenna is dependent upon the relative values of the antenna loss resistance, the antenna radiation resistance, and the ATU coil loss resistance.

b. The rf output (50 watts carrier maximum) from the NDB transmitter is connected to the ATU through a 50-ohm coaxial cable Power for the ATU (+24 Vdc) is obtained from the NDB transmitter. The ATU has a POWER ON/OFF switch S1 and a POWER light DS1

c. The ATU power probe AI operates TEST meter M1 to provide a reading for the forward power, reflected power, and rf current. The TEST meter has a meter calibration control R1 and an on/off switch S3. The on/off switch S3, located on the side of the ATU cabinet, is used to switch the meter off when not required, without opening the cabinet.

d. The servo probe A2 monitors the phase relationship between the current and voltage of the rf output. When an off-tune condition exists (voltage and current out of phase), the servo probe A2 actuates the tuning motor to raise or lower tuning slugs in the loading coils This maintains a tuned condition to compensate for changes in the antenna reactance caused by environ-

mental changes The increase/decrease switch S4 is connected to the servo probe A2 and permits manual slewing of the tuning drive. When switch S4 is operated, the automatic tuning function is bypassed.

e. The matching transformer matches the antenna

impedance to the ATU. The loading coils tune the reactive component of the antenna impedance for the frequency in use, while the servo probe A2 and tuning motor provide the automatic fine tuning. The rf output from the loading coils is applied to the antenna.

### Section III. DETAILED FUNCTIONAL DESCRIPTION NDB TRANSMITTER

#### 2-13. Transformer Chassis Assembly (fig. FO-3)

a. All external connections to the NDB transmitter, except the rf output, are made through TB1 and TB2. The power supply A1A1 is connected to XA1, and TB3 provides connections to the wiring harness within the NDB transmitter.

b. Choke L1 provides smoothing of the unregulated 50 Vdc supply from the power supply A1A1 through XA1, pins 23 and 14. Transformer T1 can be wired for 115 Vac or 220 Vac primary power and supplies the following voltages to XA1:

- (1) 20 Vac between XA1-1 and XA1-2
- (2) 108-120 Vac between XA1-16 and XA1-13.

c. Secondary taps 7, 8, and 9 and 11, 12, and 13 of T1 are selected according to the nominal ac input line voltage as follows

Nominal Line Voltage	T1 Taps
107 Vac (214 Vac)	7 and 13
118 Vac (236 Vac)	8 and 12
131 Vac (262 Vac)	9 and 11

#### 2-14. Power Supply A1A1 (fig. FO-4)

a. *Power On/Off.* The 115 or 230 volt ac input is applied to transformer T1 on the transformer chassis assembly (fig. FO-3) through the POWER ON/OFF switch S1 and POWER fuse F1. The output from the center-tapped secondary winding of T1 is applied to full-wave rectifier CR1/CR2. The voltage across TP1 and TP2 is 114 Vac nominal, and the voltage from TP1 or TP2 to ground is approximately 57 Vac. The dc from the cathodes of CR1/CR2 is smoothed by L1 on the transformer chassis (fig. FO-3), and then routed through the current shunt (R12/R13/R25) to P1-11. The unregulated dc, approximately +50 vdc, from the current shunt is also fed to the 24V regulator. The outputs at P1-6 and P1-7 are used for metering and indicate the current load on the power supply. The unregulated +50 Vdc at P1-11 is applied to the pa module A1 A4; this voltage varies with ac line variations and output power setting, but should be approximately +50V at full power

output and nominal ac line voltage.

b. *24V Regulator.* The unregulated +50V from current shunt R12/R13/R25 is applied, through fuses F2 and F3, to two series regulators comprising Q3, Q4, Q5 and associated components. Zener diode CR8 establishes a 24.7V reference at the collector of Q3. The resulting +24V at the emitter of Q4 is applied directly to power light DS1 and to P1-21 as the transmitter dc supply. Zener diode CR9 is normally reverse-biased and serves as a safety device to prevent the emitter voltage of Q4 from rising above + 28V in the event Q3 or CR8 become open circuits. Series regulator Q5 provides a regulated dc voltage slightly less than + 24V. This 24V output is used as the ATU supply and for remote status dc monitoring. Fuses F2 and F3 provide protection for the regulated 24V outputs.

c. *Battery Charger.* The input to the battery charger circuit is the unregulated dc output from full-wave rectifier CR1/CR2, applied through the transient suppressor network R5/RV1. The voltage at the base of Q2 is set by R7, Q1 and CR3. The current through Q2 is restricted by the voltage drop across R11. When the voltage drop across R11 exceeds 0.7V, diodes CR4 and CR5 are forward biased and, form a current bypass for the Q2 base supply. Initially, with the POWER ON/OFF switch S1 closed, the charge is at a constant current. As the battery voltage rises, the charging current decreases, tapering off to zero when the battery becomes fully charged.

d. *Battery Switch.* The battery switch consists of Q6, Q7, and Q8 and associated components. Under normal conditions (ac present), the battery switch isolates the battery's positive terminal at P1-4 from the unregulated dc input at P1-23. The ac supply P1-13 is rectified by CR7/C1 and applied to the base of Q6 through voltage divider network R21/R22. This causes Q6 to conduct, and Q7/Q8 to cut off. In the event of ac failure, Q6 switches off because ac voltage at P1-13 is no longer present, and Q8 is turned on by the battery voltage through R23. As a result, Q7 conducts and con-

nects the external battery to the unregulated supply line through isolation diode CR10.

*e. AC Remote Monitor.* A secondary winding of T11 on the transformer chassis provides 20 Vac across P1-1 and P1-2 (fig. FO-3). The output between P1-1 and P1-3 can be used for monitoring at a remote site. This output can be adjusted by R4 from 0.5 to 5.0 Vac, when terminated by a 600 ohm load.

## 2-15. Exciter Assembly A1A2

(fig FO-5 (1))

*a. 12Vregulator.* The +24 Vdc at P1-14 is scaled down to +12V by R13/R14. Transistor Q1 is a voltage follower, providing a low Impedance + 12V supply for circuitry within the exciter assembly A1A2.

*b. RF Oscillator.* The switched 24 Vdc for the rf oscillator is received at P1-5 from contacts 4-7 of shutdown relay K1 (fig. FO-1). When 24 Vdc supply at P1-5 is present (normal operation), the rf oscillator circuit operates at 10 times the carrier frequency. Crystal Y1, operated at series resonance, introduces positive feedback from the collector of Q3 to the base of Q2. The signal level at the emitter of Q3, approximately 12V p-p, is applied to the frequency divider U9 Note that in the event of a malfunction, shutdown relay K1 deenergizes, and the 24 Vdc at P1-5 is switched off. Thus, the rf oscillator ceases to operate and the NDB transmitter is effectively turned off.

*c. Frequency Divider.* Integrated circuit U9 divides the rf output from the oscillator circuit by 10 to produce the transmitter carrier frequency. The output at U9-12, 12V p-p, is buffered by Q4. Transistors Q5 and Q6 form a complementary output stage which produces a square wave output at the carrier frequency.

*d. RF Filter and Detector* The square wave carrier signal from Q5/Q6 is passed through a low-pass filter to remove unwanted harmonics. The filter covers the frequency band of 320 to 535 kHz when links 3 and 4 are removed, or a frequency band of 190 to 320 kHz when links 3 and 4 are in place. Transformer T1 converts the output impedance of the filter to 50 ohms for proper matching with the pa module A1A4. Diode CR24 and capacitor C14 form a peak detector and its output at P1-7 is routed to TEST switch S2 and TEST meter M1 (fig. FO-2) to provide an indication of the drive level.

*e. Tone Oscillator.* Transistors Q7, Q8; and Q9 and associated components form a phase-shift oscillator operating at 1020 Hz The symmetrical clipping of the feedback signal by CR27 and CR28, and the variable dc bias at the cathode of CR28, allows adjustment of the output level (tone modulation depth) from the tone oscillator. The dc bias at the cathode of CR28, developed by R115 and ONE LEVEL potentiometer R12,

is reduced to zero when the TONE switch S3 is switched off. When the voltage at the cathodes of CR28 is zero (S3 off), the oscillator ceases to produce an output Transistor Q9 is an emitter follower, providing a low impedance tone output to the keyer gate Q10

*f. Keyer Gate.* Field-effect transistor Q10 provides transient-free gating of the 1020 Hz tone signal from Q9 When the keyer control signal at the gate of Q10 is high, Q10 is off and the tone is not fed to Q11. When the keyer control signal is low, Q10 is switched on and the tone signal is connected to amplifier Q11. The keyed tone signal from Q11, routed through R67 and C30, is used as the modulation signal for the mark/space modulator

*g. Voice Compressor.* The external voice input at P1-17 is applied to the base of Q22 through R72 and C35 Field-effect transistor Q20 acts as a variable resistor, controlled by the feedback from Q37 of the low pass filter. If the signal at output of the low pass filter, exceeds the dc bias at the base of Q21 (set by COMPRESSION LEVEL potentiometer R13), Q23 conducts and reduces the bias at the gate of Q20 This reduces the drain-source resistance of Q20 and therefore the signal level applied to Q22 At the same time, Q23 switches on Q19 which lights the COMPRESSION LIMIT lamp connected to P1-16 Diode CR34 and resistor R77 provide a fast attack/slow decay characteristic to the compressor circuit

*h. Voice Amplifier.* Transistor Q22 provides high gain amplification of the voice signal The output from Q22 is buffered by emitter follower Q24 and applied to the high pass filter circuit

*i. Voice Filter.* The voice filter consists of a high pass filter formed by Q25 through Q30 and a low pass filter comprising Q31 through Q37 Together they form a six-pole, Chebyshev filter which is flat to within 3 dB from 300 to 3000 Hz, falling off sharply below and above these frequencies. The output from the voice filter is buffered by Q37 and fed to the mark/space modulator through R113 and C52.

*j. Sawtooth Oscillator.* Transistors Q12, Q13, and Q14 form a sawtooth oscillator operating at a frequency of approximately 65 kHz The output at the emitter of Q14 is a linear ramp, rising from 3 4V to 10 4V.

*k. Mark/Space Modulator.* Transistors Q15 and Q16 form an emitter-coupled slicer circuit The sawtooth signal from Q14 is applied, through L4, to the base of Q15. The potential at the base of Q16 is proportional to the instantaneous audio level and the preset carrier level. When the base of Q16 is at a constant potential, a 1 4V square wave signal with a constant pulse width is developed at the collector of Q15 However, if the potential at the base of Q16 rises, the conduction period

of Q16 and, therefore the pulse width, also increase (mark-space ratio increases). Conversely, if the potential at the base of Q16 decreases, the conduction period of Q16 decreases, resulting in a corresponding reduction of the mark/space ratio.

(1) The 65 kHz feedback signal from the pa module A1A4 is received at P1-8. This signal is smoothed by R68 and C29, and compared with the dc reference at the cathode of zener diode CR33. When the feedback signal increases, the potential at the base of Q16 is lowered through Q18 and the mark/space ratio is decreased correspondently.

(2) The tone modulation signal (received through C30) and/or the voice modulation signal (received through C52) vary the potential at the base of Q18 (through Q16), with the result that the output at the collector of Q15 is modulated by the tone and/or voice signal. Transistor Q17, which is fed from the rf current detector in the power probe A1A6 at P1-9, is normally off. In the event of a short circuit at the transmitter output, Q17 switches on and lowers the base potential of Q16 to ensure that the rf current is kept within safe limits.

*l. Keyer.* Refer to figure FO-5 (2). Integrated circuit U1 is an oscillator/divider which divides the basic oscillator frequency (established by R1, R2, R3, and C1) by 1024. The output at pin 8 of U1 is a 10.24 Hz to 6.83 Hz signal, corresponding to a repetition rate of 100 mSec to 150 mSec. This signal is used as the clock signal for decade counter U2 which provides a four-count to the code selection matrix terminals B-G through the diode array CR1-CR10. The +4 output at U2-10 is the clock input for decade counters U3/U4. The Q outputs from U3/U4 provide a 12 count to the coding nand gates U6/U7/U8. The second input to each nand gate is received from the code matrix, terminals 1 through 12. On the diode matrix, terminals B to G can be linked to terminals 1 to 12 to provide the coding required. Unused terminals between 1 to 12 are linked to terminal A (ground). For a 2-letter code, the reset line is taken from U4-10 (link 2 installed, 48 bit operation). For a 3-letter code, the reset line is taken from U4-9 (link 1 installed, 64 bit operation). Note that keyer circuitry is enabled only when P1-1 is grounded by setting the TONE switch S3 (fig. FO-1) to key position.

## 2-16. Switched Regulator Driver A1A3

(fig. FO-6)

a. The 65 kHz input signal at TB1-1 is the output from the mark/space modulator circuit in the exciter assembly A1A2. This input causes Q1 and Q2 to switch on and off at the mark/space rate. The resulting current drawn from the pa module A1A4, through TB1-3, causes

the switched regulator circuit in the pa module A1A4 to also switch on and off at the mark/space rate.

b. Transistor Q3 and the associated components from a safety cut-off circuit which prevents over-dissipation in the pa module A1A4, should a malfunction cause the mark/space signal to assume a steady mark (high) condition. The input at TB 1-1 is filtered by R1/C2 to produce a dc voltage across C2 proportional to the mark/space ratio. If this ratio exceeds 70% for a number of audio cycles at the lowest operating modulation frequency, the voltage across C2 becomes sufficient to turn on Q3. As a result, Q2 switches off and drive to the pa module A1A4 is cut off.

## 2-17. PA Module A1A4

(fig FO-7)

a. The pa module A1A4 provides the full-power, switched waveform at the carrier frequency, amplitude modulated by the output of the switched regulator driver A1A3.

b. The unregulated dc supply at P1-1 is applied, through F1 and filter L5/C7, to the collector of Q4. The 65 kHz drive signal at P1-3, received from switched regulator driver A1A3, turns Q5 on and off which causes Q4 to switch on and off. The amplitude of the 65 kHz square wave at the emitter of Q4 is equal to the unregulated dc supply at its collector. Diode CR5 provides dc restoration by referencing the negative excursion of the signal to ground. Network L3, C5, C6, L4 and C4 filters out the 65 kHz switching frequency and produces the dc voltage used by Q2 and Q3. The amplitude of this dc voltage varies sinusoidally with the audio modulation.

c. The signal at the emitter of Q4 is routed through CR7 and used as the feedback signal for the mark/space modulator in the exciter assembly A1A2. This feedback signal adjusts the mark/space ratio to compensate for variations in the unregulated dc supply. The CARR LEVEL control R10 (fig. FO-1) sets the feedback level and, therefore, the carrier level. To summarize, the voltage at the center tap of T2, determined by CARR LEVEL control R10, is compensated for changes in the unregulated dc supply at P1-1, and varies in accordance with the filtered modulation signal. Indicator DS1 comes on when the unregulated dc supply and the switched regulator drive inputs are both present.

d. The dc bias supply for the driver Q1 is stabilized by CR1 and CR2. Transformer T1 provides a drive for the push-pull output stage Q2/Q3. Diodes CR3 and CR4 prevent reverse-current flow through the collector-base junctions of Q2 and Q3. The rf output from Q2/Q3 is taken from the secondary of T2 and applied to the rf filter A1A5 through P1-6.

**2-18. RF Filter A1A5**

(fig. FO-8)

a. The purpose of the rf filter A1A5 is to attenuate the harmonic components in the input at J1 from the pa module A1A4. The rf filter A1A5 consists of two 1/4-wavelength sections which are cascaded to produce a five-pole, 1/2-wavelength filter.

b. The rf filter A1A5 contains 10 programming straps which permit selection of appropriate component values to cover the operating range of 190 to

525 kHz in five strapping configurations, see figure 2-3. The network formed by R1, R2 and C1 provides damping for transients generated in the pa module A1A4. Transformer T1 provides impedance matching between the rf filter A1A5 and the pa module A1A4. Network comprising R3/R4, L9/L10 and C6/ C7 provides a terminating impedance for the out-of-band frequencies. This is necessary because the antenna system presents a very high impedance to frequencies outside the operating band.

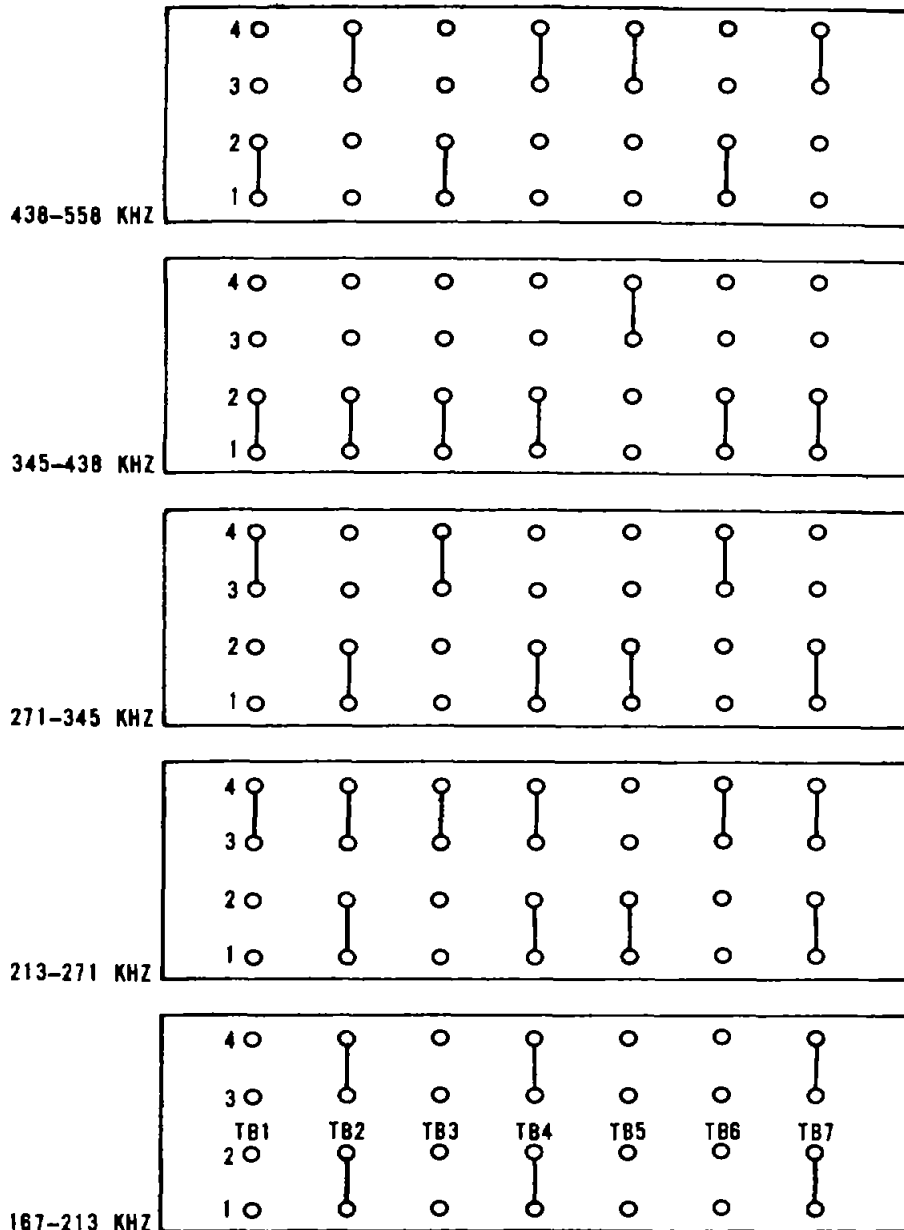

EL6ZF003

Figure 2-3. RF Filter Strapping.

**2-19. Power Probe A1A6**

(fig. FO-9)

a. Transformer T1 (winding B) and T2 form the voltage and current arms of a forward/reflected power bridge from which dc voltages are obtained. The voltages (proportional to forward power, reflected power, rf voltage, and rf current) are used for metering, shutdown control and current limiting. A dc voltage developed at the collector of Q1 is used to compensate for the pedestal of the detector diodes (CR1 through CR4) and improves the measurement accuracy at low-power levels.

b. Diode CR1 detects the rf carrier level. Filter L1/C2 transforms the detected signal to an audio signal superimposed upon a dc voltage proportional to the rf carrier level. The voltage at P1-12 is used by the monitor assembly A1A7 to control the shutdown function.

c. Secondary winding A of transformer T1 subtracts the voltage components from the signals at the junction of R3 and CR4 to produce, at the cathode of CR2, a dc voltage proportional to the rf current. The current limit signal, at P1-2, is applied to the mark/space modulator in the exciter assembly A1A2. The dc outputs at P1-6 and P1-4, derived through CR4 and CR3, are indicative of the forward and reflected power respectively.

**2-20. Monitor Assembly A1A7**

(fig. FO-10)

*a. Modulation Detector and Threshold Comparator.*

The input signal from the power probe A1A6 is received at P1-12 through potentiometer R2. The input signal is a dc voltage proportional to the carrier level and contains an ac component indicative of the modulation level. The signal from the wiper of R2 is buffered by emitter-follower Q1 and applied to two transistors, Q2 and Q3. Transistor Q3 and capacitor C4 couple the ac component (audio) to the AUDIO MON jack J2 on the control panel through P1-15, while transistor Q2 couples it to a synchronous detector formed by Q4 and Q5. When the modulation threshold level is correctly set at -3 dB by R2 and the modulation depth is at its normal level, the amplitude of the signal at the collector of Q2 is approximately 2V p-p.

(1) The 1020 Hz tone input at P1-9 causes Q5 to switch on and off at a 1020 Hz rate. Transistor Q4, which also switches on and off at 1020 Hz, acts as a gated dc restorer to the signal from C3. When the detected modulation signal is at the same frequency and in phase with the 1020 Hz tone input, a positive dc voltage is obtained at the junction of C3/R9. Any component of the modulation signal that is not the same frequency, or out of phase with the 1020 Hz,

(e.g., voice modulation), does not produce the dc voltage. Therefore, synchronous detector Q4/Q5 prevents the external voice input from interfering with the modulation monitoring circuits.

(2) Comparator U1-A compares the dc voltage from synchronous detector Q4/Q5 with a reference voltage established by the ratio of R11 and R12. When the input at pin 5 of U1-A is more positive than the reference voltage at pin 4 of U1-A, the output from U1-A at pin 2 is high. Conversely, when pin 5 of U1-A is less positive than the voltage at pin 4 of U1-A, the output from U1-A (pin 2) is low. The reference voltage at pin 4 of U1-A is chosen such that during keying the output from U1-A makes a low-to-high transition each time keying is gated on. The output from the modulation detector and threshold comparator circuit is applied to the normal and special shutdown circuits.

*b. Carrier Threshold Comparator.* The signal from the wiper of the CARR THRESHOLD potentiometer R3 is filtered by R39 and C13 to remove the audio component. The resulting dc level, proportional to the carrier level, is compared with a reference voltage determined by the ratio of R36 and R37. During normal operation, the dc voltage at pin 9 of U1-C is more positive than the reference voltage at pin 8 of U1-C. Therefore, the output from U1-C (pin 14) remains high as long as the carrier level is greater than the threshold setting of R3. If a malfunction or some abnormal operating condition causes the carrier level to drop by 3 dB or more, the output from comparator U1-C changes state, i.e., pin 14 of U1-C goes low from its normally high state. The output from U1-C (pin 14) is fed to the normal shutdown circuit.

*c. Normal Shutdown Control.* The normal shutdown control circuit is controlled by both the carrier and modulation threshold comparators. Associated with the circuit are a NORM/BYP (operate/test) switch S1 and a NORM (within limits) indicator DS1.

(1) When the modulation is within limits and keying is present, the output from U1-A is high during keying (mark) and low during a space. Provided the output from U1-C is high (carrier level within limits), the positive-going transitions from U1-A cause Q6 to momentarily switch on. If a keying failure occurs, or if the modulation level falls below the preset level, the transitions at the base of Q6 are no longer present, causing it to remain switched off. Similarly, if the carrier level falls below the present threshold, the output from U1-C goes low and Q6 remains switched off, disregarding the positive-going transitions from U1-A.

(2) Whenever Q6 is switched on, capacitor C9 is discharged. When Q6 is off, C9 is constantly charged through R17. The voltage across C9 is compared with

the reference voltage at the junction of R18 and R19 by comparator U1-D. The time constant of C9/R17 is such that during normal operation the voltage at pin 11 of U1-D never exceeds the reference voltage at pin 10 of U1-D (Q6 discharges C9 on each positive transition for U1-A, thus preventing C9 from being charged continuously), and the output from comparator U1-D (pin 13) is low. Transistors Q7 and Q8 are therefore switched on and provide indication of normal operation as follows

(a) Shutdown relay K1 is energized by Q7 and the +24V from power supply A1A1 is applied, through contacts 4-7 of K1 of the rf oscillator in the exciter assembly A1A2 (fig. FO-1).

(b) ALARM indicator DS2 is turned off.

(c) NORM indicator DS1 is turned on by Q8.

(3) If the output from U1-C is low (carrier too low) or the output from U1-1 does not change state (loss of keying), Q6 assumes a steady off state. Thus, C9 is charged continuously through R17 and, after a delay of 20-35 seconds, pin 11 of U1-D becomes more positive than the reference voltage at pin 10 of U1-D. Under this condition, the output of U1-D changes state from low to high, and transistors Q7/Q8 are both switched off, resulting in the following alarm condition.

(a) Shutdown relay K1 is deenergized and the +24V for the rf oscillator in the exciter assembly A1A2 is disconnected (fig. FO-1); the NDB transmitter is effectively switched off (no rf output).

(b) ALARM indicator DS2 is turned on.

(c) NORM indicator DS1 is turned off.

(4) NORM/BYP switch S1 applies a ground (low) to either P1-2 or P1-3. During testing or troubleshooting, S1 is set to BYP position. Thus, Q7 is held conducting regardless of the output level of U1-D, ensuring that the system cannot shutdown. Transistor Q8, however, is still controlled by the output of U1-D. At the same time, the BYP setting of S1 removes the ground from P1-3, effectively removing C9 from the collector of Q6 and eliminating the time delay formed by R17/C9. Instantaneous indication of the transmitter status is, therefore, provided at P1-5, as Q8/DS1 are switched on and off at the keying rate.

*d. Special Shutdown Circuit.* This circuit is formed by U2-C, Q9 through Q11 and associated components. The operation of the special shutdown circuit is similar to the normal shutdown control circuit described in *c* above,

except that comparator U2-C responds only to the output from modulation detector and threshold comparator. During normal operation Q11 is saturated, and +24V is available through P1-1, for the rf oscillator in the exciter assembly A1A2.

#### NOTE

The +24V for the rf oscillator in the exciter assembly A1A2 is routed through the normal link or special link (fig. FO-1) as determined at the time of installation. When normal link is installed (special link removed), the +24V output from the special shutdown circuit (P1-1, fig FO-10) is not used. When special link is installed (normal link removed), the output from the normal shutdown control circuit still controls the shutdown relay K1, but the +24V for the rf oscillator in the exciter assembly A1A2 is taken from P1-1 (fig FO-10).

*e. Modulation Detector.* This circuit is used to provide a reading of the modulation depth on the control panel TEST meter. The input at P1-13, obtained from the power probe A1A6, is applied to comparator U2-A which operates as a minimum voltage detector, i.e., the output of U2-A assumes a steady potential equal to the minimum positive excursion of the input signal. The time constant of U2-A is chosen so that voltage at pin 2 of U2-A follows the keying signal. When the NDB transmitter is operating without modulation, the output from U2-A is a voltage proportional to the carrier level. When modulation is keyed on, the level falls abruptly, reaching zero for 100% modulation. Comparator U2-B is used as a voltage-follower, providing a high input impedance and a low output impedance. The output from U2-B is connected to the voltage divider formed by set zero potentiometer R1. The wiper of ZERO SET potentiometer R1 is connected, through the TEST meter M1 and MOD % CAL potentiometer R4, to a fixed dc potential. The circuit forms a bridge, balanced by potentiometers R4 and R1. When modulation is off, potentiometer R1 is adjusted for zero reading on the TEST meter M1. When 100% modulation is present or is simulated by removing the rf input at P1-13, potentiometer R4 is adjusted to read full scale deflection of TEST meter M1.

## Section IV. DETAILED FUNCTIONAL DESCRIPTION, ATU

**2-21. Power**

(fig. FO-11)

The 24 Vdc input at J2-A and J2-B (operating power for the ATU) is received from the NDB transmitter in single installations or from the change-over unit in the case of dual installations. Switch S1 is the POWER ON/OFF switch and DS1 is the POWER ON indicator. Switch S3 controls the on/off operation of the TEST switch S2, which selects forward power, reflected power, or the current reading on TEST meter M1. Switch S3 is located on the side of the ATU cabinet, allowing meter MI to be turned on and off without opening the ATU front cover.

**2-22. Power Probe AIA1**

(fig. FO-11)

The power probe AIA1 provides forward power, reflected power and rf current signals to the TEST meter M1, and permits the operator to monitor the performance of the NDB transmitter. The power probe AIA1 used in the ATU is identical to the power probe employed in the NDB transmitter; refer to paragraph 2-19 for detailed functional description. Note, however, that in the case of power probe AIA1 in the ATU, the current limit output at P1-2 and the rf level output at P1-12 are not used.

**2-23. Servo Probe AIA2**

(fig FO-11)

a. The servo probe AIA2 continuously monitors the phase relationship between the current voltage of the rf output and, in the event of a phase difference, operates motor B1 which fine tunes the loading coils L1/L2 to null the phase error. This process eliminates the effect of antenna reactance changes on the VSWR.

b. The servo probe AIA2 consists of current transformer T1 with secondary windings across which identical voltages are obtained from the induced current. Two diode bridges, CR1 to CR4 and CR5 to CR8, act as rf switches which, since they are connected in opposite phases, are alternately switched on by the positive and negative half-cycles of the current waveform. The rf signal voltage is fed to both of these rf switches, shifted 90 degrees by C1 and R1. If the antenna voltage and current are in phase, the net dc potential at the output of both switches is zero. If a phase difference between the antenna voltage and current exists, the output voltage at one switch is positive, and output from the other switch is negative. This causes a positive voltage to appear at the base of either Q2 or Q3. Thus, Q2 or Q3 switches on and, by providing ground at the cathode of either CR12

or CR13, switches on Q5 or Q4. This causes motor B1 to turn in the correct direction to eliminate the phase difference between the voltage and current waveforms. For example, when a positive voltage is applied to the base of Q2, Q2 conducts and motor current flows from B+ to Q5, then through the tuning motor M1 to S5 and S6, and finally through CR12/Q2 to ground. When Q3 is switched on by a positive voltage, the current flows in the opposite direction from B+ through Q4, S5, S6, B1, CR13 and Q3 to ground. Components R1, R6 and CR9 bias the input to the rf switches to increase system sensitivity.

c. Manual override switch S4 applies ground potential directly to the cathode of either CR12 or CR13, thus switching the motor on to slew the tuning drive manually. Transistor Q1 is biased on by the override switch S4 to inhibit the servo action while manual tuning is performed.

**2-24. Matching Transformer A1A3**

(fig. FO-11)

The matching transformer A1A3 has seven taps to match the net series-resonated antenna resistance to the 50 ohm NDB transmitter output. The appropriate tap is selected on TB 1.

**2-25. Loading Coils**

(fig. FO-11)

a. The ATU contains two loading coils, L1 and L2. In addition to the upper and lower terminals, each coil has an intermediate tap, permitting selection of a partial value of the coil inductance. Coils L1 and L2 can be connected in series or in parallel between the matching transformer and the antenna terminal. Therefore, a number of alternate connections are possible to tune the reactive component of the antenna impedance for the frequency in use.

b. Each loading coil (L1 and L2) has a ferrite tuning slug, driven by motor B1, and controlled by the servo probe AIA2 to provide fine tuning of the antenna. The upper and lower limit switches S5/S6 open when the tuning slugs reach the appropriate travel limit. Diodes CR1 and CR2 provide a current path to allow retuning of tuning slugs in a direction away from the actuated limit switch (S5 or S6).

c. In all, there are three pairs of loading coil assemblies available, each designed to cover a specified portion of the operating frequency. The loading coil assemblies are supplied with each ATU to suit the operating frequency.



**Section V. DETAILED FUNCTIONAL DESCRIPTION,  
CHANGE-OVER UNIT****2-26. Change-Over Unit**

(fig. FO-12)

a. The change-over unit is used only in dual transmitter systems. In the case of a shutdown of the main NDB transmitter, the change-over unit automatically switches on the standby NDB transmitter. The rf outputs of the two NDB transmitters (main and standby) are applied to the change-over unit and the switched rf output of the change-over unit is applied to the ATU.

b. Relay K1 switches the NDB transmitter outputs to the ATU, and K2 provides control function switching. During normal operation, both K1 and K2 are energized by the 48V supply from the main NDB

transmitter. This removes the ac line and battery supply from the standby NDB transmitter, connects the battery supply to the main NDB transmitter, and connects the main NDB transmitter rf output to the ATU.

c. In the event of a failure of the main NDB transmitter, the 48V supply at TB2-1 is not present and relays K1/K2 are deenergized. This connects the ac line and battery supply to the standby NDB transmitter and connects the standby NDB transmitter rf output to the ATU. Diodes CR3 and CR4 provide isolation between the + 24 Vdc supplies from the two NDB transmitters. The ATU supply is always taken from the NDB transmitter that is on.

## CHAPTER 3 DIRECT SUPPORT MAINTENANCE INSTRUCTIONS

### Section I. GENERAL

#### 3-1. Introduction

a. This chapter contains the direct support maintenance instructions for the NDB transmitter and the ATU. There is no direct support maintenance for the change-over unit.

b. Direct support maintenance for the NDB transmitter and ATU comprises removal and replacement of authorized assemblies, subassemblies and certain chassis-mounted components. Procedures are included in this chapter to make sure that repair has been successfully accomplished.

#### 3-2. Voltage, Resistance and Waveform Measurements

a. Overall voltage or resistance checks are not applicable to the maintenance of the NDB transmitter and ATU. Pertinent resistance and voltage measurements are given in the

troubleshooting/maintenance instructions in TM 11-5825-271-12.

b. Appropriate waveforms are shown on the schematic diagrams, figures FO-2 to FO-12. These waveforms are provided as a reference and are not required for direct support maintenance tasks.

#### 3-3. Tools and Test Equipment

Tools and test equipment required for direct support maintenance tasks are listed in TM 11-5825-271-12

#### 3-4. Troubleshooting

Maintenance procedures, including troubleshooting instructions, for direct support maintenance are identical to those authorized at the organizational maintenance level; refer to TM 11-5825-271-12.

### Section II. DIRECT SUPPORT MAINTENANCE OF NDB TRANSMITTER

#### 3-5. General

a. This section provides instructions for performing the maintenance functions allocated to direct support maintenance on the NDB transmitter.

b. Support illustrations are provided to aid in the performance of procedures. The numbers in parentheses referenced in the text, e.g., (1), (2), etc, correspond to the item callout on the illustration.

c. All wires removed/unsoldered during the disassembly procedure, should be tagged for identification.

#### WARNING

Make sure that external ac circuit breaker and battery supply are switched off and tagged with a warning not to be turned on while maintenance is being performed

#### 3-6. Removal and Replacement of Control Panel Assembly

a. *Removal.* Proceed as follows.

(1) Refer to figure 3-1. Disengage two captive screws (12) on the control panel assembly (13) and swing the control panel assembly out.

(2) Carefully remove two nuts (14), lockwashers (15), and flat washers (16) securing two solder lugs (17) to back of TEST meter M1 (11). Tag solder lugs and replace the attaching hardware on TEST meter M1.

(3) Tag and unsolder all cableform wires terminated at the control panel assembly (13). Before unsoldering any wire, slide the rubber sleeving away from the solder joint so as not to burn it inadvertently

(4) Remove one screw (10), nut (5), lockwasher (6), and flat washer (7) securing cable clamp (8). Remove cable clamp from cableform and reinstall on control panel assembly (13).

(5) Remove three screws (9), nuts (1), lockwashers (2), and flat washers (3) securing the control panel assembly (13) to the board chassis. Note the location of the cable clamp (18) and solder lug (4) on the hinge. Leave cable clamp on cableform and retain all attaching hardware for reassembly.

b. *Replacement.* Proceed as follows.

(1) Refer to figure 3-1. Prepare the control panel assembly by removing the cable clamp (8). Retain cable clamp and attaching hardware (5), (6), (7), and (9) for later use.

(2) Align three holes in control panel assembly (13) with three holes in the hinge on board chassis, and insert three screws (9) from outside of control panel assembly (13).

(3) Place solder lug (4) and cable clamp (18) on two of the three screws (9) as noted in 3-6a(5), above.

(4) Secure control panel assembly (13) using three flat washers (3), lockwashers (2), and nuts (1).

(5) Secure portion of cableform near R1 on the

control panel assembly (13) by installing cable clamp (8) removed in 3-6b(1), above.

(6) Remove two nuts (14), lockwashers (15), and flat Washers (16) from the back of TEST meter M1 (11) and reinstall two solder lugs (17).

(7) Solder all tagged wires from the cableform to the control panel components, and slide rubber sleeveings over the connections.

(8) Swing the control panel assembly (13) in and tighten two captive screws (12).

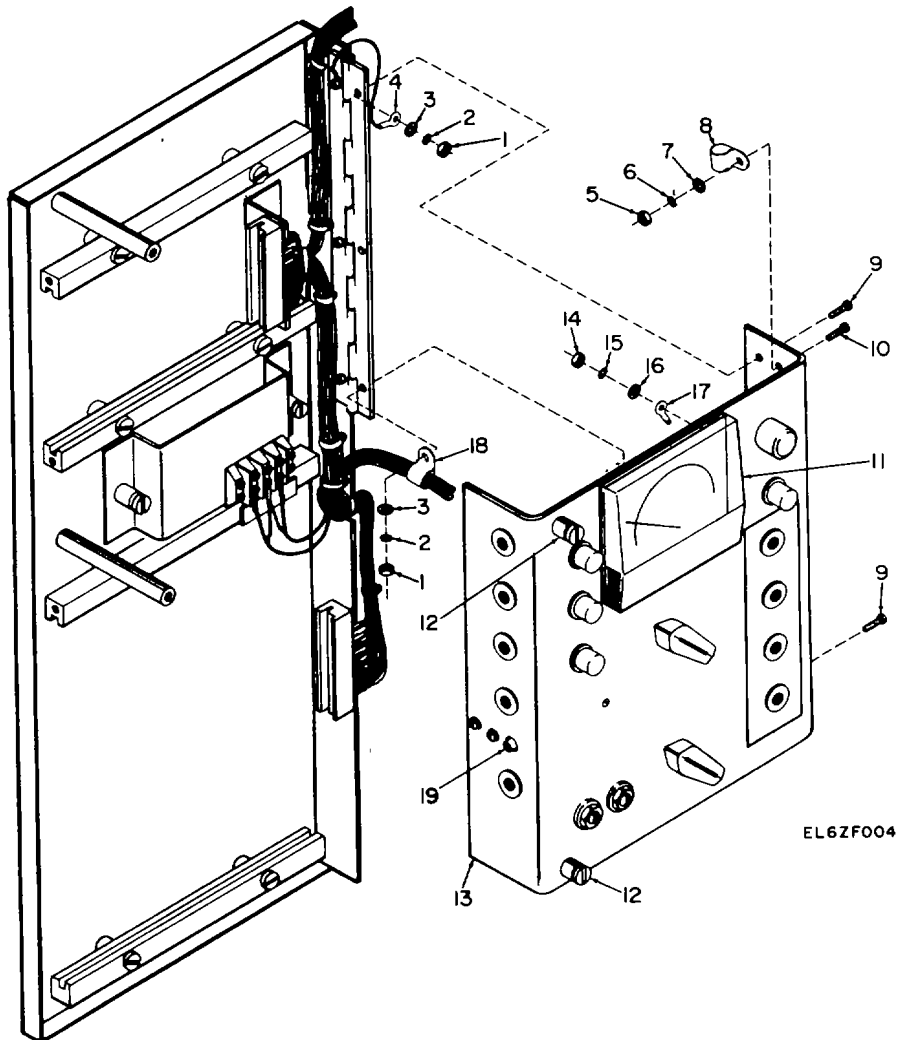

EL6ZF004

- |                |                            |
|----------------|----------------------------|
| I. NUT         | II. TEST METER             |
| 2. LOCKWASHER  | 12. CAPTIVE SCREW          |
| 3. FLATWASHER  | 13. CONTROL PANEL ASSEMBLY |
| 4. SOLDER LUG  | 14. NUT                    |
| 5. NUT         | 15. LOCKWASHER             |
| 6. LOCKWASHER  | 16. FLATWASHER             |
| 7. FLATWASHER  | 17. SOLDER LUG             |
| 8. CABLE CLAMP | 18. CABLE CLAMP            |
| 9. SCREW       | 19. SWITCH SI              |
| 10. SCREW      |                            |

Figure 3-1. Removal and Replacement of Control Panel Assembly

### 3-7. Removal and Replacement of Resistor Bracket Assembly

#### a. *Removal.* Proceed as follows

(1) Refer to figure 3-1. Disengage two captive screws (12) on the control panel assembly (13) and swing the control panel assembly out.

(2) Tag and remove solder lug from ground terminal on NORM/BYP switch S1 (19), refer to figure FO-2.

(3) Refer to figure 3-2. Slide rubber sleeveings off potentiometer terminals on the resistor bracket assembly (10)

(4) Tag and unsolder all wires connected to the components on the resistor bracket assembly (10) from sources outside the assembly. Leave all rubber sleeveings on wires for reassembly

(5) Remove two screws (18), nuts (13), lock-

washers (12), and flat washers (11) securing the resistor bracket assembly (10) to the control panel (17). The resistor bracket assembly is now free to be removed. Retain the attaching hardware for reassembly

#### b. *Replacement.* Proceed as follows

(1) Refer to figure 3-2. Position resistor bracket assembly (10) on control panel (17) and align two mounting holes.

(2) Install and tighten two screws (18), flat washers (11), lockwashers (12), and nuts (13) to secure the assembly.

(3) Solder all tagged wires to the resistor bracket assembly (10), and slide rubber sleeveings over connections.

(4) Refer to figure 3-1 and reconnect solder lug to ground terminal of switch S1 (19), refer to figure FO-2.

(5) Swing the control panel assembly (13) in and tighten two captive screws (12).

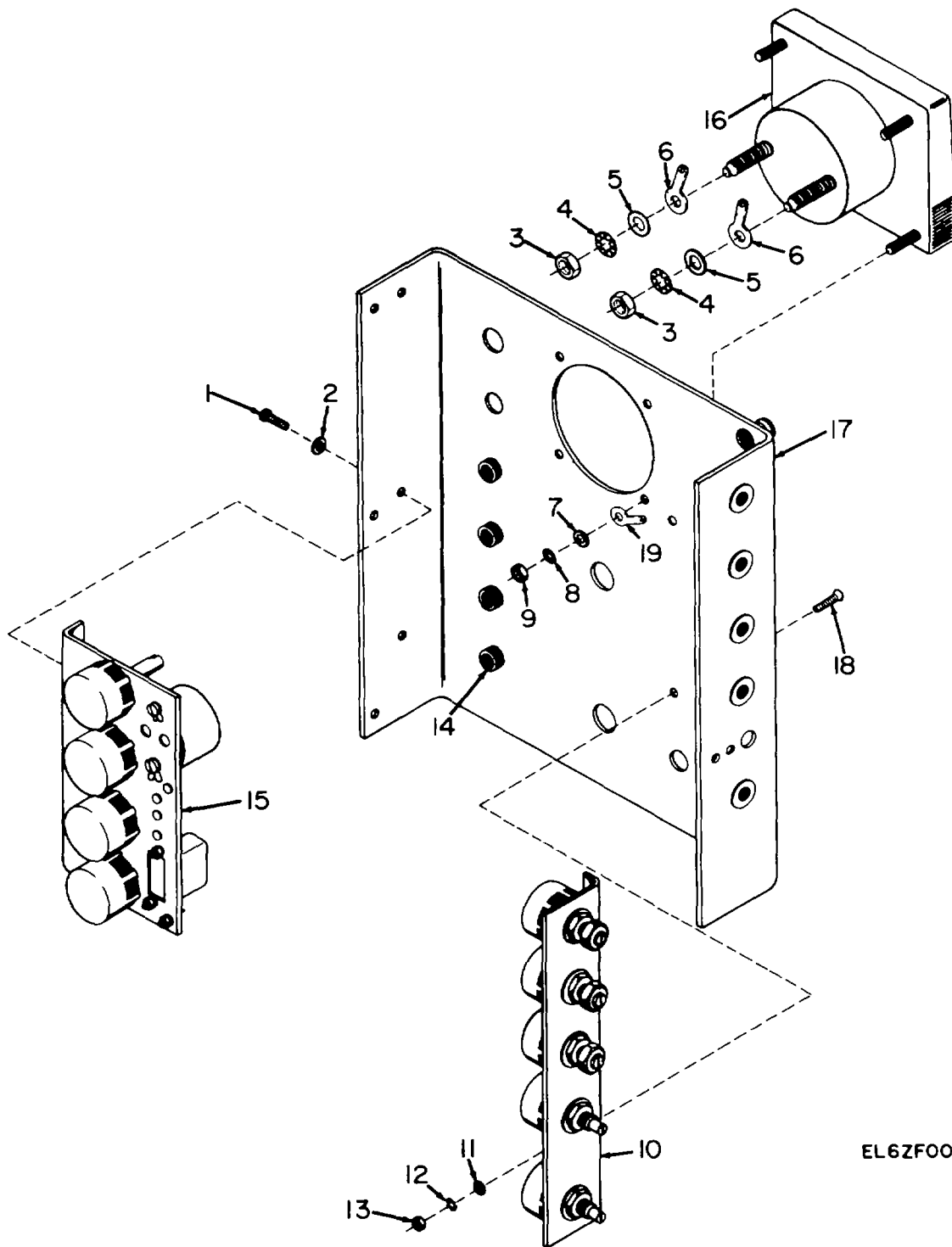

EL6ZF005

- |                |                               |                            |
|----------------|-------------------------------|----------------------------|
| 1. SCREW       | 8. LOCKWASHER                 | 14. BUSHING                |
| 2. FLATWASHER- | 9. NUT                        | 15. RELAY BRACKET ASSEMBLY |
| 3. NUT         | 10. RESISTOR BRACKET ASSEMBLY | 16. TEST METER             |
| 4. LOCKWASHER  | 11. FLATWASHER                | 17. FRONT PANEL            |
| 5. FLATWASHER  | 12. LOCKWASHER                | 18. SCREW                  |
| 6. SOLDER LUG  | 13. NUT                       | 19. SOLDER LUG             |
| 7. FLATWASHER  |                               |                            |

Figure 3-2. Removal and Replacement of Resistor Bracket and Relay Bracket Assemblies

**3-8. Removal and Replacement of Resistor Bracket Potentiometers**

*a. Removal.* Proceed as follows

(1) Refer to figure 3-1. Disengage two captive screws (12) on the control panel assembly (13) and swing the control panel assembly out.

(2) Refer to figure 3-3. Slide rubber sleeveings off terminals on potentiometer (4) to be removed.

(3) Tag and unsolder all wires connected to the potentiometer (4).

(4) Remove all attaching hardware securing the potentiometer (4).

**NOTE**

When removing potentiometers R5 and R6, it is necessary to remove the adjustment set nut (3) before removing the attaching hardware.

*b. Replacement.* Proceed as follows

(1) Refer to figure 3-3. Install replacement potentiometer (4) on the resistor bracket (2). Ensure that the locating pin (1) is properly seated in the hole in resistor bracket, and that the terminal designations (stamped on the resistor bracket) correspond with the potentiometer terminals.

(2) Secure potentiometer (4) to the resistor bracket (2) using the attaching hardware. Replace adjustment set nut (3) if either R5 or R6 is installed.

(3) Solder all tagged wires to potentiometer (4) and slide rubber sleeveings over connections.

(4) Refer to figure 3-1. Swing the control panel assembly (13) in and tighten two captive screws (12).

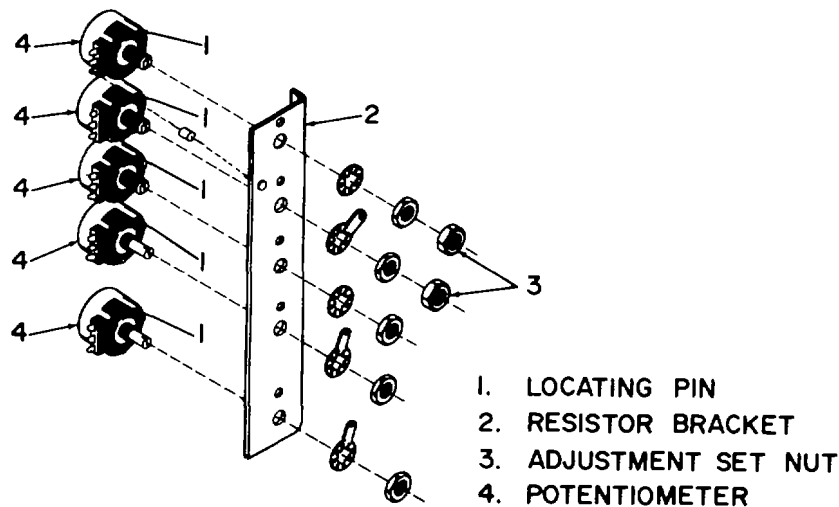

EL6ZF006

Figure 3-3. Removal and Replacement of Resistor Bracket Potentiometers.

**3-9. Removal and Replacement of Relay Bracket Assembly**

*a. Removal.* Proceed as follows

(1) Refer to figure 3-1. Disengage two captive screws (12) on the control panel assembly (13) and swing the control panel assembly out.

(2) Refer to figure 3-2. Slide rubber sleeveings off the potentiometer terminals on the relay bracket assembly (15).

(3) Tag and unsolder all wires connected to the components on the relay bracket assembly (15) from sources outside the assembly. Leave all rubber sleeveings on wires for reassembly

(4) Swing the control panel (17) in and remove two screws (1) and flat washers (2) securing the relay bracket assembly (15) to the control panel. Slide rubber sleeveings over the connections.

(5) Raise the control panel (17), the relay bracket assembly (15) is now free to be removed

*b. Replacement.* Proceed as follows.

(1) Refer to figure 3-2. With the control panel (17) partially closed, position the relay bracket assembly (15) so that the shafts of the potentiometers are directed towards the bushings (14) in the control panel.

(2) Align the mounting holes in the relay bracket assembly (15) with the two holes in the control panel (17).

(3) Install and tighten two screws (1) and flat washers (2) to secure the relay bracket assembly (15) to control panel (17).

(4) Swing the control panel (17) out, and solder all tagged wires to the relay bracket assembly (15) Slide rubber sleeveings over the connections.

(5) Refer to figure 3-1. Swing the control panel assembly (13) in and tighten two captive screws (12).

**3-10. Removal and Replacement of Relay Bracket Potentiometers**

*a. Removal.* Proceed as follows.

(1) Refer to figure 3-2. Remove two screws (1), and flat washers (2) securing the relay bracket assembly (15) to the control panel (17). Retain the attaching hardware for reassembly.

(2) Refer to figure 3-1. Disengage two captive screws (12) on the control panel assembly (13) and swing the control panel assembly out.

(3) Refer to figure 3-4. Slide rubber sleeveings off terminals on potentiometer (15) to be removed.

(4) Tag and unsolder all wires connected to the potentiometer (15).

(5) Remove one nut and one lockwasher securing the potentiometer (15).

*b. Replacement.* Proceed as follows.

(1) Refer to figure 3-4. Install replacement potentiometer on the relay bracket (1). Ensure that the locating pin (12) is properly seated in the hole in relay bracket, and that the terminal designations (stamped on the relay bracket) correspond with the potentiometer (15) terminals.

(2) Secure potentiometer (15) to the relay bracket (1) using one lockwasher and one nut

(3) Solder all tagged wires to potentiometer (15) and slide rubber sleeveings over soldered connections

(4) Refer to figure 3-2. With the control panel (17) partially closed, align the mounting holes in the relay bracket assembly (15) with the two holes in the control panel.

(5) Install and tighten two screws (1) and flat washers (2) to secure the relay bracket assembly (15) to control panel (17)

(6) Refer to figure 3-1. Swing the control panel assembly (13) in and tighten two captive screws (12)

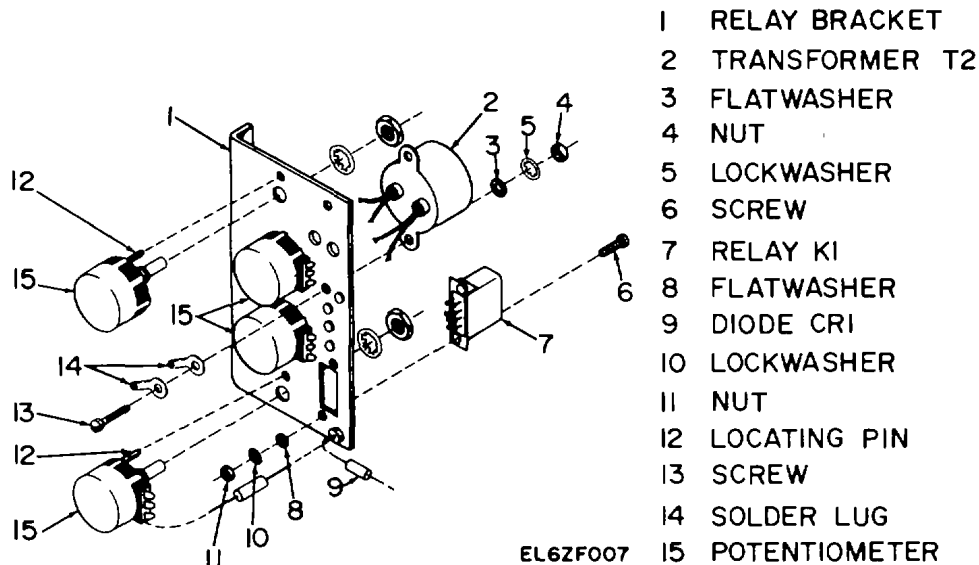

Figure 3-4. Removal and Replacement of Relay Bracket Components.

**3-11. Removal and Replacement of Relay K1**

*a. Removal.* Proceed as follows.

(1) Refer to figure 3-2. Remove two screws (1) and flat washers (2) securing the relay bracket assembly (15) to the control panel (17). Retain the attaching hardware for reassembly.

(2) Refer to figure 3-1. Disengage two captive screws (12) on the control panel assembly (13), and swing the control panel assembly out.

(3) Refer to figure 3-4. Tag and unsolder diode CR1 (9) and all wires connected to relay K1 (7).

(4) Remove two screws (6), nuts (11), lockwashers (10), and flat washers (8) securing relay K1 (7);

remove relay K1. Retain the attaching hardware for reassembly.

*b. Replacement.* Proceed as follows.

(1) Refer to figure 3-4. Position relay K1 (7) on the relay bracket (1) and align the two mounting holes.

(2) Install and tighten two screws (6), flat washers (8), lockwashers (10), and nuts (11) to secure relay K1 (7).

(3) Solder tagged wires and diode CR1 (9) to relay K1 (7).

(4) Refer to figure 3-2. With the control panel (17) partially closed, align the mounting holes in the relay bracket assembly (15) with the two holes in the control

panel.

(5) Install and tighten two screws (1) and flat washers (2) to secure relay bracket assembly (15) to the control panel (17).

(6) Refer to figure 3-1. Swing the control panel assembly (13) in and tighten two captive screws (12).

### 3-12. Removal and Replacement of Transformer T2

*a. Removal.* Proceed as follows.

(1) Refer to figure 3-2. Remove two screws (1) and flat washers (2) securing the relay bracket assembly (15) to the control panel (17). Retain the attaching hardware for reassembly.

(2) Refer to figure 3-1. Disengage two captive screws (12) on the control panel assembly (13) and swing the control panel assembly out.

(3) Refer to figure 3-4. Tag and unsolder four wires leading from transformer T2 (2) at their destination.

(4) Remove two screws (13), nuts (4), lockwashers (5), and flat washers (3) securing transformer T2 (2); remove transformer T2. Note location of three solder lugs (14) secure by the attaching hardware. Retain the attaching hardware for reassembly.

*b. Replacement.* Proceed as follows.

(1) Refer to figure 3-4. Position transformer T2 (2) on the relay bracket (1), and align the two mounting holes. Ensure that all four wires from transformer T2 are inserted through the hole in the relay bracket.

(2) Install and tighten two screws (13), flat washers (3), lockwashers (5), and nuts (4) to secure transformer T2 (2) to the relay bracket (1). Ensure that three solder lugs (14) are located as noted in 3-12a(4), above.

(3) Solder four tagged wires leading from transformer T2 (2).

(4) Refer to figure 3-2. With the control panel (17) partially closed, align the mounting holes in the

relay bracket assembly (15) with the two holes in the control panel.

(5) Install and tighten two screws (1) and flat washers (2) to secure the relay bracket assembly (15) to the control panel (17)

(6) Refer to figure 3-1. Swing the control panel assembly (13) in and tighten two captive screws (12).

### 3-13. Removal and Replacement of Control Panel TEST Meter M1

*a. Removal.* Proceed as follows.

(1) Refer to figure 3-1. Disengage two captive screws (12) on the control panel assembly (13) and swing control panel assembly out.

(2) Refer to figure 3-2. Remove two nuts (3), lockwashers (4), and flat washers (5) securing the two solder lugs (6) to the back of TEST meter M1 (16). Tag and remove the two solder lugs and retain the attaching hardware for reassembly.

(3) Remove four nuts (9), lockwashers (8), and flat washers (7) securing the TEST meter M1 (16) to the control panel (17). Tag solder lug (19), and remove the TEST meter M1. Retain the attaching hardware for reassembly.

*b. Replacement.* Proceed as follows.

(1) Refer to figure 3-2. Install TEST meter M1 (16) on the control panel (17).

(2) Place solder lug (19) on stud and secure TEST meter M1 (16) to the control panel (17) using four nuts (9), lockwashers (8), and flat washers (7).

(3) Place two solder lugs (6) on the terminals at the back of TEST meter M1 (16). Fasten solder lugs using two nuts (3), lockwashers (4), and flat washers (5).

(4) Refer to figure 3-1. Swing the control panel assembly (13) in and tighten two captive screws (12) to secure.

## Section III. DIRECT SUPPORT MAINTENANCE OF ATU

### 3-14. General

*a.* This section provides instructions for performing the maintenance functions allocated to direct support maintenance on the ATU.

*b.* Support illustrations are provided to aid in the performance of procedures. The numbers in parentheses referenced in the text, e.g., (1), (2), etc, correspond to the item callout on the illustration.

*c.* All wires removed/unsoldered during the disassembly procedure should be tagged for identification.

### WARNING

Make sure that external ac circuit breaker and battery supply are switched off and tagged with a warning not to be turned on while maintenance is being performed.

### 3-15. Removal and Replacement of Core Assembly

*a. Removal.* Proceed as follows.

(1) Refer to figure 3-5 (2). Using a slot screwdriver, unlock the ATU front cover (12) by turning latch screw (13).



(2) Raise ATU front cover (12) and insert the door support rod (18) into the door stop bracket (19). Insert the hitch pin clip through the hole at end of the door support rod.

(3) Refer to figure 3-5 (1). Disconnect the external connections to each loading coil (4). Note and record the loading coil connections.

(4) Remove two screws (1), lockwashers (2) and flat washers (3) holding each loading coil (4) to the ceramic pillars (6). Note and record the part number of each loading coil and its position (left or right). Remove both loading coils and retain the attaching hardware for reassembly.

(5) Loosen nut (8) securing core assembly (5). Do not bear on the ferrite slug or ceramic pillar; bear on the standoff (7)

(6) Unscrew core assembly (5), bearing on the lower female standoff (7) only

b. *Replacement.* Proceed as follows.

(1) Refer to figure 3-5 (1). Install core assembly (5) on the tuning spindle, bearing on the lower female standoff (7) only.

(2) Tighten nut (8) to secure core assembly (5) into place. Do not bear on core or ceramic pillar.

(3) Install each loading coil (4) on the ceramic pillars (6) using two flat washers (3), lockwashers (2) and screws (1). Check that the loading coils have the same part number and are installed as noted in 3-15a(4), above.

(4) Restore all external connections to the loading coils (4) as recorded in 3-15a(3), above (5) Refer to figure 3-5 (2). Remove the hitch pin clip from the door support rod (18) and disengage the door support rod from the door stop bracket insert the door support rod into the retainer and close the ATU front cover (12)

(6) Using a slot screwdriver, lock the ATU front cover (12) by turning the latch screw (13).

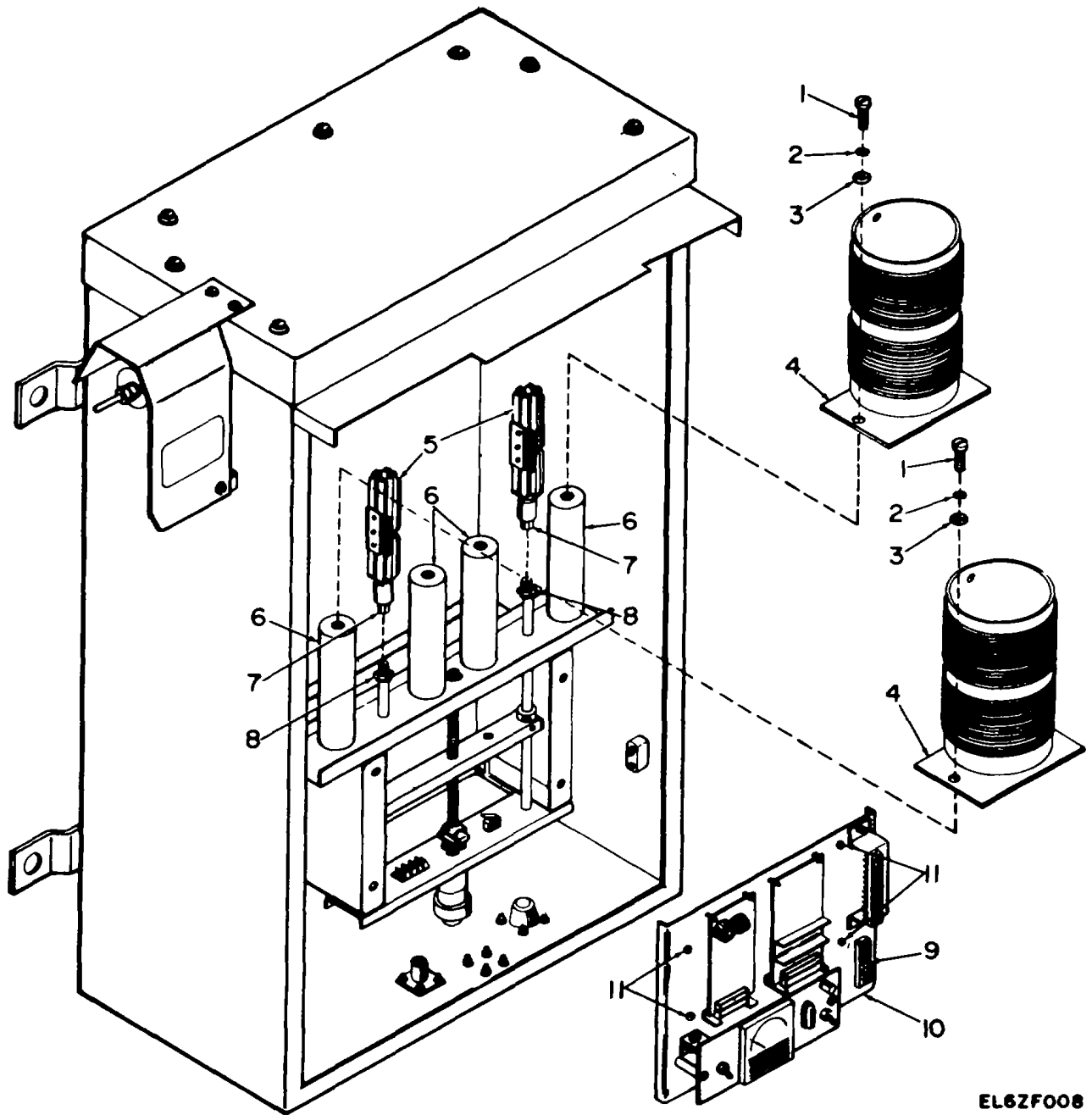

EL6ZF008

- |                    |                         |
|--------------------|-------------------------|
| 1. SCREW           | 8. NUT                  |
| 2. LOCKWASHER      | 9. TERMINAL STRIP TBI   |
| 3. FLATWASHER      | 10. ELECTRONIC ASSEMBLY |
| 4. LOADING COIL    | 11. CAPTIVE SCREW       |
| 5. CORE ASSEMBLY   |                         |
| 6. CERAMIC PILLAR  |                         |
| 7. FEMALE STANDOFF |                         |

Figure 3-5 (1). Removal and Replacement of Core Assembly and Motor Tuning Assembly (Sheet 1 of 2).

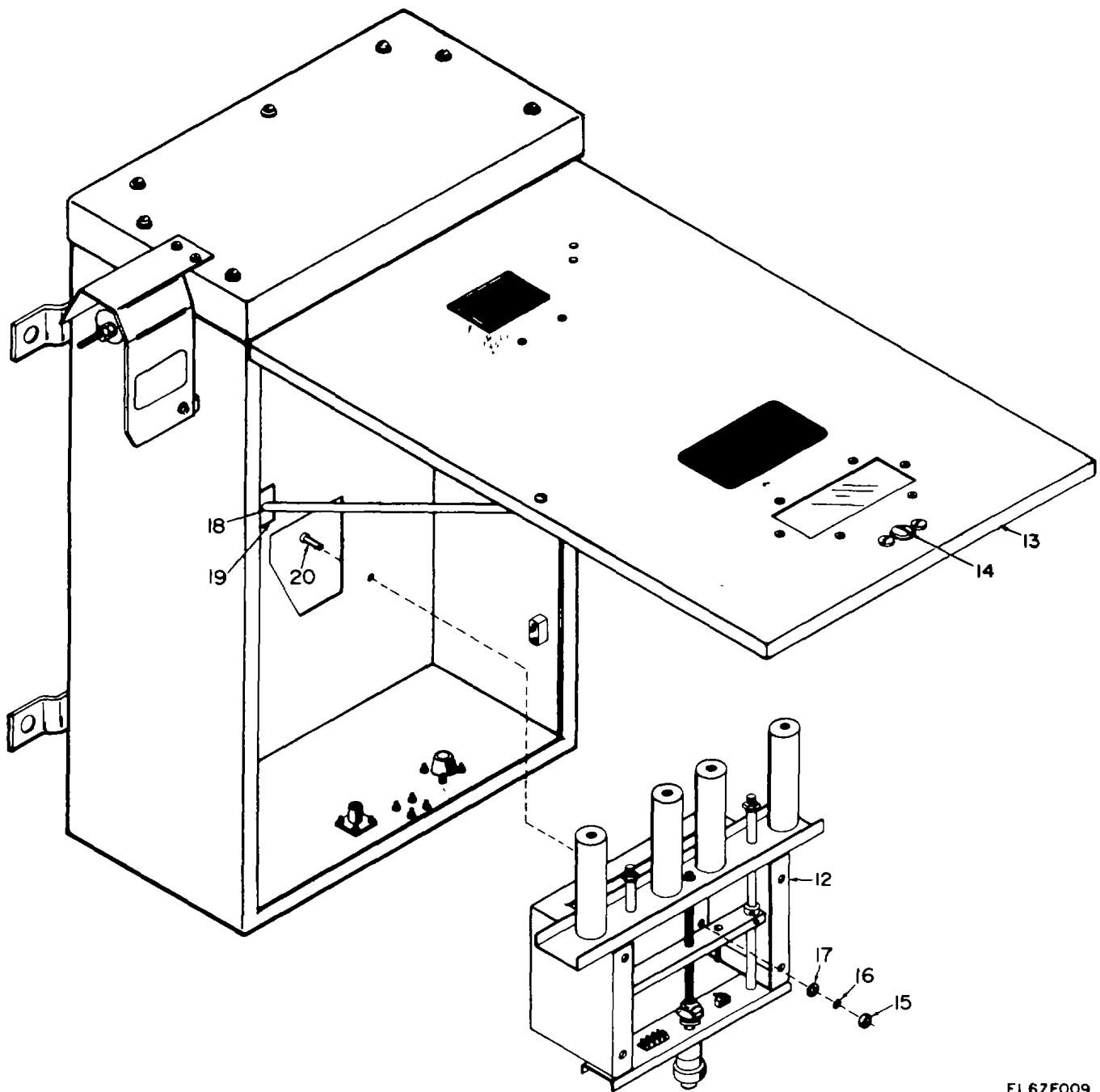

- 12. MOTOR TUNING ASSEMBLY
- 13. FRONT COVER
- 14. LATCH SCREW
- 15. NUT
- 16. LOCKWASHER

- 17. FLATWASHER
- 18. DOOR SUPPORT ROD
- 19. DOOR STOP BRACKET
- 20. BOLT

EL62F009

Figure 3-5 (2). Removal and Replacement of Core Assembly and Motor Tuning Assembly (Sheet 2 of 2)

**3-16. Removal and Replacement of Motor Tuning Assembly**

*a. Removal.* Proceed as follows.

(1) Remove the core assembly as instructed in 3-15a, above.

(2) Refer to figure 3-5 (1). On the electronic assembly (10), tag and remove two wires from terminals 3 and 4 of TB1 (9) (right side).

(3) Support the electronic assembly (10) and disengage four captive screws (11).

**CAUTION**

When performing the following procedure, take care not to disconnect any wires connected to the electronic assembly.

(4) Position the electronic assembly (10) such that the motor tuning assembly (14) is accessible.

(5) Refer to figure 3-5 (2). From the rear of the ATU cabinet remove four bolts (20), nuts (15), lock-washers (16), and flat washers (17) securing motor tuning assembly (14). The assembly is now free to be removed. Retain the attaching hardware for reassembly.

*b. Replacement.* Proceed as follows.

(1) Refer to figure 3-5 (2). Position motor tuning assembly (14) inside ATU cabinet and align four mounting holes.

(2) Insert four bolts (20) through the back of the ATU cabinet. Install and tighten four nuts (15), lock-washers (16), and flat washers (17) to secure the motor tuning assembly (14) to the ATU cabinet.

(3) Refer to figure 3-5 (1). Place electronic assembly (10) on the motor tuning assembly (14).

(4) Align four captive screws (11) on the electronic assembly (10) with the four clinch nuts on the motor tuning assembly (14).

(5) Tighten four captive screws (11) to secure the electronic assembly (10) to the motor tuning assembly (14).

(6) Reconnect the two tagged wires removed in 3-16a(2), above, to terminals 3 and 4 of TB1 (9) on the electronic assembly (10).

(7) Replace the core assembly as instructed in 3-15b, above.

**Section IV. DIRECT SUPPORT TESTING PROCEDURES**

There are no special direct support testing procedures for the NDB transmitter, ATU, or the changeover unit. However, upon completion of the required

repair, direct support personnel must test the entire unit in accordance with the testing procedures in TM 11-5825-271-12.

**CHAPTER 4**  
**GENERAL SUPPORT MAINTENANCE INSTRUCTIONS**

---

**Section I. GENERAL**

**4-1. Introduction**

a. This chapter contains the general support maintenance instructions for the NDB transmitter and the ATU. There is no general support maintenance for the change-over unit.

b. General support maintenance for the NDB transmitter and ATU comprises removal and replacement of authorized assemblies, subassemblies and certain chassis-mounted components. Procedures are included in this chapter to make sure that repair has been successfully accomplished.

**4-2. Voltage, Resistance and Waveform Measurements**

a. Overall voltage or resistance checks are not applicable to the maintenance of the NDB transmitter and ATU. Pertinent resistance and voltage measure-

ments are given in the troubleshooting/maintenance instructions in TM 11-5825-271-12.

b. Appropriate waveforms are shown on the schematic diagrams, figures FO-2 to FO-12. These waveforms are provided as a reference and are not required for general support maintenance tasks.

**4-3. Tools and Test Equipment**

Tools and test equipment required for general support maintenance tasks are listed in TM 11-5825-271-12.

**4-4. Troubleshooting**

Maintenance procedures, including troubleshooting instructions, for general support maintenance are identical to those authorized at the organizational maintenance level; refer to TM 11-5825-271-12.

**Section II. GENERAL SUPPORT MAINTENANCE OF NDB TRANSMITTER**

**4-5. General**

a. This section provides instructions for performing the maintenance functions allocated to general support maintenance on the NDB transmitter.

b. Support illustrations are provided to aid in the performance of procedures. The numbers in parentheses referenced in the text, e.g., (1), (2), etc, correspond to the item callout on the illustration.

c. All wires removed/unsoldered during the disassembly procedure, should be tagged for identification.

**WARNING**

Make sure that external ac circuit breaker and battery supply are switched off and tagged with a warning not to be turned on while maintenance is being performed.

**4-6. Removal and Replacement of NDB Board Chassis Assembly**

a. *Removal.* Proceed as follows.

(1) Refer to figure 4-1 (1). Loosen three screws (2) securing the fanning strip (1) to the power probe assembly A1A6 (6) terminal strip and disconnect the fanning strip.

(2) Remove two screws (3), lockwashers (4), and flat washers (5) securing the power probe assembly A1A6 (6). Remove the power probe assembly A1A6 by pulling it up out of connector XA6 (15). Retain power probe assembly A1A6 and the attaching hardware for reassembly.

(3) Remove two screws (14), nuts (7), lockwashers (8), and flat washers (9) securing connector XA6 (15) to the mounting bracket. Identify the attaching hardware and retain for reassembly.

(4) Remove on nut (10), flat washer (12), and lockwasher (11) securing the solder lug (13) to the mounting bracket. Tag solder lug and replace nut, lockwasher and flat washer on the screw for reassembly.

(5) Remove five cable clamps securing the cableform to the interior of the cabinet. Retain the cable clamps and attaching hardware for reassembly.

(6) Refer to figure 4-1 (2). Disengage one captive screw (17) securing the 50W pa assembly A1A4 (16). Remove the 50W pa assembly A1A4.

(7) Remove two flathead screws (28), nuts (23), lockwashers (24), flat washers (25), and hex pillars (27) securing connector XA4 (22). Identify the attaching hardware and retain for assembly.

**NOTE**

Identify the location of the two solder lugs (26) held in place by the connector XA4 attaching hardware.

(8) Remove one nut (21), lockwasher (20) and flat washer (19) securing two solder lugs (18) to the mounting bracket. Tag two solder lugs and replace the attaching hardware on the screw for reassembly.

(9) Refer to figure 4-1 (3). Loosen 12 screws (30) securing the fanning strip (29) to the terminal strip TB3 on the transformer chassis assembly; disconnect the fanning strip.

(10) Remove four screws (32), nuts (36), lockwashers (35), and flat washers (34) securing BNC connector J3 (31) to the cabinet. Tag BNC connector and the one solder lug (33), identify the attaching hardware and retain for reassembly.

(11) Refer to figure 4-1 (4). Tag and disconnect two BNC connectors (37) from the rf filter assembly A1A5 (38).

(12) Remove one nut (41), lockwasher (40), and flat washer (39) securing the solder lug (42) to the rf filter assembly A1A5 (38) Tag solder lug and replace the attaching hardware on the screw for reassembly.

(13) Refer to figure 4-1 (5). Using the pcb extractors (47), remove the monitor assembly A1A7 (48) and the exciter assembly A1A2 (46). Retain both assemblies for reassembly

(14) Disengage two captive screws (50) on the control panel assembly (49) and swing the control panel out.

(15) Remove eight screws (45), lockwashers (44), and flat washers (43) securing the board chassis assembly to the cabinet cover; carefully remove the board chassis assembly. Retain the attaching hardware for reassembly.

*b. Replacement.* Proceed as follows.

(1) Refer to figure 4-1 (5). Position board chassis assembly so that the eight holes in the board chassis assembly align with the eight clinch nuts on the inside front cover. Place the loose ends of the cableform into the cabinet.

(2) Install and tighten eight screws (45), lockwashers (44) and flat washers (43) to secure the board chassis assembly to the inside of the cabinet cover.

(3) Swing the control panel assembly (49) in. Engage and tighten two captive screws (50) to secure the control panel assembly.

(4) Replace monitor assembly A1A7 (48) and the exciter assembly A1A2 (46) by inserting pcb into guide rails (51) and pushing pcb connector into the cableform connector.

(5) Refer to figure 4-1 (4). Remove one nut

(41), lockwasher (40), and flat washer (39) and reinstall securing solder-lug (42).

(6) Connect two BNC connectors (37) to the rf filter assembly A1A5 (38).

(7) Refer to figure 4-1 (3). From the inside of the cabinet, insert BNC connector J3 (31) through the hole in the cabinet and align the four mounting holes.

(8) Secure BNC connector (31) and solder lug (33) to the cabinet using four screws (32), nuts (36), lockwashers (35), and flat washers (34).

(9) Install fanning strip (29) on terminal strip TB3 of the transformer chassis assembly. Tighten 12 screws (30) on the terminal strip to secure the fanning strip.

(10) Refer to figure 4-1 (2). Secure connector XA4 (22) to the bracket using two flathead screws (28), hex pillars (27), nuts (23), lockwashers (24), and flat washers (25). Ensure that two solder lugs (26) are secured by attaching hardware.

**NOTE**

When installing connector XA4, make certain that pins 1 through 4 are at the front.

(11) Remove one nut (21), lockwasher (20) and flat washer (19) and reinstall securing the two solder lugs (18).

(12) Reinstall 50W pa assembly A1A4 (16) in connector XA4 (22) and secure by engaging captive screw (17).

(13) Refer to figure 4-1 (1). Remove one nut (13), lockwasher (12) and flat washer (11) and reinstall securing solder lug (10).

(14) Install connector XA6 (15) on the mounting bracket using two screws (14), nuts (7), lockwashers (8), and flat washers (9).

**NOTE**

When installing connector XA6, make certain that pin 17 is positioned near the front of the cabinet

(15) Insert power probe assembly A1A6 (6) into connector XA6 (15) and secure to the hex pillars using two screws (3), lockwashers(4), and flat washers (5).

(16) Install fanning strip (1) on the power probe terminal strip and secure by tightening three screws (2) on the terminal strip.

(17) Install the five cable clamps to secure the cableform to the cabinet.

**NOTE**

The one small cable clamp must be used to retain the two coaxial cables leading to the power probe assembly A1A6.

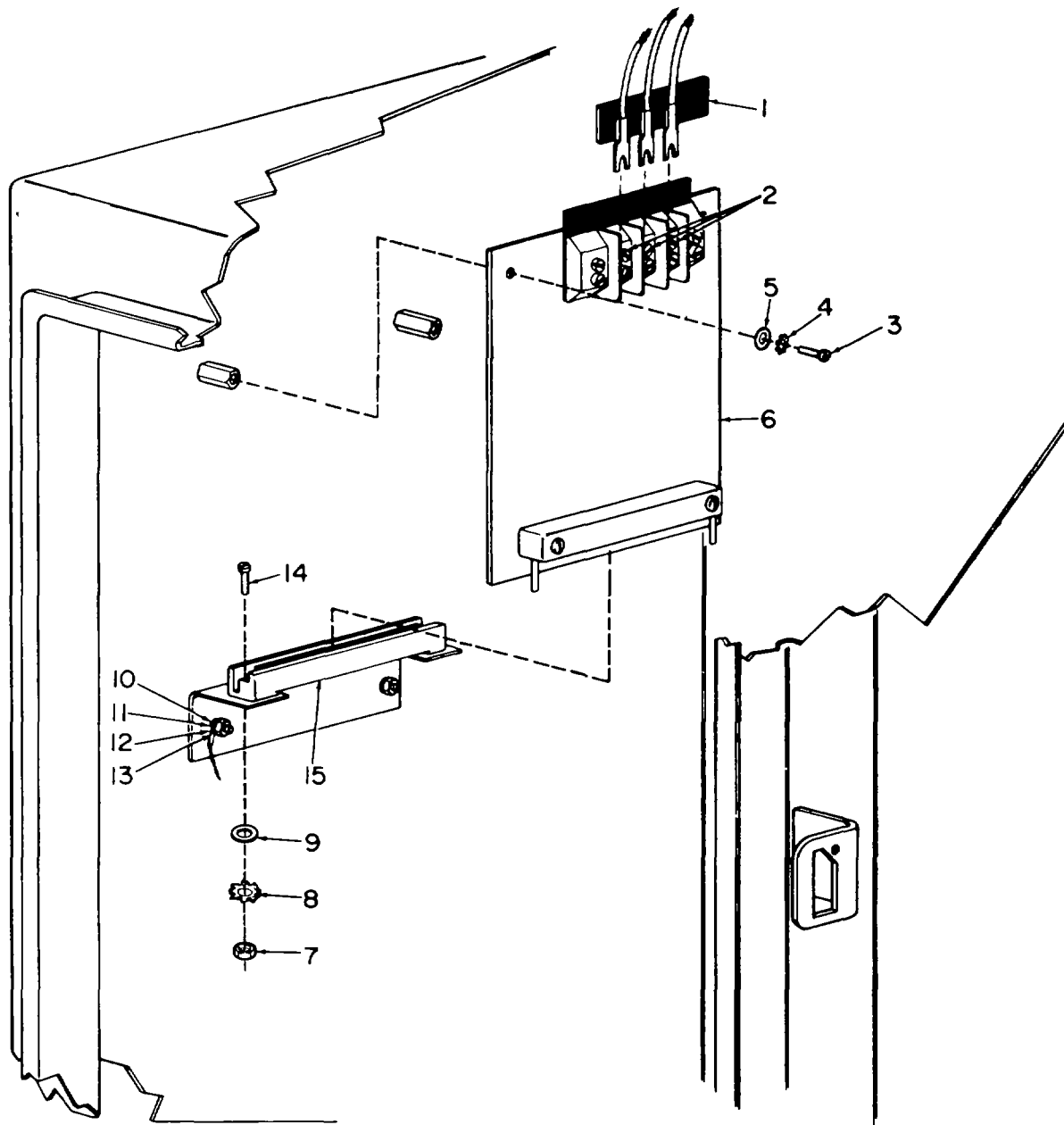

EL6ZFO10

- |                                 |                   |
|---------------------------------|-------------------|
| 1. FANNING STRIP                | 9. FLATWASHER     |
| 2. SCREW                        | 10. NUT           |
| 3. SCREW                        | 11. LOCKWASHER    |
| 4. LOCKWASHER                   | 12. FLATWASHER    |
| 5. FLATWASHER                   | 13. SOLDER LUG    |
| 6. POWER PROBE<br>ASSEMBLY A1A6 | 14. SCREW         |
| 7. NUT                          | 15. CONNECTOR XA6 |
| 8. LOCKWASHER                   |                   |

Figure 4-1 (1). Removal and Replacement of Board Chassis Assembly (Sheet 1 of 5).

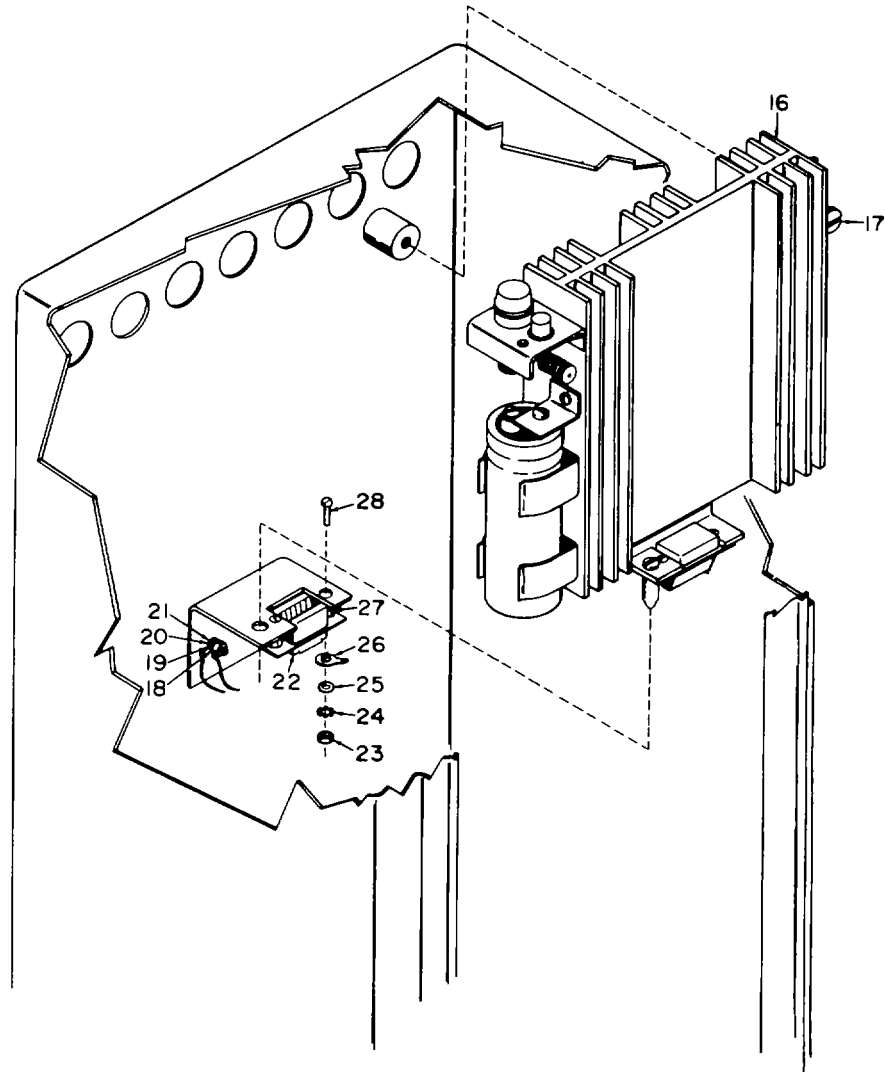

EL6ZF011

- |                          |                     |
|--------------------------|---------------------|
| 16. 50W PA ASSEMBLY A1A4 | 23. NUT             |
| 17. CAPTIVE SCREW        | 24. LOCKWASHER      |
| 18. NUT                  | 25. FLATWASHER      |
| 19. LOCKWASHER           | 26. SOLDER LUG      |
| 20. FLATWASHER           | 27. HEX PILLAR      |
| 21. SOLDER LUG           | 28. FLAT HEAD SCREW |
| 22. CONNECTOR XA4        |                     |

Figure 4-1 (2). Removal and Replacement of Board Chassis Assembly (Sheet 2 of 5).



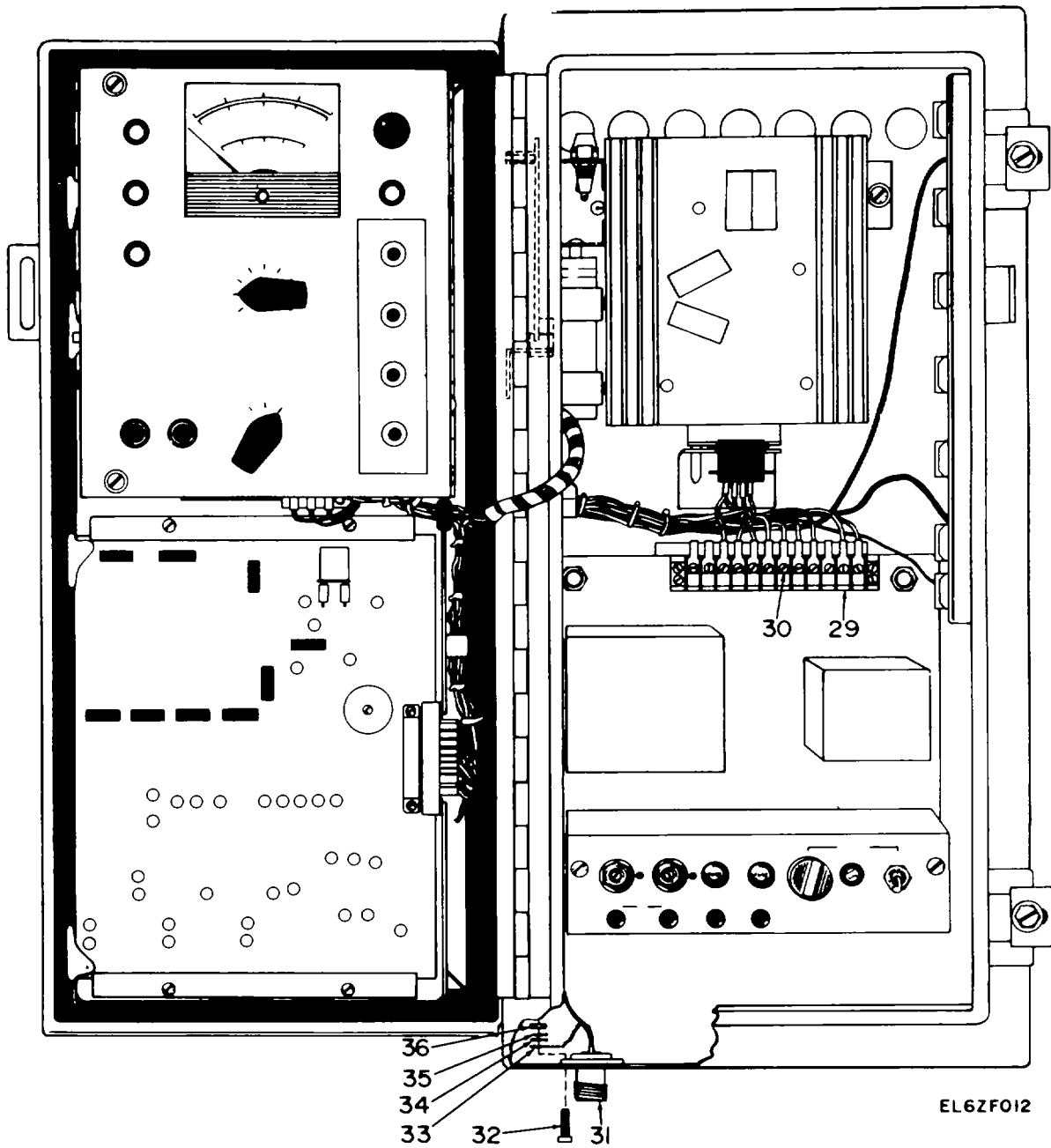

- |                      |                |
|----------------------|----------------|
| 29. FANNING STRIP    | 33. SOLDER LUG |
| 30. SCREW            | 34. FLATWASHER |
| 31. BNC CONNECTOR J3 | 35. LOCKWASHER |
| 32. SCREW            | 36. NUT        |

Figure 4-1 (3). Removal and Replacement of Board Chassis Assembly (Sheet 3 of 5).

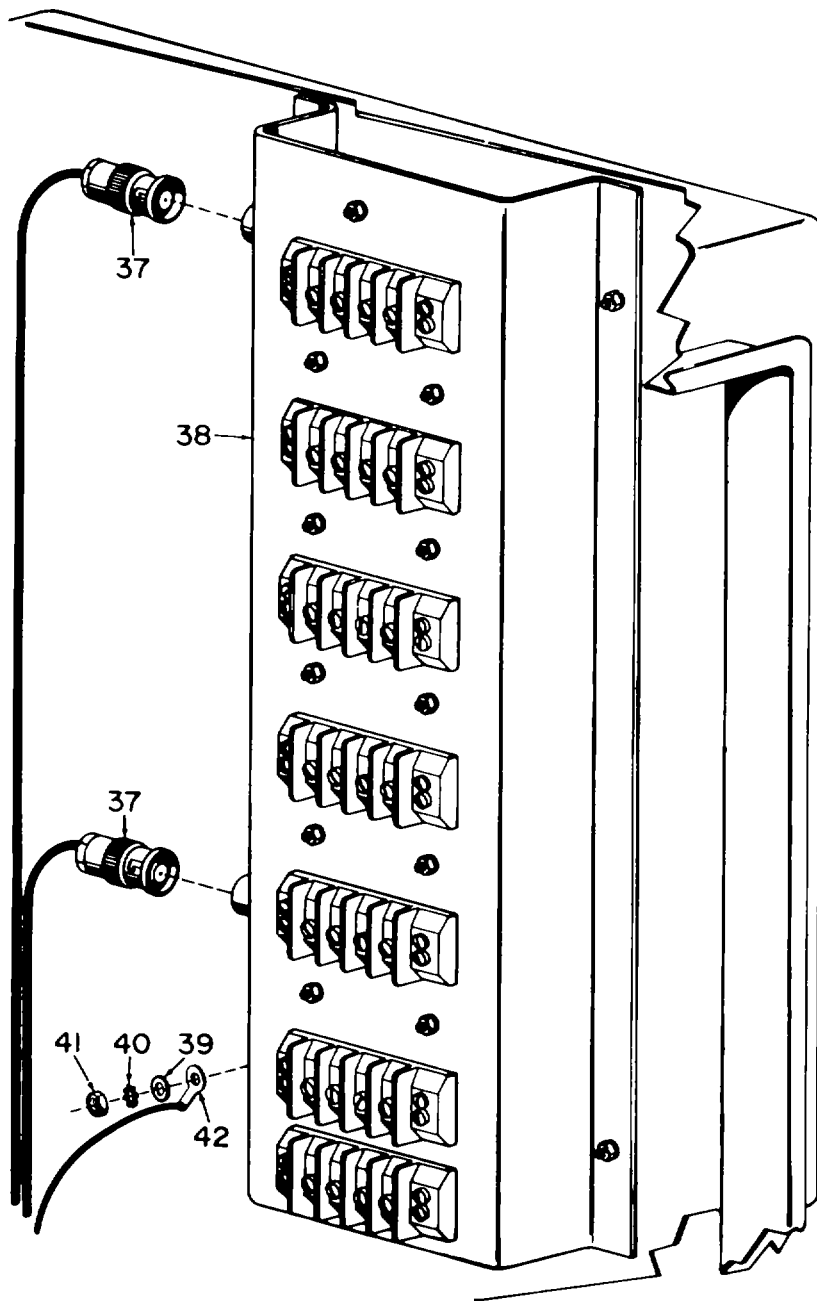

EL6ZF013

- 37. BNC CONNECTOR
- 38. RF FILTER ASSEMBLY A1A5
- 39. FLATWASHER
- 40. LOCKWASHER
- 41. NUT
- 42. SOLDER LUG

Figure 4-1 (4). Removal and Replacement of Board Chassis Assembly (Sheet 4 of 5).

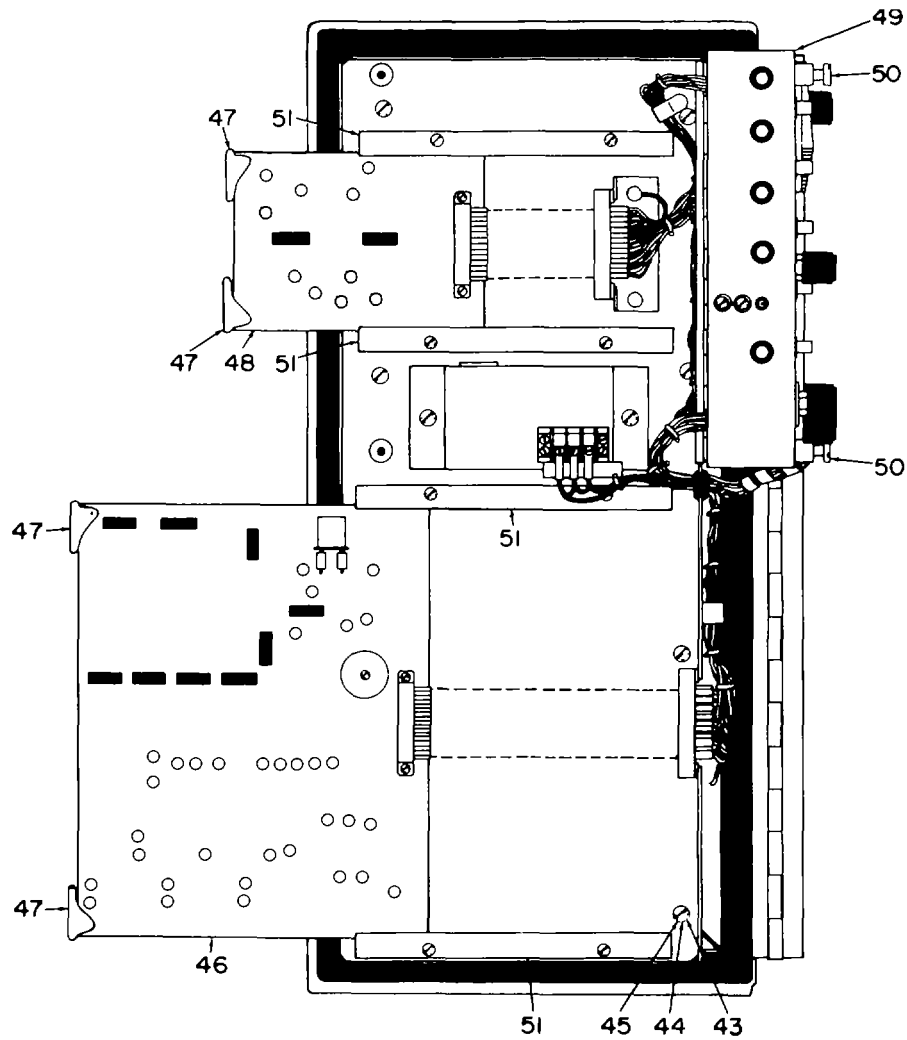

EL6ZF014

- |                           |                            |
|---------------------------|----------------------------|
| 43. FLATWASHER            | 48. MONITOR ASSEMBLY A1A7  |
| 44. LOCKWASHER            | 49. CONTROL PANEL ASSEMBLY |
| 45. SCREW                 | 50. CAPTIVE SCREW          |
| 46. EXCITER ASSEMBLY A1A2 | 51. GUIDE RAIL             |
| 47. PCB EXTRACTOR         |                            |

Figure 4-1 (5). Removal and Replacement of Board Chassis Assembly (Sheet 5 of 5).

### Section III. GENERAL SUPPORT MAINTENANCE OF ATU

#### 4-7. General

a. This section provides instructions for performing the maintenance functions allocated to general support maintenance on the ATU.

b. Support illustrations are provided to aid in the performance of procedures. The numbers in parentheses referenced in the text, e.g., (1), (2), etc. correspond to the item callout on the illustration.

c. All wires removed/unsoldered during the disassembly procedure should be tagged for identification.

#### WARNING

Make sure that external ac circuit breaker and battery supply are switched off and tagged with a warning not to be turned on while maintenance is being performed.

#### 4-8. Removal and Replacement of ATU Electronic Assembly

a. Proceed as follows.

(1) Refer to figure 4-2 Using a slot screwdriver, unlock the ATU front cover (1)

(2) Raise the ATU front cover (1) and insert the door support rod (10) into the doorstop bracket (9).

Insert the hitch pin clip through the hole at end of the door support rod.

(3) Tag and disconnect all wires on the electronic assembly (8) leading from sources outside the assembly.

(4) Disengage the captive screws (3) securing the electronic assembly (8) to the motor tuning assembly (2) and remove the assembly.

b. Replacement Proceed as follows.

(1) Place the electronic assembly (8) on the motor tuning assembly (2).

(2) Align four captive screws (3) on the electronic assembly (8) with four clinch nuts on the motor tuning assembly (2).

(3) Tighten four captive screws (3) to secure electronic assembly (8) to motor tuning assembly (2).

(4) Reconnect all tagged wires to the electronic assembly (8).

(5) Remove the hitch pin clip from the door support rod (10) and disengage the door support rod from the doorstop bracket (9). Insert the door support rod in the retainer and lower the ATU front cover (1).

(6) Using a slot screwdriver, lock the ATU front cover.

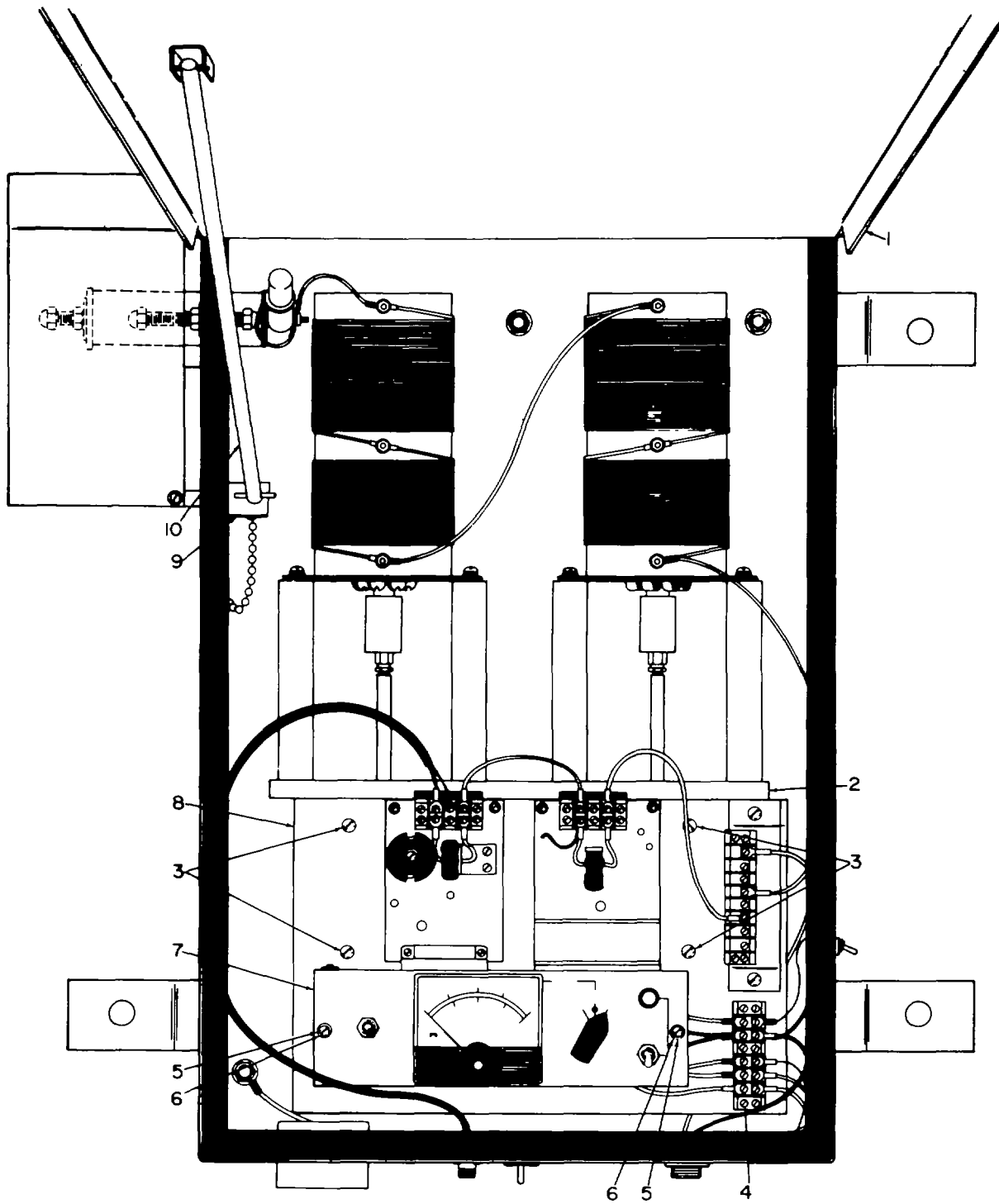

EL6ZF015

- |                          |                       |                           |                               |
|--------------------------|-----------------------|---------------------------|-------------------------------|
| 1. ATU FRONT COVER       | 3. CAPTIVE SCREW      | 5. SCREW                  | 8. ELECTRONIC ASSEMBLY        |
| 2. MOTOR TUNING ASSEMBLY | 4. TERMINAL STRIP TBI | 6. FLATWASHER             | 9. DOOR STOP BRACKET          |
|                          |                       | 7. CONTROL PANEL ASSEMBLY | 10. DOOR SUPPORT ROD ASSEMBLY |

Figure 4-2. Removal and Replacement of Electronic Assembly and Control Panel.

#### 4-9. Removal and Replacement of ATU Control Panel Assembly

a. *Removal* Proceed as follows.

(1) Refer to figure 4-2. Using a slot screwdriver, unlock the ATU front cover (1).

(2) Raise the ATU front cover (1) and insert the door support rod (10) into the doorstop bracket (9) Insert the hitch pin clip through the hole at the end of the door support rod.

(3) Remove two screws (5) and flat washers (6) securing the control panel assembly (7) to the two large standoffs Retain the attaching hardware for reassembly

(4) Allow control panel assembly (7) to swing down, so as to expose the connections at the rear of the assembly.

(5) Remove one nut and flat washer securing the cable clamp to the control panel assembly (7). Retain cable clamp and attaching hardware for reassembly.

(6) On the electronic assembly (8), tag and remove one wire from the control panel assembly (7) at terminal 5 of TB1 (4).

#### NOTE

There are two wires connected to terminal 5 of TB 1 Remove only the wire which connects to the control panel assembly.

(7) Tag and disconnect all wires connected to the control panel assembly (7) from sources outside the

assembly. The control panel assembly is now free to be removed.

b. *Replacement* Proceed as follows.

(1) Refer to figure 4-2. Reconnect all tagged wires to the control panel assembly (7).

(2) Reconnect wire removed and tagged in 4-9a(6), above, to terminal 5 of TB1 (4).

(3) Secure cable clamp along with cableform to the control panel assembly (7), using one nut and one flat washer .

(4) Swing the control panel assembly (7) up onto the two large standoffs and aline the two mounting holes.

#### CAUTION

Before securing control panel assembly, ensure that there are not wires which could possibly be pinched between the standoff and the control panel assembly.

(5) Install two screws (5) and flat washer (6) to secure the control panel assembly (7) to the two standoffs.

(6) Remove the hitch pin clip from the door support rod (10) and disengage the door support rod from the doorstop bracket (9). Insert the door support rod in the retainer and lower the ATU front cover (1).

(7) Using a slot screwdriver, lock the ATU front cover (1).

### Section IV. GENERAL SUPPORT TESTING PROCEDURES

There are no special general support testing procedures for the NDB transmitter, ATU or the change over unit. However, upon completion of the required

repair, general support maintenance personnel must test the entire unit in accordance with the testing procedures in TM 11-5825-271-12.

**APPENDIX A****REFERENCES**

---

DA Pam 310-1 SB 38-100	Consolidated Index of Army Publications and Blank Forms. Preservation, Packaging, Packing and Marking Materials, Supplies, and Equipment Used by the Army.
TM 11-5825-271-12	Operator's and Organizational Maintenance Manual, Transmitter, Radio T-1428/FRN (NSN 5895-01-099-3576), Tuner, Radio Frequency TN-588/ FRN (NSN 5895-01-107-2124), Switching Unit, Power Transfer SA-2318/ FRN (NSN 6110-01-099-3573).
TM 38-750	The Army Maintenance Management System (TAMMS).
TM 740-90-1	Administrative Storage of Equipment.
TM 750-244-2	Procedures for Destruction of Electronics Materiel to Prevent Enemy Use.

**A-1/(A-2 blank)**

INDEX

	<i>Paragraph</i>	<i>Page</i>		<i>Paragraph</i>	<i>Page</i>
Administrative storage .....	1-4	1-1	Monitor assembly A1A7		
ATU			Detailed functional description .....	2-20	2-9
Detailed functional description .....	2-21	2-11	Overall functional description .....	2-10	2-4
Direct support maintenance instructions .....	3-1	3-1	NDB transmitter		
Direct support removal and replacement .....	3-14	3-7	Detailed support maintenance instructions .....	3-1	3-1
Direct support testing procedures .....		3-11	Direct support removal and replacement .....	3-5	3-1
Direct support troubleshooting .....	3-4	3-1	Direct support testing procedures .....		3-11
General support maintenance instructions .....	4-1	4-1	Direct support troubleshooting .....	3-4	3-1
General support removal and replacement .....	4-7	4-8	General support maintenance instructions .....	4-1	4-1
General support testing procedures .....		4-10	General support removal and replacement .....	4-5	4-1
General support troubleshooting .....	4-4	4-1	General support testing procedures .....		4-10
Overall functional description .....	2-12	2-4	General support troubleshooting .....	4-4	4-1
Change-over unit			Overall functional description .....	2-3	2-3
Detailed functional description .....	2-26	2-12	Overall functional description		
Detailed functional description			ATU .....	2-12	2-4
Change-over unit .....	2-26	2-12	Exciter assembly A1A2 .....	2-5	2-3
Exciter assembly A1A2 .....	2-15	2-6	Monitor assembly A1A7 .....	2-10	2-4
Loading coils .....	2-25	2-11	NDB transmitter .....	2-3	2-3
Matching transformer A1A3 .....	2-24	2-11	PA module A1A4 .....	2-7	2-3
Monitor assembly A1A7 .....	2-20	2-9	Power probe A1A6 .....	2-9	2-4
PA module A1A4 .....	2-17	2-7	Power supply A1A1 .....	2-4	2-3
Power probe A1A1 (ATU) .....	2-22	2-11	RF filter A1A5 .....	2-8	2-3
Power probe A1A6 .....	2-19	2-9	Switched regulator driver A1A3 .....	2-6	2-3
Power supply A1A1 .....	2-14	2-5	Transformer chassis assembly .....	2-4	2-3
RF filter A1A5 .....	2-18	2-8	PA module A1A4		
Servo probe A1A2 .....	2-23	2-11	Detailed functional description .....	2-17	2-7
Switched regulator driver A1A3 .....	2-16	2-7	Overall functional description .....	2-7	2-3
Transformer chassis assembly .....	2-13	2-5	Power probe A 1A1 (ATU)		
Direct support maintenance .....			Detailed functional description .....	2-22	2-11
Maintenance instructions .....	3-1	3-1	Power probe A1A6		
Removal and replacement .....	3-5	3-1	Detailed functional description .....	2-19	2-9
Testing procedures .....		3-11	Overall functional description .....	2-9	2-4
Troubleshooting .....	3-4	3-1	Power supply A1A1		
Exciter assembly A1A2			Detailed functional description .....	2-14	2-5
Detailed functional description .....	2-15	2-6	Overall functional description .....	2-4	2-3
Overall functional description .....	2-5	2-3	Removal and replacement		
General support maintenance			Board chassis assembly .....	4-6	4-1
Maintenance instructions .....	4-1	4-1	Control panel assembly .....	3-6	3-1
Removal and replacement .....	4-5	4-1	Control panel assembly (ATU) .....	4-9	4-10
Testing procedures .....		4-10	Core assembly .....	3-15	3-7
Troubleshooting .....	4-4	4-1			
Loading coils					
Detailed functional description .....	2-25	2-11			
Matching transformer A1A3					
Detailed functional description .....	2-24	2-11			
Metering .....	2-11	2-4			



	<i>Paragraph</i>	<i>Page</i>		<i>Paragraph</i>	<i>Page</i>
Electronic assembly .....	4-8	4-8	Overall functional descrip- tion .....		2-3
Motor tuning assembly .....	3-16	3-11	Servo probe A1A2	2-8	
Relay bracket assembly .....	3-9	3-5	Detailed functional descrip- tion .....	2-23	2-11
Relay bracket potentiometers .....	3-10	3-6	Switched regulator driver A1A3		
Relay K1 .....	3-11	3-6	Detailed functional descrip- tion .....	2-16	2-7
Resistor bracket assembly .....	3-7	3-3	Overall functional descrip- tion .....	2-6	2-3
Resistor bracket potentiometer .....	3-8	3-5	System description .....	2-2	2-1
TEST meter M1 .....	3-13	3-7	Test procedures		
Transformer T2 .....	3-12	3-7	Direct support .....		3-11
Reports			General support .....		4-10
Discrepancy in shipment report .....	1-3c	1-1	Transformer chassis assembly		
Equipment improvement recom- mendations .....	1-6	1-1	Detailed functional description .....	2-13	2-5
Packing and handling defi- ciencies .....	1-3b	1-1	Overall functional description .....	2-4	2-3
Maintenance and unsatis- factory equipment .....	1-3a	1-1	Troubleshooting		
RF filter A1A5			Direct support .....	3-4	3-1
Detailed functional descrip- tion .....	2-18	2-8	General support .....	4-4	4-1
			Warnings .....	Inside front cover	

**Index 2**

By Order of the Secretary of the Army:

Official:

ROBERT M. JOYCE  
Major General, United States Army  
The Adjutant General

JOHN A. WICKHAM JR.  
General, United States Army  
Chief of Staff

Distribution:

To be distributed In accordance with special list.

\*U.S. GOVERNMENT PRINTING OFFICE : 1993 0 - 342-421 (63337)

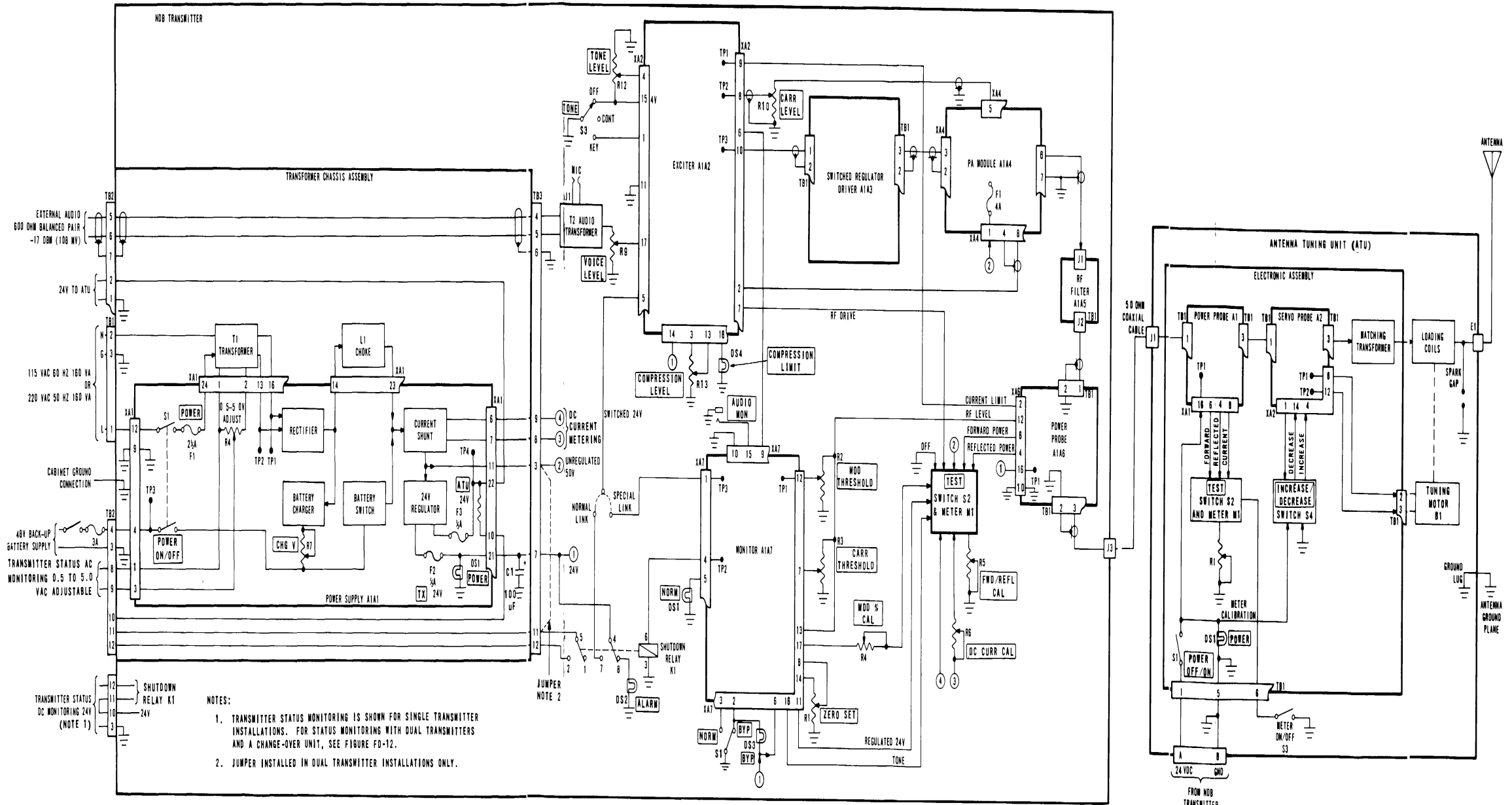

FO-1. Single Transmitter Installation, Interconnection Diagram

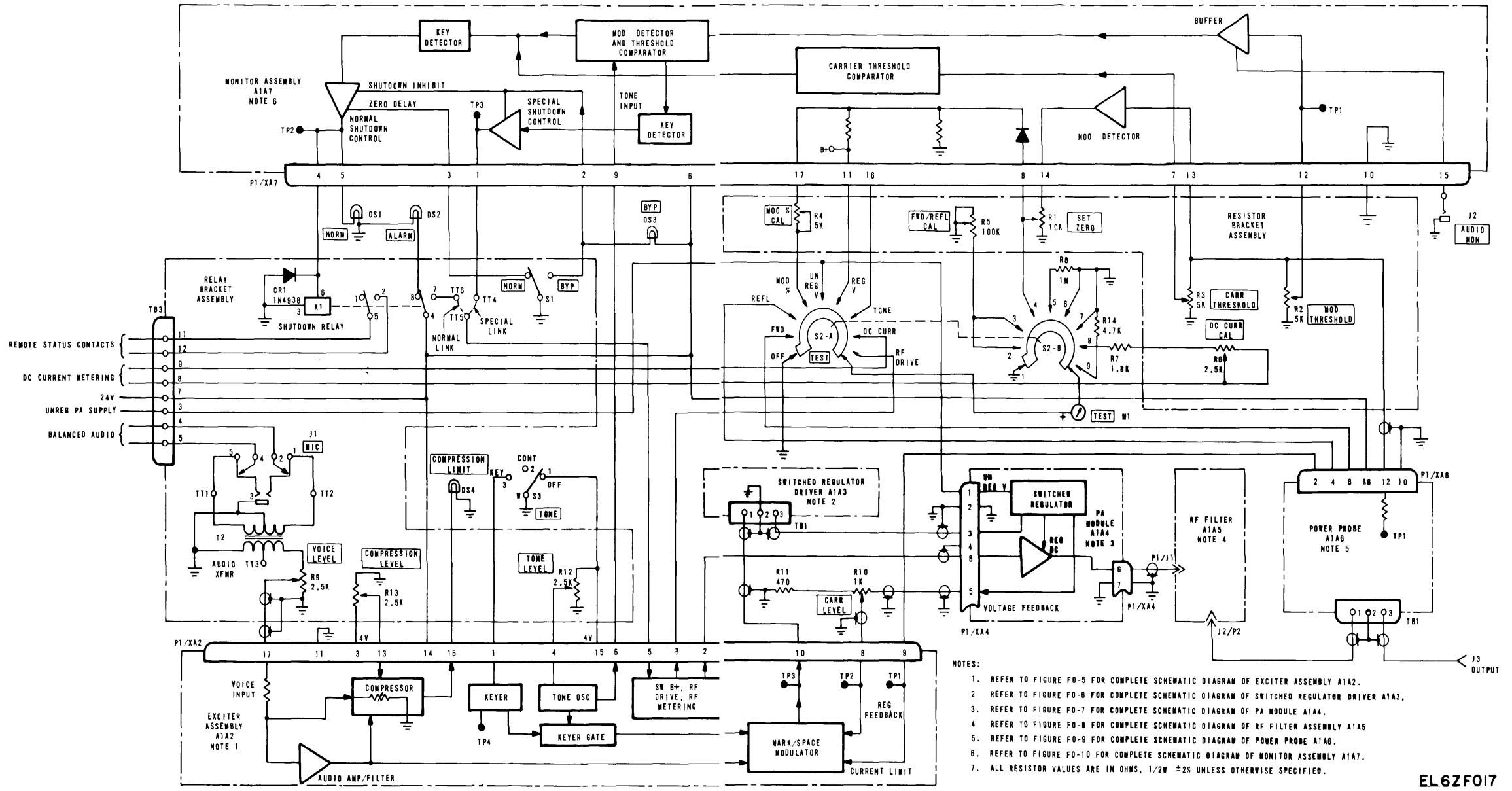

- NOTES:
1. REFER TO FIGURE FO-5 FOR COMPLETE SCHEMATIC DIAGRAM OF EXCITER ASSEMBLY A1A2.
  2. REFER TO FIGURE FO-6 FOR COMPLETE SCHEMATIC DIAGRAM OF SWITCHED REGULATOR DRIVER A1A3.
  3. REFER TO FIGURE FO-7 FOR COMPLETE SCHEMATIC DIAGRAM OF PA MODULE A1A4.
  4. REFER TO FIGURE FO-8 FOR COMPLETE SCHEMATIC DIAGRAM OF RF FILTER ASSEMBLY A1A5.
  5. REFER TO FIGURE FO-9 FOR COMPLETE SCHEMATIC DIAGRAM OF POWER PROBE A1A6.
  6. REFER TO FIGURE FO-10 FOR COMPLETE SCHEMATIC DIAGRAM OF MONITOR ASSEMBLY A1A7.
  7. ALL RESISTOR VALUES ARE IN OHMS, 1/2W ±2% UNLESS OTHERWISE SPECIFIED.

EL6ZF017

FO-2. NDB Transmitter, Interconnection Diagram

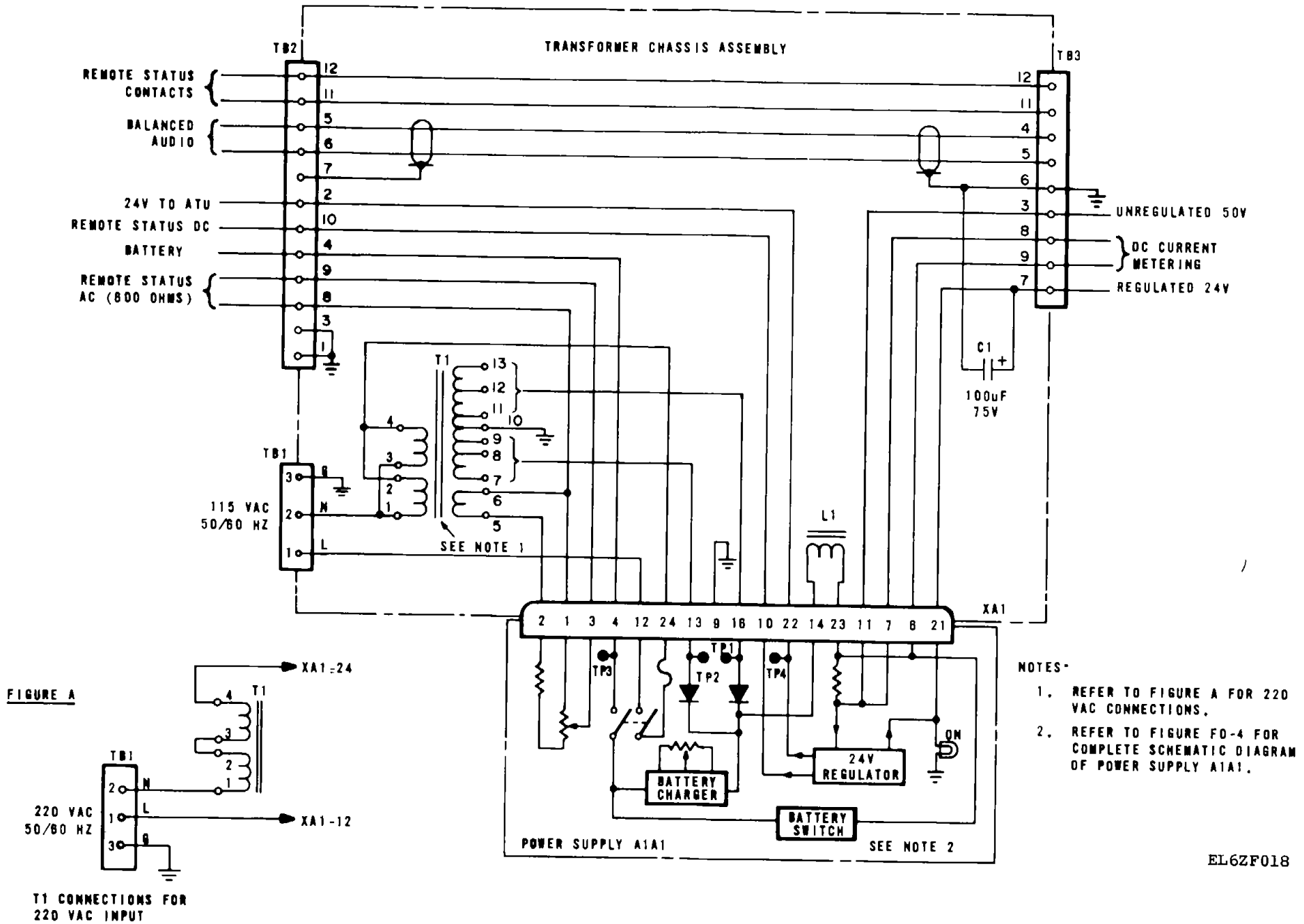

FO-3. Transformer Chassis Assembly, Schematic Diagram

EL6ZF018

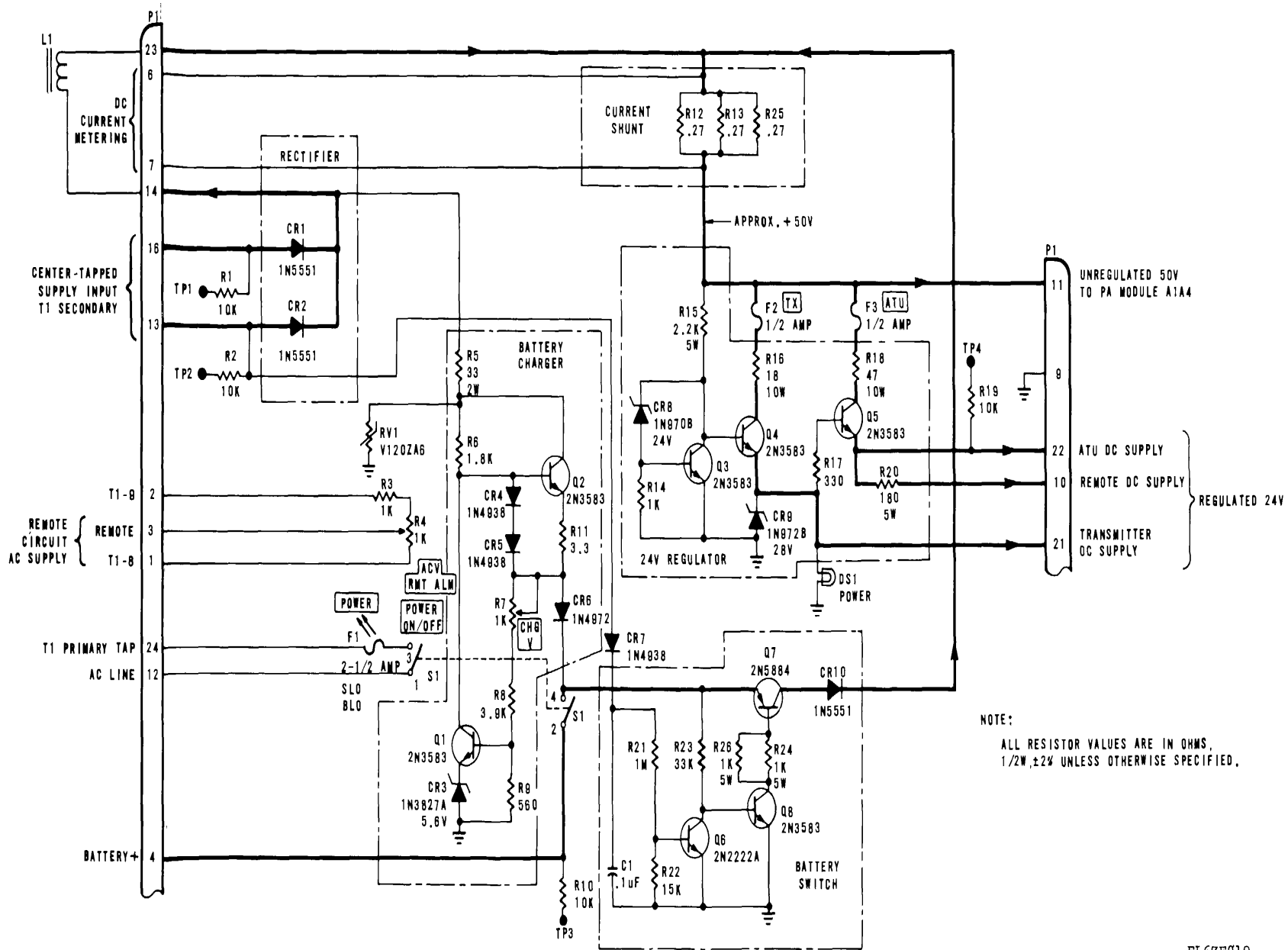

EL6ZF019

FO-4. Power Supply A1A1, Schematic Diagram.

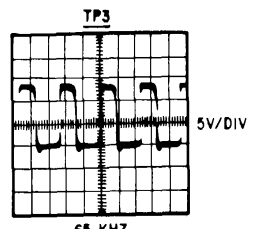
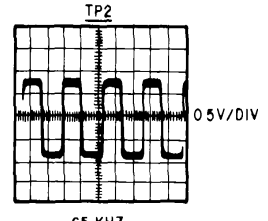
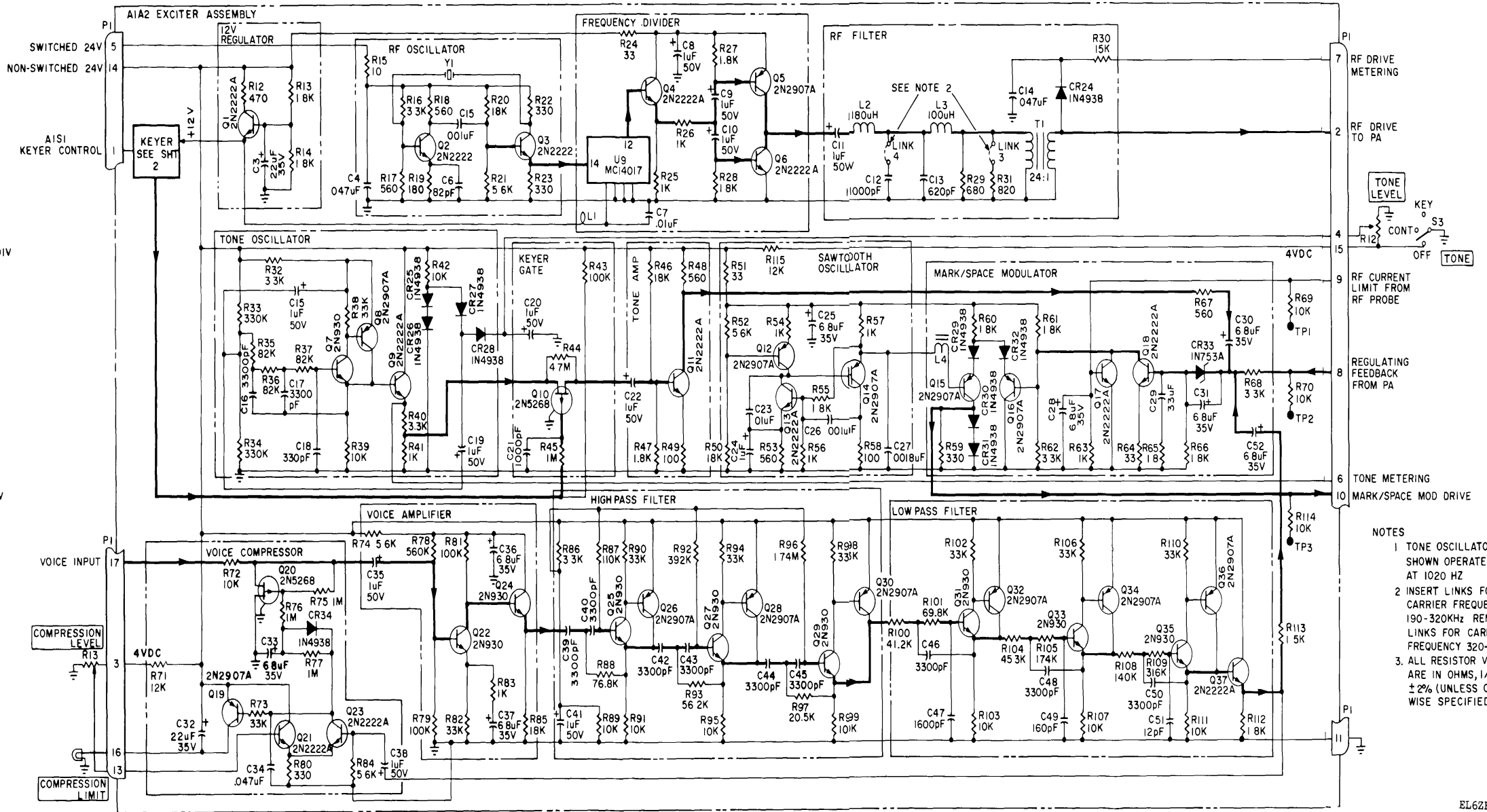

- NOTES
- 1 TONE OSCILLATOR AS SHOWN OPERATES AT 1020 HZ
  - 2 INSERT LINKS FOR CARRIER FREQUENCY 190-320KHZ REMOVE LINKS FOR CARRIER FREQUENCY 320-535KHZ
  3. ALL RESISTOR VALUES ARE IN OHMS, 1/2W, ±2% (UNLESS OTHERWISE SPECIFIED)

FO-5 (1). Exciter Assembly A1A2, Schematic Diagram (Sheet 1 of 2).

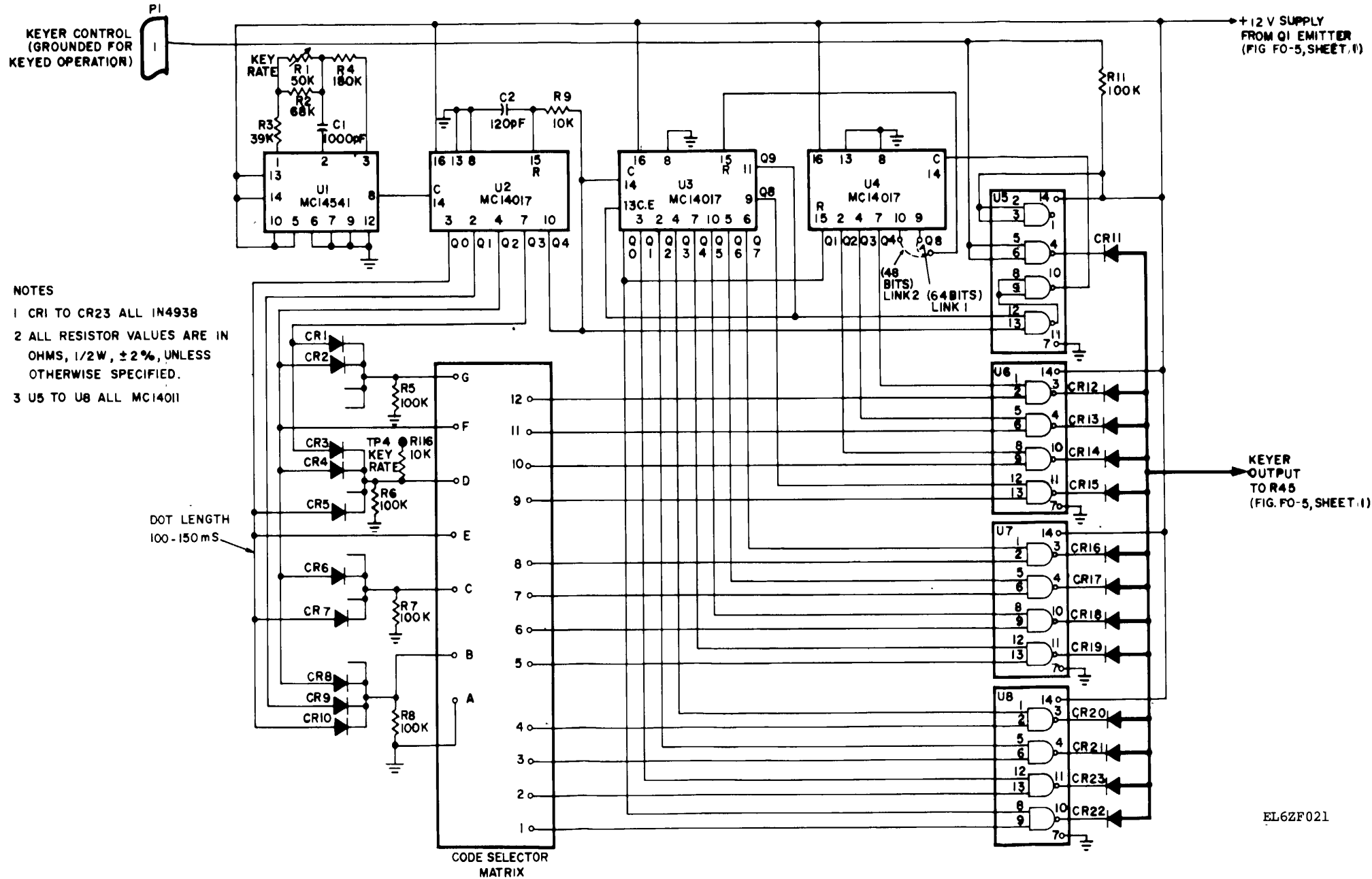

NOTES  
1 CR1 TO CR23 ALL IN4938  
2 ALL RESISTOR VALUES ARE IN OHMS, 1/2W, ± 2%, UNLESS OTHERWISE SPECIFIED.  
3 U5 TO U8 ALL MC14011

DOT LENGTH  
100-150mS

EL6ZF021

FO-5 (2). Exciter Assembly A1A2, Schematic Diagram (Sheet 2 of 2).



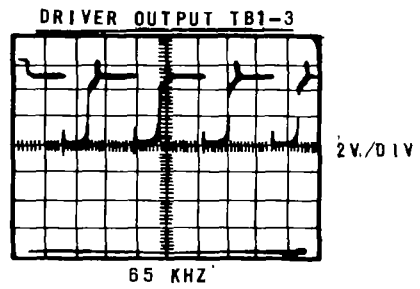
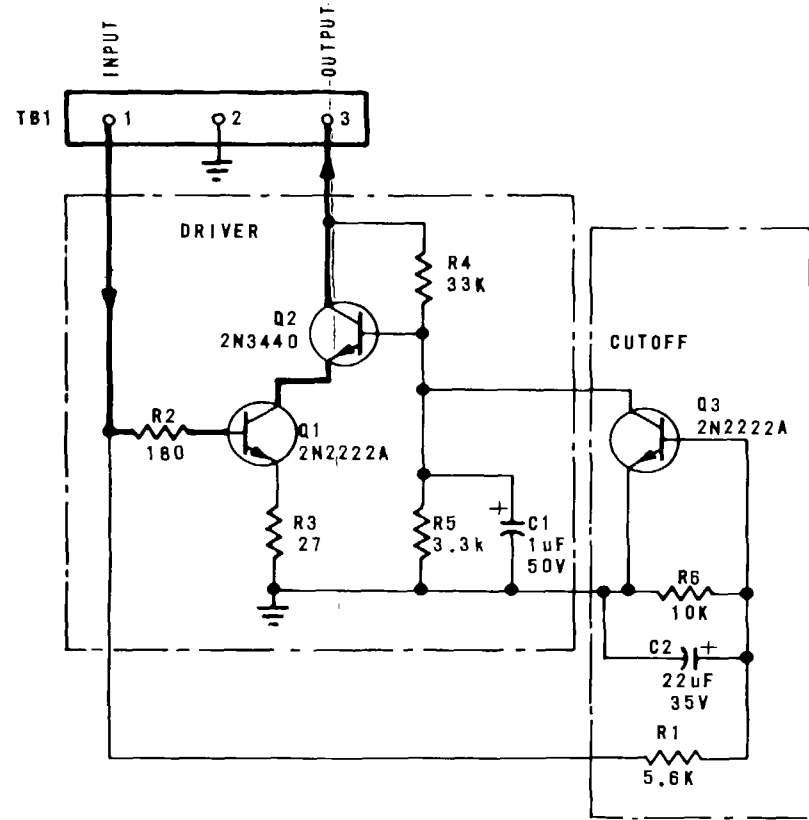

NOTE:  
 ALL RESISTOR VALUES ARE IN OHMS,  
 1/2W, ±2% UNLESS OTHERWISE SPECIFIED.

EL6ZF022

FO-6. Switched Regulator Driver A1A3, Schematic Diagram.



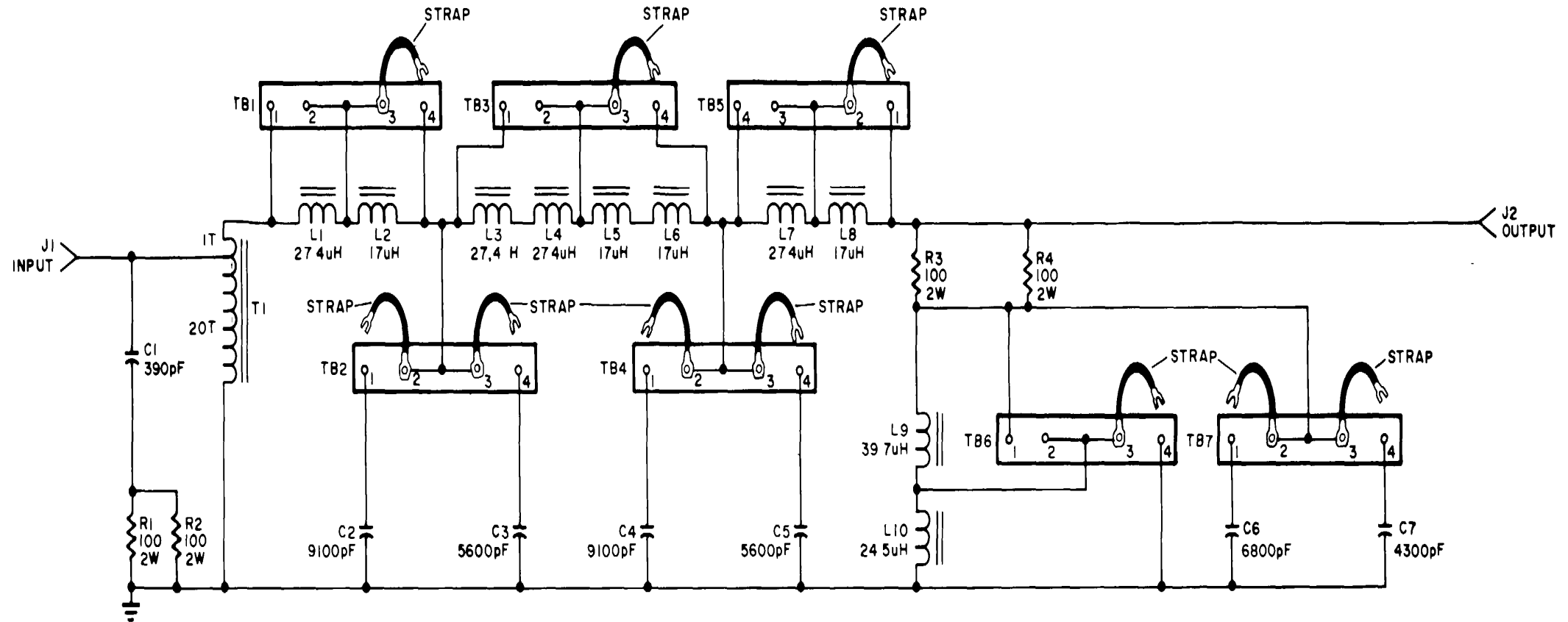

XA4 - 6  
RF FILTER INPUT (TONE OFF)

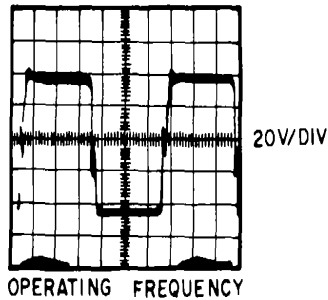

NOTE  
ALL RESISTORS VALUES ARE IN OHMS, 1/2 W,  
± 2%, UNLESS OTHERWISE SPECIFIED

EL6ZF024

FO-8. RF Filter A1A5, Schematic Diagram.

RF OUTPUT TB1-3  
TONE CONTINUOUS (90% MODULATION)

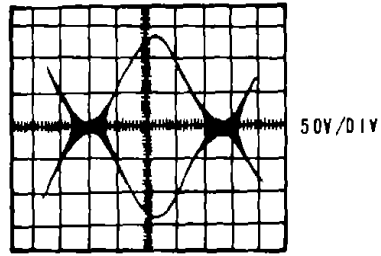

OPERATING FREQUENCY

TONE OFF

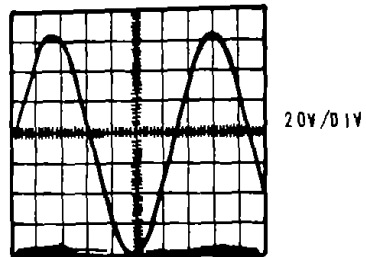

0.2 mSEC/DIV

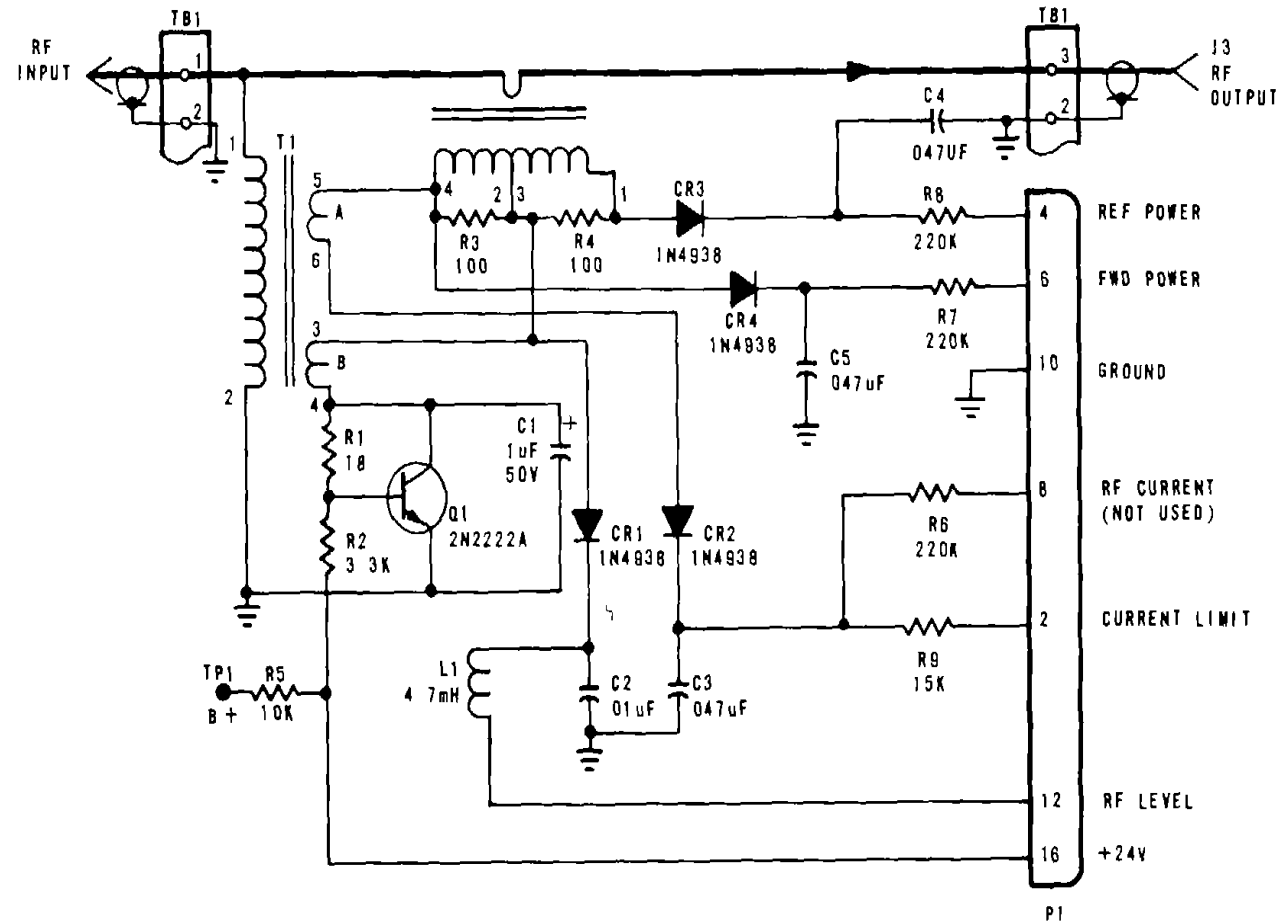

NOTE -

ALL RESISTOR VALUES ARE IN OHMS  
1/2W ±2% UNLESS OTHERWISE SPECIFIED.

EL6ZF025

FO-9. Power Probe A1A6, Schematic Diagram

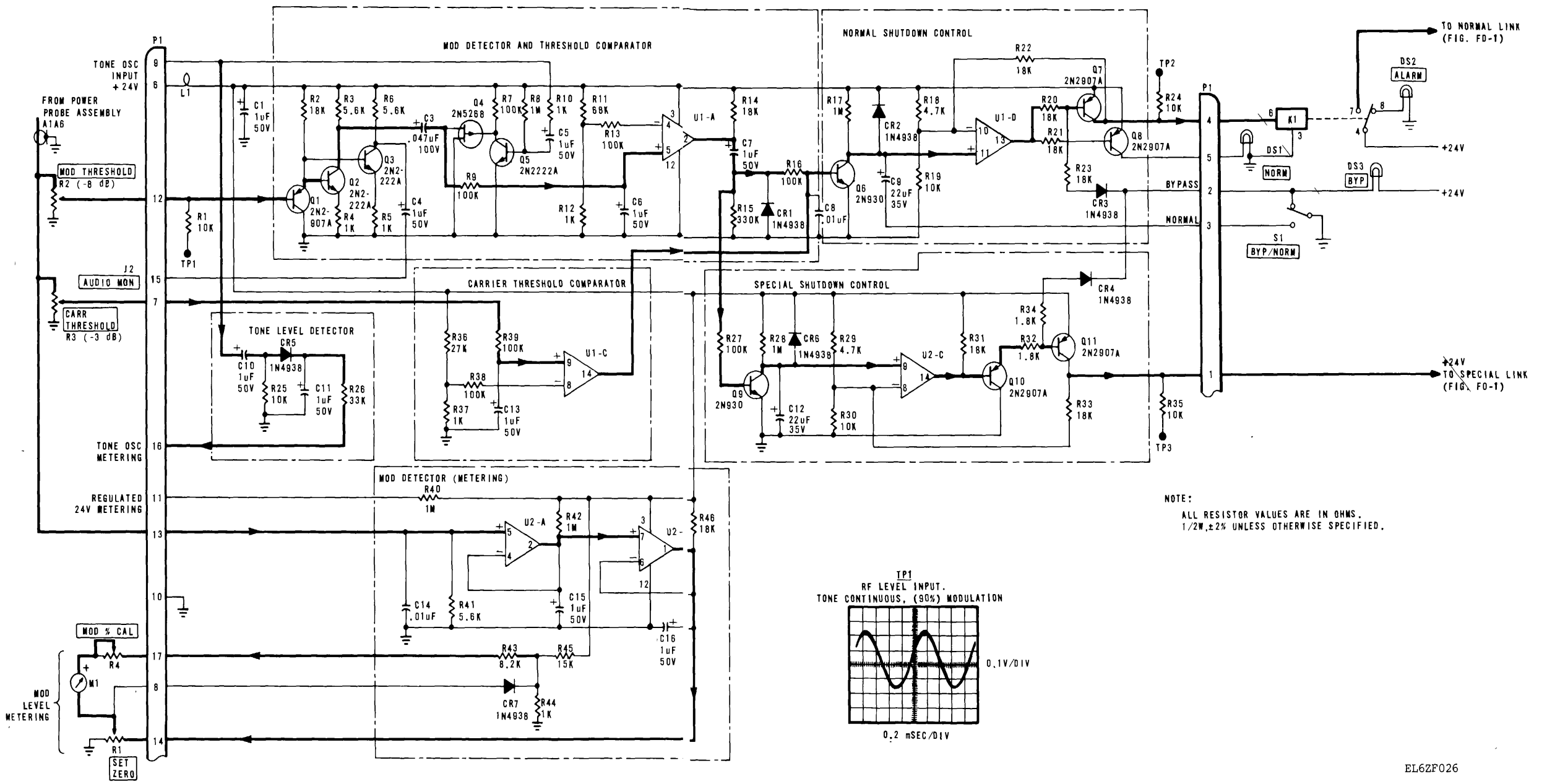

FO-10. Monitor Assembly A1A7, Schematic Diagram.

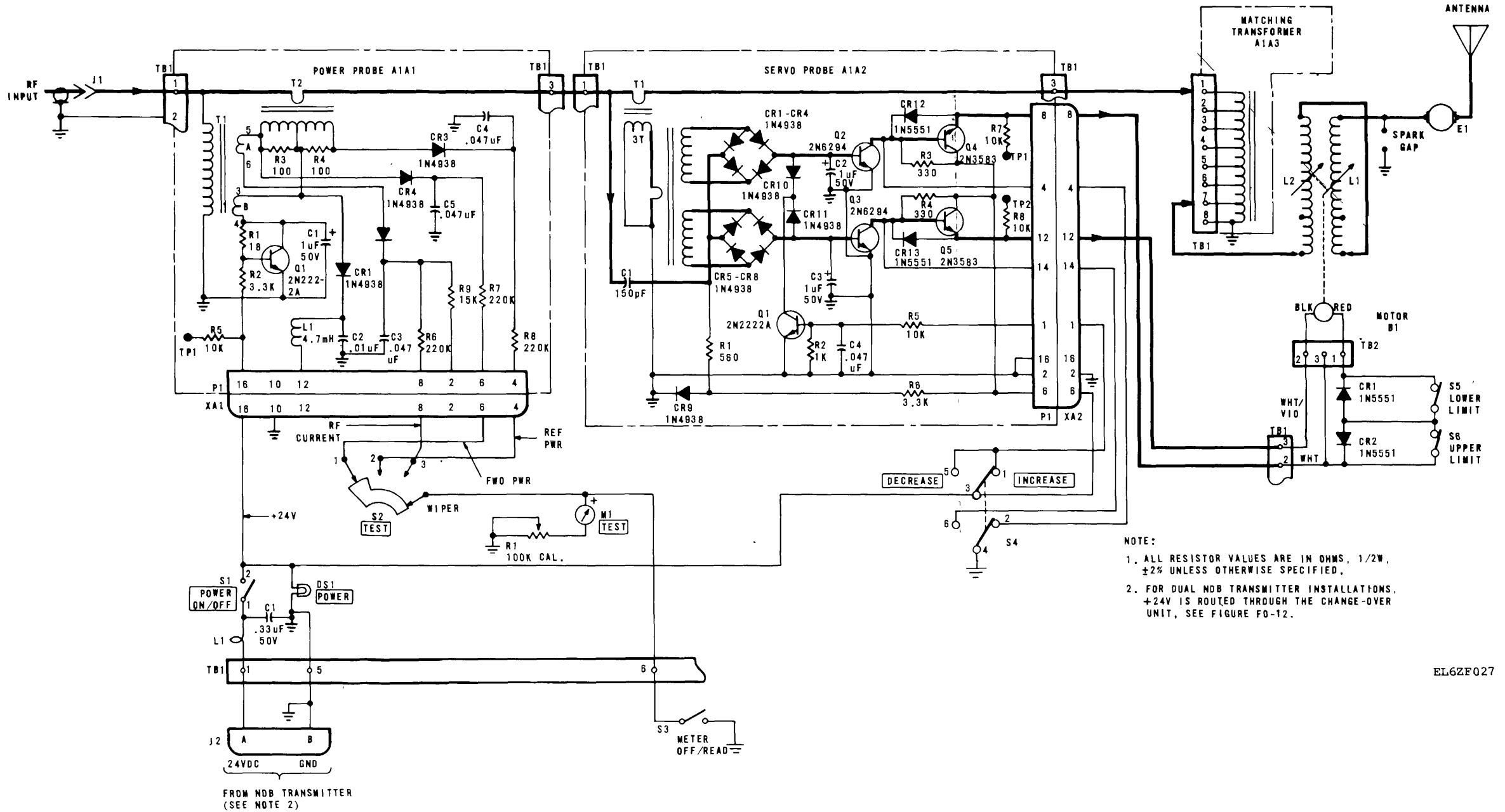

EL6ZF027

FO-11. ATU, Schematic Diagram.

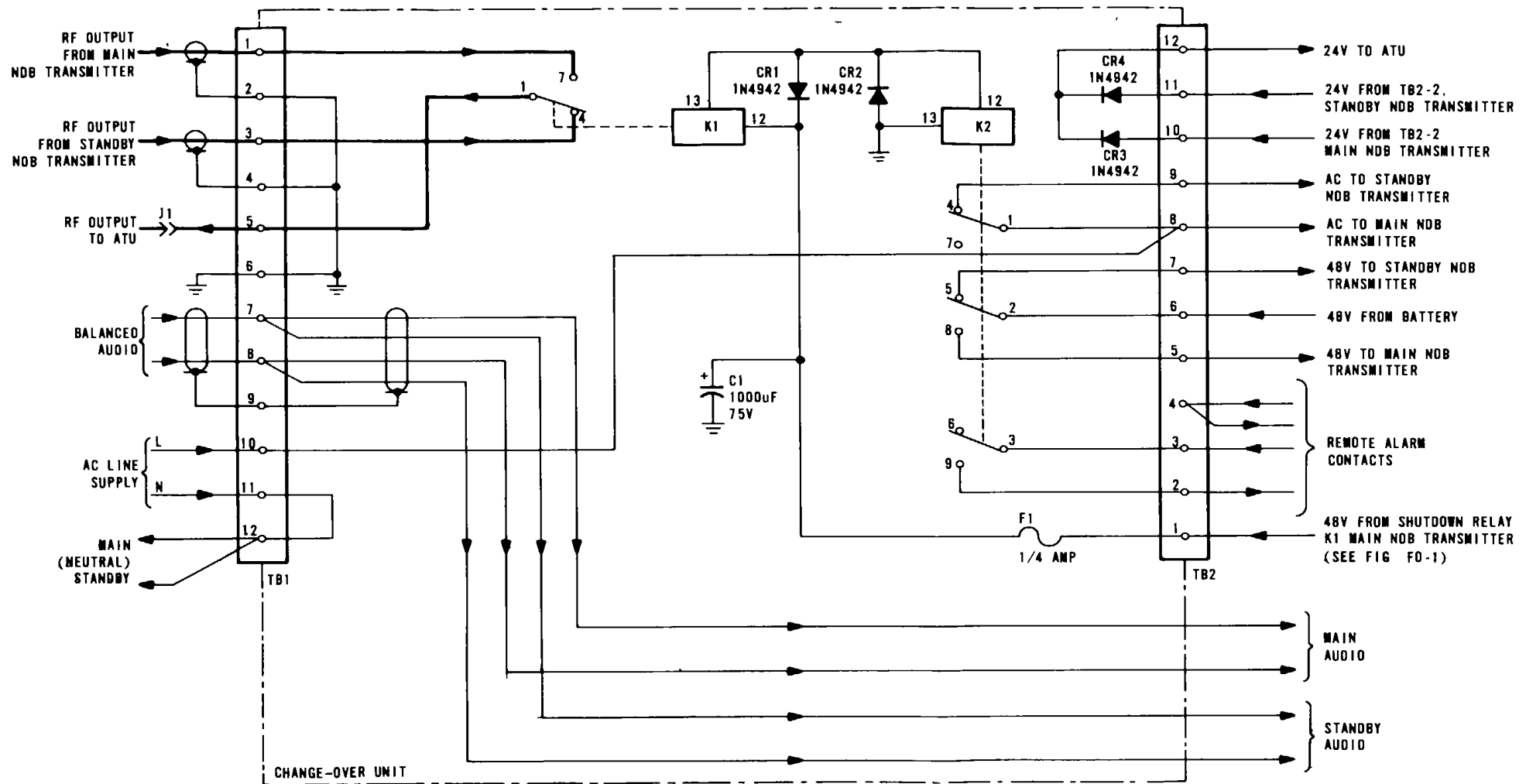

EL6ZF028

FO-12. Change-over Unit, Schematic Diagram.

RECOMMENDED CHANGES TO EQUIPMENT TECHNICAL PUBLICATIONS



THEN... JOT DOWN THE DOPE ABOUT IT ON THIS FORM, CAREFULLY TEAR IT OUT, FOLD IT AND DROP IT IN THE MAIL!

**SOMETHING WRONG WITH THIS PUBLICATION?**

FROM: (PRINT YOUR UNIT'S COMPLETE ADDRESS)

DATE SENT

PUBLICATION NUMBER

PUBLICATION DATE

PUBLICATION TITLE

BE EXACT... PIN-POINT WHERE IT IS

PAGE NO.

PARA-GRAPH

FIGURE NO.

TABLE NO.

IN THIS SPACE TELL WHAT IS WRONG AND WHAT SHOULD BE DONE ABOUT IT:

TEAR ALONG PERFORATED LINE

PRINTED NAME, GRADE OR TITLE, AND TELEPHONE NUMBER

SIGN HERE:

DA FORM 2028-2  
1 JUL 79

PREVIOUS EDITIONS ARE OBSOLETE.

P.S.—IF YOUR OUTFIT WANTS TO KNOW ABOUT YOUR RECOMMENDATION MAKE A CARBON COPY OF THIS AND GIVE IT TO YOUR HEADQUARTERS.





This fine document...

Was brought to you by me:



## [Liberated Manuals -- free army and government manuals](#)

Why do I do it? I am tired of sleazy CD-ROM sellers, who take publicly available information, slap “watermarks” and other junk on it, and sell it. Those masters of search engine manipulation make sure that their sites that sell free information, come up first in search engines. They did not create it... They did not even scan it... Why should they get your money? Why are not letting you give those free manuals to your friends?

I am setting this document FREE. This document was made by the US Government and is NOT protected by Copyright. Feel free to share, republish, sell and so on.

I am not asking you for donations, fees or handouts. If you can, please provide a link to [liberatedmanuals.com](http://liberatedmanuals.com), so that free manuals come up first in search engines:

<A HREF=<http://www.liberatedmanuals.com/>>Free Military and Government Manuals</A>

- Sincerely  
Igor Chudov  
<http://igor.chudov.com/>
- [Chicago Machinery Movers](#)