

TECHNICAL MANUAL

UNIT AND DIRECT SUPPORT MAINTENANCE
REPAIR PARTS AND SPECIAL TOOLS LIST

FOR

TENT, GENERAL PURPOSE
SMALL NSN 8340-00-470-2335
MEDIUM NSN 8340-00-482-3963
LARGE NSN 8340-00-470-2342

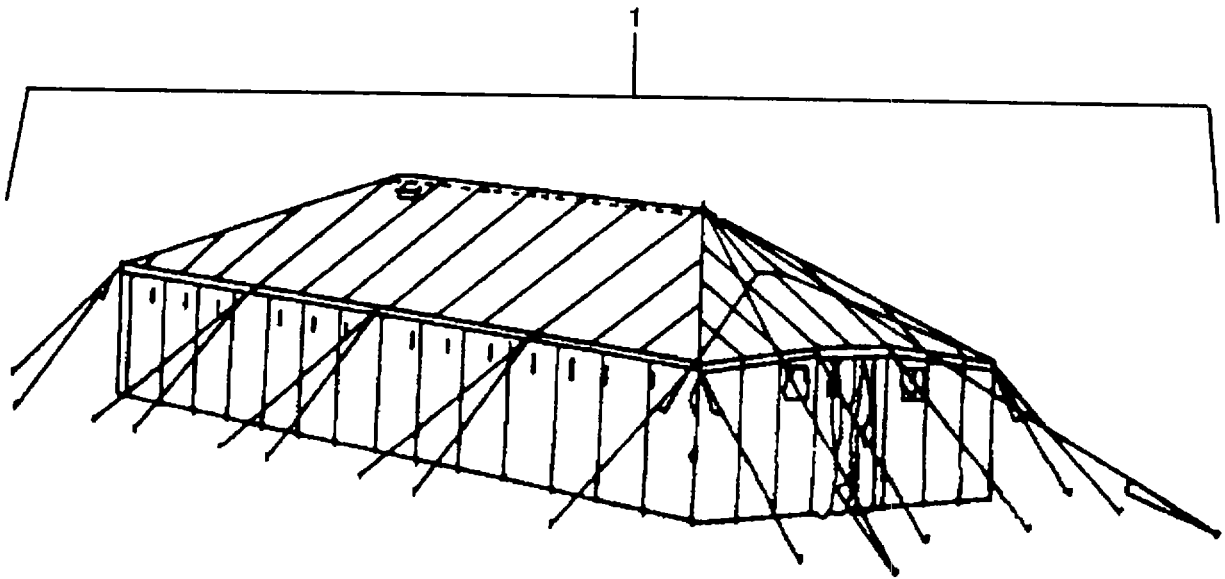

DISTRIBUTION STATEMENT A: Approved for public release; distribution is unlimited.

* This manual supersedes TM 10-8340-211-23P dated 7 January 1972, including all changes

HEADQUARTERS, DEPARTMENT OF THE ARMY

31 AUGUST 1995

TECHNICAL MANUAL
UNIT AND DIRECT SUPPORT MAINTENANCE
REPAIR PARTS AND SPECIAL TOOLS LIST
FOR

TENT, GENERAL PURPOSE
SMALL NSN 8340-00-470-2335
MEDIUM NSN 8340-00-482-3963
LARGE NSN 8340-00-470-2342

Current as of 19 July 1995

REPORTING ERRORS AND RECOMMENDING IMPROVEMENTS

You can help improve this manual. If you find any mistakes or if you know of a way to improve the procedures, please let us know. Mail your letter or DA Form 2028 (Recommended Changes to Publications and Blank Forms), or DA Form 2028-2 located in the back of this manual directly to: Commander, US Army Aviation and Troop Command, ATTN: AMSAT-I-MP, 4300 Goodfellow Blvd., St. Louis, MO 63120-1798. You may also submit your recommended changes by E-mail directly to <daf2028@st-louis-emh7.army.mil>.. A reply will be furnished directly to you.

DISTRIBUTION STATEMENT A: Approved for public release; distribution is unlimited

TABLE OF CONTENTS

	PAGE	ILLUS/ FIGURE
Section I. Introduction	1	
Section II. Repair Parts List	1-1	
Group 00 Tent, General, Purpose		
Tent, General, Purpose	1-1	1
Group 01 Tent Body and Liner		
Traverse Cable and Ventilator Line (Large)	2-1	2
Tent Door W/Screen, Inside (Small)	3-1	3
Personnel Door, W/Screen and Tent Poles (Large)	4-1	4
Tentage Hardware (Large)	5-1	5
Window (Large)	6-1	6
Group 02 Tent Support and Anchoring Components		
Tent Liner W/Screening and Tent Poles (Large)	7-1	7
Tent Support and Anchoring Components (Large)	8-1	8

*This manual supersedes TM 10-8340-211-23P dated 7 January 1972, including all changes.

TABLE OF CONTENTS (Continued)

		PAGE	ILLUS/ FIGURE
Group 03	Tent Accessories		
	Cover and Tent Liner	9-1	9
	Tent Cover (Small)	10-1	10
	Vestibule, Side View (Small)	11-1	11
Group 04	Hardware and Fastening Devices		
	Vestibule, Side View (Small)	11-3	11
Group 05	Bulk Materials		
	Bulk	BULK-1	
Section III.	Special Tools List (Not Applicable)		
Section IV.	Cross Reference Index		
	National Stock Number Index	I-1	
	Part Number Index	I-5	
	Figure and Item Number Index	I-12	

**UNIT AND DIRECT SUPPORT MAINTENANCE
REPAIR PARTS AND SPECIAL TOOLS LIST**

SECTION I. INTRODUCTION

1. **SCOPE** This RPSTL lists and authorizes spares and repair parts; special tools, special test, measurement, and diagnostic equipment (TMDE); and other special support equipment required for performance of unit and direct support maintenance of the Tent, General, Purpose It authorizes the requisitioning, issue, and disposition of spares, repair parts and special tools as indicated by the source, maintenance and recoverability (SMR) codes.

2. **GENERAL** In addition to this section, Introduction, this Repair Parts and Special Tools List is divided into the following sections

a. **Section II. Repair Parts List.** A list of spares and repair parts authorized by this RPSTL for use in the performance of maintenance. This list also includes parts which must be removed for replacement of the authorized parts. Parts lists are composed of functional groups in ascending alphanumeric sequence, with the parts in each group listed in ascending figure and item number sequence. Bulk materials are listed in item name sequence. Items are shown in the associated illustration(s)/figure(s).

b. **Section III. Special Tools List.** A list of special tools, special TMDE, and other special support equipment authorized by this RPSTL (as indicated by Basis of Issue (BOI) information in DESCRIPTION AND USABLE ON CODE column) for the performance of maintenance.

c. **Section IV. Cross-Reference Index** A list, in National Item Identification Number (NIIN) sequence, of all National stock numbered items appearing in the listing, followed by a list in alphanumeric sequence of all part numbers appearing in the listings. National stock numbers and part numbers are cross referenced to each illustration figure and item number appearance. The figure and item number index lists figure and item numbers in alphanumeric sequence and cross references NSN, CAGEC and part number.

3. **EXPLANATION OF COLUMNS (SECTIONS II AND III).**

a. **ITFM NO. (Column (1))** Indicates the number used to identify items called out in the illustration.

b. **SMR Code (Column (?))** The Source, Maintenance, and Recoverability (SMR) code is a 5-position code containing supply/requisitioning information, maintenance category authorization criteria, and disposition instruction, as shown in the following breakout:

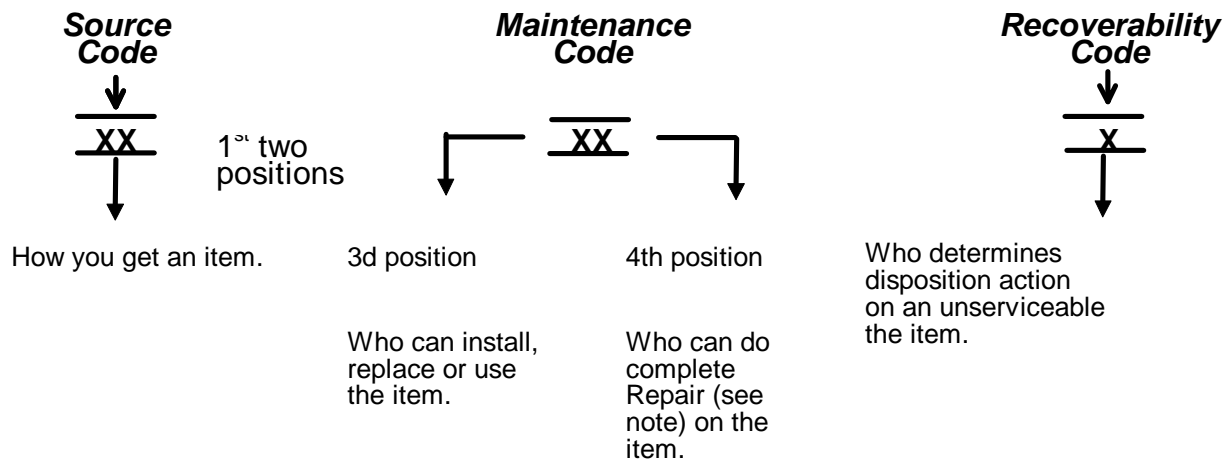

* Complete Repair: Maintenance capacity, capability, and authority to perform all corrective maintenance tasks of the "Repair" function in a use/user environment in order to restore serviceability to a failed item.

(1) Source Code. The source code tells you how to get an item needed for maintenance, repair, or overhaul of an end item/equipment. Explanations of source codes follows:

Source Code	Explanation
PA PB PC** PD PE PF PG	<p>Stocked items; use the applicable NSN to request(requisition items with these source codes. They are authorized to the category indicated by the code entered in the 3rd position of the SMR code.</p> <p>**NOTE: Items coded PC are subject to deterioration.</p>
KD KF KB	<p>Items with these codes are not to be requested/requisitioned individually. They re part of a kit which is authorized to the maintenance category indicated in the 3rd position of the SMR code. The complete kit must be requisitioned and applied.</p>
MO- (Made at Unit/AVUM Level) MF- (Made at DS/AVUM Level) MH- (Made at GS Level) ML- (Made at Specialized Repair Activity (SRA)) MD- (Made at Depot)	<p>Items with these codes are not to be requested/requisitioned individually. They must be made from bulk material which is identified by the part number in the DESCRIPTION and USABLE ON CODE (UOC) column and listed in the Bulk Material group of the repair parts list in this RPSTL. H the item is authorized to you by the 3rd position code of the SMR code, but the source code indicates it is made at a higher level, order the item from the higher level of maintenance.</p>
AO- (Assembled by Unit/AVUM Level) AF- (Assembled by DS/AVIM Level) AH- (Assembled by GS Category) AL- (Assembled by SRA) AD- (Assembled by Depot)	<p>Items with these codes are not to be requested/ requisitioned individually. The puts that make up the assembled item must be requisitioned or fabricated and assembled at the level of maintenance indicated by the source code. H the 3rd position code of the SMR code authorizes you to replace the item, but the source code indicates the items are assembled at a higher level, order the item from the higher level of maintenance.</p>
XA-	Do not requisition "XA"-coded item. Order its next higher assembly. (Refer to the NOTE below.)
XB-	If an UXB" item is not available from salvage, order it using the CAGEC and part number given.
XC-	Installation drawing, diagram, instruction sheet, field service drawing, that is identified manufacturer's part number.
XD-	Item is not stocked. Order an XD"-coded item through normal supply channels using the CAGEC and part number given, if no NSN is available.

NOTE

Cannibalization or controlled exchange, when authorized, may be used as a source or supply for items with the above codes, except for those source coded "XA" or those aircraft support items restricted by requirement of AR 750-1.

(2) Maintenance Code. Maintenance codes tell you the level(s) of maintenance authorized to USE and REPAIR support items. The maintenance codes are entered in the third and fourth positions of the SMR code as follows:

(a) The maintenance code entered in the third position tells you the lowest maintenance level authorized to remove, replace, and use an item. The maintenance code entered in the third position will indicate authorization to the following levels of maintenance.

Maintenance Code	Application/Explanation
C -	Crew or operator maintenance done within unit/AVUM maintenance.
O -	Unit level/VAVUM maintenance can remove, replace, and use the item.
F -	Direct support/AVIM maintenance can remove, replace, and use the item.
H -	General support maintenance can remove, replace, and use the item.
L -	Specialized repair activity can remove, replace, and use the item.
D -	Depot can remove, replace, and use the item.

(b) The maintenance code entered in the fourth position tells whether or not the item is to be repaired and identifies the lowest maintenance level with the capability to do complete repair (i.e., perform all authorized repair functions.)

NOTE

Some limited repair may be done on an item at a lower level of maintenance, if authorized by the Maintenance Allocation Chart and SMR codes.

Maintenance Code	Application/Explanation
O-	Unit/AVUM is the lowest level that can do complete repair of the item.
F-	Direct support/AVIM is the lowest level that can do complete repair of the item.
H-	General Support is the lowest level that can do complete repair of the item.
L-	Specialized repair activity is the lowest level that can do complete repair of the item.
D-	Depot is the lowest level that can do complete repair of the item.
Z-	Nonreparable. No repair is authorized
B-	No repair is authorized. No parts or special tools are authorized for the maintenance of a 'B coded item. However, the item may be reconditioned by adjusting, lubricating, etc., at the user level.

(3) Recoverability Code. Recoverability codes are assigned to items to indicate the disposition action on unserviceable items. The recoverability code is entered in the fifth position of the SMR Code as follows:

**Recoverability
Codes**

Application/Explanation

- Z- Nonreparable item. When unserviceable, condemn and dispose of the item at the level of maintenance shown in 3d position of SMR Code.
- O- Reparable item. When not economically repairable, condemn and dispose of the item at unit or AVUM level.
- F - Reparable item. When uneconomically repairable, condemn and dispose of the item at the direct support or AVIM level.
- H - Reparable item. When uneconomically repairable, condemn and dispose of the item at the general support level.
- D - Reparable item. When beyond lower level repair capability, return to depot. Condemnation and disposal of item not authorized below depot level.
- L- Reparable item. Condemnation and disposal not authorized below specialized repair activity (SRA).
- A - Item requires special handling or condemnation procedures because of specific reasons (e.g, precious metal content, high dollar value, critical material, or hazardous material). Refer to appropriate manuals/directives for specific instructions

c. CAGEC (Column (3)). The Commercial and Government Entity Code (CAGEC) is a 5-digit numeric code which is used to identify the manufacturer, distributor, or Government agency/activity that supplies the item.

d. PART NUMBER (Column (4)). Indicates the primary number used by the manufacturer, (individual, company, firm, corporation, or Government activity), which controls the design and characteristics of the item by means of its engineering drawings, specifications, standards, and inspection requirements to identify an item or range of items.

NOTE

When you use an NSN to requisition an item, the item you receive may have a different part number from the number listed.

e. DESCRIPTION AND USABLE ON CODE (UOC) (Column (5)). This column includes the following information:

- (1) The Federal item name and, when required, a minimum description to identify the item.
- (2) Part numbers of bulk materials are referenced in this column in the line entry to be manufactured/fabricated
- (3) The statement "END OF FIGURE " appears just below the last item description in Column (5) for a given figure in both Section II and Section III.

f. QTY (Column (6)). The QTY (quantity per figure) column indicates the quantity of the item used in the breakout shown on the illustration figure, which is prepared for a functional group, subfunctional group, or an assembly. A "v" appearing in this column instead of a quantity indicates that the quantity is variable and may vary from application to application.

4. EXPLANATION OF INDEX FORMAT AND COLUMNS (SECTION IV).

a. NATIONAL STOCK NUMBER (NSN) INDEX.

(1) STOCK NUMBER Column. This column lists the NSN in national item identification number (NIIN) sequence. The NIIN consists of the last nine digits of the NSN, i.e.

NSN
5305-01-574-1467
NIIN

When using this column to locate an item, ignore the first four digits of the NSN. Use the complete NSN (13 digits) when requisitioning items by stock number.

(2) FIG. Column. This column lists the number of the figure where the item is identified/located. The figures are in numerical order in Section II and Section III.

(3) ITEM Column. The item number identifies the Item associated with the figure listed in the adjacent FIG. column. This item is also identified by the NSN listed on the same line.

b. PART NUMBER INDEX. Part numbers in this index are listed by part number in ascending alphanumeric sequence (i.e., vertical arrangement of letter and number combination which places the first letter or digit of each group in order A through Z, followed by the numbers 0 through 9, and each following letter or digit in like order).

(1) CAGEC Column. The Commercial and Government Entry Code (CAGEC) is a 5-digit numeric code used to identify the manufacturer, distributor, or Government agency/activity that supplies the item.

(2) PART NUMBER Column. Indicates the primary number used by the manufacturer (individual, firm, corporation, or Government activity), which controls the design and characteristics of the item by means of its engineering drawings, specifications, standards, and inspection requirements to identify an item or range of items.

(3) STOCK NUMBER Column. This column lists the NSN for the associated part number and manufacturer identified in the PART NUMBER and CAGEC columns to the left.

(4) FIG. Column. This column lists the number of the figure where the item is identified/located in Section II and Section III.

(5) ITEM Column. The item number is that number assigned to the item as it appears in the figure referenced in adjacent figure number column.

c. FIGURE AND ITEM NUMBER INDEX.

(1) FIG. Column. This column lists the number of the figure where the item is identified/located in Section II and Section III.

(2) ITEM Column. The item number is that number assigned to the item as it appears in the figure referenced in the adjacent figure number column.

(3) STOCK NUMBER Column. This column lists the NSN for the item.

(4) CAGEC Column. The Commercial and Government Entity Code (CAGEC) is a 5-digit numeric code used to identify the manufacturer, distributor, or Government agency/activity that supplies the item.

(5) PART NUMBER Column. Indicates the primary number used by the manufacturer (individual, firm, corporation, or Government activity), which controls the design and characteristics of the item by means of its engineering drawings, specifications, standards, and inspection requirements to identify an item or range of items.

5. SPECIAL INFORMATION.

a. USABLE ON CODE. The usable on code appears in the lower left corner of the Description Column heading. Usable on codes are shown as "UOC:..." in the Description Column (justified left) on the last line of the applicable item description/nomenclature. Uncoded items are applicable to all models. Identification of the usable on codes used in this RPSTL are:

<u>Code</u>	<u>Used On</u>
APX	Model, Small
APY	Model, Medium
APZ	Model, Large

b. FARRICATION INSTRUCTIONS. Bulk materials required to manufacture items are listed in the Bulk Material Functional Group of this RPSTL Part numbers for bulk materials are also referenced in the description column of the line entry for the item to be manufactured/fabricated. Detailed fabrication instructions for items source coded to be manufactured or fabricated are found in TM 10-8340-211-13.

c. INDEX NUMBERS. Items which have the word BULK in the figure column will have an index number shown in the item number column. This index number is a cross-reference between the National Stock Number/Part Number Index and the bulk material list in Section II.

d. ASSOCIATED PURIFICATIONS. The publications listed below pertain to the Tent, General, Purpose and its components.

Publication	Short Title
TM 10-8340-211-13	Operator, Unit, Direct Support and General Support Maintenance Manual.

6. HOW TO LOCATE REPAIR PARTS.

a. When National Stock Numbers or Part Numbers are NOT Known.

(1) First. Using the table of contents, determine the assembly or subassembly group to which the item belongs. This is necessary since figures are prepared for assembly groups and subassembly groups, and listings are divided into the same groups.

(2) Second. Find the figure covering the assembly group or subassembly group to which the item belongs.

(3) Third. Identify the item on the figure and use the Figure and Item Number Index to find the NSN.

b. When National Stock Number or Part Number is Known.

(1) First Using the National Stock Number and Part Number Indexes find the pertinent National Stock Number or Part Number. The NSN index is in National Item Identification Number (NIIN) sequence (see paragraph 4.a.). The part numbers in the Part Number index are listed in ascending alphanumeric sequence (see paragraph 4.b.). Both indexes cross-reference you to the illustration/figure and item number of the item you are looking for.

(2) Second. Turn to the figure and item number, verify that the item is the one you are looking for, then locate the item number in the repair parts list for the figure.

7. ARRRVIATIONS. Abbreviations used in this manual are listed in MIL-STD-12.

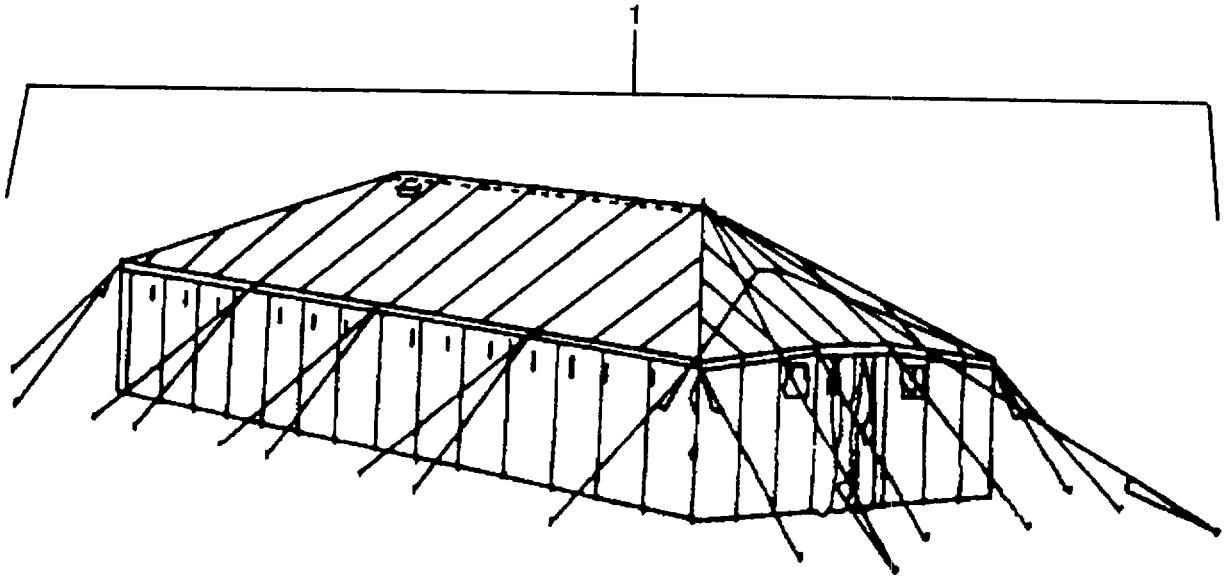

Figure 1. Tent, General, Purpose.

SECTION II

TM 10-8340-211-23P

(1) ITEM NO.	(2) SMR CODE	(3) CAGEC	(4) PART NUMBER	(5) DESCRIPTION AND USABLE ON CODES	(6) QTY
1	PAOFF		NOT FURNISHED NOT FURNISHED NOT FURNISHED	GROUP 00 TENT, GENERAL, PURPOSE SMALL 8340-00-470-2335 MEDIUM 8340-00-482-3963 LARGE 8340-00-470-2342 FIG. 1 TENT, GENERAL, PURPOSE TENT, GENERAL, PURPOSE..... END OF FIGURE	1

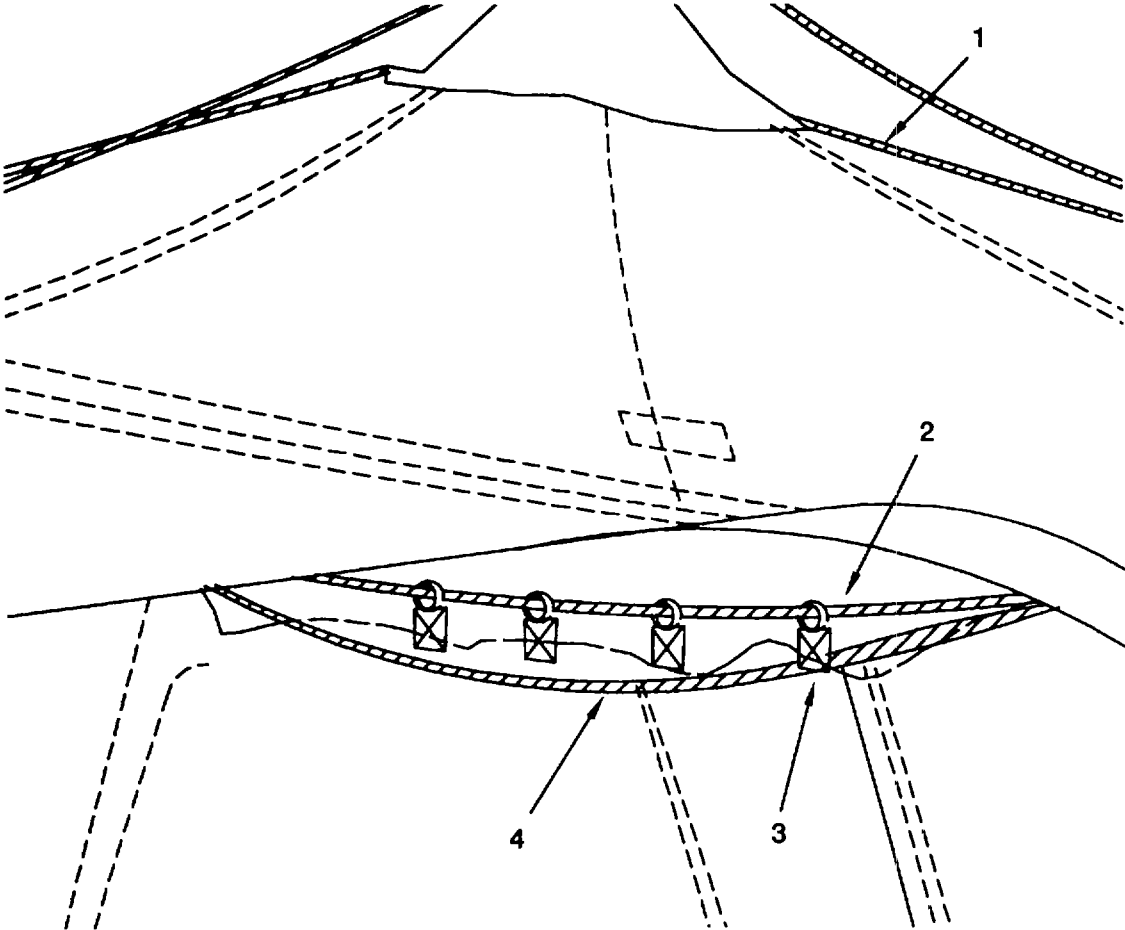

Figure 2. Traverse Cable and Ventilator Line (Large)

(1) ITEM NO.	(2) SMR CODE	(3) CAGEC	(4) PART NUMBER	(5) DESCRIPTION AND USABLE ON CODES (UOC)	(6) QTY
				GROUP 01 TENT BODY AND LINER FIG. 2 TRAVERSE CABLE AND VENTILATOR LINE (LARGE) NOTE Repair parts which are not assigned item numbers are not shown in the related figure. Many of these items are 'make from' (SMR Coded MF) parts and are fabricated or repaired at Direct Support maintenance from bulk materials	
1	PAOZZ	64067	8340-00-252-2280	LINE, TENT: MANILA VENTILATOR FLAP, ONE END SEWED, 1/4-INCH DIA., 14-FEET LG., TYPE XXIII, CLASS A, MIL-SPEC L-1709	4
2	MFFZZ	81348	 UOC:APY, APZ CABLE, DOOR, TRAVERSE: MAKE FROM: WIRE ROPE 8-FT., 3-IN., REQUIRED, RRW410	2
	MFFZZ	81349	 UOC: APY, APZ CHAPE, COTTON, DOOR SCREEN LUG RING: MAKE FROM: TAPE, TEXTILE, 2-IN, REQUIRED, MIL-T-43566..... UOC APY, APZ	4
3	MFFZZ	81349		CHAPE, COTTON, DOOR TRAVERSE RING: MAKE FROM: TAPE, TEXTILE, 4 1/2-IN., REQUIRED, MIL-T-43566..... UOC:APY, APZ	32
4	PAFZZ	76691	2-134J	SWAGGING, SLEEVE, WIRE ROPE 2-134J (76691) UOC:APY, APZ	2
				END OF FIGURE	

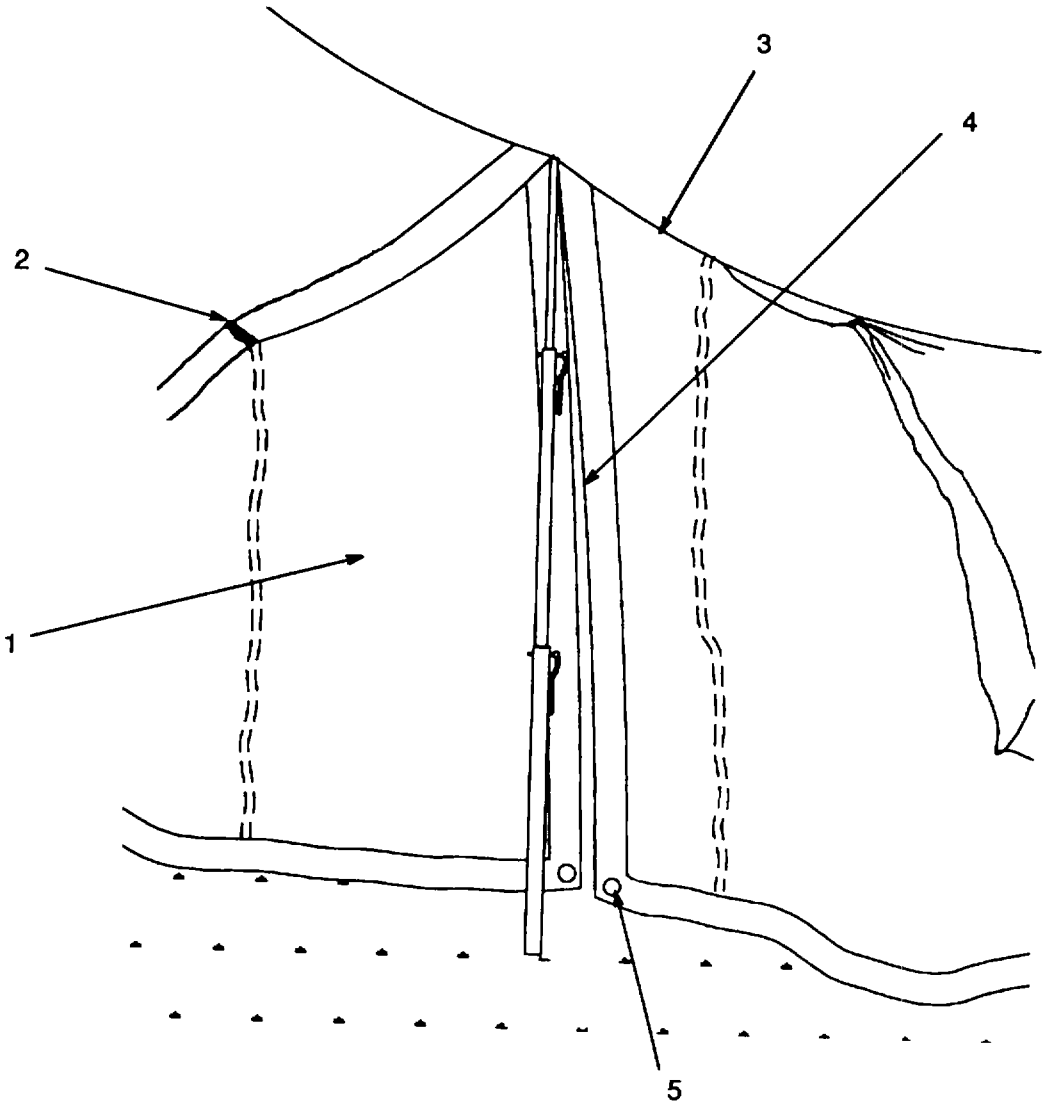

Figure 3. Tent Door W/Screen, Inside (Small)

(1) ITEM NO.	(2) SMR CODE	(3) CAGEC	(4) PART NUMBER	(5) DESCRIPTION AND USABLE ON CODES (UOC)	(6) QTY
				GROUP 01 TENT BODY AND LINER FIG. 3 TENT DOOR W/SCREEN, INSIDE (SMALL) NOTE Repair parts which are not assigned item numbers are not shown in the related figure. Many of these items are "make from" (SMR Coded MF) parts and are fabricated or repaired at Direct Support maintenance from bulk materials.	
1	MFFZZ	81349		SCREEN, NYLON, OD DOOR, MAKE FROM: CLOTH NETTING, NYLON LS125 UOC:APX	4
2	MFFZZ	81349		TIE TAPE, NYLON, 112-IN., W/FRONT AND REAR WALK, MAKE FROM: TAPE, TEXTILE, 18-IN., REQUIRED, MIL-T-5038 UOC APX	4
3	PAOFF	81349	MIL-T-43333	. LINER, TENT, COTTON, OXFORD NATURAL, FIRE, MILDEW AND WATER RESISTANT, MIL-SPEC-T-12354 UOC:APX	1
	MFFZZ	81349 81349 96906		BINDING, COTTON, PEAK OPENING MAKE FROM: TAPE, TEXTILE, MIL-T43566; WEBBING TEXTILE, MIL-W43638; GROMMET, METALLIC, LINER ROOF AND SIDES, BRASS, NO. 2, MS20230BS2 UOC:APX	1
	MFFZZ	81349		REINFORCEMENT, COTTON, FRONT AND REAR WALL, MAKE FROM: TAPE, TENT, MIL-T-43566 UOC:APX	1
	MFFZZ	81349		REINFORCEMENT, COTTON, GROMMET AND LINER, MAKE FROM: CLOTH, OXFORD, COTTON, MIL-C-10859 UOC:APX	1
	MFFZZ	81349		REINFORCEMENT, COTTON LINER, MAKE FROM: WEBBING, TEXTILE, MIL-W43638 UOC:APX	1
	MFFZZ	96906 81349 81349		STRAP, COTTON LINER ADJUSTING, MAKE FROM: BUCKLE, MS51944-10; RING, PEG, MIL-R-3390; WEBBING, TEXTILE, MIL-W-43638 UOC:APX	8

(1) ITEM NO.	(2) SMR CODE	(3) CAGEC	(4) PART NUMBER	(5) DESCRIPTION AND USABLE ON CODES (UOC)	(6) QTY
				GROUP 01 TENT BODY AND LINER (CONTINUED)	
				FIG. 3 TENT DOOR W/SCREEN, INSIDE (SMALL) (CONTINUED)	
	MFFZZ	81349		THONG, COTTON, SLIDE FASTENER, MAKE FROM: BRAID, TEXTILE, MIL-B-371 UOC:APX	4
	MFFZZ	81349		TIE, TAPE, NYLON, 1/2-IN., LG., STOVE PIPE 8 OPENING, MAKE FROM- TAPE, TEXTILE, 12-IN., REQUIRED, MIL-T-5038..... UOC:APX	
4	PAFZZ	81348	VF106TYPE3	FASTENER, SLIDE, INTERLOCKING, SIZE H, STYLE1SIZEH80-IN. LG., TENT DOOR AND SCREEN DOOR UOC:APX	4
5	PAOFF	96906	MS20230BS4	GROMMET, METALLIC, BRASS, NO. 4 EAVE16 DOOR CENTER, TENT CORNER EAVE, SCREEN DOOR, AND TENT DOOR UOC:APX	
				END OF FIGURE	

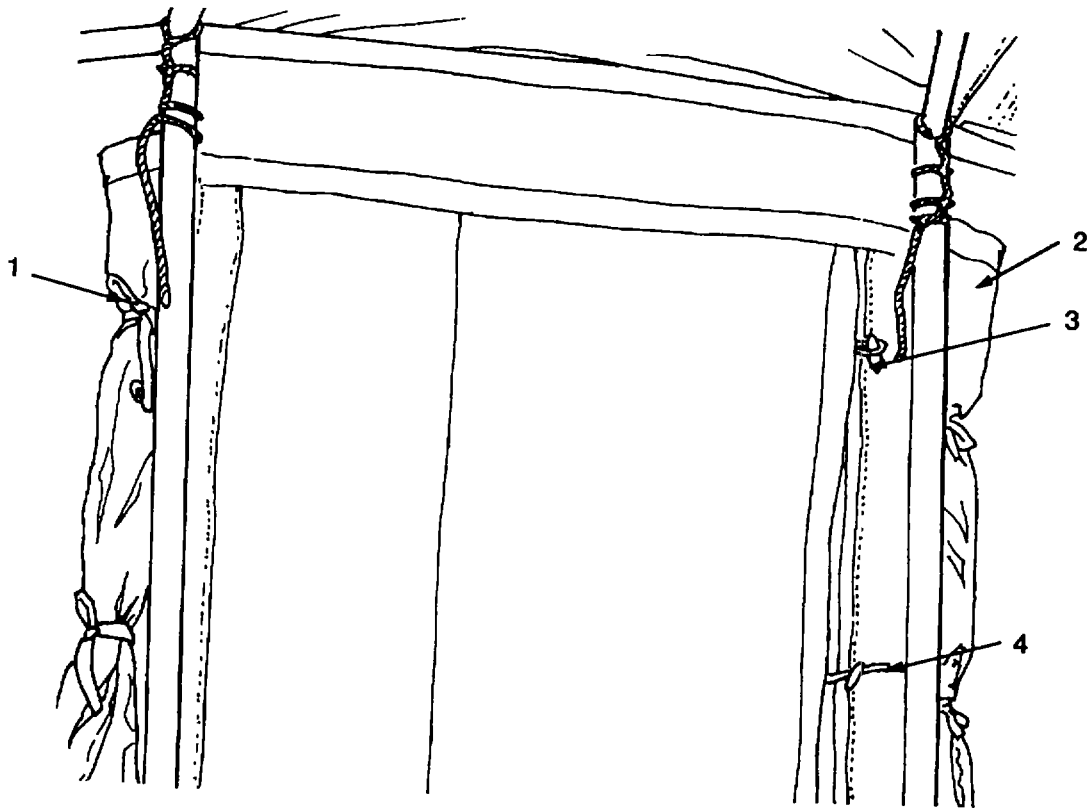

Figure 4. Personnel Door W/Screen and Tent Poles (Large)

(1) ITEM NO.	(2) SMR CODE	(3) CAGEC	(4) PART NUMBER	(5) DESCRIPTION AND USABLE ON CODES (UOC)	(6) QTY
1	MFFZZ	81349		GROUP 01 TENT BODY AND LINER FIG. 4 PERSONNEL DOOR, W/SCREEN AND TENT POLES (LARGE) TIE, TAPE, COTTON, SIDEWALL, MAKE FROM: TAPE, TEXTILE, 131/2-IN. REQUIRED, MIL-T-43566 UOC:APZ	100
2	MFFZZ	81349		SCREEN, PLASTIC, 22 MESH, DOOR VENTILATOR, MAKE FROM: SCREEN, NONMETALLIC, INSECT, LS 125 UOC:APZ	6
3	MFFZZ	81349 81348		TOGGLE, LOOP, END WALL, MAKE FROM: CORD, 8-IN., REQUIRED, MIL-C-2533ATYPE2 CLASS2SIZE4; TC 571 UOC:APZ, APY	12
4	MFFZZ	81349 81348		TOGGLE, CHAPE, END WALL, MAKE FROM: CORD, 9-IN., REQUIRED, MIL-C-2533ATYPE2 CLASS2SIZE4; TC 571 UOC-APZ, APY	12
END OF FIGURE					

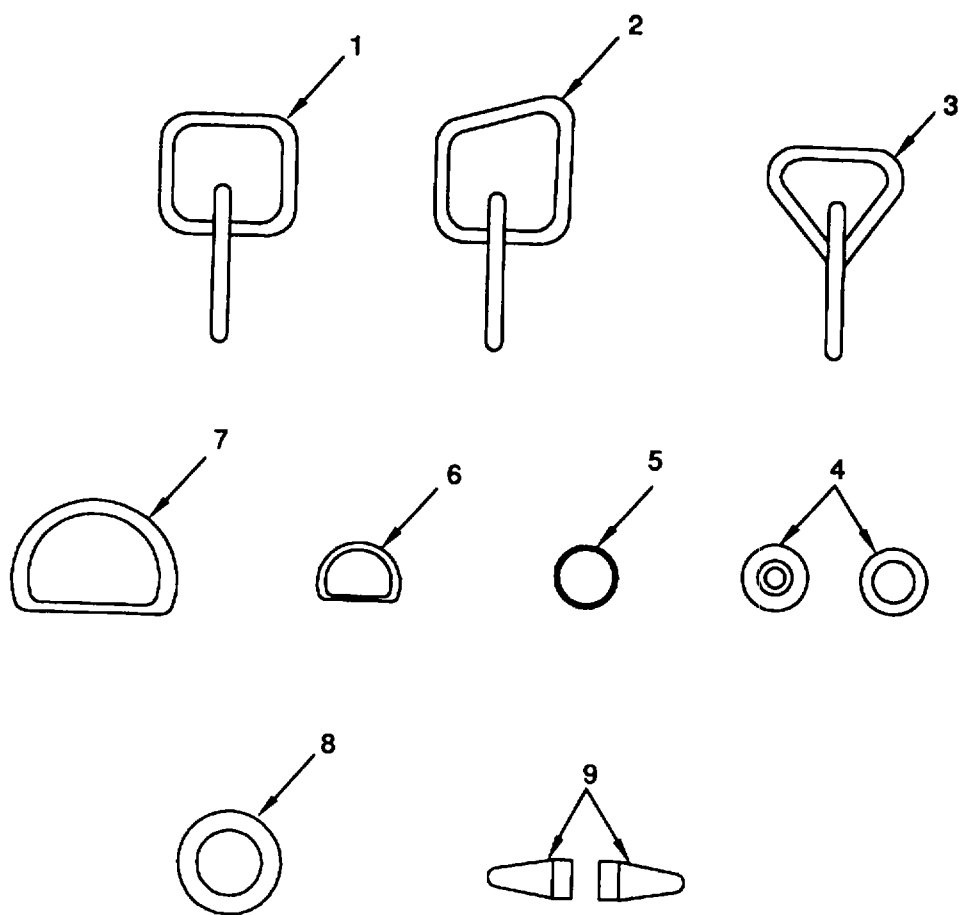

Figure 5. Tentage Hardware (Large)

(1) ITEM NO.	(2) SMR CODE	(3) CAGEC	(4) PART NUMBER	(5) DESCRIPTION AND USABLE ON CODES (UOC)	(6) QTY
1	PAFZZ	81349	MIL-H-1608 MIL-SPEC H-1608,	GROUP 01 TENT BODY AND LINER FIG. 5 TENTAGE HARDWARE (LARGE) HOOK, TENT, STEEL, SQUARE EYE, TYPE III, TENT EAVE, TENT DOOR UOC:APZ	10
2	PAFZZ	81349	MIL-H-1608	HOOK, TENT, STEEL DOOR, TRAPEZOID EYE, TYPE IV, MIL-SPEC H-1608 UOC:APZ	2
3	PAFZZ	81349	MIL-H-1608	HOOK, TENT, STEEL RIDGE, PLATE, AMEND 2TRIANGLE EYE, TYPE I, MIL-SPEC H-1608 UOC:APZ	20
4	PAFZZ	96906	MS20230BS4	GROMMET, METALLIC, NO. 4, EAVE GUY LINE, FOOTSTOP, AND VENTILATOR FLAP UOC-APZ	92
5	PAFZZ	81349	MIL-R-2327	RING, CONNECTING, ROUND, DOOR TRAVERSE CABLE, MULLABLE IRON, GALVANIZED, 3/4IN, CLASS A, MIL-SPEC 4-1482 UOC:APZ	10
6	PAFZZ	81349	ML-R-3390	RING, DEE, BRASS OR BRONZE, EAVE SUSPENSION LINE, 1 X 3/4-IN., CLASS I, MIL-SPEC R-3370, 100 PER PACK UOC:APZ	6
7	PAFZZ	81349	MIL-R-3390	RING, DEE, BRASS OR BRONZE, TENT RIDGE, 1 1/2 X 1 1/2-IN. LG., CLASS I, MIL-SPEC R-3390 UOC:APZ	3
8	PAFZZ	81337	MIL-G-61491 TYPEVIII CLASS4B6	GROMMET, METALLIC, TENT DOOR, TENT EAVE, AND TENT RIDGE UOCAPZ	20
9	PAOZZ	81349	MIL-T-10035	TOGGLE, TENT, WOOD, DOOR, 211/16-IN. LG., MIL-SPECT-10035C UOC:APY, APZ END OF FIGURE	12

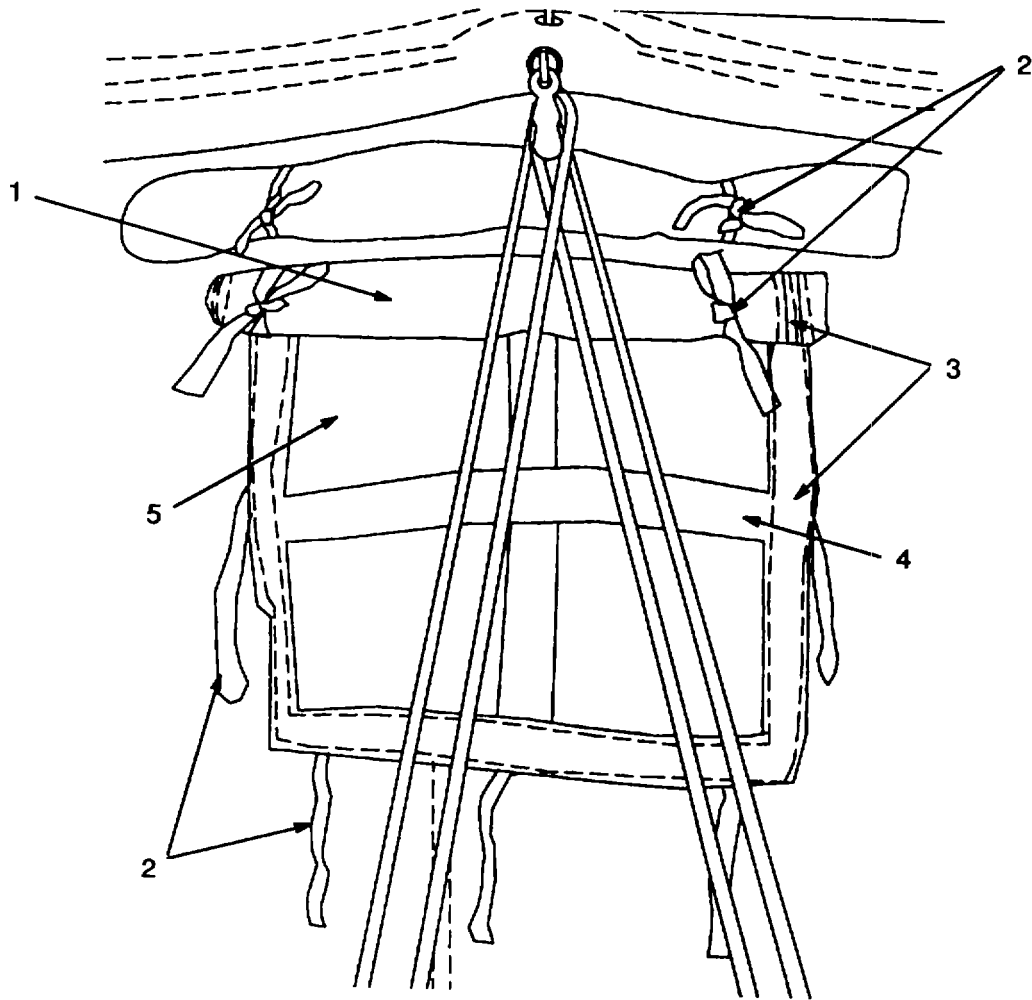

Figure 6. Window (Large)

(1) ITEM NO.	(2) SMR CODE	(3) CAGEC	(4) PART NUMBER	(5) DESCRIPTION AND USABLE ON CODES (UOC)	(6) QTY
				GROUP 01 TENT BODY AND LINER	
				FIG. 6 WINDOW (LARGE) NOTE	
				Repair parts which are not assigned item numbers are not shown in the related figure. Many of these items are "make from" (SMR Coded MF) parts and are fabricated or repaired at Direct Support maintenance from bulk materials.	
1	MFFZZ	81348		WINDOW, PLASTIC, .020-IN THK., MAKE FROM: PLASTIC FILM, L-P-375	8
2	MFFZZ	81349	 UOC:APZ . TIE TAPE, COTTON, WINDOW OPENING AND BLACKOUT FLAP, MAKE FROM. TAPE, TEXTILE, 24-IN., REQUIRED, MIL-T-43566 UOC:APZ	12
3	PAFZZ	81348	VF106 TYPE1STYLE2 SIZEH	. FASTENER, SLIDE, INTERLOCKING WINDOW, 64-IN. LG, TYPE I, STYLE 2, SIZE H, CLASS A, FED SPEC V-F-106 . UOC:APZ	8
4	MFFZZ	81349		. FACING, COTTON, WINDOW SCREEN, MAKE FROM: TAPE, TEXTILE, MIL-T-43566 UOC:APZ	8
5	MFFZZ	81349		. SCREEN, PLASTIC, 22 MESH, WINDOW, MAKE FROM CLOTH, NETTING, LS 125 UOC:APZ	8
	MFFZZ	81349		. BECKET, LACING, NYLON, CONNECTING LUG MAKE FROM: CORD, NYLON, MIL-C-5040 UOC:APX	2
	MFFZZ	81349		BINDING, COTTON, STOVE PIPE OPENING AND VENTILATOR OPENING, MAKE FROM: WEBBING, TEXTILE, MIL-W-43638 UOC:APX	3
	MFFZZ	81349		. BINDING, COTTON, PEAK CAP ASSEMBLY AND VENTILATOR DUCT OPENING, MAKE FROM: WEBBING, TEXTILE, MIL-W-43638 UOC:APX	5
	MFFZZ	81349		. CHAPE, COTTON, EAVE SUSPENSION LINE, 6-IN., LG., MAKE FROM- TAPE, TEXTILE, MIL-T43566 UOC:APZ	16

SECTION II

TM 10-8340-211-23P

(1) ITEM NO.	(2) SMR CODE	(3) CAGEC	(4) PART NUMBER	(5) DESCRIPTION AND USABLE ON CODES (UOC)	(6) QTY
				GROUP 01 TENT BODY AND LINER (CONTINUED)	
4	MFFZZ	81349		FIG. 6 WINDOW (LARGE) (CONTINUED) CHAPE, COTTON, DOOR SCREEN LUG RING, 2-IN. LG., MAKE FROM: TAPE, TEXTILE, MIL-TZ43566UOC:APY, APZ	
6	MFFZZ	81349		CHAPE, COTTON, DRIP RING, 3/2-IN. LG. MAKE FROM: TAPE, TEXTILE, MIL-T-43566 UOC APZ	
4	MFFZZ	81349		CHAPE, COTTON, DRIP RING, MAKE FROM TAPE, TEXTILE, 3-IN. REQUIRE(), MIL-T-43566 UOC:APY	
	MFFZZ	81349 81349		. CHAPE, COTTON, DOOR, FRONT AND REAR, MAKE FROM RING, DEE, MIL-FI-3390; WEBBING, TEXTILE, MIL-W-436318 UOC:APX	4
	MFFZZ	81349 81349		CHAPE, COTTON, DOOR, FRONT AND REAR 1-IN. WIDE, MAKE FROM: SNAP HOOK, MIL-S-43384, WEBBING, TEXTILIE, ML-W-43638 UOC:APX	4
	MFFZZ		NOT FURNISHED	CHAPE, COTTON, GUY LINE, 1 IN. WIDE., MAKE FROM: WEBBING, TEXTILE, NSN 8305-00-889-8682 UOC:APX	20
	MFFZZ	81349 81349		. CHAPE, NYLON, DRIP CAP RING, 1/2-IN. WIDE, MAKE FROM: RING, CONNECTING, MIL-R-2327 CLASS2SIZE2; TAPE, TEXTILE, MIL-T-5038 UOC:APX	2
	MFFZZ	81349 81349		. CHAPE, NYLON, TOGGLE, LINER, SECURING, 1/2-IN. WIDE, MAKE FROM: TAPE, TEXTILE, MIL-T-5038; TOGGLE, TENT, MIL-T-10035 UOC:APX	48
	MFFZZ	81349 81349		. COVER, VENTILATOR, COTTON, ROOF, MAKE FROM. CLOTH, COTTON DUCK, MIL-C-43627; WEBBING, TEXTILE, MIL-W-530 UOC:APX	4
	MFFZZ		NO RECORD	DUCT, VENTILATOR, COTTON, ROOF, MAKE FROM: CLOTH, COTTON DUCK, NSN 8305-00-170-3319 UOC:APX	4
	MFFZZ	81349		FACING, COTTON, WINDOW PANE, MAKE FROM: CLOTH, COTTON DUCK, MIL-C-43627 UOC:APZ	8

(1) ITEM NO.	(2) SMR CODE	(3) CAGEC	(4) PART NUMBER	(5) DESCRIPTION AND USABLE ON CODES (UOC)	(6) QTY
				GROUP 01 TENT BODY AND LINER (CONTINUED)	
				FIG. 6 WINDOW (LARGE) (CONTINUED)	
	MFFZZ	81349		FACING, COTTON, WINDOW, MAKE FROM WEBBING, TEXTILE, MIL-W-43638 UUC APZ	8
	MFFZZ PAFZZ	81349 81337		FACING, COTTON, DOOR FLAP, 2-IN WIDE	4
			MIL-G-61491	FASTENER, SLIDE, INTERLOCKING, CORNER 538225 (00000)UOC.APY	4
	MFFZZ	81349		FLAP, COTTON, STOVE PIPE OPENING, MAKE FROM. CLOTH, COTTON DUCK, MIL-C-43627 UOC'APX	2
	PAFZZ	81348	VF106	GROMMET, METALLIC, BRASS, BLACK CHEMICAL FINISH EYELET W/RING, NO 6, TYPE VIII, CLASS 4B, MIL-SPEC G-1 649, TENT DOOR, TENT EAVE, TENT RIDGE UOC:APX	16
	MFFZZ	81349 96906		FLAP, COTTON, VENTILATOR, ROOF, MAKE FROM: CLOTH, COTTON, DUCK, MIL-C-43627; GROMMET, METALLIC, UOC:APX	4
			MS20230BS1		
	PAOZZ	96906	MS20230BS4	GROMMET, METALLIC, NO. 4, EAVE AND GUY LINE, FOOTSTOP VENTILATOR FLAP	17
	PAOZZ	81349	MIL-G-16491 TYPE3CLASS3 SIZE4	GROMMET, METALLIC, NO. 4, EAVE SUSPENSION LINEUOC:APZ	16
	PAFZZ	96906	MS20230BS2	GROMMET, METALLIC, FOOTSTOP, BRASS, NO. 2 UOC:APX	12
	PAOZZ	81349	MILG-16491	GROMMET, METALLIC, FOOTSTOP, NO. 4 TYPE3CLASS3UOC.APZ	54
			SIZE4		
	PAFZZ	81349	MIL-G-16491 TYPE3CLASS3 SIZE4	GROMMET, METALLIC, SUSPENSION LINE FOOTSTOP, RIDGE SUSPENSION LINEUOC APY	52
	PAOZZ	81349	MIL-G-16491 TYPE3CLASS3 SIZE 4	GROMMET, METALLIC, NO. 4, RIDGE SUSPENSION LINE UOC:APZ	6
	PAOZZ	81349	MIL-H-1608	HOOK, TENT, STEEL CORNER SHACKLE, TYPE VI, MIL SPEC H-1608 UOC.APY, APZ	4

SECTION II

TM 10-8340-211-23P

(1) ITEM NO.	(2) SMR CODE	(3) CAGEC	(4) PART NUMBER	(5) DESCRIPTION AND USABLE ON CODES (UOC)	(6) QTY
				GROUP 01 TENT BODY AND LINER (CONTINUED)	
				FIG. 6 WINDOW (LARGE) (CONTINUED)	
	PAFZZ	81349	MIL-H-1608 AMEND2	HOOK, TENT, STEEL, RIDGE PLATE UOC:APY	12
	PAFZZ	81349	MIL-H-1608	HOOK, TENT, STEEL, SQUARE EYE, TYPE II, MIL SPEC H-1608 UOC:APY	10
	PAOZZ	81349	MIL-T-14056	LINER, TENT, COTTON, NATURAL, FIRE, MILDEW, AND WATER RESISTANT, W/PLASTIC SCREENING ON SIDEWALLS, MIL SPEC T-14056 UOC:APZ	1
	MFFZZ	81349		BINDING, COTTON, CENTER POLE SLEEVE , MAKE FROM: TAPE, TEXTILE, 21-IN. REQUIRED, MIL-T-43566 UOC:APZ	4
	MFFZZ	81349		BINDING, COTTON, STOVE PIPE COVER, MAKE FROM- TAPE, TEXTILE, D4-IN. REQUIRED, MIL-T-43566 UOC:APZ	3
	MFFZZ	81349	MIL-W-43638	CHAPE, COTTON, DEE RING, MAKE FROM:16 WEBBING, TEXTILE, 4 3/4-IN REQUIRED, UOC:APZ	
	PAOZZ	81349	MIL-T-12919	LINER, TENT, COTTON, NATURAL, FIRE, MILDEW, AND WATER RESISTANT, W/PLASTIC SCREENING AND SIDEWALLS UOC:APY	1
	PAFZZ	81349	MIL-C-10859	CLOTH, COTTON, OXFORD..... UOC:APY	V
	MFFZZ		NO RECORD	BINDING, COTTON, CENTER POLE SLEEVE, MAKE FROM: TAPE, TEXTILE, 21-IN. REQUIRED FOR EACH BINDING, NSN 8315-00-262-3372 UOC:APY	2
	MFFZZ	NO RECORD		BINDING, COTTON, STOVE PIPE COVER, MAKE FROM: TAPE, TEXTILE, 44-1N. REQUIRED FOR EACH BINDING, NSN 8315-00-262-3372 UOC:APY	2
		81349	MFFZZ	CHAPE, COTTON, BUCKLE, MAKE FROM: WEBBING, TEXTILE, 21/2-IN. REQUIRED, MIL-W-43638 UOC:APY	14
		81349	MFFZZ	CHAPE, COTTON, DEE RING, MAKE FROM: WEBBING, TEXTILE, 5 1/2-IN. REQUIRED, MIL-W-43638 UOC:APY	14

SECTION II

TM 10-8340-211-23P

(1) ITEM NO.	(2) SMR CODE	(3) CAGEC	(4) PART NUMBER	(5) DESCRIPTION AND USABLE ON CODES (UOC)	(6) QTY
				GROUP 01 TENT BODY AND LINER (CONTINUED)	
				FIG. 6 WINDOW (LARGE) (CONTINUED)	
	MFFZZ	81349		CHAPE, COTTON, EAVE SUSPENSION LINE , MAKE FROM' WEBBING, TEXTILE, 6-IN. REQUIRED, MIL-W-43638 UOC:APY	14
	MOOZZ	81349	MIL-C-5040	LINE, NYLON, VENTILATOR FLAP, MAKE FROM: CORD, NYLON, 12-FT. REQUIRED, NSN 4020-00-262-2019 UOC:APX	4
	PAFZZ	81349	MIL-L-1709	LINE, TENT, COTTON, DRIP CAP STIFFENER, 3-STRANDS, 1/4-IN. DIA., TYPE I, CLASS C, MIL SPEC L-1709 UOC:APX	1
	MFFZZ	81349		LOOP, TOGGLE, NYLON, DOOR FLAP, MAKE FROM: CORD, NYLON, MIL-C-5040 UOC:APX	28
	MFFZZ	81349 81349 96906		LUG, CONNECTING, COTTON, TENT TO VESTIBULE, 19-FT., 2-IN. LG., MAKE FROM: CLOTH, COTTON DUCK, MIL-C-43627; CORD, NYLON, MIL-C-5040; GROMMET,	2
	MFFZZ	81349		METALLIC, MS20230BS1 UOC:APX LUG, COTTON, TENT GUY LINE, 1-IN. W., MAKE FROM: WEBBING, TEXTILE, MIL-W-43638 UOC:APX	10
	PAOZZ	81349	MIL-P-500	PLATE, RIDGE, TENT, ROOF UOC:APY	2
	PAOZZ	81349	MIL-P-500	PLATE, PEAK, TENT, ROOF, TYPE XVIII, MIL SPEC P-5000 UOC:APX	1
	MFFZZ	81349		REINFORCEMENT, COTTON, SIDEWALL, MAKE FROM: TAPE, TEXTILE, MIL-T-43566 UOC:APZ	8
	MFFZZ	81349		REINFORCEMENT, COTTON, SIDEWALL, MAKE FROM. TAPE, TEXTILE, MIL-T-43566 UOC:APY	6
	MFFZZ	81349		REINFORCEMENT, COTTON, SLIDE FASTENER, MAKE FROM: WEBBING, TEXTILE, MIL-W-530 UOC APY	4
	MFFZZ	81349		REINFORCEMENT, COTTON, TENT, MAKE FROM: WEBBING, TEXTILE, MIL-W-43638 UOC:APY, APZ	V
	MFFZZ	81349		REINFORCEMENT, COTTON, TENT RIDGE, MAKE FROM: WEBBING, TEXTILE, MIL-W-43638 UOC:APZ	V

(1) ITEM NO.	(2) SMR CODE	(3) CAGEC	(4) PART NUMBER	(5) DESCRIPTION AND USABLE ON CODES (UOC)	(6) QTY
				GROUP 01 TENT BODY AND LINER (CONTINUED)	
	MFFZZ		NO RECORD	FIG. 6 WINDOW (LARGE) (CONTINUED) REINFORCEMENT, COTTON, GROMMET, RIDGE SUSPENSION LINE, MAKE FROM: WEBBING, TEXTILE, 5-IN REQLJURED, NSN 8305-00-261-8460 UOC:APZ	3
	MFFZZ		NO RECORD	REINFORCEMENT, COTTON, GROMMET, RIDGE SUSPENSION LINE, MAKE FROM: WEBBING, TEXTILE, 5-IN REQUIRED, NSN 5305-00-261-8460 UOC APY	2
	MFFZZ	81349		REINFORCEMENT, COTTON, LINER, MAKE FROM: WEBBING, TEXTILE, MIL-W-43638 UOC:.....APZ	V
	MFFZZ	81349		REINFORCEMENT, COTTON, LINER, MAKE FROM: WEBBING, TEXTILE, MIII-W-530 UOC APZ	V
	MFFZZ		NO RECORD	REINFORCEMENT, COTTON, SIDEWALL, SCREEN TO BODY, MAKE FROM: WEBBING, TEXTILE, NSN 8305-00-261-8460 UOC:APY, APZ	1
	MFFZZ	81349		REINFORCEMENT, COTTON, TENT BODY VENTILATOR FLAP, MAKE FROM. CLOTH, COTTON DUCK, MIL-C-43627 UOC:APX	V
	MFFZZ	81349		REINFORCEMENT, COTTON, SCREEN DOOR, MAKE FROM: TAPE, TEXTILE, MIL-T-43566 UOC:APZ	V
	MFFZZ	81349		REINFORCEMENT, COTTON, SIDEWALL, MAKE FROM: WEBBING, TEXTIILE, 66 3/4-IN., REQUIRED, MIL-W-43638 UOC:APZ	8
	MFFZZ	81349		REINFORCEMENT, COTTON, SIDEWALL, MAKE FROM: WEBBING, TEXTILE, 66 3/4-IN., REQUIRED, MIL-W-530 UOC:APY	6
	MFFZZ	81349		REINFORCEMENT, COTTON, TENT BODY, MAKE FROM. WEBBING, TEXTILI-, MIL-W-43638 UOC: APX	1
	PAFZZ	81349	MIL-R-2327 CLASS2SIZE2	RING, CONNECTING, ROUND, DOOR TRAVERSE CABLE, MALLEABLE IRON, GALVANIZED, 3/4-IN., CLASS A, AMIL SPEC 4-1482 UOC:APZ	32

(1) ITEM NO.	(2) SMR CODE	(3) CAGEC	(4) PART NUMBER	(5) DESCRIPTION AND USABLE ON CODES (UOC)	(6) QTY
				GROUP 01 TENT BODY AND LINER (CONTINUED) FIG. 6 WINDOW (LARGE) (CONTINUED)	
	PAFZZ	81349	MIL-R-2327 CLASS2SIZE2	RING, CONNECTING, ROUND, DOOR SCREEN LUG, DOOR TRAVERSE, AND DRIP CAP, MALLEABLE IRON, GALVANIZED, 3/4-IN., CLASS A, MIL SPEC 4-1402 UOC:APY	40
	PAFZZ	81349	MIL-R-3390	RING, DEE, BRASS OR BRONZE, TENT RIDGE UOC:APY	V
	PAFZZ	81349	MIL-R-3390	RING, DEE, BRASS OR BRONZE, EAVE 14 SUSPENSION LINE, 1-IN. X 3/4-IN., CLASS I, MIL SPEC R-3390, 100 PER PACK .. UOC:APY	
	PAFZZ	81337	MIL-R-2583 CLASSA83-8	RIVET, SOLID, SLIDE FASTENER, REINFORCEMENT, NO 8, CLASS A, MIL SPEC R-2583, UOC:APY, APZ	8
	MFFZZ	81349		SCREEN, PLASTIC, 22 MESH, SIDEWALL AND VENTILATOR, MAKE FROM: SCREENING, NON-METALLIC, INSECT, LS 125 UOC APY, APZ	4
	MFFZZ	81349		SCREEN, PLASTIC, 22 MESH, DOOR AND VENTILATOR, MAKE FROM: SCREEN, NONMETALLIC, INSECT, LS 125 UOC:APY	6
	MFFZZ	81349		SCREEN, PLASTIC, 22 MESH, VENTILATOR DUCT, FACE SLEEVE AND ROOF, MAKE FROM: SCREEN, NONMETALLIC, INSECT, LS 125 UOC:APX	V
	PAFZZ	81349	MIL-S43002	SHIELD, STOVE PIPE UOC:APY, APZ	1
	PAFZZ		NO RECORD	SHIELD, PIPE, SPACE HEATER, TENT STOVE PIPE OPENING UOC:APX	1
	MFFZZ	81348		STIFFENER, DRIP CAP, MAKE FROM: ROPE, MANILA, 5/16-IN. DIA., 18-IN. REQUIRED, TR 605 UOC:APY	3
	MFFZZ	81348		STIFFENER, CHIP CAN, MAKE FROM: ROPE, MANILA, 17 1/2-IN. REQUIRED, TR 605 UOC:APY	2
	MFFZZ	81349		STIFFENER, COTTON, DRIP CAN, MAKE FROM: LINE, TENT, 18-IN. REQUIRED, MIL-L-1709 UOC:APX	1

(1) ITEM NO.	(2) SMR CODE	(3) CAGEC	(4) PART NUMBER	(5) DESCRIPTION AND USABLE ON CODES (UOC)	(6) QTY
				GROUP 01 TENT BODY AND LINER (CONTINUED)	
	MFFZZ	81349		FIG. 6 WINDOW (LARGE) (CONTINUED) STIFFENER, COTTON, VENTILATOR, DUCT, 4 MAKE FROM: WEBBING, TEXTILE, MIL-W-530 UOC:APX	
	MFFZZ	90172		STIFFENER, WINDOW BLACKOUT FLAP, MAKE FROM: ROPE, MANILA, 33-IN. REQUIRED, 41495-5..... UOC:APZ	8
	MFFZZ	81349		STRAP, COTTON, HOOK, MAKE FROM. WEBBING, TEXTILE, MIL-W-43638 UOC:APY, APZ	1
	MFFZZ	81349		THONG, SLIDE FASTENER, MAKE FROM. BRAID, TEXTILE, MIL-B-371 UOC:APX	8
	PAOZZ	81348	V-T-285	THREAD, POLYESTER, OD, TICKET NO. E	V
	PAOZZ	70167	23B28030-4	THREAD, POLYESTER, OD, TICKET NO. F	V
	PAFZZ	81348	V-T-285	THREAD, POLYESTER, NATURAL, TICKET NO. E UOC:APY, APX	V
	PAFZZ	81348	V-T-285	THREAD, POLYESTER, NATURAL, TICKET NO. F UOC:APY, APX	V
	PAFZZ	81348	V-T-285	THREAD, POLYESTER, NATURAL, TICKET NO. FF UOC:APY	V
	PAOZZ	70167	23B28030-3	THREAD, POLYESTER, OD, TICKET NO. FF UOC:APY, APZ	V
	MFFZZ	81349		TIE TAPE, COTTON, CORNER LUG, MAKE FROM TAPE, TEXTILE, 14-IN. REQUIRED, MIL-T3566 UOC:APY, APZ	32
	MFFZZ	81349		TIE TAPE, COTTON, CORNER LUG AND END WALL, MAKE FROM: TAPE, TEXTILE, 15 1/2-IN. REQUIRED, MIL-T-43566 UOC:APY	8
	MFFZZ	81349		TIE TAPE, COTTON, DRIP CAP, MAKE FROM: TAPE, TEXTILE, 15-IN. REQUIRE'D, MIL-T-43566 UOC:APZ	6
	MFFZZ	81349		TIE TAPE, COTTON, INSTRUCTION FLAP, 8 MAKE FROM: TAPE, TEXTILE, 10-IN. REQUIRED, MIL-T-43566 UOC:APZ	8
	MFFZZ	81349		TIE TAPE, COTTON, INSTRUCTION FLAP, MAKE FROM: TAPE, TEXTILE, 10 1/2-IN. REQUIRED, MIL-T43566..... UOC:APY	8

SECTION II

TM 10-8340-211-23P

(1) ITEM NO.	(2) SMR CODE	(3) CAGEC	(4) PART NUMBER	(5) DESCRIPTION AND USABLE ON CODES (UOC)	(6) QTY
				GROUP 01 TENT BODY AND LINER (CONTINUED)	
				FIG 6 WINDOW (LARGE) (CONTINUED)	
	MFFZZ	81349		TIE TAPE, COTTON, INSTRUCTION FLAP AND WINDOW BLACKOUT FLAP, MAKE FROM: TAPE, TEXTILE, MIL-T-43566 UOC:APZ	88
	MFFZZ	81349		TIE TAPE, COTTON, SCREEN DOOR, MAKE FROM: TAPE, TEXTILE, 24-IN. REQUIRED, MIL-T-43566 UOC:APZ	20
	MFFZZ	81349		TIE TAPE, COTTON, SIDE WALL, MAKE FROM: TAPE, TEXTILE, 13 1/2-IN. REQUIRED, MIL-T-43566 UOC:APY	60
	MFFZZ	81349		TIE TAPE, COTTON, STOVE PIPE OPENING 12 FLAP, MAKE FROM: TAPE, TEXTILE, 8 1/2-IN. REQUIRED, MIL-T-43566 UOC:APZ	
	MFFZZ	81349		TIE TAPE, COTTON, STOVE PIPE OPENING 8 FLAP, MAKE FROM: TAPE, TEXTILE, 8 1/2-IN. REQUIRED, MIL-T-43566 UOC:APY	12
	MFFZZ	81349		TIE TAPE, COTTON, STOVE PIPE OPENING 8 FLAP, MAKE FROM: TAPE, TEXTILE, 14 1/2-IN. REQUIRED, MIL-T-43566 UOC:APZ	
	MFFZZ	81349		TIE TAPE, COTTON, STOVE PIPE, OPENING 8 FLAP, MAKE FROM: TAPE, TEXTILE, 14 1/2-IN. REQUIRED, MIL-T-43566 UOC:APY	4
	MFFZZ	81349		TIE TAPE, COTTON, CENTER POLE SLEEVES, MAKE FROM: TAPE, TEXTILE, 14-IN. REQUIRED, MIL-T-43566 UOC:APZ	2
	MFFZZ	81379		TIE TAPE, COTTON, CENTER POLE SLEEVE, MAKE FROM: TAPE, TEXTILE, 24-1N. REQUIRED, MIL-T-43566 UOC:APY	32
	MFFZZ	81379		TIE TAPE, COTTON, CORNER LUG, MAKE FROM: TAPE, TEXTILE, 15-IN. REQUIRED, MIL-T-43566 UOC:APY, APZ	16
	MFFZZ	81379		TIE TAPE, COTTON, DOOR, MAKE FROM: TAPE, TEXTILE, 24-1N. REQUIRED, MIL-T-43566 UOC:APY, APZ	12
	MFFZZ	81379		TIE TAPE, COTTON, STOVE PIPE OPENING AND COVER, MAKE FROM: TAPE, TEXTILE, 12-IN. REQUIRED, MIL-T-43566 UOC:APZ	

SECTION II

TM 10-8340-211-23P

(1) ITEM NO.	(2) SMR CODE	(3) CAGEC	(4) PART NUMBER	(5) DESCRIPTION AND USABLE ON CODES (UOC)	(6) QTY
				GROUP 01 TENT BODY AND LINER (CONTINUED)	
				FIG. 6 WINDOW (LARGE) (CONTINUED)	
	MFFZZ	81379		TIE TAPE, COTTON, STOVE PIPE OPENING AND COVER, MAKE FROM- TAPE, TEXTILE, 12-IN. REQUIRED, MIL-T-43566	8
	MFFZZ	81379	 UOC:APY TIE TAPE, COTTON, WALL TIE A, MAKE FROM: TAPE, TEXTILE, 12 3/4-1N. REQUIRED,	36
	MFFZZ	81349		MIL-T43566 UOC:APZ TIE TAPE, COTTON, WALL TIE A, MAKE FROM: TAPE, TEXTILE, 12 3/4-IN. REQUIRED,	24
	MFFZZ	81349		MIL-T43566 UOC:APY TIE TAPE, COTTON, WALL TIE B, MAKE FROM: TAPE, TEXTILE, 12-IN. REQUIRED, MIL-T-43566	36
	MFFZZ	81349	 UOC:APZ TIE TAPE, COTTON, WALL TIE B, MAKE FROM: TAPE, TEXTILE, 12-IN. REQUIRED, MIL-T-43566	24
	MFFZZ	81349	 UOC :APY TIE TAPE, NYLON, FRONT AND REAR WALL, MAKE FROM: TAPE, TEXTILE, 24-IN	4
	MFFZZ	81349		REQUIRED, MIL-T-5038 UOC:APX TIE TAPE, NYLON, FRONT AND REAR WALL, MAKE FROM: TAPE, TEXTILE, 40-IN	4
	MFFZZ	81349		REQUIRED, MIL-T-5038 UOC:APX TIE TAPE, NYLON, SCREEN DOOR, MAKE FROM: TAPE, TEXTILE, 18-IN. REQUIRED,	4
	MFFZZ	81349		MIL-T-5038 UOC:APX TIE TAPE, NYLON, SCREEN DOOR, MAKE FROM: TAPE, TEXTILE, 34-IN. REQUIRED,	4
	MFFZZ	81349		MIL-T-5038 UOC:APX TIE TAPE, NYLON, SCREEN DOOR, MAKE FROM: TAPE, TEXTILE, 48-IN. REQUIRED,	4
	MFFZZ	81349		MIL-T-5038 UOC:APX TIE TAPE, NYLON, STOVE PIPE OPENING FLAP, MAKE FROM: TAPE, TEXTILE, 9-IN.	4
	MFFZZ	81349		REQUIRED, MIL-T-5038 TIE TAPE, NYLON, STOVE PIPE OPENING FLAP, MAKE FROM: TAPE, TEXTILE, 16-IN.	2
				REQUIRED, MIL-T-5038 UOC:APX	

(1) ITEM NO.	(2) SMR CODE	(3) CAGEC	(4) PART NUMBER	(5) DESCRIPTION AND USABLE ON CODES (UOC)	(6) QTY
				GROUP 01 TENT BODY AND LINER (CONTINUED)	
				FIG. 6 WINDOW (LARGE) (CONTINUED)	
	MFFZZ	81349		TIE TAPE, NYLON, STOVE PIPE OPENING FLAP, MAKE FROM: TAPE, TEXTILE, 18-IN. REQUIRED, MIL-T-5038 UOC:APX	4
	MFFZZ	81349		TIE TAPE, NYLON, STOVE PIPE OPENING PANEL, MAKE FROM TAPE, TEXTILE, MIL-T-5038 UOC:APX	4
	MFFZZ	81349		TIE TAPE, NYLON, VENTILATOR DUCT, MAKE FROM: TAPE, TEXTILE, 12-IN. REQUIRED, MIL-T-5038	4
	MFFZZ	81349 81348		TOGGLE CHAPE, END WALL, MAKE FROM CORD, COTTON, 9-IN, REQUIRED, MIL-C-2533A TYPE2CLASS2 SIZE4; TC571 UOC:APY	12
	MFFZZ	81349 81348		TOGGLE LOOP, END WALL, MAKE FROM CORD, COTTON, 8-IN. REQUIRED, MIL-C-2533A TYPE2CLASS2 SIZE4; TC 571 UOC:APY	12
	PAOZZ PAOZZ	81349 58536	MIL-T-10035 A-A-1451	TOGGLE, TENT, WOOD, DOOR UOC:APX	28
	PAOZZ	58536	A-A-1451	TWINE, COTTON, TOGGLE CHAPE AND LOOP, 5-PLY, TYPE I UOC:APZ	V
	PAOZZ	81348	TT871	TWINE, COTTON, TOGGLE CHAPE AND LOOP 5-PLY, TYPE I UOC:APY	V
	PAOZZ	81348		TWINE, COTTON, DOOR TOGGLE, NATURAL, 8-PLY UOC:APX	V
	MFFZZ	81348		WINDOW, PLASTIC, .020-IN. THK., MAKE FROM: PLASTIC FILM, L-P-375 UOC:APY	8
	MFFZZ	81348		WINDOW, PLASTIC, .020-IN. THK, MAKE FROM: PLASTIC FILM, L-P-375 UOC:APY	8
	PAOZZ	81349	MIL-P-40180 UOC:APY POLE, TENT, ALUMINUM, CENTER, UPRIGHT, TELESCOPIC, W/HARDWARE, W/O CLEATS, ADJUSTABLE, 8-FT 6-IN., 10-FT. 6-IN, MIL SPEC R-40148 UOC:APX	1
	PAOZZ	81349	MIL-P-40180	POLE, TENT, ALUMINUM, EAVE, UPRIGHT , TELESCOPIC, W/HARDWARE, W/O CLEATS, ADJUSTABLE, 3-FT. 5-IN., 7-FT., MIL SPEC P-40148 UOC:APX	11

(1) ITEM NO.	(2) SMR CODE	(3) CAGEC	(4) PART NUMBER	(5) DESCRIPTION AND USABLE ON CODES (UOC)	(6) QTY
				GROUP 01 TENT BODY AND LINER (CONTINUED)	
				FIG. 6 WINDOW (LARGE) (CONTINUED)	
	PAOZZ	54636	E90Y3	. PRIMER, COATING, ZINC CHROMATE, CORROSION INHIBITING, FED SPEC TT-P-666, 1 -GAL, CN. ... UOC:APX	V
	PAOZZ	96906	MS35530-2	ENAMEL, SEMI-GLOSS, OD, SHAPE X24087, TYPE II, FED SPEC T7-3-485, 11-GAL . UOC:APX	1
	PAOZZ	81349	MIL-P-549	POLE, TENT, WOOD CENTER, UPRIGHT, JOINTED, 10-FT. 3-IN. LG., TYPE I, CLASS 2, MIL SPEC P-549 UOC:APY	2
				END OF FIGURE	

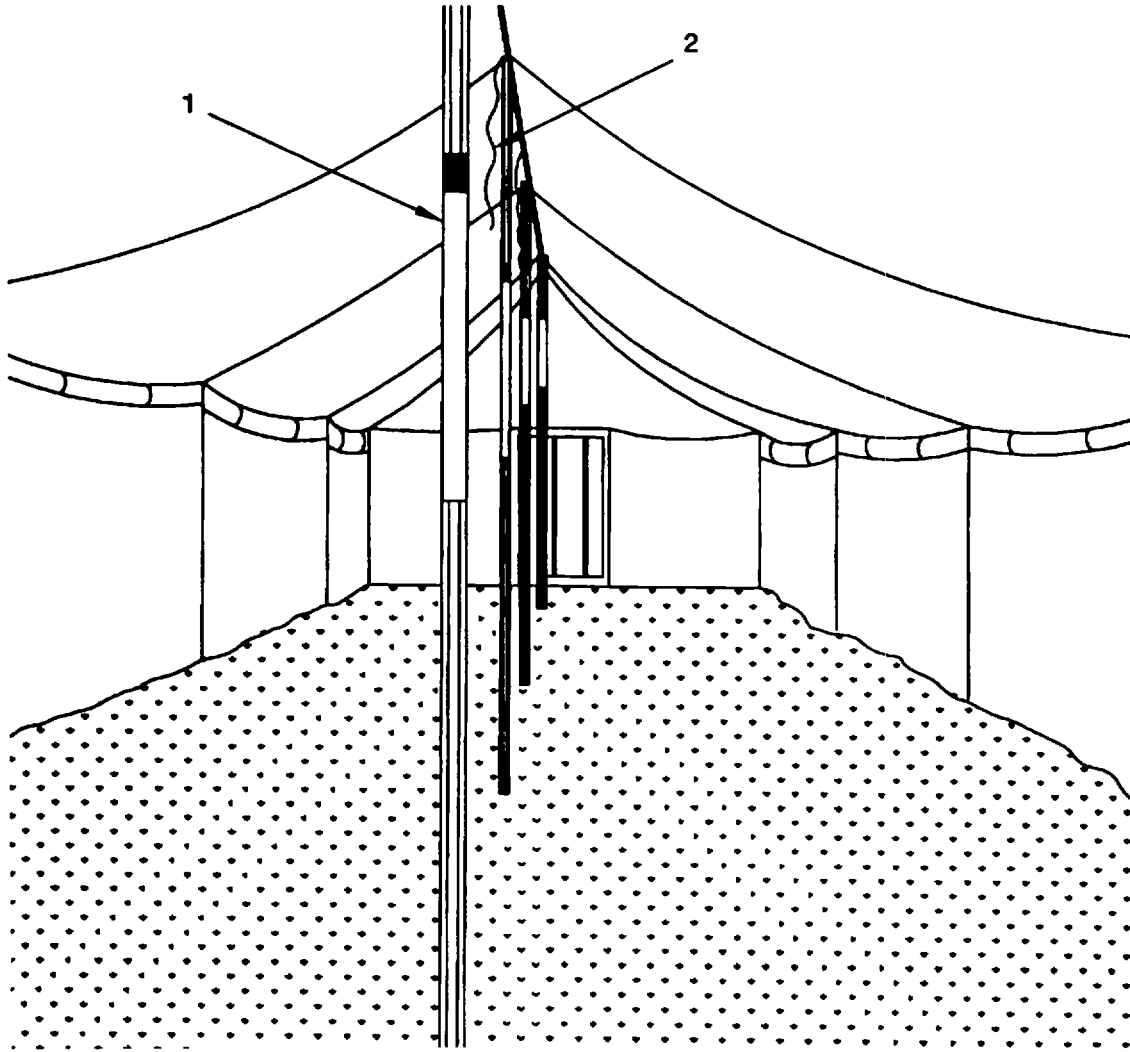

Figure 7. Tent Liner W/Screening and Tent Poles (Large)

(1) ITEM NO.	(2) SMR CODE	(3) CAGEC	(4) PART NUMBER	(5) DESCRIPTION AND USABLE ON CODES (UOC)	(6) QTY
				GROUP 02 TENT SUPPORT AND ANCHORING COMPONENTS FIG. 7 TENT LINER W/SCREENING AND TENT POLES (LARGE) NOTE Repair parts which are not assigned item numbers are not shown in the related figure. Many of these items are *make from' (SMR Coded MF) parts and are fabricated or repaired at Direct Support maintenance from bulk materials.	
1	PAOZZ	81349	MIL-P-549	POLE, TENT, WOOD; CENTER UPRIGHT JOINTED, 12-FT. 3-IN. LG., TYPE I, CLASS 2, MIL SPEC P-549 UOC:APZ	4
2	PAOZZ	64067	8340-00-252-2291	LINE, TENT, LANTERN AND RIDGE SUSPENSION LINE, MANILA, ONE END SEWED, 1/4-IN. DIA., 3-FT. 4-IN. LG UOC:APZ	4
	PAOZZ	81349	MIL-P-549	POLE, TENT, WOOD, DOOR, UPRIGHTS, SOLID, 6-FT. 2-IN. LG., TYPE I, CLASS I, MIL SPEC P-549 UOC:APY, APZ	4
	PAOZZ	81349	MIL-P-549	POLE, TENT, WOOD, EAVE UPRIGHT, SOLID 5FT. 8-IN. LG., TYPE I, CLASS I, MIL SPEC P-549 UOC:APZ	12
	PAOZZ	81349	MIL-P-549	POLE, TENT, WOOD, EAVE UPRIGHT, SOLID 5-FT. 8-IN. LG., TYPE I, CLASS I, MIL SPEC P-549 UOC:APY	10
	PAOZZ	81349	MIL-P-549	POLE, TENT, WOOD, RIDGE, JOINTED, 17-FT LG., TYPE II, CLASS 2, MIL SPEC P-549 UOC:APY	1
				END OF FIGURE	

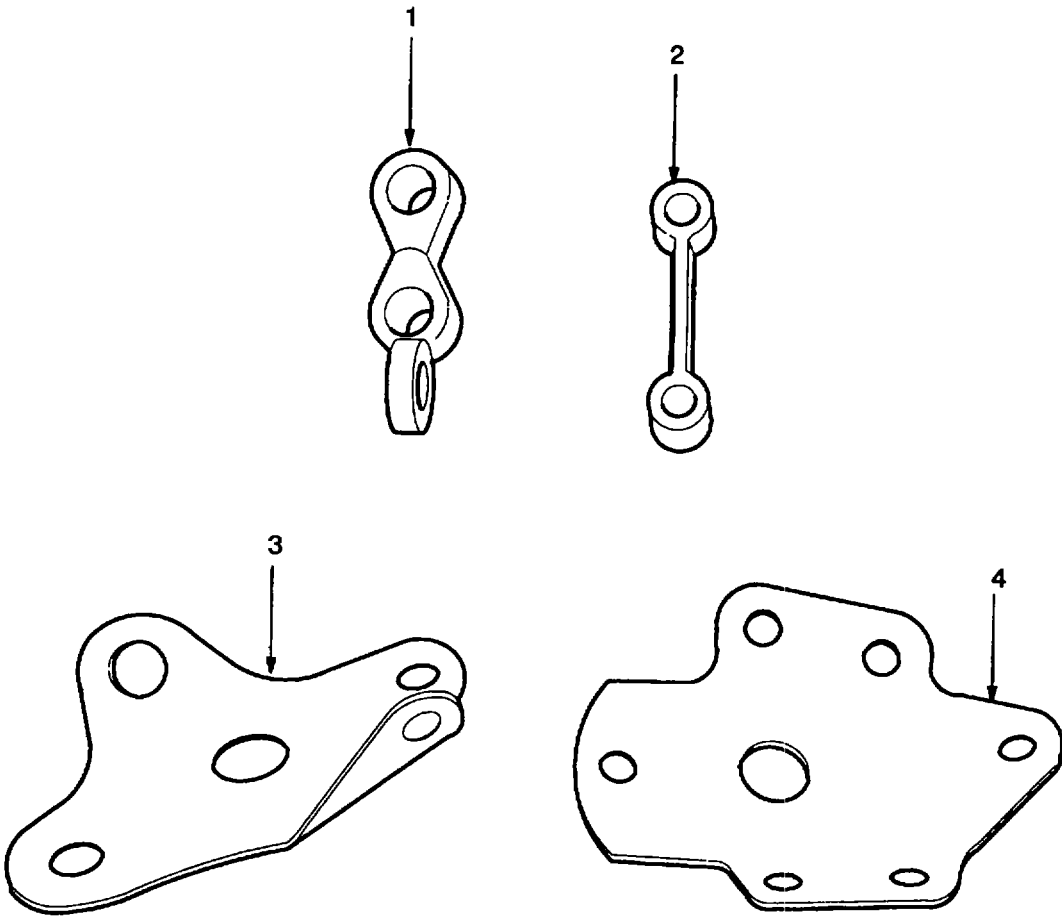

Figure 8. Tent Support and Anchoring Components (Large)

(1) ITEM NO.	(2) SMR CODE	(3) CAGEC	(4) PART NUMBER	(5) DESCRIPTION AND USABLE ON CODES (UOC)	(6) QTY
				<p>GROUP 02 TENT SUPPORT AND ANCHORING COMPONENTS</p> <p>FIG. 8 TENT SUPPORT AND ANCHORING COMPONENTS (LARGE)</p> <p>NOTE</p> <p>Repair parts which are not assigned item numbers are not shown in the related figure. Many of these items are 'make from (SMR Coded MF) parts and are fabricated or repaired at Direct Support maintenance from bulk materials.</p>	
1	PAOZZ	81349	MIL-F-1611	FAIRLEAD, TENT LINE, MAGNESIUM, 4 5/8-IN. LG., MIL SPEC F-1611 UOC:APZ	16
2	PAOZZ	70167	23B28045-1	SLIP, TENT, LINE, MAGNESIUM, 3 1/4-IN. LG, TYPE II, MIL SPEC 5-1734 UOC:APZ	32
3	PAOZZ	81349	MIL-P-500	PLATE, RIDGE, TENT, ROOF, 5 X 5-IN., TYPE XIII, MIL SPEC P-500 UOC:APZ	2
4	PAOZZ	81349	MIL-P-500	PLATE, RIDGE, TENT, ROOF, 5 3/4-IN. X 6 1/2-IN., TYPE XIV, MIL SPEC P-500... UOC:APZ	2
	PAOZZ	81349	MIL-F-1611	FAIRLEAD, TENT LINE UOC:APY	14
	PAOZZ	81349	MIL-F-1709	LINE, TENT, COTTON, FOOTSTOP, 1/4-IN. DIA., 18-IN. LG UOC:APZ	126
	PAOZZ	81349	MIL-F-1709	LINE, TENT, COTTON, FOOTSTOP, 1/4-IN. DIA., 19-IN. LG UOC:APY	86
	PAOZZ	81349	MIL-L-1709	LINE, TENT, COTTON, FOOTSTOP, 1/4-IN. DIA., 19-IN. LG UOC:APX	3
	PAOZZ	64067	8340-00-252-2271	LINE, TENT, MANILA, EAVE GUY LINE ONE.... END W/EYE, ONE END SEWED, 5/16-IN. DIA., 13-FT. LG UOC:APZ	28
	PAOZZ	64067	8340-00-252-2271	LINE, TENT, MANILA, EAVE GUY LINE, ONE END W/EYE, ONE END SEWED, 5/16-IN. DIA, 13-FT. LG UOC:APY	24
	MFFZZ	81348		LINE, TENT, COTTON, YELLOW, TENT CORNER GUY LINE, MAKE FROM- CORD, COTTON, 24-FT. REQUIRED, TC571 UOC:APX	6
	MFFZZ	81348		LINE, TENT, COTTON, YELLOW, TENT DOOR, EAVED GUY LINE, MAKE FROM: CORD, COTTON, 24-FT. REQUIRED, TC571 UOC:APX	2

(1) ITEM NO.	(2) SMR CODE	(3) CAGEC	(4) PART NUMBER	(5) DESCRIPTION AND USABLE ON CODES (UOC)	(6) QTY
				GROUP 02 TENT SUPPORT AND ANCHORING COMPONENTS (CONTINUED)	
				FIG. 8 TENT SUPPORT AND ANCHORING COMPONENTS (LARGE) (CONTINUED)	
	MFFZZ	81348		LINE, TENT, COTTON, YELLOW, TENT INTER-MEDIATE, EAVE GUY LINE, MAKE FROM CORD, COTTON, 151/2-FT, REQUIRED, TC571 UOC:APX	4
	MFFZZ	81348		LINE, TENT, COTTON, YELLOW, VESTIBULE CORNER EAVE GUY LINE, MAKE FROM CORD, COTTON, 151/2-FT REQUIRED, TC571 UOC:APX	2
	MFFZZ	81348		LINE, TENT, COTTON, YELLOW, VESTIBULE, EAVE GUY LINE, MAKE FROM: CORD, COTTON, 241/2-FT REQUIRED, TC571 UOC:APX	1
	MFFZZ	81348		LINE, TENT, TENT CORNER, EAVE GUY LINE, COTTON, YELLOW, MAKE FROM: CORD, COTTON, TC571..... UOC:APX	6
	PAOZZ	64067	8340-00-252-2293	LINE, TENT, MANILA, RIDGE GUY LINE, BOTH ENDS SEWED, CUT SPLICE IN CENTER, 5/16-IN. DIA., 50-FT LG., TYPE XXXV 888, CLASS A, MIL SPEC L-1709 UOC:APY, APZ	2
	PAOZZ	81349	MIL-L-1709	LINE, TENT, MANILA, RIDGE, JUMPER LINE, ONE END SEWED, 1/4-IN. DIA., 6-FT. LG., TYPE X, CLASS A, MIL SPEC L-1709 UOC:APZ	4
	PAOZZ	81349	MIL-L-1709	LINE, TENT, MANILA, RIDGE LINE, ONE END SEWED, 1/4-IN DIA., 6-FT. LG., TYPE X, CLASS A, MIL SPEC L-1709..... UOC:APY	2
	PAOZZ	64067	8340-00-252-2291	LINE, TENT, MANILA, ONE END SEWED, 1/4-IN. DIA., 3-FT. 4-IN. LG UOC:APY	8
	PAOZZ	64067	8340-00-261-9749	PIN, TENT, ALUMINUM, 9-IN. LG., TYPE 1, MIL SPEC P-501 UOC:APZ	66
	PAOZZ	64067	8340-00-261-9749	PIN, TENT, ALUMINUM, 9-IN. LG., TYPE 1, MIL SPEC P-501 UOC:APY	48
	PAOZZ	64067	8340-00-261-9749	PIN, TENT, ALUMINUM, 9-IN. LG., TYPE 1, MIL SPEC P-501 UOC:APX	41
	PAOZZ	70167	23B28126-1	PIN, TENT, STEEL, 12-IN. LG., TYPE 11, MIL SPEC P-501 UOC:APZ	32
	PAOZZ	70167	23B28126-1	PIN, TENT, STEEL, 12-IN LG., TYPE 11, MIL SPEC P-501 UOC:APY	28

(1) ITEM NO.	(2) SMR CODE	(3) CAGEC	(4) PART NUMBER	(5) DESCRIPTION AND USABLE ON CODES (UOC)	(6) QTY
				GROUP 02 TENT SUPPORT AND ANCHORING COMPONENTS (CONTINUED)	
				FIG. 8 TENT SUPPORT AND ANCHORING COMPONENTS (LARGE) (CONTINUED)	
	PAOZZ	64067	8340-00-261-9750	PIN, TENT, WOOD, 16-IN. LG, TYPE 1, MIL SPEC P-2383..... UOC:APZ	68
	PAOZZ	64067	8340-00-261-9750	PIN, TENT, WOOD, 16-IN. LG, TYPE 1, MIL SPEC P-2383..... UOC:APY	48
	PAOZZ	64067	8340-00-261-9750	PIN, TENT, WOOD, 24-IN LG., TYPE I MIL SPEC P-2383..... UOC:APZ	32
	PAOZZ	64067	8340-00-261-9751	PIN, TENT, WOOD, 24-IN. LG., TYPE 11, MIL SPEC P-2383..... UOC:APY	28
	PAOZZ	70167	23B28045-1	SLIP, TENT LINE, MAGNESIUM, 3/4-1N. LG., TYPE II, MIL SPEC P-2383..... UOC:APY	28
	PAOZZ	49671	A4640-1	SLIP, TENT LINE, TENT AND VESTIBULE, MAGNESIUM, FLAT, 4-IN. LG., TYPE III, MIL SPECS-1734 UOC APX	21
				END OF FIGURE	

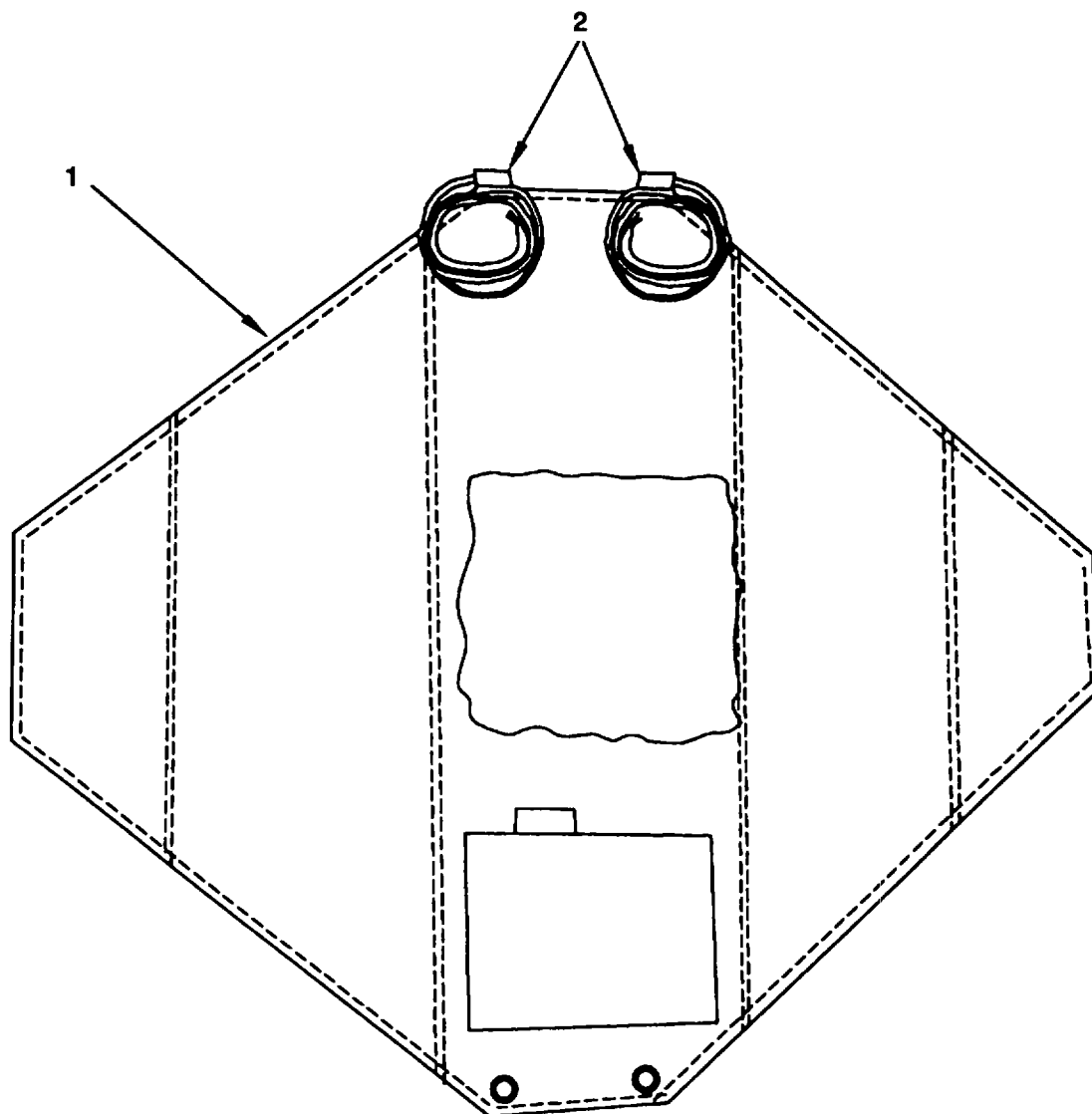

Figure 9. Cover end Tent Liner (Large)

(1) ITEM NO.	(2) SMR CODE	(3) CAGEC	(4) PART NUMBER	(5) DESCRIPTION AND USABLE ON CODES (UOC)	(6) QTY
				GROUP 03 TENT ACCESSORIES FIG. 9 COVER AND TENT LINER NOTE Repair parts which are not assigned item numbers are not shown in the related figure. Many of these items are made from (SMR Coded MF) parts and are fabricated or repaired at Direct Support maintenance from bulk materials.	
1	PAOZZ	64067	8340-00-262-2397	COVER, TENT, COTTON DUCK LINER, OD, FIRE, MILDEW, AND WATER RESISTANT, MIL SPEC T-1712 UOC:APY, APZ	1
	PAOZZ	81349	MIL-C-43627	CLOTH, COTTON DUCK, TENT AND LINES COVER, OD	V
	PAOZZ	81349	MIL-G-16491 TYPE3CLASS3 SIZE4	GROMMET, METALLIC, NO. 4, LINER COVER AND TENT COVER	8
2	PAOZZ	64067	8340-00-252-2271	LINE, TENT, MANILA, ONE END W/EYE, ONE END SEWED, 5/16-IN. DIA., 13-FT. LG., TENT COVER TIE LINES AND LINER COVER, TIE LINE..... END OF FIGURE	4

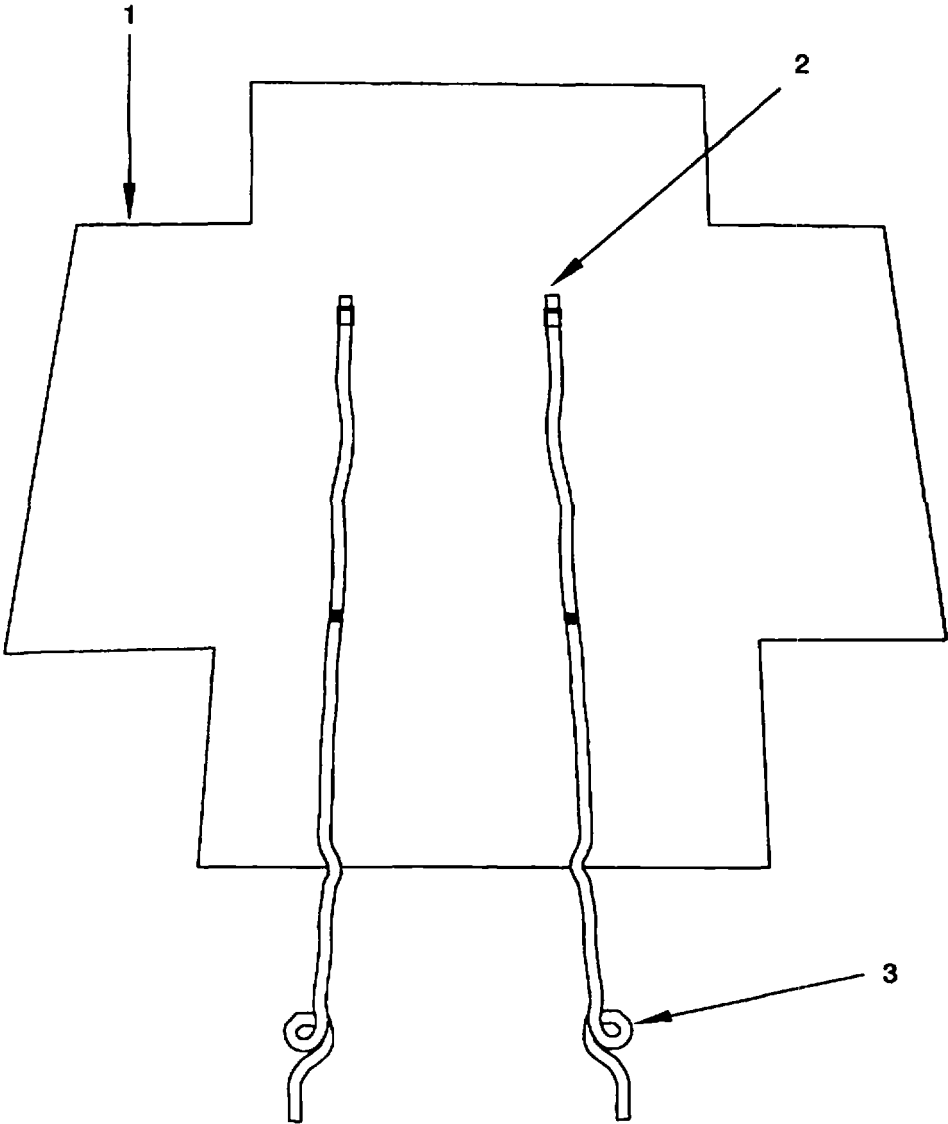

Figure 10. Tent Cover (Small)

(1) ITEM NO.	(2) SMR CODE	(3) CAGEC	(4) PART NUMBER	(5) DESCRIPTION AND USABLE ON CODES (UOC)	(6) QTY
1	PAOZZ	81349	MIL-T-41810	GROUP 03 TENT ACCESSORIES FIG. 10 TENT COVER (SMALL) COVER, TENT, COTTON DUCK, OD, FIRE, MILDEW, WATER, AND WEATHER RESISTANT UOC:APX	1
2	MFFZZ	81349		TAB, COTTON, COVER, SECURING, MAKE FROM: TAPE, TEXTILE, MIL-T-43566 UOC:APX	2
3	MFFZZ	81349 96906		STRAP, COTTON, COVER SECURING, MAKE FROM: LOOP, STRAP, FASTENER, MIL-L-11075; CLIP, END, BALL TYPE COVER, MS51926-3 UOC:APX	2
END OF FIGURE					

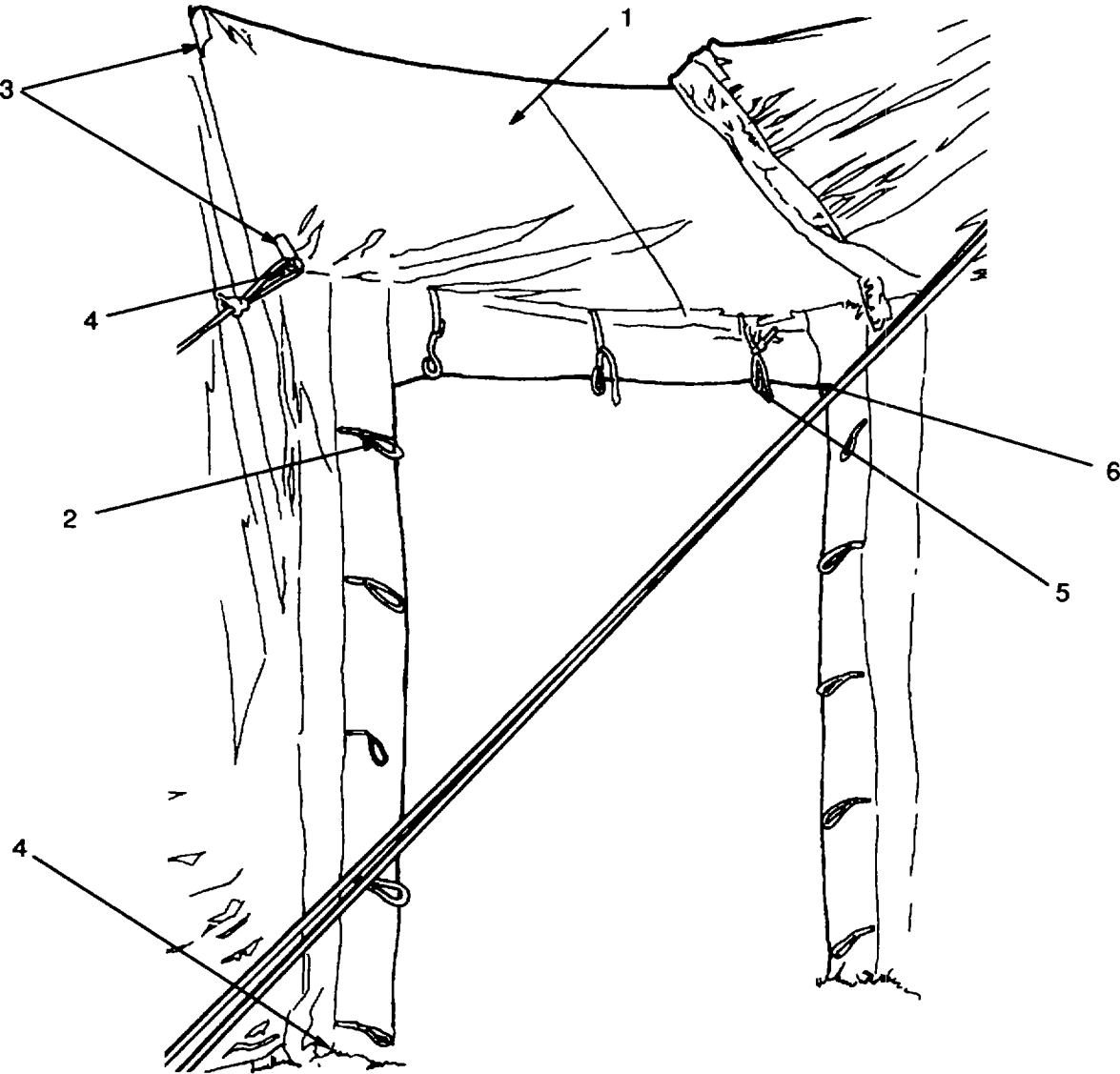

Figure 11. Vestibule, Side View (Small)

(1) ITEM NO.	(2) SMR CODE	(3) CAGEC	(4) PART NUMBER	(5) DESCRIPTION AND USABLE ON CODES (UOC)	(6) QTY
				GROUP 03 TENT ACCESSORIES FIG. 11 VESTIBULE, SIDE VIEW (SMALL) NOTE Repair parts which are not assigned item numbers are not shown in the related figure. Many of these items are "make from" (SMR Coded MF) parts and are fabricated or repaired at Direct Support maintenance from bulk materials.	
1	PAOZZ	81349	MIL-T-41810	VESTIBULE, TENT, COTTON DUCK, OD, FIRE, MILDEW, WATER, AND WEATHER RESISTANT UOC:APX	1
2	MFFZZ	81349		LOOP, TOGGLE, NYLON DOOR FLAP, MAKE FROM: CORD, NYLON, MIL-C-5040 UOC:APX	10
3	MFFZZ	81349		CHAPE, COTTON, GUY LINE, MAKE FROM: WEBBING, TEXTILE, MIL-W-43638 UOC:APX	7
4	PAOZZ	81349	MIL-G-16491 TYPE3CLASS3 SIZE4	GROMMET, METALLIC, BRASS, NO. 4, EAVE AND FUEL STOP UOC:APX	12
	PAOZZ	64067	8340-00-261-9749	PIN..... UOC:APX	9
	PAOZZ	NOT FURNISHED		POLE UOC:APX	3
5	MFFZZ	81349		TIE TAPE, NYLON, DOOR, MAKE FROM: TAPE, TEXTILE, MIL-T-5038..... UOC:APX	6
6	PAFZZ	81348	V-106	FASTENER, SLIDE, INTERLOCKING, DOOR, SIZE H, 60-IN. LG UOC APX	2
	PAOZZ	96906	MS20230BS1	GROMMET, METALLIC, VESTIBULE, CONNECTING TO TENT LUG, BRASS, NO. 1 UOC:APX	39
	MFFZZ	81349		REINFORCEMENT, CORNER, MAKE FROM: WEBBING, TEXTILE, COTTON, OD, 1-IN. W. MIL-W43638..... UOC:APX	4
	MFFZZ	81349		REINFORCEMENT, COTTON COVER STRAP, MAKE FROM: CLOTH, COTTON DUCK, MIL-C-43627..... UOC APX	2

(1) ITEM NO.	(2) SMR CODE	(3) CAGEC	(4) PART NUMBER	(5) DESCRIPTION AND USABLE ON CODES (UOC)	(6) QTY
				GROUP 03 TENT ACCESSORIES (CONTINUED)	
				FIG. 11 VESTIBULE, SIDE VIEW (SMALL) (CONTINUED)	
	MFFZZ	81349		REINFORCEMENT, COTTON, SLIDE FASTENER, MAKE FROM: TAPE, TEXTILE MIL-T-43566.....	2
	MFFZZ	81349		REINFORCEMENT, COTTON, TENT POLE EAVE GROMMET, MAKE FROM: CLOTH, COTTON DUCK, MIL-C-43627 UOC:APX	3
	MFFZZ	81349		REINFORCEMENT, COTTON, VESTIBULE, MAKE FROM: WEBBING, TEXTILE, MIL-W43638 UOC:APX	2
	MFFZZ	81349		STOP, COTTON, SLIDE FASTENER, MAKE FROM: WEBBING, TEXTILE, MIL-W43638 UOC:APX	2
	MFFZZ	81349		THONG, COTTON, SLIDE FASTENER, MAKE FROM: BRAID, TEXTILE, MIL-B-371 UOC:APX	4
	PAOZZ	81348	V-T-285	THREAD, POLYESTER, OD, TICKET NO. E UOC:APX	V
	PAOZZ	70167	23B28030-4	THREAD, POLYESTER, OD, TICKET NO. F UOC: APX	V
	PAOZZ	81349	MIL-T-10035	TOGGLE, TENT, WOOD, DOOR, 211/16-IN. LG. UOC:APX	10
	PAOZZ	81349	MIL-T-14038	COVER, TENT, COTTON DUCK, OD, FIRE, MILDEW, AND WATER RESISTANT, MIL SPEC T-14038..... UOC:APZ	1
	MFFZZ	81349		COVER, TENT, COTTON DUCK, OD, FIRE, MILDEW, WATER, AND WEATHER RESISTANT, MIL SPEC T-12919, MAKE FROM: CLOTH, COTTON DUCK, 8-FT. 2-IN. LG. REQUIRED, MIL-C-43627..... UOC:APY	1
	PAOZZ	64067	8340-00-261-9749	PIN, VESTIBULE ASSEMBLY, MIL SPEC P-501	V
	PAOZZ	81349	MIL-P40180	POLE, VESTIBULE 5-4-1091.....	V
				END OF FIGURE	

(1) ITEM NO.	(2) SMR CODE	(3) CAGEC	(4) PART NUMBER	(5) DESCRIPTION AND USABLE ON CODES (UOC)	(6) QTY
				GROUP 04 HARDWARE AND FASTENING DEVICES FIG. 11 VESTIBULE, SIDE VIEW (SMALL) (CONTINUED) NOTE Repair parts which are not assigned item numbers are not shown in the related figure. Many of these items are "make from" (SMR Coded MF) parts and are fabricated or repaired at Direct Support maintenance from bulk materials.	
	PAFZZ	96906	MS51944-10	BUCKLE, TONGUES, DOUBLE BARS, DULL BLACK FINISH, 1-IN., TYPE II, CLASS 3, MIL SPEC B-543 UOC:APX	8
	PAOZZ	96906	MS51926	CLIP, END, BELL TYPE, BRASS, BLACK CHEMICAL FINISH, 1-IN., MIL SPEC C-496	2
	PAOZZ	81349	MIL-F-1611	FAIRLEAD, TENT LINE UOC:APZ	16
	PAOZZ	81349	MIL-F-1611	FAIRLEAD, TENT LINE UOC:APY	14
	PAFZZ	81337	MIL-G-61491 TYPEVIII CLASS4B6	GROMMET, METALLIC..... UOC:APZ	20
	PAOZZ	96906	MS20230BS4	GROMMET, METALLIC, BRASS, BLACK FINISH, NO. 4, 8460200 (00000) UOC:APZ	176
	PAFZZ	81337	MIL-G-6149 TYPEVIII CLASS4B6	GROMMET, METALLIC..... UOC:APY	16
	PAFZZ	81349	MILG16491 TYPE3CLASS3 SIZE4	GROMMET, METALLIC, NO. 4..... UOC:APY	52
	PAOZZ	96906	MS20230BS4	GROMMET, METALLIC, BRASS, BLACK CHEMICAL FINISH, NO. 4..... UOC:APY	145
	PAFZZ	96906	MS20230BS1	GROMMET, METALLIC, BRASS, BRIGHT FINISH, NO. 1, TYPE II, CLASS B UOC:APX	121
	PAFZZ	96906	MS20230BS2	GROMMET, METALLIC, BRASS, BRONZE FINISH, NO. 2, TYPE II, CLASS B . UOC:APX	68
	PAOZZ	96906	MS20230BS4	GROMMET, METALLIC, BRASS, BLACK CHEMICAL FINISH, NO. 4..... UOC:APX	28
	PAFZZ	81349	MIL-H-1608 AMEND2	HOOK, TENT..... UOC:APZ	20

(1) ITEM NO.	(2) SMR CODE	(3) CAGEC	(4) PART NUMBER	(5) DESCRIPTION AND USABLE ON CODES (UOC)	(6) QTY
				GROUP 04 HARDWARE AND FASTENING DEVICES (CONTINUED)	
				FIG. 11 VESTIBULE, SIDE VIEW (SMALL) (CONTINUED)	
	PAFZZ	81349	MIL-H-1608 AMEND 2	HOOK, TENT, STEEL, TRIANGLE EYE, TYPE 1, MIL SPEC H-1608 UOC:APY	12
	PAFZZ	81349	MIL-H-1608	HOOK, TENT..... UOC:APY, APZ	10
	PAFZZ	81349	MIL-H-1608	HOOK, TENT..... UOC APZ	2
	PAOZZ	81349	MIL-H-1608	HOOK, TENT, STEEL, CORNEFIS SHACKLE, TYPE VI, MIL SPEC H-1608 UOC:APY, APZ	8
	PAFZZ	81349	MIL-L-11075	LOOP, STRAP FASTENER, BRASS, 1/2-IN. X 1-IN., TYPE III, STYLE B, MIL SPEC L-11075 UOC.APX	4
	PAOZZ	81349	MIL-P-500	PLATE, RIDGE, TENT UOCAPZ	2
	PAOZZ	81349	MIL-P-500	PLATE, RIDGE, TENT ROOF, 5 3/4-IN. X 6 1/2-IN., TYPE XIV, MIL SPEC P-500 UOC:APY, APZ	2
	PAFZZ	81349	MIL-R-2327	RING, CONNECTING, ROUND . UOC:APY, APZ CLASS2SIZE2	42
	PAFZZ	81349	MIL-R-3390	RIND, DEE UOC:APY, APZ	16
	PAFZZ	81349	MIL-R-3390	RING, DEE UOC:APY, APZ	3
	PAFZZ	81349	MIL-R-2327 CLASS2SIZE2	RING, CONNECTING, ROUND, MALLEABLE IRON OR STEEL, GALVANIZED, 1/2-IN., TYPE I, CLASS 2 OR 5, MIL SPEC R-2327 UOC:APX	2
	PAOZZ	NOT FURNISHED		PIN ASSEMBLY, AL 3/8-IN. X 1 1/2-IN. UOC:APY, APX, APZ	1
	PAOZZ	NOT FURNISHED		PIN ASSEMBLY, AL 3/8-IN. X 2-IN UOC:APY, APX, APZ	1
	PAOZZ	NOT FURNISHED		PIN ASSEMBLY, AL 3/8-IN. X 2 1/2-IN. UOC:APY, APX, APZ	1
	PAOZZ	NOT FURNISHED		PIN ASSEMBLY, AL 1/4-IN. X 1-IN. UOC:APY, APX, APZ	1
	PAOZZ	NOT FURNISHED		PIN ASSEMBLY, AL 1/4-IN X 1 1/2-IN UOC:APY, APX, APZ	1
	PAFZZ	81349	MIL-R-3390	RING, DEE, BRASS OR BRONZE, 1-IN. X 0.75-IN., CLASS 1, MIL SPEC R-3390, 100 PER PACK UOC:APX	12
	PAFZZ	81337	MIL-R-2583 CLASSA83-8	RIVET, SOLID UOC:APY, APZ	8

(1) ITEM NO.	(2) SMR CODE	(3) CAGEC	(4) PART NUMBER	(5) DESCRIPTION AND USABLE ON CODES (UOC)	(6) QTY
				GROUP 04 HARDWARE AND FASTENING DEVICES (CONTINUED)	
				FIG. 11 VESTIBULE, SIDE VIEW (SMALL) (CONTINUED)	
	PAOZZ	70167	23B28045-1	SLIP, TENT LINE..... UOC:APZ	32
	PAFZZ	81349	MIL-S43384	SNAP HOOK, SPRING BLADE, IRON-BRONZE24 FINISH, 1-IN., TYPE I, MIL SPEC S-2147 UOC:APX	
	PAFZZ	76691	2-134J	SWAGGING, SLEEVE, WIRE ROPE 2134J UOC:APY, APZ	2
	PAFZZ	81349	MIL-T-10035	TOGGLE, TENT, STEEL, 1 3/4-1N. LG., MIL SPEC T-10035..... UOC:APX	48
	PAOZZ	81349	MIL-T-10035	TOGGLE, TENT, WOOD, 211/16-IN. LG., MIL SPEC T-10035.....	38
				END OF FIGURE	

(1) ITEM NO.	(2) SMR CODE	(3) CAGEC	(4) PART NUMBER	(5) DESCRIPTION AND USABLE ON CODES (UOC)	(6) QTY
				GROUP 05 BULK MATERIALS	
				FIG. BULK	
1	PAFZZ	81349	MIL-B-371	BRAID, TEXTILE	V
2	PAFZZ	96906	MS51944-10	BUCKLE	V
3	PAFZZ	96906	MS51926	CLIP, END, BALL TYPE COVER	V
4	PAFZZ		NO RECORD	CLOTH, COTTON DUCK.....	V
5	PAFZZ	81349	MIL-C-43627	CLOTH, COTTON DUCK.....	V
6	PAFZZ	81349	LS 125	CLOTH, NETTING, NYLON.....	V
7	PAFZZ	81349	MIL-C-10859	CLOTH, OXFORD, COTTON.....	V
8	PAFZZ	81349	MIL-C-2533A TYPE2CLASS2 SIZE4	CORD.....	V
		81348	TC571		
9	PAFZZ	81348	TC571	CORD, COTTON.....	V
10	PAFZZ	81348	TC571	CORD, COTTON.....	V
11	PAOZZ	81349	MIL-C-5040	CORD, NYLON.....	V
12	PAFZZ	96906	MS20230BS1	GROMMET, METALLIC.....	V
13	PAFZZ	96906	MS20230BS2	GROMMET, METALLIC.....	V
14	PAFZZ	81349	MIL-L-1709	LINE, TENT	V
15	PAFZZ	81349	MIL-L-11075	LOOP, STRAP FASTENER	V
16	PAOZZ	64067	NSN 8340-00- 261-9749	PIN, VESTIBULE	V
17	PAFZZ	81348	L-P-375	PLASTIC FILM.....	V
18	PAOZZ	81349	MIL-P-40180	POLE, VESTIBULE.....	V
19	PAFZZ	81349	MIL-R-2327 CLASS2SIZE2	RING, CONNECTING	V
20	PAFZZ	81349	MIL-R-3390	RING, PEG	V
21	PAFZZ	81348	TR 605	ROPE, MANILA	V
22	PAFZZ	90172	41495-5	ROPE, MANILA	V
23	PAFZZ		NO RECORD	TAPE, TEXTILE.....	V
24	PAFZZ	81349	MIL-T-43566	TAPE, TEXTILE.....	V
25	PAFZZ	81349	MIL-T-43566	TAPE, TEXTILE.....	V
26	PAFZZ	81349	MIL-T-5038	TAPE, TEXTILE.....	V
27	PAFZZ	81349	MIL-T-43566	TAPE, TEXTILE.....	V

(1) ITEM NO.	(2) SMR CODE	(3) CAGEC	(4) PART NUMBER	(5) DESCRIPTION AND USABLE ON CODES (UOC)	(6) QTY
				GROUP 05 BULK MATERIALS (CONTINUED)	
				FIG. BULK (CONTINUED)	
28	PAFZZ	81349	MIL-T-43566	TAPE, TEXTILE.....	V
29	PAOZZ	81348	V-T-285	THREAD, POLYESTER, OD, TICKET NO. E	V
30	PAOZZ	70167	23B28030-4	THREAD, POLYESTER, OD, TICKET NO. F	V
31	PAFZZ	81348	V-T-285	THREAD, POLYESTER, NATURAL, TICKET..... NO. E	V
32	PAFZZ	81348	V-T-285	THREAD, POLYESTER, NATURAL, TICKET NO. F	V
33	PAFZZ	81348	V-T-285	THREAD, POLYESTER, NATURAL, TICKET NO. FF	V
34	PAOZZ	70167	23B28030-4	THREAD, POLYESTER, OD, TICKET NO. FF..	V
35	PAFZZ	81349	MIL-T-10035	TOGGLE, TENT	V
36	PAOZZ	58536	A-A-1451	TWINE, COTTON.....	V
37	PAOZZ	81348	TT871	TWINE, COTTON.....	V
38	PAFZZ	81349	MIL-W-530	WEBBING, TEXTILE	V
39	PAFZZ	81349	ML-W43638	WEBBING, TEXTILE	V
40	PAFZZ		NO RECORD	WEBBING, TEXTILE	V
41	PAFZZ	81349	MIL-W-530	WEBBING, TEXTILE	V
42	PAFZZ	81349	MIL-W-530	WEBBING, TEXTILE	V
43	PAFZZ	81349	MIL-W-43638	WEBBING, TEXTILE	V
44	PAFZZ		NOT FURNISHED	WEBBING, TEXTILE	V
45	PAFZZ	81349	MIL-W-530	WEBBING, TEXTILE	V
46	PAFZZ	81348	RRW410	WIRE ROPE.....	V
				END OF FIGURE	

SECTION III. SPECIAL TOOLS LIST

(Not Applicable)

SECTION IV. CROSS-REFERENCE INDEXES

CROSS-REFERENCE INDEXES

NATIONAL STOCK NUMBER INDEX

STOCK NUMBER	FIG.	ITEM	STOCK NUMBER	FIG.	ITEM
8340-01-036-3779	11			11	
8340-01-036-3780	11			BULK	12
8340-01-036-3781	11		5325-00-231-6622	6	
8340-01-036-3782	11			6	
8340-01-036-3783	11			6	
8135-00-050-7698	6			6	
	6			9	
	6			11	
	BULK	17		11	
8010-00-161-7339	6		4020-00-231-9005	6	
8305-00-174-3319	6			BULK	21
5325-00-174-2908	11	5	4020-00-233-5980	6	
5325-00-1 749014	3	4		BULK	36
5325-00-175-9017	6		4020-00-233-6555	4	
8340-00-188-8400	7			4	
8340-00-188-8405	7			6	
8340-00-188-8406	7			6	
8340-00-188-8411	7			BULK	8
8340-00-205-2579	6		4020-00-233-6561	8	
8340-00-205-2753	5	3		8	
	6			8	
	11			8	
8340-00-205-2754	5	1		BULK	10
	6	10	4020-00-238-7732	6	
8340-00-205-2755	5	2		BULK	22
8340-00-205-2757	6		8340-00-242-7872	6	
	8	4		BULK	35
	11		8340-00-252-2271	8	
8340-00-205-2758	8	3		8	
8340-00-205-2759	8	2		9	2
	8		8340-00-252-2280	2	1
	11		8340-00-252-2286	8	
8340-00-227-1400	5			8	
5325-00-231-6586	3	5	8340-00-252-2291	7	2
	5	4		8	
	6		8340-00-252-2293	8	
	11		8340-00-252-2299	6	
	11			6	
	11			8	
5325-00-231-6619	6			8	
	6			8	
	6			BULK	14
	11				

CROSS-REFERENCE INDEXES

NATIONAL STOCK NUMBER INDEX (CONTINUED)

STOCK NUMBER	FIG.	ITEM	STOCK NUMBER	FIG.	ITEM
8315-00-253-6289	2			6	
	2			11	
	4			BULK	26
	6		5340-00-260-1414	3	
	6			5	6
	6			6	
	6			6	
	6			11	
	6			11	
	6			BULK	20
	6		5340-00-260-1419	5	7
	6			6	
	6			11	
	6		8305-00-261-8460	6	
	6			6	
	6			6	
	6			BULK	40
6		8340-00-261-9749	8		
6			8		
6			8		
10			11		
BULK	25		BULK	16	
8315-00-253-6292	6		8340-00-261-9750	8	
BULK	24		8		
8315-00-253-6293	3		8340-00-261-9751	8	
6			8		
6			4020-00-262-2019	6	
6			6		
6			6		
11			6		
BULK	28		6		
8315-00-255-7673	3		11		
3			BULK	11	
6			9	1	
6		8340-00-262-2397	6		
6		8340-00-262-2402	3		
6		8315 00-262-2784	6		
6			11		
6			BULK	1	
6		8315-00-262-3372	3		
6			6		
6			BULK	23	
6		8315-00-262-3373	6		
6			6		
6			6		

CROSS-REFERENCE INDEXES

NATIONAL STOCK NUMBER INDEX (CONTINUED)

STOCK NUMBER	FIG.	ITEM	STOCK NUMBER	FIG.	ITEM
	6		5325-00-291-0289	3	
	6			6	
	6			BULK	13
	6		8010-00-297-2124	6	
	6		5340-00-297-6592	6	
	6			11	
	6		5340-00-297-6833	10	
	6			11	
	6			BULK	3
	BULK	27	5340-00-297-6837	10	
8340-00-262-3698	3	3		11	
8305-00-262-7309	3			BULK	15
	6		8340-00-376-1295	5	9
	BULK	7		6	
8305-00-263-2475	6			11	
	BULK	42		11	
8305-00-263-2477	6		8340-00-470-2335	1	1
	BULK	38	8340-00-470-2342	1	1
8305-00-263-2479	6		8340-00-482-3963	1	1
	BULK	45	8305-00-634-5048	6	
4020-00-263-3482	6			6	
	BULK	37		6	
5340-00-264-1221	6			BULK	39
	11		4010-00-641-6183	2	
	BULK	19		BULK	1
5340-00-264-1222	5	5	8340-00-753-6573	11	
	6		8340-00-753-6574	6	
	6		8340-00-753-6575	6	
	11			11	
8305-00-268-2434	6			BULK	18
	BULK	41	8310-00-823-6888	6	
4020-00-271-1914	BULK	9		BULK	33
8340-00-272-2999	8	1	8340-00-823-7451	8	
	8		8340-00-889-0034	6	
	11			11	
	11		8305-00-889-3682	3	
	11			3	
	11			3	
5325-00-279-1133	6			6	
8340-00-285-5033	6			6	
8340-00-285-8432	11			6	
5340-00-290-0939	3			6	
	11			6	
	BULK	2		6	

CROSS-REFERENCE INDEXES

NATIONAL STOCK NUMBER INDEX (CONTINUED)

STOCK NUMBER	FIG.	ITEM	STOCK NUMBER	FIG.	ITEM
	6			9	
	6			11	
	6			11	
	6			11	
	6			BULK	5
	6		8340-00-965-4432	6	
	6		4030-00-972-5264	2	4
	11			11	
	11		5320-00-972-5266	6	
	11			11	
	11		5325-00-972-5270	5	8
	BULK	43		6	
8305-00-889-8682	6			11	
	BULK	44		11	
8340-00-896-9053	6		8310-00-988-1297	6	
8340-00-896-9054	6			BULK	31
8305-00-926-1613	3		8310-00-988-1298	6	
	4			11	
	6			BULK	29
	6		8310-00-988-1299	6	
	6			BULK	32
	BULK	6	8310-00-988-1300	6	
8305-00-926-6171	6			11	
	6			BULK	30
	6		8310-00-988-1301	6	
	6			BULK	34
			9150-00-999-7548	3	

CROSS-REFERENCE INDEXES

PART NUMBER INDEX

CAGEC	PART NUMBER	STOCK NUMBER	FIG.	ITEM
	NOT FURNISHED	8340-00-470-2335 (S)	1	1
	NOT FURNISHED	8340-00-482-3963 (M)		
	NOT FURNISHED	8340-00-470-2342 (L)		
58536	A-A-1451	4020-00-233-5980	BULK	36
			6	
			6	
49671	A4640-1	8340-00-205-2759	8	
54636	E90Y3	8010-00-515-2208	6	
81348	L-P-375	8135-00-050-7698	BULK	17
			6	1
			6	
			6	
81349	LS125	8305-00-926-1613	BULK	6
			3	1
			4	2
			6	5
			6	
			6	
81349	MIL-B-371	8315-00-262-2784	BULK	1
			3	
			6	
			11	
81349	MIL-C-1 0859	8305-00-262-7309	BULK	7
			3	
			6	
81349	MIL-C-2533ATYPE2CLASS2SIZE4	4020-00-233-6555	BULK	8
			4	3
			4	4
			6	
			6	
81349	MIL-C-43627	8305-00-926-6171	BULK	5
			6	
			6	
			6	
			6	
			6	
			9	
			11	
			11	
			11	
81349	MIL-C-5040	4020-00-262-2019	BULK	11
			5	
			6	
			6	

CROSS-REFERENCE INDEXES

PART NUMBER INDEX (CONTINUED)

CAGEC	PART NUMBER	STOCK NUMBER	FIG.	ITEM
			6	
81349	MIL-F-1611	8340-00-272-2999	11	2
			8	1
			8	
			11	
81349	MIL-G-16491TYPE3CLASSSIZE4	5325-00-231-6622	11	
			6	
			6	
			6	
			9	
			11	4
			11	
81337	MILG-61491		6	
81337	MILG-61 491TYPEVIIIICLASS4B6	5325-00-972-5270	5	8
			11	
			11	
81349	MIL-H-1 608	8340-00-205-2754	5	1
			5	2
			6	
			6	
			11	
			11	
			11	
81349	MIL-H-1 608AMEND2		5	3
			6	
			11	
			11	
81349	MIL-L-11075	5340-00-297-6837	BULK	15
			10	
			11	
81349	MIL-L-1709	8340-00-252-2299	BULK	14
			6	
			6	
			8	
			8	
			8	
			8	
			8	
81349	MIL-P-40180	8340-00-753-6575	BULK	18
			6	
			6	
			10	1

CROSS-REFERENCE INDEXES

PART NUMBER INDEX (CONTINUED)

CAGEC	PART NUMBER	STOCK NUMBER	FIG.	ITEM
81349	MIL-P-500	8340-00-205-2757	6	
			6	
			8	3
			8	4
			11	
			11	
81349	MIL-P-549	8340-00-227-1400	6	
			7	1
			7	
			7	
			7	
81349	MIL-R-2327	5340-00-264-1222	5	5
81349	MIL-R-2327CLASS2SIZE2	5340-00-264-1221	BULK	19
			6	
			6	
			6	
			11	
			11	
81337	MIL-R-2583CLASSA83-8	5340-00-972-5266	6	
			11	
81349	MIL-R-3390	5340-00-260-1414	BULK	20
			3	
			5	6
			5	7
			6	
			6	
			6	
			11	
			11	
			11	
81349	MIL-S-43002	8340-00-896-9053	6	
81349	MIL-S-43384	5340-00-297-6592	6	
			11	
81349	MIL-T-10035	8340-00-242-7872	BULK	35
			5	9
			6	
			6	
			11	
			11	
			11	
81349	MIL-T-12919	8340-00-262-2402	6	
81349	MIL-T-14038	8340-00-285-8432	11	
81349	MIL-T-14056	8340-00-285-5033	6	

CROSS-REFERENCE INDEXES

PART NUMBER INDEX (CONTINUED)

CAGEC	PART NUMBER	STOCK NUMBER	FIG.	ITEM
81349	MIL-W-530	8305-00-263-2475	BULK	42
			6	
81349	MIL-W-530	8305-00-263-2477	BULK	38
			6	
81349	MIL-W-530	8305-00-263-2479	BULK	45
			6	
81349	MIL-W-530	8305-00-268-2434	BULK	41
			6	
96906	MS20230BS1	5325-00-231-6619	BULK	12
			6	
			6	
			11	
			11	
96906	MS20230BS2	5325-00-291-0289	BULK	13
			3	
			6	
			11	
96906	MS20230BS4	5325-00-231-6586	3	5
			5	4
			6	
			11	
			11	
			11	
96906	MS35530-2	8010-00-297-2124	6	
96906	MS51926	5340-00-297-6833	BULK	3
			11	
96906	MS51926-3	5340-00-297-6833	10	
96906	MS519441 0	5340-00-290-0939	BULK	2
			3	
			11	
81348	RRW410	4010-00-641-6183	BULK	46
			2	2
81348	TC571	4020-00-233-6555	BULK	8
			4	3
			4	4
			6	
			6	
81348	TC571	4020-00-233-6561	BULK	10
			8	
			8	
			8	
			8	
			8	

CROSS-REFERENCE INDEXES

PART NUMBER INDEX (CONTINUED)

CAGEC	PART NUMBER	STOCK NUMBER	FIG.	ITEM
81348	TC571	4020-00-271-1914	BULK	9
			8	
81348	TC571	4020-00-231-9005	BULK	21
			6	
			6	
81348	TR605	4020-00-263-3482	BULK	37
			6	
81348	V106	5325-00-174-2908	11	6
81348	VF106	5325-00-174-9017	6	
81348	VF106TYPE3STYLE1 SIZEH	5325-00-174-9014	3	4
			6	3
81348	V-T-285	8310-00-823-6888	BULK	33
			6	
81348	V-T-285	8310-00-988-1297	BULK	31
			6	
81348	V-T-285	8310-00-988-1298	BULK	29
			6	
			11	
81348	V-T-285	8310-00-988-1299	BULK	32
			6	
76691	2-128030-4	8310-00-972-5264	2	4
			11	
70167	23B28030-3	8310-00-988-1301	6	
70167	23B28030-4	8310-00-988-1300	BULK	30
			6	
			11	
70167	23B28030-4	8310-00-988-1301	BULK	34
70167	23B28045-1	8340-00-205-2759	8	2
			8	
			11	
70167	23B28126-1	8430-00-823-7451	8	
			8	
90172	41495-5	4020-00-238-7732	BULK	22
			6	

CROSS-REFERENCE INDEXES

FIGURE AND ITEM NUMBER INDEX

FIG.	ITEM	STOCK NUMBER	CAGEC	PART NUMBER
BULK	1	8315-00-262-2784	81349	MIL-B-371
	2	5340-00-290-0939	96906	MS5194410
	3	5340-00-297-6833	96906	MS51926
	4	8305-00-170-3319		NO RECORD
	5	8305-00-926-6171	81349	MIL-G43627
	6	8305-00-926-1613	81349	LS 125
	7	8305-00-262-7309	81349	MIL-C.-10859
	8	4020-00-233-6555	81349	MIL-C-2533ATYPE2CLASS2SIZE4
	9		81348	TC571
	10	4020-00-271-1914	81348	TC571
	11	4020-00-233-6561	81348	TC571
	12	4020-00-262-2019	81349	MIL-CG5040
	13	5325-00-231-6619	96906	MS2030BS1
	14	5325-00-291-0289	96906	MS2030BS2
	15	8340-00-252-2299	81349	MIL-L-1709
	16	5340-00-297-6837	81349	MIL-L-11075
	17	8340-00-261-9749	64067	8340-00-261-9749
	18	8135-00-050-7698	81348	L-P-375
	19	8344-00-753-6575	81349	MIL-P 40180
	20	5340-00-264-1221	81349	MIL-R-2327CLASS2SIZE2
	21	5340-00-260-1414	81349	MIL-R-3390
	22	4020-00-231-9005	81348	TR 605
	23	4020-00-238-7732	90172	41495-5
	24	8315-00-262-3372		NO RECORD
	25	8315-00-253-6292	81349	MIL-T-43566
	26	8315-00-253-6289	81349	MIL-T-43566
	27	8315-00-255-7673	81349	MIL-T-5038
	28	8315-00-262-3373	81349	MIL-T-43566
	29	8315-00-253-6293	81349	MIL-T-43566
	30	8310-00-988-1298	81348	V-T-285
	31	8310-00-988-1300	70167	23B28030-4
	32	8310-00-988-1297	81348	V-T-285
	33	8310 00-988-1299	81348	V-T-285
	34	8310-00-823-6888	81348	V-T-285
	35	8310-00-988-1301	70167	23B28030-4
	36	8340-00-242-7872	81349	MIL-T-10035
	37	4020-00-233-5980	58536	A-A-1451
	38	4020-00-263-3482	81348	TT871
	39	8305-00-263-2477	81349	MIL-W-530
	40	8305-00-634-5048	81349	MIL-W-43638
	41	8305-00-261-8460		NO RECORD
	42	8305-00-268-2434	81349	MIL-W-530
	43	8305-00-263-2475	81349	MIL-W-530
	44	8305-00-889-3682	81349	MIL-W43638
	45	8305-00-889-8682		NOT FURNISHED
	8305-00-263-2479	81348	MIL-W-530	

CROSS-REFERENCE INDEXES

FIGURE AND ITEM NUMBER INDEX (CONTINUED)

FIG.	ITEM	STOCK NUMBER	CAGEC	PART NUMBER
BULK 1	46	4010-00-641-6183	81348	RRW410
	1	8340-00-470-2335		NOT FURNISHED
		8340-00-482-3963		NOT FURNISHED
		8340-00-470-2342		NOT FURNISHED
2	1	8340-00-252-2280	64067	8340-00-252-2280
	2	4010-00-641-6183	81348	RRW410
		8315-00-253-6289	81349	MIL-T-43566
		8315-00-253-6289	81349	MIL-T-43566
3	4	4030-00-972-5264	76691	2-134J
	1	8305-00-926-1613	81349	LS1 25
	2	8315-00-255-7673	81349	MIL-T-5038
	3	8340-00-262-3698	81349	MIL-T-43333
		8315-00-262-3373	81349	MIL-T-43566
		8305-00-889-3682	81349	MIL-W-43638
		5325-00-291-0289	96906	MS20230BS2
		8315-00-253-6293	81349	MIL-T-43566
		8305-00-262-7309	81349	MIL-C-10859
		8305-00-889-3682	81349	MIL-W-43638
		5340-00-290-0939	96906	MS51944-10
		5340-00-260-1414	81349	MIL-R-3390
		8305-00-889-3682	81349	MIL-W-43638
		8315-00-262-2784	81349	MIL-B-371
		8315-00-255-7673	81349	MIL-T-5038
	4	4	5325-00-174-9014	81348
5		5325-00-231-6586	96906	MS20230BS4
1		8315-00-253-6289	81349	MIL-T-43566
2		8305-00-926-1613	81349	LS 125
3		4020-00-233-6555	81349	MIL-C-2533ATYPE2CLASS3SIZE4
5	4	4020-00-233-6555	81348	TC571
	1	8340-00-205-2754	81349	MIL-H-1608
	2	8340-00-205-2755	81349	MIL-H-1608
	3	8340-00-205-2753	81349	MIL-H-1608AMEND2
	4	5325-00-231-6586	96906	MS20230BS4
	5	5340-00-264-1222	81349	MIL-R-2327
	6	5340-00-260-1414	81349	MIL-R-3390
	7	5340-00-260-1416	81349	MIL-R-3390
6	8	5325-00-972-5270	81337	MIL-G-61491TYPEVIII CLASS4B6
	9	8340-00-376-1295	81349	MIL-T-10035
	1	8135-00-050-7698	1348	L-P-375
	2	8315-00-253-6289	81349	MIL-T-43566
	3	5325-00-279-1133	81348	VF106TYPE1STYLE2SIZEH
	4	8315-00-253-6293	81349	MIL-T-43566
	5	8305-00-926-1613	81349	LS 125
		4020-00-262-2019	81349	MIL-C-5040
		8305-00-889-3682	81349	MIL-W-43638
		8305-00-889-3682	81349	MIL-W-43638

CROSS-REFERENCE INDEXES

FIGURE AND ITEM NUMBER INDEX (CONTINUED)

FIG.	ITEM	STOCK NUMBER	CAGEC	PART NUMBER
6		8315-00-253-6289	81349	MIL-T-43566
		8315-00-253-6289	81349	MIL-T-43566
		8315-00-253-6289	81349	MIL-T-43566
		8315-00-253-6289	81349	MIL-T-43566
		5340-00-260-1414	81349	MIL-R-3390
		8305-00-889-3682	81349	MIL-W-43638
		5340-00-297-6592	81349	MIL-S-43384
		8305-00-889-3682	81349	MIL-W-43638
		8305-00-889-8682		NOT FURNISHED
		5340-00-264-1221	81349	MIL-R-2327CLASS2SIZE2
		8315-00-255-7673	81349	MIL-T-5038
		8315-00-255-7673	81349	MIL-T-5038
		8340-00-242-7872	81349	MIL-T-10035
		8305-00-926-6171	81349	MIL-C-43627
		8305-00-263-2479	81349	MIL-W-530
		8305-00-170-3319		NO RECORD
		8305-00-926-6171	81349	MIL-C-43627
		8305-00-889-3682	81349	MIL-W-43638
		8315-00-253-6293	81349	MIL-T-43566
		5325-00-972-5270	81337	MIL-61491
		8305-00-926-6171	81349	MIL-C-43627
		5325-00-174-9017	81348	VF106
		8305-00-926-6171	81349	MIL-C-43627
		5325-00-231-6619	96906	MS20230BS1
		5325-00-231-6586	96906	MS20230BS4
		5325-00-231-6622	81349	MIL-G-16491TYPE3CLASS3SIZE4
		5325-00-291-0289	96906	MS20230BS2
		5325-00-231-6622	81349	MIL-G-16491TYPE3CLASS3SIZE4
		5325-00-231-6622	81349	MIL-G-16491TYPE3CLASS3SIZE4
		5325-00-231-6622	81349	MIL-G-16491TYPE3CLASS3SIZE4
		8340-00-899-0034	81349	MIL-H-1608
		8340-00-205-2753	81349	MIL-H-1608AMEND2
		8340-00-205-2754	81349	MIL-H-1608
		8340-00-285-5033	81349	MIL-T-14056
		8315-00-262-3373	81349	MIL-T-43566
		8315-00-262-3373	81349	MIL-T-43566
		8305-00-889-3682	81349	MIL-W-43638
		8340-00-262-2402	81349	MIL-T-12919
		8305-00-262-7309	81349	MIL-C-10859
		8315-00-262-3372		NO RECORD
		8315 00-262-3372		NO RECORD
		8305-00-889-3682	81349	MIL-W43638
		8305-00-889-3682	81349	MIL-W-13638
		8305-00-889-3682	81349	MIL-W-13638
		4020-00-262-2019	81349	MIL-C-5040
		8340-00-252-2299	81349	MIL-L-1709

CROSS-REFERENCE INDEXES

FIGURE AND ITEM NUMBER INDEX (CONTINUED)

FIG.	ITEM	STOCK NUMBER	CAGEC	PART NUMBER
6		4020-00-262-2019	81349	MIL-C-5040
		8305-00-926-6171	81349	MIL-C-43627
		4020-00-262-2019	81349	MIL-C-5040
		5325-00-231-6619	96906	MS20230BS1
		8305-00-889-3682	81349	MIL-W-43638
		8340-00-205-2757	81349	MIL-P-500
		8340-00-965-4432	81349	MIL-P-500
		8315-00-253-6293	81349	MIL-T-43566
		8315-00-253-6293	81349	MIL-T-43566
		8305-00-263-2477	81349	MIL-W-530
		8305-00-634-5048	81349	MIL-W-43638
		8305-00-634-5048	81349	MIL-W43638
		8305-00-261-8460		NO RECORD
		8305-00-261-8460		NO RECORD
		8305-00-889-3682	81349	MIL-W-43638
		8305-00-268-2434	81349	MIL-W-530
		8305-00-261-8460		NO RECORD
		8305-00-926-6171	81349	MIL-C-43627
		8315-00-253-6292	81349	MIL-T-43566
		8305-00-889-3682	81349	MIL-W-3638
		8305-00-268-2434	81349	MIL-W-530
		8305-00-889-3682	81349	MIL-W-43638
		5340-00-264-1222	81349	MIL-R-2327CLASS2SIZE2
		5340-00-264-1222	81349	MIL-R-2327CLASS2SIZE2
		5340-00-260-1419	81349	MIL-R-3390
		5340-00-260-1414	81349	MIL-R-3390
		5340-00-972-5266	81349	MIL-R-2583CLASSA83-8
		8340-00-926-1613	81349	LS 125
		8305-00-926-1613	81349	LS 125
		8305-00-926-1613	81349	LS 125
		8340-00-896-9053	81349	MIL-S-43002
		8340-00-896-9054		NO RECORD
		4020-00-231-9005	81348	TR 605
		4020-00-231-9005	81348	TR 605
		8340-00-252-2299	81349	MIL-L-1709
		8305-00-263-2475	81349	MIL-W-530
		4020-00-238-7732	90172	41495-5
		8305-00-634-5048	81349	MIL-W-43638
		8315-00-262-2784	81349	MIL-B-371
		8310-00-988-1298	81348	V-T-285
		8310-00-988-1300	70167	23B28030-4
		8310-00-988-1297	81348	V-T-285
		8310-00-988-1299	81348	V-T-285
		8310-00-823-6888	70167	V-T-285
		8310-00-988-1301	81349	23B28030-3
		8315-00-253-6289	81349	MIL-T-43566

CROSS-REFERENCE INDEXES

FIGURE AND ITEM NUMBER INDEX (CONTINUED)

FIG.	ITEM	STOCK NUMBER	CAGEC	PART NUMBER
6		8315-00-253-6289	81349	MIL-T-43566
		8315-00-253-6289	81349	MIL-T-43566
		8315-00-253-6289	81349	MIL-T-43566
		8315-00-253-6289	81349	MIL-T-43566
		8315-00-253-6289	81349	MIL-T-43566
		8315-00-253-6289	81349	MIL-T-43566
		8315-00-253-6289	81349	MIL-T-43566
		8315-00-253-6289	81349	MIL-T-43566
		8315-00-253-6289	81349	MIL-T-43566
		8315-00-253-6289	81349	MIL-T-43566
		8315-00-262-3373	81349	MIL-T-43566
		8315-00-262-3373	81349	MIL-T-43566
		8315-00-262-3373	81349	MIL-T-43566
		8315-00-262-3373	81349	MIL-T-43566
		8315-00-262-3373	81349	MIL-T-43566
		8315-00-262-3373	81349	MIL-T-43566
		8315-00-262-3373	81349	MIL-T-43566
		8315-00-262-3373	81349	MIL-T-43566
		8315-00-262-3373	81349	MIL-T-43566
		8315-00-262-3373	81349	MIL-T-43566
		8315-00-262-3373	81349	MIL-T-43566
		8315-00-262-3373	81349	MIL-T-43566
		8315-00-262-3373	81349	MIL-T-43566
		8315-00-262-3373	81349	MIL-T-43566
		8315-00-255-7673	81349	MIL-T-5038
		8315-00-255-7673	81349	MIL-T-5038
		8315-00-255-7673	81349	MIL-T-5038
		8315-00-255-7673	81349	MIL-T-5038
		8315-00-255-7673	81349	MIL-T-5038
		8315-00-255-7673	81349	MIL-T-5038
		8315-00-255-7673	81349	MIL-T-5038
		8315-00-255-7673	81349	MIL-T-5038
		8315-00-255-7673	81349	MIL-T-5038
		8315-00-255-7673	81349	MIL-T-5038
		8315-00-255-7673	81349	MIL-T-5038
		8315-00-255-7673	81349	MIL-T-5038
	8315-00-255-7673	81349	MIL-T-5038	
	8315-00-255-7673	81349	MIL-T-5038	
	8315-00-255-7673	81349	MIL-T-5038	
	4020-00-233-6555	81349	MIL-C-2533ATYPE2CLASS2SIZE4	
	4020-00-233-6555	81348	TC571	
	8340-00-376-1295	81349	MIL-T-10035	
	4020-00-233-5980	58536	A-A-1451	
	4020-00-233-5980	58536	A-A-1451	
	4020-00-263-3482	81348	TT871	
	8135-00-050-7698	81348	L-P-375	
	8135-00-050-7698	81348	L-P-375	
	8340-00-753-6574	81349	MIL-P-40180	
	8340-00-753-6575	81349	MIL-P-40180	
	8010-00-515-2208	54636	E90Y3	
	8010-00-297-2124	96906	MS35530-2	
	8340-00-227-1400	81349	MIL-P-549	
7	1	8340-00-188-8411	81349	MIL-P-549
	2	8340-00-252-2291	64067	8340-00-252-2291

CROSS-REFERENCE INDEXES

FIGURE AND ITEM NUMBER INDEX (CONTINUED)

FIG.	ITEM	STOCK NUMBER	CAGEC	PART NUMBER	
7	2	8340-00-188-8406	81349	MIL-P-549	
		8340-00-188-8405	81349	MIL-P-549	
		8340-00-188-8405	81349	MIL-P-549	
		8340-00-188-8400	81349	MIL-P-549	
8	1	8340-00-272-2999	81349	MIL-F-1611	
		8340-00-205-2759	70167	23B28045-1	
		8340-00-205-2758	81349	MIL-P-500	
		8340-00-205-2757	81349	MIL-P-500	
		8340-00-272-2999	81349	MIL-F-1611	
		8340-00-252-2299	81349	MIL-L-1709	
		8340-00-252-2299	81349	MIL-L-1709	
		8340-00-252-2299	81349	MIL-L-1 709	
		8340-00-252-2271	64067	8340-00-252-2271	
		8340-00-252-2271	64067	8340-00-252-2271	
		4020-00-271-1914	81348	TC571	
		4020-00-233-6561	81348	TC571	
		4020-00-233-6561	81348	TC571	
		4020-00-233-6561	81348	TC571	
		4020-00-233-6561	81348	TC571	
		4020-00-233-6561	81348	TC571	
		4020-00-233-6561	81348	TC571	
		8340-00-252-2293	64067	8340-00-252-2293	
		8340-00-252-2286	81349	MIL-L-1 709	
		8340-00-252-2286	81349	MIL-L-1 709	
8340-00-252-2291	64067	8340-00-252-2291			
8340-00-261-9749	64067	8340-00-261-9749			
8340-00-261-9749	64067	8340-00-261-9749			
8340-00-261-9749	64067	8340-00-261-9749			
8340-00-261-9749	64067	8340-00-261-9749			
8340-00-823-7451	70167	23B28126-1			
8340-00-823-7451	70167	23B28126-1			
8340-00-261-9750	64067	8340-00-261-9750			
8340-00-261-9750	64067	8340-00-261-9750			
8340-00-261-9750	64067	8340-00-261-9750			
8340-00-261-9751	64067	8340-00-261-9751			
8340-00-205-2759	70167	23B28045-1			
8340-00-205-2759	49671	A4640-1			
9	1	8340-00-262-2397	64067	8340-00-262-2397	
		8305-00-926-6171	81349	MIL-C-43627	
		5325-00-231-6622	81349	MIL-G-16491TYPE3CLASS3SIZE4	
10	2	8340-00-252-2271	64067	8340-00-252-2271	
		1	8340-00-841-4648	81349	MIL-T-41810
			8315-00-253-6289	81349	MIL-T-43566
11	1	5340-00-297-6837	81349	MIL-L-11075	
		5340-00-297-6833	96906	MS51926-3	
		8340-00-753-6573	81349	MIL-T-41810	
11	2	4020-00-262-2019	81349	MIL-C-5040	
		8305-00-889-3682	81349	MIL-W-43638	

CROSS-REFERENCE INDEXES

FIGURE AND ITEM NUMBER INDEX (CONTINUED)

FIG.	ITEM	STOCK NUMBER	CAGEC	PART NUMBER
11	4	5325-00-231-6622	81349	MIL-G-16491TYPE3CLASS3SIZE4
		8340-00-261-9749	64067	8340-00-261-9749
		8340-00-753-6579		NOT FURNISHED
	5	8315-00-255-7673	81349	MIL-T-5038
6	6	5325-00-174-2908	81348	V106
		5325-00-231-6619	96906	MS20230BS1
		8305-00-889-3682	81349	MIL-W-43638
		8305-00-926-6171	81349	MIL-C-43627
		8315-00-253-6293	81349	MIL-T-43566
		8305-00-926-6171	81349	MIL-C-43627
		8305-00-889-3682	81349	MIL-W-43638
		8305-00-889-3682	81349	MIL-W-43638
		8315-00-262-2784	81349	MIL-B-371
		8310-00-988-1298	81348	V-T-285
		8310-00-988-1300	70167	23B28030-4
		8340-00-376-1295	81349	MIL-T-10035
		8340-00-285-8432	81349	MIL-T-14038
		8340-00-926-6171	81349	MIL-C-436r27
		8340-00-261-9749	64067	8340-00-2!61-9749
		8340-00-753-6575	81349	MIL-P-40180
		5340-00-290-0939	96906	MS51944-10
		5340-00-297-6833	96906	MS51926
		8340-00-272-2999	81349	MIL-F-1611
		8340-00-272-2999	81349	MIL-F-1611
		5325-00-972-5270	81337	MIL-G-61491TYPEVIIIICLASS4B6
		5325-00-231-6586	96906	MS20230BS4
		5325-00-972-5270	81337	MIL-G-61491TYPEVIIIICLASS4B6
		5325-00-231-6622	81349	MIL-G-16491TYPE3CLASS3SIZE4
		5325-00-231-6586	96906	MS20230BS4
		5325-00-231-6619	96906	MS20230BS1
		5325-00-291-0289	96906	MS20230BS2
		5325-00-231-6586	96906	MS20230BS4
		8340-00-205-2753	81349	MIL-H-1608AMEND2
		8340-00-205-2753	81349	MIL-H-1608AMEND2
		8340-00-205-2754	81349	MIL-H-1608
		8340-00-205-2755	81349	MIL-H-1608
		8340-00-899-0034	81349	MIL-H-1608
		5340-00-297-6837	81349	MIL-L-11075
		8340-00-205-2758	81349	MIL-P-500
		8340-00-205-2757	81349	MIL-P-500
		5340-00-264-1222	81349	MIL-R-2327CLASS2SIZE2
		5340-00-260-1414	81349	MIL-R-3390
		5340-00-260-1419	81349	MIL-R-3390
		5340-00-264-1221	81349	MIL-R-2327CLASS2SIZE2
		8340-01-036-3781		NOT FURNISHED
		8340-01-036-3782		NOT FURNISHED

CROSS-REFERENCE INDEXES

FIGURE AND ITEM NUMBER INDEX (CONTINUED)

FIG.	ITEM	STOCK NUMBER	CAGEC	PART NUMBER
11		8340-01-036-3783		NOT FURNISHED
		8340-01-036-3779		NOT FURNISHED
		8340-01-036-3780		NOT FURNISHED
		5340-00-260-1414	81349	MIL-R-3390
		5320-00-972-5266	81337	MIL-R-2583CLASSA83-8
		8340-00-205-2759	70167	23B28045-1
		5340-00-297-6592	81349	MIL-4-3384
		4030-00-972-5264	76691	2-134J
		8340-00-242-7872	81349	MIL-T-10035
		8340-00 376-1295	81349	MIL-T-10035

By Order of the Secretary of the Army:

Official:

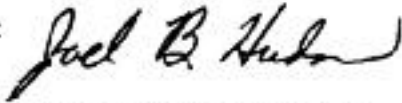

*Acting Administrative Assistant to the
Secretary of the Army
00687*

DENNIS J. REIMER
*General, United States Army
Chief of Staff*

DISTRIBUTION:

To be distributed in accordance with DA Form 12-25-E, block no. 1757, requirements for TM 10-8340-211-23P.

RECOMMENDED CHANGES TO EQUIPMENT TECHNICAL PUBLICATIONS

 <div style="border: 1px solid black; border-radius: 15px; padding: 5px; display: inline-block; margin-left: 20px;"> <p style="font-size: small; margin: 0;">THEN...JOT DOWN THE DOPE ABOUT IT ON THIS FORM. CAREFULLY TEAR IT OUT, FOLD IT AND DROP IT IN THE MAIL.</p> </div>				SOMETHING WRONG WITH PUBLICATION	
				FROM: (PRINT YOUR UNIT'S COMPLETE ADDRESS)	
PUBLICATION NUMBER		PUBLICATION DATE		PUBLICATION TITLE	
BE EXACT PIN-POINT WHERE IT IS				<p style="font-weight: bold; font-size: large;">IN THIS SPACE, TELL WHAT IS WRONG AND WHAT SHOULD BE DONE ABOUT IT.</p>	
PAGE NO.	PARA- GRAPH	FIGURE NO.	TABLE NO.		
PRINTED NAME, GRADE OR TITLE AND TELEPHONE NUMBER				SIGN HERE	

The Metric System and Equivalents

Linear Measure

1 centimeter = 10 millimeters = .39 inch
 1 decimeter = 10 centimeters = 3.94 inches
 1 meter = 10 decimeters = 39.37 inches
 1 dekameter = 10 meters = 32.8 feet
 1 hectometer = 10 dekameters = 328.08 feet
 1 kilometer = 10 hectometers = 3,280.8 feet

Weights

1 centigram = 10 milligrams = .15 grain
 1 decigram = 10 centigrams = 1.54 grains
 1 gram = 10 decigram = .035 ounce
 1 decagram = 10 grams = .35 ounce
 acres
 1 hectogram = 10 decagrams = 3.52 ounces
 1 kilogram = 10 hectograms = 2.2 pounds
 1 quintal = 100 kilograms = 220.46 pounds
 1 metric ton = 10 quintals = 1.1 short tons

Liquid Measure

1 centiliter = 10 milliliters = .34 fl. ounce
 1 deciliter = 10 centiliters = 3.38 fl. ounces
 1 liter = 10 deciliters = 33.81 fl. ounces
 1 dekaliter = 10 liters = 2.64 gallons
 1 hectoliter = 10 dekaliters = 26.42 gallons
 1 kiloliter = 10 hectoliters = 264.18 gallons

Square Measure

1 sq. centimeter = 100 sq. millimeters = .155 sq. inch
 1 sq. decimeter = 100 sq. centimeters = 15.5 sq. inches
 1 sq. meter (centare) = 100 sq. decimeters = 10.76 sq. feet
 1 sq. dekameter (are) = 100 sq. meters = 1,076.4 sq. feet
 1 sq. hectometer (hectare) = 100 sq. dekameters = 2.47
 1 sq. kilometer = 100 sq. hectometers = .386 sq. mile

Cubic Measure

1 cu. centimeter = 1000 cu. millimeters = .06 cu. inch
 1 cu. decimeter = 1000 cu. centimeters = 61.02 cu. inches
 1 cu. meter = 1000 cu. decimeters = 35.31 cu. feet

Approximate Conversion Factors

<i>To change</i>	<i>To</i>	<i>Multiply by</i>	<i>To change</i>	<i>To</i>	<i>Multiply by</i>
inches	centimeters	2.540	ounce-inches	Newton-meters	.007062
feet	meters	.305	centimeters	inches	.394
yards	meters	.914	meters	feet	3.280
miles	kilometers	1.609	meters	yards	1.094
square inches	square centimeters	6.451	kilometers	miles	.621
square feet	square meters	.093	square centimeters	square inches	.155
square yards	square meters	.836	square meters	square feet	10.764
square miles	square kilometers	2.590	square meters	square yards	1.196
acres	square hectometers	.405	square kilometers	square miles	.386
cubic feet	cubic meters	.028	square hectometers	acres	2.471
cubic yards	cubic meters	.765	cubic meters	cubic feet	35.315
fluid ounces	milliliters	29,573	cubic meters	cubic yards	1.308
pints	liters	.473	milliliters	fluid ounces	.034
quarts	liters	.946	liters	pints	2.113
gallons	liters	3.785	liters	quarts	1.057
ounces	grams	28.349	liters	gallons	.264
pounds	kilograms	.454	grams	ounces	.035
short tons	metric tons	.907	kilograms	pounds	2.205
pound-feet	Newton-meters	1.356	metric tons	short tons	1.102
pound-inches	Newton-meters	.11296			

Temperature (Exact)

°F	Fahrenheit	5/9 (after	Celsius	°C
	temperature	subtracting 32)	temperature	

PIN: 028531-000

This fine document...

Was brought to you by me:



[Liberated Manuals -- free army and government manuals](#)

Why do I do it? I am tired of sleazy CD-ROM sellers, who take publicly available information, slap “watermarks” and other junk on it, and sell it. Those masters of search engine manipulation make sure that their sites that sell free information, come up first in search engines. They did not create it... They did not even scan it... Why should they get your money? Why are not letting you give those free manuals to your friends?

I am setting this document FREE. This document was made by the US Government and is NOT protected by Copyright. Feel free to share, republish, sell and so on.

I am not asking you for donations, fees or handouts. If you can, please provide a link to liberatedmanuals.com, so that free manuals come up first in search engines:

<A HREF=<http://www.liberatedmanuals.com/>>Free Military and Government Manuals

- Sincerely
Igor Chudov
<http://igor.chudov.com/>
- [Chicago Machinery Movers](#)