

**TECHNICAL MANUAL**

**OPERATOR'S, UNIT AND  
DIRECT SUPPORT MAINTENANCE MANUAL  
(INCLUDING REPAIR PARTS AND SPECIAL TOOLS LIST)  
FOR**

**AQUA GLO WATER DETECTOR**

**MODEL GTP-322  
NSN 6640-00-244-9478**

This technical manual is an authentication of the manufacturer's commercial literature and does not conform with the format and the content requirements normally associated with Army technical manuals. This technical manual does, however, contain all essential information required to operate and maintain the equipment.

**Approved for public release; distribution is unlimited.**

---

**HEADQUARTERS, DEPARTMENT OF THE ARMY  
28 SEPTEMBER 1990**



This technical manual is an authentication of the manufacturer's commercial literature and does not conform with the format and the content requirements normally associated with Army technical manuals. This technical manual does, however, contain all essential information required to operate and maintain the equipment.

**Approved for public release; distribution is unlimited.**

### **SUPPLEMENTARY INTRODUCTORY MATERIAL**

#### 1-1. Maintenance Forms and Records.

Department of the Army forms and procedures used for equipment maintenance will be those described by DA Pam 738-750, The Army Maintenance Management System.

#### 1-2. Reporting Errors and Recommending Improvements.

You can help improve this manual. If you find any mistakes or if you know of a way to improve the procedures, please let us know. Mail your letters, DA Form 2028 (Recommended Changes to Publications and Blank Forms), or DA Form 2028-2 located in the back of this manual, directly to: Commander, U.S. Army Troop Support Command, ATTN: AMSTR-MCTS, 4300 Goodfellow Blvd., St. Louis, MO 63120-1798. A reply will be furnished to you.

#### 1-3. Destruction of Army Material to Prevent Enemy Use.

Refer to TM 750-244-3 for instructions covering the destruction of Army Material to prevent enemy use.

#### 1-4. Administrative Storage of Equipment.

a. Placement of equipment in administrative storage should be for short periods of time when a shortage of maintenance effort exists. Items should be in mission readiness within 24 hours or within the time factors as determined by the directing authority. During the storage period appropriate maintenance records will be kept.

b. Before placing equipment in administrative storage, current preventive maintenance checks and services should be completed. Shortcomings and deficiencies should be corrected, and all modification work orders (MWO'S) should be applied.

c. Storage site selection. Inside storage is preferred for items selected for administrative storage. If inside storage is not available, trucks, vans, conex containers and other containers may be used.



# GAMMON TECHNICAL PRODUCTS



INC.

235 PARKER AVE. P.O. BOX 400  
MANASQUAN, N.J. 08736  
TELEX 132484 GAMMONTEC--MNQN



AQUA GLO  
WATER DETECTOR

*Specialists in Petroleum Handling Equipment*

Phone (201) 223-4600

BULLETIN 82-86

(10-87)

## AQUA GLO® SERIES III WATER DETECTOR

MEASURES WATER CONTENT OF JET FUEL

MODEL GTP-322

- Power Selector Switch - operator chooses internal or external battery or alternating current.  
120 volts 50-60 Hz  
220 volts 50 Hz
- Nickel Cadmium rechargeable battery. Built-in recharger.
- 100% Self Contained Kit - no other equipment is required.
- Fully Instrumented - to eliminate human error.
- Detects presence of free water within 1.5 ppm.
- Test completed in less than 2 minutes.
- Portable - light weight-8 pounds.
- Permanent fluorescing standard.
- Can be recalibrated in the field.

The test requires two simple steps, First, a measured sample of fuel is passed through a paper pad that is treated with sodium fluorescein on its upstream surface. Second, the pad is compared with a fluorescing standard. Water droplets that are smaller than the eye can see will cause the sodium fluorescein to fluoresce in ultraviolet light. The degree of fluorescence is greater for increasing amounts of water in the fuel.

The AQUA-GLO Kit employs a new approach in the determination of the degree of fluorescence (or water content). A single, permanent fluorescing standard is positioned under a photographic-type iris diaphragm which can be opened or closed to increase or decrease the amount of ultraviolet light.

To determine water content, the operator merely adjusts the diaphragm lever arm until the fluorescing standard and the test pad show equal brightness in the ultraviolet light. This balance is reached when the zero-centering ammeter reads ZERO. The amount of water is read in parts per million (ppm) on the diaphragm lever arm scale which has been pre-calibrated in the factory. The scale numbers range from 1 to 12. These numbers are ppm if the test sample of fuel that flowed through the pad was 500 ml. However, if water content is in the range of 5 to 60 ppm, the test sample can be reduced to 100 ml. When a 100 ml sample is taken, the operating instructions explain that the scale reading must be multiplied by 5 to obtain the water content in ppm.

® Registered In U.S. Patent Office

MANUFACTURED SPECIFICALLY TO PERFORM TESTS PER ASTM METHOD D3240

•Patent No. 3500046 Made under licenses from Exxon Research & Engineering Co.

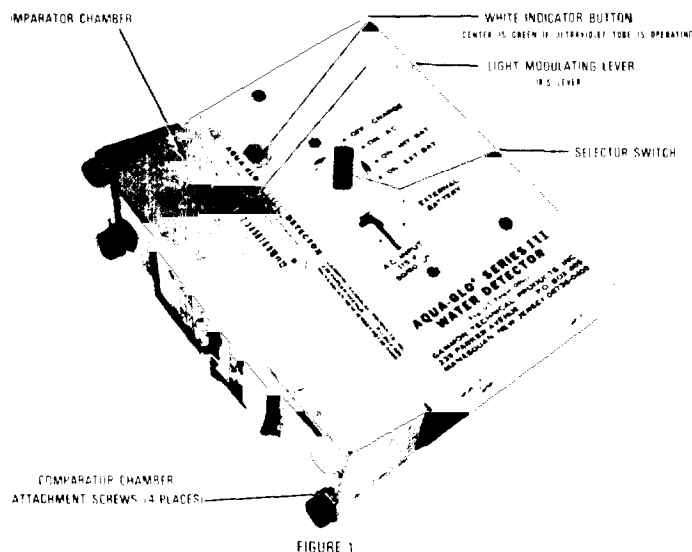
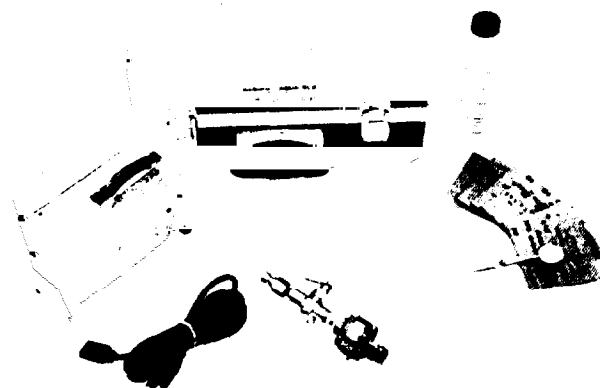

## COMBINATION KIT – MODEL GTP-323

In one carrying case: – Aqua-Glo Series III Water Detector  
– MiniMonitor Contamination Tester

Series III was introduced in 1982 with an entirely new light source. The ultra violet light that was used from 1966 to 1982 could not be operated on AC power. The new light will operate on 120 volt 50 or 60 Hz (available 220 v 50 Hz) or it will operate on its internal battery or an external battery.

The water detector pads that are used in the AQUA-GLO Kit are produced in compliance with MIL-D-81248 (WP) with the exception that the diameter is 25 mm Each pad is packaged in an air and moisture-proof envelope.

The AQUA-GLO Kit pad holder is designed for ease in sampling, and fittings are available for several different methods of taking samples. For example, the standard fitting permits direct connection to a quick disconnect. Another fitting allows the sample to be drawn through the test pad with a syringe.

The AQUA-GLO Kit is based on a technique developed by the U.S. Navy for accurate field determination of the free water content of jet fuels. Unlike the Navy equipment, the AQUA-GLO Kit requires only one fluorescing standard and is instrumented to eliminate human error.

Available Also in Combination with our MiniMonitor Kit for Contamination Testing per ASTM Methods D2276 and D3830.

See Bulletin 68-8 (6-80)  
for details of MiniMonitor Kit

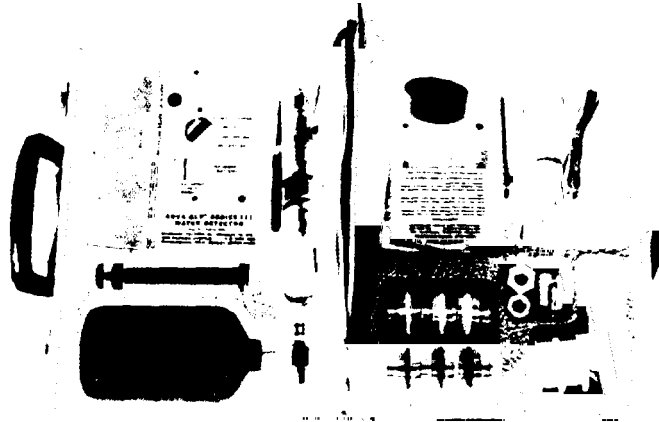

An outstanding feature of the AQUA-GLO Kit is permanency of the fluorescing standard. Extreme care has been taken in perfecting a standard that will not deteriorate with age.

### ORDERING INFORMATION

Aqua Glo Series III Kit with built-in 120 v 50 – 60 Hz Recharger	GTP-322
Aqua Glo Series III Kit with built-in 220 v 50 Hz Recharger	GTP-322-1
Combination Kit: Aqua Glo III and MiniMonitor; with 120 v Recharger	GTP-323
Combination Kit: Aqua Glo III and MiniMonitor; with 220 v Recharger	GTP-323-1

### Parts and Accessories

Water Detector Pads (25 mm dia.) box of 50	GTP-25
Internal Battery, rechargeable, nickel cadmium	GTP-2324
External Battery, same as above except with plug fitting and battery cover	GTP-2404
Replacement Tube, ultra-violet	GTP-2380
Detector Pad Holder Assembly	GTP-191
Toggle Valve, brass 1/8" FNPT	395C
Tweezers	GTP-293
Calibrated Bottle	GTP-294
Screwdriver calibrating	GTP-765
Carrying Case for GTP-322 and 323	GTP-761
Battery, 9 volt, for meter	GTP-892
Hose Assembly, outlet, for GTP-191	GTP-292
Fluorescing Standard	GTP-763
Calibrating Standard	GTP-764
Restrictor Nipple, for GTP-191	HN-2RB
Connector and 36" wire for external battery	GTP-2403
Cable/Connector assembly for recharger	GTP-2402
Color Rating Book	GTP-1074-1

**NOTE:** The Series III Ultraviolet Light is available to convert older Aqua Glo Kits. Order Conversion Light Kit GTP-2405. You will receive the new light (to replace your plastic case model) plus 4 attachment screws, recharging cable assembly and battery connector.

Color Rating Book is now included in GTP-323

# GAMMON TECHNICAL PRODUCTS



INC.

235 PARKER AVE. P.O. BOX 400  
MANASQUAN, N.J. 08736  
TELEX 132484 GAMMONTEC—MNQN



*Specialists in Petroleum Handling Equipment*

Phone (201) 223-4600

OPERATING  
PROCEDURE  
MANUAL

January, 1987  
Bulletin 80-76

## AQUA-GLO SERIES III WATER DETECTOR KIT

MODELS GTP-322 AND GTP-323

### INTRODUCTION

The Aqua-Glo Series III Water Detector Kit is used to measure the amount of undissolved water in kerosene-type jet fuels. It can be used on other fuels by following special procedures in the section titled, "Other Fluids".

A measured sample of fuel is passed through a sodium fluorescein treated detector pad or "test pad". Undissolved (free) water in the fuel will react with the sodium fluorescein. When the pad is subsequently illuminated by ultraviolet light, the coating previously contacted by free water will fluoresce a bright yellow with the brightness increasing for increasing amounts of free water in the fuel. The ultraviolet light-illuminated pad is compared to a known standard using a photocell comparator, and the free water in the fuel sample is read out in parts per million by volume. By varying the fuel sample size, the range of the test method can be increased. The usual range of test readings covers from 1 to 60 ppm of free water.

### METHOD DESCRIPTION

The primary method that is covered by this document is based on ASTM D3240-75. A copy can be obtained by writing to American Society for Testing and Materials, 1916 Race St., Philadelphia, PA. 19103.

The following procedure is applicable for dynamic line samples only; that is, taking the fuel sample directly from the fuel system and through the test pad without exposing the sample to the atmosphere or to a sample container. The use of sample containers such as bottles or cans for the temporary storage of the sample will result in large errors and is not recommended.

The amount of free water in a sample is very sensitive to the temperature of the sample. The use of sample containers such as bottles or cans can result in large errors due to changes in sample temperature adsorption of water on container walls, etc.

If there is absolutely no alternative and a test must be performed on a fuel sample that is in a container, the procedure in the section titled "Container Samples" can be used.

## CALIBRATION

An encapsulated pad labeled "Calibrating Standard" is provided in an envelope in each kit. Note the "set" number on the back of this pad and place it in the test pad window with the colored side facing the instrument. Turn on the ultraviolet lamp and then press the switch button on the photocell comparator. This button is located within a cup on the instrument. Adjust the light modulating lever until the red pointer is steady at the zero "O" in the center of the meter. Always move the light modulating lever in the same direction when zeroing the photocell comparator when calibrating or testing to eliminate errors caused by clearance in the mechanical linkage. This may take 45 seconds. If the reading obtained does not agree with the "set" number on the calibrating standard, adjust the photocell comparator by removing the plug screw on the side of the photocell comparator (at the 45 deg. bend), insert a small screwdriver, and adjust as necessary. Repeat the above procedure until the rating obtained agrees with the calibrating standard "set" number. THE INSTRUMENT SHOULD BE CALIBRATED PRIOR TO EACH DAY AND AFTER EACH HOUR OF USE.

Return the Calibrating Standard to the envelope in the kit. Do not use a calibrating standard from another kit. Each calibrating standard is matched to a fluorescing standard.

## SAMPLE CONNECTION

It has been explained that this kit is designed for dynamic line samples. The sample connection must be planned so that the flow path to the test pad is as short as possible and so that there are no traps or pockets that may collect water. The quick disconnect coupler should be attached directly to the pipe.

## FLUSHING

Attach the test pad holder assembly to the quick disconnect coupler. Open the toggle valve by lifting the handle. Allow at least 1 liter of fluid to pass through the assembly. Opening and closing the valve several times will insure better flushing. Remove the assembly after flushing.

## TEST PROCEDURE

Open the test pad holder assembly and insert a test pad using tweezers. Be sure that the orange colored side of the pad is facing upstream.

Do not remove the test pad from the hermetically sealed package until ready for use. Do not allow any discrete water droplets to come into contact with the pad (from rain, sneezing, coughing, etc.). Exposure of the test pad to the atmosphere, especially on humid days, will also ruin the pad in a matter of minutes.

Pass 500 ml of fuel through the pad, accurately measuring the test sample quantity in the calibrated plastic bottle in the kit. Normal sample volume is 500 ml of test fuel, but if the reading is off scale (on high side), sample volumes down to 100 ml in volume may be used. In the latter case, a small graduated cylinder should be used to measure the sample volume.



### RATING PROCEDURE

Remove the test pad from the holder using tweezers and press between dry paper blotters or absorbent towels to remove excess fuel. To blot, press firmly (about 5 lb. force) 3 or 4 times with heel of hand, moving the pad with tweezers each time.

For maximum accuracy, the test pad should be read within 3 minutes after sampling is initiated. If the test pad is not read immediately after sampling, it must be placed in a desiccator to prevent moisture pick up from the air. However, ratings made on dried test pads, that is, not damp with fuel, should be avoided if possible since they will give high and erroneous results. Conversely, rating a pad which has not been well blotted will give a low reading as the excess fuel will absorb part of the ultraviolet light and decrease fluorescence.

Using tweezers, put the pad into the test pad window. Turn on the lamp and press the photocell button. Continuously zero the photocell comparator by adjusting the light modulating lever until there is a steady reading for 10 to 15sec. Always move the light modulating lever in the same direction when zeroing the photocell comparator to eliminate errors caused by backlash. This may take a minute or longer. Turn off the instrument light immediately after use to conserve battery power.

The ultraviolet light must be on to get a reading. This can be verified when the selector switch is turned on. The center of the white indicator button will glow a light green if the ultraviolet tube is operating.

Record the instrument reading (estimated to the nearest tenth) and the sample volume. Record the fuel temperature at the time of the test. See section titled "Comments".

Visual observation of the used test pad is often of value. This is easily accomplished by removing the photocell comparator assembly and viewing the test pad. Free water in fuel is normally well dispersed and will form an even distribution of many small points of yellow fluorescence on the test pad when illuminated.

Large water drops, however, will form a few large spots of yellow fluorescence on the pad. These large spots may give erroneous readings; the result should be disregarded and a new sample tested.

### CALCULATION

Correct the reading if the sample volume is other than 500 ml.

$$\text{PPM free water} = \frac{\text{scale reading} \times 500}{\text{sample volume, ml.}}$$

### ASSEMBLY OF TEST PAD HOLDER

The components of the assembly must be in the following sequence:

Actuator nipple	SPEN4-2F
Hex nipple	HN2B
Toggle valve	395C
Restrictor nipple	HN2RB
Orifice end must be attached to the toggle valve.	
Test pad holder	GTP-191
Hose assembly, discharge	GTP-292

**NOTE:** The velocity of the fuel through the pad will have an influence on accuracy if the flow rate is not between 600 and 800 ml/min. The 1 mm diameter orifice in the restrictor nipple (part HN-2RB) serves to control velocity over a wide pressure range but on-site controls may be required. The orifice also serves to break up water droplets and promote uniformity of distribution on the test pad.

### STARTING THE ULTRAVIOLET LIGHT

The most significant difference between this new Series III Aqua-Glo and its predecessor, the Series II, is the selector switch on the side of the light unit. There are now 3 ways the light can be turned on, depending upon how you position a selector switch. The three positions are labeled as follows:

1. On - A.C. (Alternating Current 50 or 60 Hz, 110-120 v)
2. On - Int. Bat. (Internal Battery)
3. On - Ext. Bat. (External Battery)

Position 1 means that you can operate directly from alternating current.

Position 2 will operate the light from the built-in, internal battery.

Position 3 allows you to operate from an external battery using a wire connector, GTP-2403, supplied in the kit. This feature is especially useful if you plan to run many tests in the field and are concerned that the internal battery may not have the life you need. An external battery is not supplied with the kit but may be ordered as Model GTP-2404.

To recharge the internal battery, simply connect the wire assembly in the kit to the fitting marked "A.C. Input". A full charge requires from 14 - 16 hours.

### **CONTAINER SAMPLES**

Although we do not recommend bottle or bucket sampling if accuracy is to be achieved, it is sometimes impractical to obtain pressure to force the fuel sample through the detector pad. For this reason, we offer as an option, the model GTP-165 stainless steel syringe with an attachment fitting P/N HN25 (hex nipple). When this nipple is screwed into the outlet of the detector pad holder, the tapered fitting on the syringe will seal in the small end of the nipple. To pull a sample through the detector pad, place the entire detector pad housing in the fuel sample container and pull the syringe handle all the way out. Expel the fuel from the syringe after disconnecting it from the nipple fitting by pushing the handle all the way in while holding the syringe fitting over the polyethylene bottle in the kit. Repeat this procedure until the required fuel volume has been passed through the detector pad.

### **SPOILAGE OF WATER DETECTOR PADS**

These pads are heat sealed in triple-walled envelopes to insure that moisture from the air will not reach the sodium fluorescein. Pads that were stored for 8 years were still in good condition, but statistical studies have proved that up to 4 or 5% of the envelopes have enough water permeability to spoil the pads. This occurs in the first six months. A spoiled pad is easily identified by its yellow color. The operator should inspect every pad before it is used. If it is not *orange* in color, it must not be used. Spoiled pads will cause a high reading, if used.

### **CARE OF NEW, SERIES III ULTRAVIOLET LIGHT**

The model number of this unit is GTP-2201. It contains 4 basic items:

- Battery Pack Assembly — GTP-2324
- Light Board Assembly — GTP-2382
- Power Board Assembly — GTP-2383 (120V 50-60 HZ)
- Switch Bracket Assembly — GTP-2381
- Power Board Assembly — GTP-2383 (220V 50 HZ)

To replace anyone of these components, separate the light unit from the comparator chamber by removing 4 screws in the base. Then remove all 5 slotted head screws which hold the side cover plate on the light unit.

CARE OF ULTRAVIOLET LIGHT BATTERY (GTP-2324)

Do not leave the battery on recharge for more than 2 days without use.

Unlike the battery in the Aqua-Glo Series II Water Detector, the GTP-2324 battery is built-in and is considered a semi-permanent component. If it is ever necessary to replace it, the entire side cover of the light unit must be removed (5 screws). Then separate the wire connector having the black and red wires. The battery clamp can now be removed by first removing 2 screws, one at each end.

CARE OF THE PHOTOCCELL COMPARATOR (INSTRUMENT PACK)

Frequently wipe dust and finger marks from the green glass filters. Use a soft cloth or a bit of cotton wool. Heavy use will eventually deplete the instrument pack battery. If very frequent recalibration is necessary, this can mean that the battery is weak. If the meter responds sluggishly, this also indicates a weak battery. Replace with any good quality 9 v transistor radio battery or order our model GTP-892. Remove the 4 battery cover screws to reach the battery.

This assembly is easily damaged if it is dropped. Generally, the damage is one or more of 4 problems. Therefore, if it is dropped, the operator should inspect as follows:

1. Attachment flange bent - This can be straightened, but any black paint that is scratched must be replaced to prevent errors due to reflection. Use dull, flat black paint.
2. Green glass filters broken - Return the instrument pack to the factory for replacement.
3. Plastic lense of meter broken - Easily replaced. Order a new one from the factory.
4. Meter pivots broken or disengaged - Return the instrument pack to the factory for repair or replacement, depending upon extent of damage. To determine whether this type of damage has occurred, observe the exact position of the tip end of the pointer as the instrument is moved slowly in various positions around an orbit. If the tip of the pointer moves up and down, the pivots have been damaged.

## OTHER FLUIDS

The Aqua-Glo Water Detector Kit can be used to determine the undissolved water content of fluids that are not in the jet fuel category but there are several factors that must be considered. First of all, material comparability of the detector pad holder and its various components must be studied. The quick disconnect nipple is made of Type 303 stainless steel and the detector pad holder itself is anodized aluminum. All other components are brass. Seals are Buna N. Tubing is vinyl. Components made of other materials are available and will be quoted on request. The second consideration is the detector pad itself. Certain alcohols may remove the fluorescein coating. Strong chemicals may damage the filter paper pad itself.

Low boiling point fluids create special problems that require consideration. First of all, the volume of a fluid that evaporates rapidly cannot be determined in the open bottle that is provided in the kit. Several methods can be used, depending on the test fluid. One method is to use a sample bomb. Another is to place a graduated cylinder in a refrigerated bath. Precautions must also be taken to prevent condensation of moisture on the cold detector pad after the pad has been removed from its holder. An effective way to handle this is to immediately drop the pad in a beaker containing clean, dry kerosene. The use of kerosene as a "conditioner" is required whenever a test is to be performed on a non-jet fuel fluid. The reason is that the calibration of the Aqua-Glo scale is based on a jet fuel damp detector pad.

Heating oil and diesel fuels have a natural fluorescence that causes high readings. Accuracy can be obtained if the residual oil on the test pad is rinsed off by flushing dry kerosene through the pad after the test. See the procedure under "Container Samples". Adequate rinsing will result if the capacity of the syringe is drawn through the detector pad one or two times.

Additives in fuels, including jet fuel, have variable effects on readings. Generally, heating fuel additives tend to mask the presence of water, but experience to date indicates that additives in jet fuel tend to cause slightly high readings.

## CARE OF THE COMPARATOR CHAMBER

The inside surfaces of the chamber must be kept clean. Dust and dirt often glows brilliantly in ultraviolet light and this will cause a reading error. To test for such dirt, turn on the light in a dark room with the instrument pack removed. Remove all glowing particles, being careful not to scratch the black paint. If particles cannot be reached through the open port, remove the ultraviolet light, which is held by 4 long screws. Then remove the iris lever arm by unscrewing it. The insert on which the iris diaphragm is mounted must be removed with great care to avoid scratching the black paint. It may be necessary to gently pry upward at the end opposite the iris and shift the insert toward that end. Do not move or remove the iris diaphragm because it has been carefully positioned at the factory and cannot be adjusted in the field.

Note that there is a sliding light seal on the inside of the slot where the iris lever moves. Be sure to replace this black plastic piece when reassembling the comparator chamber.

## COMMENT

The measurement of water in jet fuel has occupied our staff for more than 30 years. We have learned from this experience that the variables are infinite and that no device or procedure has ever been developed that can be called a "referee" method. The water content of jet fuel is constantly changing as the humidity of the air above it changes.

Temperature has a substantial influence. As a general rule, 1 ppm will come out of solution in the fuel for every degree of temperature reduction. The average jet fuel will have about 70 ppm of water in solution at 70°F. At 60°F, the dissolved content is only 60 ppm. Sampling connections that are long enough to permit temperature changes will always cause anomalous results. If cooling takes place, the reading will be high and vice versa.

It is possible for free water to remain for several hours in jet fuel that is not saturated. Why water will dissolve almost instantly up to saturation in one jet fuel and not in another has never been explained.

The method that was used to calibrate the Aqua-Glo Water Detector eliminated these variables. There was no laboratory or field method that could determine undissolved water content. The method that was selected was the direct injection of a 1000 ppm water-in-fuel concentrate to the Aqua-Glo detector pad while a stream of saturated fuel was passing through the pad. To insure that the fuel was actually saturated, it was kept in a temperature controlled room in continuous contact with water in a container having a humidity controlled vent. The use of a 1000 ppm concentrate, and a hypodermic syringe to inject it, eliminated errors in measurement that would have resulted from having to measure minute quantities of water.

The Aqua-Glo Water Detector Kit has been used very extensively in the testing of filter separators. Aside from the advantage that it is fast, it completely eliminates the inaccuracy of the Karl-Fischer titration method. One problem with that method is that the fuel is usually below saturation, even after it has passed through the filter separator. If the filter separator is allowing 20 ppm of free water to pass and the fuel is 20 ppm below saturation, the Karl-Fischer results will show that there was no free water. The Aqua-Glo kit will accurately report 20 ppm.

**NOTE**

The Aqua-Glo Water Detector Kit that has been supplied to you is the new Series III model that has recently replaced the Series II. We are pleased to advise you that substantial improvements have been made in the ultraviolet light unit to insure a longer battery operating period. Other advantages are as follows:

1. The battery recharger is built into the light unit and is not a separate item. Therefore, there is no need to remove the battery to recharge it.
2. You can operate the Aqua-Glo Series III directly from 120 V, 60 Hz or 50 Hz power by turning the selector switch. If order specified 220 V, we wire the circuit accordingly, and identify the assembly with a -1 suffix, e.g. GTP-322-1 or GTP-323-1, depending upon whether it is a standard Aqua-Glo kit or a combination kit.

**CAUTION**

If it is necessary to remove the plug on the end of the power cable GTP-2304 to install one that fits your receptical, use the following table to identify the 3 conductors (wires) in the cable.

3. You can also operate from an auxiliary battery which may be carried in the field to provide supplementary power.
4. The calibration of the Aqua-Glo Water Detector is unchanged - only the ultraviolet light has been affected by these improvements.
5. Series II kits that are now in use can be modified to the new Series III configuration and will fit in the standard carrying case. Details will be announced soon.
6. You can recharge the auxiliary battery pack thru the unit, charging both internal and external batteries at the same time.

POWER CORD COLOR CODE MANUFACTURED PER U.S. STANDARD		
U.S. STANDARD		EUROPEAN STANDARD
Green	Ground	Green & Yellow
Black	Live (Hot)	Brown
White	Neutral	Blue





COMPARATOR CHAMBER

WHITE INDICATOR BUTTON

CENTER IS GREEN IF ULTRAVIOLET TUBE IS OPERATING

LIGHT MODULATING LEVER

(IRIS LEVER)

SELECTOR SWITCH

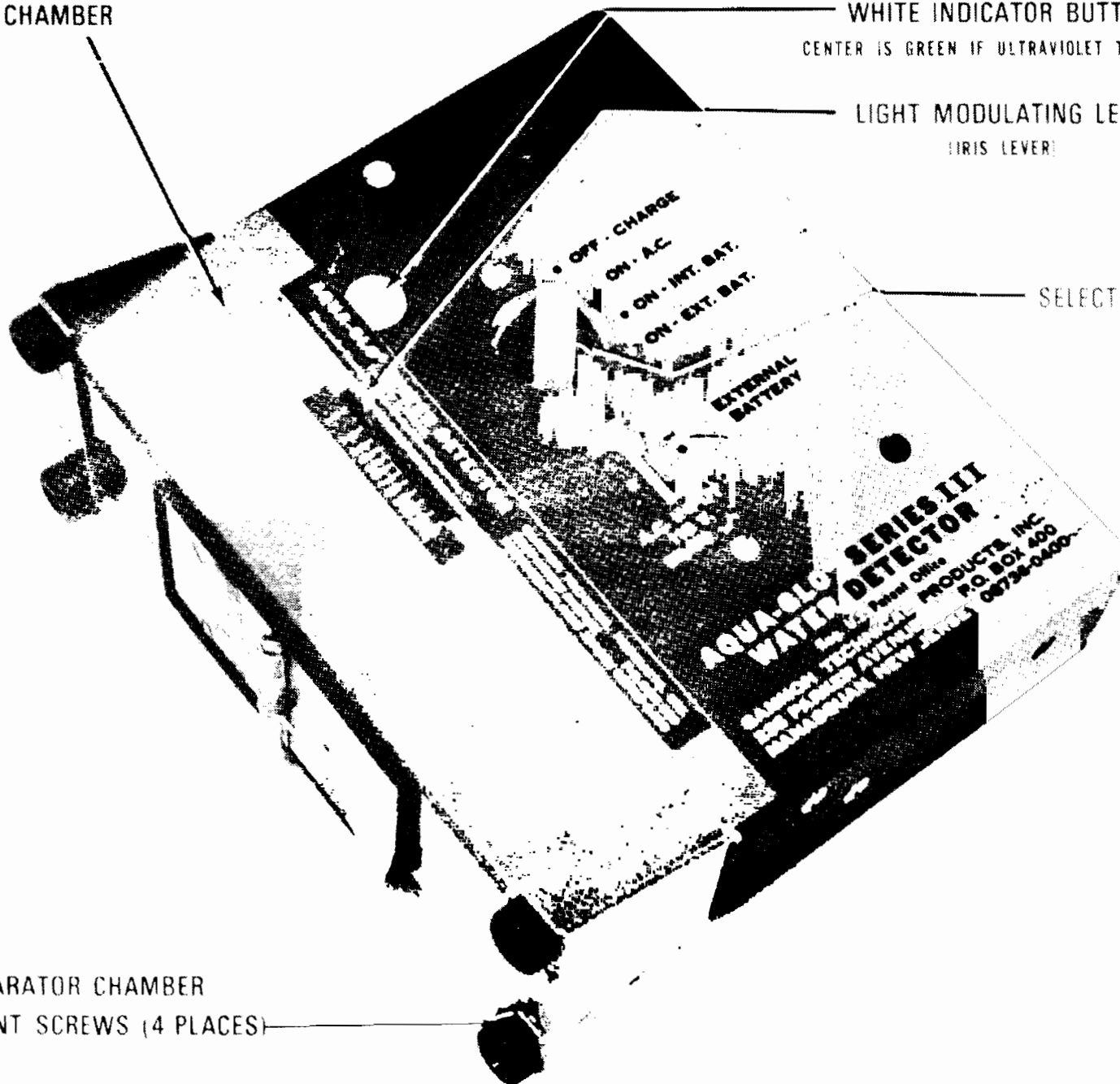

COMPARATOR CHAMBER  
ATTACHMENT SCREWS (4 PLACES)

FIGURE 1

POWER BOARD ASSEMBLY  
GTP-2383

BATTERY PACK ASSEMBLY GTP-2384

BATTERY CLAMP

SWITCH BRACKET ASSEMBLY GTP-2381

LIGHT BOARD ASSEMBLY GTP-2382

FIGURE 2

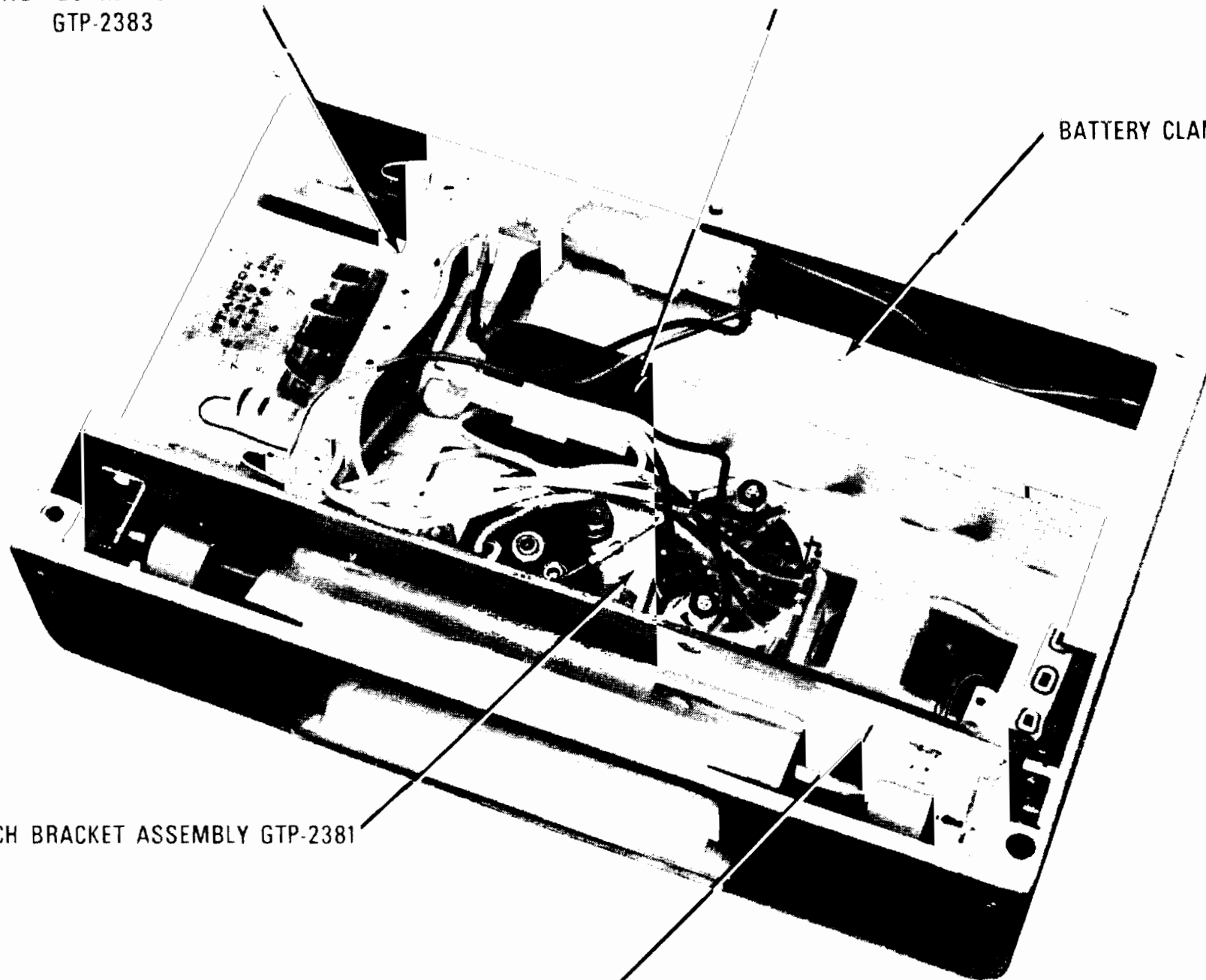

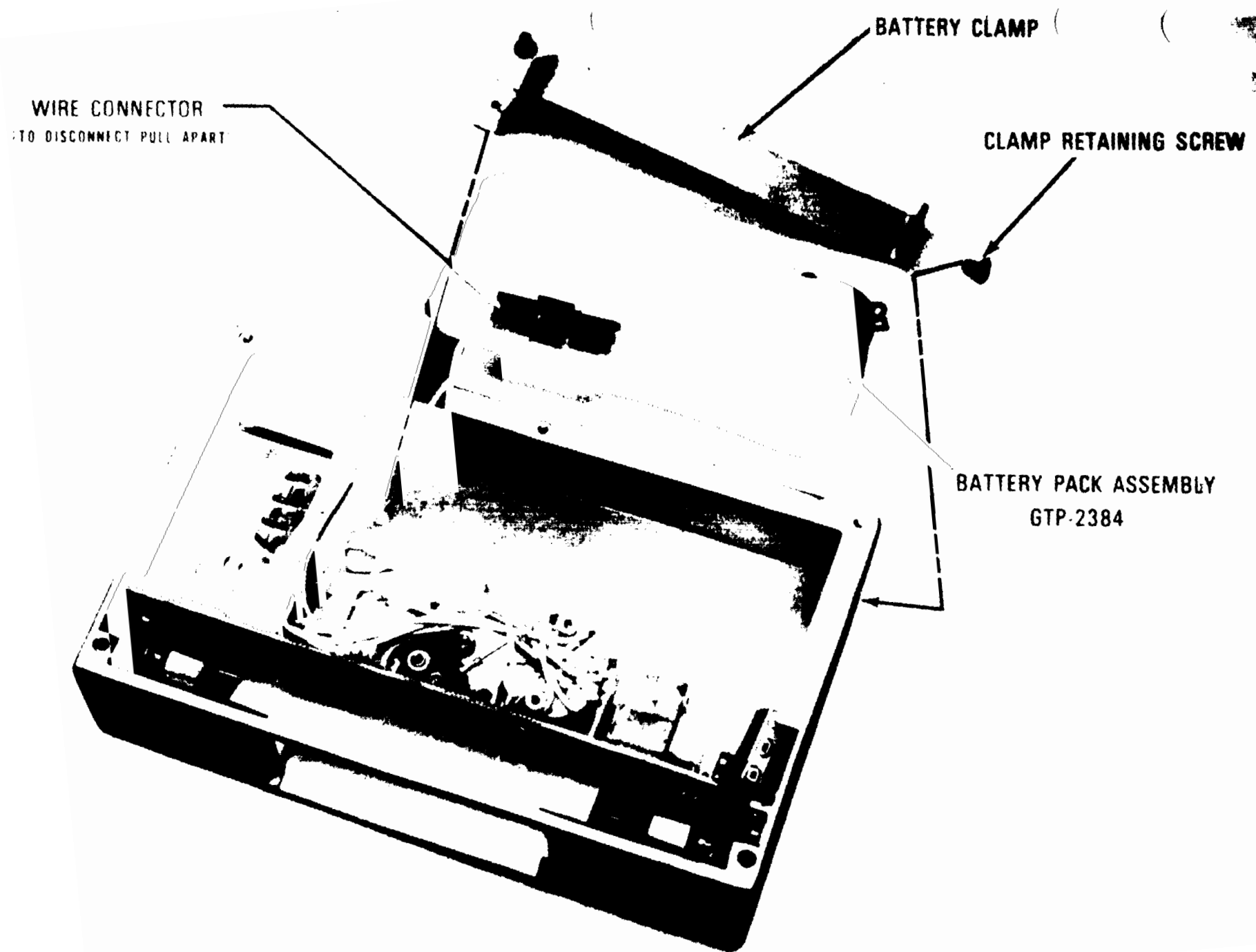
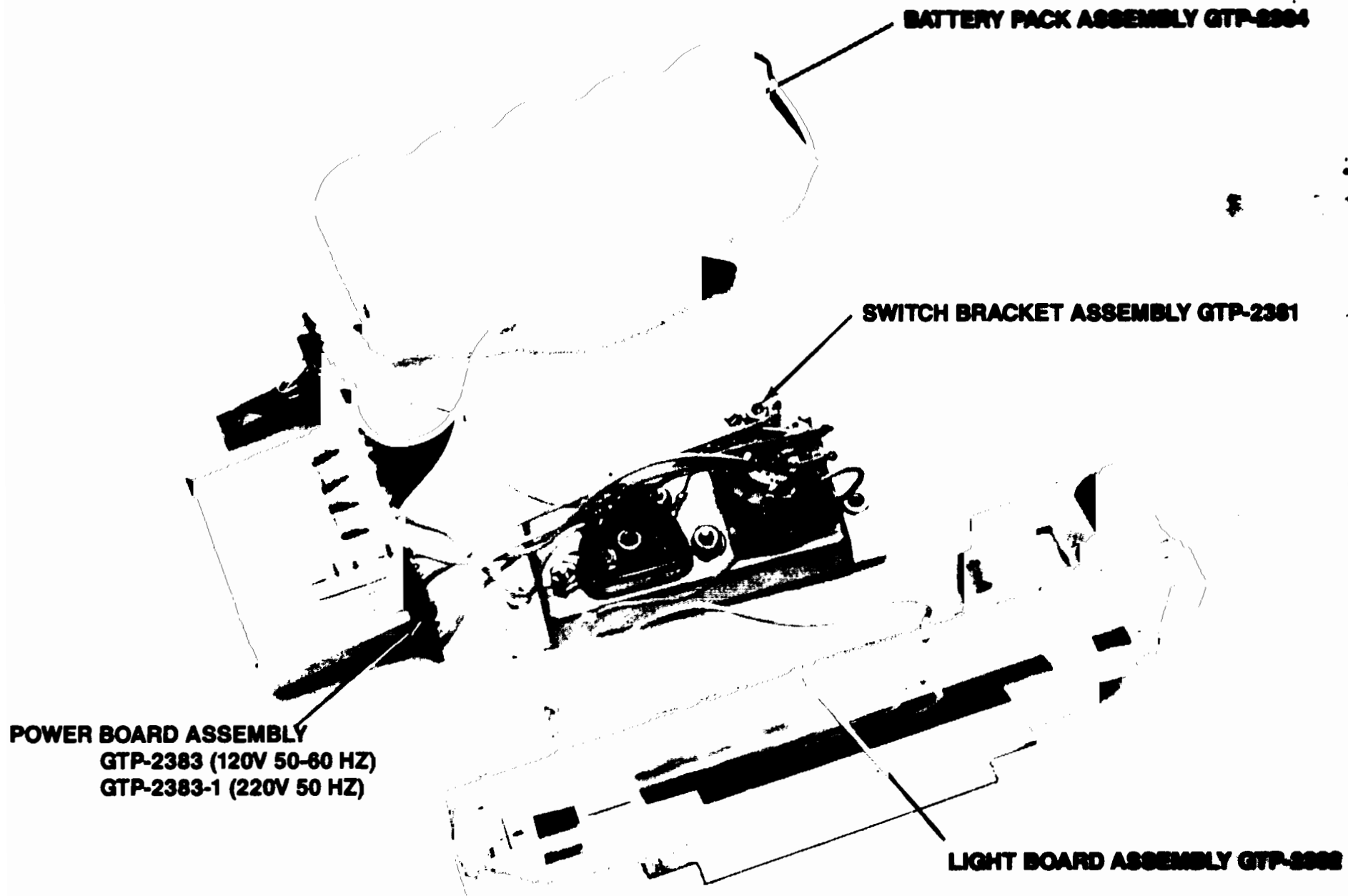
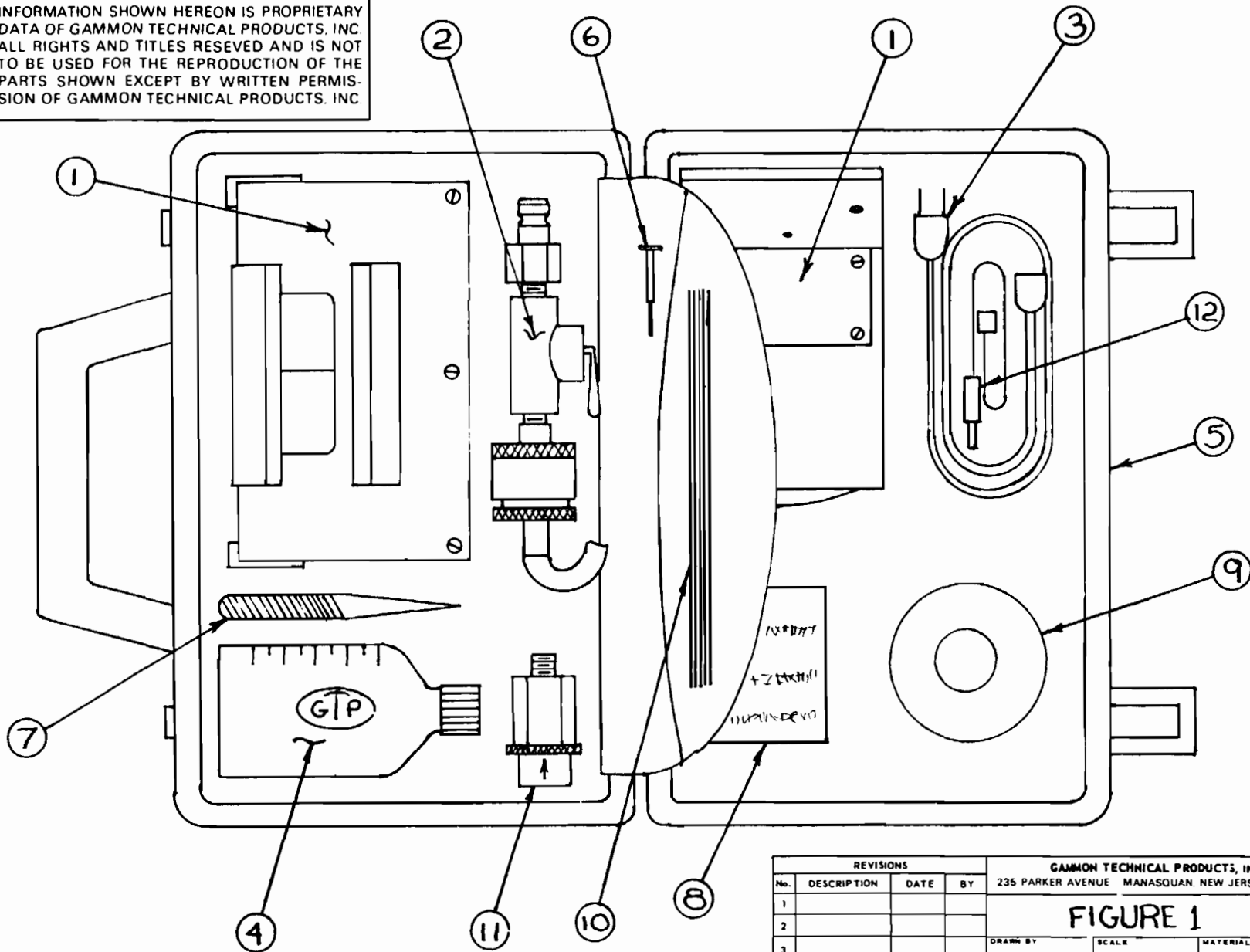

FIGURE 3



**FIGURE 4**

INFORMATION SHOWN HEREON IS PROPRIETARY DATA OF GAMMON TECHNICAL PRODUCTS, INC. ALL RIGHTS AND TITLES RESEVED AND IS NOT TO BE USED FOR THE REPRODUCTION OF THE PARTS SHOWN EXCEPT BY WRITTEN PERMISSION OF GAMMON TECHNICAL PRODUCTS, INC.



REVISIONS				GAMMON TECHNICAL PRODUCTS, INC.		
No.	DESCRIPTION	DATE	BY	235 PARKER AVENUE MANASQUAN, NEW JERSEY 08736		
1				<b>FIGURE 1</b> DRAWN BY _____ SCALE _____ MATERIAL _____ CHG'D. _____ DATE _____ DRAWING NO. _____ SHEET OF _____ APP'D. _____		
2						
3						
4						
5						

INFORMATION SHOWN HEREON IS PROPRIETARY DATA OF GAMMON TECHNICAL PRODUCTS, INC. ALL RIGHTS AND TITLES RESEVED AND IS NOT TO BE USED FOR THE REPRODUCTION OF THE PARTS SHOWN EXCEPT BY WRITTEN PERMISSION OF GAMMON TECHNICAL PRODUCTS, INC.

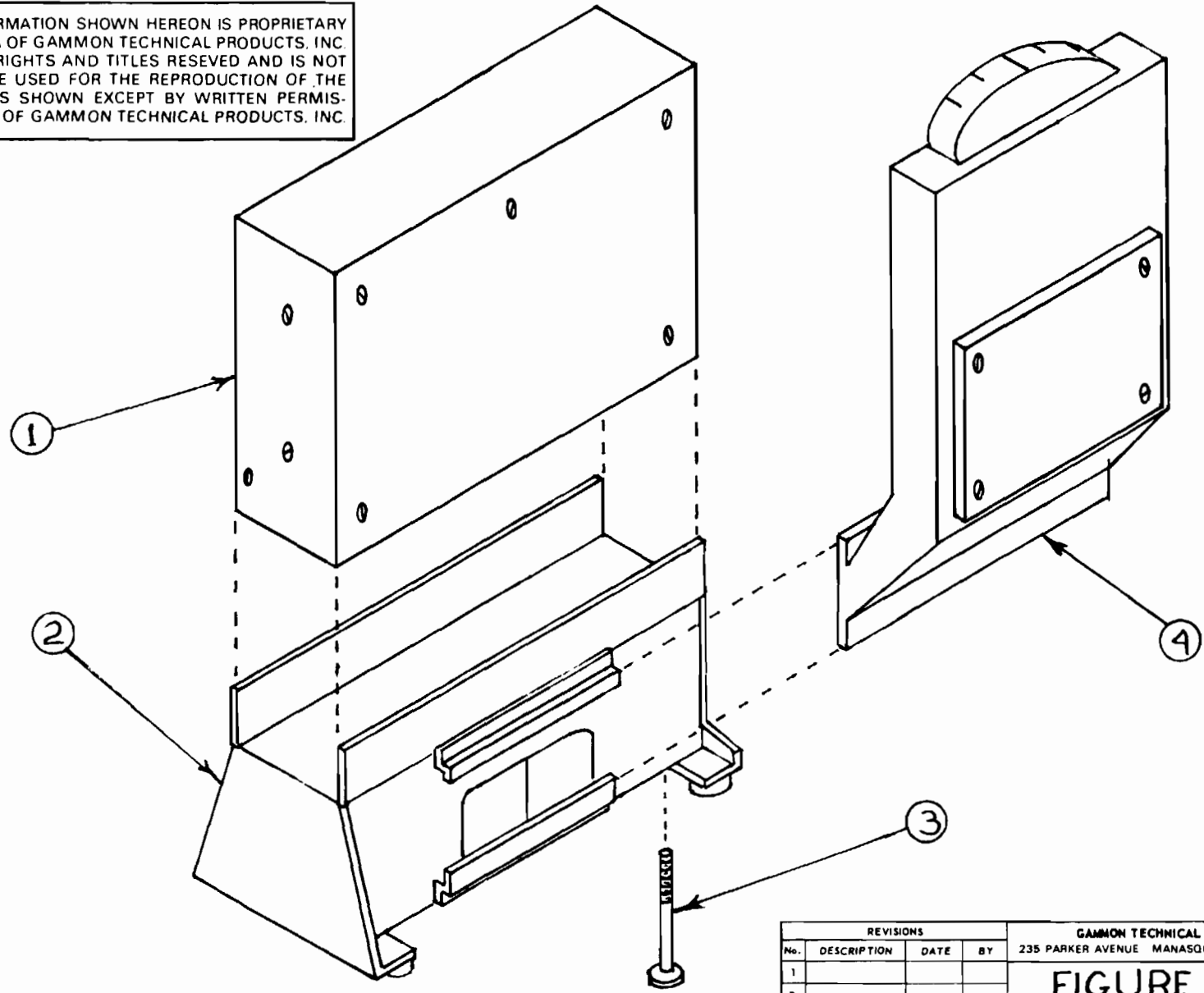

REVISIONS				GAMMON TECHNICAL PRODUCTS, INC.		
No.	DESCRIPTION	DATE	BY	235 PARKER AVENUE MANASQUAN, NEW JERSEY 08736		
1				<b>FIGURE 2</b>		
2						
3				DRAWN BY	SCALE	MATERIAL
4				CHK'D.	DATE	DRAWING NO.
5				SHEET	OF	APP'D.

INFORMATION SHOWN HEREON IS PROPRIETARY DATA OF GAMMON TECHNICAL PRODUCTS, INC. ALL RIGHTS AND TITLES RESEVED AND IS NOT TO BE USED FOR THE REPRODUCTION OF THE PARTS SHOWN EXCEPT BY WRITTEN PERMIS- SION OF GAMMON TECHNICAL PRODUCTS, INC.

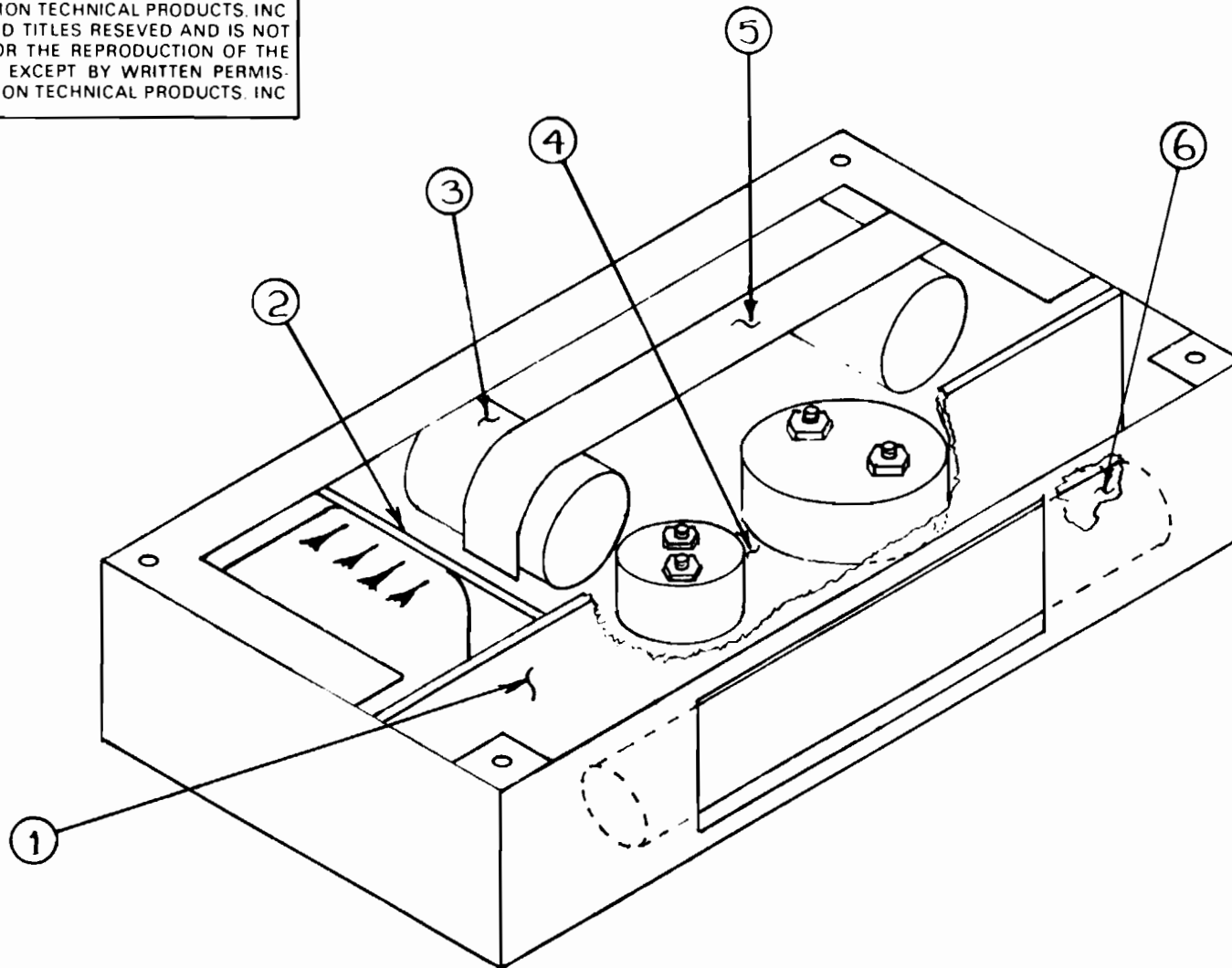

REVISIONS				GAMMON TECHNICAL PRODUCTS, INC.		
No.	DESCRIPTION	DATE	BY	235 PARKER AVENUE MANASQUAN, NEW JERSEY 08736		
1				<b>FIGURE 3</b> <small>DRAWN BY      SCALE      MATERIAL</small> <small>CHK'D.      DATE      DRAWING NO.</small> <small>SHEET      OF      APP'D.</small>		
2						
3						
4						
5						

INFORMATION SHOWN HEREON IS PROPRIETARY DATA OF GAMMON TECHNICAL PRODUCTS, INC. ALL RIGHTS AND TITLES RESEVED AND IS NOT TO BE USED FOR THE REPRODUCTION OF THE PARTS SHOWN EXCEPT BY WRITTEN PERMISSION OF GAMMON TECHNICAL PRODUCTS, INC.

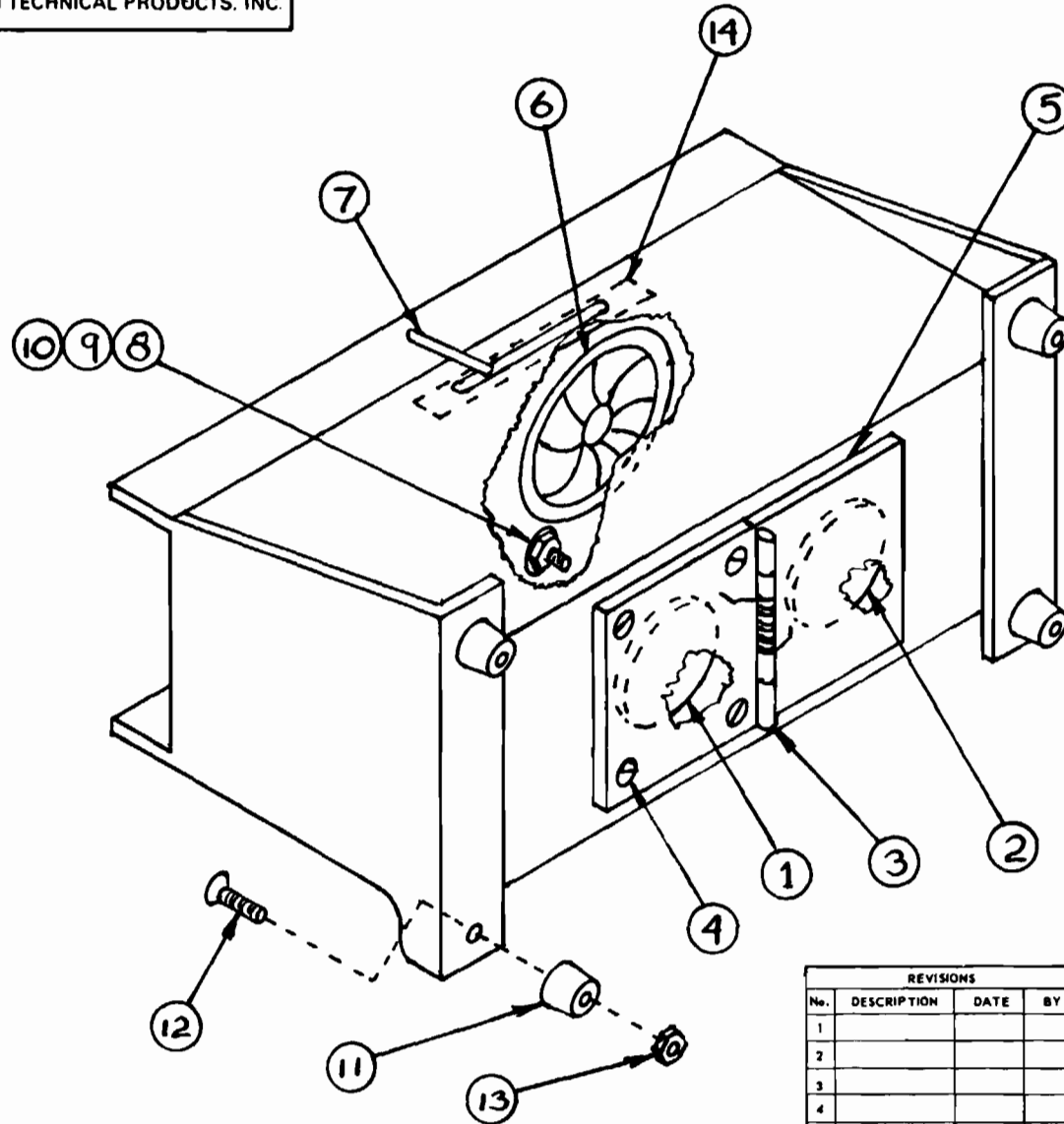

REVISIONS				GAMMON TECHNICAL PRODUCTS, INC.		
No.	DESCRIPTION	DATE	BY	235 PARKER AVENUE MANASQUAN, NEW JERSEY 08736		
1				<b>FIGURE 4</b>		
2						
3				DRAWN BY	SCALE	MATERIAL
4				CHK'D.	DATE	DRAWING NO.
5				SHEET	OF	APP'D.



INFORMATION SHOWN HEREON IS PROPRIETARY DATA OF GAMMON TECHNICAL PRODUCTS, INC. ALL RIGHTS AND TITLES RESEVED AND IS NOT TO BE USED FOR THE REPRODUCTION OF THE PARTS SHOWN EXCEPT BY WRITTEN PERMISSION OF GAMMON TECHNICAL PRODUCTS, INC

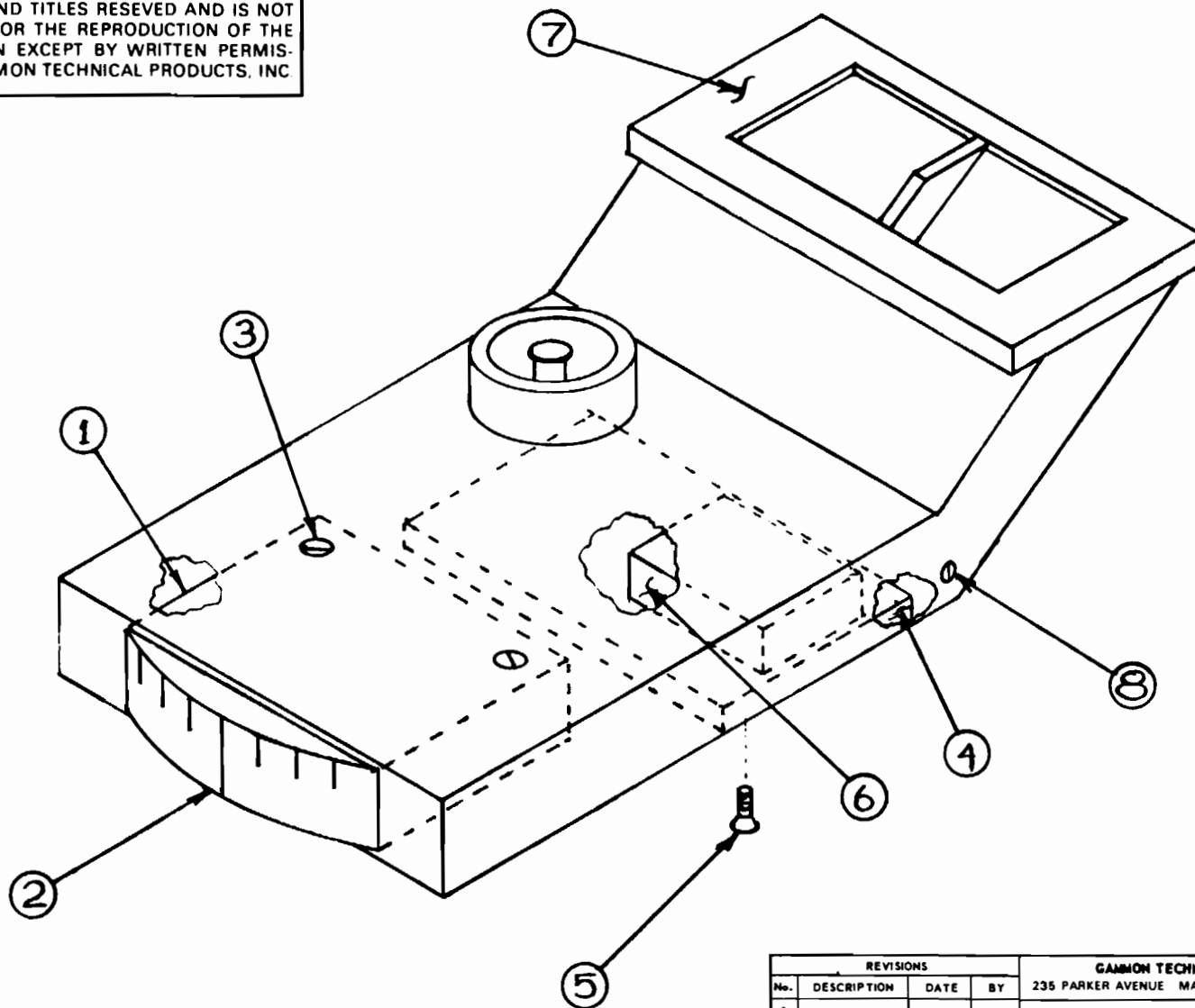

REVISIONS				GAMMON TECHNICAL PRODUCTS, INC.		
No.	DESCRIPTION	DATE	BY	235 PARKER AVENUE MANASQUAN, NEW JERSEY 08736		
1				<b>FIGURE 5</b>		
2						
3				DRAWN BY	SCALE	MATERIAL
4				CHK'D.	DATE	DRAWING NO.
5				SHEET	OF	APP'D.

INFORMATION SHOWN HEREON IS PROPRIETARY DATA OF GAMMON TECHNICAL PRODUCTS, INC. ALL RIGHTS AND TITLES RESEVED AND IS NOT TO BE USED FOR THE REPRODUCTION OF THE PARTS SHOWN EXCEPT BY WRITTEN PERMIS- SION OF GAMMON TECHNICAL PRODUCTS, INC.

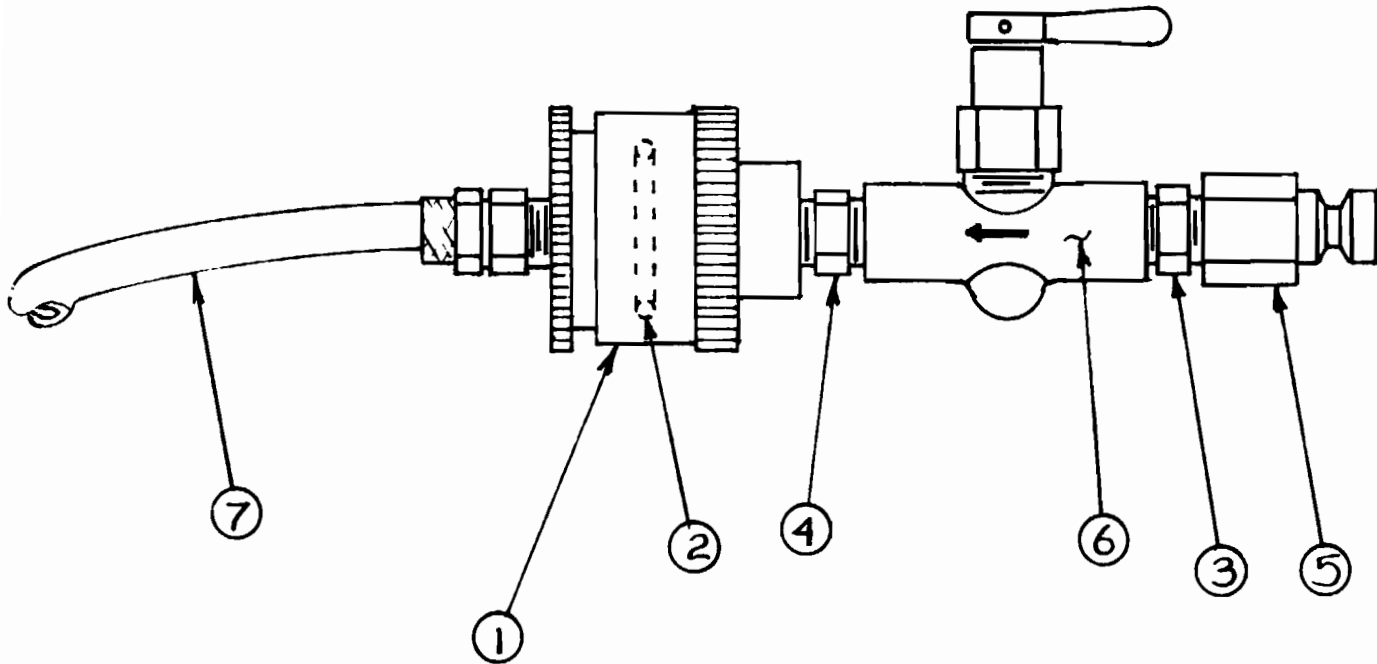

REVISIONS				GAMMON TECHNICAL PRODUCTS, INC.					
No.	DESCRIPTION	DATE	BY	235 PARKER AVENUE MANASQUAN, NEW JERSEY 08736					
1				<b>FIGURE 6</b>					
2									
3							DRAWN BY	SCALE	MATERIAL
4							CHK'D.	DATE	DRAWING NO.
5							SHEET	OF	APP'D.

GAMMON TECHNICAL PRODUCTS INC.  
 235 PARKER AVE. P.O.BOX 400 MANASQUAN, N.J. 08736

PARTS LIST BULLETIN 80-77  
 REPLACEMENTS FOR AQUA-GLO SERIES III KIT GTP-322

CABLE ADDRESS: GAMMONTECH-MANASQUAN  
 TELEEX: 132484 GAMMONTEC-MNQN (201)223-4600

ILLUSTRATION

FIG. NO.	ITEM NO.	DESCRIPTION	PART NO.	QTY/UNIT
1	1	AQUA-GLO SERIES III ASSEMBLY	GTP-766	
2	1	ULTRA-VIOLET LIGHT	GTP-2405	
1	1	AQUA-GLO SERIES III ASSEMBLY	GTP-766	
2	1	ULTRA-VIOLET LIGHT	GTP-2405	
3	1	LIGHT BOARD ASSEMBLY	GTP-2382	1
3	2	POWER BOARD ASSEMBLY (120V 50-60HZ)	GTP-2383	1
		POWER BOARD ASSEMBLY (220V 50HZ)	GTP-2383-1	1
3	3	BATTERY PACK ASSEMBLY	GTP-2324	1
3	4	SWITCH BRACKET ASSEMBLY	GTP-2381	1
3	5	BATTERY BRACKET	GTP-2203	1
3	6	ULTRA-VIOLET TUBE	GTP-2380	1
2	2	COMPARATOR CHAMBER	GTP-767	1
4	1	FLOURESCING STANDARD	GTP-763	1
4	2	CALIBRATION STANDARD	GTP-764	1
4	3	HINGE	GTP-240	1
4	4	HINGE RETAINING SCREW	GTP-894-4	4
4	5	LIGHT SHIELD W/INSTALLATION INSTRUCTION (NOTE: THIS IS AN IMPROVED PART USED UNDER THE HINGE PLATE TO AVOID LEAKAGE OF OUTSIDE LIGHT LEAKING INTO THE CHAMBER AND CAUSING ERRONEOUS READINGS.)	GTP-1927	1
4	6	IRIS DIAPHRAGM ASSEMBLY W/INSTALLATION INSTRUCTION.	GTP-897	1
4	7	IRIS	GTP-785	1
4	8	WASHER	GTP-2214-1	1
4	9	LOCK WASHER	GTP-2214-2	1
4	10	NUT	GTP-895-2	1
-	-	IRIS MOUNTING GAUGE USED TO POSTION IRS DIAPHRAGM IF IT HAS BEEN RE- MOVED. IN ABSENCE OF THIS GAUGE, ONE CAN BE CON- STRUCTION. SEE IRIS INSTALLATION INSTRUCTIONS.	GTP-2215	
4	11	FEEET	GTP-898	4
4	12	SCREW	GTP-894-7	4
4	13	NUT	GTP-895-2	4
4	14	CALIBRATION TAPE W/INSTRUCTIONS	GTP-2219	1
2	3	UV LIGHT ATTACHMENT SCREWS	GTP-894-8	4

ILLUSTRATION	ITEM NO.		PART NO.	QTY/UNIT
2	4	INSTRUMENT PACK	GTP-768	
5	1	METER	GTP-890	1
5	2	METER LENS	GTP-2216	1
5	3	METER ATTACHMENT SCREW	GTP-894-1	2
5	4	BATTERY COVER	GTP-309	1
5	5	BATTERY COVER SCREW	GTP-894-3	4
5	6	BATTERY	GTP-892	1
5	7	FELT GASKET W/INSTALLATION INSTRUCTION	GTP-885	1
5	8	POTENTIOMETER PLUG SCREW	GTP-894-5	1
1	2	DETECTOR PAD HOLDER ASSEMBLY	GTP-191	
6	1	DETECTOR PAD HOLDER	GTP-191A	1
6	2	O-RING	GTP-123	
6	3	HEX NIPPLE	HN-2B	1
6	4	RESTRICTOR ORIFICE	HN-2RB	1
6	5	QUICK DISCONNECT ACTUATOR NIPPLE	SPEN4-2F	1
6	6	TOGGLE VALVE	395C	1
6	7	OUTLET HOSE ASSEMBLY	GTP-292	1
1	3	POWER CORD, 120 V, 60HZ	GTP-2402	1
1	4	CALIBRATED SAMPLE BOTTLE, WITH CAP	GTP-294	1
1	5	CARRYING CASE	GTP-761	1
1	6	JEWELERS SCREWDRIVER (IN PACKET)	GTP-765	1
1	7	TWEEZERS	GTP-293	1
1	8	WATER DETECTOR PAD	*GTP-25	50
1	9	TEFLON PIPE THREAD SEALANT	GTP-814	1
1	10	INSTRUCTION BOOKLET	BULLETING 80-76	1
1	11	QUICK DISCONNECT COUPLER (WAS SVEC4-4M)	GTP-992-4M	1
1	12	EXTERNAL BATTERY POWER CORD	GTP-2403	1

\*P/N GTP-25 CONTAINS 50 TEST PADS-ONLY 25 ARE INCLUDED IN THE KIT GTP-322

APPENDIX A

REFERENCES

A-1. **Scope.** This appendix contains all forms, pamphlets and technical manuals referenced in both the Air mobile and Semitrailer mounted Laboratories.

A-2. **Forms.**

Recommended Changes to Publications . . . . .	DA Form 2028 DA Form 2028-2
Quality Deficiency Report . . . . .	.SF368
Equipment Inspection and Maintenance Work Sheet . . . . .	DA Form 2404
Hand Receipts . . . . .	DA Form 2062

A-3. **Field Manuals.**

Petroleum Testing Facilities:

Laboratories and Kits . . . . .	FM 10-72
Inspecting and Testing Petroleum Products . . . . .	FM 10-70
ASTM Test Method Supplement to. . . . .	FM 10-92C1/C2

A-4. **Technical Manuals.**

Atlas-Copco Compressor . . . . .	TM10-4310-392-13&P
Alcor Jet Fuel Thermal Oxidation Tester Operating and Maintenance Manual . . . . .	TM10-6635-210-13&P
Bacharach Gas Alarm and Calibration Data . . . . .	TM10-6665-297-13&P
Brother Portable Typewriter . . . . .	TM10-7430-218-13&P
Chemtrix Field Ph Meter . . . . .	TM10-6630-237-13&P
Elkay Manufacturing 30 GPH Cooler . . . . .	TM10-4130-240-13&P
Emcee Micro Separometer . . . . .	TM10-6640-222-13&P
Foxboro Pressure Recording Gauge . . . . .	TM10-6685-365-13&P
Gammon Aqua Glo Water Detector . . . . .	TM10-6640-221-13&P
Gammon Mini Monitor Fuel Sampling Kit . . . . .	TM10-6630-230-13&P
Jelrus Burn-Out Furnace . . . . .	TM10-6640-231-13&P
Koehler Cleveland Open Tester . . . . .	TM10-6630-236-13&P
Koehler Cloud and Pour Point Chamber . . . . .	TM10-6630-238-13&P
Koehler Copper Strip Corrosion Bomb Bath . . . . .	TM10-6640-220-13&P
Koehler Distillation Apparatus . . . . .	TM10-6630-233-13&P
Koehler Dropping Point Apparatus . . . . .	TM10-6635-211-13&P
Koehler Electric Pensky-Martins Tester . . . . .	TM10-6630-231-13&P
Koehler Foaming Characteristics Determination Apparatus . . . . .	TM10-6640-228-13&P
Koehler Kinematic Viscosity Bath . . . . .	TM10-6630-239-13&P
Koehler Tag Closed Cup Flash Tester . . . . .	TM10-6630-235-13&P
Lab-Line Explosion Proof Refrigerator . . . . .	TM10-6640-219-13&P
Lily Freezer . . . . .	TM10-6640-234-13&P
Millipore OM 39 Filter Holder . . . . .	TM 10-6640-225-13&P
Millipore Vacuum Pump . . . . .	TM10-6640-217-13&P
Ohaus Harvard Trip Balance . . . . .	TM 10-6670-278-13&P
Precision Gas-Oil Distillation Test Equipment . . . . .	TM10-6630-219-13&P
Precision General Purpose Water Bath . . . . .	TM10-6640-229-13&P

**TM 10-6640-221-13&P**

Precision High Temperature Bronze Block Gum Bath .....	TM10-6630-234-13&P
Precision General Purpose Ovens .....	TM10-6640-218-13&P
Precision Heater Instruction Manual and Parts List .....	TM10-6640-223-13&P
Precision Oxidation Stability Bath .....	TM10-6640-232-13&P
Precision Pensky-Martens Flash Testers .....	TM10-6630-231-13&P
Precision Reid Vapor Pressure Bath .....	TM10-6640-226-13&P
Precision Slo-Speed Stirrer .....	TM10-6640-224-13&P
Precision Universal Centrifuge .....	TM10-6640-230-13&P
Precision Universal Penetrometer .....	TM10-6640-228-13&P
Sargent-Welch Vacuum Pump .....	TM10-4310-391-13&P
Sartorius Analytical Balance .....	TM10-6670-277-13&P
Scotsman Cuber .....	TM10-6640-227-13&P
Soltec VOM-Multimeter .....	TM10-6625-3127-13&P
Teel Self-Priming Centrifugal Pump .....	TM10-6640-217-13&P
Teel Submersible Pump .....	TM10-4320-320-13&P
Texas Instrument TI-5030II Calculator .....	TM10-7420-210-13&P

**A-5. Pamphlets.**

The Army Maintenance Management System (TAMMS) .....	DA Pam 738-750
--	----------------

**A-6. Miscellaneous Publications.**

The Army Integrated Publishing and Printing Program .....	AR 25-30
Laboratory, Airmobile, Aviation Fuel .....	MIL-L-52733A(ME)
Apparatus, Instruments, Chemicals, Furniture, and Supplies for Industrial, Clinical, College and Government Laboratories .....	Fisher Scientific Laboratories Catalog
Petroleum-Petrochemical Testing Equipment .....	Precision Scientific Catalog

## APPENDIX B

## MAINTENANCE ALLOCATION CHART

## Section I. INTRODUCTION

B-1. **General.**

a. This section provides a general explanation of all maintenance and repair functions authorized at various maintenance categories.

b. The Maintenance Allocation Chart (MAC) in Section II designates overall authority and responsibility for the performance of maintenance functions on the identified end item or component. The application of the maintenance functions to the end item or component will be consistent with the capacities and capabilities of the designated maintenance categories.

c. Section III lists the tools and test equipment (both special tools and common tool sets) required for each maintenance function as referenced from Section II.

d. Section IV contains supplemental instructions and explanatory notes for a particular maintenance function.

B-2. **Maintenance Functions.** Maintenance functions will be limited to and defined as follows:

a. Inspect To determine the serviceability of an item by comparing its physical, mechanical, and/or electrical characteristics with established standards through examination (e.g., by sight, sound, or feel).

b. Test. To verify serviceability by measuring the mechanical, pneumatic, hydraulic, or electrical characteristics of an item and comparing those characteristics with prescribed standards.

c. Service. Operations required periodically to keep an item in proper operating condition, i.e., to clean (includes decontaminate, when required), to preserve, to drain, to paint, or to replenish fuel, lubricants, chemical fluids, or gases.

d. Adjust. To maintain or regulate, within prescribed limits, by bringing into proper or exact position, or by setting the operating characteristics to specified parameters.

e. Align. To adjust specified variable elements of an item to bring about optimum or desired performance.

f. Calibrate. To determine and cause corrections to be made or to be adjusted on instruments or test, measuring, and diagnostic equipments used in precision measurement. Consists of comparisons of two instruments, one of which is a certified standard of knob accuracy, to detect and adjust any discrepancy in the accuracy of the instrument being compared.

g. Remove/Install. To remove and install the same item when required to perform service or other maintenance functions. Install may be the act of emplacing, seating, or fixing into position a spare, repair part, or module (component or assembly) in a manner to allow the proper functioning of an equipment or system.

h. Replace. To remove an unserviceable item and install a serviceable counterpart in its place. "Replace" is authorized by the MAC and is shown as the third position code of the SMR code.

i. Repair. The application of maintenance services, <sup>1</sup>including fault location/troubleshooting,<sup>2</sup> removal/installation, and disassembly/assembly procedures<sup>3</sup> and maintenance actions,<sup>4</sup> to identify troubles and restore serviceability to an item by correcting specific damage, fault, malfunction, or failure in a part, subassembly, module (component or assembly), end item, or system.

j Overhaul. That maintenance effort (service/action) prescribed to restore an item to a Completely serviceable/operational condition as required by maintenance standards in appropriate technical publications (i.e, DMWR). Overhaul is normally the highest degree of maintenance performed by the Army. Overhaul does not normally return an item to like-new condition.

k. Rebuild. Consists of those services/actions necessary for the restoration of unserviceable equipment to a like-new condition in accordance with original manufacturing standards. Rebuild is the highest degree of materiel maintenance applied to Army equipment. The rebuild operation includes the act of returning to zero those age measurements (hours/miles, etc.) considered in classifying Army equipment/components.

### B-3. Explanation Of Columns In The MAC, Section II.

a. Column 1. Group Number. Column 1 lists functional group code numbers, the purpose of which is to identify maintenance significant components, assemblies, subassemblies, and modules with the next higher assembly. End item group number shall be "00."

b. Column 2. Component/Assembly. Column 2 contains the names of components, assemblies, subassemblies, and modules for which maintenance is authorized.

c. Column 3. Maintenance Function. Column 3 lists the functions to be performed on the item listed in column 2. (For a detailed explanation of these functions, see paragraph B-2.)

d. Column 4. Maintenance C-. Column 4 specifies, by the listing of a work time figure in the appropriate subcolumn(s), the category of maintenance authorized to perform the function listed in column 3. This figure represents the active time required to perform that maintenance function at the indicated category of maintenance. If the number or complexity of the tasks within the listed maintenance function vary at different maintenance categories, appropriate work time figures will be shown for each category. The work time figure represents the average time required to restore an item (assembly, subassembly, component, module, end item, or system) to a serviceable condition under typical field operating conditions. This time includes preparation time (including any necessary disassembly/assembly time), troubleshooting/fault location time, and quality assurance/quality control time in addition to the time required to perform the specific tasks identified for the maintenance functions authorized in the maintenance allocation chart. The symbol designations for the various maintenance categories are as follows:

---

<sup>1</sup>Services - inspect, test, service, adjust, align, calibrate, and/or replace.

<sup>2</sup>Fault locate/troubleshoot-the process of investigating and detecting the cause of equipment malfunctioning; the act of isolating a fault within a system or unit under test (UUT).

<sup>3</sup> Disassemble/assemble – encompasses the step-by-step taking apart (or breakdown) of a spare/functional group coded item to the level of its least component identified as maintenance significant (i. e., assigned an SMR code) for the category of maintenance under consideration.

<sup>4</sup>Actions – welding, grinding, riveting, straightening, facing, remachining, and/or resurfacing.



- C ..... Operator/Crew
- O ..... Unit Maintenance
- F ..... Direct Support Maintenance
- H ..... General Support Maintenance
- D ..... Depot Maintenance

e. Column 5 Tools and Equipment. Column 5 specifies, by code, those common tool sets (not individual tools) and special tools, TMDE, and support equipment required to perform the designated function.

f. Column 6. Remarks. This column shall, when applicable, contain a letter code, in alphabetic order, which shall be keyed to the remarks contained in section IV.

**B-4. Explanation Of Columns In Tool And Test Equipment Requirements, Section III.**

a. Column 1. Reference Code. The tool and test equipment reference code correlates with a code used in the MAC, section II, column 5.

b. Column 2. Maintenance Category. - The lowest category of maintenance authorized to use the tool or test equipment.

c. Column 3. Nomenclature. Name or identification of the tool or test equipment.

d. Column 4. National Stock Number. The National stock number of the tool or test equipment.

e. Column 5. Tool Number. The manufacturer's part number.

**B-5. Explanation Of Columns In Remarks, Section IV.**

a. Column 1. Reference Code. The code recorded in column 6, Section II.

b. Column 2. Remarks. This column lists information pertinent to the maintenance function being performed as indicated in the MAC, section II.

**Section II. MAINTENANCE ALLOCATION CHART**

(1) GROUP NUMBER	(2) COMPONENT/ ASSEMBLY	(3) MAINTENANCE FUNCTION	(4) MAINTENANCE LEVEL					(5) TOOLS AND EQUIPMENT	(6) REMARKS
			UNIT		DS	GS	DEPOT		
			c	o	F	H	D		
01	WATER DETECTOR KIT	INSPECT TEST REPLACE REPAIR CALIBRATE	0.1 0.3	0.3	2.0			1	A

**Section III. TOOL AND TEST EQUIPMENT REQUIREMENTS  
FOR  
MAINTENANCE ALLOCATION CHART**

(1) TOOL/TEST EQUIP. REF CODE	(2) MAINTENANCE CATEGORY	(3) NOMENCLATURE	(4) NSN	(5) TOOL NUMBER
1	F	TOOL KIT, GENERAL AUTOMOTIVE	5180-00-177-7033	(50980) SC SC 5180-90- CL-N26

**Section IV. REMARKS**

REFERENCE CODE	REMARKS
A	Repairs at this level may require use of commercial activity.

## APPENDIX C

## COMPONENTS OF END ITEM AND BASIC ISSUE ITEMS LISTS

## Section I. INTRODUCTION

C-1. **Scope.**

This appendix lists components of end item and basic issue items for the Aqua Glo Water Detector to help you inventory items required for safe and efficient operation.

C-2. **General.**

The Components of End Item and Basic Issue Items Lists are divided into the following sections:

a. Section II Components of End Item. This listing is for informational purposes only, and is not authority to requisition replacements. These items are part of the end item, but are removed and separately packaged for transportation or shipment. As part of the end item, these items must be with the end item whenever it is issued or transferred between property accounts. Illustrations are furnished to assist you in identifying the items.

b. Section III. Basic Issue Items. These are the minimum essential items required to place the Aqua Glo Water Detector in operation, to operate it, and to perform emergency repairs. Although shipped separately packaged, BII must be with the shelter during operation and whenever it is transferred between property accounts. The illustrations will assist you with hard-to-identify items. This manual is your authority to request/requisition replacement BII, based on TOE/MTOE authorization of the end item.

C-3. **Explanation of Columns.**

The following provides an explanation of columns found in the tabular listings:

a. Column (1) – Illustration Number (Illus Number). This column indicates the number of the illustration in which the item is shown.

b. Column (2) – National Stock Number. Indicates the National stock number assigned to the item and will be used for requisitioning purposes.

c. Column (3) – Description. Indicates the Federal item name and, if required, a minimum description to identify and locate the item. The last line for each item indicates the CAGEC (in parentheses) followed by the part number.

d. Column (4) – Unit of Measure (U/M). Indicates the measure used in performing the actual operational/maintenance function. This measure is expressed by a two-character alphabetical abbreviation (e.g., ea, in, pr).

e. Column (5) – Quantity required (QTY RQR). Indicates the quantity of the item authorized to be used with/on the equipment.

SECTION II. COMPONENTS OF END ITEM

(1) ILLUS	NUMBER	(2) NATIONAL STOCK CAGEC AND PART NUMBER	USABLE ON CODE	(4) U/M	(5) QTY
		ACTUATOR NIPPLE (32218) SPEN4-2F		EA	1
		HEX NIPPLE (32218) H7V 2B		EA	1
		TOGGLE VALVE (32218) 395C		EA	1
		RESTRICTOR NIPPLE (32218) HN 2RB		EA	1
		TEST PAD HOLDER (32218) GTP191		EA	1
		HOSE ASSEMBLY DISCHARGE (32218) GTP-292		EA	1
	6665-00-410-4951	DETECTOR ELEMENT, GENERAL PURPOSES (05083) NO. 800-080-20		EA	1
	6640-00-235-3820	PAD, WATER DETECTOR KIT (32218) GTP-25		BX	3
	6640-00-360-0021	TONG, LABORATORY: UTILITY; 7 IN. LONG WITH SERRATED STIRRUP JAWS; (22527) 15-202		EA	1
		BOTTLE, WASHING: POLYETHYLENE GRADUATED, 500ML (15747) 62757E		EA	1

SECTION III. BASIC ISSUE ITEMS

NOT APPLICABLE

APPENDIX D  
ADDITIONAL AUTHORIZATION LIST  
NOT APPLICABLE



## APPENDIX E

## EXPENDABLE/DURABLE SUPPLIES AND MATERIALS LIST

## Section I. INTRODUCTION

E-1. **Scope.** This listing is for informational purposes only and is not authority to requisition the listed items. These items are authorized to you by CTA 50-970, Expendable/Durable Items (except medical, class V, repair parts, and heraldic items).

E-2. **Explanation of Columns.**

a. Column (1) – Item Number. This number is assigned to the entry in the listing and is referenced in the narrative instructions to identify the material (e.g., Use cleaning compound, item 5, appendix C).

b. Column (2) – Level. This column identifies the lowest level of maintenance that requires the listed item.

C - Operator/Crew

O - Unit Maintenance

F - Direct Support Maintenance

H - General Support Maintenance

c. Column (3) – National Stock Number. This is the National stock number assigned to the item; use it to request or requisition the item.

d. Column (4) – Description. Indicates the Federal item name, and, if required, a description to identify the item. The last line for each item indicates the Commercial and Government Entity Code (CAGEC) in parentheses followed by the part number.

e. Column (5) – Unit of Measure (UM). Indicates the measure used in performing the actual maintenance function. This measure is expressed by a two-character alphabetical abbreviation (e.g., EA, IN, PR). If the unit of measure differs from the unit of issue, requisition the lowest unit of issue that will satisfy your requirements.

SECTION II. EXPENDABLE/DURABLE SUPPLES AND MATERIALS LIST				
(1) ITEM NUMBER	(2) LEVEL	(3) NATIONAL STOCK NUMBER	(4) DESCRIPTION	(5) U/M
		5350-00-184-6255	CARBORUNDUM POWDER: SILICON CARBIDE; 140 MESH, 1LB CAN; MIL-A-21380 TYPE III	EA
		6510-00-201-4000	COTTON, PUFIFIED: ROLLED;USP 12 IN. WIDE, 10 FT.LONG; 1LB PACKAGE; GRADE A CLASS 2, SIZE 4	PKG
		5350-00-721-8117	PAPER, ABRASIVE: SILICON CARBIDE; 9X11 IN. SHEETS; GRIT NO. 180;CLOSED COATING; WATER PROOF PACKAGE	BX
		5350-00-240-2920	STEEL WOOL: 1 LB ROLL; FF-W-1825 TYPE I, CLASS 00,FINE	PKG



By Order of the Secretary of the Army:

**CARL E. VUONO**  
*General, United States Army*  
*Chief of Staff*

Official:

**THOMAS F. SIKORA**  
*Brigadier General, United States Army*  
*The Adjutant General*

DISTRIBUTION:

To be distributed in accordance with DA Form 12-21 A, Operator, Unit and Direct Support Maintenance requirements for Laboratory, Air Mobile, Aviation Fuel and Laboratory, Petroleum, MTD



RECOMMENDED CHANGES TO EQUIPMENT TECHNICAL PUBLICATIONS



THEN... JOT DOWN THE DOPE ABOUT IT ON THIS FORM. CAREFULLY TEAR IT OUT. FOLD IT AND DROP IT IN THE MAIL!

SOMETHING WRONG WITH THIS PUBLICATION?

FROM: (PRINT YOUR UNIT'S COMPLETE ADDRESS)

PFC JOHN DOE  
COA, 3d ENGINEER BN  
FT. BELLEARDWOOD, MD 63108

DATE SENT

PUBLICATION NUMBER  
TM 10-6640-221-13&P

PUBLICATION DATE  
28 Sep 1990

PUBLICATION TITLE Aqua Glo Water  
Detector

BE EXACT. PIN-POINT WHERE IT IS

PAGE NO	PARA-GRAPH	FIGURE NO	TABLE NO
6	2-1 a		
B1		4-3	
125	line 20		

IN THIS SPACE TELL WHAT IS WRONG AND WHAT SHOULD BE DONE ABOUT IT:

In line 6 of paragraph 2-1a the manual states the engine has 6 Cylinders. The engine on my set only has 4 Cylinders. Change the manual to show 4 Cylinders.

Callout 16 on figure 4-3 is pointing at a bolt. In key to figure 4-3, item 16 is called a shim - Please correct one or the other.

I ordered a gasket, item 19 on figure B-16 by NSN 2 910-00-762-3001. I got a gasket but it doesn't fit. Supply says I got what I ordered, so the NSN is wrong. Please give me a good NSN

PRINTED NAME, GRADE OR TITLE, AND TELEPHONE NUMBER

JOHN DOE, PFC (268) 317-7111

SIGN HERE

JOHN DOE

TEAR ALONG PERFORATED LINE

FILL IN YOUR  
UNIT'S ADDRESS

FOLD BACK

DEPARTMENT OF THE ARMY

---

---

OFFICIAL BUSINESS

COMMANDER  
U.S. ARMY TROOP SUPPORT COMMAND  
ATTN: AMSTR-MCTS  
4300 GOODFELLOW BOULEVARD  
ST. LOUIS, MO 63120-1798

TEAR ALONG PERFORATED LINE

RECOMMENDED CHANGES TO EQUIPMENT TECHNICAL PUBLICATIONS



THEN... JOT DOWN THE DOPE ABOUT IT ON THIS FORM. CAREFULLY TEAR IT OUT. FOLD IT AND DROP IT IN THE MAIL!

**SOMETHING WRONG WITH THIS PUBLICATION?**

FROM: (PRINT YOUR UNIT'S COMPLETE ADDRESS)

DATE SENT

PUBLICATION NUMBER  
TM 10-6640-221-13&P

PUBLICATION DATE  
28 Sep 1990

PUBLICATION TITLE  
Aqua Glo Water  
Detector

BE EXACT PIN-POINT WHERE IT IS

PAGE NO	PARA-GRAPH	FIGURE NO	TABLE NO
---------	------------	-----------	----------

IN THIS SPACE TELL WHAT IS WRONG AND WHAT SHOULD BE DONE ABOUT IT:

TEAR ALONG PERFORATED LINE

PRINTED NAME, GRADE OR TITLE, AND TELEPHONE NUMBER

SIGN HERE

DA FORM 2028-2  
1 JUL 79

PREVIOUS EDITIONS ARE OBSOLETE.  
DRSTS-M Overprint 2, 1 Nov 80.

P.S.--IF YOUR OUTFIT WANTS TO KNOW ABOUT YOUR RECOMMENDATION MAKE A CARBON COPY OF THIS AND GIVE IT TO YOUR HEADQUARTERS.

FILL IN YOUR  
UNIT'S ADDRESS



FOLD BACK

DEPARTMENT OF THE ARMY

---

---

OFFICIAL BUSINESS

COMMANDER  
U.S. ARMY TROOP SUPPORT COMMAND  
ATTN: AMSTR-MCTS  
4300 GOODFELLOW BOULEVARD  
ST. LOUIS, MO 63120-1798

TEAR ALONG PERFORATED LINE

RECOMMENDED CHANGES TO EQUIPMENT TECHNICAL PUBLICATIONS

**SOMETHING WRONG WITH THIS PUBLICATION?**



THEN... JOT DOWN THE DOPE ABOUT IT ON THIS FORM. CAREFULLY TEAR IT OUT. FOLD IT AND DROP IT IN THE MAIL!

FROM: (PRINT YOUR UNIT'S COMPLETE ADDRESS)

DATE SENT

PUBLICATION NUMBER

TM 10-6640-221-13&P

PUBLICATION DATE

28 Sep 1990

PUBLICATION TITLE

Aqua Glo Water

Detector

BE EXACT PIN-POINT WHERE IT IS

PAGE NO

PARA-GRAPH

FIGURE NO

TABLE NO

IN THIS SPACE TELL WHAT IS WRONG AND WHAT SHOULD BE DONE ABOUT IT:

TEAR ALONG PERFORATED LINE

PRINTED NAME, GRADE OR TITLE, AND TELEPHONE NUMBER

SIGN HERE

DA FORM 2028-2  
1 JUL 79

PREVIOUS EDITIONS ARE OBSOLETE.  
DRSTS-M Overprint 2, 1 Nov 80.

P.S.--IF YOUR OUTFIT WANTS TO KNOW ABOUT YOUR RECOMMENDATION MAKE A CARBON COPY OF THIS AND GIVE IT TO YOUR HEADQUARTERS.

FILL IN YOUR  
UNIT'S ADDRESS



FOLD BACK

DEPARTMENT OF THE ARMY

---

---

OFFICIAL BUSINESS

COMMANDER  
U.S. ARMY TROOP SUPPORT COMMAND  
ATTN: AMSTR-MCTS  
4300 GOODFELLOW BOULEVARD  
ST. LOUIS, MO 63120-1798

TEAR ALONG PERFORATED LINE



RECOMMENDED CHANGES TO EQUIPMENT TECHNICAL PUBLICATIONS



THEN... JOT DOWN THE DOPE ABOUT IT ON THIS FORM. CAREFULLY TEAR IT OUT. FOLD IT AND DROP IT IN THE MAIL!

**SOMETHING WRONG WITH THIS PUBLICATION?**

FROM: (PRINT YOUR UNIT'S COMPLETE ADDRESS)

DATE SENT

PUBLICATION NUMBER

TM 10-6640-221-13&P

PUBLICATION DATE

28 Sep 1990

PUBLICATION TITLE

Aqua Glo Water

Detector

BE EXACT PIN-POINT WHERE IT IS

PAGE NO

PARA-GRAPH

FIGURE NO

TABLE NO

IN THIS SPACE TELL WHAT IS WRONG AND WHAT SHOULD BE DONE ABOUT IT:

TEAR ALONG PERFORATED LINE

PRINTED NAME, GRADE OR TITLE, AND TELEPHONE NUMBER

SIGN HERE

DA FORM 2028-2  
1 JUL 79

PREVIOUS EDITIONS ARE OBSOLETE.  
DRSTS-M Overprint 2, 1 Nov 80.

P.S.--IF YOUR OUTFIT WANTS TO KNOW ABOUT YOUR RECOMMENDATION MAKE A CARBON COPY OF THIS AND GIVE IT TO YOUR HEADQUARTERS.

FILL IN YOUR  
UNIT'S ADDRESS



FOLD BACK

DEPARTMENT OF THE ARMY

---

---

OFFICIAL BUSINESS

COMMANDER  
U.S. ARMY TROOP SUPPORT COMMAND  
ATTN: AMSTR-MCTS  
4300 GOODFELLOW BOULEVARD  
ST. LOUIS, MO 63120-1798

TEAR ALONG PERFORATED LINE

# The Metric System and Equivalents

## Linear Measure

1 centimeter = 10 millimeters = .39 inch  
 1 decimeter = 10 centimeters = 3.94 inches  
 1 meter = 10 decimeters = 39.37 inches  
 1 dekameter = 10 meters = 32.8 feet  
 1 hectometer = 10 dekameters = 328.08 feet  
 1 kilometer = 10 hectometers = 3,280.8 feet

## Weights

1 centigram = 10 milligrams = .15 grain  
 1 decigram = 10 centigrams = 1.54 grains  
 1 gram = 10 decigrams = .035 ounce  
 1 dekagram = 10 grams = .35 ounce  
 1 hectogram = 10 dekagrams = 3.52 ounces  
 1 kilogram = 10 hectograms = 2.2 pounds  
 1 quintal = 100 kilograms = 220.46 pounds  
 1 metric ton = 10 quintals = 1.1 short tons

## Liquid Measure

1 centiliter = 10 milliliters = .34 fl. ounce  
 1 deciliter = 10 centiliters = 3.38 fl. ounces  
 1 liter = 10 deciliters = 33.81 fl. ounces  
 1 dekaliter = 10 liters = 2.64 gallons  
 1 hectoliter = 10 dekaliters = 26.42 gallons  
 1 kiloliter = 10 hectoliters = 264.18 gallons

## Square Measure

1 sq. centimeter = 100 sq. millimeters = .155 sq. inch  
 1 sq. decimeter = 100 sq. centimeters = 15.5 sq. inches  
 1 sq. meter (centare) = 100 sq. decimeters = 10.76 sq. feet  
 1 sq. dekameter (are) = 100 sq. meters = 1,076.4 sq. feet  
 1 sq. hectometer (hectare) = 100 sq. dekameters = 2.47 acres  
 1 sq. kilometer = 100 sq. hectometers = .386 sq. mile

## Cubic Measure

1 cu. centimeter = 1000 cu. millimeters = .06 cu. inch  
 1 cu. decimeter = 1000 cu. centimeters = 61.02 cu. inches  
 1 cu. meter = 1000 cu. decimeters = 35.31 cu. feet

## Approximate Conversion Factors

To change	To	Multiply by	To change	To	Multiply by
inches	centimeters	2.540	ounce-inches	newton-meters	.007062
feet	meters	.305	centimeters	inches	.394
yards	meters	.914	meters	feet	3.280
miles	kilometers	1.609	meters	yards	1.094
square inches	square centimeters	6.451	kilometers	miles	.621
square feet	square meters	.093	square centimeters	square inches	.155
square yards	square meters	.836	square meters	square feet	10.764
square miles	square kilometers	2.590	square meters	square yards	1.196
acres	square hectometers	.405	square kilometers	square miles	.386
cubic feet	cubic meters	.028	square hectometers	acres	2.471
cubic yards	cubic meters	.765	cubic meters	cubic feet	35.315
fluid ounces	milliliters	29.573	cubic meters	cubic yards	1.308
pints	liters	.473	milliliters	fluid ounces	.034
quarts	liters	.946	liters	pints	2.113
gallons	liters	3.785	liters	quarts	1.057
ounces	grams	28.349	liters	gallons	.264
pounds	kilograms	.454	grams	ounces	.035
short tons	metric tons	.907	kilograms	pounds	2.205
pound-feet	newton-meters	1.356	metric tons	short tons	1.102
pound-inches	newton-meters	.11296			

## Temperature (Exact)

°F	Fahrenheit temperature	$\frac{5}{9}$ (after subtracting 32)	Celsius temperature	°C
----	------------------------	--------------------------------------	---------------------	----



This fine document...

Was brought to you by me:



## [Liberated Manuals -- free army and government manuals](#)

Why do I do it? I am tired of sleazy CD-ROM sellers, who take publicly available information, slap “watermarks” and other junk on it, and sell it. Those masters of search engine manipulation make sure that their sites that sell free information, come up first in search engines. They did not create it... They did not even scan it... Why should they get your money? Why are not letting you give those free manuals to your friends?

I am setting this document FREE. This document was made by the US Government and is NOT protected by Copyright. Feel free to share, republish, sell and so on.

I am not asking you for donations, fees or handouts. If you can, please provide a link to [liberatedmanuals.com](http://liberatedmanuals.com), so that free manuals come up first in search engines:

<A HREF=<http://www.liberatedmanuals.com/>>Free Military and Government Manuals</A>

- Sincerely  
Igor Chudov  
<http://igor.chudov.com/>
- [Chicago Machinery Movers](#)