

**OPERATOR'S AND UNIT
MAINTENANCE MANUAL**
for

**TEST KIT PETROLEUM,
AVIATION FUEL CONTAMINANT
MODEL PTK-100
NSN: 6630-01-347-9670**

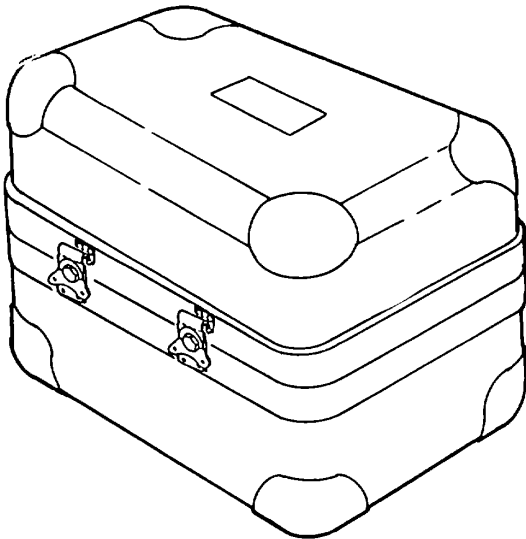

Approved for public release,
Distribution is unlimited.

TABLE OF CONTENTS	i	
EQUIPMENT DESCRIPTION	1-3	
OPERATING INSTRUCTIONS	2-1	
OPERATOR MAINTENANCE	3-1	
UNIT MAINTENANCE	4-1	
MAINTENANCE ALLOCATION CHART	B-1	
REPAIR PARTS AND SPECIAL TOOLS LIST	C-1	
COMPONENTS OF END ITEM AND BASIC ISSUE LIST	D-1	
ADDITIONAL AUTHORIZATION LIST	E-1	
EXPENDABLE/DURABLE SUPPLIES AND MATERIALS LIST	F-1	

CHANGE

HEADQUARTERS
DEPARTMENT OF THE ARMY AND
HEADQUARTERS, U.S. MARINE CORPS
WASHINGTON, D.C., 18 September 1996

NO. 3

Operator's and Unit Maintenance Manual

**TEST KIT PETROLEUM, AVIATION FUEL CONTAMINANT
MODEL PTK-100
NSN 6630-01-347-9670**

DISTRIBUTION STATEMENT A: Approved for public release; distribution is unlimited.

TM 10-6630-240-12&P/TM 01461 B-12&P/1, 31 July 1992, is changed as follows:

1. Remove and insert pages as indicated below. New or changed text material is indicated by a vertical bar in the margin. An illustration change is indicated by a miniature pointing hand.

Remove pages

i and ii
1-1 and 1-2
C-21 through C-28

Insert pages

i and ii
1-1 and 1-2
C-21 through C-28

2. Retain this sheet in front of manual for reference purposes.

By Order of the Secretaries of the Army and Navy (Including the Marine Corps):

DENNIS J. REIMER
General, United States Army
Chief of Staff

Official:



JOEL B. HUDSON
Administrative Assistant to the
Secretary of the Army
02328

J. E. BUFFINGTON
Rear Admiral, CEC, US Navy
Commander
Navy Facilities Engineering
Command

D. R. BLOOMER
Colonel, USMC
Director, Program Support
Marine Corps Systems Command

DISTRIBUTION:

To be distributed in accordance with DA Form 12-25-E, block no. 5958, requirements for TM 10-6630-240-12&P.

CHANGE

NO. 2

HEADQUARTERS,
DEPARTMENT OF THE ARMY, AND
HEADQUARTERS, U.S. MARINE CORPS
WASHINGTON, D.C., 31 March 1993

Operator's and Unit Maintenance Manual

**TEST KIT PETROLEUM, AVIATION FUEL CONTAMINANT
MODEL PTK-100
NSN 6630-01-347-9670**

DISTRIBUTION STATEMENT A: Approved for public release; distribution is unlimited.

TM 10-6630-240-12&P/TM 01461B-12&P/1, 31 July 1992, is changed as follows:

1. Remove and insert pages as indicated below. New or changed text material is indicated by a vertical bar in the margin. An illustration change is indicated by a miniature pointing hand.

Remove pages

Insert pages

F-1 and F-2

F-i and F-2

2. Retain this sheet in front of manual for reference purposes.

By Order of the Secretary of the Army:

GORDON R. SULLIVAN
General, United States Army
Chief of Staff

Official:

MILTON H. HAMILTON
Administrative Assistant to the
Secretary of the Army
03840

DISTRIBUTION:

To be distributed in accordance with DA Form 12-25-E, block no. 5958, requirements for TM 10-6630-240-12&P.

CHANGE

NO. 1

HEADQUARTERS,
DEPARTMENT OF THE ARMY, AND
HEADQUARTERS, U.S. MARINE CORPS
WASHINGTON, D.C., 9 NOVEMBER 1992

Operator's and Unit Maintenance Manual

**TEST KIT PETROLEUM, AVIATION FUEL CONTAMINANT
MODEL PTK-100
NSN 6630-01-347-9670**

Approved for public release; distribution is unlimited

TM 10-6630-240-12&P/TM 01461 B-1 2&P/1, 31 July 1992, is changed as follows:

1. Remove and insert pages as indicated below. New or changed text material is indicated by a vertical bar in the margin. An illustration change is indicated by a miniature pointing hand.

Remove pages

i and ii
C-1/(C-2 blank)

Insert pages

i and ii
C-1 and C-2
C-3 through (C-9 blank)/C-10
C-11 through C-28

2. Retain this sheet in front of manual for reference purposes.

By Order of the Secretaries of the Army and Navy (Including the Marine Corps):

GORDON R. SULLIVAN
General, United States Army
Chief of Staff

Official:

MILTON H. HAMILTON
Administrative Assistant to the
Secretary of the Army
02839

DAVID E. BOTTORFF
Rear Admiral, CEC, US Navy
Commander
Navy Facilities Engineering Command

RONALD D. ELLIOT
Executive Director
Marine Corps Systems Command

DISTRIBUTION:

To be distributed in accordance with DA Form 12-25-E, block 5958, requirements for TM 10-6630-240-12&P.

WARNING

FLAMMABLE

Petroleum liquids should be kept away from heat, sparks, and open flame.

WARNING

VAPORS

Be careful to keep containers closed, avoid prolonged breathing of vapor, avoid prolonged or repeated skin contact, and use with adequate ventilation.

WARNING

HAZARDOUS CHEMICAL

Petroleum Ether - Be careful to keep container closed, avoid prolonged breathing of vapor, avoid prolonged or repeated skin contact, and use with adequate ventilation.

a/(b blank)

TECHNICAL MANUAL

HEADQUARTERS
DEPARTMENT OF THE ARMY
AND HEADQUARTERS, U.S. MARINE CORPS.
WASHINGTON, D.C., 31 July 1992

NO. 10-6630-240-12&P

**OPERATOR'S AND UNIT
MAINTENANCE MANUAL
FOR
TEST KIT PETROLEUM, AVIATION FUEL CONTAMINANT
MODEL PTK-100
NSN: 6630-01-347-9670**

REPORTING ERRORS AND RECOMMENDING IMPROVEMENTS

You can help improve this manual. If you find any mistakes, or if you know of a way to improve these procedures, please let us know. Mail your letter or DA Form 2028 (Recommended Changes to Publications and Blank Forms), or DA Form 2028-2 located in the back of this manual directly to: Commander, US Army Aviation Troop Command, ATTN: AMSAT-I-MP, 4300 Goodfellow Blvd., St. Louis, MO 63120-1798. You may also submit your recommended changes by E-mail directly to <mpmt%avma28@st-louis-emh7.army.mil>. A reply will be furnished directly to you. Instructions for sending an electronic 2028 may be found at the back of this manual immediately preceding the hard copy 2028.

Marine Corps users submit NAVMC 10772 Form to Commanding General, Marine Corps Logistics Base (Code 850) Albany, GA 31704-5000.

DISTRIBUTION STATEMENT A: Approved for public release; distribution is unlimited.

TABLE OF CONTENTS

	PAGE
HOW TO USE THE MANUAL	iii
CHAPTER 1. INTRODUCTION	
Section I. General Information.....	1-1
Section II. Equipment Description	1-3
Section III. Principles of Operation	1-4
CHAPTER 2. OPFRA[NG INSTRUCTIONS	
Section I. Description and Use of Operator's Controls and Indicators	2-1
Section II. Operator Preventive Maintenance Checks and Services (PMCS)	2-1
Section III. Operation Under Usual Conditions	2-3
CHAPTER 3. OPE,RATOR MAINTENANCE	
Section I. Lubrication Instructions (No Lubrication Required)	3-1
Section II. Operator Troubleshooting (No Troubleshooting Required)	3-1
Section III. Maintenance Procedures (Not Applicable)	3-1
CHAPTER 4. UNIT MAINTFENANCE	
Section I. Repair Parts and Special Tools Lists.....	
Section II. Unit Maintenance Procedures	4-1
Section III. Preparation for Storage or Shipment	4-2

TABLE OF CONTENTS - cont

APPENDICES		Page	Illustration/ Figure
APPENDIX A	REFERENCES	A-1	
APPENDIX B	MAINTENANCE ALLOCATION CHART	B-1	
Section I.	Introduction.....	B-1	
Section II.	Maintenance Allocation Chart	B-4	
Section III.	Tools and Test Equipment Requirements	B-4	
Section IV.	Remarks.....	B-4	
APPENDIX C	REPAIR PARTS AND SPECIAL TOOL LIST	C-1	
Section I.	Introduction.....	C-1	
Section II.	Repair Parts List	C15	
Group 01	Sampler, Valve Hose Assembly	C15	1
Group 02	Remote, Sampling Assembly.....	C15	1
Group 03	Detector Unit	C15	1
Group 04	Carrying Case, Petroleum Test Kit.....	C15	1
Group 05	Set, Standards.....	C15	1
Group 06	Bulk Material	C19	
Section III.	Special Tools List (Not Applicable)	C20	
Section IV.	Cross References Indexes.....	C21	
	National Stock Number Index	C22	
	Part Number Index	C23	
	Figure and Item Number Index	C26	
APPENDIX D	COMPONENTS OF END ITEM AND BASIC ISSUE ITEMS LIST..	D-1	
APPENDIX E	ADDITIONAL AUTHORIZATION LIST (Not Applicable)	E-1	
APPENDIX F	EXPENDABLE/DURABLE SUPPLIES AND MATERIALS LIST	F-1	
Section I.	Introduction	F-1	
Section II.	Expendable/Durable Supplies and Materials List	F-2	
ALPHABETICAL INDEX.....		G-1	

HOW TO USE THIS MANUAL

CONTENT

This manual is provided for your use in operating and maintaining the Petroleum Test Kit. You must familiarize yourself with the entire maintenance procedures before beginning the maintenance task. Maintaining the Petroleum Test Kit includes preventive maintenance checks and services.

MANUAL OVERVIEW

To help you become familiar with this new kind of manual as quickly as possible, spend some time looking through the pages. The manual has a new look that is different from the look of the manuals you've been using. You'll find that it's a lot easier to use and you'll be able to find what you're looking for faster. The following is a list and description of each chapter and appendix.

a. Chapter 1 Introduction.

Contains general information, purpose of equipment, equipment description, and technical principles of operation regarding the complete Petroleum Test Kit.

b. Chapter 2 Operating Instructions.

Contains operating instructions, both under usual and unusual conditions, operation of auxiliary equipment, and preventive maintenance checks and services (PMCS).

c. Chapter 3 Operator Maintenance.

Contains lubrication instructions, operator troubleshooting, and maintenance procedures.

d. Chapter 4 Unit Maintenance.

Contains references to technical manuals covering the auxiliary equipment.

e. Appendix A References.

Contains a listing of all forms and technical manuals referred to in this manual.

f. Appendix B Maintenance Allocation Chart (MAC).

Contains a listing of all maintenance significant items and their applicable maintenance functions assigned to each maintenance category.

g. Appendix C Repair Parts and Special Tools List.

h. Appendix D Components of End Item and Basic Issue Items List.

Contains listings for components of the end item, and basic issue items.

i. Appendix E Additional Authorization List (AAL).

Not Applicable.

j. Appendix F Expendable/Durable Supplies and Materials List.

Contains an alphabetized tabular listing of all consumable items used in the maintenance or repair of the Petroleum Test Kit.

k. INDEX.

Contains an alphabetical index by subject matter contained in this manual.

CHAPTER 1
INTRODUCTION

SECTION I

1-1	Scope	1-1
1-2	Maintenance Forms, Records, and Reports	1-1
1-3	Destruction of Army Materiel to Prevent Enemy Use	1-1
1-4	Corrosion Prevention and Control	1-1
1-5	Report Equipment Improvement Recommendations (EIRs)	1-2
1-6	Nomenclature Cross Reference List	1-2
1-7	List of Abbreviations	1-2

SECTION II

1-8	Equipment Characteristics, Capabilities, and Features.....	1-3
1-9	Location and Description of Major Components	1-3
1-10	Equipment Data.....	1-3

SECTION III

1-11	System Technical Principles of Operation	1-4
------	--	-----

1-1. SCOPE.

This manual covers the use of the Petroleum Test Kit, PTK-100, in testing aviation fuel for contamination.

1-2. MAINTENANCE FORMS, RECORDS, AND REPORTS.

- a. Reports of Maintenance and Unsatisfactory Equipment. Department of the Army forms and procedures used for equipment maintenance will be those prescribed by DA PAM 738-750, as contained in Maintenance Management Update. Marine Corps personnel will refer to TM 4700-15/1 for equipment records and forms procedures.
- b. Report of Packaging and Handling Deficiencies. Fill out and forward SF 364 [Report of Discrepancy ROD] as prescribed in AR 735-11/MCO 4430.3J.
- c. Discrepancy in Shipment Report (DISREP) (SF 361). Fill out and forward Discrepancy in Shipment Report (DISREP) (SF 361) as prescribed in AR 55-38/MCO P4610.19D.

1-3. DESTRUCTION OF ARMY MATERIEL TO PREVENT ENEMY USE.

Methods and/or procedures for the destruction of Army materiel to prevent enemy use are covered in TM 750-244-3.

1-4. CORROSION PREVENTION AND CONTROL

- a. Corrosion Prevention and Control (CPC) of Army Materiel is a continuing concern. It is important that any corrosion problems with this item be reported so that the problem can be corrected and improvements can be made to prevent the problem in future items.
- b. While corrosion is typically associated with rusting of metals, it can also include deterioration of other materials, such as rubber and plastic. Unusual cracking, softening, swelling or breaking of the materials may be a corrosion problem.

1-4. CORROSION PREVENTION AND CONTROL - Cont.

- c. If a corrosion problem is identified, it can be reported using Standard Form 368, Product Quality Deficiency Report. Using key words such as "rust", "deterioration", or "cracking" will insure that the information is identified as a CPC problem. The form should be submitted to the address specified in DA Pam 738-750.

1-5. REPORT EQUIPMENT IMPROVEMENT RECOMMENDATIONS (EIRs).

If your Petroleum Test Kit needs improvement, let us know. Send us an EIR. You, the user, are the only one who can tell us what you don't like about your equipment. Put it on an SF-368 (Quality Deficiency Report). Mail it to us at: Commander, U.S. Army Aviation and Troop Command, ATTN: AMSAT-I-MDO, 4300 Goodfellow Boulevard, St. Louis, MO 63120-1798. We'll send you a reply. USMC personnel are encouraged to submit PIP MCL 1650.17.

1-6. NOMENCLATURE CROSS REFERENCE LIST.

Common Name	Official Nomenclature
Crescent Wrench	Wrench, Adjustable
Nipple	Nipple, Pipe

1-7. LIST OF ABBREVIATIONS.

AAL	Additional Authorization List	mfg	Manufacturing
API	American Petroleum Institute	max	Maximum
ASTM	American Standards Testing and Materials	MI	Milliliters
BII	Basic Issue List	min	Minimum or minute
Bx	Box	NSN	National Stock Number
COEIL	Components of End Item List	No.	Number(s)
cont	continued	Pg	Package
DA	Department of the Army	para.	Paragraph
DS	Direct Support	P/N	Part Number
EIRs	Equipment Improvement Recommendations	PMCS	Preventive Maintenance Checks and Services
ES&ML	Expendable Supplies	qty	Quantity
F	Direct Support	RL	Roll
FM	Field Manual	TAMMS	The Army Maintenance Management System
GL	Gallon	TB	Technical Bulletin
GS	General Support	TM	Technical Manual
LO	Lubrication Order	U/M	Unit of measure
MAC	Maintenance Allocation Chart	wt	Weight

Section II. EQUIPMENT DESCRIPTION AND DATA

1-8. EQUIPMENT CHARACTERISTICS, CAPABILITIES, AND FEATURES.

- a. Self-Contained suitcase unit consisting of components and testing equipment.
- b. One-man portable kit.
- c. Equipment housed in waterproof and water-vaporproof case.

1-9. LOCATION AND DESCRIPTION OF MAJOR COMPONENTS.

- a. For location of components, refer to Appendix C, Repair Parts and Special Tool Lists (RPSTL,).
- b. General Description. The aviation Fuel Contamination Test Kit is a one-man portable kit consisting of various types of testing equipment with the capability of determining temperature and API gravity, free water content, and particulate contaminants in aviation fuels.
- c. Case Assembly. The waterproof and water-vaporproof fiberglass case is designed to house and transport all of the equipment required for testing aviation fuels for contamination. The top half and bottom half contains cushioning material to provide shock and vibration protection to the contents of the case during transport.

1-10. EQUIPMENT DATA.

- a. Equipment data listing. Refer to placard attached to case for a tabulated equipment data on the Petroleum Test Kit.

PETROLEUM TEST KIT
General Information

Manufacturer	Engineered Air Systems Inc.
Manufacture Model Number	PTK-100
National Stock Number	6630-01-347-9670

Dimensions and Weights:

Width	15 inches
Length	21 inches
Height	16 inches
Weight	45 lbs.

Section III. PRINCIPLES OF OPERATION

1-11. SYSTEM TECHNICAL PRINCIPLES OF OPERATION.

- a. Technical Principle. Sampling of fuels from pressurized systems through contamination analysis monitors for gravimetric determination of contaminant level.
- b. Principles of Operation as follows:
 - (1) Particulate Contaminants. A fuel sample is taken from pressurized systems with a sampler-valve hose assembly containing monitor pads. The color of the pad is compared with the Fuel Color Standards provided.
 - (2) Undissolved Water. A fuel sample is passed through Free Water Pads, then the pad is placed under ultra violet light (Detector Unit, Free Water) and read out in parts per million water.
 - (3) American Petroleum Institute (API) Gravity Procedure. A fuel sample is placed in a test cylinder and a hydrometer is inserted. The degrees API are read and the sample temperature recorded. Using the gravity computer, the API is determined.

CHAPTER 2
OPERATING INSTRUCTIONS

SECTION I	
2-1 Petroleum Testing Kit	2-1
SECTION II	
2-2 General	2-1
2-3 Warnings and Cautions.....	2-1
2-4 PMCS Table	2-2
SECTION III	
2-5 Assembly and Preparation for Use.....	2-3
2-6 Operating Procedures PMCS Table	2-3
2-7 Decals and Instruction Plates.....	2-3
SECTION IV	
2-9 Operation in Extreme Cold	2-3

Section I. DESCRIPTION AND USE OF OPERATOR'S CONTROLS AND INDICATORS

2-1. PETROLEUM TESTING KIT.

The Aqua-Glo Detector Unit with Instrument Pack and Cable used for the undissolved water procedures has an operational instruction plate attached, also refer to TM 10-6640-221-13&P (Aqua Glo Water Detector).

Section II. OPERATOR PREVENTIVE MAINTENANCE CHECKS AND SERVICES (PMCS)

2-2. GENERAL..

The Preventive Maintenance Checks and Services presented in Table 2-1 list the inspections and care of your equipment required to keep it in good operating condition and ready for its primary mission.

2-3. WARNINGS AND CAUTIONS.

Always observe the WARNINGS and CAUTIONS appearing in the PMCS table. Warnings and cautions appear before applicable procedures. You must observe WARNINGS and CAUTIONS to prevent serious injury to yourself and others or prevent your equipment from being damaged.

2-4. PMCS TABLE.

Refer to Table 2-1 for Preventive Maintenance Checks and Services.

NOTE

Be sure to observe all special information and notes that appear in your table.

- a. Item Number Column. Numbers in this column are for reference. When completing DA Form 2404 (Equipment Maintenance and Inspection Worksheet), include the item number for the check/service indicating a fault. Item numbers also appear in the order that you must do checks and services for the intervals listed,
- b. Interval Columns. This column tells you when you must do the procedure in the procedure column. BEFORE procedures must be done before you operate or use the equipment for its intended mission. DURING procedures must be done during the time you are operating or using the equipment for its intended mission. AFTER procedures must be done immediately after you have operated or used the equipment.
- c. Location, Check/Service Column. This column provides the location and the item to be checked or serviced. The item location is underlined.
- d. Procedure Column. This column gives the procedure you must do to check or service the item listed in the Check/Service column to know if the equipment is ready or available for its intended mission or for operation. You must do the procedure at the time stated in the interval column.
- e. Not Fully Mission Capable If: Column. Information in this column tells you what faults will keep your equipment from being capable of performing its mission. If you make check and service procedures that show faults listed in this column, do not operate the equipment. Follow standard operating procedures for maintaining the equipment or reporting equipment failure.

Table 2-1. Operator Preventive Maintenance Checks and Services

Item No	Interval	Location	Procedures	Not Fully Mission Capable If:
		Item To Be Check/Service		
	Before	CASE ASSEMBLY	<ol style="list-style-type: none"> a. Inspect the case for cut, dented, or broken surfaces. b. Check for loose or missing rivets (1), bent broken or loose handles (2), hooks (3), latches (4), and hinges (5). c. Make certain the hooks and latches will lock and unlock, and hinges operate without binding. 	
	Before	HOSES	Inspect hoses for cracks, dryrot or grounding wire missing.	Hoses are cracked or grounding wire missing.
	Before	COMPONENTS	Inspect for damage and serviceability of components.	components are unserviceable.

Section III. OPERATION UNDER USUAL CONDITIONS

2-5. ASSEMBLY AND PREPARATION FOR USE.

- a. Unlatch the case and open to gain access to the equipment and instructions.
- b. Depending on the type of petroleum test to be performed, various pieces of equipment will be removed from the case to accomplish the testing. See instructions placards for equipment utilized for each test.
- c. Using the eight-inch adjustable wrench, attach the quick-release valve (1) to the system fitting (2) (this will vary with the type of equipment you are using, however, attach the valve in a horizontal position on the system or at the top of the system to allow for proper flushing). Keep the valve plug (3) in its fitting when valve is not in use.(Figure 2.1).

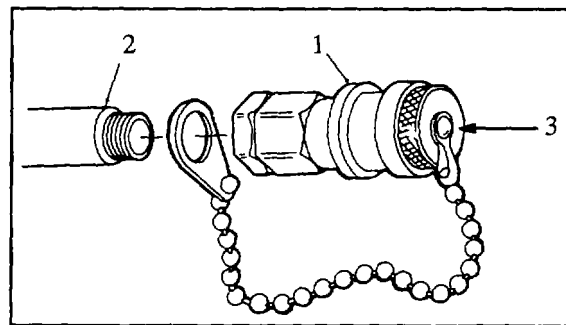

Figure 2-1

2-26. OPERATING INSTRUCTIONS FOR PARTICULATE CONTAMINANT TEST.

- a. With the quick - release valve in place, you are ready to select a monitor. Use contamination monitors (blue and red protective plugs) for color comparator testing and matched weight monitors (yellow and red protective plugs) for gravimetric testing. Remove the plugs from the monitor; remove the bottom (red) plug from the monitor first, followed by the top (blue or yellow) plug. Keep plugs in a safe place for replacement on monitors when test is completed.
- b. Unscrew the sampler cover (1) from the sampler base (2) and insert the monitor (3) spoke-side down into the base. Insert the sampler base (2) with the monitor (3) in place into the sampler cover (2) and screw the two pieces(1 & 2) together to a snug hand tightness. (Figure 2.2).

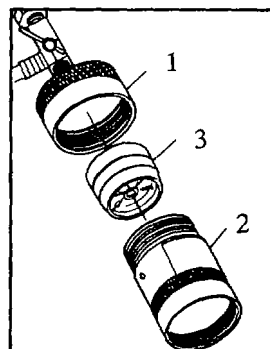

Figure 2-2

CAUTION

Do not over-tighten or damage to the monitor membrane may occur.

c. Connect the bypass hose (1) from the three-way valve (2) to either bypass port (3) located on the sides of the sampler valve base (4). Press the hose down firmly into the port for a tight fit. (figure 2-3)

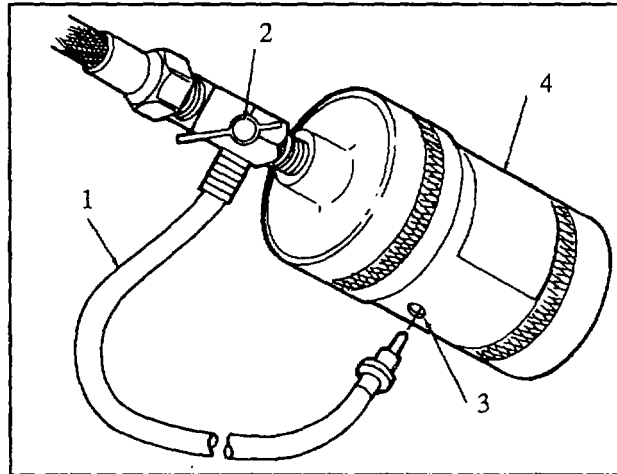

Figure 2-3

d. Screw the remote sampling assembly (1) onto the sampler base (2). Force the nylon plug (3) into the open port (4) on the side of the sampler base tightly plugging the port hole to prevent leakage. (figure 2-4)

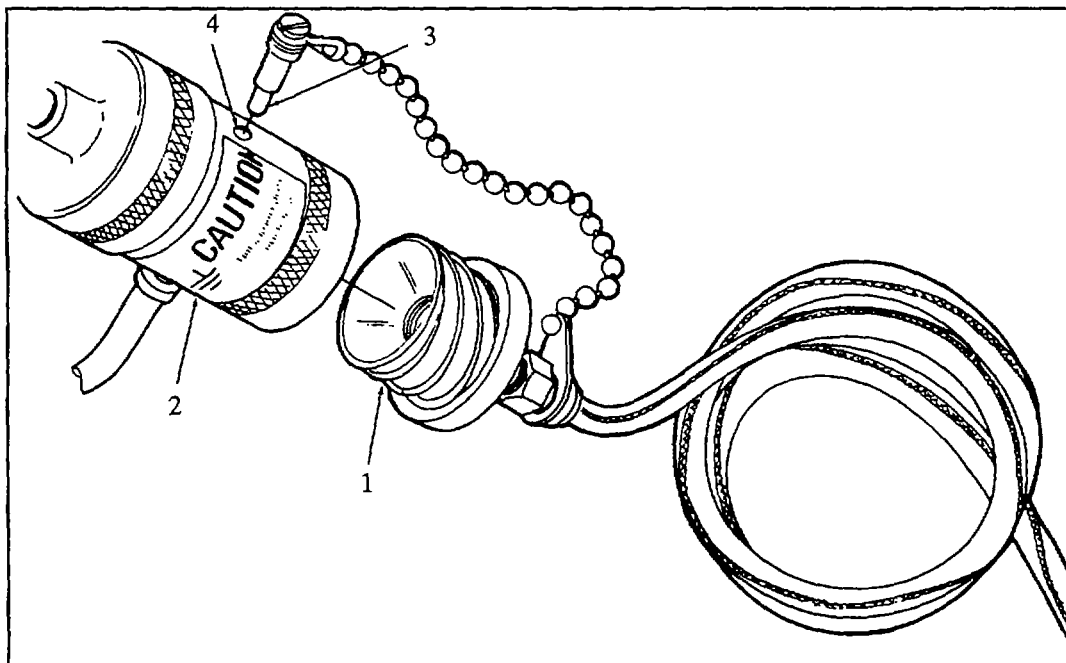

Figure 2-4

e. Connect the Sampler Valve Hose Assembly(1) to the Quick-Release Valve (2). The three way valve (3) must be in the off position before attaching the Sampler to the hose assembly. Remove protective cap (4) from inlet hose nipple (5) and plug (6) from the quick-release valve collar (7). Insert sampler hose nipple (5) into quick-release collar (7). (figure 2-5)

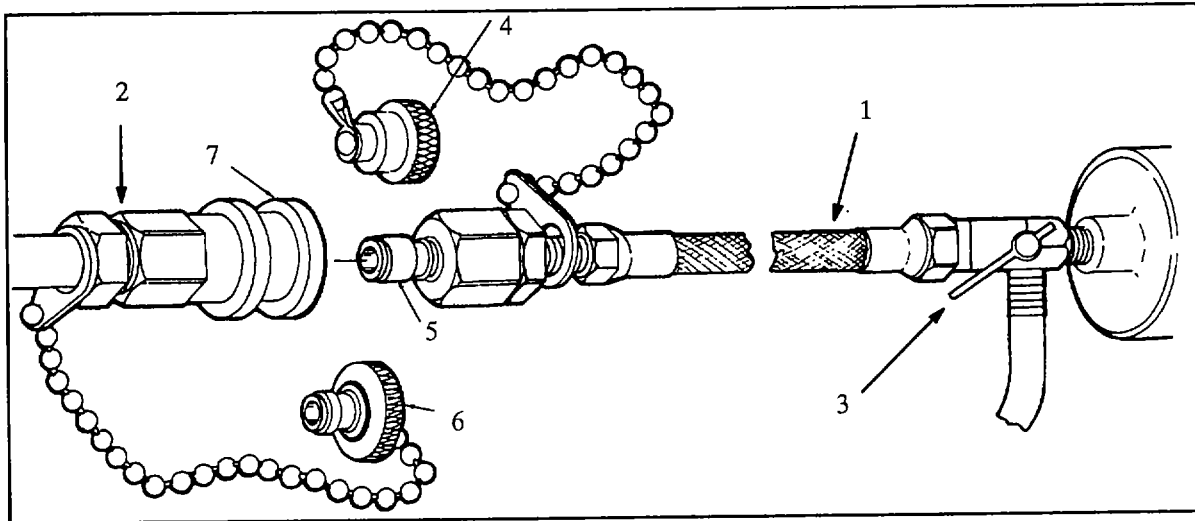

Figure 2-5

WARNING

The Sampler Valve Hose Assembly must be properly grounded to avoid possible fire or explosion from static electrical charges. An electrical continuity test of the ground hook-up should be performed prior to test to assure conductance of electrical charges from system to ground.

f. Attach one end of ground wire (1) on any metal part of the hose assembly (2) and the other end to a ground. (figure 2-6)

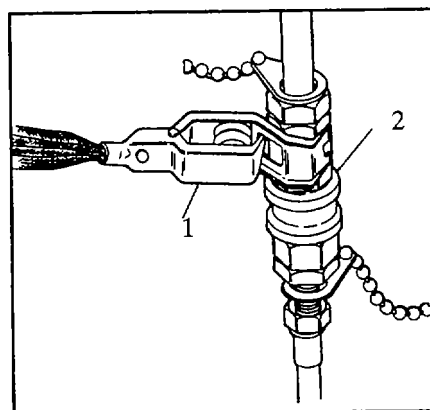

Figure 2-6

g. Flush the inlet hose by turning the three-way valve (1) to the FLUSH position: the valve arm is horizontal to the base of the valve (2). Pass at least 3.2 quarts (3 or more liters) into a 5 gallon receptacle to remove contaminants from the inlet valve. (figure 2-6)

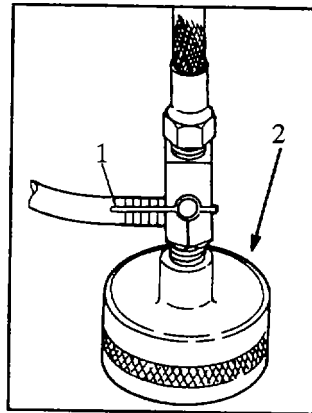

Figure 2-6

h. Take a sample by holding the sampler in an upright (vertical) position, turn the three-way valve (1) to the TEST position. Allow no more than 1 liter (1.0 qt) to flow through the monitor. Record the sample volume for reporting. When the collection is completed turn the three-way valve to the off position before turning off the system pump. Remove the sampler from the system fitting and replace the protective cap and plug. (figure 2-7)

CAUTION

Some pumping systems (e.g. aircraft refuelers) develop a vacuum when closed which can cause backflow and rupture the monitor filter, rendering the test ineffective.

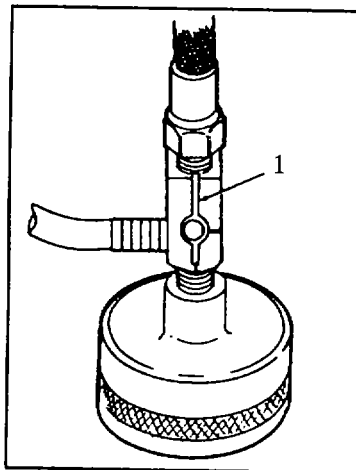

Figure 2-7

i. Disconnect the bypass hose (1) from the side of the sampler and unscrew the sampler base (2) from the sampler cover. Hold the sampler in an upright position and remove the monitor (3). (figure 2-8)

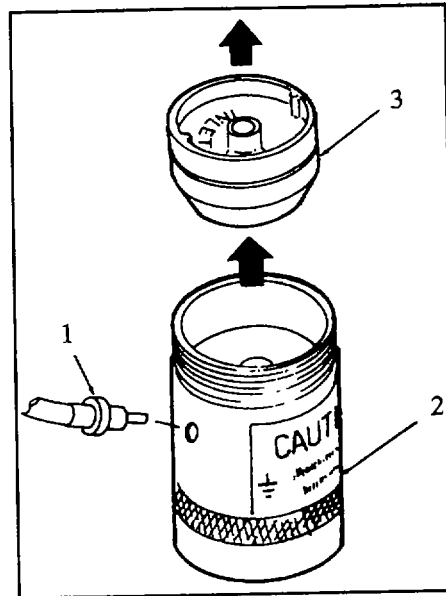

Figure 2-8

CAUTION
Drain the excess fuel into a proper receptacle

j. Pump the monitor dry by securely fitting the bottom or spoke -side of the monitor (1) onto the syringe valve (2) and pump the syringe arm (3): point the syringe (4) away from you and pump the arm, holding the extended arm for 5 seconds before releasing each time. Pump the arm two or three times, or until the filter inside the monitor appears dry of fuel and remove the syringe (4). (figure 2-9)

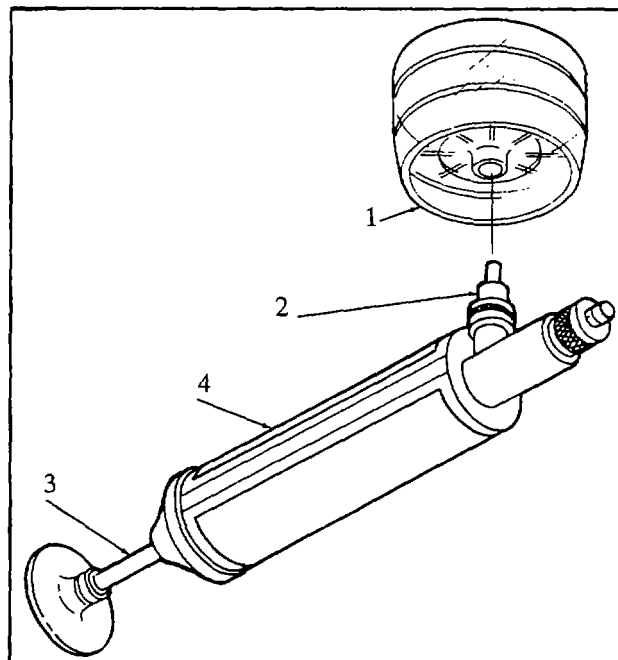

Figure 2-9

k. Preparing the monitor for Assessment of particulate contamination.

(1) If you are testing the fuel using the Color Comparator Method, refer to the *Aviation Turbine Fuel Contamination Standards* contained in the kit. Pry off the top of the monitor. Match the gradation of color and determine if the gross particles are acceptable or unacceptable. If the results are marginal or unacceptable, retest the fuel using the Gravimetric Method.

(2) If you are testing fuel using the Gravimetric Method, replace the monitor's protective plug (top and bottom, label the monitor, wrap in a protective covering and ship to a laboratory.

2-7. OPERATING INSTRUCTIONS FOR API GRAVITY TESTS.

- a. Refer to paragraph 2-5 for installing the quick release valve.
- b. Refer to paragraphs 2-6 b, c (less monitor) for assembling the Sampler Valve Hose Assembly.
- c. Attach The PVC Sample Bottle (1) to the Remote Sampling Assembly (2). (figure 2-10)

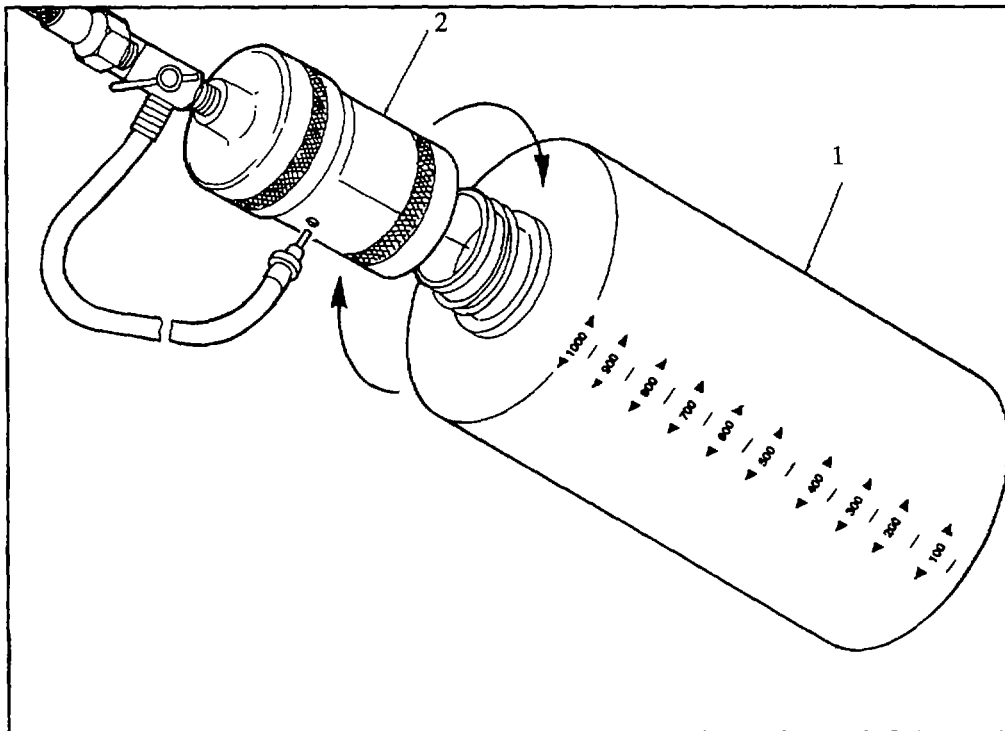

Figure 2-10

d. Refer to paragraphs 2-6 e, f. & g to connect the sampler hose valve assembly to the quick release valve, grounding procedures and procedures for flushing the inlet hose. (If one or all test procedures are performed within the same hour refushing the lines is not required. However if the system has not been flushed, **DO NOT** use the PVC bottle to contain the sample. Allow 200 milliliters (7 oz) to be flushed through the system before taking the sample.

e. Take a sample by holding the sampler upright and turn the three-way valve (1) to the test position. Collect enough fuel to fill the PVC sample bottle - no more than 1 quart. (figure 2-11)

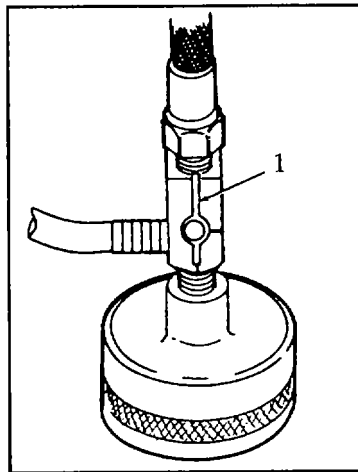

Figure 2-11

f. When the sample has been taken turn the three-way valve (1) to the OFF position before turning off the system pump. Remove the sample bottle from the sampler. Remove the sampler nipple from the quick-release valve and replace the protective cap and plug. (figure 2-12)

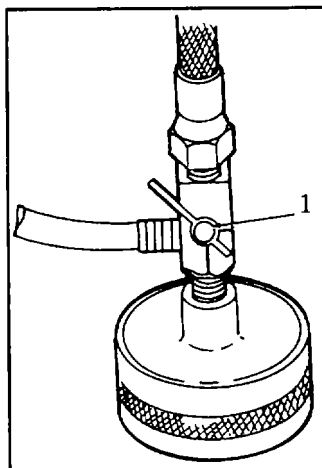

Figure 2-12

g. To determine the API Gravity and temperature, fill the clear plastic cylinder (1) half-full with fuel (2) - - pour the fuel at an angle to minimize air entrapment from the PVC sample bottle (3). (figure 2-13)

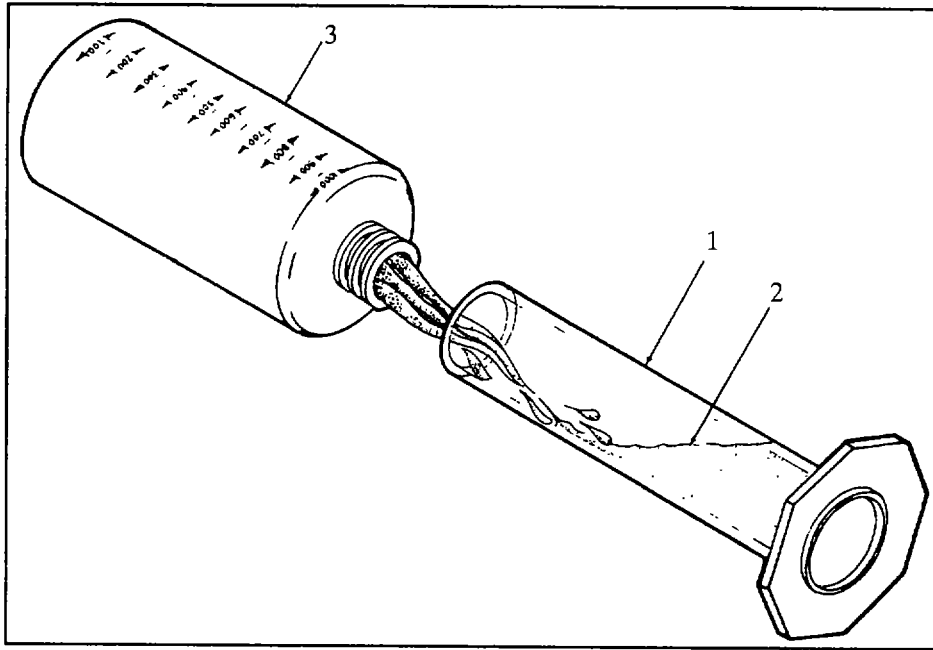

Figure 2-13

h. Select a hydrometer (1) which allows the scale (2) to fall within the fuel cap. Place the hydrometer into the cylinder (3) giving it a slight twist as you release it into the fuel (4). (figure 2-14)

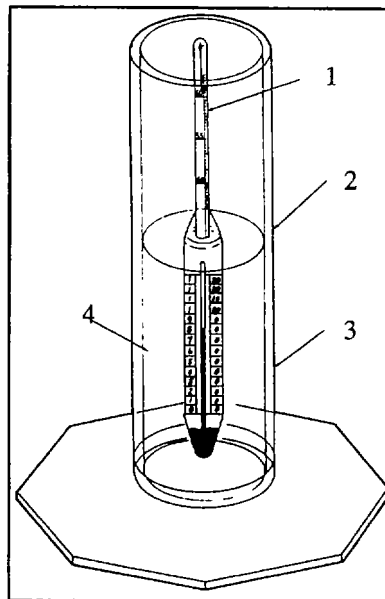

Figure 2-14

i. Allow approximately 5 minutes for the temperature of the hydrometer (1) to equilibrate with the temperature of the fuel sample. With the hydrometer in the fuel (2), read the degrees API to the nearest 0.1 at the meniscus cut point. Remove the hydrometer from the fuel and take a temperature reading. Record the readings. (figure 2-15)

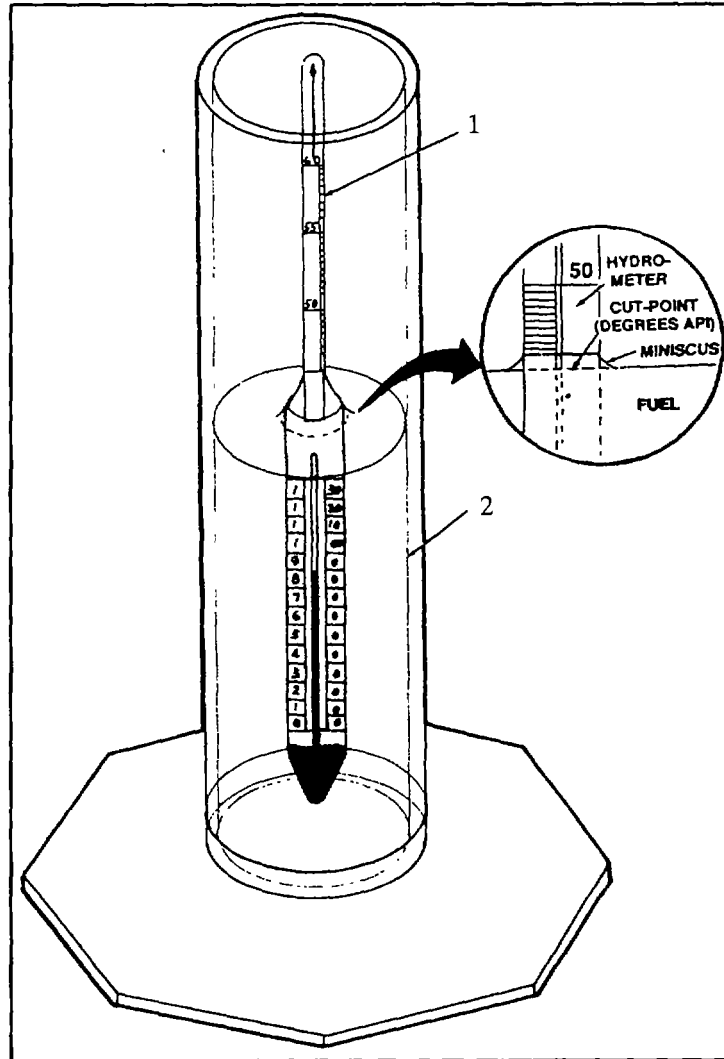

Figure 2-15

j. Use the gravity calculator (1) attached to the test kit placard, to determine the correct API: select the appropriate type of fuel being tested (2) and turn the computer slide to match the recorded API gravity with the recorded temperature. Read and record the corrected gravity, temperature, and relative density indicated at the 60° (3) mark on the computer scale. Refer to the example shown on the gravity calculator as well. Compare the readings to the established site standards and record the test results. Determine if the fuel sample satisfies specified site standards.(figure 2-16)

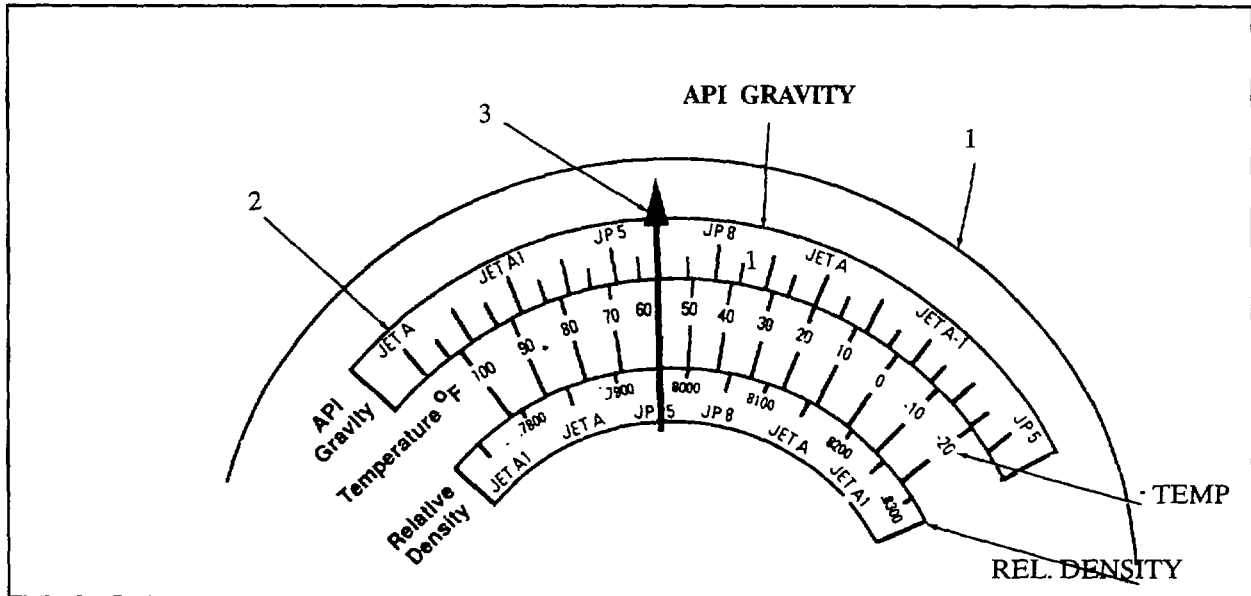

Figure 2-16

2-8. METHOD FOR UNDISSOLVED WATER TESTING.

Collect a 500 milliliter (17.0 ounce) sample of fuel. Pass the fuel through the sampler with the free-water test pad contained within the stainless steel monitor. Remove the free water test pad from the monitor and blot dry between paper towels. Insert free-water test pad into Aqua-Glo Water Detector and record ppm of water.

2-9. CALIBRATING THE AQUA-GLO WATER DETECTOR.

NOTE

To insure accurate undissolved water detection, calibrate the AQUA-GLO Water Detector before each daily use and after every hour of use.

- a. Turn on the water detector (1), setting the indicator switch (2) to the appropriate power source: set to either AC (power cord (3)), internal, or external battery. (figure 2-17)

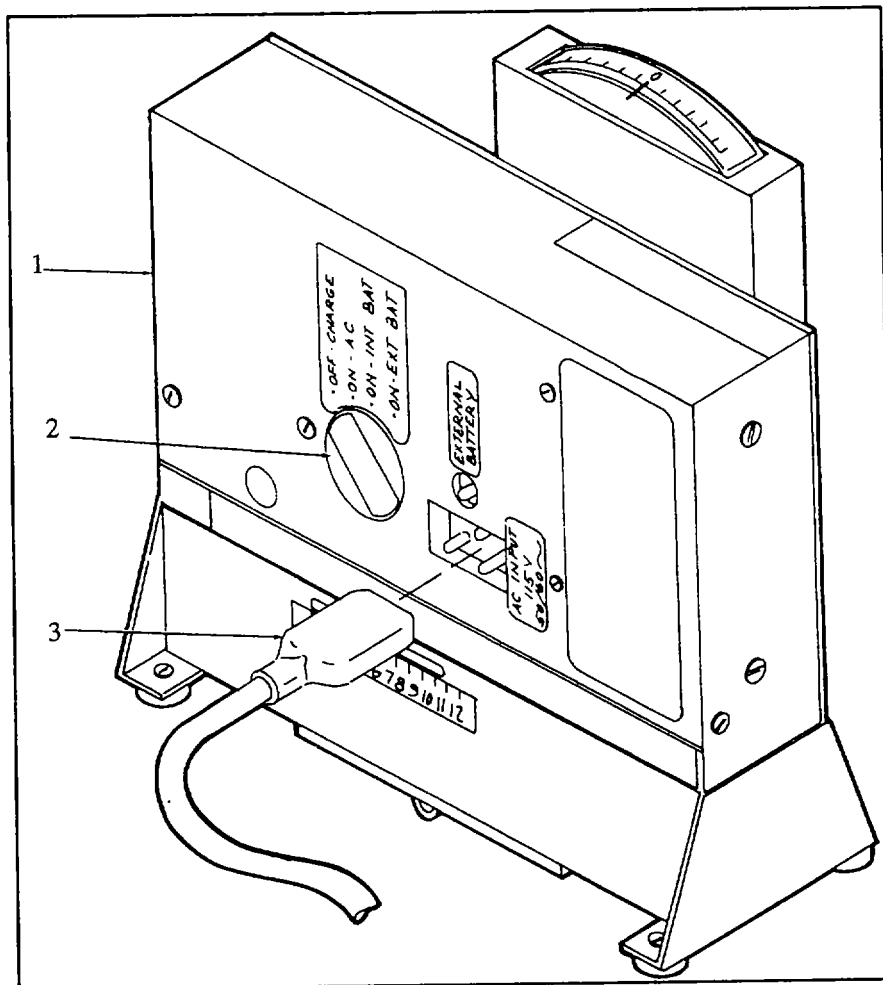

Figure 2-17

b. Remove the calibration pad (1) stored in kit. The pad is covered with a clear plastic shielding and has a coding standard written on one side. Note the "Set" code in the center of the pad: this is the calibration setting you will use for calibrating. The sample pad shown in Figure 2.18 has a calibration set code of 5.3 (2).

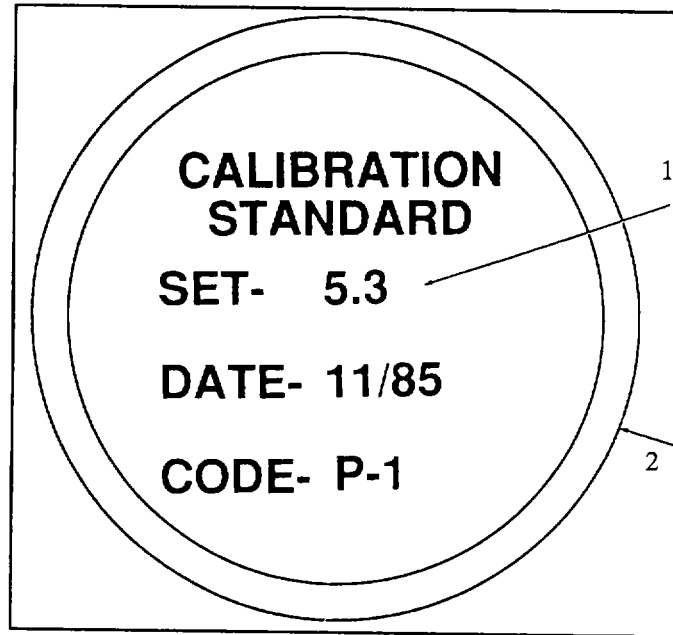

Figure 2-18

c. Insert the Calibration Pad (1) in test area window (2) located on the bottom of the water detector (3): lift the cover's curved metal tab (4) and place the pad (1) (text facing you) in the depressed circular area (5) or "window" located in the center of the test area . Close the test area cover and stand the water detector upright. (figure 2-19)

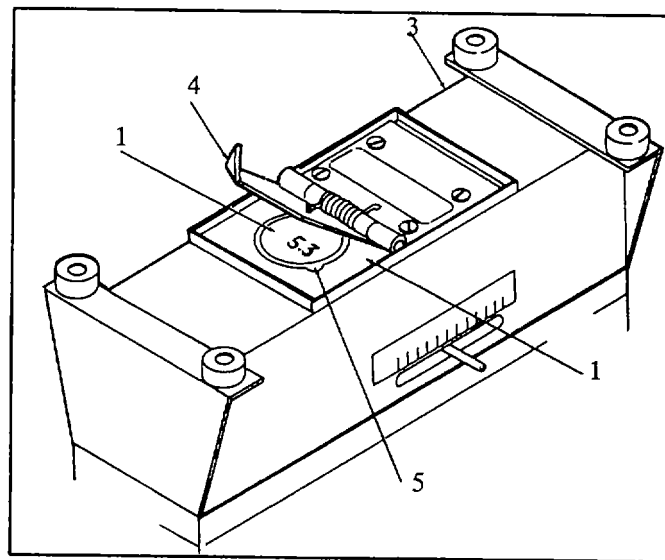

Figure 2-19

d. Position the light-modulator lever (1), located on the side of the water detector (2), (move the lever left or right), until the lever is directly above the number on the scale which corresponds to the set number shown on the calibration pad (i.e., 5.3). (figure 2-20)

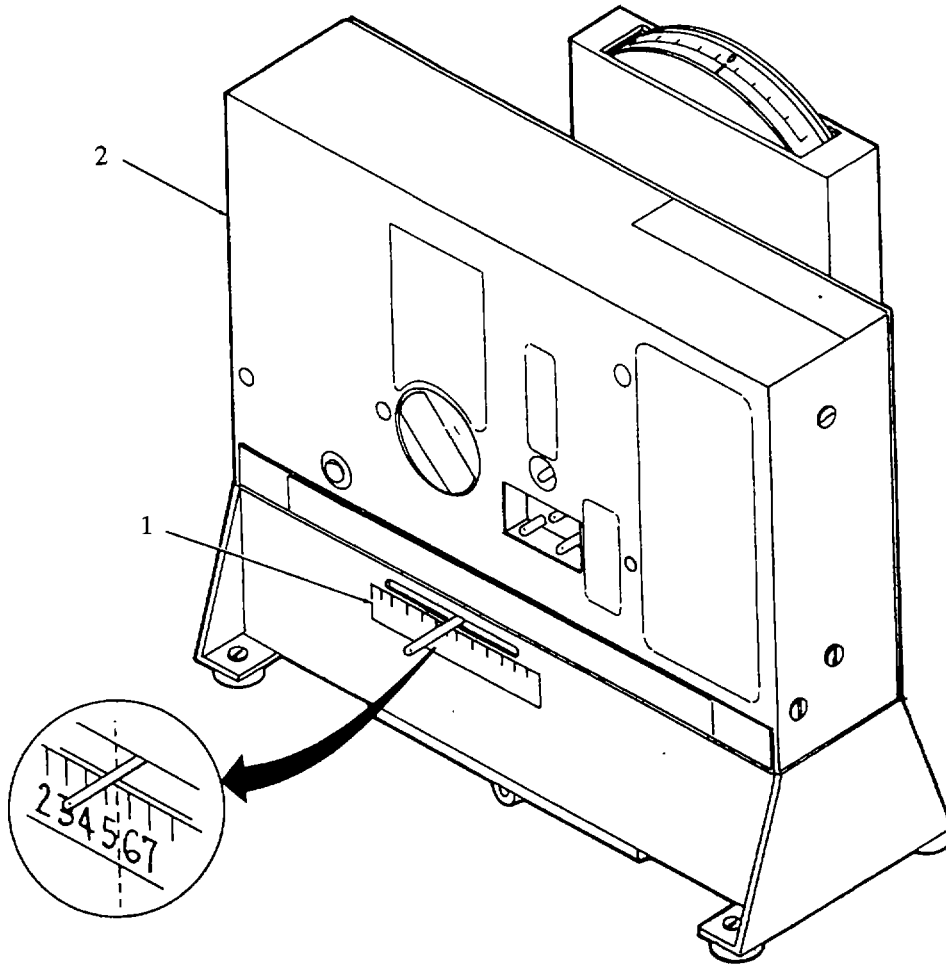
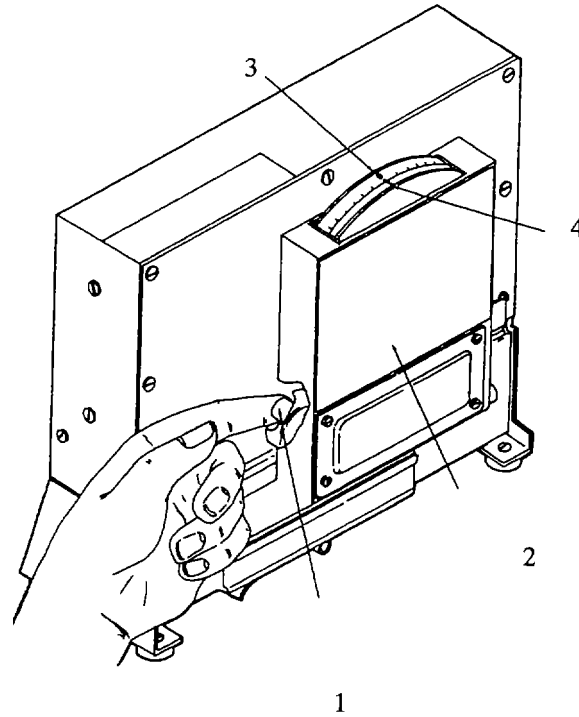

Figure 2-20

e. Depress the switch button on the instrument pack and read the calibration meter: if the meter reads "0", the water detector calibration procedure is complete (Figure 2.25). If the meter reads any increment other than "0", you must adjust the internal calibration screw until the water detector is "zeroed-out" (i.e., the meter lever shaft reads "0"). See f., g., and h. below for instructions. Also refer to the calibration card stored with kit. (figure 2-21)



1
Figure 2-21

f. Using the jeweler's screwdriver (1), remove the outer screw (2) on the side of the calibration meter housing (3). This provides access to the internal adjustment screw which allows adjustment to the meter lever. (figure 2-22)

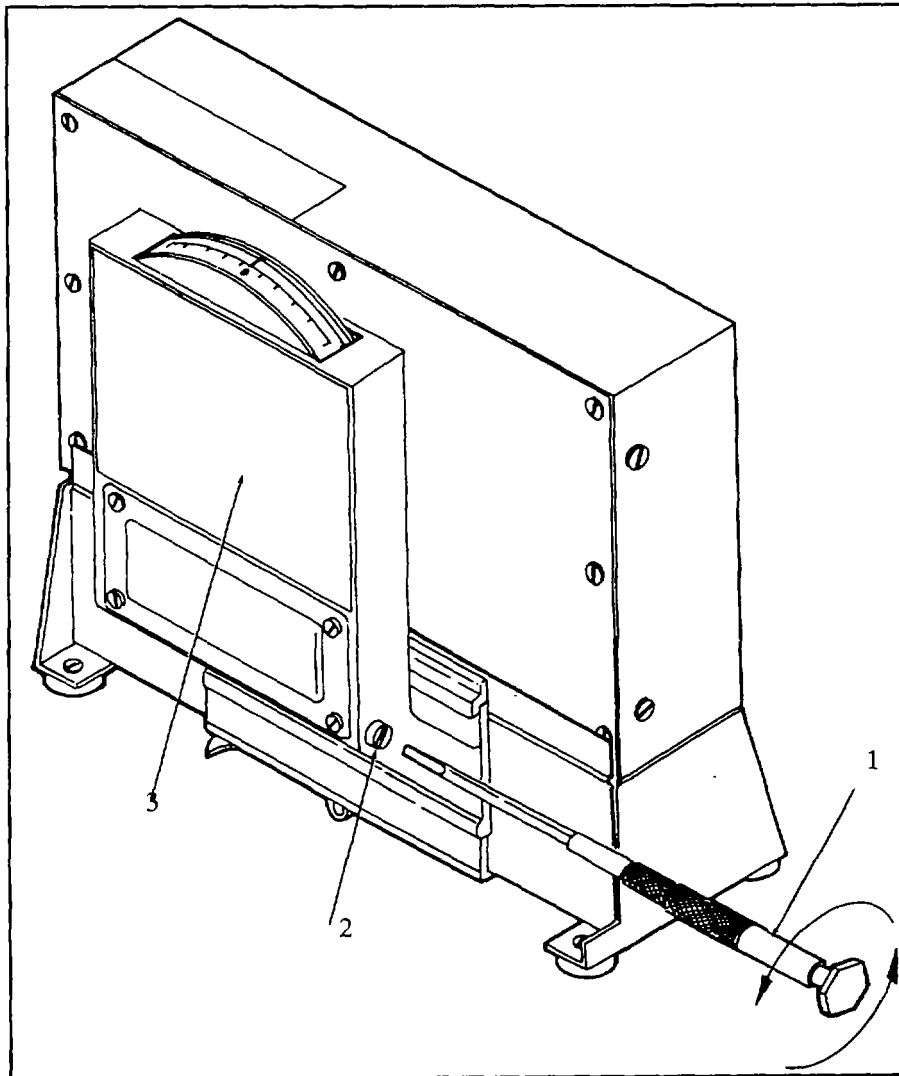

Figure 2-22

g. Insert the tip of the jeweler's screwdriver (1) into the housing (2) and turn the internal adjustment screw (in either a right or left direction). Depress the switch button (3) on the instrument pack as you turn the screw until the meter lever reads "O" (4). (figure 2-23)

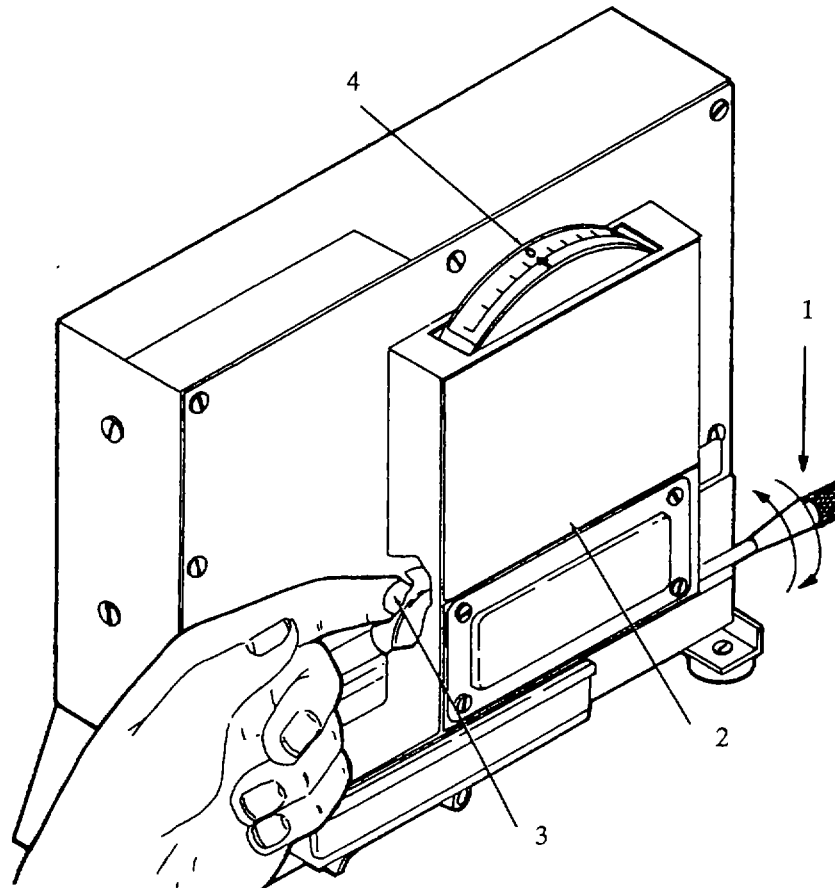

Figure 2-23

h. Replace the outer screw and the calibration of the water detector is completed. You are ready to begin the undissolved water test procedure. First collect a sample and prepare the stainless steel monitor.

2-10. PREPARING THE STAINLESS STEEL MONITOR.

a. Pry open the top of the stainless steel monitor (1) using the back end of the tweezers (2). Carefully remove the free-water test pad from its sealing package using clean, dry tweezers. **Take care not to touch the pad; oil from your fingers may contaminate the dye.** (figure 2-24)

CAUTION

Do not remove the test pad from its sealed package until you are ready to place it into the monitor. Do not allow any discrete water droplets to come into contact with the pad. Do not expose the pad to humidity or the atmosphere. Contact with these elements may effect the accuracy of the test results.

- b. The pad (3) has an orange, fluffy-textured top and a white backing. Insert the pad orange-side up towards the inlet of the monitor (the orange side should be facing upstream of the fuel flow). (figure2-24)

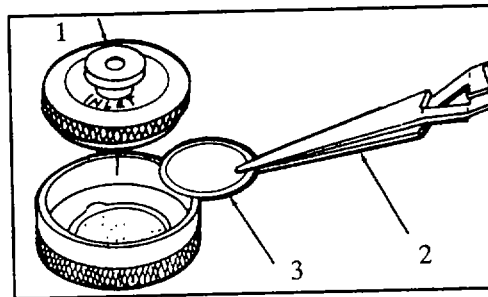

Figure 2-24

- c. Insert the Stainless Steel Monitor into the sampler by unscrewing the sampler cover (1) and inserting the stainless steel monitor (2) containing the free-water test pad (inlet side facing upstream). Screw the sampler base (3) into the sampler cover (1) hand-tight. Connect the bypass hose (4) from the three-way valve to either bypass port (5) located on the sides of the base (Figure 2.6). Press the by-pass hose (4) down firmly into the port for a tight fit. (figure 2-25)

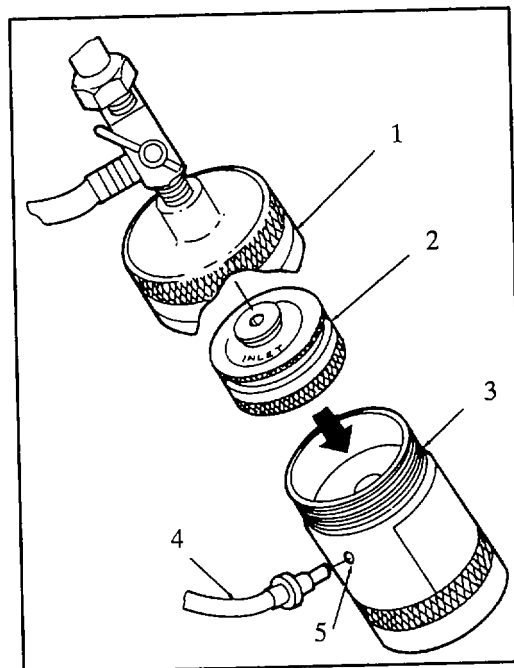

Figure 2-25

d. Connect the sampler to the quick-release valve on the system. The three-way valve (1) must be in the OFF position (2) before attaching the sampler to the remote assembly: the valve is closed or off when the valve arm is positioned approximately 45 degrees from the base of the valve . (figure 2-26)

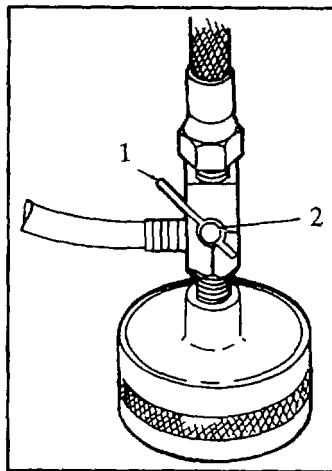

Figure 2-26.

WARNING

The Sampler Valve Hose Assembly must be properly grounded to avoid possible fire or explosion from static electrical charges. An electrical continuity test of the ground hook-up should be performed prior to test to assure conductance of electrical charges from system to ground.

e. Attach one end of ground wire (1) on any metal part of the hose assembly (2) and the other end to a ground. (figure 2-27)

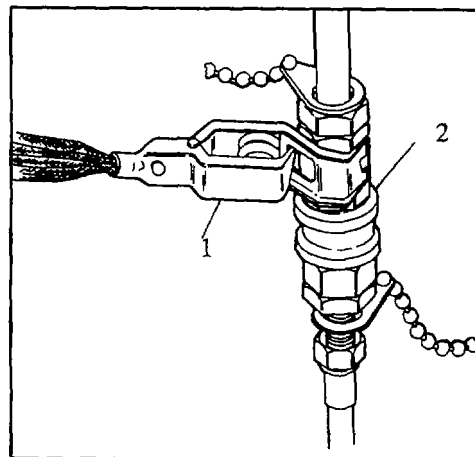

Figure 2-27

f. Flush the inlet hose by turning the three-way valve (1) to the FLUSH position: the valve arm is horizontal to the base of the valve (2). Pass at least 3.2 quarts (3 or more liters) into a 5 gallon receptacle to remove contaminants from the inlet valve. (figure 2 - 27)

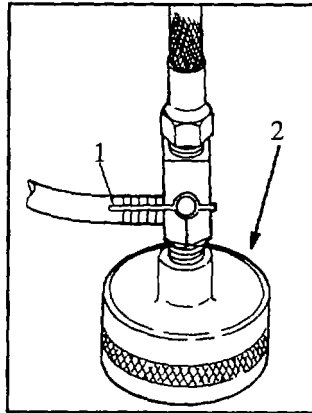

Figure 2-27

g. Take a sample by holding the sampler upright and turn the three-way valve (1) to the test position. Collect enough fuel to fill the PVC sample bottle - no more than 1 quart. (figure 2-28)

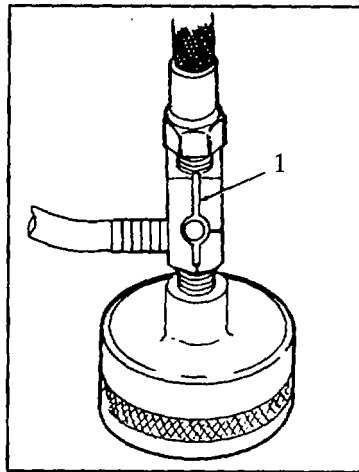

Figure 2-28

h. Allow 500 milliliters (17 ounces) or less of fuel to pass through the assembly and free-water test pad. Record sample volume for reporting.

i. When the sample has been taken turn the three-way valve (1) to the OFF position before turning off the system pump. Remove the sample bottle from the sampler. Remove the sampler nipple from the quick release valve and replace the protective cap and plug. (figure 2 - 29)

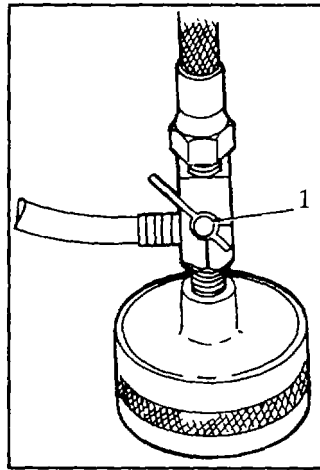

Figure 2-29

CAUTION

Some pumping systems (e.g. aircraft refuelers) develop a vacuum when closed which can cause backflow and rupture the monitor filter, rendering the test ineffective.

j. Take a sample by holding the sampler in an upright (vertical) position, turn the three-way valve (1) to the **TEST** position. Allow no more than 1 liter (1.0 qt) to flow through the monitor. Record the sample volume for reporting. When the collection is completed turn the three-way valve to the off position before turning off the system pump. Remove the sampler from the system fitting and replace the protective cap and plug. (figure 2-30)

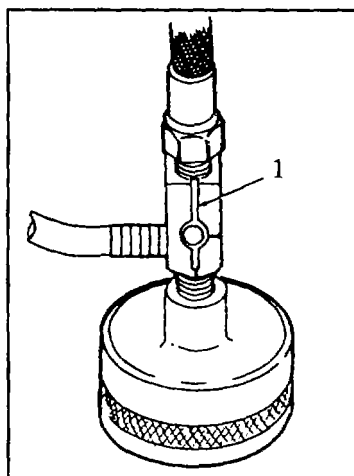

Figure 2-30

k. Disconnect the bypass hose (1) from the side of the sampler base (2) and unscrew the sampler base from the sampler cover (3). Hold the sampler in an upright position and remove the stainless steel monitor (4). (figure 2- 31)

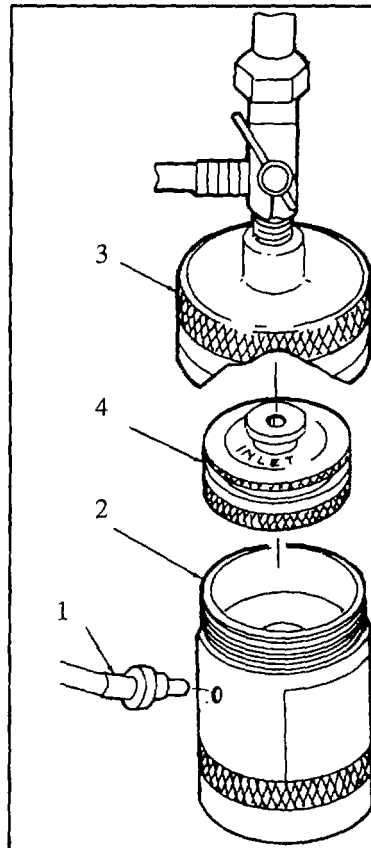

Figure 2-31

NOTE

To maximize the accuracy of the reading, the free water test pad should be read within 3 minutes of initiating the sampling.

1. Disassemble the stainless steel monitor and gently remove the free water pad. Place the pad between two dry clean paper towels and blot out excess fluids.

NOTE

A pad not properly blotted will result in a low reading because the excess fuel will absorb part of the ultraviolet light and decrease fluorescence.

m. Test for undissolved water level: open the test area cover (1) located on the bottom side of the water detector (2). Place the free-water pad (3) (orange- side down) in the test area window (4) Close the cover and turn the water detector upright. (figure 2-32)

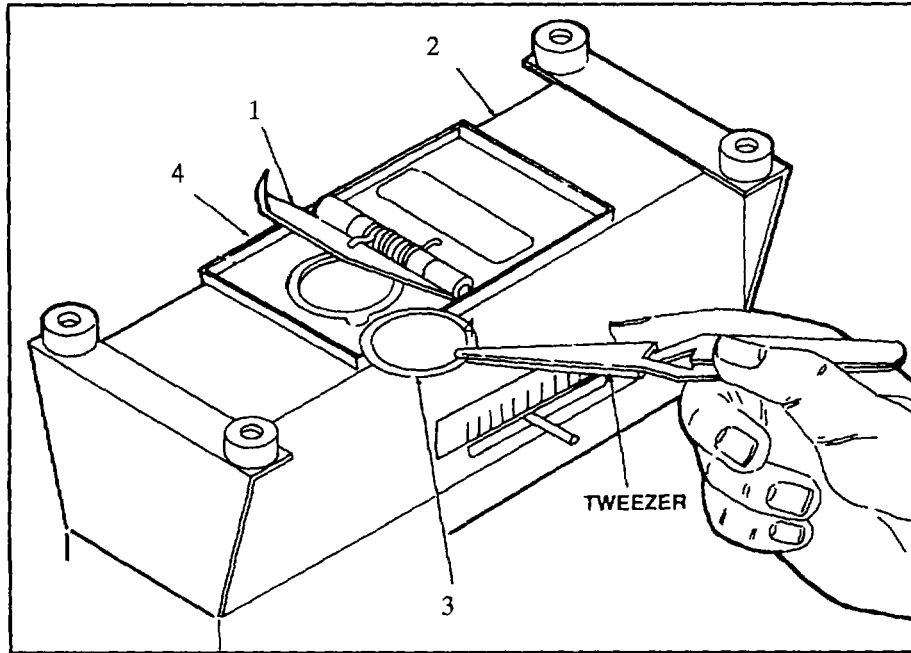

Figure 2-32

n. Turn the power setting knob to the appropriate power source (i.e., AC, external or internal battery). Depress the switch button (1) on the instrument pack (2) and adjust the light-modulator lever (3) until the meter reads "0". Read the undissolved water level where the lever crosses the scale. Record the reading to the nearest whole number as ppm by volume of undissolved water in fuel.

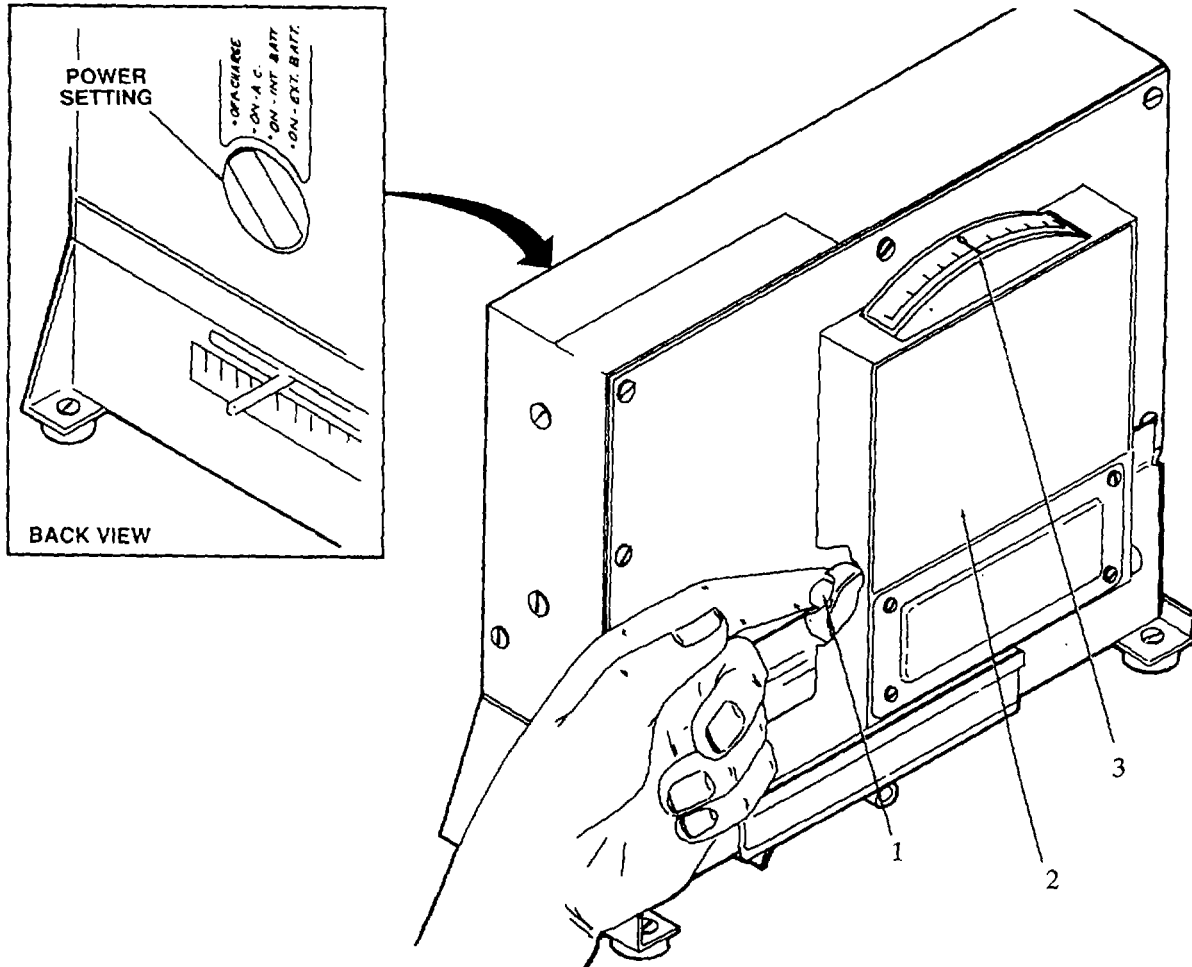

Figure 2-33

2-11. DECALS AND INSTRUCTION PLATES.

- Instruction placards for the various tests to be performed are located inside the case.
- Operational instruction plate for the Aqua-Glo Detector Unit is attached to the unit.
- Warning decal for operation of vent valve is located on front of the case.
- Hazardous chemical warning label on petroleum ether bottle.

Section IV. OPERATION UNDER UNUSUAL CONDITIONS

2-12. OPERATION UNDER UNUSUAL CONDITIONS.

This section covers the necessary operating instructions, in addition to those previously covered, that are necessary for the components of the petroleum test kit to function properly under unusual conditions, such as in extreme cold.

2-13. OPERATION IN EXTREME COLD.

During extreme cold replace preformed gaskets in dust caps.

CHAPTER 3

OPERATOR MAINTENANCE INSTRUCTIONS

**Section I. LUBRICATION INSTRUCTIONS
(No Lubrication Required)**

**Section II. OPERATOR TROUBLESHOOTING
(No Troubleshooting Required)**

**Section III. MAINTENANCE PROCEDURES
(Not Applicable)**

3-1/(3-2 Blank)

CHAPTER 4
UNIT MAINTENANCE

SECTION I

4-1	Common Tools and Equipment.....	4-1
4-2	Special Tools, TMDE, and Support Equipment	4-1
4-3	Repair Parts	4-1

SECTION II

4-4	General	4-1
4-5	Sampler Valve Assembly.....	4-1
4-6	Remote Sampling Assembly	4-1
4-7	Detector Unit	4-1
4-8	Carrying Case.....	4-1

SECTION III

4-9	Preparation for Movement	4-2
4-10	Administrative Storage	4-2

Section I. REPAIR PARTS AND SPECIAL TOOLS LIST

Page

4-1. COMMON TOOLS AND EQUIPMENT.

For authorized common tools and equipment, refer to the Modified Table of Organization and Equipment (MTOE) applicable to your unit.

4-2. SPECIAL TOOLS, TMDE, AND SUPPORT EQUIPMENT.

Refer to the Appendix B Maintenance Allocation Chart, for a list of special tools, TMDE, and support equipment and Repair Parts and Special Tools List (RPSTL).

4-3. REPAIR PARTS.

Repair parts are listed and illustrated in Appendix C, Repair Parts and Special Tools List (RPSTL) covering unit maintenance for this equipment.

Section II. UNIT MAINTENANCE PROCEDURES

4-4. GENERAL..

The procedures in this section have been arranged in the order in which the items appear in the unit (O) Maintenance level column on the Maintenance Allocation Chart (MAC) which is provided in Appendix B.

4-5. SAMPLER VALVE ASSEMBLY.

This task consists of:

- | | | |
|-----------------|------------|-----------|
| a. Inspection | b. Removal | c. Repair |
| d. Installation | | |

INITIAL SETUP:

Tools:

General Mechanics Tool Kit (Item 1, App B, Sect III)

Material/Parts:

Antiseize, Tape (Item 2, App F)

a. Inspection.

- (1) Inspect sampler valve hose (1) for cracks, cuts or damage.
- (2) Inspect connections for leaks.

b. Removal.

Grasp sampler valve hose assembly (1) and remove from sampler valve (2).

c. Repair.

Repair consists of tightening connections or retaping thread connections with new antiseize tape.

d. Installation.

Install sampler valve hose assembly (1) to sampler valve (2).

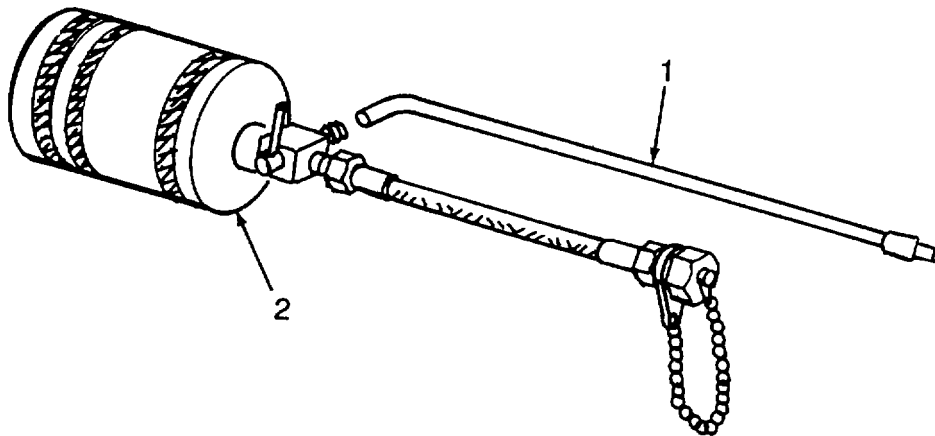

4-6. REMOTE SAMPLING ASSEMBLY.

This task consists of:

a. Inspection

b. Removal

c. Installation

INITIAL SETUP:

Tools:

General Mechanics Tool Kit (Item 1, App B, Sect III)

Material/Parts:

Antiseize, Tape (Item 2, App F)

a. Inspection.

(1) Inspect remote sampling hose assembly (1) for cracks, cuts damage or loose or missing ground wire.

b. Removal.

Remove remote sampling hose assembly (1) from sampler plug (2).

c. Installation.

Install antiseize tape on threads and install remote sampling hose assembly (1) to sampler plug (2).

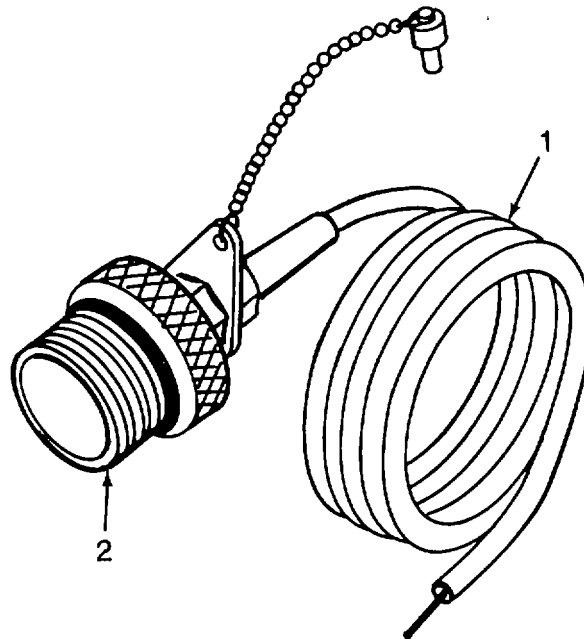

4-7. DETECTOR UNIT.

For repair of detector unit refer to TM 10-6640-221-13&P, Aqua Glo Water Detector.

4-8. CARRYING CASE.

This task consists of:

a. Inspection

b. Removal

c. Installation

INITIAL SETUP:

Tools:

General Mechanics Tool Kit (Item 1, App B, Sect III)

Drill Hand Portable 1/4 inch (Item 2, App B, Sect III)

Drill Set Twist (Item 2, App B, Sect III)

Material/Parts:

Antiseize, Tape (Item 2, App F)

a. Inspection.

- (1) Inspect case (1) for dents, broken latches, rust or damage.
- (2) Inspect gasket (2) for dryrot, cracks or tears.
- (3) Inspect placard (3) for damaged or missing calculator (4), cracks or missing rivets.
- (4) Inspect foam packing for damage.

b. Removal.

- (1) Remove gasket (2) from case (1).
- (2) Remove placard (3) by removing three pop rivets (5) from hinge (6).
- (3) Remove calculator (4) from placard (3) by removing one pop rivet (7).

c. Installation

- (1) Install gasket (2) in case (1).
- (2) Position calculator (4) in place and install one pop rivet(7).
- (3) Position placard (3) on hinge (6) and install three pop rivets (5).

4-8. CARRYING CASE.

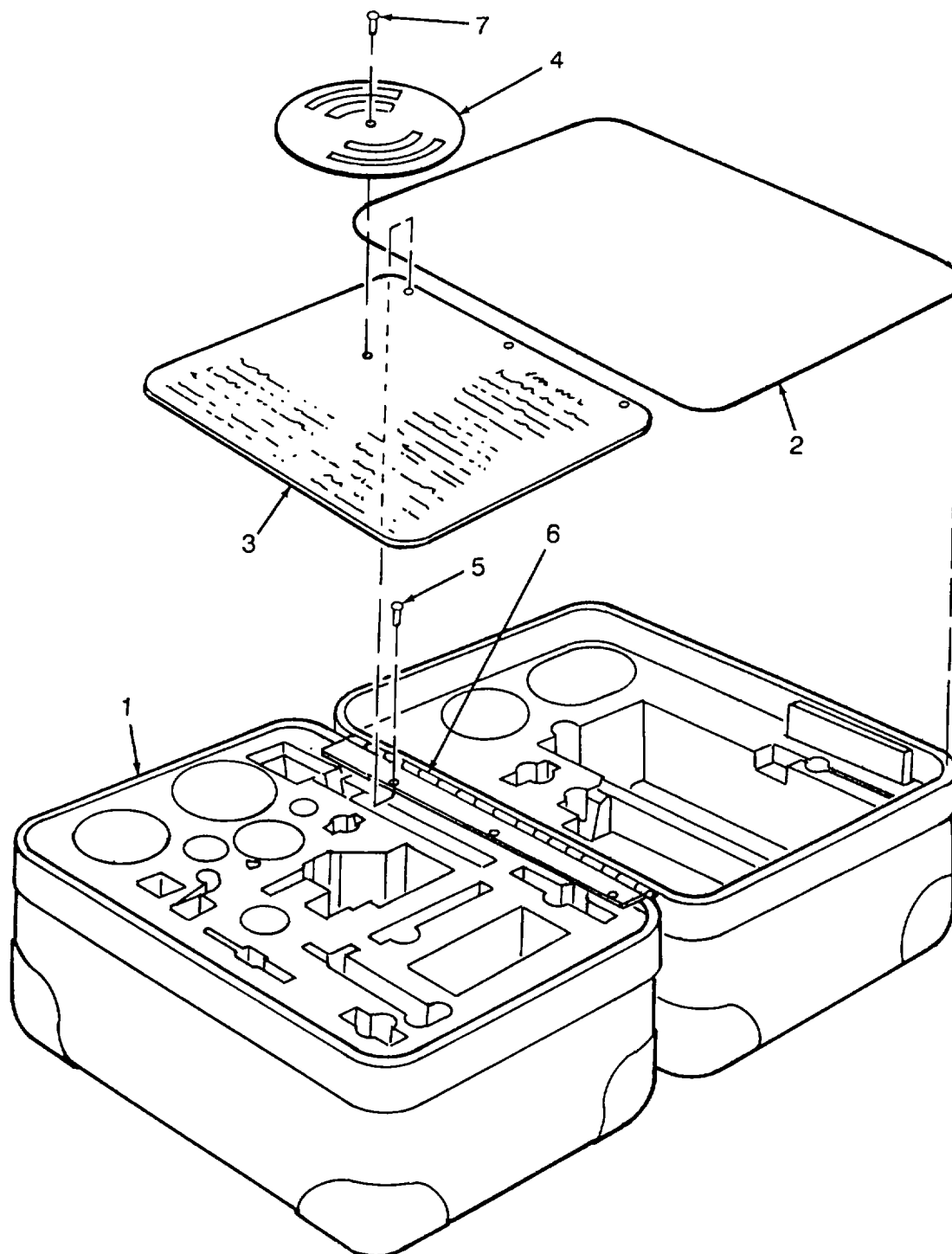

Section III. PREPARATION FOR STORAGE OR SHIPMENT

4-9. PREPARATION FOR MOVEMENT.

- a. Secure all lids on bottles and boxes.
- b. Inventory and secure all equipment in proper compartments per loading plan on placards.
- c. Close case lid and secure all latches.
- d. The valve on the front of the case must be opened before air flight and closed after air flight. This is noted on a warning decal above the valve.

4-10. ADMINISTRATIVE STORAGE.

- a. Placement of equipment in administrative storage should be for short periods of time when a shortage of maintenance efforts exists. Items should be in mission readiness within 24 hours or within the time factors as determined by the directing authority. During the storage period appropriate maintenance records will be kept.
- b. Before placing equipment in administrative storage, current maintenance services and equipment serviceable criteria (ECS) evaluations should be completed, shortcomings and deficiencies should be corrected, and all modification work orders (MWO's) should be applied.
- c. Storage site selection. Inside storage is preferred for items selected for administrative storage. If inside storage is not available, trucks, vans, convex containers and other containers may be used.

4-7 (4-8 Blank)

**APPENDIX A
REFERENCES**

A-1. SCOPE. This appendix lists all forms, field manuals, technical manuals, and other publications referenced in this manual.

A-2. FORMS

Discrepancy in Shipment Report	SF 361
Report of Discrepancy	sf 364
Quality Deficiency Report	SF 368
Equipment Inspection and Maintenance Worksheet	DA Form 2404
Recommended Changes to Publications and Blank Forms	DA Form 2028
Recommended Changes to Equipment Technical Publications	DA Form 2028-2

A-3. TECHNICAL MANUALS

Aqua-Glo Water Detector Operator's, Unit and Direct support Maintenance Manual Including Repair Parts and Special Tools List (RPSTL)	TM 10-6640-221-13&P
Procedures for Destruction of Equipment to Prevent Enemy Use	TM 750-244-3
Equipment Records Procedures	TM 4700-15/1

A-4. MISCELLANEOUS.

Aircraft Refueling	FM 10-68
Density, Specific Gravity, or API Gravity of Crude Petroleum and Liquid Petroleum Products by Hydrometer Methods	ASTM D 1298
Discrepancy and Shipment Report	MCO P4610.19
Filter Membrane Color Ratings of Aviation Turbine Fuels	ASTM D3830
Marine Corps, Military Incentive Awards Program	MCO 1650.17
Packaging Improvement Report	AR 735-11/2
Particulate Contaminant in Aviation Turbine Fuels	ATM D2276
Report of Item Packaging Discrepancy	NAVMATINST 4355.73B
Report of Transportation Discrepancies in Shipment	AR 55-38
The Army Maintenance Management System (TAMMS)	DA Pam 738-750
Undissolved Water in Aviation Turbine Fuels	ASTM D3240

A-1(A -2 blank)

**APPENDIX B
MAINTENANCE ALLOCATION CHART**

Section I. INTRODUCTION

B-1. GENERAL.

- a. This section provides a general explanation of all maintenance and repair function authorized at various maintenance categories.
- b. The Maintenance Allocation Chart (MAC) in Section II designates overall authority and responsibility for performance of maintenance functions on the identified end item or component. The application of the maintenance functions to the end item or component will be consistent with the capacities and capabilities of the designated maintenance categories.
- c. Section III lists the tools and test equipment (both special tools and common tool sets) required for each maintenance function as referenced from Section II.
- d. Section IV contains supplemental instructions and explanatory notes for a particular maintenance function.

B-2. MAINTENANCE FUNCTIONS.

Maintenance functions will be limited to and are defined as follows:

- a. Inspect. To determine the serviceability of an item by comparing its physical, mechanical, and/or electrical characteristics with established standards through examination (e.g., by sight, sound, or feel).l
- b. Test. To verify serviceability by measuring the mechanical, pneumatic, hydraulic, or electrical characteristics of an item and comparing those characteristics with prescribed standards.
- c. Service. Operations required periodically to keep an item in proper operating condition, i.e., to clean (includes decontaminate, when required), to preserve, to drain, to paint, or to replenish fuel, lubricants, chemical fluids, or gases.
- d. Adjust. To maintain or regulate, within prescribed limits, by bringing into proper or exact position, or by setting the operating characteristics to specified parameters.
- e. Aline. To adjust specified variable elements of an item to bring about a optimum performance.
- f. Calibrate. To determine and cause corrections to be made or to be adjusted on instruments or test, measuring, and diagnostic equipments used in precision measurement. Consists of comparisons of two instruments, one of which is a certified standard of known accuracy, to detect and adjust any discrepancy in the accuracy of the instrument being compared.

B-2. MAINTENANCE FUNCTIONS- cont

- g. Remove/Install. To remove and install the same item when required to perform service or other maintenance functions. Install may be the act of emplacing, seating, or fixing into position a spare, repair part, or module (component or assembly) in a manner to allow the proper functioning of an equipment or system.
- h. Replace. To remove an unserviceable item and install a serviceable counterpart in its place. "Replace" is authorized by the MAC and is shown as the 3rd position code of the SMR code.
- i. Repair. The application of maintenance services, including fault location/troubleshooting, removal/installation, and disassembly/assembly procedures, and maintenance actions to identify troubles, and restore serviceability to an item by correcting specific damage, fault, malfunction, or failure in a part, subassembly, module (component or assembly) end item, or system.
- j. Overhaul. That maintenance effort (service/action) prescribed to restore an item to a completely serviceable/operational condition as required by maintenance standards in appropriate technical publications (i.e., DMWR). Overhaul is normally the highest degree of maintenance performed by the Army. Overhaul does not normally return an item to like new condition.
- k. Rebuild. Consists of those services/actions necessary for the restoration of unserviceable equipment to a like new condition in accordance with original manufacturing standards. Rebuild is the highest degree of material maintenance applied to Army equipment. The rebuild operation includes the act of returning to zero those age measurements (hours/miles, etc.) considered in classifying Army equipment/components.

B-3. EXPLANATION OF COLUMNS IN THE MAC SECTION II.

- a. Column 1, Group Number. Column 1 lists functional group code numbers, the purpose of which is to identify maintenance significant components, assemblies, subassemblies, and modules with the next higher assembly. End item group numbers are "00".
- b. Column 2, Component/Assembly. Column 2 contains the names of components, assemblies, subassemblies, and modules for which maintenance is authorized.
- c. Column 3, Maintenance Function. Column 3 lists the functions to be performed on the item listed in Column 2. (For a detailed explanation of these functions, see paragraph B-2).
- d. Column 4, Maintenance Level. Column 4 specifies, by the listing of a work time figure (expressed as man-hours shown as whole hours or decimals) in the appropriate subcolumn(s), the level of maintenance authorized to perform the function listed in Column (3). This figure represents the active time required to perform that maintenance function at the indicated level of maintenance. If the number or the complexity of the tasks within the listed maintenance function vary at different maintenance levels, appropriate work time figures will be shown for each level. The work time figure represents the average time required to restore an item (assembly, subassembly, component, module, end item, or system) to a serviceable condition under typical field operating conditions. This time includes preparation item including any necessary disassembly/assembly time), troubleshooting/fault location time, and quality assurance/quality control time in addition to the time required to perform

the specific tasks identified for the maintenance functions authorized in the maintenance allocation chart. The system designations for the various maintenance levels are shown on the following page.

C	Operator or crew
O	Unit Maintenance
F	Direct Support Maintenance
H	General Support Maintenance
D	Depot Maintenance

- e. Column 5, Tools and Equipment. Column 5 specifies, by code, those common tool sets (not individual tools) common TMDE, and special tools, special TMDE, and support equipment required to perform the designated function.
- f. Column 6, Remarks. This column, when applicable, contains a letter code, in alphabetic order, which is keyed to the remarks contained in Section IV.

B-4. EXPLANATION OF COLUMNS IN TOOL AND TEST EQUIPMENT REQUIREMENTS, SECTION III.

- a. Column 1, Reference Code. The tool and test equipment reference code correlates with a code used in the MAC, Section 11, Column 5.
- b. Column 2, Maintenance Level. The lowest category of maintenance authorized to use the tool or test equipment.
- c. Column 3, Nomenclature. Name or identification of the tool or test equipment.
- d. Column 4, National Stock Number. The national stock number of the tool or test equipment.
- e. Column 5, Tool Number. The manufacturer's part number.

B-5. EXPLANATION OF COLUMNS IN REMARKS, SECTION IV.

- a. Column 1, Reference Code. The code recorded in column 6, Section II.
- b. Column 2, Remarks. This column lists information pertinent to the maintenance function being performed as indicated in the MAC, Section 11.

Section II. MAINTENANCE ALLOCATION CHART

(1) GROUP NUMBER	(2) COMPONENT/ ASSEMBLY	(3) MAINTENANCE FUNCTION	(4) MAINTENANCE CATEGORY					(5) TOOLS AND EQUIPMENT	(6) REMARKS
			UNIT		DS	GS	DEPOT		
			C	O	F	H	D		
00	TEST KIT PETROLEUM AVIATION FUEL CONTAMINANT	INSPECT REPLACE	0.5						
01	SAMPLER, VALVE HOSE ASSY	REPAIR INSPECT		1.0				A	
02	REMOTE SAMPLING ASSY	REPLACE REPAIR	0.2	0.3			1		
03	DETECTOR UNIT	INSPECT REPLACE		1.0			1		
04	CARRYING CASE	REPAIR INSPECT REPLACE	0.2	1.0				B	
			0.3				1,2		

Section III. TOOLS AND TEST EQUIPMENT REQUIREMENTS

(1) REFERENCE CODE	(2) MAINTENANCE CATEGORY	(3) NATIONAL STOCK NOMENCLATURE	(4) TOOL NUMBER (NSN)	(5) NUMBER
1	0	TOOL KIT, GENERAL MECHANICS	5180-00-177-7033	SC-5180-90-CL-N26
2	0	TOOL KIT, COMMON NO. 1	4910-00-754-0654	SC-4910-95-CL-A72

Section IV. REMARKS

REFERENCE CODE	REMARKS
A	REPAIR IS LIMITED TO REPLACEMENT OF COMPONENTS
B	REFER TO TM 10-6640-221-13&P, AQUA GLO WATER DETECTOR UNIT

APPENDIX C

UNIT MAINTENANCE MANUAL REPAIR PARTS AND SPECIAL TOOLS LIST

Section I. INTRODUCTION

C-1. SCOPE.

This Repair Parts and Special Tools List (RPSTL) lists and authorizes spares and repair parts; special tools; special Test, Measurement, and Diagnostic Equipment (TMDE); and other special support equipment required for performance of unit level maintenance on the Petroleum Test Kit. It authorizes the requisitioning, issue, and disposition of spares, repair parts and special tools as indicated by the Source, Maintenance and Recoverability (SMR) codes.

C-2. GENERAL.

In addition to Section I, Introduction, this Repair Parts and Special Tools List is divided into the following sections:

- a. Section II. Repair Parts List. A list of spares and repair parts authorized by this RPSTL for use in the performance of maintenance. This list also includes parts which must be removed for replacement of the authorized parts. Parts lists are composed of functional groups in ascending alphanumeric sequence, with the parts in each group listed in ascending figure and item number sequence. Bulk materials are listed in item name sequence. Repair parts kits are listed separately in their own functional group within Section II. Repair parts for repairable special tools are also listed in this section. Items listed are shown on the associated illustration(s)/figure(s).
- b. Section III. Special Tools List. A list of special tools, special TMDE, and other special support equipment authorized by this RPSTL (as indicated by Basis of Issue (BOI) information in DESCRIPTION AND USABLE ON CODE column) for the performance of maintenance.
- c. Section IV. Cross-Reference Indexes. A list, in National Item Identification Number (NIIN) sequence, of all National stock numbered items appearing in the listing, followed by a list in alphanumeric sequence of all part numbers appearing in the listings. National stock numbers and part numbers are cross referenced to each illustration figure and item number appearance. The figure and item number index lists figure and item number in alphanumeric sequence and cross-references NSN, CAGE and part number.

C-3. EXPLANATION OF COLUMNS (SECTIONS II AND III).

- a. ITEM NO. (Column (1)). Indicates the number used to identify items called out in the illustration.
- b. SMR CODE (Column (2)). The Source, Maintenance, and Recoverability (SMR) code is a 5-position code containing supply/requisitioning information, maintenance category authorization criteria, and disposition instruction, as shown in the following breakout:

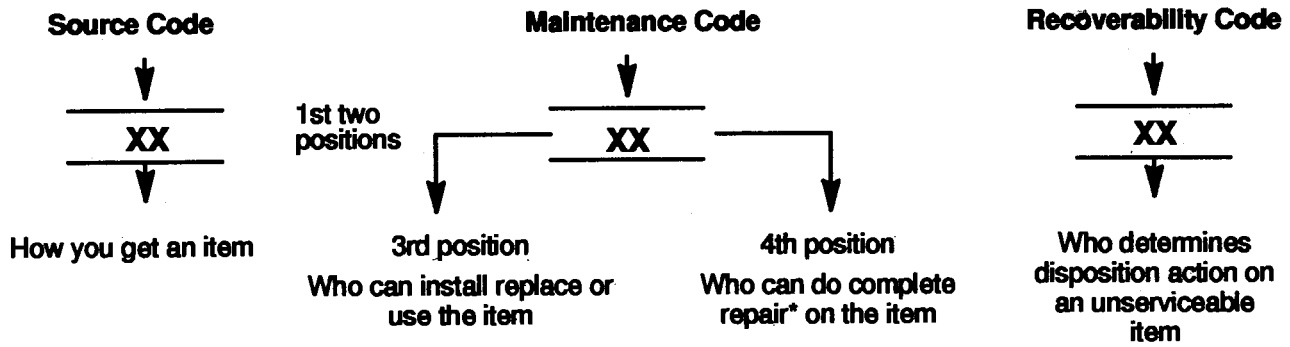

*Complete Repair: Maintenance capacity, capability, and authority to perform all corrective maintenance tasks of the "Repair" functions in a use/user environment in order to restore serviceability to a failed item.

(1) **Source Code.** The source code tells you how to get an item needed for maintenance, repair, or overhaul of an end item/equipment. Explanations of source codes follows:

Code

Explanation

PA
 PB
 PC**
 PD
 PE
 P
 PG

Stocked items; use the applicable NSN to request/requisition items with these source codes. They are authorized to the category indicated by the code entered in the 3d position of the SMR code.

****NOTE:** Items coded PC are subject to deterioration.

Items with these codes are not to be requested/requisitioned individually. They are a part of a kit which is authorized to the maintenance category indicated in the 3d position of the SMR code. The complete kit must be requisitioned and applied.

KD
 KF
 KB

Explanation

Items with these codes are not to be requested/requisitioned individually. They must be made from bulk material which is identified by the part number in the DESCRIPTION and USABLE ON CODE (UOC) column and listed in the Bulk Material group of the repair parts list in the RPSTL. If the item is authorized to you by the 3d position code of the SMR code, but the source code indicates it is made at higher level, order the item from the higher level of maintenance.

AVMO - (Made at org. AVUM level)
 MF - (Made at DS/AVUM Level)
 MH - (Made at GS Level)
 ML - (Made at Specialized Repair Activity (SRA))
 MD - (Made at Depot)

<u>Code</u>	<u>Explanation</u>
AO	- (Assembled by org/AVUM Level)
AF	- (Assembled by DS/AVUM Level)
AH	- (Assembled by GS Category)
AL	- (Assembled by SRA)
AD	- (Assembled by Depot)
XA	- Do not requisition an "XA"-coded item. Order its next higher assembly (also, refer to the NOTE below).
XB	- If an "XB" item is not available from salvage, order it using the CAGEC and part number given.
XC	- Installation drawing, diagram, instruction sheet, field service drawing, that is identified by manufacturer's part number.
XD	- Item is not stocked. Order an "XD"-coded item through normal supply channels using the CAGEC and part number given, if no NSN is available.

NOTE

Cannibalization or controlled exchange, when authorized, may be used as a source of supply for items with the above source codes, except for those source coded "XA" or those aircraft support items restricted by requirements of AR 750-1.

(2) Maintenance Code. Maintenance codes tell you the level(s) of maintenance authorized to use and repair support items. The maintenance codes are entered in the third and fourth positions of the SMR Code as follows:

(a) The maintenance code entered in the third position tells you the lowest maintenance level authorized to remove, replace and use an item. The maintenance code entered in third position will indicate authorization to one of the following levels of maintenance.

<u>Code</u>	<u>Application/Explanation</u>
C	- Crew or operator maintenance done within organizational or aviation unit maintenance.
O	- Unit or aviation unit category can remove, replace, and use the item.
F	- Direct support or aviation intermediate level can remove, replace, and use the item.
H	- General support level can remove, replace, and use the item.
L	- Specialized repair activity can remove, replace, and use the item.
D	- Depot level can remove, replace, and use the item.

(b) The maintenance code entered in the fourth position tell you whether or not the item is to be repaired and identifies the lowest maintenance level with the capability to do complete repair (i.e., perform all authorized repair functions.) (NOTE: Some limited repair may be done on the item at a lower level of maintenance, if authorized by the Maintenance Allocation Chart (MAC) and SMR codes.) This position will contain one of the following maintenance codes.

Code	Application/Explanation
O	- Unit or (aviation unit) is the lowest level that can do complete repair of the item.
F	- Intermediate direct support or aviation intermediate is the lowest level that can do complete repair of the item.
H	- Intermediate general support is the lowest level that can do complete repair of the item.
L	- The designated specialized repair activity is the lowest level that can do complete repair of the item.
D	- Depot is the lowest level that can do complete repair of the item.
Z	- Nonrepairable. No repair is authorized.
B	- No repair is authorized. (No parts or special tools are authorized for the maintenance of a "B" coded item). However, the item may be reconditioned by adjusting, lubricating, etc., at the user level.

- (3) Recoverability Code. Recoverability codes are assigned to items to indicate the disposition action on unserviceable items. The recoverability code is entered in the fifth position of the SMR Code as follows:

Recoverability Codes	Application/Explanation
Z	- Nonrepairable item. When unserviceable, condemn and dispose of the item at the level of maintenance shown in 3d position of SMR Code.
O	- Repairable item. When uneconomically repairable, condemn and dispose of the item at unit or aviation unit level.
F	- Repairable item. When uneconomically repairable, condemn and dispose of the item at the intermediate direct support or aviation intermediate level.
H	- Repairable item. When uneconomically repairable, condemn and dispose of the item at the intermediate general support level.
D	- Repairable item. When beyond lower level repair capability, return to depot. Condemnation and disposal of item not authorized below depot level.
L	- Repairable item. Condemnation and disposal not authorized below specialized repair activity (SRA).
A	- Item requires special handling or condemnation procedures because of specific reasons (e.g., precious metal content, high dollar value, critical material, or hazardous material). Refer to appropriate manuals/ directives for specific instructions.

c. CAGE (Column (3)). The Commercial and Government Entity Code (CAGEC) is a 5-digit numeric code which is used to identify the manufacturer, distributor, or Government agency, etc., that supplies the item.

d. PART NUMBER (Column (4)). Indicates the primary number used by the manufacturer (individual, company, firm, corporation, or Government activity), which controls the design and characteristics of the item by means of item engineering drawings, specifications standards, and inspection requirements to identify and item or range of items.

NOTE

When you use a NSN to requisition an item, the item you receive may have a different part number from the part ordered.

- e. DESCRIPTION AND USABLE ON CODE (UOC) (Column (5)). This column includes the following information:
- (1) The Federal item name and, when required, a minimum description to identify the item.
 - (2) The physical security classification of the item if applicable is indicated by the parenthetical entry e.g., Phy Sec C1 (C) - Confidential, Phy Sec C1 (S) - Secret, Phy Sec C1 (T) Top Secret).
 - (3) Items that are included in kits and sets are listed below the name of the kit or set.
 - (4) Spare/repair parts that make up an assembled item are listed immediately following the assembled item line entry.
 - (5) Part numbers for bulk materials are referenced in this column in the line item entry for the item to be manufactured/fabricated.
 - (6) When the item is not used with all serial numbers of the same model, the effective serial numbers are shown on the last line(s) of the description (before UOC).
 - (7) The usable on code, when applicable (see paragraph C- 5, Special information.)
 - (8) In the Special Tools List section, the basis of issue (BOI) appears as the last line(s) in the entry for each special tools, special TMDE, and other special support equipment. When density of equipments supported exceeds density spread indicated in the basis of issue, the total authorization is increased proportionately.
 - (9) The statement "END OF FIGURE" appears just below the last item description in Column 5 for a given figure in both Section II and Section III.
 - (10) The indenture, shown as dots appearing before the repair part, indicates that the item is a repair part of the next higher assembly.
- f. QTY (Column (6)). The QTY (quantity per figure column) indicates the quantity of the item used in the breakout shown on the illustration figure, which is prepared for a functional group, subfunctional group, or an assembly. A "V" appearing in this column in lieu of a quantity indicates that the quantity is variable and the quantity may vary from application to application.

C-4. EXPLANATION OF COLUMNS (SECTION IV).

a. NATIONAL STOCK NUMBER (NSN) INDEX.

- (1) STOCK NUMBER column. this column lists the NSN by National Item Identification Number (NIIN) Sequence. The NIIN consists of the last nine digits of the NSN, i.e.

$$\begin{array}{r} \text{NSN} \\ \hline 6630-01-008-9670 \\ \text{NIIN} \end{array}$$

When using this column to locate an item, ignore the first 4 digits of the NSN. However, the complete NSN should be used when ordering items by stock number.

- (2) FIG. Column. This column lists the number of the figure where the item is identified/located. The figures are in numerical order in Section II and Section III.

- (3) ITEM Column. The item number identifies the item associated with the figure listed in the adjacent FIG. column. This item is also identified by the NSN listed on the same line.
- b. **PART NUMBER INDEX.** Part numbers in this index are listed by the number in ascending alphanumeric sequence (i.e., vertical arrangement of letter and number combination which places the first letter or digit of each item in order A through Z, followed by the number 0 through 9 and each following letter or digit in like order).
- (1) CAGEC Column. The Commercial and Government Entity Code (CAGEC) is a 5-digit numeric code used to identify the manufacturer, distributor, or Government agency, etc., that supplies the item.
 - (2) PART NUMBER Column. Indicates the primary number used by the manufacturer (individual, firm, corporation or Government activity), which controls the design and characteristics of the item by means of its engineering drawings, specifications standards, and inspection requirements to identify an item or range of items.
 - (3) STOCK NUMBER Column. This column lists the NSN for the associated part number and manufacturer identified in the PART NUMBER and CAGEC columns to the left.
 - (4) FIG. Column. This column lists the number of the figure where the item is identified/located in Section II and III.
 - (5) ITEM Column. The item number is that number assigned to the item as it appears in the figure referenced in the adjacent figure number column.

c. FIGURE AND ITEM NUMBER INDEX

- (1) FIG Column. The column lists the number of the figure where the item is identified/located in Section II and III.
- (2) ITEM Column. The item number is that number assigned to the item as it appears in the figure referenced in the adjacent number column.
- (3) STOCK NUMBER Column. This column lists the NSN for the item.
- (4) CAGEC Column. The Commercial and Government Entity Code (CAGEC) is a 5-digit numeric code used to identify the manufacturer, distributor, or Government agency, etc., that supplies the item.
- (5) PART NUMBER Column. Indicates the primary number used by the manufacturer (individual, firm, corporation or Government activity), which controls the design and characteristics of the item by means of its engineering drawings, specifications standards, and inspection requirements to identify an item or range of items.

C-5. SPECIAL INFORMATION.

a. USABLE ON CODE. The usable on code appears in the lower left corner of the Description column heading. Usable on codes are shown as "UOC:" in the Description Column (justified left) on the last line applicable item description/nomenclature. Uncoded items are applicable to all models.

b. ASSOCIATED PUBLICATIONS. Refer to Appendix A, References.

C-6. HOW TO LOCATE REPAIR PARTS.

a. When National Stock Number or Part Number is Not Known:

- (1) First. Using the table of contents, determine the assembly group or subassembly group to which the item belongs. This is necessary since figures are prepared for assembly groups and subassembly groups, and listings are divided into the same groups.
- (2) Second. Find the figure covering the assembly group or subassembly group to which the item belongs.
- (3) Third. Identify the item on the figure and note the item number.
- (4) Fourth. Refer to the Repair Parts List for the figure to find the part number for the item number noted on the figure
- (5) Fifth. Refer to the Part Number Index to find the NSN, if assigned.

b. When National Stock Number or Part Number is Known:

- (1) First. Using the Index of National Stock Numbers and Part numbers, find the pertinent National Stock Number or Part Number. The NSN index is in national Item identification Number (NIIN) sequence (see C-4.a(1)). The part numbers in the Part Number index are listed in ascending alphanumeric sequence (see C-4.b). Both indexes cross-reference you to the illustration figure and item number of the item you are looking for.
- (2) Second. After finding the figure and item number, verify that the item is the one you are looking for, then locate the item number in the repair parts list for the figure.

C-7. ABBREVIATIONS.

Abbreviations used in this manual are listed in MIL-STD-12.

C-8. FEDERAL SUPPLY CODES FOR MANUFACTURES.

CODE	MANUFACTURER	CODE	MANUFACTURER
05178	Nalge Co. Div of Sybron Corp. 75 Panorama Creek Dr. Rochester, NY 14625-2303	32218	Gammon Technical Products Inc. 235 Parker Ave Rt 71 Manasquan, NJ 08736-0400
08070	Parker-Hannifan Corp Auto Service Products Div Minneapolis, MN	54938	Parker-Hannifin Corp. Fluid Connector Div Instrumentation Connectors Div 9400 S Memorial Pky P.O. Box 400004-1505 Huntsville, AL 35815-1504
08071	Millipore Corp. Customer Service Dept 397 Williams St Marlborough, MA. 01752	71731	Crescent Tool Co. Cincinnati, OH 45234
16428	Cooper Industries Inc. Belden Div Richmond Plant 350 NW N St Richmond, IN. 47374	74284	Brooks and Perkins Skydyne Unit Div of AAR Corp. River Rd P.O. BOX 1106 Port Jervis, NY 12771-9504
19099	US Army Troop Support Command 4300 Goodfellow Blvd St. Louis, MO 63120-1702	76545	Mueller Electric Co. 1583 East 31 st St Cleveland, OH 44114-4322
2E919	Daigger A and Co of California 10 Harbour Way Richmond, CA. 94801-3552	81349	Federal Specification Promulgated by Standardization Division Directorate of Logistic Services DSA Washington, DC 20001
2P332	Greers Ferry Glass Works Inc. Rt 2 Box 161 Quitman, AR 72131-9739	90598	Engineered Air Systems, Inc. 1270 North Price Rd St. Louis, MO. 63132
22527	Fisher Scientific Co. 585 Alpha Dr Pittsburgh, PA 15328-2911		

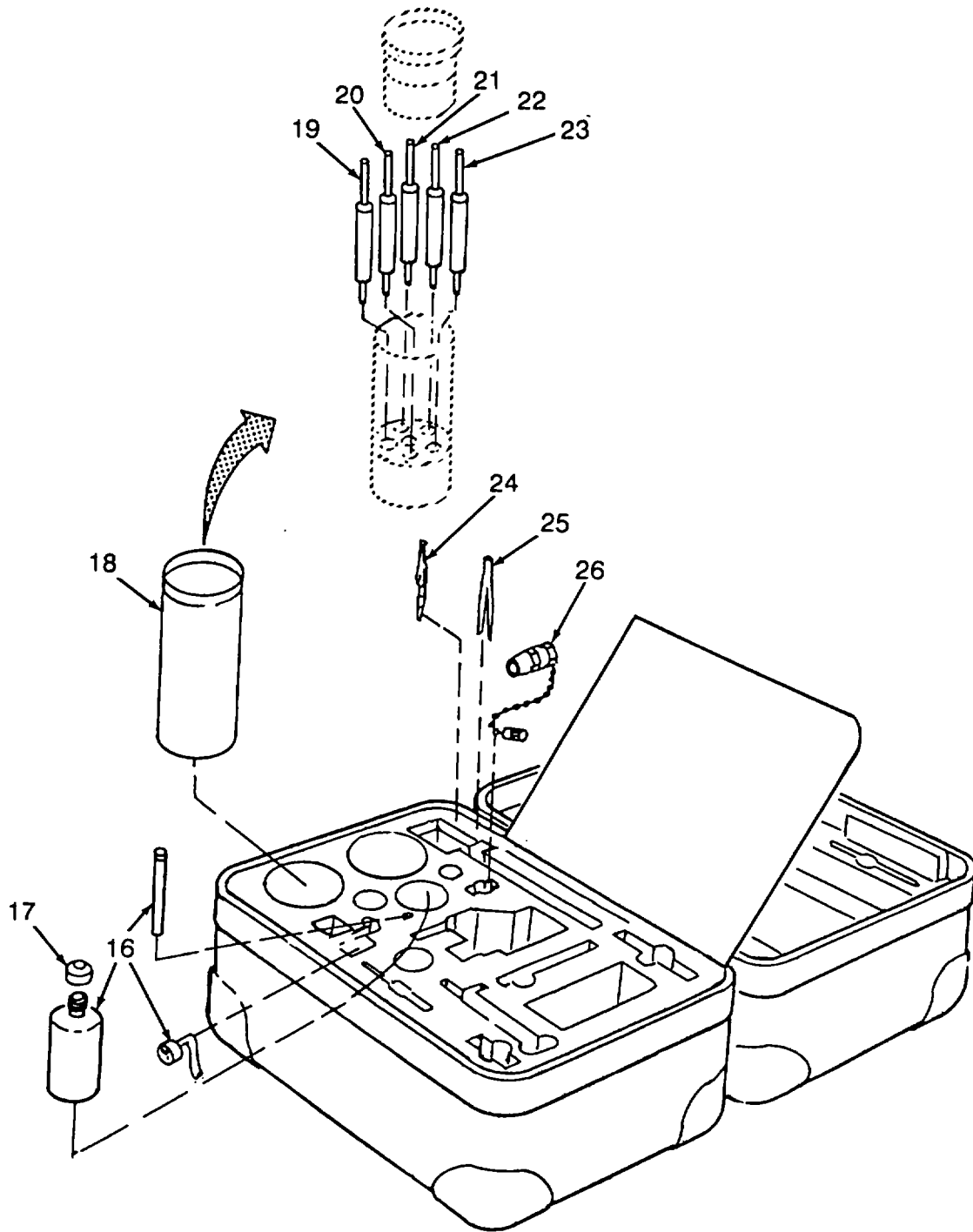

Figure 1. Petroleum Test Kit (Sheet 2 of 5)

Change 1 C-11

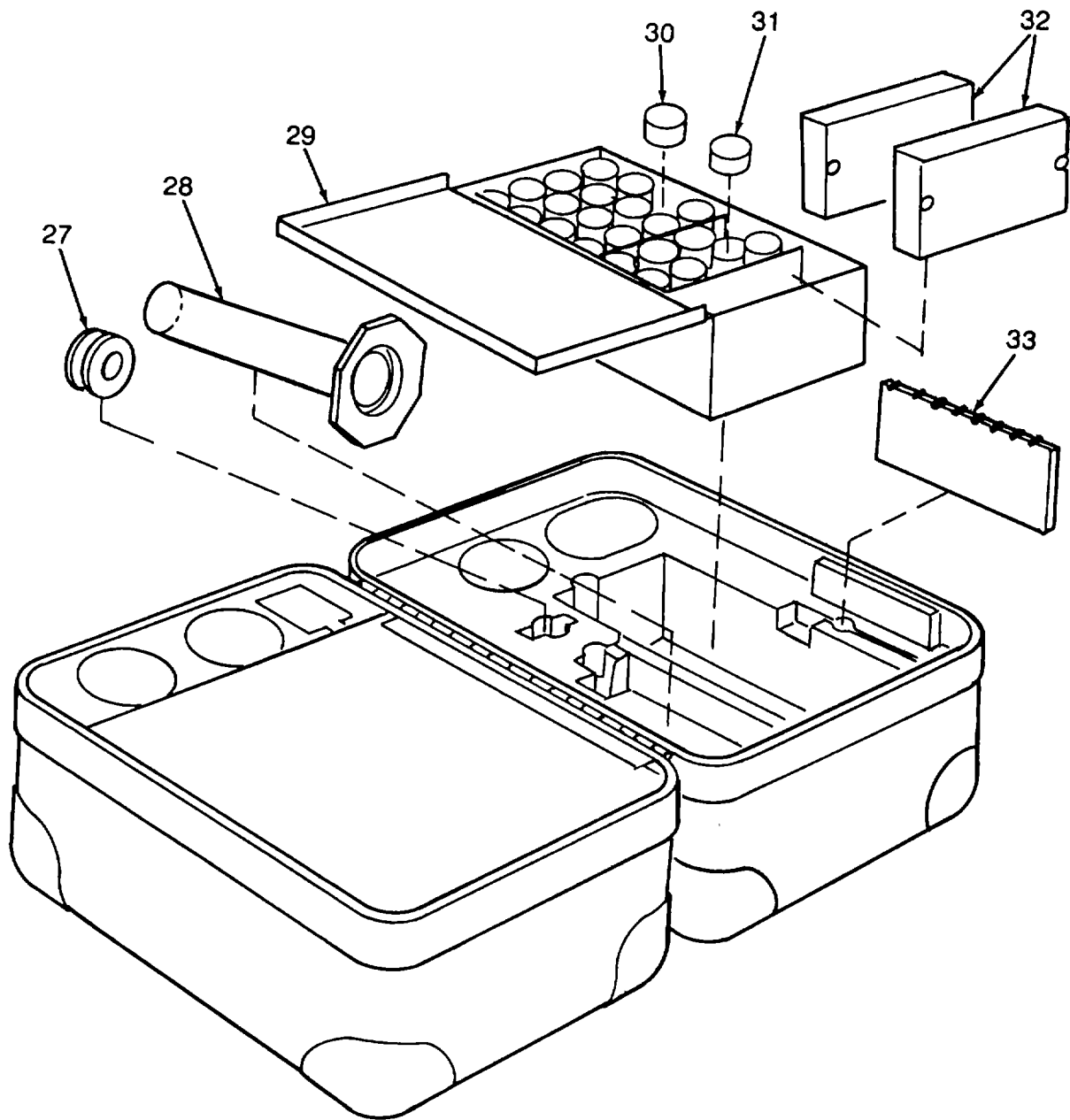

Figure 1. Petroleum Test Kit (Sheet 3 of 5)

Change 1 C-12

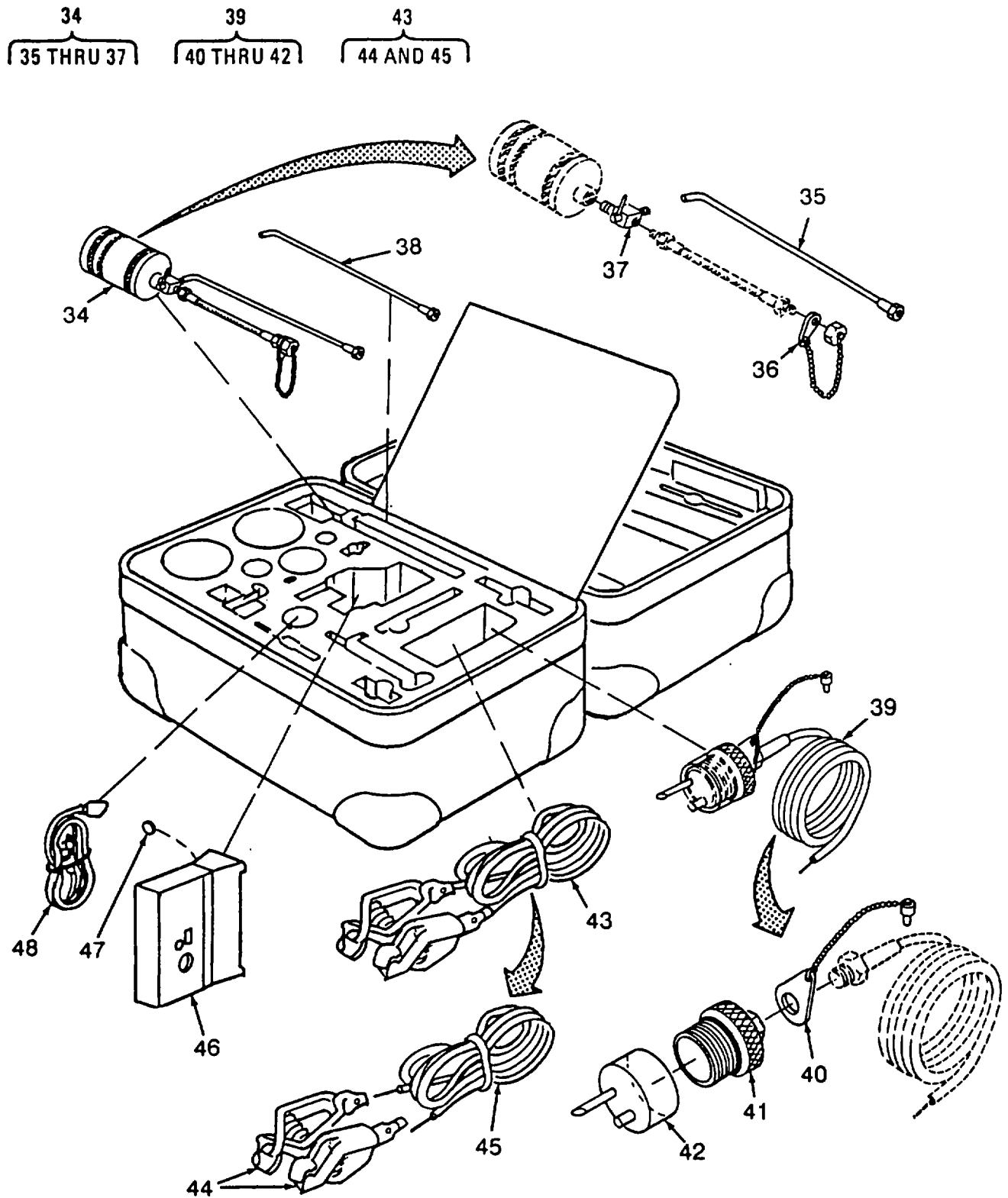

Figure 1. Petroleum Test Kit (Sheet 4 of 5)

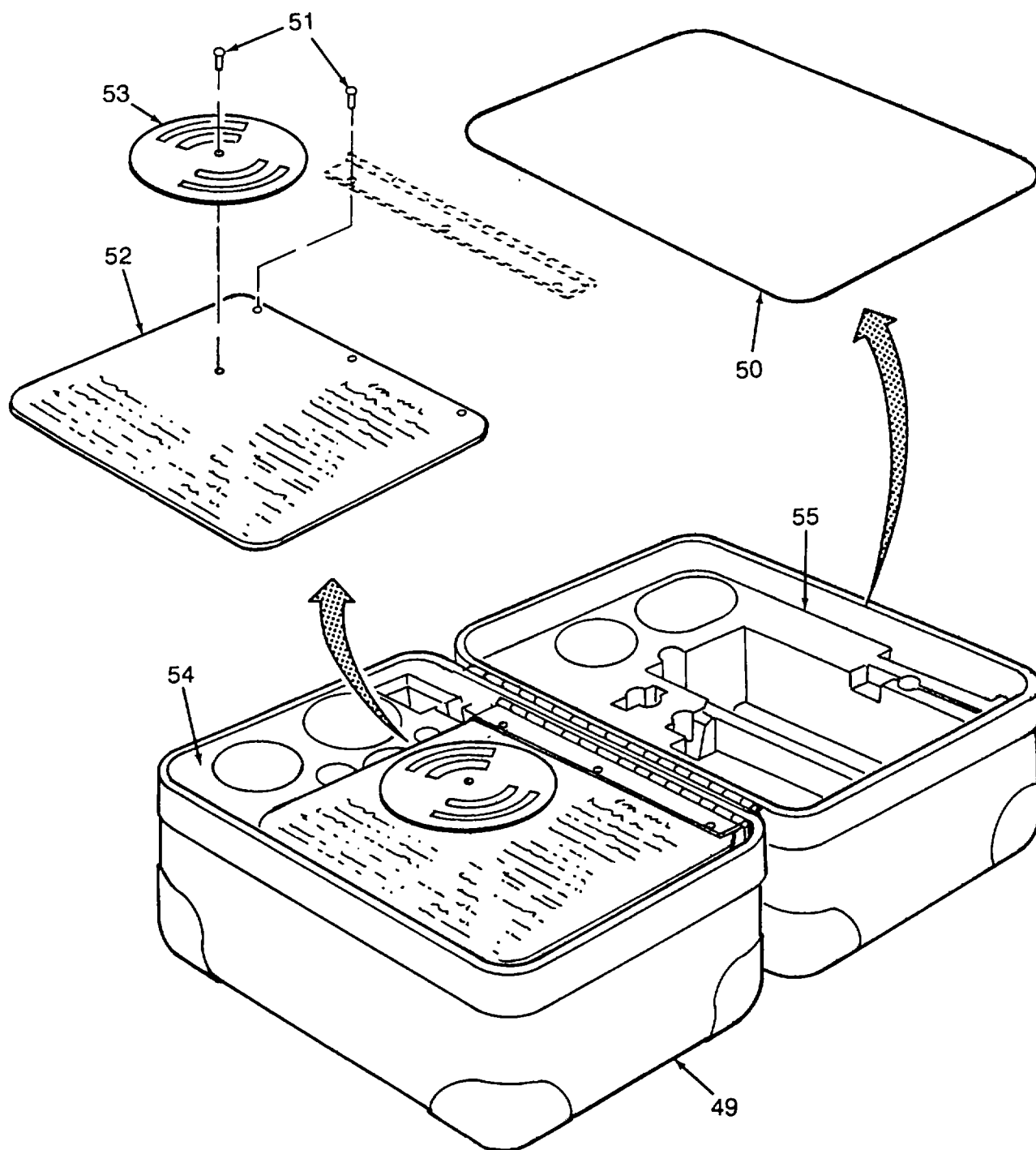

Figure 1. Petroleum Test Kit (Sheet 5 of 5)

Change 1 C-14

SECTION II

REPAIR PARTS LIST

(1) ILLUST.		(2) SMR CODE		(3) CAGEC	(4) PART NUMBER	(5) DESCRIPTION AND USABLE ON CODE	(6) QTY	(7) USMC QTY PER EQUIP
a FIG. NO.	b. ITEM NO.	a. ARMY	b. USMC					
						GROUP 01 SAMPLER VALVE HOSE ASSEMBLY		
						GROUP 02 REMOTE, SAMPLING ASSEMBLY		
						GROUP 03 DETECTOR UNIT		
						GROUP 04 CARRY CASE, PETROLEUM TEST KIT		
						GROUP 05 SET, STANDARDS		
						FIGURE 1 PETROLEUM TEST KIT		
1	1	PDOOO		90598	TL-MIL-T52849	TEST KIT, PETROLEUM	1	
1	2	PAOZZ	PAOZZ	32218	GTP-765	SCREWDRIVER, CALIBRATION	1	
1	3	PAOZZ	PAOZZ	08071	XX6403717	PACKING, PREFORMED	3	
1	4	PEOZZ	PEOZZ	32218	GTP--764	PAD, CALIBRATED	1	
1	5	XDOZZ	XBOZZ	2E919	G28320J	PLASTIC CONTAINER	1	
1	6	PBOZZ	PBOZZ	32218	GTP-2380	BULB, ULTRA-VIOLET	1	
1	7	PBOZZ	PBOZZ	32218	GTP-2404	BATTERY PAC, EXTERNAL	1	
1	8	PBOZZ	PBOZZ	32218	GTP-2403	CONNECTORWIRE	1	
1	9	XDOOO	XBOOO	08071	XX6200035	SYRINGE AND VALVE	1	
1	10	PAOZZ	PAOZZ	71731	AC18	WRENCH,ADJUSTABLE	1	

SECTION II

REPAIR PARTS LIST

(1) ILLUST.		(2) SMR CODE		(3) CAGEC	(4) PART NUMBER	(5) DESCRIPTION AND USABLE ON CODE	(6) QTY	(7) USMC QTY PER EQUIP
a FIG. NO.	b. ITEM NO.	a. ARMY	b. USMC					
1	11	PBOZZ	PBOZZ	54938	4-2RA-SS	REDUCER, PIPE	1	
1	12	PBOZZ	PBOZZ	54938	4-4 MHLN-2-SS	NIPPLE, HEX	1	
1	13	PBOZZ	PBOZZ	32218	GTP-3326	MONITOR	1	
1	14	PAOZZ	PAOZZ	22527	2-923F	BOTTLE	1	
1	15	PBOZZ	PBOZZ	08071	XX6403716	CAP AND BEAD CHAIN	1	
1	16	PAOZZ	PAOZZ	22527	03-409-10OBB	BOTTLE	1	
1	17	PAOZZ	PAOZZ	22527	02-923-14B	CLOSURE, RED	1	
1	18	XDOZZ	XBOZZ	90598	MFG0615	HOLDER, HYDROMETER	1	
1	19	PAOZZ	PAOZZ	2P332	2504C	HYDROMETER	1	
1	20	PAOZZ	PAOZZ	2P332	2505C	HYDROMETER	2	
1	21	PAOZZ	PAOZZ	2P332	2506C	HYDROMETER	2	
1	22	PAOZZ	PAOZZ	2P332	2507C	HYDROMETER	1	
1	23	PAOZZ	PAOZZ	2P332	2508C	HYDROMETER	1	
1	24	PAOZZ	PAOZZ	22527	8-906	TWEEZER	1	
1	25	PAOZZ	PAOZZ	22527	10-300	FORCEPS	1	
1	26	PBOZZ	PBOZZ	08071	XX6403735	VALVE-PLUG, QUICK RELEASE	1	
1	27	PAOZZ	PAOZZ	81349	MIL-T-27730 SIZE 11	TAPE, ANTISEIZE	1	
1	28	PBOZZ	PBOZZ	22527	8-572-5F	CYLINDER, POLYMETHYL	1	
1	29	XDOZZ	XBOZZ	90598	MFG0618	CHEST, STORAGE	1	
1	30	PAOZZ	PAOZZ	32218	GTP-1986	MATCH WEIGHT MONITOR	1	

SECTION II

REPAIR PARTS LIST

(1) ILLUST.		(2) SMR CODE		(3) CAGEC	(4) PART NUMBER	(5) DESCRIPTION AND USABLE ON CODE	(6) QTY	(7) USMC QTY PER EQUIP
a FIG. NO.	b. ITEM NO.	a. ARMY	b. USMC					
1	31	PAOZZ	PAOZZ	32218	GTP-1985	CONTAMINATION MONITOR	1	
1	32	PAOZZ	PAOZZ	32218	GTP-25	FREE WATER PADS	1	
1	33	XDOZZ	XCOZZ	32218	GTP-1074-1	STANDARDS.FUELCOLOR	1	
1	34	PBOOO	PBOOO	08071	XX6403708	SAMPLER, VALVE HOSE	1	
1	35	PBOZZ	PBOZZ	08071	XX6403780	*TUBE, PLASTIC	1	
1	36	PBOZZ	PBOZZ	08071	XX6403716	*CAP AND BEAD CHAIN	1	
1	37	XDOZZ	XBOZZ	08071	XX6403714	*VALVE, 3-WAY	1	
1	38	PBOZZ	PBOZZ	08071	XX6403780	TUBE, PLASTIC	1	
1	39	PAOOO	PAOOO	08071	XX6403705	REMOTE SAMPLING	1	
1	40	PBOZZ	PBOZZ	08071	XX6403781	*PLUG AND BEAD	1	
1	41	PAOZZ	PAOZZ	08071	XX6403720	*PLUG, SAMPLER	1	
1	42	PAOZZ	PAOZZ	05178	2176-0384	*SPOUT, POUR	1	
1	43	AOOOO	AOOOO	90598	PTK-100-2	GROUND WIRE ASSY	1	
1	44	PAOZZ	PAOZZ	76545	24-A	*CLIP, ELECTRICAL	2	
1	45	MOOZZ	MOOZZ	19099	PTK-100-2-1	*BRAID, WIRE MAKE FROM WIRE BRAID P/N 8661,CUT TO LENGTH	2	
1	46	PAOOO	PAOOO	32218	GTP-2855	DETECTORUNIT	1	
1	47	PEOZZ	PEOZZ	32218	GTP-763	*FLUORESCING STANDARDS	1	
1	48	PBOZZ	PBOZZ	32218	GTP-2402	CABLE	1	
1	49	XAOZZ	XAOZZ	90598	PTK-100-1	CASE, CARRY, TESTING	1	

SECTION II

REPAIR PARTS LIST

(1) ILLUST.		(2) SMR CODE		(3) CAGEC	(4) PART NUMBER	(5) DESCRIPTION AND USABLE ON CODE	(6) QTY	(7) USMC QTY PER EQUIP
a FIG. NO.	b. ITEM NO.	a. ARMY	b. USMC					
1	50	XDOZZ	XBOZZ	74284	SKM-518	GASKET, TUBULAR	1	
1	51	PAOZZ	PAOZZ	81349	M24243/1-B404	RIVET, BLIND	4	
1	52	XDOZZ	XBOZZ	90598	01-232-9531-P	PLACARD, INSTRUCTION	1	
1	53	XDOZZ	XBOZZ	32218	GTP-3012	API GRAVITY CALCULATOR	1	
1	54	XDOZZ	XBOZZ	90598	MFG-0613	FOAM LINER, CASE	1	
1	55	XDOZZ	XBOZZ	90598	MFG-0614	FOAM LINER, LID	1	
		PBOZZ	PBOZZ	32218	GTP-835	SET, STANDARDS PAD, CALIBRATED (1) (1-4)	V	
		PBOZZ	PBOZZ	08071	XX6200036	FLUORESCING STANDARD (1) (1-47) KIT, REPLACEMENT SYRINGE	V	
						END OF FIGURE		

SECTION II

REPAIR PARTS LIST

(1) ILLUST.		(2) SMR CODE		(3) CAGEC	(4) PART NUMBER	(5) DESCRIPTION AND USABLE ON CODE	(6) QTY	(7) USMC QTY PER EQUIP
a FIG. NO.	b. ITEM NO.	a. ARMY	b. USMC					
BULK	1	PAOZZ	PAOZZ	16428	8661	GROUP 06 BULK MATERIALS FIGURE BULK BRAID, WIRE END OF FIGURE	V	

Change 1 C-19

SECTION III

SPECIAL TOOLS LIST

(NOT APPLICABLE)

Change 1 C-20

CROSS-REFERENCE INDEXES
NATIONAL STOCK NUMBER INDEX

STOCK NUMBER	FIG. NO.	ITEM NO.
6630-00-009-1423	1	29
6640-00-086-6326	1	9
4730-00-105-5684	1	11
6640-00-235-3820	1	36
5120-00-240-5328	1	10
6630-00-265-7758	1	22
6630-00-265-7759	1	23
6630-00-265-7764	1	24
6630-00-265-7764	1	25
6640-00-326-7684	1	37
6640-00-426-0300	1	28
6630-00-445-3662	1	35
6630-00-488-6622	1	37
5330-00-490-4600	1	3
999-00-636-5344	1	44
6630-00-764-5761	1	34
6145-00-765-4280	BULK	1
6630-00-815-2267	1	26
5330-00-889-1566	1	50
8030-00-889-3535	1	31
6630-00-999-0753	1	17
6630-00-999-0754	1	5
5330-01-015-6896	1	51
4730-01-035-9960	1	40
6625-01-111-2571	1	14
4720-01-229-7045	1	18
6630-01-232-9534	1	15
6536-01-232-9536	1	27
6640-01-232-9538	1	6

SECTION IV

**TM 10-6630-240-12&P
TM 01461B-12&P/1**

**CROSS-REFERENCE INDEXES
NATIONAL STOCK NUMBER INDEX**

STOCK NUMBER	FIG. NO.	ITEM NO.
6640-01-232-9541	1	57
6630-01-232-9542	1	13
5120-01-232-9543	1	2
6140-01-232-9546	1	7
6630-01-232-9547	1	8
1730-01-232-9608	1	12
6640-01-235-7877	1	30
6630-01-245-5989	1	56
6630-01-347-9670	1	1

Change 3 C-22

SECTION IV**TM 10-6630-240-12&P
TM 01461B-12&P/1****CROSS-REFERENCE INDEXES****PART NUMBER INDEX**

CAGEC	PART NUMBER	STOCK NUMBER	FIG.	ITEM
71731	AC18	5120-00-240-5328	1	10
32218	GTP-1074-1	6640-00-326-7684	1	33
32218	GTP-1985	6630-00-445-3662	1	31
32218	GTP-1986	6630-00-764-5761	1	30
32218	GTP-2380	6640-01-232-9538	1	6
32218	GTP-2402		1	48
32218	GTP-2403	6630-01-232-9547	1	8
32218	GTP-2404	6630-01-232-9546	1	7
32218	GTP-25	6640-00-235-3820	1	32
32218	GTP-2855	6640-01-235-7877	1	46
32218	GTP-3012		1	53
32218	GTP-3326	663001-232-9542	1	13
32218	GTP-763		1	47
32218	GTP-764		1	4
32218	GTP-765	5120-01-232-9543	1	2
32218	GTP-835	6630-01-245-5989	1	56
2E919	G28320J		1	5
90598	MFG-0613		1	54
90598	MFG-0614		1	55
90598	MFG-0615		1	18
90598	MFG-0618		1	29
81349	MIL-T-27730 SIZE 11	8030-00-889-3535	1	27
81349	M2424311-B404	5330-01-015-6896	1	51

SECTION IV**TM 10-6630-240-12&P
TM 01461B-12&P/1****CROSS-REFERENCE INDEXES****PART NUMBER INDEX**

CAGEC	PART NUMBER	STOCK NUMBER	FIG.	ITEM
90598	PTK- 100-1		1	49
90598	PTK- 100-2		1	43
90598	PTK-100-2-1		1	45
74284	SKM-518	5330-00-889-1566	1	50
90598	TL-MIL-T-52849	6630-01-347-9670	1	1
08071	XX6200035	6640-00-086-6326	1	9
08071	XX6200036	6640-01-232-9541	1	57
08071	XX6403705	6630-00-999-0754	1	39
08071	XX6403708	6630-00-999-0753	1	34
08071	XX6403714	6630-00-488-6622	1	37
08071	XX6403716	6630-01-232-9534	1	15
08071	XX6403716	6630-01-232-9534	1	36
08071	XX6403717	5330-00-490-4600	1	3
08071	XX6403720		1	41
08071	XX6403735	6630-00-009-1423	1	26
08071	XX6403780	4720-01-229-7045	1	35
08071	XX6403780	4720-01-229-7045	1	38
08071	XX6403781	4730-01-035-9960	1	40
90598	01-232-9531-P		1	52
22527	02-923-14B		1	17
22527	03-409-1 OBB		1	16
22527	10-300	6640-00-426-0300	1	25
22527	2-923F	6625-01-111-2571	1	14

Change 3 C-24

SECTION IV

**TM 10-6630-240-12&P
TM 01461B-12&P/1**

CROSS-REFERENCE INDEXES

PART NUMBER INDEX

CAGEC	PART NUMBER	STOCK NUMBER	FIG.	ITEM
05178	2176-0384		1	42
76545	24-A	5999-00-636-5344	1	44
2P332	2504C	6630-00-265-7758	1	19
2P332	2505C	6630-00-265-7759	1	20
2P332	2506C	6630-00-265-7764	1	21
2P332	2507C	6630-00-265-7765	1	22
2P332	2508C	6630-00-815-2267	1	23
54938	4-2RA-SS	4730-00-105-5684	1	11
54938	4-4 MHLN-2-SS		1	12
22527	8-572-5F		1	28
22527	8-906	6536-01-232-9536	1	24
16428	8661	6145-00-765-4280	BULK	1

Change 3 C-25

SECTION IV**TM 10-6630-240-12&P
TM 01461B-12&P/1****CROSS-REFERENCE INDEXES
FIGURE AND ITEM NUMBER INDEX**

FIG.	ITEM	STOCK NUMBER	CAGEC	PART NUMBER
1	1	6630-01-347-9670	90598	TL-MIL-T-52849
1	2	5120-01-232-9543	32218	GTP-765
1	3	5330-00-490-4600	08071	XX6403717
1	4	32218	GTP-764	
1	5	2E919	G28320J	
1	6	6640-01-232-9538	32218	GTP-2380
1	7	6630-01-232-9546	32218	GTP-2404
1	8	6630-01-232-9547	32218	GTP-2403
1	9	6640-00-086-6326	08071	XX6200035
1	10	5120-00-240-5328	71731	AC18
1	11	4730-00-105-5684	54938	4-2RA-SS
1	12	54938	4-4 MHLN-2-SS	
1	13	6630-01-232-9542	32218	GTP-3326
1	14	6625-01-111-2571	22527	2-923F
1	15	6630-01-232-9534	08071	XX6403716
1	16	22527	03-409-10BB	
1	17	22527	02-923-14B	
1	18	90598	MFG-0615	
1	19	6630-00-265-7758	2P332	2504C
1	20	6630-00-265-7759	2P332	2505C
1	21	6630-00-265-7764	2P332	2506C
1	22	6630-00-265-7765	2P332	2507C
1	23	6630-00-815-2267	2P332	2508C

Change 1 C-26

SECTION IV

TM 10-6630-240-12&P
TM 01461B-12&P/1

CROSS-REFERENCE INDEXES
FIGURE AND ITEM NUMBER INDEX

FIG.	ITEM	STOCK NUMBER	CAGEC	PART NUMBER
1	24	6536-01-232-9536	22527	8-906
1	25	6640-00-426-0300	22527	10-300
1	26	6630-00-009-1423	08071	XX6403735
1	27	8030-00-889-3535	81349	MIL-T-27730 SIZE 11
1	28		22527	8-572-5F
1	29		90598	MFG-0618
1	30	6630-00-764-5761	32218	GTP-1986
1	31	6630-00-445-3662	32218	GTP-1985
1	32	6640-00-235-3820	32218	GTP-25
1	33	6640-00-326-7684	32218	GTP-1074-1
1	34	6630-00-999-0753	08071	XX6403708
1	35	4720-01-229-7045	08071	XX6403780
1	36	6630-01-232-9534	08071	XX6403716
1	37	6630-00-488-6622	08071	XX6403714
1	38	4720-01-229-7045	08071	XX6403780
1	39	6630-00-999-0754	08071	XX6403705
1	40	4730-01-035-9960	08071	XX6403781
1	41		08071	XX6403720
1	42		05178	2176-0384
1	43		90598	PTK-100-2
1	44	5999-00-636-5344	76545	24-A
1	45		90598	PTK-100-2-1
1	46	6640-01-235-7877	32218	GTP-2855

SECTION IV

**TM 10-6630-240-12&P
TM 01461B-12&P/1**

**CROSS-REFERENCE INDEXES
FIGURE AND ITEM NUMBER INDEX**

FIG.	ITEM	STOCK NUMBER	CAGEC	PART NUMBER
1	47		32218	GTP-763
1	48		32218	GTP-2402
1	49		90598	PTK- 100-1
1	50	5330-00-889-1566	74284	SKM-518
1	51	5330-01-015-6896	81349	M24243/1-B404
1	52		90598	01-232-9531-P
1	53		32218	GTP-3012
1	54		90598	MFG-0613
1	55		90598	MFG-0614
1	56	6630-01-245-5989	32218	GTP-835
1	57	6640-01-232-9541	08071	XX6200036
BULK	1	6145-00-765-4280	16428	8661

***U.S. GOVERNMENT PRINTING OFFICE: 1996 - 755-025/40228**

Change 3 C-28

APPENDIX D

COMPONENTS OF END ITEM AND BASIC ISSUE ITEMS LIST

Section I. INTRODUCTION

D-1. SCOPE

This appendix lists components of end item and basic issue items for the Petroleum Test Kit to help you inventory items required for safe and efficient operation.

D-2. GENERAL

The Components of End Item and Basic Issue Items List are divided into the following sections:

- a. Section II. Components of End Item. This listing is for informational purposes only, and is not authority to requisition replacements. These items are part of the end item, but are removed separately packaged for transportation or shipment. As part of the end item, these items must be with the end item whenever it is issued or transferred between property accounts. Illustrations are furnished to assist you in identifying the items.
- b. Section III. Basic Issue Items. These are the minimum essential items required to place the Petroleum Test Kit in operation, to operate it, and to perform emergency repairs. Although shipped separately packaged, BII must be with the Petroleum Test Kit during operation and whenever it is transferred between property accounts. The illustrations will assist you with hard-to-identify items. This manual is your authority to request/requisition replacement BII, based on TOE/MTOE authorization of the end item.

D-3. EXPLANATION OF COLUMNS

The following provides an explanation of columns found in the tabular listing:

- a. Column (1) - Illustration Number (Illus Number). This column indicates the number of the illustration in which the item is shown.
- b. Column (2) - National Stock Number. Indicates the national stock number assigned to the item and will be used for requisitioning purposes.
- c. Column (3) - Description. Indicates the Federal item and name and, if required, a minimum description to identify and locate the item. The last line for each item indicates the FSCM (in parentheses) followed by the part number.
- d. Column (4) - Unit of Measure (U/M). Indicates the measure used in performing the actual operational/maintenance function. This measure is expressed by a two-character alphabetical abbreviation (e.g., ea, in, pr).
- e. Column (5) - Quantity required (Qty reqd). Indicates the quantity of the item authorized to be used with/on the equipment.

Section II. COMPONENT OF END ITEM

(1) ILLUS NUMBER	(2) NATIONAL STOCK NUMBER	(3) DESCRIPTION FSCM AND PART NUMBER	USABLE ON CODE	(4) U/I	(5) QTY RQD
		NOT APPLICABLE			

Section III. BASIC ISSUE ITEMS

(1) ILLUS NUMBER	(2) NATIONAL STOCK NUMBER	(3) DESCRIPTION FSCM AND PART NUMBER	USABLE ON CODE	(4) U/I	(5) QTY RQD
1		TM 10-6630-240-12&P TM 01461B-12P/1 OPERATORS AND UNIT MAINTENANCE MANUAL (INCLUDING REPAIR PARTS AND SPECIAL TOOLS LIST) FOR TEST KIT PETROLEUM AVIATION FUEL CONTAINMINANT TM 10-6640-221-13&P OPERATORS, UNIT AND DIRECT SUPPORT MAINTENANCE MANUAL (INCLUDING REPAIR PARTS AND SPECIAL TOOLS LIST) FOR AQUA GLO WATER DETECTOR		EA	1
				EA	1

APPENDIX E

ADDITIONAL AUTHORIZATION LIST
(Not Applicable)

E-1/(E-2) Blank



APPENDIX F

EXPENDABLE/DURABLE SUPPLIES AND MATERIALS LIST

Section I. INTRODUCTION

F-1. SCOPE

This appendix lists expendable/durable supplies and materials you will need to operate and maintain the Petroleum Test Kit. This listing is for informational purpose only and is not authority to requisition the listed items. These items are authorized to you by CTA 50-970, Expendable/Durable Items (Except Medical, Class V, Repair Parts, and Heraldic Items), or CTA 8-100, Army Medical Department Expendable/Durable Items.

F-2. EXPLANATION OF COLUMNS

- a. Column 1 - Item Number. This number is assigned to the entry in the listing and is referenced in the task Initial Setup instructions to identify the material; e.g., "Drycleaning solvent (Appx F)."
- b. Column 2 - Category. This column identified the lowest category of maintenance that required the listed item:
 - C - Operator/Crew
 - O - Unit Maintenance
 - F - Direct Support Maintenance
 - G - General Support Maintenance
- c. Column 3 - National Stock Number. This is the national stock number assigned to the item; use it to request or requisition the items.
- d. Column 4 - Description. Indicates the federal item name and, if required, a description to identify the item. The last line for each item indicates the part number followed by the Commercial And Government Entity (CAGE) Code for Manufacturer in parentheses, if applicable.
- e. Column 5 - Unit of Measure (U/M). Indicates the measure used in performing the actual maintenance function. This measure is expressed by a two character alphabetical abbreviation (e.g., ea, in, pr). If the unit of measure differs from the rest of the issue, requisition the lowest unit of issue that will satisfy your requirements.

SECTION II. EXPENDABLE AND DURABLE ITEMS LIST

(1) ITEM NUMBER	(2) CATEGORY	(3) NATIONAL STOCK NUMBER	(4) ITEM NAME, DESCRIPTION	(5) U/M
1	0	6810-O-584-3079	Petroleum Ether, Technical (81348) O-E-751	GL
2	O	8030-00-889-3535	Tape, Antiseize (81349) MIL-T-27730	EA
3	O	6630-00-764-5761	Match Weight Monitors (32218) GTP-1986	PG
4	O	6630-00-445-3662	Contamination Monitors (32218) GTP-1985	BX
5	O	6640-00-235-3820	Free Water Pads (32218) GTP-25	PG
6	O	6640-01-232-9538	Bulb (32218) GTP-2380	EA
7	O	6140-01-232-9546	Battery Pac (32218) GTP-2404	EA
8	O		Rivets (81349) M24243/1 B404	EA

*U.S. GOVERNMENT PRINTING OFFICE: 1995 - 388-421/43230

PIN: 070510-002

ALPHABETICAL INDEX

	Page
Additional authorization List	E-1
Component of End Item and Basic Issue Items	D-1
Description and Use of Operator's Controls and Indicators	2-1
Equipment Description and Data	1-3
Expendable/Durable Supplies and Materials List	F-1
General Information	1-1
Lubrication Instructions	3-1
Maintenance Allocation Chart	B-1
Maintenance Procedures	3-1
Operator Preventive Maintenance	2-1
Operator Troubleshooting	3-1
Operation Under Usual Conditions	2-3
Preparation for Storage or Shipment	4-2
Principles of Operation	1-4
References	A-1
Repair Parts and Special Tools List	C-1
Tools and Test Equipment Requirements	B-4
Unit Maintenance Procedures	4-1

G- 1/(G-2 Blank)

By Order of the Secretaries of the Army and Navy (Including the Marine Corps):

GORDON R. SULLIVAN
General, United States Army
Chief of Staff

Official:

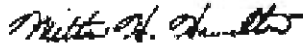

MILTON H. HAMILTON
Administrative Assistant to the
Secretary of the Army
02590

DAVID E. BOTFORFF
Rear Admiral, CEC, US Navy
Commander
Navy Facilities Engineering Command

H. E. REESE
Deputy for Support
Marine Corps Research, Development and
Acquisition Command

DISTRIBUTION:

To be distributed in accordance with DA Form 12-25-E, block 5958, Operator and Unit Maintenance requirements for TM 10-6630-240-12&P.

These are the instructions for sending an electronic 2028

The following format must be used if submitting an electronic 2028. The subject line must be exactly the same and all fields must be included; however only the following fields are mandatory: 1, 3, 4, 5, 6, 7, 8, 9, 10, 13, 15, 16, 17, and 27.

From: "Whomever" <whomever@avma27.army.mil>
To: mpmt%avma28@st-louis-emh7.army.mil

Subject: DA Form 2028

1. **From:** Joe Smith
2. Unit: home
3. **Address:** 4300 Park
4. **City:** Hometown
5. **St:** MO
6. **Zip:** 77777
7. **Date Sent:** 19-OCT-93
8. **Pub no:** 55-2840-229-23
9. **Pub Title:** TM
10. **Publication Date:** 04-JUL-85
11. Change Number: 7
12. Submitter Rank: MSG
13. **Submitter FName:** Joe
14. Submitter MName: T
15. **Submitter LName:** Smith
16. **Submitter Phone:** 123-123-1234
17. Problem: 1
18. Page: 2
19. Paragraph: 3
20. Line: 4
21. NSN: 5
22. Reference: 6
23. Figure: 7
24. Table: 8
25. Item: 9
26. Total. 123
27. **Text:**

This is the text for the problem below line 27.

RECOMMENDED CHANGES TO EQUIPMENT TECHNICAL PUBLICATIONS

 <p>THEN...JOT DOWN THE DOPE ABOUT IT ON THIS FORM. CAREFULLY TEAR IT OUT, FOLD IT AND DROP IT IN THE MAIL.</p>				SOMETHING WRONG WITH PUBLICATION	
				FROM: (PRINT YOUR UNIT'S COMPLETE ADDRESS)	
				DATE SENT	
PUBLICATION NUMBER			PUBLICATION DATE		PUBLICATION TITLE
BE EXACT PIN-POINT WHERE IT IS				IN THIS SPACE, TELL WHAT IS WRONG AND WHAT SHOULD BE DONE ABOUT IT.	
PAGE NO.	PARA-GRAPH	FIGURE NO.	TABLE NO.		
PRINTED NAME, GRADE OR TITLE AND TELEPHONE NUMBER				SIGN HERE	

The Metric System and Equivalents

Linear Measure

1 centimeter = 10 millimeters = .39 inch
 1 decimeter = 10 centimeters = 3.94 inches
 1 meter = 10 decimeters = 39.37 inches
 1 dekameter = 10 meters = 32.8 feet
 1 hectometer = 10 dekameters = 328.08 feet
 1 kilometer = 10 hectometers = 3,280.8 feet

Weights

1 centigram = 10 milligrams = .15 grain
 1 decigram = 10 centigrams = 1.54 grains
 1 gram = 10 decigrams = .035 ounce
 1 decagram = 10 grams = .35 ounce
 1 hectogram = 10 decagrams = 3.52 ounces
 1 kilogram = 10 hectograms = 2.2 pounds
 1 quintal = 100 kilograms = 220.46 pounds
 1 metric ton = 10 quintals = 1.1 short tons

Liquid Measure

1 centiliter = 10 milliliters = .34 fl. ounce
 1 deciliter = 10 centiliters = 3.38 fl. ounces
 1 liter = 10 deciliters = 33.81 fl. ounces
 1 dekaliter = 10 liters = 2.64 gallons
 1 hectoliter = 10 dekaliters = 26.42 gallons
 1 kiloliter = 10 hectoliters = 264.18 gallons

Square Measure

1 sq. centimeter = 100 sq. millimeters = .155 sq. inch
 1 sq. decimeter = 100 sq. centimeters = 15.5 sq. inches
 1 sq. meter (centare) = 100 sq. decimeters = 10.76 sq. feet
 1 sq. dekameter (are) = 100 sq. meters = 1,076.4 sq. feet
 1 sq. hectometer (hectare) = 100 sq. dekameters = 2.47 acres
 1 sq. kilometer = 100 sq. hectometers = .386 sq. mile

Cubic Measure

1 cu. centimeter = 1000 cu. millimeters = .06 cu. inch
 1 cu. decimeter = 1000 cu. centimeters = 61.02 cu. inches
 1 cu. meter = 1000 cu. decimeters = 35.31 cu. feet

Approximate Conversion Factors

To change	To	Multiply by	To change	To	Multiply by
inches	centimeters	2.540	ounce-inches	Newton-meters	.007062
feet	meters	.305	centimeters	inches	.394
yards	meters	.914	meters	feet	3.280
miles	kilometers	1.609	meters	yards	1.094
square inches	square centimeters	6.451	kilometers	miles	.621
square feet	square meters	.093	square centimeters	square inches	.155
square yards	square meters	.836	square meters	square feet	10.764
square miles	square kilometers	2.590	square meters	square yards	1.196
acres	square hectometers	.405	square kilometers	square miles	.386
cubic feet	cubic meters	.028	square hectometers	acres	2.471
cubic yards	cubic meters	.765	cubic meters	cubic feet	35.315
fluid ounces	milliliters	29.573	cubic meters	cubic yards	1.308
pints	liters	.473	milliliters	fluid ounces	.034
quarts	liters	.946	liters	pints	2.113
gallons	liters	3.785	liters	quarts	1.057
ounces	grams	28.349	liters	gallons	.264
pounds	kilograms	.454	grams	ounces	.035
short tons	metric tons	.907	kilograms	pounds	2.205
pound-feet	Newton-meters	1.356	metric tons	short tons	1.102
pound-inches	Newton-meters	.11296			

Temperature (Exact)

°F	Fahrenheit temperature	5/9 (after subtracting 32)	Celsius temperature	°C
----	------------------------	----------------------------	---------------------	----

PIN: 070510-000

This fine document...

Was brought to you by me:



[Liberated Manuals -- free army and government manuals](#)

Why do I do it? I am tired of sleazy CD-ROM sellers, who take publicly available information, slap “watermarks” and other junk on it, and sell it. Those masters of search engine manipulation make sure that their sites that sell free information, come up first in search engines. They did not create it... They did not even scan it... Why should they get your money? Why are not letting you give those free manuals to your friends?

I am setting this document FREE. This document was made by the US Government and is NOT protected by Copyright. Feel free to share, republish, sell and so on.

I am not asking you for donations, fees or handouts. If you can, please provide a link to liberatedmanuals.com, so that free manuals come up first in search engines:

<A HREF=<http://www.liberatedmanuals.com/>>Free Military and Government Manuals

- Sincerely
Igor Chudov
<http://igor.chudov.com/>
- [Chicago Machinery Movers](#)