

TECHNICAL. MANUAL

**OPERATOR'S, UNIT,
AND DIRECT SUPPORT,
MAINTENANCE MANUAL
INCLUDING REPAIR PARTS AND
SPECIAL TOOLS LIST**

**CHEST, STORAGE, TANK
FOR 50,000 GALLON WATER TANK
MODEL M-1795
NSN 5430-01-375-2148**

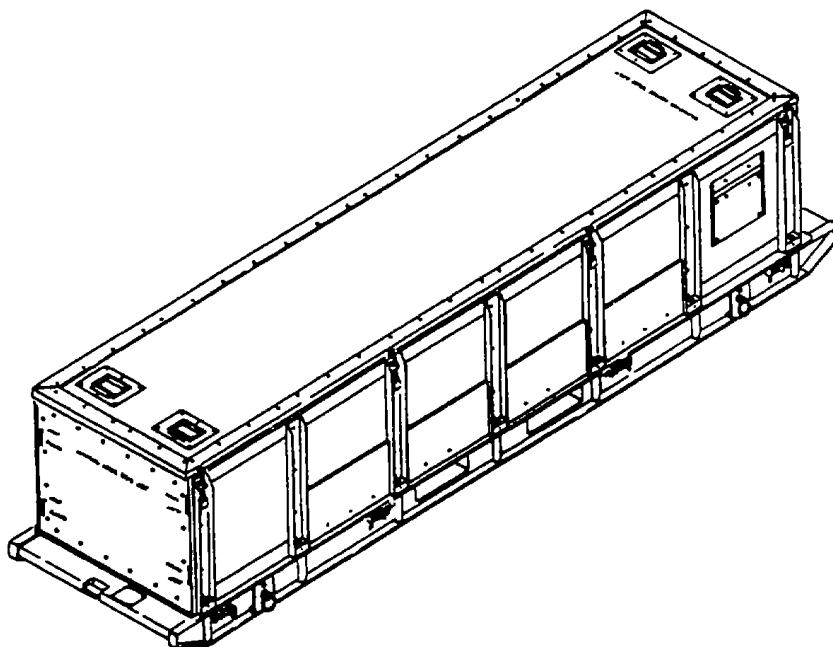

INTRODUCTION

**OPERATING
INSTRUCTIONS**

**OPERATOR
MAINTENANCE**

**UNIT
MAINTENANCE**

**DIRECT SUPPORT
MAINTENANCE**

**COMPONENTS OF
END ITEM LIST**

**ALPHABETICAL
INDEX**

Distribution statement A: Approved for public release; distribution is unlimited.

**HEADQUARTERS, DEPARTMENT OF THE ARMY
30 DECEMBER 1993**

WARNING

Lifting or moving heavy equipment can cause serious injury. Do not try to lift or move more than 50 pounds by yourself. Get an assistant. Bend legs while lifting. Don't support heavy weight with your back.

Always use assistants during lifting operations. Use guide ropes to move hanging assemblies.

A lack of attention or being in an improper position during lifting operations can result in serious injury or death. Pay close attention to movements of assemblies being lifted. Do not stand under lifted assembly or in a position where you could be pinned against another object. Watch your footing.

Hoist used to lift water tanks from water chests must have a minimum lifting capacity of 750 pounds.

WARNING

Serious injury can result in breathing fumes of dry cleaning solvent A-A-711. Serious injury or death can result from explosion of fumes from solvent. When using this solvent:

- Clean parts in a well ventilated area
- Avoid inhalation of solvent fumes and prolonged exposure of skin to cleaning solvent. Wash exposed skin thoroughly.
- Do not use near open flame or excessive heat. Flash point of solvent is 100° F to 138° F (38° C to 59° C)
- Wear eye protection when blowing solvent from parts. Air pressure should not exceed 30 psig (2.1 kg/cm²).

FIRST AID

In the event that first aid is required for injured operating or maintenance personnel, refer to FM21-11 for proper first aid procedures.

**Operator's, Unit, and Direct
Support Maintenance Manual
Including Repair Parts and Special Tools List**

For

**CHEST, STORAGE, TANK,
FOR 50,000 GALLON WATER TANKS
MODEL M-1795**

NSN 5430-01-375-2148

CURRENT AS OF 8 DECEMBER 1993

DISTRIBUTION STATEMENT A: Approved for public release; distribution is unlimited

REPORTING ERRORS AND RECOMMENDING IMPROVEMENTS

You can help improve this manual. If you find any mistakes or if you know of a way to improve the procedures, please let us know. Mail your letter, DA Form 2028 (Recommended Changes to Publications and Blank Forms) or DA Form 2028-2 located in the back of this manual direct to: Commander, U.S. Army Aviation and Troop Command, ATTN: AMSAT-I-MP, 4300 Goodfellow Blvd., St. Louis, MO. 63120-1798. A reply will be furnished to you.

TABLE OF CONTENTS

	Page
How To Use This Manual	v
CHAPTER 1. INTRODUCTION	1-1
Section I. General Information	1-1
Section II. Equipment Description and Data	1-2
Section III. Principles of Operation.....	1-4
CHAPTER 2. OPERATING INSTRUCTIONS	2-1
Section I. Operator's Controls and Indicators	2-2
Section II. Operator Preventive Maintenance Checks and Services	2-4

TABLE OF CONTENTS - Continued

	Page
Section III. Operation Under Usual Conditions	2-10
Section IV. Operation Under Unusual Conditions	2-16
CHAPTER 3. OPERATOR MAINTENANCE INSTRUCTIONS	3-1
Section I. Lubrication Instructions	3-1
Section II. Operator Troubleshooting Procedures.....	3-1
Section III. Operator Maintenance Procedures.....	3-2
CHAPTER 4. UNIT MAINTENANCE INSTRUCTIONS	4-1
Section I. Repair Parts, Special Tools; Test, Measurement, and Diagnostic Equipment, and Support Equipment.....	4-1
Section II. Service Upon Receipt and Preparation for Movement.....	4-1
Section III. Unit Preventive Maintenance Checks and Services	4-2
Section IV. Unit Troubleshooting Procedures	4-2
Section V. Unit Maintenance Procedures	4-2
Section VI. Preparation for Storage or Shipment.....	4-19
CHAPTER 5. DIRECT SUPPORT MAINTENANCE INSTRUCTIONS	5-1
Section I. Direct Support Troubleshooting Procedures	5-1
Section II. Direct Support Maintenance Procedures	5-1
APPENDIX A. REFERENCES	A-1
APPENDIX B. MAINTENANCE ALLOCATION CHART	B-1
Section I. Introduction.....	B-1
Section II. Maintenance Allocation Chart	B-5
Section III. Tool and Test Equipment Requirements	B-6
Section IV. Remarks	B-7

TABLE OF CONTENTS - Continued

		Page
APPENDIX C.	UNIT MAINTENANCE REPAIR PARTS AND SPECIAL TOOLS LIST	C-1
Section I.	Introduction	C-1
Section II.	Repair Parts List	C-11
	Group 01 Top Cover Assembly	C-11
	Group 02 Document Pouch	C-13
	Group 03 End Panel Assemblies	C-15
	Group 04 Side Panel Assemblies	C-17
	Group 05 Strap Assemblies	C-19
	Group 06 Skid Assembly	C-21
	Group 07 Bulk Items	C-23
Section III.	Special Tools List Not Applicable	
Section IV.	Cross-Reference Indices	
	National Stock Number Index	C-27
	Part Number Index	C-29
	Figure and Item Number Index	C-31
APPENDIX D.	COMPONENTS OF END ITEM AND BASIC ISSUE ITEMS LIST	D-1
Section I.	Introduction	D-1
Section II.	Components of End Item Table	D-2
Section III.	Basic Issue Item Table	D-3
APPENDIX E.	ADDITIONAL AUTHORIZATION LIST	E-1
Section I.	Introduction	E-1
Section II.	Additional Authorization List	E-1
APPENDIX F.	EXPENDABLE/DURABLE SUPPLIES AND MATERIALS LIST	F-1
Section I.	Introduction	F-1
Section II.	Expendable/Durable Supplies and Materials List	F-2
APPENDIX G.	ILLUSTRATED LIST OF MANUFACTURED ITEMS	G-1
APPENDIX H.	TORQUE LIMITS	H-1

TABLE OF CONTENTS

APPENDIX I.	MANDATORY REPLACEMENT PARTS	Page I-1
	ALPHABETICAL INDEX	Index-1

LIST OF ILLUSTRATIONS

Figure No.	Title	Page
1-1.	Storage Chest, Tank	1-0
1-2.	Location of Major Components.....	1-3
2-1.	Operator's Controls and Indicators.....	2-3
2-2.	Operator Preventive Maintenance Checks and Services Routing Diagram	2-7
2-3.	Assembly and Preparation for Use	2-11
2-4.	Unpacking Water Storage Tanks From Chest.....	2-13
2-5.	Decals and Instruction Plates	2-15
4-1.	Top Cover Assembly Repair.....	4-5
4-2.	Document Pouch Replacement	4-7
4-3.	End Panel Assemblies Repair	4-9
4-4.	Side Panel Assembly Repair	4-11
4-5.	Strap Assemblies Replacement.....	4-15
4-6.	Skid Assembly.....	4-17

LIST OF TABLES

Table No.	Title	Page
1-1.	Equipment Data	1-4
2-1.	Operator Preventative Maintenance Checks and Services	2-6
3-1.	Operator Troubleshooting.....	3-2

HOW TO USE THIS MANUAL

GENERAL. This technical manual provides you with the information needed to operate and to maintain the Water Tank Storage Chest (WTSC). By properly using this manual, you will be able to identify any problem you may have in operating the WTSC and then locate the proper procedure needed to correct any problem found.

MANUAL ORGANIZATION. This manual has been organized in a manner that groups together the information that an operator or a maintenance technician will need to perform their duties. The following list indicates how this information has been organized.

- Chapter 1** This chapter contains a complete description of the WTSC and includes such information as general equipment data, location/descriptions of major WTSC components, and general theory of operations for the WTSC.
- Chapter 2** The information needed to set up and to operate the WTSC are included in this chapter. It includes assembly information, operator preventive maintenance checks and services, and special instructions for unusual or emergency conditions.
- Chapter 3** All operator maintenance procedures have been placed within this chapter.
- Chapter 4** In the event that unit level maintenance is required for the WTSC, the required maintenance instructions can be found in this chapter.
- Chapter 5** This chapter contains all direct support level maintenance for the WTSC.
- Appendix A** Some of the procedures in this manual have references to other military technical manuals and forms. A complete list of all of these Reference Documents is included in this appendix.
- Appendix B** This appendix contains the Maintenance Allocation Chart for the WTSC. This chart defines which of the items on the WTSC will likely require maintenance and what military maintenance level is authorized to perform these maintenance procedures.
- Appendix C** If you find that a part or component of the WTSC is damaged and must be replaced, you can identify the part needed by referring to the illustrations and parts lists found in this Repair Parts and Special Tools List.
- Appendix D** The Components of End Item List containing a complete listing of all of the items required for a complete WTSC and the Basic Issue Items List showing the essential items needed to operate the WTSC are contained in this appendix.

- Appendix E** If any additional items are authorized for support of the WTSC, they will be shown on the Additional Authorization List contained in this appendix.
- Appendix F** As you operate and maintain the WTSC you will be required to use some special expendable items. The Expendable/Durable Supplies and Materials List in this appendix is a complete list of these items which appear elsewhere in the operating and maintenance procedures in this manual.
- Appendix G** Some components of the WTSC must be manufactured from bulk or stock material before they can be replaced on the unit. A complete set of instructions required to manufacture these items from bulk stock is included in this Illustrated List of Manufactured Parts.
- Appendix H** It is very important to properly tighten all fasteners used in the WTSC to insure proper operation of the chest and to protect operating personnel. To assist you in properly tightening these fasteners, this appendix contains the standard Torque Limits for the fasteners used on the WTSC.
- Appendix I** During maintenance of the WTSC there are some components of the chest which are not reusable when removed from the unit. This Mandatory Replacement Parts appendix lists all of the WTSC components which must always be replaced if they are removed from the chest.

AIDS TO FINDING INFORMATION. The following aids have been placed within this technical manual to help you quickly locate the information you may need.

- Front Cover Index** To provide you with a quick reference to the most used portions of this manual, an index has been placed on the cover of this manual.
- Bleeder Edges On Pages** On the right edge of the front cover index of this manual you will see a black box area that goes to the edge of the front cover page. If you hold this manual with you left hand and bend back the outer right edges of the pages with your right hand, you will find that there are pages inside the technical manual that also have black boxes on the right edges of the page and that these boxes line up with the boxes on the front cover index. By turning to the page in the technical manual that lines up with the box on the front cover, you will be able to quickly turn to the topic shown in the front cover index.
- Table Of Contents And Boxed Titles** In the event that the front cover has been removed from this manual, the items that appear in appear in the front cover index have also been placed in a box where they appear in the Table of Contents of this manual.

Alphabetical Index To assist you in locating any other information not found in the front cover index or the Table of Contents, an alphabetical index has been placed in the back of this manual to help you find any information you may need.

GENERAL MAINTENANCE METHOD. Although your local standard operating and maintenance procedure may vary, a simple method of using this technical manual to operate and maintain the WTSC is shown in the following steps.

WARNINGS And CAUTIONS.
Always Read, Understand, and Perform ALL WARNINGS and CAUTIONS
Found In This Technical Manual BEFORE Performing
The Step Immediately Following The
WARNING or CAUTION.

Throughout this technical manual there are certain procedures and operations that are hazardous to you or to the W. If you see a WARNING, pay special attention to the information stated in it because **all WARNINGS provide you with data that will prevent serious injury to you or others around you.** When you see a CAUTION read it carefully because the information given in it will keep you from damaging the WTSC and making the WTSC unable to fulfill its mission.

Equipment Set Up And Operation. Unpack and set up the WTSC in accordance with the procedures shown in Chapter 2.

Preventive Maintenance Checks And Services (PMCS). Perform the operator PMCS procedures shown in Chapter 2.

Troubleshooting Procedures. If the WTSC should not operate properly, refer to either the operating troubleshooting procedures in Chapter 3, the unit troubleshooting procedures in Chapter 4, or the direct support troubleshooting procedures in Chapter 5. The most likely WTSC malfunctions have been placed within these troubleshooting procedures and a test and/or repair procedure paragraph has been indicated to correct the malfunction found. If a repair is required, refer to the maintenance paragraph shown in the troubleshooting procedure.

Maintenance Procedures. The complete repair procedures needed to correct a problem found with the WTSC have been included in Chapters 3, 4, and 5.

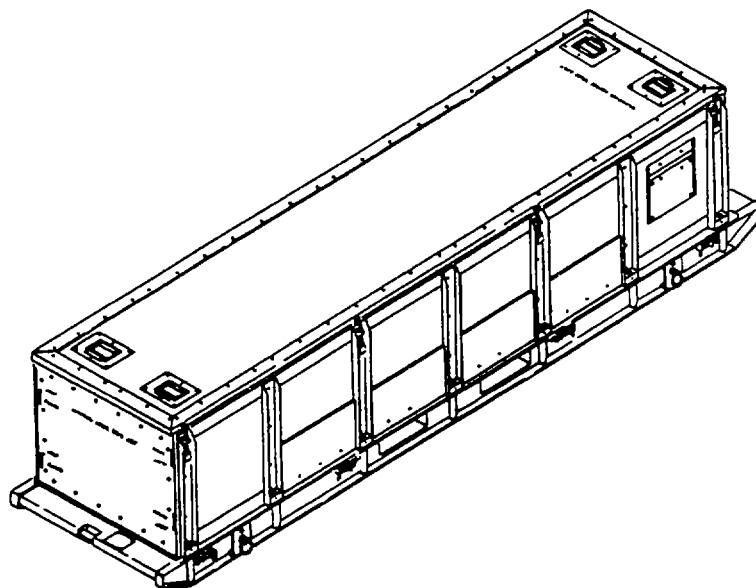

Figure 1-1. Storage Chest, Tank

CHAPTER 1

INTRODUCTION

Section I. GENERAL INFORMATION

1-1. SCOPE.

a. Type of Manual. Operator's, Unit, and Direct Support Maintenance Manual including Repair Parts and Special Tools list.

b. Model Number and Equipment Name. Model M-1795 Chest, Water Tank, 50K

c. Purpose of Equipment. The Water Tank Storage Chest (WTSC) covered by this manual is intended for use in storing 50,000 gallon and 20,000 gallon water tanks.

1-2. MAINTENANCE FORMS, RECORDS, AND REPORTS. Department of the Army forms and procedures used for equipment maintenance will be those prescribed by DA PAM 738-750. The Army Maintenance Management System (TAMMS) (Maintenance Management UPDATE).

1-3. CORROSION AND PREVENTION CONTROL. Corrosion Prevention and Control (CPC) of Army materiel is a continuing concern. It is important that any corrosion problems with this item be reported so that the problem can be corrected and improvements can be made to prevent the problem in future items.

While corrosion is typically associated with the rusting of metals, it can also include deterioration of other materials such as rubber and plastic. Unusual cracking, softening, swelling, or breaking of the materials may be a corrosion problem.

If a corrosion problem is identified, it can be reported using Standard Form 368, Product Quality Deficiency Report. Use of key words such as "rust", "deterioration", "corrosion", or "cracking" will insure that the information is identified as a CPC problem. The form should be submitted to the address specified in the DA PAM 738-750.

1-4. DESTRUCTION OF ARMY MATERIEL TO PREVENT ENEMY USE. Refer to TM 750-244-3, Procedures for Destruction of Equipment to Prevent Enemy Use.

1-5. PREPARATION FOR STORAGE OR SHIPMENT. Contact unit maintenance for preparation and storage or shipment. Refer to Section VI, Chapter 4.

1-6. REPORTING EQUIPMENT IMPROVEMENT RECOMMENDATIONS (EIR'S). If your WTSC needs improvement, let us know. Send us an EIR. You, the user, are the only one who can tell us what you don't like about your equipment. Let us know why you don't like the design or performance. Put it on a SF 368 (Product Quality Deficiency Report). Mail it to us at;

Commander
U.S. Army Aviation and Troop Support Command
Attention: AMSAT-I-MDO
4300 Goodfellow Blvd.
St. Louis, Missouri 63120-1798.

We will send you a reply.

1-7. LIST OF ABBREVIATIONS. All abbreviations use within this technical manual conform to the standard military abbreviations found in MIL-STD-12, Abbreviations for Use on Drawings, and in Specifications, Standards, and Technical Documents.

Section II. EQUIPMENT DESCRIPTION AND DATA

1-8. EQUIPMENT CHARACTERISTICS, CAPABILITIES, AND FEATURES.

a. Characteristics and Capabilities. The WTSC is designed to provide storage for 50,000 gallon and 20,000 gallon water tanks and has the following major characteristics and capabilities.

- (1) Capable of storing one 50,000 gallon water tank assembly or two 20,000 gallon water tank assemblies for storage or shipment.
- (2) Lightweight skid constructed of high strength aluminum alloy.
- (3) Top cover, side panels, and end panels are constructed of fiberglass reinforced plywood material.

b. Features. The WTSC has the following major features.

- (1) Recessed handle assemblies on the top cover for removal of the top cover.
- (2) Hoisting straps and tie-down straps are furnished for holding the water tank in place and for removing the water tank from the storage chest.
- (3) The skid is equipped with cargo rings to allow the storage chest to be secured during transportation on flatbed trailers, rail cars, and aircraft.
- (4) Latches on the side panel channel assemblies are provided for securing the top cover to the side panel assemblies and the skid is equipped with locking pin assemblies to secure the side panel channel assemblies to the skid.

1-9. LOCATION AND DESCRIPTION OF MAJOR COMPONENTS. The following major components of the WTSC are described below and are located as shown on Figure 1-2.

a. Hoisting Straps (1). Four hoisting straps are provided to allow the water storage tank to be hoisted away from the WTSC.

b. Side Panel Assemblies (2) and End Panel Assemblies (3). The side panel assemblies and the end panel assemblies provide the structure required to contain the water storage tank on the skid assembly.

c. Skid Assembly (4). All of the above components are mounted onto the skid assembly which acts as the primary carrying structure for the water storage tank assembly.

d. Tie-Down Straps (5). Four tie-down straps are furnished to secure the water storage tank inside the WTSC during storage and shipment.

e. Top Cover Assembly (6). The top cover assembly provides the final covering for the water tank stored inside the storage chest.

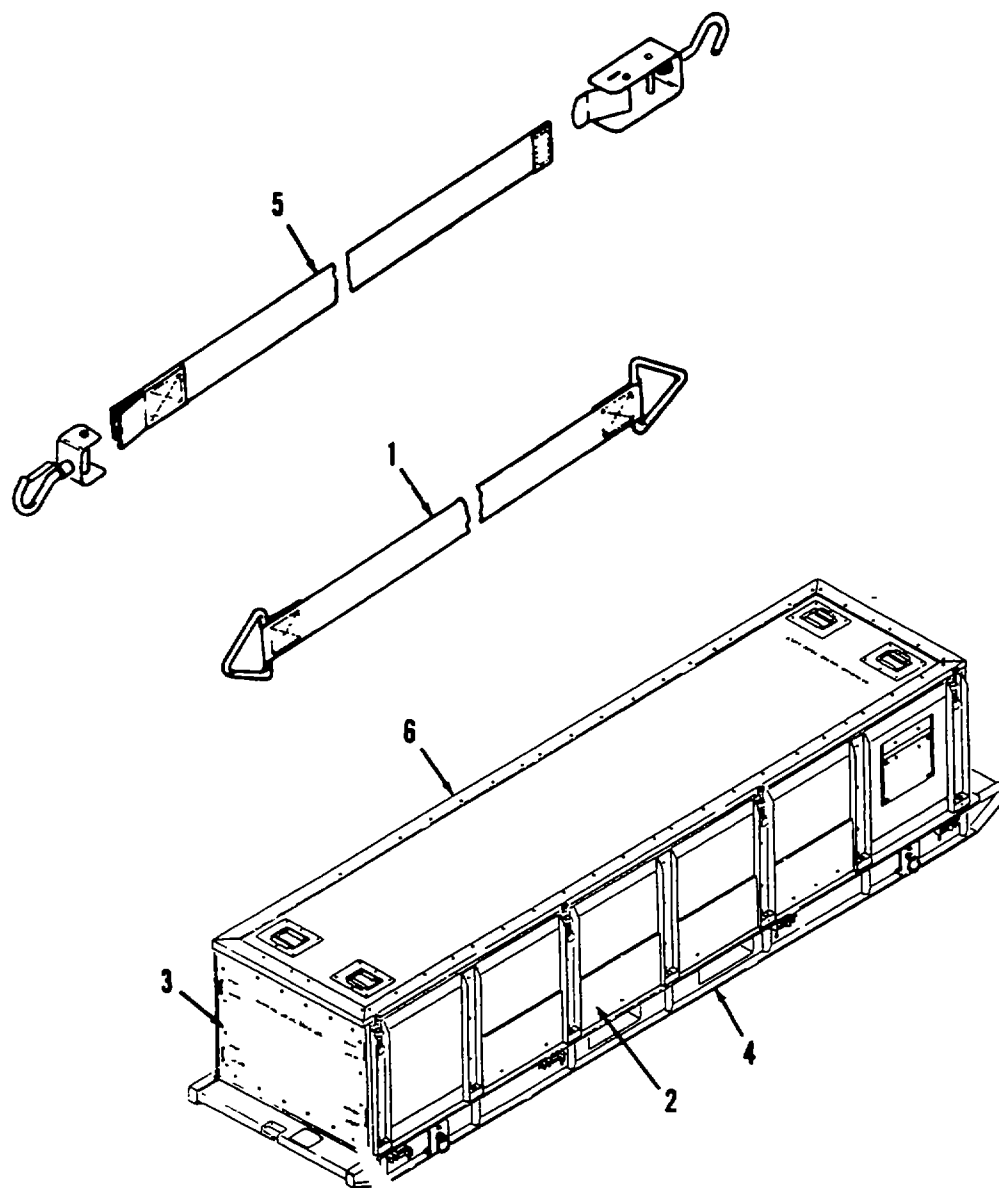

Figure 1-2. Location of Major Components

1-10. EQUIPMENT DATA. Refer to Table 1-1. for general equipment and performance data for the WTSC.

Table 1-1. Equipment Data.

Manufacturer.....	Williamson Metal Works, Inc.
Overall Width.....	44.00 in (111.76 cm)
Overall Length	163.25 in (414.66 cm)
Overall	36.75 in (93.35 cm)
Tare Weight.....	850.00 lbs (386.36 kg)
Gross Weight.....	2,200.00 lbs (1,000.00 kg)
Inside Shipping Volume.....	111.14 cubic feet (3.15 cubic meter)

Section III. PRINCIPLES OF OPERATION

1-11. THEORY OF OPERATIONS. The WTSC, constructed of lightweight aluminum and fiberglass, is a container designed to store and transport one 50,000 gallon water tank or two 20,000 gallon water tank assemblies. The empty tank(s) is folded and placed into the storage chest using tie-down straps. Forklift slots are provided in the skid portion of the WTSC for mobility of the chest. Top, side, and end panel assemblies are designed to connect together on a lightweight skid with latches, turnlocks, and locking pin assemblies.

CHAPTER 2
OPERATING INSTRUCTIONS

CHAPTER 2 INDEX

Section I. Description and Use of Operator's Controls and Indicators	2-2
2-1. Introduction	2-2
2-2. Operator's Controls and Indicators.....	2-2
Section II. Operator Preventive Maintenance Checks and Services.....	2-4
2-3. General	2-4
2-4. PMCS Procedures.....	2-4
2-5. Special Instructions	2-5
Section III. Operation Under Usual Conditions	2-10
2-6. Assembly and Preparation for Use	2-10
2-7. Initial Adjustments, Daily Checks, and Self Tests	2-12
2-8. Operating Procedures	2-12
2-9. Operation Instructions on Decals and Instruction Plates.....	2-15
2-10. Preparation for Movement.....	2-16
Section IV. Operation Under Unusual Conditions	2-16
2-11. Operation Under Unusual Weather.....	2-16
a. Operation In Extreme Cold	2-16
b. Operation In Extreme Heat.....	2-16
c. Operation In Sandy or Dusty Areas	2-16
d. Operation In Salt Water Areas.....	2-16
2-12. Nuclear, Biological, and Chemical Decontamination Procedures	2-16

Section I. DESCRIPTION AND USE OF OPERATOR'S CONTROLS AND INDICATORS

2-1. INTRODUCTION. The WTSC is designed for operation in a wide range of climatic conditions. Operators must be aware of any peculiarities or operational limitations for their specific use of the WTSC. Before using the WTSC, be sure that you have determined how each of the controlling devices on the WTSC operate. This section contains the description and use of each of these operator controls.

2-2. OPERATOR'S CONTROLS AND INDICATORS. For the WTSC controls and indicators, refer to the following descriptions and to Figure 2-1

a. Cargo Rings (1). The skid assembly is equipped with four cargo rings. These rings are used to secure the assembled WTSC to the carrier being used to store or transport the WTSC.

b. End Panel Turnlock Assemblies (2). Each of the end panel assemblies is equipped with four turnlock assemblies. When the end panels have been placed into position against the installed side panel assemblies, these turnlock assemblies are rotated to secure the end panel assemblies to the side panel assemblies. The end panels are stenciled with the words "OPEN" and "CLOSED" to indicate the position the turnlock handle should be in to remove or install the end panel assembly.

c. Hoisting Straps (3). Four hoisting straps are supplied to provide a means of lifting the 50,000 water tank from the inside of the WTSC. When not in use, these hoisting straps are stored between one end panel assembly and the divider storage pan provided with the WTSC.

d. Locking Pins (4). When the side panel assemblies are placed into position on the skid assembly, they are held onto the skid by a series of locking pins which are fixed onto the skid assembly. A locking pin located on the bottom of the channel assemblies of the side panel assemblies is inserted into the locking pin area of the skid assembly. The locking pin bolts on the skid assembly are then adjusted to insert the skid assembly locking pin bolts into the channel assembly locking pins.

e. Side Panel Channel Latches (5). To secure the top cover to the side panel assemblies, each of the center channel assemblies of the side panels is equipped with a latch. When the top panel is in place, these latches are set to engage the top cover frame to hold the top cover securely in place.

f. Skid Tie-Down Bars (6). One tie-down bar is located on each end of the skid assembly for use in securing the skid during transport of the WTSC.

g. Tie-Down Straps (7). To secure the water storage tank into the WTSC compartment, four tiedown straps are included with the WTSC. When in use, each end of these tie-down straps is engaged with a number of tie down pins which are welded into the skid assembly.

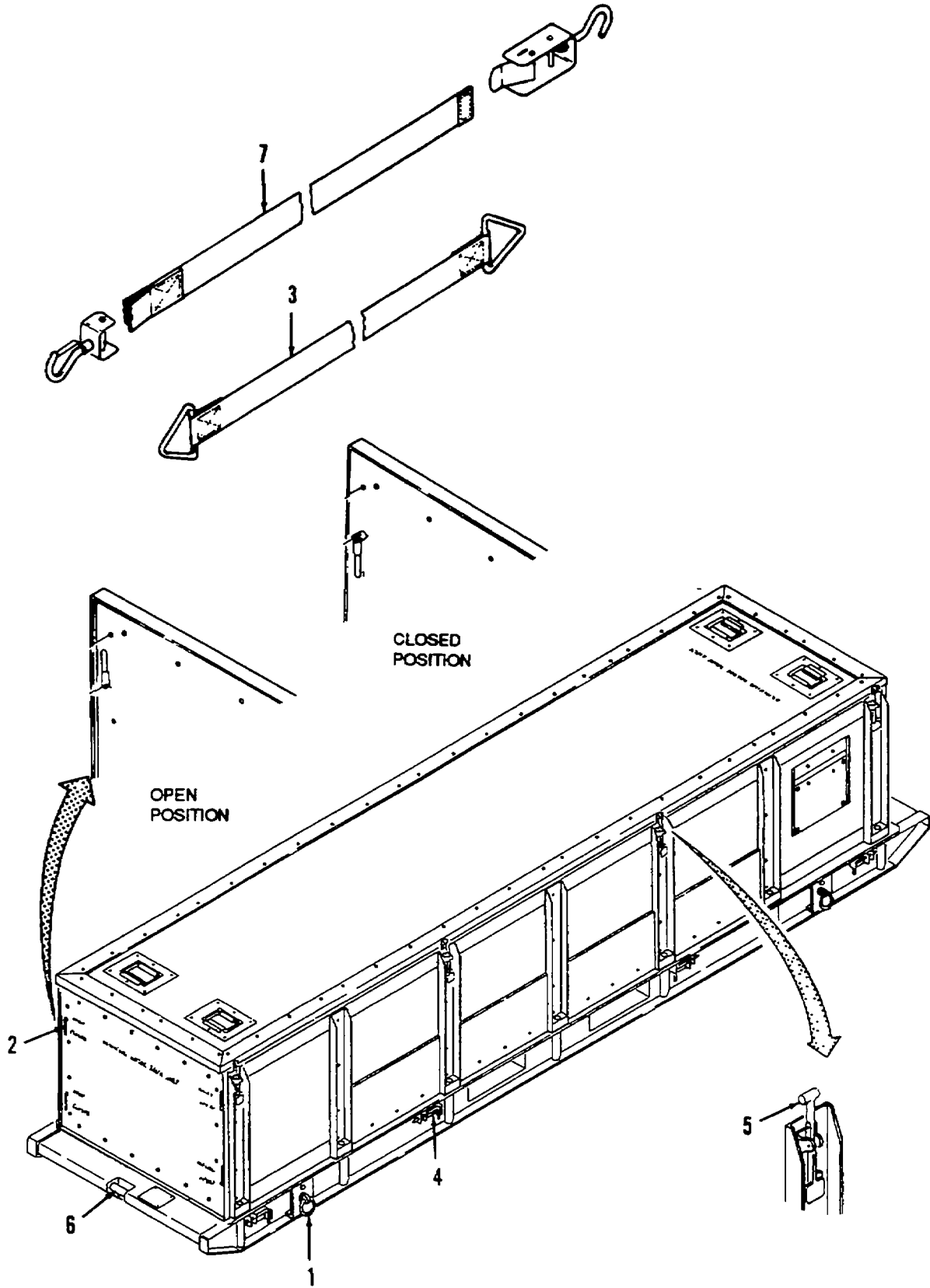

Figure 2-1. Operator's Controls and Indicators.

Section II. OPERATOR PREVENTIVE MAINTENANCE CHECKS AND SERVICES

2-3. GENERAL. Preventive Maintenance Checks and Services (PMCS) means systematic caring, inspecting, and servicing of equipment to keep it in good condition and to prevent breakdowns. As the operator of the WTSC, your mission is to:

- a. Be sure to perform your PMCS each time you operate your WTSC. Always do your PMCS in the same order, so it gets to be a habit. Once you've had some practice, you'll quickly spot anything wrong.
- b. Do your **BEFORE (B)** PMCS just before you operate the WTSC. Pay special attention to all WARNINGS, CAUTIONS, and NOTES.
- c. Do your **DURING (D)** PMCS while you are operating the WTSC. During operations means to monitor the WTSC and its related components while it is actually being operated. Pay special attention all WARNINGS, CAUTIONS, and NOTES.
- d. Do your **AFTER (A)** PMCS right after you have operated the WTSC. Pay special attention to all WARNINGS, CAUTIONS, and NOTES.
- e. Use DA Form 2404 (Equipment Inspection and Maintenance Worksheet) to record any faults that you discover before, during, or after operation unless you can fix them. You do not need to record faults that you fix.
- f. Be prepared to assist unit maintenance in any lubrication procedures. Perform any other services when required by unit maintenance.

2-4. PMCS PROCEDURES.

- a. Your Preventive Maintenance Checks and Services, Table 2-1, lists inspections and care to keep your WTSC in good operating condition. Use Figure 2-2 as a routing diagram to perform your PMCS procedures. It is set up so you can make your BEFORE (B) Operation checks as you perform a general examination of the WTSC.
- b. The "INTERVAL" column of Table 2-1 tells you when to do a certain check or service.
- c. The "PROCEDURE" column of Table 2-1 tells you how to do required checks and services. Carefully follow these instructions. If you do not have tools or if the procedure tells you to, notify your supervisor.

NOTE

Terms "ready/available" and "mission capable" refer to the same status: Equipment is on hand and ready to perform combat missions. (See DA PAM 738-750.)

- d. The "NOT FULLY MISSION CAPABLE IF:" column in Table 2-1 tells you when your WTSC is not capable and why the WTSC cannot be used.
- e. If the WTSC does not perform as required, refer to Section III, Operator Troubleshooting.
- f. If anything looks wrong and you can't fix it, write it on your DA Form 2404 IMMEDIATELY and report it to your supervisor.

g. When you do your PMCS, you will always need a rag or two. The following items are common to all of the WTSC components:

(1) Keep It Clean. Dirt, grease, oil, and debris only get in the way and may cover up a serious problem. Clean as you work and as needed. Use dry cleaning solvent (Appendix F, Item 3) on all metal surfaces. Use soap (Appendix F, Item 5) when you clean rubber or plastic material.

(2) Rust and Corrosion. Check the components of the WTSC for rust and corrosion. If any bare metal or corrosion exists, clean and apply a thin coat of oil. Report it to your supervisor.

(3) Bolts, Nuts, and Screws. Check them for obvious looseness, missing, bent, or broken condition. You can't try them all with a tool, but look for chipped paint, bare metal, or rust around bolt heads. If you find a bolt, nut, or screw you think is loose, tighten it or report it to your supervisor.

(4) Welds. Look for loose or chipped paint, rust, or gaps where metal parts are welded together. If you find a bad weld, report it to your supervisor.

h. When you check for "proper operating condition", you look at the component to see if its serviceable.

2-5. SPECIAL INSTRUCTIONS. If the equipment must be kept in continuous operation, check and service only those items that can be checked and serviced without disturbing operation. Make the complete checks and services when the equipment can be shut down.

Table 2-1. Operator Preventive Maintenance Checks and Services For Tank Storage Chest

Item No.	Interval	Location	Procedure	Not Fully Mission
		Item to Check/Service		Capable if:
1	Before	TOP COVER ASSEMBLY	<p>a. Inspect handle assemblies for damage. Check for loose or missing attaching hardware.</p> <p>b. Inspect panel for holes and cracks. Check for Loose or missing attaching hardware.</p>	<p>Handle assemblies are damaged. Attaching hardware is loose or missing.</p> <p>Panel assembly has holes or is cracked. Attaching hardware is loose or missing.</p>
2	Before	DOCUMENT POUCH	Check for torn or missing document pouch.	
3	Before	END PANEL ASSEMBLIES	<p>a. Inspect for bent turnlock handles.</p> <p>b. Inspect panel for holes and cracks. Check for loose or missing attaching hardware</p>	<p>Turnlock handle is bent.</p> <p>Panel assembly has holes or is cracked. Attaching hardware is loose or missing.</p>
4	Before	SIDE PANEL ASSEMBLIES	<p>a. Check channel assemblies for bent metal. Insure that all latching assemblies are operable and are operable and not damaged. Inspect for bent or missing locking pins.</p> <p>b. Inspect panel for holes and cracks. Check for loose or missing attaching hardware.</p>	<p>Channels are badly bent. Latching assemblies do not function properly. Locking pins are bent or missing.</p> <p>Panel assembly has holes or is cracked. Attaching hardware is loose or missing.</p>
5	Before	STRAP ASSEMBLIES	<p>a. Check for missing hoisting straps. Inspect straps for fraying</p> <p>b. Check for missing tiedown straps. Inspect straps for fraying.</p>	<p>Hoisting straps are missing. Straps are badly frayed.</p> <p>Tie-down straps are missing. Straps are badly frayed.</p>
6	Before	DIVIDER, STORAGE PAN	Inspect for bent or missing divider pan.	

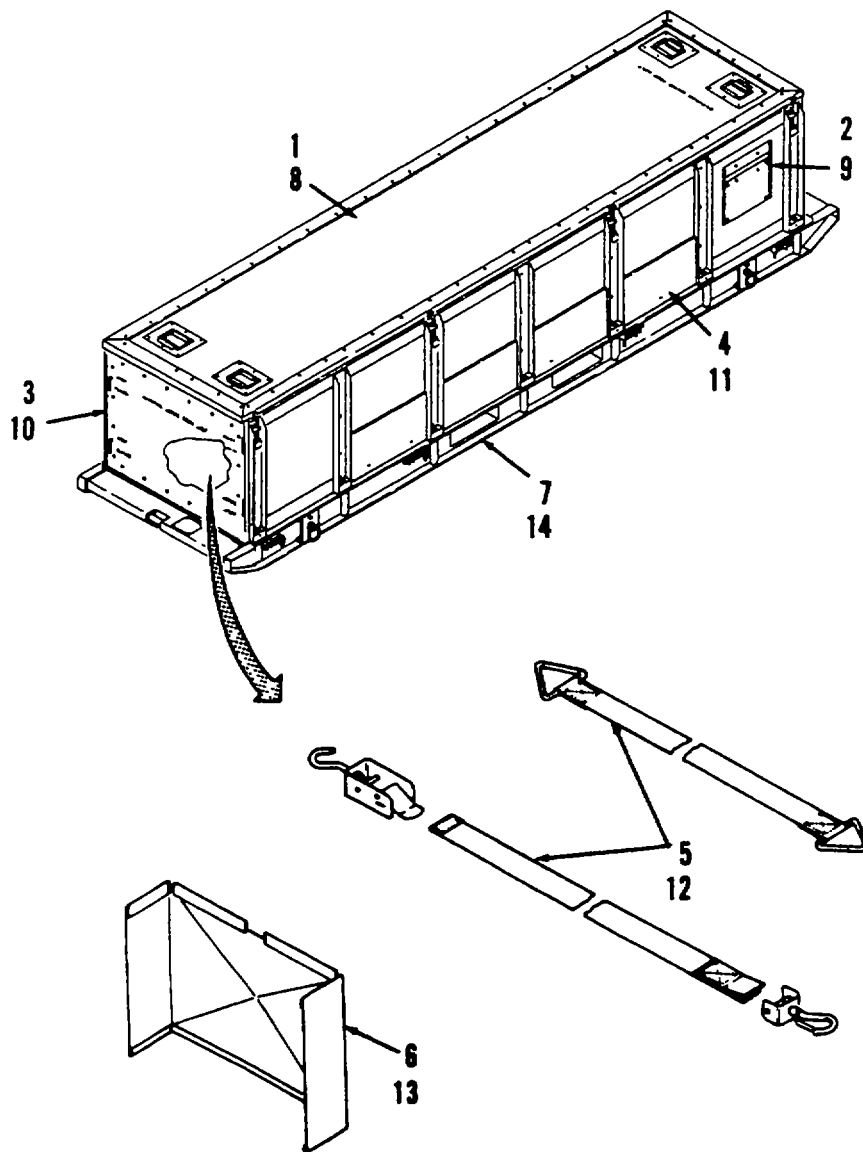

Figure 2-2. Operator's Preventive Maintenance Checks and Services Routing Diagram.

**Table 2-1. Operator Preventive Maintenance Checks and Services
For Tank Storage Chest - Continued.**

Item No.	Interval	Location	Procedure	Not Fully Mission
		Item to Check/Service		Capable if:
7	Before	SKID ASSEMBLY	<p>a. Inspect skid locking pin assemblies for damage. Check for loose or missing attaching hardware.</p> <p>b. Inspect for bent or missing cargo rings. Check for loose or missing attaching hardware.</p> <p>c. Inspect readability of identification plate. Check for loose or missing attaching hardware.</p> <p>d. Inspect skid for cracked or bent metal surfaces.</p>	<p>Locking pins are damaged. Attaching hardware is loose or missing.</p> <p>Cargo rings are bent or missing. Attaching hardware is loose or missing.</p> <p>Skid is cracked or bent badly.</p>
8	After	TOP COVER ASSEMBLY	<p>a. Inspect handle assemblies for damage. Check for loose or missing attaching hardware.</p> <p>b. Inspect panel for holes and cracks. Check for loose or missing attaching hardware.</p>	<p>Handle assemblies are damaged. Attaching hardware is loose or missing.</p> <p>Panel assembly has holes or is cracked. Attaching hardware is loose or missing.</p>
9	After	DOCUMENT POUCH	Check for torn or missing document pouch.	
10	After	END PANEL ASSEMBLIES	<p>a. Inspect for bent turnlock handles.</p> <p>b. Inspect panel for holes and cracks. Check for loose or missing attaching hardware.</p>	<p>Turnlock handle is bent.</p> <p>Panel assembly has holes or is cracked. Attaching hardware is loose or missing.</p>
11	After	SIDE PANEL ASSEMBLIES	a. Check channel assemblies for bent metal. Insure that all latching assemblies are operable and are operable and not damaged. Inspect for bent or missing locking pins.	Channels are badly bent. Latching assemblies do not function properly. Locking pins are bent or missing.

Table 2-1. Operator Preventive Maintenance Checks and Services for Tank Storage Chest.

Item No.	Interval	Location	Procedure	Not Fully Mission Capable if:
		Item to Check/Service		
12	After	STRAP ASSEMBLIES	<p>b. Inspect panel for holes and cracks. Check for loose or missing attaching hardware.</p> <p>a. Check for missing hoisting straps. Inspect straps for fraying.</p>	<p>Panel assembly has holes or is cracked. Attaching hardware is loose or missing</p> <p>Hoisting straps are missing. Straps are badly frayed.</p>
13	After	DIVIDER, STORAGE PAN	<p>b. Check for missing tiedown straps. Inspect straps for fraying.</p> <p>Inspect for bent or missing divider pan.</p>	<p>Tie-down straps are missing. Straps are badly frayed.</p>
14	After	SKID ASSEMBLY	<p>a. Inspect skid locking pin assemblies for damage. Check for loose or missing attaching hardware.</p> <p>b. Inspect for bent or missing cargo rings. Check for loose or missing attaching hardware.</p> <p>c. Inspect readability of identification plate. Check for loose or missing attaching hardware.</p> <p>d. Inspect skid for cracked or bent metal surfaces.</p>	<p>Locking pins are damaged. Attaching hardware is loose or missing.</p> <p>Cargo rings are bent or missing. Attaching hardware is loose or missing</p> <p>Skid is cracked or bent badly.</p>

Section III. OPERATION UNDER USUAL CONDITIONS

2-6. ASSEMBLY AND PREPARATION FOR USE. This paragraph shows how to assemble the WTSC and prepare it for use. The steps provided and the illustrations shown are for a typical set up of the WTSC. Always be sure that you follow your local operating procedures first if there is a conflict. The WTSC is ready for use when it has been removed from its shipping and packing material. In the event that the WTSC has been sent to you in an unassembled state, use the following procedures to assemble the WTSC for use (Refer to Figure 2-3.)

WARNING

Serious injury could occur if heavy equipment is moved/lifted without sufficient personnel to do the job. Wear safety shoes, gloves, and other suitable protective clothing. Do not try to lift more than 50 pounds by yourself.

a. Place the skid assembly (1) into position on a level surface. Contact unit maintenance for help in positioning the WTSC.

NOTE

- Before installing side panels, be sure that all holes in the top surface of the skid are free from dirt and debris.
- Be sure that all end panel and side panel gasket material is undamaged before installing panels onto skid.

b. Install each of the two side panel assemblies (2) onto the skid assembly (1). Make sure that the locking pins (3) on the bottoms of the channel assemblies (4) on the side panel assemblies are properly aligned in the channel mounting holes of the skid assembly.

c. Lift up the locking pin latches (5) on the skid assembly (1) and move them either to the left or to the right as required to insert the ends of the skid assembly locking pins into the locking pins (3) on the channel assemblies (4) which are equipped with locking pins.

NOTE

When installing the end panel assemblies, be sure that the lettering on the end panel is right side up and that the gasket material on each end panel is positioned to rest on the top of the skid assembly.

d. Place each of the two end panel assemblies (6) into position on each end of the skid assembly (1). Rotate each of the four turnlock handles (7) 90° counterclockwise to latch the end panels into each of the side panels (2).

e. Place the top cover (8) onto the top of the side panels (2) and the end panels (6). Be sure that the strike catches on the top cover align with the latching devices (9) on the side panel channel assemblies (4) that have latches.

f. Lift the handles of the channel assembly (4) latching devices (9) to engage the bolt of the latching devices with the strike catches on the top cover (8). Pull the handles of the latching devices over and down until the handles are vertical and the latch snaps into place securing the top cover to the side panel assemblies (2).

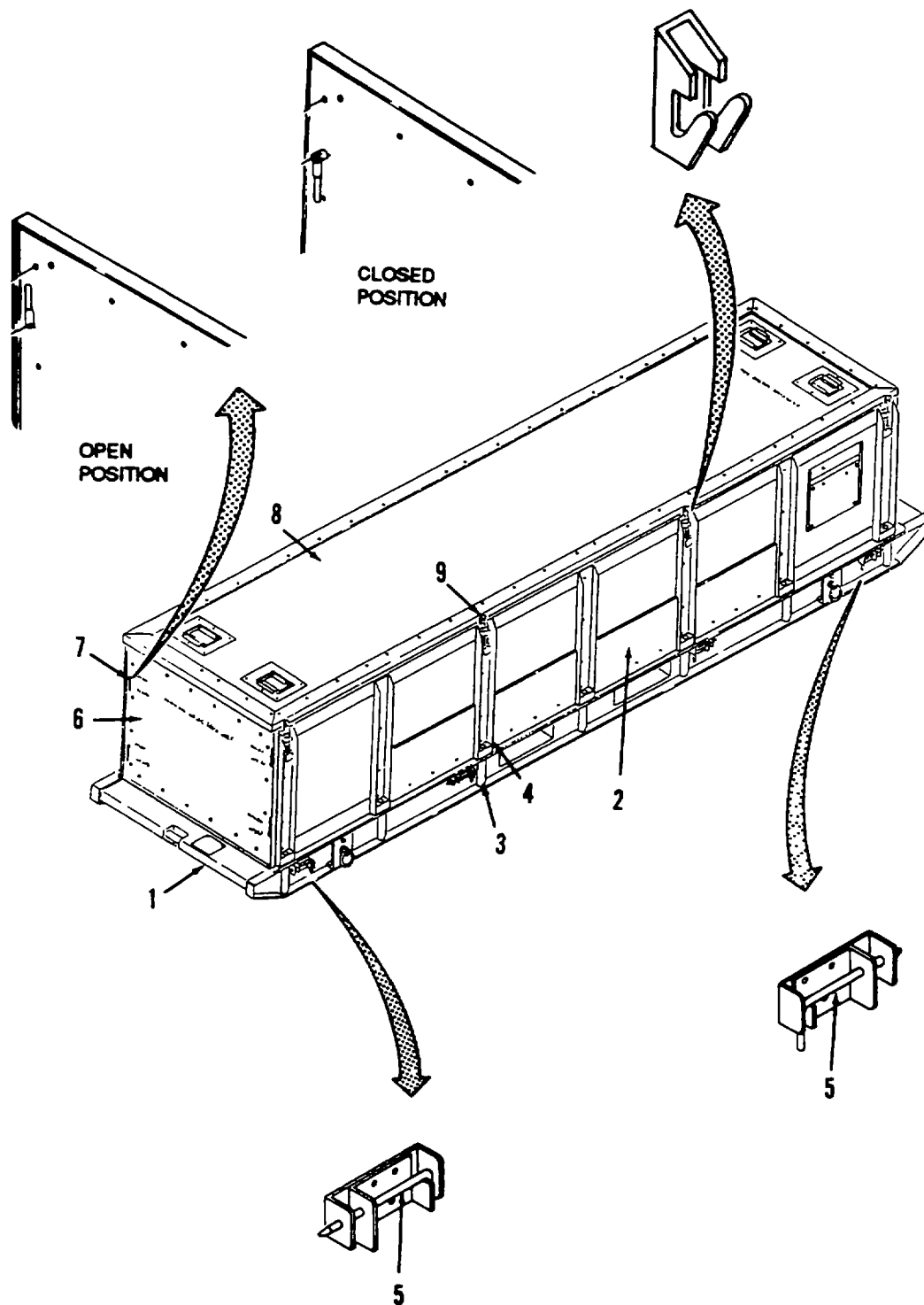

Figure 2-3. Assembly and Preparation for Use.

2-6. ASSEMBLY AND PREPARATION FOR USE. Continued.

g. If the latches on the side panel assembly do not tightly engage the top cover assembly, adjust the latch drawbolts as follows:

- (1) Disengage channel assembly drawbolt from strike catch on top cover assembly.
- (2) Rotate drawbolt either counterclockwise to lengthen the drawbolt reach or clockwise to shorten the drawbolt reach as needed.
- (3) Attempt to engage latch drawbolt with top cover assembly again.
- (4) Repeat steps (1) through (3) as needed until latch drawbolt properly secures the top cover assembly.

2-7. INITIAL ADJUSTMENTS, DAILY CHECKS, AND SELF TESTS.

a. Inspect the WTSC for completeness, damage, and for proper operation as applicable. Report any deficiencies to unit maintenance.

b. Perform the preventative maintenance checks and services listed in Table 2-1.

2-8. OPERATING PROCEDURES.

a. Storing one 50,000 Gallon or Two 20,000 Gallon Water Tank. After insuring that the WTSC has been placed on a level surface, one 50,000 gallon or two 20,000 gallon water storage tank can be placed into the WTSC by performing the following steps.

- (1) Perform all before Operator PMCS listed in Table 2-1.
- (2) (Refer to Figure 2-3.) Disengage the latching devices (9) on the side panel assembly channel latches and remove the top cover assembly (8).
- (3) Engage one end of each of the four tie-down straps into the tie-down rods located in the floor of one side of the skid assembly (1) and drape the other end of the straps over the top of the side panel assemblies (2).

WARNING

Serious injury could occur if heavy equipment is moved/lifted without sufficient personnel to do the job. Wear safety shoes, gloves, and other suitable protective clothing. Do not attempt to lift more than 50 pounds by yourself.

(4) (Refer to Figure 2-4.) After folding the one 50,000 gallon water tank or the two 20,000 gallon water tanks as specified by the applicable tank technical manual, use the four hoisting straps to place the water tank(s) into the WTSC. Remove hoisting straps and store them in the divider storage pan area of the WTSC.

(5) (Refer to Figure 2-3.) Attach the loose ends of the tie-down straps onto the remaining tie-down rods located on the floor of the skid assembly (1).

(6) Place the top cover (8) onto the top of the side panel assemblies (2) and the end panels (6). Be sure that the strike catches on the top cover align with the latching devices (9) on the side panel channel assemblies that have latches.

(7) Lift the handles of the channel assembly latching devices (9) to engage the bolt of the latching devices with the strike catches on the top cover (8). Pull the handles of the latching devices over and down until the handles are vertical and the latch snaps into place securing the top cover to the side panel assemblies (2).

WARNING

Serious injury could occur if the WTSC falls from a forklift. Do not attempt to lift a WTSC with a forklift if the chest is loaded with only one 20,000 gallon storage tank.

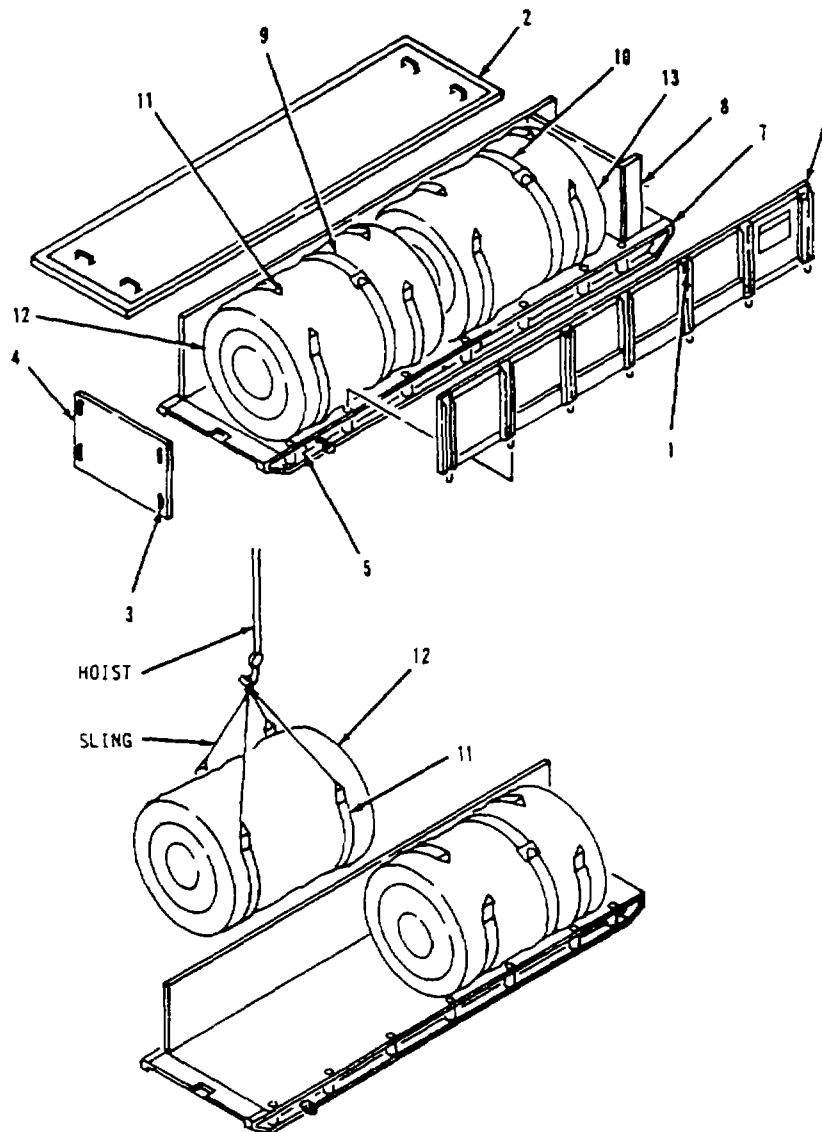

Figure 2-4. Unpacking Water Storage Tank(s) From Chest.

b. Unpacking One 50,000 Gallon Water Tank or Two 20,000 Gallon Water Tanks From the WTSC. To remove one 50,000 gallon water storage tank or two 20,000 gallon water tanks from the WTSC, refer to the following steps and to Figure 2-4.

NOTE

Unpacking of one 50,000 gallon water tank from WTSC is shown. Unpacking of two 20,000 tanks is similar.

- (1) Unfasten eight latches (1).

WARNING

Serious injury could occur if heavy equipment is moved/lifted without sufficient personnel to do the job. Wear safety shoes, gloves, and other suitable protective clothing. Do not attempt to lift more than 50 pounds by yourself.

- (2) Lift top cover assembly (2) from WTSC.
- (3) Move four turnlock handles (3) to OPEN position and remove end panel (4) from WTSC. Repeat for other end panel.

WARNING

Serious injury could occur if heavy equipment is moved/lifted without sufficient personnel to do the job. Wear safety shoes, gloves, and other suitable protective clothing. Do not attempt to lift more than 50 pounds by yourself.

- (4) Unlatch four locking pins (5) and lift side panel (6) from skid (7).
- (5) Remove accessory components from WTSC.
- (6) Lift divider pan (8) from skid (7).
- (7) Unfasten two tie-down straps (9 and (10)).

WARNING

Serious injury could occur if improper lifting equipment is to move heavy objects. Be sure that the lifting device is capable of lifting at least 750 pounds.

NOTE

Contact unit maintenance for assistance in unpacking water storage tank(s) from the WTSC

- (8) Connect ends of two hoisting straps (11) to hoist, crane, or similar type equipment.
- (9) Lift water tank(s) (12) from skid (7).
- (10) Repeat steps (8) and (9) for other water tank, if required.

2-9. OPERATION INSTRUCTIONS ON DECALS AND INSTRUCTION PLATES. To assist the operator in the use of the WTSC, various stencils and an information plate have been placed on the unit. The location of each of this lettering and the instruction plate as well as the wording of each is shown in Figure 2-5.

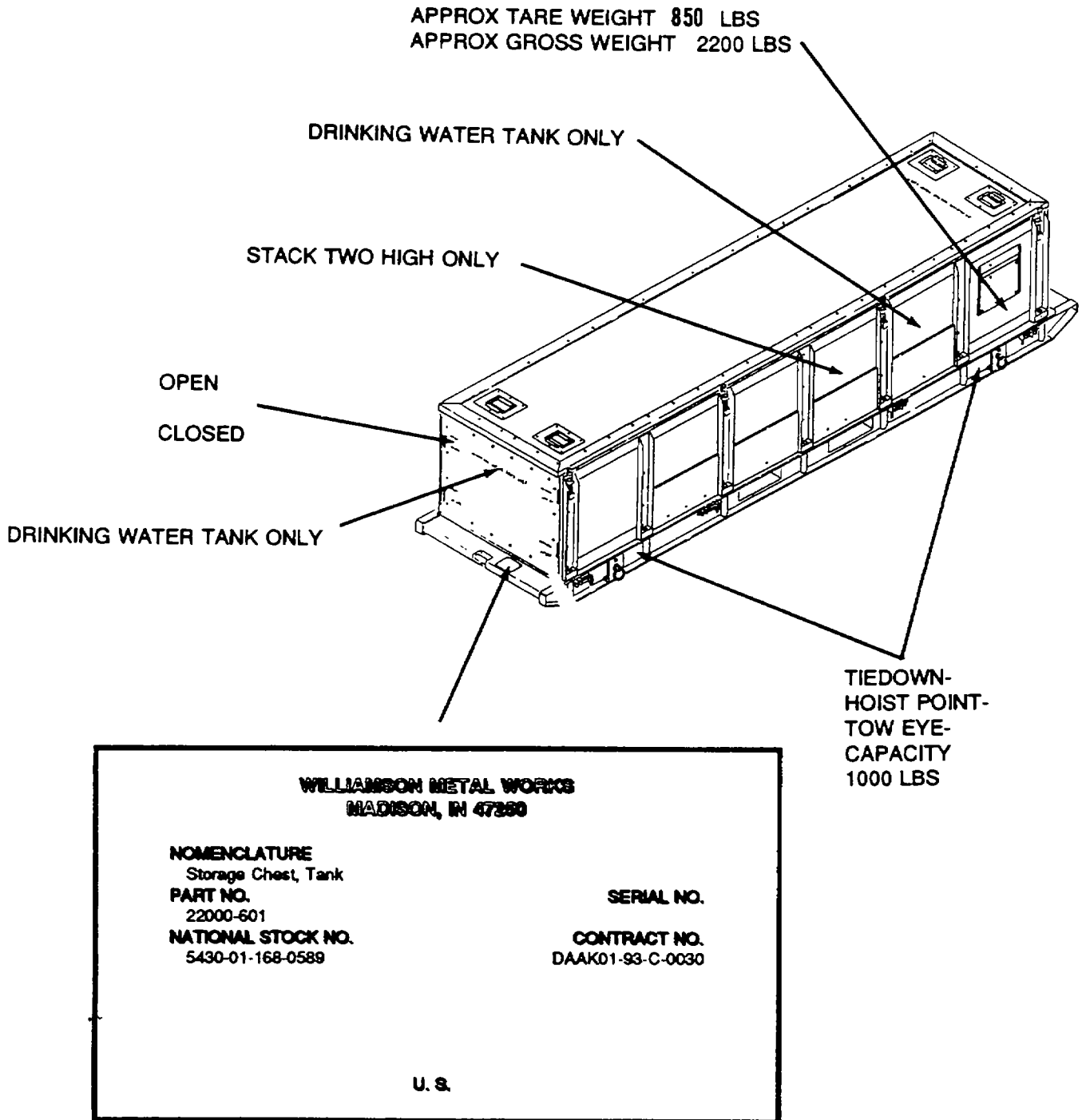

Figure 2-5. Decals and Instruction Plates.

2-10. PREPARATION FOR MOVEMENT.**WARNING**

Serious injury could occur if the WTSC falls from a forklift. Do not attempt to lift a WTSC with a forklift if the chest is loaded with only one 20,000 gallon storage tank.

When the WTSC is to be moved, the services of unit maintenance shall be employed for the necessary preparations. If the WTSC is disassembled, prepare it for movement by performing the steps indicated in Assembly and Preparation for Use (Refer to paragraph 2-7).

Section IV. OPERATION UNDER UNUSUAL CONDITIONS

2-11. OPERATION UNDER UNUSUAL WEATHER. The WTSC is designed to operate normally within a wide range of climatic conditions. However, some extreme conditions require special operating and servicing procedures to prevent undue loading and excessive wear on the equipment. These unusual conditions and the special steps to be performed are listed in the following paragraphs.

a. Operation in Extreme Cold.**CAUTION**

Freezing water can badly damage the WTSC components. When using the WTSC at temperatures below 32°F (0°C), be sure to drain all water that may have collected in the unit to prevent freezing water from damaging the WTSC.

b. Operation in Extreme Heat.**WARNING**

Hot metal surfaces can badly burn operating personnel. When the WTSC has been standing in direct sunlight, either do not allow unprotected skin to come into contact with the metal surfaces of the WTSC or wear proper gloves or other clothing when assembling or using the WTSC.

c. Operation in Sandy or Dusty Areas. Dusty and sandy conditions can affect the operation of the WTSC. When operating the WTSC in these dusty and sandy conditions, perform the following steps.

(1) Accumulation of dust or sand in the side panel assembly channel latches and the end panel turnlock assemblies can damage the equipment or cause it to fail to operate smoothly. Clean areas of dust and sand accumulation frequently. In extreme conditions, daily cleaning may be necessary.

(2) When the WTSC is used in desert conditions, there is an increased possibility that the WTSC may be subjected to intense sand storms. In the event that a sand storm is imminent, the WTSC should be covered with a tarp or placed in an area protected from the direct wind blasts of a sand storm.

d. Operation in Salt Water Areas. The nature of salt presents serious corrosion problems. Frequent cleaning is necessary during which all exposed surfaces should be thoroughly sprayed, rinsed, or sponged with fresh water to remove salt. Keep latch assemblies and turnlock assemblies free from dried salt to insure that these components will not be damaged by salt corrosion.

2-12. NUCLEAR, BIOLOGICAL, AND CHEMICAL (NBC) DECONTAMINATION PROCEDURES.

In the event that the WTSC has been subjected to NBC contamination, follow the NBC procedures in FM 3-3, FM 3-4, and FM 3-5.

**CHAPTER 3
OPERATOR MAINTENANCE INSTRUCTIONS**

Section I. LUBRICATION INSTRUCTIONS

3-1. GENERAL. The water tank storage chest requires no lubrication.

Section II. OPERATOR TROUBLESHOOTING PROCEDURES

3-2. INTRODUCTION. This section contains troubleshooting information for locating and correcting most of the operating troubles which may develop in the water tank storage chest. Each malfunction for an individual component, unit, or system is followed by a list of tests or inspections which will help you to determine corrective actions to take. You should perform the tests/inspections and corrective actions in the order listed.

This manual cannot list all malfunctions that may occur, nor all tests or inspections and corrective actions. If a malfunction is not listed, or is not corrected by listed corrective actions, notify your supervisor.

Table 3-1 lists the common malfunctions which you may find during the operation or maintenance of the water tank storage chest or its components. You should perform the tests/inspections and corrective actions in the order listed.

3-3. MALFUNCTION INDEX.

MALFUNCTION	PAGE NO.
TOP COVER HANDLE ASSEMBLIES WILL NOT OPEN	3-2
END PANEL TURNLOCK ASSEMBLIES WILL NOT LOCK	
END PANELS TO SIDE PANELS	3-2
CHANNEL ASSEMBLY LATCHES WILL NOT SECURE TOP COVER	3-2
TIE-DOWN STRAP WILL NOT SECURE STORAGE TANK.....	3-2

3-4. OPERATOR TROUBLESHOOTING TABLE. Refer to Table 3-1 for the operator troubleshooting procedures authorized for the water tank storage chest.

Table 3-1. Operator Troubleshooting.

MALFUNCT/ON	TEST OR INSPECTION	CORRECTIVE ACTION
1. TOP COVER HANDLE ASSEMBLIES WILL NOT OPEN.	Examine handles for damage or corrosion.	If handles are damaged or corroded, notify unit maintenance.
2. END PANEL TURNLOCK ASSEMBLIES WILL NOT LOCK END PANELS TO SIDE PANELS.	Check that end panels are in upright position.	Place end panels in position so that lettering on end panel is upright. Rotate turnlocks 90° clockwise to lock handles. If turnlocks fail to operate properly after turning in counterclockwise manner, turnlock is damaged. Notify unit maintenance for repairs.
3. CHANNEL ASSEMBLY LATCHES WILL NOT SECURE TOP COVER.	Step 1. Check for out of adjustment channel latch drawbolt.	Disengage channel assembly latch drawbolt from strike catch of top cover. Rotate drawbolt either counterclockwise to lengthen drawbolt reach or clockwise to shorten drawbolt reach and attempt to secure top cover again. Re-adjust length of drawbolt as required to achieve proper length of drawbolt. If drawbolt will not turn by hand, notify unit maintenance.
	Step 2. Check for damaged channel assembly latch.	If channel assembly latch is damaged in any way, notify unit, maintenance.
4. TIE-DOWN STRAP WILL NOT SECURE STORAGE TANK.	Step 1. Check for loose strap adjustment.	Tighten strap by pulling on loose end of strap located at the tie-down strap buckle.
	Step 2. Check tie-down strap for damage.	If tie-down strap is damaged in any way, notify unit maintenance.

Section III. OPERATOR MAINTENANCE PROCEDURES

3-5. GENERAL. No operator maintenance is authorized to the operator of the WTSC.

CHAPTER 4

UNIT MAINTENANCE INSTRUCTIONS

Section I. REPAIR PARTS, SPECIAL TOOLS, TEST, MEASUREMENT, AND DIAGNOSTIC EQUIPMENT (TMDE), AND SUPPORT EQUIPMENT

4-1. COMMON TOOLS AND EQUIPMENT. For authorized common tools and equipment, refer to the Modified Table of Organization and Equipment (MTOE), CTA 50-970, or CTA-8-100, as applicable to your unit. Unit maintenance for the WTSC will require the use of a Tool Kit, General Mechanic's, (Appendix B, Item 1) and Shop Equipment, General Automotive, (Appendix B, Item 2).

4-2. SPECIAL TOOLS, TMDE, AND SUPPORT EQUIPMENT. Special tools are required for maintenance of the equipment. These special tools are listed in the Special Tools section of the Maintenance Allocation Chart in Appendix B of this technical Manual. Test, Measurement, and Diagnostic Equipment and Support Equipment include standard equipment found in any maintenance shop.

4-3. REPAIR PARTS. Repair parts needed by unit maintenance of the WTSC are listed and illustrated in the Repair Parts and Special Tools List (RPSTL) provided in Appendix C to this technical manual.

Section II. SERVICE UPON RECEIPT AND PREPARATION FOR MOVEMENT

4-4. SITE AND SHELTER REQUIREMENTS. The WTSC should be assembled on a level area free of debris and large rocks. Be sure that the site allows for enough room to assemble the tank storage chest and for packing or unpacking water tanks into the WTSC.

4-5. SERVICE UPON RECEIPT OF MATERIAL. The following paragraphs contain the procedures for unloading, unpacking, and general checking of the unpacked WTSC.

a. Unloading. The WTSC is shipped in one package. The package may be lifted by fork-lift, crane, or sling. To unload the WTSC, perform the following steps.

- (1) Check the shipping package for damage. Damaged packages indicate probable damage to equipment.
- (2) Remove all blocking and tie downs that may have been used to secure the package onto the carrier.

WARNING

Serious injury could occur if heavy equipment is moved/lifted without sufficient personnel to do the job. Wear safety shoes, gloves, and other suitable protective clothing. Do not try to lift more than 50 pounds by yourself.

WARNING

Serious injury could occur if the WTSC falls from a forklift. Do not attempt to lift a WTSC with a forklift if the chest is loaded with only **one 20,000 gallon** storage tank.

- (3) Use a forklift truck or other suitable material handling equipment to remove package from carrier.

b. Unpacking.

- (1) Remove shipping straps and other packaging material used to secure the WTSC components during shipment.
- (2) Remove the technical publications envelope that is attached to the inside of the crate and put them in a safe place.
- (3) Carefully remove all WTSC components from package.

c. Checking Unpacked Equipment. Check the unpacked WTSC as follows:

- (1) Inspect each of the WTSC components for damage that may have been occurred during shipment, especially if shipping package is damaged. If any component has been damaged, report damage on SF 364, Report of Discrepancy.
- (2) Check the quantities and type of each component against the packing slip to see if the shipment is complete. Report all discrepancies in accordance with the instructions as defined within DA PAM 738-750. See that all Components of End Item and Basic Issue Items (See Appendix D) are with the tank storage chest.
- (3) Check to see whether the equipment has been modified.

4-6. PRELIMINARY SERVICING AND ADJUSTMENT OF EQUIPMENT. The WTSC requires no preliminary servicing or adjustment before use.

Section III. UNIT PREVENTIVE MAINTENANCE CHECKS AND SERVICES

4-7. UNIT PMCS. The WTSC has no authorized unit maintenance PMCS

Section IV. UNIT TROUBLESHOOTING PROCEDURES

4-8. INTRODUCTION. There are no unit maintenance troubleshooting procedures for the WTSC.

Section V. UNIT MAINTENANCE PROCEDURES

4-9. GENERAL INFORMATION. This section contains the maintenance procedures authorized for the unit maintenance of the WTSC as defined in the Maintenance Allocation Chart located in Appendix B.

4-10. TOP COVER ASSEMBLY REPAIR.**This Task Covers:**

a. Disassembly b. Cleaning c. Inspection d. Repair e. Assembly

Initial Setup:**Tools Required**

Tool Kit, General Mechanic's (Appendix B, Item 1)
 Drill, Hand Portable (Appendix B, Item 2)
 Riveter, Blind, Hand (Appendix B, Item 3)

Material's Required

Cloth, Lint-Free (Appendix F, Item 1)
 Brush, Medium Bristle (Appendix F, Item 2)
 Solvent, Dry Cleaning (Appendix F, Item 3)
 Rivets (Appendix I, Item 1)

Equipment Condition

Top cover assembly removed from tank storage chest (see paragraph 2-8).

a. Disassembly. (Refer to Figure 4-1.)

- (1) Using a drill bit slightly smaller than the rivet (1) diameter, drill out fourteen rivets (1).
- (2) Remove handle assembly (2) from handle mounting plate (3).
- (3) Repeat for steps (1) and (2) other three handle assemblies as required.
- (4) Remove gasket material (5), if defective. Discard gasket material.

b. Cleaning.

- (1) Remove all build up of dirt, oil, and debris from all surfaces.

WARNING

Serious injury can result in breathing fumes of dry cleaning solvent A-A-711. Serious injury or death can result from explosion of fumes from solvent. When using this solvent:

- Clean parts in a well ventilated area
- Avoid inhalation of solvent fumes and prolonged exposure of skin to cleaning solvent. Wash exposed skin thoroughly.
- Do not use near open flame or excessive heat. Flash point of solvent is 100° F to 138° F (38° C to 59° C).
- Wear eye protection when blowing solvent from parts. Air pressure should not exceed 30 psig (2.1 kg/cm²).

(2) Clean all metallic parts with a clean soft cloth or a medium bristle brush, and cleaning solvent. Be sure that all gasket adhesive residue is removed if gasket material is being replaced.

(3) Allow parts to dry.

c. **Inspection.** Inspect all metal parts for cracks, corrosion, or broken fittings.

d. **Repair.** Repair is limited to replacement of the parts found defective during inspection.

e. **Assembly.**

(1) Install new gasket material (5), if removed. Refer to Appendix G for manufacturing instructions.

(2) Install handle assembly (2) onto handle mounting plate (3).

(3) Insert fourteen new rivets (1) into mounting holes of handle assembly (2) and install rivets.

(4) Repeat steps (2) and (3) for other three handles assemblies (2) as required.

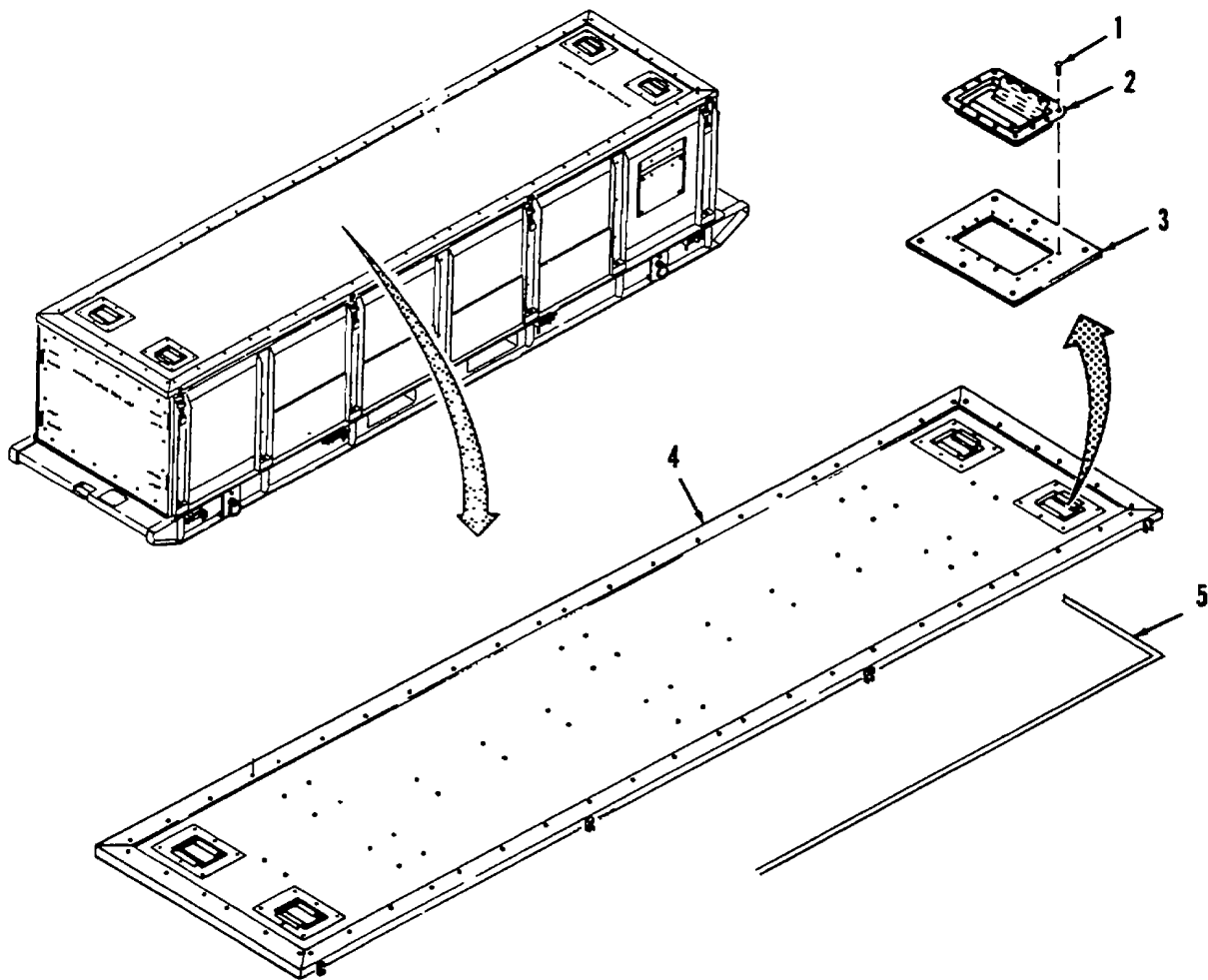

Figure 4-1. Top Cover Assembly Repair.

4-11. DOCUMENT POUCH REPLACEMENT.**This Task Covers:**

- a. Removal b. Cleaning c. Inspection d. Installation

Initial Setup:**Tools Required**

None

Material's Required

Cloth, Lint-Free (Appendix F, Item 1)
 Brush, Medium Bristle (Appendix F, Item 2)
 Solvent, Dry Cleaning (Appendix F, Item 3)
 Soap (Appendix F, Item 4)

Equipment Condition

Not applicable.

a. Removal. (Refer to Figure 4-2.) Remove document pouch (1) from side panel assembly (2) by unsnapping pouch from snap fasteners on side panel assembly.

b. Cleaning.

(1) Remove all build up of dirt, oil, and debris from all metal surfaces.

WARNING

Serious injury can result in breathing fumes of dry cleaning solvent A-A-711. Serious injury or death can result from explosion of fumes from solvent. When using this solvent:

- Clean parts in a well ventilated area.
- Avoid inhalation of solvent fumes and prolonged exposure of skin to cleaning solvent. Wash exposed skin thoroughly.
- Do not use near open flame or excessive heat. Flash point of solvent is 100° F to 138° F (38° C to 59° C).
- Wear eye protection when blowing solvent from parts. Air pressure should not exceed 30 psig (2.1 kg/cm²).

(2) Clean all metallic parts with a clean soft cloth or a medium bristle brush and cleaning solvent.

(3) Clean other non-metallic document pouch material with a solution of soap and water.

(4) Allow parts to dry.

c. **Inspection.** Inspect document pouch for torn material or damaged snaps.

d. **Installation.** Install document pouch (1) onto side panel assembly (2) by attaching snaps on document pouch onto snap fasteners on side panel assembly.

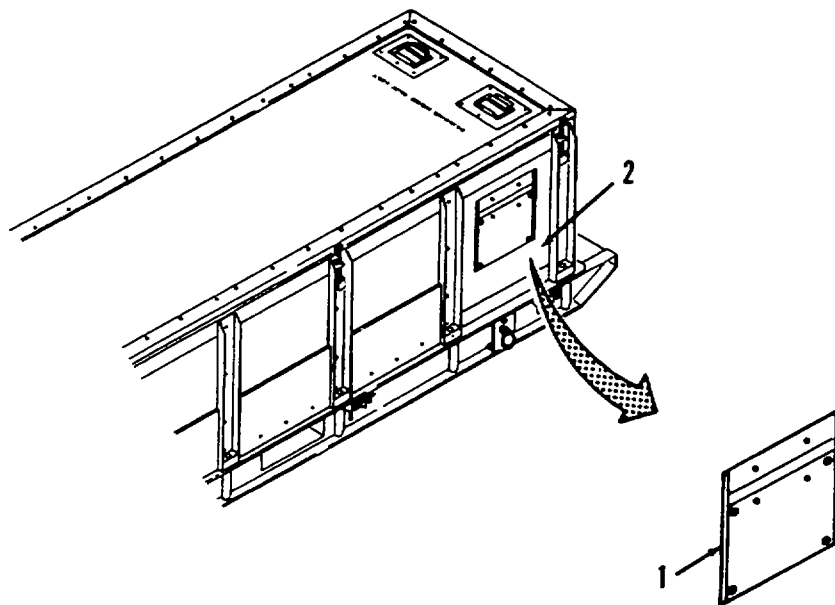

Figure 4-2. Document Pouch Replacement.

4-12. END PANEL ASSEMBLIES REPAIR.

This Task Covers:

- a. Disassembly b. Cleaning c. Inspection d. Repair e. Assembly

Initial Setup:

Tools Required

Tool Kit, General Mechanic's (Appendix B, Item 1)

Material's Required

- Cloth, Lint-Free (Appendix F, Item 1)
- Brush, Medium Bristle (Appendix F, Item 2)
- Solvent, Dry Cleaning (Appendix F, Item 3)

Equipment Condition

- Top cover assembly removed from storage chest (see paragraph 2-8)
- End panel assembly removed from tank storage chest (see paragraph 2-8)

NOTE

The WTSC has two identical end panel assemblies. This maintenance paragraph contains the procedures for the repair of one of these panels.

a. Disassembly. (Refer to Figure 4-3.)

- (1) Remove cross pin (1) from turnlock (2)
- (2) Remove turnlock (2) and washer (3) from end panel assembly (4).
- (3) Remove gasket material (5), if defective.

b. Cleaning.

- (1) Remove all build up of dirt, oil, and debris from all metal surfaces

WARNING

Serious injury can result in breathing fumes of dry cleaning solvent A-A-711. Serious injury or death can result from explosion of fumes from solvent When using this solvent:

- Clean parts in a well ventilated area.
- Avoid inhalation of solvent fumes and prolonged exposure of skin to cleaning solvent Wash exposed skin thoroughly.
- Do not use near open flame or excessive heat. Flash point of solvent is 100° F to 138° F (38° C to 59° C)
- Wear eye protection when blowing solvent from parts. Air pressure should not exceed 30 psig (2.1 kg/cm²).

(2) Clean all metallic parts with a clean soft cloth or a medium bristle brush, and cleaning solvent. Be sure to remove all gasket adhesive residue if gasket material is being replaced.

(3) Allow parts to dry.

c. Inspection. Inspect all metal parts for cracks, corrosion, or broken fittings.

d. Repair. Repair is limited to the replacement of parts found defective during inspection.

e. Assembly.

(1) Install gasket material (5), if removed. Refer to Appendix G for manufacturing instructions.

(2) Install washer (3) and turnlock (2) into end panel assembly (4).

(3) Install cross pin (1) into turnlock (2).

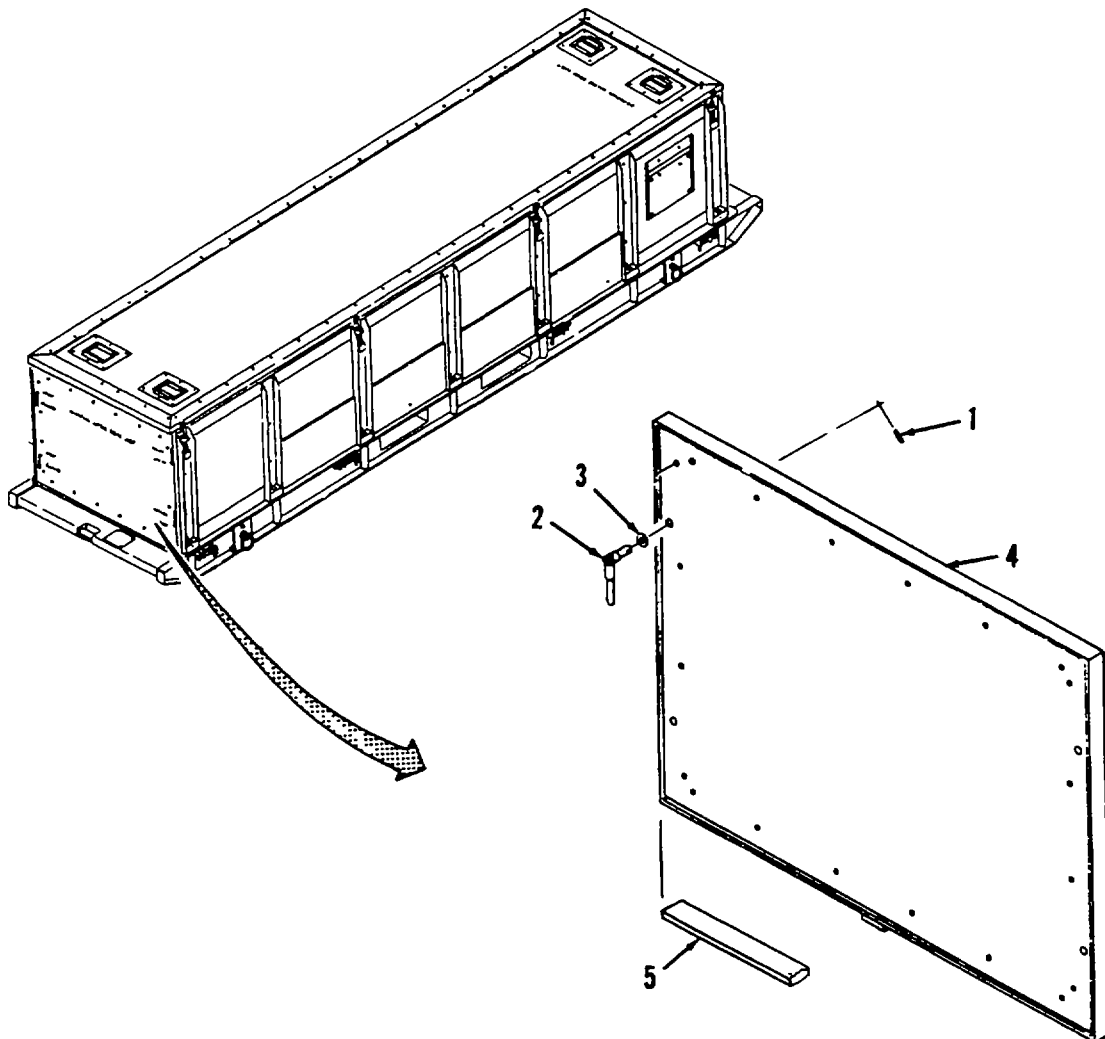

Figure 4-3. End Panel Assemblies Repair.

4-13. SIDE PANEL ASSEMBLY REPAIR.

This Task Covers:				
a. Disassembly	b. Cleaning	c. Inspection	d. Repair	e. Assembly
Initial Setup:				
<u>Tools Required</u>				
Tool Kit, General Mechanic's (Appendix B, Item 1)				
Drill, Hand, Portable (Appendix B, Item 2)				
Riveter, Blind, Hand (Appendix B, Item 3)				
<u>Material's Required</u>				
Cloth, Lint-Free (Appendix F, Item 1)				
Brush, Medium Bristle (Appendix F, Item 2)				
Solvent, Dry Cleaning (Appendix F, Item 3)				
Rivets (Appendix I, Item 3)				
Adhesive (Appendix F, Item 5)				
<u>Equipment Condition</u>				
Side panel assembly removed from tank storage chest (see paragraph 2-8)				
Document pouch removed from side panel (see paragraph 4-11).				

a. Disassembly. (Refer to Figure 4-4.)

- (1) Remove cotter pin (1), washer (2), pin (3), and drawbolt (4) from latch assembly (5).
- (2) Squeeze ends of latch assembly handle (6) together and remove latch assembly handle from side panel assembly (7)
- (3) Repeat steps (1) and (2) for other latch assemblies as required.
- (4) Drill out eight rivets (8) and remove four turnlock receptacles (9) from side panel assembly (7) Discard rivets.
- (5) Remove spring pin (10) and pin (11) from side panel assembly (7)
- (6) Repeat step (5) for other pins (11) as required
- (7) Remove four snap fasteners (12) from side panel assembly (7).
- (8) Remove all gasket material (13), if defective, from side panel assembly (7). Discard gasket material.
- (9) Remove four bumpers (14) from side panel assembly (7)

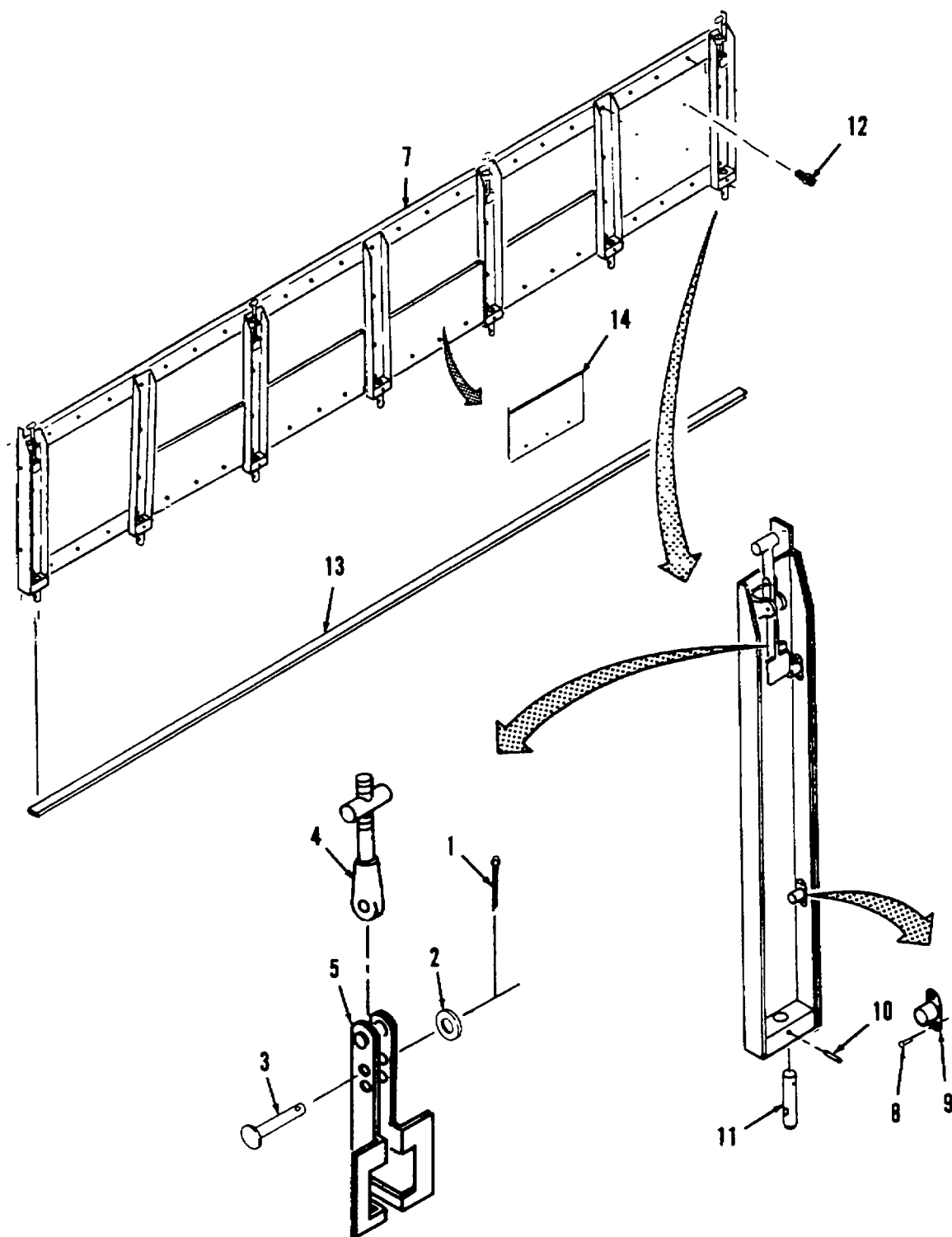

Figure 4-4. Side Panel Assembly Repair.

b. Cleaning.

- (1) Remove all build up of dirt, oil, and debris from all surfaces.

WARNING

Serious injury can result in breathing fumes of dry cleaning solvent A-A-711. Serious injury or death can result from explosion of fumes from solvent When using this solvent:

- Clean parts in a well ventilated area.
- Avoid inhalation of solvent fumes and prolonged exposure of skin to cleaning solvent Wash exposed skin thoroughly.
- Do not use near open flame or excessive heat. Flash point of solvent is 100° F to 138° F (38° C to 59° C)
- Wear eye protection when blowing solvent from parts. Air pressure should not exceed 30 psig (2.1 kg/cm²).

(2) Clean all metallic parts with a clean soft cloth or a medium bristle brush, and cleaning solvent Be sure to remove all gasket adhesive residue if gasket material is being replaced.

- (3) Allow parts to dry.

c. Inspection. Inspect all metal parts for cracks, corrosion, or broken fittings.

d. Repair. Repair of limited to the replacement of parts found defective during inspection.

e. Assembly. (Refer to Figure 4-4.)

- (1) Apply adhesive to four bumpers (14) and install bumpers onto side panel assembly (7).

(2) Install new gasket material (13) if old gasket material was removed. Refer to Appendix G for gasket material manufacturing instructions.

- (3) Install four snap fastener (12) into side panel assembly (7).

- (4) Install pin (11) and spring pin (10) Repeat for other pins.

- (5) Install eight new rivets (8) and four turnlock receptacles (9) into side panel assembly (7).

(6) Squeeze open ends of latch assembly handle (6) together, place ends of latch assembly handle into latch retainer on side panel assembly (7), and release ends of latch assembly handle to engage handle with latch retainer.

- (7) Install drawbolt (4), pin (3), and washer (2), and cotter pin (1) into latch assembly (5).

- (8) Repeat steps (5) and (6) for other latch assembly handles (6) as required.

- (9) Install side panel assembly onto skid per paragraph 2-8.

- (10) Install end panel assemblies per paragraph 2-8.
- (11) Install top cover assembly per paragraph 2-8.
- (12) Adjust latch assemblies (5) per paragraph 2-7(f) to properly engage latch with retainers on top cover assembly.

4-14. STRAP ASSEMBLIES REPLACEMENT.

<p>This Task Covers:</p> <p>a. Removal b. Cleaning c. Inspection d. Installation</p>
<p>Initial Setup:</p> <p><u>Tools Required</u> None</p> <p><u>Material's Required</u> Cloth, Lint-Free (Appendix F, Item 1) Brush, Medium Bristle (Appendix F, Item 2) Solvent, Dry Cleaning (Appendix F, Item 3)</p> <p><u>Equipment Condition</u> Top cover assembly removed from tank storage chest (refer to paragraph 2-8).</p>

a. Removal. (Refer to Figure 4-5.)

- (1) Remove four hoisting straps (1) from storage area between end panel assembly (2) and storage divider pan (3).
- (2) Remove four tie-down straps (4) from storage area between end panel assembly (2) and storage divider pan (3).

b. Cleaning.

- (1) Remove all build up of dirt, oil, and debris from all surfaces

WARNING

Serious injury can result in breathing fumes of dry cleaning solvent A-A-711. Serious injury or death can result from explosion of fumes from solvent When using this solvent:

- Clean parts in a well ventilated area.
- Avoid inhalation of solvent fumes and prolonged exposure of kin to cleaning solvent Wash exposed skin thoroughly.
- Do not use near open flame or excessive heat. Flash point of solvent is 100° F to 138° F (38° C to 59° C)
- Wear eye protection when blowing solvent from parts. Air pressure should not exceed 30 psig (2.1 kg/cm2).

- (2) Clean all metallic parts with a clean soft cloth or a medium bristle brush, and cleaning solvent.
- (3) Allow parts to dry.

c. Inspection.

- (1) Inspect all metal parts for cracks, corrosion, or broken fittings.
- (2) Inspect strap webbing for frayed material and broken stitching.

d. Installation.

- (1) Install four tie-down straps (4) into storage area between end panel assembly (2) and storage divider pan (3).
- (2) Install four hoisting straps (1) into storage area between end panel assembly (2) and storage divider pan (3).

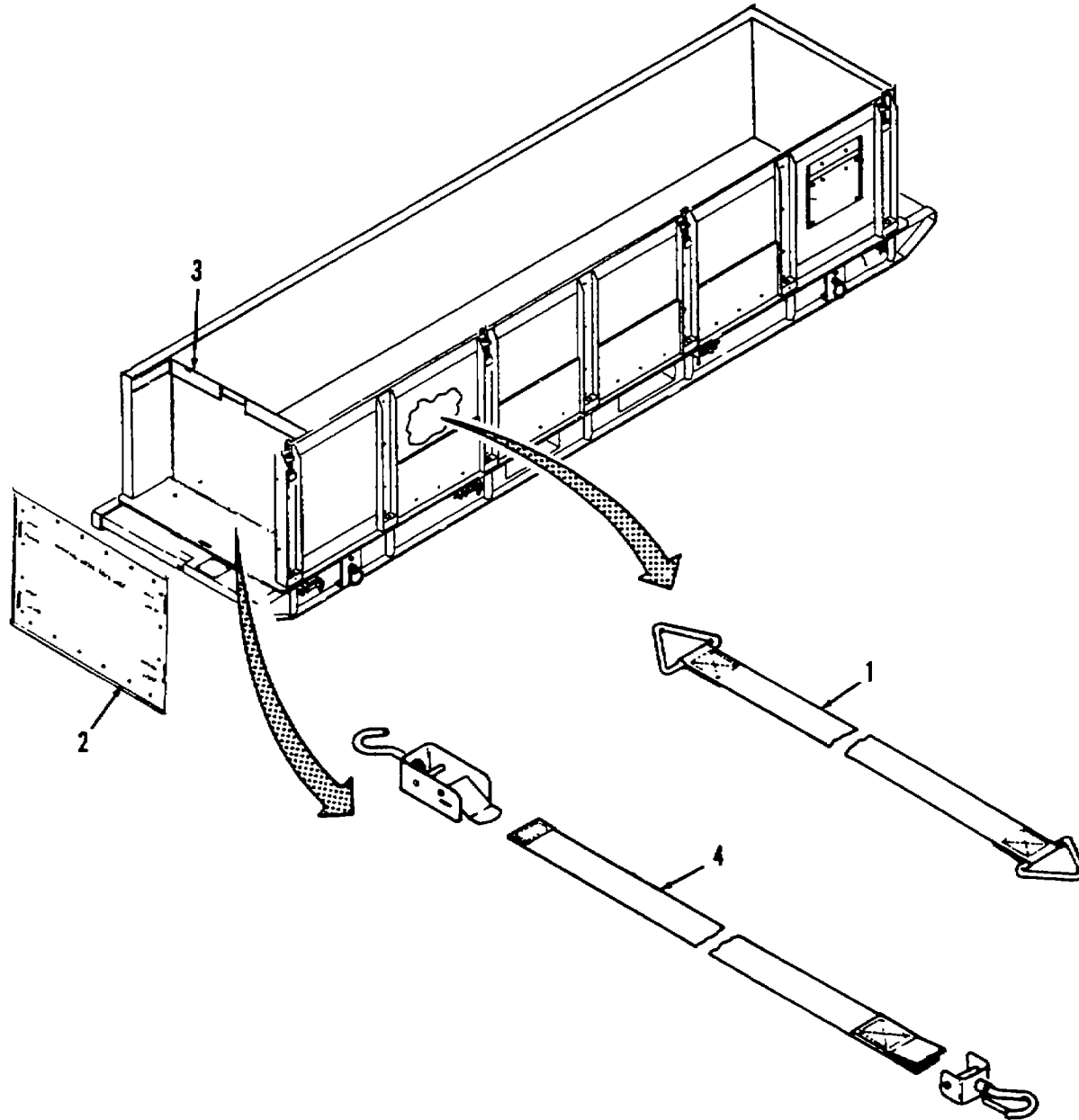

Figure 4-5. Strap Assemblies Replacement.

4-15. SKID ASSEMBLY REPAIR.

This Task Covers:				
a. Disassembly	b. Cleaning	c. Inspection	d. Repair	e. Assembly
Initial Setup:				
<u>Tools Required</u>				
Tool Kit, General Mechanic's (Appendix B, Item 1)				
Drill, Hand, Portable (Appendix B, Item 3)				
Riveter, Blind, Hand (Appendix B, Item 2)				
<u>Material's Required</u>				
Cloth, Lint-Free (Appendix F, Item 1)				
Brush, Medium Bristle (Appendix F, Item 2)				
Solvent, Dry Cleaning (Appendix F, Item 3)				
Rivets (Appendix I, Item 4)				
Lock Nuts (Appendix I, Item 5)				
Lock Nuts (Appendix I, Item 6)				
Rivets (Appendix I, Item 7)				
Adhesive (Appendix F, Item 5)				
<u>Equipment Condition</u>				
Top cover assembly removed from tank storage chest (see paragraph 2-8).				
End panels assemblies removed from tank storage chest (see paragraph 2-8).				
Side panel assemblies removed from tank storage chest (see paragraph 2-8).				

a. Disassembly. (Refer to Figure 4-6.)**NOTE**

Steps (1) through (6) are for the removal of one cargo tie down ring assembly and one locking pin assembly. Repeat steps as required for additional cargo rings and locking pins.

- (1) Remove three cap screws (1), six flat washers (2), and three lock nuts (3). Discard lock nuts.
- (2) Remove outer latch bracket (4), inner latch bracket (5), and locking pin (6) from skid (7).
- (3) Drill out rivet (8) and remove spring clip (9) from outer latch bracket (4). Discard rivet.
- (4) Remove cargo tie down ring (10) from nut plate (11).
- (5) Remove two cap screws (12), two flat washers (13), and two lock nuts (14) from skid (7). Discard lock nuts.
- (6) Remove nut plate (11) from skid (7)
- (7) Drill out four rivets (15) and identification plate (16) from skid (7) Discard rivets.

NOTE

Do not remove bumpers unless they are defective and are being replaced.

- (8) Remove four bumpers (17) from skid(7).

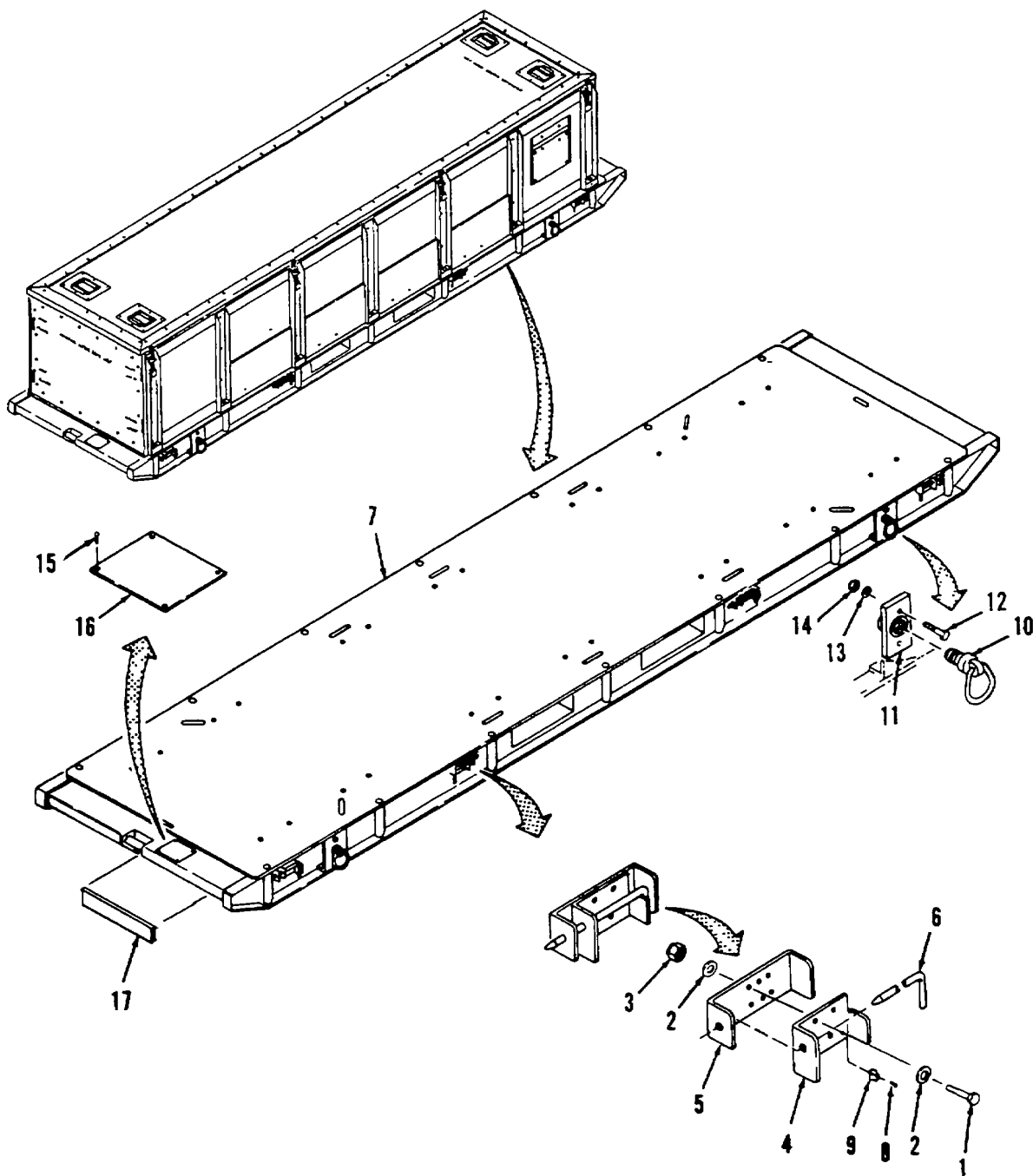

Figure 4-6. Skid Assembly, Repair.

b. Cleaning.

- (1) Remove all build up of dirt, oil, and debris from all surfaces.

WARNING

Serious injury can result in breathing fumes of dry cleaning solvent A-A-711. Serious injury or death can result from explosion of fumes from solvent When using this solvent:

- Clean parts in a well ventilated area.
- Avoid inhalation of solvent fumes and prolonged exposure of skin to cleaning solvent Wash exposed skin thoroughly.
- Do not use near open flame or excessive heat. Flash point of solvent is 100° F to 138° F (38° C to 59° C)
- Wear eye protection when blowing solvent from parts. Air pressure should not exceed 30 psig (2.1 kg/cm²).

- (2) Clean all metallic parts with a clean soft cloth or a medium bristle brush, and cleaning solvent.
- (3) Allow parts to dry.

c. Inspection.

- (1) Inspect all metal parts for cracks, corrosion, or broken fittings.
- (2) Check identification plate for readability.

(3) Inspect skid for broken welds or broken material If welds are broken or material is cracked, notify direct support maintenance.

d. Repair. Repair is limited to replacement of parts found defective during inspection.

e. Assembly.

- (1) Apply adhesive to four bumpers (18) and install bumpers onto skid (7).
- (2) Install identification plate (17) and four new rivets (16) onto skid (7).

NOTE

Steps (3) through (7) are for the installation of one cargo tie down ring assembly and one locking pin assembly. Repeat steps as required for additional cargo rings and locking pins

- (3) Install two new lock nuts (14), two flat washers (13), and two cap screws (12) onto skid (7).
- (4) Install cargo tie down ring (10) into nut plate (11).
- (5) Install new rivet (8) and spring clip (9) onto outer latch bracket (4).
- (6) Place inner latch bracket (5), locking pin (6), and outer latch bracket (4) onto skid (7).

(7) Install three new lock nuts (3), six flat washers (2), and three cap screws (1).

Section VI. PREPARATION FOR STORAGE OR SHIPMENT

4-16. PREPARATION FOR STORAGE.

a. Intermediate Storage (46 to 180 days).

(1) Drain all water from the WTSC and all of its components.

(3) Mark the WTSC for intermediate storage in accordance with the standard Army procedures contained in TM 740-90-1, Administrative Storage of Equipment.

b. Long Term or Flyable Storage (Indefinite time) . Long term storage procedures are the same as for intermediate storage except the WTSC shall be marked for long term storage in accordance with TM 740-90-1, Administrative Storage of Equipment.

4-17. ADMINISTRATIVE STORAGE. Placement of equipment in administrative storage should be for short periods of time when a shortage of maintenance effort exists. Items should be in mission readiness within 24 hours or within the time factors determined by the directing authority. During the storage period appropriate maintenance records will be kept.

Before placing equipment in administrative storage, perform all PMCS procedures. All shortcomings and deficiencies should be corrected, and all Modification Work Orders (MWO) should be applied.

Storage site selection. Inside storage is preferred for items selected for administrative storage. If inside storage is not available, trucks, vans, conex containers and other containers may be used.

CHAPTER 5

DIRECT SUPPORT MAINTENANCE INSTRUCTIONS

Section I. DIRECT SUPPORT TROUBLESHOOTING.

5-1. INTRODUCTION. There are no direct support troubleshooting procedures for the WTSC.

Section II. DIRECT SUPPORT MAINTENANCE PROCEDURES

5-2. GENERAL INFORMATION. This section contains the maintenance procedures authorized for the direct support maintenance as defined in the Maintenance Allocation Chart located in Appendix B.

5-3. SKID ASSEMBLY REPAIR. Repair of the skid assembly is limited to welds per TM 9-237, Welding Theory and Operations.

APPENDIX A

REFERENCES

A-1. SCOPE. This appendix lists all forms, field manuals, technical manuals, and miscellaneous publications referenced in this manual.

A-2. FORMS.

Report of Discrepancy	SF 364
Equipment Inspection and Maintenance Worksheet	DA Form 2404
Product Quality Deficiency Report	SF 368
Recommended Changes to Equipment Technical Publications	DA Form 2028-2
Recommended Changes to Publications and Blank Forms	DA Form 2028

A-3. FIELD MANUALS.

First Aid For Soldiers	FM 21-11
NBC Contamination Avoidance.....	FM 3-3
NBC Protection.....	FM 34
NBC Decontamination	FM 3-5

A-4. TECHNICAL MANUALS.

Administrative Storage of Equipment.....	TM 740-90-1
Procedures for Destruction of Equipment to Prevent Enemy Use (Mobility Equipment Command)	TM 750-244-3
Welding Theory and Operations.....	TM 9-237

A-5. MISCELLANEOUS PUBLICATIONS AND STANDARDS.

The Army Maintenance Management System	DA PAM 738-750
Abbreviations for Use on Drawings, And Standards, Specifications and Technical Documents	MIL-STD-12
Army Medical Department Expendable/Durable Items	CTA 8-100
Expendable Items (Except Medical Class V, Repair Parts and Heraldic Items)	CTA 50-970

APPENDIX B

MAINTENANCE ALLOCATION CHART

Section I. INTRODUCTION

B-1. The Army Maintenance System MAC.

a. This introduction (section I) provides a general explanation of all maintenance and repair functions authorized at various maintenance categories under the standard Army Maintenance System concept.

b. The Maintenance Allocation Chart (MAC) in section II designates overall authority and responsibility for the performance of maintenance functions on the identified end item or component. The application of the maintenance functions to the end item or component will be consistent with the capacities and capabilities of the designated maintenance levels which are shown on the MAC in column (4) as:

Unit - includes two subcolumns, C (operator/crew) and O (unit Maintenance)

Direct Support - includes and F subcolumn.

General Support - includes an H subcolumn.

Depot - includes a D subcolumn.

c. Section III lists the tools and test equipment (both special tools and common tool sets) required for each maintenance function as referenced from section II.

d. Section IV contains supplemental instructions and explanatory notes for a particular maintenance function.

B-2. Maintenance Functions. Maintenance functions are limited to and defined as follows:

a. **Inspect.** To determine the serviceability of an item by comparing its physical, mechanical, and/or electrical characteristics with established standards through examination (e.g., by sight, sound, or feel).

b. **Test.** To verify serviceability by measuring the mechanical, pneumatic, hydraulic, or electrical characteristics of an item and comparing those characteristics with prescribed standards.

c. **Service.** Operations required periodically to keep an item in proper operating condition, e.g., to clean (includes decontaminate, when required), to preserve, to drain, to paint, or to replenish fuel, lubricants, chemical fluids, or gases.

d. **Adjust.** To maintain or regulate, within prescribed limits, by bringing into proper or exact position, or by setting the operating characteristics to specified parameters.

e. **Align.** To adjust specified variable elements of an item to bring about optimum or desired performance.

f. **Calibrate.** To determine and cause corrections to be made or to be adjusted on instruments or test, measuring, and diagnostic equipments used in precision measurement. Consists of comparisons of two instruments, one of which is a certified standard of known accuracy, to detect and adjust any discrepancy in the accuracy of the instrument being compared.

g. **Remove / Install.** To remove and install the same item when required to perform service or other maintenance functions. Install may be the act of emplacing, seating, or fixing into position a spare, repair part, or module (component or assembly) in a manner to allow the proper functioning of an equipment or system.

h. **Replace.** To remove an unserviceable item and install a serviceable counterpart in its place "Replace" is authorized by the MAC and assigned maintenance level is shown as the 3rd position code of the SMR code.

i. **Repair.** The application of maintenance services¹, including fault location/trouble-shooting, removal/installation, and disassembly/assembly procedures, and maintenance actions⁴ to identify troubles and restore serviceability to an item by correcting specific damage, fault, malfunction, or failure in a part, subassembly, module (component or assembly), end item, or system.

j. **Overhaul.** That maintenance effort (service/action) prescribed to restore an item to a completely serviceable/operational condition as required by maintenance standards in appropriate technical publications (i.e., DMWR). Overhaul is normally the highest degree of maintenance performed by the Army. Overhaul does not normally return an item to like new condition

k. **Rebuild.** Consists of those services/actions necessary for the restoration of unserviceable equipment to a like new condition in accordance with original manufacturing standards. Rebuild is the highest degree of material maintenance applied to Army equipment. The rebuild operation includes the act of returning to zero those age measurements (hours/miles, etc.) considered in classifying Army equipment/components.

¹Services - Inspect, test, service, adjust, align, calibrate, and/or replace.

²Fault location/troubleshooting - The process of investigating and detecting the cause of equipment malfunctioning; the act of isolating a fault within a system or unit under test (UUT).

³Disassembly/ assembly - The step-by-step breakdown (taking apart) of a spare/functional group coded item to the level of its least component, that is assigned an SMR code for the level of maintenance under consideration (i. e., identified as maintenance significant).

⁴Actions - Welding, grinding, riveting, straightening, facing, machining, and or resurfacing.

B-3. Explanation of Columns in the MAC, Section II.

a. **Column 1, Group Number.** Column 1 lists functional group code numbers, the purpose of which is to identify maintenance significant components, assemblies, subassemblies, and modules with the next higher assembly.

b. **Column 2, Component/Assembly.** Column 2 contains the names of components, assemblies, subassemblies, and modules for which maintenance is authorized.

c. **Column 3, Maintenance Function.** Column 3 lists the functions to be performed on the item listed in Column 2. (For detailed explanation of these functions, see paragraph B-2.)

d. **Column 4, Maintenance Level.** Column 4 specifies each level of maintenance authorized to perform each function listed in Column 3, by indicating work time required (expressed as man hours in whole hours or decimals) in the appropriate subcolumn. This work-time figure represents the active time required to perform that maintenance function at the indicated level of maintenance. If the number or complexity of the tasks within the listed maintenance function vary at different maintenance levels, appropriate work-time figures are to be shown for each level. The work-time figure represents the average time required to restore an item (assembly, subassembly, component, module, end item, or system) to a serviceable condition under typical field operating conditions. This time includes preparation time (including any necessary disassembly/assembly time), troubleshooting/fault location time, and quality assurance/quality control time in addition to the time required to perform the specific tasks identified for the maintenance functions authorized in the maintenance allocation chart. The symbol designations for the various maintenance levels are as follows:

- C Operator or crew maintenance
- O Unit maintenance
- F..... Direct support maintenance
- L..... Specialized Repair Activity (SRA)
- H General support maintenance
- D Depot maintenance

e. **Column 5, Tools and Test Equipment reference code.** Column 5 specifies, by code, those common tools sets (not individual tools), common TMDE, and special tools, special TMDE, and support equipment required to perform the designated function. Codes are keyed to tools and test equipment in section III.

f. **Column 6, Remarks.** When applicable, this column contains a letter code, in alphabetical order, which is keyed to the remarks contained in Section IV.

B-4. Explanation of Columns in Tools and Test Equipment Requirements, Section III.

a. **Column 1, Reference Code.** The tool and test equipment reference code correlates with a code used in the MAC, Section II, Column 5.

b. **Column 2, Maintenance Level.** The lowest level of maintenance authorized to use the tool or test equipment.

c. **Column 3, Nomenclature.** Name or identification of the tool or test equipment.

d. **Column 4, National Stock Number.** The National stock number of the tool or test equipment.

- e. **Column 5, Tool Number.** The manufacturer's part number, model number, or type number.

B-5. Explanation of Columns in Remarks, Section IV.

- a. **Column 1, Reference Code.** The code recorded in column 6, Section II.
- b. **Column 2, Remarks.** This column lists information pertinent to the maintenance function being performed as indicated in the MAC, Section II.

**Section II. MAINTENANCE ALLOCATION CHART
FOR
WATER TANK STORAGE CHEST**

(1) GROUP NO.	(2) COMPONENT/ ASSEMBLY	(3) MAINTENANCE FUNCTION	(4) MAINTENANCE CATEGORY					(5) TOOLS AND EQUIPMENT REF CODE	(6) REMARKS CODE
			UNIT		DIRECT SUPPORT	GENERAL SUPPORT	DEPOT		
			C	O	F	H	D		
00	STORAGE CHEST, TANK								
01	TOP COVER ASSEMBLY	Inspect Repair Replace	0.1	0.5 0.2				1, 2, 3	
02	DOCUMENT POUCH	Inspect Replace	0.1	0.2					
03	END PANEL ASSEMBLIES	Inspect Repair Replace	0.3	1.9	0.5			1 1 A	
04	SIDE PANEL ASSEMBLIES	Inspect Repair Replace	0.5	0.5 0.5				1, 2, 3 A	
05	STRAP ASSEMBLIES	Inspect Replace	0.2	0.8				1	
06	SKID ASSEMBLY	Inspect Repair Replace	0.7	1.3	0.5 0.4			1, 2, 3 A, B	

Section III. SPECIAL TOOLS AND TEST EQUIPMENT REQUIREMENTS

(1) REFERENCE TOOL CODE	(2) MAINTENANCE LEVEL	(3) NOMENCLATURE	(4) NATIONAL/AUTO STOCK NUMBER	(5) TOOL NUMBER
		Standard tools and test equipment contained in the following kit are adequate to perform the maintenance functions listed in Section II		
1	O	Tool Kit, General Mechanic's	5180-00-177-7033	SC 5180-90 -CL-N26 (19099)
2	O	Shop Equipment, Automotive Maintenance	4910-00-017-2849	SC 4910-95 -CL-A74 (19099)
3	O	Riveter, Blind, Hand	5120-00-017-2849	

Section IV. REMARKS.

REFERENCE CODE	REMARKS
A	Repair is limited to the replacement of components found defective during inspection.
B	Repair at direct support level is limited to welding repairs.

APPENDIX C

REPAIR PARTS AND SPECIAL TOOLS LIST

Section I. INTRODUCTION

C-1. SCOPE.

This Repair Parts and Special Tools List (RPSTL) lists and authorizes spares and repair parts; special tools; special test, measurement, and diagnostic equipment (TMDE); and other special support equipment required for performance of unit and direct support maintenance of the Water Tank Storage Chest. It authorizes the requisitioning, issue, and disposition of spares, repair parts and special tools as indicated by the source, maintenance and recoverability (SMR) codes.

C-2. GENERAL.

In addition to Section I, Introduction, this Repair Parts and Special Tools List is divided into the following sections:

a. Section II. Repair Parts List. A list of spares and repair parts authorized by this RPSTL for use in the performance of maintenance. The list also includes parts which must be removed for replacement of the authorized parts. Parts lists are composed of functional groups in ascending alphanumeric sequence, with the parts in each group listed in ascending figure and item number sequence. Bulk materials are listed in item name sequence. Repair parts kits are listed separately in their own functional group within Section II. Repair parts for repairable special tools are also listed in this section. Items listed are shown on the associated illustration(s) or figure(s).

b. Section III. Special Tools List. A list of special tools, special TMDE, and other special support equipment authorized by this RPSTL (as indicated by Basis of Issue (BOI) information in DESCRIPTION AND USABLE ON CODE column) for the performance of maintenance.

c. Section IV. Cross-reference Index. A list, in National item identification number (NIN) sequence, of all National stock numbered items appearing in the listing, followed by a list in alphanumeric sequence of all part numbers appearing in the listings. National stock numbers and part numbers are cross-referenced to each illustration figure and item number appearance. The figure and item number index lists figure and item numbers in alphanumeric sequence and cross-references NSN, CAGEC and part numbers.

C-3. EXPLANATION OF COLUMNS (Sections II and III).

- a. **Item No. (Column (1)).** Indicates the number used to identify items called out in the illustration.
- b. **SMR Code (Column (2)).** The Source, Maintenance, and Recoverability (SMR) code is a 5-position code containing supply and requisitioning information, maintenance category authorization criteria, and disposition instruction, as shown in the following breakout:

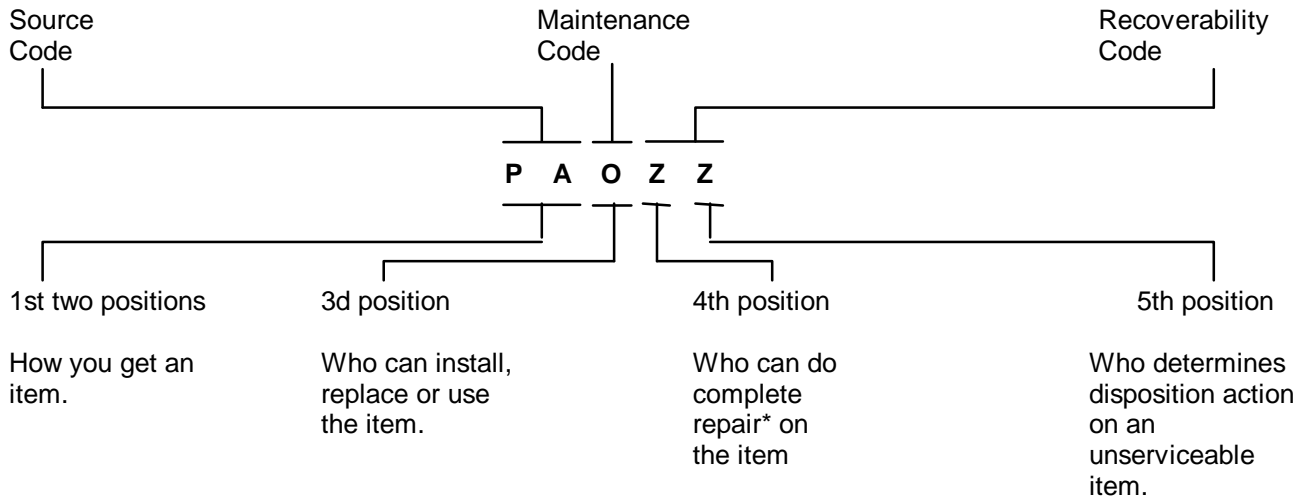

***Complete Repair:** Maintenance capacity, capability, and authority to perform all corrective maintenance tasks of the "Repair" function in a use/user environment in order to restore serviceability to a failed item.

(1) Source Code. The source code tells you how to get an item needed for maintenance, repair, or overhaul of an end item or equipment. Explanations of source codes follows:

Code	Explanation
PA	Stocked Items; use the applicable NSN to request/requisition items with these source codes. They are authorized to the category indicated by the code entered in the 3rd position of the SMR code. ** NOTE: Items coded PC are subject to deterioration.
PB	
PC**	
PD	
PE	
PF	
PG	
KD	Items with these codes are not to be requested/requisitioned individually. They are part of a kit which is authorized to the maintenance category indicated in the 3rd position of the SMR code. The complete kit must be requisitioned and applied.
KF	
KB	

Code	Explanation
MO - (Made at UNIT AVUM Level)	Items with these codes are not to be requested/requisitioned individually. They must be made from bulk material which is identified by the part number in the DESCRIPTION and USABLE ON CODE (UOC) column and listed on the Bulk Material group of the repair parts list in this RPSTL. If the item is authorized to you by the 3rd position of the SMR code, but the source code indicates it is made at a higher level, order the item from the higher level of maintenance.
MF - (Made at DS/AVUM Level)	
MH - (Made at GS Level)	
ML - (Made at Specialized Repair Activity (SRA)'	
MD - (Made at Depot)	

Code	Explanation
AO - (Assembled by UNIT/AVUM Level)	Items with these codes are not to be requested/requisitioned individually. The parts that make up the assembled item must be requisitioned or fabricated and assembled at the level of maintenance indicated by the source code. If the 3rd position of the SMR code authorizes you to replace the item, but the source code indicates the items are assembled at a higher level, order the item from the
AF - (Assembled by DS/AVUM Level)	
AH - (Assembled by GS Level)	
AL - (Assembled by SRA)	
AD - (Assembled by Depot)	
higher level of maintenance.	

Code	Explanation
XA --	Do not requisition an "XA"-coded item. Order its next higher assembly. (Also, refer to the NOTE below.)
XB --	If an "XB" item is not available from salvage, order it using the CAGEC and part number given.
XC --	Installation drawing, diagram, instruction sheet, field service drawing, that is identified by manufacturer's part number.
XD--	Item is not stocked. Order an 'XD"-coded item through normal supply channels using the CAGEC and part number given, if no NSN is available.

NOTE

Cannibalization or controlled exchange, when authorized, may be used as a source of supply for items with the above source codes, except for those source coded "XA" or those aircraft support items restricted by requirements of AR 700-42.

(2) Maintenance Code. Maintenance codes tells you the level(s) of maintenance authorized to USE and REPAIR support items. The maintenance codes are entered in the third and fourth positions of the SMR Code as follows:

(a) The maintenance code entered in the third position tells you the lowest maintenance level authorized to remove, replace, and use an item. The maintenance code entered in the third position will indicate authorization to one of the following levels of maintenance.

Code	Application/Explanation
C --	Crew or operator maintenance done within unit or aviation unit maintenance.
O --	Unit or aviation unit category can remove, replace, and use the item.
F --	Direct support or aviation intermediate level can remove, replace, and use the item.
H --	General support level can remove, replace, and use the item.
L --	Specialized repair activity can remove, replace, and use the item.
D --	Depot level can remove, replace, and use the item.

(b) The maintenance code entered in the fourth position tells whether or not the item is to be repaired and identifies the lowest maintenance level with the capability to do complete repair (i.e., perform all authorized repair functions.) (NOTE: Some limited repair may be done on the item at a lower level of maintenance, if authorized by the Maintenance Allocation Chart (MAC) and SMR codes.) This position will contain one of the following maintenance codes.

Code	Application/Explanation
O --	Unit or (aviation unit) is the lowest level that can do complete repair of the item.
F --	Direct support or aviation intermediate is the lowest level that can do complete repair of the item.
H --	General support is the lowest level that can do complete repair of the item.
L --	Specialized repair activity (designate the specialized repair activity) is the lowest level that can do complete repair of the item.
D --	Depot is the lowest level that can do complete repair of the item.
Z --	Nonrepairable. No repair is authorized.
B --	No repair is authorized. (No parts or special tools are authorized for the maintenance of a "B" coded item). However, the item may be reconditioned by adjusting, lubricating, etc., at the user level.

(3) Recoverability Code. Recoverability codes are assigned to items to indicate the disposition action on un-serviceable items. The recoverability code is entered in the fifth position of the SMR Code as follows:

Recoverability Codes	Application/Explanation
Z	-- Nonrepairable item. When un-serviceable, condemn and dispose of the item at the level of maintenance shown in 3d position of SMR Code.
O	-- Repairable item. When uneconomically repairable, condemn and dispose of the item at unit or aviation unit level.
F	-- Repairable item. When uneconomically repairable, condemn and dispose of the item at the direct support or aviation intermediate level.
H	-- Repairable item. When uneconomically repairable, condemn and dispose of the item at the general support level.
D	-- Repairable item. When beyond lower level repair capability, return to depot. Condemnation and disposal of item not authorized below depot level.
L	-- Repairable item. Condemnation and disposal not authorized below specialized repair activity (SRA).
A	-- Item requires special handling or condemnation procedures because of specific reasons (e.g., precious metal content, high dollar value, critical material, or hazardous material). Refer to appropriate manuals or directives for specific instructions.

c. CAGEC (Column (3)). The Federal Supply Code for Manufacturer (CAGEC) is a 5-digit numeric code which is used to identify the manufacturer, distributor, or Government agency, etc., that supplies the item.

d. Part Number (Column (4)). Indicates the primary number used by the manufacturer (individual, company, firm, corporation, or Government activity), which controls the design and characteristics of the item by means of its engineering drawings, specifications standards, and inspection requirements to identify an item or range of items.

NOTE

When you use a NSN to requisition an item, the item you receive may have a different part number from the part ordered.

e. Description and Usable On Code (UOC) (Column (5)). This column includes the following information:

- (1) The Federal item name and, when required, a minimum description to identify the item.

(2) The physical security classification of the item is indicated by the parenthetical entry, e.g., Phy Sec C1 (C) - Confidential, Phy Sec C1 (S) -Secret, Phy Sec C1 (T) Top Secret).

(3) Items that are included in kits and sets are listed below the name of the kit or set.

(4) Spare/repair parts that make up an assembled item are listed immediately following the assembled item line entry.

(5) Part numbers for bulk materials are referenced in this column in the line entry for the item to be manufactured/fabricated.

(6) When the item is not used with all serial numbers of the same model, the effective serial numbers are shown on the last line(s) of the description (before UOC).

(7) The usable on code, when applicable (see paragraph C-5, Special Information).

(8) In the Special Tools List section, the basis of issue (BOI) appears as the last line(s) in the entry for each special tool, special TMDE, and other special support equipment. When density of equipments supported exceeds density spread indicated in the basis of issue, the total authorization is increased proportionately.

(9) The statement "END OF FIGURE" appears just below the last item description in Column 5 for a given figure in both Section II and Section III.

f. **Qty (Column 6).** The QTY (quantity per figure column) indicates the quantity of the item used in the breakout shown on the illustration figure, which is prepared for a functional group, subfunctional group, or an assembly. A "V." appearing in this column in lieu of a quantity indicates that the quantity is variable and the quantity may vary from application to application.

C-4. EXPLANATION OF COLUMNS (Section IV).

a. **National Stock Number (NSN) Index.**

(1) **Stock Number column.** This column lists the NSN by National item identification number (NIIN) sequence. The NIIN consists of the last nine digits of the NSN. For example, if the NSN is 5305-01-674-1467 then the set of last nine digits (01-674-1467) is the NIIN. When using this column to locate an NIIN item, ignore the first four digits of the NSN. However, the complete NSN should be used when ordering items by stock number.

(2) **Fig. column.** This column lists the number of the figure where the item is identified/located. The figures are in numerical order in Section II and Section III.

(3) **Item column.** The item number identifies the item associated with the figure listed in the adjacent FIG. column. This item is also identified by the NSN listed on the same line.

b. **Part Number Index** Part numbers in this index are listed by part number in ascending alphanumeric sequence (i.e. vertical arrangement of letter and number combination which places the first letter or digit of each group in order A through Z, followed by the numbers 0 through 9 and each following letter or digit in like order).

(1) **CAGEC column.** The Federal Supply Code for Manufacturer (CAGEC) is a 5-digit numeric code used to identify the manufacturer, distributor, or Government agency, etc., that supplies the item.

(2) **Part Number column.** Indicates the primary number used by the manufacturer, LaBarge Military Products, which controls the design and characteristics of the item by means of its engineering drawings, specifications standards, and inspection requirements to identify an item or range of items.

(3) **Stock Number column.** This column lists the NSN for the associated part number and manufacturer identified in the PART NUMBER and CAGEC columns to the left.

(4) **Fig. column.** This column lists the number of the figure where the item is identified/located in Section II and III.

(5) **Item column-** The item number is that number assigned to the item as it appears in the figure referenced in the adjacent figure number column.

c. Figure and Item Number Index.

(1) **Fig. column.** This column lists the number of the figure where the item is identified/located in Section II and III.

(2) **Item column.** The item number is that number assigned to the item as it appears in the figure referenced in the adjacent figure number column.

(3) **Stock Number column.** This column lists the NSN for the item.

(4) **CAGEC column.** The Federal Supply Code for Manufacturer (CAGEC) is a 5-digit numeric code used to identify the manufacturer, distributor, or Government agency, etc., that supplies the item.

(5) **Part Number column-** Indicates the primary number used by the manufacturer which controls the design and characteristics of the item by means of its engineering drawings, specifications standards, and inspection requirements to identify an item or range of items.

C-5. SPECIAL INFORMATION. Use the following subparagraphs as applicable:

a. **Usable On Code.** The usable on code appears in the lower left corner of the Description column heading. Usable on codes are shown as "UOC:" in the Description Column (justified left) on the first line applicable item description/ nomenclature. Uncoded items are applicable to all models. Identification of the usable on codes used in the RPSTL are:

<u>Code</u>	<u>Used On</u>
FJN	M-1795

b. Fabrication Instructions. Bulk materials required to manufacture items are listed in the Bulk Material Functional Group of this RPSTL. Part numbers for bulk materials are also referenced in the description column of the line item entry for the item to be manufactured/fabricated. Detailed fabrication instructions for items source codes to be manufactured or fabricated (if any) are found in Appendix G of this technical manual.

c. Assembly Instructions. Detailed assembly instructions for items source coded to be assembled from component spare/repair parts are found in the repair sections of this technical manual. Items that make up the assembly are listed immediately following the assembly item entry or reference is made to an applicable figure.

d. Kits. Line item entries for repair parts kits appear in a group in Section II (see table of contents).

e. Index Numbers. Items which have the word BULK in the figure column will have an index number shown in the item number column. This index number is a cross-reference between the National Stock Number/Part Number Index and the bulk material list in Section II.

f. Associated Publications. The publication(s) listed below pertain to Water Tank Storage Chest and its components:

Publication (Not Applicable)	Short Title (Not Applicable)
--	--

C-6. HOW TO LOCATE SPARE PARTS.

a. When National Stock Number or Part Number is Not Known.

(1) First. Using the table of contents, determine the assembly group or subassembly group to which the item belongs. This is necessary since figures are prepared for assembly groups and sub-assembly groups, and listings are divided into the same groups.

(2) Second. Find the figure covering the assembly group or subassembly group to which the item belongs.

(3) Third. Identify the item on the figure and use the Figure and Item Number Index to find the NSN.

b. When National Stock Number or Part Number is Known.

(1) First. Using the National Stock Number or the Part Number Index, find the pertinent National Stock Number or Part Number. The NSN index is in National Item Identification Number (NIIN) sequence (see 4.a(1)). The part numbers in the Part Number index are listed in ascending alphanumeric sequence (see 4.b). Both indexes cross-reference you to the illustration/figure and item number of the item you are looking for.

(2) Second. Turn to the figure and item number, verify that the item is the one you're looking for, then locate the item number in the repair parts list for the figure.

C-7. ABBREVIATIONS. All abbreviations used in this manual are listed in MILSTD-12.

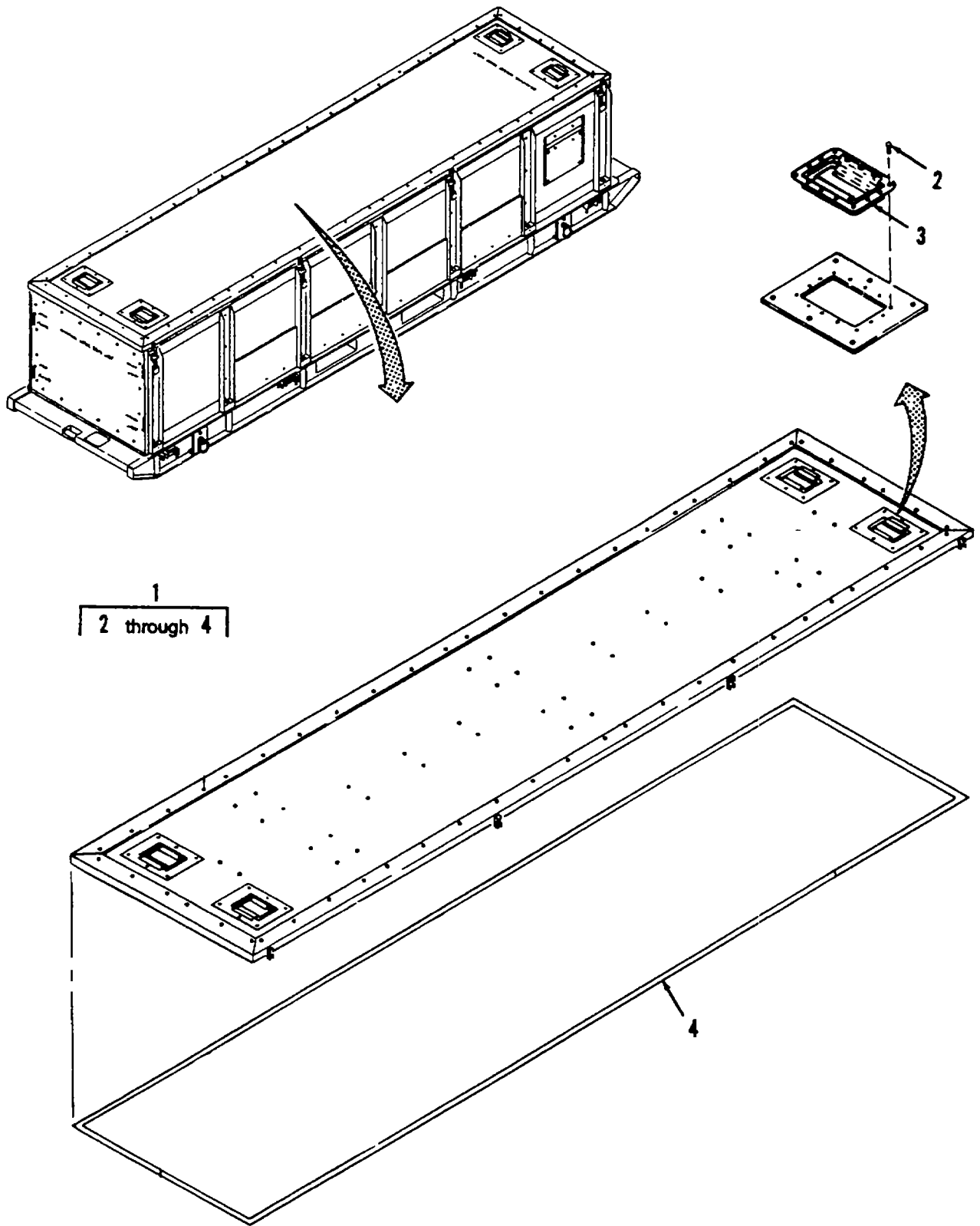

Figure C-1. Top Cover Assembly

SECTION II

(1) ITEM NO	(2) SMR CODE	(3) CAGEC	(4) PART NUMBER	(5) DESCRIPTION AND USABLE ON CODES(UOC)	(6) QTY
-------------------	--------------------	--------------	-----------------------	---	------------

GROUP 01 TOP COVER ASSEMBLY

FIG. C-1 TOP COVER ASSEMBLY

1	XDOOO	97403	13225E9207	COVER ASSEMBLY, TOP	1
2	PAOZZ	81349	M24243/1-D404	.RIVET,BLIND OPEN-ENDED, DOMED HD,125 DIA.....	14
3	XDOZZ	98003	H561-LS-2-RG	.HANDLE	1
4	MOOZZ	97403	13225E9207-8	.GASKET, CLOSED CELL 1.25 X .25	1

MAKE FROM GASKET, CLOSED CELL
P/N IND SPEC

SCE-41 W/PCA,
1.25 INCHES WIDE X .25 INCHES
THICK, ADHESIVE
BACKED.....

END OF FIGURE

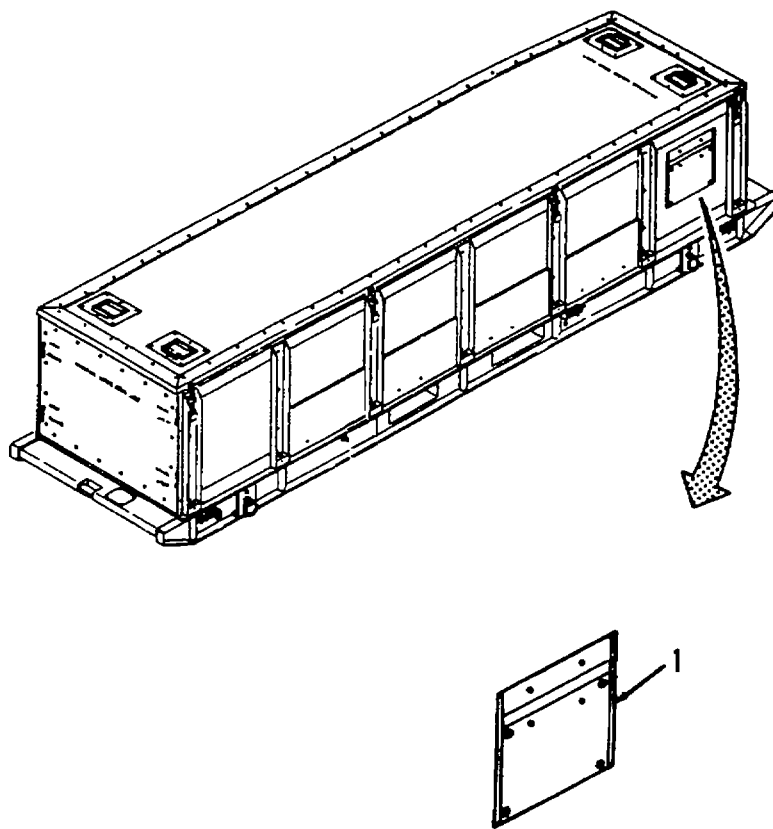

Figure C-2. Document Pouch

SECTION II

(1) ITEM NO	(2) SMR CODE	(3) CAGEC	(4) PART NUMBER	(5) DESCRIPTION AND USABLE ON CODES(UOC)	(6) QTY
				GROUP 02 DOCUMENT POUCH	
				FIG. C-2 DOCUMENT POUCH	
1	PAOZZ	97403	13225E9208	POUCH, DOCUMENT	1
				END OF FIGURE	

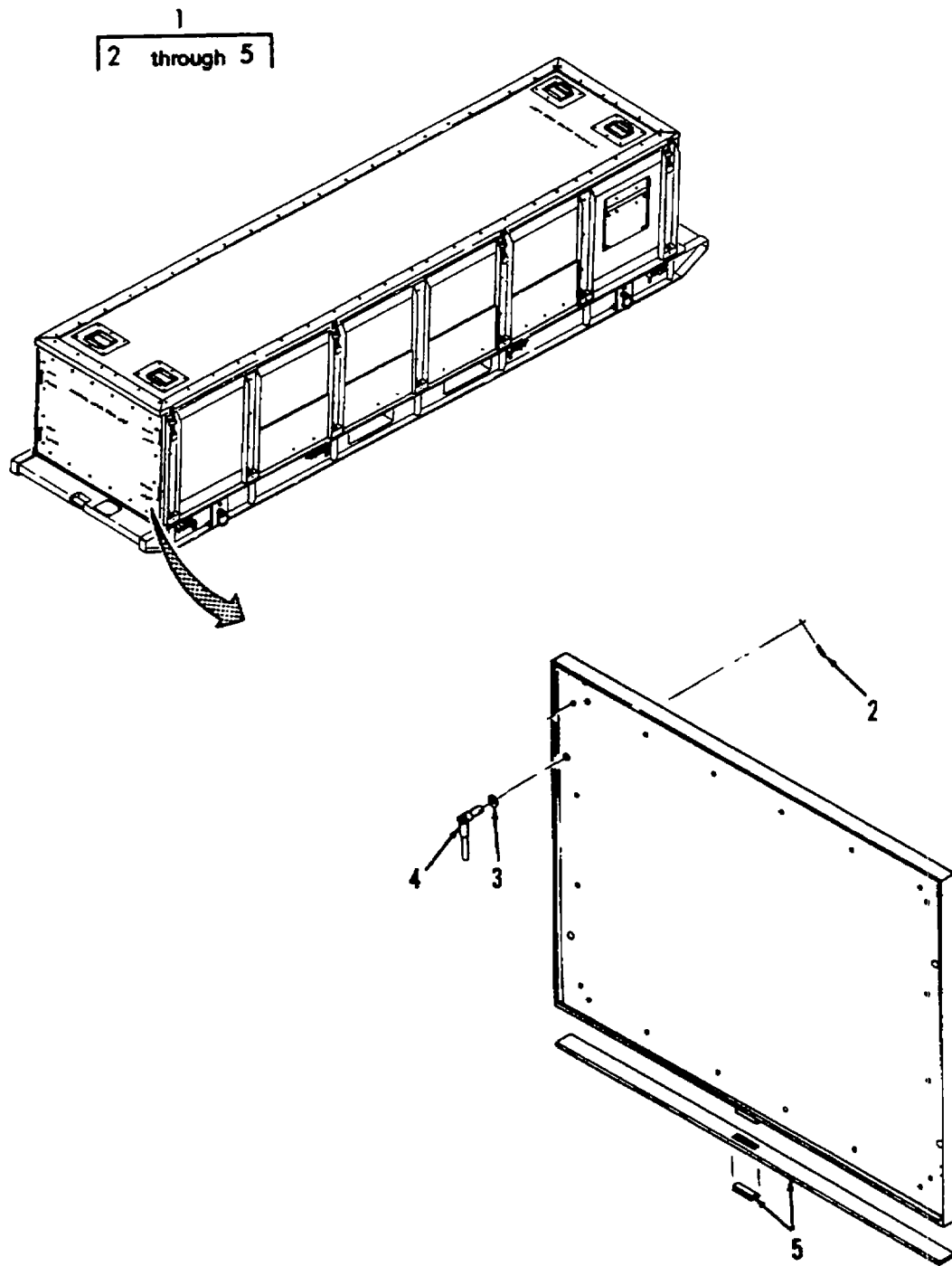

Figure C-3. End Panel Assemblies

SECTION II				TM10-5430-229-13&P	
(1)	(2)	(3)	(4)	(5)	(6)
ITEM NO	SMR CODE	CAGEC	PART NUMBER	DESCRIPTION AND USABLE ON CODES(UOC)	QTY
GROUP 03 END PANEL ASSEMBLIES					
FIG. C-3 END PANEL ASSEMBLIES					
1	XD000	97403	13225E9205	PANEL ASSEMBLY, END	2
2	XD0ZZ	71286	39S02-1-1AA	PIN,STRAIGHT,HEADLE.....	4
3	PA0ZZ	96906	MS27183-15	WASHER,FLAT.438	4
4	XD0ZZ	71286	39S11-3-1AA	STUD,TURNLOCK FASTE	4
5	M00ZZ	97403	13225E9205-8	GASKET, CLOSED CELL MAKE FROM.....	1
				GASKET, CLOSED CELL P/N IND SPEC SCE-41 W/PCA, 1.25 INCHES WIDE X .25 INCHES THICK, ADHESIVE BACKED.....	
END OF FIGURE					

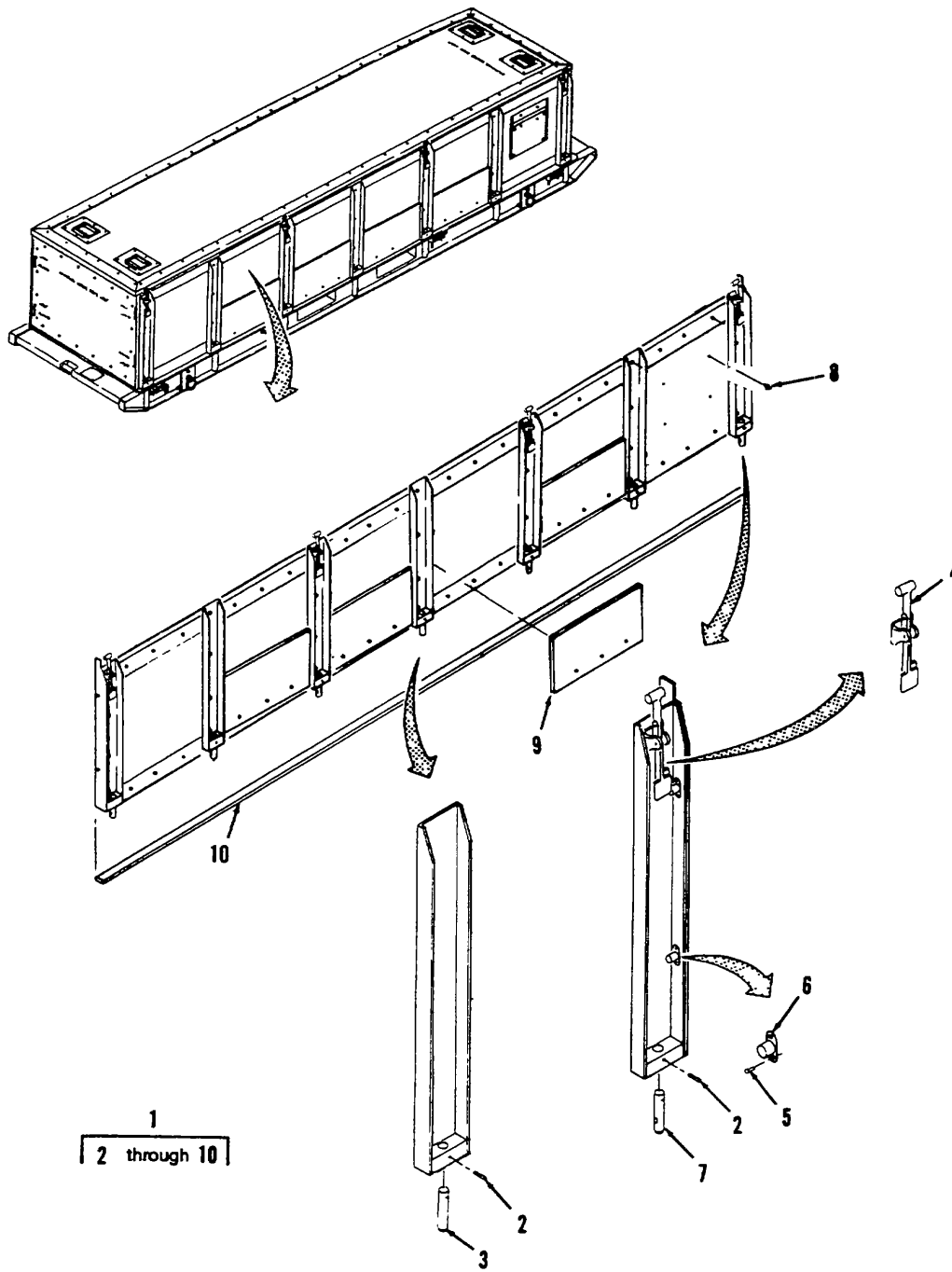

Figure C-4. Side Panel Assemblies

SECTION II

TM10-5430-229-13&P

(1) ITEM NO	(2) SMR CODE	(3) CAGEC	(4) PART NUMBER	(5) DESCRIPTION AND USABLE ON CODES(UOC)	(6) QTY
-------------------	--------------------	--------------	-----------------------	---	------------

GROUP 04 SIDE PANEL ASSEMBLIES

FIG. C-4 SIDE PANEL ASSEMBLIES

1	XDOOO	97403	13225E9204	PANEL ASSEMBLY,SIDE	2
2	PAOZZ	96906	MS16562-66	PIN,SPRING TUBULAR, SLOTTED, .250.....	1
				X 1.50 LG	
3	XDOZZ	97403	13225E9231-2	PIN, SIDE PANEL	1
4	XDOZZ	71286	37L-1	LATCH	1
5	PAOZZ	81349	M24243/1-D506	RIVET, BLIND .156 DIA	4
6	XDOZZ	71286	39RO1-1-1AA	RECEPTACLE,TURNLOCK	2
7	XDOZZ	97403	13225E9231-1	PIN, SIDE PANEL	1
8	PAOZZ	96906	MS27977-59	FASTENER,SNAP STYLE	4
9	XDOZZ	97403	13225E9217-2	BUMPER, PROTECTION	4
10	MOOZZ	97403	13225E9204-11	GASKET, CLOSED CELL MAKE FROM.....	1
				GASKET, CLOSED CELL	
				P/N IND SPEC SCE-41 W/PCA,	
				1.25	
				INCHES WIDE X .25 INCHES THICK,	
				ADHESIVE BACKED	

END OF FIGURE

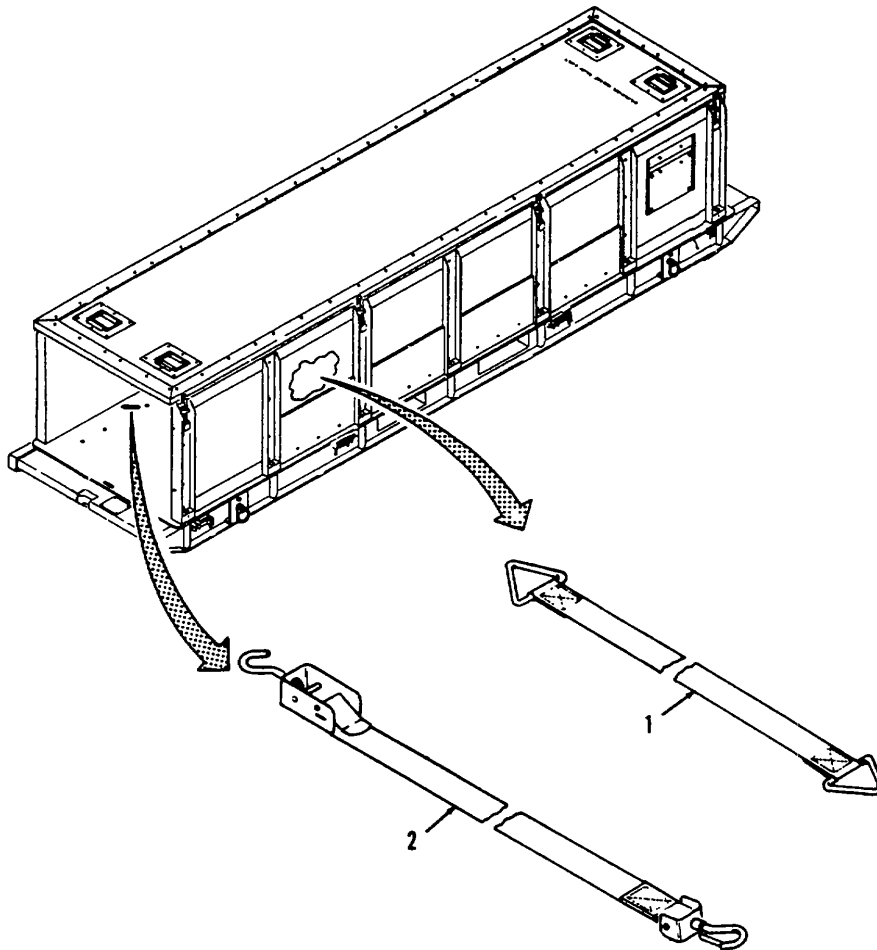

Figure C-5. Strap Assemblies

SECTION II

TM10-5430-229-13&P

(1) ITEM NO	(2) SMR CODE	(3) CAGEC	(4) PART NUMBER	(5) DESCRIPTION AND USABLE ON CODES(UOC)	(6) QTY
-------------------	--------------------	--------------	-----------------------	---	------------

GROUP 05 STRAP ASSEMBLIES

FIG. C-5 STRAP ASSEMBLIES

1	PAOZZ	39428	3403T999-14FT	STRAP, HOISTING	4
2	PAOZZ	26938	22077-1	STRAP,WEBBING.....	4

END OF FIGURE

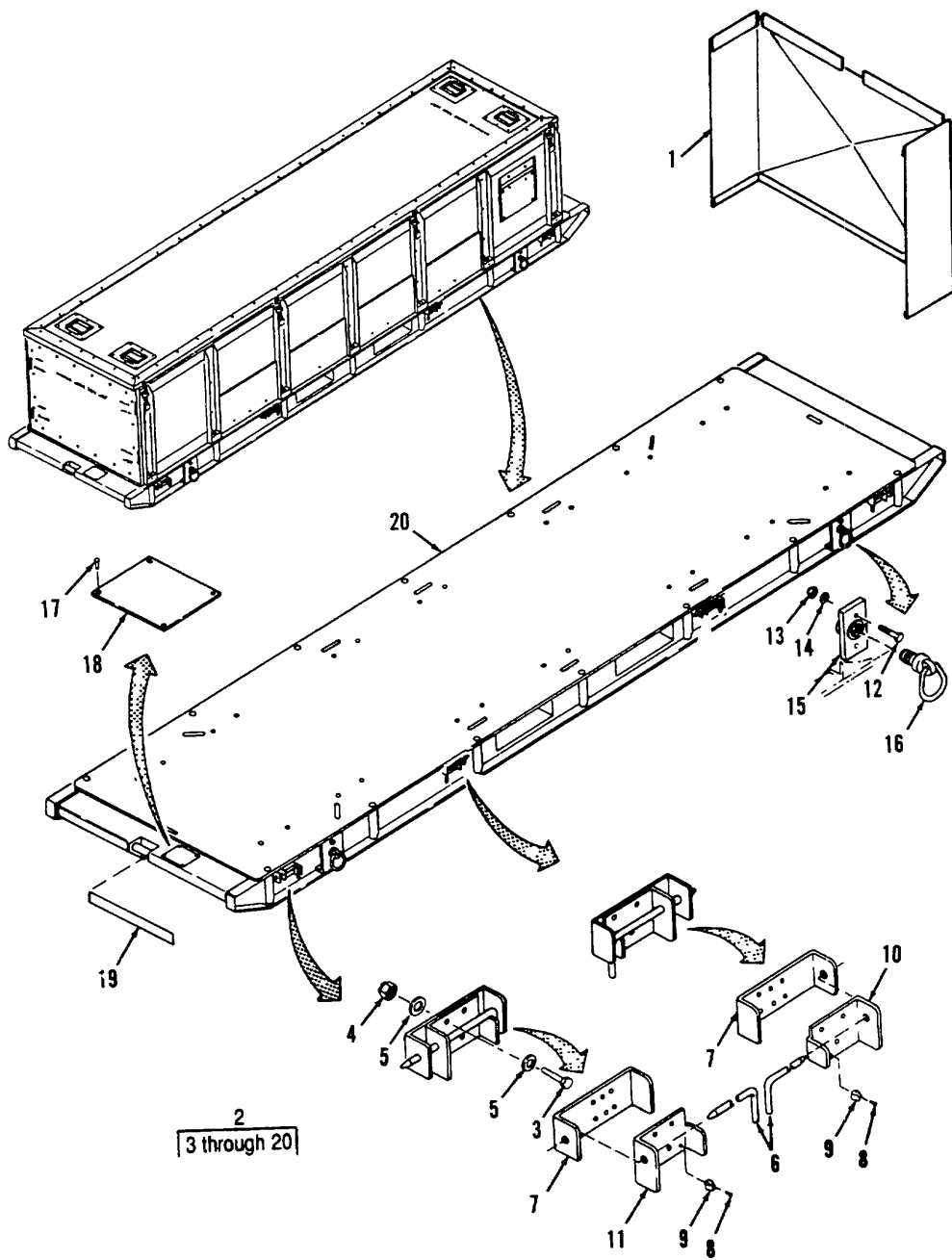

Figure C-6. Skid Assembly

SECTION II

TM10-5430-229-13&P

(1) ITEM NO	(2) SMR CODE	(3) CAGEC	(4) PART NUMBER	(5) DESCRIPTION AND USABLE ON CODES(UOC) QTY	(6)
GROUP 06 SKID ASSEMBLY					
FIG. C-6 SKID ASSEMBLY					
1	XDOZZ	97403	13225E9206	PAN,DIVIDER STORAGE	1
2	XDOFF	97403	13225E9203	SKID ASSEMBLY.....	1
3	PAOZZ	96906	MS90725-8	SCREW, CAP.250-28 UNF-2A X 1.00	24
				LG	
4	PAOZZ	96906	MS21044-N4	NUT,SELF-LOCKING,HE .250-28 UNJF-.....	24
				3B.....	
5	PAOZZ	96906	MS27183-10	WASHER,FLAT .281 ID	48
6	XDOZZ	97403	13225E9213	PIN, LOCKING	8
7	XDOZZ	97403	13225E9215	BRACKET,LATCH OUTER	8
8	PAOZZ	81349	M24243/1-D604	RIVET,BLIND .188 DIA	8
9	PAOZZ	86928	4508-50-62-2C	CLIP,SPRING TENSION	8
10	XDOZZ	97403	13225E9214-1	BRACKET,LATCH INNER	8
11	XDOZZ	97403	13225E9214-2	BRACKET,LATCH INNER	8
12	PAOZZ	96906	MS-90727-90	SCREW,CAP,HEXAGON H .438-20 UNF-.....	8
				2A X 1.75 LG	
13	PAOZZ	96906	MS21044-N7	NUT, SELF-LOCK .438-20 UNJF-3B	8
14	PAOZZ	96906	MS27183-16	WASHER,FLAT .469 ID	8
15	XDOZZ	04368	AF54B6236	PLATE, NUT, HOIST	4
16	PAOZZ	96906	MS21236-2	RING ASSY,CARGO TIE.....	4
17	PAOZZ	81349	M24243/1-A403	.RIVET,BLIND .125 DIA	4
18	XDOZZ	97403	13225E9216	PLATE, IDENT	1
19	XDOZZ	97403	13225E9217-1	BUMPER, PROTECTION	4
20	XDOZZ	97403	13225E9211	SKID	1

END OF FIGURE

SECTION II

(1)	(2)	(3)	(4)	(5)	(6)
ITEM	SMR		PART		
NO	CODE	CAGEC	NUMBER	DESCRIPTION AND USABLE ON CODES(UOC)	QTY

GROUP 07 BULK

FIG. BULK

1	PAOZZ	90598	IND SPEC SCE-41 W/PCA	GASKET, CLOSED CELL.....	V
---	-------	-------	--------------------------	--------------------------	---

END OF FIGURE

CROSS-REFERENCE INDEXES

STOCK NUMBER	FIGURE	NATIONAL STOCK NUMBER INDEX		FIGURE	ITEM
		ITEM	STOCK NUMBER		
5320-00-083-5009	6	17			
5305-00-225-3839	6	3			
1670-00-294-2954	6	16			
5305-00-709-8540	6	12			
5310-00-809-4058	6	5			
5310-00-809-4061	3	3			
5310-00-809-4085	6	14			
5315-00-838-4584	4	2			
5320-00-850-3233	6	8			
5320-00-865-8994	1	2			
5310-00-877-5796	6	4			
5340-01-205-2263	6	9			
5340-01-381-9894	5	2			

CROSS-REFERENCE INDEXES

CAGEC	PART NUMBER	PART NUMBER INDEX STOCK NUMBER	FIG.	ITEM
04368	AF54B6236		6	15
98003	H561-LS-2-RG		1	3
90598	IND SPEC SCE-41 W/PCA		BULK	1
96906	MS16562-66	5315-00-838-4584	4	2
96906	MS21044-N4	5310-00-877-5796	6	4
96906	MS21044-N7		6	13
96906	MS21236-2	1670-00-294-2954	6	16
96906	M5S27183-10	5310-00-809-4058	6	5
96906	MS27183-15	5310-00-809-4061	3	3
96906	MS27183-16	5310-00-809-4085	6	14
96906	MS27977-59		4	8
96906	MS90725-8	5305-00-225-3839	6	3
96906	MS90727-90	5305-00-709-8540	6	12
81349	M24243/1-A403	5320-00-083-5009	6	17
81349	M24243/1-D404	5320-00-865-8994	1	2
81349	M24243/1-D506		4	5
81349	M24243/1-D604	5320-00-850-3233	6	8
97403	13225E9203		6	2
97403	13225E9204		4	1
97403	13225E9204-11		4	10
97403	13225E9205		3	1
97403	13225E9205-8		3	5
97403	13225E9206		6	1
97403	13225E9207		1	1
97403	13225E9207-8		1	4
97403	13225E9208		2	1
97403	13225E9211		6	20
97403	13225E9213		6	6
97403	13225E9214-1		6	10
97403	13225E9214-2		6	11
97403	13225E9215		6	7
97403	13225E9216		6	18
97403	13225E9217-1		6	19
97403	13225E9217-2		4	9
97403	13225E9231-1		4	7
97403	13225E9231-2		4	3
26938	22077-1	5340-01-381-9894	5	2
39428	3403T999-14FT		5	1
71286	37L-1		4	4
71286	39RO1-1-IAA		4	6
71286	39S02-1-1AA		3	2
71286	39S11-3-1AA		3	4
86928	4508-50-62-2C	5340-01-205-2263	6	9

CROSS-REFERENCE INDEXES

FIG.	ITEM	FIGURE AND ITEM NUMBER INDEX		PART NUMBER
		STOCK NUMBER	CAGEC	
BULK	1		90598	IND SPEC SCE-41 W/PCA
1	1		97403	13225E9207
1	2	5320-00-865-8994	81349	M24243/1-D404
1	3		98003	H561-LS-2-RG
1	4		97403	13225E9207-8
2	1		97403	i3225E9208
3	1		97403	13225E9205
3	2		71286	39S02-1-1AA
3	3	5310-00-809-4061	96906	MS27183-15
3	4		71286	39S11-3-1AA
3	5		97403	13225E9205-8
4	1		97403	13225E9204
4	2	5315-00-838-4584	96906	MS16562-66
4	3		97403	13225E9231-2
4	4		71286	37L-1
4	5		81349	M24243/1-D506
4	6		71286	39R01-1-1AA
4	7		97403	13225E9231-1
4	8		96906	MS27977-59
4	9		97403	13225E9217-2
4	10		97403	13225E9204-11
5	1		39428	3403T999-14FT
5	2	5340-01-381-9894	26938	22077-1
6	1		97403	13225E9206
6	2		97403	13225E9203
6	3	5305-00-225-3839	96906	MS90725-8
6	4	5310-00-877-5796	96906	MS21044-N4
6	5	5310-00-809-4058	96906	MS27183-10
6	6		97403	13225E9213
6	7		97403	13225E9215
6	8	5320-00-850-3233	81349	M24243/1-D604
6	9	5340-01-205-2263	86928	4508-50-62-2C
6	10		97403	13225E9214-1
6	11		97403	13225E9214-2
6	12	5305-00-709-8540	96906	MS90727-90
6	13		96906	MS21044-N7
6	14	5310-00-809-4085	96906	MS27183-16
6	15		04368	AF54B6236
6	16	1670-00-294-2954	96906	MS21236-2
6	17	5320-00-083-5009	81349	M24243/1-A403
6	18		97403	13225E9216
6	19		97403	13225E9217-1
6	20		97403	13225E9211

APPENDIX D

COMPONENTS OF END ITEM AND BASIC ISSUE ITEMS LISTS

Section I. INTRODUCTION

D-1. SCOPE. This appendix lists components of end item and basic issue items for the Water Tank Storage Chest to help you inventory items required for safe and efficient operation.

D-2. GENERAL. The Components of End Item and Basic Issue Items Lists are divided into the following sections:

a. Section II Components of End Item. This listing is for informational purposes only, and is not authority to requisition replacements. These items are part of the end item, but are removed and separately packaged for transportation or shipment. As part of the end item, these items must be with the end item whenever it is issued or transferred between property accounts.

b. Section III Basic Issue Items (BII). These essential items required to place the Tank Storage Chest in operation, to operate it, and to do emergency repairs. Although shipped separately packaged, BII must be with the system during operation and whenever it is transferred between property accounts. Listing these items is your authority to request/requisition them for replacement, based on authorization of the end item by TOE/MTOE. Illustrations are furnished to help you find and identify the items.

D-3. EXPLANATION OF COLUMNS. The following provides an explanation of columns found in the tabular listings:

a. Column (1) - Illustration Number (Illus. Number). This column indicates the number of the illustration in which the item is shown.

b. Column (2) - National Stock Number. Indicates the National stock number of the item to be used for requisitioning purposes.

c. Column (3) - Description. Identifies the Federal item name (in all capital letters) followed by a minimum description when needed. The last line below the description is the CAGEC (Commercial and Government Entity Code) (in parentheses) and the part number.

d. Column (4) - Unit of Issue (U/I). Indicates how the item is issued for the National Stock Number shown in column two.

e. Column (5) - Quantity required (Qty Rqr). Indicates the quantity required.

Section II. COMPONENTS OF END ITEM.

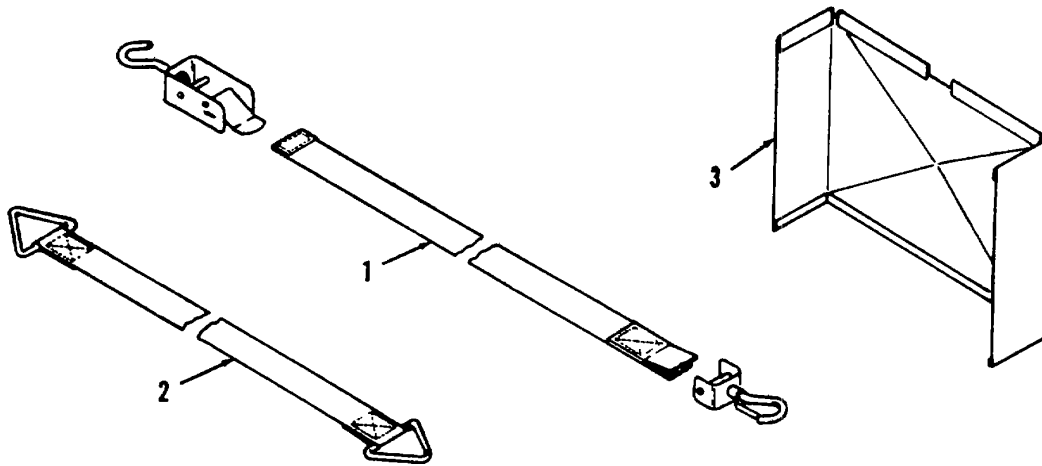

(1) Description Illus Number	(2) National Stock Number	(3) Description CAGEC and Part Number Usable On Code	(4) U/M	(5) Qty. Rqr
1		TIE-DOWN STRAP ASSEMBLY (90598) 22077-1	EA	4
2		HOISTING STRAP ASSEMBLY (90598) 22074-1	EA	4
3		DIVIDER-STORAGE PAN (90598) 22050-1	EA	1

Section III. BASIC ISSUE ITEMS.

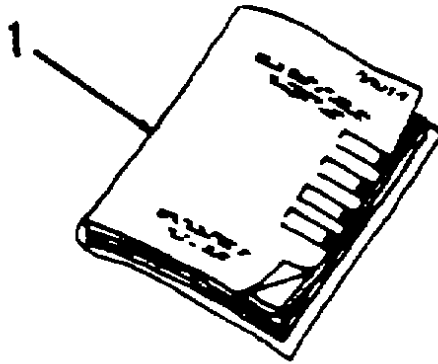

(1) Illus Number	(2) National Stock C CAGEC and Part Number Number	(3) Description Usable On Code	(4) U/M	(5) Qty. Rqr
1	TM10-5430-229-13&P	Technical Manual: Operator's, Unit, Direct Support Including Repair Parts and Special Tools List for Storage Chest, Tank	EA	1

APPENDIX E

ADDITIONAL AUTHORIZATION LIST

Section I. INTRODUCTION

E-1. SCOPE.

This appendix lists additional items you are authorized for the support of the Water Tank Storage Chest

E-2. GENERAL

This list identifies items that do not have to accompany the Water Tank Storage Chest and that do have to be turned in with it. These items are all authorized to you by CTA, MTOE, TDA, OR JTA.

E-3. EXPLANATION OF LISTING.

National stock numbers, descriptions, and quantities are provided to help you identify and request the additional items you require to support this equipment. The items are listed in alphabetical sequence by item name. If the item you require differs between serial numbers of the same model, effective serial numbers are shown in the last line of the description. If item required differs for different models of this equipment, the model is shown under the "Usable on" heading in the description column. These codes are identified as:

Section II. ADDITIONAL AUTHORIZATION ITEMS LIST

(1) National Stock Number	(2) Description CAGEC and Part Number	(3) Usable On Code	(4) U/i	(4) Qty rqr
5120-00-357-6065	River, Blind, Hand			1

APPENDIX F

EXPENDABLE / DURABLE SUPPLIES AND MATERIALS LIST

Section I. INTRODUCTION

F-1. SCOPE.

1. This appendix lists expendable supplies and materials you will need to operate and maintain the Water Tank Storage Chest. This listing is for information only and is not authority to requisition the listed items. These items are authorized to you by CTA 50-970, Expendable Items (except medical, class V, repair parts, and heraldic items) or CTA 8-100, Army Medical Department Expendable/Durable Items.

F-2. EXPLANATION OF COLUMNS.

a. Column (1) - Item number. This number is assigned to the entry in the listing and is referenced in the narrative instructions to identify the material (e.g., "Use clearing compound, item 5, Appendix F").

b. Column (2) - Level. This column identifies the lowest level of maintenance that requires the listed item.

C - Operator/Crew
0 - Unit Maintenance
F - Direct Support Maintenance
H - General Support Maintenance

c. Column (3) - National Stock Number. This is the National stock number assigned to the item which you can use to requisition it.

d. Column (4) - Item Name, Description, Commercial and Government Entity Code (CAGEC), and Part Number. This provides the other information you need to identify the item.

e. Column (5) - Unit of Measure (U/M). This code shows the physical measurement or count of an item, such as gallon, dozen, gross, etc.

Section II. EXPENDABLE / DURABLE SUPPLIES AND MATERIALS LIST

(1) ITEM NUMBER	(2) LEVEL	(3) NATIONAL STOCK NUMBER	(4) ITEM NAME, DESCRIPTION CAGEC, PART NUMBER	(5) U/M
1	0	7920-00-205-1711	Cloth, Lint-Free	ea
2	0	8020-00-207-6658	Brush, Medium, Oval	ea
3	0	6850-00-274-5421	Dry Cleaning Solvent, A-A-711 Type I, (81348)	gl
4	0	7930-00-068-166	Soap, Mild	gl
5	0		Adhesive, Rubber and Gasket (81348) MIL-M-81288	qt

APPENDIX G

ILLUSTRATED LIST OF MANUFACTURED ITEMS

Section I. INTRODUCTION

G-1. INTRODUCTION.

a. This appendix includes complete instructions for making items authorized to be manufactured or fabricated at unit maintenance level (or aviation maintenance level, if applicable).

b. A part number index in alphabetical order is provided for cross-referencing the part number of the item to be manufactured to the figure which covers fabrication criteria.

c. All bulk materials needed for manufacture of an item are listed by the part number or specification in a tabular list on the illustration.

PART NUMBER INDEX

Part Number to Be Manufactured	Part Name	Manufacturing Figure
22036-9	GASKET, CLOSED CELL	1
22003-8	GASKET, CLOSED CELL	1
22002-17	GASKET, CLOSED CELL	1

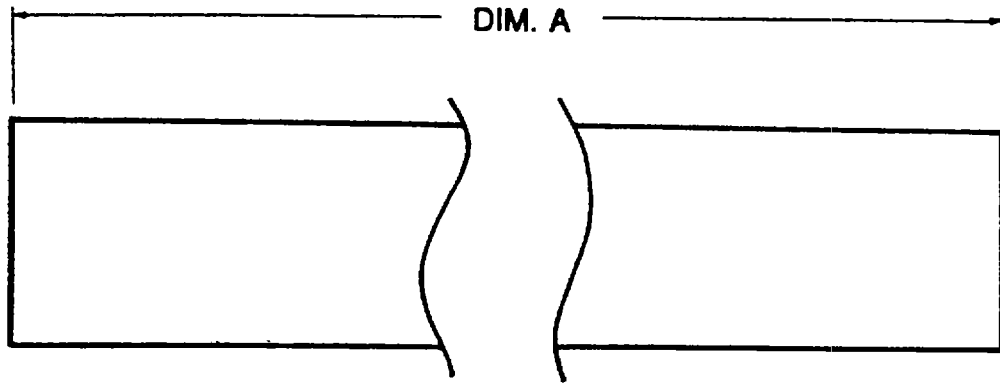

PART TABULATION

Part Number	Dim .A
22036-9	34.00 feet
22003-8	8.50 feet
22002-17	15.00 feet

- NOTES:** 1. Material; All parts are to be made from:
 Gasket, Closed Cell per IND SP,EC
 SCE41 W/PCA, 1.25 inches wide x
 .25 inches thick, adhesive backed.
2. Trim length of gasket to match panel assembly.

Figure G-1. Gaskets.

APPENDIX H

TORQUE LIMITS

H-1. GENERAL. This appendix provides general torque limits for fasteners. Special torque values are indicated in the maintenance procedures for applicable components. The general torque values given in this appendix shall be used when specific torque values are not indicated in the maintenance procedures.

H-2. TORQUE LIMITS. Torque limits are listed in Table H-1 for fasteners. Dry fasteners are defined as fasteners on which no lubricants are applied to the threads. Wet fasteners are defined as fasteners on which graphite or molydisulfide greases or other extreme pressure lubricants are applied to the threads. Table H-2 lists the minimum breakaway torque values for locknuts.

Table H-1. General Torque Requirements for Dry Fasteners.¹

Bolt/Screw Size	Torque Requirement in lb ft (N•m)			
	SAE Grade 1 or 2	SAE Grade 5	SAE Grade 6 or 7	SAE Grade 8
1/4-20 UNC	5 (7)	8 (11)	10 (14)	12 (16)
1/4-28 UNF	6 (8)	10 (14)	12 (16)	14 (19)
5/16-18 UNC	11 (15)	17 (23)	19 (26)	24 (33)
5/16-24 UNF	13 (18)	19 (26)	23 (31)	27 (37)
3/8-16 UNC	18 (24)	31 (42)	34 (46)	44 (60)
3/8-24 UNF	20 (27)	35 (47)	42 (57)	49 (66)
7/16-14 UNC	28 (38)	49 (66)	55 (75)	70 (95)
7/16-20 UNF	30 (41)	55 (75)	67 (91)	78 (106)
1/2-13 UNC	39 (53)	75 (102)	85 (115)	105 (142)
1/2-20 UNF	41 (56)	85 (115)	102 (138)	120 (163)
9/16-12 UNC	51 (69)	110 (149)	120 (163)	155 (210)
9/16-18 UNF	55 (75)	120 (163)	145 (197)	170 (231)
5/8-11 UNC	63 (85)	150 (203)	167 (226)	210 (285)
5/8-18 UNF	95 (129)	170 (231)	205 (278)	240 (325)
3/4-10 UNC	105 (142)	270 (366)	280 (380)	375 (509)
3/4-16 UNF	115 (156)	295 (400)	357 (484)	420 (570)
7/8-9 UNC	160 (217)	395 (536)	440 (597)	605 (820)
7/8-14 UNF	175 (237)	435 (590)	555 (753)	675 (915)

Table H-1. General Torque Requirements for Dry Fasteners. - Continued.

Bolt/Screw Size	Torque Requirement in lb ft (N•m)			
	SAE Grade 1 or 2	SAE Grade 5	SAE Grade 6 or 7	SAE Grade 8
1-8 UNC 1-14 UNF	235 (319) 250 (339)	590 (800) 660 (895)	660 (895) 825 (1119)	910 (1234) 990 (1342)
1-1/8-7 UNC 1-1/8-12 UNF	350 (475) 400 (542)	800 (1085) 880 (1193)	1000 (1356) 1050 (1424)	1280 (1736) 1440 (1953)
1-1/4-7 UNC 1-1/4-12 UNF	500 (678) 550 (746)	1080 (1464) 1125 (1526)	1325 (1797) 1325 (1797)	1820 (2468) 1820 (2712)
1-3/8-6 UNC 1-3/8-12 UNF	660 (895) 740 (1003)	1460 (1980) 1680 (2278)	1800 (2441) 1960 (2658)	2380 (3227) 2720 (3688)
1-1/2-6 UNC 1-1/2-12 UNF	870 (1180) 980 (1329)	1940 (2631) 2200 (2983)	2913 (3950) 3000 (4068)	3160 (4285) 3560 (4827)

**Torque given is for clean, dry threads Reduce by 10% when engine oil is used as lubricant*

Table H-2. Locknut Breakaway Torque Values.

NOTE

To determine breakaway torque, thread lock nut onto screw or bolt until at least two threads stick out. Locknut shall not make contact with a mating part. Stop the locknut. Torque necessary to begin turning locknut again is the breakaway torque. Do not reuse locknuts that do not meet minimum breakaway torque.

Thread Size	Minimum Breakaway Torque	
	LB-in.	(N•m)
10-32	2.0	(0.23)
1/4-28	3.5	(0.40)
5/16-24	6.5	(0.73)
3/8-24	9.5	(1.07)
7/16-20	14.0	(1.58)
1/2-20	18.0	(2.03)
9/16-18	24.0	(2.71)
5/8-18	32.0	(3.62)
3/4-16	50.0	(5.65)
7/8-14	70.0	(7.91)
1-12	90.0	(10.17)
1-1/8-12	117.0	(13.22)

APPENDIX I

MANDATORY REPLACEMENT PARTS

Section I. INTRODUCTION

I-1. SCOPE. This appendix lists mandatory replacement parts you will need to have when performing maintenance on the Water Tank Storage Chest (WTSC). Any time a maintenance procedure is performed that requires you to remove any of the items shown on this list, you are required to replace that item with a new one. You will know that your procedure requires one of these replacement parts when the statement "(Appendix I, Item X)" appears in the "Materials Required" area of the Initial Setup portion of the maintenance procedures in Chapter 4.

I-2. EXPLANATION OF COLUMNS. The table shown in Section II identifies the parts which must be replaced during maintenance of the WTSC. An explanation of the columns in each in this table is as follows.

a. Column (1) - Item number. This number is assigned to the entry in this listing and is referenced in the narrative instructions to identify the material (e.g., "Rivet (Appendix I, Item 1)").

b. Column (2) - CAGEC. The Contractor and Government Entity Code (CAGEC) is a 5-digit numeric code which is used to identify the manufacturer, distributor, or Government agency, etc., that supplies the item.

c. Column (3) - Part Number. Indicates the primary number used by the manufacturer (individual, company, firm, corporation, or Government activity), which controls the design and characteristics of the item by means of its engineering drawings, specifications standards, and inspection requirements to identify an item or range of items.

d. Column (4) - Nomenclature. This column identifies the common name for the part in accordance with the name given to the part on the applicable engineering drawing or specification.

Section II. MANDATORY REPLACEMENT PARTS UST.

(1) ITEM NUMBER	(2) CAGEC	(3) PART NUMBER	(4) NOMENCLATURE
1	83149	M24243/1-D506	RIVET
2	81349	M24243/1-604	RIVET
3	96906	MS21044-N4	LOCK NUT
4	96906	MS21044-N7	LOCK NUT
5	81349	M24243/1/A403	RIVET

ALPHABETICAL INDEX

	Paragraph	Page
A		
Abbreviations, List of	1-7	1-2
Additional Authorization List.....	E-1	E-1
Adjustments, Daily Checks, and Self Tests, Initial	2-7	2-12
Assembly and Preparation for Use	2-6	2-10
B		
Basic Issue Item List.....	D-1	D-3
C		
Components, Major, Location and Description of	1-9	1-2
Components of End Item List.....	D-1	D-2
Corrosion Prevention and Control	1-3	1-1
D		
Decals and Instruction Plates, Operation Instructions On	2-9	2-15
Decontamination Procedures	2-12	2-16
Destruction of Army Materiel to Prevent Enemy Use.....	1-4	1-1
Document Pouch Replacement.....	4-11	4-6
E		
End Panel Assembly Repair.....	4-12	4-8
Equipment Characteristics, Capabilities, and Features.....	1-8	1-2
Equipment Data	1-10	1-4
Expendable / Durable Supplies and Materials List.....	F-1	F-1
I		
Illustrated List of Manufactured Parts	G-1	G-1
L		
Lubrication Instructions	3-1	3-1
M		
Maintenance Allocation Chart	B-1	B-1
Maintenance Forms and Records.....	1-2	1-1
Mandatory Replacement Parts.....	I-1	I-1
O		
Operating Procedures	2-8	2-12
Operation Under Unusual Weather	2-11	2-16
Operator's Controls and Indicators	2-2	2-2

ALPHABETICAL INDEX - Continued

	Paragraph	Page
P		
PMCS, Operator's.....	2-4	2-4
PMCS, Unit	4-8	4-2
Preparation for Movement.....	2-10	2-16
Preparation for Storage	4-16	4-19
Preparation for Storage or Shipment	1-5	1-1
R		
References.....	A-1	A-1
Repair Parts	4-3	4-1
Reporting Equipment Improvement Recommendations (EIR's).....	1-6	1-1
S		
Scope.....	1-1	1-1
Service Upon Receipt.....	4-5	4-1
Side Panel Assembly Repair	4-13	4-10
Site and Shelter Requirements	4-4	4-1
Skid Assembly Repair (Unit Support).....	4-15	4-16
Skid Assembly Repair (Direct Support).....	5-1	5-1
Special Tools, TMDE, and Support Equipment	4-2	4-1
Storage, Administrative	4-17	4-19
Strap Assemblies Replacement	4-14	4-14
T		
Theory of Operations.....	1-11	1-4
Top Cover Assembly Repair	4-10	4-4
Torque Limits	H-1	H- 1
Troubleshooting Table, Direct Support.....	5-2	5-1
Troubleshooting Table, Operator	3-4	3-1
Troubleshooting Table, Unit.....	4-10	4-3

By Order of the Secretary of the Army:

Official:

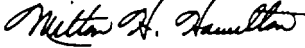
MILTON H. HAMILTON
*Administrative Assistant to the
Secretary of the Army*
06092

GORDON R. SULLIVAN
*General, United States Army
Chief of Staff*

DISTRIBUTION:

To be distributed in accordance with DA Form 12-25-E, block no. 6191, requirements for TM 10-5430-229-13&P

The Metric System and Equivalents

Linear Measure

1 centimeter = 10 millimeters = .39 inch
 1 decimeter = 10 centimeters = 3.94 inches
 1 meter = 10 decimeters = 39.37 inches
 1 dekameter = 10 meters = 32.8 feet
 1 hectometer = 10 dekameters = 328.08 feet
 1 kilometer = 10 hectometers = 3,280.8 feet

Weights

1 centigram = 10 milligrams = .15 grain
 1 decigram = 10 centigrams = 1.54 grains
 1 gram = 10 decigrams = .035 ounce
 1 decagram = 10 grams = .35 ounce
 1 hectogram = 10 decagrams = 3.52 ounces
 1 kilogram = 10 hectograms = 2.2 pounds
 1 quintal = 100 kilograms = 220.46 pounds
 1 metric ton = 10 quintals = 1.1 short tons

Liquid Measure

1 centiliter = 10 milliliters = .34 fl. ounce
 1 deciliter = 10 centiliters = 3.38 fl. ounces
 1 liter = 10 deciliters = 33.81 fl. ounces
 1 dekaliter = 10 liters = 2.64 gallons
 1 hectoliter = 10 dekaliters = 26.42 gallons
 1 kiloliter = 10 hectoliters = 264.18 gallons

Square Measure

1 sq. centimeter = 100 sq. millimeters = .155 sq. inch
 1 sq. decimeter = 100 sq. centimeters = 15.5 sq. inches
 1 sq. meter (centare) = 100 sq. decimeters = 10.76 sq. feet
 1 sq. dekameter (are) = 100 sq. meters = 1,076.4 sq. feet
 1 sq. hectometer (hectare) = 100 sq. dekameters = 2.47 acres
 1 sq. kilometer = 100 sq. hectometers = .386 sq. mile

Cubic Measure

1 cu. centimeter = 1000 cu. millimeters = .06 cu. inch
 1 cu. decimeter = 1000 cu. centimeters = 61.02 cu. inches
 1 cu. meter = 1000 cu. decimeters = 35.31 cu. feet

Approximate Conversion Factors

To change	To	Multiply by	To change	To	Multiply by
inches	centimeters	2.540	ounce-inches	Newton-meters	.007062
feet	meters	.305	centimeters	inches	.394
yards	meters	.914	meters	feet	3.280
miles	kilometers	1.609	meters	yards	1.094
square inches	square centimeters	6.451	kilometers	miles	.621
square feet	square meters	.093	square centimeters	square inches	.155
square yards	square meters	.836	square meters	square feet	10.764
square miles	square kilometers	2.590	square meters	square yards	1.196
acres	square hectometers	.405	square kilometers	square miles	.386
cubic feet	cubic meters	.028	square hectometers	acres	2.471
cubic yards	cubic meters	.765	cubic meters	cubic feet	35.315
fluid ounces	milliliters	29.573	cubic meters	cubic yards	1.308
pints	liters	.473	milliliters	fluid ounces	.034
quarts	liters	.946	liters	pints	2.113
gallons	liters	3.785	liters	quarts	1.057
ounces	grams	28.349	liters	gallons	.264
pounds	kilograms	.454	grams	ounces	.035
short tons	metric tons	.907	kilograms	pounds	2.205
pound-feet	Newton-meters	1.356	metric tons	short tons	1.102
pound-inches	Newton-meters	.11296			

Temperature (Exact)

°F	Fahrenheit temperature	5/9 (after subtracting 32)	Celsius temperature	°C
----	------------------------	----------------------------	---------------------	----

This fine document...

Was brought to you by me:



[Liberated Manuals -- free army and government manuals](#)

Why do I do it? I am tired of sleazy CD-ROM sellers, who take publicly available information, slap “watermarks” and other junk on it, and sell it. Those masters of search engine manipulation make sure that their sites that sell free information, come up first in search engines. They did not create it... They did not even scan it... Why should they get your money? Why are not letting you give those free manuals to your friends?

I am setting this document FREE. This document was made by the US Government and is NOT protected by Copyright. Feel free to share, republish, sell and so on.

I am not asking you for donations, fees or handouts. If you can, please provide a link to liberatedmanuals.com, so that free manuals come up first in search engines:

<A HREF=<http://www.liberatedmanuals.com/>>Free Military and Government Manuals

- Sincerely
Igor Chudov
<http://igor.chudov.com/>
- [Chicago Machinery Movers](#)