

TECHNICAL MANUAL

**OPERATOR'S, UNIT, DIRECT SUPPORT
MAINTENANCE MANUAL
FOR**

COMPLEXING KIT PASSAGEWAYS

COMPLEXING KIT PASSAGEWAYS, TYPE II, CLASS A

- STYLE 1, SAND, P/N 5-4-6730-1 (81337)
- STYLE 2, SAND, P/N 5-4-6730-3 (81337)
- STYLE 1, GREEN, P/N 5-4-6730-2 (81337)
- STYLE 2, GREEN, P/N 5-4-6730-4 (81337)

COMPLEXING KIT PASSAGEWAYS, TYPE II, CLASS B

- STYLE 1, SAND, P/N 5-4-6731-1 (81337)
- STYLE 2, SAND, P/N 5-4-6731-3 (81337)
- STYLE 1, GREEN, P/N 5-4-6731-2 (81337)
- STYLE 2, GREEN, P/N 5-4-6731-4 (81337)

COMPLEXING KIT PASSAGEWAYS, TYPE I

- STYLE 1, SAND, P/N 5-4-6732-1 (81337)
- STYLE 2, SAND, P/N 5-4-6732-3 (81337)
- STYLE 3, SAND, P/N 5-4-6732-5 (81337)
- STYLE 1, GREEN, P/N 5-4-6732-2 (81337)
- STYLE 2, GREEN, P/N 5-4-6732-4 (81337)
- STYLE 3, GREEN, P/N 5-4-6732-6 (81337)

TYPE I

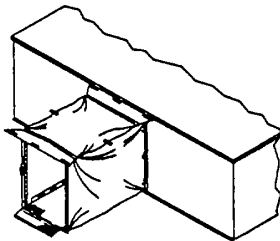

TYPE II

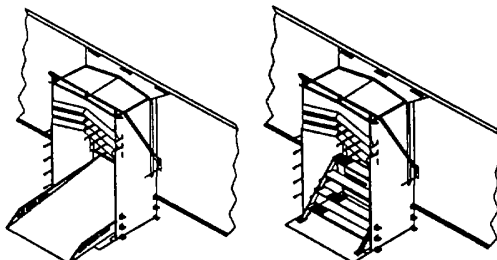

CLASS A

CLASS B

INTRODUCTION	1-1	
OPERATING INSTRUCTIONS	2-1	
OPERATOR MAINTENANCE	3-1	
UNIT MAINTENANCE	4-1	
DIRECT SUPPORT MAINTENANCE	5-1	
MAINTENANCE ALLOCATION CHART (MAC)	B-1	
ALPHABETICAL INDEX	Index-1	

DISTRIBUTION STATEMENT A: Approved for public release; distribution is unlimited.

*This manual supersedes TM 10-5411-203-13, dated 29 December 1989.

**HEADQUARTERS, DEPARTMENT OF THE ARMY
15 JANUARY 1993**

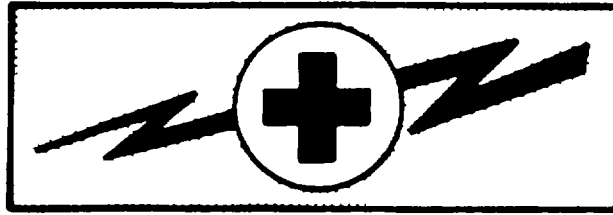
WARNING**WARNING****HEAVY EQUIPMENT**

The Complexing Kit Passageway components include two ramps and a stairway. The ramps weigh approximately 145 pounds (65.77 kg) and 195 pounds (88.45 kg) respectively, and the stairs (complete assembly) weigh approximately 70 pounds (31.75 kg). Four persons are required to handle each of these components. Attempting to lift or carry any one of them by yourself could result in serious injury or damage to the equipment.

WARNING

When installing or removing weather barrier between hinged roof panel and hinged sidewall of ISO shelter, take care to avoid getting fingers caught. Failure to do so may result in serious injury.

WARNING

The adhesive has a high alcohol content and is highly flammable. Use only in a well-ventilated area away from open flame. Do not smoke. Failure to follow these safety precautions could result in dizziness, fainting, severe burns, or death.

WARNING

Wear safety glasses while drilling out rivets. Failure to do so could result in serious eye injury or blindness.

For first aid procedures, refer to FM 21-11.

a/(b blank)

TECHNICAL MANUAL

NO. 10-5411-203-13

HEADQUARTERS
DEPARTMENT OF THE ARMY
WASHINGTON, D.C., 15 JANUARY 199:

TECHNICAL MANUAL

Operator's, Unit, Direct Support
Maintenance Manual

FOR

COMPLEXING KIT PASSAGEWAYS

COMPLEXING KIT PASSAGEWAYS, TYPE II, CLASS A

- STYLE 1, SAND, P/N 5-4-6730-1 (81337)
- STYLE 2, SAND, P/N 5-4-6730-3 (81337)
- STYLE 1, GREEN, P/N 5-4-6730-2 (81337)
- STYLE 2, GREEN, P/N 5-4-6730-4 (81337)

COMPLEXING KIT PASSAGEWAYS, TYPE II, CLASS B

- STYLE 1, SAND, P/N 5-4-6731-1 (81337)
- STYLE 2, SAND, P/N 5-4-6731-3 (81337)
- STYLE 1, GREEN, P/N 5-4-6731-2 (81337)
- STYLE 2, GREEN, P/N 5-4-6731-4 (81337)

COMPLEXING KIT PASSAGEWAYS, TYPE I

- STYLE 1, SAND, P/N 5-4-6732-1 (81337)
- STYLE 2, SAND, P/N 5-4-6732-3 (81337)
- STYLE 3, SAND, P/N 5-4-6732-5 (81337)
- STYLE 1, GREEN, P/N 5-4-6732-2 (81337)
- STYLE 2, GREEN, P/N 5-4-6732-4 (81337)
- STYLE 3, GREEN, P/N 5-4-6732-6 (81337)

REPORTING ERRORS AND RECOMMENDING IMPROVEMENTS

You can help improve this manual. If you find any mistakes or if you know of a way to improve these procedures, please let us know. Mail your letter or DA Form 2028 (Recommended Changes to Publications and Blank Forms), or DA Form 2028-2 located in the back of this manual directly to: Commander, US Army Aviation and Troop Command, ATTN: AMSAT-I-MTS, 4300 Goodfellow Blvd., St. Louis, MO 63120-1798. A reply will be furnished directly to you.

DISTRIBUTION STATEMENT A: Approved for public release; distribution is unlimited.

CHAPTER 1	INTRODUCTION	Page 1-1
Section I	General Information	1-1
Section II	Equipment Description and Data	1-2
Section III	Technical Principles of Operation (not applicable)	1-6

*This manual supersedes TM 10-5411-203-13, dated 29 December 1989

		Page
CHAPTER 2	OPERATING INSTRUCTIONS	2-1
Section I	Description and Use of Operator's Controls and Indicators (not applicable)	2-1
Section II	Operator Preventive Maintenance Check's and Services (PMCS)	2-1
Section III	Operation Under Usual Conditions	2-6
Section IV	Operation Under Unusual Conditions	2-44
CHAPTER 3	OPERATOR MAINTENANCE	3-1
Section I	Lubrication Instructions (not applicable)	3-1
Section II	Troubleshooting Procedures (not applicable)	3-1
CHAPTER 4	UNIT MAINTENANCE	4-1
Section I	Repair Parts; Special Tools; Test, Measurement, and Diagnostic Equipment (TMDE); and Support Equipment	4-1
Section II	Service Upon Receipt	4-1
Section III	Maintenance Procedures	4-1
Section IV	Preparation for Storage or Shipment	4-45
CHAPTER 5	DIRECT SUPPORT MAINTENANCE	5-1
Section I	Maintenance Procedures	5-1
APPENDIX A	REFERENCES	A-1
APPENDIX B	MAINTENANCE ALLOCATION CHART (MAC)	B-1
Section I	Introduction	B-1
Section II	Maintenance Allocation Chart	B-5
Section III	Tool and Test Equipment Requirements	B-6
Section IV	Remarks	B-7
APPENDIX C	COMPONENTS OF END ITEM AND BASIC ISSUE ITEMS LISTS	C-1
Section I	Introduction	C-1
Section II	Components of End Item	C-3
Section III	Basic Issue Items	C-5
APPENDIX D	EXPENDABLE/DURABLE SUPPLIES AND MATERIALS LIST	D-1
Section I	Introduction	D-1
Section II	Expendable/Durable Supplies and Materials List.....	D-2
APPENDIX E	ILLUSTRATED LIST OF MANUFACTURED ITEMS	E-1
GLOSSARY	Glossary 1
ALPHABETIC INDEX	Index 1

TYPE I

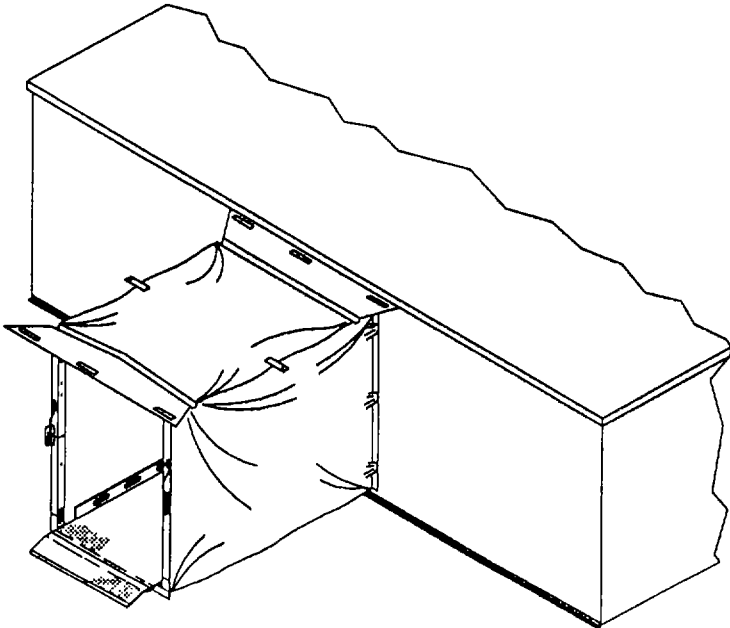

TYPE II

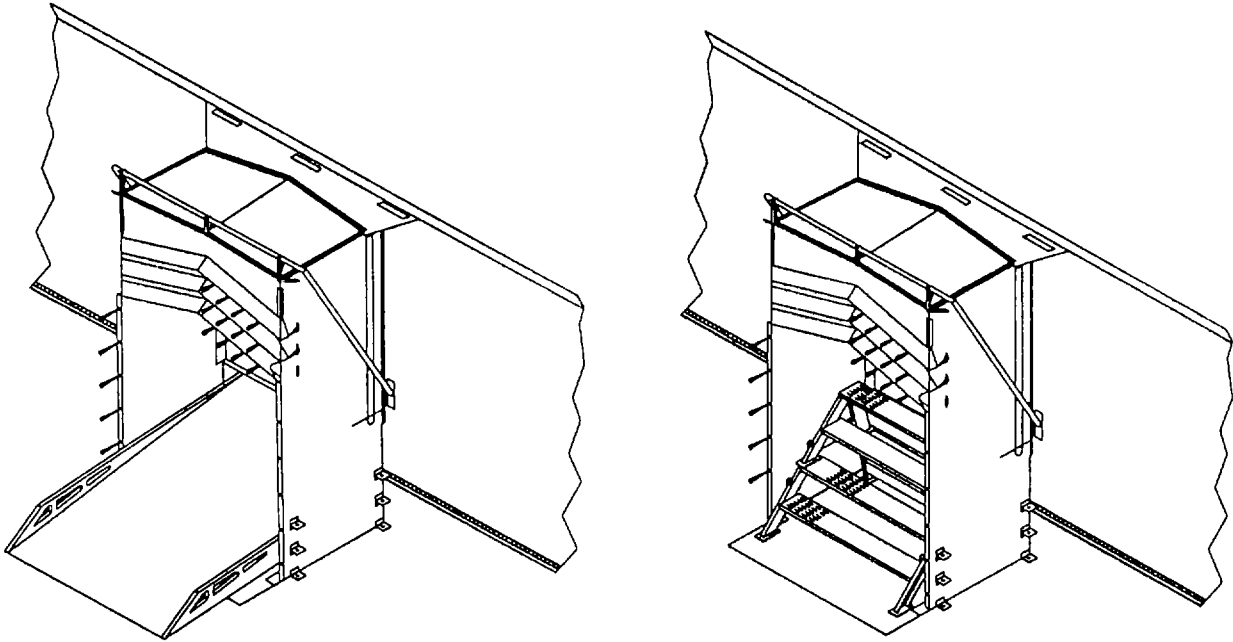

CLASS A

CLASS B

COMPLEXING KIT PASSAGEWAYS

CHAPTER 1 INTRODUCTION

Section I. GENERAL INFORMATION

1-1. SCOPE. This manual contains instructions for operator, unit, and direct support maintenance for the Complexing Kit Passageway. There are two models. One model (Type I) fits between two ISO expandable shelters. The other (Type II) fits between an ISO shelter and an extendable modular personnel tent (TEMPER). This manual covers both. The purpose of the Complexing Kit Passageway is to provide an environmentally sealed walkway for personnel and equipment to move from one shelter to another.

1-2. MAINTENANCE FORMS, RECORDS, AND REPORTS. Department of the Army forms and procedures used for equipment maintenance will be those prescribed by DA PAM 738-750, The Army Maintenance Management System (TAMMS).

1-3. DESTRUCTION OF MATERIEL TO PREVENT ENEMY USE. For destruction procedures for this equipment, see TM 750-244-3, Procedures for Destruction of Equipment to Prevent Enemy Use.

1-4. PREPARATION FOR STORAGE OR SHIPMENT.

a. Placement of equipment in administrative storage should be for short periods of time when a shortage of maintenance effort exists. Items should be in mission readiness within 24 hours or within the time factors as determined by the directing authority. During the storage period, appropriate maintenance will be kept.

b. Before placing equipment in administrative storage, current maintenance services and equipment serviceable criteria (ESC) evaluations should be completed, shortcomings and deficiencies should be corrected and all modification work orders (MWO's) should be applied.

c. Storage Site Selection. Inside storage is preferred for items selected for administrative storage. If inside storage is not available, trucks, vans, conex containers and other containers may be used.

1-5. OFFICIAL NOMENCLATURE, NAMES, AND DESIGNATIONS. The following list contains cross-reference to nomenclature used in this manual.

Common Name
ISO Shelter
TEMPER

Official Nomenclature
Shelter, Tactical, Expandable
Tent, Extendable, Modular, Personnel

1-6. REPORTING EQUIPMENT IMPROVEMENT RECOMMENDATIONS. If your Complexing Kit Passageway needs improvement, let us know. Send us an EIR. You, the user, are the only one who can tell us what you do not like about your equipment. Let us know what you do not like about the design or performance. Put it on an SF 368 (Quality Deficiency Report). Mail it to us at: Commander, U.S. Army Troop Support Command, ATTN: AMSTR-MOF, 4300 Goodfellow Blvd., St. Louis, MO 63120-1798. We'll send you a reply.

Section II. EQUIPMENT DESCRIPTION AND DATA

1-7. EQUIPMENT CHARACTERISTICS, CAPABILITIES, AND FEATURES.

a. Characteristics.

- Lightweight and portable
- Small number of components
- Quickly assembled and disassembled
- Easily transported or stored
- No special tools required
- Very little maintenance required
- Standard width and height

b. Capabilities and Features.

- Provides protected access to and from two shelters.
- Bump thru doors can be installed to minimize climate control effort and provide privacy.
- Can be assembled and disassembled in less than 45 minutes.
- Can be assembled in any kind of weather.
- Provides flexibility of shelters in a military shelter complex.

1-8. LOCATION AND DESCRIPTION OF MAJOR COMPONENTS. The Complexing Kit Passageway has two models. Type I fits between two ISO shelters. Type II, Class A and Class B, fit between an ISO shelter and a TEMPER.

1-8. LOCATION AND DESCRIPTION OF MAJOR COMPONENTS (CONT)

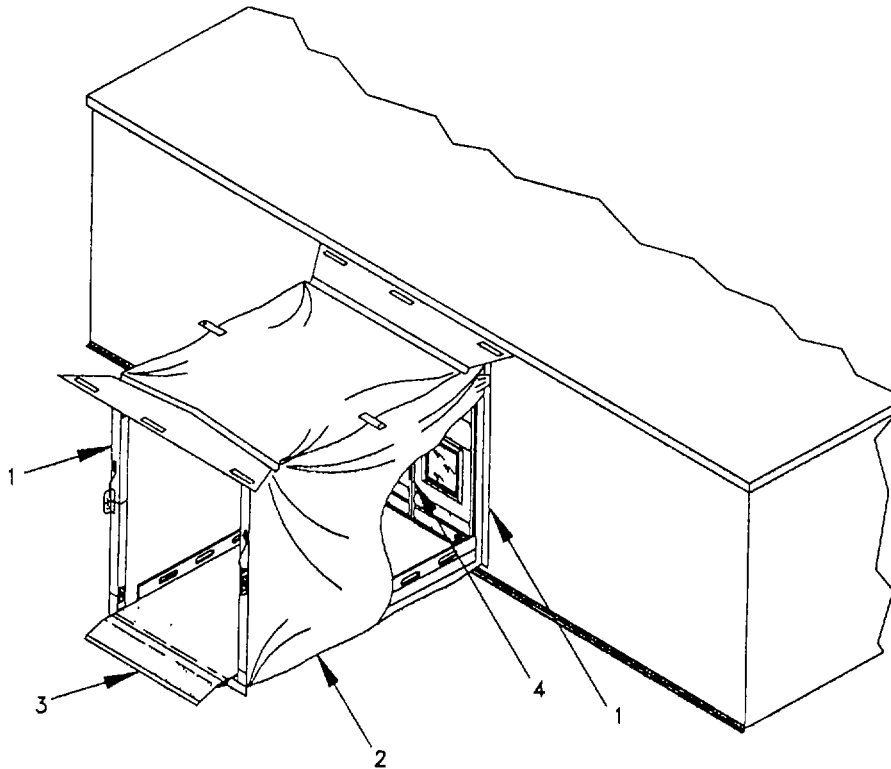
TYPE I

Type I is composed of two frame assemblies (1) with attached connector assembly (2), a ramp (3), bump thru doors (4). The frame assemblies are made of lightweight aluminum. A one piece connector assembly is mounted between the two frames. The two frames fit into the sidewall closeout panels of the two ISO shelters. An aluminum ramp with non-skid surface fits between the two ISO shelters serving as a firm walkway between the ISO shelters. Bump thru doors can be installed on the frame of one (Style 2) or both shelters (Style 3).

1-8. LOCATION AND DESCRIPTION OF MAJOR COMPONENTS (CONT)

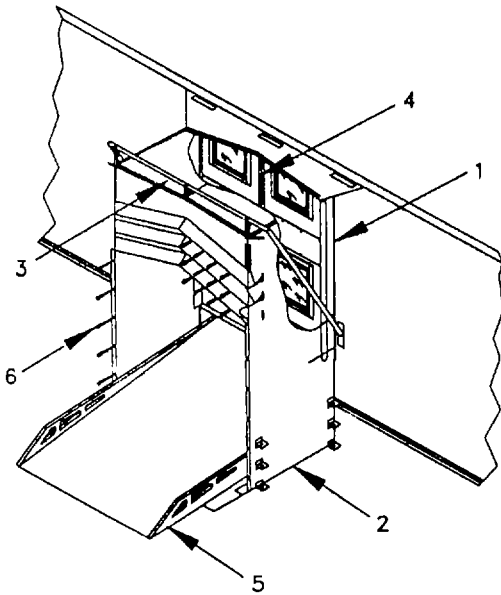

Class A

TYPE II

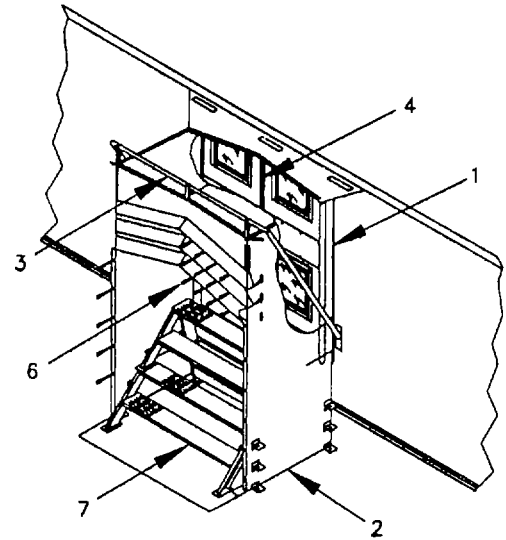

Class B

Type II, Class A contains five components: a frame assembly (1) with attached weather resistant connector assembly (2), an exterior frame assembly (3), bump thru doors (4), and a ramp (5). The frame assembly (1) is made of lightweight aluminum and fits into the sidewall or endwall closeout panels on an ISO shelter. A one piece, weather resistant connector assembly (2) is mounted to the frame assembly (1). Becket loops (6) on the connector assembly attach to the TEMPER. The exterior frame assembly (3) connects to the ISO shelter. It is made of lightweight aluminum poles and supports the connector assembly (2) on the frame assembly (1). Bump thru doors (4) can be installed into the frame assembly (1) to minimize temperature loss thru passageway. The aluminum ramp (5) with non-skid surface serves as a firm walkway between the ISO shelter and TEMPER.

Type II, Class B consists of the same frame assembly (1) with attached connector assembly (2), exterior frame assembly (3) and bump thru doors (4), but includes an adjustable aluminum stairway assembly (7) in lieu of the ramp (5).

1-9. DIFFERENCE BETWEEN MODELS. There are two types of the Complexing Kit Passageway. Type I attaches between two ISO shelters. Type II attaches between an ISO shelter and a TEMPER. All configurations are available in green and also in tan. See the following table for more information.

1-9. DIFFERENCE BETWEEN MODELS (CONT)

Differences Between Models

Type I ISO Shelter to ISO Shelter	Type II ISO Shelter to TEMPER	
	Class A	Class B
Two Frames Connector Assembly Two Weather Barriers	One Frame Connector Assembly One weather Barrier Becket Loops Support Straps	One Frame Connector Assembly One weather Barrier Becket Loops Support Straps
Bump Thru Doors (Style 1 - none) (Style 2 - one set) (Style 3 - two sets)	Bump Thru Doors (Style 1 - none) (Style 2 - one set)	Bump Thru Doors (Style 1 - none) (Style 2 - one set)
Ramp (ISO to ISO)	Exterior Frame Assembly Header Bar Upright Bars Ramp (ISO to TEMPER)	Exterior Frame Assembly Header Bar Upright Bars Stairway Assembly

1-10. EQUIPMENT DATA. Inspect the Complexing Kit Passageway to ensure that all parts are present. Use the following data as your checklist. Report any extra or missing parts to your supervisor. The "Item Itself" column represents the item in a deployed or in-use state. The "Item Packaged" column represents the item packaged in its original shipping crate.

	<u>Item Itself</u>	<u>Item Packaged</u>
a. <u>Complexing Kit Passageway, Type I (ISO to ISO)</u>		
(1) <u>Hinged Frame/Fabric Assembly</u>		
Weight:	115 lb (52.21 kg)	225 lb (102.15 kg)
Dimensions:	1.5 x 1.5 x 5.5 ft (457.2 x 574.2 x 1676.4 mm)	2.3 x 6.2 x 1.3 ft (7010.4 x 1889.76 x 396.24 mm)
(2) <u>Bump Thru Doors</u>		
Weight:	50 lb (22.72 kg)	86 lb (39.09 kg)
Dimensions:	2.38 x 5.98 x 0.05 ft (725.4 x 1822.7 x 15.49 mm)	2.58 x 6.63 x 0.5 ft (768.38 x 2020.82 x 152.4 mm)
(3) <u>Ramp</u>		
Weight:	145 lb (65.83 kg)	300 lb (136.20 kg)
Dimensions:	4.0 x 8.0 x 0.5 ft (457.2 x 574.2 x 1676.4 mm)	4.1 x 8.5 x 0.8 ft (1249.68 x 2590.8 x 243.84 mm)

1-10. EQUIPMENT DATA (CONT)

	<u>Item Itself</u>	<u>Item Packaged</u>
b. <u>Complexing Kit Passageway, Type II, Class A (ISO to TRMPPR with Ramp)</u>		
(1) <u>Hinged Frame/Fabric Assembly*</u>		
Weight:	65 lb (29.51 kg)	175 lb (79.45 kg)
Dimension:	1.2 x 1.2 x 5.5 ft (365.76 x 365.75 x 1676.4 mm)	2.3 x 6.2 x 1.3 ft (701.04 x 1889.76 x 396.24 mm)
(2) <u>Bump Thru Doors</u>		
Weight:	50 lb (22.72 kg)	86 lb (39.09 kg)
Dimensions:	2.38 x 5.98 x 0.05 ft (725.4 x 1822.7 x 15.49 mm)	2.58 x 6.63 x 0.5 ft (768.38 x 2020.82 x 152.4 mm)
(3) <u>Ramp</u>		
Weight:	195 lb (88.53 kg)	450 lb (204.3 kg)
Dimensions:	4.0 x 12.0 x 1.0 ft (1219.2 x 3657.6 x 304.8 mm)	4.1 x 12.8 x 1.3 ft (1249.68 x 3901.44 x 396.24 mm)
c. <u>Complexing Kit Passageway, Type II, Class B (ISO to TEMPER with Stairs)</u>		
(1) <u>Hinged Frame/Fabric Assembly*</u>		
Weight:	65 lb (29.51 kg)	175 lb (79.45 kg)
Dimension:	1.2 x 1.2 x 5.5 ft (365.76 x 365.75 x 1676.4 mm)	2.3 x 6.2 x 1.3 ft (701.04 x 1889.76 x 396.24 mm)
(2) <u>Bump Thru Doors</u>		
Weight:	50 lb (22.72 kg)	86 lb (39.09 kg)
Dimensions:	2.38 x 5.98 x 0.05 ft (725.4 x 1822.7 x 15.49 mm)	2.58 x 6.63 x 0.5 ft (768.38 x 2020.82 x 152.4 mm)
(3) <u>Stairs</u>		
Weight:	70 lb (31.78 kg)	175 lb (79.45 kg)
Dimensions:	2.0 x 2.0 x 5.0 ft (609.6 x 609.6 x 1524.00 mm)	3.0 x 3.0 x 5.5 ft (914.4 x 914.4 x 1676.4 mm)

*The Type II Passageway includes an exterior tubular frame which is packaged with the hinged frame/fabric assembly. Its total weight is less than ten (10) pounds and is included in the packaged weight and dimensions of transport container.

Section III. TECHNICAL PRINCIPALS OF OPERATION

Not Applicable.

CHAPTER 2
OPERATING INSTRUCTIONS

Section I. DESCRIPTION AND USE OF OPERATOR'S CONTROLS AND INDICATORS

Not applicable.

Section II. OPERATOR PREVENTIVE MAINTENANCE

CHECKS AND SERVICES (PMCS)

2-1. GENERAL. The Complexing Kit Passageway must be inspected at intervals to find and correct defects.

- a. Before you operate. Always keep in mind the CAUTIONS and WARNINGS. Perform your before (B) PMCS.
- b. While you operate. Always keep in mind the CAUTIONS and WARNINGS. Perform your during (D) PMCS.

2-2. PMCS PROCEDURES

- a. Your Preventive Maintenance Checks and Services table lists the inspections and care of your equipment to keep it in good operating condition.
- b. Use the "Item No." column of the PMCS table to supply the item number used in the "TM Number" column of DA Form 2404, Equipment Inspection and Maintenance Worksheet, in recording results of PMCS.
- c. The "Interval" column of your PMCS table tells you when to do a certain check or service: all PMCS actions are performed before and during use.
- d. The "Procedure" column of your PMCS table tells you how to do the required checks and services. Carefully follow these instructions.
- e. The "Equipment Is Not Ready/Available If:" column tells you when and why your equipment cannot be used.

NOTE

The terms ready/available and mission capable refer to the same status: Equipment is on hand and is able to perform its combat missions. Refer to DA Pam 738-750, The Army Maintenance Management System (TAMMS).

Operator Preventive Maintenance

Checks and Services Table

B - Before D - During

Item No.	Interval		Item To Be Inspected Procedure	Equipment Is Not Ready/Available If:
	B	D		

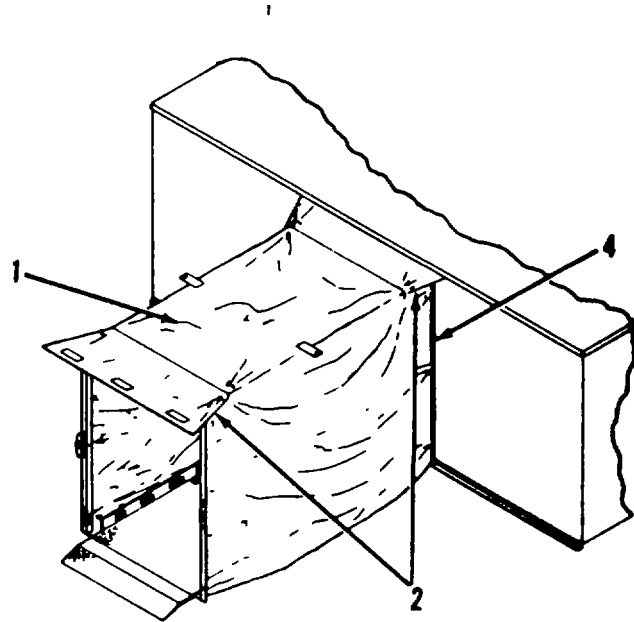
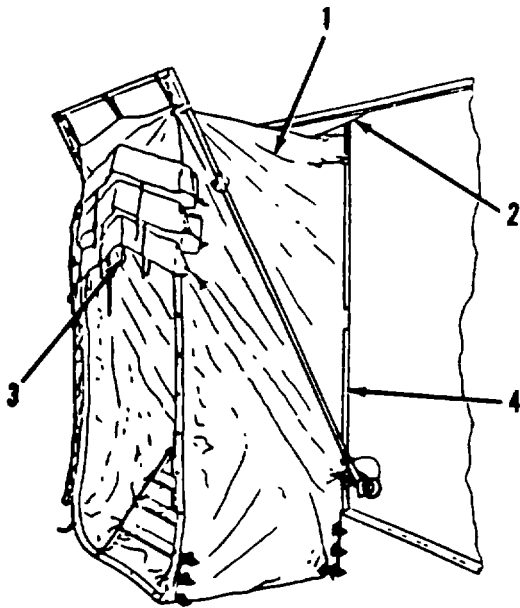

NOTE

Daily checks are to be made in severe weather conditions.

The following PMCS procedures pertain to both Type I and Type II shelters.

1

-
-

CONNECTOR ASSEMBLY. Check connector assembly (1) inside and outside for broken stitches, holes, worn spots, or tears in Check weather barriers (2) and becket loops (3) for secure installation or damage. Tighten as needed.

Connector assembly (1) has large hole or tear that decreases protection. Weather barriers (2) and becket loops (3) are severely damaged.

Operator Preventive Maintenance

Checks and Services Table

B - Before D - During

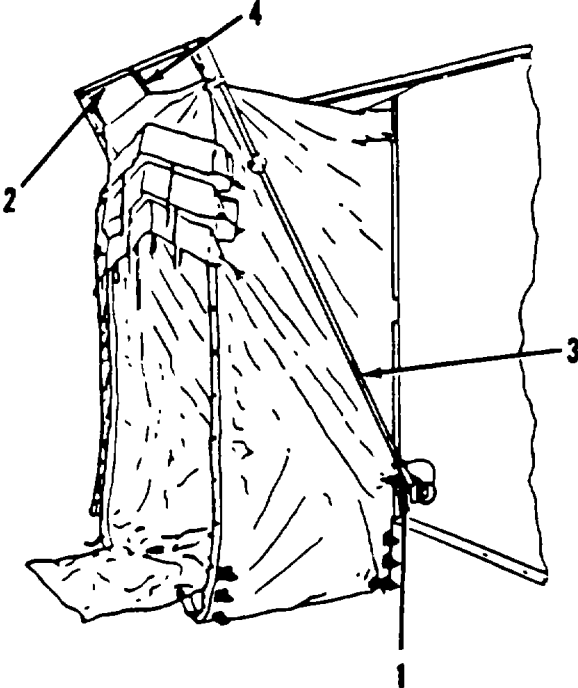
Item No.	Interval		Item To Be Inspected Procedure	Equipment Is Not Ready/Available If:
	B	D		
2	•	•	Remove debris, snow, or ice from top or sides of connector assembly (1) as needed.	Frame assembly (4) or hinges are damaged so frame assembly is not usable.
		•	<p>FRAME ASSEMBLY. Check frame assembly (4) for bends, breaks, and broken or missing parts. Check frame assembly's hinges, locking pins, and seals for breakage.</p> 	
3	•	•	<p>EXTERIOR FRAME ASSEMBLY (TYPE II ONLY). Check swivel feet (1), header bar (2), and upright bars (3) for dents, bends, breaks, loose fittings, and broken or missing parts. Check support straps (4) for tears or breakage.</p>	Exterior frame assembly will not support fabric properly.

Operator Preventive Maintenance

Checks and Services Table

B - Before D - During

Item No.	Interval		Item To Be Inspected Procedure	Equipment Is Not Ready/Available If:
	B	D		

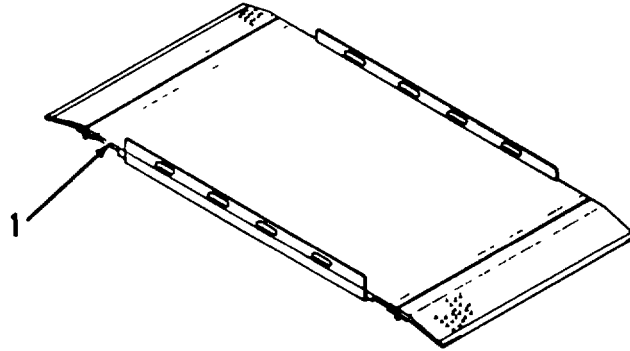

TYPE I

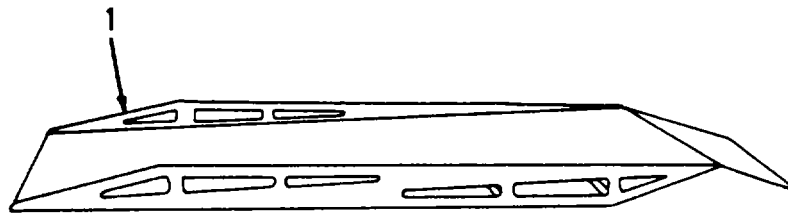

TYPE II

4

•

•

RAMP. Check ramp (1) for cracks and broken or missing parts.

Ramp will not support weight of personnel.

Operator Preventive Maintenance

Checks and Services Table

B - Before D - During

Item No.	Interval		Item To Be Inspected Procedure	Equipment Is Not Ready/Available If:
	B	D		



5	•	•	STAIRWAY (TYPE II, CLASS B ONLY). Check stairway (1) for cracks, dents, and broken or missing parts.	Stairway will not support weight of personnel.
---	---	---	---------------------------------------------------------------------------------------------------------	------------------------------------------------

Operator Preventive Maintenance

Checks and Services Table

B - Before D - During

Item No.	Interval		Item To Be Inspected Procedure	Equipment Is Not Ready/Available If:
	B	D		

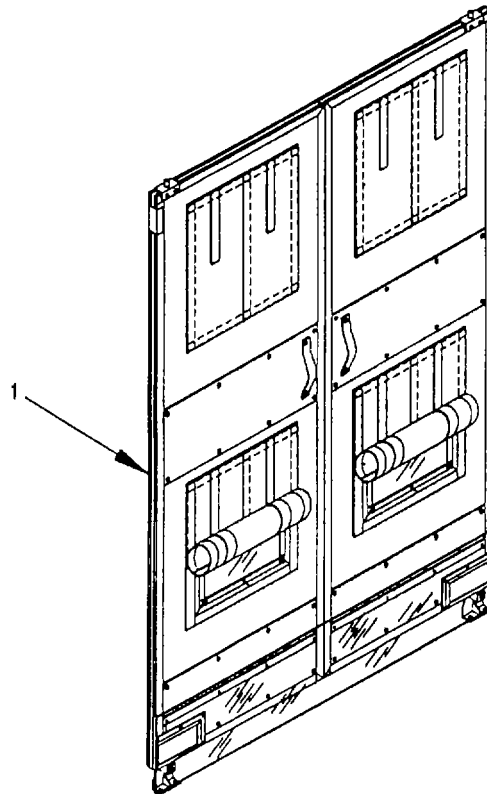

5	•	•	BUMP THRU DOORS (STYLE 1 - N/A). Check doors (1) for proper operation, lack of damage, and broken or missing parts.	Doors do not permit free passage of personnel and equipment.
---	---	---	------------------------------------------------------------------------------------------------------------------------	--------------------------------------------------------------

2-3. IF YOUR EQUIPMENT FAILS TO OPERATE. Defects discovered before and during use will be noted for future correction, to be made as soon as use is discontinued. Stop use immediately if any defect is noted that would impare continued use of the Complexing Kit Passageway or endanger personnel. Report all defects on DA Form 2404. Refer to DA PAM 738-750, The Army Maintenance Management System (TAMMS), for instructions.

Section III. OPERATION UNDER USUAL CONDITIONS

2-4. INSTALLATION AND PREPARATION FOR USE

- a. Installing Complexing Kit Passageway - Type I (ISO Shelter to ISO Shelter)

NOTE

The following procedure requires four personnel.

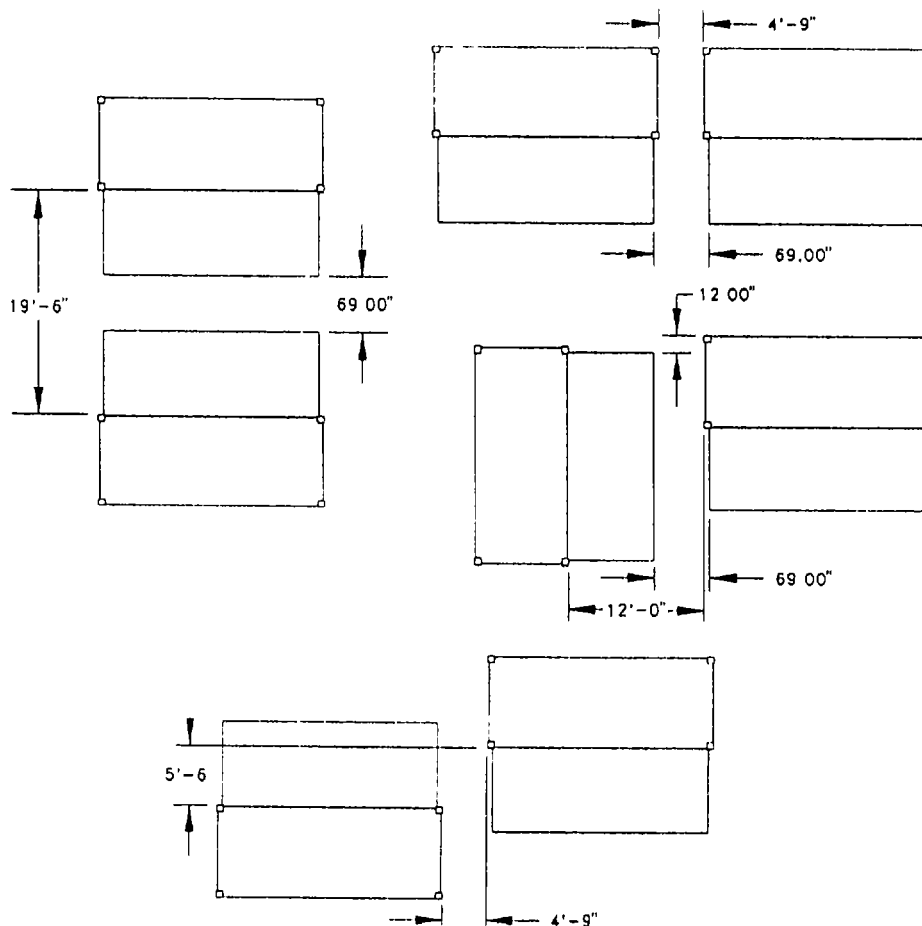

- (1) Be sure the desired sidewall or endwall closeout panels face each other and ISO shelters are no more than 69 in. (1752 mm) apart.

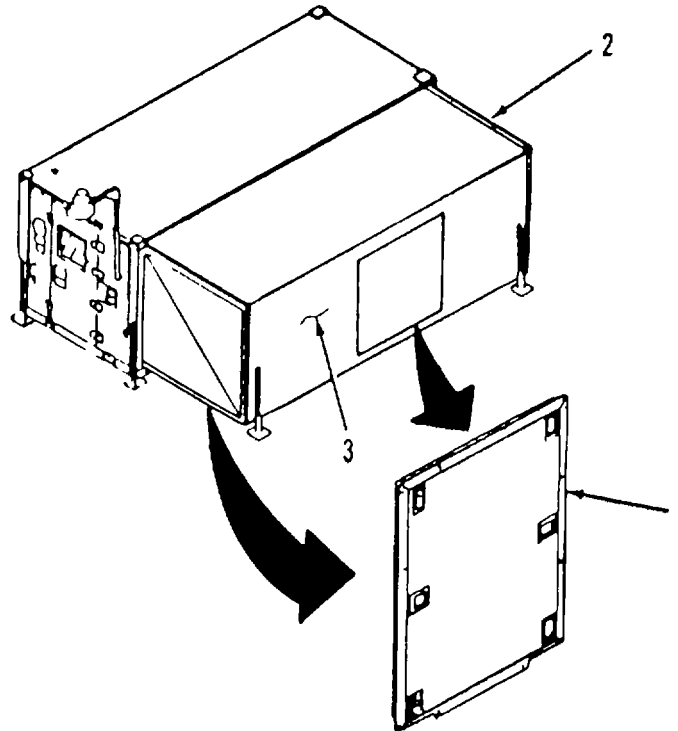
2-4. INSTALLATION AND PREPARATION FOR USE (CONT)**a. Installing Complexing Kit Passageway - Type I (ISO Shelter to ISO Shelter) (Cont)****NOTE**

The next procedure requires two persons on the outside and two persons on the inside of ISO shelter.

- (2) Remove chosen sidewall or endwall closeout panels (1) from both ISO shelters (2) using the following steps:
 - (a) Using wide flat-tip screwdriver, loosen 12 captive screws on closeout panel (1).
 - (b) Remove closeout panel (1) and stow on outside hinged sidewall (3) or other location while not in use.
 - (c) Repeat steps (a) and (b) for closeout panel (1) on second ISO shelter

2-4. INSTALLATION AND PREPARATION FOR USE (CONT)

a. Installing Complexing Kit Passageway - Type I (ISO Shelter to ISO Shelter) (Cont)

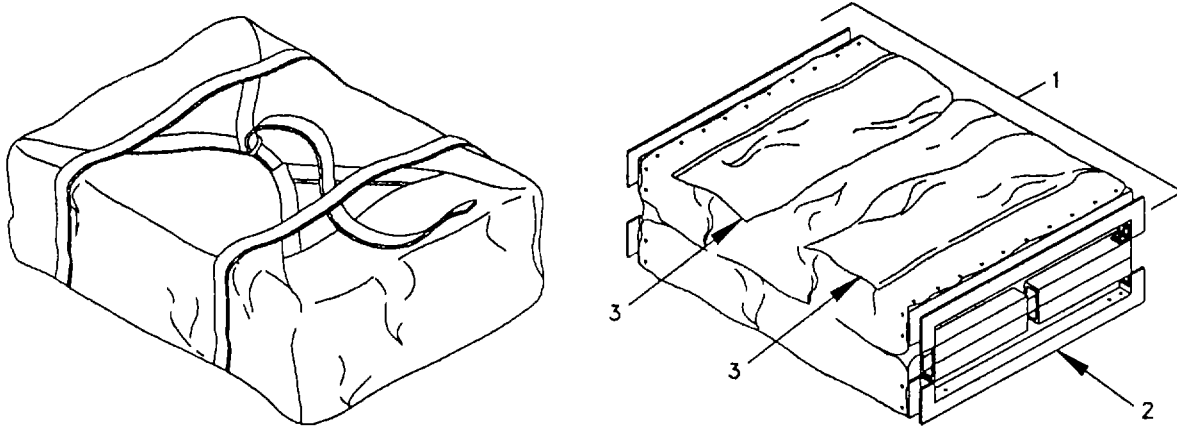

WARNING

The Complexing Kit Passageway components include two ramps and a stairway. The ramps weigh 145 pounds (65.77 kg) and 195 pounds (88.45 kg) respectively, and the stairway (complete assembly) weighs approximately 70 pounds (31.75 kg). Four personnel are required to handle each of these components. Attempting to lift or carry any one of them by yourself could result in serious injury or damage to the equipment.

CAUTION

When cutting tie-down straps to unpack Complexing Kit Passageway, be sure not to cut canvas. Damage to equipment may result.

- (3) Unpack Complexing Kit Passageway - Type I (1). Carefully check all parts. Report any discrepancies to your supervisor.
- (4) Place ramp inside one ISO shelter for later placement.
- (5) Align Complexing Kit Passageway (2) with ISO shelter openings. Make sure weather barriers (3) are on top.

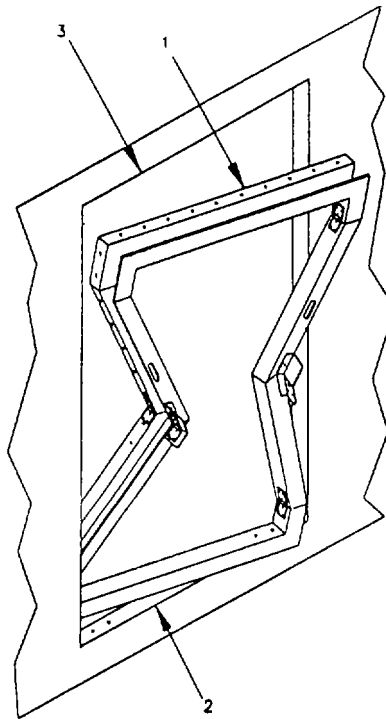
2-4. INSTALLATION AND PREPARATION FOR USE (CONT)a. Installing Complexing Kit Passageway - Type I (ISO Shelter to ISO Shelter) (Cont)**WARNING**

When installing or removing frame assembly, take care to avoid getting fingers caught in hinged joints. Failure to do so may result in serious injury.

NOTE

The following procedures are done at the same time in each shelter.

- (6) Place bottom of frame assembly (1) over lip (2) of ISO shelter opening (3).
 - (a) Place one corner of bottom frame assembly on the shelter opening lips.
 - (b) Raise one corner of upper frame assemblies.
 - (c) Step down on bottom frame assemblies to seat frame assemblies on lower lips of shelter openings.

2-4 INSTALLATION AND PREPARATION FOR USE (CONT)

a. Installing Complexing Kit Passageway - Type I (ISO Shelter to ISO Shelter) (Cont)

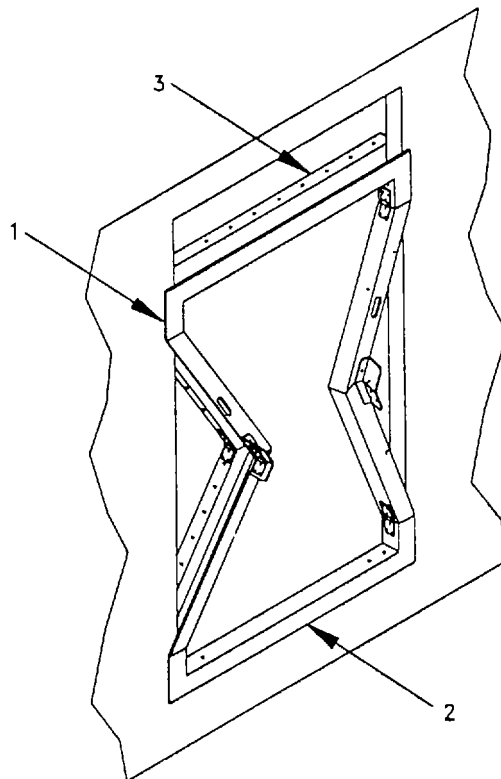

NOTE

The next procedure is done inside ISO shelter.

(7) Erect frame assembly (1) using the following steps:

(a) Position one person on each side of frame assembly (1).

CAUTION

Be sure fabric of connector assembly is not caught in frame assembly hinges when frame assembly is installed. Damage to connector assembly may result.

(b) Keeping bottom assembly header frame (?) in place, push top assembly header frame (3) to top lip of ISO shelter opening

2-4. INSTALLATION AND PREPARATION FOR USE (CONT)

a. Installing Complexing Kit Passageway - Type I (ISO Shelter to ISO Shelter) (Cont)

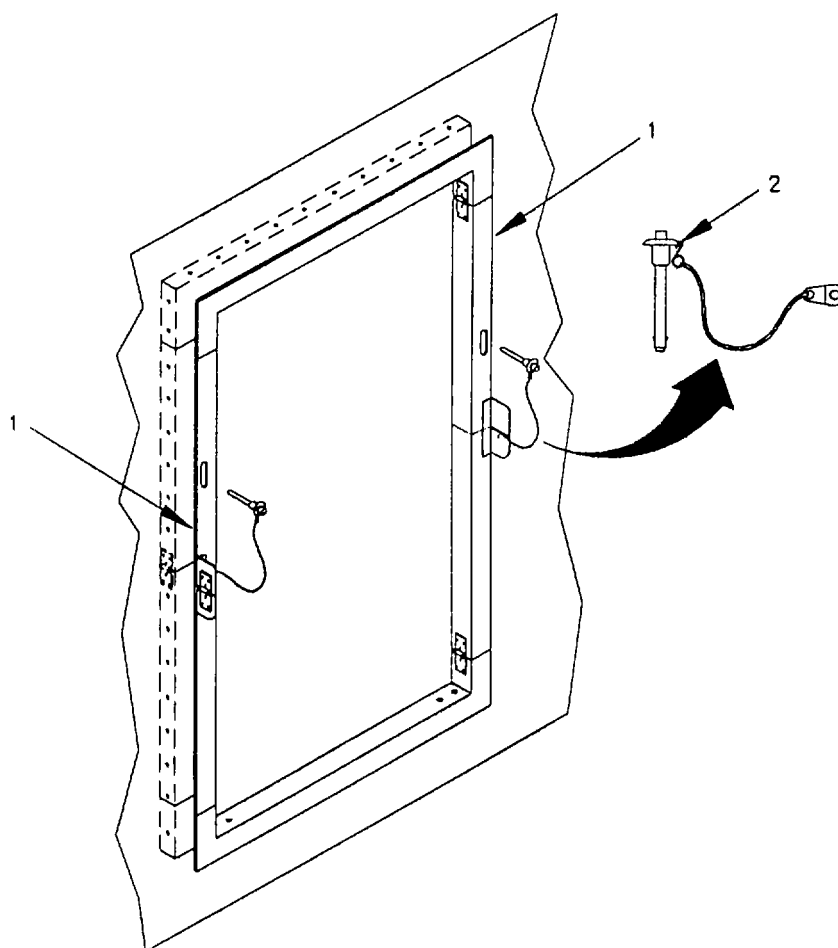

(c) Press on frame sides (1) until frame assemblies are fully seated in shelter openings.

(d) Insert locking pins (2)

2-4. INSTALLATION AND PREPARATION FOR USE (CONT)

a. Installing Complexing Kit Passageway - Type I (ISO Shelter to ISO Shelter) (Cont)

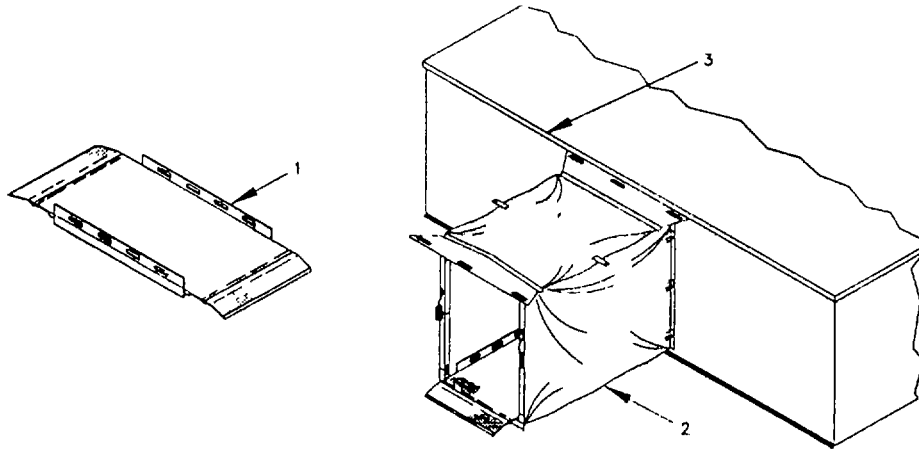

WARNING

The Complexing Kit Passageway components include two ramps and a stairway. The ramps weigh 145 pounds (65.77 kg) and 195 pounds (88.45 kg) respectively, and the stairway (complete assembly) weighs approximately 70 pounds (31.75 kg). Four personnel are required to handle each of these components. Attempting to lift or carry any one of them by yourself could result in serious injury or damage to the equipment.

CAUTION

Do not permit ramp to drop. Support ramp throughout lowering procedure to prevent damage to connector assembly.

Do not step on fabric floor of connector assembly. Damage to connector assembly may result.

- (8) Place ramp (1) inside complexing kit passageway (2) using the following steps.
- (a) Lift ramp (1) and place on side.
 - (b) Lift ramp and pass end through opening to personnel in other ISO shelter (3).
 - (c) Lower ramp (1) into position.

2-4. INSTALLATION AND PREPARATION FOR USE (CONT)

a. Installing Complexing Kit Passageway - Type I (ISO Shelter to ISO Shelter) (Cont)

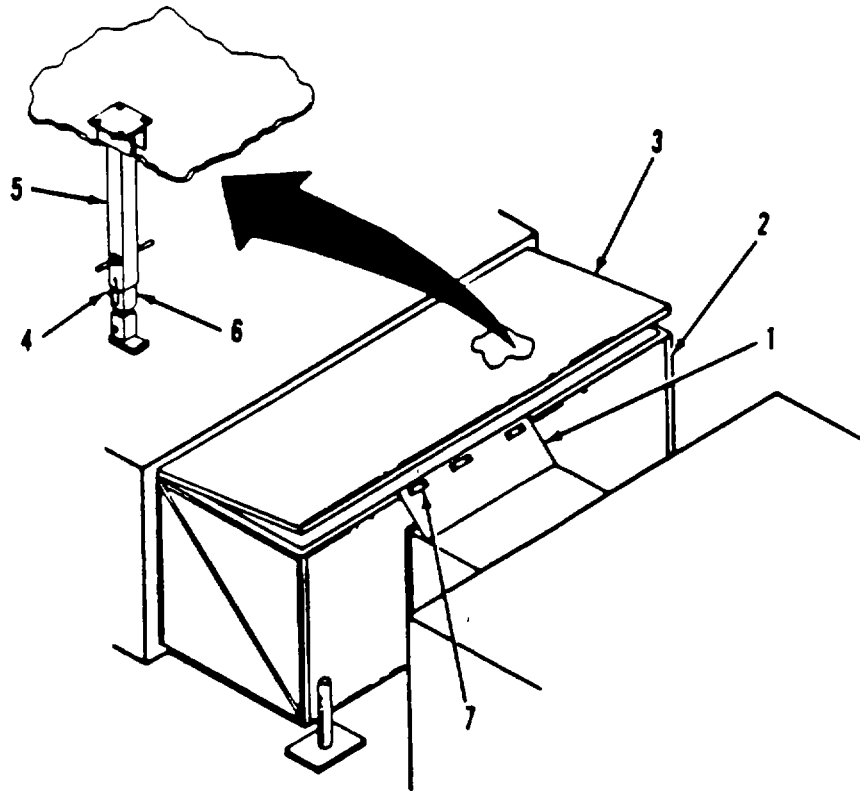

NOTE

This next procedure requires two persons on the inside and two persons on the outside of the ISO shelter.

- (9) Secure weather barriers (1) to ISO shelter (2) using the following steps:
 - (a) Unlatch all roof panel latches to release hinged roof panel (3) from ISO shelter (2).
 - (b) Pull locking pins (4) to allow roof support struts (5) to swing down from hinged roof panel (3).
 - (c) Extend inner tube (6) of roof support struts (5).
 - (d) Insert locking pins (4) through holes in roof support struts (5) and inner tubes (6) when holes align.
 - (e) Using the two roof support struts (5), push up hinged roof panel (3) until roof support struts are in full upright position.

2-4. INSTALLATION AND PREPARATION FOR USE (CONT)

a. Installing Complexing Kit Passageway - Type I (ISO Shelter to ISO Shelter) (Cont)

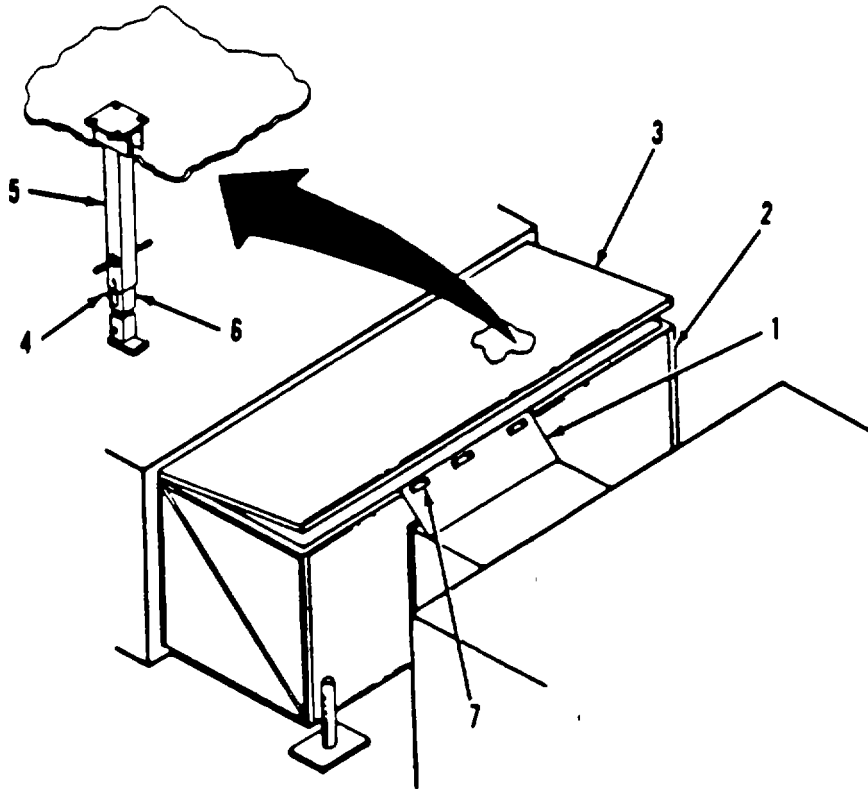

- (f) Lower hinged roof support struts to floor until hinged roof panel (3) is supported on struts.

WARNING

When installing or removing weather barrier between hinged roof panel and hinged sidewall or endwall of ISO shelter, take care to avoid fingers getting caught. Failure to do so may result in serious injury.

- (g) Insert weather barrier (1) through open space between hinged roof panel (3) and ISO shelter (2).
- (h) Using handles (7), pull weather barrier (1) inside ISO shelter (2) until edge of weather barrier covers top of frame.
- (i) Using two hinged roof support struts, lower hinged roof panel (3) onto weather barrier (1) and ISO shelter (2).
- (j) Repeat steps (a) through (i) for other weather barrier (1).

2-4. INSTALLATION AND PREPARATION FOR USE (CONT)a. Installing Complexing Kit Passageway - Type I (ISO Shelter to ISO Shelter) (Cont)**CAUTION**

Avoid excessive stress on fabric when adjusting weather barriers. Failure to do so may result in fabric damage or separation of seams.

NOTE

When adjusting weather barriers, ensure material lays flat without creases or folds.

- (k) Repeat steps (e) thru (i), adjust weather barriers until fabric roof of connector assembly does not sag.
 - (l) Store hinged roof support struts in stowage brackets.
 - (m) Latch all inside panel latches to secure hinged roof panel (1) to ISO shelters (2).
- (10) Tighten strap assemblies located at each inside corner of the connector assembly.

2-4. INSTALLATION AND PREPARATION FOR USE (CONT)

a Installing Complexing Kit Passageway - Type I (ISO Shelter to ISO Shelter) (Cont)

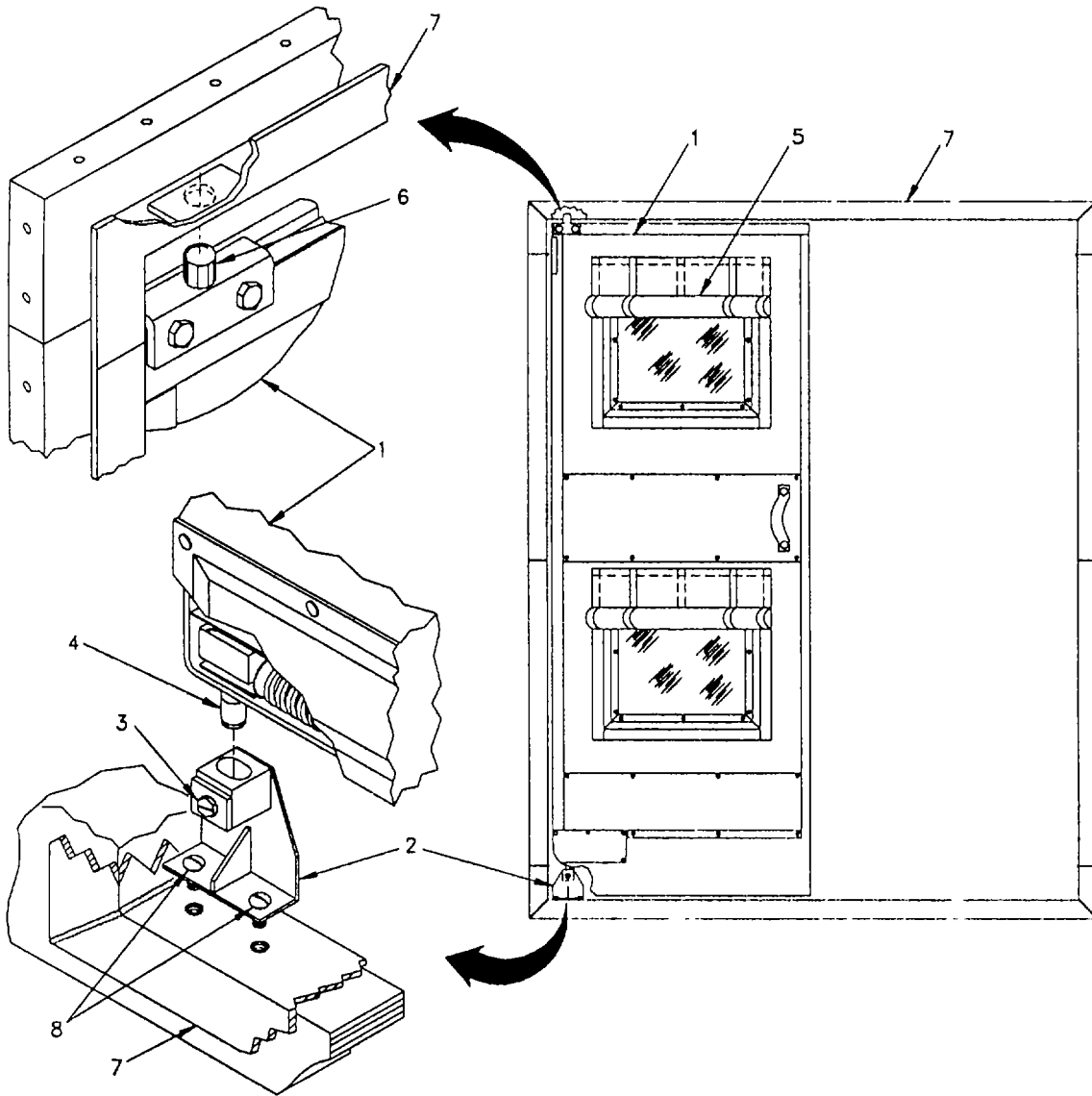

2-4. INSTALLATION AND PREPARATION FOR USE (CONT)**a Installing Complexing Kit Passageway - Type I (ISO Shelter to ISO Shelter) (Cont)**

- (11) Install bump thru doors using the following steps:
- (a) Remove door (1) and pedestal assembly (2) from carrying container.
 - (b) Using flat-tip screwdriver, turn height adjustment screw (3) on pedestal assembly (2) counter-clockwise all the way.
 - (c) Mount and hold pedestal assembly (2) on hinge pin (4).

NOTE

Doors should be mounted with blackout or privacy curtains facing inside shelter.

- (d) Keeping height adjustment screw (3) and blackout curtains (5) facing inside the ISO shelter, insert pivot pin (6) into bushing in top of frame (7).
- (e) Position pedestal assembly (2) so that hinge pin captive screws (8) align with threaded inserts in frame assembly (7).
- (f) Thread captive screws but do not tighten.
- (g) Repeat (a) thru (f) above for other door.

2-4. INSTALLATION AND PREPARATION FOR USE (CONT)

a. Installing Complexing Kit Passageway - Type I (ISO Shelter to ISO Shelter) (Cont)

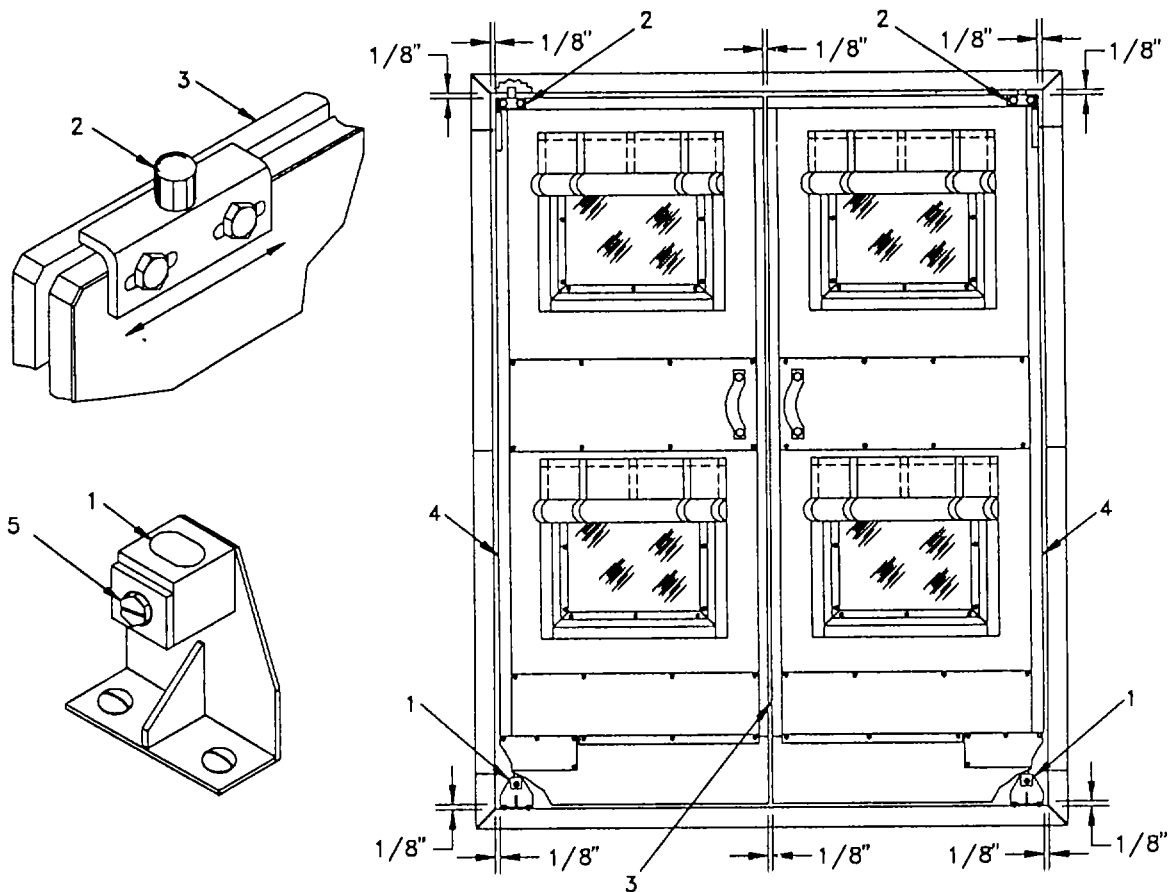

(12) Adjust doors using the following steps:

- (a) By moving pedestal assemblies (1) and pivot assemblies (2) on each door, adjust gap (3) between doors and gap (4) between doors and sides of the passageway frame. Gaps should be approximately 1/8 in. After an even gap is obtained, tighten mounting screws on pedestal assemblies (1) and pivot assemblies (2).
- (b) Adjust gap at top of door and top of passageway frame by turning height adjusting screw (5) clockwise to raise door.
- (c) Test doors by swinging one, then the other thru full range of motion. If any interference is encountered, additional adjustment may be necessary.

2-4. INSTALLATION AND PREPARATION FOR USE (CONT)

b. Installing Complexing Kit Passageway Type II, Class A and Class B (ISO Shelter to TEMPER)

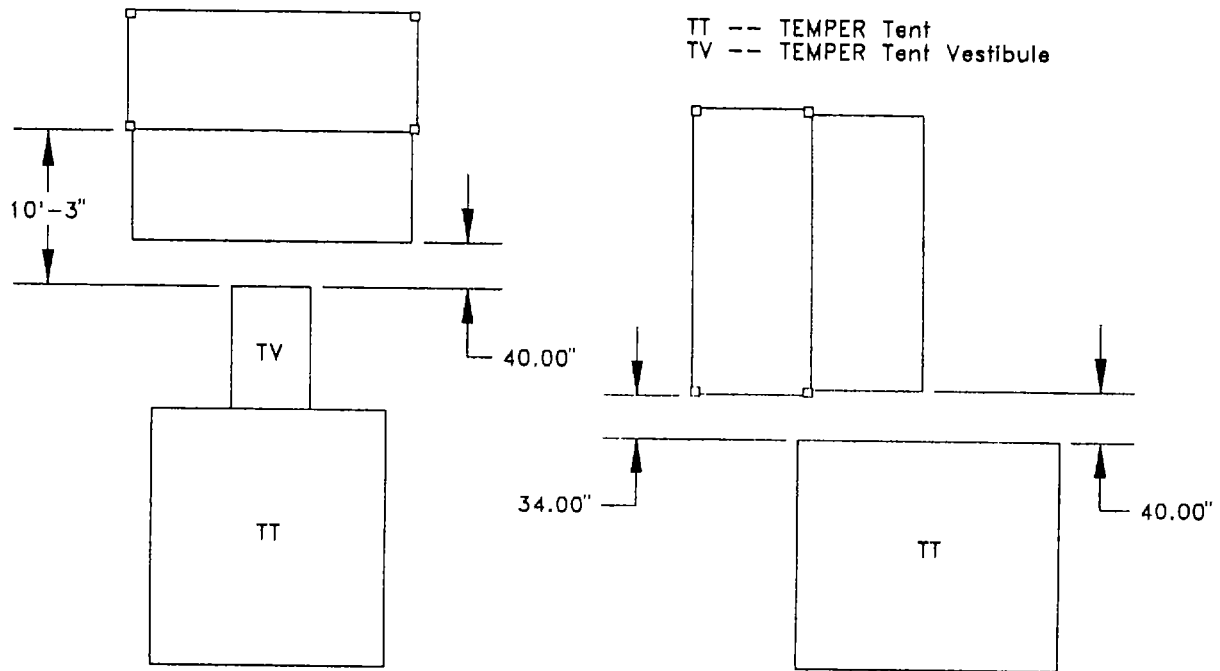

- (1) Set up ISO shelter and TEMPER within 40 in. (1016.0 mm) of each other with desired sidewall or endwall closeout panel facing TEMPER.

2-4. INSTALLATION AND PREPARATION FOR USE (CONT)**b. Installation Complexing Kit Passageway - Type II, Class A and Class B (ISO Shelter to TEMPER) (Cont)****NOTE**

The next procedure requires two persons on outside and one person on the inside of the ISO shelter.

- (2) Remove sidewall or endwall closeout panel (1) and (2) using the following steps:
 - (a) Locate desired closeout panel inside ISO shelter (3).
 - (b) Using wide flat-tip screwdriver, loosen 12 captive screws on closeout panel.
 - (c) Remove closeout panel and store on outside of shelter (2) or other location while not in use.
 - (d) For end wall installation, refer to TM 10-5411-200-14 or TM 10-5411-201-14 for disengagement of support cables.
- (3) Unpack Complexing Kit Passageway - Type II, Class A and Class B using the following steps:
 - (a) Remove frame-connector assembly and exterior frame assembly from packing container.
 - (b) Carefully check all parts. Report any discrepancies to your supervisor.
 - (c) Lay aside exterior frame assembly header bar and upright bars
- (4) Align frame assembly with ISO shelter opening.
- (5) Make sure weather barrier is on top.

2-4. INSTALLATION AND PREPARATION FOR USE (CONT)**b. Installing Complexing Kit Passageway - Type II, Class A and Class B (ISO Shelter to TEMPER) (Cont)****WARNING**

The Complexing Kit Passageway components include two ramps and a stairway. The ramps weigh approximately 145 pounds (65.77 kg) and 195 pounds (88.45 kg) respectively, and the stairs (complete assembly) weighs approximately 70 pounds (31.75 kg). Four persons are required to handle each of these components. Attempting to lift or carry any one of them by yourself could result in serious injury and/or damage to equipment.

CAUTION

Do not permit ramp or stairway to drop. Support ramp or stairway throughout lowering process. Failure to do so may result in damage to equipment.

- (6) Remove ramp or stairway from shipping container.
- (7) Place ramp or stairway inside ISO shelter or TEMPER for later placement.

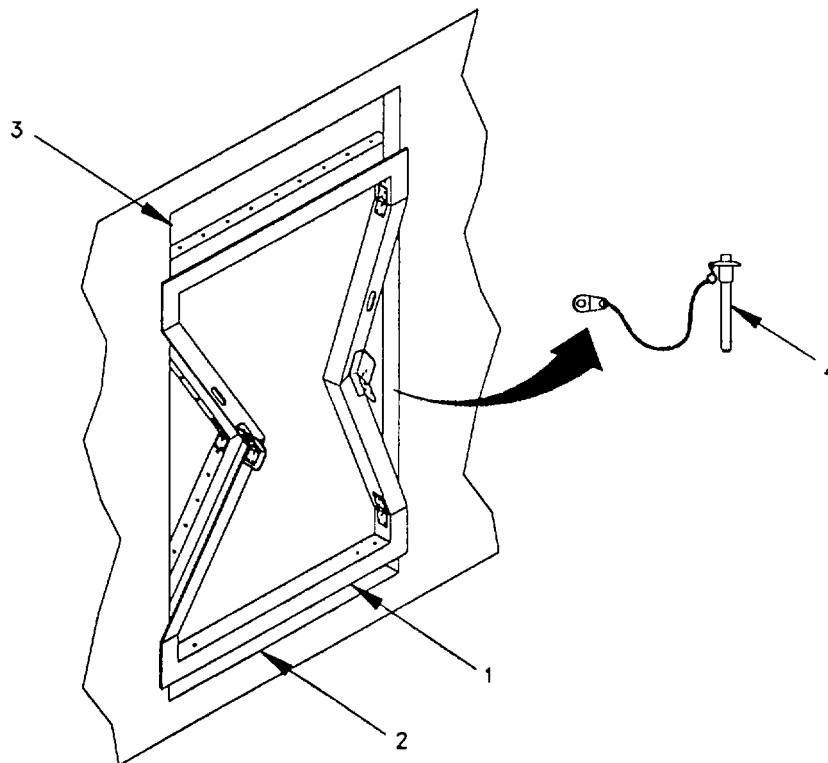

2-4. INSTALLATION AND PREPARATION FOR USE (CONT)**b. Installing Complexing Kit Passageway - Type II, Class A and Class B (ISO Shelter to TEMPER) (Cont)****WARNING**

When installing or removing frame assembly, take care to avoid getting fingers caught in hinged joints. Failure to do so may result in serious injury.

NOTE

The next step requires two persons on the outside and two persons on the inside of the ISO shelter. (8) Place bottom of frame assembly (1) over lip (2) of ISO shelter opening (3).

WARNING

When installing or removing frame assembly, avoid getting fingers caught in hinged joints. Failure to do so may result in serious injury.

CAUTION

Ensure fabric of connector assembly is not caught in frame assembly hinges when frame assembly is installed.

NOTE

The next procedure is done inside ISO shelter.

- (9) Erect frame assembly (1) using the following steps:
- (a) Position one person on each side of frame (1).
 - (b) As one person holds bottom of frame (1), other person pushes top of frame to top lip of ISO shelter opening.
 - (c) Press on frame sides until frame assembly is fully seated in shelter opening and insert locking pins (4).

2-4. INSTALLATION AND PREPARATION FOR USE (CONT)

b. Installing Complexing Kit Passacewav - Type II. Class A and Class B (ISO Shelter to TEMPER) (Cont)

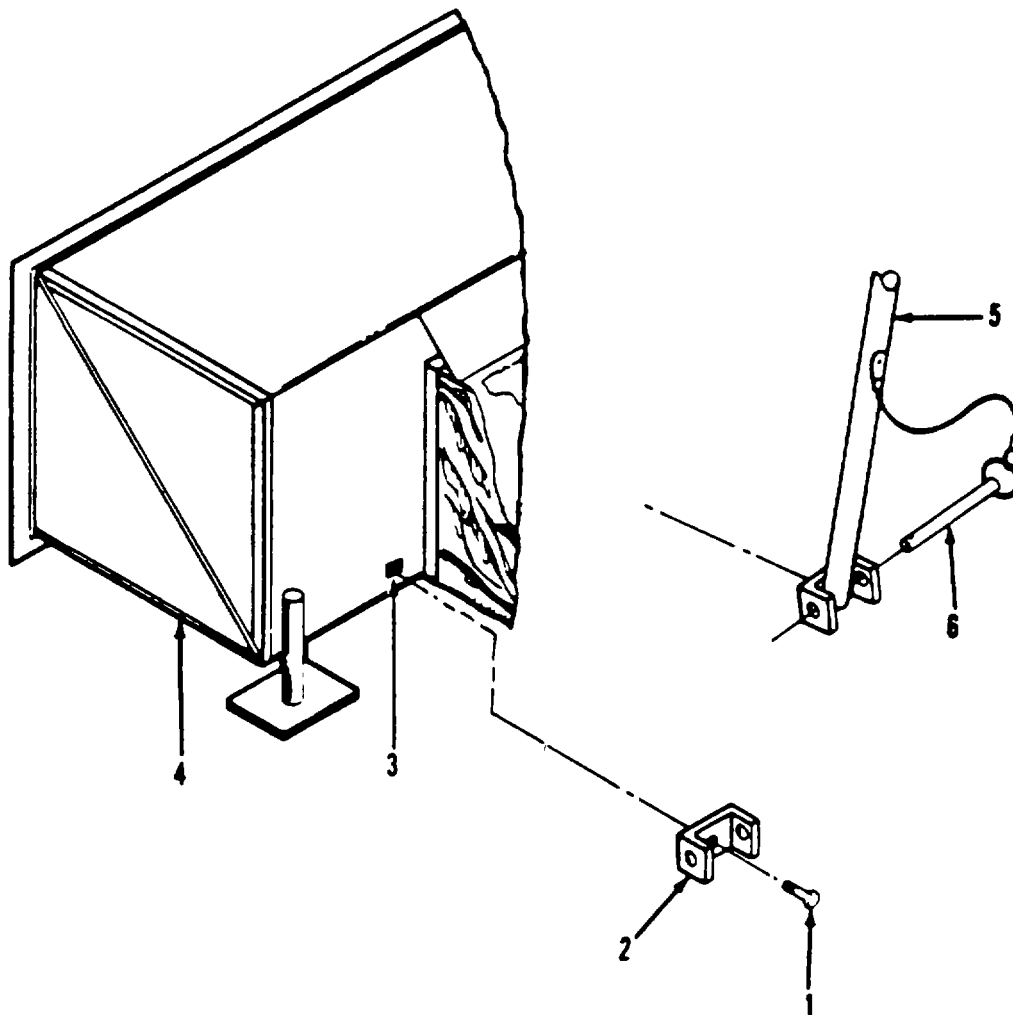

- (10) Using a flat-tip screwdriver and captive screws (1), attach swivel feet (2) snugly to threaded inserts (3) on ISO shelter (4).

NOTE

It may be necessary to rotate swivel feet slightly to allow insertion of locking pin.

- (11) Insert exterior frame assembly upright bars (5) into swivel feet (2) and secure with locking pins (6).

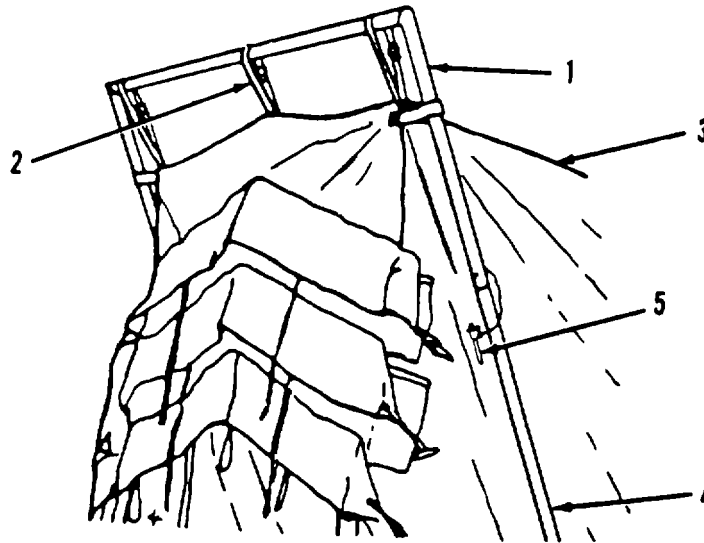
2-4. INSTALLATION AND PREPARATION FOR USE (CONT)**b. Installing Complexing Kit Passageway - Type II, Class A and Class B (ISO Shelter to TEMPER) (Cont)**

- (12) Place header bar (1) through support straps (2) along roof of connector assembly (3).
- (13) Connect upright bars (4) to header bar (1) using the following steps:
- (a) Insert both upright bars (4) into header bar (1).
 - (b) Insert locking pins (5) into holes to secure upright bars (4) to header bar (1).

WARNING

The Complexing Kit Passageway components include two ramps and a stairway. The ramps weigh approximately 145 pounds (65.77 kg) and 195 pounds (88.45 kg) respectively, and the stairs (complete assembly) weigh approximately 70 pounds (31.75 kg). Four persons are required to handle each of these components. Attempting to lift or carry any one of them by yourself could result in serious injury or damage to the equipment.

CAUTION

Do not permit ramp or stairway to drop. Support ramp or stairway throughout lowering procedure to prevent damage to connector assembly.

- (14) For Type II, Class A, place ramp inside Complexing Kit Passageway.

2-4. INSTALLATION AND PREPARATION FOR USE (CONT)

b. Installing Complexing Kit Passageway - Type II, Class A and Class B (ISO Shelter to TEMPER) (Cont)

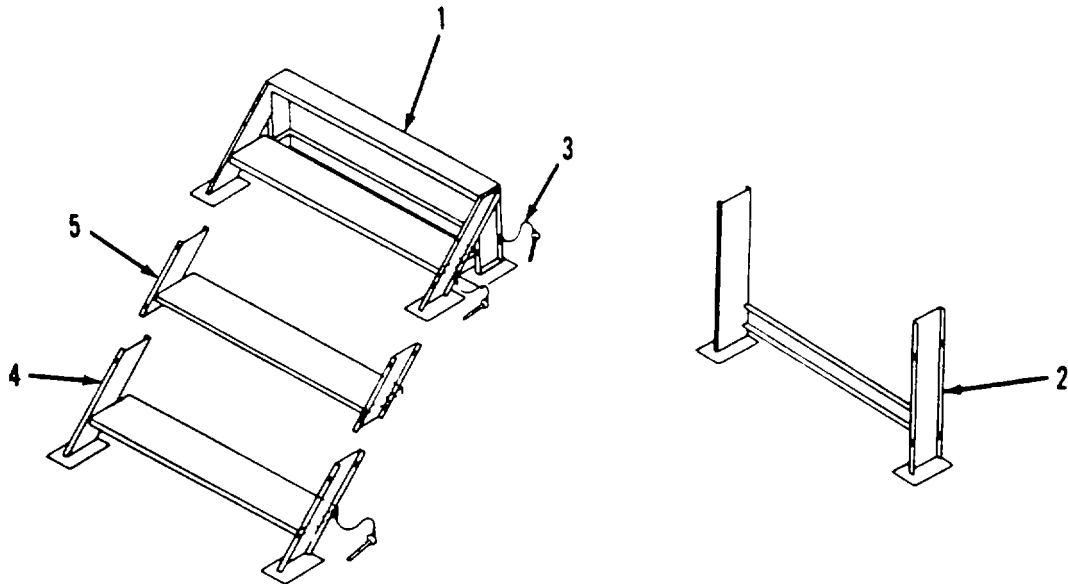

(15) For Type II, Class B, determine the number of steps required, assemble and place stairway inside Complexing Kit Passageway using the following steps.

(a) For 2-step stairway, place 2-step stairway (1) in passageway. Store remainder of stairway components.

(b) To assemble 3-step stairway:

1 Insert rear stairway support assembly (2) uprights into rear legs of stairway assembly (1). Insert locking pins (3) through holes in stairway assembly rear legs and lower holes in stairway support assembly legs.

2 Insert lower riser assembly (4) legs into front risers of stairway assembly and insert locking pins.

3 Place assembled 3-step stairway in passageway and store stairway's middle rear assembly.

2-4. INSTALLATION AND PREPARATION FOR USE (CONT)**b. Installing Complexing Kit Passageway - Type II, Class A and Class B (ISO Shelter to TEMPER) (Cont)**

(c) For 4-step stairway:

- 1 Insert rear stairway support assembly (2) uprights into rear legs of stairway assembly (1). Insert locking pins (3) through holes in stairway assembly rear legs and upper holes in stairway support assembly legs.
- 2 Insert middle riser assembly (5) upper risers into lower risers of stairway assembly (1) and insert locking pins.
- 3 Insert lower riser assembly (4) upper risers into lower risers of middle riser assembly (5) and insert locking pins.
- 4 Place assembled 4-step stairway in passageway.

2-4. INSTALLATION AND PREPARATION FOR USE (CONT)

b. Installing Complexing Kit Passageway - Type II. Class A and Class B (ISO Shelter to TEMPER) (Cont)

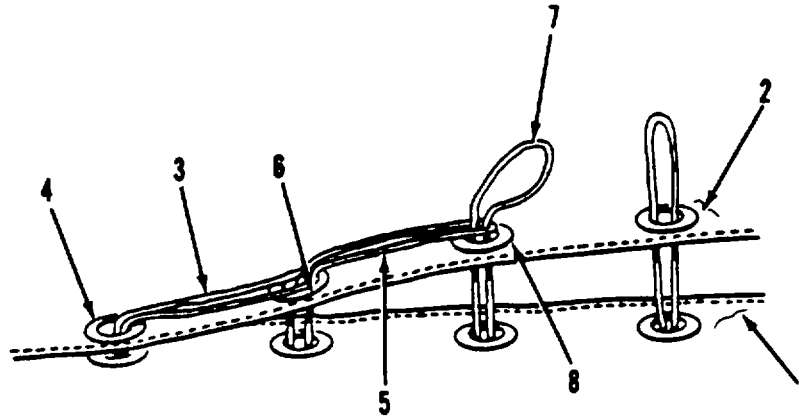

- (16) Ready connector assembly (1) for becket lacing using the following steps:
- (a) Select connector's becket assembly level which most closely matches the same height as that by the TEMPER entrance.
 - (b) Locate first top center loop on connector assembly (1) and first top center grommet on grommet flap (2) of TEMPER.
 - (c) Overlap TEMPER grommet flap (2) onto connector assembly (1).
- (17) Becket lace connector assembly (1) to grommet flap (2) using the following steps:
- (a) Starting from top center of connector assembly (1), insert loop (3) into grommet (4) and loop (5) into grommet (6) of grommet flap (2).
 - (b) Insert loop (5) up through loop (3).
 - (c) Pull loop (5) tight.
 - (d) Insert loop (7) through grommet (8) and through loop (5).
 - (e) Pull loop (7) tight.
 - (f) Continue becketing procedure all the way across crown of grommet flap (2) until top cover of grommet flap (2) is reached.

2-4. INSTALLATION AND PREPARATION FOR USE (CONT)

b. Installing Complexing Kit Passageway - Type II, Class A and Class B (ISO Shelter to TEMPER) (Cont)

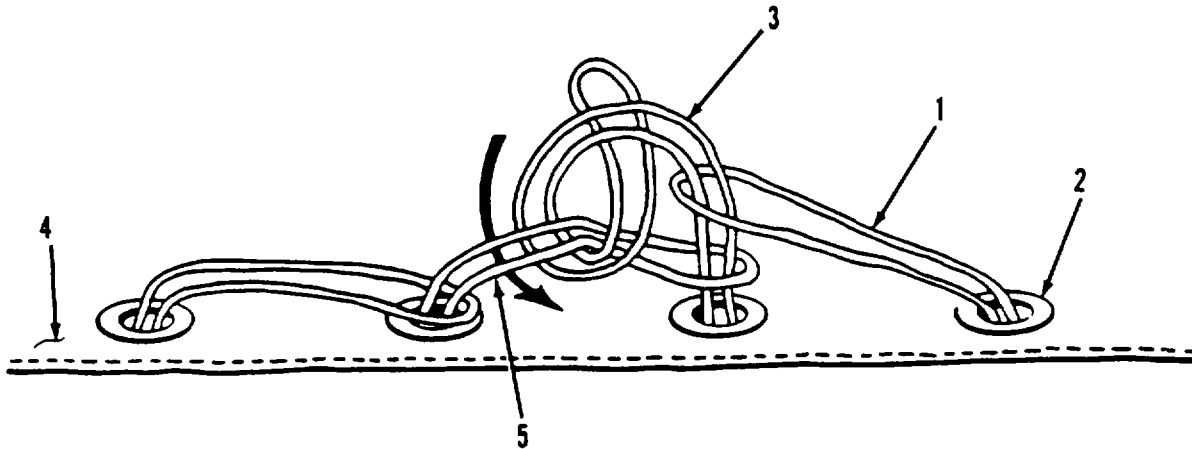

- (18) Tie off becket lacing with half-hitch knot using the following steps:
 - (a) Upon reaching the last loop (1) and inserting through last grommet (2), insert next-to-last loop (3) through last loop (1).
 - (b) Pull next-to-last loop (3) up towards top of grommet flap (4).
 - (c) Push under second-from-last loop (5) and pull through until tight to form half-hitch knot.
- (19) Repeat steps (16), (17), and (18) to secure other top side of passageway/TEMPER connection using loops from TEMPER and grommets from passageway.
- (20) Repeat steps (16), (17), and (18) to secure sides of passageway/ TEMPER connection.
- (21) Cover becket laces with flap and secure with attached hook and loop strips.
- (22) Slip loops at ends of becket flap over corresponding wooden toggles located in sides of connector.

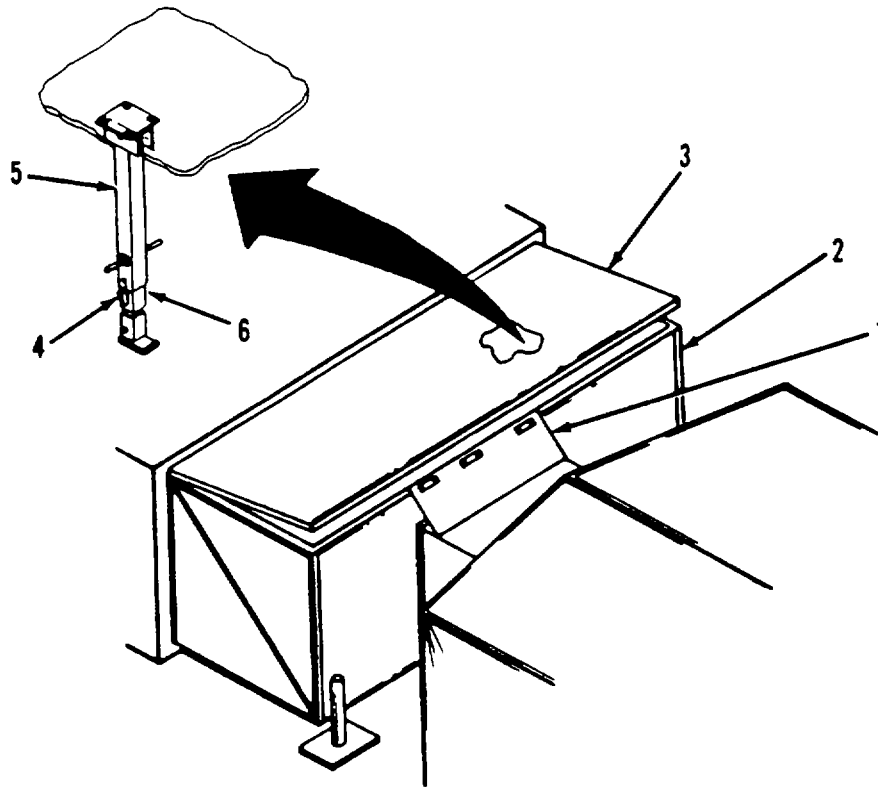
2-4. INSTALLATION AND PREPARATION FOR USE (CONT)**b. Installing Complexing Kit Passageway - Type II, Class A and Class B (ISO Shelter to TEMPER) (Cont)**

(23) Secure weather barrier (1) to ISO shelter (2) using the following steps:

CAUTION

Do not step on fabric floor of connector assembly.
Damage to connector assembly may result.

- (a) Unlatch all inside roof panel latches to release hinged roof panel (3) from ISO shelter (2).
- (b) Pull locking pins (4) to allow roof support struts (5) to swing down from hinged roof panel (3).
- (c) Extend inner tube (6) of roof support struts (5).
- (d) Insert locking pins (4) through holes in roof support struts (5) and inner tubes (6) when holes align.

2-4. INSTALLATION AND PREPARATION FOR USE (CONT)**b. Installing Complexing Kit Passageway - Type II, Class A and Class B (ISO Shelter to TEMPER) (Cont)****WARNING**

When raising or lowering hinged roof panel and hinged sidewall of ISO shelter, take care to avoid getting fingers caught. Failure to do so may result in serious injury.

- (e) Raise hinged roof panel (3) to full height using roof support struts (5).
- (f) Rotate roof support struts (5) to upright position. Then lower roof support struts (5) to floor until hinged roof panel (3) is supported on struts (5).

NOTE

The next procedure requires two persons on the inside and two persons on the outside of the ISO shelter.

- (g) Insert weather barrier (1) through open space between hinged roof panel (3) and and ISO shelter (2).

CAUTION

Avoid excessive stress on fabric when adjusting weather barrier. Failure to do so may result in fabric damage or separation of seams.

NOTE

When adjusting weather barrier, make sure fabric lays flat without creases or folds.

- (h) Pull weather barrier (1) inside ISO shelter (2) until edge of weather barrier covers top of frame.
- (i) Using two roof support struts (5), lower hinged roof panel (3) onto weather barrier (1) and ISO shelter (2).
- (j) Store roof support struts (5) in stowage brackets.
- (k) Latch all inside panel latches to secure hinged roof pane] (3) to ISO shelter (2).

2-4. INSTALLATION AND PREPARATION FOR USE (CONT)

b. Installing Complexing Kit Passageway - Type II, Class A and Class B (ISO Shelter to TEMPER) (Cont)

- (24) Stake bottom corners of connector assembly to ground using tent pins.
- (25) Tighten strap assemblies located at each inside corner of the connector assembly.

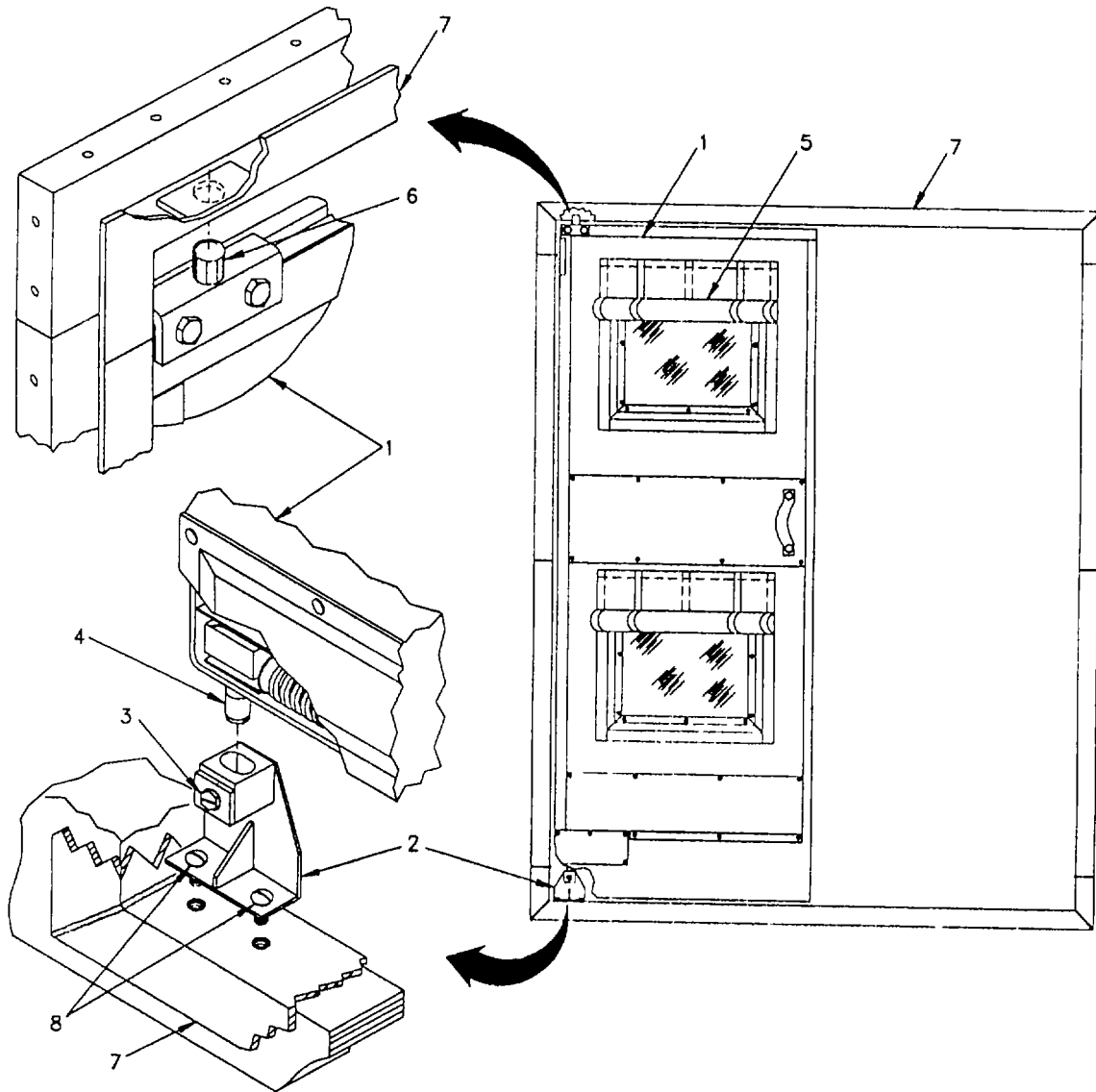

2-4. INSTALLING AND PREPARATION FOR USE (CONT)**b. Installing Complexing Kit Passageway - Type II, Class A and Class B (ISO Shelter to TEMPER) (Cont)**

- (26) Install bump thru doors using the following steps:
- (a) Remove door (1) and pedestal assembly (2) from carrying container.
 - (b) Using flat-tip screwdriver, turn height adjustment screw (3) on pedestal assembly (2) counter-clockwise all the way.
 - (c) Mount and hold pedestal assembly (2) on hinge pin (4).

NOTE

Doors should be mounted with blackout or privacy curtains facing inside shelter.

- (d) Keeping height adjustment screw (3) and blackout curtains (5) facing inside the ISO shelter, insert pivot pin (6) into bushing in top of frame (7).
- (e) Position pedestal assembly (2) so that hinge pin captive screws (8) align with threaded inserts in frame assembly (7).
- (f) Thread captive screws but do not tighten.
- (g) Repeat (a) thru (f) above for other door.

2-4. INSTALLING AND PREPARATION FOR USE (CONT)

b. Installing Complexing Kit Passageway - Type II, Class A and Class B (ISO Shelter to TEMPER) (Cont)

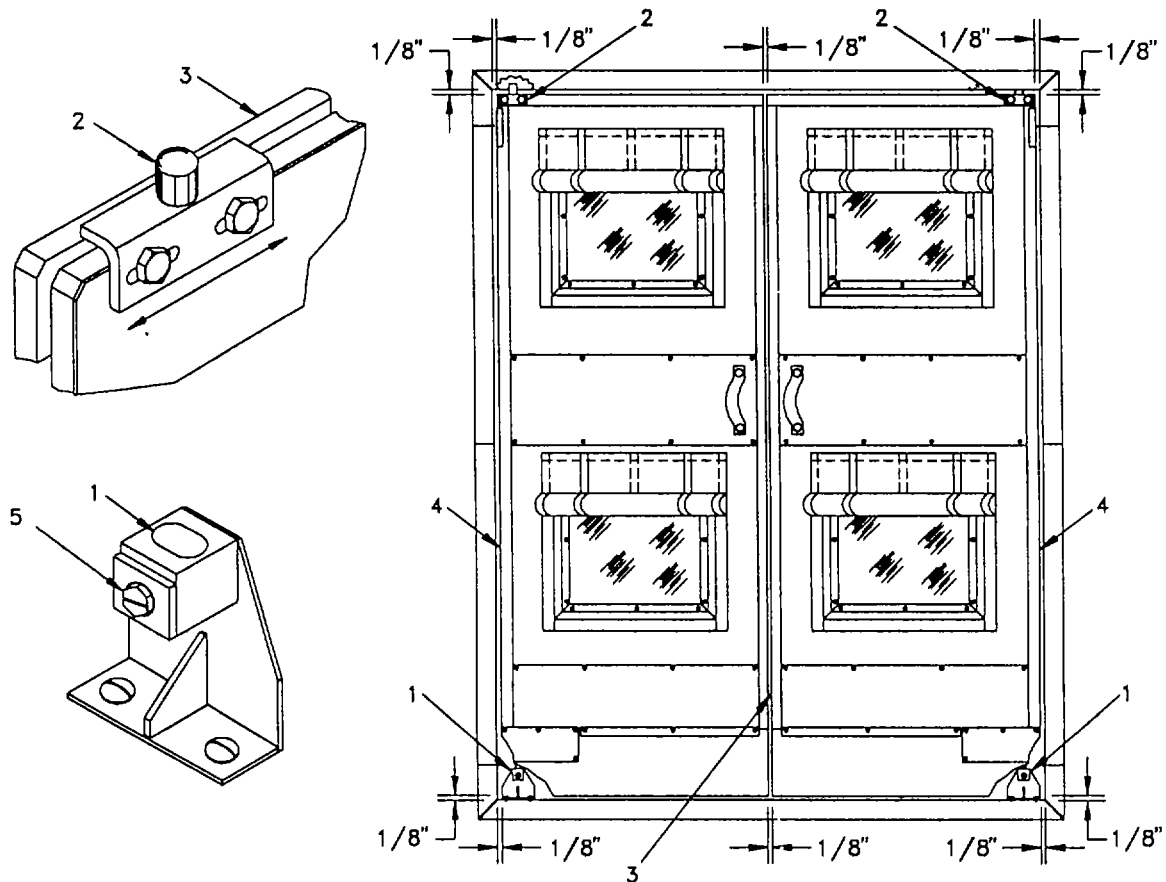

(27) Adjust the doors using the following steps:

- By moving pedestal assemblies (1) and pivot assemblies (2) on each door, adjust gap (3) between doors and gap (4) between doors and sides of passageway frame. Gaps should be approximately 1/8 in. After an even gap is obtained, tighten mounting screws on pedestal assemblies (1) and pivot assemblies (2).
- Adjust gap between top of door and top of passageway frame by turning height adjusting screw (5) clockwise to raise door.
- Test doors by swinging one, then the other thru full range of motion. If any interference is encountered additional adjustment may be necessary.

2-5. REMOVAL PROCEDURES

a. Removal of Complexing Kit Passageway - Type I (ISO Shelter to ISO Shelter)

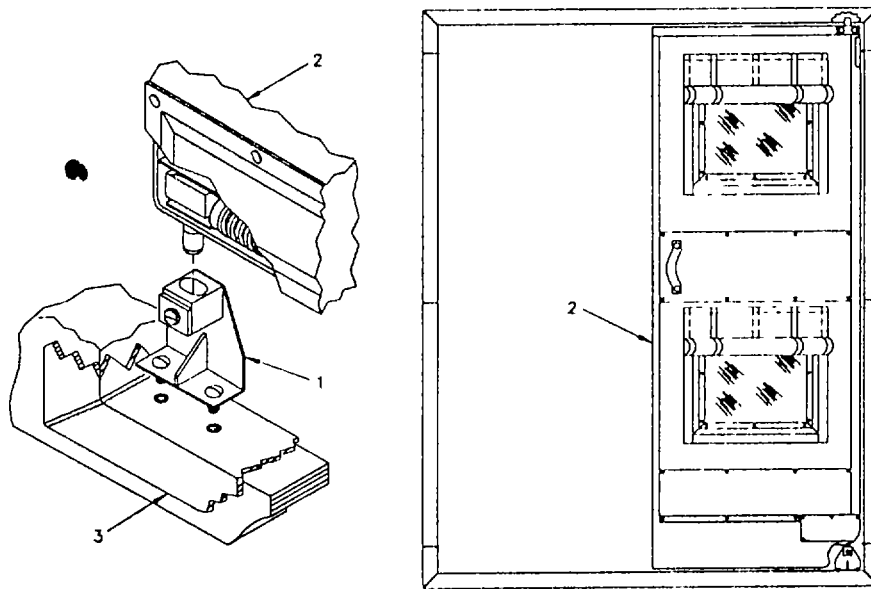

- (1) Remove bump thru doors using the following steps:
 - (a) Using flat-tip screwdriver, unthread captive screws on pedestal assembly (1) at bottom of door (2).
 - (b) Remove door (2) and pedestal (1) from frame (3) of Complexing kit passageway.
 - (c) Store door and pedestal in storage container.
 - (e) Repeat (a) thru (c) above for other door.

2-5. REMOVAL PROCEDURES (CONT)

a. Removal of Complexing Kit Passageway - Type I (ISO Shelter to ISO Shelter) (Cont)

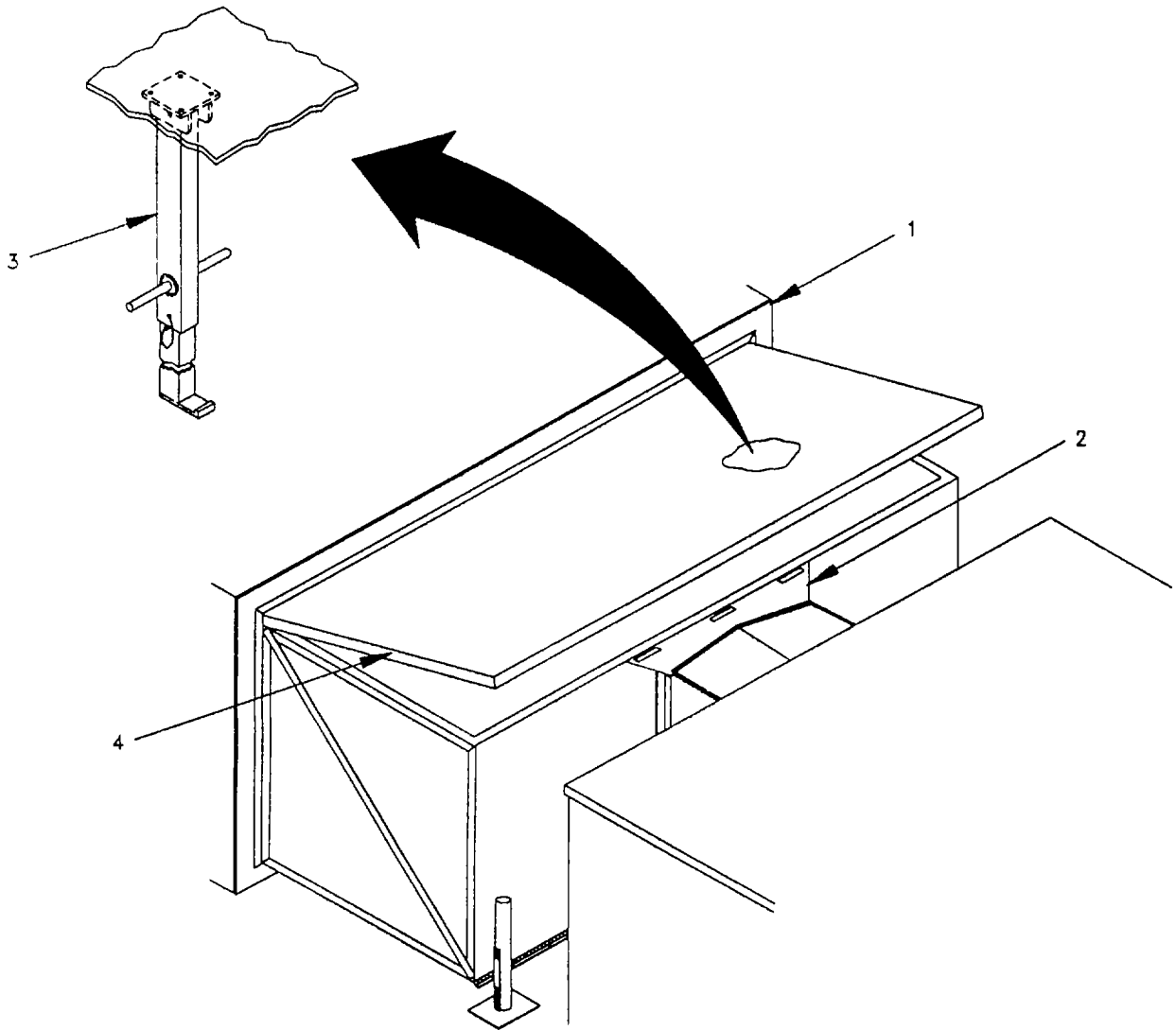

2-5. REMOVAL PROCEDURES (CONT)

a. Removal of Complexing Kit Passageway - Type I (ISO Shelter to ISO Shelter) (Cont)

NOTE

The next procedure requires two persons in- side the ISO shelter (1) and two persons out- side the ISO shelter (1)

(1.1) Remove weather barriers (2) from ISO shelter (1) using the following steps:

- (a) Unlatch all roof panel latches.
- (b) Using two roof panel struts (3), push up hinged roof panel (4) until roof support struts (3) are in the upright position.
- (c) Lower struts (3) to floor until hinged roof panel (4) is supported by struts (3).

WARNING

When removing the weather barriers between hinged roof panel and ISO shelter wall, take care to avoid getting fingers caught. Failure to do so may result in serious injury.

- (d) Pull weather barriers (2) out of open space between hinged roof panel (4) and ISO shelter (1).
- (e) Using the two hinged roof support struts (3), lower roof panel (4) onto ISO shelter (1).
- (f) Store hinged roof support struts (3) on stowage brackets.
- (g) Latch all panel latches to secure hinged roof panel (4) to ISO shelter (1).
- (h) Repeat steps (a) thru (g) above for other weather barrier.

2-5. REMOVAL PROCEDURES (CONT)

a. Removal of Complexing Kit Passageway - Type I (ISO Shelter to ISO Shelter) (Cont)

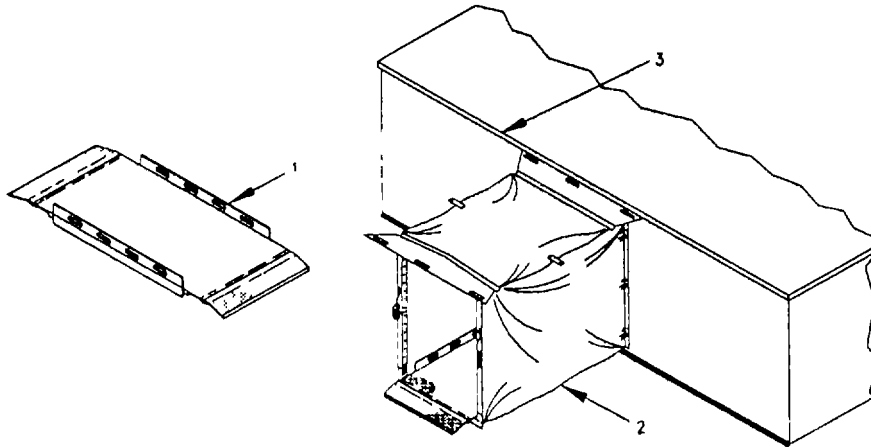

WARNING

The Complexing Kit Passageway components include two ramps and a stairway. The ramps weigh approximately 145 pounds (65.77 kg) and 195 pounds (88.45 kg) respectively, and the stairs (complete assembly) weighs approximately 70 pounds (31,75 kg). Four persons are required to handle each of these components. Attempting to lift or carry one of these components by yourself may result in serious injury or damage to equipment.

NOTE

The following procedures require two persons in each ISO shelter.

- (2) Remove ramp (1) from inside Complexing Kit Passageway - Type I (2) using the following steps:
- (a) Lift ramp (1) and place it on its side.

CAUTION

Do not step on fabric floor of connector assembly. Damage to connector assembly may result.

- (b) Lift ramp (1) and pass it through to personnel in other ISO shelter (3).
- (c) Remove ramp (1) from ISO shelter (3).

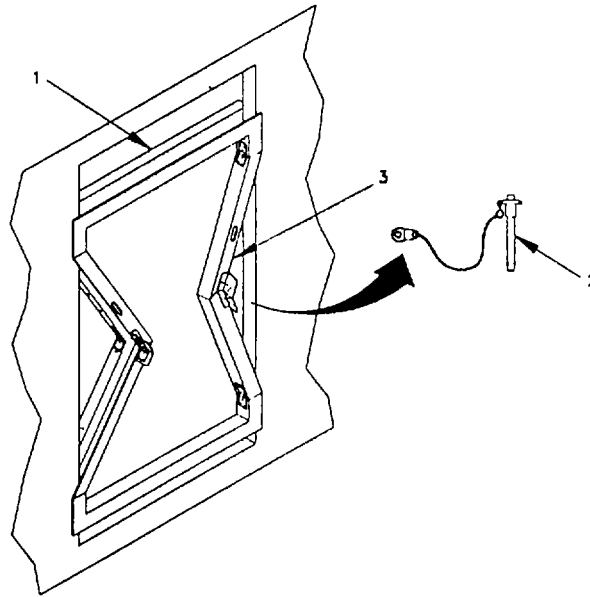
2-5. REMOVAL PROCEDURES (CONT)**a. Removal of Complexing Kit Passageway - Type I (ISO Shelter to ISO Shelter) (Cont)****WARNING**

When installing or removing frame assembly, take care to avoid getting fingers caught in hinged joints. Failure to do so may result in serious injury.

NOTE

The next procedure requires two persons in the ISO shelter.

- (3) Remove frame assemblies (1) from both ISO shelter openings using the following steps:
- (a) Unlatch and remove locking pins (2) on sides (3) of frame assembly (1) and insert locking pins in retainer tubes.

NOTE

The following steps must be performed at the same time in both ISO shelters.

- (b) Pull sides (3) toward center until top assembly header frame starts coming down.

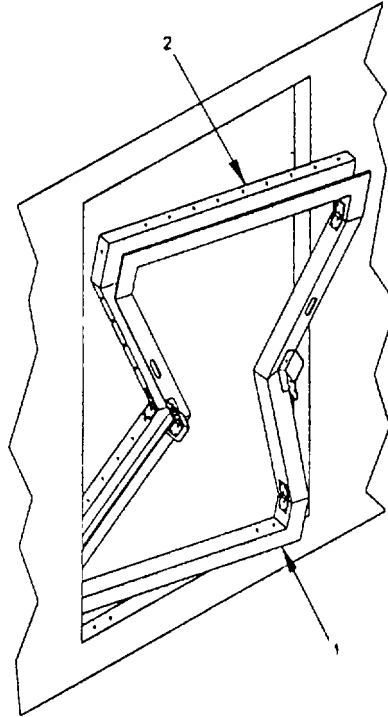
2-5. REMOVAL PROCEDURES (CONT)**a. Removal of Complexing Kit Passageway - Type I (ISO Shelter to ISO Shelter) (Cont)**

- (c) Raise one corner of the bottom assembly header frame (1) until the corner of frame is free of ISO shelter wall.
 - (d) Gradually lower opposite upper corner of frame assembly (2) until top assembly header frame is free of ISO shelter wall.
 - (e) Move lower frame assembly off lip of ISO shelter opening.
 - (f) Gradually lower top assembly header frame (2) until top assembly header frame rests on bottom assembly header frame.
- (4) Pick up and move Complexing Kit Passageway from between ISO shelters.
- (5) For packaging procedures for the Complexing Kit Passageway, refer to paragraph 2-6a.

2-5. REMOVAL PROCEDURES (CONT)

a. Removal of Complexing Kit Passageway - Type I (ISO Shelter to ISO Shelter) (Cont)

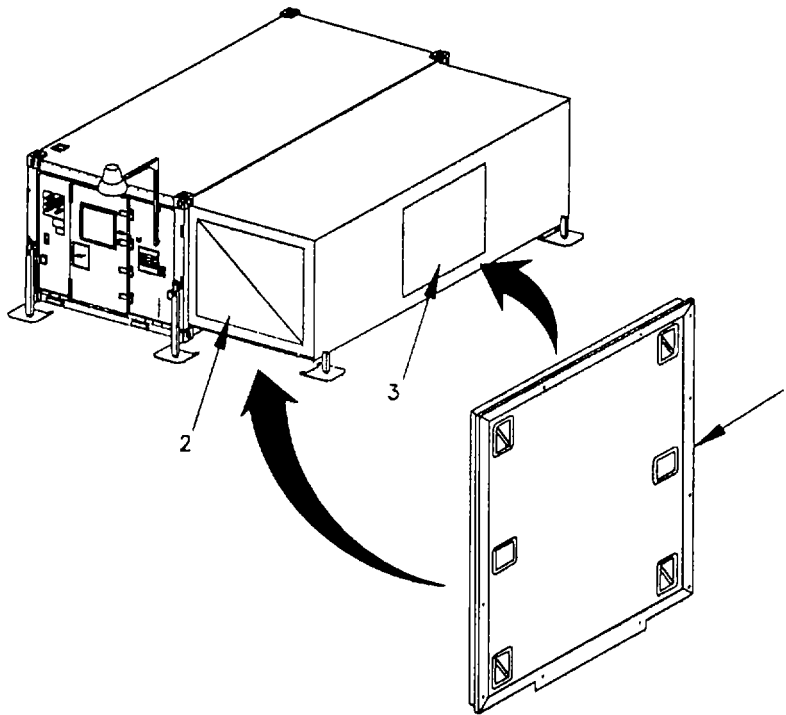

NOTE

The next procedure requires two persons on the outside and one person on the inside of the ISO shelter.

- (6) Replace sidewall or endwall closeout panels (1) and (2) on both ISO shelters using the following steps-
 - (a) Remove closeout panel from outside hinged endwall (2) of ISO shelter or retrieve panel from other storage location.
 - (b) Place closeout panel into ISO shelter opening (3) and hold in place.
 - (c) Using wide flat-tip screwdriver, tighten 12 captive screws in closeout panel on ISO shelter.
 - (d) Repeat steps (a) through (c) for other ISO shelter's closeout panel.

2-5. REMOVAL PROCEDURES (CONT)

b. Removal of Complexing Kit Passageway - Type II, Class A and Class B (ISO Shelter to TEMPER)

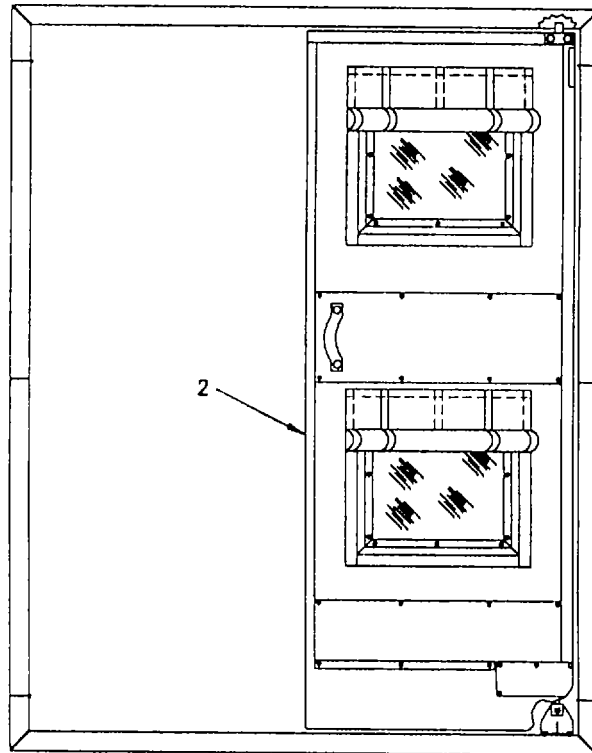
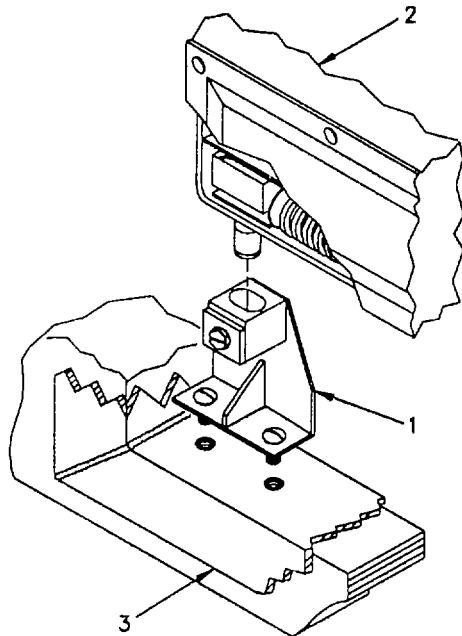

- (1) Remove bump thru doors using the following steps:
 - (a) Using flat-tip screwdriver, unthread captive screws on pedestal assembly (1) at bottom of door (2).
 - (b) Remove door (2) and pedestal (1) from frame (3) of Complexing kit passageway.
 - (c) Store door and pedestal in storage container.
 - (d) Repeat (a) thru (c) above for other door.

2-5. REMOVAL PROCEDURES (CONT)

b. Removal of Complexing Kit Passageway - Type II, Class A and Class B (ISO Shelter to TEMPER) (Cont)

NOTE

The following procedure requires four persons

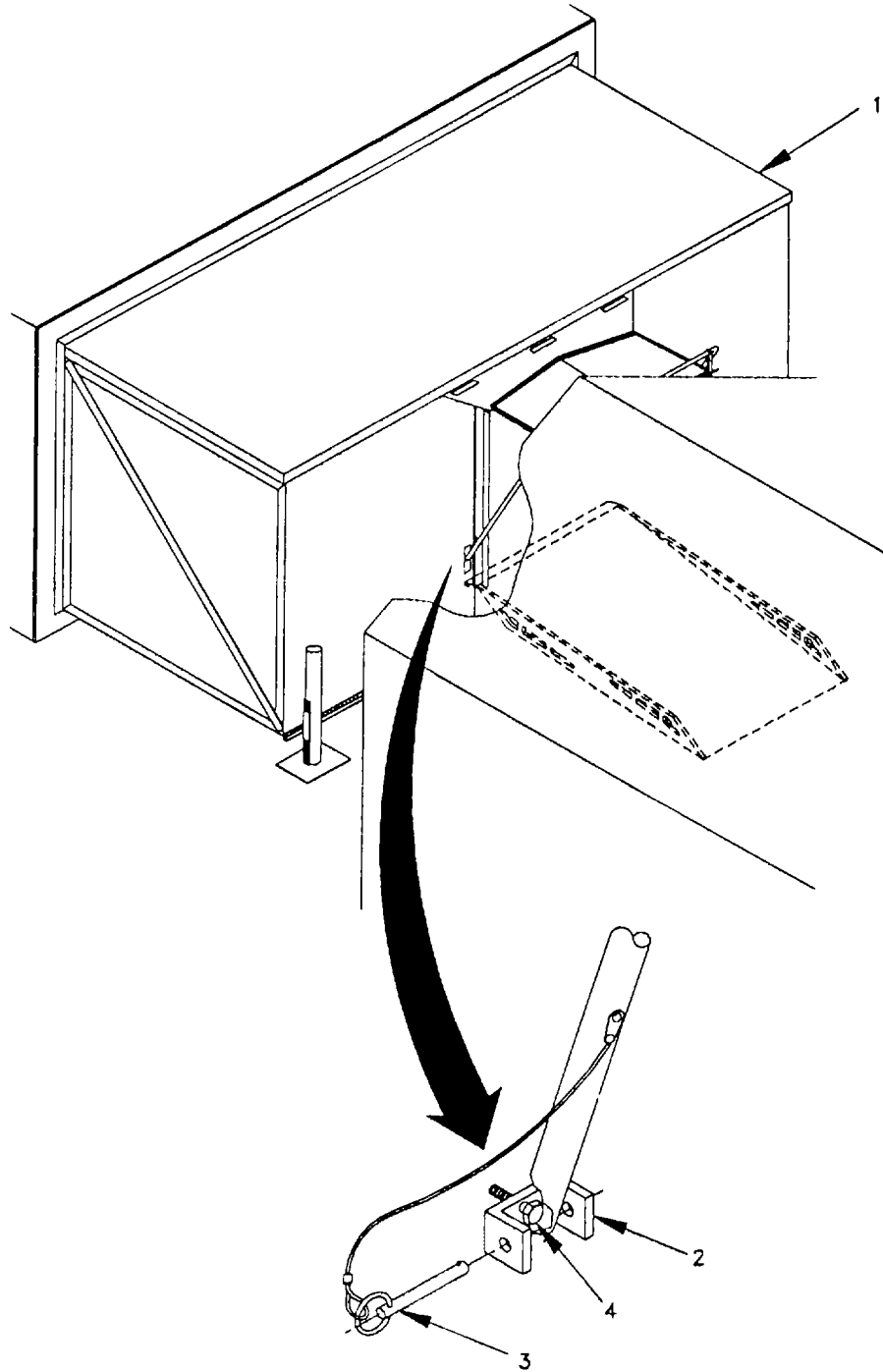

2-5. REMOVAL PROCEDURES (CONT)

b. Removal of Complexing Kit Passageway - Type II, Class A and Class B (ISO Shelter to TEMPER) (Cont)

WARNING

The Complexing Kit Passageway includes two ramps and a stairway. The ramps weigh approximately 145 pounds (65.77 kg) and 195 pound (88.45 kg) respectively, and the stairs weigh approximately 70 pounds (31.75 kg). Four persons are required to handle each of these components. Attempting to lift or carry any of these items by yourself could result in serious injury or damage to the equipment.

NOTE

It may be necessary to rotate swivel feet slightly to allow removal of locking pins

- (1.1) Remove locking pins (1) and remove exterior frame assembly upright bars.
- (2) Using flat-tip screwdriver, Remove captive screws (3) that secure swivel feet (2) to ISO shelter (4). Set swivel feet aside.

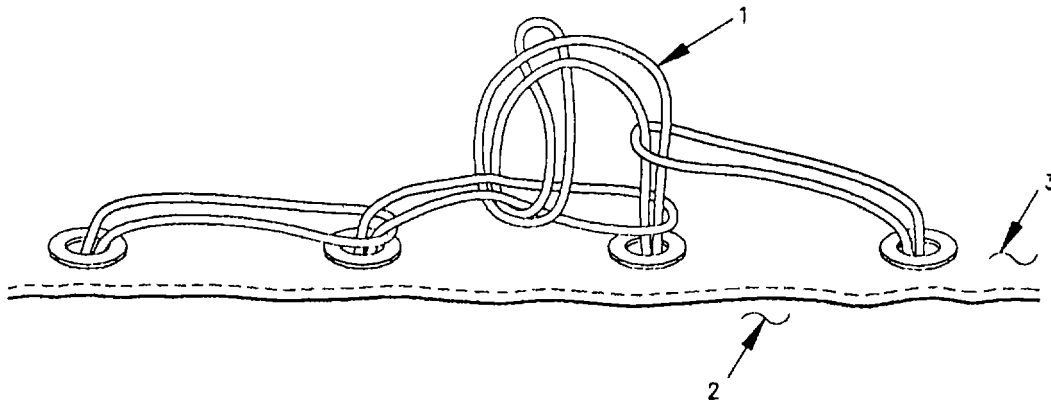

- (3) Untie becket lacing using the following steps:
 - (a) Remove becket flap loops from wooden toggles on sides of connector.
 - (b) Untie half-hitch knots (1) in becket lacing attaching connector assembly (2) to TEMPER (3).
 - (c) Unlace becket lacing until connector assembly is free from TEMPER.

2-5. REMOVAL PROCEDURES (CONT)

b. Removal of Complexing Kit Passageway - Type II, Class A and Class B (ISO Shelter to TEMPER) (Cont)

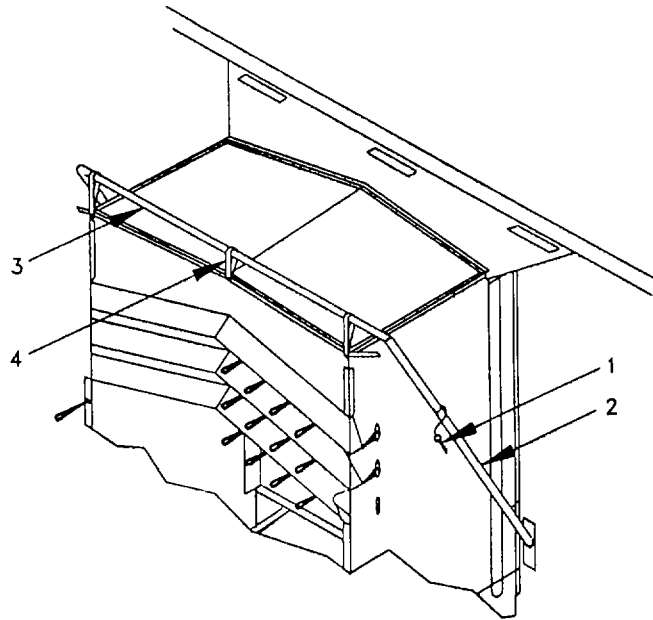

- (4) Remove locking pins (1) from holes on upright bar (2).
- (5) Remove upright bars (2) from header bar (3) and set aside.
- (6) Remove header bar (3) from support straps (4) on roof of connector assembly and set aside.

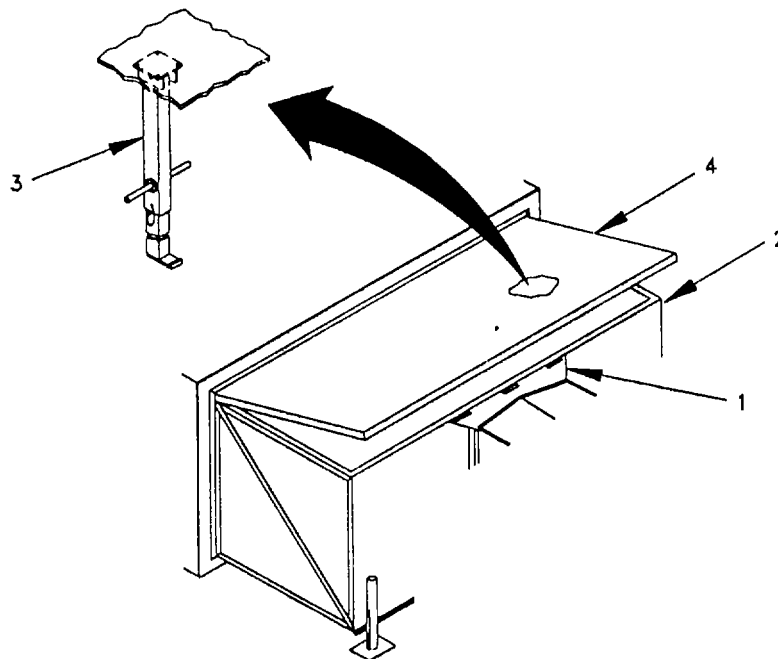

2-5. REMOVAL PROCEDURES (CONT)**b. Removal of Complexing Kit Passageway - Type II, Class A and Class B (ISO Shelter to TE.MPER) (Cont)****NOTE**

The next procedure requires two persons inside and two persons outside of the ISO shelter.

- (7) Remove weather barrier (1) from ISO shelter (2) using the following steps:
- (a) Unlatch all inside roof panel latches.
 - (b) Using two hinged roof support struts (3), push up hinged roof panel (4) from inside ISO shelter (2).
 - (c) Rotate roof support struts (3) to upright position. Lower struts to floor until hinged roof panel (4) is supported on struts (3).

WARNING

When installing or removing weather barrier between hinged roof panel and hinged sidewall or endwall of ISO shelter, take care to avoid getting fingers caught. Failure to do so may result in serious injury.

- (d) Pull weather barrier (1) out of open space between hinged roof panel (4) and ISO shelter (2).
 - (e) Lower hinged roof panel (4) onto ISO shelter (2) using roof support struts.
 - (f) Store roof support struts in stowage brackets.
 - (g) Latch all inside panel latches to secure hinged roof panel (4) to ISO shelter (2).
- (8) If Type II, Class B, disassemble stairway by removing locking pins and separating joined stairway assemblies.
- (9) Remove ramp or stairway from inside Complexing Kit Passageway. Place ramp or stairway inside ISO shelter or TEMPER.

2-5. REMOVAL PROCEDURES (CONT)

- b. Removal of Complexing Kit Passageway - Type II., Class A and Class B (ISO Shelter to TEMPER) (Cont)

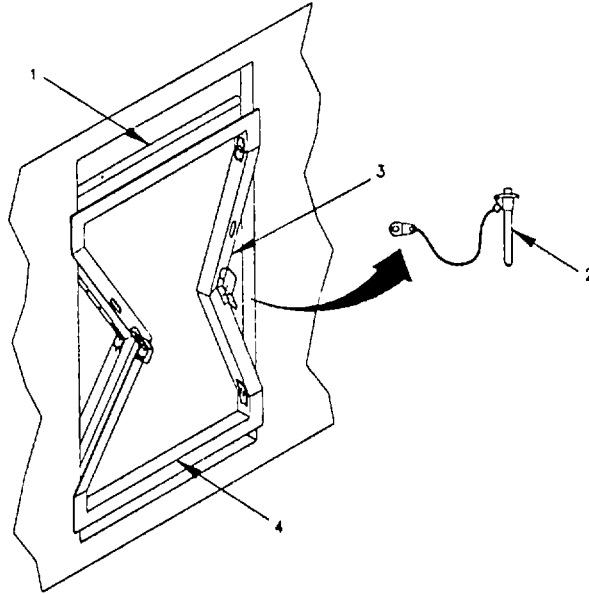

WARNING

When installing or removing frame assembly, avoid getting fingers caught in hinged joints. Failure to do so may result in severe injury.

NOTE

The next procedure requires two persons inside ISO shelter.

- (10) Remove frame assembly (1) from ISO shelter opening using the following steps:
- (a) Remove and store tent pins used to stake bottom corners of connector to ground.
 - (b) Loosen strap assemblies located at each inside corner of connector assembly.
 - (c) Unlatch locking pins (2) on sides (3) of frame assembly (1) and insert locking pins into retainer tubes.

2-5. REMOVAL PROCEDURES (CONT)

- b. Removal of Complexing Kit Passageway - Type II, Class A and Class B (ISO Shelter to TEMPER) (Cont)
- (d) Pull sides (3) toward center until top of frame assembly (1) starts coming down.
 - (e) Raise one corner of lower frame (4) until frame is free of ISO shelter wall.
 - (f) Gradually lower opposite upper corner of frame assembly (1) until upper frame is free of ISO shelter wall.
 - (g) Gradually lower upper frame (1) until upper frame rests on lower frame.
 - (h) Move frame assembly off lip of ISO shelter opening.
- (11) Pick up and move Complexing Kit Passageway from between ISO shelter and TEMPER.
- (12) For packing procedures for the Complexing Kit Passageway, refer to paragraph 2-6b.

2-5. REMOVAL PROCEDURES (CONT)

- b. Removal of Complexing Kit Passageway - Type II, Class A and Class B (ISO Shelter to TEMPER) (Cont)

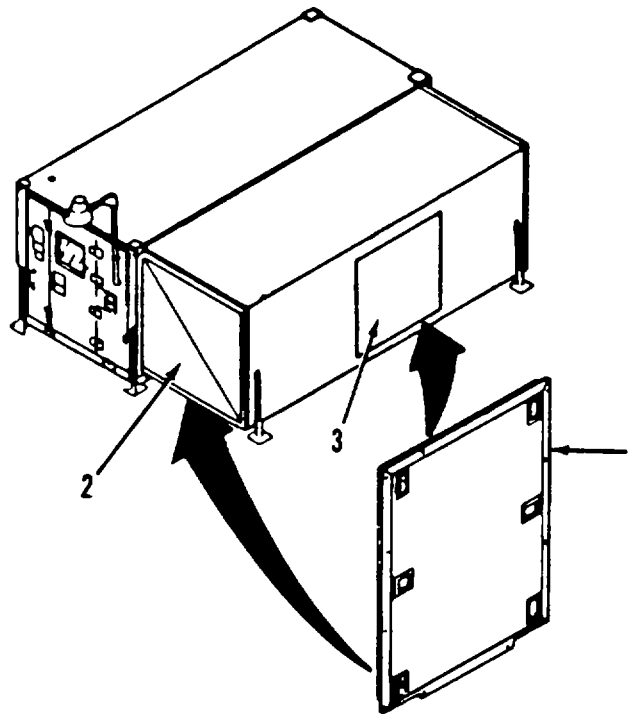

NOTE

The next procedure requires two persons on the outside and two persons on the inside of ISO shelter.

- (13) Replace sidewalk or endwall closeout panel (1) and (2) using the following steps:
- (a) Remove closeout panel from outside hinged endwall (2) of ISO shelter or retrieve panel from other storage location.
 - (b) Place closeout panel into ISO shelter opening (3) and hold in place.
 - (c) Using flat-tip screwdriver, tighten 12 captive screws in closeout panel.

2-6. PREPARATION FOR MOVEMENT

- a. packing Procedure for Comolexiq Kit Passaqewav - Type I (ISO Shelter to ISO Shelter)

WARNING

The Complexing Kit Passageway components include two ramps and a stairway. The ramps weigh approximately 145 pounds (65.77 kg) and 195 pounds (88.45 kg) re- spectively, and the stairs (complete assembly) weigh approximately 70 pounds (31.75 kg). Four persons are required to handle each of these components. Attempt- ing to lift or carry any one of them by yourself could result in serious injury or damage to the equipment.

NOTE

The following procedure requires four persons.

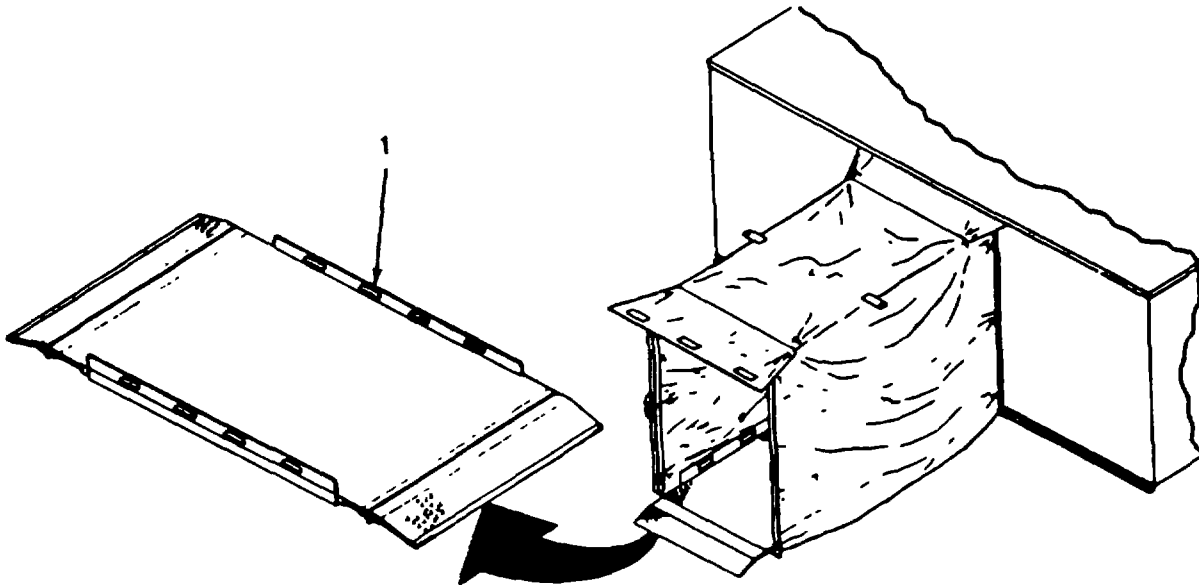

- (1) Remove ramp (1) and Complexing Kit Passageway. (Refer to para 2-5a.)
- (2) Clean ramp and inspect for damage. (Refer to para 2-2.) Report all defects on DA Form 2404.
- (3) Place ramp (1) in ramp shipping container and secure container cover.

2-6. PREPARATION FOR MOVEMENT (CONT)

- a. Packing Procedure for Complexing Kit Passageway - Type I (ISO Shelter to ISO Shelter) (Cont)

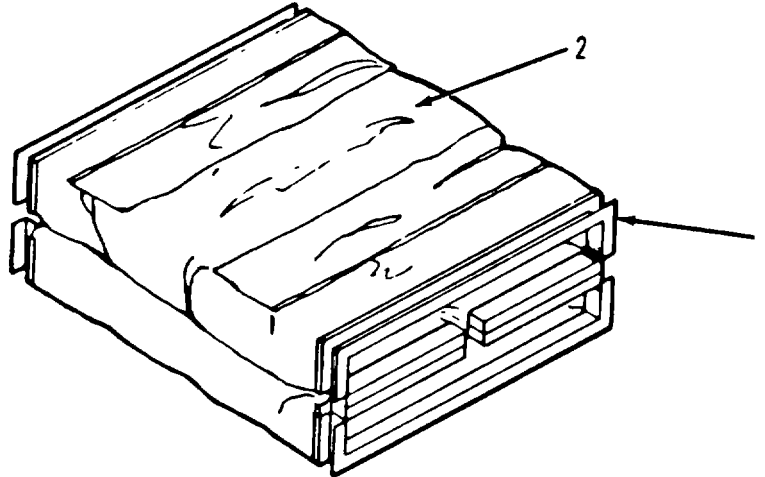

CAUTION

When packing Complexing Kit Passageway, ensure connector assembly is not pinched by frame assemblies. Damage to connector assembly may result.

NOTE

The following procedures require four persons.

- (4) Pack Complexing Kit Passageway as follows:
- (a) Pull frame assemblies (1) away from each other until connector assembly (2) is stretched tight; set assembly down.
 - (b) Remove any foreign matter from connector assembly (2).
 - (c) Fold one end of connector assembly (2) until frame assembly sets on opposite frame assembly.
 - (d) Fold connector assembly toward frame assemblies.
 - (e) Place folded Complexing Kit Passageway in shipping container with frame assemblies on bottom.

2-6. PREPARATION FOR MOVEMENT (CONT)**b. Packing Procedures for Complexing Kit Passageway - Type II (ISO Shelter to TEMPER) (Cont)**

- (1) Remove ramp, passageway assembly, and exterior frame assembly. (Refer to para 2-5b.)
- (2) Place ramp (Type II, Class A) in shipping container and secure container cover.
- (3) Place disassembled stairway assembly (Type II, Class B) in shipping container and secure container cover.

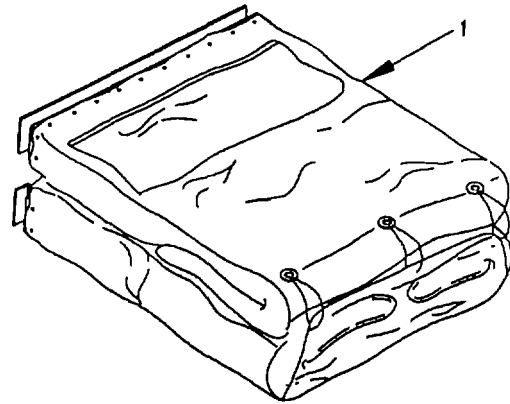
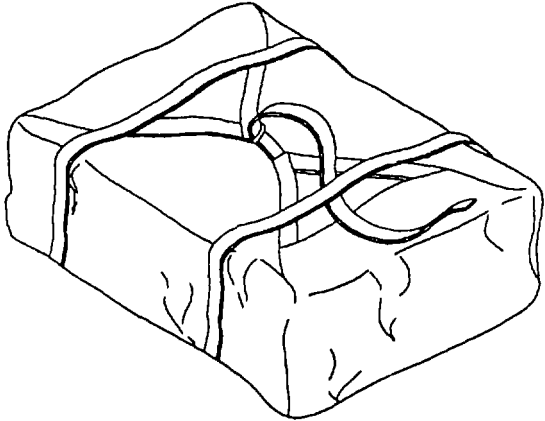

- (4) Pull connector with frame assembly ends away from each other until connector assembly is stretched tight; set assembly down.
- (5) Remove any foreign matter from connector assembly.
- (6) Fold connector assembly end to end toward the frame assembly.
- (7) If diaper is to be used, wrap folded connector assembly in diaper and secure.
- (8) Place exterior frame assembly in the bottom of the shipping container.
- (9) Place the folded connector assembly in the shipping container and on top of the exterior frame.
- (10) Secure the shipping container.

Section IV. OPERATION UNDER UNUSUAL CONDITIONS**2-7. OPERATION IN UNUSUAL WEATHER**a. Operation in Rain and/or Mud

- (1) Dig a drainage ditch along outside of Complexing Kit Passageway to prevent standing water.
- (2) A chape (tab with grommet) is provided on each side (top centered) of the Type I passageway. The chapes are provided to attach tie-downs to provide water runoff. Chapes may be tied down if necessary at the user's discretion.
- (3) Frequently check fabric for holes or tears. Promptly report any damage to your supervisor,
- (4) Make sure connector assembly is dry before packing to prevent mildew. Ensure other parts are free from moisture before packing to prevent mildew on fabric.

b. Operation in Snow, Ice, and/or Extreme Cold

WARNING

In extremely cold weather, do not touch metal parts with bare hands. Wear gloves to prevent injuries to hands. Severe skin damage may result.

- (1) Frequently remove snow from roof of connector assembly by gently pushing roof from inside with hands to keep roof clear of snow or ice.
- (2) Prior to assembling Complexing Kit Passageway on snow-covered ground, inspect surface for holes or crevices.
- (3) Before assembly of Complexing Kit Passageway, pack/stamp down snow with feet to provide firm surface.
- (4) Frequently check fabric for holes or tears. Promptly report any damage to your supervisor,

c. Operation in High Wind

- (1) Frequently check lacing to ensure tightness. If loose, re-lace becket lacing and tie securely.
- (2) Frequently check straps holding passageway to exterior frame assembly for tightness, Promptly report any damage to your supervisor.
- (3) Frequently check exterior frame assembly to ensure tightness of fittings. Promptly report any loose fittings or damage to your supervisor.

CHAPTER 3
OPERATOR MAINTENANCE

Section I. LUBRICATION INSTRUCTIONS

There are no lubrication procedures for the Complexing Kit Passageway.

Section II. TROUBLESHOOTING PROCEDURES

There are no troubleshooting procedures for the Complexing Kit Passageway.

CHAPTER 4

UNIT MAINTENANCE

Section I. REPAIR PARTS; SPECIAL TOOLS; TEST MEASUREMENT, AND DIAGNOSTIC EQUIPMENT (TMDE; AND SUPPORT EQUIPMENT

4-1. COMMON TOOLS AND EQUIPMENT. For authorized common tools and equipment, refer to the Modified Table of Organization and Equipment applicable to your unit.

4-2. SPECIAL TOOLS, TMDE, AND SUPPORT EQUIPMENT. There are no special tools required for the Complexing Kit Passageway. For TMDE and support equipment, refer to the Maintenance Allocation Chart (Appendix B).

4-3. REPAIR PARTS. Repair parts for the Complexing Kit Passageway are listed and illustrated in TM 10-5411-203-23P, Unit and Direct Support Repair Parts and Special Tools List for Complexing Kit Passageway Type I and Type II. For initial issue, selected spare/repair parts are provided as Basic Issue Items and are listed and illustrated in Appendix C, Section III of this manual.

Section II. SERVICE UPON RECEIPT

4-4. SERVICE UPON RECEIPT OF MATERIEL. The unit maintenance technician should inspect the equipment before it is used. The technician will make the following checks when the equipment is unpacked:

a. Inspect the equipment using the preventive maintenance checks and services listed in paragraph 2-2. If the equipment has been damaged in shipment, report the damage on DD Form 6, Packaging Improvement Report.

b. Check the equipment against the packing list to see if the shipment is complete. Report all discrepancies in accordance with DA PAM 738-750.

c. Check to see whether the equipment has been modified.

d. Service damaged equipment, as necessary, using unit maintenance procedures in Section III of this chapter to restore equipment to operable condition.

Section III. MAINTENANCE PROCEDURES

4-5. GENERAL. This Section contains maintenance instructions authorized by the Maintenance Allocation Chart (Appendix B) to the unit maintenance level. Unit maintenance personnel can perform all maintenance at the operator level.

4-6. RAMP EDGE PROTECTOR MAINTENANCE INSTRUCTIONS (TYPE I AND TYPE II, CLASS A)

This task covers: Replace

INITIAL SETUP**Parts/Materials**

Ramp edge protector

Equipment Condition

Ramp taken out of service. (Refer to para 2-5.)

REMOVE

CAUTION

Do not step on fabric floor of connector assembly when ramp is not in place. Damage to connector assembly may result.

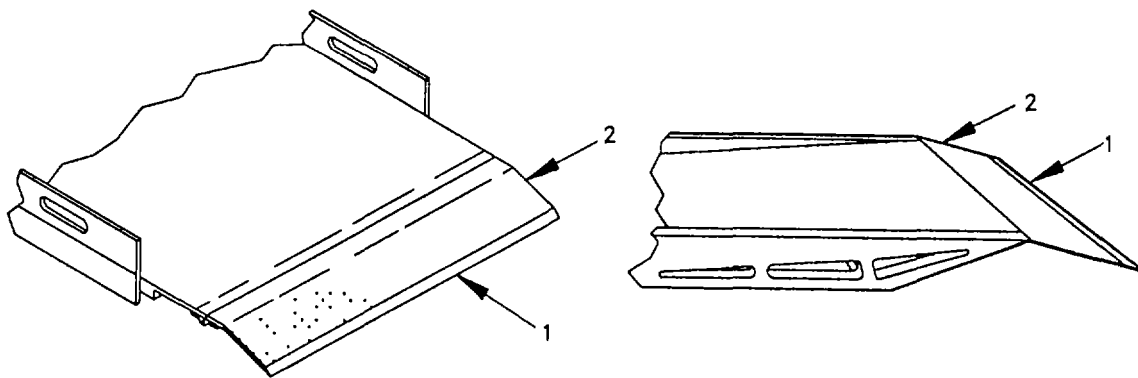

Remove edge protector (1) by sliding it off edge of ramp end plate assembly (2).

INSTALL

Slide edge protector (1) onto ramp end plate assembly (2).

NOTE

FOLLOW-ON MAINTENANCE: If required, place ramp in service. (Refer to para 2-4.)

4-7. RAMP END PLATE ASSEMBLY MAINTENANCE INSTRUCTIONS (TYPE II, CLASS A ONLY)

This task covers: Replace

INITIAL SETUP:

Tools

Tool kit, general mechanic's (Appendix B, Section III, Item 1)

Parts/Materials

End plate assembly

Equipment Condition

Ramp removed from Complexing Kit Passageway. (Refer to para 2-5.)

REMOVE

CAUTION

Do not step on fabric floor of connector assembly when ramp is not in place. Damage to connector assembly may result.

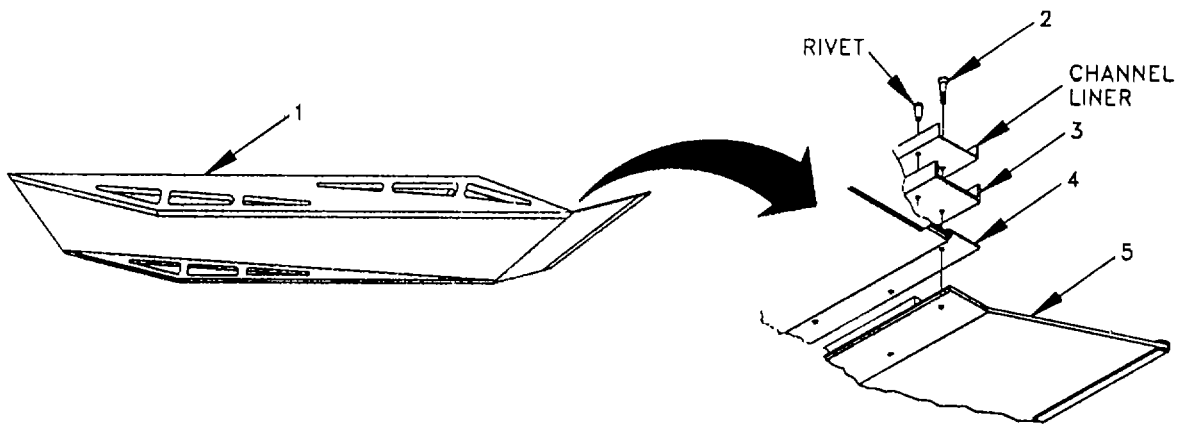

4-7. RAMP END PLATE ASSEMBLY MAINTENANCE INSTRUCTIONS (TYPE II, CLASS A ONLY) (CONT)

1. Turn ramp (1) over and lay flat on work surface.
2. Remove six screws (2) connecting threshold channel (3), ramp assembly hinge (4), and end plate assembly (5).

INSTALL

1. Align holes in end plate assembly (3) with holes in ramp assembly hinge. (4)
2. Align holes in threshold channel (3) with holes in end plate assembly (3) and ramp assembly hinge (4).
3. Install six screws

NOTE

FOLLOW-ON MAINTENANCE: 1. Replace edge protector (refer to para 4-6), and 2. If required, place ramp in service (refer para 2- 4).

4-8. RAMP THRESHOLD CHANNEL MAINTENANCE INSTRUCTIONS (TYPE II, CLASS A ONLY)

This task covers: Replace

INITIAL SETUP:**Tools**

Drill, electric, portable (Appendix B, Section III, Item 3)
Drill set, twist (Appendix B, Section III, Item 4)
Stake, sheetmetal working (Appendix B, Section III, Item 8)
Tool kit, general mechanic's (Appendix B, Section III, Item 1)

Parts/Materials

Threshold channel
Threshold channel liner
Rivets, solid (Appendix D, Item 8)

Equipment Condition

Ramp assembly disassembled. (Refer to para 4-7.)

REMOVE

CAUTION

Do not step on fabric floor of connector assembly when ramp is not in place. Damage to connector assembly may result.

Drill out rivets that secure threshold channel liner to threshold channel.

INSTALL

1. Insert threshold channel liner into threshold channel, aligning holes.
2. Install six rivets.

NOTE

FOLLOW-ON MAINTENANCE: 1. Assemble ramp (refer to para 4-7), and 2. if required, place ramp in service (refer to para 2-4).

4-9. STAIRWAY RISER AND SUPPORT ASSEMBLIES MAINTENANCE INSTRUCTIONS (TYPE II, CLASS B ONLY)

This task covers: Replace

INITIAL SETUP:

Parts/Materials

Riser assembly, lower
Riser assembly, middle
Stair and riser assembly, upper
Cross support assembly, rear

Equipment Condition

Stairway assembly removed from service. (Refer to para 2-4.)

REMOVE

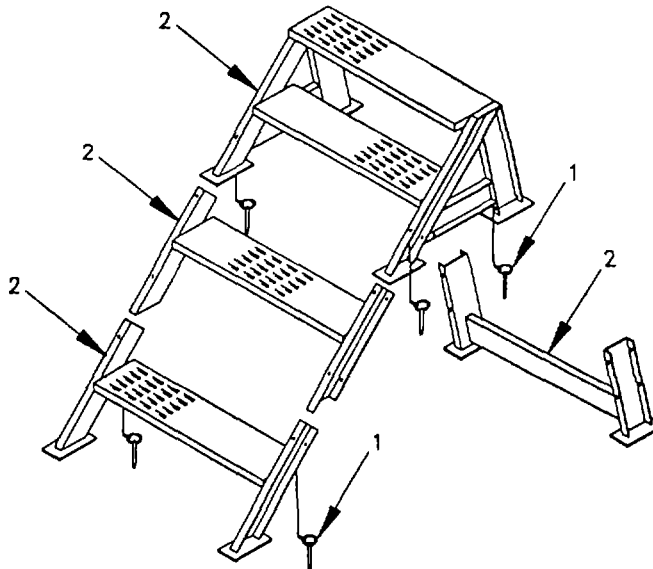

1. Remove retaining pins (1) from stairway components (2).
2. Separate stairway components (2) as required.

INSTALL

1. Assemble stairway components (2) as required.
2. Insert retaining pins (1) to secure.

NOTE

FOLLOW-ON MAINTENANCE: If required, place stairway assembly in service. (Refer to para 2-5.)

4-10. STAIRWAY PIN AND LANYARD ASSEMBLY MAINTENANCE INSTRUCTIONS (TYPE II, CLASS B ONLY)

This task covers: Replace

INITIAL SETUP:**Parts/Materials**

Pin and lanyard assembly
Sleeve, swaging

Equipment Condition

Stairway assembly removed from service. (Refer to para 2-4.)

REMOVE

Remove any remaining portion of pin and lanyard assembly.

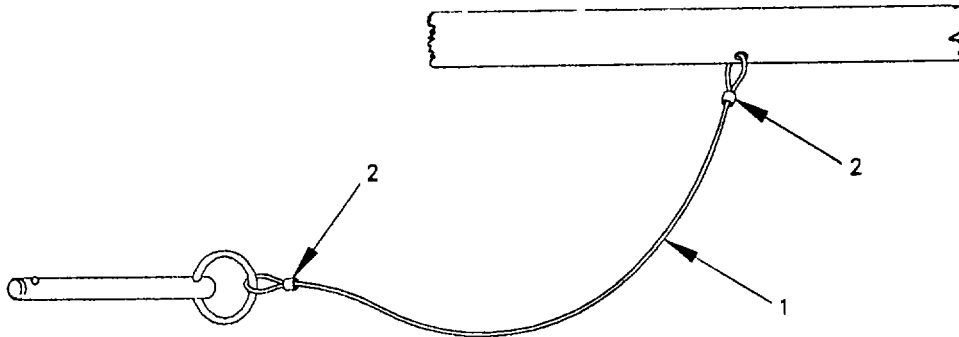
**INSTALL**

1. Feed free end of wire rope (1) through the swaging sleeve (2) and on through the appropriate hole in stairway section.
2. Form a loop and feed the free end through the swaging sleeve. The correct loop size is attained by working with the stripped end of the wire rope.
3. Hold the assembly in place and crimp sleeve with slip joint pliers.
4. Check the holding strength of the replaced assembly.

NOTE

FOLLOW-ON MAINTENANCE: If required, place stairway assembly in service. (Refer to para 2-5.)

4-11. EXTERIOR FRAME ASSEMBLY HEADER BAR MAINTENANCE INSTRUCTIONS (TYPE II ONLY)

This task covers: Replace

INITIAL SETUP:

Parts/Materials
Header bar

REMOVE

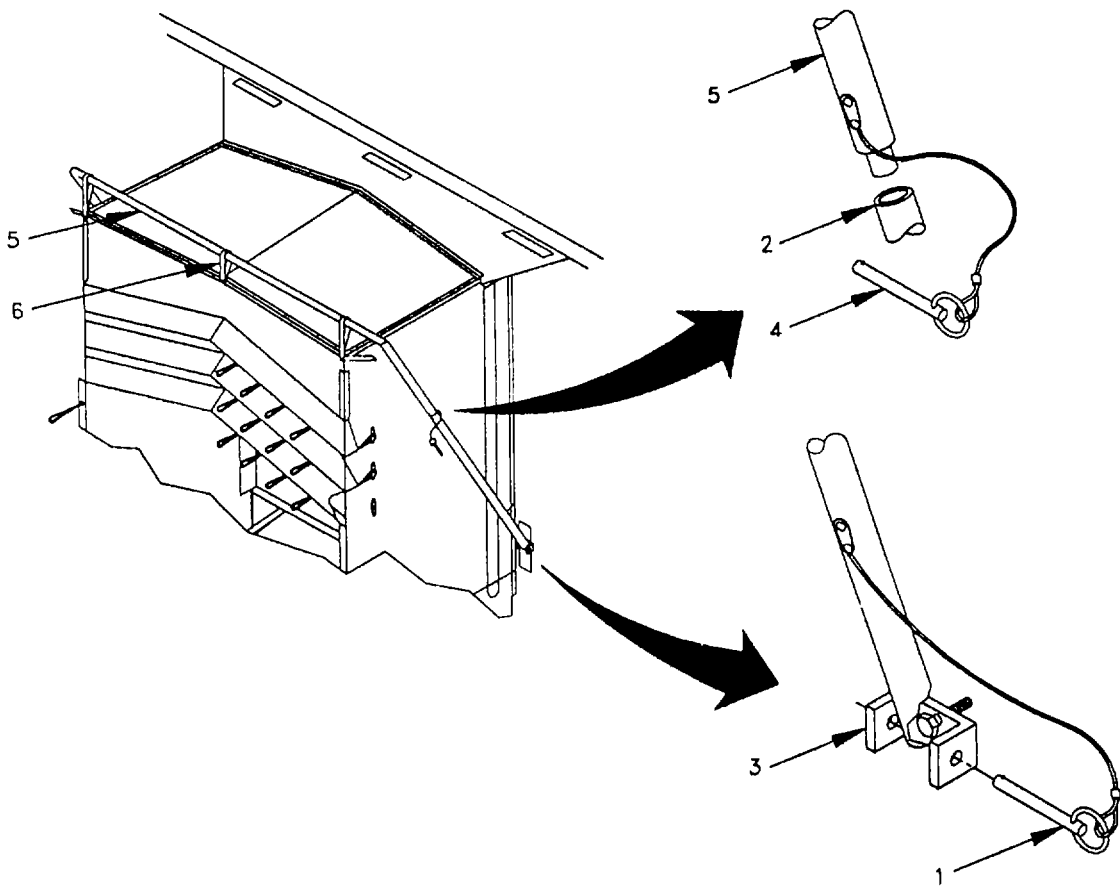

4-11. EXTERIOR FRAME ASSEMBLY HEADER BAR MAINTENANCE INSTRUCTIONS (TYPE II ONLY) (CONT)

1. Disconnect locking pins (1) that secure upright bars (2) to swivel feet (3) attached to ISO shelter.
2. Disconnect locking pins (4) that secure upright bars (2) to header bar (5)
3. Remove upright bars (2) from header bar (5).
4. Remove header bar (5) from support straps (6) on connector assembly roof.

INSTALL

1. Insert header bar (5) through support straps (6) on connector roof assembly.
2. Connect upright bars (2) to header bar (5).
3. Insert locking pins (4) into holes in upright bars (2).
4. Insert locking pins (1) to secure upright bars (2) to swivel feet (3) attached to ISO shelter.

4-12. EXTERIOR FRAME ASSEMBLY UPRIGHT BAR MAINTENANCE INSTRUCTIONS (TYPE II ONLY)

This task covers: Replace

INITIAL SETUP:

Parts/Materials
Upright bar

REMOVE

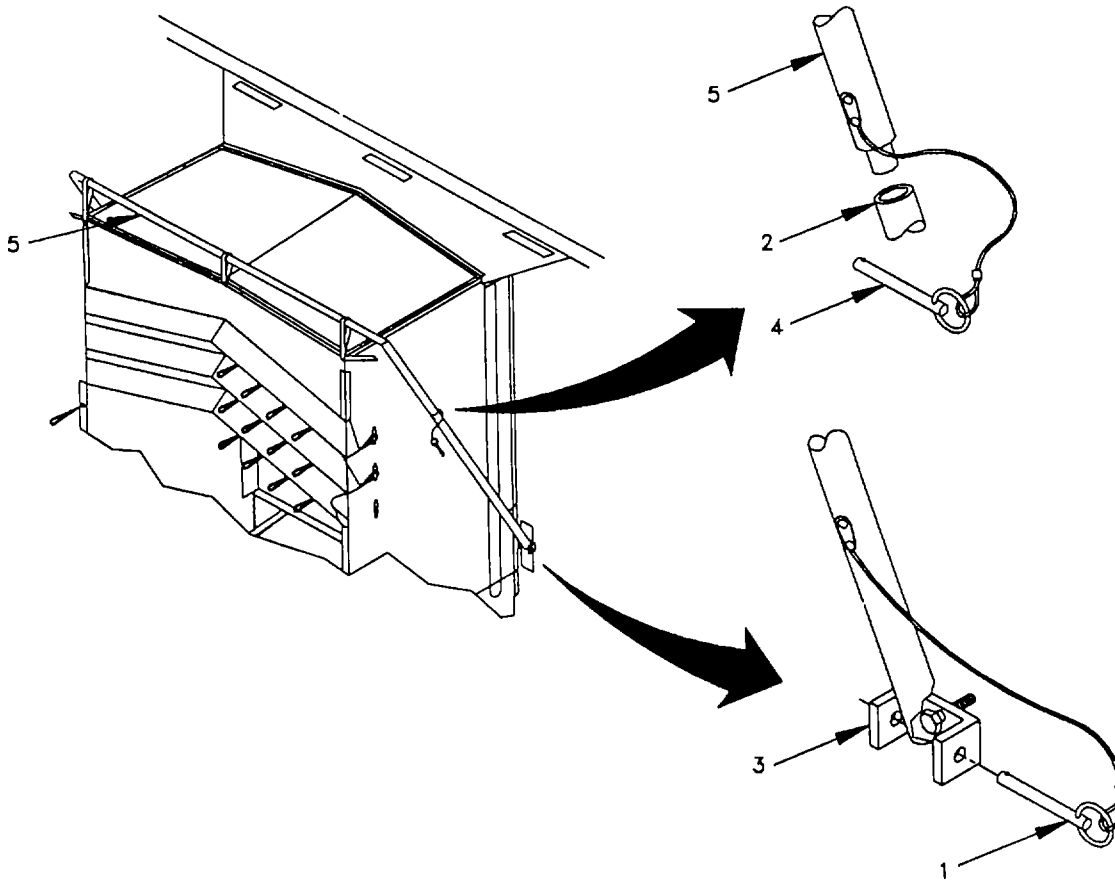

4-12, EXTERIOR FRAME ASSEMBLY UPRIGHT BAR MAINTENANCE INSTRUCTIONS (TYPE II ONLY) (CONT)

1. Disconnect locking pins (1) that secure upright bars (2) to swivel feet (3) attached to ISO shelter.
2. Disconnect locking pins (4) that secure upright bars (2) to header bars (5)
3. Remove upright bars (2) from header bar (5).

INSTALL

1. Connect upright bars (2) to header bar (5).
2. Insert locking pins (4) into holes in upright bars (2).
3. Insert locking pins (1) to secure upright bars (2) to swivel feet (3) attached to ISO shelter.

4-13. EXTERIOR FRAME PIN AND LANYARD ASSEMBLY MAINTENANCE INSTRUCTIONS (TYPE II ONLY)

This task covers: Replace

INITIAL SETUP:**Tools**

- Drill, electric, portable (Appendix B, Section III, Item 3)
- Drill set, twist (Appendix B, Section III, Item 4)
- Stake, sheetmetal working (Appendix B, Section III, Item 8)
- Tool kit, general mechanic's (Appendix B, Section III, Item 1)

Parts/Materials

- Pin and lanyard assembly
 - Rivet, solid (Appendix D, Item 8)
-

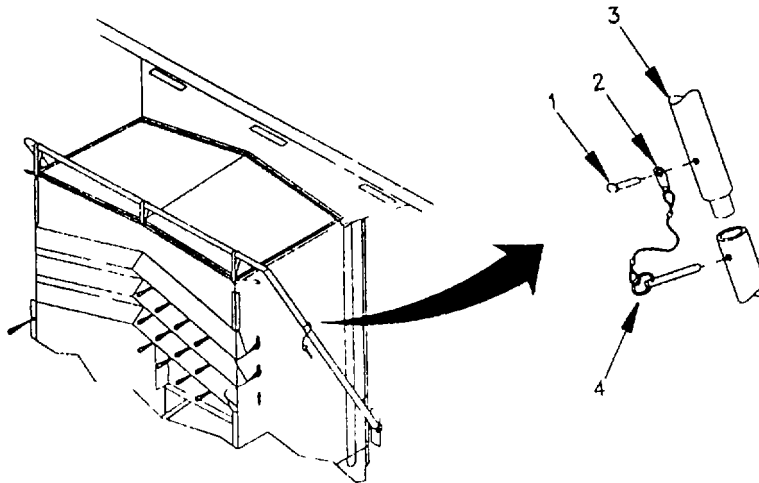
REMOVE**WARNING**

Wear safety glasses while drilling out rivets. Failure to do so could result in serious eye injury.

1. Drill out rivet (1) connecting tab (2) to bar (3).
2. Remove any remaining portion of pin and lanyard assembly (4).

INSTALL

1. Hold the tab (2) in place and install rivet (1) to secure to bar (3).
2. Check the holding strength of the replaced assembly (4).

4-14. FRAME ASSEMBLY MAINTENANCE INSTRUCTIONS

This task covers: Replace

INITIAL SETUP:**Tools**

- Drill, electric, portable (Appendix B, Section III, Item 3)
- Drill set, twist (Appendix B, Section III, Item 4)
- Riveter set (Appendix B, Section III, Item 5)
- Tool kit, general mechanic's (Appendix B, Section III, Item 1)

Parts/Materials

- Frame assembly
- Rivets, pop (Appendix D, Item 9)

Equipment Condition

Complexing Kit Passageway removed from shelter. (Refer to para 2-5.)

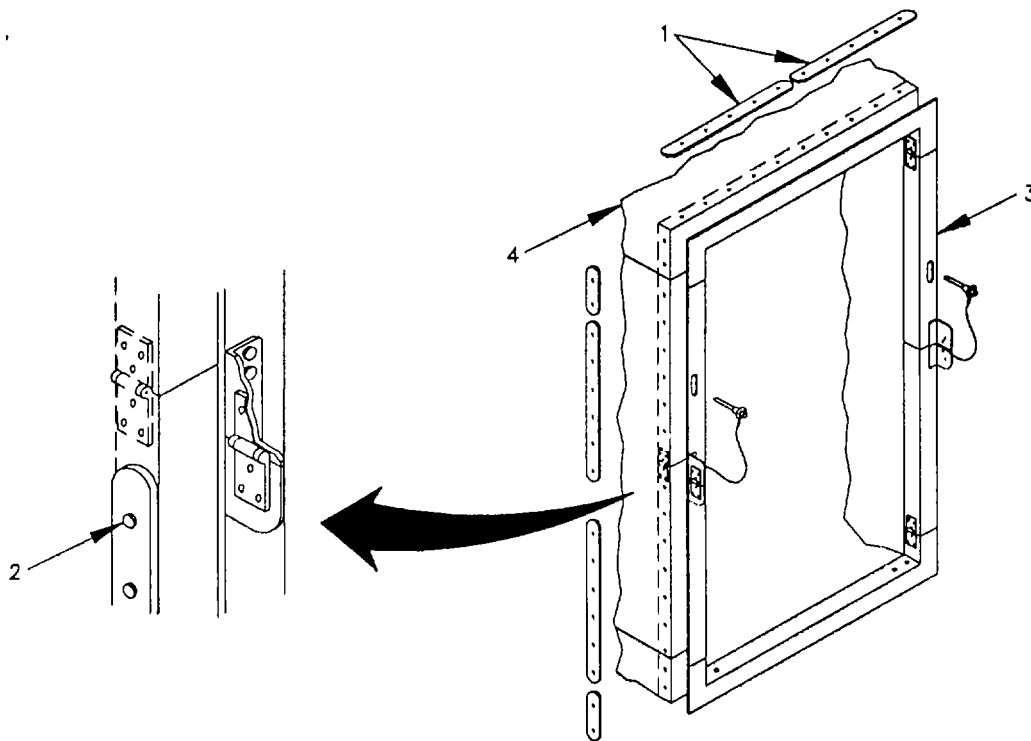
REMOVE

1. Tag all retainer strips (1).

4-14. FRAME ASSEMBLY MAINTENANCE INSTRUCTIONS (CONT)**WARNING**

Wear safety glasses while drilling out rivets. Failure to do so could result in serious eye injury or blindness.

2. Drill out all pop rivets (2) that secure retainer strips (1) and frame assembly (3) to connector assembly (4).
3. Remove remaining pop rivet fragments (2).
4. Remove retainer strips (1) and frame assembly (3).

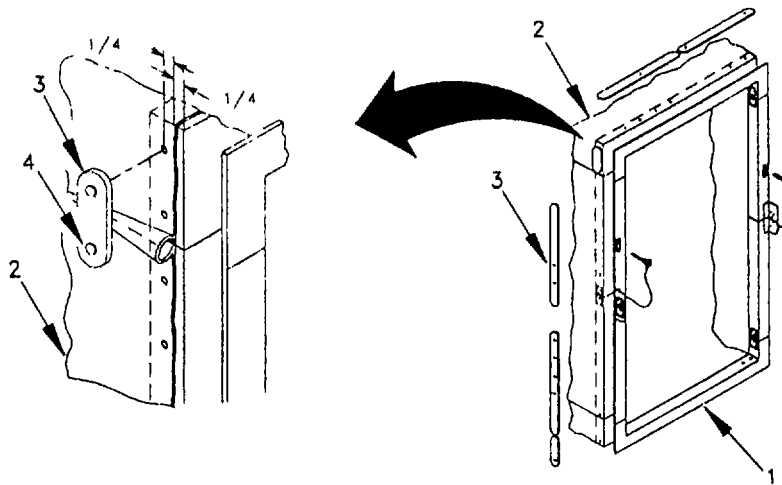
INSTALL**NOTE**

Ensure frame and connector are not assembled upside down.

1. Hold frame assembly (1) against connector assembly (2) and align as shown. Be sure weather barrier (on connector) and door pivot bushing (on frame) are on same end.
2. Align retainer strips (3) with holes in frame (1).
3. Using retainer strips (3) as guides, drill holes through connector assembly (2)
4. Install new pop rivets (4) through holes in retainer strips (3), connector assembly (2), and frame assembly (1).

NOTE

FOLLOW-ON MAINTENANCE: If required, install Complexing Kit Passageway. (Refer to para 2- 4.)

4 - 15. FRAME LOCKING PIN ASSEMBLY MAINTENANCE INSTRUCTIONS

This task covers: Replace

INITIAL SETUP:**Tools**

- Drill, electric, portable (Appendix B, Section III, Item 3)
- Drill set, twist (Appendix B, Section III, Item 3)
- Riveter set (Appendix B, Section III, Item 5)
- Tool kit, general mechanic's (Appendix B, Section III, Item 1)

Parts/Materials

- Locking pin assembly
- Rivet, blind (Appendix D, Item 9)

Equipment Condition

Complexing Kit Passageway removed from shelter. (Refer to para 2-5.)

REMOVE

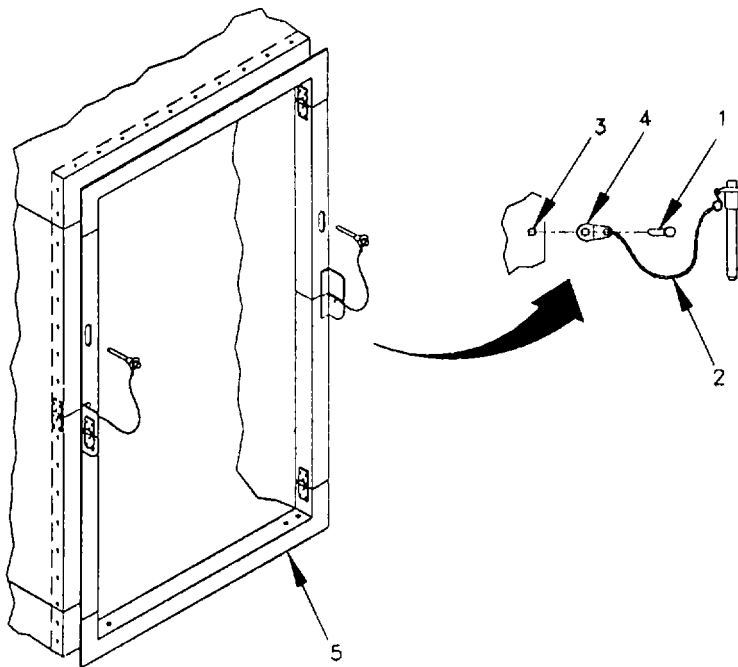

WARNING

Wear safety glasses while drilling out rivets. Failure to do so could result in serious eye injury or blindness.

1. Drill out rivet (1) of locking pin assembly (2).
2. Knock out remainder of rivet (1) from hole (3).

INSTALL

1. Position tab (4) of locking pin assembly (2) in place on frame.
2. Install rivet (1) to secure tab (4) to frame.

NOTE

FOLLOW-ON MAINTENANCE: If required, install Complexing Kit Passageway (Refer to para 2- 4.)

4 - 16. FRAME HINGE MAINTENANCE INSTRUCTIONS

- This task covers:
- a. Replace
 - b. Manufacture
-

INITIAL SETUP:

Tools

- Drill, electric, portable (Appendix B, Section III, Item 3)
- Drill set, twist (Appendix B, Section III, Item 3)
- Riveter set (Appendix B, Section III, Item 5)
- Tape, measuring (Appendix B, Section III, Item 7)
- Tool kit, general mechanic's (Appendix B, Section III, Item 1)

Parts/Materials

- Hinge, frame
- Rivet, blind (Appendix D, Item 9)
- Hinge (bulk) (Appendix D, Item 10)

Equipment Condition

Complexing Kit Passageway removed from shelter. (Refer to para 2-5.)

REMOVE

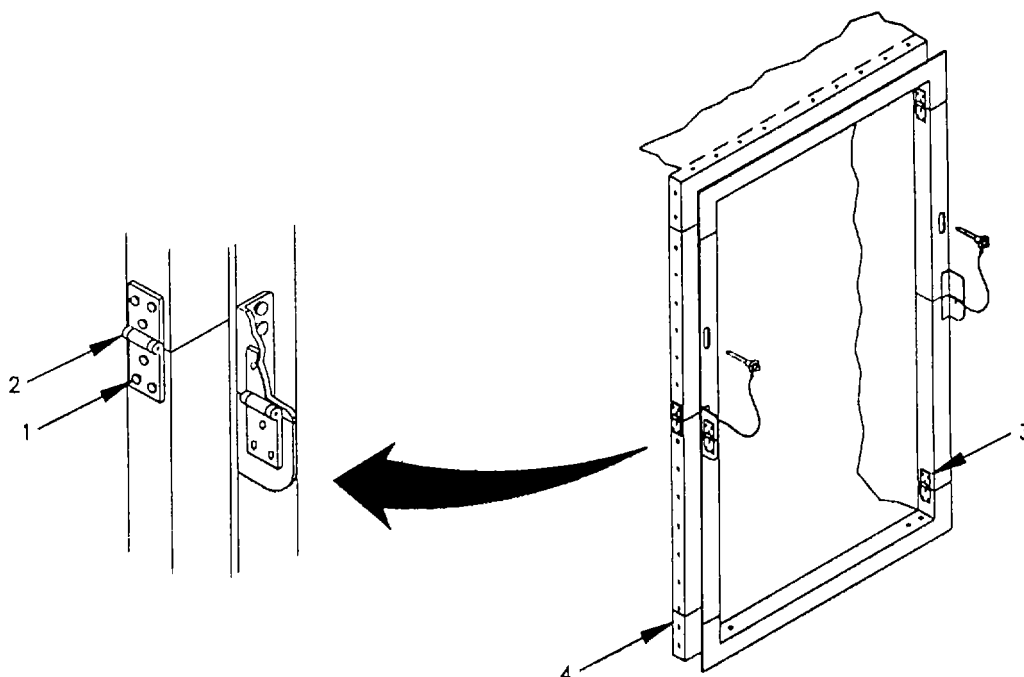

4-16. FRAME HINGE MAINTENANCE INSTRUCTIONS (CONT)**WARNING**

Wear safety glasses while drilling out rivets. Failure to do so could result in serious eye injury.

1. Drill out pop rivets (1) that secure hinge (2) or (3) to frame (4).
2. Knock out remaining fragments of pop rivet (1).

INSTALL

1. Align holes in hinge (2) or (3) with holes in frame assembly (4).
2. Install rivets (1) to secure hinge (2) or (3) to frame (4)

NOTE

FOLLOW-ON MAINTENANCE: If required, install Complexing Kit Passageway. (Refer to para 2- 4.)

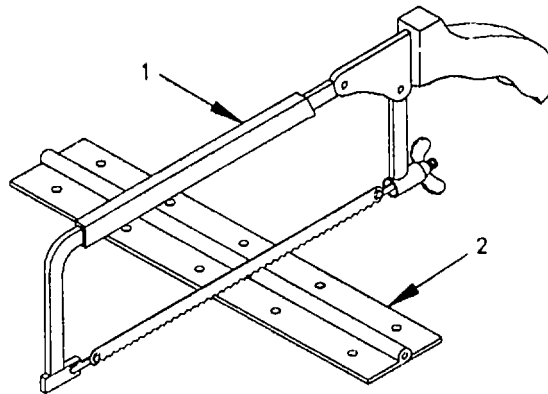
MANUFACTURE**NOTE**

When supply of hinges from Basic Issue Items List (Appendix C) are not available, the hinges are manufactured from bulk.

1. Measure and mark size of hinge to be manufactured,
2. Using suitable cutting tool, such as a hacksaw (1), cut hinge from bulk stock (2) as required.

4-16. FRAME HINGE MAINTENANCE INSTRUCTIONS (CONT)

3. Remove hinge pin and cut 1/16 in. (1.6 mm) shorter than hinge length)
4. Re-insert pin and adjust for shorter dimension.
5. Stake and knuckles at both ends to retain pin.
6. Drill holes 13/64 in. (5,2 mm) diameter in a pattern as required
7. Remove all burrs and sharp edges.

4 - 17. FRAME ENDCAP MAINTENANCE INSTRUCTIONS

This task covers: Replace

INITIAL SETUP:

Parts/Materials

- Endcap, frame
- Adhesive and Catalyst, silicone (Appendix D, Item 2)

Equipment Condition

Complexing Kit Passageway removed from shelter. (Refer to para 2-5.)

REMOVE

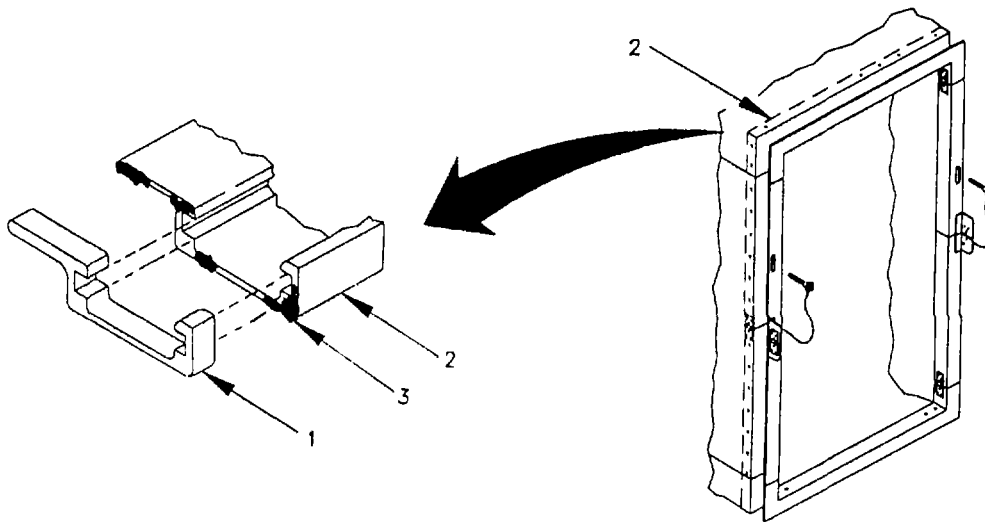

1. Remove frame endcap (1) from frame (2).
2. Scrape adhesive residue (3) from frame (2) as required.

INSTALL

1. Apply adhesive (3) to frame (2).
2. Install endcap (1) on frame (2).

NOTE

FOLLOW-ON MAINTENANCE: If required, install Complexing Kit Passageway (Refer to para 2- 4.)

4-18. FRAME SEAL ENDCAP MAINTENANCE INSTRUCTIONS

This task covers: Replace

INITIAL SETUP

Tools

Tool kit, general mechanic's (Appendix B, Section III, Item 1)

Parts/Materials

Endcap, seal

Sealant, adhesive (Appendix D, Item 11)

Equipment Condition

Complexing Kit Passageway removed from shelter. (Refer to para 2-5.)

REMOVE

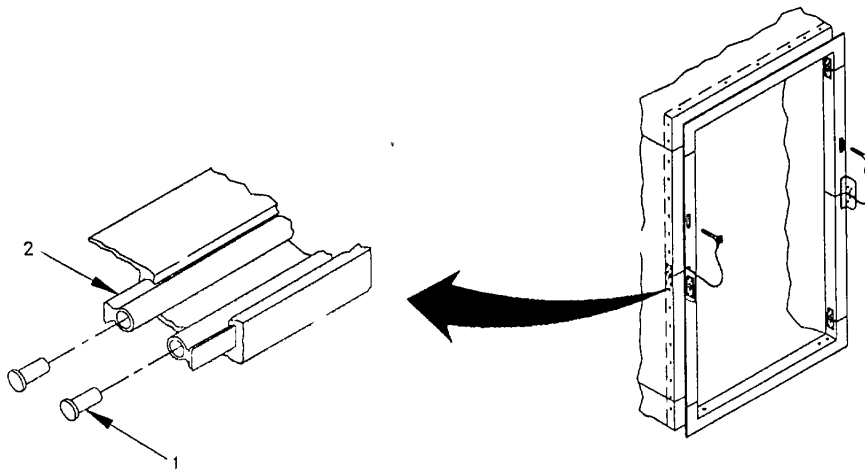

Remove seal endcap (1) from sea (2)

INSTALL

1. Apply adhesive sealant to seals (2).
2. Insert seal endcaps (1) into seals (2)

NOTE

FOLLOW-ON MAINTENANCE: If required, install Complexing Kit Passageway (Refer to para 2-4.)

4-19. FRAME SEAL MAINTENANCE INSTRUCTIONS

This task covers: Replace

INITIAL SETUP

Tools/Materials

Tool kit, general mechanic's (Appendix B, Section III, Item 1)

Parts/Materials

Seal, silicone

Adhesive and Catalyst, silicone (Appendix D, Item 2)

Equipment Condition

Complexing Kit Passageway removed from shelter. (Refer to para 2-5.)

REMOVE

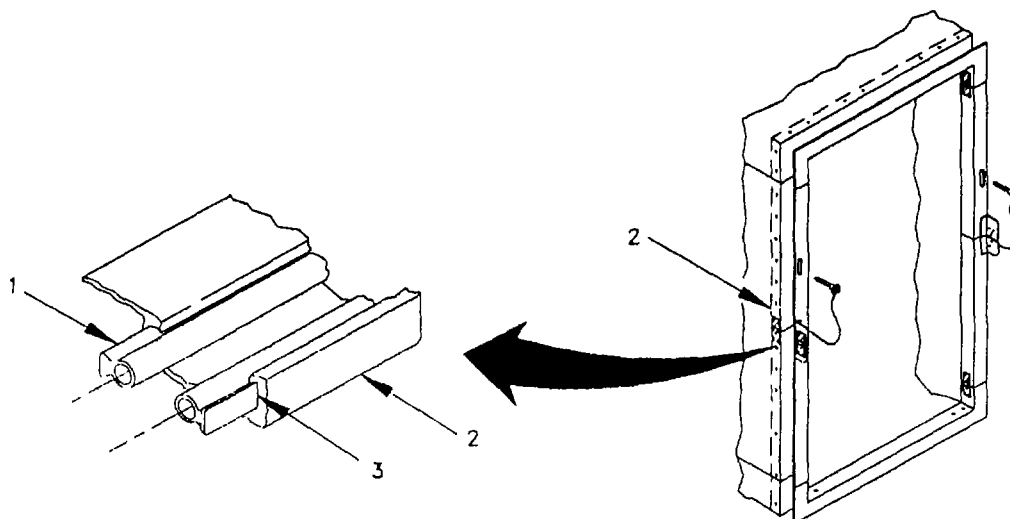

1. Pull seal (1) out of frame (2),

NOTE

If seal is difficult to remove, use pliers to pull seal out of seal guide.

2. Scrape adhesive residue (3) from frame (2) as required.

4-19. FRAME SEAL MAINTENANCE INSTRUCTIONS (CONT)

INSTALL

1. Apply adhesive (3) to frame (2).
2. Install seals (1) in frame (2).

NOTE

FOLLOW-ON MAINTENANCE: 1. Install seal endcaps (refer to para 4-18), and 2. If required, install Complexing Kit Passageway (refer to para 2-4).

4-20. CONNECTOR ASSEMBLY REPLACEMENT INSTRUCTIONS

This task covers: Replace

INITIAL SETUP**Tools**

- Drill, electric, portable (Appendix B, Section III, Item 3)
- Drill set, twist (Appendix B, Section III, Item 4)
- Riveter set (Appendix B, Section III, Item 5)
- Tool kit, general mechanic's (Appendix B, Section III, Item 1)

Parts/Materials

- Frame assembly
- Rivets, blind (Appendix D, Item 9)
- Chalk, marking (Appendix D, item 3)

Equipment Condition

- Complexing Kit Passageway removed from shelter, (Refer to para 2-5.)
-

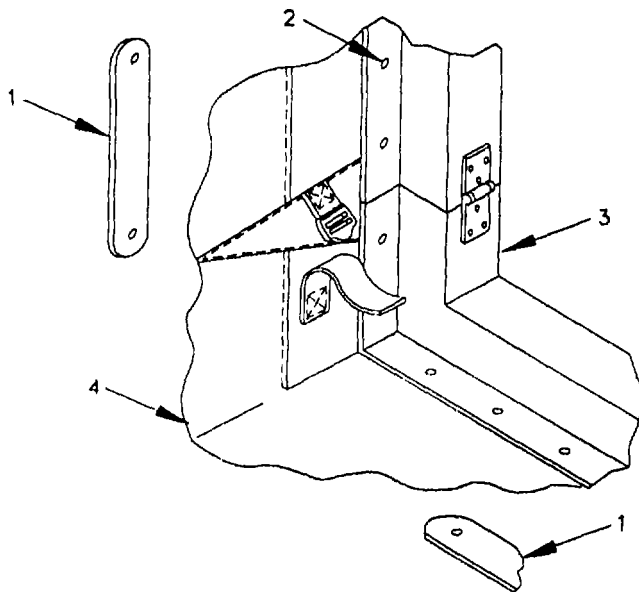
REMOVE

1. Tag all retainer strips (1).

4-20. CONNECTOR ASSEMBLY REPLACEMENT INSTRUCTIONS (CONT)**WARNING**

Wear safety glasses while drilling out rivets. Failure to do so could result in serious eye injury or blindness.

2. Drill out all pop rivets (2) that secure retainer strips (1) and frame assembly (3) to connector assembly (4).
3. Remove remaining pop rivet fragments (2).
4. Remove retainer strips (1) and frame assembly (3).

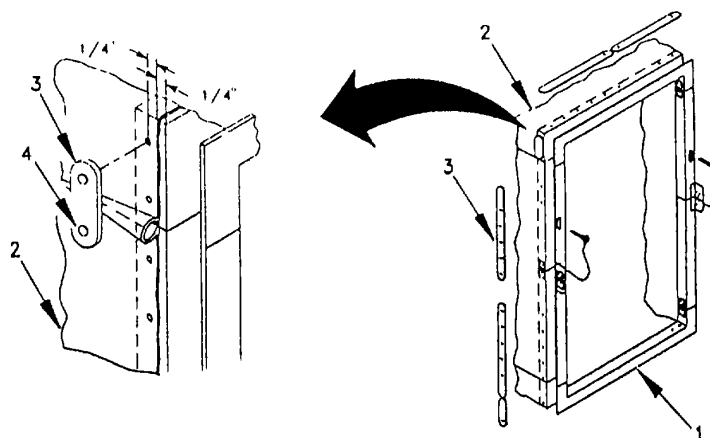
INSTALL**NOTE**

Ensure frame and connector are not secured upside down.

1. Hold frame assembly (1) against connector assembly (2) and align as shown. Be sure weather barrier (on connector) and door pivot bushing (on frame) are on same end.
2. Align retainer strips (3) with holes in frame (1).
3. Using retainer strips (3) as guides, drill holes through connector assembly (2)
4. Install new pop rivets (4) through holes in retainer strips (3), connector assembly (2), and frame assembly (1).

NOTE

FOLLOW-ON MAINTENANCE: If required, install Complexing Kit Passageway . (Refer to para 2-4).

4-21. CONNECTOR ASSEMBLY PUNCTURE REPAIR INSTRUCTIONS

This task covers: Repair

INITIAL SETUPTools

Repair kit, tentage (Appendix B, Section III, Item 2)
Tape, measuring (Appendix B, Section III, Item 7)

Parts/Materials

Cloth, coated (Appendix D, Item 12)
Tongue Depressor (Appendix D, Item 5)

Equipment Condition

Complexing Kit Passageway removed from shelter. (Refer to para 2-5.)

REPAIR**WARNING**

The adhesive has a high alcohol content and is highly flammable. Use only in a well ventilated area away from open flame. Do not smoke. Failure to follow these safety precautions could result in dizziness, fainting, severe burns or death,

NOTE

Adhesive dries quickly. Do not leave lid off adhesive can for more than five minutes. Replace lid on adhesive can immediately after use.

1. Measure hole in connector assembly to see if 1/8 in. (3.2 mm) across or less in all directions. To repair holes larger than 1/8 in. (3.2 mm) across refer to paragraph 4-22.

4-21. CONNECTOR ASSEMBLY PUNCTURE REPAIR INSTRUCTIONS (CONT)

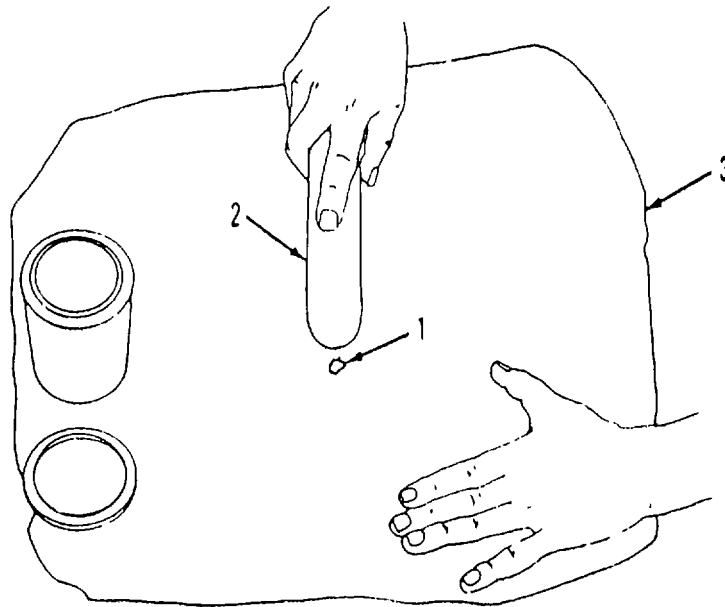

2. Clean area around hole (1).
3. Using tongue depressor (2), dab adhesive onto hole (1) in connector assembly (3),
4. Work adhesive into connector assembly (3) immediately and bridge hole (1) with adhesive to seal it.
5. Let adhesive dry.

NOTE

FOLLOW-ON MAINTENANCE: If required, install Complexing Kit Passageway. (Refer to para 2-4.)

4-22. HOLE AND TEAR REPAIR INSTRUCTIONS

This task covers: Repair

INITIAL SETUP

Tools

Repair kit, tentage (Appendix B, Section III, Item 2)
Roller, hand (Appendix B, Section III, Item 6)
Tape, measuring (Appendix B, Section III, Item 7)

Parts/Materials

Cloth, coated
Chalk, marking (Appendix D, Item 3)
Cloth, wiping (Appendix D, Item 4)
Tongue depressor (Appendix D, Item 5)
Lumber, softwood (Appendix D, Item 6)

Equipment Condition

Complexing Kit Passageway removed from shelter. (Refer to para 2-5.)

REPAIR

WARNING

The adhesive has a high alcohol content and is highly flammable. Use only in a well ventilated area away from open flame. Do not smoke. Failure to follow these safety precautions could result in dizziness, fainting, severe burns or death.

NOTE

Adhesive dries quickly. Do not leave lid off adhesive can for more than five minutes. Replace lid on adhesive can immediately after use.

Holes 1/8 in. (3.2 mm) across or less in all directions can be repaired using procedures in para 4-21.

1. Measure hole in connector assembly to determine size of patch required.

4-22. HOLE AND TEAR REPAIR INSTRUCTIONS (CONT)

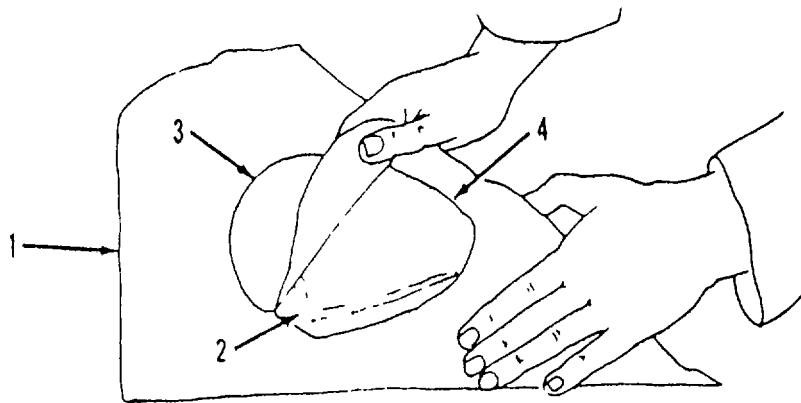

2. Flatten out connector assembly (1) and edges of damaged area (2) as much as possible.
3. Cut round patch (3) from piece of matching fabric 3/4 in. (19.1 mm) or larger in all directions than the damaged area (2)
4. Place softwood lumber (or equivalent) under damaged area (2).
5. Center patch (3) over damaged area (2). Draw circle around patch (3), then remove patch (3).
6. Clean fabric (1) inside circle (4), and clean bottom of patch (3).
7. Place patch (3) face-down over damaged area (2).
8. Coat patch (3) evenly with adhesive. Let adhesive overlap edge patch (3) to form adhesive circle on fabric (1).
9. Remove patch (3), turn adhesive side up, and set aside.
10. Coat fabric (1) with adhesive inside adhesive circle. Let adhesive dry on both adhesive circle and patch (3).
11. Apply second coat of adhesive to patch (3) and inside adhesive circle.
12. Wait ten to fifteen minutes for adhesive to become tacky to touch.
13. Hold patch (3) face up over adhesive circle. After centering patch (3), press the two sticky surfaces together.

4-22. HOLE AND TEAR REPAIR INSTRUCTIONS (CONT)

14. Using hand roller, press excess adhesive and air bubbles from under patch. Roll first in one direction, then in opposite direction.
15. Using tongue depressor, apply small amount of adhesive to edge of patch (3). Run tongue depressor around patch (3) to seal edge and prevent fraying.
16. Let adhesive dry.

NOTE

FOLLOW-ON MAINTENANCE: If required, install Complexing Kit Passageway (Refer to para 2-4.)

4-23. STITCHING REPAIR INSTRUCTIONS

This task covers: Repair

INITIAL SETUP

Tools

Repair kit, tentage (Appendix B, Section II, Item 2)
Tape, measuring (Appendix B, Section III, Item 7)

Parts/Materials

Beeswax (Appendix D, Item 1)

Equipment Condition

Complexing Kit Passageway removed from shelter. (Refer to para 2-5.)

REPAIR

NOTE

Stitching repair should be done by sewing machine if possible. Hand sewing repairs are done only in an emergency. Temporary hand sewing repairs should machine sewn as soon possible. Refer to Chapter 5. Machine sewing instructions.

1. Measure damage and determine total length of repair. Estimate how much thread is needed and cut to proper length.

NOTE

Waxing thread keeps it from fraying, protects it from weather, and helps the thread pass more easily through the fabric.

4-23. STITCHING REPAIR INSTRUCTIONS (CONT)

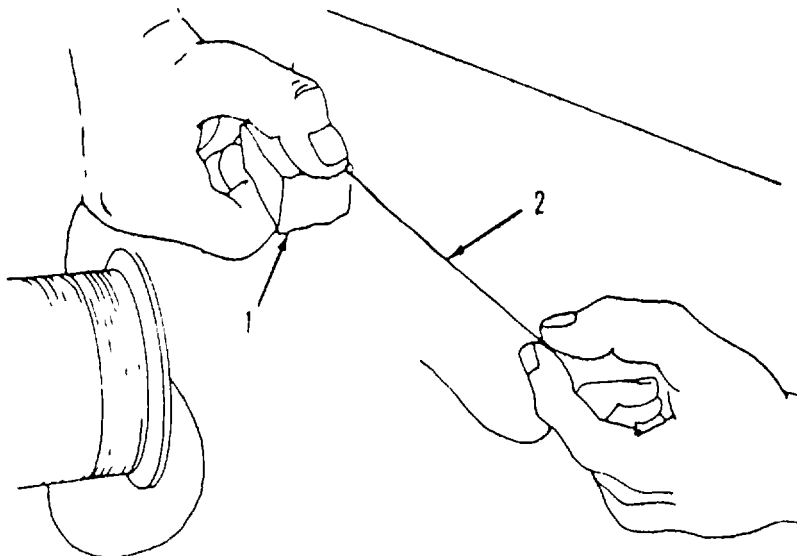

2. Using beeswax (1), wax piece of thread (2) using the following steps:
 - a. Hold one end of thread (2) against piece of beeswax as shown above.
 - b. Pull entire length of thread (2) across the surface of beeswax (1) with other,
 - c. Repeat above steps until thread is sticky.

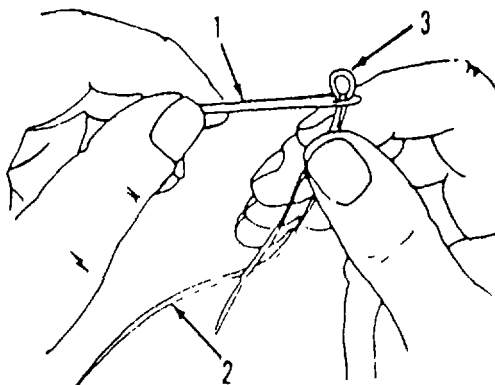

3. Thread sailmaker's needle (1) with waxed thread (2).
 - a. Fold over a piece of waxed thread (2) to form small loop (3).

NOTE

Make loop at end of thread if two stands are used. Make loop at point halfway between ends if four strands are used.

4-23. STITCHING REPAIR INSTRUCTIONS(CONT)

- b. Stick loop (3) through eye of needle (1).
 - c. Pull half of thread (2) through eye and make ends even.
 - d. Tie ends in knot.
4. Rewax thread for added protection.
- a. Hold thread near needle firmly with one hand,
 - b. Grasp section of thread with fingertips of other hand and twist strands together.
 - c. Rub this section of thread on beeswax.
 - d. Repeat above step until entire length of thread has been rewaxed.

NOTE

Wear sewing palm to protect the hand when sewing with the sailmaker's needle. The palm has a metal sheet inset which is used to push the needle through the fabric.

The running stitch is used to hold two pieces of fabric together until machine repairs can be made. The backstitch is on fabric to close an open seam and to tack at the beginning and end of a row of hand stitches,

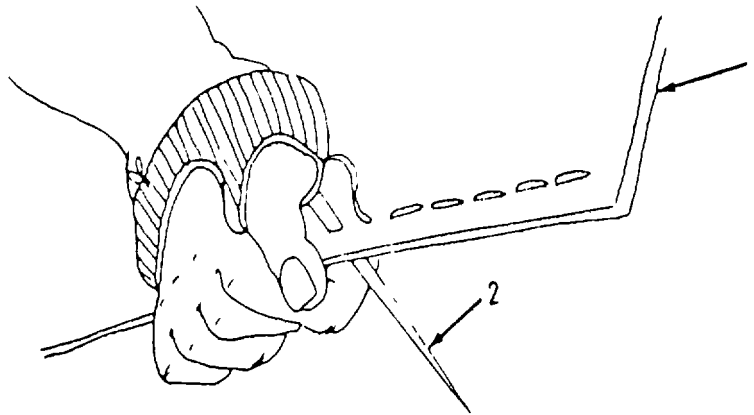

4-23. STITCHING REPAIR INSTRUCTIONS (CONT)

5. Put running stitch into fabric (1) to repair broken stitches.
 - a. Push sailmaker's needle (2) through fabric (1) and pull thread through to knot.
 - b. Tack beginning and end row by making two small stitches on top of the other.
 - (1) Take a small stitch back, pushing needle (2) down into fabric (1).
 - (2) Push needle up through fabric (1) at beginning of stitch where not is located.
 - (3) Repeat steps (1) and (2).
 - c. Push needle (2) down through fabric (1) and then up through fabric (1).
 - d. Continue to make one stitch at a time to end of row. Make stitches uniform in appearance and same distance apart.
 - e. Backstitch 1 in. to tack end of row.
 - (1) Leaving at least 1 in. (25.4 mm), push needle up one stitch from last two stitches.
 - (2) Take one stitch back, pushing needle down into patch at end of last two stitches.
 - (3) Push needle up through patch one stitch length in front of previous stitch.
 - (4) Stitch back, pushing needle down into patch at end of previous stitch.
 - (5) Continue to stitch to end of row as in above steps.
 - (6) Make a knot in thread close to fabric and cut off remaining thread

NOTE

FOLLOW-ON MAINTENANCE: If required, install Complexing Kit Passageway, (Refer to para 2-4.)

4-24. RIVET RIPS REPAIR INSTRUCTIONS

This task covers: Repair

INITIAL SETUP

Tools

- Drill, electric, portable (Appendix B, Section III, Item 3)
- Drill set, twist (Appendix B, Section III, Item 4)
- Repair kit, tentage (Appendix B, Section III, Item 2)
- Riveter set (Appendix B, Section III, Item 5)
- Tape, measuring (Appendix B, Section III, Item 7)

Parts/Materials

- Rivets, pop (Appendix D, Item 9)
- Chalk, marking (Appendix D, Item 3)

Equipment Condition

- Complexing Kit Passageway removed from shelter. (Refer to para 2-5.)
-

REPAIR

NOTE

If connector assembly is damaged extensively, repair should be referred to Chapter 5, Direct Support Maintenance,

Rivet rips are caused by fabric ripping away from the rivets on the frame assembly.

4-24. RIVET RIPS REPAIR INSTRUCTIONS (CONT)

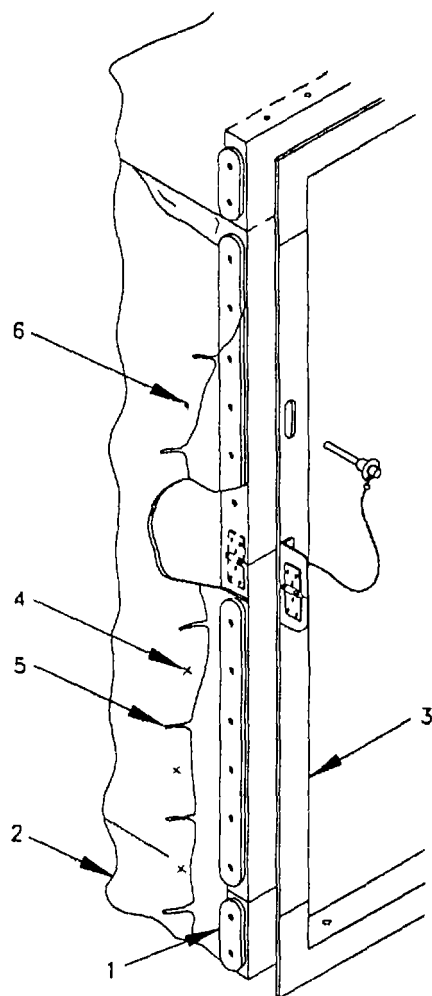
**WARNING**

Wear safety glasses while drilling out rivets. Failure to do so could result in serious eye injury or blindness.

1. Drill out all pop rivets that secure retainer strip (1) and connector assembly (2) to frame assembly (3)
2. Remove retainer strip (1).
3. Remove any remaining pop rivet fragments.
4. Hold ripped connector assembly (2) against frame assembly (3). Using marking chalk, mark X-spots (4) where holes are to be drilled. Mark X-spots (4) about halfway between rips (5) or between rips (5) and original rivet (6).

4-24. RIVET RIPS REPAIR INSTRUCTIONS (CONT)

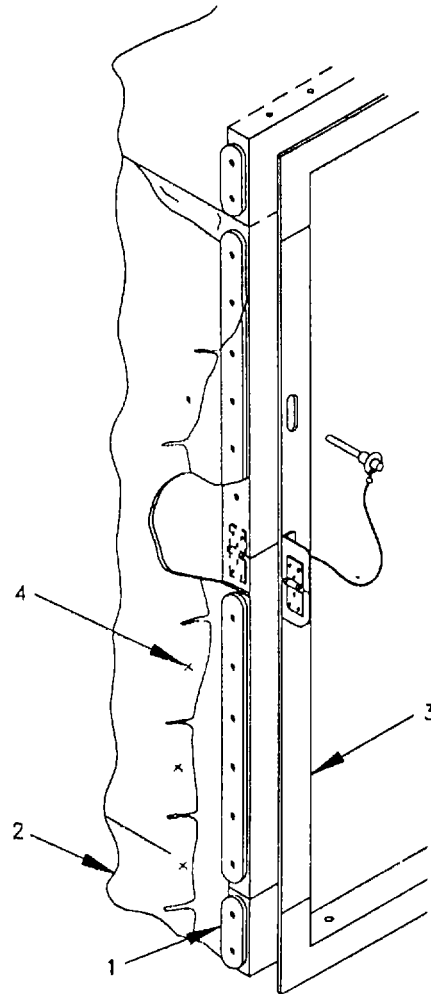

5. Holding retainer strip (1) and connector assembly (2) in place against the frame (3), use portable electric drill and twist drill set (appropriate to size of pop rivet) to drill holes through retainer strip (1), connector assembly (2), and frame assembly (3) at X-spots (4).
6. Using riveter and appropriate size pop rivets, secure retainer strip (1) and connector assembly (2) to frame assembly (3).

NOTE

FOLLOW-ON MAINTENANCE: If required, install Complexing Kit Passageway. (Refer to para 2-4.)

4-25. GROMMET MAINTENANCE INSTRUCTIONS

This task covers: Replace

INITIAL SETUP

Tools

- Repair kit, tentage (Appendix B, Section III, Item 2)
- Tool kit, general mechanic's (Appendix B, Section III, Item 2)

Parts/Materials

- Grommet
- Lumber, softwood (Appendix D, Item 6)

Equipment Condition

- Complexing Kit Passageway removed from shelter. (Refer to para 2-5.)
-

REMOVE

NOTE

The first step applies only if grommet has not been completely torn away from fabric.

Cut damaged grommet from connector assembly.

NOTE

If fabric repair is required, refer to paragraph 5-2.

INSTALL

2. Insert a grommet.

NOTE

A die inserted grommet consists of two brass parts. The male half, called a barrel, is smooth. The female half, called a washer, has spurs that grip the fabric.

4-25. GROMMET MAINTENANCE INSTRUCTIONS (CONT)

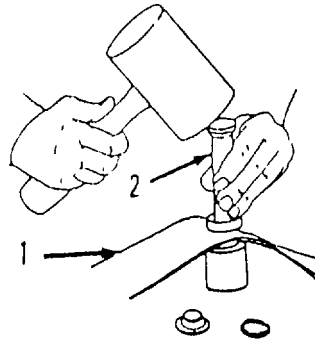

- a. Position connector assembly (1) face up on end grain surface of softwood lumber.
- b. Using a size 5 cutting punch for a size 4 grommet (or a size 6 cutting punch for a size 5 grommet) and a rawhide mallet, cut a grommet hole in a patch by hitting top of cutting punch (2) with rawhide mallet.

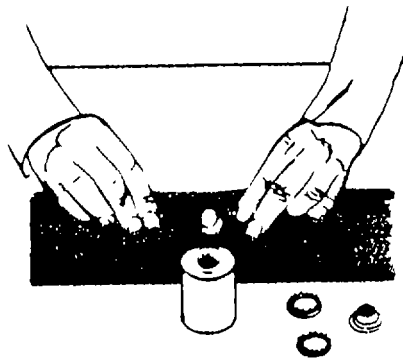

- c. Insert a grommet barrel into hole of fabric from underside.
- d. Place fabric and flat bottom pail of grommet barrel on grommet die.
- e. Place grommet washer, spurs down, over barrel.
- f. Insert cutting punch into grommet barrel and hold in place.
- g. Hit top of cutting punch with rawhide mallet hard enough to clinch the parts to the fabric without damaging grommet or fabric.

NOTE

When parts are clinched properly, the edge of the grommet barrel has a smooth roll.

FOLLOW-ON MAINTENANCE: If required, install Complexing Kit Passageway. (Refer to para 2-4.)

4-26. BECKET LOOP MAINTENANCE INSTRUCTIONS (TYPE II ONLY)

This task covers: Replace

INITIAL SETUP

Tools

- Repair kit, tentage (Appendix B, Section III, Item 2)
- Tape, measuring (Appendix B, Section III, Item 7)

Parts/Materials

- Cord, polyester
- Beeswax (Appendix D, Item 1)

Equipment Condition

Complexing Kit Passageway removed from TEMPER. (Refer to para 2-5.)

REMOVE

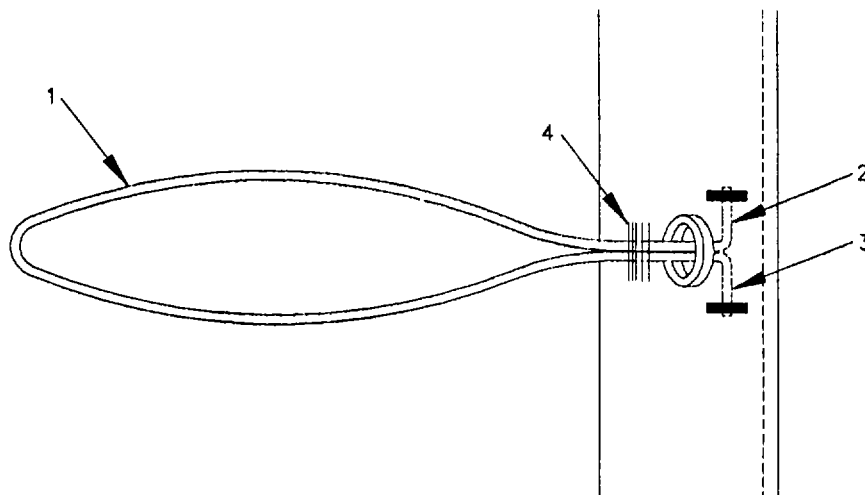

4-26. BECKET LOOP MAINTENANCE INSTRUCTIONS (TYPE II ONLY) (CONT)

NOTE

Becket loops are made of polyester cord and are used for attaching Type II of the Complexing Kit Passageway from an ISO shelter to a TEMPER.

Temporary unit level becket loop replacement should be followed by permanent loop replacement as soon as possible. Refer to Chapter 5 for permanent becket loop replacement.

Cut becket loop at grommet level.

INSTALL

1. Cut polyester cord to length.
2. Fold polyester cord to form loop (1).
3. Insert one loose end (2) of the loop through the grommet and feed towards the preceding becket loop. Handstitch the fabric and cord end to fix the loop in place.
4. Insert remaining loose end (3) of the loop through the grommet and feed towards the following becket loop. Handstitch the fabric and cord end to fix the loop in place.
5. Using thread, wrap and tie loop as close as possible (4) to its exit from grommet,

NOTE

FOLLOW-ON MAINTENANCE: If required, install Complexing Kit Passageway. (Refer to para 2-4.)

4-27. BUMP THROUGH DOORS PEDESTAL ASSEMBLY MAINTENANCE INSTRUCTIONS

This task covers: Replace

INITIAL SETUP**Tools**

Tool kit, general mechanic's (Appendix B, Section III, Item 1)

Parts/Materials

Pedestal assembly

Equipment Condition

Door removed from ISO frame assembly (Refer to para 2-5.)

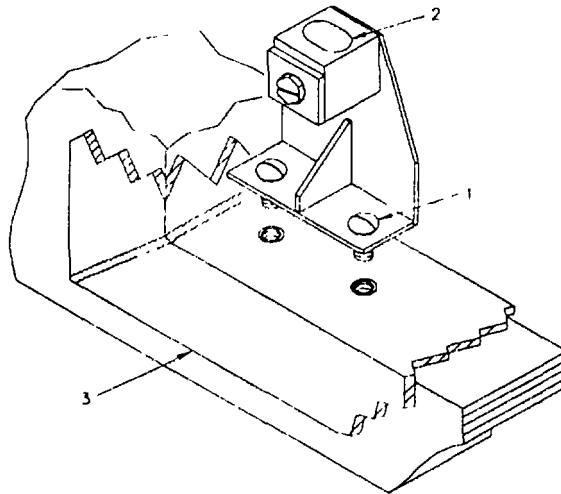
REMOVE

Loosen captive two screws (1) securing pedestal assembly (2) to ISO frame (3).

INSTALL

1. With height adjustment screw facing inside ISO shelter, align captive two screws (1) on pedestal assembly (2) with holes ISO frame (3).
2. Tighten two screws (1).

NOTE

FOLLOW-ON MAINTENANCE: Install and adjust door. (Refer to para 2-4.)

4-28. BUMP THROUGH DOORS PIVOT ASSEMBLY MAINTENANCE INSTRUCTIONS

This task covers: Replace

INITIAL SETUP**Tools**

Tool kit, general mechanic's (Appendix B, Section III, Item 1)

Parts/Materials

Pivot assembly

Equipment Condition

Door removed from ISO frame assembly. (Refer to para 2-5.)

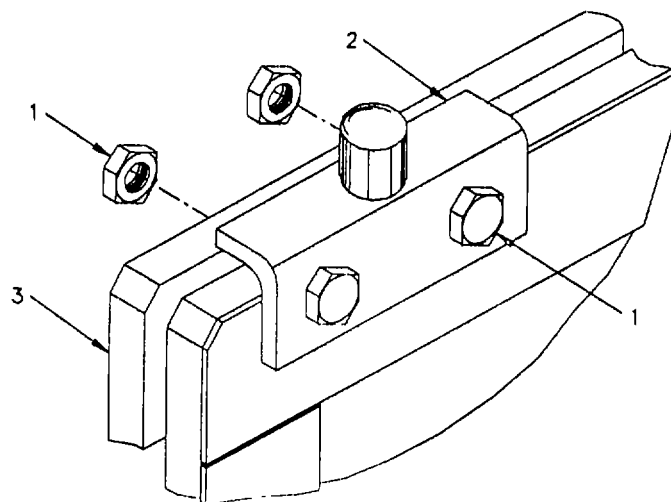
REMOVE

1. Loosen and remove two nuts and bolts (1) securing pivot assembly (2) to door (3).
2. Remove pivot assembly (2) from door (3).

INSTALL

1. Mount pivot assembly (2) on inside of door (3), aligning holes.
2. Install two nuts and bolts (1).

NOTE

FOLLOW-ON MAINTENANCE: Install and adjust door. (Refer to para 2-4.)

4-29. BUMP THROUGH DOORS HANDLE ASSEMBLY MAINTENANCE INSTRUCTIONS

This task covers: Replace

INITIAL SETUPTools

- Drill, electric portable (Appendix B, Section III, Item 3)
- Drill set, twist (Appendix B, Section III, Item 4)
- Riveter set (Appendix B, Section III, Item 5)

Parts/Materials

- Nylon handle
- Rivets, blind (Appendix D, Item 9)

Equipment Condition

Door removed from ISO frame assembly. (Refer to para 2-5.)

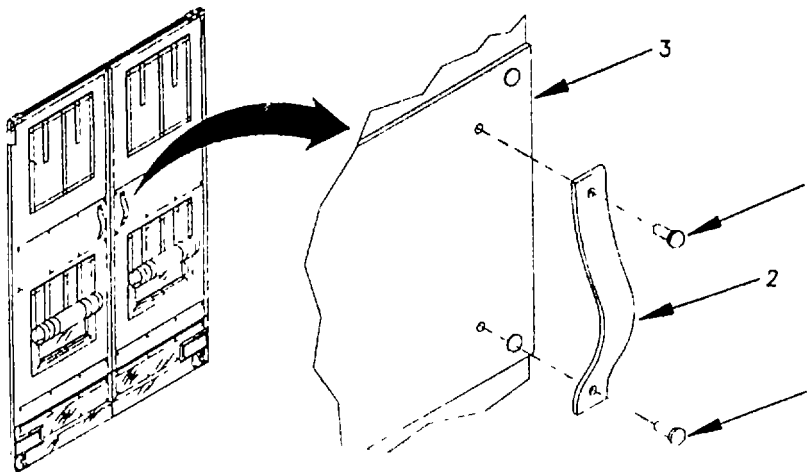
REMOVE**NOTE**

Twist drill size is determined by size of rivet used in handle installation.

Drill out both rivets (1) securing nylon handle (2) to door (3).

INSTALL

Mount handle (2) to door (3) by installing two rivets (1).

NOTE

FOLLOW-ON MAINTENANCE: If required, install and adjust door (Refer to para 2-4.)

Section IV. PREPARING FOR STORAGE OR SHIPMENT

4-30. GENERAL. To prepare the Complexing Kit Passageway for shipment or storage, refer to removal procedures, paragraphs 1-4, 2-5

4-31. ADMINISTRATIVE STORAGE REQUIREMENTS. For further storage and shipment procedures, see paragraph 1-4.

CHAPTER 5

DIRECT SUPPORT MAINTENANCE

Section I. MAINTENANCE PROCEDURES

5-1. GENERAL. This Section contains maintenance instructions authorized by the Maintenance Allocation Chart (Appendix B) to the Direct Support maintenance level. Direct support maintenance personnel can also perform all maintenance at the operator and unit maintenance levels. Maintenance will be performed by a fabric repair specialist, MOS 43M10, unless otherwise specified.



5-2. TEARS, WORN AREAS, AND MILDEW-ROTTED AREAS REPAIR INSTRUCTIONS

This task covers: Repair of fabric tears

INITIAL SETUP

Tools

- Repair kit, tentage (Appendix B, Section III, Item 2)
- Tape, measuring (Appendix B, Section III, Item 7)
- Sewing machine, industrial (Appendix B, Section III, Item 9)

Materials/Parts

- Chalk, marking (Appendix D, Section II, Item 3)
- Cloth (Appendix C, Section III, Item 3)

Equipment Condition

Complexing Kit Passageway removed from shelter. (Refer to para 2-5.)

REPAIR

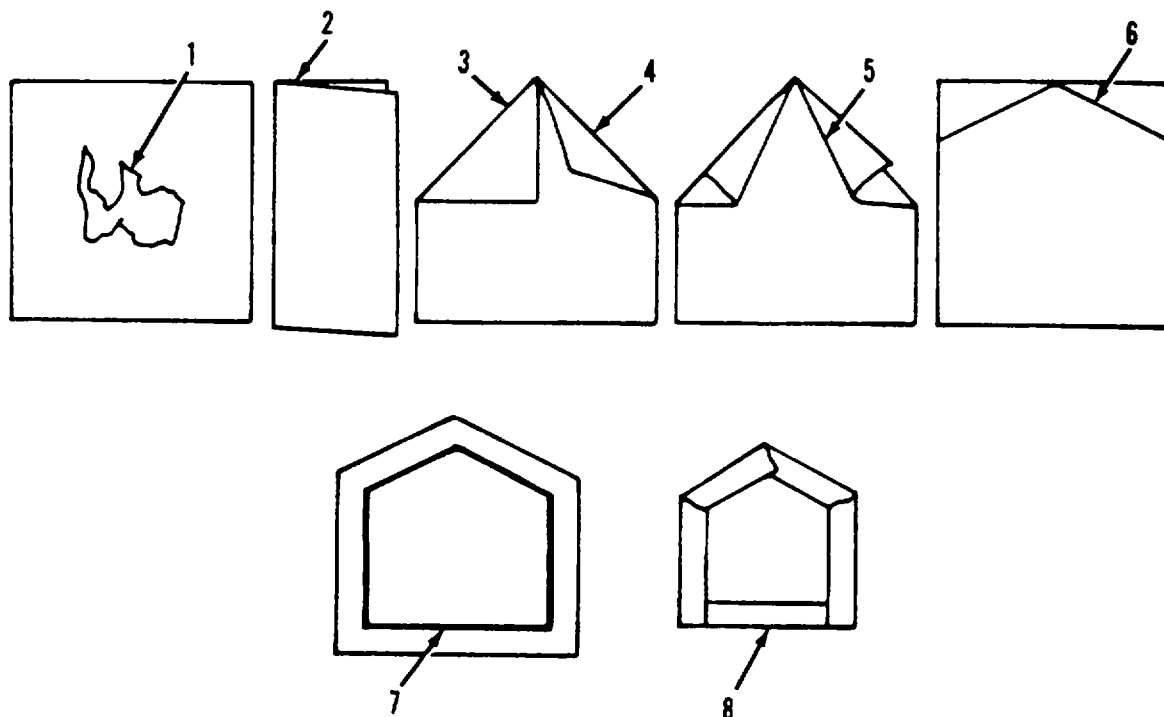

5-2. TEARS, WORN AREAS, AND MILDEW-ROTTED AREAS REPAIR INSTRUCTIONS (CONT)

1. Measure damaged area (1).
2. Cut watershed patch from matching fabric. Make patch large enough to extend 2-3/4 in. (69.9 mm) beyond damaged area on all four sides.
3. Fold patch in half lengthwise (2). Crease folded edge with handle of bent trimmer's shears.
4. Unfold patch.
5. Fold top left-hand corner (3) to crease in center.
6. Fold top right-hand corner (4) to crease in center. Align right-hand corner (4) with left-hand corner (3).
7. Crease folds in place.
8. Fold inside corner (5) of each triangle to edge of outside fold.
9. Crease folds in place.
10. Unfold patch.
11. Cut off top corners. Use creases (6) closest to corners as cutting lines.
12. Turn patch face up.
13. Draw chalk lines (7) 3/4 in. (19.1 cm) from raw edges of patch.
14. Fold under raw edges along chalk lines.
15. Crease folded edges (8) in place.
16. Center patch on damaged area (1) so two slanted edges at top of patch point toward top of water run-off.

NOTE

- Use single-needle, industrial sewing machine with compound feed and high-lift alternating pressure to sew fabric.
- Slanted edges of patch are to point towards direction of water run off.

5-2. TEARS, WORN AREAS, AND MILDEW-ROTTED AREAS REPAIR INSTRUCTIONS (CONT)

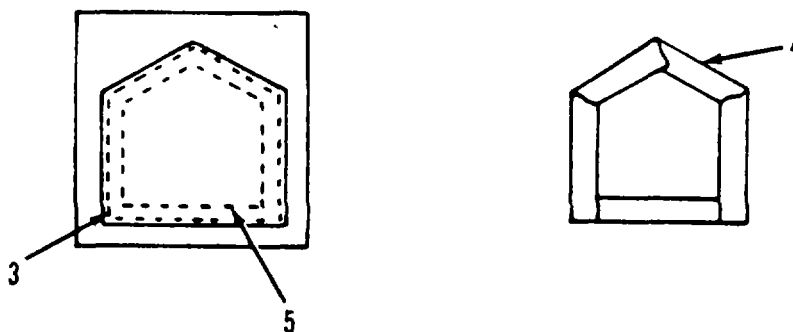
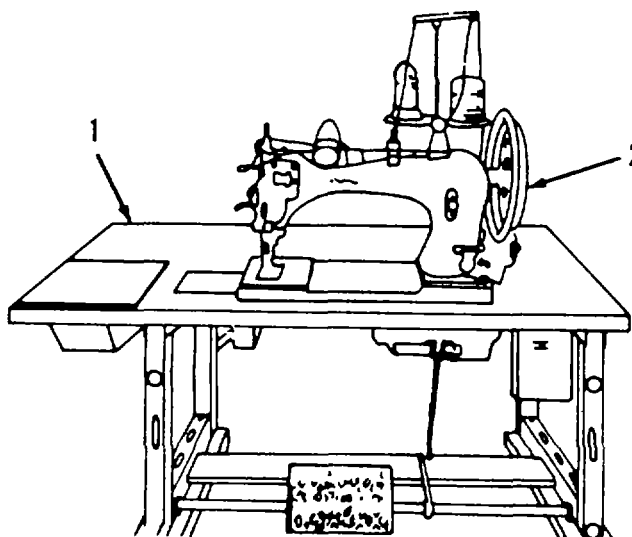

17. Place fabric and patch on sewing table (1) of industrial sewing machine (2).
18. Sew patch to fabric by stitching a seam (3) $\frac{1}{8}$ in. (3.2 mm) from folded edges (4). Tack first seam (3) by stitching over first stitches by at least 1 in. (25.4 mm).
19. Sew second seam (5) $\frac{3}{8}$ to $\frac{1}{2}$ in. (9.5 to 12.7 mm) inside first seam. Tack second seam (5) by stitching over first stitches for at least 1 in. (25.4 mm).
20. Cut out damaged area on inside of fabric to within $\frac{1}{8}$ in. (3.2 mm) of second seam (5).

5-3. STITCHING REPAIR INSTRUCTIONS

This task covers: Repair

INITIAL SETUP

Tools

Sewing machine, industrial (Appendix B, Section III, Item 9)

Equipment Condition

Complexing Kit Passageway removed from shelter (Refer to para 2-5.)

REPAIR

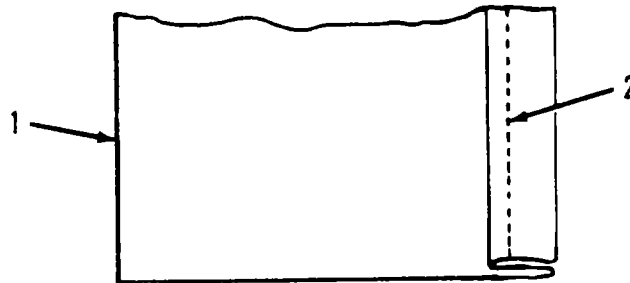

1. Place fabric (1) face down on sewing table.
2. Tack beginning of seam (2) by sewing a few stitches, then stitching over first stitches again.
3. Sew row of stitches along seam (2) of broken or open stitches until seam is complete again. Tack end of seam (2) by sewing over last inch (25.4 mm) of repair seam.

5-4. RIVET RIPS REPAIR INSTRUCTIONS

This task covers: Repair

INITIAL SETUP

Tools

Drill, electric, portable (Appendix B, Section III, Item 3)
Drill set, twist (Appendix B, Section III, Item 4)
Repair kit, tentage (Appendix B, Section III, Item 2)
Riveter set (Appendix B, Section III, Item 5)
Sewing machine, industrial (Appendix B, Section III, Item 9)
Tape, measuring (Appendix B, Section III, Item 7)
Tool kit, general mechanic's (Appendix B, Section III, Item 1)

Materials/Parts

Chalk, marking (Appendix D, Section II, Item 3)
Cloth (Appendix C, Section III, Item 3)

Equipment Condition

Complexing Kit Passageway removed from shelter. (Refer to para 2-5.)
Connector assembly separated from frame assembly. (Refer to para 4-6.)

REPAIR

NOTE

- Connector assembly must be completely removed from the frame to be repaired at the direct support maintenance level.
- Rivet rips are tears in the fabric caused by the fabric ripping away from the rivets on the frame.
- Twist drill size is determined by size of pop rivet used in frame.

5-4. RIVET RIPS REPAIR INSTRUCTIONS (CONT)

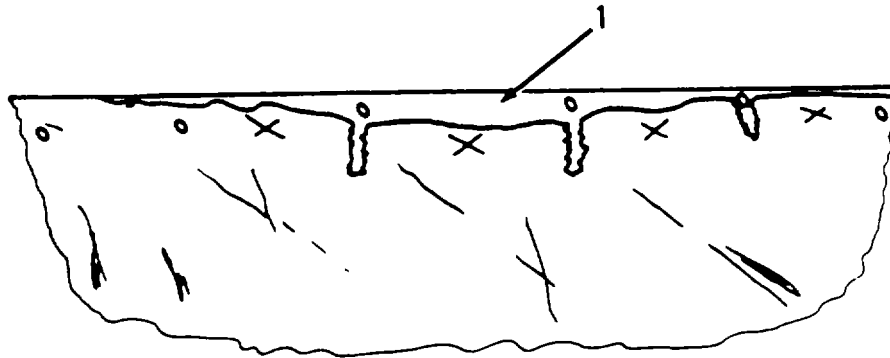

1. Measure length of damaged area (1).
2. Cut patch from matching fabric. Patch must be large enough to cover damage on top and underside and to extend 2-3/4 in. (69.9 mm) beyond damage on all sides.

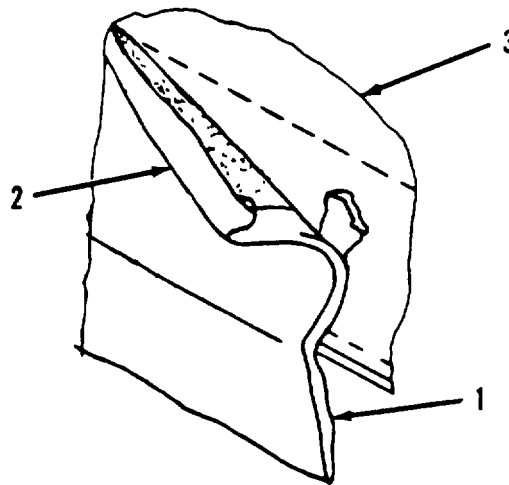

3. Turn patch (1) face up.
4. Draw chalk line 3/4 in. (19.1 mm) from edges on all sides of patch.
5. Fold under edges along chalk lines.
6. Crease folded edges (2) in place.
7. Fold patch (1) in half.
8. Overlap damaged fabric (3) using folded patch.
9. Place fabric (3) and patch (1) on sewing table.

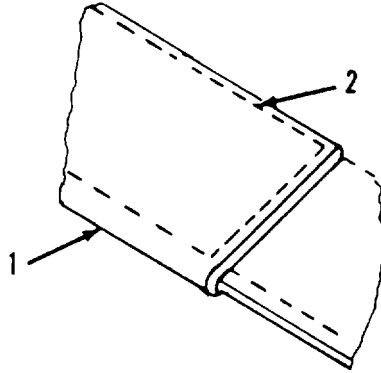
5-4. RIVET RIPS REPAIR INSTRUCTIONS (CONT)**NOTE**

When sewing patch through damaged fabric, be sure to sew through all layers of material.

10. Sew patch (1) in place by stitching seam (2) around the patch (1) 1/8 in. (3.2 mm) from all edges. Sew through all layers. Tack seam (2) by sewing over first stitches at least 1 in. (25.4 mm).

5-5. BUCKLES, FASTENERS, AND WEBBING MAINTENANCE INSTRUCTIONS (CONT)

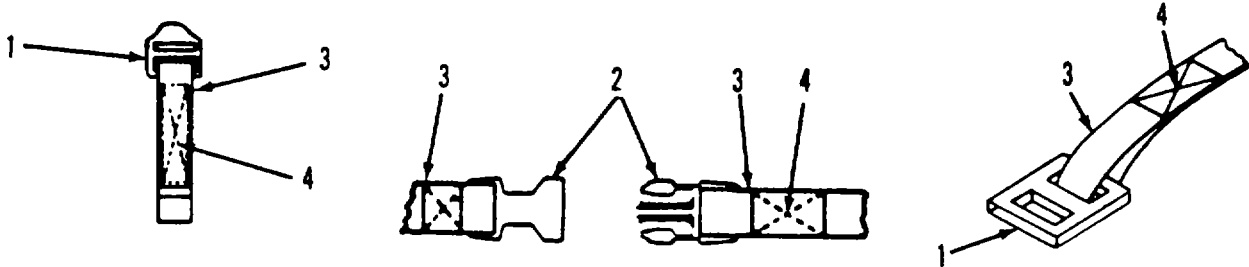
REPLACEMENT

NOTE

- Webbing is used as strapping by which cloth/fabric items are held, fastened, pulled, or lifted. The ends of the webbing are left plain or rolled, angled, or shaped to take hardware.
- Stitching repair should be done by sewing machine if possible. Hand sewing repairs are done only in an emergency. Temporary hand sewing repairs should be machine sewn as soon as possible.

1. Notice which bar of the buckle (1) or fastener (2) the webbing (3) is lapped over. On some items, it is the center bar. On others, it is one of the end bars.
2. Cut through and remove stitches (4) at the end of the overlap.
3. Unfold the overlap and remove the buckle or fastener. Retain the hardware for reuse when the webbing is being replaced.
4. When the hardware is defective, obtain a new or salvaged item the same type and size as the original one.
5. Measure webbing, including folded under section, to determine length of webbing needed.

5-5. BUCKLES, FASTENERS, AND WEBBING MAINTENANCE INSTRUCTIONS (CONT)

6. Cut piece or pieces of webbing to required length.
7. Pass the end of the webbing through the hardware, turn under the raw edge, and fold under at the buckle or fastener.
8. Stitch the underlap in place with two rows of stitching 1/8-inch from the edge. Tack all seams.
9. Sew the webbing to the connector assembly with X-shaped seams and border. Refer to para 4-9 for stitching procedures.

5-6. GROMMET MAINTENANCE INSTRUCTIONS

This task covers: Repair

INITIAL SETUP

Tools

Repair kit, tentage (Appendix B, Section III, Item 2)
Sewing machine, industrial (Appendix B, Section III, Item 9)

Materials/Parts

Lumber, softwood (Appendix D, Section II, Item 6)

Equipment Condition

Complexing Kit Passageway removed from shelter. (Refer to para 2-5.)

REPAIR

NOTE

The first two steps apply only if grommet has not been completely torn away from fabric.

1. Cut damaged grommet from connector assembly.
2. Discard damaged grommet.

5-6. GROMMET MAINTENANCE INSTRUCTIONS (CONT)

3. Measure damaged area (1).

NOTE

If connector assembly has a row of damaged grommets, replace entire section with one patch and a row of new grommets. Overlap should be larger and an extra seam added for support.

4. Cut a patch (2) from matching fabric. Make patch large enough to fold over and cover damage (1) on both sides and extend 2-3/4 in. (69.9 mm) beyond damage (1) on both sides.
5. Turn patch (2) face up and mark chalk lines on patch (2) 3/4 in. (19.1 mm) from all edges.
6. Fold under edges along chalk lines and crease folded edges (3) in place.
7. Fold patch (2) in half and lap over edge of connector assembly (4) covering damaged area (1).
8. Place fabric (1) and patch (2) on sewing table.
9. Sew patch (2) in place by stitching a seam (5) around patch 1/8 in. (3.2 mm) from folded edges (3). Sew through all layers. Tack seam (5) by sewing over at least 1 in. (25.4 mm) from end of seam (5).
10. Insert grommets (6) into patch (2). Refer to para 4-11, step 3, for procedure on inserting grommets.

5-7. TOGGLE MAINTENANCE INSTRUCTIONS (TYPE II ONLY)

This task covers: Replacement of toggle and cord

INITIAL SETUPTools

Repair kit, tentage (Appendix B, Section III, Item 2)

Tape, measuring (Appendix B, Section III, Item 7)

Materials/Parts

Cord, polyester (RPSTL item)

Toggle wood (RPSTL item)

Equipment Condition

Complexing Kit Passageway removed from shelter. (Refer to para 2-5.)

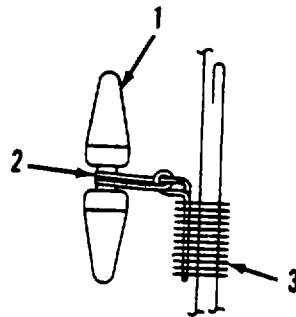
REPLACE

1. Cut and remove all the cord stitches that anchors the toggle. Clean away all pieces of thread.
2. Obtain a new or salvaged toggle (1) the same type and size as the defective toggle. If the toggle is missing, check the repair parts technical manual for the correct replacement item.
3. Measure and cut a piece of new cord long enough to make the repairs.
4. Wrap the cord (2) around the center of the toggle one and a half times and secure with a single overhand knot in a manner that prevents removal of the toggle.
5. Machine sew (3) the toggle cord to secure the cord to the connector fabric.

5-8. BECKET LOOP MAINTENANCE INSTRUCTIONS (TYPE II ONLY)

This task covers: Replacement of becket loop

INITIAL SETUP

Tools

Repair kit, tentage (Appendix B, Section III, Item 2)
 Tape, measuring (Appendix B, Section III, Item 7)
 Sewing machine, industrial (Appendix B, Section III, Item 9)

Materials/Parts

Cord, polyester (RPSTL item)

Equipment Condition

Complexing Kit Passageway removed from shelter. (Refer to para 2-5.)

REPLACEMENT

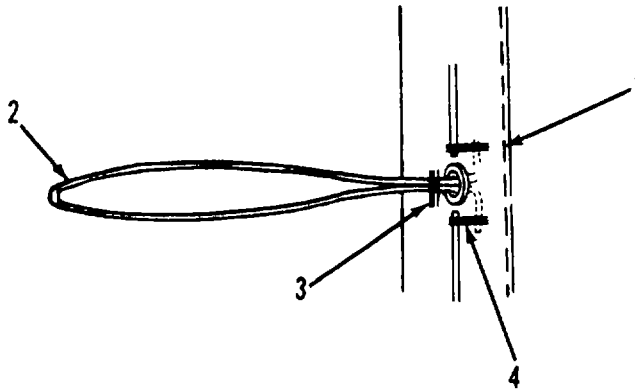

NOTE

Becket loops are made of polyester cord and are used for attaching Type II of the Complexing Kit Passageway from an ISO shelter to a TEMPER.

1. Cut stitches (1) and open seam of flat which encloses polyester cord used to form becket loops.

5-8. BECKET LOOP MAINTENANCE INSTRUCTIONS (TYPE II ONLY) (CONT)

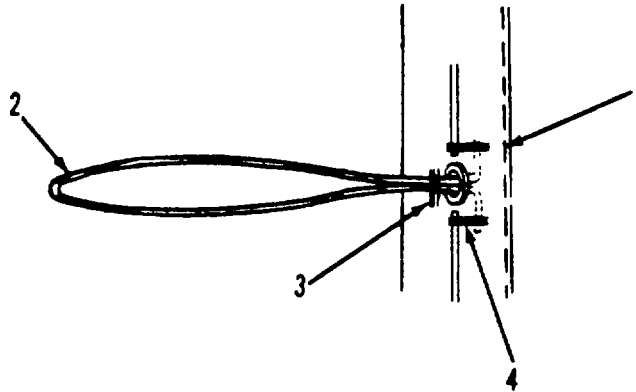

2. Cut portion of polyester cord containing unserviceable becket loop away and discard.
3. Cut new polyester cord to correct length.
4. Fold new section of polyester cord to form loop (2) and stitch (3) open end of loop together 6 in. (152.4 mm) from open end of loop.
5. Insert loose ends of polyester cord through grommet, directing ends of cord towards cut locations until ends overlap original cord by 1 in.
6. Machine sew (4) flap and sections of polyester cord together at each location.
7. Close and restitch flap enclosing polyester cord.

APPENDIX A

REFERENCES

A-1. SCOPE. This appendix lists all forms, field manuals, technical manuals, and miscellaneous publications referenced in this manual.

A-2. FORMS

Equipment Inspection and Maintenance Worksheet.....	DA Form 2404
Packaging Improvement Report	DD Form 6
Quality Deficiency Report	SF 368
Recommended Changes to Publications and Blank Forms	DA Form 2028
Recommended Changes to Equipment Technical Publications	DA Form 2028-2

A-3. FIELD MANUALS

First Aid Procedures	FM 21-11
General Fabric Repair	FM 10-16

A-4. TECHNICAL MANUALS

Procedures for Destruction to Prevent Enemy Use.....	TM 750-244-3
Operation, Organizational, Direct Support, and General Support Maintenance for the Shelter, Tactical, Expandable, Two-Sided.....	TM 10-5411-200-14
Operation, Organizational, Direct Support, and General Support Maintenance for the Shelter, Tactical, Expandable, One-Sided.....	TM 10-5411-201-14
Operator's, Unit, and Direct Support Maintenance Repair Parts and Special Tools List for the Complexing Kit Passageway.....	TM 10-5411-203-23P

A-5. MISCELLANEOUS

Army Medical Department Expendable/Durable Items	CTA 8-100
Expendable/Durable Items	CTA 50-970
The Army Maintenance Management System (TAMMS)	DA PAM 738-750

APPENDIX B
MAINTENANCE ALLOCATION CHART

Section I. INTRODUCTION

B-1. GENERAL

- a. This section provides a general explanation of all maintenance and repair functions authorized at various maintenance categories,
- b. The Maintenance Allocation Chart (MAC) in section II designates overall authority and responsibility for the performance of maintenance functions on the identified end item or component. The application of the maintenance functions to the end item or component will be consistent with the capacities and capabilities of the designated maintenance categories.
- c. Section III lists the tools and test equipment (both special tools and common tool sets) required for each maintenance function as referenced in section II.
- d. Section IV contains supplemental instructions and explanatory notes for a particular maintenance function.

B-2. MAINTENANCE FUNCTIONS . Maintenance functions will be limited to and defined as follows:

- a. Inspect. To determine the serviceability of an item by comparing its physical, mechanical, and/or electrical characteristics with established standards through examination (e.g., by sight, sound, or feel).
- b. Test. To verify serviceability by measuring the mechanical, pneumatic, hydraulic, or electrical characteristics of an item and comparing those characteristics with prescribed standards.
- c. Service. Operations required periodically to keep an item in proper operating condition, i.e., to clean (includes decontaminate, when required), to preserve, to drain, to paint, or to replenish fuel, lubricants, chemical fluids, or gases.
- d. Adjust. To maintain or regulate, within prescribed limits, by bringing into proper or exact position, or by setting the operating characteristics to specified parameters.
- e. Align. To adjust specified variable elements of an item to bring about optimum or desired performance.
- f. Calibrate. To determine and cause corrections to be made or to be adjusted on instruments or test, measuring, and diagnostic equipments used in precision measurement. Consists of comparisons of two instruments, one

B-2. MAINTENANCE FUNCTIONS (CONT)

of which is a certified standard of known accuracy, to detect and adjust any discrepancy in the accuracy of the instrument being compared.

g. Remove/Install. To remove and install the same item when required to perform service or other maintenance functions. Install may be the act of emplacing, seating, or fixing into position a spare, repair part, or module (component or assembly) in a manner to allow the proper functioning of an equipment or system.

h. Replace. To remove an unserviceable item and install a serviceable counterpart in its place. "Replace" is authorized by the MAC and is shown as the third position code of the SMR code.

i. Repair. The application of maintenance services¹, including fault location/troubleshooting², removal/installation, and disassembly/assembly³ procedures, and maintenance actions⁴ to identify troubles and restore serviceability to an item by correcting specific damage, fault, malfunction, or failure in a part, subassembly, module (component or assembly), end item, or system.

j. Overhaul. That maintenance effort (service/action) prescribed to restore an item to a completely serviceable/operational condition as required by maintenance standards in appropriate technical publications (i.e., DMWR). Overhaul is normally the highest degree of maintenance performed by the Army. Overhaul does not normally return an item to like-new condition.

k. Rebuild. Consists of those services/actions necessary for the restoration of unserviceable equipment to a like-new condition in accordance with original manufacturing standards. Rebuild is the highest degree of materiel maintenance applied to Army equipment. The rebuild operation includes the act of returning to zero those age measurements (hours/miles, etc.) considered in classifying Army equipments/components.

¹Services - inspect, test, service, adjust, align, calibrate, and/or replace.

²Fault locate/troubleshoot - the process of investigating and detecting the cause of equipment malfunctioning; the act of isolating a fault within a system or unit under test (UUT).

³Disassemble/assemble - encompasses the step-by-step taking apart (or breakdown) of a spare/functional group coded item to the level of its least componentry identified as maintenance significant (i.e., assigned an SMR code) for the category of maintenance under consideration.

⁴Actions - welding, grinding, riveting, straightening, facing, remachining, and/or resurfacing.

B-3. EXPLANATION OF COLUMNS IN THE MAC, SECTION II

a. Column 1, Group Number. Column 1 lists the functional group code numbers, the purpose of which is to identify maintenance significant components, assemblies, subassemblies, and modules with the next higher assembly. End item group number shall be "00."

b. Column 2, Component/Assembly. Column 2 contains the names of components, assemblies, subassemblies, and modules for which maintenance is authorized.

c. Column 3, Maintenance Functions. Column 3 lists the functions to be performed on the item listed in column 2. (For detailed explanation of these functions, see paragraph B-2.)

d. Column 4, Maintenance Category. Column 4 specifies, by the listing of a work-time figure in the appropriate subcolumn(s), the category of maintenance authorized to perform the function listed in column 3. This figure represents the active time required to perform that maintenance function at the indicated category of maintenance. If the number or complexity of the tasks within the listed maintenance function vary at different maintenance categories, appropriate work-time figures will be shown for each category. The work-time figure represents the average time required to restore an item (assembly, subassembly, component, module, end item, or system) to a serviceable condition under typical field operating conditions. This time includes preparation time (including any necessary disassembly/assembly time), troubleshooting/fault location time, and quality assurance/quality control time in addition to the time required to perform the specific tasks identified for the maintenance functions authorized in the maintenance allocation chart. The symbol designations for the various maintenance categories are as follows:

- C - Operator or Crew
- O - Unit
- F - Direct Support
- H - General Support
- L - Specialized Repair Activity (SRA)
- D - Depot

e. Column 5, Tools and Equipment. Column 5 specifies, by code, those common tool sets (not individual tools) and special tools, TMDE, and support equipment required to perform the designated function.

f. Column 6, Remarks. This column shall, when applicable, contain a letter code, in alphabetical order, which shall be keyed to the remarks contained in section IV.

B-4. EXPLANATION OF COLUMNS IN TOOL AND TEST EQUIPMENT REQUIREMENTS, SECTION III

- a. Column 1, Reference Code. The tool and test equipment reference code correlates with a code used in the MAC, section II, column 5.
- b. Column 2, Maintenance Category. The lowest category of maintenance authorized to use the tool or test equipment.
- c. Column 3, Nomenclature. Name or identification of the tool or test equipment.
- d. Column 4, National Stock Number. The National stock number of the tool or test equipment.
- e. Column 5, Tool Number. The manufacturer's part number.

B-5. EXPLANATION OF COLUMNS IN REMARKS, SECTION IV

- a. Column 1, Reference Code. This column refers to the code recorded in column 6, Section II.
- b. Column 2, Remarks. This column lists information pertinent to the maintenance function being performed as indicated in the MAC, section II.

Section II. MAINTENANCE ALLOCATION CHART

(1) GROUP NO.	(2) COMPONENT/ ASSEMBLY	(3) MAINTENANCE FUNCTION	(4) MAINTENANCE CATEGORY			(5) TOOLS & TEST EQUIP	(6) REMARKS
			C	O	F		
00	COMPLEXING KIT PASSAGEWAYS						
01	TYPE II - ISO TO TEMPER	INSPECT SERVICE REPAIR	0.6 0.3				
0101	RAMP (CLASS A ONLY)	INSPECT REPAIR	0.1	0.4		1, 3, 4, 8	
0102	STAIR ASSY (CLASS B ONLY)	INSPECT REPAIR	0.1	1.0		1	C
0103	EXTERIOR FRAME ASSY	INSPECT REPAIR	0.1	0.8		1	B
0104	FRAME ASSY (ISO)	INSPECT REPLACE REPAIR	0.1	0.8 1.5		1, 3, 4, 5 1, 3, 4, 5, 7, 8	A
0105	CONNECTOR ASSY	INSPECT REPLACE REPAIR	0.1	0.8 2.0	2.5	1, 3, 4, 5 1, 2, 3, 4, 5, 6, 7, 9	
0106	BUMP THRU DOORS (STYLE 2	INSPECT REPAIR	0.1	1.0		1, 3, 4, 5	
02	TYPE I - ISO TO ISO	INSPECT SERVICE REPAIR	0.4 0.2				
0201	RAMP (ISO-ISO)	INSPECT REPAIR	0.1	0.4		1, 3, 4, 8	
0202	FRAME	INSPECT REPLACE REPAIR	0.1	1.0 1.5		1, 3, 4, 5 1, 3, 4, 5, 7, 8	A
0203	FRAME	INSPECT REPLACE REPAIR	0.1	1.0 1.5	2.0	1, 3, 4, 5 1, 2, 3, 4, 5, 6, 7, 8, 9	
0204	BUMP THRU DOORS (STYLES 2 & 3 ONLY)	INSPECT REPAIR	0.1	1.0		1, 3, 4, 5	

Section III. TOOL AND TEST EQUIPMENT REQUIREMENTS
FOR
COMPLEXING KIT PASSAGEWAY

TOOL OR TEST EQUIPMENT REF CODE	MAINTENANCE CATEGORY	NOMENCLATURE	NATIONAL/NATO STOCK NUMBER	TOOL NUMBER
1	C	Tool kit, general mechanic's	5180-00-177-7033	
2	0	Repair kit, tentage	8340-00-262-5767 (8340-90-CL-P01)	
3	0	Drill, electric, portable	5130-00-935-7354	
4	0	Drill set, twist	5133-00-293-0981	
5	0	Riveter set	5120-00-017-2849	
6	0	Roller, hand	5120-00-243-9401	
7	0	Tape, measuring	5210-00-245-0301	
8	0	Stake, sheetmetal-working	5120-00-222-4447	
9	F	Sewing machine, industrial	3530-00-892-4631	

Section IV. REMARKS
FOR
COMPLEXING KIT PASSAGEWAY

REFERENCE CODE	REMARKS
A	Repair of the collapsible frame at the unit level is limited to replacement of unserviceable components.
B	Repair of the center support frame assembly (Type I only) at the unit level is limited to replacement of unserviceable components.
C	Repair of the stairway at the unit level is limited to replacement of the locking pins.

APPENDIX C

COMPONENTS OF END ITEMS AND BASIC ISSUE ITEMS

Section I. INTRODUCTION

C-1. SCOPE. This appendix lists components of end item and basic issue items for the Complexing Kit Passageway to help you inventory items required for safe and efficient operation.

C-2. GENERAL. The Component of End Item and Basic Issue Items Lists are divided into the following sections:

a. Section II. Components of End Items. This listing is for informational purposes only, and is not authority to requisition replacements. These items are part of the end item, but are removed and separately packaged for transportation or shipment. As part of the end item, these items must be with the end items whenever it is issued or transferred between property accounts. Illustrations are furnished to help you identify the items.

b. Section III. Basic Issue Items. These are the minimum essential items required to place the Complexing Kit Passageway in operation, to operate it, and perform emergency repairs. Although shipped separately packaged, BII must be with the Complexing Kit Passageway during operation and whenever it is transferred between property accounts. The illustrations will assist you with hard-to-identify items. This manual is your authority to request/requisition replacement BII, based on TOE/MTOE authorization of the end items.

C-3. EXPLANATION OF COLUMNS. The following provides an explanation of columns found in the tabular listing:

a. Column (1) - Illustration Number (Illus No). This column indicates the number of the illustration in which the item is shown.

b. Column (2) - National Stock Number. Indicates the National Stock Number (NSN) assigned to the item and will be used for requisitioning purposes.

c. Column (3) - Description. Indicates the Federal name and, if required, a minimum description to identify and locate the item. The last line for each item indicates the CAGEC (in parenthesis) followed by the part number. The Usable On Codes (UOC) listed at right of each item refer to the following Complexing Kit Passageway configurations:

CODE	USED ON
EQR . . .	ISO to TEMPER, (w/ramp), green
EQS . .	ISO to TEMPER, (w/stairs), green
EQW . . .	ISO to ISO, green
EQX . .	ISO to TEMPER, (w/ramp), tan
EQY . . .	ISO to TEMPER, (w/stairs), tan
EQZ . .	ISO to ISO, tan
EZT . . .	ISO to TEMPER, (w/ramp and bump thru doors), green
EZU . .	ISO to TEMPER, (w/stairs and bump thru doors), green
EZV . . .	ISO to ISO, (w/one set bump thru doors), green
EZW . . .	ISO to TEMPER, (w/ramp and bump thru doors), tan
EZX . . .	ISO to TEMPER, (w/stairs and bump thru doors), tan
EZY . . .	ISO to ISO, (w/one set bump thru doors), tan
FAA . . .	ISO to ISO, (w/two sets bump thru doors), green
FAB . . .	ISO to ISO, (w/two sets bump thru doors), tan

- d. Column (4) - Unit of Measure (U/M). Indicates the measure used in performing the actual operation/maintenance function. This measure is expressed by a two-character alphabetical abbreviation (e.g., ea, in., pr).
- e. Column (5) - Quantity Required (Qty Req). Indicates the quantity of the item to be used with/on the equipment.

Section II. COMPONENTS OF END ITEMS

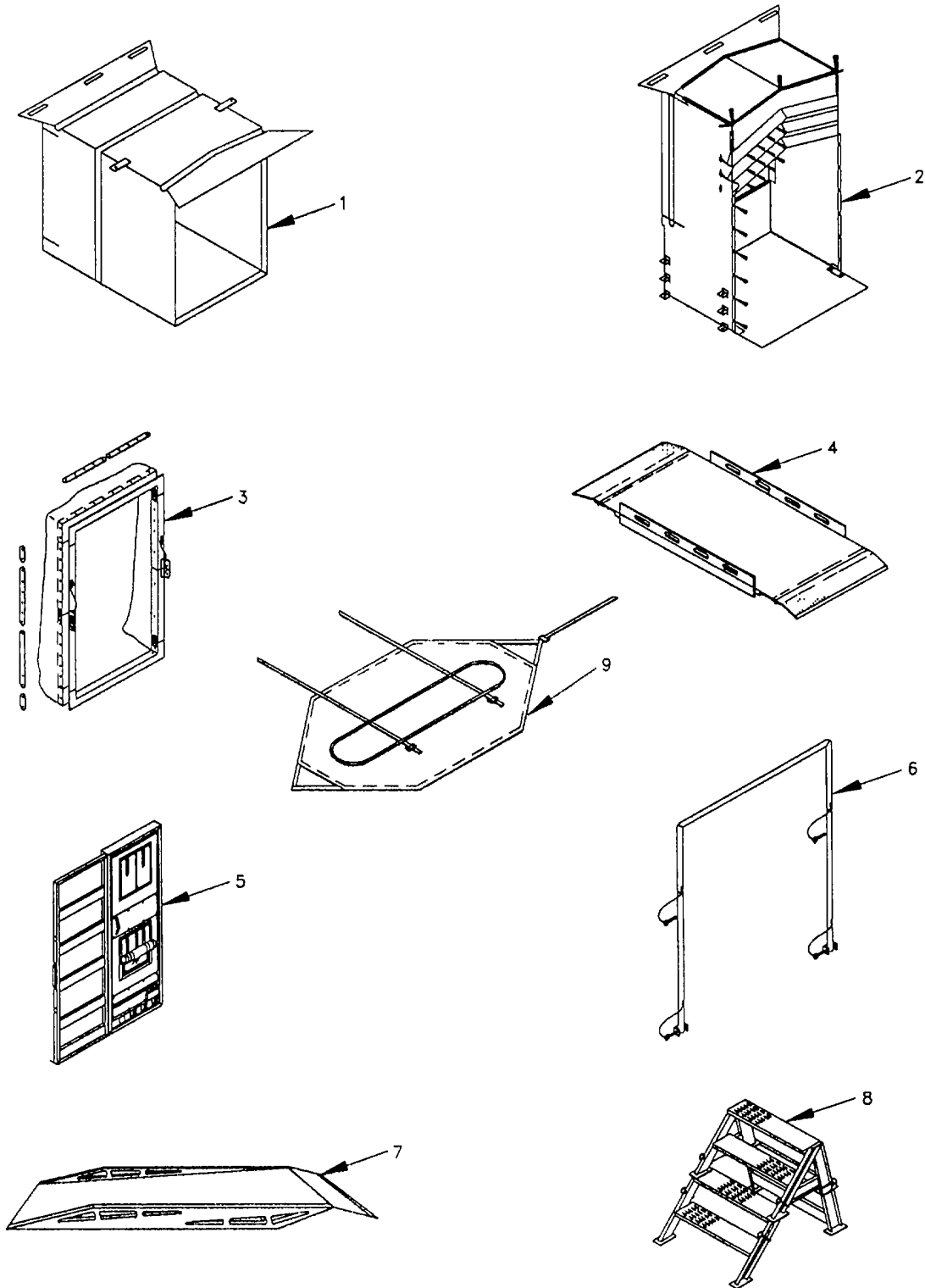

Section II. COMPONENTS OF END ITEMS (CONT)

(1) Illus No	(2) National Stock Number	(3) Description, CAGEC and Part Number	Usable on Codes	(4) U/M	(5) Qty Req
1		CONNECTOR ASSEMBLY (ISO-ISO) TAN (81337) 5-4-4202-1	EQZ, EYZ, FAB	EA	1
1		CONNECTOR ASSEMBLY (ISO-ISO) GREEN (81337) 5-4-4202-2	EQW, EZV, FAA	EA	1
2		CONNECTOR ASSEMBLY, TAN (81337) 5-4-4181-1	EQX, EQY, EZW, EZX	EA	1
2		CONNECTOR ASSEMBLY, GREEN (81337) 5-4-4181-2	EQR, EQS, EZT, EZU	EA	1
3		FRAME ASSEMBLY, TAN (81337) 5-4-4204-1	EQZ, EYZ, FAB	EA	2
3		FRAME ASSEMBLY, GREEN (81337) 5-4-4204-2	EQW, EZV, FAA	EA	2
3		FRAME ASSEMBLY, TAN (81337) 5-4-4204-1	EQX, EQY, EZW, EZX	EA	1
3		FRAME ASSEMBLY, GREEN (81337) 5-4-4204-2	EQR, EQS, EZT, EZU	EA	1
4		RAMP ASSEMBLY, TAN (81337) 5-4-5890-1	EQZ, EYZ, FAB	EA	1
4		RAMP ASSEMBLY, GREEN (81337) 5-4-5890-2	EQW, EZV, FAA	EA	1
5		BUMP THRU DOORS, W/CASE, ASSY TAN (81337) 5-4-7532-1	EZW, EZX, EYZ	EA	1
5		BUMP THRU DOORS, W/CASE, ASSY GREEN (81337) 5-4-7532-2	EZT, EZU, EZV	EA	1
5		BUMP THRU DOORS, W/CASE, ASSY TAN (81337) 5-4-7532-1	FAB	EA	2
5		BUMP THRU DOORS, W/CASE ASSY GREEN (81337) 5-4-7532-2	FAA	PR	2
6		EXTERIOR FRAME ASSEMBLY, TAN (81337) 5-4-4196-1	EQX, EQY, EZW, EZX	EA	1
6		EXTERIOR FRAME ASSEMBLY, GREEN (81337) 5-4-4196-3	EQR, EQS, EZT, EZU	EA	1
7		RAMP ASSEMBLY, TAN (81337) 5-4-6733-1	EQX, EZW	EA	1
7		RAMP ASSEMBLY, GREEN (81337) 5-4-6733-2	EQR, EZT	EA	1
8		STAIRWAY, ADJUSTABLE ASSY, TAN (81337) 5-4-4029-1	EQY, EZX	EA	1
8		STAIRWAY, ADJUSTABLE ASSY, GREEN (81337) 5-4-4029-2	EQS, EZU	EA	1
9		DIAPER, TAN (81337) 5-4-6942-1	EQX, EQY, EQZ, EZW EZX, EYZ, FAB	EA	1
9		DIAPER, GREEN (81337) 5-4-6942-2	EQR, EQS, EQW, EZT EZU, EZV, FAA	EA	1

Section III. BASIC ISSUE ITEMS

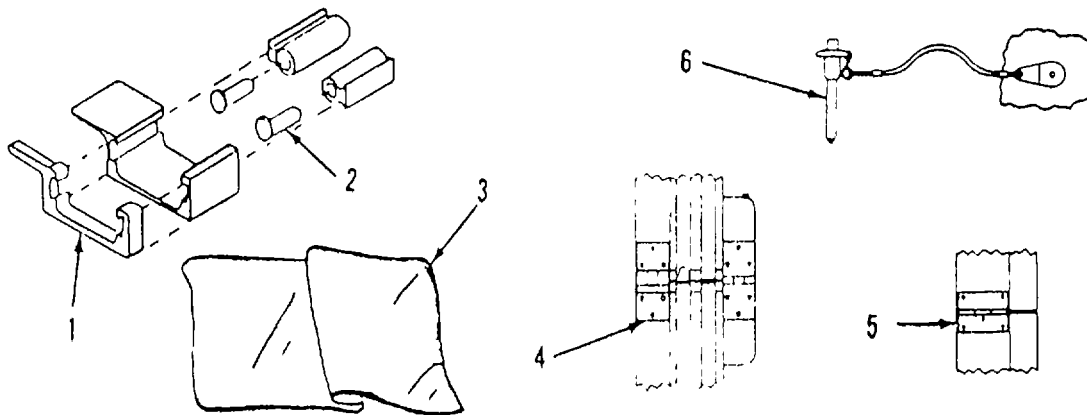

(1) Illus Number	(2) National Stock Number	(3) Description FSCM and Part Number	(4) U/M	(5) Qty Rqr
1		ENDLAP (81337) 5-4-5882	EA	8
2		JOINT, SEAL (81337) 5-4-4439	EA	8
3		CLOTH (81349) MIL-C-43285 TY1 CL III TAN OR FOREST GREEN	EA	1 SQ YD
4		HINGE, 1-1/2 IN. TYPE I (81337) 5-4-5538-1	EA	8
		TYPE II (81337) 5-4-5538-1	EA	4
5		HINGE, 2-1/2 IN, TYPE I EA (81337) 5-4-5538-2		8
		TYPE II (81337) 5-4-5538-2	EA	4
6		PIN, LOCKING, WITH LANYARD (81337) 5-4-5540-2	EA	2

Section III. BASIC ISSUE ITEMS (CONT)

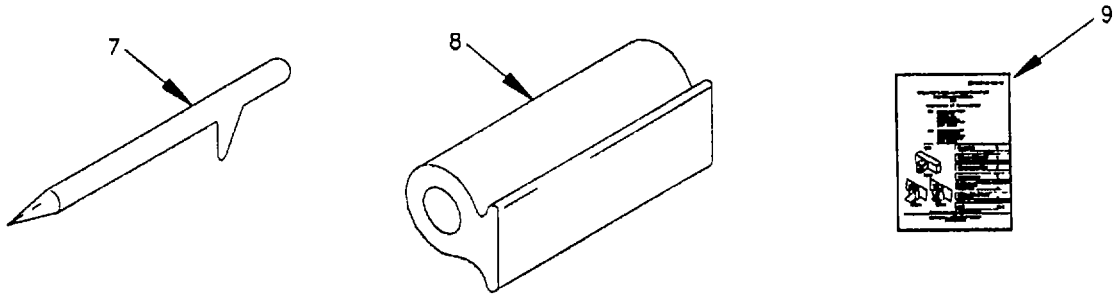

(1) Illus Number	(2) National Stock Number	(3) Description	(4) U/M	(5) Qty Rqr
7	8340-00-832-7451	PIN, TENT (TYPE II ONLY)	EA	4
8		SEAL, SILICONE (81337) 5-4-5537	EA	20 FT
9		TECHNICIAN MANUAL TM 10-5411-203-13	EA	1

APPENDIX D

EXPENDABLE/DURABLE SUPPLIES AND MATERIALS LISTS

Section I. INTRODUCTION

D-1. SCOPE. This appendix lists expendable/durable supplies and materials you will need to operate and maintain the Complexing Kit Passageway. This listing is for informational purposes only and is not authority to requisition the listed items. These items are authorized to you by CTA 50-970, Expendable/Durable Items (except Medical, Class V, Repair Parts and Heraldic Items), or CTA 8-100, Army Medical Department Expendable/Durable Items.

D-2. EXPLANATION OF COLUMNS.

a. Column (1) - Item Number. This number is assigned to the entry in the listing and is referenced in the narrative instructions to identify the material (e.g, "Use cleaning compound, Appendix D, Item 5").

b. Column (2) - Level. This column identifies the lowest level of maintenance that requires the listed item.

C - Operator

O - Unit maintenance

F - Direct support maintenance

c. Column (3) - National Stock Number. Indicates the National Stock Number (NSN) assigned to the item and will be used for requisitioning purposes.

d. Column (4) - Description. Indicates the Federal name and, if required, a description to identify the item. The last line for each item indicates the Federal Supply Code for Manufacturer (FSCM) (in parenthesis) followed by the part number.

e. Column (5) - Unit of Measure (UM). Indicates the measure used in performing the actual maintenance function. The measure is expressed in two-character alphabetical abbreviation (e.g., ea, in, pr). If the unit of measure differs from the unit of issue, requisition the lowest unit of issue that will satisfy your requirements

Section II. EXPENDABLE/DURABLE SUPPLIES AND MATERIALS LIST

(1) Item Number	(2) Level	(3) National Stock Number	(4) Description	(5) U/M
1	O	9160-00-253-17.3	BFESWAX	EA
2	O	804C-00-201-8835	ADHESIVE AND CATALYST, SILICONE	EA
3	O	7510-00-223-6706	CHALK, MARKING	EA
4	O	7920-00-165-7154	CLOTH, WIPING,	EA
5	O	6515-00-324-5500	TONGUE DEPRESSOR	EA
6	O	5510-01-039-4856	LUMBER, SOFTWOOD	EA
7	O	4020-00-141-7152	ROPE NYLON	IN
8	O		RIVET, SOLID (96906) MS20613-6C24	EA EA
9	O		RIVET, BLIND (81349) M24243/6-A6066F	EA
10	O		HINGE (96906) MS20001-14	FT
11	O		ADHESIVE, SEALANT (81349)MIL-A-46146	EA

APPENDIX E

ILLUSTRATED LIST OF MANUFACTURED ITEMS

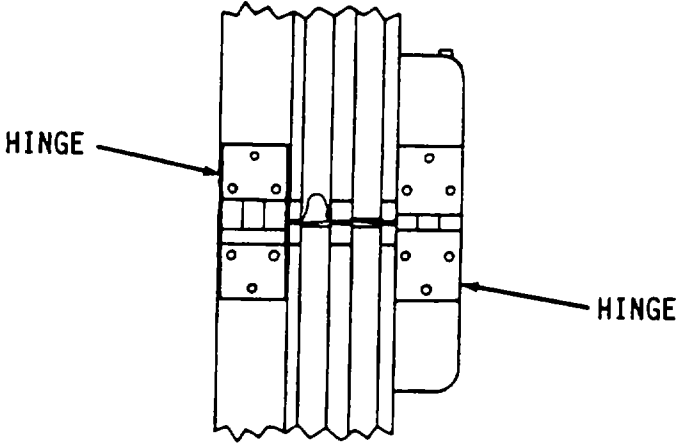
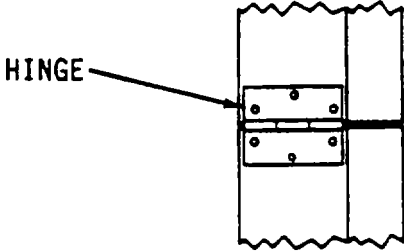
FSCM	PART NUMBER	DESCRIPTION	QTY
<div style="display: flex; justify-content: space-around; align-items: center;">  <div style="text-align: right;"> <p>CENTER CUTAWAY VIEW FRAME ASSY (5-4-4204)</p> </div> </div>			
81337	5-4-5538-1	HINGE, FRAME, CENTER, 1.50 IN. LG, MAKE FROM HINGE P/N MS20002-14	4
<div style="display: flex; justify-content: space-around; align-items: center;">  <div style="text-align: right;"> <p>CORNER CUTAWAY VIEW FRAME ASSY (5-4-4204)</p> </div> </div>			
81337	5-4-5538-2	HINGE, FRAME, CORNER, TOP AND BOTTOM 2.50 IN. LG, MAKE FROM HINGE, P/N MS20001-14	4

GLOSSARY

Section I. ABBREVIATIONS

ISO	International Standardization Organization
.....	
.....	
TEMPER.....	Tent, Extendible, Modular, Personnel

Section II. DEFINITION OF UNUSUAL TERMS

Becket.....	A loop of rope to catch in the eye of another loop for lacing procedures.
Environmentally sealed	Protected from all kinds of weather
Grommet.....	A metal eyelet used to reinforce a preformed hole in fabric

ALPHABETIC INDEX

SUBJECT	PARAGRAPH TABLE APPENDIX
A	
Administrative Storage Requirements	4-31
B	
Basic issue items	C
Becket loop maintenance instructions (Type TT only).....	4-25, 5-8
Buckles, fasteners, and webbing maintenance instructions.....	5-5
Bump thru doors nylon handle replacement instructions.....	4-29
Bump thru doors pedestal assembly replacement instructions.....	4-27
Bump thru doors pivot assembly replacement instructions	4-28
C	
Characteristics, capabilities, and features, equipment	1-7
Chart (MAC), maintenance allocation.....	B
Common tools and equipment.....	4-1
Components of end item and basic issue items list.....	C
Connector assembly replacement instructions.....	4-20
Connector assembly puncture repair instructions.....	4-21
D	
Data, equipment.....	1-10
Destruction of Army materiel to prevent enemy use	1-3
Difference between models.....	1-9
Doors bump thru, nylon handle replacement instructions.....	4-29
Doors, hump thru, pedestal assembly replacement instr's	4-27
Doors bump thru, pivot assembly replacement instructions	4-28
E	
End item, components of	C
Equipment characteristics, capabilities, and features.....	1-7
Equipment, common tools and	4-1
Equipment data.....	1-10
Expendable/durable supplies and materials list	D
Exterior frame assembly header bar maintenance instructions (Type II only).....	4-11
Exterior frame assembly upright bar maintenance instructions (Type II only).....	4-12
Exterior frame assembly pin and lanyard assembly maintenance instructions (Type II only).....	4-13

ALPHABETIC INDEX

SUBJECT	PARAGRAPH TABLE APPENDIX
F	
Forms, records and reports, maintenance	1-2
Frame assembly replacement instructions.....	4-14
Frame endcap maintenance instructions	4-17
Frame hinge maintenance.....	4-16
Frame locking pin assembly maintenance instructions	4-15
Frame seal end cap maintenance instructions	4-18
Frame seal maintenance instructions	4-19
G	
General operator PMCS.....	2-1
Grommet maintenance instructions	4-25, 5-6
H	
Handle, bump thru doors, replacement instructions	4-29
Hole and tear repair instructions	4-22
I	
If your equipment fails to operate	2-3
Illustrated list of manufactured items	E
Improvement recommendations (EIR), reporting equipment.....	1-6
Installation and preparation for use.....	2-4
J	
K	
L	
Location and description of major components.....	1-8
M	
Maintenance allocation chart (MAC).....	B
Maintenance forms, records, and reports.....	1-2
Maintenance procedures	
Becket loop (Type II only)	4-26, 5-8
Buckles, fasteners, and webbing	5-5
Connector assembly puncture repair.....	4-21
Connector assembly replacement	4-20
Exterior frame assembly header bar (Type II only).....	4-10

ALPHABETIC INDEX

SUBJECT	PARAGRAPH TABLE APPENDIX
Exterior frame assembly upright bar (Type II only)	4-12
Exterior frame assembly pin and lanyard (Type II only)	4-13
Frame assembly replacement	4-14
Frame endcap	4-17
Frame hinge	4-16
Frame locking pin assembly	4-15
Frame seal	4-19
Frame seal endcap	4-18
Grommet	4-25, 5-6
Handle replacement	4-29
Hole and tear repair	4-22
Pedestal assembly replacement	4-27
Pivot assembly replacement	4-28
Ramp edge protector	4-6
Ramp end plate assembly	4-7
Ramp threshold channel	4-8
Rivet rips repair	4-24, 5-4
Stairway riser and support assemblies	4-9
Stairway pin and lanyard assembly	4-10
Stitching repair	4-23, 5-3
Tears, worn areas and mildew-rotted areas repair	5-2
Toggle (Type II only)	5-7
Maintenance procedures, general	4-5, 5-1
Major components, location and description of	1-8
Manufactured items, illustrated list of	E
Material, service upon receipt	4-4
Models difference between	1-9
Movement, preparation for	2-6
N	
Nomenclature, names and designations, official	1-5
O	
Official nomenclature, names and designations	1-5
Operation in unusual weather	2-7
Operator PMCS, general	2-1
P	
Parts, repair	4-3
Pedestal assembly replacement instructions	4-27
Pivot assembly replacement instructions	4-28
PMCS, operator, general	2-1
PMCS procedures	2-6

ALPHABETIC INDEX

SUBJECT	PARAGRAPH TABLE APPENDIX
Preparation for movement.....	2-6
Preparation for storage or shipment	1-4, 4-30
Preparation for use, installation and	2-4
Prevent enemy use, destruction of army materiel to.....	1-3
Preventive maintenance checks and services (PMCS), operator, general.....	2-1
Preventive maintenance checks and services (PMCS) Procedures.....	2-2
Maintenance - see Maintenance Procedures	
Maintenance, general.....	4-5, 5-1
PMCS	2-2
Removal	2-5
Q	
R	
Ramp edge protector maintenance instructions	4-6
Ramp end plate assembly maintenance instructions	4-7
Ramp threshold channel maintenance instructions	4-8
Receipt of materiel, service upon	4-4
References.....	A
Removal procedures	2-5
Repair parts	4-3
Replacement instructions	
Connector assembly	4-20
Frame assembly	4-14
Handle	4-29
Pedestal assembly.....	4-27
Pivot assembly	4-28
Reporting equipment improvement recommendations (EIR)	1-6
Rivet rips repair instructions	4-24, 5-4
S	
Scope	1-1
Service upon receipt of materiel.....	4-4
Special tools, TMDE and support equipment.....	4-2
Stairway riser and support assemblies maintenance instructions.....	4-9
Stairway pin and landyard maintenance instructions.....	4-10
Stitching repair instructions	4-23, 5-3
Storage or shipment, preparation for	1-4, 4-30
Storage requirements, administrative	4-31
Supplies and materials list, expendable/durable	D
Support equipment, special tools, TMDE and	4-2

ALPHABETIC INDEX

SUBJECT

PARAGRAPH
TABLE
APPENDIX

T

Tears, worn areas and mildew-rotted areas repair instructions.....	5-2
Toggle maintenance instructions (Type II only).....	5-7

U

Unusual weather, operation in	2-7
-------------------------------------	-----

V

W

X

Y

Z

By Order of the Secretary of the Army:

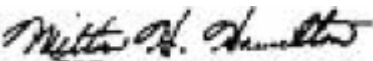
Official: 

MILTON H HAMILTON
*Administrative Assistant to the
Secretary of the Army*
03594

GORDON R SULLIVAN
*General, United States Army
Chief of Staff*

DISTRIBUTION:

To be distributed accordance with DA Form 12-25-E, block no. 5350, requirements for TM-10-5411-203-13.

RECOMMENDED CHANGES TO EQUIPMENT TECHNICAL PUBLICATIONS



SOMETHING WRONG WITH PUBLICATION

FROM: (PRINT YOUR UNIT'S COMPLETE ADDRESS)

DATE SENT

PUBLICATION NUMBER

PUBLICATION DATE

PUBLICATION TITLE

BE EXACT PIN-POINT WHERE IT IS

PAGE NO.

PARA-GRAPH

FIGURE NO.

TABLE NO.

IN THIS SPACE, TELL WHAT IS WRONG AND WHAT SHOULD BE DONE ABOUT IT.

TEAR ALONG PERFORATED LINE

PRINTED NAME, GRADE OR TITLE AND TELEPHONE NUMBER

SIGN HERE

The Metric System and Equivalents

Linear Measure

1 centimeter = 10 millimeters = .39 inch
 1 decimeter = 10 centimeters = 3.94 inches
 1 meter = 10 decimeters = 39.37 inches
 1 dekameter = 10 meters = 32.8 feet
 1 hectometer = 10 dekameters = 328.08 feet
 1 kilometer = 10 hectometers = 3,280.8 feet

Weights

1 centigram = 10 milligrams = .15 grain
 1 decigram = 10 centigrams = 1.54 grains
 1 gram = 10 decigram = .035 ounce
 1 decagram = 10 grams = .35 ounce
 acres
 1 hectogram = 10 decagrams = 3.52 ounces
 1 kilogram = 10 hectograms = 2.2 pounds
 1 quintal = 100 kilograms = 220.46 pounds
 1 metric ton = 10 quintals = 1.1 short tons

Liquid Measure

1 centiliter = 10 milliliters = .34 fl. ounce
 1 deciliter = 10 centiliters = 3.38 fl. ounces
 1 liter = 10 deciliters = 33.81 fl. ounces
 1 dekaliter = 10 liters = 2.64 gallons
 1 hectoliter = 10 dekaliters = 26.42 gallons
 1 kiloliter = 10 hectoliters = 264.18 gallons

Square Measure

1 sq. centimeter = 100 sq. millimeters = .155 sq. inch
 1 sq. decimeter = 100 sq. centimeters = 15.5 sq. inches
 1 sq. meter (centare) = 100 sq. decimeters = 10.76 sq. feet
 1 sq. dekameter (are) = 100 sq. meters = 1,076.4 sq. feet
 1 sq. hectometer (hectare) = 100 sq. dekameters = 2.47
 1 sq. kilometer = 100 sq. hectometers = .386 sq. mile

Cubic Measure

1 cu. centimeter = 1000 cu. millimeters = .06 cu. inch
 1 cu. decimeter = 1000 cu. centimeters = 61.02 cu. inches
 1 cu. meter = 1000 cu. decimeters = 35.31 cu. feet

Approximate Conversion Factors

<i>To change</i>	<i>To</i>	<i>Multiply by</i>	<i>To change</i>	<i>To</i>	<i>Multiply by</i>
inches	centimeters	2.540	ounce-inches	Newton-meters	.007062
feet	meters	.305	centimeters	inches	.394
yards	meters	.914	meters	feet	3.280
miles	kilometers	1.609	meters	yards	1.094
square inches	square centimeters	6.451	kilometers	miles	.621
square feet	square meters	.093	square centimeters	square inches	.155
square yards	square meters	.836	square meters	square feet	10.764
square miles	square kilometers	2.590	square meters	square yards	1.196
acres	square hectometers	.405	square kilometers	square miles	.386
cubic feet	cubic meters	.028	square hectometers	acres	2.471
cubic yards	cubic meters	.765	cubic meters	cubic feet	35.315
fluid ounces	milliliters	29,573	cubic meters	cubic yards	1.308
pints	liters	.473	milliliters	fluid ounces	.034
quarts	liters	.946	liters	pints	2.113
gallons	liters	3.785	liters	quarts	1.057
ounces	grams	28.349	liters	gallons	.264
pounds	kilograms	.454	grams	ounces	.035
short tons	metric tons	.907	kilograms	pounds	2.205
pound-feet	Newton-meters	1.356	metric tons	short tons	1.102
pound-inches	Newton-meters	.11296			

Temperature (Exact)

°F	Fahrenheit temperature	5/9 (after subtracting 32)	Celsius temperature	°C
----	------------------------	----------------------------	---------------------	----

PIN: 067457-000

This fine document...

Was brought to you by me:



[Liberated Manuals -- free army and government manuals](#)

Why do I do it? I am tired of sleazy CD-ROM sellers, who take publicly available information, slap “watermarks” and other junk on it, and sell it. Those masters of search engine manipulation make sure that their sites that sell free information, come up first in search engines. They did not create it... They did not even scan it... Why should they get your money? Why are not letting you give those free manuals to your friends?

I am setting this document FREE. This document was made by the US Government and is NOT protected by Copyright. Feel free to share, republish, sell and so on.

I am not asking you for donations, fees or handouts. If you can, please provide a link to liberatedmanuals.com, so that free manuals come up first in search engines:

<A HREF=<http://www.liberatedmanuals.com/>>Free Military and Government Manuals

- Sincerely
Igor Chudov
<http://igor.chudov.com/>
- [Chicago Machinery Movers](#)