

**TECHNICAL MANUAL  
OPERATOR'S, UNIT AND DIRECT SUPPORT  
MAINTENANCE MANUAL  
FOR  
STANDARD INTEGRATED COMMAND POST SYSTEMS BOOT WALLS  
TYPES I, II, & IV  
CLASSES 1 (GREEN) AND 2 (TAN)**

Type I, Class 1, NSN 5410-01-378-8301  
 Type 1, Class 2, NSN 5410-01-380-2241  
 Type II, Class 1, NSN 5410-01-364-4497  
 Type II, Class 2, NSN UNASSIGNED  
 Type IV, Class 1, NSN 5410-01-364-4496  
 Type IV, Class 2, NSN UNASSIGNED

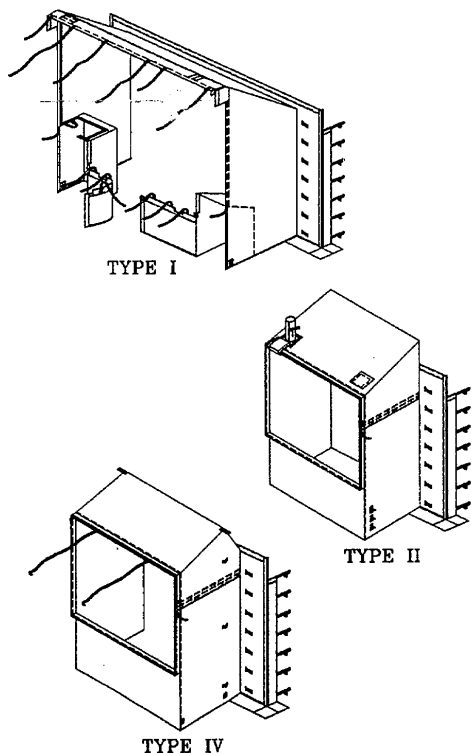

CHAPTER 1 INTRODUCTION.....	1-1
CHAPTER 2 OPERATING INSTRUCTIONS.....	2-1
CHAPTER 3 OPERATOR MAINTENANCE.....	3-1
CHAPTER 4 UNIT MAINTENANCE .....	4-1
CHAPTER 5 DIRECT SUPPORT MAINTENANCE.....	5-1
APPENDIX A REFERENCES .....	A-1
APPENDIX B MAINTENANCE ALLOCATION CHART .....	B-1
APPENDIX C. COMPONENT OF END ITEM/BASIC ISSUE ITEM LISTS .....	C-1
APPENDIX D ADDITIONAL AUTHORIZATION LIST.....	D-1
APPENDIX E EXPENDABLE/DURABLE ITEMS LIST .....	E-1
ALPHABETICAL INDEX .....	INDEX-1

DISTRIBUTION STATEMENT A: Approved for public release; distribution is unlimited.

**HEADQUARTERS, DEPARTMENT OF THE ARMY  
28 NOVEMBER 1994**



**WARNING**

Use a ground guide when backing any vehicle. Failure to observe this warning may result in death, serious injury, and/or damage to equipment.

Make sure the radio sets are turned off during the boot wall installation. Personal injury may result if sets are used during boot wall installation.

Carbon monoxide gas can be fatal. Do not allow vehicle exhaust to enter the tent. Failure to observe this warning may result in death or serious injury.

FLAMMABLE. Do not smoke or use seam sealer near open flame.

HARMFUL FUMES. Use seam sealer in well ventilated area only. Use personal protective equipment to prevent inhalation of fumes. Failure to observe this warning may result in serious injury to personnel from inhalation of seam sealer fumes.

The adhesive used in Boot Walls has a high alcohol content and is highly flammable. Use only in well ventilated areas away from open flame. Do not smoke. In case of dizziness, leave area immediately and allow to ventilate. Failure to observe this warning may result in severe injury or death.



CHANGE  
NO. 1

HEADQUARTERS, DEPARTMENT OF THE ARMY  
WASHINGTON, DC, 31 AUGUST 2005

TECHNICAL MANUAL

OPERATOR'S, UNIT AND DIRECT SUPPORT MAINTENANCE MANUAL

FOR  
STANDARD INTEGRATED COMMAND POST SYSTEMS (SICPS) BOOT WALLS  
TYPES I, II, & IV  
CLASSES 1 (GREEN) AND 2 (TAN)

TYPE I	CLASS 1	NSN 5410-01-378-8301
TYPE I	CLASS 2	NSN 5410-01-380-2241
TYPE II	CLASS 1	NSN 5410-01-364-4497
TYPE II	CLASS 2	NSN UNASSIGNED
TYPE IV	CLASS 1	NSN 5410-01-364-4496
TYPE IV	CLASS 2	NSN UNASSIGNED

DISTRIBUTION STATEMENT A: Approved for public release; distribution is unlimited.

TM 10-5410-230-13, 28 November 1994, is updated as follows:

1. File this sheet in front of the manual for reference.
2. This change implements Army Maintenance Transformation and changes the Maintenance Allocation Chart (MAC) to support Field and Sustainment Maintenance.
3. New or updated change information is indicated by a vertical bar in the outer margin of the page.
4. Remove old pages and insert new pages as indicated below:

<b><u>Remove Pages</u></b>	<b><u>Insert Pages</u></b>
	A/(B Blank)
B-1 – B-6	B-1 – B-6 Electronic 2028 Instructions/Blank Sample 2028 Front/Back
DA 2028	DA 2028 Front/Back DA 2028 Front/Back DA 2028 Front/Back

ARMY TM 10-5410-230-13  
C1

By Order of the Secretary of the Army:

PETER J. SCHOOMAKER  
General, United States Army  
*Chief of Staff*

Official:

  
SANDRA R. RILEY  
*Administrative Assistant to the  
Secretary of the Army*  
0521006

**Distribution:** To be distributed in accordance with initial distribution number (IDN) 256249 requirements for TM 10-5410-230-13.

INSERT LATEST CHANGED PAGES. DESTROY SUPERSEDED PAGES.

**LIST OF EFFECTIVE PAGES**

NOTE: The portion of text affected by the changes is indicated by a vertical line in the outer margins of the page. Changes to illustrations are indicated by shaded or screened areas, or by miniature pointing hands. Zero in the "Change No." column indicates an original page.

Dates of issue for original and changed pages are:

Original .. 0 .. 28 November 1994

Change .. 1 .. 31 August 2005

**TOTAL NUMBER OF PAGES IN THIS PUBLICATION IS 108, CONSISTING OF THE FOLLOWING:**

<b>Page No.</b>	<b>Change No.</b>	<b>Page No.</b>	<b>Change No.</b>
Title	0		
a/(b blank)	0		
i - iii	0		
1-0 – 1-6	0		
2-1 – 2-31/(2-32 blank)	0		
3-1 – 3-5/(3-6 blank)	0		
4-1 – 4-11/(4-12 blank)	0		
5-1 – 5-5/(5-6 blank)	0		
A-1/(A-2 blank)	0		
B-1 - B-6	1		
C-1 - C-3/(C-4 blank)	0		
D-1/(D-2 blank)	0		
E-1 - E-2	0		
INDEX-1 - INDEX-3/(Index-4 blank)	0		
Back Cover	0		





**OPERATOR'S, UNIT, AND DIRECT SUPPORT MAINTENANCE MANUAL  
FOR  
STANDARD INTEGRATED COMMAND POST SYSTEMS BOOT WALLS  
TYPES I, II & IV  
CLASSES 1 (GREEN) AND 2 (TAN)**

Type I, Class 1, NSN 5410-01-378-8301, Type I, Class 2, NSN 5410-01-380-2241  
Type II, Class 1, NSN 5410-01-364-4497, Type II, Class 2, NSN UNASSIGNED  
Type IV, Class 1, NSN 5410-01-3644496, Type IV, Class 2, NSN UNASSIGNED

**REPORTING ERRORS AND RECOMMENDING IMPROVEMENTS**

You can help improve this manual. If you find any mistakes or if you know of a way to improve the procedures, please let us know. Mail your letter, DA Form 2028 (Recommended Changes to Publications and Blank Forms), or DA Form 2028-2 (located in the back of this manual) direct to: Commander, U.S. Army Aviation and Troop Command, ATTN.: AMSAT-I-MP, 4300 Goodfellow Blvd., St. Louis, MO 63120-1798. A reply will be furnished to you.

DISTRIBUTION STATEMENT A: Approved for public release; distribution is unlimited.

Table of Contents

	Page
HOW TO USE THIS MANUAL.....	iii
<b>CHAPTER 1. INTRODUCTION</b> .....	<b>1-1</b>
Section I. General Information .....	1-1
Section II. Equipment Description .....	1-2
Section III. Principles of Operation.....	1-6
<b>CHAPTER 2. OPERATING INSTRUCTIONS</b> .....	<b>2-1</b>
Section I. Description and Use of Operator's Control's and Indicators .....	2-1
Section II. Operator Preventive Maintenance Checks and Services .....	2-1
Section III. Operation Under Usual Conditions .....	2-9
Section IV. Operation Under Unusual Conditions .....	2-31
<b>CHAPTER 3. OPERATOR MAINTENANCE INSTRUCTIONS</b> .....	<b>3-1</b>
Section I. Lubrication Instructions .....	3-1
Section II. Troubleshooting Procedures .....	3-1
Section III. Operator Maintenance Procedures .....	3-5
<b>CHAPTER 4. UNIT MAINTENANCE INSTRUCTIONS</b> .....	<b>4-1</b>
Section I. Unit Lubrication Procedures .....	4-1
Section II. Service Upon Receipt .....	4-1
Section III. Maintenance Instructions.....	4-2

<b>CHAPTER 5. DIRECT SUPPORT MAINTENANCE INSTRUCTION</b> .....	<b>5-1</b>
Section I. Repair Parts; Special Tools; Test, Measurement and Diagnostic Equipment (TMDE) and Support Equipment .....	5-1
Section II. Maintenance Procedures .....	5-1
<b>APPENDIX A. REFERENCES</b> .....	<b>A-1</b>
<b>APPENDIX B. MAINTENANCE ALLOCATION CHART</b> .....	<b>B-1</b>
Section I. Introduction .....	B-1
Section II. Maintenance Allocation Chart .....	B-5
Section III. Tool and Test Equipment List .....	B-6
Section IV. Remarks .....	B-6
<b>APPENDIX C. COMPONENTS OF END ITEM AND BASIC ISSUE ITEMS</b> .....	<b>C-1</b>
Section I. Introduction .....	C-1
Section II. Components of End Item .....	C-2
Section III. Basic Issue Items .....	C-3
<b>APPENDIX D. ADDITIONAL AUTHORIZATION LIST</b> .....	<b>D-1</b>
Section I. Introduction .....	D-1
Section II. Additional Authorization List .....	D-1
<b>APPENDIX E. EXPENDABLE AND DURABLE ITEMS LIST</b> .....	<b>E-1</b>
Section I. Introduction .....	E-1
Section II. Expendable and Durable Materials List .....	E-2
<b>ALPHABETICAL INDEX</b> .....	<b>INDEX-1</b>

HOW TO USE THIS MANUAL

This manual (Operator's, Unit, and Direct Support Maintenance Manual for SICPS Boot Walls Types I, II, and IV) contains general information, operating instructions, and operator preventive maintenance checks and services (PMCS) for the SICPS Boot Walls. It also contains Unit and Direct Support level maintenance instructions. Use the front cover index and thumb bleeds at the edge of the pages to quickly find the sections of the manual shown on the cover.

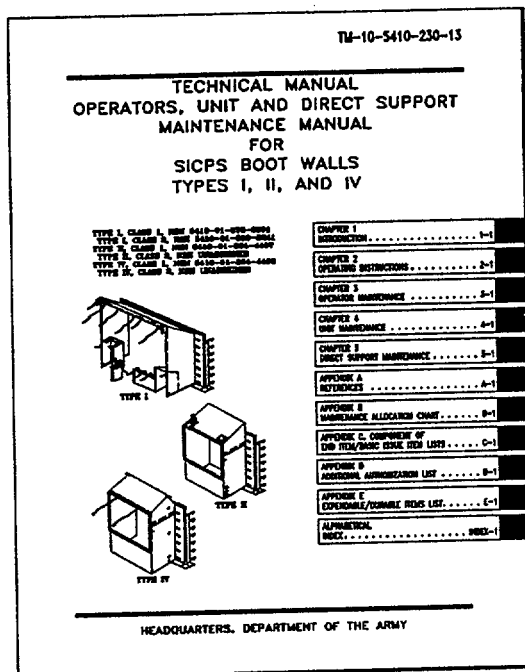

The manual is divided into chapters, sections and paragraphs that are numbered in sequence. Pages, paragraphs and tables are numbered by chapter. For example, page 3 of Chapter 2 is marked 2-3; the second table of Chapter 1 is labeled Table 1-2.

To quickly find specific information, use the Table of Contents on page i. The Table of Contents lists paragraph and page numbers by chapter and section. For example, the front cover index tells you that Chapter 1, General Information begins on page 1-1. The Table of Contents on page i tells you the exact page where each section of Chapter 1 is located. Detailed tables of contents have been placed at the beginning of each chapter. A comprehensive alphabetical index starts on page Index-1 at the end of the manual.

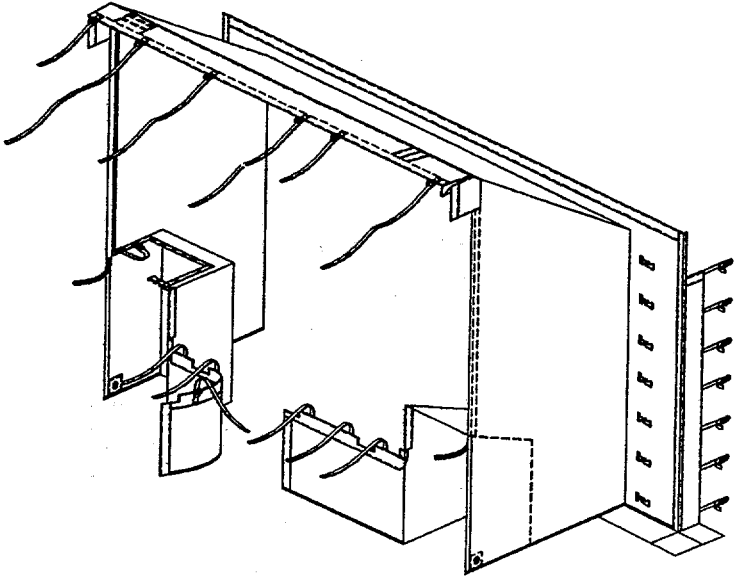

TYPE I

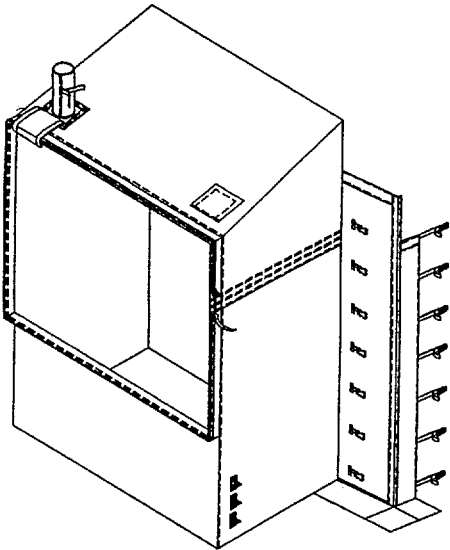

TYPE II

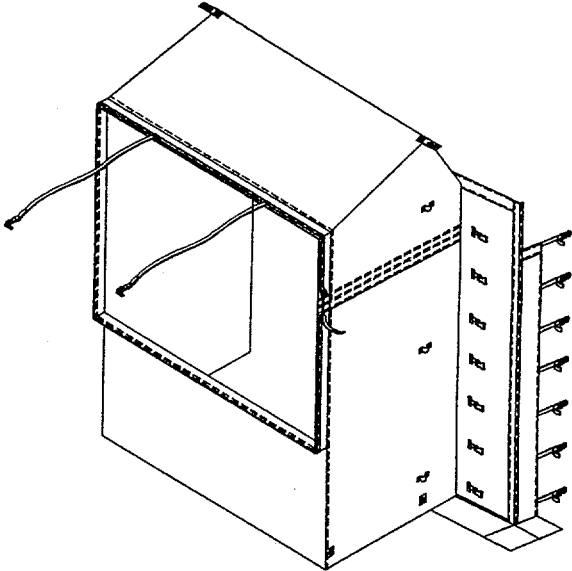

TYPE IV

**CHAPTER 1**  
**INTRODUCTION**

Subject	Page
Section I GENERAL INFORMATION .....	1-1
1-1 SCOPE .....	1-1
1-2 MAINTENANCE FORMS AND PROCEDURES .....	1-1
1-3 DESTRUCTION-OF ARMY MATERIEL TO PREVENT ENEMY USE .....	1-1
1-4 PREPARATION FOR STORAGE OR SHIPMENT .....	1-1
1-5 REPORTING EQUIPMENT IMPROVEMENT RECOMMENDATIONS (EIR).....	1-2
1-6 CORROSION PREVENTION AND CONTROL .....	1-2
Section II EQUIPMENT DESCRIPTION.....	1-2
1-7 EQUIPMENT CHARACTERISTICS, CAPABILITIES AND FEATURES.....	1-2
1-8 LOCATION AND DESCRIPTION OF MAJOR COMPONENTS.....	1-3
1-9 EQUIPMENT DATA.....	1-6
Section III PRINCIPLES OF OPERATION .....	1-6
1-10 GENERAL .....	1-6

Section I. GENERAL INFORMATION

**1-1. SCOPE.** This manual describes operation, unit and direct support maintenance procedures for the Standard Integrated Command Post System (SICPS) Boot Walls. The SICPS Boot Walls are a family of five fabric passageways used to join a Modular Command Post System (MCPS) tent to a vehicle or shelter. This manual covers the following three Boot Wall types:

- Type I: MCPS tent to M577 Tracked Command Post Boot Wall
- Type II: MCPS tent to Rigid Wall Shelter (RWS) Boot Wall
- Type IV: MCPS tent to S-250E Boot Wall

**1-2. MAINTENANCE FORMS AND PROCEDURES** Department of the Army forms and procedures used for Boot Wall maintenance shall be those prescribed by DA PAM 738-750, The Army Maintenance Management System (TAMMS) (Maintenance Management Update).

**1-3. DESTRUCTION OF ARMY MATERIEL TO PREVENT ENEMY USE.** Destruction of Army materiel to prevent enemy use shall be in accordance with TM 750-244-3.

**1-4. PREPARATION FOR STORAGE OR SHIPMENT.** Refer to paragraph 2-10 for procedures to prepare Boot Walls for movement.

- a. Placement of equipment in storage should be for short periods when a shortage of maintenance effort exists. Items should be in mission readiness within 24 hours, or within time factors determined by directing authority. During storage periods appropriate maintenance records will be kept.
- b. Before placing equipment in administrative storage, current maintenance services should be completed, shortcomings and deficiencies should be corrected, and all Modification Work Orders (MWO's) should be applied.
- c. Storage Site Selection. Inside storage is preferred for items selected for administrative storage. If inside storage is not available, trucks, vans, conexes and other containers may be used.

**1-5. REPORTING EQUIPMENT IMPROVEMENT RECOMMENDATIONS (EIR).** If your Boot Wall needs improvement, let us know. You, the user, are the only one who can tell us what you don't like about your equipment. Let us know why you don't like the design or performance. Put it on SF 368 (Product Quality Deficiency Report). Mail it to us at: Commander, U.S. Army Aviation and Troop Command, ATTN: (AMSAT-I-MDO), 4300 Goodfellow Blvd., St. Louis, MO, 63120-1798. We will send you a reply.

#### **1-6. CORROSION PREVENTION AND CONTROL.**

a. Corrosion Prevention and Control (CPC) of Army materiel are a continuing concern. It is important that any corrosion problems with Boot Walls be reported so that the problem can be corrected and improvements can be made to prevent the problem in future items.

b. While corrosion is typically associated with rusting of metals, it can also include deterioration of other materials, such as rubber and plastic. Unusual cracking, softening, swelling or breaking of these materials may be a corrosion problem.

c. If a corrosion problem is identified, it can be reported using Standard Form 368, Quality Deficiency Report. Use of key words such as "corrosion," "rust," "deterioration," or "cracking" will assure that the information is identified as a CPC problem. This form should be submitted to: Commander, U.S. Army Aviation and Troop Command, ATTN: AMSAT-I-MDO, 4300 Goodfellow Blvd., St. Louis, MO 63120-1798

### **Section II. EQUIPMENT DESCRIPTION**

#### **1-7. EQUIPMENT CHARACTERISTICS, CAPABILITIES AND FEATURES.**

a. Characteristics.

- Deployable in a variety of climates.
- Lightweight construction of water and mildew-resistant polyester duck.

b. Capabilities and Features.

- Quick, two soldier setup under normal operating conditions.
- Uses quick-release fasteners throughout.
- Provides blackout protection.

## 1-8. LOCATION AND DESCRIPTION OF MAJOR COMPONENTS.

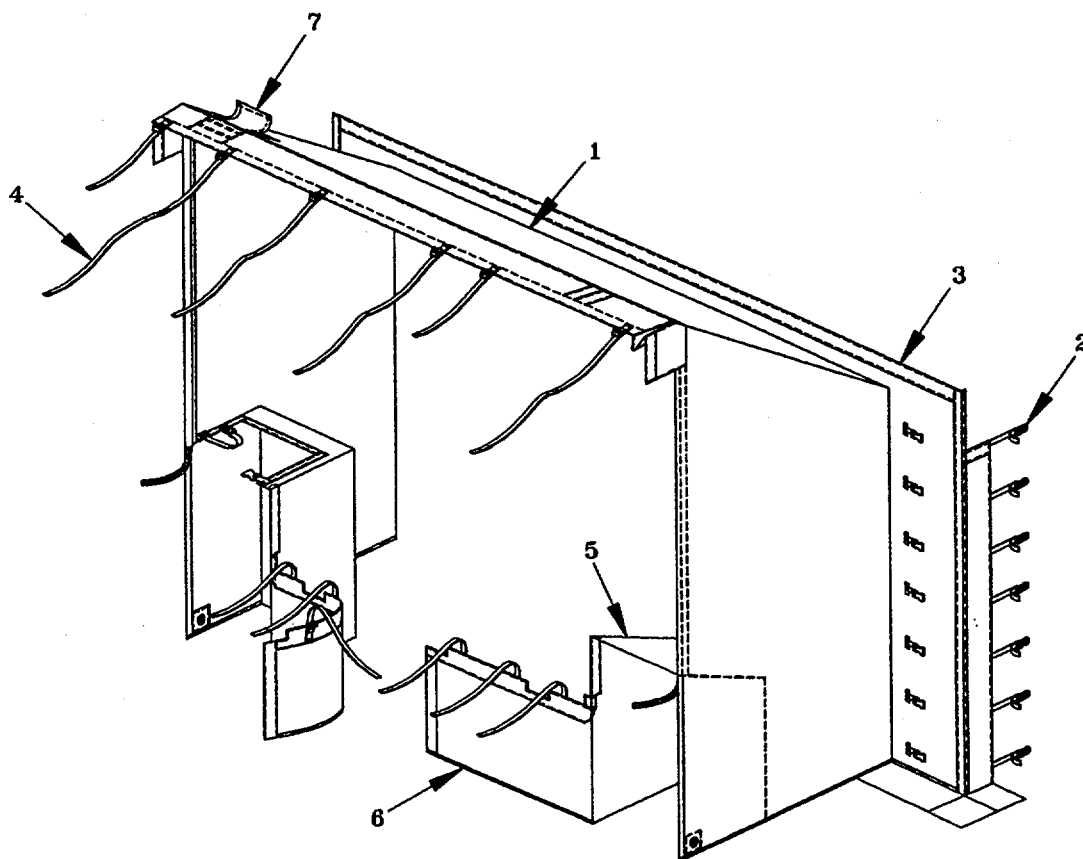

a. Type I. The M577 Boot Wall (1) is constructed of mildew and flame resistant polyester duck and is 11 feet wide, 8 feet high and 5 feet deep. It is interchangeable with any other wall assembly of the MCPS tent. Quick release fasteners (2) and hook and pile fastener tapes (3) connect the Boot Wall to the MCPS tent roof cap and adjacent walls. Web straps (4) secure the Boot Wall to the M577. Two fender skirts (5) cover the rear end of the M577 fenders. A blackout skirt (6) attaches to the underside of the M577. An antenna flap (7) allows the antenna to protrude through a sleeve on some models (not all production models include this feature).

## 1-8. LOCATION AND DESCRIPTION OF MAJOR COMPONENTS (CONT).

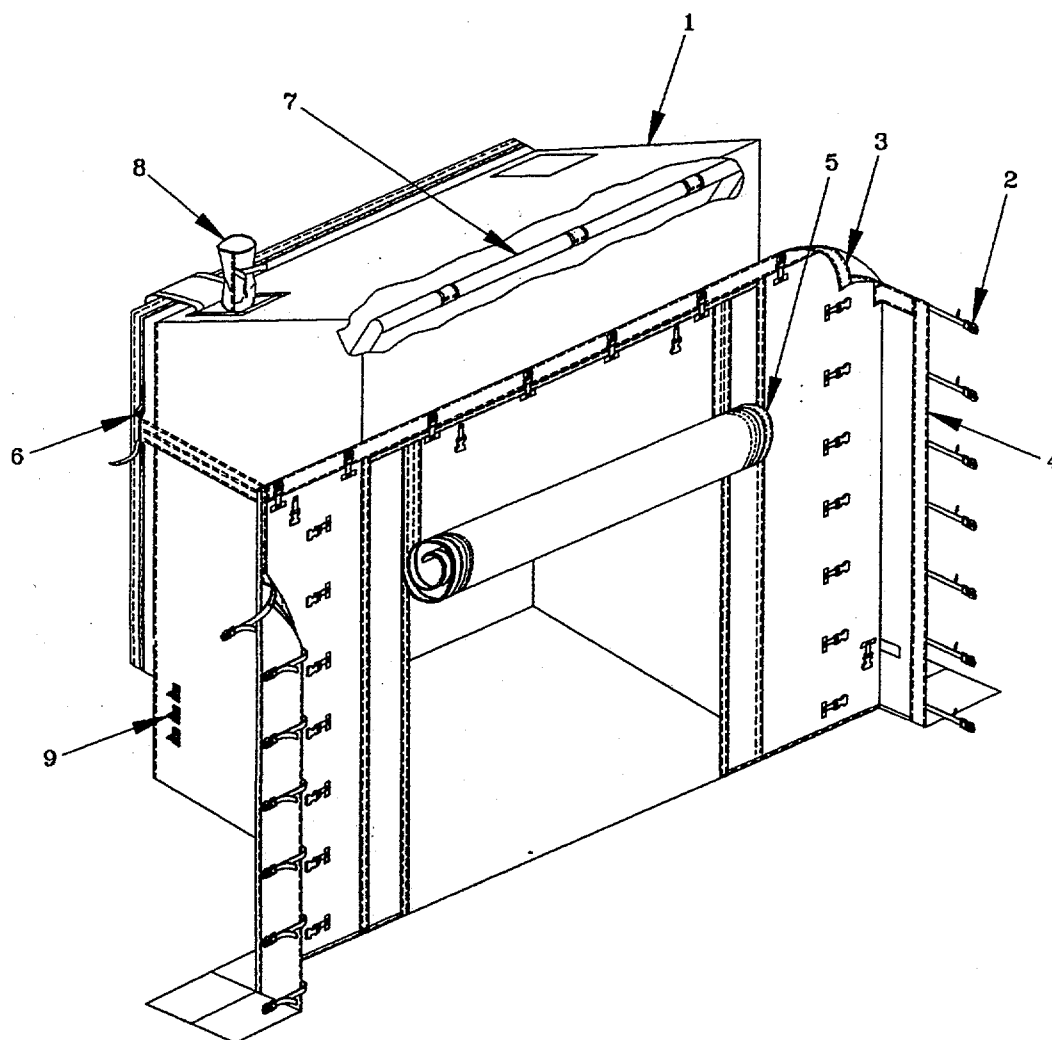

b. Type II. The RWS Boot Wall (1) is constructed of mildew and flame resistant polyester duck and is 11 feet wide, 8 feet high and 5 feet deep. It is interchangeable with any other wall assembly of the MCPS tent. Quick release fasteners (2) and hook and pile fastener tapes (3) connect the Boot Wall end panel (4) to the MCPS tent roof cap and adjacent walls. The end panel assembly is fitted with a rollup fabric door (5). An adjustable belly band (6) wraps around the RWS to secure the Boot Wall in place. A rigid U-shaped frame (7) attaches to the rear of the RWS to support the Boot Wall fabric. Antenna sleeves (8) are provided on the Boot Wall roof. Three foot loops (9) on each side provide a means of staking the Boot Wall to the ground.



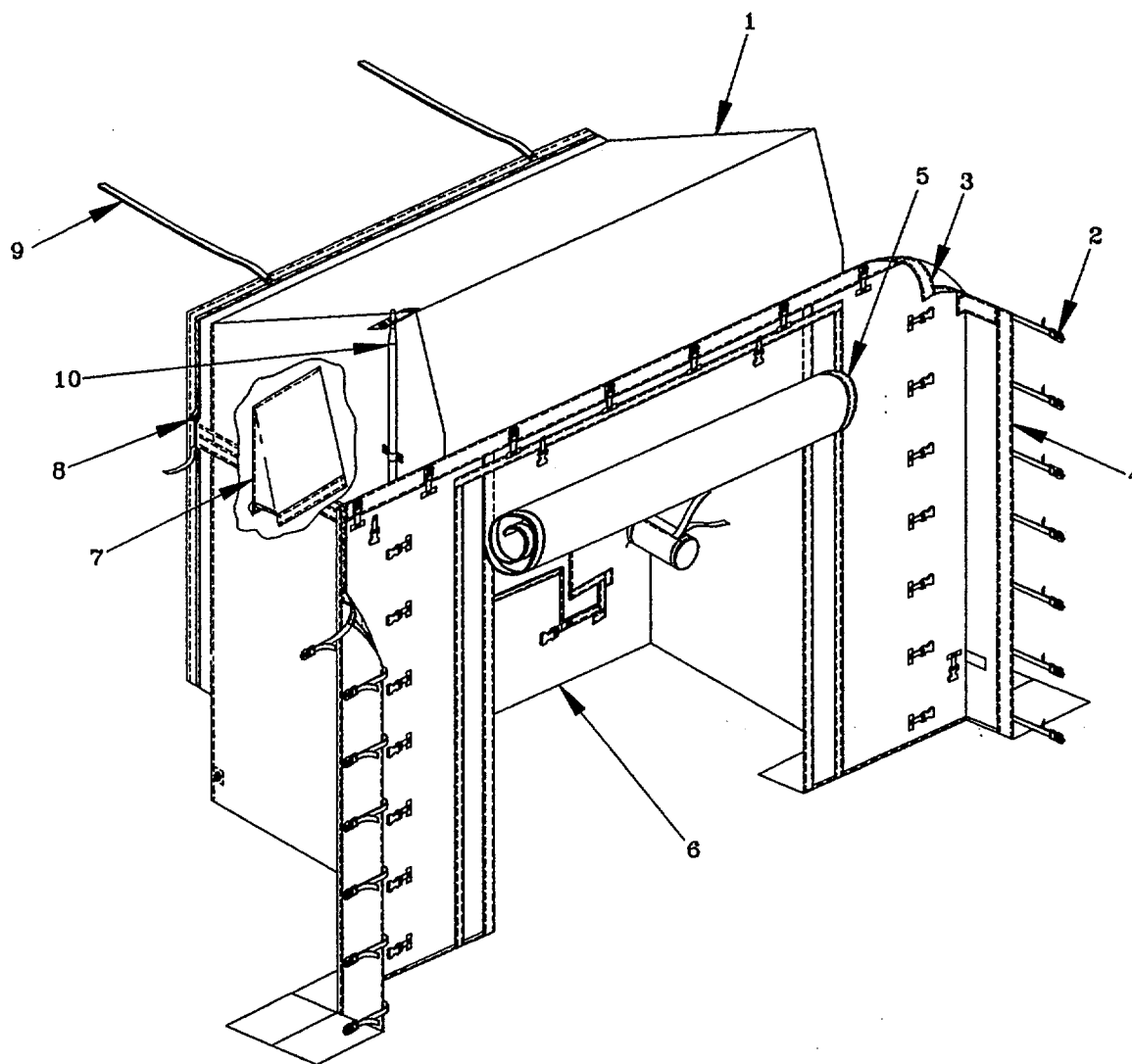

c. Type IV. The S-250E Boot Wall (1) is constructed of mildew and flame resistant polyester duck and is 11 feet wide, 8 feet high, and 5 feet deep. It is interchangeable with any other wall assembly of the MCPS tent. Quick release fasteners (2) and hook and pile fastener tapes (3) connect the Boot Wall end panel assembly (4) to the MCPS tent roof cap and adjacent walls. The end panel assembly is fitted with a roll-up fabric door (5). A blackout wall (6) provides light discipline and an electric panel access (7). An adjustable belly band assembly (8) and web straps (9) with hooks secures boot assembly to the shelter and HMMWV hood. Two SICPS tent poles (10) support the S-250E Boot Wall fabric.

**1-9. EQUIPMENT DATA.**

	TYPE I	TYPE II	TYPE IV
WEIGHT:	45 lbs(21 kg)	45 lbs(21 kg)	45 lbs(21 kg)
DIMENSIONS:			
Length	5 ft(1.52m)	5 ft(1.52m)	5 ft(1.52m)
Width	8 ft(2.44m)	8 ft(2.44m)	8 ft(2.44m)
Height	11 ft(3.36)	11 ft(3.36m)	11 ft(3.36m)
ENVIRONMENTAL:			
Setup	-20°-110°F	-20°-110°F	-20°-110°F
Operate	-40°-120°F	-40°-120°F	-40°-120°F

## Section III. PRINCIPLES OF OPERATION

**1-10. GENERAL.** The Boot Walls are installed between the MCPS tent and another shelter or vehicle. Once installed, the Boot Wall provides a weather barrier allowing transit between MCPS tent and vehicle or shelter. The Boot Walls are designed to be interchangeable with a standard MCPS tent wall section. To install the Boot Wall, an existing tent wall is removed and replaced by the Boot Wall. The vehicle or shelter is then fastened to the Boot Wall to complete the passageway.

The M577 Boot Wall (type I) is used between the MCPS tent and the M577 tracked command post vehicle.

The RWS Boot Wall (type II) is used between the MCPS tent and M1037/M1042 HMMWV equipped with a Rigid Wall Shelter.

The S-250E Boot Wall (type IV) is used between MCPS tent and M1037/M1042 HMMWV equipped with the S-250E electrical equipment shelter.

CHAPTER 2

OPERATING INSTRUCTIONS

Subject	Page
Section I DESCRIPTION AND USE OF OPERATOR'S CONTROLS AND INDICATORS .....	2-1
Section II OPERATOR PREVENTIVE MAINTENANCE CHECKS AND SERVICES (PMCS).....	2-1
2-1. GENERAL .....	2-1
Section III OPERATION UNDER USUAL CONDITIONS.....	2-9
2-2 SITE SELECTION.....	2-9
2-3 REMOVAL OF MCPS TENT WALL .....	2-9
2-4 INSTALLING M577 BOOT WALL TYPE I .....	2-10
2-5 INSTALLING THE RIGID WALL SHELTER BOOT WALL TYPE II .....	2-14
2-6 INSTALLING THE S-250E BOOT WALL TYPE IV .....	2-19
2-7 REMOVING THE M577 BOOT WALL TYPE I.....	2-24
2-8 REMOVING THE RIGID WALL SHELTER BOOT WALL TYPE II .....	2-26
2-9 REMOVING THE S-250E BOOT WALL TYPE IV .....	2-29
2-10 PREPARATION FOR MOVEMENT.....	2-31
Section IV OPERATION UNDER UNUSUAL CONDITIONS.....	2-31
2-11 GENERAL.....	2-31

Section I. DESCRIPTION AND USE OF OPERATOR'S CONTROLS AND INDICATORS

Not applicable.

Section II. OPERATOR PREVENTIVE MAINTENANCE CHECKS AND SERVICES (PMCS)

**2-1. GENERAL.** Table 2-1, Preventive Maintenance Checks and Procedures for SICPS Boot Walls, has been provided so you can keep your equipment in good operating condition and ready for its primary mission.

a. Warnings and Cautions. Always observe Warnings and Cautions appearing in your PMCS table. Warnings and Cautions appear before applicable procedures. You must observe these Warnings and Cautions to prevent serious injury to yourself and others or prevent your equipment from being damaged.

b. Explanation of Table Entries.

(1) *Item Number Column.* Numbers in this column are for reference. When completing DA Form 2404 (Equipment Inspection and Maintenance Worksheet), include the item number for the check/service indicating a fault. Item numbers also appear in the order in which you must do the checks and services listed.

(2) *Interval Column.* This column tells you when you must do the procedure in the procedure column. The **BEFORE** procedures must be done before you operate or use the equipment for its intended mission. **DURING** procedures must be done during the time you are operating or using the equipment for its intended mission. **AFTER** procedures must be done immediately after you have operated or used the equipment.

(3) *Location, Check/Service Column.* This column provides the location and the item to be checked or serviced. The item location is underlined.

(4) *Procedure Column.* This column gives the procedure you must do to check or service the item listed in the Check/Service column to know if the equipment is ready or available for its intended mission or for operation. You must do the procedure at the time specified in the interval column.

(5) *Not Fully Mission Capable If: Column.* Information in this column tells you what faults will keep your equipment from being capable of performing its primary mission. If you make check and service procedures that show faults listed in this column, do not operate the equipment. Follow standard operating procedures for maintaining the equipment or reporting equipment failure.

- c. Other Table Entries. Be sure to observe all special information and notes that appear in your table.

Table 2-1. OPERATOR PREVENTIVE MAINTENANCE CHECKS AND SERVICES

Item No.	Interval	Location Item to check/service M577 Boot Wall, RWS Boot Wall, S-250E Boot Wall	Procedure	Not Fully Mission Capable If:
1	Before	Boot Assembly, End Panel Assembly	Check for tears, punctures, and separated seams on boot assembly (1) and end panel assembly (2)	Tears, punctures or separated seams exist which allow weather to enter or light to escape Boot Wall.
2	Before	Hook and Pile Fasteners	Inspect all hook and pile fasteners (3) for cleanliness and secure hold. Remove dirt by brushing fastener strips. Inspect Fasteners for loose stitching to fabric.	Boot Wall can not be secured in place because hook and pile fasteners do not hold securely when pressed together or are loosely stitched to fabric.
3	Before	Straps, Quick Disconnect Fasteners	Check Straps (4) and quick disconnect fasteners (5) for fraying, tears, broken hardware and loose stitching to fabric.	Boot Wall can not be secured in place because straps and quick disconnect fasteners are frayed, torn, broken or loosely stitched to fabric.

Table 2-1. OPERATOR PREVENTIVE MAINTENANCE CHECKS AND SERVICES (CONT).

Item No.	Interval	<u>Location</u> Item to check/service	Procedure	Not Fully Mission Capable If:
4	Before	Frame (RWS Boot Wall) and Tent Pole (S-250E Boot Wall)	 <p>Inspect frame (1) or pole (2) for broken or missing hardware. Inspect pole for ability to lock securely when compressed.</p>	Frame or tent pole can not support weight of Boot Wall. Tent pole can be adjusted to proper height.

Table 2-1. OPERATOR PREVENTIVE MAINTENANCE CHECKS AND SERVICES (CONT).

Item No.	Interval	Location Item to check/service M577 Boot Wall, RWS Boot Wall, S-250E Boot Wall	Procedure	Not Fully Mission Capable If:
5	During	Boot Assembly, End Panel Assembly	Check for tears, punctures, and separated seams on boot assembly (1) and end panel assembly (2).	Tears, punctures or separated seams exist which allow weather to enter or light to escape Boot Wall.
6	During	Hook and Pile Fasteners	Inspect all hook and pile fasteners (3) for cleanliness and secure hold. Remove dirt by brushing fastener strips. Inspect Fasteners for loose stitching to fabric.	Boot Wall can not be secured in place because hook and pile fasteners do not hold securely when pressed together or are loosely stitched to fabric.
7	During	Straps, Quick Disconnect Fasteners	Check Straps (4) and quick disconnect fasteners (5) for fraying, tears, broken hardware and loose stitching to fabric.	Boot Wall can not be secured in place because straps and quick disconnect fasteners are frayed, torn, broken or loosely stitched to fabric.

Table 2-1. OPERATOR PREVENTIVE MAINTENANCE CHECKS AND SERVICES (CONT).

Item No.	Interval	Location Item to check/service	Procedure	Not Fully Mission Capable If:
8	During	Frame (RWS Boot Wall) and Tent Pole (S-250E Boot Wall)	Inspect frame (1) or pole (2) for broken or missing hardware. Inspect pole for ability to lock securely when compressed.	Frame or tent pole can not support weight of Boot Wall. Tent pole can be adjusted to proper height.

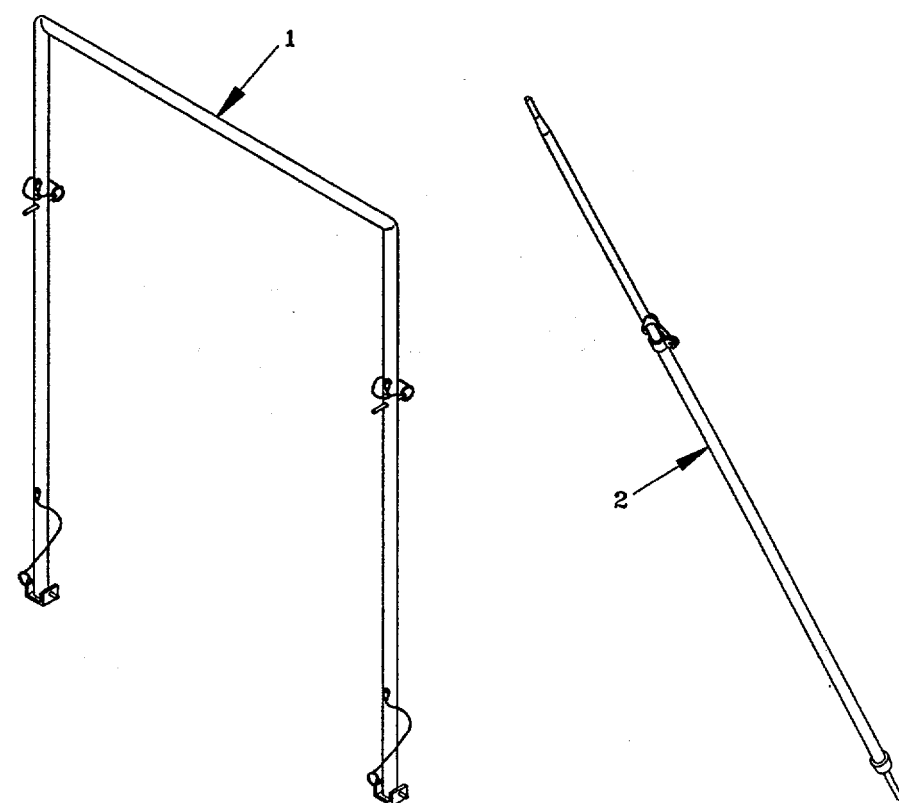
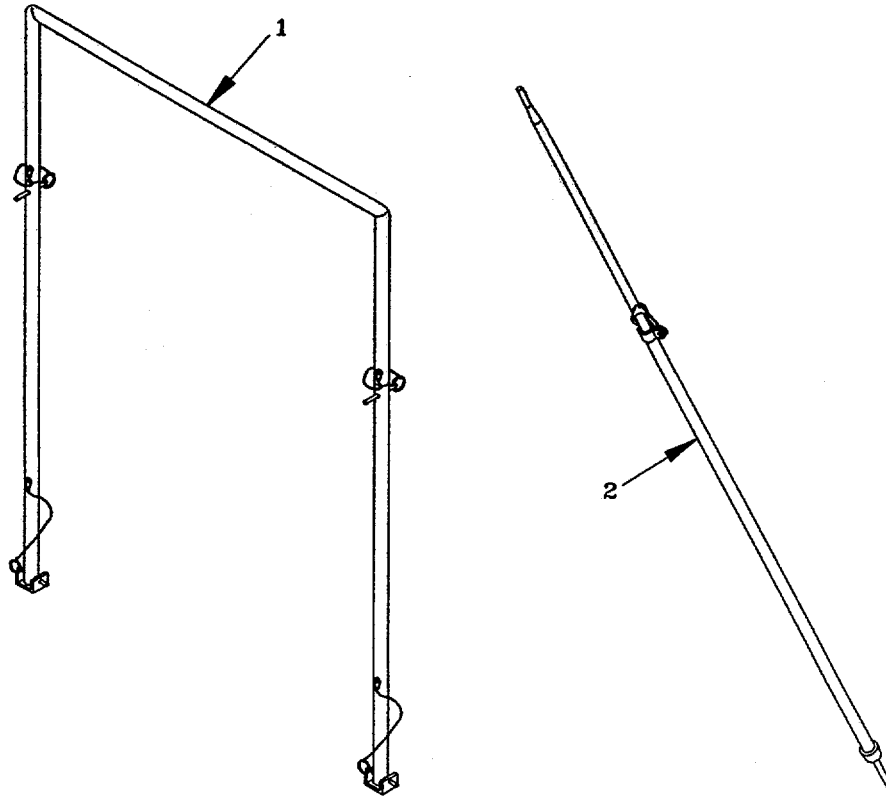



Table 2-1. OPERATOR PREVENTIVE MAINTENANCE CHECKS AND SERVICES (CONT).

Item No.	Interval	Location Item to check/service M577 Boot Wall, RWS Boot Wall, S-250E Boot Wall	Procedure	Not Fully Mission Capable If:
				
9	After	Boot Assembly, End Panel Assembly	Check for tears, punctures, and separated seams on boot assembly (1) and end panel assembly (2).	Tears, punctures or separated seams exist which allow weather to enter or light to escape Boot Wall.
10	After	Hook and Pile Fasteners	Inspect all hook and pile fasteners (3) for cleanliness and secure hold. Remove dirt by brushing fastener strips. Inspect Fasteners for loose stitching to fabric.	Boot Wall can not be secured in place because hook and pile fasteners do not hold securely when pressed together or are loosely stitched to fabric.
11	After	Straps, Quick Disconnect Fasteners	Check Straps (4) and quick disconnect fasteners (5) for fraying, tears, broken hardware and loose stitching to fabric.	Boot Wall can not be secured in place because straps and quick disconnect fasteners are frayed, torn, broken or loosely stitched to fabric.

Table 2-1. OPERATOR PREVENTIVE MAINTENANCE CHECKS AND SERVICES (CONT).

Item No.	Interval	Location Item to check/service	Procedure	Not Fully Mission Capable If:
12	After	Frame (RWS Boot Wall) and Tent Pole (S-250E Boot Wall)	 <p>The diagram illustrates two structural components. On the left, a frame structure is shown with a diagonal member labeled '1' and a vertical pole labeled '2'. On the right, a single pole is shown with a label '2' pointing to its main shaft.</p>	Frame or tent pole can not support weight of Boot Wall. Tent pole can be adjusted to proper height.

## Section III. OPERATION UNDER USUAL CONDITIONS

**2-2. SITE SELECTION.** Select an area large enough for vehicle and erected Boot Wall. Ensure that area is relatively level and is free of large holes, trees, rocks, and debris. Make sure that site will drain properly in event of inclement weather. Positioning front of vehicle lower than rear will encourage proper drainage. Check unit SOP to ensure that site selection and MCPS tent layout will be acceptable.

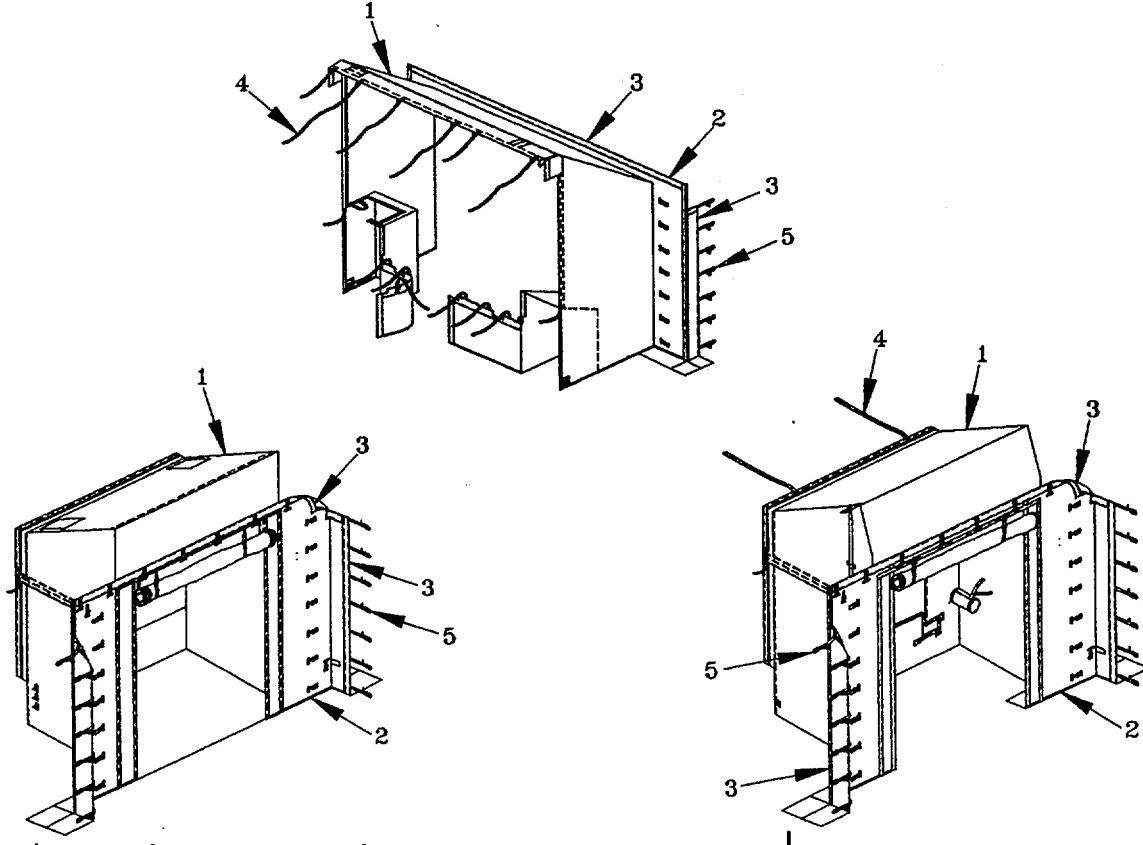
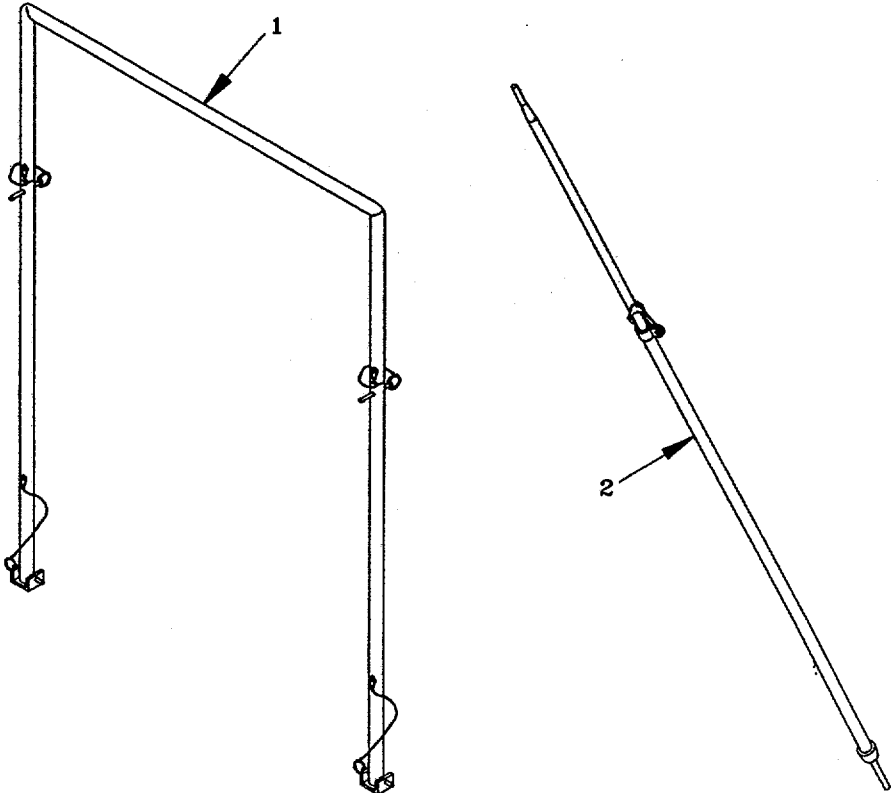
**2-3. REMOVAL OF MCPS TENT WALL.** If a wall assembly is already in place on the side of the MCPS tent that will be attached to Boot Wall, it must be removed as follows:

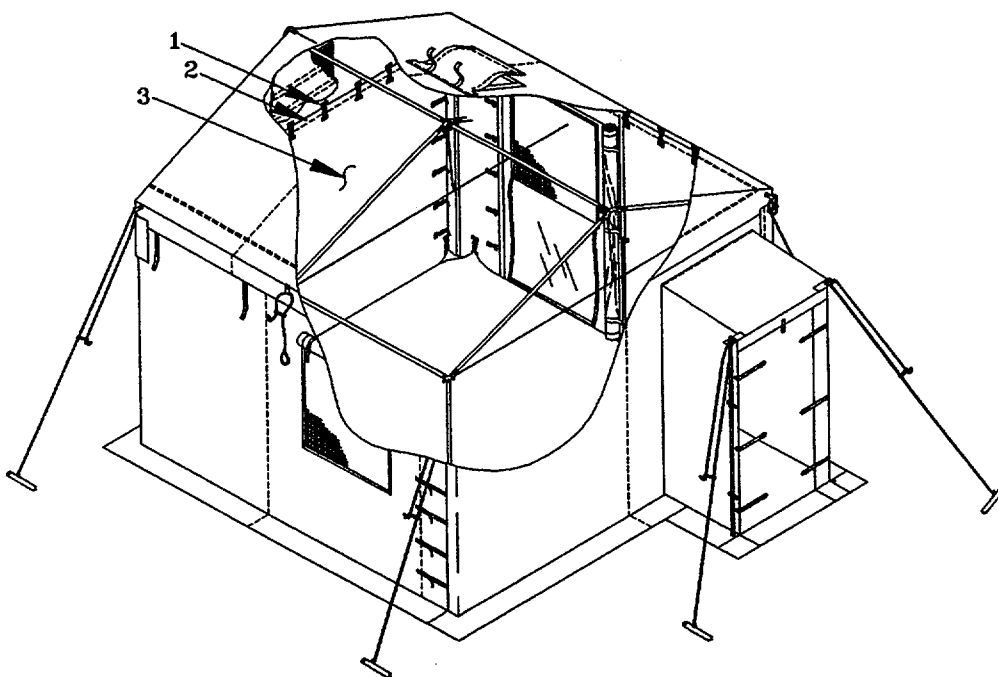

- a. Release all quick disconnect (1) and hook and pile fasteners (2) at inside and outside corners.
- b. Remove wall (3) by releasing all quick disconnect (1) and hook and pile fasteners (2) from roof assembly.
- c. Fold wall (3) with identification label visible and place in fabric transport bag.

**2-4. INSTALLING M577 BOOT WALL TYPE I.****NOTE**

If a wall assembly is in place where Boot Wall is to be installed, it must be removed prior to installation. See paragraph 2-3 for removal instructions.

- a. Unpack M577 Boot Wall type I and inspect in accordance with Table 2-1, Operator PMCS.'

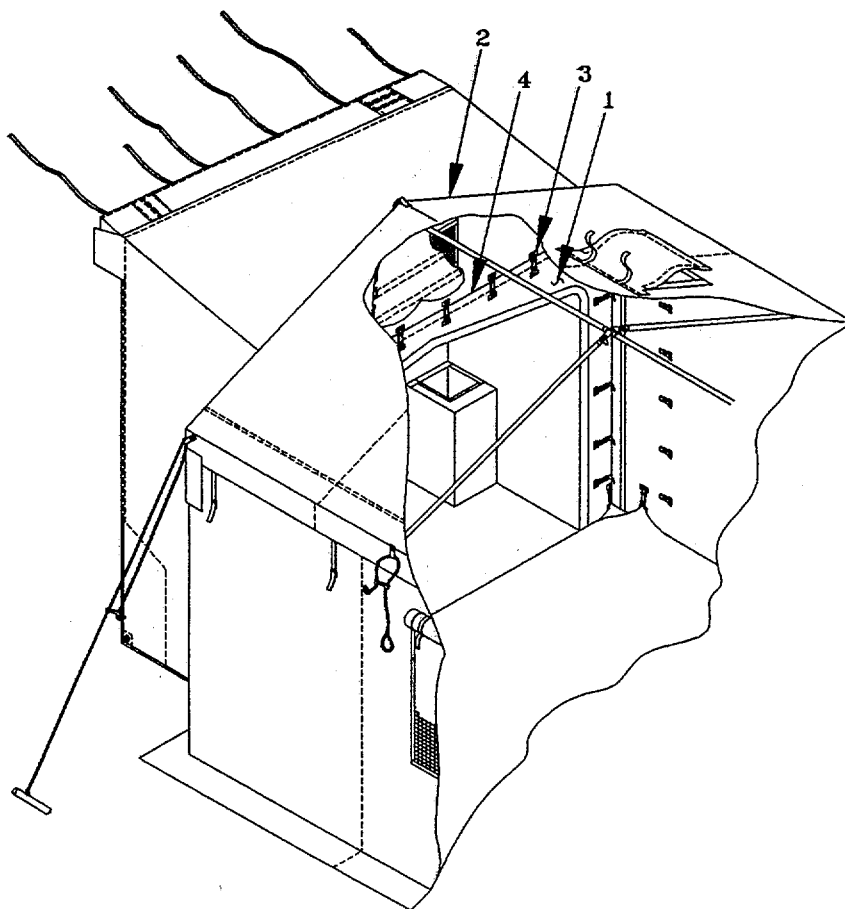

- b. Standing inside MCPS tent, line up Boot Wall end panel (1) and fasten it to MCPS tent roof cap (2) with quick release fasteners (3).
- c. Starting at center of Boot Wall, line up pile fastener tape (4) on end panel assembly (1) with hook fastener tape (4) on MCPS tent roof cap assembly (2) and press them together. Work from center outward in order to prevent wrinkles in hook and pile fastener tapes.

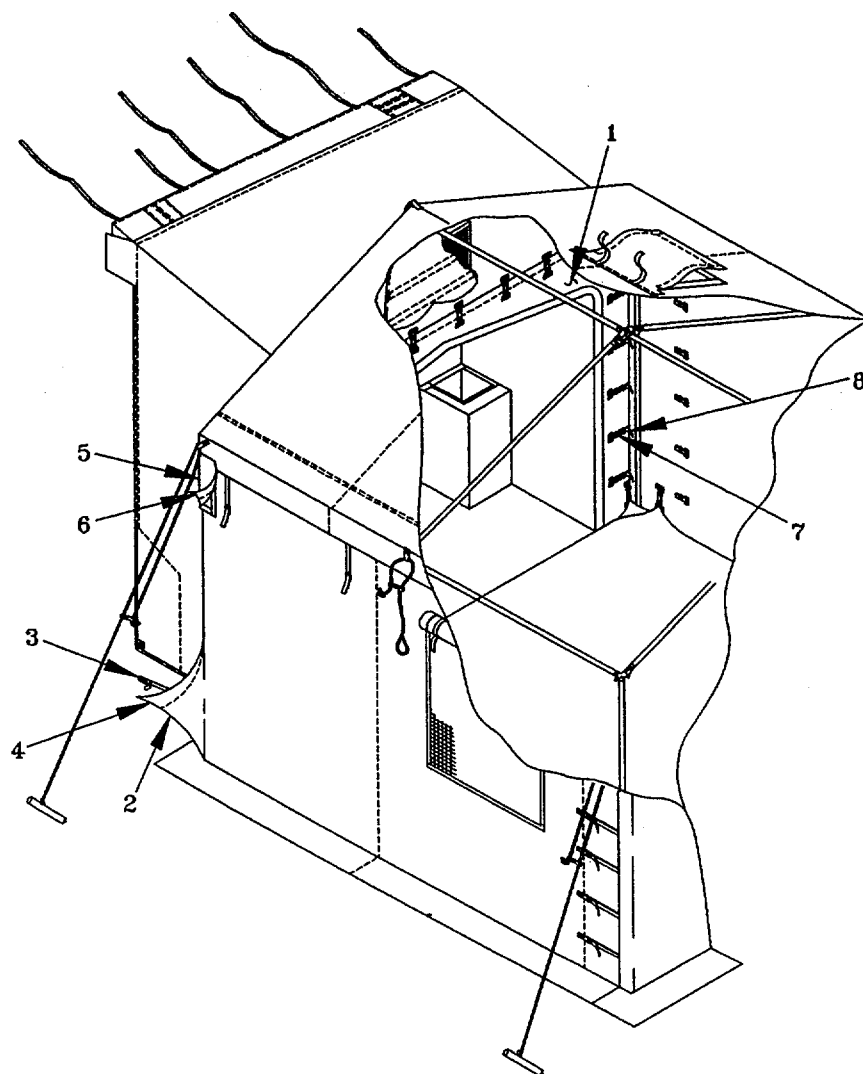

- d. From outside MCPS tent overlap Boot Wall end wall panel (1) and existing walls (2) and connect corresponding quick release fasteners (3) and side hook and pile fastener tapes (4). Make sure leg assemblies stay inside MCPS tent.
- e. Pull outside roof cap corner flaps (5) down and press the hook and pile fasteners (6).
- f. Fasten the row of quick disconnect fasteners (7) on the inside corners of each wall. Draw the buckle straps (8) tight. Make sure leg assemblies stay inside MCPS tent.

2-4. INSTALLING M577 BOOT WALL TYPE I (CONT).

**WARNING**

•Use a ground guide when backing a vehicle. Failure to observe this warning may result in death or serious injury.

•Make sure radio sets are turned off for the rest of the Boot Wall installation. Personal injury may result if radio sets are used during Boot Wall installation.

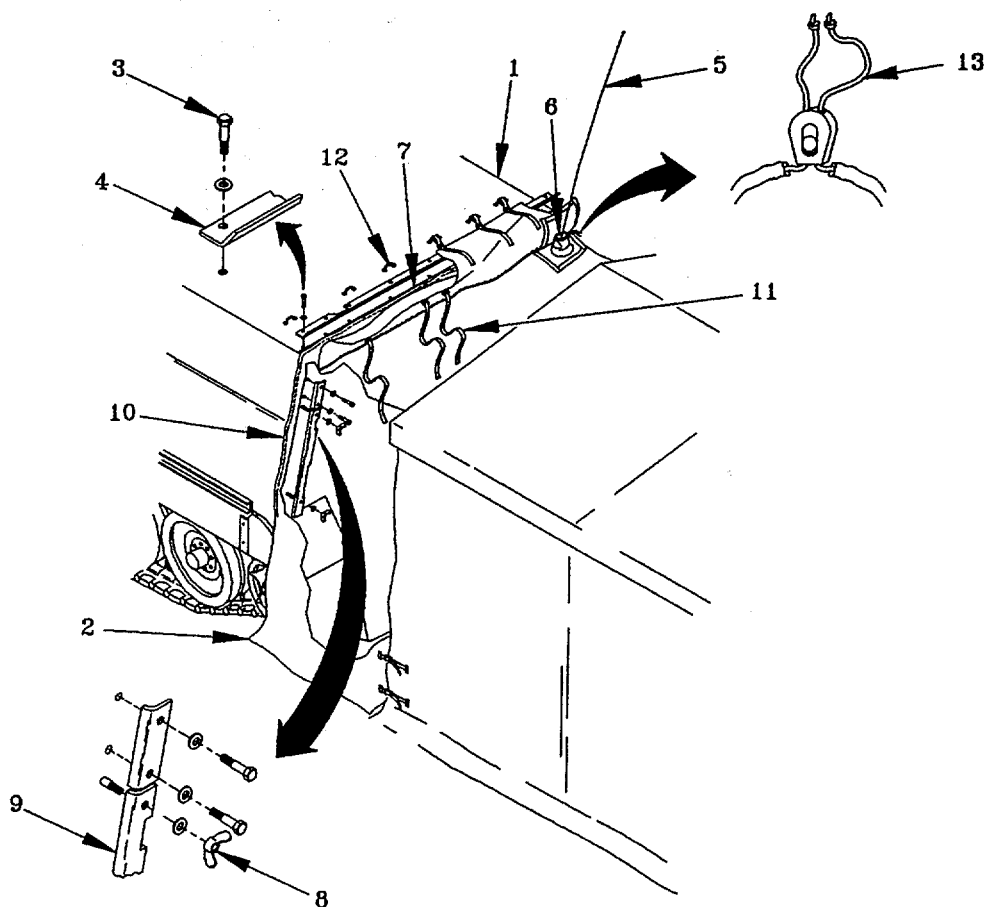

- g. Center rear of M577 (1) on Boot Wall (2) and position it four to five feet away from the MCPS tent.
- h. Loosen bolts (3) that attach hold-down track (4) along top rear of the M577 (1).
- i. If antenna (5) is present, place sleeve (6) over antenna cylinder. If your Boot Wall has no antenna sleeve, antenna (5) must be removed.

- j. Push hem (7) along top forward edge of Boot Wall under track (4), making sure hem (7) is centered on M577, then tighten bolts (3) securing track (4).
- k. From inside Boot Wall (2), loosen wing nuts (8) securing tracks (9) along right and left rear sides of M577 (1). Place hems (10) under tracks (9) and tighten wing nuts (8).
- l. Attach straps (11) on top of Boot Wall (2) to corresponding loops (12) on top of the M577 (1) and tighten straps (11).
- m. If antenna is present, tighten sleeve (6) around antenna cylinder (5) using draw string (13).

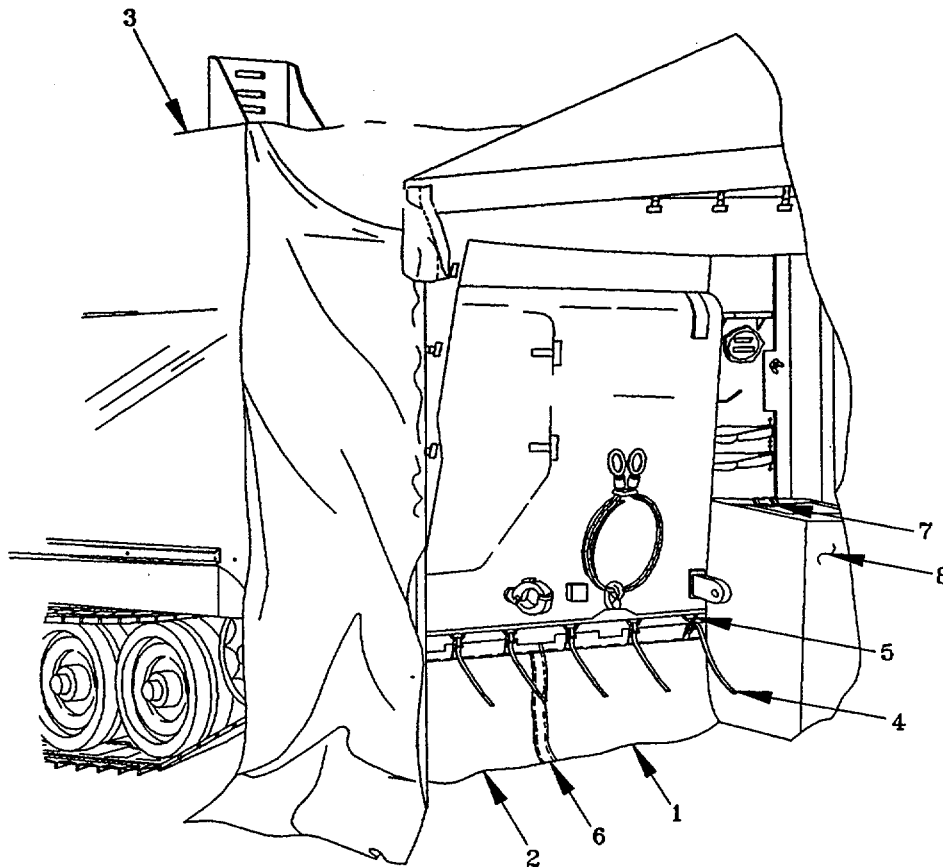

- n. Attach right (1) and left (2) halves of blackout skirt to underside of M577 (3) by attaching straps (4) to loops (5) on underside of M577.
- o. Connect right (1) and left (2) halves of the blackout skirt together with hook and pile fasteners tapes (6).
- p. Fasten quick release fastener (7) on right fender skirt (8)

## 2-5. INSTALLING THE RIGID WALL SHELTER BOOT WALL TYPE II.

### NOTE

If a wall assembly is in place where Boot Wall is to be installed, it must be removed prior to installation. See paragraph 2-3 for removal instructions.

- a. Unpack the Rigid Wall Shelter (RWS) Boot Wall and inspect in accordance with Table 2-1, Operator PMCS.

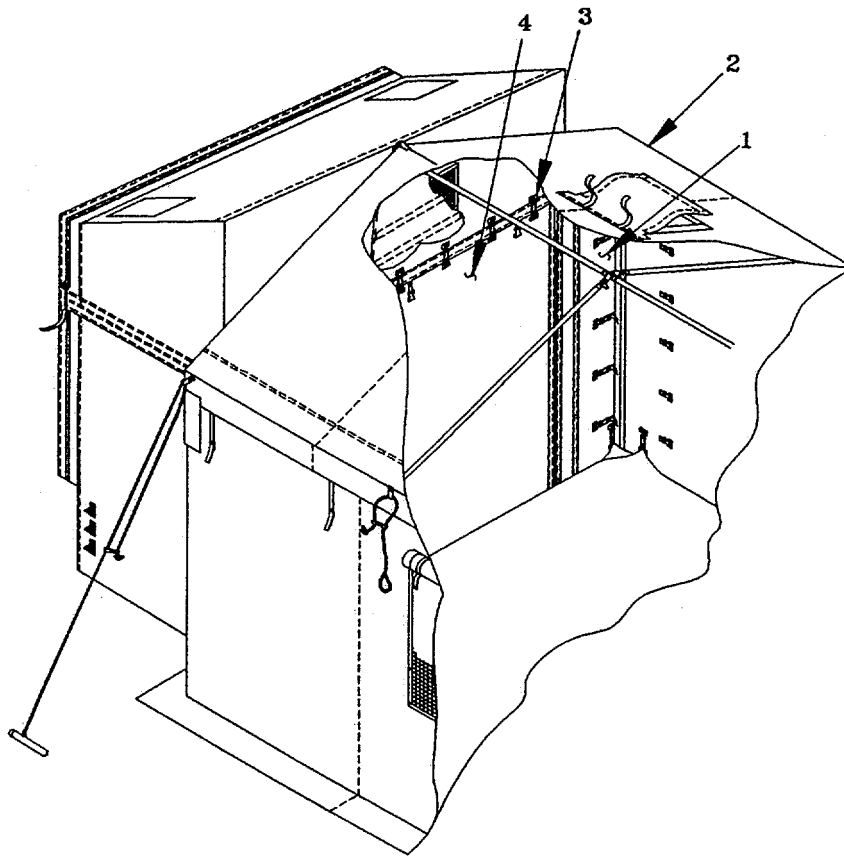

- b. Standing inside the MCPS tent, line up Boot Wall end panel (1) and fasten it to MCPS tent roof cap (2) with quick release fasteners (3). Ensure that roll-up door (4) is down (closed) and secured with hook and pile fastener tapes.
- c. Starting in center of Boot Wall, line up pile fastener tape on end panel assembly (1) with hook fastener tape on MCPS tent roof cap assembly (2) and press them together. Work from center outward in order to prevent wrinkles in hook and pile fastener tapes.



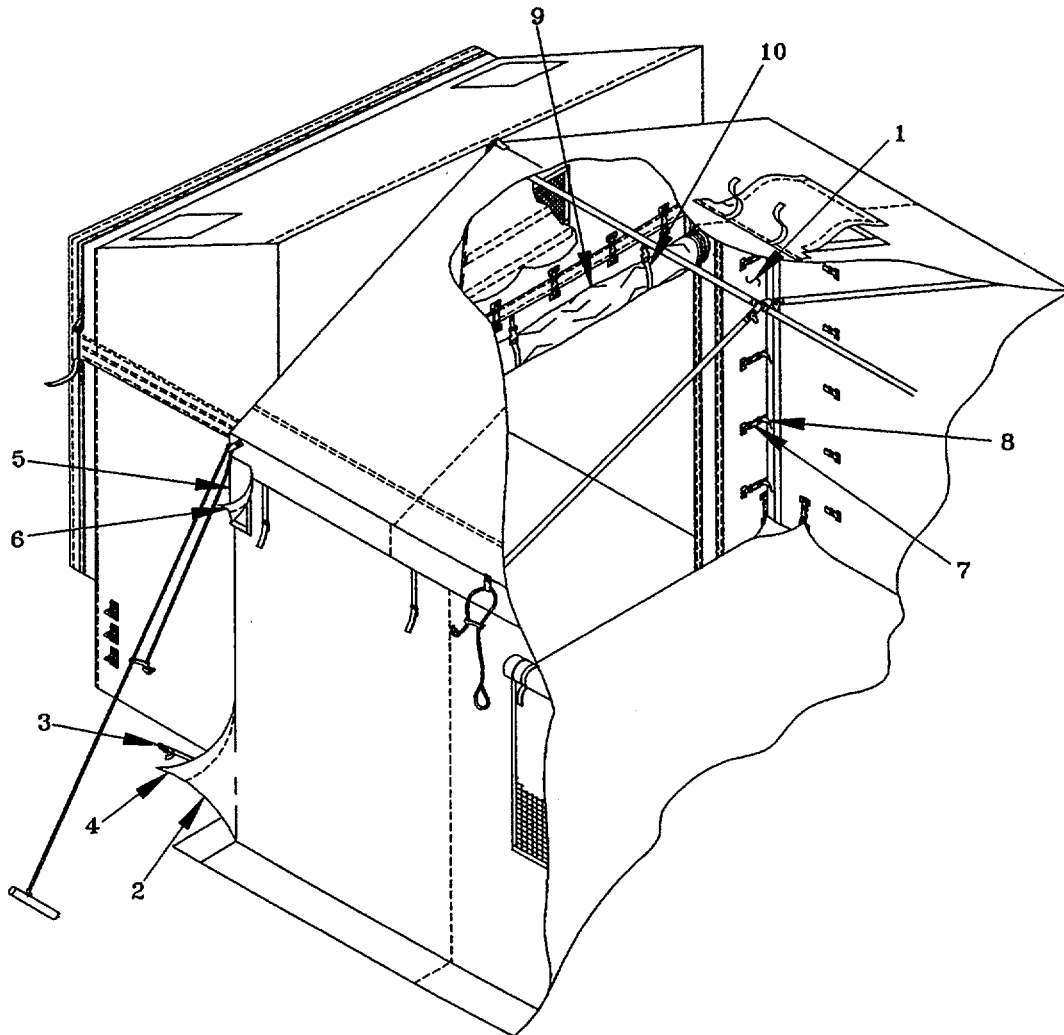

- d. From outside MCPS tent overlap Boot Wall end wall panel (1) with two adjacent walls (2), and connect corresponding quick release fasteners (3) and side hook and pile fastener tapes (4). Make sure leg assemblies stay inside fabric.
- e. Pull the outside roof cap corner flaps (5) down and press the hook and pile fasteners (6).
- f. Fasten the row of quick disconnect fasteners (7) on inside corners of each wall. Draw buckle straps (8) tight. Make sure leg assemblies stay inside fabric.
- g. Open roll-up door (9) and secure with straps (10).

## 2-5. INSTALLING THE RIGID WALL SHELTER BOOT WALL TYPE II (CONT).

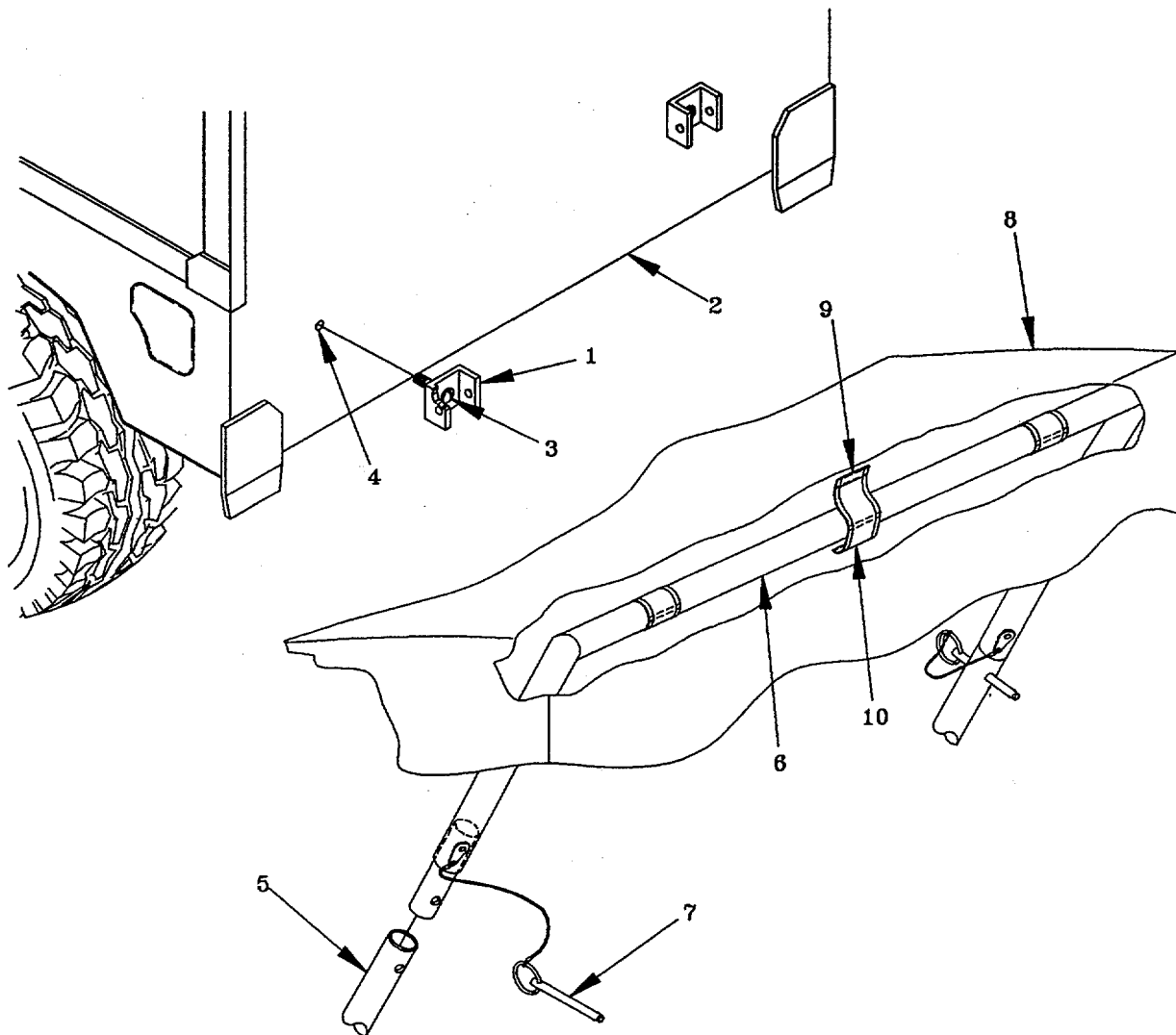
**NOTE**

Swivel feet may already be installed on rear of RWS.

- h. Attach swivel feet (1) to RWS (2) using captive screws (3) and two threaded inserts (4) already installed in rear of RWS (2).
- i. Assemble frame by attaching upright bars (5) to U-shaped header (6) and inserting locking pins (7).
- j. Place frame header bar (6) into boot assembly (8) and fasten hook and pile fastener tapes (9) on three header flaps (10) around header bar (6).

**WARNING**

- Use a ground guide when backing a vehicle. Failure to observe this warning may result in death or serious injury.
- Make sure the radio sets are turned off for the rest of the Boot Wall installation. Personal injury may result if radio sets are used during Boot Wall installation.

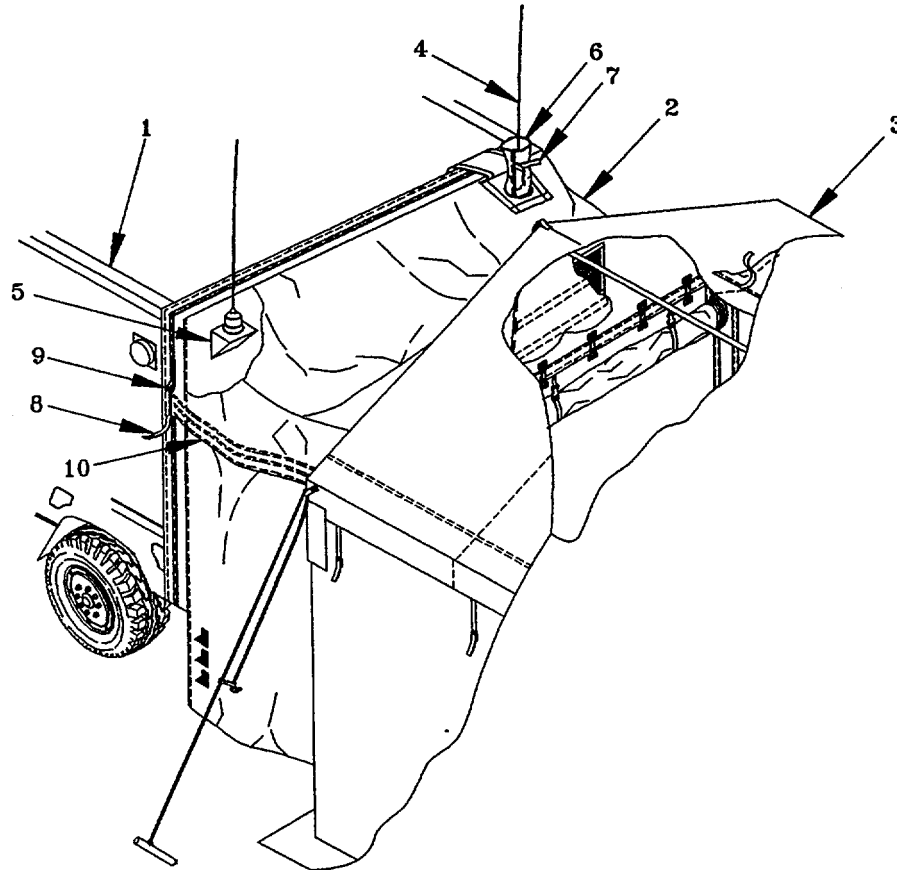

- k. Center HMMWV with RWS (1) on Boot Wall (2) and back it up to within four to five feet of MCPS tent (3).
- l. Remove whip antennas (4) from their mounts (5) on rear of RWS (1). (Use folding steps on passenger side of RWS to access roof.)
- m. Lift top of boot assembly (2) over antenna mounts (5) on RWS (1). Place the antenna sleeves (6) over the antenna mounts (5).
- n. Install whip antennas (4) into mounts (5). Tighten sleeves (6) using tie tapes (7).
- o. Remove belly band webbing (8) from dee-ring buckle (9) and separate hook and pile fastener tapes (10) on driver side of boot assembly.

## 2-5. INSTALLING THE RIGID WALL SHELTER BOOT WALL TYPE II (CONT).

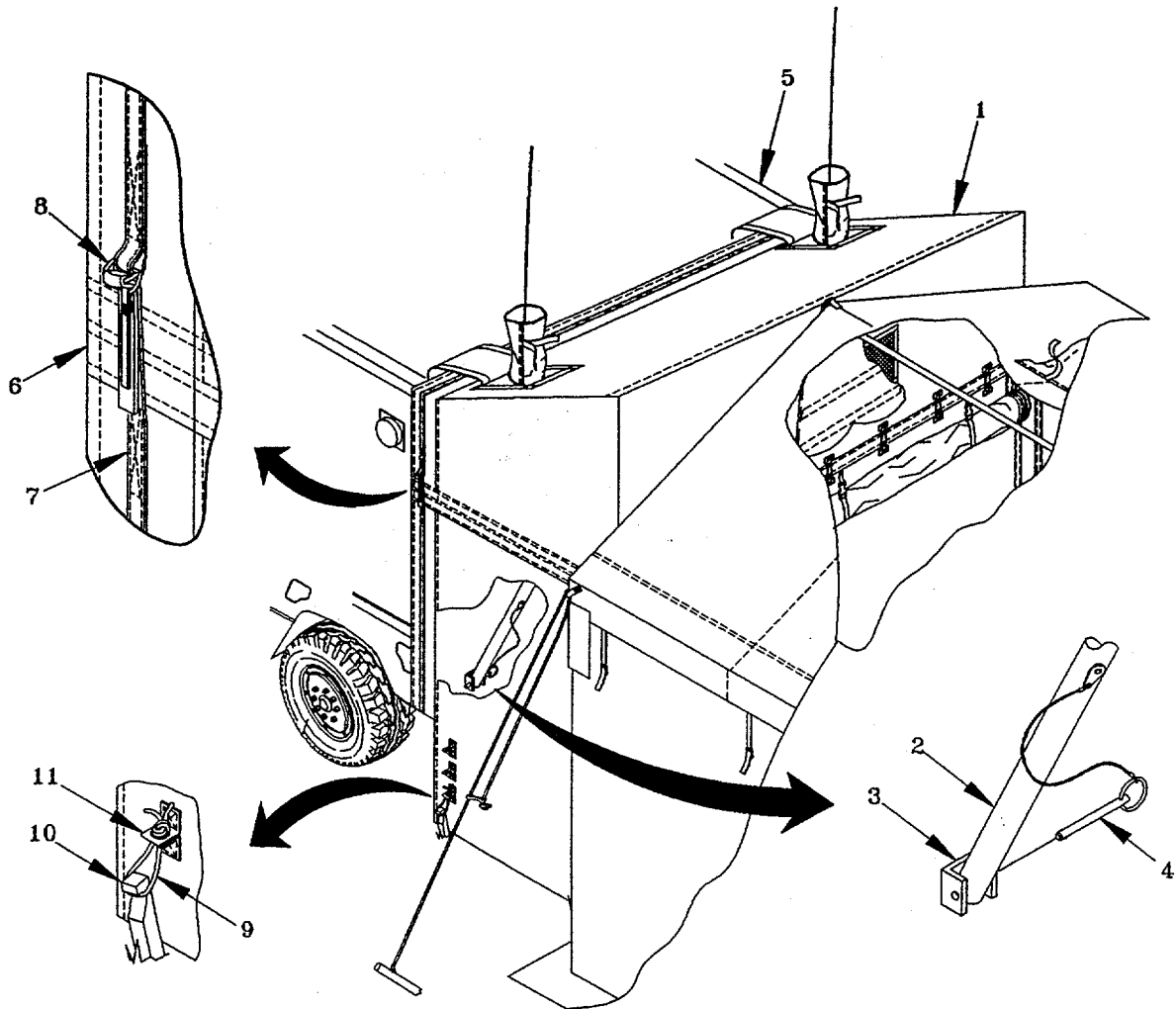
**NOTE**

Ensure frame stays in corner of fabric to ensure proper fit.

- p. Lift boot assembly (1) up using frame (2). Place ends of upright bars (2) onto swivel feet (3) and fasten using locking pins (4).
- q. Wrap remaining portion of boot assembly (1) completely around RWS (5).
- r. Thread belly band webbing (7) through dee-ring buckle (8) and tighten.
- s. Fasten upper and lower portions of the boot assembly (1) together with hook and pile fastener tapes (6) on driver side.
- t. If high winds are expected, install rope loops (9) (Appendix E, Item 1) and tent stakes (10) (Appendix E, Item 2) on both sides of boot assembly. Use whichever foot loop (11) is closest to ground level or provides best hold.

## 2-6. INSTALLING THE S-250E BOOT WALL TYPE IV.

### NOTE

If a wall assembly is in place where Boot Wall is to be installed, it must be removed prior to installation. See paragraph 2-3 for removal instructions.

- a. Unpack S-250E Boot Wall and inspect in accordance with Table 2-1, Operator PMCS.

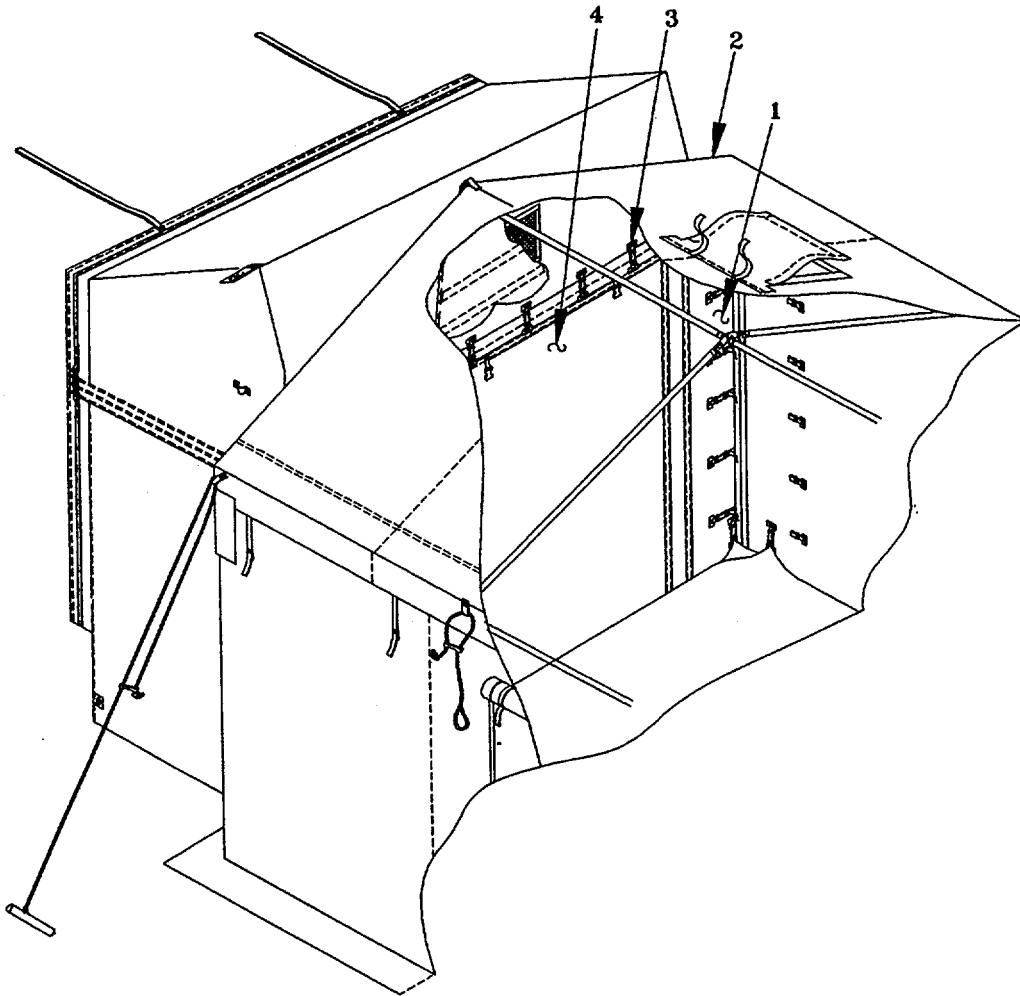

- b. Standing inside MCPS tent, line up Boot Wall end panel (1) and fasten it to roof cap (2) with quick release fasteners (3). Ensure that roll-up door (4) is down (closed) and secured with hook and pile fastener tapes.
- c. Starting in center of end panel, line up the pile fastener tape on end panel assembly (1) with hook fastener tape on MCPS tent roof cap assembly (2) and press them together. Work from center outward in order to prevent wrinkles in hook and pile fastener tapes.

## 2-6. INSTALLING THE S-250E BOOT WALL TYPE IV (CONT).

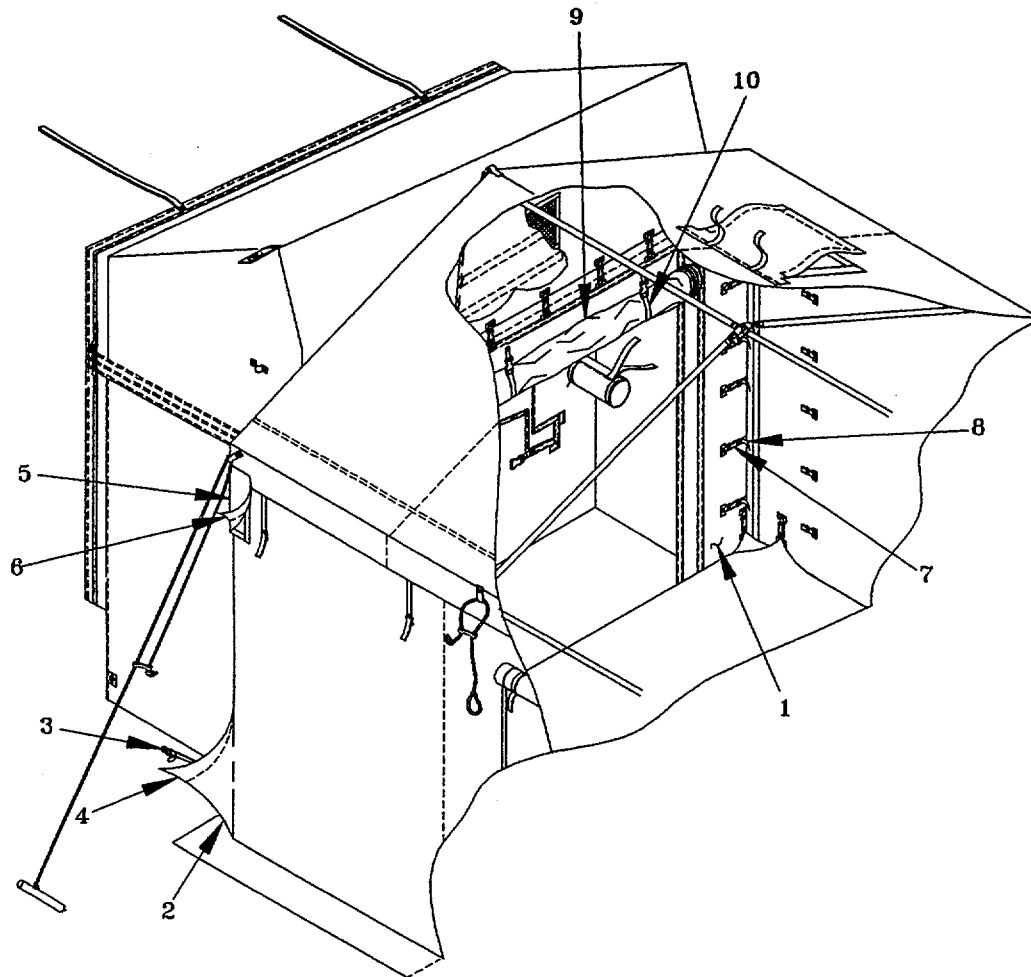

- d. From outside MCPS tent, overlap end wall panel (1) with adjacent walls (2) and connect corresponding quick release fasteners (3) and side hook and pile fastener tapes (4). Make sure leg assemblies stay inside the MCPS tent.
- e. Pull outside roof cap corner flaps (5) down and press hook and pile fasteners (6).
- f. Fasten row of quick disconnect fasteners (7) on inside corners of each wall. Draw the buckle straps (8) tight.
- g. Open roll-up door (9) and secure with straps (10).

**WARNING**

- Use a ground guide when backing a vehicle. Failure to observe this warning may result in death or serious injury.
- Make sure the radio sets are turned off for the rest of the Boot Wall installation. Personal injury may result if radio sets are used during Boot Wall installation.

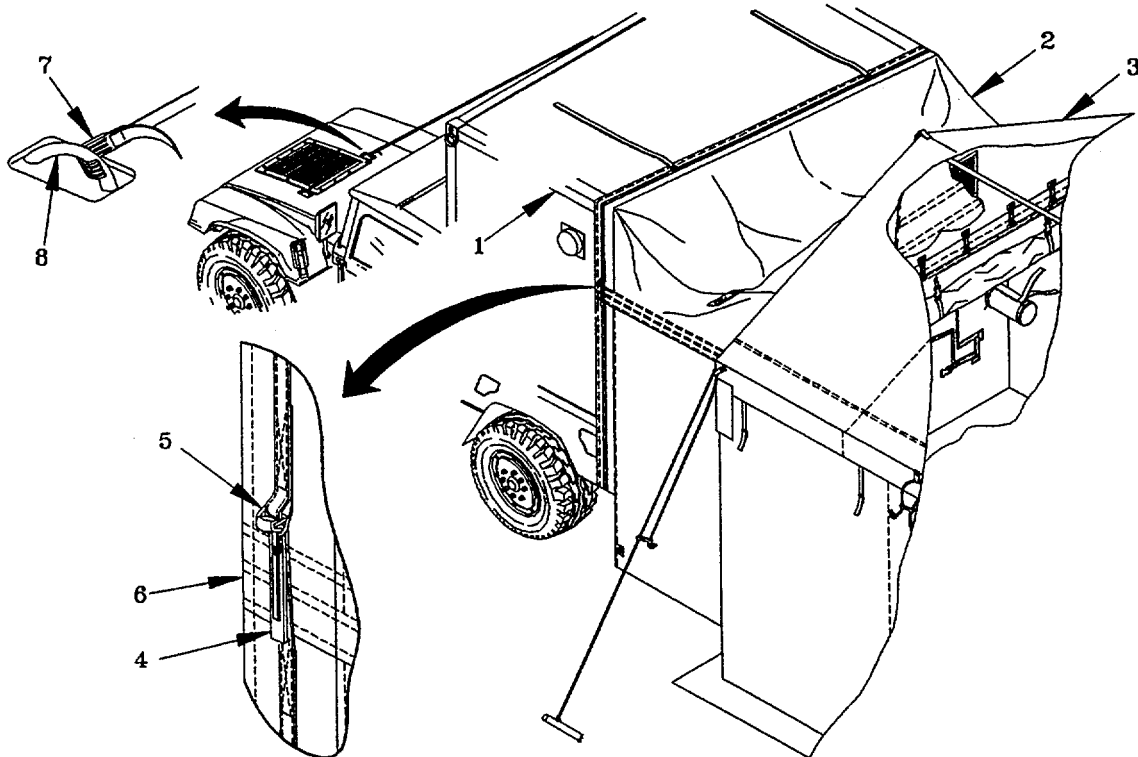

- h. Center HMMWV with S-250E shelter (1) on Boot Wall (2) and back up to within four to five feet of MCPS tent (3).
- i. Remove ladder from storage bracket on rear of S-250E and ensure HMMWV tailgate is up and secured.
- j. Remove web belly band (4) from dee-ring buckle (5) and separate hook and pile fastener tapes (6) on driver's side of Boot Wall (2) and blackout wall inside.
- k. Pull Boot Wall (2) over top of S-250E shelter (1). Boot wall should overlap S-250E approximately 15-18 inches. The blackout wall should fit flush against rear of S-250E and the ladder bracket should be placed into the pocket in blackout wall. If necessary, readjust HMMWV to attain proper fit.
- l. Attach web strap hooks (7) to lifting eyes (8) located on hood of HMMWV and tighten webs straps so that blackout wall is snug against rear of S-250E shelter.

**2-6. INSTALLING THE S-250E BOOT WALL TYPE IV (CONT).**

- m. Wrap remainder of boot assembly (2) around S-250E shelter and thread web belly band (4) through dee-ring buckle (5) and tighten.
- n. Fasten upper and lower portions of boot assembly (2) together with hook and pile fastener tapes (6) on driver's side.

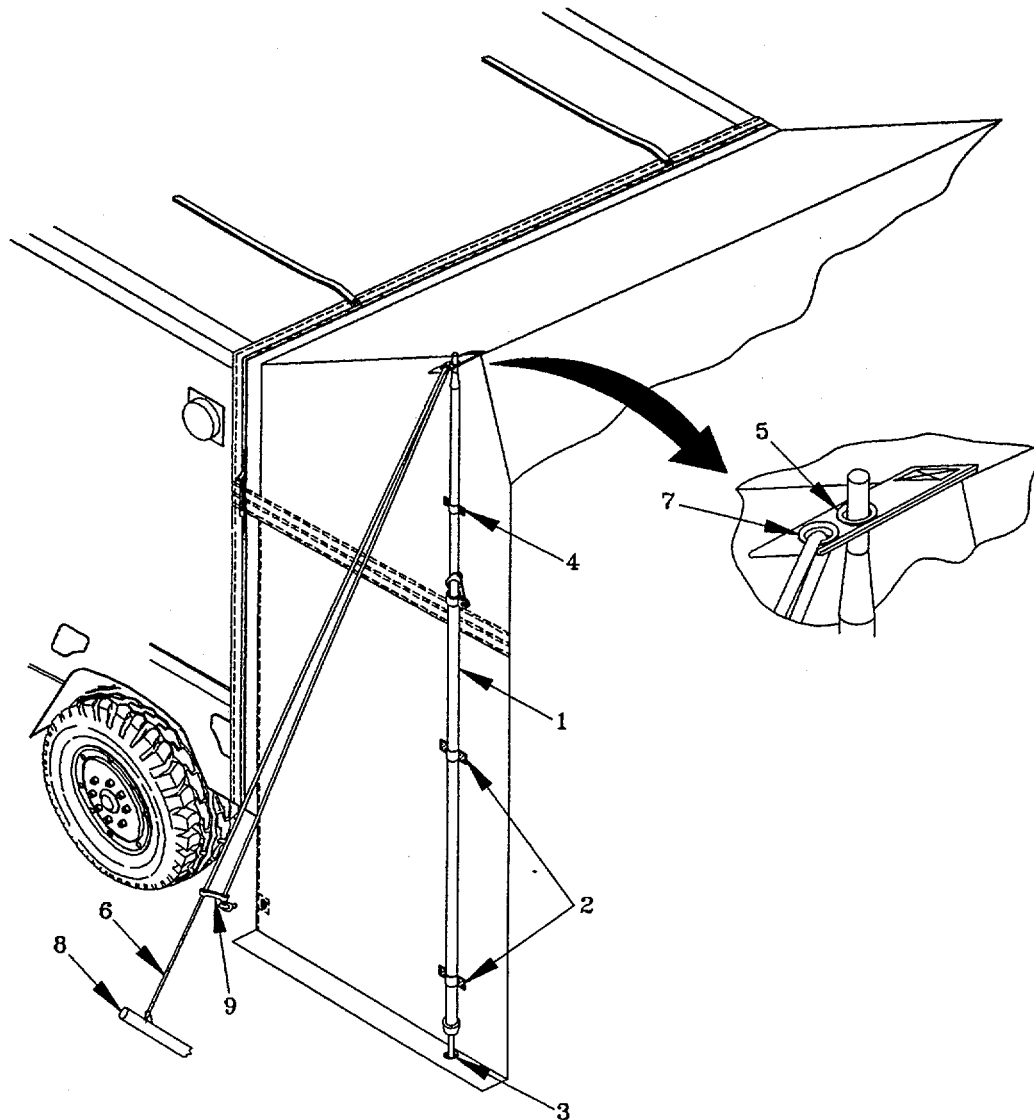

- o. Insert telescopic poles (1) into second and third loops (2) and bottom grommet (3).
- p. Extend poles (1) by raising upper portion thru upper loop (4) and inner grommet (5) at top of Boot Wall until Boot Wall is taut.
- q. Secure guy lines (6) (Appendix C, Section III, Item 1) from outer grommet (7) on each side of Boot Wall by staking into ground with tent stakes (8) (Appendix C, Section III, Item 2), or connecting to existing MCPS tent stakes. Adjust slips (9) (Appendix C, Section III, Item 3) to secure.



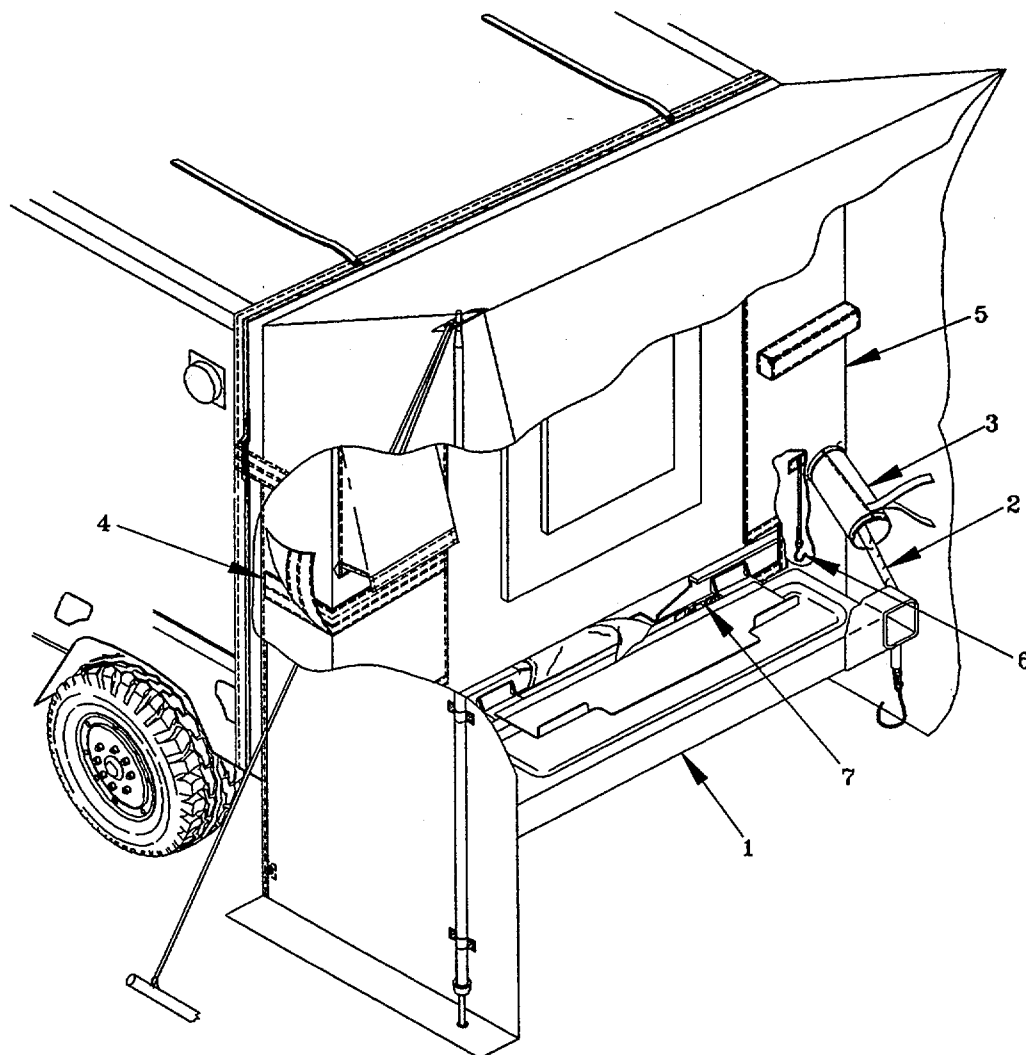

- r. Lower HMMWV tailgate (1) and pass tailgate chains (2) thru sleeves (3) and connect to HMMWV. Secure sleeves (3) with tie-tapes.
- s. From inside Boot Wall, connect fastener tapes (4) on upper and lower portions of blackout wall (5).
- t. Pull shock cords (6) between S-250E and bumper and secure to frame of HMMWV.
- u. Fasten buckle (7) and tuck flap between cradle and S-250E.

2-7. REMOVING THE M577 BOOT WALL TYPE L

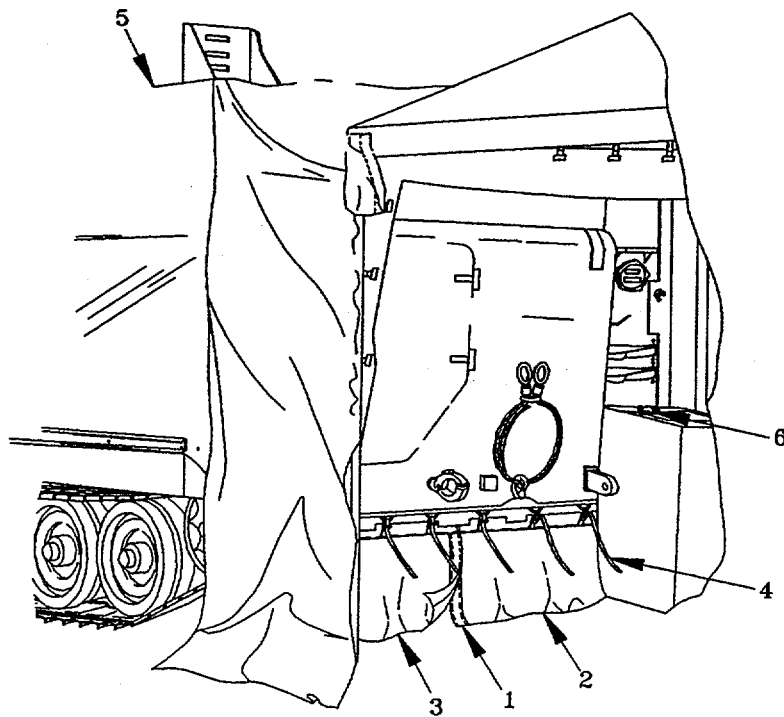

- a. Separate hook and pile fasteners (1) joining right (2) and left (3) halves of blackout skirt together.
- b. Release straps (4) from underside of M577 (5) to free right (2) and left (3) halves of the blackout skirt.
- c. Disconnect quick release fastener (6) on right fender assembly.

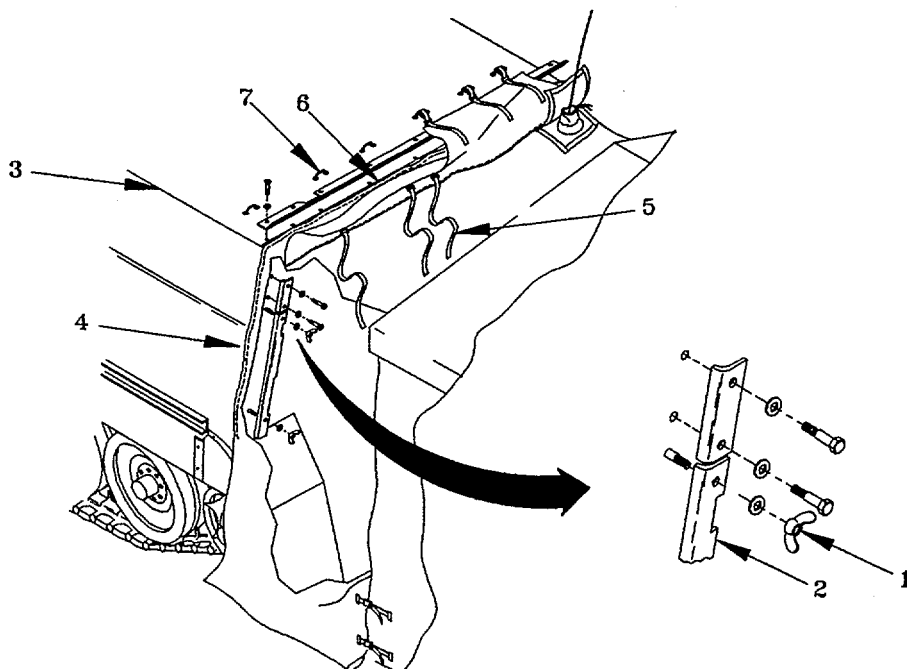

- d. Loosen wing nuts (1) securing hold down track (2) along sides of the M577 (3). Remove hem (4) from hold down track (2) and tighten wing nuts (1).
- e. Unfasten straps (5) securing upper hem (6) of Boot Wall to loops (7).

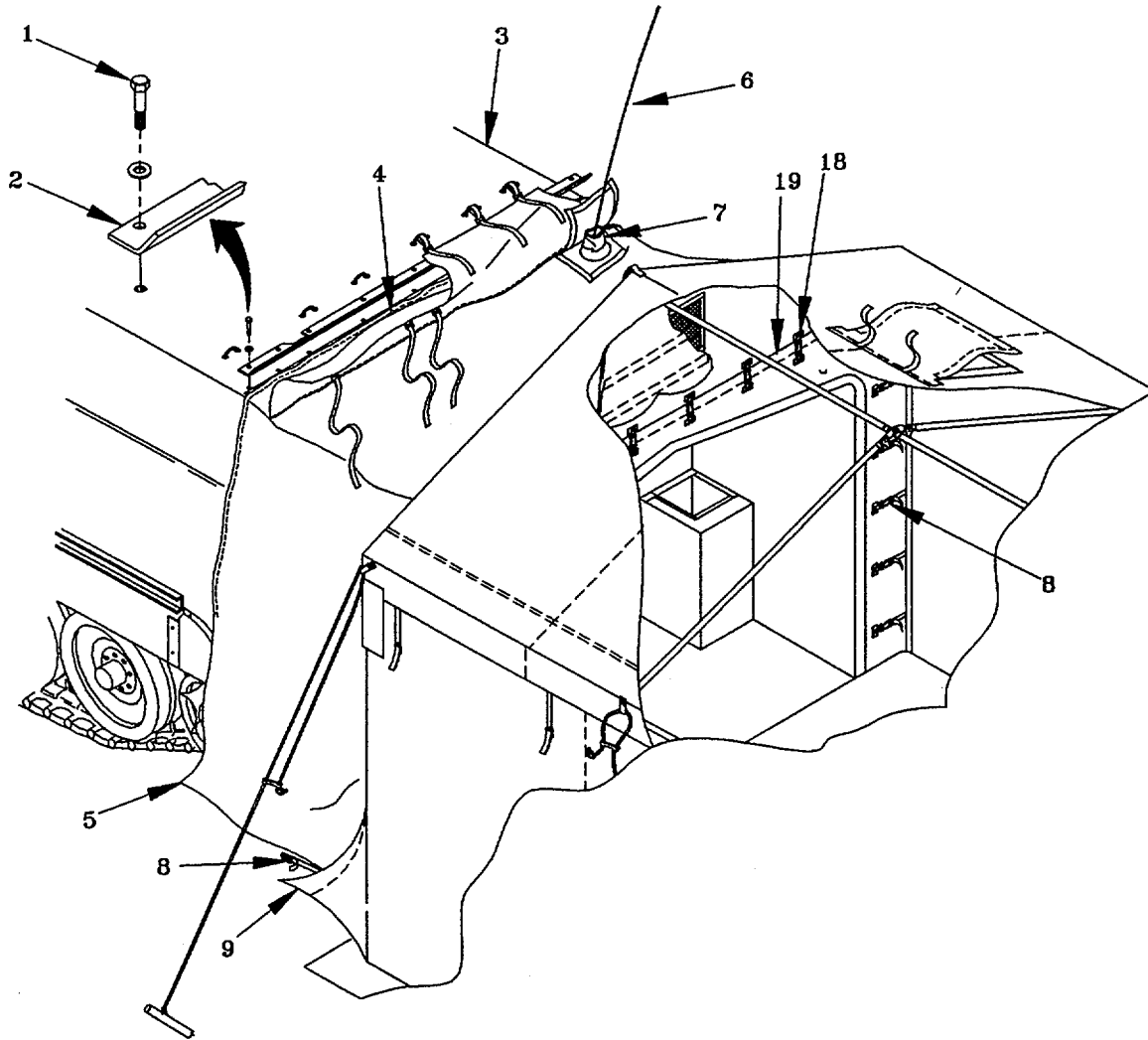

- f. Loosen bolts (1) securing hold down track (2) to top of the M577 (3). Remove hem (4) of Boot Wall (5) and tighten bolts (1).
- g. If antenna (6) is present, remove antenna (6) from sleeve (7).
- h. Remove Boot Wall (5) by releasing all quick disconnect (8) and hook and pile fasteners (9). Start from lower sides and work upwards and then in towards center.
- i. Fold Boot Wall with the identification label visible and stow.

**NOTE**

If MCPS tent is to remain in service, install wall unit in accordance with TM 10-5410-229-13&P.

2-8. REMOVING THE RIGID WALL SHELTER BOOT WALL TYPE II.

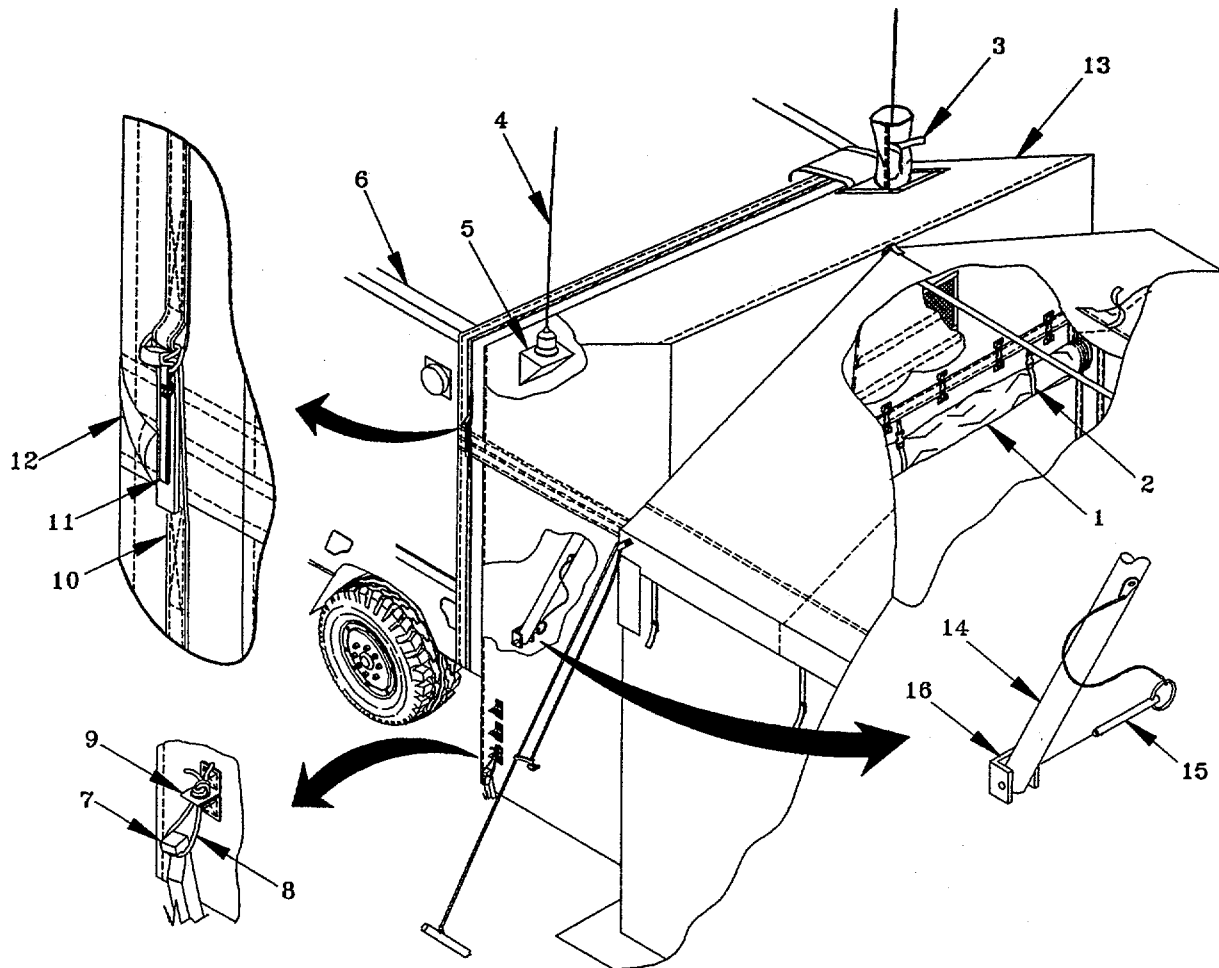

- a. Open roll-up door (1) and secure with straps (2).
- b. Untie antenna sleeve tie tapes (3) and disconnect whip antennae (4) from their mounts (5) on Rigid Wall Shelter (RWS) (6).
- c. If used, remove stakes (7) and loops (8) from foot loops (9) on both sides of Boot Wall.
- d. Unthread belly band webbing (10) by lifting dee ring tab (11).
- e. Separate hook and pile fastener tapes (12) on driver's side of boot assembly (13).
- f. Holding frame (14) securely, remove locking pins (15) from swivel feet (16) and lower frame (14).
- g. Lift boot assembly (13) up and over antenna mounts (5) and remove from RWS (6).

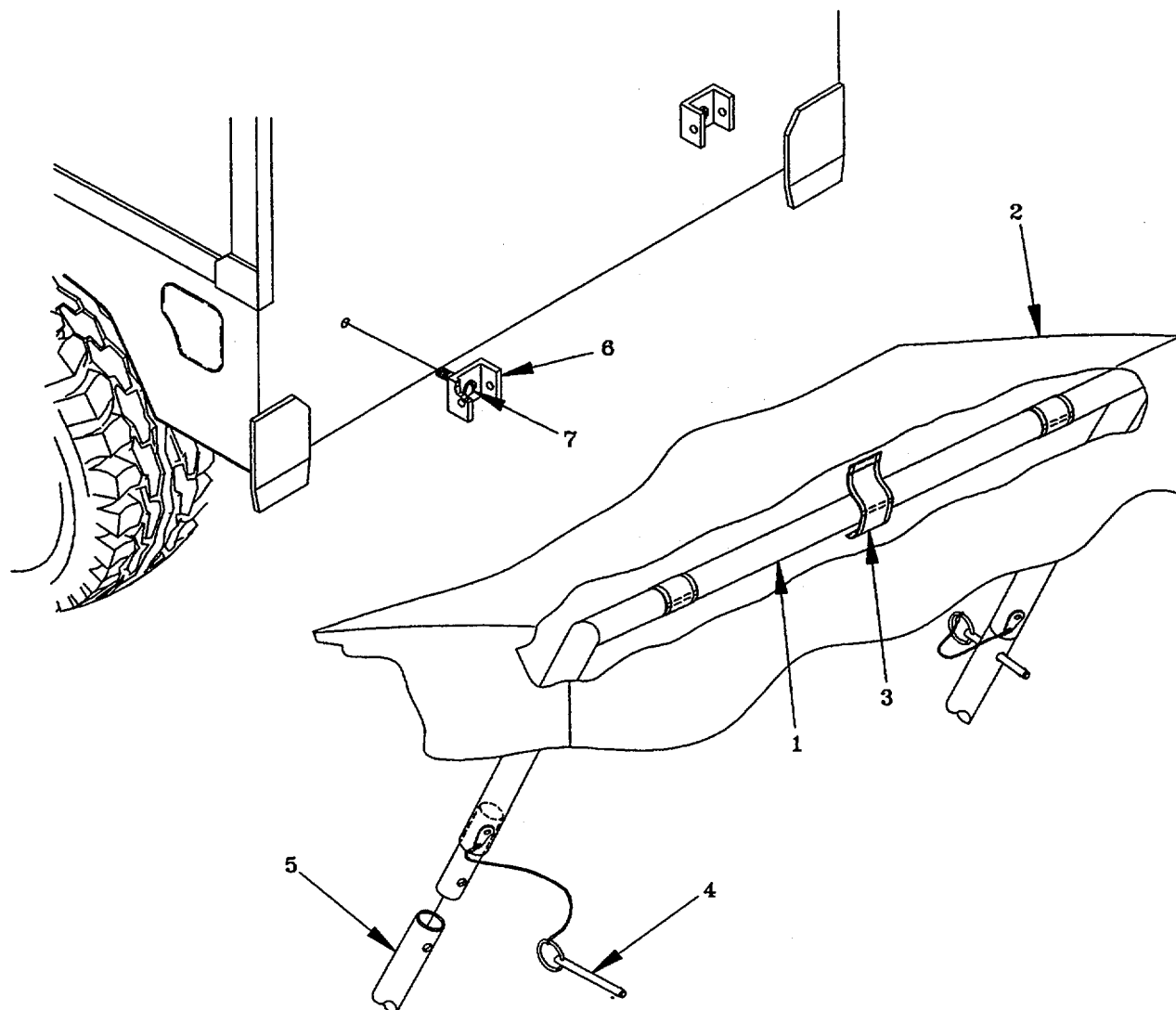

- g. Remove frame (1) from boot assembly (2) by opening header flaps (3).
- h. Disassemble frame by removing locking pins (4) and separating upright bars (5) from header bar (1).

**NOTE**

Swivel feet may be left on RWS for future use, but should be removed and packaged with boot wall when boot wall is to be permanently separated from RWS.

- i. Remove two swivel feet (6) from RWS by loosening captive screw (7). Stow swivel feet (6) with upright bars (5).

## 2-8. REMOVING TIE RIGID WALL SHELTER BOOT WALL TYPE II (CONT).

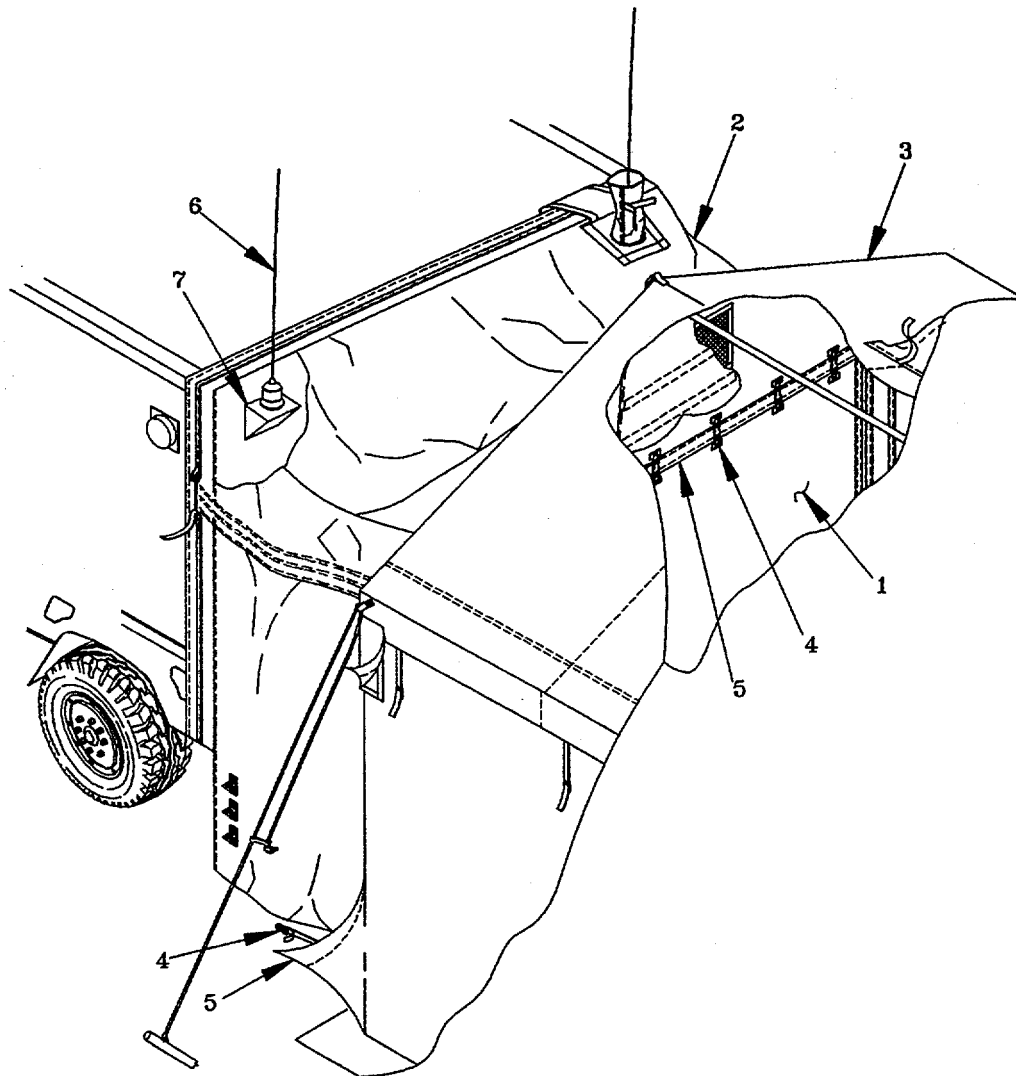

- j. Close roll-up door (1) and secure hook and pile fastener tapes.
- k. Remove Boot Wall (2) from MCPS tent (3) by releasing all quick release (4) and hook and pile fasteners (5). Start on lower sides and work upwards and then in toward center.
- l. Fold the Boot Wall (2) with the identification label on door (1) visible and stow.
- m. Install antennae (6) on mounts (7) on RWS.

**NOTE**

If MCPS tent is to remain in service, Install wall unit in accordance with TM 10-5410-229-13&P.

## 2-9. REMOVING THE S-250E BOOT WALL TYPE IV.

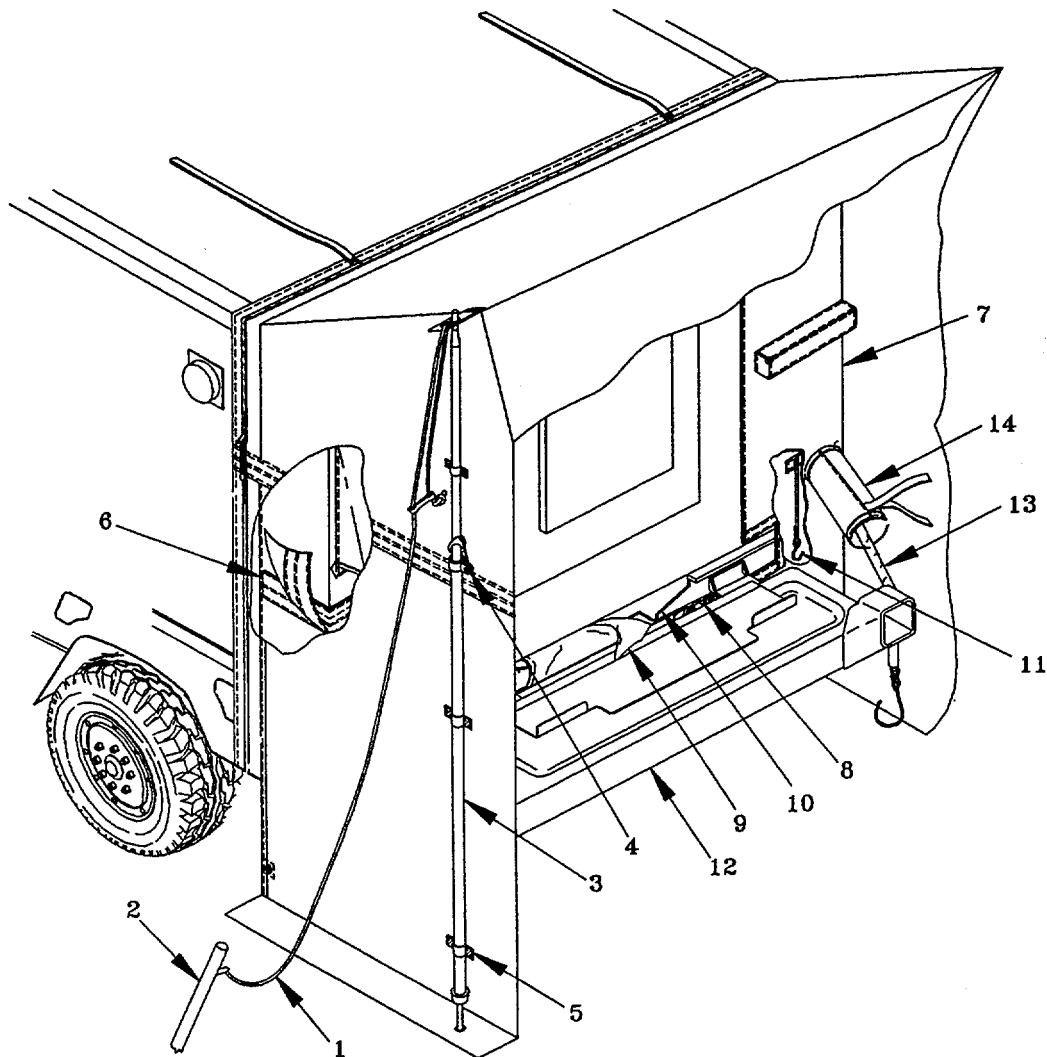

- a. Release guy lines (1) on each side of Boot Wall and pull out tent stakes (2) if possible.
- b. Collapse telescopic poles (3) by raising upper portion of pole (3) slightly, holding locks (4), then lower pole completely.
- c. Remove each pole (3) from three loops (5) on side of Boot Wall.
- d. Separate hook and pile fastener tapes (6) on upper and lower portions of blackout wall (7).
- e. Release buckle (8) and remove bottom panel assembly (9) from cradle (10). Release shock cords (11) from HMMVW frame.
- f. Untie tie tapes, raise tailgate (12), and remove remove tailgate chains (13) from sleeves (14). Close and secure tailgate.

2-9. REMOVING TEE S-250E BOOT WALL TYPE IV (CONT).

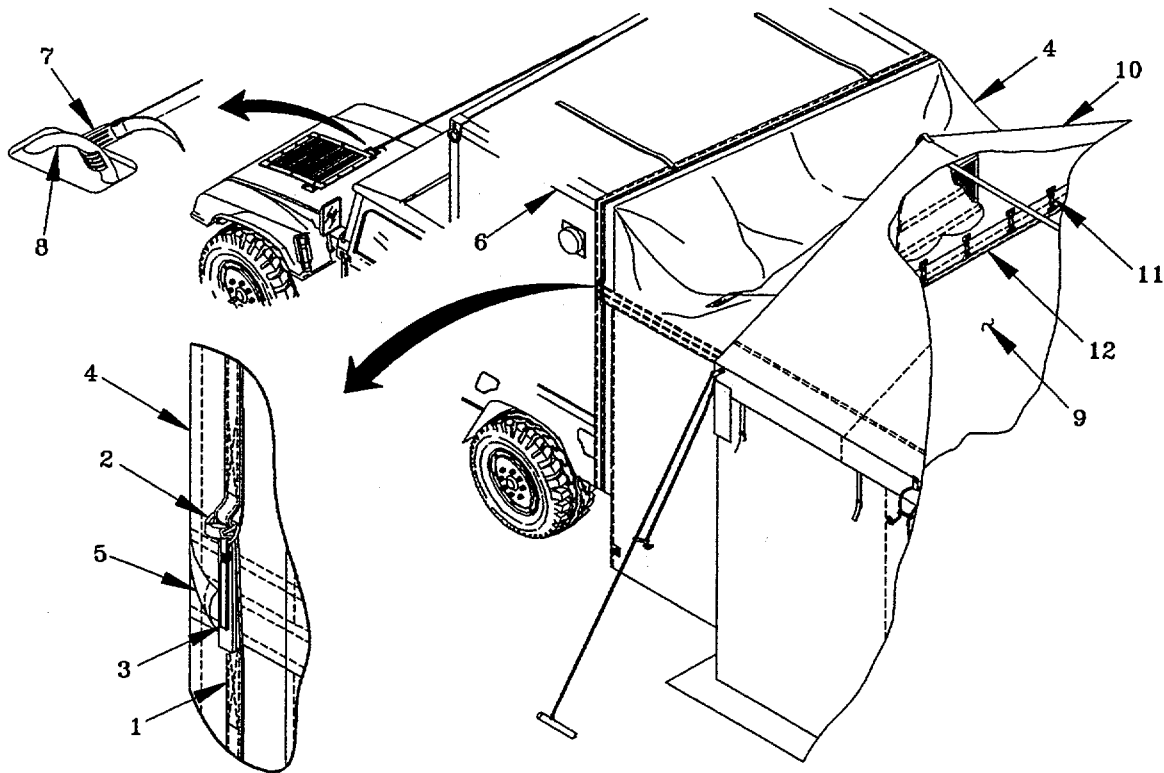

- g. Unfasten belly band strap (1) from dee-ring buckle (2) by lifting tab (3) on driver's side of Boot Wall (4).
- h. Separate hook and pile fastener tapes (5) located on driver's side of Boot Wall (4).
- i. Remove blackout wall ladder bracket pocket from ladder bracket and remove lower portion of Boot Wall from around S-250E shelter (6).
- j. Disconnect web straps (7) attached to lifting eyes (8) on hood of HMMWV.
- k. Close roll-up door (9) and secure with hook and pile fastener tape.
- l. Remove Boot Wall (4) from S-250E shelter (6).
- m. Remove Boot Wall (4) from MCPS tent (10) by removing all quick release fasteners (11) and hook and pile fastener tapes (12). Work from lower sides upward and then inward toward center.
- n. Fold Boot Wall with identification label visible and stow.
- o. Install ladder onto bracket on rear of S-250E shelter.

**NOTE**

If MCPS tent is to remain in service, Install wall unit in accordance with TM 10-5410-229-13&P.



**2-10. PREPARATION FOR MOVEMENT.** Ensure that the Boot Wall is properly secured on or in vehicle prior to any movements. If wet, avoid storing Boot Wall for a prolonged period to prevent mildew from occurring. Do not allow the fabric to come in contact with a hot exhaust pipe.

#### **Section IV. OPERATION UNDER UNUSUAL CONDITIONS**

**2-11. GENERAL.** Use the following information during unusual climatic conditions.

a. Operation in Wet Climate.

- (1) Make sure no leaks occur over map boards or tables. Protect them if leaks occur.
- (2) Make sure that all fasteners are connected and all hook and pile sections are mated.
- (3) Dry the Boot Wall thoroughly before repacking.

b. Operation in Snow.

- (1) Gently push up on the roof cap from inside the tent and Boot Wall to remove snow that may have piled up.
- (2) Remove as much snow and ice as possible before taking the Boot Wall down.



CHAPTER 3

OPERATOR MAINTENANCE INSTRUCTIONS

Subject	Page
Section I LUBRICATION INSTRUCTIONS .....	3-1
3-1 GENERAL .....	3-1
Section II TROUBLESHOOTING PROCEDURES .....	3-1
3-2 INTRODUCTION TO TROUBLESHOOTING TABLE .....	3-1
Section III OPERATOR MAINTENANCE PROCEDURES .....	3-5
3-3 INSPECTION .....	3-5
3-4 CLEANING .....	3-5
3-5 SEAM SEALING .....	3-5

**Section I. LUBRICATION INSTRUCTIONS**

**3-1. GENERAL.** No lubrication is required.

**Section II. TROUBLESHOOTING PROCEDURES**

**3-2. INTRODUCTION TO TROUBLESHOOTING TABLE**

a. Table 3-1 contains procedures to isolate Boot Wall defects that you can correct. The symptom index lists the common malfunctions which may be encountered during inspection and operation of the Boot Walls. Use this index as a quick access to the troubleshooting procedures in Table 3-1.

b. After finding the malfunction you are experiencing in the table, perform the tests, inspections, and corrective actions in the order in which they appear.

c. This table can not list all malfunctions that may occur, all tests or all inspections needed to find the fault, nor all corrective actions required to correct the fault. If your malfunction is not listed or not corrected by corrective action, notify your supervisor.

**MALFUNCTION INDEX**

	Troubleshooting Procedure (paragraph)
M577 BOOT WALL TYPE I	
Boot Wall will not stay taut .....	1
RWS BOOT WALL TYPE II	
Boot Wall will not stay taut .....	2
S-250E BOOT WALL TYPE IV	
Boot Wall will not stay taut .....	3

Table 3-1. OPERATOR TROUBLESHOOTING

---

MALFUNCTION	TEST OR INSPECTION	CORRECTIVE ACTION
-------------	--------------------	-------------------

---

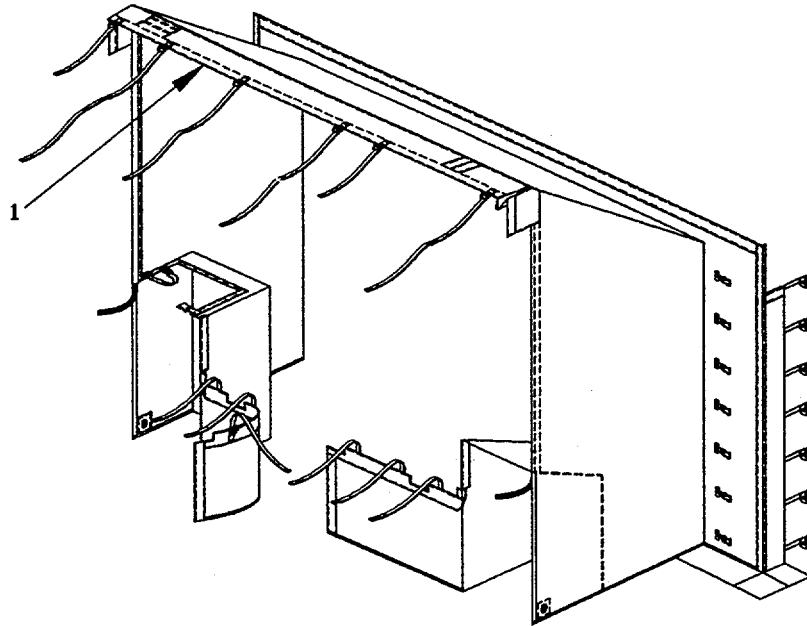
**1. M577 BOOT WALL WILL NOT STAY TAUT.**

Step 1. Boot Wall hem (1) not secured in hold down tracks.

- Insert boot wall hem (1) into hold down tracks and tighten hold down tracks.

Step 2. Vehicle improperly positioned.

- Position vehicle so it is centered on the MCPS and is within four to five feet (1.22m to 1.52m) of MCPS

Table 3-1. OPERATOR TROUBLESHOOTING (CONT)

MALFUNCTION	TEST OR INSPECTION	CORRECTIVE ACTION
-------------	--------------------	-------------------

**2. RWS BOOT WALL WILL NOT STAY TAUT.**

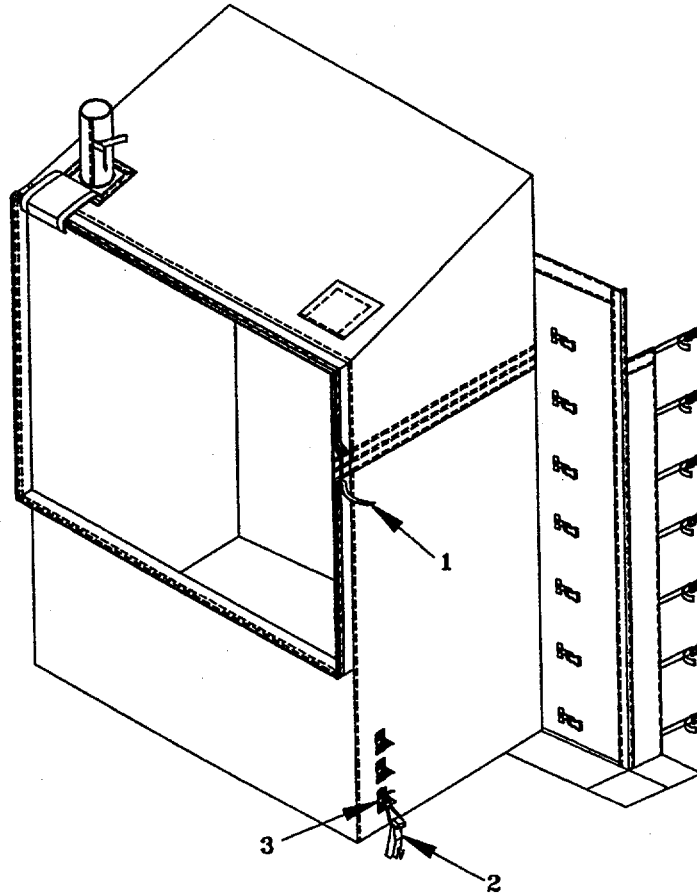

Step 1. Belly band (1) not secure around shelter.

- Tighten belly band (1).

Step 2. Check tent stakes (2) on Boot Wall foot loops (3).

- Anchor foot loops (3) securely with tent stakes (2).

Step 3. Vehicle improperly positioned.

- Position vehicle so it is centered on the MCPS and is within four to five feet (1.22m to 1.52m) of MCPS

Table 3-1. OPERATOR TROUBLESHOOTING (CONT)

MALFUNCTION	TEST OR INSPECTION	CORRECTIVE ACTION
-------------	--------------------	-------------------

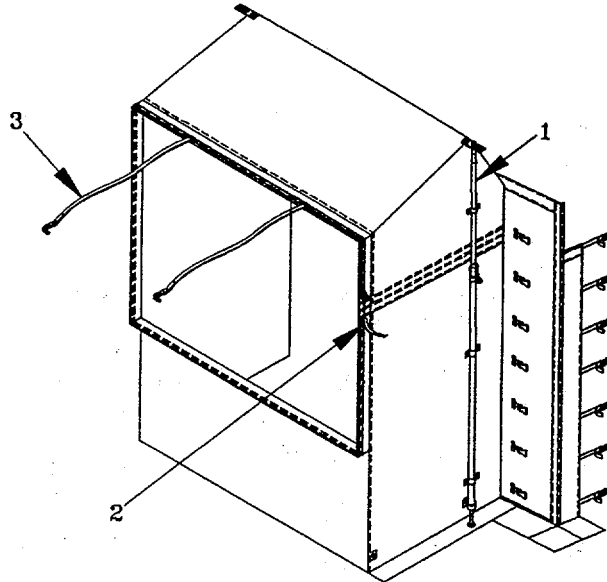
**3. S-250E BOOT WALL WILL NOT STAY TAUT.**

Step 1. Telescopic (1) poles not fully extended.

- Extend poles (1) until taut.

Step 2. Belly band (2) not secure around shelter.

- Tighten belly (2) band assembly.

Step 3. Web hood straps (3) not installed or not tight.

- Install and tighten both web hood straps (3) to lifting eyes on HMMWV hood.

Step 4. Vehicle improperly positioned.

- Position vehicle so it is centered on the MCPS and is within four to five feet (1.22m to 1.52m) of MCPS

### Section III. OPERATOR MAINTENANCE PROCEDURES

**3-3. INSPECTION.** Refer to Table 2-1, Operator PMCS for inspection procedures.

**3-4. CLEANING.** Clean all fabric components with mild soapy water (Appendix E, Item 1) and brush (Appendix E, Item 2). Let fabric components air dry.

#### **3-5. SEAM SEALING.**

---

This task covers: Repair

---

#### **NOTE**

This procedure applies to all Boot Wall types.

#### INITIAL SETUP

##### Materials/Parts:

Brush, varnish (Appendix E, Item 3)  
Goggles, chemical splash (Appendix E, Item 7)  
K-Cote seam sealer (Appendix E, Item 4)  
Latex gloves (Appendix E, Item 5)  
Respirator, air filtering (Appendix E, Item 8)  
Wiping rags (Appendix E, Item 9)

##### Equipment Condition:

Area to be sealed must be clean and dry (refer to paragraph 3-4). Boot Wall may be left in service or removed and laid flat. Refer to paragraphs 2-7, 2-8, or 2-9 for removal procedures.

---

#### **WARNING**

FLAMMABLE. Do not smoke or use seam sealer near open flame.

HARMFUL FUMES. Use seam sealer in well ventilated area only. Use personal protective equipment to prevent inhalation of fumes. Failure to observe this warning may result in serious injury to personnel from inhalation of seam sealer fumes.

- a. Brush seam sealer onto seam or area to be sealed. Seam sealer may be applied to inside or outside of fabric. Ensure to overlap onto serviceable fabric by 1/2 inch.
- b. Allow seam sealer to become dry to touch.
- c. Apply a second coat if desired.





CHAPTER 4

UNIT MAINTENANCE INSTRUCTIONS

---

Subject	Page
Section I UNIT LUBRICATION PROCEDURES .....	4-1
Section II SERVICE UPON RECEIPT .....	4-1
4-1 SERVICE UPON RECEIPT OF MATERIAL .....	4-1
Section III. MAINTENANCE INSTRUCTIONS .....	4-2
4-2 GENERAL .....	4-2
4-3 REPAIR OF PUNCTURES IN FABRIC ASSEMBLIES .....	4-3
4-4 REPAIR OF HOLES AND TEARS IN FABRIC ASSEMBLIES .....	4-4
4-5 HAND STITCHING REPAIR IN FABRIC ASSEMBLIES .....	4-6
4-6 GROMMET MAINTENANCE INSTRUCTIONS .....	4-9
4-7 FRAME ASSEMBLY (TYPE II ONLY) .....	4-11

**Section I. UNIT LUBRICATION PROCEDURES**

Not applicable.

**Section II. SERVICE UPON RECEIPT**

**4-1. SERVICE UPON RECEIPT OF MATERIAL** The Unit Maintenance technician should inspect the equipment before it is used. The technician will make the following checks when the equipment is unpacked:

- a. Inspect the equipment for damage incurred during shipment. If the equipment has been damaged in shipment, report the damage on SF 364, Report of Discrepancy.
- b. Check the equipment against the packing list to see if the shipment is complete. Report all discrepancies in accordance with DA Pam 738-750.
- c. Check to see whether the equipment has been modified.
- d. Service damaged equipment, as necessary, using Unit Maintenance procedures in Section III of this chapter to restore equipment to operable condition.

**Section III. MAINTENANCE INSTRUCTIONS**

**4-2. GENERAL.**

a. This section contains unit maintenance applicable to the SICPS Boot Walls as authorized by the Maintenance Allocation Chart (MAC), Appendix B, of this manual. Unit Maintenance personnel may also perform all functions allocated to Operator Maintenance Level. The following topics are included as applicable: inspect, service, and repair.

b. All maintenance procedures in this section can be performed by one person unless otherwise indicated in the initial setup. Read all warnings, cautions, notes and instructions carefully before attempting the procedures. Read and understand all warnings at the front of this manual.

c. Fabric Repair and Stitching. Unit Maintenance repairs to the tent fabric assemblies will be limited to the capabilities of the tentage repair kit (Appendix B, Section III, Item 1). Repair punctures up to 1/8" (3.2mm) in diameter using procedures in paragraph 4-3. For rips and tears not exceeding 12 inches in length and holes not larger than 4 inches in diameter, refer to paragraph 4-4. Refer to paragraph 4-5 for hand stitching instructions. Whenever possible, repairs to fabric requiring stitching should be accomplished by sewing machine at Direct Support Maintenance level. Consult FM 10-16 for more guidance on repairing fabric.

**MAINTENANCE PROCEDURES**

4-3 REPAIR OF PUNCTURES IN FABRIC ASSEMBLIES ..... 4-3  
 4-4 REPAIR OF HOLES AND TEARS IN FABRIC ASSEMBLIES ..... 4-4  
 4-5 HAND STITCHING REPAIR IN FABRIC ASSEMBLIES ..... 4-6  
 4-6 GROMMET MAINTENANCE INSTRUCTIONS ..... 4-9  
 4-7 FRAME ASSEMBLY ..... 4-11

### 4-3. REPAIR OF PUNCTURES IN FABRIC ASSEMBLIES.

---

This task covers: Repair of punctures 1/8 in. (3.2 mm) diameter or less

---

#### NOTE

This procedure applies to all Boot Wall types.

#### INITIAL SETUP

##### Tools:

Tool Kit, Canvas Workers (Appendix B, Section III, Item 3)

##### Materials/Parts:

Cloth, coated

Scrub brush (Appendix E, Item 2)

Soap, toilet, hand, cake (Appendix E, Item 1)

##### Equipment Conditions:

Although the fabric assemblies can be repaired during operational use of the Boot Wall when necessary, it is recommended that the fabric be repaired when the Boot Wall is not in use (refer to Chapter 2 for removal instructions). The fabric assemblies should be clean and dry.

---

#### **WARNING**

The adhesive has a high alcohol content and is highly flammable. Use only in well ventilated areas away from open flame. Do not smoke. In case of dizziness, leave area immediately and allow to ventilate. Failure to observe this warning may result in severe injury or death.

- b. Clean fabric (1) around hole (2) with mild soapy water and brush, and allow to air dry
- c. Using tongue depressor (3), dab adhesive (4) onto hole (2).
- c. Work adhesive (4) into fabric (1) and hole (2) immediately and bridge hole (2) with adhesive (4) to seal it.
- d. Allow adhesive (4) to dry.

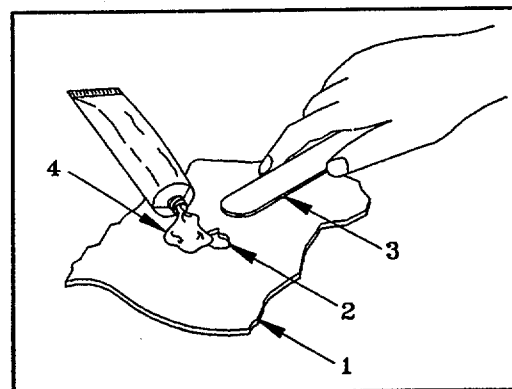

**4-4. REPAIR OF HOLES AND TEARS IN FABRIC ASSEMBLIES.**

This task covers: Repair of holes and tears up to 4 in. (10.16 cm) in diameter

**NOTE**

This procedure applies to all Boot Wall types.

**INITIAL SETUP**Tools:

Tentage Repair Kit (Appendix B, Section III, Item 1)

Materials/Parts:

Tentage Repair Kit (Appendix B, Section III, Item 1)

Fabric

Equipment Conditions:

Although the fabric assemblies can be repaired during operational use of the Boot Wall when necessary, it is recommended that the fabric be repaired when the Boot Wall is not in use (refer to Chapter 2 for removal instructions). The fabric assemblies should be clean and dry.

- a. Obtain a clean, round patch (1) from bulk material or salvage that is at least 1 in. larger than the damaged fabric area (2) in all directions.
- b. Place the damaged fabric area (2) on a flat surface, or place a piece of softwood (or similar) under the damaged fabric area (2).
- c. Center patch (1) over damaged fabric area (2). Draw a circle on fabric (2) around patch (1), then remove patch (1).
- d. Clean damaged fabric area (2) inside circle.

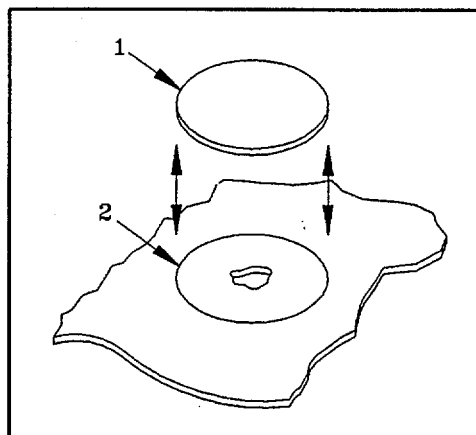
**WARNING**

The adhesive has a high alcohol content and is highly flammable. Use only in well ventilated areas away from open flame. Do not smoke. In case of dizziness, leave area immediately and allow to ventilate. Failure to observe this warning may result in severe injury or death.

- e. Place patch (1) face-down over circle (2). Coat patch evenly with adhesive (3), allowing adhesive (3) to overlap onto fabric (4) to form an adhesive circle. Remove patch (1) and set aside with adhesive side up.
- f. Coat damaged fabric (4) with adhesive (3) inside circle (2). Allow adhesive (3) on patch (1) and adhesive circle (2) to dry.

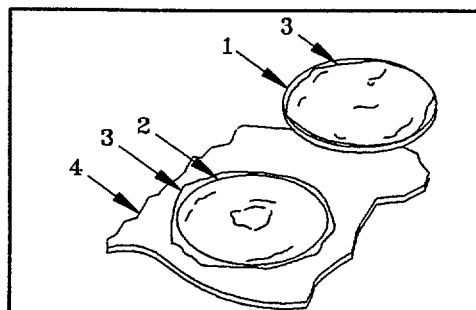

- g. Apply a second coat of adhesive (3) to patch and inside adhesive circle.
- h. Wait ten to fifteen minutes for adhesive (3) to become tacky to touch.
- i. Center patch (1) over circle, adhesive side down, and press the two sticky surfaces together.
- j. Using hand roller (2), press excess adhesive (3) and air bubbles (4) from under patch. Roll first in one direction, then in opposite direction.
- k. Using tongue depressor (1), apply a small amount of adhesive (2) to edge of patch (3). Run tongue depressor (1) around patch (3) to seal and prevent fraying.
- l. Allow adhesive (2) to dry.

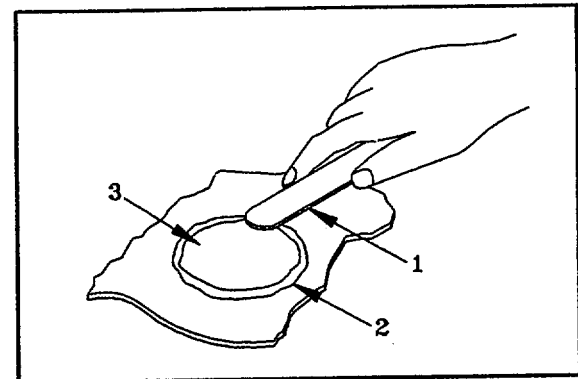
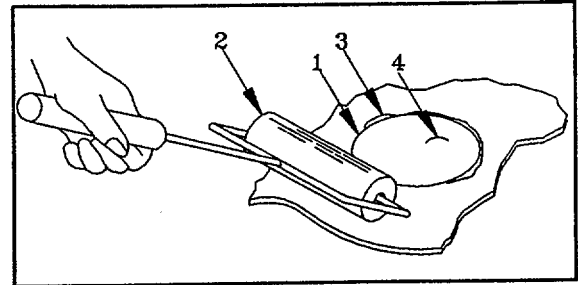

#### 4-5. HAND STITCHING REPAIR IN FABRIC ASSEMBLIES.

---

This task covers: Repair

---

#### NOTE

This procedure applies to all Boot Wall types. Whenever possible, machine stitching is preferred over hand stitching.

#### INITIAL SETUP

##### Tools:

Tentage Repair Kit (Appendix B, Section III, Item 1)

##### Materials/Parts:

Tentage Repair Kit (Appendix B, Section III, Item 1)

Thread

##### Equipment Conditions:

Although the fabric assemblies can be repaired during operational use of the Boot Wall when necessary, it is recommended that the fabric be repaired when the Boot Wall is not in use (refer to Chapter 2 for removal instructions). The fabric assemblies should be clean and dry.

---

##### a. Preparing Needle and Thread.

#### NOTE

If you use two-strand thread you will need twice as much; if you use four-strand, you will need four times as much.

- (1) Estimate amount of thread required to complete stitching and cut thread to length.
- (2) Wax thread (1) by pressing between it-thumb and beeswax (2) and drawing entire length over beeswax (2).

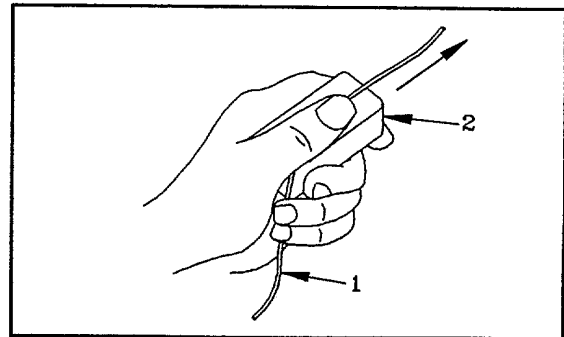

- (3) Thread sailmaker's needle (1) with waxed thread to form a single, two-, or four-strand thread as follows:
- (a) Single. Form a small loop near one end and push the loop through the eye of the needle.
  - (b) Two-Strand. To make a double strand thread, pull the thread through the needle until the needle is at the midpoint of the single thread strand.
  - (c) Four-strand. To form four-strand thread, bend a length of thread in half and insert the loop end into the eye of the needle, pulling it through so that the eye is at the midpoint of the double strand of thread.
- (4) Twist the strands together and rewax the entire length of thread.
- (5) Tie knot at far end of the single, two-, or four-strand thread.

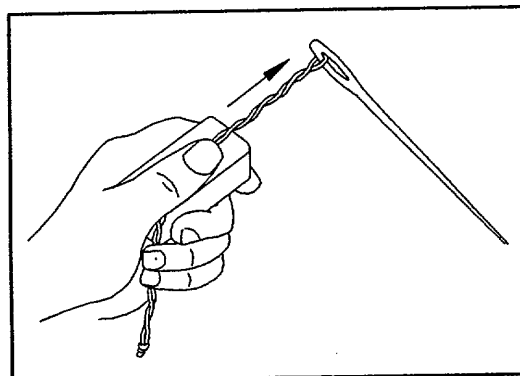
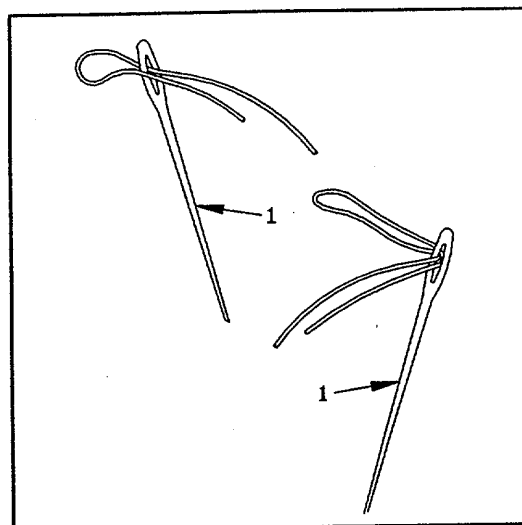

**4-5. HAND STITCHING REPAIR IN FABRIC ASSEMBLIES (CONT).**

b. Handstitches. There are five common hand stitches used to mend fabric in different situations. Choose the one that most closely resembles the repair you are making.

- (1) Flat Stitch. This stitch is used as a temporary fastening until machine repairs can be made. Pass the needle over and under an equal amount of material, each successive entering the material from the opposite side.

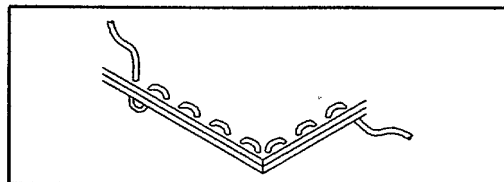

- (2) Round Stitch. This stitch is used to hand-work grommets. Insert the materials at right angles to the edge of material and bring cord around edge before making the next stitch.

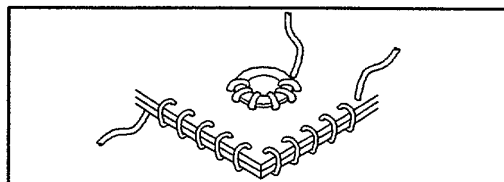

- (3) Overcast Stitch. This stitch is used to apply a hand-sewn patch. Insert the needle through the material at an angle so that it comes out to one side and ahead of the point of insertion, and bring the cord over to the original line of insertion before making the next stitch.

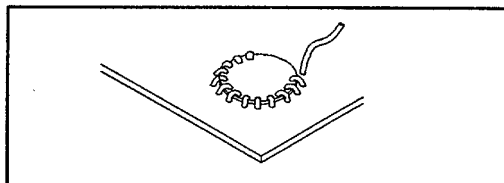

- (4) Backstitch. This stitch is used to secure an open seam. It is so named because the needle is always set back one half of a stitch length into the last stitch made. Make two small stitches in the same place to secure the cord ends. Continue by inserting the needle into the middle of the preceding stitch and bringing it out on the same side of the material one stitch length in advance of the preceding stitch.

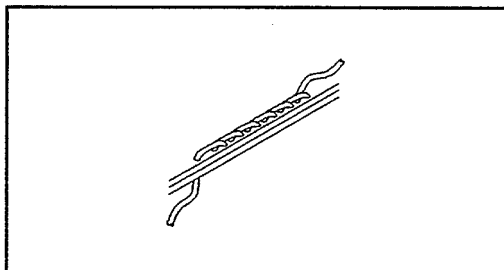

- (5) Fishbone Stitch. This stitch is used to join edges of a tear until a patch can be applied. Insert needle between two edges of material to be sewn together. Take a diagonal stitch from one side toward the other, bringing the needle out between the two edges. Repeat this operation on the opposite side, and continue alternating stitches from side to side. To keep the stitches uniform, hold the edges smoothly together. Make stitches firmly, but do not pull them tight enough to pucker the fabric.

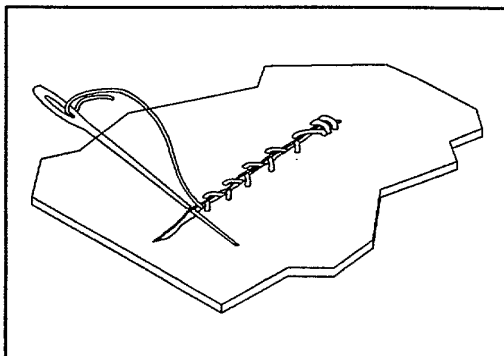



#### 4-6. GROMMET MAINTENANCE INSTRUCTIONS.

---

This task covers: Repair

---

##### INITIAL SETUP

##### Tools:

Lumber, softwood (Appendix E, Section II, Item 3)  
 Tool kit, general mechanic's (Appendix B, Section III, Item 2)  
 Repair kit, tentage (Appendix B, Section III, Item 1)

##### Materials/Parts:

Grommet

##### Equipment Condition:

Boot Wall removed (refer to paragraph 2-7, 2-8, or 2-9).

---

- a If still attached, cut damaged grommet from fabric.

##### NOTE

- If fabric repair is required, refer to paragraphs 4-4 and 4-5 for repair and stitching instructions.
- A die-inserted grommet consists of two brass parts. The male half, called a barrel, is smooth. The female half, called a washer, has spurs that grip the fabric.

- b. Insert a grommet.

- (1) Position fabric (1) face up on end grain surface of softwood lumber.
- (2) Using a size 5 cutting punch for a size 4 grommet (or a size 6 cutting punch for a size 5 grommet) and a rawhide mallet, cut a grommet hole in patch by hitting top of cutting punch (2) with rawhide mallet.

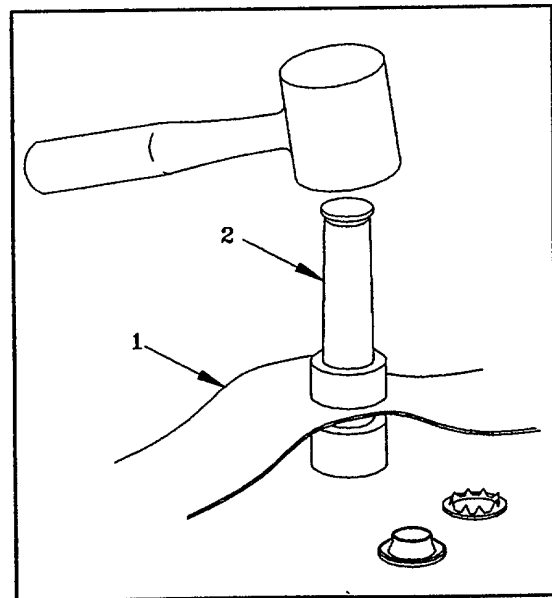

**4-6. GROMMET MAINTENANCE INSTRUCTIONS (CONT).**

b. Insert a grommet. (Cont)

- (3) Insert grommet barrel (1) into hole of fabric (2) from the underside.
- (4) Place fabric (2) and bottom (flat) part of grommet barrel (1) on grommet die (3).
- (5) Place the grommet washer (4), spurs down, over grommet barrel (1).
- (6) Insert cutting punch (5) into grommet barrel (1) and hold in place.
- (7) Hit top of cutting punch (5) with rawhide mallet (6) hard enough to clinch the parts to fabric without damaging grommet or fabric (2).

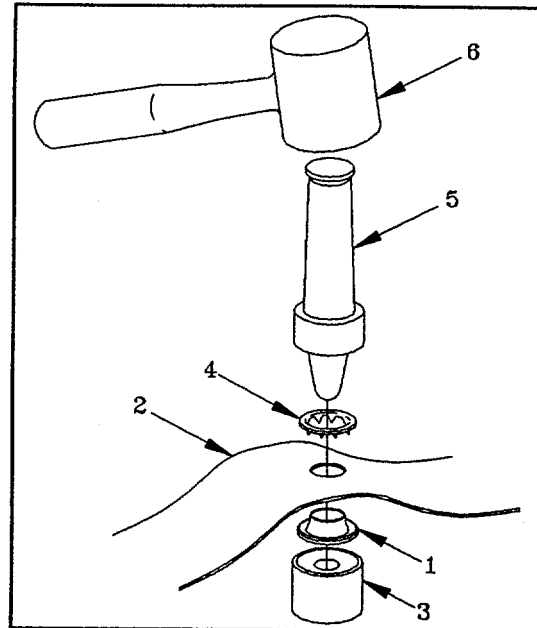

**NOTE**

When parts are clinched properly, the edge of the grommet barrel has a smooth roll.

**4-7. FRAME ASSEMBLY (TYPE II ONLY).**

This task covers: Repair

**INITIAL SETUP**Tools:

Tool Kit, General Mechanics (Appendix B, Section III, Item 2)

Materials/Parts:

Header bar

Upright bar

Equipment Condition:

Frame removed from Boot Wall (refer to paragraph 2-8).

**REPAIR****a. Remove Header and/or Upright Bar.**

- (1) Disconnect locking pins (1) that secure upright bars (2) to swivel feet (3) attached to HMMWV.
- (2) Disconnect locking pins (4) that secure upright bars (2) to header bar (5).
- (3) Remove upright bars (2) from header bar (5).
- (4) Remove damaged upright bar (2) and/or header bar (5).

**b. Install Header and/or Upright Bar.**

- (1) Position header bar (5) and/or upright bar (2) inside Boot Wall.
- (2) Connect upright bars (2) to header bar (5) and secure with locking pins (4).
- (3) Insert locking pins (1) to secure upright bars (2) to swivel feet (3) attached to HMMWV.

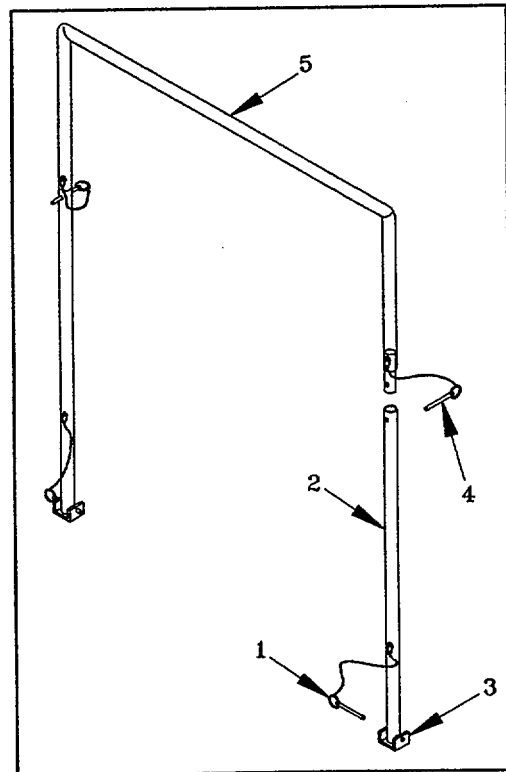
**REPLACE**

Replace unserviceable frame assembly with a serviceable one from stock.



**CHAPTER 5  
DIRECT SUPPORT MAINTENANCE INSTRUCTIONS**

---

Subject	Page
Section I REPAIR PARTS, SPECIAL TOOLS; TEST MEASUREMENT DIAGNOSTIC EQUIPMENT (TMDE) AND SUPPORT EQUIPMENT .....	5-1
5-1 COMMON TOOLS AND EQUIPMENT .....	5-1
5-2 SPECIAL TOOLS, TMDE, AND SUPPORT EQUIPMENT .....	5-1
5-3 REPAIR PARTS .....	5-1
Section II. MAINTENANCE PROCEDURES .....	5-1
5-4 GENERAL .....	5-1
5-5 MACHINE STITCHING .....	5-1
5-6 AUTOMATIC STITCHING .....	5-2
5-7 BOOT WALL ASSEMBLIES .....	5-3
5-8 FRAME ASSEMBLY (TYPE II ONLY) .....	5-5

Section I. REPAIR PARTS, SPECIAL TOOLS; TEST MEASUREMENT DIAGNOSTIC EQUIPMENT (TMDE) AND SUPPORT EQUIPMENT

**5-1. COMMON TOOLS AND EQUIPMENT.** For authorized common tools and equipment, refer to the Modified Table of Organization and Equipment (MTOE), CTA 50-970, or CTA 8-100, as applicable to your unit.

**5-2. SPECIAL TOOLS, TMDE, AND SUPPORT EQUIPMENT.** No special tools or equipment are required to perform direct support maintenance on the SICPS Boot Walls.

**5-3. REPAIR PARTS.** Repair parts are listed and illustrated in the repair parts and special tools list TM 10-5410-230-13P covering unit maintenance for this equipment. Section II. MAINTENANCE PROCEDURES

**5-4. GENERAL.** This section contains Direct Support maintenance functions applicable to the SICPS Boot Walls as authorized by the Maintenance Allocation Chart (MAC), Appendix B, Section II, of this manual. The following functions are included: repair. Procedures for machine stitching are provided in paragraph 5-5. Direct Support maintenance personnel may also perform all functions allocated to the Unit and Operator levels. Additional guidance for repair of canvas and webbing is provided by FM 10-16.

**5-5. MACHINE STITCHING.** All stitch types, except bartacking, shall conform to FED-STD 751. Type 301 and 401 stitching requires 5-7 stitches per inch. Bartacking shall be 1/8 inch in width and free of thread breaks and loose stitching. All stitching will be 1/8 inch from edge or spaced 1/8 inch apart, unless otherwise specified.

a. Thread Breaks. Thread breaks in stitching shall be overstitched not less than 1 inch at each break on stitch type 301, and not less than 1 1/2 inches at each break at stitch type 401. Thread breaks in type 401 may be overstitched with stitch type 301. Thread breaks noted during inspection must be repaired by overstitching the existing stitching starting from a distance of 1 inch beyond the break. The ends of repair stitching are not required to be backstitched.

b. Stitching Ends. The ends of all type 301 and type 401 stitching shall be back stitched not less than one inch unless turned under by a hem or held down by other stitching. Where 301 stitchings performed automatically on stitch patterns such as box, box with cross-stitch, "W" stitching or straight line tacking, at least three tying, overlapping, or back stitches shall be used to secure the ends of stitching. For size FF or F thread use 6 to 8 stitches per inch, unless otherwise specified, stitch type shall be type 301 per FED-STD-751. Fuse all exposed ends of nylon webbing to prevent fraying. Avoid forming sharp edges.

c. Skipped Stitches. Two or more consecutively skipped stitches occurring in type 301 stitching shall be overstitched not less than one inch. Any skipped stitches in type 401 stitching may be overmitched with type 301 stitching. Skipped stitches noted during inspection shall be repaired as specified for thread breaks in a., above.

d. Stitching Tolerances. Unless otherwise specified, tolerances shall be as follows:

1/8 inch or more but less than 2 inches .....	±1/16
2 inches or more but less than 10 inches .....	±1/8
10 inches or more but less than 30 inches .....	±1/4
30 inches or more but less than 60 inches .....	±3/8
60 inches or more .....	±1/2

**5-6. AUTOMATIC STITCHING.** Automatic stitching machines may be used to perform any of the required stitch patterns. However, the requirements of the stitch pattern, stitches per inch, and size and type of thread must be met. At least three or more overlapping, tying, or backstitches shall secure the ends of the stitching.

**5-7. BOOT WALL ASSEMBLIES.**

---

This task covers: Repair

---

**NOTE**

This procedure applies to all Boot Wall fabric components.

**INITIAL SETUP**Tools:

Tentage Repair Kit (Appendix B, Section III, Item 1)

Industrial Sewing Machine (Appendix B, Section III, Item 4)

Materials/Parts:

Tentage Repair Kit (Appendix B, Section III, Item 1)

Equipment Condition:

Boot Wall removed (refer to paragraph 2-7, 2-8, or 2-9). The fabric assemblies should be clean and dry.

---

**REPAIR**

- a. Fabric. Refer to paragraphs 4-3 and 4-4 for fabric repair instructions. Any fabric component may be patched or sewn provided the repaired assembly provides a suitable degree of climatic protection and light discipline.
- b. Fastener Tapes.

**NOTE**

It is not necessary to replace an entire piece of fastener tape when only a small portion is damaged. The damaged area can be cut out and replaced, leaving a portion of the original piece in place.

- (1) Carefully remove stitching (1), cut and remove damaged length of fastener tape (2). Ensure edges are cut straight and no jagged edges remain.
- (2) Measure width and length of damaged fastener tape (hook or pile) (2) to be replaced.
- (3) Obtain a replacement part, or fabricate one from bulk or serviceable salvage stocks.
- (4) Position fastener tape (2) and sew approximately 1/8 inch in from each edge. Ensure stitching (1) runs over from existing portion of fastener tape to the newly inserted portion (2).

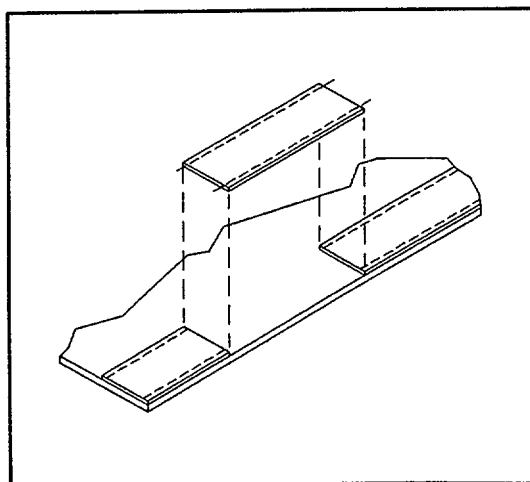

**5-7. BOOT WALL ASSEMBLIES. (CONT)**c. Webbing and Buckles.**NOTE**

It is not necessary to replace an entire piece of webbing when only a small portion is damaged and webbing does not need to be threaded through a buckle for adjustment. The damaged area can be cut out and replaced, leaving a portion of the original piece in place.

- (1) Identify the webbing (1) or buckle component (2) that is damaged and obtain a replacement, or fabricate one from bulk or serviceable salvage stocks. For fixed webbing pieces, add an inch to length of replacement piece.
- (2) Remove unserviceable webbing (1) or buckle (2) from assembly. Undamaged components should be removed and salvaged wherever possible.
- (3) Assemble and sew buckles (2) and webbing (1) as required to form new assemblies.
- (4) Position webbing (1) and buckle (2) assemblies on Boot Wall and sew. For fixed webbing pieces (3), overlap each end by 1/2-inch.

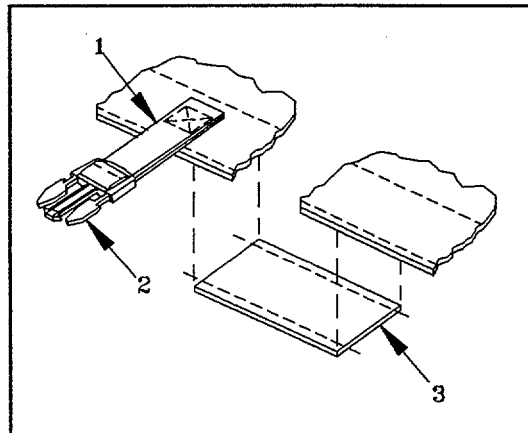



**5-8. FRAME ASSEMBLY (TYPE II ONLY).**

This task covers: Repair

**INITIAL SETUP**Tools:

Tool Kit, Common No 1 (Appendix B, Section III, Item 4)  
 Riveter, blind, hand (Appendix B, Section III, Item 5)

Materials/Parts:

Pin and lanyard assembly  
 Sleeve swaging  
 Rivets (Appendix B, Section III, Item 5)

Equipment Condition:

Frame assembly may be removed from service, but is not required to perform maintenance steps.

## a. Replace Pin Assembly.

- (1) Remove damaged pin (1) by separating ring end (2), inserting cable loop (3) under ring end (2) and twisting ring (2) until cable loop (3) is free.
- (2) Obtain a new pin assembly (1) and install onto cable loop (3) by separating ring end (2), inserting cable loop (3) under ring end (2) and twisting ring (2) until loop (3) is captive inside ring.

## b. Replace Pin and Lanyard Assembly.

- (1) Drill out rivet (1) securing tab (2) to frame (3).
- (2) Position new pin and lanyard assembly and rivet tab (2) to frame (3).

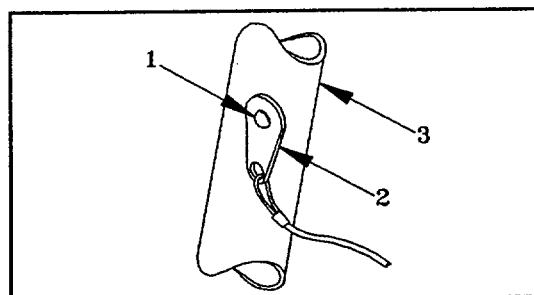
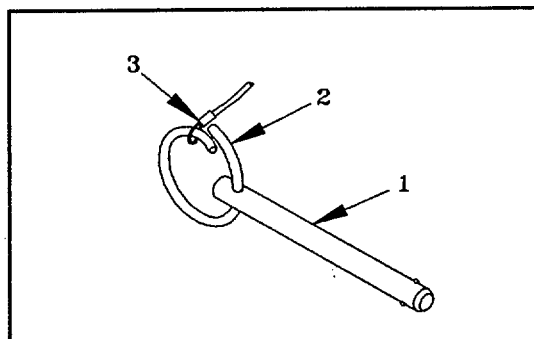

5-5/(5-6 blank)



## APPENDIX A

## REFERENCES

**A-1. SCOPE.** This appendix lists all forms, pamphlets, field manuals, technical manuals, army regulations, military specifications, and military standards referenced in the manual.

**A-2. DA PAMPHLETS.**

The Army Maintenance Management System (TAMMS) ..... DA PAM 738-750

**A-3. FEDERAL STANDARDS.**

Colors . FED-STD-595  
Stitches, Seams and Stitching ..... FED-STD-751

**A-4. FIELD MANUALS.**

Decontamination Procedures ..... FM 3-5  
First Aid for Soldiers ..... FM 21-11  
General Repair of Tents, Canvas, and Webbing ..... FM 10-16

**A-5. FORMS.**

Discrepancy in Shipment Report ..... SF 361  
Equipment Inspection and Maintenance Worksheet ..... DA Form 2404  
Quality Deficiency Report ..... SF 368  
Recommended Changes to Equipment Technical Publications ..... DA Form 2028-2  
Report of Discrepancy ..... SF 364  
Report of Packaging and Handling Deficiencies ..... SF 362

**A-6. MILITARY STANDARDS.**

Palletizing Unit Loads ..... MIL-STD-147  
Quality of Wood Members for Containers and Pallets ..... MILSTD-731  
Treatment and Painting of Material ..... MILSTD-704

**A-7. TECHNICAL MANUALS.**

Camouflage Screen and Screen Support Systems ..... TM 5-1080-200-13&P  
Destruction of Army Material to Prevent Enemy Use ..... TM 750-244-3  
Administrative Storage of Equipment ..... TM 740-90-1  
Operators, Unit, and Direct Support Maintenance Manual including Repair Parts and Special  
Tools List for Modular Command Post System (MCPS) ..... TM 10-5410-229-13&P  
Preservation, Packaging, and Packing of Military Supplies and Equipment ..... TM 38-230-2  
Unit and Direct Support Maintenance Repair Parts and Special Tools List for SICPS  
Boot Walls Type I, II, and IV ..... TM 10-5410-230-23P

**A-8. MISCELLANEOUS**

Army Medical Department Expendable/Durable Items ..... CTA 8-100  
Expendable/Durable Items ..... CTA 50-970  
Metal Body Repair and Related Operations ..... TC 9-510



**APPENDIX B****MAINTENANCE ALLOCATION CHART (MAC)**

---

**Section I. INTRODUCTION****B-1. THE ARMY MAINTENANCE SYSTEM MAC**

This introduction provides a general explanation of all maintenance and repair functions authorized at the two maintenance levels under the Two-Level Maintenance System concept.

This MAC (immediately following the introduction) designates overall authority and responsibility for the performance of maintenance functions on the identified end item or component. The application of the maintenance functions to the end item or component shall be consistent with the capacities and capabilities of the designated maintenance levels, which are shown on the MAC in column (4) as:

Field - includes two columns, Unit maintenance and Direct Support maintenance. The Unit maintenance column is divided again into two more subcolumns, C for Operator or Crew and O for Unit maintenance.

Sustainment – includes two subcolumns, General Support (H) and Depot (D).

The tools and test equipment requirements (immediately following the MAC) list the tools and test equipment (both special tools and common tool sets) required for each maintenance function as referenced from the MAC.

The remarks (immediately following the tools and test equipment requirements) contain supplemental instructions and explanatory notes for a particular maintenance function.

**B-2. MAINTENANCE FUNCTIONS**

Maintenance functions will be limited to and are defined as follows:

1. Inspect. To determine the serviceability of an item by comparing its physical, mechanical, and/or electrical characteristics with established standards through examination (e.g., by sight, sound, or feel.) This includes scheduled inspection and gagings and evaluation of cannon tubes.
2. Test. To verify serviceability by measuring the mechanical, pneumatic, hydraulic, or electrical characteristics of an item and comparing those characteristics with prescribed standards on a scheduled basis, i.e., load testing of lift devices and hydrostatic testing of pressure hoses.
3. Service. Operations required periodically to keep an item in proper operating condition, e.g., to clean (includes decontaminate, when required), to preserve, to drain, to paint, or to replenish fuel, lubricants, chemical fluids, or gases. This includes scheduled exercising and purging of recoil mechanisms. The following are examples of service functions:
  - a. Unpack. To remove from packing box for service or when required for the performance of maintenance operations.
  - b. Repack. To return item to packing box after service and other maintenance operations.
  - c. Clean. To rid the item of contamination.

- d. Touch up. To spot paint scratched or blistered surfaces.
  - e. Mark. To restore obliterated identification.
4. Adjust. To maintain or regulate, within prescribed limits, by bringing into proper position, or by setting the operating characteristics to specified parameters.
  5. Align. To adjust specified variable elements of an item to bring about optimum or desired performance
  6. Calibrate. To determine and cause corrections to be made or to be adjusted on instruments of test, measuring, and diagnostic equipment used in precision measurement. Consists of comparisons of two instruments, one of which is a certified standard of known accuracy, to detect and adjust any discrepancy in the accuracy of the instrument being compared.
  7. Remove/Install. To remove and install the same item when required to perform service or other maintenance functions. Install may be the act of emplacing, seating, or fixing into position a spare, repair part, or module (component or assembly) in a manner to allow the proper functioning of an equipment or system.
  8. Paint. To prepare and spray color coats of paint so that the ammunition can be identified and protected. The color indicating primary use is applied, preferably, to the entire exterior surface as the background color of the item. Other markings are to be repainted as original so as to retain proper ammunition identification.
  9. Replace. To remove an unserviceable item and install a serviceable counterpart in its place. "Replace" is authorized by the MAC and assigned maintenance level is shown as the third position code of the Source, Maintenance and Recoverability (SMR) code.
  10. Repair. The application of maintenance services, including fault location/troubleshooting, removal/installation, disassembly/assembly procedures and maintenance actions to identify troubles and restore serviceability to an item by correcting specific damage, fault, malfunction, or failure in a part, subassembly, module (component or assembly), end item, or system.

### NOTE

The following definitions are applicable to the "repair" maintenance function:

**Services.** Inspect, test, service, adjust, align, calibrate, and/or replace.

**Fault location/troubleshooting.** The process of investigating and detecting the cause of equipment malfunctioning; the act of isolating a fault within a system or Unit Under Test (UUT).

**Disassembly/assembly.** The step-by-step breakdown (taking apart) of a spare/functional group coded item to the level of its least component, that is assigned an SMR code for the level of maintenance under consideration (i.e., identified as maintenance significant).

**Actions.** Welding, grinding, riveting, straightening, facing, machining, and/or resurfacing.

11. Overhaul. That maintenance effort (service/action) prescribed to restore an item to a completely serviceable/operational condition as required by maintenance standards in appropriate technical publications. Overhaul is normally the highest degree of maintenance performed by the Army. Overhaul does not normally return an item to like new condition.
12. Rebuild. Consists of those services/actions necessary for the restoration of unserviceable equipment to a like new condition in accordance with original manufacturing standards. Rebuild is the highest degree of material maintenance applied to Army equipment. The rebuild operation includes the act of returning to zero those age measurements (i.e., hours/miles) considered in classifying Army equipment/components.

**B-3. EXPLANATION OF COLUMNS IN THE MAC, SECTION II**

Column (1) Group Number. Column (1) lists Functional Group Code (FGC) numbers, the purpose of which is to identify maintenance significant components, assemblies, subassemblies, and modules with the Next Higher Assembly (NHA).

Column (2) Component/Assembly. Column (2) contains the names of components, assemblies, subassemblies, and modules for which maintenance is authorized.

Column (3) Maintenance Function. Column (3) lists the functions to be performed on the item listed in column (2). (For detailed explanation of these functions refer to "Maintenance Functions" outlined above).

Column (4) Maintenance Level. Column (4) specifies each level of maintenance authorized to perform each function listed in column (3), by indicating work time required (expressed as manhours in whole hours or decimals) in the appropriate subcolumn. This work time figure represents the active time required to perform that maintenance function at the indicated level of maintenance. If the number or complexity of the tasks within the listed maintenance function varies at different maintenance levels, appropriate work time figures are to be shown for each level. The work time figure represents the average time required to restore an item (assembly, subassembly, component, module, end item, or system) to a serviceable condition under typical field operating conditions. This time includes preparation time (including any necessary disassembly/assembly time), troubleshooting/fault location time, and quality assurance time in addition to the time required to perform the specific tasks identified for the maintenance functions authorized in the MAC. The system designations for the various maintenance levels are as follows:

Field:

- C Operator or Crew maintenance
- O Unit maintenance
- F Direct Support maintenance

Sustainment:

- L Specialized Repair Activity
- H General Support maintenance
- D Depot maintenance

## NOTE

The "L" maintenance level is not included in column (4) of the MAC. Functions to this level of maintenance are identified by work time figure in the "H" column of column (4), and an associated reference code is used in the REMARKS column (6). This code is keyed to the remarks and the SRA complete repair application is explained there.

Column (5) Tools and Equipment Reference Code. Column (5) specifies, by code, those common tool sets (not individual tools), common Test, Measurement and Diagnostic Equipment (TMDE), and special tools, special TMDE and special support equipment required to perform the designated function. Codes are keyed to the entries in the tools and test equipment table.

Column (6) Remarks Code. When applicable, this column contains a letter code, in alphabetic order, which is keyed to the remarks table entries.

### **B-4. EXPLANATION OF COLUMNS IN THE TOOLS AND TEST EQUIPMENT REQUIREMENTS, SECTION III**

Column (1) - Tool or Test Equipment Reference Code. The tool or test equipment reference code correlates with a code used in column (5) of the MAC.

Column (2) - Maintenance Level. The lowest level of maintenance authorized to use the tool or test equipment.

Column (3) - Nomenclature. Name or identification of tool or test equipment.

Column (4) - National Stock Number (NSN). The NSN of the tool or test equipment.

Column (5) - Tool Number. The manufacturer's part number.

### **B-5. EXPLANATION OF COLUMNS IN REMARKS, SECTION IV**

Column (1) - Remarks Code. The code recorded in column (6) of the MAC.

Column (2) - Remarks. This column lists information pertinent to the maintenance function being performed as indicated in the MAC.



**Section II. MAINTENANCE ALLOCATION CHART  
FOR  
SICPS BOOT WALLS TYPES I, II, & IV**

(1) GROUP NUMBER	(2) COMPONENT/ ASSEMBLY	(3) MAINTENANCE FUNCTION	(4) MAINTENANCE LEVEL					(5) TOOLS AND EQUIPMENT REFERENCE CODE	(6) REMARKS CODE
			FIELD		SUSTAINMENT				
			UNIT		DIRECT SUPPORT	GENERAL SUPPORT	DEPOT		
			C	O	F	H	D		
00	SICPS BOOT WALLS								
01	M577 BOOT WALL	Inspect Service Repair Replace	0.1 0.2 0.2	0.1 0.5 0.5	1.0		1,2,3,4	A	
02	RWS BOOT WALL	Inspect Service Repair Replace	0.1 0.2 0.2	0.1 1.0 0.5	1.5		1,2,3,4,5		
0201	BOOT WALL ASSEMBLY, TYPE II (RWS)	Inspect Repair Replace	0.1 0.2	0.1 1.0 0.5	1.0		1,2,3,4	A	
0202	FRAME ASSEMBLY	Inspect Repair Replace	0.1	0.1 0.5 0.2	0.5		2,5		
03	S-250E BOOT WALL	Inspect Service Repair Replace	0.1 0.2 0.2	0.1 0.5 0.5	1.0		1,2,3,4		
0301	BOOT WALL ASSEMBLY TYPE IV (S-250E)	Inspect Repair Replace	0.1 0.2	0.1 1.0 0.5	1.0		1,2,3,4	A	
0302	TENT POLE	Inspect Replace	0.1	0.1 0.1					

**Section III. TOOLS AND TEST EQUIPMENT  
FOR  
SICPS BOOT WALLS TYPES I, II, & IV**

(1) TOOL OR TEST EQUIPMENT REFERENCE CODE	(2) MAINTENANCE LEVEL	(3) NOMENCLATURE	(4) NATIONAL STOCK NUMBER	(5) TOOL NUMBER
1	0	Repair Kit Tentage	8340-00-262-5767	
2	0	Tool Kit, General Mechanic's	5180-00-177-7033	
3	0	Tool Kit, Canvas Workers	5180-00-754-0731	
4	F	Sewing Machine, Industrial	3530-00-8924631	
5	F	Riveter, Blind, Hand, W/ Rivets	5120-01-289-4310	

**Section IV. REMARKS  
FOR  
SICPS BOOT WALLS TYPES I, II, & IV**

(1) REMARKS CODE	(2) REMARKS
A	Unit Level Repair is limited to the capabilities of the Tentage Repair Kit.

APPENDIX C

COMPONENTS OF END ITEM AND BASIC ISSUE ITEMS

---

Section I. INTRODUCTION

**C-1. SCOPE.** This appendix lists components of end item (COEI) and basic issue items (BII) for SICPS Boot Walls. Use it to help inventory items required for safe and efficient operation.

**C-2. GENERAL.** The Components of End Item and Basic Issue Items Lists are divided into the following sections.

a. Section II. Components of End Item List. This listing is for informational purposes only, and is not authority to requisition replacements. These items are part of the end item. They are removed and separately packaged for transportation or shipment only when necessary. As part of the end item, these items must be with the end item whenever it is issued or transferred between property accounts. Illustrations are furnished to assist you in identifying the items.

b. Section III. Basic Issue Items List. These are the minimum essential items required to place the bootwalls in operation and to perform emergency repairs. Although shipped separately packaged, BII must be with the bootwalls during operation and whenever it is transferred between property accounts. The illustrations will assist you with hard-to-identify items. This manual is your authority to request/requisition replacement BII based on TOE/MTOE authorization of the end item.

**C-3. EXPLANATION OF COLUMNS** The following provides an explanation of columns found in the tabular listings:

a. Column (1) - Illustration/Item Number. Indicates the number of the illustration in which the item is shown and the number of the item.

b. Column (2) - National Stock Number. Indicates the National stock number assigned to the item and is used for requisitioning purposes.

c. Column (3) - Description. Indicates the federal item name and if required a minimum description to identify and locate the item. The last line for each item indicates the Federal Supply Code for Manufacturer (FSCM) or Commercial and Government Entity Code (CAGEC) in parentheses, followed by the part number. If the item you need is not the same for different models of the equipment, a Usable On Code (UOC) will appear on the right side of the description column on the same line as the part number. These codes are identified below:

UOC ..... MODEL  
 FJG ..... M577 BOOT WALL, TYPE I, GREEN  
 FJH ..... M577 BOOT WALL, TYPE I, TAN  
 FJJ ..... RWS BOOT WALL, TYPE II, GREEN  
 FJL ..... RWS BOOT WALL, TYPE II, TAN  
 FJL ..... S-250E BOOT WALL, TYPE IV, GREEN  
 FJM ..... S-250E BOOT WALL, TYPE IV, TAN

d. Column (4) - Unit of Measure (U/M). Indicates the measure used in performing the actual operational/maintenance function. This measure is expressed by a two-character alphabetical abbreviation (e.g. ea, in, pr.)

e. Column (5) - Quantity required (Qty rqr). Indicates the quantity of the item authorized to be used with/on the equipmentment.

Section II. COMPONENTS OF END ITEM LIST

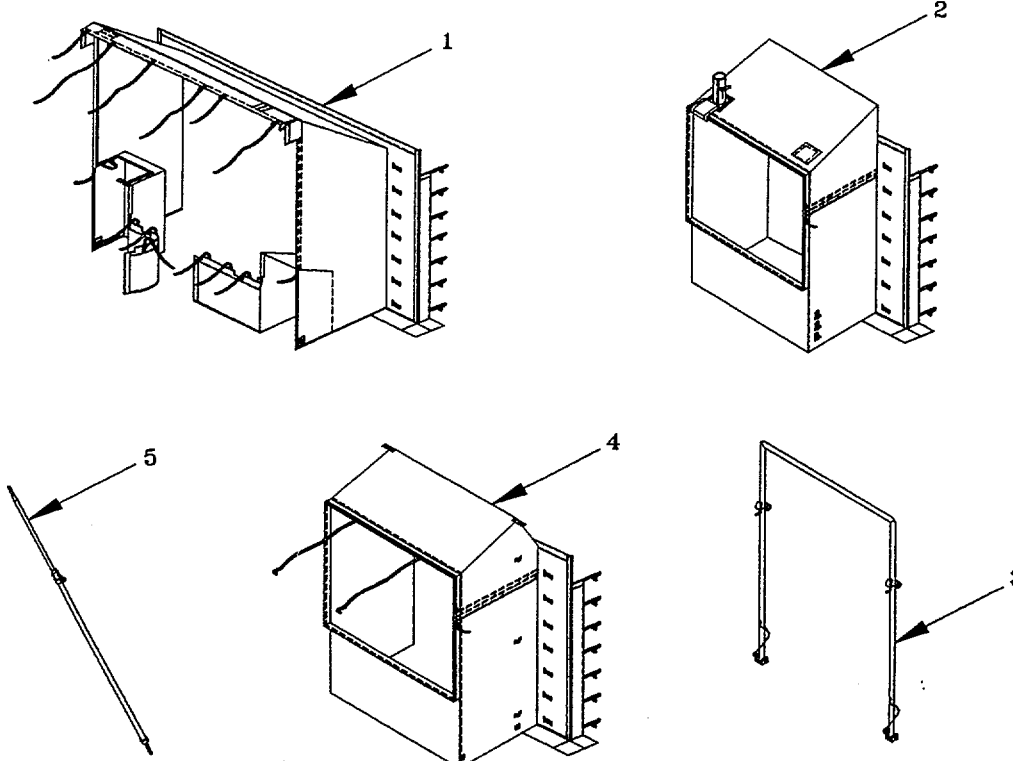
(1) ILLUS/ITEM NO	(2) NATIONAL STOCK NUMBER	(3) DESCRIPTION (CAGEC)PART NUMBER	UOC	(4) U/M	(5) QTY REQD
					
1	5410-01-378-8301 5410-01-380-2241	M577 BOOT.WALL ASSEMBLY (TYPE I, CLASS 1, GREEN (FJG) CLASS 2, TAN (FJH)	EA	EA	1
2	5420-02-3644497 UNASSIGNED	RWS BOOT ASSEMBLY (TYPE II) CLASS 1, GREEN (FJJ) CLASS 2, TAN (FJK) (81337)54-8184-2	EA	EA	1
3		FRAME ASSEMBLY, RWS BOOTWALL (81337)5-48202 (FJJ, FJK)	EA	EA	1
4	5420-02364-4497 UNASSIGNED	S-250E BOOT WALL ASSEMBLY CLASS 1, GREEN (FJL) CLASS 2, TAN (FJM) (81337)5-4-8213-2	EA	EA	1
5	5410-01333-4128	TELESCOPIC POLE (81337)5-46980 (FJL,FJM)	EA	EA	2

Section III. COMPONENTS OF END ITEM LIST

(1) ILLUS/ITEM NO	(2) NATIONAL STOCK NUMBER	(3) DESCRIPTION  (CAGEC)PART NUMBER      UOC		(4) U/M	(5) QTY REQD	
1		GUY LINE		(FFJ, FJM)	EA	2
2	8340-00-823-7451	TENT PIN, WOOD		(FFJ, FJM)	EA	2
3		SLIP, TENT GUY LINE		(FFJ, FJM)	EA	2
4		TECHNICAL MANUAL, OPERATOR'S, UNIT AND DIRECT SUPPORT MAINTENANCE MANUAL FOR SICPS BOOT WALLS TYPE I, 11, AND IV, TM 10-5410-230-13		EA	2	
5		REPAIR PARTS AND SPECIAL TOOLS LIST FOR SICPS BOOT WALLS TYPES I, 11, AND IV, TM 10- 5410-230-23P		EA	1	



APPENDIX D

ADDITIONAL AUTHORIZATION LIST

Section I. INTRODUCTION

**D-1. SCOPE.** This appendix lists additional items that you are authorized for the support of the Boot walls, Type I, Type II, and Type IV.

**D-2. GENERAL.** This list identifies items that do not have to accompany the boot walls and that do not have to be turned in with it. These items are authorized to you by CTA, MTD, TDA, or JTA.

**D-3. EXPLANATION OF LISTING.** National stock number, descriptions, and quantities are provided to help you identify and request the additional items you require to support this equipment. If the item required differs for different models of this equipment, see the "USED ON CODE" (UOC) column for the applicable model or models. Codes used are:

- UOC..... MODEL
- FJG ..... M577 BOOT WALL, TYPE I, GREEN
- FJH ..... M577 BOOT WALL, TYPE I, TAN
- FJJ ..... RWS BOOT WALL, TYPE II GREEN
- FJK ..... RWS BOOT WALL, TYPE II TAN
- FJL ..... S-250E BOOT WALL, TYPE IV GREEN
- FJM ..... S-250E BOOT WALL, TYPE IV TAN

Section II. ADDITIONAL AUTHORIZATION LIST

(1) Item No.	(2) National stock number	(3) Description (CAGEC)Part Number	UOC	(4) U/M	(5) Qty Auty
1		ROPE	(FJJ,FJK)	FT	2
2	8340-00-823-7451	TENT PIN, WOOD	(FJJ, FJK)	EA	2





## APPENDIX E

## EXPENDABLE AND DURABLE ITEMS LIST

## Section I. INTRODUCTION

**E-1. SCOPE.** This appendix lists expendable and durable items that you will need to operate and maintain the Boot Walls. This listing is for information only and is not authority to requisition the listed items. These items are authorized to you by CTA 50-970, Expendable/Durable Items (except Medical, Class V, Repair Parts, and Heraldic Items), or CTA 8-100, Army Medical Department Expendable/Durable Items.

**E-2. EXPLANATION OF COLUMNS.**

a. Column 1. Item Number. This number is assigned to the entry in the listing and is referenced in the narrative instructions to identify the item (e.g. "Use dry cleaning solvent, item 4, App. F").

b. Column 2. Level. This column identifies the lowest level of maintenance that requires the item.

C ..... Crew/Operator  
 O ..... Unit maintenance  
 F ..... Direct support maintenance

c. Column 3. National Stock Number. This is the national stock number assigned to the item. Use it to requisition the item.

d. Column 4. Item Name, Description, Commercial and Government Entity Code (CAGEC), and Part Number. This provides the other information you need to identify the item.

e. Column 5. Unit of Measure (U/M). This code shows the physical measurement or count of an item, such as gallon, dozen, gross, etc.

Section II. EXPENDABLE AND DURABLE ITEMS LIST

(1) Item No	(2) Level	(3) National Stock Number	(4) Description (CAGEC) Part Number UOC	(5) U/M
1	C	8520-00-129-0803	SOAP, TOILET, HAND, CAKE	BX
2	C	7920-00-240-7174	BRUSIH, SCRUB, W/OUT HANDLE	EA
3	C	8020-00-597-4761	BRUSH, VARNISH	EA
4	C	8030-01-350-4984	K-KOTE SEAM SEALER (0R6N1)83-234C	GL
5	C		GLOVES, LATEX-NTIRILE (55799)695456 [SIZE 8 - 8 1/2] (55799)695457 [SIZE 9 - 9 1/2] (55799)695458 [SIZE 10- 10 1/2]	PR
6	C	4240-01-204-2827	FPILTER CARTRIDGE (55799)464023	EA
7	C		GOGLES, CHEMICAL SPLASH (55799)695877	EA
8	C	4240-01-315-1864 4240-01-315-1863 4240-01-311-9013	RESPIRATOR, AIR FILTERING SMALL MEDIUM LARGE	GL
9	C	7920-00-205-1711	WIPING RAGS	BL

ALPHABETICAL INDEX

SUBJECT	PARAGRAPH
<b>A</b>	
Administrative Storage Requirements .....	2-10
Automatic stitching.....	5-6
<b>B</b>	
Basic issue items .....	C-3
Buckles, fastners, and webbing maintenance instructions .....	5-5
<b>C</b>	
Characteristics, capabilities, and features, equipment .....	1-7
Chart (MAC), maintenance allocation.....	B-6
Common tools and equipment .....	1-11
Components of end item and basic issue items list .....	C-1
<b>D</b>	
Data, equipment .....	1-9
Destruction of Army materiel to prevent enemy use .....	1-3
<b>E</b>	
End item, components of .....	C-1
Equipment characteristics, capabilities, and features.....	1-7
Equipment, common tools and .....	1-11
Equipment data.....	1-9
Expendable and durable items list.....	E-1
Exterior frame assembly header bar maintenance instructions (Type II only) .....	4-4
Exterior frame assembly upright bar maintenance instructions (Type II only) .....	4-5
<b>F</b>	
Forms, records and reports, maintenance .....	1-2
Frame assembly replacement instructions .....	44
<b>G</b>	
General operator PMCS.....	2-1
Grommet maintenance instructions .....	4-3
<b>H</b>	
Hole and tear repair instructions.....	4-2,5-2

**I**

Improvement recommendations (EIR), reporting equipment ..... 1-5  
 Installation and preparation for use ..... 24,5,6

**J**

**K**

**L**

Location and description of major components ..... 1-8

**M**

Maintenance allocation chart (MAC) ..... B-6  
 Maintenance forms, records, and reports ..... 1-2  
 Maintenance procedures  
     Buckles, fasteners, and webbing ..... 5-7  
     Exterior frame assembly header bar (Type II only) ..... 44  
     Exterior frame assembly upright bar (Type II only) ..... 4-5  
     Frame assembly replacement ..... 44,5  
     Grommet ..... 4-3  
     Hole and tear repair ..... 4-3  
     Rivet replacement ..... 4-6  
     Seam sealing ..... 3-5  
     Stitching repair ..... 4-3, 5-5  
     Tears, worn areas and mildew-rotted areas repair ..... 4-3, 5-7  
 Maintenance procedures, general ..... 42, 54  
 Major components, location and description of ..... 1-8  
 Material, service upon receipt ..... 4-1  
 Movement, preparation for ..... 2-10

**N**

Nomenclature, names and designations, official ..... 1-5

**O**

Operations under unusual conditions ..... 2-18  
 Operator PMCS, general ..... 2-1

**P**

Parts, repair ..... 1-13,5-3  
 PMCS, operator, general ..... 2-1  
 PMCS procedures ..... 2-1  
 Preparation for movement ..... 2-10  
 Preparation for storage or shipment ..... 1-4  
 Preparation for use, installation and ..... 24,5,6  
 Prevent enemy use, destruction of army materiel to ..... 1-3  
 Preventive maintenance checks and services (PMCS),  
     operator, general ..... 2-1  
 Preventive maintenance checks and services (PMCS)  
 Procedures ..... 2-1  
     Maintenance - see Maintenance Procedures

Maintenance, general.....	4-2, 5-4
PMCS.....	2-1
Removal.....	2-3

**Q**

**R**

Receipt of materiel, service upon.....	4-1
References.....	A-1
Removal procedures.....	2-3
Repair parts.....	1-13,5-3
Reporting equipment improvement recommendations EIR).....	1-5

**S**

Scope.....	1-1
Seam sealing.....	3-5
Service upon receipt of materiel.....	4-1
Special tools, TMDE and support equipment.....	5-2
Stitching repair instructions.....	4-3,5-5,5-6
Storage or shipment, preparation for.....	1-4
Support equipment, special tools, TMDE and.....	5-2

**T**

Tears, worn areas and mildew-rotted areas repair instructions.....	4-3,5-7
---	---------

**U**

Unusual conditions, operation in.....	2-11
---------------------------------------	------

**V**

**W**

**X**

**Y**

**Z**



By Order of the Secretary of the Army:

Official:

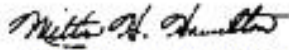

MILTON H. HAMILTON  
*Administrative Assistant to the  
Secretary of the Army*  
07672

GORDON R. SULLIVAN  
*General, United States Army  
Chief of Staff*

DISTRIBUTION:

To be distributed in accordance with DA Form 12-25-E, block no. 6249, requirements for TM 10-5410-230-13.





## ***These are the instructions for sending an electronic 2028***

The following format must be used if submitting an electronic 2028. The subject line must be exactly the same and all fields must be included; however only the following fields are mandatory: 1, 3, 4, 5, 6, 7, 8, 9, 10, 13, 15, 16, 17, and 27.

From: "Whomever" <whomever@avma27.army.mil>  
To: amssbriml@natick.army.mil

Subject: DA Form 2028

1. From: Joe Smith
2. Unit: home
3. Address: 4300 Park
4. City: Hometown
5. St: MO
6. Zip: 77777
7. Date Sent: 19-OCT-93
8. Pub no: 55-2840-229-23
9. Pub Title: TM
10. Publication Date: 04-JUL-85
11. Change Number: 7
12. Submitter Rank: MSG
13. Submitter FName: Joe
14. Submitter MName: T
15. Submitter LName: Smith
16. Submitter Phone: 123-123-1234
17. Problem: 1
18. Page: 2
19. Paragraph: 3
20. Line: 4
21. NSN: 5
22. Reference: 6
23. Figure: 7
24. Table: 8
25. Item: 9
26. Total: 123
27. Text:

This is the text for the problem below line 27.



<b>RECOMMENDED CHANGES TO PUBLICATIONS AND BLANK FORMS</b> For use of this form, see AR 25-30; the proponent agency is ODISC4.						Use Part II (reverse) for Repair Parts and Special Tool Lists (RPSTL) and Supply Catalogs/Supply Manuals (SC/SM).	<b>DATE</b> 21 October 2003
<b>TO:</b> (Forward to proponent of publication or form) (Include ZIP Code) COMMANDER U.S. ARMY TANK-AUTOMOTIVE AND ARMAMENT COMMAND ATTN: AMSTA-LC-CECT 15 KANSAS STREET NATICK, MA 01760-5052						<b>FROM:</b> (Activity and location) (Include ZIP Code)  <i>PFC Jane Doe</i> <i>CO A 3<sup>rd</sup> Engineer BR</i> <i>Ft. Leonardwood, MO 63108</i>	
<b>PART I – ALL PUBLICATIONS (EXCEPT RPSTL AND SC/SM) AND BLANK FORMS</b>							
<b>PUBLICATION/FORM NUMBER</b> TM 10-1670-296-23&P				<b>DATE</b> 30 October 2002	<b>TITLE</b> Unit Manual for Ancillary Equipment for Low Velocity Air Drop Systems		
<b>ITEM NO.</b>	<b>PAGE NO.</b>	<b>PARA-GRAPH</b>	<b>LINE NO. *</b>	<b>FIGURE NO.</b>	<b>TABLE NO.</b>	<b>RECOMMENDED CHANGES AND REASON</b> <i>(Provide exact wording of recommended changes, if possible).</i>	
	0036 00-2				1	<i>In table 1, Sewing Machine Code Symbols, the second sewing machine code symbol should be MD ZZ not MD 22.</i>  <i>Change the manual to show Sewing Machine, Industrial: Zig-Zag; 308 stitch; medium-duty; NSN 3530-01-181-1421 as a MD ZZ code symbol.</i>	
<small>*Reference to line numbers within the paragraph or subparagraph.</small>							
<b>TYPED NAME, GRADE OR TITLE</b>  Jane Doe, PFC				<b>TELEPHONE EXCHANGE/AUTOVON, PLUS EXTENSION</b>  508-233-4141		<b>SIGNATURE</b>  Jane Doe <i>Jane Doe</i>	

<b>TO:</b> <i>(Forward direct to addressee listed in publication)</i> COMMANDER U.S. ARMY TANK-AUTOMOTIVE AND ARMAMENT COMMAND ATTN: AMSTA-LC-CECT 15 KANSAS STREET NATICK, MA 01760-5052	<b>FROM:</b> <i>(Activity and location) (Include ZIP Code)</i> <i>PFC Jane Doe</i> <i>CO A 3<sup>rd</sup> Engineer BR</i> <i>Ft. Leonardwood, MO 63108</i>	<b>DATE</b> <i>21 October 2003</i>
--	---	---------------------------------------

**PART II – REPAIR PARTS AND SPECIAL TOOL LISTS AND SUPPLY CATALOGS/SUPPLY MANUALS**

<b>PUBLICATION NUMBER</b> TM 10-1670-296-23&P	<b>DATE</b> 30 October 2002	<b>TITLE</b> Unit Manual for Ancillary Equipment for Low Velocity Air Drop Systems
--	--------------------------------	---

PAGE NO.	COLM NO.	LINE NO.	NATIONAL STOCK NUMBER	REFERENCE NO.	FIGURE NO.	ITEM NO.	TOTAL NO. OF MAJOR ITEMS SUPPORTED	RECOMMENDED ACTION
0066 00-1					4			<i>Callout 16 in figure 4 is pointed to a <u>D-Ring</u>. In the Repair Parts List key for figure 4, item 16 is called a <u>Snap Hook</u>. Please correct one or the other.</i>

**PART III – REMARKS**

*(Any general remarks or recommendations, or suggestions for improvement of publications and blank forms. Additional blank sheets may be used if more space is needed.)*

--	--	--

TYPED NAME, GRADE OR TITLE	TELEPHONE EXCHANGE/AUTOVON, PLUS EXTENSION	SIGNATURE
----------------------------	--	-----------

<p align="center"><b>RECOMMENDED CHANGES TO PUBLICATIONS AND BLANK FORMS</b></p> <p>For use of this form, see AR 25-30; the proponent agency is ODISC4.</p>						Use Part II (reverse) for Repair Parts and Special Tool Lists (RPSTL) and Supply Catalogs/Supply Manuals (SC/SM).	DATE
<b>TO:</b> (Forward to proponent of publication or form) (Include ZIP Code) COMMANDER U.S. ARMY TANK-AUTOMOTIVE AND ARMAMENT COMMAND ATTN: AMSTA-LC-CECT 15 KANSAS STREET NATICK, MA 01760-5052						<b>FROM:</b> (Activity and location) (Include ZIP Code)	
<b>PART I – ALL PUBLICATIONS (EXCEPT RPSTL AND SC/SM) AND BLANK FORMS</b>							
PUBLICATION/FORM NUMBER TM 10-5410-230-13				DATE 28 November 1994	TITLE Operator's, Unit and Direct Support Maintenance Manual, For Standard Integrated Command Post Systems Boot Walls Types I, II, & IV Classes 1 (Green) and 2 (Tan).		
ITEM NO.	PAGE NO.	PARA-GRAPH	LINE NO. *	FIGURE NO.	TABLE NO.	RECOMMENDED CHANGES AND REASON <i>(Provide exact wording of recommended changes, if possible).</i>	
<i>*Reference to line numbers within the paragraph or subparagraph.</i>							
TYPED NAME, GRADE OR TITLE				TELEPHONE EXCHANGE/AUTOVON, PLUS EXTENSION		SIGNATURE	

<b>TO:</b> <i>(Forward direct to addressee listed in publication)</i> COMMANDER U.S. ARMY TANK-AUTOMOTIVE AND ARMAMENT COMMAND ATTN: AMSTA-LC-CECT 15 KANSAS STREET NATICK, MA 01760-5052	<b>FROM:</b> <i>(Activity and location) (Include ZIP Code)</i>	<b>DATE</b>
--	--	-------------

**PART II – REPAIR PARTS AND SPECIAL TOOL LISTS AND SUPPLY CATALOGS/SUPPLY MANUALS**

<b>PUBLICATION NUMBER</b> TM 10-5410-230-13	<b>DATE</b> 28 November 1994	<b>TITLE</b> Operator's, Unit and Direct Support Maintenance Manual, For Standard Integrated Command Post Systems Boot Walls Types I, II, & IV Classes 1 (Green) and 2 (Tan).
--	---------------------------------	---

PAGE NO.	COLM NO.	LINE NO.	NATIONAL STOCK NUMBER	REFERENCE NO.	FIGURE NO.	ITEM NO.	TOTAL NO. OF MAJOR ITEMS SUPPORTED	RECOMMENDED ACTION

**PART III – REMARKS** *(Any general remarks or recommendations, or suggestions for improvement of publications and blank forms. Additional blank sheets may be used if more space is needed.)*

TYPED NAME, GRADE OR TITLE	TELEPHONE EXCHANGE/AUTOVON, PLUS EXTENSION	SIGNATURE
----------------------------	--	-----------

<p align="center"><b>RECOMMENDED CHANGES TO PUBLICATIONS AND BLANK FORMS</b></p> <p>For use of this form, see AR 25-30; the proponent agency is ODISC4.</p>						Use Part II (reverse) for Repair Parts and Special Tool Lists (RPSTL) and Supply Catalogs/Supply Manuals (SC/SM).	DATE
<b>TO:</b> (Forward to proponent of publication or form) (Include ZIP Code) COMMANDER U.S. ARMY TANK-AUTOMOTIVE AND ARMAMENT COMMAND ATTN: AMSTA-LC-CECT 15 KANSAS STREET NATICK, MA 01760-5052						<b>FROM:</b> (Activity and location) (Include ZIP Code)	
<b>PART I – ALL PUBLICATIONS (EXCEPT RPSTL AND SC/SM) AND BLANK FORMS</b>							
PUBLICATION/FORM NUMBER TM 10-5410-230-13				DATE 28 November 1994	TITLE Operator's, Unit and Direct Support Maintenance Manual, For Standard Integrated Command Post Systems Boot Walls Types I, II, & IV Classes 1 (Green) and 2 (Tan).		
ITEM NO.	PAGE NO.	PARA-GRAPH	LINE NO. *	FIGURE NO.	TABLE NO.	RECOMMENDED CHANGES AND REASON <i>(Provide exact wording of recommended changes, if possible).</i>	
<i>*Reference to line numbers within the paragraph or subparagraph.</i>							
TYPED NAME, GRADE OR TITLE				TELEPHONE EXCHANGE/AUTOVON, PLUS EXTENSION		SIGNATURE	

<b>TO:</b> (Forward direct to addressee listed in publication) COMMANDER U.S. ARMY TANK-AUTOMOTIVE AND ARMAMENT COMMAND ATTN: AMSTA-LC-CECT 15 KANSAS STREET NATICK, MA 01760-5052	<b>FROM:</b> (Activity and location) (Include ZIP Code)	<b>DATE</b>
---	---	-------------

**PART II – REPAIR PARTS AND SPECIAL TOOL LISTS AND SUPPLY CATALOGS/SUPPLY MANUALS**

<b>PUBLICATION NUMBER</b> TM 10-5410-230-13	<b>DATE</b> 28 November 1994	<b>TITLE</b> Operator's, Unit and Direct Support Maintenance Manual, For Standard Integrated Command Post Systems Boot Walls Types I, II, & IV Classes 1 (Green) and 2 (Tan).
--	---------------------------------	---

PAGE NO.	COLM NO.	LINE NO.	NATIONAL STOCK NUMBER	REFERENCE NO.	FIGURE NO.	ITEM NO.	TOTAL NO. OF MAJOR ITEMS SUPPORTED	RECOMMENDED ACTION

**PART III – REMARKS** (Any general remarks or recommendations, or suggestions for improvement of publications and blank forms. Additional blank sheets may be used if more space is needed.)

TYPED NAME, GRADE OR TITLE	TELEPHONE EXCHANGE/AUTOVON, PLUS EXTENSION	SIGNATURE
----------------------------	--	-----------



<b>RECOMMENDED CHANGES TO PUBLICATIONS AND BLANK FORMS</b>						Use Part II (reverse) for Repair Parts and Special Tool Lists (RPSTL) and Supply Catalogs/Supply Manuals (SC/SM).	DATE
For use of this form, see AR 25-30; the proponent agency is ODISC4.							
<b>TO:</b> (Forward to proponent of publication or form) (Include ZIP Code) COMMANDER U.S. ARMY TANK-AUTOMOTIVE AND ARMAMENT COMMAND ATTN: AMSTA-LC-CECT 15 KANSAS STREET NATICK, MA 01760-5052						<b>FROM:</b> (Activity and location) (Include ZIP Code)	
<b>PART I – ALL PUBLICATIONS (EXCEPT RPSTL AND SC/SM) AND BLANK FORMS</b>							
PUBLICATION/FORM NUMBER TM 10-5410-230-13				DATE 28 November 1994	TITLE Operator's, Unit and Direct Support Maintenance Manual, For Standard Integrated Command Post Systems Boot Walls Types I, II, & IV Classes 1 (Green) and 2 (Tan).		
ITEM NO.	PAGE NO.	PARA-GRAPH	LINE NO. *	FIGURE NO.	TABLE NO.	RECOMMENDED CHANGES AND REASON (Provide exact wording of recommended changes, if possible).	
*Reference to line numbers within the paragraph or subparagraph.							
TYPED NAME, GRADE OR TITLE				TELEPHONE EXCHANGE/AUTOVON, PLUS EXTENSION		SIGNATURE	

<b>TO:</b> <i>(Forward direct to addressee listed in publication)</i> COMMANDER U.S. ARMY TANK-AUTOMOTIVE AND ARMAMENT COMMAND ATTN: AMSTA-LC-CECT 15 KANSAS STREET NATICK, MA 01760-5052	<b>FROM:</b> <i>(Activity and location) (Include ZIP Code)</i>	<b>DATE</b>
--	--	-------------

**PART II – REPAIR PARTS AND SPECIAL TOOL LISTS AND SUPPLY CATALOGS/SUPPLY MANUALS**

<b>PUBLICATION NUMBER</b> TM 10-5410-230-13	<b>DATE</b> 28 November 1994	<b>TITLE</b> Operator's, Unit and Direct Support Maintenance Manual, For Standard Integrated Command Post Systems Boot Walls Types I, II, & IV Classes 1 (Green) and 2 (Tan).
--	---------------------------------	---

PAGE NO.	COLM NO.	LINE NO.	NATIONAL STOCK NUMBER	REFERENCE NO.	FIGURE NO.	ITEM NO.	TOTAL NO. OF MAJOR ITEMS SUPPORTED	RECOMMENDED ACTION

**PART III – REMARKS** *(Any general remarks or recommendations, or suggestions for improvement of publications and blank forms. Additional blank sheets may be used if more space is needed.)*

<b>TYPED NAME, GRADE OR TITLE</b>	<b>TELEPHONE EXCHANGE/AUTOVON, PLUS EXTENSION</b>	<b>SIGNATURE</b>
-----------------------------------	---	------------------

# The Metric System and Equivalents

## Linear Measure

1 centimeter = 10 millimeters = .39 inch  
 1 decimeter = 10 centimeters = 3.94 inches  
 1 meter = 10 decimeters = 39.37 inches  
 1 dekameter = 10 meters = 32.8 feet  
 1 hectometer = 10 dekameters = 328.08 feet  
 1 kilometer = 10 hectometers = 3,280.8 feet

## Weights

1 centigram = 10 milligrams = .15 grain  
 1 decigram = 10 centigrams = 1.54 grains  
 1 gram = 10 decigrams = .035 ounce  
 1 dekagram = 10 grams = .35 ounce  
 1 hectogram = 10 dekagrams = 3.52 ounces  
 1 kilogram = 10 hectograms = 2.2 pounds  
 1 quintal = 100 kilograms = 220.46 pounds  
 1 metric ton = 10 quintals = 1.1 short tons

## Liquid Measure

1 centiliter = 10 milliliters = .34 fl. ounce  
 1 deciliter = 10 centiliters = 3.38 fl. ounces  
 1 liter = 10 deciliters = 33.81 fl. ounces  
 1 dekaliter = 10 liters = 2.64 gallons  
 1 hectoliter = 10 dekaliters = 26.42 gallons  
 1 kiloliter = 10 hectoliters = 264.18 gallons

## Square Measure

1 sq. centimeter = 100 sq. millimeters = .155 sq. inch  
 1 sq. decimeter = 100 sq. centimeters = 15.5 sq. inches  
 1 sq. meter (centare) = 100 sq. decimeters = 10.76 sq. feet  
 1 sq. dekameter (are) = 100 sq. meters = 1,076.4 sq. feet  
 1 sq. hectometer (hectare) = 100 sq. dekameters = 2.47 acres  
 1 sq. kilometer = 100 sq. hectometers = .386 sq. mile

## Cubic Measure

1 cu. centimeter = 1000 cu. millimeters = .06 cu. inch  
 1 cu. decimeter = 1000 cu. centimeters = 61.02 cu. inches  
 1 cu. meter = 1000 cu. decimeters = 35.31 feet

## Approximate Conversion Factors

<i>To change</i>	<i>To</i>	<i>Multiply by</i>	<i>To change</i>	<i>To</i>	<i>Multiply by</i>
inches	centimeters	2.540	ounce-inches	newton-meters	.007062
feet	meters	.305	centimeters	inches	.394
yards	meters	.914	meters	feet	3.280
miles	kilometers	1.609	meters	yards	1.094
square inches	square centimeters	6.451	kilometers	miles	.621
square feet	square meters	.093	square centimeters	square inches	.155
square yards	square meters	.836	square meters	square feet	10.764
square miles	square kilometers	2.590	square meters	square yards	1.196
acres	square hectometers	.405	square kilometers	square miles	.386
cubic feet	cubic meters	.028	square hectometers	acres	2.471
cubic yards	cubic meters	.765	cubic meters	cubic feet	35.315
fluid ounces	milliliters	29.573	cubic meters	cubic yards	1.308
pints	liters	.473	milliliters	fluid ounces	.034
quarts	liters	.946	liters	pints	2.113
gallons	liters	3.785	liters	quarts	1.057
ounces	grams	28.349	liters	gallons	.264
pounds	kilograms	.454	grams	ounces	.035
short tons	metric tons	.907	kilograms	pounds	2.205
pound-feet	newton-meters	1.356	metric tons	short tons	1.102
pound-inches	newton-meters	.11296			

## Temperature (Exact)

  \_F Fahrenheit temperature    5/9 (after subtracting 32)    Celsius temperature      \_C

**PIN: 073358-000**

This fine document...

Was brought to you by me:



## [Liberated Manuals -- free army and government manuals](#)

Why do I do it? I am tired of sleazy CD-ROM sellers, who take publicly available information, slap “watermarks” and other junk on it, and sell it. Those masters of search engine manipulation make sure that their sites that sell free information, come up first in search engines. They did not create it... They did not even scan it... Why should they get your money? Why are not letting you give those free manuals to your friends?

I am setting this document FREE. This document was made by the US Government and is NOT protected by Copyright. Feel free to share, republish, sell and so on.

I am not asking you for donations, fees or handouts. If you can, please provide a link to [liberatedmanuals.com](http://liberatedmanuals.com), so that free manuals come up first in search engines:

<A HREF=<http://www.liberatedmanuals.com/>>Free Military and Government Manuals</A>

- Sincerely  
Igor Chudov  
<http://igor.chudov.com/>
- [Chicago Machinery Movers](#)