

TM 10-5410-223-24

DEPARTMENT OF THE ARMY TECHNICAL MANUAL

ORGANIZATIONAL, DIRECT AND GENERAL SUPPORT
MAINTENANCE MANUAL

CONTAINER, SERVICE WARD, RIGID CONSTRUCTION
APPROXIMATE EXPANDED DIMENSIONS 10 FT. 10³/₄ IN. LONG,
12 FT. WIDE, 7 FT. 3 IN. HIGH
FSN 5410-809-6634

HEADQUARTERS, DEPARTMENT OF THE ARMY
DECEMBER 1969

SAFETY PRECAUTIONS

Adhesives and solvents are highly flammable; perform work in well ventilated area and away from fire. Do not store adhesives or solvents in or near shelter.

Do not use lifting equipment with capacity of less than 7500 pounds. Do not allow Container, Service Ward, to swing back and forth when it is suspended. Failure to observe this warning may result in damage to equipment, or severe injury or death to personnel.

Do not attach hoisting sling to the lifting equipment in such a manner that the angle between any of the hoist lines and the top of the Container, Service Ward, is less than 45 degrees. Any angle less than 45 degrees will cause an excessive strain, which could damage the Container, Service Ward.

Fork extensions are required for fork lifting the Container, Service Ward, in order to prevent damage to the raceways located on the underside of the Container, Service Ward.

Do not use fork lift with capacity of less than 7500 pounds. Do not allow Container, Service Ward, to rock excessively on fork lift. Failure to observe this warning may result in damage to equipment, or severe injury or death to personnel.

Limit skidding of the Container, Service Ward, to short distances over smooth level terrain to prevent damage to Container, Service Ward, skids.

Position Container, Service Ward, with skid base parallel to the longitudinal axis of the carrier to prevent excessive side loads on the skids. Make sure the carrier and restraining method are capable of supporting a weight of 7500 pounds minimum.

Use extreme care in cutting stitches to prevent cutting or other damage to fabric. If fabric is cut or otherwise damaged, apply patch to damaged area as described in paragraph 5-4.

CHANGE
NO. 1

HEADQUARTERS,
DEPARTMENT OF THE ARMY
WASHINGTON, DC, 30 SEPTEMBER 2005

TECHNICAL MANUAL
ORGANIZATIONAL, DIRECT AND GENERAL SUPPORT
MAINTENANCE MANUAL FOR
CONTAINER, SERVICE WARD, RIGID CONSTRUCTION
APPROXIMATE EXPANDED DIMENSIONS 10 FT. 10 ¾ IN. LONG,
12 FT. WIDE, 7 FT. 3 IN. HIGH
(FSN: 5410-809-6634)

DISTRIBUTION STATEMENT A: Approved for public release; distribution is unlimited.

TM 10-5410-223-24, 15 December 1969, is updated as follows:

1. File this sheet in front of the manual for reference.
2. This change implements Army Maintenance Transformation and changes the Maintenance Allocation Chart (MAC) to support Field and Sustainment Maintenance.
3. New or updated change information is indicated by a vertical bar in the outer margin of the page.
4. Remove old pages and insert new pages as indicated below:

Remove Pages

B-1 – B-2

Insert Pages

A/(B Blank)
B-1 – B-5/(B-6 Blank)
Electronic 2028 Instructions/Blank
Sample 2028 Front/Back
2028 Front/Back
2028 Front/Back
2028 Front/Back

TM 10-5410-223-24
C1

By Order of the Secretary of the Army:

PETER J. SCHOOMAKER
General, United States Army
Chief of Staff

Official:

SANDRA R. RILEY
*Administrative Assistant to the
Secretary of the Army*
0523402

Distribution: To be distributed in accordance with initial distribution number (IDN) 250500 requirements for TM 10-5410-223-24

INSERT LATEST CHANGED PAGES. DESTROY SUPERSEDED PAGES.

LIST OF EFFECTIVE PAGES

NOTE: The portion of text affected by the changes is indicated by a vertical line in the outer margins of the page. Changes to illustrations are indicated by shaded or screened areas, or by miniature pointing hands. Zero in the "Change No." column indicates an original page.

Dates of issue for original and changed pages are:

Original .. 0 .. 15 December 1969
 Change .. 1 .. 30 September 2005

TOTAL NUMBER OF PAGES IN THIS PUBLICATION IS 76, CONSISTING OF THE FOLLOWING:

Page No.	Change No.	Page No.	Change No.
Title	0		
Warning	0		
i	0		
1-1 - 1-4	0		
2-1 - 2-12	0		
3-1 - 3-3	0		
4-1	0		
5-1	0		
6-1 - 6-18	0		
A-1	0		
B-1 - B-6	1		
I-1 - I-2	0		
Back Cover	0		

TECHNICAL MANUAL }
 No. 10-5410-223-24 }

HEADQUARTERS
 DEPARTMENT OF THE ARMY
 WASHINGTON, D. C., 15 December 1969

OPERATOR, ORGANIZATIONAL, DIRECT AND GENERAL SUPPORT
 MAINTENANCE MANUAL

CONTAINER, SERVICE WARD, RIGID CONSTRUCTION APPROXIMATE
 EXPANDED DIMENSIONS 10 FT. 10³/₄ IN. LONG, 12 FT. WIDE, 7 FT. 3 IN. HIGH
 FSN 5410-809-6634

	Paragraph	Page
Chapter 1. INTRODUCTION		
Section I. General	1-1, 1-2	
II. Description and tabulated data	1-3 - 1-5	
Chapter 2. ORGANIZATIONAL MAINTENANCE INSTRUCTION		
Section I. Special tools and equipment	2-1, 2-2	
II. Lubrication		
III. Preventive maintenance services.	2-3, 2-4	
IV. Troubleshooting	2-5, 2-6	
v. Field expedient repairs	2-7, 2-8	
VI. General fabric repair procedures	2-9, 2-10	
VII. General rivet and insert repair	2-11 - 2-13	
VIII. General honeycomb panel repair	2-14, 2-15	
IX. Container, service ward, accessories	2-16 - 2-18	
Chapter 3. SHIPMENT AND LIMITED STORAGE AND DEMOLITION TO PREVENT ENEMY USE		
Section I. Shipment and limited storage	3-1 - 3-4	
II. Demolition to prevent enemy use	3-5, 3-6	
Chapter 4. DIRECT AND GENERAL SUPPORT MAINTENANCE INSTRUCTIONS		
Section I. General	4-1, 4-2	
II. Description and tabulated data	4-3, 4-4	
Chapter 5. GENERAL MAINTENANCE INSTRUCTIONS		
Section I. Special tools and equipment	5-1, 5-2	
II. Troubleshooting		
III. Removal and installation of major components or auxiliaries		
IV. General fabric repair procedures	5-3 - 5-5	
Chapter 6. CONTAINER, SERVICE WARD, BODY ASSEMBLY		
Section I. Folding panel assemblies	6-1 - 6-5	
II. Fixed panel assemblies	6-6 - 6-10	
III. Container, service ward, body assembly overhaul	6-11 - 6-15	
Appendix A References	A1 - A3	
B Maintenance Allocation Chart	B1 - B4	
Index		

CHAPTER 1 INTRODUCTION

Section I. GENERAL

1-1. Scope

a. These instructions are published for use by personnel to whom the Container, Service Ward, is issued. Chapters 1 through 2 provide information for organizational maintenance of equipment, accessories, components and attachments. Chapter 3 contains Storage and Demolition Instructions. Chapters 4 through 6 provide information for direct and general support maintenance.

b. Numbers in parentheses following nomenclature callouts on illustrations indicate quantity; numbers preceding nomenclature callouts indicate preferred sequence of disassembly.

1-2. Record and Report Forms

a. DA Form 2258 (Depreservation Guide for Vehicles and Equipment).

b. For other record and report forms applicable to organizational maintenance, refer to TM 38-750.

c. Direct reporting of errors, omissions and recommendations for improving this equipment manual by the individual user is authorized and encouraged. Prepare DA Form 2028 (Recommended Changes to Publications) and forward direct to Commanding General, U. S. Army Mobility Equipment Command, ATTN: AMSME-MPP, 4300 Goodfellow Blvd, St. Louis, Mo. 63120.

Note. Applicable forms, excluding Standard Form 46 (United States Government Motor Vehicles Operator's Identification Card) which is carried by the operator, shall be kept in a canvas bag mounted on equipment.

Section II. DESCRIPTION AND TABULATED DATA

1-3. Description

a. General. The Container, Service Ward, is an element of the Medical Unit Self-Contained, Transportable and provides an environment controlled shelter for lavatory facility, toilet and sanitizer facility, bathing facility, water purification, waste water treatment, battalion aid station, dental clinic, minor surgery, maintenance shop, optical shop, linen exchange and shipping container; or other similar uses. (fig. 1-1 and 1-2). The Container, Service Ward, is an expandable structure constructed of aluminum-faced foam filled honeycomb panels. The Container, Service Ward, is supported by a central skid base, and is equipped with built-in leveling jacks. The basic Container, Service Ward, includes imbedded inserts for the mounting of lights and required electrical equipment. A conditioned air duct provides passage for conditioned air from an external source to the Container, Service Ward, through openings in the roof.

b. Leveling Jacks. Manually operated, adjustable screw type jacks on the Container, Service Ward, allow for vertical adjustment to compensate for irregular terrain.

1-4 Identification and Tabulated Data

a. Identification. The Container, Service Ward, is identified as Part No. MRL 890331-1, Model No. MR

68. An identification nameplate is attached to the Container, Service Ward, center section.

b. Tabulated Data.

(1) *Ward container.*

Manufacturer Missouri Research Laboratories, Inc.
St. Charles, Missouri

Part No. MRL-890331-1
Model No MR 68

(2) *Dimensions (fig. 1-2 and 1-3).*

Expanded shelter

Length 10 feet, 10¼ inches
Width 12 feet
Height 7 feet, 3 inches
Floor Space 131 square feet

Folded shelter

Length 12 feet, 10¼ inches
Width 7 feet, 1 inch
Height 7 feet, 3 inches
Weight 1840 lbs.

1-5. Differences in Models

This manual covers only the Model MR 68 Ward Container. No known unit differences exist for the model covered by this manual.

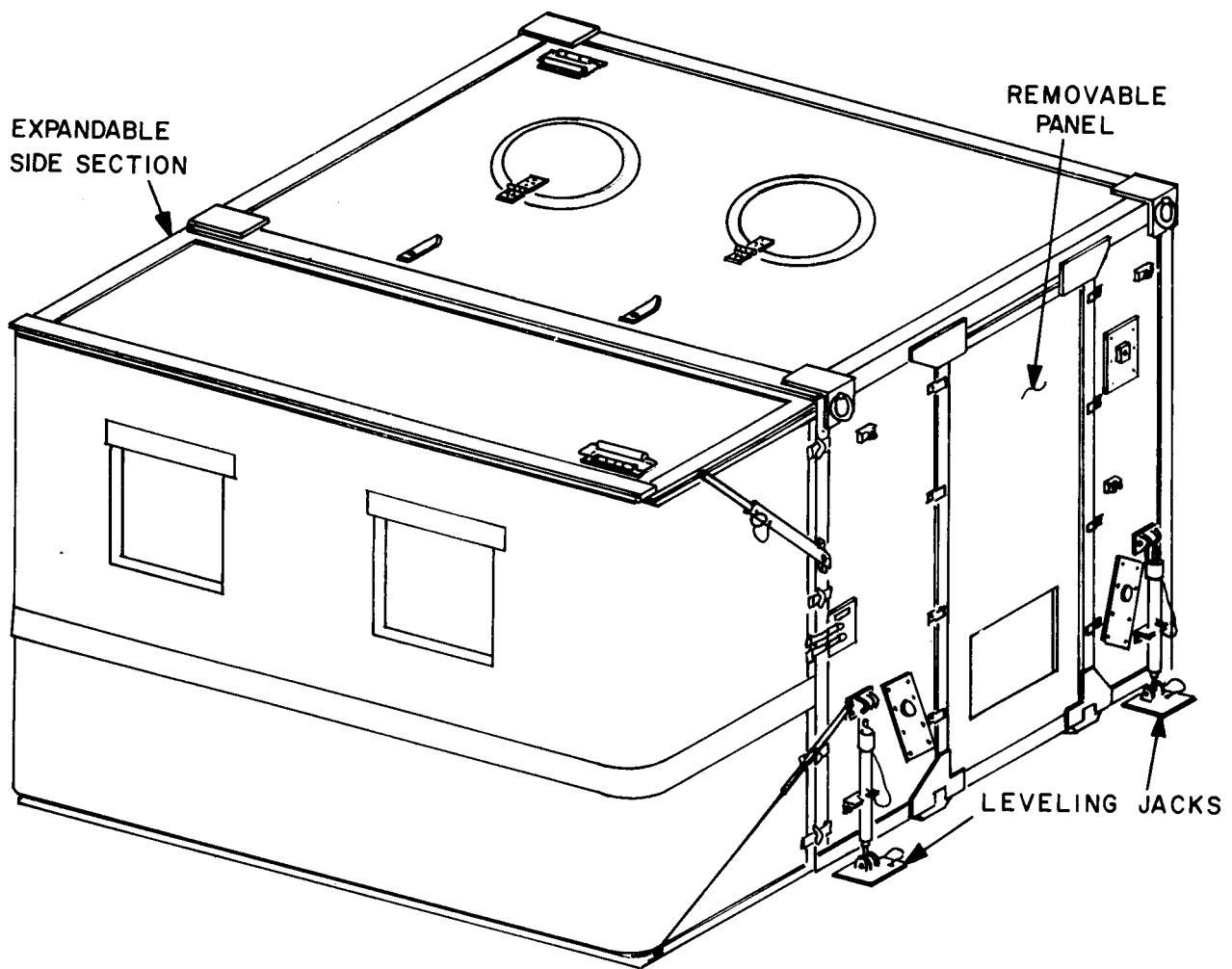

ME 5410-223-24/1-1

Figure 1-1. Expanded view, container, service ward.

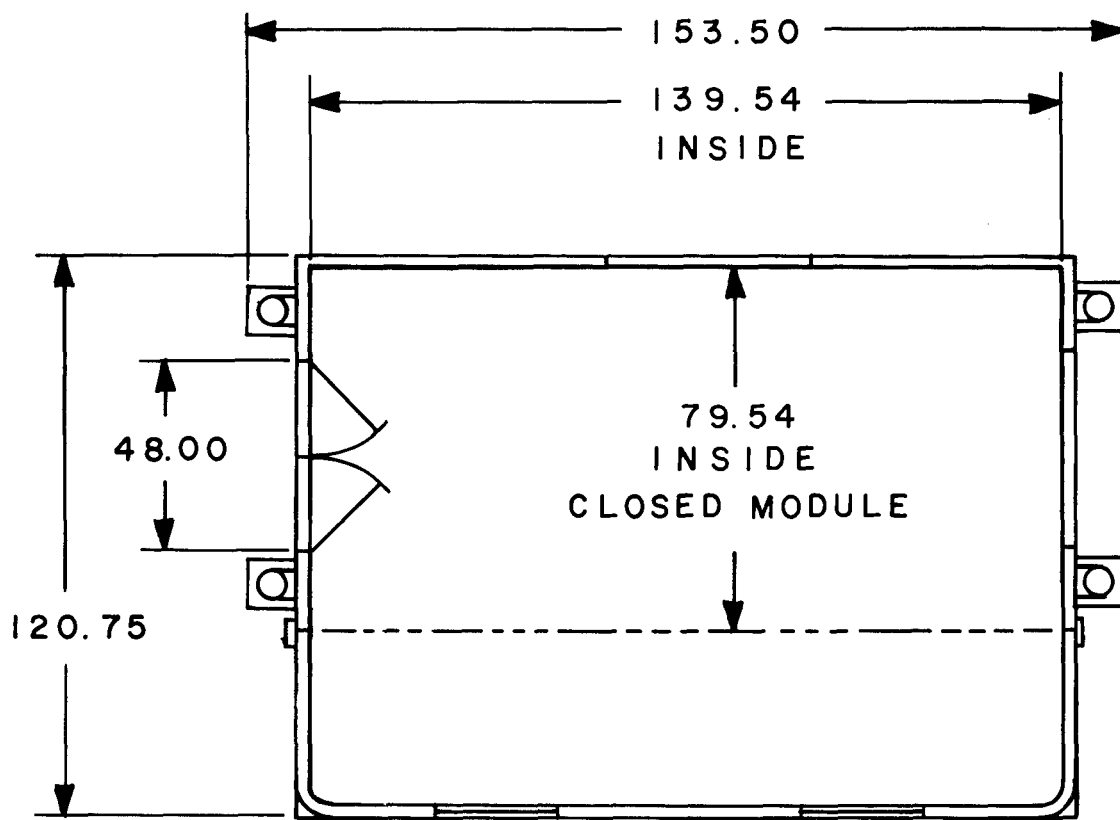

ME 5410-223-24 /1-2

Figure 1-2. Container, service ward, plan view

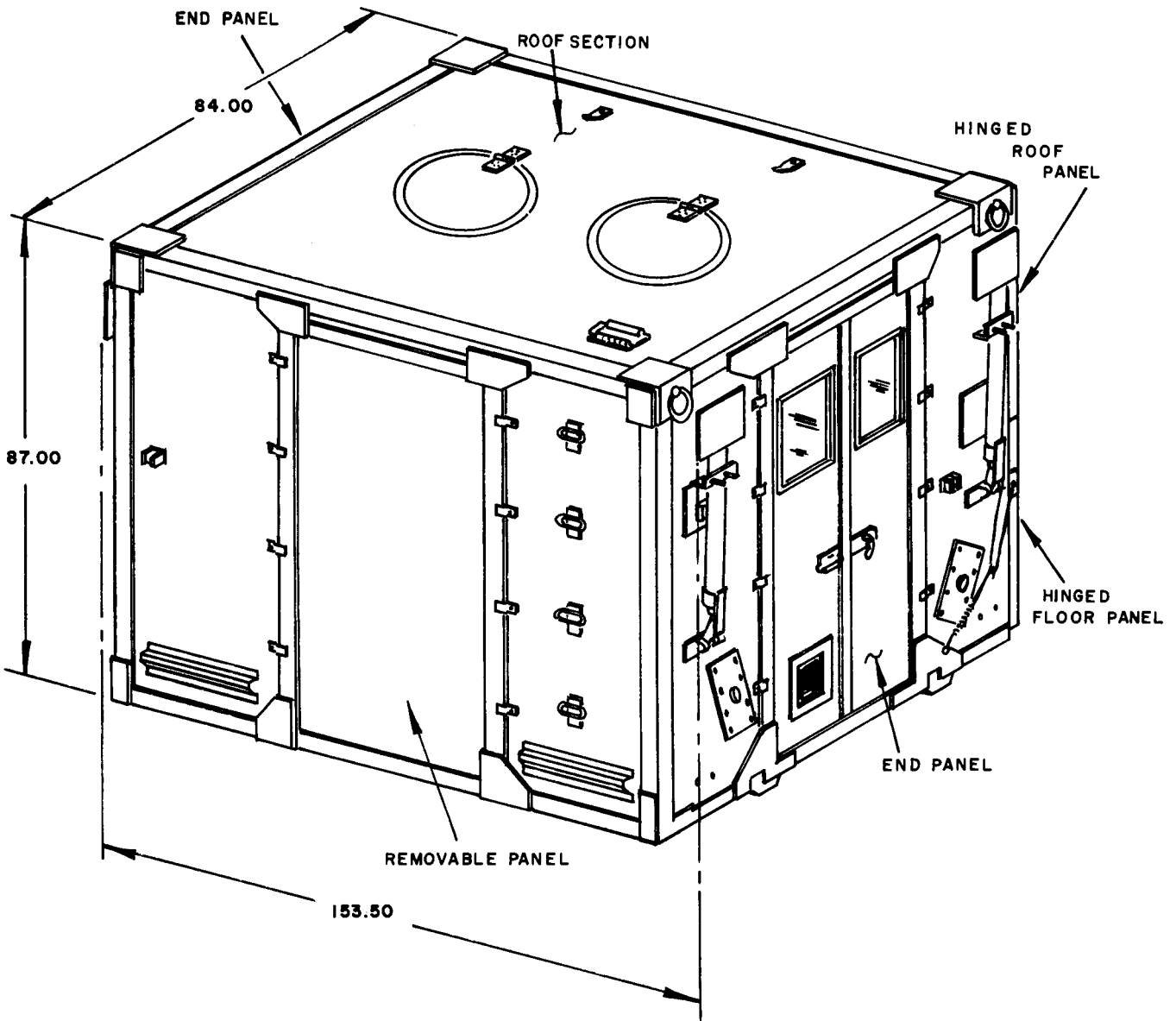

ME 5410-223-24/1-3

Figure 1-3. Container, Service Ward, Shipping Dimensions

CHAPTER 2 ORGANIZATIONAL MAINTENANCE INSTRUCTION

Section I. SPECIAL TOOLS AND EQUIPMENT

2-1. Special Tools and Equipment

Special tools or equipment required by organizational personnel for maintenance of the Container, Service Ward, are listed in table 2-1.

Table 2-1. Special Tools

Item	FSN or part No.	Reference		Use
		Figure	Paragraph	
Riveter, Hand Nose-piece	PRG402-8	2-3	2-12, C	Pop rivet application on shelter. This item accomodates only two size pop rivets.
	PRN314	2-3	2-12, C	

2-2. Specially Designed Tools and Equipment

No specially designed tools or equipment are required by organizational personnel for maintenance of the Container, Service Ward.

Section II. LUBRICATION

Lubrication of the Container, Service Ward, is not required.

Section III. PREVENTIVE MAINTENANCE SERVICES

2-3. General

To ensure that the Container, Service Ward, is ready for operation at all times, it must be inspected systematically so that defects may be discovered and corrected before they result in serious damage or failure. The necessary preventive maintenance services to be performed are listed and described in paragraph 2-4. Item numbers indicate the sequence of minimum inspection requirements. All deficiencies and shortcomings will be recorded together with

the corrective action taken on DA Form 2404 at the earliest possible opportunity.

2-4. Weekly Preventive Maintenance Services

This paragraph contains an illustrated tabulated listing of preventive maintenance services which must be performed by organizational maintenance personnel at weekly intervals. Refer to table 2-2 for the preventive maintenance services.

Table 2-2. Preventive Maintenance Checks and Services

Item number	Interval				Org.		Item to be inspected	Procedure	Reference
	Operator				B - Before operation	A - After operation			
	Daily				M	Q	D - During operation	W - Weekly	M - Monthly
	B	D	A	W				Q - Quarterly	
1				X			Cover fabric	Check fabric inside and outside for wear at seams, for broken stitches, for holes, for weak spots or other damage. Repair as required.	Paras 5-4 and 5-5
2				X			Slide fastener	Check for smooth operation, complete closure, missing teeth, unstitched seams or other damage. Apply "zipper-ease" to teeth for lubrication	Para 5-5
3				X			Fabric fastener latches	Check for damage and unsnapped latches. Repair as required.	

Section IV. TROUBLESHOOTING

2-5. General

This section provides information useful in diagnosing and correcting unsatisfactory operation or failure of the Container, Service Ward, and its com-

ponents. Malfunctions which may occur are listed in table 2-3. Each trouble symptom stated is followed by a list of probable causes. The corrective action recommended is described opposite the probable cause.

Table 2-3. Troubleshooting

Malfunction	Probable cause	Possible remedy
Water leakage into Container, Service Ward	Weather seal assemblies damaged, loose, or improperly positioned	<p>a. Replace damaged seal assemblies</p> <p>b. Position seal assemblies to cover joints in Container, Service Ward, and secure (para 6-2 through 6-14).</p>

2-6. Maintenance Support

Any trouble beyond the scope of organizational maintenance shall be reported to direct support maintenance.

Section VI. FIELD EXPEDIENT REPAIRS

2-7. General

Organizational maintenance troubles may occur while the Container, Service Ward, is operating in the field where supplies and repair parts are not available and normal corrective action cannot be performed. When this condition exists, the following expedient repairs may be used in emergencies upon the decision of the unit commander. Equipment so repaired must be removed from operation as soon as possible and properly repaired before being placed in operation again.

2-8. Torn or Otherwise Damaged Fabric, Panels or Fasteners

<i>Trouble</i>	<i>Expedient remedy</i>
Damaged fabric or honey-comb panels.	Repair damage with adhesive tape until normal repairs can be made.
Damaged or missing fasteners.	If possible, use rope, cord, wire or other material to replace fastener. If not possible, evacuate to next higher level maintenance as assigned.

Section VII. GENERAL FABRIC REPAIR PROCEDURES

2-9. General

This section provides organizational maintenance personnel with general repair instructions applicable to the repair parts of the Container, Service Ward.

not adhere to painted surfaces. Dampen a clean cloth with approved solvent and rotate over the area until all paint is removed.

(2) Apply first coat of adhesive (from repair kit) to both surfaces to be cemented in medium to heavy coats. Brush back and forth to work adhesive in.

2-10 Fabric Repair Procedures Using Adhesive

Note. Two fabric repair kits are furnished with each field hospital or evacuation hospital. The fabric repair kit is to be used in making fabric repairs to components of the Container, Service Ward.

Note. Coated side of fabric (side with smooth slick surface) requires only one coat of adhesive. Uncoated side of fabric requires three coats of adhesive. The first coat of adhesive should be applied within 30 seconds after cleaning. If more than 30 seconds elapses, reclean surfaces. Thin adhesive with an approved solvent as required to obtain smooth brushing consistency.

a. *Application of Adhesive.* Apply adhesive for installation of patches to cover holes or other damage to fabric, to re-cement seams and to replace damaged cemented fabric as follows.

(3) Allow adhesive to dry to a tacky condition (approx 15 minutes) before applying next coat. Test for proper drying of adhesive by lightly pressing finger-knuckle against the adhesive surface. If there is a snap when the knuckle is pulled away from the adhesive, the surface is ready for another coat of adhesive.

Warning: Adhesives and solvents are highly flammable; perform work in well-ventilated area and away from fire. Do not store adhesives or solvents in or near Container, Service Ward.

Note. Drying time will differ under cold or extremely hot weather conditions. In direct sunlight at 70° F or higher, the drying time required between coats of adhesive is approximately eight minutes.

(1) Clean the area to be cemented with the clean cloth dampened (but not saturated) with an approved solvent to remove dust and foreign material. Do not allow excess solvent to collect at edges of seams. If the area is painted, remove all paint; adhesive will

(4) Apply a second even coat of adhesive to both surfaces. Allow second coat to dry to a tacky condition as determined in step (3), then apply a third

even coat of adhesive.

(5) Activate the adhesive surfaces by wiping the surfaces with a clean cloth wet (not damp, not dripping) with approved solvent.

Note. This activates the adhesive and makes the surfaces ready for joining, which can be done up to eight hours after second coat of adhesive. Otherwise apply one more coat of adhesive.

(6) Press the adhesive surfaces together using rubber roller provided in repair kit. Be sure the fabric is backed up against a smooth, hard surface to provide pressure and ensure a good bond. After completion of cementing procedure, dust the cemented area with talc or powdered soapstone to cover up any exposed adhesive.

Note. Do not stress the cemented area for at least 4 hours after cementing.

b. Patching Holes. Apply patches to small holes in fabric as follows.

Note. Immediately repair of small pin or nail holes is not required. However, repair of small holes should be made as soon as it is convenient to do so.

(1) Cut a round patch from the bulk material provided in the repair kit. Use a one inch diameter patch for holes up to 1/16 inch, a two inch patch for holes up to ¼ inch and a 3½ inch patch for holes up to ½ inch. For larger holes, cut a patch large enough to allow a three inch overlay beyond the edges of the hole.

(2) Clean both the area to be patched and the patch, then apply and activate adhesive as described in paragraph *a*, above.

Note. Clean and apply adhesive to the proper side of the patch so that, after installation, the same color will be visible on the patch and the shelter.

(3) Join the adhesive surface of the patch to the adhesive surface of the shelter. Squeeze out all air bubbles between joined surfaces.

Note. The patch should be laid on gradually, one side on the other or from the center to the edges, to minimize the possibility of entrapped air. Use two men to apply patches larger than four inches, one to hold the top edges up and away from prepared surface while the other starts applying patch evenly and smoothly from the bottom. This will prevent the patch from wrinkling and forming air bubbles.

(4) Press the joined surfaces together using roller provided in repair kit.

Note. Pressure is important for a good bond. Be sure the fabric is backed up against a smooth hard surface.

(5) After pressing, dust the cemented areas with talc or powdered soapstone.

c. Patching Tears. Apply patches to the inside and outside of a tear as follows.

(1) Trim off loose threads from the tear with shears provided in the repair kit.

(2) From bulk material provided in repair kit, cut a patch large enough to allow a two inch overlap

beyond torn edges.

(3) Clean the surface around the tear and clean the applicable side of the patch. Apply adhesive as described in paragraph *a*, above.

(4) Join the adhesive surface on the patch to the adhesive surface on the Container, Service Ward. Squeeze all air bubbles from between the adhesive surfaces and use roller with pressure to bond the patch to the fabric. Dust the cemented area with talc or powdered soapstone.

d. Repairing Cemented Seams and Replacing Cemented Parts. Repair separated or damaged cemented seams and parts as follows.

(1) Carefully peel the cemented parts to separate, keeping the cloth soaked with solvent as the parts are peeled apart. Examine the separated parts for damage and repair damage by patching or replacement, before re-cementing parts.

(2) Thoroughly clean surfaces to be cemented as described in paragraph *a*, above.

(3) Apply adhesive as described in paragraph *a*, above. Activate about 10 to 12 inches of the adhesive surfaces at a time as described in paragraph, above. Allow the activating solvent to evaporate slightly (not wet) and press together about six to eight inches of the seam to ensure that no more seal will be joined at a time than has been activated.

(4) Join seams gradually. Press the surfaces together by moving the finger or thumb along the seam. Squeeze out all air bubbles from between the adhesive surfaces.

(5) Roll each six to eight inch section immediately with the roller provided in the repair kit. When the seam is completely joined, reroll the length of the seam with roller.

e. Replacing Repair Patches (patches over holes, tears, etc.). If a repair patch loosens at the edges, do not remove the complete patch for repair; cut off loose or fringed ends and cover the old patch with a new larger patch as follows.

Note. If the old patch is off or has been removed, install over-size patch to replace old patch.

(1) Repair a one inch patch with a three inch patch, a two inch patch with six inch patch and all larger patches with a patch extending three inches beyond the old area.

(2) Clean the area to be cemented and the applicable side of the patch as described in paragraph *a*, above.

(3) Apply adhesive and activate adhesive as described in paragraph *a*, above.

(4) Install new patch and use roller with pressure to bond patch.

Section VIII. GENERAL RIVET AND INSERT REPAIR

2-11. General

This section provides organizational maintenance

personnel with general repair and replacement instructions applicable to rivets and inserts used in the Container, Service Ward.

2-12. Pop Rivet Replacement

a. *Storage and Handling.* Rivets must be stored in the original labeled packages. The packages shall be kept closed when not in use to prevent dirt, grit, metal chips, etc., from coming in contact with the lubricated stems.

b. *Removal.* Rivets which are damaged or used for securing a replaceable part shall be removed as follows.

(1) Drill through the center of the rivet. Use a drill bit with the same diameter as the original rivet hole. The drill must be held perpendicular to the surface to prevent enlargement or damage to the existing hole. Drill through just deep enough to sever the rivet head from the shank.

(2) Remove any remaining rivet with a pin punch and remove any burrs from rivet hole.

c. *Rivet Replacement.* Select a rivet of the proper diameter and length and install as follows.

Note. Proper length of rivet to be used shall be determined by measuring the actual thickness of material through which the rivet will go and then selecting proper grip length per table 2-3. Proper rivet diameter is important as blind rivets installed in oversize holes will not retain the stem satisfactorily. Undersize holes will not permit proper pull-in of stems. (fig. 2-3).

(1) Hold parts to be riveted tightly together with epoxy or other satisfactory method.

(2) Insert proper rivet in hole and apply with gun (supplied with repair kit) by inserting stem head of rivet in bottom slot in gun pulling head (nose piece).

Note. Wet all rivets with sealant (PRC 611, Products Research Co., Burbank, California, or equivalent) before installation.

(3) Hold gun at right angle to work. Push gun against work with just enough force to firmly seat rivet and to aid in avoiding sheet or other part separation.

(4) Pull rivet until stem breaks.

(5) Installed blind rivets shall be checked per paragraph 1-12d, before proceeding.

(6) Trim the broken stem flush with the rivet head.

(7) Firmly press on the installed rivet to assure tightness.

d. *Inspection of Installed Rivets.* Installed rivets shall be inspected as follows.

Table 2-3. Blind Rivet Selection Chart

Nominal rivet diameter	Hole size and drill number	Diameter	Length	Grip range	Rivet No.
3/32	0.096-.100 #41	.094	.212	.020-.125	32
			.337	.126-.250	34
			.170	.020-.062	41
			.232	.063-.125	42
			.294	.126-.187	43
1/8	.128-.132		.357	.188-.250	44

Nominal rivet diameter	Hole size and drill number	Diameter	Length	Grip range	Rivet No.
	#30	.125	.419	.251-.312	45
			.481	.313-.375	46
			.628	.376-.500	48
5/32	.160-.164 #20	.156	.254	.020-.125	52
			.316	.126-.187	
			.379	.188-.250	54
			.504	.251-.375	56
			.629	.376-.500	
3/16	.192-.196 #11	.187	.277	.020-.125	62
			.402	.126-.250	64
			.527	.251-.375	66
			.652	.376-.500	68
			.777	.501-.625	610
			.902	.626-.750	
1/4	.257-.261 F	.250	.447	.125-.250	84
			.572	.251-.375	86
			.697	.376-.500	88
			.947	.626-.750	812

(1) The rivet stem and collar shall be flush with in the limits described in figure 2-2.

(2) A slight "flash" caused by the pressure necessary to drive the rivet is acceptable within the limits shown in figure 2-2.

(3) The configurations of installed rivets with the blind side visible shall be similar to those shown in figure 2-2.

(4) Superficial stretch marks which may appear on the rivet are not detrimental to rivet strength and are acceptable.

(5) After stem trimming, stem can be checked for tightness by applying a force of approximately ten pounds to the trimmed stem of the rivet, push steadily; do not strike. If the stem is neither pushed out or loose, tightness is satisfactory.

(6) Rivet head gapping shall be checked with a 0.002 feeler gage. Rivets with a 0.002 gap on more than 40 percent of the rivet head circumference shall not be acceptable.

(7) A partial gap on a round surface is acceptable, provided the rivet head bears at tangent points, as shown in figure 2-2.

2-13. Insert Replacement

a. *Removal.* Inserts which are damaged or missing shall be removed as follows.

(1) Using a drill with the same size as the initial potting hole, drill out the insert.

(2) Remove loose particles from the hole using a compressed air blast with clean air.

b. *Potting Resin (adhesive) Mixing.* The adhesive compound shall be blended using a 50% resin and 50% curing agent ratio. Blend the resin and the curing agent together in a paper mixing cup using long, smooth strokes, rather than a whipping motion. Pot life after mixing is 10 minutes and the adhesive shall be discarded after 8 minutes.

c. *Application of Potting Compound.* Apply the adhesive compound observing the following.

- (1) Using a clean tongue depressor, trowel the adhesive compound into the insert hole.
- (2) Exercise care during the troweling operation to prevent trapping air pockets in the insert hole.
- (3) Use enough adhesive to ensure that the hole is completely full after the insert is put in.

d. *Installation of Inserts.* Use the same size and type of insert as the one removed, observing the following.

- (1) Tape over bottom of insert to prevent epoxy from entering inside of insert.
- (2) Turn screw and washer completely and

tighten into insert.

- (3) Clean outside of insert with a lint-free cloth soaked with methl ethyl ketone. Allow insert to dry.
- (4) Place insert in hole and press down firmly.
- (5) Remove adhesive residue left on the surface by wiping hole area with lint-free cloth soaked with methl ethyl ketone.
- (6) Cover the hole area with tape, making sure that the washer is held down firmly by the tape. A diagram of a typical installation of an insert in a honeycomb panel is given in figure 2-3.
- (7) Cure at room temperature for 4 hours; after one day, the tape can be removed and parts handled and fasteners inserted.

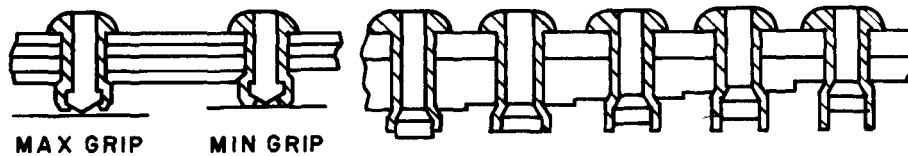
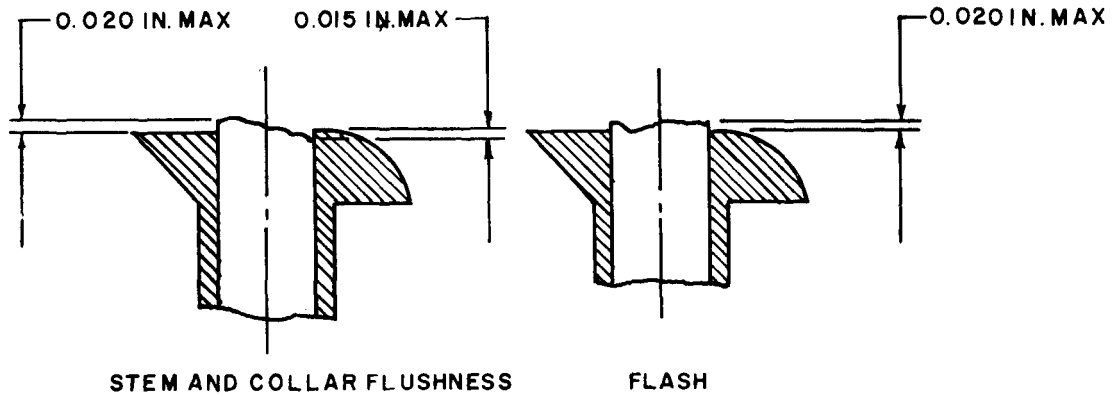

SATISFACTORY CONFIGURATION

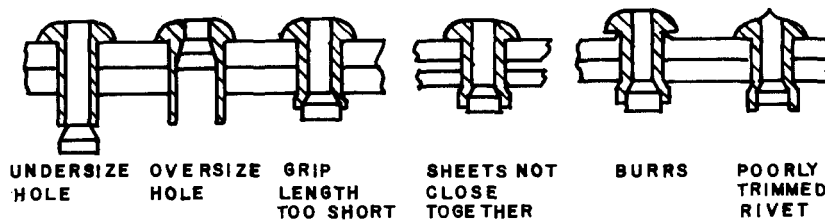

UNSATISFACTORY CONFIGURATION

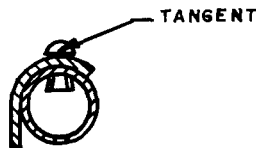

ROUND SURFACE INSTALLATION

ME 5410-223-24/2-2

Figure 2-2. Rivet inspection.

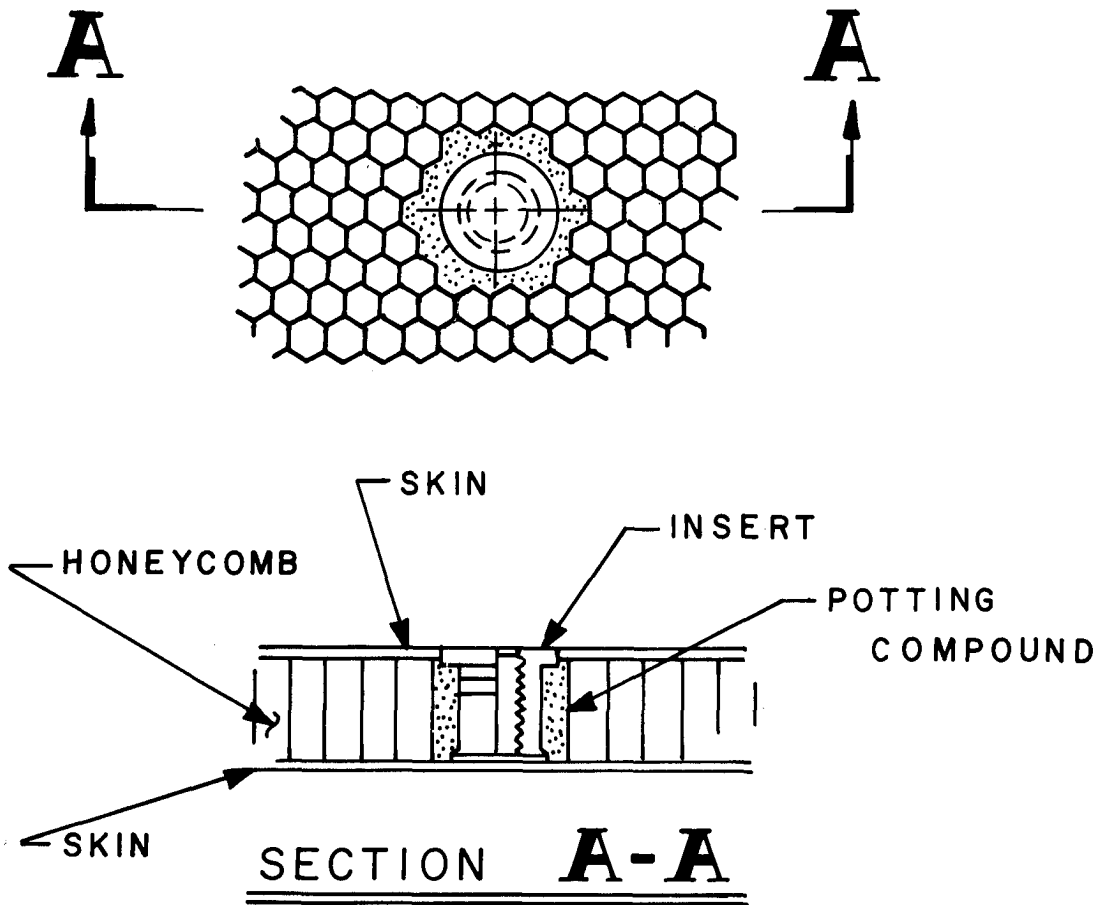

ME 5410-223-24/2-3

Figure 2-3. Typical insert installation.

Section IX. GENERAL HONEYCOMB PANEL REPAIR

2-14. General

This section provides organizational maintenance personnel with general repair instructions applicable to the honeycomb parts of the Container, Service Ward.

2-15. Repair Procedures Using Plug Patches and Adhesive

a. *Mixing of Two Part Adhesive.* Mixing of adhesive used for repair of honeycomb core shall be ac-

complished as follows.

(1) Use a mixing ratio of 50 parts accelerator to 100 parts base by volume.

Warning: Adhesives and solvents are highly flammable; perform work in well-ventilated area and away from fire.

(2) Add the proper amount of adhesive base and accelerator to a mixing cup (from repair kit) and mix thoroughly using a mixing paddle from the repair kit. The pot life of the adhesive after mixing is 45 minutes.

b. *Repairing Honeycomb Panel with Damage to One Surface Only.* Repair damaged honeycomb panel as follows.

(1) Trim the damaged area of the aluminum fac-

ing using tin snips, circular saw or other suitable tool. (fig. 2-4).

(2) With a knife, cut into the entire thickness of the honeycomb, trimming the core to the same size as

**D = DIAMETER OF RIVET
(1/8 IN. = 0.125)**

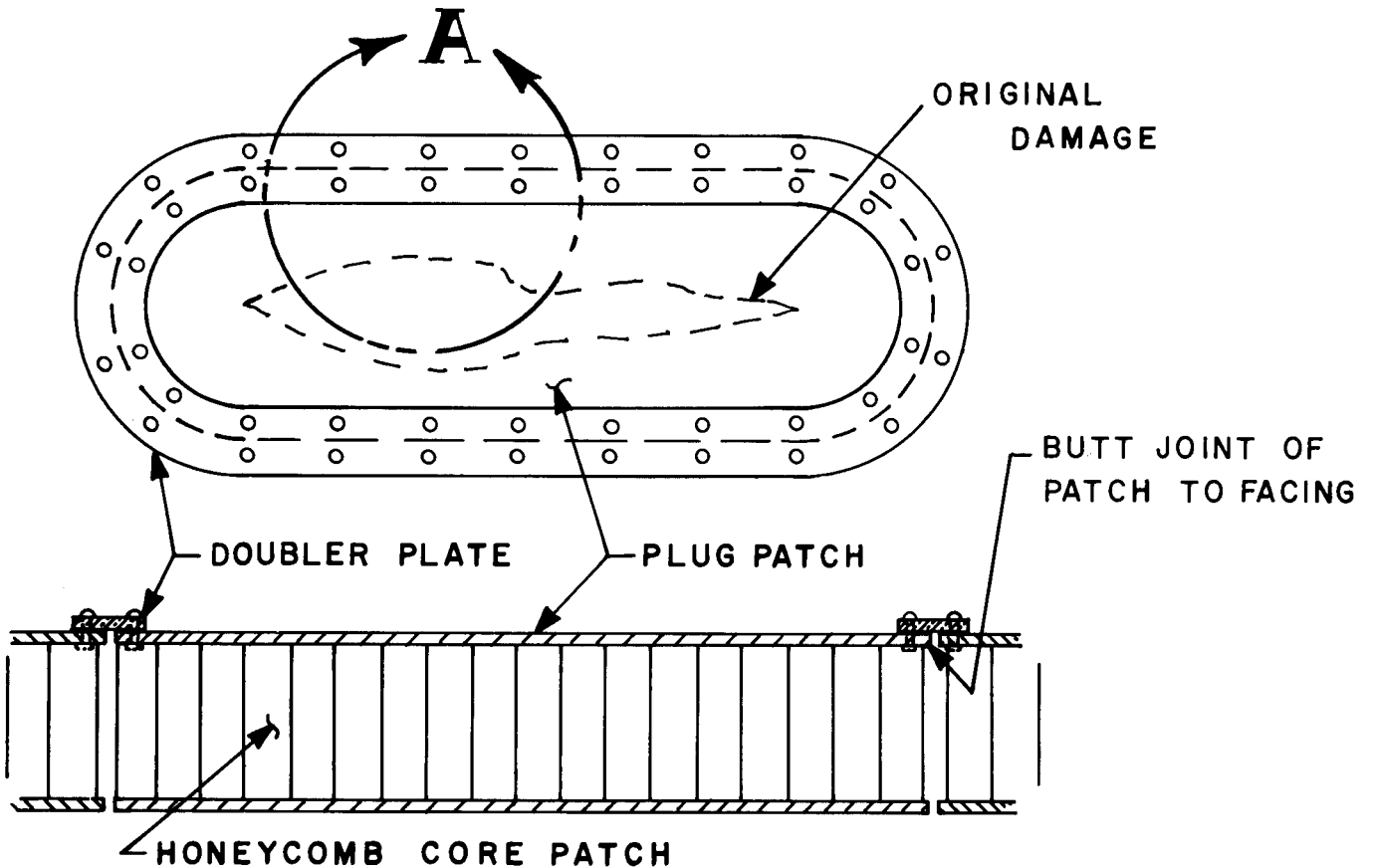
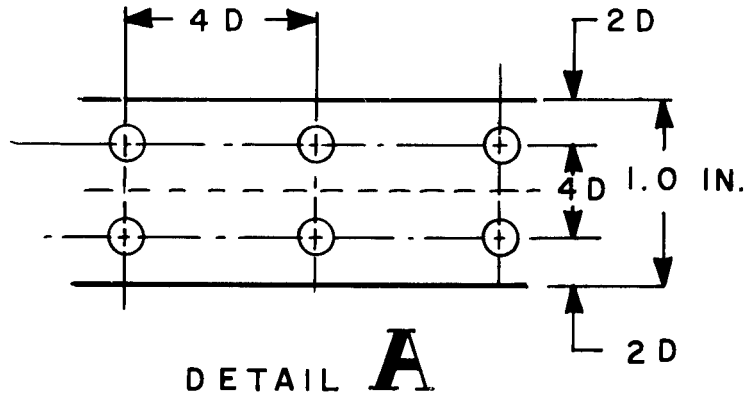

ME 5410-223-24/2-4

Figure 2-4. Typical honeycomb panel repair.

the trimmed hole in the facing (fig. 2-4).

Note. In general, trimmed holes are not restricted as to size or shape; however, those of rectangular, circular, square and oval and rectangular with round ends usually are more desirable as to appearance and ease of installation.

(3) Clean the interior surface of the undamaged facing with emery cloth, and a clean lint-free cloth soaked with methyl ethyl ketone.

(4) Cut a plug patch plate of the same size as the trimmed hole using the aluminum facing furnished with the repair kit.

(5) Cut a section of honeycomb core material the same size as the trimmed hole using the honeycomb core furnished with the repair kit.

(6) Fabricate a doubler plate the same shape as the trimmed area using figure 2-4 as a guide.

(7) Drill rivet holes in the doubler plate using a number 30 drill (0.128-0.132 inch diameter) and spaced as illustrated in figure 2-4.

(8) Drill matching holes in the plug patch plate and panel using the doubler plate as a template.

(9) Apply a thin coat of adhesive to the cleaned interior facing (step 3, above) to the edges of the honeycomb core and to the back of the plug patch plate.

(10) Insert the honeycomb core into the trimmed area of the panel and press firmly in place. Place the plug patch plate in position and press firmly.

(11) Secure the patch plate in position using 1/8 inch domed head blind rivets (from repair kit), using procedures given in Section VIII as a guide. (fig. 2-4).

(12) Apply primer and, after primer is dry, re-paint repair area using paint conforming to Federal Standard 595, Color Chip X34087. (para 6-12).

c. Repair to Honeycomb Panel with Damage to Both Surfaces. Panel damage which penetrates both surfaces shall be repaired using the procedure given in paragraph (b), above. Both facings shall be repaired.

- | | |
|------------------------------------|---------------------------------|
| 1. Fabric assembly, upper | 47. Plate (2 req'd) |
| 2. Zipper | 48. Rivet (4 req'd) |
| 3. Fabric assembly, lower | 49. Nut (2 req'd) |
| 4. Flap assembly (2 req'd) | 50. Ring (2 req'd) |
| 5. Screen assembly (2 req'd) | 51. Bracket (2 req'd) |
| 6. Extrusion | 52. Shoulder bolt (2 req'd) |
| 7. Spacer (4 req'd) | 53. Washer (2 req'd) |
| 8. Spacer (4 req'd) | 54. Extrusion (2 req'd) |
| 9. Keeper plate (4 req'd) | 55. Bar (2 req'd) |
| 10. Rivet (6 req'd) | 56. Shoulder bolt (2 req'd) |
| 11. Rivet (4 req'd) | 57. Bolt (2 req'd) |
| 12. No. 2 Link Lock (4 req'd) | 58. Washer (4 req'd) |
| 13. Spacer (4 req'd) | 59. Seal |
| 14. Spacer (4 req'd) | 60. Strip (2 req'd) |
| 15. Extrusion | 61. Rivet |
| 16. Strip (2 req'd) | 62. Screw (2 req'd) |
| 17. Strip (2 req'd) | 63. Screw (2 req'd) |
| 18. Post, corner support (2 req'd) | 64. Washer (2 req'd) |
| 19. Rope | 65. Washer (2 req'd) |
| 20. Plug assembly (2 req'd) | 66. Hinge pin (2 req'd) |
| 21. Tape, hook | 67. Spacer (8 req'd) |
| 22. Tape, pile | 68. Link lock striker (8 req'd) |
| 23. Plate, cover shear (2 req'd) | 69. Rivet (24 req'd) |
| 24. Screw, flathead (6 req'd) | |
| 25. Plate, filler shear (2 req'd) | |
| 26. Plate, shear (2 req'd) | |
| 27. Angle, corner brace (12 req'd) | |
| 28. Rivet (48 req'd) | |
| 29. Screw (96 req'd) | |
| 30. Screw (16 req'd) | |
| 31. Washer (16 req'd) | |
| 32. Bracket strap (8 req'd) | |
| 33. Spacer (24 req'd) | |
| 34. Clamp (24 req'd) | |
| 35. Nut (24 req'd) | |
| 36. Screw (24 req'd) | |
| 37. Nut (2 req'd) | |
| 38. Tie block (2 req'd) | |
| 39. Bolt (2 req'd) | |
| 40. Spring (2 req'd) | |
| 41. Cable assembly (2 req'd) | |
| 42. Washer (2 req'd) | |
| 43. Screw (2 req'd) | |
| 44. Pin assembly (2 req'd) | |
| 45. Rivet (2 req'd) | |
| 46. Pin (2 req'd) | |

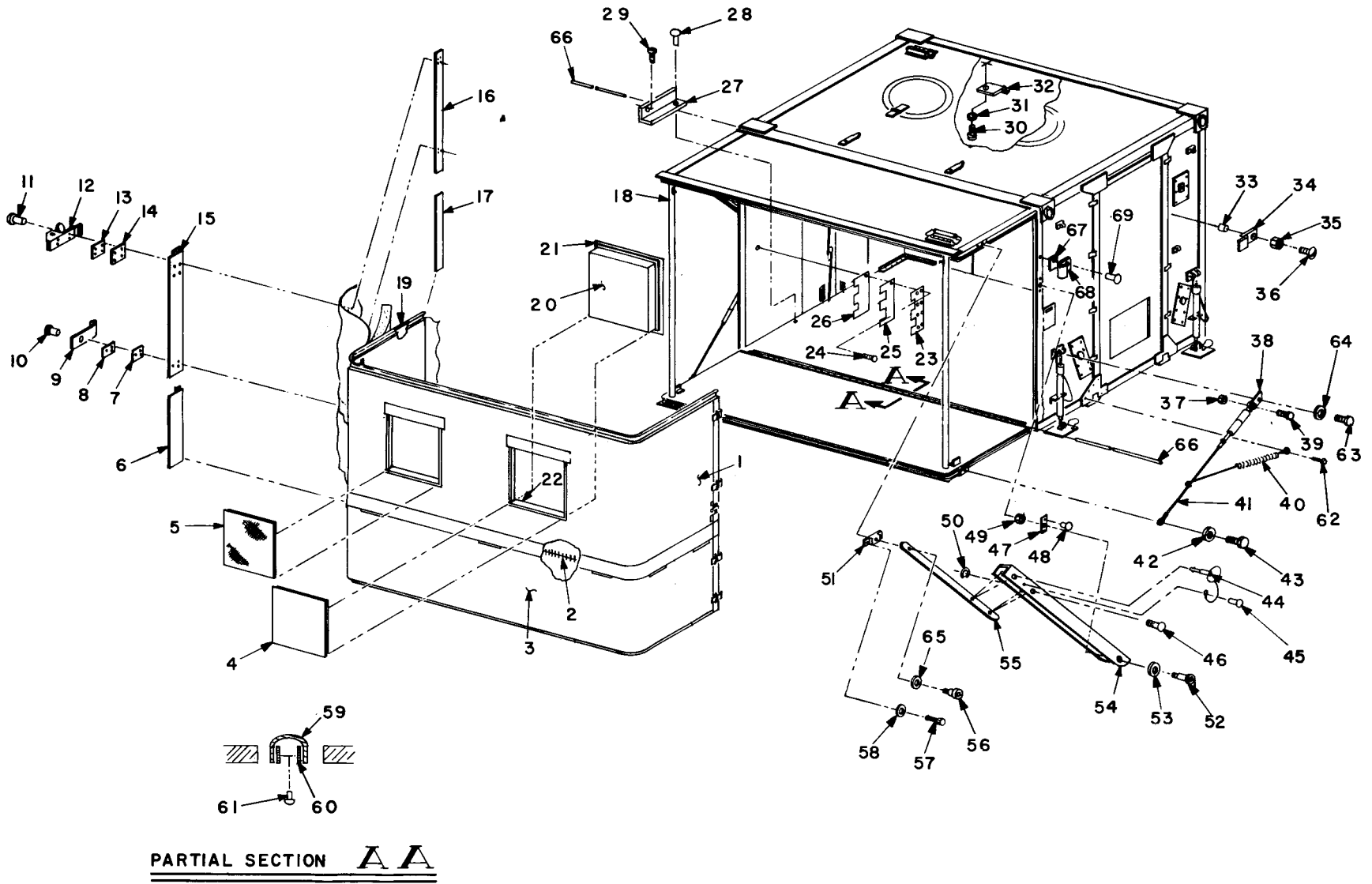

PARTIAL SECTION **A A**

ME 5410-223-24/2-5

Figure 2-5. Container, Service Ward, accessories disassembly.

d. Repair to Damaged Honeycomb Panel Edging (closeouts). Repair damaged panel edging as follows:

(1) Remove the damaged phenolic edging with a sharp knife to cut away from honeycomb core, using care to prevent damage to honeycomb core and aluminum facing edge.

(2) Cut a section of phenolic edging the same size as the damaged area and apply a thin coat of the two part adhesive to the phenolic edging back.

(3) Press the edging firmly in place and allow to cure for a minimum of 8 hours.

e. Repair to Honeycomb Floor Panel. Repair the damaged floor panel as follows.

(1) Trim and clean damaged surface as described in paragraph *b* above.

(2) Attach doubler plate (fig. 2-4) to exterior surface of floor panel only.

(3) Fill interior floor surface around repair patch with epoxy.

(4) After epoxy has hardened, smooth with sandpaper.

(5) Refinish floor surface as described in paragraph *6-10h*.

Section X. CONTAINER, SERVICE WARD, ACCESSORIES

2-16. General

This section provides instructions for repair and replacement of those items considered as accessories to the Container, Service Ward. These accessories consist of the jack assemblies and cargo tiedown components. (fig. 2-5).

2-17. Jack Assemblies (Fixed End)

a. Removal. The fixed end jack assemblies (2, fig. 2-6) shall be removed as follows.

(1) Remove cotter pin (1) from clevis pin (6) and push clevis pin (6) from hole.

(2) Unscrew bolts (4) from Container, Service Ward, panel, allowing jack leg to be removed from Container, Service War.

b. Disassembly. To disassemble the jack, proceed as follows.

(1) Drive roll pin (item 9, fig. 2-6) from the drive shank. Pull drive shank off jack leg.

(2) Entire jack screw assembly can now be pulled out of bottom end of jack leg. The screw assembly consists of the following retracting tube, retracting screw, thrust bearing, thrust washer, and a rectangular key.

(3) Dismantle retracting screw assembly as follows.

(a) Turn retracting screw out (counterclockwise) until the roll pin in the screw shaft aligns with the holes in the retracting tube.

(b) Drive out roll pin.

(c) Continue turning retracting screw until it disengages from the threads in the retracting tube.

c. Repair. Clean and inspect all jack parts. Replace any faulty or defective part.

d. Reassembly. Reassemble in the reverse order of disassembly. Lubricate all moving parts with a suitable high-temperature water-resistant greast (NLGI #2 automotive chassis lubricant is satisfactory).

When installing screw assembly in jack leg tube, place rectangular key in its slot in the upper part of the leg also, align the slot in the retracting tube with the rectangular key, thereby assuring the screw assembly is rigid to the jack leg.

e. Installation. Install jack assembly (2, fig. 2-6) in reverse order of removal procedure using figure 2-6 as a guide and observing the following.

(1) Place jack assembly (2) into position and insert pin (6) into hole and install new cotter pin (1).

(2) Secure jack to shelter with bolts (4).

2-18. Cargo Tie Down Installation

a. Removal. Removal of the cargo tiedown installation shall be accomplished using figure 2-7 as a guide and observing the following.

(1) Remove the rope net assembly (3, fig. 2-7) by removing the tiedown ropes securing it to the strap assembly (1).

(2) Remove the web net assembly (2) from the cargo top.

(3) Remove the strap assembly (1) from the shelter tiedown fitting by disconnecting the metal ring.

b. Repair. Inspect all cargo tiedown parts. Replace any that are faulty or defective.

c. Installation. Install the cargo tiedown assembly in reverse order of removal using figure 2-7 as a guide and observing the following.

(1) Attach the metal ring of the strap assembly (1, fig. 2-7) to the shelter tiedown fittings and tighten the strap assembly.

(2) Place the web net assembly (2) over the cargo and fasten securely.

(3) Place miscellaneous cargo on top of main cargo and secure with the rope net assembly (3) using the strap assembly (1) as a means of attachment.

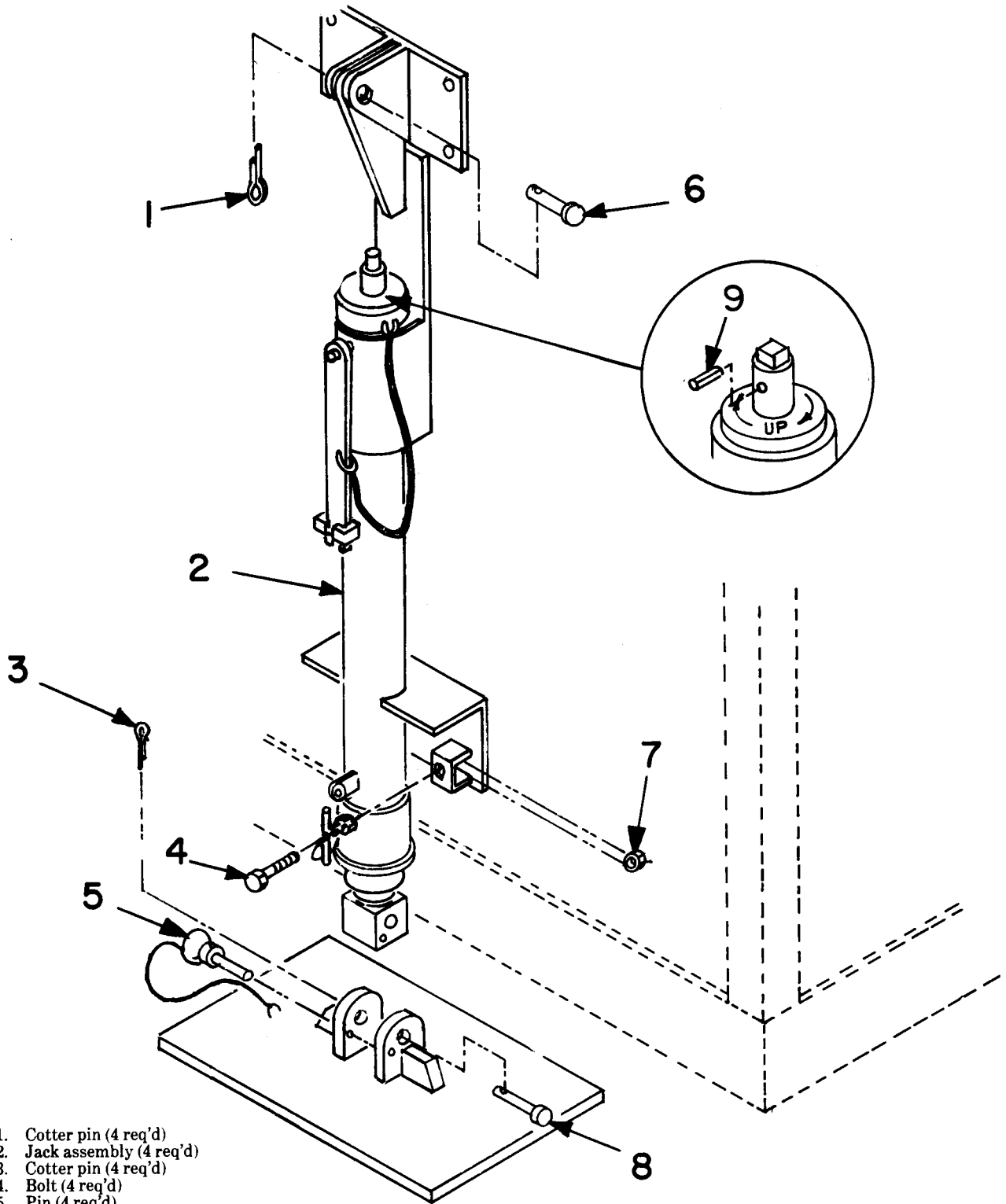

- 1. Cotter pin (4 req'd)
- 2. Jack assembly (4 req'd)
- 3. Cotter pin (4 req'd)
- 4. Bolt (4 req'd)
- 5. Pin (4 req'd)
- 6. Pin (4 req'd)
- 7. Nut (4 req'd)
- 8. Pin (4 req'd)
- 9. Roll pin (1 req'd)

ME 5410-223-24/2-6

Figure 2-6. Jack assembly removal.

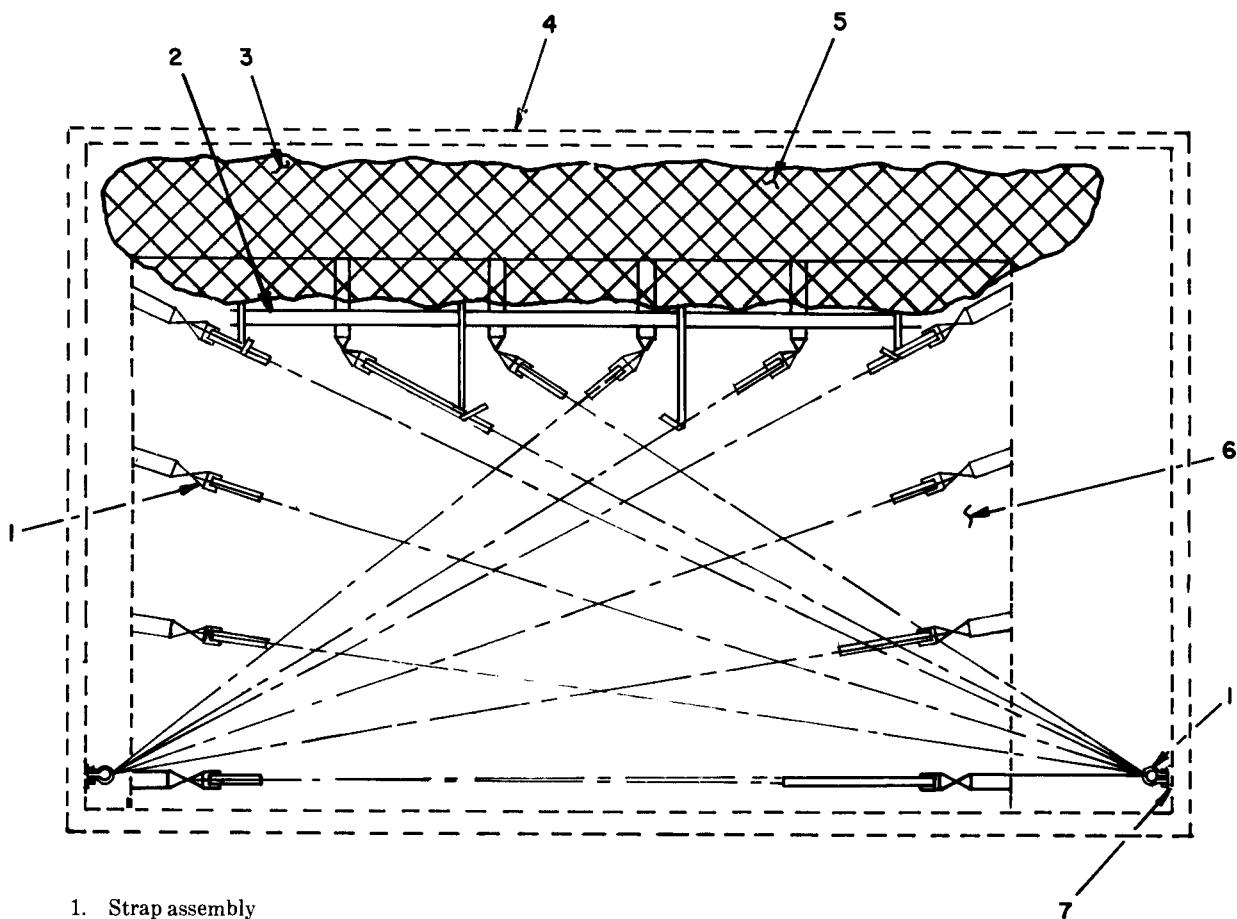

1. Strap assembly
2. Web net assembly
3. Rope net assembly
4. Shelter
5. Miscellaneous cargo
6. Cargo
7. Existing tiedown fitting

ME 5410-223-24/2-7

Figure 2-7. Cargo tiedown installation.

CHAPTER 3

SHIPMENT AND LIMITED STORAGE AND DEMOLITION TO PREVENT ENEMY USE

Section I. SHIPMENT AND LIMITED STORAGE

3-1. General

This section provides instructions for handling, shipment, and limited storage of the Container, Service Ward.

3-2. Handling

Handling of the Container, Service Ward, may be accomplished by crane hoist hooked to the lifting eyes on the Container, Service Ward, by fork lift or hi-lift, by wheeled transporter; or the Container, Service Ward, may be skidded for short distances. See figure 3-1 for location and identification of handling points and hardware. Perform the various handling operations as follows.

a. Hoisting. Attach a hoisting sling (7500 pound minimum capacity) to the four lifting rings. (fig. 3-1). Secure sling to a crane or other lifting device capable of raising a minimum of 7500 pounds and hoist to the desired location.

Warning: Do not use lifting equipment with capacity of less than 7500 pounds. Do not allow Container, Service Ward, to swing back and forth when it is suspended. Failure to observe this warning may result in damage to equipment or severe injury or death to personnel.

Caution: Do not attach hoisting sling to the lifting equipment in such a manner that the angle between any of the hoist lines and the top of the Container, Service Ward, is less than 45 degrees. Any angle less than 45 degrees will cause an excessive strain, which could damage the Container, Service Ward.

b. Fork Lift. Position the 7500 pound minimum capacity fork lift at the lift points designated on the Container, Service Ward, and shown in figure 3-1, and lift Container, Service Ward, for loading or transport for short distances.

Caution: Fork extensions are required for fork-lifting the Container, Service Ward, in order to prevent damage to the raceways located on the underside of the Container, Service Ward.

Warning: Do not use fork lifts with capacity of less than 7500 pounds. Do not allow Container, Service Ward, to rock excessively on fork lift. Failure to observe this warning may result in damage to equipment, severe injury or death to personnel.

c. Wheeled Transporter. A wheeled transporter or mobilizer may be attached to the Container, Service Ward, to permit towing as follows.

(1) Separate transporter sections and prepare

transporter for use observing all recommendations of transporter manufacturer.

(2) Position transporter sections at ends of Container, Service Ward, adjacent to mobilizer brackets at ends of Container, Service Ward. (fig. 3-1).

(3) Position transporter brackets to connect with Container, Service Ward.

(4) Operate transporter according to transporter manufacturer's instructions to raise Container, Service Ward, to towing height.

(5) Connect towing equipment to transporter tow bar or manually move Container, Service Ward, to desired position.

(6) When Container, Service Ward, is in desired position, operate transporter to lower Container, Service Ward, then remove transporter sections.

d. Skidding. Attach a cable or chain sling to towing rings identified on the Container, Service Ward, and shown in figure 3-1. Connect cable or chain sling to suitable equipment for skidding the Container, Service Ward.

Caution: To prevent damage to Container, Service Ward, skids, limit skidding of the Container, Service Ward, to short distances and only over smooth level terrain.

3-3. Preparation of Equipment for Shipment

a. Inspection. Examine the Container, Service Ward, for any unusual conditions such as damage or missing components. Inspect the Container, Service Ward, in accordance with steps outlined in Weekly Preventive Maintenance Services (para 2-5). Record on DA Form 2404 (TM 38-750) deficiencies and shortcomings along with corrective action taken.

b. Preparation for Shipment. The following shall be performed prior to folding the Container, Service Ward, for shipment. Detach, disassemble, and stack for storage all Medical Corps equipment in accordance with instructions on instruction placard located on inside of access door. Secure equipment with applicable tiedown apparatus in accordance with instructions placard.

c. Marking. Mark Container, Service Ward, in accordance with MIL-STD-129.

d. Shipment. The Container, Service Ward, maybe transported by airplane, helicopter, ship, truck, or train. Using the various tiedown and hoisting rings identified on the Container, Service Ward, and shown in figure 3-1, secure the Container, Service Ward, to the transport equipment. Refer to Association of American Railroads Rules Governing the Loading of Commodities on Open Top Cars (see 4, fig. 1A) for

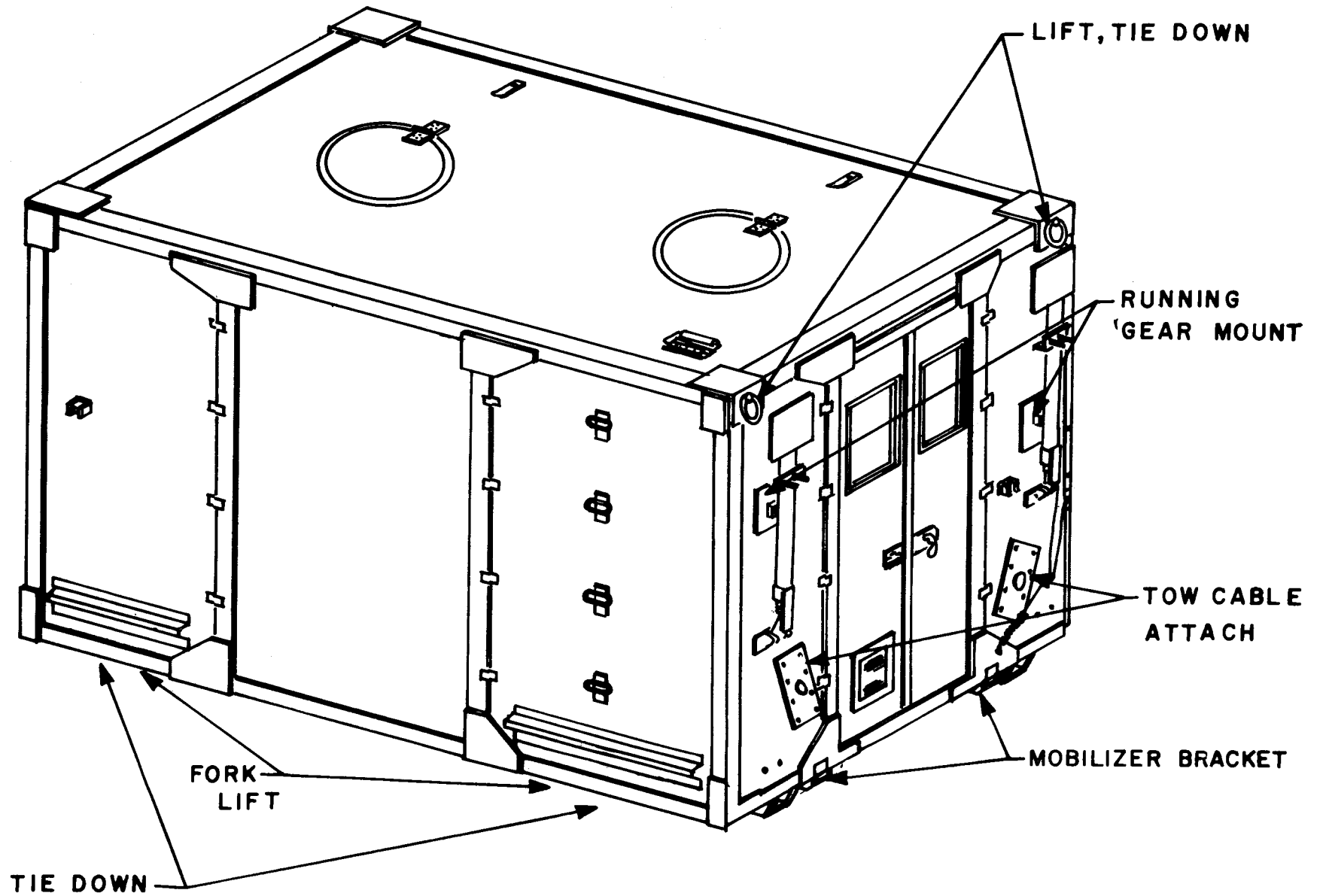

ME 5410-223-24/3-1

Figure 3-1. Container, Service Ward, handling points.

blocking and tiedown procedures when shipment is by railroad flatcar.

Caution: Position Container, Service Ward, with skid base parallel to the longitudinal axis of the carrier to prevent excessive side loads on the skids. Make sure the carrier and restraining methods are capable of supporting a weight of 7500 pounds minimum.

3-4. Limited Storage

a. General. Every effort should be made to provide covered storage for the Container, Service Ward. If this is not possible, select a firm, level, well-drained storage location, protected from prevailing winds. Position the Container, Service Ward, on heavy planking. Cover with a tarpaulin or other suitable waterproof covering and secure in a manner that will provide the Container, Service Ward, maximum protection from the elements.

b. Inspection. Examine the Container, Service Ward, for any unusual conditions such as damage or missing components. Inspect in accordance with steps outlined in Weekly Preventive Maintenance Services (para 2-4). Record on DA Form 2404 (TM-38-750) deficiencies and shortcomings along with corrective action.

c. Preparation for Limited Storage. The following shall be performed prior to folding the Container,

Service Ward, for limited storage. Detach, disassemble, and stack for storage all Medical Corps equipment in accordance with instructions on instruction placard located on inside of access door. Secure equipment with applicable tiedown apparatus in accordance with instructions placard.

d. Inspection and Maintenance of Equipment in Limited Storage. After Container, Service Ward, has been placed in limited storage, suspend all regularly-scheduled preventive maintenance services and inspect as specified herein. Visual inspection of the Container, Service Ward, in limited storage must consist of at least a walk-around examination to observe any deficiencies that may have occurred. Inspect Container, Service Ward, in open storage weekly and that in covered storage monthly. Immediately after any severe storm or environmental change inspect all equipment. Record on DA Form 2404 all deficiencies and shortcomings together with corrective action taken. Keep Container, Service Ward, in an optimum state of readiness. Accomplish required services and repairs as expeditiously as possible. Whenever possible, perform all maintenance "on-site". To assure utilization of all assigned material, rotate in accordance with any rotational plan that will keep Containers, Service Ward, in an operational condition and reduce maintenance effort.

Section II. DEMOLITION TO PREVENT ENEMY USE

3-5. Authority

The Container, Service Ward, is to be destroyed only if it is in danger of being captured and used by the enemy, and only upon the order of the unit commander.

3-6. Method

Destroy the same parts on all similar equipment to prevent enemy use through cannibalization.

a. Destruction by Hand.

- (1) Use sledge hammers, axes, crowbars, or any

other heavy tools to smash the components.

- (2) Slash electrical cables, cords, and fabric.

- (3) Remove easily removable assemblies.

- (4) If a stream is nearby, throw loose parts into the water. Bury or scatter remaining parts.

b. Destruction by Explosives. If demolition explosives are available, charges should be placed inside the Container, Service Ward, and ignited.

c. Destruction by Weapon Fire. Fire into the Container, Service Ward, using the largest practical weapon available.

CHAPTER 4
DIRECT AND GENERAL SUPPORT MAINTENANCE INSTRUCTIONS

Section I. GENERAL

4-1. Scope

These instructions are published for the use of direct and general support maintenance personnel maintaining the Container, Service Ward. They provide maintenance information which is beyond the scope of tools, equipment, personnel, or supplies normally available to using organization.

4-2. Record and Report Forms

For record and report forms applicable to direct support maintenance, refer to TM 38-750.

Note. Applicable forms, excluding Standard Form 46 which is carried by the operator, shall be kept in a container mounted on the equipment.

Section II. DESCRIPTION AND TABULATED DATA

4-3. Description

For a complete description of the Container, Service Ward, see paragraph 1-3.

4-4. Tabulated Data Section

For tabulated data on the Container, Service Ward, see paragraph 1-4.

CHAPTER 5

GENERAL MAINTENANCE INSTRUCTIONS

I. SPECIAL TOOLS AND EQUIPMENT

5-1. Special Tools and Equipment

Special tools or equipment required by direct and general support maintenance personnel for maintenance of the Container, Service Ward, are listed in table 2-1. References and illustrations indicating the

use of these tools are listed in the table.

5-2. Specially Designed Tools and Equipment

No specially designed tools or equipment are required by direct and general support maintenance personnel for maintenance of the Container, Service Ward.

Section II. TROUBLESHOOTING

Refer to Chapter 2, Section IV for troubleshooting information for Container, Service Ward.

Section III. REMOVAL AND INSTALLATION OF MAJOR COMPONENTS OR AUXILIARIES

Refer to Chapter 2, Section IX and X for removal and installation of major components and auxiliaries.

Section IV. GENERAL FABRIC REPAIR PROCEDURES

5-3. General

This section provides direct and general support maintenance personnel with general repair instructions applicable to the fabric parts of Container, Service Ward.

5-4. Fabric Repair Procedures Using Adhesive

Refer to paragraph 2-15 for repair of fabric or replacement of fabric parts using adhesive.

5-5. Repair Procedures for Sewn Fabric Parts

a. Removal of Sewn Fabric Parts. Remove sewn fabric parts by carefully cutting stitches from fabric parts, with a seam ripper or other sharpened tool. Remove cut stitches from fabric parts.

Caution: Use extreme care in cutting stitches to prevent cutting or other damage to fabric. If fabric is cut or otherwise damaged, apply patch to damaged area as described in paragraph 2-15.

b. Installation of Sewn Fabric Parts. Position parts to be sewn together and temporarily secure the position of parts. Sew parts together according to Method 301 of Federal Standard 751, with five to nine stitches per inch. Use single needle or double needle stitching as noted on removed part.

c. Replacement of Cover Clamps. To remove and replace the clamps on the fabric cover, proceed as follows.

(1) Drill out and remove the 5/32" rivets holding the clamp to the fabric.

(2) Drill holes in replacement clamp, metal back-up strip and H-extrusion to accept a 3/16" rivet.

(3) Dip rivet in Sealant PRC-611 and install as per paragraph 2-12.

d. Slide Fastener Repairs. Due to the method of attachment, the cover slide fastener cannot be replaced in the field. Field expedient repair consists of using a wide strip of adhesive tape to hold the cover halves together until direct support or general support repairs can be made. To replace the slide fastener at depot level, proceed as follows.

(1) Remove stitching and take off old slide fastener. Replace with the No. 10 2/8" long slide fastener listed in the repair parts manual.

(2) To stitch on new slide fastener, place cover on edge and run through a drop-table sewing machine.

Note. Attach slide fastener to close from left to right as viewed from outside of Container, Service Ward, with cover in installed position.

CHAPTER 6

CONTAINER, SERVICE WARD, BODY ASSEMBLY

Section i. FOLDING PANEL ASSEMBLIES

6-1. General

This section provides instructions for replacement of those items considered as part of the folding panel assemblies. They consist of four door panel assemblies, folding end jack assemblies, folding side panels, folding end panels, folding floor panels, and folding roof panels. (fig. 6-1).

6-2. Door Panel Assemblies

a. General. The door panel assemblies are a metal faced honeycomb core panel. They consist of a weather seal assembly on the door inner edge, a hinge assembly, door stops, window assemblies with blackout curtains, and an anti-backdraft valve located on one of the panel assemblies (fig. 6-2).

b. Removal. Remove the door assemblies according to sequence of index numbers assigned to figure 6-2 and observing the following.

(1) Remove the captive screws (70, fig. 6-2) on the side panel side of the hinge (6) and the screws securing the hinge to the edge of the side panels (69, fig. 6-2).

(2) Remove doors (67, 68, fig. 6-2) from the side panels.

c. Disassembly. Disassemble the door panel assemblies for replacement of damaged parts according to sequence of index numbers assigned to figure 6-2 and observing the following.

(1) Remove washer (72) and retainer washer (71) from captive screw (70).

(2) Remove screw (40), rivets (41) which secure hinges (6) to door panel assemblies. Remove blind nut (only if required in accordance with para 2-13a).

(3) Remove hinges pin (73), separate hinge halves (75, 76), and torsion springs (74).

(4) Remove screw (48) to remove upper bar retainer (50) from panel.

(5) Remove screws from lock assembly plate and remove lock assembly from door. Disassemble door lock assembly according to sequence of index numbers assigned to Detail A and observing the following.

(a) Remove screws (26) and remove handle bar (29). Remove nut (25), washer (26), and screw (27); remove locking bar (23), handle bail (39), keeper plate (32).

(b) Remove screw (36) and remove idler block (30).

(c) Remove cotterpin (38) to remove interior handle bar (39), and handle bail.

(6) Remove rivet (25), window frame (56), spacer (62) and window (60). Remove blackout curtain pile tape (5) by peeling from window frame (56) in accord-

ance with paragraph 2-20d. Remove closeouts (2, 61) by running a knife or other sharp instrument between closeout and paper honeycomb core.

(7) Remove door stop (43) by removing screws (46). Remove kick plate (44) by removing rivets (45).

(8) Remove rivnut (1) from door by drilling out with drill bit of the same diameter as the rivnut.

(9) Remove and disassemble anti-backdraft valve by observing the following.

(a) Remove screws (11) and remove housing assembly (8), gasket (9), and grill (7).

(b) Remove damper assembly (12) by removing cotter pin (24) from pin (21). Remove pin (21) and washers (21A) from hinges to allow damper assembly (12) to be removed from housing assembly (8).

(c) Remove counterweight (16) by removing nut (17) and screw (16A) from counterweight support (13).

(d) Remove hinges (2;, 23) by removing rivet (21).

(e) Remove counterweight support (13) by removing rivet (19).

(10) Remove door pull (74) from door panel assemblies (75, 76) by removing rivets (73).

d. Overhaul. Overhaul the door panel assemblies as required to return to a serviceable condition per paragraph 6-12.

e. Assembly. Assemble the door panel assemblies in reverse order by disassembly using figure 6-2 as a guide and observing the following.

(1) Install blind nuts and rivnuts using installation procedures recommended by the manufacturer.

(2) Replace rivets observing procedures outlined in paragraph 2-12c.

(3) During assembly of door window assemblies, place a bead of PRC 611 sealant, Product Research Co., Burbank, California, or equivalent, around edge of outer window (39, fig. 6-2). Paint interior surface of spacer (38) with one coat of TT-E-527, Color 3407 per Federal Standard 595.

(4) Assemble closeouts (40, 66, 67, 71, 72) on door panel assemblies using procedures outlined in paragraph 2-15e.

f. Installation. Install the door assemblies in reverse order of removal procedure observing the following.

(1) Position the doors and secure the hinges to the side panels with the captive screws (1, fig. 6-2). Adjust doors to assure that no binding or rubbing is present.

(2) Replace the grounding straps at the upper left and right hand corners.

Figure 6-1. Container, Service Ward, body assembly panel identification.

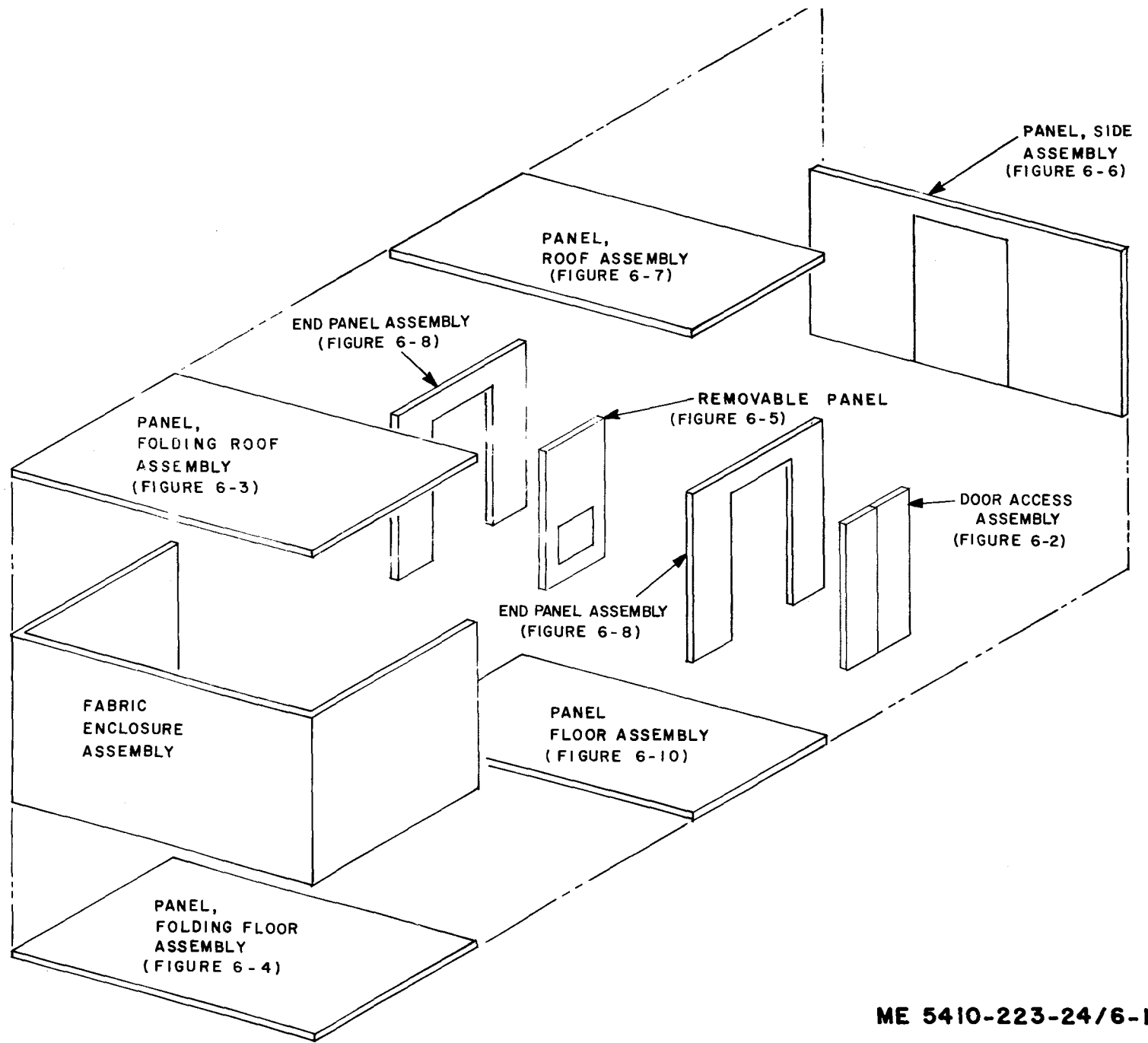

ME 5410-223-24/6-1

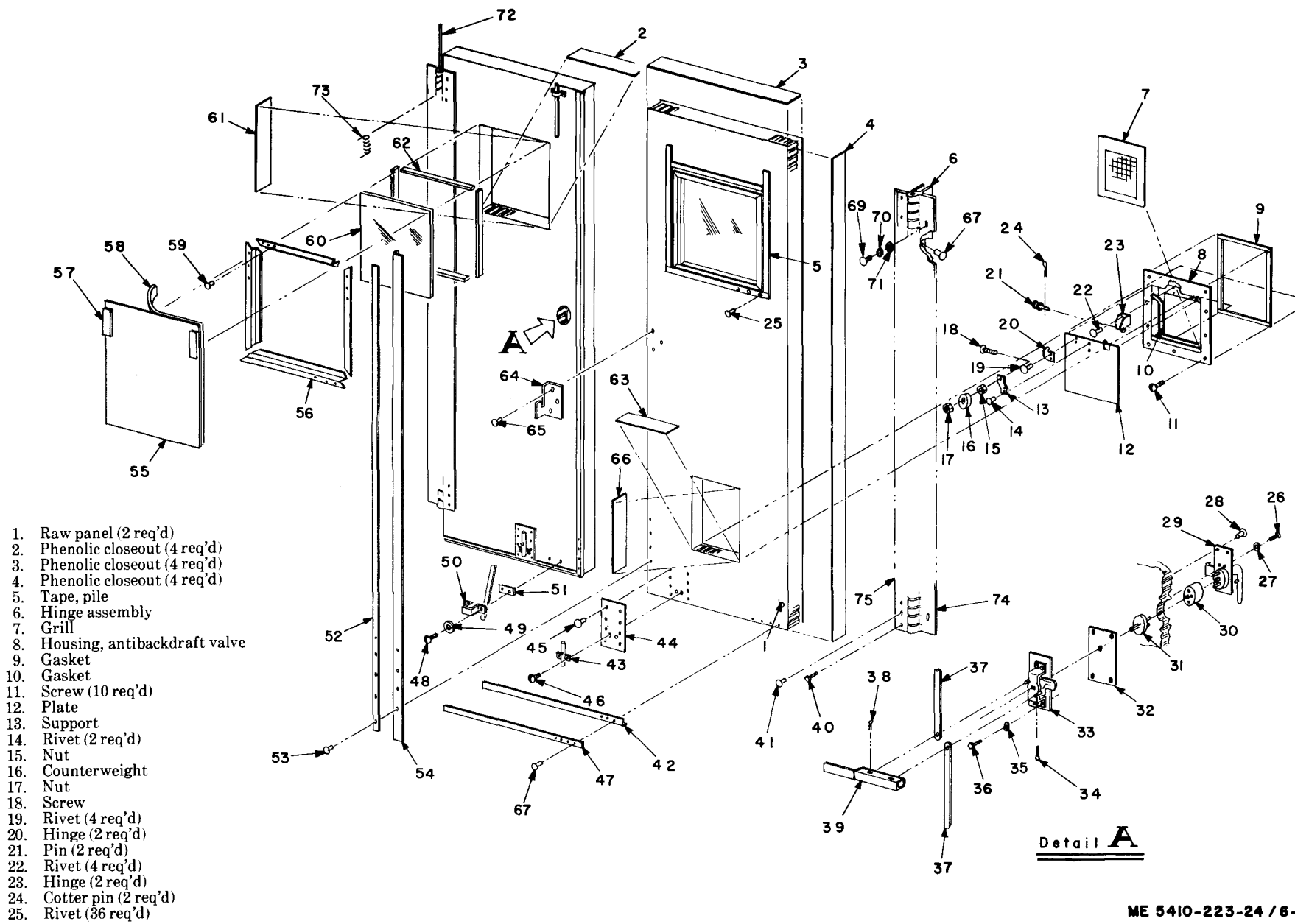

1. Raw panel (2 req'd)
2. Phenolic closeout (4 req'd)
3. Phenolic closeout (4 req'd)
4. Phenolic closeout (4 req'd)
5. Tape, pile
6. Hinge assembly
7. Grill
8. Housing, antibackdraft valve
9. Gasket
10. Gasket
11. Screw (10 req'd)
12. Plate
13. Support
14. Rivet (2 req'd)
15. Nut
16. Counterweight
17. Nut
18. Screw
19. Rivet (4 req'd)
20. Hinge (2 req'd)
21. Pin (2 req'd)
22. Rivet (4 req'd)
23. Hinge (2 req'd)
24. Cotter pin (2 req'd)
25. Rivet (36 req'd)

Detail **A**

ME 5410-223-24 / 6-2

Figure 6-2. Door assembly disassembly.

6-3. Folding Roof Panel Assembly Repair

a. General. There is one folding roof panel assembly on the Container, Service Ward. As shown in figure 6-3, the folding roof is an aluminum faced honeycomb core panel hinged to the top of the Container, Service Ward.

b. Removal. Remove the folding roof panel assembly as required to replace damaged components using figure 6-3 as a guide and observing the following.

(1) If the folding roof is raised, lower it to gain access to the hinge assembly that secures the folding roof to the fixed roof.

(2) If the folding roof is in the closed position, disengage all latches that secure it to the end panel.

(3) Using a screwdriver, remove shoulder screw (56, fig. 2-5) and washer (65), thereby allowing the support bracket to drop away from the roof panel.

(4) Drill out and remove the rivets (32, fig. 6-3) in retainer stop (33). Remove the retainer stop.

(5) Using the closed folding floor panel to support the weight of the folding roof panel, remove hinge pin (59, fig. 2-5). After starting pin removal with a drift punch, pull it out using a clamping pliers.

c. Disassembly. Disassemble the folding roof panel as required to replace damaged parts according to sequence of index numbers assigned in figure 6-3 and observing the following.

(1) Remove handles (10) by removing bolts (11) and washers (12).

(2) Remove brackets (19) at the outer edges of the folding roof panel by removing screws (18) and washers (17).

(3) Remove angle brackets (5) by removing screws (3) and washers (4).

(4) Remove slide brackets (9) and (29) by drilling out rivets (30).

(5) Remove hinge half (25), rubber seal (31) and retainer strip (2) by drilling out rivets (27) and (23) and removing screws (26).

d. Repair. Repair damage to honeycomb panel using procedures given in paragraph 2-15. If possible, straighten any bent plates, latches, angles or extrusions, using hammer, pliers, vise or other suitable tools.

e. Overhaul. Overhaul the folding roof panel as required to return to a serviceable condition as per Chapter 6, Section III.

f. Assembly. Assemble the folding roof panel in reverse order of disassembly using figure 6-3 as a guide and observing the following.

(1) Install all rivets as per Chapter 2, Section III.

(2) Replace potted inserts using procedures given in paragraph 2-14b.

(3) Seal all cracks around hinge edges using sealant PRC 611, Products Research Co., Burbank, California, or equivalent.

(4) Ensure that the flanges on slide brackets (9) and (29) face each other.

g. Installation. Install the folding roof panel assembly in reverse order of removal using figure 6-3 as a guide and observing the following.

(1) Use the folding floor panel in closed position to support the weight of the folding roof panel while positioning the hinge valves together and installing the hinge pin.

(2) Carefully inspect the rubber seal (31) before installing and replace with a new one if damaged or defective.

(3) Rivet the retainer strips in place using the rivet procedure given in Chapter 2, Section III.

6-4. Folding Floor Panel Assembly Repair

a. General. There is one folding floor panel assembly on the Container, Service Ward. As shown in figure 6-4, the folding floor is an aluminum faced honeycomb core panel hinged to the bottom edge of the Container, Service Ward.

b. Removal. Remove the folding floor panel assembly as required to replace damaged components using figure 6-4 as a guide and observing the following.

(1) Raise the folding roof panel and latch in the raised position to provide working space in removing the floor panel assembly.

(2) Make sure the folding floor panel is closed and held secure by closure of the side panel latches.

(3) Remove the bolts and washers (43 and 42, fig. 2-5) to disconnect the cable assembly (41) from the folding floor panel assembly.

(4) Drill out and remove the rivets (27, fig. 6-4) in retainer strip (28). Remove the retainer strip.

(5) Using wood shoring underneath the edge to support the weight of the folding floor panel assembly, remove the hinge pin (59, fig. 2-5). After starting pin removal with a drift punch, pull it out using a clamping pliers.

c. Disassembly. Disassemble the folding floor panel assembly as required to replace damaged parts according to sequence of index numbers assigned in figure 6-4 and observing the following.

(1) Remove brackets (6) at the outer edges of the folding floor panel by removing screws (8) and washers (7).

(2) Remove angles (9) by removing bolts (11) and washers (10).

(3) Remove angles (21) by removing bolts (23) and washers (22).

(4) Remove spirit level (29) by removing bolts (30) and washers (31).

(5) Remove rubber seal (25) and retainer strip (28) by drilling out and removing rivets (27).

(6) Remove hinge half (17) by drilling out rivets (14) and removing screws (15).

(7) Remove rub strip (16) by drilling out and removing rivets (13).

d. Repair. Repair damage to honeycomb panel using procedures given in paragraph 2-15. If possible, straighten any bent plates, latches, angles or extrusions, using hammer, pliers, vise or other suitable tool.

e. Overhaul. Overhaul the folding floor panel as required to return to a serviceable condition as per Chapter 6, Section III.

f. Assembly Assemble the folding floor assembly in reverse order of disassembly using figure 6-4 as a guide and observing the following.

(1) Install all rivets as per Chapter 2, Section III.

(2) Replace all potted inserts using procedures given, in paragraph 2-14b.

(3) Seal all cracks around hinge ends using sealant PRC 611, Products Research Co., Burbank, California, or equivalent.

g. Installation. Install the folding floor panel assembly in reverse order of removal using figure 6-4 as a guide and observing the following.

(1) Shore up the folding floor panel to support its weight while positioning the hinge halves together and installing the hinge pin.

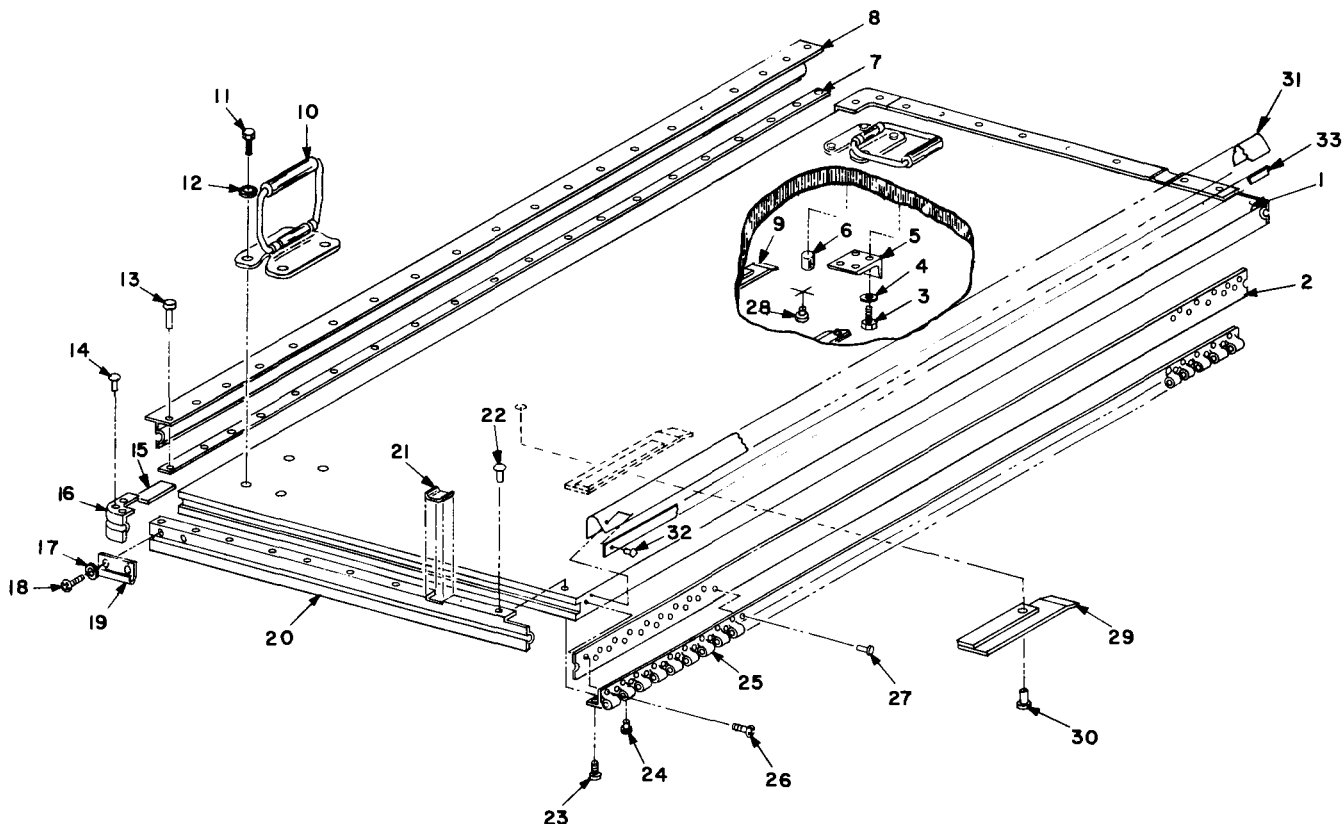

- | | |
|-------------------------------------|--------------------------------------|
| 1. Panel | 18. Screw (4 req'd) |
| 2. Phenolic closeout | 19. Plate (2 req'd) |
| 3. Bolt (8 req'd) | 20. Extrusion |
| 4. Washer (8 req'd) | 21. Channel (2 req'd) |
| 5. Angle (2 req'd) | 22. Rivet (14 req'd) |
| 6. Cup (2 req'd) | 23. Screw (10 req'd) |
| 7. Spacer | 24. Rivet (83 req'd) |
| 8. Extrusion | 25. Hinge half |
| 9. Slide bracket assembly (2 req'd) | 26. Screw (4 req'd) |
| 10. Handle (2 req'd) | 27. Rivet (88 req'd) |
| 11. Bolt (8 req'd) | 28. Fastener, snap (3 req'd) |
| 12. Washer (8 req'd) | 29. Slide bracket assembly (2 req'd) |
| 13. Rivet (26 req'd) | 30. Rivet (12 req'd) |
| 14. Rivet (2 req'd) | 31. Rubber seal |
| 15. Spacer (2 req'd) | 32. Rivet (37 req'd) |
| 16. Casting (2 req'd) | 33. Retainer strip |
| 17. Washer, lock (4 req'd) | |

ME 5410-223-24/6-3

Figure 6-3. Folding roof panel assembly disassembly.

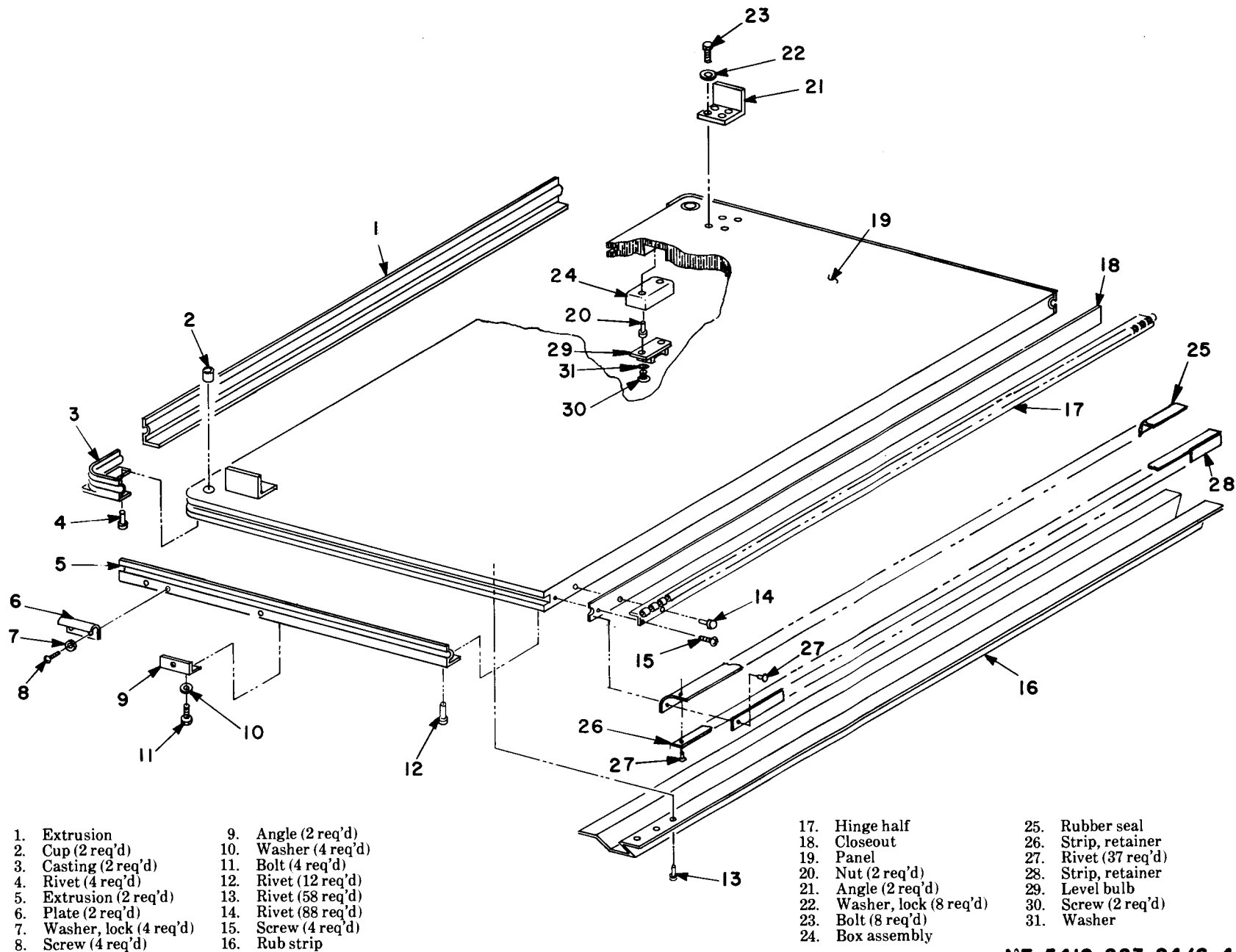

ME 5410-223-24/6-4

Figure 6-4. Folding floor panel assembly disassembly.

(2) Carefully inspect the rubber seal (25) before installing and replace with a new one if damaged or defective.

(3) Rivet the retainer strips in place using the rivet procedure given in Chapter 2, Section III.

6-5. Removable Door Panel Repair

a. General. As shown in figure 6-5, the removable door panel is an aluminum faced honeycomb core panel mounted in either the Container, Service Ward, end panel or side panel assembly. A smaller utility panel is mounted in one of the removable door panels.

b. Removal. Remove the removable door panel as required to replace damaged components using figure 6-5 as a guide and observing the following.

(1) Remove the utility panel (18) by removing all ten captive screws (28) and brackets (27).

(2) Loosen all ten captive screws (28) in attachment strips (4) located on each side of the removable door panel.

(3) From the inside of the Container, Service Ward, lift out the door panel using handles (6).

c. Disassembly. Disassemble the removable door panel as required to replace damaged parts according to sequence of index numbers assigned in figure 6-5 and observing the following.

(1) Remove handle plate (5) by drilling out and removing rivets (14) around the perimeter of the plate.

(2) Remove handle (6) from plate (5) by drilling out and removing rivets (15).

(3) Remove attachment strips (4) by drilling out and removing rivets (16).

(4) With a screwdriver, remove snaps (7).

(5) Remove strip (13) and seal (12) by drilling out and removing rivets (17).

d. Repair. Repair damage to honeycomb panel using procedures given in paragraph 2-15. If possible, straighten any bent plates, latches, angles or extrusions using hammer, pliers, vise or other suitable tool.

e. Overhaul. Overhaul the removable door panel assembly as required to return to a serviceable condition per Chapter 6, Section III.

f. Assembly. Assemble the removable door panel assembly in reverse order of disassembly using figure 6-5 as a guide and observing the following.

(1) Install all rivets as per Chapter 3, Section III.

(2) Replace all potted inserts using procedures given in paragraphs 2-14b.

g. Installation. Install the removable door panel and utility panel in reverse order of disassembly and observing the following.

(1) When installing utility panel (18) attach screw (25) clip (27) and spacer (26) in order shown in figure 6-5.

(2) Install handles (6) to spring closed in downward direction.

(3) Inspect seal (11) and replace if necessary using sealant PRC 611, Products Research Co., Burbank, California, or equivalent.

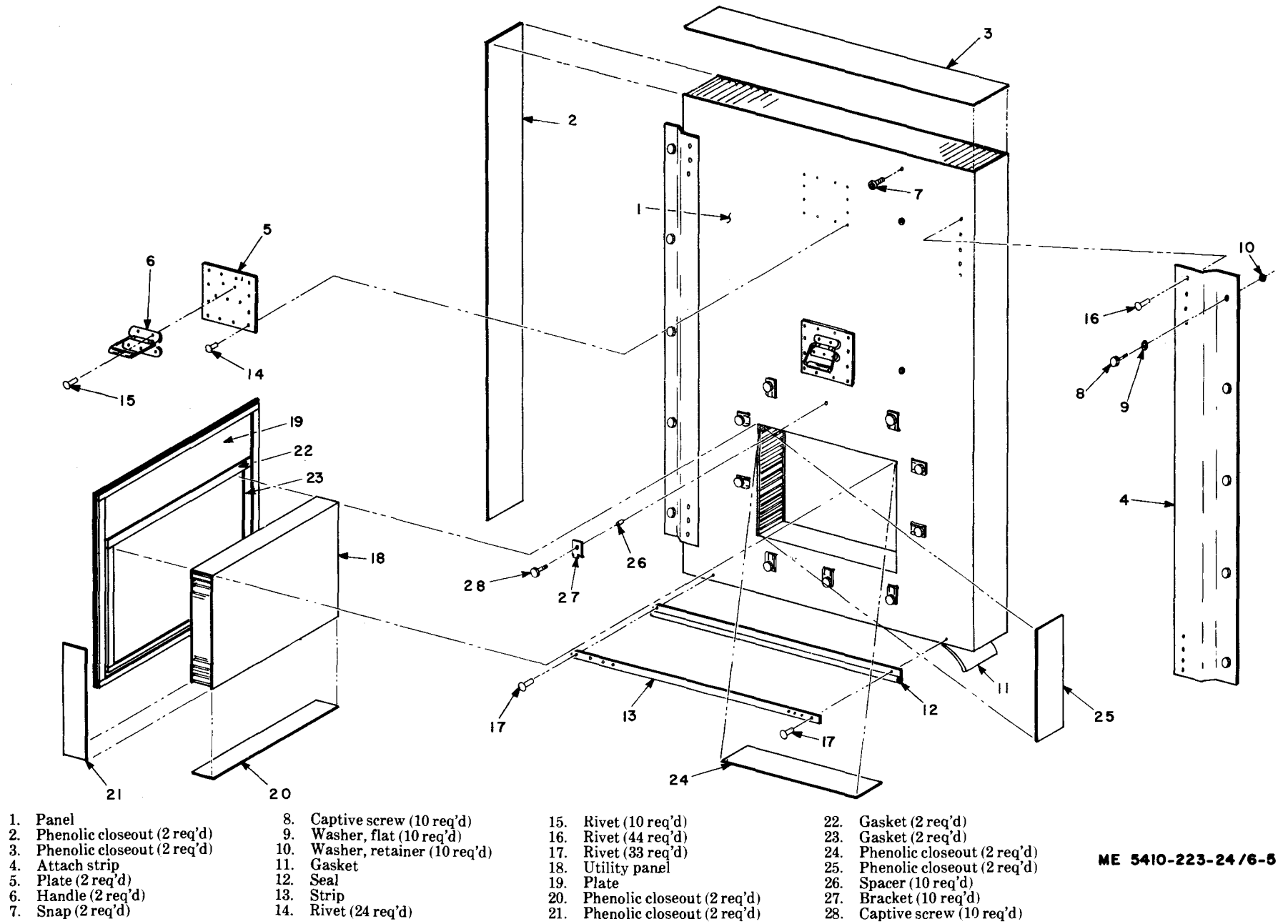

Figure 6-5. Removable door panel assembly disassembly.

6-6. GENERAL

This section provides instruction for the replacement of those items considered as being fixed panel assemblies. The fixed panel assemblies are the roof panel, the side panel, the end panels and the floor (fig. 6-1).

6-7. Roof Panel Assembly Disassembly

a. General. The roof panel assembly is an aluminum faced honeycomb core panel. Figure 6-6 (1) illustrates the topside of the roof panel and figure 6-6 (2) illustrates the underside.

b. Removal. Remove the roof panel assembly as required to replace damaged components using figures 6-6 as a guide and observing the following.

(1) Remove the folding roof panel using the procedure given in paragraph 6-3.

(2) Remove lift rings (26) by removing bolts (33).

(3) Remove screws (11, 12, fig. 6-7) and screws (36, 37, fig. 6-9) in doubler plates.

(4) Remove screws (31, fig. 6-7) in upper tension plates (32, fig. 6-7).

(5) Drill out all rivets (53, fig. 6-6) around perimeter of roof panel assembly.

(6) Remove wall panel screws (52, fig. 6-6) from angle brackets (1).

(7) Using one man at each inside corner, raise off the roof panel assembly.

c. Disassembly. Disassemble the roof panel assembly as required to replace damaged parts according to sequence of index numbers assigned in figures 6-6 and observing the following.

(1) Remove hinge half (5) by drilling out and removing rivets (6) and (7).

(2) Remove lift rings (26) by removing bolts (33).

(3) Remove handle (41) by drilling out and removing rivets (40).

(4) Remove clamps (16) by removing screw (19), washer (18) and spacer (17).

(5) Remove brackets (42) by removing screws (52).

(6) Remove brackets (43) by drilling out and removing rivets (44).

(7) Remove brackets (46) and (48) by drilling out and removing rivets (47).

(8) Remove brackets (50) and (51) by drilling out and removing rivets (49).

(9) Remove clip (54) by removing screws (55).

(10) Using a screwdriver, remove snap fasteners (45).

d. Duct Port Disassembly. Disassemble the roof duct port as follows.

(1) Remove grounding strap (35) by removing screw (37) and washers (34, 36).

(2) Remove hinge (30) by drilling out and removing rivets (39).

(3) Remove cover (38) and flange assembly (8) by loosening latches (11).

(4) Remove latch strike (29) from cover (38) by drilling out and removing rivets (28).

(5) Remove latch strike (31) from cover (38) by drilling out and removing rivets (27).

(6) Remove duct port angle ring (13) by drilling out and removing rivets (12).

e. Repair. Repair damage to honeycomb panel using procedures given in paragraph 2-15. If possible, straighten any bent plates, latches, angles and extrusions using hammer, pliers, vise or similar tool. Replace defective parts that are irreparable.

f. Overhaul. Overhaul the roof assembly as required to return to serviceable condition as per Chapter 6, Section III.

g. Assembly. Assemble the roof panel in reverse order of disassembly using figures 6-6 as a guide and observing the following.

(1) Install all rivets as per Chapter 2, Section III.

(2) Replace all potted inserts using procedures given in paragraph 2-14b.

(3) Seal all joints with sealant PRC 611, Products Research Co., Burbank, California, or equivalent.

(4) Install handle assembly (40) positioned so that spring return closes handle in direction away from nearest edge of roof panel.

h. Installation. Install the roof panel assembly in reverse order of removal using figures 6-6 as a guide and observing the following.

(1) Install hinges half (5) and bracket assemblies (42) before placing roof assembly on Container, Service Ward.

(2) Because of the weight of the roof assembly, four men, one at each corner, are required to lift it back onto the Container, Service Ward.

(3) In installing latches (11), observe that four latches point upward to mate with strikes (31), the other four point downward.

6-8. Side Panel Assembly Repair

a. General. As can be seen in figure 6-1, there is only one side panel assembly on the Container, Service Ward. The folding roof and folding floor panels constitute the other side. Space is provided in the side panel for mounting a folding door (para 6-2) or a removable door panel (para 6-5). The side panel assembly, shown in figure 6-7, consists of two aluminum faced honeycomb core panels fastened to the Container, Service Ward, roof, floor and end panels, and joined by a connecting sill panel across the top of the door opening.

b. Removal. Remove the side panel assembly as required to replace damaged components using figure 6-7 as a guide and observing the following.

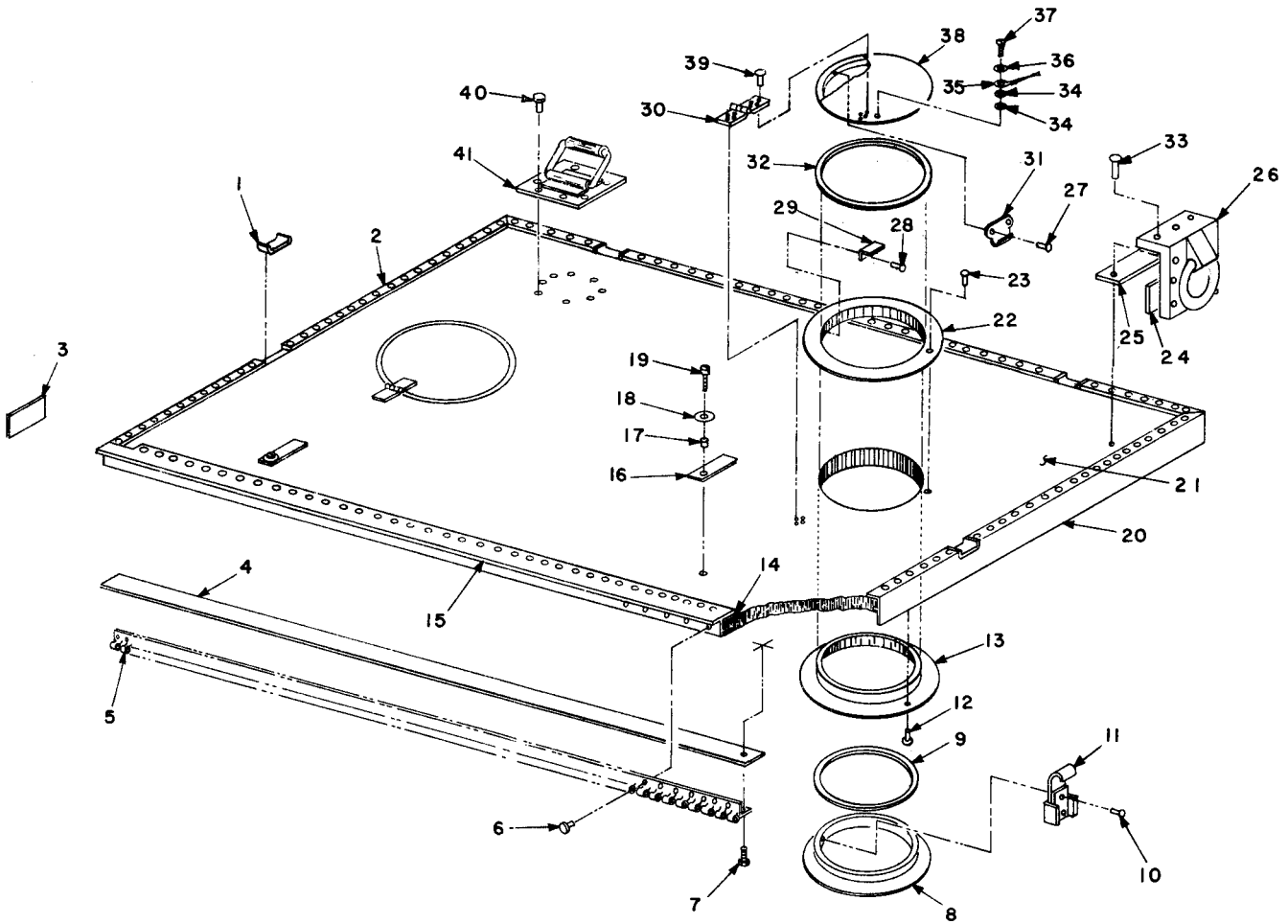

ME 5410-223-24/6-6 ①

- | | |
|--|---------------------------------|
| 1. Channel (4 req'd) | 29. Latch strike (8 req'd) |
| 2. Extrusion F | 30. Hinge (2 req'd) |
| 3. Phenolic closeout (2 req'd) | 31. Latch strike (4 req'd) |
| 4. Phenolic strip | 32. Seal (2 req'd) |
| 5. Hinge half | 33. Rivet (48 req'd) |
| 6. Rivet (88 req'd) | 34. Washer (4 req'd) |
| 7. Screw (10 req'd) | 35. Strap (2 req'd) |
| 8. Flange assembly, air duct (2 req'd) | 36. Washer (2 req'd) |
| 9. Seal (2 req'd) | 37. Screw (2 req'd) |
| 10. Rivet (32 req'd) | 38. Cover, duct, port (2 req'd) |
| 11. Latch (16 req'd) | 39. Rivet (15 req'd) |
| 12. Rivet (24 req'd) | 40. Rivet (12 req'd) |
| 13. Angle, duct, port (2 req'd) | 41. Handle, plate assembly |
| 14. Bar | |
| 15. Extrusion ft | |
| 16. Clamp (2 req'd) | |
| 17. Spacer (2 req'd) | |
| 18. Washer (2 req'd) | |
| 19. Screw (2 req'd) | |
| 20. Extrusion F | |
| 21. Panel | |
| 22. Angle, duct, port (2 req'd) | |
| 23. Rivet (24 req'd) | |
| 24. Spacer (4 req'd) | |
| 25. Spacer (4 req'd) | |
| 26. Lift ring (4 req'd) | |
| 27. Rivet (8 req'd) | |
| 28. Rivet (16 req'd) | |

Figure 6-6 Roof panel assembly disassembly.

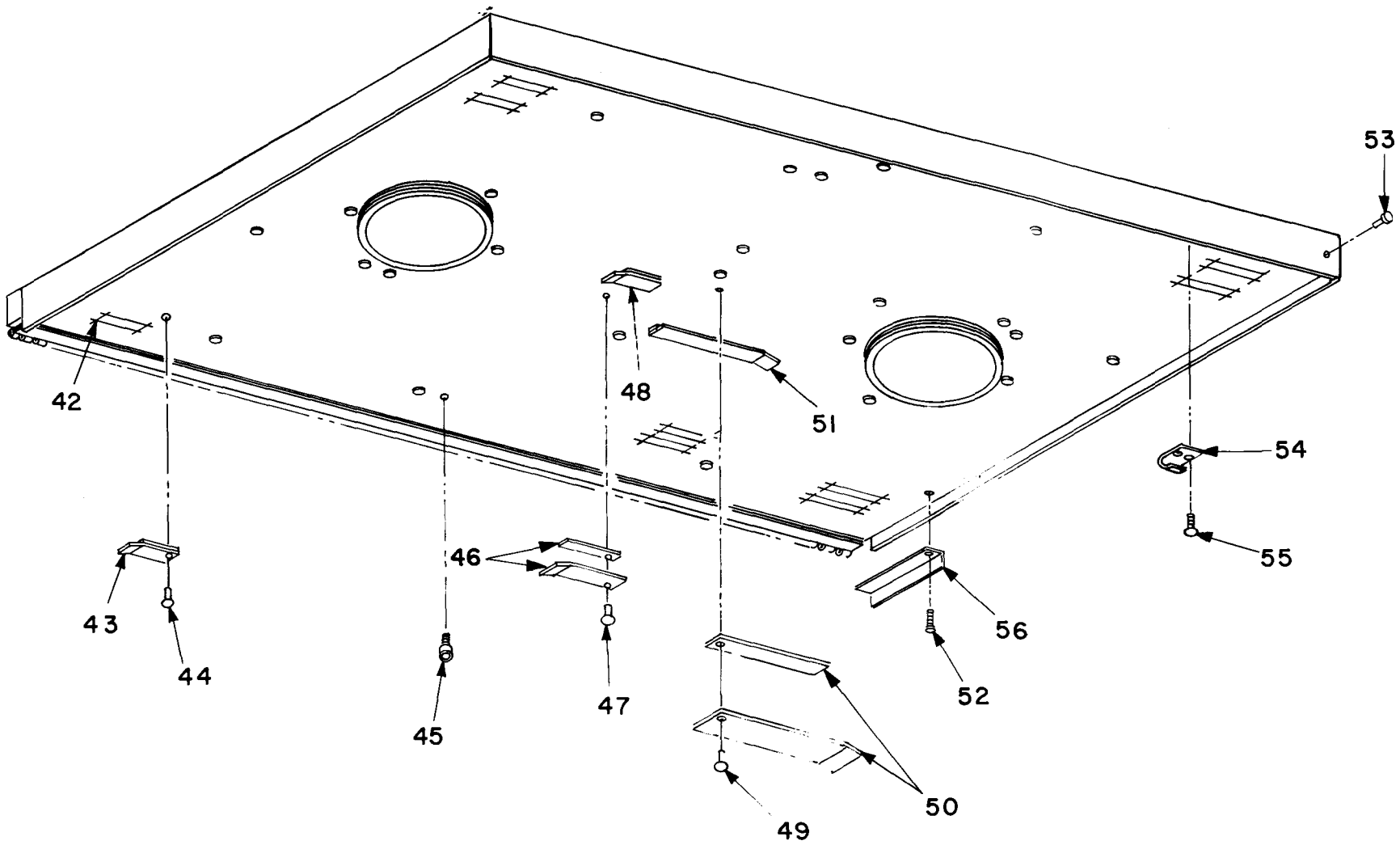

- 42. Bracket assembly (5 req'd)
- 43. Bracket assembly (5 req'd)
- 44. Rivet (40 req'd)
- 45. Snap fastener (17 req'd)
- 46. Bracket assembly
- 47. Rivet (10 req'd)
- 48. Bracket assembly

- 49. Rivet (18 req'd)
- 50. Bracket assembly
- 51. Bracket assembly
- 52. Screw (48 req'd)
- 53. Rivet (157 req'd)
- 54. Clip (8 req'd)
- 55. Screw (16 req'd)

Figure 6-6 . Roof panel assembly disassembly inside view — Continued.

1. Raw panel
2. Phenolic closeout (2 req'd)
3. Phenolic closeout
4. Phenolic closeout
5. Raw panel
6. Phenolic closeout
7. Filler plate (2 req'd)
8. Ft extrusion closeout
9. Filler plate
10. Plate (2 req'd)
11. Screw (6 req'd)
12. Screw (4 req'd)
13. Rivet (16 req'd)
14. Box assembly
15. Nut (2 req'd)
16. Vial, level
17. End cup (2 req'd)
18. Screw (2 req'd)
19. Level assembly
20. Plate, tension (2 req'd)
21. Screw (16 req'd)
22. Rivet (6 req'd)
23. Filler plate
24. Spacer (9 req'd)

25. Clamp (9 req'd)
26. Nut (9 req'd)
27. Screw (9 req'd)
28. Rivet (18 req'd)
29. Rub strip (2 req'd)
30. Rivet (32 req'd)
31. Screw (32 req'd)
32. Tension plate side panel (4 req'd)
33. Bolt (2 req'd)
34. Washer (2 req'd)
35. Step, folding (4 req'd)

36. Filler plate
37. Extrusion, closeout
38. Phenolic closeout
39. Rivet
40. Phenolic closeout
41. Rivet (90 req'd)
42. Side bracket (2 req'd)
43. Base bracket (2 req'd)
44. Rivet (50 req'd)
45. Rivet

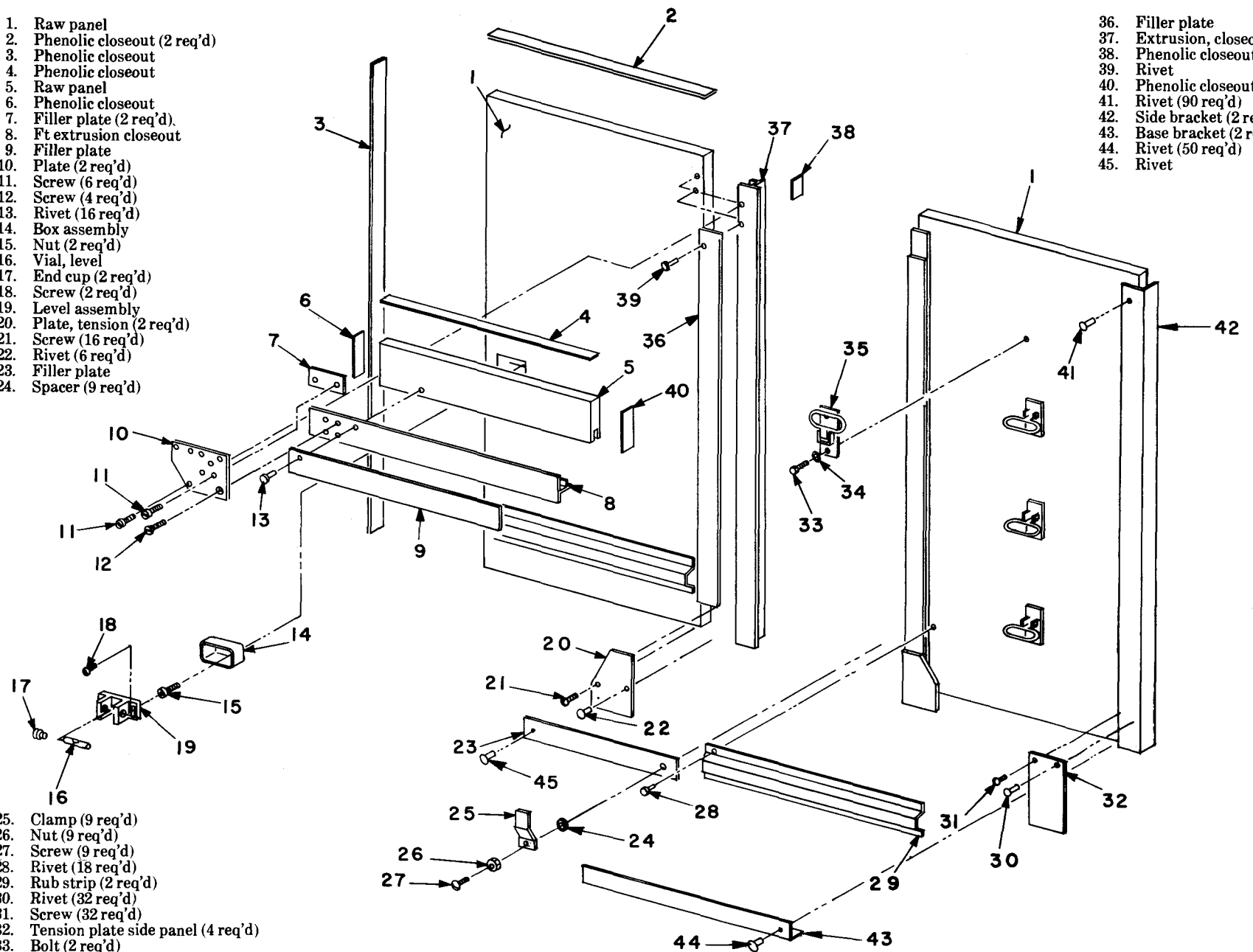

Figure 6-7. Side panel assembly disassembly.

ME 5410-223-24/6-7

(1) Remove the folding roof assembly as described in paragraph 6-3.

(2) Remove the fixed roof assembly as described in paragraph 6-6.

(3) Remove doubler plate (10) by removing screws (11) and (12).

(4) Remove tension plate (20) by removing screws (21) and rivets (22).

(5) Lift out door sill assembly (5, 8, 9).

(6) Remove plate (23) by drilling out and removing rivets (45).

(7) Remove side panels (1) by drilling out and removing rivets (41) in side brackets (42), also rivets (44) in base brackets (43).

c. Disassembly. Disassemble the side panel assembly as required to replace damaged parts according to sequence of index numbers assigned in figure 6-7 and observing the following.

(1) Remove folding steps (35) by removing bolts (33) and washers (34).

(2) Remove level assembly (19) by removing screws (19).

(3) Remove drip cap assembly (4, fig. 6-8) from door sill (5, fig. 6-7) by removing screws (6, fig. 6-8).

(4) Remove plate (9), and closeout (8) from door sill (5) by drilling out and removing rivets (13).

(5) Remove all airlock clamps (25) around door frame by loosening nut (26) and removing screw (27) and spacer (24).

(6) Remove filler plate (36) and extrusion closeout (37) from side panels (1) by drilling out and removing rivets (39).

(7) Remove rub strips (29) by drilling out and removing rivets (28).

d. Repair. Repair damage to honeycomb panel using procedures given in paragraph 2-15. If possible, straighten any bent plates, latches, angles and extrusions using hammer, pliers, vise or similar tools. Replace irreparable parts.

e. Overhaul. Overhaul the side panel assembly as required to restore to serviceable condition using the methods given in Chapter 6, Section III.

f. Assembly. Assemble the side panel in reverse order of disassembly using figure 6-7 as a guide and observing the following.

(1) Install all rivets as per Chapter 2, Section III.

(2) Replace all potted inserts as necessary using procedures given in paragraph 2-14b.

(3) Seal all joints with Sealant PCR 611, Products Research Co., Burbank, California, or equivalent.

(4) Install folding steps (35) positioned to hinge upward in closing.

g. Installation.

(1) Install the side panel assembly in reverse order of removal using figure 6-7 as a guide and observing the following.

(2) Adjust sight level assembly (19).

6-9. End Panel Assembly Repair

a. General. The panel assemblies at both sides of the Container, Service Ward, are identical. Because of the number of attaching parts involved, two views of the end panel assembly, figure 6-8 ① and figure 6-8 ② are utilized. As shown in figures 6-8, each end panel consists of two aluminum faced honeycomb core panels fastened to the Container, Service Ward, roof, floor and side panels, and joined by a connecting sill panel across the top of the door opening.

b. Removal. Remove the end panel assembly as required to replace damaged components using figures 6-8 ① and 6-8 ② as a guide, and observing the following.

(1) Remove the folding roof assembly as described in paragraph 6-3.

(2) Remove the fixed roof assembly as described in paragraph 6-6.

(3) Remove folding floor cable assembly (41, fig. 2-5) by removing bolt and nut (39 and 37, fig. 2-5).

(4) Remove doubler plate (35, fig. 6-8) by removing bolts (36) and screws (37). Lift out sill assembly (30, 32, 34).

(5) Remove tension plate (21) by removing screws (18 and 20) and washers (19).

(6) Drill out and remove rivets (8) from side angle bracket (26).

(7) Drill out and remove rivets in floor extrusion (1, fig. 6-9).

(8) Remove threshold (24, fig. 6-8) by drilling out and removing rivets (23). Lift out side panel assemblies (66).

c. Disassembly. Disassemble the end panel assembly as required to replace damaged parts according to sequence of index numbers assigned in figure 6-8 and observing the following.

(1) Remove jack (13) by removing screw (10) and washer (9), also screw (4, fig. 2-6) and washer (7, fig. 2-6).

(2) Remove jack stowage assembly (62) by removing screw (60) and washer (61).

(3) Remove level assembly (43) by removing screws (44).

(4) Remove tow cable attachment bracket (53) by removing screws (46) and screws (52).

(5) Remove mobilizer attachment plate (63) by removing screws (56) and washers (64).

(6) Remove mobilizer attachment plate (40) by removing screws (45) and screws (48).

(7) Remove latch assembly (49) from mobilizer attachment plate (40) by removing screws (50).

(8) Remove cargo tiedown (58) by loosening screws (59).

(9) Remove door latch riser (65) and guide (67) by removing screw (69).

(10) Remove link-latch stake and spacer (61 and 60, fig. 2-5) by drilling out and removing rivets (62, fig. 2-5).

(11) Remove drip cap assembly (4, fig. 6-8) from sill (30) by removing screws (6).

(12) Remove spacer (34) and closout (32) from sill panel (30) by drilling out and removing rivets (38).

d. Repair. Repair damage to honeycomb panel using procedures given in paragraph 2-15. If possible, straighten any bent plates, latches, angles and extrusions using hammer, pliers, vise or similar tools. Replace irreparable parts.

e. Assembly. Assemble the end panel in reverse order of disassembly using figures 6-8 as a guide and observing the following.

(1) Install all rivets as per Chapter 2, Section III.

(2) Replace all potted inserts as necessary using procedures given in paragraph 2-14b.

(3) Seal all joints with Sealant PCR 611, Products Research Co., Burbank, California, or equivalent.

f. Installation. Install the end panel assembly in reverse order of removal using figures 6-8 as a guide and observing the following.

(1) Adjust sight level assembly (41, 42, 43).

(2) With folding roof and floor panels in closed position, adjust folding panel latches (49) by means of adjusting screw accessible from outboard end of latch to ensure tight closure of folding panels.

(3) Remove nut plate (27) from channel (13) by drilling out and removing rivets (18).

(4) Remove skid assembly (37) by drilling out and removing rivets (24).

(5) Remove rub assembly (38) and reinforcement plate (29) from skid (37) by drilling out and removing rivets (24).

(6) Remove tiedown ring (35) from skid (37) by removing bolts (34).

(7) Remove nut plate (32) from skid (37) by drilling out and removing rivets (36).

(8) Remove end closeout (21) from skid (37) by removing bolts (19) and washers (20).

(9) Remove plug assembly (42) by prying loose epoxy seal.

(10) Remove valve assembly (5) by drilling out and removing rivets (4).

(11) Remove plate (26) by drilling out and removing rivets (25).

(12) Remove support plates (30) and (10) by removing screws (31).

(13) Separate plate (10) from plate (30) by drilling out and removing rivets (9).

(14) Remove hinge strip (44) and seal (43) by drilling out and removing rivet (45).

(15) Remove hinge half (3) by drilling out and removing rivets (7).

(16) Remove closeout extrusions (1) by drilling out and removing rivets (6) and (10), then by prying loose from panel (39).

d. Repair. Repair damage to honeycomb panel structure using procedures given in paragraph 2-15. If possible, straighten any bent plates, latches, angles and extrusions using hammer, pliers, vise or similar tool. Replace irreparable parts.

e. Overhaul. Overhaul the floor assembly as required to return to serviceable condition as per Chapter 6, Section III.

f. Assembly. Assemble the floor panel in reverse order of disassembly using figure 6-9 as a guide and observing the following.

(1) Install all rivets as per Chapter 2, Section III.

(2) Replace all potted inserts as necessary using procedures given in paragraph 2-14b.

(3) Seal all joints with Sealant PRC 611, Products Research Co., Burbank, California, or equivalent.

g. Installation. Install the floor panel by attaching the side, end and roof assemblies in reverse order of removal.

h. Refinish. The floor covering is a polyurethane coating, part number SS516, light green, manufactured by the Zerock Corp. To refinish a repaired floor section, proceed as follows.

(1) Smooth all repair joints with sandpaper. Featheredge existing coating at edge of repaired area.

(2) Mix the 2-component floor coating material

6-10. Fixed Floor Panel Assembly Repair

a. General. The fixed floor panel assembly is an aluminum faced honeycomb core panel. The fixed floor panel assembly provides mounting for the Container, Service Ward, skid assembly.

b. Removal. Remove the fixed floor assembly as required to replace damaged components using figure 6-9 as a guide and observing the following.

(1) Remove the folding roof and folding floor panels as described in paragraphs 6-3 and 6-4.

(2) Remove the fixed roof panel as described in paragraph 6-7.

(3) Remove the fixed side and fixed end panels as described in paragraphs 6-8 and 6-9.

(4) With other panels removed the floor panel can be raised and positioned for disassembly.

c. Disassembly. Disassemble the fixed floor panel as required to replace damaged parts according to sequence of index numbers assigned in figure 6-9 and observing the following.

(1) Remove channel (13) and doubler (11) by removing bolts (12).

(2) Remove tiedown ring (17) from channel (13) by removing bolts (15).

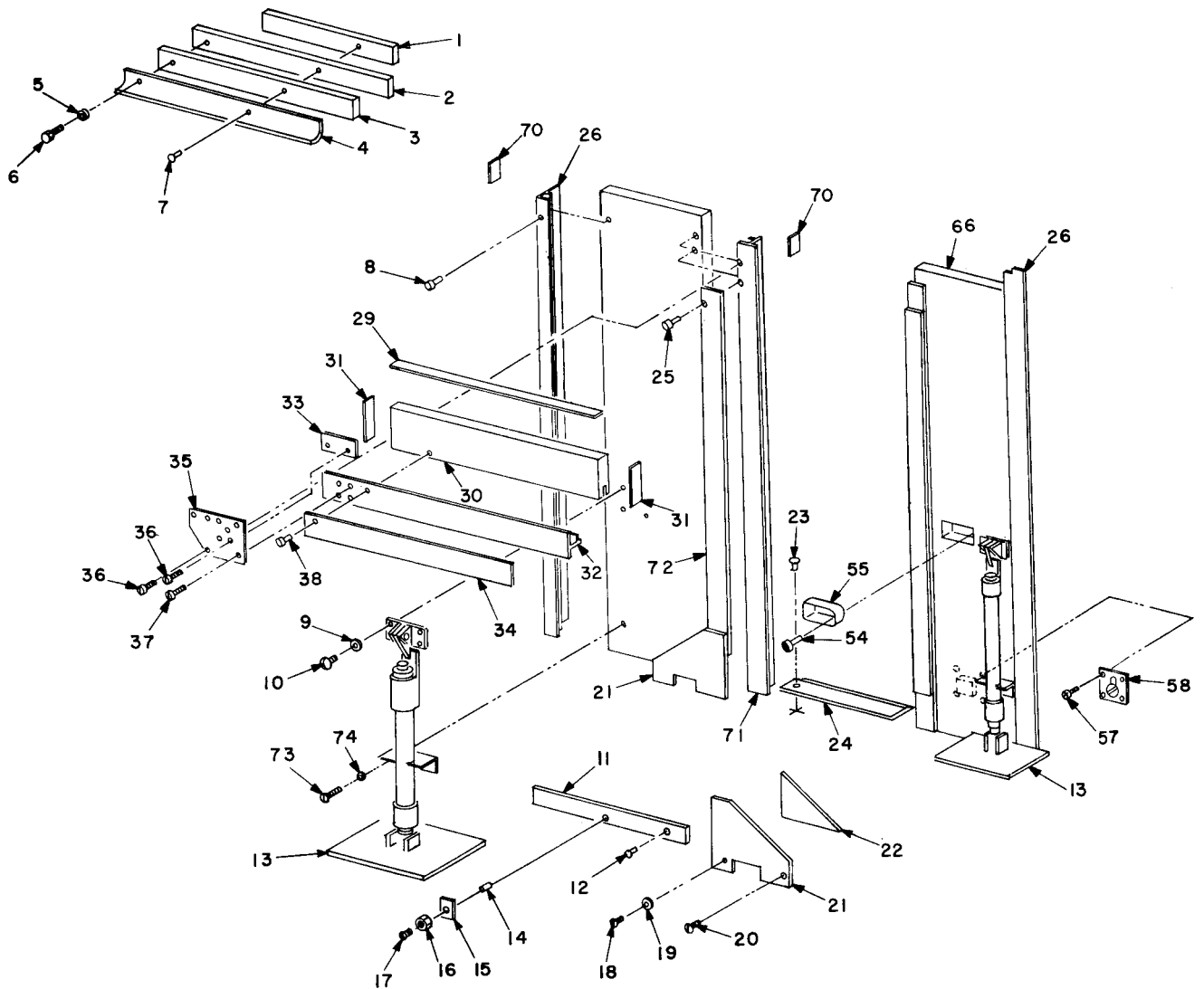

ME 5410-223-24/6-8①

1. Spacer (3 req'd)
2. Spacer (3 req'd)
3. Spacer (3 req'd)
4. Drip cap (3 req'd)
5. Washer (27 req'd)
6. Bolt (27 req'd)
7. Rivet (9 req'd)
8. Rivet (40 req'd)
9. Washer (16 req'd)
10. Screw (16 req'd)
11. Filler plate (2 req'd)
12. Rivet (16 req'd)
13. Jack assembly (4 req'd)
14. Spacer (9 req'd)
15. Clamp, airlock adapter (9 req'd)
16. Nut (9 req'd)
17. Screw (9 req'd)
19. Screw (6 req'd)
20. Screw (8 req'd)
21. Plate assembly, tension & cable guide (4 req'd)
22. Doubler (4 req'd)
23. Rivet (17 req'd)
24. Threshold (3 req'd)
25. Rivet (22 req'd)

Figure 6-8 ① .End panel assembly "A" disassembly.

- 26. F Extrusion closeout
- 27. Phenolic closeout
- 28. Raw panel
- 29. Phenolic closeout
- 30. Raw panel
- 31. Phenolic closeout (2 req'd)
- 32. Ft Extrusion closeout
- 33. Filler plate (2 req'd)
- 34. Filler plate
- 35. Plate (2 req'd)
- 36. Screw (12 req'd)
- 37. Screw (8 req'd)
- 38. Rivet (16 req'd)
- 39. Phenolic closeout
- 40. Plate, mobilizer attachment
- 41. End cup (2 req'd)
- 42. Vial, level
- 43. Level assembly
- 44. Screw (2 req'd)
- 45. Screw, flat head
- 46. Screw, flat head (2 req'd)
- 47. Washer (7 req'd)
- 48. Screw (7 req'd)
- 49. Latch assembly (2 req'd)

- 63. Plate, attach, mobilizer
- 64. Washer (6 req'd)
- 65. Rivet
- 66. Panel assembly
- 67. Guide
- 68. Washer (2 req'd)
- 69. Screw (2 req'd)
- 70. Phenolic closeout
- 71. Ft extrusion closeout

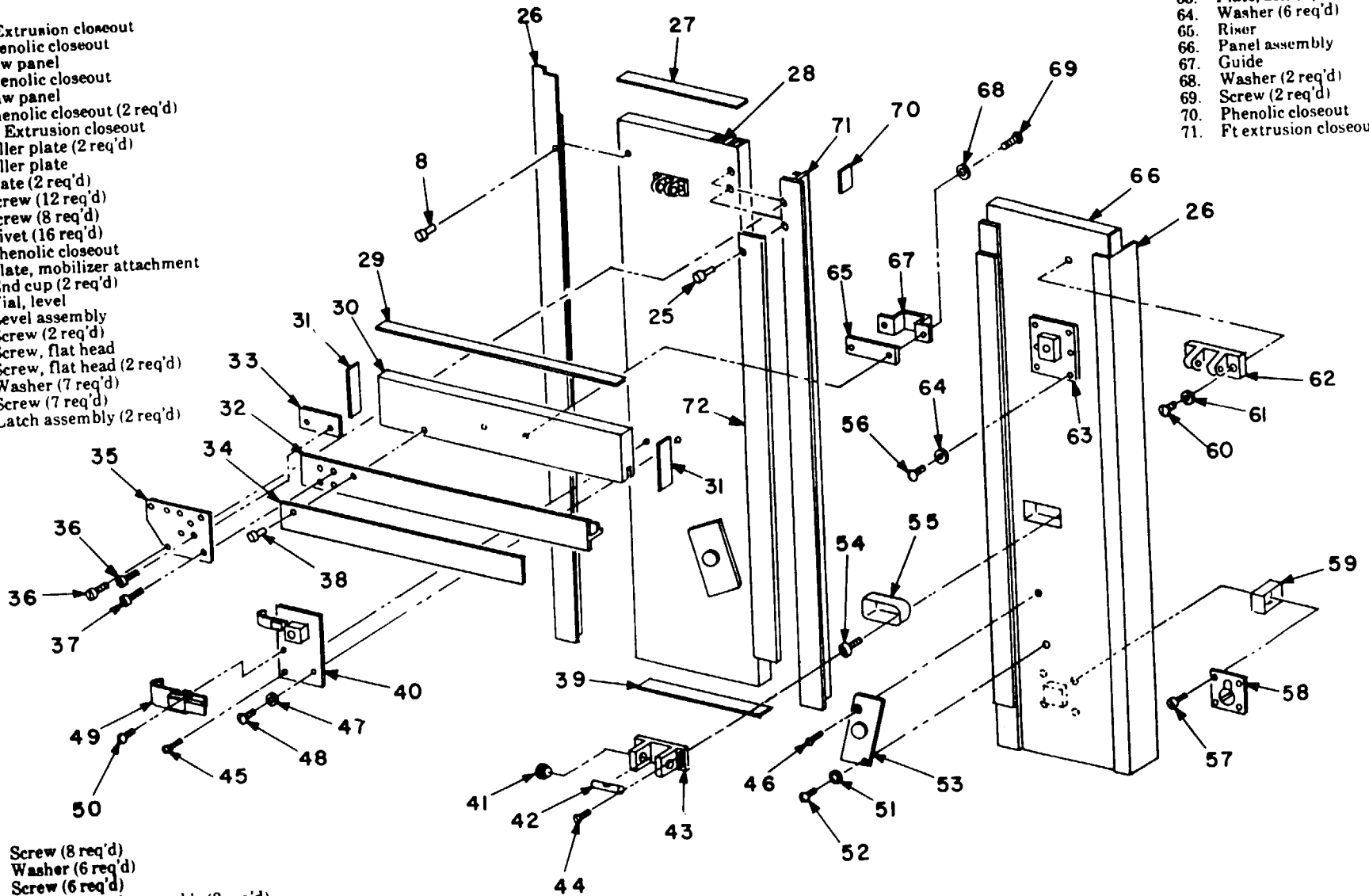

- 50. Screw (8 req'd)
- 51. Washer (6 req'd)
- 52. Screw (6 req'd)
- 53. Bracket, attach tow cable (2 req'd)
- 54. Nut (2 req'd)
- 55. Box assembly
- 56. Screw (6 req'd)
- 57. Screw (4 req'd)
- 58. Tiedown cargo
- 59. Can, deep drawn
- 60. Screw (8 req'd)
- 61. Washer (8 req'd)
- 62. Storage assembly (4 req'd)

ME 5410-223-24/6-8 ②

Figure 6-8. ② End panel assembly "B" disassembly.

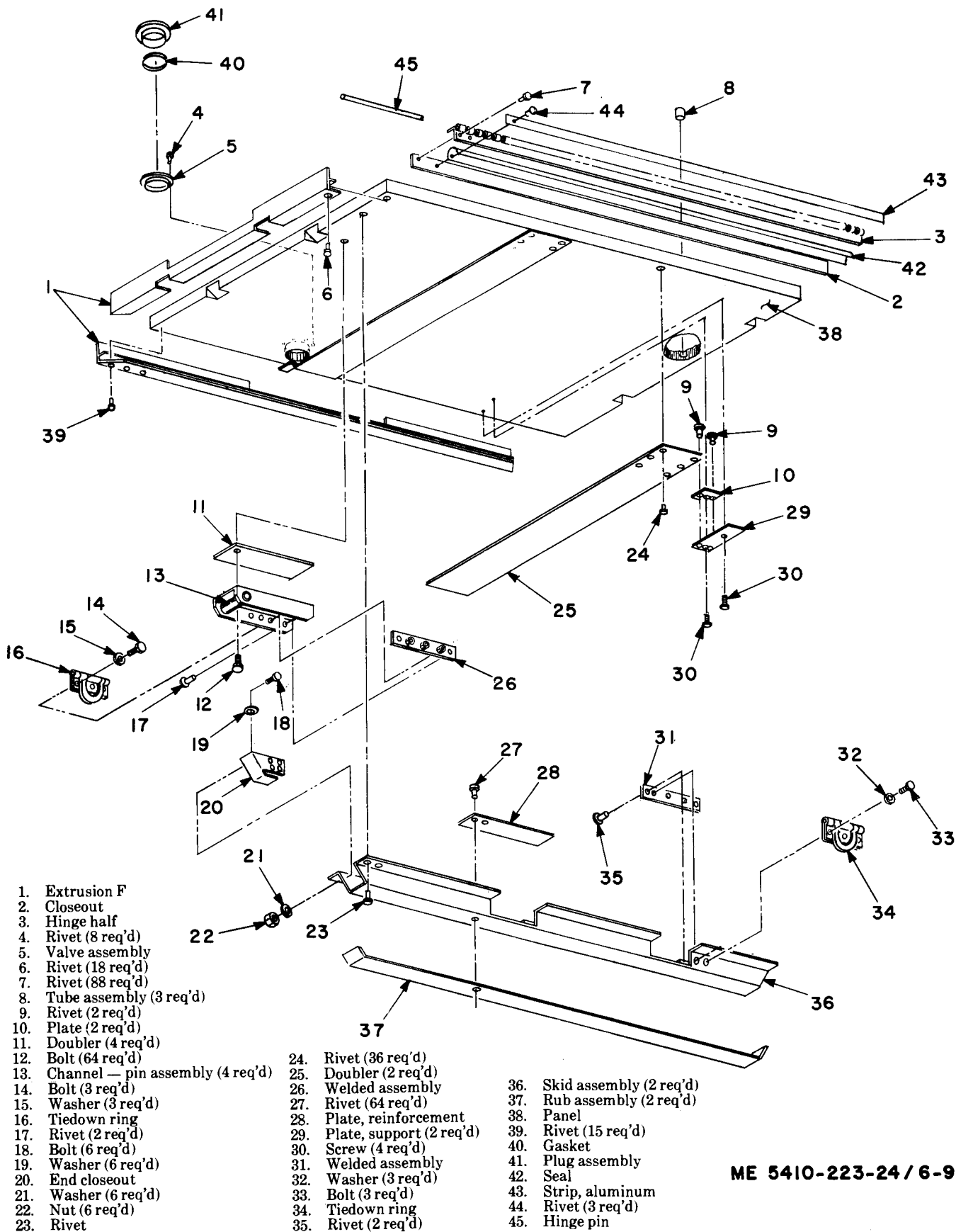

ME 5410-223-24 / 6-9

Figure 6-9. Floor panel assembly disassembly.

according to manufacturer's instructions.

(3) With a paint roller, roll on a suitably thick layer of floor covering. If no roller is available, pour

the material on and strike-off with a straightedge.

(4) Allow coating to cure as per manufacturer's recommendations before using floor.

Section III. CONTAINER, SERVICE WARD, BODY ASSEMBLY OVERHAUL

6-11. General

This section provides information necessary for the overhaul of the Container, Service Ward, body assembly. Seal assemblies are to be removed and replaced on a yearly basis. The interior and exterior shall be painted on a yearly basis.

6-12. Panel Assemblies Overhaul

Overhaul of the panel assemblies shall consist of a complete inspection for corrosion, dents, scratches, nicks, or other surface irregularities. Use emery cloth to dress to a smooth surface all nicks, cuts, corrosion and scratches. Minor dents are acceptable. Cuts through the aluminum facing or large dents shall be repaired in accordance with paragraph 2-15.

6-13. Seal Placement

Replace seal assemblies as outlined in panel disassembly paragraphs, Sections I and II, Chapter 6.

6-14. Painting

a. General. This procedure defines the surface preparation, type of primer, paint, and colors to be used on all surfaces to be painted.

b. Surface Preparation. The surface preparation shall be in accordance with MIL-T-704.

c. Exterior Surfaces. Exterior surfaces and components shall be primed with one coat per TT P666. Dry film thickness shall be 0.3 to 0.4 mils. Apply two finish coats of Specification TT-E-527 enamel (color X34087). Air dry 8 hours. Dry film thickness shall be 1.2 ± 0.2 mils per coat.

d. All Interior Surfaces. Interior shall be primed with one coat of Primer per TTP666. Dry film thickness to be 0.3 to 0.4 mil. Apply two finish coats of SPEC TTE 527, Color 24516 of FED STD 593 (catalyzer per manufacturer's instructions). Air dry 3 hours. Dry film to be 1.2 ± 0.2 mils per coat.

e. Quality Control Requirements.

(1) A sufficient number of parts shall be examined to assure acceptable quality of finishing on all parts. In general, the criteria listed in steps (2) and (3) shall be evaluated. Properties or performance characteristics other than those shown below may be required by applicable drawings or other authoritative documents.

(2) The finish in all types shall show no visual indication of alligating, blistering, chalking, checking, cracking, crawling, flaking, lifting, peeling, or sealing. The finish shall exhibit no sags, runs, skips, shading, dusting, or dry overspray.

(3) Adhesion test shall be conducted on finished parts at regular intervals. The tests shall be conducted on a sufficient number of parts selected at random to assure maintenance of a satisfactory level of adhesion on all parts. In performing this test, it is suggested that a plastic or wood stylus be used to scratch the paint films. A metal stylus may be used, but extreme care must be exercised to avoid damaging the basic surface of the part. Several parallel scratches shall be made approximately one-sixteenth inch apart. Apply a one-inch wide strip of tape, adhesive side down, over the scratches. Only newly manufactured tape less than six months old shall be used. Press the tape down with a firm pressure of the hand. Remove the tape in one abrupt action and examine the tested area for any paint damage such as removal of paint at one of the layers of the finishing system or removal of the entire system from the surface. Test panels may be used.

(4) Touch-up after test. Areas which have been used for testing shall be refinished to equal as nearly as possible the original finish requirement. Any color of touched up areas shall be reasonable close to that of the surrounding area.

6-15. Container, Service Ward, Air Leakage Test

a. Repair. Make the following checks and correct if adequate water pressure cannot be maintained.

(1) Inspect for loose window assemblies on doors. Replace or repair as required.

(2) Inspect drain, for damaged or missing potting compound. Repot if required using RTV rubber, or equivalent.

(3) Check seal assemblies around doors for leakage, and reposition or replace as required.

(4) Check panel assemblies seals for proper installation or damage. Repair or replace as required.

(5) Check seals on removable panel assemblies for damage or improper installation. Replace or repair as required.

APPENDIX A
REFERENCES

A-1. Fire Protection

TB 5-4200-200-10

Hand Portable Fire Extinguishers for Army use.

A-2. Preventive Maintenance

TM 38-750

Army Equipment Records Procedures

Federal Standard 751-

Stitch

Specification MIL-S-6872

Specification QQ-S-571

Federal Standard 595

Specification MIL-T-704

TM 10-5410-223-10

Seam and Stitching

Soldering Process

Solder

Painting

Surface Preparation

Operator's Manual

A-3. Shipment

American Railroads Operation and Maintenance Loading of Commodities
on Open Top Flat Cars (Sec. 4, fig. 1A)

APPENDIX B

MAINTENANCE ALLOCATION CHART (MAC)

Section I. INTRODUCTION

B-1. The Army Maintenance System MAC

This introduction provides a general explanation of all maintenance and repair functions authorized at the two maintenance levels under the Two-Level Maintenance System concept.

This MAC (immediately following the introduction) designates overall authority and responsibility for the performance of maintenance functions on the identified end item or component. The application of the maintenance functions to the end item or component shall be consistent with the capacities and capabilities of the designated maintenance levels, which are shown on the MAC in column (4) as:

Field - includes two columns, Unit Maintenance and Direct Support maintenance. The Unit maintenance column is divided again into two more subcolumns, C for Operator or Crew and O for Unit maintenance.

Sustainment – includes two subcolumns, General Support (H) and Depot (D).

The tools and test equipment requirements (immediately following the MAC) list the tools and test equipment (both special tools and common tool sets) required for each maintenance function as referenced from the MAC.

The remarks (immediately following the tools and test equipment requirements) contain supplemental instructions and explanatory notes for a particular maintenance function.

B-2. Maintenance Functions

Maintenance functions are limited to and defined as follows:

1. Inspect. To determine the serviceability of an item by comparing its physical, mechanical, and/or electrical characteristics with established standards through examination (e.g., by sight, sound, or feel.) This includes scheduled inspection and gagings and evaluation of cannon tubes.
2. Test. To verify serviceability by measuring the mechanical, pneumatic, hydraulic, or electrical characteristics of an item and comparing those characteristics with prescribed standards on a scheduled basis, i.e., load testing of lift devices and hydrostatic testing of pressure hoses.
3. Service. Operations required periodically to keep an item in proper operating condition; e.g., to clean (includes decontaminate, when required), to preserve, to drain, to paint, or to replenish fuel, lubricants, chemical fluids, or gases. This includes scheduled exercising and purging of recoil mechanisms. The following are examples of service functions:
 - a. Unpack. To remove from packing box for service or when required for the performance of maintenance operations.
 - b. Repack. To return item to packing box after service and other maintenance operations.
 - c. Clean. To rid the item of contamination.

- d. Touch up. To spot paint scratched or blistered surfaces.
 - e. Mark. To restore obliterated identification.
4. Adjust. To maintain or regulate, within prescribed limits, by bringing into proper position, or by setting the operating characteristics to specified parameters.
 5. Align. To adjust specified variable elements of an item to bring about optimum or desired performance
 6. Calibrate. To determine and cause corrections to be made or to be adjusted on instruments of test, measuring, and diagnostic equipment used in precision measurement. Consists of comparisons of two instruments, one of which is a certified standard of known accuracy, to detect and adjust any discrepancy in the accuracy of the instrument being compared.
 7. Remove/Install. To remove and install the same item when required to perform service or other maintenance functions. Install may be the act of emplacing, seating, or fixing into position a spare, repair part, or module (component or assembly) in a manner to allow the proper functioning of an equipment or system.
 8. Paint. To prepare and spray color coats of paint so that the ammunition can be identified and protected. The color indicating primary use is applied, preferably, to the entire exterior surface as the background color of the item. Other markings are to be repainted as original so as to retain proper ammunition identification.
 9. Replace. To remove an unserviceable item and install a serviceable counterpart in its place. "Replace" is authorized by the MAC and assigned maintenance level is shown as the third position code of the Source, Maintenance and Recoverability (SMR) code.
 10. Repair. The application of maintenance services, including fault location/troubleshooting, removal/installation, disassembly/assembly procedures and maintenance actions to identify troubles and restore serviceability to an item by correcting specific damage, fault, malfunction, or failure in a part, subassembly, module (component or assembly), end item, or system.

NOTE

The following definitions are applicable to the "repair" maintenance function:

Services. Inspect, test, service, adjust, align, calibrate, and/or replace.

Fault location/troubleshooting. The process of investigating and detecting the cause of equipment malfunctioning; the act of isolating a fault within a system or Unit Under Test (UUT).

Disassembly/assembly. The step-by-step breakdown (taking apart) of a spare/functional group coded item to the level of its least component, that is assigned an SMR code for the level of maintenance under consideration (i.e., identified as maintenance significant).

Actions. Welding, grinding, riveting, straightening, facing, machining, and/or resurfacing.

11. Overhaul. That maintenance effort (service/action) prescribed to restore an item to a completely serviceable/operational condition as required by maintenance standards in appropriate technical publications. Overhaul is normally the highest degree of maintenance performed by the Army. Overhaul does not normally return an item to like new condition.
12. Rebuild. Consists of those services/actions necessary for the restoration of unserviceable equipment to a like new condition in accordance with original manufacturing standards. Rebuild is the highest degree of material maintenance applied to Army equipment. The rebuild operation includes the act of returning to zero those age measurements (e.g., hours/miles.) considered in classifying Army equipment/components.

B-3. Explanation of Columns in the MAC, Section II

Column (1) Group Number. Column (1) lists Functional Group Code (FGC) numbers, the purpose of which is to identify maintenance significant components, assemblies, subassemblies, and modules with the Next Higher Assembly (NHA).

Column (2) Component/Assembly. Column (2) contains the names of components, assemblies, subassemblies, and modules for which maintenance is authorized.

Column (3) Maintenance Function. Column (3) lists the functions to be performed on the item listed in column (2). (For a detailed explanation of these functions refer to "Maintenance Functions" outlined above).

Column (4) Maintenance Level. Column (4) specifies each level of maintenance authorized to perform each function listed in column (3), by indicating work time required (expressed as manhours in whole hours or decimals) in the appropriate subcolumn. This work time figure represents the active time required to perform that maintenance function at the indicated level of maintenance. If the number or complexity of the tasks within the listed maintenance function varies at different maintenance levels, appropriate work time figures are to be shown for each level. The work time figure represents the average time required to restore an item (assembly, subassembly, component, module, end item, or system) to a serviceable condition under typical field operating conditions. This time includes preparation time (including any necessary disassembly/assembly time), troubleshooting/fault location time, and quality assurance time in addition to the time required to perform the specific tasks identified for the maintenance functions authorized in the MAC. The system designations for the various maintenance levels are as follows:

Field:

- C Operator or Crew maintenance
- O Unit maintenance
- F Direct Support maintenance

Sustainment:

- L Specialized Repair Activity
- H General Support maintenance
- D Depot maintenance

NOTE

The "L" maintenance level is not included in column (4) of the MAC. Functions to this level of maintenance are identified by work time figure in the "H" column of column (4), and an associated reference code is used in the REMARKS column (6). This code is keyed to the remarks and the SRA complete repair application is explained there.

Column (5) Tools and Equipment Reference Code. Column (5) specifies, by code, those common tool sets (not individual tools), common Test, Measurement and Diagnostic Equipment (TMDE), and special tools, special TMDE and special support equipment required to perform the designated function. Codes are keyed to the entries in the tools and test equipment table.

Column (6) Remarks Code. When applicable, this column contains a letter code, in alphabetic order, which is keyed to the remarks table entries.

B-4. Explanation of Columns in the Tools and Test Equipment Requirements, Section III

Column (1) - Tool or Test Equipment Reference Code. The tool or test equipment reference code correlates with a code used in column (5) of the MAC.

Column (2) - Maintenance Level. The lowest level of maintenance authorized to use the tool or test equipment.

Column (3) - Nomenclature. Name or identification of tool or test equipment.

Column (4) - National Stock Number (NSN). The NSN of the tool or test equipment.

Column (5) - Tool Number. The manufacturer's part number.

B-5. Explanation of Columns in Remarks, Section IV

Column (1) - Remarks Code. The code recorded in column (6) of the MAC.

Column (2) - Remarks. This column lists information pertinent to the maintenance function being performed as indicated in the MAC.

**Section II. MAINTENANCE ALLOCATION CHART FOR
CONTAINER, SERVICE WARD, RIGID CONSTRUCTION**

(1) GROUP NUMBER	(2) COMPONENT/ ASSEMBLY	(3) MAINTENANCE FUNCTION	(4) MAINTENANCE LEVEL					(5) TOOLS AND EQUIPMENT REFERENCE CODE	(6) REMARKS CODE	
			FIELD		SUSTAINMENT					
			UNIT		DIRECT SUPPORT	GENERAL SUPPORT	DEPOT			
			C	O	F	H	D			
5401	SHELTER BODY ASSY	Inspect		0.2						
		Test		0.2						
		Service		0.6						
		Install		2.0				1		
		Replace		1.5				1		
		Repair		2.0				1	A	
		Overhaul				6.0		1	A	
5405	SHELTER ACCESSORIES	Inspect		0.5						
		Test		0.6						
		Service		1.0						
		Install		2.0				1		
		Replace		1.5				1		
		Repair		1.0				1	B	
		Overhaul				2.0		1		

**Section III. TOOLS AND TEST EQUIPMENT FOR
CONTAINER, SERVICE WARD, RIGID CONSTRUCTION**

(1) TOOL OR TEST EQUIPMENT REFERENCE CODE	(2) MAINTENANCE LEVEL	(3) NOMENCLATURE	(4) NATIONAL STOCK NUMBER	(5) TOOL NUMBER
1	O, F, H	Pop Rivet Tools, Plier Type, with 1/8 inch and 3/16 inch diameter heads. For application of 1/8 and 3/16 inch diameter Pop Rivets		

**Section IV. REMARKS FOR
CONTAINER, SERVICE WARD, RIGID CONSTRUCTION**

(1) REMARKS CODE	(2) REMARKS
A-I	All seals to prevent air leakage must be replaced every 12 months. Plus the entire shelter will be repainted interior and exterior.
A-J	Same info for A-I.
B-I	Machine sewing at Direct Support Level for the airlock assembly.

INDEX

	Paragraph	Page
A		
Adhesive, application of	2-10	2-2
Air leakage test	6-15	6-16
B		
Body assembly overhaul	6-11	6-16
C		
Cargo tiedown		
Installation	2-18	2-10
Removal	2-18	2-10
Cemented seams, repairing	2-10	2-2
Closeouts, repairing	2-15	2-6
D		
Damaged fabric, panels, fasteners	2-8	2-2
Demolition to prevent enemy use	3-5	3-3
Difference in models	1-5	1-1
Dimensions, ward container	1-4	1-1
Door panel assembly repair	6-2	6-1
Assembly	6-2	6-1
Disassembly	6-2	6-1
Installation	6-2	6-1
Overhaul	6-2	6-1
Removal	6-2	6-1
Duct port assembly	6-7	6-9
E		
End panel assembly	6-9	6-13
Assembly	6-9	6-13
Disassembly	6-9	6-13
Installation	6-9	6-13
Removal	6-9	6-13
Repair	6-9	6-13
Errors, reporting of	1-2	1-1
F		
Fabric repair	5-4	5-1
Field expedient repairs	2-7	2-2
Floor panel assembly repair	6-10	6-14
Assembly	6-10	6-14
Disassembly	6-10	6-14
Installation	6-10	6-14
Overhaul	6-10	6-14
Removal	6-10	6-14
Repair	6-10	6-14
Folding floor panel assembly repair	6-4	6-4
Assembly	6-4	6-4
Disassembly	6-4	6-4
Installation	6-4	6-4
Overhaul	6-4	5-4
Removal	6-4	6-4
Repair	6-4	6-4
Folding roof panel assembly repair	6-3	6-4
Assembly	6-3	6-4
Disassembly	6-3	6-4
Installation	6-3	6-4
Overhaul	6-3	6-4
Removal	6-3	6-4
Repair	6-3	6-4
H		
Handling ward container	3-2	3-1
Forklift	3-2	3-1
Skidding	3-2	3-1
Wheeled Transporter	3-2	3-1
Holes, patching	2-10	2-2
Honeycomb panel repair	2-14	2-6
I		
Identification, ward container	1-4	1-1
Insert installation	2-13	2-4
Insert replacement	2-13	2-4

	J	Paragraph	Page
Jack Assemblies			
Installation2-17	2-10
Removal2-17	2-10
Jacks, leveling1-3	1-1
	L		
L e v e l i n g j a c k s1-3	1-1
Limited storage		3-4	3-3
Inspection and maintenance in limited storage3-4	3-3
Lubrication2-2	2-1
	O		
Organization maintenance instructions2-1	2-1
	P		
Painting ward container6-14	6-16
Plug patches2-15	2-6
Preventive maintenance services2-3	2-1
Weekly.2-4	2-1
Quality control requirements6-14	6-16
	R		
Records and report forms.1-2	1-1
Removable door panel repairs6-5	6-7
Assembly6-5	6-7
D i s a s s e m b l y		6 - 5	6-7
Installation6-5	6-7
Overhaul6-5	6-7
Removal6-5	6-7
R e p a i r		6 - 5	6-7
Repair kit...2-19	
Rivet, blind type, replacement2-12	2-4
Rivet selection chart.2-12	2-4
R o o f p a n e l a s s e m b l y r e p a i r		6 - 7	6-9
Assembly		6-7	6-9
Disassembly6-7	6-9
I n s t a l l a t i o n		6 - 7	6-9
Overhaul6-7	6-9
Removal6-7	6-9
Repair.6-7	6-9
	S		
Safety precautions			
Seal replacement6-13	6-16
Sewn fabric parts, installation of.....		...5-5	5-1
Shipment, preparation for3-3	3-1
Side panel assembly repair6-8	6-9
Assembly6-8	6-9
Disassembly6-8	6-9
Installation6-8	6-9
Overhaul6-8	6-9
Removal6-8	6-9
Repair6-8	6-9
S l i d e f a s t e n e r		5 - 5	5-1
Special tools and equipment2-1	2-1
	T		
Tears, patching2-10	2-2
Troubleshooting2-5	2-1
	W		
Ward container description1-3	1-1
Ward container dimensions1-4	1-1

By Order of the Secretary of the Army:

W. C. WESTMORELAND,
General, United States Army,
Chief of Staff.

Official:

KENNETH G. WICKHAM,
Major General, United States Army,
The Adjutant General.

Distribution:

To be distributed in accordance with DA Form 12-25, Sec I (qty rqr Block #278), Organizational maintenance requirements for Tents.

These are the instructions for sending an electronic 2028

The following format must be used if submitting an electronic 2028. The subject line must be exactly the same and all fields must be included; however only the following fields are mandatory: 1, 3, 4, 5, 6, 7, 8, 9, 10, 13, 15, 16, 17, and 27.

From: "Whomever" <whomever@avma27.army.mil>

To: amssbriml@natick.army.mil

Subject: DA Form 2028

1. From: Joe Smith
2. Unit: home
3. Address: 4300 Park
4. City: Hometown
5. St: MO
6. Zip: 77777
7. Date Sent: 19-OCT-93
8. Pub no: 55-2840-229-23
9. Pub Title: TM
10. Publication Date: 04-JUL-85
11. Change Number: 7
12. Submitter Rank: MSG
13. Submitter FName: Joe
14. Submitter MName: T
15. Submitter LName: Smith
16. Submitter Phone: 123-123-1234
17. Problem: 1
18. Page: 2
19. Paragraph: 3
20. Line: 4
21. NSN: 5
22. Reference: 6
23. Figure: 7
24. Table: 8
25. Item: 9
26. Total: 123
27. Text:

This is the text for the problem below line 27.

RECOMMENDED CHANGES TO PUBLICATIONS AND BLANK FORMS For use of this form, see AR 25-30; the proponent agency is ODISC4.						Use Part II (reverse) for Repair Parts and Special Tool Lists (RPSTL) and Supply Catalogs/Supply Manuals (SC/SM).	DATE 21 October 2003
TO: (Forward to proponent of publication or form) (Include ZIP Code) COMMANDER U.S. ARMY TANK-AUTOMOTIVE AND ARMAMENT COMMAND ATTN: AMSTA-LC-CECT 15 KANSAS STREET NATICK, MA 01760-5052						FROM: (Activity and location) (Include ZIP Code) <i>PFC Jane Doe</i> <i>CO A 3rd Engineer BR</i> <i>Ft. Leonardwood, MO 63108</i>	
PART I – ALL PUBLICATIONS (EXCEPT RPSTL AND SC/SM) AND BLANK FORMS							
PUBLICATION/FORM NUMBER TM 10-1670-296-23&P				DATE 30 October 2002	TITLE Unit Manual for Ancillary Equipment for Low Velocity Air Drop Systems		
ITEM NO.	PAGE NO.	PARA-GRAPH	LINE NO. *	FIGURE NO.	TABLE NO.	RECOMMENDED CHANGES AND REASON <i>(Provide exact wording of recommended changes, if possible).</i>	
	0036 00-2				1	<i>In table 1, Sewing Machine Code Symbols, the second sewing machine code symbol should be MD ZZ not MD 22.</i> <i>Change the manual to show Sewing Machine, Industrial: Zig-Zag; 308 stitch; medium-duty; NSN 3530-01-181-1421 as a MD ZZ code symbol.</i>	
<small>*Reference to line numbers within the paragraph or subparagraph.</small>							
TYPED NAME, GRADE OR TITLE Jane Doe, PFC				TELEPHONE EXCHANGE/AUTOVON, PLUS EXTENSION 508-233-4141		SIGNATURE Jane Doe <i>Jane Doe</i>	

TO: <i>(Forward direct to addressee listed in publication)</i> COMMANDER U.S. ARMY TANK-AUTOMOTIVE AND ARMAMENT COMMAND ATTN: AMSTA-LC-CECT 15 KANSAS STREET NATICK, MA 01760-5052	FROM: <i>(Activity and location) (Include ZIP Code)</i> <i>PFC Jane Doe</i> <i>CO A 3rd Engineer BR</i> <i>Ft. Leonardwood, MO 63108</i>	DATE 21 October 2003
--	---	--------------------------------

PART II – REPAIR PARTS AND SPECIAL TOOL LISTS AND SUPPLY CATALOGS/SUPPLY MANUALS

PUBLICATION NUMBER TM 10-1670-296-23&P	DATE 30 October 2002	TITLE Unit Manual for Ancillary Equipment for Low Velocity Air Drop Systems
--	--------------------------------	---

PAGE NO.	COLM NO.	LINE NO.	NATIONAL STOCK NUMBER	REFERENCE NO.	FIGURE NO.	ITEM NO.	TOTAL NO. OF MAJOR ITEMS SUPPORTED	RECOMMENDED ACTION
0066 00-1					4			<i>Callout 16 in figure 4 is pointed to a <u>D-Ring</u>. In the Repair Parts List key for figure 4, item 16 is called a <u>Snap Hook</u>. Please correct one or the other.</i>

SAMPLE

PART III – REMARKS *(Any general remarks or recommendations, or suggestions for improvement of publications and blank forms. Additional blank sheets may be used if more space is needed.)*

TYPED NAME, GRADE OR TITLE	TELEPHONE EXCHANGE/AUTOVON, PLUS EXTENSION	SIGNATURE
----------------------------	--	-----------

RECOMMENDED CHANGES TO PUBLICATIONS AND BLANK FORMS For use of this form, see AR 25-30; the proponent agency is ODISC4.						Use Part II (reverse) for Repair Parts and Special Tool Lists (RPSTL) and Supply Catalogs/Supply Manuals (SC/SM).	DATE
TO: (Forward to proponent of publication or form) (Include ZIP Code) COMMANDER U.S. ARMY TANK-AUTOMOTIVE AND ARMAMENT COMMAND ATTN: AMSTA-LC-CECT 15 KANSAS STREET NATICK, MA 01760-5052						FROM: (Activity and location) (Include ZIP Code)	
PART I – ALL PUBLICATIONS (EXCEPT RPSTL AND SC/SM) AND BLANK FORMS							
PUBLICATION/FORM NUMBER TM 10-5410-223-24				DATE 15 December 1969		TITLE Organizational, Direct and General Support Maintenance Manual for Container, Service Ward, Rigid Construction	
ITEM NO.	PAGE NO.	PARA-GRAPH	LINE NO. *	FIGURE NO.	TABLE NO.	RECOMMENDED CHANGES AND REASON <i>(Provide exact wording of recommended changes, if possible).</i>	
<i>*Reference to line numbers within the paragraph or subparagraph.</i>							
TYPED NAME, GRADE OR TITLE				TELEPHONE EXCHANGE/AUTOVON, PLUS EXTENSION		SIGNATURE	

TO: (Forward direct to addressee listed in publication) COMMANDER U.S. ARMY TANK-AUTOMOTIVE AND ARMAMENT COMMAND ATTN: AMSTA-LC-CECT 15 KANSAS STREET NATICK, MA 01760-5052	FROM: (Activity and location) (Include ZIP Code)	DATE
---	---	-------------

PART II – REPAIR PARTS AND SPECIAL TOOL LISTS AND SUPPLY CATALOGS/SUPPLY MANUALS

PUBLICATION NUMBER TM 10-5410-223-24	DATE 15 December 1969	TITLE Organizational, Direct and General Support Maintenance Manual for Container, Service Ward, Rigid Construction
---	--------------------------	---

PAGE NO.	COLM NO.	LINE NO.	NATIONAL STOCK NUMBER	REFERENCE NO.	FIGURE NO.	ITEM NO.	TOTAL NO. OF MAJOR ITEMS SUPPORTED	RECOMMENDED ACTION

PART III – REMARKS (Any general remarks or recommendations, or suggestions for improvement of publications and blank forms. Additional blank sheets may be used if more space is needed.)

--

TYPED NAME, GRADE OR TITLE	TELEPHONE EXCHANGE/AUTOVON, PLUS EXTENSION	SIGNATURE
----------------------------	--	-----------

<p align="center">RECOMMENDED CHANGES TO PUBLICATIONS AND BLANK FORMS</p> <p>For use of this form, see AR 25-30; the proponent agency is ODISC4.</p>						Use Part II (reverse) for Repair Parts and Special Tool Lists (RPSTL) and Supply Catalogs/Supply Manuals (SC/SM).	DATE
TO: (Forward to proponent of publication or form) (Include ZIP Code) COMMANDER U.S. ARMY TANK-AUTOMOTIVE AND ARMAMENT COMMAND ATTN: AMSTA-LC-CECT 15 KANSAS STREET NATICK, MA 01760-5052						FROM: (Activity and location) (Include ZIP Code)	
PART I – ALL PUBLICATIONS (EXCEPT RPSTL AND SC/SM) AND BLANK FORMS							
PUBLICATION/FORM NUMBER TM 10-5410-223-24				DATE 15 December 1969		TITLE Organizational, Direct and General Support Maintenance Manual for Container, Service Ward, Rigid Construction	
ITEM NO.	PAGE NO.	PARA-GRAPH	LINE NO. *	FIGURE NO.	TABLE NO.	RECOMMENDED CHANGES AND REASON <i>(Provide exact wording of recommended changes, if possible).</i>	
<i>*Reference to line numbers within the paragraph or subparagraph.</i>							
TYPED NAME, GRADE OR TITLE				TELEPHONE EXCHANGE/AUTOVON, PLUS EXTENSION		SIGNATURE	

TO: (Forward direct to addressee listed in publication) COMMANDER U.S. ARMY TANK-AUTOMOTIVE AND ARMAMENT COMMAND ATTN: AMSTA-LC-CECT 15 KANSAS STREET NATICK, MA 01760-5052	FROM: (Activity and location) (Include ZIP Code)	DATE
---	---	-------------

PART II – REPAIR PARTS AND SPECIAL TOOL LISTS AND SUPPLY CATALOGS/SUPPLY MANUALS

PUBLICATION NUMBER TM 10-5410-223-24	DATE 15 December 1969	TITLE Organizational, Direct and General Support Maintenance Manual for Container, Service Ward, Rigid Construction
---	--------------------------	---

PAGE NO.	COLM NO.	LINE NO.	NATIONAL STOCK NUMBER	REFERENCE NO.	FIGURE NO.	ITEM NO.	TOTAL NO. OF MAJOR ITEMS SUPPORTED	RECOMMENDED ACTION

PART III – REMARKS (Any general remarks or recommendations, or suggestions for improvement of publications and blank forms. Additional blank sheets may be used if more space is needed.)

TYPED NAME, GRADE OR TITLE	TELEPHONE EXCHANGE/AUTOVON, PLUS EXTENSION	SIGNATURE
----------------------------	--	-----------

RECOMMENDED CHANGES TO PUBLICATIONS AND BLANK FORMS For use of this form, see AR 25-30; the proponent agency is ODISC4.						Use Part II (reverse) for Repair Parts and Special Tool Lists (RPSTL) and Supply Catalogs/Supply Manuals (SC/SM).	DATE
TO: (Forward to proponent of publication or form) (Include ZIP Code) COMMANDER U.S. ARMY TANK-AUTOMOTIVE AND ARMAMENT COMMAND ATTN: AMSTA-LC-CECT 15 KANSAS STREET NATICK, MA 01760-5052						FROM: (Activity and location) (Include ZIP Code)	
PART I – ALL PUBLICATIONS (EXCEPT RPSTL AND SC/SM) AND BLANK FORMS							
PUBLICATION/FORM NUMBER TM 10-5410-223-24				DATE 15 December 1969		TITLE Organizational, Direct and General Support Maintenance Manual for Container, Service Ward, Rigid Construction	
ITEM NO.	PAGE NO.	PARA-GRAPH	LINE NO. *	FIGURE NO.	TABLE NO.	RECOMMENDED CHANGES AND REASON (Provide exact wording of recommended changes, if possible).	
<i>*Reference to line numbers within the paragraph or subparagraph.</i>							
TYPED NAME, GRADE OR TITLE				TELEPHONE EXCHANGE/AUTOVON, PLUS EXTENSION		SIGNATURE	

TO: (Forward direct to addressee listed in publication) COMMANDER U.S. ARMY TANK-AUTOMOTIVE AND ARMAMENT COMMAND ATTN: AMSTA-LC-CECT 15 KANSAS STREET NATICK, MA 01760-5052	FROM: (Activity and location) (Include ZIP Code)	DATE
---	---	-------------

PART II – REPAIR PARTS AND SPECIAL TOOL LISTS AND SUPPLY CATALOGS/SUPPLY MANUALS

PUBLICATION NUMBER TM 10-5410-223-24	DATE 15 December 1969	TITLE Organizational, Direct and General Support Maintenance Manual for Container, Service Ward, Rigid Construction
---	--------------------------	---

PAGE NO.	COLM NO.	LINE NO.	NATIONAL STOCK NUMBER	REFERENCE NO.	FIGURE NO.	ITEM NO.	TOTAL NO. OF MAJOR ITEMS SUPPORTED	RECOMMENDED ACTION

PART III – REMARKS (Any general remarks or recommendations, or suggestions for improvement of publications and blank forms. Additional blank sheets may be used if more space is needed.)

TYPED NAME, GRADE OR TITLE	TELEPHONE EXCHANGE/AUTOVON, PLUS EXTENSION	SIGNATURE
----------------------------	--	-----------

The Metric System and Equivalents

Linear Measure

1 centimeter = 10 millimeters = .39 inch
 1 decimeter = 10 centimeters = 3.94 inches
 1 meter = 10 decimeters = 39.37 inches
 1 dekameter = 10 meters = 32.8 feet
 1 hectometer = 10 dekameters = 328.08 feet
 1 kilometer = 10 hectometers = 3,280.8 feet

Weights

1 centigram = 10 milligrams = .15 grain
 1 decigram = 10 centigrams = 1.54 grains
 1 gram = 10 decigrams = .035 ounce
 1 dekagram = 10 grams = .35 ounce
 1 hectogram = 10 dekagrams = 3.52 ounces
 1 kilogram = 10 hectograms = 2.2 pounds
 1 quintal = 100 kilograms = 220.46 pounds
 1 metric ton = 10 quintals = 1.1 short tons

Liquid Measure

1 centiliter = 10 milliliters = .34 fl. ounce
 1 deciliter = 10 centiliters = 3.38 fl. ounces
 1 liter = 10 deciliters = 33.81 fl. ounces
 1 dekaliter = 10 liters = 2.64 gallons
 1 hectoliter = 10 dekaliters = 26.42 gallons
 1 kiloliter = 10 hectoliters = 264.18 gallons

Square Measure

1 sq. centimeter = 100 sq. millimeters = .155 sq. inch
 1 sq. decimeter = 100 sq. centimeters = 15.5 sq. inches
 1 sq. meter (centare) = 100 sq. decimeters = 10.76 sq. feet
 1 sq. dekameter (are) = 100 sq. meters = 1,076.4 sq. feet
 1 sq. hectometer (hectare) = 100 sq. dekameters = 2.47 acres
 1 sq. kilometer = 100 sq. hectometers = .386 sq. mile

Cubic Measure

1 cu. centimeter = 1000 cu. millimeters = .06 cu. inch
 1 cu. decimeter = 1000 cu. centimeters = 61.02 cu. inches
 1 cu. meter = 1000 cu. decimeters = 35.31 feet

Approximate Conversion Factors

<i>To change</i>	<i>To</i>	<i>Multiply by</i>	<i>To change</i>	<i>To</i>	<i>Multiply by</i>
inches	centimeters	2.540	ounce-inches	newton-meters	.007062
feet	meters	.305	centimeters	inches	.394
yards	meters	.914	meters	feet	3.280
miles	kilometers	1.609	meters	yards	1.094
square inches	square centimeters	6.451	kilometers	miles	.621
square feet	square meters	.093	square centimeters	square inches	.155
square yards	square meters	.836	square meters	square feet	10.764
square miles	square kilometers	2.590	square meters	square yards	1.196
acres	square hectometers	.405	square kilometers	square miles	.386
cubic feet	cubic meters	.028	square hectometers	acres	2.471
cubic yards	cubic meters	.765	cubic meters	cubic feet	35.315
fluid ounces	milliliters	29.573	cubic meters	cubic yards	1.308
pints	liters	.473	milliliters	fluid ounces	.034
quarts	liters	.946	liters	pints	2.113
gallons	liters	3.785	liters	quarts	1.057
ounces	grams	28.349	liters	gallons	.264
pounds	kilograms	.454	grams	ounces	.035
short tons	metric tons	.907	kilograms	pounds	2.205
pound-feet	newton-meters	1.356	metric tons	short tons	1.102
pound-inches	newton-meters	.11296			

Temperature (Exact)

 _F Fahrenheit temperature $\frac{5}{9}$ (after subtracting 32) Celsius temperature _C

TM 10-5410-223-24 CONTAINER, SERVICE WARD, RIGID CONSTRUCTION - 1970

PIN: 028402-000

This fine document...

Was brought to you by me:



[Liberated Manuals -- free army and government manuals](#)

Why do I do it? I am tired of sleazy CD-ROM sellers, who take publicly available information, slap “watermarks” and other junk on it, and sell it. Those masters of search engine manipulation make sure that their sites that sell free information, come up first in search engines. They did not create it... They did not even scan it... Why should they get your money? Why are not letting you give those free manuals to your friends?

I am setting this document FREE. This document was made by the US Government and is NOT protected by Copyright. Feel free to share, republish, sell and so on.

I am not asking you for donations, fees or handouts. If you can, please provide a link to liberatedmanuals.com, so that free manuals come up first in search engines:

<A HREF=<http://www.liberatedmanuals.com/>>Free Military and Government Manuals

- Sincerely
Igor Chudov
<http://igor.chudov.com/>
- [Chicago Machinery Movers](#)