

TECHNICAL MANUAL  
OPERATOR, UNIT, AND DIRECT SUPPORT  
MAINTENANCE MANUAL

HYPOCHLORINATION UNIT  
NSN 4610-01-364-4485  
Model AHY001

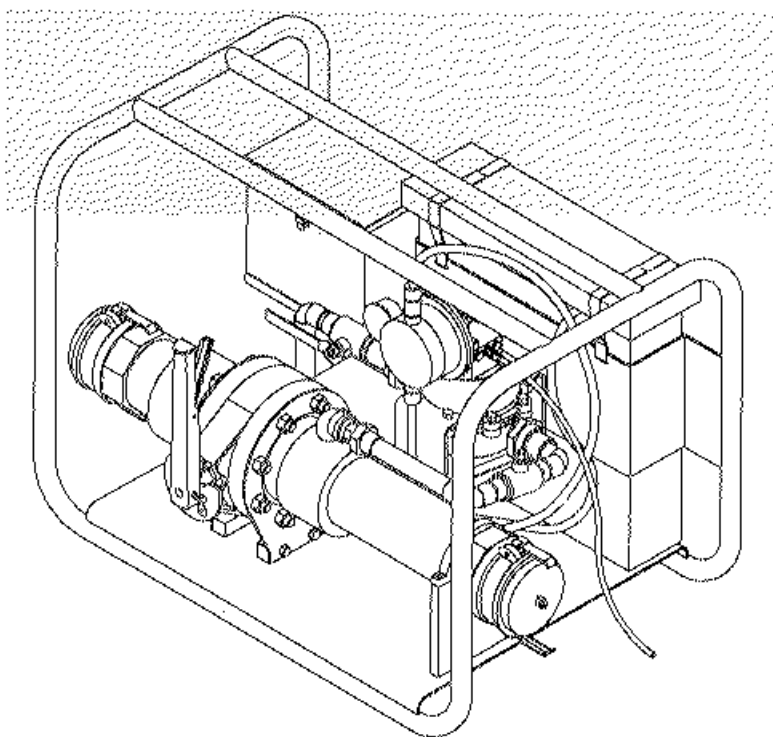

OPERATING INSTRUCTIONS  
Page 2-1

OPERATOR TROUBLESHOOTING  
Page 3-2

UNIT MAINTENANCE  
INSTRUCTIONS Page 4-1

UNIT TROUBLESHOOTING  
Page 4-6

DIRECT SUPPORT  
MAINTENANCE INSTRUCTIONS  
Page 5-1

DIRECT SUPPORT  
TROUBLESHOOTING Page 5-2

DISTRIBUTION STATEMENT A: Approved for public release; distribution is unlimited.

HEADQUARTERS, DEPARTMENT OF THE ARMY  
HEADQUARTERS, U. S. MARINE CORPS  
15 DECEMBER 1993

**WARNING**

Death or severe injury can occur from ingestion of hypochlorite solution. Do not swallow solution.

Do not breathe fumes from solution or dust from hypochlorite powder.

**WARNING**

Death or severe injury can occur from explosion, fire, or chlorine gas caused by contamination of hypochlorite solution with organic matter, or other chemicals. Use only clean, dry utensils when handling solution. Do not add solution to any dispensing device containing residue or another substance.

**WARNING**

Hypochlorite is caustic and can cause severe chemical burns. To avoid injury:

- Wear required protective clothing any time you are handling calcium hypochlorite.
- If hypochlorite solution comes in contact with skin or eyes, flush immediately with large amounts of water, and seek medical attention.
- If hypochlorite solution spills on equipment, rinse with large amounts of water.

**WARNING**

Hypochlorite solution may be on the suction valve and can cause severe chemical burns. To avoid injury wear gloves while working on it.

**WARNING**

Hypochlorite solution may be on the injection valve and can cause severe chemical burns. To avoid injury wear gloves while working on it.

**WARNING**

Hypochlorite solution may be on the pumphead and chemical side diaphragm and can cause severe chemical burns. To avoid injury wear gloves while working on them

**WARNING**

The water side diaphragm is under spring pressure, uncontrolled release may cause injury. Maintain pressure on the water side diaphragm when removing it during maintenance.

b

TECHNICAL MANUAL  
TM 10-4610-244-13  
TM 09476B-13/1

HEADQUARTERS, DEPARTMENT OF THE ARMY,  
AND HEADQUARTERS, U.S. MARINE CORPS  
WASHINGTON D.C., 15 December 1993

**Operator, Unit, and Direct Support  
Maintenance Manual**

**For**

**Hypochlorination Unit  
NSN 4610-01-364-4485  
Model AHY001**

**REPORTING ERRORS AND RECOMMENDING IMPROVEMENTS.** You can help improve this manual. If you find any mistakes or if you know of a way to improve the procedures, please let us know. Mail your letter, DA Form 2028 (Recommended Changes to Publications and Blank Forms) or DA form 2028-2 located in the back of this manual direct to: Commander, U.S. Aviation and Troop Command, ATTN: AMSAT-I-MP, 4300 Goodfellow Blvd., St. Louis, MO 63120-1798, or Commanding General, Code 850, Marine Corps Logistics Base, 814 Radford Blvd., Albany, GA 31704-1128. A reply will be furnished to you.

**DISTRIBUTION STATEMENT A:** Approved for public release, distribution is unlimited.

**TABLE OF CONTENTS**

<b>Subject</b>	<b>Page</b>
<b>How to Use This Manual</b> .....	iv
<b>Chapter 1. Introduction</b> .....	1-1
Section I. General Information .....	1-2
Section II. Equipment Description and Data .....	1-3
Section III. Principles of Operation .....	1-6
<b>Chapter 2. Operating Instructions</b> .....	2-1
Section I. Description and Use of Operator's Controls and Indicators .....	2-2
Section II. Preventive Maintenance Checks and Services (PMCS) .....	2-3
Section III. Operation Under Usual Conditions. ....	2-7
Section IV. Operation Under Unusual Conditions .....	2-15

TABLE OF CONTENTS (Cont'd)

Subject	Page
<b>Chapter 3. Operator Maintenance Instructions</b> .....	3-1
Section I. Lubrication Instructions .....	3-2
Section II. Operator Troubleshooting.....	3-2
Section III. Operator Maintenance Procedures.....	3-3
Section II. Operator Troubleshooting.....	3-2
Section III. Operator Maintenance Procedures.....	3-3
<b>Chapter 4. Unit Maintenance Instructions</b> .....	4-1
Section I. Repair Parts, Special Tools, Test, Measurement, and Diagnostic Equipment (TMDE), and Support Equipment.....	4-3
Section II. Receiving and Preparing for Movement .....	4-3
Section III. Unit Preventive Maintenance Checks and Services.....	4-4
Section IV. Unit Troubleshooting .....	4-6
Section V. Unit Maintenance Procedures .....	4-7
Section VI. Preparation for Storage or Shipment .....	4-37
<b>Chapter 5. Direct Support Maintenance Instructions</b> .....	5-1
Section I. Repair Parts, Special Tools, Test, Measurement, and Diagnostic Equipment (TMDE), and Support Equipment.....	5-2
Section II. Direct Support Troubleshooting .....	5-2
Section III. Direct Support Maintenance Procedures . .....	5-3
<b>Appendix A. References</b> .....	A-1
<b>Appendix B. Maintenance Allocation Chart (MAC)</b> .....	B-1
Section I. Introduction .....	B-1
Section II. Maintenance Allocation Chart.....	B-5
Section III. Tool and Test Equipment Requirements.....	B-7
<b>Appendix C. Components of End Items List and Basic Issue Items List</b> .....	C-1
Section I. Introduction .....	C-1
Section II. Components of End Items (COEI) List .....	C-2
Section III. Basic Issue Items (BII) List.....	C-3

TABLE OF CONTENTS (Cont'd)

Subject	Page
<b>Appendix D. Additional Authorization List</b> .....	D-1
Section I. Introduction .....	D-1
Section II. Additional Authorization List .....	D-1
<b>Appendix E. Expendable/Durable Items List</b> .....	E-1
Section I. Introduction .....	E-1
Section II. Expendable/Durable Items List .....	E-2
<b>Appendix F. Lubrication Instructions</b> .....	F-1
<b>Appendix G. Illustrated List of Manufactured Items</b> .....	G-1
<b>Appendix H. Torque Limits</b> .....	H-1
<b>Appendix I. Mandatory Replacement Parts</b> .....	I-1
<b>Glossary</b> .....	Glossary-1
Section I. Abbreviations .....	Glossary-1
Section II. Definitions of Unusual Terms .....	Glossary-2
<b>Alphabetical Index</b> .....	Index-1

## HOW TO USE THIS MANUAL

**GENERAL.** This technical manual provides you with the information needed to operate and maintain the hypochlorination unit. By properly using this manual, you will be able to identify any problem you may have in operating the hypochlorination unit and then locate the procedure needed to correct the problem.

**MANUAL ORGANIZATION.** This manual has been organized in a manner that groups together information that an operator or a maintenance technician will need to perform the required duties. The following list indicates how this information has been organized.

- |           |  |
|-----------|--|
| Chapter 1 | This chapter contains a complete description of the hypochlorination unit and includes such information as general equipment data, location/descriptions of major hypochlorination unit components, and general theory of operations of the hypochlorination unit. |
| Chapter 2 | Information needed to set up and operate the hypochlorination unit is included in this chapter. It includes assembly information, operator PMCS, and special instructions for unusual or emergency conditions.   |
| Chapter 3 | All operator maintenance procedures are in this chapter.   |
| Chapter 4 | If unit level maintenance is needed for the hypochlorination unit, required maintenance instructions can be found in this chapter.   |
| Chapter 5 | This chapter contains maintenance instructions for direct support activities.  |

**AIDS TO FINDING INFORMATION.** The following aids have been placed in this technical manual to help you quickly locate the information you may need.

**Front Cover Index** To provide you with a quick reference to the most used portions of this technical manual, an index of these areas has been placed on the front cover of this manual.

**Bleeder Edges on Pages** On the right edge of the front cover index of this manual you will see a black box area that goes to the edge of the front cover page. If you hold this manual with your left hand and bend back the outer right edges of the pages with your right hand, you will find that there are pages inside the manual that also have black boxes on the right edges, and that these boxes line up with the boxes on the front cover index. By turning to the page in the manual that lines up with the box on the front cover, you will be able to quickly turn to the topic shown in the front cover index.

<b>Table of Contents And Boxed Titles</b>	In the event that the front cover has been removed from this manual, the items that appear in the front cover index have also been placed in a box where they appear in the Table of Contents of this manual
<b>Alphabetical Index</b>	To assist you in locating any other information not found in the front cover index or the Table of Contents, an alphabetical index has been placed in the back of this manual.

**GENERAL MAINTENANCE METHOD.** Although your local standard operating and maintenance procedure may vary, a simple method of using this technical manual to operate and maintain the hypochlorination unit is shown in the following steps

## **WARNINGS AND CAUTIONS**

**Always Read, Understand, and Perform ALL WARNINGS and CAUTIONS Found in This Technical Manual BEFORE Performing the Step Immediately Following the WARNING or CAUTION.**

Throughout this technical manual are certain procedures and operations that are hazardous to you or the hypochlorination unit. If you see a WARNING, pay special attention to the information stated in it, because **all WARNINGS provide you with data that will prevent serious injury to you or others around you.** When you see a CAUTION read it carefully because information given in it will keep you from damaging the hypochlorination unit and making it unable to fulfill its mission.

**Equipment Set-Up and Operation.** Unpack and set up the hypochlorination unit in accordance with procedures shown in Chapters 2 and 4.

**Troubleshooting.** If the hypochlorination unit does not operate properly, refer to the operating troubleshooting procedures in Chapter 3, the unit troubleshooting procedures in Chapter 4, or the direct support troubleshooting procedures in Chapter 5. The most likely hypochlorination unit malfunctions have been placed in these troubleshooting procedures and a test and/or repair procedure paragraph has been indicated to correct the malfunction found. If a repair is required, refer to maintenance shown in the troubleshooting procedure.

**Maintenance Procedures.** Complete repair procedures needed to correct a problem found with the hypochlorination unit have been included in Chapters 3, 4 and 5.



CHAPTER 1.  
INTRODUCTION  
CHAPTER INDEX

Subject	Page
<b>SECTION I. GENERAL INFORMATION.</b>	
1-1. Scope .....	1-2
1-2. Maintenance Forms and Procedures .....	1-2
1-3. Corrosion Prevention and Control (CPC) .....	1-2
1-4. Destruction of Army Material to Prevent Enemy Use .....	1-2
1-5. Reporting Equipment Improvement Recommendations (EIR) .....	1-2
1-6. Warranty Information .....	1-2
<b>SECTION II. EQUIPMENT DESCRIPTION AND DATA.</b>	
1-7. Equipment Characteristics, Capabilities, and Features .....	1-3
1-8. Location and Description of Major Components .....	1-3
1-9. Equipment Data .....	1-5
<b>SECTION III. PRINCIPLES OF OPERATION.</b>	
1-10. Theory of Operation .....	1-5

## SECTION I. GENERAL INFORMATION.

### 1-1. SCOPE.

- a. Type of Manual. Operator, Unit, and Direct Support Maintenance Manual.
- b. Model Number and Equipment Name. Model AHYOO1 Hypochlorination Unit.
- c. Purpose of Equipment. The hypochlorination unit covered in this manual is to be used in water storage and distribution systems to chlorinate water.

**1-2. MAINTENANCE FORMS AND PROCEDURES.** Department of the Army forms and procedures used for equipment maintenance will be those prescribed by DA PAM 738-750, The Army Maintenance Management System (TAMMS) (Maintenance Management UPDATE).

**1-3. CORROSION PREVENTION AND CONTROL (CPC).** Corrosion Prevention and Control (CPC) of Army material is a continuing concern. It is important that any corrosion problems with this item be reported so that the problem can be corrected and Improvements can be made to prevent the problem In future items.

While corrosion is typically associated with rusting of metals, it can also include deterioration of other materials such as rubber and plastic Unusual cracking, softening, swelling, or breaking of materials may be a corrosion problem.

If a corrosion problem is identified, it can be reported using Standard Form 368, Product Quality Deficiency Report. Use of key words such as "rust", "deterioration", "corrosion", or "cracking" will insure that the information is identified as a CPC problem. The form should be submitted to the address specified in the DA PAM 738-750.

**1-4. DESTRUCTION OF ARMY MATERIAL TO PREVENT ENEMY USE.** Refer to TM 750244-3, Procedures for Destruction of Equipment to Prevent Enemy Use.

**1-5. REPORTING EQUIPMENT IMPROVEMENT RECOMMENDATIONS (EIR).** If the hypochlorination unit needs improvement, let us know Send us an EIR. The user is the only one who can tell us how the equipment can be improved. Let us know why you do not like the design or operation Put it on an SF 368 (Product Quality Deficiency Report) Mail it to Commander, U.S Army Aviation and Troop Command ATTN AMSAT-I-NLDO,4300 Goodfellow Blvd., St Louis, MO 63120-1798; or Commanding General, Code 850, Marine Corps Logistics Base, 814 Radford Blvd., Albany, GA 31704-1128. We will send you a reply.

**1-6. WARRANTY INFORMATION.** Warranty coverage is for a twelve-month period from date of issue not to exceed one year from date of delivery as shown on the Material Inspection and Receiving Report (DD Form 250) Report all defects in material or workmanship to your supervisor.

## SECTION II. EQUIPMENT DESCRIPTION AND DATA.

**1-7. EQUIPMENT CHARACTERISTICS, CAPABILITIES, AND FEATURES.** The hypochlorination unit is designed to chlorinate water in a water supply line before or after storage, and is capable of feeding hypochlorite solution in direct proportion to water demand over a range of 2 gpm to 350 gpm. It can operate in a temperature range of 32° F to 140° F. It is a light weight, independent unit that can be carried by two men and has little maintenance. It is easily operated by one person who only needs to check unit periodically after start up. It is provided with quick connecting camlocks making it easy to install, secure, or replace for maintenance.

**1-8. LOCATION AND DESCRIPTION OF MAJOR COMPONENTS.** The hypochlorination unit consists of following major components:

1. **Accessory Box** is provided for storage and transportation of chlorine analysis kit and miscellaneous equipment.
2. **Ball Valves** are used to isolate proportioning pump for maintenance.
3. **Camlock Fittings** connect hypochlorination unit to hose from unchlorinated water supply on inlet side and to hose going to chlorinated water holding tank on discharge side.
4. **Chlorine Analysis Kit** is provided to test treated water for chlorine residual concentration and is stored in accessory box.
5. **Frame Assembly** supports individual components and allows for ease of transportation.
6. **Mainline Pipe** is pipe through which bulk of water flows during treatment.
7. **Proportioning Pump** is a chemical metering pump. It measures water flow and adds hypochlorite solution to water flow in direct proportion, and is completely water powered.
8. **Range Adjusting Valve** is a butterfly valve used to control amount of water sent through proportioning pump. This allows for a wide range of flow rates with greater accuracy.
9. **Solution Reservoir** holds hypochlorite solution to be drawn into proportioning pump.
10. **Y-Strainer** holds a screen that filters out particles and protects proportioning pump from damage or clogging.

1-8. LOCATION AND DESCRIPTION OF MAJOR COMPONENTS (Cont'd).

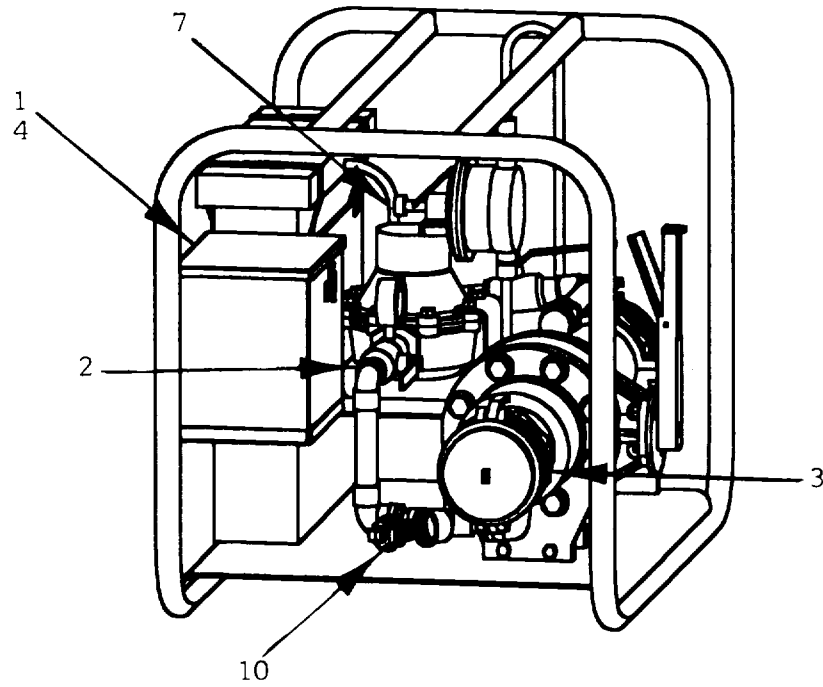
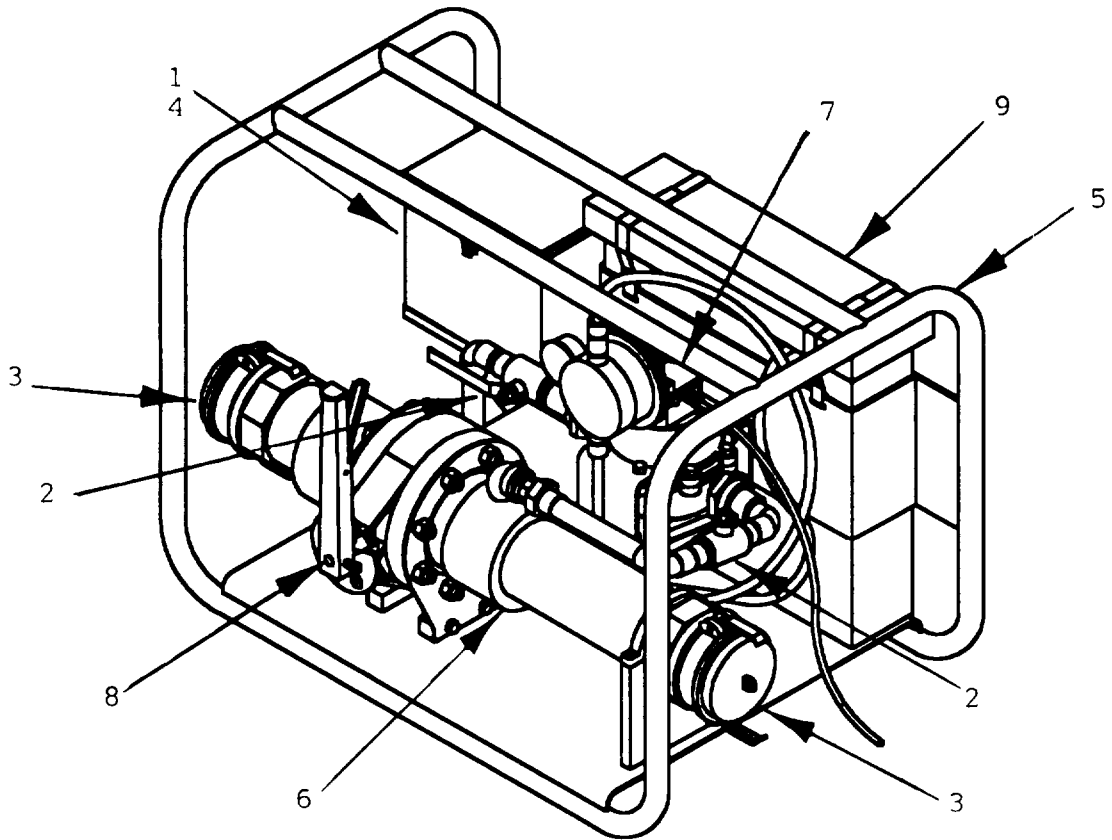

**1-9. EQUIPMENT DATA.** Refer to Table 1-1 for performance data on hypochlorination unit

**Table 1-1.  
Equipment Data.**

SHIPPING WEIGHT 175 lbs

**DIMENSIONS**

Width	24 3/4"
Length	39 3/4"
Height	26 1/4"

MAXIMUM PRESSURE 125 psi.

MAXIMUM FLOW RATE 350 gpm.

MAXIMUM OPERATING TEMPERATURE 140° F (60°C).

MINIMUM OPERATING TEMPERATURE 32° F (0°C).

**SECTION III. PRINCIPLES OF OPERATION.**

**1-10. THEORY OF OPERATION.** The hypochlorination unit chlorinates water and is used in conjunction with water storage and distribution systems. It consists of several simple parts combined into one unit, and may be used in the system before or after storage tanks. Primary component is the proportioning pump of which upper housing and pumphead assemblies are shown. Rotary motion of the flow meter (not shown) is used to turn cam (1). Cam pushes and releases valve arm (2). When valve arm (2) is pushed completely by cam, it pushes on R-valve (3) and shuts it. After R-valve (3) is shut, the valve arm (2) then pushes on the bal-valve (4) to open it. When the bal-valve (4) is open, water from the lower housing assembly flows through the hole (5) and pressurizes upper housing assembly. This pressurized water passes through a pipe to the pumphead assembly where it pushes on the water side diaphragm (6). The pressure overcomes spring pressure pushing the chemical diaphragm (7) which pumps calcium hypochlorite out the discharge valve (8). When the cam (1) releases valve arm (2), spring pressure allows bal-valve (4) to shut and R-valve (3) to open. The R-valve (3) discharges water to environment. When water pressure is no longer on water side diaphragm (6), spring pressure pushes diaphragm to original position and pulls chemical side diaphragm (7) away from pump housing causing calcium hypochlorite to be drawn through suction valve (9). The cam (1) continues to turn and repeat this action as long as there is flow through the water meter.

1-10. THEORY OF OPERATION (Cont'd).

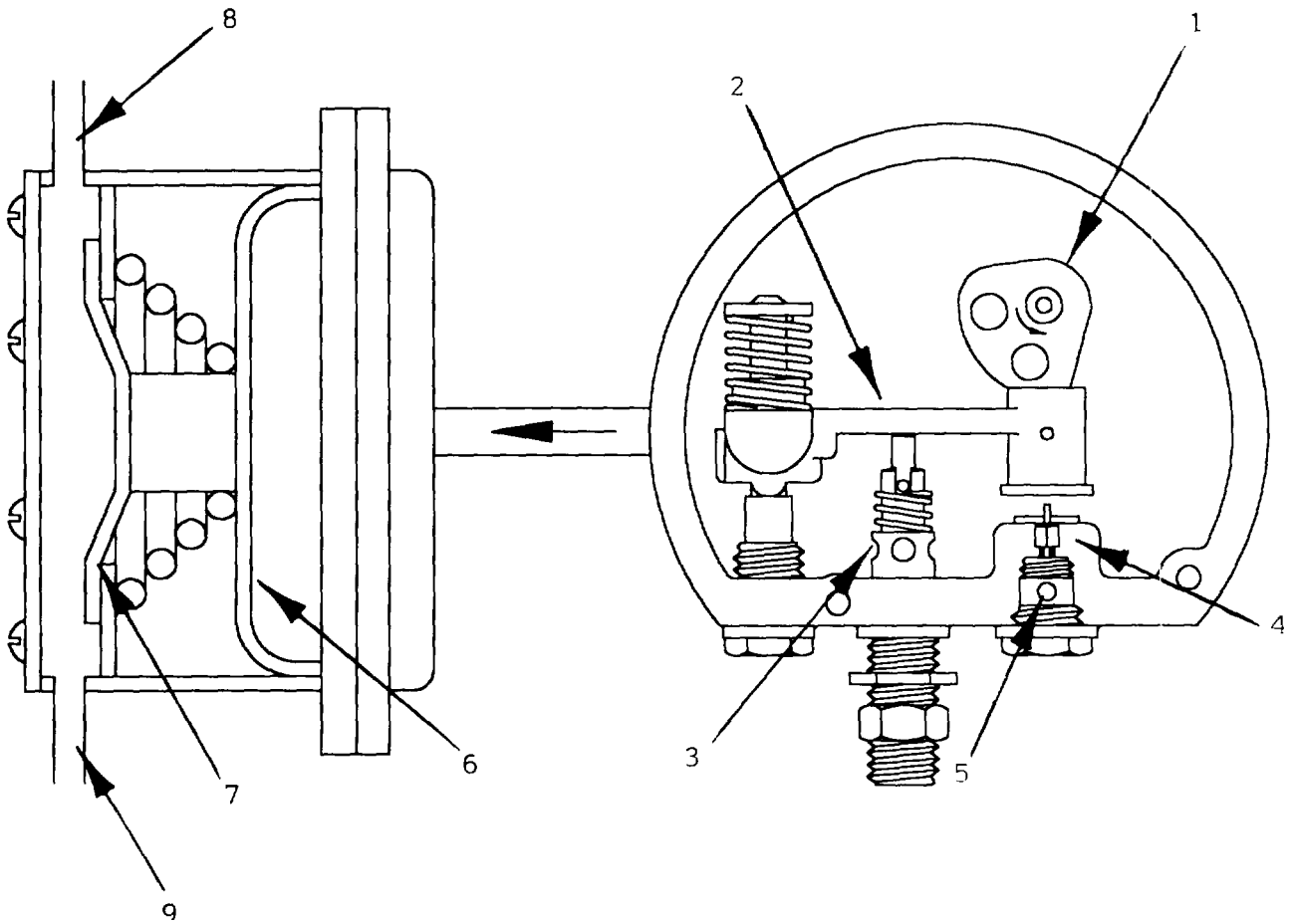

CHAPTER 2.  
OPERATING INSTRUCTIONS  
CHAPTER INDEX

Subject	Page
<b>SECTION I. DESCRIPTION AND USE OF OPERATOR'S CONTROLS AND INDICATORS.</b>	
2-1. Operator's Controls and Indicators .....	2-2
<b>SECTION II. PREVENTIVE MAINTENANCE CHECKS AND SERVICES (PMCS).</b>	
2-2. General .....	2-3
2-3. PMCS Procedures .....	2-3
2-4. Leakage Definitions for Operator PMCS .....	2-4
2-5. Special Instructions .....	2-5
2-6. PMCS Table .....	2-5
<b>SECTION III. OPERATION UNDER USUAL CONDITIONS.</b>	
2-7. Siting Requirements .....	2-8
2-8. Assembly and Preparation for Use. ....	2-8
2-9. Initial Adjustments and Checks .....	2-8
2-10. Operating Procedures .....	2-9
2-11. Decals and Instruction Plates .....	2-15
2-12. Preparation for Movement .....	2-17
<b>SECTION IV. OPERATION UNDER UNUSUAL CONDITIONS.</b>	
2-13. Operation in Unusual Weather .....	2-18
2-14. NBC Decontamination Procedures .....	2-19

## SECTION I. DESCRIPTION AND USE OF OPERATOR'S CONTROLS AND INDICATORS.

**2-1. OPERATOR'S CONTROLS AND INDICATORS.** Controls and indicators you need to operate the hypochlorination unit are shown.

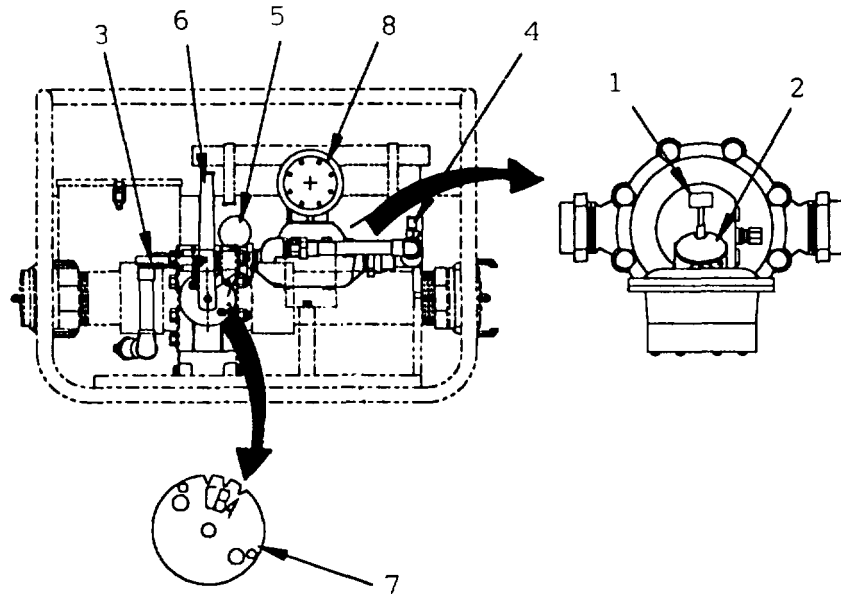

1. **DOSAGE CONTROL KNOB** adjusts amount of hypochlorite injected into mainline.
2. **DOSAGE DIAL INDICATOR** gives setting of dosage control.
3. **INLET BALL VALVE** isolates proportioning pump for maintenance and is used in conjunction with the outlet ball valve.
4. **OUTLET BALL VALVE** isolates the proportioning pump for maintenance and is used in conjunction with the inlet ball valve.
5. **PROPORTIONAL PUMP PRESSURE GAGE** monitors water pressure in hypochlorination unit.
6. **RANGE ADJUSTING VALVE** adjusts bypass flow needed to operate proportioning pump.
7. **RANGE ADJUSTING VALVE POSITION PLATE** indicates position of range adjusting valve.
8. **SIGHT ASSEMBLY** gives visual indication of solution flow through unit.



## SECTION II. PREVENTIVE MAINTENANCE CHECKS AND SERVICES (PMCS).

**2-2. GENERAL.** Preventive Maintenance Checks and Services (PMCS) means systematic caring, inspecting, and servicing of equipment to keep it in good condition and to prevent breakdowns. As the hypochlorination unit's operator, your mission is to:

- a. Be sure to perform PMCS each time you operate the hypochlorination unit. Always do PMCS in same order, so it gets to be a habit. Once you've had some practice, you'll quickly spot anything wrong.
- b. Do BEFORE (B) PMCS just before you operate the hypochlorination unit. Pay attention to WARNINGS, CAUTIONS, and NOTES.
- c. Do DURING (D) PMCS while you operate the hypochlorination unit. During operation means to monitor hypochlorination unit and related components while it is actually being operated. Pay attention to WARNINGS, CAUTIONS, and NOTES.
- d. Do AFTER (A) PMCS right after operating the hypochlorination unit. Pay attention to WARNINGS, CAUTIONS, and NOTES.
- e. Use DA Form 2404 (Equipment Inspection and Maintenance Worksheet) to record any faults that you discover before, during, or after operation, unless you can fix them. You DO NOT need to record faults that you fix.
- f. Perform any other services when required by organizational maintenance.

### 2-3. PMCS PROCEDURES.

- a. Your Preventive Maintenance Checks and Services, Table 2-1, lists inspections and care required to keep hypochlorination unit in good operating condition.
- b. The "INTERVAL" column of Table 2-1 tells you when to do a certain check or service.
- c. The "PROCEDURE" column of Table 2-1 tells you how to do required checks and services. Carefully follow these instructions. If you do not have tools, or if the procedure tells you to, notify your supervisor.
- d. The "NOT FULLY MISSION CAPABLE IF: " column in Table 2-1 tells you when your hypochlorination unit is nonmission capable and why it cannot be used.

### 2-3. PMCS PROCEDURES (Cont'd).

- e. If hypochlorination unit does not perform as required, refer to Chapter 3, Section II, Troubleshooting.
- f. If anything looks wrong and you can't fix it, write It on your DA Form 2404 IMMEDIATELY report it to your supervisor.
- g. Following are checks that are common to the entire hypochlorination unit
  - (1) **Keep it clean.** Dirt, grease, oil, and debris only get in the way and may cover up a serious problem. Clean as you work and as needed.
  - (2) **Rust and Corrosion.** Check hypochlorination unit for rust and corrosion. If any bare metal or corrosion exists, clean, and apply thin coat of oil Report it to your supervisor.
  - (3) **Bolt, Nuts, and Screws.** Check all for obvious looseness, missing, bent, or broken condition You can't try them all with a tool, but look for chipped paint, bare metal, or rust around bolt heads If you find a bolt, nut, or screw you think is loose, tighten it or report it to your supervisor.
  - (4) **Welds.** Look for loose or chipped paint, rust, or gaps where parts are welded together. If you find a bad weld, report it to your supervisor.
  - (5) **Hoses and Fluid Lines.** Look for wear, damage, and leaks, and make sure clamps and fittings are tight. Wet spots show leaks, but a stain around a fitting or connector can also mean a leak. If leak comes from loose fitting of connector, tighten It If something is broken or worn out, report it to your supervisor

**2-4. LEAKAGE DEFINITIONS FOR OPERATOR PMCS.** You must know how fluid leakage affects the status of the hypochlorination unit Following are types/classes of leakage an operator needs to know to be able to determine the status of the hypochlorination unit Learn these leakage definitions and remember' when in doubt, notify your supervisor

#### CAUTION

•**Equipment operation is allowable with minor leakages (Class I or II). Of course, consideration must be given to fluid capacity in the item/system being checked/inspected. When in doubt, notify your supervisor.**

•**When operating with Class I or II leaks, continue to check fluid levels as required in your PMCS.**

• **Class III leaks should be reported immediately to your supervisor.**

- a. CLASS I Seepage of fluid (as indicated by wetness or discoloration) not great enough to form drops.
- b. CLASS II Leakage of fluid great enough to form drops but not enough to cause drops to drip from item being checked/inspected

**2-4. LEAKAGE DEFINITIONS FOR OPERATOR PNICS (Cont'd).**

c. CLASS III Leakage of fluid great enough to form drops that fall from item being checked/inspected.

**2-5. SPECIAL INSTRUCTIONS.** If equipment must be kept in continuous operation, check and service only those items that can be checked and serviced without disturbing operation. Make complete checks and services when hypochlorination unit can be shut down.

**2-6. PMCS TABLE.** Refer to Table 2-1 for operator Preventive Maintenance Checks and Service for hypochlorination unit.

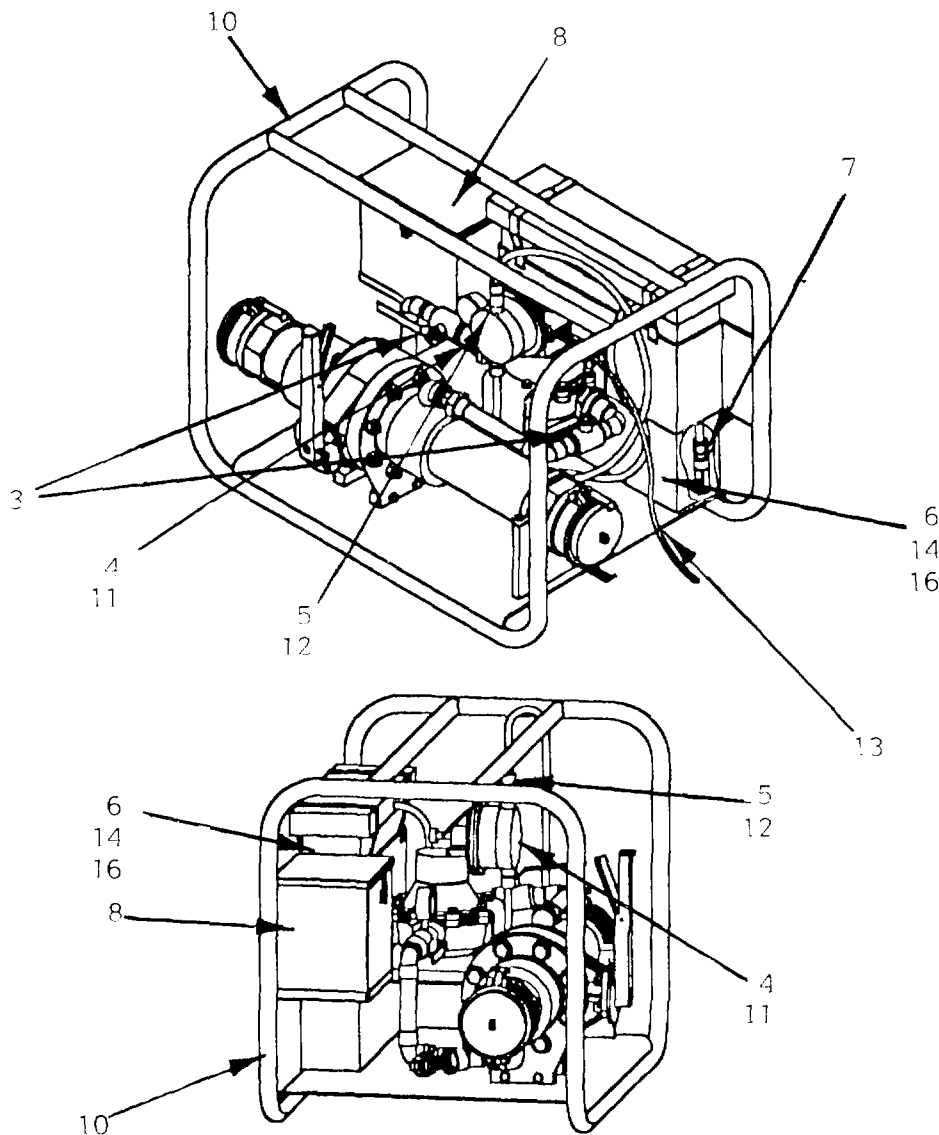

**Table 2-1.  
Operation Preventive Maintenance Checks  
and Service for Hypochlorination Unit**

ITEM NO	INTERVAL	LOCATION ITEM TO BE CHECK/SERVICE	PROCEDURES	NOT FULLY MISSION CAPABLE IF:
1	Before	Cover	Inspect for tears, holes	
2	Before	Camlocks: gaskets	Inspect gaskets for nicks or deterioration	Gaskets are brittle or cracked
3	Before	Ball valves	Inspect for free movement of valve lever	Valve lever does not move
4	Before	Sight assembly	Inspect casing for cracks and screws.	Cracks
5	Before	Lines and fittings`	Inspect lines for evidence of deterioration Inspect fittings for cracks or looseness	Leaks
6	Before	Reservoir	<p style="text-align: center;"><b>WARNING</b></p> <p><b>Death or severe injury can occur from explosion, fire, or chlorine gas caused by contamination of hypochlorite solution with organic matter, or other chemicals. Use only clean, dry utensils when handling solution. Do not add solution to any dispensing device containing residue or another substance.</b></p> <p>a. Inspect reservoir and ensure it is completely clean, dry, and has no foreign matter.</p> <p>b. Inspect reservoir for dents, cracks, holes or other damage.</p>	Contaminants are present
7	Before	Foot valve	Inspect strainer for clogging or damage	Unable to hold 5 gallons of Solution without leaking.
8	Before	Accessory box	Inspect for dents, broken latch, broken lid Hinges, or large holes	Strainer cracked, clogged and not cleanable
9	Before	Chlorine analysis kit	Inspect for cracks or breaks to comparator, broken or missing test vials: ensure kit contains several reagent tablets (mimumum 10)	Comparator damaged, test vials broken or missing, less than 10 reagent tablets

**Table 2-1.  
 Operator Preventive Maintenance Checks  
 and Service for Hypochlorination Unit (Cont'd).**

ITEM NO	INTERVAL	LOCATION ITEM TO BE CHECK/SERVICE	PROCEDURES	NOT FULLY MISSION CAPABLE IF:
10	Before	Frame	Inspect frame for chips In paint or bare metal or evidence of corrosion	
11	During	Sight assembly	a. Inspect to ensure portioning pump is pumping as evidenced by movement of diaphragms  b. Inspect for leaks	Class III leak
12	During	Lines and fitting,	Inspect for leaks	Class III leak
13	During	Wasteline	Check that waste, water is discharging	No water discharging
14	During	Reservoir	Check level of solution in reservoir	less than 3 Inches of Solution
15	During	Treated water	Sample for chlorine content  <b>CAUTION</b>  <b>Hypochlorite solution is corrosive and sedimentary. Do not leave solution sedimentary in reservoir, or lines</b>	
16	After	Reservoir and solution tubing	Flush with clean water for ten minutes (Paragraph 2-12)	
17	After	All components that are in contact with Liquid	Drain unit completely) Paragraph 2-12)	

### SECTION III. OPERATION UNDER USUAL CONDITIONS.

**2-7. SITING REQUIREMENTS.** The hypochlorination unit should be situated so that it is stable, and allows for free movement by operator around equipment during operation. It should also be situated so as to prevent hypochlorite solution from spilling from reservoir.

#### 2-8. ASSEMBLY AND PREPARATION FOR USE.

- a. Remove packing material from hypochlorination unit
- b. Remove and retain technical publications envelope

#### NOTE

Waste water line must not be elevated or restricted in any way

- c. Remove packing material from waste water hose, and extend waste water hose to full length. Ensure waste water hose is going to suitable drain location and that discharge of hose is at level lower than chemical pump. Also, secure drain end of hose, as it may jerk when water is discharged

#### 2-9. INITIAL ADJUSTMENTS AND CHECKS.

- a. Remove cover, check condition of gasket and female camlock, and replace if necessary. Use camlocks to install hypochlorination unit in water distribution system as detailed in appropriate system manual
- b. Check to ensure dosage dial indicator is at position 5, as shown below. It may be necessary, to change position at a later time, but you should start operations at position 5

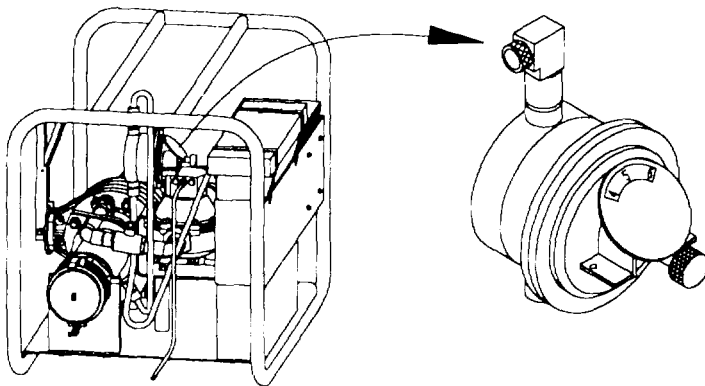

## 2-9. INITIAL ADJUSTMENTS AND CHECKS (Cont'd).

### WARNING

Death or severe injury can occur from explosion, fire, or chlorine gas caused by contamination of hypochlorite solution with moisture, organic matter, or other chemicals. Use only clean, dry utensils when handling solution. Do not add solution to any dispensing device containing residue or another substance.

- c Check that all tubes (chemical suction hose, for example) are connected
- d Check that foot valve is in reservoir, and reservoir oil is clean
- e Ensure all valves on hypochlorination unit are open (1), not shut (2)

## 2-10. OPERATING PROCEDURES.

### WARNING

Hypochlorite is caustic and can cause severe chemical burns. To avoid injury.

- Wear required protective clothing any time you are handling calcium hypochlorite
- If hypochlorite solution comes in contact with skin or eyes, flush immediately with large amounts of water, and seek medical attention
- If hypochlorite solution spills on equipment, rinse with large amounts of water.

2-10. OPERATING PROCEDURES (Cont'd).

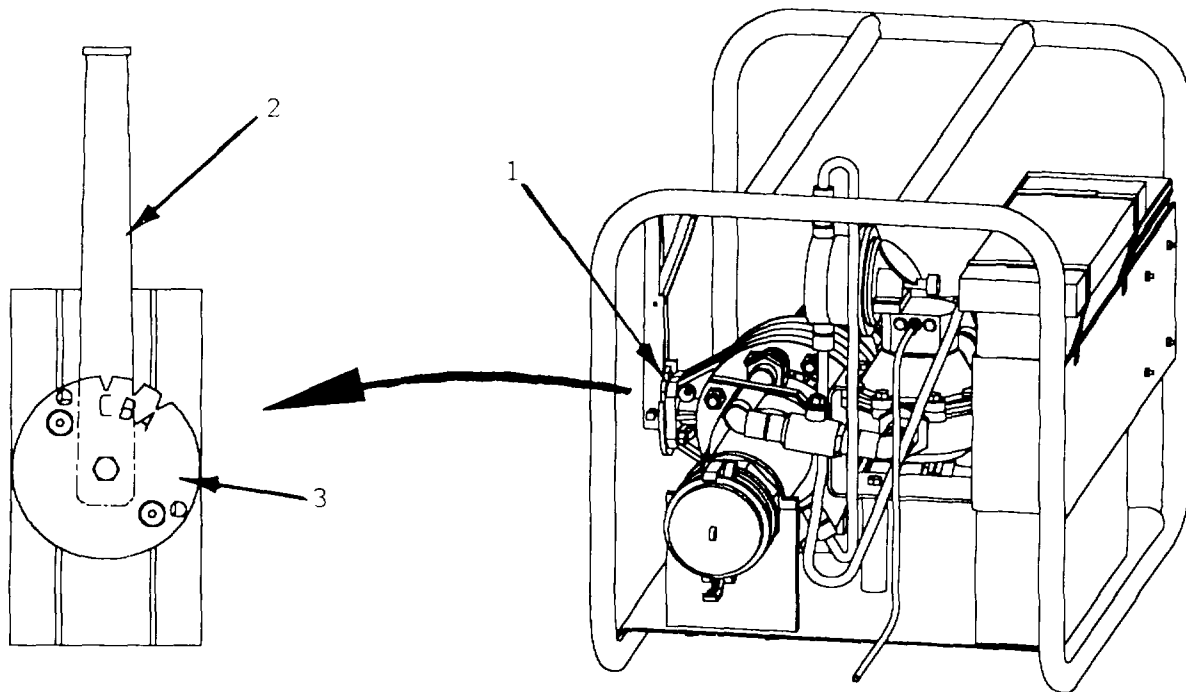

a. Estimate amount of water that will be flowing through mainline and set range adjusting valve (1) to proper position based on estimate. Make sure range adjusting handle (2) locks into position plate (3)

<u>FLOW RATE</u>	<u>VALVE POSITION</u>
350-70 gpm	A
70-15 gpm	B
15- 2 gpm	C

- b. Fill mixing bucket (appendix C, Item 4) to 2.5 gallon mark with water
- c. Perform chlorine residual test on source water in accordance with step d



**2-10. OPERATING PROCEDURES (Cont'd).**

d. Chlorine residual test

(1) Rinse test tube (1) with sample water. Fill to line with sample water.

(2) Add one DPD tablet (2) Install cap (3) and shake test tube until tablet dissolves.

(3) Remove cap (3).

(4) Place test tube in reader (4) at back of comparator (5), in a slot directly behind clear window.

(5) Match sample color to color standard. Move sample tube from behind one clear window to behind other until color match is made.

(6) If color is darker than 1.0 ppm Cl (2.0-10.0 ppm Cl), place test sample tube in open windows (6) at top of comparator (5).

(7) Move sample tube from one position to another until color match is made. If color of test sample falls between two values,

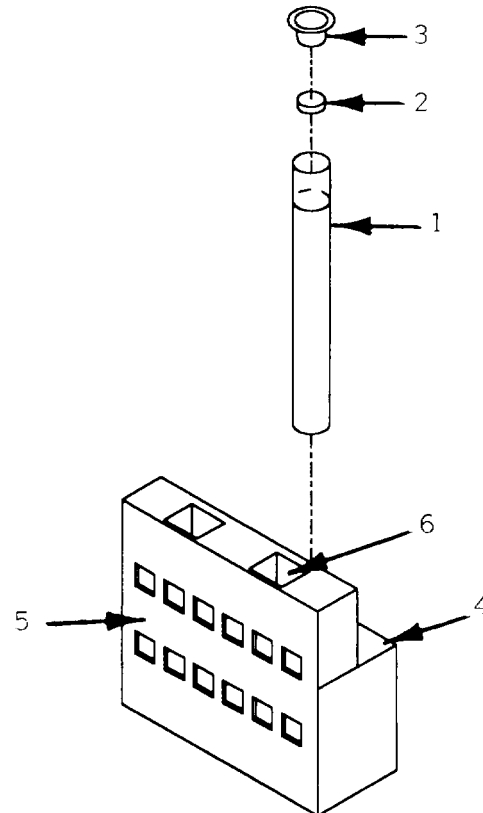

the result is average of the two values. Record as ppm Cl residual chlorine

(8) If color is darker than 5.0 ppm Cl color standard, amount of chlorine present cannot be measured accurately with one DPD tablet (2). Add an additional DPD tablet to test tube (1), install cap (3) and shake until tablet dissolves. Repeat step (6).

(9) Rinse test tube (1) with treated water and store in test kit.

e. Determine chlorine dosage requirement by subtracting ppm of source water chlorine residual from the desired chlorine residual (as prescribed by TB-MED-577) For example

Desired Chlorine Residual	3 ppm
Source Water Chlorine Residual	<u>-1 ppm</u>
Chlorine Dosage Requirement	2 ppm

f. If the chlorine dosage requirement is 2 ppm, for example, find a dosage ppm of 2 in 2-11 table 2-2. If the dosage requirement is 2 ppm and the hypochlorination unit will be run at 50 gpm, 7.5 ounces of 70% calcium hypochlorite will be mixed with 5 gallons of water

**Table 2-2.**  
**Amount of 70% Calcium Hypochlorite (Ounces)**  
**in Five Gallons of Solution.**

Dosage PPM	1	2	3	4	5	6	7	8	9	10
350-70 GPM	10.6	21.2	31.8	42.4	53.0	63.6	74.2	84.8	95.4	106
70-15 GPM	3.7	7.5	11.2	15.0	18.7	22.4	26.2	29.9	33.7	37.4
15-2 GPM	0.76	1.5	2.33	3.8	4.6	5.3	6.1	6.8	7.6	

- g. Add calcium hypochlorite to mixing bucket and mix thoroughly until dissolved
- h. Add water to mixing bucket to 5 gallon mark while mixing.

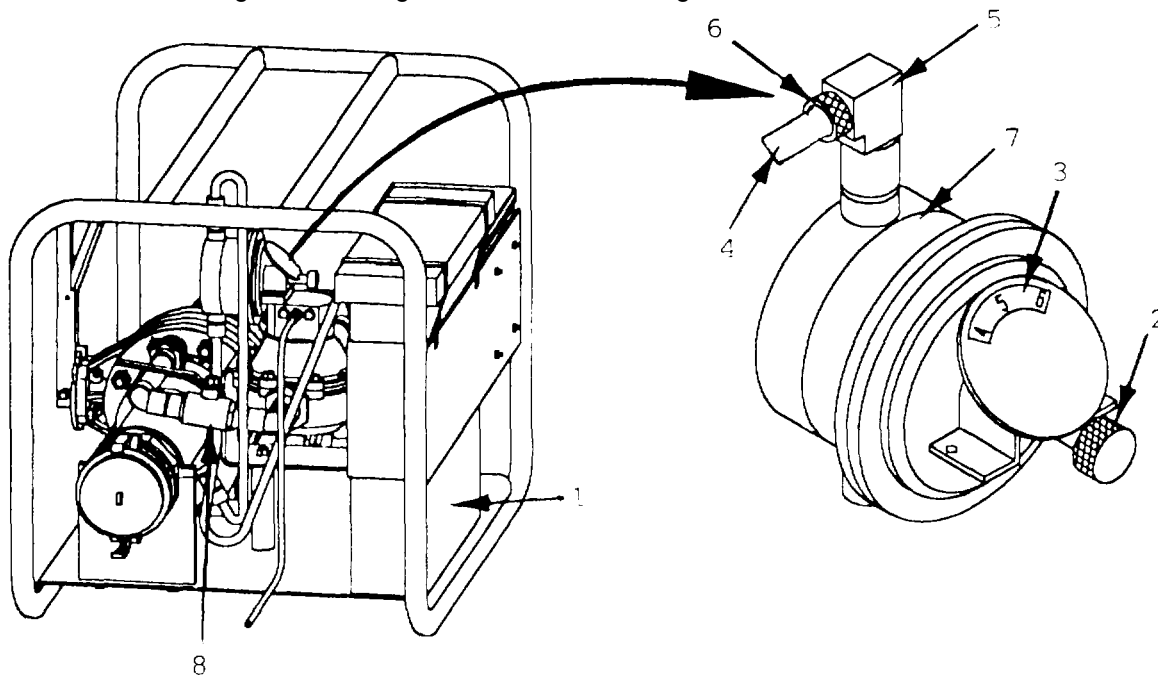

- i. Pour 1/2 of the solution from mixing bucket into hypochlorination unit reservoir (i), and set bucket with remainder aside.
- j. Set stroke adjusting knob (2) at position 5 as read on dosage dial indicator (3)
- k. Start system water flow. Refer to applicable system manual

2-10. OPERATING PROCEDURES (Cont'd).

**WARNING**

**Hypochlorite is caustic and can cause severe chemical burns To avoid injury**

- **Wear required protective clothing any time you are handling calcium hypochlorite.**
  - **If hypochlorite solution comes in contact with skin or eyes, flush immediately with large amounts of water, and seek medical attention**
  - **If hypochlorite solution spills on equipment, rinse with large amounts of water**
- l. Disconnect tubing (4) from discharge valve (5) by unscrewing tube nut (6)
  - m. As soon as liquid comes from discharge valve (5) and no air is trapped in pump head (7), shut outlet ball valve (8)
  - n. Reconnect tubing (4) to discharge valve (5)
  - o. Open outlet ball valve (8) and allow hypochlorination unit to run for approximately 30 minutes, then perform chlorine residual test, using test kit provided (refer to step d for details of procedure)
  - p. If residual reading is too high, turn stroke setting down to 3
- (1) Allow unit to run for another 30 minutes and then repeat residual test (2) If reading remains high, lower stroke setting again to 1.
  - (3) If reading remains high after another 30 minutes, double check estimate of flow rate and ensure that range adjusting valve is in correct position (refer to step a. for correct position of range adjusting valve)
  - (4) If range adjusting valve is in correct position already and residual reading still remains high, dilute solution at a 2 1 ratio, and start testing procedures over
  - (5) After desired chlorine levels are reached, go to Step r

**2-10. OPERATING PROCEDURES (Cont'd).**

q. If residual reading is too low, turn stroke setting up to 8

(1) Allow unit to run for another 30 minutes, then repeat residual test (refer to step c for details of procedure).

(2) If reading remains low, raise stroke setting to 10.

(3) If reading remains low after another 30 minutes double check estimate of flow rate to ensure that range adjusting valve is in correct position. Also, make sure that water pressure is greater than 15 psi.

(4) If range adjusting valve is in correct position and residual reading still remains low, increase solution strength by adding enough calcium hypochlorite to raise one ppm per Table 2-2. If already at 10 ppm, add 10 ounces for 350-70 gpm, 37 ounces for 15-70 gpm or 0.8 ounces for 2-15 gpm.

(5) After desired chlorine levels are reached, go to Step r

r Fill reservoir (1) with remaining by hypochlorite solution from mixing bucket.

s Place cover on reservoir. No other action is required other than periodically sampling in accordance with TB-MED-577 and FM 10-52-I and refilling reservoir as necessary, referring to steps g through l for mixing instructions Hypochlorination unit should be able to produce following amounts of water from one reservoir full of, solution (based on control valve being set at 5).

Setting A;	58,600 gals
Setting B:	19,600 gals
Setting C:	3,600 gals

2-11. DECALS AND INSTRUCTION PLATES

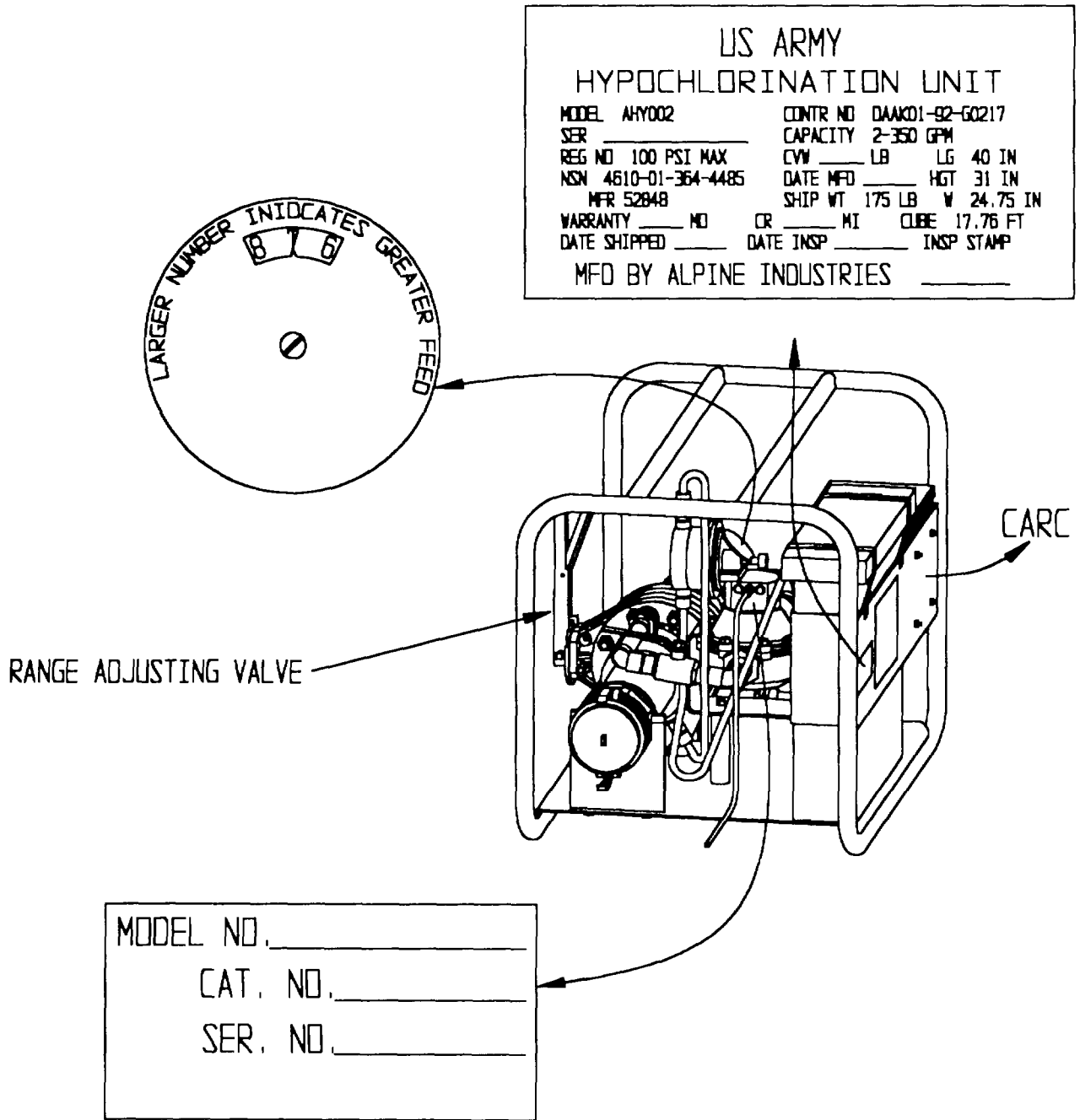

2-11. DECALS AND INSTRUCTION PLATES (CONT'D).

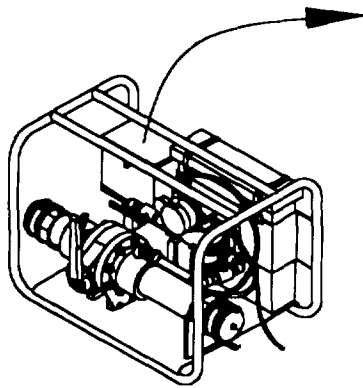

INSTRUCTIONS

HYPOCHLORINATION UNIT MODEL NO. AHY001 NSN 4610-01-364-4485

WARNING: Calcium hypochlorite and solution are extremely caustic! Wear protective gear Per TM 10-4610-244-13.

1. Set range adjusting valve to proper position.
  - 350-70 gpm A
  - 70-15 gpm B
  - 15-2 gpm C
2. Fill mixing bucket approx. 1/2 full of water.
3. Determine required amount of hypochlorite from table below to achieve desired concentration.
4. Add calcium hypochlorite to mixing bucket. Mix until dissolved.
5. Add water to bucket while mixing until completely full.
6. Pour half of solution from mixing bucket to hypochlorination unit reservoir.
7. Set dosage control knob at position 5.
8. Start mainline flow.
9. Disconnect tubing at outlet of discharge valve. As soon as liquid comes out of discharge valve shut outlet ball valve. Reconnect tubing. Open outlet ball valve.
10. Let run for approx. 30 minutes and then sample.
11. If residual chloride is not desired amount, adjust dosage control knob as necessary.
12. If desired residual is not found at maximum valve setting, an increase in solution strength is required. See TM 10-4610-244-13.

CALCIUM HYPOCHLORITE REQUIRED (In ounces)

PPM	1	2	3	4	5	6	7	8	9	10
350-70 GPM	10.6	21.2	31.8	42.4	53.0	63.6	74.2	84.8	95.4	106
70-15 GPM	3.7	7.5	11.2	15.0	18.7	22.4	26.2	29.9	33.7	37.4
15-2 GPM	0.76	1.5	2.3	3.0	3.8	4.6	5.3	6.1	6.8	7.6

## 2-12. PREPARATION FOR MOVEMENT.

### CAUTION

**Hypochlorite solution is corrosive and sedimentary Do not leave solution sediment in reservoir or lines**

- a. To prepare hypochlorination unit for storage or shipment, perform following

### WARNING

**Hypochlorite is caustic and can cause severe chemical burns. To avoid injury**

- **Wear required protective clothing any time you are handling calcium hypochlorite**
- **If hypochlorite solution comes in contact with skin or eyes, flush immediately with large amounts of water, and seek medical attention**
- **If hypochlorite solution spills on equipment, rinse with large amounts of water**

(1) Remove plastic tubing and foot valve (1) from chemical reservoir (2) Lift reservoir and dispose of contents in accordance with FM 10-52-1 Replace reservoir.

(2) Flush reservoir (2) with water and then refill with water Replace plastic tubing with foot valve (1) into reservoir.

(3) Set chemical adjusting knob (3) to 10 and allow water to flow through mainline for five minutes in order to flush out chemical suction and discharge lines and clean out all hypochlorite solution. After five minutes, remove foot valve (1) from reservoir (2), and allow unit to continue to pump to expel all water out of pumphead Shut outlet ball valve (4) after it discharges water out of waste line (5).

(4) Remove reservoir (2) and dump contents to waste. Replace reservoir. Replace plastic tubing with foot valve (1) into reservoir. Replace lid on reservoir and strap down with Velcro straps (6).

(5) Open camlocks (7) and remove inlet and outlet lines, and open outlet ball valve (4) Place range adjusting valve (8) in position "A" Open drain valve (9) on proportioning pump (10), and drain pump With drain valve open, tip unit as necessary to drain all water.

(6) Remove vent screws (11 and 12) and drain screw (13) from proportioning pump (10). Allow water to drain from proportioning pump (approx. 10 min) Replace vent screws and drain screw.

**2-12. PREPARATION FOR MOVEMENT (Cont'd).**

(7) Place chlorine test kit in accessory box. Replace dust covers.

(8) When all water is drained, place cloth cover over unit, zip cover shut, and pull and tie drawstring tight. Unit is now ready for transport or storage.

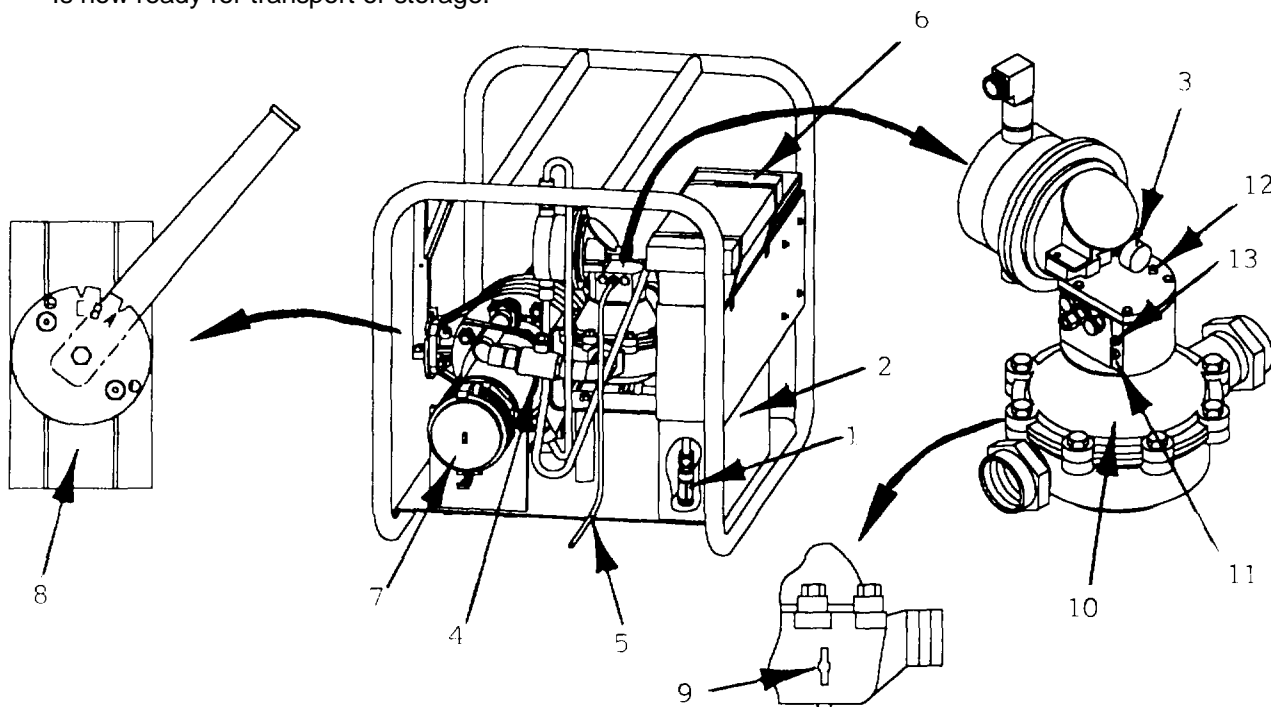

**SECTION IV. OPERATIONS UNDER UNUSUAL CONDITIONS.**

**2-13. OPERATION IN UNUSUAL WEATHER.**

- a. Cold Weather. The hypochlorination unit is not designed to operate in temperatures below 32° F (0° C). If water or chemical freezes, severe damage will occur. If air temperature nears 32° F, cover unit and move unit to a warmer area to prevent freeze up. If the unit cannot be moved to a warmer area, drain and prepare it for storage by following procedure in Paragraph 2-1 (Preparation for Movement) to prevent damage.
- b. Dusty or Sandy Conditions. Use existing shelter and windbreaks to keep sand and dirt from equipment during refill of reservoir. Keep cover on reservoir. Be careful when mixing hypochlorite solution to prevent getting sand or grit into solution. When equipment is not in use, in tail appropriate dust cap and plug on camlocks, and cover unit.



## 2-14. NBC DECONTAMINATION PROCEDURES.

### WARNING

**Wear protective gear when performing emergency decontamination. Failure to do so may lead to death.**

- a. General. The following emergency procedures can be performed until field NBC decontamination facilities are available. Detailed decontamination procedures can be found in FM 3-3, FM 3-4, and FM 3-5.
- b. Interim Decontamination Procedures.
  - (1) Continue operation of hypochlorination unit.
  - (2) Mark unit as externally contaminated for later decontamination.
  - (3) Keep lid on reservoir to prevent contamination of hypochlorite solution.
  - (4) Do not open camlocks or expose interior of unit to environment.
  - (5) If interior is exposed to environment, mark unit as contaminated internally
  - (6) Emergency Hasty Decontamination: Mix a solution of 6 gallons treated water and approximately 5.5 pounds of calcium hypochlorite. Pour this solution over hypochlorination unit, thoroughly dousing all surfaces.

**CHAPTER 3.**  
**OPERATOR MAINTENANCE INSTRUCTIONS**

**CHAPTER INDEX**

Subject	Page
<b>SECTION I. LUBRICATION INSTRUCTIONS.</b>	
3-1. General.....	3-2
<b>SECTION II. OPERATOR TROUBLESHOOTING.</b>	
3-2 Introduction .....	3-2
3-3. Operator Troubleshooting Table.....	3-2
<b>SECTION III. OPERATOR MAINTENANCE PROCEDURE.</b>	
3-4. General .....	3-3

**SECTION I. LUBRICATION INSTRUCTIONS.**

**3-1. GENERAL.** Lubrication is not required on hypochlorination unit

**SECTION II. OPERATOR TROUBLESHOOTING.**

**3-2. INTRODUCTION.** This section covers troubleshooting procedures for most frequent problems encountered in operating the hypochlorination unit

**3-3. OPERATOR TROUBLESHOOTING TABLE.**

- a. Use of Table Table 3-1 lists common malfunctions which may be encountered during operation or maintenance of hypochlorination unit Tests, Inspections, and corrections should be made or taken in order listed.
- b. Limitations This manual cannot list all problems that may occur, or all tests, inspections, and corrective actions If a problem is not listed, or is not corrected after corrective actions are taken, notify Unit Maintenance

**Table 3-1.  
Operator Troubleshooting Table.**

<b>MALFUNCTION</b>
<b>TEST OR INSPECTION</b>
<b>CORRECTIVE ACTION</b>

**1. PROPORTIONING PUMP STOPS PUMPING**

**STEP 1** Make sure system inlet and outlet valves are open  
Open valves, if necessary

**STEP 2** Check Inlet and outlet ball valves  
Open ball valves, if necessary

**STEP 3** Make sure proportioning pump is not airbound  
Follows instructions for Initial start-up in paragraph 2-8

**STEP 4** Inspect waste water hose for blockage  
Remove blockage from end of waste water hose

**STEP 3** Check foot valve strainer  
Make sure strainer is not clogged. If clogged, clean ( paragraph 4-17)

**STEP 5** Contact unit maintenance

Table 3-1.  
Operator Troubleshooting Table (Cont'd).

MALFUNCTION
TEST OR INSPECTION
CORRECTIVE ACTION

**2. PROPORTIONING PUMP SLOWS DOWN - MAINLINE FLOW RATE REMAINS CONSTANT.**

STEP 1. Check position of range adjusting valve Make sure setting is correct. If incorrect, place in correct position (Refer to Paragraph 2-10 a).

STEP 2. Check that proportioning pump's inlet and outlet ball valves are fully open If not fully open, open

STEP 3. Notify unit maintenance to check Y-strainer (Refer to Paragraph 4-21)I

**SECTION III. OPERATOR MAINTENANCE PROCEDURE.**

**3-4. GENERAL.** Operator maintenance on hypochlorination unit consists of only tasks and procedures stated in operator Preventive Maintenance Checks and Services (PMCS) (Table 2-1) Refer to operator's PMCS and perform all tasks outlined at intervals specified

CHAPTER 4.

UNIT MAINTENANCE INSTRUCTIONS

CHAPTER INDEX

Subject	Page
<b>SECTION I. REPAIR PARTS, SPECIAL TOOLS, TEST, MEASUREMENT, AND DIAGNOSTIC EQUIPMENT (TMDE), AND SUPPORT EQUIPMENT.</b>	
4-1. Common Tools and Equipment.....	4-3
4-2. Special Tools, Test, Measurement and Diagnostic Equipment.....	4-3
4-3. Repair Parts .....	4-3
<b>SECTION II. RECEIVING AND PREPARING FOR MOVEMENT.</b>	
4-4. Service Upon Receipt.....	4-3
4-5. Installation Instructions .....	4-4
<b>SECTION III. UNIT PREVENTIVE MAINTENANCE CHECKS AND SERVICES (PMCS).</b>	
4-6. General .....	4-4
4-7. PMCS Procedures.....	4-4
4-8. Special Instructions.....	4-4
<b>SECTION IV. UNIT TROUBLESHOOTING.</b>	
4-9. Introduction.....	4-6
4-10. Unit Troubleshooting Table.....	4-6
<b>SECTION V. UNIT MAINTENANCE PROCEDURES.</b>	
4-11. General Information .....	4-7
4-12. Maintenance Instructions .....	4-8
4-13. Service Foot Valve and Tubing.....	4-9
4-14. Repair Suction Valve and Discharge Valve.....	4-12
4-15. Replace Pumphead Assembly .....	4-14
4-16. Replace Outlet Ball Valve Assembly.....	4-16
4-17. Replace Proportioning Pump .....	4-18
4-18. Repair Injection Valve.....	4-20
4-19. Replace Mainline Piping Assembly .....	4-22
4-20. Repair Camlocks .....	4-24
4-21. Repair Inlet Ball Valve Assembly .....	4-26

**SECTION V. UNIT MAINTENANCE PROCEDURES (Cont'd).**

4-22	Repair Mainline Piping and Range Adjusting Valve.....	4-28
4-23.	Replace Solution Reservoir .....	4-31
4-24.	Replace Accessory Box .....	4-33
4-25	Replace/Repair Frame.....	4-35

**SECTION VI. PREPARATION FOR STORAGE OR SHIPMENT.**

4-26.	General Information.....	4-37
4-27	Preservation, Packaging, Marking, and Shipping Requirements .....	4-37

**SECTION I. REPAIR PARTS, SPECIAL TOOLS, TEST, MEASUREMENT, AND DIAGNOSTIC EQUIPMENT (TMDE), AND SUPPORT EQUIPMENT.**

**4-1. COMMON TOOLS AND EQUIPMENT.**

- a. For authorized common tools and equipment, refer to the Modified Table of Organization and Equipment (MTOE), CTA 50-970 or CTA 8-100 as applicable to your unit
- b. For mechanics tool kit, refer to Appendix B, Section II, Maintenance Allocation Chart for tool reference usage.

**4-2. SPECIAL TOOLS, TEST, MEASUREMENT AND DIAGNOSTIC EQUIPMENT.** No special tools, test, measurement and diagnostic equipment are required (see Appendix B, Section) III)

**4-3. REPAIR PARTS.** Repair parts are listed and illustrated in the Repair Parts and Special Tools List (RPSTL, TM 10-4610-244-23P, TM 09476B-23 P/2)

**SECTION II. RECEIVING AND PREPARING FOR MOVEMENT.**

**4-4. SERVICE UPON RECEIPT.** The following steps should be followed upon receipt of hypochlorination unit

- a. **Unloading.** Hypochlorination unit is shipped in one crate. To unload, do following.
  - (1) Check shipping crate for damage A damaged crate indicates possible damage to equipment.
  - (2) Remove all blocking and tie downs that may have been used to secure crate to carrier
  - (3) Using suitable material handling equipment, remove crate from carrier.
- b. **Unpacking.**
  - (1) Remove packing material from hypochlorination unit.
  - (2) Remove and retain technical publications envelope.
- c. **Checking Unpacked Equipment.** To check unpacked hypochlorination unit, do following:
  - (1) Inspect equipment for damage incurred during shipment If equipment has been damaged, report damage on SF 364, Report of Discrepancy
  - (2) Check equipment against packing slip to see if shipment is complete Report all discrepancies in accordance with instructions of DA PAM 738-750 or DA PAM 738- 751 as applicable.

**4-5. INSTALLATION INSTRUCTIONS.** Refer to operation instructions in Chapter 2 of this technical manual for installation

### **SECTION III. UNIT PREVENTIVE MAINTENANCE CHECKS AND SERVICES (PMCS).**

**4-6. GENERAL.** Preventive Maintenance Checks and Services (PMCS) means systematic caring, inspecting, and servicing of equipment to keep it in good condition and to prevent breakdowns.

- a. Do WEEKLY (W) PMCS once a week.
- b. Do MONTHLY (M) PMCS once a month.
- c. Use DA Form 2404 (Equipment Inspection and Maintenance Worksheet) to record any faults that you discover before, during, or after operation, unless you can fix them. You DO NOT need to record faults that you fix.

#### **4-7. PMCS PROCEDURES.**

- a. Your Preventive Maintenance Checks and Services, Table 4-1, lists inspections and care required to keep your hypochlorination unit in good operating condition.
- b. The "INTERVAL" column of Table 4-1 tells you when to do a certain check or service.
- c. The "PROCEDURE" column of Table 4-1 tells you how to do required checks and services. Carefully follow these instructions. If you do not have tools, or if procedure tells you to, notify your supervisor.
- d. The "NOT FULLY MISSION CAPABLE IF-" column in Table 4-1 tells you when your hypochlorination unit is nonmission capable and why the hypochlorination unit cannot be used.
- e. If the hypochlorination unit does not perform as required, refer to Section V, Troubleshooting.
- f. If anything looks wrong and you can't fix it, write it on your DA Form 2404. IMMEDIATELY report it to your supervisor.



4-7 PMCS PROCEDURES (Cont'd).

g. Following are checks that are common to the entire hypochlorination unit.

- (1) **Keep it clean.** Dirt, grease, oil, and debris only get in the way and may cover up a serious problem. Clean as you work and as needed.
- (2) **Rust and Corrosion.** Check hypochlorination unit for rust and corrosion. If any bare metal or corrosion exists, clean, and apply a thin coat of oil. Report it to your supervisor.
- (3) **Bolts, Nuts, and Screws.** Check them all for obvious looseness, missing, bent, or broken condition. You can't try them all with a tool, but look for chipped paint, bare metal, or rust around bolt heads. If you find a bolt, nut, or screw you think is loose, tighten it or report it to your supervisor.
- (4) **Welds.** Look for loose or chipped paint, rust, or gaps where parts are welded together. If you find a bad weld, report it to your supervisor.
- (5) **Hoses and Fluid Lines.** Look for wear, damage, and leaks, and make sure clamps and fittings are tight. Wet spots show leaks, but a stain around a fitting or connector can also mean a leak. If a leak comes from a loose fitting or connector, tighten it. If something is broken or worn out, report it to your supervisor.

4-8. **SPECIAL INSTRUCTIONS.** If equipment must be kept in continuous operation, check and service only those items that can be checked and serviced without disturbing operation. Make complete checks and services when hypochlorination unit can be shut down.

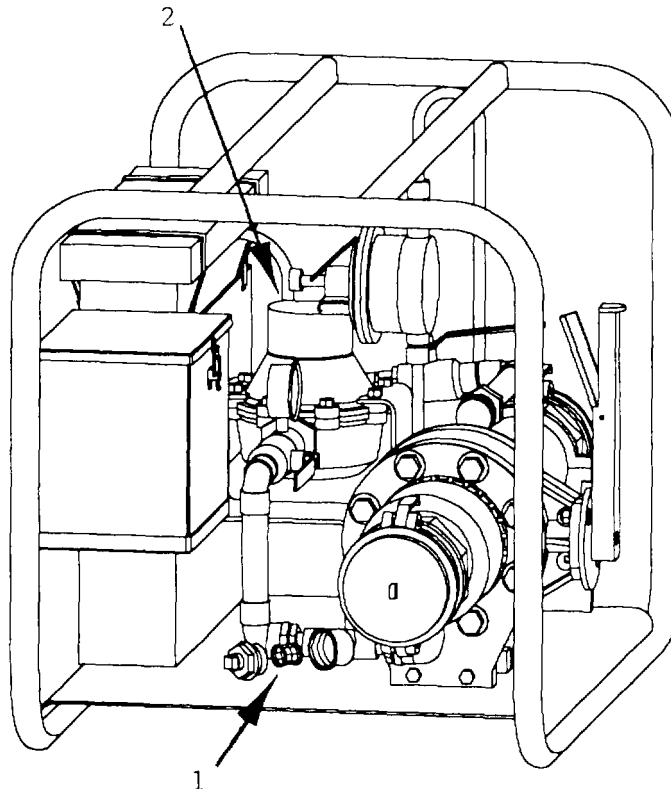

**Table 4-1.  
Unit Preventive Maintenance Checks and Services  
for Hypochlorination Unit.**

M - Monthly

Q - Quarterly

A - Annually

ITEM NO.	INTERVAL	ITEM TO BE CHECKED OR SERVICED	PROCEDURE	NOT FULLY MISSION CAPABLE IF:
1	Q	Y-strainer	Clean and inspect.	Clogged or damaged.
2	A	Upper housing Assembly	Clean and grease.	

**SECTION IV. UNIT TROUBLESHOOTING.**

**4-9. INTRODUCTION.** This section covers troubleshooting procedures which are for most frequent problems encountered in operating hypochlorination unit

**4-10. UNIT TROUBLESHOOTING TABLE.**

a. Use of Table. Table 4-2 lists common malfunctions which could be encountered during operation or maintenance of hypochlorination unit Tests, Inspections, and corrective actions should be made or taken in order listed.

b. Limitation This manual cannot list all the problems that may occur, or all tests. inspections, and corrective actions If a problem is not listed. or Is not corrected after corrective actions are taken, notify Direct Support

**Table 4-2.  
Unit Troubleshooting.**

MALFUNCTION	TEST OR INSPECTION	CORRECTIVE ACTION
-------------	--------------------	-------------------

1. PROPORTIONING PUMP STOPS PUMPING

Step 1. Inspect suction valve

Make sure valve not clogged or damaged. If clogged, clean or replace If damaged, replace (Paragraph 4-14)

**Table 4-2.  
 Unit Troubleshooting (Cont'd).**

MALFUNCTION	TEST OR INSPECTION	CORRECTIVE ACTION
	Step 3.	Inspect suction valve packing, preformed for damage If preformed packing is damaged, replace suction valve (Paragraph 4-14)
	Step 4.	Check movement of suction valve poppet. If movement of poppet is restricted in any way, clean or replace it (Paragraph 4-14).
	Step 5.	Inspect discharge valve for clog. If clogged, clean or replace the discharge valve (Paragraph 4-14)
	Step 6.	Inspect discharge valve preformed packing for damage. If preformed packing is damaged, replace (Paragraph 4-14).
	Step 7.	Check movement of discharge valve poppet If movement is restricted in any way, clean or replace it (Paragraph 4-14).
	Step 8.	Inspect injection valve. Make sure scale has not formed on injection point. If scale is present, clean it off. If scale cannot be easily cleaned off, replace injection valve (Paragraph 4-18).
	Step 9.	Check movement of injection valve poppet. If movement is restricted in any way, clean or replace it (4-18).
	Step 10.	Inspect suction hose. Look for holes or damage If hose is damaged, replace it (4-13).
2.	PUMP RATE SLOWS - MAINLINE FLOW RATE REMAINS CONSTANT	
	Step 1.	Check Y-strainer Remove Y-strainer and check for blockage. If blockage exists, clean Y-strainer If unable to clear blockage completely, replace Y-strainer (Paragraph 4-21)

**SECTION V. UNIT MAINTENANCE PROCEDURES.**

**4-11. GENERAL INFORMATION.** This section contains maintenance procedures which Maintenance Allocation Chart authorizes Unit to perform. If hypochlorination unit still does not operate properly after performing these maintenance procedures, contact Direct Support for assistance.

#### 4-12. MAINTENANCE INSTRUCTIONS.

##### WARNING

hypochlorite is caustic and can cause severe chemical burns. To avoid injury:

- Wear required protective clothing any time you are handling calcium hypochlorite.
- If hypochlorite solution comes in contact with skin or eyes, flush immediately with large amounts of water, and seek medical attention.
- If hypochlorite solution spills on equipment, rinse with large amounts of water.

- a. Whenever performing maintenance on hypochlorination unit, ensure that it is secured, and that proportioning pump is drained and flushed, if possible.
- b. Whenever receiving pumphead from Direct Support, perform following calibration:

##### NOTE

Pumphead must be calibrated while unit is in operation.

- (1) Turn pumphead completely off by turning dosage control knob (1) clockwise as far as possible, while pump is in operation. Turn dosage control knob only during pumping stroke, until knob will turn no farther.
- (2) Remove screw (2) from dial cover (3) and remove cover.
- (3) Carefully lift out numbered dial (4) and reposition it in dial holder (5) with number 0 at top.
- (4) Make sure teeth on edge of numbered dial (4) mesh with teeth of spline gear (6).
- (5) Replace dial cover (3) so that line in window lines up with mark at number 0.
- (6) Install screw (2) in dial cover (3).

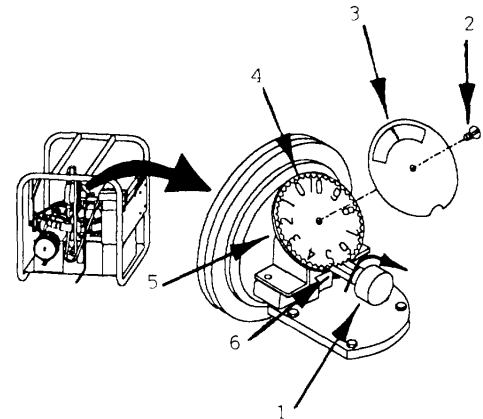

## MAINTENANCE OF PROPORTIONING PUMP CHEM VALVES AND TUBING

### 4-13. SERVICE FOOT VALVE AND TUBING.

This task covers a. Removal b. Service c Installation

#### INITIAL SETUP

##### Tools:

Tool Kit, General Mechanics (Appendix B,  
Sec III, Item 1)

##### Equipment Condition:

Proportioning pump isolated

##### Materials:

Rags (Appendix E, Sec. II, Item 7)  
Faceshield (Appendix E, Sec. II, Item 4)  
Gloves (Appendix E, Sec. II, Item 5)

##### General Safety Instructions:

Wear protective gloves and faceshield  
when working on items containing  
hypochlorite solution

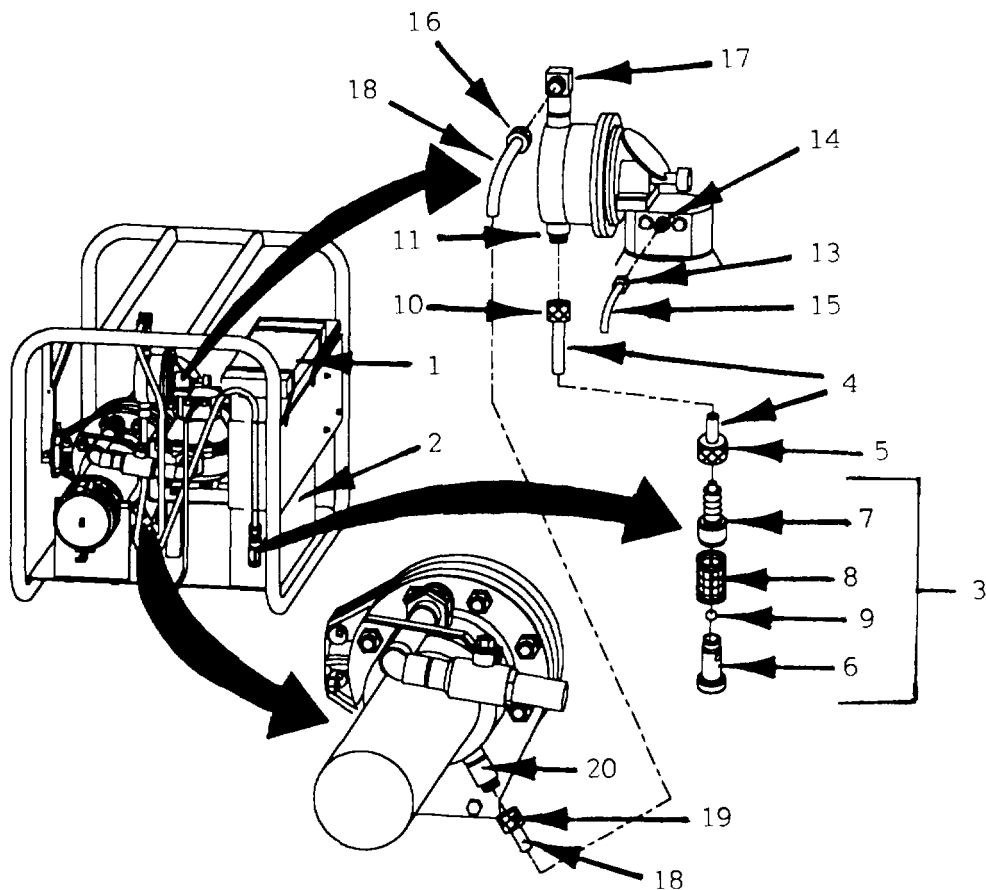

#### 4-13. SERVICE FOOT VALVE AND TUBING (Cont'd).

##### a. REMOVAL

#### WARNING

Hypochlorite is caustic and can cause severe chemical burns. To avoid injury:

- Wear required protective clothing any time you are handling calcium hypochlorite.
  - If hypochlorite solution comes in contact with skin or eyes, flush immediately with large amounts of water, and seek medical attention.
  - If hypochlorite solution spills on equipment, rinse with large amounts of water.
- (1) Remove lid (1) from reservoir (2).
  - (2) Remove foot valve (3) from reservoir (2), and allow to drain.
  - (3) Unscrew foot valve (3) from suction tubing (4) by turning tube nut (5) counterclockwise, and pull tube (4) off.

#### NOTE

Care must be taken to prevent ceramic poppet from falling out of valve and becoming lost or damaged.

- (4) Unscrew valve body (6) from tubing adapter (7).
- (5) Slide screen (8) off valve body (6).
- (6) Carefully remove ceramic poppet (9) by tipping body (6).
- (7) Unscrew tube nut (103) from suction valve (11), and pull tube (4) off.
- (8) Unscrew tube nut (13) from it-valve (14), and pull tube (15) off.
- (9) Unscrew tube nut (16) from discharge valve (17), and pull tube (18) off.
- (10) Unscrew tube nut (19) from injection valve (20), and pull tube (18) off.

#### 4-13. SERVICE FOOT VALVE AND TUBING (Cont'd).

##### b. SERVICE

- (1) Replace tube in accordance with Appendix G, Item 4.
- (2) Clean all components of foot valve (3).
- (3) Inspect all components of foot valve (3) for damage. Replace entire foot valve if any component damaged.

##### c. INSTALLATION

- (1) Install ceramic poppet (9) in body (6).
- (2) Slide screen (8) over body (6) and install adapter (7) onto body.
- (3) Push suction tube (4) onto adapter (7) of foot valve and screw tube nut (5) onto adapter.
- (4) Push tube (18) onto injection valve (20), and screw tube nut (19) on.
- (5) Push tube (18) onto discharge valve (17), and screw tube nut (16) on.
- (6) Push tube (15) onto R-valve (14), and screw tube nut (13) on.
- (7) Push tube (4) onto suction valve (11), and screw tube nut (10) on.

#### 4-14. REPAIR SUCTION VALVE AND DISCHARGE VALVE.

This task covers: a. Removal b. Repair. c. Installation

---

#### INITIAL SETUP

##### Tools:

Tool Kit, General Mechanics (Appendix B, Sec. III, Item 1) 4-13).

##### Material:

Preformed packing (Appendix I, Item 5)  
Faceshield (Appendix E, Sec. II, Item 4)  
Gloves (Appendix E, Sec. II, Item 5)

##### Equipment Condition:

Foot valve and tubing removed (Paragraph

##### General Safety Instructions:

Wear protective gloves and faceshield when working on items containing hypochlorite solution.

---

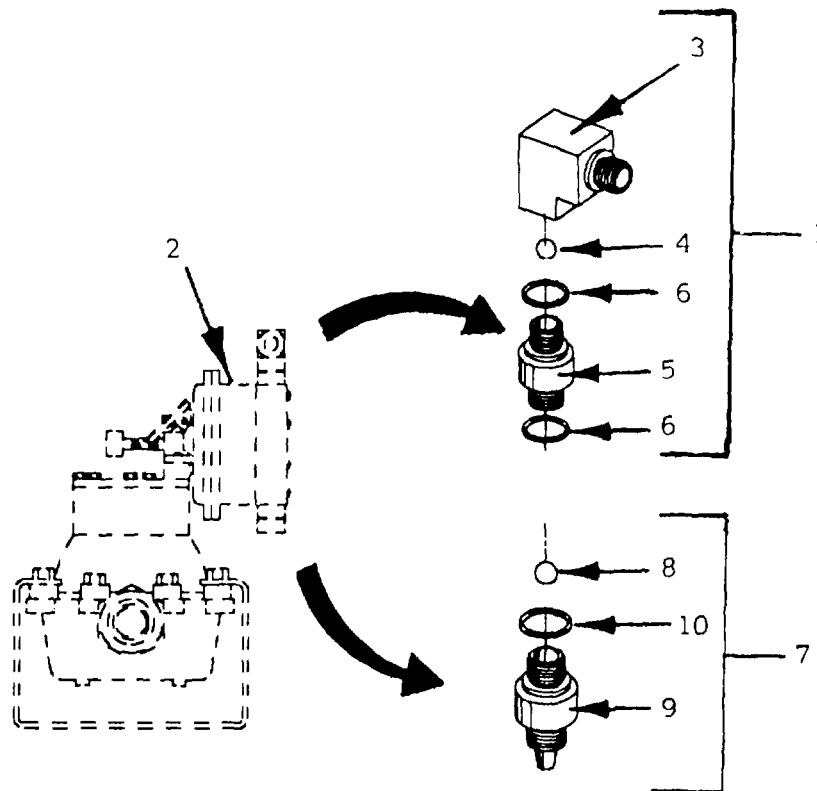



#### 4-14. REPAIR SUCTION VALVE AND DISCHARGE VALVE (Cont'd).

##### WARNING

Hypochlorite solution may be on the suction valve and can cause severe chemical burns. To avoid injury wear gloves while working on it

##### a. REMOVAL

- (1) Unscrew discharge valve (1) from pumphead (2)

##### NOTE

Care must be taken to prevent ceramic poppet from falling out of valve and becoming lost or damaged.

- (2) Remove valve adaptor (3)
- (3) Remove ceramic poppet (4) from discharge valve body (5)
- (4) Remove and discard preformed packing (6)

##### NOTE

Care must be taken to prevent ceramic poppet from falling out of valve and becoming lost or damaged

- (5) Unscrew suction valve (7) from pumphead (2).
- (6) Remove ceramic poppet (8) from suction valve body (9)
- (7) Remove and discard preformed packing (10).

##### b. REPAIR

- (1) Clean all components.
- (2) Inspect valves for nicked or damaged seating surfaces or threads and replace if damaged.

##### c. INSTALLATION

- (1) Install ceramic poppet (8) in suction valve body (9).
- (2) Install new preformed packing (10)
- (3) Screw suction valve (7) into pumphead (2).
- (4) Install ceramic poppet (4) in discharge valve body (5)
- (5) Install new preformed packing (6).
- (6) Install valve adaptor (3).
- (7) Screw discharge valve (1) Into pumphead (2)

#### 4-15. REPLACE PUMPHEAD ASSEMBLY.

This task covers: a. Removal b. Installation

---

#### INITIAL SETUP

##### Tools:

Tool Kit, General Mechanics (Appendix B, Sec. III, Item 1)

##### Materials:

Faceshield (Appendix E, Sec II, Item 4)  
Gloves (Appendix E, Sec II, Item 5)

##### Equipment Condition:

Suction and discharge valves removed (Paragraph 4-14)

##### General Safety Instructions:

Wear protective gloves and faceshield when working on items containing hypochlorite solution.

---

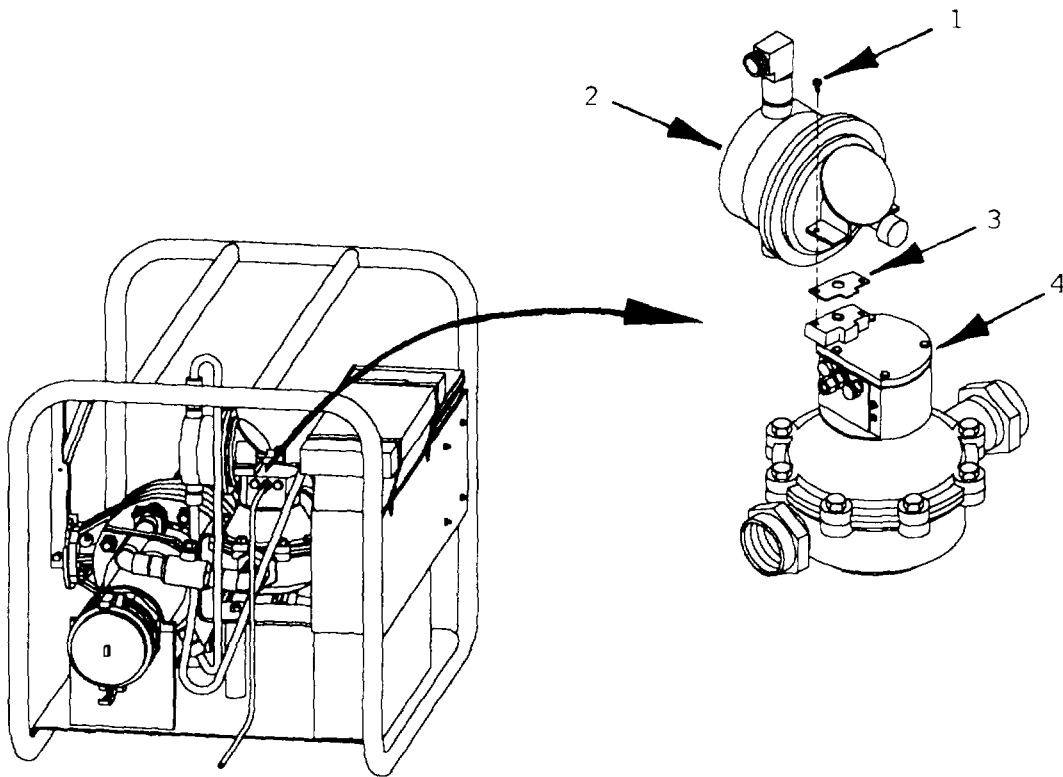

**4-15. REPLACE PUMPHEAD ASSEMBLY (Cont'd).**

**WARNING**

**Calcium hypochlorite solution is caustic and can cause severe chemical burns. To avoid injury:**

•Wear required protective gear.

•If hypochlorite solution comes in contact with skin or eyes, flush immediately with large amounts of water and seek medical attention.

**a. REMOVAL**

- (1) Remove two screws (1)
- (2) Remove pumphead assembly (2)
- (3) Remove gasket (3), inspect for cracks, deformation, or deterioration. If any, discard

**b. INSTALLATION**

- (1) Position gasket (3) on upper housing assembly (4).
- (2) Position pumphead assembly (2) on gasket (3).
- (3) Install 2 screws (1).

**4-16. REPLACE OLUTLET BALL VALVE ASSEMBLY.**

This task covers:     a. Removal     b. Installation

---

**INITIAL SETUP**

**Tools:**

Tool Kit, General Mechanics (Appendix B,  
Sec III, Item 1)  
Pipe Wrench (Appendix B, Sec III, Item 2)

**Equipment Condition:**

Hypochlorination unit flushed and drained  
(Paragraph 2-12)

**Materials:**

Anti-seize tape (Appendix E., Sec II, Item 8)

---

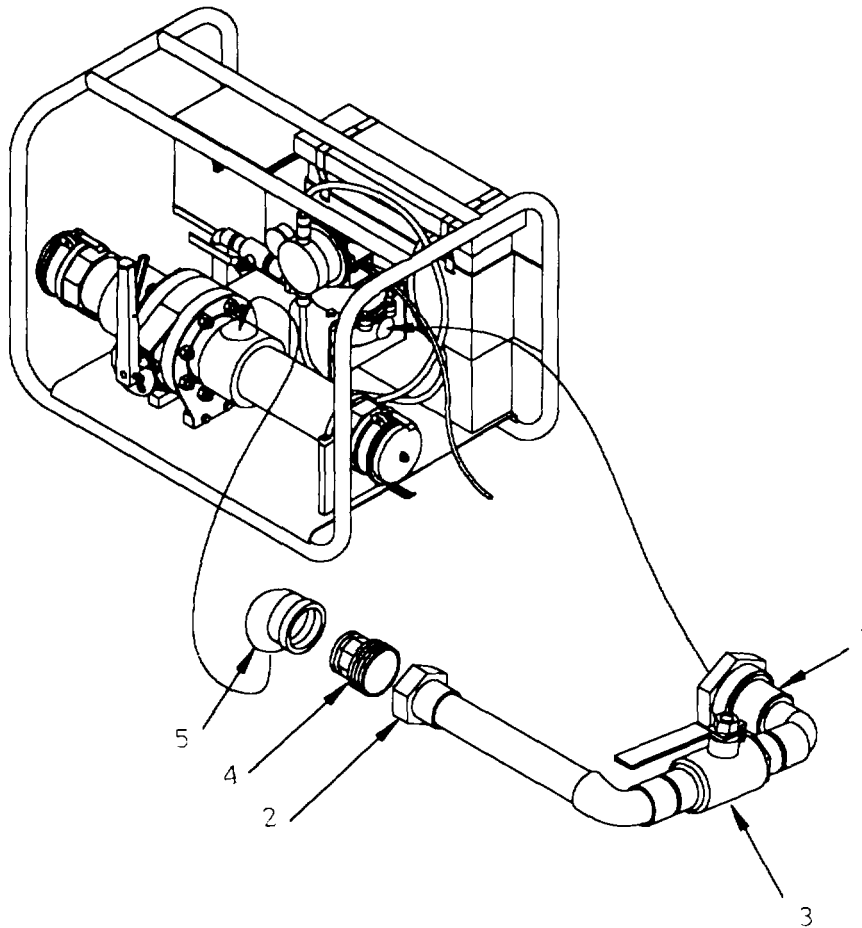

**4-16. REPLACE OUTLET BALL VALVE ASSEMBLY (Cont'd).**

**a. REMOVAL**

- (1) Unscrew unions (1 and 2).
- (2) Remove outlet ball valve assembly (3).
- (3) Remove union half (4) from elbow (5).
- (4) Remove elbow (5) from mainline piping (6).

**b. INSTALLATION**

- (1) Wrap all male threads with anti-seize tape, making sure to wrap in same direction of threads
- (2) Install elbow (5) in mainline piping (6).
- (3) Install union half (4) on elbow (5).
- (4) Make sure seating surfaces are clean
- (5) Position outlet ball valve assembly (3) so that unions (1 and 2) line up.
- (6) Screw unions (1 and 2) on

#### 4-17. REPLACE PROPORTIONING PUMP.

This task covers a. Removal b. Installation

---

#### INITIAL SETUP

##### Tools:

Tool Kit, General Mechanics (Appendix B,  
Sec. III, Item 1)  
Torque wrench (Appendix B, Sec III, Item 3)

##### Equipment Condition:

Hypochlorination unit flushed and drained  
(Paragraph 2-12).  
Suction and discharge valves removed  
(Paragraph 4-14).  
Outlet ball valve removed (Para 4-16).

---

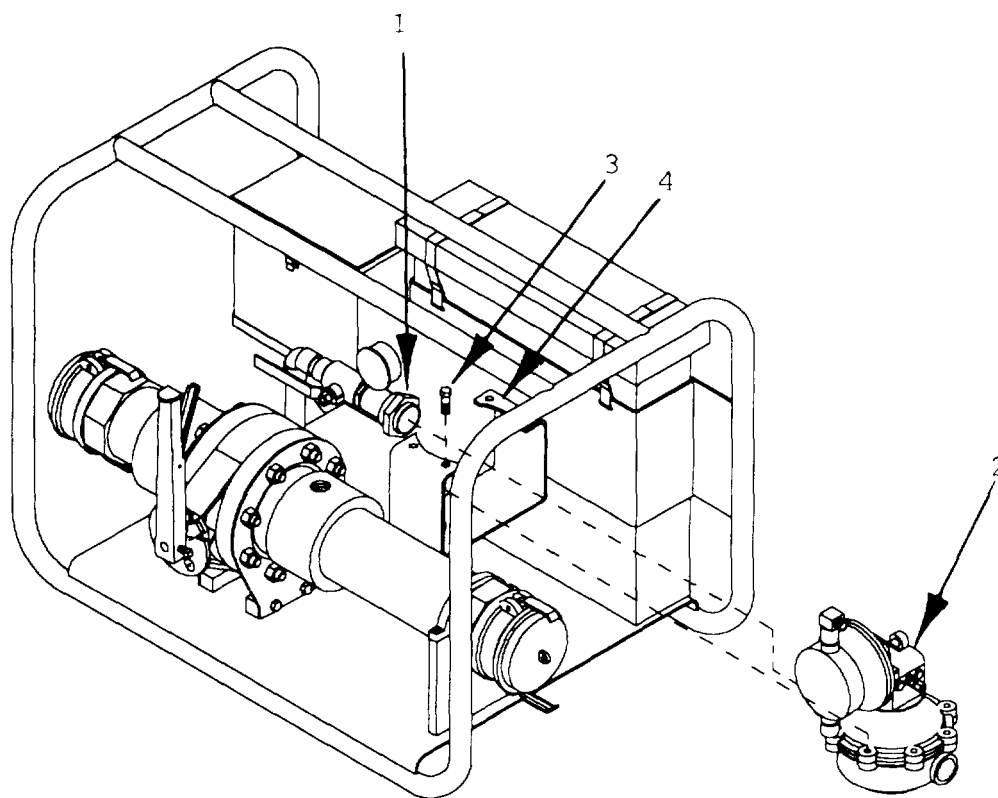

4-18

#### 4-17. REPLACE PROPORTIONING PUMP (Cont'd).

##### WARNING

Hypochlorite solution is caustic and can cause severe chemical burns. To avoid injury:

- Wear required protective gear.
- If hypochlorite solution comes in contact with skin or eyes, flush immediately with large amounts of water and seek medical attention.

##### a. REMOVAL

- (1) Unscrew inlet ball valve union (1) from proportioning pump (2).
- (2) Remove 4 bolts (3) attaching proportioning pump (2) to frame (4).
- (3) Remove proportioning pump (2).

##### b. INSTALLATION

- (1) Position proportioning pump (2) in frame (4), ensuring that pumphead is facing front
- (2) Install 4 bolts (3).
- (3) Torque 8 bolts (3) using torque pattern shown

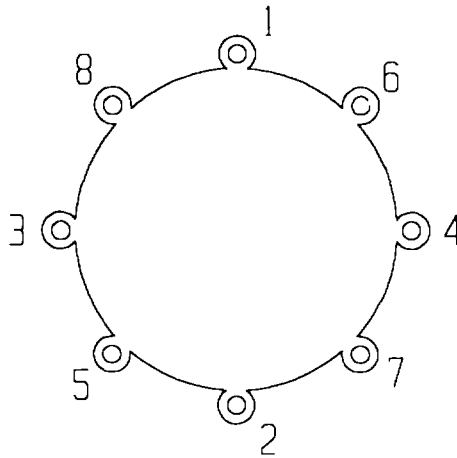

- (4) Screw inlet ball valve assembly (1) union to proportioning pump (2).

**4-18. REPAIR INJECTION VALVE.**

This task covers a Removal b. Repair c. Installation

---

**INITIAL SETUP**

**Tools:**

Tool Kit, General Mechanics (Appendix B, Sec III, Item 1)

**Materials:**

Faceshield (Appendix E, Sec II, Item 4)  
Gloves (Appendix E, Sec. II, Item 5)  
Packing, preformed (Appendix I, Item 5)

**Equipment Condition:**

Hypochlorination unit shut down and drained (Paragraph 2-12).  
Tubing removed (Paragraph 4-13).

**General Safety Instructions:**

Wear protective gloves and faceshield when working on items containing hypochlorite solution.

---

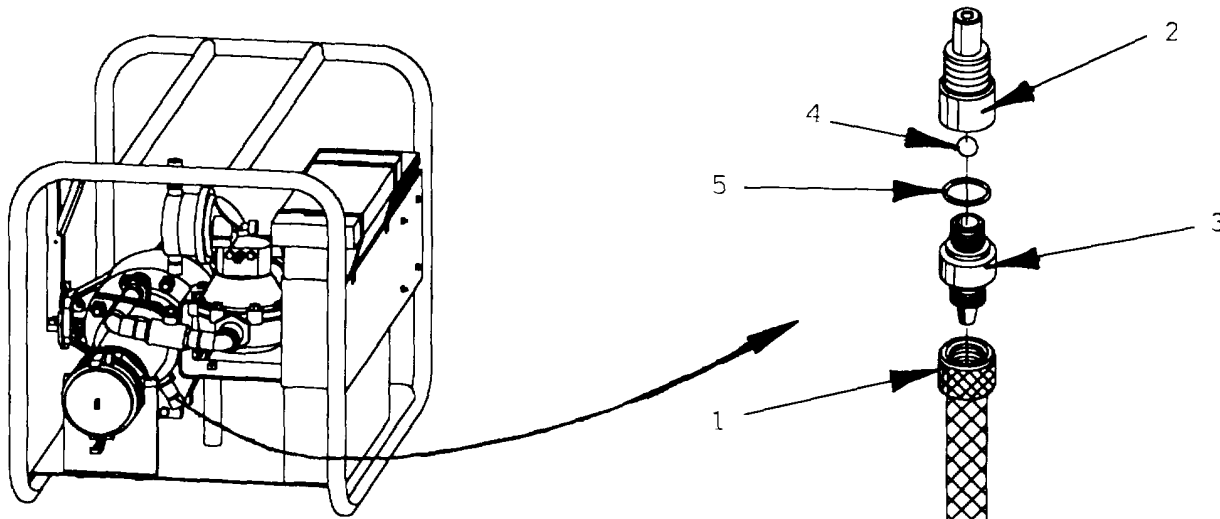



#### 4-18. REPAIR INJECTION VALVE (Cont'd).

##### WARNING

Hypochlorite solution may be on the injection valve and can cause severe chemical burns. To avoid injury wear gloves while working on it.

##### a. REMOVAL

- (1) Unscrew injection valve body (1) from bottom of mainline pipe (2).

##### NOTE

Care must be taken to prevent ceramic poppet from falling out of valve and becoming lost or damaged.

- (2) Remove valve adaptor (3).
- (3) Remove ceramic poppet (4).
- (4) Remove and discard preformed packing (5).

##### b. REPAIR

- (1) Clean all components. Pay particular attention to possible chemical buildup.
- (2) Inspect valve for nicked or damaged seating surfaces or threads and discard if damaged.

##### c. INSTALLATION

- (1) Install ceramic poppet (4) in injection valve adaptor (3).
- (2) Install new preformed packing (5).
- (3) Screw injection valve (1) into bottom of mainline pipe (2).

**4-19. REPLACE MAINLINE PIPING ASSEMBLY.**

This task covers:

a. Removal

b. Installation

**INITIAL SETUP:**

**Tools:**

Tool Kit, General Mechanics (Appendix B,  
Sec. III, Item 1)  
Torque Wrench (Appendix B, Sec. III, Item 3)

**Equipment Condition:**

Injection valve removed (Paragraph 4-18).  
Outlet ball valve removed (Paragraph 4-16).

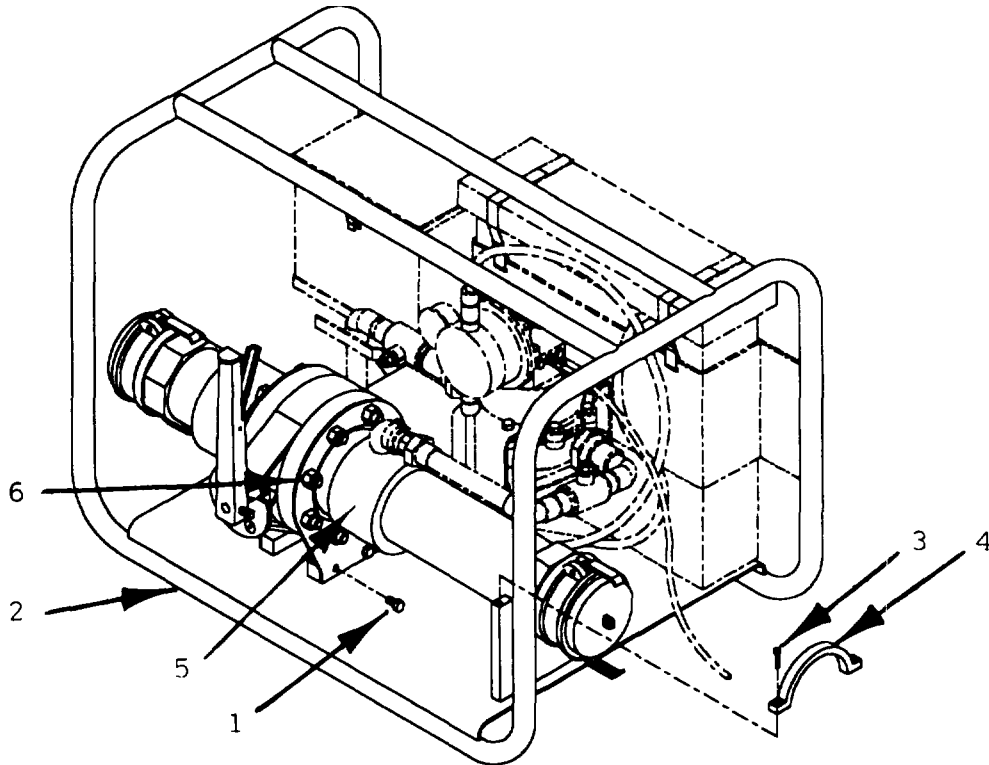

**4-19. REPLACE MAINLINE PIPING ASSEMBLY (Cont'd).**

**a. REMOVAL**

- (1) Unscrew four bolts (1) from frame (2).
- (2) Remove two socket screws (3) from bracket top (4).
- (3) Remove bracket top (4).
- (4) Remove mainline pipe assembly (5) from frame (2).

**b. INSTALLATION**

- (1) Position mainline piping assembly (5) in frame (2).
- (2) Install bracket top (5) over mainline piping assembly (5), and install two socket screws (3).
- (3) Install four bolts (1) through hangers into frame (2).
- (4) Torque eight bolts (6) on range adjusting valve to 50 foot/pounds using torque pattern shown below.

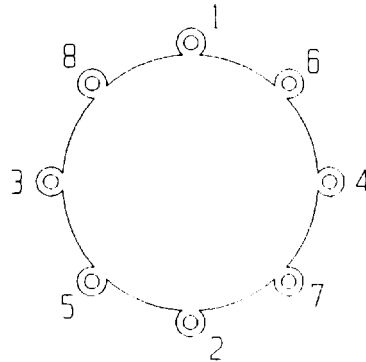

**4-20. REPAIR CAMLOCKS.**

This task covers:

a. Removal

b. Repair

c. Installation

**INITIAL SETUP:**

**Tools:**

Tool Kit, General Mechanics (Appendix B,  
Sec. III, Item 1)

**Equipment Condition:**

Mainline piping assembly removed  
(Paragraph 4-19).

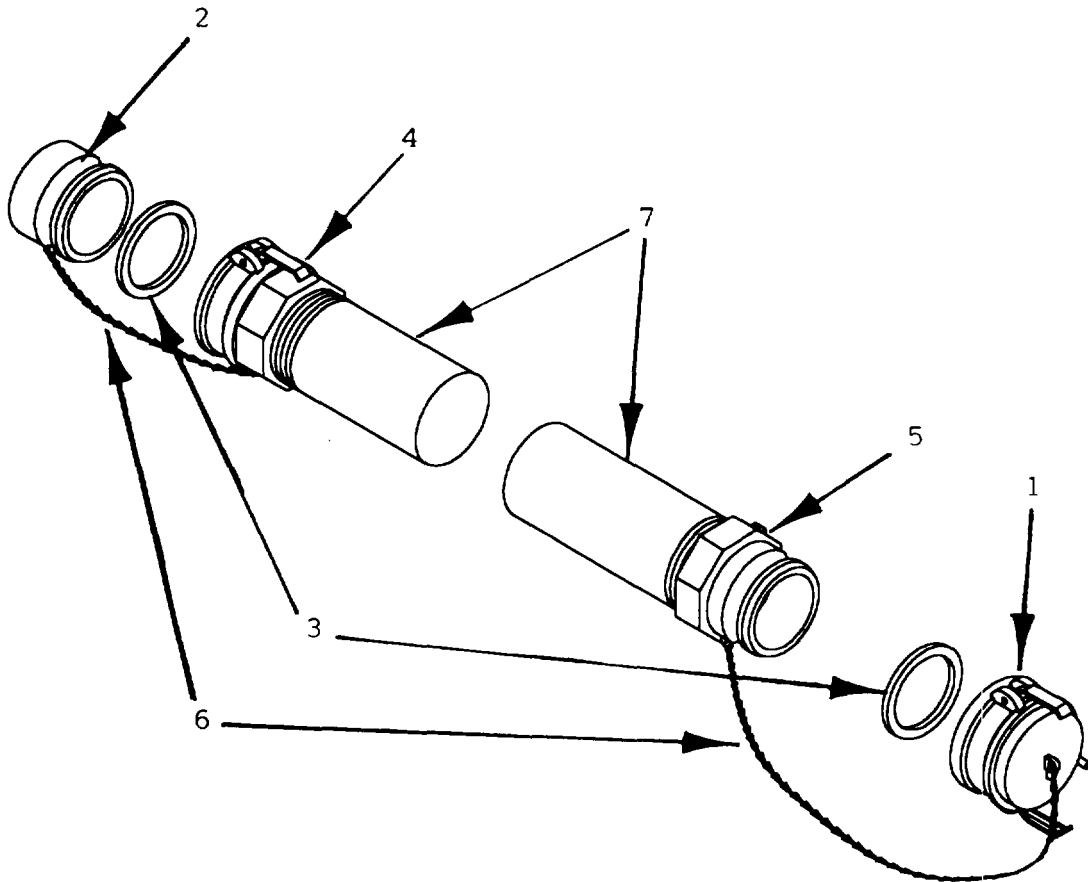

#### 4-20. REPAIR CAMLOCKS (Cont'd).

##### a. REMOVAL

- (1) Disconnect dust cap (1) and plug (2) with gaskets (3) from connectors (4 and 5).
- (2) Remove chain (6) from dust cap (1) and plug (2).
- (3) Unscrew connectors (4 and 5) from mainline pipe (7).
- (4) Remove gasket (3) from dust cap (1).

##### b. REPAIR

- (1) Replace gasket (3) if damaged.
- (2) Replace dust cap (1) and plug (2) and connectors (4 and 5) if damaged.
- (3) Manufacture chain (6) in accordance with Appendix G, Item 1.

##### c. INSTALLATION

- (1) Screw connectors (4 and 5) onto mainline pipe (7).
- (2) Attach chain (6) to dust cap (1) and plug (2).
- (3) Install gasket (3) and dust caps (1 and 2) onto connectors (4 and 5).

**4-21. REPAIR INLET BALL VALVE ASSEMBLY.**

This task covers:

a. Disassembly

b. Repair

c. Assembly

**INITIAL SETUP:**

**Tools:**

Tool Kit, General Mechanics (Appendix B,  
Sec. III, Item 1)  
Pipe Wrench (Appendix B, Sec. III, Item 2)

**Equipment Condition:**

Mainline pipe assembly removed  
(Paragraph 4-19).

**Materials:**

Anti-seize tape (Appendix E, Sec. II, Item 8)

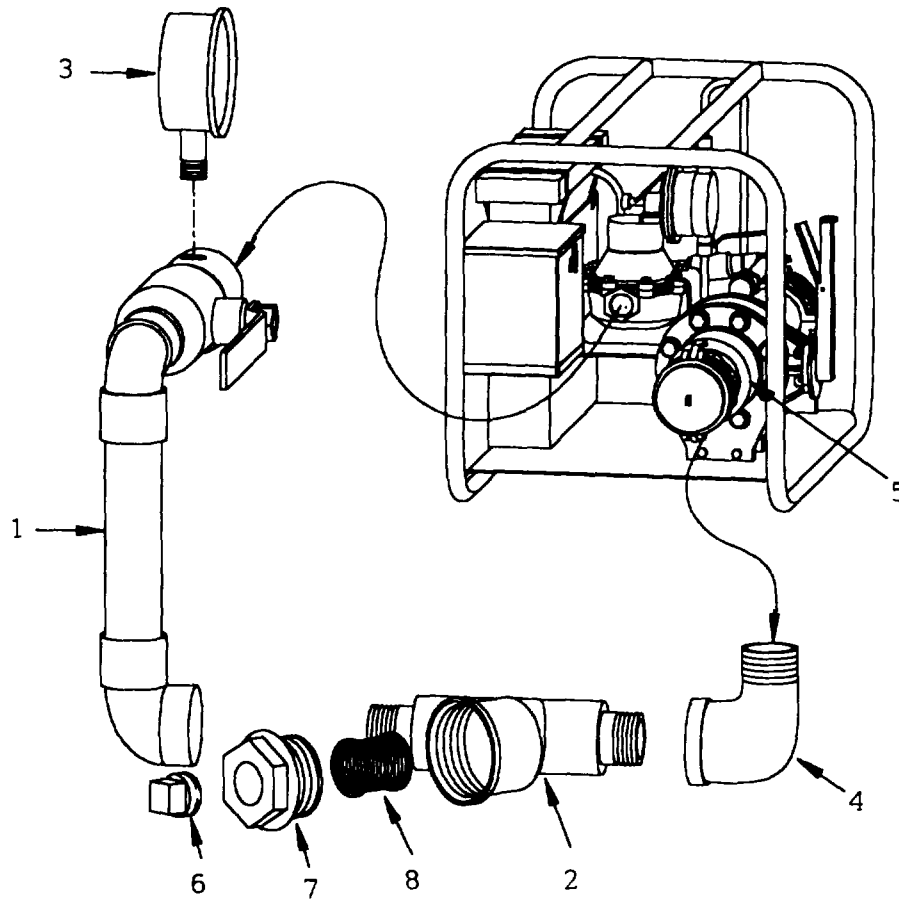

#### 4-21. REPAIR INLET BALL VALVE ASSEMBLY (Cont'd).

##### a. DISASSEMBLY

- (1) Unscrew ball valve assembly (1) from Y-strainer assembly (2)
- (2) Remove gage (3) from ball valve assembly (1).
- (3) Unscrew Y-strainer assembly (2) from elbow (4).
- (4) Unscrew elbow (4) from mainline pipe (5).
- (5) Remove plug (6) from cap (7).
- (6) Remove cap (7) from Y-strainer assembly (2).
- (7) Remove strainer (8) from Y-strainer assembly (2).

##### b. REPAIR

- (1) Clean and inspect all components, and replace if damaged.

##### c. ASSEMBLY

- (1) Wrap all male threads with anti-seize tape, making sure to wrap in same direction of threads.
- (2) Install strainer (8) in Y-strainer assembly (2).
- (3) Install cap (7) in Y-strainer assembly (2)
- (4) Install plug (6) in cap (7).
- (5) Screw elbow (4) into mainline piping (5).
- (6) Screw Y-strainer assembly (2) into elbow (4).
- (7) Screw gage (3) into ball valve assembly (1).
- (8) Screw ball valve assembly (1) into Y-strainer assembly (2).

4-22. REPAIR MAINLINE PIPING AND RANGE ADJUSTING VALVE.

This task covers:

a. Disassembly

b. Repair

c. Assembly

**INITIAL SETUP:**

**Tools:**

Tool Kit, General Mechanics (Appendix B, Sec III, Item 1)

**Equipment Condition:**

Inlet ball valve removed (Paragraph 4-21).  
Mainline piping removed (Paragraph 4-19).  
Camlocks removed (Paragraph 4-20).

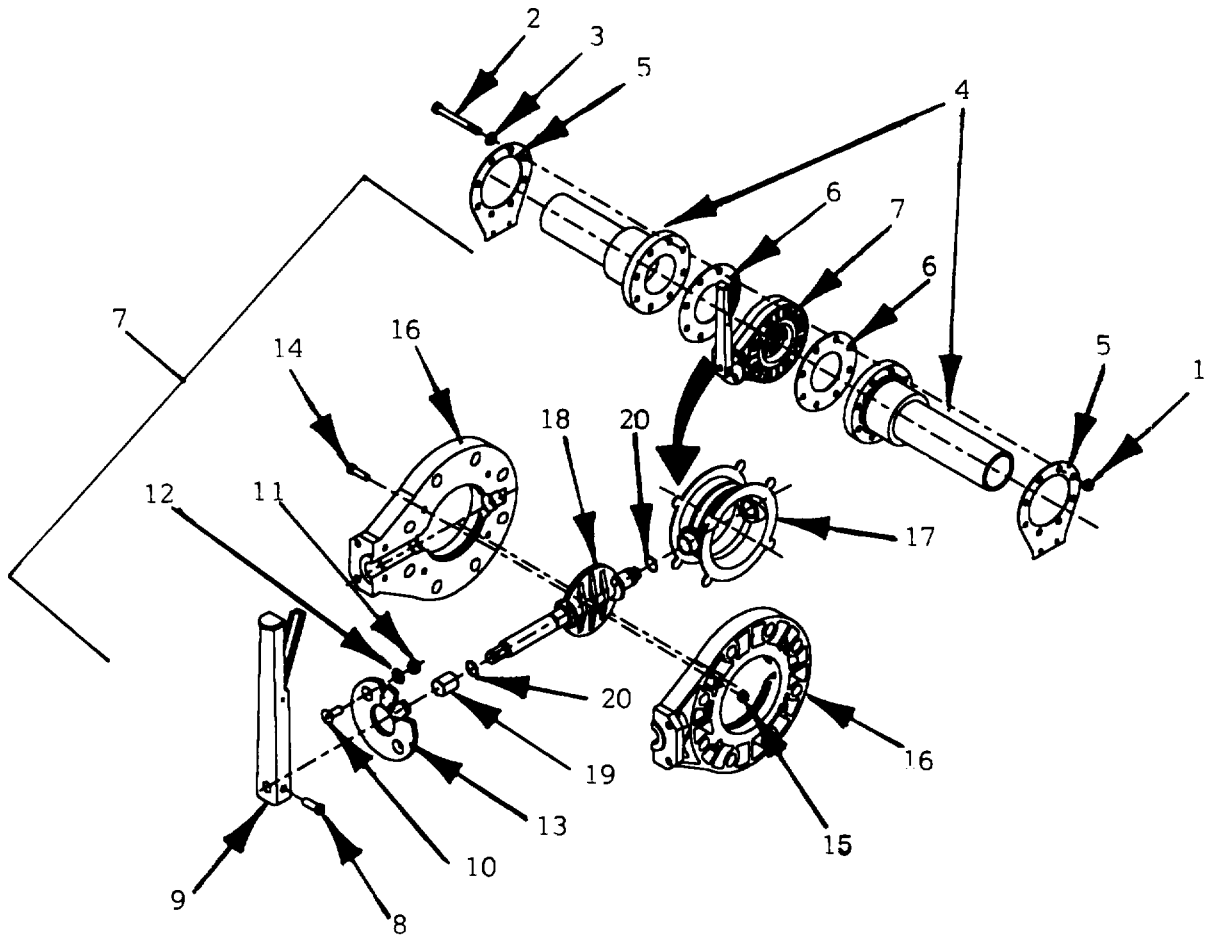



## 4-22. REPAIR MAINLINE PIPING AND RANGE ADJUSTING VALVE (Cont'd).

### a. DISASSEMBLY

- (1) Mark position of mainline pipe (4), hangers (5) and range adjusting valve (7) for later assembly.
- (2) Remove eight locknuts (1), bolts (2) and washers (3) from mainline pipes (4). Discard locknuts (1).
- (3) Remove hangers (5) from ends of mainline pipes (4), remove gaskets (6), and remove range adjusting valve (7).
- (4) Remove handle set screw (8) and remove handle (9).
- (5) Mark position of position plate (13) for later assembly
- (6) Remove two socket screws (10), nuts (11), and washers (12), and remove position plate (13).
- (7) Remove six socket screws (14) and nuts (15) from range adjusting valve (7).
- (8) Pull range adjusting valve halves (16) apart, collapsing seat (17) to make easier
- (9) Remove stem/disc (18), and seat (17) from valve half (16)
- (10) Remove bearing (19) from stem/disc (18).
- (11) Remove seat (17) from stem/disc (18) by collapsing and sliding off of end of stem
- (12) Remove and discard preformed packing (20).

### b. REPAIR

- (1) Clean all components
- (2) Inspect seat (17) for brittleness, tears, or grooves Replace if necessary
- (3) Inspect stem/disc (18) for cracks, grooves, chips, or wear on sealing surfaces Replace if necessary.
- (5) Ensure bearing (19) fits snugly on stem/disc (18). Replace if necessary.
- (6) Inspect handle (9) for broken spring, or worn tip. Replace if necessary
- (7) Inspect valve body halves (16) for cracks or breaks. Replace if necessary.
- (8) Inspect all screws, bolts and nuts for corrosion, or worn threads Replace if necessary
- (9) Inspect mainline pipes (4) for holes, or cracks. Replace if necessary
- (10) Inspect gaskets (6) for tears, brittleness, or deterioration Replace if necessary

## 4-22. REPAIR MAINLINE PIPING AND RANGE ADJUSTING VALVE (Cont'd).

### c. ASSEMBLY

- (1) Place preformed packing (20) on stem/disc (18).
- (2) Install seat (17) on stem/disc (18)
- (3) Install stem/disc (18) and seat (17) in valve half (16).
- (4) Combine two halves (16), collapsing seat (17) to fit through.
- (5) Install six socket screws (14) and nuts (15) in range adjusting valve (7).
- (6) Using previously made markings, install position plate (13) and attach with socket screws (10), washers (12) and nuts (11).
- (7) Install handle (9) and handle set screw (8).
- (8) Install gaskets (6), and, using previously made markings as guide, line up two sections of mainline pipes (4), range adjusting valve (7) and hangers (5). Install eight bolts (2), washers (3), and new locknuts (1).

**4-23. REPLACE SOLUTION RESERVOIR.**

This task covers:

a. Removal

b. Installation

**INITIAL SETUP:**

**Materials:**

Rags (Appendix E, Sec. II, Item 7)

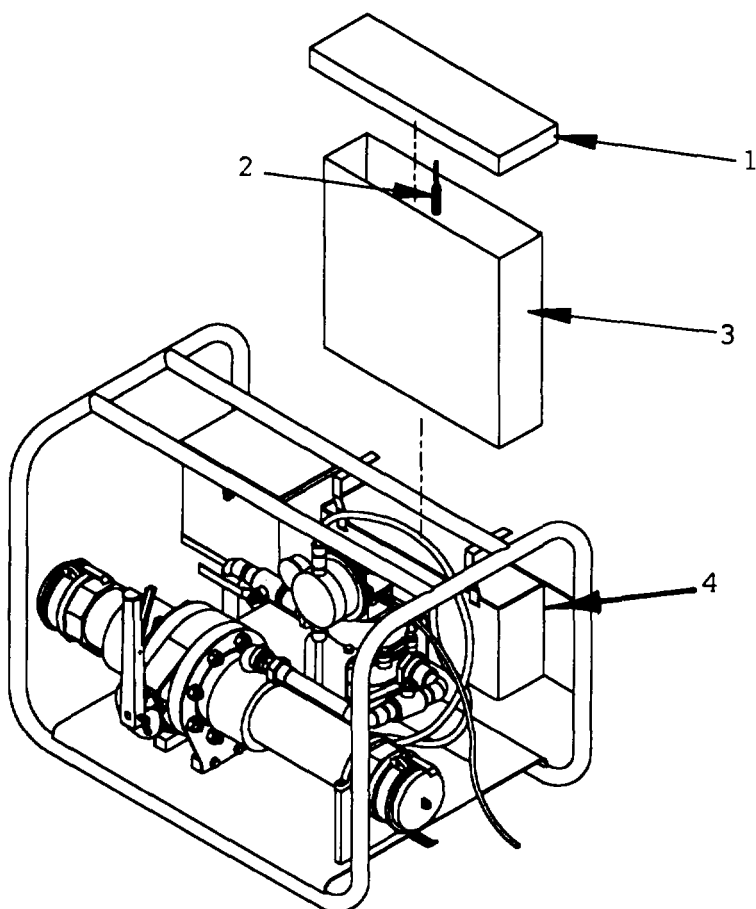

#### 4-23. REPLACE SOLUTION RESERVOIR (Cont'd).

##### WARNING

Hypochlorite is caustic and can cause severe chemical burns. To avoid injury:

- Wear required protective clothing any time you are handling calcium hypochlorite.
- If hypochlorite solution comes in contact with skin or eyes, flush immediately with large amounts of water, and seek medical attention.
- If hypochlorite solution spills on equipment, rinse with large amounts of water.

##### a. REMOVAL

- (1) Remove reservoir lid (1).
- (2) Remove foot valve (2) from reservoir (3).
- (3) Slide solution reservoir (3) out of bracket on frame (4).

##### b. INSTALLATION

- (1) Clean replacement reservoir (3).
- (2) Slide solution reservoir (3) into bracket on frame (4).
- (3) Place foot valve (2) into solution reservoir (3).
- (4) Install reservoir lid (1) on reservoir (3).

4-24. REPLACE ACCESSORY BOX.

This task covers:

a. Removal

b. Installation

**INITIAL SETUP:**

**Tools:**

Tool Kit, General Mechanics (Appendix B,  
Sec. III, Item 1)

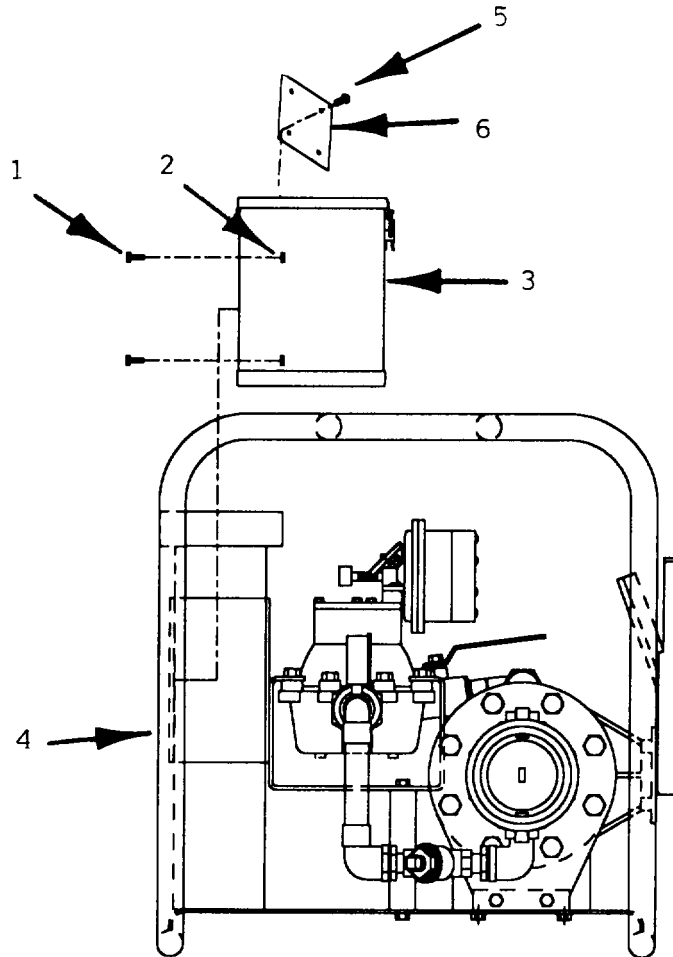

**4-24. REPLACE ACCESSORY BOX (Cont'd).**

**a. REMOVAL**

- (1) Remove four bolts (1) and nuts (2) connecting accessory box (3) to frame (4).
- (2) Remove accessory box (3).
- (3) Remove four plate screws (5) from instruction plate (6), and remove instruction plate

**b. INSTALLATION**

- (1) Install instruction plate (6) on accessory box (3), and plate screws (5).
- (2) Install accessory box (3) on frame (4), tighten down bolts (1) and nuts (2).

**4-25. REPLACE/REPAIR FRAME.**

This task covers:

a. Disassembly

b. Repair

c. Assembly

**INITIAL SETUP:**

**Tools:**

Tool Kit, General Mechanics (Appendix B,  
Sec. III, Item 1)

**Equipment Condition:**

Proportioning pump removed  
(Paragraph 4-17).  
Mainline piping assembly removed  
(Paragraph 4-19).  
Reservoir removed (Paragraph 4-23).  
Accessory box removed (Paragraph 4-24).

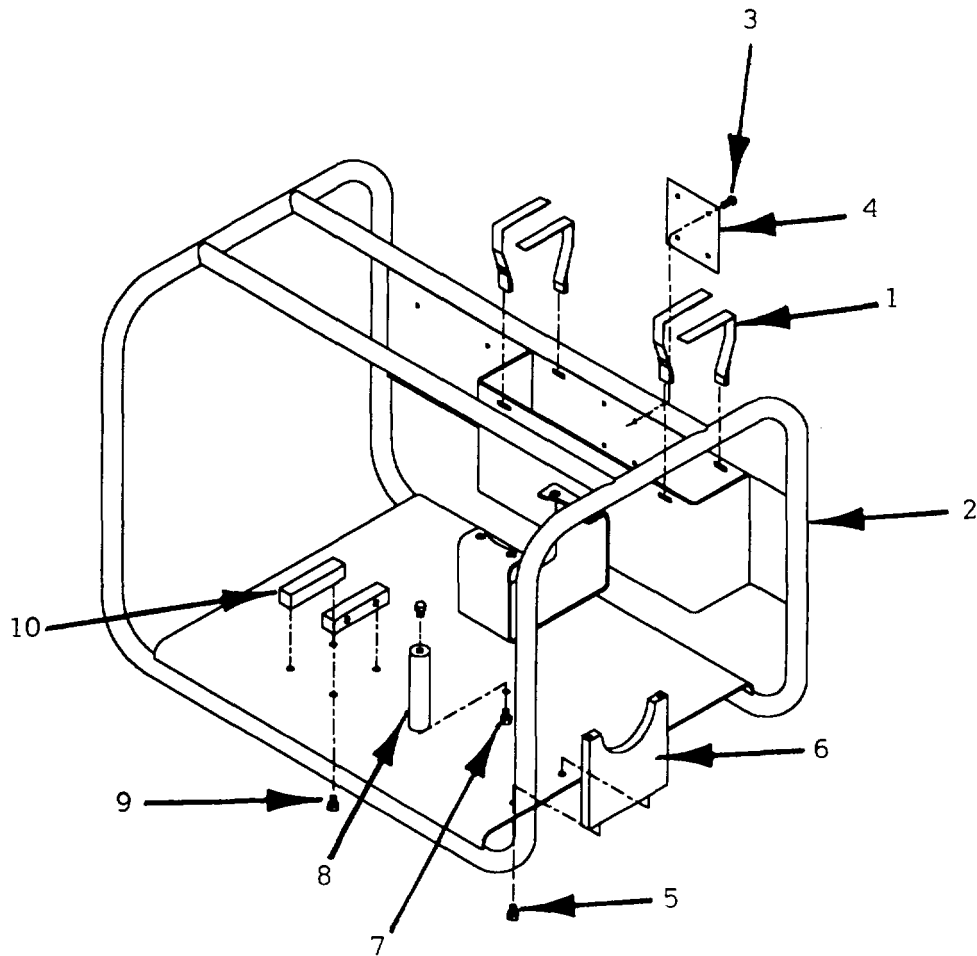

#### 4-25. REPLACE/REPAIR FRAME (Cont'd).

##### a. DISASSEMBLY

- (1) Remove velcro straps (1) from frame (2).
- (2) Remove plate screws (3) and ID plate (4) from frame (2)
- (3) Remove bracket screws (5) and bracket (6)
- (4) Remove post screws (7) and post (8).
- (5) Remove anchor block screws (9) and anchor blocks (10)

##### b. REPAIR

- (1) Inspect velcro straps (1) for tears, fraying, or deterioration. Replace if necessary
- (2) Inspect all screws for corrosion, or damaged threads Replace if necessary
- (3) Check frame (2) for broken welds Notify Direct Support for welding repair.

##### c. ASSEMBLY

- (1) Install velcro straps (1) In frame (2)
- (2) Install ID plate (4) and plate screws (3).
- (3) Install post (8) and post screws (7).
- (4) Install bracket (6) and bracket screws (5)
- (5) Install anchor blocks (10) and anchor block screws (9)



## SECTION VI. PREPARATION FOR STORAGE OR SHIPMENT.

### 4-26. GENERAL INFORMATION.

#### Special Instructions for Administrative Storage.

Placement of equipment in administrative storage should be for short periods of time when a shortage of maintenance effort exists. Items should be in mission readiness within 24 hours or within time factors as determined by the directing authority. During the storage period, appropriate maintenance records will be kept.

Before placing equipment in administrative storage, current preventive maintenance checks and services should be completed, shortcomings and deficiencies should be corrected, and all Modification Work Orders should be applied.

Storage site selection. Inside storage is preferred for items selected for administrative storage. If inside storage is not available, trucks, vans, conex containers, and other containers may be used.

### 4-27. PRESERVATION, PACKAGING, MARKING, AND SHIPPING REQUIREMENTS.

Refer to MIL-P-116 for preservation, packaging, marking and shipping requirements.

4-37/(4-38 blank)

CHAPTER 5.  
DIRECT SUPPORT MAINTENANCE INSTRUCTIONS  
CHAPTER INDEX

<b>Subject</b>	<b>Page</b>
<b>SECTION I. REPAIR PARTS, SPECIAL TOOLS, TEST, MEASUREMENT, AND DIAGNOSTIC EQUIPMENT (TMDE), AND SUPPORT EQUIPMENT.</b>	
5-1. Common Tools and Equipment .....	5-2
5-2. Special Tools, Test, Measurement and Diagnostic Equipment, and Support Equipment .....	5-2
5-3. Repair Parts .....	5-2
<b>SECTION II. DIRECT SUPPORT TROUBLESHOOTING.</b>	
5-4. General .....	5-2
5-5. Direct Support Troubleshooting Table.....	5-2
<b>SECTION III. DIRECT SUPPORT MAINTENANCE PROCEDURES.</b>	
5-6. Repair Pumphead Assembly .....	5-3
5-7. Repair Upper Housing Assembly .....	5-6
5-8. Repair Lower Housing Assembly .....	5-9
5-9. Inspect and Repair Cover .....	5-12
5-10. Repair Accessory Box .....	5-14
5-11. Repair Frame .....	5-15

**SECTION I. REPAIR PARTS, SPECIAL TOOLS, TEST, MEASUREMENT,  
AND DIAGNOSTIC EQUIPMENT (TMDE), AND SUPPORT EQUIPMENT.**

**5.1. COMMON TOOLS AND EQUIPMENT.** For authorized common tools and equipment, refer to the Modified Table of Organization and Equipment (MTOE), CTA 50-970 or CTA 8-100 as applicable to your unit.

**5.2. SPECIAL TOOLS, TEST, MEASUREMENT AND DIAGNOSTIC EQUIPMENT, AND SUPPORT EQUIPMENT.** No special tools, test equipment, or support equipment are required (see Appendix B, Section III).

**5.3. REPAIR PARTS.** Repair parts are listed and illustrated in the Repair Parts and Special Tools List (RPSTL, TM 10-4610-244-23P, TM 09476B-23 P/2)

**SECTION II. DIRECT SUPPORT TROUBLESHOOTING.**

**5.4. General.** This section covers problems which may be encountered by Unit Maintenance but which must be referred to Direct Support for service

**5.5. Direct Support Troubleshooting Table.** Refer to Table 5-1, Direct Support Troubleshooting.

**Table 5-1.  
Direct Support Troubleshooting.**

<b>MALFUNCTION</b>
<b>TEST OR INSPECTION</b>
<b>CORRECTIVE ACTION</b>

**1. PROPORTIONING PUMP SOLUTION STOPS PUMPING.**

Step 1. Check chemical side diaphragm.

If chemical side diaphragm is sticking to inside of pumphead replace chemical side diaphragm (Paragraph 5-6).

Step 2. Check drive dog movement in lower maincase.

If movement is restricted in any way, repair upper housing assembly (Paragraph 5-8)

Step 3. Check lower housing disc.

If movement of disc is restricted in any way, replace disc (Paragraph 5-8).

Step 4. Check valve timing.

Make sure R-valve and bal-valve are timed correctly. If not timed correctly set timing (Paragraph 5-8).

**SECTION III. DIRECT SUPPORT MAINTENANCE PROCEDURES.**

**MAINTENANCE OF PLUMPHEAD ASSEMBLY**

**5-6. REPAIR PUMPHEAD ASSEMBLY.**

This task covers:    a. Disassembly                      b. Repair                      c. Assembly

**INITIAL SETUP:**

**Tools:**

Tool Kit, General Mechanics (Appendix B, Sec III, Item 1)

**Materials:**

Faceshield (Appendix E, Sec. II, Item 4)  
Gloves (Appendix E, Sec Item 5)  
Grease (Appendix E, Sec. Item 6)  
Preformed packing (Appendix I, Item 4)

**Equipment Condition**

Pumphead removed (Paragraph 4-15)

**General Safety Instructions:**

Wear protective gloves and faceshield when working on items containing hypochlorite solution

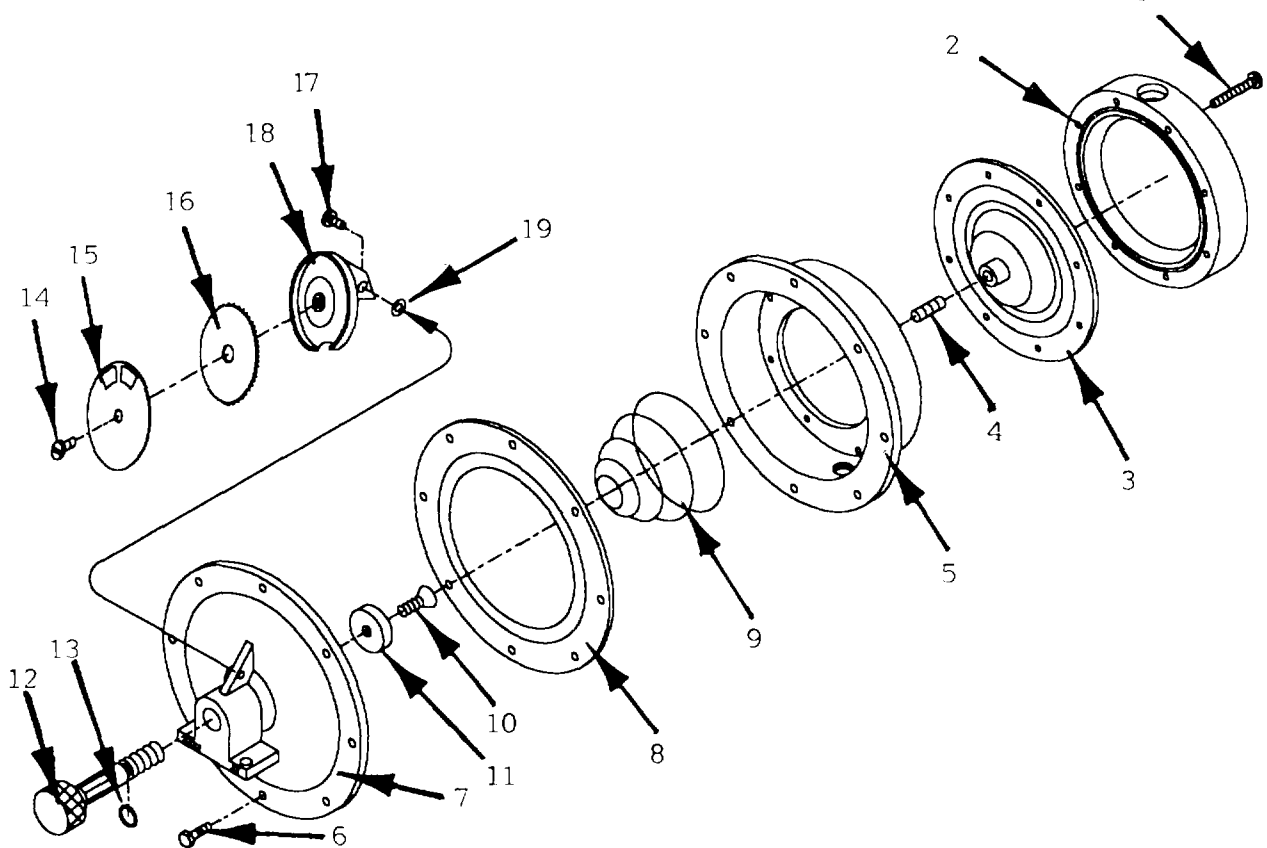

## 5-6. REPAIR PUMPHEAD ASSEMBLY (Cont'd).

### a. DISASSEMBLY

#### WARNING

**Hypochlorite solution may be on the pumphead and chemical side diaphragm and can cause severe chemical burns. To avoid injury wear gloves while working on them.**

- (1) Remove 8 screws (1) and plastic pumphead (2).
- (2) Turn stroke adjusting knob (12) until dial reads 9 or less.

#### NOTE

**Threaded stud may stay in either diaphragm and must not be discarded**

- (3) Unscrew and remove chemical side diaphragm (3).
- (4) Unscrew stud (4) from chemical side diaphragm (3). If stud is in water side diaphragm (8), unscrew it from water side diaphragm.
- (5) Place small end of cylinder (5) face down on work bench.
- (6) Remove all but two screws (6), which will be opposite each other.

#### WARNING

**The water side diaphragm is under spring pressure, uncontrolled release may cause injury. Maintain pressure on the water side diaphragm when removing it during maintenance.**

- (7) Push top (7) down to relieve spring pressure and remove remaining two screws (6).
- (8) Slowly lift top (7) off, releasing spring pressure.
- (9) Remove spring (9).
- (10) Remove water side diaphragm (8).
- (11) Remove pad retaining screw (10).
- (12) Remove pad (11).
- (13) Remove dosage control knob (12).
- (14) Remove and discard preformed packing (13).
- (15) Remove screw (14), dial cover (15), and dial gear (16).
- (16) Remove dial holder screw (17), dial holder (18), and star washer (19).

## 5-6. REPAIR PUMPHEAD ASSEMBLY (Cont'd).

### b REPAIR

- (1) Clean all components with soapy water.
- (2) Inspect diaphragms (3 and 8) for tears, holes, or brittleness. If damaged, replace.
- (3) Inspect dial gear (16) for bent, damaged, or missing teeth. If damaged, replace.
- (4) Inspect dosage control knob (12) for damaged threads, and spline gear on dosage control knob for damaged teeth. If damaged, replace dosage control knob.
- (5) Inspect pumphead (2) for clarity. If it cannot be seen through, replace.

### c. ASSEMBLY

- (1) Place star washer (19) over hole in flange of cover (7)
- (2) Place dial holder (18) over star washer (19) and install screw (17).
- (3) Install preformed packing (13) on dosage control knob (12), and install dosage control knob.
- (4) Install dial gear (16), making sure that teeth match with dosage control knob (12), and position dial cover (15) over dial gear and install screw (14).
- (5) Position pad (11) on dosage control knob with beveled end up.
- (6) Install screw (10).
- (7) Install water side diaphragm (8) and spring (9).
- (8) Place cover (7) over water side diaphragm (8) with mounting base on flange aligned with tell-tale drain.

### WARNING

**The water side diaphragm is under spring pressure, uncontrolled release may cause injury. Maintain pressure on the water side diaphragm when removing it during maintenance.**

- (9) Install two screws (6) through flange on cover (7), diaphragm (8), and cylinder (5), and tighten enough to hold assembly together
- (10) Install and tighten all remaining screws (6).
- (11) Lubricate and install stud (4) on chemical side diaphragm (3)
- (12) Install chemical side diaphragm (3).
- (13) If the holes in chemical side diaphragm (3) do not line up with the holes in cylinder (5), unscrew chemical side diaphragm until they line up
- (14) Install plastic head (2), making sure one of fittings for discharge and suction valves will line up with tell-tale drain when installed

**MAINTENANCE OF UPPER HOUSING ASSEMBLY.**

**5-7. REPAIR UPPER HOUSING ASSEMBLY.**

This task covers : a. Disassembly                      b. Service                      c. Repair                      d. Assembly

---

**INITIAL SETUP:**

**Tools:**

Tool Kit, General Mechanics (Appendix B.  
Sec III, Item 1)

**Equipment Condition:**

Proportioning pump removed (Paragraph 4-17).

**Materials:**

Packing, preformed (Appendix I, Item 4)  
Grease (Appendix E. Sec II, Item 6)

---

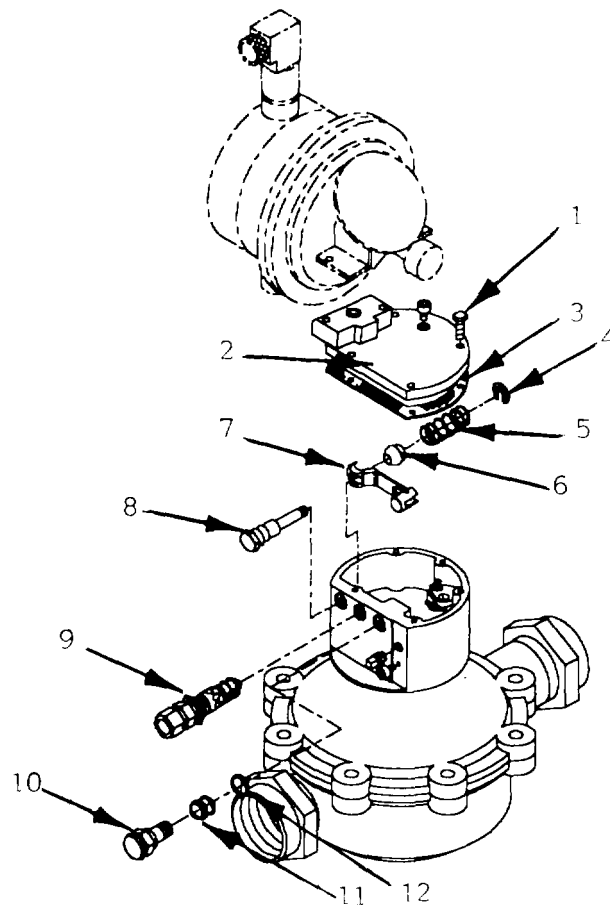

**5-7. REPAIR UPPER HOUSING ASSEMBLY (Cont'd).****a. DISASSEMBLY**

- (1) Remove five hex screws (1) and lift cover (2) from upper housing assembly.
- (2) Remove gasket (3).
- (3) Remove retainer washer (4) by compressing spring (5) and sliding washer out of groove in arm retainer (8).
- (4) Unscrew arm retainer (8) from upper housing and remove spring (5), ball pivot (6), and arm (7).
- (5) Unscrew R-valve (9) from upper housing.
- (6) Unscrew bal-valve (10) from upper housing. If bal-valve cap (11) remains inside housing, push cap out of upper housing. Remove preformed packing (12) from cap and discard.

**b. SERVICE**

- (1) Clean all components
- (2) Inspect arm retainer (8) for flat areas, ensure ball pivot (6) moves freely on arm Retain arm retainer, if necessary.
- (3) Inspect spring (5) for damage. Replace if necessary.
- (4) Inspect cam bearing on arm (7) for free movement.
- (5) Apply grease to arm retainer (8) and ball pivot (6)

**c. REPAIR**

- (1) Inspect R-valve (9) and ensure that plunger moves freely. Hold R-valve in hand and blow into it to make sure air moves through freely. Seating plunger, blow again; no air should go through. If you are able to blow through with plunger seated, replace.
- (2) Inspect bal-valve (10) and ensure needle moves freely and seats securely. If not, replace.

**d. ASSEMBLY**

- (1) Position arm retainer (8) through threaded hole in upper maincase.
- (2) Place arm (7) on arm retainer (8).
- (3) Place ball pivot (6) on arm retainer (8), ensuring that ball pivot fits into arm cradle.
- (4) Place spring (5) on arm retainer (8)
- (5) Screw arm retainer (8) into threads in housing until head bottoms out



### 5-7. REPAIR UPPER HOUSING ASSEMBLY (Cont'd).

- (6) Compress spring (5) and place retaining washer (4) onto arm retainer (8), snapping into grooves
- (7) Insert bal-valve (11) into threaded hole in housing, using slow firm pressure to carefully force preformed packing (12) past threads of hole
- (8) Screw bal-valve (11) into threaded hole in housing until head bottoms out
- (9) Insert R-valve (9) into hole in housing
- (10) Back locknut on R-valve (9) away from housing
- (11) Screw R-valve (9) into threaded hole three turns.
- (12) Set timing of R-valve (9) by

- (a) Rotate cam (1) until arm (2) is 0.005 to 0.010 inches from needle (3). Hold in this position.
- (b) Screw R-valve (4) in until its piston just seats. This is the point at which arm (2) will just begin to move away from face of arm retainer (6).
- (c) Tighten lock nut (5) to hold R-valve (4) in position.
- (d) Hold this position of cam (1) and check clearance between needle (3) and arm (2).
- (e) Readjust R-valve (4) if necessary to obtain 0.005 to 0.010 inch clearance when R-valve has just closed.

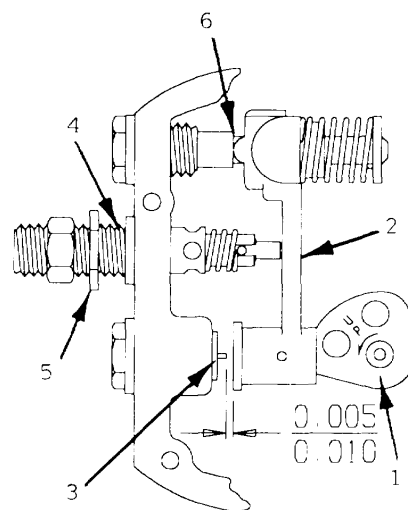

- (13) Place new gasket (3) around top of housing.
- (14) Place cover (2) on housing.
- (15) Fasten cover (2) into place with hex head screws (1).

**MAINTENANCE OF LOWER HOUSING ASSEMBLY**

**5-8. REPAIR LOWER HOUSING ASSEMBLY.**

This task covers:    a. Disassembly                      b. Service                      c. Repair  
                              d. Assembly

---

**INITIAL SETUP:**

**Tools:**

Tool Kit, General Mechanics (Appendix B,  
Sec. III, Item 1)

**Equipment Condition:**

Proportioning pump removed (Paragraph 4-17).

---

**Materials:**

Gasket (Appendix I, Item 1)

---

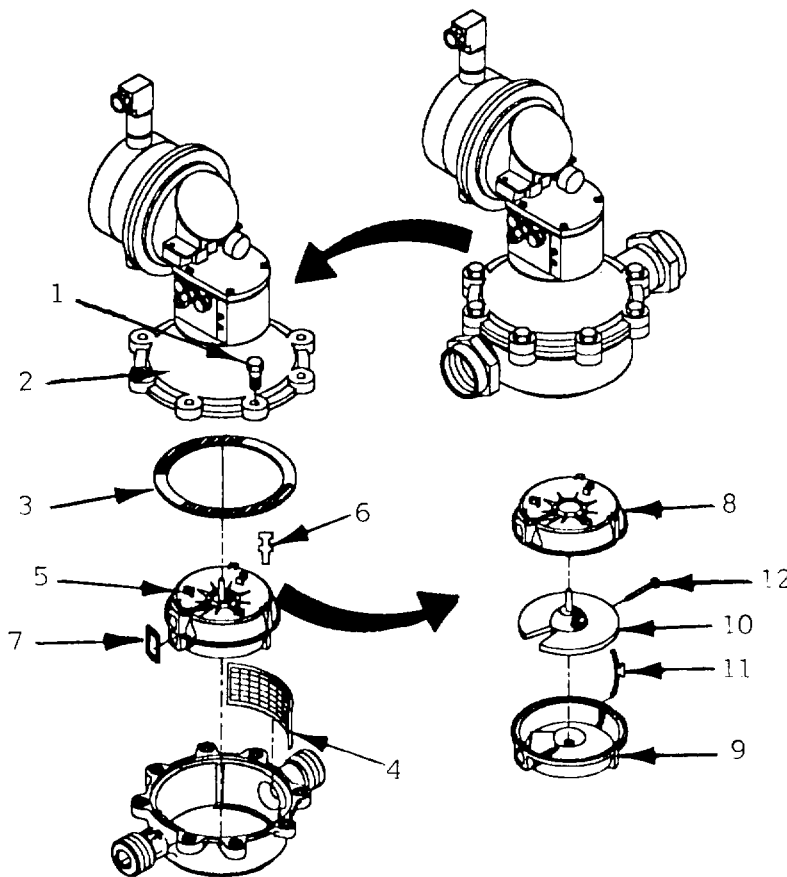

## 5-8. REPAIR LOWER HOUSING ASSEMBLY (Cont'd).

### a. DISASSEMBLY

- (1) Remove four bolts (1).
- (2) Remove upper housing assembly (2).
- (3) Remove gasket (3) and screen (4) from lower housing assembly.
- (4) Remove chamber disc assembly (5) by sticking finger in outlet pipe of lower housing and pushing up.
- (5) Remove retaining spring (6).
- (6) Remove port gasket (7) and discard.
- (7) Pull the two halves (8 and 9) of disc assembly apart.
- (8) Remove disc (10) and thrust insert (11).
- (9) Remove thrust roller (12).

### b. SERVICE

- (1) Clean all components as needed by flushing with clear water. Pay particular attention to debris or sediment which may collect in screen (4)

### c. REPAIR

- (1) Check screen (4) for clogging or damage to screen. If damaged, replace.
- (2) Inspect disc (10) for wear around edges or around the center ball. If the spindle is worn to half its normal diameter or is damaged, replace.

#### NOTE

**Disc halves must be replaced as a set**

- (3) Inspect chamber halves (8 and 9) for grooves or pitting. If such damage is found, replace.
- (4) Inspect upper gasket (3) for tears and deformation. It should also be pliable. Replace if torn, deformed, or brittle.

## 5-8. REPAIR LOWER HOUSING ASSEMBLY (Cont'd).

### d. ASSEMBLY

- (1) Place screen (4) in lower housing.
- (2) Insert thrust roller (12) into disc (10).
- (3) Place disc (10) in lower chamber half (9).
- (4) Place thrust insert (11) In groove of lower chamber half (9), with smooth edge to the inside.
- (5) Place upper chamber half (8) on lower chamber half (9), fitting insert (11) into slot in upper chamber half (8).
- (6) Place port gasket (7) over hole in chamber assembly (5).
- (7) Place retaining spring (6) in its slot on chamber assembly (5) Retaining spring will sit in slots with crosspieces up.
- (8) Slide chamber assembly (5) into lower housing Ensure that port gasket (7) is lined up with outlet port in lower housing.
- (9) Check disc (10) to make sure it is installed correctly by blowing into outlet port on lower housing. It should nutate with little blowing effort. If it does not nutate freely, make sure you are blowing into outlet port. If it still does not nutate freely, replace chamber disc assembly.
- (10) Place new upper gasket (3) over chamber assembly (5)
- (11) Attach lower housing assembly to upper housing assembly (2) finger-tight with four bolts (1), leaving the four which will attach to the bracket on hypochlorination unit frame.

**5-9. INSPECT AND REPAIR COVER.**

This task covers: a. Inspection                      b. Repair

---

**INITIAL SETUP**

**Tools:**  
Refer to FM 43-3.

**Equipment Condition:**  
Cover removed from equipment

---

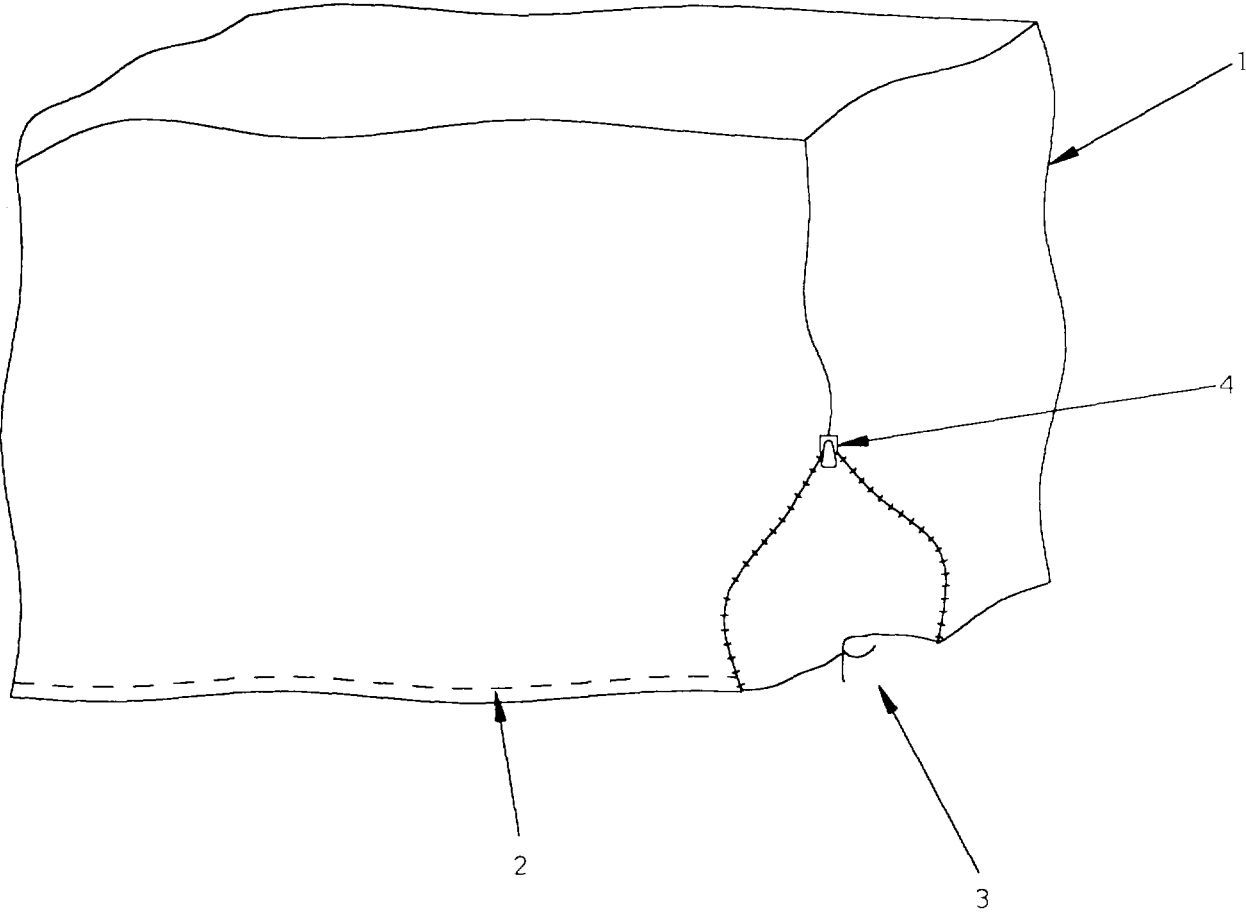

**5-9. INSPECT AND REPAIR COVER (Cont'd).**

**a. INSPECTION**

- (1) Spread cover (1) flat on a clean surface. Ensure outside of cover is up.
- (2) Inspect rim strip (2) around edge of cover for loose stitching. Mark loose stitching for repair.
- (3) Inspect cover for tears. Mark tears for repair.
- (4) Inspect drawstring (3) for fraying. If frayed or missing, replace.
- (5) Inspect zipper (4) for breaks, missing teeth. Replace if damaged.

**b. REPAIR**

- (1) Sew patches on tears. Refer to FM 43-3.
- (2) Sew loose rim strip. Refer to FM 43-3.
- (3) Make drawstring in accordance with Appendix G, Item 3.
- (4) Feed drawstring (3) through rimstrip (2) so that ends meet at zippered opening.

## 5-10. REPAIR ACCESSORY BOX.

This task covers: a. Repair

---

### INITIAL SET-UP

**Tools:**

Shop set (Appendix B, Sec III, Item 2)

**Equipment Condition:**

Accessory box removed (Paragraph 4-24)

**Materials:**

Rivets (RPSTL, TM 10-4610-244-23P  
TM 09476B-23/P)

---

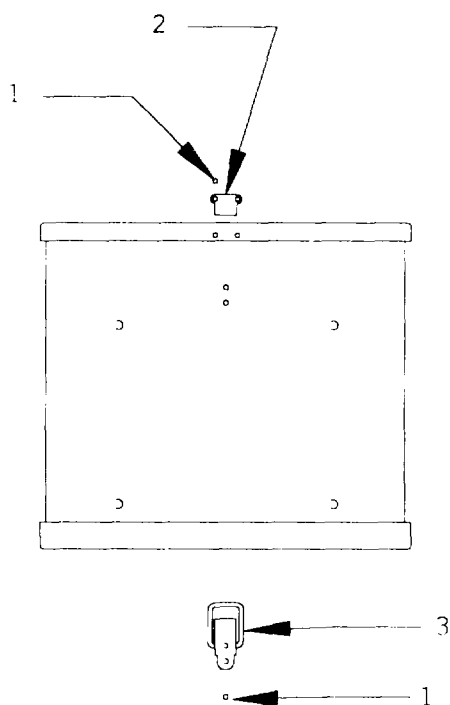

### a. REPAIR

- (1) Drill out old rivets (1).
- (2) Remove latch (2 and 3) and discard.
- (3) Install news latch (2 and 3) with rivets (1).

**5-11. REPAIR FRAME.**

**This task covers:** a. Repair

---

**INITIAL SET-UP**

**Tools:**

Field Maintenance Welding Shop Equipment  
(Appendix B, Sec. III, Item 3)

**Equipment Condition:**

Frame removed (Paragraph 4-25).

---

**a. REPAIR**

- (1) For welding procedures, refer to TM 9-237
- (2) For repair of metal bodies, refer to TM 9-450

**5-15/(5-16 Blank)**



**APPENDIX A.  
REFERENCES**

**Scope.** This appendix lists all forms, field manuals, and technical manuals referenced in tills manual.

**Forms**

Report of Discrepancy.....	SF 364
Product Quality Deficiency Report.....	SF 368
Equipment Inspection and Maintenance Worksheet .....	DA Form 2404
Recommended Changes to Publications and Blank Forms.....	DA Form 2028
Recommended Changes to Equipment Technical Publication .....	DA Form 2028-2
Material Inspection and Receiving Report .....	DD Form 250

**Field Manuals**

NBC Contamination Avoidance .....	FM 3-3
NBC Protection .....	FM 3-4
NBC Decontamination .....	FM 3-5
Water Supply in Theaters of Operations.....	FM 10-52-1
Petroleum Supply Point Equipment and Operation (Dispensing Fuel/Water).....	FM 10-69
General Repair for Canvas and Webbing.....	FM 43-3

**Pamphlets**

Functional User's Manual for the Army Maintenance Management System (TAMMS) .....	DA PAM 738-750
Functional User's Manual for the Army Maintenance Management System-Aviation (TAMMS-A).....	DA PANI 738-751

**APPENDIX A.  
REFERENCES (Cont'd)**

**Technical Manuals**

Operator's and Organizational Maintenance manual for Water Quality Analysis/Sets:  
Preventative Medicine..... TM 5-6630-215-12  
Operator's Manual: Welding Theory and Application ..... TM 9-237  
Metal Body Repair and Related Operations..... TM 9-450  
Repair Parts and Special Tools List..... TM 10-4610-244-23P  
TM 09476B-23/P  
Painting Instructions for Army Equipment..... TM 43-139  
Procedures for Destruction of Equipment to Prevent Enemy Use ..... TM 750-244-3

**Specifications**

Methods of Preservation . .....MIL-P-116

**Technical Bulletins**

Occupational and Environmental Health .....TB-MED-577

**APPENDIX B.  
MAINTENANCE ALLOCATION CHART (MAC)**

**SECTION I. INTRODUCTION.**

**B-1. GENERAL.**

a. This introduction (Section I) provides a general explanation of all maintenance and repair functions authorized at various maintenance levels.

b. The Maintenance Allocation Chart (MAC) in Section II designates overall authority and responsibility for the performance of maintenance functions on the identified end item or component. The application of the maintenance functions to the end item or component will be consistent with the capacities and capabilities of the designated maintenance level.

c. Section III lists the tools and test equipment (both special tools and common tool sets) required for each maintenance function as referenced from Section II.

d. Section IV contains remarks referred to in Section II.

**B-2. MAINTENANCE FUNCTIONS.**

Maintenance functions will be limited to and defined as follows

a. **Inspect** To determine the serviceability of an item by comparing its physical, mechanical, hydraulic, or electrical characteristics with established standards through examination (e.g., by sight, sound, or feel).

b. **Test** To verify serviceability by measuring the mechanical, hydraulic, or electrical characteristics of an item and comparing those characteristics with prescribed standards

c. **Service** Operations required periodically to keep an item in proper operating condition, i.e., to clean (includes decontamination, when required), to preserve, to drain, to paint, or to replenish fuel, lubricants, chemical fluids, or gases

d. **Adjust** To maintain or regulate, within prescribed limits, by bringing into proper or exact position, or by setting the operating features to specified parameters

e. **Align** To adjust specified elements of an item in order to bring about the best or the desired performance.

**B-2. MAINTENANCE FUNCTIONS (Cont'd).**

f. Calibrate. To determine and make corrections or to adjust instruments or test, measuring, and diagnostic equipment used in precision measurement. It consists of comparisons of two instruments, one being a certified standard of known accuracy, to detect and adjust any discrepancy in the accuracy of the instrument being compared.

g. Remove/Install. To remove and install the same item when required to perform service or other maintenance functions. Install may be the act of emplacing, seating, or fixing into position a spare, repair part, or module (component or assembly) in a manner to allow the proper functioning of an equipment or system.

h. Replace. To remove an unserviceable item and install a serviceable counterpart in its place. "Replace" is authorized by the MAC and is shown as the 3rd position code of the SMR code.

i. Repair. The application of maintenance services, including fault location/trouble-shooting, removal/installation, and disassembly/assembly procedures, and maintenance actions to identify troubles and restore serviceability to an item by correcting damage, fault, malfunction, or failure in a part, subassembly, module (component or assembly), end item, or system.

j. Overhaul. That maintenance effort (service/action) prescribed to restore an item to a completely serviceable/operational condition as required by maintenance standards in an appropriate technical publication (i.e., DMWR). Overhaul is normally the highest degree of maintenance performed by the Army. Overhaul does not normally return an item to like new condition.

k. Rebuild. Consists of those services/actions necessary for the restoration of unserviceable equipment to a like new condition in accordance with original manufacturing standards. Rebuild in the highest degree of material maintenance applied to Army equipment. The rebuild operation includes the act of returning to zero those age measurements (hours/miles, etc.) considered in classifying Army equipment/components.

**B-3. EXPLANATION OF COLUMNS IN THE MAC, SECTION II.**

a. Column 1, Group Number. Column 1 lists the functional group code numbers, in order to identify maintenance significant components, assemblies, subassemblies, and modules with the next higher assembly. End item group shall be "00."

b. Column 2, Component/Assembly. Column 2 contains the name of components, assemblies, subassemblies, and modules for which maintenance is authorized.

c. Column 3, Maintenance Function. Column 3 lists the functions to be performed on the item listed in Column 2. (For detailed explanation of these functions, see paragraph B-2.)

**B-3. EXPLANATION OF COLUMNS IN THE MAC, SECTION II (Cont'd).**

d. Column 4, Maintenance Category. Column 4 specifies, by the listing of a work time figure in the appropriate subcolumn(s), the category of maintenance authorized to perform the function listed in Column 3. This figure represents the active time required, in hours, to perform that maintenance function at the Indicated category of maintenance. If the number or complexity of the tasks within the listed maintenance function vary at different maintenance categories, appropriate work time figures will be shown for each category. The work time figure represents the average time required to restore an item (assembly, subassembly, component, module, end item, or system) to a serviceable condition under typical field operating conditions. This time includes preparation time (including any necessary disassembly/assembly time), troubleshooting/fault location time, and quality assurance/quality control time in addition to the time required to perform the specific tasks identified for the maintenance functions authorized in the maintenance allocation chart. The symbol designations for the various maintenance categories are as follows:

C.....Operator or crew  
O .....Unit Maintenance  
F .....Direct Support Maintenance  
H.....General Support Maintenance  
D.....Depot Maintenance

e. Column 5, Tools and Equipment. Column 5 specifies, by code, those common tool sets (not individual tools) and special tools, TNMDE, and support equipment required to perform the designated function.

f. Column 6, Remarks Column 6 shall, when applicable, contain a letter code, in alphabetic order, which shall be keyed to the remarks contained in Section IV.

**B-4. EXPLANATION OF COLUMNS IN TOOL AND TEST EQUIPMENT REQUIREMENTS, SECTION III.**

- a. Column 1, Reference Code. The tool and test equipment reference code correlates with a code used in the MAC, Section II, Column 5.
- b. Column 2, Maintenance Category. The lowest category of maintenance authorized to use the tool or test equipment.
- c. Column 3, Nomenclature. Name or Identification of the tool or test equipment.
- d. Column 4, National Stock Number. The National stock number of the tool or test equipment.
- e. Column 5, Tool Number. The manufacturer's part number.

**B-5. EXPLANATION OF COLUMNS IN REMARKS, SECTION IV.**

- a. Column 1, Reference Code. The code recorded in column 6, Section II.
- b. Column 2, Remarks. This column lists information pertinent to the maintenance function being performed as indicated in the MAC, Section II.

SECTION II. MAINTENANCE ALLOCATION CHART.

(1) GROUP NUMBER	(2) COMPONENT/ ASSEMBLY	(3) MAINTENANCE FUNCTION	(4) MAINTENANCE CATEGORY					(5) TOOLS AND EQUIPMENT	(6) REMARKS
			C	O	F	H	D		
			00	Hypochlorination Unit					
01	Proportioning Pump	Inspect	0.1						
		Replace		0.5			1,3	A	
0101	Lower Housing Assembly	Replace			0.3		1		
		Repair			0.5		1		
010101	Chamber Disc Assembly	Replace	:		0.5		1		
		Repair			0.6		1		
0102	Upper Housing Assembly	Inspect			0.5				
		Service			0.5		1		
		Repair			1.0		1		
0103	Proportioning Pump Chem Valve & Tubing Assembly	Inspect	0.1						
		Service		0.2					
		Replace		0.2			1		
		Repair		0.5			1		
010302	Suction Valve	Inspect	0.1						
		Service		0.2			1		
		Repair		0.2			1		
010303	Injection Valve	Inspect		0.2					
		Service		0.2					
		Repair		0.2			1		
010304	Discharge Valve	Inspect		0.2					
		Service		0.2					
		Repair		0.2			1		
0104	Pumphead Assembly	Inspect	0.2						
		Replace		0.3			1		
		Repair			1.0		1		

SECTION II. MAINTENANCE ALLOCATION CHART (Cont'd).

(1) GROUP NUMBER	(2) COMPONENT/ ASSEMBLY	(3) MAINTENANCE FUNCTION	(4) MAINTENANCE CATEGORY					(5) TOOLS AND EQUIPMENT	(6) REMARKS
			C	O	F	H	D		
02	Mainline Pipe Assembly	Inspect Replace Repair	0.1	0.5 1.5 1.5				1,3 1,2	A
0201	Range Adjusting Valve	Replace Repair		0.5 1.0				1 1	
0202	Camlock Fitting Assemblies	Inspect Replace Repair	0.2	0.5 0.5				1 1	
03	Frame Assembly	Inspect Replace Repair	0.1	2.0 0.5	0.3			1 1,3	
04	Accessory Box	Inspect Replace Repair	0.1 0.2 0.5					1 2	
05	Cover	Inspect Repair	0.1	0.5				1 2	



**SECTION III. TOOL AND TEST EQUIPMENT REQUIREMENTS.**

(1) REFERENCE TOOL CODE	(2) MAINTENANCE LEVEL	(3) NOMENCLATURE	(4) NATIONAL STOCK NUMBER	(5) TOOL NUMBER
1	O	Standard tools and test equipment contained in the following kits are adequate to perform the maintenance functions listed in Section II.  Tool Kit, General Mechanics	5180-00-177-7033	SC 5180-90-CL-N26 (19099)
2	O	Shop Equipment, Automotive Maintenance and Repair; Organizational Maintenance, Common No. 1	4910-00-754-0654	SC 4910-95-CL-A74
3	O	Shop Equipment, Automotive Maintenance and Repair, Organizational Maintenance, Common No. 2	4910-00-754-0650	SC 4910-95-CL-A72

**Section IV. Remarks**

REMARKS CODE

A

REMARKS

Torque limits must be observed.

**B-7/(B-8 Blank)**

**APPENDIX C.  
COMPONENTS OF END ITEMS AND BASIC ISSUE ITEMS LISTS**

**SECTION I. INTRODUCTION.**

**C-1. SCOPE.**

This appendix lists components of end items and basic issue items for the Hypochlorination Unit to help you inventory items required for safe and efficient operation

**C-2. GENERAL**

The Components of End Items and Basic Issue Items Lists are divided into the following sections

**a Section II. Components of End Item (COEI).** This listing is for informational purposes only, and is not authority to requisition replacements These items are part of the end item, but are removed and separately packaged for transportation or shipment. As part of the end item, these items must be with the end item wherever it is Issued or transferred between property accounts.

**b. Section III. Basic Issue Items (BII).** These essential items required to place the Hypochlorination Unit in operation, to operate it, and to do emergency repairs Although shipped separately packaged, BII must be with the system during operation and whenever it is transferred between property accounts. Listing these items is your authority to request/requisition them for replacement, based on authorization of the end item by TOE!/MTOE. Illustrations are furnished to help you find and identify the items

**C-3. EXPLANATION OF COLUMNS.**

The following provides an explanation of columns found in the tabular listings

**a. Column (1) - Illustration Number- (Illus. Number).** This column indicates the number of the illustration in which the item is shown

**b. Column (2) - National Stock Number:** Indicates the national stock number of to be used for requisitioning purposes.

**c. Column (3) - Description.** Identifies the Federal item name (in all capital letters) followed by a minimum description when needed The last line below the description is the CAGEC (Commercial and Government Entity Code) (in parentheses) and the part number

**d. Column (4) - Unit of Issue (U/I).** Indicates how the item is issued for the National Stock Number shown in Column (2)

**e. Column (5) - Quantity Required (Qty Reqd).** Indicates the quantity required

**SECTION II. COMPONENTS OF END ITEMS (COEI) LIST.**

<b>ILLUS. NUMBER</b>	<b>NSN</b>	<b>DESCRIPTION</b>	<b>U/I</b>	<b>QTY REQD</b>
		There are no COEI associated with the hypochlorination unit		

SECTION III. BASIC ISSUE ITEMS (BII) LIST.

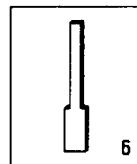
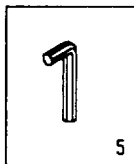
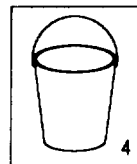
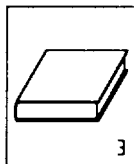
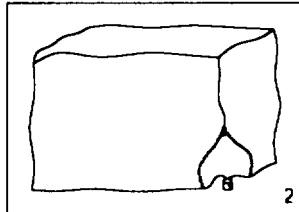
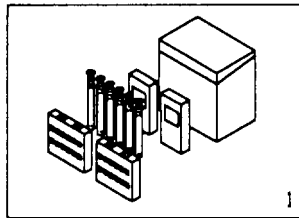

ILLUS. NUMBER	NSN	DESCRIPTION	U/I	QTY REQD
1	6630-01-067-3827	Chlorine Analysis Kit	EA	1
2		Cover	EA	1
3		Manual, Technical TM 10-4610-224-13 TM 09476B-13/1	EA	1
4	7240-01-094-4605	Mixing Bucket	EA	1
5	5120-00-240-5292	Socket Head Wrench, 3/32"	EA	1
6	7330-00-782-3247	Stirring Paddle	EA	1

**APPENDIX D.  
ADDITIONAL AUTHORIZATION LIST**

**SECTION I. INTRODUCTION.**

**D-1. SCOPE.**

This appendix lists additional items you are authorized for the support of the Hypochlorination Unit

**D-2. GENERAL.**

This list identifies items that do not have to accompany the Hypochlorination Unit and that do not have to be turned in with it. These items are all authorized to you by CTA, MTOE, TDA, or JTA.

**D-3. EXPLANATION OF LISTING.**

National stock numbers, descriptions, and quantities are provided to help you identify and request the additional items you require to support this equipment. The items are listed in alphabetical sequence by item name. If the item you require differs between the serial numbers of the same model, effective serial numbers are shown in the last line of the description. If the item required differs for different model numbers of this equipment, the model number is shown under the "Usable On" heading in the description column.

**Section II. Additional Authorization List.**

NSN	DESCRIPTION	U/M	QYT
	NO ADDITIONAL ITEMS ARE AUTHORIZED		

**APPENDIX E.  
EXPENDABLE/DURABLE ITEMS LIST**

**SECTION I. INTRODUCTION.**

**E-1. SCOPE.**

This appendix lists expendable items you will need to operate and maintain the Hypochlorination Unit. This listing is for Information only, and is not authority to requisition the listed items. These items are authorized to you by CTA 50-970, Expendable Items (except medical, class V, repair parts, and heraldic items) or CTA 8-100, Army Medical Department Expendable/Durable Items.

**E-2. EXPLANATION OF COLUMNS.**

**a. Column (1) Item Number.** This number is assigned to the entry in the listing and is referenced in the narrative instructions to identify the material (e.g., "Use cleaning compound, item 5, Appendix E")

**b. Column (2) Level.** This column identifies the lowest level of maintenance that requires the listed item.

C -Operator/Crew  
O-Unit Maintenance  
F-Direct Support Maintenance

**c. Column (3) National Stock Number:** This is the National stock number assigned for requisitioning purposes.

**d. Column (4) Item Number, Description, Commercial and Government Entity Code (CAGEC) and Part Number.** This provides the other information you need to identify the item.

**e. Column (5) Unit of Measure (U/M).** This code shows the physical measurement or count of an item such as gallon, dozen, gross, etc.

SECTION II. EXPENDABLE/DURABLE ITEMS LIST.

(1) ITEM NUMBER	(2) LEVEL	(3) NATIONAL STOCK NUMBER	(4) DESCRIPTION	(5) U/M
1	C	8415-01-333-4158	Apron	EA
2	C	6810-00-242-4770	Calcium Hypochlorite	BX
3	C	6810-01-044-0315	Chlorine Indicator	BX
4	C	4240-01-099-8520	Faceshield	EA
5	C	8415-01-112-1885	Gloves	PR
6	0	0150-00-584-4299	Grease	TL
7	C	7020-00-205-1711	Rags	EA
8	0	8030-00-889-3535	Tape. Anti-Seize	RL

**APPENDIX F.  
LUBRICATION INSTRUCTIONS**

No lubrication is required.

**F-1/(F-2 Blank)**



**APPENDIX G.  
ILLUSTRATED LIST OF MANUFACTURED ITEMS**

**G-1. INTRODUCTION.** This appendix includes complete instructions for making items authorized to be manufactured or fabricated at unit maintenance level and direct support level. All bulk materials needed for manufacture of an item are listed by part number or specification number in a tabular list on the illustration

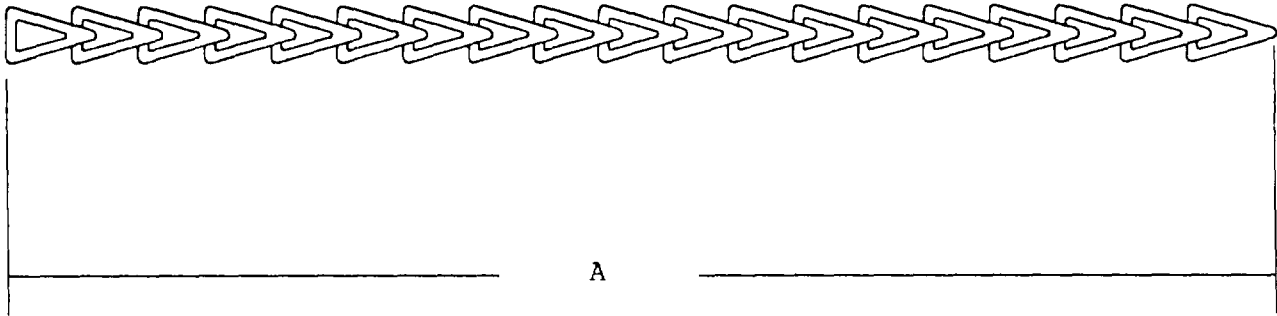

Item 1. Chain



Item 2. Key ring

MATERIAL				
ITEM NO.	DESCRIPTION	PART NO AND CAGEC	QTY	NSN
1	Chain	NAS1455C0-240 (IB934)	2	
2	Key ring	90104 (07527)	4	

PROCEDURE:

1. Cut chain (Item 1) length "A" to 2 feet.
2. Install key ring (Item 2) on each end of chain.
3. Refer to paragraph 4-20 for installation.

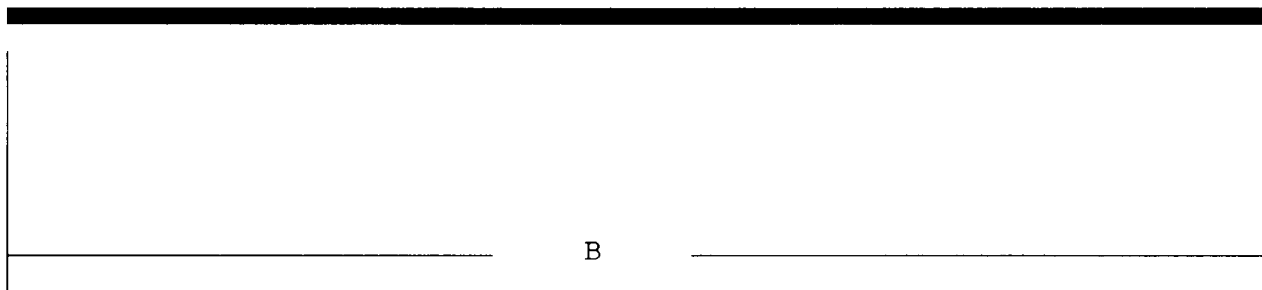

**Item 3. Drawstring**

MATERIALS				
ITEM NO	DESCRIPTION	PART NO. AND CAGEC	QTY	NSN
3	Drawstring	MIL-C-5040 (00768)	1	

**PROCEDURES:**

- 1 Cut draw stringlength "B" to 140 inches
- 2 Refer to paragraph 5-9 for installation

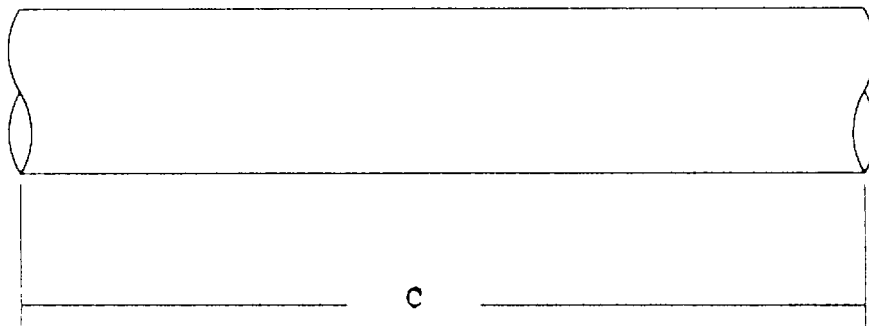

Item 4. Tubing



Item 5. Tubing nut.

MATERIALS				
ITEM NO.	DESCRIPTION	PART NO. AND CAGEC	QTY	NSN
4	Tubing, 3/8" OD Nylabraid	IIHNB045 (06034)	1	
5	Tube nut	174-3 (0K616)	2	

PROCEDURE:

1. Cut tubing (Item 4) to length shown in table:

PART NUMBER	LENGTH "C"
1010-8 (52848)	3 Feet
671-9 (52848)	10 Feet

2. Slip tube nut (Item 5) over each end of tubing with threads toward end of tubing
3. Refer to paragraph 4-13 for installation.

**APPENDIX H.  
TORQUE LIMITS**

**H-1. GENERAL.** This appendix provides general torque limits for fasteners. Special torque values are indicated in the maintenance procedures for applicable components. The general torque values given in this appendix shall be used when specific torque values are not indicated in the maintenance procedures.

**H-2. TORQUE LIMITS.** Torque limits are listed in Table H-1 for fasteners. Table H-2 lists the minimum breakaway torque values for locknuts.

**Table H-1. General Torque Requirements.**

Torque Requirement in ft lb (N m)				
Bolt/Screw Size	SAE Grade 1 or 2	SAE Grade 5	SAE Grade 6 or 7	SAE Grade 8
1/4-20 UNC	5 (7)	8 (11)	10 (14)	12 (16)
1/4-28 UNF	6 (8)	10 (14)	12 (16)	14 (19)
5/16-18 UNC	11 (15)	17 (23)	19 (26)	24 (33)
5/16-24 UNF	13 (18)	19 (26)	23 (31)	27 (37)
3/8-16 UNC	18 (24)	31 (42)	34 (46)	44 (60)
3/8-24 UNF	20 (27)	35 (47)	42 (57)	49 (66)
7/16-14 UNC	28 (38)	49 (66)	55 (7)	7 (95)
7/16-20 UNF	30 (41)	55 (75)		7X (106)
1/2-13 UNC	39 (53)	75 (102)	85 (115)	115 (142)
1/2-20 UNF	41 (56)	85 (115)	102 (138)	12 (163)
9/16-12 UNC	51 (69)	110 (149)	12 (163)	155 (211)
9/16-18 UNF	55 (75)	12 (163)	145 (197)	170 (231)
5/8-11 UNC	63 (85)	15 (213)	167 (226)	210 (285)
5/8-18 UNF	95 (129)	17 (231)	20 (278)	240 (325)
3/4-10 UNC	105 (142)	270 (366)	28 (38)	375 (509)
3/4-16 UNF	115 (156)	295 (41)	357 (484)	42 (570)
7/8-9 UNC	160 (217)	39 (536)	44 (57)	605 (820)
7/8-14 UNF	175 (237)	435 (59)	555 (753)	675 (915)

**Table H-1.**  
**General Torque Requirements (Cont'd).**

Bolt/Screw Size	Torque Requirement in ft lb (N. m)			
	SAE Grade 1 or 2	SAE Grade 5	SAE Grade 6 or 7	SAE Grade 8
1-8 UNC 1-14 UNF	235 (319) 250 (339)	590 (800) 660 (895)	660 (895) 82 (1119)	910 (1234) 990 (1342)
1-1/8-7 UNC 1-1/8-12 UNF	350 (475) 400 (542)	800 (185) 881 (1193)	1000 (1356) 1050 (1424)	1280 (1736) 1440 (1953)
1-1/4-7 UNC 1-1/4-12 LUNF	500 (678) 550 (746)	1080 (1404) 1125( 1526)	1325 (1797) 1325 (1797)	1820 (2468) 1820 (2712)
1-3/8-6 UNC 1-3/8-12 UNF	660 (895) 740 (1003)	1460 (1980) 1680 (2278)	1800 (2441) 1960 (2658)	2380 (3227) 2720 (3688 0)
1-1/2-6 UNC 1-1/2-12 UNF	870 (118)) 98() (1329)	1940 (2031) 2200 (2983)	2913 (3950) 3000 (4068)	3160 (4285) 3560 (4827)

**Table H-2.**  
**Locknut Breakaway Torque Values.**

**NOTE**

To determine breakaway torque, thread locknut onto screw or bolt until at least two threads stick out Locknut shall not make contact with a mating part. Stop the locknut. Torque necessary to begin turning locknut again is the breakaway torque Do not reuse locknuts that do not meet min1iLmum breakaway torque

THREAD SIZE	MINIMUM BREAKAWAY TORQUE in-lb (N m)
10-32	2 0 (0.23)
1/4-28	3 5 (0. 40)
5/16-24	6.5(0.73)
3/8-24	9 5 (1.07)
7/16-20	14.0 (1.58)
1/2-20	18.0 (2.03)
9/16-18	24.0 (2.71)
5/8-18	32 0 (3.62)
3/4-16	50.0 (5.65)
7/8-14	70 0 (7.91)
1-12	90.0 (10.17)
1-1/8-12	117.0 (13 22)

**APPENDIX I.**  
**MANDATORY REPLACEMENT PARTS**

**1-1. SCOPE.** This appendix lists all mandatory replacement parts referenced in the task setups in this manual.

(1) Item Number	(2) Part Number and CAGEC	(3) Nomenclature
1	70-3 (OK616)	Gasket
2	E6CRIO1IP (26233)	Locknut
3	48-0 (OK616)	Packing, Preformed
4	136-3 (OK616)	Packing, Preformed
5	168-6 (OK616)	Packing, Preformed

**GLOSSARY**  
**SECTION I. ABBREVIATIONS.**

Approx.	.....	Approximately
Bal-valve	.....	balance valve
C	.....	celsius
CPC	.....	corrosion prevention and control
EIR	.....	Equipment improvement recommendations
F	.....	Fahrenheit
FM	.....	Field Manual
Gals	.....	gallons
gpm	.....	gallons per minute
max	.....	maximum
min	.....	minimum
NBC	.....	nuclear, biological, chemical
NSN	.....	national stock number
PMCS	.....	preventive maintenance checks and services
p/n	.....	part number
ppm	.....	parts per million
psig	.....	pounds per square inch gage
RPSTL	.....	repair parts special tools list
R-valve	.....	relief
Temp	.....	temperature
TM	.....	Technical Manual



## SECTION II. DEFINITIONS OF UNUSUAL TERMS.

*Camlock Fittings* -- Pipe connections

*Chlorinate* -- Add chlorine to water to control biological growth in water

*Foot Valve* -- Valve at the end of suction hose that, when placed on bottom of solution reservoir, screens foreign particles and helps maintain priming of pump

*Hypochlorination Unit* -- Device whose function is to add chlorine to water.

*Impulse Motor*-- Motor which works by pressure impinging directly on moving parts

*Nutate*—Wobbling motion made by a rotating disc

*Poppet* --, Valve ball that allows flow, in one direction

*Poppet Valve*, -- Valve having a poppet

Potable Water -- Water meeting military standards for drinkability

*Range Adjusting Valve* -- Butterfly valve to control the amount of sent through the Proportioning Pump

*Reciprocating* –Moving back and forth

Siting -- Placing of equipment at site

Turbidity -- Cloudy or murky appearance

## INDEX

SUBJECT	PAGE
<b>A</b>	
Abbreviations .....	Glossary 1
Accessory Box, Repair .....	5-14
Accessory Box, Replace.....	4-33
Adjustments and Checks, Initial.....	2-8
Administrative Storage. Special Instructions for .....	4-37
Assembly and Preparation for Use .....	2-8
Assembly. Inlet Ball Valve , Repair .....	4-26
Assembly, Lower Housing. Repair .....	5-9
Assembly, Mainline Piping, Replace.....	4-22
Assembly, Outlet Ball Valve, Replace.....	4-16
Assembly, Pumphead, Removal of .....	4-14
Assembly, Upper Housing, Repair .....	5-6
<b>B</b>	
Ball Valve Assembly, Inlet, Repair .....	4-26
Ball Valve Assembly, Outlet, Replace .....	4-16
<b>C</b>	
Camlocks, Repair .....	4-24
Characteristics, Capabilities, and Features, Equipment .....	1-3
Chlorine Residual Test .....	2-11
Common Tools and Equipment .....	4-3
Controls and Indicators, Operator's .....	2-2
Corrosion Prevention and Control (CPC).....	1-2
Cover, Inspect and Repair.....	5-12
<b>D</b>	
Data, Equipment .....	1-5
Decals and Instruction Plates .....	2-15
Decontamination Procedures, NBC .....	2-19
Definition of Unusual Terms .....	Glossary 2
Destruction of Army Material to Prevent Enemy Use.....	1-2
Direct Support Troubleshooting, .....	5-2
Discharge Valve, Suction Valve and, Repair .....	4-12
<b>E</b>	
Equipment Improvement Recommendations (EIR).....	1-2
Equipment Characteristics, Capabilities and Features .....	1-3
Equipment Data .....	1-5

INDEX (CONT'D)

SUBJECT	PAGE
<b>F</b>	
Foot Valve and Tubing, Service.....	4-9
Frame, Repair.....	5-15
Frame, Replace .....	4-35
<b>H</b>	
Hypochlorilte Required.....	2-12
<b>I</b>	
Initial Adjustments and Checks.....	2-8
Injection , Repair.....	4-20
Inspect and Repair Cover.....	5-12
Inlet Ball Valve Assembly. Repair .....	4-26
<b>L</b>	
Leakage Definitions for Operator P. ....	2-4
Location and Description of Major Components.....	1-3
Lower Housing Assembly, Repair .....	5-9
<b>M</b>	
Mainline Piping and Range Adjusting Valve, Repair.....	4-2
Mainline Piping Assembly,. Replace.....	4-22
Maintenance Forms and Procedures .....	1-2
Maintenance Procedure, Operator.....	3-3
Major Components, Location and Description of .....	1-3
Movement, Preparation for ,.....	2-17
<b>N</b>	
NBC Decontamination Procedures .....	2-19
<b>O</b>	
Operating Procedures .....	2-9
Operation in Unusual Weather .....	2-18
Operator PMCS Procedures.....	2-3
Operator Troubleshooting.....	3-2
Operator's Controls and Indicators	
Operator Maintenance Procedure.....	3-3
Outlet Ball Valve Assembly, Replace.....	4-16

INDEX (Cont'd)

SUBJECT	PAGE
<b>P</b>	
Parts, Repair .....	4-3
Piping Assembly, Mainline, Replace.....	4-22
Piping, i, and Range Adjusting Valve, Repair .....	4-28
PMCS Procedures. Operator.....	2-3
PMNCS Procedures. Unit.....	4-4
Preparation for Movement.....	2-17
Preparation for Storage or Shipment .....	4-37
Preparation for Use. Assembly and .....	2-8
Proportioning Pump. Removal of .....	4-18
Pumphead Assembly, Remove-al of .....	4-14
Pumphead Assembly, Repair .....	5-3
<b>R</b>	
Range Adjusting Valve, Mainline Piping Repair.....	4-28
Receipt. Service Upon.....	4-3
Removal of Proportioning Pump .....	4-18
Removal of Pumphead Assembly .....	4-14
Repair Accessory, Box .....	5- 14
Repair Camlocks.....	4-26(
Repair Frame.....	5-9
Repair Injection Valve.....	4-20
Repair- Inlet Ball Assembly .....	4-26
Repair Lower Housing Assembly	
Repair Mainline Piping and Range Adjusting ve .....	4-28
Repair Parts .....	4-3
Repair Pumphead Assembly .....	5-3
Repair Suction Valve and Discharge-.....	4-12
Repair Upper Housing( Assembly .....	5-6
Replace Accessory , Box.....	4-33
Replace Frame .....	4-35
Replace Mainline Piping Assembly.....	4-22
Replace Outlet Ball Assembly .....	4-16
Replace Solution Reser4voir.....	4-31
<b>S</b>	
Service Foot ,Valve and Tubing.....	4-9
Service Upon Receipt.....	4-3
Siting Requirements.....	2-8
Special Tools. Test, Measurement and Diagnostic Equipment.....	4-3
Suction and Discharge Valve, Repair .....	4-12
Solution Reservoir. Replace.....	4-31

INDEX (Cont'd)

SUBJECT	PAGE
<b>T</b>	
Test, Measurement and Diagnostic, Special Tools .....	4-3
Theory of Operation .....	1-5
Tools and Equipment, Common .....	4-3
Tools, Special. Test. Measurement and Diagnostic Equipment.....	4-3
Troubleshooting, Direct Support .....	5-2
Troubleshooting, Unit .....	4-6
Troubleshooting, Operator.....	3-2
Tubing. Foot Valve and Service.....	4-9
<b>U</b>	
Unit PNI(CS Procedures.....	4-4
Unit Troubleshooting .....	4-6
Unusual Weather, Operation In .....	2-18
Upper Housing Assembly, Repair .....	5-6
<b>V</b>	
Valve, Discharge, Suction Valve and, Service.....	4-12
Valve, Injection. Service.....	4-20
Valve, Suction, and Discharge . Service.....	4-12
<b>W</b>	
Warrant Information .....	1-2

By Order of the Secretaries of the Army and Navy (Including the Marine Corps):

Official:

  
MILTON H. HAMILTON  
Administrative Assistant to the  
Secretary of the Army  
05882

GORDON R. SULLIVAN  
General, United States Army  
Chief of Staff

DAVID E. BOTTORFF  
Rear Admiral, CEC, US Navy  
Commander  
Navy Facilities Engineering  
Command

RONALD D. ELLIOTT  
Executive Director  
Marine Corps Systems Command

**DISTRIBUTION:**

To be distributed in accordance with DA Form 12-25-E, block no. 6189,  
requirements for TM 10-4610-244-13.

RECOMMENDED CHANGES TO EQUIPMENT TECHNICAL PUBLICATIONS

 <div style="border: 1px solid black; border-radius: 15px; padding: 5px; display: inline-block; margin-left: 20px;"> <p style="margin: 0;"><i>THEN...JOT DOWN THE DOPE ABOUT IT ON THIS FORM. CAREFULLY TEAR IT OUT, FOLD IT AND DROP IT IN THE MAIL.</i></p> </div>		SOMETHING WRONG WITH PUBLICATION	
		FROM: (PRINT YOUR UNIT'S COMPLETE ADDRESS)	
PUBLICATION NUMBER		DATE SENT	
PUBLICATION DATE		PUBLICATION TITLE	
BE EXACT PIN-POINT WHERE IT IS			
PAGE NO.	PARA- GRAPH	FIGURE NO.	TABLE NO.
<div style="text-align: center; font-weight: bold; margin-bottom: 20px;">IN THIS SPACE, TELL WHAT IS WRONG AND WHAT SHOULD BE DONE ABOUT IT.</div> <div style="border: 1px dashed black; width: 20%; margin: auto; height: 20px;"></div>			
PRINTED NAME, GRADE OR TITLE AND TELEPHONE NUMBER			SIGN HERE

## The Metric System and Equivalents

### Linear Measure

1 centimeter = 10 millimeters = .39 inch  
 1 decimeter = 10 centimeters = 3.94 inches  
 1 meter = 10 decimeters = 39.37 inches  
 1 dekameter = 10 meters = 32.8 feet  
 1 hectometer = 10 dekameters = 328.08 feet  
 1 kilometer = 10 hectometers = 3,280.8 feet

### Weights

1 centigram = 10 milligrams = .15 grain  
 1 decigram = 10 centigrams = 1.54 grains  
 1 gram = 10 decigrams = .035 ounce  
 1 decagram = 10 grams = .35 ounce  
 1 hectogram = 10 decagrams = 3.52 ounces  
 1 kilogram = 10 hectograms = 2.2 pounds  
 1 quintal = 100 kilograms = 220.46 pounds  
 1 metric ton = 10 quintals = 1.1 short tons

### Liquid Measure

1 centiliter = 10 milliliters = .34 fl. ounce  
 1 deciliter = 10 centiliters = 3.38 fl. ounces  
 1 liter = 10 deciliters = 33.81 fl. ounces  
 1 dekaliter = 10 liters = 2.64 gallons  
 1 hectoliter = 10 dekaliters = 26.42 gallons  
 1 kiloliter = 10 hectoliters = 264.18 gallons

### Square Measure

1 sq. centimeter = 100 sq. millimeters = .155 sq. inch  
 1 sq. decimeter = 100 sq. centimeters = 15.5 sq. inches  
 1 sq. meter (centare) = 100 sq. decimeters = 10.76 sq. feet  
 1 sq. dekameter (are) = 100 sq. meters = 1,076.4 sq. feet  
 1 sq. hectometer (hectare) = 100 sq. dekameters = 2.47 acres  
 1 sq. kilometer = 100 sq. hectometers = .386 sq. mile

### Cubic Measure

1 cu. centimeter = 1000 cu. millimeters = .06 cu. inch  
 1 cu. decimeter = 1000 cu. centimeters = 61.02 cu. inches  
 1 cu. meter = 1000 cu. decimeters = 35.31 cu. feet

## Approximate Conversion Factors

<i>To change</i>	<i>To</i>	<i>Multiply by</i>	<i>To change</i>	<i>To</i>	<i>Multiply by</i>
inches	centimeters	2.540	ounce-inches	Newton-meters	.007062
feet	meters	.305	centimeters	inches	.394
yards	meters	.914	meters	feet	3.280
miles	kilometers	1.609	meters	yards	1.094
square inches	square centimeters	6.451	kilometers	miles	.621
square feet	square meters	.093	square centimeters	square inches	.155
square yards	square meters	.836	square meters	square feet	10.764
square miles	square kilometers	2.590	square meters	square yards	1.196
acres	square hectometers	.405	square kilometers	square miles	.386
cubic feet	cubic meters	.028	square hectometers	acres	2.471
cubic yards	cubic meters	.765	cubic meters	cubic feet	35.315
fluid ounces	milliliters	29.573	cubic meters	cubic yards	1.308
pints	liters	.473	milliliters	fluid ounces	.034
quarts	liters	.946	liters	pints	2.113
gallons	liters	3.785	liters	quarts	1.057
ounces	grams	28.349	liters	gallons	.264
pounds	kilograms	.454	grams	ounces	.035
short tons	metric tons	.907	kilograms	pounds	2.205
pound-feet	Newton-meters	1.356	metric tons	short tons	1.102
pound-inches	Newton-meters	.11296			

### Temperature (Exact)

°F	Fahrenheit temperature	5/9 (after subtracting 32)	Celsius temperature	°C
----	---------------------------	-------------------------------	------------------------	----



**PIN: 072060-000**

This fine document...

Was brought to you by me:



## [Liberated Manuals -- free army and government manuals](#)

Why do I do it? I am tired of sleazy CD-ROM sellers, who take publicly available information, slap “watermarks” and other junk on it, and sell it. Those masters of search engine manipulation make sure that their sites that sell free information, come up first in search engines. They did not create it... They did not even scan it... Why should they get your money? Why are not letting you give those free manuals to your friends?

I am setting this document FREE. This document was made by the US Government and is NOT protected by Copyright. Feel free to share, republish, sell and so on.

I am not asking you for donations, fees or handouts. If you can, please provide a link to [liberatedmanuals.com](http://liberatedmanuals.com), so that free manuals come up first in search engines:

<A HREF=<http://www.liberatedmanuals.com/>>Free Military and Government Manuals</A>

- Sincerely  
Igor Chudov  
<http://igor.chudov.com/>
- [Chicago Machinery Movers](#)