

***TM 10-4330-230-12&P**

TECHNICAL MANUAL

**OPERATOR'S AND UNIT MAINTENANCE MANUAL
(INCLUDING REPAIR PARTS AND
SPECIAL TOOLS LIST)
FOR**

**FILTER/ SEPARATOR, LIQUID FUEL
15 GPM, ALUMINUM, SKID MOUNTED
(NSN 4330-00-438-1460)**

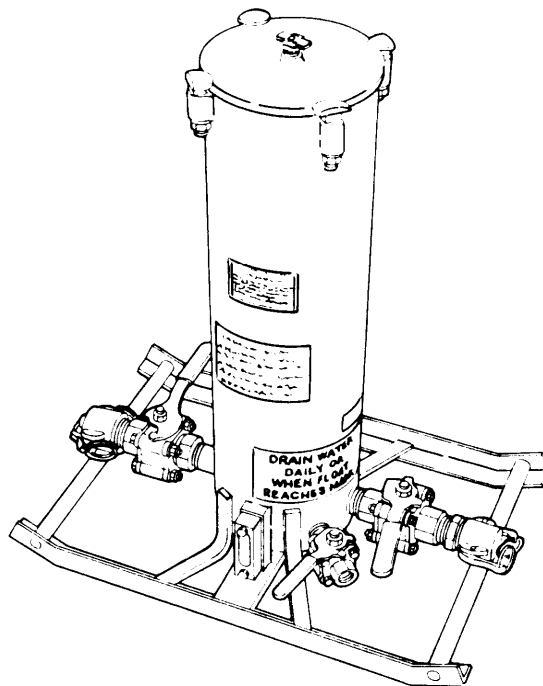

Approved for public release; Distribution is unlimited.

*This manual supersedes TM 5-4330-230-12, dated 26 September 1970.

HEADQUARTERS, DEPARTMENT OF THE ARMY

31 MARCH 1992

WARNINGS

Take particular heed to specific WARNINGS and CAUTIONS throughout this manual.

Dry cleaning solvent, PD-680, used to clean parts is potentially dangerous to personnel and property. Avoid repeated or prolonged skin contact. Do not use near open flame or excessive heat. Flash point of solvent is 100 – 138 °F (38 – 60°C).

Do not smoke or use open flame in vicinity of filter separator.

Make sure fire extinguishers and fire fighting equipment are available in the immediate area. Be extremely careful when using a fire extinguisher in an enclosed area. Provide adequate ventilation.

Do not drain fuel from the unit on the ground. Drain fuel into a container that can be closed, otherwise a fire hazard or environmental contamination could result.

Use protective equipment to prevent skin and eye contact with fuel.

Use rubber fuel resistant gloves when replacing filter elements due to toxic effects of some fuel additives.

Dispose of filter elements in accordance with local policy.

Do not operate the filter/separator unit until it has been connected to suitable ground. A static discharge could ignite the fuel or cause an explosion of the fuel vapor.

For artificial respiration, refer to FM 21-11.

TECHNICAL MANUAL
NO. 10-4330-230-12&P

HEADQUARTERS,
DEPARTMENT OF THE ARMY
WASHINGTON, D.C., 31 MARCH 1992

Operator's and Unit Maintenance Manual
(Including Repair Parts and Special Tools List)
for
FILTER/SEPARATOR, LIQUID FUEL, ALUMINUM, SKID MOUNTED, 15 GPM CAPACITY
NSN 4330-00-438-1460

Current as of 20 November 1990

REPORTING ERRORS AND RECOMMENDING IMPROVEMENTS

You can help improve this manual. If you find any mistakes or if you know of a way to improve the procedures, please let us know. Mail your letter, DA Form 2028 (Recommended Changes to Publications and Blank Forms) or DA Form 2028-2 located in the back of this manual directly to: Commander, U.S. Army Troop Support Command, ATTN: AMSTR-MMTS, 4300 Goodfellow Boulevard, St. Louis, MO 63120-1798. A reply will be furnished directly to you.

Approved for public release; distribution is unlimited

TABLE OF CONTENTS

	Page
CHAPTER 1	INTRODUCTION
	OVERVIEW 1-1
Section I	General 1-1
Section II	Equipment Description and Data... 1-2
Section III	Technical Principles of Operation 1-5
CHAPTER 2	OPERATING INSTRUCTIONS
	OVERVIEW 2-1
Section I	Operator's Controls and Indicators 2-1
Section II	Operator's Preventive Maintenance Checks and Services (PMCS) 2-3
Section III	Operation Under Usual Conditions 2-6
Section IV	Operation Under Unusual Conditions 2-11
CHAPTER 3	OPERATOR'S MAINTENANCE INSTRUCTIONS
	OVERVIEW 3-1
Section I	Lubrication Instructions 3-1
Section II	Operator's Troubleshooting Procedures 3-1
Section III	Operator's Maintenance Procedures. 3-3
CHAPTER 4	UNIT MAINTENANCE
	OVERVIEW 4-1
Section I	Repair Parts, Special Tools, and Support Equipment 4-1
Section II	Service Upon Receipt 4-1
Section III	Unit Preventive Maintenance Checks and Services (PMCS) 4-4
Section IV	Unit Troubleshooting Procedures 4-5
Section V	Unit Maintenance Instructions 4-8
Section VI	Preparation for Shipment or Storage. 4-16

* This manual supersedes TM 5-4330-230-12&P dated 26 September 1970.

TABLE OF CONTENTS (cont)

	Page
APPENDIX A REFERENCES	A-1
APPENDIX B MAINTENANCE ALLOCATION CHART	B-1
APPENDIX C COMPONENTS OF END ITEM AND BASIC ISSUE ITEMS LISTS	C-1
APPENDIX D ADDITIONAL AUTHORIZATION LIST	D-1
APPENDIX E EXPENDABLE/DURABLE SUPPLIES AND MATERIALS LIST	E-1
APPENDIX F REPAIR PARTS AND SPECIAL TOOLS LIST	F-1
Section I Introduction	F-1
Section II Repair Parts List	F-1
INDEX	Index 1

LIST OF ILLUSTRATIONS

Figure Number	Title	Page
1-1	Filter/Separator, Liquid Fuel, Skid Mounted 15 GPM Capacity	1-0
1-2	Location and Description of Major Components	1-4
2-1	Operator's Controls and Indicators	2-2
2-2	Starting the Filter/Separator	2-8
2-3	Operating the Filter/Separator	2-10
2-4	Stopping the Filter/Separator	2-11
4-1	Installing Filter/Separator	4-3
4-2	Typical Operational Layout	4-4
4-3	Cover Assembly, Repair	4-8
4-4	Sightgage, Repair	4-9
4-5	Canister and Filter Element, Repair	4-11
4-6	inlet Valve, Repair	4-14
4-7	Outlet Valve, Repair	4-14
4-8	Water Drain Valve, Repair	4-15

LIST OF TABLES

Table Number	Title	Page
2-1	Operator Preventive Maintenance Checks and Services (PMCS)	2-6
3-1	Operator Troubleshooting Procedures	3-2
4-1	Unit Preventive Maintenance Checks and Services (PMCS)	4-5
4-2	Unit Troubleshooting Procedures	4-6

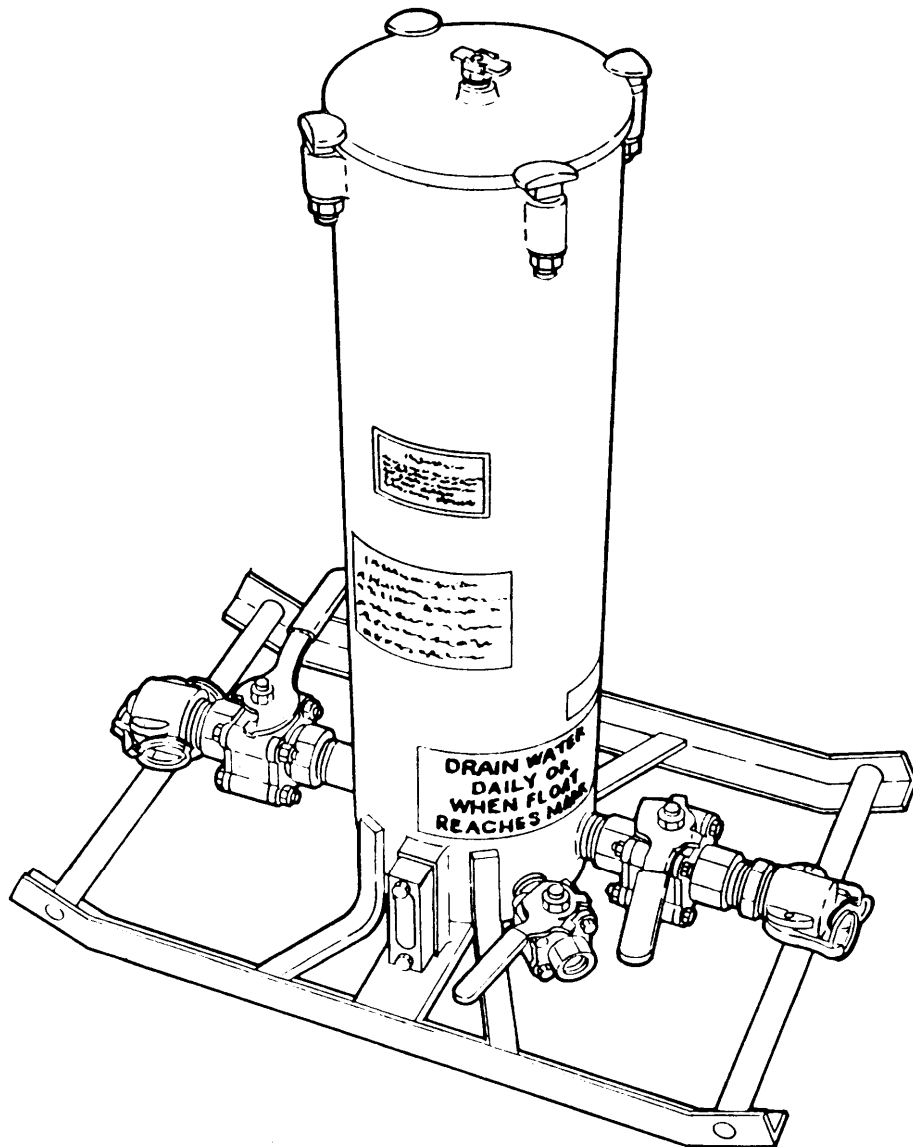

Figure 1-1. Filter/Separator, Liquid Fuel, Skid Mounted 15 GPM Capacity.

CHAPTER 1

INTRODUCTION

	Page
	OVERVIEW 1-1
Section I.	General 1-1
Section II.	Equipment Description and Data.. . . . 1-2
Section III.	Technical Principles of Operation 1-5

OVERVIEW

This chapter includes general information regarding the filter/separator as well as specific information pertinent to equipment description and data and technical principles of operation.

Section I. GENERAL

Paragraph	Page
1-1	Scope 1-1
1-2	Maintenance Forms, Records and Reports 1-1
1-3	Reporting of Equipment improvement Recommendations (Ear) 1-2
1-4	Destruction of Army Materiel to Prevent Enemy Use 1-2
1-5	Preparation for Storage or Shipment 1-2

1-1. Scope. The scope of this manual is described in the following subparagraphs.

a. Type of Manual This manual provides operator and unit maintenance instructions for Filter/Separator, Liquid Fuel, Skid Mounted, 15 GPM Capacity NSN 4330-00-438-1460 (figure 1-1). This manual also provides a Repair Parts and Special Tools List in Appendix F.

b. Equipment Name 15 GPM Capacity Aluminum Skid Mounted Liquid Fuel Filter/Separator, hereinafter, referred to as the filter/separator.

c. Purpose of Equipment. The filter/separator is a static device which is installed in a fuel system. The filter/separator is capable of removing entrapped water and solid contaminants from fuel.

1-2. Maintenance Forms, Records and Reports.

a. Reports of Maintenance and Unsatisfactory Equipment Department of the Army forms and procedures used for equipment maintenance will be those prescribed by DA Pam 738-750, The Army Maintenance Management System (TAMMS).

b. Reporting of Item and Packaging Discrepancies Fill out and forward SF 364 (Report of Discrepancy (ROD)) as prescribed in AR735-11-2.

c. Transportation Discrepancy Report (TDR) (SF 361). Fill out and forward Transportation Discrepancy Report (TDR) (SF 361) as prescribed in AR 55-28.

1-3. **Reporting of Equipment Improvement Recommendations (EIR)**. If your filter/separator needs improvement, let us know. Send us an EIR. You, the user, are the only one who can tell us what you don't like about your equipment. Let us know why you don't like the design or performance. Put it on an SF 368 (Product Quality Deficiency Report). Mail it to us at: Commander, U.S. Army Troop Support Command, ATTN: AMSTR-MOF, 4300 Goodfellow Boulevard, St. Louis, Missouri 63120-1 798. We **will** send you a reply.

1-4. **Destruction of Army Materiel to Prevent Enemy Use**. Refer to TM 750-244-3 for procedures to destroy equipment to prevent enemy use.

1-5. **Preparation for Storage or Shipment**. Refer to Chapter 4, section VI, for procedures to place the equipment into storage.

Section II. EQUIPMENT DESCRIPTION AND DATA

Paragraph		Page
1-6	Equipment Characteristics, Capabilities and Features	1-2
1-7	Location and Description of Major Components	1-3
1-8	Equipment Data	1-5
1-9	Safety, Care and Handling	1-5

1-6 **Equipment Characteristics, Capabilities and Features.**

a. Characteristics. The filter/separator is an upright unit made up of an aluminum shell mounted within an aluminum skid. Inlet, outlet, and drain connections are provided. A liquid level gage (sight glass), a pressure vent valve, and manual water drain valve are mounted on the tank.

b. Capabilities and Features.

- (1) Highly portable.
- (2) All weather operational.
- (3) Manual water drain valve.
- (4) 15 GPM (57 LPM) rating.

1-7. Location and Description of Major Components. (Figure 1-2)

FILTER/SEPARATOR TANK (1). Consists of an aluminum shell mounted on an aluminum skid.

FILTERING SECTION (2). The center portion of the filter/separator shell contains 2 filter separating devices.

WATER DRAIN VALVE (3). Manually operated valve used to drain water from filter/separator.

SIGHT GAGE (4). The sight gage gives a visual indication of where water and fuel interface.

PRESSURE VENT VALVE (5). A manually operated valve used to repressurize the filter/separator.

ALUMINUM SKID (6). Provides a mounting surface and base for tank.

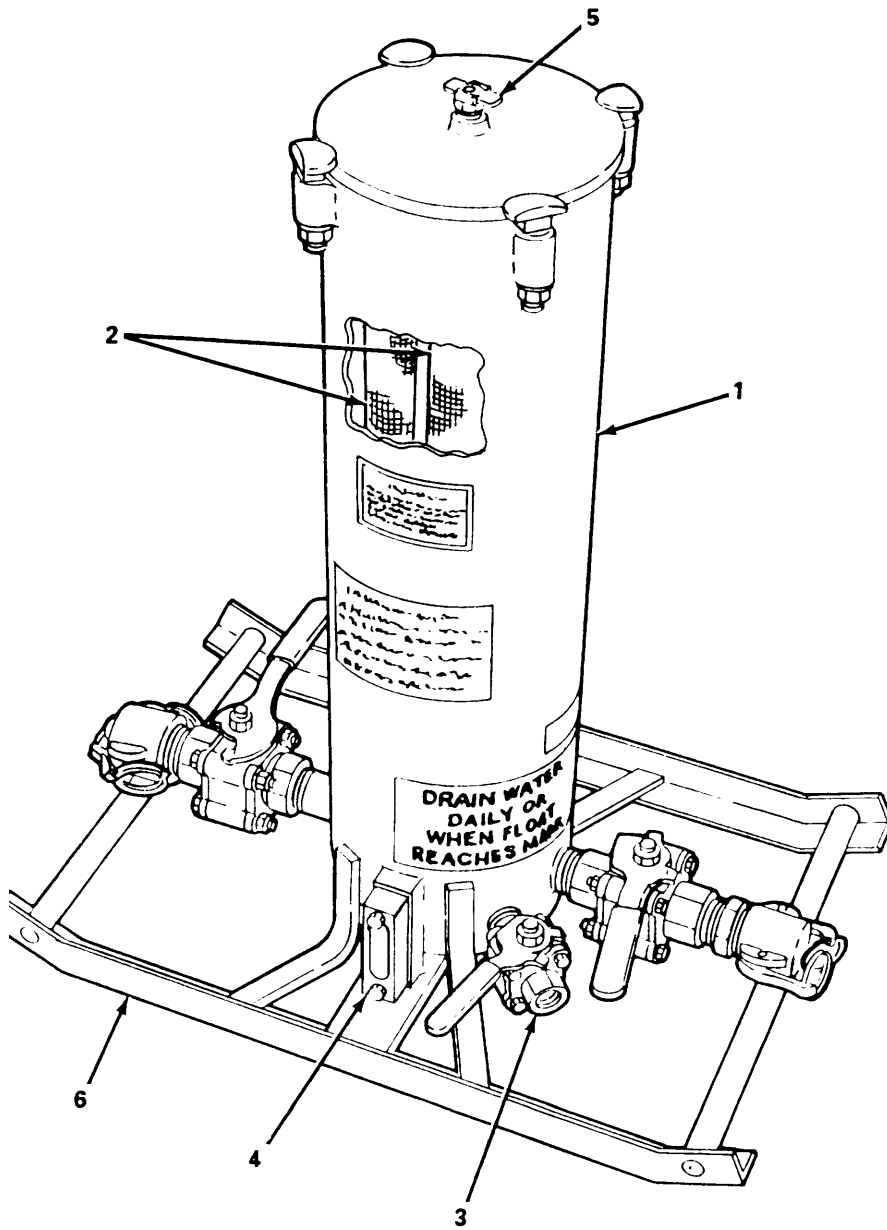

Figure 1-2. Location and Description of Major Components.

1-8, **Equipment Data.**

a. Filter/Separator.

Rating 15 GPM (57 LPM)
 Working Pressure 25 PSI(3.6kPa)
 Working Temperature Range 33-155° F (.55-68.33° C)

b. Dimension and Weight.

Height 27.50 in. (69.85 cm)
 Width 14.00 in. (35.56 cm)
 Length 22.50 in. (57.15cm)
 Weight (dry) 25.1b(55 kg)
 Weight (wet) 44 lb(97.80 kg)
 Shipping Cube (crated) 7.5 cu ft(.21 cu m)

1-9, **Safety, Care, and Handling.** Observe all WARNINGS, CAUTIONS, and NOTES in this manual. This equipment can be extremely dangerous if these instructions are not followed.

Section III. TECHNICAL PRINCIPLES OF OPERATION

1-10. Technical Principles of Operation.

a. General. The filter/separator is a static device which is installed in a fuel system to remove water and solid contaminants from the fuel. The filter/separator is normally installed between the fuel system pump and the fuel dispensing equipment. Thus, fuel is pushed through the filter/separator by pump action.

b. Simplified Principles of Operation. Fuel enters through the inlet connection and passes through the filter center tube and passes towards the outside of the element. Upon reaching the exterior of the element the fuel passes through the layers of pleated paper, cotton knit and screen. The water droplets, being heavier than fuel, fall to the bottom of the tank. As water collects in the tank, the water level rises. Clean fuel floats on top of this water, The point at which the fuel and water meet is the interface. The liquid level gage gives a visual indication of this interface. Manual controls permit the discharge of the separated water and prevent the flow of fuel out of the filter/separator.

CHAPTER 2

OPERATING INSTRUCTIONS

		Page
	OVERVIEW	2-1
Section I.	Operator's Controls and Indicators	2-1
Section II.	Operator's Preventive Maintenance Checks and Services(PMCS)	2-3
Section II.	Operation Under Usual Conditions	2-6
Section IV.	Operation Under Unusual Conditions	2-11

OVERVIEW

This chapter covers operator controls and indicators, operator PMCS, and operation of the filter/separator under usual and unusual conditions.

Section I. OPERATOR'S CONTROLS AND INDICATORS

		Page
Paragraph		
2-1	General	2-1
2-2	Operator's Controls and Indicators	2-1

2-1. **General.** The filter-separator is equipped with manual water drain valve, pressure vent valve, and a liquid level sight gage.

2-2. **Operator's Controls and Indicators.** Figure 2-1 illustrates the operator's controls and indicators for the filter/separator.

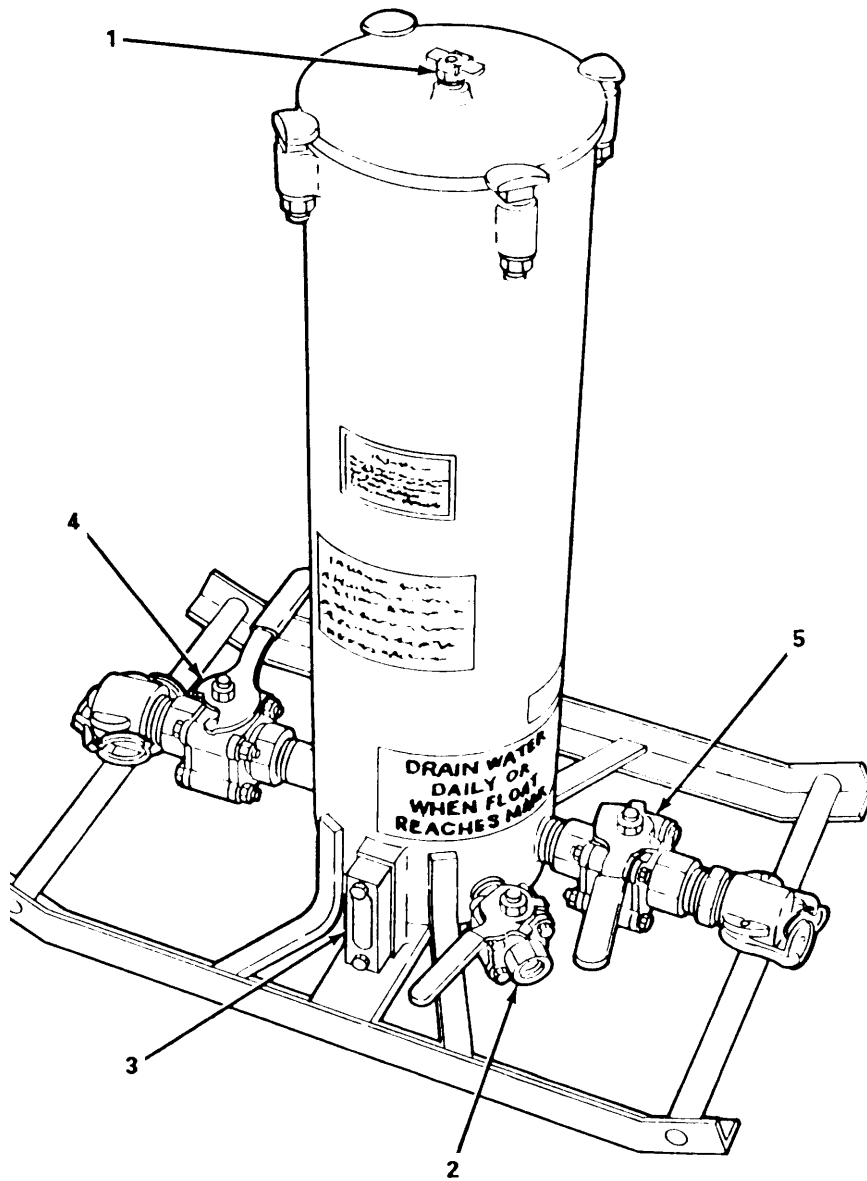

Figure 2-1. Operator's Controls and Indicators.

Key	Control or Indicator	Function
1	Pressure Vent Valve	Manually operated to repressurize the filter/separator.
2	Water Drain Valve	Provides a way to manually drain the filter/separator tank.
3	Sight Gage	Gives a visual indication of where water and fuel interface.
4	Inlet Valve	Provides a way to terminate inlet fuel flow.
5	Outlet Valve	Provides a way to terminate outlet fuel flow.

Section II. OPERATOR'S PREVENTIVE MAINTENANCE CHECKS AND SERVICES (PMCS)

Paragraph	Page
2-3 General	2-3
2-4 Purpose of PMCS Table	2-3
2-5 Explanation of Columns	2-4
2-6 Equipment is Not Ready/Available if.	2-4
2-7 Reporting Deficiencies	2-4
2-8 Special Instructions	2-4

2-3. **General.** Operator's PMCS are performed to ensure that the filter/separator is ready for operation at all times. Perform the checks and services at the specified intervals.

- a. Before you operate, perform your before (B) PMCS. Observe all CAUTIONS and WARNINGS.
- b. While you operate, perform your during (D) PMCS. Observe all CAUTIONS and WARNINGS.
- c. After you operate, be sure to perform your after (A) PMCS.
- d. If your equipment fails to operate, refer to paragraph 3-3, Operator's Troubleshooting Procedures.

2-4. **Purpose of PMCS Table.** The purpose of the PMCS table is to provide a systematic method of inspecting and servicing the equipment. In this way, small defects can be detected early before they become a major problem causing the equipment to fail to complete its mission. The PMCS table is arranged with the individual PMCS procedures listed in sequence under assigned intervals. The most logical time (before, during, or after operation) to perform each procedure determines the interval to which it is assigned. Make a habit of doing the checks in the same order each time and anything wrong will be detected quickly. See paragraphs 2-5 and 2-6 for an explanation of the columns in table 2-1.

2-5. Explanation of Columns. The following is a list of the PMCS table column headings with a description of the information found in each column.

- a. Item No. This column shows the sequence in which the checks and services are to be performed, and is used to identify the equipment area on the Equipment Inspection and Maintenance Worksheet, DA Form 2404.
- b. Interval. This column shows a dot. ● when each check is to be done.
- c. Item to be Inspected. This column identifies the general area or specific part where the check or service is to be done.
- d. Procedures. This column shall contain a brief description of the procedure by which the checks are to be performed.
- e. Equipment is Not Ready/Available if. See paragraph 2-6

2-6. Equipment is Not Ready/Available if. This column lists conditions that make the equipment unavailable for use because it is unable to perform its mission, or because it would represent a safety hazard. Do not accept or operate equipment with a condition in the "Equipment is Not Ready/Available If" column.

NOTE

The terms ready/available and mission capable refer to the same status: Equipment is on hand and is able to perform its combat mission. Refer to DA Pam 738-750.

2-7. Reporting Deficiencies. If any problem with the equipment is discovered during PMCS or while it is being operated that cannot be corrected at the operator/crew maintenance level, it must be reported. Refer to DA Pam 738-750 and report the deficiency using the proper forms.

2-8. Special Instructions. Preventive maintenance is not limited to performing the checks and services listed in the PMCS table.

WARNING

Drycleaning solvent PD-680 used to clean parts is potentially dangerous to personnel and property. Avoid repeated and prolonged skin contact. Do not use near open flame or excessive heat. Flash point of solvent is 100 – 138°F (38 – 60°C).

- a. Keep it clean. Dirt, grease, oil, and debris get in the way and may cover up a serious problem. Clean as you work and as needed. Use drycleaning solvent on all metal surfaces. Use soap and water to clean rubber or plastic material.
- b. Bolts, Nuts, and Screws. Check them all for obvious looseness, missing, bent, or broken condition. You can't try them all with a tool, but look for chipped paint, bare metal, or rust around boltheads. If you find one you think is loose, tighten it, or report it to unit maintenance if you can't tighten it.

c. Fluid Lines. Look for wear, damage, and leaks. Make sure clamps and fittings are tight. Wet spots and stains around a fitting or connector can mean a leak. If a leak comes from a loose connector, tighten it. If something is broken or worn out, report it to unit maintenance.

d. Painting. Touch-up filter/separator as needed. Refer to TM 43-0139 for specific painting procedures.

Table 2-1. Operator's Preventive Maintenance Checks and Services (PMCS).

NOTE

Within designated intervals, these checks are to be performed in the order listed.

B – Before

D – During

A – After

Item no.	Interval			Item to be Inspected	Procedure	Equipment is Not Ready/Available If:
	B	D	A			
1	•	•	•	Filter/Separator and Skid	Inspect filter/separator and skid for leaks and damaged or missing parts.	Filter/separator leaks or parts are damaged or missing
2	•	•		Sight Gage	Inspect for leaks, cracked or broken glass.	Sight gage is broken or leaking.
3		•	•	Pressure Vent Valve	Inspect pressure vent valve for leaks and proper operation.	Pressure vent valve is inoperable.
4		•	•	Water Drain Valve	Inspect water drain valve for leaks and proper operation	Water drain valve leaks or is inoperable.
5		•	•	Inlet and Outlet Valves	Inspect inlet and outlet valves for leaks and proper operation.	Inlet or outlet valves leak or are inoperable.

Section III. OPERATION UNDER USUAL CONDITIONS

Paragraph	Page
2-9 Starting Procedure	2-6
2-10 Operating Procedures	2-7
2-11 Stopping Procedure	2-7

2-9. Starting Procedure. (Figure 2-2)

WARNINGS

- Do not operate the filter/separator unit until it has been connected to a suitable ground. A static discharge could ignite the fuel or cause an explosion of the fuel vapor.
- Do not smoke or use open flame in vicinity of filter /separator. Use protective equipment to prevent skin and eye contact with fuel.
- Make sure fire extinguishers and fire fighting equipment are available in the immediate area. Be extremely careful when using a fire extinguisher in an enclosed area. Provide adequate ventilation.

- a. Make sure water drain valve (1) is closed.
- b. Ensure the inlet (2) and outlet (3) connections are tight.
- c. Slightly open the pressure vent valve (4) to allow entrapped air to escape.
- d. Start the system pumping unit. Refer to the applicable pumping system technical manual.
- e. Open inlet valve (2) slightly to allow the filter/separator (5) to fill slowly with as little pressure as possible.

NOTE

When the unit is completely filled, fuel will come through the vent pressure valve.

- f. Close pressure vent valve (4). Make a visual inspection of all connections, joints, and piping components for leaks.
- g. Fully open inlet valve (2).

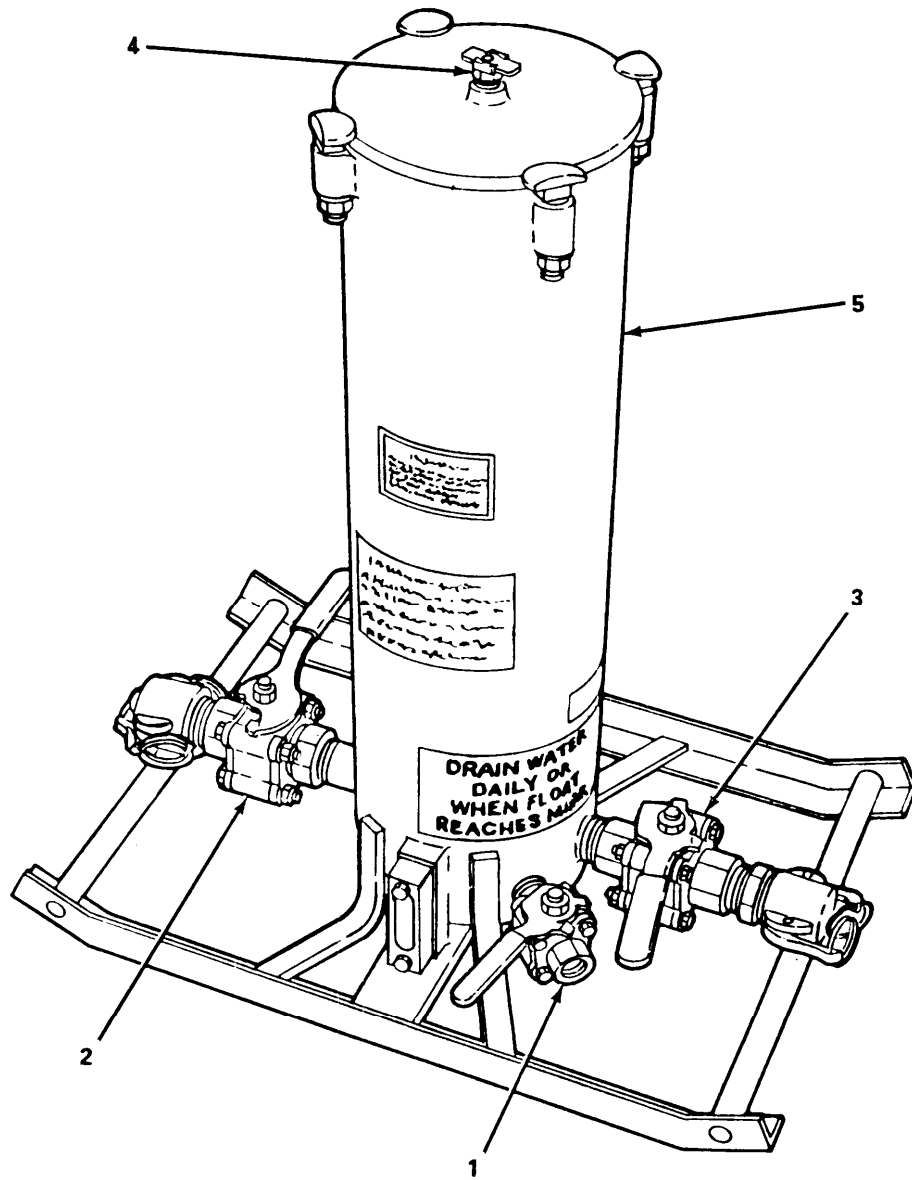

Figure 2-2. Starting the Filter/Separator.

2-10. **Operating Procedures.** (Figure 2-3)

- a. Open outlet side valve (1) to full open position.

WARNING

Do not operate the filter/separator until the bonding cable on the fuel nozzle has been attached to the vehicle. This bonding must be accomplished prior to opening the filler cap.

- b. Observe the water level sight gage (2). If level of water is above upper line, open the manual drain valve (3) and drain water into suitable container until water level is at lower line.
- c. Drain water daily or when ball in sight gage reaches the top mark on the sight gage.

2-11 **Stopping Procedure.** (Figure 2-4)

- a. Stop the system pumping unit. Refer to the applicable pumping system technical manual.
- b. Close the inlet valve (1).
- c. Close the outlet valve (2).

WARNINGS

- Do not drain fuel from the unit on the ground. Drain fuel into a container that can be closed otherwise fire hazard or environmental contamination could result
- Use protective equipment to prevent skin and eye contact with fuel.

NOTE

If the filter/separator is not to be in frequent use, drain the tank. Use following instructions.

- d. Open pressure vent valve (3) to repressurize unit.
- e. Open manual drain valve (4) and drain contents of filter/separator (5) into suitable container.

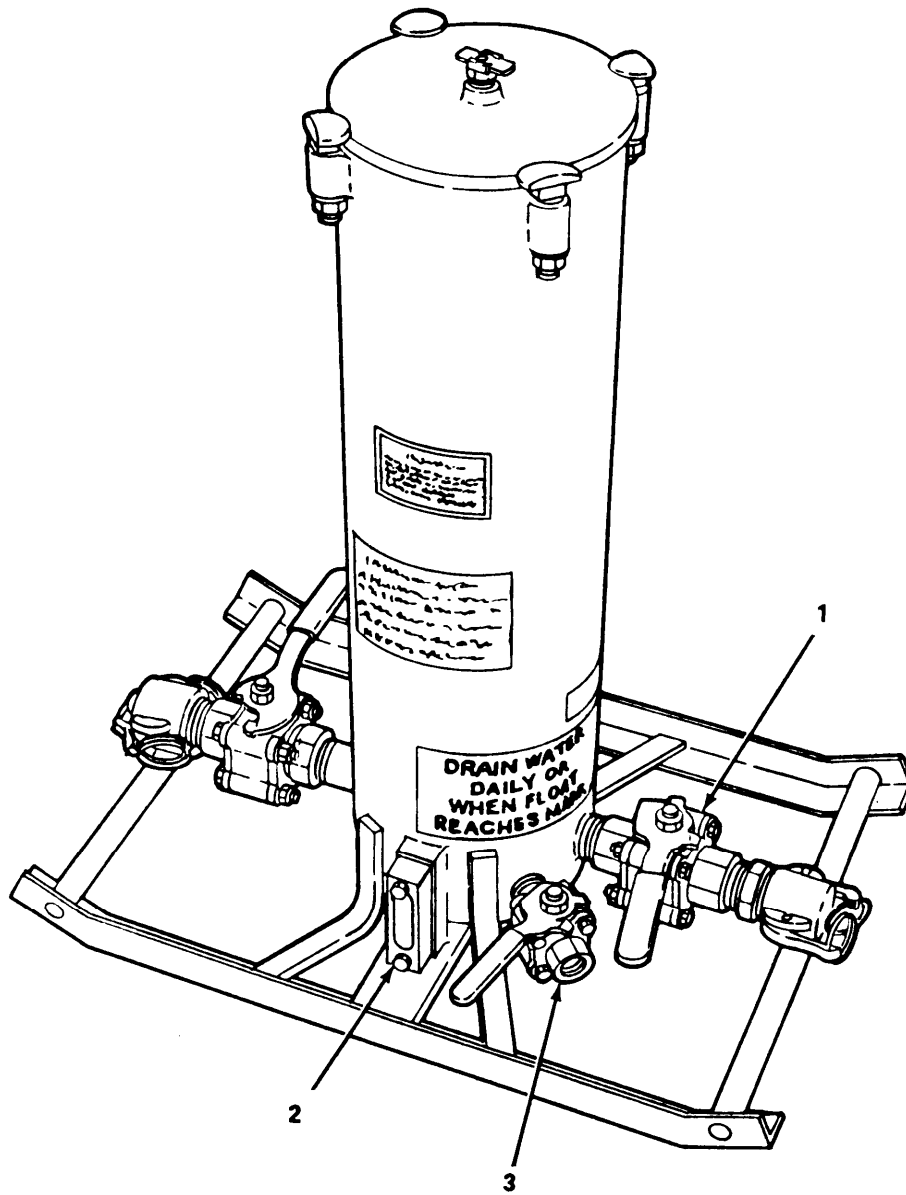

Figure 2-3. Operating the Filter/Separator.

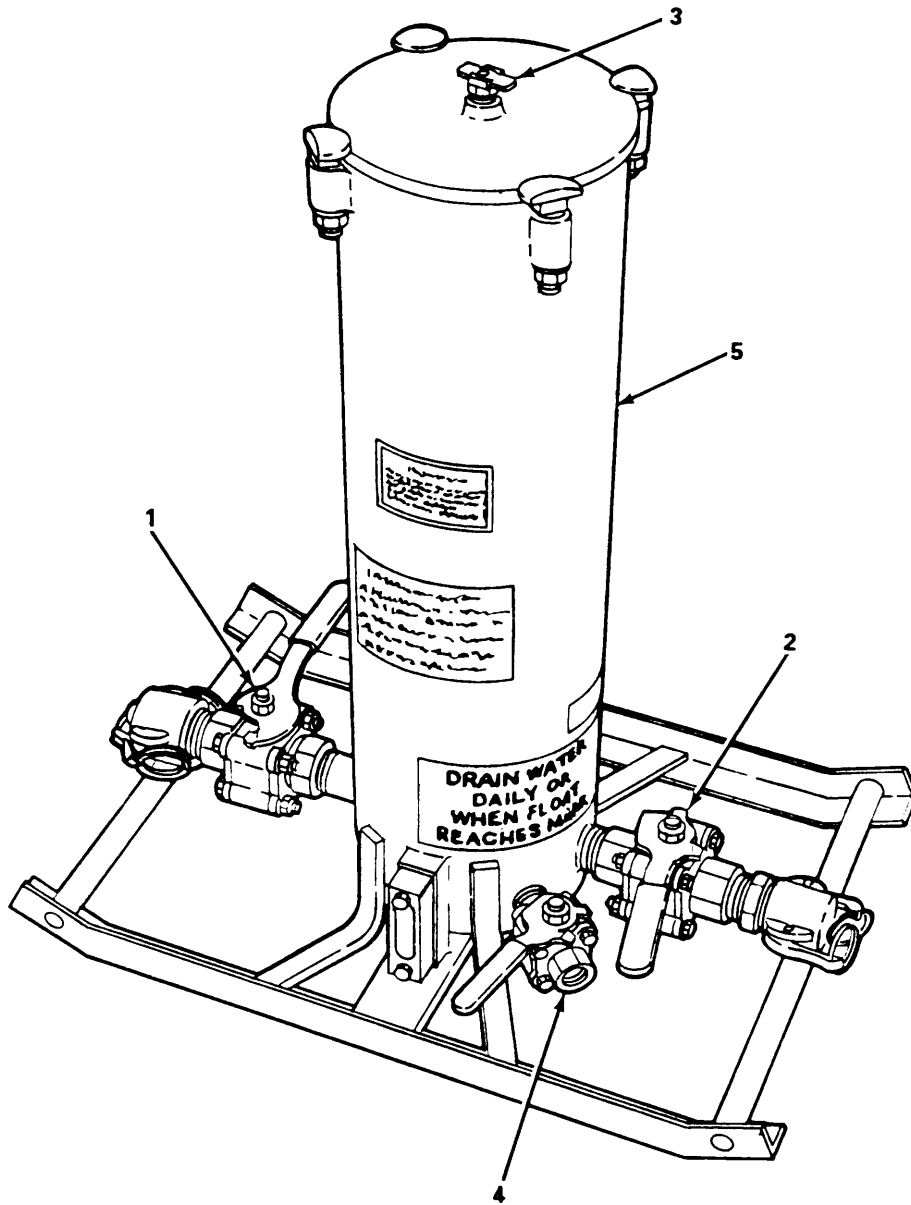

Figure 2-4. Stopping the Filter/Separator.

Section IV. OPERATION UNDER UNUSUAL CONDITIONS

Paragraph	Page
2-12	Operation in Extreme Cold 2-11
2-13	Operation in Extreme Heat..... 2-11
2-14	Operation in Dusty or Sandy Areas 2-11
2-15	Operation in Rainy or Humid Conditions 2-11
2-16	Operation in Salt Water Areas. 2-11
2-17	Operation at High Altitudes 2-11

2-12. Operation in Extreme Cold. The procedures for starting and stopping the filter/separators are the same as under usual conditions except for the following special precautions.

- a. Water must be drained more frequently than usual and at each shut down to avoid freezing.
- b. If possible provide a heated shelter.

2-13. Operation in Extreme Heat. The procedures for starting and stopping the filter/separators are the same as under usual conditions except for the following special precautions.

- a. Erect a screen or shelter to provide shade.
- b. Vent filter/separator when not in service.

2-14. Operation in Dusty or Sandy Areas. The procedures for starting and stopping the filter/separator are the same as under usual conditions except for the following special precautions:

- a. Select a work site protected by natural barriers or erect screens of dustproof material.
- c. Keep the unit free of dust and dirt, especially when the unit is open for servicing or repair.

2-15. Operation in Rainy or Humid Conditions. The procedures for starting and stopping the filter/separator are the same as under usual conditions except for the following special precautions.

- a. Water must be drained more often than under normal conditions.
- b. Erect a shelter to prevent the entrance of rain into the interior of the unit when it is opened for servicing.

2-16. Operation In Salt Water Areas. The procedures for starting and stopping the filter/separator are the same as under usual conditions except for the following special precautions.

- a. After operation wipe down filter/separator with clean lightly oiled rag.
- b. Inspect filter/separator and repaint exposed areas immediately.

2-17. Operation at High Altitudes. The procedures for starting and stopping the filter/separator are the same as under usual conditions.

CHAPTER 3

OPERATOR'S MAINTENANCE INSTRUCTIONS

		Page
	OVERVIEW	3-1
Section I.	Lubrication Instructions	3-1
Section II.	Operator's Troubleshooting Procedures	3-1
Section III.	Operator's Maintenance Procedures	3-3

OVERVIEW

This chapter contains operator level troubleshooting and maintenance.

Section I. LUBRICATION INSTRUCTIONS PROCEDURES

		Page
Paragraph		
3-1	General	3-1

3-1. **General.** The filter/separator requires no lubrication.

Section II. OPERATOR'S TROUBLESHOOTING PROCEDURES

		Page
Paragraph		
3-2	General	3-1
3-3	Operator's Troubleshooting Procedures	3-1

3-2. **General.** This section contains troubleshooting procedures to determine the probable cause of observed equipment malfunctions. Inspections are provided to isolate the faulty component and corrective actions are provided to eliminate the malfunction.

3-3. **Operator's Troubleshooting Procedures.** Refer to symptom index to locate the troubleshooting procedure of the observed malfunction.

a. Table 3-1 lists the common malfunctions which you may find during operation or maintenance of the filter/separator or its components. You should perform the tests/inspections and corrective actions in the order listed.

b. This manual cannot list all malfunctions that may occur, nor all test or inspections and corrective actions. If a malfunction is not corrected by listed corrective actions, notify your supervisor.

SYMPTOM INDEX

Symptom	Page
No fuel delivery	3-2
Contaminated fuel at nozzle	3-2
Low discharge flow rate	3-2

Table 3-1. Operator Troubleshooting Procedures.

Malfunction	Test or Inspection	Corrective Action
1. NO FUEL DELIVERY.		
	Step 1. Check to see if inlet/outlet valves are open.	If closed, open valves.
	Step 2. Check to see if system pumping unit is working.	a. Refer to applicable pump unit technical manual. b. If pumping unit is working and malfunction still exists, notify your supervisor.
2. CONTAMINATED FUEL AT NOZZLE.		
	Check sight gage for water level.	a. Drain water to lower level mark. b. If fuel is still contaminated, notify your supervisor.
3. LOW DISCHARGE FLOW RATE.		
	Step 1. Check inlet valve.	Fully open inlet valve.
	Step 2. Check outlet valve.	a. Fully open outlet valve. b. If flow rate is still low, notify unit maintenance.

Section III. OPERATOR'S MAINTENANCE PROCEDURES

Paragraph		Page
3-4	General	3-3
3-4.	General. There are no operator maintenance procedures for the filter/separator.	

CHAPTER 4

UNIT MAINTENANCE

		Page
	OVERVIEW	4-1
Section I.	Repair Parts, Special Tools, and Support Equipment	4-1
Section II.	Service Upon Receipt	4-1
Section III.	Unit Preventive Maintenance Checks and Services (PMCS)	4-4
Section IV.	Unit Troubleshooting Procedures	4-5
Section V.	Unit Maintenance Instructions..	4-8
Section VI.	Preparation for Shipment or Storage	4-16

OVERVIEW

This chapter contains unit level maintenance instructions for the filter/separator. It includes references to the Repair Parts and Special Tools List (RPSTL) in Appendix F, service upon receipt, unit PMCS and unit troubleshooting procedures.

Section I. REPAIR PARTS, SPECIAL TOOLS, AND SUPPORT EQUIPMENT

Paragraph		Page
4-1	Common Tools and Test Equipment..	4-1
4-2	Special Tools and Support Equipment.	4-1
4-3	Repair Parts...	4-1

4-1. Common Tools and Test Equipment. For authorized common tools and equipment, refer to the Modified Table of Organization and Equipment (MTOE) applicable for your unit.

4-2. Special Tools and Support Equipment. For a listing of special tools and support equipment authorized for use on this equipment, refer to the Repair Parts and Special Tools List, Appendix F, and the maintenance allocation chart (MAC), Appendix B of this manual.

4-3. Repair Parts. Repair parts required for maintenance of the filter/separator are listed and illustrated in Appendix F of this manual.

Section II. SERVICE UPON RECEIPT

Paragraph		Page
4-4	Unpacking	4-2
4-5	Checking Unpacked Equipment	4-2
4-6	Installation	4-2

4-4. Unpacking.

- a. Dismantle the crate, removing top, sides, and ends from the skid base.
- b. Remove all tie downs and blocking that secure the filter/separator to the skid base.
- c. Carefully lift the unit from the skid base and place it in position.

4-5. Checking Unpacked Equipment.

- a. Inspect the equipment for damage incurred during shipment. If the equipment has been damaged, report the damage on SF-364, Report of Discrepancy.
- b. Check the equipment against the packing slip to see if the shipment is complete. Report all discrepancies in accordance with the instructions of DA Pam 738-750 or DA Pam 738-751 as applicable.

4-6. Installation. (Figure 4-1)

a. This unit will usually be installed in a pipeline, therefore it's installation will be of a more or less permanent nature.

b. The filter/separator must be placed at a level site in an upright position.

c. Ground filter/separator as follows:

- (1) Attach first grounding rod (1) and coupling (2) to the driver/puller rod (3).

NOTE

Before driving grounding rod, be certain that driver/puller rod and grounding rod are fully threaded into coupling. Be sure collar is hand tight against coupling

- (2) Place driver/puller (4) on driver/puller rod (3) and drive grounding rod (1) into ground approximately 30 inches.

CAUTION

Do not allow grounding rod to rotate when disconnecting the driver/puller rod from the grounding rod. Grounding sections must be kept screwed together to ensure a good electrical ground.

- (3) Remove driver/puller rod (3) and driver/puller (4) from first grounding rod section.
- (4) Attach second section of grounding rod (5) to first section and attach driver/puller (4) to second section and drive into ground.
- (5) Repeat step (4) and drive third section of grounding (6) rod into ground until only 12 in. (30.5 cm) of rod is above ground.
- (6) Remove driver/puller (4) and driver/puller rod (3) from third section of grounding rod (6).
- (7) Place driver/puller (4) and driver/puller rod (3) in overpack box.
- (8) Slide grounding cable clamp (7) over grounding rod (6).

- (9) Attach grounding cable (8) to grounding rod (6) with grounding clamp (7) and secure.
- (10) Attach grounding cable (8) to ground clamp (9) and tighten screw (10).
- d. Connect outlet hose from fuel system to inlet connection (11) on the filter/separator. Connect dispensing hose to outlet connection (12) on the filter/separator.
- e. Refer to figure 4-2 for typical operational layout.

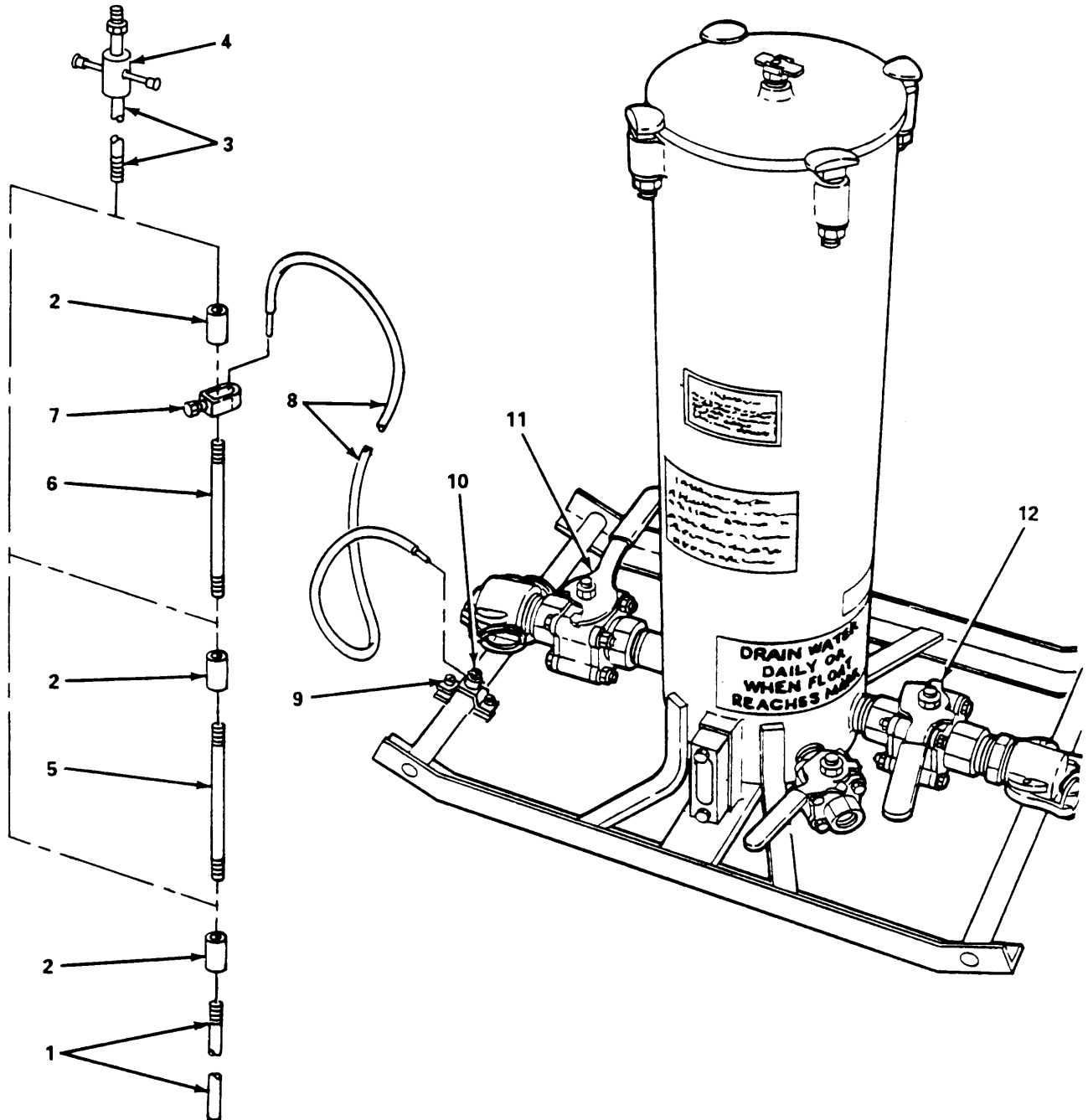

Figure 4-1. Installing Filter/Separator.

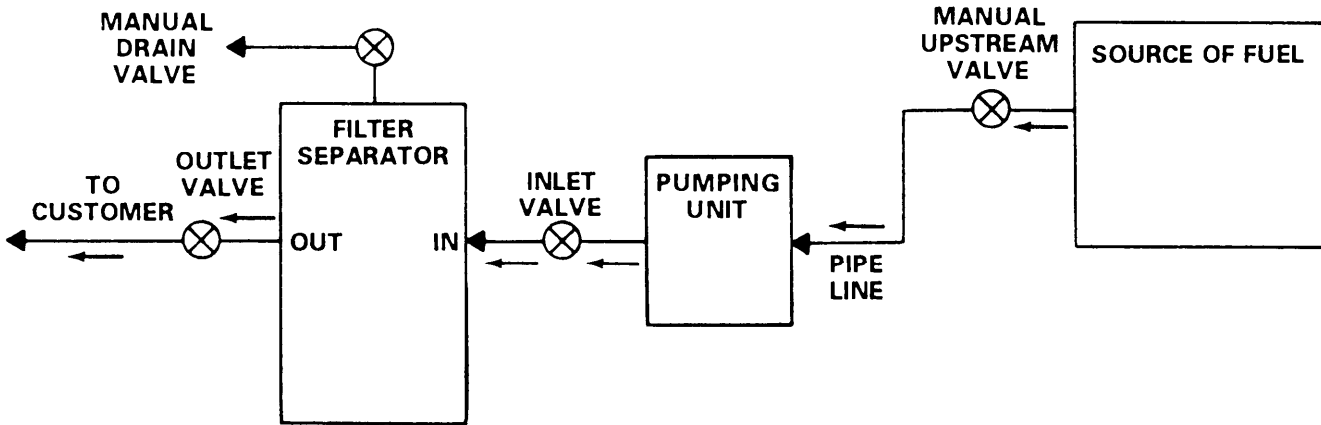

Figure 4-2. Typical Operational Layout.

Section III. UNIT PREVENTIVE MAINTENANCE CHECKS AND SERVICES (PMCS)

Paragraph	Page
4-8 General	4-4
4-9 PMCS Procedures	4-4

4-8. **General.** Unit level maintenance PMCS are done to ensure that the filter/separator is in operating condition. A comprehensive PMCS program reduces equipment downtime and increases the operational readiness of the filter/separator.

4-9. **PMCS Procedures.** Unit level PMCS is contained in table 4-1. The numbers in the Item No. column show the order in which the check or service should be done. These numbers should be used when recording deficiencies and shortcomings on DA Form 2404. Equipment inspection and Maintenance Worksheet. The ● in the interval column indicates when a check or service should be done, as follows:

Table 4-1. Unit Preventive Maintenance Checks and Services (PMCS).

Q - Quarterly

Item No.	Interval	Item to be inspected	Procedures
	Q		
1	•	Filter/Separator	Inspect filter/separator for damaged or missing items. Replace or repair if damaged or missing items (para. 4-13).
2	•	Sight Gage	Inspect sight gage for leaks or other damage. Replace if leaking or otherwise damaged (para. 4-1 3).
3	•	Inlet and Outlet Valves	Inspect inlet and outlet valves and repair if leaking or otherwise damaged (para. 4-15).
4	•	Inlet and Outlet Connections/Dust Protectors	Inspect inlet and outlet connections and dust protectors. Replace if damaged or missing (para. 4-15).
5	•	Water Drain Valve	Inspect water drain valve and replace if leaking or damaged (para. 4-15).
6	•	Pressure Vent Valve	Inspect pressure vent valve for damaged and proper operation.

Section IV. UNIT TROUBLESHOOTING PROCEDURE

Paragraph		Page
4-10	General	4-5
4-11	Unit Troubleshooting Procedures	4-5

4-10. General. This section contains troubleshooting procedures to determine the probable cause of observed equipment malfunctions. Test or inspections are provided to isolate the faulty component and corrective actions are provided to eliminate the malfunction.

4-11. Unit Troubleshooting Procedures. Refer to the symptom index to locate the troubleshooting procedure for the observed malfunction. The table lists the common malfunctions that may occur during the operation or maintenance of the filter/separator. Perform the tests or inspections, and the recommended corrective action in the order listed in the troubleshooting table. If the malfunction is corrected by a specific corrective action, do not continue with any remaining steps of the troubleshooting procedure. If the malfunction is not corrected by the listed corrective actions, notify your supervisor.

SYMPTOM INDEX

Symptom	Page
No fuel delivery '	4-6
Contaminated fuel at nozzle	4-6
General fuel leakage	4-6

Table 4-2. Unit Troubleshooting Procedures.

Malfunction
Test or Inspection
Corrective Action
<p>1. NO FUEL DELIVERY.</p> <p style="padding-left: 20px;">Check valves for proper operation.</p> <p style="padding-left: 40px;">Replace damaged valves (para. 4-15).</p>
<p>2. CONTAMINATED FUEL AT NOZZLE.</p> <p style="padding-left: 20px;">Step 1. Inspect filter element.</p> <p style="padding-left: 40px;">Replace filter element (para. 4-14).</p> <p style="padding-left: 20px;">Step 2. Inspect canister and grommet.</p> <p style="padding-left: 40px;">Replace canister and grommet (para. 4-14).</p>
<p>3. GENERAL FUEL LEAKAGE.</p> <p style="padding-left: 20px;">Step 1. Check cover, pressure vent valve, and gasket for damage.</p> <p style="padding-left: 40px;">Replace damaged component(s) para. 4-12).</p> <p style="padding-left: 20px;">Step 2. Check tank.</p> <p style="padding-left: 40px;">Replace a damaged tank.</p> <p style="padding-left: 20px;">Step 3. Check valve(s) for proper operations.</p> <p style="padding-left: 40px;">Replace damaged valve(s) (para. 4-15).</p> <p style="padding-left: 20px;">Step 4. Check sight glass.</p> <p style="padding-left: 40px;">Replace sight glass if broken or gasket leaks (para. 4-13).</p>

Section V. UNIT MAINTENANCE INSTRUCTIONS

Paragraph		Page
4-12	Cover Assembly	4-8
4-13	Sight Gage	4-10
4-14	Canister and Filter Element	4-12
4-15	Valves	4-15

4-12. Cover Assembly.

This task covers: Repair

INITIAL SETUP

Tools

Materials/Parts

General Mechanic's Tool Kit (Item 1, Appendix B)

Lubricant, Silicone (Item 6, Appendix E)
Sealing Compound (Item 5, Appendix E)

Repair. (figure 3-1)

WARNING

Do not smoke or use an open flame in the vicinity of filter/separator.

- (1) Loosen four nuts (1) until flush with bottom of bolts (2).
- (2) Lift up bolts (2) and turn 180°.
- (3) Remove cover (3) and gasket (4).
- (4) Remove pressure vent valve (5) from cover (3).
- (5) Inspect cover (3) and replace if cracked or otherwise damaged.
- (6) Inspect pressure vent valve (5) and replace if threads are stripped or valve (5) is otherwise damaged.
- (7) Inspect gasket (4) and replace if cracked or otherwise damaged.
- (8) Apply sealing compound to threads on pressure vent valve (5) and install pressure vent valve (5).
- (9) Apply a thin coat of silicone lubricant to gasket (4) and install in cover (3).
- (10) install cover (3) and gasket (4) and raise bolts (2) and turn 180°.
- (11) Tighten nuts (1) evenly.

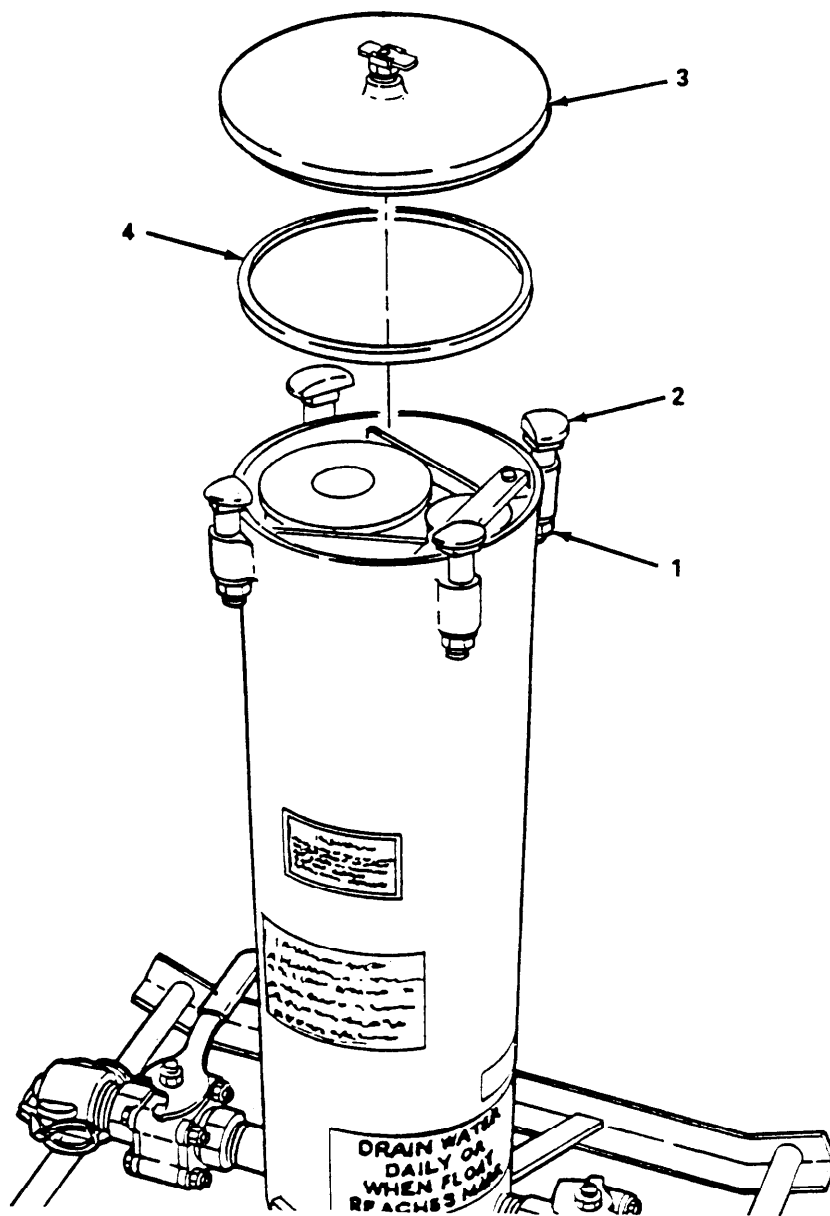

Figure 4-3. Cover Assembly, Repair.

4-13. Sight Gage.

This task covers: Repair

INITIAL SETUP

Tools

General Mechanic's Tool Kit (Item 1, Appendix B)

Materials/Parts

Sealing Compound (Item 5, Appendix E)
Gasket, Sight Gage (Item 6, Appendix F)

Repair. (figure 4-4)

WARNING

Do not smoke or use an open flame in the vicinity of filter/separator.

- (1) Remove two screws (1) and flat washers (2) and remove sight gage (3), ball (4), and gasket (5).
- (2) Install sight gage (3), ball (4), and gasket (5) and secure with two screws (1) and flat washers (2).

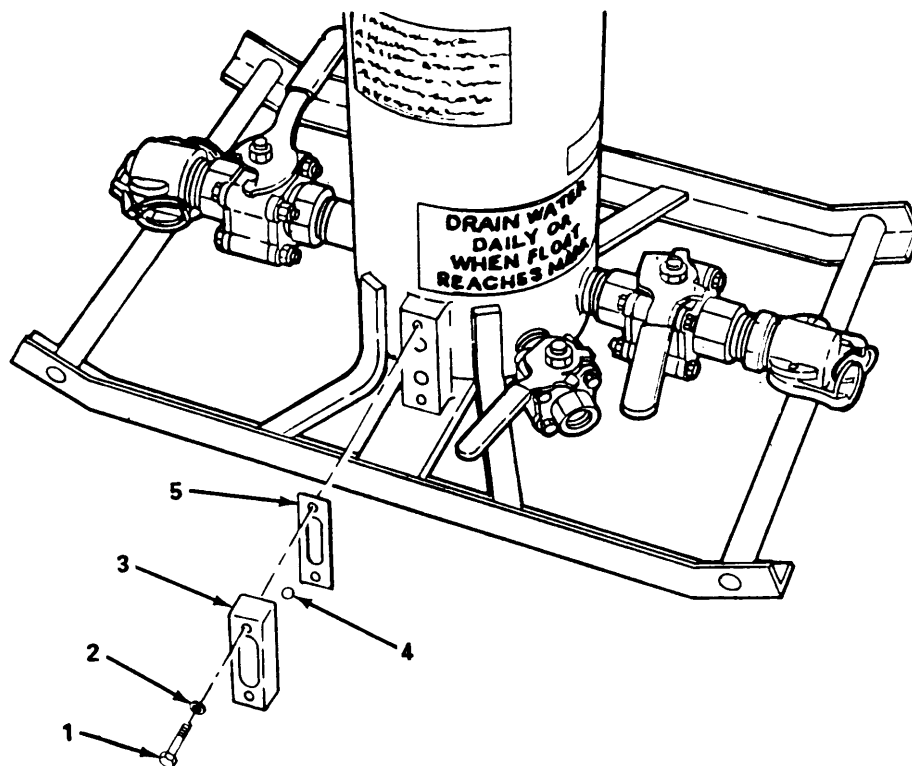

Figure 4-4. Sight Gage, Repair

4-14. Canister and Filter Element.

This task covers: Repair

INITIAL SETUP

Tools

General Mechanic's Tool Kit (Item 1, Appendix B)

Materials/Parts

Lubricant, Silicone (Item 6, Appendix E)
Solvent, Drycleaning (Item 1, Appendix E)

Materials/Parts (Cont)

Rags, Wiping (Item 4, Appendix E)
Gloves, Rubber (Item 2, Appendix E)
Goggles, Safety (Item 3, Appendix E)
Lockwashers (Appendix F)

Repair. (figure 4-5)

WARNING

Do not smoke or use an open flame in the vicinity of filter/separator.

- (1) Loosen four nuts (1) until flush with bottom of bolts (2).
- (2) Lift up four bolts (2) and turn 180°.
- (3) Remove cover (3) and gasket (4).
- (4) Remove two screws (5) and lockwashers (6) and remove bracket (7).

WARNING

The toxic affects of some fuel additives are potentially dangerous to personnel and property. Avoid repeated or prolonged skin contact. Use rubber fuel restraint gloves when replacing elements.

- (5) Remove element (8), canister (9), standpipe (10) and grommet (11)

WARNING

Drycleaning solvent, PD-680, used to clean parts is potentially dangerous to personnel and property. Avoid repeated or prolonged skin contact. Do not use near open flame or excessive heat. Flash point of solvent is 100 – 138°F (38 – 60°C).

- (6) Clean canister (9), and standpipe (10) with drycleaning solvent and dry thoroughly.
- (7) inspect canister (9) and replace if screen is ripped or canister (9) is otherwise damaged.

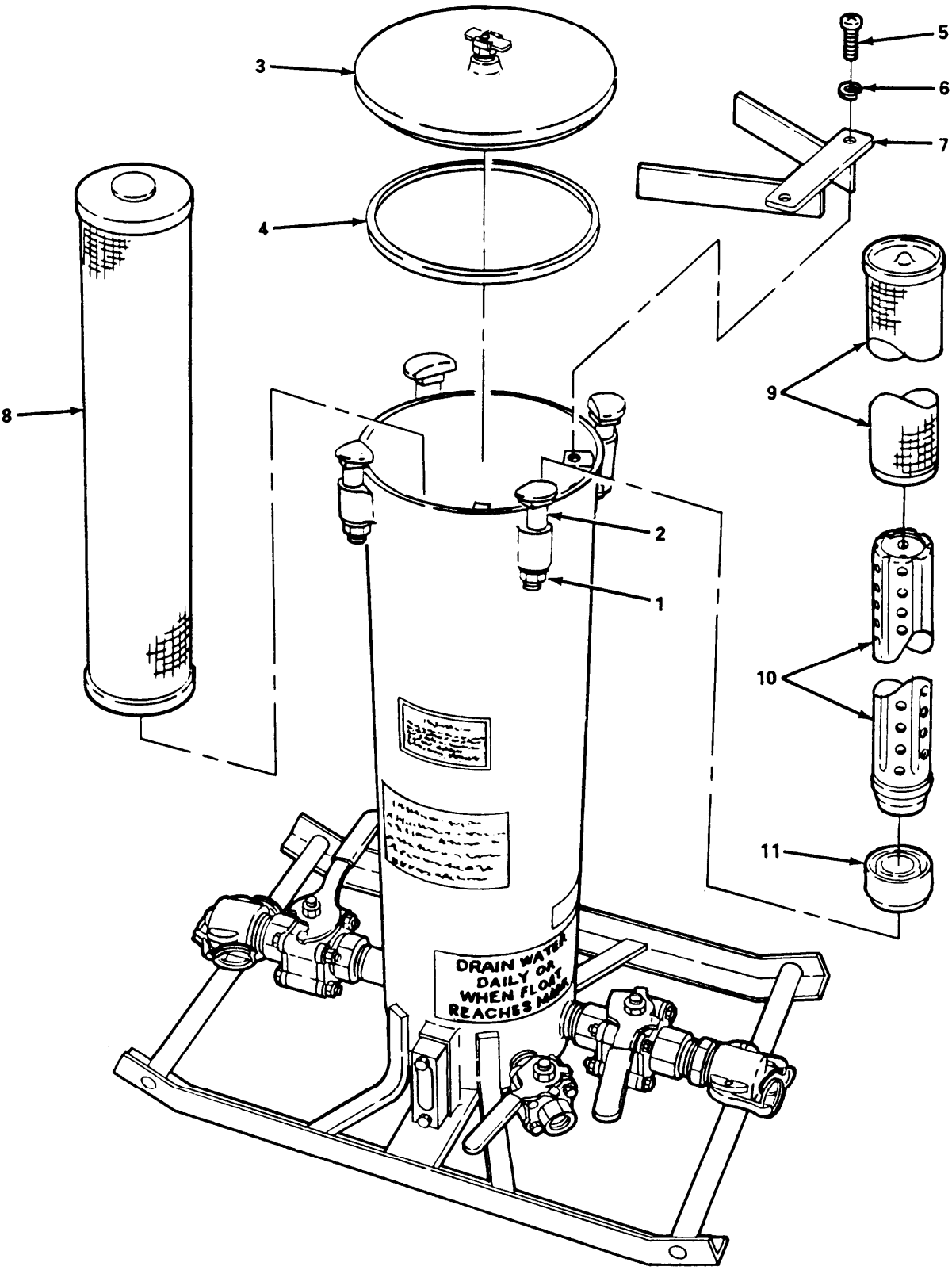

Figure 4-5. Canister and Filter Element, Repair.

4-14. Canister and Filter Elements (Cont).

(8) Inspect standpipe (10) and replace if clogged, dented or otherwise damaged.

WARNING

Dispose of filter elements in accordance with local policy.

(9) Inspect element (8) and replace if torn, dirty, or otherwise damaged.

(10) Inspect grommet (11) and replace if ripped, cracked or otherwise damaged.

(11) Install grommet (11), standpipe (10), canister (9) and element (8) and secure with bracket (7) and two screws (5) and new lockwashers (6).

(12) Apply a thin layer of silicone lubricant to gasket (4) and install in cover (3).

(13) Install cover (3) and gasket (4).

(14) Lift up four bolts (2) and turn 180°.

(15) Tighten four nuts (1).

4-15. Valves.

This task covers: Repair

INITIAL SETUP**Tools***Materials/Parts*

General Mechanic's Tool Kit (Item 1, Appendix B)

Sealing Compound (Item 5, Appendix B)

NOTE

Some models of the fitter/separator are equipped with gate valves. The procedures to replace and test the valves are the same for all types.

Repair.**(1) Inlet valve.** (figure 4-6)

- (a) Remove quick disconnect (1) from inlet valve (2).
- (b) Remove inlet valve (2) from tank (3).
- (c) Apply sealing compound to all pipe threads.
- (d) Install inlet valve (2).
- (e) Install quick disconnect (1).

(2) Outlet valve. (figure 4-7)

- (a) Remove quick disconnect (1) from outlet valve (2).
- (b) Remove outlet valve (2) from tank (3).
- (c) Apply sealing compound to all pipe threads.
- (d) Install outlet valve (2).
- (e) Install quick disconnect (1).

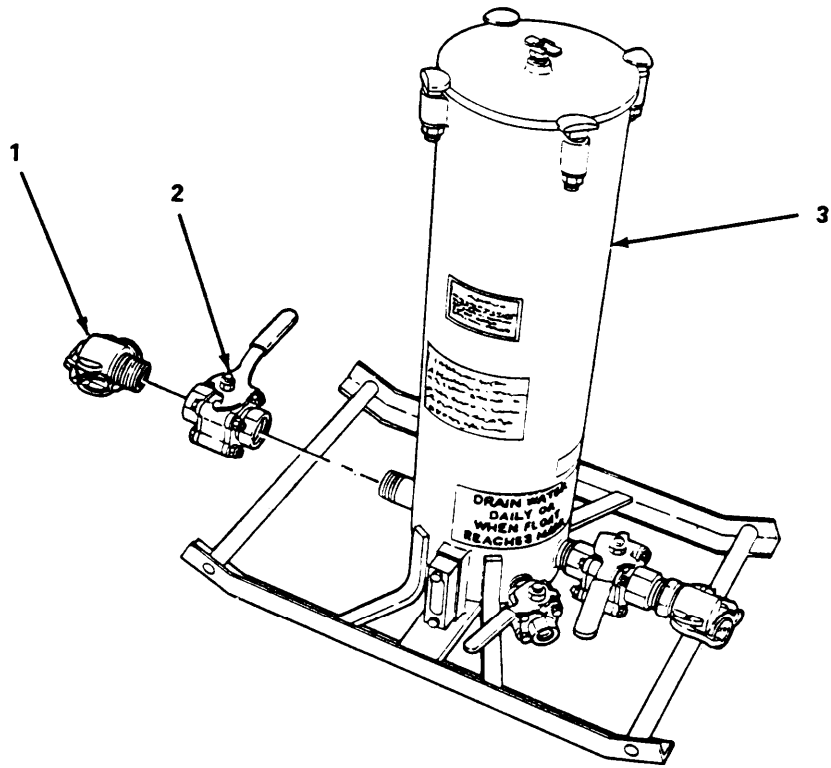

Figure 4-6. Inlet Valve, Repair.

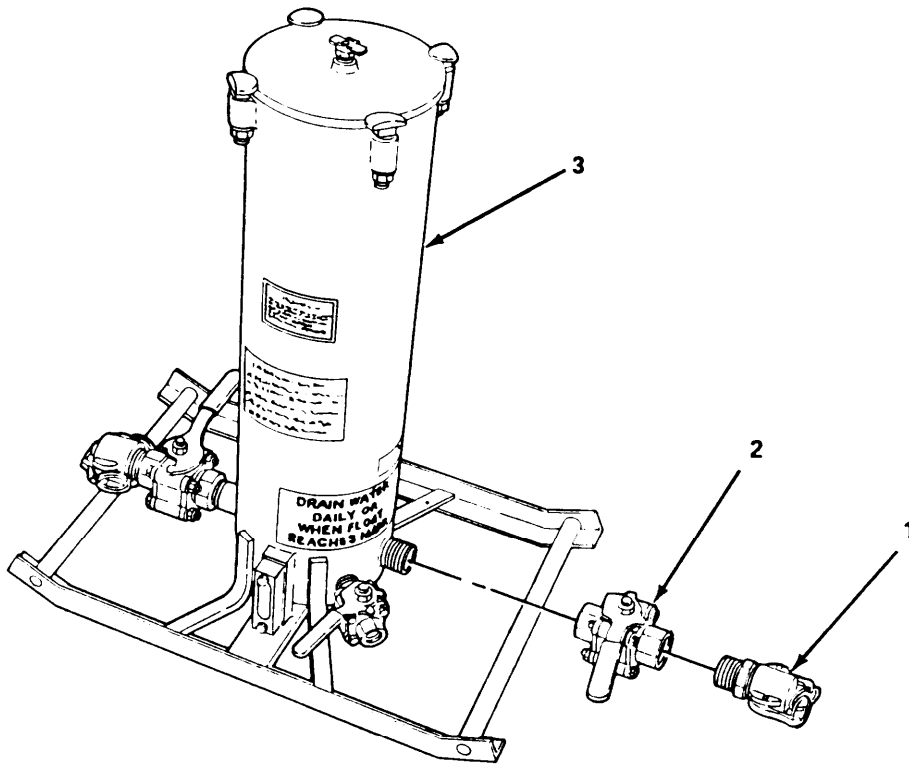

Figure 4-7. Outlet Valve, Repair.

4-15. Valves (Cont).

(3) *Water drain valve.* (figure 4-8)

NOTE

Some models of the filter/separator are equipped with petcock drain valve, which require a 1/2 in. pipe coupling for installation.

- (a) Remove water drain valve (1) from tank (2).
- (b) Apply sealing compound to threads on water drain valve (1).
- (c) Install water drain valve (1).

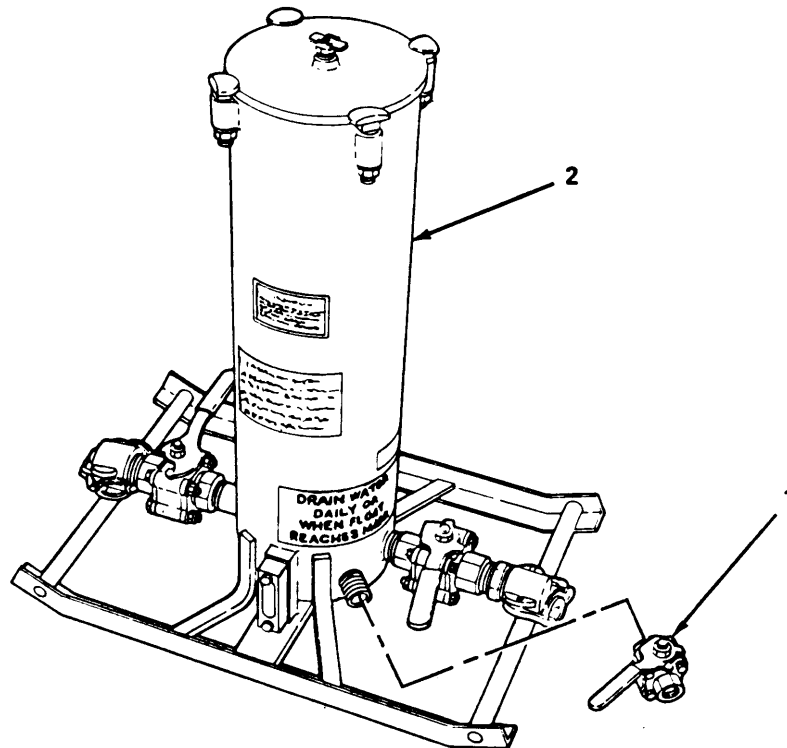

Figure 4-8. Water Drain Valve, Repair.

Section VI. PREPARATION FOR SHIPMENT OR STORAGE

Paragraph		Page
4-16	Short Term Storage	4-16
4-17	Intermediate Storage	4-16
4-18	Administrative Storage	4-16
4-19	Preparation for Shipment	4-16

4-16. Short Term Storage. Store the filter/separator as follows:

- a.* Isolate the filter/separator from the pipeline by closing the inlet and outlet valves.
- b.* Open the manual drain valve and pressure vent valve to drain fuel from tank into a suitable container
- c.* Close manual drain valve and pressure vent valve.
- d.* Disconnect inlet and outlet hoses from filter/separator, Drain fuel from hoses into suitable container.
- e.* Disconnect ground rod,
- f.* Remove unit from pipeline.

4-17. Intermediate Storage, Refer to the following documents for information relative to storing the filter/separator.

- a.* TM 38-230-1, -2 Packaging of Material: Preservation Vol. I and II.
- b.* TM 743-200-3 Storage and Material Handling.
- c.* MIL-F-52429 Filter Separator, Liquid Fuel; Skid Mounted, 15 GPM Capacity.

4-18. Administrative Storage

a. Placement of equipment in administrative storage should be for short periods of time when a shortage of maintenance effort exists. Items should be in mission readiness within 24 hours or within the time factors as determined by the directing authority, During the storage period appropriate maintenance records will be kept

b. Before placing equipment in administrative storage, current preventive maintenance checks and services (PMCS) should be completed, shortcomings and deficiencies should be corrected, and all modification work orders (MWO's) should be applied.

c. Storage site selection. Inside storage is preferred for items selected for administrative storage, If Inside storage is not available, trucks, vans, conex containers and other containers may be used.

4-19. Preparation for Shipment. Refer to the following documents.

- a.* TM 38-230-1, -2 Packaging of Material: Preservation Vol. I and II.
- b.* MIL-F-52429 Filter Separator, Liquid Fuel; Skid Mounted, 15 GPM Capacity.

APPENDIX A

REFERENCES

A-1. **Scope.** This appendix contains all forms, pamphlets and technical manuals referenced in this manual.

A-2. **Forms.**

Recommended Changes to Publications	DA Form 2028
Recommended Changes to Publications	DA Form 2028-2
Equipment inspection and Maintenance Worksheet	DA Form 2404
Product Quality Deficiency Report (PQDR)	SF 368
Transportation Discrepancy Report (TDR)	SF 361
Report of Discrepancy (ROD)	SF 364
Filter Separator, Liquid Fuel; Skid Mounted, 15 GPM Capacity	MIL-F-52429

A-3. **Pamphlets.**

The Army Maintenance Management System(TAMMS)	DA Pam 738-750
Consolidated Index of Army Publication and Blank Forms	DA Pam 25-30

A-4. **Technical Manuals.**

Painting instructions for Army Materiel	TM 43-0139
Procedures for Destruction of Equipment to Prevent Enemy Use	TM 750-244-3
Storage and Material Handling.	TM 743-200-3
Packaging of Material: Preservation Vol. I	TM 38-230-1
Packaging of Material: Preservation Vol.II	TM 38-230-2

A-5. **Technical Bulletins.**

Hand Portable Fire Extinguishers Approved for Army Use	TB 5-4200-200-10
--	------------------

A-6. **Field Manuals.**

First Aid for Soldiers	FM 21-11
----------------------------------	----------

APPENDIX B

MAINTENANCE ALLOCATION CHART

Section I. INTRODUCTION

B-1. General.

a. This section provides a general explanation of all maintenance and repair functions authorized at various maintenance levels.

b. The Maintenance Allocation Chart (MAC) in Section II designates overall authority and responsibility for the performance of maintenance functions on the filter/separator. The application of the maintenance functions to the filter/separator will be consistent with the capacities and capabilities of the designated maintenance levels.

c. Section III lists the tools and test equipment (both special tools and common tool sets) required for each maintenance function as referenced from Section II.

d. Section IV contains supplemental instructions and explanatory notes for a particular maintenance function.

B-2. **Maintenance Functions.** Maintenance functions will be limited to and defined as follows:

a. Inspect. To determine the serviceability of an item by comparing its physical, mechanical, and or electrical characteristics with established standards through examination (e.g. by sight, sound, or feel).

b. Test. To verify serviceability by measuring the mechanical, pneumatic, hydraulic, or electrical characteristics of an item and comparing those characteristics with prescribed standards.

c. Service. Operations required periodically to keep an item in proper operating condition, i.e., clean (includes decontaminate, when required), to preserve, to drain, to paint, or to replenish fuel, lubricants, chemical fluids *or* gases.

d. Adjust. To maintain or regulate, within prescribed limits, by bringing into proper or exact position, or by setting the operating characteristics to specified parameters.

e. Aline. To adjust specified variable elements of an item to bring about optimum Or desired performance.

f. Calibrate. To determine and cause corrections to be made Or to be adjusted On instruments Or test, measuring, and diagnostic equipment used in precision measurement. Consists of comparisons of two instruments, one of which is a certified standard of known accuracy, to detect and adjust any discrepancy in the accuracy of the instrument being compared.

g. Remove/Install. To remove and install the same item when required to perform service or other maintenance functions. Install may be the act of emplacing, seating or fixing into position a spare, repair part, or module (component or assembly) in a manner to allow the proper functioning of equipment or system.

h. Replace. To remove an unserviceable item and install a serviceable counterpart in its place. "Replace" is authorized by the MAC and is shown as the 3rd position code of the SMR code.

i. Repair. The application of maintenance Services, including fault location/troubleshooting, removal/installation, and disassembly/assembly procedures, and maintenance actions to identify trouble and restore serviceability to an item by correcting specific damage, fault, malfunction, or failure in a part, subassembly, module (component or assembly), end item, or system.

j. Overhaul. The maintenance effort (service/action) prescribed to restore an item to a completely serviceable/operational condition as required by maintenance standards in appropriate technical publications (i.e., DMWR). Overhaul is normally the highest degree of maintenance performed by the Army. Overhaul does not normally return an item to like new condition.

k. Rebuild. Consists of those services/actions necessary for the restoration of unserviceable equipment to like new condition in accordance with original manufacturing standards. Rebuild is the highest degree of materiel maintenance applied to Army equipment. The rebuild operation include the act of returning to zero those age measurements (hours/miles, etc.) considered in classifying Army equipment/components.

B-3. Explanation of Columns in the MAC, Section II.

a. Column 1. Group Number. Column 1 list s functional group code numbers the purpose of which is to identify maintenance significant components, assemblies, subassemblies, and modules with the next higher assembly. End item group shall be "00".

b. Column 2. Component/Assembly. Column 2 contains the names of components, assemblies, subassemblies, and modules for which maintenance is authorized.

c. Column 3. Maintenance Function. Column 3 lists the functions to be performed on the item listed in Column 2. (For detailed explanation of these functions, see paragraph B-2).

d. Column 4. Maintenance Level. Column 4 specifies, by the listing to work time figure in the appropriate subcolumn(s), the level of maintenance authorized to perform the function listed in Column 3. This figure represents the active time required to perform the functions listed in indicated level of maintenance. If the number or complexity of the tasks within the listed maintenance functions vary at different maintenance levels, appropriate work time figures will be shown, for each level. The work time figure represents the average time required to restore an item (assembly, subassembly, component, module end item, or system) to a serviceable condition under typical field operating conditions. This time includes preparation time (including any necessary disassembly/assembly time), troubleshooting/fault location time, and quality assurance/quality control time in addition to the time required to perform the specific tasks identified for the maintenance functions authorized in the maintenance allocation chart. The symbol designations for the various maintenance levels are as follows:

- C - Operator or crew
- O - Unit Maintenance
- F - Direct Support Maintenance
- H - General Support Maintenance
- D - Depot Maintenance

e. Column 5. Tools and Equipment. Column 5 specifies by code, those common tool sets (not individual tools) and special tools, TM DE, and support equipment required to perform the designated function.

f. Column 6. Remarks. This column shall, when applicable contain a letter code, in alphabetic order, which shall be keyed to the remarks contained in Section IV.

B-4. Explanation of Columns in Tool and Test Equipment Requirements, Section III.

a. Column 1. Reference Code. The tool and test equipment reference code correlates with a code used in the MAC, Section II, Column 5.

b. Column 2. Maintenance Category. The lowest category of maintenance authorized to use the tool or test equipment.

c. Column 3. Nomenclature. Name or identification of the tool or test equipment.

d. Column 4. National Stock Number. The National stock number of the tool or test equipment.

e. Column 5. Tool Number. The manufacturer's part number.

B-5. Explanation of Columns in Remarks, in Section IV.

a. Column 1. Reference Code. The code recorded in column 6, Section II.

b. Column 2. Remarks. This column lists information pertinent to the maintenance function being performed as indicated in the MAC, Section II.

Section II. MAINTENANCE ALLOCATION CHART

(1) GROUP NUMBER	(2) COMPONENT/ ASSEMBLY	(3) MAINTENANCE FUNCTION	(4) MAINTENANCE LEVEL					(5) TOOLS AND EQUIPMENT	(6) REMARKS
			UNIT		DS	GS	DEPOT		
			C	O	F	H	D		
00	Filter/Separator								
01	Cover Assembly	Inspect	0.2						
	Cover	Inspect Repair	0.2	0.2			1	A	
02	Pressure Vent Valve	Inspect Repair	0.2	0.2			1	A	
	Tank and Skid Assembly	Inspect Repair	0.2	0.5			1	B	
03	Canister/Grommet	Inspect Repair	0.2	0.2			1	A	
	Sight Gage	Inspect Repair	0.2	0.2			1	A	
03	Valves and Lines	Inspect Repair	0.2	1.0			1	A	

Section III. TOOL AND TEST EQUIPMENT REQUIREMENTS

(1) TOOL/TEST EQUIP. REF CODE	(2) MAINTENANCE CATEGORY	(3) NOMENCLATURE	(4) NSN	(5) TOOL NUMBER
1	O	General Mechanic's Tool Kit	5180-00-177-7033	

Section IV. REMARKS

REFERENCE CODE	REMARKS
A	Repair is limited to replacement of the item.
B	Repair of the tank and skid assembly consists of removal of all component parts for reinstallation on a new tank and skid.

APPENDIX C

COMPONENTS OF END ITEM AND BASIC ISSUE ITEMS LISTS

Section I. INTRODUCTION

C-1 . Scope.

This appendix lists components of end item and basic issue items for the filter/separator to help you inventory items required for safe and efficient operation.

C-2. General.

The Components of End Item and Basic Issue Items Lists are divided into the following sections:

a. Section II. Components of End Item. This listing is for informational purposes only, and is not authority to requisition replacements. These items are part of the end item, but are removed and separately packaged for transportation or shipment. As part of the end item, these items must be with the end item whenever it is issued or transferred between property accounts. Illustrations are furnished to assist you in identifying the items.

b. Section III. Basic Issue Items. These are the minimum essential items required to place the filter/separator in operation, to operate it, and to perform emergency repairs. Although shipped separately packaged, Bll must be with the filter/separator during operation and whenever it is transferred between property accounts. The illustrations will assist you with hard-to-identify items. This manual is your authority to request/requisition replacement Bll, based on TOE/MTOE authorization of the end item.

C-3. Explanation of Columns.

The following provides an explanation of columns found in the tabular listings:

a. Column (1) - Illustration Number (Illus Number). This column indicates the number of the illustration in which the item is shown,

b. Column (2) - National Stock Number. Indicates the National stock number assigned to the item and will be used for requisitioning purposes.

c. Column (3) - Description. Indicates the Federal item name and, if required, a minimum description to identify and locate the item. The last line for each item indicates the Contractor and Government Entity Code CAGEC (in parentheses) followed by the part number.

d. Column (4) - Unit of Measure (U/M). Indicates the measure used in performing the actual operational/maintenance function, This measure is expressed by a two-character alphabetical abbreviation (e.g., ea, in, pr).

e. Column (5) -Quantity required (QTY RQD). Indicates the quantity of the item authorized to be used with/on the equipment.

Section II. COMPONENTS OF END ITEM

NOT APPLICABLE

Section III. BASIC ISSUE ITEMS

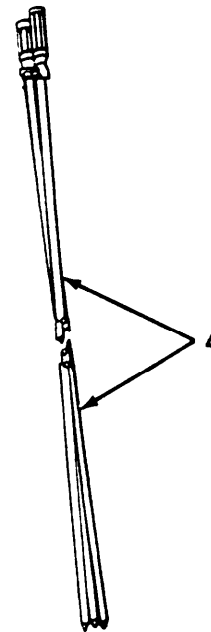
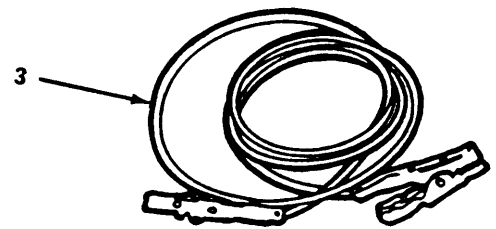
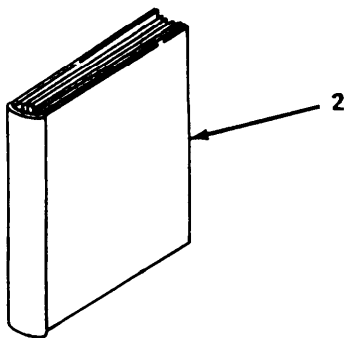
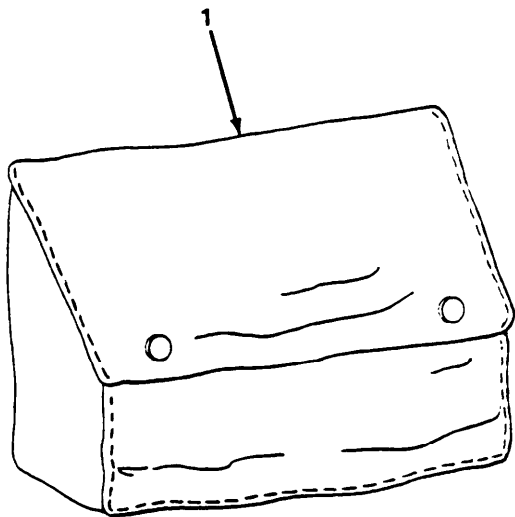

(1) Illus Number	(2) National Stock Number	(3) Description CAGEC and Part Number	Usable On Code	(4) U/M	(5) Qty Rqr
1	5220-00-559-9618	Case, Department of Army Technical Manual		ea	1
2		Technical Manual Operator, and Unit Maintenance Manual (Including Repair Parts and Special Tools List) TM 10-4330-230-12&P		ea	1
3	6150-01-197-6335	GROUND WIRE ASSY 13220E1127		ea	1
4	5975-00-878-3791	Grounding Rod Assembly		ea	1

APPENDIX D
ADDITIONAL AUTHORIZATION LIST

NOT APPLICABLE

APPENDIX E

EXPENDABLE/DURABLE SUPPLIES AND MATERIALS LIST

Section I. INTRODUCTION

E-1. **Scope.** This listing is for informational purposes only and is not authority to requisition the listed items. These items are authorized to you by CTA 50-970, Expendable/Durable Items (except medical, class V, repair parts, and heraldic items).

E-2. Explanation of Columns.

a. Column (1) - Item Number. This number is assigned to the entry in the listing and is referenced in the narrative instructions to identify the material (e.g., "Use cleaning compound, item 5, appendix C").

b. Column (2) - Level. This column identifies the lowest level of maintenance that requires the listed item.

O - Unit Maintenance

c. Column (3) - National Stock Number This is the national stock number assigned to the item; use it to request or requisition the item.

d. Column (4) -Description. Indicates the Federal item name, and, if required, a description to identify the item. The last line for each item indicates the Contractor and Government Entity Code (CAGEC) in parentheses followed by the part number.

e. Column (5) - Unit of Measure (U/M). indicates the measure used in performing the actual maintenance function. This measure is expressed by a two-character alphabetical abbreviation (e.g., ea, in., pr). If the unit of measure differs from the unit of issue, requisition the lowest unit of issue that will satisfy your requirements.

Section II. EXPENDABLE/DURABLE SUPPLIES AND MATERIALS LIST

(1) Item number	(2) Level	(3) National stock number	(4) Description	(5) U/M
1	O	6850-00-281-1985	Cleaning Solvent, Fed. Spec. PD-680	gl
2	O		Gloves, Rubber	pr
3	O		Goggles, Safety	ea
4	O		Rags, Wiping	bl
5	O		Sealing Compound, MIL-S-7916(81349)	qt
6	O	6850-00-664-4959	Lubricant, Silicone, MIL-C-21567	

UNIT MAINTENANCE REPAIR PARTS
AND SPECIAL TOOLS LIST

SECTION I. INTRODUCTION

F-1. **SCOPE.** This RPSTL lists and authorizes spares and repair parts; special tools; special test, measurement, and diagnostic equipment (TMDE); and other special support equipment required for performance of unit maintenance of the Filter Separator, 50 GPM. It authorizes the requisitioning issue, and disposition of spares, repair parts and special tools as indicated by the source, maintenance and recoverability (SMR) codes.

F-2. **GENERAL.** In addition to this section, Introduction, this Repair Parts and Special Tools List is divided into the following sections:

a. Section II. Repair Parts List. A list of spares and repair parts authorized by this RPSTL for use in the performance of maintenance. The list also includes parts which must be removed for replacement of the authorized parts. Parts lists are composed of functional groups in ascending alphanumeric sequence, with the parts in each group listed in ascending figure and item number sequence. Bulk materials are listed in item name sequence. Repair parts kits are listed separately in their own functional group within Section II, Repair parts for repairable special tools are also listed in this section. Items listed are shown on the associated illustration(s)/figure(s).

b. Section III. Special Tools List. A list of special tools, special TMDE, and other special support equipment authorized by this RPSTL (as indicated by Basis of Issue (BOI) information in DESCRIPTION AND USABLE ON CODE column) for the performance of maintenance.

c. **Section IV. Cross-references Indexes.** A list, in National Item Identification Number (NIIN) sequence, of all National stock numbered items appearing in the listing, followed by a list in alphanumeric sequence of all part numbers appearing in the listings. National stock numbers and part numbers are cross referenced to each illustration figure and item number appearance. The figure and item number index lists figure and item number in alphanumeric sequence and cross references NSN, CAGEC and part number.

F-3 EXPLANATION OF COLUMNS (SECTIONS II AND III).

- a. ITEM NO. (Column (1)). Indicates the number used to identify items called out in the illustration.
- b. SMR Code (Column (2)). The Source, Maintenance, and Recoverability (SMR) code is a 5-position code containing supply/requisitioning information, maintenance category authorization criteria, and disposition instruction, as shown in the following breakout:

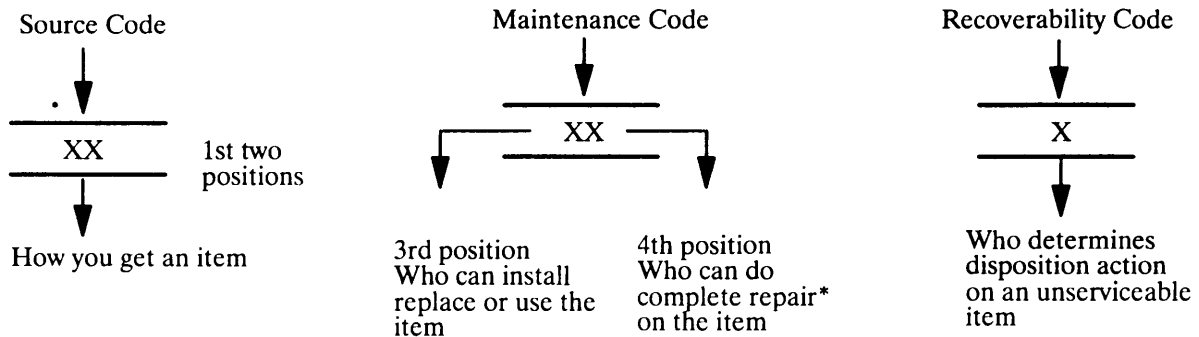

*Complete Repair: Maintenance capacity, capability, and authority to perform all corrective maintenance tasks of the "Repair" function in a use/user environment in order to restore serviceability to a failed item.

(1) **Source Code.** The source code tells you how to get an item needed for maintenance, repair, or overhaul of an end item/equipment. Explanations of source codes follows:

Code	Explanation
PA	Stocked items; use the applicable NSN to request/requisition items with these source codes. They are authorized to the category indicated by the code entered in the 3rd position of the SMR code.
PB	
PC**	
PD	
PE	
PF	
PG	**NOTE: Items coded PC are subject to deterioration.
KD	Items with these codes are not to be requested/requisitioned individually. They are part of a kit which is authorized to the maintenance category indicated in the 3rd position of the SMR code. The complete kit must be requisitioned and applied,
KF	
KB	
MO — (Made at org AVUM Level)	Items with these codes are not to be requested/requisitioned individually. They must be made from bulk material which is identified by the part number in the DESCRIPTION and USABLE ON CODE (UOC) column and listed in the Bulk Material group of the repair parts list in this RPSTL. If the item is authorized to you by the 3rd position code of the SMR code, but the source code indicates it is made at a higher level, order the item from the higher level of maintenance.
MF — (Made at DS/AVUM Level)	
MN — (Made at GS Level)	
ML — (Made at Specialized Repair Activity (SRA))	
MD — (Made at Depot)	
AO — (Assembled by org/AVUM Level)	Items with these codes are not to be requested/requisitioned individually. The parts that make up the assembled item must be requisitioned or fabricated and assembled at the level of maintenance indicated by the source code. If the 3rd position code of the SMR code authorizes you to replace the item, but the source code indicates the items are assembled at a higher level, order the item from the higher level of maintenance.
AF — (Assembled by DS/AVIM Level)	
AN — (Assembled by GS Category)	
AL — (Assembled by SRA)	
AD — (Assembled by Depot)	
XA — Do not requisition "XA" coded item. Order its next higher assembly. (Also, refer to the NOTE below.)	
XB — If an "XB" item is not available from salvage, order it using the CAGEC and part number given.	
XC — Installation drawing, diagram, instruction sheet, field service drawing, that is identified by Reciprocating Compressor manufacturer's part number.	
XD — Item is not stocked. Order an "XD" coded item through normal supply channels using the CAGEC and part number given if no NSN is available.	

NOTE

Cannibalization or controlled exchange, when authorized, may be used as a source of supply for items with the above source codes, except for those source coded "XA" or those aircraft support items restricted by requirements of AR 750- 1.

(2) **Maintenance Code.** Maintenance codes tells you the level(s) of maintenance authorized to USE and REPAIR support items. The maintenance codes are entered in the third and fourth positions of the SMR code as follows:

(a) The maintenance code entered in the third position tells you the lowest maintenance level authorized to remove, replace, and use an item. The maintenance code entered in the third position will indicate authorization to one of the following levels of maintenance,

Code	Application/Explanation
C	— Crew or operator maintenance done within organizational or aviation unit maintenance.
O	— Organizational or aviation unit category can remove, replace, and use the item.
F	— Direct support or aviation intermediate level can remove, replace, and use the item.
N	— General support level can remove, replace, and use the item.
L	— Specialized repair activity can remove, replace, and use the item.
D	— Depot level can remove, replace, and use the item.

(b) The maintenance code entered in the fourth position tells whether or not the item is to be repaired and identifies the lowest maintenance level with the capability to do complete repair (i.e. , perform – ill authorized repair functions.) NOTE: Some limited repair may be done on the item at a lower level of maintenance if authorized by the Maintenance Allocation Chart (MAC) and SMR codes. This position will contain one of the following maintenance codes.

Code	Application/Explanation
O	— Organizational or (aviation unit) is the lowest level that can do complete repair of the item.
F	— Direct support or aviation intermediate is the lowest level that can do complete repair of the item.
N	— General Support is the lowest level that can do complete repair of the item.
L	— Specialized repair activity is the lowest level that can do complete repair of the item.
D	— Depot is the lowest level that can do complete repair of the item.
Z	— Nonreparable. No repair is authorized.
B	— No repair is authorized. (No parts or special tools are authorized for the maintenance of a “B” coded item). However, the item may be reconditioned by adjusting, lubricating, etc., at the user level.

(3) **Recoverability Code.** Recoverability codes are assigned to items to indicate the disposition action on unserviceable items. The recoverability code is entered in the fifth position of the SMR Code as follows:

Recoverability

Codes

Application/Explanation

- Z — Nonreparable item. When unserviceable, condemn and dispose of the item at the level of maintenance shown in third position of SMR Code.
- O — Repairable item. When not economically repairable, condemn and dispose of the item at organizational or aviation unit level
- F — Repairable item. When uneconomically repairable, condemn and dispose of the item at the direct support or aviation intermediate level
- H — Repairable item. When uneconomically repairable, condemn and dispose of the item at the general support level.
- D — Repairable item. When beyond lower level repair capability, return to depot Condemnation and disposal of item not authorized below depot level.
- L — Repairable item. Condemnation and disposal not authorized below specialized repair activity (SRA).
- A — Item requires special handling or condemnation procedures because of specific reasons (e.g., precious metal content, high dollar value, critical material, or hazardous material). Refer to appropriate manuals/directives for specific instructions.

c. CAGEC (Column (3)). The Commercial and Government Entity Code (CAGEC) is a 5 -digit numeric code which is used to identify the manufacturer, distributor, or Government agency, etc., that supplies the item.

d. PART NUMBER (Column (4)). Indicates the primary number used by the manufacturer, (individual, company, firm, corporation, or Government activity), which controls the design and characteristics of the item by means of its engineering drawings, specifications standards, and inspection requirements to identify an item or range of items.

NOTE

When you use an NSN to requisition an item, the item you receive may have a different part number from the part ordered.

e. **DESCRIPTION AND USABLE ON CODE (UOC) (Column (5)).** This column includes the following information:

- (1) The Federal item name and, when required, a minimum description to identify the item.
- (2) The physical security classification of the item is indicated by the parenthetical entry, e.g., Phy Sec Cl – Confidential, Phy Sec Cl (S) – Secret, Phy Sec Cl (T) – Top Secret.
- (3) Items that are included in kits and sets are listed below the name of the kit or set.
- (4) Spare/repair parts that make up an assembled item are listed immediately following the assembled item line entry.
- (5) Part numbers for bulk materials are referenced in this column in the line item entry for the item to be manufactured/fabricated.

(6) When the item is not used with all serial numbers of the same model, the effective serial numbers are shown on the last line(s) of the description (before UOC).

(7) The usable on code, when applicable (see paragraph 5, Special Information).

(8) In the Special Tools List section, the basis of issue (BOI) appears as the last line(s) in the entry for each special tool, special TMDE, and other special support equipment. When density of equipments supported exceeds density spread indicated in the basis of issue, the total authorization is increased proportionately.

(9) The statement "END OF FIGURE" appears just below the last item description in Column 5 for a given figure in both Section II and Section III.

(10) The indenture, shown as dots appearing before the repair part, indicates that the item is a repair part of the next higher assembly.

f. QTY (Column (6)). The QTY (quantity per figure column) indicates the quantity of the item used in the breakout shown on the illustration figure, which is prepared for a functional group, subfunctional group, or an assembly. A "V" appearing in this column in lieu of a quantity indicates that the quantity is variable and may vary from application to application.

F-4. EXPLANATION OF COLUMNS (SECTION IV).

a. NATIONAL STOCK NUMBER (NSN) INDEX.

(1) STOCK NUMBER column. This column lists the NSN by National item identification number (NIIN) sequence. The NIIN consists of the last nine digits of the NSN, i.e.

NSN
5305-01-574-1467
NIIN

When using this column to locate an item, ignore the first 4 digits of the NSN. However, the complete NSN should be used when ordering items by stock number.

(2) FIG. column. This column lists the number of the figure where the item is identified/located. The figures are in numerical order in Section II and Section III.

(3) ITEM column. The item number identifies the item associated with the figure listed in the adjacent FIG. column. This item is also identified by the NSN listed on the same line.

b. PART NUMBER INDEX. Part numbers in this index are listed by part number in ascending alphanumeric sequence (i.e., vertical arrangement of letter and number combination which places the first letter or digit of each group in order A through Z, followed by the numbers 0 through 9 and each following letter or digit in like order).

(1) CAGEC column. The Commercial and Government Entity Code (CAGEC) is a 5 -digit numeric code used to identify the manufacturer, distributor, or Government agency, etc., that supplies the item.

(2) PART NUMBER column. Indicates the primary number used by the manufacturer (individual, firm, corporation, or Government activity), which controls the design and characteristics of the item by means of its engineering drawings, specifications standards, and inspection requirements to identify an item or range of items.

(3) **STOCK NUMBER column.** This column lists the NSN for the associated part number and manufacturer identified in the PART NUMBER and CAGEC columns to the left.

(4) **FIG. column.** This column lists the number of the figure where the item is identified/located in Sections 11 and III.

(5) **ITEM column.** The item number is that number assigned to the item as it appears in the figure referenced in adjacent figure number column.

c. FIGURE AND ITEM NUMBER INDEX.

(1) **FIG. column.** This column lists the number of the figure where the item is identified/located in Section II and III.

(2) **ITEM column.** The item number is that number assigned to the item as it appears in the figure referenced in the adjacent figure number column.

(3) **STOCK NUMBER column.** This column lists the NSN for the item.

(4) **CAGEC column.** The Commercial and Government Entity Code (CAGEC) is a 5 -digit numeric code used to identify the manufacturer, distributor, or Government agency, etc., that supplies the item.

(5) **PART NUMBER column.** Indicates the primary number used by the manufacturer (individual, firm, corporation, or Government activity), which controls the design and characteristics of the item by means of its engineering drawings, specifications standards, and inspection requirements to identify an item or range of items.

F-5. SPECIAL INFORMATION.

a. **USABLE ON CODE.** The usable on code appears in the lower corner of the Description column heading. Usable on codes are shown as "UOC: . . ." in the Description Column (justified left) on the last line applicable item description/nomenclature. Uncoded items are applicable to all models.

b. **ASSOCIATED PUBLICATIONS.** Not applicable

F-6. HOW TO LOCATE REPAIR PARTS.

a. When National Stock Number or Part Number is NOT Known.

(1) **First.** Using the table of contents, determine the assembly group or subassembly group to which the item belongs. This is necessary since figures are prepared for assembly groups and subassembly groups, and listings are divided into the same groups.

(2) **Second.** Find the figure covering the assembly group or subassembly group to which the item belongs.

(3) **Third.** Identify the item on the figure and note the item number.

(4) **Fourth.** Refer to the Repair Parts List for the figure to find the part number for the item number noted on the figure.

(5) **Fifth.** Refer to the Part Number Index to find the NSN, if assigned.

b. When National Stock Number or Part Number is Known.

(1) **First.** Using the Index of National Stock Numbers and Part Numbers, find the pertinent National Stock Number or Part Number. The NSN index is in National Item Identification Number (NIIN) sequence (see c -4a(1)), The part numbers in the Part Number index are listed in ascending alphanumeric sequence (see paragraph c -4.b). Both indexes cross—reference you to the illustration figure and item number of the item you are looking for.

(2) **Second.** After finding the figure and item number, verify that the item is the one you are looking for, then locate the item number in the repair parts list for the figure.

F-7. ABBREVIATIONS. Abbreviations used in this manual are listed in MIL-STD-12.

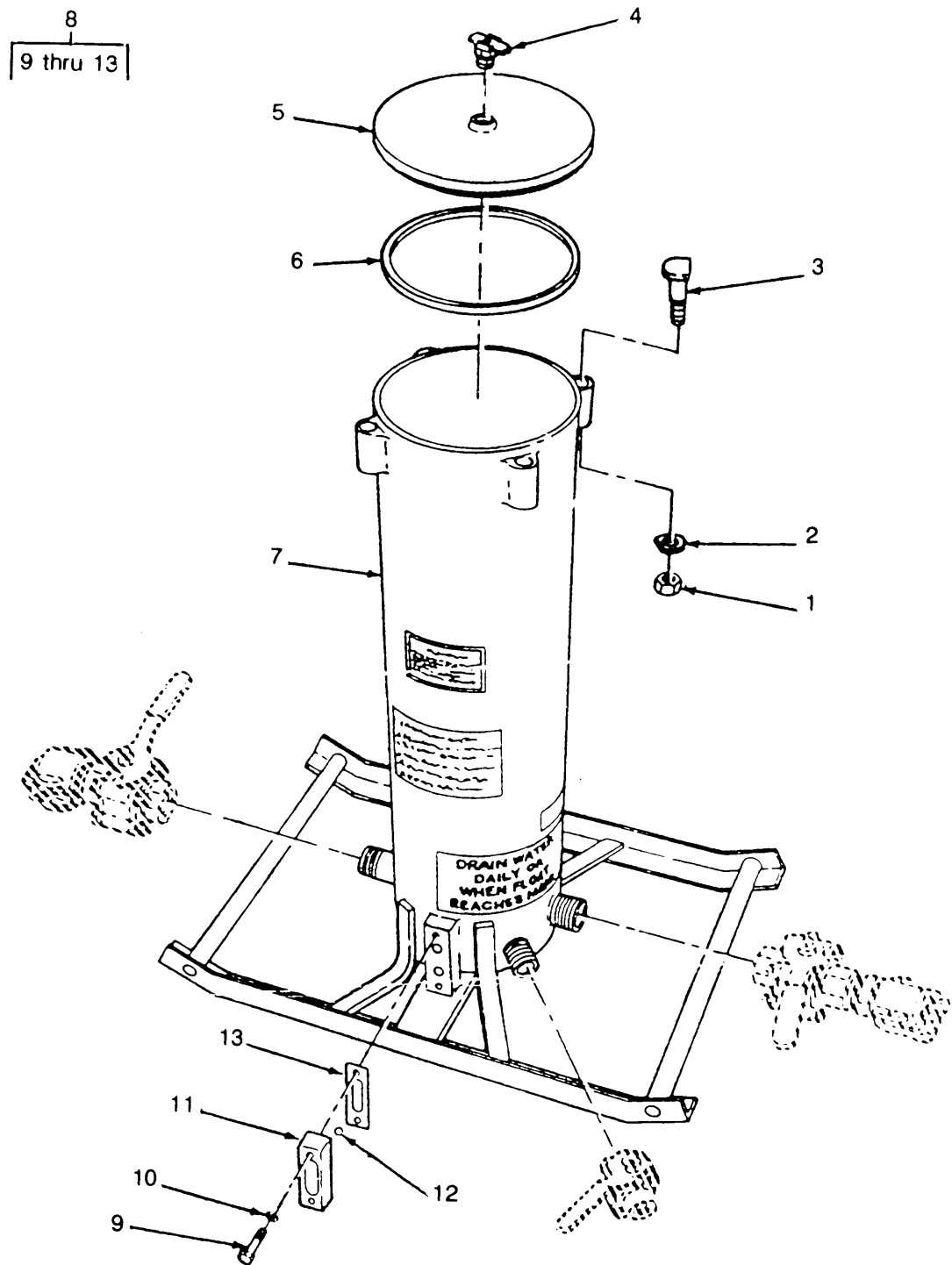

Figure F-1. Vessel and Skid Assembly (Sheet 1 of 2)

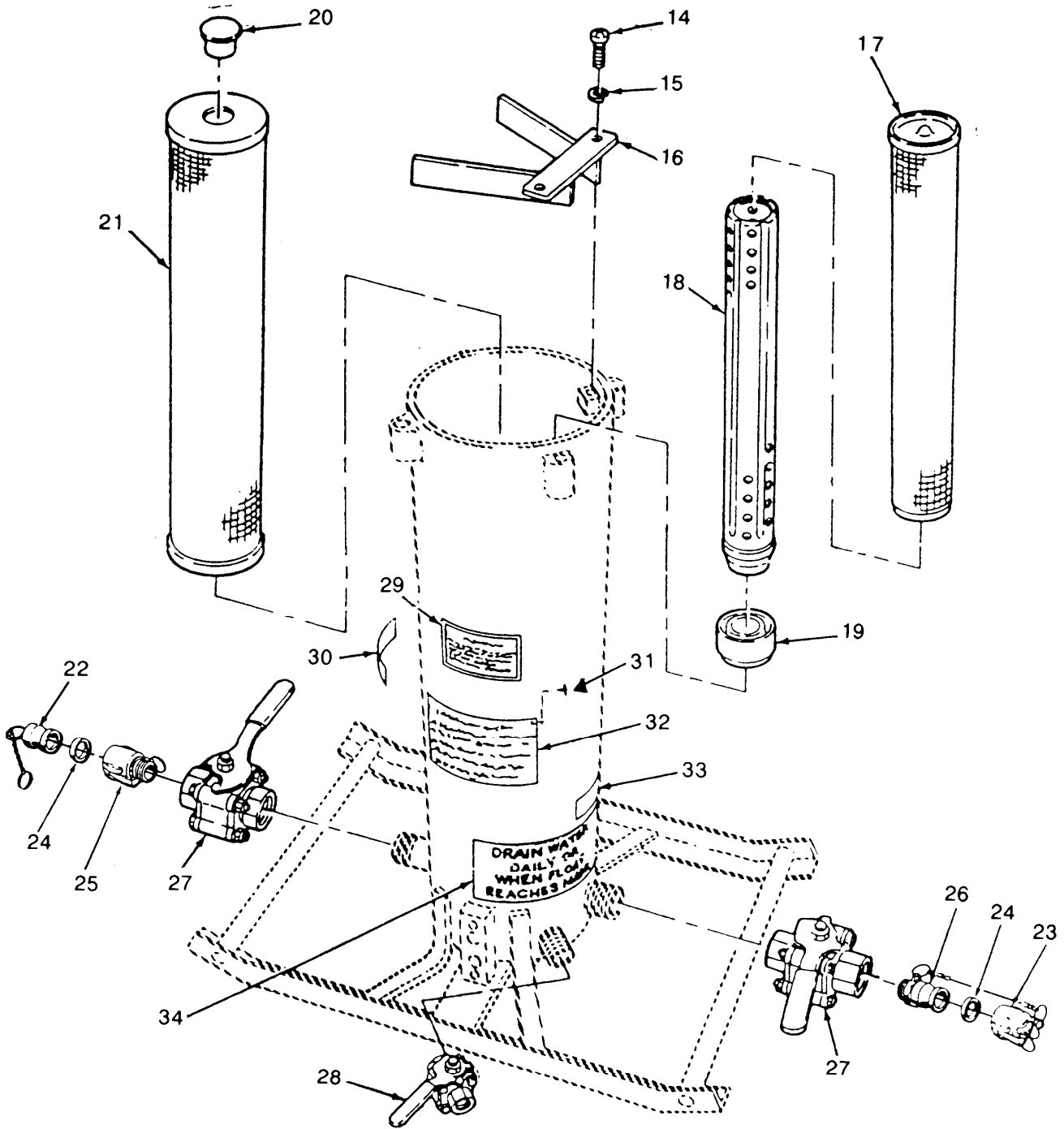

Figure F-1. Vessel and Skid Assembly (Sheet 2 of 2)

(1) ITEM NO	(2) SMR CODE	(3) CAGEC	(4) PART NUMBER	(5) DESCRIPTION AND USABLE ON CODES (UOC)	(6) QTY
GROUP OO FILTER/SEPARATOR					
FIG. F-1 FILTER SEPARATOR					
1	PAOZZ	96906	MS51967-14	NUT, HEX	4
2	PAOZZ	96906	MS27183-18	WASHER, FLAT	4
3	XDOZZ	97403	13217E6628	BOLT, SQUARE NECK	4
4	PAOZZ	97403	13216E2798	VALVE, SAFETY RELIEF	1
5	XBOZZ	97403	13217E6625	COVER, FLUID FILTER	1
6	PAOZZ	97403	13217E6624	GASKET	1
7	XAOZZ	97403	13217E6630	TANK AND SKID	1
8	PAOZZ	97403	13217E5360	GLASS, LIQUID SIGHT	1
9	PAOZZ	96906	MS51957-85	●SCREW, MACHINE	2
10	PAOZZ	96906	MS15795-810	●WASHER, FLAT	2
11	PBOZZ	97403	13217E5361	●INDICATOR, SIGHT, LIQ	1
12	PAOZZ	97403	13217E5362	●FLOAT, SIGHT INDICAT	1
13	PAOZZ	97403	13217E5363	●GASKET	1
14	PAOZZ	96906	MS51957-68	SCREW, MACHINE	2
15	PAOZZ	96906	MS35338-138	WASHER, LOCK	2
16	PAOZZ	97403	13217E6622	BRACKET, FILTER MOUN	1
17	PAOZZ	97403	13217E6631	FILTER ELEMENT, FLUI	1
18	XDOZZ	97403	13217E6633	STANDPIPE	1
19	XBOZZ	97403	13217E6623	GROMMET	1
20	XDOZZ	97403	13217E6627	PLUG, FILTER	1
21	PAOZZ	81349	MILF52308	FILTER ELEMENT, FLUI	1
22	PAOZZ	96906	MS27029-5	PLUG, QUICK DISCONNE	1
23	PAOZZ	96906	MS27028-5	DUST CAP, 1 IN	1
24	PAOZZ	96906	MS27030-3	WASHER, FLAT	2
25	PAOZZ	96906	MS27026-5	COUPLING HALF, QUICK	1
26	PAOZZ	96906	MS27022-5	COUPLING HALF, QUICK	1
27	PAOZZ	97403	13207E9044-1	VALVE, BALL	2
28	PAOZZ	97403	13207E9044-2	VALVE, BALL TYPE, 1/2	1
29	XBOZZ	97403	13217E6632	PLATE, INSTRUCTION (ELEMENT)	1
30	XBOZZ	97403	13216E2767	PLATE, INSTRUCTION (INLET)	
				UOC:CFU	
31	PAOZZ	96906	MS24662-7	DRIVE PIN, RIVET	4
				UOC:CVU	
32	XBOZZ	97403	13217E6629	PLATE	1
33	XBOZZ	97403	13216E2766	PLATE INSTRUCTION (OUTLET)	1
34	XBOZZ	97403	13216E2768	PLATE, INSTRUCTION (WATER DRAIN)	1

END OF FIGURE

SECTION III.

Special Tools List
(Not Applicable)

CROSS-REFERENCE INDEXES

NATIONAL STOCK NUMBER INDEX

STOCK NUMBER	FIG.	ITEM	STOCK NUMBER	FIG.	ITEM
5305-00-050-9234	F-1	14			
5305-00-071-2088	F-1	9			
4730-00-084-7435	F-1	26			
5330-00-088-9167	F-1	24			
6680-00-197-4941	F-1	8			
6680-00-197-4942	F-1	12			
4330-00-197-4976	F-1	17			
4330-00-197-4977	F-1	16			
5330-00-235-4716	F-1	13			
4730-00-360-0710	F-1	25			
4730-00-360-0715	F-1	22			
4820-00-407-2581	F-1	4			
4820-00-407-6449	F-1	27			
5330-00-408-4558	F-1	6			
5320-00-754-4501	F-1	31			
5310-00-809-5998	F-1	2			
4820-00-923-9981	F-1	28			
4730-00-929-0791	F-1	23			
5310-00-933-8120	F-1	15			
4330-00-983-0998	F-1	21			
6680-01-030-4391	F-1	11			
5310-01-091-1248	F-1	10			

CROSS-REFERENCE INDEXES

CAGEC	PART NUMBER	PART NUMBER INDEX		FIG.	ITEM
		STOCK NUMBER			
81349	MILF52308	4330-00-983-0998		F-1	21
96906	MS15795-810	5310-01-091-1248		F-1	10
96906	MS24662-7	5320-00-754-4501		F-1	31
96906	MS27022-5	4730-00-084-7435		F-1	26
96906	MS27026-5	4730-00-360-0710		F-1	25
96906	MS27028-5	4730-00-929-0791		F-1	23
96906	MS27029-5	4730-00-360-0715		F-1	22
96906	MS27030-3	5330-00-088-9167		F-1	24
96906	MS27183-18	5310-00-809-5998		F-1	2
96906	MS35338-138	5310-00-933-8120		F-1	15
96906	MS51957-68	5305-00-050-9234		F-1	14
96906	MS51957-85	5305-00-071-2088		F-1	9
96906	MS51967-14			F-1	1
97403	13207E9044-1	4820-00-407-6449		F-1	27
97403	13207E9044-2	4820-00-923-9981		F-1	28
97403	13216E2766			F-1	33
97403	13216E2767			F-1	30
97403	13216E2768			F-1	34
97403	13216E2798	4820-00-407-2581		F-1	4
97403	13217E5360	6680-00-197-4941		F-1	8
97403	13217E5361	6680-01-030-4391		F-1	11
97403	13217E5362	6680-00-197-4942		F-1	12
97403	13217E5363	5330-00-235-4716		F-1	13
97403	13217E6622	4330-00-197-4977		F-1	16
97403	13217E6623			F-1	19
97403	13217E6624	5330-00-408-4558		F-1	6
97403	13217E6625			F-1	5
97403	13217E6627			F-1	20
97403	13217E6628			F-1	3
97403	13217E6629			F-1	32
97403	13217E6630			F-1	7
97403	13217E6631	4330-00-197-4976		F-1	17
97403	13217E6632			F-1	29
97403	13217E6633			F-1	18

SECTION IV

CROSS-REFERENCE INDEXES

FIGURE AND ITEM NUMBER INDEX				
FIG.	ITEM	STOCK NUMBER	CAGEC	PART NUMBER
F-1	1		96906	MS51967-14
F-1	2	5310-00-809-5998	96906	MS27183-18
F-1	3		97403	13217E6628
F-1	4	4820-00-407-2581	97403	13216E2798
F-1	5		97403	13217E6625
F-1	6	5330-00-408-4558	97403	13217E6624
F-1	7		97403	13217E6630
F-1	8	6680-00-197-4941	97403	13217E5360
F-1	9	5305-00-071-2088	96906	MS51957-85
F-1	10	5310-01-091-1248	96906	MS15795-810
F-1	11	6680-01-030-4391	97403	13217E5361
F-1	12	6680-00-197-4942	97403	13217E5362
F-1	13	5330-00-235-4716	97403	13217E5363
F-1	14	5305-00-050-9234	96906	MS51957-68
F-1	15	5310-00-933-8120	96906	MS35338-138
F-1	16	4330-00-197-4977	97403	13217E6622
F-1	17	4330-00-197-4976	97403	13217E6631
F-1	18		97403	13217E6633
F-1	19		97403	13217E6623
F-1	20		97403	13217E6627
F-1	21	4330-00-983-0998	81349	MILF52308
F-1	22	4730-00-360-0715	96906	MS27029-5
F-1	23	4730-00-929-0791	96906	MS27028-5
F-1	24	5330-00-088-9167	96906	MS27030-3
F-1	25	4730-00-360-0710	96906	MS27026-5
F-1	26	4730-00-084-7435	96906	MS27022-5
F-1	27	4820-00-407-6449	97403	13207E9044-1
F-1	28	4820-00-923-9981	97403	13207E9044-2
F-1	29		97403	13217E6632
F-1	30		97403	13216E2767
F-1	31	5320-00-754-4501	96906	MS24662-7
F-1	32		97403	13217E6629
F-1	33		97403	13216E2766
F-1	34		97403	13216E2768

INDEX

Subject **Paragraph**

A

Administrative Storage 4-17

Appendices:

 A - R e f e r e n c e s
 B-Maintenance Allocation Chart B-1
 C-Components of End Item and Basic Issue Items C-1
 D- Additional Authorization List D-1
 E - Expendable/Durable Supplies and Material List E-1
 F - Repair Parts and Special Tools List F-1

B

C

Canister and Filter Element 4-14

Checking Unpacked Equipment 4-5

Cover Assembly 4-12

D

Discription and Use of Operator's Controls and Indicators 2-2

Destruction of Army Material to Prevent Enemy Use 1-4

E

Equipment Characteristics, Capabilities and Features 1-6

Equipment Data 1-8

F

G

Grounding Assembly 4 - 6

H

INDEX (Cont)

Subject	Paragraph
I	
Installtion	4-6
J	
K	
L	
Location and Description of Major Components	1-7
M	
Maintenance Forms, Records and Reports	1-2
N	
O	
Operating	2-10
Operation at High Altitudes	2-17
Operation in Dusty or Sandy Areas	2-14
Operation in Extreme Cold	2-12
Operation in Extreme Heat.....	2-13
Operation in Rainy or Humid Conditions	2-15
Operation in Saltwater Areas..	2-16
Operators Controls and Indicators	2-2
P	
Preparation for storage or shipment	1-5
Preventive Maintenance Checks and Services	
Operator	2-3
Unit	4-9
Principles of Operation	1-10
Q	

INDEX (Cont)

Subject	Paragraph
R	
Repair Parts, Special Tools, and Support Equipment	4-2,4-3
Reporting Equipment improvement Recommendations (EIR)	1-3
S	
Safety, Care and Handling	1-9
Sight Gage	4-13
Special Tools and Support Equipment	4-2
Starting Procedure	2-9
Stopping Procedure	2-11
T	
Tank	4-14
Troubleshooting Procedures	
Operator	3-3
Unit	4-11
U	
Unit Maintenance	
Canister and Filter Elements	4-14
Cover Assembly	4-12
Sight Gage	4-13
Valves	4-15
Unit Preventive Maintenance Checks and Services (PMCS)	4-9
Unit Troubleshooting	4-11
Unpacking	4-4
V	
Valves	4-15
Valve, Pressure Vent	3-7
W	
X	
Y	
Z	

By Order of the Secretary of the Army:

Official:

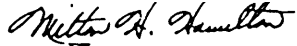

MILTON H. HAMILTON
*Administrative Assistant to the
Secretary of the Army
00871*

GORDON R. SULLIVAN
*General, United States Army
Chief of Staff*

DISTRIBUTION:

To be distributed in accordance with DA Form 12-25E, (Qty rqr blk no 0784)



THEN... JOT DOWN THE DOPE ABOUT IT ON THIS FORM. CAREFULLY TEAR IT OUT, FOLD IT AND DROP IT IN THE MAIL!

SOMETHING WRONG WITH THIS PUBLICATION?

FROM (PRINT YOUR UNIT'S COMPLETE ADDRESS)
PFC JOHN DOE
COA, 3d ENGINEER BN
FT. LEONARD WOOD, MD 63108
 DATE SENT

PUBLICATION NUMBER: **TM 10-4330-230-12&P**
 PUBLICATION DATE: **31 MARCH 1992**
 PUBLICATION TITLE: **FILTER SEPARATOR**

BE EXACT PIN-POINT WHERE IT IS				IN THIS SPACE TELL WHAT IS WRONG AND WHAT SHOULD BE DONE ABOUT IT:
PAGE NO	PARA-GRAPH	FIGURE NO	TABLE NO	
6	2-1 a			<i>In line 6 of paragraph 2-1a the manual states the engine has <u>6</u> cylinders. The engine on my set only has <u>4</u> cylinders. Change the manual to show <u>4</u> cylinders.</i>
B1		4-3		<i>Callout 16 on figure 4-3 is pointing at a <u>bolt</u>. In key to figure 4-3, item 16 is called a <u>shim</u> - Please correct one or the other.</i>
125	line 20			<i>I ordered a gasket, item 19 on figure B-16 by NSN 2 910-00-762-3001. I got a gasket but it doesn't fit. Supply says I got what I ordered, so the NSN is wrong. Please give me a good NSN</i>

PRINTED NAME, GRADE OR TITLE AND TELEPHONE NUMBER: **JOHN DOE, PFC (268) 317-7111**
 SIGN HERE: **JOHN DOE**

TEAR ALONG PERFORATED LINE

FILL IN YOUR
UNIT'S ADDRESS



FOLD BACK

DEPARTMENT OF THE ARMY



OFFICIAL BUSINESS

COMMANDER
U.S. ARMY TROOP SUPPORT COMMAND
ATTN: AMSTR-MMTS
4300 GOODFELLOW BOULEVARD
ST. LOUIS, MO 63120-1798

TEAR ALONG PERFORATED LINE

FILL IN YOUR
UNIT'S ADDRESS



FOLD BACK

DEPARTMENT OF THE ARMY

OFFICIAL BUSINESS

COMMANDER
U.S. ARMY TROOP SUPPORT COMMAND
ATTN: AMSTR-MMTS
4300 GOODFELLOW BOULEVARD
ST. LOUIS, MO 63120-1798

TEAR ALONG PERFORATED LINE

FILL IN YOUR
UNIT'S ADDRESS



FOLD BACK

DEPARTMENT OF THE ARMY

OFFICIAL BUSINESS

COMMANDER
U.S. ARMY TROOP SUPPORT COMMAND
ATTN: AMSTR-MMTS
4300 GOODFELLOW BOULEVARD
ST. LOUIS, MO 63120-1798

TEAR ALONG PERFORATED LINE

FILL IN YOUR
UNIT'S ADDRESS



FOLD BACK

DEPARTMENT OF THE ARMY

OFFICIAL BUSINESS

COMMANDER
U.S. ARMY TROOP SUPPORT COMMAND
ATTN: AMSTR-MMTS
4300 GOODFELLOW BOULEVARD
ST. LOUIS, MO 63120-1798

TEAR ALONG PERFORATED LINE

The Metric System and Equivalents

Linear Measure

1 centimeter = 10 millimeters = .39 inch
 1 decimeter = 10 centimeters = 3.94 inches
 1 meter = 10 decimeters = 39.37 inches
 1 dekameter = 10 meters = 32.8 feet
 1 hectometer = 10 dekameters = 328.08 feet
 1 kilometer = 10 hectometers = 3,280.8 feet

Weights

1 centigram = 10 milligrams = .15 grain
 1 decigram = 10 centigrams = 1.54 grains
 1 gram = 10 decigram = .035 ounce
 1 dekagram = 10 grams = .35 ounce
 1 hectogram = 10 dekagrams = 3.52 ounces
 1 kilogram = 10 hectograms = 2.2 pounds
 1 quintal = 100 kilograms = 220.46 pounds
 1 metric ton = 10 quintals = 1.1 short tons

Liquid Measure

1 centiliter = 10 milliliters = .34 fl. ounce
 1 deciliter = 10 centiliters = 3.38 fl. ounces
 1 liter = 10 deciliters = 33.81 fl. ounces
 1 dekaliter = 10 liters = 2.64 gallons
 1 hectoliter = 10 dekaliters = 26.42 gallons
 1 kiloliter = 10 hectoliters = 264.18 gallons

Square Measure

1 sq. centimeter = 100 sq. millimeters = .155 sq. inch
 1 sq. decimeter = 100 sq. centimeters = 15.5 sq. inches
 1 sq. meter (centare) = 100 sq. decimeters = 10.76 sq. feet
 1 sq. dekameter (are) = 100 sq. meters = 1,076.4 sq. feet
 1 sq. hectometer (hectare) = 100 sq. dekameters = 2.47 acres
 1 sq. kilometer = 100 sq. hectometers = .386 sq. mile

Cubic Measure

1 cu. centimeter = 1000 cu. millimeters = .06 cu. inch
 1 cu. decimeter = 1000 cu. centimeters = 61.02 cu. inches
 1 cu. meter = 1000 cu. decimeters = 35.31 cu. feet

Approximate Conversion Factors

To change	To	Multiply by	To change	To	Multiply by
inches	centimeters	2.540	ounce-inches	newton-meters	.007062
feet	meters	.305	centimeters	inches	.394
yards	meters	.914	meters	feet	3.280
miles	kilometers	1.609	meters	yards	1.094
square inches	square centimeters	6.451	kilometers	miles	.621
square feet	square meters	.093	square centimeters	square inches	.155
square yards	square meters	.836	square meters	square feet	10.764
square miles	square kilometers	2.590	square meters	square yards	1.196
acres	square hectometers	.405	square kilometers	square miles	.386
cubic feet	cubic meters	.028	square hectometers	acres	2.471
cubic yards	cubic meters	.765	cubic meters	cubic feet	35.315
fluid ounces	milliliters	29.573	cubic meters	cubic yards	1.308
pints	liters	.473	milliliters	fluid ounces	.034
quarts	liters	.946	liters	pints	2.113
gallons	liters	3.785	liters	quarts	1.057
ounces	grams	28.349	liters	gallons	.264
pounds	kilograms	.454	grams	ounces	.035
short tons	metric tons	.907	kilograms	pounds	2.205
pound-feet	newton-meters	1.356	metric tons	short tons	1.102
pound-inches	newton-meters	.11296			

Temperature (Exact)

°F	Fahrenheit temperature	5/9 (after subtracting 32)	Celsius temperature	°C
----	------------------------	----------------------------	---------------------	----

This fine document...

Was brought to you by me:



[Liberated Manuals -- free army and government manuals](#)

Why do I do it? I am tired of sleazy CD-ROM sellers, who take publicly available information, slap “watermarks” and other junk on it, and sell it. Those masters of search engine manipulation make sure that their sites that sell free information, come up first in search engines. They did not create it... They did not even scan it... Why should they get your money? Why are not letting you give those free manuals to your friends?

I am setting this document FREE. This document was made by the US Government and is NOT protected by Copyright. Feel free to share, republish, sell and so on.

I am not asking you for donations, fees or handouts. If you can, please provide a link to liberatedmanuals.com, so that free manuals come up first in search engines:

<A HREF=<http://www.liberatedmanuals.com/>>Free Military and Government Manuals

- Sincerely
Igor Chudov
<http://igor.chudov.com/>
- [Chicago Machinery Movers](#)