

TECHNICAL MANUAL

**OPERATOR'S, UNIT, DIRECT
SUPPORT AND GENERAL SUPPORT
MAINTENANCE MANUAL**

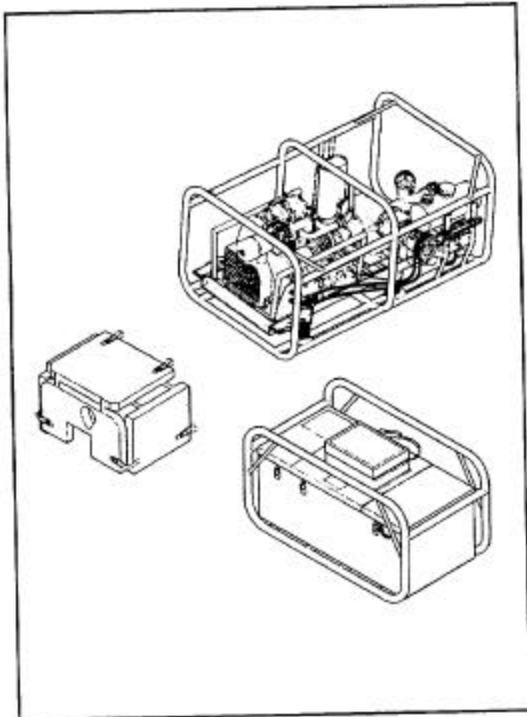

**PUMPING ASSEMBLY FOR
ADVANCED AVIATION
FORWARD AREA
REFUELING SYSTEM
(AAFARS)
NSN 4320-01-434-4653**

EQUIPMENT DESCRIPTION	1-5
PRINCIPLES OF OPERATION	1-10
CONTROLS AND INDICATORS	2-2
PREVENTIVE MAINTENANCE CHECKS AND SERVICES (PMCS)	2-3
OPERATION UNDER USUAL CONDITIONS	2-11
OPERATION UNDER UNUSUAL CONDITIONS	2-25
OPERATOR MAINTENANCE PROCEDURES	3-3
UNIT MAINTENANCE PROCEDURES	4-9
DIRECT SUPPORT MAINTENANCE PROCEDURES	5-7
GENERAL SUPPORT MAINTENANCE PROCEDURES	6-1

DISTRIBUTION STATEMENT A: Approved for Public Release; distribution is unlimited.

HEADQUARTERS, DEPARTMENT OF THE ARMY

1 MARCH 1999

WARNING SUMMARY**WARNING**

- **Death or personal injury may result from the explosion of fuel fumes exposed to an open flame or spark, or to static discharge. Do not permit smoking, any open flame, or spark producing equipment within fifty (50) feet of the pumping assembly. Ensure all equipment is well grounded prior to commencing any operation or maintenance task. Always ensure the ground connection from the aircraft is complete prior to beginning any fueling operation.**
- **The exhaust system will remain hot for some time after engine shut down. Avoid contact with exhaust system components until they have cooled sufficiently for safe handling. Serious personal injury may occur from contact with hot metal.**
- **DO NOT use diesel fuel, gasoline, or benzine (benzol) for cleaning.**
- **DO NOT SMOKE when using cleaning solvent. NEVER USE IT NEAR AN OPEN FLAME. Be sure there is a fire extinguisher nearby and use cleaning solvent only in well-ventilated places. Flash point of solvent is 138°F (600C).**
- **USE CAUTION when using cleaning solvents. Cleaning solvents evaporate quickly and can irritate exposed skin. In cold weather, contact of exposed skin with cleaning solvents can cause frostbite.**
- **All petroleum products contain additives that may be harmful to personnel and the environment. All leaks must be corrected as soon as possible. Wash fuel or oil from skin immediately. Remove and wash contaminated clothing immediately. Spills of fuel or oil must be cleaned up in accordance with local area direction to prevent harm to personnel or damage to the environment.**
- **Serious injury could occur if heavy equipment is moved/lifted without sufficient personnel to do the job. Use proper physical lifting procedures or use a suitable lifting device or dolly. Wear safety shoes, goggles and other suitable protective clothing.**
- **Use single hearing protection within 22 feet. Hearing can be permanently damaged if exposed to constant high noise.**
- **Carbon Monoxide (exhaust gas) can kill you. Operate system outdoors or duct system outdoors.**

FIRST AID

FIRST AID instructions are given in FM 21-11, First Aid For Soldiers.

HOW TO USE THIS MANUAL

Be sure you read all Warnings before using your equipment.

This manual incorporates a quick reference tab feature that allows you to quickly locate the most often referenced subjects and topics appearing in this manual. The quick tab feature is composed of the following components.

Cover Index Page

Index boxes are located on the right-hand edge of the cover page. Each box contains a subject title, page number and black index tab.

Table of Contents

The table of contents lists all the major subjects contained in this manual. Subjects that are surrounded by a black box correspond to those that appear on the cover page index.

Page Numbers and Index Tabs

Each page of this manual is identified with a two-part number consisting of the chapter number followed by the page number. Pages that contain the subjects identified on the cover page index also contain a black tab on the outside edge of the page, aligned with the cover page index tab.

To use the quick reference tab feature, select the title of the subject you are trying to find from the cover page index. You can turn to the indicated page number or bend the pages back and locate the page tab that aligns with cover index tab.

If the cover page index is lost or badly worn, page numbers and index tabs can be located by referring to the table of contents.

OPERATOR'S, UNIT, DIRECT SUPPORT AND GENERAL SUPPORT
MAINTENANCE MANUAL

PUMPING ASSEMBLY FOR
ADVANCED AVIATION FORWARD AREA REFUELING SYSTEM (AAFARS)
(NSN 4320-01-434-4653)

REPORTING ERRORS AND RECOMMENDING IMPROVEMENTS

You can help improve this publication. If you find any mistakes or if you know of a way to improve the procedures, please let us know. Submit your DA Form 2028-2 (Recommended Changes to Equipment Technical Publications), through the Internet, on the Army Electronic Product Support (AEPS) website. The Internet address is <http://aeps.ria.army.mil>. If you need a password, scroll down and click on "ACCESS REQUEST FORM". The DA Form 2028 is located in the ONLINE FORMS PROCESSING section of the AEPS. Fill out the form and click on SUBMIT. Using this form on the AEPS will enable us to respond quicker to your comments and better manage the DA Form 2028 program. You may also mail, fax or email your letter, DA Form 2028, or DA Form 2028-2 direct to: Commander, U.S. Army Tank automotive and Armaments Command, ATTN: AMSTA-AC-NML, Rock Island, IL 61299-7630. The email address is [amsta-ac-nml\(ria.army.mil\)](mailto:amsta-ac-nml(ria.army.mil)). The fax number is DSN 793-0726 or Commercial (309) 7820726.

Distribution Statement A: Approved for Public Release; distribution is unlimited.

TABLE OF CONTENTS

Page

CHAPTER 1	INTRODUCTION	1-1
Section I	General Information	1-1
Section II	Equipment Description	1-5
Section III	Principles of Operation	1-10
CHAPTER 2	OPERATING INSTRUCTIONS	2-1
Section I	Description and Use of Operator's Controls and Indicators	2-2
Section II	Operator'S Preventive Maintenance Checks and Services (PMCS)	2-3
Section III	Operation Under Usual Conditions	2-11
Section IV	Operation Under Unusual Conditions	2-25
CHAPTER 3	OPERATOR MAINTENANCE INSTRUCTIONS	3-1
Section I	Lubrication Instructions	3-1
Section II	Troubleshooting Procedures	3-1
Section III	Operator Maintenance Procedures	3-3
CHAPTER 4	UNIT MAINTENANCE	4-1
Section I	Lubrication Instructions	4-2
Section II	Service Upon Receipt	4-2
Section III	Unit Preventive Maintenance Checks and Services (PMCS)	4-3
Section IV	Unit Troubleshooting Procedures	4-7
Section V	Unit Maintenance Procedures	4-9
Section VI	Preparation for Storage or Shipment	4-55
CHAPTER 5	DIRECT SUPPORT MAINTENANCE	5-1
Section I	Direct Support Troubleshooting Procedures	5-1
Section II	Direct Support Maintenance Procedures	5-7
CHAPTER 6	GENERAL SUPPORT MAINTENANCE PROCEDURES	6-1
APPENDIX A	REFERENCES	A-1

TABLE OF CONTENTS (Continued)

	Page
APPENDIX B	MAINTENANCE ALLOCATION CHART (MAC).....B-1
APPENDIX C	REPAIR PARTS AND SPECIAL TOOLS LIST (RPSTL)C-1
APPENDIX D	COMPONENTS OF END ITEM (COEI) AND BASIC ISSUE ITEM (BII) LIST.....D-1
APPENDIX E	ADDITIONAL AUTHORIZATION LIST (AAL)E-1
APPENDIX F	EXPENDABLE/DURABLE SUPPLIES AND MATERIALS LIST (EDSML)F-1
APPENDIX G	ILLUSTRATED LIST OF MANUFACTURED ITEMSG-1
APPENDIX H	TORQUE LIMITSH-1
APPENDIX I	MANDATORY REPLACEMENT PARTS.....I-1
APPENDIX J	WIRING DIAGRAMS.....J-1
	ALPHABETIC INDEX.....Index-1

List of Illustrations

Figure		Page
1-1	Pumping Assembly, Advanced Aviation Forward Area Refueling System	1-4
1-2	Pump-Engine Module	1-6
1-3	Engine Module	1-7
1-4	Accessory Module.....	1-8
1-5	Power Subsystem.....	1-10
1-6	Fuel Transfer Pump	1-11
1-7	Control Panel	1-12
2-1	Control Panel	2-2
2-2	Engine Module Electrical Connection Panel	2-3
2-3	Typical AAFARS Setup.....	2-12
2-4	Engine Module Removal from Pump-Engine Module	2-14
2-5	Manual Throttle Control	2-14
2-6	Decals and Instruction Plates, Pump-Engine Module	2-18
2-7	Decals - Accessory Module	2-20
2-8	Instruction Plates - Accessory Module	2-21
3-1	Unisex Coupling Face Seal Replacement	3-4
4-1	Fuel Filter Replacement	4-10
4-2	Pumpage Overtemperature Sensor Replacement	4-12
4-3	Engine Air Filter Element Replacement	4-13
4-4	Air Filter Hose Replacement	4-14
4-5	Inlet Manifold Outlet O-Ring Replacement	4-16
4-6	Inlet Manifold Unisex Coupling Replacement	4-17
4-7	Flange Mount Unisex Coupling O-Ring Replacement	4-19
4-8	Flange Mounted Unisex Coupling Replacement	4-21
4-9	Fuel Transfer Pump Replacement	4-23
4-10	Fuel Transfer Pump Discharge Housing O-Ring Replacement	4-25
4-11	Fuel Transfer Pump Discharge Valve Replacement	4-26
4-12	Engine Module Carrying Handle Replacement	4-27
4-13	Pulley Guard Replacement	4-28
4-14	Alignment Bolt Replacement	4-29
4-15	Cable Assembly W01 Replacement	4-31
4-16	Starter Replacement	4-33

List of Illustrations (Continued)

Figure		Page
4-17	Fuel Pump Replacement	4-35
4-18	Valve Adjustment	4-37
4-19	Fuel Injector Removal	4-39
4-20	Fuel Injector Nozzle Cleaning	4-40
4-21	Exhaust Manifold Replacement	4-41
4-22	Intake Manifold Replacement	4-43
4-23	Decompression Arm O-Ring Replacement	4-44
4-24	Battery Replacement	4-46
4-25	Control Box Replacement	4-47
4-26	Battery Cable Repair.....	4-49
4-27	Control Cable W201 Replacement	4-51
4-28	Battery Holddown Repair	4-53
4-29	Data Plate Replacement	4-54
5-1	Pumping Assembly Interconnecting Diagram	5-4
5-2	Pumping Assembly Electrical Schematic	5-5
5-3	Fuel Transfer Pump Inlet O-Ring Replacement	5-8
5-4	Shaft Seal Assembly/O-Ring Replacement	5-10
5-5	Vane Pump Housing O-Ring Replacement	5-14
5-6	Rotary Vane Pump Repair	5-16
5-7	Three-Inch Valved Unisex Coupling Disassembly	5-20
5-8	Two-Inch Valved Unisex Coupling Disassembly	5-24
5-9	Control Panel Component Location.....	5-26
5-10	Control Panel Lamp/Panel Light Assembly Replacement	5-28
5-11	Panel Lights Dimmer Potentiometer R1 Replacement	5-30
5-12	Emergency Stop Switch Replacement	5-32
5-13	Control Panel Toggle Switch Replacement	5-34
5-14	Capacitor C1 Replacement	5-36
5-15	Circuit Breaker Replacement	5-38
5-16	Relay K1 Replacement	5-39
5-17	Voltage Regulator Replacement	5-41
6-1	Removal of Engine from Engine Module	6-4
6-2	Engine Oil Pan Removal	6-6
6-3	Shroud, Cylinder Casing and Gates Removal	6-9
6-4	Flywheel and Alternator Removal.....	6-11
6-5	Fuel Flow Solenoid Removal	6-12
6-6	Decompression Lever Removal	6-13
6-7	Fuel System Components Removal.....	6-15
6-8	Injection Pump Removal	6-16
6-9	Fuel Injector Removal	6-18
6-10	Cylinder Head Removal.....	6-20
6-11	Cylinder Removal	6-21
6-12	Piston and Rings Removal	6-23
6-13	Oil Pump Removal	6-24
6-14	Timing Cover Removal	6-26
6-15	Governor Assembly and Speed Control Removal	6-28
6-16	High Speed Adjustment Screw Removal	6-28

List of Illustrations (Continued)

Figure		Page
6-17	Camshaft and Valve Tappets Removal	6-29
6-18	Rear Crankshaft Support Removal	6-30
6-19	Crankshaft Gear, Crankshaft and Bearings Removal	6-32
6-20	Oil Pressure Relief Valve Removal	6-33
6-21	Cylinder Head Disassembly	6-35
6-22	Crankshaft Assembly	6-37
6-23	Front Crankshaft Bearing Installation.....	6-38
6-24	Rear Crankshaft Support Installation	6-40
6-25	Oil Pressure Relief Valve Installation.....	6-41
6-26	Piston Ring Installation	6-43
6-27	Cylinder Check	6-45
6-28	Piston Assembly Installation	6-47
6-29	Camshaft Inspection	6-48
6-30	Camshaft and Tappet Installation	6-49
6-31	Governor and Speed Control Installation	6-52
6-32	High Speed Adjustment Installation.....	6-52
6-33	Oil Pump Installation	6-54
6-34	Timing Cover Installation.....	6-56
6-35	Piston Protrusion Check.....	6-56
6-36	Cylinder Head Repair and Assembly	6-59
6-37	Pushrod Measurement	6-61
6-38	Injector Protrusion Measurement	6-62
6-39	Cylinder Head Installation	6-63
6-40	Cylinder Head Alignment	6-64
6-41	Flywheel/Alternator Installation	6-66
6-42	Injection Pump Installation.....	6-68
6-43	Fuel Injector Nozzle Cleaning	6-70
6-44	Fuel Injector Installation	6-71
6-45	Fuel Pump Installation.....	6-72
6-46	Valve Cover Installation.....	6-73
6-47	Decompression Lever Installation	6-74
6-48	Fuel Flow Solenoid Installation	6-76
6-49	Oil Pan Installation	6-78
6-50	Shroud, Gates and Oil Cooler Installation	6-81
6-51	Engine Flexible Coupling Adapter and Guard Installation	6-82
6-52	Installation of Engine in Engine Module.....	6-84
6-53	Fuel Injection Pump Timing Adjustment	6-87
6-54	Casing Installation.....	6-88

CHAPTER 1 INTRODUCTION

Section I. GENERAL INFORMATION

1.1 SCOPE.

Type of Manual:	Operator's, Unit, Direct Support and General Support Maintenance Including Repair Parts and Special Tools List (RPSTL)
Model Number and Name:	Pumping Assembly, Advanced Aviation Forward Area Refueling System, Part Number 13230E5865
Purpose of Equipment:	To provide a day or night, soldier-portable, pumping assembly capable of providing fuel at a rate of fifty-five gallons per minute to each of four nozzles separated by a distance of 100 feet (30.5 m), and to operate satisfactorily from 120°F (48.9°C) to -25°F (-31.7°C).

1.2 MAINTENANCE FORMS AND PROCEDURES.

Department of the Army forms and procedures used for equipment maintenance will be those prescribed by DA Pam 738-750 as contained in Maintenance Management Update.

1.3 CORROSION PREVENTION AND CONTROL.

Corrosion Prevention and Control (CPC) of Army material is a continuing concern. It is important that any corrosion problem with this item be reported so that the problem can be corrected and improvements can be made to prevent the problem in future items.

While corrosion is typically associated with rusting of metals, it can also include deterioration of other materials such as rubber and plastic. Unusual cracking, softening, swelling, or breaking of these materials may be a corrosion problem.

If a corrosion problem is identified, it can be reported using Standard Form 368, Product Quality Deficiency Report. Use of keywords such as "corrosion", "rust", "deterioration", or "cracking" will ensure that the information is identified as a CPC problem. The form should be submitted to the address specified in DA Pam 738-750.

1.4 SAFETY, CARE AND HANDLING.

The pumping assembly may be used to pump various fuels. It must be assumed that residual fuel and fuel vapors are always present in the pumping assembly, even after draining or purging. Therefore the equipment must always be handled with the same degree of caution as actual fuel. One or more fully charged fire extinguishers must be present at all times, not only during fueling operation. In addition, fuels may contain toxic additives. Rubber gloves should always be worn when handling pumping assembly components that are in regular contact with fuel.

A static electric charge is always present in all fuels. The charge increases when the fuel is being pumped, stirred, shook, or splashed. Any physical movement of the fuel will increase the static charge. If the charge is allowed to build sufficiently it will discharge, causing a spark that will ignite fuel vapors. The build up of static electric charge is controlled by bonding and grounding of all fuel handling equipment. Ground rods and grounding cable assemblies must be inspected, maintained and used consistently and conscientiously to prevent fuel ignition due to electrostatic discharge.

Fuels are dangerous under all conditions. Always observe fuel handling safety precautions.

1.5 DESTRUCTION OF MATERIEL TO PREVENT ENEMY USE.

Refer to TM 750-244-3 for information and instructions covering destruction of Army Materiel.

1.6 REPORTING EQUIPMENT IMPROVEMENT RECOMMENDATIONS (EIR).

If your pumping assembly needs improvement, let us know. Send us an EIR. You, the user, are the only one who can tell us what you don't like about your equipment. Let us know why you don't like the design or performance. Put it on an SF 368 (Product Quality Deficiency Report). Mail it to us at:

Commander
U.S. Army Tank-Automotive and Armaments

Command, ATTN: AMSTA-TR-E/MPA Warren, Mi. 48397-50000. We will send you a reply.

We will send you a reply.

1.7 REFERENCE INFORMATION.

1.7.1 List of Abbreviations.

AMP	Ampere
C	Centigrade
CAGEC	Commercial and Government Entity Code
cm	centimeter
cm ²	square centimeter
cm ³	cubic centimeter
DC	Direct Current
F	Fahrenheit
ft	foot
GFE	Government Furnished Equipment
gpm	gallons per minute
HP	Horsepower
in	inch
L	Liter
lb	pound
lpm	liters per minute
Max	Maximum
m	meter
mm	millimeter
PMCS	Preventive Maintenance Checks and Services
psi	pounds per square inch
PTO	Power Take Off
QD	Quick Disconnect
qt	quart
QTY	Quantity
RPM	Revolutions Per Minute
SMR code	Source, Maintenance and Recoverability Code
VDC	Volts, Direct Current

1.7.2 Glossary.

Bonding	Electrically connecting units before operations begin in order to equalize any static potential that might exist and to provide a continuous path for any static potential that might be generated after operations begin. Static potential is eliminated or prevented by grounding one or more of the bonded units.
Defective	Condition of a part that prevents the part from performing its intended function, caused by normal aging, accident or manufacturing imperfection.
Deterioration	Condition of a part caused by weathering, excessive heat, excessive cold, chemical action, etc.
Dry break	Separation of couplings without loss of fuel.
Energize	Apply electrical power.
Grounding	Connecting single or bonded units to a ground rod so that any static potential will be discharged into the earth. If two or more units are bonded and one is grounded, the entire system is effectively grounded.
Malfunction	Failure to operate normally.
Monitor	To observe a condition or operation such as that indicated by an indicator light or meter.
Pumpage	The fluid being pumped by the fuel transfer pump

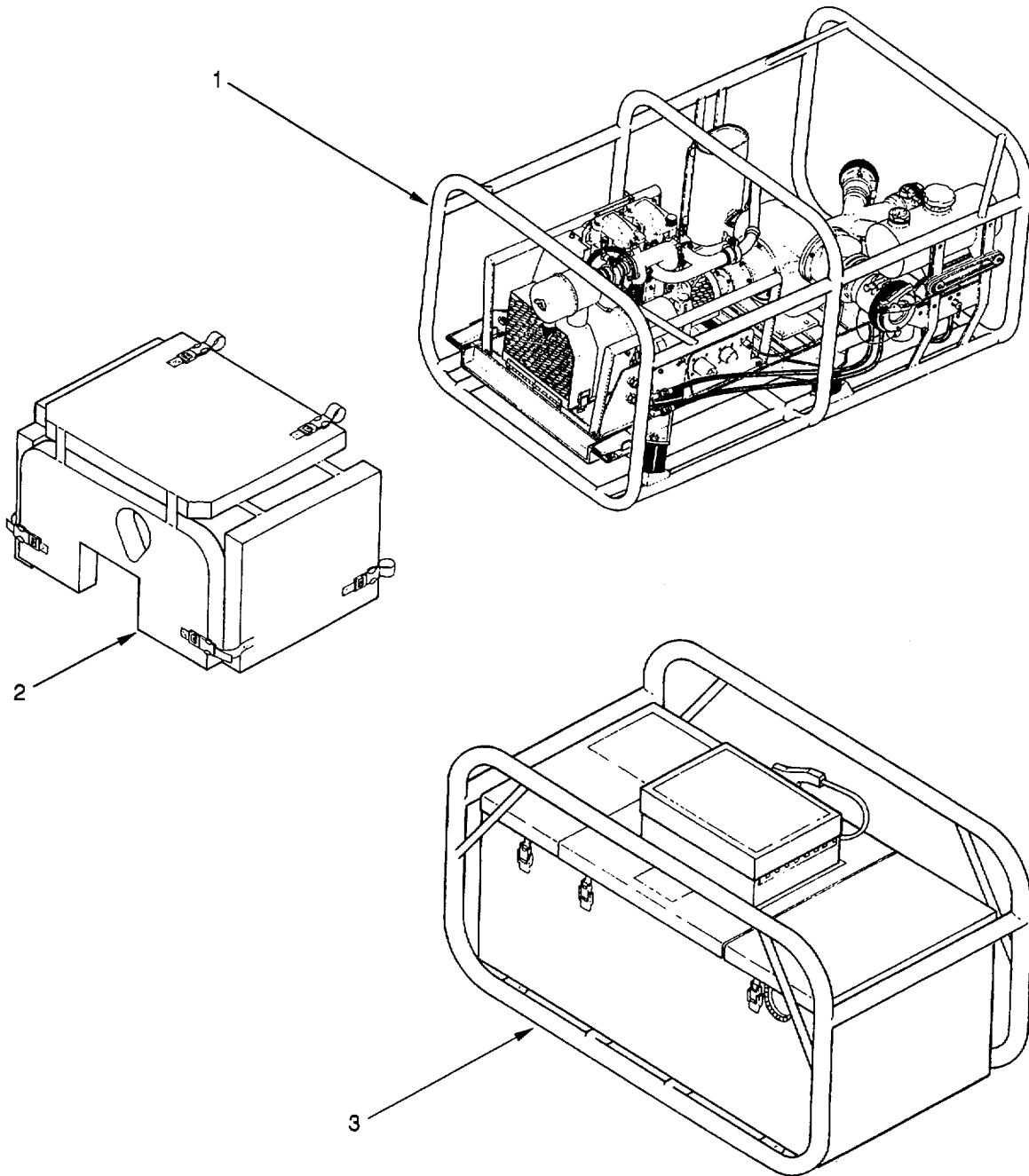

Figure 1-1. Pumping Assembly, Advanced Aviation Forward Area Refueling System

Section II. EQUIPMENT DESCRIPTION

1.8 CHARACTERISTICS, CAPABILITIES AND FEATURES. (Refer to figure 1-1.)

The Pumping Assembly is a modular, soldier-portable pumping system. It can pump fifty-five gallons per minute to each of four nozzles 100 feet apart. The system will operate properly from 120°F (48.9°C) to -250F (-31.7°C). It will pump and run the engine on JP-4, JP-5 or JP-8 jet fuel.

The pumping assembly consists of the pump-engine module (1), an optional acoustic cover (2) and the accessory module (3). The pump-engine module houses a self-priming pump that provides a flow of 225 gpm at 3400 rpm. The prime mover is a removable engine that connects to the pump by a flexible coupling. The acoustic cover fits over the engine and reduces engine noise to an acceptable level. Inlet and outlet points feature valved unisex dry-break couplings. Valved unisex couplings can be connected or disconnected only when the valves are closed. This allows components to be disconnected without fuel spills. When connected (with valves open) the unisex couplings are locked together. They cannot be disconnected by accident.

The accessory module houses a 28 VDC battery for starting the engine and a control box for single point operator control. The module also includes storage space for the starter and control cables (which are connected to the pump-engine module during operation). The detachable engine air filter and the starter rope are also stored in this module.

The engine is a two cylinder, air cooled diesel with direct fuel injection. Cooling air is provided by the flywheel fan; air circulation is controlled by shrouds that conduct the air over the block. The engine is normally started by an electric starter. A notched pulley is provided for manual (rope) starting if required. A manually operated compression release relieves engine compression force during a manual start. The manual start feature allows the engine to be started and run without the accessory module.

1.9 LOCATION AND DESCRIPTION OF MAJOR COMPONENTS.

The Pumping Assembly, illustrated in figure 1-1, consists of the Pump-Engine module, the Accessory module and interconnecting cables.

1.9.1 Pump-Engine Module. (Refer to figure 1-2.)

The Pump-Engine module (1) consists of:

- a. A removable engine module (2) that slides in or out on plastic glides. Adjustable-force latches (3) secure the engine module to the pump-engine module.
- b. A muffler (4) with a replaceable insulating cover.
- c. An exhaust line (5) with a replaceable insulating cover. An over-center clamp (6) connects the exhaust line to the engine exhaust manifold.
- d. A shaft-driven fuel transfer pump (7) with a positive displacement rotary vane priming pump mounted internally on the same shaft as the main impeller.
- e. A three-way inlet manifold (8) with each leg terminated by a two-inch, valved unisex coupling (9). The inlet manifold is coupled directly to the inlet of the fuel transfer pump.

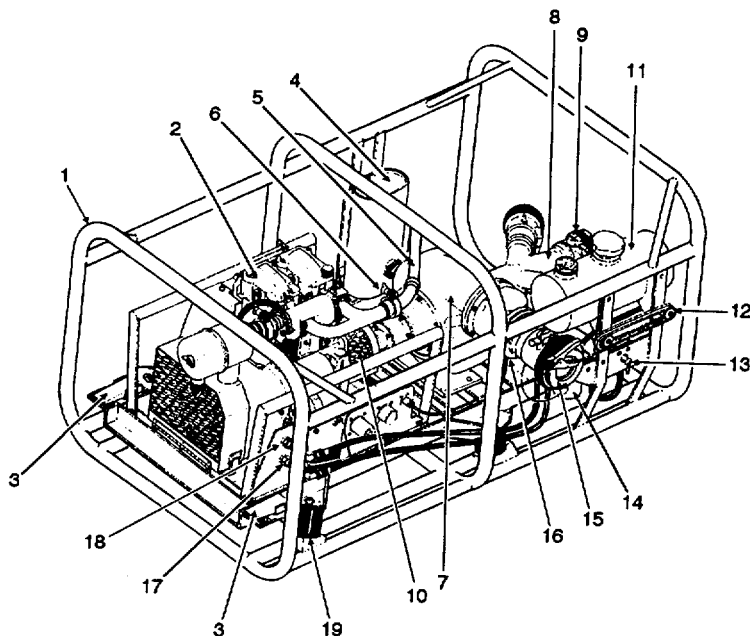

Figure 1-2. Pump-Engine Module

- f. A detachable flexible coupling (10) connects the engine output shaft to the fuel transfer pump input shaft.
- g. A 1.2 gallon (4.5 liter) fuel tank (11) provides sufficient fuel to operate the engine for at least one hour fifteen minutes under full load.
- h. A 12 ft (3.65 m) ground cable assembly (12) is stowed on two spools mounted below the fuel tank.
- i. A three-position fuel selector valve (13) allows engine fuel to be supplied from the fuel tank or an external source.
- j. A canister type filter/water coalescer assembly (14) is mounted downstream of the fuel selector valve to remove impurities and water from the fuel before it reaches the engine.
- k. A three-inch, valved unisex coupling (15) at the pump outlet provides connection to a three-inch discharge hose and also serves as an emergency shutoff valve.
- l. An overtemperature sensor (16) located at the underside of the fuel transfer pump outlet will shut down the engine if the pumpage temperature reaches 175°F (79°C).
- m. An engine fuel supply line (17) terminated with a quick disconnect fitting to facilitate removal and installation of the engine module.
- n. An engine fuel return line (18) terminated with a quick disconnect fitting to facilitate removal and installation of the engine module.
- o. Four solid rubber shock mounts (19) to support and isolate the engine and fuel transfer pump from the module frame.

1.9.1.1 Engine Module. (Refer to figure 1-3.)

The engine module (1) consists of:

- a. A 17-horsepower diesel engine (2) which serves as the prime mover for the pumping assembly.
- b. Carrying handles (3) on either side of the engine module that allow the engine module to be carried by four persons.
- c. Alignment bolts (4) that engage slots in the pump-engine module frame to eliminate movement from engine vibration.
- d. A detachable air filter (5) which is attached by an over-center clamp (6) to the engine intake manifold (7) during setup. (The air filter is stowed, transported and accounted for in the accessory module.)
- e. A Power Take Off (PTO) guard (8) covers the engine output shaft and flexible coupling adapter to provide protection from rotating parts on the rear of the engine.
- f. A pulley guard (9) encloses the engine pulley to provide protection from rotating parts on the front of the engine.
- g. A female quick disconnect fitting (10) is used to connect the fuel supply line from the pump-engine module to the engine module.
- h. A male quick disconnect fitting (11) is used to connect the fuel return line from the engine module to the pump-engine module.
- i. A group of electrical connectors (12) are used to connect the battery power cable, the control cable and the pumpage overtemperature cable to the engine module.

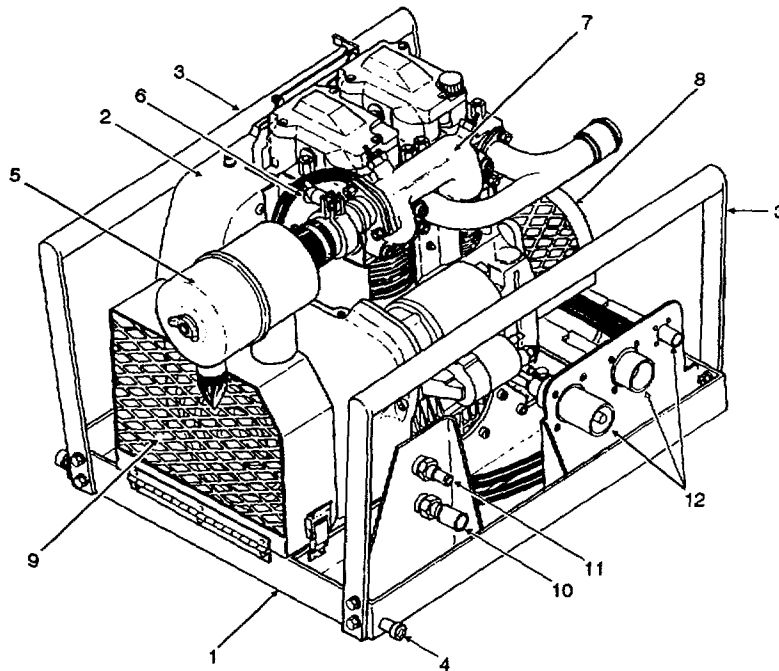

Figure 1-3. Engine Module

1.9.2 Accessory Module. (Refer to figure 1-4.)

The accessory module (1) consists of:

- a. A tubular frame housing a three-compartment chest (2). A 28 VDC maintenance free aircraft battery (3) is located inside the center compartment (4). A two-conductor battery power cable (W202) (5) with an auxiliary pump power leg (6) is connected to the battery and stowed in the right-hand compartment (7) of the chest. A multi-conductor control cable (W201) (8) is connected to the control box and also stowed in the right-hand compartment of the chest. The left-hand storage compartment (9) is used to stow the engine air cleaner and manual starter rope during transport.
- b. A control box (10) located on top of the center compartment contains the voltage regulator and control panel. Controls and indicators on the control panel, including an emergency stop switch, are used to start and stop the engine and to indicate system malfunctions. A ground cable (11) is attached to a stud on the rear of the control box.

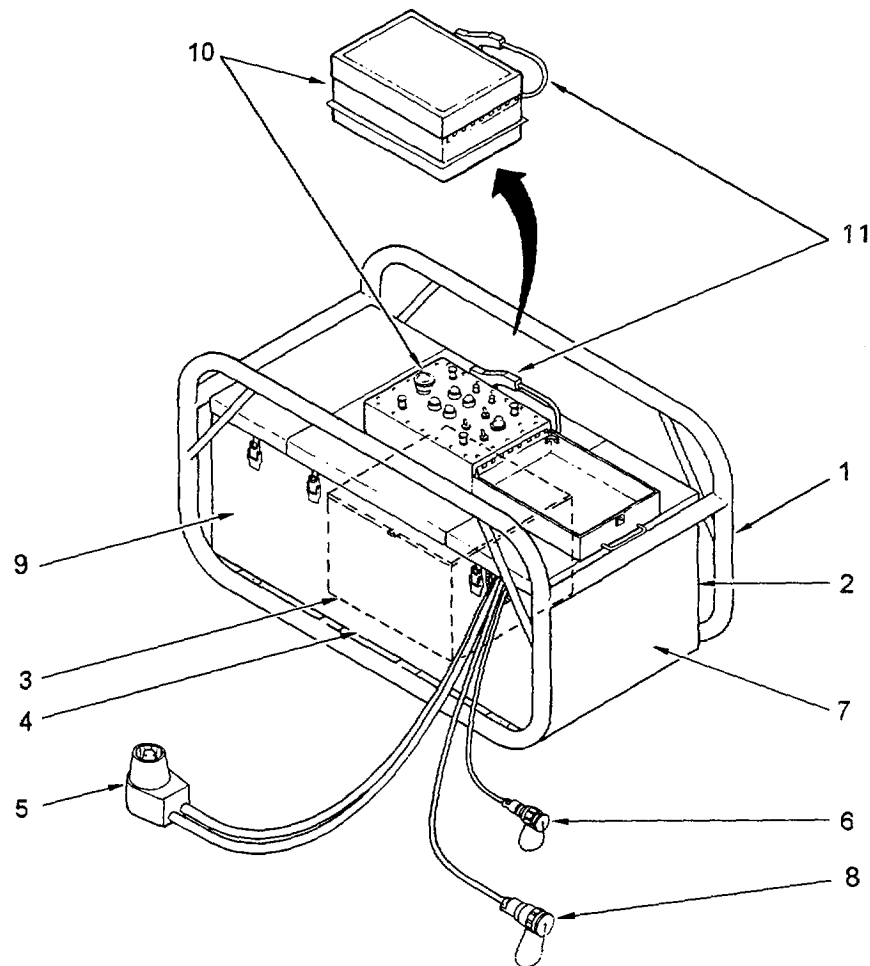

Figure 1-4. Accessory Module

1.10 EQUIPMENT DATA.

The following is a tabular presentation of all physical and performance data required for operation and/or unit level, direct support and general support maintenance.

Table 1-1. Equipment Data

Description	Quantity	Leading Particulars	
Pump-Engine Module	1	Dry Weight:	336 lbs (152.4 kg) with Engine Module installed 170 lbs (77.1 kg) with Engine Module removed
		Length:	56 in (1422.4 mm)
		Width:	36.25 in (920.8 mm)
		Height:	28 in (711.2 mm)
		Fuel Tank Capacity:	1.2 gal (4.5 l)
Engine Module		Weight:	166 lbs (75.3 kg)
		Length:	23 in (584 mm)
		Width:	20.5 in (520.7 mm)
		Height:	19.5 in (495.3 mm)
Engine		Shipping volume:	5.32 cu ft (0.15m ³)
		Deutz Ruggerini Model MD 191 Four Cycle, Air Cooled, Direct-Injected Diesel 2 cylinder Displacement: 52 cu. in. (851 cm ³) Output (max): 19 HP @ 3400 RPM Torque (max): 29.9 ft. lbs (40.5 nm) @ 2400 RPM Compression ratio: 19:1 Dry weight: 117 lbs (53 kg) Oil Capacity: 1.9 qt (1.8 l)	
Fuel Transfer Pump		Weight:	39 lbs (17.7 kg)
		Operating Temperature Range:	120°F (48.9 C) to -25o F (-31.7 C)
		Flow Rate:	225 gpm (852 lpm) minimum
Accessory Module	1	Weight:	156 lbs (70.76 kg) with battery installed 78 lbs (35.4 kg) with battery removed
		Length:	40.25 in (1022.4 mm)
		Width:	21.75 in (552.5 mm)
		Height:	22 in (558.8 mm)
Battery		Shipping volume:	11.14 cu ft (0.32 m ³)
		Weight:	80 lbs (36.4 kg)

Section III. PRINCIPLES OF OPERATION

1-11 GENERAL FUNCTIONAL DESCRIPTION.

1.11.1 System Power. (Refer to figure 1-5.)

The diesel engine (1), fuel tank (2), fuel selector valve (3), fuel filter (4), and fuel supply line (5) and fuel return line (6) comprise the pumping assembly power system. A splined flexible coupling adapter (7) on the diesel engine output shaft mates with a flexible coupling (8) on the input shaft of the fuel transfer pump to move the pumpage.

The diesel is a compression ignition engine: ignition is achieved by compressing a fuel-air mixture in a cylinder until the heat generated by compression causes the mixture to ignite. The resulting combustion causes the mixture to expand, forcing the piston to move. The diesel engine is a two cylinder, direct injection engine. An individual fuel injector and injection pump supplies pressurized fuel alternately to each cylinder. The engine is set to run at 3400 rpm, the optimum speed for the fuel transfer pump to provide a 225 gpm (852 lpm) flow. A flyweight governor operates from the camshaft to maintain engine speed constant.

An on board fuel tank is the normal fuel source for engine operation. However, a fuel selector valve allows selection of an external fuel source, if desired. JP-4, JP-5 or JP-8 jet fuel may be used. A fuel filter/water coalescer in the supply line removes impurities and water from the fuel, regardless of the source. The engine fuel pump continuously supplies fuel to the fuel injection pumps; a fuel return line allows surplus fuel to return to the fuel tank.

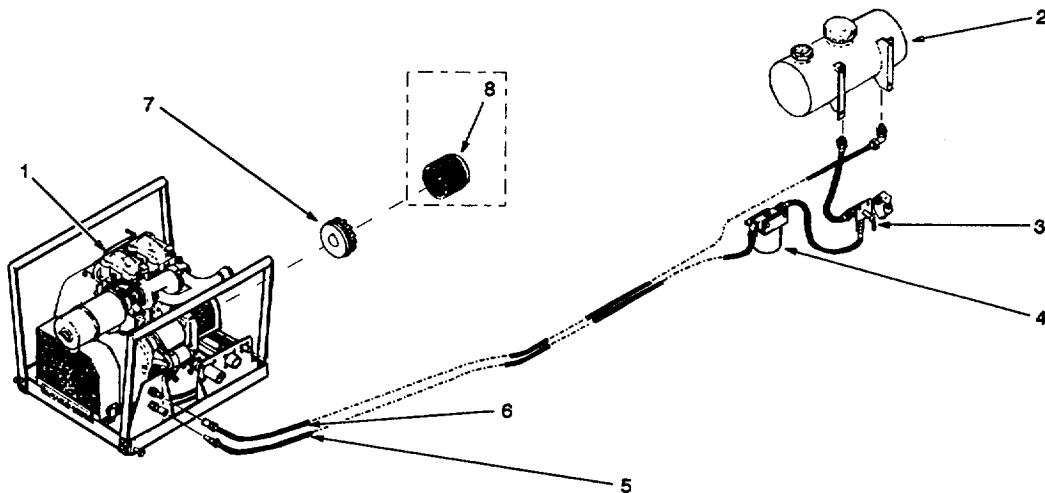

Figure 1-5. Power Subsystem

1.11.2 Fuel Transfer Pump. (Refer to figure 1-6.)

The fuel transfer pump (1) is a centrifugal pump with a precision ground impeller. A positive displacement, rotary vane pump on the same shaft serves as a priming pump for the main impeller. This allows the pump to be started with a dry system. Fuel is drawn from the fuel drums through suction hoses into a three-way inlet manifold (2). The convergence of the three streams of fuel creates a swirling motion in the body of the manifold which, if not corrected, would cause a heavy load on the pump. To correct this situation, three equally spaced fins in the manifold outlet straighten the flow, reducing pump loading and increasing efficiency. The inlet manifold empties directly into the main impeller cavity of the fuel transfer pump which discharges the pumpage through a discharge housing (4) to the filtration module. A flapper check valve (3) in the discharge housing (4) prevents back flow to the fuel transfer pump.

The priming pump draws a suction on the fuel transfer pump inlet and discharges through a small outlet below the check valve. The check valve is closed until the main impeller forces it open with pumpage flow. As long as the check valve is closed, the priming pump continues to draw a suction. When the pumpage flow opens the check valve, pressure equalizes across the priming pump and it loses suction. If pumpage flow is interrupted, the check valve closes and the priming pump again draws a suction. If the system is flooded by gravity before starting, the priming pump has no effect.

The pump is designed to be operated at a constant speed of 3,600 rpm but can operate continuously at any lower speed as long as the graphite journal bearings are lubricated. The pump can operate dry for periods of up to fifteen minutes without lubrication. However, the pump should not be operated partially wet. If the pump has been running wet and the inlet is depleted or closed, some pumpage will remain in the pump. The amount remaining will be sufficient to load the impeller but not sufficient for pressurized lubrication of the bearings. Under this condition, the bearings will overheat and seize, or deteriorate rapidly.

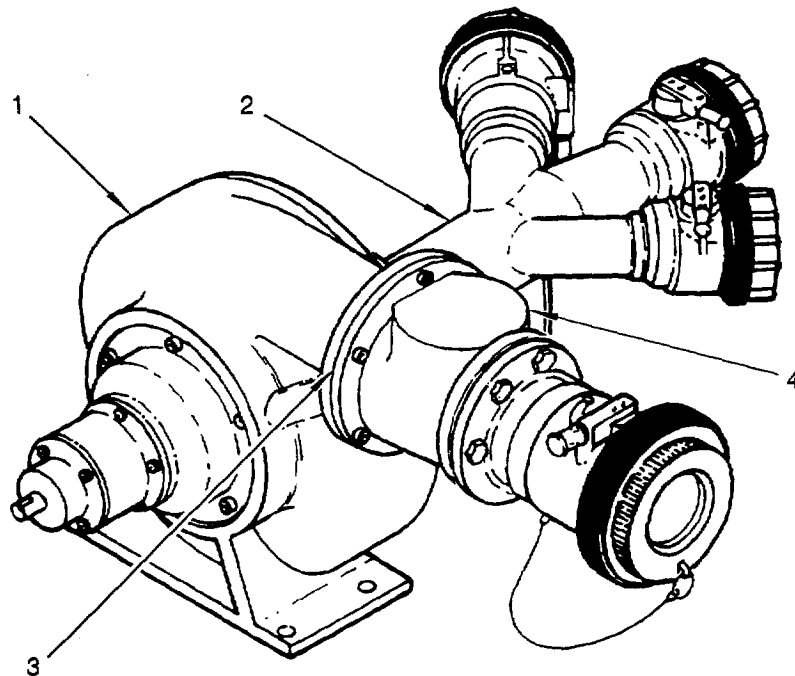

Figure 1-6. Fuel Transfer Pump

1.11.3 System Electrical. (Refer to figure 1-7.)

All electrical power distribution, control and monitoring is performed by the electrical system. The system consists of the system battery; the control panel; the alternator; the voltage regulator; the engine starting motor; the auxiliary pump; various engine and pumpage sensors and controls; and the interconnecting cables. All electrical components except the battery and the auxiliary pump are controlled or monitored by the control panel (1).

The ENGINE START-RUN-STOP (2) switch operates the starter to start the diesel engine and shuts off the fuel supply to stop the diesel engine. The INTAKE HEATER switch (3) supplies power to the intake heater on the diesel engine to make starting easier in cold weather. The EMERGENCY STOP switch (4) shuts off the fuel supply to the diesel engine when pushed in. Four fault lights provide indication of a problem in the system:

- The ENGINE HOT indicator (5) lights if the engine oil becomes too hot for normal operation.
- The ALTNTR indicator (6) lights if the alternator voltage drops to less than the battery voltage.
- The LOW OIL PRESSURE indicator (7) lights if the engine oil pressure drops too low for normal operation.
- The PUMPAGE HOT indicator (8) lights if the system pumpage becomes too hot for safety. A separate circuit stops the engine.

The FAULT LIGHTS switch (9) allows the operator to disable the fault indicators during a blackout. A 5 amp circuit breaker (10) opens and removes all electrical power from the pumping assembly if a malfunction or overload causes power usage to exceed five amps. A 30 amp circuit breaker (11) protects the intake heater and auxiliary pump, if used. Four panel lights (12) provide illumination for night operations. The PANEL LIGHTS dimmer control (13) allows the operator to control the brightness of the panel lights.

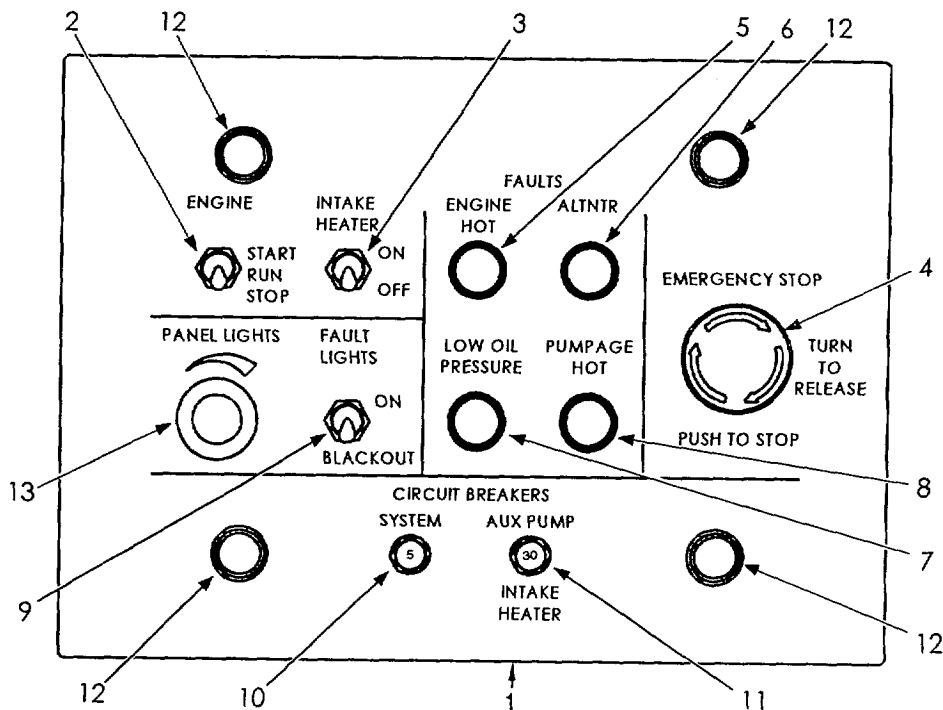

Figure 1-7. Control Panel

CHAPTER 2
OPERATING INSTRUCTIONS

		Page
Section I	Description and Use of Operator's Controls and Indicators	2-2
Section II	Operator Preventive Maintenance Checks and Services (PMCS)	2-3
2.1	General	2-3
2.2	Leakage Criteria	2-4
2.3	PMCS Procedures	2-5
Section III	Operation Under Usual Conditions	2-11
2.4	System Assembly and Preparation for Use	2-11
2.5	Operating Procedures	2-16
2.6	Normal System Shutdown	2-17
2.7	Emergency System Shutdown	2-18
2.8	Decals and Instruction Plates	2-18
2.9	Preparation for Movement	2-24
Section IV	Operation Under Unusual Conditions	2-25
2.10	Operation Under Extreme Environmental Conditions	2-25
2.11	Emergency Operating Procedures	2-26
2.12	NBC Decontamination	2-27/(2-28 blank)

Section I. DESCRIPTION AND USE OF OPERATOR'S CONTROLS AND INDICATORS

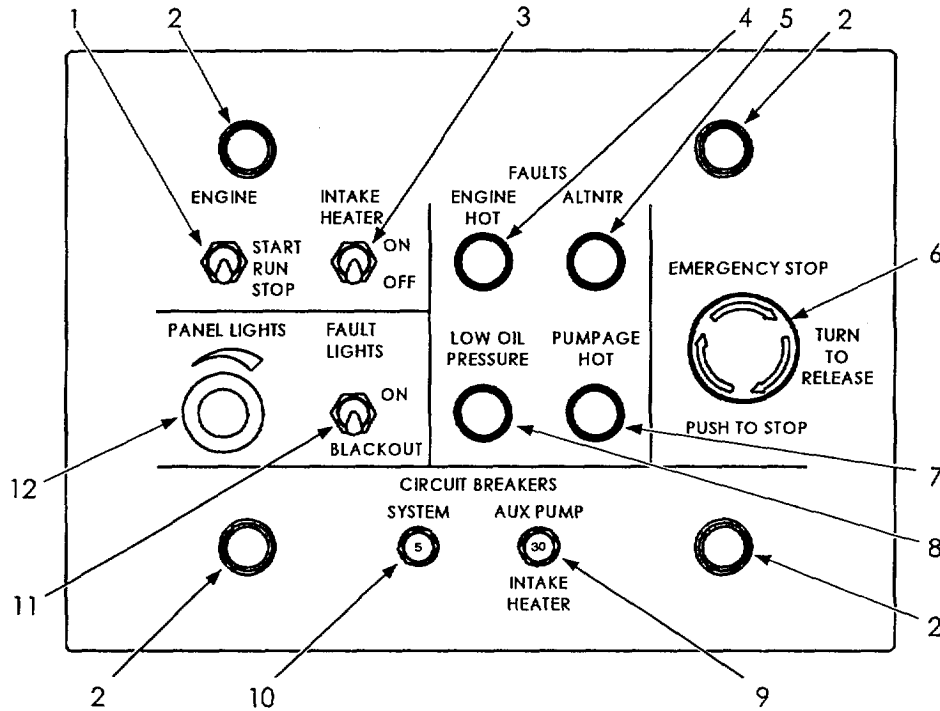

Figure 2-1. Control Panel

Table 2-1. Control Panel Controls and Indicators

No	Name	Function
1	ENGINE START/RUN/STOP toggle switch	Momentary START position operates engine starter; RUN position enables system operating power; STOP position stops engine.
2	Panel Light	Hooded LEDs provide illumination for control panel.
3	INTAKE HEATER ON/OFF switch	Enables power to engine intake air heater.
4	ENGINE HOT indicator	Illuminates RED when engine oil temperature exceeds 275°F (135°C).
5	ALTNTR indicator	Illuminates YELLOW when alternator output is less than battery voltage.
6	EMERGENCY STOP operator	Stops engine when depressed; latches in stop position, must be rotated in direction of arrows to release.
7	PUMPAGE HOT indicator	Illuminates RED when pumpage temperature exceeds 175°F (79°C).
8	LOW OIL PRESSURE indicator	Illuminates RED when engine oil pressure decreases below safe limits.
9	AUX PUMP/INTAKE HEATER circuit breaker	30 amp, push-to-reset circuit breaker for auxiliary pump and engine intake heater.
10	SYSTEM circuit breaker	5 amp, push-to-reset circuit breaker for system electrical power.
11	FAULT LIGHTS ON/BLACKOUT switch	Enables/disables control panel fault lights and panel lights.
12	PANEL LIGHTS dimmer	Dims or brightens panel lights when rotated.

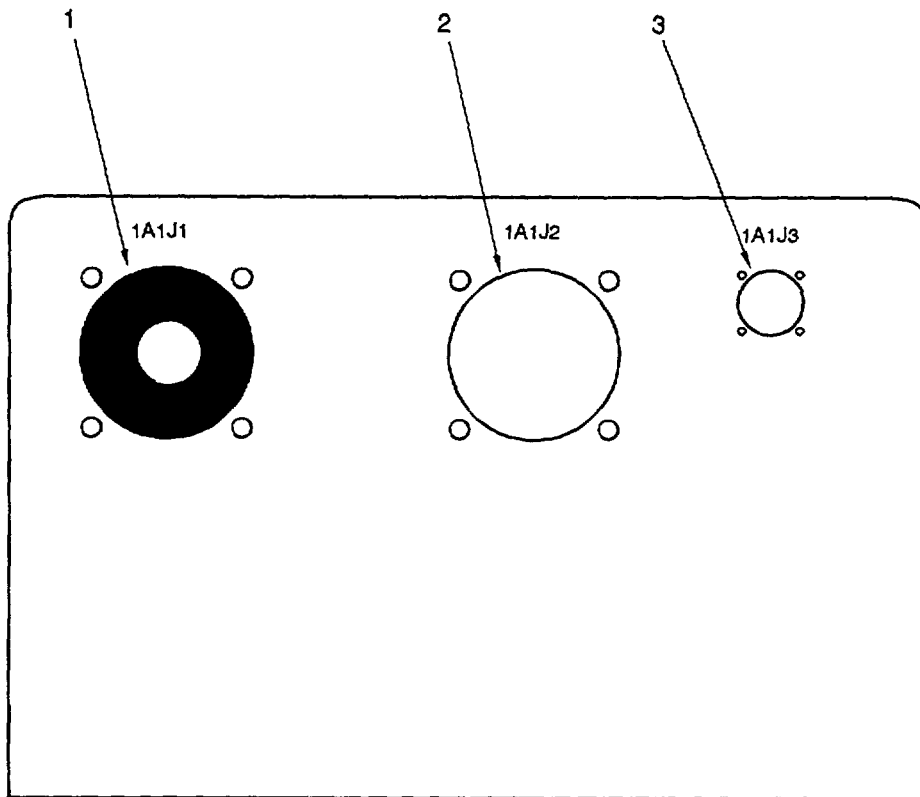

Figure 2-2. Engine Module Electrical Connection Panel

Table 2-2. Electrical Connection Panel Connectors

No.	Name	Function
1	NATO Connector 1A1J1	Battery input connector or other external 28 VDC source.
2	Connector 1A1J2	Control cable connector from accessory module.
3	Connector 1A1J3	Pumpage overtemperature sensor cable connector.

Section II. OPERATOR PREVENTIVE MAINTENANCE CHECKS AND SERVICES (PMCS)

2.1 GENERAL.

Preventive Maintenance Checks and Services (PMCS) involves systematic caring, inspection, and servicing of equipment to keep it in good condition and prevent breakdowns. Table 2-3 lists the pumping assembly PMCS. Service intervals are divided into categories: B - Before Operation; D - During Operation; A - After Operation; and various other checks and services to be performed at prescribed hourly intervals. Table 2-3 organizes your PMCS tasks in chronological sequence. As the pumping assembly operator, you should:

- a. Perform your PMCS as scheduled in table 2-3. Always do your PMCS in the same order, so it gets to be a habit. Always assume explosive vapors are present at the pumping assembly. Do not allow any smoking or spark producing equipment within fifty feet of the pumping assembly while performing your PMCS.

- b Do your BEFORE (B) PMCS prior to the equipment leaving its staging/service area or performing its intended mission. Keep in mind the WARNINGS and CAUTIONS.
- c. Do your DURING (D) PMCS during pumping assembly operation. Leaks can be spotted only during operation. Keep in mind the WARNINGS and CAUTIONS.
- d. Do your AFTER (A) PMCS as soon as possible after the pumping assembly has been taken out of its mission mode or returned to its containment area. Keep in mind the WARNINGS and CAUTIONS.
- e. If your equipment fails to operate, perform the operator troubleshooting procedures presented in this manual. Report unresolved maintenance problems to unit maintenance personnel.

WARNING

- **DO NOT use diesel fuel, gasoline, or benzine (benzol) for cleaning.**
- **DO NOT SMOKE when using cleaning solvent. NEVER USE IT NEAR AN OPEN FLAME. Be sure there is a fire extinguisher nearby and use cleaning solvent only in well-ventilated places. Flash point of solvent is 138° F (60° C).**
- **USE CAUTION when using cleaning solvents. Cleaning solvents evaporate quickly and can irritate exposed skin. In cold weather, contact of exposed skin with cleaning solvents can cause frostbite.**

- f. Cleanliness. Dirt, grease, oil and debris only get in the way and may cover up a serious problem. Use dry cleaning solvent SD (P-D-680) or some other suitable cleaning solvent on all metal surfaces.
- g. Bolts, Nuts and Screws. Check bolts, nuts and screws for obvious looseness and missing, bent or broken conditions. Look for chipped paint, bare metal or rust around bolt heads. If any part is loose, notify Unit Maintenance.
- h. Welds. Look for loose or chipped paint, rust or gaps where parts are welded together. If a bad weld is found, notify Unit Maintenance.
- i. Electric Wires and Connections. Look for cracked or broken insulation, bare wires and loose connectors. If a bad wire or connector is found, notify Unit Maintenance.

2.2 LEAKAGE CRITERIA.

Wetness around seals, gaskets, fittings or connections indicates leakage. A stain also indicates leakage. If a fitting or connector is loose, broken or defective, report it. Definitions of the classes of leaks are listed below. Become familiar with each class of leak so that you are aware of the status of your equipment. When in doubt, notify your supervisor.

WARNING

All petroleum products contain additives that may be harmful to personnel and the environment. All leaks must be corrected as soon as possible. Wash fuel or oil from skin immediately. Remove and wash contaminated clothing immediately. Spills of fuel or oil must be cleaned up in accordance with local area direction to prevent harm to personnel or damage to the environment.

CAUTION

Equipment operation is allowable with minor oil leakages (Class I or Class II). If leakage is present at the engine, check lubricating oil level more often than usual. Do not allow oil level to fall below the ADD OIL mark. When in doubt, notify your supervisor.

- a. Class I - Leakage indicated by wetness or discoloration not great enough to form drops.
- b. Class II - Leakage great enough to form drops but not enough to cause drops to drip from item being checked or inspected.
- c. Class III - Leakage great enough to form drops that fall from item being checked or inspected.

2.3 PMCS PROCEDURES.

Table 2-3 lists the checks and services required to keep your pumping assembly in good operating condition. They are listed in chronological order and should be performed in this order so they become a habit. An explanation of each column is provided below.

- a. The "Item No." column provides the sequential identification number for each task.
- b. The "Interval" column tells you when to do a certain check or service.
- c. The "Location - Item to Check/Service" column tells you on which item the procedure is performed.
- d. The "Procedure" column tells you how to do the required checks and services. Carefully follow these instructions. If you do not have the required tools, or if the procedure tells you to, notify your supervisor.
- e. The "Not Fully Mission Capable If" column tells you the conditions under which your pumping assembly is not capable of performing its intended mission.

Table 2-3. Operator's Preventive Maintenance Checks and Services for Pumping Assembly

Item No.	Interval	Location Item to Check/ Service	Procedure	Not Fully Mission Capable if:
1	Before	Pump-Engine Module	<p style="text-align: center;">WARNING</p> <ul style="list-style-type: none"> · Fuel fumes are always present in the vicinity of the Pumping Assembly. Death or personal injury may result from the explosion of fuel fumes exposed to an open flame or spark. Do not permit any smoking, any open flame or spark producing equipment within 50 feet (15 m) of the Pumping Assembly. · Be sure the flex coupling guard is in place. <p>Check engine crankcase oil level on dipstick (1). Oil is at correct level when between upper (2) and lower (3) marks on dipstick. Top off at oil filler (4) as necessary with:</p> <p style="padding-left: 40px;">-25°F (-17°C) to +40°F (4.5°C): MIL-L-46167 OEA (SAE 0W-20)</p> <p style="padding-left: 40px;">+5°F (-15°C) to +120°F (49°C): MIL-L-2104 OE/HDO-15/40 (SAE 15W-40)</p> 	Oil level is above upper mark or below lower mark on dipstick.

Table 2-3. Operator's Preventive Maintenance Checks and Services for Pumping Assembly

Item No.	Interval	Location	Procedure	Not Fully Mission Capable if:
		Item to Check/Service		
2	Before	Air Filter	<p>Check condition of air filter element (1). Remove element and tap lightly against hand to remove clogging. Replace element if required. Verify that dust ejector (2) points down when cover (3) is installed. Check condition of hose (4) and tightness of hose clamps (5).</p> 	
3	Before	Pump-Engine Module Ground Cable	Inspect ground cable for cuts, breaks or loose connections.	Cuts, breaks or loose connections make ground cable unusable.
4	B	Pump-Engine Module Fuel and Oil Lines	Inspect fuel and oil lines for cuts, breaks or loose connections.	Fuel or oil lines are cut,

Table 2-3. Operator's Preventive Maintenance Checks and Services for Pumping Assembly

Item No.	Interval	Location	Procedure	Not Fully Mission Capable if:
		Item to Check/Service		
5	B	Engine Fuel Filter	<p>Open vent (1) on filter head assembly. Open drain valve (2) and drain water until fuel appears.</p> 	Filter will not drain or water continues to appear.
6	Before	Engine	<p>Verify that black start control cable (1) and knobs (2) are down against casing (3).</p> 	Knobs are up, preventing normal stop.

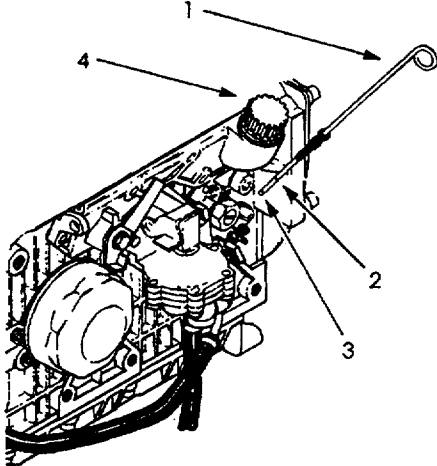
Table 2-3. Operator's Preventive Maintenance Checks and Services for Pumping Assembly

Item No.	Interval	Location	Procedure	Not Fully Mission Capable if:
		Item to Check/Service		
7	Before	Engine	<p>Check that pulley guard screen (1) and latches (2) are not broken or damaged.</p> 	Screen or latches are broken or damaged.
8	Before	Pump-Engine Module	<p>Inspect shock mounts (1) for breaks, cuts or looseness.</p> 	Shock mounts are broken, loose or have deep cuts.

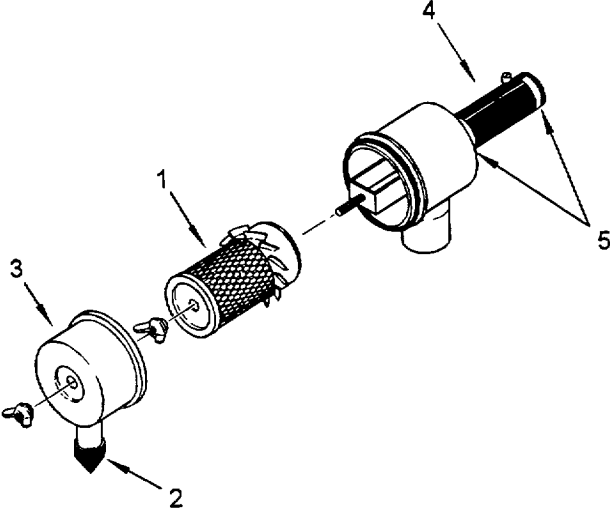
Table 2-3. Operator's Preventive Maintenance Checks and Services for Pumping Assembly

Item No.	Interval	Location	Procedure	Not Fully Mission Capable if:
		Item to Check/Service		
9	Before	Emergency Shutoff Valve	<p>Remove dust cap (1), depress continuity ball (2) on valve seat, release and observe that ball pops back out. If ball does pop back freely, electrical continuity is lost and static discharge is possible. The coupling must be replaced. Notify unit maintenance.</p> 	Continuity ball does not pop back out.
10	Before	Accessory Module Electrical Cables	Inspect for connector tightness, and cuts or breaks in cables broken, or connectors are loose.	Cables are cut or
11	Before	Accessory Module Ground Cable	Inspect ground cable for cuts, breaks or loose connections. connections make ground cable unusable.	Cuts, breaks or loose
12	Before	Accessory Module Battery Cable	Inspect connector at battery for corrosion. Clean as required.	Connector is corroded.
13	During	Pump-Engine module	Inspect for leaks. Operation may continue with class I or class II oil leaks.	Any fuel leak or class III oil leaks are present.

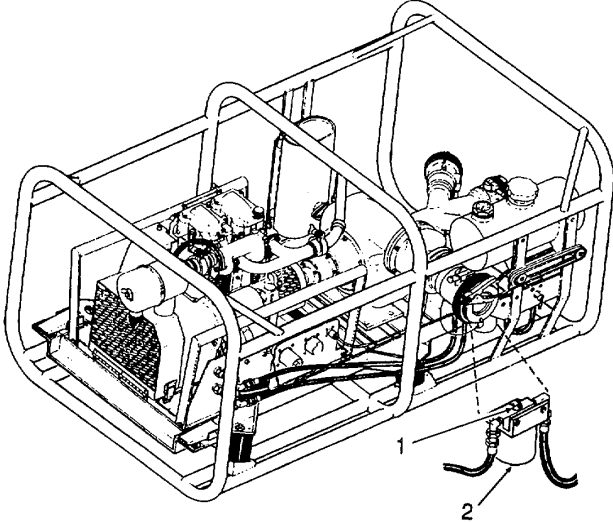
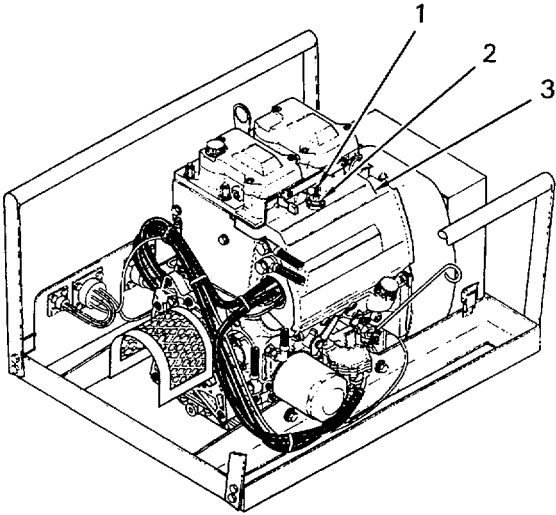
Section III. OPERATION UNDER USUAL CONDITIONS

2.4 SYSTEM ASSEMBLY AND PREPARATION FOR USE.

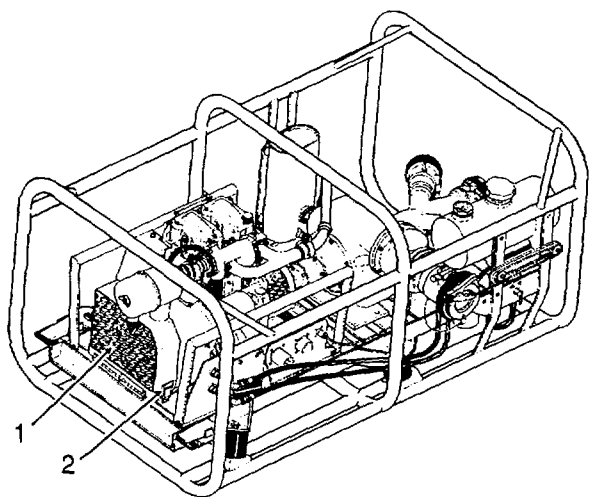
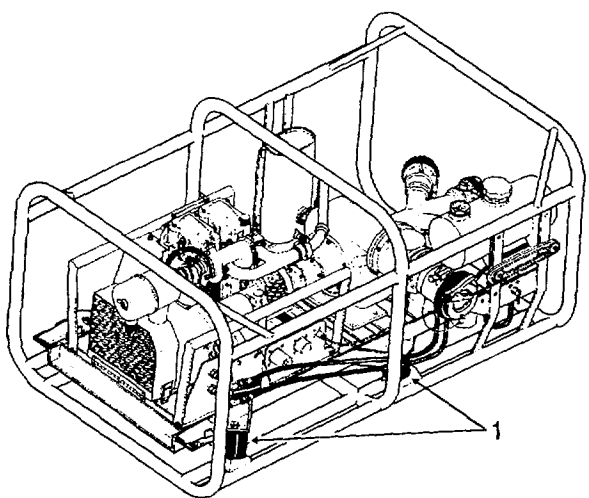
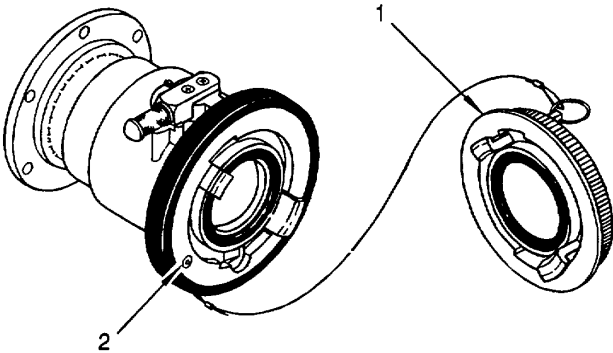
CAUTION

The fuel transfer pump may be damaged by running dry longer than two minutes. If running of the engine is desired, uncouple the engine from the fuel transfer pump.

Figure 2-3 illustrates a typical setup, showing the operational relationship of the pump-engine module and the accessory module to overall system. The illustration is not drawn to scale. It is similar to the layout diagram displayed on the accessory module and is provided as a visual reference only. Actual emplacement may require a slightly different configuration due to terrain or mission constraints.

WARNING

Death or personal injury may result from the explosion of fuel fumes exposed to an open flame or spark, or to static discharge. Do not permit smoking, any open flame, or spark producing equipment within 50 feet (15 m) of the pumping assembly. Ensure all equipments are well grounded prior to commencing any operation or maintenance task. Always ensure the ground connection from the aircraft is complete prior to beginning any fueling operation.

CAUTION

All couplings have caps that must be removed before a connection is made. Ensure the cap remains in place until just before connection to prevent contamination of the fueling system by foreign materials. Once the caps are removed, couple adjacent caps to reduce the probability of foreign materials contaminating the aircraft fuel.

- a. Inspect the pumping assembly for damage that may have occurred during transport and ensure that the received assemblies are complete.

NOTE

Steps "b", "c" and "d" apply if the pump-engine module must be repositioned. If the module position is satisfactory proceed to step "e".

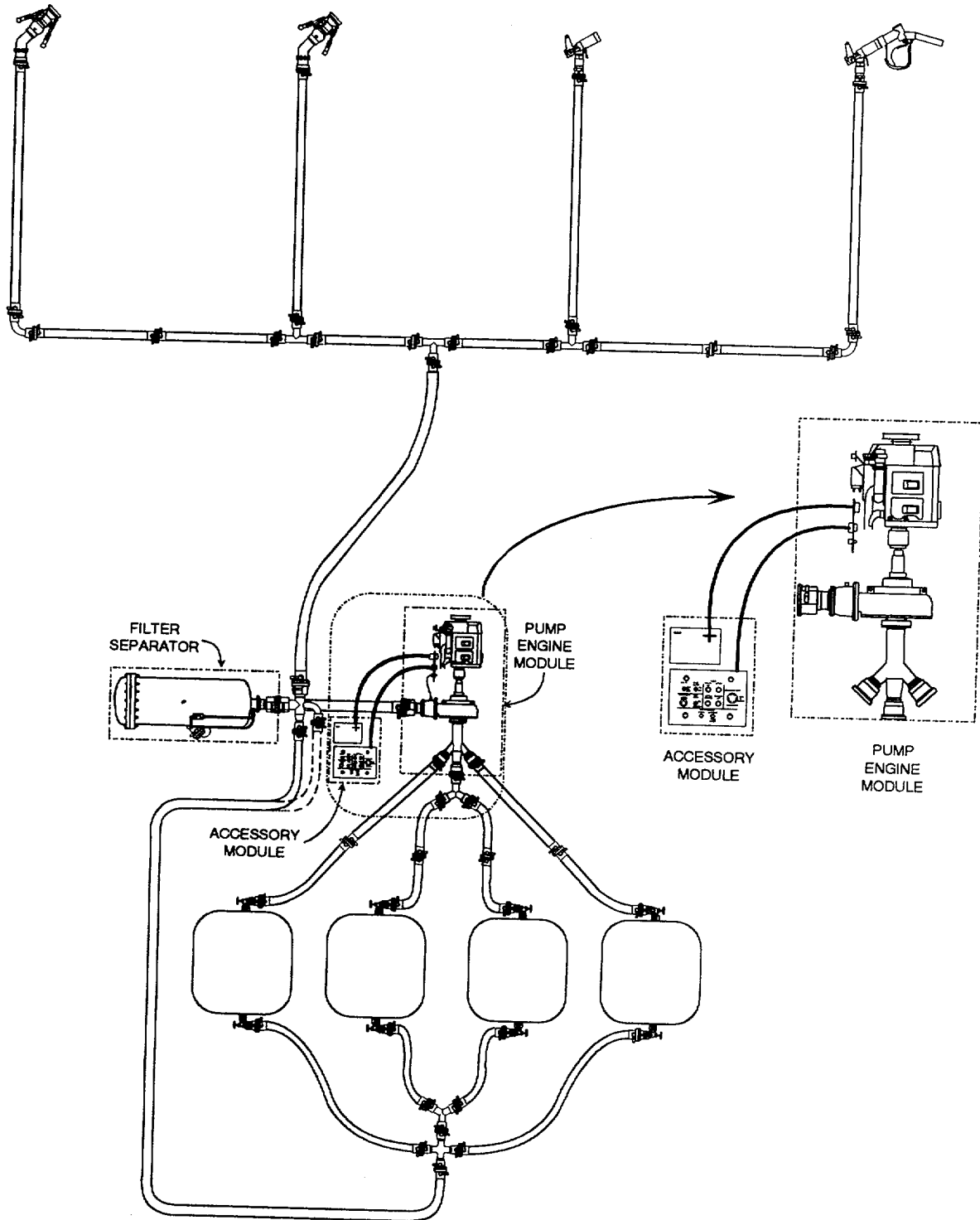

Figure 2-3. Typical AAFARS Setup

WARNING

Serious injury could occur if heavy equipment is moved/lifted without sufficient personnel to do the job. Always use four personnel to move or relocate the modules and kits. Use proper physical lifting procedures or use a suitable lifting device or dolly. Wear safety shoes, gloves and other suitable protective clothing.

- b. Remove engine module from pump-engine module. Refer to figure 2-4.
 - (1) Unclamp exhaust pipe (1) from exhaust manifold (2).
 - (2) Disconnect pumpage overtemperature cable (3) at engine module connection panel (4). Install dust caps on connectors. Wrap free end of cable around fuel transfer pump outlet (5).
 - (3) Disconnect fuel supply line (6) and fuel return line (7) at engine module. Connect free ends of lines together.
 - (4) Unlatch (8) engine module (9) from pump-engine frame (10) and slide engine module out of frame.
- c. Position pump module 6-8 feet (1.8-2.4 m) from drums with the pump inlet manifold facing drum outlets.
- d. Install engine module in pump-engine module. Refer to figure 2-4.
 - (1) Slide engine module into pump-engine module, PTO end first. If flex coupling will not engage it may be necessary to rotate the flex portion slightly to align with the engine adapter.
 - (2) Latch (8) engine module to pump-engine frame.
 - (3) Clamp exhaust pipe (1) to exhaust manifold (2).
 - (4) Connect pumpage overtemperature cable at engine module connection panel connector 1A1J3 (4). Couple together adjacent dust caps.
 - (5) Connect fuel supply line (6) and fuel return line (7) at engine module.
 - (6) Check that throttle control is at max position (fully right). Refer to figure 2-5.
- e. Verify/install thermal blankets on muffler and exhaust line.
- f. Position the accessory module between the pump-engine module and the filtration module as shown in figure 2-3 so operator has a clear view and easy access to all system components.
- g. Drive a grounding rod near the pump-engine module and connect pump-engine module grounding cable and accessory module grounding cable to grounding rod.
- h. Remove the engine air filter from the storage cabinet in the accessory module, remove cap from engine air intake and install the filter with clamp handle facing up.

i. Unlatch and open control box cover. Verify position of switches on control panel as follows.

- (1) START-RUN-STOP switch in STOP position.
- (2) INTAKE HEATER switch in OFF position.
- (3) FAULT LIGHTS switch in BLACKOUT position.
- (4) EMERGENCY STOP switch released.

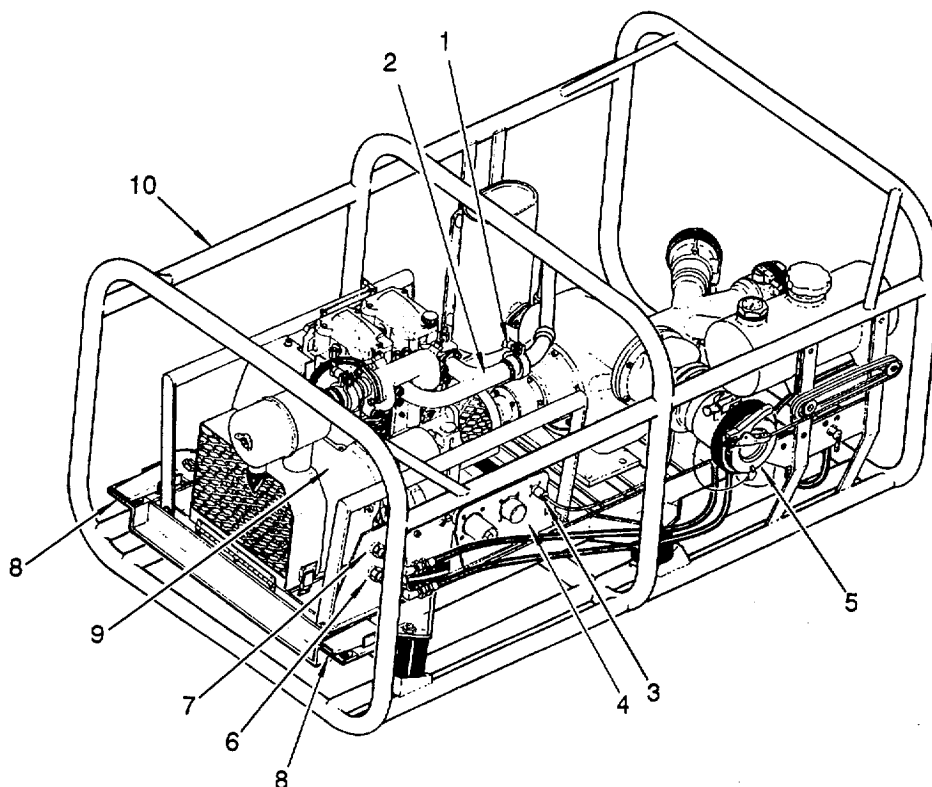

Figure 2-4. Engine Module Removal from Pump-Engine Module

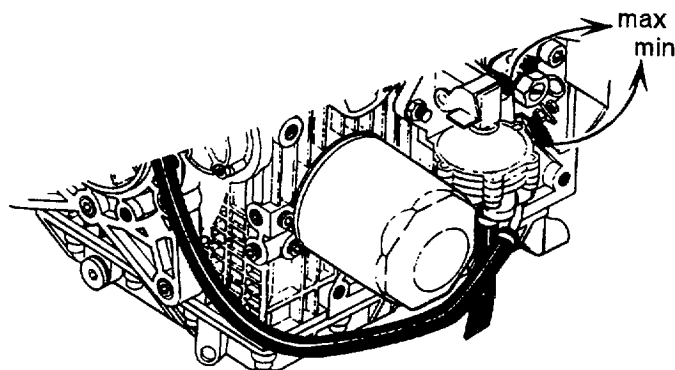

Figure 2-5. Manual Throttle Control

- j. Close and latch control box cover.

NOTE

Control cable W201 is separated into two legs. The shorter leg connects to the pumpengine module. The longer leg is used to supply power to the auxiliary pump module and should not be removed from storage cabinet until required for use.

- k. Remove control cable W201, short leg, from the storage cabinet in the accessory module, route through cut out on upper lip of cabinet and connect to connector 1A1J2 on the engine module. Connect adjacent dust caps together.
- l. Remove battery power cable from storage cabinet in the accessory module, route through cut out on upper lip of cabinet and connect to NATO connector 1A1J1 on engine module. Connect adjacent dust caps together.
- m. Verify that both cables are in storage cabinet cut out, then close and latch storage cabinet cover.
- n. Position ENGINE switch to RUN and observe the malfunction indicators. Failure to achieve the following indicates a system fault. Determine cause before attempting to operate the pumping system.
 - (1) PUMPAGE HOT indicator flashes once.
 - (2) ALTNTR indicator illuminates.
 - (3) LOW OIL PRESSURE indicator illuminates.
 - (4) ENGINE HOT indicator does not illuminate.
- o. Place FAULT LIGHTS switch in BLACKOUT position.
- p. Restore ENGINE switch to STOP position.
- q. Position a fire extinguisher adjacent to pump-engine module.
- r. Fill engine fuel tank or connect external fuel source.
- s. If provided, install acoustic cover.

2.5 OPERATING PROCEDURES.

WARNING

Death or personal injury may result from the explosion of fuel fumes exposed to an open flame or spark, or to static discharge. Do not permit smoking, any open flame, or spark producing equipment within 50 feet (15 m) of the pumping assembly. Ensure all equipments are well grounded prior to commencing any operation or maintenance task. Always ensure the ground connection from the aircraft is complete prior to beginning any fueling operation.

CAUTION

The fuel transfer pump may be damaged by running dry longer than two minutes. If running of the engine is desired, uncouple the engine from the fuel transfer pump.

CAUTION

System components are subject to damage from thermal expansion. As the temperature increases, the pumpage in any component will expand. If trapped in a component, the expanding pumpage may rupture seals and cause a leak or equipment malfunction. For this reason, all system valves should remain open as long as the system is flooded. With all valves open, the hoses will absorb the expansion and protect system seals. If any component must be isolated, it should be drained or defueled immediately to prevent damage.

- a. Conduct a visual inspection of the pumping assembly setup to ensure the system is properly assembled and ready to pump fuel. Verify system grounding.
- b. Verify/Position fuel selector valve in ON or EXTERNAL ON position, according to desired fuel source.
- c. Verify that black start control is fully lowered.

NOTE

Step d describes an electric start of the Pumping Assembly. If a manual start is to be attempted, proceed to step e.

- d. Perform normal electric engine start.
 - (1) Unlatch and open control box cover.
 - (2) At the control panel, hold the ENGINE switch in the START position until the engine starts. If engine fails to start within 15 seconds, release switch and allow starter to cool for a minute before continuing. When the ambient temperature is below 200 F (-7° C), position and hold INTAKE HEATER switch in the ON position while ENGINE switch is in START position.
 - (3) Adjust the control panel lights to the desired brightness.
 - (4) Disconnect battery power cable from NATO connector 1A1J1 on engine module. Install dust caps on NATO connector and free end of battery power cable. Stow battery power cable in accessory module.

- e. Perform manual engine start.
- (1) Remove acoustic cover, if installed.
 - (2) Disconnect battery cable from engine module.
 - (3) Unlatch and lower pulley guard.
 - (4) Turn upper black start knob left until knob touches compression release lever.
 - (5) Align flywheel to timing mark.
 - (6) Position decompression lever toward pulley end of engine.
 - (7) Wind rope on start pulley.

WARNING

Serious personal injury could result from contact with rotating parts such as the engine pulley. Keep body well clear of pulley while rotating. Do not allow loose clothing near engine where it may be caught on rotating parts. Handle pulley guard by sides when raising and keep fingers well clear of pulley. Stay clear of whipping rope. Wear goggles to protect eyes during rope start.

- (8) Pull rope to start engine.
- (9) Raise and latch pulley guard.

CAUTION

- **System components are subject to damage from thermal expansion. As the temperature increases, the pumpage in any component expands. If trapped in a component, the expanding pumpage may rupture seals and cause a leak or equipment malfunction. For this reason, all system valves should remain open as long as the system is flooded. With all valves open, the hoses will absorb the expansion and protect system seals. If any component must be isolated, it should be drained or defueled immediately to prevent damage.**
 - **Equipment damage may occur if the fuel transfer pump is allowed to run dry. When the fuel transfer pump primes and moves pumpage, the outlet hose will expand. If the hose remains flat, the fuel transfer pump has not primed and is running dry.**
- f. Verify that pump outlet hose pressurizes (hose expands). If hose has not pressurized after two minutes of operation, shut down system and determine why pump has not primed.

2.6 NORMAL SYSTEM SHUTDOWN.

- a. After electric start, at accessory module, position engine switch to STOP position.
- b. After manual start, position and hold fuel shutoff lever in OFF position until engine stops.

2.7 EMERGENCY SYSTEM SHUTDOWN.

- a. At accessory module, press EMERGENCY STOP switch.
- b. If EMERGENCY STOP malfunctions, position and hold fuel shutoff lever in off position until engine stops.

2.8 DECALS AND INSTRUCTION PLATES.

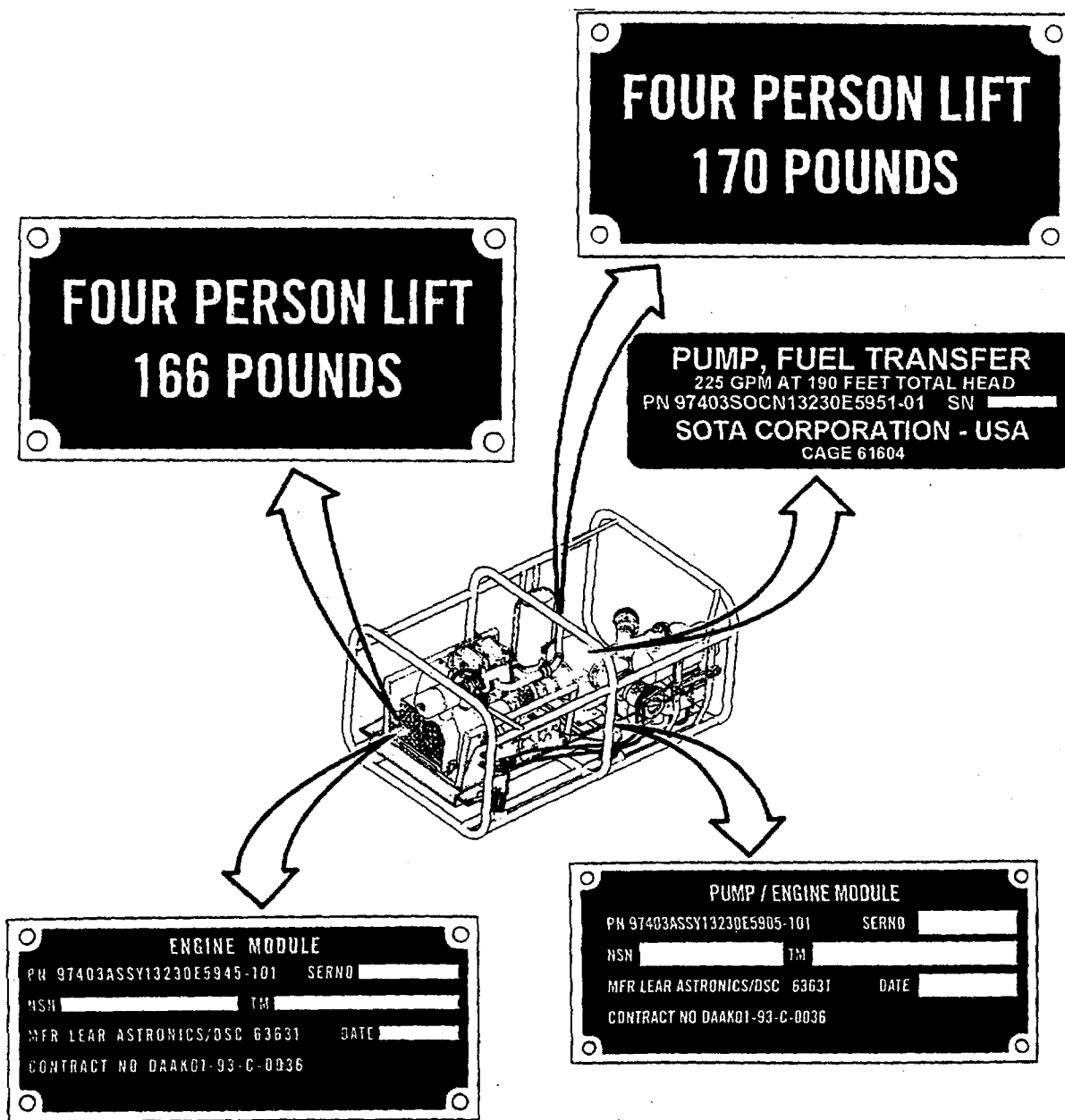

Figure 2-6. Decals and Instruction Plates, Pump-Engine Module (Sheet 1 of 2)

2.8 DECALS AND INSTRUCTION PLATES. (Continued)

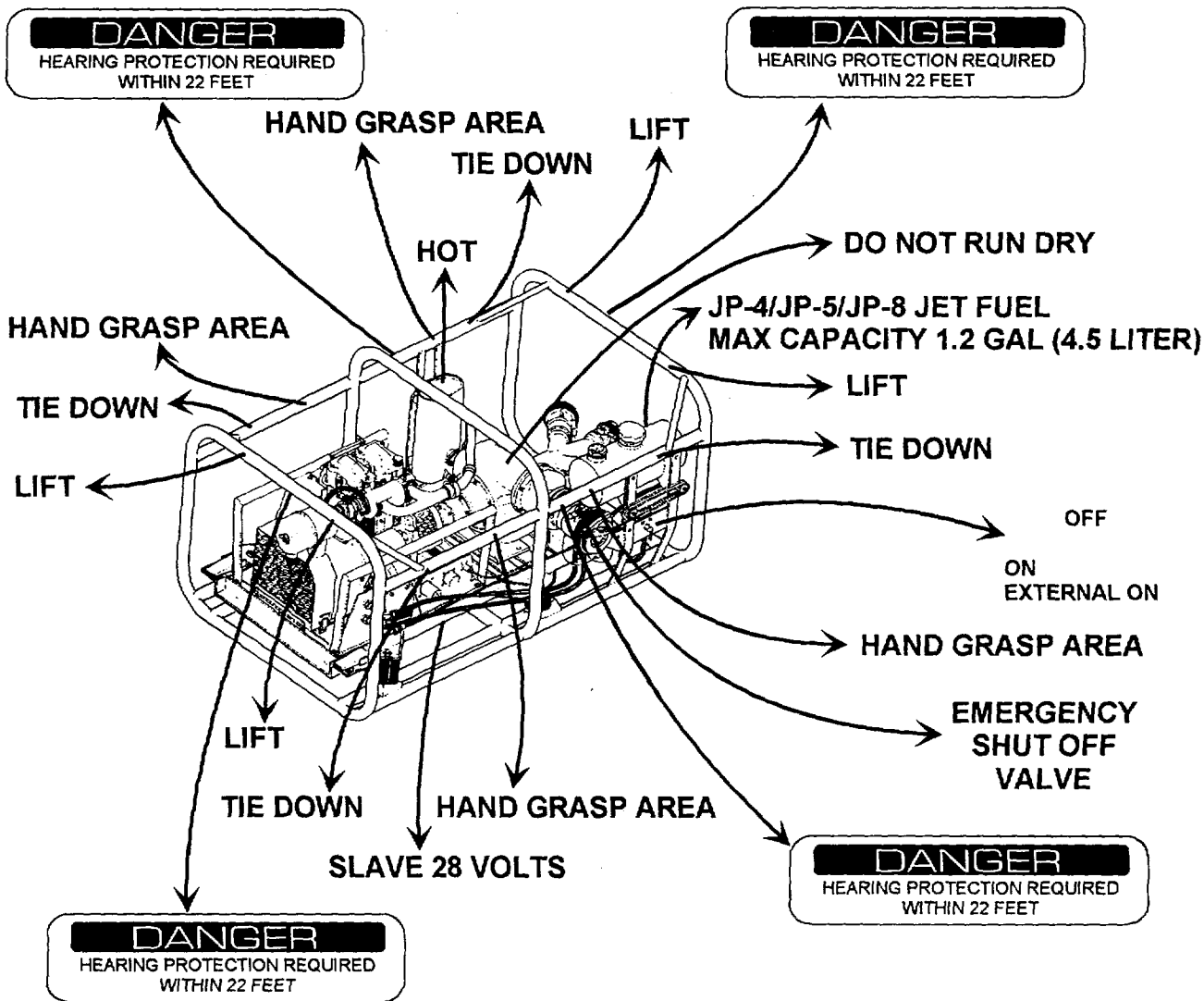

Figure 2-6. Decals and Instruction Plates, Pump-Engine Module (Sheet 2 of 2)

2.8 DECALS AND INSTRUCTION PLATES. (Continued)

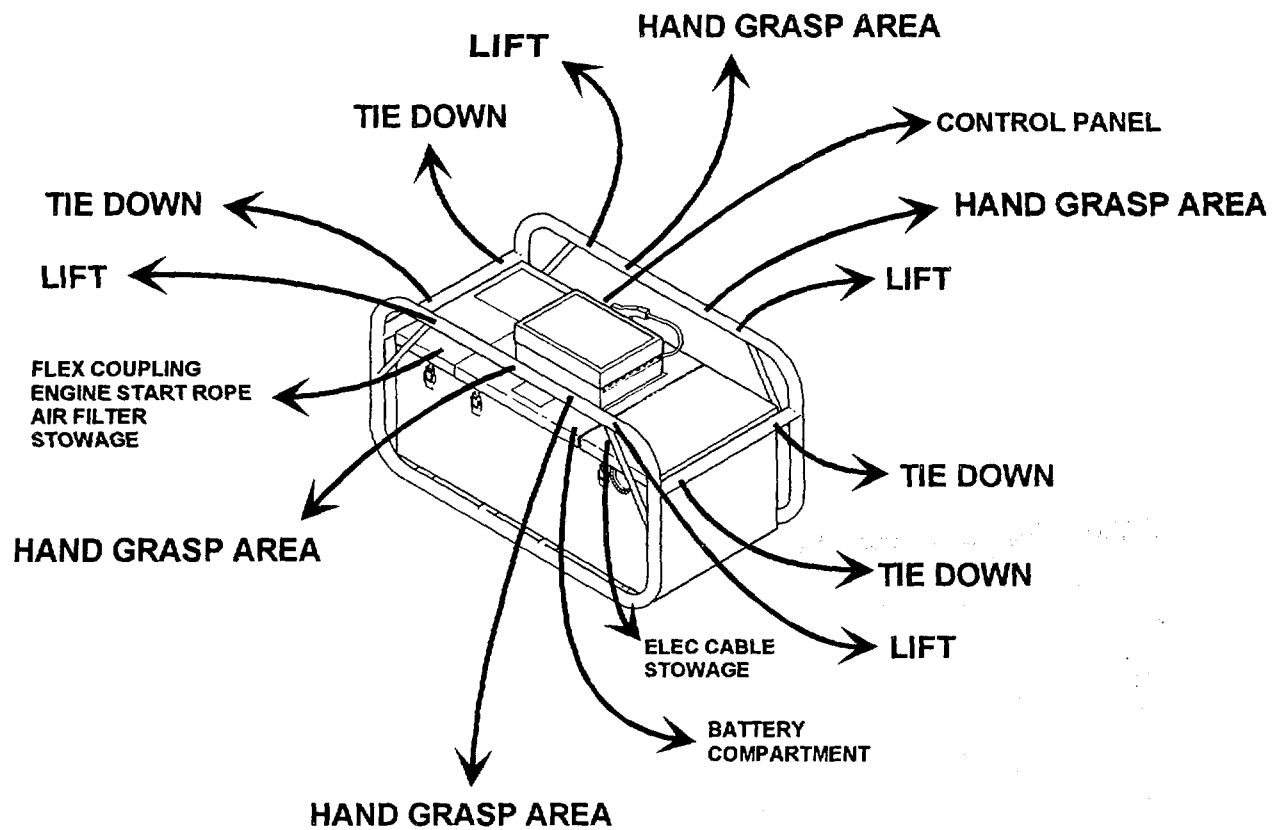
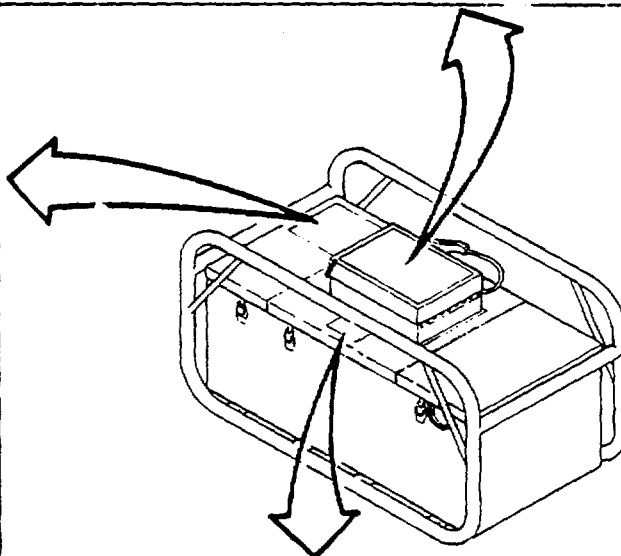
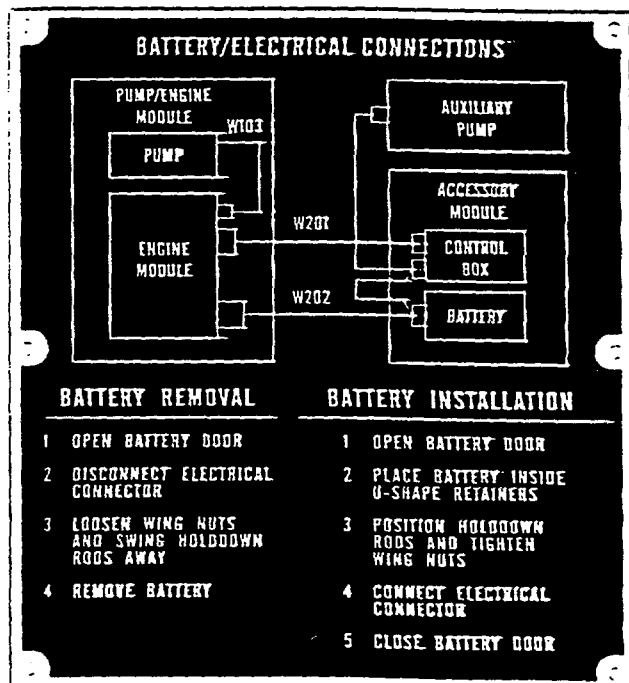
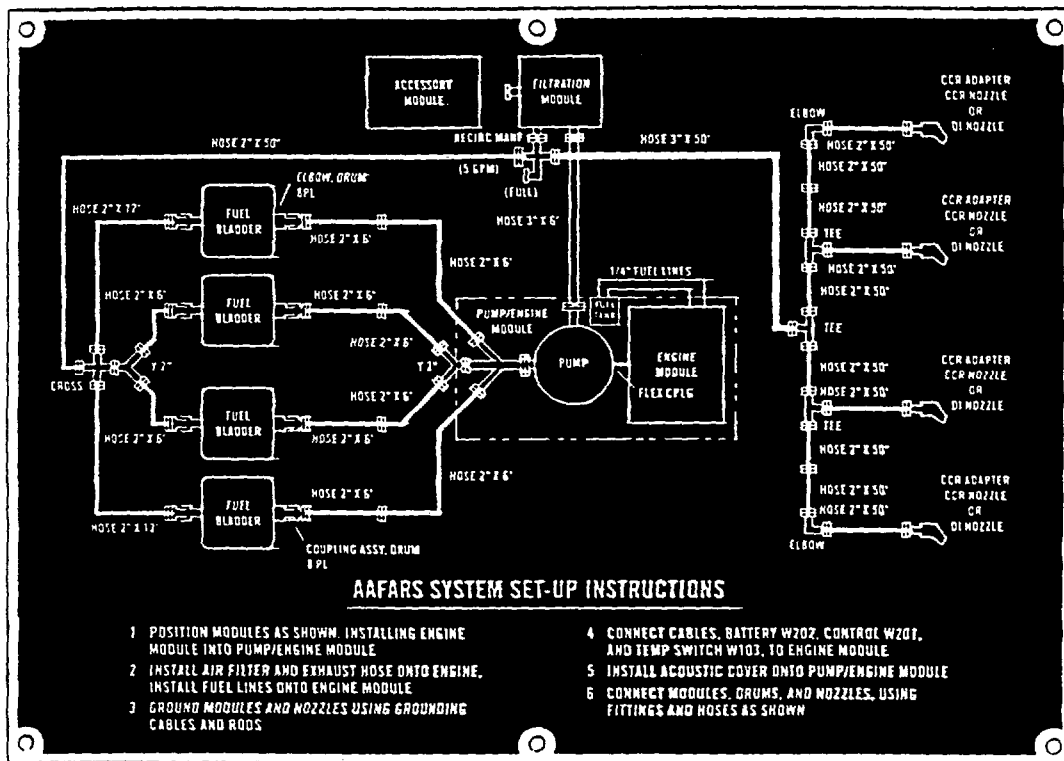

Figure 2-7. Decals - Accessory Module

2.8 DECALS AND INSTRUCTION PLATES. (Continued)



**FOUR PERSON LIFT
156 POUNDS**

Figure 2-8. Instruction Plates - Accessory Module (Sheet 1 of 3)

2.8 DECALS AND INSTRUCTION PLATES. (Continued)

OPERATING INSTRUCTIONS

ELECTRIC START		MANUAL START	
STEP	ACTION	STEP	ACTION
1	SET UP AAFAAS	1	SET UP AAFAAS
2	CHECK GROUNDING	2	CHECK GROUNDING
3	PERFORM "BEFORE" PMCS	3	PERFORM "BEFORE" PMCS
4	FILL ENGINE FUEL TANK	4	FILL ENGINE FUEL TANK
5	OPEN FUEL DRUM OUTLET VALVES	5	ACCESS ROPE START PULLEY
6	RELEASE EMERGENCY STOP SWITCH	6	MANUALLY OPEN FUEL SOLENOID
7	HOLD ENGINE SWITCH IN START POSITION UNTIL ENGINE STARTS, RELEASE TO RUN POSITION (BELOW +20 DEGREE F, HOLD INTAKE HEATER SWITCH "ON" UNTIL ENGINE STARTS)	7	ALIGN FLYWHEEL TO TIMING MARKS
8	VENT AIR FROM FILTER MODULE	8	POSITION DECOMPRESSION LEVER TOWARD PULLEY END OF ENGINE
9	INSPECT FOR LEAKS	9	WIND ROPE ON PULLEY, CLOCKWISE
10	PUMP FUEL	10	PULL ROPE TO START ENGINE (BELOW +20 DEGREE F, IF SOME BATTERY CHARGE EXISTS, HOLD INTAKE HEATER SWITCH "ON" UNTIL ENGINE STARTS)
NORMAL SHUTDOWN: PLACE ENGINE SWITCH IN STOP POSITION		11	OPEN FUEL DRUM OUTLET VALVES
EMERGENCY SHUTDOWN: PRESS EMERGENCY STOP SWITCH		12	VENT AIR FROM FILTER MODULE
MANUAL SHUTDOWN: ACTUATE MANUAL SHUTDOWN LEVER RESET FUEL SOLENOID MANUAL OVERRIDE		13	INSPECT FOR LEAKS
		14	PUMP FUEL

LUBRICATION CHART

FUEL TYPES JP-4, JP-5 AND JP-8	
REPLACE ENGINE OIL (1.9 QUARTS / 1.8 LITERS) AFTER EVERY 100 HOURS OF OPERATION WITH MIL-L-46167 DEB (SAE OW-20)	OR MIL-L-2104 DE/MDL-15/40 (SAE 15W-40)
-25 DEGREE F TO +40 DEGREE F OPERATION	+5 DEGREE F TO +120 DEGREE F OPERATION

CAUTION
 HIGH INTENSITY NOISE
 HEARING PROTECTION
 REQUIRED

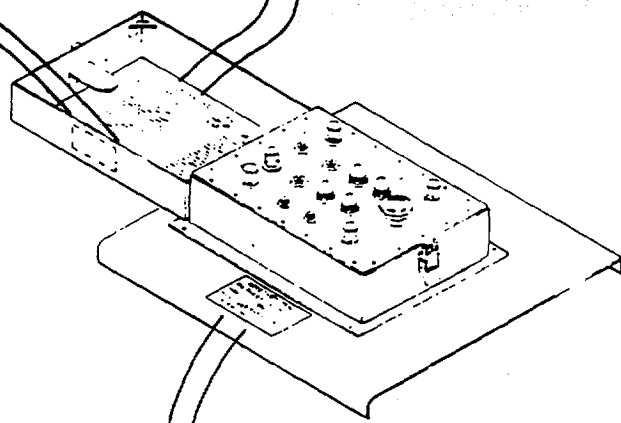

ACCESSORY MODULE

PN 97403455Y13230E6000-101 SERNO _____

NSN _____ TM _____

MFR LEAR ELECTRONICS/DSC 63631 C:11 _____

CONTRACT NO DAAX01-93-C-0036

Figure 2-8. Instruction Plates - Accessory Module (Sheet 2 of 3)

2.8 DECALS AND INSTRUCTION PLATES. (Continued)

DEFUELING PROCEDURE

WITH THE FUEL TRANSFER PUMP RUNNING:

CLOSE ALL FUEL DRUM OUTLET ELBOW VALVE COUPLINGS AND UNISEX COUPLINGS AT FUEL DRUM END OF SUCTION HOSES.

BEGINNING AT FUEL DRUMS, DISCONNECT SUCTION HOSES ONE AT A TIME. OPEN UNISEX COUPLING, HOLD HOSE END HIGHER THAN INTAKE MANIFOLD AND CLOSE UNISEX COUPLING AT FAR END (INTAKE MANIFOLD) OF SUCTION LEG. CLOSE UNISEX COUPLING AT FREE END OF LEG AND INSTALL DUST CAP.

REPEAT STEP FOR EACH OF THE THREE REMAINING SUCTION LEGS.

CLOSE 3 INCH EMERGENCY SHUT OFF VALVE AS SOON AS FUEL TRANSFER PUMP UNLOADS.

AT THE ACCESSORY MODULE CONTROL PANEL, POSITION ENGINE SWITCH TO STOP POSITION.

NOTE

IF NOZZLE RECIRCULATION WYE WAS IN USE, DISCONNECT AND DRAIN WYE. CONNECT 2 INCH DISCHARGE HOSE TO RECIRCULATION MANIFOLD FULL FLOW LEG.

CLOSE NOZZLE UNISEX COUPLING VALVES, AND DISCONNECT AND DRAIN NOZZLES.

DEFUEL LIQUID FUEL FILTER-SEPARATOR.

CLOSE UNISEX COUPLING ON LIQUID FUEL FILTER-SEPARATOR OUTLET VALVE.

DISCONNECT 2 INCH DISCHARGE HOSE FROM RECIRCULATION MANIFOLD.

DISCONNECT ONE OF THE SUCTION HOSES FROM FUEL TRANSFER PUMP INLET AND CONNECT TO THE LIQUID FUEL FILTER-SEPARATOR DEFUELING UNISEX COUPLING AND THE UNISEX COUPLING ON THE INLET SIDE OF THE AUXILIARY PUMP. OPEN UNISEX COUPLING VALVES.

CONNECT 2 INCH DISCHARGE HOSE TO AUXILIARY PUMP OUTLET SIDE AND OPEN UNISEX COUPLING VALVES.

CONNECT AUXILIARY POWER CABLE TO AUXILIARY PUMP.

OPEN LIQUID FUEL FILTER-SEPARATOR MANUAL VENT VALVE.

TURN ON AUXILIARY PUMP TO PUMP DOWN LIQUID FUEL FILTER-SEPARATOR AND 3 IN. X 6 FT. DISCHARGE HOSE FROM FUEL TRANSFER PUMP.

CLOSE LIQUID FUEL FILTER-SEPARATOR INLET VALVE AND MANUAL VENT VALVE WHEN AIR IS SEEN IN THE SIGHT GAUGE.

TURN OFF AUXILIARY PUMP, AND CLOSE AUXILIARY PUMP UNISEX INLET AND OUTLET VALVES.

DISCONNECT DISCHARGE HOSE FROM AUXILIARY PUMP AND CONNECT TO RECIRCULATION MANIFOLD FULL FLOW UNISEX COUPLING.

DISCONNECT SUCTION HOSE FROM AUXILIARY PUMP AND LIQUID FUEL FILTER-SEPARATOR.

DEFUEL SYSTEM FUEL HOSES.

AT SELECTED FUEL DRUM, CLOSE INLET ELBOW VALVE AND UNISEX COUPLING VALVE ON DISCHARGE HOSE, DISCONNECT DISCHARGE HOSE FROM THE INLET ELBOW VALVE. CONNECT THE DISCHARGE HOSE TO THE INLET OF THE AUXILIARY PUMP, AND OPEN UNISEX COUPLING VALVES ON INLET OF AUXILIARY PUMP AND DISCHARGE HOSE.

CONNECT AUXILIARY PUMP OUTLET UNISEX COUPLING TO DRUM INLET ELBOW VALVE UNISEX COUPLING, AND OPEN UNISEX COUPLING VALVE AND INLET ELBOW VALVE.

CLOSE THE FUEL DRUM INLET ELBOW VALVE COUPLINGS ON THE REMAINING DRUMS.

TURN ON AUXILIARY PUMP.

ONE AT A TIME, OPEN UNISEX VALVES ON DISCHARGE HOSES AT FUELING POINTS. CLOSE UNISEX VALVE AS HOSE COLLAPSES.

ONE AT A TIME, DISCONNECT THE INLET ELBOW VALVE CAMLOCK COUPLER FROM THE OTHER THREE FUEL DRUM HOSES, ALLOW THE HOSE TO PUMP DOWN AND CLOSE UNISEX VALVE.

WHEN HOSES ARE COLLAPSED/DEFUELED, CLOSE INLET ELBOW VALVE ON LAST FUEL DRUM.

TURN OFF AUXILIARY PUMP.

DISCONNECT DISCHARGE HOSE FROM AUXILIARY PUMP.

DISCONNECT INLET ELBOW VALVE FROM FUEL DRUM.

HOLD AUXILIARY PUMP OVER CONTAINER AND DISCONNECT AUXILIARY PUMP FROM INLET ELBOW VALVE.

HOLD AUXILIARY PUMP OVER CONTAINER, OPEN UNISEX COUPLING VALVES AND DRAIN FUEL. CLOSE UNISEX COUPLING VALVES.

DISCONNECT AUXILIARY PUMP POWER CABLE FROM AUXILIARY PUMP MODULE.

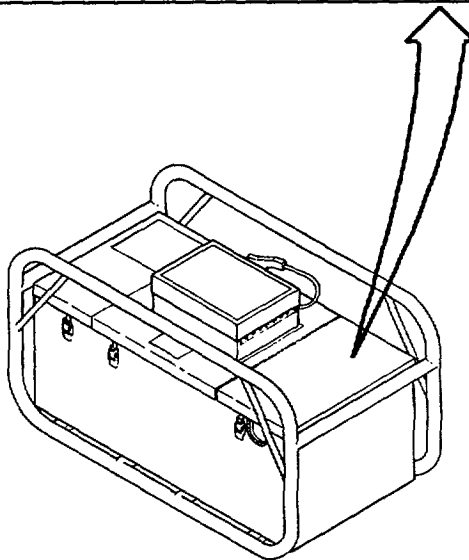

Figure 2-8. Instruction Plates - Accessory Module (Sheet 3 of 3)

2.9 PREPARATION FOR MOVEMENT.

WARNING

The exhaust system will remain hot for some time after engine shut down. Avoid contact with exhaust system components until they have cooled sufficiently for safe handling. Serious personal injury may occur from contact with hot metal.

CAUTION

During recovery ensure dust caps are installed on couplings immediately after disconnection. This practice will protect the couplings and reduce fuel contamination and spills.

- a. Pull ground rod at pumping station and return to recovery area.
- b. Disconnect and stow electrical cables in accessory module compartment. Install dust caps on connectors.
- c. Remove air cleaner from engine and stow in accessory module. Replace cap on intake manifold.
- d. Return accessory module to recovery area.

WARNING

Serious injury could occur if heavy equipment is moved/lifted without sufficient personnel to do the job. Always use four personnel to move or relocate the pumping assembly. Use proper physical lifting procedures or use a suitable lifting device or dolly. Wear safety shoes, gloves and other suitable protective clothing.

- e. Remove engine module from pump-engine module.
 - (1) Unclamp exhaust pipe from exhaust manifold.
 - (2) Disconnect pumpage overtemperature cable at engine module connection panel. Install dust caps on connectors. Wrap free end of cable around fuel transfer pump outlet.
 - (3) Disconnect fuel supply line and fuel return line at engine module. Connect free ends of lines together.
 - (4) Unlatch engine module from pump-engine frame and slide engine module out of frame.
- f. Return engine module to recovery area.
- g. Return pump-engine module to recovery area.
- h. Install engine module in pump-engine module.
 - (1) Slide engine module into pump-engine module, PTO end first. If flex coupling will not engage it may be necessary to rotate the flex portion slightly to align with the engine adapter.
 - (2) Latch engine module to pump-engine frame.

- (3) Clamp exhaust pipe to exhaust manifold.
- (4) Connect pumpage overtemperature cable at engine module connection panel connector 1A1J3. Connect adjacent dust caps together.
- (5) Connect fuel supply line and fuel return line at engine module.

Section IV. OPERATION UNDER UNUSUAL CONDITIONS

2.10 OPERATION UNDER EXTREME ENVIRONMENTAL CONDITIONS.

2.10.1 Operation in Extreme Heat.

Operation under conditions of high heat may cause equipment problems due to thermal expansion. Fuel transfer pump seals are especially subject to damage. Basic system operation is as described in paragraphs 2.4 and 2.5. The following additional steps and recommendations should be implemented to protect the system to the extent possible.

- a. Protect the system from direct sunlight if possible.
 - (1) Position system components in the shade of trees, buildings, etc. If shade is available only part of the day, choose afternoon shade.
 - (2) Use any material available to create shade without blocking air circulation. Keep fabric wet if possible. Do not block air circulation.

2.10.2 Operation in Extreme Cold.

Operation under conditions of extreme cold may cause equipment problems due to loss of flexibility. Coupling face seals are especially subject to damage. Basic system operation is as described in paragraphs 2.4 and 2.5. The following additional steps and recommendations should be implemented to protect the system to the extent possible.

- a. General Recommendations.
 - (1) Fill engine crankcase with MIL-L-46167 OEA (SAE OW-20) lubricating oil. Refer to unit maintenance.
 - (2) Set up system in area protected from wind, if possible.
 - (3) Handle all components with care to avoid cracking or fracture.
 - (4) Remove snow or ice from coupling ends before making connections to prevent entry of foreign material into system.
 - (5) Make and break connections slowly and carefully to avoid cracking or splitting of face seals.
- b. Engine Cold Start.

NOTE

Under conditions of extreme cold, it is necessary to use the intake heaters to warm the intake manifold before attempting to start the engine. The amount of warming required increases as the temperature decreases. At 20° F (-7° C), holding the intake heaters on for 30 seconds is sufficient; at -25° F (31.7° C) approximately 2.5 minutes is required.

- (1) Unlatch engine module from pump-engine module frame and slide engine module out far enough to disengage engine flexible coupling adapter from the flexible coupling (5-6 inches).
- (2) Insert spare flexible coupling between the lower part of the engine module and the subframe to prevent the engine accidentally sliding back and engaging fuel transfer pump.
- (3) At the control panel, hold the ENGINE switch in the START position for 30 seconds, then release. If engine starts, proceed to step 7.
- (4) Hold INTAKE HEATER switch in the ON position for 2 minutes to heat intake air and allow battery time to thaw.
- (5) At the control panel, hold INTAKE HEATER switch in the ON position and lift and hold the ENGINE switch in the START position until engine starts. If engine does not start within 2 minutes, release the ENGINE start switch and the INTAKE HEATER switch and allow system to rest for 5 minutes. (Battery will thaw and starter will cool.)
- (6) Repeat steps 4 and 5 as required.
- (7) Allow engine to run 2-3 minutes.
- (8) Shut down engine IAW para. 2.6.
- (9) Remove spare flexible coupling from subframe and stow in accessory module.
- (10) Slide engine module into pump-engine module and engage engine adapter with flexible coupling.
- (11) Latch engine module to pump-engine frame.
- (12) Perform normal engine start IAW para. 2.5.

2.10 .3 Operation in Strong Winds and Under Sandy or Dusty Conditions.

- a. Shield couplings during connection or disconnection to prevent entry of foreign material into system.
- b. Keep dust caps in place on all disconnected couplings.
- c. Inspect and clean engine air filter frequently to avoid accumulation of sand or dust.

2.11 EMERGENCY OPERATING PROCEDURES.

2.11.1 Emergency Stop.

- a. At accessory module, press EMERGENCY STOP switch.
- b. If EMERGENCY STOP malfunctions, position and hold fuel shutoff lever in OFF position until engine stops.

2.11.2 Emergency Operation.

There are no provisions for "Battle Short" operation of the pumping assembly. Emergency operation consists of continuing operation in spite of conditions such as noisy or erratic engine operation, illumination of FAULTS indicators on control panel, or other conditions which would normally require immediate shut down. Emergency operation only applies in a wartime situation where continued aircraft refueling is of paramount importance. The consequences of ignoring FAULTS indicators are:

- a. ENGINE HOT indicator - loss of power followed by engine seizure.
- b. LOW OIL PRESSURE indicator - loss of power followed by engine seizure. ENGINE HOT indicator may illuminate.
- c. ALTNTR - system will continue to operate until battery is depleted.
- d. PUMPAGE HOT - engine will stop and may not be restarted until pumpage has cooled to 125°F (52°C).

2.12 NBC DECONTAMINATION.

NOTE

Detailed decontamination procedures can be found in FM 3-3, FM 3-4, and FM 3-5.

CHAPTER 3

OPERATOR MAINTENANCE INSTRUCTIONS

Section I. Lubrication Instructions.....3-1

3.1 Lubrication3-1

Section II. Troubleshooting Procedures3-1

3.2 Operator Troubleshooting.....3-1

Section III. Operator Maintenance Procedures.....3-3

3.3 Replace Unisex Coupling Face Seal/Dust Cap Seal.....3-3

Section I. LUBRICATION INSTRUCTIONS

3.1 LUBRICATION.

Lubrication by the operator/crew is limited to checking the engine oil level and adding oil as required by the PMCS schedule.

Section II. TROUBLESHOOTING PROCEDURES

3.2 OPERATOR TROUBLESHOOTING.

Troubleshooting table 3-1 is provided to assist you in locating and correcting system faults. This table cannot list all the malfunctions that may occur, all the tests and inspections needed to find the fault, or all the corrective actions needed to correct the fault. If the equipment malfunction is not listed or actions listed do not correct the fault, notify your supervisor.

TABLE 3-1. TROUBLESHOOTING

MALFUNCTION
TEST OR INSPECTION
CORRECTIVE ACTION

1. Unisex coupling leaks at interface with dust cap or other coupling.

Inspect coupling and dust cap face seals for physical damage or wear.

Replace damaged or worn face seal. Refer to paragraph 3.3.

TABLE 3-1. TROUBLESHOOTING (Continued)

MALFUNCTION	TEST OR INSPECTION	CORRECTIVE ACTION
2. Engine will not crank	Check electrical connections to starter	<ul style="list-style-type: none"> a. Make sure all connections between battery and starter are tight and clean. b. Verify that control cable is connected between accessory module and engine module. c. Attempt manual start. If engine cranks, a weak or dead battery, or damaged starting circuit cable is probable. d. If manual start fails, notify unit maintenance.
3. Engine cranks but will not start	Check fuel supply to engine	<ul style="list-style-type: none"> a. Add fuel to fuel tank if required. b. Check that fuel selector valve is in ON or EXTERNAL ON position. c. Make sure all fuel lines between fuel tank and engine are connected: d. Notify unit maintenance.
4. Engine starts but lacks power or will not continue running		<ul style="list-style-type: none"> a. Check for blockage at air intake. b. Inspect air filter element for clogging. Tap lightly against hand to remove clogging. c. Notify unit maintenance.
5. Engine will not start electrically		<p>Manually raise black start control and attempt to start.</p> <p>If engine starts, notify unit maintenance of electrical problem in fuel shutoff solenoid circuit.</p>
6. Engine exhaust produces black smoke.		<p>Step 1. Check for clogged air intake.</p> <p>Remove filter element from air filter. Check for blockage at air intake.</p>

TABLE 3-1. TROUBLESHOOTING (Continued)

MALFUNCTION	TEST OR INSPECTION	CORRECTIVE ACTION
-------------	--------------------	-------------------

Step 2. Inspect filter element for clogging.

Tap lightly against hand to remove clogging.

7. Engine exhaust produces blue smoke.

Stop engine and wait 2-3 minutes for oil to drain down. Check level on dipstick.

If level is above maximum mark, notify unit maintenance.

8. Fuel transfer pump will not prime.

Ensure that all valves on inlet side are open.

Notify unit maintenance.

9. Fuel transfer pump does not provide flow and pressure when engine is running.

Step 1. Verify that all system valves are open.

Step 2. Ensure no kinks in hoses.

Notify unit maintenance.

Section III. OPERATOR MAINTENANCE PROCEDURES

3.3 REPLACE UNISEX COUPLING FACE SEAL/DUST CAP SEAL.

This procedure applies to all pumping assembly unisex couplings. The seal in each coupling face and the dust cap are identical, and may be interchanged as a temporary repair.

The face plate and dust cap of pumping assembly unisex couplings employ a U-ring type seal which is designed to seat with pressure. The seal is slightly higher than the groove it sits in, so that the top protrudes above the surface. Pressurized fluid enters beneath this protrusion and expands the seal against the bottom of the seal groove and against the corresponding seal in the dust cap or other face place. Special care must be taken during installation to ensure the seal is fully seated in the groove. If it is not, pressurized fluid will be forced under the seal and the coupling will leak.

3.3.1 Replace Face Seal. (Refer to figure 3-1.)

a. Removal.

Remove face seal (1) by hand.

b. Installation.

(1) Wipe seal groove clean.

(2) Press seal in groove with a smoothing motion of fingertips. Note that when fully seated, the outer lip of the seal protrudes slightly above the surface. Ensure the seal is not twisted or kinked.

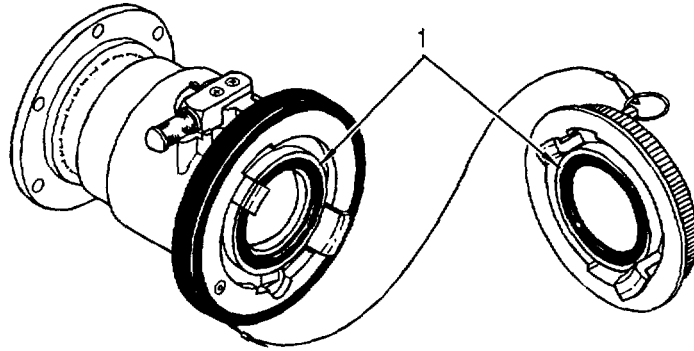

Figure 3-1. Unisex Coupling Face Seal Replacement

**CHAPTER 4
UNIT MAINTENANCE**

Section I.	Lubrication Instructions	4-2
4.1	Lubrication	4-2
Section II.	Service upon Receipt	4-2
4.2	Unpacking	4-2
4.3	Inspection	4-2
4.4	Engine Service	4-2
Section III.	Unit Preventive Maintenance Checks and Services (PMCS).....	4-3
4.5	General	4-3
4.6	Leakage Criteria	4-4
4.7	PMCS Procedures	4-4
Section IV.	Unit Troubleshooting Procedures	4-7
4.8	Troubleshooting.....	4-7
Section V.	Unit Maintenance Procedures	4-9
4.9	Pump-Engine Module Maintenance.....	4-9
4.9.1	Replace Engine Fuel Filter.....	4-9
4.9.2	Replace Pumpage Overtemperature Sensor/Sensor Cable (W103).....	4-11
4.9.3	Replace Engine Air Filter Element	4-12
4.9.4	Replace Engine Air Filter Hose	4-13
4.10	Repair Inlet Manifold Assembly.....	4-15
4.10.1	Replace Outlet O-Ring	4-15
4.10.2	Replace Two-Inch Valved Unisex Coupling.....	4-16
4.11	Flange Mounted Three-inch Unisex Coupling Maintenance.....	4-19
4.11.1	Replace Flange Mounted Three-Inch Unisex Coupling O-Ring.....	4-19
4.11.2	Replace Flange Mounted Three-Inch Unisex Coupling.. ..	4-20
4.12	Fuel Transfer Pump Maintenance	4-22
4.12.1	Replace Fuel Transfer Pump.....	4-22
4.12.2	Replace Fuel Transfer Pump Discharge Housing O-Ring.....	4-24
4.12.3	Replace Fuel Transfer Pump Discharge Valve	4-26
4.13	Engine Module Maintenance.....	4-27
4.13.1	Replace Carrying Handle.....	4-27
4.13.2	Replace Pulley Guard	4-28
4.13.3	Replace Engine Module Alignment Bolt	4-29
4.13.4	Replace Cable Assembly W101	4-30
4.14	Engine Assembly Maintenance.....	4-32
4.14.1	Replace Starter.....	4-32
4.14.2	Replace Fuel Pump.....	4-34
4.14.3	Adjust Valves.....	4-36
4.14.4	Clean Fuel Injector Nozzle.....	4-37
4.14.5	Replace Exhaust Manifold	4-41

4.14.6 Replace Intake Manifold 4-42

4.14.7 Replace Decompression Arm O-Ring 4-44

4.15 Accessory Module Maintenance..... 4-45

4.15.1 Replace Battery 4-45

4.15.2 Replace Control Box 4-46

4.15.3 Repair Battery Cable 4-49

4.15.4 Replace Control Cable (W201) 4-50

4.15.5 Repair Battery Holddown..... 4-52

4.15.6 Data Plate Replacement (Typical)..... 4-54

Section VI. Preparation for Storage or Shipment 4-55

4.16 Preparation for Storage 4-55

4.16.1 Engine Preparation 4-55

4.16.1.1 Engine Preparation for Short Term Storage (Up To Six Months) 4-55

4.16.1.2 Engine Preparation for Long Term Storage (More Than Six Months) 4-56

4.17 Preparation for Shipment 4-56

4.18 Special Instructions for Administrative Storage 4-57

Section I. LUBRICATION INSTRUCTIONS

4.1 LUBRICATION.

The unit maintenance lubrication requirement is an engine oil change which is included in table 4-1, Unit Preventive Maintenance Checks and Services (PMCS).

Section II. SERVICE UPON RECEIPT

4.2 UNPACKING.

The pumping assembly is part of the Advanced Aviation Forward Area Refueling System (AAFARS). Refer to TM 10-4930-250-12&P for unpacking instructions.

4.3 INSPECTION.

Inspect the pumping assembly for damage incurred during shipment. If the equipment has been damaged, report the damage on SF 364, Report of Discrepancy.

Check the pumping assembly against the packing slip to see if the shipment is complete. Report all discrepancies in accordance with the instructions of DA PAM 738-750.

4.4 ENGINE SERVICE.

The engine is shipped complete with the exception of lubricating oil. Refer to table 4-1, Unit Preventive Maintenance Checks and Services for Pumping Assembly. After filling with the correct amount of lubricating oil, turn the engine several times by hand to be sure it turns freely.

Section III. UNIT PREVENTIVE MAINTENANCE CHECKS AND SERVICES (PMCS)

4.5 GENERAL.

Preventive Maintenance Checks and Services (PMCS) involves systematic caring, inspection, and servicing of equipment to keep it in good condition and prevent breakdowns. Table 4-1 lists the pumping assembly PMCS. Service intervals are divided into categories: B Before Operation; D During Operation; A After Operation; and various other checks and services to be performed at prescribed hourly intervals. Table 4-1 organizes your PMCS tasks in chronological sequence. As the pumping assembly operator, you should:

- a. Perform your PMCS as scheduled in table 4-1. Always do your PMCS in the same order, so it gets to be a habit. Always assume explosive vapors are present at the pumping assembly. Do not allow any smoking or spark producing equipment within fifty feet of the pumping assembly while performing your PMCS.
- b. Do your BEFORE (B) PMCS prior to the equipment leaving its staging/service area or performing its intended mission. Keep in mind the WARNINGS and CAUTIONS.
- c. Do your DURING (D) PMCS during pumping assembly operation. Leaks can be spotted only during operation. Keep in mind the WARNINGS and CAUTIONS.
- d. Do your AFTER (A) PMCS as soon as possible after the pumping assembly has been taken out of its mission mode or returned to its containment area. Keep in mind the WARNINGS and CAUTIONS.
- e. If your equipment fails to operate, perform the operator troubleshooting procedures presented in this manual. Report unresolved maintenance problems to unit maintenance personnel.

WARNING

- **DO NOT use diesel fuel, gasoline, or benzine (benzol) for cleaning.**
 - **DO NOT SMOKE when using cleaning solvent. NEVER USE IT NEAR AN OPEN FLAME. Be sure there is a fire extinguisher nearby and use cleaning solvent only in well-ventilated places. Flash point of solvent is 138° F (60° C).**
 - **USE CAUTION when using cleaning solvents. Cleaning solvents evaporate quickly and can irritate exposed skin. In cold weather, contact of exposed skin with cleaning solvents can cause frostbite.**
- f. Cleanliness. Dirt, grease, oil and debris only get in the way and may cover up a serious problem. Use dry cleaning solvent SD (P-D-680) or some other suitable cleaning solvent on all metal surfaces.
 - g. Bolts, Nuts and Screws. Check bolts, nuts and screws for obvious looseness and missing, bent or broken conditions. Look for chipped paint, bare metal or rust around bolt heads. If any part is loose, notify Unit Maintenance.
 - h. Welds. Look for loose or chipped paint, rust or gaps where parts are welded together. If a bad weld is found, notify Unit Maintenance.
 - i. Electric Wires and Connections. Look for cracked or broken insulation, bare wires and loose connectors. If a bad wire or connector is found, notify Unit Maintenance.

4.6 LEAKAGE CRITERIA.

Wetness around seals, gaskets, fittings or connections indicates leakage. A stain also indicates leakage. If a fitting or connector is loose, broken or defective, report it. Definitions of the classes of leaks are listed below. Become familiar with each class of leak so that you are aware of the status of your equipment. When in doubt, notify your supervisor.

WARNING

All petroleum products contain additives that may be harmful to personnel and the environment. All leaks must be corrected as soon as possible. Wash fuel or oil from skin immediately. Remove and wash contaminated clothing immediately. Spills of fuel or oil must be cleaned up in accordance with local area direction to prevent harm to personnel or damage to the environment.

CAUTION

Equipment operation is allowable with minor oil leakages (Class I or Class II). If leakage is present at the engine, check lubricating oil level more often than usual. Do not allow oil level to fall below the ADD OIL mark. When in doubt, notify your supervisor.

- a. Class I - Leakage indicated by wetness or discoloration not great enough to form drops.
- b. Class II Leakage great enough to form drops but not enough to cause drops to drip from item being checked or inspected.
- c. Class III - Leakage great enough to form drops that fall from item being checked or inspected.

4.7 PMCS PROCEDURES.

Table 4-1 lists the checks and services required to keep your pumping assembly in good operating condition. They are listed in chronological order and should be performed in this order so they become a habit. An explanation of each column is provided below.

- a. The "Item No." column provides the sequential identification number for each task.
- b. The "Interval" column tells you when to do a certain check or service.
- c. The "Location - Item to Check/Service" column tells you on which item the procedure is performed.
- d. The "Procedure" column tells you how to do the required checks and services. Carefully follow these instructions. If you do not have the required tools, or if the procedure tells you to, notify your supervisor.
- e. The "Not Fully Mission Capable If" column tells you the conditions under which your pumping assembly is not capable of performing its intended mission.

INITIAL SETUP FOR PUMPING ASSEMBLY LUBRICATION (ENGINE OIL CHANGE)

Tools

Pan, Drain (Appendix B, Section III, Item 1)
Wrench, Oil Filter (Appendix B, Section III, Item 1)

Materials/Parts

Rags, Wiping (Appendix F, Section II, Item 4)

Personnel Required

Four, any MOS

Table 4-1. Unit Preventive Maintenance Checks and Services for Pumping Assembly

Item No.	Interval	Location	Procedure	Not Fully Mission Capable if:
		Item to Check/Service		
1	Weekly	Pump Overtemp Switch	Perform electrical circuit test. Refer to paragraph 4.9.2.c(a).	Switch fails test
2	Annually	Pump Overtemp Sensor	Perform test of the thermostat over-temperature sensor. Refer to paragraph 4.9.2. c (b). WARNING Fuel fumes are always present in the vicinity of the pumping assembly. Death or personal injury may result from the explosion of fuel fumes exposed to an open flame or spark. Do not permit smoking, any open flame, or spark producing equipment within 50 feet (15 m) of the pumping assembly.	Sensor is open
3	200 hours	Engine	Perform engine oil change. Oil filters shall be serviced/cleaned/changed as applicable, when: a. They are known to be contaminated or clogged. b. Service is recommended by AOAP laboratory analysis. c. At prescribed hardtime intervals. This pumping assembly is not enrolled in the Army Oil Analysis Program. HARDTIME INTERVALS APPLY. a. Remove engine module from pump-engine module (Refer to paragraph 2.4.b) and place engine module high enough to allow oil drain pan to fit beneath oil drain plug. b. Remove oil filler cap next to dipstick. c. Place oil drain pan beneath oil drain plug, remove the drain plug and drain the oil. Dispose of in accordance with local SOP. d. Remove the oil filter, taking care not to spill oil from filter. Dispose of in accordance with local SOP.	Oil level is above MAX or below MIN mark on dipstick.

Item No.	Interval	Location	Procedure	Not Fully Mission Capable if:									
		Item to Check/Service											
			e. Install the oil drain plug. f. Lightly lubricate the seal on the oil filter. <p style="text-align: center;">CAUTION</p> <p style="text-align: center;">Do not use oil filter wrench. Over-tightening may damage the seal or allow the filter to seize.</p> g. Install the oil filter hand tight.										
<table border="1"> <thead> <tr> <th colspan="3">EXPECTED TEMPERATURES</th> </tr> </thead> <tbody> <tr> <td>REFILL CAPACITY</td> <td>+5°F (-15°C) to +120°F (49°)</td> <td>-25°F (-32°C) to +40°F (4.5°C)</td> </tr> <tr> <td>1.9 QT (1.8L)</td> <td>MIL-L-2104 OE/HDO-15/40 (SAE15W-40)</td> <td>MIL-L-46167 OEA (SAE 0W-20)</td> </tr> </tbody> </table>					EXPECTED TEMPERATURES			REFILL CAPACITY	+5°F (-15°C) to +120°F (49°)	-25°F (-32°C) to +40°F (4.5°C)	1.9 QT (1.8L)	MIL-L-2104 OE/HDO-15/40 (SAE15W-40)	MIL-L-46167 OEA (SAE 0W-20)
EXPECTED TEMPERATURES													
REFILL CAPACITY	+5°F (-15°C) to +120°F (49°)	-25°F (-32°C) to +40°F (4.5°C)											
1.9 QT (1.8L)	MIL-L-2104 OE/HDO-15/40 (SAE15W-40)	MIL-L-46167 OEA (SAE 0W-20)											
			h. Add 1.9 qt (1.8 l) oil to the engine. i. Install the oil filler cap. j. Install the engine module in the pump-engine module. Refer to paragraph 2.4.d. k. Start and run the engine for two or three minutes, checking for oil leaks. l. Stop engine; wait 2-3 minutes. m. Check the engine oil level. Add oil to a level between MIN and MAX marks on dipstick.										
4	300h	Engine	Perform valve lash check and adjustment. Refer to paragraph 4.14.3.	Valves are out of adjustment.									
5	500h 6 mo	Engine	Clean and inspect fuel injectors. Refer to paragraph 4.14.4.	Fuel injector service limit is exceeded.									

PMCS MANDATORY REPLACEMENT PARTS LIST

Item No.	Part No.	NSN	Nomenclature	Qty
1	7717525	Not Assigned	Filter, Oil	1

Section IV. UNIT TROUBLESHOOTING PROCEDURES

4.8 TROUBLESHOOTING.

Troubleshooting table 4-2 is provided to assist you in locating and correcting system faults. This table cannot list all the malfunctions that may occur, all the tests and inspections needed to find the fault, or all the corrective actions needed to correct the fault. If the equipment malfunction is not listed or actions listed do not correct the fault, notify your supervisor.

TABLE 4-2. TROUBLESHOOTING

MALFUNCTION	TEST OR INSPECTION	CORRECTIVE ACTION
-------------	--------------------	-------------------

ENGINE

1. Engine will not crank

Step 1. Check electrical power to starter

- a. Check for +24 VDC at "+" terminal (1) of starter solenoid (2). If present, go to step 2.a.
- b. Disconnect battery power cable from engine module and check connector for +24 VDC between outer and inner conductor.

Step 2. Check continuity of starter power circuit

- a. Disconnect and remove wires from starter terminal (3) of starter solenoid. Check that resistance from starter wire to ground is approximately zero (0) ohms. If the resistance is infinite or very high, replace starter. Refer to paragraph 4.14.1.
- b. Check that resistance from center terminal of engine module NATO connector to "+" terminal (1) of starter solenoid (2) is zero (0). If the resistance is infinite or very high, conduct a visual inspection of the NATO connector and the starter power cable for broken or loose connections or cables.
- c. Disconnect battery power cable from battery. Check that resistance from center conductor of NATO connector to "+" terminal of the battery connector is zero (0). Check that resistance from outer conductor of NATO connector to "-" terminal of the battery connector is zero (0). If the resistance is infinite or very high, repair or replace battery power cable W202.

2. Engine cranks but will not start

Check fuel supply to engine

- a. Drain and check fuel filter. Replace if clogged. Refer to paragraph 4.9. 1.
- b. Refer to direct support maintenance.

TABLE 4-2. TROUBLESHOOTING (Continued)

MALFUNCTION	TEST OR INSPECTION	CORRECTIVE ACTION
-------------	--------------------	-------------------

3. Engine starts but lacks power or will not run.

Step 1. Check for clogged air intake.

- a. Remove filter element from air filter.
- b. Check for blockage at air intake.
- c. Inspect filter element for clogging; replace if necessary. Refer to paragraph 4.9.3

Step 2. Check for clogged fuel filter.

- a. Drain and check fuel filter. Replace if clogged. Refer to paragraph 4.9.1
- b. Refer to Direct Support Maintenance.

FUEL TRANSFER PUMP

1. Pump will not prime

Check discharge check valve for proper seating.

- a. Check for debris or damage that prevents check valve from seating fully. Clean valve seat and surface.
- b. Replace check valve. Refer to paragraph 4.12.3

2. Pump leaks at inlet

Check inlet mounting screws.

Verify that all inlet mounting screws are evenly tightened

3. Emergency Shutoff Valve leaks.

Inspect to determine area of leak.

- a. If leak is at face of unisex coupling, replace face seal. Refer to paragraph 3.3.
- b. Replace emergency shutoff valve.
- c. Refer valve to Direct Support Maintenance for repair.

Section V. UNIT MAINTENANCE PROCEDURES

4.9 PUMP-ENGINE MODULE MAINTENANCE.

4.9.1 Replace Engine Fuel Filter. (Refer to figure 4-1.)

This task consists of: a. Removal b. Installation

INITIAL SET-UP:**Tools:**

Tool Kit, General Mechanics
(Appendix B, Section III, Item 1)

Materials/Parts Required:

Sealing compound, LH-150
(Appendix F, Section II, Item 1)
Nuts, self-locking (Appendix I, Item 43)

General Safety Requirements:**WARNING**

Fuels are toxic and flammable. Do not get on person or clothing. Work in well ventilated area. Do not smoke. Ensure equipment is well grounded.

Equipment Condition:

Pumping assembly shut down (para. 2.6)

WARNING

Death or personal injury may result from the explosion of fuel fumes exposed to an open flame or spark, or to static discharge. Do not permit smoking, any open flame, or spark producing equipment within fifty (50) feet of the pumping assembly. Ensure all equipments are well grounded prior to commencing any operation or maintenance task.

a. Removal.

- (1) Disconnect fuel supply line (1) and fuel return line (2) at engine module quick-disconnect connections.
- (2) Place fuel selector valve (3) to OFF.
- (3) Place container under engine fuel filter (4), open drain valve (5) on bottom of filter and drain completely.
- (4) Open vent (6) on top of engine fuel filter to ensure complete draining. Dispose of drained fuel in accordance with SOP.
- (5) At the engine fuel filter, remove the fuel line (7) from the fuel selector valve.
- (6) At the engine fuel filter, remove the fuel supply line (8) to the engine.

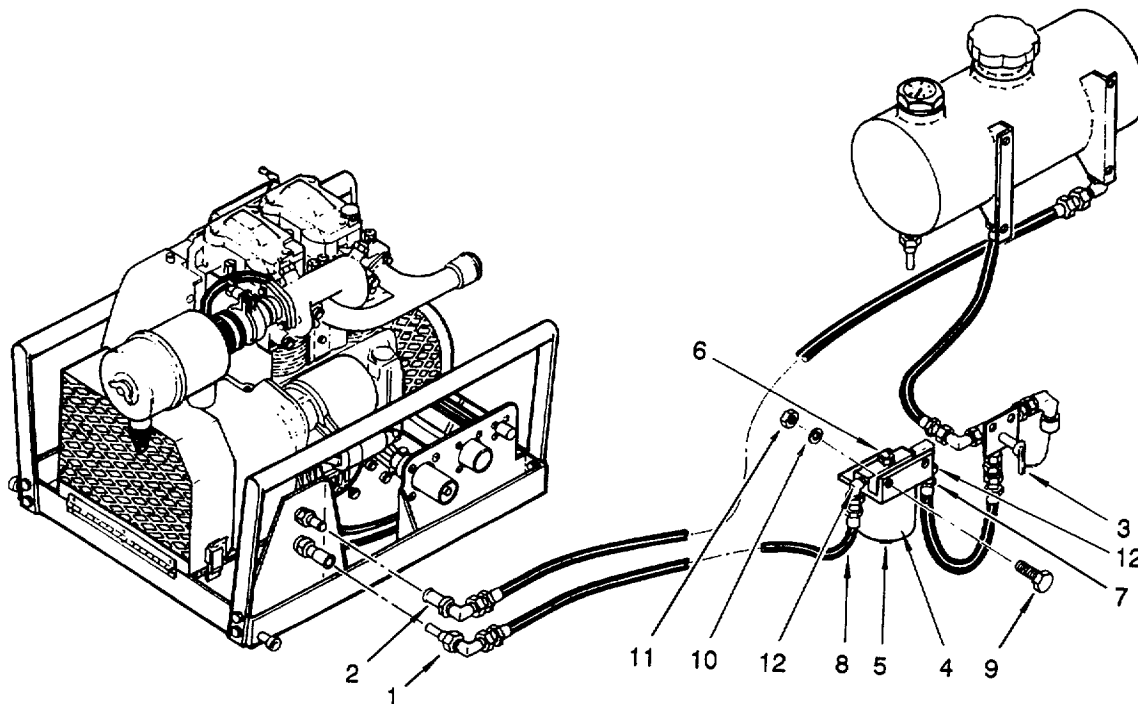

Figure 4-1. Fuel Filter Replacement

- (7) Remove the two bolts (9), flat washers (10) and self-locking nuts (11) that secure the engine fuel filter to the module. Discard the self-locking nuts.
- (8) Remove the elbows (12) from the inlet and outlet of the engine fuel filter assembly. Dispose of the engine fuel filter assembly in accordance with SOP.

b. Installation.

- (1) Clean threads on elbows (12) as required, apply a light, even coat of sealing compound to threads and install on engine fuel filter assembly.
- (2) Verify that drain valve (5) and vent valve (6) on engine fuel filter are closed.
- (3) Install fuel inlet and outlet line elbows (12) on engine fuel filter
- (4) Install engine fuel filter on module frame with two bolts (9), flat washers (10) and new self-locking nuts (11).

- (5) Install the fuel lines (7 and 8) to the elbows (12) at the engine fuel filter inlet and outlet.
- (6) Connect the fuel supply line (1) and fuel return line (2) at the engine module quick disconnect connections.
- (7) Position the fuel selector valve (3) to ON or EXTERNAL ON.
- (8) Crack open engine fuel filter vent valve (6) to allow air to escape. Close immediately at first indication of fuel.

4.9.2 Replace Pumpage Overtemperature Sensor/Sensor Cable (W103). (Refer to figure 4-2.)

This task consists of: a. Removal b. Installation c. Test

INITIAL SET-UP:

Tools:

- Tool Kit, General Mechanics
(Appendix B, Section III, Item 1)
- Multimeter
(Appendix B, Section III, Item 10)
- Tester, Thermostat
(Appendix B, Section III, Item 11)
- Thermometer
(Appendix B, Section III, Item 12)

Materials/Parts Required:

- Sealing Compound, LH-150
(Appendix F, Section II, Item 1)

General Safety Requirements:

Equipment Condition:

- Pumping assembly shut down and all valves closed.
(See paragraph 2.6)

WARNING

Fuels are toxic and flammable. Do not get on person or clothing. Work in well ventilated area. Do not smoke. Ensure equipment is well grounded.

- a. Removal.
 - (1) Place drain pan under pumpage overtemperature sensor (1).
 - (2) Disconnect cable assembly W103 (2) at engine module electrical connection panel.
 - (3) Remove pumpage overtemperature sensor (1) from bottom of fuel transfer pump discharge housing (3).
- b. Installation.
 - (1) Clean sensor threads as required in fuel transfer pump discharge housing (3).
 - (2) Apply a light, even coat of sealing compound to pumpage overtemperature sensor (1) threads and install in fuel transfer pump discharge housing (3).
 - (3) Connect cable assembly W103 (2) at engine module electrical connection panel.
- c. Test.
 - (a) Sensor Cable

NOTE

The following procedure shall be successfully completed prior to deployment with the engine operating.

- (1) Disconnect the connector to 1A1J3 receptacle.
 - (2) The engine should shut down.
 - (3) "PUMPAGE HOT" indicator light on the control panel should illuminate.
 - (4) If (2) or (3) do not occur, repair unit before deployment.
- (b) Sensor

CAUTION

Adhere to all safety requirements and provide adequate ventilation and fire protection.

NOTE

Check sensor continuity at room temperature before starting test.

- (1) Connect the overtemperature sensor (1) wire leads to the multimeter leads.
- (2) Record whether or not the overtemperature sensor is closed, continuity; or open, no continuity.
- (3) If sensor is open, stop test and replace sensor. If sensor is closed, continue to step 4.

NOTE

The following steps must be done in the sequence shown.

- (4) Attach thermometer to the top edge, and inside, of the test container.
- (5) Attach the sensor to one end of the suspension wire and hook the other end over the edge of the test container so that the sensor is close to, but not touching, the thermometer or the bottom of the container.
- (6) Fill the test container with water so that the sensor and at least 2 inches of the thermometer are covered.
- (7) Connect the sensor wire leads to the multimeter leads.
- (8) Plug the test container into a 1 10v outlet and observe temperature and multimeter until the sensor opens and/or the water heats to +190F.
- (9) If sensor does not open, no continuity, stop test and replace sensor. If sensor opens, proceed to step 10.
- (10) Unplug the test container and let water cool to room temperature (less than +100F).
- (11) If sensor does not close, continuity, stop test and replace sensor. If sensor closed, proceed to step 12.
- (12) If the sensor opened (step 9) and closed (step 11), the sensor is acceptable.

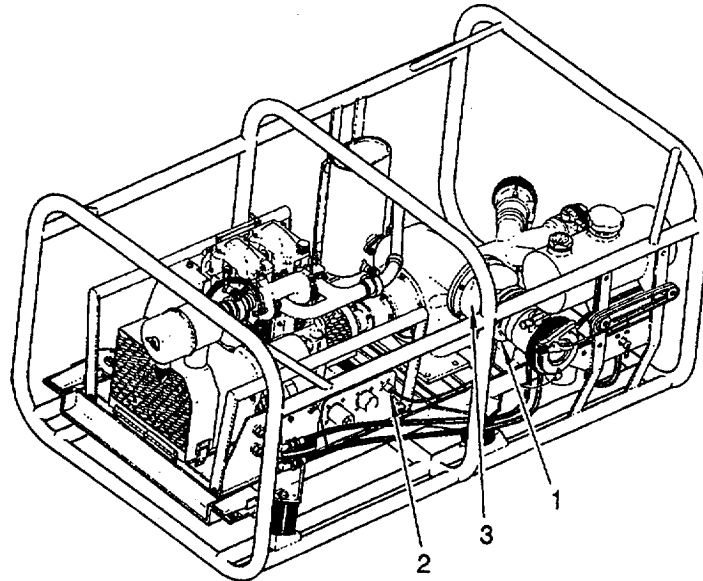

Figure 4-2. Pumpage Overtemperature Sensor Replacement

4.9.3 Replace Engine Air Filter Element. (Refer to figure 4-3.)

This task consists of: a. Removal b. Installation

INITIAL SET-UP:

Tools:

No tools required

Materials/Parts Required:

O-ring (Appendix I, Item 67)

Equipment Condition:

Pumping assembly shutdown (See para. 2.6)

a. Removal.

- (1) Remove wing nut (1) and remove cover (2).
- (2) Remove wing nut (3) and slide filter element (4) out of filter body (5).
- (3) Remove and discard O-ring (6).

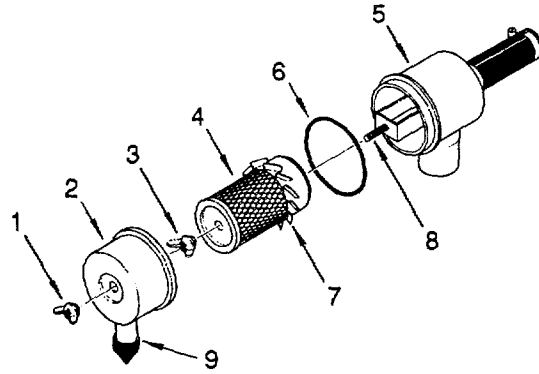

Figure 4-3. Engine Air Filter Element Replacement

b. Installation.

- (1) Install O-ring (6) on filter body (5).
- (2) With separator fins (7) at top, slide filter element (4) over threaded rod (8).

CAUTION

Do not overtighten filter element wing nut. Too much stress on the metal disk on the end of the element may cause the disk to fracture and be drawn into the engine.

- (3) Install and hand tighten wing nut (3) on threaded rod (8). Ensure wing nut (3) is just tight enough to prevent rotation of filter element (4) on threaded rod (8).
- (4) Using wing nut (1), install cover (2) on filter body (5) with dust ejector (9) pointing down.

4.9.4 Replace Engine Air Filter Hose. (Refer to figure 4-4.)

This task consists of: a. Removal b. Installation

INITIAL SET-UP:

Tools:

Tool Kit, General Mechanics
(Appendix B, Section III, Item 1)

Materials/Parts Required:

None

Equipment Condition:

Pumping assembly shut down (See para. 2.6)

a. Removal.

- (1) Remove clamp (1) from coupler (2).

- (2) Remove clamp (3) from filter body (4).
- (3) Remove hose (5) from filter body (4).

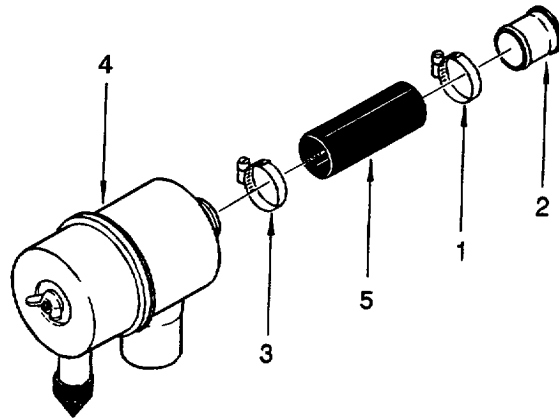

Figure 4-4. Air Filter Hose Replacement

b. Installation.

- (1) Using clamp (3), install hose (5) on filter body (4).
- (2) Using clamp (1), install coupler (2) on hose.

4.10 REPAIR INLET MANIFOLD ASSEMBLY.

Inlet manifold maintenance is limited to replacement of the O-ring located on the outlet flange of the manifold, and replacement of the three unisex couplings located on the inlet.

4.10.1 Replace Outlet O-Ring. (Refer to figure 4-5.)

This task consists of: a. Removal b. Installation

INITIAL SET-UP:

Tools:

Tool Kit, General Mechanics
(Appendix B, Section III, Item 1)

Materials/Parts Required:

Nut, Self-Locking (Appendix I, Item 43)
Nut, Self-Locking (Appendix I, Item 44)
Petrolatum (Appendix F, Section II, Item 10)

General Safety Requirements:

WARNING

- **Fuels are toxic and flammable. Do not get on person or clothing. Work in well ventilated area. Do not smoke. Ensure equipment is well grounded.**

Equipment Condition:

Pump assembly shut down (para. 2.6)
All fuel hoses removed from inlet manifold
(TM 10-4930-250-13&P)

a. Removal.

- (1) Remove the two bolts (1), flat washers (2) and self-locking nuts (3) that secure the inlet manifold (4) to the module sub-frame. Discard the self-locking nuts.
- (2) Remove the six bolts (5), flat washers (6) and self-locking nuts (7) that secure the inlet manifold to the fuel transfer pump. Discard the self-locking nuts. Remove the inlet manifold, and remove and discard the manifold outlet O-ring (8).

b. Installation.

- (1) Lightly lubricate with petrolatum and install an O-ring (8) on the inlet manifold (4).
- (2) Install the six bolts (5), flat washers (6) and self-locking nuts (7) to secure the inlet manifold to the fuel transfer pump. Torque in a crossing pattern to 120-130 in. lb. (13.3-14.4 Nm).
- (3) Install and tighten the two bolts (1), flat washers (2) and self-locking nuts (3) that secure the inlet manifold to the module sub-frame.

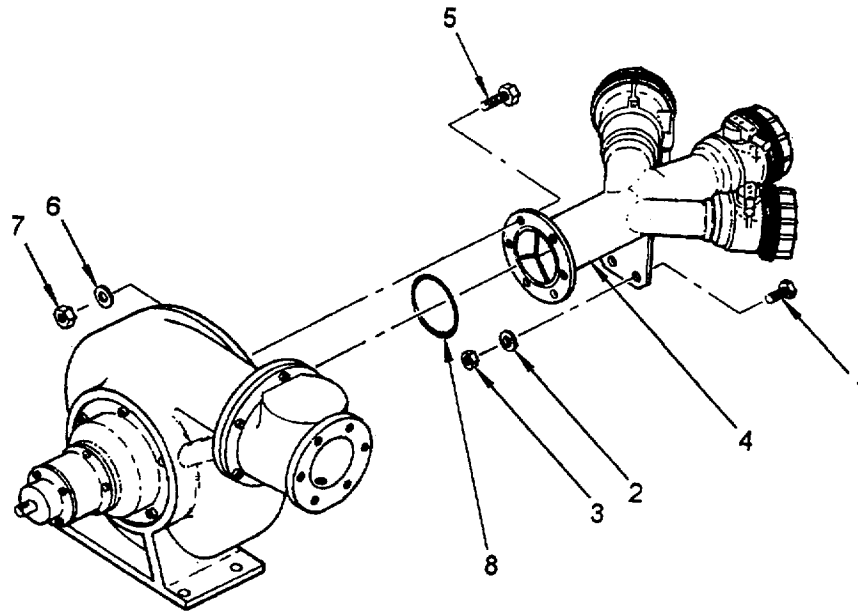

Figure 4-5. Inlet Manifold Outlet O-Ring Replacement

4.10.2 Replace Two-Inch Valved Unisex Coupling. (Refer to figure 4-6.)

This task consists of: a. Removal b. Installation

INITIAL SET-UP:

Tools:

- Tool Kit, General Mechanics
(Appendix B, Section III, Item 1)
- Chemical and Oil Protective Gloves
(Appendix B, Section III, Item 2)

Materials/Parts Required:

- Petrolatum (Appendix F, Section II, Item 10)
- Rag, Wiping (Appendix F, Section II, Item 4)
- Seal (Appendix I, Item 3)
- O-Ring (Appendix I, Item 48)
- O-Ring (Appendix I, Item 57)
- O-Ring (Appendix I, Item 51)

General Safety Requirements:

WARNING

- Fuels are toxic and flammable. Do not get on person or clothing. Work in well ventilated area. Do not smoke. Ensure equipment is well grounded.
- Using dry cleaning solvents incorrectly can cause injury or even death.
- Fuel is flammable. Do not smoke.

Equipment Condition:

- Pump assembly shut down (para. 2.6)
- All fuel hoses removed from inlet manifold (TM 10-4930-250-13&P)

a. Removal.

WARNING

Rubber gloves should be worn when handling fueling system components due to the toxic effects of some fuel additives.

- (1) Remove ball retaining screw (1) and O-ring (2). Discard O-ring (2).
- (2) Position a wiping rag under coupling (3) and orient coupling (3) screw hole toward wiping rag. Push in and rotate unisex coupling (3) back and forth until all 41 balls (4) have collected in the wiping rag.
- (3) Pull unisex coupling (3) from inlet (5).
- (4) Remove and discard outside O-ring (6) from inlet (5).
- (5) Remove and discard nylon seal (7) and inside O-ring (8) from inlet (5).
- (6) Remove and retain eight springs (9).

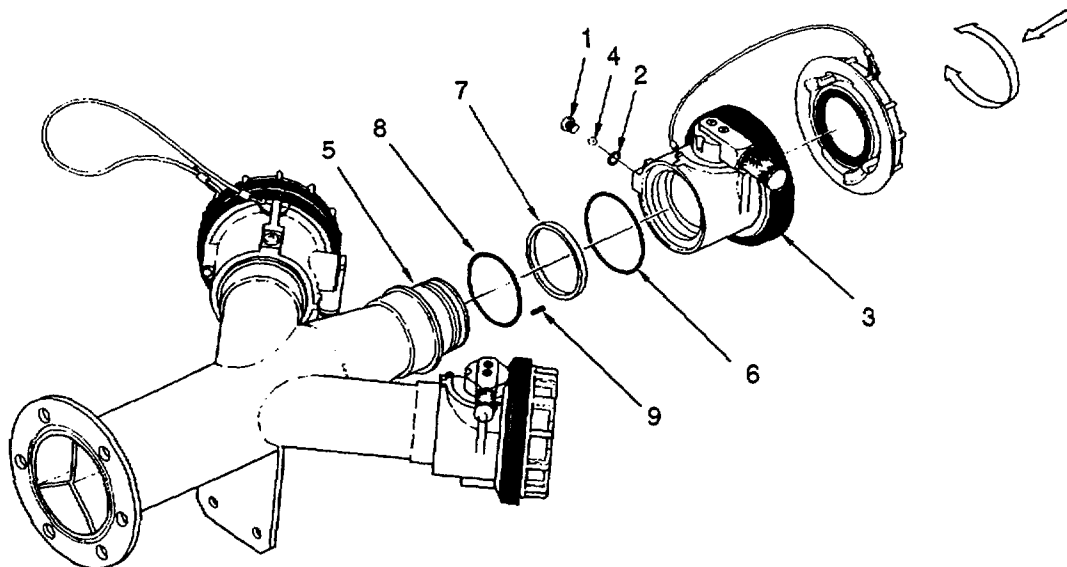

Figure 4-6. Inlet Manifold Unisex Coupling Replacement

b. Installation.

WARNING

Rubber gloves should be worn when handling fueling system components due to the toxic effects of some fuel additives.

NOTE

When inserting balls in unisex coupling ball race, use caution to avoid dropping loose balls. Work over a wiping rag.

- (1) Lightly lubricate outside O-ring (6) with petrolatum and install in second (square) groove of inlet (5).
- (2) Lightly lubricate inside O-ring (8) with petrolatum and install inside inlet (5).
- (3) Place springs (9) in inlet (5).
- (4) Install nylon seal (7) in inlet (5).

NOTE

Assembly of the unisex coupling on to the inlet requires two persons, one to hold the unisex coupling on the inlet against spring pressure and one to insert the balls. Alternatively, one person can perform the task if the unisex coupling is pressed against some object heavy enough to compress and hold the inlet springs while the balls are inserted in the race.

- (5) Place a wiping rag under the unisex coupling (3). Slide the unisex coupling (3) on to the inlet (5) and adjust position until screw hole is facing up and ball race (rounded groove) in inlet is centered under screw hole. Install balls (4) one at a time, rotating unisex coupling (3) back and forth until all 41 balls (4) have been inserted.
- (6) Install ball retaining screw (1) and O-ring (2) in unisex coupling (3). Tighten retaining screw.

4.11 FLANGE MOUNTED THREE-INCH UNISEX COUPLING MAINTENANCE.

4.11.1 Replace Flange Mounted Three-Inch Unisex Coupling O-Ring. (Refer to figure 4-7.)

This task consists of: a. Removal b. Installation

INITIAL SET-UP:

Tools:

Tool Kit, General Mechanics
(Appendix B, Section III, Item 1)

Materials/Parts Required:

Washer, Lock (Appendix I, Item 61)
Petrolatum (Appendix F, Section II, Item 10)

General Safety Requirements:

Equipment Condition:

Pump assembly shut down (para. 2.6)

WARNING

- **Fuels are toxic and flammable. Do not get on person or clothing. Work in well ventilated area. Do not smoke. Ensure equipment is well grounded.**

a. Removal.

- (1) Connect the module grounding cable to a secure ground.
- (2) Remove the six bolts (1), lock washers (2) and flat washers (3) that secure the coupling assembly (4) to the fuel transfer pump (5). Discard the lock washers (2).
- (3) Remove O-ring (6) from groove in coupling flange face and dispose of in accordance with SOP.

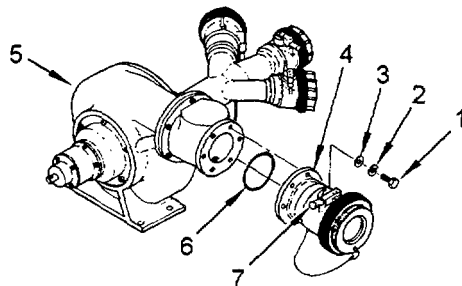

Figure 4-7. Flange Mounted Unisex Coupling O-Ring Replacement

b. Installation.

- (1) Wipe clean the O-ring groove.
- (2) Lightly lubricate with petrolatum and install O-ring (6) in groove.
- (3) Position coupling assembly (4) on fuel transfer pump (5) so that valve handle (7) is on top, and install the six bolts (1), lock washers (2) and flat washers (3) to secure the coupling to the fuel transfer pump. Torque bolts in a crossing pattern to 80-90 in. lbs. (8.8-9.9 Nm).

4.11.2 Replace Flange Mounted Three-Inch Unisex Coupling. (Refer to figure 4-8.)

This task consists of: a. Removal b. Installation

INITIAL SET-UP:**Tools:**

Tool Kit, General Mechanics ' (Appendix B, Section III, Item 1)
 Chemical and Oil Protective Gloves (Appendix B, Section II, Item 2)

Materials/Parts Required:

Petrolatum (Appendix F, Section II, Item 10)
 O-Ring (Appendix I, Item 46)
 O-Ring (Appendix I, Item 58)

General Safety Requirements:**Equipment Condition:**

Pumping assembly shut down (para. 2.6)

WARNING

Fuels are toxic and flammable. Do not get on person Or clothing. Work in well ventilated area. Do not Smoke. Ensure equipment is well grounded.

a. Removal.

WARNING

Rubber gloves should be worn when handling fueling system components due to the toxic effects of some fuel additives.

- (1) Remove ball retaining screw (1) and O-ring (2). Discard O-ring (2).
- (2) Position a wiping rag under coupling (3) and orient coupling (3) screw hole toward wiping rag. Rotate unisex coupling (3) back and forth to allow the 41 balls (4) to collect in the wiping rag.
- (3) Separate the unisex coupling (3) and inlet (5). Collect the continuity ball (6) and spring (7).
- (4) Remove and discard outside O-ring (8).

a. Installation.

WARNING

Rubber gloves should be worn when handling fueling system components due to the toxic effects of some fuel additives.

NOTE

When inserting balls in unisex coupling ball race, use caution to avoid dropping loose balls. Recommend working over a wiping rag.

- (1) Lightly lubricate outside O-ring (8) with petrolatum and install in second (square) groove of inlet (5).

- (2) Start the unisex coupling (3) on to the inlet (5). Install continuity ball (6) and spring (7) into hole in inlet (5) and hold in the compressed position while completing installation of unisex coupling (3) onto inlet (5).
- (3) Place a wiping rag beneath the unisex coupling (3). Adjust coupling position until screw hole is facing up and ball race (rounded groove) in inlet is centered under screw hole. Insert the balls (4) one at a time into the hole in the housing by rotating the unisex coupling (3) while installing the balls (4). Once all 41 balls (4) are installed, place O-ring (2) onto ball retaining screw (1) and install the ball retaining screw (1). Tighten retaining screw (1).

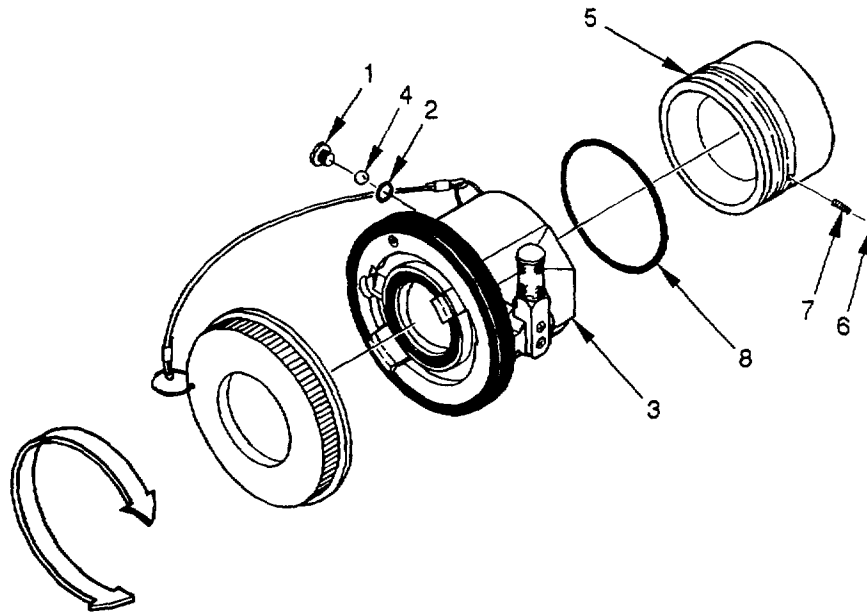

Figure 4-8. Flange Mounted Unisex Coupling Replacement

4.12 FUEL TRANSFER PUMP MAINTENANCE.

4.12.1 Replace Fuel Transfer Pump. (Refer to figure 4-9.)

This task consists of: a. Removal b. Installation

INITIAL SET-UP:

Tools:

Tool Kit, General Mechanics
(Appendix B, Section III, Item 1)

Materials/Parts Required:

Washer, Lock (Appendix I, Item 65)

General Safety Requirements:

WARNING

Fuels are toxic and flammable. Do not get on person or clothing. Work in well ventilated area. Do not smoke. Ensure equipment is well grounded.

Equipment Condition:

Pumpage overtemperature sensor removed
(para. 4.9.2)
Inlet manifold removed (para. 4.10.1)

a. Removal.

- (1) Remove the four bolts (1), flat washers (2), lock washers (3) and jam nuts (4) that secure the fuel transfer pump (5) to the module sub-frame. Discard the lock washers (3).
- (2) Disconnect the exhaust line (6) from the engine module, slide the fuel transfer pump away to separate the flexible coupling (7), then lift fuel transfer pump from module.
- (3) Loosen the set screw (8) and slide the flexible coupling (7) from the fuel transfer pump input shaft. Remove key (9) from shaft.

b. Installation.

- (1) Place key (9) in slot in fuel transfer pump (5) input shaft and install the flexible coupling (7) on the input shaft of the fuel transfer pump (5). Install and tighten set screw (8). Ensure a gap of approximately 1/16 inch (1.6 mm) between splined flexible coupling adapter and shaft nut cover (10).

CAUTION

Installation of a fuel transfer pump includes alignment of the flexible coupling adapters on the fuel transfer pump and the engine. Damage to the engine or fuel transfer pump may result from misalignment.

- (2) Position the fuel transfer pump (5) on the module sub-frame and mate the flexible coupling (7) on the pump with the splined flexible coupling adapter (11) on the engine.

- (3) With the pump fully coupled to the engine, install and tighten the four bolts (1), flat washers (2), lock washers (3) and jam nuts (4) that secure the fuel transfer pump (5) to the module sub-frame.
- (4) Clamp exhaust line (6) to engine.
- (5) Install pumpage overtemperature sensor and test (para. 4.9.2.c).

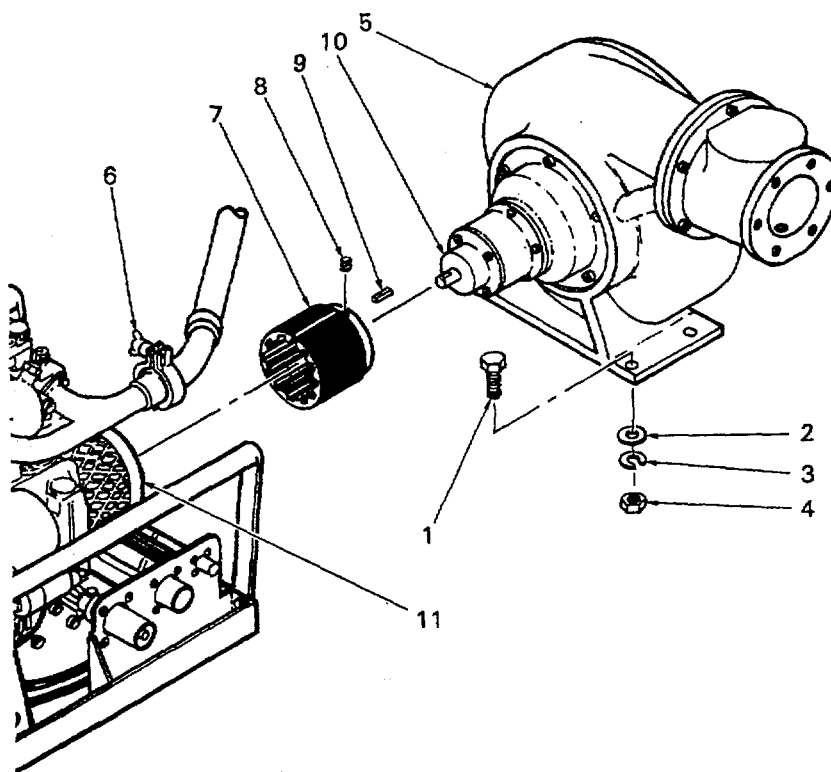

Figure 4-9. Fuel Transfer Pump Replacement

4.12.2 Replace Fuel Transfer Pump Discharge Housing O-Ring. (Refer to figure 4-10.)

This task consists of: a. Removal b. Installation

INITIAL SET-UP:

Tools:

Tool Kit, General Mechanics
(Appendix B, Section III, Item 1)

Materials/Parts Required:

Petrolatum (Appendix F, Section II, Item 10)
Anti-Seize Compound, Molybdenum Disulfide
(Appendix F, Section II, Item 3)

General Safety Requirements:

Equipment Condition:

Pump assembly shut down (para. 2.6)

WARNING

Fuels are toxic and flammable. Do not get on person or clothing. Work in well ventilated area. Do not smoke. Ensure equipment is well grounded.

a. Removal.

- (1) Disconnect pumpage overtemperature cable W103 (1) at engine module electrical connector panel.
- (2) Remove the six socket head screws (2) and flat washers (3) that secure the discharge housing assembly (4) to the fuel transfer pump (5).
- (3) Remove discharge housing (4). Use care to avoid damage to the pumpage overtemperature sensor on bottom of housing.
- (4) Remove and discard the O-ring (6) from the discharge housing assembly.
- (5) Inspect and clean O-ring groove as required. Any debris or foreign material may prevent the O-ring from seating properly.
- (6) Inspect discharge valve (7) for dents, bending or any damage that prevents free action or seating. Replace discharge valve if damaged. Refer to paragraph 4.12.3.

b. Installation.

- (1) Lightly lubricate O-ring (6) with petrolatum and install in o-ring groove. Do not allow the O-ring to twist or roll during installation.
- (2) Lubricate with anti-seize compound and install the six socket head screws (2) and flat washers (3) that secure the discharge housing assembly to the fuel transfer pump. Tighten socket head screws in a crossing pattern.
- (3) Connect pumpage overtemperature cable W103 (1) to engine module electrical connector panel and perform test (para. 4.9.2.c.).

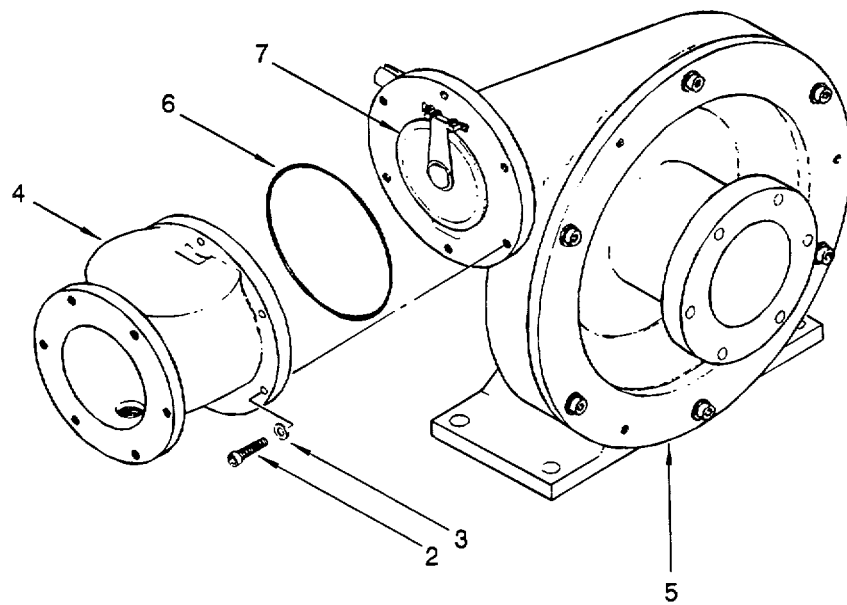
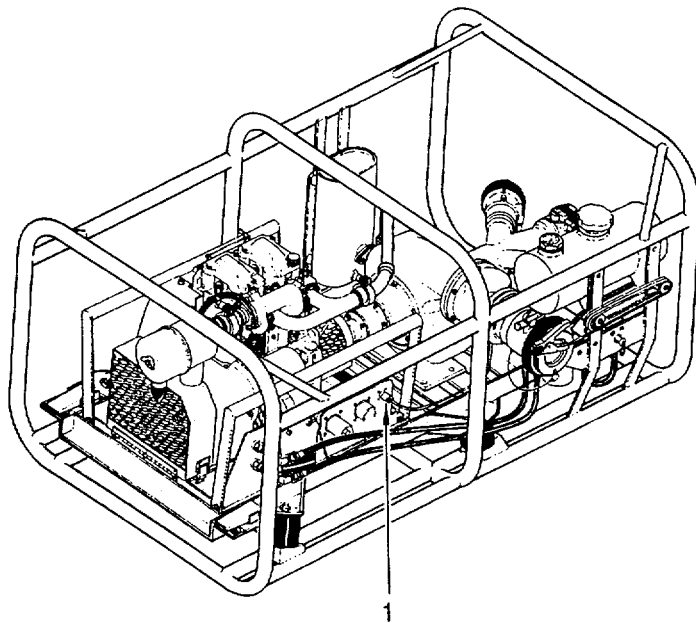

Figure 4-10. Fuel Transfer Pump Discharge Housing O-Ring Replacement

4.12.3 Replace Fuel Transfer Pump Discharge Valve. (Refer to figure 4-11.)

This task consists of: a. Removal b. Installation

INITIAL SET-UP:

Tools:

Tool Kit, General Mechanics
(Appendix B, Section III, Item 1)
Wire Twister, Plier
(Appendix B, Section III, Item 2)

Materials/Parts Required:

Safety Wire (Appendix F, Section II, Item 5)
Washer, Lock (Appendix I, Item 60)

General Safety Requirements:

WARNING

Fuels are toxic and flammable. Do not get on person or clothing. Work in well ventilated area. Do not smoke. Ensure equipment is well grounded.

Equipment Condition:

Pump assembly shut down (para. 2.6)
Discharge housing removed (para. 4.12.2)

a. Removal.

- (1) Remove the safety wire (1) from the discharge valve retaining screws (2).
- (2) Remove the two screws (2) and lock washers (3) that secure the discharge valve (4) to the fuel transfer pump outlet (5). Discard the lock washers (3).

b. Installation.

- (1) Install the two screws (2) and lock washers (3) that secure the discharge valve (4) to the fuel transfer pump outlet (5). Test valve freedom by lifting with finger and allowing to fall back in place.
- (2) Install safety wire (1) on two screws (2) that attach the discharge valve (4) to the fuel transfer pump outlet (5).

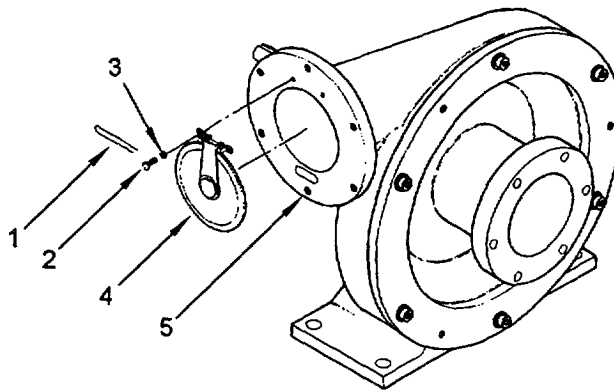

Figure 4-11. Fuel Transfer Pump Discharge Valve Replacement

4.13 ENGINE MODULE MAINTENANCE.

4.13.1 Replace Carrying Handle. (Refer to figure 4-12.)

NOTE

This task applies to either carrying handle.

This task consists of: a. Removal b. Installation

INITIAL SET-UP:

Tools:

Tool Kit, General Mechanics
(Appendix B, Section III, Item 1)

Materials/Parts Required:

Nut, Self-Locking (Appendix I, Item 45)

Equipment Condition:

Pumping assembly shut down (See para. 2.6)

a. Removal.

- (1) Remove the four bolts (1), flat washers (2) and self-locking nuts (3) that secure the carrying handle (4) to the engine module frame (5). Discard the self-locking nuts (3).

b. Installation.

- (1) Position the carrying handle (4) and install the four bolts (1), flat washers (2) and self-locking nuts (3) to secure the carrying handle (4) to the engine module frame (5).

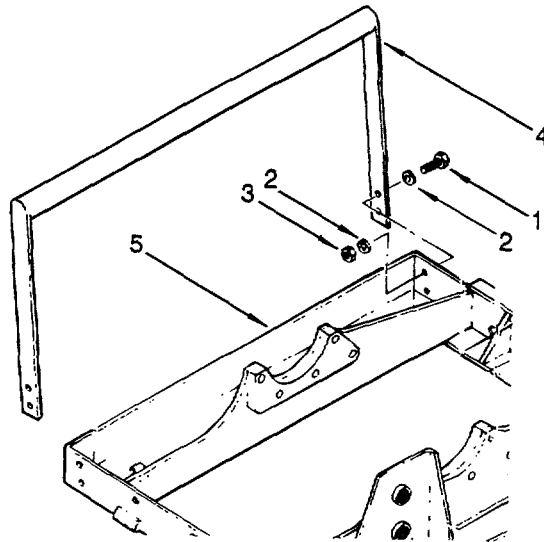

Figure 4-12. Engine Module Carrying Handle Replacement

4.13.2 Replace Pulley Guard. (Refer to figure 4-13.)

This task consists of: a. Removal b. Installation

INITIAL SET-UP:

Tools:

Tool Kit, General Mechanics
(Appendix B, Section III, Item 1)

Materials/Parts Required:

Nut, Self-Locking (Appendix I, Item 42)

Equipment Condition:

Pumping assembly shut down (See para. 2.6)

a. Removal.

- (1) Remove the three cross-tip screws (1), flat washers (2) and self-locking nuts (3) that secure the pulley guard (4) to the engine module frame (5). Discard the self-locking nuts (3).

b. Installation.

- (1) Install the three cross-tip screws (1), flat washers (2) and self-locking nuts (3) to secure the pulley guard (4) to the engine module frame (5). Raise and latch the pulley guard.

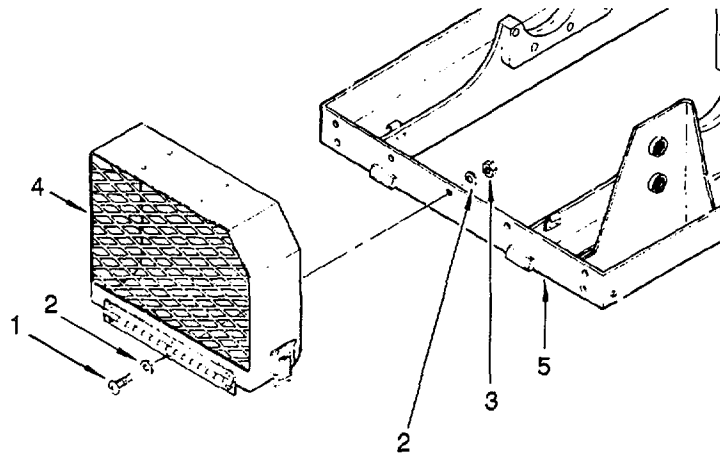

Figure 4-13. Pulley Guard Replacement

4.13.3 Replace Engine Module Alignment Bolts. (Refer to figure 4-14.)

NOTE

This task applies to either alignment bolt.

This task consists of: a. Removal b. Installation

INITIAL SET-UP:

Tools:

Tool Kit, General Mechanics
(Appendix B, Section III, Item 1)

Materials/Parts Required:

None

Equipment Condition:

Engine module removed from pump-engine module.
(para. 2.4.b)

a. Removal.

(1) Remove the nut (1) and flat washer (2) that secure the alignment bolt (3) to the engine module frame (4).

b. Installation.

(1) Install the nut (1) and flat washer (2) to secure the alignment bolt (3) to the engine module frame (4).

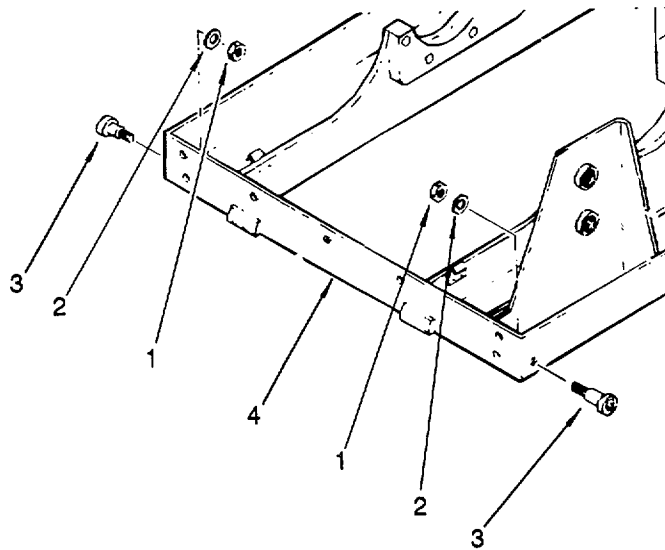

Figure 4-14. Alignment Bolt Replacement

4.13.4 Replace Cable Assembly W101. (Refer to figure 4-15.)

This task consists of: a. Removal b. Installation

INITIAL SET-UP:

Tools:

Tool Kit, General Mechanics
(Appendix B, Section III, Item 1)

Materials/Parts Required:

Tags, Electrical (Appendix F, Section II, Item 16)
Strap, Tiedown (Appendix F, Section II, Item 8)

Equipment Condition:

Engine module removed from pump-engine
module. (para. 2.4.b)

a. Removal.

NOTE

Before beginning removal of cable harness W101, observe general layout of cable harness as guide to installation.

- (1) Cut and remove tiedown straps from electrical wiring harness.
- (2) Tag and disconnect fuel shutoff solenoid electrical wires (1) at in-line connectors in wiring harness.
- (3) Tag and disconnect electrical wire from engine temperature sensor (2).
- (4) At intake manifold, lift boots from air intake heaters (3). Tag and remove electrical wires from air intake heaters.
- (5) Tag and remove electrical wire from oil pressure switch (4).
- (6) Tag and remove small electrical wire (5) from starter solenoid.
- (7) Tag and disconnect alternator wires (6) at in-line connectors.
- (8) At pumpage overtemperature connector 1A1J3 (7), remove the four cross tip screws and flat washers that secure connector 1A1J3 to module frame. Remove connector; retain mounting flange from rear of connector.
- (9) At control cable connector 1A1J2 (8), remove the four cross tip screws and flat washers that secure connector 1A1J2 to the module frame. Remove the connector; retain the mounting flange from rear of connector.
- (10) At rear of NATO connector 1A1J1 (9), tag and remove the small electrical wires (3 terminal lugs) from the negative terminal of connector 1A1J1.

b. Installation.

- (1) At rear of NATO connector 1A1J1 (9), install the small electrical wires (3 terminal lugs) to the negative terminal of connector 1A1J1 as tagged.

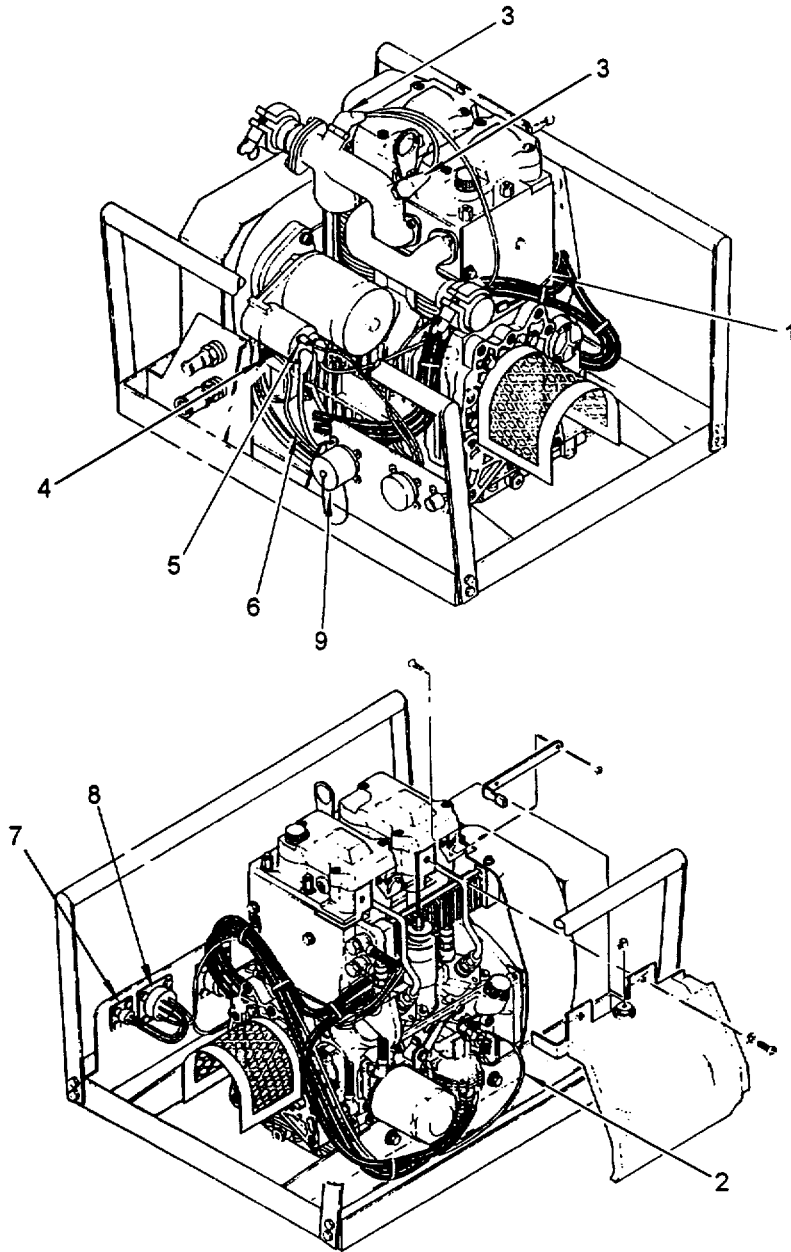

Figure 4-15. Cable Assembly W101 Replacement

- (2) From rear of electrical connection panel, insert control cable connector 1A1J2 (8) through center hole in panel, position and hold the mounting flange on rear of connector, and install and tighten the four cross tip screws and flat washers that secure connector 1A1J2 to the module frame.
- (3) From rear of electrical connection panel, insert pumpage overtemperature connector 1A1J3 (7) through right-hand hole in panel, position and hold the mounting flange on rear of connector, and install and tighten the four cross tip screws and flat washers that secure connector 1A1J3 to the module frame.
- (4) Connect alternator wires (6) at in-line connectors as tagged.
- (5) Connect small electrical wire (5) to starter solenoid as tagged.
- (6) Connect electrical wire to oil pressure switch (4) as tagged.
- (7) At intake manifold, connect electrical wires to air intake heaters (3) as tagged. Install boots over connectors.
- (8) Install electrical wire to engine temperature sensor (2) as tagged.
- (9) Connect fuel shutoff solenoid electrical wires (1) at in-line connectors as tagged.
- (10) Group and route wires of cable assembly W101 in general layout observed at removal, and install tiedown straps as necessary to secure wiring harness.

4.14 ENGINE ASSEMBLY MAINTENANCE.

4.14.1 Replace Starter. (Refer to figure 4-16.)

This task consists of: a. Removal b. Installation

INITIAL SET-UP:

Tools:

Tool Kit, General Mechanics
(Appendix B, Section III, Item 1)

Materials/Parts Required:

Tags, Electrical (Appendix F, Section II, Item 16)

Equipment Condition:

Pumping assembly shut down. (para. 2.6)

a. Removal.

- (1) Tag and remove electrical leads (1) from solenoid (2).
- (2) Loosen the two cap screws (3 and 4) that secure the starter (5) to the engine block (6).
- (3) Tag leads, and remove the lower cap screw (4), washer (7) and ground leads (8).
- (4) Support the starter and remove the upper cap screw (3) and washer (9). Remove the starter.

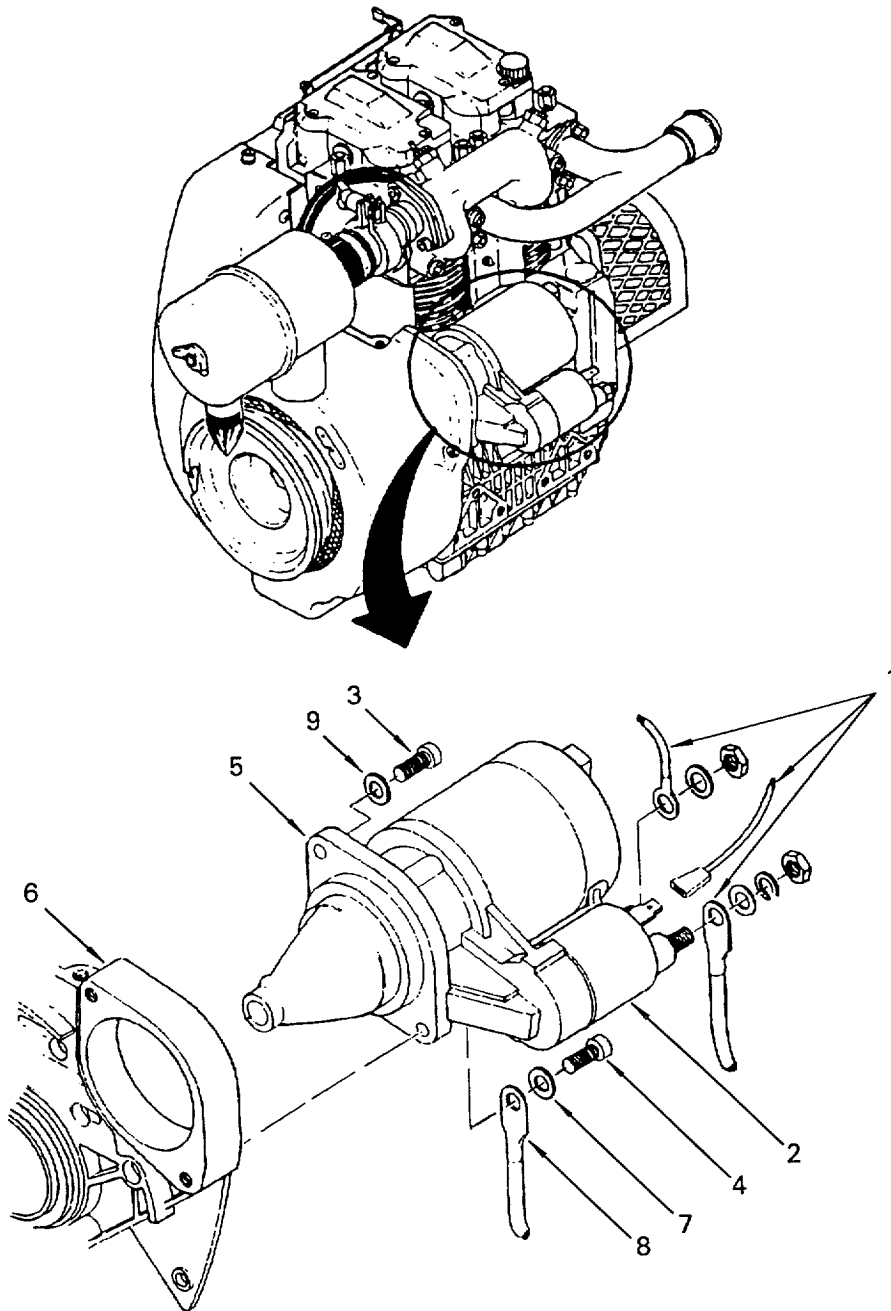

Figure 4-16. Starter Replacement

b. Installation.

- (1) Position the starter (5) on the engine (6) and loosely install the upper mounting cap screw (3) and washer (9).
- (2) Install washer (7) and ground leads (8) on cap screw (4), and install in lower mounting hole. Remove tags.
- (3) Tighten both mounting cap screws.
- (4) Install electrical leads (1) to solenoid as tagged. Remove tags.

4.14.2 Replace Fuel Pump. (Refer to figure 4-17.)

This task consists of: a. Removal b. Installation

INITIAL SET-UP:**Tools:**

Tool Kit, General Mechanics
(Appendix B, Section III, Item 1)

Materials/Parts Required:

Washer (Appendix I, Item 32)
Nut, Self-Locking (Appendix I, Item 1)

General Safety Requirements:**Equipment Condition:**

Pumping assembly shut down. (para 2.6)

WARNING

Fuels are toxic and flammable. Do not get on person or clothing. Work in well ventilated area. Do not smoke. Ensure equipment is well grounded.

a. Removal.

- (1) Disconnect fuel feed line (1) from fuel pump (2). Remove union bolt (3), union (4) and two copper washers (5 and 6). Discard copper washers (5 and 6).
- (2) Disconnect fuel supply line (7) from fuel pump (2). Remove union bolt (8), union (9) and two copper washers (10 and 11). Discard copper washers (10 and 11).
- (3) Remove the two self-locking nuts (12) that attach the fuel pump to the block (13). Discard the self-locking nuts (12).
- (4) Remove the fuel pump (2), drive rod (14) and gasket (15).

b. Installation.

- (1) Clean gasket surface on block (13).
- (2) Install gasket (15) over mounting studs (16).

- (3) Install drive rod (14) in fuel pump (2) and position fuel pump on mounting studs (16).
- (4) Install and tighten the two self-locking nuts (12) that secure the fuel pump (2) to the engine block (13).
- (5) Using two new copper washers, assemble washers (10 and 11) and fuel supply line (7) as illustrated on union (9). Use bolt (8) to install assembly on fuel pump (2).
- (6) Using two new copper washers, assemble washers (5 and 6) and fuel feed line (1) as illustrated on union (4). Use bolt (3) to install assembly on fuel pump (2).

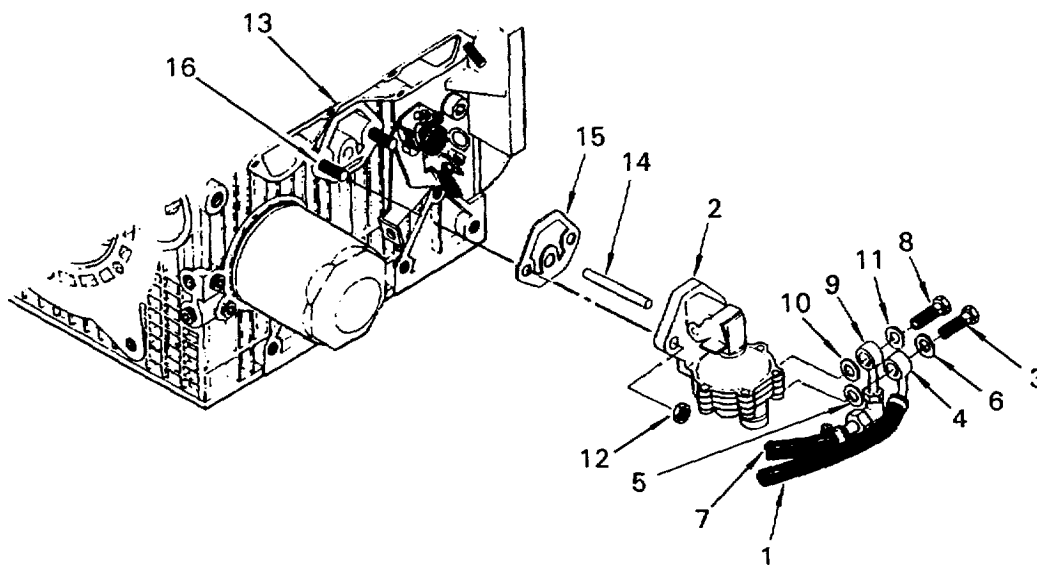

Figure 4-17. Fuel Pump Replacement

4.14.3 Adjust Valves. (Refer to figure 4-18.)

This procedure may be performed with the engine module mounted in the pump-engine module or removed to a workbench, as desired. The procedure applies to either cylinder head.

This task consists of: a. Adjustment

INITIAL SET-UP:**Tools:**

Tool Kit, General Mechanics
(Appendix B, Section III, Item 1)

Materials/Parts Required:

Gasket (Appendix I, Item 23)

Equipment Condition:

Pumping assembly shut down (para. 2.6)

- a. Remove the three socket head screws (1) that secure each valve cover (2). Remove valve cover and gasket (3) from each cylinder head. Discard gaskets (3).
- b. Lower pulley guard.

NOTE

To adjust valves, piston must be at TDC on the compression stroke.

- c. While holding decompression lever (4) in engaged position, rotate crankshaft (5) until intake valve (6) opens and closes. Continue to rotate to align timing mark (7) with indicator on shroud (8). Piston should be at TDC on the compression stroke.
- d. Check intake valve clearance for 0.006 in. (0.15mm) gap. Perform the following steps if adjustment is necessary. If valve clearance is satisfactory, repeat procedure for exhaust valve (9).
- e. Loosen intake valve push rod retaining nut (10).
- f. Turn push rod adjusting screw (11) to adjust intake valve (6) gap to 0.006 in. (0.15mm).
- g. Hold adjusting screw (11) in position and tighten push rod retaining nut (10).
- h. Check valve clearance to ensure gap remains at 0.006 in. (0.15 mm). If gap has changed, repeat adjustment procedure.
- i. Repeat procedure for exhaust valve (9).
- j. Repeat entire procedure for both valves in other cylinder head.
- k. Use gasket (3) and three socket head screws (1) to install valve covers (2).
- l. Raise and latch pulley guard.

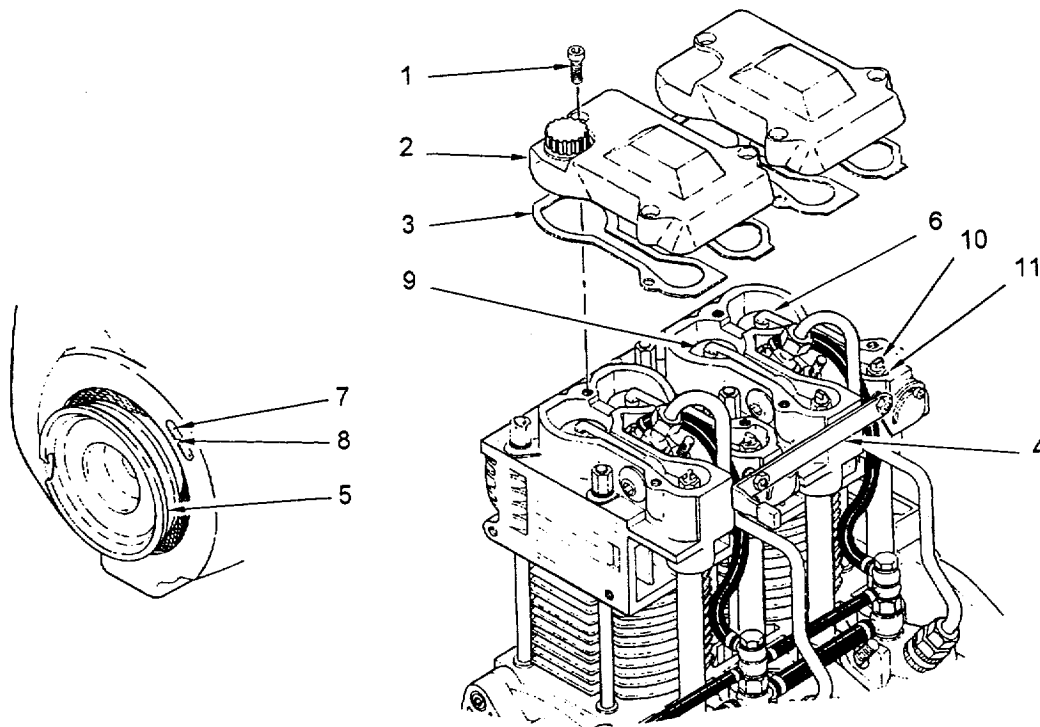

Figure 4-18. Valve Adjustment

4.14.4 Clean Fuel Injector Nozzle.

This task consists of: a. Removal b. Cleaning c. Installation

INITIAL SET-UP:

Tools:

- Tool Kit, General Mechanics
(Appendix B, Section III, Item 1)
- Vise, Machinist's (Appendix B, Section III, Item 2)
- Torque Wrench, 5-75 ft lb
(Appendix B, Section III, Item 2)

Materials/Parts Required:

- Safety Wire (Appendix F, Section II, Item 17)
- Washer, Copper (Appendix I, Item 39)
- Washer, Copper (Appendix I, Item 36)
- Gaskets (Appendix I, Item 23)

General Safety Requirements:

WARNING

Fuels are toxic and flammable. Do not get on person or clothing. Work in well ventilated area. Do not smoke. Ensure equipment is well grounded.

Equipment Condition:

Pumping assembly shut down (para. 2.6)

- a. Removal. (Refer to figure 4-19.)
- (1) Remove screws (1) and nuts (2) from decompression lever (3).
 - (2) Remove cable clamp (4) from fuel flow solenoid wire cable at black start control knob (5).
 - (3) Remove two socket head cap screws (6) and washers (7) securing cylinder casing (8) to cylinder heads (9).
 - (4) Remove three socket head cap screws (10) from valve cover (11). Remove cover and gasket (12). Discard gasket (12).
 - (5) Remove any remaining gasket material from the valve cover (11) and cylinder head (9).
 - (6) Disconnect and remove fuel feed line (13) between fuel injector pump and fuel injector (14).
 - (7) Remove brace nut (15), washer (16) and brace (17) from mounting stud.
 - (8) Raise injector to access union bolt (18). Remove bolt, union (19) and washers (20) and (21). Discard washers (20 and 21).
 - (9) Remove fuel injector. If copper washers (22) come out with fuel injector, remove and install in cylinder head.
- b. Clean Injector. (Refer to figure 4-20.)
- (1) Clamp inlet end (1) of injector in vise.
 - (2) Loosen retaining nut (2) on injector nozzle.
 - (3) Carefully disassemble injector, noting order of components for reassembly.
 - (4) Using a 0.01 in. (0.25 mm) steel wire, clean the four nozzle tip holes (3). Inspect holes for wear or out-of-round condition. If holes are badly deformed, replace injector.
 - (5) Blow out interior of injector to remove any debris.
 - (6) Assemble injector components in order noted during disassembly.
 - (7) Torque nozzle retaining nut (2) to 25 ft lb (34.3 Nm).
- c. Installation. (Refer to figure 4-19.)
- (1) Install and tighten union bolt (18), union (19) and new copper washers (20 - thick) and (21).
 - (2) Position fuel injector (14) in cylinder head.
 - (3) Install and tighten brace (17), washer (16) and nut (15) on mounting stud.
 - (4) Install and tighten fuel supply line (13) on fuel injector.
 - (5) Position gasket (12) on cylinder head.

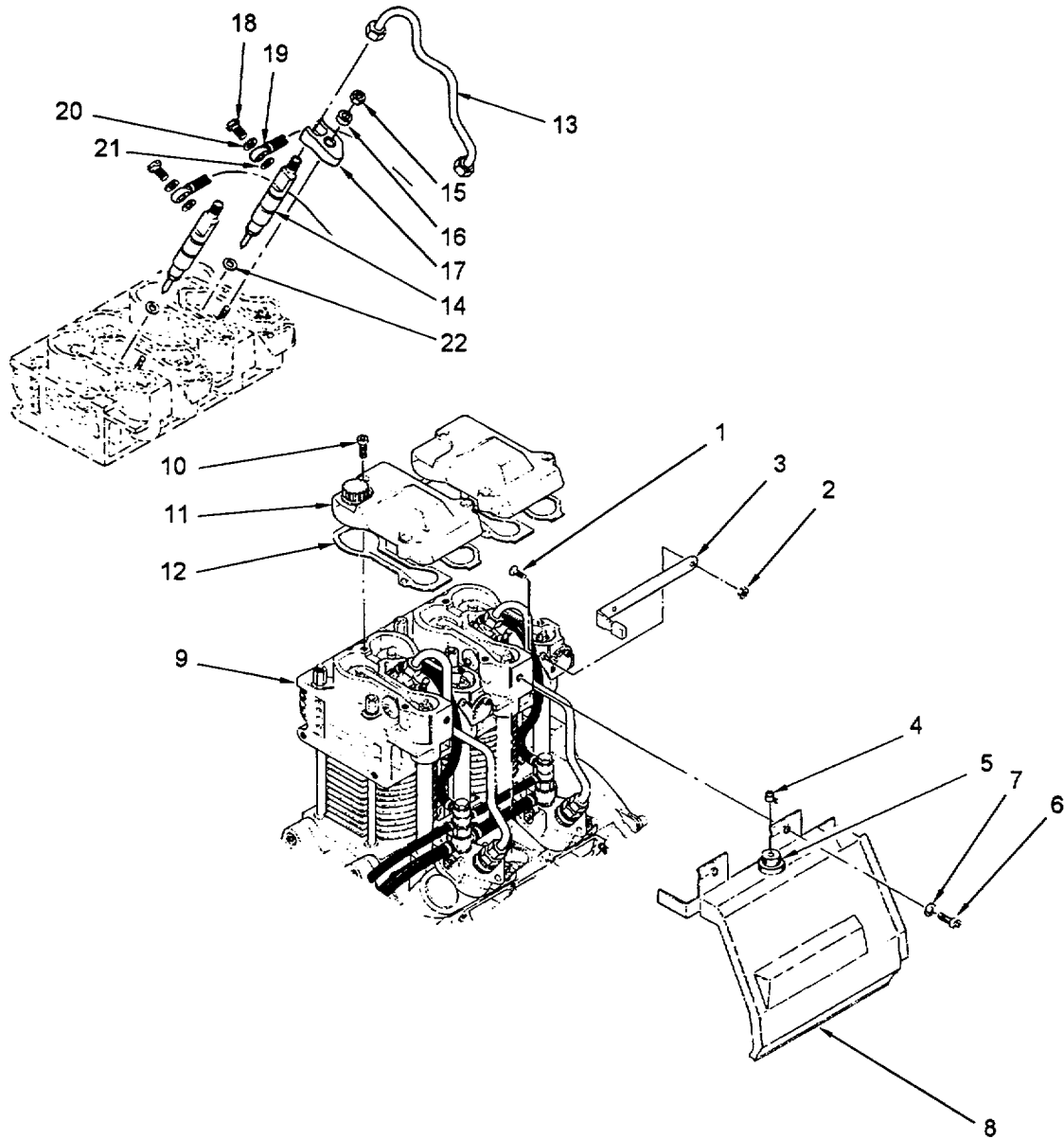

Figure 4-19. Fuel Injector Removal

NOTE

Valve cover with oil fill cap is positioned toward the PTO end of the engine.

- (6) Position valve cover (11) on gasket (12) and cylinder head (9).
- (7) Install and alternately tighten the socket head screws (10) attaching valve covers (11) to cylinder head (9).
- (8) Thread fuel solenoid wire cable through the black start control knob (5), position cylinder casing (8) on engine, and install and tighten the two socket head cap screws (6) and washers (7) that secure the casing to the cylinder heads (9).
- (9) Install cable clamp (4) on fuel solenoid cable.
- (10) Position decompression lever (3) and install screws (1) and secure nuts (2).
- (11) Cycle the decompression lever to ensure freedom of movement.

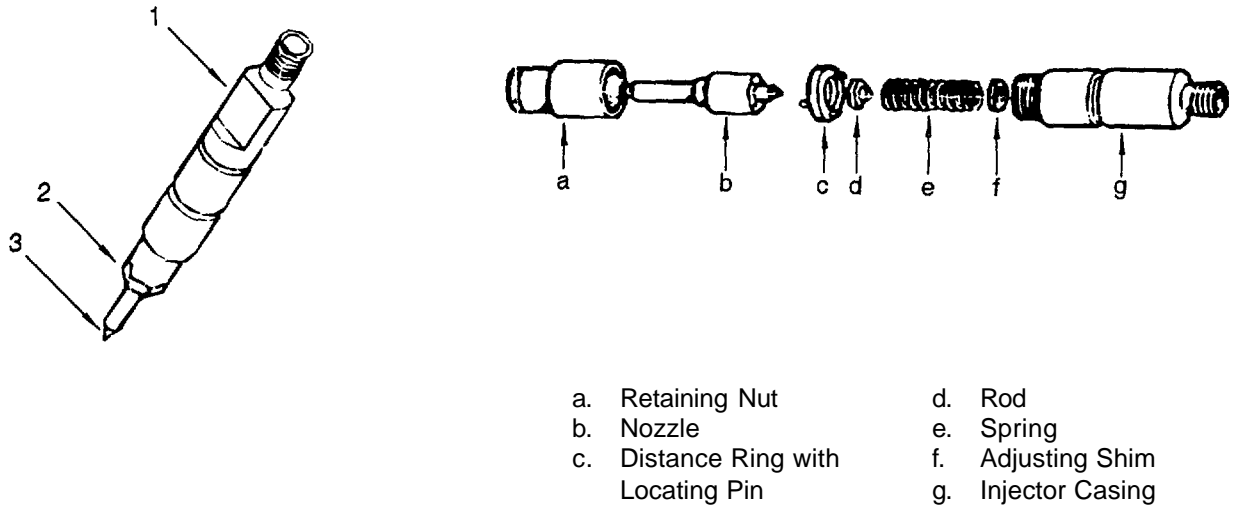

Figure 4-20. Fuel Injector Nozzle Cleaning

4.14.5 Replace Exhaust Manifold. (Refer to figure 4-21.)

This task consists of: a. Removal b. Installation

INITIAL SET-UP

Tools:

Tool Kit, General Mechanics
(Appendix B, Section III, Item 1)

Materials/Parts Required:

Gasket (Appendix I, Item 50)
Lock Washers (Appendix I, Item 63)

General Safety Requirements:

Equipment Condition:

Pumping assembly shut down (para. 2.6)

WARNING

Fuels are toxic and flammable. Do not get on person or clothing. Work in well ventilated area. Do not smoke. Ensure equipment is well grounded.

a. Removal.

- (1) Remove the four nuts (1), lock washers (2) and flat washers (3) from cylinder head studs (4). Discard lock washers.
- (2) Remove exhaust manifold (5) and two gaskets (6). Discard gaskets (6).
- (3) Clean remaining gasket material from cylinder head flange (7) and exhaust manifold (5) flange.

b. Installation.

- (1) Position gaskets (6) on cylinder heads (4).
- (2) Place exhaust manifold (5) on cylinder heads (4).
- (3) Install and hand tighten nuts (1), lock washers (2) and flat washers (3) that secure exhaust manifold (5). Tighten nuts (1) alternately.

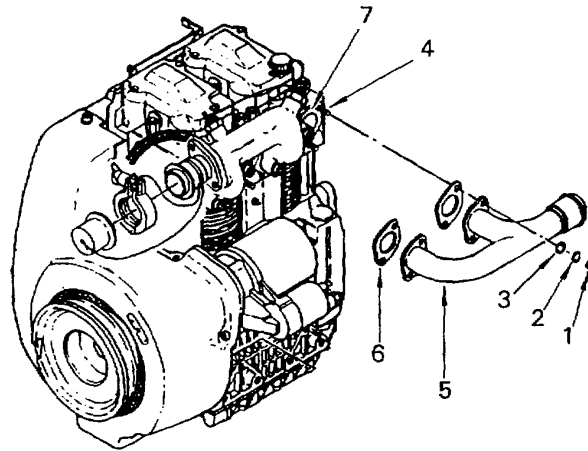

Figure 4-21. Exhaust Manifold Replacement

4.14.6 Replace Intake Manifold. (Refer to figure 4-22.)

This task consists of: a. Removal b. Installation

INITIAL SET-UP:

Tools:

Tool Kit, General Mechanics
(Appendix B, Section III, Item 1)

Materials/Parts Required:

Gasket (Appendix I, Item 18)
Washer, Lock (Appendix I, Item 74)

Equipment Condition:

Pumping assembly shut down. (para. 2.6.)

a. Removal.

- (1) Loosen clamp (1) and detach air filter, if installed. Install and clamp dust cap (2).
- (2) Lift boots (3), and remove power lead (4) and connecting wire (5) from intake air heaters (6).
- (3) Remove intake air heaters (6) from intake manifold (7).
- (4) Remove two nuts (8) and flat washers (9) attaching air intake adapter (10) to the intake manifold (7).
- (5) Remove clamp (11) and hose (12) from intake manifold (7).

CAUTION

The four socket head cap screws are of two lengths. Note that the longer cap screws come out of the portion of the intake manifold with thicker lands.

- (6) Remove the four socket head cap screws (13) and lock washers (14) from the cylinder heads. Discard lock washers (14).
- (7) Remove intake manifold (7) and two gaskets (15). Discard gaskets (15).
- (8) Clean any gasket material residue from cylinder head flange (16) and intake manifold (7) flange.

b. Installation.

- (1) Install two gaskets (15) on cylinder heads (16).

CAUTION]

Ensure that the two longer socket head cap screws are used to secure the portion of the intake manifold with thicker lands.

- (2) Position intake manifold (7), and install the four socket head cap screws (13) and lock washers (14) to attach manifold to cylinder heads (16). Alternately tighten the socket head cap screws (13).

- (3) Install and tighten two nuts (8) and flat washers (9) to attach intake adapter (10), clamp (1) and dust cap (2).
- (4) Spread clamp (11) and attach hose (12) to intake manifold (7).

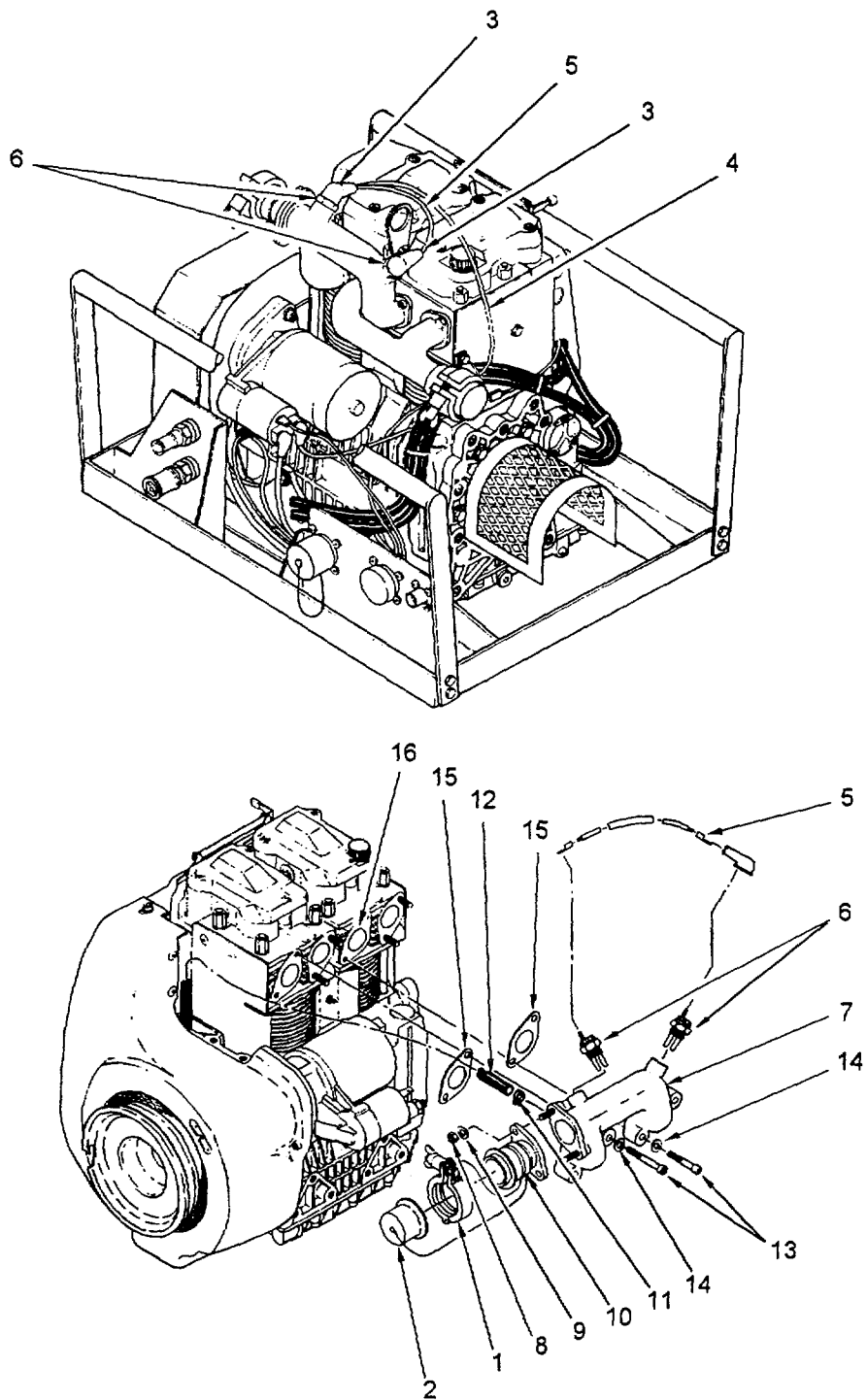

Figure 4-22. Intake Manifold Replacement

- (5) Install intake air heaters (6) on intake manifold (7).
- (6) Install power lead (4) and connecting wire (5) on intake air heaters (6). Install boots (3) over terminals.
- (7) If previously removed, attach air filter to air intake adapter (10) with clamp (1).

4.14.7 Replace Decompression Arm O-Rinn. (Refer to figure 4-23.)

This task consists of: a. Removal b. Installation

INITIAL SET-UP:

Tools:

Tool Kit, General Mechanics
(Appendix B, Section III, Item 1)

Materials/Parts Required:

Petrolatum (Appendix F, Section II, Item 10)
O-Ring (Appendix I, Item 75)

Equipment Condition:

Pumping assembly shut down. (para. 2.6.)

a. Removal.

- (1) Remove screws (1) and nuts (2) from decompression lever (3). Remove decompression lever (3).
- (2) Remove screw (4). Remove decompression arm (5).
- (2) Remove O-ring (6) from decompression arm (5). Discard O-ring (6).

b. Installation.

- (1) Position spacer (7) flush on decompression arm (5) shaft.
- (2) Lightly lubricate with petrolatum and install O-ring (6) on decompression arm (5).

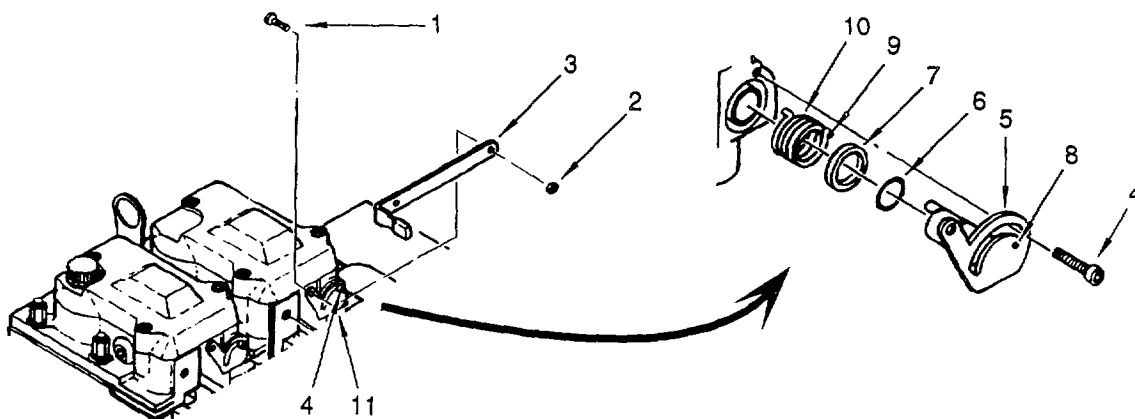

Figure 4-23. Decompression Arm O-Ring Replacement

- (3) Mate small hole (8) in decompression arm (5) with tang (9) on spring (10) and slide decompression arm (5) into place in cylinder head (11).
- (4) Install screw (4) to attach decompression arm (5) to cylinder head (11).
- (5) Use screws (1) and nuts (2) to install decompression lever (3).

4.15 ACCESSORY MODULE MAINTENANCE.

4.15.1 Replace Battery. (Refer to figure 4-24.)

This task consists of: a. Removal b. Installation

INITIAL SET-UP:

Tools:

No tools required

Materials/Parts Required:

Compound, Corrosion Preventive
(Appendix F, Section II, Item 18)

General Safety Requirements:

WARNING

- **Serious injury could occur if heavy equipment is lifted without sufficient personnel. Use proper physical lifting procedures**

Equipment Condition:

Pumping assembly shut down. (para. 2.6)
Battery cable disconnected from engine module.
(para. 2.5)

Personnel Required

Two, any MOS

a. Removal.

- (1) At accessory module, unlatch and open fully the center cover (1) on the stowage chest battery compartment (2).
- (2) Pull vent line (3) from battery vent tube (4).
- (3) Unscrew and remove battery cable (5) from battery.
- (4) Loosen wing nuts (6) on battery hold down rods (7) and push rods out of hold down ears (8).
- (5) Two persons lift battery from chest.

b. Installation.

- (1) Lower replacement battery into compartment, ensuring battery is fully seated.
- (2) Install hold down rods (7) on battery ears (8) with a nut (9) and one flat washer (10) below and one flat washer (11), lock washer (12) and wing nut (6) above each ear.
- (3) Tighten wing nuts finger tight to secure battery in place. Do not wrench wing nuts.
- (4) Install vent line (3) on battery vent tube (4).

- (5) Apply corrosion preventive compound and attach battery cable (5) to battery.
- (6) Lower and latch the battery compartment cover (1).

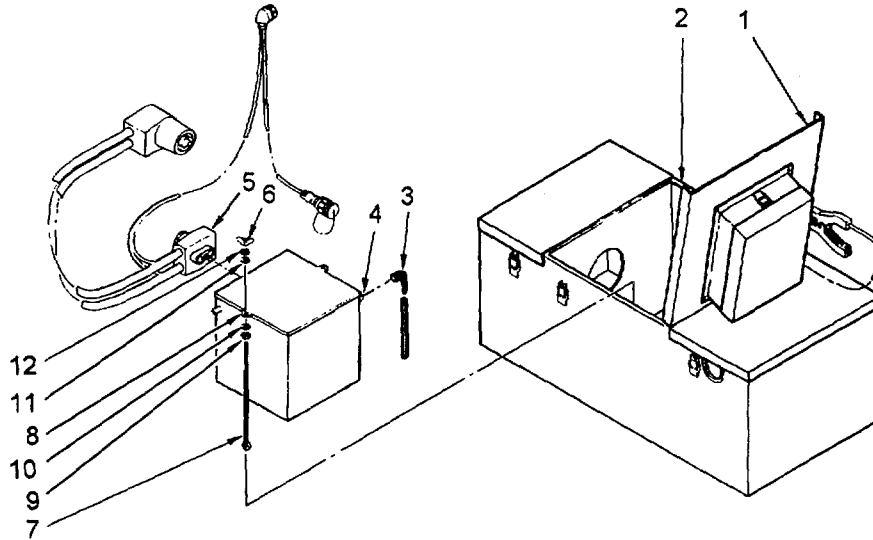

Figure 4-24. Battery Replacement

4.15.2 Replace Control Box. (Refer to figure 4-25.)

This task consists of: a. Removal b. Installation

INITIAL SET-UP:

Tools:

Tool Kit, General Mechanics
(Appendix B, Section III, Item 1)

Materials/Parts Required:

None

Equipment Condition:

Accessory module removed from system
(para. 2.9)

a. Removal.

- (1) At the accessory module, open center cover (1).
- (2) Disconnect control cable W201 (2) from control box. Install dust caps on connector and cable end.
- (3) Disconnect battery cable W202 (3) from control box. Install dust caps on connector and cable end.
- (4) Close center cover.
- (5) Remove the four cross tip screws (4) and washers (5) that secure the control box (6) to the accessory module and remove the control box.

b. Installation.

- (1) Install the control box (6) on the accessory module with four cross tip screws (4) and washers (5).
- (2) Open center cover (1).
- (3) Remove dust caps from control cable (2) and connector, and install control cable W201 to control box connector. Connect dust caps together.
- (4) Remove dust caps from battery cable (3) and connector, and install control cable W202 to control box connector. Connect dust caps together.
- (4) Close and latch center cover.

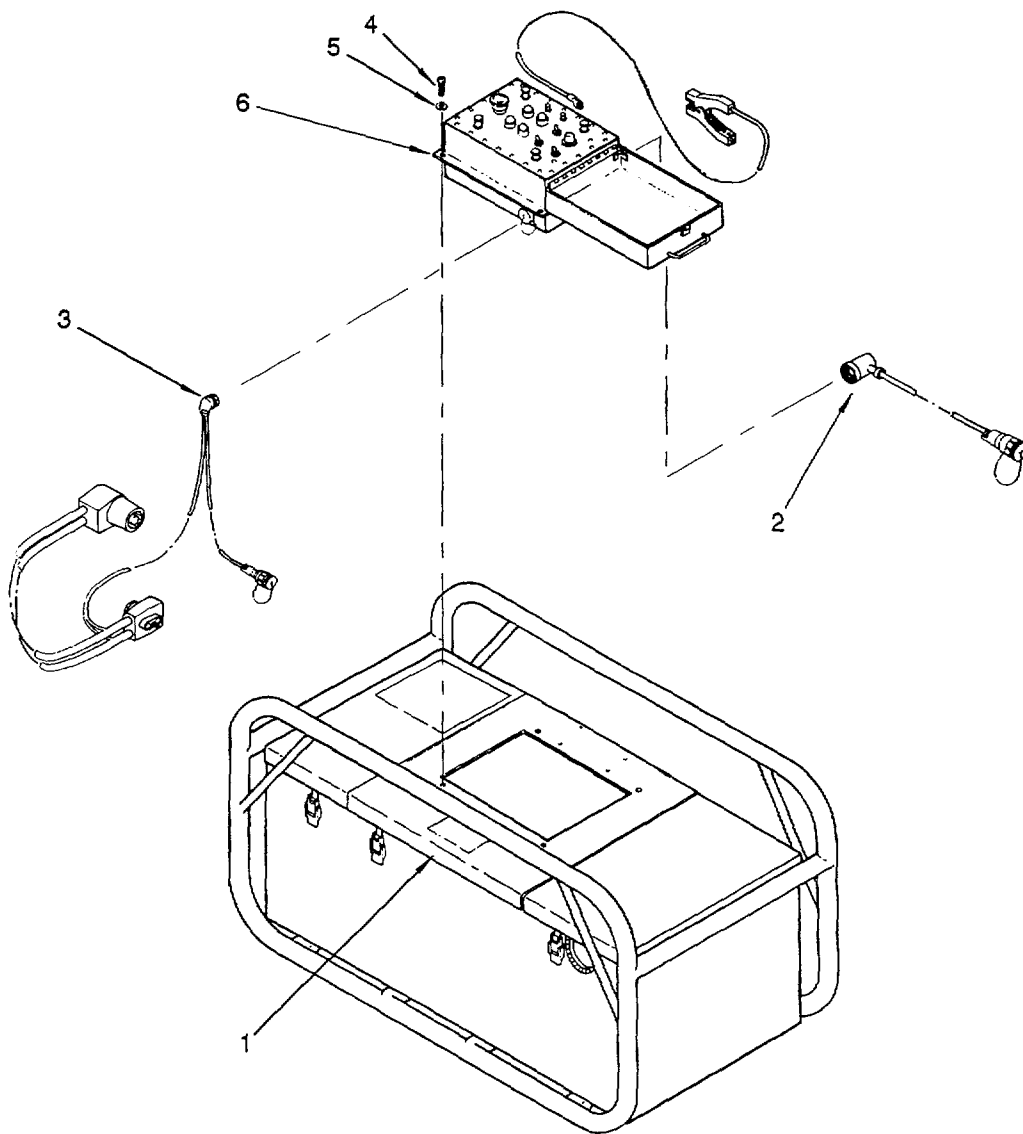

Figure 4-25. Control Box Replacement

4.15.3 Repair Battery Cable. (Refer to figure 4-26.)

This task consists of: a. Removal b. Disassembly c. Assembly d. Installation

INITIAL SET-UP:**Tools:**

Tool Kit, General Mechanics
(Appendix B, Section III, Item 1)

Materials/Parts Required:

Strap, Tiedown (Appendix F, Section II, Item 8)
Packing (Appendix I, Item 75)
Washer, Lock (Appendix I, Item 78)
Washer, Lock (Appendix I, Item 79)

Equipment Condition:

Accessory module removed from system
(para. 2.9)

a. Removal.

- (1) At the accessory module, open the center cover (1) and cable storage compartment cover (2).
- (2) Disconnect battery cable from battery.
- (3) Push battery cable through lower cut out into cable storage compartment and remove from accessory module.

b. Disassembly.

- (1) Remove tiedown straps and cable tags from battery cable.
- (2) At NATO connector (3), remove the six cross tip screws (4) and washers (5) that secure the cover (6) to the connector.
- (3) Loosen the two jam nuts (7) completely.
- (4) Remove the two bolts (8) and lock washers (9) from the cable terminations. Remove the cables, jam nuts (7), bushings (10) and packings (11) from the connector (3). Discard the lock washers (9) and packings (11).
- (5) At the battery connector, remove two bolts (12) and flat washers (13) to separate connector (14).
- (6) Remove the two nuts (15) and lock washers (16) from the cable terminations. Remove the cables. Discard the lock washers (16).

c. Assembly.

- (1) At the battery connector (14), install two nuts (15) and lock washers (16) to secure the cable terminations to the connector (14).
- (2) Install two bolts (12) and flat washers (13) to secure the connector (14) halves together.

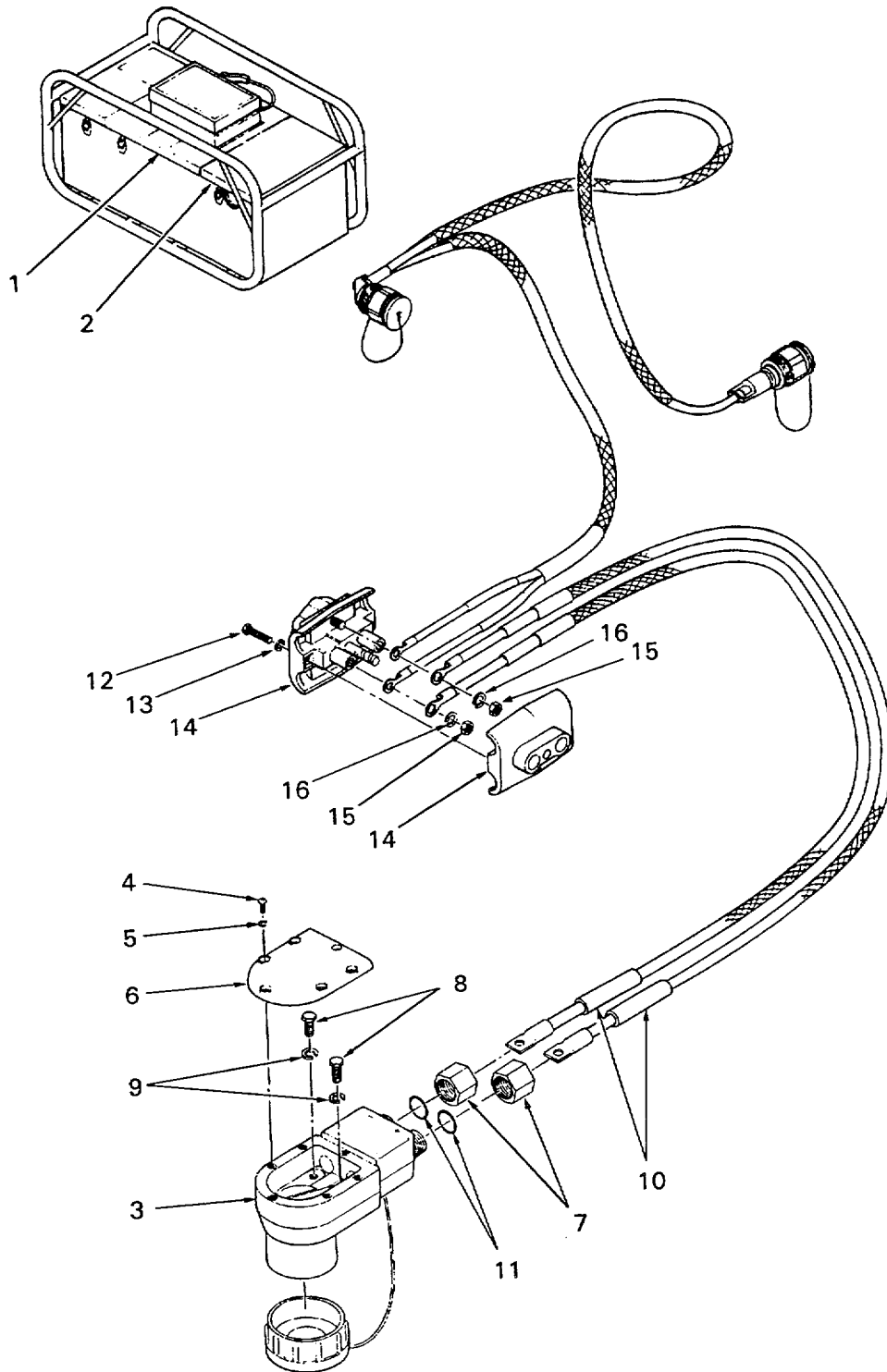

Figure 4-26. Battery Cable Repair

CAUTION

Make sure each cable is connected to the same polarity terminal in each connector ("+" to "+" and "-" to "-"). Equipment damage may result from improper connections.

- (3) At the NATO connector (3), slide the jam nuts (7), bushings (10) and packings (11) onto the cables and insert the cables into the connector (3).
- (4) Install the two bolts (8) and lock washers (9) to secure cables to connector (3) and tighten jam nuts (7). Observe proper polarity. Ensure cable connected to "-" terminal of battery connector is connected to "-" terminal of NATO connector.
- (5) Install the six cross tip screws (4) and washers (5) that secure the cover (6) to the connector. Ensure the cover lanyard is secured to one of the screws.
- (6) Install tiedown straps as required. Thread tiedown straps through slots in cable tags and attach to cable, one near each end and one near the middle.

d. Installation.

- (1) At the accessory module, push battery connector through lower cut out in cable storage compartment (2) and install connector on battery. Coil remainder of cable in cable storage compartment (2).
- (2) Close and latch the center cover (1) and cable storage compartment cover (2).

4.15.4 Replace Control Cable (W201). (Refer to figure 4-27.)

This task consists of: a. Removal b. Installation

INITIAL SET-UP:

Tools:
No tools required

Materials/Parts Required:
None

General Safety Requirements:
None

Equipment Condition:
Accessory module removed from system.
(para. 2.9)

a. Removal.

- (1) At the accessory module, open the center cover (1) and cable storage compartment cover (2).
- (2) Disconnect control cable W201 (3) from control box.
- (3) Install dust caps on control cable (3) and control box connector.
- (4) Push control cable through upper cut out (4) into cable storage compartment and remove from accessory module.

b. Installation.

- (1) Push control box connector (right angle connector) (3) through upper cut out (4) in cable storage compartment, remove dust caps from control cable (3) and control box connector, and install connector on control box. Coil remainder of cable in cable storage compartment.
- (2) Close and latch the center cover (1) and cable storage compartment cover (2).

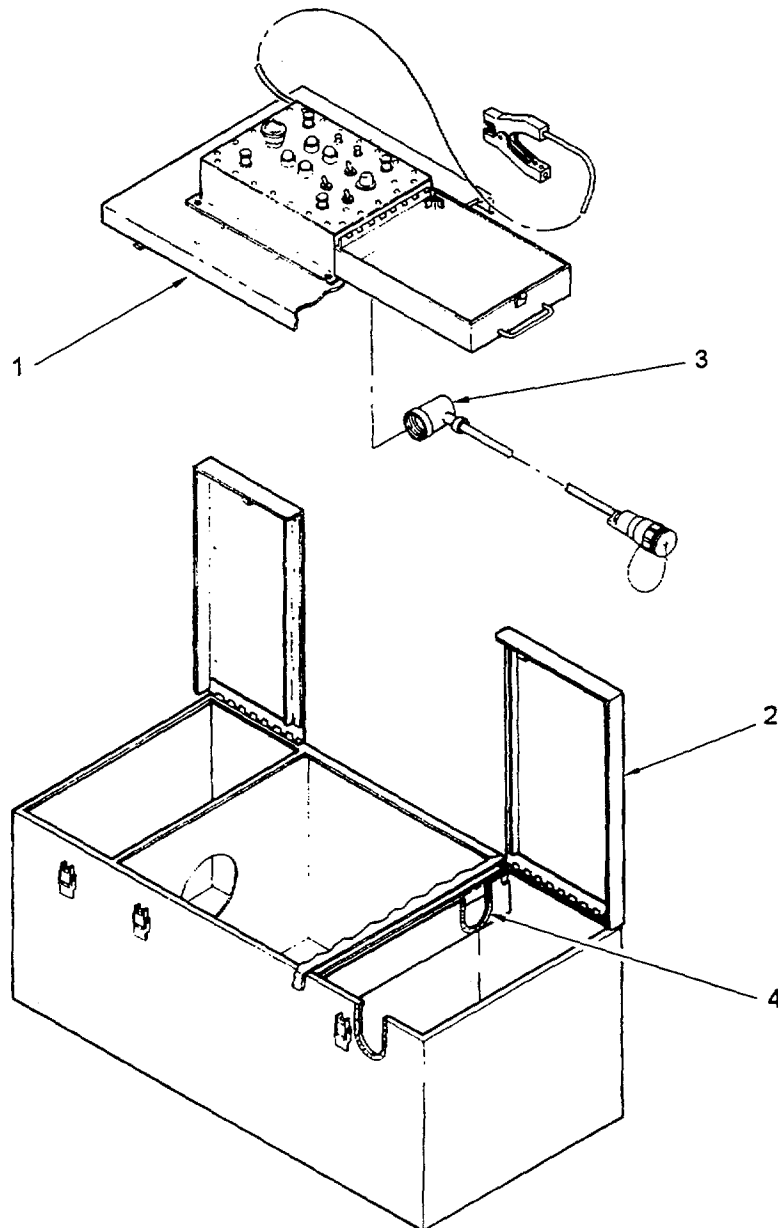

Figure 4-27. Control Cable W201 Replacement

4.15.5 Repair Battery Holddown. (Refer to figure 4-28.)**NOTE**

This procedure applies to either battery holddown.

This task consists of: a. Disassembly b. Assembly

INITIAL SET-UP:**Tools:**

Tool Kit, General Mechanics
(Appendix B, Section III, Item 1)

Materials/Parts Required:

Nut, Self-Locking (Appendix I, Item 66)
Washer, Lock (Appendix I, Item 62)
Washer, Lock (Appendix I, Item 64)

General Safety Requirements:**Equipment Condition:**

Accessory module removed from system
(para. 2.6)
Battery removed from accessory module
(para. 4.15.1)

a. Disassembly.

- (1) At accessory module, unlatch and raise battery compartment cover (1).
- (2) At holddown eyebolt (2), remove wingnut (3), two flat washers (4), lock washer (5) and self-locking nut (6). Discard lock washer (5) and self-locking nut (6).
- (3) At bottom of eyebolt (2), remove shoulder bolt (7), flat washer (8), lock washer (9) and hex nut (10). Discard lock washer (9). Remove eyebolt from battery compartment.

b. Assembly.

- (1) Insert eyebolt (2) through bottom of battery compartment, align eye with mounting hole in frame, and install shoulder bolt (7), flat washer (8), lock washer (9) and hex nut (10).
- (2) At upper end of holddown eyebolt (2), install self-locking nut (6), two flat washers (4), lock washer (5) and wingnut (3).
- (3) Adjust wingnut for snug fit of holddown assembly under battery ear.

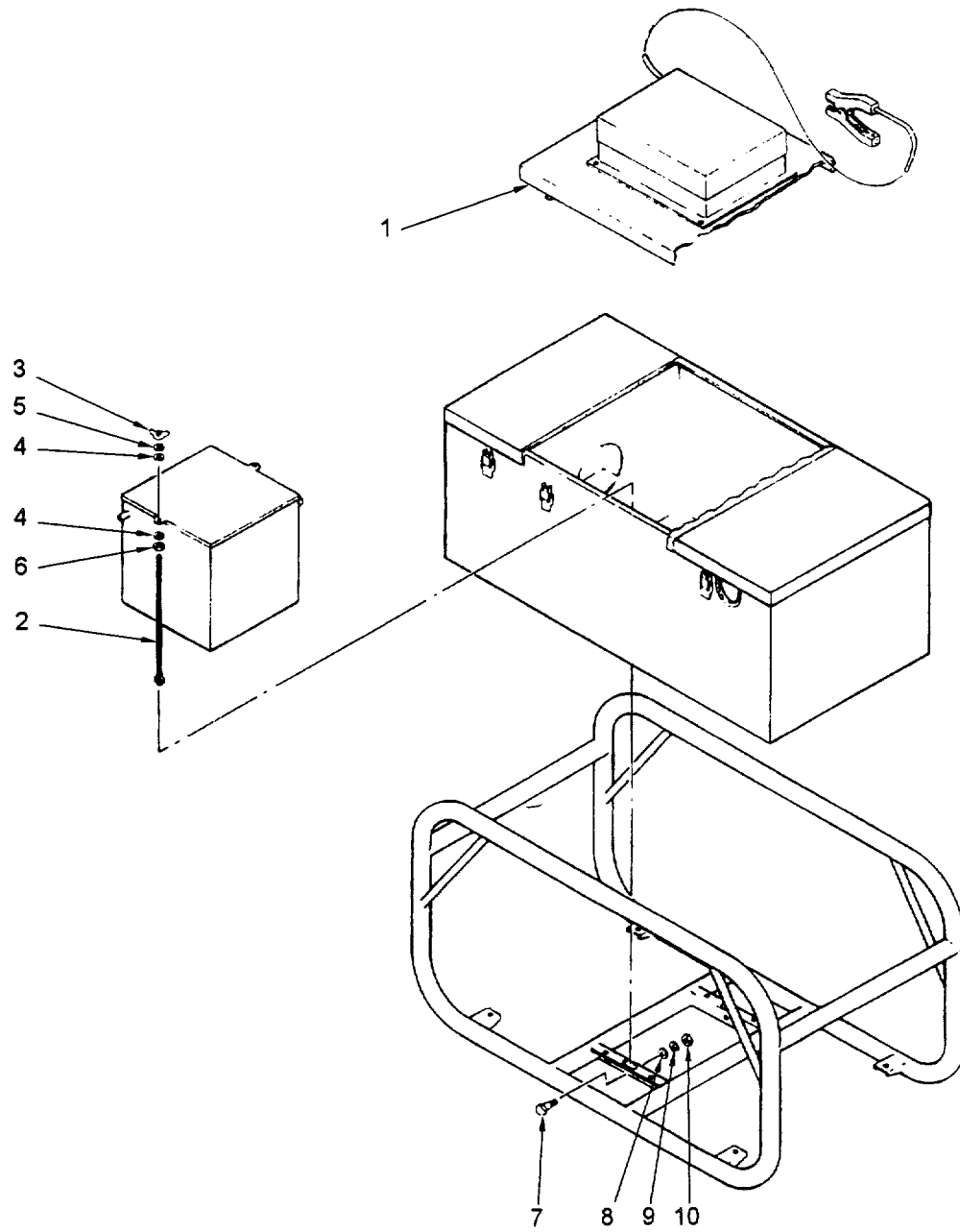

Figure 4-28. Battery Holddown Repair

4.15.6 Data Plate Replacement (Typical). (Refer to figure 4-29.)

This task consists of: a. Removal b. Installation

INITIAL SET-UP:

Tools:

- Drill, Electric, 3/8 inch
(Appendix B, Section III, Item 2)
- Drill Set, Twist
(Appendix B, Section III, Item 2)
- Tool Kit, Blind Rivet
(Appendix B, Section III, Item 2)
- Goggles, Industrial
(Appendix B, Section III, Item 2)

Materials/Parts Required:

- Rivet (Appendix I, Item 41)

General Safety Requirements:

WARNING

**Wear eye protection when using power tools.
Personal injury may result from flying particles.**

Equipment Condition:

- Accessory module removed from system
(para. 2.9)

a. Removal.

WARNING

Serious personal eye injury may result from flying particles when operating power tools. Always wear eye protection.

Drill out rivets (1) attaching the data plate (2).

b. Installation.

Attach data plate (2) with 1/8-inch pop rivets (1).

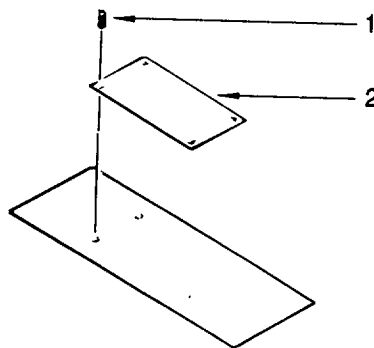

Figure 4-29. Data Plate Replacement

Section VI. PREPARATION FOR STORAGE OR SHIPMENT

4.16 PREPARATION FOR STORAGE.

4.16.1 Engine Preparation.

This task consists of: a. Preservation

INITIAL SET-UP:

Tools:

Tool Kit, General Mechanics
(Appendix B, Section III, Item 1)

Materials/Parts Required:

Tape, Adhesive (Appendix F, Section II, Item 14)
Sheeting, Plastic (Appendix F, Section II, Item 15)
Oil, Lubricating (Appendix F, Section II, Item 23)
Oil, Preservative (Appendix F, Section II, Item 24)
Compound, Corrosion Prevention
(Appendix F, Section II, Item 25)

General Safety Requirements:

Operational pumping assembly.

Equipment Condition:

WARNING

- **Fuels are toxic and flammable. Do not get on person or clothing. Work in well ventilated area. Do not smoke. Ensure equipment is well grounded.**

4.16.1.1 Preparation for Short Term Storage (UD To Six Months).

- a. At the engine module, disconnect the fuel supply and return lines.
- b. Disconnect the exhaust line at the exhaust manifold.
- c. Unlatch engine module and carefully slide out approximately six inches.
- d. Remove the flexible coupling section from the fuel transfer pump.
- e. Slide engine module into pump-engine module and latch in place.
- f. Connect the fuel supply line and fuel return line to the engine module.
- g. Verify/Connect the accessory module control cable to the engine module.
- h. Verify/Connect the accessory module battery cable to the engine module.
- i. Verify/Connect the pumpage overtemperature cable to the engine module.
- j. Start and run the engine at idle for approximately fifteen minutes.
- k. Stop engine.

- l. Add one pint MIL-L-644B preservative oil to fuel tank; fill tank with fuel.
- m. Start and run engine for approximately ten minutes at half speed to fill engine fuel system components with preservative oil.
- n. Stop engine.
- o. Remove all fuel and electrical lines from engine module, and remove engine module from pump-engine module.
- p. Drain oil from engine crankcase and dispose of in accordance with SOP.
- q. Spray light oil in the intake and exhaust manifolds.
- r. Thoroughly clean all external engine surfaces.
- s. Apply MIL-C-16173 corrosion prevention compound to all unpainted external engine surfaces.
- t. Tape over all engine openings.
- u. Wrap the module in plastic sheeting and store in a dry place.

4.16.1.2 Preparation for Long Term Storage (More Than Six Months).

- a. Prepare for short term storage. Refer to paragraph 4.16.1.1
- b. Inspect every six months for rust or corrosion. Clean as required and apply MIL-C-16173 corrosion prevention compound to cleaned surfaces.

4.17 PREPARATION FOR SHIPMENT.

The pump-engine module and accessory module are shipped and stored as part of the Advanced Aviation Forward Area Refueling System (AAFARS). To prepare the pump-engine and accessory modules for shipment, perform the following steps:

- a. Pump-engine module:
 - (1) If necessary, remove the air filter (para. 4.9.3) and store it in the accessory module.
 - (2) Drain the crankcase (table 4-1).
 - (3) Drain the fuel tank into an approved container using a short length of hose and the fuel drain valve on the bottom of the fuel tank.
 - (4) Replace the fuel filter (para. 4.9.1).
 - (5) Defuel the fuel transfer pump (para. 4.12.1).
- b. Accessory module:
 - (1) Disconnect battery power cable at battery (para. 2.5).
 - (2) Ensure all covers are latched.

4.18 SPECIAL INSTRUCTIONS FOR ADMINISTRATIVE STORAGE.

Placement of equipment in administrative storage should be for short periods of time when a shortage of maintenance effort exists. Items should be in mission readiness within 24 hours or within the time factors as determined by the directing authority. During the storage period, appropriate maintenance records will be kept.

Before placing the equipment in administrative storage, current preventive maintenance should be completed, shortcomings and deficiencies should be corrected, and all Modification Work Orders (MWO) should be applied.

Storage site selection. Inside storage is preferred for items selected for administrative storage. If inside storage is not available, trucks, vans, conex containers, and other containers may be used.

CHAPTER 5

DIRECT SUPPORT MAINTENANCE

Section I. Direct Support Troubleshooting Procedures..... 5-1

5.1 Introduction 5-1

5.2 Electrical System Malfunctions..... 5-3

5.3 Pumping Assembly Principles Of Operation..... 5-3

Section II. Direct Support Maintenance Procedures 5-7

5.4 Repair of Fuel Transfer Pump..... 5-7

5.4.1 Replace Fuel Transfer Pump Inlet O-Ring..... 5-7

5.4.2 Replace Fuel Transfer Pump Shaft Seal Assembly/O-Rings .5..... 5-9

5.4.3 Replace Fuel Transfer Pump Vane Pump Housing O-Rings 5-12

5.4.4 Repair of Rotary Vane Pump..... 5-15

5.4.5 Replace Fuel Transfer Pump Impeller-Shaft Assembly..... 5-17

5.5 Repair Three-Inch Valved Unisex Coupling..... 5-19

5.6 Repair Two-Inch Valved Unisex Coupling 5-23

5.7 Repair of Control Box 5-26

5.7.1 Replace Control Panel Lamp Assemblies/Panel Lights..... 5-27

5.7.2 Replace Panel Lights Dimmer Potentiometer R1 5-29

5.7.3 Repair Emergency Stop Switch (S4) 5-31

5.7.4 Replace Control Panel Toggle Switches 5-33

5.7.5 Replace Capacitor C1 5-35

5.7.6 Replace Circuit Breakers CB1 or CB2 5-37

5.7.7 Replace Relay K1 5-39

5.7.8 Replace Voltage Regulator 5-40

Section I. DIRECT SUPPORT TROUBLESHOOTING PROCEDURES

5.1 INTRODUCTION.

The troubleshooting procedures provided in this chapter assume that unit troubleshooting has been performed unsuccessfully. To repeat unit level troubleshooting, refer to chapter 4, section IV.

Troubleshooting table 5-1 cannot list all malfunctions that may occur, all the tests and inspections needed to find the fault, or all the corrective actions needed to correct the fault.

TABLE 5-1. TROUBLESHOOTING

MALFUNCTION	TEST OR INSPECTION	CORRECTIVE ACTION
FUEL TRANSFER PUMP		
1. Pump will not prime		Inspect vane pump. a. Disassemble rotary vane pump, inspect components for cuts, scratches, burrs, etc. and replace any that are damaged. Refer to paragraph 5.4.4. b. Replace vane pump packings. Refer to paragraph 5.4.3.
2. Pump leaks at inlet		Inspect inlet packing. a. Remove inlet. b. Check for debris around O-ring. Check physical condition of O-ring. Clean inlet or replace O-ring, as required. Refer to paragraph 5.4.1.
3. Pump leaks at input shaft		Inspect shaft seal and O-rings. a. Remove shaft seal housing. b. Replace shaft seal and O-rings. Refer to paragraph 5.4.2.
4. Pump leaks at vane pump housing		Inspect vane pump O-rings. a. Remove vane pump housing. b. Replace vane pump housing O-rings. Refer to paragraph 5.4.3.
5. Pump does not provide flow and pressure when engine is running.		Inspect pump. a. Disassemble pump. Refer to paragraph 5.4.4.

TABLE 5-1. TROUBLESHOOTING (Continued)

MALFUNCTION	TEST OR INSPECTION	CORRECTIVE ACTION
-------------	--------------------	-------------------

a. Inspect components. Replace as necessary.

6. Three-inch valved unisex coupling leaks at body or fails to operate properly.

Disassemble and inspect coupling.

Repair or replace faulty components. Refer to paragraph 5.6.

5.2 ELECTRICAL SYSTEM MALFUNCTIONS.

Pumping assembly electrical system malfunctions are problems related to the control box, interconnecting cables, alternator, starter and pumping assembly sensors. Electrical troubleshooting of the pumping assembly is best accomplished by continuity and voltage checks of the circuitry associated with a reported problem. A system schematic and a functional description of the electrical system are provided in this section, as well as a system interconnecting drawing (figure 5-1), as a troubleshooting aid. In addition, the wiring diagrams for the control box, and pumping assembly cables and wiring harnesses are provided in Appendix J at the back of this manual.

5.3 PUMPING ASSEMBLY PRINCIPLES OF OPERATION. (Refer to figure 5-2.)

When the battery is initially connected to the system through the NATO connector (NATO CONN), 28 VDC is applied:

- to the BATT input of VR1, the system voltage regulator.
- across circuit breaker CB2 to the auxiliary pump module and the input side of INTAKE HEATER switch S2.
- across circuit breaker CB1 to the input side of ENGINE START-RUN-STOP switch S3, shown in the STOP position.

When ENGINE switch S3 is placed in the momentary START position, 28 VDC is applied from switch terminal 1 to the starter solenoid, energizing the starter to crank the engine. At the same time, 28 VDC is applied from the output side of the starter solenoid to the pick up coil of FUEL SHUTOFF SOLENOID L1 on the engine, opening fuel ports to the engine fuel injectors.

After the engine starts, the ENGINE switch is released to the RUN position. The starter solenoid is deenergized, power is removed from the starter and FUEL SHUTOFF SOLENOID L1 pick up coil is deenergized. Simultaneously, the alternator output is applied to the voltage regulator/rectifier where it is rectified to DC and regulated to 28 VDC. The regulator output at terminal "P" is applied across the EMERGENCY STOP switch to provide electrical power to the system. The regulator output is also applied through relay K1 to FUEL SHUTOFF SOLENOID L1 hold coil to hold the fuel ports open.

System power is available at the input of FAULT LIGHTS switch S5 any time the system is operating or the ENGINE START-RUN-STOP switch is in the RUN position. In the BLACKOUT position, no power is applied to the panel lights or the fault lights. When switch S5 is placed in the ON position, power is applied across dimmer control R1 to panel lights CR1, CR2, CR3 and CR4. The illumination level is adjusted by operating dimmer control R1. All panel lights are Light Emitting Diodes (LEDs) to assure high reliability and long life.

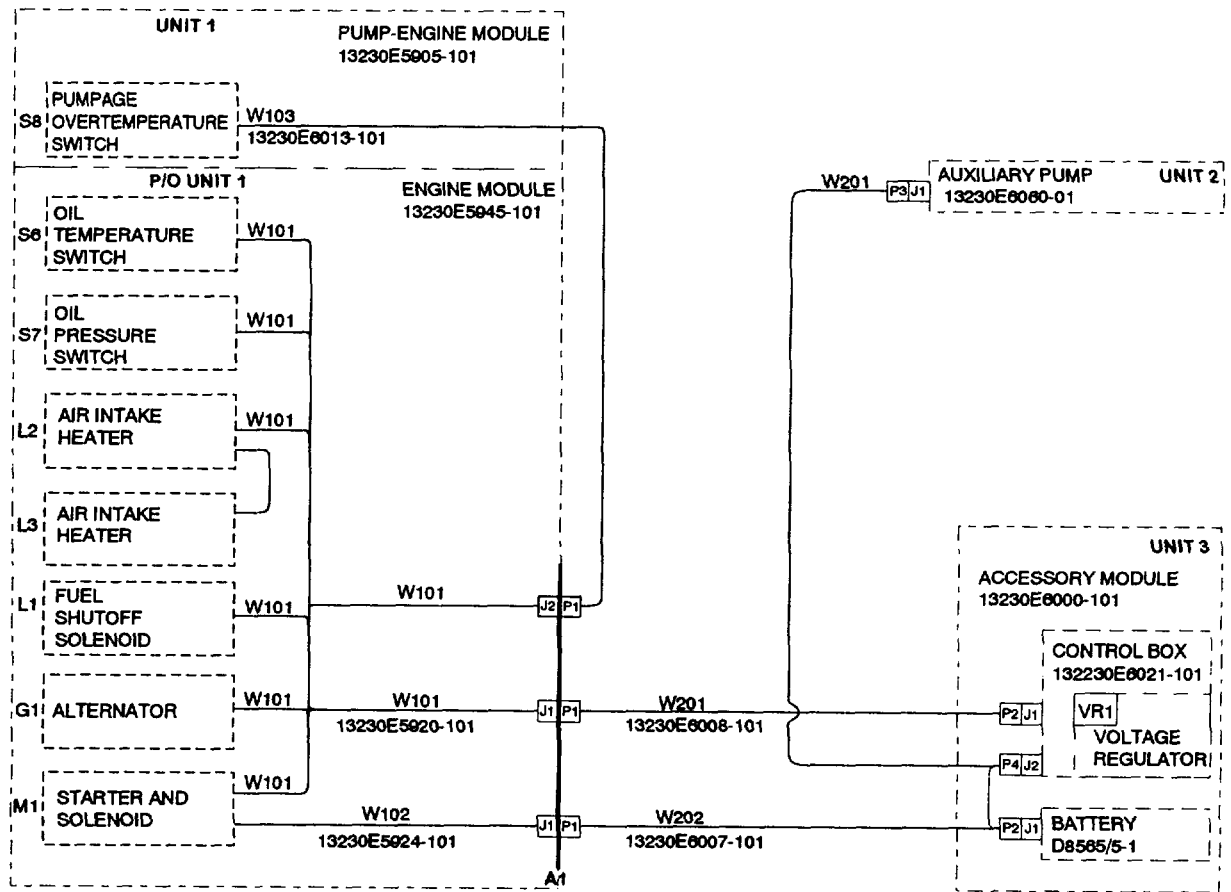

Figure 5-1. Pumping Assembly Interconnecting Diagram

The four system fault lights are grouped in the center of the control panel. The ENGINE HOT, LOW OIL PRESSURE and PUMPAGE HOT indicators illuminate red to warn the operator of a condition dangerous to personnel or the system. The ALTNR indicator illuminates yellow to caution the operator of an electrical malfunction which may limit or preclude continued system operation. FAULT LIGHTS switch S5 must be ON for any of the fault lights to operate.

The LOW OIL PRESSURE fault light is controlled by a pressure sensor on the engine. If the oil pressure decreases to an unsafe level during operation, the contacts in sensor S7 close, providing a current path from ground through the sensor, LED CR6 and FAULT LIGHTS switch S5 to the 28 VDC line after EMERGENCY STOP switch S5.

The ENGINE HOT fault light is controlled by a temperature sensor mounted on the engine. If the engine oil temperature increases to 2750F (135°C) during operation, the contacts in sensor S8 close, providing a current path from ground through the sensor, led CR7 and FAULT LIGHTS switch S5 to the 28 VDC line after EMERGENCY STOP switch S5.

The PUMPAGE HOT fault light is controlled by a temperature sensor mounted on the fuel transfer pump discharge housing. If the pumpage temperature increases to 175°F (79°C) during operation, the contacts in pumpage overtemperature sensor S8 open, removing the ground from relay K1 and the 28 VDC buss. The contacts of relay K1 return to the deenergized position, removing power from the fuel shutoff solenoid which closes the fuel ports to the fuel injectors and

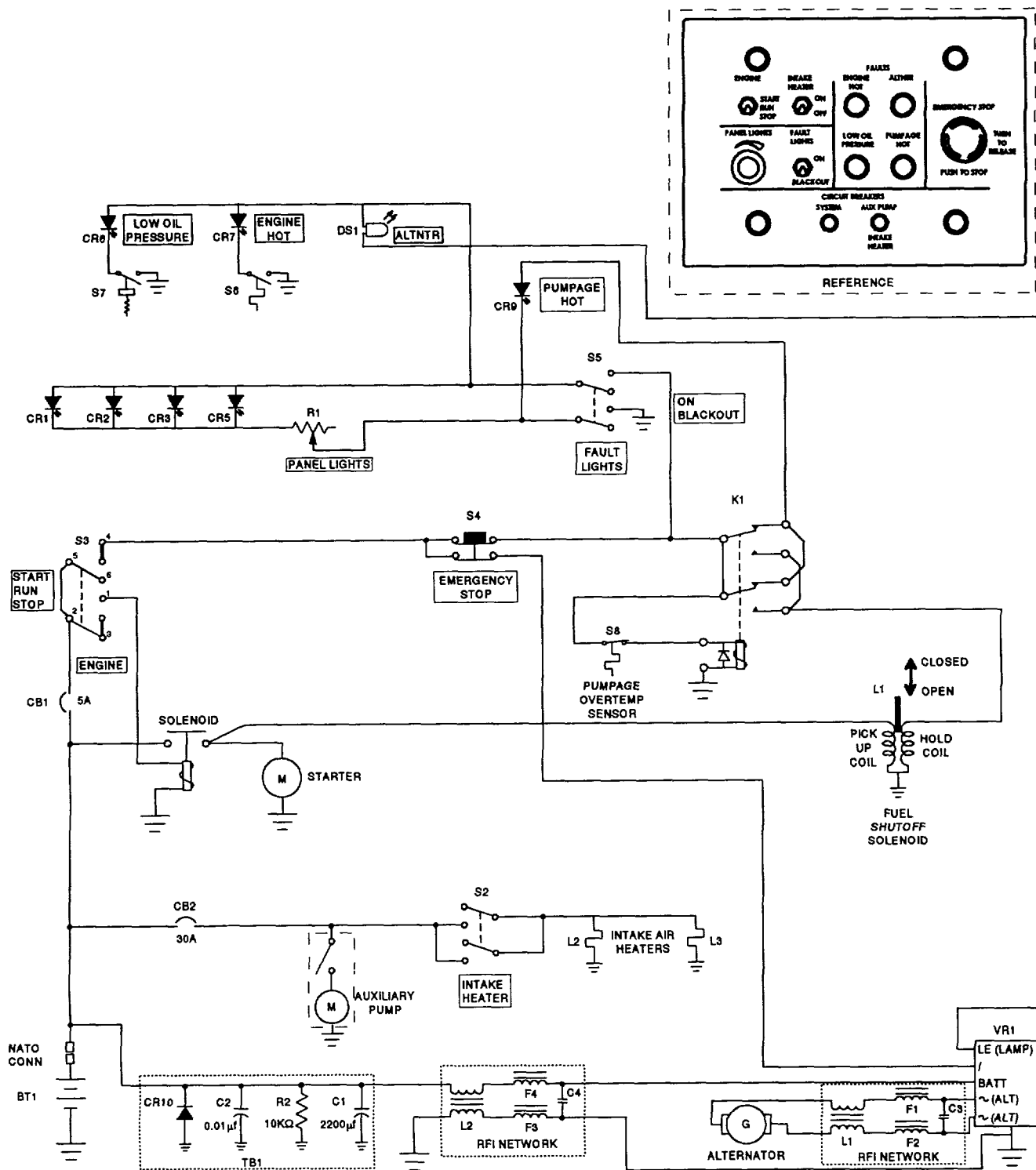

Figure 5-2 . Pumping Assembly Electrical Schematic

stops the engine. When relay K1 deenergizes, a current path is created through FAULT LIGHTS switch S5, LED CR9 and the contacts of relay KI to the 28 VDC line after EMERGENCY STOP switch S5. High pumpage temperature is the only fault condition which causes an automatic system shut down. The alternator output will decrease to zero when the engine stops but the PUMPAGE HOT fault light will remain illuminated if the battery is connected at the NATO connector.

The ALTNTR fault light is controlled by circuits in the voltage regulator which use battery voltage as a reference. The fault light illuminates any time the rectified alternator output is less than the reference battery voltage.

Two RFI networks, one between the battery and voltage regulator VR1 and one between the alternator and voltage regulator VRI suppress any Radio Frequency Interference (RFI) generated or radiated by AAFARS.

SECTION II. DIRECT SUPPORT MAINTENANCE PROCEDURES

5.4 REPAIR OF FUEL TRANSFER PUMP.

5.4.1 Replace Fuel Transfer Pump Inlet O-Ring. (Refer to figure 5-3.)

This task consists of: a. Removal b. Installation

INITIAL SET-UP:**Tools:**

Key, Socket Head Screw, 5/6 in.
 (Appendix B, Section III, Item 3)
 Wrench, Combination, 7/16 in.
 (Appendix B, Section III, Item 3)
 Goggles
 (Appendix B, Section III, Item 2)
 Gloves (Appendix B, Section III, Item 2)

General Safety Requirements:**WARNING**

- **Fuels are toxic and flammable. Do not get on person Or clothing. Work in well ventilated area. Do not Smoke. Ensure equipment is well grounded.**
-

Materials/Part Required:

Petrolatum (Appendix F, Section II, Item 10)
 Anti-Seize Compound, Molybdenum Disulfide
 (Appendix F, Section II, Item 3)
 Dry Cleaning Solvent
 (Appendix F, Section II, Item 2)
 Washer, Lock (Appendix I, Item 68)
 O-Ring (Appendix I, Item 56)

Equipment Condition:

Fuel transfer pump removed from pump-engine module (para. 4.12.1)

a. Removal.

NOTE

Mark inlet (1) and pump housing (2) to establish assembly orientation.

- (1) Remove inlet (1) from pump.
 - (a) Remove the six socket head screws (3), lock washers (4) and flat washers (5) that secure the inlet to the pump. Discard lock washers (4).
 - (b) Install three, 1/4 -28 x 1 1/2 inch jack bolts in the threaded holes spaced around the inlet circumference. Remove inlet from housing by alternately tightening the jack bolts until inlet is free. Remove jack bolts from inlet.
- (2) Remove O-ring (6) from inlet and discard.
- (3) Inspect impeller (7) and housing interior for damage. Minor scratches and dents will not affect operation. If severe damage is noted, report to supervisor.
- (4) Inspect and clean O-ring groove as required. Any debris or foreign material may prevent the O-ring from seating properly.

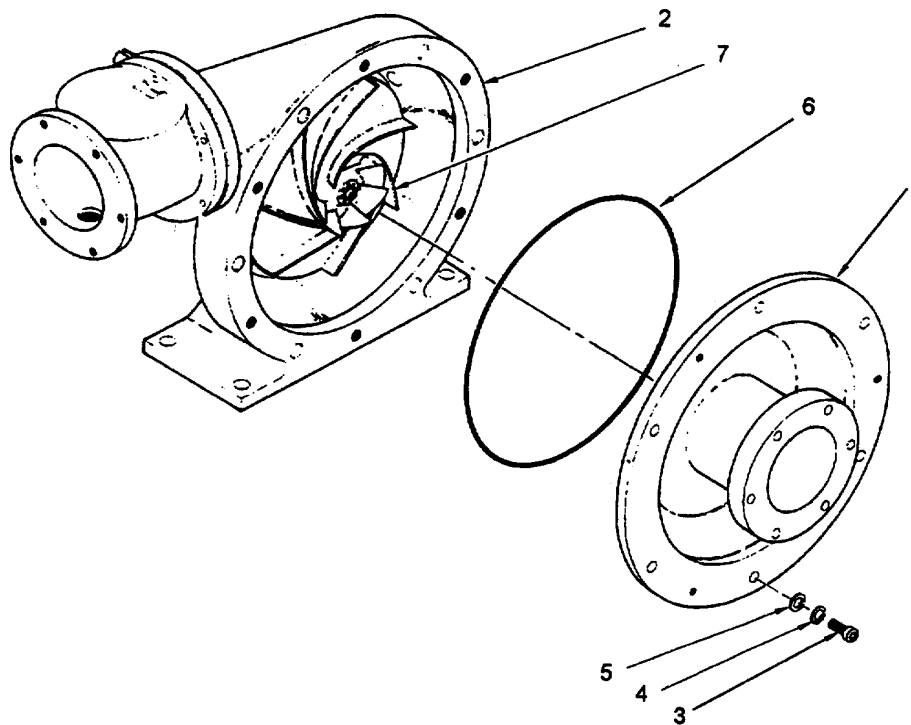

Figure 5-3. Fuel Transfer Pump Inlet O-Ring Replacement

WARNING

Dry cleaning solvent, P-D-680, Type III, is potentially dangerous to personnel and property. Eye and skin protection is required. Avoid repeated and prolonged skin contact. Wash hands immediately after exposure. Do not use near open flame or excessive heat. Use only in areas with good ventilation. Rubber gloves should be worn when handling fueling system components due to the toxic effects of some fuel additives and the dry cleaning solvent.

(5) Clean interior of pump housing with dry cleaning solvent SD (P-D-680), if required.

a. Installation.

- (1) Lightly lubricate O-ring (6) with petrolatum and install in inlet O-ring groove. Do not allow the O-ring to twist or roll during installation.
- (2) Install inlet in pump.
 - (a) Install the inlet (1) by aligning the six retaining screw holes and the jack bolt holes with corresponding holes in the housing body (2). Tap inlet lightly around circumference with rubber mallet or heel of palm to seat inlet in housing. If inlet does not install easily, install the 1/4-28 x 1 1/2 in. jack bolts in the inlet and adjust bolts until inlet is parallel to impeller housing, then back out jack bolts alternately 1/2 turn at a time until mounting screws (3) can be started.
 - (b) Lubricate with anti-seize compound and loosely install the six socket head screws (3), lock washers (4) and flat washers (5) in the inlet (1). Tighten in a crossing pattern, one or two turns at a time, to fully seat the inlet in the housing (2). When all six screws are snug, tighten alternately until secure.

5.4.2 Replace Fuel Transfer Pump Shaft Seal Assemble/O-Rings. (Refer to figure 5-4.)

This task consists of: a. Removal b. Installation

INITIAL SET-UP:

Tools:

Wrench, Strap
(Appendix B, Section III, Item 3)
Key, Socket Head Screw, 3/16"
(Appendix B, Section III, Item 3)
Wrench, Combination, 1-1/16"
(Appendix B, Section III, Item 3)
Adapter, Crow Foot
(Appendix B, Section III, Item 3)
Screwdriver, Flat Blade, 1/4" x 4"
(Appendix B, Section III, Item 3)
Wire Twister, Plier
(Appendix B, Section III, Item 3)
Plier, Diagonal Cutting
(Appendix B, Section III, Item 3)
Wrench, Torque, 0-150 ft lb
(Appendix B, Section III, Item 3)

General Safety Requirements:

WARNING

- Fuels are toxic and flammable. Do not get on person or clothing. Work in well ventilated area. Do not smoke. Ensure equipment is well grounded.

Materials/Parts Required:

Safety Wire (Appendix F, Section II, Item 5)
Petrolatum (Appendix F, Section II, Item 10)
Anti-Seize Compound, Molybdenum Disulfide
(Appendix F, Section II, Item 3)

Equipment Condition:

Fuel transfer pump removed from pump-engine module (para.4.12.1)

Personnel Required:

Two, any MOS

a. Removal.

- Lay fuel transfer pump on inlet side.
- Remove safety wire from shaft nut cover screws (1).
- Remove the four screws (1) and flat washers (2) that secure the shaft nut cover (3) to the seal housing (4). Remove the cover.
- Install splined flexible coupling adapter (5) on pump input shaft in accordance with paragraph 4.12.1.

NOTE

Removal of the fuel transfer pump shaft nut will require two persons. The nut is torqued to 100-110 ft lb (135-149 Nm) and may require one person to hold the strap wrench and one person to turn the nut.

- Position strap wrench around splined flexible coupling adapter (5) as near to set screw as possible to hold pump shaft. Loosen shaft nut (6) as far as possible without jamming the nut against the splined flexible coupling adapter.
- Remove the flexible coupling adapter (5).

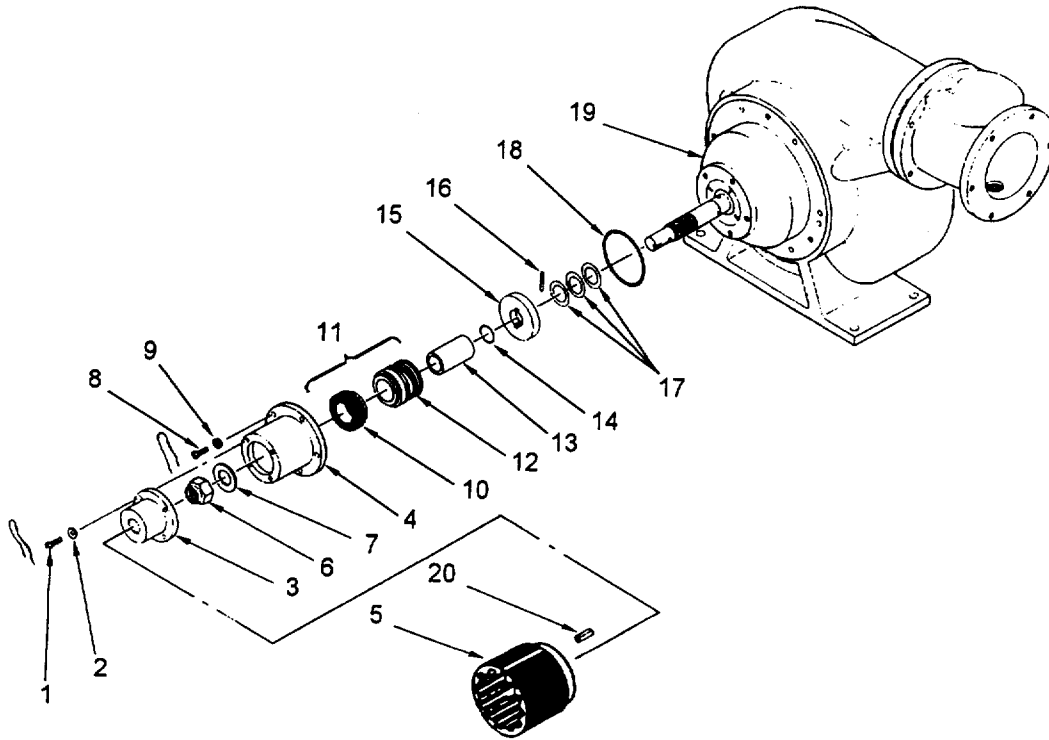

Figure 5-4. Shaft Seal Assembly/O-Ring Replacement

- (7) Remove the shaft nut (6) and flat washer (7).
- (8) Remove safety wire from seal housing screws (8).
- (9) Remove the five seal housing screws (8) and flat washers (9); remove the shaft seal housing.

NOTE

The stationary seal portion of the rotating shaft seal will remain in the shaft seal housing and must be pushed out.

- (10) Remove the stationary seal portion (10) of the rotating shaft seal (11) from the shaft seal housing (4). Discard the seal (10).

NOTE

Note installation direction of rotating spring portion of shaft seal for reassembly.

- (11) Remove spring (12) and spacer (13) as a unit.
- (12) Press spring (12) off spacer (13) and discard spring (12).
- (13) Remove and discard shaft O-ring (14). Do not remove other shaft components (thrust washer [15], dowel [16] and shims [17]) unless replacement is necessary.

- (14) Remove and discard the shaft seal housing O-ring (18).
- (15) Inspect and clean O-ring grooves as required. Any debris or foreign material may prevent the O-rings from seating properly.

b. Installation.

- (1) Lubricate lightly and install O-ring (18) in vane pump housing (19).
- (2) Lubricate lightly and install O-ring (14) on shaft.
- (3) Lubricate stationary seal (10) and push into shaft seal housing (4) so that elastomer portion seats against housing.
- (4) Install rotating spring (12) on spacer (13), and install on shaft so that lipped portion of seal faces out (to interface with stationary seal installed in previous step).
- (5) Apply anti-seize compound to the five shaft seal housing screws (8). Place shaft seal housing (4) over shaft with weep hole facing down and mounting holes aligned, hold housing down against spring pressure, and install the five screws (8) and flat washers (9) that secure shaft seal housing (4) to vane pump housing (19).
- (6) Rotate shaft by hand to check freedom of rotation. Some rubbing at the inlet is normal but if the shaft binds or will not turn, remove shaft seal housing (4) and check rotating shaft seal (11) for proper assembly.
- (7) Install washer (7) and shaft nut (6) on shaft hand tight.
- (8) Install splined flexible coupling adapter (5) on pump shaft. Tighten set screw against shaft key (20).

NOTE

The shaft nut (4) must be torqued to a specific value to provide the proper tension on the rotating shaft seal (11). However, a standard socket on a torque wrench cannot be used. A crow foot adapter, as shown in the illustration below, will allow access to the nut but adding the adapter will also cause the torque reading on the wrench to be different from the actual torque applied to the nut. To calculate the torque value to be indicated when the required torque is known, perform the following procedure:

- 1. Measure the distance L_1 on the torque wrench to be used.
- 2. Install the crow foot adapter and measure the distance L_2 .
- 3. Divide L_2 into L_1 .
- 4. Multiply the quotient by the torque specified for the nut. The product is the torque value that will be indicated on the wrench when the specified torque has been reached on the nut.

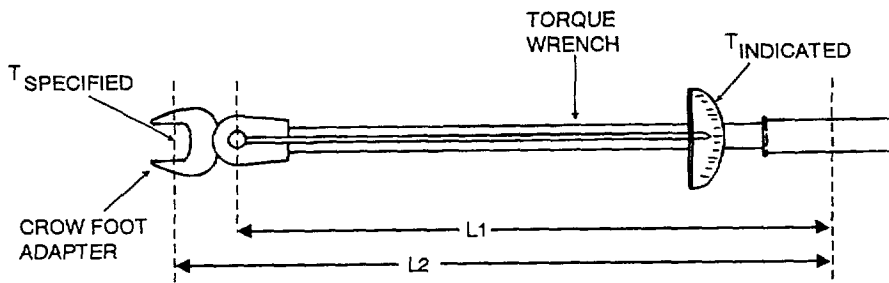

For example: The specified torque value for the shaft nut is 100-110 ft lb (135-149 Nm). The distance L1 measured on your torque wrench is 19 inches. The distance L2 measured on your torque wrench is 21 inches. In the following formula, $T_{INDICATED}$ is the value you should read on your torque wrench with the crow foot adapter installed. $T_{SPECIFIED}$ is the torque value specified for the nut.

$$T_{INDICATED} = (L1/L2)T_{SPECIFIED}$$

Substituting actual values: $T_{INDICATED} = (19/21)100-110$
 $T_{INDICATED} = 90-99 \text{ ft lb (122-134 Nm)}$

In this example, 100-110 ft lb (135-149 Nm) is applied to the nut when your torque wrench reads 90-99 ft lb (122-134 Nm).

- (9) Position strap wrench around flexible coupling as near to set screw as possible to hold pump shaft. Torque the shaft nut to 100-110 ft lb (135-149 Nm).
- (10) Rotate shaft by hand to check for freedom of rotation. Some rubbing at the inlet is normal but if the shaft binds or will not turn, remove shaft housing (4) and inspect for proper assembly or cause of misalignment.
- (11) Remove flexible coupling (5) from input shaft.
- (12) Install shaft nut cover (3) using four screws (1) and flat washers (2).
- (13) Install safety wire on shaft nut cover retaining screws (1).
- (14) Install splined flexible coupling adapter (5) on pump shaft. Tighten set screw securely against shaft key (19).

5.4.3 Replace Fuel Transfer Pump Vane Pump Housing O-Rings. (Refer to figure 5-5.)

This task consists of: a. Removal b. Installation

INITIAL SET-UP:

Tools:

- Key, Socket Head Screw, 3/16"
(Appendix B, Section III, Item 3)
- Wrench, Combination, 7/16"
(Appendix B, Section III, Item 3)

Materials/Parts Required:

- Anti-Seize Compound, Molybdenum Disulfide
(Appendix F, Section II, Item 3)

General Safety Requirements:

Equipment Condition:

- Fuel transfer pump removed from pump-engine module. (para. 4.12.1)

WARNING

Fuels are toxic and flammable. Do not get on person or clothing. Work in well ventilated area. Do not smoke. Ensure equipment is well grounded.

a. Removal.

- (1) Lay pump on inlet.
- (2) Remove rotary shaft seal housing and components. Refer to paragraph 5.4.2
- (3) Remove thrust washer (1) from shaft.
- (4) Remove dowel pin (2) from shaft.
- (5) Remove the six socket head screws (3) and flat washers (4) that secure the vane pump housing (5) to the impeller housing (6).
- (6) Install three 1/4-28 x 1-1/2 inch jack bolts in the threaded holes spaced around the vane pump housing circumference. Remove vane pump housing by alternately tightening the jack bolts until housing is free.

NOTE

Count shims to ensure same number is installed during assembly.

- (7) Lift housing (5) and shims (7) from shaft.

CAUTION

Do not attempt to remove carbon bearing in vane pump housing. Bearing can only be replaced at the depot.

- (8) Remove and discard both O-rings (8) from face of vane pump housing.
- (9) Inspect and clean O-ring grooves as required. Any debris or foreign matter may prevent O-ring from seating properly.
- (10) Inspect and clean the mounting surface and vertical lip of the pump housing where the vane pump housing is attached. Ensure all paint and debris have been removed.

b. Installation.

CAUTION

Ensure inlet is installed before commencing this procedure. Inlet installation will prevent the thrust washer dowel falling out of place. Equipment damage will occur if pump is run with a loose dowel. Ensure all paint and debris have been removed from area of vane pump housing seat. Any debris will cause vane pump housing to be misaligned and equipment damage will result.

- (1) Lightly lubricate O-rings (8) with petrolatum and install in O-ring grooves on vane pump housing (5). Do not allow the O-rings to twist or roll during installation.

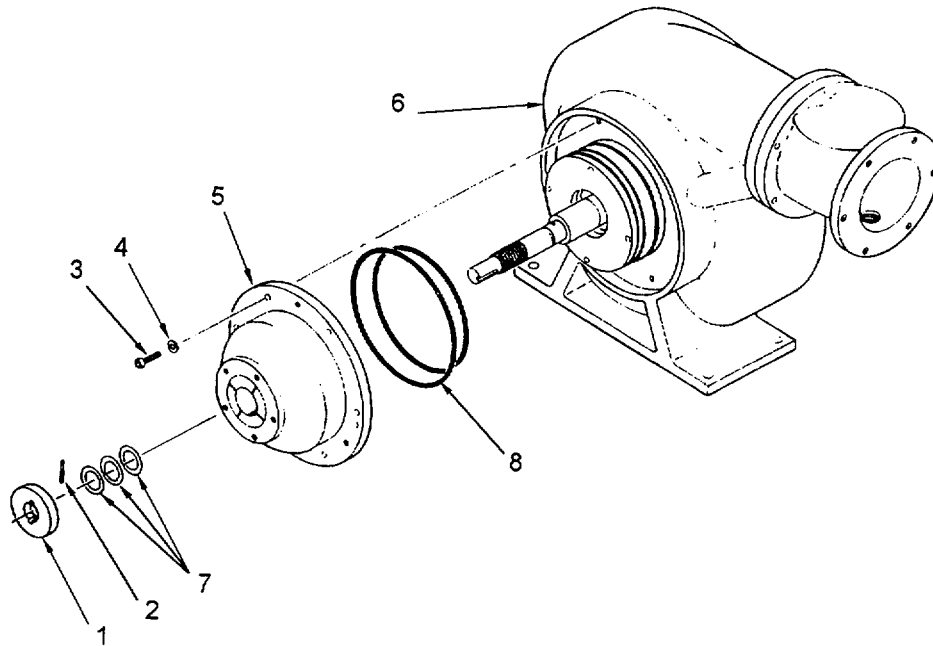

Figure 5-5. Vane Pump Housing O-Ring Replacement

- (2) Install vane pump housing (5).
 - (a) Hold vane pump housing (5) over shaft so that mounting holes and guide pin holes are aligned, and install three 1/4" x 28 bolts through housing into mounting holes. Space the bolts approximately equal distances apart and tighten finger tight. Using the bolts as guides, push the vane pump housing onto the shaft. Remove the three guide bolts.
 - (b) Apply anti-seize compound to and install the six socket head screws (3) and flat washers (4) to secure the vane pump housing (5) to the impeller housing (6). Alternately tighten screw pairs to draw housing down evenly. Rotate shaft by hand after each tightening sequence to ensure binding has not occurred. When all six screws are finger tight, repeat pattern to secure tightly. Verify proper alignment by rotating shaft by hand. Shaft will rotate freely without binding when all screws are tightened evenly.
- (3) Install shims (7) on shaft.

- (4) Install thrust washer (1).
 - (a) Install dowel pin (2) in shaft.
 - (b) Install thrust washer (1) so that dowel pin (2) engages slots in washer.
- (5) Install shaft seal assembly and shaft nut. Refer to paragraph 5.4.2.

5.4.4 Repair of Rotary Vane Pump. (Refer to figure 5-6.)

This task consists of: a. Removal b. Repair c. Installation

INITIAL SET-UP:

Tools:

Key, Socket Head Screw, 9/64"
(Appendix B, Section III, Item 3)

Materials/Parts Required:

Washer, Lock (Appendix I, Item 59)
Anti-Seize Compound, Molybdenum Disulfide
(Appendix F, Section II, Item 3)

General Safety Requirements:

WARNING

- **Fuels are toxic and flammable. Do not get on person or clothing. Work in well ventilated area. Do not smoke. Ensure equipment is well grounded.**

Equipment Condition:

Fuel transfer pump removed from pump-engine module. (para. 4.12.1)

Shaft nut and shaft seal assembly removed. (para. 5.4.2)

Vane pump housing removed. (para. 5.4.3)

- a. Removal.
 - (1) Remove rotary shaft seal housing and components. Refer to paragraph 5.4.2.
 - (2) Remove rotary vane pump housing. Refer to paragraph 5.4.3.
 - (3) Remove the four socket head screws (1), lock washers (2) and flat washers (3) that secure the rotary vane pump to the impeller housing (4). Discard lock washers (2).
- b. Repair.
 - (1) Lift off the vane pump clamp plate (5) and outer side plate (6), and inspect pump for physical damage (nicks, burrs, scratches, etc.). Replace any component that has physical damage exceeding minor scratching.
 - (2) Observe length of vanes (7); each vane should be long enough to be easily retained in rotor (8) at farthest extension. Replace vanes if excessively worn.
 - (3) Remove vane pump components (7, 8, 10 and 14) as required for inspection. Be careful to retrieve rotor key (9) when removing rotor. Replace any component that has physical damage exceeding minor scratching.

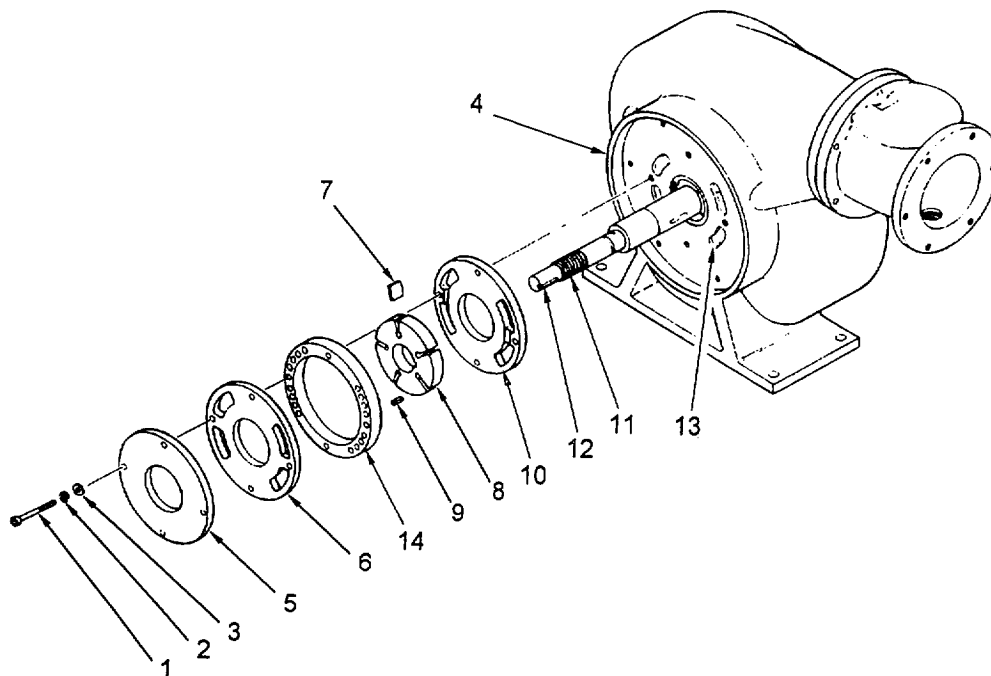

Figure 5-6. Rotary Vane Pump Repair

c. Installation.

- (1) Set pump on base.
- (2) Place vane pump inner side plate (10) over shaft with outside face towards the impeller. (The inside face has grooves connecting the inlet/outlet ports.)
- (3) Rotate impeller-shaft assembly (11) to place vane pump rotor key way (12) at top of shaft.
- (4) Place rotor key (9) in key way (12).
- (5) Hold impeller shaft (11) and slide vane pump rotor (8) over shaft and key (9).
- (6) Lay fuel transfer pump on inlet side and align inner side plate (10) mounting holes and fuel inlet/outlet ports (13).
- (7) Place cam ring (14) over rotor (8) so that mounting holes are aligned, and the sixteen flow holes are aligned with the corresponding inlet/outlet ports in the inner side plate (10).
- (8) Carefully place a carbon vane (7) in each of the five slots in the rotor (8). New vanes will be square on both ends and may be installed without regard for direction. Vanes that have been run in will have worn shorter in the direction of rotation. Install used vanes so that short side leads in the clockwise direction of rotation.

- (9) Place the outer side plate (6) over the rotor (8) so that mounting holes are aligned, and the fuel inlet/outlet ports are aligned with sixteen flow holes in the cam ring (14). (The inside face has grooves connecting the inlet/outlet ports.)
- (10) the clamp plate (5) over the outer side plate (6) so that mounting holes are aligned. Apply anti-seize compound to and install the four socket head screws (1), lock washers (2) and flat washers (3). Tighten the screws finger tight, then tighten in a crossing pattern.
- (11) rotary vane pump housing. Refer to paragraph 5.4.3.
- (12) Install rotary shaft seal housing and components. Refer to paragraph 5.4.2.

5.4.5 Replace Fuel Transfer Pump Impeller-Shaft Assembly.

This task consists of: a. Removal b. Installation

INITIAL SET-UP:

Tools:

- Key, Socket Head Screw, 9/64 in.
(Appendix B, Section III, Item 3)
- Key, Socket Head Screw, 3/16 in.
(Appendix B, Section III, Item 3)
- Key, Socket Head Screw, 5/16 in.
grounded.
(Appendix B, Section III, Item 3)
- Wrench, Combination, 7/16 in.
(Appendix B, Section III, Item 3)
- Wrench, Combination, 1-1/16 in.
(Appendix B, Section III, Item 3)
- Wrench, Strap
(Appendix B, Section III, Item 3)
- Adapter Crow Foot
(Appendix B, Section III, Item 3)
- Screwdriver, Flat Blade, 1/4 in. x 4 in.
(Appendix B, Section III, Item 3)
- Wire Twister, Plier
(Appendix B, Section III, Item 3)
- Plier, Diagonal Cutting
(Appendix B, Section III, Item 3)
- Wrench, Torque, 0-150 ft lb
(Appendix B, Section III, Item 3)

Material/Part Required:

WARNING

- **Fuels are toxic and flammable. Do not get on person or clothing. Work in well ventilated area. Do not smoke. Ensure equipment is well**

Materials/Parts Required:

- Petrolatum (Appendix F, Section II, Item 10)
- Anti-Seize Compound, Molybdenum Disulfide
(Appendix F, Section II, Item 3)
- Safety Wire, MS20995C20
(Appendix F, Section II, Item 5)

Equipment Condition:

Fuel transfer pump removed from pump-engine module. (para. 4.12.1)

Personnel Required:

Two, any MOS

a. Removal.

- (1) Remove rotary shaft seal housing and components. Refer to paragraph 5.4.2.

- (2) Remove rotary vane pump housing. Refer to paragraph 5.4.3.
- (3) Remove rotary vane pump components. Refer to paragraph 5.4.4.
- (4) Remove inlet. Refer to paragraph 5.4.1.
- (5) Slide impeller-shaft assembly out of housing.

NOTE

Do not attempt to remove carbon bearing in impeller housing. This bearing can only be installed at the depot.

b. Installation.

- (1) Slide replacement impeller-shaft assembly into housing.
- (2) Install inlet. Refer to paragraph 5.4.1.
- (3) Install rotary vane pump components. Refer to paragraph 5.4.4.
- (4) Install rotary vane pump housing. Refer to paragraph 5.4.3.
- (5) Install rotary shaft seal housing and components. Refer to paragraph 5.4.2.

5.5 REPAIR THREE-INCH VALVED UNISEX COUPLING. (Refer to figure 5-7.)

This task consists of: a. Disassembly b. Inspection c. Assembly

INITIAL SET-UP:**Tools:**

Screwdriver, Cross Tip, Size 2
 (Appendix B, Section III, Item 2)
 Key, Socket Head Screw, 7/64 in.
 (Appendix B, Section III, Item 2)
 Key, Socket Head Screw, 9/64 in.
 (Appendix B, Section III, Item 2)
 Key, Socket Head Screw, 7/32 in.
 (Appendix B, Section III, Item 2)
 Punch (Drift Pin)
 (Appendix B, Section III, Item 2)
 Pick (or machinist's scribe)
 (Appendix B, Section III, Item 2)
 Chemical and Oil Protective Gloves
 (Appendix B, Section III, Item 2)
 Goggles
 (Appendix B, Section III, Item 2)

Material/Part Required:

Solvent, Dry Cleaning
 (Appendix F, Section II, Item 2)
 Cloth, Lint Free (Appendix F, Section II, Item 13)
 Petrolatum (Appendix F, Section II, Item 10)
 Grit Paper (Appendix F, Section II, Item 11)
 O-Ring (Appendix I, Item 47)
 O-Ring (Appendix I, Item 50)
 Bushing (Appendix I, Item 5)
 Bushing (Appendix I, Item 7)
 Seal (Appendix I, Item 6)
 O-Ring (Appendix I, Item 46)

General Safety Requirements:**WARNING**

- **Fuels are toxic and flammable. Do not get on person or clothing. Do not use near open flame. Area should be well ventilated.**
 - **Using dry cleaning solvents incorrectly can cause injury or even death.**
 - **Fuel is flammable. Do not smoke.**
-

Equipment Condition:

Three inch valved unisex coupling detached
 (para. 4.11.2)

- a. Disassembly.

WARNING

Rubber gloves should be worn when handling fuel system components due to toxic effects of some additives.

- (1) Unthread dust cap attaching cable (1) from split rings (2).
- (2) Place handle assembly (3) in closed position, rotate and remove dust cap (4) from coupling, then place handle assembly (3) in open position
- (3) Remove screws (5) and handle assembly (3).
- (4) If handle assembly (3) requires repair, remove socket head screw (6), spring (7), and knob (8) from handle (9).
- (5) Hold valve ball (10) with thumb and remove socket head screw (11) from handle-side shaft (12).

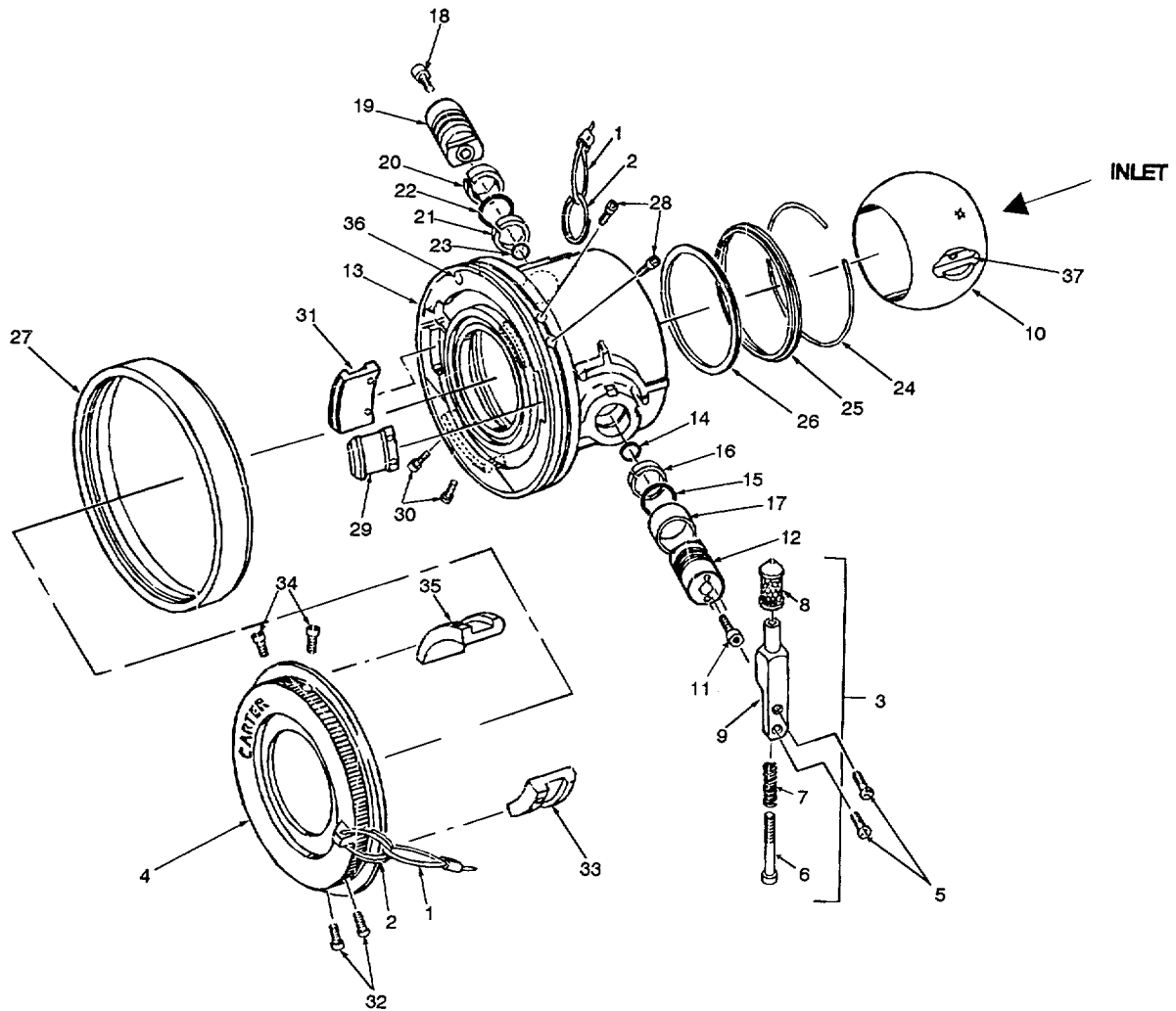

Figure 5-7. Three-Inch Valved Unisex Coupling

- (6) Install one screw (5) in the handle-side shaft (12) and pull shaft (12) from housing (13). Remove and discard O-ring (14).
- (7) Remove and discard O-ring (15) and bushings (16) and (17).
- (8) Hold valve ball (10) with thumb and remove socket head screw (18) from attaching-cable-side shaft (19).
- (9) Reaching in the inlet end, rotate the valve ball (10) by hand and remove it from the housing (13).
- (10) Push out the attaching-cable-side shaft (19). Remove and discard bushings (20) and (21) and O-rings (22) and (23).
- (11) Use pick or scribe to remove seal wire (24).

CAUTION

Avoid scratching or gouging beveled edge of seal retainer (25) under seal wire (24), or any sealing surface. Gouges or burrs may cause the valve to malfunction.

- (12) Use pick (or scribe) to remove seal retainer (25). Insert pick between inner edge of retainer and seal, work down to bottom of retainer, rotate under retainer and lift to unseat and remove retainer. Repeat this process all around inner edge of the retainer until it is free.
- (13) Remove and discard seal (26).
- (14) Remove the bumper (27) by hand.
- (15) Remove screws (28) and lug (29).
- (16) Remove screws (30) and lug (31).
- (17) Remove screws (32) and lug (33).
- (18) Remove screws (34) and lug (35).

b. Inspection.

- (1) Inspect all metal parts for dings, gouges, abrasions etc. On all parts except the ball (10), use 320 grit paper to smooth and remove sharp edges. If ball (10) is damaged (scratched, gouged, etc.) it should be replaced.
- (2) Check the groove (round bottom) in the inlet for burrs on the corners. If groove is worn such that burrs exist, use 320 grit paper to smooth and remove sharp edges.
- (3) Inspect the small spring-loaded continuity ball (36) located in the face of the unit. Push the ball in and be sure that it pops back into place. If the ball does not pop back freely, electrical continuity is lost and static discharge is possible. Replace entire coupling if continuity ball does not pop back out.
- (4) Inspect screw (6) and handle (9) for damage. If either part is bent, replace it.

WARNING

Dry cleaning solvent, P-D-680, Type III, is potentially dangerous to personnel and property. Eye and skin protection is required. Avoid repeated and prolonged skin contact. Wash hands immediately after exposure. Do not use near open flame or excessive heat. Use only in areas with good ventilation.

Rubber gloves should be worn when handling fueling system components due to the toxic effects of some fuel additives and the dry cleaning solvent.

- (5) Make certain all components are clean and free from oil, grease, or dirt. Wash all parts with an approved dry cleaning solvent and dry thoroughly with a clean, lint-free cloth.

c. Assembly.

- (1) Place seal (26) into housing (13) with the flat surface inserted into the housing. Press into place with fingers.
- (2) Insert seal retainer (25). Work into place with fingers to seat seal (26) and clear groove for seal wire (24).

CAUTION

Avoid damage (scratching, gouging, etc.) to housing surfaces and seal retainer (25) during installation of wire seal. Gouges or burrs may cause valve to malfunction.

- (3) Install open end of seal wire (24) into housing (13) at an angle and slide seal wire down into groove.
- (4) Install screws (28) and lug (29).
- (5) Install screws (30) and lug (31).
- (6) Install screws (32) and lug (33).
- (7) Install screws (34) and lug (35).
- (8) Install bumper (27) onto housing (13) such that the tapered edge is facing toward the housing.
- (9) Insert valve ball (10) into housing (13) with shaft flats (37) on ball aligned with shaft holes in housing.
- (10) Lightly lubricate replacement O-ring (22) with petrolatum and install bushings (20) and (21) and O-ring (22) onto attaching-cable-side shaft (19).
- (11) Place O-ring (23) into groove in inside end of attaching-cable-side shaft (19) and insert attaching-cable-side shaft (19) into housing (13) and ball (10).

NOTE

It is normally possible to install the valve ball without regard to left-right or front-rear position. Occasionally, however, a ball will not be perfectly machined and the operating shafts will engage in one position only. If this problem occurs when installing the shafts, it will be necessary to remove the valve ball and install in a different position to allow the shafts to align properly for engagement with the valve ball.

- (12) Install bushing (17) onto the handle-side shaft (12). Lightly lubricate O-ring (15) with petrolatum and install bushing (16) and O-ring (15) onto handle-side shaft (12). Place O-ring (14) into inside end of groove in handle-side shaft (12) and insert handle-side shaft (12) into housing (13) and valve ball (10). If handle-side shaft (12) will not mate with ball (10), remove handle-side shaft (12), rotate ball (10) and insert handle-side shaft (12). Install retaining screw (11) to secure handle-side shaft (12) to valve ball (10). Hold valve ball (10) with fingers while tightening screw (11).
- (13) Install screw (18) to attach attaching-cable-side shaft (19) to valve ball. Hold valve ball with fingers while tightening screw (18).
- (14) If removed, install spring (7) and socket head screw (6) into handle (9), place knob (8) on handle and tighten.
- (15) Install handle assembly (3) to housing (13) using screws (5).

- (16) Open and close coupling valve twice to be sure it operates properly.
- (17) Place handle assembly (3) in closed position and install dust cap (4).
- (18) Thread attaching cable (1) through split rings (2).

5.6 REPAIR TWO-INCH VALVED UNISEX COUPLING. (REFER TO FIGURE 5-8.)

This task consists of: a. Disassembly b. Inspection c. Assembly

INITIAL SET-UP:

Tools:

Tool Kit, General Mechanics
 (Appendix B, Section III, Item 1)
 Chemical and Oil Protective Gloves
 (Appendix B, Section III, Item 2)
 Goggles
 (Appendix B, Section III, Item 2)

Material/Parts Required:

Solvent, Dry Cleaning
 (Appendix F, Section II, Item 2)
 Lint Free Cloth (Appendix F, Section II, Item 13)
 Petrolatum (Appendix F, Section II, Item 10)
 O-Ring (Appendix I, Item 49)
 O-Ring (Appendix I, Item 52)
 Seal (Appendix I, Item 4)

General Safety Requirements:

WARNING

- **Fuels are toxic and flammable. Do not get on person or clothing. Do not use near open flame. Area should be well ventilated.**
- **Using dry cleaning solvents incorrectly can cause injury or even death.**
- **Fuel is flammable. Do not smoke.**

Equipment Condition:

Detached 2 inch valved unisex coupling
 (para. 4.10.2)

WARNING

Rubber gloves should be worn when handling fuel system components due to toxic effects of some additives.

NOTE

Inspect the coupling components as they are disassembled. Repair is limited to replacement of unserviceable components discovered during disassembly. Removed O-rings and seals shall be replaced.

a. Disassembly.

- (1) Place handle assembly (1) in closed position and remove dust cap (2) from 2 inch valved unisex coupling (3).
- (2) Remove screws (4) from handle assembly (1). Remove handle assembly (1).
- (3) If necessary to disassemble handle assembly (1), remove screw (5), spring (6) and grip (7) from handle (8).

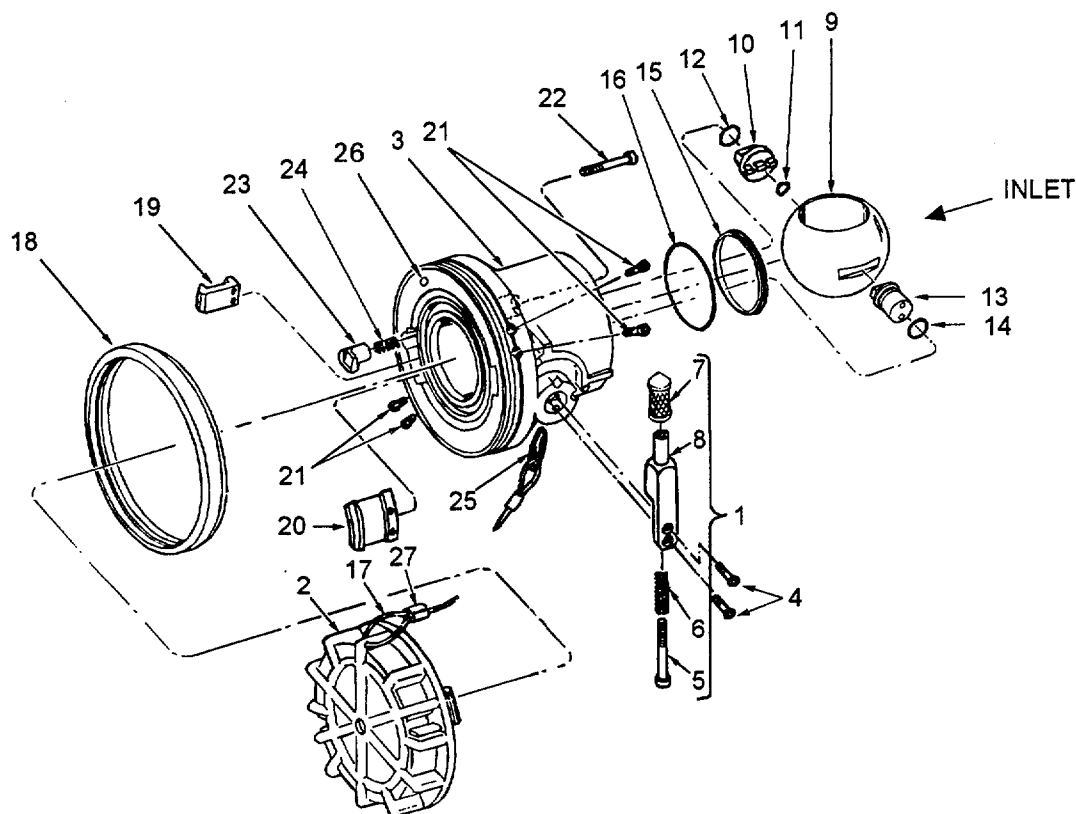

Figure 5-8. Two Inch Valved Unisex Coupling

- (4) Remove ball (9) from 2 inch valved unisex coupling (3).
- (5) Remove stop pin (10) and wave washer (11) along with O-ring (12). Discard O-ring.
- (6) Remove shaft (13) from inside 2 inch valved unisex coupling (3). Remove and discard O-ring (14).
- (7) Remove downstream seal (15) and O-ring (16) from 2 inch valved unisex coupling (3).
- (8) If the dust cap (2) or attaching cable (17) is to be replaced, cut the cable (17).
- (9) Remove bumper (18) only if it is to be replaced or it is necessary to remove lugs (19 or 20).
- (10) To remove lugs (19 or 20), remove screws (21).
- (11) If interlock mechanism removal is necessary, remove screw (22), lockout pin (23) and spring (24).
- (12) If cable (17) is to be removed from 2 inch valved unisex coupling (3) remove split ring (25) from 2 inch valved unisex coupling (3).

b. Inspection.

- (1) Inspect all metal parts for dings, gouges, abrasions etc. On all parts except the ball (9), use 320 grit paper to smooth and remove sharp edges. If ball (9) is damaged (scratched, gouged, etc.) it should be replaced.
- (2) Check the groove (round bottom) in the inlet for burrs on the corners. If groove is worn such that burrs exist, use 320 grit paper to smooth and remove sharp edges.
- (3) Inspect the small spring-loaded continuity ball (26) located in the face of the unit. Push the ball in and be sure that it pops back into place. If the ball does not pop back freely, electrical continuity is lost and static discharge is possible. Replace entire coupling if continuity ball does not pop back out.
- (4) Inspect screw (5) and handle (8) for damage. If either part is bent, replace it.

WARNING

Dry cleaning solvent, P-D-680, Type III, is potentially dangerous to personnel and property. Eye and skin protection is required. Avoid repeated and prolonged skin contact. Wash hands immediately after exposure. Do not use near open flame or excessive heat. Use only in areas with good ventilation.

Rubber gloves should be worn when handling fueling system components due to the toxic effects of some fuel additives and the dry cleaning solvent.

- (5) Make certain all components are clean and free from oil, grease, or dirt. Wash all parts with an approved dry cleaning solvent and dry thoroughly with a clean, lint-free cloth.

c. Assembly.

NOTE

During assembly, apply a light coat of petrolatum to O-rings before installation.

- (1) If interlock mechanism was removed, install lockout pin (23), spring (24) and screw (22) in 2 inch valved unisex coupling (3).

CAUTION

The lugs used in AAFARS unisex couplings are made of two different materials, stainless steel and aluminum. The two-inch suction hoses, two-inch wyes and all three-inch unisex couplings have stainless steel long and short lugs in the coupling body; three-inch dust caps have aluminum lugs. The discharge hoses, tees, crosses, manifolds and elbow unisex couplings have aluminum long and short lugs. Verify the correct lugs by using the parts listing in Appendix C of this manual.

- (2) If lugs (19 or 20) were removed, install lugs (19 or 20) and screws (21).
- (3) If removed, install bumper (18) such that tapered edge is facing toward the housing.
- (4) If dust cap cable (17) was cut to remove it from dust cap (2), thread cable through dust cap (2) forming a loop. Use a sleeve (27) and crimp loose end of cable to itself.
- (5) Install O-ring (16) and downstream seal (15) in 2 inch valved unisex coupling (3).
- (6) Install O-ring (14) on shaft (13) and install shaft from inside 2 inch valved unisex coupling (3).
- (7) Using screws (4) install handle assembly (1) on shaft (13). Rotate handle assembly to closed position.

NOTE

When installing stop pin, position the coupling body with the inlet toward you and rotated so hole for stop pin is at the bottom. Install the stop pin in the hole with the half shaft to your left. After stop pin installation, depress lock pin to ensure it can be fully depressed into the cavity.

- (8) Install O-ring (12) in groove on stop pin (10).
- (9) Position wave washer (11) on stop pin and install stop pin (10).

NOTE

When installing the ball in the valve body some movement of the ball and valve lever arm may be necessary align the stop pin, lever arm shaft and the ball.

- (10) Install ball (9) in 2 inch valved unisex coupling (3).
- (11) Install dust cap (2) on 2 inch valved unisex coupling (3).

5.7 REPAIR OF CONTROL BOX.

All control box components with the exception of the voltage regulator are mounted on the rear of the control panel. Access is most convenient if the control box is removed from the accessory module to a work bench. However, all control box components may be tested, removed and replaced with the box installed in the module, using the storage chest surface for a work space. Figure 5-9 is a front and rear view of control panel component location, applicable to all control panel repair procedures in this chapter. For clarity, wiring is not shown.

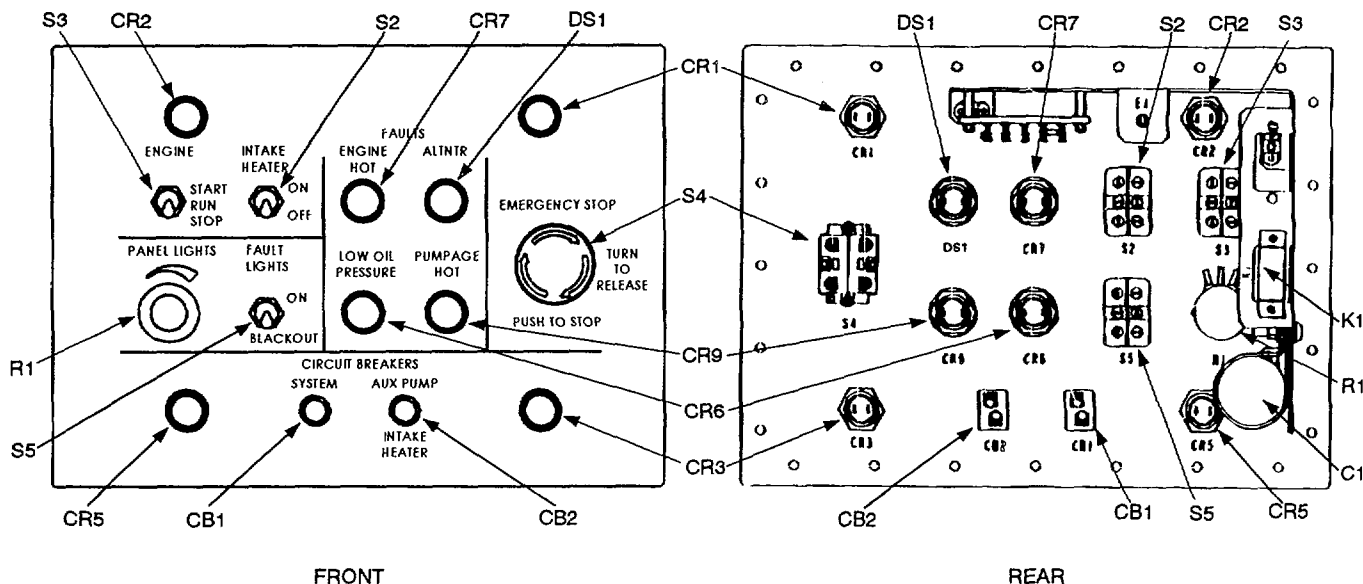

Figure 5-9. Control Panel Component Location

5.7.1 Replace Control Panel Lamp Assemblies/Panel Lights. (Refer to figure 5-10.)

This procedure applies to the four panel lamps (CR1, CR2, CR3 and CR5), and the four malfunction indicators (CR6, CR7, CR8 and CR9). Refer to figure 5-9 for component location.

This task consists of: a. Removal b. Installation

INITIAL SET-UP:**Tools:**

Screwdriver, Cross Tip, #2
(Appendix B, Section III, Item 3)
Combination Wrench, 1/2"
(Appendix B, Section III, Item 3)
Pliers, Long Nose, 7"
(Appendix B, Section III, Item 3)
Soldering Iron, Pencil Tip, 700°F
(Appendix B, Section III, Item 3)

Materials/Parts Required:

Solder (Appendix F, Section II, Item 6)
Flux, Soldering (Appendix F, Section II, Item 7)
Strap, Tiedown (Appendix F, Section II, Item 8)
Strap, Tiedown (Appendix F, Section II, Item 19)
Tags, Electrical (Appendix F, Section II, Item 16)

Equipment Condition:

Accessory module removed from system.
(para. 2.9)

- a. Remove Lamp Assembly/Panel Light.
 - (1) Remove the twenty-four screws (1) and flat washers (2) that secure the control panel (3) to the control box.
 - (2) Lift the control panel (3) from the control box and set on edge convenient to lamp assembly to be replaced.
 - (3) Remove tie wraps from lamp assembly wires as required.
 - (4) Tag leads near base of lamp assembly (4) for installation.
 - (5) Remove indicator light lens (5)/miniature indicator cap (6) and lamp (7 or 8).
 - (6) Desolder leads from indicator light housing (4) terminals.
 - (7) Remove nut (9) and lock washer (10) that secure indicator light housing to control panel
- b. Install Lamp Assembly/Panel Light.
 - (1) Install indicator light housing (4) on control panel (3) with nut (9) and lock washer (10).
 - (2) Solder leads to indicator light housing (4) terminals as tagged. Remove tags.
 - (3) Install tie wraps on wiring harness as required.

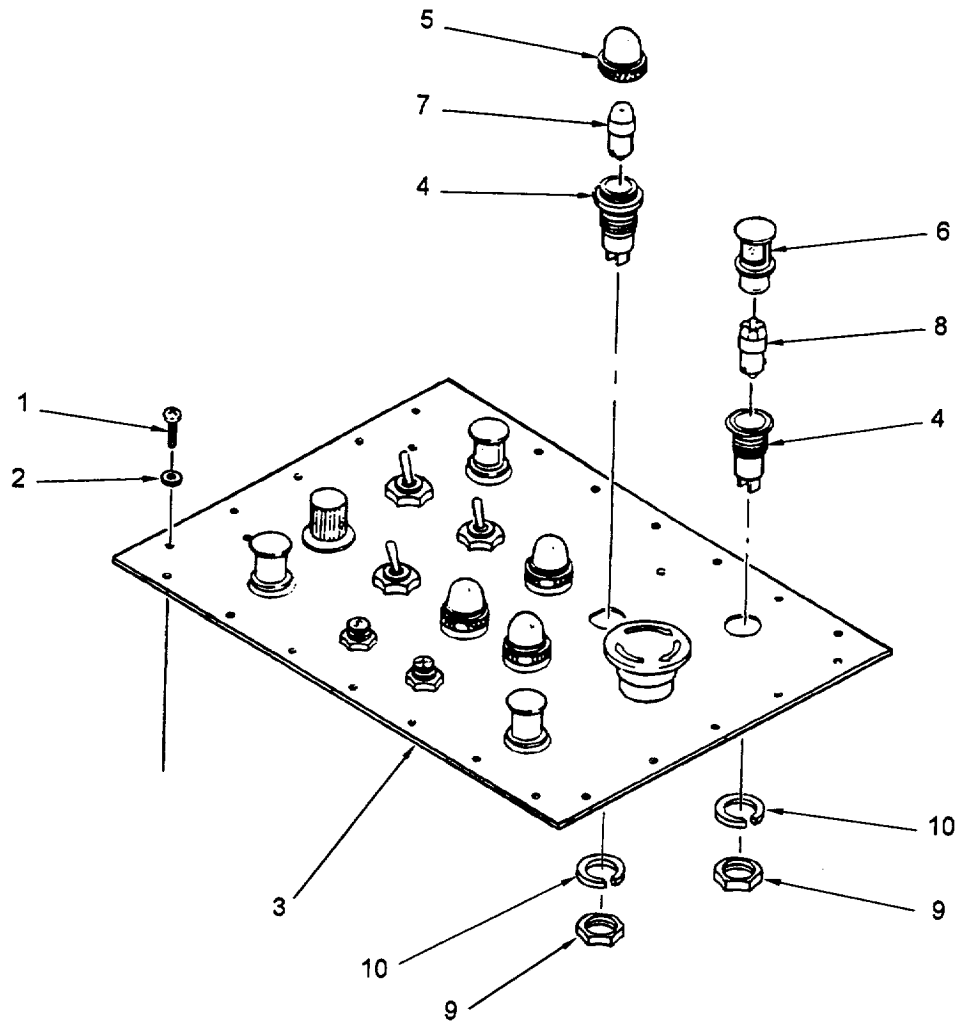

Figure 5-10. Control Panel Lamp/Panel Light Assembly Replacement

- (4) Install lamp (7 or 8) and indicator light lens (5)/miniature indicator cap (6).
- (5) Install control panel (3) in control box with twenty-four screws (1) and flat washers (2).

5.7.2 Replace Panel Lights Dimmer Potentiometer R1. (Refer to figure 5-11.)

This task consists of: a. Removal b. Installation

INITIAL SET-UP:

Tools:

Screwdriver, Cross Tip, #2
(Appendix B, Section III, Item 3)
Combination Wrench, 1/2"
(Appendix B, Section III, Item 3)
Pliers, Long Nose, 7"
(Appendix B, Section III, Item 3)
Key, Socket Head Screw, .050"
(Appendix B, Section III, Item 3)
Soldering Iron, Pencil Tip, 700°F
(Appendix B, Section III, Item 3)

Materials/Parts Required:

Solder (Appendix F, Section II, Item 6)
Flux, Soldering (Appendix F, Section II, Item 7)
Strap, Tiedown (Appendix F, Section II, Item 8)
Strap, Tiedown (Appendix F, Section II, Item 19)
Tags, Electrical (Appendix F, Section II, Item 16)

General Safety Requirements:

Equipment Condition:

Accessory module removed from system.
(para. 2.9)

a. Removal.

- (1) Remove the twenty-four screws (1) and flat washers (2) that secure the control panel (3) to the control box.
- (2) Lift the control panel (3) from the control box and set on edge convenient to potentiometer R1.
- (3) Remove tiedown straps as required.

NOTE

Access to potentiometer R1 is partially blocked by an L-shaped bracket. To provide easier access and prevent damage to other components, separate the bracket from the control panel and moved aside. The wiring harnesses have enough slack to allow this.

- (4) Remove the three screws (4) and flat washers (5) that secure the "L' bracket (6) to the panel. Move the bracket aside for access to potentiometer R1.
- (5) Tag leads (7) near terminals of potentiometer R1 (8) for installation on replacement potentiometer.
- (6) Desolder leads (7) from potentiometer terminals.
- (7) Loosen two set screws (9) and remove control knob (10).
- (8) Remove nut (11) and lock washer (12) that secure potentiometer R1 (8) to control panel (3).

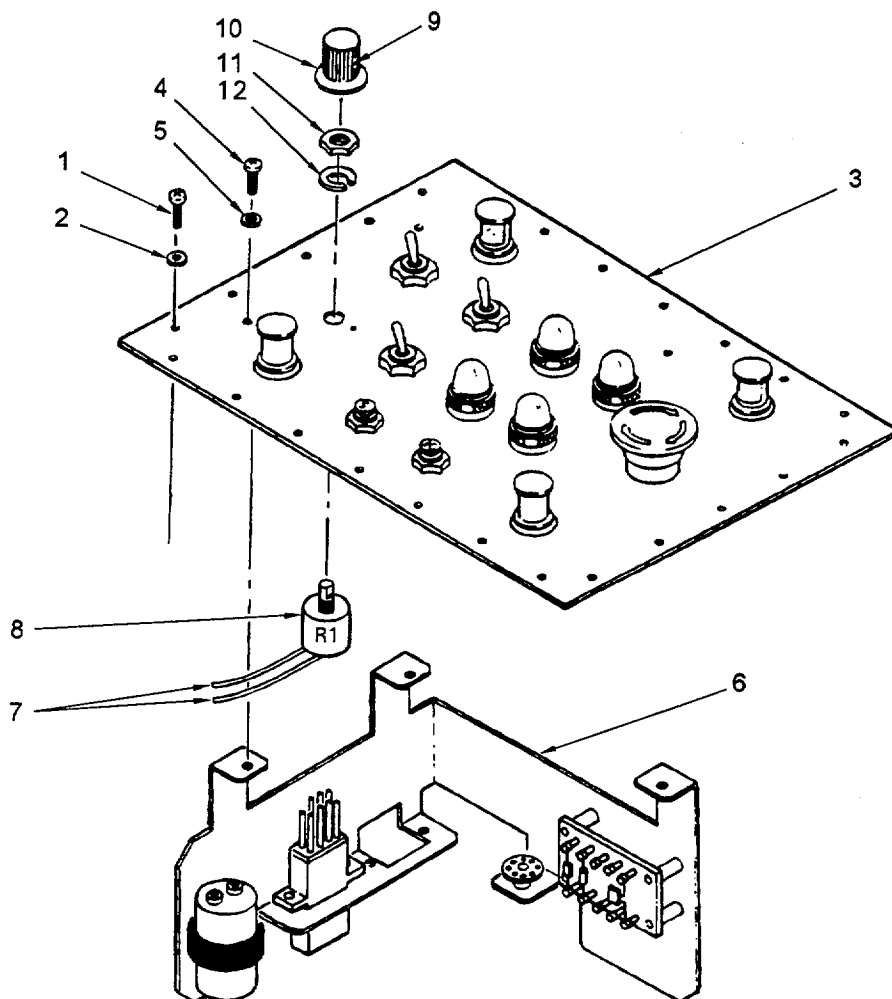

Figure 5-11. Panel Lights Dimmer Potentiometer R1 Replacement

b. Installation.

- (1) Install potentiometer (8) on control panel (3) with nut (11) and lock washer (12).
- (2) Install knob (10) on potentiometer shaft and tighten two set screws (9).
- (3) Solder leads (7) to potentiometer terminals as tagged. Remove tags.
- (4) Install tiedown straps on wiring harness as required.
- (5) Install the "L" bracket (6) on the control panel (3) with three screws (4) and flat washers (5).
- (6) Install control panel (3) in control box with twenty-four screws (1) and flat washers (2).

5.7.3 Repair Emergency Stop Switch (S4). (Refer to figure 5-12.)

The emergency stop switch is a four part component, as shown: a spring loaded operator (red button), a mounting base and two contact blocks. When mounted on the control panel, these parts form a double pole, normally closed switch. Depressing the operator (red button) opens both switch sections. The physical configuration of the operator (red button) and the mounting base causes the operator (red button) to latch when depressed, holding the parallel switch sections in the open position. Rotating the operator in the direction of the arrows releases it from the latched position and allows the switches in the contact blocks to close.

The contact blocks are the most likely electrical failure, but the operator (red button) is subject to physical abuse and also may have to be replaced. The four parts can be replaced individually.

This task consists of: a. Removal b. Installation

INITIAL SET-UP:

Tools:

- Screwdriver, Cross Tip, #2
(Appendix B, Section III, Item 3)
- Screwdriver, Flat Blade, 3/16" x 4"
(Appendix B, Section III, Item 3)
- Soldering Iron, Pencil Tip, 700°F
(Appendix B, Section III, Item 3)

Materials/Parts Required:

- Solder (Appendix F, Section II, Item 6)
- Flux, Soldering (Appendix F, Section II, Item 7)
- Strap, Tiedown (Appendix F, Section II, Item 8)
- Strap, Tiedown (Appendix F, Section II, Item 19)
- Tags, Electrical (Appendix F, Section II, Item 16)

General Safety Requirements:

Equipment Condition:

- Accessory module removed from system.
(para. 2.9)

a. Removal.

- (1) Remove the twenty-four screws (1) and flat washers (2) that secure the control panel (3) to the control box.
- (2) Lift the control panel (3) from the control box and set on edge convenient to emergency stop switch S4.
- (3) Tag the wires associated with the contact block(s) (4) to be removed.
- (4) On the contact block (4), loosen the wire terminal retaining screws (5) and pull the terminals (6) from the contact block.
- (5) Desolder terminals (6) from wires.
- (6) Loosen the contact block (4) retaining screw (7) and remove the contact block (4).
- (7) Loosen the two compression screws (8) on the mounting base (9); rotate and remove the mounting base from the operator (red button) (10).
- (8) Lift operator (red button) (10) clear of the control panel (3).

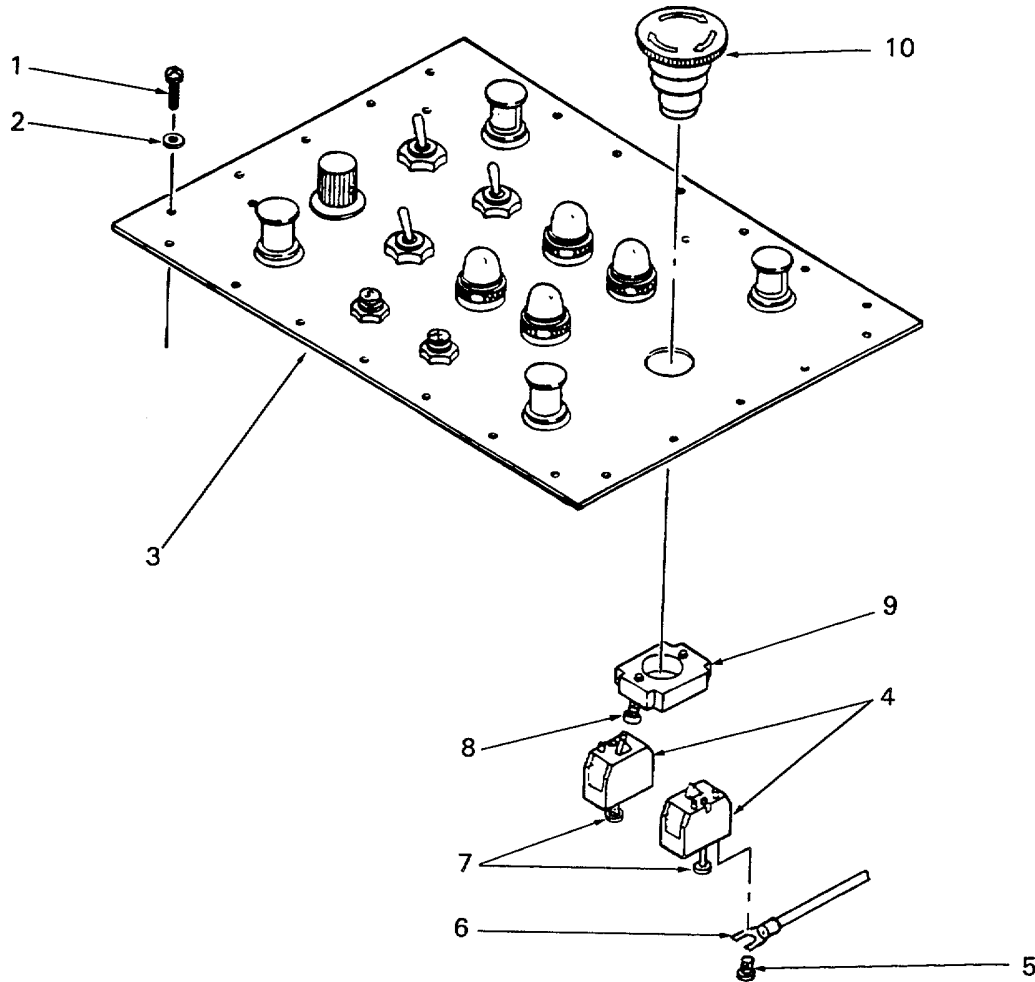

Figure 5-12. Emergency Stop Switch Replacement

c. Installation.

- (1) Insert operator (red button) (10) through control panel (3), slip mounting base (9) over operator (red button) (10) and hold in place while tightening the two compression screws (8). Test operation for assurance of proper mounting and mechanical action.

NOTE

Contact blocks are keyed so they will only fit one way.

- (2) Install contact blocks (4) on mounting base (9).
- (3) Remove terminals (6) from contact block (4). Solder wires as tagged to terminals (6).
- (4) Install terminals (6) onto contact block with wire terminal retaining screws (5). Remove tags.
- (5) Install two contact blocks (4) with two contact block retaining screws (7) onto mounting base (9).
- (6) Install control panel (3) in control box with twenty-four screws (1) and flat washers (2).

5.7.4 Replace Control Panel Toggle Switches. (Refer to figure 5-13.)

This procedure applies to replacement of the INTAKE HEATER, ENGINE START/RUN/STOP and FAULT LIGHTS ON/BLACKOUT toggle switches (S2, S3 and S5) on the control panel. Although not interchangeable, the switches are physically similar.

This task consists of: a. Removal b. Installation

INITIAL SET-UP:

Tools:

Screwdriver, Cross Tip, #2
(Appendix B, Section III, Item 3)
Screwdriver, Flat Blade, 1/4" x 4"
(Appendix B, Section III, Item 3)
Combination Wrench, 9/16"
(Appendix B, Section III, Item 3)

Materials/Parts Required:

Tags, Electrical (Appendix F, Section II, Item 16)

Equipment Condition:

Accessory module removed from system.
(para. 2.9)

a. Removal.

- (1) Remove the twenty-four screws (1) and flat washers (2) that secure the control panel (3) to the control box.
- (2) Lift the control panel (3) from the control box and set on edge convenient to toggle switch to be replaced.
- (3) Tag all leads attached to the toggle switch (4).
- (4) Remove all leads from the toggle switch.

NOTE

Note mounting orientation of switch, using one of the switch terminal numbers as a reference, to avoid installing the replacement switch upside down.

- (5) Remove nut (5), washer (6) and toggle switch (4) from control panel.

b. Installation.

- (1) Insert toggle switch (4) in control panel (3) in the orientation noted during removal. Adjust rear nut (7) as required to obtain a protrusion that just allows complete threading of front nut (5) and washer (6). Tighten front nut and washer.
- (2) Install leads to switch terminals as tagged. Remove tags.
- (3) Install control panel (3) in control box with twenty-four screws (1) and flat washers (2).

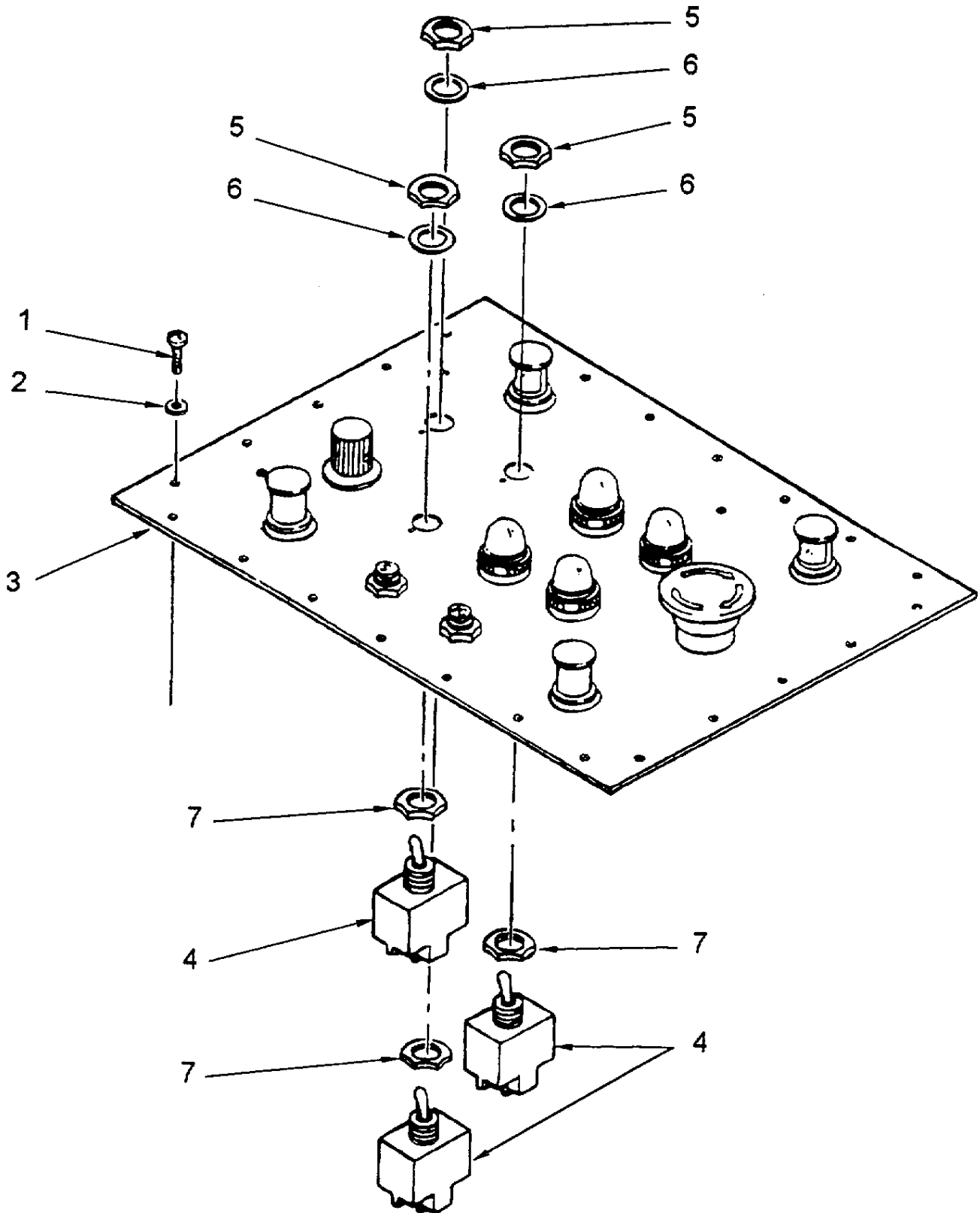

Figure 5-13. Control Panel Toggle Switch Replacement

5.7.5 Replace Capacitor C1. (Refer to figure 5-14.)

This task consists of: a. Removal b. Installation

INITIAL SET-UP:

Tools:

Screwdriver, Cross Tip, #2
(Appendix B, Section III, Item 3)
Wrench, Socket, 1/4", 1/4" square drive
(Appendix B, Section III, Item 3)
Handle, Socket Wrench (Nutdriver Type)
(Appendix B, Section III, Item 3)

Materials/Parts Required:

Tags, Electrical (Appendix F, Section II, Item 16)

General Safety Requirements:

Equipment Condition:

Accessory module removed from system.
(para. 2.9)

a. Removal.

- (1) Remove the twenty-four screws (1) and flat washers (2) that secure the control panel (3) to the control box.
- (2) Lift the control panel (3) from the control box and set on edge convenient to capacitor C1 (4).
- (3) Remove screw (5), washers (6), and nut (7) attaching capacitor C1 (4) to the "L" bracket (8). Retain mounting hardware.
- (4) Remove clamp (9) from capacitor C1 (4).
- (5) Tag and remove leads (10) from capacitor C1 (4).

b. Installation.

- (1) Install leads on capacitor C1 (4) as tagged. Remove tags.
- (2) Position clamp (9) around center of capacitor C1 (4).
- (3) Attach capacitor C1 (4) to "L" bracket (8) using screw (5), washers (6) and nut (7).
- (4) Install control panel (3) in control box using twenty-four screws (1) and flat washers (2).

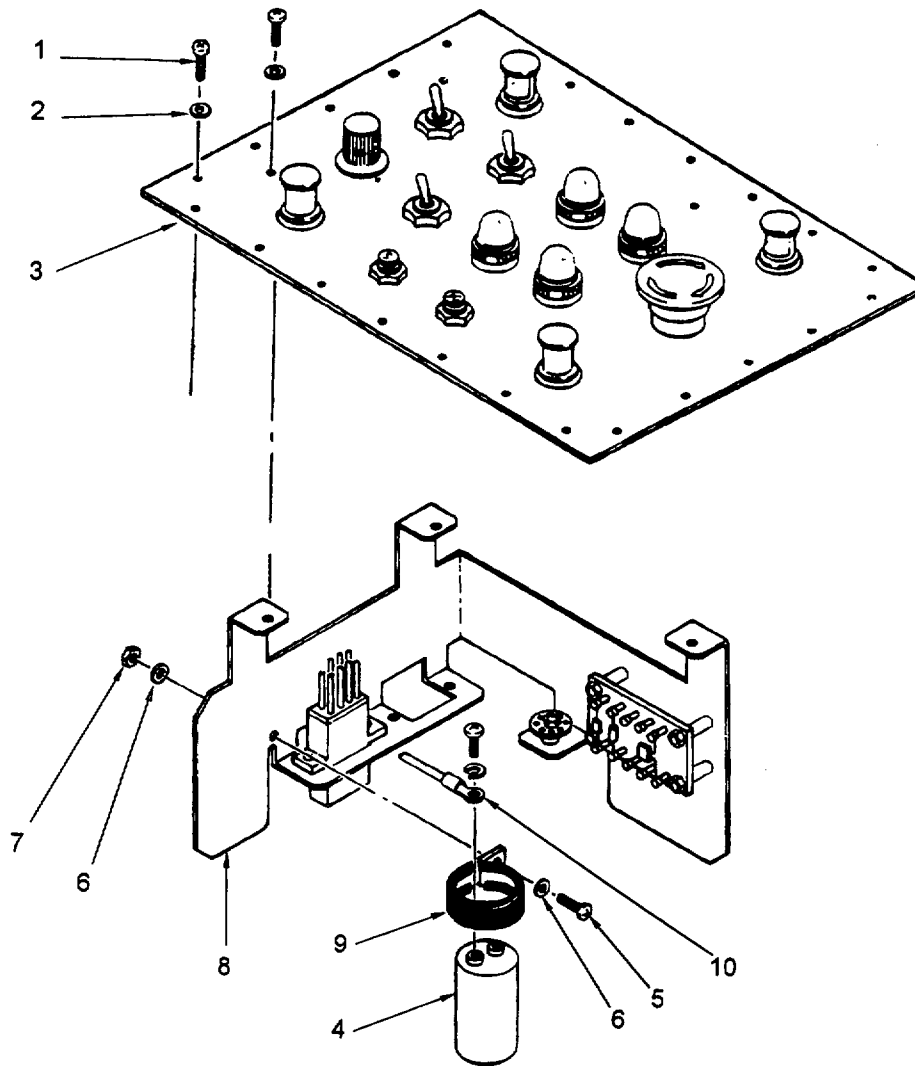

Figure 5-14. Capacitor C1 Replacement

5.7.6 Replace Circuit Breakers CB1 or CB2. (Refer to figure 5-15.)

This task consists of: a. Removal b. Installation

INITIAL SET-UP:**Tools:**

Screwdriver, Cross Tip, #2
(Appendix B, Section III, Item 3)
Combination Wrench, 1/2"
(Appendix B, Section III, Item 3)

Materials/Parts Required:

Tags, Electrical (Appendix F, Section II, Item 16)

General Safety Requirements:

None

Equipment Condition:

Accessory module removed from system.
(para. 2.9)

a. Removal.

- (1) Remove the twenty-four screws (1) and flat washers (2) that secure the control panel (3) to the control box.
- (2) Lift the control panel (3) from the control box and set on edge convenient to circuit breaker (5) to be replaced.
- (3) Tag and remove the leads (4) attached to the circuit breaker (5).
- (4) Remove the nut (6) and lock washer (7) that secure the circuit breaker (5) to the panel. Remove the circuit breaker (5).

b. Installation.

- (1) Install circuit breaker (5) on control panel (3) with key fully engaged. Install and tighten nut (6) and washer (7).
- (2) Install leads on circuit breaker (5) as tagged. Remove tags.
- (3) Install control panel (3) in control box with twenty-four screws (1) and flat washers (2).

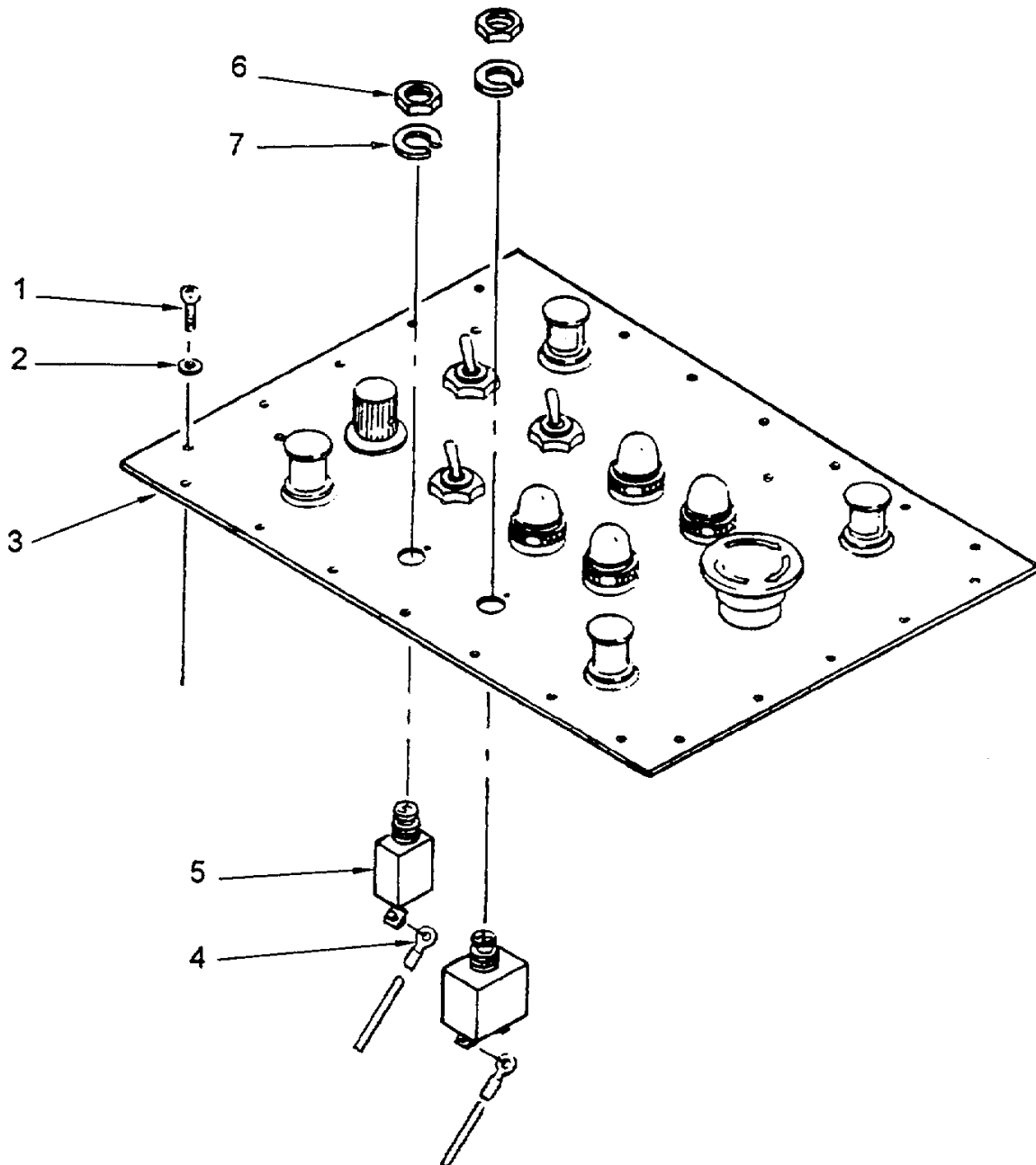

Figure 5-15. Circuit Breaker Replacement

5.7.7 Replace Relay K1. (Refer to figure 5-16.)

This task consists of: a. Removal b. Installation

INITIAL SET-UP:

Tools:

Screwdriver, Cross Tip, #2
(Appendix B, Section III, Item 3)
Combination Wrench, 1/4"
(Appendix B, Section III, Item 3)
Combination Wrench, 3/16"
(Appendix B, Section III, Item 3)

Materials/Parts Required:

Nut, Self-Locking (Appendix I, Item 43)

Equipment Condition:

Accessory module removed from system.
(para. 2.9)

a. Removal.

- (1) Remove twenty-four screws (1) and flat washers (2) that secure the control panel (3) to the control box.
- (2) Lift the control panel (3) from the control box and set on edge convenient to relay K1 (4).
- (3) Remove the two self-locking nuts (5) and remove the K1 relay (4). Discard the self-locking nuts (5).

b. Installation.

- (1) Install relay K1 (4) in socket (6) with two self-locking nuts (5). (Relay is keyed to fit one way only.)
- (2) Install control panel (3) in control box with twenty-four screws (1) and flat washers (2).

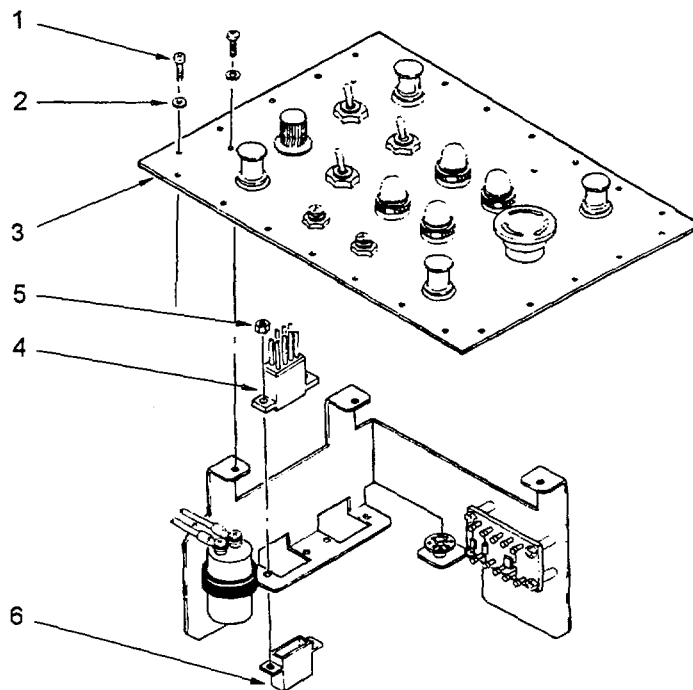

Figure 5-16. Relay K1 Replacement

5.7.8 Replace Voltage Regulator. (Refer to figure 5-17.)

This task consists of: a. Removal b. Installation

INITIAL SET-UP:**Tools:**

Screwdriver, Cross Tip, #2
(Appendix B, Section III, Item 3)
Key, Socket Head Screw, 3/16"
(Appendix B, Section III, Item 3)

Materials/Parts Required:

Tags, Electrical (Appendix F, Section II, Item 16)

Equipment Condition:

Accessory module removed from system.
(para. 2.9)

a. Removal.

- (1) Remove the twenty-four screws (1) and flat washers (2) that secure the control panel (3) to the control box (4).
- (2) Lift the control panel (3) from the control box and set on edge clear of work area.
- (3) Tag all voltage regulator leads and remove from voltage regulator (5).
- (4) Remove the two socket head screws (6), flat washers (7) and ground wire (8). Remove the voltage regulator (5).

b. Installation.

- (1) Install voltage regulator (5) and ground wire (8) in control box with two socket head screws (6) and flat washers (7).
- (2) Install leads on voltage regulator (5) as tagged. Remove tags.
- (3) Install control panel (3) in control box with twenty-four screws (1) and flat washers (2).

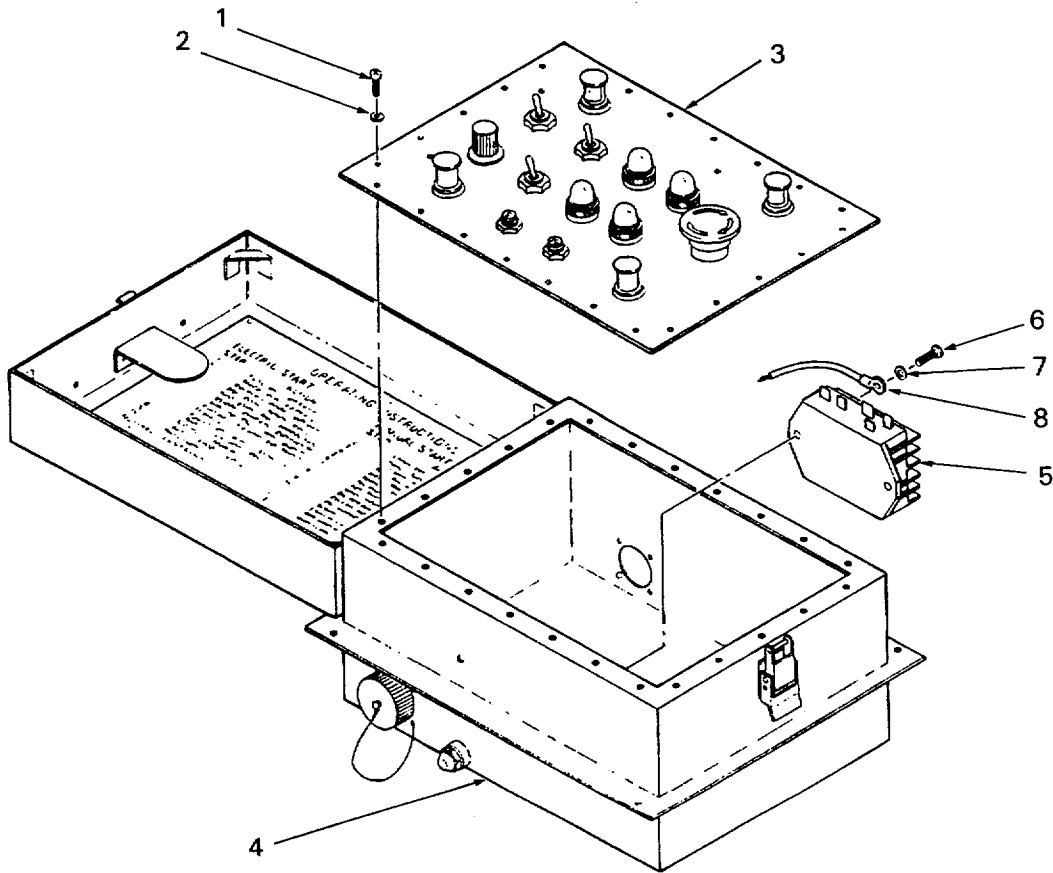

Figure 5-17. Voltage Regulator Replacement

CHAPTER 6

GENERAL SUPPORT MAINTENANCE PROCEDURES

6.1	General.....	6-2
6.2	Remove Engine From Engine Module	6-2
6.3	Engine Disassembly.....	6-5
6.3.1	Remove and Clean Oil Pan	6-5
6.3.2	Remove Engine Shroud, Cylinder Casing and Gates.....	6-7
6.3.3	Remove Flywheel/Alternator Rotor and Stator.....	6-10
6.3.4	Remove Fuel Flow Solenoid.....	6-11
6.3.5	Remove Starter Motor	6-12
6.3.6	Remove Valve Covers.....	6-12
6.3.7	Remove Decompression Lever	6-13
6.3.8	Remove Injection Pump	6-14
6.3.9	Remove Fuel Pump	6-17
6.3.10	Remove Fuel Injectors	6-17
6.3.11	Remove Cylinder Head and Cylinder.....	6-19
6.3.12	Remove Piston and Rings	6-22
6.3.13	Remove and Check Oil Pump.....	6-23
6.3.14	Remove Timing (Pulley End) Cover.....	6-25
6.3.15	Remove Governor Assembly and Speed Control	6-27
6.3.16	Remove Camshaft and Valve Tappets	6-29
6.3.17	Remove Rear Crankshaft Support.....	6-30
6.3.18	Remove Crankshaft Gear, Crankshaft and Bearings	6-31
6.3.19	Remove Oil Pressure Relief Valve	6-33
6.3.20	Disassemble Cylinder Head.....	6-34
6.4	Assemble Engine.....	6-36
6.4.1	Install Crankshaft	6-36
6.4.2	Install Rear Crankshaft Support	6-39
6.4.3	Install Oil Pressure Relief Valve	6-40
6.4.4	Install Piston Rings	6-42
6.4.5	Check Cylinder	6-44
6.4.6	Install Piston Assembly and Cylinder.....	6-46
6.4.7	Install Camshaft	6-48
6.4.8	Install Governor Assembly and Speed Control	6-50
6.4.9	Install Oil Pump.....	6-53
6.4.10	Install Timing (Pulley End) Cover	6-55
6.4.11	Check Piston Protrusion	6-55
6.4.12	Assemble Cylinder Head.....	6-57
6.4.13	Install Cylinder Head	6-60
6.4.14	Install Flywheel/Alternator Rotor and Stator	6-65
6.4.15	Install Intake Manifold.....	6-67
6.4.16	Install Exhaust Manifold.....	6-67
6.4.17	Adjust Valves.....	6-67
6.4.18	Install Injection Pump.....	6-67
6.4.19	Clean Fuel Injector Nozzle.....	6-69
6.4.20	Install Fuel Injector.....	6-70
6.4.21	Install Fuel Pump	6-72
6.4.22	Install Valve Cover	6-73
6.4.23	Install Decompression Lever.....	6-74
6.4.24	Install Fuel Flow Solenoid.....	6-75
6.4.25	Install Oil Pan and Oil Filter	6-77

6.4.26 Install Starter..... 6-79
 6.4.27 Install Gates, Shroud and Oil Cooler 6-79
 6.4.28 Install Flexible Coupling Adapter and Guard to Engine 6-82
 6.4.29 Install Engine in Engine Module..... 6-83
 6.4.30 Adjust Fuel Injection Pump..... 6-85
 6.4.31 Install Casing..... 6-88

6.1 GENERAL.

The engine maintenance procedures provided in this chapter are presented in disassembly-reassembly order. Performance of all procedures in sequence will accomplish a total engine overhaul. Maintenance functions not comprising an overhaul may be performed by selecting the appropriate disassembly procedures and corresponding assembly procedures.

6.2 REMOVE ENGINE FROM ENGINE MODULE. (Refer to figure 6-1.)

This task consists of: a. Removal

INITIAL SET-UP:

Tools:

- Plier, Diagonal Cutting
(Appendix B, Section III, Item 3)
- Wrench, Combination, 7/16"
(Appendix B, Section III, Item 3)
- Screwdriver, Cross-Tip, Size 2
(Appendix B, Section III, Item 3)
- Screwdriver, Flat Blade, 1/4" x 4"
(Appendix B, Section III, Item 3)
- Drain Pan
(Appendix B, Section III, Item 3)
- Wrench, Combination, 6 mm
(Appendix B, Section III, Item 3)
- Key, Socket Head Screw, 6 mm
(Appendix B, Section III, Item 3)
- Key, Socket Head Screw, 3 mm
(Appendix B, Section III, Item 3)
- Wrench, Combination, 13 mm
(Appendix B, Section III, Item 3)
- Wrench, Combination, 17 mm
(Appendix B, Section III, Item 3)

General Safety Requirements:

WARNING

- **Fuels are toxic and flammable. Do not get on person or clothing. Work in well ventilated area. Do not smoke. Ensure equipment is well grounded.**
- **Always use four personnel to move or relocate the engine module. Use proper physical lifting procedures or use a suitable lifting device or dolly. Wear safety shoes, gloves and other suitable protective clothing.**

Materials/Parts Required:

- Tags, Electrical (Appendix F, Section II, Item 16)
- Washer, Lock (Appendix I, Item 69)

Equipment Condition:

- Engine module removed from pump-engine module (para. 2.4)
-

- a. Cut and remove tiedown straps (1) from engine fuel supply line and engine fuel return line.
- b. Remove cable loop (2) from PTO end of engine.
- c. Remove screws (3) and nuts (4) from decompression lever (5). Remove lever (5).
- d. Remove cable clamp (6) from fuel flow solenoid wire cable at black start control knob (7).

- e. Remove two socket head cap screws (8) and washers (9) securing cylinder casing (10) to cylinder heads. Remove casing (10).
- f. Place drain pan under fuel pump (11).
- g. Remove fuel supply line (12) from fuel pump (11).
- h. Remove fuel return line from fuel fitting (13) on #2 fuel injection pump.
- i. Cut and remove tiedown straps from electrical wiring harness.
- j. Tag and disconnect fuel shutoff solenoid electrical wires (14) at in-line connectors in wiring harness.
- k. Tag and disconnect engine temperature sensor electrical wire (15) at in-line connector in wiring harness.
- l. At intake manifold, lift boots (16) from air intake heaters.
- m. Tag and remove electrical wires (17) from air intake heaters.
- n. Tag and remove electrical wire (18) from oil pressure switch.
- o. Tag and disconnect alternator wires (19) at in-line connector in wiring harness.
- p. Tag and remove small electrical wire (20) from starter solenoid.
- q. Tag and remove cables and wires (21) from starter solenoid.
- r. At lower starter mounting bolt (22), tag and remove all electrical wires.
- s. Unlatch and lower pulley guard (23).

WARNING

Serious injury could occur if heavy equipment is moved/lifted without sufficient personnel to do the job. Always use four personnel to move or relocate the engine module. Use proper physical lifting procedures or use a suitable lifting device or dolly. Wear safety shoes, gloves and other suitable protective clothing.

NOTE

The engine is secured to the module frame by ten hex head bolts, five on each side of the engine. Before removing these bolts, the engine must be supported to take the weight off the mounting bolts. A hoist may be attached to the engine lifting eye or the engine may be blocked from underneath if a hoist is not available.

- t. Attach hoist to engine lifting eye (24) and take all slack out of hoist cable/chain, or block engine from underneath to take engine weight off mounting bolts.
- u. Remove the ten mounting bolts (25), lock washers and flat washers and hoist the engine from the module. Discard the lock washers.

- v. Remove the splined flexible coupling adapter (26) from PTO end of engine crankshaft.

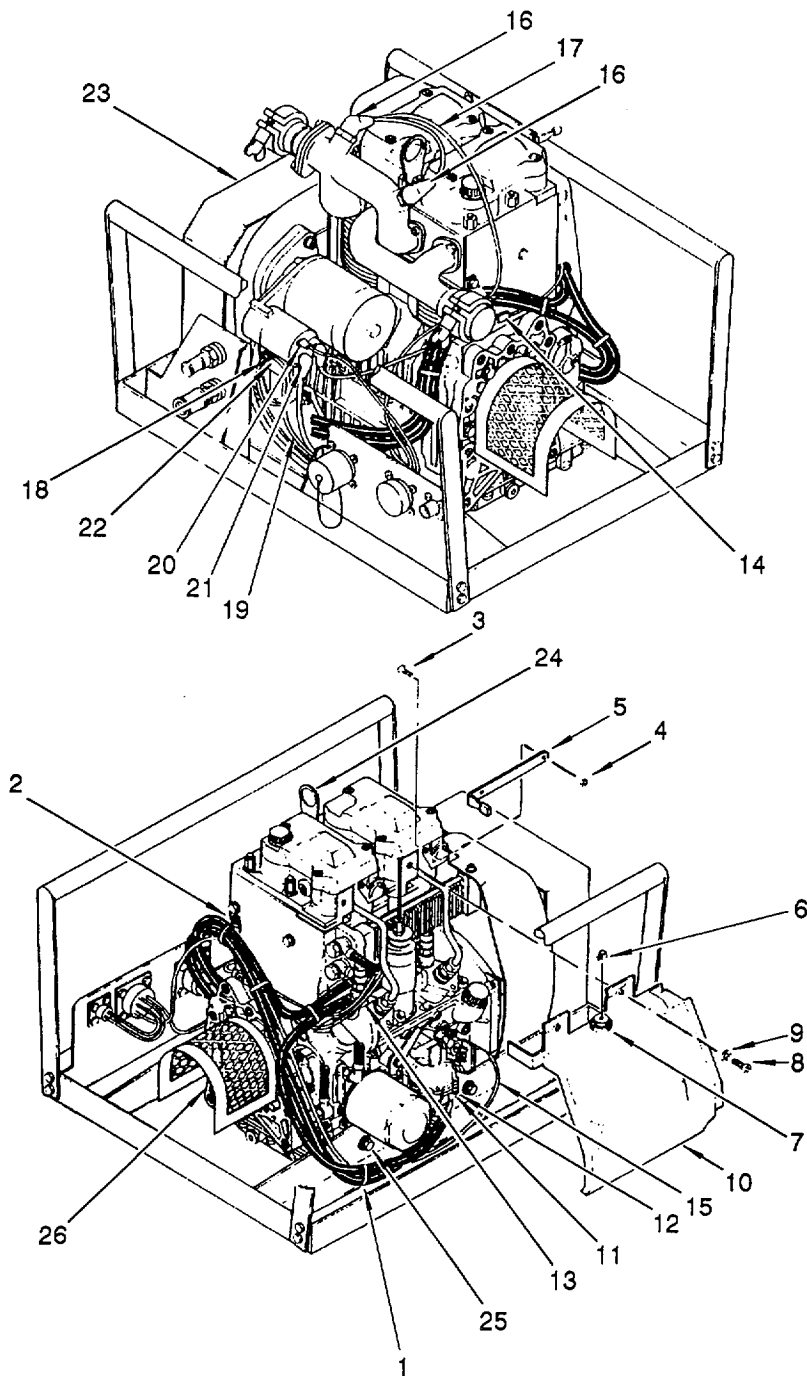

Figure 6-1. Removal of Engine from Engine-Module

6.3 ENGINE DISASSEMBLY.

6.3.1 Remove and Clean Oil Pan. (Refer to figure 6-2.)

This task consists of: a. Removal

INITIAL SET-UP:

Tools:

Key, Socket Head Screw, 6 mm
 (Appendix B, Section III, Item 3)
 Key, Socket Head Screw, 5 mm
 (Appendix B, Section III, Item 3)
 Socket, 10 mm
 (Appendix B, Section III, Item 3)
 Socket, 13 mm, deep well
 (Appendix B, Section III, Item 3)
 Ratchet wrench, 3/8" drive
 (Appendix B, Section III, Item 3)

Materials/Parts Required:

None

Equipment Condition:

Engine removed from engine module
 (para. 6.2)
 Engine oil drained
 (Table 4-1)

- a. Remove dipstick (1).
- b. Place engine on pulley end.
- c. Rotate engine to a position to allow for oil pan removal.
- d. Remove the fifteen cap screws (2) and flat washers (3) attaching oil pan (4) to crankcase (5). Remove oil pan.
- e. Remove gasket (6) and clean gasket residue from crankcase and oil pan.
- f. Remove cap screw (7), washer (8) and net (9). Inspect and clean net and oil pan. Reinstall net.

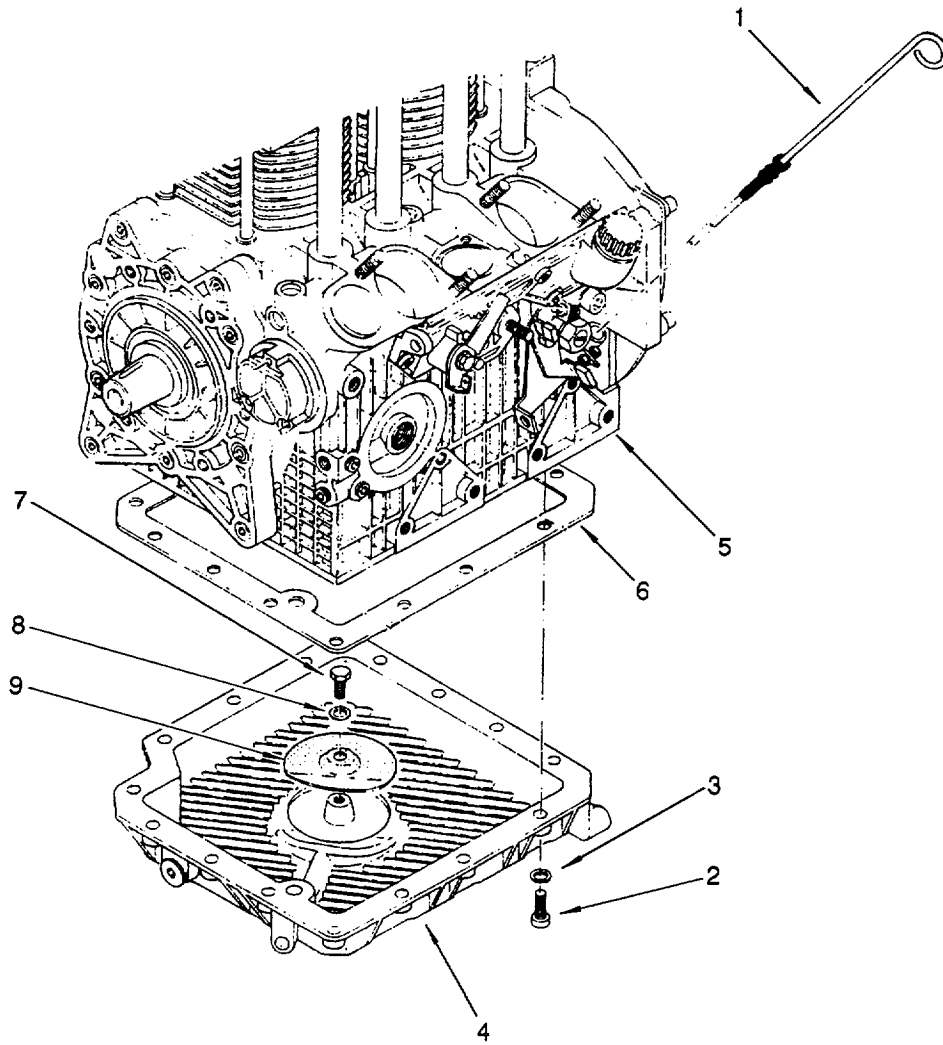

Figure 6-2. Engine Oil Pan Removal

6.3.2 Remove Engine Shroud, Cylinder Casing and Gates. (Refer to figure 6-3.)

This task consists of: a. Removal

INITIAL SET-UP:**Tools:**

Combination Wrench, 6 mm
 (Appendix B, Section III, Item 3)
 Key, Socket Head Screw, 5 mm
 (Appendix B, Section III, Item 3)
 Combination Wrench, 19 mm
 (Appendix B, Section III, Item 3)
 Combination Wrench, 13 mm
 (Appendix B, Section III, Item 3)
 Handle, Socket Wrench, Ratchet, 1/4" Drive
 (Appendix B, Section III, Item 3)
 Socket, Deep Well, 7 mm, 1/4" Drive
 (Appendix B, Section III, Item 3)
 Extension, Socket, 3 in., 1/4" Drive
 (Appendix B, Section III, Item 3)
 Handle, Socket Wrench, Ratchet, 1/2" Drive
 (Appendix B, Section III, Item 3)
 Socket, Deep Well, 13 mm, 1/2" Drive
 (Appendix B, Section III, Item 3)
 Extension, Socket, 3 in., 1/2" Drive
 (Appendix B, Section III, Item 3)
 Screwdriver, Cross Tip, #2
 (Appendix B, Section III, Item 3)
 Combination Wrench, 1/4 in.
 (Appendix B, Section III, Item 3)

General Safety Requirements:

Fuels are toxic and flammable. Do not get on person or clothing. Work in well ventilated area. Do not smoke. Ensure equipment is well grounded.

Materials/Parts Required:

None

Equipment Condition:

Engine removed from engine module
 (para. 6.2)
 Engine oil drained
 (Table 4-1)

- a. Remove cable clamp (1) from fuel flow solenoid cable at black start control knob (2).
- b. Remove two socket head cap screws (3) and washers (4). Remove cylinder casing (5).
- c. Remove the socket head cap screw (6), lock washer (7) and flat washer (8) attaching oil cooler (9) to shroud (10). Discard lock washer (7).
- d. Remove the two cross tip screws (11) at top/intake side of shroud (10).
- e. Remove four socket head cap screws (12) and washers (13) attaching shroud (10). Remove shroud (10).
- f. Remove two cross tip screws (14) attaching gate (15) and bracket (16).

WARNING

Fuel vapors are flammable. Residual fuel may be present in the fuel line. Catch the fuel in a drain pan. Immediately wipe up any fuel that may spill.

- g. Remove union bolt (17), union (18) and washers (19). Discard washers (19).

NOTE**Support oil cooler during removal of oil lines.**

- h. Remove union bolt (20), washer (21) union (22), and spacer (23) connecting the oil supply line to the oil cooler (9). Discard washer (21).
- i. Remove union bolt (24), washer (25), union (26), spacer (27) and connecting the oil return line to the oil cooler (9). Discard washer (25).
- j. Remove the socket head cap screw (28) and washer (29) securing the oil cooler to gate (30). Remove oil cooler (9).
- k. Remove oil supply line (31) at the crankcase.
- i. Remove oil return line (32) at the crankcase.
- m. Remove fuel shutoff solenoid wire from clip (33).
- n. Remove the two bolts (34) and washers (35) attaching gate (30). Remove gate, snaking fuel feed line from the fuel feed pump through the gate.
- o. Remove nut (36) and washer (37) attaching gate (38) to tie rod (39).
- p. Remove tie rod (39) from between cylinders.
- q. Remove nut (40) and washer (41) attaching lifting eye (42) to cylinder head.

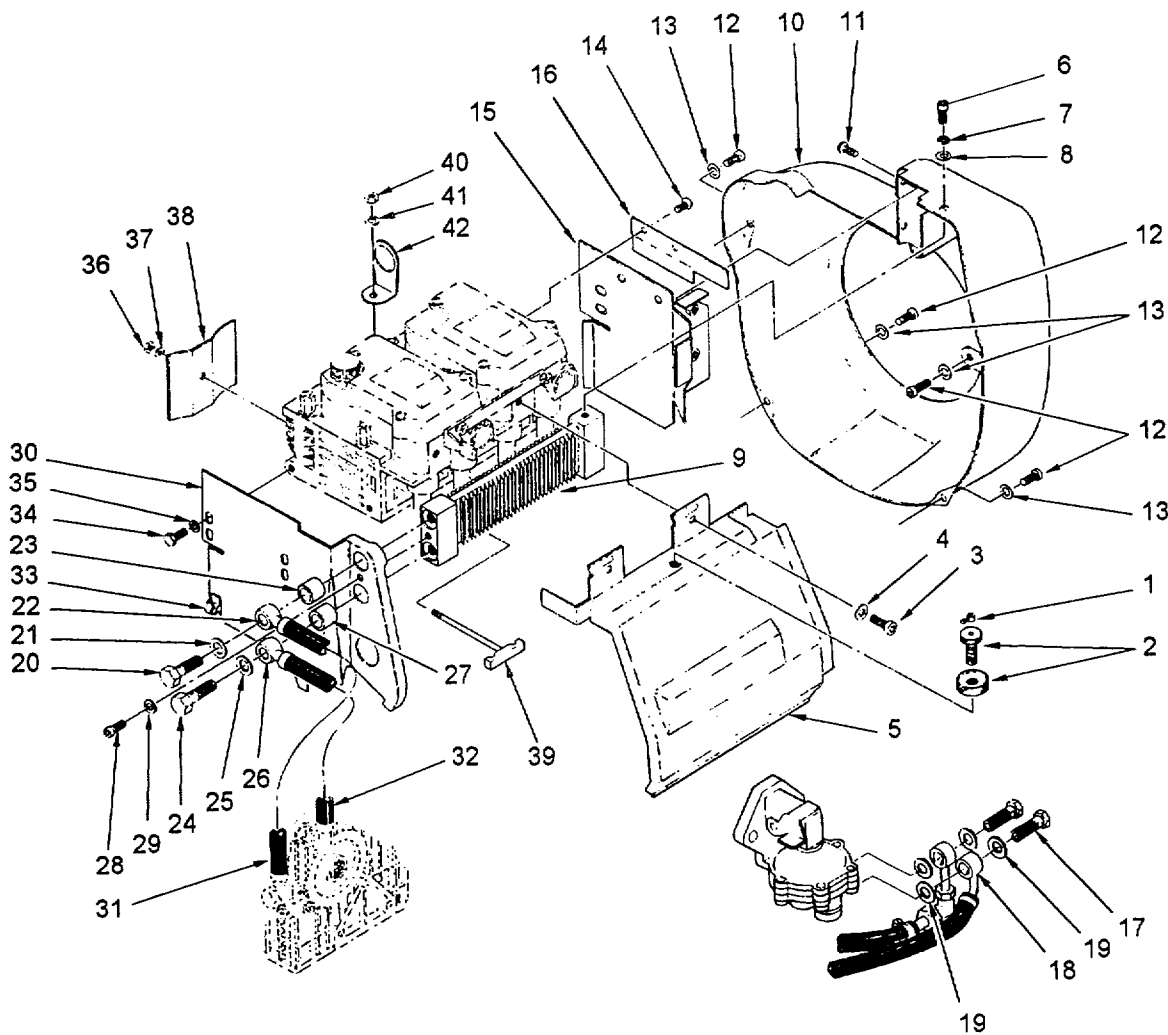

Figure 6-3. Shroud, Cylinder Casing and Gates Removal

6.3.3 Remove Flywheel/Alternator Rotor and Stator. (Refer to figure 6-4.)

This task consists of: a. Removal

INITIAL SET-UP:**Tools:**

Socket, 1-5/8 ", 1/2" Drive
 (Appendix B, Section III, Item 3)
 Flywheel Puller
 (Appendix B, Section III, Item 4)
 Key, Socket Head Screw, 5 mm
 (Appendix B, Section III, Item 3)
 Key, Socket Head Screw, 4 mm
 (Appendix B, Section III, Item 3)
 Key, Socket Head Screw, 6 mm
 (Appendix B, Section III, Item 3)
 Handle, Socket Wrench, Ratchet, 1/2" Drive
 (Appendix B, Section III, Item 3)
 Pliers, Vise Grip
 (Appendix B, Section III, Item 3)
 Adapter, Socket, 12 " to 3A/4
 (Appendix B, Section III, Item 3)

Materials/Parts Required:

None

Equipment Condition:

Engine removed from engine module
 (para. 6.2)
 Engine oil drained
 (Table 4-1)

- a. Hold/lock flywheel (1) in place.
- b. Remove pulley wheel nut (2), flat washer (3), pulley (4), roll pin (5), spacer (6), and net (7).

CAUTION

Do not allow flywheel to drop when removing from shaft.

- c. Using a flywheel puller with four jack screws, remove flywheel (1) and tab (8).
- d. Remove the five socket head cap screws (9) attaching the alternator rotor (10) to flywheel. Remove rotor (10).
- e. Remove socket head screw (11) and washer (12) and outboard clamp (13).
- f. Remove four socket head cap screws (14) attaching the alternator stator (15) to the timing cover. Remove stator (15).
- g. Remove socket head screw (16), washer (17) and wire clamp (18) under stator.

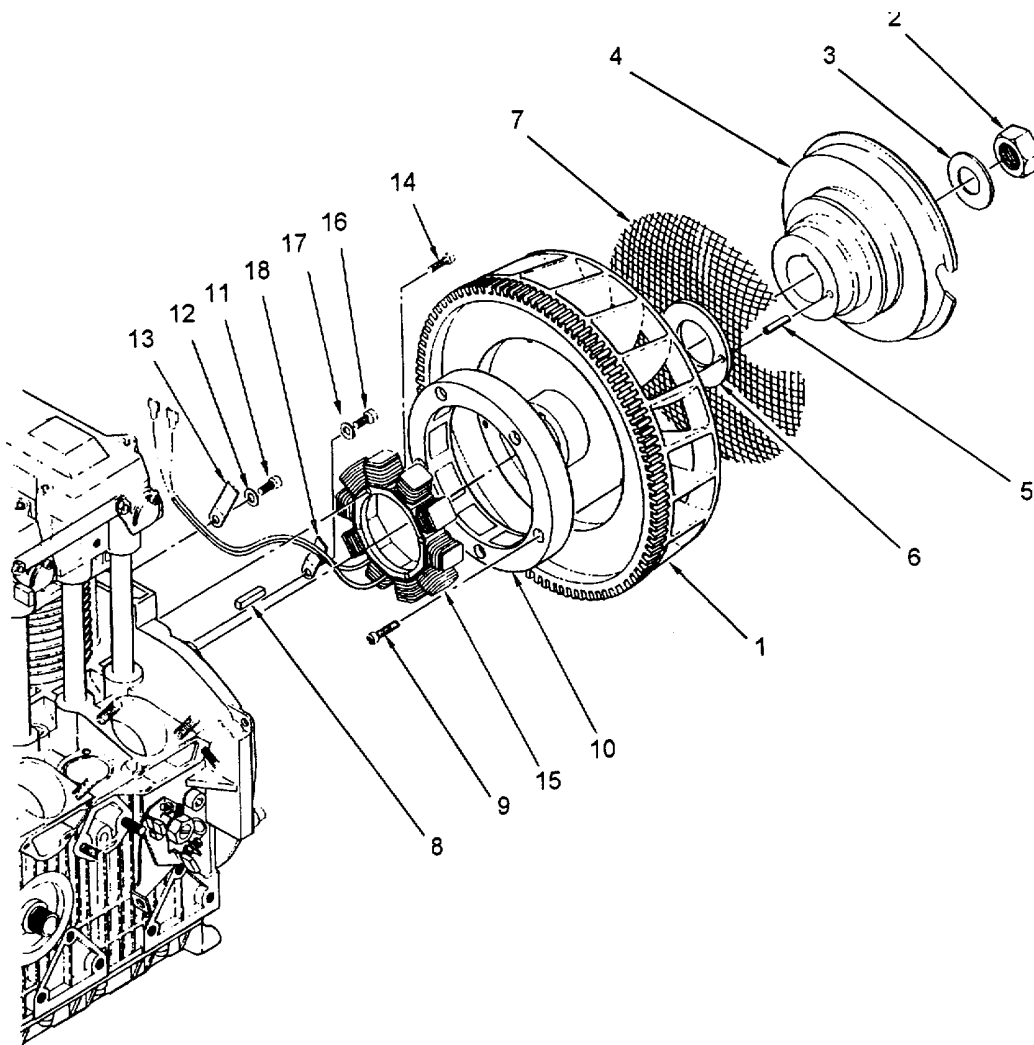

Figure 6-4. Flywheel and Alternator Removal

6.3.4 Remove Fuel Flow Solenoid. (Refer to figure 6-5.)

This task consists of: a. Removal

INITIAL SET-UP:

Tools:

Key, Socket Head Screw, 5 mm
(Appendix B, Section III, Item 3)

Materials/Parts Required:

None

Equipment Condition:

Cylinder casing removed (para. 6.3.2)

- a. Disconnect electrical wires (1).
- b. Remove two socket head screws (2) attaching fuel flow solenoid (3) to crankcase (4). Remove and discard O-ring (5).

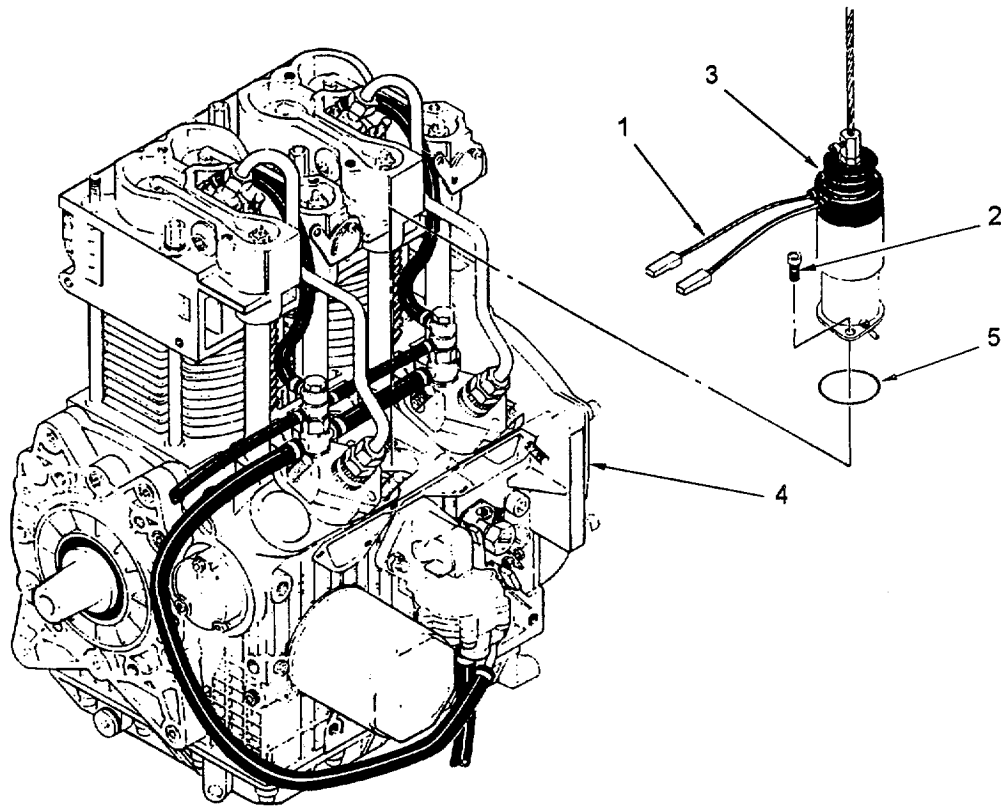

Figure 6-5. Fuel Flow Solenoid Removal

6.3.5 Remove Starter Motor.

Refer to paragraph 4.14. 1.

6.3.6 Remove Valve Covers.

Refer to paragraph 4.14.3.

6.3.7 Remove Decompression Lever. (Refer to figure 6-6.)

This task consists of: a. Removal

INITIAL SET-UP:**Tools:**

Key, Socket Head Screw, 3 mm
(Appendix B, Section III, Item 3)
Combination Wrench, 13 mm
(Appendix B, Section III, Item 3)

Materials/Parts Required:

None

Equipment Condition:

Pumping Assembly shut down (para. 2.9)

- a. Remove two screws (1) and nuts (2) from decompression lever (3).

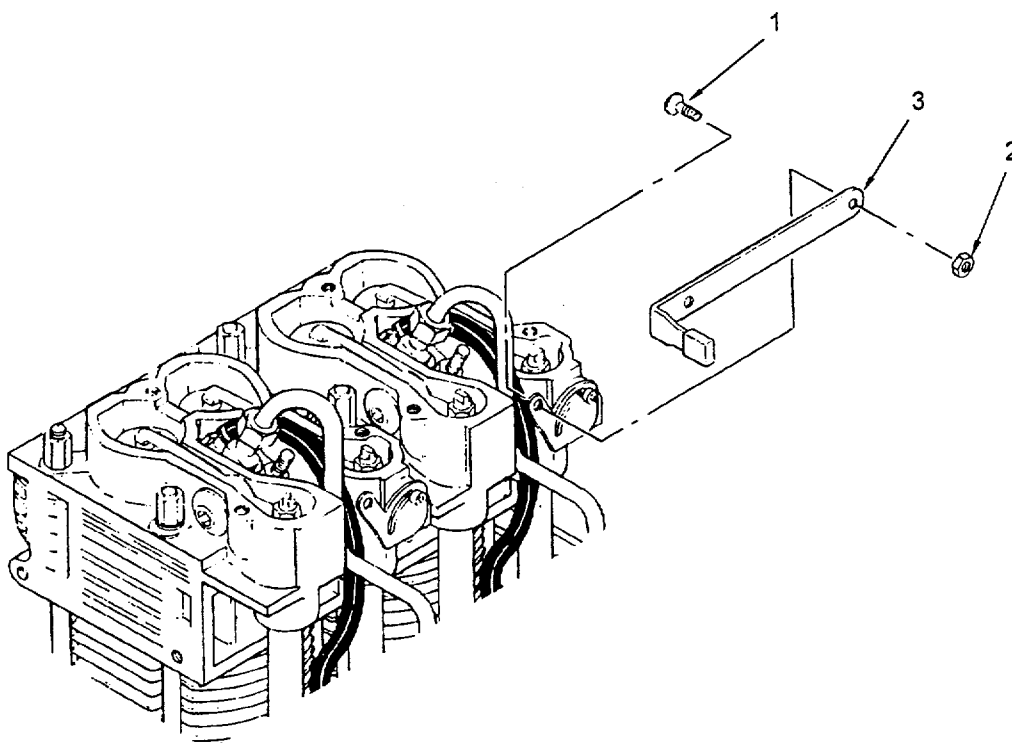

Figure 6-6. Decompression Lever Removal

6.3.8 Remove Injection Pump. (Refer to figure 6-7.)

This task consists of: a. Removal

INITIAL SET-UP:**Tools:**

Key, Socket Head Screw, 5 mm
 (Appendix B, Section III, Item 3)
 Key, Socket Head Screw, 3 mm
 (Appendix B, Section III, Item 3)
 Combination Wrench, 13 mm
 (Appendix B, Section III, Item 3)
 Combination Wrench, 17 mm
 (Appendix B, Section III, Item 3)
 Socket, Socket Wrench, 10 mm
 (Appendix B, Section III, Item 3)
 Socket, Socket Wrench, 13 mm
 (Appendix B, Section III, Item 3)
 Handle, Socket Wrench, Ratchet, 3/8" Drive
 (Appendix B, Section III, Item 3)
 Pliers, Needle Nose
 (Appendix B, Section III, Item 3)

Materials/Parts Required:

None

Equipment Condition:

Cylinder casing removed (para. 6.3.2)

NOTE

The following task applies to removal of either injection pump.

- a. Remove fuel line (1) at fuel injection pump (2) and fuel injector (3).
- b. Disconnect fuel return lines by removing union bolt (4), washer (5), union (6), washer (7), union (8) and washer (9). Retain used washers (5, 7 and 9) for injector pump adjustments.
- c. Disconnect fuel supply line by removing union bolt (10), washer (11), union (12) and washer (13). Retain used washers (11 and 13) for injector pump adjustments.
- d. Loosen the two nuts (14) securing injection pump to crankcase.

NOTE

Copper washers are used under the two socket head cap screws at the lower side of the fuel control cover.

- e. Remove the five socket head cap screws (15) and flat washers (16 and 17) attaching fuel control cover (18) to crankcase. Discard the two copper washers (17).
- f. Remove the nut (19) and washer (20) attaching fuel control cover (17) to crankcase.

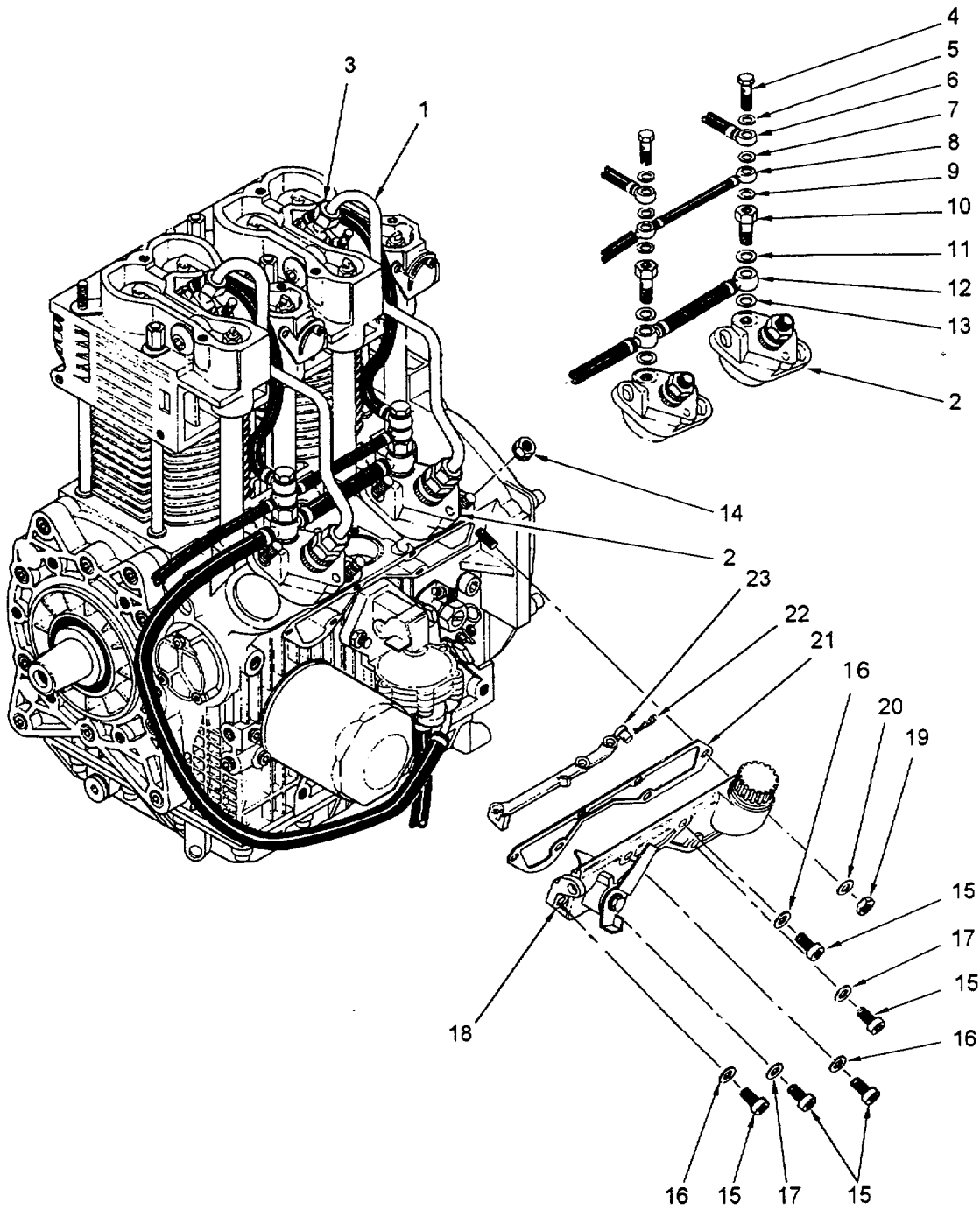

Figure 6-7. Fuel System Components Removal

- g. Remove cover (18) and gasket (21). Discard gasket (21). Remove any gasket residue from the cover (18) and crankcase.
- h. Remove two nuts (14) securing injection pump (2) to crankcase.
- i. Using needle nose pliers, remove three spring clips (22) from control rod (23), fuel injection pump and governor. Raise fuel injection pumps enough to allow removal of control rod (23) from crankcase.

NOTE

Refer to figure 6-8. Before removal, mark each fuel injection pump to ensure that the pump will be reinstalled in the same location. Record and retain the number of gaskets, if any, that were between the injection pump and the crankcase. The same number of gaskets must be used upon reassembly.

Refer to figure 6-8.

- j. Remove injection pump (1) and gasket(s) (2) from crankcase.
- k. Remove expansion plug (3) and tappet (4) from crankcase.

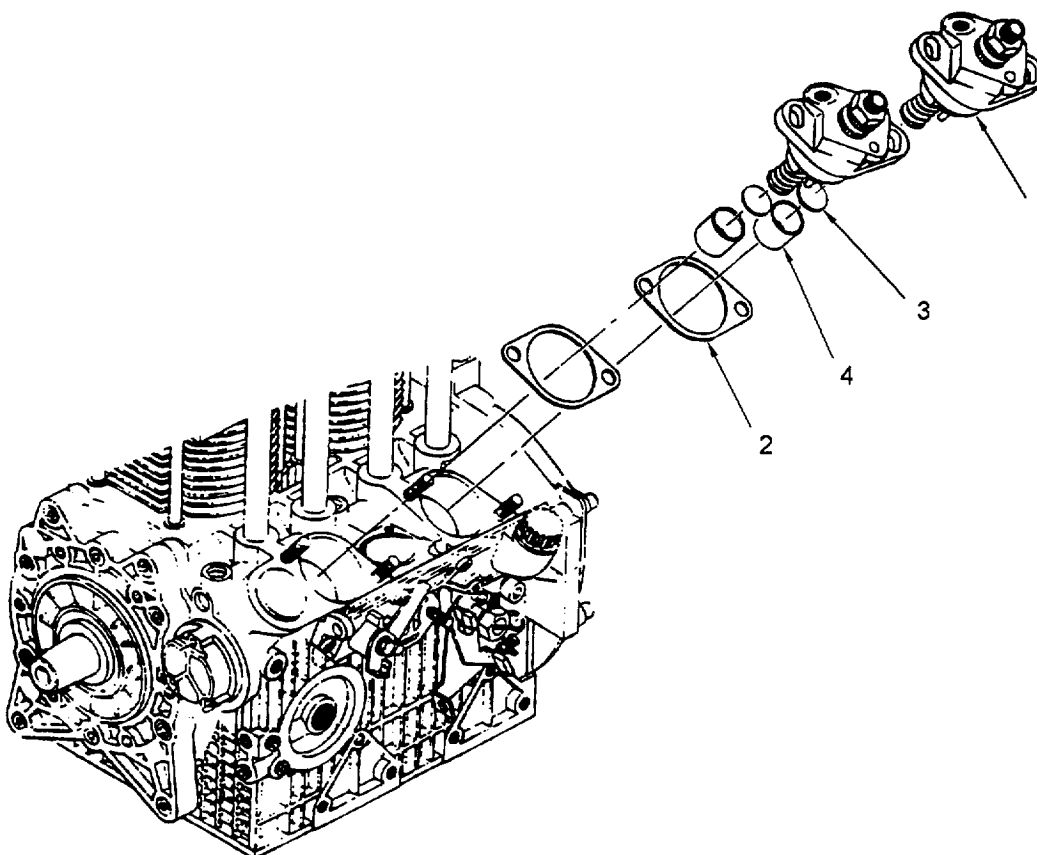

Figure 6-8. Injection Pump Removal

6.3.9 Remove Fuel Pump.

Refer to paragraph 4.14.2

6.3.10 Remove Fuel Injectors. (Refer to figure 6-9.)

This task applies to either fuel injector.

This task consists of: a. Removal

INITIAL SET-UP:**Tools:**

Combination Wrench, 10 mm
(Appendix B, Section III, Item 3)
Combination Wrench, 13 mm
(Appendix B, Section III, Item 3)
Combination Wrench, 17 mm
(Appendix B, Section III, Item 3)

Materials/Parts Required:

None

General Safety Requirements:**WARNING**

Fuels are toxic and flammable. Do not get on person or clothing. Work in well ventilated area. Do not smoke. Ensure equipment is well grounded.

Equipment Condition:

Cylinder casing removed (para. 6.3.2)
Valve covers removed (para. 4.14.3)
Injector fuel feed lines removed (para. 6.3.8)

NOTE

Copper washers under fuel injectors are used to adjust fuel injector protrusion into combustion chamber of cylinder head. Record the number of washers removed, if any, so that the same number of new washers will be installed upon reassembly.

- a. Remove brace nut (1), washer (2) and brace (3) from mounting stud (4).
- b. Raise fuel injector (5) for access and remove bolt (6), washer (7), union (8) and washer (9). Discard washers (7 and 9).
- c. Remove fuel injector (5) and washer(s) (10). Note number of washers (10) under fuel injector. Discard washers (10).

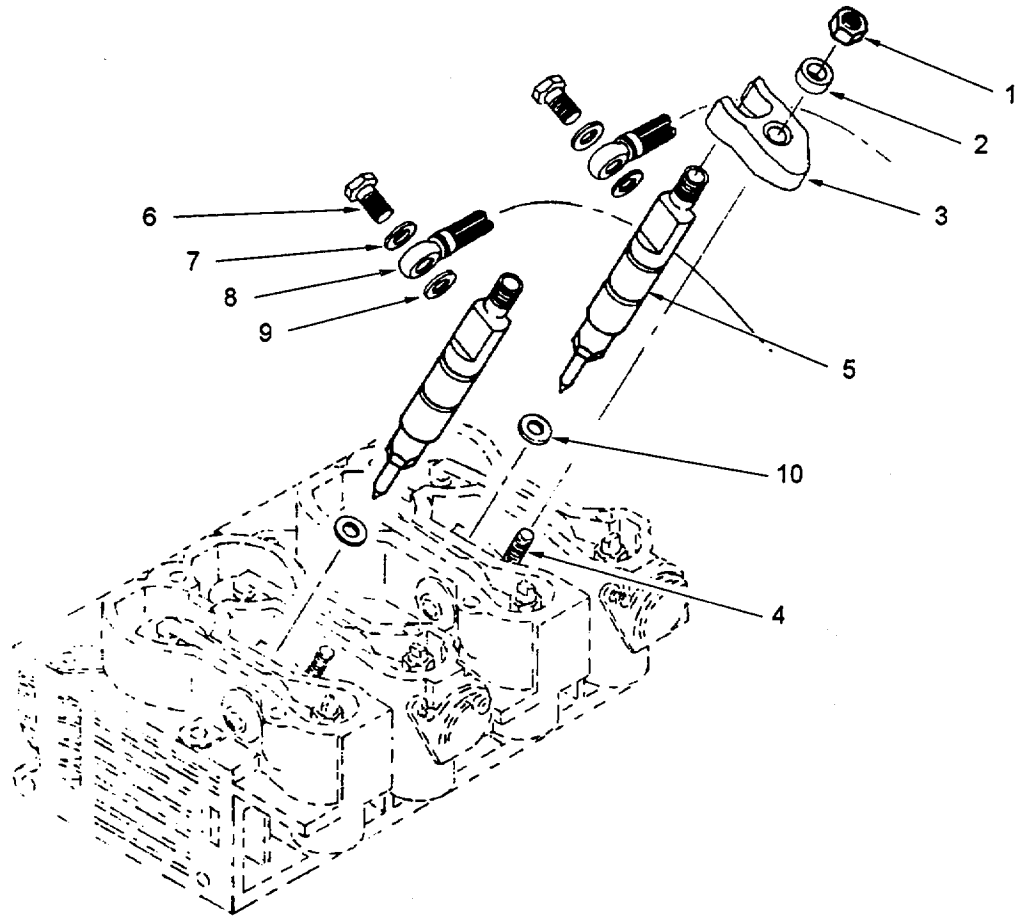

Figure 6-9. Fuel Injector Removal

6.3.11 Remove Cylinder Head and Cylinder.

This task applies to either cylinder head.

This task consists of: a. Removal

INITIAL SET-UP:**Tools:**

Socket, Socket Wrench, Deep Well, 13 mm
 (Appendix B, Section III, Item 3)
 Handle, Socket Wrench, Ratchet, 3/8" Drive
 (Appendix B, Section III, Item 3)

Materials/Parts Required:

None

Equipment Condition:

Fuel injectors removed (para. 6.3.10)

Refer to figure 6-10.

NOTE

One cylinder head nut is a studnut used to mount the lifting eye and oil fill cap lanyard. Note location for reassembly.

- a. Remove the four cylinder head nuts (1) and washers (2).
- b. Mark cylinder head to ensure replacement on same cylinder.
- c. Remove cylinder head (3) and copper gasket (4). Discard copper gasket (4).
- d. Remove any remaining gasket material from flange.

NOTE

Tag the location of pushrods before removal. Valve pushrods wear differently. Ensure pushrods are put back in the same location or the engine may not run properly.

- e. Tag and remove pushrods (5). Remove pushrod pipes (6) and O-rings (7). Discard O-rings (7).

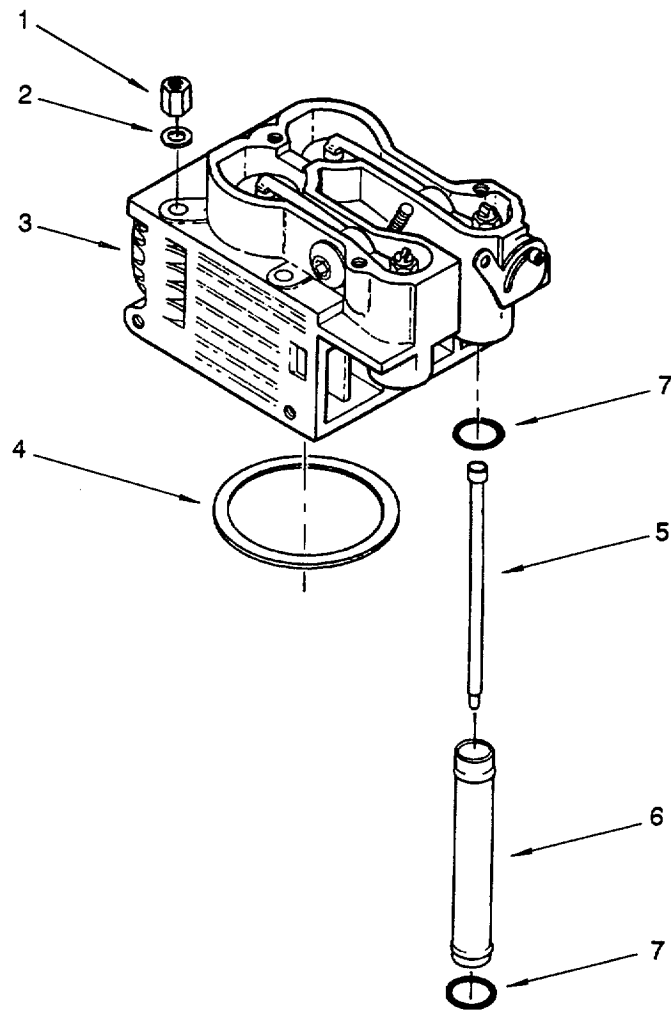

Figure 6-10. Cylinder Head Removal

Refer to figure 6-11.

NOTE

Mark cylinder before removing to show which side faces injection pumps.

- f. Turn flywheel to TDC of each cylinder. Lift cylinder (1) from crankcase (2). Remove and discard cylinder gasket(s) (3). Note quantity of gaskets (3) removed. The same quantity must be installed initially during assembly.

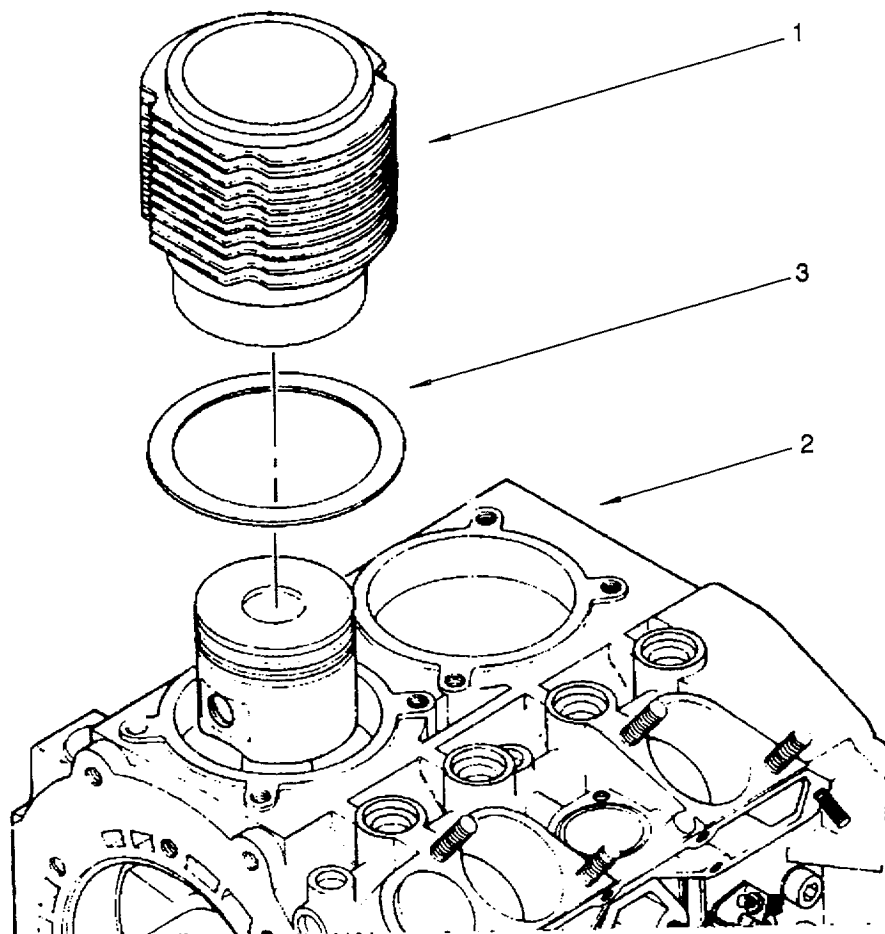

Figure 6-11. Cylinder Removal

6.3.12 Remove Piston and Rings. (Refer to figure 6-12.)

This task applies to either cylinder.

This task consists of: a. Removal

INITIAL SET-UP:**Tools:**

Socket, Socket Wrench, 14 mm
 (Appendix B, Section III, Item 3)
 Handle, Socket Wrench, Ratchet, 3/8" Drive
 (Appendix B, Section III, Item 3)
 Pliers, Needle Nose
 (Appendix B, Section III, Item 3)

Materials/Parts Required:

None

Equipment Condition:

Cylinder head and cylinder removed
 (para. 6.3.11)

CAUTION

- **With piston detached from connecting rod, the connecting rod can easily jam and cause damage in the crankcase. Use caution when turning crankshaft in order to avoid damage.**
- **Mark each piston to ensure replacement in correct cylinder; i.e., flywheel-end piston and PTO-end piston.**

- a. Remove the two piston pin snap rings (1) and push the piston pin (2) free of the piston (3). Separate and remove piston (3) from connecting rod (4).
- b. Remove three rings (5) from piston (3). Discard rings (5).

CAUTION

Note markings on connecting rod and cap or mark them to ensure that they can be reassembled properly.

- c. Remove cap screws (6) from caps (7) at bottom of connecting rod (4). Remove connecting rod (4) and cap (7) from crankshaft (8).
- d. Remove and discard rod bearings (9).

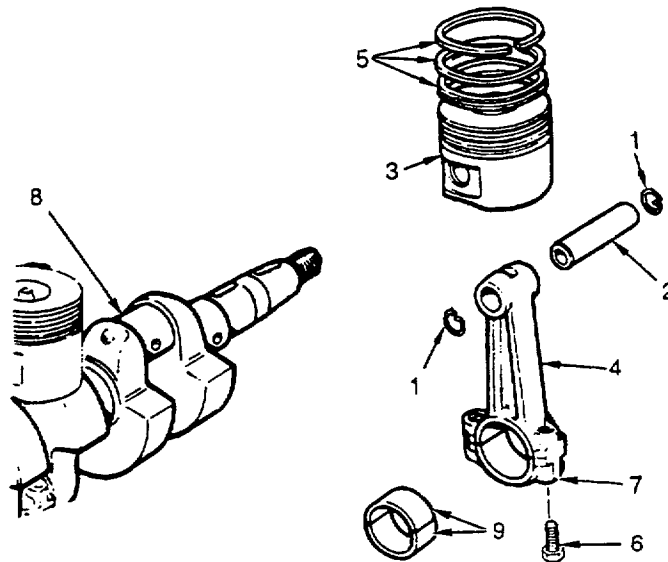

Figure 6-12. Piston and Rings Removal

6.3.13 Remove and Check Oil Pump. (Refer to figure 6-13.)

This task consists of: a. Removal

INITIAL SET-UP:

Tools:

- Combination Wrench, 7 mm
(Appendix B, Section III, Item 3)
- Key, Socket Head Screw, 4 mm
(Appendix B, Section III, Item 3)
- Rule, Machinist's, 6 in.
(Appendix B, Section III, Item 3)
- Caliper, Vernier
(Appendix B, Section III, Item 3)
- Gauge, Thickness
(Appendix B, Section III, Item 3)

General Safety Requirements:

WARNING

- **Fuels are toxic and flammable. Do not get on person or clothing. Work in well ventilated area. Do not smoke. Ensure equipment is well grounded.**

Materials/Parts Required:

None

Equipment Condition:

Engine removed from engine module
(para. 6.2)

- a. Remove the two socket head cap screws (1).
- b. Remove the nut (2) from the oil pump cover (3).

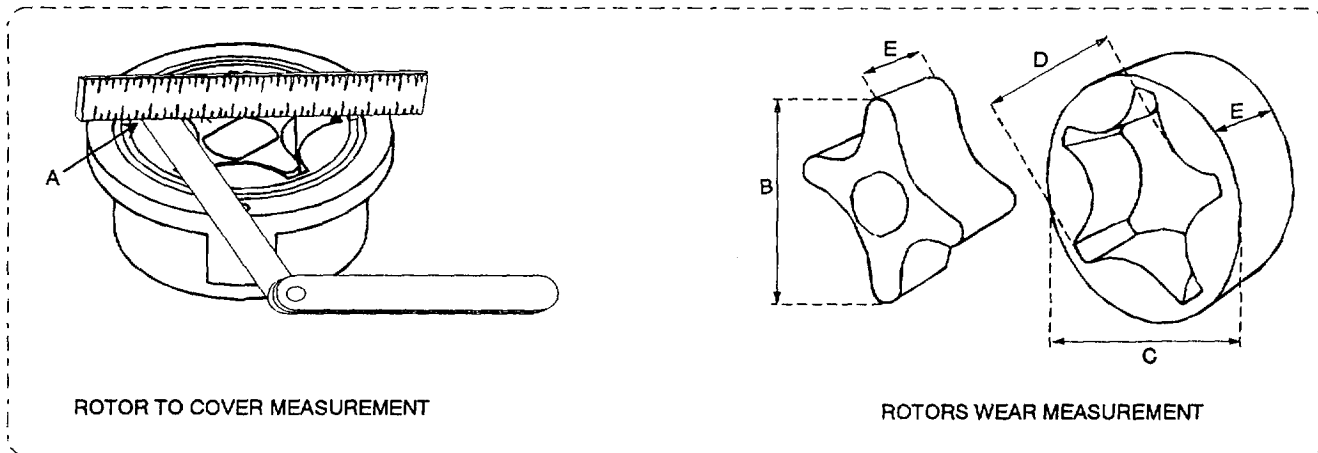
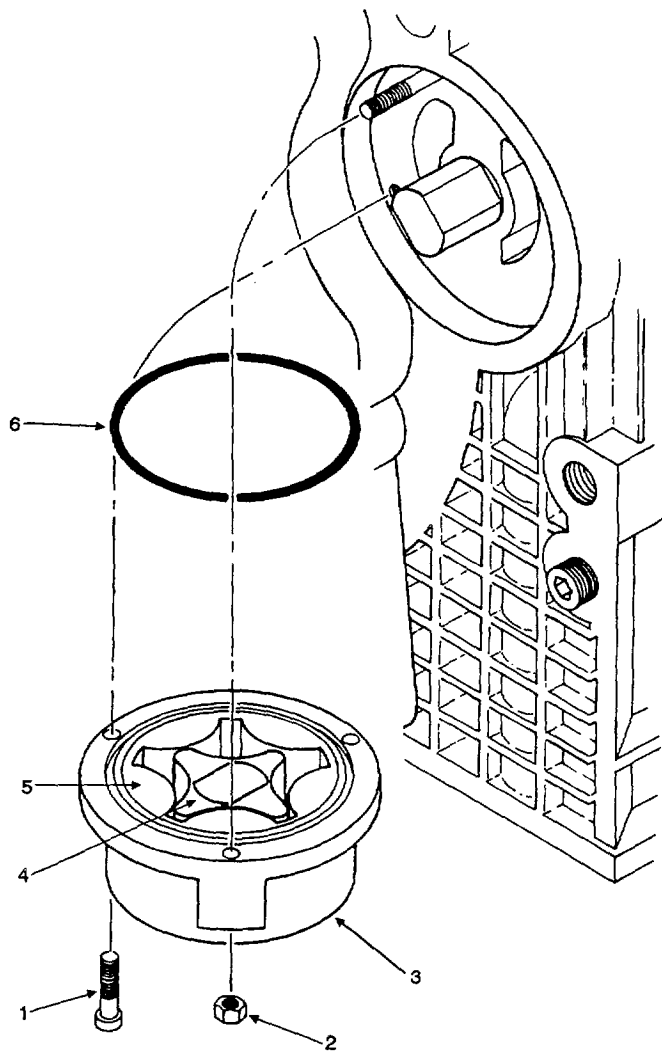

Figure 6-13. Oil Pump Removal

NOTE

Use care when removing oil pump cover. The rotor's position in the oil pump cover are to be measured.

- c. Remove the oil pump cover (3) with inner rotor (4), outer rotor (5) and O-ring (6). Discard O-ring (6). Wipe rotors (4 and 5) and cover (3) clean.
- d. Lay the oil pump cover (3) on a flat surface with the rotors (4 and 5) facing up. Measure the clearance (A) between the outer rotor and the cover mating surface. The rotor must be 0.010-0.024 in. (0.27-0.60 mm) below the mating edge of the oil pump cover. If measurement is out of tolerance, replace the rotor.
- e. Remove rotors (4 and 5) from oil pump cover (3). Make the following measurements for wear. If any measurement is out of tolerance, replace the rotor(s).
 - (1) Measurement B (Inner Rotor Diameter): 1.167-1.172 in. (29.65-29.77 mm)
 - (2) Measurement C (Outer Rotor Diameter): 1.592-1.597 in. (40.45-40.58 mm)
 - (3) Measurement D (Outer Rotor Inside Diameter): 1.182-1.185 in. (30.03-30.1 mm)
 - (4) Measurement E (Rotor Thickness - Both Rotors): 0.704-0.706 in. (17.89-17.94 mm)

6.3.14 Remove Timing (Pulley End) Cover. (Refer to figure 6-14.)

This task consists of: a. Removal

INITIAL SET-UP:

Tools:

Key, Socket Head Screw, 6 mm
(Appendix B, Section III, Item 3)

Materials/Parts Required:

None

Equipment Condition:

Flywheel and alternator stator removed
(para. 6.3.3)

- a. Remove crankcase breather hose (1).
- b. Remove the ten socket head cap screws (2) from engine timing cover (3).
- c. Remove timing cover (3) and gasket (4). Discard gasket(4). Remove gasket material residue from crankcase (5) and timing cover (3).
- d. Remove rear engine oil seal (6) from timing cover. Discard seal (6).

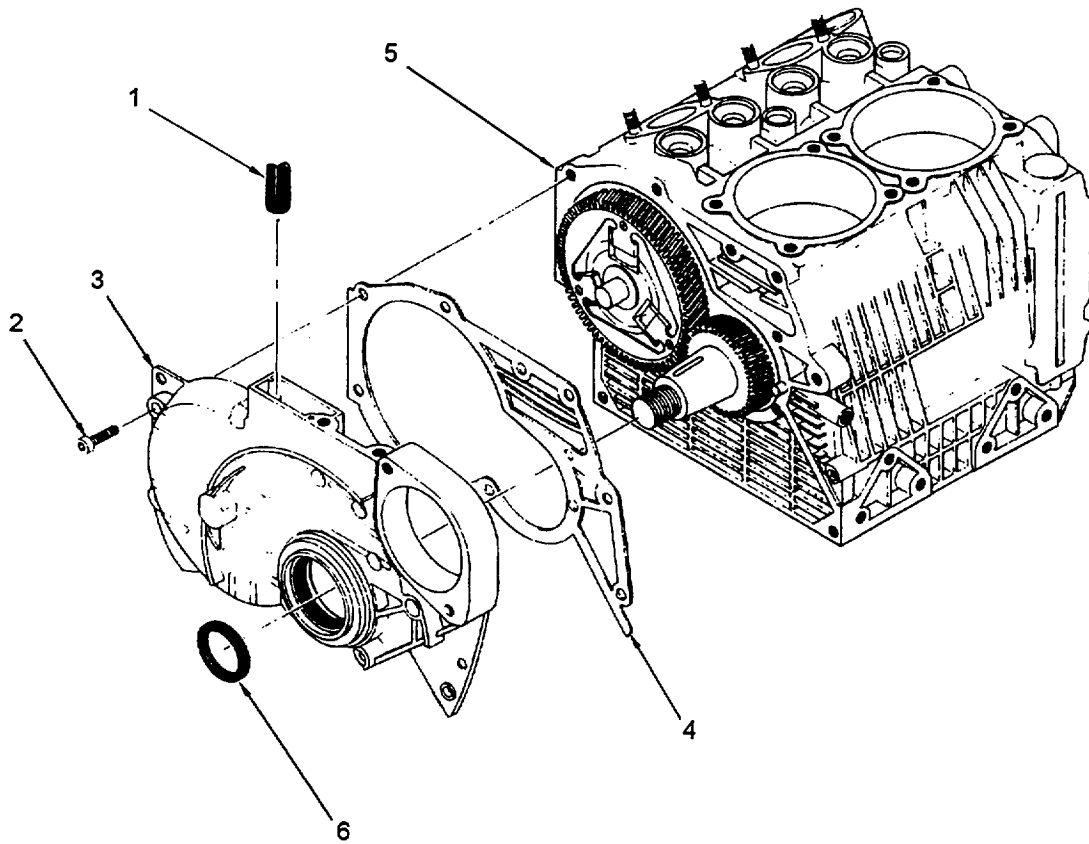

Figure 6-14. Timing Cover Removal

6.3.15 Remove Governor Assembly and Speed Control.

This task consists of: a. Removal

INITIAL SET-UP:

Tools:

Socket, Socket Wrench, 10 mm
 (Appendix B, Section III, Item 3)
 Handle, Socket Wrench, Ratchet, 3/8" Drive
 (Appendix B, Section III, Item 3)
 Pliers, Needle Nose
 (Appendix B, Section III, Item 3)
 Key, Socket Head Screw, 8 mm
 (Appendix B, Section III, Item 3)
 Magnetic Retrieval Tool
 (Appendix B, Section III, Item 3)
 Combination Wrench, 19 mm
 (Appendix B, Section III, Item 3)
 Screwdriver, Flat Blade, Large
 (Appendix B, Section III, Item 3)

Materials/Parts Required:

None

Equipment Condition:

Oil pan removed (para. 6.3.1)
 Fuel control cover removed (para. 6.3.8)

Refer to figure 6-15.

- a. Position crankcase with oil sump facing up.
- b. Remove governor arm retaining clip (1) securing governor spring (2) to governor arm (3); remove governor spring from governor arm. Remove other end of governor spring (2) from speed control lever (inside crankcase) (4).
- c. Partially extend camshaft out of crankcase for easier access to governor assembly.
- d. Remove engine governor plug (5) and washer (6).
- e. Using a magnetic retrieval tool, remove the governor journal (7) from crankcase.
- f. Remove governor (8) with governor joint (9).
- g. From outside crankcase, remove mounting screw (10), flat washer (11), throttle lever (12) and three compression springs (13).
- h. Remove compression washers (14) and three compression springs (15).
- i. Remove mounting screw (16) and safety plate (17).
- j. Remove and discard inside speed control retaining clip (18).
- k. Remove and discard inside speed control lever O-ring (19). From inside crankcase, remove inside speed control lever (4).

Refer to figure 6-16.

1. Remove protective cover (1) from high speed adjustment screw (2). Loosen jam nut (3) and remove set screw (2) from crankcase.

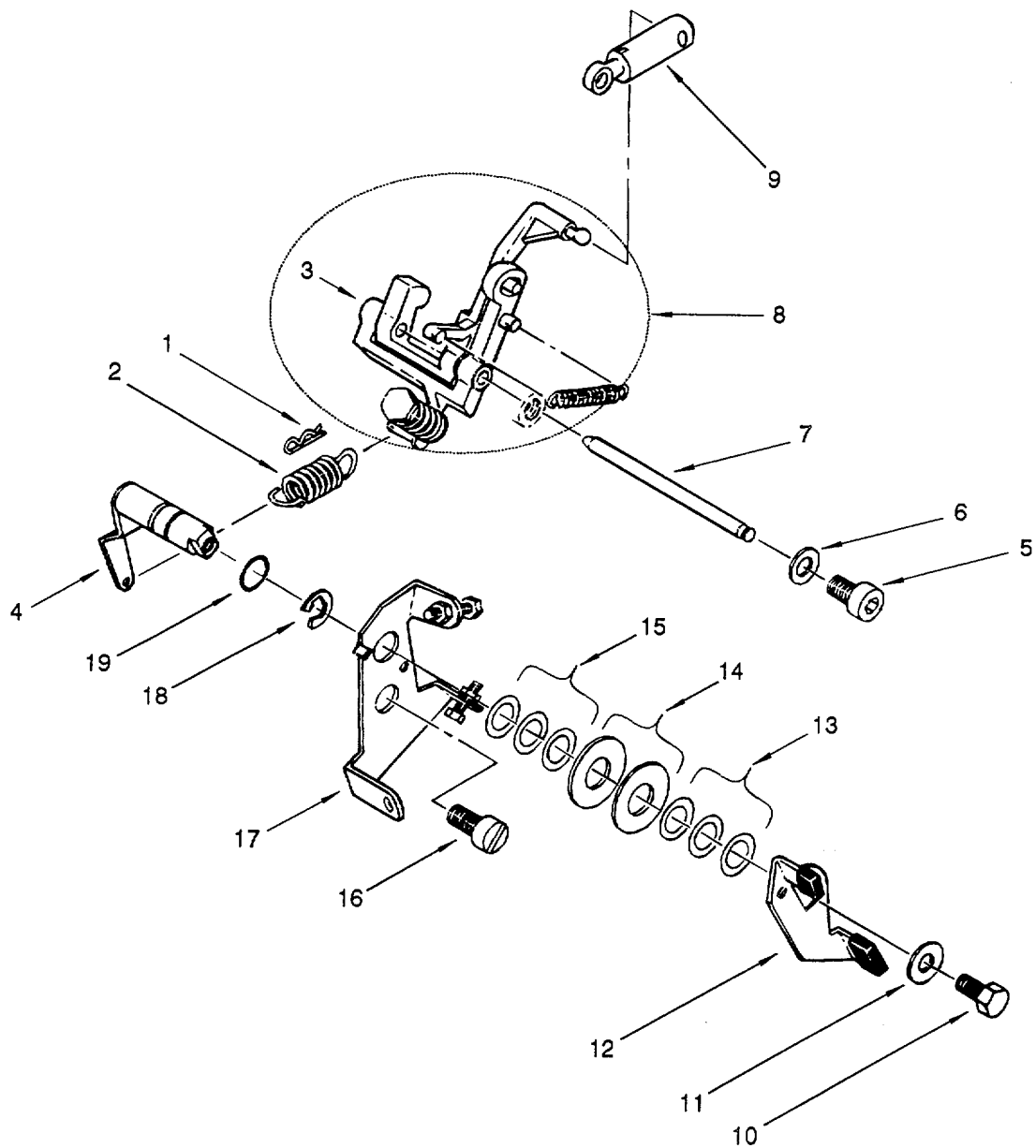

Figure 6-15. Governor Assembly and Speed Control Removal

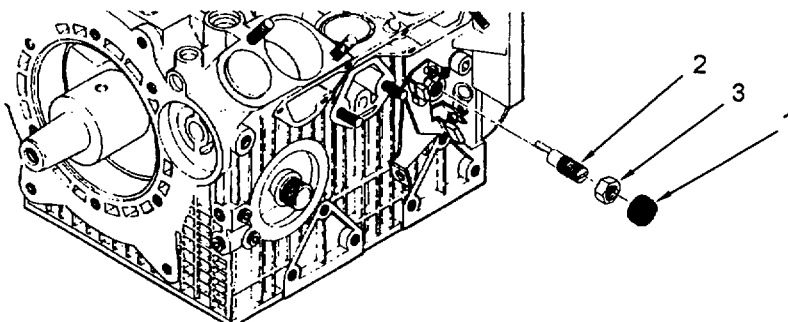

Figure 6-16. High Speed Adjustment Screw Removal

6.3.16 Remove Camshaft and Valve Tappets. (Refer to figure 6-17.)

This task consists of: a. Removal

INITIAL SET-UP:

Tools:
None

Materials/Parts Required:
None

Equipment Condition:
Governor assembly and speed control removed
(para. 6.3.15)

- a. Remove camshaft (1).

NOTE

Ensure valve tappets are marked for reinstallation. If they are to be reused they should go back in same place.

- b. Remove intake and exhaust valve tappets (2) from crankcase. Ensure tappets are marked so they are installed in original location.

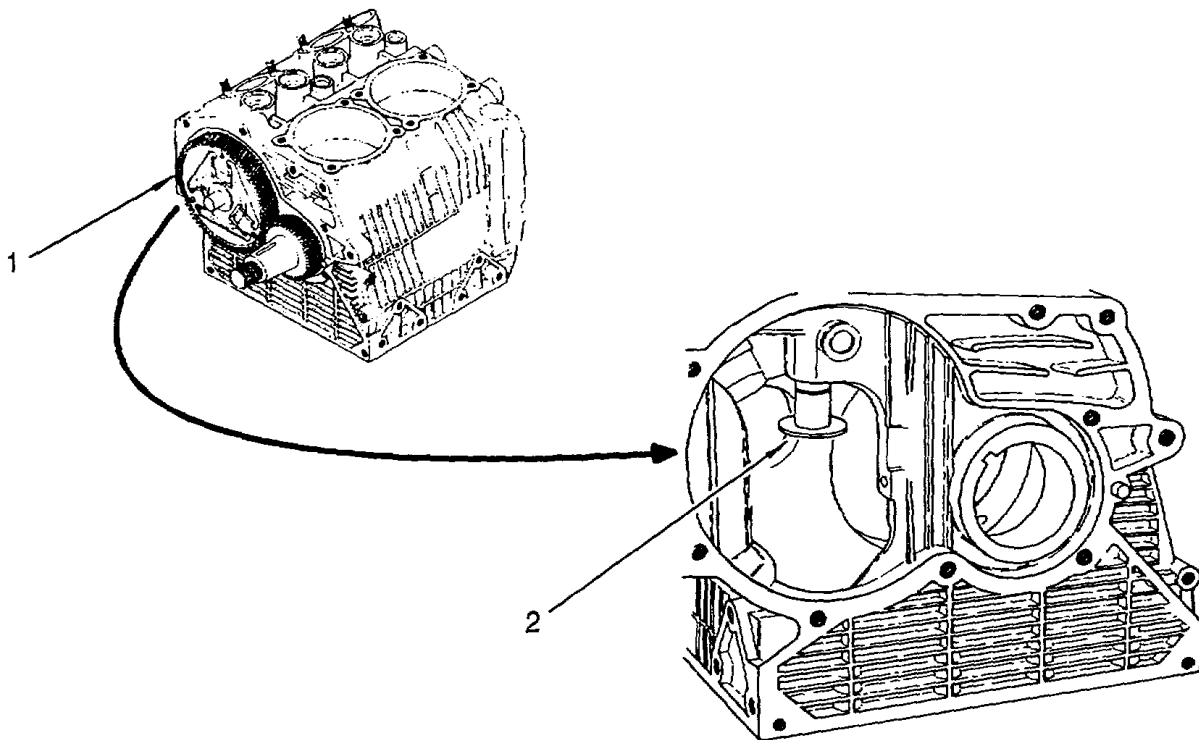

Figure 6-17. Camshaft and Valve Tappets Removal

6.3.17 Remove Rear Crankshaft Support. (Refer to figure 6-18)

This task consists of: a. Removal

INITIAL SET-UP:**Tools:**

Key, Socket Head Screw, 6 mm
(Appendix B, Section III, Item 3)
Flywheel Puller
(Appendix B, Section III, Item 4)
Remover, Bearing and Bushing
(Appendix B, Section III, Item 6)

Materials/Parts Required:

None

Equipment Condition:

Camshaft and tappets removed (para. 6.3.16)

- a. Remove the ten socket head cap screws (1) from engine rear support (2).
- b. Using flywheel puller and two of the rear support mounting screws, remove engine rear support (2) and O-ring (3). Discard O-ring (3).
- c. Remove rear engine oil seal (4). Discard seal (4).
- d. Using bushing extractor tool, remove engine rear main bearing (5) from engine rear support. Discard bearing (5).

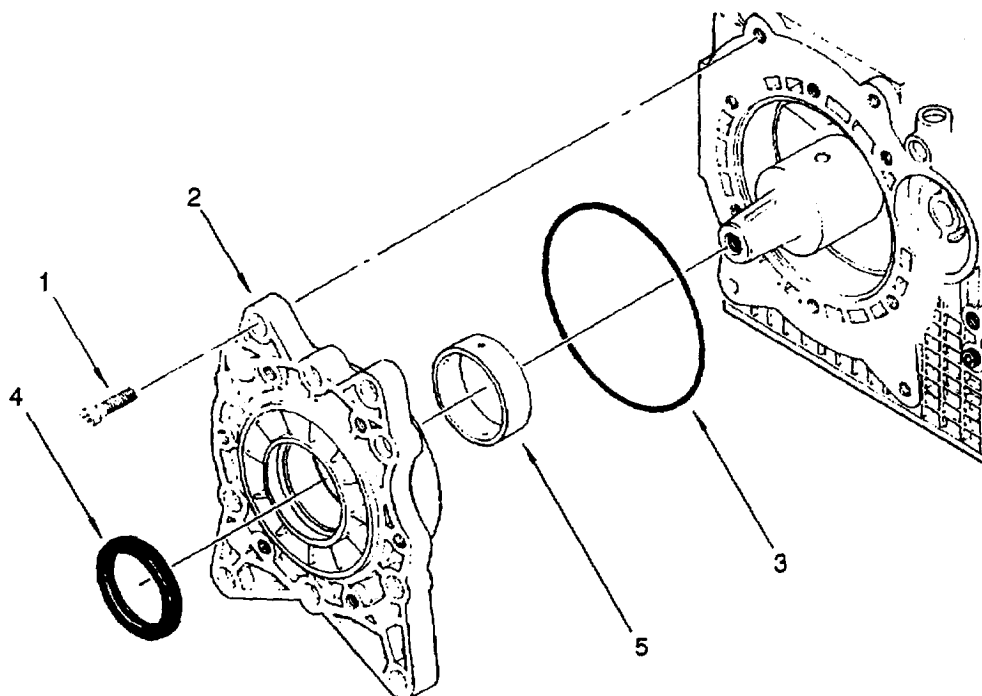

Figure 6-18. Rear Crankshaft Support Removal

6.3.18 Remove Crankshaft Gear, Crankshaft and Bearings. (Refer to figure 6-19.)

This task consists of: a. Removal

INITIAL SET-UP:**Tools:**

Socket, Socket Wrench, 6 mm
(Appendix B, Section III, Item 3)
Gear Extractor Tool
(Appendix B, Section III, Item 5)
Remover, Bearing and Bushing
(Appendix B, Section III, Item 6)
Handle, Socket Wrench, Ratchet, 3/8" Drive
(Appendix B, Section III, Item 3)
Extension, 3 in., 3/8 in. drive
(Appendix B, Section III, Item 3)

Materials/Parts Required:

None

Equipment Condition:

Rear crankshaft support removed (para. 6.3.17)

NOTE

Use a block of wood or other soft material to prevent the crankshaft from rotating.

- a. Using crankshaft gear extractor tool, remove crankshaft gear (1) and key (2).
- b. Remove two 6 mm screws (3) and flat washers (4) holding center crankshaft bearing support (5).
- c. Gently tap on front end of crankshaft (6) to break free and move crankshaft with crankshaft bearing support toward rear of cylinder block. Slide crankshaft (6) to the rear and remove from cylinder block.
- d. Remove two 6 mm crankshaft bearing support screws (7) holding two parts of center crankshaft bearing support (5) to crankshaft (6). Remove center crankshaft bearing support (5).
- e. Remove two crankshaft bearing halves (8) from center crankshaft bearing support (5). Discard crankshaft bearing halves (8).
- f. Using the bearing and bushing remover, remove rear crankshaft bearing (9) from crankcase. Discard bearing (9).

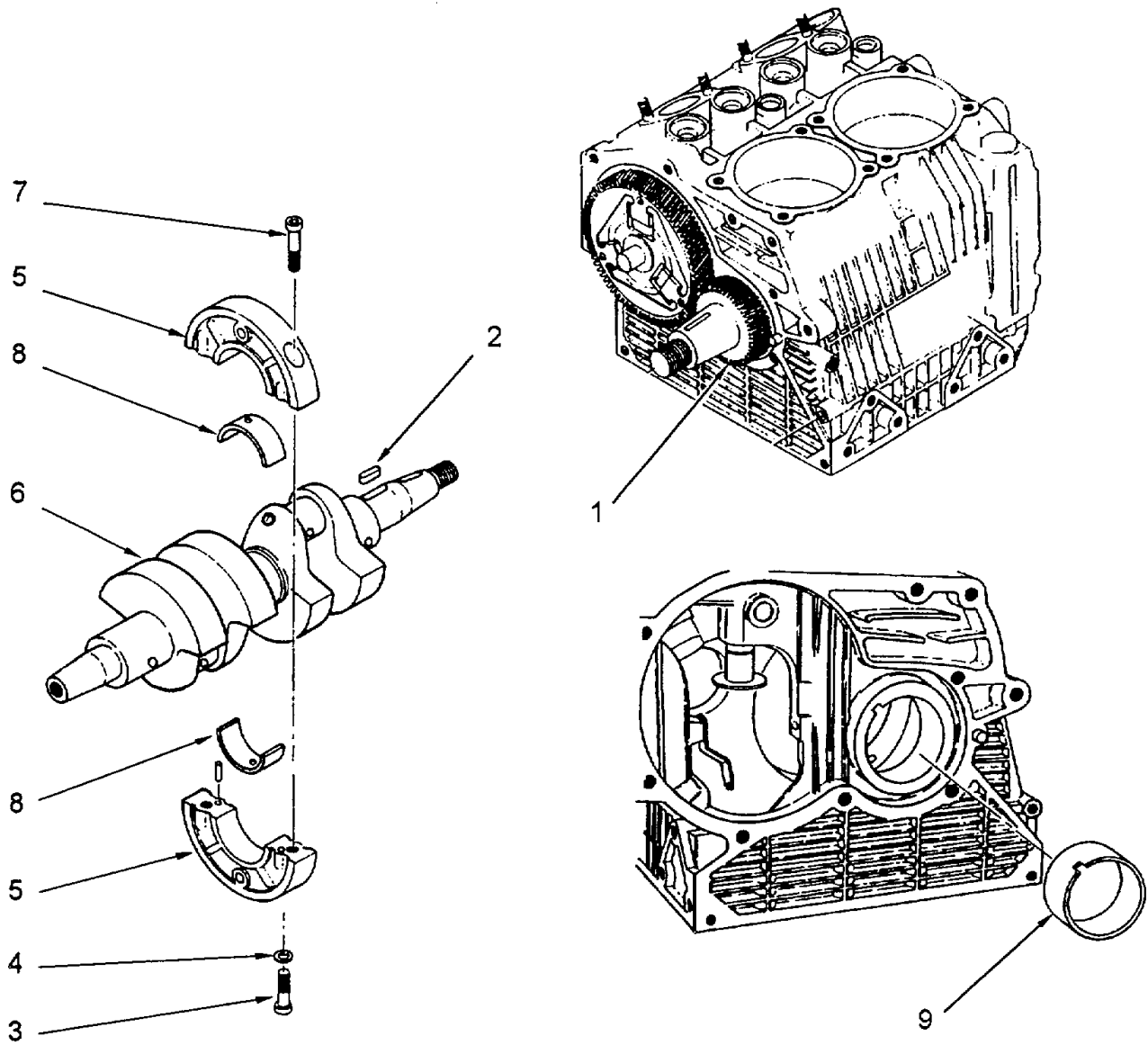

Figure 6-19. Crankshaft Gear, Crankshaft and Bearings Removal

6.3.19 Remove Oil Pressure Relief Valve. (Refer to figure 6-20.)

This task consists of: a. Disassembly

INITIAL SET-UP:**Tools:**

Key, Socket Head Screw, 7 mm
(Appendix B, Section III, Item 3)
Pliers, Snap Ring (0.046 straight tips)
(Appendix B, Section III, Item 3)

Materials/Parts Required:

None

Equipment Condition:

Oil pan removed (para. 6.3.1)

- a. Remove oil pressure relief valve plug (1) from inside lower crankcase (2) at the power take off end.
- b. Remove plug and relief valve assembly (3). Inspect valve parts. If undamaged, clean thoroughly and reassemble. If any part is damaged, discard entire assembly.

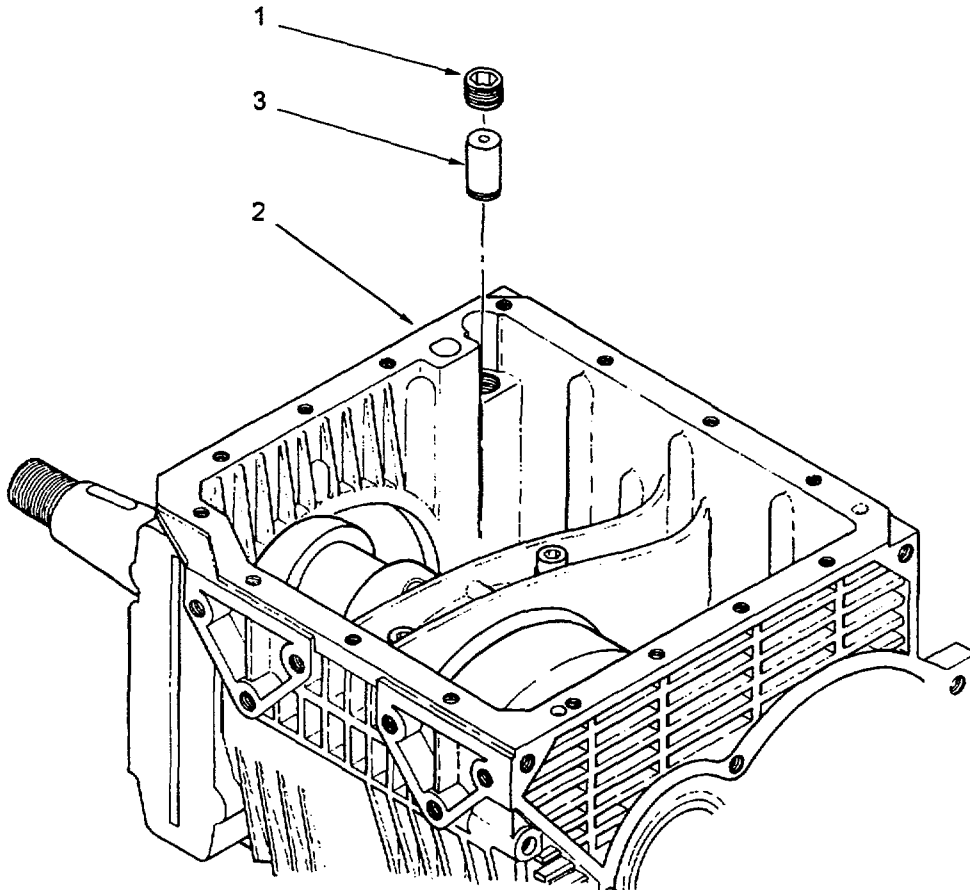

Figure 6-20. Oil Pressure Relief Valve Removal

6.3.20 Disassemble Cylinder Head. (Refer to figure 6-21.)

This task consists of: a. Removal

INITIAL SET-UP:**Tools:**

Key, Socket Head Screw, 8 mm
(Appendix B, Section III, Item 3)
Key, Socket Head Screw, 3 mm
(Appendix B, Section III, Item 3)
Valve Spring Compressor
(Appendix B, Section III, Item 3)
Pliers, Needle Nose
(Appendix B, Section III, Item 3)

Materials/Parts Required:

None

Equipment Condition:

Cylinder head removed (See para. 6.3.11)

NOTE

For clarity, only the exhaust valve assembly is shown exploded in figure 6-21. The following procedure also applies to the intake rocker arm assembly and to either cylinder head.

- a. Remove exhaust rocker arm journal (1), and washer (2) from cylinder head (3). Discard washer (2). Remove rocker arm (4) from cylinder head.
- b. Inspect and clean rocker arm lubrication hole (5).
- c. Using a valve spring compressor, push down on upper exhaust valve spring retainer (6) and spring (7). Remove valve cotter (8).
- d. Remove upper exhaust valve spring retainer (6), spring (7), lower valve spring retainer (9), valve guide seal (10), and ring (11).
- e. Remove exhaust valve (12) and valve guide (13) from cylinder head. Inspect for damage.
- f. Remove socket head screw (14) from decompression arm (15). Remove decompression arm (15), O-ring (16), washer (17) and spring (18). Discard O-ring (16). Thoroughly clean decompression arm cavity (19).

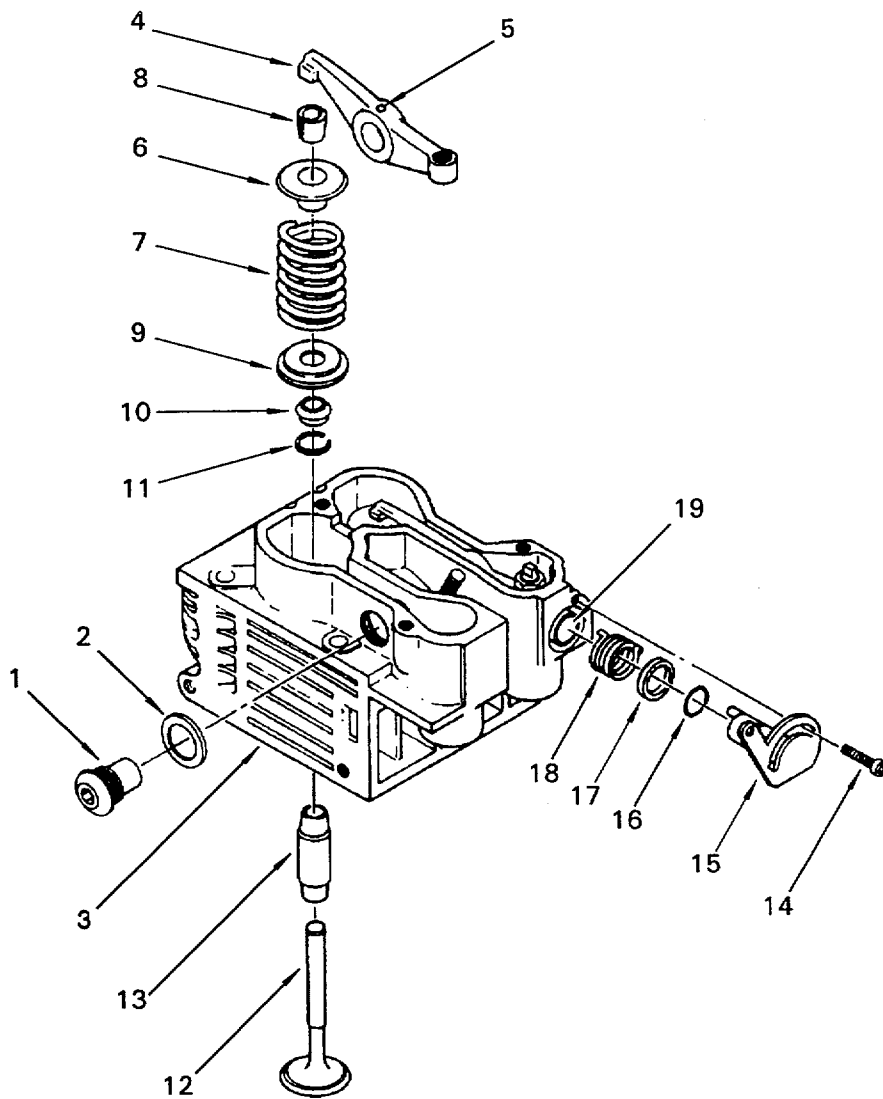

Figure 6-21. Cylinder Head Disassembly

6.4 ASSEMBLE ENGINE.

Follow good engineering practice during engine assembly. Clean and inspect all parts before assembly. Replace any part that is damaged or out of tolerance. Use assembly lube or equivalent on all mechanical parts to prevent damage during first start of reassembled engine. Clean oil passages in block and all components before assembly.

6.4.1 Install Crankshaft.

This task consists of: a. Installation
Refer to Figure 6-22.

INITIAL SET-UP:

Tools:

Screwdriver, Flat blade
(Appendix B, Section III, Item 3)
Thickness Gauge, 0.006
(Appendix B, Section III, Item 3)
Wrench, Torque, 0-300 in. lb
(Appendix B, Section III, Item 3)
Extension, 6 in., 3/8 in. drive
(Appendix B, Section III, Item 3)
Socket, Socket wrench, 6 mm
(Appendix B, Section III, Item 3)
Center Bearing Mounting Tool
(Appendix B, Section III, Item 7)
Bushing Extractor Tool
(Appendix B, Section III, Item 6)
Gloves, Welder
(Appendix B, Section III, Item 3)

Materials/Parts Required:

Bearing (Appendix I, Item 12)
Bearing (Appendix I, Item 13)

Equipment Condition:

Crankshaft removed (para. 6.3.18)

-
- a. Temporarily reassemble the two halves (1) of the center crankshaft bearing support. Check for excessive wear of the center crankshaft bearing support as follows. If any measurement is out of tolerance, replace the bearing support.
 - (1) Measurement A (Bearing Support Outer Diameter): 4.645-4.646 in. (117.99-118.01 mm).
 - (2) Measurement B (Bearing Support Inner Diameter): 1.888-1.889 in. (47.965-47.985 mm).
 - (3) Measurement C (Bearing Support Thickness): Not less than 1.06 in. (27 mm).
 - b. Measure diameter of crankshaft main journal, the two end journals and the two connecting rod journals. Measure again at points that are 90° from first measurement. Use the smaller of the two numbers for each measurement. Use the smaller of the two numbers for each measurement. Check for excessive wear in accordance with the following. If any measurement is out of tolerance, replace the crankshaft.
 - (1) Measurement D (Main and End Journals): 1.772-1.769 in. (45.01-44.93 mm).
 - (2) Measurement E (Connecting Rod Journals): 1.575-1.572 in. (40.005-39.925 mm).
 - c. Install crankshaft bearing halves (2) in center bearing support halves (1).

- d. Line up the matching reference numbers on the center bearing support halves (1) and install the center bearing support halves around the crankshaft (3).
- e. Install two 6 mm crankshaft support screws (4).
- f. Torque crankshaft support screws to 190 to 195 in. lbs (21-23 m).

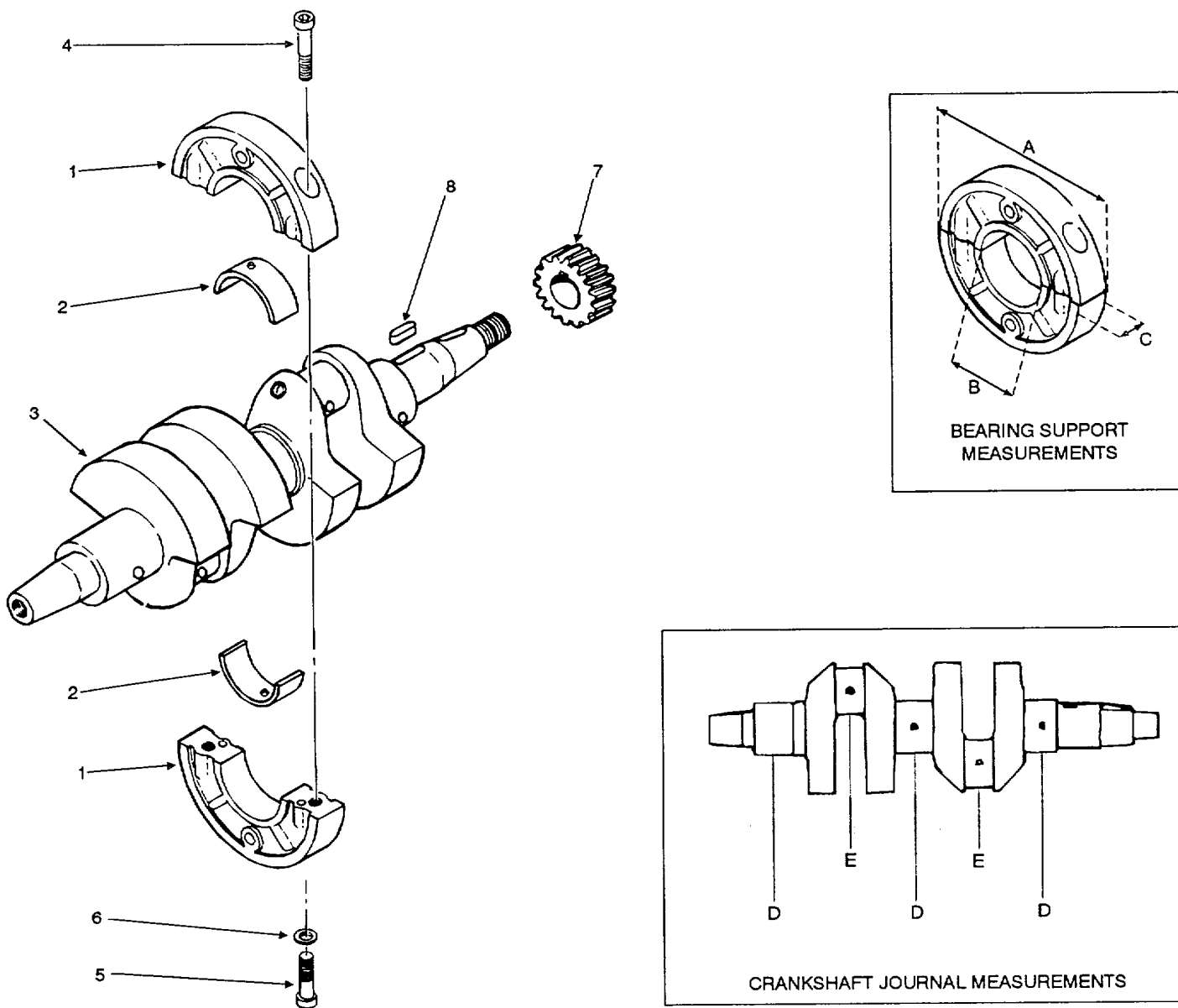

Figure 6-22. Crankshaft Assembly

Refer to figure 6-23.

NOTE

The notch (1) on rear crankshaft bearing (2) must be aligned with matching notch (3) on crankcase (4) during installation.

- g. Using bushing extractor tool, carefully install front crankshaft bearing (2) into flywheel end of crankcase (4).

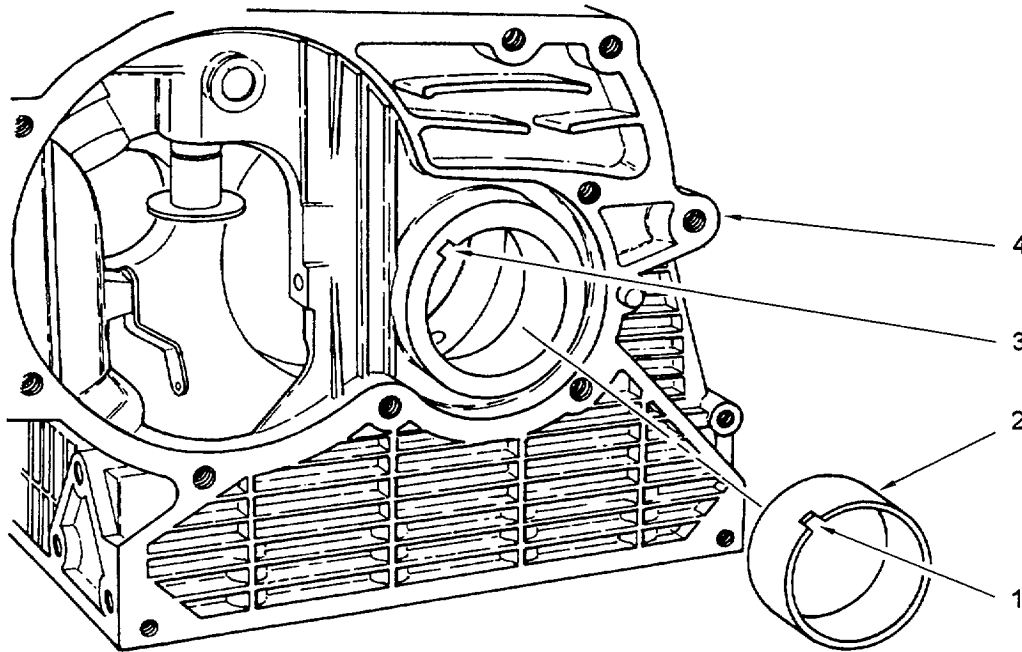

Figure 6-23. Front Crankshaft Bearing Installation

Refer to figure 6-22.

- h. Install crankshaft (3) in crankcase using center bearing mounting tool to match hole in crankcase with hole in center bearing support. Install center bearing support retaining screws (5) and flat washers (6).
- i. Torque center bearing support retaining screws (5) to 190 to 195 in. lbs. (21-23 Nm).
- j. Install rear crankshaft support in accordance with paragraph 6.4.2.
- k. Insert a 0.006 in. (0.15 mm) thickness gauge between crankshaft (3) and crankcase. Place a screwdriver between the crankcase center bearing support web and crankshaft throw to force crankshaft toward rear of crankcase.

WARNING

Hot metal can burn and cause severe personal injury. Wear protective gloves.

- l. Using a warming oven, heat crankshaft gear (7) to 356°F - 392°F (180°C - 200°C) for 20 to 30 minutes.

- m. Install key (8) on flywheel end of crankshaft (3).
- n. With crankshaft gear (7) timing mark facing flywheel end, install hot crankshaft gear over key (8) on crankshaft (3). Allow crankshaft gear (7) to cool down. Remove screwdriver and thickness gage from crankcase.
- o. Check crankshaft end float clearance between crankcase and crankshaft gear (3). Clearance should be 0.004-0.0008 in. (0.10-0.20 mm). Crankshaft (3) should turn freely.

6.4.2 Install Rear Crankshaft Support. (Refer to figure 6-24.)

This task consists of: a. Installation

INITIAL SET-UP:

Tools:

- Wrench, Torque, 200 in lb
(Appendix B, Section III, Item 3)
- Extension, 6 in., 3/8 in. Drive
(Appendix B, Section III, Item 3)
- Socket, Socket Wrench, 6 mm
(Appendix B, Section III, Item 3)
- Bushing Extractor Tool, P/N 7736590
(Appendix B, Section III, Item 3)

Materials/Parts Required:

- Seal (Appendix I, Item 10)
- Bearing (Appendix I, Item 13)
- O-Ring (Appendix I, Item 25)

Equipment Condition:

Rear crankshaft support removed (para. 6.3.17)

NOTE

Alignment of rear main bearing (1) oil passage hole (2) and rear crankshaft support (3) oil holes must be maintained during installation of rear main bearing.

- a. Using bushing extractor tool, install engine rear main bearing (1) in rear crankshaft support (3).
- b. Install rear engine oil seal (4) in rear crankshaft support (3).
- c. Install O-ring (5) on rear crankshaft support (3).

NOTE

Two of the socket head cap screws (6) are slightly shorter than the other eight. They are to be inserted at the 11 and 12 o'clock screw holes.

- d. Position rear crankshaft support (3) and install ten socket head cap screws (6) attaching engine rear crankshaft support to crankcase.
- e. Using a crossing pattern, torque socket head cap screws (6) to 190-195 in. lbs (21-23 Nm).

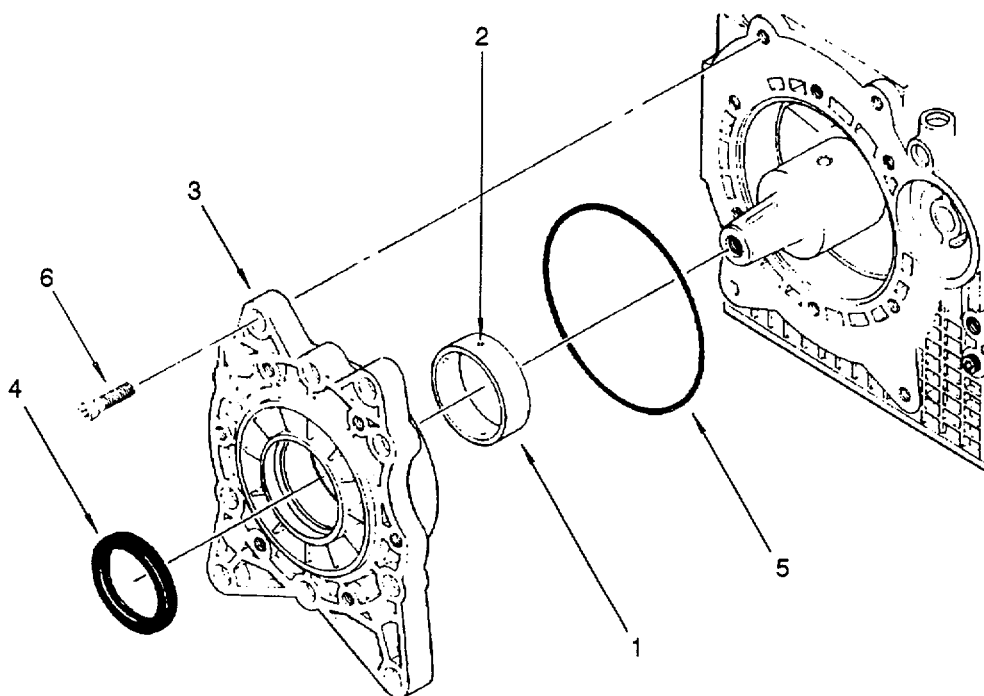

Figure 6-24. Rear Crankshaft Support Installation

6.4.3 Install Oil Pressure Relief Valve. (Refer to figure 6-25.)

This task consists of: a. Installation

INITIAL SET-UP:

Tools:

- Key, Socket Head Screw, 7 mm
(Appendix B, Section III, Item 3)
- Pliers, Snap Ring (.046 straight tips)
(Appendix B, Section III, Item 3)

Materials/Parts Required:

None

Equipment Condition:

Oil pan removed (para. 6.3.1)

- a. Position crankcase (1) bottom side up.
- b. Install oil pressure relief valve assembly (2) in crankcase (1).
- c. Install and tighten relief valve plug (3).

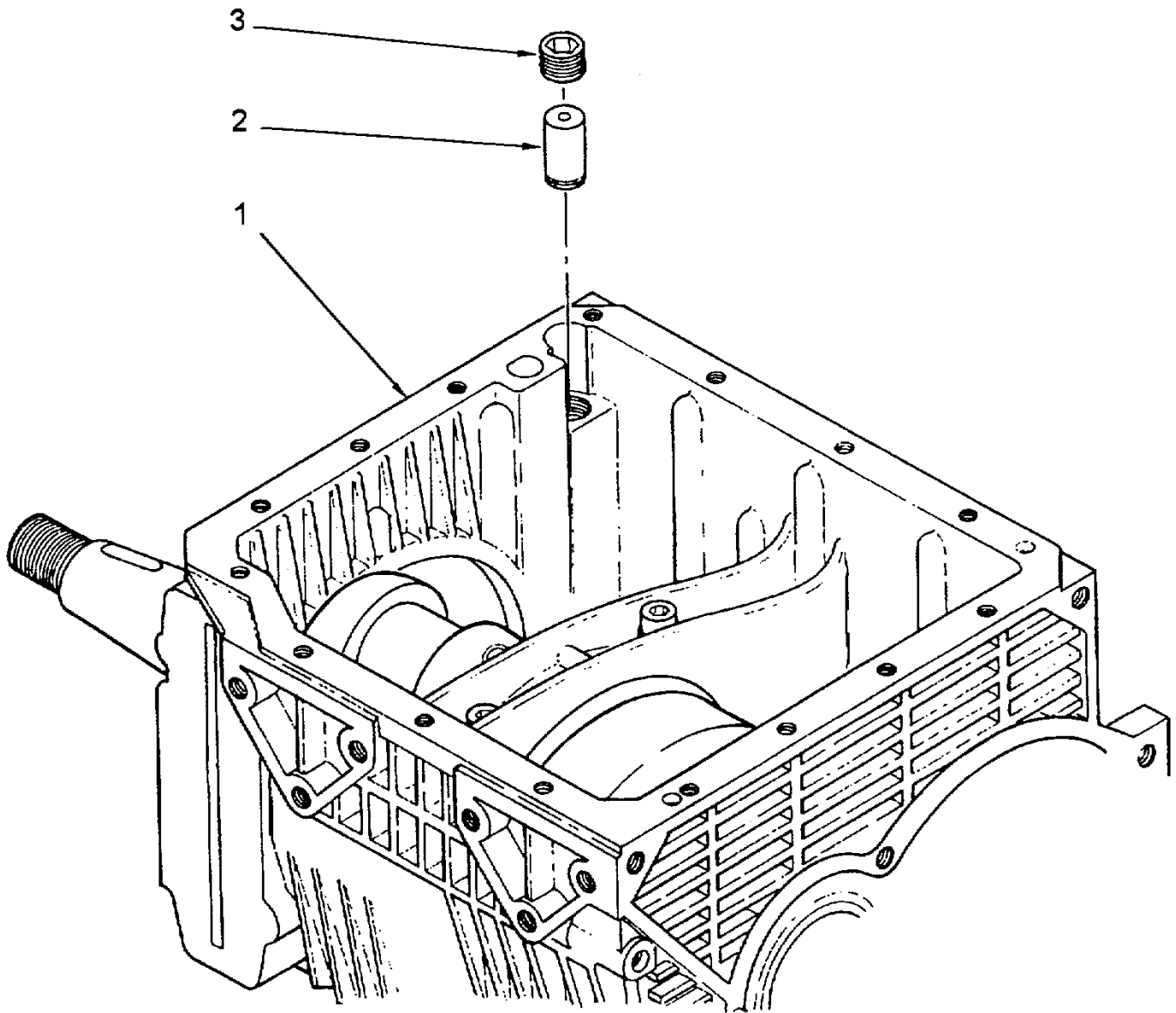

Figure 6-25. Oil Pressure Relief Valve Installation

6.4.4 Install Piston Rings. (Refer to figure 6-26.)

This procedure applies to either piston.

This task consists of: a. Installation

INITIAL SET-UP:**Tools:**

Caliper, Vernier
(Appendix B, Section III, Item 3)

Materials/Parts Required:

None

Equipment Condition:

Piston and rings removed (para. 6.3.12)

- a. Inspect cylinder, piston and piston rings.
 - (1) Insert the first compression ring (1) in the top of the cylinder. Measure and record the gap between the ends of the ring. Remove the ring and repeat the procedure with the second compression ring (2) and the oil scraper ring (3). If the ring gap is more than 0.02 inches or less than 0.01 inches, replace the cylinder.
 - (2) Measure and record the piston skirt diameter (4) between 0.200 and 0.393 inches from the base of the piston skirt.
 - (3) Measure and record the inside diameter of the cylinder.
 - (4) Subtract the piston skirt diameter (4) from the cylinder inside diameter. The difference should be 0.002 - 0.003 inches. If clearance is greater than 0.003 inches, replace cylinder/piston.
- b. Thoroughly clean piston (5) ensuring all carbon deposits are removed from piston top and ring grooves.
- c. Install rings on piston using the following steps:

NOTE**Install piston rings from top of piston.**

- (1) Install oil scraper ring (3) in bottom piston groove. Rotate ring to place gap in line with one end of piston pin (6).
 - (2) Install second compression ring (2) in middle piston ring groove with internal bevel toward top of piston (5). Rotate ring to place gap 120° in either direction from the gap in the oil scraper ring (3).
 - (3) Install first compression ring (1) in top piston groove. Rotate ring to place gap midway on the longer arc between oil scraper ring (3) gap and second compression ring (2) gap (120° from each of the other two rings).
- d. Inspect rings to ensure all three piston rings move freely in grooves. Check the clearance between each piston groove and each piston ring as follows. If any measurement exceeds the specified value, replace the piston.

- (1) First compression ring (1) must have 0.009 inches clearance.
- (2) Second compression ring (2) must have 0.007 inches clearance.
- (3) Oil scraper ring (3) must have 0.006 inches clearance

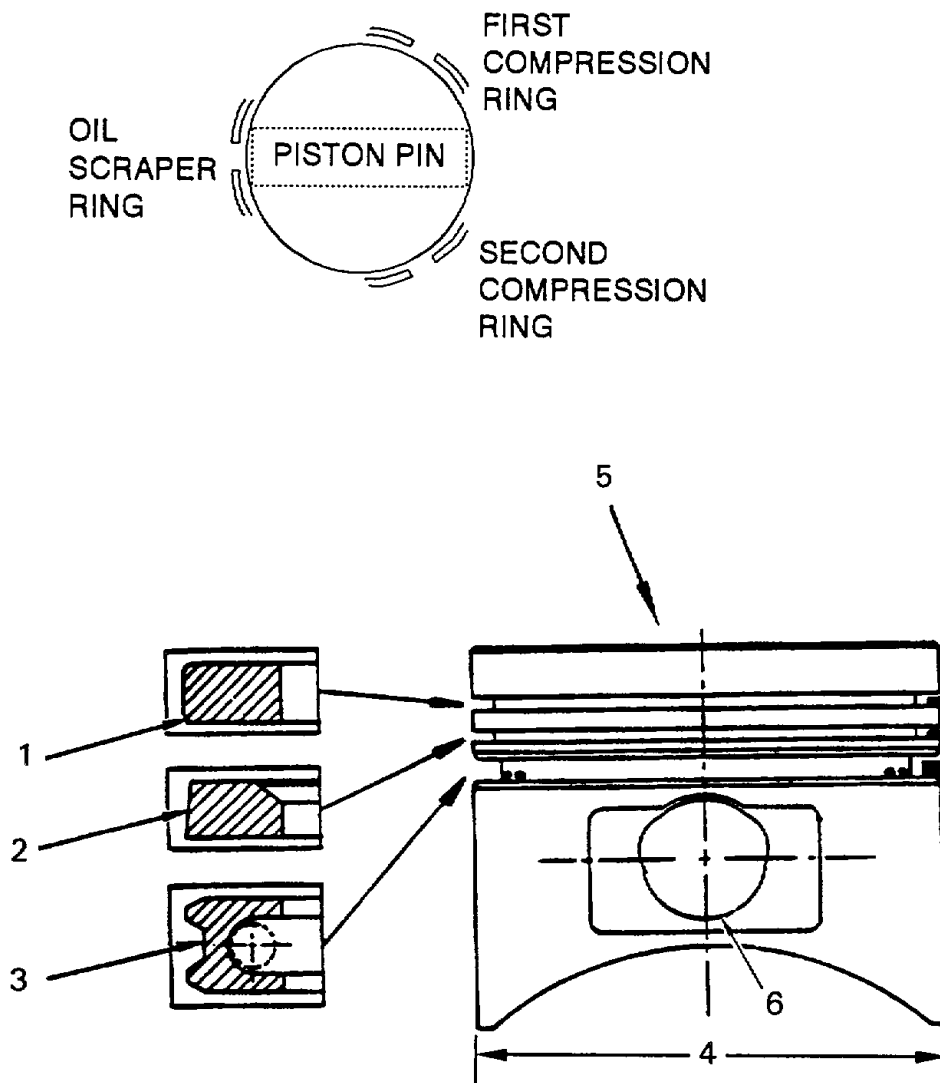

Figure 6-26. Piston Ring Installation

6.4.5 Check Cylinder. (Refer to figure 6-27.)

This procedure applies to either cylinder.

This task consists of: a. Installation

INITIAL SET-UP:**Tools:**

Caliper, Vernier
 (Appendix B, Section III, Item 3)
 Honing Kit, Cylinder
 (Appendix B, Section III, Item 3)
 Chemical and Oil Protective Gloves
 (Appendix B, Section III, Item 2)
 Goggles (Appendix B, Section III, Item 2)

Materials/Parts Required:

Solvent, Dry Cleaning, SD (P-D-680)
 (Appendix F, Section II, Item 2)

General Safety Requirements:**Equipment Condition:**

Cylinder head and cylinder removed (para. 6.3.11)

WARNING

Dry cleaning solvent is toxic and flammable. Wear Protective goggles and gloves. Use only in well Ventilated area. Avoid contact with skin, eyes and clothes. Do not breathe vapors. Do not use near open flame.

a. Check cylinder bore (1) for taper and out-of-round.

(1) Cylinder bore is checked for taper by measuring at bottom of finned area (2), middle of finned area (3) and top of finned area (4). Maximum difference between bottom of finned area and top of finned area is 0.002 in. (0.05mm). Measure middle of finned area approximately midway between bottom of finned area and top of finned area. Measure for out-of-round by measuring diameter of cylinder bore and then measuring again at 90° from first measurement. The two measurements must be within 0.002 in. (0.05 mm).

b. Inspect cylinder (5) for a ridge at top of finned area. A pronounced ridge is cause for replacement.

NOTE

Failure to properly hone cylinder can cause early failure and excessive oil consumption. Crosshatch pattern generally indicates proper honing.

c. Using a honing unit and 80 to 100 grit honing stones, hone cylinder wall to develop a 90° to 1200 cross hatch pattern.

WARNING

Dry cleaning solvent is toxic and flammable. Wear protective goggles and gloves. Use only in a well ventilated area. Avoid contact with the skin, eyes and clothes. Do not breathe vapors. Do not use near open flame or excessive heat. If you become dizzy while using the solvent get fresh air immediately as well as medical aid. If contact with eyes is made, flood your eyes with water and get immediate medical aid.

- d. Thoroughly clean cylinder with dry cleaning solvent to eliminate any residue from the honing process.

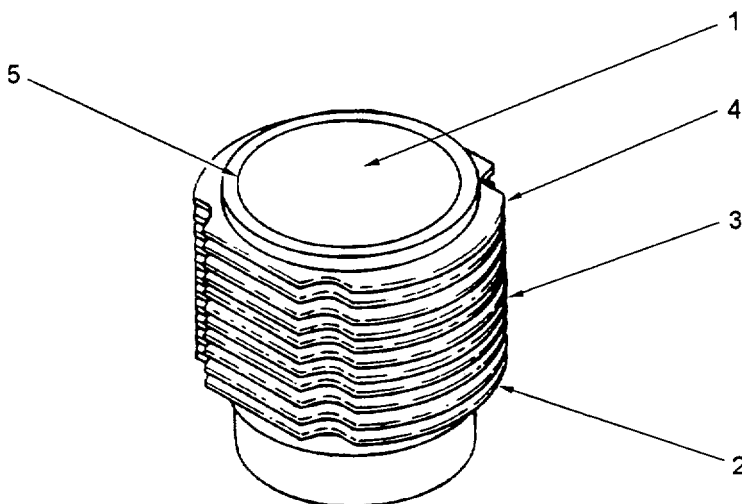

Figure 6-27. Cylinder Check

6.4.6 Install Piston Assembly and Cylinder. (Refer to figure 6-28.)

This task consists of: a. Removal b. Installation

INITIAL SET-UP:**Tools:**

Snap Ring Pliers (or Needle Nose)
(Appendix B, Section III, Item 3)
Socket, Socket Wrench, 14 mm
(Appendix B, Section III, Item 3)
Torque Wrench, 50 ft. lb. capacity
(Appendix B, Section III, Item 3)

Materials/Parts Required:

Bearings (Appendix I, Item 14)
Gasket (Appendix I, Item 24)

Equipment Condition:

Crankshaft installed (para. 6.4.1)
Piston rings installed (para. 6.4.4)
Cylinder checked (para. 6.4.5)

NOTE

The cylinder is off-set. Ensure cylinder (1) is correctly positioned inside cylinder studs (2).

- a. Turn flywheel so that crankshaft journal (3) for cylinder being installed is at TDC.
- b. Insert connecting rod (4) in piston (5). Install piston pin (6) through piston (5) and connecting rod (4). Install the two snap rings (7) to hold piston pin (6) in place.

NOTE

When installing piston, combustion chamber recess must be positioned toward injector side of engine. Bottom end of cylinders are chamfered for easier piston ring installation.

- c. Insert piston assembly (4 thru 7) up into bottom end of cylinder (1) until piston rings have passed into cylinder,
- d. Install cylinder gasket (8). Set cylinder (1) in crankcase (9). Press cylinder (1) into crankcase (9).
- e. Align and install new bearing half (10).

NOTE

Bearing halves (10) are keyed together one way. Connecting rod (4) and rod cap (11) are also keyed together one way.

- f. Install new bearing half (10) on rod cap (11).
- g. Position connecting rod (4) around crank shaft journal (3). Insert and start cap screws (12) in rod cap (11).
- h. Install and torque cap screws (12) to 26 to 30 ft. lbs. (35-41 Nm).

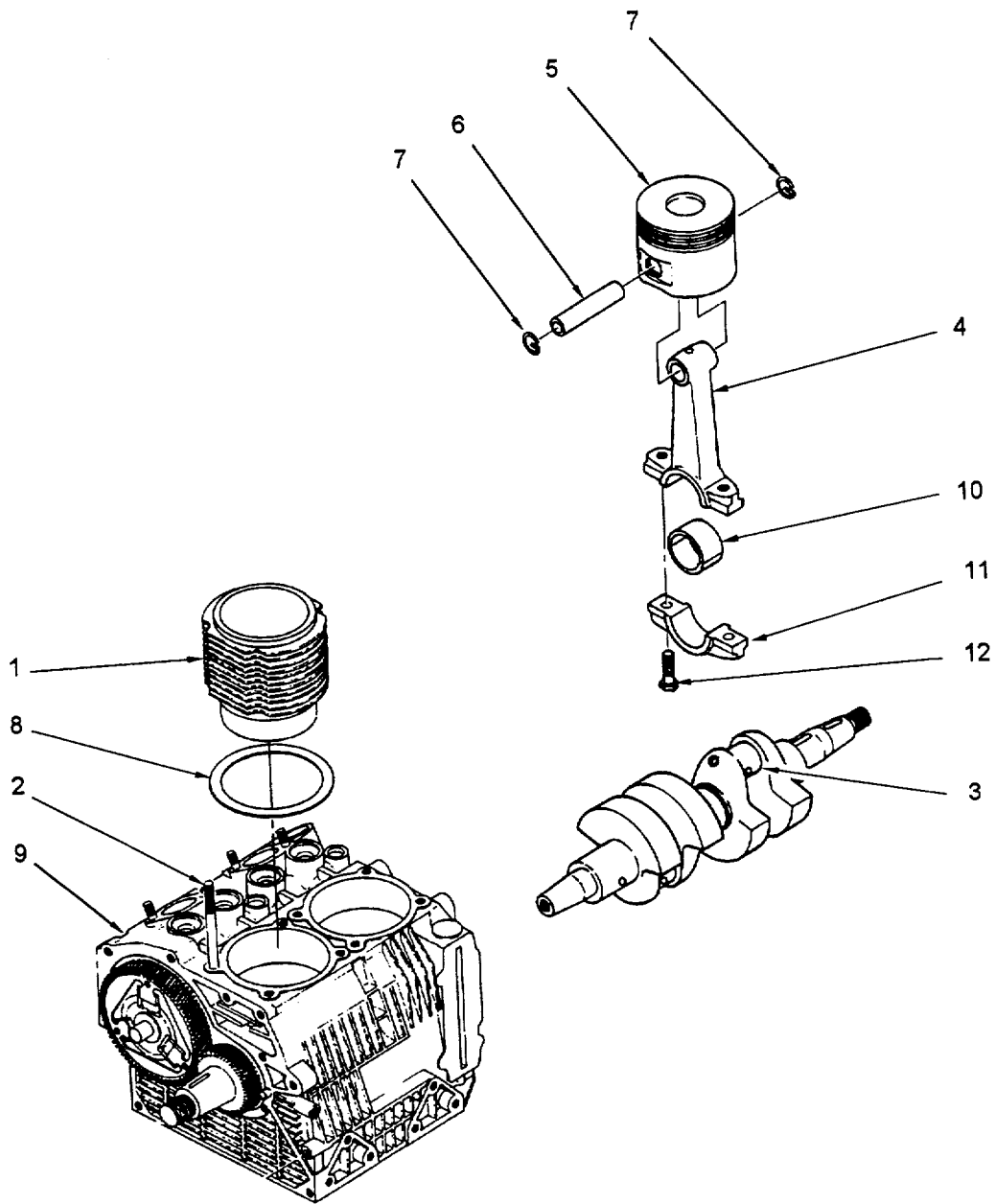

Figure 6-28. Piston Assembly Installation

6.4.7 Install Camshaft.

This task consists of: a. Inspection b. Installation

INITIAL SET-UP:

Tools:

Dial caliper
(Appendix B, Section III, Item 3)
Micrometer
(Appendix B, Section III, Item 3)

Materials/Parts Required:

None

Equipment Condition:

Camshaft and tappets removed (para. 6.3.16)
Crankshaft installed (para. 6.4.1)

Refer to figure 6-29.

- a. Clean and inspect camshaft gear (1) for worn or broken teeth and loose or unserviceable counter weights (2).
- b. Using dial caliper inspect camshaft (3) and bearing surfaces for wear in accordance with the following. If any measurement is out of tolerance, replace the camshaft.

- (1) Valve lifter cams (A) must be no less than 1.366 inches from tip of cam to opposite point.
- (2) Flattened injection pump cams (B) must be no less than 1.377 inches from center of flattened area to opposite point.
- (3) Fuel pump cam (C) must be no less than 0.984 inches in diameter.
- (4) Outer bearing surface (D) must be no less than 0.708 inches in diameter.
- (5) Inner bearing surface (E) must be no less than 1.690 inches in diameter.

NOTE

Valve tappets to be reused were marked for reinstallation and should be installed in same bores.

- c. Using a micrometer check tappets for wear. Small end of tappet (F) must be 0.471-0.472 in. (11.977-11.993 mm) in diameter. If not within limits, replace tappet.

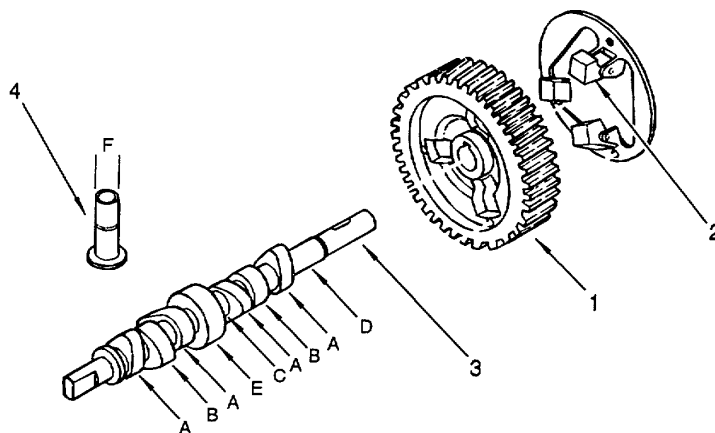

Figure 6-29. Camshaft Inspection

Refer to figure 6-30.

- d. Position crankcase so tappets (1) will not fall out during installation. Install intake and exhaust valve tappets (1) in crankcase bores.
- e. Install camshaft. Ensure timing marks (2) on camshaft gear are on either side of timing mark (3) on crankshaft gear.

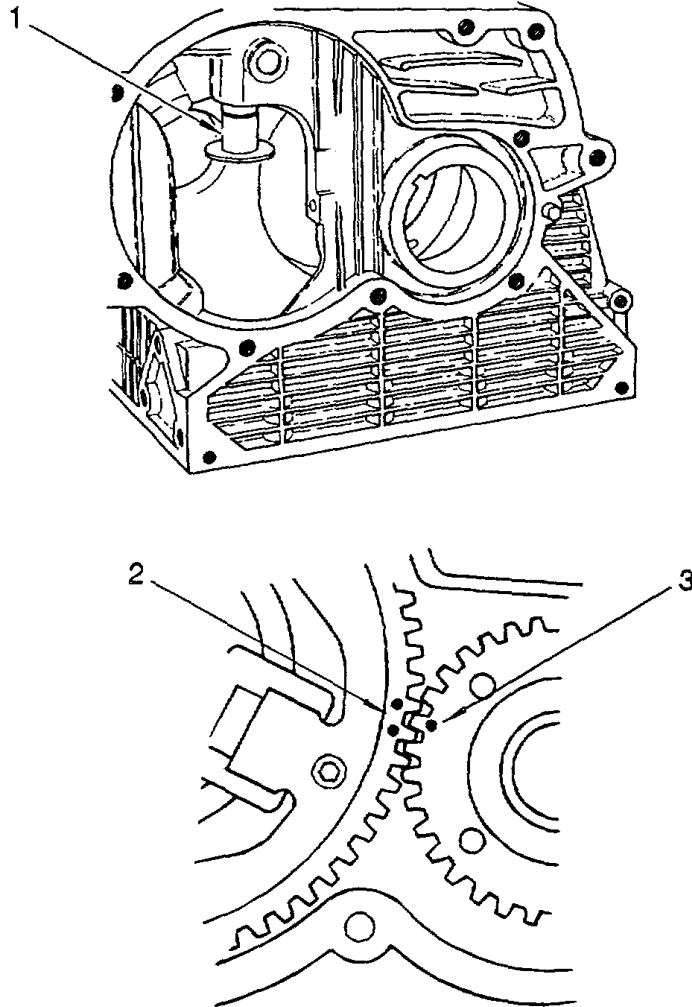

Figure 6-30. Camshaft and Tappet Installation

6.4.8 Install Governor Assembly and Speed Control.

This task consists of: a. Installation/Adjustments

INITIAL SET-UP:

Tools:

Caliper, Vernier (Appendix B, Section III, Item 3)
 Socket, Socket Wrench, 10 mm
 (Appendix B, Section III, Item 3)
 Combination Wrench, 19 mm
 (Appendix B, Section III, Item 3)
 Handle, Socket Wrench, Ratchet, 3/8" Drive
 (Appendix B, Section III, Item 3)
 Key, Socket Head Screw, 8 mm
 (Appendix B, Section III, Item 3)
 Screwdriver, Flat Blade (1/8 x 6 in.)
 (Appendix B, Section III, Item 3)

Materials/Parts Required:

Rubber Band, No. 18
 (Appendix F, Section II, Item 20)
 O-Ring (Appendix I, Item 25)
 Clip, Retaining (Appendix I, Item 9)

Equipment Condition:

Camshaft installed (para. 6.4.7)

Refer to figure 6-31.

NOTE

- **The adjustments described in the following steps are critical to proper operation of the engine. Improper adjustment will cause RPM fluctuation, hard starting and loss of engine power.**
- **Installation of the governor assembly and speed control involves shifting the camshaft in and out of the crankcase to provide access for installation of governor assembly and speed control.**

- a. Using a vernier caliper, adjust governor rod (1) until the distance (A) between governor rod bearing holes is 1.476 in. (36.5 mm) center to center, ± 1 turn.
- b. Assemble the two pieces (2 and 3) of the governor assembly (4), using a rubber band to temporarily hold those two pieces of the governor assembly together. Attach governor rod (1) to governor assembly.

NOTE

For ease of installation of the governor assembly, as necessary, partially remove the camshaft to gain access during installation of the governor assembly.

- c. Lift the camshaft enough to insert and align the governor assembly in the crankcase. Insert the governor journal (5) through external crankcase hole (6), through the holes (7) in the governor assembly (4) and into mounting hole on opposite side of crankcase. Press governor journal (5) into position. Ensure governor is free to move without binding. Remove rubber band.
- d. Install washer (8) and governor plug (9) over the governor journal (5).
- e. Install O-ring (10) on inside speed control lever (11).
- f. Attach governor spring (12) to inside engine speed control lever (11).

NOTE

It may be necessary to rotate camshaft to allow for installation of speed control lever. After completion of speed control lever installation, ensure timing marks on camshaft gear are on either side of timing mark on crankshaft gear (figure 6-30).

- g. Install inside speed control lever (11, figure 6-31) from inside crankcase. On outside of crankcase install retaining clip (13) on inside speed control lever (11).

NOTE

Ensure retaining spring (14) is installed so the governor (4) has full freedom of movement and does not come in contact with the crankcase.

- h. Attach governor spring (12) to governor assembly connection point (2). Install retaining spring (14).
- i. Install safety plate (15) and mounting screw (16).

NOTE

Compression washers (18) are concave. When reassembling, the concave faces of the washers should face each other.

- j. Position compression springs (17), compression washers (18), compression springs (19) and throttle lever (20) on speed control lever (11).

NOTE

The safety plate (15) should be moveable, but not move freely, after tightening screw (21).

- k. Install and tighten screw (21) and washer (22).

Refer to figure 6-32.

NOTE

Set screw (1) adjusts top end RPM of engine. The set screw (1) has a small "indented dot" which should be positioned at 7:00 o'clock. This will provide a top engine speed of approximately 3600 RPM.

- l. Install set screw (1) and jam nut (2) in crankcase. Install protective cover (3).

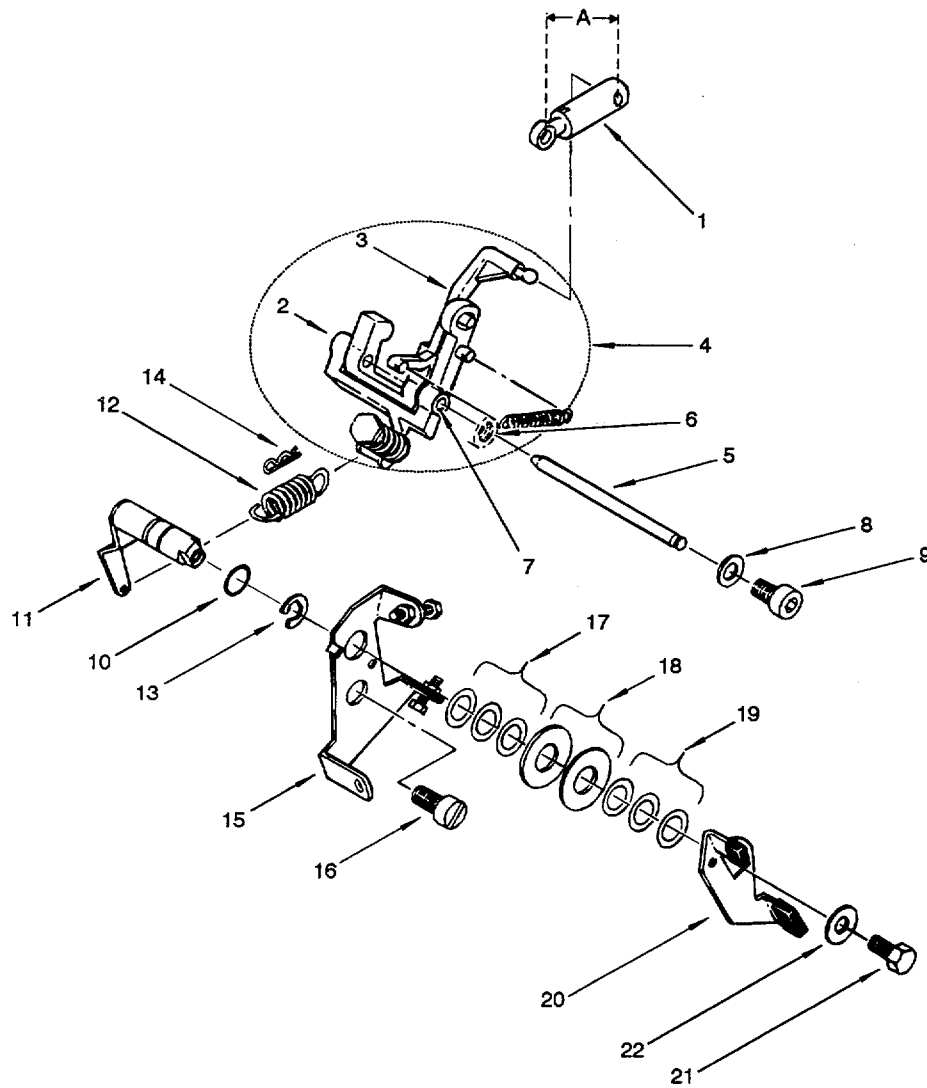

Figure 6-31. Governor and Speed Control Installation

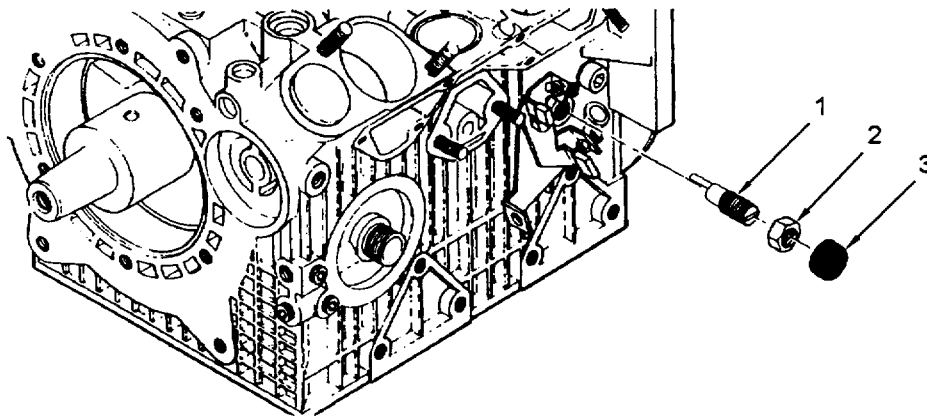

Figure 6-32. High Speed Adjustment Installation

6.4.9 Install Oil Pump. (Refer to figure 6-33.)

This task consists of: a. Installation

INITIAL SET-UP:**Tools:**

Combination Wrench, 7 mm
(Appendix B, Section III, Item 3)
Key, Socket Head Screw, 4 mm
(Appendix B, Section III, Item 3)
Torque Wrench, 75 in. lb capacity
(Appendix B, Section III, Item 3)

Materials/Parts Required:

O-Ring (Appendix I, Item 27)

Equipment Condition:

Oil pump removed (para. 6.3.13)
Camshaft installed (para. 6.4.7)

- a. Position O-ring (1) in oil pump cover (2).
- b. Insert external oil pump rotor (3) in oil pump cover (2) with bevel facing oil pump cover.
- c. Install internal oil pump rotor (4) on camshaft (5).
- d. Insert oil pump cover (2) with external oil pump rotor (3) over internal oil pump rotor (4) on camshaft (5).
- e. Install two oil pump cover socket head screws (6).
- f. Install and tighten nut (7) attaching oil pump cover (2) to crankcase.
- g. Torque socket head screws (6) to 43-52 in. lbs (5-6 Nm).

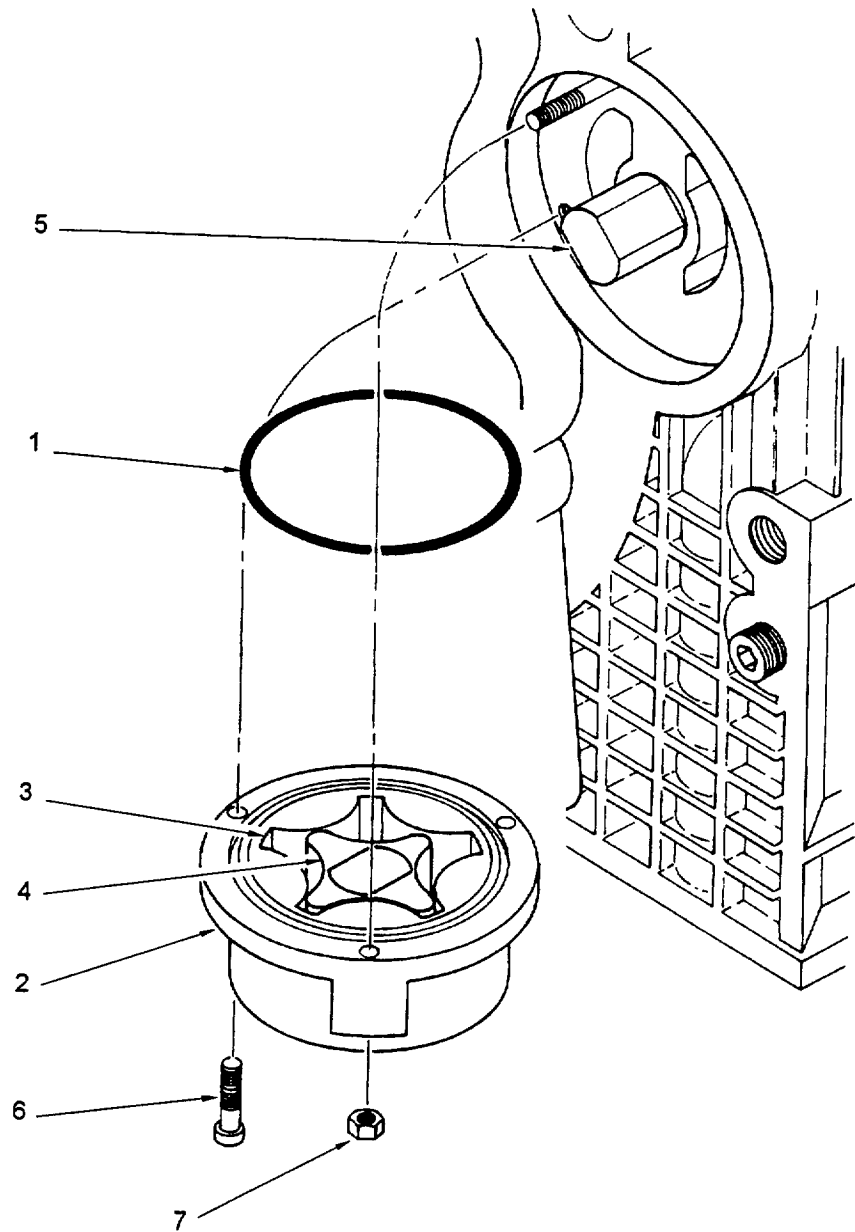

Figure 6-33. Oil Pump Installation

6.4.10 Install Timing (Pulley End) Cover. (Refer to figure 6-34.)

This task consists of: a. Installation

INITIAL SET-UP:

Tools:

- Socket, Hex Driver, 6 mm
(Appendix B, Section III, Item 3)
- Torque Wrench, 0-250 in. lb.
(Appendix B, Section III, Item 3)

Materials/Parts Required:

- Seal, Oil (Appendix I, Item 10)
- Gasket, Timing Cover (Appendix I, Item 15)

Equipment Condition:

- Camshaft installed (para. 6.4.7)

- a. Insert new oil seal (1) in timing cover (2).
- b. Attach new timing cover gasket (3) to crankcase (4).

NOTE

Two stator wire clamps are attached to timing cover with two of the ten cap screws attaching timing cover. These two cap screws (5) and flat washers (6) do not need to be torqued down until the procedure attaching the stator to timing cover (2). The two screws (5) are located at the 5 and 6 o'clock positions of the timing cover (2).

- c. Install the ten socket head cap screws (7) attaching timing cover (2) to crankcase (4). Torque to 190 to 195 in. lbs. (21-23 Nm).
- d. Attach crankcase breather hose (8) to timing cover (2).

6.4.11 Check Piston Protrusion. (Refer to figure 6-35.)

This procedure applies to both/either cylinder.

This task consists of: a. Adjustment

INITIAL SET-UP:

Tools:

- Feeler Gauge with 0.004 and 0.008 inch leaves
(Appendix B, Section III, Item 3)
- Machinists Rule
(Appendix B, Section III, Item 3)

Materials/Parts Required:

- Gasket, Cylinder (Appendix I, Item 24)

Equipment Condition:

- Piston assembly installed in cylinder (para. 6.4.6)

- a. Slowly rotate flywheel to the right until piston (1) is at TDC (highest point).

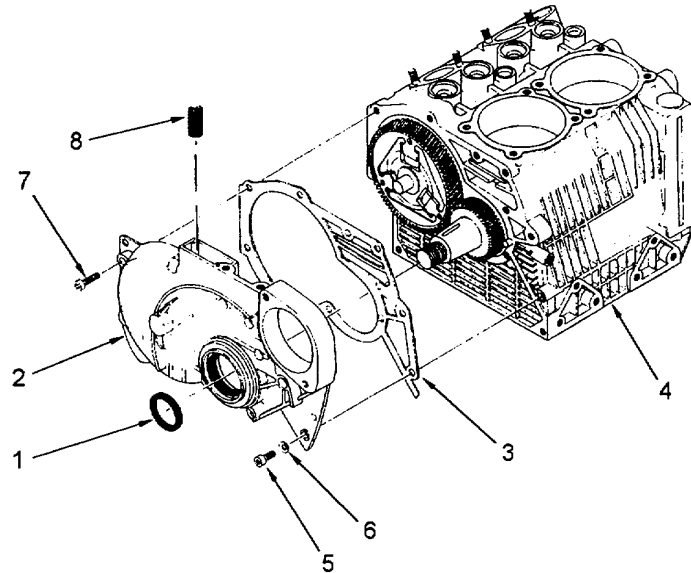

Figure 6-34. Timing Cover Installation

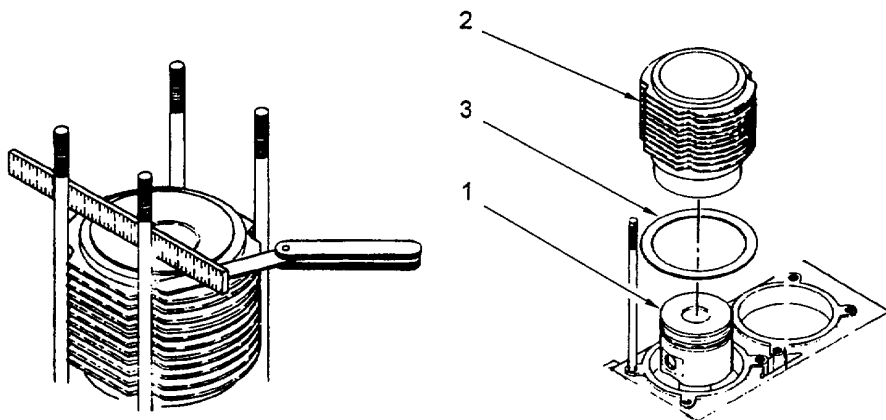

Figure 6-35. Piston Protrusion Check

- b. Using a feeler gauge and a machinist's rule (or other straight edge) as illustrated below, verify piston (1) is above top of cylinder (2) by 0.004 to 0.008 in. (0.1-0.2 mm). If measurement is within this range, piston (1) protrusion is satisfactory. If reading is less than 0.004 in. (0.1 mm) above top of cylinder (2), gaskets (3) must be added between cylinder and crankcase. If reading is more than 0.008 in. (0.2 mm) above top of cylinder (2), gaskets (3) must be removed between cylinder and crankcase.

NOTE

When adding or removing cylinder gaskets (3), measure thickness of gasket(s) to ensure proper range will be attained.

- c. Remove cylinder (1) from piston (2). Add or remove gaskets (3) as required to obtain piston (1) protrusion of 0.004 to 0.008 in. (0.1-0.2 mm).
- d. Refer to paragraph 6.4.6 for cylinder installation.

6.4.12 Assemble Cylinder Head. (Refer to figure 6-36)

This task consists of: a. Repair b. Assembly

INITIAL SET-UP:**Tools:**

Caliper, Vernier
 (Appendix B, Section III, Item 3)
 Depth Micrometer
 (Appendix B, Section III, Item 3)
 Key, Socket Head Wrench, 8 mm
 (Appendix B, Section III, Item 3)
 Valve Grinding Kit
 (Appendix B, Section III, Item 3)
 Valve Spring Compressor
 (Appendix B, Section III, Item 3)
 Torque Wrench, 50 ft. lb capacity

Materials/Parts Required:

Lapping Compound
 (Appendix F, Section II, Item 21)
 Washer, Copper (Appendix I, Item 33)
 O-Ring (Appendix I, Item 75)

Equipment Condition:

Cylinder head disassembled (para.6.3.20)

- a. Using a dial caliper, measure journals, cylinder head and rocker arms for excessive wear in accordance with the following.
 - (1) Measurement A (Cylinder Head Rocker Arm Cavity): 0.355-0.356 in. (9.03-9.06 mm) in width at the position of the journal hole.
 - (2) Measurement B (Rocker Arm Journal Hole): 0.591-0.592 in. (15.03-15.05 mm) in diameter.
 - (3) Measurement C (Rocker arm): 0.352-0.354 in. (8.93-8.98 mm) in width at the position of the journal hole.
 - (4) Measurement D (Journal): 0.590-0.591 in. (14.99-15.00 mm) in diameter at the narrow end.
- b. Remove carbon deposits from cylinder head (1). Check cylinder head (1) combustion chamber for deformation. If deformed, smooth out to a maximum depth of 0.010 in. (0.254 mm). If deformation remains after smoothing of combustion chamber, replace cylinder head (1).
- c. Measure valve stem diameter (a) and valve guide inner diameter (b) for each valve. If the difference between the two measurements is greater than 0.004 in. (0.10 mm), replace the valve (4 or 6) and the valve guide (5 or 7).
- d. Using a 45 degree seat grinding wheel, carefully polish the hardened surface of valve seat faces (2 and 3) in cylinder head (1) until an even seating surface is achieved.
- e. Coat valve seat faces (2 and 3) with lapping compound.
- f. Place a new intake valve (4) in valve guide (5) in cylinder head (1). Using a valve lapper, lap intake valve (4) until a perfect finished surface is achieved on valve seat (2).
- g. Place a new exhaust valve (6) in valve guide (7) in cylinder head (1). Using a valve lapper, lap exhaust valve (5) until a perfect finished surface is achieved on valve seat (1).
- h. Remove both valves and clean all lapping compound from cylinder head valve seat faces (2 and 3) and valves.

- i. Install intake and exhaust valve rings (8).
- j. Install intake and exhaust valve guide seals (9).
- k. Install intake and exhaust lower valve spring retainers (10).
- l. Install intake valve (4) in valve guide (5) and exhaust valve (6) in valve guide (7). Position both valves in cylinder head (1).

NOTE

Depth measurement between valve faces and cylinder head surface is critical. If not within tolerance, piston and valve may strike each other and cause damage.

- m. Using a depth micrometer, check depth of valve faces (11 and 12) relative to cylinder head surface (13). The measurements must be 0.031 to 0.051 in. (0.8 to 1.3 mm).
- n. Assemble valve spring (14) and upper valve spring retainer (15). Install intake valve (4) stem. Use valve spring compressor or equivalent to push down on upper valve spring retainer (15) and install valve cotters (16).
- o. Repeat procedure (step n) for exhaust valve (6).

NOTE

For clarity of illustration, the exhaust rocker arm assembly is not illustrated. Assembly is the same as the intake rocker arm (19).

- p. Loosely install rocker arm adjusting screw (17) and jam nut (18) in rocker arm (19). The rocker arm screw (17) and jam nut (18) will be secured during valve adjustment procedure.
- q. Install rocker arm (19) in cylinder head (20).
- r. Install rocker arm journal (21) through cylinder head and into rocker arm (19) with new copper washer (22).
- s. Position spacer (23) flush on decompression arm (24) shaft.
- t. Lightly lubricate with petrolatum and install O-ring (25) on decompression arm (24).
- u. Mate small hole (26) in decompression arm (24) with tang (27) on spring (28) and slide decompression arm into place in cylinder head (20).
- v. Install screw (29) to attach decompression arm (24) to cylinder head (20).

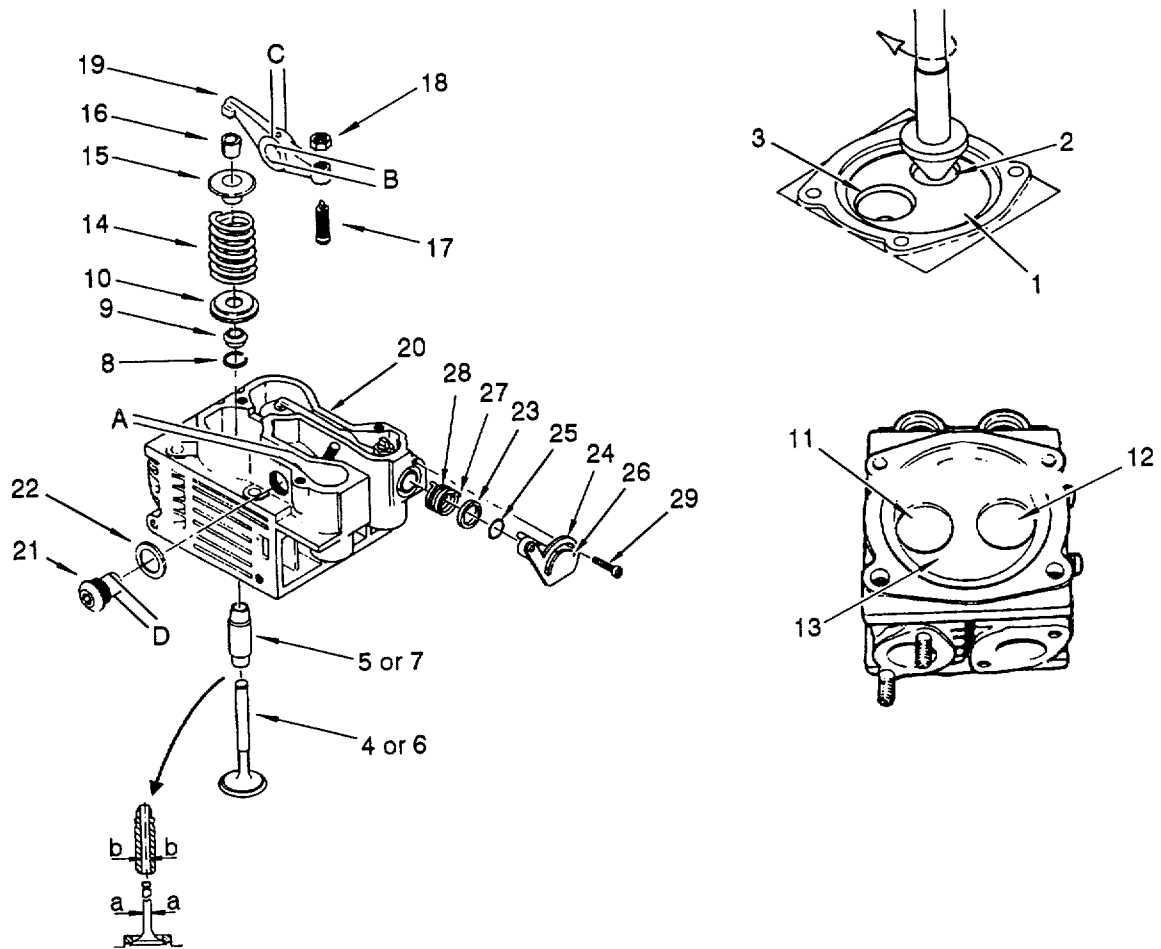

Figure 6-36. Cylinder Head Repair and Assembly

6.4.13 Install Cylinder Head.

This procedure applies to either or both cylinder heads.

This task consists of: a. Adjustment b. Installation

INITIAL SET-UP:**Tools:**

Torque Wrench, 50 ft. lb. capacity
(Appendix B, Section III, Item 3)
Socket, Socket Wrench, Deep Well, 13 mm
(Appendix B, Section III, Item 3)
Handle, Socket Wrench, Ratchet
(Appendix B, Section III, Item 3)
Straight Edge
(Appendix B, Section III, Item 3)
Depth Micrometer
(Appendix B, Section III, Item 3)

Materials/Parts Required:

Gasket (Appendix I, Item 20)
O-Ring (Appendix I, Item 26)

Equipment Condition:

Cylinder head assembled (para. 6.4.12)
Timing cover installed (6.4.10)
Piston protrusion checked (para. 6.4.11)

Refer to figure 6-37.

- a. Clean each pushrod (1). Ensure lubrication passages in pushrods are clean and clear.
- b. Measure overall length of pushrod (2). Using a depth micrometer, measure depth of pushrod cup (3). Subtract cup depth from overall length. The result should be 6.362-6.386 in. (161.6-162.2 mm). If measurement is out of tolerance, replace pushrod.
- c. While holding cylinder in place, slowly turn engine crankshaft to position piston at Top Dead Center (TDC).
- d. Clean carbon, dirt and other foreign material from piston surface. Remove any remaining gasket materials.

Refer to figure 6-38.

- e. Insert the same number of copper washers (1) in fuel injector port as were removed from cylinder head (2).
- f. Temporarily secure fuel injector in cylinder head by installing injector (3), brace (4), flat washer (5) and nut (6) on stud (7). Tighten nut.
- g. Using a depth gauge (8), measure protrusion of fuel injector tip (9) into combustion chamber (10) of cylinder head. Protrusion should be 0.069-0.088 in. (1.75-2.25 mm). If adjustment is required, remove the fuel injector and remove or add new copper washer(s) (1) to adjust the tip protrusion.
- h. Remove fuel injector (3), brace (4), flat washer (5) and nut (6) after protrusion check is completed.

Refer to figure 6-39.

- i. Install new O-rings (1) on the pushrod pipes (2) and insert pipes in crankcase. Insert pushrods (3) in same pipes they were removed from.

- j. Install new head gasket (4) on cylinder and install cylinder head.
- k. Install cylinder head (5) on cylinder. Ensure pushrods are aligned with rocker arms (6) and pushrod pipes are aligned with cylinder head.
1. Install cylinder head nuts (7) and washers (8) finger tight, with lifting eye studnut in same location as observed during removal.

Refer to figure 6-40.

- m. Place a straight edge (1) across intake and exhaust ports to align the cylinder heads. Use a 13 mm socket to snug the cylinder head nuts (2).
- n. Gradually torque the head nuts in an alternating diagonal pattern. to 15 ft. lbs. (21.8 Nm), then to 23 ft. lbs. (33.5 Nm) and finally to 30 ft. lbs. (43.7 Nm).

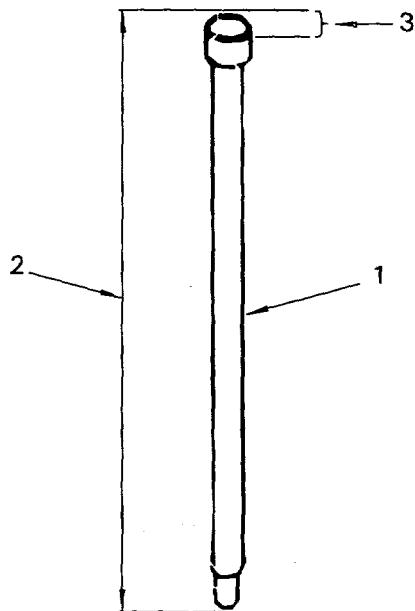

Figure 6-37. Pushrod Measurement

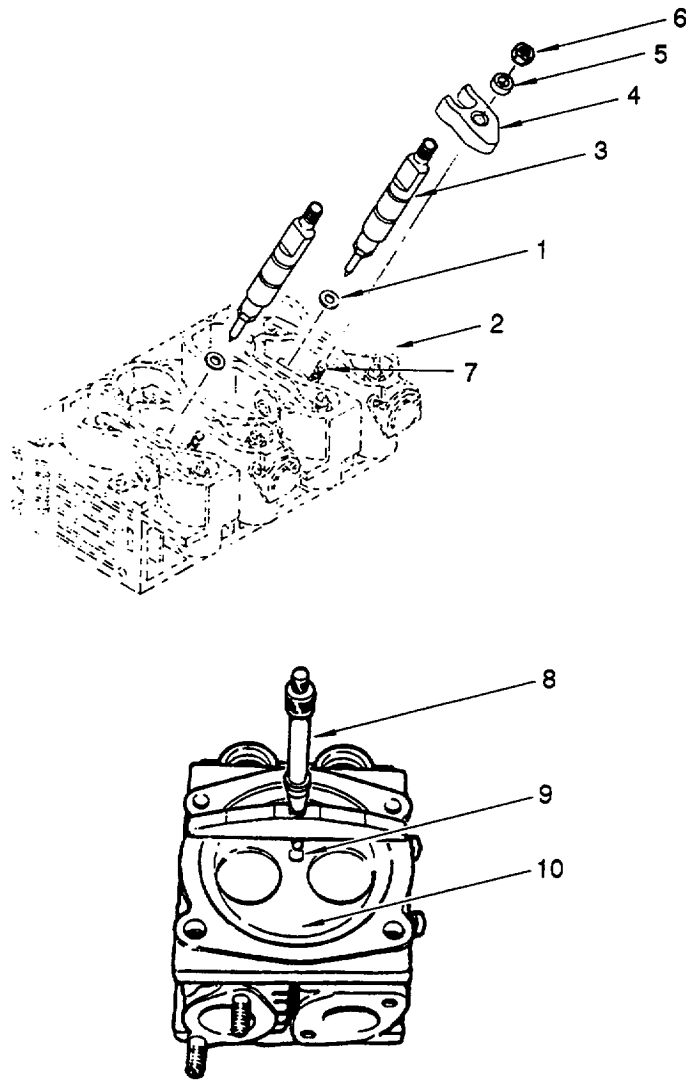

Figure 6-38. Injector Protrusion Measurement

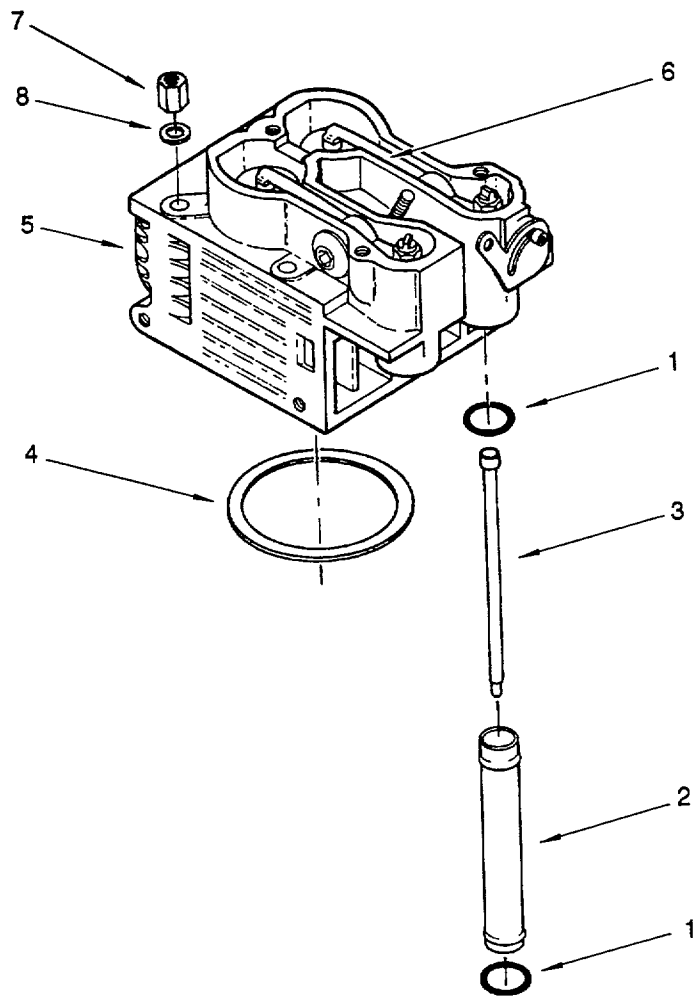

Figure 6-39. Cylinder Head Installation

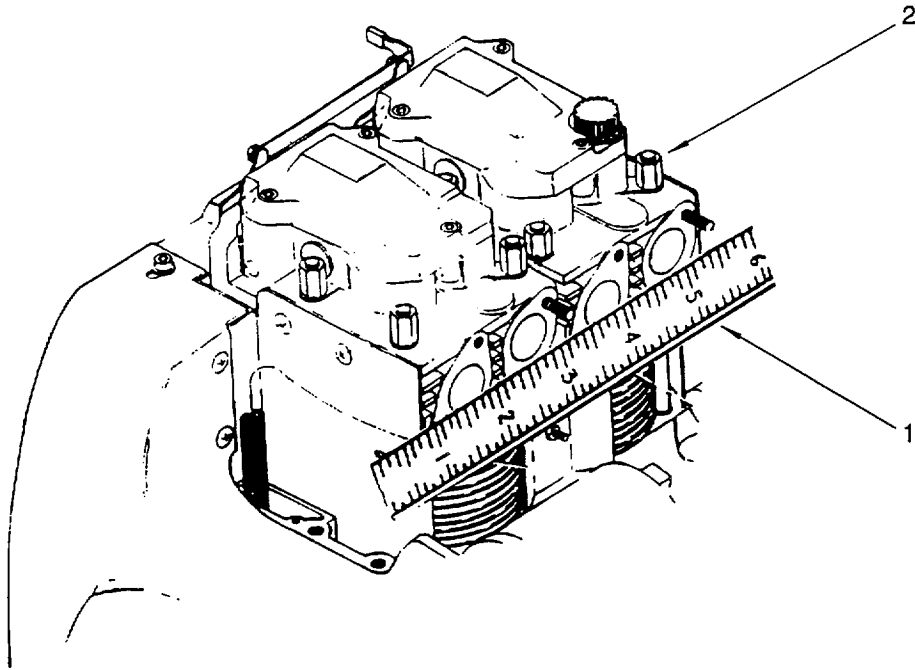

Figure 6-40. Cylinder Head Alignment

6.4.14 Install Flywheel/Alternator Rotor and Stator. (Refer to figure 6-41.)

This task consists of: a. Installation

INITIAL SET-UP:**Tools:**

Socket, Hex Driver, 4 mm
 (Appendix B, Section III, Item 3)
 Socket, Hex Driver, 5 mm
 (Appendix B, Section III, Item 3)
 Socket, Hex Driver, 6 mm
 (Appendix B, Section III, Item 3)
 Soft Tip Hammer/Mallet
 (Appendix B, Section III, Item 3)
 Torque Wrench, 200 ft. lb. capacity
 (Appendix B, Section III, Item 3)
 Socket, Socket Wrench, 1-5/8 in.
 (Appendix B, Section III, Item 3)
 Handle, Socket Wrench, Ratchet
 (Appendix B, Section III, Item 3)

Materials/Parts Required:

None

Equipment Condition:

Cylinder heads installed (para. 6.4.13)

-
- a. Insert tab/key (1) on crankshaft.
 - b. Position the alternator rotor (2) in the flywheel (3). Install the five socket head cap screws (4) attaching the rotor to the flywheel.
 - c. Position the alternator stator (5) on the timing cover (6).
 - d. Remove two washers (7) and socket head cap screws (8) located at the 5 and 6 o'clock position on the timing cover (6).
 - e. Attach a cable clamp (9) under each removed washer (7) and socket head cap screw (8). Install screws (8) with cable clamps (9). Lace wire attached to stator (5) under cable clamps (9) and through hole in timing cover (6) above socket head screw (8) and clamp at 5 o'clock position. Ensure wires connected to the stator (5) will be clear of the rotor (2).
 - f. Torque the two socket head screws (7) to 190 to 195 in. lbs (21-23 Nm).
 - g. Install the four socket head cap screws (10) attaching the stator (5) to the timing cover (6).
 - h. Using a soft tip hammer/mallet, position and tap the roll pin (11) in flywheel (3).
 - i. Install flywheel (3), net (12), spacer (13), pulley (14), washer (15) and nut (16) on crankshaft. Lock flywheel (3) in position.
 - j. Torque nut (10) to 130-135 ft. lbs. (19.7 Nm).

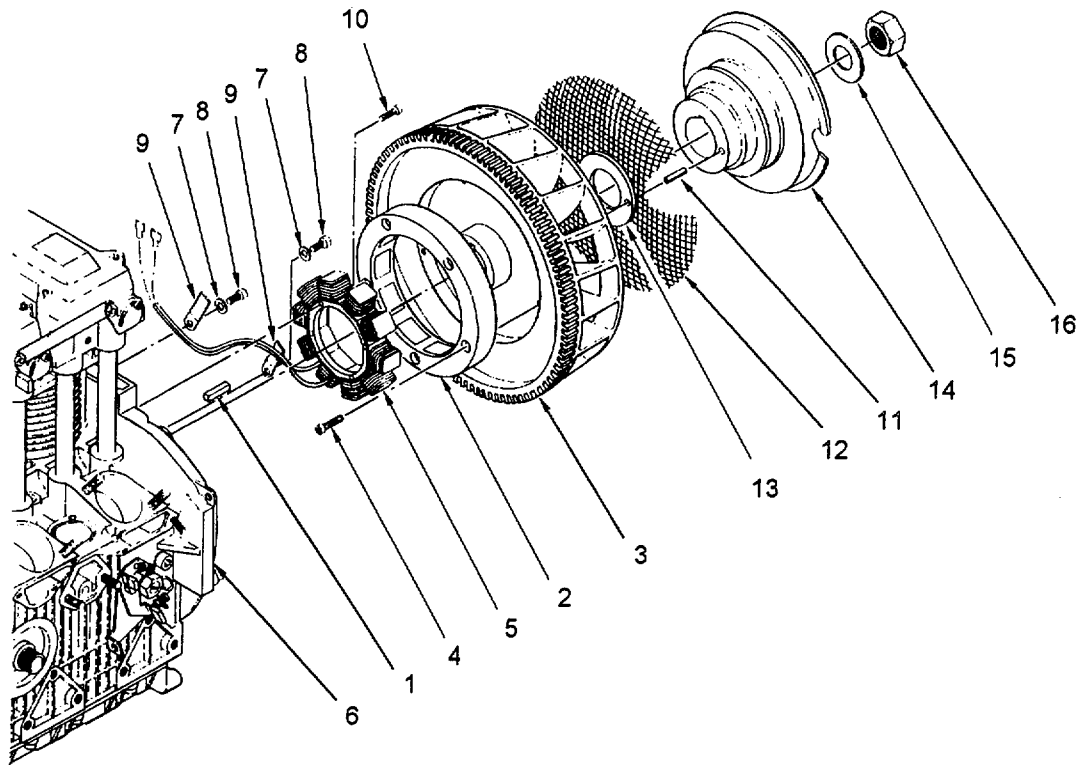

Figure 6-41. Flywheel/Alternator Installation

6.4.15 Install Intake Manifold.

Refer to paragraph 4.14.6.

6.4.16 Install Exhaust Manifold.

Refer to paragraph 4.14.5.

6.4.17 Adjust Valves.

Refer to paragraph 4.14.3.

6.4.18 Install Injection Pump. (Refer to figure 6-42.)

This task applies to either injection pump.

This task consists of: a. Installation

INITIAL SET-UP:**Tools:**

Combination Wrench, 13 mm
 (Appendix B, Section III, Item 3)
 Combination Wrench, 17 mm
 (Appendix B, Section III, Item 3)
 Pliers, Needle Nose
 (Appendix B, Section III, Item 3)

Materials/Parts Required:

Safety wire, 0.032
 (Appendix F, Section II, Item 22)
 Gasket (Appendix I, Item 16)

Equipment Condition:

Injection pump installed (para. 6.4.18)

- a. Install tappet (1) in crankcase (2). If reinstalling previously used tappet, ensure tappet is reinstalled in same hole.

NOTE

Injection pumps are supplied by two different manufacturers: Ruggerini and Bosch. Ruggerini injection pumps do not have expansion plugs (3).

- b. Install expansion plug (3) in crankcase (2).
 c. Install gaskets (4) in crankcase (2).
 d. Rotate flywheel counterclockwise until tappet (1) is resting in down position.

NOTE

When installing spring clips (5), run a length of safety wire through the eye of the clip to prevent the clip from falling into the crankcase (2).

- e. Attach control rod (6) to governor joint (7) and secure with spring clip (5).
 f. Position injection pump (8) in crankcase (2). Ensure injection pump (8) is in same position as it was removed from. Ensure same number of gaskets (4) that were removed are placed between fuel injection pump (8) and crankcase (2).

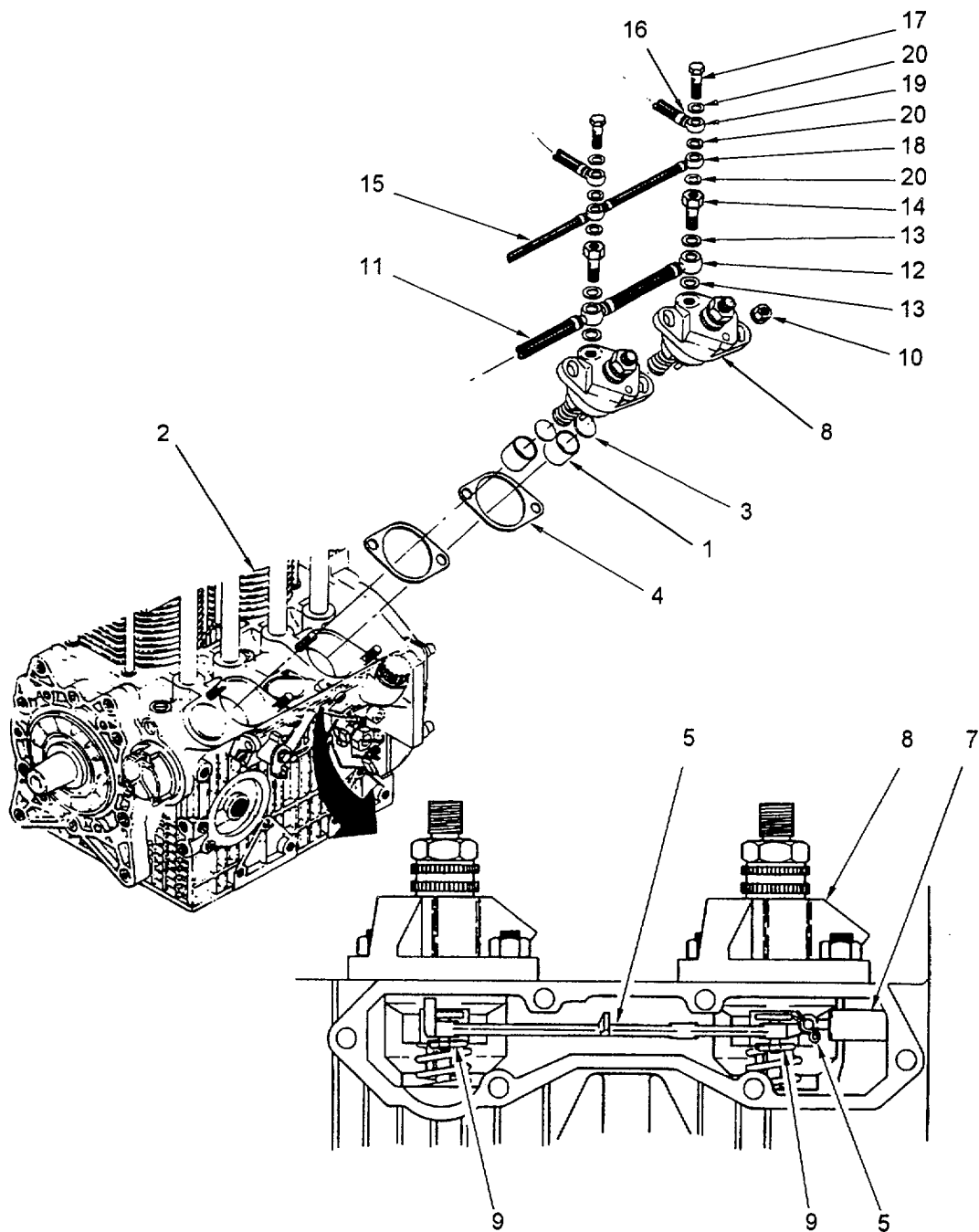

Figure 6-42. Injection Pump Installation

- g. Attach control rod (6) to fuel injection pump(s) (8) and secure with spring clip (9).
- h. Install nuts (10) securing injection pumps (8) to crankcase (2).

NOTE

For steps "i" and "j", install previously removed washers (13 and 20) that were saved for use later in injector pump timing and delivery tests.

- i. Connect fuel supply line (11) (to fuel pump) by installing union (12), washers (13) and union bolt (14).
- j. Connect fuel return line (15) and injector return line (16) by installing union bolt (17), unions (18 and 19) and washers (20).

6.4.19 Clean Fuel Injector Nozzle. (Refer to figure 6-43.)

This task consists of: a. Disassembly b. Cleaning c. Assembly

INITIAL SET-UP:

Tools:

- Combination Wrench, 15 mm
(Appendix B, Section III, Item 3)
- Vise
(Appendix B, Section III, Item 3)

Materials/Parts Required:

- Safety Wire (or other steel wire), 0.25 mm
(Appendix F, Section II, Item 17)

Equipment Condition:

Fuel injector removed (para. 6.3.10)

- a. Clamp inlet end (1) of injector in vise.
- b. Loosen retaining (2) nut on injector nozzle.
- c. Carefully disassemble injector, noting order of components for assembly.
- d. Using a 0.01 in. (0.25 mm) steel wire, clean the four nozzle tip holes (3). Inspect holes for wear or out-of-round condition. If holes are badly deformed, replace injector.
- e. Blow out interior of injector to remove any debris.
- f. Assemble injector components in order shown.
- g. Torque nozzle retaining nut to 25 ft. lbs. (34.3 Nm).

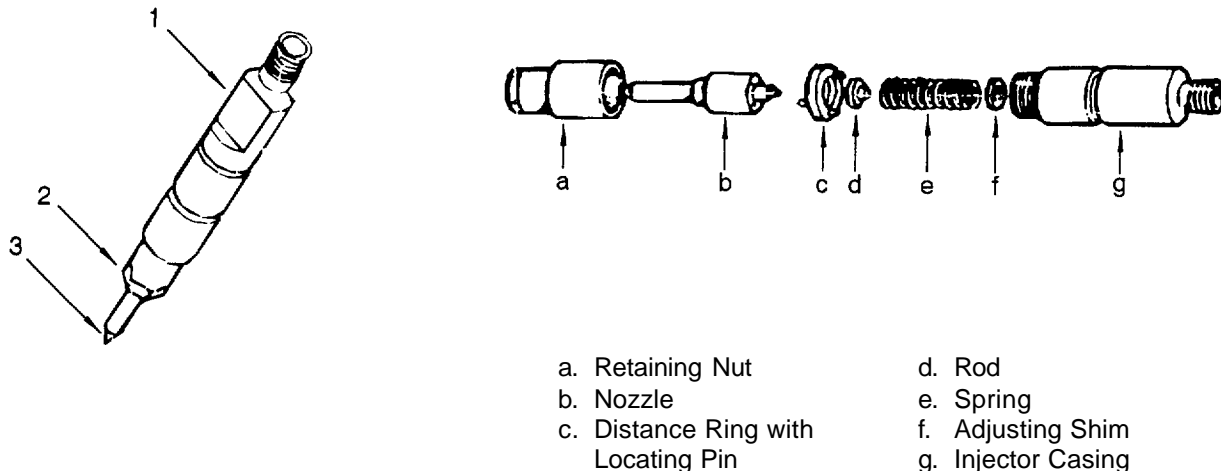

Figure 6-43. Fuel Injector Nozzle Cleaning

6.4.20 Install Fuel Injector. (Refer to figure 6-44.)

This task consists of: a. Installation

INITIAL SET-UP:

Tools:

- Ratchet Wrench, 3/8 in. Drive
(Appendix B, Section III, Item 3)
- Socket, Socket Wrench, 13 mm
(Appendix B, Section III, Item 3)
- Combination Wrench, 10 mm
(Appendix B, Section III, Item 3)
- Combination Wrench, 17 mm
(Appendix B, Section III, Item 3)

Materials/Parts Required:

- Washer (Appendix I, Item 34)
- Washer (Appendix I, Item 36)
- Washer (Appendix I, Item 39)

Equipment Condition:

- Fuel injectors cleaned (para. 6.4.19)
- Cylinder head installed (para. 6.4.13)

NOTE

Copper washers (1) under fuel injectors are used to adjust injector protrusion into the combustion chamber of cylinder head. If the old fuel injector is being installed, ensure number of washers are the same number that were removed. If a new fuel injector is to be installed measure the nozzle length of the old and new injectors, remove or insert copper washers to adjust the protrusion of the new injector in the cylinder head to achieve the same protrusion as with the old injector.

- a. Insert copper washer(s) (1) in cylinder head.
- b. Install and tighten union bolt (2), union (3) and copper washers (4 and 5).
- c. Position fuel injector (6) in cylinder head.

- d. Install and tighten brace (7), washer (8) and nut (9) on mounting stud (10).
- e. Install and tighten fuel supply line (11) on fuel injector.

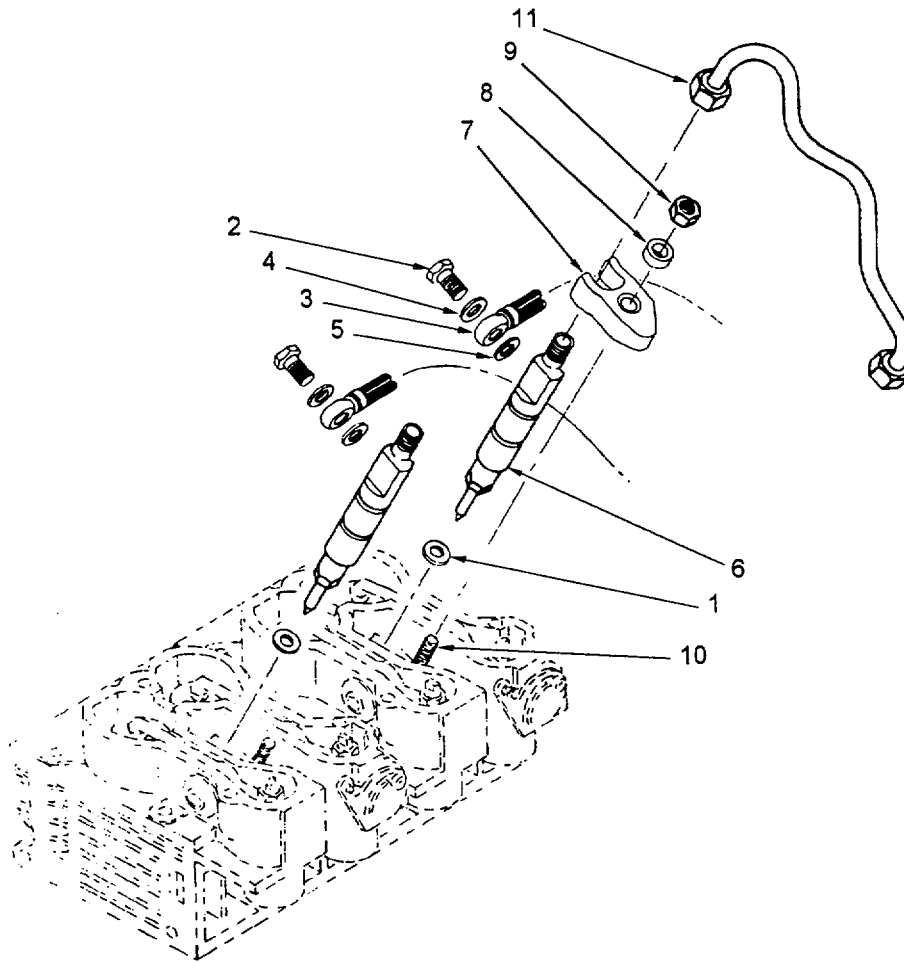

Figure 6-44. Fuel Injector Installation

6.4.21 Install Fuel Pump. (Refer to figure 6-45.)

This task consists of: a. Installation

INITIAL SET-UP:

Tools:

- 13 mm socket wrench
(Appendix B, Section III, Item 3)
- 14 mm combination wrench
(Appendix B, Section III, Item 3)
- 3/8 in. drive ratchet wrench
(Appendix B, Section III, Item 3)

Materials/Parts Required:

- Nut, Self-Locking (Appendix I, Item I)
- Gasket (Appendix I, Item 77)

Equipment Condition:

- Fuel pump removed (para. 6.3.9)
 - Camshaft installed (para. 6.4.7)
-

- a. Position gasket (1) on crankcase (2).
- b. Position drive rod (3) and fuel pump (4) on crankcase (2).
- c. Install and tighten self-locking nuts (5) securing fuel pump (4).

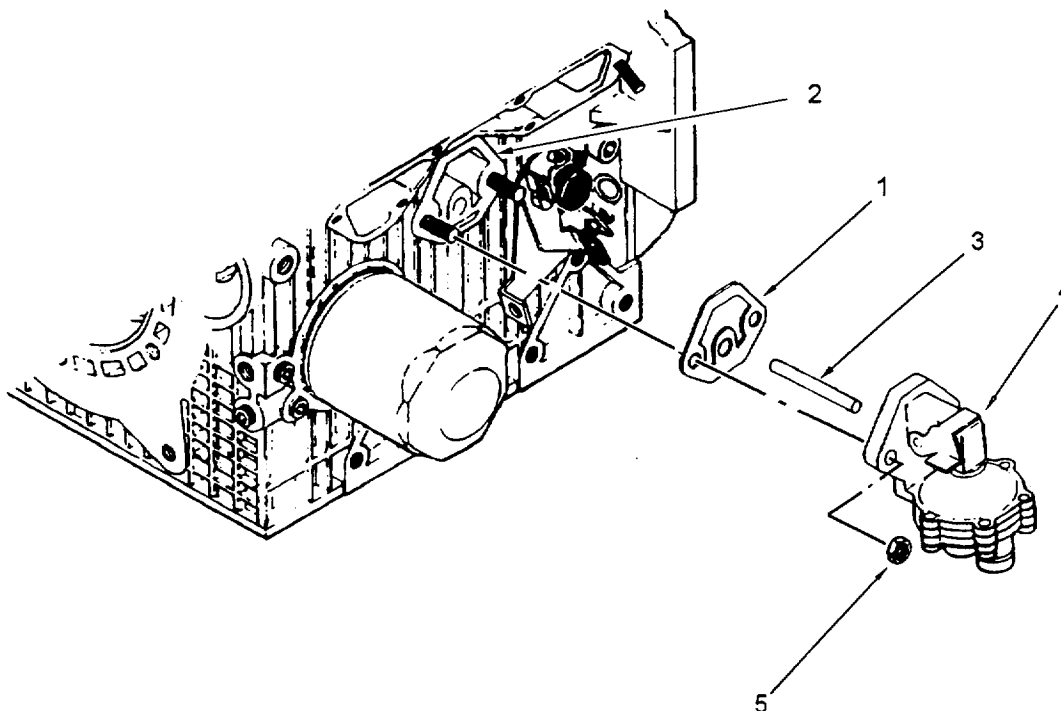

Figure 6-45. Fuel Pump Installation

6.4.22 Install Valve Covers. (Refer to figure 6-46.)

This task consists of: a. Installation

INITIAL SET-UP:**Tools:**

- 5 mm socket head wrench
(Appendix B, Section III, Item 3)
- 3/8 in. drive ratchet wrench
(Appendix B, Section III, Item 3)

Materials/Parts Required:

- Gasket (Appendix I, Item 23)

Equipment Condition:

- Fuel injectors installed (para. 6.4.20)
-

- a. Position valve cover gasket (1) on cylinder head.

NOTE

Valve cover (2) with oil fill cap is positioned toward the PTO end of the engine.

- b. Position valve cover (2) on gasket (1) and cylinder head (3).
- c. If not adjusting fuel injection pump later, install and alternately tighten the socket head screws (4) attaching valve covers (2) to cylinder head (3). If adjusting fuel injection pump 3, hand tighten only.

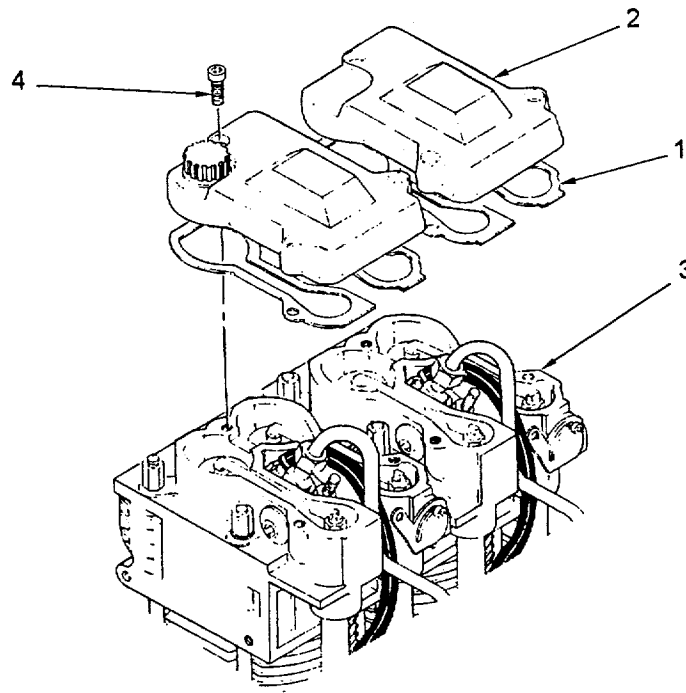

Figure 6-46. Valve Cover Installation

6.4.23 Install Decompression Lever. (Refer to figure 6-47.)

This task consists of: a. Installation

INITIAL SET-UP:**Tools:**

- 3 mm key wrench
(Appendix B, Section III, Item 3)
- 13 mm combination wrench
(Appendix B, Section III, Item 3)

Materials/Parts Required:

None

Equipment Condition:Fuel injectors installed (para. 6.4.20)

- a. Position decompression lever (1) on plates (2), and install and tighten screws (3) and nuts (4).
- b. Operate the decompression lever to ensure freedom of movement.

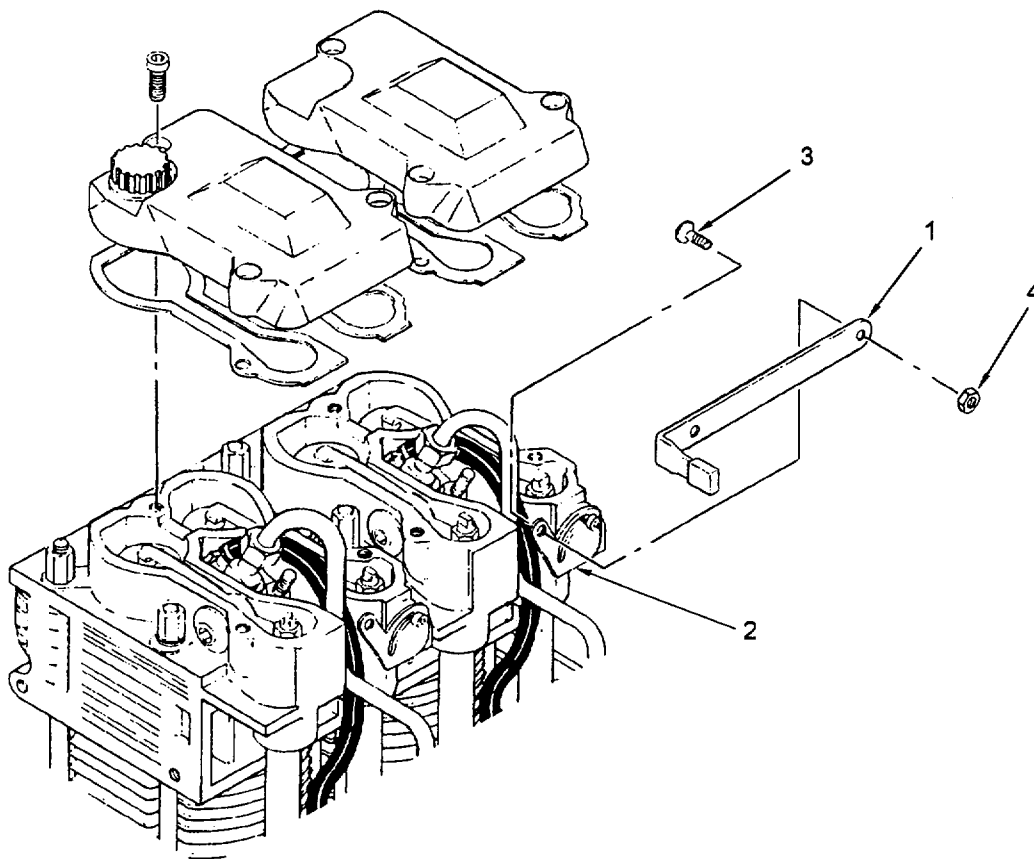

Figure 6-47. Decompression Lever Installation

6.4.24 Install Fuel Flow Solenoid. (Refer to figure 6-48.)

This task consists of: a. Installation

INITIAL SET-UP:**Tools:**

Socket, Socket Wrench, 5 mm
(Appendix B, Section III, Item 3)
Ratchet Wrench, 3/8 in. Drive
(Appendix B, Section III, Item 3)
Extension, 6 in., 3/8 in. Drive
(Appendix B, Section III, Item 3)

Materials/Parts Required:

O-Ring (Appendix I, Item 29)
Gasket (Appendix I, Item 19)

Equipment Condition:

Fuel injectors installed (para. 6.4.20)

- a. Insert O-ring (1) in crankcase.

NOTE

When the solenoid is installed in the crankcase, ensure solenoid arm is positioned to the right of the control rod center lever arm.

- b. Hold control rod (2) center lever arm (3) fully to the left, position solenoid (4) on crankcase and install two socket head screws (5) to attach solenoid to crankcase. Release control rod (2) and verify that solenoid arm (6) is to the right of the control rod center lever arm (3).
- c. Loosely install the five socket head screws (7) and flat washers (8) to attach the fuel control cover (9) and gasket (10) to the crankcase. (Fuel control cover (9) must be removed later for injector timing.)

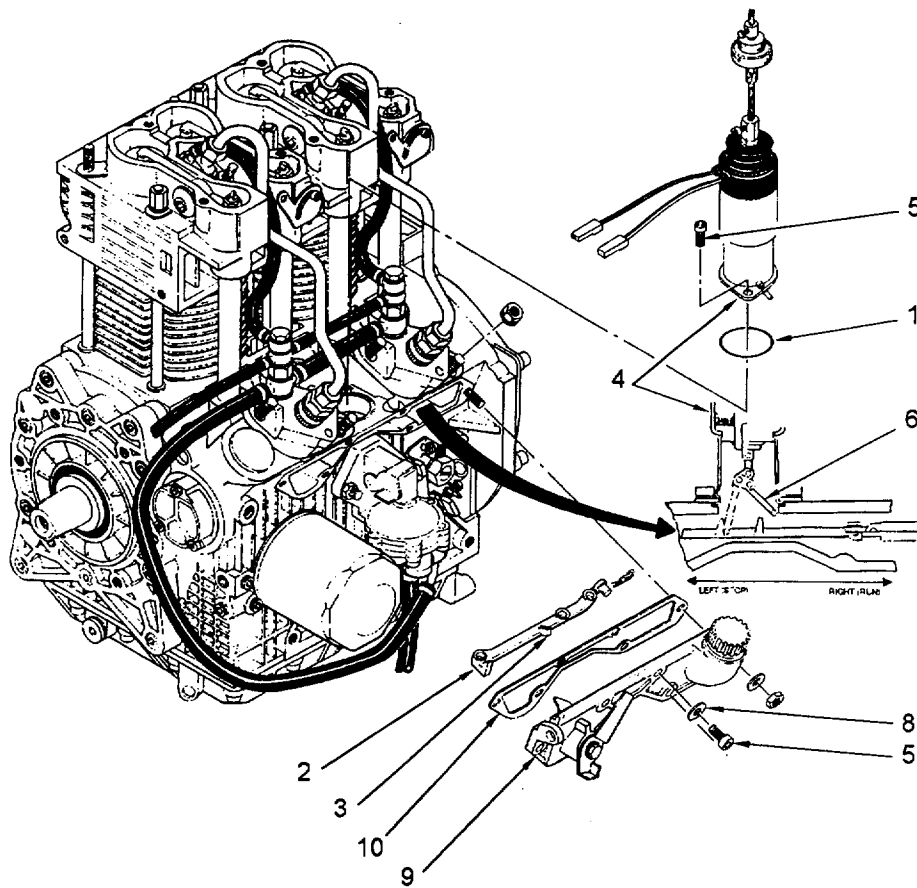

Figure 6-48. Fuel Flow Solenoid Installation

6.4.25 Install Oil Pan and Oil Filter. (Refer to figure 6-49.)

This task consists of: a. Installation

INITIAL SET-UP:**Tools:**

- 7/8 in combination wrench
(Appendix B, Section III, Item 3)
- 6 mm socket
(Appendix B, Section III, Item 3)
- 3/8 in. drive ratchet wrench
(Appendix B, Section III, Item 3)
- 10 mm socket
(Appendix B, Section III, Item 3)
- 6 mm socket head wrench
(Appendix B, Section III, Item 3)

Materials/Parts Required:

- Gasket, Pan (Appendix I, Item 21)

Equipment Condition:

- Oil pan removed (para. 6.3.1)

- a. Install cap screw (1), washer (2) and nut (3).
- b. Position pan gasket (4) on oil pan (5).
- c. Insert and tighten in an alternating pattern the fifteen socket head cap screws (6) and washers (7) attaching oil pan (5) to the crankcase (8).
- d. Install oil drain plug (9) and washer (10).
- e. Install oil temperature sensor (11). Torque to 22.11-29.48 ft. lbs. (30-40 Nm).
- f. Install dipstick (12).
- g. Loosely install oil filter (13). (Oil filter (13) must be removed later for fuel injector timing.)

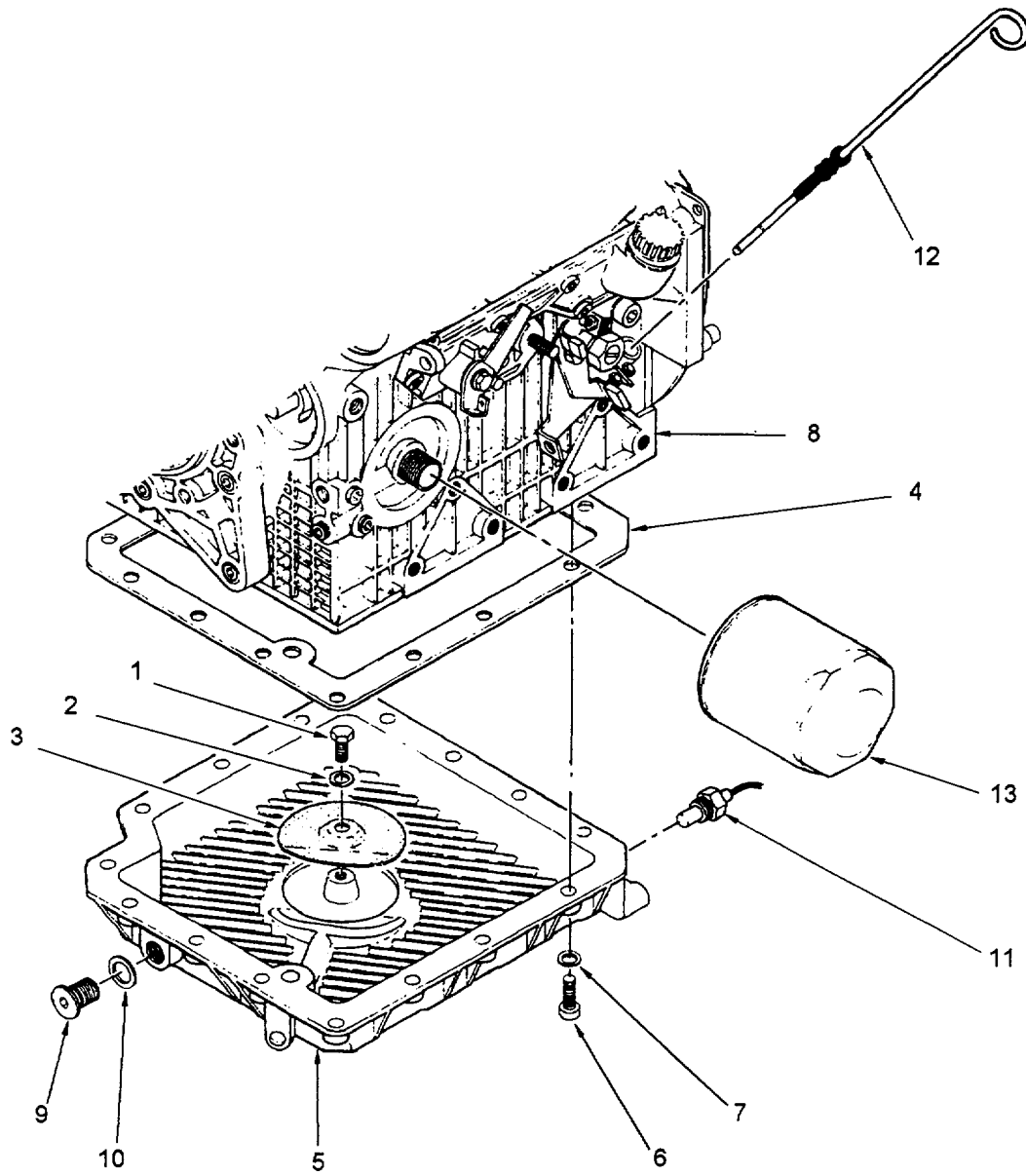

Figure 6-49. Oil Pan Installation

6.4.26 Install Starter.

Refer to paragraph 4.14.1.

6.4.27 Install Gates, Shroud and Oil Cooler. (Refer to figure 6-50.)

This task consists of: a. Installation

INITIAL SET-UP:**Tools:**

Wrench, combination, 6 mm
(Appendix B, Section III, Item 3)
Wrench, combination, 1/4 in.
(Appendix B, Section III, Item 3)
Socket, socket wrench, 5 mm
(Appendix B, Section III, Item 3)
Key, socket head wrench, 5 mm
(Appendix B, Section III, Item 3)
Screwdriver, cross tip, #2
(Appendix B, Section III, Item 3)
Combination wrench, 19 mm
(Appendix B, Section III, Item 3)
Combination wrench, 13 mm
(Appendix B, Section III, Item 3)
Socket, socket wrench, deep well, 5 mm
(Appendix B, Section III, Item 3)
Socket, socket wrench, deep well, 13 mm
(Appendix B, Section III, Item 3)
Extension, Socket Wrench, 3/8 in. drive, 3 in.
(Appendix B, Section III, Item 3)
Wrench, ratchet, 11/4 in. drive
(Appendix B, Section III, Item 3)
Wrench, ratchet 3/8 in. drive
(Appendix B, Section III, Item 3)

Materials/Parts Required:

Engine Lubricating Oil, 2 quarts
(Appendix F, Section II, Item 23)
Washer (Appendix I, Item 32)
Washer (Appendix I, Item 71)
Washer (Appendix I, Item 72)
Washer, Lock (Appendix I, Item 70)

General Safety Requirements:**Equipment Condition:**

Oil pan and oil filter installed (para. 6.4.25)
Starter installed (para. 6.4.26)

- a. From fuel injector side of engine, insert tie rod (1) between cylinders, hooking tie rod to the two inboard cylinder head studs.
- b. Install nut (2) and washer (3) attaching gate (4) to tie rod.

NOTE

Fuel supply line from fuel feed pump to injection pumps, fuel return line and fuel solenoid wires will have to be fed through gate (7). They may have been connected in a previous procedure. Disconnect and reconnect after installing gate (7).

- c. Install the two bolts (5) and washers (6) attaching gate (7). Feed fuel lines from injection pumps through lower hole in gate (7).
- d. Position oil cooler (8) between crankcase and the fuel lines from injection pumps to the fuel injectors.
- e. Install socket head cap screw (9) and washer (10) attaching oil cooler to gate (7).
- f. Install two cross tip screws (11) attaching gate (12) and bracket (13) to cylinder head.
- g. Install union bolt (14), union (15), washer (16) and spacer (17) connecting the oil supply line at the oil cooler.
- h. Install union bolt (18), union (19), washer (20) and spacer (21) connecting the oil return line at the oil cooler.
- i. Install oil return line (22) to union (23) on crankcase.
- j. Install union bolt (24), washer (25), washer (26) and union (27) to connect oil supply line to crankcase.
- k. Install hand tight socket head cap screw (28) and washer (29) on back side of shroud (30).
- l. Install hand tight two cross tip screws (31) at top/intake side of shroud.
- m. Install hand tight socket head cap screws (32, 34 and 36) and washers (33, 35 and 37) attaching shroud.
- n. Tighten securely all shroud fasteners.
- o. Align oil cooler (8) and shroud (30). Install socket head cap screw (38), lock washer (39) and flat washer (40) attaching shroud (30) to oil cooler (8).
- p. Install lifting eye (41), washer (42) and nut (43) on lifting eye studnut.
- q. On fuel feed line, assemble washers (44 and 45) as illustrated on union (46). Use bolt (47) to install assembly on fuel pump.
- r. Use screw (49) , washer (50) and nut (51) to loosely install clamp (48) on gate (7).
- s. Fill engine with lubricating oil. Refer to table 4-1, item 1.

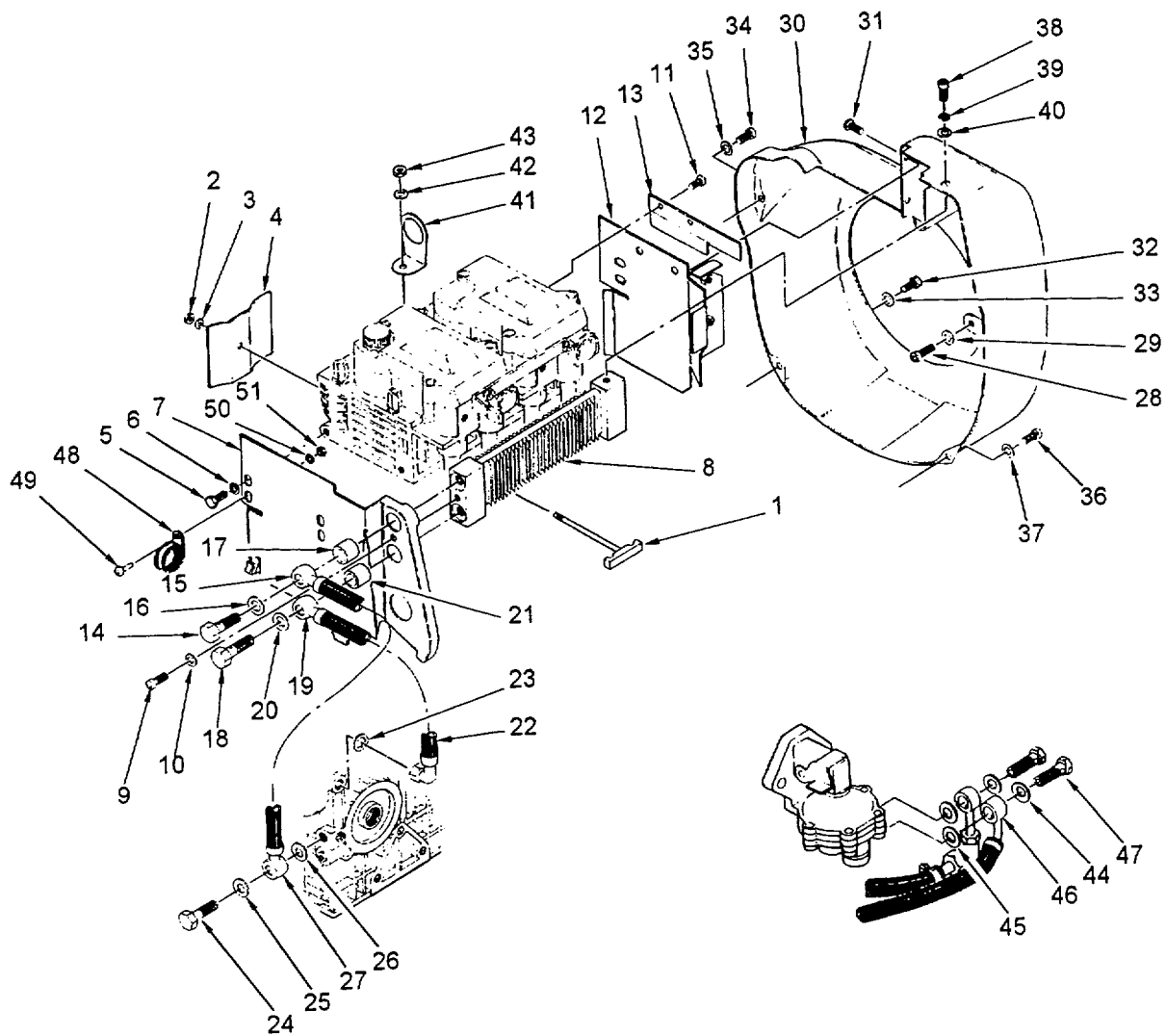

Figure 6-50. Shroud, Gates and Oil Cooler Installation

6.4.28 Install Flexible Coupling Adapter and Guard to Engine. (Refer to figure 6-51.)

This task consists of: a. Installation

INITIAL SET-UP:

Tools:

- Socket, Socket Wrench, 1-5/8 inch
(Appendix B, Section III, Item 3)
- Wrench, Torque, 150 ft lb capacity
(Appendix B, Section III, Item 3)
- Wrench, Combination, 1/2 inch
(Appendix B, Section III, Item 3)

Materials/Parts Required:

- Washers, Lock (Appendix I, Item 63)

Equipment Condition:

- Gates, shroud and oil cooler installed (para. 6.4.27)

- a. Install splined flexible coupling adapter (1), bushing (2) and bolt (3) on PTO. Torque to 80 ft. lbs. (109.76 Nm).
- b. Install the four bolts (4), lock washers (5) and flat washers (6) to secure the flexible coupling guard (7) to the engine.

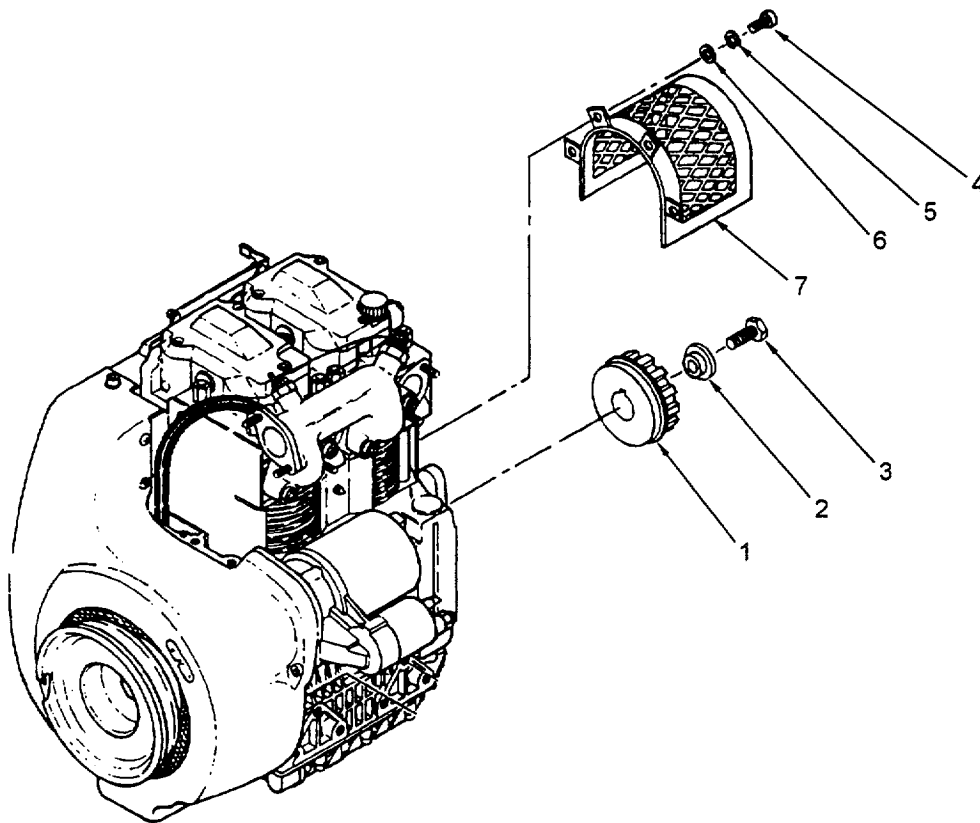

Figure 6-51. Engine Flexible Coupling Adapter and Guard Installation

6.4.29 INSTALL ENGINE IN ENGINE MODULE. (Refer to figure 6-52.)

- a. Attach hoist to engine lifting eye, raise engine and position above engine module with engine pulley aligned with pulley guard (1) on module.
- b. Lower pulley guard (1) and carefully lower replacement engine into module frame, aligning mounting holes in frame and engine.
- c. Install and alternately tighten the ten bolts (2), lock washers and flat washers that secure the engine to the frame. Remove hoist (or blocks) and check that mounting bolts are securely tightened.
- d. Locate alternator wires (3) in wiring harness and connect at in-line connectors as tagged. Remove tags.
- e. At lower starter mounting bolt (4), connect starter ground cable and other ground wires as tagged. Remove tags.
- f. At starter solenoid, install the cables (5) and other wires as tagged to the solenoid studs. Remove tags.
- g. At the oil pressure switch (6), connect the switch wire as tagged. Remove tag.
- h. At intake manifold, connect the electrical wires (7) to the air intake heaters as tagged. Remove tags. Place boots (8) over connector.
- i. Connect the engine temperature sensor wire (9) at in-line connector in wiring harness as tagged. Remove tag.
- j. Locate the fuel shutoff solenoid wires (10) and connect to the wiring harness as tagged. Remove tags.
- k. Group and route wires of cable in general layout observed at removal, and install wire ties as necessary to secure wiring harness.
- l. Install fuel return line at fuel fitting (11) on #2 fuel injection pump.
- m. Install fuel supply line (12) on fuel pump (13).
- n. Install carrying handles. Refer to paragraph 4.13.1.
- o. Raise and latch pulley guard.
- p. Install engine module in pump-engine module. Refer to paragraph 2.4.d.

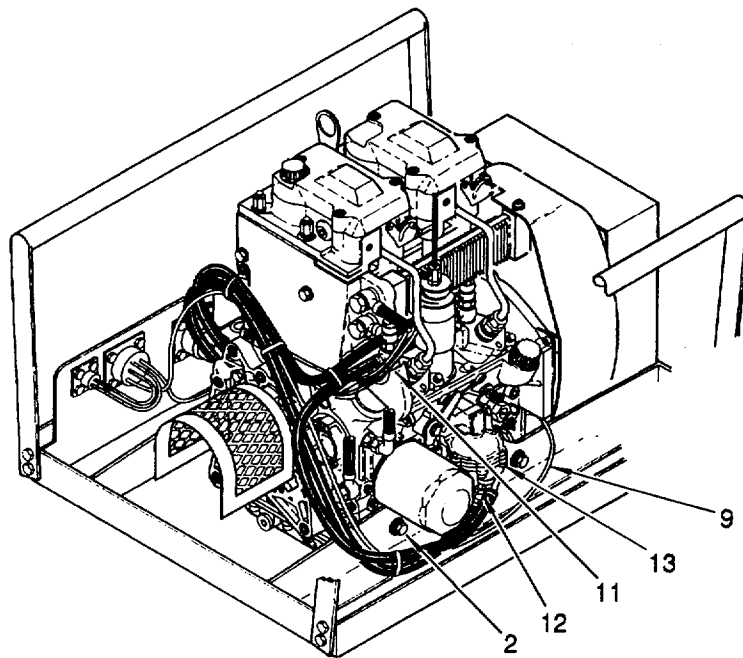
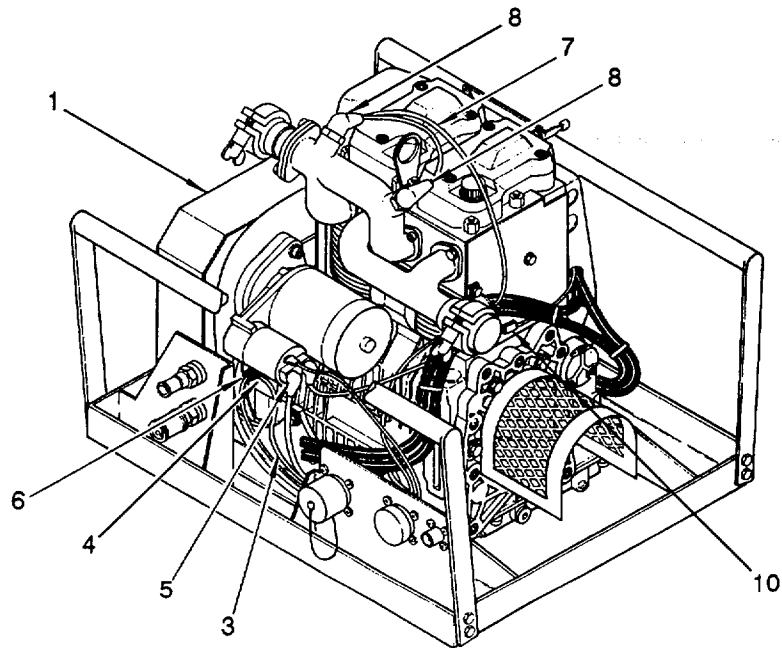

Figure 6-52. Installation of Engine in Engine Module

6.4.30 Adjust Fuel Injection Pump. (Refer to figure 6-53.)

This task must be accomplished any time the fuel injection pumps have been removed and replaced.

This task consists of: a. Adjustment

INITIAL SET-UP:**Tools:**

Key, Socket Head Screw, 5 mm
(Appendix B, Section III, Item 3)
Combination Wrench, 10 mm
(Appendix B, Section III, Item 3)
Combination Wrench, 13 mm
(Appendix B, Section III, Item 3)
Combination Wrench, 17 mm
(Appendix B, Section III, Item 3)
Combination Wrench, 19 mm
(Appendix B, Section III, Item 3)
Screwdriver, Flat Blade (1/8 x 8 in.)
(Appendix B, Section III, Item 3)
Injection Advance Control Tool
(Appendix B, Section III, Item 8)

Materials/Parts Required:

Rubber Band, No. 18
(Appendix F, Section II, Item 20)
Gasket (Appendix I, Item 19)

General Safety Requirements:**WARNING**

Fuels are toxic and flammable. Do not get on person or clothing. Work in well ventilated area. Do not smoke. Ensure equipment is well grounded.

Equipment Condition:

Engine module installed in pump-engine module.
Valve covers removed (para. 6.3.6)

-
- a. Remove five socket head screws (1) and washers (2) attaching fuel control rod cover (3) to crankcase.
 - b. Remove remaining nut (4) and washer (5) from fuel control rod cover (3). Remove cover and gasket (6); discard gasket if socket head screws (1) and nut (4) were fully tightened. Remove gasket residue from crankcase and cover.
 - c. Attach a rubber band to control rod end (7) and any attaching point at the pulley end of the engine to hold control rod fully right. Set throttle lever (8) to maximum fuel position.
 - d. Set cylinder of injection pump (9) being timed to TDC on the compression stroke. Turn flywheel until intake valve (10) opens. Rotate flywheel to the right until intake valve (10) closes. Continue turning flywheel until timing mark (11) on flywheel is aligned with indicator (12) on shroud.
 - e. Remove fuel feed line (13) from injection pump (9) and fuel injector (14) being timed.
 - f. Install injector pump adjustment tool (15) on pump being timed. Turn thumbscrew (16) on tool fully clockwise to close.
 - g. Slowly turn flywheel clockwise until column of fuel in tool starts to move.

- h. Open tool by turning thumbscrew (16) counter-clockwise until fuel level drops to mark (17) on tool, close tool by turning thumbscrew fully clockwise.
- i. At this point fuel would be going in the injector nozzle. Check timing mark (11) and indicator (12) on the shroud to see that they are aligned.
 - (1) If timing mark on the flywheel is before the indicator on the shroud, injection pump timing is too fast. The fuel injection pump must be removed and additional gasket(s) must be added between the injection pump and the crankcase.
 - (2) If timing mark on the flywheel is after the indicator on the shroud, injection pump timing is too slow. The fuel injection pump must be removed and gasket(s) must be removed from between the injection pump and the crankcase.
- j. Repeat steps "d" through "i" until timing is correct.
- k. Adjust the other fuel injection pump by repeating steps "d" through "j".
- l. Remove rubber band from control rod (7) and engine.
- m. Attach new gasket (6) to control rod cover (3) if previous gasket was discarded. Position control rod cover (3) on the crankcase. Install five socket head cap screws (1) and washers (2) attaching the cover to the crankcase.
- n. Install nut (4) and washer (5) attaching the control rod cover (3) to the crankcase.
- o. Install valve covers (para. 6.4.22).

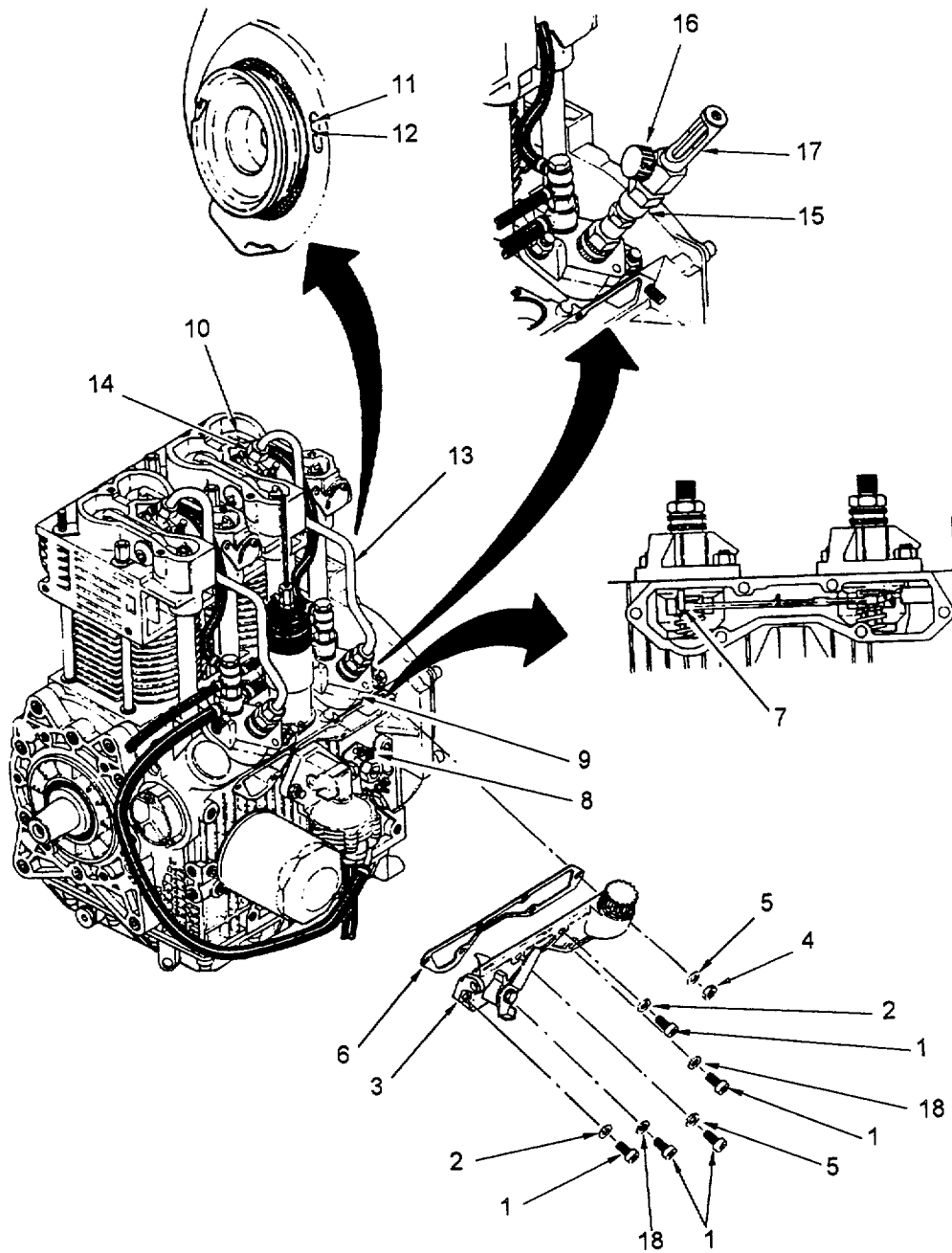

Figure 6-53. Fuel Injection Pump Timing Adjustment

6.4.31 Install Casino. (Refer to figure 6-54.)

This task consists of: a. Installation

INITIAL SET-UP:

Tools:

Tool Kit, General Mechanics
(Appendix B, Section III, Item 1)

Materials/Parts Required:

None

Equipment Condition:

Fuel injection pump adjusted (para. 6.4.30)
or
All maintenance complete

- a. Thread fuel solenoid wire cable (1) through the black start control knob (2), position cylinder casing (3) on engine, and install and tighten the two socket head cap screws (4) and washers (5) that secure the casing to the cylinder heads (6).
- b. Install cable clamp (7) on fuel solenoid cable.

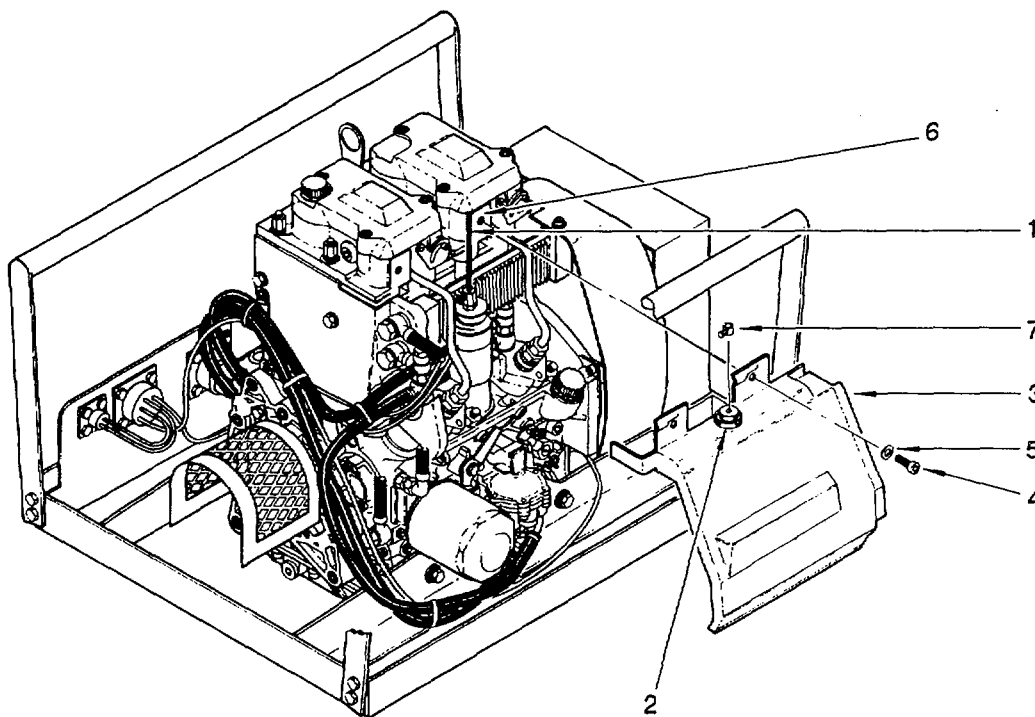

Figure 6-54. Casing Installation

APPENDIX A

REFERENCES

A.1 Scope.

This appendix lists all forms, pamphlets and technical manuals referenced in this manual.

A.2 Forms.

Recommended Changes to Publications DA Form 2028
 Report of Discrepancy..... SF 364
 Product Quality Deficiency Report SF 368

A.3 Pamphlets.

Maintenance Management Update..... DA PAM 738-750
 Functional Users Manual for the Army Maintenance Management System - Aviation (TAMMS - A)..... DA PAM 738-751

A.4 Field Manuals.

NBC Contamination Avoidance..... FM 3-3
 NBC Protection..... FM 3-4
 NBC Decontamination..... FM 3-5
 First Aid for Soldiers FM 21-11

A.5 Technical Manuals.

Procedures for Destruction of Equipment to Prevent Enemy Use TM 750-244-3
 Operator's, Unit and Direct Support Maintenance Manual Including Repair Parts and Special Tools:
 Advanced Aviation Forward Area Refueling System (AAFARS)..... TM 10-4930-250-13&P

APPENDIX B
MAINTENANCE ALLOCATION CHART (MAC)

Section I. INTRODUCTION

B.1 THE ARMY MAINTENANCE SYSTEM MAC.

a. This introduction (section 1) provides a general explanation of all maintenance and repair functions authorized at various maintenance levels under the standard Army Maintenance System concept.

b. The Maintenance Allocation Chart (MAC) in section II designates overall authority and responsibility for the performance of maintenance functions on the identified end item or component. The application of the maintenance functions to the end item or component will be consistent with the capacities and capabilities of the designated maintenance levels, which are shown on the MAC in column (4) as:

Unit - includes two subcolumns, C (operator/crew) and O (unit) maintenance.

Direct Support - includes an F subcolumn.

General Support - includes an H subcolumn.

Depot - includes a D subcolumn.

c. Section III lists the tools and test equipment (both special tools and common tool sets) required for each maintenance function as referenced from section II.

d. Section IV contains supplemental instructions and explanatory notes for a particular maintenance function.

B.2 MAINTENANCE FUNCTIONS. Maintenance functions are limited to and defined as follows:

a. Inspect. To determine the serviceability of an item by comparing its physical, mechanical, and/or electrical characteristics with established standards through examination (e.g., by sight, sound or feel).

b. Test. To verify serviceability by measuring the mechanical, pneumatic, hydraulic, or electrical characteristics of an item/end item and comparing those characteristics with prescribed standards.

c. Service. Operations required periodically to keep an item in proper operating condition; e.g., to clean (includes decontaminate, when required), to preserve, to drain, to paint, or to replenish fuel, lubricants, chemical fluids, or gases.

d. Adjust. To maintain or regulate, within prescribed limits, by bringing into proper position, or by setting the operating characteristics to specified parameters.

e. Align. To adjust specified variable elements of an item to bring about optimum or desired performance.

f. Calibrate. To determine and cause corrections to be made or to be adjusted on instruments or test, measuring, and diagnostic equipment used in precision measurement. Consists of comparisons of two instruments, one of which is a certified standard of known accuracy, to detect and adjust any discrepancy in the accuracy of the instrument being compared.

- g. Remove/Install. To remove and install the same item when required to perform service or other maintenance functions. Install may be the act of emplacing, seating, or fixing into position a spare, repair part, or module (component or assembly) in a manner to allow the proper functioning of an equipment or system.
- h. Replace. To remove an unserviceable item and install a serviceable counterpart in its place. "Replace" is authorized by the MAC and assigned maintenance level is shown as the third position code of the SMR code.
- i. Repair. The application of maintenance services¹ including fault location/troubleshooting, removal/installation, disassembly/assembly³ procedures, and maintenance actions⁴ to identify troubles and restore serviceability to an item by correcting specific damage, fault, malfunction, or failure in a part, subassembly, module (component or assembly), end item or system.
- j. Overhaul. That maintenance effort (service/action) prescribed to restore an item to a completely serviceable/operational condition as required by maintenance standards in appropriate technical publications (i.e., DMWR). Overhaul is normally the highest degree of maintenance performed by the Army. Overhaul does not normally return an item to like-new condition.
- k. Rebuild. Consists of those services/actions necessary for the restoration of unserviceable equipment to a like-new condition in accordance with original manufacturing standards. Rebuild is the highest degree of material maintenance applied to Army equipment. The rebuild operation includes the act of returning to zero those age measurements (e.g., hours/miles) considered in classifying Army equipment/components.

B.3 EXPLANATION OF COLUMNS IN THE MAC, SECTION II.

- a. Column 1, Group Number. Column 1 lists functional group code numbers, the purpose of which is to identify maintenance significant components, assemblies, subassemblies, and modules to the next higher assembly.
- b. Column 2, Component/Assembly. Column 2 contains the item names of components, assemblies, subassemblies, and modules for which maintenance is authorized.
- c. Column 3, Maintenance Function. Column 3 lists the functions to be performed on the item listed in column 2. (For detailed explanation of these functions, see paragraph B.2.)
- d. Column 4, Maintenance Level. Column 4 specifies each level of maintenance authorized to perform each function listed in column 3, by indicating work time required (expressed as man-hours in whole hours or decimals) in the appropriate subcolumn. This work-time figure represents the active time required to perform that maintenance function at the indicated level of maintenance. If the number or complexity of the tasks within the listed maintenance function vary at different maintenance levels, appropriate work-time figures are shown for each level. The worktime figure represents the average time required to restore an item (assembly, subassembly, component, module, end item, or system to a serviceable condition under typical field operating conditions. This time includes preparation time (condition/followon tasks)(including any necessary disassembly/assembly time), troubleshooting/fault location time, and quality assurance time in addition to the time required to perform the specific tasks identified for the maintenance functions authorized in the MAC. The symbol designations for the various maintenance levels are as follows.

¹Services - Inspect, test, service, adjust, align, calibrate, and/or replace.

²Fault location/troubleshooting - The process of investigating and detecting the cause of equipment malfunction. The act of isolating a fault within a system or unit under test (UUT).

³Disassembly/assembly - The step-by-step breakdown (taking apart) of a spare/functional group coded item to the level of its least component that is assigned an SMR code for the level of maintenance under consideration (i.e., identified as maintenance significant).

⁴Actions - Welding, grinding, riveting, straightening, facing, machining, and /or resurfacing.

- COperator or crew maintenance
- OUnit maintenance
- FDirect support maintenance
- LSpecialized Repair Activity (SRA)⁵
- HGeneral support maintenance
- DDepot maintenance

- e. Column 5, Tools and Test Equipment reference code. Column 5 specifies, by code, those common tool sets (not individual tools), common TMDE, and special tools, special TMDE, and special support equipment required to perform the designated function. Codes are keyed to tools and test equipment in section III.
- f. Column 6, Remarks. When applicable, this column contains a letter code, in alphabetical order, which is keyed to the remarks contained in section IV.

B.4 EXPLANATION OF COLUMNS IN TOOL AND TEST EQUIPMENT REQUIREMENTS, SECTION III.

- a. Column 1, Reference Code. The tool and test equipment reference code correlates with a code used in the MAC, section II, column 5.
- b. Column 2, Maintenance Level. The lowest level of maintenance authorized to use the tool or test equipment.
- c. Column 3, Nomenclature. Name or identification of the tool or test equipment.
- d. Column 4, National Stock Number. The National Stock Number of the tool or test equipment.
- e. Column 5, Tool Number. The manufacturer's part number, model number, or type number.

B.5 EXPLANATION OF COLUMNS IN REMARKS, SECTION IV.

- a. Column 1, Remarks Code. The code recorded in column 6, section II.
- b. Column 2, Remarks. This column lists information pertinent to the maintenance function being performed as indicated in the MAC, section II.

⁵This maintenance level is not included in section II, column (4) of the MAC. Functions to this level of maintenance are identified by a work-time figure in the "H" column of section II, column (4) and an associated reference code is used in the Remarks column (6). This code is keyed to section IV, Remarks, and SRA complete repair application is explained there.

**Section II. MAINTENANCE ALLOCATION CHART
FOR
PUMPING ASSEMBLY**

(1) Group Number	(2) Component/Assembly	(3) Maintenance Function	(4) Maintenance Level					(5) Tools and Equipment Ref Code	(6) Remarks Code
			Unit	Direct Support		General Support	Depot		
			C	O	F	H	D		
00	Pumping Assembly								
01	Pump-Engine Module	Inspect Service Repair	0.1	0.5 0.5			2 2		
0101	Cable Assembly W103	Inspect Repair Replace	0.1	0.1	0.8		3, 9		
0102	Cable Assembly, Ground	Inspect Repair Replace	0.1	0.5 0.2			1, 9 1		
0103	Fuel Line Assembly (Return)	Inspect Repair Replace	0.1	0.5 0.3			1 1		
0104	Fuel Line Assembly (Supply)	Inspect Repair Replace	0.1	0.5 0.3			1		
0105	Unisex Coupling, 3 in., Flange Mount	Inspect Repair Replace	0.1 0.1	0.3 0.3	0.5		2 1	A	
0106	Inlet Manifold Assembly	Inspect Repair Replace	0.1 0.1	0.3 0.4	0.5		2 1	A	

**Section II. MAINTENANCE ALLOCATION CHART
FOR
PUMPING ASSEMBLY**

(1) Group Number	(2) Component/Assembly	(3) Maintenance Function	(4) Maintenance Level					(5) Tools and Equipment Ref Code	(6) Remarks Code
			Unit	Direct Support	General Support	Depot			
			C	O	F	H	D		
0107	Pump, Fuel Transfer	Inspect Repair Replace	0.1 0.3 0.5		1.0			2 1	
0108	Engine Module Assembly	Inspect Repair Replace	0.1 0.1	0.5				2, 9	
010801	Engine	Inspect Service Adjust Repair Replace	0.1	0.5 0.5		0.5 16.0 2.0		2 2, 8 2, 3, 4, 5, 6, 7, 8 3	
010802	Cable Assembly W101 (Engine Harness)	Inspect Repair Replace	0.1	0.5	0.8			3, 9 1	
010803	Cable Assembly W102 (Starter Cables) -	Inspect Repair Replace	0.1	0.8 0.3				1, 9 1	
010804	Frame, Engine Mount	Inspect Repair	0.1	0.5		0.5		1	B
0109	Flexible Coupling Assembly Replace	Inspect Repair	0.1	0.5 0.1				1 1	
0110	Subframe Assembly, Pump- Engine Module	Inspect Repair	0.1	0.5		0.5		1	B

**Section II. MAINTENANCE ALLOCATION CHART
FOR
PUMPING ASSEMBLY**

(1) Group Number	(2) Component/Assembly	(3) Maintenance Function	(4) Maintenance Level					(5) Tools and Equipment Ref Code	(6) Remarks Code
			Unit	Direct Support	General Support	Depot			
			C	O	F	H	D		
0111	Frame Assembly, Pump-Engine Module	Inspect	0.1					C	
		Repair			0.5				
02	Accessory Module	Inspect	0.1					2	
		Repair		0.3					
0201	Cable Assembly, Battery Power	Test		0.1				9	
		Repair		0.5				2, 9	
		Replace		0.1					
0202	Cable Assembly, Control (W201)	Inspect	0.1					3, 9	
		Repair			0.8				
		Replace		0.1					
0203	Cable Assembly, Ground	Inspect	0.1					1, 9	
		Repair		0.5					
		Replace		0.2					
0204	Air Filter Assembly	Inspect	0.1					1	
		Repair		0.2					
0205	Battery	Inspect	0.1						
		Clean		0.3					
		Replace		0.2					
0206	Control Box Assembly	Test		0.3				2, 9	
		Repair		0.1	0.5				
		Replace		0.2					

**Section II. MAINTENANCE ALLOCATION CHART
FOR
PUMPING ASSEMBLY**

(1) Group Number	(2) Component/Assembly	(3) Maintenance Function	(4) Maintenance Level					(5) Tools and Equipment Ref Code	(6) Remarks Code
			Unit		Direct Support	General Support	Depot		
			C	O	F	H	D		
020601	Control Panel Assembly	Test Repair		0.3 0.1	1.0			2, 9	
0207	Frame Assembly, Accessory Module	Inspect Repair	0.1		0.5				C

**Section III. TOOLS AND TEST EQUIPMENT
FOR
PUMPING ASSEMBLY**

Tool or Test Equipment Ref Code	Maintenance Level	National Nomenclature	Stock Number	Tool Number
1	O	Tool Kit, General Mechanics: Automotive	5180-00-177-7033	
2	O	Shop Equipment, Automotive Maintenance and Repair: Organizational Maintenance Common No 1	4910-00-754-0654	
3	F	Shop Equipment, Automotive Maintenance and Repair: Field Maintenance, Basic, less Power	4910-00-754-0705	
4	H	Flywheel Puller		7736502
5	H	Gear Extractor	5120-01-411-2234	7736589
6	H	Remover, Bearing and Bushing	5120-01-410-8262	7736590
7	H	Central Bearing Assembly Tool	5120-01-413-8731	7736591
8	H	Injection Advance Control Tool		7736594
9	O	Multimeter, Digital	4935-01-068-7870	
10	O	Multimeter	6625-01-139-2512	T00377
11	O	Tester, Thermostat	4910-01-023-7842	678
12	O	Thermometer	6685-01-022-6096	678A

**Section IV. REMARKS
FOR
PUMPING ASSEMBLY**

Remarks Code	Remarks
A	Operator replace unisex coupling face seal using seal from dust cap for temporary repair.
B	Weld fractures in accordance with American Welding Society specification D1. 2.
C	Weld fractures in accordance with American Welding Society specification D1. 1.

APPENDIX C
REPAIR PARTS AND SPECIAL TOOLS LIST

Refer to TM 10-4320-351-24P

APPENDIX D

COMPONENTS OF END ITEM AND BASIC ISSUE ITEM LIST

Section I. INTRODUCTION

D-1. Scope.

This appendix lists components of the end item and basic issue items for the pumping assembly to help you inventory the items for safe and efficient operation of the equipment.

D-2. General.

The Components of End Item (COEI) and Basic Issue Items (BII) Lists are divided into the following sections.

a. Section II, Components of End Item. This listing is for information purposes only and is not authority to requisition replacements. These items are part of the pumping assemblies. As part of the end item, these items must be with the end item whenever it is issued or transferred between property accounts. Items of COEI are removed and separately packaged for transportation or shipment only when necessary. Illustrations are furnished to help you find and identify the items.

b. Section III, Basic Issue Items. These essential items are required to place the pumping assembly in operation, operate it, and to do emergency repairs. Although shipped separately, BII must be with the pumping assembly during operation and when it is transferred between property accounts. This list is your authority to request/requisition them for replacement based on authorization of the end item by the TOE/MTOE. Illustrations are furnished to help you find and identify the items.

D-3. Explanation of Columns.

a. Column (1), Illus Number, gives you the number of the item illustrated.

b. Column (2), National Stock Number, identifies the stock number of the item to be used for requisitioning purposes.

c. Column (3), Description and Usable On Code, identifies the Federal item name followed by a minimum description when needed. The last line below the description is the Commercial and Government Entity Code (CAGEC) and the part number.

d. Column (4), U/I (Unit of Issue) indicates how the item is issued for National Stock Number shown in column two.

e. Column (5), Qty Rqd, indicated the quantity required.

Section II. COMPONENTS OF END ITEM

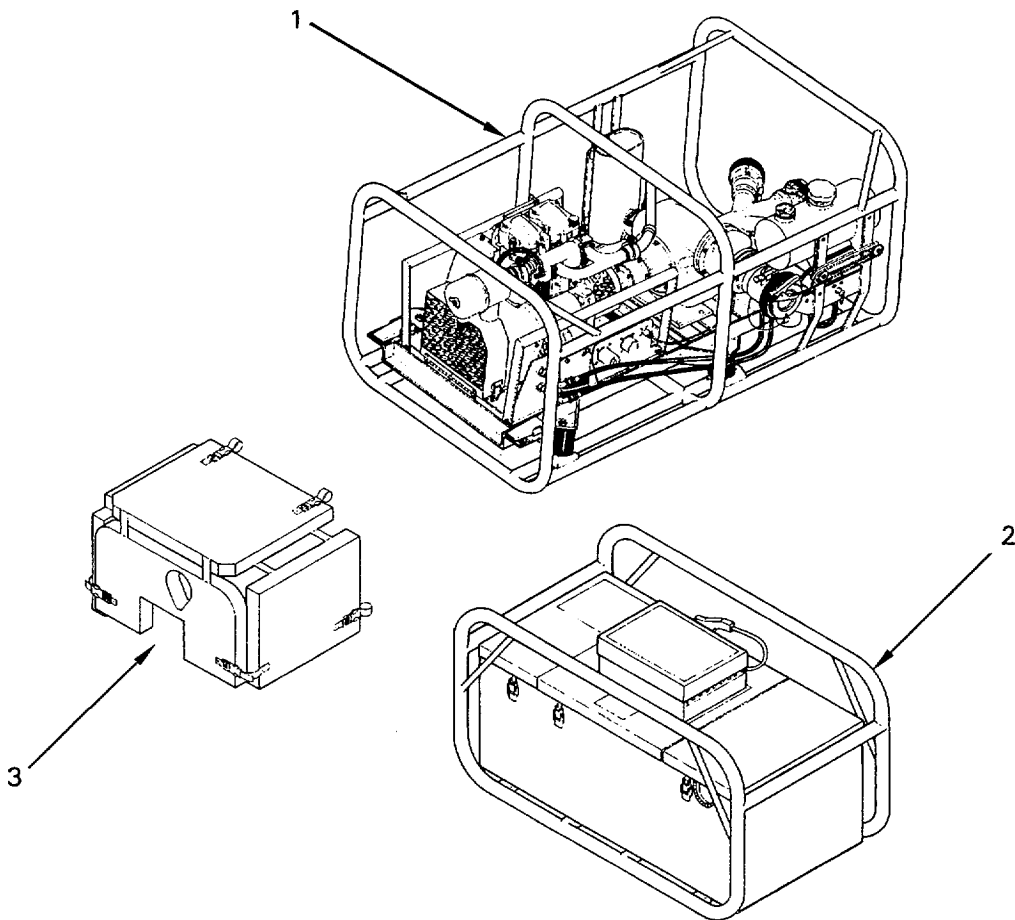

Figure D-1. Pumping Assembly Components

(1) Illus Number	(2) National Stock Number	(3) Description CAGEC and Part Number	(4) U/I	(5) Qty Rqd
1		PUMP-ENGINE MODULE (97403) 13230E5905	EA	1
2		ACCESSORY MODULE (97403) 13230E6000	EA	1
3		COVER, ACOUSTIC (97403) 13230E5884	EA	1

Section III. BASIC ISSUE ITEMS

1

TM 10-4320-351-14

TECHNICAL MANUAL
OPERATOR'S, UNIT, DIRECT SUPPORT AND GENERAL SUPPORT MAINTENANCE MANUAL

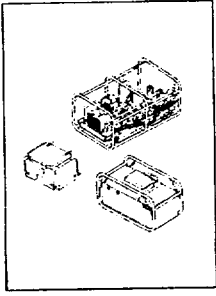

PUMPING ASSEMBLY FOR ADVANCED AVIATION FORWARD AREA REFUELING SYSTEM (AAFARS)
 NSN 4320-01-434-4653

DISTRIBUTION STATEMENT A. Approved for Public Release; Distribution is unlimited.

HEADQUARTERS, DEPARTMENT OF THE ARMY

EQUIPMENT DESCRIPTION	1-5
PRINCIPLES OF OPERATION	1-10
CONTROLS AND INDICATORS	2-2
PREVENTIVE MAINTENANCE CHECKS AND SERVICES (PMCS)	2-3
OPERATION UNDER USUAL CONDITIONS	2-11
OPERATION UNDER UNUSUAL CONDITIONS	2-24
OPERATOR MAINTENANCE PROCEDURES	3-3
UNIT MAINTENANCE PROCEDURES	4-9
DIRECT SUPPORT MAINTENANCE PROCEDURES	5-7
GENERAL SUPPORT MAINTENANCE PROCEDURES	6-1

2

TM 10-4320-351-24P
 HEADQUARTERS DEPARTMENT OF THE ARMY
 Washington, D.C.

ORGANIZATIONAL, DIRECT SUPPORT AND GENERAL SUPPORT MAINTENANCE REPAIR PARTS AND SPECIAL TOOLS LIST FOR PUMPING ASSEMBLY NSN 4320-01-434-4653
 Current as of (Date)

REPORTING ERRORS AND RECOMMENDING IMPROVEMENTS

You can help improve this manual. If you find any mistake or if you know of a way to improve the procedure, please let us know. Mail your letter or DA Form 2028 (Recommended Changes to Publications and Blank Forms), or DA Form 2028-2 located in the back of this manual directly to: Commander, U.S. Army Aviation and Troop Command, ATTN: AMSA/TM-HP, 4300 Goodfellow Boulevard, St. Louis, MO 63120-1798. You may also submit your recommended changes by E-mail directly to <mpmrt%avma28@st-louis-army.af.mil>. A reply will be furnished directly to you. Instructions for sending an electronic 2028 may be found at the back of

TABLE OF CONTENTS		Page	Blk./Figure
Section I	INTRODUCTION	1	
Section II	REPAIR PARTS LIST	1-1	
Group 00	Pumping Assembly	1-1	1
Group 01	Pump-Engine Module	2-1	2
0101	Cable Assembly W103	3-1	3
0102	Cable Assembly, Ground	4-1	4
0103	Fuel Line Assembly (Return)	5-1	5
0104	Fuel Line Assembly (Supply)	6-1	6
0106	Unseal Coupling, 3-Inch, Flange Mount	7-1	7
0106	Inlet Manifold Assembly	8-1	8
0107	Fuel Transfer Pump Assembly	8-1	9

Figure D-2. Basic Issue Items

(1) Illus Number	(2) National Stock Number	(3) Description CAGEC and Part Number	(4) U/I	(5) Qty Rqd
1		OPERATOR'S, UNIT, DIRECT SUPPORT AND GENERAL SUPPORT MAINTENANCE MANUAL FOR PUMPING ASSEMBLY FOR ADVANCED AVIATION FORWARD AREA REFUELING SYSTEM (AAFARS). TM 10-4320-351-14	EA	1
2		ORGANIZATIONAL, DIRECT SUPPORT AND GENERAL SUPPORT MAINTENANCE REPAIR PARTS AND SPECIAL TOOLS LIST (RPSTL) FOR PUMPING ASSEMBLY NSN 4320-01-434-4653 TM 10-4320-351-24P	EA	1

APPENDIX E

ADDITIONAL AUTHORIZATION LIST

Section I. INTRODUCTION

E-1 SCOPE.

This appendix lists additional items that you are authorized for the support of the pumping assembly.

E-2 GENERAL.

This list identifies items that do not have to accompany the pumping assembly and that do not have to be turned in with it. These items are authorized to you by MTOE, TDA, CTA or JTA.

E-3 EXPLANATION OF LISTING.

National Stock Numbers, description and quantities are provided to help you identify and request the additional items you require to support this equipment.

Section II. ADDITIONAL AUTHORIZATION LIST

There are no additional items authorized for the pumping assembly.

APPENDIX F**EXPENDABLE/DURABLE ITEMS LIST**

Section I. INTRODUCTION**F-1. SCOPE.**

This appendix lists expendable and durable items that you will need to operate and maintain the pumping assembly. This listing is for information only and is not authority to requisition the listed items. These items are authorized to you by CTA 50790, Expendable/Durable Items (except medical, class V repair parts, and heraldic items) or CTA 8-100, Army Medical Department Expendable/Durable Items.

F-2 EXPLANATION OF COLUMNS.

- a. Column (1), Item Number. This number is assigned to the entry in the listing and is referenced in the narrative instructions to identify the item (e.g., "Use cleaning compound, item 5, appendix F).
- b. Column (2), Level. This column identifies the lowest level of maintenance that requires the item.
- c. Column (3), National Stock Number. This is the national stock number assigned to the item, which you can use to requisition it.
- d. Column (4), Item Name, Description, Commercial and Government Entity Code (CAGEC), and Part Number. This provides additional information you can use to identify the item.
- e. Column (5), Unit of Measure (U/M). This code shows the physical measurement or count of an item, such as gallon, dozen, gross, etc.

Section II. EXPENDABLE/DURABLE ITEMS LIST

(1) Item Number	(2) Level	(3) National Stock Number	(4) Description	(5) (U/M)/ (U/I)
1	O	8030-01-329-6338	Sealant, Thread, Multipurpose..... (97403) 13230E5929	EA
2	O	6850-01-331-3349	Dry Cleaning Solvent (81348) P-D-680	CN
3	O	6810-00-816-1025	Compound, Anti-Seize, Molybdenum Disulfide (81349) MIL-M-7866	BT
4	O	7920-00-295-1711	Rags, Wiping..... (58536) A-A-531	LB
5	O	9505-00-221-2650	Wire, Nonelectrical (Safety Wire, 0.020 in. [0.51 mm])..... (96906) MS20995C20	LB
6	F	3439-01-415-2258	Solder, Paste SN63PB37..... (81348)	EA
7	F		Flux, Soldering, HF1189 .	
8	H	5975-00-984-6582	Strap, Tiedown..... (96906) MS3367-1-0	EA
9	H	7050-00-961-7663	Assembly Lube (Lubriplate) (90536) ST40334	TU
10	O	9150-00-250-0926	Petrolatum VV-P-236 (81348)	PG
11	F	5350-00-867-7665	320 Grit Paper..... (06565) DURITE320A	SH
12	O	8030-00-137-1671	Compound, Corrosion Preventive (81355) MIL-C-16173	GL
13	F	7920-00-401-8034	Cloth, Lint Free..... (81348) CCC-C-46	HD
14	O	5640-00-103-2254	Tape, Adhesive (52152) 393	RL
15	O	8135-00-0507698	Plastic Sheeting..... (80244) L-P-375	RL
16	O		Tags, Electrical	HD
17	O		Wire, Nonelectrical (Safety Wire, 0.010 in. [0.25 mm])	LB
18	O	8030-00-546-8637	Compound, Corrosion Preventive (81349) M81309-B2	PG
19	F	5975-00-903-2284	Strap, Tiedown (96906) MS3367-4-0	HD
20	H	7510-00-285-1787	Rubber Band	HD
21	H	5350-00-193-7227	Compound, Lapping and Grinding	LB

(1) Item Number	(2) Level	(3) National Stock Number	(4) Description	(5) (U/M)/ (U/I)
22	H		Wire, Nonelectrical (Safety Wire, 0.032 in. [0.81 mm])	LB
23	O	9150-01-152-4117	Oil, Lubricating, Engine (+50 F [-15° C] to +120° F [49° C]) . MIL-L-2104 OE/HDO-15/40 (SAE 15W-40)	GL
24	O		Oil, Preservative	PT
25	O	9150-00-402-4478	MIL-L-644B Oil, Lubricating, Engine	QT
			(52195) APG 1 OEA (SAE OW-20)	

APPENDIX G

ILLUSTRATED LIST OF MANUFACTURED ITEMS

G-1 INTRODUCTION.

- a. This appendix includes complete instructions for making items authorized to be manufactured or fabricated at unit maintenance level.
- b. A part number index in alphanumeric order is provided for cross-referencing the part number of the item to be manufactured to the figure which covers fabrication criteria.
- c. All bulk materials needed for manufacture of an item are listed by part number or specification number in a tabular listing on the illustration.

G-2 MANUFACTURED ITEMS PART NUMBER INDEX.

Part Number	Figure
13230E5923	G-1

NOTES: UNLESS OTHERWISE SPECIFIED

1. MAKE FROM CLAMP CONNECTOR PN M83413/7-1, CAGE NO 81349.
2. REMOVE SET SCREWS, DRILL AND COUNTERSINK AS SHOW AND REINSTALL SET SCREWS.

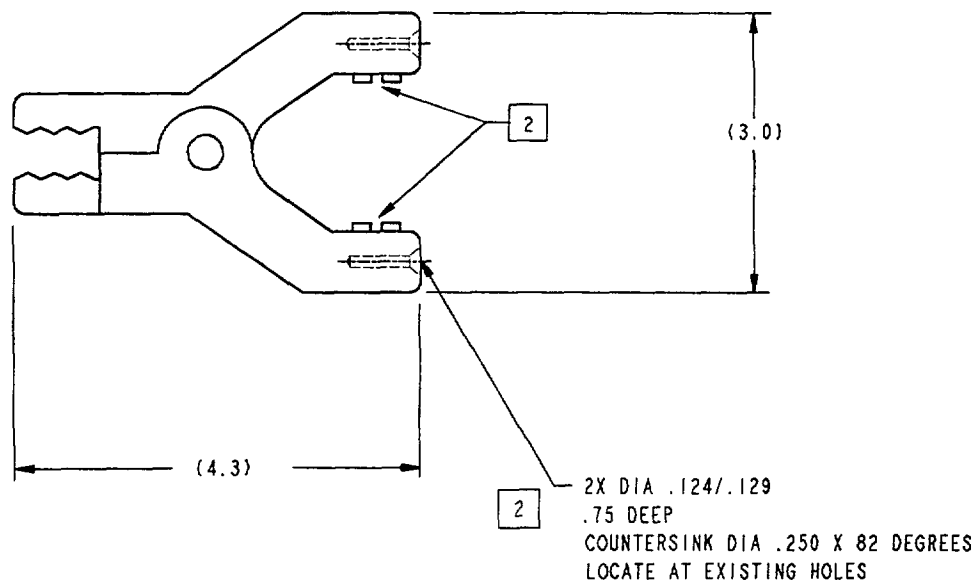

CLAMP, GROUNDING			
SIZE		DWG NO.	13230E5923
C			
SCALE	1 / 1		SHEET 1 OF 1

Figure G-1. Clamp, Grounding

APPENDIX H

TORQUE LIMITS

H-1 INTRODUCTION.

This appendix provides general torque data to allow you to determine the torque requirements for a pumping assembly fastener if a specific value is not listed in the text. Specific values are provided for the most critical requirements. Most threaded fasteners are covered by specifications that define mechanical properties such as tensile strength, yield strength, proof load and hardness. These specifications are carefully considered in initial selection of fasteners for a given application. To assure continued satisfactory performance, replacement fasteners should be of the correct strength, nominal diameter, thread pitch, length and finish.

Most original equipment fasteners (English or metric) are identified with markings or numbers indicating the strength of the fastener. These markings are identified in the paragraphs that follow. Attention to these markings is important in assuring that the proper replacement fasteners are used.

H-2 PUMPING ASSEMBLY SPECIFIC TORQUE DATA.

Fuel Transfer Pump Specific Torque Data

Item	Torque Value
Impeller Shaft Nut	100 - 110 ft lb (135.6 - 149.2 Nm)

Engine Specific Torque Data

Item	Torque Value
Crankshaft Support Screws	190-195 in lb (21-23 Nm)
Crankshaft Center Bearing Support	190-195 in lb (21-23 Nm)
Front Crankshaft Support	190-195 in lb (21-23 Nm)
Connecting Rod Bearing Screws	26-30 ft lb (35-41 Nm)
Oil Pump Cover Screws	43-52 in lb (5-6 Nm)
Timing Cover Screws	190-195 in lb (21-23 Nm)
Cylinder Head Retaining Nuts	Step 1: 15 ft lb (20.4 Nm), Step 2: 23 ft lb (31.2 Nm), Step 3: 30 ft lb (43.7 Nm)

H-3 GENERAL TORQUE DATA.

BOLT STRENGTH IDENTIFICATION, ENGLISH SYSTEM

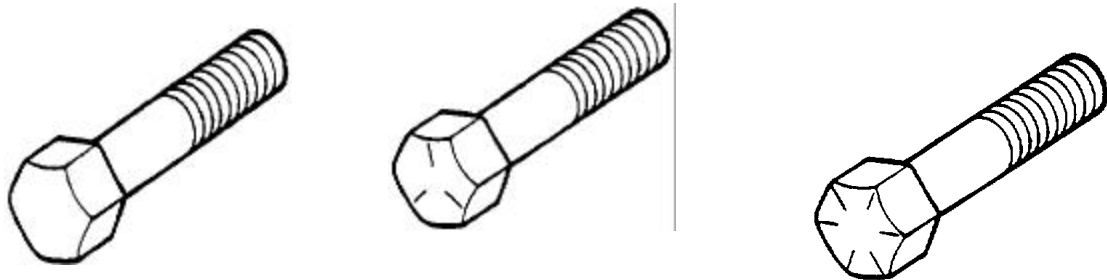

Grade 1 or 2

Grade 5

Grade 8



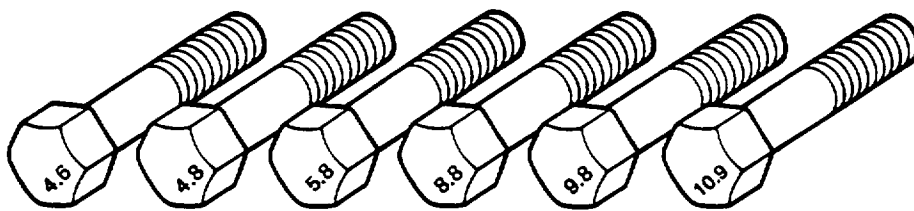

Identification marks correspond to bolt strength - increasing number of slashes represent increasing strength.

BOLT STRENGTH IDENTIFICATION, METRIC SYSTEM



Identification class numbers correspond to bolt strength - increasing numbers represent increasing strength.

HEX NUT STRENGTH IDENTIFICATION

English System		Metric System	
Grade	Identification	Grade	Identification
Hex Nut Grade 5	 3 Dots	Hex Nut Property Class 9	 Arabic 9
Hex Nut Grade i	 6 Dots	Hex Nut Property Class 10	 Arabic 10
Increasing dots represent increasing strength		Increasing numbers represent increasing strength	

BOLT NOMENCLATURE

ENGLISH SYSTEM		METRIC SYSTEM	
Example: $\frac{1}{4}$ - 28 x 1.25 D T L		Example: M8 - 1.0 x 25 D T L	
D = Diameter (inches)	L = Length (inches)	D = Diameter (millimeters)	L = Length (millimeters)
G = Grade (bolt strength)	T = Threads/inch	P = Property (bolt strength)	T = Thread width (millimeters)





STANDARD TORQUE VALUES - ENGLISH SYSTEM

In the absence of specific torque values, the following chart can be used as a guide to the maximum safe torque for a particular size/grade of fastener. There is no torque difference for fine or coarse threads. Torque values are based on clean, dry threads. Reduce value by 10% if threads are oiled before assembly.

SAE Grade Number		1		2		5		8	
Number of slashes always 2 less than grade number									
Dia.	Wrench Size	Maximum Torque		Maximum Torque		Maximum Torque		Maximum Torque	
		lb in	Nm	lb in	Nm	lb in	Nm	lb in	Nm
#6		6	0.7		15	1.7			
#8		11	1.2		28	3.2			
#10		16	1.8		41	4.6			
#12		25	2.8		65	7.3			
		lb ft	Nm	lb ft	Nm	lb ft	Nm	lb ft	Nm
1/4	7/16	3	4	5	7	8	11	12	16
5/16	1/2	6.5	9	10	14	17	23	24	32
3/8	9/16	12	16	18	24	30	41	40	54
7/16	5/8	19	26	30	41	50	68	70	95
1/2	3/4	30	41	45	61	75	102	105	142
9/16	13/16	40	54	65	88	105	142	150	203
5/8	15/16	55	75	90	122	145	197	205	278
3/4	1-1/8	100	136	160	217	260	353	365	495
7/8	1-5/16	165	224	165	224	415	563	590	800
1	1 1/2	245	332	245	332	625	848	880	1193
1-1/8	1-11/16	345	468	345	468	780	1058	1250	1695
1-1/4	1-7/8	490	664	490	664	1100	1492	1765	2393
1-3/8	2-1/16	640	868	640	868	1440	1953	2315	3140
1-1/2	2-1/4	850	1153	850	1153	1910	2590	3070	4163

STANDARD TORQUE VALUES - METRIC SYSTEM

In the absence of specific torque values, the following chart can be used as a guide to the maximum safe torque for a particular size/grade of fastener. There is no torque difference for fine or coarse threads. Torque values are based on clean, dry threads. Reduce value by 10% if threads are oiled before assembly.

Relative Strength Marking		4.6		4.8		8.8 or 9.8		10.9		12.9	
Bolt Markings											
Dia. Size	Wrench lb ft	Maximum Torque		Maximum Torque		Maximum Torque		Maximum Torque		Maximum Torque	
		Nm	lb ft	Nm	lb ft	Nm	lb ft	Nm	lb ft	Nm	lb ft
M3	5.5mm	3	5	5	7	1	1.3	1.5	2	1.5	2
M4	7mm	8	1.1	1	1.5	2	3	3	4.5	4	5
M5	8mm	1.5	2.5	2	3	4.5	6	6.5	9	7.5	10
M6	10mm	3	4	4	5.5	7.5	10	11	15	13	18
M8	13mm	7	9.5	10	13	18	25	26	35	33	45
M10	16mm	14	19	18	25	37	50	55	75	63	85
M12	18mm	26	35	33	45	63	85	97	130	111	150
M14	21mm	37	50	55	75	103	140	151	205	177	240
M16	24mm	59	80	85	115	159	215	232	315	273	370
M18	27mm	81	110	118	160	225	305	321	435	376	510
M20	30mm	118	160	166	225	321	435	457	620	535	725
M22	33mm	159	215	225	305	435	590	620	840	726	985
M24	36mm	203	275	288	390	553	750	789	1070	926	1255
M27	41mm	295	400	417	565	811	1100	1154	1565	1353	1835
M30	46mm	402	545	568	770	1103	1495	1571	2130	1837	2490

APPENDIX I

MANDATORY REPLACEMENT PARTS

Item No.	Part Number	NSN	Nomenclature	Qty Req
1	13230E5898 (9T403)		Nut, Metric, Self-Locking	2
2	220146 (ODT23)	5330-01-433-9203	Seal	2
3	220157 (ODT23)		Seal, Upstream.....	1
4	220158 (ODT23)		Seal, Downstream	1
5	220464 (ODT23)		Bushing.....	3
6	220465 (ODT23)		Seal	1
7	220466 (ODT23)		Bushing.....	1
8	220467 (ODT23)		Seal	2
9	7701601 (62445)		Clip, Retaining	1
10	7712125 (62445)	5330-01-396-5884	Oil Seal	1
11	7717525 (62445)	4330-01-331-2704	Filter, Oil	1
12	7731031 (62445)		Bearing	1
13	7731077 (62445)	3120-01-396-8425	Bearing	1
14	7731657 (62445)		Bearing Half	1
15	7745059 (62445)		Gasket, Timing Cover	1
16	7745067 (62445)	5365-01-406-6401	Gasket	3
17	7745075 (62445)		Gasket	1
18	7745062 (62445)		Gasket, Intake Manifold.....	2
19	7745108 (62445)		Gasket	1
20	7745115 (62445)		Gasket	1
21	7745122 (62445)		Gasket, Pan	1
22	7745124 (62445)		Gasket, Exhaust Manifold	2
23	7745131 (62445)		Gasket	2
24	7745173 (62445)		Gasket	3
25	7757901 (62445)		O-Ring	1
26	7757912 (62445)	5330-01-396-5886	O-Ring	4
27	7757949 (62445)		O-Ring	1
28	7757978 (62445)		O-Ring	1
29	7757979 (62445)		O-Ring	1
30	7775402 (62445)		Washer	3
31	7775408 (62445)		Washer	2
32	7775409 (62445)		Washer, Copper	4
33	7775434 (62445)		Washer, Copper	2
34	7775435 (62445)	5330-01-313-7899	Washer, Copper	2
35	7775438 (62445)		Washer	2

Item No.	Part Number	NSN	Nomenclature	Qty Req
36	7775439 (62445)	5310-01-357-5762	Washer, Copper	2
37	7775439 (62445)	5310-01-357-5762	Washer	1
38	7775450 (62445)		Washer	2
39	7775450 (62445)		Washer, Copper	2
40	8423-32		Seal, Shaft	1
41	MS20604R4W2 (96906)	5320-01-359-4667	Rivet, 0.125 dia	6
42	MS21043-08 (96906)	5310-00-878-7196	Nut, Self-Locking	3
43	MS21043-04 (96906)	5310-00-844-4872	Nut, Self-Locking	2
44	MS21043-05 (96906)	5310-00-881-0944	Nut, Self-Locking	6
45	MS21044C4 (96906)	5310-00-889-2589	Nut, Self-Locking	4
46	MS29512-03 (96906)	5330-00-263-8011	O-Ring	1
47	MS29513-009 (96906)	5330-00-248-3834	O-Ring	2
48	MS29513-010 (96906)	5330-00-248-3835	O-Ring	1
49	MS29513-014 (96906)	5330-00-248-3840	O-Ring	2
50	MS29513-016 (96906)	5330-00-248-3845	O-Ring	2
51	MS29513-133 (96906)	5330-00-291-7384	O-Ring	1
52	MS29513-134 (96906)	5330-00-641-0119	O-Ring	1
53	MS29513-141 (96906)	5330-00-527-8555	O-Ring	1
54	MS29513-157 (96906)	5330-00-182-3170	O-Ring	1
55	MS29513-160 (96906)	5330-00-860-2395	O-Ring	1
56	MS29513-175 (96906)	5330-00-172-6348	O-Ring	1
57	MS29513-227 (96906)	5330-00-260-9338	O-Ring	1
58	MS29513-234 (96906)	5330-00-251-9367	O-Ring	1
59	MS35338-137 (96906)	5330-00-933-8119	Washer, Lock	4
60	MS35338-137 (96906)	5330-00-933-8119	Washer, Lock	2
61	MS35338-139 (96906)	5310-00-933-8121	Washer, Lock	6
62	MS35338-139 (96906)	5310-00-933-8121	Washer, Lock	1
63	MS35338-140 (96906)	5310-00-974-6623	Washer, Lock	4
64	MS35338-141 (96906)	5310-01-385-9419	Washer, Lock	1
65	MS35338-143 (96906)	5310-01-180-7157	Washer, Lock	4
66	MS51922-2 (96906)	5310-00-929-1807	Nut, Self-Locking	1
67	Q04188		O-Ring	1
68			Washer, Lock, Stainless Steel, 3/8 Inch	6
69	MS35338-140 (96906)	5310-00-974-6623	Washer, Lock	10
70	7777105 (62445)		Washer, Lock	1
71	7775438 (62445)		Washer	3
72	7775407 (62445)		Washer	2
73	7777111 (62445)	5310-01-422-0728	Washer	4
74	1320E5909 (97403)		O-Ring	2

Item No.	Part Number	NSN	Nomenclature	Qty Req
75	M83461/1-207	(81349)	Packing	2
76	P140351	(05593)	Washer, Lock	4
77	7745076 (62445)		Gasket, Fuel Pump	1
78	MS35338-140	(96906)	Washer, Lock	2
79	MS35338-141	(96906)	Washer, Lock	2

APPENDIX J

WIRING DIAGRAMS

J-1 SCOPE

This appendix contains the pumping assembly wiring diagrams for the accessory module control box and all cables. These diagrams are provided as troubleshooting aids and do not include all the information required to manufacture the component parts illustrated.

J-2 ABBREVIATIONS

All abbreviations used in the wiring diagrams in this appendix conform to the requirements of MIL-STD-12.

J-3 CONTENTS

Each diagram contained in this appendix is listed below. Cable wiring diagram titles include the cable designation and common name.

<u>Figure</u>	<u>Title</u>	<u>Page</u>
J-1	Control Panel Wiring Diagram	J-2
J-2	Cable Assembly W101 Wiring Diagram (Engine Wiring Harness)	J-3
J-3	Cable Assembly W102 Wiring Diagram (Engine Starter Cable)	J-4
J-4	Cable Assembly W103 Wiring Diagram (Pumpage Overtemperature Cable)	J-5
J-5	Cable Assembly W201 Wiring Diagram (Accessory Module Control Cable)	J-6
J-6	Cable Assembly W202 Wiring Diagram (Battery Power Cable)	J-7

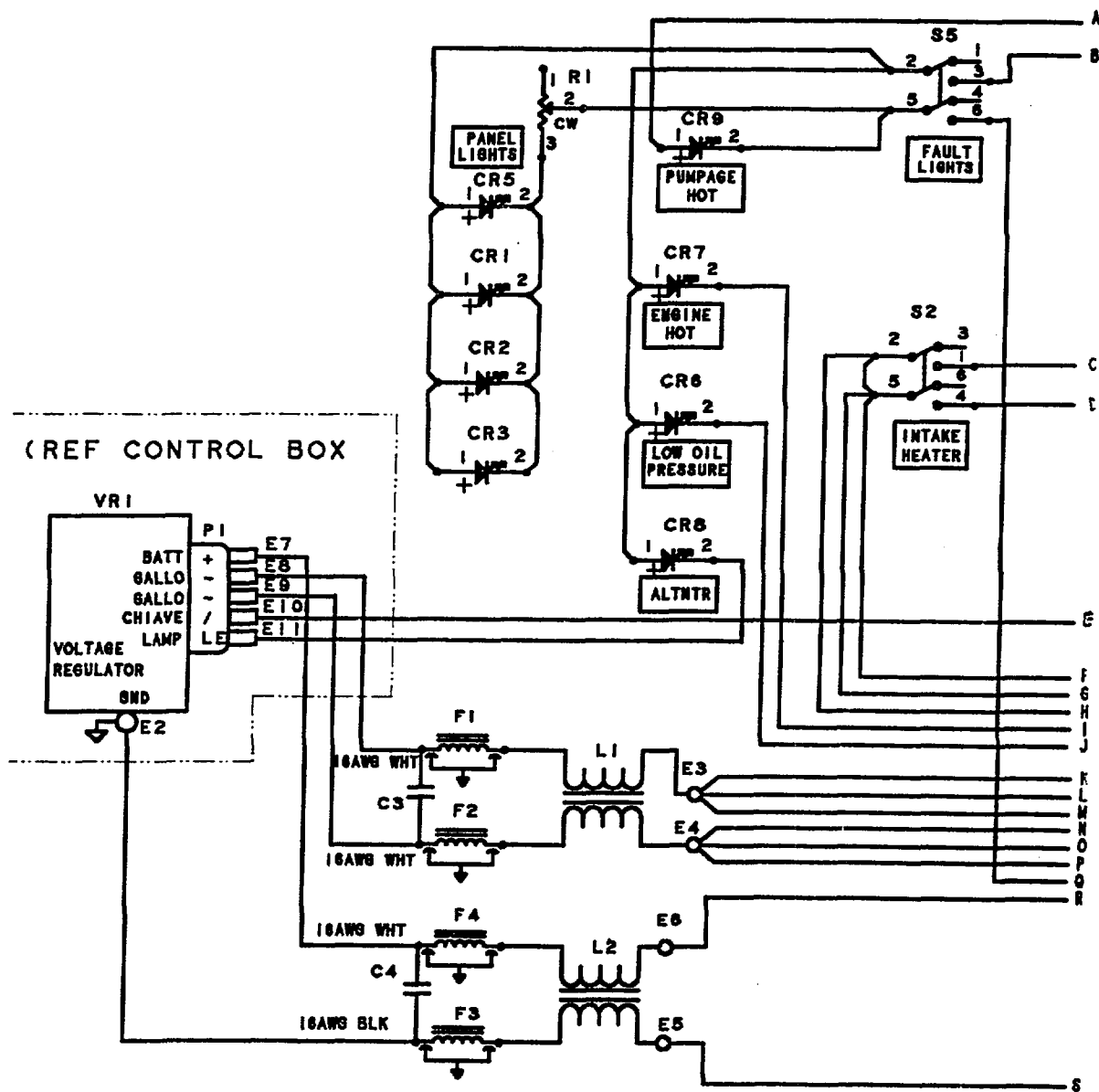

Figure J-1. Control Panel Wiring Diagram (Sheet 1 of 2)

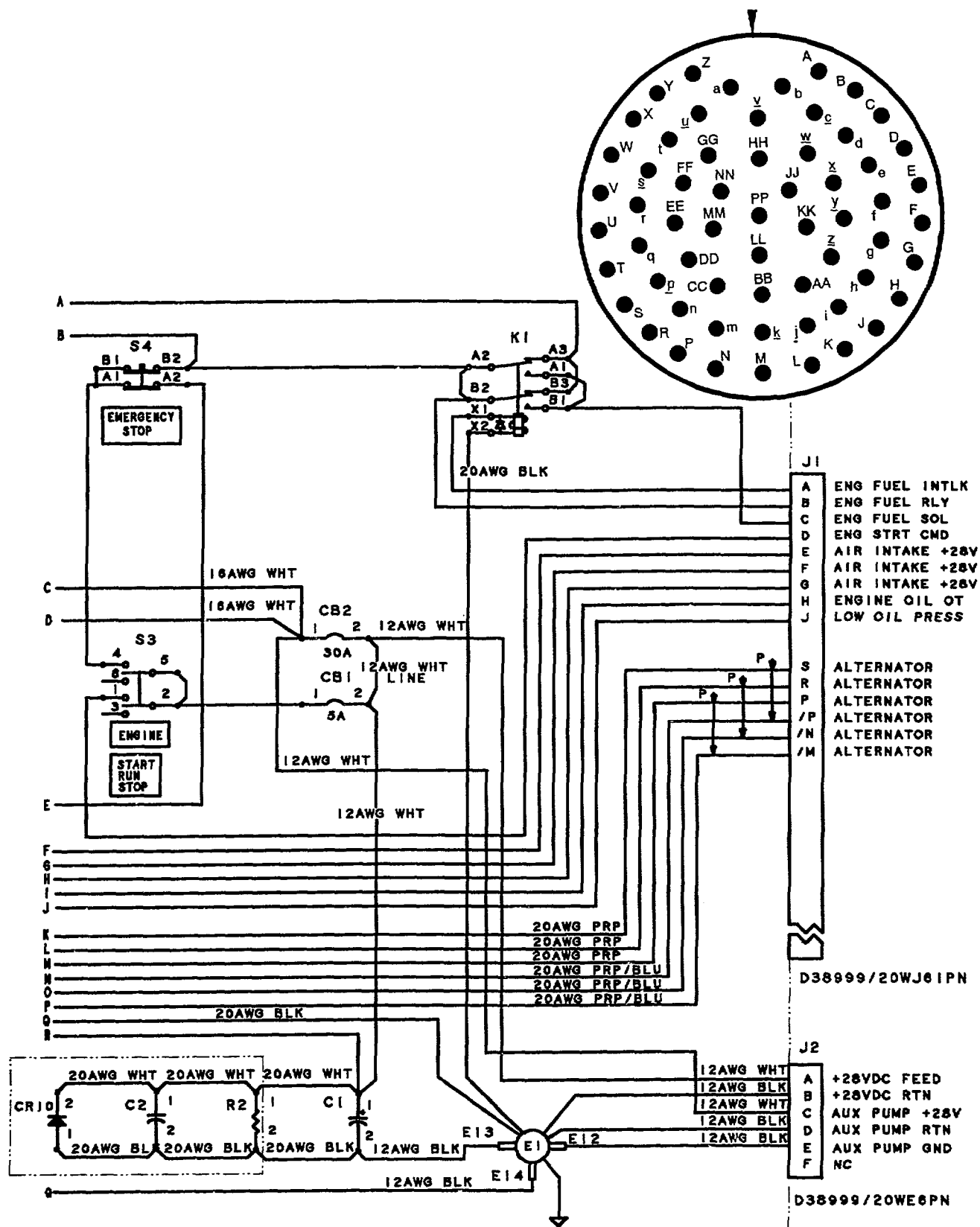

Figure J-1. Control Panel Wiring Diagram (Sheet 2 of 2)

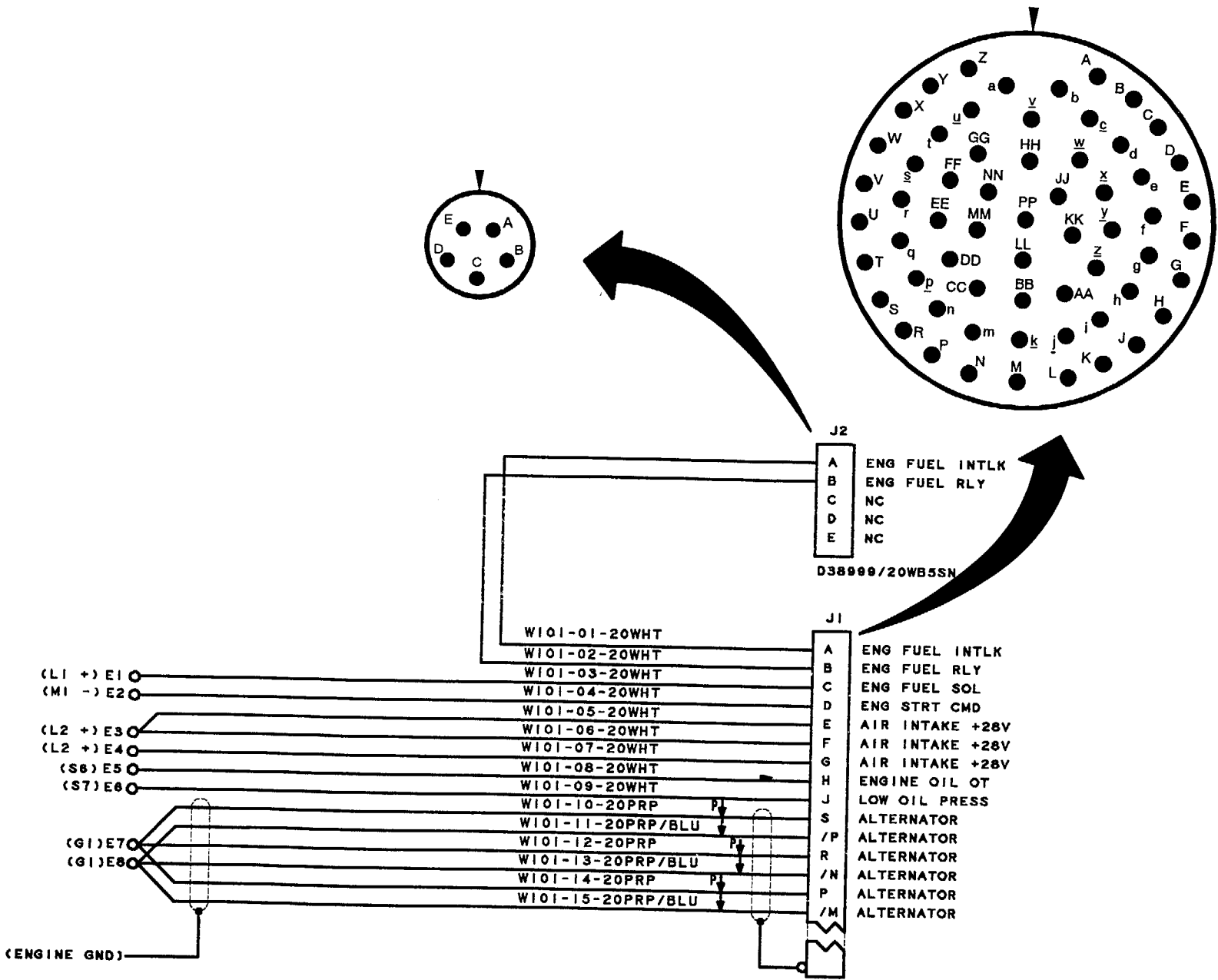

Figure J-2. Cable Assembly W101 Wiring Diagram

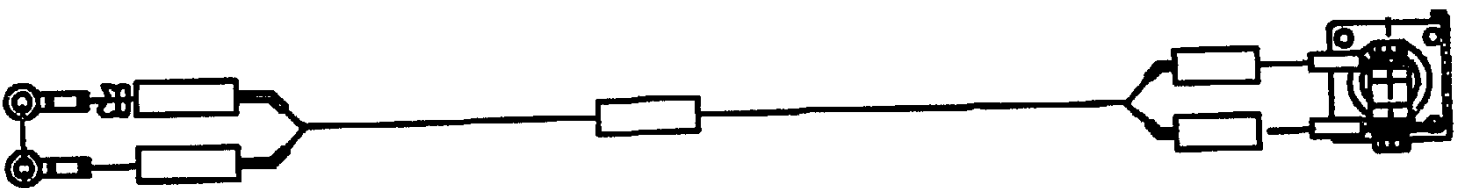
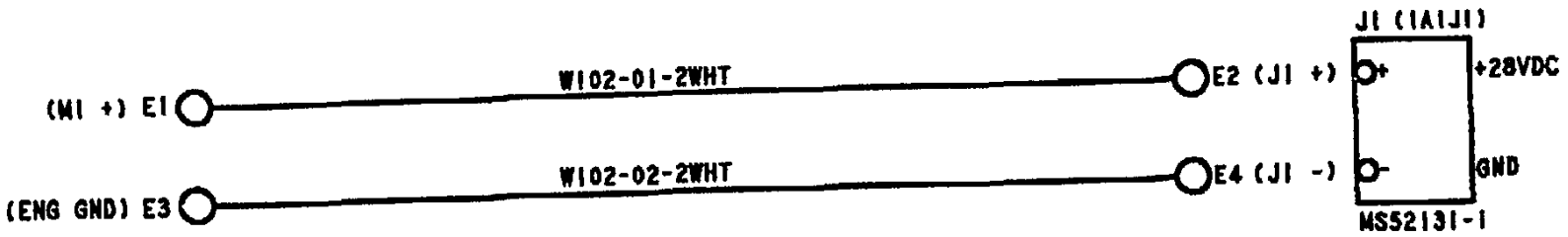

Figure J-3. Cable Assembly W102 Wiring Diagram

Figure J-4. Cable Assembly W103 Wiring Diagram

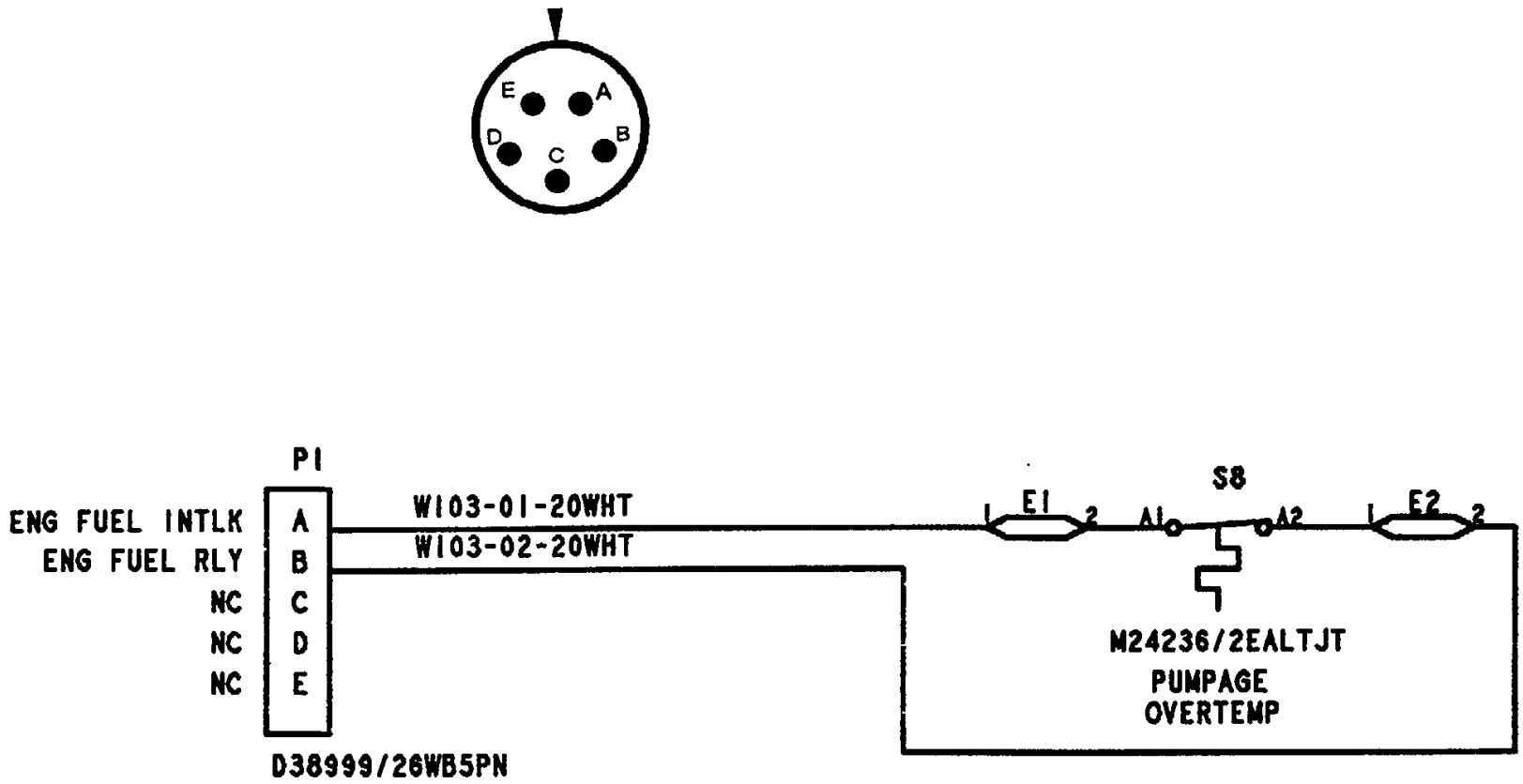

Figure J-5. Cable Assembly W201 Wiring Diagram

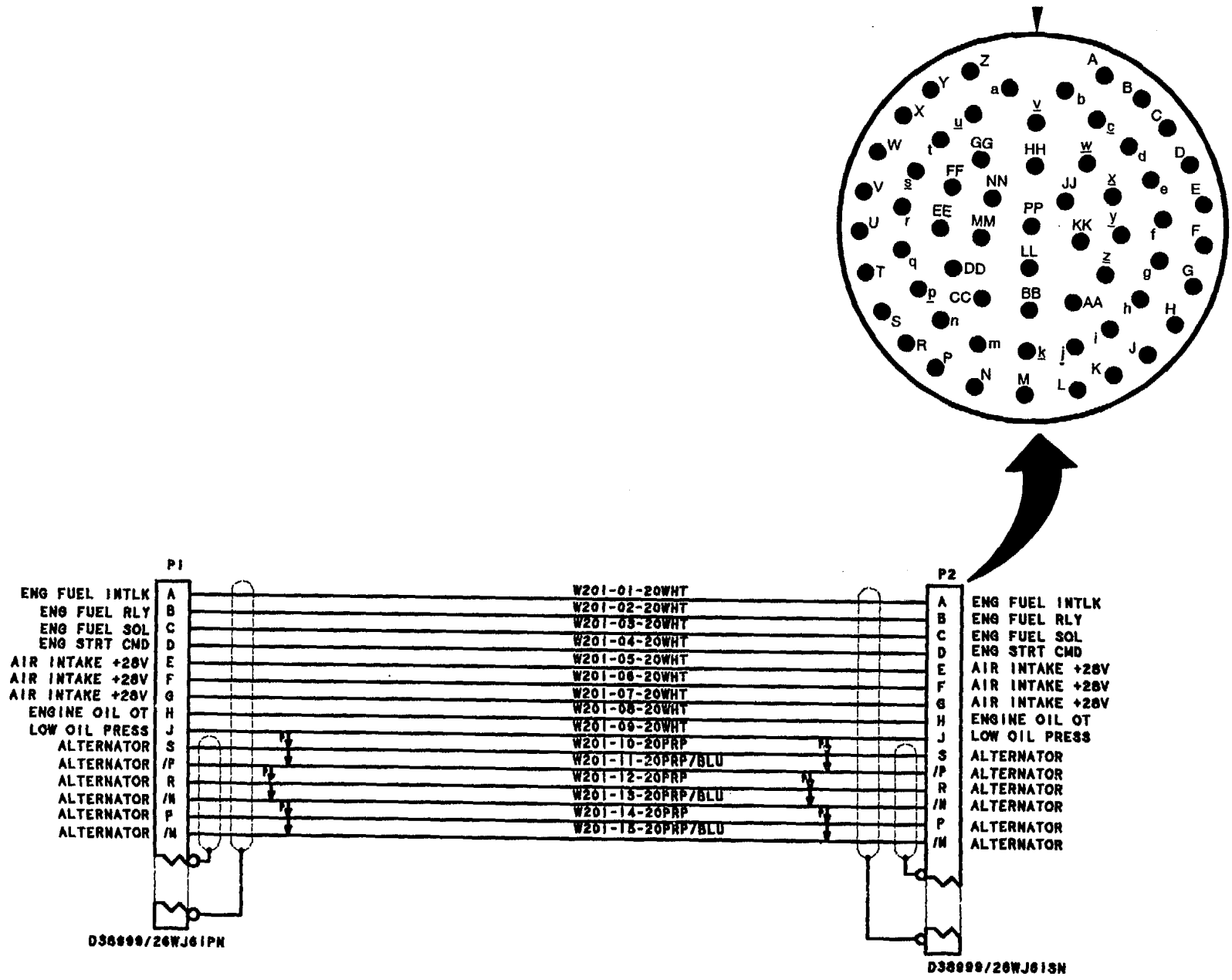
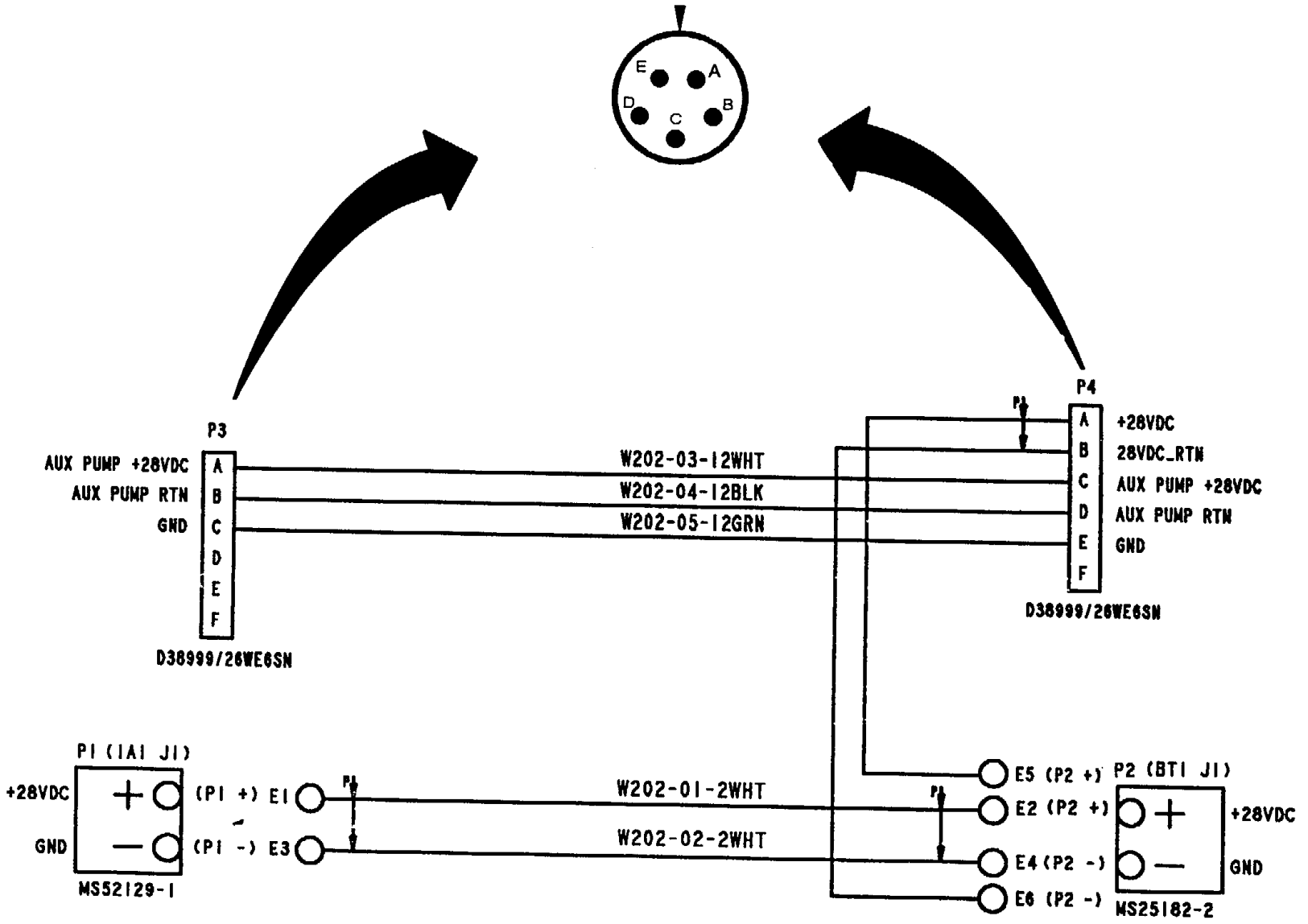

Figure J-6. Cable Assembly W202 Wiring Diagram



INDEX

<u>Subject</u>	<u>Paragraph, Figure, Table Number</u>
-A-	
Administrative Storage, Special Instructions	4.19
Accessory Module	
Physical Description	1.9.2
Accessory Module Maintenance	
Battery, Replace	4.16.1
Control Box, Replace	4.16.2
-B-	
Battery	
Replace	4.16.1
-C-	
Circuit Breakers, Replace	5.3.6
Control Box	
Physical Description	1.9.2.1
Replace	4.16.2
Control Panel	
Capacitor C1, Replace	5.3.5
Circuit Breakers, Replace	5.3.6
Controls and Indicators	2-1
Dimmer, Panel Lights, Replace	5.3.2
Emergency Stop Switch, Replace	5.3.3
Malfunction Indicator, Replace	3.4
Panel Lamp Assemblies, Replace	5.3.1
Panel Lamps, Replace	3.5
Potentiometer R1, Replace	5.3.2
Relay K1, Replace	5.3.7
Toggle Switches, Replace	5.3.4
Voltage Regulator	5.3.8
-D-	
Emergency Stop Switch, Replace	5.3.3
Engine Assembly Maintenance	
Fuel Pump, Replace	4.15.2
Starter, Replace	4.15.1

INDEX

<u>Subject</u>	<u>Paragraph, Figure, Table Number</u>
Engine	
Assemble	6.3
Disassemble	6.2
Overhaul	6.2.1
Physical Data	1-1
Engine Module	
Air Filter Element, Replace	3.6
Electrical Connection Panel	2-2
Engine, Replace	4.14.1
Engine Oil, Change	4.1.1
Physical Data	1-1
Physical Description	1.9.1.2
Emergency Operating Procedures	2.8
Equipment Data	1-1
 -F- 	
Fuel Shutoff Valve Maintenance	
Flange Packing, Replace	4.13.1
Unisex Coupling, Overhaul	4.13.3
Unisex Coupling, Replace	4.13.2
Fuel Transfer Pump	
Physical Description	1.9.1.11
Fuel Transfer Pump Maintenance	
Discharge Housing O-Ring, Replace	4.11.3
Discharge Valve, Replace	4.11.4
Fuel Transfer Pump, Replace	4.11.1
Impeller-Shaft Assembly, Replace	4.11.8
Inlet O-Ring, Replace	4.11.2
Shaft Seal Assembly/O-Rings, Replace	4.11.5
Vane Pump Components, Replace	4.11.7
Vane Pump Housing O-Rings, Replace	4.11.6
 -I- 	
Inlet Manifold Maintenance	
Outlet O-Ring, Replace	4.12.1
Unisex Coupling, Replace	4.12.2
 -N- 	
NBC Decontamination	2.9

INDEX

<u>Subject</u>	<u>Paragraph, Figure, Table Number</u>
-O-	
Operating Procedures	2.5
Operation Under Extreme Environmental Conditions	2.7
Operator Troubleshooting	3.2
-P-	
Pump-Engine Module	
Physical Data	1-1
Physical Description	1.9.1
Pump-Engine Module Maintenance	
Replace Engine Fuel Filter	4.10.1
Replace Pumpage Overtemperature Sensor/Sensor Cable W103	4.9.2
Pumping Assemblies Operation	
Emergency Operating Procedures	2.8
NBC Decontamination	2.9
Operating Procedures	2.5
Operation in Extreme Cold	2.7.2
Operation in Extreme Heat	2.7.1
Operation in Rain	2.7.5
Operation in Strong Winds	2.7.3
Operation Under Sandy or Dusty Conditions	2.7.4
Preparation for Movement	2.6
System Assembly and Preparation for Use	2.4
PMCS	
Operator	2-3
Unit	4-1
Preparation for Movement	2.6
Preparation for Shipment	4.18
Preparation for Storage	4.17
Preparation for Use	2.4
-T-	
Troubleshooting, Direct Support	5.1
Troubleshooting, General Support	6.1
Troubleshooting, Operator	3.2
Troubleshooting, Unit	4.9

INDEX

<u>Subject</u>	<u>Paragraph, Figure, Table Number</u>
-U-	
Unisex Coupling Face Seal, Replace.....	3.3
Unisex Coupling, 2-Inch Overhaul	5.6
Replace	4.10.2
Unisex Coupling, 3-Inch Overhaul	5.5
Replace.....	4.11.2
Unisex Coupling, 3-Inch, Flange Packing Install.....	4.13.1.2
Remove	4.13.1.1

By Order of the Secretary of the Army:

DENNIS J. REIMER
General, United States Army
Chief of Staff

Official:

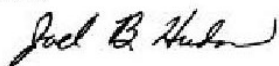

JOEL B. HUDSON
Administrative Assistant to the
Secretary of the Army
05757

DISTRIBUTION: To be distributed in accordance with the initial distribution number (IDN) 256429, requirements for TM 10-4320-351-14.

RECOMMENDED CHANGES TO EQUIPMENT TECHNICAL PUBLICATIONS



THEN... JOT DOWN THE DOPE ABOUT IT ON THIS FORM. CAREFULLY TEAR IT OUT. FOLD IT AND DROP IT IN THE MAIL!

SOMETHING WRONG WITH THIS PUBLICATION?

FROM: (PRINT YOUR UNIT'S COMPLETE ADDRESS)
 PFC JOHN DOE
 COA, 3d ENGINEER BN
 FT. LEONARD WOOD, MO 63108
 DATE SENT

PUBLICATION NUMBER: TM 10-4320-351-14
 PUBLICATION DATE: 1 March 1999
 PUBLICATION TITLE: Operator's Unit Direct & General Support Maintenance Pumping Assembly for AAFARS (NSN) 4320-01-434-4653

BE EXACT PIN-POINT WHERE IT IS			
PAGE NO	PARA-GRAPH	FIGURE NO	TABLE NO
6	2-1 a		
B1		4-3	
125	line 20		

IN THIS SPACE TELL WHAT IS WRONG AND WHAT SHOULD BE DONE ABOUT IT:

In line 6 of paragraph 2-1a the manual states the engine has 6 cylinders. The engine on my set only has 4 cylinders. Change the manual to show 4 cylinders.

c. figure 4-3 is a bolt. In key 4-3, item 16 is called rim - Please correct or the other.

I ordered a gasket, item 19 on figure B-16 by NSN 2 910-00-762-3001. I got a gasket but it doesn't fit. Supply says I got what I ordered, so the NSN is wrong. Please give me a good NSN.

Sample

PRINTED NAME, GRADE OR TITLE, AND TELEPHONE NUMBER: JOHN DOE, PFC (268) 317-7111
 SIGN HERE: JOHN DOE

YEAR ALONG REPERATED DAY

FILL IN YOUR
UNIT'S ADDRESS



FOLD BACK

DEPARTMENT OF THE ARMY



OFFICIAL BUSINESS

NO POSTAGE
NECESSARY
IF MAILED
IN THE
UNITED STATES

BUSINESS REPLY MAIL

FIRST CLASS

BRM PERMIT NO. 82

ROCK ISLAND, IL

POSTAGE WILL BE PAID BY ROCK ISLAND ARSENAL



HQ, US ARMY TANK-AUTOMOTIVE AND
ARMAMENTS COMMAND
ATTN: AMSTA-LC-CI (TECH PUBS CONTROL POINT)
ROCK ISLAND, IL 61201-9948

TEAR ALONG PERFORATED LINE



FILL IN YOUR
UNIT'S ADDRESS



FOLD BACK

DEPARTMENT OF THE ARMY



OFFICIAL BUSINESS

NO POSTAGE
NECESSARY
IF MAILED
IN THE
UNITED STATES

BUSINESS REPLY MAIL

FIRST CLASS

BRM PERMIT NO. 82

ROCK ISLAND, IL

POSTAGE WILL BE PAID BY ROCK ISLAND ARSENAL

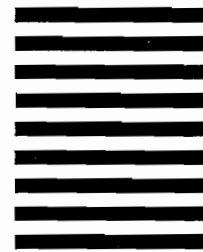

HQ, US ARMY TANK-AUTOMOTIVE AND
ARMAMENTS COMMAND
ATTN: AMSTA-LC-CI (TECH PUBS CONTROL POINT)
ROCK ISLAND, IL 61201-9948

TEAR ALONG PERFORATED LINE



THE METRIC SYSTEM AND EQUIVALENTS

LINEAR MEASURE

1 Centimeter = 10 Millimeters = 0.01 Meter = 0.3937 Inch
 1 Decimeter = 10 Centimeters = 3.94 Inches
 1 Meter = 10 Decimeters = 100 Centimeters
 = 1000 Millimeters - 39.37 Inches
 1 Dekameter = 10 Meters = 32.8 Feet
 1 Hectometer = 10 Dekameters = 328.08 Feet
 1 Kilometer = 10 Hectometers = 1000 Meters
 = 0.621 Mile = 3,280.8 Feet
 Millimeters = Inches times 25.4
 Inches = Millimeters divided by 25.4

WEIGHTS

1 Centigram = 10 Milligrams = 0.154 Grain
 1 Decigram = 10 Centigrams = 1.543 Grains
 1 Gram = 0.001 Kilogram = 10 Decigrams
 = 1000 Milligrams = 0.035 Ounce
 1 Dekagram = 10 Grams = 0.353 Ounce
 1 Hectogram = 10 Dekagrams = 3.527 Ounces
 1 Kilogram = 10 Hectograms = 1000 Grams = 2.205 Pounds
 1 Quintal = 100 Kilograms = 220.46 Pounds
 1 Metric Ton = 10 Quintals = 1000 Kilograms = 1.102 Short Tons

LIQUID MEASURE

100° Fahrenheit is equivalent to 380 Celsius
 1 Milliliter = 0.001 Liter = 0.034 Fluid Ounce
 1 Centiliter = 10 Milliliters = 0.34 Fluid Ounce
 1 Deciliter = 10 Centiliters = 3.38 Fluid Ounces
 1 Liter = 10 Deciliters = 1000 Milliliters = 33.82 Fluid Ounces
 1 Dekaliter = 10 Liters = 2.64 Gallons
 1 Hectoliter = 10 Dekaliters = 26.42 Gallons
 1 Kiloliter = 10 Hectoliters = 264.18 Gallons

SQUARE MEASURE

1 Sq Centimeter = 100 Sq Millimeters - 0.155 Sq Inch
 1 Sq Decimeter = 100 Sq Centimeters = 15.5 Sq Inches
 1 Sq Meter (Centare) = 100 Sq Decimeters
 = 10,000 Sq Centimeters 10.764 Sq Feet
 1 Sq Dekameter (Are) = 100 Sq Meters = 1,076.4 Sq Feet
 1 Sq Hectometer (Hectare) = 100 Sq Dekameters = 2.471 Acres
 1 Sq Kilometer = 100 Sq Hectometers = 1,000,000 Sq Meters
 = 0.386 Sq Mile

CUBIC MEASURE

1 Cu Centimeter = 1000 Cu Millimeters = 0.061 Cu Inch
 1 Cu Decimeter = 1000 Cu Centimeters = 61.02 Cu Inches
 1 Cu Meter - 1000 Cu Decimeters = 1,000,000 Cu Centimeters
 = 35.31 Cu Feet

TEMPERATURE

5/9 (F - 320) = °C
 9/5 (OC+ 32°) = °F
 -35° Fahrenheit is equivalent to -37° Celsius
 0° Fahrenheit is equivalent to -18° Celsius
 32° Fahrenheit is equivalent to 00 Celsius
 90° Fahrenheit is equivalent to 32.2° Celsius
 212° Fahrenheit is equivalent to 100° Celsius

APPROXIMATE CONVERSION FACTORS

<u>TO CHANGE</u>	<u>TO</u>	<u>MULTIPLY BY</u>	<u>TO CHANGE</u>	<u>TO</u>	<u>MULTIPLY BY</u>
Inches	Centimeters	2.540	Meters	Feet	3.281
Feet	Meters	0.305	Meters.....	Yards	1.094
Yards	Meters	0.914	Kilometers.....	Miles	0.621
Miles	Kilometers	1.609	Square Centimeters.....	Square Inches	0.155
Square Inches	Square Centimeters	6.452	Square Meters.....	Square Feet	10.764
Square Feet.....	Square Meters	0.093	Square Meters.....	Square Yards	1.196
Square Yards.....	Square Meters	0.836	Square Kilometers	Square Miles	0.386
Square Miles	Square Kilometers	2.590	Square Hectometers.....	Acres	2.471
Acres	Square Hectometers	0.405	Cubic Meters.....	Cubic Feet	35.315
Cubic Feet.....	Cubic Meters	0.028	Cubic Meters.....	Cubic Yards	1.308
Cubic Yards	Cubic Meters	0.765	Milliliters	Fluid Ounces	0.034
Fluid Ounces	Milliliters	29.574	Liters	Pints	2.113
Pints	Liters	0.473	Liters	Quarts	1.057
Quarts	Liters	0.946	Liters	Gallons	0.264
Gallons	Liters	3.785	Grams	Ounces	0.035
Ounces	Grams	28.350	Kilograms	Pounds	2.205
Pounds	Kilograms	0.454	Metric Tons	Short Tons	1.102
3hortTons	Metric Tons	0.907	Newton-Meters	Pound-Feet	0.738
Pound-Feet.....	Newton-Meters	1.356	Kilopascals	Pounds per Square Inch	0.145
Pounds-inches.....	Newton-Meters	0.11298	Kilometers per Liter	Miles per Gallon	2.352
Pounds per Square Inch...	Kilopascals	6.895	Kilometers per Hour.....	Miles per Hour	0.621
Ounce-inches	Newton-Meters	0.007062	°Fahrenheit	°Celsius	°C(°F-32)x5/9
Miles per Gallon.....	Kilometers per Liter	0.425	°Celsius	°Fahrenheit.....	°F - (9/5x °C)+32
Miles per Hour	Kilometers per Hour	1.609			
Centimeters	Inches	0.394			

This fine document...

Was brought to you by me:



[Liberated Manuals -- free army and government manuals](#)

Why do I do it? I am tired of sleazy CD-ROM sellers, who take publicly available information, slap “watermarks” and other junk on it, and sell it. Those masters of search engine manipulation make sure that their sites that sell free information, come up first in search engines. They did not create it... They did not even scan it... Why should they get your money? Why are not letting you give those free manuals to your friends?

I am setting this document FREE. This document was made by the US Government and is NOT protected by Copyright. Feel free to share, republish, sell and so on.

I am not asking you for donations, fees or handouts. If you can, please provide a link to liberatedmanuals.com, so that free manuals come up first in search engines:

<A HREF=<http://www.liberatedmanuals.com/>>Free Military and Government Manuals

- Sincerely
Igor Chudov
<http://igor.chudov.com/>
- [Chicago Machinery Movers](#)