

TECHNICAL MANUAL

OPERATOR'S, UNIT, AND DIRECT  
SUPPORT MAINTENANCE MANUAL  
INCLUDING REPAIR PARTS AND SPECIAL TOOLS LIST

PUMPING UNIT, 35 GPM,  
CENTRIFUGAL, FUEL TRANSFER  
24 VDC MOTOR DRIVEN  
MODEL FB 4320-35  
NSN 4320-01-386-5913

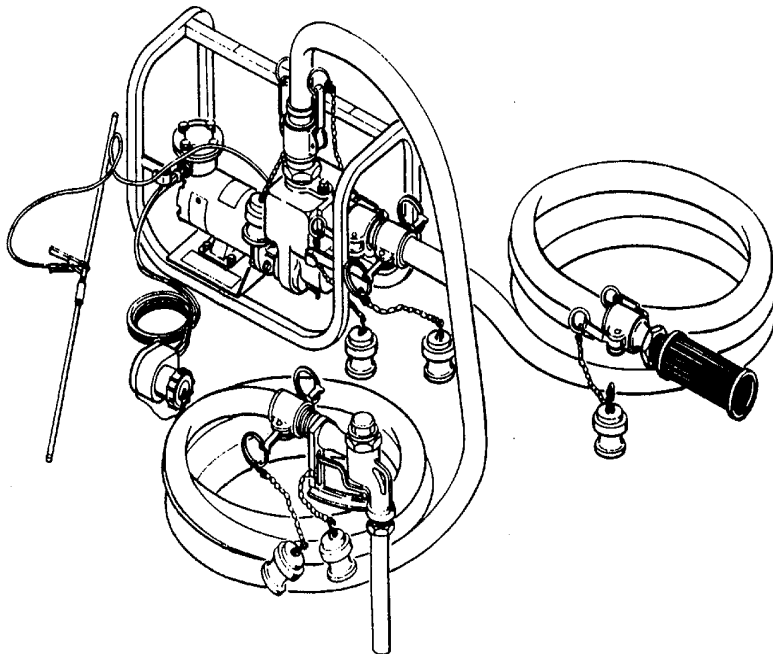

HOW TO USE THIS MANUAL	v
EQUIPMENT DESCRIPTION	1-3
OPERATION UNDER USUAL CONDITIONS	2-11
OPERATOR MAINTENANCE TROUBLESHOOTING PROCEEDURES	3-3
DIRECT SUPPORT MAINTENANCE PROCEEDURES	5-1
MAINTENANCE ALLOCATION CHART	B-1
REPAIR PARTS AND SPECIAL TOOLS LIST	C-1
COMPONENTS OF END ITEM AND BASIC ISSUE ITEMS LIST	D-1
EXPENDABLE SUPPLIES AND MATERIALS LIST	E-1

Distribution statement A. Approved for public release; distribution is unlimited.

HEADQUARTERS, DEPARTMENT OF THE ARMY  
30 NOVEMBER 1994

# WARNING

## SERVICING PUMP ASSEMBLY

If motor is not turned off during service or maintenance, serious injury may result.

## GROUNDING AND BONDING

The pumping assembly must be connected to a suitable ground before operation. Arcing caused by buildup of static electricity may ignite volatile fluids and cause explosion and fire.

## FUEL HANDLING

Use in a well-ventilated area away from open flame, arcing equipment, ignition sources, heater, or excessive heat. Engines must be turned off and cool before refueling. Use proper refueling procedures and equipment to avoid spillage. Do not run engines near open fuel containers. Always store fuel in proper, marked containers. DO NOT SMOKE. Improper fuel handling may cause serious injury or death.

## SEVERE BURNS

could result from handling heating parts. Use proper equipment to handle parts.

## WARNING

Observe all warnings and cautions on containers when using consumables. When applicable, wear necessary protective gear during handling and use. If a consumable is flammable or explosive, MAKE CERTAIN fire fighting equipment is readily available for use.

## CLEANING SOLVENTS

Cleaning solvents may be toxic. Use in well-ventilated areas. Avoid prolonged inhalation of fumes or direct contact with skin. Do not use solvents near open flames or in areas where very high temperatures prevail. Solvent flash point must not be less than 100° F.

## HEAVY EQUIPMENT

Serious injury could occur if heavy equipment is moved/lifted without sufficient personnel to do the job. Always use two personnel to move and relocate the pumping assembly. Use proper physical lifting procedures or use a suitable lifting device or dolly. Wear safety shoes, gloves and other suitable protective clothing.

## FIRST AID

Refer to FM 21-11 for first aid procedures.

a/(b Blank)

TECHNICAL MANUAL  
 NO. 10-4320-347-13&P

HEADQUARTERS  
 DEPARTMENT OF THE ARMY  
 WASHINGTON, D.C., 30 November 1994

Operator's, Unit, and Direct Support,  
 Maintenance Manual

For

PUMPING UNIT, 35 GPM, CENTRIFUGAL, FUEL TRANSFER  
 24 VDC MOTOR DRIVEN  
 MODEL FB 4320-35  
 NSN 4320-01-386-5913  
 CURRENT AS OF 22 NOVEMBER 1994

Distribution Statement A: Approved for public release; distribution is unlimited.

**REPORTING ERRORS AND RECOMMENDING IMPROVEMENTS**

You can help improve this manual. If you find any mistakes or if you know of a way to improve the procedures, please let us know. Mail your letter, DA Form 2028 (Recommended Changes to Publications and Blank Forms) or DA Form 2028-2 located in the back of this manual direct to: Commander, U.S. Army Aviation and Troop Command, ATTN: AMSAT-I-MP, 4300 Goodfellow Blvd., St. Louis, MO. 63120-1798. A reply will be furnished to you.

**TABLE OF CONTENTS**

	Page
<b>How To Use This Manual</b> .....	v
<b>CHAPTER 1. INTRODUCTION</b> .....	1-1
Section I. General Information .....	1-1
Section II. Equipment Description and Data .....	1-3
Section III. Principles of Operation.....	1-5
<b>CHAPTER 2. OPERATING INSTRUCTIONS</b> .....	2-1
Section I. Description and Use of Operator's Controls and Indicators .....	2-2
Section II. Operator Preventive Maintenance Checks and Services.....	2-3

TABLE OF CONTENTS - Continued

		Page
Section III.	Operation Under Usual Conditions .....	2-10
Section IV.	Operation Under Unusual Conditions .....	2-16
<b>CHAPTER 3.</b>	<b>OPERATOR MAINTENANCE INSTRUCTIONS .....</b>	<b>3-1</b>
Section I.	Lubrication Instructions .....	3-2
Section II.	Operator Troubleshooting Procedures .....	3-2
Section III.	Operator Maintenance Procedures .....	3-6
<b>CHAPTER 4.</b>	<b>UNIT MAINTENANCE INSTRUCTIONS .....</b>	<b>4-1</b>
Section I.	Lubrication Instructions .....	4-1
Section II.	Service Upon Receipt and Preparation for Movement .....	4-1
Section III.	Unit Maintenance Procedures .....	4-3
Section IV.	Preparation for Storage or Shipment .....	4-13
<b>CHAPTER 5.</b>	<b>DIRECT SUPPORT MAINTENANCE INSTRUCTIONS .....</b>	<b>5-1</b>
Section I.	Repair Parts, Special Tools; Test, Measurement, and Diagnostic Equipment (TMDE), and Support Equipment .....	5-1
Section II.	Direct Support Troubleshooting Procedures .....	5-1
Section III.	Direct Support Maintenance Procedures .....	5-1
<b>APPENDIX A.</b>	<b>REFERENCES .....</b>	<b>A-1</b>
<b>APPENDIX B.</b>	<b>MAINTENANCE ALLOCATION CHART .....</b>	<b>B-1</b>
Section I.	Introduction .....	B-1
Section II.	Maintenance Allocation Chart .....	B-5
Section III.	Special Tool and Test Equipment Requirements .....	B-6
Section IV.	Remarks .....	B-6
<b>APPENDIX C.</b>	<b>UNIT MAINTENANCE REPAIR PARTS AND SPECIAL TOOLS LIST .....</b>	<b>C-1</b>
Section I.	Introduction .....	C-1
Section II.	Repair Parts List .....	C-11
	<b>Group 00 Pumping Assembly</b>	
	Pumping Assembly .....	C-11

TABLE OF CONTENTS

		Page
	<b>Group 01 Hose Assemblies, Suction, Discharge</b>	
	Hose assembly, Suction, Discharge.....	C-13
	<b>Group 02 Nozzle Assembly</b>	
	Nozzle Assembly.....	C-15
	<b>Group 03 Grounding Cable</b>	
	Grounding Cable.....	C-17
	<b>Group 04 Pump Assembly</b>	
	Pump Assembly.....	C-19
	<b>Group 05 Motor Assembly</b>	
	Motor Assembly.....	C-21
	<b>Group 06 Slave Cable</b>	
	Slave Cable.....	C-23
	<b>Group 07 Frame Assembly</b>	
	Frame Assembly.....	C-25
	<b>Group 08 Bulk Items</b>	
	Bulk Items.....	C-27
Section III.	Special Tools List	
	<b>Group 99 Special Tools</b>	
	Special Tools.....	C-29
Section IV.	Cross-Reference Indices	
	National Stock Number Index.....	C-31
	Part Number Index.....	C-33
	Figure and Item Number Index.....	C-35
<b>APPENDIX D. COMPONENTS OF END ITEM AND BASIC ISSUE ITEMS LIST</b>		
	.....	D-1
Section I.	Introduction.....	D-1
Section II.	Components of End Item Table.....	D-2
Section III.	Basic Issue Item Table.....	D-4
<b>APPENDIX E. EXPENDABLE/DURABLE SUPPLIES AND MATERIALS LIST</b>		
	.....	E-1
Section I.	Introduction.....	E-1
Section II.	Expendable/Durable Supplies and Materials List.....	E-2
<b>APPENDIX F.</b>	<b>ILLUSTRATED LIST OF MANUFACTURED PARTS</b> .....	F-1
<b>APPENDIX G.</b>	<b>TORQUE LIMITS</b> .....	G-1
<b>APPENDIX H.</b>	<b>MANDATORY REPLACEMENT PARTS</b> .....	H-1

**TABLE OF CONTENTS - Continued**

	<b>Page</b>
<b>INDEX</b> .....	Index-1

**LIST OF ILLUSTRATIONS**

<b>Figure No.</b>	<b>Title</b>	<b>Page</b>
1-1	Pump Unit, 35 GPM, Centrifugal, 24 VDC Motor Driven .....	1-0
1-2	Location of Major Components .....	1-4
2-1	Operator's Controls and Indicators .....	2-2
2-2	Routing Diagram for Operator PMCS.....	2-7
2-3	Assembly of Pump Assembly .....	2-11
2-4	Priming Pump.....	2-13
2-5	Starting and Operating Pump Assembly .....	2-14
2-6	Decals and Instruction Plates.....	2-15
3-1	Hose Assembly (Suction and Discharge) Repair .....	3-7
3-2	Nozzle Assembly Replacement .....	3-8
3-3	Ground Cable Replacement.....	3-9
4-1	Unpacking Pump Assembly .....	4-2
4-2	Nozzle Assembly Repair .....	4-5
4-3	Ground Cable Assembly Repair.....	4-7
4-4	Slave Cable Replacement .....	4-9
4-5	Slave Cable Repair.....	4-10
4-6	Frame Assembly Replacement .....	4-12
5-1	Pump Assembly Replacement .....	5-3
5-2	Pump Assembly Repair .....	5-4
5-3	Motor Assembly Replacement .....	5-7
5-4	Frame Assembly Repair .....	5-8

**LIST OF TABLES**

<b>Table No.</b>	<b>Title</b>	<b>Page</b>
1-1	Equipment Data.....	1-5
2-1	Operator Preventive Maintenance Checks and Services.....	2-6
3-1	Operator Troubleshooting Table .....	3-3

## HOW TO USE THIS MANUAL

**GENERAL.** This technical manual provides you with the information needed to operate and to maintain the Pumping Unit. By properly using this manual, you will be able to identify any problem you may have in operating the pumping unit and then locate the proper procedure needed to correct any problem found.

**MANUAL ORGANIZATION.** This manual has been organized in a manner that groups together the information that an operator or a maintenance technician will need to perform their duties. The following list indicates how this information has been organized.

- Chapter 1** This chapter contains a complete description of the pumping unit and includes such information as general equipment data, location/descriptions of major pumping unit components, and general theory of operations for the pumping unit.
- Chapter 2** The information needed to set up and to operate the pumping unit are included in this chapter. It includes unit information, operator PMCS, and special instructions for unusual or emergency conditions.
- Chapter 3** All operator maintenance procedures have been placed within this chapter.
- Chapter 4** In the event that unit level maintenance is required for the pumping unit, the required maintenance instructions can be found in this chapter.
- Chapter 5** The required maintenance instructions authorized for direct support level maintenance can be found in this chapter.
- Appendix A** Some of the procedures in this manual have references to other military technical manuals and forms. A complete list of all of these Reference Documents is included in this appendix.
- Appendix B** This appendix contains the Maintenance Allocation Chart for the pumping unit. This chart defines which of the items on the pumping unit will likely require maintenance and what military maintenance level is authorized to perform these maintenance procedures.
- Appendix C** If you find that a component of the pumping unit is damaged and must be replaced, you can identify the part needed by referring to the illustrations and parts lists found in this Repair Parts and Special Tools List.
- Appendix D** The Components of End Item List containing a complete listing of all of the items required for a complete pumping unit and the Basic Issue Items List showing essential items needed to operate the pumping unit are contained in this

the  
appendix.

**Appendix E** As you operate and maintain the pumping unit you will be required to use some special expendable items. The Expendable/Durable Supplies and Materials List in this appendix is a complete list of these items which appear elsewhere in the operating and maintenance procedures in this manual.

**Appendix F** Some components of the pumping unit must be manufactured from bulk or stock material before they can be replaced on the unit. A complete set of instructions required to manufacture these items from bulk stock is included in this Illustrated List of Manufactured Parts.

**Appendix G** It is very important to properly tighten all fasteners used in the pumping unit to ensure proper operation of the pumping unit and to protect operating personnel. To assist you in properly tightening these fasteners, this appendix contains the standard Torque Limits for the fasteners used on the pumping unit.

**Appendix H** During maintenance of the pumping unit there are some components of the unit which are not reusable when removed. This Mandatory Replacement Parts appendix lists all of the pumping unit components which must always be replaced if they are removed from the unit.

**AIDS TO FINDING INFORMATION.** The following aids have been placed within this technical manual to help you quickly locate the information you may need.

**Front Cover Index** To provide you with a quick reference to the most used portions of this manual, an index has been placed on the cover of this manual.

**Bleeder Edges On Pages** On the right edge of the front cover index of this manual you will see a black box area that goes to the edge of the front cover page. If you hold this manual with your left hand and bend back the outer right edges of the pages with your right hand, you will find that there are pages inside the technical manual that also have black boxes on the right edges of the page and that these boxes line up with the boxes on the front cover index. By turning to the page in the technical manual that lines up with the box on the front cover, you will be able to quickly turn to the topic shown in the front cover index.

**Table Of Contents and Boxed Titles** In the event that the front cover has been removed from this manual, the items that appear in the front cover index have also been placed in a box where they appear in the Table of Contents of this manual.



**Alphabetical Index** To assist you in locating any other information not found in the front cover index or the Table of Contents, an alphabetical index has been placed in the back of this, manual to help you find any information you may need.

**GENERAL MAINTENANCE METHOD.** Although your local standard operating and maintenance procedure may vary, a simple method of using this technical manual to operate and maintain the pumping unit is shown in the following steps.

### **WARNINGS and CAUTIONS.**

Always read, understand, and perform ALL WARNINGS and CAUTIONS found in this technical manual BEFORE performing the step immediately following the WARNING or CAUTION.

Throughout this technical manual there are certain procedures and operations that are hazardous to you or to the pumping unit. If you see a **WARNING**, pay special attention to the information stated in it **because all WARNINGS provide you with data that will prevent serious injury to you or others around you.** When you see a **CAUTION** read it carefully because the information given in it will keep you from damaging the pumping unit and making the pumping unit unable to fulfill its mission.

**Equipment Set Up And Operation.** Unpack and set up the pumping unit in accordance with the procedures shown in Chapter 2.

**Preventive Maintenance Checks And Services (PMCS).** Perform the operator PMCS procedures shown in Chapter 2.

**Troubleshooting Procedures.** If the pumping unit should not operate properly, refer to either the operating troubleshooting procedures in Chapter 3, the unit troubleshooting procedures in Chapter 4, or the direct support troubleshooting procedures in Chapter 5. The most likely pumping unit malfunctions have been placed within these troubleshooting procedures and a test and/or repair procedure paragraph has been indicated to correct the malfunction found. If a repair is required, refer to the maintenance paragraph shown in the troubleshooting procedure.

**Maintenance Procedures.** The complete repair procedures needed to correct a problem found with the pumping unit have been included in Chapters 3, 4, 5, and 6.

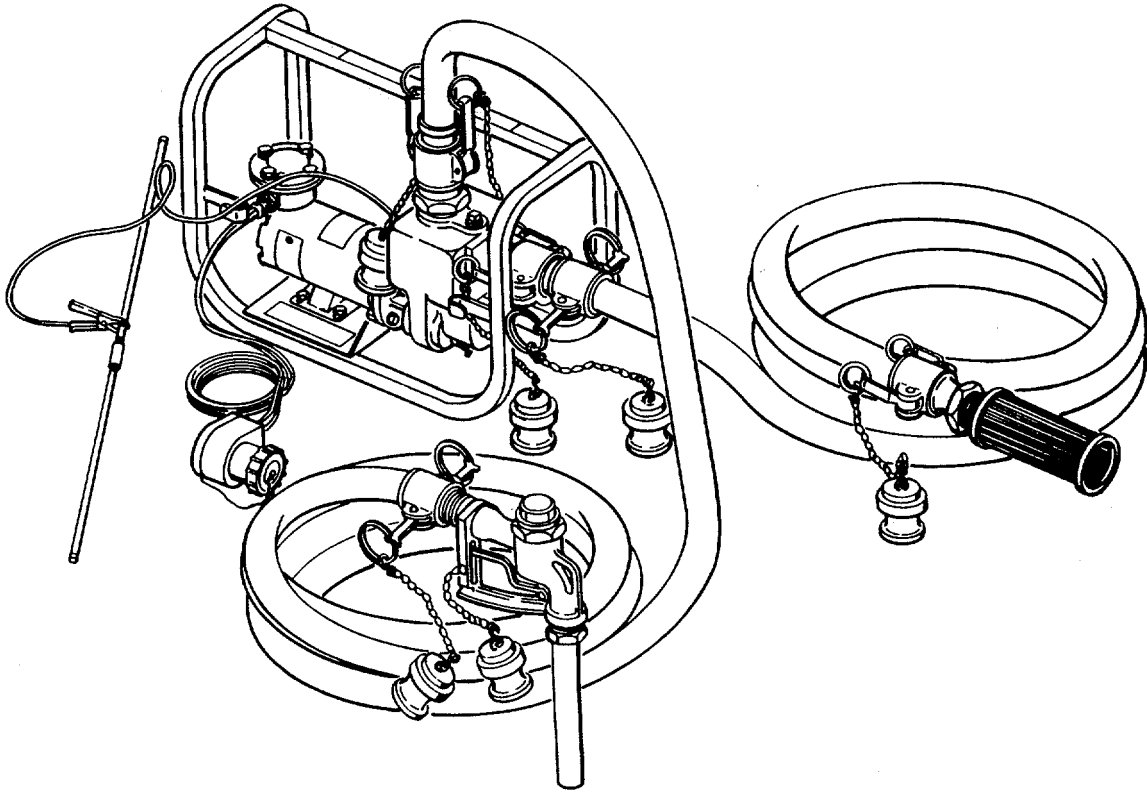

Figure 1-1. Pumping Unit, 35 GPM, Centrifugal, Fuel Transfer, 24 VDC Motor Driven

## CHAPTER 1

## INTRODUCTION

## SECTION 1. GENERAL INFORMATION

## 1.1. SCOPE.

- 1.1.1. **Type of Manual.** Operator's, Unit, and Direct Support Maintenance Manual Including Repair Parts and Special Tools List.
- 1.1.2. **Model Number and Equipment Name.** Model FB 4320-35 Pumping Unit, 35 GPM, Centrifugal, Fuel Transfer, 24 VDC motor Driven.
- 1.1.3. **Purpose of Equipment.** The pumping unit covered by this manual is intended for use in pumping liquid petroleum fuel.

**1.2. MAINTENANCE FORMS AND PROCEDURES.** Department of the Army forms and procedures used for equipment maintenance will be those prescribed by DA PAM 738-750. The Army Maintenance Management System (TAMMS) (Maintenance Management UPDATE).

**1.3. SAFETY, CARE, AND HANDLING.** No special safety precautions are needed for the operation and repair of the pumping assembly. Standard warnings, cautions, and notes are provided when required.

**1.4. CORROSION AND PREVENTION CONTROL.** Corrosion Prevention and Control (CPC) of Army materiel is a continuing concern. It is important that any corrosion problems with this item be reported so that the problem can be corrected and improvements can be made to prevent the problem in future items.

While corrosion is typically associated with the rusting of metals, it can also include deterioration of other materials such as rubber and plastic. Unusual cracking, softening, swelling, or breaking of the materials may be a corrosion problem.

If a corrosion problem is identified, it can be reported using Standard Form 368, Product Quality Deficiency Report. Use of key words such as "rust", "deterioration", "corrosion", or "cracking" will ensure that the information is identified as a CPC problem. The form should be submitted to the address specified in the DA PAM 738-750.

**1.5. DESTRUCTION OF ARMY MATERIEL TO PREVENT ENEMY USE.** Refer to TM 750-244-3, Procedures for Destruction of Equipment to Prevent Enemy Use.

**1.6. PREPARATION FOR STORAGE OR SHIPMENT.** Contact unit maintenance for preparation and storage or shipment. Refer to Section V, Chapter 4.

**1.7. REPORTING EQUIPMENT IMPROVEMENT RECOMMENDATIONS (EIR'S).** If your pumping unit needs improvement, let us know. Send us an EIR. You, the user, are the only one who can tell us what you don't like about your equipment. Let us know why you don't like the design or performance. Put it on a SF 368 (Product Quality Deficiency Report). Mail it to us at; Commander, U.S. Army Aviation and Troop Command, ATTN: AMSAT-I-MDO, 4300 Goodfellow Blvd., St. Louis, Missouri 63120-1798. We will send you a reply.

**1.8. WARRANTY INFORMATION.**

1.8.1. The pumping units are warranted by Faifer Body Company against defective workmanship and materials for 9 months after the date of installation or 36 months from the date of manufacture, whichever occurs first. The installation date may be found in block 23, DA Form 2408-9, in the logbook. The date manufactured appears on the identification plate.

1.8.2. Report all defects in material or workmanship to your supervisor who will take appropriate action through your maintenance shop.

1.8.3. Faifer Body Company limits its obligation under this warranty to furnishing or replacing any product found to be defective as a result of workmanship or materials. They reserve the right to have the defective product returned at the expense of the user in order to establish claim. If the responsibility for the failure is that of Faifer Body Company, they will absorb the transportation charges. The costs of labor, such as for removal and reinstallation of the product are not covered under this warranty.

1.8.4. Faifer Body Company does not guarantee to maintain this product in order when its capacity is too small for the requirements, or where the pumping assembly is subject to extraordinary use.

1.8.5. Faifer Body Company assumes no liability for incidental and consequential damages which may result from the use or misuse of its product. Some states do not allow the exclusion of limitation of incidental or consequential damages, however, so this limitation of exclusion may not apply.

1.8.6. This warranty provides specific legal rights, and you may also have other rights which may vary from state to state.

**1.9. NOMENCLATURE CROSS-REFERENCE LIST.** To simplify the use of certain terms used in this technical manual, some common names to replace longer or more complex terms. The following list shows the common name used in this technical manual and the official nomenclature of the terms these common names replace.

<u>Common Name</u>	<u>Official Nomenclature</u>
Pumping Assembly	Pumping Unit, 35 GPM, Centrifugal, Fuel Transfer, 24 VDC Motor Driven
Pump Assembly	Pump Assembly (Pump and Motor)
Motor	24 VDC Motor
Pump	Centrifugal Pump

**1.10. LIST OF ABBREVIATIONS.** All abbreviations used within this technical manual conform to the standard military abbreviations found in MIL-STD-12, Abbreviations for Use on Drawings, and in Specifications, Standards, and Technical Documents.

**1.11. QUALITY ASSURANCE.** The operator or direct support personnel shall be responsible for determining and certifying personnel skills, equipment, and material to meet the requirements of the work to be accomplished.

## SECTION II. EQUIPMENT DESCRIPTION

### 1.12. EQUIPMENT CHARACTERISTICS, CAPABILITIES, AND FEATURES.

**1.12.1. Characteristics and Capabilities.** The pumping unit is designed for transferring liquid petroleum to and from bulk storage facilities and dispensing in 55 gallon drums, 5 gallon cans, vehicles, and aircraft.

1.12.1.1. Frame-mounted - To provide two soldier carry and ease of handling.

1.12.1.2. Self-priming - The pumping unit will draw fuel without priming.

**1.12.2. Features.** The pumping unit has the following features.

1.12.2.1. Pumps fuel at a rate of 35 GPM with a vertical lift of 5 feet at 15° angle.

1.12.2.2. Hoses for suction and discharge provide 100 feet of access from supply to nozzle.

1.12.2.3. Multi-fuel all weather capability, all fuel designated for ground or aircraft use can be pumped.

**1.13. LOCATION AND DESCRIPTION OF MAJOR COMPONENTS.** The following major components of the pumping unit are described below and are located as shown on FIGURE 1-2.

**1.13.1. Control Switch.** A control switch (4) is built into the motor to provide a means of turning the pumping unit on and off.

**1.13.2. Discharge Hose.** A discharge hose (7) is provided to allow the fuel being pumped by the pumping unit to be directed to a specific discharge point.

**1.13.3. Electric Motor.** A 24 volt direct current electric motor (2) is provided to drive the pump.

**1.13.4. Frame Assembly.** All of the above items are mounted and assembled to a frame (1). This frame is designed to protect the pumping unit and to allow for easier movement of the pumping unit to other locations.

**1.13.5. Grounding Cable.** The grounding cable (11) is attached to the grounding rod assembly and to the pumping unit to act as a conductor for the safe discharge of the static electricity.

**1.13.6. Grounding Rod Assembly.** This ground rod (10) is provided to reduce the possibility of explosion due to static electricity discharge. When this grounding rod is placed into the ground and then attached to the pumping unit by the grounding cable, it will serve as a means to safely drain the static electricity which may build up during unit operation.

**1.13.7. Nozzle.** The nozzle assembly (8) is connected to the end of the discharge hose and meters the amount of fuel being discharged by the pumping unit.

**1.13.8. Pump.** A self-priming pump (3) is attached to the electric motor. This centrifugal type pump uses an impeller to provide the pumping capability of the pumping unit.

1.13.9. **Slave Cable Assembly.** This slave cable (9) is provided to allow the pumping unit to be connected to the slave outlet receptacles on military vehicles to provide a power source for the pumping unit.

1.13.10. **Suction Hose.** Suction hoses (5) are provided to provide a way of connecting the pumping unit to a source of fuel.

1.13.11. **Suction Strainer.** Because the fuel pumped by the pumping assembly must be as pure as possible, a suction strainer (6) is furnished which can be attached to the end of the suction hose. This strainer acts as primary filtering device to clean any contaminating particles from the fuel being drawn into the pumping unit.

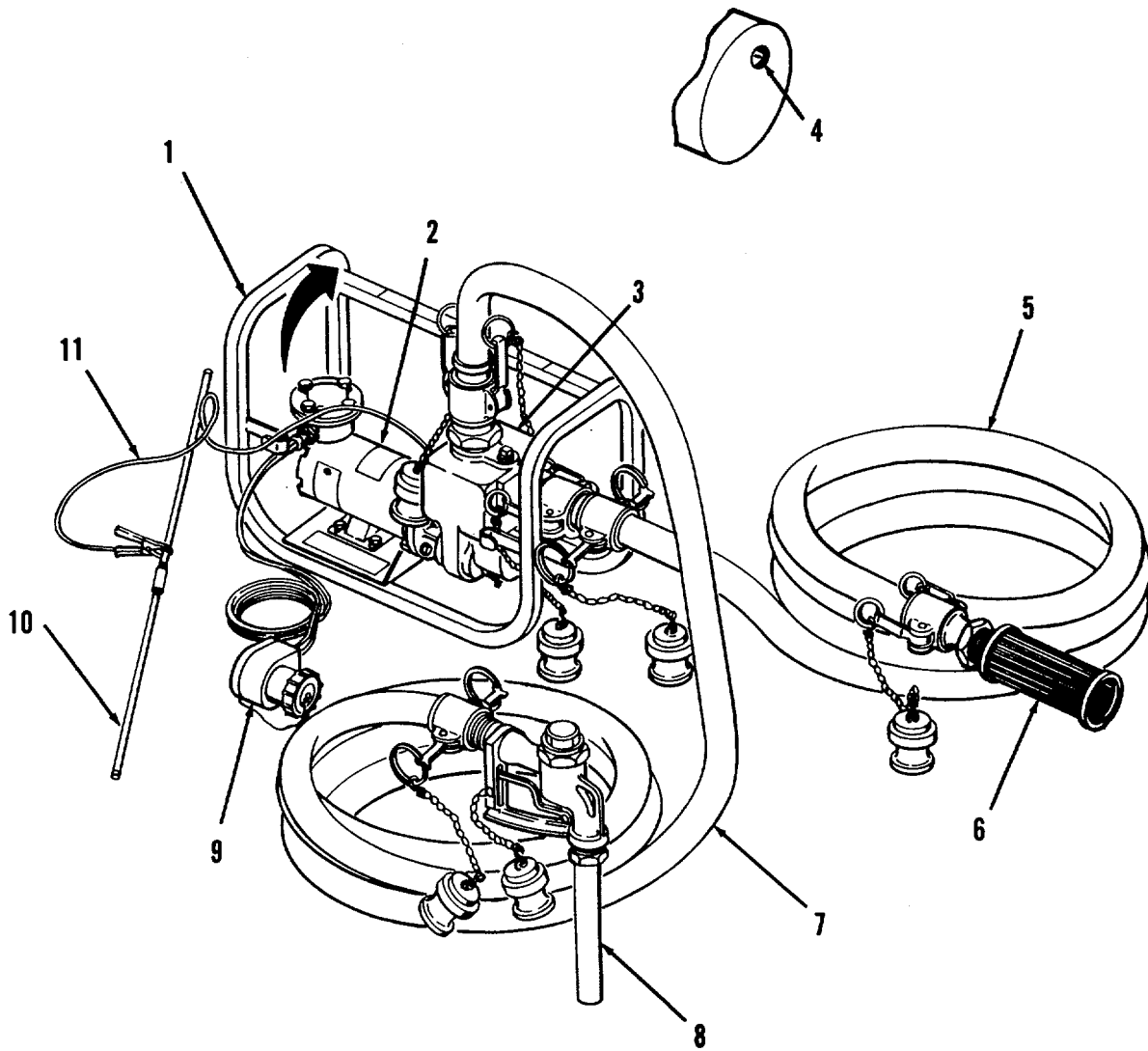

Figure 1-2. Location of Major Components.

**1.14. EQUIPMENT DATA.** Refer to Table 1-1 for general equipment and performance data for the pumping unit.

**Table 1-1. Equipment Data.**

**PUMP**

Manufacturer.....	CH & E Manufacturing Company
Part Number.....	4059
Type.....	Self-priming Centrifugal
Service.....	Liquid Petroleum Fuel
Duty Cycle.....	Continuous
Rated Output.....	35 GPM at 20 feet total head
Suction (Intake) Port.....	1.50 inch NPT
Discharge Port.....	1.50 inch NPT
Priming Port.....	3/4 inch NPT
Priming Method.....	Self-priming system
Case Drain.....	3/8 in. NPT
Rotation.....	Counterclockwise (facing pump end)

**MOTOR**

Manufacturer.....	Faifer Body Company
Model.....	FB94001
Type.....	NEMA MG1, TENV, Explosion Proof
Horsepower.....	1/2 HP
RPM.....	2500

**DIMENSIONS AND WEIGHT**

Overall Width.....	12.0 in (30.5 cm)
Overall Length.....	24.0 in (61.0 cm)
Overall Height.....	18.0 in (45.7 cm)
Gross Weight.....	196.0 lbs (89.1 kg)
Shipping Volume.....	15.0 cubic feet (0.4 cubic meter)
Shipping Weight.....	235.0 lbs. (106.8 kg)

**SECTION III. PRINCIPLES OF OPERATION**

**1.1 5. THEORY OF OPERATIONS.** The pumping unit is a self contained, transportable, electric motor driven centrifugal pump unit designed for pumping liquid fuel. It consists of a self-priming pump, a 24 volt direct current electric motor, and a frame for mounting the pump and motor together for easier transportability. The pumping unit performs its pumping operations in the following manner (Refer to Figure 1-2).

**1.15.1. Pumping Capability.** The pumping capability of the pumping unit is provided by the pump unit contained within the assembly. This pump is a centrifugal type pump which means that it provides its pumping action by using an internal rotating impeller to sling the fuel from the center of the impeller to the outer edges of the impeller as it rotates. This throwing action, technically known as centrifugal force, causes a vacuum in the inlet pipe of the pump to draw more fuel into the pump. The fuel which has been forced to the outer edges of the impeller is further forced into the outlet pipe of the pump to eventually leave the pump unit. As the fuel leaves the pumping unit, it enters the discharge hose where it is distributed as needed through the discharge nozzle.

**1.15. THEORY OF OPERATIONS. - Continued.**

**1.15.2. Electric Motor**. To cause the impeller inside the pump to rotate, the impeller is connected to the output shaft of a 24 volt direct current electric motor. This motor is equipped with a toggle switch built into the motor casing which is used to start and stop the pumping unit. When the electric motor is operating, it develops 112 horsepower at a rotating speed of 2500 rpm. At this horsepower, the pumping unit is capable of providing 35 gallons of fuel per minute at 20 feet total head.



**CHAPTER 2**

**OPERATING INSTRUCTIONS**

**SECTION I. Description and Use of Operator's Controls and Indicators ..... 2-2**

2.1 Introduction..... 2-2

2.2 Operator's Controls and Indicators ..... 2-2

**SECTION II. Operator Preventive Maintenance Checks and Services (PMCS) ..... 2-4**

2.3 General..... 2-4

2.4 PMCS Procedures ..... 2-4

2.5 Leakage Definitions for Operator PMCS ..... 2-5

2.6 Special Instructions..... 2-5

2.7 Operator PMCS Table ..... 2-5

**SECTION III. Operation Under Usual Conditions ..... 2-9**

2.8 Siting ..... 2-10

2.9 Assembly and Preparation for Use ..... 2-10

2.10 Initial Adjustments, Daily Checks, and Self Tests ..... 2-12

2.11 Operating Procedures ..... 2-12

2.12 Preparation for Movement ..... 2-15

2.13 Decals and Instruction Plates ..... 2-15

**SECTION IV. Operation Under Unusual Conditions ..... 2-16**

2.14 Operation Under Unusual Weather ..... 2-16

    a. Operation In Extreme Cold..... 2-16

    b. Operation In Extreme Heat ..... 2-16

    c. Operation In Sandy or Dusty Areas ..... 2-16

    d. Operation In Salt Water Areas ..... 2-17

2.15 Emergency Procedures..... 2-17

2.16 Nuclear, Biological, and Chemical (NBC) Decontamination Procedures ..... 2-17

**Section 1. DESCRIPTION AND USE OF OPERATOR'S CONTROLS AND INDICATORS**

**2.1. INTRODUCTION.** The pumping unit is designed for operation in a wide range of climatic conditions. Operators must be aware of any peculiarities or operational limitations for their specific installation. Before setting up and operating this system, be sure that you have determined the type of terrain and climate in which you will use the unit and that you have assembled and serviced the system to match the existing needs.

**2.2. OPERATOR'S CONTROLS AND INDICATORS.** For controls and indicators applicable to the pumping unit, refer to the following descriptions and to Figure 2-1.

**2.2.1. Pumping Assembly Control Switch (1).** The control switch controls the electric motor by turning it on and off.

**WARNING**

Personal injury may result if the motor is not turned off during service of maintenance.

**2.2.2. Nozzle Assembly (2).** When fuel is being pumped by the pumping unit, it is discharged by the operator through the use of the nozzle assembly attached to the discharge end of the discharge hose. Depressing the nozzle handle will allow fuel to flow from the spout of the nozzle. When the handle is released, it will automatically retract to stop the flow of fuel from the spout of the nozzle. Figure 2-1. Operator's Controls and Indicators.

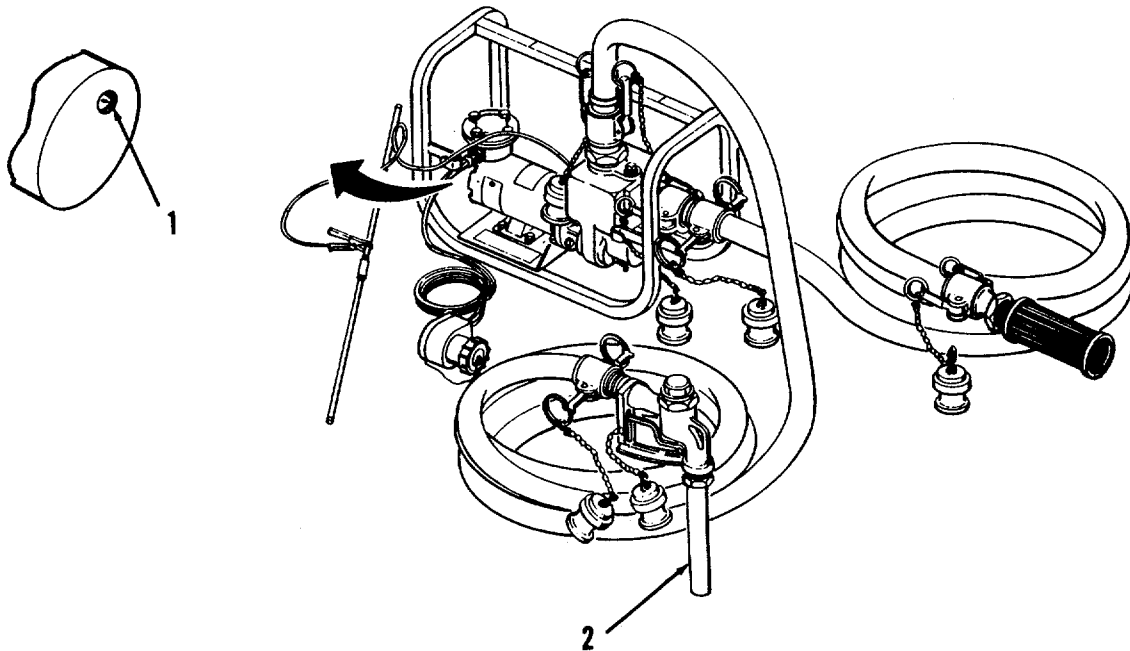

**Figure 2-1. Operator's Control and Indicator**  
2-2

## SECTION II. OPERATOR PREVENTIVE MAINTENANCE CHECKS AND SERVICES (PMCS)

**2.3. GENERAL.** Preventive Maintenance Checks and Services (PMCS) means systematic caring, inspecting, and servicing of equipment to keep it in good condition and to prevent breakdowns. As the operator of the pumping unit, your mission is to:

- a. Be sure to perform your PMCS each time you operate your pump assembly. Always do your PMCS in the same order, so it gets to be a habit. Once you've had some practice, you'll quickly spot anything wrong.
- b. Do your **BEFORE (B)** PMCS just before you operate the pump assembly. Pay special attention to all WARNINGS, CAUTIONS, and NOTES.
- c. Do your **DURING (D)** PMCS while you are operating the pump assembly. During operations means to monitor the pump assembly and its related components while it is actually being operated. Pay special attention all WARNINGS, CAUTIONS, and NOTES.
- d. Do your **AFTER (A)** PMCS right after you have operated the pump assembly. Pay special attention to all WARNINGS, CAUTIONS, and NOTES.
- e. Do your **WEEKLY PMCS** once a week.
- f. Do your **MONTHLY PMCS** once a month.
- g. Use DA Form 2404 (Equipment Inspection and Maintenance Worksheet) to record any faults that you discover before, during, or after operation unless you can fix them. You do not need to record faults that you fix.
- h. Be prepared to assist unit maintenance in any lubrication procedures. Perform any other services when required by unit maintenance.

### 2.4. PMCS PROCEDURES.

- a. Your Preventive Maintenance Checks and Services, Table 2-1, lists inspections and care to keep your pump assembly in good operating condition. It is set up so you can make your BEFORE (B) Operation checks as you perform a general examination of the pump assembly.
- b. The "INTERVAL" column of Table 2-1 tells you when to do a certain check or service.
- c. The "PROCEDURE" column of Table 2-1 tells you how to do required checks and services. Carefully follow these instructions. If you do not have tools or if the procedure tells you to, notify your supervisor.

#### NOTE

Terms "ready/available" and "mission capable" refer to the same status: Equipment is on hand and ready to perform combat missions. (See DA PAM 738-750.)

- d. The "NOT FULLY MISSION CAPABLE IF:" column in Table 2-1 tells you when your pump assembly is not capable and why the pump assembly cannot be used.

- e. If the pump assembly does not perform as required, refer to Section III, Operator Troubleshooting.
- f. If anything looks wrong and you can't fix it, write it on your DA Form 2404 IMMEDIATELY and report it to your supervisor.
- g. When you do your PMCS, you will always need a rag or two. The following items are common to all of the pump assembly components:
  - (1) **Keep It Clean.** Dirt, grease, oil, and debris only get in the way and may cover up a serious problem. Clean as you work and as needed. Use dry cleaning solvent (Appendix E, Item 3) on all metal surfaces. Use soap (Appendix E, Item 10) when you clean rubber or plastic material.
  - (2) **Rust and Corrosion.** Check the components of the pump assembly for rust and corrosion. If any bare metal or corrosion exists, clean and apply a thin coat of oil. Report it to your supervisor.
  - (3) **Bolts, Nuts, and Screws.** Check them for obvious looseness, missing, bent, or broken condition. You can't try them all with a tool, but look for chipped paint, bare metal, or rust around bolt heads. If you find a bolt, nut, or screw you think is loose, tighten it or report it to your supervisor.
  - (4) **Welds.** Look for loose or chipped paint, rust, or gaps where metal parts are welded together. If you find a bad weld, report it to your supervisor.
  - (5) **Electric Wires and Connections.** Look for cracked, frayed, or broken insulation, bare wires, and loose or broken connectors. Tighten loose connectors. Report any damaged wires to your supervisor.
  - (6) **Hoses.** Look for wear, damage, or leaks and make sure clamps and fittings are tight. Wet spots show obvious leaks, but a stain around a fitting or connector can also mean a leak. If a leak comes from a loose fitting or connector, tighten it. If something is broken or worn out, report it to your supervisor.
- h. When you check for "proper operating condition", you look at the component to see if its serviceable.
- i. Cleaning Agents.

### WARNING

DO NOT use diesel fuel, gasoline, or benzene (benzol) for cleaning.

DO NOT SMOKE when using cleaning solvent. NEVER USE IT NEAR AN OPEN FLAME. Be sure there is a fire extinguisher nearby and use cleaning solvent only in well-ventilated places. Flash point of solvent is 138°F (59°C).

USE CAUTION when using cleaning solvents. Cleaning solvents evaporate quickly and can irritate exposed skin if solvents contact skin. In cold weather, contact of exposed skin with cleaning solvents can cause frostbite.

**NOTE**

Only use those authorized cleaning solvents or agents listed in Appendix F.

**CAUTION**

Keep cleaning solvents, gasoline, and lubricants away from rubber or soft plastic parts. They will deteriorate material.

**Cleaning Rust or Grease.** When cleaning grease buildup or rusty places, use cleaning solvent (P-D-680). Then apply a thin coat of light oil to affected area.

**2.5. LEAKAGE DEFINITIONS FOR OPERATOR PMCS.** Because the pump assembly is designed to be used in the pumping of extremely flammable liquid fuels, **NO LEAKS ARE PERMITTED.** If any component of the pumping assembly exhibits any type of leak (including even simple seepage of fluid as indicated by wetness or discolorization), stop the pumping unit immediately and notify your supervisor.

**2.6. SPECIAL INSTRUCTIONS.** If the equipment must be kept in continuous operation, check and service only those items that can be checked and serviced without disturbing operation. Make the complete checks and services when the equipment can be shut down.

Perform weekly as well as before operation PMCS if:

- (1) You are the assigned operator and have not operated the item since the last weekly.
- (2) You are operating the item for the first time.

Within designated interval, these checks are to be performed in the order listed.

**2.7. OPERATOR'S PMCS TABLE.**

TABLE 2-1. Operator Preventive Maintenance Checks and Services for Model FB4320-35.

**CAUTION**

During PMCS it may be necessary to run the pumping assembly. Since the pump is directly coupled to the motor, the pump will run when the motor runs. Running the pumping assembly for longer than a few seconds without liquid in the pump side will damage the pump. When necessary to run the pump for longer than a few seconds, make sure that suction and discharge hoses are installed and a source of fuel is available. Start pumping assembly, prime and operate pump to duplicate normal operation and prevent pump from overheating.

**Table 2-1. Operator Preventive Maintenance Checks and Services  
for 35GPM Pump Assembly.**

Item No	Interval	Location	Procedure	Not Fully Mission Capable If:
		Item To Check/Service		
1	Before	<b>Hose</b>	<b>Suction Hose Assemblies .</b> Check for evidence of tears or collapsed walls. detected.	Cracks, abrasions, collapsed walls, or other damage is
	Before	<b>Gaskets</b>	Inspect gaskets for nicks or deterioration.	Gaskets are brittle or cracked.
	Before	<b>Strainer</b>	Inspect strainer for dirt and debris. Remove all dirt or debris from strainer element.	Strainer is clogged with dirt or debris.
2	Before	<b>Hose</b>	<b>Discharge Hose Assemblies .</b> Check for evidence of tears or collapsed walls. detected.	Cracks, abrasions, collapsed walls, or other damage is
	Before	<b>Gaskets</b>	Inspect gaskets for nicks or deterioration.	Gaskets are brittle or cracked.
3	Before	<b>Body and Spout</b>	<b>Nozzle Assemblies .</b> Inspect the nozzles for cracks distortion, or other visible damage.	Cracks, distortion, or other damage is detected.
	Before	<b>Handle</b>	Press operating handle of nozzle assembly several times to assure that it operates freely without binding or sticking.	Jerky movements or sticking of handle.
	Before	<b>Gaskets</b>	Check gaskets in couplings for damage.	Cracked, torn, or nicked gaskets.
4	Before	Wire and Ends	<b>Grounding Cable .</b> Inspect for corroded terminals or frayed wires.	Broken, frayed, or corroded wire.

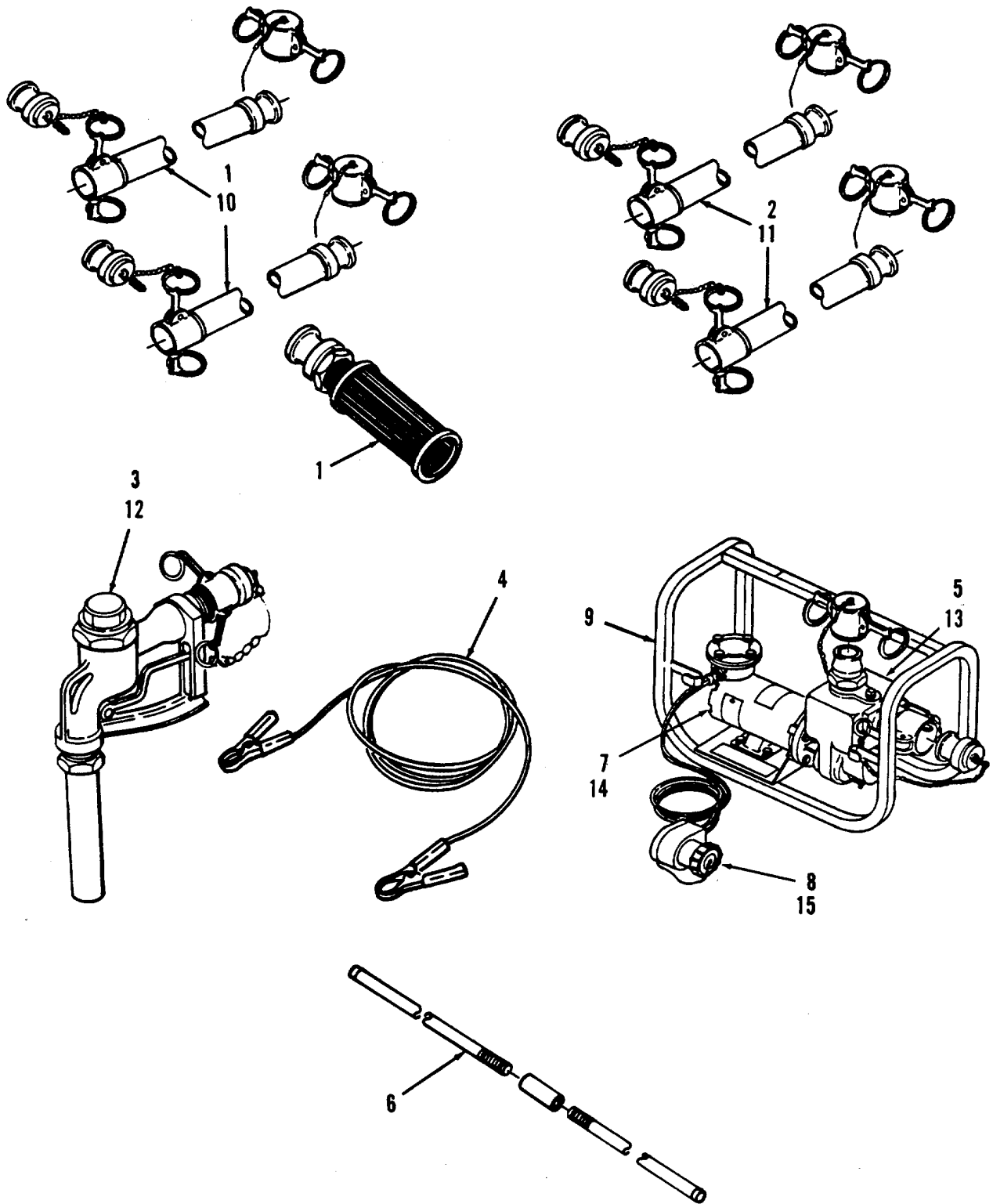

Figure 2-2. Routing Diagram for Operator PMCS

**TABLE 2-1. Operator Preventive Maintenance Checks and Services  
for 35GPM Pump Assembly - Continued.**

Item No	Interval	Location	Procedure	Not Fully Mission Capable If:	
		Item To Check/Service			
5	Before	Bolts	<b><i>Pump Assembly.</i></b>		
			Bolts	Check that pump is securely mounted to motor.	Pump assembly and motor bolts loose or broken.
			Plugs	Check that pipe plugs are securely installed.	Pipe plugs loose or missing.
			Pump Inlet	Visually check interior of suction (intake) for foreign matter that could enter pump during operation.	Foreign material is in pump inlet capable of damaging pump.
6	Before	Gaskets	Gaskets	Check gaskets in couplings for damage.	Cracked, torn, or nicked gaskets.
			<b><i>Ground Rod.</i></b>		
			Rod	Check rod for bent parts or damaged threads. Check for missing parts.	Rod is not suitable for driving into ground.
			<b><i>Motor Assembly.</i></b>		
7	Before	Motor	Motor	Inspect housing for cracks or damaged hardware.	Housing is cracked or hardware is broken.
			<b><i>Slave Cable.</i></b>		
8	Before	Wire	Wire	Inspect for cracked, frayed or broken insulation on wire. Check for broken wire.	Insulation is frayed, cracked or broken. Wire is broken.
			<b><i>Frame Assembly.</i></b>		
9	Before	Frame	a. Visually inspect all frame welds for cracks. Inspect only is loose. those welds that can be seen without disassembly.	Frame is cracked or motor	
			b. Check visible areas of base for corrosion or damage.	Base is corroded or damaged.	
			c. Check for indications of corrosion in areas between all mated parts.	Corrosion is detected.	



**TABLE 2-1. Operator Preventive Maintenance Checks and Services  
for 35 GPM Pump Assembly.**

Item No	Interval	Location	Procedure	Not Fully Mission Capable If:
		Item To Check/Service		
10	During	Couplings	<b><i>Suction Hose Assemblies.</i></b>	Hose assembly leaks.
			Inspect hose assemblies for leaks.	
11	During	Couplings	<b><i>Discharge Hose Assemblies.</i></b>	Hose assembly leaks.
			Inspect hose assemblies for leaks.	
12	During	Couplings	<b><i>Nozzle Assembly.</i></b>	Nozzle assembly leaks.
			Inspect nozzle assembly for leaks.	
			Spout	
13	During	Pump	<b><i>Pump Assembly.</i></b>	Leak found between pump and motor.
			Inspect mating surfaces between pump and motor for evidence of leaks.	
14	During	Motor	<b><i>Motor Assembly.</i></b>	Motor is over heating. Motor makes noise indicating defective bearings.
			Check motor for signs of over heating. Listen for noises from motor which may indicate defective bearings.	
15	During	Wire	<b><i>Slave Cable.</i></b>	Cable is overheating.
			Check cable for over heating. Inspect cable for distortion.	

### SECTION III. OPERATION UNDER USUAL CONDITIONS

**2.8. SITING REQUIREMENTS.** Locate pumping assembly on firm, moderately level area as close as conveniently possible to source of fuel supply. Choose an area which will provide enough room around pumping assembly to allow convenient servicing.

**2.9. ASSEMBLY AND PREPARATION FOR USE.** This paragraph shows how to assemble the pump assembly and prepare it for use. The steps provided and the illustrations shown are for a typical pump set up. Always be sure that you follow your local standard operating procedures (SOP) first if there is a conflict between the steps shown here and your SOP. (Refer to Figure 2-3).

#### WARNING

Death or serious injury could occur if fuel is not handled carefully. Use in a well-ventilated area away from open flame, arcing equipment, ignition sources, heaters, or excessive heat. Vehicle engine must be turned off and cool before refueling. Use proper refueling procedures and equipment to avoid spillage. Always store fuel in properly marked containers. DO NOT SMOKE.

#### WARNING

Fire and explosion can cause death or serious injury to personnel. Before operating the pumping assembly, ALWAYS connect the unit to a suitable ground. Arcing caused by buildup of static electricity can ignite volatile fluids and cause fire and explosion.

- (1) Assemble ground rod and drive it (1) into a good earth ground area.
- (2) Connect grounding cable (2) to the pump (3) at point A and to ground rod assembly (1) at point B. Be sure that clamps on grounding cable make good metal-to-metal contact with pump and with ground rod assembly.
- (3) Remove dust plug (4) from pump female suction coupling (5) and dust cap (6) from suction hose assembly (7). Connect male end of suction hose assembly to pump female suction coupling.
- (4) Remove dust plug (8) from suction hose (9). Connect male coupling of suction strainer (10) to female coupling of suction hose (9). Remove remaining caps and plugs on suction hoses (7) and (9) and connect hoses together.
- (5) Remove dust cap (11) from pump discharge male coupling (12) and dust plug (13) from discharge hose assembly (14). Connect female end of discharge hose assembly to pump discharge male coupling.
- (6) Remove dust cap (15) from discharge hose assembly (16) and dust plug (17) from nozzle assembly (18). Connect discharge hose assembly male coupling to nozzle assembly female coupling. Remove remaining caps and plugs on discharge hoses (14) and (16) and connect hoses together.
- (7) Place pump switch (19) in OFF position.
- (8) Remove dust cap (20) from slave connector (21) and attach slave receptacle to appropriate connector of 24 volt direct current power source to be used.

2-9. ASSEMBLY AND PREPARATION FOR USE . - Continued.

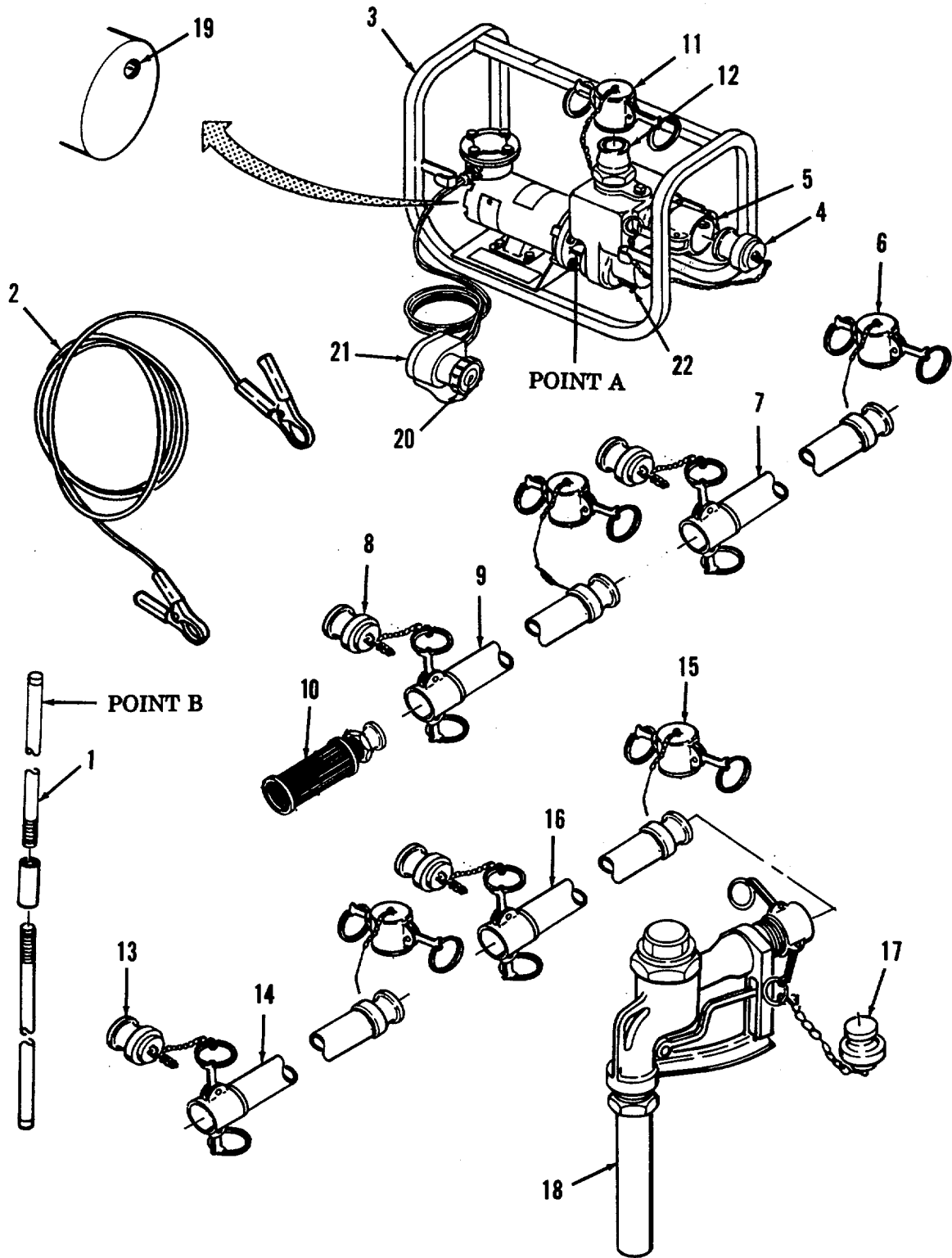

Figure 2-3. Assembly of Pump Assembly.

**2.10. INITIAL ADJUSTMENTS, DAILY CHECKS, AND SELF TESTS .**

2.10.1. Inspect all pump assembly for completeness, damage, and for proper operation as applicable. Report any deficiencies to unit maintenance.

2.10.2. Perform the "Before" preventative maintenance checks and services listed in Table 2-1.

2.10.3. Check that all hoses (suction and discharge) are properly connected.

2.10.4. Make sure hoses (suction and discharge) are not restricted in any way.

**2.11. OPERATING PROCEDURES.** The following paragraphs provide the general operating procedures for the pumping assembly. For further detailed instructions in operating fuel transfer equipment, refer to FM 10-69, Petroleum Supply Point Equipment and Operation.

**CAUTION**

Starting the pump assembly before the pump has been initially primed can cause serious damage to the pump. Be sure that the pump has been initially primed as shown below.

a. Priming the Pump. Although the centrifugal pump used in the pump assembly is a self-priming pump, it is self-priming only after an initial prime is provided during its first start up. Pump must again be initially primed if pumping assembly is disassembled. To initially prime the pump, perform the following steps. (Refer to Figure 2-4.)

- (1) Disconnect the discharge hose assembly (1) from pump discharge outlet (2) on top of the pump assembly.
- (2) Check that drain cock (3) is closed.

**WARNING**

Improper care in handling fuel can cause fire and explosion which can cause severe injury or death to operating personnel. To avoid fire or explosion during engine refueling:

- DO NOT allow any flame producing material within 50 feet (15.25 m) of fuel during equipment filling.
  - DO NOT smoke while transferring fuel.
  - DO NOT let fuel drip onto any hot surface.
  - DO NOT overfill any fuel container.
- (3) Fill the pump by pouring fuel into the discharge outlet (2) of the pump until pump is full of fuel.
  - (4) Install discharge hose assembly (1) onto discharge outlet (2) of pump.

## 2.11. OPERATING PROCEDURES. - Continued.

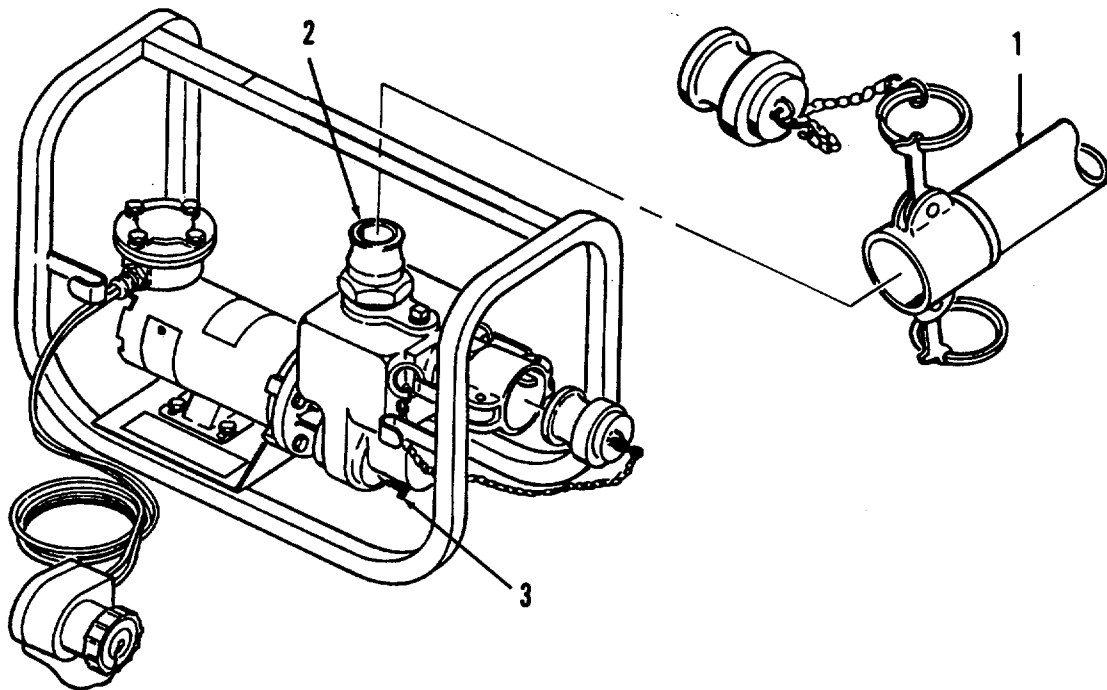

Figure 2-4. Priming Pump.

b. **Starting and Operating.** After insuring that the pump assembly has been properly assembled as indicated in paragraph 2.9 and that the pump has been initially primed as defined in step a. above, the pump assembly may be operated by performing the following steps. (Refer to Figure 2-5.)

- (1) Perform all "Before" Operator PMCS listed in Table 2-1.
- (2) Place the toggle switch (1) on the motor housing in the ON position to turn on the pump motor.

**WARNING**

Improper care in handling fuel can cause fire and explosion which can cause severe injury or death to operating personnel. To avoid fire or explosion during engine refueling:

- DO NOT allow any flame producing material within 50 feet (15.25 m) of fuel during equipment filling.
  - DO NOT smoke while transferring fuel.
  - DO NOT let fuel drip onto any hot surface.
  - DO NOT overfill any fuel container.
- (3) Place the spout of the nozzle assembly (2) into the container which is to be filled with fuel and depress the handle (3) of the nozzle assembly to dispense fuel.
  - (4) When fuel transfer is complete, release the handle (3) on the nozzle assembly (2) to stop the flow of fuel from the nozzle spout.

- c. Stopping. To shutdown the pump assembly, place the toggle switch (1) on the motor housing to the OFF position. (Refer to Figure 2-5.)

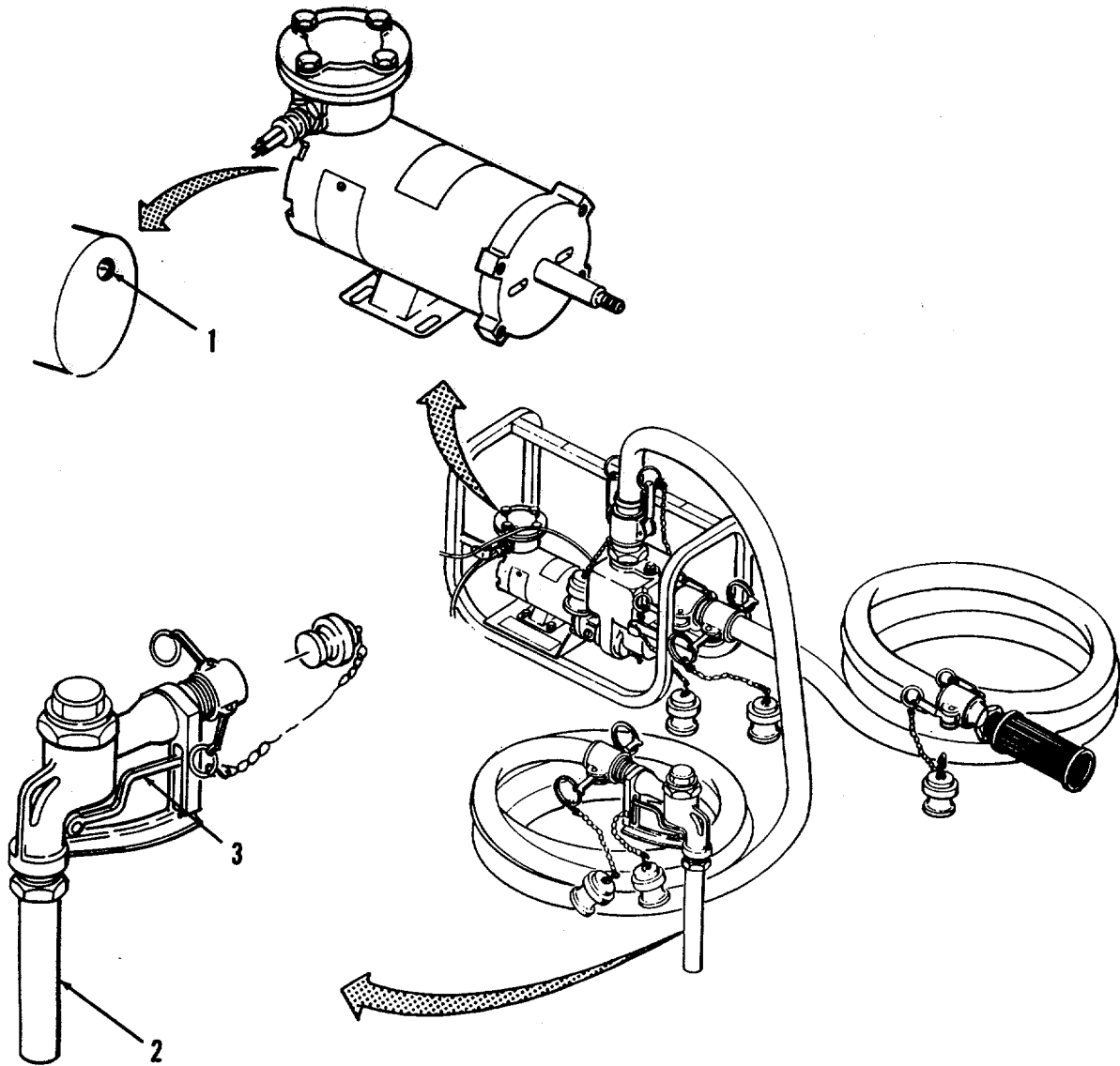

Figure 2-5. Starting and Operating the Pump Assembly.

**2.12. PREPARATION FOR MOVEMENT.** For general preparation of the pump assembly for movement, perform the following steps (Refer to Figure 2-3).

- a. Disconnect slave connector (21) from the 24 volt direct current power supply and place dust cap (20) onto slave connector.

**NOTE**

Always drain fuel into an appropriate container. Dispose of collected fuel per local standard operating procedures.

- b. Drain all fuel from all suction and discharge hoses.
- c. Remove nozzle assembly (18) from discharge hose assembly (16). Connect dust cap (15) onto the discharge hose assembly and the dust plug (17) into the nozzle assembly.
- d. Remove discharge hose assembly (14) from the pump discharge male coupling (12). Connect dust cap (11) onto pump discharge male coupling and dust plug (13) into to discharge hose assembly.
- e. Remove suction strainer (10) from suction hose assembly (9). Connect dust plug (8) into suction hose assembly.
- f. Remove suction hose assembly (7) from pump female suction coupling (5). Connect dust cap (6) onto suction hose assembly (7) and connect dust plug (4) into pump female suction coupling (5).
- g. Remove grounding cable (2) from pump (3) and ground rod assembly (1).
- h. Drain fuel from pump housing by opening drain cock (22) on side of pump.

**2.13. DECALS AND INSTRUCTION PLATES.** To assist the operator in the use of the pump assembly, various decals and information plates have been placed on the unit. The location of each of these decals or instruction plates and the wording of each one is shown in Figure 2-6.

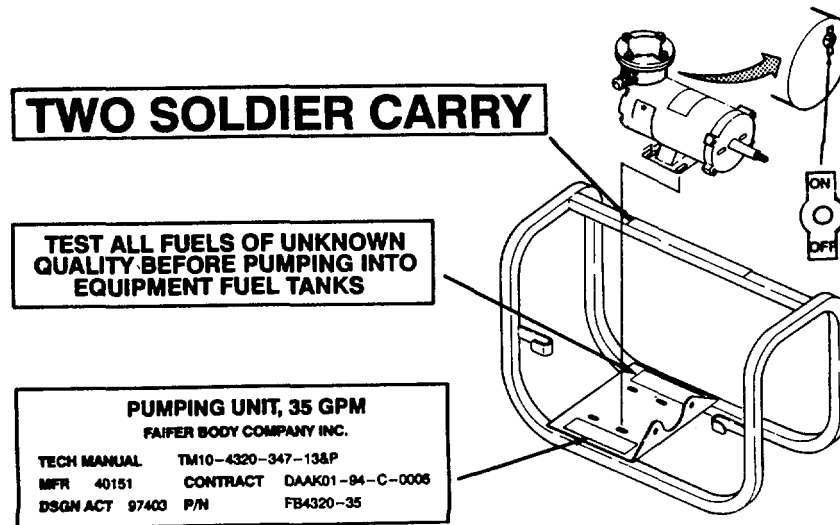

Figure 2-6. Decals and Instruction Plates.

**SECTION IV. OPERATION UNDER UNUSUAL CONDITIONS**

**2.14. OPERATION UNDER UNUSUAL WEATHER.** The pump assembly is designed to operate normally within a wide range of climatic conditions. However, some extreme conditions require special operating and servicing procedures to prevent undue loading and excessive wear on the equipment. These unusual conditions and the special steps to be performed are listed in the following paragraphs.

**a. Operation in Extreme Cold.**

**WARNING**

Wear gloves, avoid touching metal surfaces with bare hands. Personal injury can result from freezing.

**CAUTION**

Rubber and plastic parts such as hoses and nozzle end piece become stiff and are more easily damaged when they are cold. Take additional care when handling these items.

**b. Operation in Extreme Heat.**

- (1) Protect pump assembly from direct heat of the sun.
- (2) If pumping assembly is not in use and suction and/or discharge hose assemblies are not installed, be sure that suction (intake) and discharge couplings are covered with dust caps or dust plugs as applicable.
- (3) Increase the frequency of PMCS as needed to match the local warmer weather conditions.

**c. Operation in Sandy or Dusty Areas.** Dusty and sandy conditions can seriously affect the operation of the pump assembly. When operating the pump assembly in these dusty and sandy conditions, perform the following steps.

- (1) Fuel which has been contaminated by dust and sand can severely affect the usability of the fuel being pumped by the pump assembly. Special care must be taken to ensure that the fuel being pumped does not have dust or sand in it when using the pump assembly in dusty and sandy conditions. Be sure that all hose and piping connections are tight. Be sure that the insides of all pump assembly components are clean before piping connections are made during pump assembly set up and assembly.
- (2) During the handling of fuel, while performing any PMCS procedure, or while dispensing fuel, be sure that sand or dust is not allowed to mix with fuel.
- (3) If pumping assembly is not in use and suction and/or discharge hose assemblies are not installed, be sure that suction (intake) and discharge couplings are covered with dust caps or dust plugs as applicable.



**2.14. OPERATION UNDER UNUSUAL WEATHER . - Continued.**

- d. **Operation in Salt Water Areas.** The nature of salt presents serious corrosion problems. Frequent cleaning is necessary during which all exposed surfaces should be thoroughly sprayed, rinsed, or sponged with fresh water to remove salt. Keep couplings on the pump assembly free from dried salt.

**2.15. EMERGENCY PROCEDURES.** Loss of suction requires a shutdown of the electric motor driven centrifugal pump as soon as possible. In the event such loss occurs, turn off pump motor by placing toggle switch in the OFF position to stop pump operation.

**2.16. NUCLEAR, BIOLOGICAL, AND CHEMICAL (NBC) DECONTAMINATION PROCEDURES .** In the event that the pumping assembly has been subjected to NBC contamination, the following emergency procedures can be performed until field NBC decon facilities are available.

**Emergency Procedures.** If NBC attack is known or suspected, mask at once and continue mission. If outside, follow decontamination procedures below to avoid taking contamination into controlled area. Do not unmask until told to do so.

- (1) **Nuclear decontamination.** Brush fallout from skin, clothing, and equipment with available brushes, rags, or tree branches. Wash skin and have radiation check made as soon as tactical situation permits.
- (2) **Biological decontamination .** Remain masked and continue mission until told to unmask.
- (3) **Chemical detection and decontamination .**

**WARNING**

Prolonged exposure to equipment decontamination spray can cause injury to personnel. Do not use equipment decontamination spray on personnel unless it can be washed from exposed skin.

- (a) Use M8 paper from the M256 Chemical Agent Detector Kit or M9 paper to determine if liquid agent is present on the equipment.
  - (b) If exposure to liquid agent is known or suspected, clean exposed skin, clothing, personal gear, and equipment, in that order using M258A1 kit. Use the buddy system. Wash exposed skin and thoroughly decontaminate as soon as tactical situation permits.
  - (c) If the M8 or M9 paper indicates that liquid chemical agent is present on the equipment, use the NBC-M11 decon apparatus for decon of equipment.
- (4) Reference Material. For further detailed information on NBC decon procedures, refer to the information in FM 3-3, FM 3-4, and FM 3-5.

**CHAPTER 3**  
**OPERATOR MAINTENANCE INSTRUCTIONS**

<b>Section I. Lubrication Instructions .....</b>	<b>3-2</b>
3.1    General .....	3-2
<b>Section II Operator Troubleshooting Procedures .....</b>	<b>3-2</b>
3.2    Introduction.....	3-2
3.3    Troubleshooting Table .....	3-2
<b>Section III. Operator Maintenance Procedures.....</b>	<b>3-6</b>
3.4    General .....	3-6
3.5    Hose Assemblies (Suction and Discharge) Repair .....	3-6
3.6    Nozzle Assembly Replacement .....	3-8
3.7    Ground Cable Assembly Replacement .....	3-9

## SECTION I. LUBRICATION INSTRUCTIONS

**3.1. GENERAL.** The pumping unit is designed to operate without the need for any lubrication. The pumping assembly does not require any lubrication instructions.

## SECTION II. OPERATOR TROUBLESHOOTING INSTRUCTIONS

**3.2. INTRODUCTION.** This section contains troubleshooting information for locating and correcting most of the operating troubles which may develop in the pumping assembly. Only those functions within the scope of operator maintenance are listed. Each malfunction for an individual component, unit, or system is followed by a list of tests or inspections which will help you to determine corrective actions to take. You should perform the tests/inspections and corrective actions in the order listed.

This manual cannot list all malfunctions that may occur, nor all tests or inspections and corrective actions. If a malfunction is not listed, or is not corrected by listed corrective actions, notify your supervisor.

Table 3-1 lists the common malfunctions which you may find during the operation or maintenance of the pump assembly or its components. You should perform the tests/inspections and corrective actions in the order listed.

**3.3. TROUBLESHOOTING TABLE.** Refer to Table 3-1 for operator troubleshooting procedures.

Table 3-1. Operator Troubleshooting Table.

MALFUNCTION 1. PUMP WILL NOT RUN.

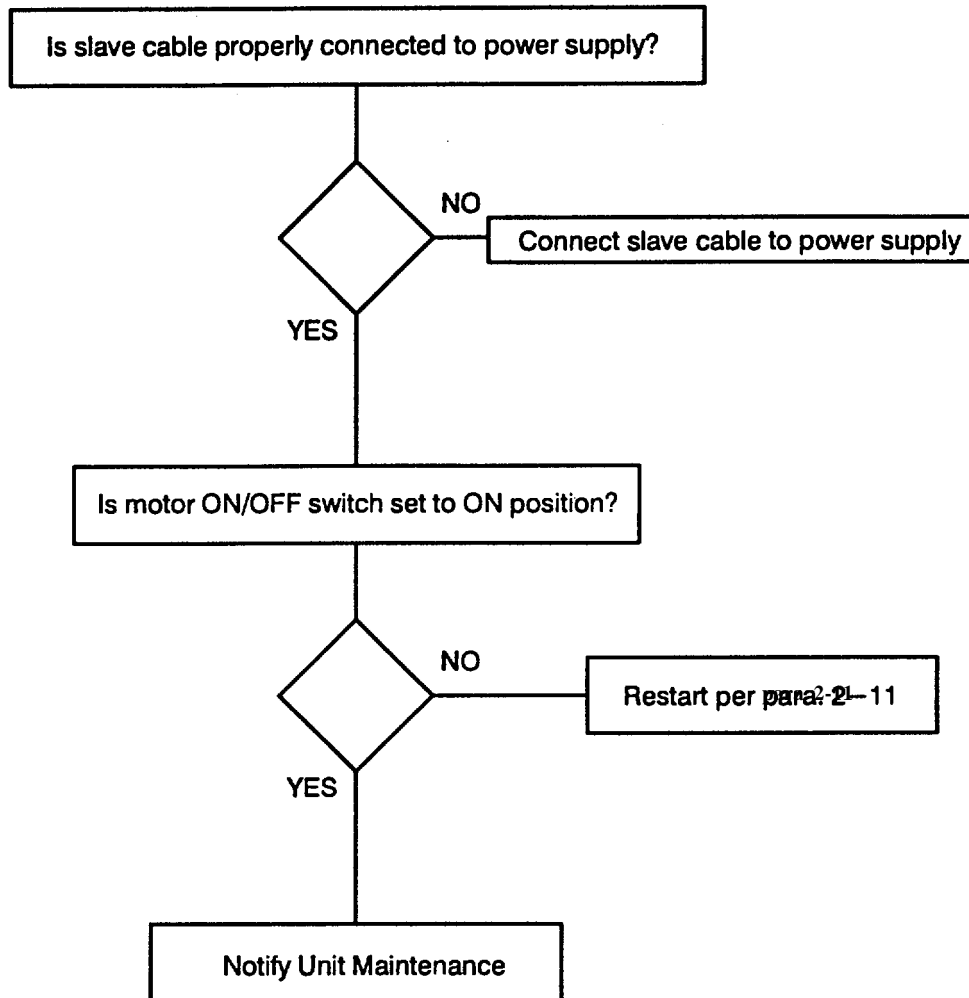

Table 3-1. Operator Troubleshooting Table.

MALFUNCTION 2. PUMP RUNS, BUT THERE IS NO FUEL FLOW.

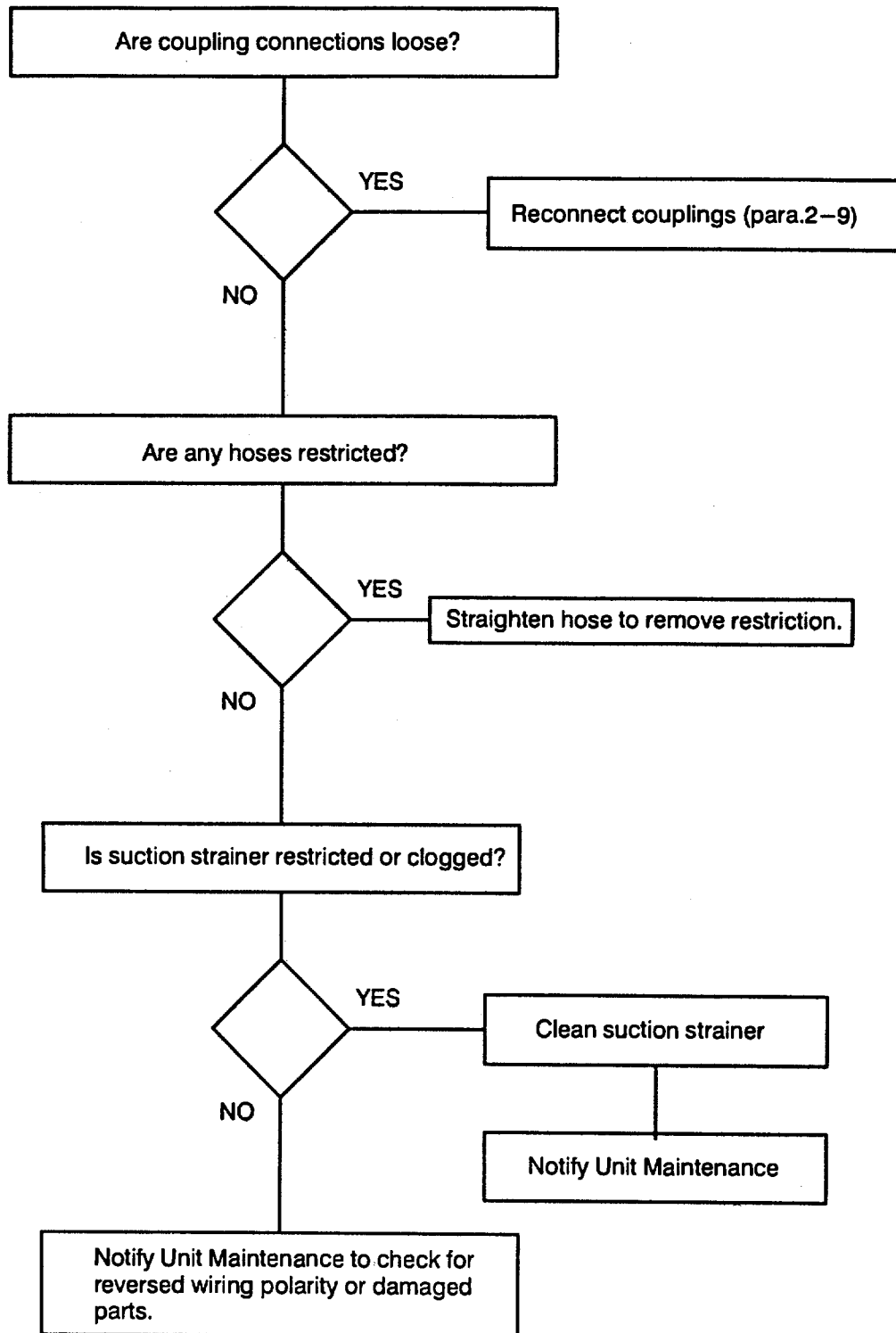
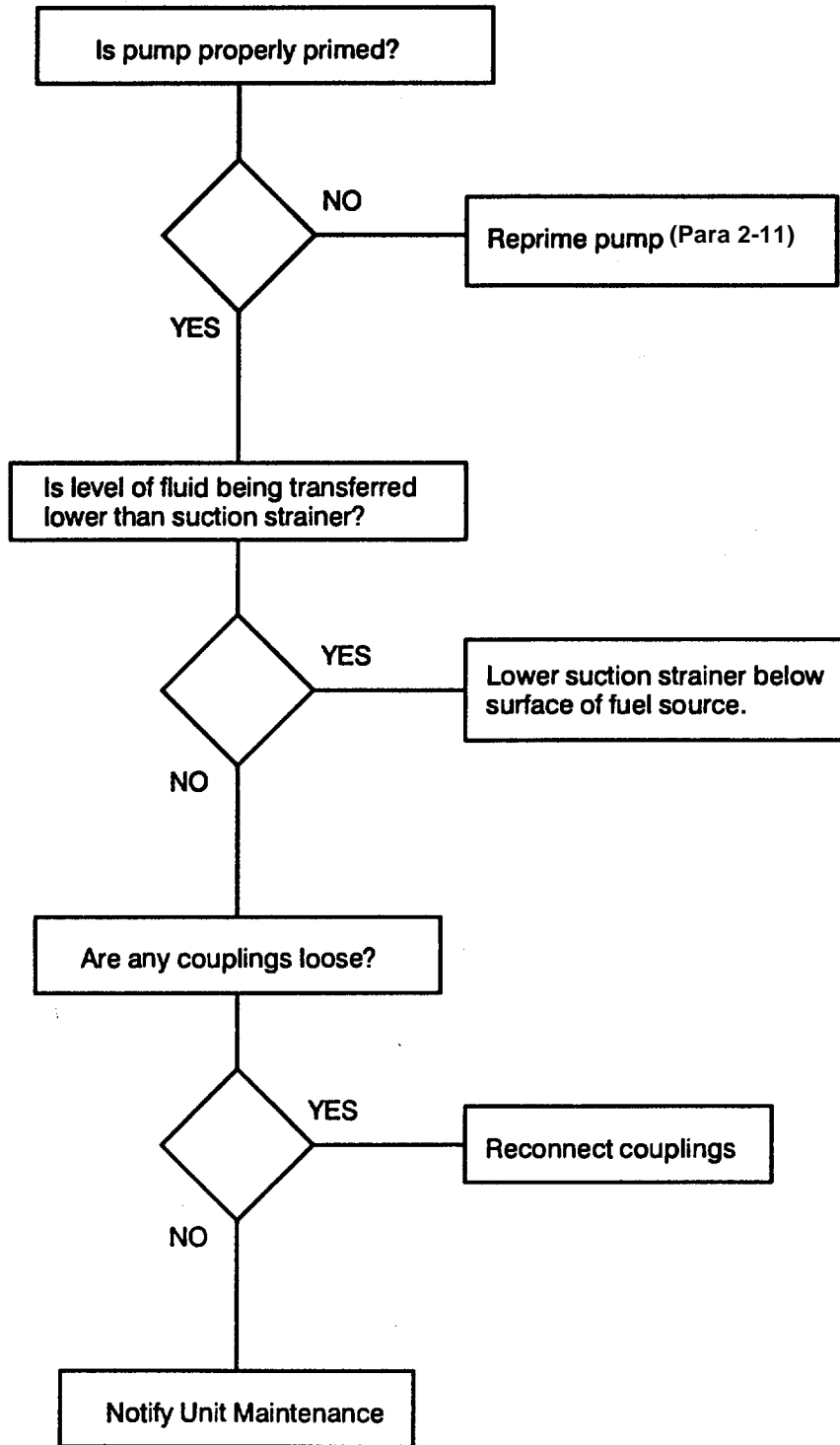

Table 3-1. Operator Troubleshooting Table.

MALFUNCTION 3. NOISY OPERATION.



### SECTION III. OPERATOR MAINTENANCE PROCEDURES

**3.4. GENERAL.** This section contains the maintenance procedures which the Maintenance Allocation Chart authorizes the operator to perform. If the pump assembly still does not operate properly after performing these maintenance procedures, contact unit maintenance for assistance.

#### 3.5. HOSE ASSEMBLIES (SUCTION AND DISCHARGE) REPLACEMENT AND REPAIR.

---

**This task covers:**

- |                       |                    |
|-----------------------|--------------------|
| a. <b>Disassembly</b> | c. <b>Assembly</b> |
| b. <b>Repair</b>      |                    |
- 

**INITIAL SETUP:**

Tools Required

None

Materials Required

None

Equipment Condition

Pump assembly shut down and cool.  
Fuel drained from system.

---

- a. Disassembly.** (Refer to Figure 3-1).
- (1) Remove hose assembly to be repaired from the pump assembly.
  - (2) Remove quick disconnect cap (1) and gasket (2) from coupling half (3).
  - (3) Remove quick disconnect plug (4) and gasket (5) from coupling half (6).
- b. Repair.** Repair of the hose assemblies is limited to the replacement of defective parts.
- c. Assembly.**
- (1) Install gasket (5) and quick disconnect plug (4) into coupling half (6).
  - (2) Install gasket (2) into cap (1) and install cap onto disconnect fitting (3).
  - (3) Install hose assembly onto pumping assembly.

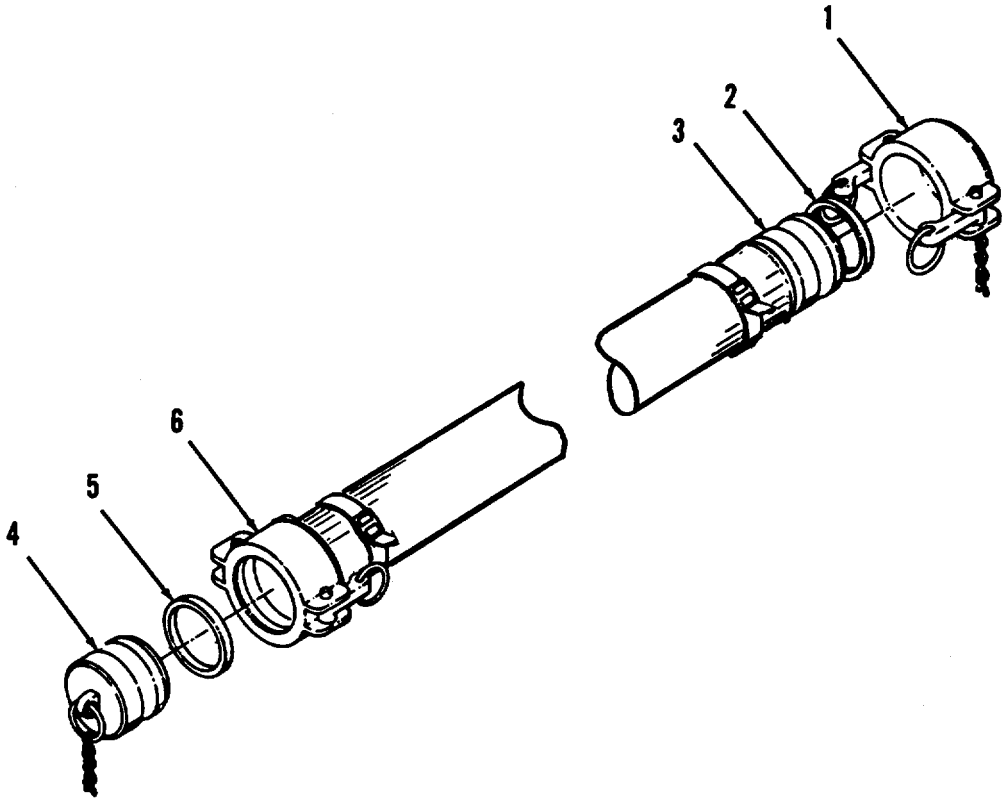

Figure 3-1. Hose Assembly (Suction and Discharge) Replacement and Repair.



### 3.6. NOZZLE ASSEMBLY REPLACEMENT.

---

This task covers:

- a. Remove
  - b. Replace
- 

#### INITIAL SETUP:

##### Tools Required

None

##### Material's Required

None

##### Equipment Condition

Pump assembly shut down and cool.  
Fuel drained from system.

---

- a. **Removal.** (Refer to Figure 3-2). Remove nozzle (1) and gasket (2) from discharge hose assembly (3).
- b. **Replace.** Install gasket (2) and nozzle (1) onto discharge hose assembly (3).

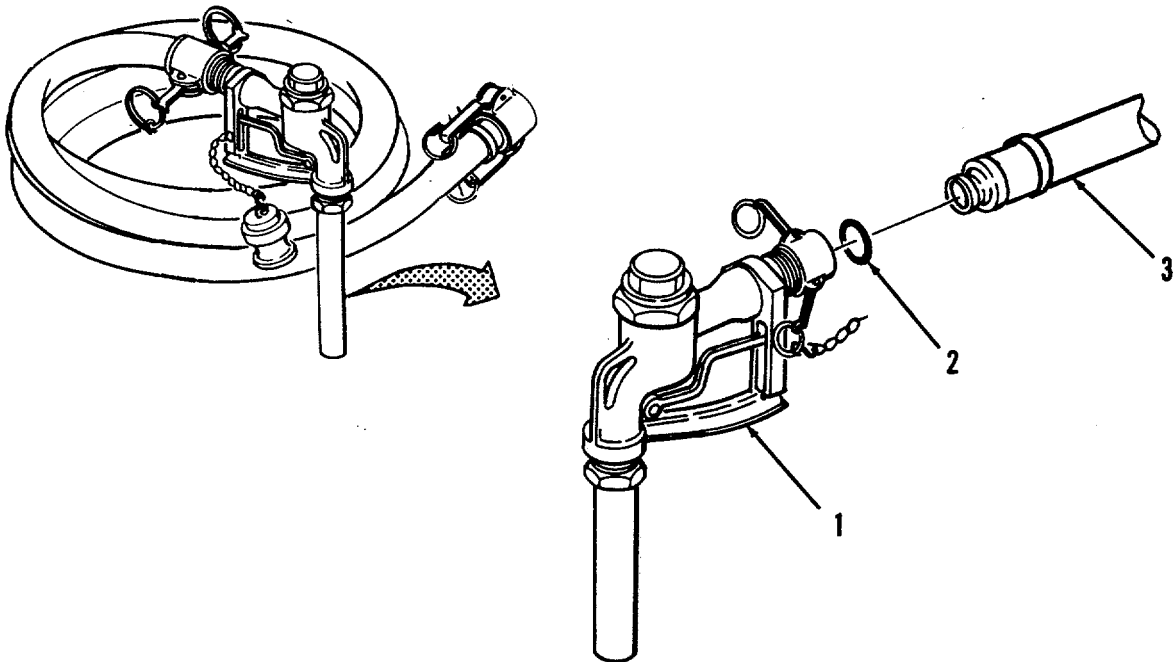

Figure 3-2. Nozzle Assembly Replacement.

### 3.7. GROUND CABLE REPLACEMENT.

---

This task covers:

- a. Remove
  - b. Replace
- 

#### INITIAL SETUP:

##### Tools Required

None

##### Materials Required

None

##### Equipment Condition

Pump assembly shut down and cool.

---

- a. Removal (Refer to Figure 3-3). Remove ground cable assembly (1) from ground rod assembly (2) and from pump assembly (3).
- b. Replace. Install ground cable assembly (1) onto pump assembly (3) and onto ground rod assembly (2).

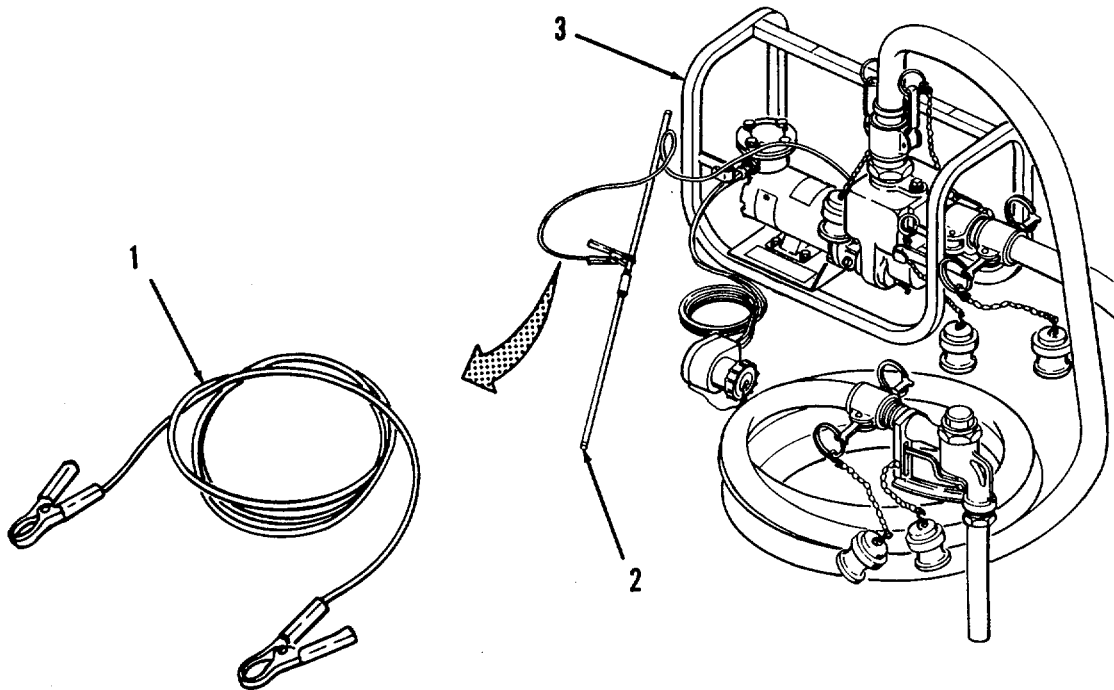

Figure 3-3. Ground Cable Replacement.

**CHAPTER 4****UNIT MAINTENANCE INSTRUCTIONS****SECTION I. LUBRICATION INSTRUCTIONS**

- 4.1. LUBRICATION INSTRUCTIONS** . The pumping assembly does not require any lubrication.

**SECTION II. SERVICE UPON RECEIPT AND PREPARATION FOR MOVEMENT**

- 4.2. SITE REQUIREMENTS** . The pumping assembly shall be set up on a level area with enough free room to allow unpacking and assembly of all items.

- 4.3. SERVICE UPON RECEIPT** . The following paragraphs contain the procedures for unloading, unpacking and general checking of the unpacked pumping assembly.

- a. Unloading. The pumping assembly is packaged in a container designed for shipment and handling with the unit in an upright position. The unit may be lifted by fork-lift, crane, or sling. To unload the pumping assembly, perform the following steps.

- (1) Remove all blocking and tie downs that may have been used to secure the shipping container to the carrier.

**WARNING**

Do not allow the unit to swing while suspended from a lifting device. Failure to observe this warning may result in injury to personnel and damage to the equipment.

**CAUTION**

Use care in handling to avoid damage to the pumping assembly. If an overhead lifting device must be used, use an appropriate sling so that the weight of the unit is supported by the base of the shipping container.

- (2) Use a forklift truck or other suitable material handling equipment to remove the unit from the carrier.
- b. Unpacking. (Refer to Figure 4-1).

**CAUTION**

To protect the pumping assembly, the pumping assembly should be left packaged until it is moved to the location where it is to be installed.

**NOTE**

The shipping container is of such a design that it may be retained for re-use for mobility purposes if frequent relocation of the pumping assembly is anticipated.

- (1) Open the top of the fiberboard shipping container (1). Remove the technical publications envelope and put it in a safe place.

4.3. SERVICE UPON RECEIPT. - (Continued.)

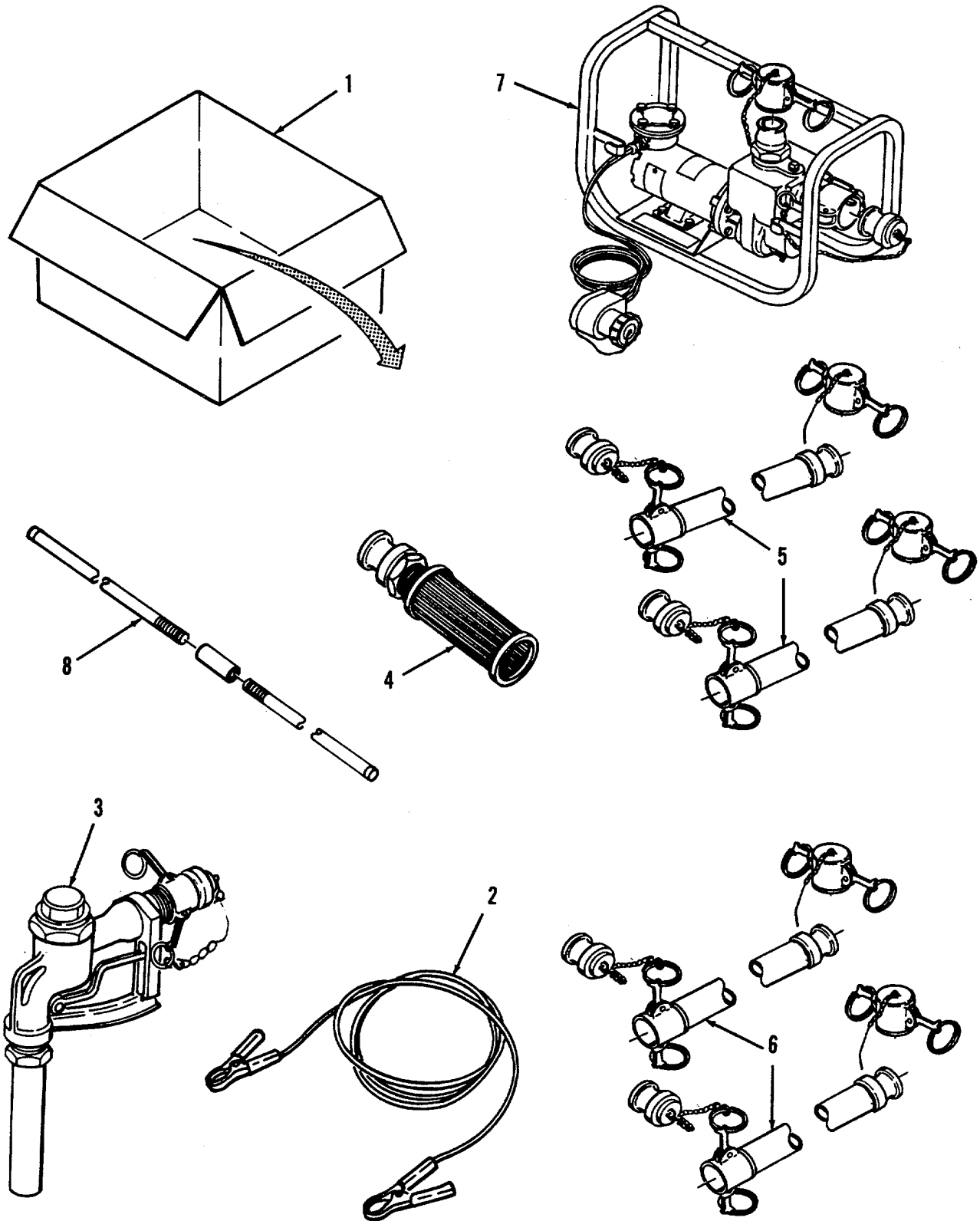

Figure 4-1. Unpacking Pump Assembly.

- (2) Remove ground cable (2).
- (3) Remove nozzle assembly (3), suction strainer (4), two suction hose assemblies (5), two discharge hose assemblies (6) from around the pumping assembly (7) in the fiberboard storage container (1).

### **WARNING**

To avoid serious injury to personnel, always use two personnel to move or lift pumping assembly.

- (4) Grasp the pumping assembly (7) by the cradle grip areas and lift the pumping assembly from the fiberboard storage container (1). Place the unit into a position where it can be checked for completeness and possible shipping damage.
- (5) Remove grounding rod (8) from fiberboard storage container (1).
- (6) Retain the shipping container for re-use. Be sure to remove all remaining barrier material from the underside of the unit.

**c. Checking Unpacked Equipment.** To check the unpacked pumping assembly, perform the following steps.

- (1) Inspect the equipment for damage incurred during shipment. If the equipment has been damaged, report damage on DD Form 6, Packaging Improvement Report.
- (2) Check the equipment against the packing slip to see if the shipment is complete. Report all discrepancies in accordance with the instructions as defined within DA PAM 738-750. See that all Components Of End Item (COEI) and Basic Issue Items (BII) are with the equipment.
- (3) Check to see whether the equipment has been modified.

## **SECTION III. UNIT MAINTENANCE PROCEDURES**

**4.4. GENERAL INSTRUCTIONS.** Most maintenance instructions in this section will list resources required and equipment condition for the start of the procedure. In performing these maintenance procedures, note the following:

- Resources required are not listed unless they apply to the procedures.
- Personnel required are listed only if the task requires more than one. If PERSONNEL is not listed, it means one person can do the task.
- The normal standard equipment condition to start a maintenance task is with the pump motor stopped. EQUIPMENT CONDITION is not listed unless some other condition is required.
- Refer to Appendix G to determine torque requirements when tightening threaded fasteners, unless a specific torque value is given in procedure. Standard torque values given in Appendix G are determined by thread size.

#### 4.5. NOZZLE ASSEMBLY REPAIR.

---

**This task covers:**

- a. **Disassembly**
  - b. **Repair**
  - c. **Assembly**
- 

#### INITIAL SETUP:

##### Tools Required

Tool Kit, General Mechanic's (Appendix B, Item 1)

##### Material's Required

Tape, Anti-seize (Appendix E, Item 4)

##### Equipment Condition

Pump assembly shut down and cool.

#### **WARNING**

Death or serious injury could occur if fuel is not handled carefully. Use in a well-ventilated area away from open flame, arcing equipment, ignition sources, heaters, or excessive heat. Use proper marked containers. DO NOT SMOKE.

Fuel drained from discharge hose assembly (see para. 2.12.).

Nozzle assembly removed from discharge hose assembly (see para. 3.6.).

---

**a. Disassembly.** (Refer to Figure 4-2).

- (1) Remove quick disconnect plug (1) and gasket (2) from coupling half (3).
- (2) Remove coupling half (3) from nozzle (4).

**b. Repair.** Repair is limited to replacement of defective parts.

**c. Assembly.**

- (1) Apply tape anti-seize (Appendix E, Item 4) to all external pipe threads and install coupling half (3) into nozzle (4).
- (2) Install gasket (2) and quick disconnect plug (1) into coupling half (3).

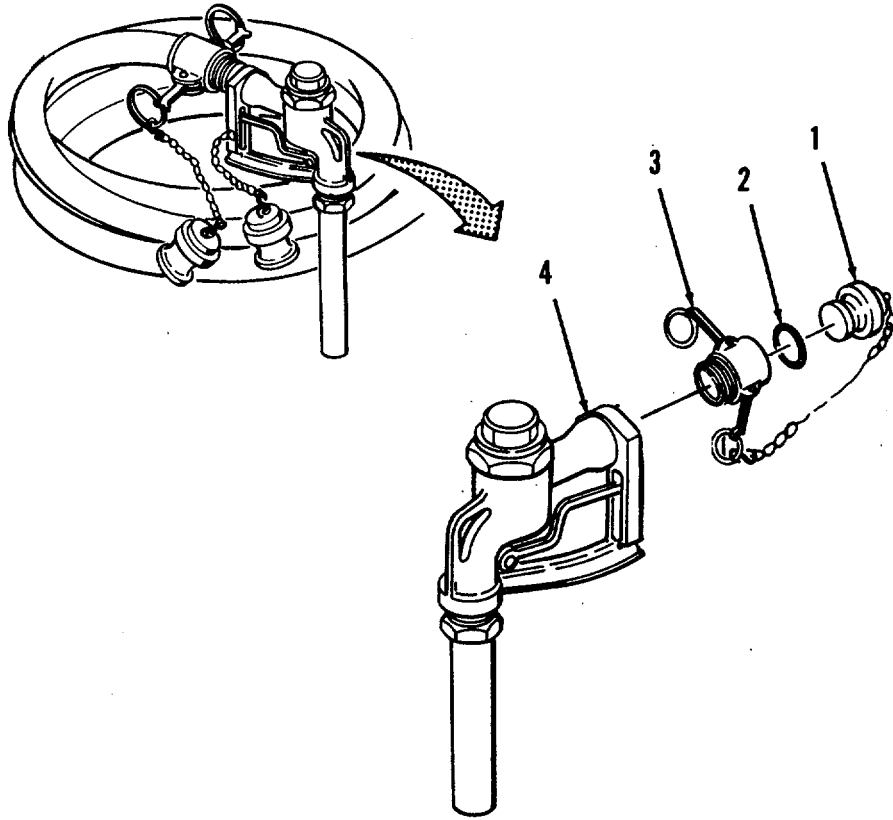

Figure 4-2. Nozzle Assembly Repair.

**4.6. GROUND CABLE REPAIR.**

---

This task covers:

- a. **Disassembly**
  - b. **Repair**
  - c. **Assembly**
- 

**INITIAL SETUP:**Tools Required

Tool Kit, General Mechanic's (Appendix B, Item 1)

Materials Required

None

Equipment Condition

Pump assembly shut down and cool.

Ground cable assembly removed pump assembly (see para. 2.12.).

---

**a. Disassembly.** (Refer to Figure 4-3).

- (1) Pull protective sleeve (1) down clamp handle (2) until sleeve is away from clamp handle.
- (2) Remove wire (3) from clamp (2).
- (3) Repeat for other clamp if required.

**b. Repair.** Repair is limited to replacement of defective parts.

**c. Assembly.**

- (1) Strip 1.00 inch of insulation from wire (3) as shown.
- (2) Insert stripped portion of wire (3) into crimping area of clamp (2) and crimp clamp handle to secure the wire into the clamp handle.
- (3) Repeat for other handle if required.



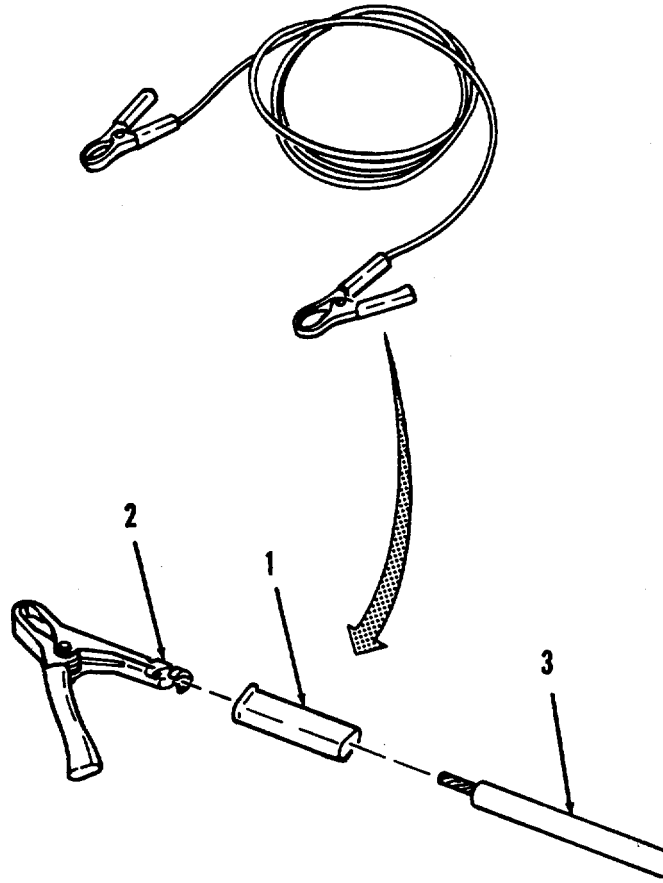

Figure 4-3. Ground Cable Assembly Repair.

#### 4.7. SLAVE CABLE REPAIR AND REPLACEMENT.

---

**This task covers:**

- |                       |                    |                        |
|-----------------------|--------------------|------------------------|
| a. <b>Removal</b>     | c. <b>Repair</b>   | e. <b>Installation</b> |
| b. <b>Disassembly</b> | d. <b>Assembly</b> |                        |
- 

**INITIAL SETUP:**

Tools Required

Tool Kit, General Mechanic's (Appendix B, Item 1)

Material's Required

RTV Sealant (Appendix E, Item 5)

Equipment Condition

Pump assembly shut down and cool.  
Slave cable disconnected from 24 volt power source.

---

a. **Removal** (Refer to Figure 4-4).

- (1) Remove four bolts (1), four washers (2), and junction box cover (3) from motor junction box (4).
- (2) Remove two wire nuts (5) from motor wires (6).
- (3) Remove strain relief nut (7), disconnect slave cable wires (8) from motor wires (6), and pull slave cable wires through strain relief.
- (4) Remove rubber seal (9) and strain relief nut (7) from slave cable wires (8).

b. **Disassembly**. (Refer to Figure 4-5).

- (1) Remove six screws (1), six flat washers (2), cap retaining cable (3), and cover (4) from receptacle (5).
- (2) Remove two bolts (6), two lock washers (7), and two wire assemblies (8) from receptacle (5).
- (3) Thoroughly remove all RTV sealant from two wire assemblies (8).

c. **Repair**.

- (1) Remove terminal (9) from wire (10). Discard defective terminal or wire as required.
- (2) Strip .50 inch of insulation from new wire (10) and insert wire into terminal (9).
- (3) Crimp terminal (9) to captivate wire (10).

**d. Assembly.**

- (1) Place one of the wires (8) into each of the cutouts in the receptacle (5) and install two wire assemblies (8), two lock washers (7), and two bolts (6) into receptacle (5).
- (2) Install cover (4), cap retaining cable (3), six flat washers (2), and six screws (1).
- (3) Squeeze RTV sealant into two cable openings where two wire assemblies (8) enter the receptacle. Be sure RTV sealant will provide a watertight seal around wire assemblies.

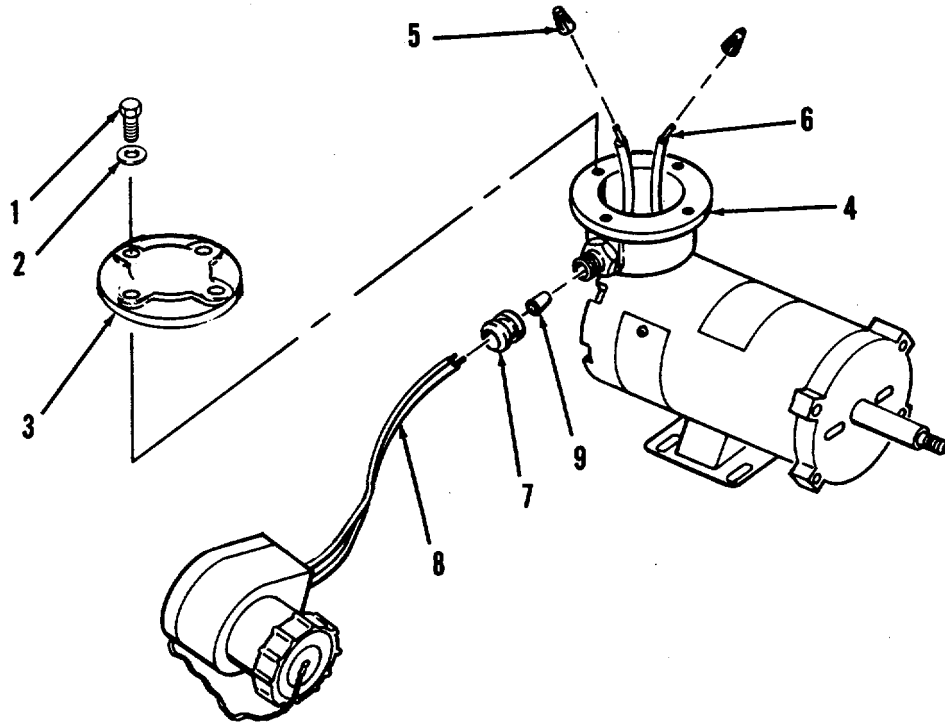

Figure 4-4. Slave Cable Replacement.

**c. Installation.** (Refer to Figure 4-4).

- (1) Place strain relief nut (7) and rubber seal (9) on slave cable wires (8).
- (2) Install slave cable wires (8) into motor junction box (4). Pull about 6" of slave cable wires through strain relief nut (7).
- (3) Snug rubber seal (9) down to strain relief. Tighten strain relief nut (7).

## 4.7. SLAVE CABLE REPAIR AND REPLACEMENT - (Continued.)

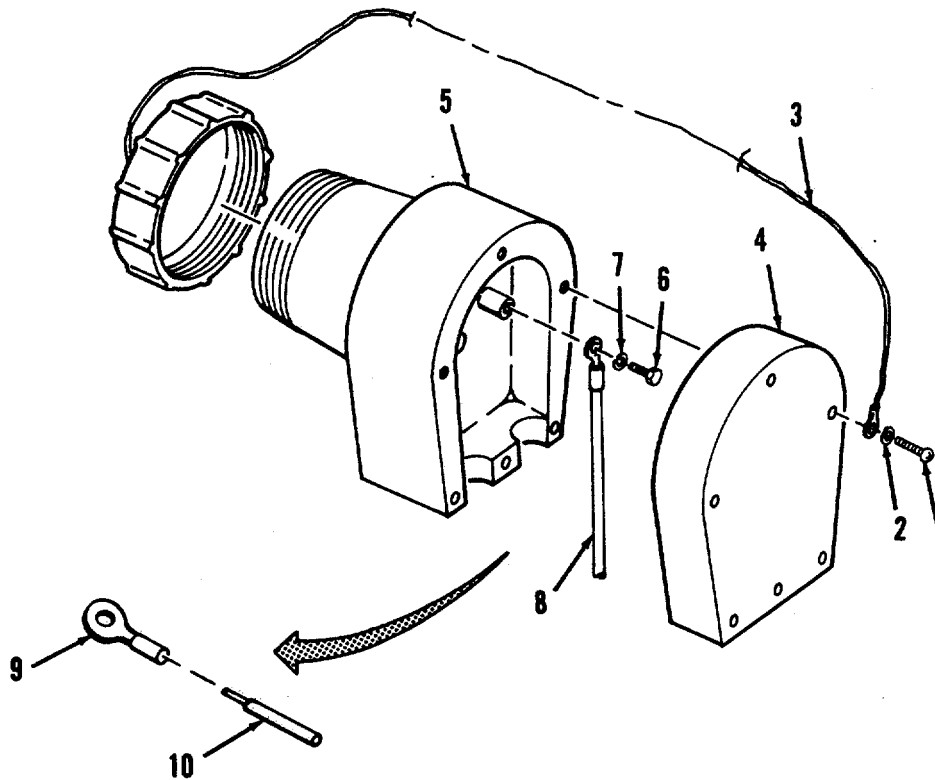

Figure 4-5. Slave Cable Repair.

**CAUTION**

Improper installation of wiring can damage the pump or cause the pumping assembly to fail to operate. Be sure to properly connect the positive and negative wires or pump will rotate in wrong direction and will not pump fluid.

**NOTE**

Wires must be traced to receptacle to determine which wire is positive or negative.

- (4) Twist black motor wire lead (6) together with ( - ) negative lead of slave cable wire (8). Install wire nut (5).
- (5) Twist red motor wire lead (6) together with ( + ) positive lead of slave cable wire (8). Install wire nut (5).
- (6) Stuff wiring into junction box and install junction box cover (3), four bolts (1), and four washers (2) onto junction box (4).

#### 4.8. FRAME ASSEMBLY REPLACEMENT.

---

**This task covers:**

- a. Removal
  - b. Replacement
- 

#### INITIAL SETUP:

##### Tools Required

Tool Kit, General Mechanic's (Appendix B, Item 1)

##### Materials Required

Lock Nuts (Appendix H, Item 2)  
Lock Washers (Appendix H, Item 1)

##### Equipment Condition

Pump assembly shut down and cool.

---

#### WARNING

Death or serious injury could occur if fuel is not handled carefully. Use in a well-ventilated area away from open flame, arcing equipment, ignition sources, heaters, or excessive heat. Use proper marked containers. DO NOT SMOKE.

Fuel drained from system (see para. 2.12.).

Slave cable disconnected from 24 volt power source.

All hose assemblies disconnected from pump (see para. 2.12.).

a. **Removal** (Refer to Figure 4-6).

- (1) Remove two bolts (1) and two lock washers (2) from frame (3). Discard lock washers.
- (2) Remove four bolts (4), eight flat washers (5), and four lock nuts (6). Discard lock nuts.
- (3) Remove pump and motor assembly (7).

b. **Replacement.**

- (1) Install pump and motor assembly (7) into frame (3).
- (2) Install four bolts (4), eight flat washers (5), and four lock nuts (6) through frame (3). Do not tighten hardware.
- (3) Install two lock washers (2) and two bolts (1).
- (4) Tighten all mounting hardware. Refer to Appendix G for torque values.,

4.8. FRAME ASSEMBLY REPLACEMENT - (Continued.)

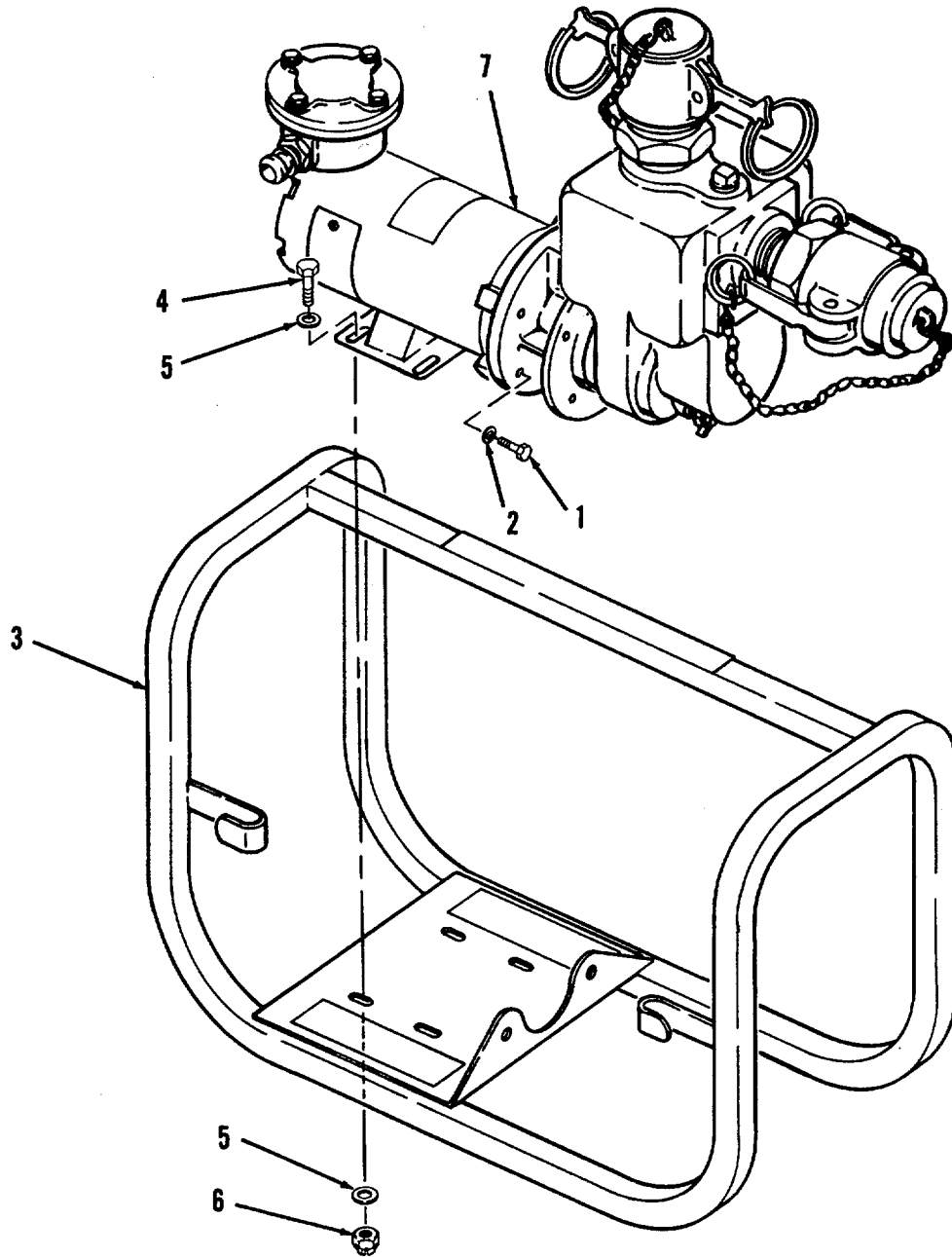

Figure 4-6. Frame Assembly Replacement.

**SECTION IV. PREPARATION FOR STORAGE OR SHIPMENT**

**4.9. PREPARATION FOR GENERAL STORAGE OR SHIPMENT .** Before storing the pumping assembly, it must be properly prepared. To ensure that the unit will operate properly when it is removed from storage or shipment, the following procedures must be performed.

**WARNING**

Death or serious injury could occur if fuel is not handled carefully. Use in a well-ventilated area away from open flame, arcing equipment, ignition sources, heaters, or excessive heat. Use proper marked containers. DO NOT SMOKE.

- a. Open drain cock on bottom of pump and allow all fuel to drain from pump housing.
- b. Drain all fuel from all suction and discharge hose assemblies.
- c. Install all dust caps and dust plugs onto all hose assemblies.

**4.10. ADMINISTRATIVE STORAGE OF EQUIPMENT.****a. General.**

- (1) Placement of equipment in administrative storage should be for short periods of time when a shortage of maintenance effort exists. Items should be in mission readiness within 24 hours or within the time factors determined by the directing authority. During the storage period appropriate maintenance records will be kept.
- (2) Before placing equipment in administrative storage, current maintenance services and Equipment Serviceable Criteria (ESC) evaluations should be completed, shortcomings and deficiencies should be corrected, and all Modification Work Orders (MWO) should be applied.
- (3) Storage site selection. Inside storage is preferred for items selected for administrative storage. If inside storage is not available, trucks, vans, conex containers and other containers may be used.

**b. Intermediate Storage (46 to 180 days).** No special handling is required other than protection from damage and the elements.

**c. Long Term or Flyable Storage (Indefinite time).**

- (1) Place the unit into a container, preferably the original container used to ship the unit if it has been preserved.
- (2) Wrap the unit with two layers of heavy plastic sheet or barrier paper.
- (3) Tape and strap the wrapping in place.
- (4) Mark the pumping assembly in accordance with the standard Army procedures contained in TM 740-90-1, Administrative Storage of Equipment.

**CHAPTER 5  
DIRECT SUPPORT MAINTENANCE INSTRUCTIONS**

**SECTION I. DIRECT SUPPORT REPAIR PARTS, SPECIAL TOOLS, TEST  
MEASUREMENT AND DIAGNOSTIC EQUIPMENT (TMDE),  
AND SUPPORT EQUIPMENT**

**5.1. COMMON TOOLS AND EQUIPMENT .** For authorized common tools and equipment, refer to the Modified Table of Organization and Equipment (MTOE) applicable to your unit.

**5.2. SPECIAL TOOLS, TMDE, AND SUPPORT EQUIPMENT .** No special tools are required to service the pumping assembly. The standard tools in the general mechanic's tool kit listed in the Maintenance Allocation Chart (MAC) located in Appendix B of this manual are the only tools required for maintenance of the pumping assembly.

**5.3. REPAIR PARTS.** Repair parts are listed in the Repair Parts and Special Tools List in Appendix C of this technical manual.

**SECTION II. DIRECT SUPPORT TROUBLESHOOTING**

**5.4. GENERAL.** No direct support troubleshooting procedures are applicable to the pumping assembly.

**SECTION III. DIRECT SUPPORT MAINTENANCE PROCEDURES**

**5.5. DIRECT SUPPORT MAINTENANCE PROCEDURES .** Maintenance procedures at direct support maintenance level include as necessary: removal, cleaning and inspection, repair or replacement, and installation.



**5.6. PUMP ASSEMBLY REPLACEMENT AND REPAIR.**

---

**This Task Covers:**

**a. Removal b. Disassembly c. Clean d. Inspection e. Repair f. Assembly g. Replacement**

---

**Initial Setup:****Tools Required**

Tool Kit, General Mechanic's (Appendix B, Item 1)

**Material's Required**

Solvent, Dry Cleaning (Appendix E, Item 1)  
 Brush, Medium Bristle (Appendix B, Item 1)  
 Cloth, Lint Free (Appendix E, Item 3)  
 Tape, Anti-seize (Appendix E, Item 4)  
 Preformed Packing (Appendix H, Item 5)  
 Seal Element (Appendix H, Item 6)  
 Shim Set (Appendix H, Item 7)  
 Slinger (Appendix H, Item 8)

**Equipment Condition**

Pump assembly shut down and cool.

**WARNING**

Death or serious injury could occur if fuel is not handled carefully. Use in a well-ventilated area away from open flame, arcing equipment, ignition sources, heaters, or excessive heat. Use proper marked containers. DO NOT SMOKE.

Fuel drained from system (see para. 2.12.).  
 Slave receptacle disconnected from 24 volt power source.  
 Pump and motor assembly removed from frame (see paragraph 4.8.).

---

**a. Removal.** (Refer to Figure 5-1).

- (1) Remove four bolts (1) and four lock washers (2) from pump side housing (3).
- (2) Remove pump housing (4) from pump side housing (3).
- (3) Remove preformed packing (5) from pump side housing (3).

**NOTE**

Do not damage vane tips during removal.

- (4) Loosen and remove impeller (6) by striking it along the periphery in a counter-clockwise manner and remove shims (7) and (8).
- (5) Remove two bolts (12), two lock washers (13), pump side housing (3), rotating portion of seal element (9), and non-rotating portion of seal element (10) from shaft of motor (11).
- (6) Remove slinger (14) from motor (11).

**b. Disassembly.** (Refer to Figure 5-2).

- (1) Remove dust cap (1), gasket (2), and coupling half (3) from pump (4).
- (2) Remove dust plug (5), gasket (6), coupling half (7), and pipe nipple (8) from pump (4).
- (3) Remove drain cock (9) from pump (4).

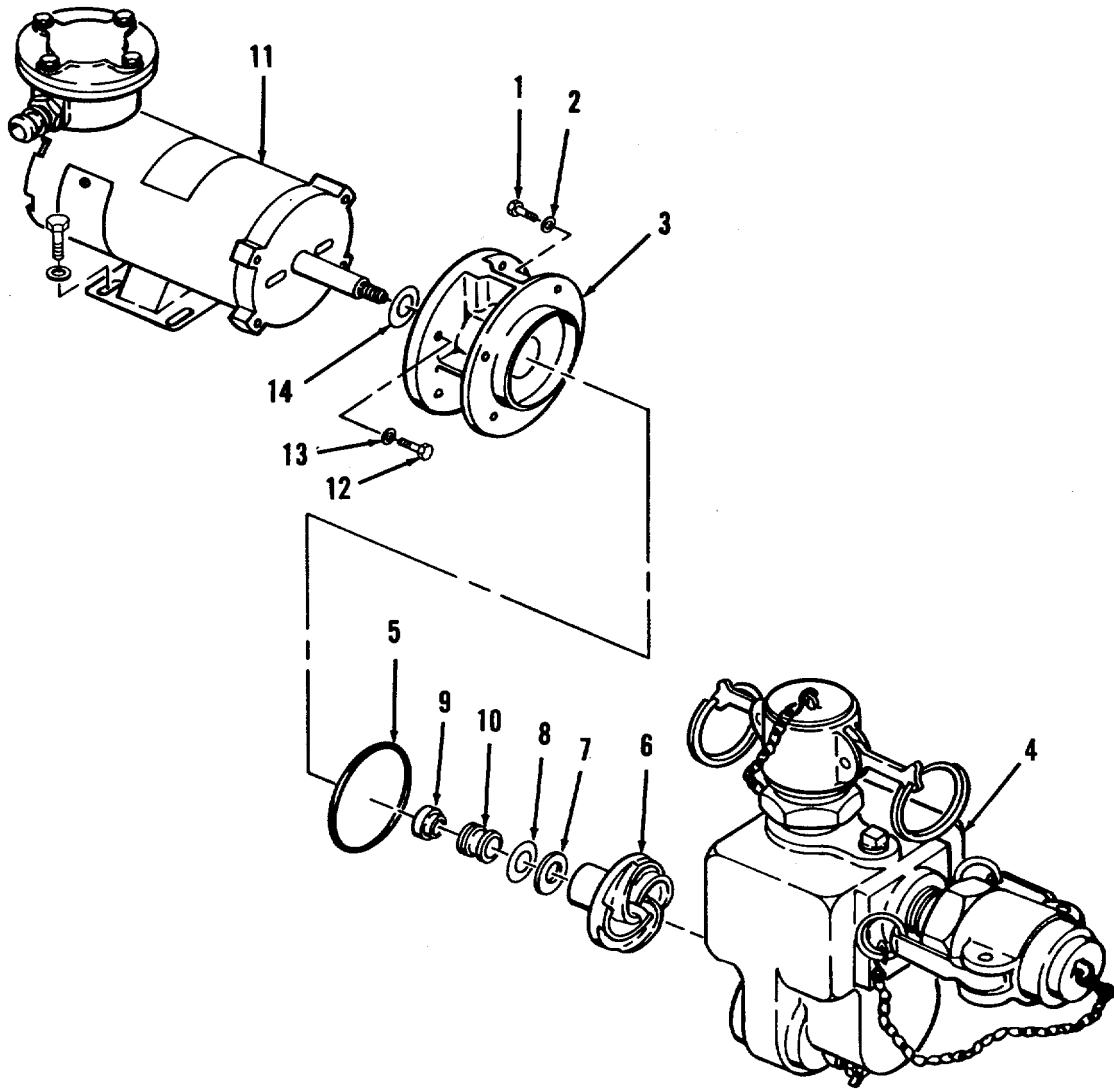

Figure 5-1. Pump Assembly Replacement.

## 5.6. PUMP ASSEMBLY REPAIR AND REPLACEMENT. - Continued.

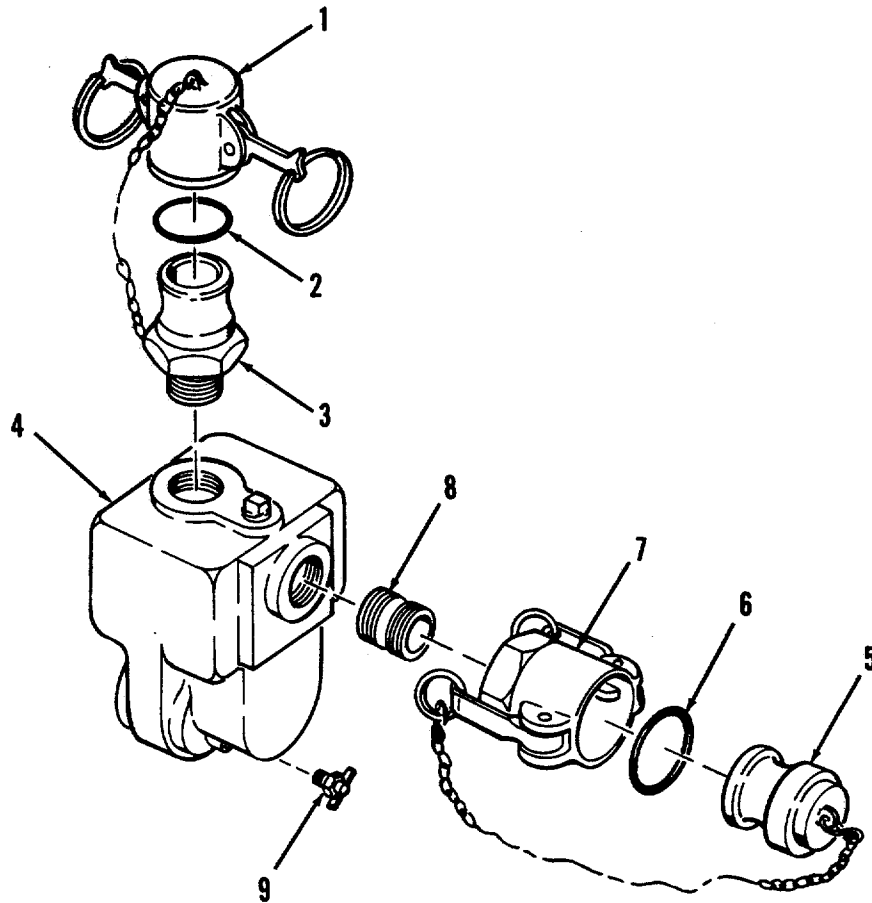

Figure 5-2. Pump Assembly Repair.

c. Clean.

- (1) Remove all build up of dirt, oil, and debris from all surfaces.

**CLEANING SOLVENTS**

Cleaning solvents may be toxic. Use in well-ventilated areas. Avoid prolonged inhalation of fumes or direct contact with skin. Do not use solvents near open flames or in areas where very high temperatures prevail. Solvent flash point must not be less than 100°F.

- (2) Clean all metallic parts with a clean soft cloth or a medium bristle brush, and cleaning solvent.
- (3) Allow parts to dry.

**d. Inspection.**

- (1) Inspect all metal parts for cracks, corrosion, or broken fittings.
- (2) Examine pump seals and packings for cracks or damage.

**e. Repair.** Repair is limited to replacement of defective parts.

**f. Assembly.** (Refer to Figure 5-2).

**NOTE**

Apply anti-seize tape to all male pipe threads before installation.

- (1) Install drain cock (9) onto pump (4).
- (2) Install pipe nipple (8), coupling half (7), gasket (6), and dust plug (5) onto pump (4).
- (3) Install coupling half (3), gasket (2), and dust cap (1) onto pump (4).

**g. Replacement.** (Refer to Figure 5-1).

- (1) Install slinger (14) onto shaft of motor (11).

**CAUTION**

Improper installation of seal will damage pump. Be sure ceramic portion of seal is installed facing pump.

- (2) Moisten the outside diameter of the new non-rotating portion of seal (9) with water and press firmly into place using thumb pressure.
- (3) Install two lock washers (13), two bolts (12), and pump side housing (3) (with drain slot on pump side housing pointing down) onto motor (11). Install bolts into top two holes of pump side housing and motor. Bottom two holes are used to mount motor to frame.
- (4) Install rotating element of seal (10) with large collar end facing motor (11).
- (5) Install shim (8) and shim (7) on shaft of motor (11).
- (6) Screw impeller (6) onto shaft of motor (11) by striking along the periphery in clockwise direction.
- (7) Install preformed packing (5) onto pump side housing (3).
- (8) Install pump case (4), four lock washers (2), and four bolts (1) onto pump side housing (3).
- (9) Install pump and motor assembly onto frame (see paragraph 4.8.).

**5.7. MOTOR ASSEMBLY REPLACEMENT.**

---

**This Task Covers:**

- a. Removal      b. Clean      c. Inspection      d. Replacement**
- 

**Initial Setup:****Tools Required**

Tool Kit, General Mechanic's (Appendix B, Item 1)

**Materials Required**

Solvent, Dry Cleaning (Appendix E, Item 1)  
 Brush, Medium Bristle (Appendix B, Item 1)  
 Cloth, Lint Free (Appendix E, Item 3)  
 Tape, anti-seize (Appendix E, Item 4)  
 Lock nuts (Appendix H, Item 2)

**Equipment Condition**

Pump assembly shut down and cool.  
 Slave cable assembly removed (see paragraph 4.7.).  
 Pump removed from unit (see paragraph 5.6.).

---

**a. Removal.** (Refer to Figure 5-3).

- (1) Remove four bolts (1), eight flat washers (2), and four lock nuts (3). Discard lock nuts.
- (2) Remove motor (4) from frame (5).

**b. Clean.**

- (1) Remove all build up of dirt, oil, and debris from all surfaces.

**CLEANING SOLVENTS**

Cleaning solvents may be toxic. Use in well-ventilated areas. Avoid prolonged inhalation of fumes or direct contact with skin. Do not use solvents near open flames or in areas where very high temperatures prevail. Solvent flash point must not be less than 100°F.

- (2) Clean all metallic parts with a clean soft cloth or a medium bristle brush and cleaning solvent.
- (3) Allow parts to dry.

**c. Inspection.**

Inspect all metal parts for cracks, corrosion, or broken fittings.

**d. Replacement.**

- (1) Place motor (5) into position onto frame (4).
- (2) Install four new lock nuts (3), eight flat washers (2), and four bolts (1).

- (3) Install slave cable assembly (see paragraph 4.7.).
- (4) Install pump assembly (see paragraph 5.6.).

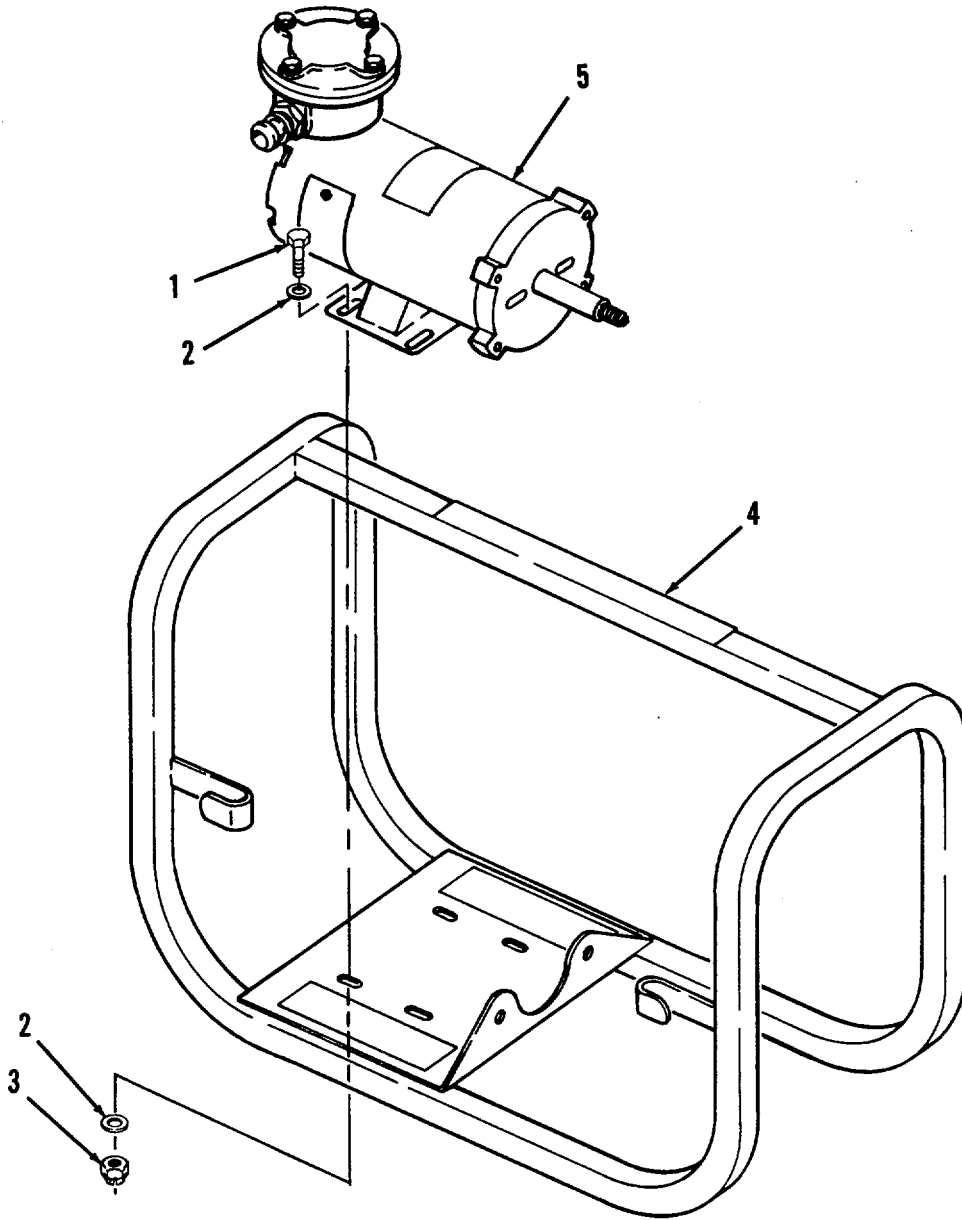

Figure 5-3. Motor Assembly Replacement.

**5.8. FRAME ASSEMBLY REPAIR.**

---

**This Task Covers:****a. Repair**

---

**Initial Setup:****Tools Required**

Tool Kit, General Mechanic's (Appendix B, Item 1)

**Materials Required**

None

**Equipment Condition**

Pump assembly shut down and cool.

Pump assembly removed (see paragraph 5.6.).

Motor assembly removed (see paragraph 5.7.).

---

**a. Repair.** (Refer to Figure 5-4).

Repair of the frame assembly is limited to repair of welds in accordance with TM 9-237, Welding Theory and Operations. The weld areas to be examined are indicated in Figure 5-4 .

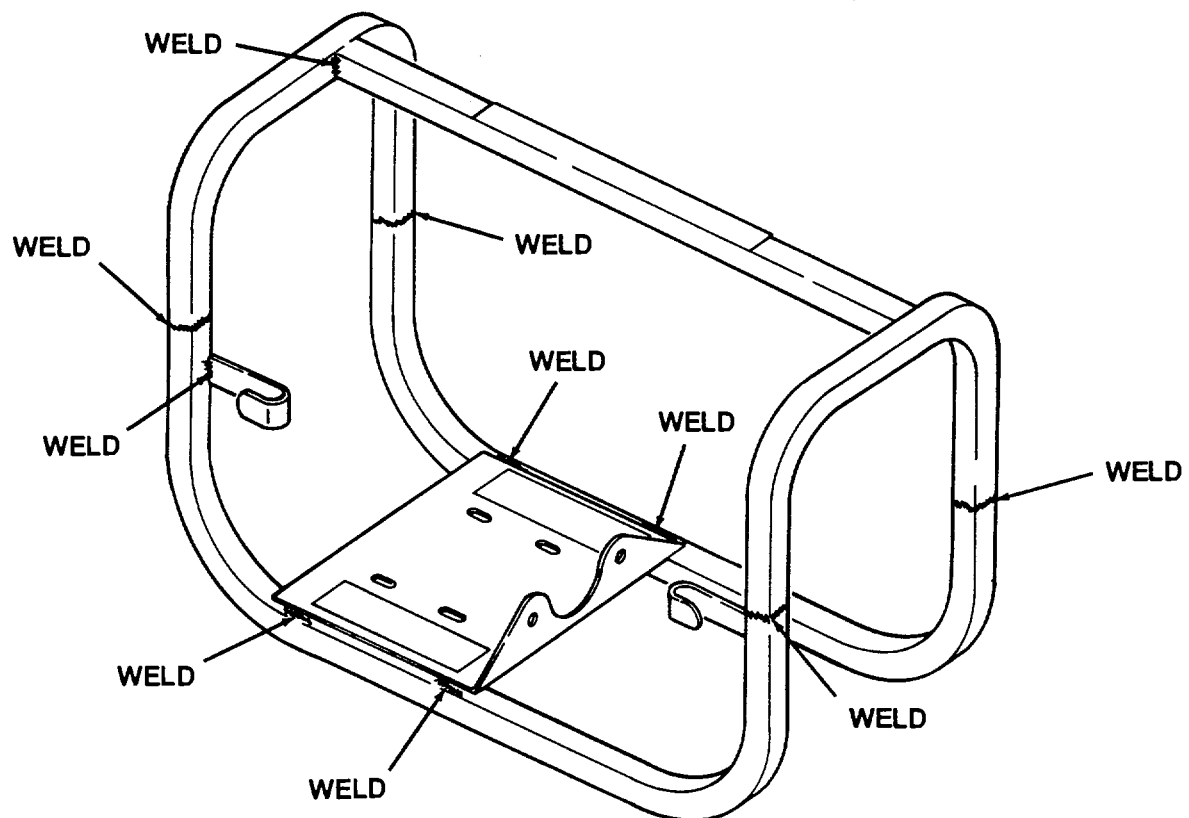

Figure 5-4. Frame Assembly Repair.

**APPENDIX A**

**REFERENCES**

**A.1. SCOPE.** This appendix lists all forms, field manuals, technical manuals, and miscellaneous publications referenced in this manual.

**A.2. FORMS.**

Report of Discrepancy .....	SF 364
Equipment Inspection and Maintenance Worksheet.....	DA Form 2404
Product Quality Deficiency Report.....	SF 368
Recommended Changes to Equipment Technical Publications .....	DA Form 2028-2
Recommended Changes to Publications and Blank Forms.....	DA Form 2028
Equipment Control Record .....	DA Form 2408-9
Packaging Improvement Report .....	DD Form 6

**A.3. FIELD MANUALS.**

First Aid For Soldiers.....	FM 21-11
NBC Contamination Avoidance .....	FM 3-3
NBC Protection.....	FM 3-4
NBC Decontamination.....	FM 3-5
Petroleum Supply Point Equipment and Operation .....	FM 10-69
Additional Procedures on Grounding and Bonding.....	FM 10-68

**A.4. TECHNICAL MANUALS.**

Administrative Storage of Equipment .....	TM 740-90-1
Procedures for Destruction of Equipment to Prevent Enemy Use (Mobility Equipment Command) .....	TM 750-244-3
Welding Theory and Application .....	TM9-237

**A.5. MISCELLANEOUS PUBLICATIONS AND STANDARDS.**

The Army Maintenance Management System (TAMMS) .....	DA PAM 738-750
Abbreviations for Use on Drawings, And Standards, Specifications and Technical Documents .....	MIL-STD-12
Army Medical Department Expendable/Durable Items.....	CTA 8-100
Expendable Items (Except Medical Class V, Repair Parts and Heraldic Items).....	CTA 50-970



## APPENDIX B

## MAINTENANCE ALLOCATION CHART

## SECTION I. INTRODUCTION

**B.1. The Army Maintenance System MAC.**

a. This introduction (section I) provides a general explanation of all maintenance and repair functions authorized at various maintenance categories under the standard Army Maintenance System concept.

b. The Maintenance Allocation Chart (MAC) in section II designates overall authority and responsibility for the performance of maintenance functions on the identified end item or component. The application of the maintenance functions to the end item or component will be consistent with the capacities and capabilities of the designated maintenance levels which are shown on the MAC in column (4) as:

**Unit** - includes two subcolumns, C (operator/crew) and O (unit Maintenance).

**Direct Support** - includes and F subcolumn.

**General Support** - includes an H subcolumn.

**Depot** - includes a D subcolumn.

c. Section III lists the tools and test equipment (both special tools and common tool sets) required for each maintenance function as referenced from section II.

d. Section IV contains supplemental instructions and explanatory notes for a particular maintenance function.

**B.2. Maintenance Functions.** Maintenance functions are limited to and defined as follows:

a. **Inspect.** To determine the serviceability of an item by comparing its physical, mechanical, and/or electrical characteristics with established standards through examination (e.g., by sight, sound, or feel).

b. **Test.** To verify serviceability by measuring the mechanical, pneumatic, hydraulic, or electrical characteristics of an item and comparing those characteristics with prescribed standards.

c. **Service.** Operations required periodically to keep an item in proper operating condition, e.g., to clean (includes decontaminate, when required), to preserve, to drain, to paint, or to replenish fuel, lubricants, chemical fluids, or gases.

d. **Adjust.** To maintain or regulate, within prescribed limits, by bringing into proper or exact position, or by setting the operating characteristics to specified parameters.

e. **Align.** To adjust specified variable elements of an item to bring about optimum or desired performance.

**f. Calibrate.** To determine and cause corrections to be made or to be adjusted on instruments or test, measuring, and diagnostic equipments used in precision measurement. Consists of comparisons of two instruments, one of which is a certified standard of known accuracy, to detect and adjust any discrepancy in the accuracy of the instrument being compared.

**g. Remove/Install.** To remove and install the same item when required to perform service or other maintenance functions. Install may be the act of emplacing, seating, or fixing into position a spare, repair part, or module (component or assembly) in a manner to allow the proper functioning of an equipment or system.

**h. Replace.** To remove an unserviceable item and install a serviceable counterpart in its place. "Replace" is authorized by the MAC and assigned maintenance level is shown as the 3rd position code of the SMR code.

**i. Repair.** The application of maintenance services<sup>1</sup>, including fault location/trouble-shooting<sup>2</sup>, removal/installation, and disassembly/assembly<sup>3</sup> procedures, and maintenance actions<sup>4</sup> to identify troubles and restore serviceability to an item -by correcting specific damage, fault, malfunction, or failure in a part, subassembly, module (component or assembly), end item, or system.

**j. Overhaul.** That maintenance effort (service/action) prescribed to restore an item to a completely serviceable/operational condition as required by maintenance standards in appropriate technical publications (i.e., DMWR). Overhaul is normally the highest degree of maintenance performed by the Army. Overhaul does not normally return an item to like new condition.

**k. Rebuild.** Consists of those services/actions necessary for the restoration of unserviceable equipment to a like new condition in accordance with original manufacturing standards. Rebuild is the highest degree of material maintenance applied to Army equipment. The rebuild operation includes the act of returning to zero those age measurements (hours/miles, etc.) considered in classifying Army equipment/components.

---

<sup>1</sup>Services - *Inspect, test, service, adjust, align, calibrate, and /or replace.*

<sup>2</sup>Fault location/troubleshooting - *The process of investigating and detecting the cause of equipment malfunctioning; the act of isolating a fault within a system or unit under test (UUT).*

<sup>3</sup>Disassembly /assembly - *The step-by-step breakdown (taking apart) of a spare /functional group coded item to the level of its least component, that is assigned an SMR code for the level of maintenance under consideration (i.e., identified as maintenance significant).*

<sup>4</sup>Actions - *Welding, grinding, riveting, straightening, facing, machining, and or resurfacing.*

**B.3. Explanation of Columns in the MAC, Section II.**

a. **Column 1, Group Number.** Column 1 lists functional group code numbers, the purpose of which is to identify maintenance significant components, assemblies, subassemblies, and modules with the next higher assembly.

b. **Column 2, Component/Assembly.** Column 2 contains the names of components, assemblies, subassemblies, and modules for which maintenance is authorized.

c. **Column 3, Maintenance Function.** Column 3 lists the functions to be performed on the item listed in Column 2. (For detailed explanation of these functions, see paragraph B-2.)

d. **Column 4, Maintenance Level.** Column 4 specifies each level of maintenance authorized to perform each function listed in Column 3, by indicating work time required (expressed as man hours in whole hours or decimals) in the appropriate subcolumn. This work-time figure represents the active time required to perform that maintenance function at the indicated level of maintenance. If the number or complexity of the tasks within the listed maintenance function vary at different maintenance levels, appropriate work-time figures are to be shown for each level. The work-time figure represents the average time required to restore an item (assembly, subassembly, component, module, end item, or system) to a serviceable condition under typical field operating conditions. This time includes preparation time (including any necessary disassembly/assembly time), troubleshooting/fault location time, and quality assurance/quality control time in addition to the time required to perform the specific tasks identified for the maintenance functions authorized in the maintenance allocation chart. The symbol designations for the various maintenance levels are as follows:

- C .....Operator or crew maintenance
- O .....Unit maintenance
- F .....Direct support maintenance
- L .....Specialized Repair Activity (SRA)
- H .....General support maintenance
- D .....Depot maintenance

e. **Column 5, Tools and Test Equipment reference code.** Column 5 specifies, by code, those common tools sets (not individual tools), common TMDE, and special tools, special TMDE, and support equipment required to perform the designated function. Codes are keyed to tools and test equipment in section III.

f. **Column 6, Remarks.** When applicable, this column contains a letter code, in alphabetical order, which is keyed to the remarks contained in Section IV.

**B.4. Explanation of Columns in Tools and Test Equipment Requirements, Section III.**

a. **Column 1, Reference Code.** The tool and test equipment reference code correlates with a code used in the MAC, Section II, Column 5.

b. **Column 2, Maintenance Level.** The lowest level of maintenance authorized to use the tool or test equipment.

c. **Column 3, Nomenclature.** Name or identification of the tool or test equipment.

d. **Column 4, National Stock Number.** The National stock number of the tool or test equipment.

- e. **Column 5, Tool Number**. The manufacturer's part number, model number, or type number.

**B.5. Explanation of Columns in Remarks, Section IV.**

- a. **Column 1, Reference Code**. The code recorded in column 6, Section II.
- b. **Column 2, Remarks**. This column lists information pertinent to the maintenance function being performed as indicated in the MAC, Section II.

**SECTION II. MAINTENANCE ALLOCATION CHART FOR PUMP UNIT, 35 GPM, CENTRIFUGAL.**

(1) GROUP NUMBER	(2) COMPONENT/ ASSEMBLY	(3) MAINTENANCE FUNCTION	(4) MAINTENANCE CATEGORY					(5) TOOLS & EQUIPMENT	(6) REMARKS
			C	O	F	H	D		
00	PUMPING ASSEMBLY								
01	HOSE ASSEMBLIES SUCTION AND DISCHARGE	Inspect Replace Repair	0.1 0.1 0.1						
02	NOZZLE ASSEMBLY	Inspect Replace Repair	0.1 0.1	2.0			1	A, B	
03	GROUNDING CABLE	Inspect Replace Repair	0.1 0.1	0.2			1	B	
04	PUMP ASSEMBLY	Inspect Replace Repair		0.2	1.5 0.5		1 1	B	
05	MOTOR ASSEMBLY	Inspect Replace	0.2		1.5		1	A	
06	SLAVE CABLE	Inspect Replace Repair	0.1	0.5 0.5			1 1	B	
07	FRAME ASSEMBLY	Inspect Replace Repair	0.1	1.5	2.5			C	

**SECTION III. SPECIAL TOOLS AND TEST EQUIPMENT REQUIREMENTS**

(1) REFERENCE TOOL CODE	(2) MAINTENANCE LEVEL	(3) NOMENCLATURE	(4) NATIONAL/AUTO STOCK NUMBER	(5) TOOL NUMBER
1	0	<p>Standard tools and test equipment contained in the following kit are adequate to perform the maintenance functions listed in Section II</p> <p>Tool Kit, General Mechanic's</p>	5180-00-177-7033	SC 5180-90 -CL-N26 (19099)

**SECTION IV. REMARKS.**

REFERENCE CODE	REMARKS
A	Adjust to specifications
B	Repair is limited to the replacement of components found defective during inspection
C	Weld and straighten in accordance with TM 9-237, Operator 28 Manual, Welding Theory and Application. Rev. June 1991

## APPENDIX C

## REPAIR PARTS AND SPECIAL TOOLS LIST

## SECTION I. INTRODUCTION

**C.1. SCOPE.** This Repair Parts and Special Tools List (RPSTL) lists and authorizes spares and repair parts; special tools; special test, measurement, and diagnostic equipment (TMDE); and other special support equipment required for performance of unit and direct support maintenance of the Pumping Assembly. It authorizes the requisitioning, issue, and disposition of spares, repair parts and special tools as indicated by the source, maintenance and recoverability (SMR) codes.

**C.2. GENERAL.** In addition to Section I, Introduction, this Repair Parts and Special Tools List is divided into the following sections:

**a. Section II. Repair Parts List.** A list of spares and repair parts authorized by this RPSTL for use in the performance of maintenance. The list also includes parts which must be removed for replacement of the authorized parts. Parts lists are composed of functional groups in ascending alphanumeric sequence, with the parts in each group listed in ascending figure and item number sequence. Bulk materials are listed in item name sequence. Repair parts kits are listed separately in their own functional group within Section II. Repair parts for repairable special tools are also listed in this section. Items listed are shown on the associated illustration(s) or figure(s).

**b. Section III. Special Tools List.** A list of special tools, special TMDE, and other special support equipment authorized by this RPSTL (as indicated by Basis of Issue (BOI) information in DESCRIPTION AND USABLE ON CODE column) for the performance of maintenance.

**c. Section IV. Cross-reference Index.** A list, in National item identification number (NIIN) sequence, of all National stock numbered items appearing in the listing, followed by a list in alpha-numeric sequence of all part numbers appearing in the listings. National stock numbers and part numbers are cross-referenced to each illustration figure and item number appearance. The figure and item number index lists figure and item numbers in alphanumeric sequence and cross-references NSN, CAGEC and part numbers.

**C.3. EXPLANATION OF COLUMNS (Sections II and III).**

- a. **Item No. (Column (1)).** Indicates the number used to identify items called out in the illustration.
- b. **SMR Code (Column (2)).** The Source, Maintenance, and Recoverability (SMR) code is a 5-position code containing supply and requisitioning information, maintenance category authorization criteria, and disposition instruction, as shown in the following breakout:

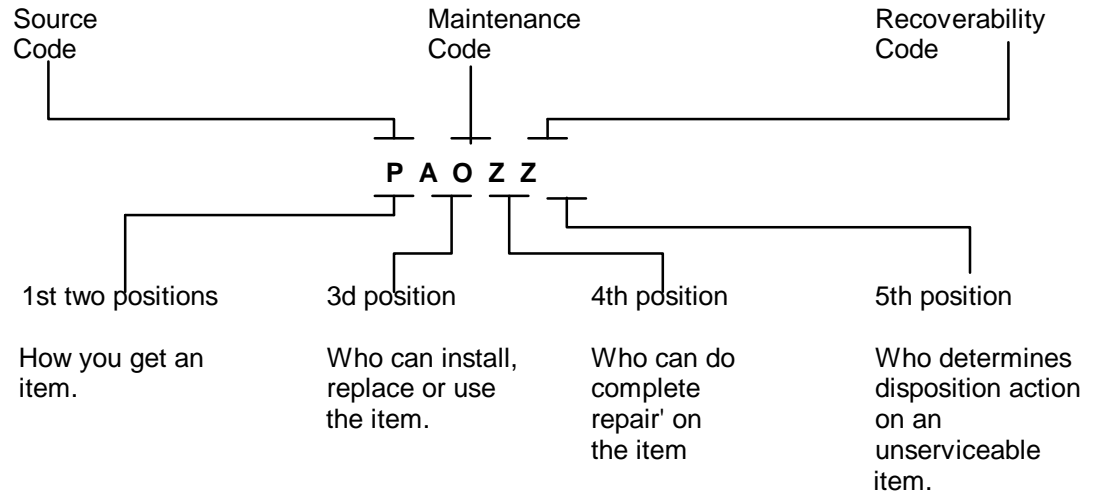

**\*Complete Repair:** Maintenance capacity, capability, and authority to perform all corrective maintenance tasks of the "Repair" function in a use/user environment in order to restore serviceability to a failed item.

**(1) Source Code.** The source code tells you how to get an item needed for maintenance, repair, or overhaul of an end item or equipment. Explanations of source codes follows:

Code	Explanation
PA PB PC** PD PE PF PG	Stocked items; use the applicable NSN to request/requisition items with these source codes. They are authorized to the category indicated by the code entered in the 3rd position of the SMR code.  **NOTE : Items coded PC are subject to deterioration.
KD KF KB	Items with these codes are not to be requested/requisitioned individually. They are part of a kit which is authorized to the maintenance category indicated in the 3rd position of the SMR code. The complete kit must be requisitioned and applied.



Code	Explanation
MO (Made at UNIT AVUM level)	Items with these codes are not to be requested/requisitioned individually. They must be made from bulk material which is identified by the part number in the DESCRIPTION and USABLE ON CODE (UOC) column and listed in the Bulk Material group of the repair parts list in the RPSTL. If the item is authorized to you by the 3rd position code of the SMR code, but the source code indicates it is made at a higher level, order the item from the higher level of maintenance.
MF (Made at DS/AVUM level)	
MH (Made at GS level)	
ML (Made at Specialized Repair Activity (SRA))	
MD (Made at Depot)	
AO (Assembled by UNIT/AVUM Level)	Items with these codes are not to be requested/requisitioned individually. The parts that make up the assembled item must be requisitioned or fabricated and assembled at the level of maintenance indicated by the source code. If the 3rd position code of the SMR code, authorizes you to replace the item, but the source code indicates the items are assembled at a higher level, order the item from the higher level of maintenance.
AF (Assembled by DS/AVUM Level)	
AH (Assembled by GS Category)	
AL (Assembled by SRA)	
AD (Assembled by Depot)	

Code	Explanation
XA - Do not requisition an "XA"-coded item. Order its next higher assembly. (Also, refer to the NOTE below.)	
XB - If an "XB" item is not available from salvage, order it using the CAGE Code and part number given.	
XC - Installation drawing, diagram, instruction sheet, field service drawing, that is identified by manufacturer's part number.	
XD - Item is not stocked. Order an "XD"-coded item through normal supply channels using the CAGE Code and part number given, if no NSN is available.	

**NOTE**

Cannibalization or controlled exchange, when authorized, may be used as a source of supply for items with the above source codes, except for those source coded "XA" or those aircraft support items restricted by requirements of AR 700-42.

**(2) Maintenance Code.** Maintenance codes tell you the level(s) of maintenance authorized to USE and REPAIR support items. The maintenance codes are entered in the third and fourth positions of the SMR code as follows:

(a) The maintenance code entered in the third position tells you the lowest maintenance level authorized to remove, replace, and use an item. The maintenance code entered in the third position will indicate authorization to the following levels of maintenance.

<b>Code</b>	<b>Application/Explanation</b>
C	Crew or operator maintenance done within unit/AVUM maintenance.
O	Unit level VAVUM maintenance can remove, replace, and use the item.
F	Direct support/AVIM maintenance can remove, replace, and use the item.
H	General support maintenance can remove, replace, and use the item.
L	Specialized repair activity can remove, replace, and use the item.
D	Depot can remove, replace, and use the item.

(b) The maintenance code entered in the fourth position tells whether or not the item is to be repaired and identifies the lowest maintenance level with the capability to do complete repair (i.e., perform all authorized repair functions). (NOTE: Some limited repair may be done on the item at a lower level of maintenance, if authorized by the Maintenance Allocation Chart (MAC) and SMR codes.) This position will contain one of the following maintenance codes.

<b>Code</b>	<b>Application/Explanation</b>
O	Unit or (aviation unit) is the lowest level that can do complete repair of the item.
F	Direct support or aviation intermediate is the lowest level that can do complete repair of the item.
H	General Support is the lowest level that can do complete repair of the item.
L	Specialized repair activity (designate the specialized repair activity) is the lowest level that can do complete repair of the item.
D	Depot is the lowest level that can do complete repair of the item.
Z	Nonreparable. No repair is authorized.
B	No repair is authorized. (No parts or special tools are authorized for the maintenance of a "B" coded item). However, the item may be reconditioned by adjusting, lubricating, etc., at the user level.

**(3) Recoverability Code.** Recoverability codes are assigned to items to indicate the disposition action on unserviceable items. The recoverability code is entered in the fifth position of the SMR Code as follows:

<b>Recoverability Codes</b>	<b>Application/Explanation</b>
Z -	Nonreparable item. When unserviceable, condemn and dispose of the item at the level of maintenance shown in 3rd position of SMR Code.
O -	Reparable item. When not economically repairable, condemn and dispose of the item at unit or AVUM level.
F -	Reparable item. When uneconomically repairable, condemn and dispose of the item at the direct support or AVIM level.
H -	Reparable item. When uneconomically repairable, condemn and dispose of the item at the general support level.
D -	Reparable item. When beyond lower level repair capability, return to depot. Condemnation and disposal of item not authorized below depot level.
L -	Reparable item. Condemnation and disposal not authorized below specialized repair activity (SRA).
A -	Item requires special handling or condemnation procedures because of specific reasons (e.g., precious metal content, high dollar value, critical material, or hazardous material). Refer to appropriate manuals/directives for specific instructions.

**c. CAGEC (Column (3)).** The Commercial and Government Entity Code (CAGEC) is a 5-digit numeric code which is used to identify the manufacturer, distributor, or Government agency/activity that supplies the item.

**d. Part Number (Column (4)).** Indicates the primary number used by the manufacturer, (individual, company, firm, corporation, or Government activity), which controls the design and characteristics of the item by means of its engineering drawings, specifications, standards, and inspection requirements to identify an item or range of items.

**NOTE**

When you use an NSN to requisition an item, the item you receive may have a different part number from the number listed.

**e. DESCRIPTION AND USABLE ON CODE (UOC) (Column (5)).** This column includes the following information:

- (1) The Federal item name and, when required, a minimum description to identify the item.

(2) The physical security classification of the item is indicated by the parenthetical entry, e.g., Phy Sec C1 (C)-Confidential, Phy Sec C1 (S)-Secret, Phy Sec C1 (T)-Top-Secret.

(3) Items that are included in kits and sets are listed below the name of the kit or set.

(4) Spare/repair parts that make up an assembled item are listed immediately following the assembled item line entry.

(5) Part numbers of bulk materials are referenced in this column in the line entry for the item to be manufactured/fabricated.

(6) When the item is not used with all serial numbers of the same model, the effective serial numbers are shown on the last line(s) of the description (before UOC).

(7) The usable on code, when applicable (reference paragraph 5, Special Information).

(8) In the Special Tools List Section, the basis of issue (BOI) appears as the last line(s) in the entry for each special tool, special TMDE, and other special support equipment. When density of equipment supported exceeds density spread indicated in the basis of issue, the total authorization is increased proportionately.

(9) The statement "END OF FIGURE" appears just below the last item description in Column (5) for a given figure in both Section II and Section III.

**f. QTY (Column (6)).** The QTY (quantity per figure) column indicates the quantity of the item used in the breakout shown on the illustration/figure, which is prepared for a functional group, subfunctional group, or an assembly. A "V" appearing in this column instead of a quantity indicates that the quantity is variable and may vary from application to application.

#### **C.4. EXPLANATION OF INDEX FORMAT AND COLUMNS (SECTION IV).**

##### **a. NATIONAL STOCK NUMBER (NSN) INDEX.**

(1) **STOCK NUMBER Column.** This column lists the NSN in national item identification number (NIIN) sequence. The NIIN consists of the last nine digits of the NSN, i.e. For example, if the NSN is 5305-01-674-1467 then the set of last nine digits (01-674-1467) is the NIIN. When using this column to locate an item, ignore the first four digits of the NSN. However, the complete NSN (13 digits) when requisitioning items by stock number.

(2) **FIG. Column.** This column lists the number of the figure where the item is identified/located. The figures are in numerical order in Section II and Section III.

(3) **ITEM Column.** The item number identifies the item associated with the figure listed in the adjacent FIG. column. This item is also identified by the NSN listed on the same line.

**b. PART NUMBER INDEX.** Part numbers in this index are listed in ascending alphanumeric sequence (i. e., vertical arrangement of letter and number combinations which place the first letter or digit of each group in order A through Z, followed by the numbers 0 through 9, and each following letter or digit in like order).

(1) **CAGEC Column**. The Federal Supply Code for Manufactures (CAGEC) is a 5-digit numeric code used to identify the manufacturer, distributor, or Government agency/activity that supplies the item.

(2) **PART NUMBER Column**. Indicates the primary number used by the manufacturer (individual, firm, corporation, or Government activity), which controls the design and characteristics of the item by means of its engineering drawings, specifications, standards, and inspection requirements to identify an item or range of items.

(3) **STOCK NUMBER Column**. This column lists the NSN for the associated part number and manufacturer identified in the PART NUMBER and CAGEC columns to the left..

(4) **FIG. Column**. This column lists the number of the figure where the item is identified/located in Section II and Section II and III.

(5) **ITEM Column**. The item number is that number assigned to the item as it appears in the figure referenced in the adjacent figure number column.

**c. FIGURE AND ITEM NUMBER INDEX.**

(1) **FIG. Column**. This column lists the number of the figure where the item is identified/located in Section II and Section III.

(2) **ITEM Column**. The item number is that number assigned to the item as it appears in the figure referenced in the adjacent figure number column.

(3) **Stock Number column.** This column lists the NSN for the item.

(4) **CAGEC column.** The Federal Supply Code for Manufacturer (CAGEC) is a 5-digit numeric code used to identify the manufacturer, distributor, or Government agency, etc., that supplies the item.

(5) **Part Number column.** Indicates the primary number used by the manufacturer which controls the design and characteristics of the item by means of its engineering drawings, specifications standards, and inspection requirements to identify an item or range of items.

**C.5. SPECIAL INFORMATION.**

a. **USABLE ON CODE.** The usable on code appears in the lower left corner of the Description column heading. Usable on codes are shown as "UOC:.." in the Description Column justified left) on the last line of the applicable item description/nomenclature. Uncoded items are applicable to all models.

**b. FABRICATION INSTRUCTIONS.** Bulk materials required to manufacture items are listed in the Bulk Material Functional Group of this RPSTL. Part numbers for bulk materials are also referenced in the description column of the line item entry for the item to be manufactured/fabricated. Detailed fabrication instructions for items source coded to be manufactured or fabricated are found in TM 9-4120-404-14.

**c. ASSEMBLY INSTRUCTIONS.** Detailed assembly instructions for items source coded to be assembled from component spare/repair parts are found in TM 9-4120-404-14. Items that make up the assembly are listed immediately following the assembly item entry or reference is made to an applicable figure.

**d. Kits**

**e. Index Numbers.** Items which have the word BULK in the figure column will have an index number shown in the item number column. This index number is a cross-reference between the National Stock Number/Part Number Index and the bulk material list in Section II.

**f. Associated Publications.** The publications listed below pertain to the Air Conditioner and its components.

<b>Publication</b>	<b>Short Title</b>
(Not Applicable)	(Not Applicable)

**C.6. HOW TO LOCATE REPAIR PARTS.**

**a. When National Stock Numbers or Part Numbers are NOT Known.**

(1) First. Using the table of contents, determine the assembly or subassembly group to which the item belongs. This is necessary since figures are prepared for assembly groups and subassembly groups, and listings are divided into the same groups.

(2) Second. Find the figure covering the assembly group or subassembly group to which the item belongs.

(3) Third. Identify the item on the figure and use the Figure and Item Number Index to find the NSN.

**b. When National Stock Number or Part Number is Known.**

(1) **First.** Using the of National Stock Number and Part Number Indexes find the pertinent National Stock Number or Part Number. The NSN index is in National Item Identification Number (NIIN) sequence (see paragraph 4.a.). The part numbers in the Part Number index are listed in ascending alphanumeric sequence (see paragraph 4.b.). Both indexes cross-reference you to the illustration/figure and item number of the item you are looking for.

(2) **Second.** Turn to the figure and item number, verify that the item is the one you are looking for, then locate the item number in the repair parts list for the figure.

(3) **Third.** Identify the item on the figure and use the Figure and Item Number Index to find the NSN.

**b. When National Stock Number or Part Number is Known.**

(1) **First.** Using the National Stock Number or the Part Number Index, find the pertinent National Stock Number or Part Number. The NSN index is in National Item Identification Number (NIIN) sequence (see 4.a(1)). The part numbers in the Part Number index are listed in ascending alphanumeric sequence (see 4.b). Both indexes cross-reference you to the illustration/figure and item number of the item you are looking for.

(2) **Second.** Turn to the figure and item number, verify that the item is the one you're looking for, then locate the item number in the repair parts list for the figure.

**C.7. ABBREVIATIONS.** Abbreviations used in this manual are listed in MIL-STD-12.

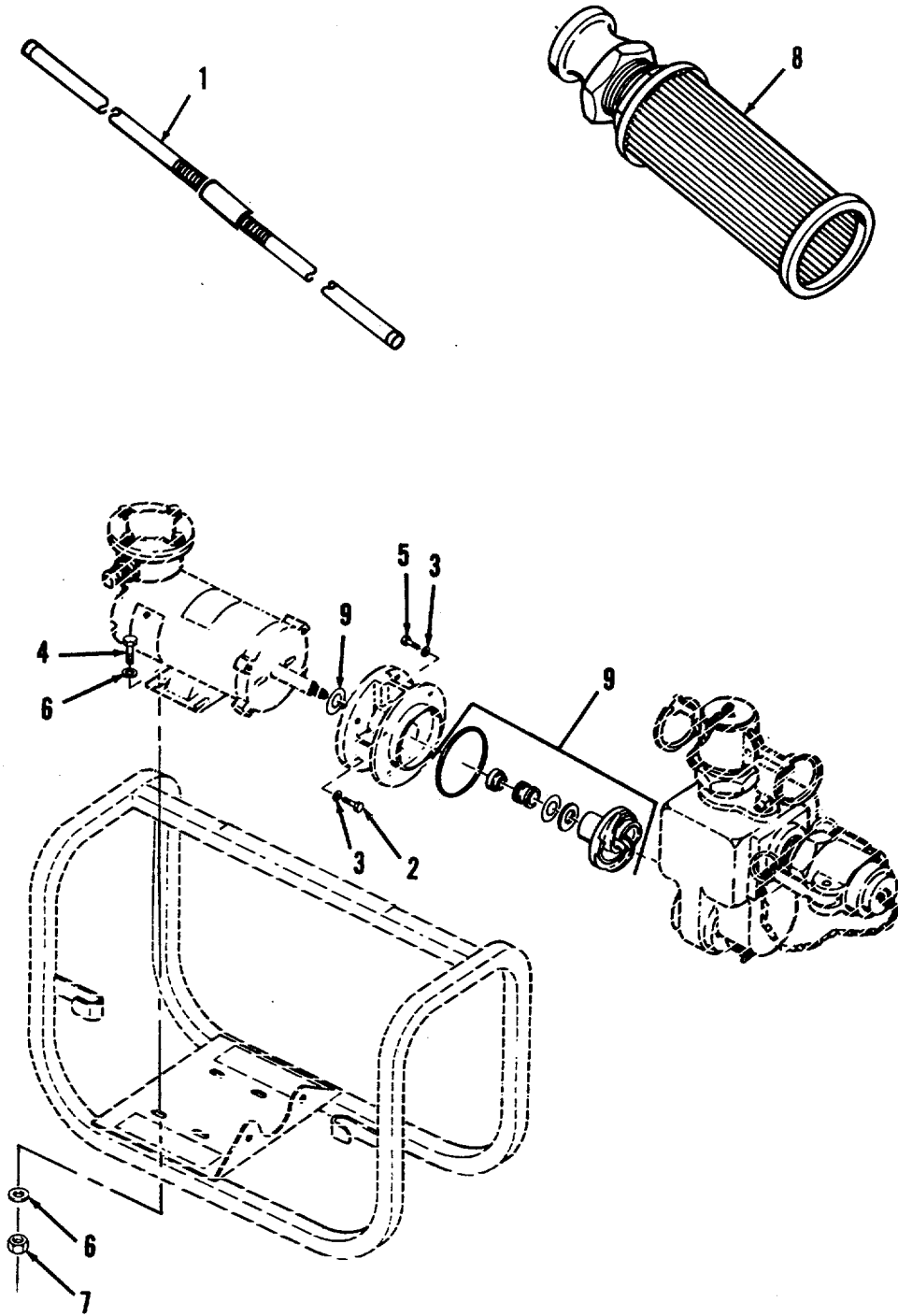

Figure C-1. Pumping Assembly.

(C-9 Blank) / C-1 0

SECTION II

TM 10-4320-347-13&P

(1) ITEM NO	(2) SMR CODE	(3) CAGEC	(4) PART NUMBER	(5) DESCRIPTION AND USABLE ON CODES(UOC)	(6) QTY
1	PAOZZ	40151	FB550-5	ROD, GROUND .....	1
2	PAOZZ	39428	91247A624	CAPSCREW, HEX HEAD.....	4
3	PAOZZ	96906	MS51415-7	WASHER, LOCK.....	8
4	PAOZZ	39428	91247A628	CAPSCREW, HEX HEAD.....	4
5	PAOZZ	39428	91247A581	CAPSCREW, HEX HEAD.....	4
6	PAOZZ	88044	AN960-516	WASHER, FLAT.....	8
7	PAOZZ	96906	MS17829-5C	NUT, SELF LOCKING, HEX.....	4
8	PAOZZ	40151	FBS-108	STRAINER, SUCTION .....	1
9	PDFZZ	40151	FBK-1	PUMP SEAL REPAIR KIT .....	1
		P3397	10190	KIT CONSISTS OF:	
		62709	W105-7V	PREFORMED PACKING.....	1
		40151	FB3238	SHAFT, SEAL, PUMP .....	1
		10190	P3241	SHIM SET .....	1
				SLINGER .....	1
				END OF FIGURE	



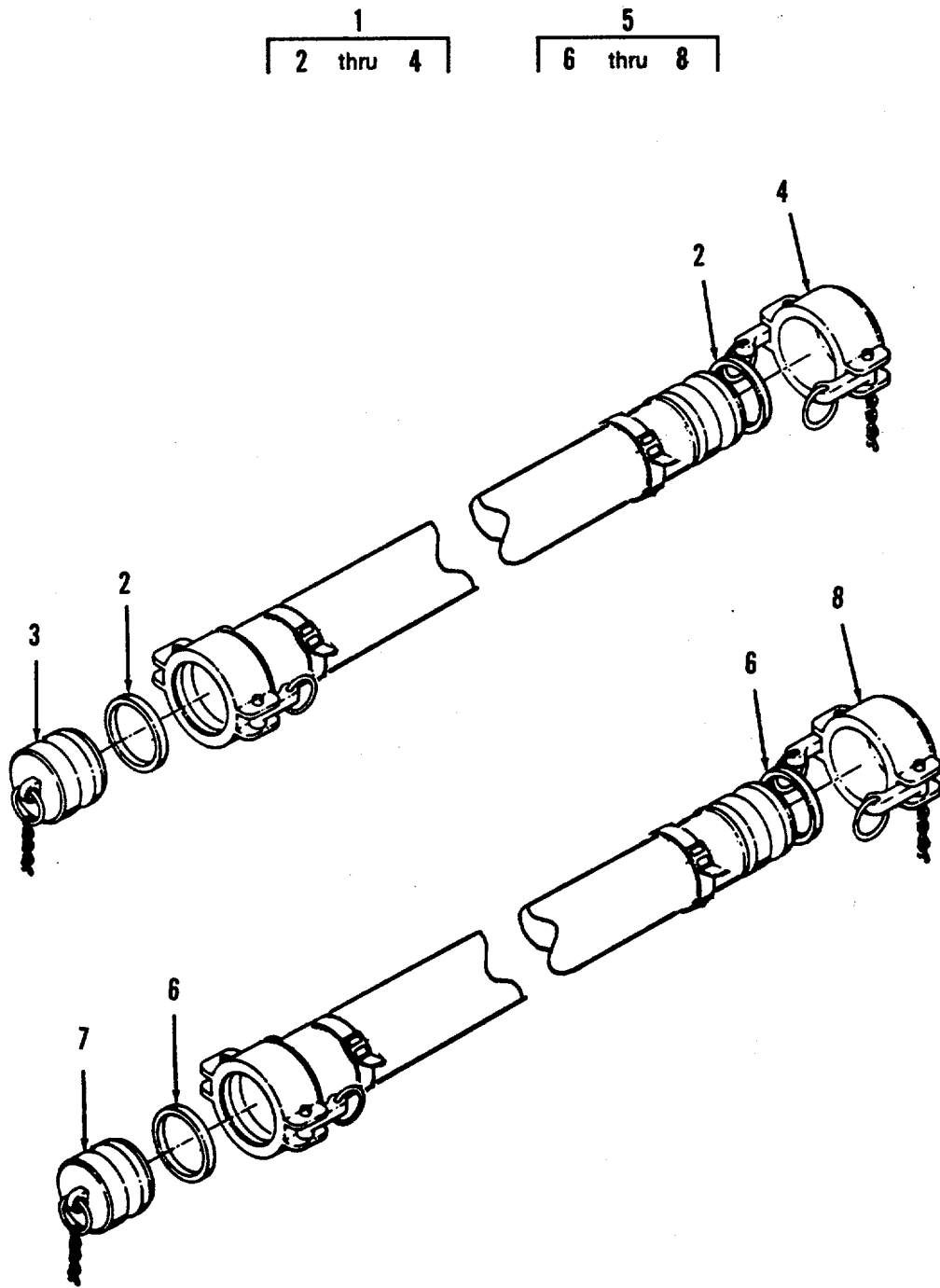

Figure C-2. Hose Assemblies, Suction, Discharge

SECTION II

TM 10-4320-347-13&P

(1) ITEM NO	(2) SMR CODE	(3) CAGEC	(4) PART NUMBER	(5) DESCRIPTION AND USABLE ON CODES(UOC)	(6) QTY
1	PAOOO	81349	M370-A05B2A3000	HOSE, SUCTION FUEL.....	2
2	PAOZZ	96906	MS27030-5	GASKET .....	2
3	PAOZZ	96906	MS27029-9	PLUG, QD W/CHAIN.....	1
4	PAOOO	96906	MS27028-9	CAP, OD W/CHAIN.....	1
5	PAOOO	81349	M11588- 310732/25 FT	HOSE, DISCHARGE, FUEL.....	2
6	PAOZZ	96906	MS27030-5	GASKET .....	2
7	PAOZZ	96906	MS27029-9	PLUG, QD W/CHAIN.....	1
8	PAOOO	96906	MS27028-9	CAP, QD W/CHAIN.....	1
END OF FIGURE					

1  
| 2 thru 5 |

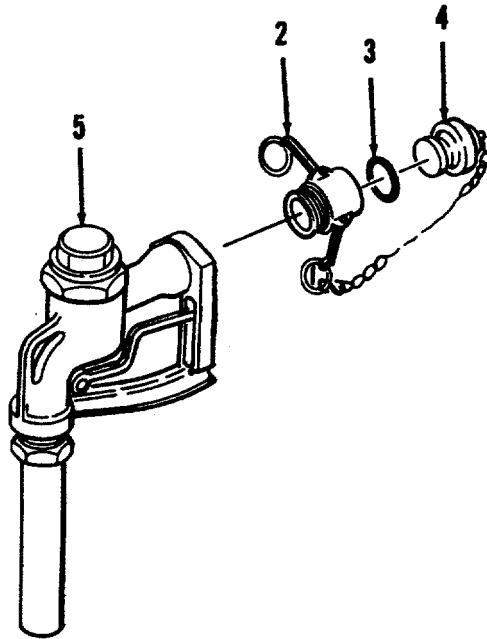

Figure C-3. Nozzle Assembly

SECTION II

TM 10-4320-347-13&P

(1) ITEM NO	(2) SMR CODE	(3) CAGEC	(4) PART NUMBER	(5) DESCRIPTION AND USABLE ON CODES(UOC)	(6) QTY
				GROUP 02 NOZZLE ASSEMBLY	
				FIG. C-3. NOZZLE ASSEMBLY	
1	PAOOO	40151	490FB	NOZZLE ASSEMBLY .....	1
2	PAOOO	96906	MS27026-6	COUPLING HALF, QD .....	1
3	PAOZZ	96906	MS27030-5	GASKET .....	1
4	PAOZZ	96906	MS27029-9	PLUG, QD W/CHAIN .....	1
5	PAOZZ	96906	A-A-52030	NOZZLE, FUEL AND OIL .....	1
				END OF FIGURE	

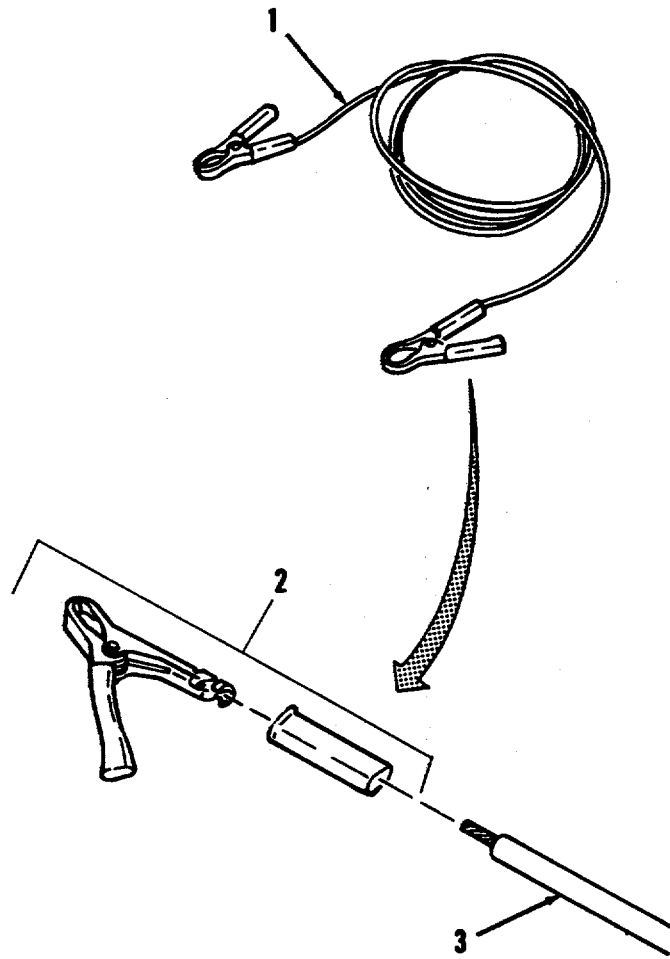

Figure C-4. Grounding Cable.

SECTION II

TM 10-4320-347-13&P

(1) ITEM NO	(2) SMR CODE	(3) CAGEC	(4) PART NUMBER	(5) DESCRIPTION AND USABLE ON CODES(UOC)	(6) QTY
				GROUP 03 GROUNDING CABLE	
				FIG. C-4. GROUNDING CABLE	
1	PAOOO	40151	FB551-1	CABLE, GROUND.....	1
2	PAOOO	81349	MIL-C-83413/7	CONNECTOR, ELECTRICAL.....	2
3	MOOZZ	40151	FB551-1-1	WIRE, COPPER #10 AWG .....	2
				MAKE FROM WIRE, THHN, CAGE 39428, PART NO. 7125K26, GREEN, CUT TO 77.00 IN.	
				END OF FIGURE	

1  
2 thru 9

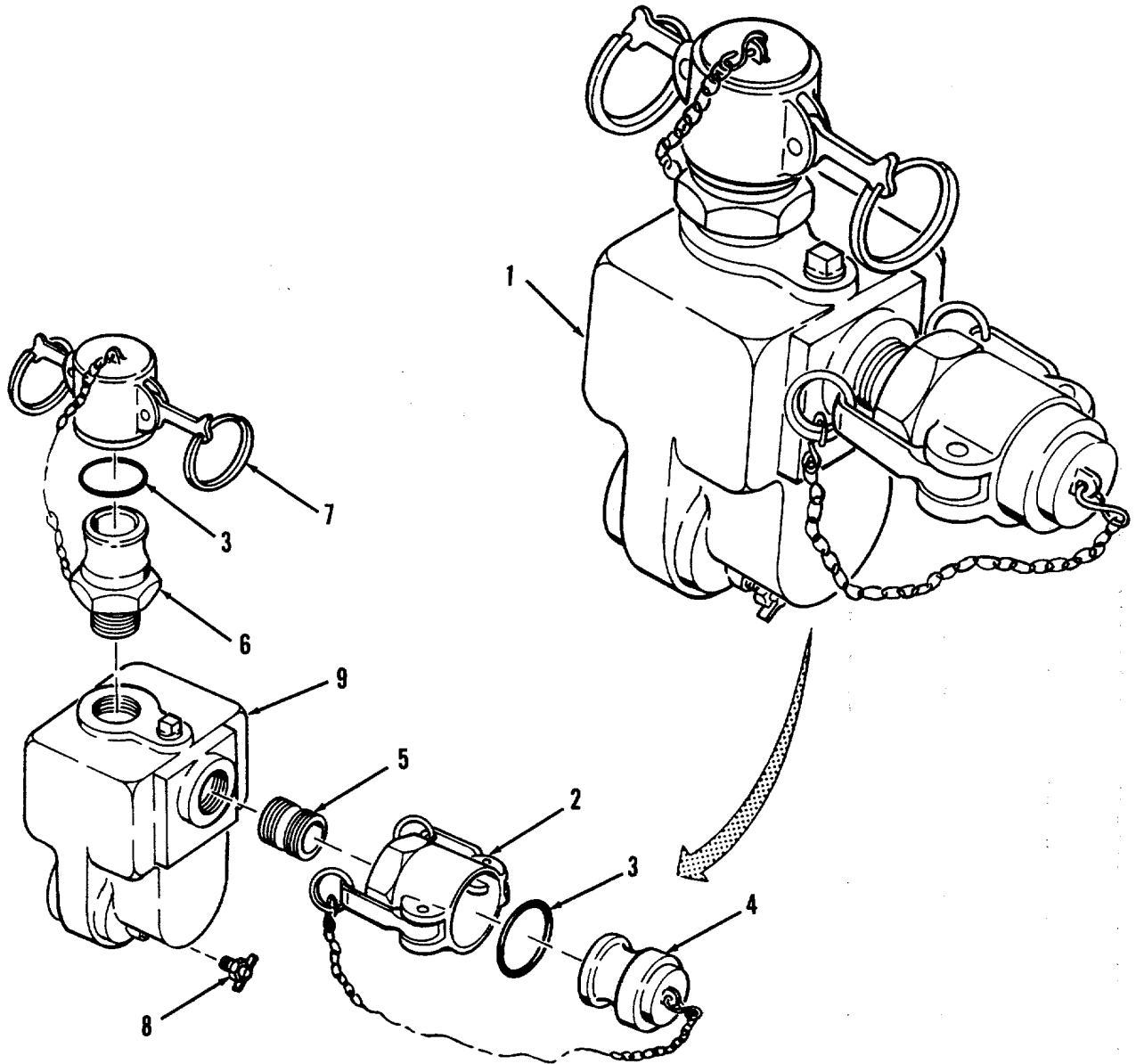

Figure C-5. Pump Assembly

SECTION II

TM 10-4320-347-13&P

(1) ITEM NO	(2) SMR CODE	(3) CAGEC	(4) PART NUMBER	(5) DESCRIPTION AND USABLE ON CODES(UOC)	(6) QTY
				GROUP 04 PUMP ASSEMBLY	
				FIG. C-5. PUMP ASSEMBLY	
1	PAFFF	40151	FB4000	PUMP, ASSEMBLY .....	1
2	PAOZZ	96906	MS27024-9	COUPLING HALF, QD .....	1
3	PAOZZ	96906	MS27030-5	GASKET .....	2
4	PAOZZ	96906	MS27029-9	PLUG, QD W/CHAIN .....	1
5	PAFZZ	96906	MS51953-169	NIPPLE, PIPE .....	1
6	PAFZZ	96906	MS27022-9	COUPLING HALF, QD .....	1
7	PAOZZ	96906	MS27028-9	CAP, QD W/CHAIN.....	1
8	PAOZZ	96906	MS35782-6	COCK DRAIN.....	1
9	PAFFF	10190	4059	Pump .....	1
				END OF FIGURE	



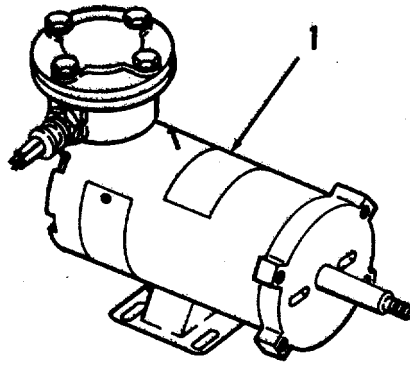

*Figure C-6. Motor Assembly*

SECTION II

TM 10-4320-347-13&P

(1) ITEM NO	(2) SMR CODE	(3) CAGEC	(4) PART NUMBER	(5) DESCRIPTION AND USABLE ON CODES(UOC)	(6) QTY
1	PAOZZ	40151	FB94001	GROUP 05 MOTOR ASSEMBLY FIG. C-6. MOTOR ASSEMBLY MOTOR, 24 VDC ..... END OF FIGURE	1

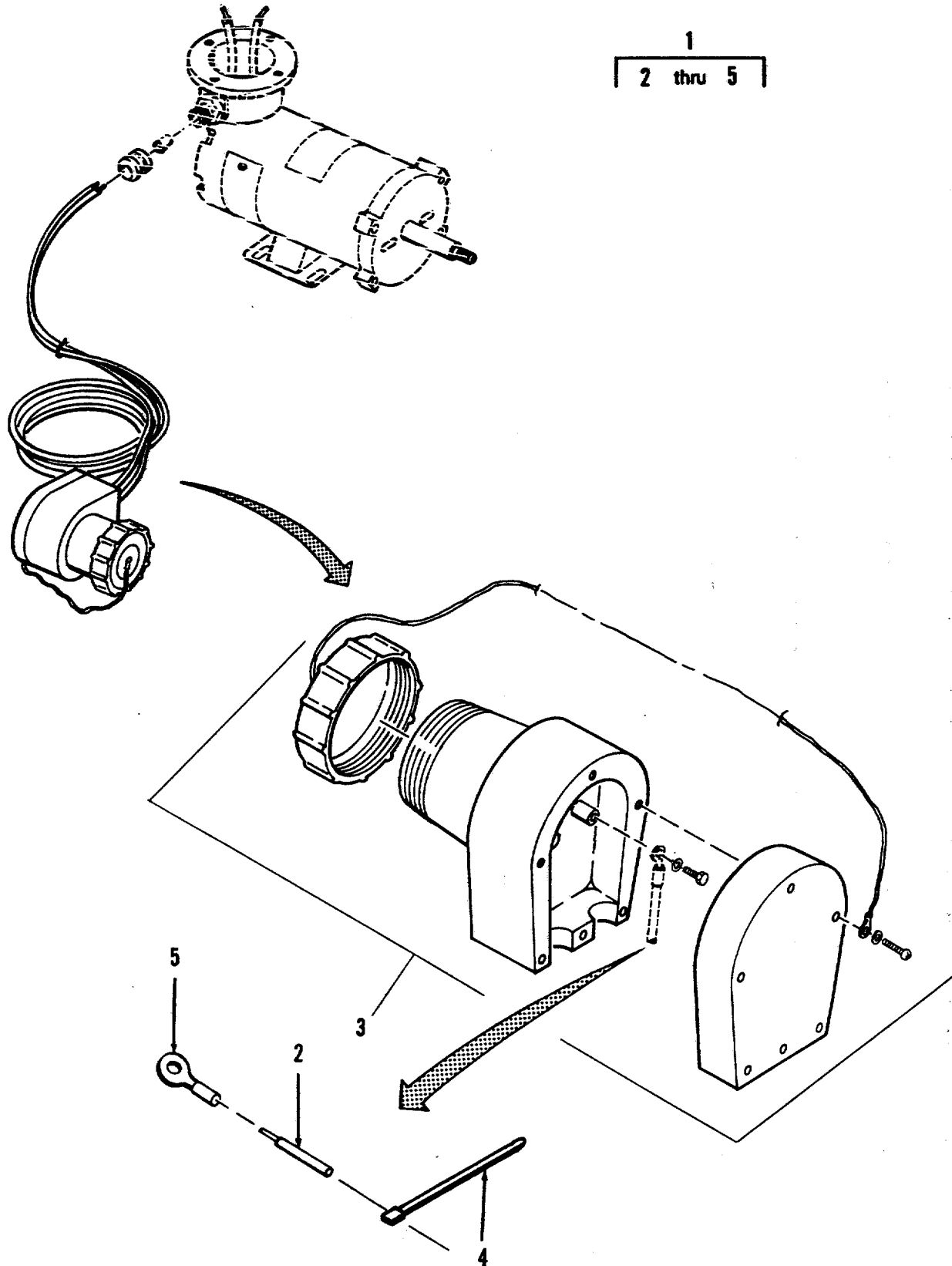

Figure C-7. Slave Cable

SECTION II

TM 10-4320-347-13&P

(1) ITEM NO	(2) SMR CODE	(3) CAGEC	(4) PART NUMBER	(5) DESCRIPTION AND USABLE ON CODES(UOC)	(6) QTY
				GROUP 06 SLAVE CABLE	
				FIG. C-7. SLAVE CABLE	
1	PAOFF	40151	FB1-107	CABLE, ASSY, SLAVE .....	1
2	MFOZZ	40151	FB1-107-2	WIRE .....	2
				MAKE FROM WIRE, 8 AWG, (1BT92), P/N 8\133 EPDM, BLK, 186.00 IN. LG.	
3	PAOZZ	19207	11682338	CONNECTOR, VEHICLE, PW .....	1
4	PAOZZ	96906	MS3367-5-0	STRAP, TIE, ELECTRICAL .....	8
5	PAOZZ	96906	MS20659-129	TERMINAL, ELECTRICAL .....	2
				END OF FIGURE	

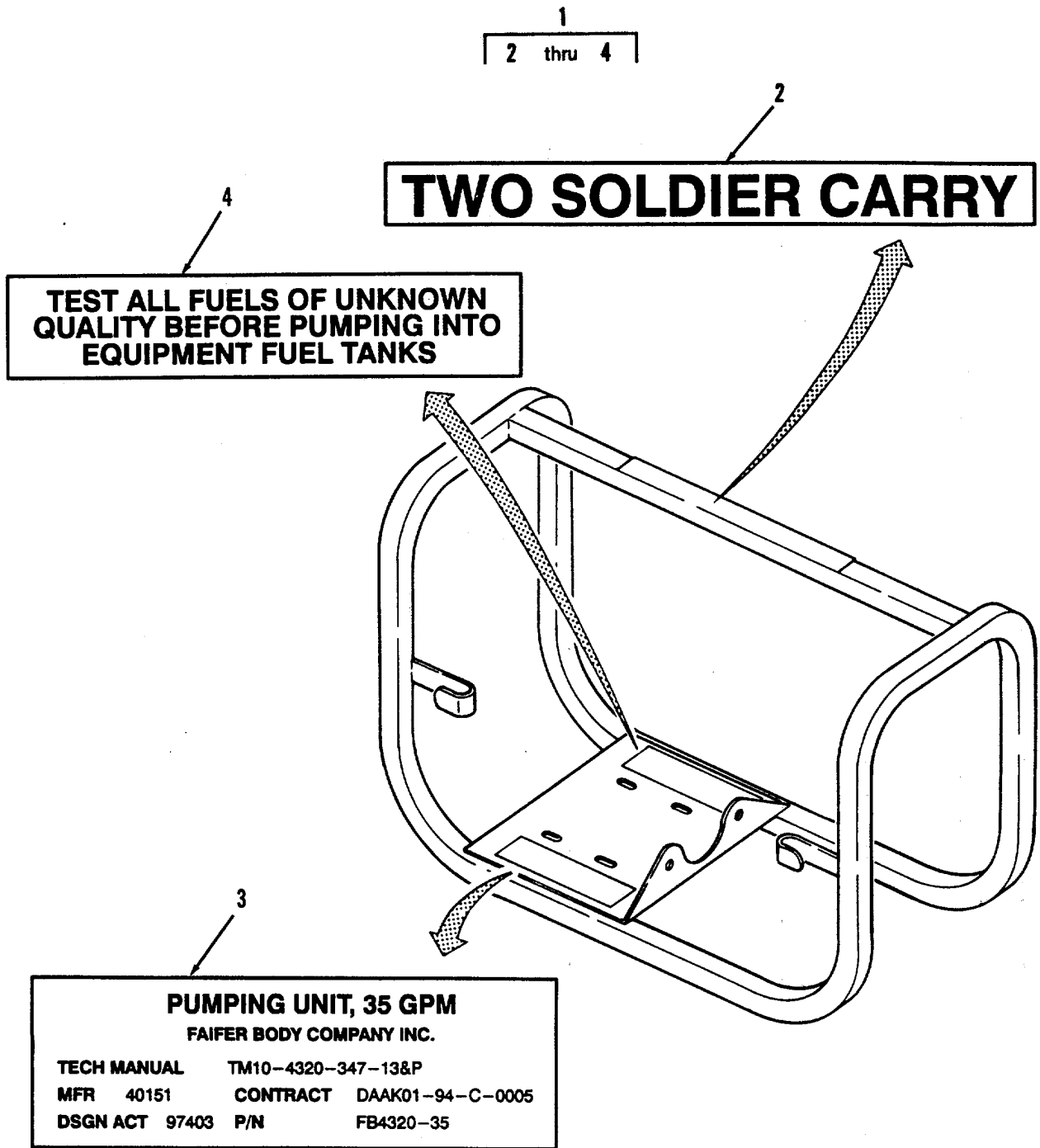

Figure C-8. Frame Assembly

**SECTION II**

**TM 10-4320-347-13&P**

(1) ITEM NO	(2) SMR CODE	(3) CAGEC	(4) PART NUMBER	(5) DESCRIPTION AND USABLE ON CODES(UOC)	(6) QTY
				GROUP 07 FRAME ASSEMBLY	
				FIG. C-8. FRAME ASSEMBLY	
1	PAOFF	40151	FB1-35	FRAME, ASSY .....	1
2	XBOZZ	40151	FB1-109	• LABEL.....	1
3	XBOZZ	40151	FB1-108	• LABEL I/D .....	1
4	XBOZZ	40151	FB1-110	• LABEL.....	1
				END OF FIGURE	

**SECTION II**

**TM 10-4320-347-13&P**

(1) ITEM NO	(2) SMR CODE	(3) CAGEC	(4) PART NUMBER	(5) DESCRIPTION AND USABLE ON CODES(UOC)	(6) QTY
1 2	PAOZZ PAOZZ	39428 7125K26 1BT92 833	GREEN EPDM BLK	GROUP 08 BULK ITEMS  FIG. C-BULK  WIRE, THHN ..... WIRE, 8 AWG.....   END OF FIGURE	AR AR

**SECTION II**

**TM 10-4320-347-13&P**

<b>(1) ITEM NO</b>	<b>(2) SMR CODE</b>	<b>(3) CAGEC</b>	<b>(4) PART NUMBER</b>	<b>(5) DESCRIPTION AND USABLE ON CODES(UOC)</b>	<b>(6) QTY</b>
				GROUP 99 SPECIAL TOOLS  No special tools are required.  END OF FIGURE	



CROSS-REFERENCE INDEXES  
NATIONAL STOCK NUMBER INDEX

STOCK NUMBER	FIG.	ITEM	STOCK NUMBER	FIG.	ITEM
4730-00-084-7436	3	2			
4730-00-196-1471	5	5			
4730-00-360-0589	5	6			
4730-00-823-5316	2	3			
4730-00-823-5316	2	7			
4730-00-823-5316	3	4			
4730-00-823-5316	5	4			
4730-00-869-5246	2	4			
4730-00-869-5246	2	8			
4730-00-869-5246	5	7			
4730-00-980-9411	5	2			
4820-00-276-9041	5	8			
4930-00-902-4642	3	5			
5310-00-167-0820	1	6			
5310-00-245-3424	1	7			
5935-00-567-0128	7	3			
5940-00-114-1314	7	5			
5975-00-133-8687	7	4			

## CROSS-REFERENCE INDEXES

CAGEC	PART NUMBER	PART NUMBER INDEX STOCK NUMBER	FIG.	ITEM
10190	4059		5	9
19207	11682338	5935-00-567-0128	7	3
1BT92	8/133 EPDM, BLK		BULK	2
39428	7125K26GREEN		BULK	1
39428	91247A581		1	5
39428	91247A624		1	2
39428	91247A628		1	4
40151	490FB		3	1
40151	FB1-107		7	1
40151	FB1-107-02		7	2
40151	FB1-108		8	3
40151	FB1-109		8	2
40151	FB1-110		8	4
40151	FB1-35		8	1
40151	FB4000		5	1
40151	FB550-5		1	1
40151	FB551-1		4	1
40151	FB551-1-1		4	3
40151	FB94001		6	1
40151	FBK-1		1	9
40151	FBS-108		1	8
81349	M11588-31C732/25FT		2	5
81349	M370-A05B2A3000		2	1
81349	MIL-C-83413/7		4	2
88044	AN960-516	5310-00-167-0820	1	6
96906	A-A-52030	4930-00-902-4642	3	5
96906	MS1 7829-5C	5310-00-245-3424	1	7
96906	MS20659-129	5940-00-114-1314	7	5
96906	MS27022-9	4730-00-360-0589	5	6
96906	MS27024-9	4730-00-980-9411	5	2
96906	MS27026-6	4730-00-084-7436	3	2
96906	MS27028-9	4730-00-869-5246	2	4
96906	MS27028-9	4730-00-869-5246	2	8
96906	MS27028-9	4730-00-869-5246	5	7
96906	MS27029-9	4730-00-823-5316	2	3
96906	MS27029-9	4730-00-823-5316	2	7
96906	MS27029-9	4730-00-823-5316	3	4
96906	MS27029-9	4730-00-823-5316	5	4
96906	MS27030-5		3	3

## CROSS-REFERENCE INDEXES

CAGEC	PART NUMBER	PART NUMBER INDEX STOCK NUMBER	FIG.	ITEM
96906	MS27030-5		5	3
96906	MS27030-5		2	2
96906	MS27030-5		2	6
96906	MS3367-5-0	5975-OO-1 33-8687	7	4
96906	MS35782-6	4820-00-276-9041	5	8
96906	MS51415-7		1	3
96906	MS51953-169	4730-00-196-1471	5	5

## CROSS-REFERENCE INDEXES

## FIGURE AND NUMBER INDEX

FIG.	ITEM	STOCK NUMBER	CAGEC	PART NUMBER
1	1		40151	FB550-5
1	2		39428	91247A624
1	3		96906	MS51415-7
1	4		39428	91247A628
1	5		39428	91247A581
1	6	5310-00-167-0820	88044	AN960-516
1	7	5310-00-245-3424	96906	MS17829-5C
1	8		40151	FBS-108
1	9		40151	FBK-1
2	1		81349	M370-A05B2A3000
2	2		96906	MS27030-5
2	3	4730-00-823-5316	96906	MS27029-9
2	4	4730-00-869-5246	96906	MS27028-9
2	5		81349	M11588-31C732/25FT
2	6		96906	MS27030-5
2	7	4730-00-823-5316	96906	MS27029-9
2	8	4730-00-869-5246	96906	MS27028-9
3	1		40151	490FB
3	2	4730-00-084-7436	96906	MS27026-6
3	3		96906	MS27030-5
3	4	4730-00-823-5316	96906	MS27029-9
3	5	4930-00-902-4642	96906	A-A-52030
4	1		40151	FB551-1
4	2		81349	MIL-C-83413/7
4	3		40151	FB551-1-1
5	1		40151	FB4000
5	2	4730-00-980-9411	96906	MS27024-9
5	3		96906	MS27030-5
5	4	4730-00-823-5316	96906	MS27029-9
5	5	4730-00-196-1471	96906	MS51953-169
5	6	4730-00-360-0589	96906	MS27022-9
5	7	4730-00-869-5246	96906	MS27028-9
5	8	4820-00-276-9041	96906	MS35782-6
5	9		10190	4059
6	1		40151	FB94001
7	1		40151	FB1-107
7	2		40151	FB1-107-02
7	3	5935-00-567-0128	19207	11682338
7	4	5975-00-133-8687	96906	MS3367-5-0
7	5	5940-00-114-1314	96906	MS20659-12981
7	6		40151	FB1-35

CROSS-REFERENCE INDEXES

FIGURE AND NUMBER INDEX

FIG.	ITEM	STOCK NUMBER	CAGEC	PART NUMBER
8	2		40151	FB1-109
8	3		40151	FB1-108
8	4		40151	FB1-110
BULK	1		39428	71 25K26GREEN
BULK	2		1BT92	833 EPDM, BLK

## APPENDIX D

## COMPONENTS OF END ITEM AND BASIC ISSUE ITEMS LISTS

## SECTION I. INTRODUCTION

**D.1. SCOPE.** This appendix lists components of end item and basic issue items for the Pumping Assembly to help you inventory items required for safe and efficient operation.

**D.2. GENERAL.** The Components of End Item and Basic Issue Items Lists are divided into the following sections:

**a. Section II. Components of End Item .** This listing is for informational purposes only, and is not authority to requisition replacements. These items are part of the end item, but are removed and separately packaged for transportation or shipment. As part of the end item, these items must be with the end item whenever it is issued or transferred between property accounts.

**b. Section III. Basic Issue Items (BII) .** These essential items required to place the Pumping Assembly in operation, to operate it, and to do emergency repairs. Although shipped separately packaged, BII must be with the system during operation and whenever it is transferred between property accounts. Listing these items is your authority to request/requisition them for replacement, based on authorization of the end item by TOE/MTOE. Illustrations are furnished to help you find and identify the items.

**D.3. EXPLANATION OF COLUMNS .** The following provides an explanation of columns found in the tabular listings:

**a. Column (1) - Illustration Number (Illus. Number).** This column indicates the number of the illustration in which the item is shown.

**b. Column (2) - National Stock Number .** Indicates the National stock number of the item to be used for requisitioning purposes.

**c. Column (3) - Description.** Identifies the Federal item name (in all capital letters) followed by a minimum description when needed. The last line below the description is the CAGEC (Commercial and Government Entity Code) (in parentheses) and the part number.

**d. Column (4) - Unit of Issue (U/I) .** Indicates how the item is issued for the National Stock Number shown in column two.

**e. Column (5) - Quantity required (Qty Rqr).** Indicates the quantity required.

SECTION II. COMPONENTS OF END ITEM.

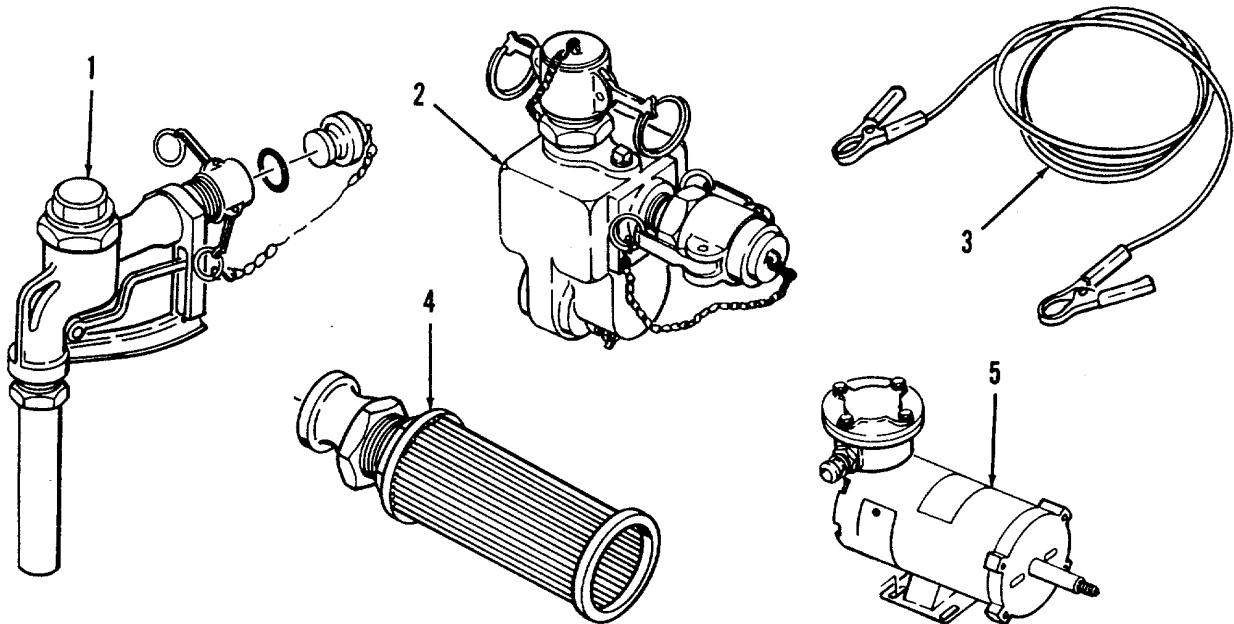

(1) Illus Number	(2) National Stock Number	(3) Description CAGEC and Part Number	(4) Usable On Code U/M	(5) Qty. Rqr
1		NOZZLE (40151) 490FB	EA	1
2		PUMP ASSEMBLY (40151) FB4000	EA	1
3		GROUNDING CABLE (40151) FB551-1	EA	1
4		SUZZLE STRAINER (40151) FBS-108	EA	1
5		MOTOR (40151) FB94001	EA	1

SECTION II. COMPONENTS OF END ITEM .

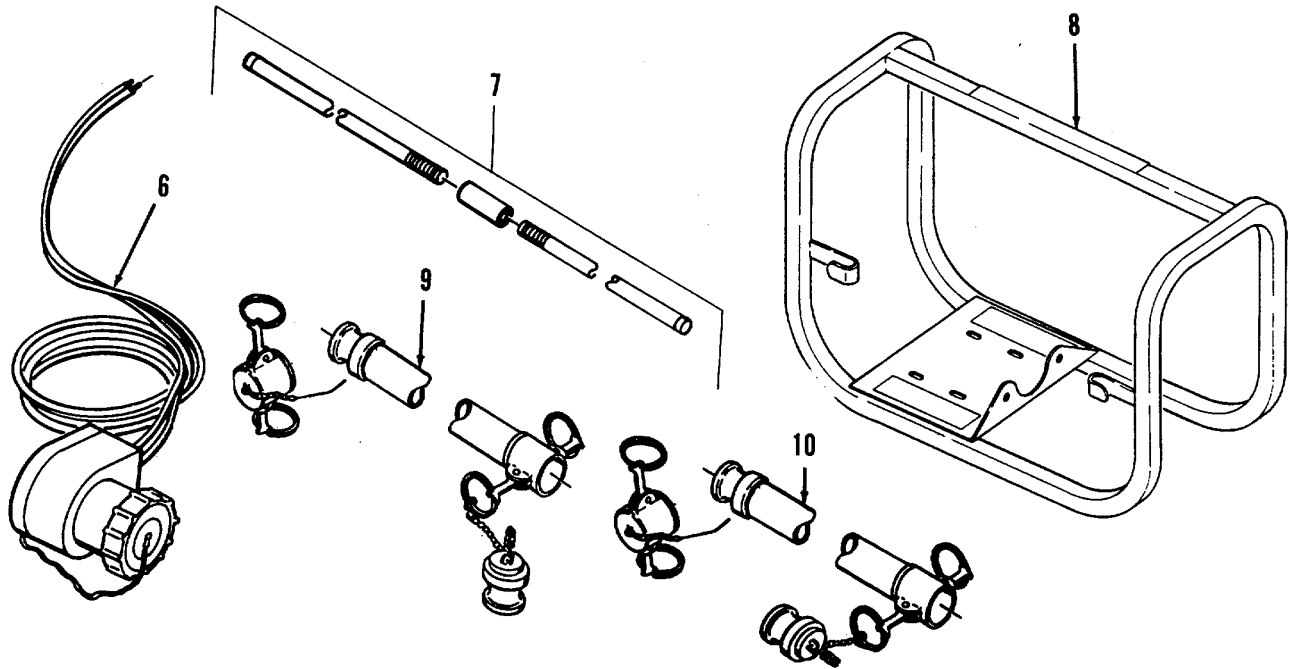

(1) Illus Number	(2) National Stock Number	(3) Description CAGEC and Part Number	(4) Usable On Code U/M	(5) Qty. RqrX
6		SLAVE CABLE (40151) FB1-107	EA	1
7		GROUNDING ROD (40151) FB550-5	EA	1
8		FRAME ASSEMBLY (40151) FB1-35	EA	1
9		HOSE ASSEMBLY, DISCHARGE (81349) M1185-310732/25FT	EA	2
10		HOSE ASSEMBLY, SUCTION (81349) M370-A0582A3000	EA	2



SECTION II. COMPONENTS OF END ITEM.

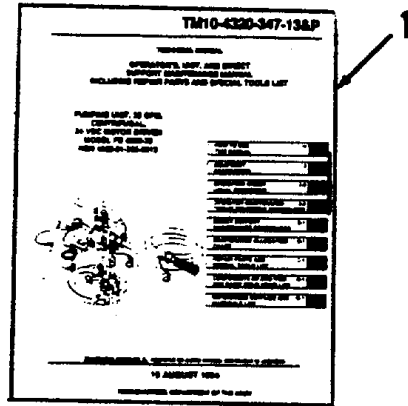

(1) Illus Number	(2) National Stock Number	(3) Description  Usable On Code	(4) U/M	(5) Qty Rqr
1	TM10-4320-347-13&P	Technical Manual: Operator's, Unit, Direct Support Maintenance Manual Including Repair Parts and Special Tools List for Pumping Unit, 35 GPM, Centrifugal, Fuel Transfer, 24 VDC Motor Driven	EA	1

## APPENDIX E

## EXPENDABLE / DURABLE SUPPLIES AND MATERIALS LIST

## SECTION I. INTRODUCTION

## E.1. SCOPE.

This appendix lists expendable supplies and materials you will need to operate and maintain the Pumping Assembly. This listing is for information only and is not authority to requisition the listed items. These items are authorized to you by CTA 50-970, Expendable Items (except medical, class V, repair parts, and heraldic items) or CTA 8-100, Army Medical Department Expendable/Durable Items.

## E.2. EXPLANATION OF COLUMNS.

**a. Column (1) - Item number.** This number is assigned to the entry in the listing and is referenced in the narrative instructions to identify the material (e.g., "Use cleaning compound, item 5, Appendix E").

**b. Column (2) - Level.** This column identifies the lowest level of maintenance that requires the listed item.

- C - Operator/Crew
- O - Unit Maintenance
- F - Direct Support Maintenance
- H - General Support Maintenance

**c. Column (3) - National Stock Number.** This is the National stock number assigned to the item which you can use to requisition it.

**d. Column (4) - Item Name, Description, Commercial and Government Entity Code (CAGEC), and Part Number.** This provides the other information you need to identify the item.

**e. Column (5) - Unit of Measure (U/M).** This code shows the physical measurement or count of an item, such as gallon, dozen, gross, etc.

**SECTLON II. EXPENDABLE / DURABLE SUPPLIES AND MATERIALS LIST**

(1) ITEM NUMBER	(2) LEVEL	(3) NATIONAL STOCK NUMBER	(4) ITEM NAME, DESCRIPTION CAGEC, PART NUMBER	(5) U/M
1	C	6850-00-274-5421	Solvent, Dry Cleaning	gl
2	C	7930-01-350-7034	Cleaning Compound, Soap Detergent	gl
3	C	7920-00-205-1711	Rag, Wiping	ea
4	O	8030-00-889-3535	Tape, Anti-seize	rl
5	O	8030-00-180-6339	RTV Sealant	tb

**APPENDIX F**

**ILLUSTRATED LIST OF MANUFACTURED ITEMS**

**SECTION I. INTRODUCTION**

**F.1. INTRODUCTION.**

**a.** This appendix includes complete instructions for making items authorized to be manufactured or fabricated at unit maintenance level (or aviation maintenance level, if applicable).

**b.** A part number index in alphabetical order is provided for cross-referencing the part number of the item to be manufactured to the figure which covers fabrication criteria.

**c.** All bulk materials needed for manufacture of an item are listed by the part number or specification in a tabular list on the illustration.

**PART NUMBER INDEX**

<b>Part Number to Be Manufactured</b>	<b>Part Name</b>	<b>Manufacturing Figure</b>
FB551-1-1	Wire, Copper	1
FB1-107-2	Wire Assembly	2

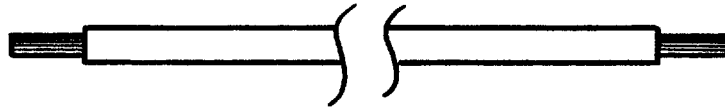

**NOTES:**

1. Material; (39428) 7125K26GREEN.
2. Cut wire to 77.00 inches long.
3. Strip .25 inch of insulation from both ends.

**Figure F-1. Wire, Copper.**

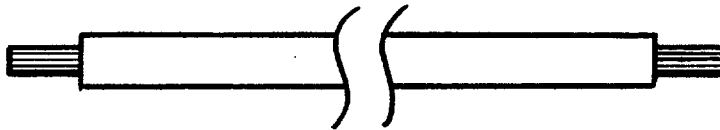

**NOTES:**

1. Material; (IBT92) 83 EDPM, BLK
2. Cut wire to 186.00 inches long.
3. Strip .38 inch of insulation from both ends.

**Figure F-1. Wire, Assembly.**

**APPENDIX G**

**TORQUE LIMITS**

**G.1. GENERAL.** This appendix provides general torque limits for fasteners. Special torque values are indicated in the maintenance procedures for applicable components. The general torque values given in this appendix shall be used when specific torque values are not indicated in the maintenance procedures.

**G.2. TORQUE LIMITS.** Torque limits are listed in Table GC1 for fasteners. Dry fasteners are defined as fasteners on which no lubricants are applied to the threads. Wet fasteners are defined as fasteners on which graphite or molydisulphide greases or other extreme pressure lubricants are applied to the threads. Table G-2 lists the minimum breakaway torque values for locknuts.

**Table G-1. General Torque Requirements for Dry Fasteners.**

Bolt/Screw Size	Torque Requirements in lb ft (N.m)			
	SAE Grade 1 or 2	SAE Grade 5	SAE Grade 6 or 7	SAE Grade 8
1/4-20 UNC 1/4-28 UNF	5 (7) 6 (8)	8 (11) 10 (14)	10 (14) 12 (16)	12 (16) 14 (19)
5/16 18 UNC 5/16-24 UNF	11 (15) 13 (18)	17 (23) 19 (26)	19 (26) 23 (31)	24 (33) 27 (37)
3/8 16 UNC 3/8-24 UNF	18 (24) 20 (27)	31 (42) 35 (47)	34 (46) 42 (57)	44 (60) 49 (66)
7/16-14 UNC 7/16-20 UNF	28 (38) 30 (41)	49 (66) 55 (75)	55 (75) 67 (91)	70 (95) 78 (106)
1/2-13 UNC 1/2-20 UNF	39 (53) 41 (56)	75 (102) 85 (115)	85 (115) 102 (138)	105 (142) 120 (163)
9/16-12 UNC 9/16-18 UNF	51 (69) 55 (75)	110 (149) 120 (163)	120 (163) 145 (197)	155 (210) 170 (231)
5/8-11 UNC 5/8-18 UNF	63 (85) 95 (129)	150 (203) 170 (231)	167 (226) 205 (278)	210 (285) 240 (325)
3/4-10 UNC 3/4-16 UNF	105 (142) 115 (156)	270 (366) 295 (400)	280 (380) 357 (484)	375 (509) 420 (570)
7/8-9 UNC 7/8-14 UNF	160 (217) 175 (237)	395 (536) 435 (590)	440 (597) 555 (753)	605 (820) 675 (915)

**Table G-1. General Torque Requirements for Dry Fasteners. - Continued.**

Bolt/Screw Size	Torque requirement in lb ft (N.m)			
	SAE Grade 1 or2	SAE Grade 5	SAE Grade 6or7	SAE Grade 8
1-8 UNC	235 (319)	590 (800)	660 (895)	910 (1234)
1-14 UNF	250 (339)	660 (895)	825 (1119)	990 (1342)
1-1/8-7 UNC	350 (475)	800 (1085)	1000 (1356)	1280 (1736)
1-1/8-12 UNF	400 (542)	880 (1193)	1050 (1424)	1440 (1953)
1-1/4-7 UNC	500 (678)	1080 (1464)	1325 (1797)	1820 (2468)
1-1/4-12 UNF	550 (746)	1125 (1526)	1325 (1797)	1820 (2712)
1-3/8-6 UNC	660 (895)	1460 (1980)	1800 (2441)	2380 (3227)
1-3/8-12 UNF	740 (1003)	1680 (2278)	1960 (2658)	2720 (3688)
1-1/2-6 UNC	870 (1180)	1940 (2631)	2913 (3950)	3160 (4285)
1-1/2-12 UNF	980 (1329)	2200 (2983)	3000 (4068)	3560 (4827)

*\* Torque given is for clean, dry threads. Reduce by 10% when engine oil is used as lubricant.*

**Table G-2. Locknut Breakaway Torque Values.**

**NOTE**

To determine breakaway torque, thread lock nut onto screw or bolt until at least two threads stick out. Locknut shall not make contact with a mating part. Stop the locknut. Torque necessary to begin turning locknut again is the breakaway torque. Do not reuse locknuts that do not meet minimum breakaway torque.

Thread Size	Minimum Breakaway Torque	
	lb-in.	(N.m)
	2.0	(0.23)
10-32		
1/4-28	3.5	(0.40)
5/16-24	6.5	(0.73)
3/8-24	9.5	(1.07)
7/16-20	14.0	(1.58)
1/2-20	18.0	(2.03)
9/16-18	24.0	(2.71)
5/8-18	32.0	(3.62)
3/4-16	50.0	(5.65)
7/8-14	70.0	(7.91)
1-12	90.0	(10.17)
1-1/8-12	117.0	(13.22)

## APPENDIX H

## MANDATORY REPLACEMENT PARTS

## SECTION I. INTRODUCTION

**H.1. SCOPE.** This appendix lists mandatory replacement parts you will need to have when performing maintenance on the Pumping Assembly. Any time a maintenance procedure is performed that requires you to remove any of the items shown on this list, you are required to replace that item with a new one. You will know that your procedure requires one of these replacement parts when the statement "(Appendix H, Item X)" appears in the "Materials Required" area of the Initial Setup portion of the maintenance procedures in Chapter 4.

**H.2. EXPLANATION OF COLUMNS .** The table shown in Section II identifies the parts which must be replaced during maintenance of the Pumping Assembly. An explanation of the columns in each in this table is as follows.

**a. Column (1) - Item number.** This number is assigned to the entry in this listing and is referenced in the narrative instructions to identify the material (e.g., "Rivet (Appendix I, Item 1)").

**b. Column (2) - CAGEC.** The Contractor and Government Entity Code (CAGEC) is a 5-digit numeric code which is used to identify the manufacturer, distributor, or Government agency, etc., that supplies the item.

**c. Column (3) - Part Number.** Indicates the primary number used by the manufacturer (individual, company, firm, corporation, or Government activity), which controls the design and characteristics of the item by means of its engineering drawings, specifications standards, and inspection requirements to identify an item or range of items.

**d. Column (4) - Nomenclature.** This column identifies the common name for the part in accordance with the name given to the part on the applicable engineering drawing or specification.



SECTION II. MANDATORY REPLACEMENT PARTS LIST.

(1) ITEM NUMBER	(2) CAGEC	(3) PART NUMBER	(4) NOMENCLATURE
1	96906	MS51415-7	WASHER, LOCK
2	96906	MS17829-5C	NUT, SELF LOCKING
3	88044	AN960-516	WASHER, FLAT
4	96906	MS20659-129	TERMINALS, ELECTRICAL
5	P3397	10190	PREFORMED PACKING
6	62709	W105-7V	SHAFT, SEAL, PUMP
7	40151	FB3238	SHIM SET
8	10190	P3241	SLINGER
9	96906	MS3367-5-0	STRAP, TIE, ELECTRICAL

ALPHABETICAL INDEX

	Paragraph	Page
<b>A</b>		
Abbreviations, List of .....	1.10	1-2
Additional Authorization List.....	D.1	D-1
Adjustments, Initial, Daily Checks, and Self tests.....	2.10	2-12
Assembly and Preparation for Use.....	2.9	2-10
<b>B</b>		
Basic Issue Items.....	C.1	C-1
<b>C</b>		
Common Tools and Equipment, Direct Support .....	5.1	5-1
Components of End Item List.....	C.1	C-1
Controls and Indicators, Operator .....	2.2	2-2
Corrosion and Prevention Control .....	1.4	1-1
<b>D</b>		
Decals and Instruction Plates.....	2.13	2-15
Destruction of Army Materiel to Prevent Enemy Use .....	1.5	1-1
<b>E</b>		
Emergency Procedures .....	2.15	2-17
Equipment Data.....	1.14	1-5
Equipment Characteristics, Capabilities, and Features.....	1.12	1-3
Expendable / Durables Supplies and Materials List.....	E.1	E-1
<b>F</b>		
Frame Assembly Repair .....	5.8	5-8
Frame Assembly Replacement .....	4.8	4-11
<b>G</b>		
Ground Cable Assembly Replacement .....	3.7	3-9
Ground Cable Assembly, Repair.....	4.6	4-6
<b>H</b>		
Hose Assemblies (Suction and Discharge) Repair .....	3.5	3-6
<b>I</b>		
Illustrated List of Manufactured Items .....	F.1	F-1

## ALPHABETICAL INDEX - Continued

	<b>Paragraph</b>	<b>Page</b>
<b>L</b>		
Lubrication Instructions .....	3.1	3-2
<b>M</b>		
Maintenance Allocation Chart .....	B.1	B-1
Maintenance Forms and Procedures.....	1.2	1-1
Major Components, Location and Description .....	1.13	1-3
Motor Assembly Replacement .....	5.7	5-6
Movement, Preparation for .....	2.12	2-15
<b>N</b>		
Nomenclature Cross-Reference .....	1.9	1-2
Nozzle Assembly, Repair.....	4.5	4-4
Nozzle Assembly Replacement .....	3.6	3-8
Nuclear, Biological, and Chemical (NBC) Decontamination Procedures.....	2.16	2-17
<b>O</b>		
Operating Procedures.....	2.11	2-12
Operation Under Unusual Weather .....	2.14	2-16
<b>P</b>		
Preventive Maintenance Checks and Services, Operator.....	2.4	2-3
Pump Assembly, Repair and Replacement .....	5.6	5-2
<b>R</b>		
References .....	A.1	A-1
Reporting Equipment Improvement Recommendations (EIR's).....	1.7	1-1
<b>S</b>		
Service Upon Receipt.....	4.3	4-1
Site Requirements .....	4.2	4-1
Slave Cable Repair and Replacement .....	4.7	4-8
Special Tools, TMDE, and Support Equipment .....	5.2	5-1
Storage or Shipment, Preparation for.....	4.9	4-13
Storage of Equipment, Administrative.....	4.10	4-13

**ALPHABETICAL INDEX**

	<b>Paragraph</b>	<b>Page</b>
<b>T</b>		
Theory of Operations.....	1.15	1-5
Torque Limits.....	G.1	G-1
Troubleshooting, Operator .....	3.2	3-2
<b>W</b>		
Warranty Information.....	1.8	1-2

**Index - 3/(Index - 4 Blank)**

By Order of the Secretary of the Army:

GORDON R. SULLIVAN  
*General, United States Army*  
*Chief of Staff*

Official:

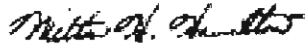

MILTON H. HAMILTON  
*Administrative Assistant to the*  
*Secretary of the Army*  
077344

DISTRIBUTION:

To be distributed in accordance with DA Form 12-25E, block no. 6256, requirements for TM 1004320-347-13&P.

RECOMMENDED CHANGES TO EQUIPMENT TECHNICAL PUBLICATIONS

 <p style="text-align: center;"><i>THEN...JOT DOWN THE DOPE ABOUT IT ON THIS FORM. CAREFULLY TEAR IT OUT, FOLD IT AND DROP IT IN THE MAIL.</i></p>		SOMETHING WRONG WITH PUBLICATION		
		FROM: (PRINT YOUR UNIT'S COMPLETE ADDRESS)		
PUBLICATION NUMBER		DATE SENT		
PUBLICATION DATE		PUBLICATION TITLE		
BE EXACT PIN-POINT WHERE IT IS				
PAGE NO.	PARA- GRAPH	FIGURE NO.	TABLE NO.	<p style="font-weight: bold; margin-top: 0;">IN THIS SPACE, TELL WHAT IS WRONG AND WHAT SHOULD BE DONE ABOUT IT.</p>
PRINTED NAME, GRADE OR TITLE AND TELEPHONE NUMBER			SIGN HERE	

# The Metric System and Equivalents

## Linear Measure

1 centimeter = 10 millimeters = .39 inch  
 1 decimeter = 10 centimeters = 3.94 inches  
 1 meter = 10 decimeters = 39.37 inches  
 1 decameter = 10 meters = 32.8 feet  
 1 hectometer = 10 decameters = 328.08 feet  
 1 kilometer = 10 hectometers = 3,280.8 feet

## Weights

1 centigram = 10 milligrams = .15 grain  
 1 decigram = 10 centigrams = 1.54 grains  
 1 gram = 10 decigram = .035 ounce  
 1 decagram = 10 grams = .35 ounce  
 1 hectogram = 10 decagrams = 3.52 ounces  
 1 kilogram = 10 hectograms = 2.2 pounds  
 1 quintal = 100 kilograms = 220.46 pounds  
 1 metric ton = 10 quintals = 1.1 short tons

## Liquid Measure

1 centiliter = 10 milliliters = .34 fl. ounce  
 1 deciliter = 10 centiliters = 3.38 fl. ounces  
 1 liter = 10 deciliters = 33.81 fl. ounces  
 1 deciliter = 10 liters = 2.64 gallons  
 1 hectoliter = 10 dekaliters = 26.42 gallons  
 1 kiloliter = 10 hectoliters = 264.18 gallons

## Square Measure

1 sq. centimeter = 100 sq. millimeters = .155 sq. inch  
 1 sq. decimeter = 100 sq. centimeters = 15.5 sq. inches  
 1 sq. meter (centare) = 100 sq. decimeters = 10.76 sq. feet  
 1 sq. decameter (are) = 100 sq. meters = 1,076.4 sq. feet  
 1 sq. hectometer (hectare) = 100 sq. decameters = 2.47 acres  
 1 sq. kilometer = 100 sq. hectometers = .386 sq. mile

## Cubic Measure

1 cu. centimeter = 1000 cu. millimeters = .06 cu. inch  
 1 cu. decimeter = 1000 cu. centimeters = 61.02 cu. inches  
 1 cu. meter = 1000 cu. decimeters = 35.31 cu. feet

## Approximate Conversion Factors

To change	To	Multiply by	To change	To	Multiply by
inches	centimeters	2.540	ounce-inches	Newton-meters	.007062
feet	meters	.305	centimeters	inches	.394
yards	meters	.914	meters	feet	3.280
miles	kilometers	1.609	meters	yards	1.094
square inches	square centimeters	6.451	kilometers	miles	.621
square feet	square meters	.093	square centimeters	square inches	.155
square yards	square meters	.836	square meters	square feet	10.764
square miles	square kilometers	2.590	square meters	square yards	1.196
acres	square hectometers	.405	square kilometers	square miles	.386
cubic feet	cubic meters	.028	square hectometers	acres	2.471
cubic yards	cubic meters	.765	cubic meters	cubic feet	35.315
fluid ounces	milliliters	29.573	cubic meters	cubic yards	1.308
pints	liters	.473	milliliters	fluid ounces	.034
quarts	liters	.946	liters	pints	2.113
gallons	liters	3.785	liters	quarts	1.057
ounces	grams	28.349	liters	gallons	.264
pounds	kilograms	.454	grams	ounces	.035
short tons	metric tons	.907	kilograms	pounds	2.205
pound-feet	Newton-meters	1.356	metric tons	short tons	1.102
pound-inches	Newton-meters	.11296			

## Temperature (Exact)

°F	Fahrenheit temperature	5/9 (after subtracting 32)	Celsius temperature	°C
----	------------------------	----------------------------	---------------------	----





This fine document...

Was brought to you by me:



## [Liberated Manuals -- free army and government manuals](#)

Why do I do it? I am tired of sleazy CD-ROM sellers, who take publicly available information, slap “watermarks” and other junk on it, and sell it. Those masters of search engine manipulation make sure that their sites that sell free information, come up first in search engines. They did not create it... They did not even scan it... Why should they get your money? Why are not letting you give those free manuals to your friends?

I am setting this document FREE. This document was made by the US Government and is NOT protected by Copyright. Feel free to share, republish, sell and so on.

I am not asking you for donations, fees or handouts. If you can, please provide a link to [liberatedmanuals.com](http://liberatedmanuals.com), so that free manuals come up first in search engines:

<A HREF=<http://www.liberatedmanuals.com/>>Free Military and Government Manuals</A>

- Sincerely  
Igor Chudov  
<http://igor.chudov.com/>
- [Chicago Machinery Movers](#)