

**TECHNICAL MANUAL
OPERATOR'S MANUAL
PUMPING ASSEMBLY, WATER
600 GPM
TRAILER MOUNTED
(NSN 4320-01-31448844)**

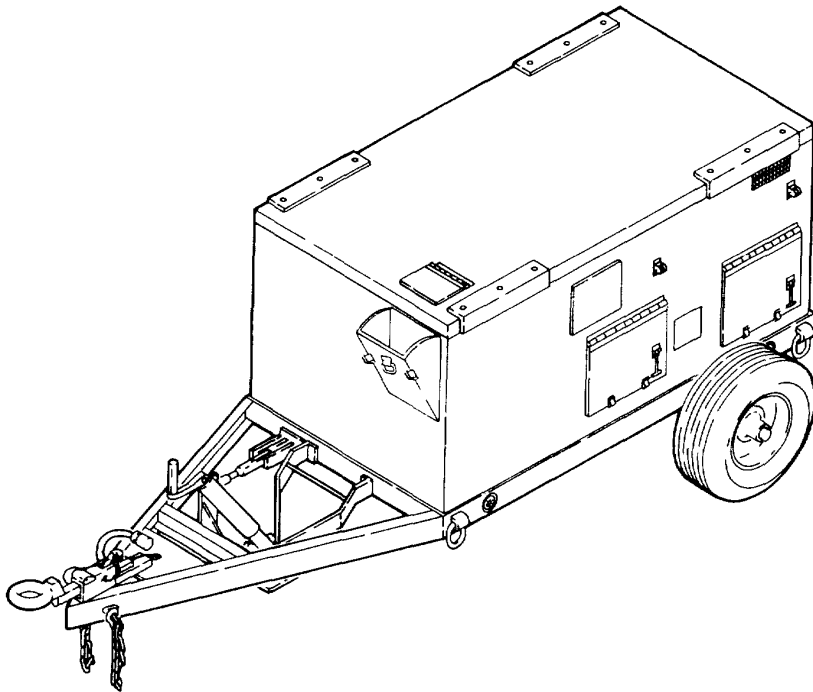

INTRODUCTION	1-1
OPERATING INSTRUCTIONS	2-1
OPERATOR MAINTENANCE	3-1
REFERENCES	A-1
COMPONENTS OF END ITEM AND BASIC ISSUE ITEMS LIST	B-1
ADDITIONAL AUTHORIZATION LIST	C-1
EXPENDABLE/DURABLE SUPPLIES AND MATERIALS LIST	D-1

Approved for public release, distribution is unlimited

HEADQUARTERS, DEPARTMENT OF THE ARMY

4 NOVEMBER 1992

WARNING

FLAMMABLE MATERIAL

- DO NOT operate engine around open fuel. Fuel presents an extreme explosion and fire hazard. Make sure fuel lines are securely connected and free of leaks. Avoid overfilling fuel tank. Always use correct type of fuel.
- To prevent fire or explosion, keep open flame, sparks, and cigarettes away from fuel tank and battery.

WARNING

SOLVENT

- Solvent may cause toxic fumes. To prevent personal injury, work only in a well-ventilated area. DO NOT breathe fumes for a long time.
- Solvent is flammable. To prevent fire or explosion, DO NOT bring open flame or sparks near solvent.

WARNING

OVERHEATED PUMP

DO NOT operate pump against a closed suction or discharge line. This can cause overheating and explosion.

WARNING

HEARING DAMAGE

Hearing protection must be worn by personnel standing within 50 ft (15 m) of operating pump when enclosure doors are opened.

WARNING

HIGH VOLTAGE

To prevent electric shock or death, always disconnect power before performing maintenance.

WARNING

SKIN BURNS

To prevent skin burns, do not touch hot engine or engine parts. Allow engine to cool before doing maintenance.

FOR FIRST AID, SEE FM 21-11.

a/(b blank)

TECHNICAL MANUAL
NO 10-4320-315-10

HEADQUARTERS
DEPARTMENT OF THE ARMY
WASHINGTON, D C, 4 NOVEMBER 1992

TECHNICAL MANUAL

Operator's Manual

PUMPING ASSEMBLY, WATER
600 GPM,
TRAILER MOUNTED
(NSN 4320-01-314-8844)

REPORTING ERRORS AND RECOMMENDING IMPROVEMENTS

You can help improve this manual. If you find any mistakes or if you know of a way to improve the procedures, please let us know. Mail your letter or DA Form 2028 (Recommended Changes to Publications and Blank Forms), or DA Form 2028-2 located in the back of this manual directly to Commander, US Army Aviation and Troop Command, ATTN- AMSAT-I-MTS, 4300 Goodfellow Blvd. , St. Louis, MO 63120-1798. A reply will be furnished directly to you.

Approved for public release, distribution is unlimited

TABLE OF CONTENTS

		PAGE
	WARNING PAGE	a
	HOW TO USE THIS MANUAL	ii
CHAPTER 1	INTRODUCTION	1-3
Section I.	General Information	1-3
Section II.	Equipment Description	1-4
Section III.	Technical Principles of Operation	1-6
CHAPTER 2	OPERATING INSTRUCTIONS	2-1
Section I.	Description and Use of Operator's Controls and Indicators	2-1
Section II.	Operator Preventive Maintenance Checks and Services (PMCS)	2-9
Section III.	Operation Under Usual Conditions	2-17
Section IV.	Operation Under Unusual Conditions	2-35
CHAPTER 3	OPERATOR MAINTENANCE	3-1
Section I.	Lubrication Instructions	3-1
Section II.	Troubleshooting Procedures	3-1
Section III.	Maintenance Procedures	3-5
APPENDIX A	REFERENCES	A-1
APPENDIX B	COMPONENTS OF END ITEM AND BASIC ISSUE LISTS	B-1
APPENDIX C	ADDITIONAL AUTHORIZATION LIST	C-1
APPENDIX D	EXPENDABLE/DURABLE SUPPLIES AND MATERIALS LIST	D-1
ALPHABETICAL INDEX		Index-1

HOW TO USE THIS MANUAL

The manual has been divided into chapters, sections, and paragraphs which are all numbered sequentially; figures and tables have also been numbered in the same manner. The manual identifies major components and their location which will aid you, the operator, in performing your PMCS. Detailed lubrication instructions, which are mandatory, are also included within the operator's maintenance section.

Use the front cover locators and "marked/tabbed" pages to quickly find the parts of the manual shown on the cover. The "blocked" titles in the table of contents are the titles for these locators. These portions of the manual were chosen because they are used most often.

Maintenance procedures used by Operator personnel are described in a step by step manner, ensuring the correct, and safe removal or repair of equipment. An alphabetical index at the back of the manual is referenced to the appropriate paragraph in the manual for ease of locating a specific task or procedure.

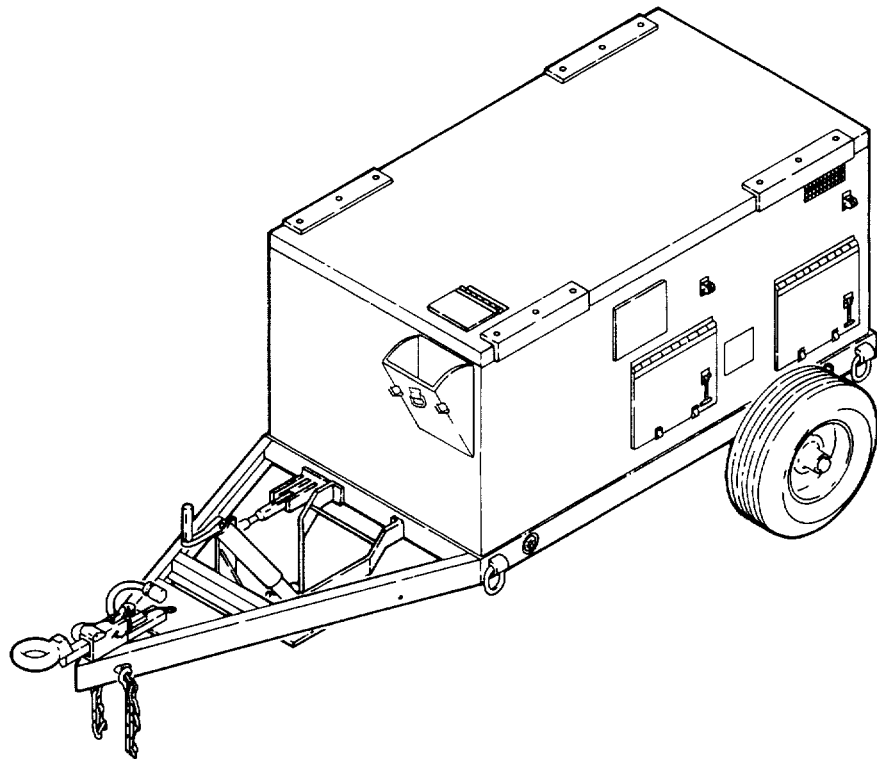
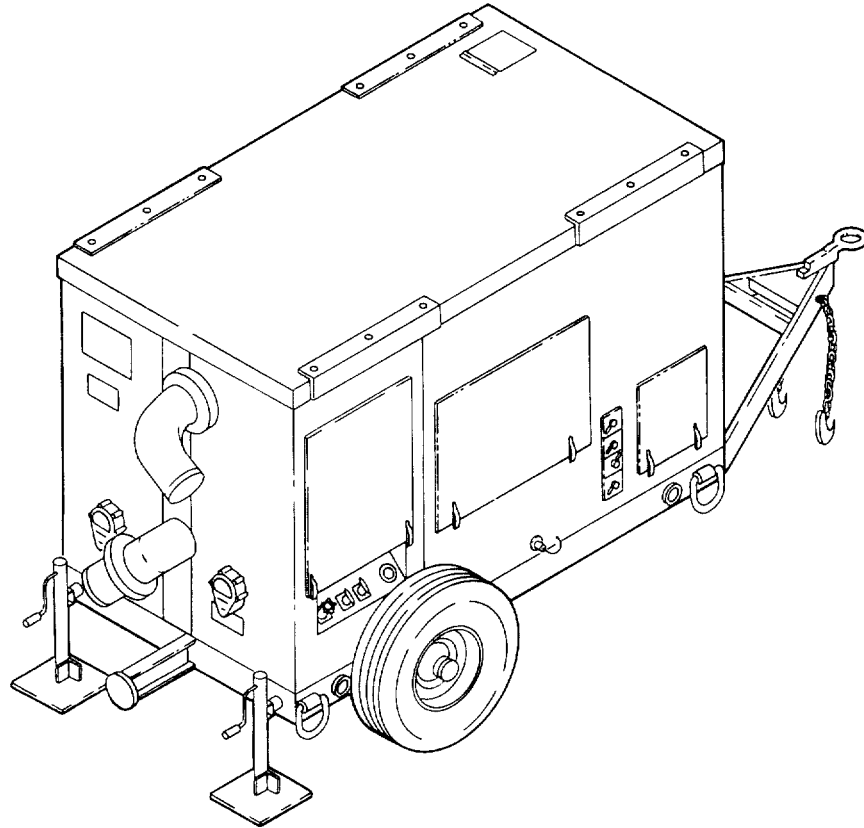

Figure 1-1. Full External View of Pumping Assembly, Water, 600 GPM, Trailer Mounted

**CHAPTER 1
INTRODUCTION**

PARAGRAPH TITLE	PARAGRAPH
Equipment Data.....	1-9
Equipment Characteristics, Capabilities, and Features.....	1-7
Hand Receipt (-HR) Manuals	1-3
List of Abbreviations	1-6
Location and Description of Major Components	1-8
Maintenance Forms, Records, and Reports	1-2
Principles of Operation	1-10
Reporting Equipment Improvement Recommendations (EIRs).....	1-4
Scope	1-1
Warranty Information.....	1-5

Section I. GENERAL INFORMATION

1-1 Scope.

- a. Type of Manual. Operators Manual
- b. Model Number and Equipment Name. Pumping Assembly, Water, 600 GPM, Model No 6 X 6 SP6, NSN 4320-01-314-8844 (hereafter called pumping assembly).
- c. Purpose of Equipment. The pumping assembly is a component of water distribution systems. It is used either singularly or in series with other pumps to supply drinking water from a source to one or more distribution points.

1-2 Maintenance Forms, Records, and Reports. Department of the Army forms and procedures used for equipment maintenance will be those prescribed by DA Pam 738-750, The Army Maintenance Management System (TAMMS).

1-3 Hand Receipt (-HR) Manuals. Not applicable

1-4 Reporting Equipment Improvement Recommendations (EIRs). If your pumping assembly needs improvement, let us know. Send us an EIR. You, the user, are the only one who can tell us what you don't like about your equipment Let us know why you don't like the design or performance Put it on an SF 368 (Product Quality Deficiency Report). Mail it to us at Commander, U S Army Troop Support Command, ATTN. AMSAT-i-MDO, 4300 Goodfellow Boulevard, St. Louis, Missouri 63120-1798 We'll send you a reply.

1-5 Warranty Information. The pumping assembly is warranted by Reddy Buffaloes Pump Inc. for 12 months. It starts on the date, found in block 23, DA form 2408-9, in the logbook. Report all defects in material or workmanship to your supervisor, who will take appropriate action through your organizational maintenance shop.

1-6 List of Abbreviations.

AAL	Additional Authorization List
BII	Basic Issue Item
COEI	Components of End Item
dc	Direct Current
EIR	Equipment Improvement Recommendation
hp	horsepower
IAW	In Accordance With

in	inches
kg	kilogram
kPa	kilopascals
kW	kilowatt
l	liters
lb	pounds
m	meters
mm	millimeter
mph	miles per hour
MTOE	Modified Table of Organization and Equipment
N•m	Newton-meters
NSN	National Stock Number
para	paragraph
psi	pounds-per-square-inch
psig	pounds-per-square-inch-gage
spm	stroke-per-minute
TAMMS	The Army Maintenance Management System
TMDE	Test, Measurement, and Diagnostic Equipment
TOE	Table of Organization and Equipment
°C	degrees Celsius
°F	degrees Fahrenheit

Section II. EQUIPMENT DESCRIPTION

1-7 Equipment Characteristics, Capabilities, and Features.

- a. Characteristics. The pumping assembly consists of a diesel-engine driven, self-priming centrifugal pump, control panel, and a noise enclosure mounted on a wheel-mounted trailer assembly.
- b. Capabilities and Features. The pumping assembly has an operational output of 600 gpm at 150 psig when pumping water
 - (1) Self-priming pump.
 - (2) Air-cooled, diesel engine driven.
 - (3) Wheel-mounted trailer unit.
 - (4) Highly mobile.
 - (5) Sound attenuated to 70db².

1-8 Location and Description of Major Components (Figure 1-2).

- a. **PUMP ASSEMBLY (1).** Rated at 600 gpm. Draws water from source or upline boost pump and feeds reservoir or next downline boost pump. Fitted with suction and discharge elbows suitable for connection to 6 in. grooved pipe couplings.
- b. **NOISE ENCLOSURE (2).** Provides for noise reduction.
- c. **DIESEL ENGINE (3).** Engine is a 4-stroke, 6 cylinder, air-cooled diesel engine that drives pump. Operating mode of engine is set on control panel. Operated in manual or automatic mode.
- d. **CONTROL PANEL (4).** Controls system operations.
- e. **JACKS (5).** Used to support and level pumping assembly.

- f. **TWO-WHEEL TRAILER ASSEMBLY (6).** Transports pumping assembly.
- g. **TRIPOD ASSEMBLY (7).** Supports front of pumping station in deployment mode. Tripod assembly is raised in travel mode
- h. **PARKING BRAKES (8).** Used to lock wheels in place when pumping assembly is not in transit.
- i. **SURGE BRAKING SYSTEM (9).** Provides braking for the pumping assembly when being towed. Activated by stopping motion of vehicle.
- j. **RUNNING/BRAKE LIGHTS (10).** Provide visual traffic signals for in-transit use.

1-9 Equipment Data.

Model.....	6 x 6 SP6
Manufacturer.....	Reddy • Buffaloes Pump, Inc.
Weight.....	5,390 lb (2447 kg)
Height.....	72 in. (182.9 cm)
Width.....	90.0 in. (228.6 cm)
Length.....	187.5 in. (476.3 cm)
Fuel tank capacity.....	42 gallons (159 l)

Diesel Engine

Power.....	108 HP at 2400 RPM (80kW)
Type.....	Six cylinder, four-stroke; air-cooled
Battery requirement.....	24 VDC (Two 12 VDC in series)
Model.....	F6L 912B

Pump

Type.....	Self-priming, centrifugal, direct coupled to diesel engine
Output volume.....	600 gpm at 350 ft tdh
Designed working pressure.....	150 psi (1034 kPa)
Designed suction pressure.....	-30 in of Hg to 150 psi (138 to 1034 kPa)
Suction and discharge size.....	6 in. (15 cm)

Section III. TECHNICAL PRINCIPLES OF OPERATION I

1-10 Principles of Operation. Once the suction and discharge valves are opened and engine started, the pump draws water from large storage source or upline boost pump. It sends the water to distribution points or another pumping assembly serving as an upline boost pump.

In automatic operation, a pressure control module responds to suction and discharge pressures. If an interruption of water flow occurs, the pressure control module automatically brings the engine speed to idle.

The functional description of controls and indicators of the pumping assembly are described in Section I of Chapter 2.

**CHAPTER 2
OPERATING INSTRUCTIONS**

PARAGRAPH TITLE	PARAGRAPH
Assembly and Preparation for Use.....	2-6
Emergency Procedures.....	2-13
Equipment is Not Ready/Available If Column.....	2-5
General, Descriptions and Use of Operator's Controls and Indicators.....	2-1
General, Operation Under Unusual Conditions.....	2-12
General, Operator Preventive Maintenance Checks and Service.....	2-3
Initial Adjustments and Daily Checks.....	2-7
Operating Instructions on Decals and Instruction Plates.....	2-11
Operating Procedures.....	2-8
Operation of Auxiliary Equipment.....	2-9
Operator's Controls and Indicators.....	2-2
PMCS Procedures.....	2-4
Preparation for Movement.....	2-10

Section I. DESCRIPTION AND USE OF OPERATOR'S CONTROLS AND INDICATORS

2-1 General. This section provides a description and use of operator controls and indicators that are used to operate the pumping assembly. The operator should become thoroughly familiar with the controls and indicators and with the proper operating procedures for the pumping assembly.

NOTE

If equipment fails to operate, refer to troubleshooting procedures in Chapter 3.

2-2 Operator's Controls and Indicators. Table 2-1 contains controls and indicators located on the control panel of pumping assembly. Table 2-2 contains engine controls and indicators located below the control panel. Table 2-3 contains pumping assembly fuel controls and indicators. Table 2-4 contains pumping assembly controls and indicators.

Table 2-1. Control Panel Controls and Indicators

Controls or indicators	Function
------------------------	----------

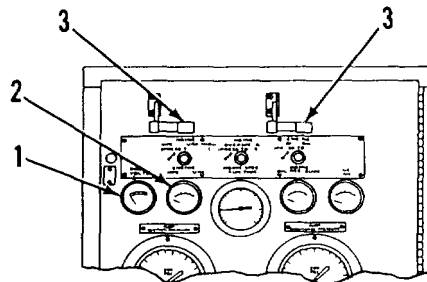

1	ENGINE VOLTS Meter	Indicates battery condition.
2.	ENGINE TEMPERATURE Gage	Indicates engine oil temperature in °F and °C.
3	PANEL LIGHTS	Illuminate control panel.

Table 2-1. Control Panel Controls and Indicators - (Cont)

Controls or indicators	Function
------------------------	----------

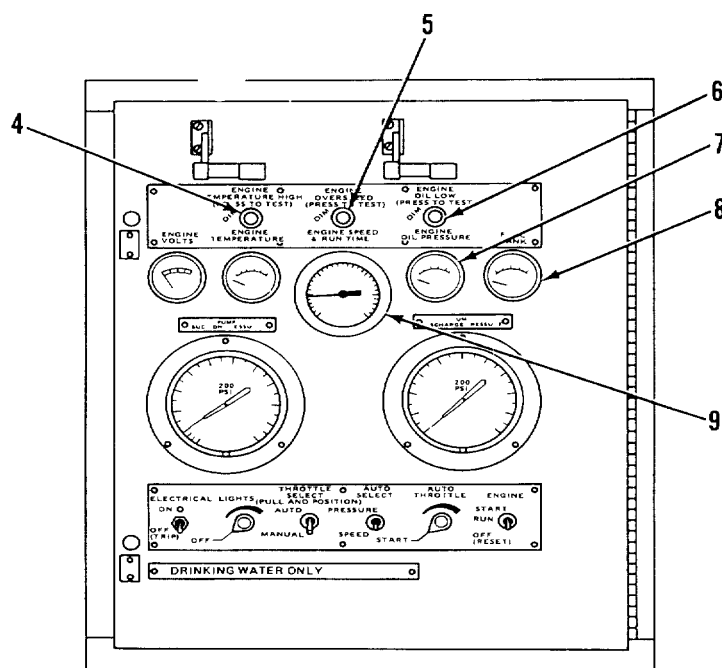

- | | |
|---|--|
| 4. ENGINE TEMPERATURE HIGH Indicator | Lights when engine overheats. Indicator has PRESS TO TEST feature Shuts down engine when activated. DIM control knob varies brightness of indicator. |
| 5. ENGINE OVERSPEED Indicator | Lights when allowable engine rpm is exceeded Indicator has PRESS TO TEST feature. Shuts down engine when activated. DIM control knob varies brightness of indicator. |
| 6. ENGINE OIL LOW Indicator | Lights when engine oil pressure is low. Indicator has PRESS TO TEST feature. Shuts down engine when activated. DIM control knob varies brightness of indicator. |
| 7. ENGINE OIL PRESSURE Gage | Indicates engine oil pressure in psi. |
| 8. FUEL TANK Gage | Indicates amount of fuel in tank. Range is 0 (empty) to 4/4 tank (full) |
| 9. ENGINE SPEED Tachometer and RUN TIME Indicator | Shows engine speed in revolutions per minute (rpm). Indicates total accumulated operating hours of engine. |

Table 2-1. Control Panel Controls and Indicators - (Cont)

Controls or indicators	Function
------------------------	----------

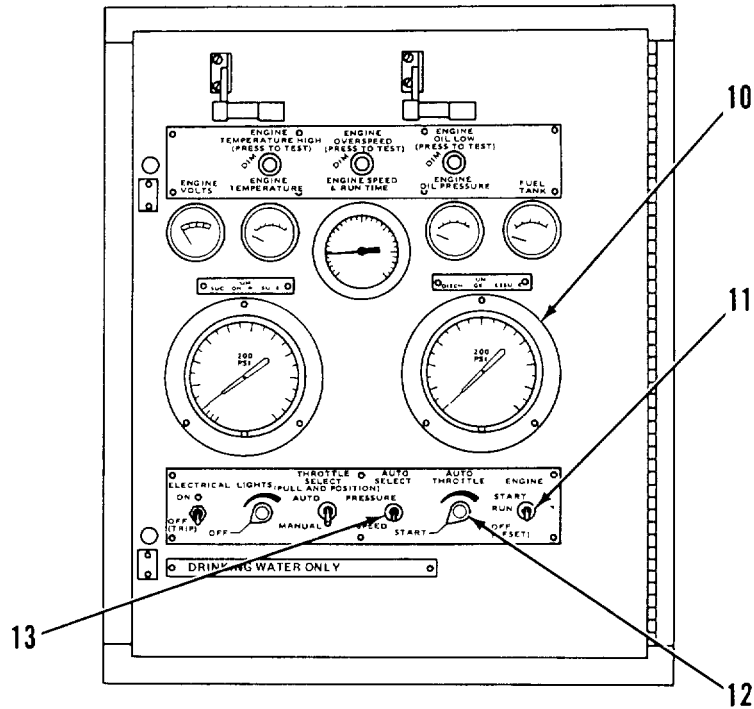

- | | |
|----------------------------------|--|
| 10. PUMP DISCHARGE PRESSURE Gage | Indicates water pressure in psi at pump discharge port. |
| 11. ENGINE Switch | Three position toggle switch used to start, run and stop engine START position is springloaded. |
| 12. AUTO THROTTLE Rheostat | Used to set desired water output pressure or engine speed, in automatic mode of operation. |
| 13. AUTO SELECT Switch | Used to select engine speed or pump pressure in automatic mode of operation. When SPEED is selected engine speed remains constant regardless of pressure. When PRESSURE is selected water pressure is constant and engine speed varies. Depending upon the suction and discharge pressure, the pressure controller feeds the speed signal. |

Table 2-1. Control Panel Controls and Indicators - (Cont)

Controls or indicators	Function
------------------------	----------

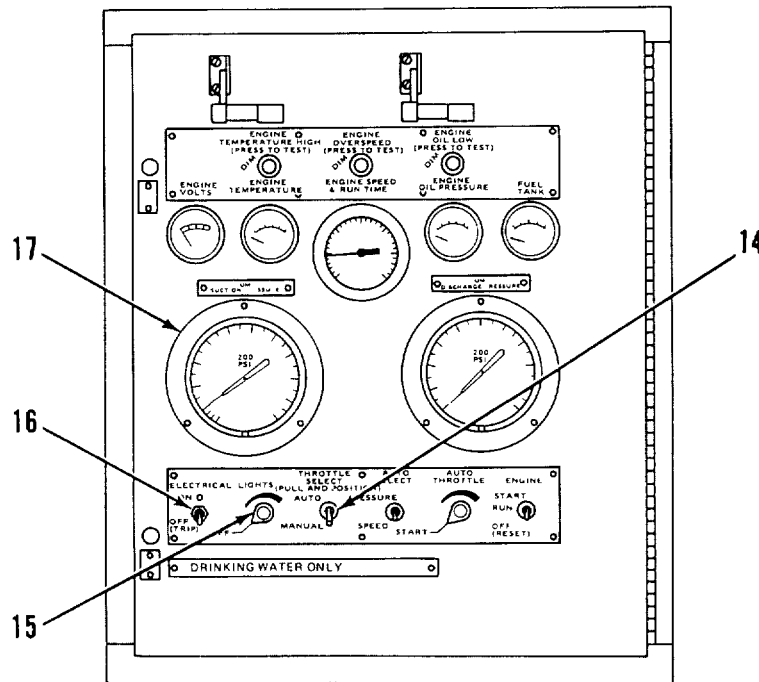

14. THROTTLE SELECT Switch	Used to select MANUAL or AUTO throttle. In AUTO, throttle speed of engine is controlled to meet the demands of system in system application and should only be used on boost stations after system is primed.
15. LIGHTS Switch/Rheostat	Turns panel illumination lights on and off and controls brightness of illumination.
16. ELECTRICAL Switch	Two position toggle switch, used to apply electrical power to system. Switch will shut off (trip) if an electrical overload condition occurs.
17. PUMP SUCTION PRESSURE Gage	Shows water pressure in psi on suction side of pump.

Table 2-2. Engine Controls and Indicators

Controls or indicators	Function
------------------------	----------

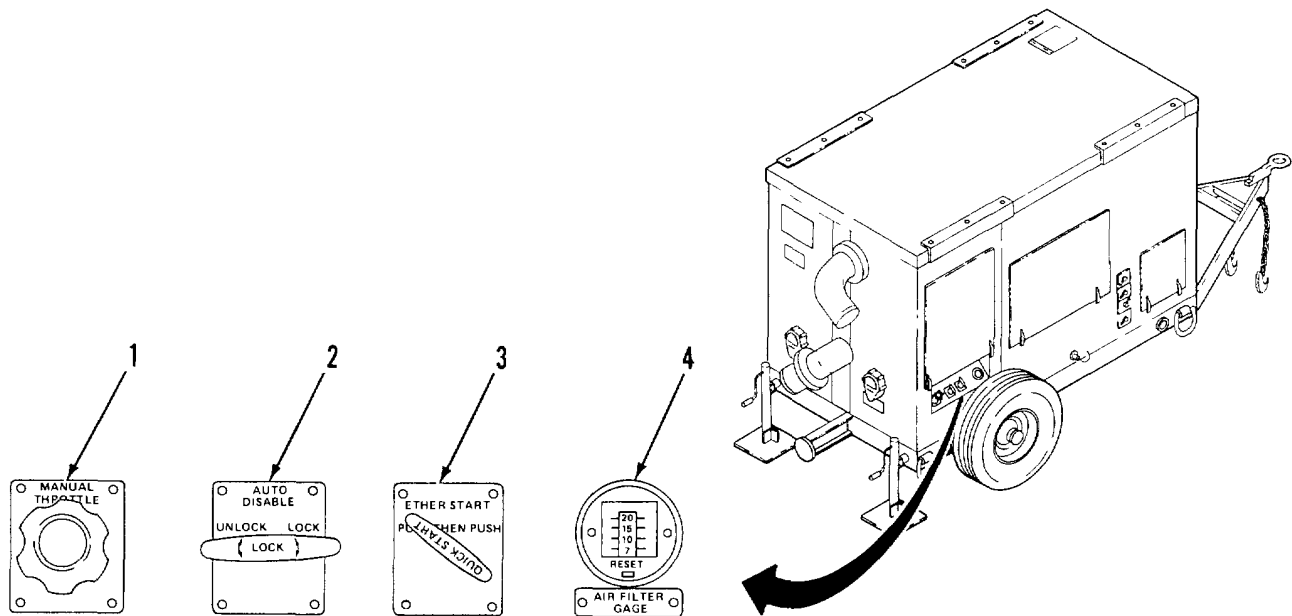

- | | | |
|----|-----------------|---|
| 1. | MANUAL THROTTLE | Used to control engine speed when AUTO THROTTLE switch is in MANUAL position. |
| 2. | AUTO DISABLE | Used to disable governor system when manual engine operation is desired. |
| 3. | ETHER START | Used to start engine in cold temperatures by injecting starting fluid from a bottle stowed in the engine compartment into the engine air intake line. Handle is pulled to inject one shot of ether into the engine air intake line. The handle is pushed in to reset the cold start aid system. |
| 4. | AIR FILTER Gage | Indicates air filter restriction. Air filter needs servicing when air filter gage indicates 20. Reset button on gage is used to reset gage after air cleaner has been serviced. |

Table 2-2. Engine Controls and Indicators - (Cont)

Controls or indicators	Function
------------------------	----------

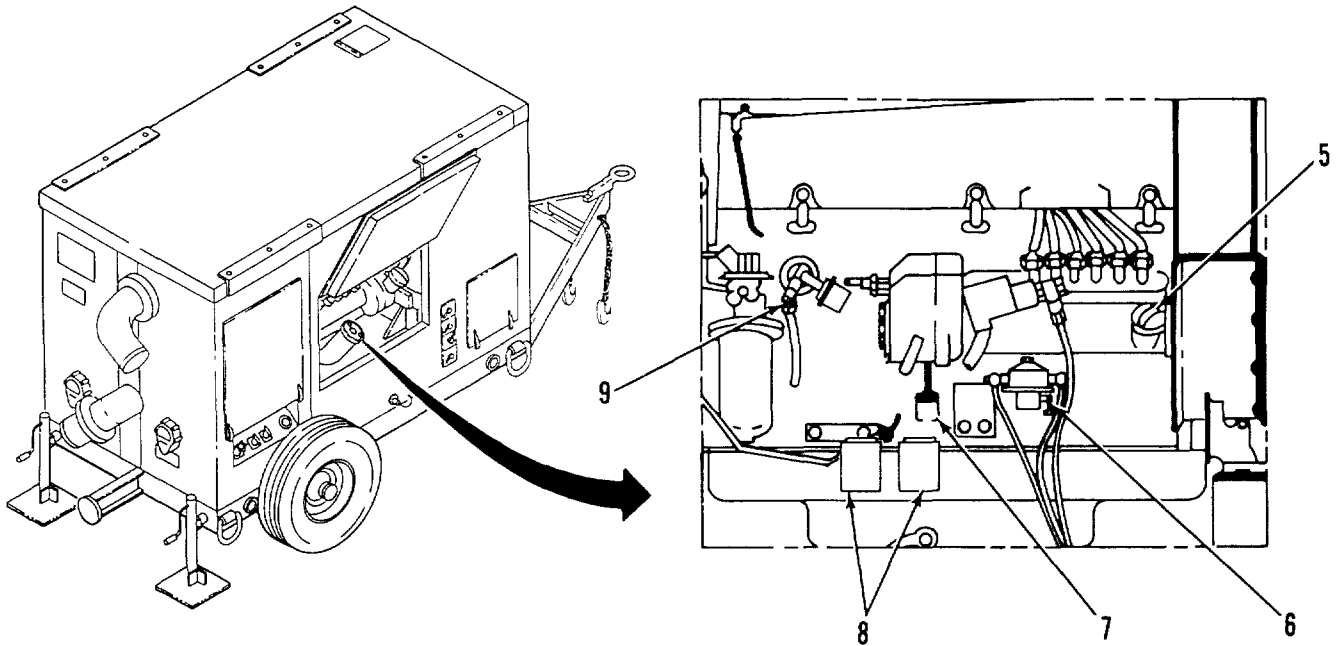

5. Oil Filler	Used to add oil to engine.
6. Fuel Supply Pump Priming Lever	Used to prime engine fuel system after servicing.
7. Dipstick	Used to check oil level with engine shut down or in operation. Dipstick has an add line and a full line. Add oil when engine oil level falls to or below the add line. Do not fill above full line.
8. Primary and Secondary Fuel Filters.	Used to collect and drain water from fuel system.
9. Oil Sample Valve	Used to collect lubricating oil sample.

Table 2-3. Pumping Assembly Fuel Controls and Indicators

Controls or indicators	Function
------------------------	----------

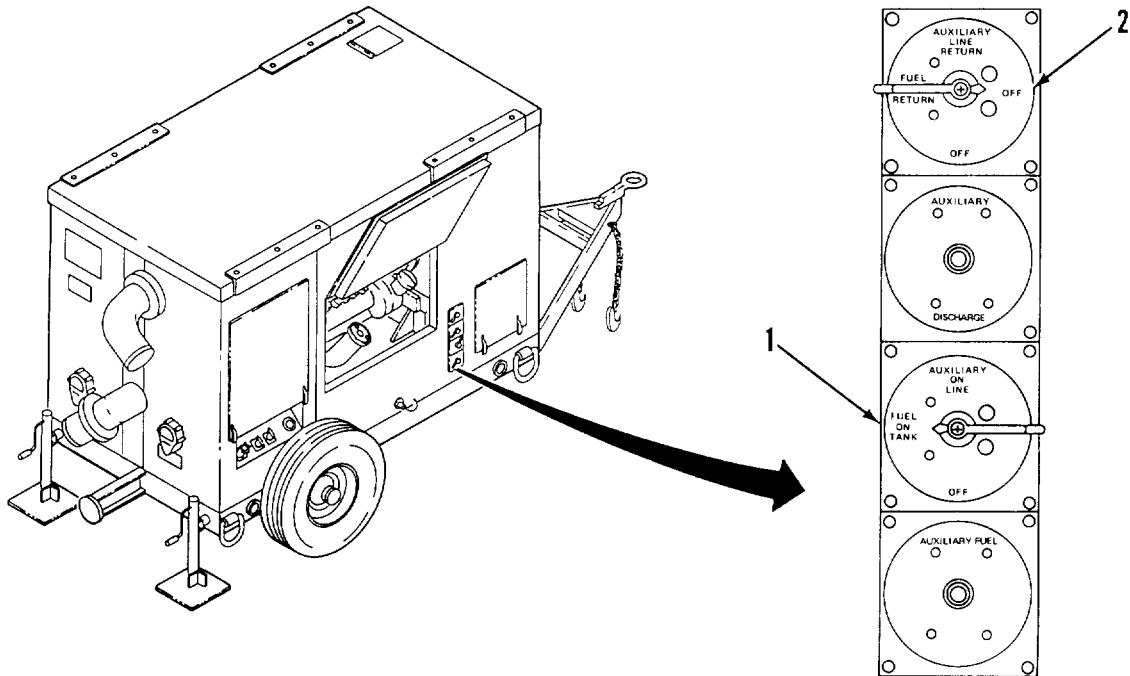

1. Fuel Selector Valve

Used to select fuel tank or auxiliary fuel supply. When AUXILIARY ON LINE position is indicated, auxiliary tank supplies fuel through AUXILIARY FUEL INLET connector to engine. When FUEL ON is indicated fuel is supplied by trailer tank.

2. Fuel Return Valve

Used to direct flow of unused fuel to either the trailer tank or auxiliary fuel supply container. When AUXILIARY LINE RETURN is indicated, excess fuel is directed to auxiliary container through AUXILIARY FUEL RETURN connector. When FUEL TANK RETURN position is selected, return flow is directed to trailer tank.

Table 2-4. Pumping Assembly Controls and Indicators

Controls or indicators	Function
------------------------	----------

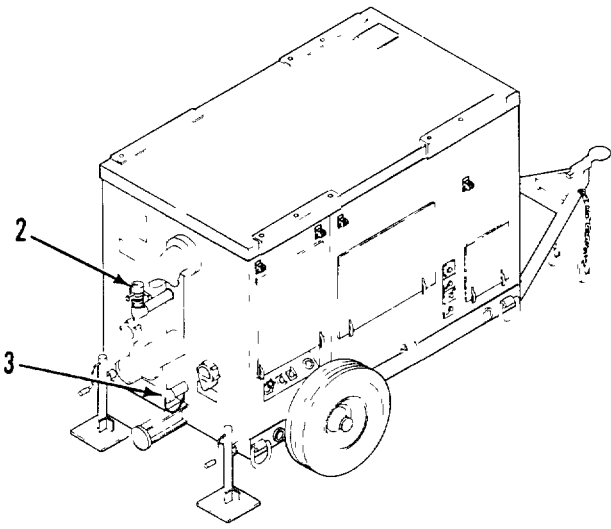
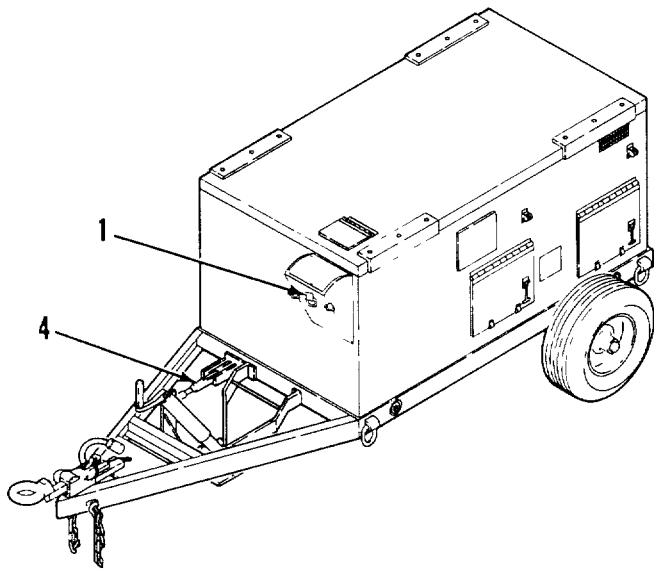

- | | |
|----------------------------|--|
| 1. Air Exhaust Door Handle | Used to open/close air exhaust door to vent engine cooling air and allows exhaust gases to exit from engine exhaust muffler. |
| 2. Priming Tube | Used to prime pump as required on initial system startup. To use, remove cap, fill with potable water and replace cap. |
| 3. Pump Drain | Used to drain water from pump after shutdown. |
| 4. Hand Brake Lever | Used to lock wheels when pumping assembly is disconnected from tow vehicle. |

Section II. OPERATOR PREVENTIVE MAINTENANCE CHECKS AND SERVICES (PMCS)

2-3 General. For the pumping assembly to be ready for use at all times, it must be inspected systematically so that defects may be discovered and corrected before they result in serious damage or failure.

- a. Before You Operate. Always keep in mind the CAUTIONS and WARNINGS. Perform your before (B) PMCS.
- b. While You Operate. Always keep in mind the CAUTIONS and WARNINGS. Perform your during (D) PMCS.
- c. After You Operate. Be sure to perform your after (A) PMCS.
- d. Weekly. Always keep in mind the CAUTIONS and WARNINGS. Perform your weekly (W) PMCS.
- e. Monthly. Always keep in mind the CAUTIONS and WARNINGS. Perform your monthly (M) PMCS.
- f. If Your Equipment Fails to Operate Troubleshoot with proper equipment. Report any deficiencies using the proper forms See DA Pam 738-750.
- g. Special Instructions. The following actions apply while performing your PMCS.
 - (1) Stop operation immediately if deficiency is noted during operation which would damage the equipment.
 - (2) Defects discovered during operation of the equipment should be noted for future correction to be made as soon as operation has ceased.

2-4 PMCS Procedures. The following paragraphs describe your PMCS table:

- a. Purpose of PMCS Table. Your Preventive Maintenance Checks and Services table (Table 2-5) lists the inspections and care your equipment requires to keep it in good operating condition.
- b. Item Number Column. Item numbers are assigned in chronological ascending sequence regardless of interval designation. These numbers are used for your TM number column on DA Form 2404, Equipment Inspection and Maintenance Worksheet in recording results of PMCS.
- c. Service Interval Column. The Interval column of your PMCS table tells you when to do certain checks or services.
- d. Item to be Inspected Column. This column lists functional groups and their respective assemblies and subassemblies. The appropriate check or service procedure follows the specific item to be inspected.
- e. Procedures Column. This column of your PMCS table tells you how to do the required checks and services. Carefully follow these instructions. If you do not have the tools, or if the procedure tells you to, have unit maintenance do the work.
- f. After Prolonged Shutdowns. Perform weekly as well as before operations if you are the assigned operator and have not operated the item since the last weekly or if you are operating the item for the first time.
- g. Reporting and Correcting Deficiencies. If your equipment does not perform as required, refer to Chapter 3 under Troubleshooting for possible problems. Report any malfunctions or failures on the proper DA Form 2404, or refer to DA Pam 738-750.
- h. Leakage. Leakage definitions for operator/crew PMCS shall be classified as follows:

Class I Seepage of fluid, as indicated by wetness or discoloration not great enough to form drops.

Class II Leakage of fluid great enough to form drops but not enough to cause drops to drip from item being checked/inspected.

Class III Leakage of fluid great enough to form drops that fall from the item being checked/inspected.

CAUTION

Equipment operation is allowable with minor leakages, Class I or 11. Of course, you must consider the fluid capacity in the item/system being checked/inspected. When in doubt, notify your supervisor.

When operating with Class I or Class II leaks, continue to check fluid levels as required in your PMCS.

Class III leaks should be reported to your supervisor or unit maintenance.

2-5 Equipment Is Not Ready/Available If Column. This column is used for identification of conditions that make the equipment not ready/available for readiness reporting purposes or denies use of the equipment until corrective maintenance is performed.

Table 2-5. Operator Preventive Maintenance Checks and Services

NOTE

If the equipment must be kept in continuous operation, check and service those items that can be checked and serviced without disturbing operation. Make the complete checks and services when the equipment can be shut down.

Item No.	Interval					Item to be Inspected	Procedures: Check for and have repaired or adjusted as necessary	Equipment Is Not Ready/ Available If:
	B	D	A	W	M			
1	•		•			Noise Enclosure Access Doors	Check if doors can be opened and closed. Check for bent or cracked panels. Check for missing or damaged hinges, latches and mounting hardware.	
2	•		•			Batteries	Check batteries for loose/corroded terminals and clamps. Clean clamps and terminals and tighten clamps as necessary. Check connections and connector of slave cable for tightness and damage. Check/add distilled water as necessary.	Battery terminals or cables loose or severely corroded.
3	•		•			Engine Volts Meter	Open control panel and check for loose connections and damaged meter. Notify unit maintenance if connections are loose or meter is damaged or inoperative	Connections loose or meter is damaged.

Table 2-5. Operator Preventive Maintenance Checks and Services - (Cont)

Item No.	Interval					Item to be Inspected	Procedures: Check for and have repaired or adjusted as necessary	Equipment Is Not Ready/ Available If:
	B	D	A	W	M			
4	•		•			Engine Temperature Gage	Open control panel and check for loose connections and damaged gage. Notify unit maintenance if connections are loose or gage is damaged or inoperative.	Connections loose or gage is damaged
5	•		•			Oil Pressure Gage	Open control panel and check for loose connections and damaged gage. Notify unit maintenance if connections are loose or gage is damaged or inoperative	Connections loose or gage is damaged.
6	•		•			Fuel Tank Gage	Open control panel and check for loose connections and damaged gage. Notify unit maintenance if connections are loose or gage is damaged or inoperative	Connections loose or gage is damaged.
7	•		•			Engine Temperature High Indicator	a. Open control panel and check for loose connections and damaged indicator. Notify unit maintenance if connections are loose or indicator is damaged or inoperative. b. Test indicator for operation and dimming adjustments	Connections loose or indicator is damaged.
8	•		•			Engine Overspeed Indicator	a. Open control panel and check for loose connections and damaged indicator. Notify unit maintenance if connections are loose or indicator is damaged or inoperative b. Test indicator for operation and dimming adjustments.	Connections loose or indicator is damaged.
9	•		•			Engine Oil Low Indicator	a. Open control panel and check for loose connections and damaged indicator. Notify unit maintenance if connections are loose or indicator is damaged or inoperative. b. Test indicator for operation and dimming adjustments	Connections loose or indicator is damaged.
10	•		•			Engine Speed Tachometer and Run Time Indicator	Open control panel and check for loose connections and damaged indicator. Notify unit maintenance if connections are loose or indicator is damaged or inoperative	Connections loose or indicator is damaged

Table 2-5. Operator Preventive Maintenance Checks and Services - (Cont)

Item No.	Interval					Item to be Inspected	Procedures: Check for and have repaired or adjusted as necessary	Equipment Is Not Ready/ Available If:
	B	D	A	W	M			
11	•		•			Pump Discharge Pressure Gage	Open control panel and check for loose connections and damaged gage. Notify unit maintenance if connections are loose or gage is damaged or inoperative	Connections loose or gage is damaged.
12	•		•			Pump Suction Pressure Gage	Open control panel and check for loose connections and damaged gage. Notify unit maintenance if connections are loose or gage is damaged or inoperative.	Connections loose or gage is damaged
13	•		•			Engine Switch	Open control panel and check for loose connections and damaged switch. Notify unit maintenance if connections are loose or switch is damaged or inoperative.	Connections loose or switch is damaged.
14	•		•			Auto Select Switch	Open control panel and check for loose connections and damaged switch. Notify unit maintenance if connections are loose or switch is damaged or inoperative.	Connections loose or switch is damaged.
15	•		•			Throttle Select Switch	Open control panel and check for loose connections and damaged switch. Notify unit maintenance if connections are loose or switch is damaged or inoperative.	Connections loose or switch is damaged.
16	•		•			Electrical Switch	Open control panel and check for loose connections and damaged switch. Notify unit maintenance if connections are loose or switch is damaged or inoperative.	Connections loose or switch is damaged.
17	•		•			Lights Switch/ Rheostat	<p>a. Open control panel and check for loose connections and damaged switch. Notify unit maintenance if connections are loose or switch is damaged or inoperative.</p> <p>b. Test rheostat for operation and dimming adjustments</p>	Connections loose or switch is damaged.
18	•		•			Auto Throttle Rheostat	Open control panel and check for loose connections and damaged rheostat. Notify unit maintenance if connections are loose or rheostat is damaged or inoperative	Connections loose or rheostat is damaged.

Table 2-5. Operator Preventive Maintenance Checks and Services - (Cont)

Item No.	Interval					Item to be Inspected	Procedures: Check for and have repaired or adjusted as necessary	Equipment Is Not Ready/ Available If:
	B	D	A	W	M			
19	•		•			Wiring	Check for loose/disconnected wires and cable connectors to control panel, alternator, starter relay, fuel solenoid shutoff valve, magnetic pickup unit, governor actuator and engine sensors.	Loose/disconnected wire or cable.
20	•	•	•			Fuel Gage	Before and during operation, check fuel level. (Add fuel as necessary.)	
21	•	•	•			Engine and Pump	<ul style="list-style-type: none"> a. Inspect ground and engine compartment for evidence of leaks. b. Check drain hole of pump bearing housing for water leaks. c. Check gage connections for pump suction and discharge pressures for leaks. d. Check fuel lines and hose connections for leaks. e. Check drain line on engine sump for oil leaks. f. Check engine and pump mounting bolts for tightness. Notify unit maintenance if loose or isolators deteriorated. 	Any evidence of leaks
22	•	•				Pump Suction and Discharge Lines	Check for leaks. Check for loose or missing hardware.	
23		•				Oil Line (Turbo-charger Feed)	Inspect for leaks. Check fitting for tightness. Tighten if necessary.	Fitting is loose and leaks oil.
24	•		•			Oil Level	Check oil level at dipstick. If low, add oil through filler neck. Do not add oil unless level is at or below "ADD" level on dipstick. Do not fill above "FULL" line.	
25	•					Cold Start Aid Hose, Bottle, and Cable	Check cold start aid for tightness of hose connections, securing clamp, and cable.	

Table 2-5. Operator Preventive Maintenance Checks and Services - (Cont)

Item No.	Interval					Item to be Inspected	Procedures: Check for and have repaired or adjusted as necessary	Equipment Is Not Ready/ Available If:
	B	D	A	W	M			
26	•					Exhaust Pipes and Muffler	Check mounting brackets and fasteners for tightness. Check discoloration for possible exhaust leaks.	
27	•		•	•		Fuel Filters	Rotate knob on bottom of primary filter to drain any accumulation of water into container. When water is drained and clear fuel comes out at drain hose, close valve. Repeat for secondary filter.	Water present in fuel.
28	•		•			Fan Belt	Check for worn, cracked, or frayed fan belt. Notify unit maintenance if belt is loose or needs to be replaced.	Fan belt is worn, cracked, or frayed.
29		•				Air Filter Gage	Check air filter gage. Push reset if indicator is at 20. If indicator still at 20, check air cleaner (para 3-6).	Air filter gage is 20 indicating engine air filter restriction.
30					•	Air Intake Line	Check clamps and rubber boots for tightness.	
31					•	Engine Cooling Fins	Remove air cowling and check for damaged fins. Check for dirt accumulation on fins and air passages. Clean as necessary. If fin is damaged, notify unit maintenance.	Fins are dirty or damaged. Air passages are clogged.

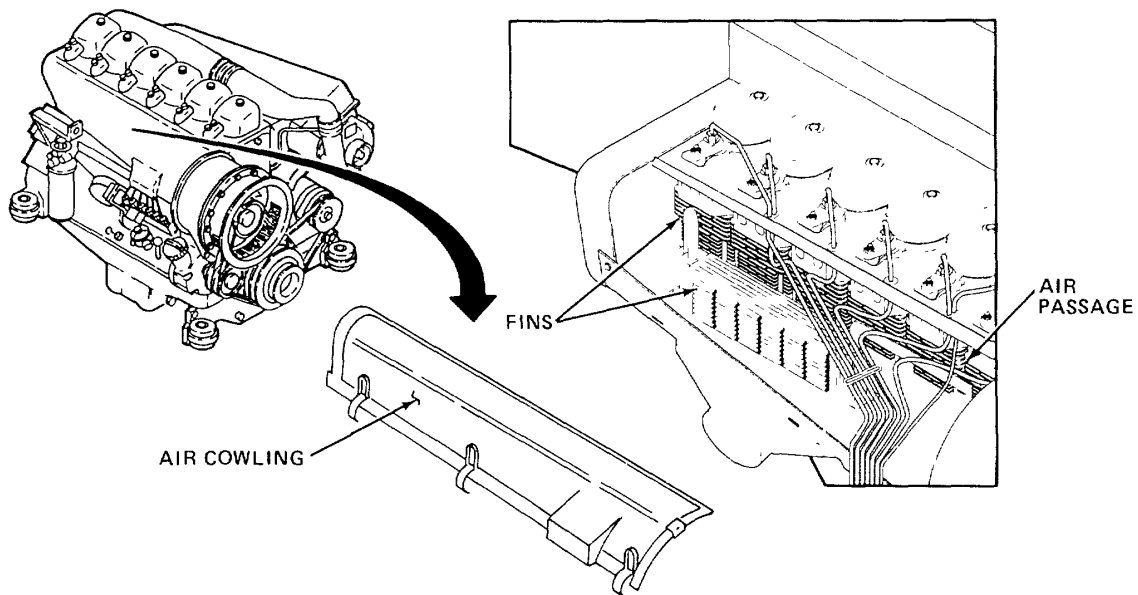

Table 2-5. Operator Preventive Maintenance Checks and Services - (Cont)

Item No.	Interval					Item to be Inspected	Procedures: Check for and have repaired or adjusted as necessary	Equipment Is Not Ready/ Available If:
	B	D	A	W	M			
32	•		•			Alternator Belt	Check for worn, cracked, frayed, or loose alternator belt. Notify unit maintenance if belt is worn, cracked, frayed, or loose.	
33		•				Fuel Hoses	Check for leaking or corroded fuel hoses and fuel hose connections at fuel tank, fuel pump, auxiliary fuel connectors and fuel filters. Tighten connections, notify unit maintenance if fuel hose leaks or is severely corroded	Fuel hose or fuel hose connection leaks. Fuel hose is severely corroded.
34	•					Fuel Strainer	Check for damage to screen	
35	•		•			Trailer Chassis	Inspect all frame seam welds and D-rings for cracks. If welds or D-rings are damaged, notify unit maintenance. Check axle, lunette, and springs for damage. If axle, lunette or spring is damaged, notify unit maintenance.	Welds are damaged. Axle, lunette, or spring is damaged
36	•		•			Hand Brake	Check that hand brake lever will lock and unlock trailer wheels. If adjustment required, adjust with handle.	Hand brake handle will not lock or unlock trailer wheels.
37	•				•	Brake Fluid Level	Check level of reservoir brake fluid level of the surge braking system. Check prior to unit movement. Add DOT 3 brake fluid if required	Low brake fluid level.

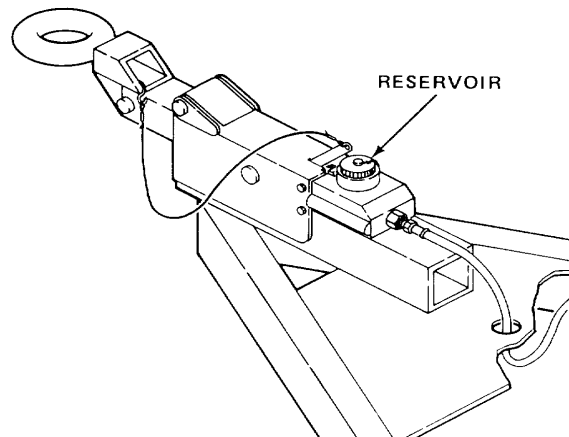

Table 2-5. Operator Preventive Maintenance Checks and Services - (Cont)

Item No.	Interval					Item to be Inspected	Procedures: Check for and have repaired or adjusted as necessary	Equipment Is Not Ready/ Available If:
	B	D	A	W	M			
38	•		•			Brake Lines	Check brake lines for leaks or damage. Notify unit maintenance if damaged.	Any leakage of brake fluid or damage lines.
39	•					Decals and Instruction Plates	Check for missing or damaged decals and instruction plates.	
40	•		•			Trailer Lights and Reflectors	Check for cracked or broken lenses With trailer connected to towing vehicle, check operation of lights. Notify unit maintenance if lens is cracked or broken or lights are inoperable	Lights do not work.
41	•		•			Tripod	Check supports and weld son tripod for damage If damaged, notify unit maintenance. Check if tripod is damaged Make sure tripod is secured and operable If tripod is damaged or not operable, notify unit maintenance.	Tripod is damaged, not secured or inoperable.
42	•		•			Tires and Rims	Check tires for wear and proper inflation Check valve stem. Check lug nuts for tightness Add air as necessary to bring to required operating pressure. Check for damaged rim	Tire is flat or excessively worn. Rim is damaged
43	•		•			Jacks	Remove jack from stow position Check for damage and proper operation Reinstall in stow position. Make sure pins and chains securing jacks in stow and operational positions are not excessively worn or damaged.	Jack is damaged, inoperable, or cannot be secured to vehicle in stow or operational position because of damaged or missing pins.
44	•		•			Safety Chains and Breakaway Cable and Trailer Cable	Check for damaged/broken safety chains and breakaway cable. Check trailer cable for damaged connector and broken pins	Chains and/or cable is broken or damaged Connector points are broken.

Section III. OPERATION UNDER USUAL CONDITIONS

2-6. **Assembly and Preparation for Use.** Refer to system manual for site requirements.

- a. Pumping Assembly Setup. Perform the following (Figure 2-1):

CAUTION

When pumping assembly is not connected to a vehicle pintle hook, set parking brake to prevent unit from moving

- (1) Place park brake lever (3) in lock position
- (2) Using procedure that follows, disconnect pumping assembly from tow vehicle:
 - (a) Disconnect trailer electrical cable (2) from trailer receptacle (1) on tow vehicle.
 - (b) Open pintle (7) on tow vehicle
 - (c) Using tripod jack (4), raise front of pumping assembly until lunette (8) clears pintle hook (7).
 - (d) Unhook safety chains (6) and breakaway cable (5) from tow vehicles at lifting shackle (14)
 - (e) Slowly move tow vehicle forward until eye of lunette (8) is clear of pintle hook (7).

CAUTION

Jack may come off bracket when pin is pulled.

- (3) Remove jacks (11) from stowed position and attach to vehicle in operating position as follows
 - (a) Remove locking pin (9).
 - (b) Rotate jack (11) on bracket (13)
 - (c) Install locking pin (9) through jack (11) and bracket (13).
 - (d) Use jack handle (12) to lower pad (10).
 - (4) Using front tripod (4) and rear jacks (11), level pumping assembly.
- b. Preparing Pumping Assembly for Operation. Connect pump suction and discharge ports in accordance with system manual.

2-7. **Initial Adjustments and Daily Checks.** Perform the following

- a. Perform before (B) PMCS.
- b. Open air exhaust door and control panel door.
- c. Close control suction and discharge valves
- d. Ensure pump drain is capped.

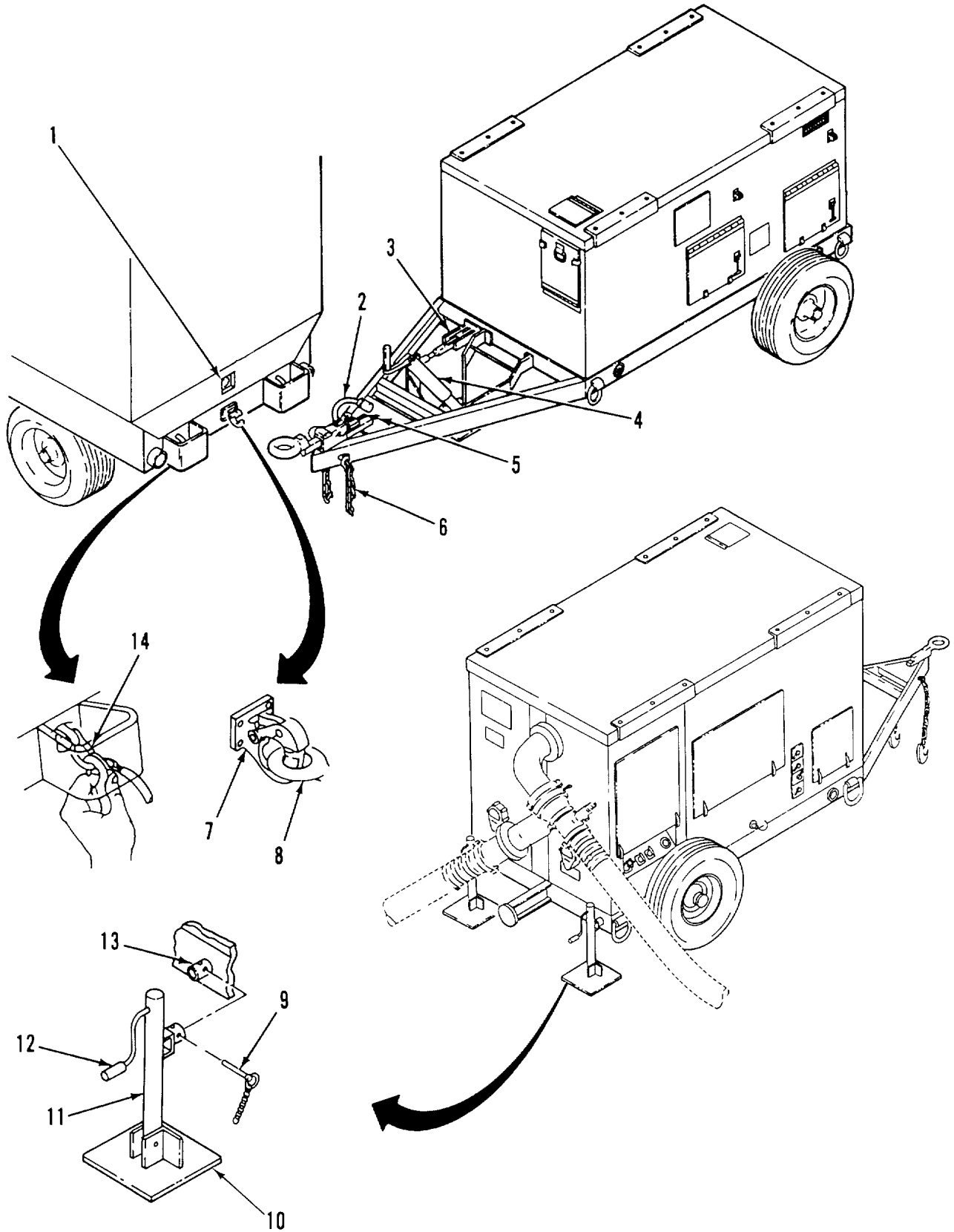

Figure 2-1. Initial Assembly Setup

CAUTION

DO NOT operate pump unless casing is filled to level of suction port. Operating a dry pump will cause overheating and damage to pump unit.

- e. Make sure drain valves (Figure 2-2) on inside of control panel are closed.

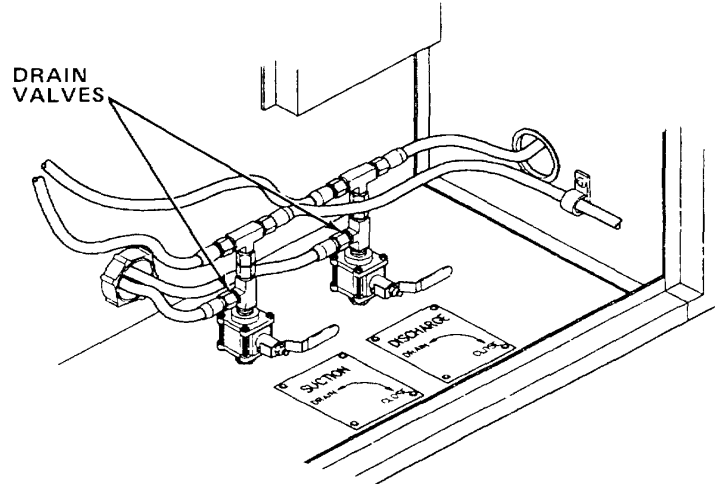

Figure 2-2. Control Panel Drain Valves

- f. Remove priming line cap and prime pump with potable water (approximately 7 gallons (26.5 l)).
- g. Install the priming line cap and open pump suction and discharge valves

WARNING

DO NOT operate engine around open fuel. Fuel presents an extreme explosion and fire hazard. Make sure fuel lines are securely connected and free of leaks. Avoid overfilling fuel tank.

CAUTION

Always use correct fuel type

- h. If engine is to be operated from external fuel supply, perform the following (Figure 2-3):
- (1) Connect fuel supply hose (4) from auxiliary fuel tank to AUXILIARY FUEL INLET connector (5)
 - (2) Connect fuel return hose (3) from auxiliary fuel tank to AUXILIARY FUEL RETURN connector (2).
 - (3) Move fuel selector valve (6) to AUXILIARY ON LINE position.
 - (4) Move fuel return valve (1) to AUXILIARY LINE RETURN position.

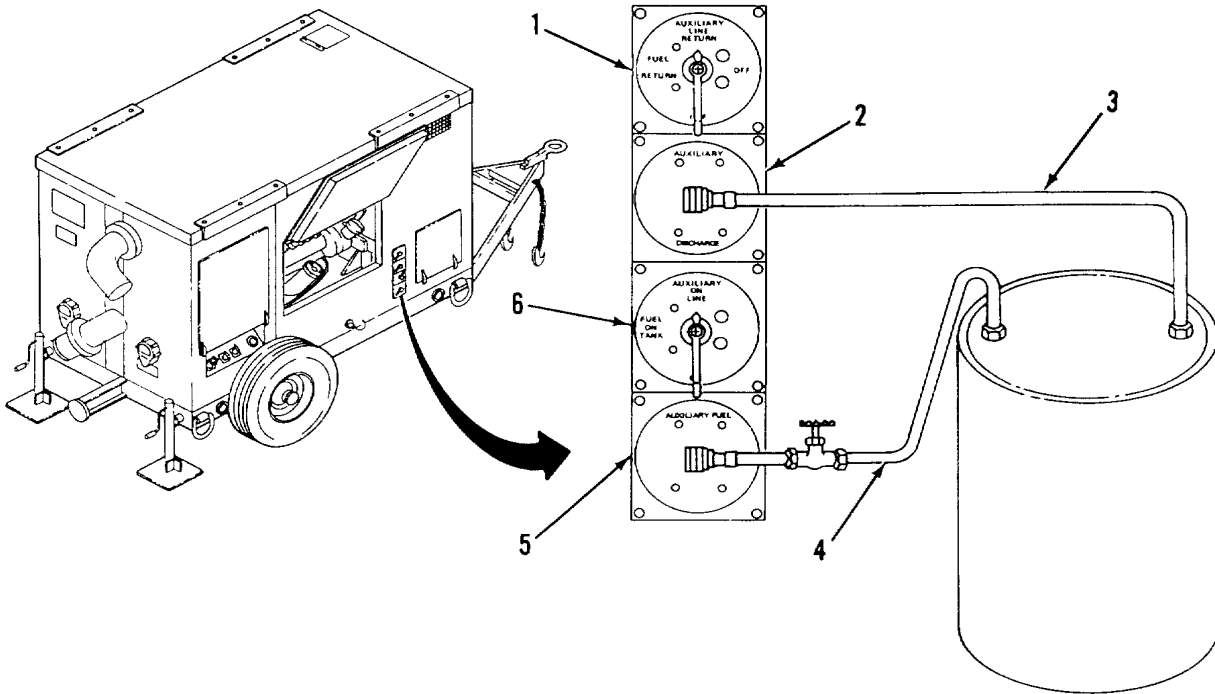

Figure 2-3. Pumping Assembly Fuel Selector Valves

- i. If engine is to be operated from trailer tank on pumping assembly, perform the following (Figure 2-3)'
 - (1) Move fuel selector valve (6) to FUEL ON TANK position.
 - (2) Move fuel return valve (1) to FUEL RETURN position.
- j. Prime fuel system (Figure 2-4).

WARNING

Cleaning any fuel spills prior to operating It is possible to pump up to one cup of fuel from overflow valve

- (1) Open engine access door (3)
- (2) Place suitable container under fuel injection pump (1).
- (3) Open overflow valve (2) on fuel injection pump (1)

- (4) Use manual primer lever (4) on fuel supply pump (5) until fuel emerges free of air bubbles at overflow valve (2).
- (5) Tighten overflow valve (2)

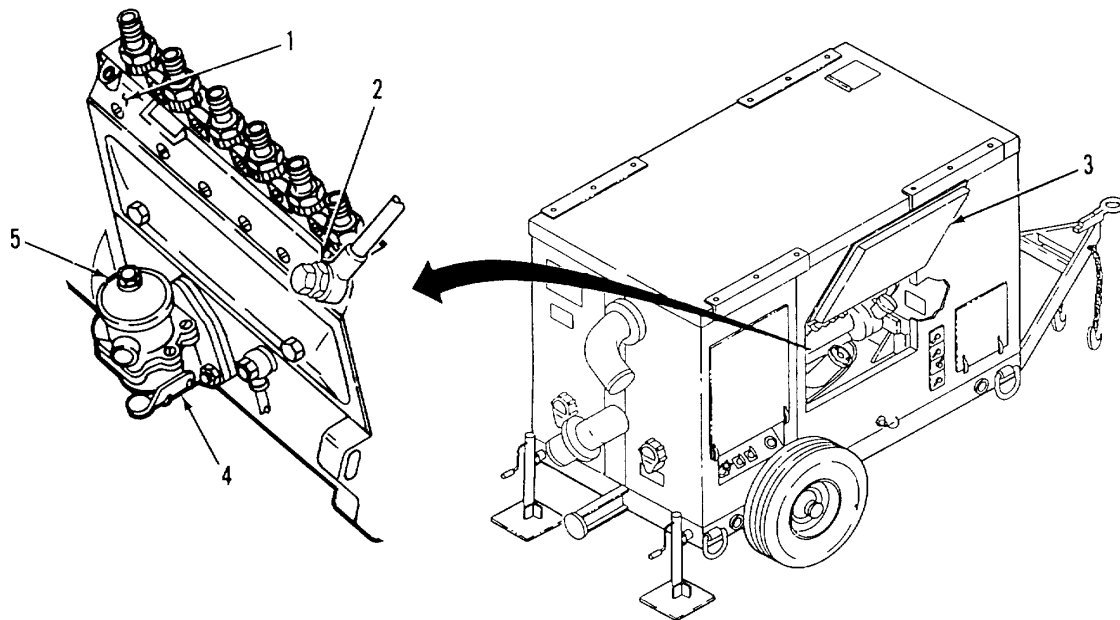

Figure 2-4. Priming Fuel System

2-8. Operating Procedures.

- a. Manual Mode Operation (Starting). Perform the following (Figure 2-5):

- (1) Set ELECTRICAL switch (10) to ON.

NOTE

Placing the ELECTRICAL switch to the OFF position deenergizes the control panel system where the engine will not start or will stop if the engine is in operation

- (2) Set THROTTLE SELECT (9) to MANUAL.
- (3) Depress red button (5) to unlock MANUAL THROTTLE (4) and turn MANUAL THROTTLE knob (6) to idle position.
- (4) Unlock and pull AUTO DISABLE (7) full out and lock by turning handle (8).
- (5) Put ENGINE switch (3) to START (10-15 seconds). Release to RUN. If engine does not start, wait 1 minute and restart (3 restart tries maximum). Refer to troubleshooting if engine does not start.
- (6) Check ENGINE OIL PRESSURE gage (2) for 40-80 psig. Shut down engine if no oil pressure.

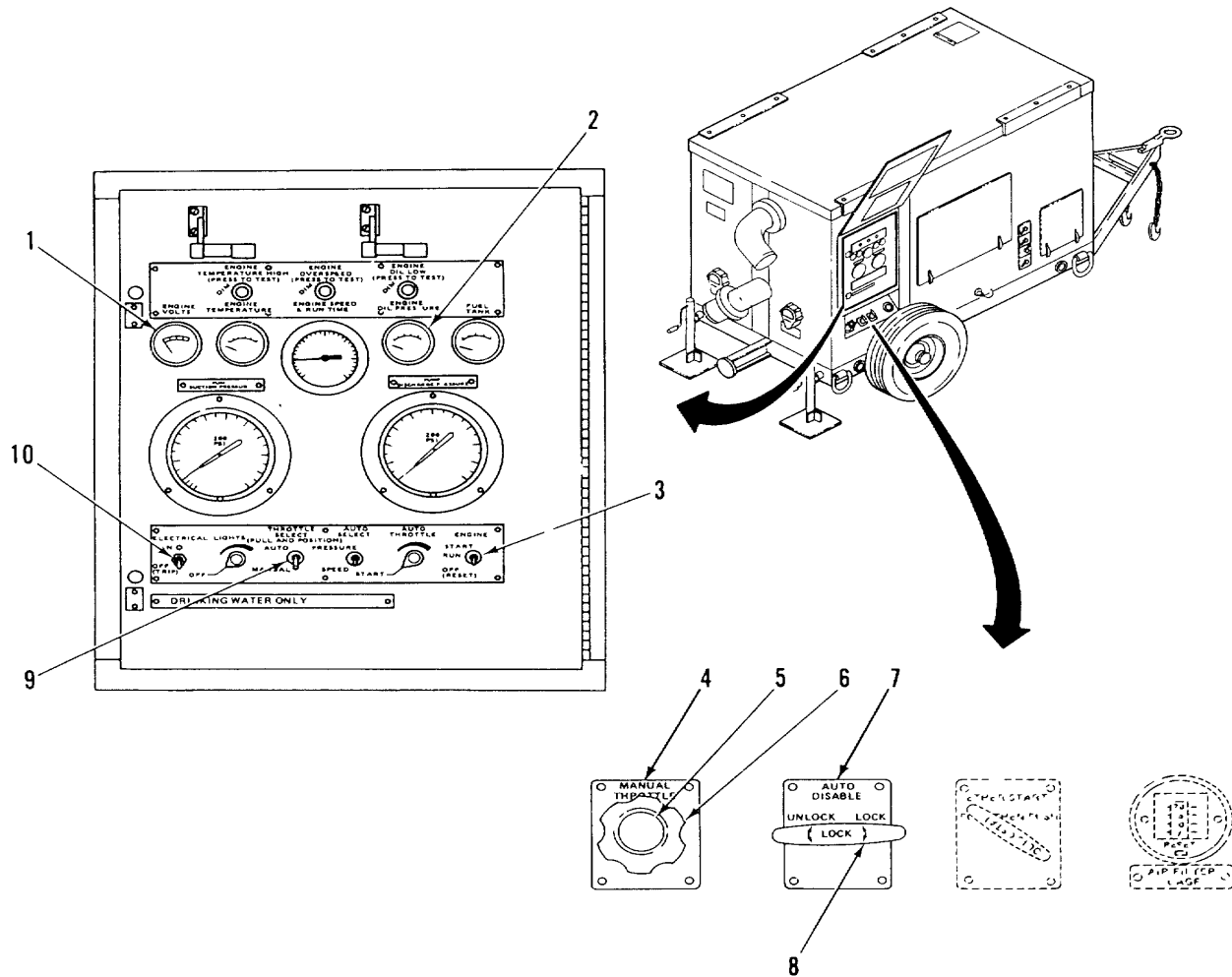

Figure 2-5. Manual Mode Operation

- (7) Check that ENGINE VOLTS meter (1) is indicating in green range.
- (8) Turn MANUAL THROTTLE (4) to desired speed. Refer to supervisor for instructions regarding desired speed. See Figure 2-8 (Control Panel Decals and Instruction Plates) operating graph.

CAUTION

The pump is self-priming after initial priming. If pump does not prime within 3 minutes, overheating and damage to seals may occur.

- (9) Check pump suction and discharge pressures. Shutdown engine if pump does not prime within 3 minutes. Refer to troubleshooting.

b. Manual Mode Operation (Shutdown). Perform the following (Figure 2-5):

- (1) Depress red button (5) to unlock MANUAL THROTTLE (4) and turn MANUAL THROTTLE knob (6) in to idle position

CAUTION

Engine is air cooled and turbocharger is hot from exhaust gases. Engine should not be shut down suddenly from full-load running or damage may occur.

- (2) Idle engine 2 to 3 minutes to allow for temperature balance.
- (3) Set ENGINE SWITCH (3) to OFF.
- (4) Set ELECTRICAL switch (10) to OFF.
- (5) Unlock and push AUTO DISABLE (7) full in and lock by turning handle (8).
- (6) Close pump suction and discharge valves
- (7) Close control panel door and air exhaust door.
- (8) Perform after (A) PMCS.

c. Automatic Mode Operation (Starting, Pump Pressure Control). Perform the following (Figure 2-6):

- (1) Depress red button (4) to unlock MANUALTHROTTLE (5) and turn MANUALTHROTTLE knob (6) to full run position. Then release red button (4) to lock.
- (2) Unlock and place AUTO DISABLE (7) fully in and lock by turning handle (8).
- (3) Set ELECTRICAL switch (12) to ON.

NOTE

Placing the ELECTRICAL switch to the OFF position deenergizes the control panel system where the engine will not start or will stop if the engine is in operation.

- (4) Set THROTTLE SELECT (11) to AUTO.
- (5) Set AUTO SELECT (10) to PRESSURE.
- (6) Turn AUTO THROTTLE (9) to START position.
- (7) Put ENGINE switch (3) to START (10-15 seconds). Release to RUN If engine does not start, wait 1 minute and restart (3 restart tries maximum). Refer to troubleshooting if engine does not start
- (8) Check ENGINE OIL PRESSURE gage (2) for 40-80 psig. Shut down engine if no oil pressure.
- (9) Check that ENGINE VOLTS meter (1) is indicating in green range.
- (10) Turn AUTO THROTTLE (9) to desired pump discharge pressure Refer to supervisor for instructions regarding desired speed

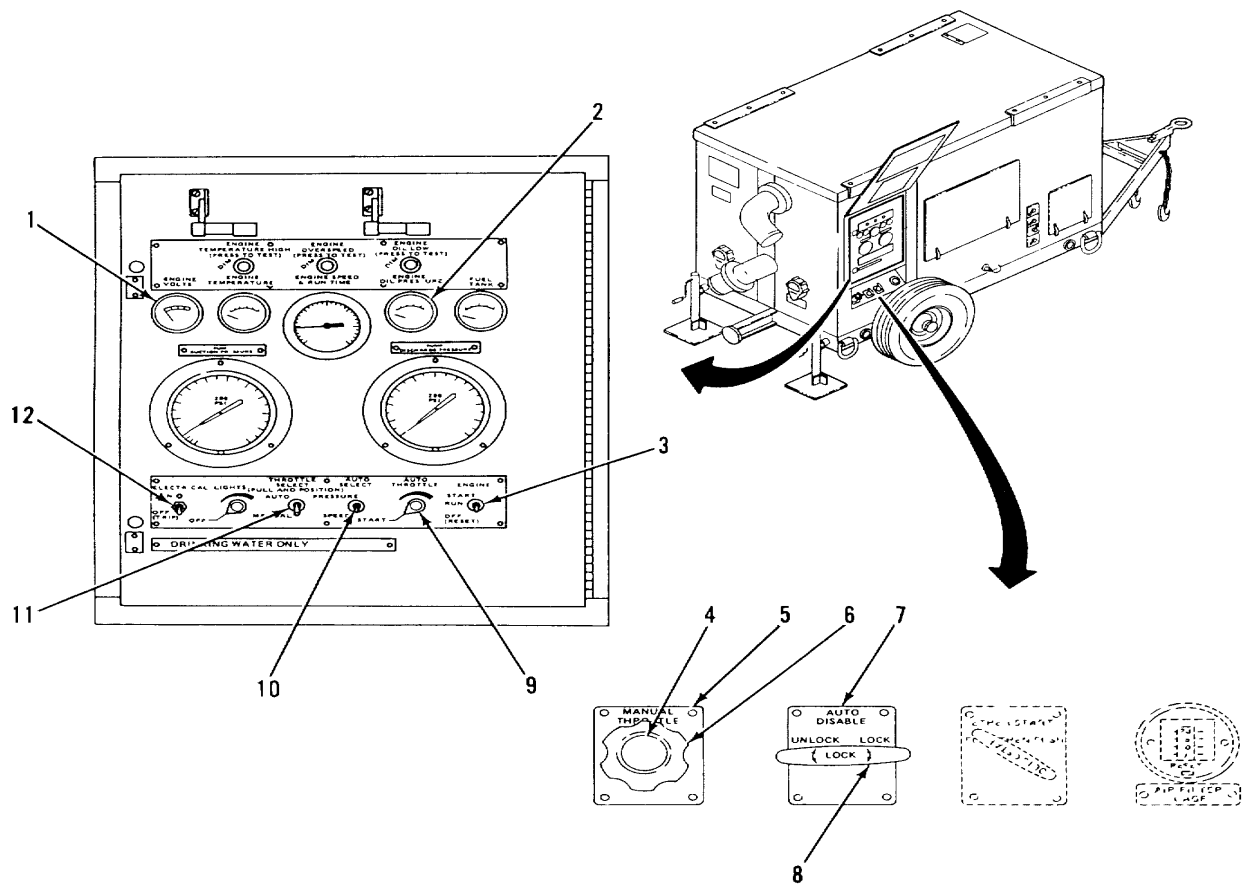

Figure 2-6. Automatic Mode Operation, Pump Pressure Control

CAUTION

The pump is self-priming after initial priming. If pump does not prime within 3 minutes, overheating and damage to seals may occur

- (11) Check pump suction and discharge pressures Shutdown engine if pump does not prime within 3 minutes. Refer to troubleshooting.

d. Automatic Mode Operation (Shutdown, Pump Pressure Control). Perform the following (Figure 2-6)

- (1) Turn AUTO THROTTLE (9) to START position

CAUTION

Engine is air cooled and turbocharger is hot from exhaust gases. Engine should not be shutdown suddenly from full-load running or damage may occur.

- (2) Idle engine 2 to 3 minutes to allow for temperature balance.
- (3) Set ENGINE SWITCH (3) to OFF.
- (4) Set ELECTRICAL SWITCH (12) to OFF.
- (5) Depress red button (4) to unlock MANUAL THROTTLE (5) and turn MANUAL THROTTLE knob (6) in to idle position
- (6) Close pump suction and discharge valves.
- (7) Close control panel door and air exhaust door.
- (8) Perform after (A) PMCS

e. Automatic Mode Operation (Starting, Pump Speed Control). Perform the following (Figure 2-7):

- (1) Depress red button (4) to unlock MANUAL THROTTLE (5) and turn MANUAL THROTTLE knob (6) to full run position. Then release red button (4) to lock.
- (2) Unlock and place AUTO DISABLE (7) fully in and lock by turning handle (8).
- (3) Set ELECTRICAL switch (12) to ON

NOTE

Placing the ELECTRICAL switch to the OFF position deenergizes the control panel system where the engine will not start or will stop if the engine is in operation.

- (4) Set THROTTLE SELECT (11) to AUTO
- (5) Set AUTO SELECT (10) to SPEED.
- (6) Turn AUTO THROTTLE (9) to START position.
- (7) Put ENGINE switch (3) to START (10-15 seconds) Release to RUN. If engine does not start, wait 1 minute and restart (3 restart tries maximum) Refer to troubleshooting if engine does not start.
- (8) Check ENGINE OIL PRESSURE gage (2) for 40-80 psig. Shut down engine if no oil pressure.
- (9) Check that ENGINE VOLTS meter (1) is indicating in green range
- (10) Turn AUTO THROTTLE to desired pump speed Refer to supervisor for instructions.

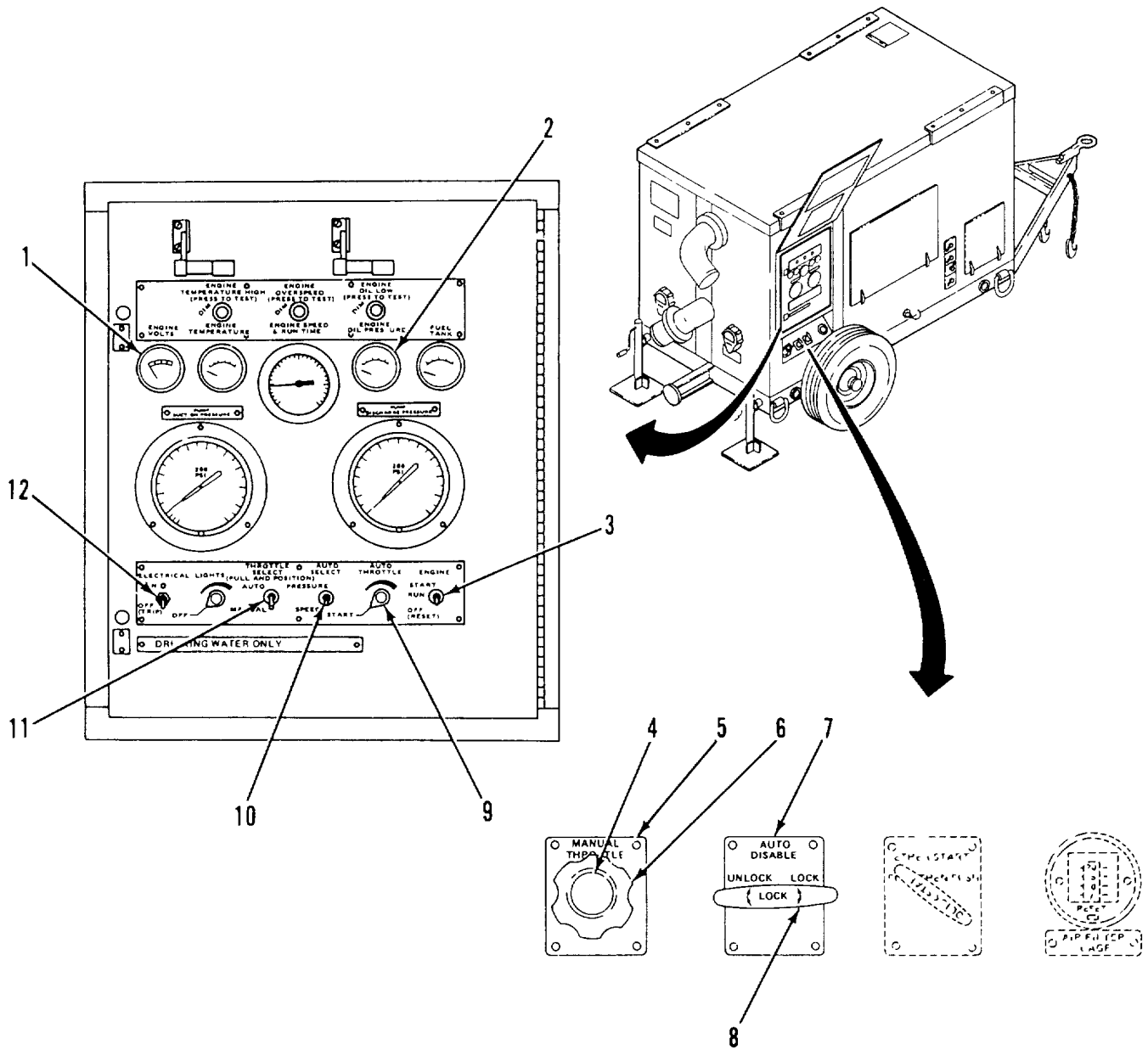

Figure 2-7. Automatic Mode Operation, Pump Speed Control

CAUTION

The pump is self-priming after initial priming. If pump does not prime within 3 minutes, overheating and damage to seals may occur.

- (11) Check pump suction and discharge pressures. Shut down engine if pump does not prime within 3 minutes. Refer to troubleshooting.

f. Automatic Mode Operation (Shutdown. Pump Steed Control). Perform the following (Figure 2-7):

- (1) Turn AUTO THROTTLE (9) to START position.

CAUTION

Engine is air cooled and turbocharger is hot from exhaust gases. Engine should not be shutdown suddenly from full-load running or damage may occur.

- (2) Idle engine 2 to 3 minutes to allow for temperature balance.
- (3) Set ENGINE SWITCH (3) to OFF
- (4) Set ELECTRICAL SWITCH (12) to OFF.
- (5) Depress red button (4) to unlock MANUAL THROTTLE (5) and turn MANUAL THROTTLE knob (6) in to idle position.
- (6) Close pump suction and discharge valves.
- (7) Close control panel door and air exhaust door.
- (8) Perform after (A) PMCS.

2-9. Operation of Auxiliary Equipment. Not applicable.

2-10. Preparation for Movement. Perform the following:

- a. Disconnect System. Disconnect pump suction and discharge lines system.
- b. Prepare Pumping Assembly. Perform the following (Figure 2-8):
 - (1) Remove pump drain cap (9) and allow pump to drain.
 - (2) When all water has drained from pump, reinstall drain cap (9).
 - (3) Install protective covers on pump suction and discharge ports (7 and 8).

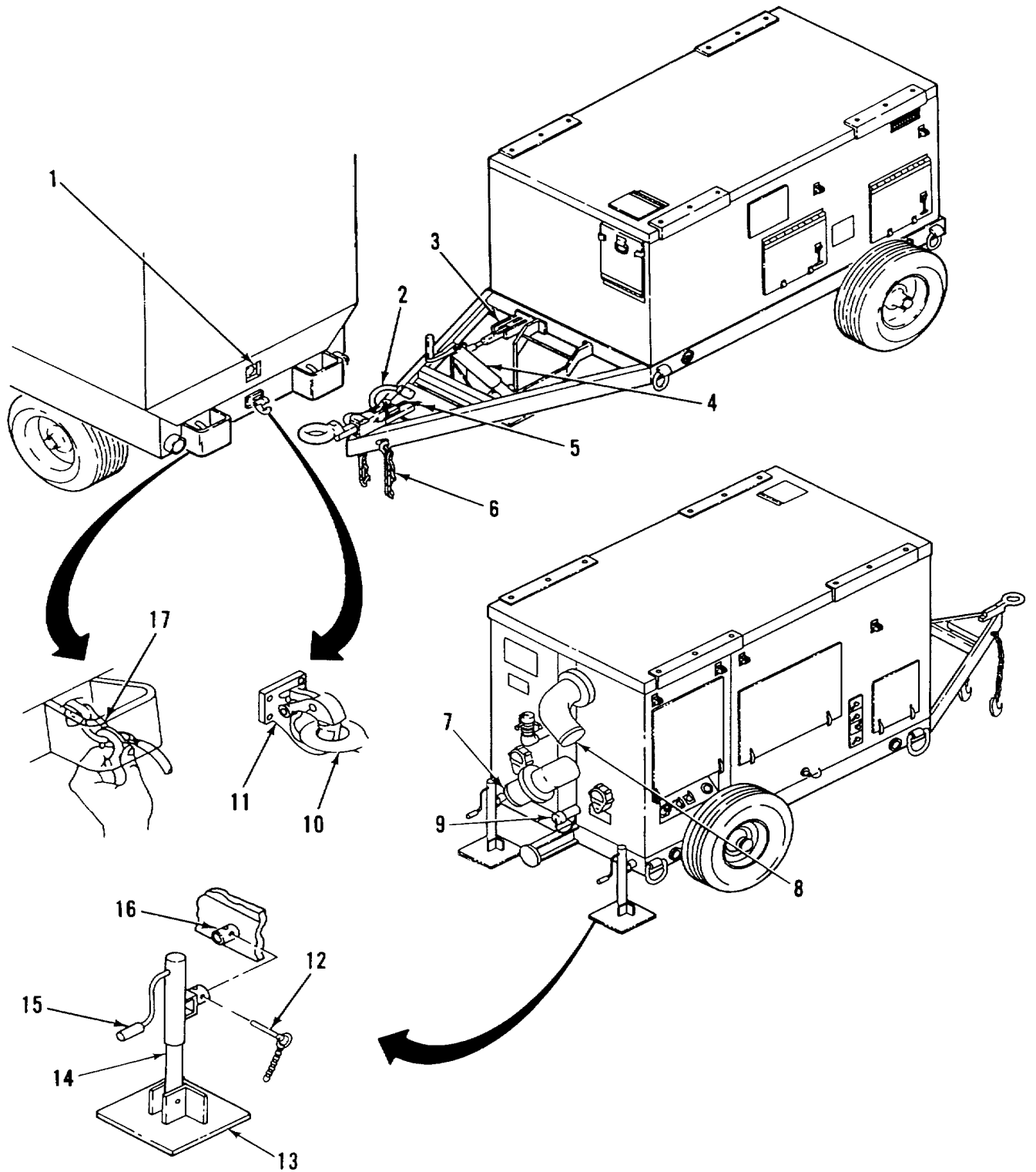

Figure 2-8. Preparation for Movement

CAUTION

Jack may come off bracket when pin is pulled

- (4) Remove jacks (14) from operation position and install in stow position as follows:
 - (a) Use jack handle (15) to raise pad (13).
 - (b) Remove locking pin (12).
 - (c) Rotate jack (14) on bracket (16) to stow position.
 - (d) Install locking pin (12) through jack (14) and bracket (16).
 - (e) Pivot pad (13) on jack (14) to where top of pad faces trailer chassis. Then use jack handle (15) to place edge of pad (13) against upper tube housing of jack (14).

NOTE

Placing pad in position against upper tube housing of jack secures the pad during transit.

- (5) Using front tripod (4), raise front of pumping assembly slightly higher than pintle hook (11) of tow vehicle.
- (6) Back towing vehicle to align with trailer lunette (10). Attach safety chains (6) to towing vehicle at lifting shackles (17) (one on each side) on towing vehicle. Lower pumping assembly to towing vehicle.
- (7) Attach breakaway cable (5) to lifting shackle (17) on towing vehicle.
- (8) Raise tripod (4) to transit position
- (9) Connect vehicle cable (2) to towing vehicle trailer receptacle (1).
- (10) Release trailer hand brake (3).

NOTE

Pumping assembly is now ready for movement

2-11. Operating Instructions on Decals and Instruction Plates. The location of decals and instruction plates are illustrated on Figure 2-9.

OPERATION
BEFORE STARTING

- CHECK ENGINE OIL LEVEL
- OPEN AIR DUCT
- SET CONTROL SUCTION AND DISCHARGE VALVES TO CLOSE
- PLUG PUMP DRAIN
- PRIME PUMP WITH CLEAN DRINKING WATER

AUTOMATIC OPERATION

DEFEAT MANUAL THROTTLE

- TURN MANUAL THROTTLE FULL OUT
- PUSH AUTO DEFEAT FULL IN AND LOCK

PUMP PRESSURE CONTROL

STARTING -- SET MAN ON SPEED

- SET THROTTLE SELECT TO AUTO
- SET AUTO SELECT TO PRESSURE
- TURN AUTO THROTTLE TO START RANGE
- SET ENGINE SWITCH TO START -- RELEASE TO RUN
- TURN AUTO THROTTLE TO DESIRED PUMP DISCHARGE PRESSURE

STOPPING -- TURN AUTO THROTTLE TO IDLE -- SET ENGINE SWITCH TO STOP

PUMP SPEED CONTROL

STARTING -- SET MAN ON

- SET THROTTLE SELECT TO AUTO
- SET AUTO SELECT TO SPEED
- TURN AUTO THROTTLE TO START RANGE
- SET ENGINE SWITCH TO START - RELEASE TO RUN
- TURN AUTO THROTTLE TO DESIRED PUMP SPEED

STOPPING -- TURN AUTO THROTTLE TO IDLE -- SET ENGINE SWITCH TO STOP

MANUAL OPERATION

STARTING -- SET MAN ON

- SET THROTTLE SELECT TO MANUAL
- TURN MANUAL THROTTLE FULL IN
- PULL AUTO DEFEAT FULL OUT AND LOCK
- SET ENGINE SWITCH TO START - RELEASE TO RUN
- TURN MANUAL THROTTLE OUT TO DESIRED

STOPPING -- TURN MANUAL THROTTLE FULL IN TO IDLE

- SET ENGINE SWITCH TO STOP
- PUSH AUTO DEFEAT FULL IN AND LOCK

SAFETY SHUTDOWN

AUTO SHUTDOWN OCCURS IF:

- ENGINE OVERSPEED
- ENGINE TEMPERATURE HIGH
- ENGINE OIL PRESSURE LOW

NOTE: SEE OPERATORS MANUAL WHEN AN AUTO SHUTDOWN OCCURS

RESET -- SET MAN TO OFF-- WAIT 10 SECONDS SET MAN TO ON

WHEN FINISHED PUMPING

- DRAIN PUMP
- SET CONTROL SUCTION AND DISCHARGE VALVES TO OPEN
- CLOSE AIR DUCT

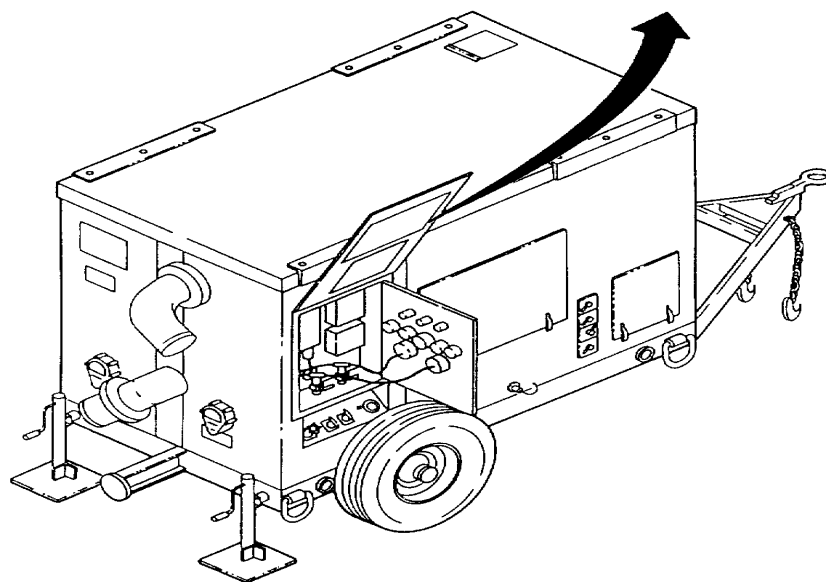

Figure 2-9. Decals and Instruction Plates (Sheet 1 of 5)

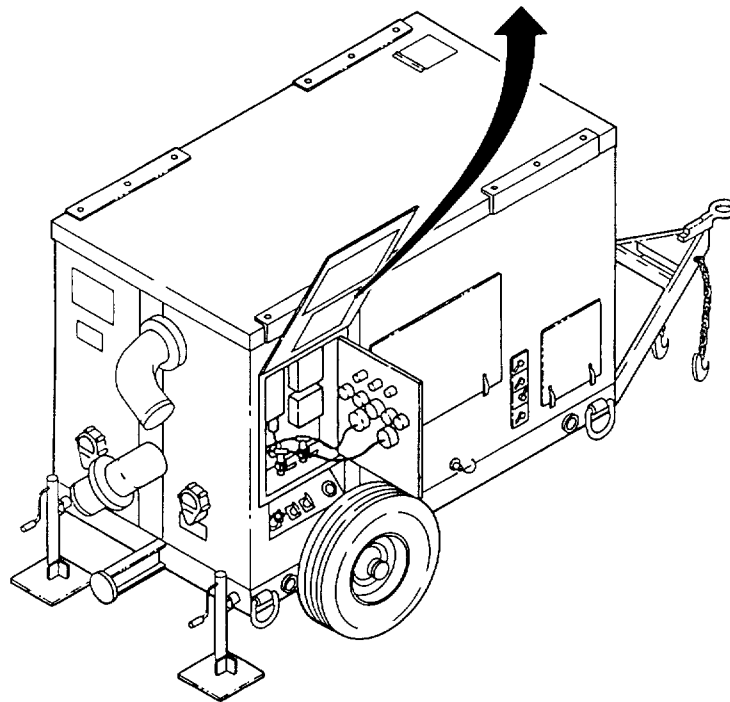
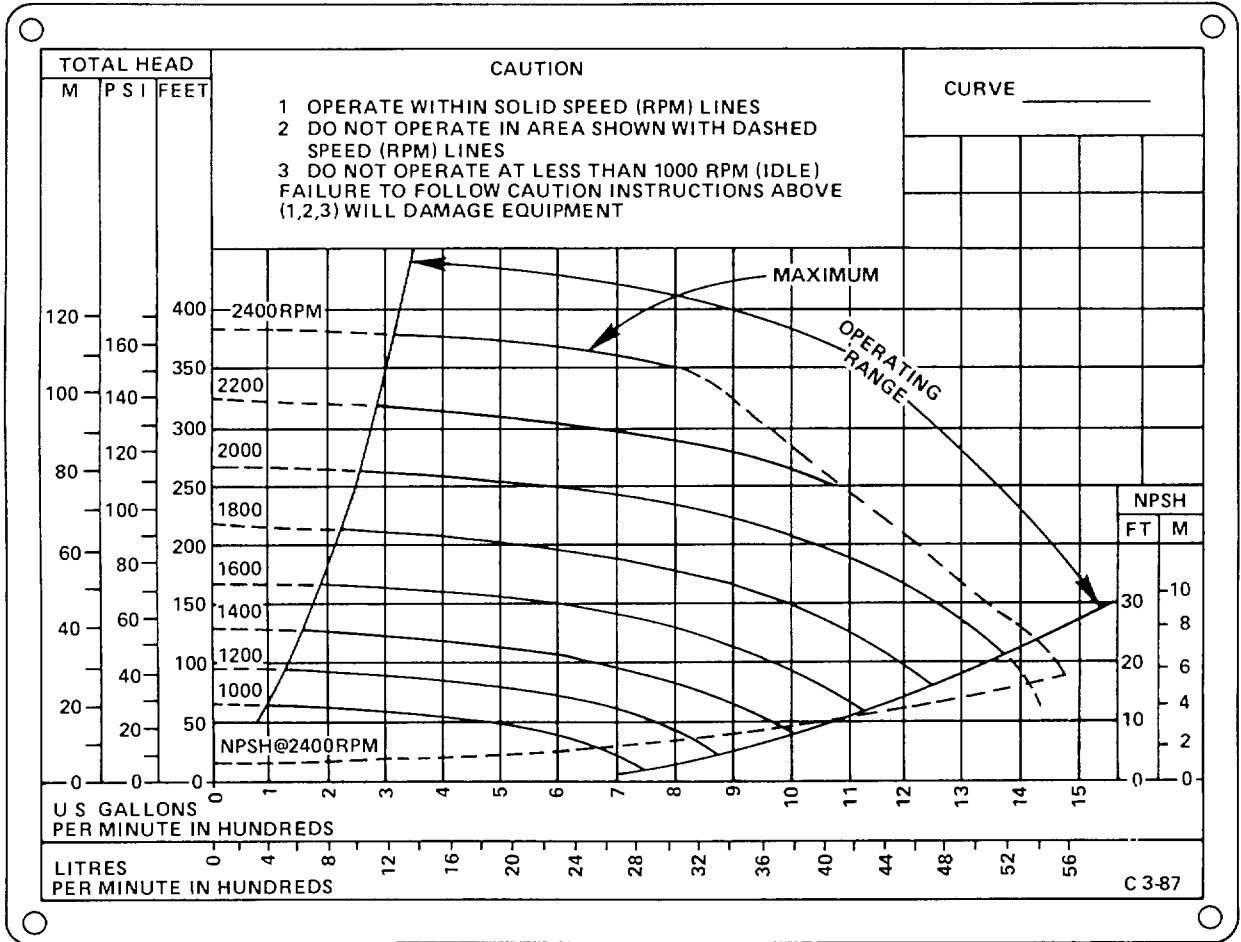
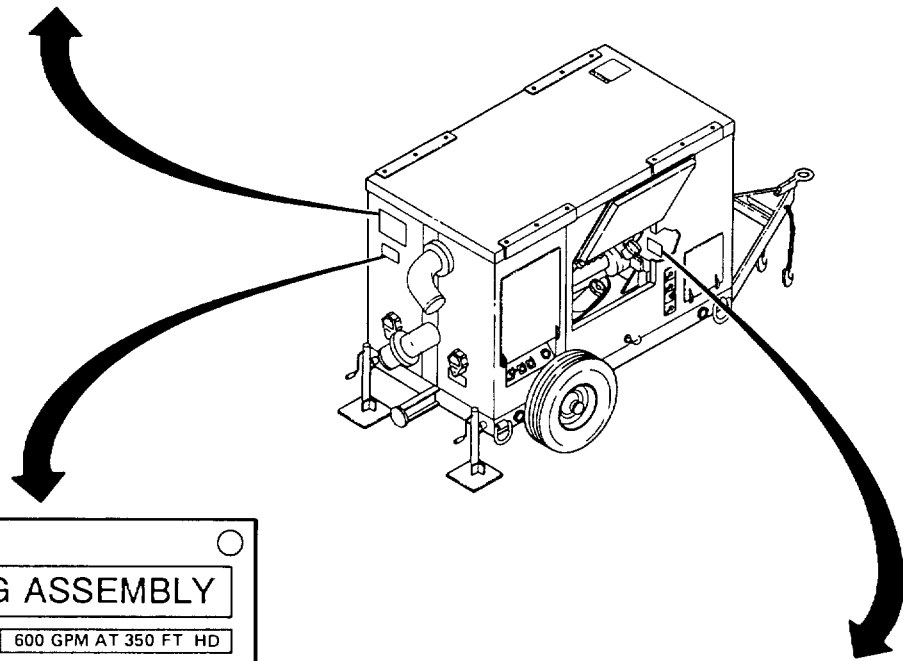
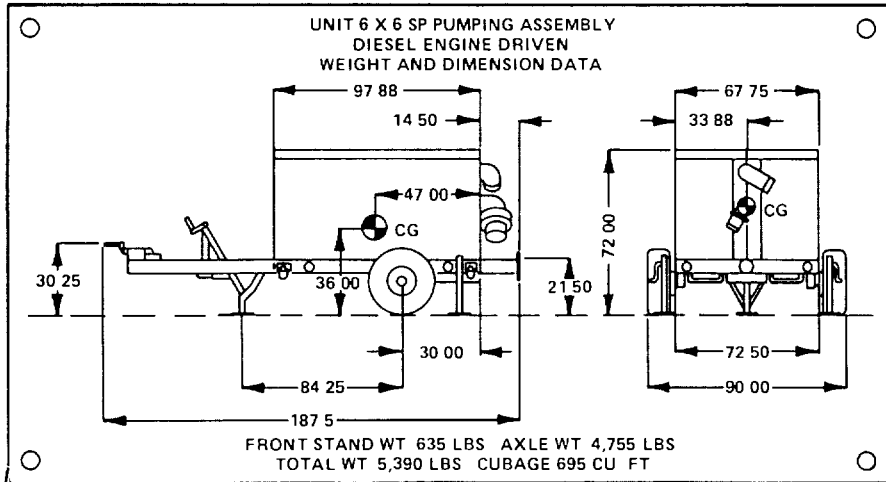

Figure 2-9. Decals and Instruction Plates (Sheet 2 of 5)



U.S.

WATER PUMPING ASSEMBLY

MODEL CAPACITY

SER DATE MANUFACTURED

ENG SER NO DATE SHIPPED

NSN CONTR NO

SHIPPING WT LB GROSS VEHICLE WT LB

LENGTH IN WIDTH IN HEIGHT IN

MFD BY

←

FILL HERE WITH

EXPECTED TEMPERATURE	LUBRICANT
BELOW 0° F	SAE 5W
- 10 TO + 60° F	SAE 10W
+ 50 TO + 85° F	SAE 20W/20
+ 70 TO + 100° F	SAE 30W
+ 85° F AND ABOVE	SAE 40W

Figure 2-9. Decals and Instruction Plates (Sheet 3 of 5)

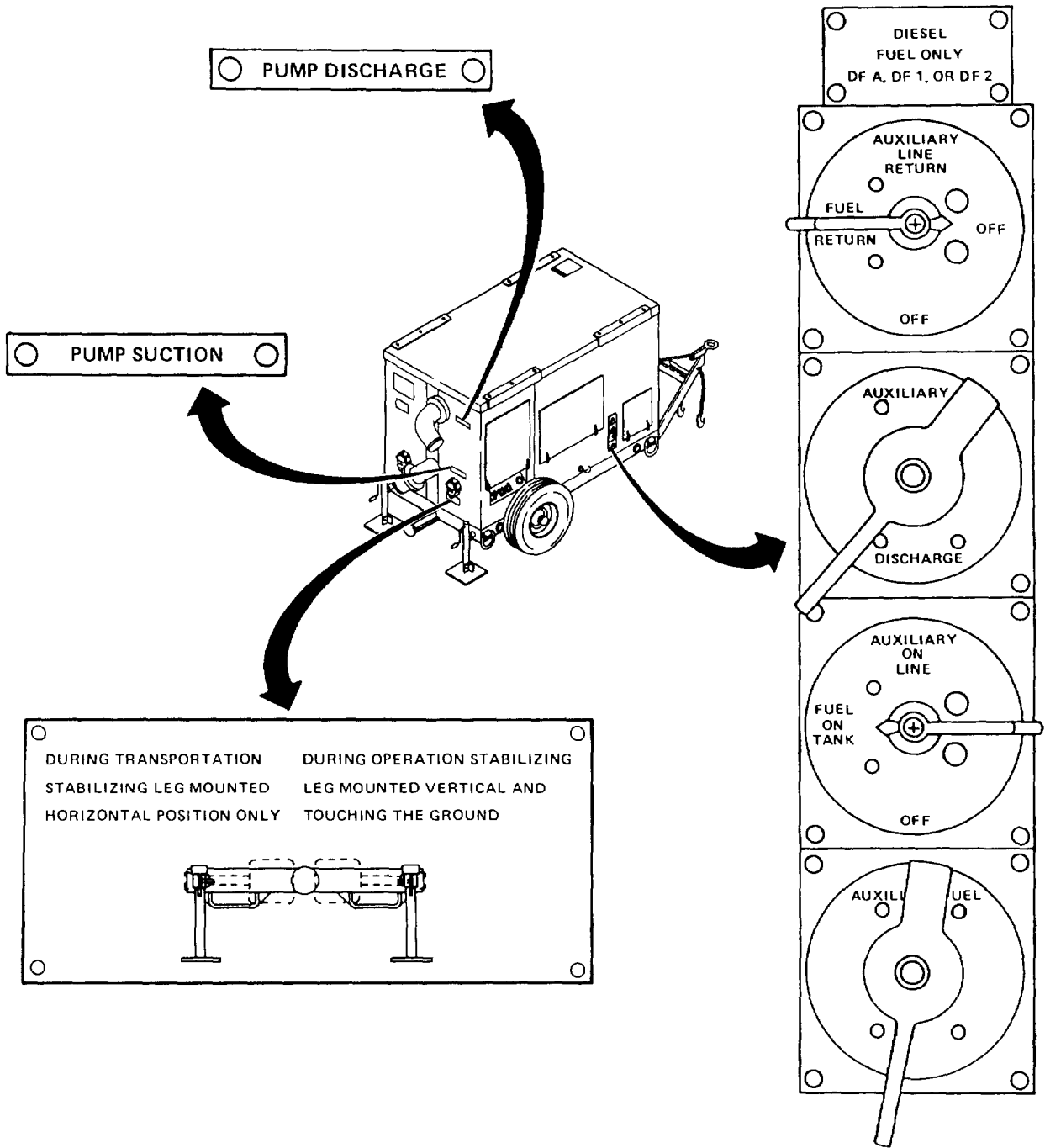

Figure 2-9. Decals and Instruction Plates (Sheet 4 of 5)

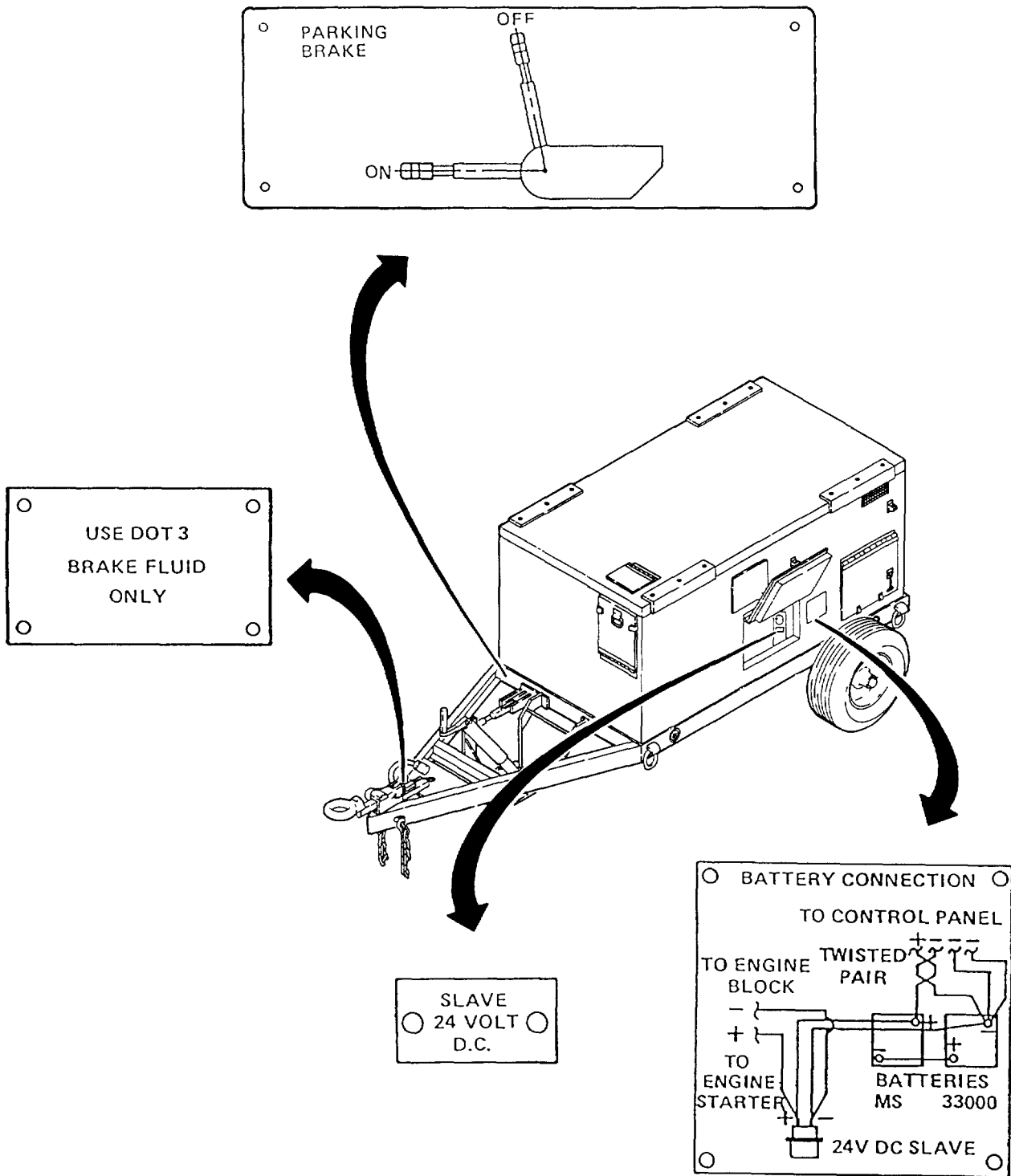

Figure 2-9. Decals and Instruction Plates (Sheet 5 of 5)

Section IV. OPERATION UNDER UNUSUAL CONDITIONS

2-12. General. This section provides instructions for operating the pumping assembly in unusual conditions.

a. Cold Climates. If freezing conditions exist (below 32°F) water in lines will freeze. If during extreme cold conditions pumping assembly is shut down, open pump drain plug and allow pump to drain. Open drain valves (1, Figure 2-10) in control panel. For operation of equipment in cold temperatures, the choice of viscosity grade lubricating oil is specified in LO 10-4320-315-12. Use ether start as cold start aid as follows (Figure 2-10).

- (1) Pull ETHER START handle (2, Figure 2-10) to inject one shot of ether into engine air cleaner line.
- (2) Push handle in to reset.

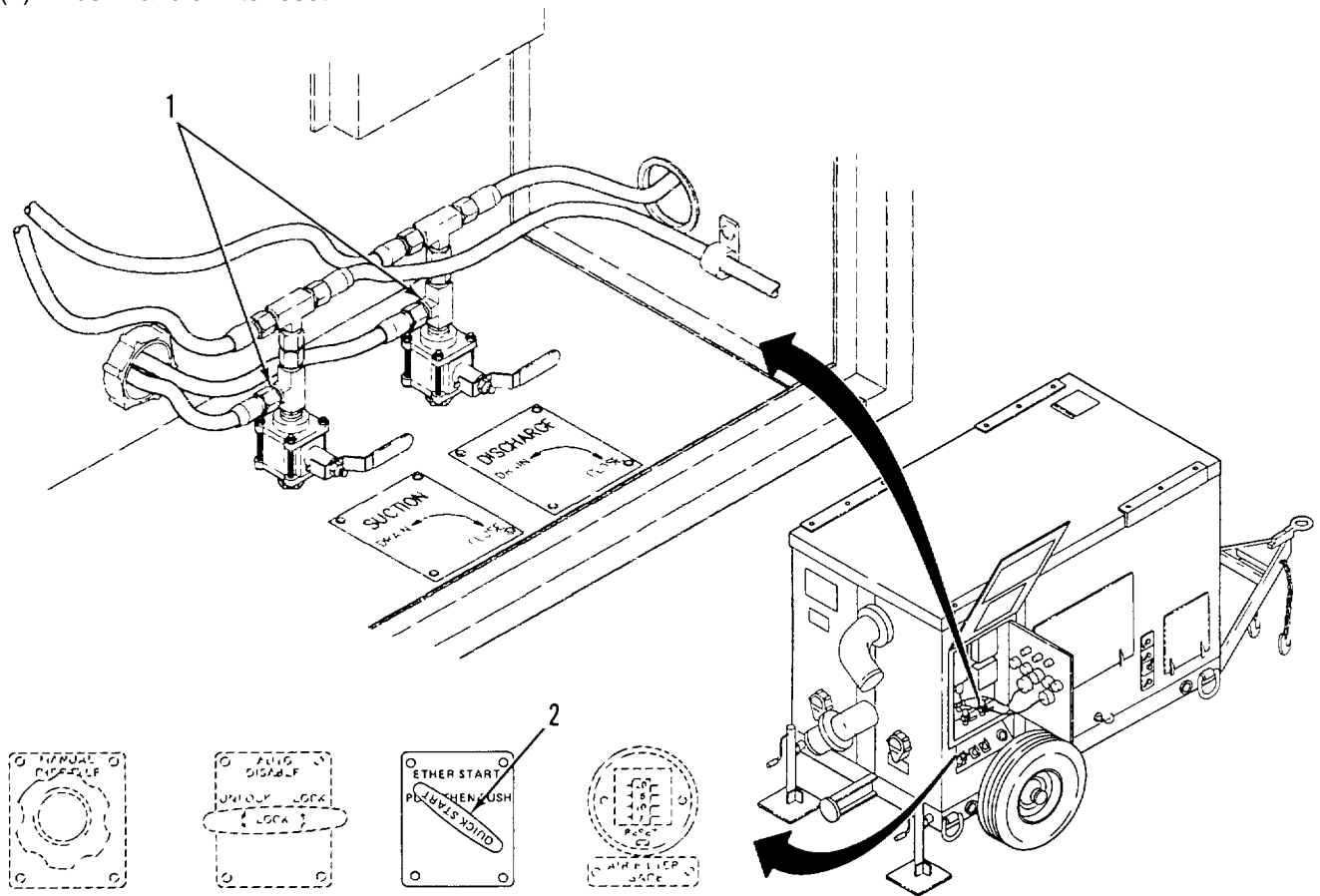

Figure 2-10. Cold Climate Operations

- b. Hot Climates. In hot climates, make sure engine receives adequate ventilation. Use the viscosity grade lubricating oil specified in LO 10-4320-315-12.
- c. Dusty or Sandy Conditions. Protect pumping assembly from sand or dust as much as possible. Check air filter restriction gage frequently.
- d. Salt Water Area. Check for rust formations weekly. Check all electrical contacts daily for evidence of corrosion.

2-13. Emergency Procedures. There are no emergency operating procedures for the pumping assembly. Refer to system manual for emergency operating procedures for operation. Automatic safety shutdown of the pumping assembly occurs from the following conditions: engine overspeeds, engine temperature high, and engine oil pressure low. The indicator lights on the control panel will indicate if anyone of these conditions occur. Refer to Table 2-1 If any indicator lights come on and engine does not shut down, the pumping assembly must be shut down manually. Refer to troubleshooting.

**CHAPTER 3
OPERATOR MAINTENANCE**

PARAGRAPH TITLE	PARAGRAPH
Air Cleaner.....	3-6
Battery	3-5
Cylinder Cooling Fins	3-7
General.....	3-2
Introduction.....	3-4
Lubrication Procedures	3-1
Operator Troubleshooting	3-3

Section I. LUBRICATION INSTRUCTIONS

3-1 Lubrication Procedures. Lubricate the pumping assembly by using lubrication order, LO 10-4320-315-12.

Section II. TROUBLESHOOTING PROCEDURES

3-2 General. This section contains troubleshooting instructions designed to be useful in diagnosing and correcting unsatisfactory operation or failure of the pumping assembly.

3-3 Operator Troubleshooting. Table 3-2 lists common malfunctions which you may find during operation or maintenance of pumping assembly or its components You should perform tests/inspections and corrective actions in order listed. Ensure that PMCS has been performed.

- a. This manual cannot list all malfunctions that may occur, nor all tests or inspections and corrective actions. If a malfunction is not listed or is not corrected by listed corrective actions, notify your supervisor.
- b. Any trouble or corrective action beyond the scope of operator maintenance shall be reported to unit maintenance.

SYMPTOM INDEX

	Troubleshooting Procedure (para.)
Engine Will Not Start or Is Hard to Start.....	1
Engine Stops Suddenly	2
Engine Hard to Start.....	3
Engine Tachometer Gage Shows Low RPM.....	4
Engine Oil Pressure Gage Shows Low Oil Pressure	5
Engine Overheating.....	6
Exhaust Smoke Excessively Black.....	7
Pump Suction and Discharge Gages Show Low Pressure	8
Running and Brake Lights Do Not Work	9

Table 3-2. Troubleshooting Procedures

MALFUNCTION	TEST OR INSPECTION	CORRECTIVE ACTION
1. ENGINE WILL NOT START OR IS HARD TO START.	Step 1. Check for loose battery connections.	Service battery (para 3-5).
	Step 2. Check fuel level gage to see if engine has enough fuel.	Add fuel.
	Step 3. Check fuel selector valves for proper alignment.	Align fuel selector valves.
	Step 4. Check initial startup procedures for correct manual/automatic operation.	If engine does not start, notify unit maintenance.
2. ENGINE STOPS SUDDENLY.	Step 1. Check if control panel indicator lights are lit.	If any are lit, notify unit maintenance.
	Step 2. Check fuel level gage to see if tank has enough fuel.	Add fuel.
	Step 3. Check throttle control linkage for secure connections.	Connect and tighten linkage.
	Step 4. Check fuel selector valves and control panel switches for proper alignment.	Align fuel selector valves and applicable startup procedures (para 2-8).
	Step 5. Check primary fuel filter for water.	Drain filter. Notify unit maintenance if engine does not start.
3. OVERSPEED INDICATOR LIGHT COMES ON.	Reset panel to initial positions and restart (para. 2-8). Notify unit maintenance if overspeed light comes on.	
4. ENGINE TACHOMETER GAGE SHOWS LOW RPM.	Step 1. Check to see if AUTO THROTTLE rheostat is at the correct position in manual/automatic mode.	Adjust rheostat (para 2-8.). If still low RPM, notify unit maintenance.

MALFUNCTION
TEST OR INSPECTION
CORRECTIVE ACTION

5. ENGINE OIL PRESSURE GAGE SHOWS LOW OIL PRESSURE.

Step 1. Check oil dipstick to see if oil level is too low.

Add oil as required.

Step 2. Check for loose wire and connections on oil sending unit sensor and oil gage.

Tighten loose connections. If still low oil pressure, notify unit maintenance.

6. ENGINE OVERHEATING.

Step 1. Check if air exhaust door is opened and air inlet openings are free of obstructions.

Open air exhaust door and remove obstructions.

Step 2. Check if cooling air blower belt is damaged or broken.

Notify unit maintenance.

Step 3. Check to see if cylinder cooling fins are clogged

Remove obstructions (para 3-7) Notify unit maintenance if engine still overheats.

7. EXCESSIVE EXHAUST SMOKE.

Step 1. Check to see if air filter gage is at 20.

Service air filter (para 3-6).

Step 2. Check oil dipstick to see if oil level is too high.

Add oil. Refer to LO 10-4320-31 -12.

Step 3. Check fuel line connections up to fuel injection pump.

Tighten connections Notify unit maintenance if still excessive exhaust smoke.

8. PUMP SUCTION AND DISCHARGE GAGES SHOW LOW PRESSURE.

Step 1. Check to see if butterfly valve in suction line is fully opened.

Open valve.

Step 2. Stop engine and check priming of pump

Prime pump (para 2-7).

Step 3. Check that gage valve on pump discharge housing is fully open.

Open gage valve.

MALFUNCTION
TEST OR INSPECTION
CORRECTIVE ACTION

8. PUMP SUCTION AND DISCHARGE GAGES SHOW LOW PRESSURE - (Cont)

Step 4. Check for proper valve positioning in system operation.

Refer to system manual Notify unit maintenance if low pressure is still indicated.

9. PUMP DOES NOT PRIME.

Step 1. Check for cracked pump housing, suction line, or discharge line.

Notify unit maintenance if leaks present.

Step 2. Check for leaking mechanical seal at pump bearing housing.

Notify unit maintenance if leaks present.

10. RUNNING AND BRAKE LIGHTS DO NOT WORK.

Step 1. Check to see if electrical cable is securely fastened to mating receptacle on tow vehicle.

Secure connection.

Step 2. Check pins on connector for damage and proper alignment.

Align pins on connector Notify unit maintenance if connector damaged.

Step 3. Remove cover and check lamps.

Replace lamps.

Step 4. Check cable for cuts or damage and proper connection to light assembly.

If cuts or damage present, notify unit maintenance

11. HANDBRAKE DOES NOT LOCK TRAILER WHEELS.

Step 1. Check handbrake tension.

Adjust handbrake tension.

Step 2. Check for damaged cables.

Notify unit maintenance if cables are damaged.

Section III. MAINTENANCE PROCEDURES

3-4 Introduction. This section contains instructions covering maintenance functions for the operator on the pumping assembly Personnel required are listed only if the task requires more than one. After completing each maintenance procedure, perform operational check to be sure that equipment is operating correctly.

3-5. MAINTENANCE OF BATTERY

This task covers: Inspect

INITIAL SETUP

Materials/Parts

Distilled Water (Item 11, Appendix D)
Wire Brush (Item 2, Appendix D)

General Safety Instructions

WARNING

Do not smoke while servicing batteries. Explosive gases are emitted from batteries in operation Ignition of these gases can cause severe personal injury. Wear safety glasses and rubber gloves.

Equipment Conditions

Pumping assembly is shutdown (para. 2-8).

INSPECT. (Figure 3-1)

- (1) Open battery access door (1).
- (2) Check cables (2) for loose connections and corrosion. Tighten loose connections. Using wire brush, clean corrosion from cables as required
- (3) Remove caps (3) and check fluid level in cells If fluid is not visible in any cell, fill to just below bottom of cap.
- (4) Close battery access door

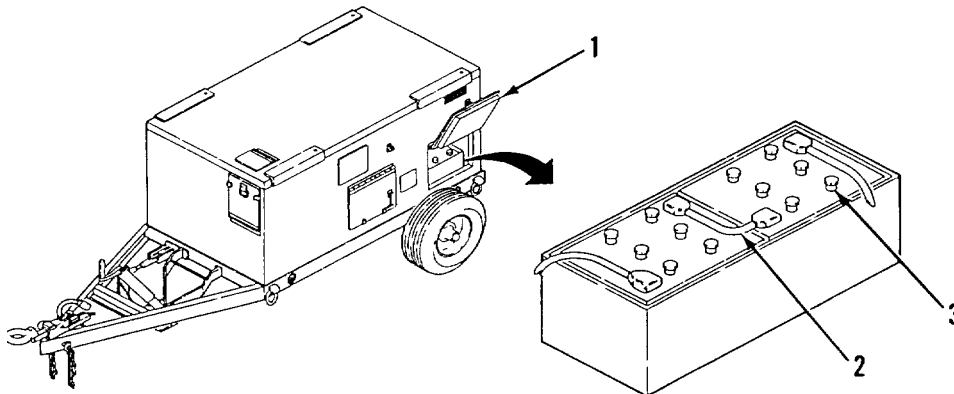

Figure 3-1. Pumping Assembly Batteries

3-6. MAINTENANCE OF AIR CLEANER

This task covers: Service

INITIAL SETUP

Materials/Parts

Cloth, Clean (Item 3, Appendix D)
Solvent, Cleaning (Item 10, Appendix D)
Filter (TM 10-4320-315-24P)
Safety Element (TM 10-4320-315-24P)

General Safety Instructions

WARNING

- Solvent may cause toxic fumes. To prevent personal injury, work only in well-ventilated area. DO NOT breath fumes for a long time.
- Solvent is flammable. To prevent fire or explosion, DO NOT bring open flame or sparks near solvent.

Equipment Conditions

Pumping assembly is shutdown (para 2-8).

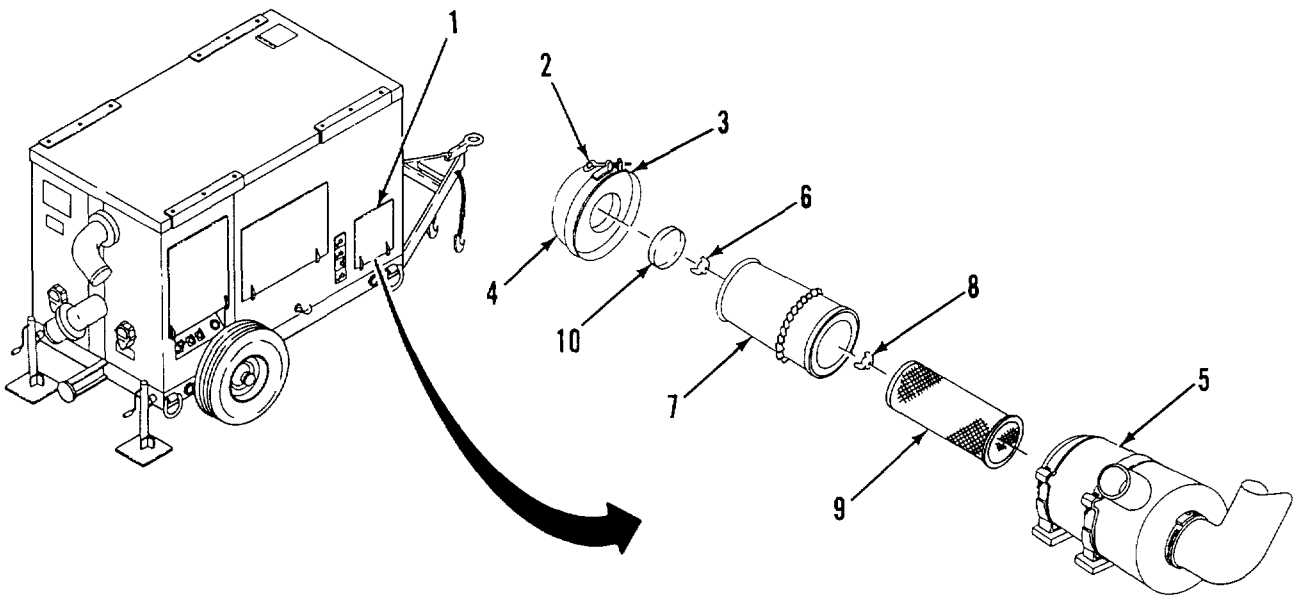

Figure 3-2. Air Cleaner

3-6. MAINTENANCE OF AIR CLEANER - (Cont)

SERVICE. (Figure 3-2)

- (1) Open air filter access door (1).
- (2) Loosen screw (2) on end cover retaining clamp (3)
- (3) Remove end cover (4) from canister body (5).
- (4) Remove filter retaining wingnut (6).
- (5) Remove filter (7) from canister body (5)
- (6) Remove safety element wingnut (8).
- (7) Remove safety element (9) from canister body (5).
- (8) Remove baffle (10) from end cover (4)
- (9) Using clean cloth dampened with cleaning solvent, wipe inside of end cover (4), canister body (5), and baffle (10).
- (10) Install baffle (10) in end cover (4).
- (11) Install safety element (9) in canister body (5). Install and tighten safety element wingnut (8).
- (12) Install filter (7) over safety element (9) and secure with filter retaining wingnut (6).
- (13) Install end cover (3) over canister body (5). Center retaining clamp (3) over end cover (4) and canister body (5).
- (14) Tighten screw (2) on end cover retaining clamp (3)

3-7. MAINTENANCE OF CYLINDER COOLING FINS

This task covers: Service

INITIAL SETUPMaterials/Parts

Brush (Item 1, Appendix D)

Equipment Conditions

Pumping assembly is shutdown (para. 2-8).

SERVICE. (Figure 3-3)

- (1) Open engine access door (1).
- (2) Remove bolts (2), flat washers (3), and access plate (4).
- (3) Unlatch and remove removable air cowling (5).
- (4) Using soft bristle brush, remove dust and dirt accumulation from cylinder cooling fins (6).
- (5) Install and latch removable air cowling (5).
- (6) Install access plate (4) with flat washers (3) and bolts (2).
- (7) Close engine access door (1).

3-7. MAINTENANCE OF CYLINDER COOLING FINS - (Cont)

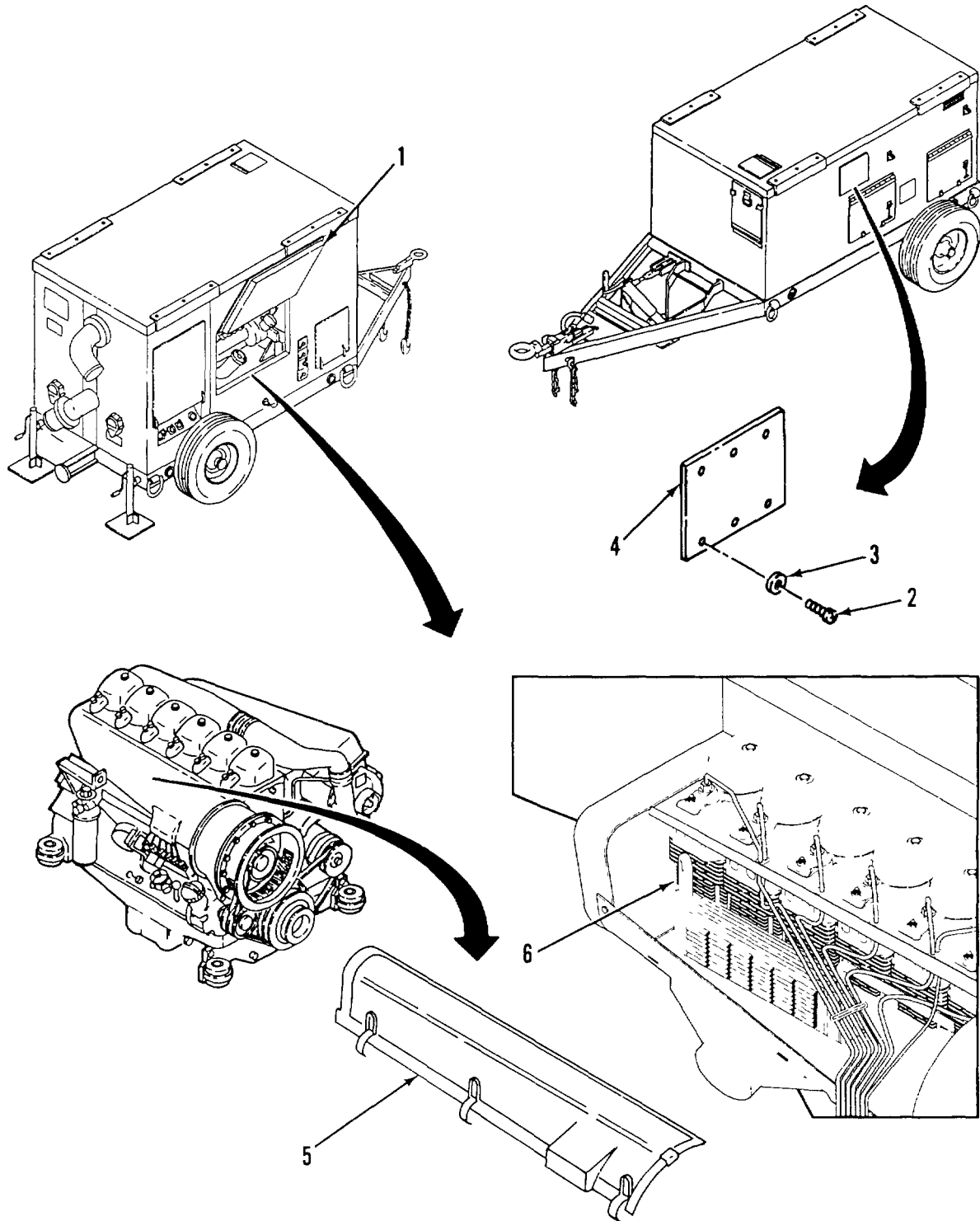

Figure 3-3. Engine Cooling Fins

3-9/(3-10 blank)

APPENDIX A

REFERENCES

A-1 SCOPE. This appendix lists all forms, field manuals, technical manuals, and miscellaneous publications referenced in this manual

A-2 FORMS.

Recommended Changes to Equipment Technical PublicationsDA-2028-2
 Recommended Changes to Publications and Blank Forms DA-2028
 Quality Deficiency ReportSF-368
 Equipment Inspection and Maintenance Worksheet DA-2404

A-3 FIELD MANUALS.

First Aid ProceduresFM 21-11

A4 TECHNICAL MANUALS.

Repair Parts and Special Tools List TM 10-4320-315-24P
 Lubrication OrderLO 10-4320-315-12
 Unit, Direct Support, and General Support
 Maintenance Manual..... TM 10-4320-315-24
 Painting Instructions for Field Use.....TM 43-0139
 Destruction of Equipment to Prevent Enemy Use TM 750-244-3

A-5 MISCELLANEOUS PUBLICATIONS.

The Army Maintenance Management System (TAMMS)DA Pamphlet 738-750
 Joint Regulation Governing the Use and Application
 of Uniform Source Maintenance and Recoverability (SMR) CodesAR 700-82
 Army Material Maintenance Concepts and PoliciesAR 750-1

A-1/(A-2 blank)

APPENDIX B

COMPONENTS OF END ITEM AND BASIC ISSUE ITEMS LISTS

SECTION I. INTRODUCTION

B-1 SCOPE. This appendix lists components of end item and basic issue items for the Pumping assembly to help you inventory items required for safe and efficient operation

B-2 GENERAL. The Components of End Item and Basic Issue Items lists are divided into the following sections:

a. Section II. Components of End Item. This listing is for informational purposes only, and is not authority to requisition replacements. As part of the end item, these items must be with the end item whenever it is issued or transferred between property accounts Illustrations are furnished to assist you in identifying the items.

b. Section III. Basic Issue Items. These are the minimum essential items required to place the Pumping assembly in operation, to operate it, and to perform emergency repairs. Although shipped separately packaged, BII must be with the Pumping assembly during operation and whenever it is transferred between property accounts. The illustrations will assist you with hard-to-identify items. This listing is your authority to request/requisition replacement BII, based on TOE/MTOE authorization of the end item

B-3 EXPLANATION OF COLUMNS. The following provides an explanation of columns found in the tabular listings.

a. Column (1) - Illustration Number (Ilus Number). This column indicates the number of the illustration in which the item is shown

b. Column (2) - National Stock Number, Indicates the national stock number assigned to the item and will be used for requisitioning purposes.

c. Column (3) - Description. Indicates the federal item name and, if required, a minimum description to identify and locate the item. The last line for each item indicates the CAGEC (in parentheses) followed by the part number.

d. Column (4) - Unit of Measure (U/M). Indicates the measure used in performing the actual operational/maintenance function This measure is expressed by a two-character alphabetical abbreviation (e.g., EA, IN, PR).

e. Column (5) - Quantity Required (Qty rqr). Indicates the quantity of the item authorized to be used with/on the equipment.

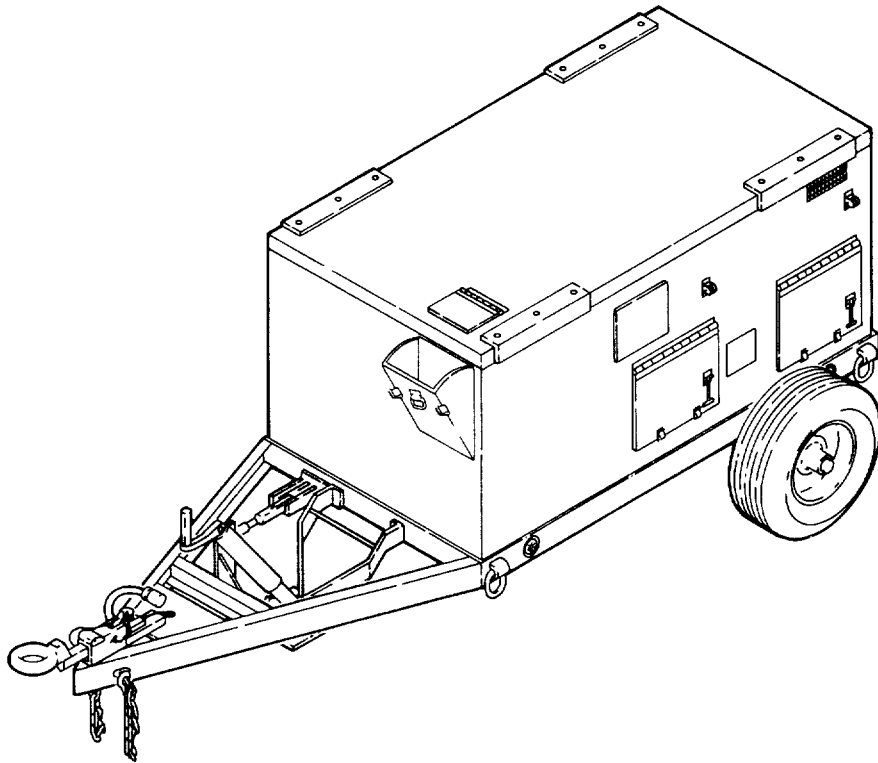

SECTION II. COMPONENTS OF END ITEM

(1) ILLUS NUMBER	(2) NATIONAL STOCK NUMBER	(3) DESCRIPTION, CAGEC and Part Number	(4) Usable On Code U/M	(5) QTY Reqd
1	4320-01-314-8844	Pumping Assembly, Water, 600 GPM, Trailer Mounted	EA	1

APPENDIX C

ADDITIONAL AUTHORIZATION LIST

SECTION I. INTRODUCTION

C-1 SCOPE. This appendix lists additional items you are authorized for the support of the pumping assembly.

C-2 GENERAL. This list identifies items that do not have to accompany the pumping assembly and that do not have to be turned in with it. These items are all authorized to you by CTA, MTOE, TDA, or JTA.

C-3 EXPLANATION OF LISTING. National stock numbers, descriptions, and quantities are provided to help you identify and request the additional items you require to support this equipment. The items are listed in alphabetical sequence by item name.

SECTION II. ADDITIONAL AUTHORIZATION LIST

(1) ILLUS NUMBER	(2) NATIONAL STOCK NUMBER	(3) DESCRIPTION CAGEC AND PART NUMBER	USABLE ON CODE	(4) U/M	(5) QTY RQR
		C-1/(C-2 blank)			

APPENDIX D

EXPENDABLE/DURABLE SUPPLIES AND MATERIALS LIST

SECTION I. INTRODUCTION

D-1 SCOPE. This appendix lists expendable supplies and materials you will need to operate and maintain the pumping assembly. This listing is for informational purposes only and is not authority to requisition the listed items. These items are authorized to you by CTA 50-970, Expendable/Durable Items (Except Medical, Class V, Repair Parts, and Heraldic Items), or CTA 8-100, Army Medical Department Expendable/Durable Items.

D-2 EXPLANATION OF COLUMNS.

a. Column (1) - Item Number. This number is assigned to the entry in the listing and is referenced in the narrative instructions to identify the material (e.g., facemask, Item 4, Appendix E).

b. Column (2) - Level. This column identifies the lowest level of maintenance that requires the listed item.

C - Operator or Crew

O - Unit Maintenance

F - Direct Support Maintenance

H - General Support Maintenance

c. Column (3) - National Stock Number. This is the national stock number assigned to the item, use it to request or requisition the item

d. Column (4) - Description. Indicates the federal item name and, if required, a description to identify the item. The last line for each item indicates the Commercial and Government Entry Code (CAGEC) in parentheses followed by the part number.

e. Column (5) - Unit of Measure (UIM). Indicates the measure used in performing the actual maintenance function. This measure is expressed by a two-character alphabetical abbreviation (e.g., EA, GL, PR). If the unit of measure differs from the unit of issue, requisition the lowest unit of issue that will satisfy your requirements.

SECTION II. EXPENDABLE/DURABLES SUPPLIES AND MATERIALS LIST

(1) ITEM NUMBER	(2) LEVEL	(3) NATIONAL STOCK NUMBER	(4) DESCRIPTION	(5) U/M
1	C	7920-00-054-7768	Brush, Cleaning Type 1 MIL-B-23958	EA
2	C	7920-00-269-1259	Brush, Wire (H-13-178)	EA
3	C	7920-00-044-9281	Cloth, Lint Free	EA
4	C	4240-00-542-2048	Faceshield	EA
5	C		Gloves, Flame Resistant	
		8415-01-134-8234	Small	PR
		8415-01-134-8232	Medium	PR
		8415-01-134-8233	Large	PR
		8415-01-135-2724	X-Large	PR
6	C	9140-00-286-5286	Oil, Fuel, Diesel DF-1, Winter (VV-F-800) Bulk	GL
7	C	9140-00-286-5294	Oil, Fuel, Diesel DF-2, Regular (W-F-800) Bulk	GL
8	C	9150-00-265-9428	Oil, Lubricating, OE/ HDO 10 (MIL-L-2104)	GL
9	C	9150-00-265-9435	Oil, Lubricating, OE/ HDO 30 (MIL-L-2104)	GL
			Oil, Lubricating, OE/ HDO 40 (MIL-L-2104)	GL
			Oil, Lubricating, OE/ 20W20 (MIL-L-46152)	GL
			Oil, Lubricating, OE/ 10W (MIL-L-46152)	GL
			Oil, Lubricating, OE/ 10W30, ML-3129 (MIL-L-46152)	GL
			Oil, Lubricating, OE/ 10W40, ML-3107 (MIL-L-46152)	GL
			Oil, Lubricating, OE/ 5W30, ML-3105 (MIL-L-46152)	GL
10	C	6850-00-281-1985	Solvent, Dry Cleaning, SD (PD-680, Type 11) 1 gal can	GL
11			Water, Distilled (O-E-41 D)	GL

GLOSSARY

Section I. ABBREVIATIONS

AAL.....	Additional Authorization List
BII.....	Basic Issue Item
COEI.....	Components of End Item
DC.....	Direct Current
EIR.....	Equipment Improvement Recommendation
kg.....	kilogram
kPa.....	kilopascals
Kw.....	kilowatt
mm.....	millimeter
MTOE.....	Modified Table of Organization and Equipment
NSN.....	National Stock Number
psi.....	pounds-per-square-inch
psig.....	pounds-per-square-inch-gage
hp.....	horsepower
IAW.....	In Accordance With
in.....	inches
l.....	liters
lb.....	pounds
m.....	meters
mm.....	millimeter
mph.....	miles per hour
N•m.....	Newton-meters
para.....	paragraph
°C.....	degrees Celsius
°F.....	degrees Fahrenheit
RPSTL.....	Repair Parts and Special Tools List
SMR.....	Source, Maintenance, and Recoverability
spm.....	stroke-per-minute
TAMMS.....	The Army Maintenance Management System
TMDE.....	Test, Measurement, and Diagnostic Equipment
TOE.....	Table of Organization and Equipment
UOC.....	Usable on Code

Section II. DEFINITION OF UNUSUAL TERMS

Pumping Assembly - Pumping Assembly, Water, 600 GPM, Trailer Mounted

Glossary-1/(Glossary-2 blank)

ALPHABETICAL INDEX

Subject, Para

A

Air Cleaner, 3-6
 Assembly and Preparation for Use, 2-6

B

Battery, 3-5

C

Cylinder Cooling Fins, 3-7

D

Destruction of Army Material to Prevent Enemy Use, 1-3

E

Emergency Procedure, 2-13
 Equipment Characteristics, Capabilities, and Features, 1-7
 Equipment Data, 1-9
 Equipment Is Not Ready/Available If Column, 2-5

F

G

General, Description and Use of Operator's Controls and Indicators, 2-1
 General, Operator Preventive Maintenance Checks and Services, 2-3
 General, Operation Under Unusual Conditions, 2-12
 General, Troubleshooting Procedures, 3-2
 Recommendations (EIRs), 1-4

H

Hand Receipt (-HR) Manuals, 1-3

I

Introduction, Maintenance Procedures, 3-4
 Initial Adjustments and Daily Checks, 2-7

J

Subject, Para

L

Location and Description of Major Components, 1-8
 Lubrication Procedure, 3-1
 List of Abbreviations, 1-6

M

Maintenance Forms, Records, and Reports, 1-2

N

O

Operating Instructions on Decals and Instruction Plates, 2-11
 Operating Procedures, 2-8
 Operator's Controls and Indicators, 2-2
 Operator Troubleshooting, 3-3
 Operation of Auxiliary Equipment, 2-9

P

Principles of Operation, 1-10
 PMCS Procedures, 2-4
 Preparation for Movement, 2-10
 Preparation for Storage or Shipment, 1-4

Q

Quality Assurance/Quality Control (QA/QC), 1-5

R

Reference Information, 1-8
 Reporting Equipment Improvement

S

Scope, 1-1

T

U

V

W

Warranty Information, 1-5

By Order of the Secretary of the Army:

Official

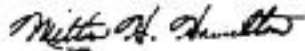

MILTON H HAMILTON
*Administrative Assistant to the
Secretary of the Army*

03146

GORDON R SULLIVAN
*General, United States Army
Chief of Staff*

DISTRIBUTION:

To be distributed in accordance with DA Form 12-25E, block no 2452, requirements for TM 10-4320-315-10

*U.S. GOVERNMENT PRINTING OFFICE: 1995 - 388-421/42011

THE METRIC SYSTEM AND EQUIVALENTS

LINEAR MEASURE

1 Centimeter	10 Millimeters	0 01 Meters	0 3937 Inches
1 Meter	100 Centimeters	1000 Millimeters	39 37 Inches
1 Kilometer	1000 Meters	0 621 Miles	

WEIGHTS

1 Gram	0 001 Kilograms	1000 Milligrams	0 035 Ounces
1 Kilogram	1000 Grams	2 2 Lb	
1 Metric Ton	1000 Kilograms	1 Megagram	1 1 Short Tons

LIQUID MEASURE

1 Milliliter	0 001 Liters	0 0338 Fluid Ounces
1 Liter	1000 Milliliters	33 82 Fluid Ounces

SQUARE MEASURE

1 Sq Centimeter	100 Sq Millimeters	0 155 Sq Inches
1 Sq Meter	10,000 Sq Centimeters	10 76 Sq Feet
1 Sq Kilometer	1,000,000 Sq Meters	0 386 Sq Miles

CUBIC MEASURE

1 Cu Centimeter	1000 Cu Millimeters	0 06 Cu Inches
1 Cu Meter	1,000,000 Cu Centimeters	35 31 Cu Feet

TEMPERATURE

5/9 (F - 32)	C
212 Fahrenheit	is equivalent to 100 Celsius
90 Fahrenheit	is equivalent to 32 2 Celsius
32 Fahrenheit	is equivalent to 0 Celsius
9/5 C + 32	F

APPROXIMATE CONVERSION FACTORS

TO CHANGE	TO	MULTIPLY BY
Inches	Centimeters	2 540
Feet	Meters	0 305
Yards	Meters	0 914
Miles	Kilometers	1 609
Square Inches	Square Centimeters	6 451
Square Feet	Square Meters	0 093
Square Yards	Square Meters	0 836
Square Miles	Square Kilometers	2 590
Acres	Square Hectometers	0 405
Cubic Feet	Cubic Meters	0 028
Cubic Yards	Cubic Meters	0 765
Fluid Ounces	Milliliters	29 573
Pints	Liters	0 473
Quarts	Liters	0 946
Gallons	Liters	3 785
Ounces	Grams	28 349
Pounds	Kilograms	0 454
Short Tons	Metric Tons	0 907
Pound-Feet	Newton-Meters	1 356
Pounds per Square Inch	Kilopascals	6 895
Miles per Gallon	Kilometers per Liter	0 425
Miles per Hour	Kilometers per Hour	1 609

TO CHANGE	TO	MULTIPLY BY
Centimeters	Inches	0 394
Meters	Feet	3 280
Meters	Yards	1 094
Kilometers	Miles	0 621
Square Centimeters	Square Inches	0 155
Square Meters	Square Feet	10 764
Square Meters	Square Yards	1 196
Square Kilometers	Square Miles	0 386
Square Hectometers	Acres	2 471
Cubic Meters	Cubic Feet	35 315
Cubic Meters	Cubic Yards	1 308
Milliliters	Fluid Ounces	0 034
Liters	Pints	2 113
Liters	Quarts	1 057
Liters	Gallons	0 264
Grams	Ounces	0 035
Kilograms	Pounds	2 205
Metric Tons	Short Tons	1 102
Newton-Meters	Pound-Feet	0 738
Kilopascals	Pounds per Square Inch	0 145
Kilometers per Liter	Miles per Gallon	2 354
Kilometers per Hour	Miles per Hour	0 621

PIN: 070768-000

This fine document...

Was brought to you by me:



[Liberated Manuals -- free army and government manuals](#)

Why do I do it? I am tired of sleazy CD-ROM sellers, who take publicly available information, slap “watermarks” and other junk on it, and sell it. Those masters of search engine manipulation make sure that their sites that sell free information, come up first in search engines. They did not create it... They did not even scan it... Why should they get your money? Why are not letting you give those free manuals to your friends?

I am setting this document FREE. This document was made by the US Government and is NOT protected by Copyright. Feel free to share, republish, sell and so on.

I am not asking you for donations, fees or handouts. If you can, please provide a link to liberatedmanuals.com, so that free manuals come up first in search engines:

<A HREF=<http://www.liberatedmanuals.com/>>Free Military and Government Manuals

- Sincerely
Igor Chudov
<http://igor.chudov.com/>
- [Chicago Machinery Movers](#)