

**TECHNICAL MANUAL
OPERATOR, UNIT, DIRECT SUPPORT, AND GENERAL SUPPORT
MAINTENANCE MANUAL**

**FOR
WATER PUMPING ASSEMBLY, DIESEL ENGINE DRIVEN,
WHEEL MOUNTED, 350 GALLONS PER MINUTE (GPM),**

275 FOOT HEAD, MODELS:

**350 PAW (NSN 4320-01-158-2954),
W-87012 (NSN 4320-01-265-2168)**

AND

350 PAWN (NSN 4320-01-436-0188)

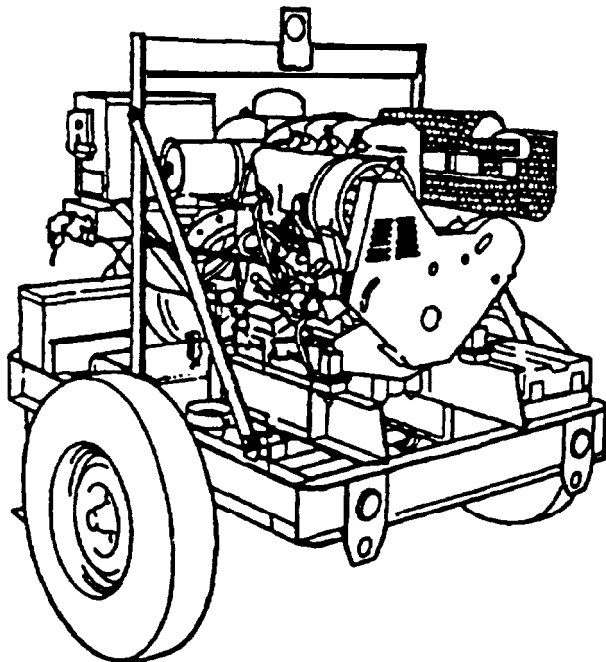

**EQUIPMENT
DESCRIPTION**

**OPERATING
INSTRUCTIONS**

**OPERATOR PREVENTIVE
MAINTENANCE CHECKS
AND SERVICES (PMCS)**

**OPERATOR MAINTENANCE
PROCEDURES**

**UNIT PREVENTIVE
MAINTENANCE CHECKS
AND SERVICES (PMCS)**

**UNIT MAINTENANCE
PROCEDURES**

**DIRECT SUPPORT
MAINTENANCE
PROCEDURES**

**GENERAL SUPPORT
MAINTENANCE
PROCEDURES**

**MAINTENANCE
ALLOCATION
CHART**

GLOSSARY

INDEX

*This manual, together with TM 10-4320-343-14, supersedes TM 5-4320-226-14, 15 August 1964

**HEADQUARTERS, DEPARTMENT OF THE ARMY
31 AUGUST 1993**

CHANGE

NO. 2

HEADQUARTERS
DEPARTMENT OF THE ARMY
WASHINGTON, D.C., 30 September 1998

Operator, Unit, Direct Support, and General Support
Maintenance Manual
for

**WATER PUMPING ASSEMBLY, DIESEL ENGINE DRIVEN,
WHEEL MOUNTED, 350 GALLONS PER MINUTE (GPM),
275 FOOT HEAD, MODELS:
350 PAW (NSN 4320-01-158-2954),
W-87012 (NSN 4320-01-265-2168)
AND
350 PAWN (NSN 4320-01-436-0188)**

DISTRIBUTION STATEMENT A: Approved for public release; distribution is unlimited.

TM 10-4320-226-14,31 August 1993, is changed as follows:

1. Remove and insert pages as indicated below. New or changed text material is indicated by a vertical bar in the margin. An illustration change is indicated by a pointing hand.

Remove Pages	Insert Pages
a/(b blank)	a/(b blank)
i - through viii/(ix blank)	i through viii
1-0	1-0
1-1 through 1-12	1-1 through 1-12
- - -	1-12.1 through 1-12.3/(1-12.4blank)
1-13and 1-14	1-13and 1-14
2-1 through 2-4	2-1 through 2-4
2-19 through 2-22	2-19 through 2-22
2-27 through 2-31/(2-32 blank)	2-27 through 2-33/(2-34 blank)
3-1 and 3-2	3-1 and 3-2
3-7 through 3-10	3-7 through 3-10
4-5 and 4-6,	4-5 and 4-6
4-17 through 4-20	4-17 through 4-20
- - -	4-20.1 through 4-20.4
4-21and4-22	4-21and4-22
4-37 and 4-38	4-37 and 4-38

Remove Pages	Insert Pages
---	4-38.1/(4-38.2 blank)
4-39 and 4-40	4-39 and 4-40
---	4-40.1 and 4-40.2
4-59 and 4-60	4-59 and 4-60
---	4-60.1/(4-60.2 blank)
4-65 and 4-66	4-65and4-66
---	4-72.1 through 4-72.3/(4-72.4 blank)
4-73 through 4-78	4-73 through 4-78
4-81 and 4-82	4-81and4-82
---	4-82.1 and 4-82.2
4-91 and 4-92	4-91 and 4-92
---	4-92.1 and 4-92.2
4-93and4-94	4-93 and 4-94
4-105 and 4-106	4-105 and 4-106
---	4-106.1 and 4-106.2
4-119/(4-120 blank)	4-119/(4-120 blank)
CI through C-3/(C-4 blank)	C-1 through C-3/(C-4 blank)
F-I through F-9/(F-10 blank)	F-1 through F-13/(F-14 blank)
Index-I through Index-6	Index-1 through Index-11/(Index-12 blank)

2 . Retain this sheet in front of the manual for reference purposes.

By Order of the Secretary of the Army:

DENNIS J. REIMER
General, United States Army
Chief of Staff

Official:

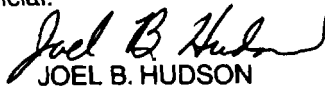

JOEL B. HUDSON

*Administrative Assistant to the
Secretary of the Army*

05359

DISTRIBUTION: To be distributed in accordance with the Initial Distribution Number (IDN) 256154, requirements for TM 10-4320-226-14.

CHANGE

NO. 1

HEADQUARTERS
DEPARTMENT OF THE ARMY
WASHINGTON, D. C., 29 July 1994

Operator, Unit, Direct Support, and General Support
Maintenance Manual
for

**WATER PUMPING ASSEMBLY, DIESEL ENGINE DRIVEN,
WHEEL MOUNTED, 350 GALLONS PER MINUTE (GPM),
275 FOOT HEAD, MODELS:
350 PAW (NSN 4320-01-158-2954)
AND
W-87012 (NSN 4320-01-265-2168)**

DISTRIBUTION STATEMENT A: Approved for public release; distribution is unlimited

TM 10-4320-226-14, 31 August 1993, is changed as follows:

1. Remove and insert pages as indicated below. New or changed text material is indicated by a vertical bar in the margin. An illustration change is indicated by a miniature pointing hand.

Remove pages

1-7 and 1-8

Insert pages

1-7 and 1-8

2. Retain this sheet in front of manual for reference purposes.

By Order of the Secretary of the Army:

Official:

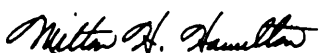
MILTON H. HAMILTON
Administrative Assistant to the
Secretary of the Army

07190

GORDON R. SULLIVAN
General, United States Army
Chief of Staff

DISTRIBUTION:

To be distributed in accordance with DA Form 12-25-E, block no. 6154, requirements for
TM 10-4320-226-14.

WARNING

Do not work on equipment that is not securely stabilized to prevent rolling or sliding.

Do not lift heavy assemblies without lifting device.

Do not operate pump unless priming port is capped. ■

Do not operate equipment in enclosed area unless exhaust gases are piped to outside and adequate ventilation is provided. Avoid inhalation of exhaust fumes.

Do not come within 50 feet of operating equipment without ear protection. ■

Do not service battery without rubber gloves and protective clothing. Electrolyte causes serious burns.

Hot surfaces can cause serious burns. Do not touch hot surfaces caused by equipment operation, ■

Do not work on equipment that is operating.

Do not smoke, use open flames or operate equipment while working with fuel. Avoid inhalation of fumes from fuel.

Dry cleaning solvent is potentially dangerous to personnel and property. Do not use dry cleaning solvent without proper ventilation and clothing. Do not smoke or use near open flame or excessive heat. Clean parts in a well-ventilated area. Avoid inhalation of solvent fumes. Wear goggles and rubber gloves to protect eyes and skin. Wash exposed skin thoroughly. Flash point of solvent is 100°F to 138°F (38°C to 59°C). ■

Failure to obey any of the above warnings may result in personnel injury or death.

Refer to FM 21-11 for first air procedures.

TECHNICAL MANUAL

NO. 10-4320-226-14

HEADQUARTERS
DEPARTMENT OF THE ARMY
WASHINGTON, D.C., 31 August 1993

OPERATOR, UNIT, DIRECT SUPPORT, AND GENERAL SUPPORT
MAINTENANCE MANUAL
FOR

WATER PUMPING ASSEMBLY, DIESEL ENGINE DRIVEN,
WHEEL MOUNTED, 350 GALLONS PER MINUTE (GPM),
275 FOOT HEAD, MODELS:
350 PAW (NSN 4320-01-158-2954),
W-87012 (NSN 4320-01-265-2168)
AND
350 PAWN (NSN 4320-01-436-0188)

REPORTING ERRORS AND RECOMMENDING IMPROVEMENTS

You can help improve this manual. If you find any mistakes, or if you know of a way to improve the procedures, please let us know. Mail your letter, DA Form 2028 (Recommended Changes to Publications and Blank Forms), or DA Form 2028-2 located in the back of this manual direct to: Commander, U.S. Army Tank-Automotive and Armaments Command ATTN: AMSTA-AC-NML, ROCK ISLAND, IL 61299-7630 A reply will be furnished to you.

DISTRIBUTION STATEMENT A. Approved for public release; distribution is unlimited.

TABLE OF CONTENTS

	Page
HOW TO USE THIS MANUAL	viii
Chapter 1 Introduction	1-1
Section I GENERAL INFORMATION	1-1
Section II EQUIPMENT DESCRIPTION	1-3
Section III PRINCIPLES OF OPERATION	1-8

* This manual, together with TM10-4320-343-14 supersedes TM5-4320-226-14,15 August 1984

TABLE OF CONTENTS - Continued

Chapter 2	Operating Instructions	2-1
Section I	Description and Use of Operator's Controls and Indicators	2-2
Section II	Operator Preventive Maintenance Checks and Services (PMCS)	2-5
Section II	Operation under Usual Conditions	2-11
Section III	Operation under Unusual Conditions	2-27
Chapter 3	Operator Maintenance Instructions	3-1
Section I	Lubrication Instructions	3-2
Section II	Operator Troubleshooting	3-2
Section III	Operator Maintenance Procedures	3-4
Chapter 4	Unit Maintenance Instructions	4-1
Section I	Repair Parts; Special Tools; Test, Measurement, Diagnostic Equipment (TMDE); and Support Equipment	4-2
Section II	Service Upon Receipt	4-3
Section III	Unit Preventive Maintenance Checks and Services (PMCS)	4-5
Section IV	Unit Troubleshooting	4-7
Section IV	Unit Maintenance Procedures	4-10
Section III	Preparation for Shipment and Storage	4-119
Chapter 5	Direct Support Maintenance Instructions	5-1
Section I	Repair Parts; Special Tools; Test, Measurement, Diagnostic Equipment (TMDE); and Support Equipment	5-2
Section II	Direct Support Troubleshooting	5-3
Section III	Direct Support Maintenance Procedures	5-5
Chapter 6	General Support Maintenance Instructions	6-1
Section I	Repair Parts; Special Tools; Test, Measurement, Diagnostic Equipment (TMDE); and Support Equipment	6-2
Section II	General Support Maintenance Procedures	6-3
Appendix A	References	A-1

TABLE OF CONTENTS - Continued

Section/Para	Page
Appendix B Maintenance Allocation Chart	B-1
Section I Introduction	B-1
Section II Maintenance Allocation Chart (MAC)	B-4
Section III Tool and Test Equipment Requirements	B-9
Section IV Remarks	B-10
Appendix C Components of End Item (COEI) and Basic Issue Items (BI) Lists	C-1
Section I Introduction	C-1
Section II Components of End Item	C-2
Section III Basic Issue Items	C-3
Appendix D Additional Authorization List (AAL)	D-1
Appendix E Expendable and Durable Items List	E-1
Section I Introduction	E-1
Section II Expendable and Durable Items List	E-2
Appendix F illustrated List of Manufactured Items	F-1
Appendix G Torque Limits	G-1
Glossary	Glossary-1
Section I Abbreviations	Glossary-1
Section II Definitions of Unusual Terms	Glossary-2
Alphabetical Index	Index-1

LIST OF ILLUSTRATIONS

Figure	Title	Page
1-1	350 GPM Pumping Assembly (AllModels)	1-0
1-2	Major Components	1-4
1-3	Electrical Schematic Diagram (Models 350 PAW and W-87012)	1-9
1-4	Fuel System Functional Diagram	1-12
1-5	Cold Start System (Models350PAWandW-87012)	1-12
1-5.1	Cold Start System (Model350PAWN)	1-12.2
1-5.2	Electrical Schematic (Model350PAWN)	1- 12.3
1-6	EngineFunctionalBlockDiagram	1-14
1-7	LubricationSystemFunctionalDiagram	1-15
1-8	ControlPanelAssemblyFunctionalDiagram	1-17
1-9	PumpAssemblyFunctionalBlockDiagram	1-18
2-1	ControlsandIndicators	2-3
2-2	OperatorPMCSRoutingDiagram(Sheet1of2)	2-6
2-3	Preparation for Use	2-12
2-4	Connecting Suction and Discharge Hoses	2-14
2-5	Pumping Assembly Operation	2-15
2-6	Performance Chart	2-18
2-7	Information Plates	2-20
2-8	Disconnecting Suction and Discharge Hoses	2-24
2-9	Preparation for Movement	2-25
2-10	ColdStartReservoirandPump(ExceptModel350PAWN)	2-28
2-10.1	Cold Start Kit (Model350PAWN)	2-30
2-11	Fuel Tank Filler Cap and Vent Valve Selector	2-31
3-1	Checking Engine Oil Level	3-4
3-2	Servicing Batteries and Cables	3-6
3-3	WaterSeparatorServicing(Models350PAWandW-87012)	3-8
3-3.1	Water/FilterSeparatorServicing(Model350PAWN)	3-9
3-4	ServicingPumpAssembly	3-10
3-5	FuelTankServicing	3-12
4-1	UnitPMCSRoutingDiagram	4-4
4-2	SparkArrestorMaintenance	4-11
4-3	ExhaustHeatShieldMaintenance	4-13
4-4	ExhaustPipeMaintenance	4-15
4-5	StartingAidHandpumpMaintenance(Models350PAWandW-87012)	4-17
4-6	StartingAidReservoirMaintenance(Models350PAWandW-87012)	4-19
4-6.1	StartingAidSolenoidMaintenance(Model350PAWN)	4-20.2
4-6.2	StartingAidTemperatureSwitchMaintenance(ModelPAWN350)	4-20.3
4-7	StartingAidNozzleMaintenance(Models350PAWandW-87012)	4-20.4
4-7.1	StartingAidNozzleMaintenance(Model350PAWN)	4-21
4-8	Air Cleaner Removal and Installation	4-22
4-9	Air Cleaner Disassembly	4-23
4-10	V-BeltGuard Removal	4-26

LIST OF ILLUSTRATIONS - Continued

Figure	Title	Page
4-11	Alternator Belt Maintenance	4-28
4-12	Cooling Fan Belt Maintenance	4-29
4-13	V-BeltContactSwitchTest	4-31
4-14	V-BeltContactSwitchReplacement	4-33
4-15	AlternatorTestConfiguration	4-33
4-16	AlternatorMaintenance	4-36
4-17	StarterAssembly	4-37
4-18	Shutdown Solenoid Test (Models350PAWandW-87012)	4-38.1
4-18.1	Shutdown Solenoid Test (Model350PAWN)	4-39
4-19	ShutdownSolenoidMaintenance(Models350PAWandW-87012)	4-40
4-19.1	ShutdownSolenoidMaintenance(Model350PAWN)	4-40.2
4-20	LowFuelPressureLines	4-43
4-21	FuelFilterOutletLine	4-45
4-22	FuelOverflowLine	4-45
4-23	SourceSelectionValveFitting	4-46
4-24	EngineReturnLines	4-46
4-25	HighPressureFuelLines.	4-47
4-26	BleedingFuelLines	4-50
4-27	FuelFeedPumpMaintenance	4-52
4-28	FuelFilterMaintenance	4-54
4-29	LowPressureSwitchandOilPressureSendingUnitMaintenance	4-55
4-30	OilLineMaintenance	4-57
4-31	CoolingFanMaintenance	4-58
4-32	CoolingCoilMaintenance(Models350PAWandW-87012)	4-60
4-32.1	CoolingCoilMaintenance(Model350PAWN)	4-60.1
4-33	EngineValveClearanceAdjustment	4-62
4-34	IdlerPulleyAssemblyMaintenance	4-63
4-35	ThrottleControlAssemblyMaintenance(AllModels)	4-65
4-36	BatteryTest	4-68
4-37	BatteryMaintenance	4-69
4-38	BatteryCableMaintenance	4-72
4-39	WiringHarnessTesting(Model350PAWN)	4-72.2
4-39.1	WiringHarnessTesting(Models350PAWandW-87012)	4-74
4-40	WiringHarnessReplacement(AllModels)	4-77
4-41	ControlPanelRemovalandInstallation	4-79
4-42	ControlPanelWiringDiagram(Models350PAWandW-87012)	4-82
4-42.1	ControlPanelWiringDiagram(Model350PAWN)	4-82.2
4-43	EmergencySwitchSIRemovalandInstallation	4-83
4-44	OilPressureBypassandPushToStartSwitchReplacement	4-85
4-45	OilPressure, Ammeter, and Tachometer/HourmeterReplacement	4-86
4-46	SuctionGauge(M4)andDischargeGauge(M5)Replacement	4-88
4-47	SafetyRelay(KI)Replacement	4-89
4-48	SafetyRelay(KI)BaseReplacement	4-90
4-49	RunRelay(K2)replacement	4-91

LIST OF ILLUSTRATIONS - Continued

Figure	Title	Page
4-50	Panel Light/Rheostat Replacement (Except on Model 350 PAWN)	4-92
4-50.1	PanelLightReplacementModel350PAWN)	4-92.2
4-51	CouplingHalfMaintenance	4-94
4-52	GateValveMaintenance	4-97
4-53	SuctionManifoldMaintenance	4-99
4-54	DischargeManifoldMaintenance	4-101
4-55	DischargeConnectionMaintenance	4-103
4-56	Water Separator Maintenance (Models350PAWandW-87012)	4-106
4-56.1	Water / Filter Separator Maintenance (Model350PAWN)	4-106.2
4-57	Tire Maintenance	4-107
4-58	Wheel Bearing Maintenance	4-109
4-59	Reflector Maintenance	4-111
4-60	Tow Bar Maintenance	4-112
4-61	Support Leg Maintenance	4-113
4-62	Tool Box Maintenance	4-115
4-63	Data Plate Maintenance	4-117
5-1	Engine Replacement	5-6
5-2	FuellInjectionPumpTiming	5-9
5-3	CompressionGaugeInstallation	5-12
5-4	IntakeManifoldMaintenance	5-14
5-5	FuellInjectionPumpMaintenance	5-17
5-6	InjectionNozzleTesting	5-19
5-7	InjectionNozzleMaintenance	5-21
5-8	EngineCowlingsMaintenance	5-24
5-9	MarkingofTopDeadCenter(TDC)	5-26
5-10	CrankshaftPulleyandSealMaintenance	5-29
5-11	CentrifugalPumpMaintenance	5-32
5-12	ImpellerMaintenance	5-35
5-13	TaperLockHubCouplingMaintenance	5-38
5-14	SleeveandRotatingAssemblyMaintenance	5-41
5-15	CouplingFlangeMaintenance	5-44
5-16	FuelTankMaintenance	5-45
5-17	AxleAssemblyMaintenance	5-47
6-1	CylinderHeadRemovalandInstallation	6-8
6-2	CylinderHeadDisassembly	6-12
6-3	CheckingCylinderHeadSeatingSurface	6-13
6-4	ValveDepthMeasurement	6-13
6-5	ValveSeatDrilling	6-14
6-6	RockerArmAssemblyMaintenance	6-17
6-7	EngineMount,FrontCover,andOilPumpRemoval	6-20
6-8	Idler Gear and Housing Adapter Removal	6-21
6-9	Cylinders,Camshaft,andFlywheelRemoval	6-23
6-10	Piston and Crank shaft Removal	6-25

LIST OF ILLUSTRATIONS - Continued

Figure	Title	Page
6-11	Crankcase Disassembly..	6-26
6-12	Checking Crankshaft Journals	6-27
6-13	Cylinder Lining Rework.	6-28
6-14	Checking Pre-Loading of Engine Bearing Bores	6-29
6-15	Timing Gears Layout with Match Marks	6-31
6-16	Piston Disassembly	6-34
F-1	Pump Wiring Harness Assembly (Models 350 PAW and W-87012)	F-2
F-1.1	Pump Wiring Harness Assembly (Model 350 PAWN)	F-4
F-2	Control Panel Wiring Harness Assembly (Models 350 PAW and W-87012)	F-7
F-2.1	Control Panel Wiring Harness Assembly (Model 350 PAWN)	F-10
F-3	Hose Assembly	F-13
G-1	Torque Instructions	G-1

LIST OF TABLES

Number	Title	Page
1-1	Nomenclature Cross-Reference List	1-2
1-2	Description of Major Components	1-3
2-1	Controls and indicators	2-2
2-2	Operator Preventive Maintenance Checks and Services for the 350 GPM Pumping Assembly	2-8
3-1	Operator Troubleshooting Table	3-2
4-1	Unit Preventive Maintenance Checks and Services for the 350 GPM Pumping Assembly	4-5
4-2	Unit Troubleshooting Table	4-7
5-1	Direct Support Troubleshooting Table	5-3
6-1	Wear Limits, Fits and Tolerances	6-3
6-2	Crankshaft Measurements	6-27
G-1	Torque Specifications for Pump Assembly	G-2
G-2	Torque Specifications for Engine	G-2

HOW TO USE THIS MANUAL

DESCRIPTION OF THE MANUAL.

Manual Organization. This manual is designed to help you operate and maintain the 350 gpm Pumping Assemblies covered in this manual. Read the warning pages, located in the front of the manual before operating or doing maintenance on the equipment.

The front cover of this manual provides an index that lists subjects that are commonly used. Each item indexed on the front cover has a black box at the edge of the cover. There is a corresponding black box on the first right-hand text page for each subject listed on the cover index.

The Table of Contents is provided for quick reference to the subjects covered by each chapter, section, and appendix. Chapters 2 through 6 also have subject indexes that list the major paragraphs in alphabetical order under the section title.

The major elements of this manual are its chapters and appendixes. The chapters and appendixes can be divided into one or more sections. This manual has six chapters and seven appendixes.

A glossary follows the last appendix. The glossary lists and explains the special or unique abbreviations and the unusual terms used in this manual.

An alphabetical index follows the glossary. That index is for use in locating specific items of information,

Locating a Malfunction. Finding the cause of a malfunction, troubleshooting, is the first step in fixing the equipment and returning it to operational readiness. Follow these simple steps to determine the root of the problem:

- a. Turn to the Table of Contents in the manual.
- b. Locate "Troubleshooting" under the chapter that covers your level of maintenance.
- c. Turn to the page indicated.

Preparing for a Task. Be sure that you understand the entire maintenance procedure before beginning any maintenance task. Make sure that all parts, materials, and tools are available. Read all steps before beginning. Prepare to do the task as follows:

- a. Carefully read the entire task before starting. It tells you what you will need and what you have to know to start the task.
- b. Obtain all listed equipment, tools and expendables.

How to do the Task. Read the entire task. Be sure that you understand the entire procedure. Perform the task. Be sure to obey all **WARNINGS** and **CAUTIONS**.

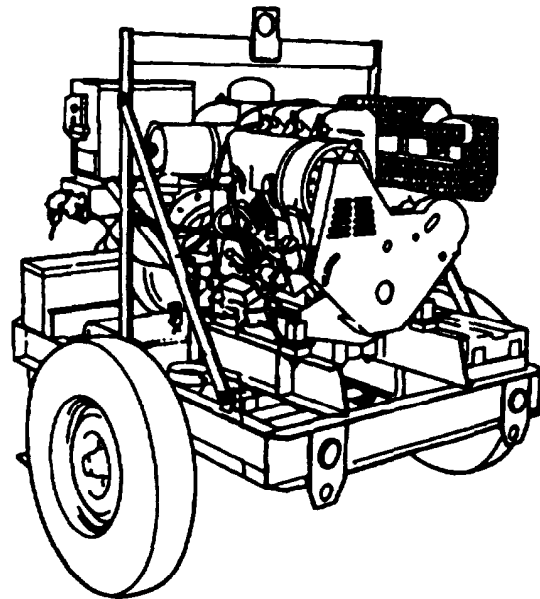
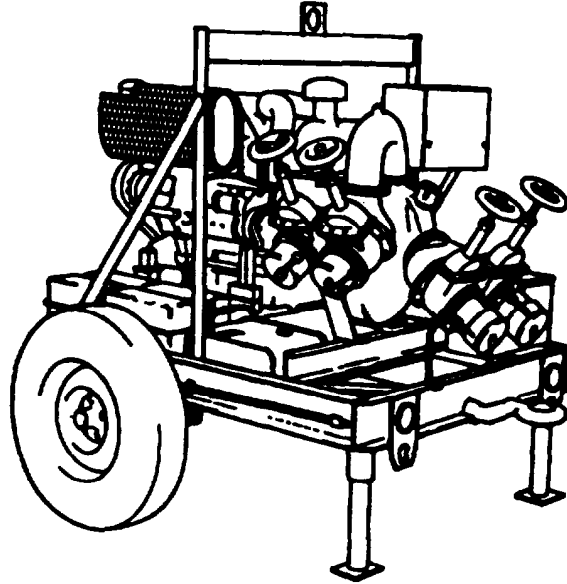

Figure 1-1. 350 GPM Pumping Assembly(All Models).

CHAPTER 1

INTRODUCTION

SECTION I. GENERAL INFORMATION

1.1 SCOPE.

This manual is for your use in operating and maintaining the 350 Gallons Per Minute (GPM), Diesel Driven Pumping Assembly, Models 350 PAW (NSN 4320-01-158-2954), W-87012 (NSN 4320-01-265-2168) and 350 PAWN (NSN 4320-01-436-0188). Figure 1-1 illustrates the equipment. The manual covers operating instructions and operator, unit, direct support, and general support maintenance requirements for the equipment.

1.2 MAINTENANCE FORMS AND PROCEDURES.

Department of the Army forms and procedures used for equipment maintenance will be those prescribed by DA PAM 738-750, (The Army Maintenance Management System (TAMMS)) (Maintenance Management Update)

1.3 CORROSION PREVENTION AND CONTROL (CPC).

Corrosion Prevention and Control (CPC) of Army material is a continuing concern. It is important that any corrosion problems with this item be reported so that the problem can be corrected and improvements can be made to prevent the problem in future items.

While corrosion is typically associated with rusting of metals, it can also include deterioration of other materials, such as rubber and plastic, Unusual cracking, softening, swelling, or breaking of these materials may be a corrosion problem.

The Form should be submitted to the address specified in DA PAM 738-750.

1.4 DESTRUCTION OF ARMY MATERIAL TO PREVENT ENEMY USE.

Refer to TM 750-244-3for instructions on destruction of Army material to prevent enemy use.

1.5 EQUIPMENT IMPROVEMENT RECOMMENDATION (EIR).

If your pumping assembly needs improvement, let us know. Send us an Equipment Improvement Recommendation (EIR). You, the user, are the only one who can tell us what you don't like about your equipment. Let us know why you don't like the design or performance. Put it on Form SF 368 (Product Quality Deficiency Report). Mail it to us at Commander, U.S. Army Tank-Automotive and Armaments Command ATTN: AMSTA-TR-E/MPA Warren, Michigan 48397-5000. We will send you a reply.

1.6 PREPARATION FOR STORAGE.

Refer to Section VI of Chapter 4 for storage requirements of the pumping assembly.

1.7 NOMENCLATURE CROSS-REFERENCE LIST

Table 1-1 provides a cross-reference listing of the common names to official nomenclature.

Table 1-1. Nomenclature Cross-Reference List.

Common Name	Official Nomenclature
Model 350 PAW	350 Gallons Per Minute (GPM) Diesel Driven Pumping Assembly
Model W-87012	350 Gallons Per Minute (GPM) Diesel Driven Pumping Assembly
Model 350 PAWN	350 Gallons Per Minute (GPM) Diesel Driven Pumping Assembly

1.8 LIST OF ABBREVIATIONS/ACRONYMS.

Refer to the glossary located in the back of this manual.

1.9 GLOSSARY.

Refer to the glossary located in the back of this manual.

SECTION II. EQUIPMENT DESCRIPTION

1.10 EQUIPMENT CHARACTERISTICS, CAPABILITIES, AND FEATURES.

The 350 GPM Pumping Assembly is designed specifically to transfer water. The unit can be transported for short distances by means of a towing vehicle or, loaded on a flatbed trailer for long distances. It consists of an air cooled, three cylinder diesel engine and a self priming centrifugal pump mounted on a two wheel frame assembly. An internal fuel; tank supplies fuel to the diesel engine, thereby making the equipment completely self supporting.

1.11 LOCATION AND DESCRIPTION OF MAJOR COMPONENTS.

Figure 1-2 illustrates the major components of the 350 GPM Pumping Assembly. Table 1-2 lists the major components and provides a description of each major component for the pumps. and provides a description of each major component of the 350 GPM Pumping Assembly.

Table 1-2. Description of Major Components.

Item No.	Item Name	Description and Purpose
1	DISCHARGE VALVE	Gate Valve, manually operated, provides positive means of pump flow shutoff. When opened, allows liquids to be discharged through centrifugal pump.
2	SUCTION VALVE	Gate Valve, manually operated, provides positive means of pump flow shutoff. When opened, allows liquids to be brought up through the centrifugal pump.
3	CENTRIFUGAL PUMP	Pumps liquids through the suction valve and out through the discharge valve.
4	CONTROL PANEL	Provides the operating controls and indicators to properly operate the pump-
5	ENGINE ASSEMBLY	An air cooled, three cylinder diesel engine that drives centrifugal pump.
6	AIR CLEANER	Filters ambient air prior to entering the diesel engine..
7	BATTERIES	Two 12 volt, 100 ampere hour, lead-acid batteries used to supply 12 V dc for engine cranking.
8	ALTERNATOR	Belt driven, provides voltage to the electrical circuits after the engine starts. In addition recharges the batteries.
9	STARTER ASSEMBLY	Turns flywheel to crank engine during start up.
10	FUEL SHUTOFF SOLENOID	Two position rack type solenoid. When either a low oil pressure condition exists, the cooling fan V-belt breaks, or the pumping assembly is to be shutdown intentionally, the solenoid interrupts fuel flow to stop the engine. The 350 PAWN uses a different fuel shutoff solenoid.
11	THROTTLE CONTROL	Controls engine speed.
12	FUEL FEED PUMP	Diaphragm type pump supplies which pumps fuel. It is actuated by cam in fuel injection pump.

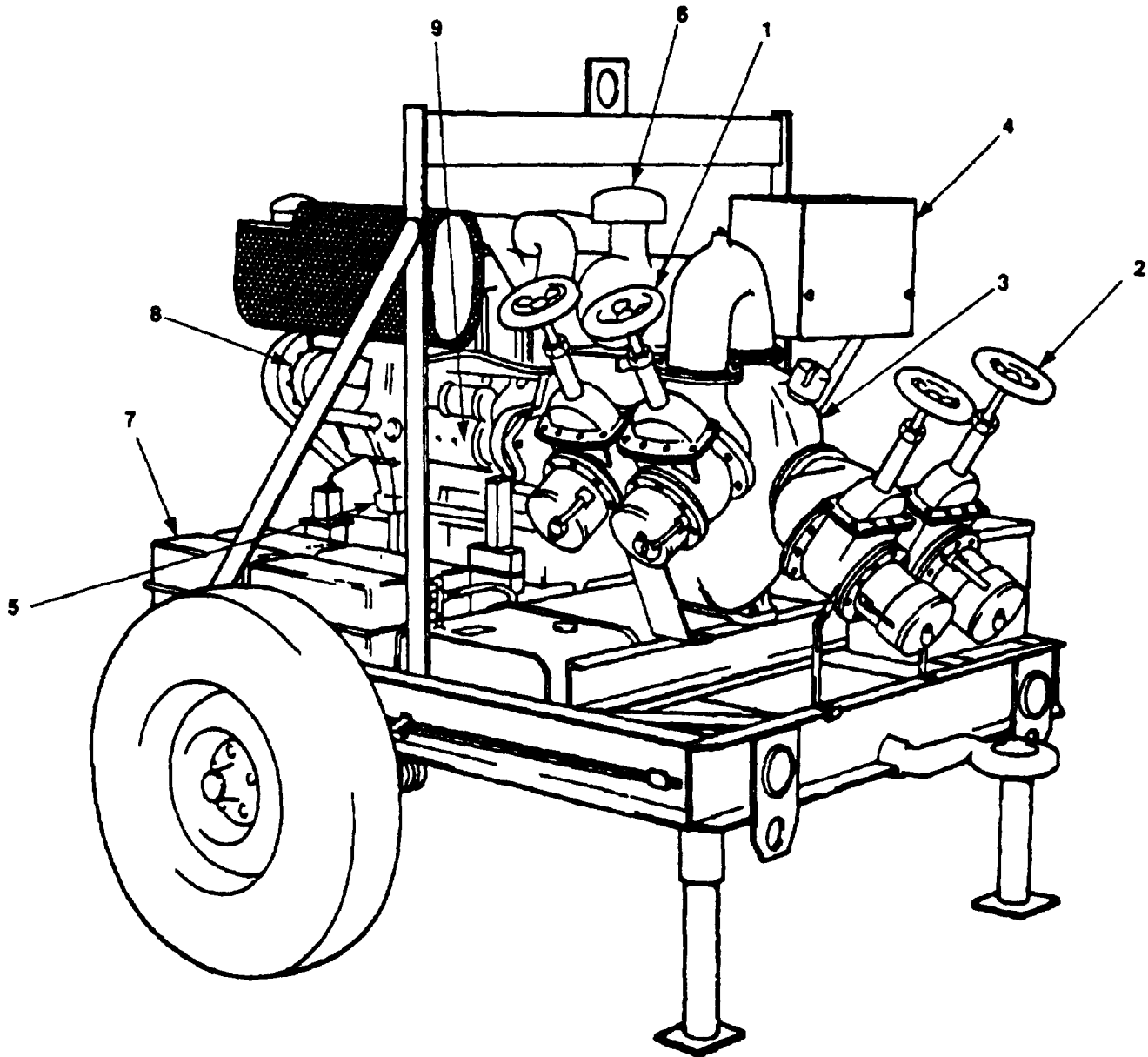

Figure 1-2. Major Components (All models) (Sheet 1 of 2).

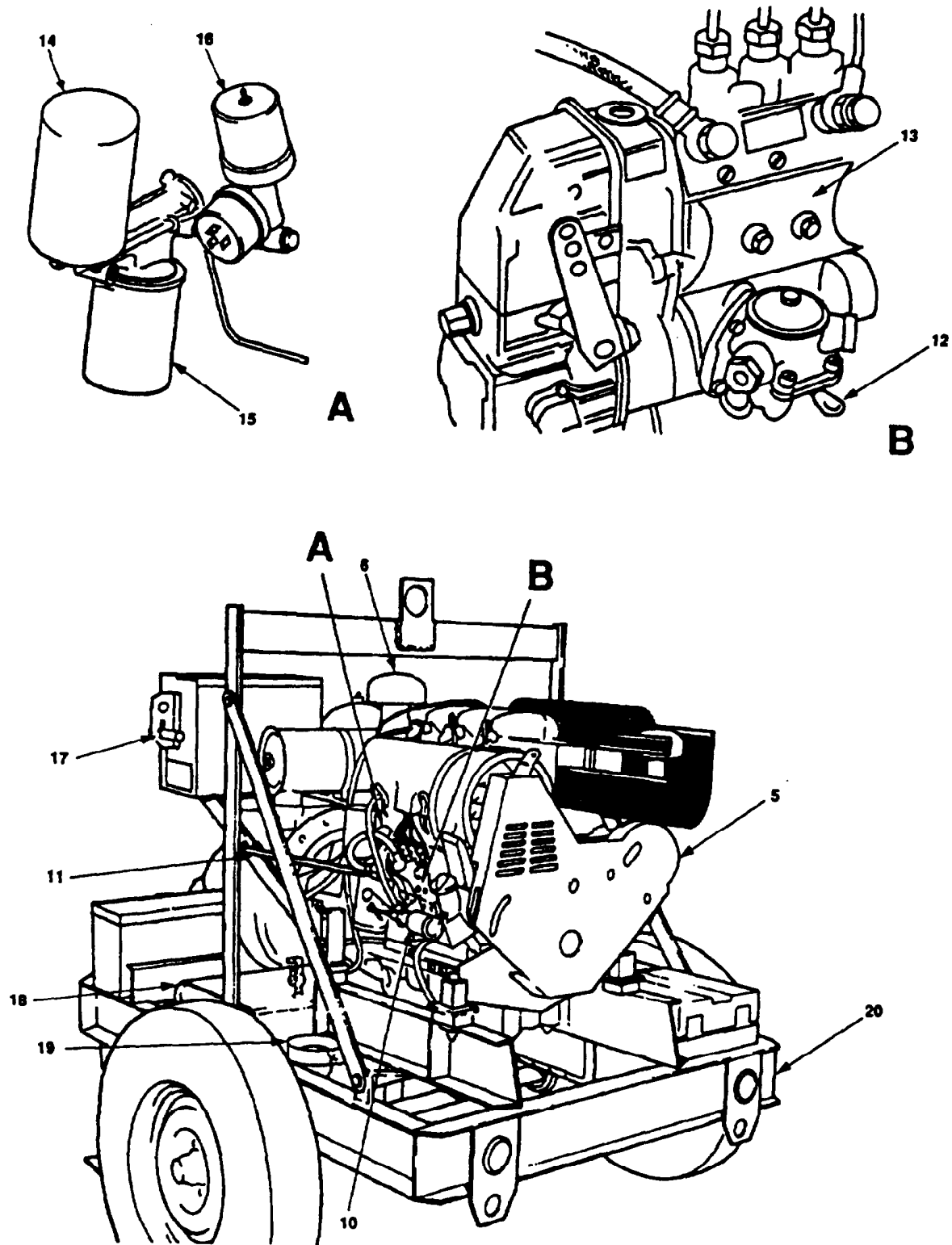

Figure 1-2. Major Components (All Models) (Sheet 2 of 2).

Table 1-2. Description of Major Components (continued).

13	FUEL INJECTION PUMP	High pressure fuel delivery pump driven by timing gear and meters high pressure fuel to injector nozzles.
14	FUEL FILTER	Throw-away element which filters fuel from internal fuel tank prior to entering fuel pump.
15	OIL FILTER	Throw-away element which filters oil from oil sump prior to entering engine.
16	LOW OIL PRESSURE SWITCH	Switch set to automatically shutdown engine when oil pressure drops below 4 psi (27.579 kPa).
17	STARTING AID HANDPUMP	Supplies ether to engine air intake for starting in cold weather. A different cold start system (not using a handpump) is used on Model 350 PAWN.
18	FUEL TANK	Retained by hold down straps to frame assembly. Provides fuel storage and has 19 gallon (71.9 liters) capacity.
19	FILTER/SEPARATOR	Throw-away element which removes nearly 100 percent of water, and solid contaminants down to one micron in size. The separator on the 350 PAWN incorporates a priming pump.
20	FRAME ASSEMBLY	Provides mounting of engine assembly, pump and components. Contains axle assembly, wheels and tires, and towbar. Towbar extends outward for towing.

1.12 DIFFERENCES BETWEEN MODELS.

Model 350 PAWN uses a different fuel shutoff solenoid, cold start system, filter(water) separator and a cleaner burning engine. The 350 PAWN also uses a rheostat to control the illumination intensity of the panel lights on the control panel.

1.13 EQUIPMENT TABULATED DATA.

Dimensions and Weights

Length	
Towbar extended	122 inches (3098.8 mm)
Towbar retracted	78 inches (1981.2 mm)
Width	70 inches (1778 mm)
Height	68 inches (1727.2 mm)
Dry Weight	2140 pounds (970.7 kg)
Maximum towing speed	
Hard surface	20 mph (32 km)
Gravel road	10 mph (16 km)
Rough cross country	8 mph (12.9 km)
Tire pressure	40 psi (275.79 kPa)
Voltage	12VDC

Engine Specifications

Number of cylinders	3
Bore (inch)	3-15/16 inch (100 mm)

Engine Specifications (continued)

Stroke (inch)	4-23/32 inch (105/120 mm)
Piston displacement (entire inch)	172.45 cubic inch (2827 cm ³)
Direction of rotation	Counterclockwise (facing flywheel)
Working principle	Four-stroke diesel with direct injection
Weight (less starter but with alternator)	595.25 pounds (270 kg)
Power output	44 hp at 2500 RPM
Speed	3000 RPM
Oil pump speed	3140 RPM
Fuel	Diesel(DF1, DF2 or DFA), JP4, JP5 or JP8
Lubrication system	Forced lubrication
Crank case: Initial fill	8.50 quarts (9.5 liters)
Refill	7.08 quarts (9.0 liters)
Valve clearance (engine cold)	0.006 inch (0.15 mm)
Inlet valves open	32° before TDC
Inlet valves close	60° before BDC
Exhaust valves open at above	32° after TDC
Piston crown clearance (measured with lead wire)	0.040 to 0.047 inch (1.0-1.2 mm)
Injection release pressure	2489.1 psi (175+8 bar)
Firing order	1-2-3
Compression ratio	17:1

Pump Specifications

Type	Single stage, centrifugal flow, variable displacement
Output volume	350 GPM at 250 ft. head
Designed working pressure	125 psi (723.9 kPa)
Designed suction pressure	20 psi (137 kPa)
Type lube system	"0" pressure, self-contained
Suction and discharge size capacities	4 inches (101 mm)
Fuel Tank	19 gallons (71.9 liters)
Pump Oil	8 ounces (226.796 grams)

SECTION III. PRINCIPLES OF OPERATION

1.14 FUNCTIONAL DESCRIPTION.

The 350 GPM pumping assembly is a mobile pump **that transfers water**. It is trailer **mounted** and is towed by a vehicle for short distances. When moved, the 350 GPM pumping assembly is connected from the towing vehicle, and then stabilized. Hoses are connected to the equipment between the water source and destination. The engine is started and the water flow is controlled by gate valves. The following paragraphs provide a functional description of the 350 GPM Pumping Assembly.

1.14.1 Operator's Functional Description.

1.14.1.1 **Exhaust System.** The exhaust system consists of the muffler, exhaust tubing, and spark arrester. The exhaust system provides a noise reduction.

1.14.1.2 **Air Cleaner.** The air cleaner provides filtered air to the combustion chambers of the engine. It consists of two filters that filter the air before it reaches the intake manifold of the engine.

1.14.1.3 **Electrical System.** The electrical system provides the power to drive the pump assembly and is controlled by either a mechanical or electrical control device.

1.14.1.4 **Fuel System.** The fuel system is attached to the fuel tank and provides fuel to the engine. The amount of fuel going to the engine determines the engine speed. On the pumps covered in this manual engine speed is controlled manually by a knob/control rod arrangement,

1.14.1.5 **Engine Assembly.** The engine assembly provides the power to operate the centrifugal pump assembly and is controlled by either a mechanical or electrical control device.

1.14.1.6 Control Panel Assembly.

The control panel assembly provides the controls and indicators indicated below. They are further discussed in Chapter 2 under controls and indicators.

- Emergency Stop Switch
- Push to Start Switch
- Oil Pressure Bypass Switch
- Oil Pressure Gauge
- Tachometer/Hourmeter
- Ammeter
- Suction Gauge
- Discharge Gauge
- Rheostat(Model350PAWN)
- Panel Lights(Model 350 PAWN)

1.14.1.7 **Pump Assembly.** The pump assembly is the unit that actually transfers fuels from **a source** (storage tank, railroad car, ship etc) to a destination point that may be another tank, downstream boost pump or using vehicle etc. All other components support this function. The pump assembly consists primarily of **an** impeller, driven by the engine, and a metal housing that surrounds the impeller. It is normally self priming, but includes a priming port that **can be used if the** pump fails to prime because of large differences in altitude between the pump and the source of fuel, pump **wear** and other reasons.

1.14.1.9 **Fuel Tank** The fuel tank provides storage for diesel fuel. It has a 19 gallon (71.9 liter) capacity, The tank has a fuel level gauge, two fuel source selector valves, filler cap, drain plug, and overflow return fitting. The fuel level gauge provides a visual indication of the fuel level inside the tank. Fuel is added to the tank via the filler **cap**.

1.14.1.10 **Wheel Mounted Frame Assembly.** The wheel mounted frame assembly allows the 350 GPM Pumping Assembly to be towed behind a mobile vehicle for short distances.

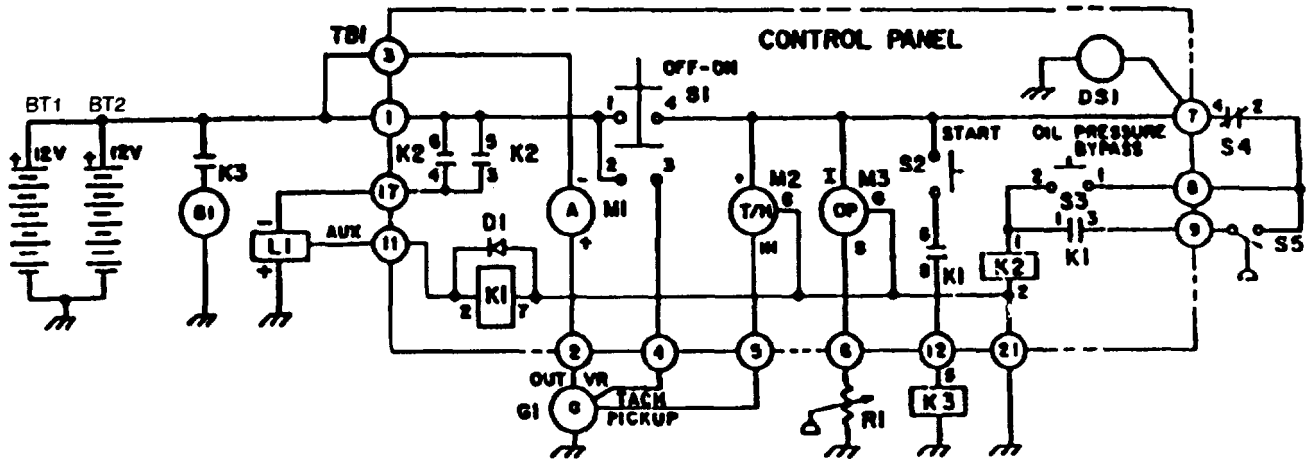

REF DES	DESCRIPTION
B 1	STARTER
BT1, 2	BATTERY
G1	ALTERNATOR
K1	RELAY, GENERAL PURPOSE
K2	RELAY, POWER
K3	RELAY, STARTER
L1	SOLENOID, FUEL SHUTOFF
M1	AMMETER
M2	TACHOMETER/HOURMETER
M3	GAUGE, OIL PRESSURE
R1	SENDING UNIT, OIL PRESSURE
S1	SWITCH, PUSH PULL
S2, 3	SWITCH, PUSHBUTTON
S4	SWITCH, V-BELT
S5	SWITCH, LOW OIL PRESSURE
TB1	TERMINAL BOARD, 38TB - 21
D1	DIODE, SILCONE RECTIFIER
DS1	PANEL LIGHT

Figure 1-3. Electrical Schematic Diagram (Models 350 PAW and W-87012).

1.14.2 Unit Maintenance Functional Description.

1.14.2.1 Exhaust System. The exhaust system consists of the muffler, exhaust tubing and spark arrester. The muffler is connected directly to the engine and provides a noise reduction. Exhaust tubing provides an enclosed path for the released gases from the muffler to the spark arrester. The spark arrester prevents sparks from entering the atmosphere and rain from entering the exhaust.

1.14.2.2 Air Cleaner. The air cleaner provides filtered air to the combustion chamber of the engine. It consists of two filters that filter the air before it reaches the intake manifold of the engine.

1.14.2.3 Electrical System (Except Model 350 PAWN). The electrical system (figure 1-3) provides the electrical control circuits and 12 V dc. Two 12 volt batteries are connected in parallel. The batteries supply the initial starting power. The electrical wiring harness connects the electrical components of the control panel and engine. When EMERGENCY-STOP (OFF-ON) switch (S1) is pulled out, S1 contacts connect ammeter (MI), START switch (S2) and switch (S4) to positive side of battery. When cooling fan blower belt is installed on engine, S4 contacts 4 and 2 are closed, connecting OIL PRESSURE BY BASS switch (S3) to positive side of battery. When S3 is pressed, relay (K2) is energized and normally open contacts of K2 are closed. Since the contacts of K2 are closed, 12 V dc is applied to fuel shutoff solenoid (L1). L1 then connects ground to K1 via auxiliary tap (AUX) and K1 energizes. Mechanical linkage is connected from L1 to the cut-off lever that controls fuel flow into engine. Since L1 retracted, fuel can be injected into engine and K1 is energized. When K1 is energized, normally open contacts 6 and 8 are closed. Since S2 is pressed, 12 V dc is applied to starter relay (K3). K3 energizes and provides 12 V dc to starter motor (B1). This causes drive gear of B1 to engage with engine flywheel and causes B1 to rotate. Rotation of B1 cranks engine until S2 is released. After starting, S2 is released and 12 V dc is removed from K3. Since no voltage is applied to K3, 12Vdc is removed from B1. When B1 has no voltage, drive gear of B1 is disengaged from engine and B1 no longer rotates. When oil pressure reaches 4 psi (27.579 kPa), oil pressure switch (S5) closes and S3 is now released. The 12 V dc is till applied to K2 via closed contacts 1 and 3 of K1, which keeps L1 retracted. Alternator (G1) is turned by engine drive pulley and outputs approximately 14V. The 14V then provides 12 V dc to keep K1 and K2 energized. In addition, 14 V from G1 recharges 12 V dc batteries.

Since the engine can be damaged by overheating, V-belt switch (S4) is provided. If the V-belt that turns the cooling fan breaks, S4 opens, When S4 is open, 12 V dc is removed from K1 and K2. This causes L1 to extend (fuel closed) and shuts off fuel flow to engine. Since no fuel is provided to engine the 350 GPM pumping assembly is stopped

Since oil provides both lubrication and cooling to the engine, an oil pressure switch (S5) is provided. If engine oil pressure drops below 4 psi (227.579 kPa), S5 opens. When S5 is open, 112 V dc for K1 and K2 is removed. This causes L1 to extend (fuel closed) and shuts off fuel flow to engine. Since no fuel is provided to engine the 350 GPM pumping assembly stops.

When operation is no longer required, S1 is pushed in and 12 V dc is removed from K1 and K2. This causes L1 to extend (fuel closed) and shuts off fuel flow to the engine. Since no fuel is provided to the engine, 350 GPM pumping assembly stops. When an emergency occurs, S1, the emergency stop switch provides rapid engine shut down. Pull position is normal operation, push position is shutdown,

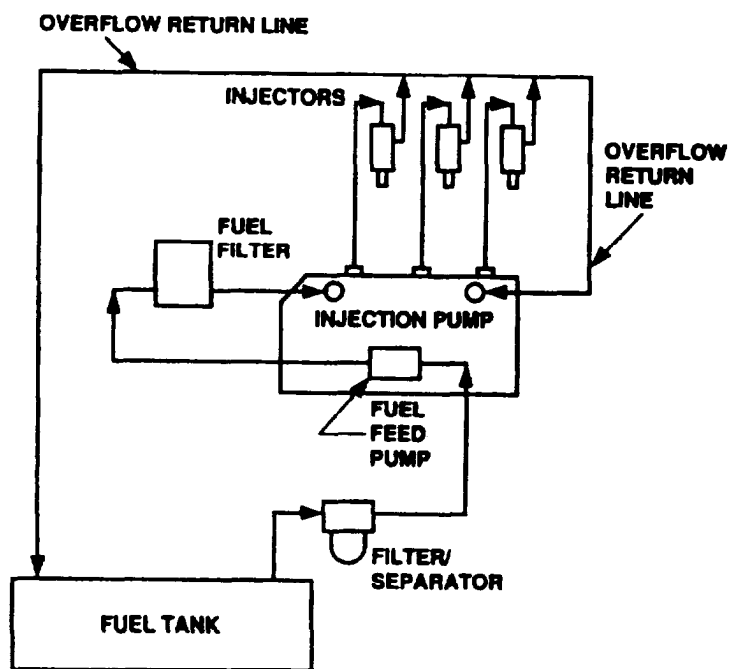

Figure 1-4. Fuel System Functional Diagram.

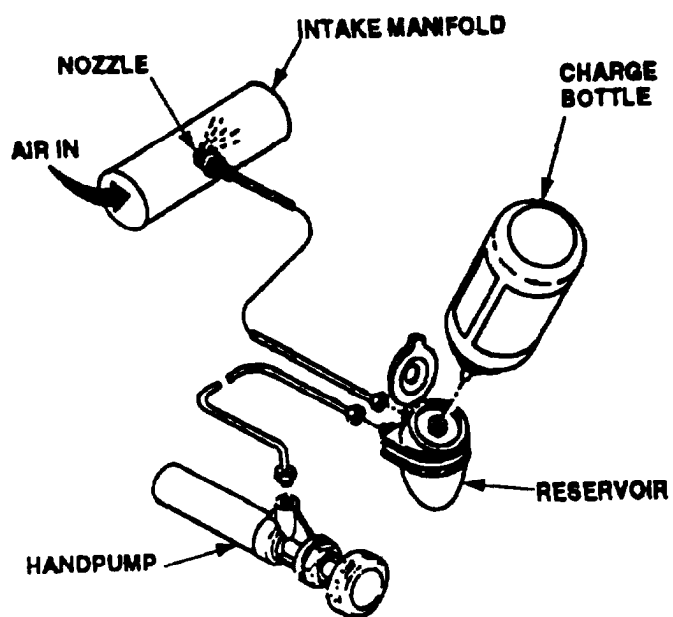

Figure 1-5. Cold Start System (Models 350 PAW and W-87012).

1.14.2.3.1 Electrical System Model (350 PAWN). The electrical system differences between the 350 PAWN and other models are three additional panel lights, cold start switch, cold start solenoid and a different fuel shutoff solenoid. Figure 1-5.2 illustrates the electrical system and figure 1-5.1 illustrates the electrical cold start system used on the 350 PAWN. The 350 PAWN electrical system operates as follows:

1.14.2.3.1.1. Start Circuits.

- a. When the emergency start switch (S1) is energized (pulled out), power is transferred through its contacts 1/4 and applied to the upper contact of S2, and to contact 1 of S3 through the closed contacts of S4.
- b. When the operator presses both the start switch S2 and the oil pressure bypass switch S3 (normal start sequence), power is applied to contact 6 of K1 where it stops, and to the coil of K2 through the closed contacts of S4 and S3. This causes relay K2 to become energized, its contacts 4/6 and 3/5 to close and power to be applied to the hold-in coil of solenoid L1, and to the coil of relay K1, But because the hold-in coil of L1 is not sufficiently powerful to energize L1, L1 stays de-energized until it receives power on its pull-in coil as described below.
- c. When voltage is applied to the coil of relay K1, K1 becomes energized (normally open contacts 6 and 8 closes) and voltage is applied to the coil of starter relay K3. Starter relay K3 then becomes energized which closes the S/M contacts.
- d. Voltage is applied to the starter motor B1 (energizing the starter for cranking the engine), to the pull-in coil of L1 (energizing L1 which starts fuel flowing to the engine) and to the cold start solenoid through the cold start switch S6 (normally closed below 40 °F) the starter fluid is injected into the engine.
- e. When engine has started and start switch (S2) is released (Oil pressure bypass switch S3 only releases after pressure is above 4 psi) voltage is terminated at the starter motor B1, pull-in coil of L1 and cold start solenoid.
- f. When oil pressure is up and oil pressure switch S5 is subsequently released, an alternate path through S5 is provided to keep K2 energized and the engine running.

1.14.2.3.1.2. Stop Circuits. The engine is stopped by pushing in the emergency stop switch (S1). The following occurs when pushing the emergency stop switch:

- a. Voltage to K2 through S1, S4, S5 and contacts 1/3 of K1 (while engine is operating) is terminated and K2 becomes de-energized (opens).
- b. Voltage to the hold-in relay of L1 is terminated at contacts 6/4 and 5/3 of K2.
- c. L1 closes the fuel shutoff valve and stops fuel flowing to the engine which results in shutdown of the engine.
- d. K2 will become de-energized and engine shutdown in the same manner if either S4 or S5 open. S4 will open if the V-belt breaks and S5 will open if oil pressure goes below 4 psi.

1.14.2.3.1.3. Light Circuits. The light circuit consist of a rheostat (R2) and four panel lights (DS1, DS2, DS3 and DS4). When both S1 and R2 are on, current flows through each of the panel light which are connected to the rheostat in parallel. Turning the knob on the rheostat controls the illumination intensity (brightness) of the panel lights.

1.14.2.3.1.4. Charging Circuit. When the engine is running the alternator (G1) turns and produces approximately 14V dc output. The 14V dc from the alternator (G1) provides 12 V dc to keep the relays energized and recharges the batteries (BT1 and BT2). Output voltage from the alternator is indicated on the ammeter by the needle pointing towards discharge (minus) or charging (plus). Initially, at startup the needle on the ammeter will indicate a discharge. When the engine is running correctly and the alternator operating properly the needle on the ammeter will indicate the batteries are charging.

b. Tachometer/Hourmeter. The tachometer/hourmeter is a dual purpose gauge that operates when the engine is running. When S1 is on (Emergency Switch pulled out) power (voltage) is supplied by the alternator (G1) to the tachometer/hourmeter. The tachometer converts this power signal to indicate engine rpm while the hourmeter converts the power signal to indicate engine operating time in hours.

1.14.2.3.1.6. Cold Start System. The cold start system operates on electrical signal from the temperature switch mounted on the side of the engine. When the temperature switch is closed (closed at 40 degrees F and below) and the engine started, the solenoid valve opens and starting fluid from the can is injected into the intake manifold through the tubing as long as the starter is energized.

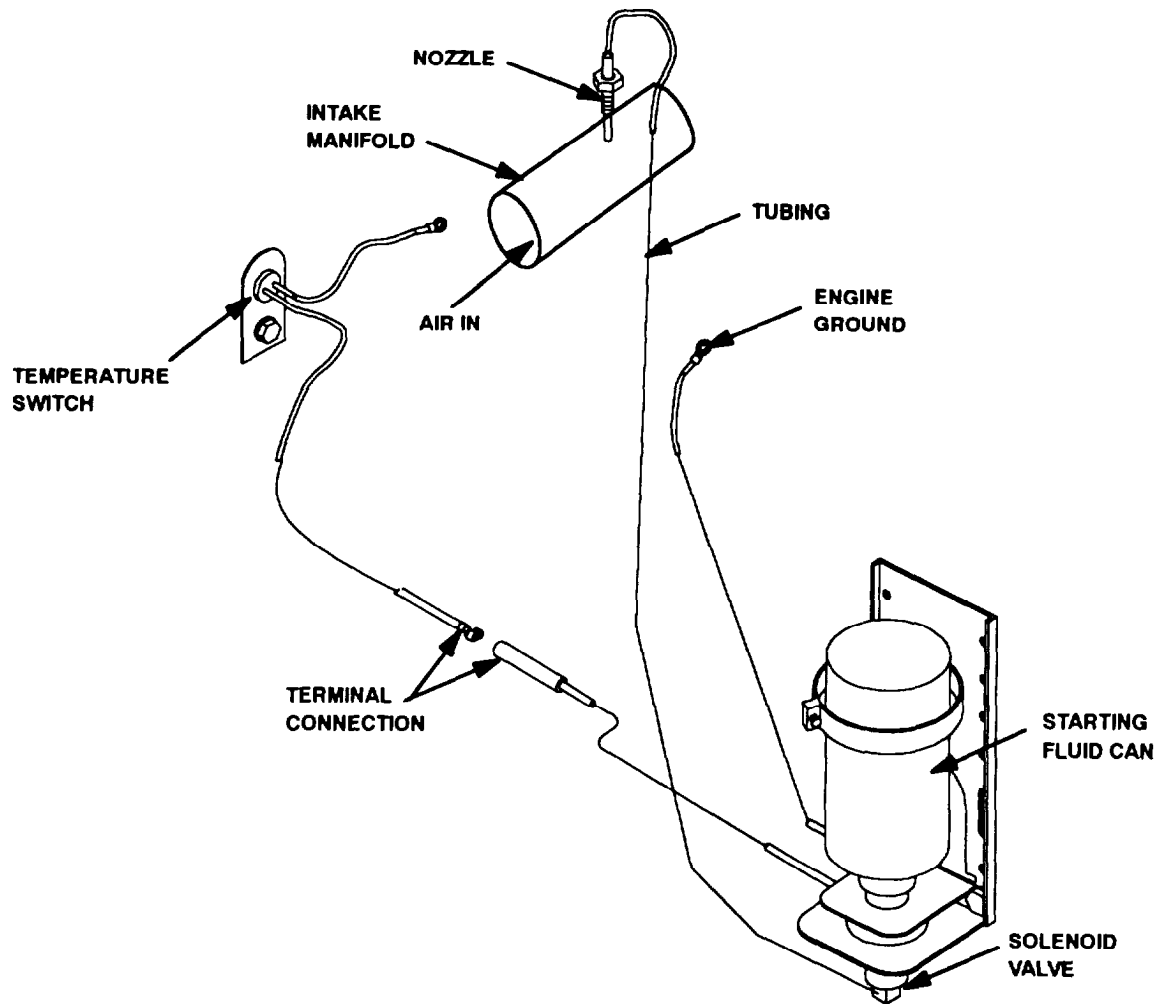
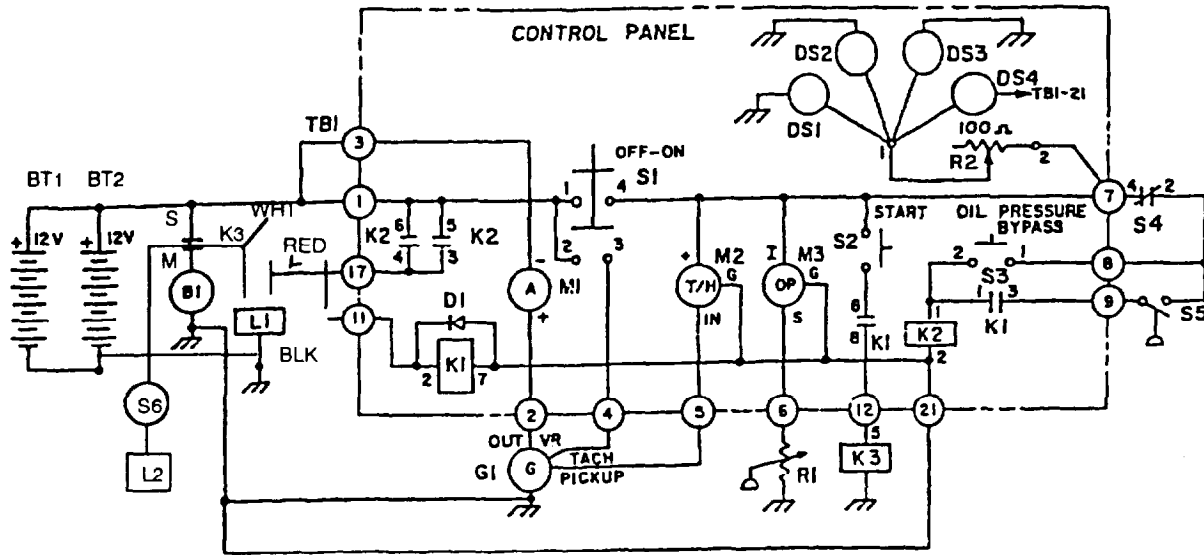

Figure 1-5.1. Cold Start System (Model 350 PAWN).



REF DES	DESCRIPTION
B1	STARTER
BT1	BATTERY
BT2	BATTERY
G1	ALTERNATOR
K1	RELAY, GENERAL PURPOSE
K2	RELAY, POWER
K3	RELAY, STARTER
L1	SOLENOID, FUEL SHUTOFF
L2	SOLENOID, COLD START
M1	AMMETER
M2	TACHOMETER/HOURMETER
M3	GAUGE, OIL PRESSURE
R1	SENDING UNIT, OIL PRESSURE
S1	SWITCH, PUSH PULL
S2, 3	SWITCH, PUSHBUTTON
S4	SWITCH, V-BELT
S5	SWITCH, LOW OIL PRESSURE
TB1	TERMINAL BOARD, 38TB - 21
D1	DIODE, SILICONE RECTIFIER
DS1,2,3,4	PANEL LIGHTS

Figure 1-5.2. Electrical System (Model 350 PAWN).

1.14.2.4 Fuel System. The fuel system is connected to the fuel tank and provides fuel to the engine. Figure 1-4 provides a functional diagram of the fuel system. When the engine is cranked or operating, the fuel feed pump draws fuel through the filter/separator that filters solid contaminants larger than one micron in size from the fuel. In addition, filter/separator removes water from the fuel. After the filter/separator, fuel is drawn to the fuel feed pump. The fuel feed pump is a diaphragm type pump actuated by a cam in the fuel injection pump. When activated, the fuel feed pump provides a positive head of pressure to the fuel injection pump via a fuel filter. The fuel filter provides additional filtering of the fuel before it enters the fuel injector pump. The fuel injection pump is a high pressure fuel delivery pump driven by a timing gear in the engine. The main shaft in the injection pump has cams which operate plungers. Plungers pump fuel into the injector nozzles. The amount of fuel injected into the nozzles is controlled mechanically. The fuel injector nozzles are single inlet, four outlet, high pressure injectors. High pressure injectors spray fuel directly into the engine cylinders. Overflow lines are provided to carry excess fuel that is not needed for combustion. The excess fuel is carried to the fuel tank and injection pump. Fuel is returned to the fuel tank by way of an overflow return fitting on the fuel tank.

1.14.2.4.1 Cold Start Systems.

a. The cold start system (figure 1-5) on all models except model 350 PAWN is strictly a mechanical system and operates as follows: The reservoir is filled with starting fluid by first opening the cover, setting the ether bottle on the reservoir and pushing down to penetrate the seal, This allows fluid to gravity feed into the reservoir. The bottle is removed when the reservoir is full to the MAXI line. The handpump is operated just prior to initiating the start sequence to inject starting fluid into the intake manifold of the engine through the nozzle.

b. The start system on Model 350 PAWN is an electrical system and consists of the components illustrated in figure 1-5.1. Its operation is covered in conjunction with the electrical system in paragraph 1.14.2.3.1.

1.14.2.5 Engine Assembly. The engine assembly (figure 1-6) is started as described in paragraph 1.14.2.3 and 1.14.2.3.1 and provides the drive for the 350 GPM pumping assembly. When the engine is started, starter motor B1 turns the crankshaft. When the crankshaft is turned, the pistons and valves move up and down. While one of the pistons is moving upward, fuel is injected into the combustion chamber and mixed with air at a controlled rate. The temperature inside the combustion chamber causes the fuel and air to burn (combustion). This combustion forces the piston downward, which causes the crankshaft to rotate and the engine to start. The starter motor B1 is then disengaged. The up and down movement of the pistons continues with fuel being injected into selected cylinders. The rotation of the crankshaft also turns the camshaft and timing gears. The timing gears turn the oil pump and the fuel pump. Oil is pumped through the lubrication system and fuel is pumped to the fuel injectors. In addition, the drive pulley rotates and drives the V-belts. The V-belts operate the cooling fan and alternator, The cooling fan keeps the oil and engine cool to prevent overheating. The alternator provides 14 V dc. The following paragraphs provide a more detailed description of diesel engine operation.

1.14.2.5.1 Engine Operation Overview. The 350GPM Pumping Assembly used _____ engine with three cylinders. The complete cycle for a four-stroke engine occurs in four events for each piston. Two revolutions of the crankshaft are required to complete one cycle. The four events are as follows:

- Intake stroke
- Compression stroke
- Power stroke
- Exhaust stroke

When the intake stroke begins the piston is pulled down into the cylinder by the crankshaft and connecting rod. When the piston is at the lowest point possible, it is at bottom dead center (BDC). During this time the intake valve is held open by the camshaft. Since the piston has moved down in the cylinder to BDC, a vacuum is created and air is forced past the intake valve into the cylinder's combustion chamber.

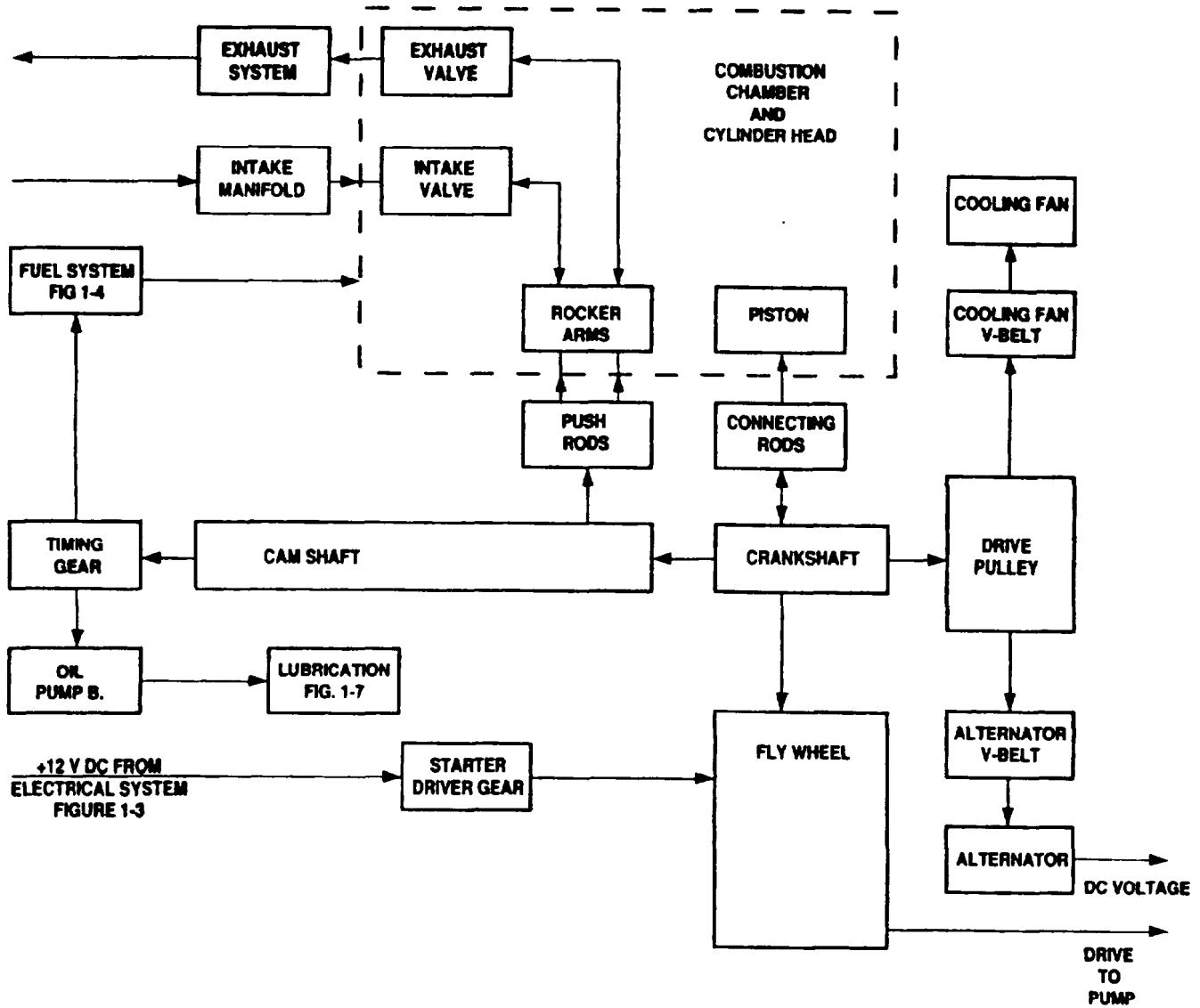

Figure 1-6. Engine Functional Block Diagram(All Models)

After the intake stroke, the compression stroke begins. The piston is moved upward by the crankshaft. The push rod controlled by the camshaft causes the intake valve to close. Air in the cylinder's combustion chamber is compressed. When air is compressed, heat is generated. When the piston reaches the uppermost position, it is at top dead center (TDC) and the air is completely compressed.

During the compression stroke, fuel is injected into the cylinder's combustion chamber. Since the temperature is sufficient to ignite fuel, combustion takes place and the power stroke begins. Combustion causes expansion of the air and fuel which increases the pressure. Increased pressure forces the piston downward causing the crankshaft to rotate. Since the amount of fuel injected to the combustion chamber is controlled, the speed of crankshaft rotation is controlled. When the amount of fuel is increased, the speed of the engine is increased.

When the power stroke moves the piston to its BDC, the exhaust valve is fully open. When the piston starts to move upward, the exhaust stroke begins. Pressure in the combustion chamber and movement of piston force exhaust gases out of the combustion chamber. At the end of exhaust stroke, the exhaust valve is closed and the intake valve is again open. The piston is at TDC and next cycle begins.

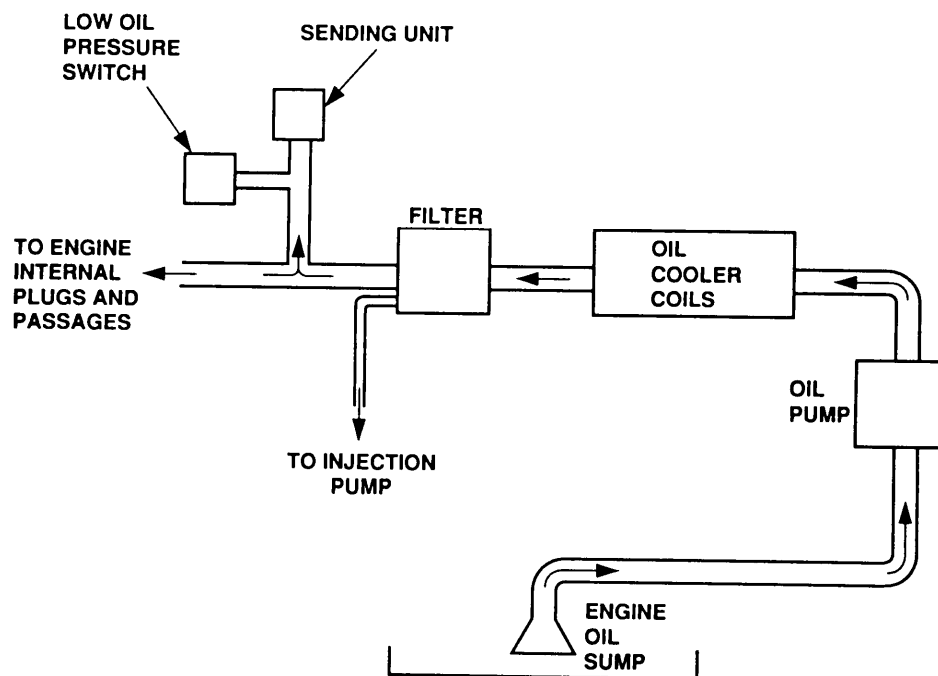

Figure 1-7. Lubrication System Functional Diagram.

1.14.2.5.2 Lubrication System. The lubrication system (figure 1-7) provides lubrication and cooling to the engine's parts. The oil sump has an 8.5 quart (8.04 liter)

capacity and is filled with oil. The oil pump is a gear type element driven by a gear in the engine's front cover. When the engine is operating, a gear drives the oil pump and oil is pumped from the oil sump to the oil cooler. The oil cooler is a coil cooled by the cooling fan. The cooling fan causes oil to cool to a lower temperature. Oil is then pumped into the oil filter which is a throw-away element. Contaminants are removed from the oil and the oil is pumped to the engine metering plugs. Metering plugs are oil jets within the engine block that spray oil on to internal parts of the engine. Oil is also pumped to the injection pump lube supply. The fuel injection pump lube supply is a line on the side of the oil filter housing and directs oil to the injection pump. Excess oil in the injection pump spills into the timing cover. In addition, the low oil pressure switch and sending unit are located at the oil filter housing discharge. The oil pressure switch is set to automatically open when the oil pressure drops below 4 psi (27.579 kPa).

1.14.2.5.3 Cooling Fan. The cooling fan is attached to the engine and is driven by a V-belt connected to the drive pulley. The cooling fan causes forced air flow across the top of the engine cylinder heads and oil cooling coil. Forced air flow cools the cylinder heads and oil. This cooling process prevents overheating of the engine.

1.14.2.5.4 Cylinder Head and Valves. The 350 GPM Pumping Assembly uses three cylinder heads. Each cylinder head functions the same and can be removed separately. The cylinder head contains an intake valve and exhaust valve. The intake and exhaust valves open and close intake and exhaust ports. The intake port is connected to the intake manifold and the exhaust port is connected to the exhaust manifold.

1.14.2.5.5 Crankshaft Block. The crankshaft block provides mounting for various engine components. It has an intake manifold that provides a connection to air assembly. Air is taken from the air assembly through the intake manifold into the combustion chamber of the cylinder head. A breather pipe is connected to release gases from the combustion chamber to prevent excess pressure buildup.

1.14.2.5.6 Camshaft and Timing Gears. The camshaft and timing gears control valve opening and closing times. The speed at which valves open and close is also determined by the camshaft and timing gears.

The time at which valves open and close (valve timing) and duration of valve opening are stated in degrees of crankshaft rotation. Timing is determined by the timing gears. Timing gears are driven by the engine's camshaft. The engine's camshaft drives the engine components that close the intake and exhaust valves. In addition, timing gears control the fuel injection and oil lubrication. Timing of the engine is critical to prevent damage.

1.14.2.5.7 Pistons and Connecting Rods. The pistons are connected to connecting rods that are attached to the crankshaft. The pistons provide the force to drive the engine's flywheel. As the crankshaft is turned, connecting rods force the pistons upward and downward. Since the pistons are in sealed cylinders, the pistons compress air that is brought into the intake openings as described in paragraph 1.14.2.5.1. The up and down movement of pistons forces connecting rods to turn the crankshaft and flywheel. Refer to paragraph 1.14.2.5.1 for a more detailed operation of the four stroke piston operation.

1.14.2.5.8 Crankshaft and Flywheel. The crankshaft and flywheel provide transfer of heat energy from the pistons into mechanical energy. When the pistons are forced downward by the ignition of fuel, the crankshaft turns, causing the flywheel to turn. In addition, the crankshaft forces the other pistons connected to the crankshaft upward. Each time a piston is forced downward, another piston is forced to TDC. The piston at TDC causes another combustion to occur and is forced downward. The 350 GPM Pumping Assembly uses three pistons that are timed together by timing gears connected to the engine's camshaft. The crankshaft is also connected to a timing gear of the engine's camshaft. Each time the crankshaft turns, it forces the camshaft to turn. The pump assembly is connected to the flywheel. Since the flywheel must turn with the crankshaft, the pump assembly is driven at the speed of the engine.

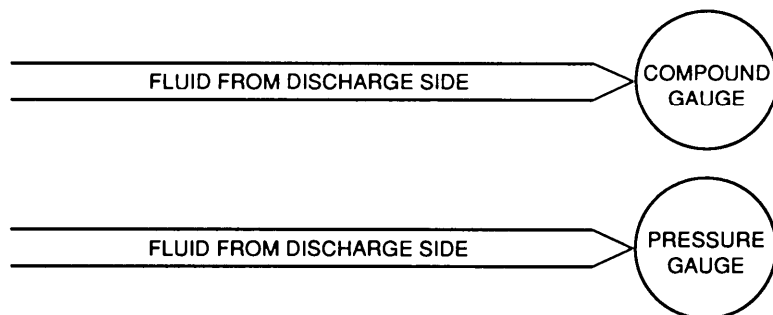
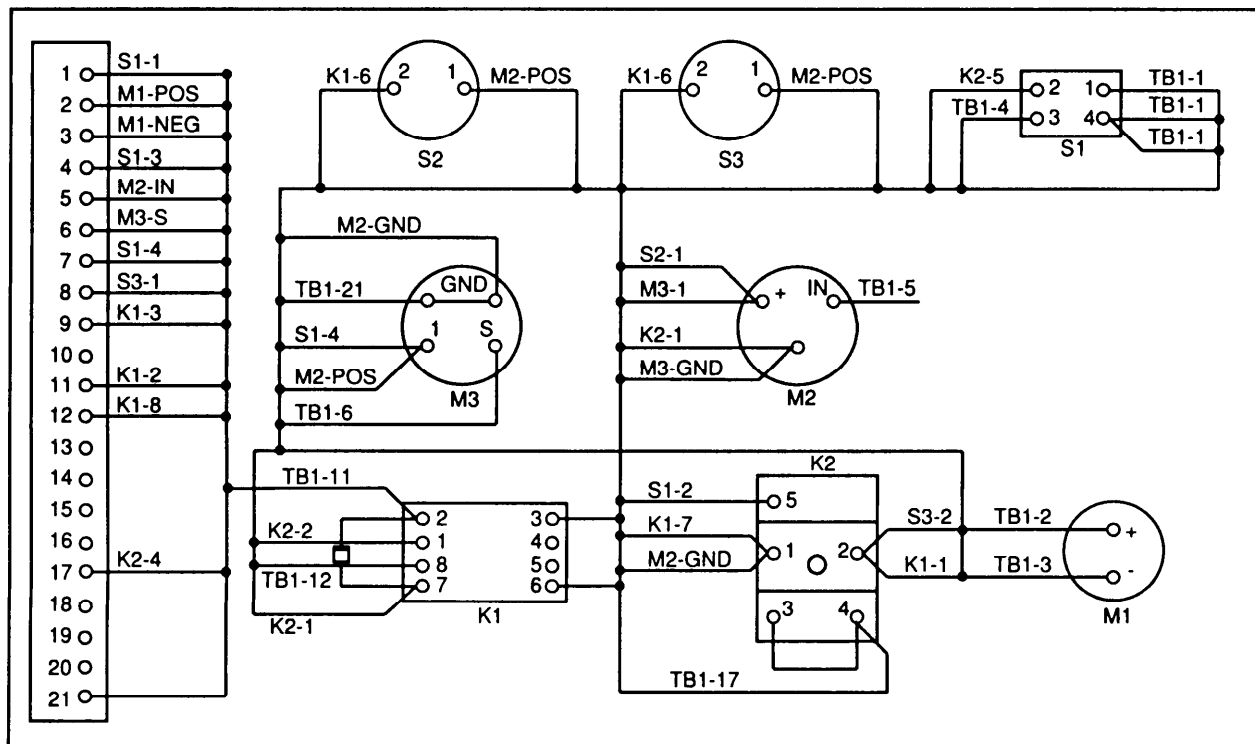

Figure 1-8. Control Panel Assembly Functional Diagram.

1.14.2.6 Control Panel Assembly. The control panel assembly provides the control and indicators required for operation. Figure 1-8 provides a functional block diagram of the control panel. The control panel receives and sends electrical signals to and from the engine. In addition, the control panel monitors the suction and discharge pressures of the pump assembly.

1.14.2.6.1 Electrical and Control Signals. The control panel provides most of the physical components of the starting system. Only the V-belt switch, oil pressure switch, starter and alternator are not part of the control panel. In addition, the engine sends an electrical signal to an oil pressure gauge to indicate engine oil pressure. The engine also sends a tachometer signal to a tachometer located on the control panel to indicate the engine speed. An ampere meter monitors output of the alternator.

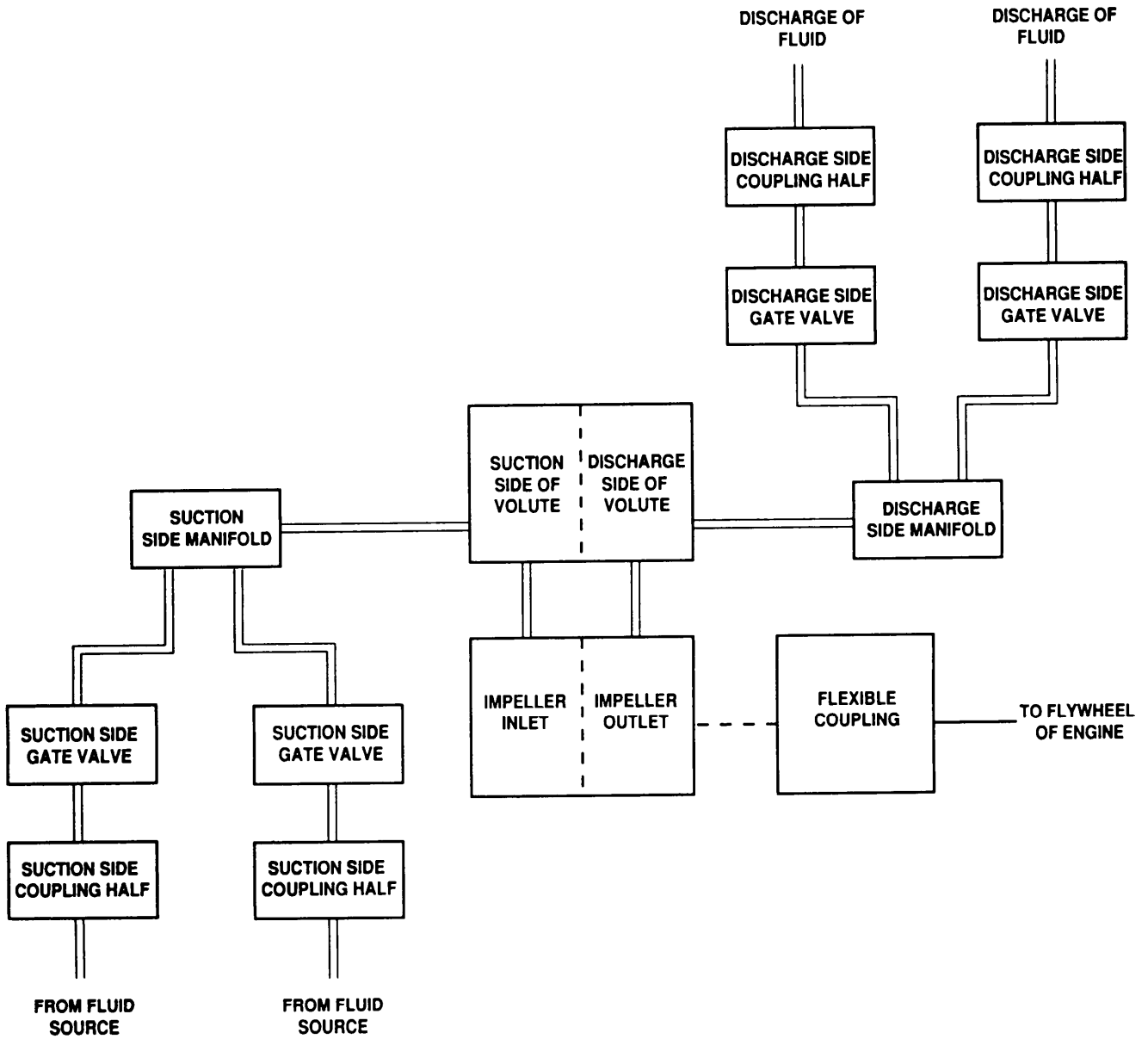

Figure 1-9. Pump Assembly Functional Block Diagram.

1.14.2.7 Pump Assembly. The pump assembly transfers fluid from one point to another point. Figure 1-9 is a functional diagram of the pump assembly. The fluid is brought into the 350 GPM pump via the suction section. The suction section provides two suction inputs. Each suction input has a valve that controls the size of opening to the suction side of the pump. In addition, each suction input has a coupling half to connect to the fluid source. Both suction inputs are connected to the suction manifold. The suction manifold is connected to the suction side of the volute. The suction section consists of two coupling halves, two gate valves, and the suction manifold.

When the engine is started, the flexible coupling attached to the shaft in the intermediate housing rotates in a clockwise direction and the shaft rotates freely on two bearings. The rotation of the shaft causes the impeller to turn in a clockwise direction. This creates a suction on the suction side of the volute and liquid is forced into the suction section. When the suction side gate valve is open, the fluid is forced through the coupling, gate valve, and suction manifold into the volute. The fluid is then forced into the small opening at the front center of the impeller. Since the impeller is turning, the fluid spins through the impeller. This spinning action increases the fluid pressure and forces the fluid to the top of the impeller. When the fluid reaches the top of the impeller, the fluid is forced out the openings in the top of the impeller into the top of the volute housing.

Openings in the volute housing and top of the impeller are the same size. The force of fluid from the impeller causes the fluid to spin upward along the opening in the volute. The force and pressure is thus increased as the fluid is forced out the discharge side of the volute into the discharge manifold. Actual fluid pressure is determined by the speed of the flywheel. Higher engine speeds increase flywheel speed which creates higher pressure outputs from the pump assembly.

Fluid is then forced out the discharge side of the volute into the discharge section. The discharge section provides two outputs. Each output has a valve that allows connection of two 4 inch hoses. The discharge section consists of two coupling halves, two gate valves, discharge manifold, and a discharge connection. When the gate valve is opened, the fluid is forced through the discharge connection, discharge manifold, gate valve and coupling half. The discharge valve controls the size of the opening from the discharge side of the pump assembly.

1.14.2.9 Fuel Tank. The fuel tank provides storage for diesel fuel and has a 19 gallon (71.9 liter) capacity. The tank has a fuel level gauge, two fuel source selector valves, filler cap, drain plug, and overflow return fitting. The fuel gage provides a visual inspection of the fuel level inside the tank. When the fuel level is low, fuel is added to the tank via the filler cap. The fuel is routed from the fuel tank to the fuel system.

1.14.2.10 Wheel Mounted Frame Assembly. The wheel mounted frame assembly allows the 350 GPM Pumping Assembly to be towed behind a mobile vehicle for short distances.

CHAPTER2

OPERATING INSTRUCTIONS

Subject Index	Page
Section I Description and Use of Operator's Controls and Indicators	2-2
2.1 Operator Controls and Indicators	2-2
Section II Operator Preventive Maintenance Checks and Services (PMCS)	2-5
2.2 General	2-5
Section III Operation Under Usual Conditions	2-11
2.3 Assembly and Preparation for Use	2-11
2.4 Initial Adjustments, Checks, and Self Test	2-16
2.5 Operation Procedures	2-16
2.6 Decals and Instruction Plates	2-19
2.7 Preparation for Movement	2-24
Section IV Operation Under Unusual Conditions	2-27
2.8 Unusual Environmental/Weather	2-27
2.9 Fording	2-32
2.10 Emergency Procedures	2-33
2.11 Nuclear, Biological, and Chemical (NBC) Decontamination	2-33

SECTION I. DESCRIPTION AND USE OF OPERATOR'S CONTROLS AND INDICATORS

2.1 OPERATOR CONTROLS AND INDICATORS.

The control panel is located on the front of the 350 GPM Pumping Assembly. It contains the operating controls and indicators. The control panel is illustrated in Figure 2-1. Table 2-1 and paragraphs 2.1.1 through 2.1.12 are keyed to figure 2-1.

Table 2-1. CONTROLS AND INDICATORS.

Item No.	Item Name	Description and Purpose
1	EMERGENCY STOP	Pull-Push switch to control 12 V DC to start circuit,
2	PUSH TO START	Spring loaded switch to start engine.
3	PUSH FOR OIL PRESSURE BYPASS	Spring loaded switch to bypass oil pressure circuit,
4	OIL PRESSURE	Gauge to indicate oil pressure.
5	TACHOMETER/HOURMETER	Gauge to indicate engine speed and engine operating hours.
6	AMMETER	Gauge to indicate ampere(battery charging or discharging)
7	SUCTION	Gauge to indicate input pressure.
8	DISCHARGE	Gauge to indicate output pressure.
9	Handpump	Used for cold starts. (Not used Model 350 PAWN)
10	Engine Throttle	Control for engine speed.
11	Panel Lights	Provides lighting for the control panel. Panel lights are mounted on brackets. and equipped with aviator's night vision hood. Model 350 PAWN has four panel lights while other models have one.
12	Rheostat/Switch	Controls illumination of the panel lights. On Model 350 a rheostat controls illumination by turning the knob clockwise or counterclockwise. Other models have a switch to turn the panel light off or on.

2.1.1 **EMERGENCY STOP (1).** This switch is a push-pull type switch and is marked EMERGENCY STOP. Switch is pulled out during engine start cycle and remains pulled out while engine is operating. When an emergency occurs, EMERGENCY STOP switch is pushed in immediately to shut down engine operation. When the 350 GPM Pumping Assembly is to be shutdown, EMERGENCY STOP switch is used to stop engine.

2.1.2 **PUSH TO START (2).** This switch is a pushbutton type switch and is used to start engine. Switch is pushed in and held during engine start to activate K3 start relay. Switch must be released upon ignition of engine.

2.1.3 **OIL PRESSURE BYPASS (3).** This switch is a pushbutton type switch and is used to bypass oil pressure sensing circuits. Switch must be pushed in simultaneously with start switch during engine start. Oil pressure bypass switch must be released after oil pressure buildup.

2.1.4 **OIL PRESSURE (4).** This gauge indicates engine oil pressure by pounds per square inch (PSI). Gauge is graduated in 10 pound increments from 0 to 80 PSI.

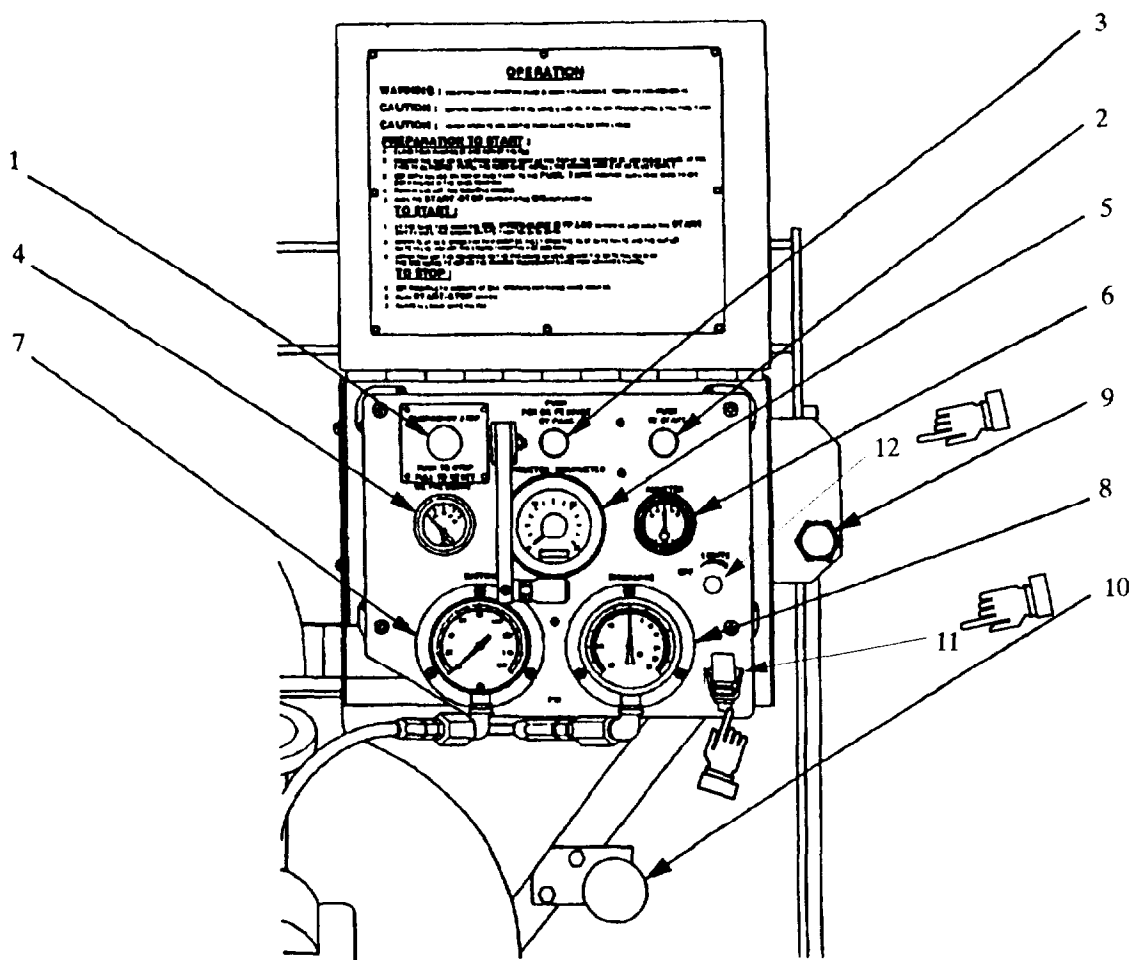

NOTE:



Control panel shows rheostat and only one panel light assembly. Model 350 PAWN has one rheostat and four panel light assemblies while other models may have one to four panel light assemblies with either a rheostat or switch.

Figure 2-1. Controls and Indicators.

2.1.5 **TACHOMETER/HOURMETER (5)**. Indicates engine speed in revolutions per minute (RPM). Meter is graduated in 100 RPM increments from 0 to 3000 RPM. The hourmeter portion of the gauge indicates the total number of hours the engine has been operated.

2.1.6 **AMMETER (6)**. Indicates alternator ampere output which indicates the batteries are charging or discharging. Meter is graduated in 30 amp increments from 0 to +60 AMPS for charging and from 0 to -60 AMPS for discharging.

2.1.7 **SUCTION (7)**. This gauge is marked SUCTION and indicates pump suction pressure and vacuum per square inch (psi). Gauge is graduated in one unit increments from 0 to 30 PSI for both vacuum and pressure with numerals at five unit intervals on the pressure side and at 10 unit intervals on vacuum side.

2.1.8 **DISCHARGE (8)**. This gauge is marked DISCHARGE and indicates pump discharge pressure in PSI. Gauge is graduated in 5 pound increments from 0 to 160 PSI with numerals at 20 PSI intervals.

2.1.9 **HANDPUMP (9)**. Used to pressurize cold start reservoir. If outside air temperature is below +40°F (+5°C) cold start system may be used to assist in starting engine. Handpump is not used on Model 350 PAWN.

2.1.10 **THROTTLE (10)**. This control is only used on the unregulated models. Provides manual speed selection for the 350 GPM Pumping Assembly. Turning throttle control counterclockwise increases engine speed. Clockwise rotation decreases engine speed.

2.1.11 **PANEL LIGHTS (11)**. Provides light for the control panel. Model 350 PAWN has four panel lights mounted on support brackets and equipped with aviator's night vision hood. Other models have only one panel light control by a rheostat or switch.

2.1.12 **RHEOSTAT/SWITCH (12)**. Rheostat on the 350 PAWN is used to control illumination brightness of the four panel lights. Other models uses a rheostat or switch to turn the panel light off and on.

SECTION II. OPERATOR PREVENTIVE MAINTENANCE CHECKS AND SERVICES (PMCS)

2.2 GENERAL.

Figure 2-2 (PMCS) routing diagram and table 2-2 (PMCS table) have been provided so you can keep your equipment in good operating condition and ready for its primary mission.

2.2.1 Warnings, Cautions, and Notes. Always observe the **WARNINGS** and **CAUTIONS** appearing in your PMCS table. Warnings and cautions appear before applicable procedures. You must observe these **WARNINGS** and **CAUTIONS** to prevent serious injury to yourself and others or prevent your equipment from being damaged.

2.2.2 Explanation of Table Entries.

2.2.2.1 Item No. Column. Numbers in this column are for reference. When completing DA Form 2404 (Equipment Inspection and Maintenance Worksheet), include the item number for the check/service indicating a fault. Item numbers also appear in the order that you must do checks and services for the intervals listed. These item numbers also correspond to the numbers on the routing diagram, figure 2-2.

2.2.2.2 Interval Column. This column tells you when you must do the procedure in the procedure column. **BEFORE** procedures must be done before you operate the equipment for its intended mission. **DURING** procedures must be done during the time you are operating the equipment for its intended mission. **AFTER** procedures must be done immediately after you have operated the equipment.

2.2.2.3 Location, Item to Check/Service Column. This column provides the location and the item to be checked or serviced. The location is underlined.

2.2.2.4 Procedure Column. This column gives the procedure you must do to check or service the item listed in the Check/Service column to know if the equipment is ready or available for its intended mission or for operation. You must do the procedure at the time stated in the interval column.

2.2.2.5 Not Fully Mission Capable if: Column. Information in this column tells you what faults will keep your equipment from being capable of performing its primary mission. If you make checks or service procedures that show faults listed in this column, do not operate the equipment. Follow standard operating procedures for maintaining the equipment or reporting equipment failure.

2.2.3 Other Table Entries. Be sure to observe all special information and notes that appear in your table.

2.2.4 Special Instructions. When a check and service procedure is required for both weekly and before intervals, it is not necessary to do the procedure twice if the equipment is operated during the weekly period.

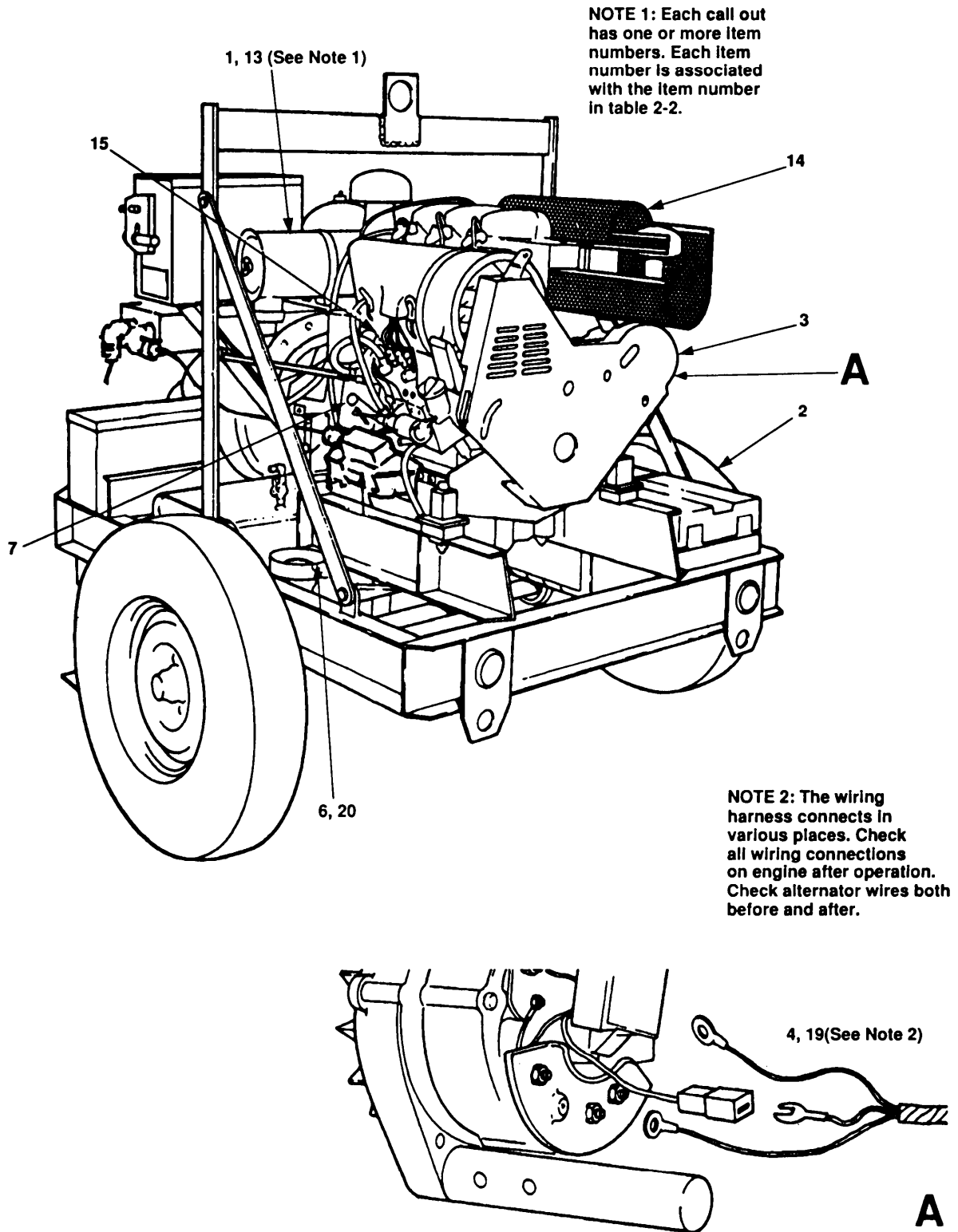

Figure 2-2. Operator PMCS Routing Diagram. (sheet 1 of 2)

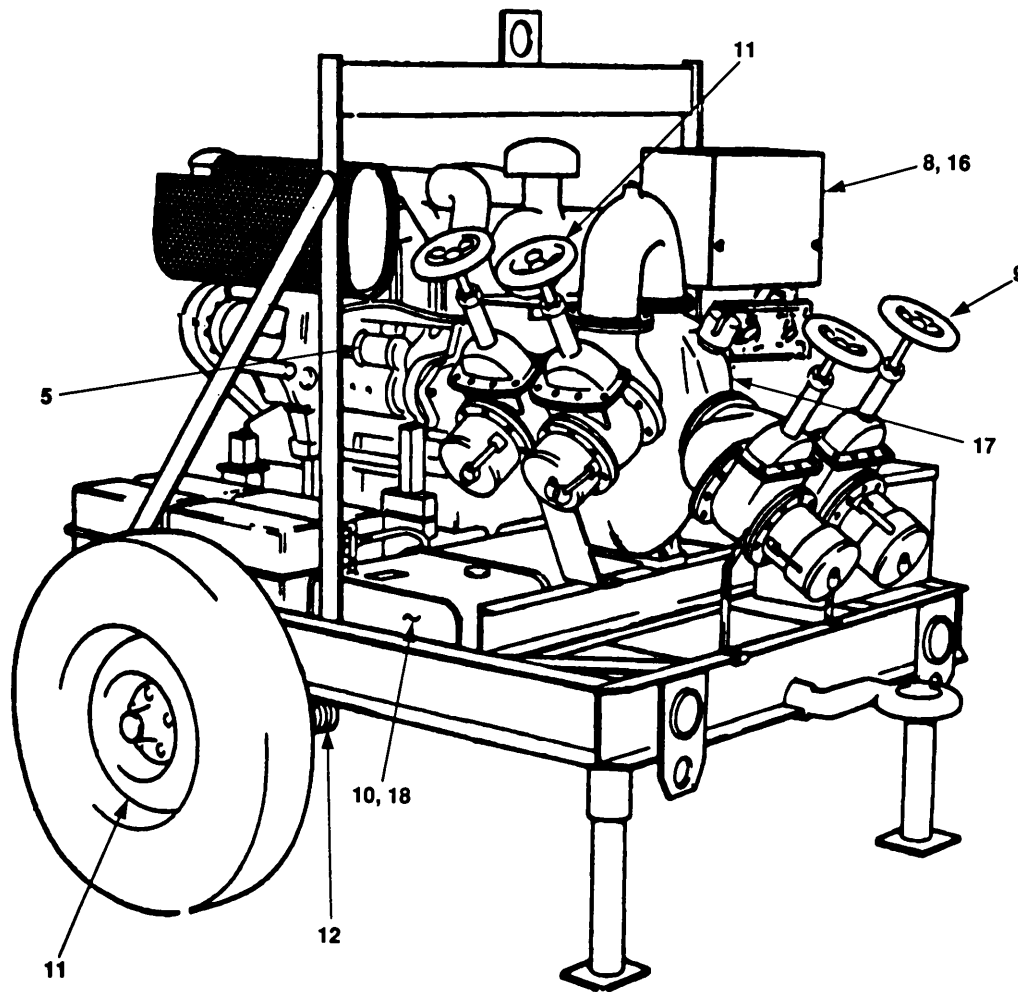

Figure 2-2. Operaor PMCS Routing Diagram. (sheet 2)

2.2.5 Leakage Classification and Definitions. Fluid leakage is classified and defined as indicated below.

Leakage Definitions.

<u>Class</u>	<u>Definition</u>
Class I	Seepage of fluid (as indicated by wetness or discoloration) not great enough to form drops.
Class II	Leakage of fluid great enough to form drops, but not enough to cause drops to drip from the item being checked/inspected.
Class III	Leakage of fluid great enough to form drops that fall from the item being checked/inspected.

NOTE

Fluid levels of items with Class I and II leaks must be checked often so proper levels can be kept.

Class III leaks must be reported to supervisors or to Unit Level Maintenance for corrective action.

Table 2-2 Operator Preventive Maintenance Checks and Services for the 350 GPM pumping Assembly.

Item No.	Interval	Location	Procedure	Not Fully Mission Capable if:
		Item to Check/Service		
1	Before	<u>AIR CLEANER ASSEMBLY</u>	Check service indicator for red signal indicating that air cleaner requires servicing.	Service indicator cannot be reset .
		<u>AIR CLEANER ASSEMBLY</u>		
2	Before	ELECTRICAL SYSTEM	Check that electrolyte is to the bottom edge of fill hole (paragraph 3.4). Check for corrosion buildup at post and loose clamps and cables.	Terminal connection loose. Excessive corrosion buildup.
		BATTERIES		
3	Before	V-BELTS	Check for loose V-belt. Check for cracks or otherwise damaged V-belt.	V-belt loose, damaged or missing.
4	Before	ALTERNATOR	Check all electrical connections are secure and no broken wires are present. Inspect for frayed or worn spots in wires.	Wires are loose or broken.
5	Before	STARTER	Check all electrical connections are secure and no broken wires are present. Inspect for frayed or worn spots in wires.	Wires are loose or broken.
6	Before	FUEL FILTER/SEPARATOR	Drain water into suitable container (paragraph 3.5) .	

Table 2-2 Operator preventive Maintenance Checks and Services for-the 350 GPM pumping Assembly. (continued)

Item No.	Interval	Location	Procedure	Not Fully Mission Capable if:
		Item to Check/Service		
7	Before	ENGINE ASSEMBLY <u>CONTROL PANEL ASSEMBLY</u>	a. Check oil level. If Engine oil level is on or below the lower mark, add oil. b. Visually inspect unit for oil leaks.	Oil leaks prevent proper oil level to be maintained.
8	Before	CONTROL PANEL <u>PUMPING ASSEMBLY</u>	Inspect for damage and secure mounting of controls and instruments.	Excessive damage to control panel .
9	Before	SUCTION AND DISCHARGE VALVES <u>FUEL TANK</u>	Check that valve turns. Check for leaks around attachment points.	Valve does not turn.
10	Before	FUEL TANK <u>WHEEL MOUNTED FRAME ASSEMBLY</u>	Service fuel tank (paragraph 3.7). Notify unit level maintenance of any leaks or problems.	Fuel tank leaks at any class or fuel tank not serviceable.
11	Before	TIRES AND WHEELS	Check for proper inflation; be sure tires are not excessively worn. Check that both tires are worn evenly. Check for damaged wheels. Check that lug nuts on wheels are securely tightened. Check that bearing caps are properly seated and tight.	Tires flat or missing.
12	Before	AXLE AND FRAME ASSEMBLY	Visually inspect for broken welds, torsion spring, bent or otherwise damaged axle. Inspect for broken welds, reflectors, damaged landing leg assemblies and damaged towbar.	

Table 2-2 Operator Preventive Maintenance Checks and Services for-the 350 GPM pumping Assembly. (continued)

Item No.	Interval	Location	Procedure	Not Fully Mission Capable if:
		Item to Check/Service		
13	During	<u>AIR CLEANER ASSEMBLY</u>	Check service indicator for red signal indicating that air cleaner requires servicing.	Service indicator cannot be reset.
		<u>EXHAUST SYSTEM</u>		
14	During	EXHAUST SYSTEM	Visually inspect spark arrestor, exhaust pipe and muffler for obvious damage. Listen for excessive noise.	
		<u>FUEL SYSTEM</u>		
15	During	FUEL LINES	Visually inspect fuel lines and connections for leaks.	Fuel leaks at any level or fuel lines damaged.
16	During	<u>CONTROL PANEL</u>	Inspect for damage, secure mounting and proper operation of controls and instruments.	Proper indications are not maintained.
		<u>PUMPING ASSEMBLY</u>		
17	During	CENTRIFUGAL PUMP	Check for signs of leakage, unusual noise, or vibration.	Any class leak, unusual noise, or vibration.
		<u>FUEL TANK</u>		
18	During	FUEL TANK	Check fuel tank gauge. When low, service tank (paragraph 3.7)	
19	After	WIRING HARNESS	Inspect for frayed or worn spots in wiring harness.	Wiring are damaged or broken.
20	After	FUEL FILTER/SEPARATOR	Drain water into suitable container.	

SECTION III. OPERATION UNDER USUAL CONDITIONS

2.3 ASSEMBLY AND PREPARATION FOR USE.

Upon reaching the operating area where pumping assembly is to be used, prepare the equipment for use as follows:

- a. Prepare a level site.
- b. Be sure all sides of the equipment and all fittings and controls are easily accessible.
- c. When connected to towing vehicle, perform following:
 - (1) Position the equipment as close as possible to the water source. Keep suction lift as low as possible.
 - (2) Remove pins (figure 2-3, 1 and 2) and extend trailer support legs (3) as far as possible.
 - (3) Reinstall pins (1 and 2) to secure trailer support legs (3).
 - (4) Release pintle (4) and disconnect pumping assembly from towing vehicle (5) .
 - (5) Secure wheels (6).
 - (6) Refer to data plate and ensure two fuel selector valves (7) are positioned as follows:
 - Fuel tank as source to TANK
 - Auxiliary supply as source to FUEL AUX
 - (7) Remove quick release pins (8 and 9) from trailer tongue and slide tongue shaft (10) inward to non-extended position and align holes.
 - (10) Insert quick release pins (8 and 9) and secure tongue in non-extended position.

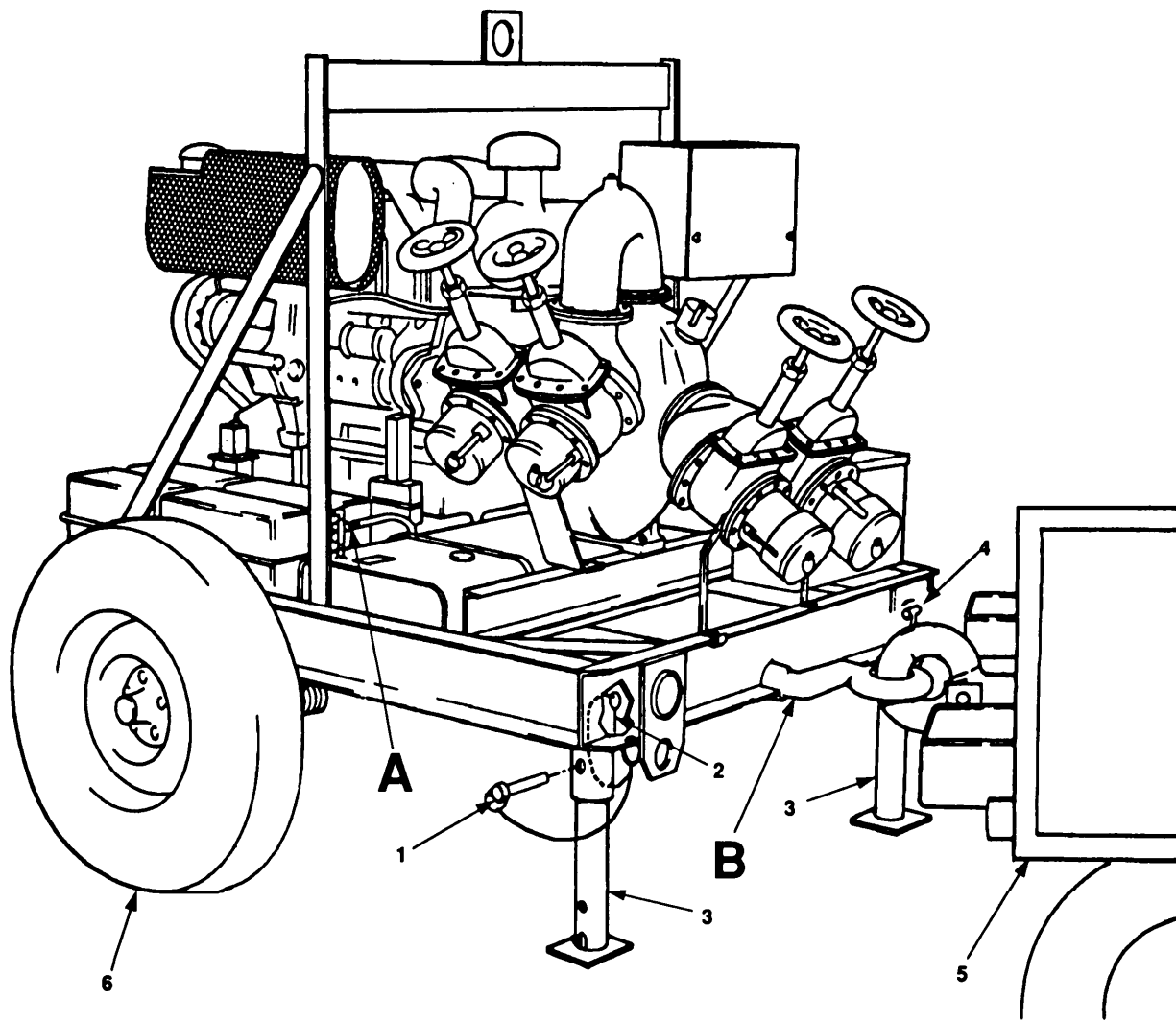
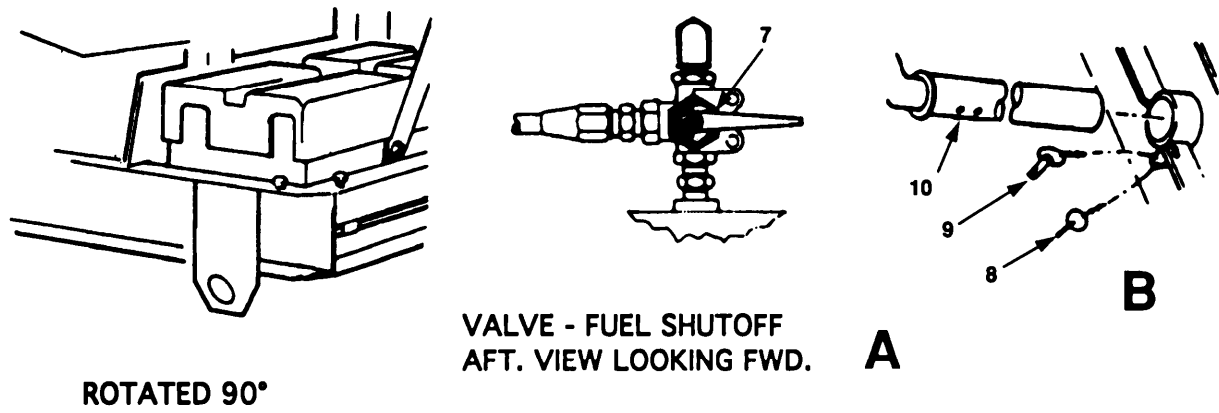

Figure 2-3. Preparation for Use.

NOTE

The following installation procedure must be made with the assistance of unit level maintenance personnel.

- d. When loaded on a flat bed truck perform the following:

WARNING

- Do not lift 350 GPM pumping assembly without lifting device. Failure to obey this warning may result in serious personal injury.
 - Do not stand under 350 GPM Pumping Assembly. Failure to obey this warning may result in serious personal injury.
- (1) Attach lifting equipment to lifting support and remove tiedown chains from 350 GPM Pumping Assembly.
 - (2) Lift the 350 GPM Pumping Assembly from flatbed trailer.
 - (3) Position pumping assembly as close as possible to water source. Keep suction lift as low as possible.

WARNING

To prevent rolling or sliding, do not work on equipment that is not securely stabilized. Ensure both wheels of the equipment are secure. Failure to obey this warning may result in serious personal injury.

- (4) Secure wheels (6).
- (5) Refer to data plate and ensure two fuel selector valves (7) are positioned as follows:
 - Fuel tank as source to TANK
 - Auxiliary supply as source to FUEL AUX

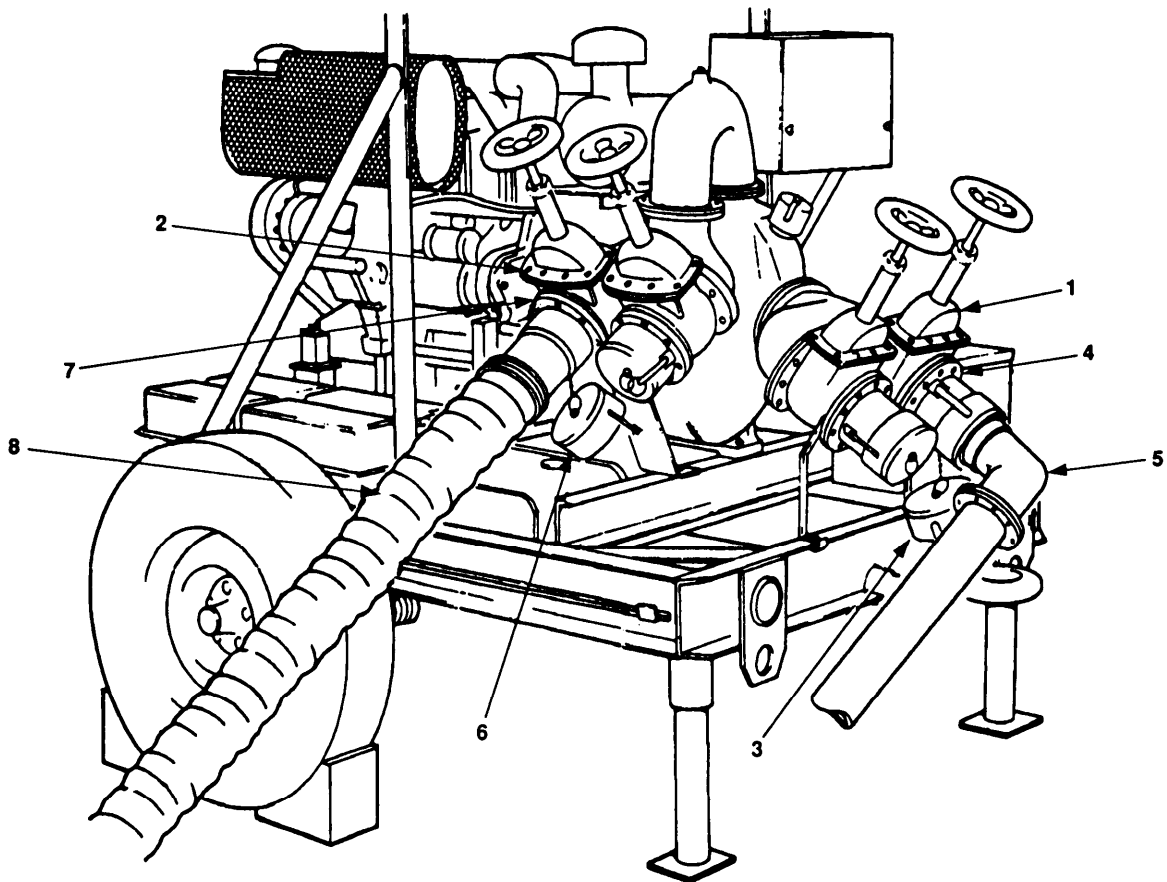

Figure 2-4. Concocting Suction and Discharge Hoses.

e. Connect suction and discharge hoses as follows:

NOTE

The first pump in a multi-pump installation must use suction hose on suction side of pump where vacuum is going to be encountered. All other hoses in a multi-pump installation will use discharge hoses making it necessary to have positive pressure (not to exceed 30 psi) on suction side of pump, to prevent hoses from collapsing.

- (1) Close suction valves (figure 2-4, 1) and discharge valves (2).
- (2) Release coupling half plug (3) from coupling half (4).
- (3) Connect suction hose (5) to coupling half (4).
- (4) Release coupling half cap (6) from coupling half (7).
- (5) Connect discharge hose (8) to coupling half (7).
- (6) Connect suction hose (5) to upline source.
- (7) Connect discharge hose (8) to downline source.

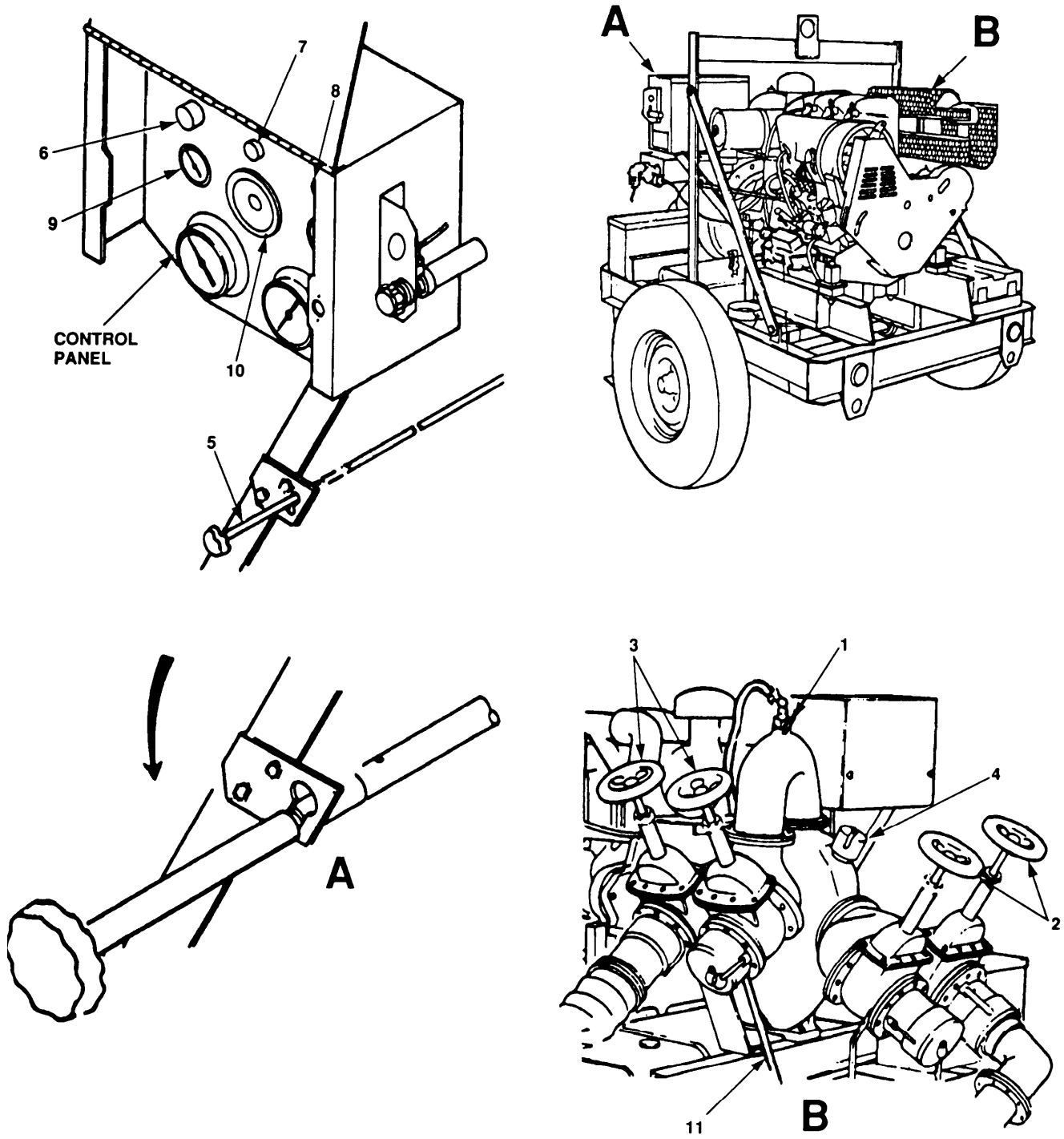

Figure 2-5. Pumping Assembly Operation.

2.4 INITIAL ADJUSTMENTS, CHECKS, AND SELF TEST.

Perform all **BEFORE** PMCS prior to operating equipment.

2.5 OPERATING PROCEDURES.

NOTE

The technical manual (TM) reference on instruction plate should refer to TM 10-4320-226-14 instead of TM 5-4320-226-14.

Operating procedures for the 350 GPM Pumping Assembly are provided in paragraphs 2.5.1 and 2.5.2. In addition, an instruction plate is provided on the lid of the Control Panel.

2.5.1 Starting. Perform the following procedures to start the equipment:



To prevent rolling or sliding, do not work on equipment that is not securely stabilized. Ensure both wheels are secure. Failure to obey this warning may result in serious personal injury.

- a. Open vent valve (figure 2-5, 1) and ensure that all suction valves (2) and discharge valves (3) are closed.



- Do not smoke or use open flames around fuel. Ensure container is used to catch fuel and fuel is disposed of properly.
 - Do not operate pump before replacing priming port cap.
 - Failure to obey these warning may result in personnel injury or death.
- b. Check pump water level by carefully opening camlock levers on priming port cap (4) and raising port cap slightly to see if water is discharged from priming port. If water is discharged, quickly install priming port cap and place camlock levers in locked position. If water is not discharged, remove port cap and add water, until level reaches the top of the priming port.
 - c. Install priming port cap (4) and place camlock levers in locked position.
 - d. Push and raise throttle control (5) from detent latch, releasing it to the idle position.
 - e. When outside temperature is below +10° F (-12° C) refer to paragraph 2-8 for operation of cold start system.
 - f. Open Control Panel as follows:
 - (1) Turn the two fasteners on Control Panel counterclockwise until fasteners release.
 - (2) Raise Control Panel cover until retaining holes in two brackets mounted on top of Control Panel align with retaining hole in bracket mounted on cover.
 - (3) Press in on end of quick release pin and insert the quick release pin through holes in brackets at top of Control Panel and Cover.
 - g. Pull out EMERGENCY STOP switch (6).

WARNING

- Do not operate pump before replacing priming port cap.
- Do not operate equipment in enclosed area unless exhaust gases are piped to outside and adequate ventilation is provided. Avoid inhalation of exhaust fumes.
- do not operate pump before replacing priming port cap.
- Do not stand within 50 feet of operating equipment without ear protection.
- Failure to obey these warning may result in personal injury or death.

CAUTION

do not operate starter motor for more than 10 seconds. Damage to starter can result.

- h. Push in oil pressure bypass switch (7) and start switch (8) simultaneously.
- i. After 10 seconds, release start switch.
 - (1) If engine does not start, release oil pressure bypass switch, wait two minutes and repeat steps h and i. If engine does not start after repeated attempts, refer to operator troubleshooting.
 - (2) When engine starts, release start switch (8).

NOTE

The engine will shutdown when oil pressure bypass switch is released if oil pressure is not equal to or greater than 4 psi (27.579).

- j. Release oil pressure bypass switch (7) when oil pressure is indicated on gauge (9).
- k. Allow engine to idle approximately two minutes.
- l. Open suction valve (2) that is connected to suction line.
- m. Observe the end of vent line (11) for liquid flowing from it. once liquid begins to flow from line, close vent valve (1).

CAUTION

Ensure discharge valve is open. pump can overheat if discharge valve is closed for long periods of time. A vapor-locked condition may result. If this occurs, shutdown engine and allow pump to cool before filling housing with liquid.

- n. Slowly open discharge valve (3) that is connected to discharge line.
- o. Smoothly turn throttle control (5) counterclockwise to increase or clockwise to decrease engine speed to approximately 2400 revolutions per minute (RPM) as indicated on TACHOMETER/HOURMETER (10).

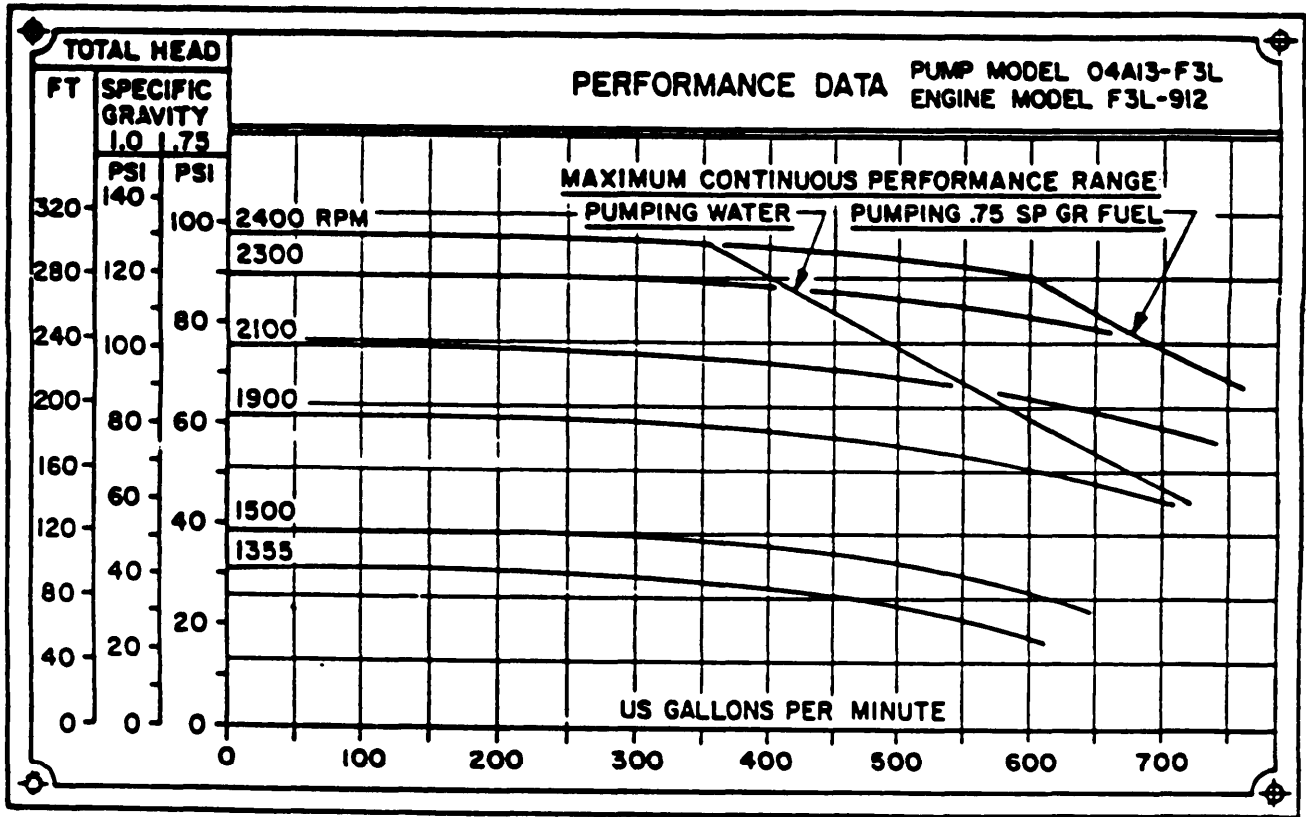

Figure 2-6. Performance Chart.

CAUTION

As pump begins to pump, reduce engine speed and reduce discharge valve opening to prevent hydraulic shock to system when line is filled too fast, causing hose rupture and fitting failure.

NOTE

When pump picks up prime, a change in engine RPM will be noted. Depending on pumping conditions, pump may not take suction immediately. It may be necessary to fill suction line with liquid before the pump takes suction. If after a reasonable time the pump fails to take suction, shut down the engine and check suction line for leaks, then repeat steps (a) through (o).

- a. Adjust pump speed to meet mission requirements. Refer to Figure 2-6.
- b. Check all control panel gauges for indications of malfunctions. If a malfunction is indicated, shut down pump immediately and refer to operator troubleshooting.
- c. Perform "during" operation PMCS (Table 2-2).

2.5.2 Shutdown.

Perform the following procedures to shut down the equipment:

WARNING

To prevent rolling or sliding, do not work on equipment that is not securely stabilized. Ensure both wheels of the equipment are chocked.

Do not stand within 50 feet of operating equipment without ear protection.

Failure to obey these warnings may result in hearing loss.

CAUTION

Do not shut engine down suddenly from full speed unless an emergency exists. Allow engine to stabilize at idle speed before shut down.

Do not allow water to remain in the water pump if the 350 GPM Pump Assembly is not going to be operated for a period of time or in inclement weather. Failure to drain the water from the water pump could result in equipment damage from freezing or sludging (deposits forming).

- a. Decrease idle speed to 800 RPM then push and raise throttle control (Figure 2-5, (5)) from detent to idle speed for two minutes.
- b. Close discharge valves (3) and suction valve (2).
- c. Push in EMERGENCY STOP switch (6).
- d. Perform "after" operation PMCS (Table 2-3).
- e. Close Control Panel as follows:
 - (1) Press in on end of quick release pin and remove pin from brackets at top of Control Panel and Cover.
 - (2) Lower control panel cover.
 - (3) Turn the two fasteners on the control panel clockwise until the fasteners engage.

2.6 DECALS AND INSTRUCTION PLATES.

Figure 2-7 provides the location and identification of decals and instruction plates located on the 350 GPM Pumping Assembly.

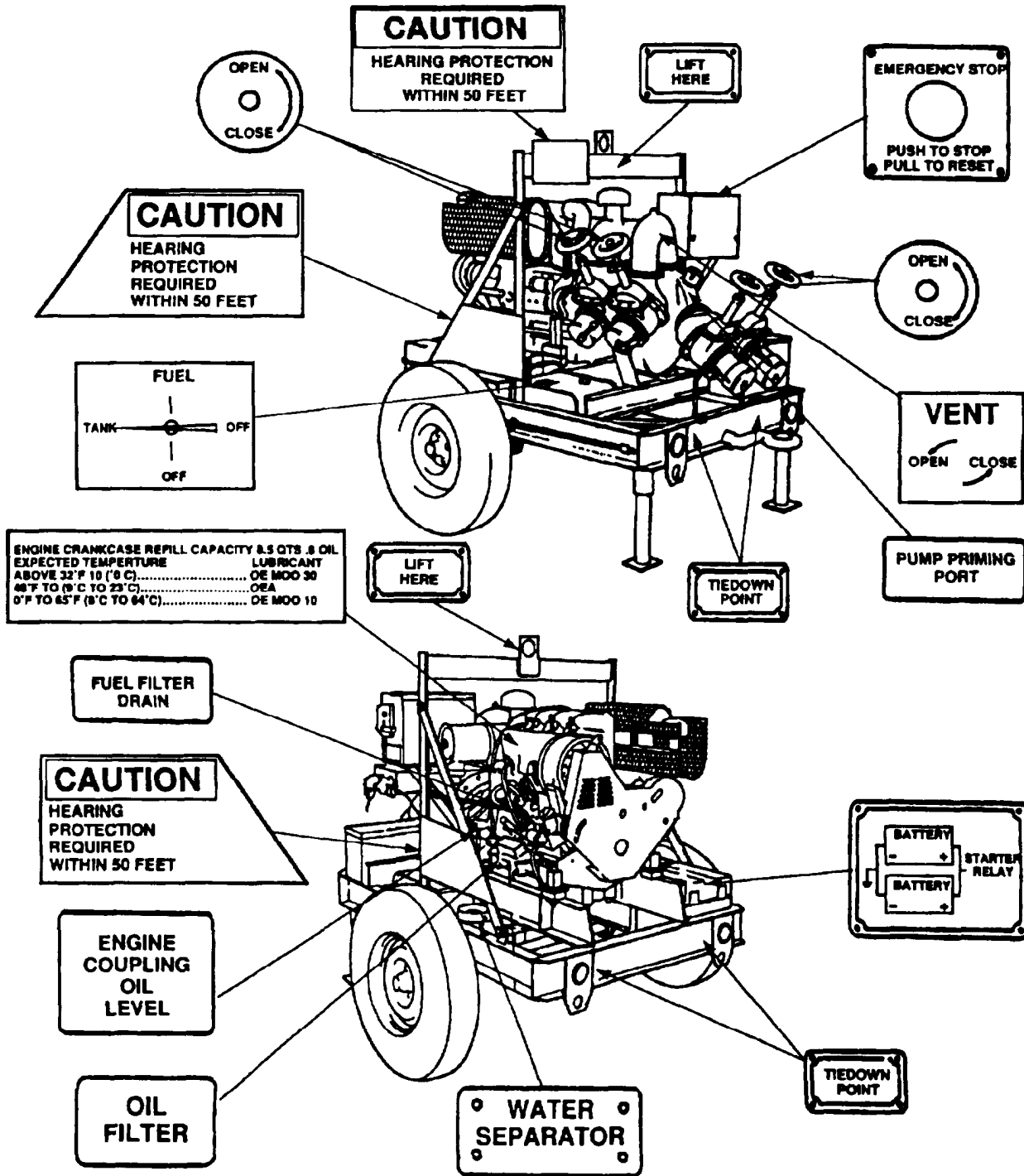

Figure 2-7. Information Plates. (Sheet 1 of 4)

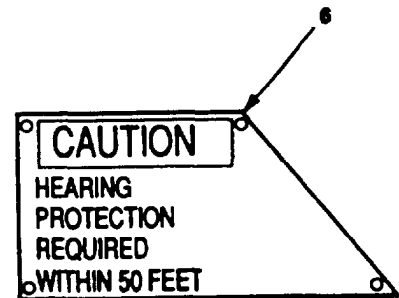
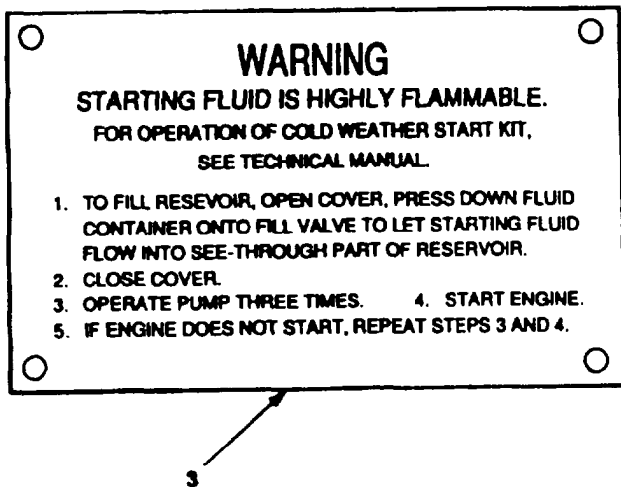
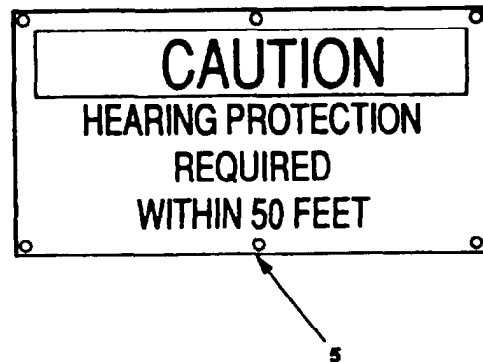
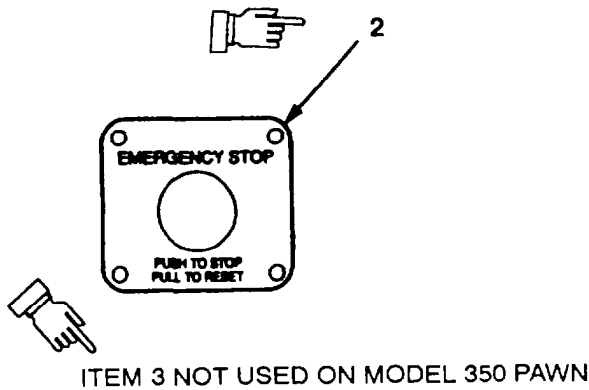
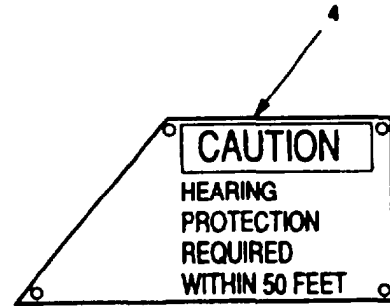
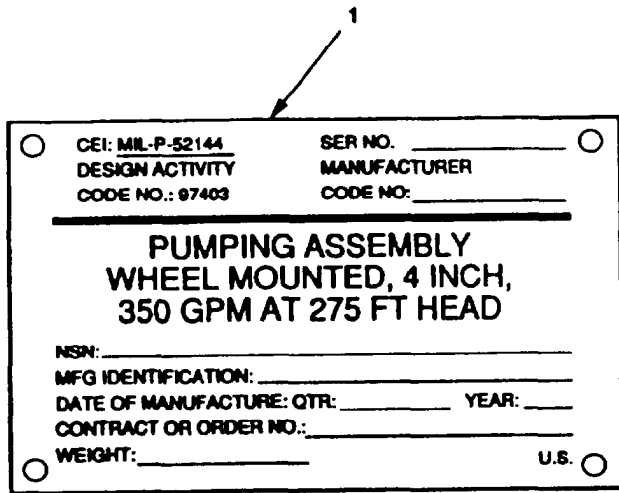

Figure 2-7. Information Plates. (sheet 2)

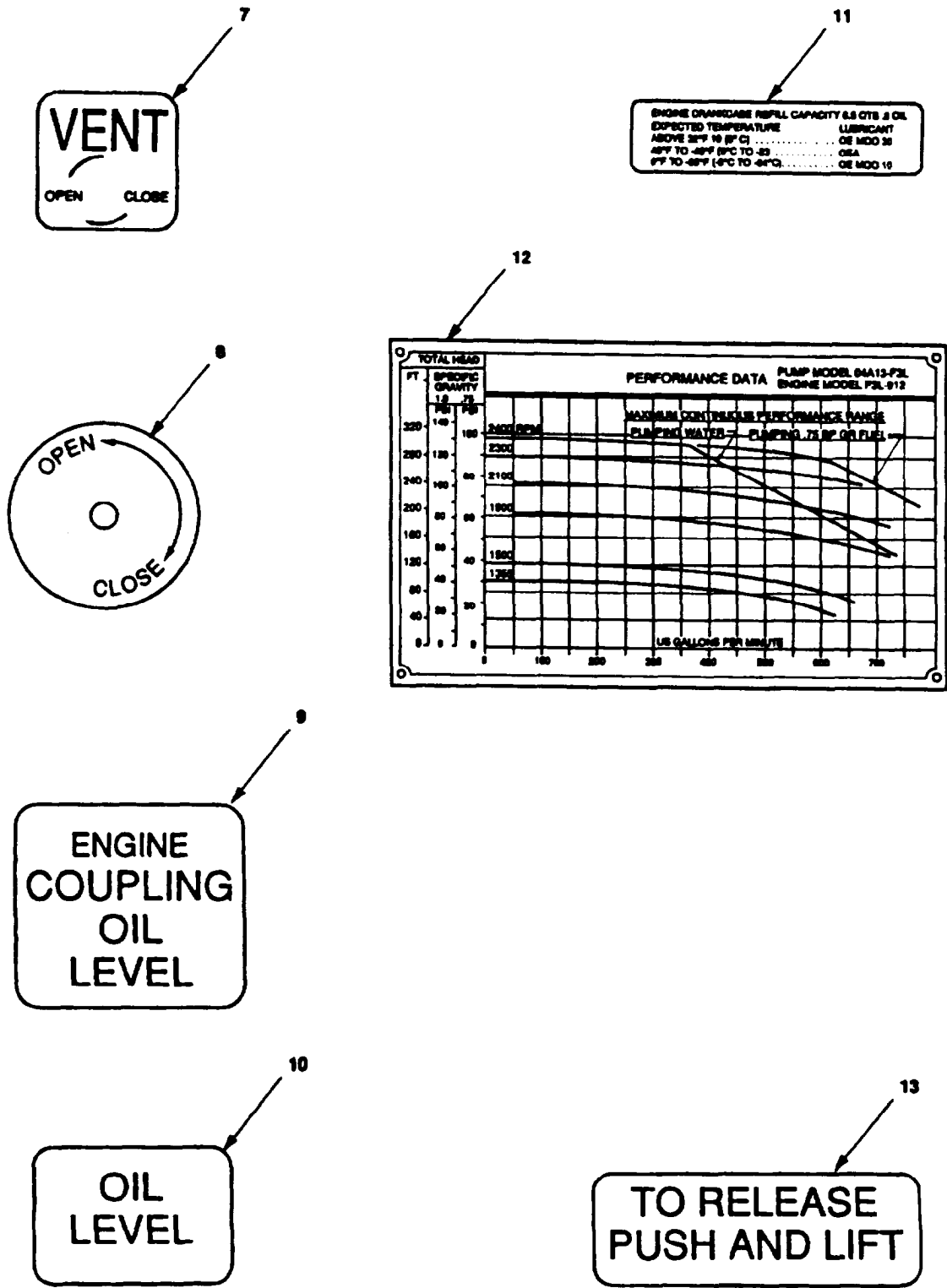

Figure 2-7. Information Plates. (Sheet 3 of 4)

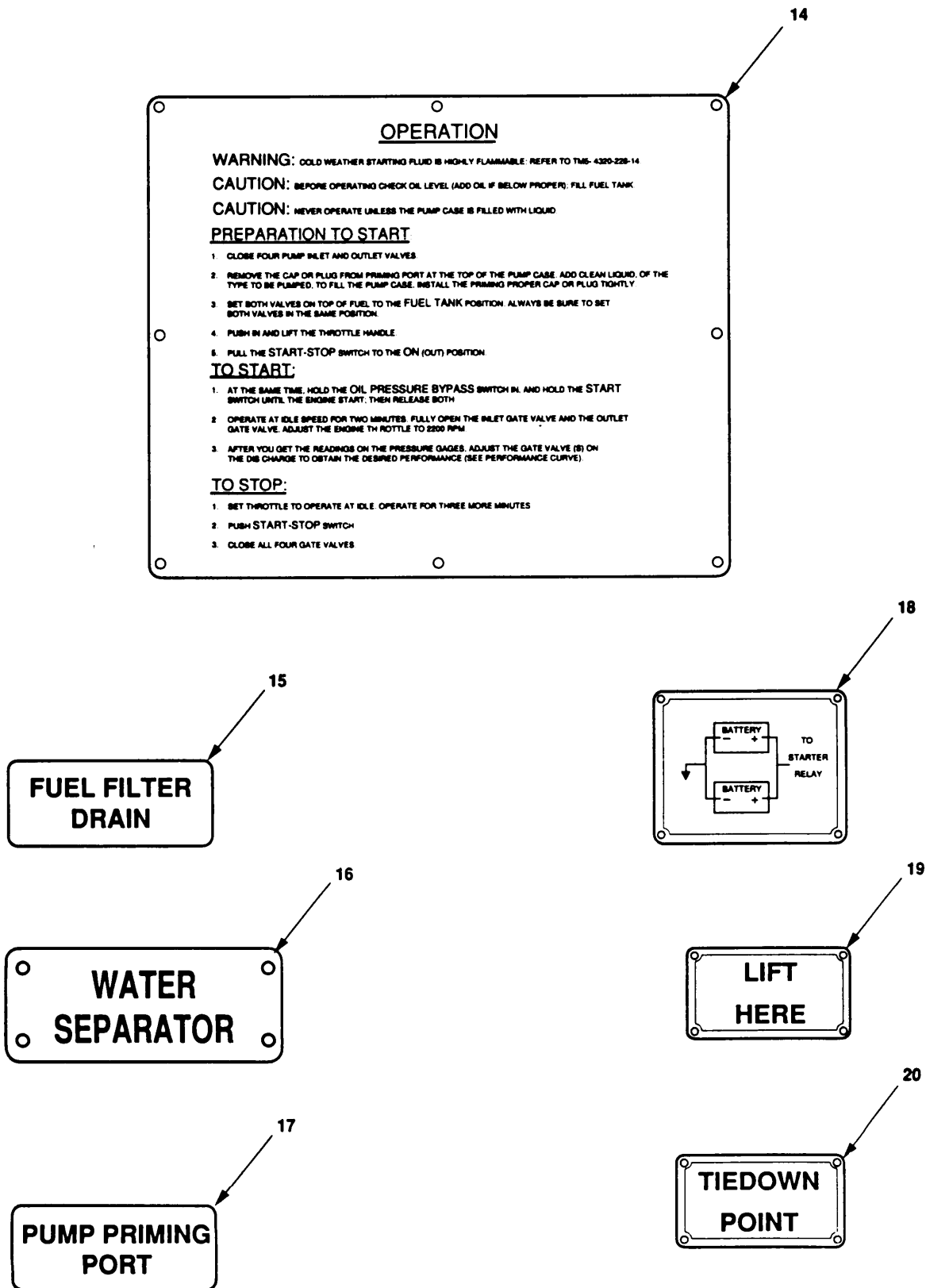

Figure 2-7. Information Plates. (sheet 4)

2.7 PREPARATION FOR MOVEMENT.

The 350 GPM Pumping Assembly can be moved either short distance around a worksite or long distance to another location. The following paragraphs provide information to prepare the 350 GPM Pumping Assembly for movement.

2.7.1 Preparation for Movement at Worksite. Perform the following to move 350 GPM Pumping Assembly to another location at a worksite.

- a. If operating, perform shutdown procedures provided in paragraph 2.5.2.

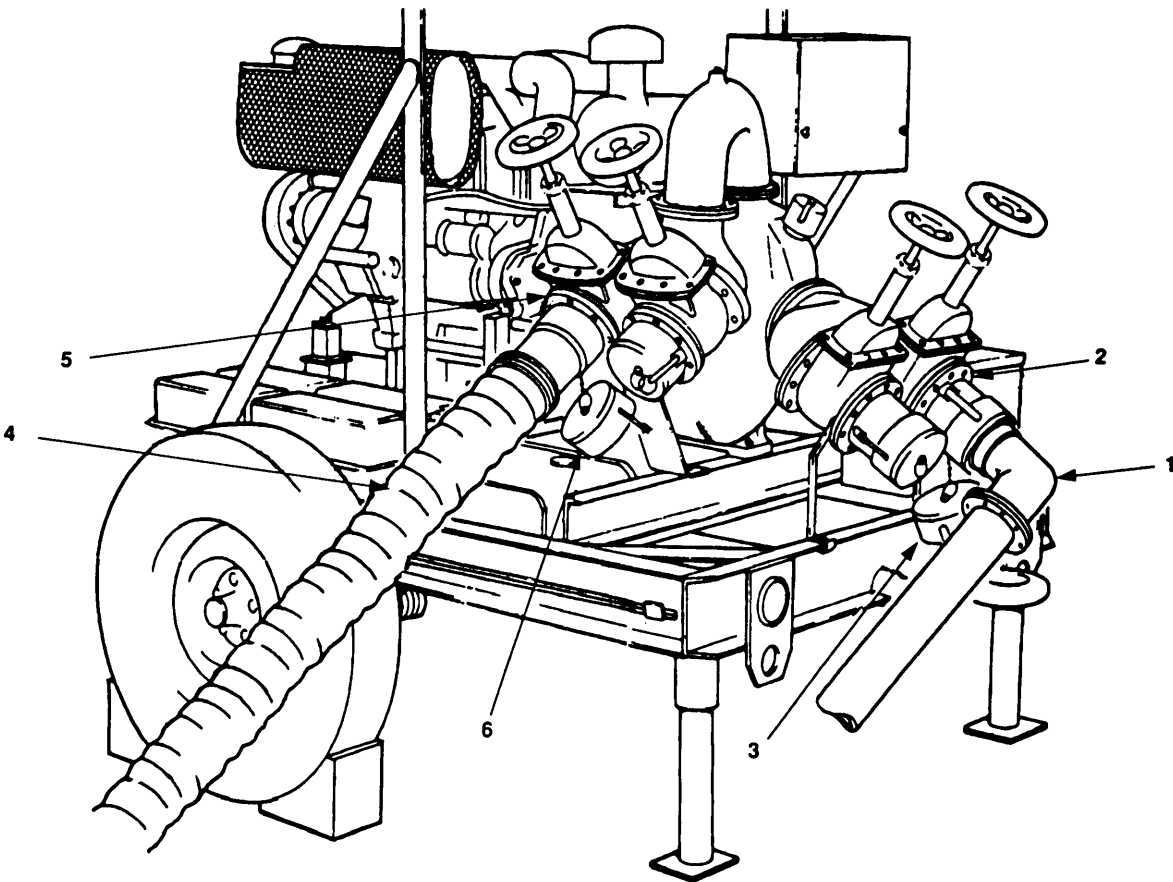

Figure 2-8. Disconnecting Suction and Discharge Hoses.

- b. Disconnect suction hose (1, figure 2-8) from coupler half (2) and connect quick disconnect plug (3) to coupler half (2).
- c. Disconnect discharge hose (4) from coupler half (5) and connect quick disconnect cap (6) to coupler half (5).

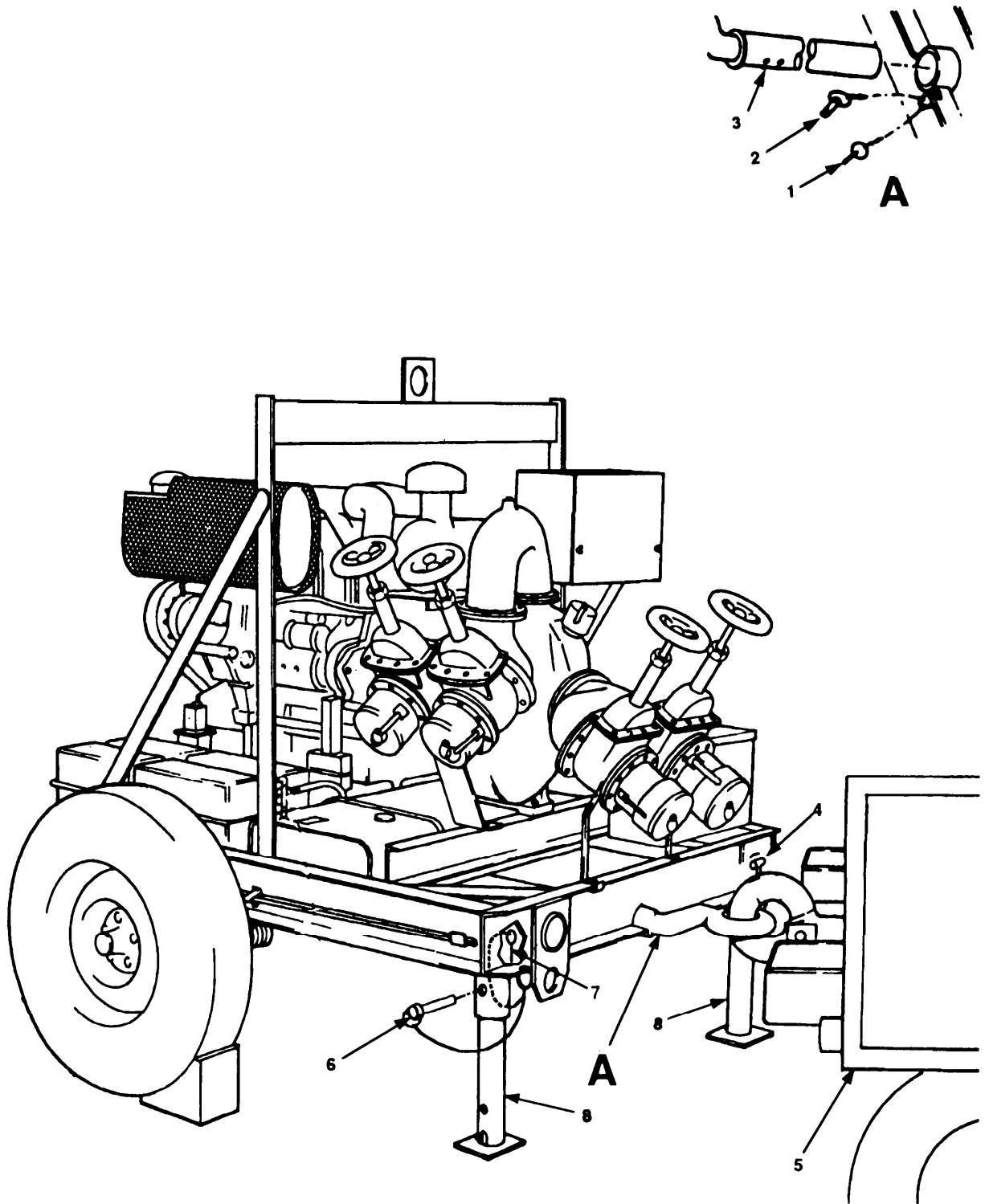

Figure 2-9. Preparation for Movement.

- d. Remove quick release pins (1 and 2, figure 2-9) from tongue and extend tongue extension (3) to full length.
- e. Insert quick release pin (1 and 2) and secure tongue.
- f. Release pintle (4) and connect pumping assembly to towing vehicle (5).
- g.* Attach and secure 350 GPM Pumping Assembly to towing vehicle.
- h. Remove pins (6 and 7) and push upward on trailer support legs (8) until holes align with mounting holes for pins (6 and 7).
- i. Reinstall pins (6 and 7) to secure trailer support legs (8).

CAUTION

Do not tow 350 GPM Pumping Assembly more than 20 miles per hour (mph). Failure to obey this caution could result in equipment damage.

- j. Tow 350 GPM Pumping Assembly to new location at worksite.

2.7.2 Preparation for Movement to New Worksite. Perform the following to move 350 GPM Pumping Assembly to another worksite.

- a. If operating, perform shutdown procedures provided in paragraph 2.5.2.
- b. Disconnect suction hose (1, figure 2-8) from coupler half (2) and connect quick disconnect plug (3) to coupler half (2).
- c. Disconnect discharge hose (4) from coupler half (5) and connect quick disconnect cap (6) to coupler half (5).
- d. Attach lifting equipment to 350 GPM Pumping Assembly and lift equipment on flatbed trailer.
- e. Secure the 350 GPM Pumping Assembly on trailer or vehicle.
- f. Transport 350 GPM Pumping Assembly to new worksite location.

SECTION IV. OPERATION UNDER UNUSUAL CONDITIONS

2.8 UNUSUAL ENVIRONMENTAL /WEATHER.

2.8.1 Cold Start System. Refer to FM 9-207, FM 9-31-70, and FM 31-71 for information on cold weather requirements. Perform the following procedures to operate the 350 GPM Pumping Assembly in cold weather.

- a. Keep fuel tank full at all times to prevent ice crystal formation.
- b. Do not disturb electrical leads or wiring unless repair is needed.

2.8.1.1 On all models except Model 350 PAWN perform the following procedures for cold starting.

NOTE

On Model 350 PAWN the cold start system is a fully-automatic engine starting fluid system designed to spray a controlled amount of starting fluid into the air intake system of an engine during and immediately after cranking. Refer to paragraph 2.8.1.2.

WARNING

Do not puncture or mishandle quick start kit container. Container contains ether-based mixture that is extremely flammable and toxic. It can be harmful or fatal if swallowed. Avoid contact with skin or eyes or breathing fumes. Failure to obey this warning may result in injury or death.

- a. Open cold start reservoir cover (1, figure 2-11) and force servicing can (2) into nipple (3) on reservoir (4) so fluid flows from can into reservoir.
- b. Remove can when reservoir level reaches "MAXI" line, then close cover.

WARNING

Do not operate the 350 GPM Pumping Assembly without grounding.

Do not operate pump before replacing priming port cap.

Do not operate equipment in enclosed area unless exhaust gases are piped to outside and adequate ventilation is provided. Avoid inhalation of exhaust fumes.

Failure to obey warnings may result in personnel injury or death.

Do not stand within 50 feet of operating equipment without ear protection. Failure to obey this warning may result in hearing loss.

CAUTION

Do not operate starter motor for more than 10 seconds, damage to starter can result.

- c. Pump hand pump (5) immediately when depressing start button (6) on control panel.

- d. Refer to operating procedures (paragraph 2.5), but allow the engine to warm up a full five minutes before accelerating to full speed RPM.

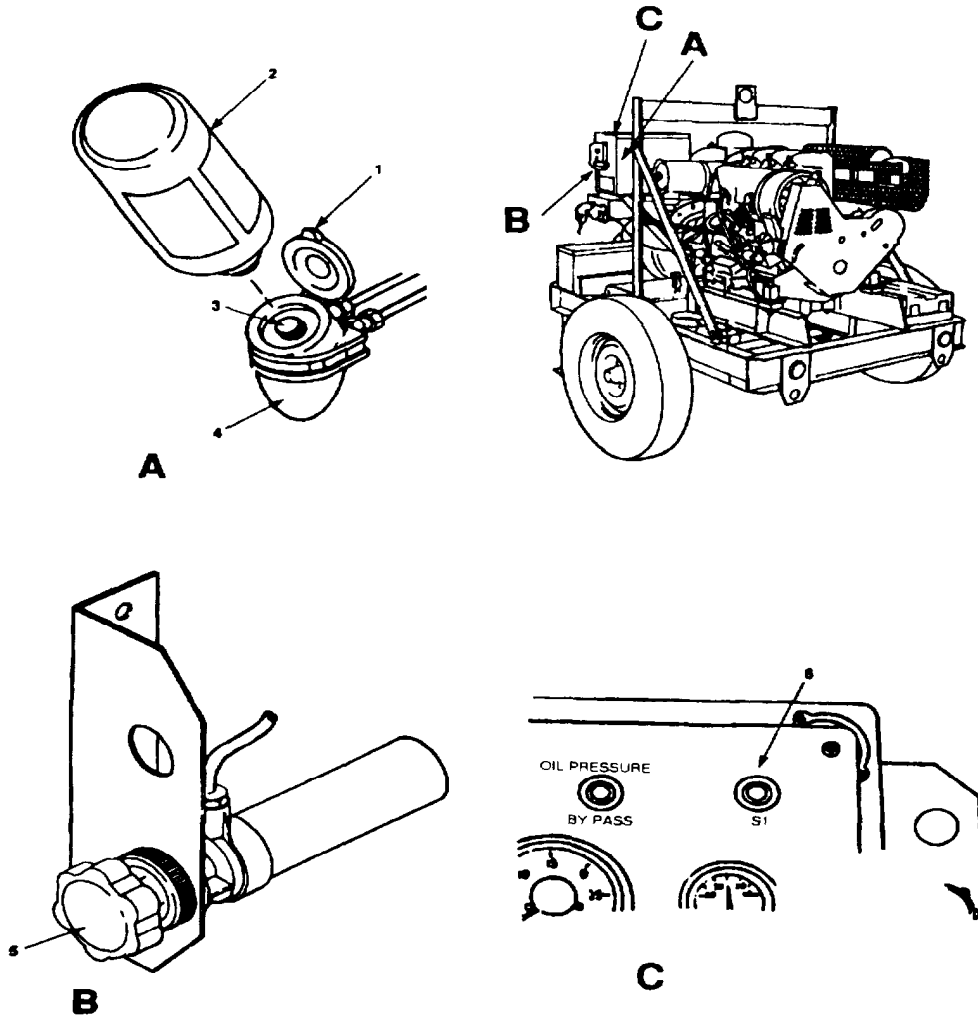

Figure 2-10. Cold Start Reservoir and Pump(Except Model 350 PAWN).

2.8.1.2 On Model 350 PAWN perform the following procedures for cold starting.

NOTE

On Model 350 PAWN the cold start system is a fully-automatic engine starting fluid system designed to spray a controlled amount of starting fluid into the air intake system of an engine during and immediately after cranking.

WARNING

Do not puncture or mishandle quick start kit container. Container contains ether-based mixture that is extremely flammable and toxic. It can be harmful or fatal if swallowed. Avoid contact with skin or eyes or breathing fumes. Failure to obey this warning may result in injury or death.

- a. The engine start cartridge(1, figure 2-10.1) is secured with clamp(2) in bracket(3) and mounted on the engine. To determine if the cartridge is serviceable or requires replacing refer to procedures in paragraph 4.10.3.1.

WARNING

Do not operate the 350 GPM Pumping Assembly without grounding.

Do not operate equipment in enclosed area unless exhaust gases are piped to outside and adequate ventilation is provided. Avoid inhalation of exhaust fumes.

Failure to obey warnings may result in personnel injury or death.

Do not stand within 50 feet of operating equipment without ear protection, Failure to obey this warning may result in hearing loss.

CAUTION

Do not operate starter motor for more than 10 seconds, damage to starter can result

- b. If, the engine start cartridge(I) is determined serviceable, depress the start button(4) on control panel.
- c. Refer to operating procedures (paragraph 2.5), but allow the engine to warm up a full five minutes before accelerating to full speed RPM.

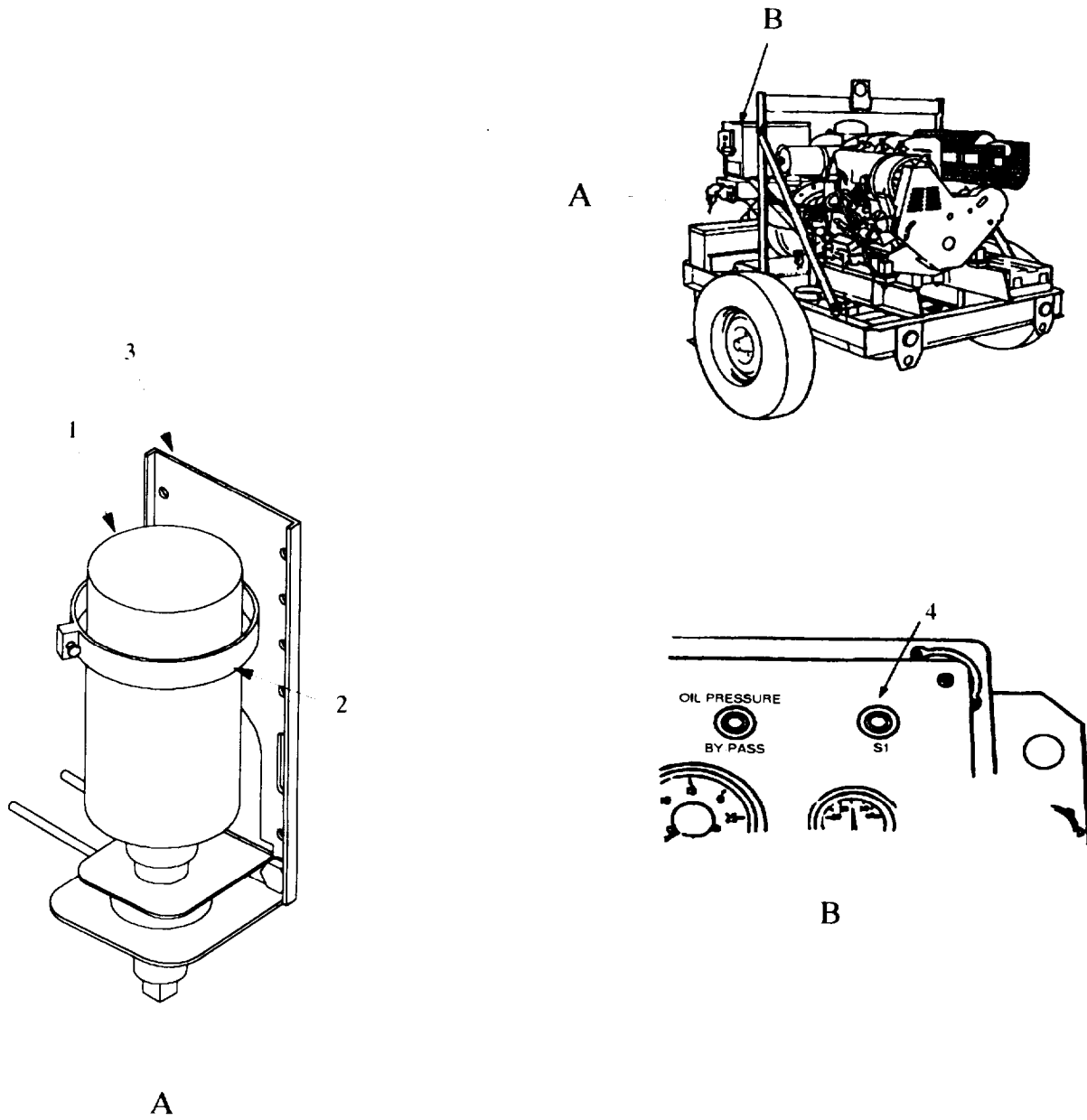

Figure 2-10.1. Cold Start Kit (Model 350 PAWN).

2.8.2 Operation In Extreme Heat. Perform the following procedures to operate the 350 GPM Pumping Assembly in extreme heat.

- a. Inspect cooling fins and cooling coil for excessive dirt buildup and carefully clean as necessary.
- b. Inspect cooling blower inlet often for any obstructions.

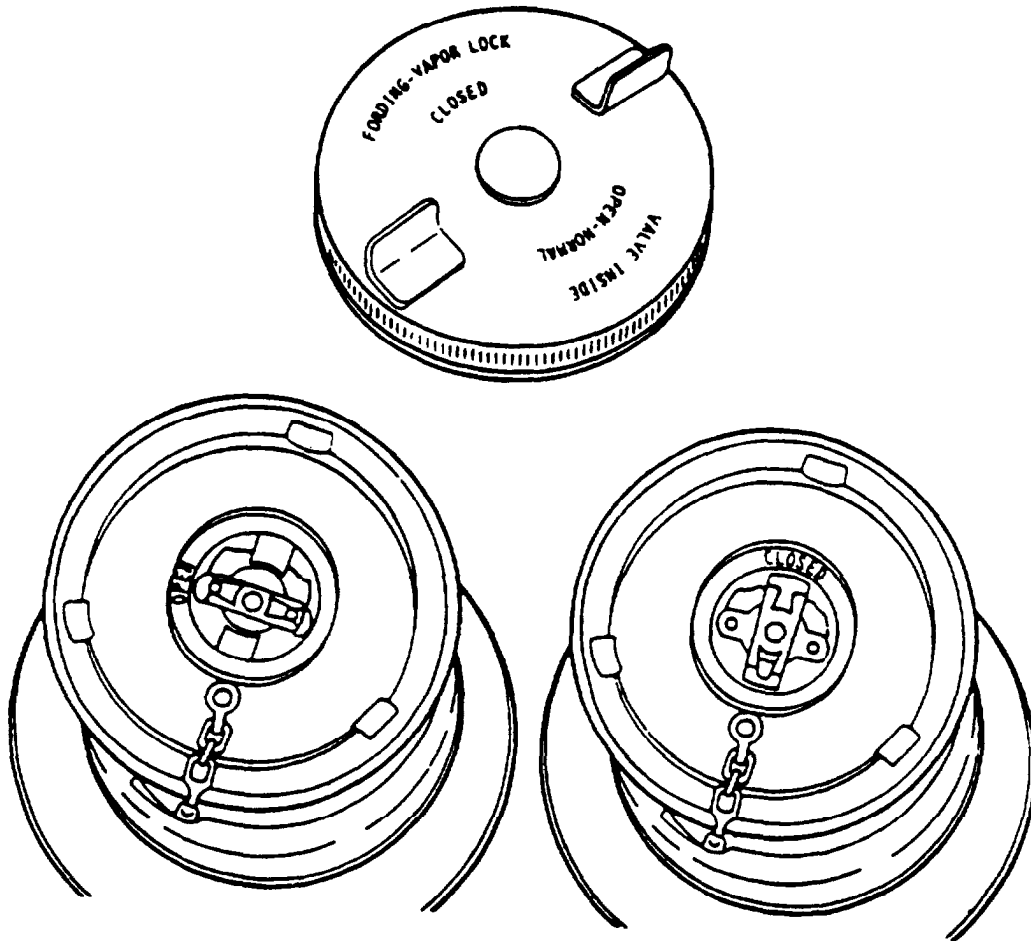

Figure 2-11. Fuel Tank Filler Cap and Vent Valve Selector.

2.8.3 Operation In Dusty Or Sandy Areas. Perform the following procedures to operate the 350 GPM Pumping Assembly in dusty or sandy areas:

- a. Keep crankcase oil fill cap tight and dipstick seated to prevent contamination.
- b. Inspect cooling fins and cooling coil for excessive dirt buildup and carefully clean as necessary.
- c. Wipe spilled lubricants from assembly to avoid collecting dust and sand.
- d. Use care when servicing fuel tank to prevent sand and dirt from entering the fuel system. Ensure that fill cap is kept tight.
- e. Pay particular attention to the air cleaner service indicator. Replace elements as required.

2.8.4 Operation In Damp Or Muddy Areas. Except for modifying PMCS time intervals and ensuring that surface under unit is firm enough to support pumping assembly, no special instructions are required for operation of pumping assembly in damp or muddy areas.

2.8.5 Operation In Salt Water Areas. When it is necessary to operate the pumping assembly near salt water, the following precautions should be observed to provide maximum protection to the unit and to assure efficient operation.

- a. Keep all electrical components clean, dry and free of corrosion.
- b. Wash unit with fresh, clean water as needed and keep fuel filler cap tight.
- c. Check all gauges for loose or broken lenses which might permit entry of moisture.

2.8.6 Operation At High Altitudes. Never run the diesel engine at altitudes above 3280 ft (1000 m) under heavy-duty conditions, unless the engine has been de-rated.

2.9 FORDING. The pumping assembly is transportable through a body of water up to 30 inches (762 mm) deep,

- a. Before fording, perform the following:
 - (1) Secure tool box cover latch,
 - (2) Secure control panel cover.
 - (3) Ensure that battery cover retaining bar is secure.

NOTE

Fuel tank incorporates a vent valve. Valve must be closed before fording to prevent water entry. During normal operation, vent valve must be open.

- (4) Remove fuel tank filler cap from tank and turn cap over,
- (5) Rotate vent valve selector to CLOSED position as shown in Figure 2-11,
- (6) Install cap and secure.

b. After fording, perform the following:

- (1) Remove fuel tank filler cap and turn cap over.
- (2) Rotate vent valve selector to OPEN position as shown in Figure 2-11.
- (3) Install cap and secure.

2.10 EMERGENCY PROCEDURES. Anytime an emergency arises while operating the pumping assembly which calls for an immediate engine shutdown, push the Start/Stop switch.

2.11 NUCLEAR, BIOLOGICAL, AND CHEMICAL (NBC) DECONTAMINATION.

- a. If attack is known or suspected, mask at once and continue mission. If inside, stay there if possible.
- b. If outside, brush fallout from skin, clothing, and equipment with available brushes and rages before going inside. Wash skin and have a radiation check made as soon as tactical situation permits.
- c. Do not unmask until told to do so.
- d. Detailed decontamination (DECON) procedures can be found in FM 3-3, FM 3-4, and FM 3-5.

CHAPTER 3

OPERATOR MAINTENANCE INSTRUCTIONS

Subject Index	Page
Section I Lubrication Instructions	3-2
3.1 Lubrication	3-2
Section II Operator Troubleshooting	3-2
3.2 Operator Troubleshooting	3-2
Section III Operator Maintenance Procedures	3-4
3.3 Engine Assembly Maintenance	3-4
3.4 Batteries and Cables Maintenance	3-6
3.5 Water Separator and Water/Filter/ Separator Servicing	3-8
3.6 Pump Assembly Maintenance	3-10
3.7 Fuel Tank Servicing	3-12

SECTION I. LUBRICATION INSTRUCTIONS

3.1 LUBRICATION.

Refer to LO 10-4320-226-12 for lubrication instructions.

SECTION II. OPERATOR TROUBLESHOOTING

3.2 OPERATOR TROUBLESHOOTING.

Use the malfunction index to locate specific troubleshooting procedures contained in Table 3-1. After locating the procedure, perform the test/inspections and corrective actions in the order listed in Table 3-1. The malfunction index and Table 3-1 cannot list all the malfunctions that may occur, all the test and inspections needed to find the fault, or all the corrective actions needed to correct the fault. If the equipment malfunction is not listed or actions listed do not correct the fault notify your supervisor.

Operator Malfunction Index

	Malfunction Number in Table 3-1
Engine will not crank	1
Engine will not start	2
Engine runs erratic after warm up	3
Engine has excessive exhaust smoke	4
Oil pressure reading low	5
No pump assembly suction or discharge pressure	6
Pump stops or fails to deliver rated flow or pressure.....	7
Pump noisy	8

Table 3-1. Operator Troubleshooting Table.

MALFUNCTION
TEST OR INSPECTION
CORRECTIVE ACTION

1. Engine will not crank.

Check electrolyte in batteries. (Paragraph 3.4)

- a. Fill batteries.
- b. Notify Unit Maintenance.

2. Engine will not start.

Check to see if fuel source is empty or low.

- a. Set fuel valves on top of fuel tanks to proper position.
- b. Fill fuel tank or auxiliary source. (Paragraph 3.7)
- c. Check fuel priming at water/filter separator and engine pump.
- d. Notify Unit Maintenance.

Table 3-1. Operator Troubleshooting Table. (continued)

MALFUNCTION	TEST OR INSPECTION	CORRECTIVE ACTION
3. ENGINE RUNS ERRATIC AFTER WARMUP.	Step 1. Visually inspect air cleaner indicator.	<ul style="list-style-type: none"> a. Reset air cleaner indicator. b. Notify unit level maintenance.
	Step 2. Check fuel supply.	<ul style="list-style-type: none"> a. Refill fuel source (paragraph 3.7). b. Drain water separator. c. Notify unit level of maintenance.
4. ENGINE HAS EXCESSIVE EXHAUST SMOKE.	Check fuel supply.	<ul style="list-style-type: none"> a. Refill fuel source (paragraph 3.7). b. Drain water separator. c. Notify unit level of maintenance.
5. OIL PRESSURE READING LOW.	Check engine oil level (paragraph 3.6).	<ul style="list-style-type: none"> a. Refer to LO 10-4320-226-12 and add oil. b. Notify unit level of maintenance.
6. NO PUMP ASSEMBLY SUCTION OR DISCHARGE PRESSURE.	Check for pump prime.	<ul style="list-style-type: none"> a. Prime pump (paragraph 2.5). b. Notify unit level maintenance.
7. PUMP STOPS OR FAILS TO DELIVER RATED FLOW OR PRESSURE.	Check that engine is operating at proper RPM.	<ul style="list-style-type: none"> a. Adjust engine speed (paragraph 2.5). b. Notify unit level maintenance.
8. PUMP NOISY.	Check oil level in intermediate housing. (paragraph 3.7)	<ul style="list-style-type: none"> a. Add oil in accordance with LO 10-4320-226-12. b. Notify unit level maintenance.

SECTION III. OPERATOR MAINTENANCE PROCEDURES

3.3 ENGINE ASSEMBLY MAINTENANCE.

This task covers: Servicing

INITIAL SETUP

Material/Parts

Cloth, lint free (appendix E, Section II, Item 4)

Oil (appendix E, Section II, Item 8)

Reference

LO 10-4320-226-12

Equipment Conditions

Engine shut down paragraph 2.5.1.2 or 2.5.2.2.

General Safety Instructions

To prevent rolling or sliding, do not work on equipment that is not securely stabilized.

Do not work on equipment without following standard shop safety precautions.

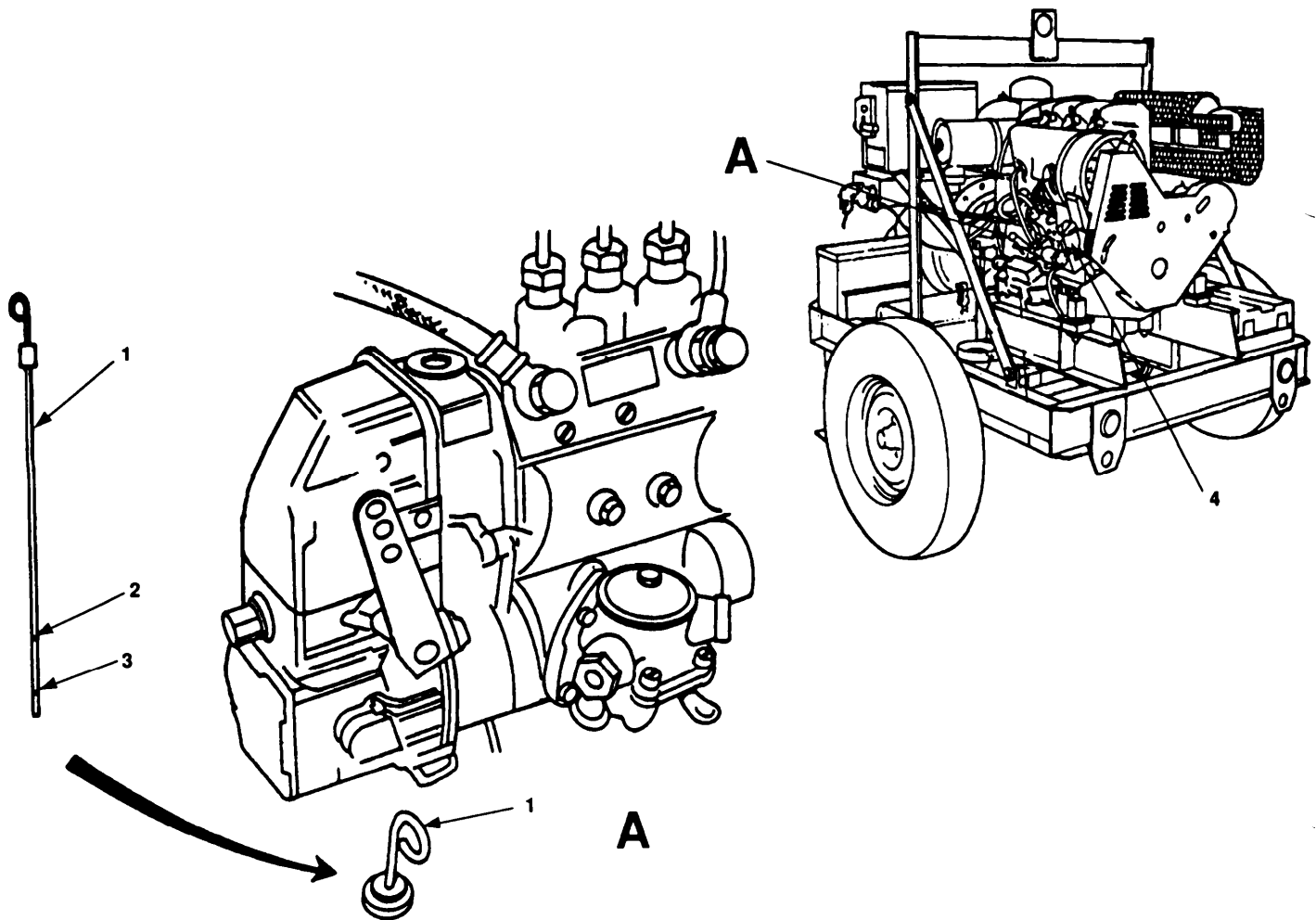

Figure 3-1. Checking Engine Oil Level.

WARNING

To prevent rolling or sliding, do not work on equipment that is not securely stabilized. Ensure both wheels are secure. Failure to obey this warning may result in serious personal injury.

NOTE

Normally, new engines have a higher oil consumption. During the breaking-in period, approximately 200 operating hours, it is essential to check oil level more frequently. One check is sufficient after the breaking-in period.

- a. Pull out dipstick (figure 3-1, 1), and wipe it clean with a rag.
- b. Replace dipstick (1) by pushing it in as far as it will go; then, withdraw it again.
- c. Check oil film left on dipstick. It should extend to upper mark (2).
- d. If level is below upper mark (2) or only reaches to lower level (3), refer to LO 10-4320-343-12 and fill to top mark (1).

3.4 BATTERIES AND CABLES MAINTENANCE.

This task covers: Inspection and servicing

INITIAL SETUP

Material/Parts

Rubber gloves
Protective clothing

Equipment Conditions

Equipment shut down
paragraph 2.5.1.2 or 2.5.2.2

General Safety Instructions

To prevent rolling or sliding, do not work on equipment that is not securely stabilized.

do not fill battery without rubber gloves and protective clothing.

Do not work on equipment without following standard shop safety precautions.

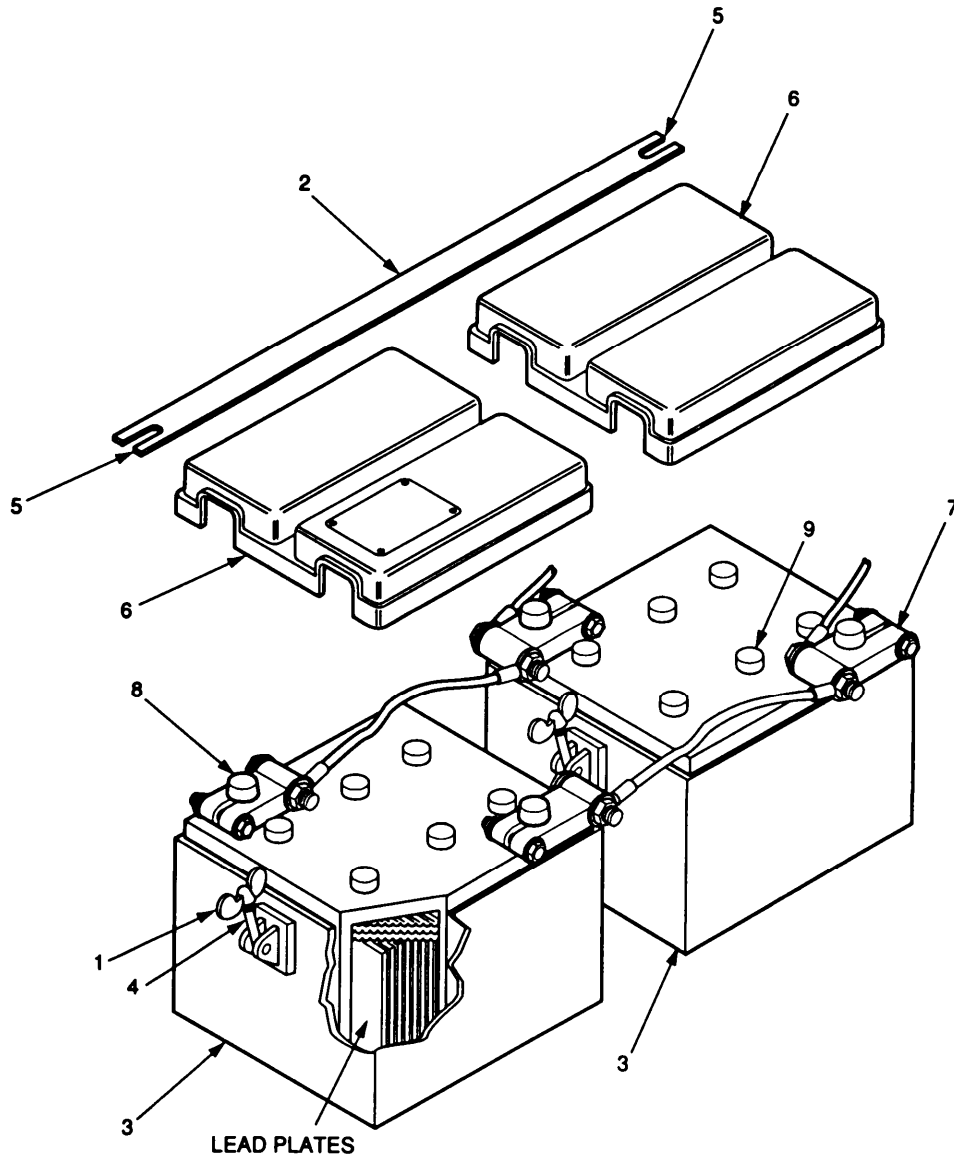

Figure 3-2. Servicing Batteries and Cables.

WARNING

To prevent rolling or sliding, do not work on equipment that is not securely stabilized. Ensure both wheels of the equipment are chocked, Failure to obey this warning may result in serious injury.

Refer to Figure 3-2 and proceed as follows:

- a. Loosen two wing nuts (1), one on each side, that secure holding strap (2) to battery cases (3).
- b. Disengage eye bolts (4) from strap slots (5).
- c. Remove strap (2)
- d. Remove battery access covers (6).
- e. Inspect battery cables (7 and 8) for corrosion, If severely corroded, notify Unit Maintenance.
- f. Remove six caps (9) on each battery.

NOTE

Electrolyte level must cover lead plates and extend to the lower edge of the fill hole.

- g. Visually check the electrolyte level of all cells,

WARNING

Electrolyte causes serious burns. Do not fill batter without rubber gloves and protective clothing. Failure to obey this warning may result in injury or death.

- h. When electrolyte level is low, add distilled water.
- i. Install six caps (9) on each battery.
- j. Position battery access covers (6) on batteries.
- k. Position strap (2) with flat side up on battery access covers (6).
- l. Engage eye bolts (4) in strap slots (5).
- m. Tighten wing nuts (1) on eye bolts (4) to apply equal pressure on strap (2).

3.5 WATER SEPARATOR/FILTER SEPARATOR SERVICING.

This task covers: Servicing

INITIAL SETUP

NOTE

This procedure must be made with the assistance of Unit level maintenance personnel.

Material/Parts

Suitable container

Equipment Conditions

Engine shut down paragraph 2.5.1.2 or 2.5.2.2.

General Safety Instructions

To prevent rolling or sliding, do not work on equipment that is not securely stabilized.

Do not work on equipment without following standard shop safety precautions.

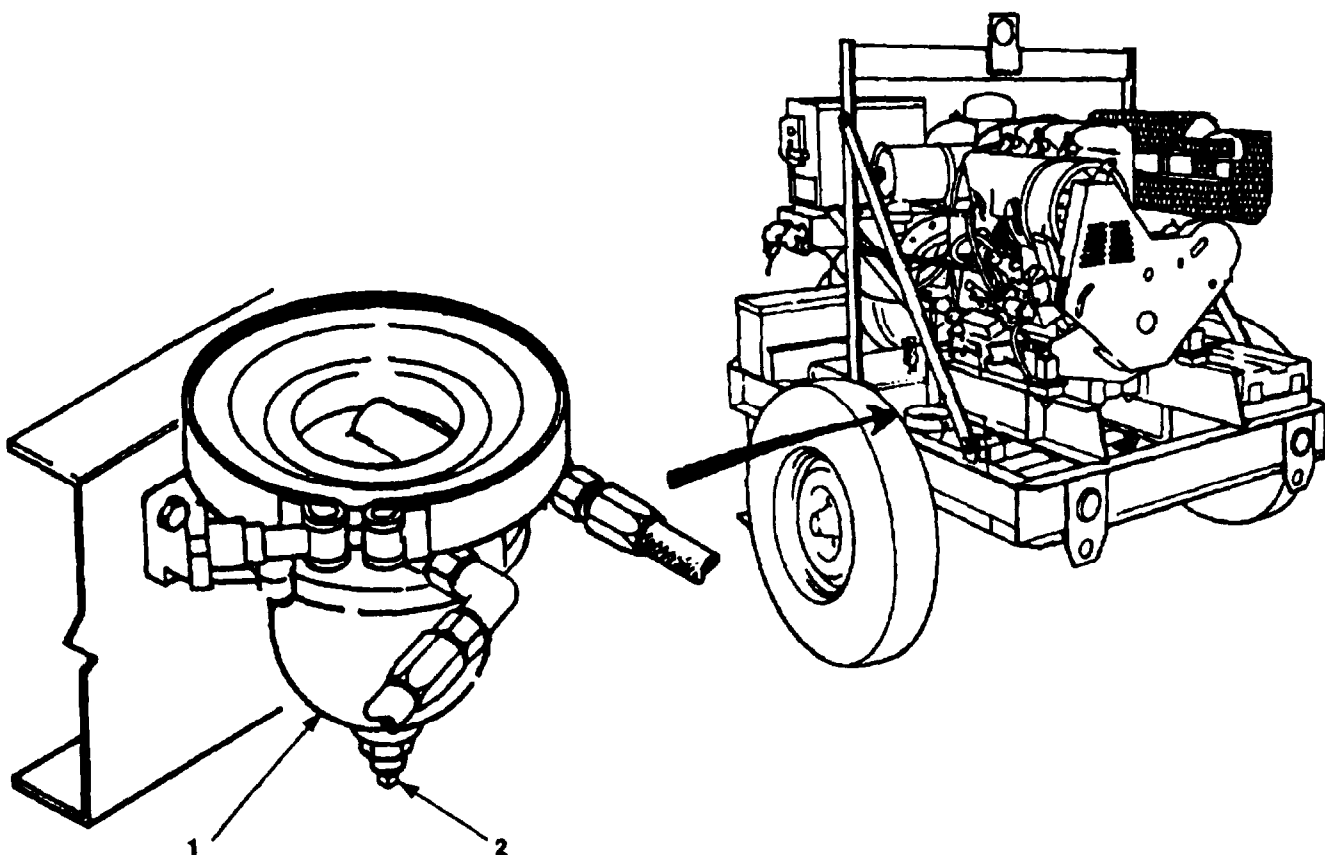

Figure 3-3. Water Separator Servicing (Models 350 PAW and W-87012).

WARNING

To prevent rolling or sliding, do not work on equipment that is not securely stabilized. Ensure both wheels are secure. Failure to obey this warning may result in serious personal injury.

CAUTION

Do allow water remain in the water/filter separator undrained after operation of equipment. Failure to obey this caution could result in equipment damage.

- a. Place suitable container under water separator (figure 3-3 or 3-3.1).

NOTE

Water/Filter separator on Model 350 PAWN may require priming after draining water.

- b. On models 350 PAW and W-87012, remove plug (figure 3-3,2) or open petcock drain valve and drain water from separator until clean fuel is observed. When clean fuel is observed, close drain valve or install plug.
- c. On Model 350 PAWN open drain valve (figure 3-3.1, 2) and drain water from separator (1) until clean fuel is observed. When clean fuel is observed close drain valve,

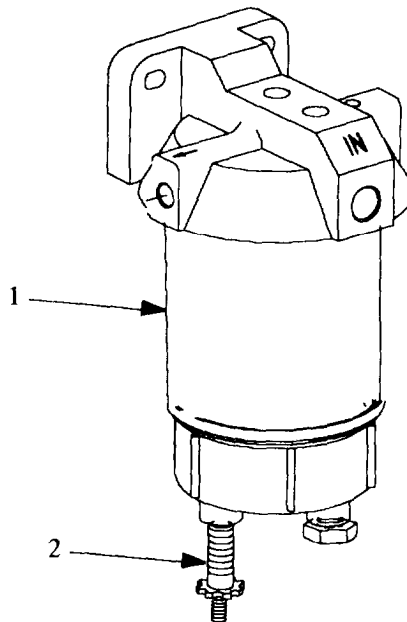

Figure 3-3.1. Water/Filter Separator Servicing (Model 350 PAWN).

3.6 PUMP ASSEMBLY MAINTENANCE.

This task covers: Servicing

INITIAL SETUP

Material/Parts

Oil (appendix E, Section II, Item 8)

Reference

LO 10-4320-226-12

Equipment Conditions

Engine shut down paragraph 2.5.1.2 or 2.5.2.2.

General Safety Instructions

To prevent rolling or sliding, do not work on equipment that is not securely stabilized.

Do not work on equipment without following standard shop safety precautions.

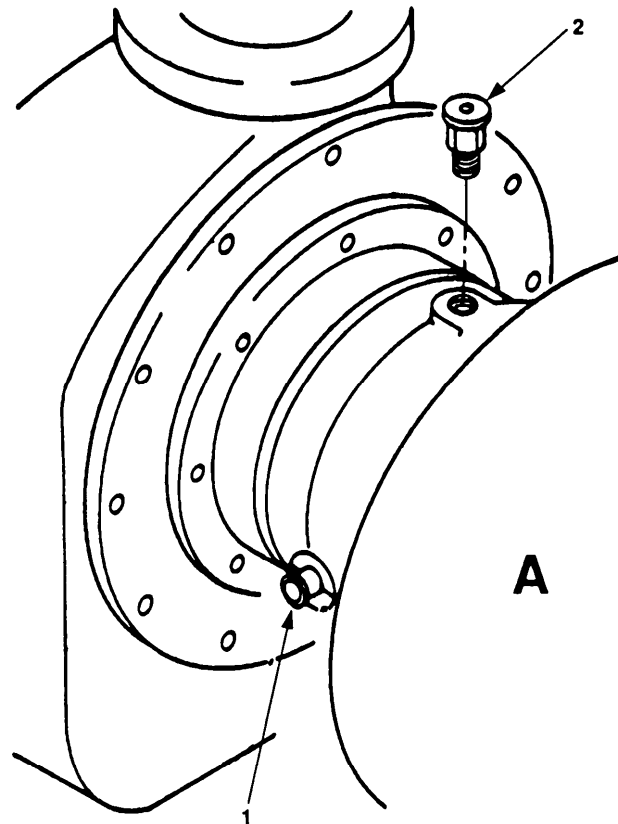

Figure 3-4. Servicing Pump Assembly.

WARNING

To prevent rolling or sliding, do not work on equipment that is not securely stabilized. Ensure both wheels are secure. Failure to obey this warning may result in serious personal injury.

NOTE

If oil level cannot be determined, notify supervisor.

- a. Look into sight gauge (figure 3-4, 1) to verify oil level.
- b. If oil level is low, remove vent cap (2) and fill to proper level in accordance with LO 10-4320-226-12.
- c. Install vent cap (2).

3.7 FUEL TANK SERVICING.

This task covers: Servicing.

INITIAL SETUP

Material/Parts

Diesel Fuel

Equipment Conditions

Equipment shut down paragraph 2.5.1.2 or 2.5.2.2.

General Safety Instructions

To prevent rolling or sliding, do not work on equipment that is not securely stabilized.

Do not fill fuel tank while equipment is operating. Do not smoke or use open flames while filling tank. Avoid inhalation of fumes from fuel.

To prevent rolling or sliding, do not work on equipment that is not securely stabilized.

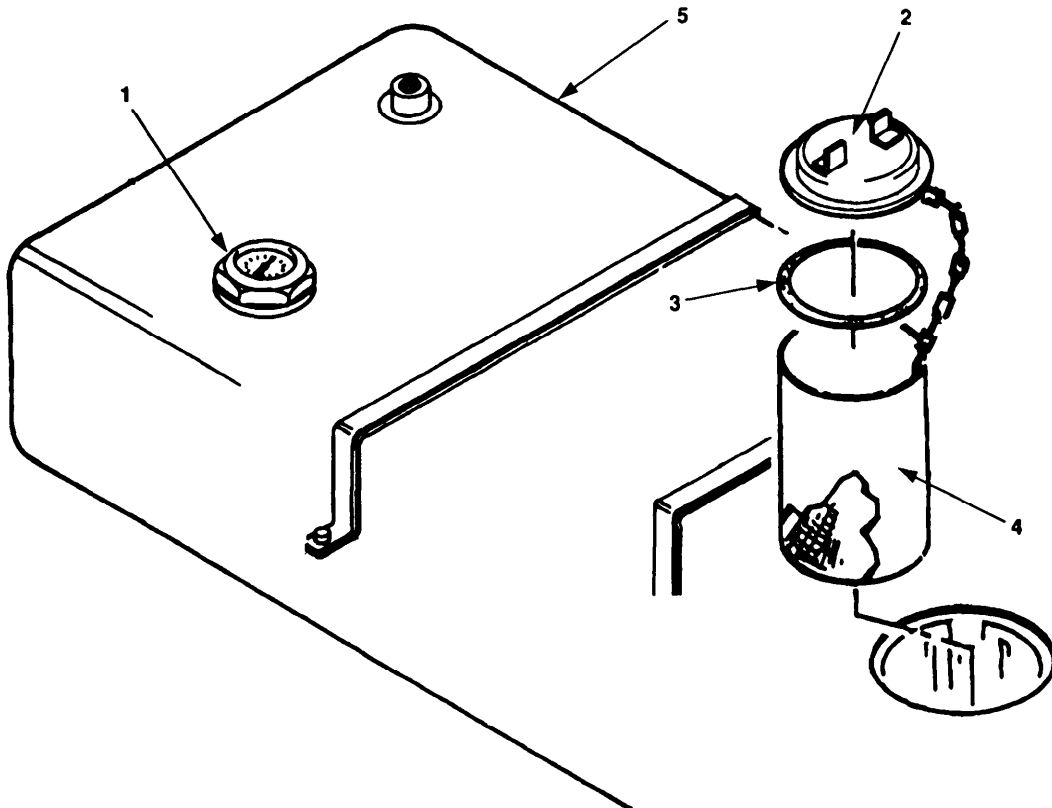

Figure 3-5. Fuel Tank Servicing.

WARNING

To prevent rolling or sliding, do not work on equipment that is not securely stabilized. Ensure both wheels are secure. Failure to obey this warning may result in personal injury.

NOTE

- Ensure that fuel tank does not run dry, otherwise fuel filter and injection lines will require bleeding of air from fuel system.
 - Observe strict cleanliness during replenishing of fuel tank. At low ambient temperatures, use winter grade fuel only.
- a. Observe fuel gauge (figure 3-5, 1) for fuel level. When below 1/4 tank, perform remaining steps of this procedure.

WARNING

Do not fill fuel tank while equipment is operating. Do not smoke or use open flames while filling tank. Avoid inhalation of fumes from fuel. Failure to obey this warning may result in personal injury or death.

- b. Remove tank filler cap (2) and inspect gasket (3) for damage.
- c. Ensure that vent valve on tank filler cap (2) is open.
- d. Remove filler neck (4) from fuel tank (5) and inspect filler neck. Clean as necessary.
- e. Install filler neck (4) into fuel tank (5).
- f. Refill fuel tank (5) until fuel is one inch from top of tank.
- g. Install tank filler cap (2).
- h. Observe fuel gauge (1). Fuel gauge should indicate full. If not, notify unit maintenance.

CHAPTER 4

UNIT MAINTENANCE INSTRUCTIONS

SUBJECT INDEX	PAGE
SECTION I. REPAIR PARTS; SPECIAL TOOLS; TEST, MEASUREMENT, AND DIAGNOSTIC EQUIPMENT (TMDE); AND SUPPORT EQUIPMENT	4-2
4.1 COMMON TOOLS AND EQUIPMENT	4-2
4.2 SPECIAL TOOLS AND SUPPORT EQUIPMENT	4-2
4.3 REPAIR PARTS	4-2
SECTION II. SERVICE UPON RECEIPT	4-3
4.4 SERVICE UPON RECEIPT OF MATERIEL	4-3
4.5 INSTALLATION INSTRUCTIONS	4-3
4.6 PUMP ASSEMBLY LUBRICATION	4-3
SECTION III. UNIT PREVENTIVE MAINTENANCE CHECKS AND SERVICES (PMCS)	4-5
4.7 GENERAL	4-5
SECTION IV. UNIT TROUBLESHOOTING	4-7
4.8 UNIT TROUBLESHOOTING	4-7
SECTION V. UNIT MAINTENANCE PROCEDURES	4-10
4.9 EXHAUST SYSTEM MAINTENANCE	4-10
4.10 ENGINE ASSEMBLY	4-15
4.11 THROTTLE CONTROL ASSEMBLY MAINTENANCE	4-65
4.12 ELECTRICAL SYSTEM MAINTENANCE	4-67
4.13 CONTROL PANEL ASSEMBLY MAINTENANCE	4-79
4.14 PUMP ASSEMBLY MANIFOLDS MAINTENANCE	4-94
4.15 WATER SEPARATOR MAINTENANCE	4-105
4.16 WHEEL MOUNTED FRAME ASSEMBLY MAINTENANCE	4-107
SECTION VI. PREPARATION FOR SHIPMENT AND STORAGE	4-119
4.17 PRESERVATION PROCEDURES	4-119
4.18 PACKING	4-119
4.19 MARKING	4-119
4.20 STORAGE	4-119

SECTION I. REPAIR PARTS; SPECIAL TOOLS; TEST, MEASUREMENT, AND DIAGNOSTIC EQUIPMENT (TMDE); AND SUPPORT EQUIPMENT

4.1 COMMON TOOLS AND EQUIPMENT.

For Authorized common tools and equipment refer to the Modified Table of Organization and Equipment (MTOE), Common Table of Allowances (CTA) 50-970 or CTA 8-100 as applicable to your unit.

4.2 SPECIAL TOOLS AND SUPPORT EQUIPMENT.

Special tools are listed and illustrated in the Repair Parts and Special Tools List (RPSTL), TM 10-4320-226-24P covering unit, direct support, and general support maintenance.

4.3 REPAIR PARTS.

Repair parts are listed and illustrated in TM 10-4320-226-24P covering unit, direct support, and general support maintenance.

SECTION II. SERVICE UPON RECEIPT

4.4 SERVICE UPON RECEIPT OF MATERIEL.

4.4.1 Checking Unpacked Equipment.

- a. Inspect the equipment for damage incurred during shipment. If the equipment has been damaged, report the damage on SF 361, Report of Discrepancy.
- b. Check the equipment against the packing slip to see if the shipment is complete. Report all discrepancies in accordance with the instructions in DA Pam 738-750.
- c. Check to see whether the equipment has been modified.

4.4.2 Processing Unpacked Equipment.

Refer to DA Form 2258, Depreservation Guide for Vehicles and Equipment, packed with the equipment. The depreservation guide explains what was done to the equipment prior to packaging. It also explains what has to be done before placing the equipment in operation. Perform all depreservation actions required by the depreservation guide.

4.5 INSTALLATION INSTRUCTIONS.

4.5.1 Tools, Test Equipment, and Materials Required for Installation. A general mechanic's tool kit is required for installation of the equipment.

4.5.2 Installation Instructions. Perform the following:

WARNING

Do not fill battery without rubber gloves and protective clothing. Electrolyte causes serious burns. Failure to obey this warning may result in personal injury or death.

NOTE

The following installation procedure must be made with the assistance of direct support level maintenance personnel.

- a. If batteries were shipped dry, remove and fill with electrolyte to a level 3/8 inch (9.5 mm) above cell plates.
- b. Install batteries, attach cables, covers, and hold-down bar (paragraph 4.12.2).
- c. Move equipment to worksite (paragraph 2.7.2).
- d. Refer to paragraph 2.3 for preparation for use of 350 GPM pumping assembly.

4.6 PUMP ASSEMBLY LUBRICATION.

Refer to LO 10-4320-226-12 for lubrication instructions.

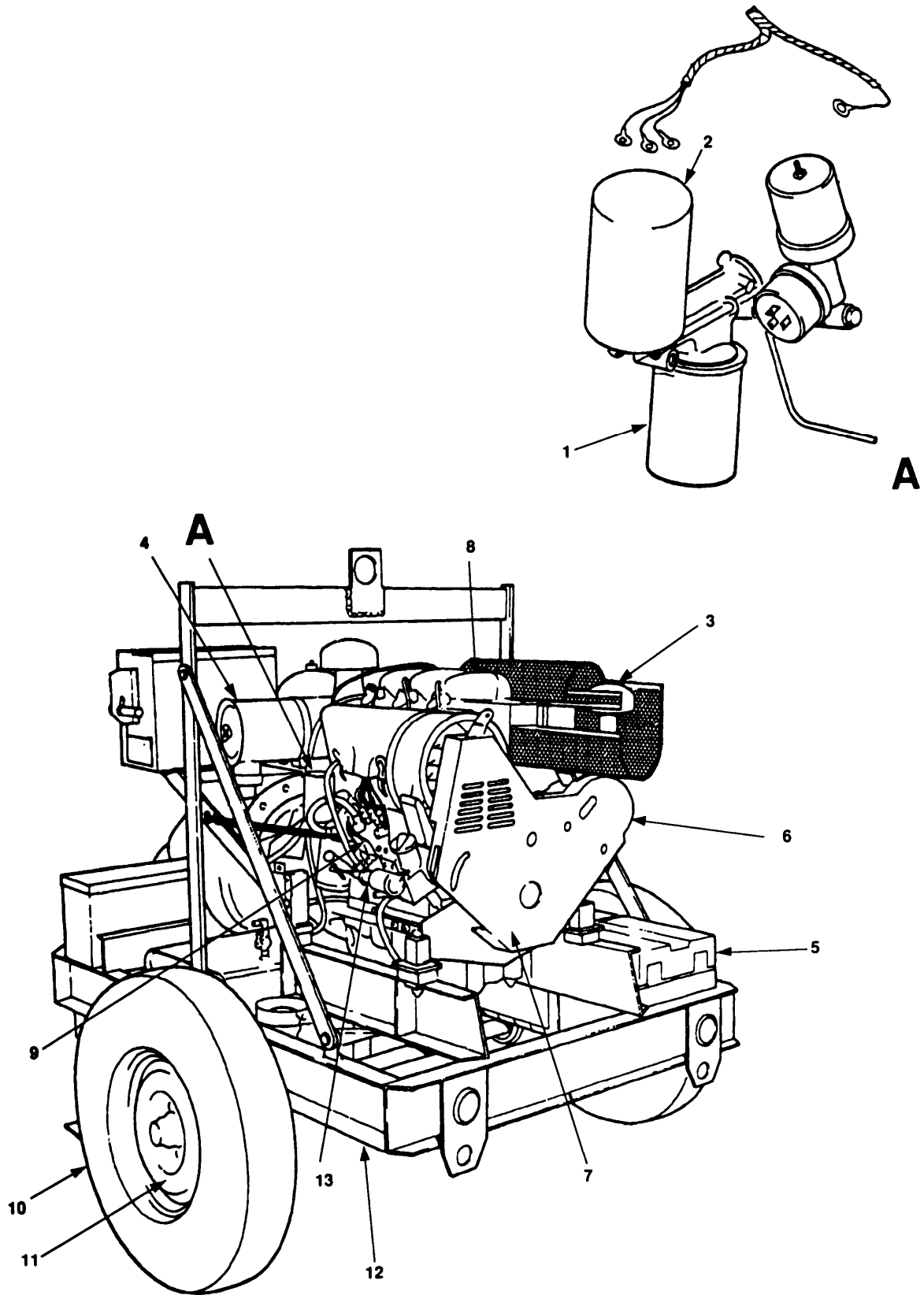

Figure 4-1. Unit PMCS Routing Diagram.

SECTION III. UNIT PREVENTIVE MAINTENANCE CHECKS AND SERVICES

4.7 GENERAL.

Figure 4-1 (PMCS routing diagram) and table 4-1 (PMCS table) have been provided so you can keep your equipment in good operating condition and ready for its primary mission.

4.7.1 Warnings, Cautions, and Notes. Always observe the **WARNING** and **CAUTIONS** appearing in your PMCS table. Warnings and cautions appear before applicable procedures. You must observe these **WARNINGS** and **CAUTIONS** to prevent serious injury to yourself and others or prevent your equipment from being damaged.

4.7.2 Explanation of Table Entries.

4.7.2.1 Item No. column. Numbers in this column are for reference. When completing DA Form 2404 (Equipment Inspection and Maintenance Worksheet), include the item number for the check/service indicating a fault. Item numbers also appear in the order that you must do checks and services for the intervals listed. These item numbers also corresponds to the numbers on the routing diagram, figure 4-1.

4.7.2.2 Interval Column. This column tells you when you must do the procedure in the procedure column.

4.7.2.3 Item to be Inspected Column. This column provides the item to be checked or serviced.

4.7.2.4 Procedure Column. This column gives the procedure you must do to check or service the item listed in the Check/Service column to know if the equipment is ready or available for its intended mission or for operation. You must do the procedure at the time stated in the interval column.

4.7.2.5 Not Fully Mission Capable if: Column. Information in this column tells you what faults will keep your equipment from performing its primary mission. If you make checks or service procedures that show faults listed in this column, do not operate the equipment. Follow standard operating procedures for maintaining the equipment or reporting equipment failure.

4.7.3 Other Table Entries. Be sure to observe all special information and notes that appear in your table.

**Table 4-1. Preventive Maintenance Checks and Services
for 350 GPM Pumping Assembly.**

Item No.	Interval	Item to be inspected	Procedures	Not Fully Mission Capable If:
NOTE				
		Change oil and oil filter in accordance with LO 10-4320-226-12		
1	200 Hours	OIL FILTER	Change oil and replace oil filter.	
2	500 Hours	FUEL FILTER	Replace fuel filter (paragraph 4.10.18)	
3	Quarterly	SPARK ARRESTOR	Remove and service spark arrestor (paragraph 4.9.1).	Spark arrestor is damaged or missing.

**Table 4-1. Preventive Maintenance Checks and Services for the 350 GPM Pumping Assembly.
(continued)**

Item No.	Interval	Item to be Inspected	Procedure	Not Fully Mission Capable If:
4	Quarterly	AIR CLEANER	Inspect for cracked, or damaged air cleaner. Check condition of filter housing. (Paragraph 4.10.5)	Air cleaner is damaged or missing.
5	Quarterly	BATTERIES	Check to ensure battery is charged.	Battery does not maintain charge.
6	Quarterly	V-BELT	Inspect V-belt for tightness. Make sure belt is not cracked, broken, stretched, or damaged.	V-belt can not be adjusted to proper tension.
7	Quarterly	V-BELT CONTACT SWITCH	Test switch to ensure it works properly. (Paragraph 4.10.9)	v-belt switch defective.
8	Quarterly	ENGINE VALVE CLEARANCE	Check engine valve clearance. (Paragraph 4.10.23)	Engine valve clearance can not be met.
9	Quarterly	CRANKCASE, BLOCKS AND CYLINDER HEAD	Inspect for cracks, or other damage. Clean block and cylinder head cooling fins.	Crankcase, blocks, and cylinder heads are not serviceable.
10	Quarterly	TIRES	Check for proper inflation, 40 psi (275.9 kPa). Measure tread depth using tread gauge at three equally spaced points on tire (should be more than 1/8 in.); inspect tires for cuts, cracks, or uneven wear.	Tires are not serviceable.
11	Quarterly	WHEELS	Check wheels and bearings for damage. Service bearings in accordance with LO 5-4320-226-12.	Wheels are not serviceable.
12	Quarterly	AXLE	Visually inspect all structural parts for excessive wear, corrosion, broken welds, cracks, and security.	
13	Annually	SHUTDOWN SOLENOID	Test solenoid to ensure it works properly. (Paragraph 4.10.14)	Shutdown solenoid is defective.
14	Annually	ENGINE START CARTRIDGE	Replace engine start cartridge(ether can). (Paragraph 4.10.3.1)	

SECTION IV. UNIT TROUBLESHOOTING

4.8 UNIT TROUBLESHOOTING.

Use the malfunction index to locate specific troubleshooting procedures contained in table 4-2. After locating the listed malfunction, perform the test/inspections and corrective actions in the order listed in table 4-2. The malfunction index and Table 4-2 cannot list all the malfunctions that may occur, all the test and inspections needed to find the fault, or all the corrective actions needed to correct the fault. If the equipment malfunction is not listed or actions listed do not correct the fault, notify your supervisor.

MALFUNCTION INDEX

	Malfunction Number in Table 4-2
Engine will not crank	1
Engine will not start	2
Engine speed does not adjust	3
Engine starts or runs erratic after warmup	4
Oil pressure reading low	5
Ammeter reading too low	6

Table 4-2. Unit Troubleshooting Table.

MALFUNCTION
TEST OR INSPECTION
CORRECTIVE ACTION
<p>1. ENGINE WILL NOT CRANK.</p> <p>Step 1. Check for loose or corroded terminals on battery and starter. Clean and tighten terminals (paragraph 4.12.2).</p> <p>Step 2 Test battery (paragraph 4.12.1). a. Recharge battery if low. b. Refer to paragraph 4.12.2 and replace battery.</p> <p>Step 3. Pull out emergency stop switch. Panel light should illuminate. If panel light does not illuminate, go to step 7.</p> <p>Step 4. Press oil pressure bypass switch and listen for audible click. a. If no click is heard, go to step 5. b. If click is heard, go to step 6.</p> <p>Step 5. Test Blower V-belt Contact Switch (paragraph 4.10.9). Replace v-belt contact switch (paragraph 4.10.10).</p>

Table 4-2. unit Troubleshooting Table. (Continued)

MALFUNCTION	TEST OR INSPECTION	CORRECTIVE ACTION
1.	ENGINE WILL NOT CRANK. (continued)	
	Step 6.	Connect multimeter between small terminal of starter solenoid and ground. Set multimeter to read +12 Vdc. Press Push to start button and push for oil pressure bypass then observe multimeter for +12 Vdc.
	a.	If +12 Vdc is present, replace starter (paragraph 4.10.13)
	b.	If +12 Vdc is not present, replace or repair wire from TB1 12 to small terminal on solenoid.
	Step 7.	Test control panel (4.13).
	a.	Repair panel as necessary.
	b.	Notify direct support maintenance.
2.	ENGINE WILL NOT START.	
	Step 1.	Check for correct installation of each fuel shut-off valve handle.
	WARNING	
	Do not fill fuel tank on equipment that is operating. Do not smoke or use open flames while filling tank. Avoid inhalation of fumes from fuel. Failure to obey this warning may result in personal injury or death.	
	a.	Remove and retain plug or elbow from valve.
	b.	Using a flashlight, observe valve passages while rotating handle.
	c.	Ensure valve handle pointer positions and valve internal passages agree with decal.
	d.	Remove and align handle in accordance with information plate.
	e.	Install plug or elbow retained in step a on valve.
	Step 2.	Test fuel shutdown solenoid (paragraph 4.10.14).
		Replace or adjust fuel shutdown solenoid as necessary (paragraph 4.10.15).
	Step 3.	Check for blocked strainer in fuel feed pump (paragraph 4.10.17).
		Clean or replace strainer as necessary.
	Step 4.	Check for air or blockage in fuel lines (paragraph 4.10.16).
	a.	Clean or replace fuel lines.
	b.	Bleed fuel lines.
	c.	Notify direct support maintenance.
3.	ENGINE SPEED DOES NOT ADJUST.	
	Step 1.	Check for bent, broken, or damaged control arm.
		Replace throttle control (paragraph 4.11).

Table 4-2. Unit Troubleshooting Table. (continued)

MALFUNCTION	TEST OR INSPECTION	CORRECTIVE ACTION
3. ENGINE SPEED DOES NOT ADJUST (continued).	Step 2. Check for seized fuel control lever at injector pump.	<ul style="list-style-type: none"> a. Free fuel control lever. b. Notify direct support maintenance.
4. ENGINE STARTS OR RUNS ERRATIC AFTER WARMUP.	Step 1. Check for blockage in fuel strainer.	<ul style="list-style-type: none"> a. Clean fuel feed pump strainer (paragraph 4.10.17). b. Replace fuel filter (paragraph 4.10.18).
	Step 2. Check valve clearance (paragraph 4.10.23).	<ul style="list-style-type: none"> b. Adjust valve clearance. c. Notify direct support maintenance.
5. OIL PRESSURE READING LOW.	Step 1. Inspect for leaks in lubrication system.	<ul style="list-style-type: none"> Tighten all connections to pumps, lines, filter, pressure gauge, and cooler.
	Step 2. Remove and check low oil pressure sending unit for obstructions. (paragraph 4.10.19).	<ul style="list-style-type: none"> a. Clear obstructions or replace oil pressure sending unit. b. Notify direct support maintenance.
6. AMMETER READING TOO LOW.	Step 1. Check alternator V-belt tension.	<ul style="list-style-type: none"> Adjust V-belt (paragraph 4.10.7).
	Step 2. Check for loose connections at alternator.	<ul style="list-style-type: none"> Tighten wiring connections at alternator.
	Step 3. Test alternator (paragraph 4.10.11).	<ul style="list-style-type: none"> a. Replace alternator (paragraph 4.10.12) b. Notify direct support maintenance.

SECTION V. UNIT MAINTENANCE PROCEDURES

4.9 EXHAUST SYSTEM MAINTENANCE.

4.9.1 Spark Arrestor Maintenance.

This task covers:	4.9.1.1 Removal	4.9.1.3 Installation
	4.9.1.2 Service	

INITIAL SETUP

Tools

General Mechanic's Tool Kit (appendix B, Section III, Item 1)

General Safety Instructions

to prevent rolling or sliding, do not work on equipment that is not securely stabilized.

Material/Parts

Wire brush (appendix E, Section II, Item 3)
 Cleaning Solvent (appendix E, Section II, item 11)

Do not touch exhaust system after shutting down engine. Allow time for exhaust to cool.

Equipment Conditions

Engine shutdown paragraph 2.5.2.

Do not use dry cleaning solvent without proper ventilation and clothing.

Do not work on equipment without following standard shop safety Precautions.

4.9.1.1 Removal.



- To prevent rolling or sliding, do not work on equipment that is not securely stabilized. Ensure both wheels of equipment are secure.
- Do not touch exhaust system after equipment operation. Exhaust systems become very hot and can cause serious burns.

Failure to obey these warnings could result in serious personal injury.

- a. Loosen nut (figure 4-2, 1) that secures clamp (2).
- b. Slide clamp (2) onto exhaust pipe (3).
- c. Remove spark arrestor (4).

4.9.1.2 Service.

- a. Remove nut (5), washer (6), and cap (7).
- b. Remove baffles (8) from base (9).
- c. Remove mounting stud (10) from base (9).

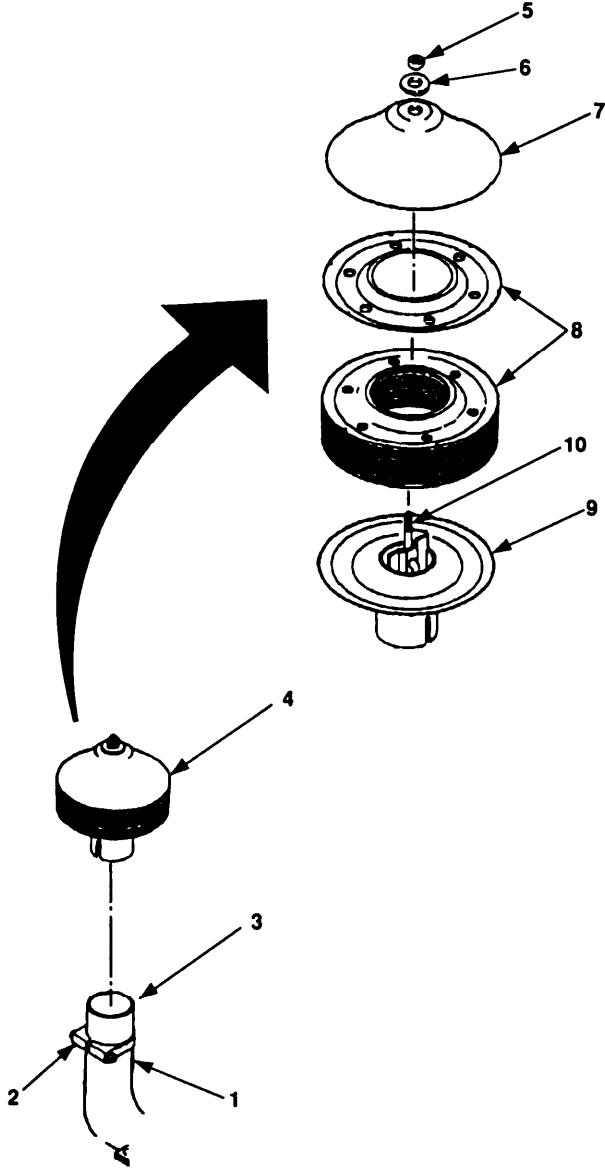

Figure 4-2. Spark Arrester Maintenance.



Do not use dry cleaning solvent without proper ventilation and clothing. Do not smoke or use near open flame or excessive heat. Dry cleaning solvent is potentially dangerous to personnel and property. Clean parts in a well-ventilated area. Avoid inhalation of solvent fumes. Wear goggles and rubber gloves to protect eyes and skin. Wash exposed skin thoroughly. Flash point of solvent is 100°F to 138°F (38°C to 59°C). Failure to obey this warning may result in personal injury or death.

- d. Clean all parts of spark arrestor with wire brush and solvent.
- e. Inspect baffles (8) for cracks, holes or other damage.
- f. Check base (9) for cracks and holes.
- g. Position mounting stud (10) in base (9).
- h. Align indentations of baffles (8) and position to base (9) as indicated in figure 4-2.
- i. Install cap (7), washer (6) and thread nut (5) on to mounting stud (10). Tighten nut.

4.9.1.3 Installation.

- a. Place spark arrestor (4) on exhaust pipe (3).
- b. Position clamp (2) so that it tightens on both spark arrestor (4) and exhaust pipe (3).
- c. Tighten nuts (1).



To prevent rolling or sliding, do not work on equipment that is not securely stabilized. Ensure both wheels of equipment are secure.

Do not touch exhaust system after equipment operation. Exhaust systems become very hot and can cause serious burns.

Failure to obey these warnings may result in serious personal injury.

- a. Remove three nuts (figure 4-3, 1), lockwashers (2), bolts (3), and one spacer (4) .
- b. Slide heat shield (5) off muffler and exhaust pipe.

4.9.2.2 Inspection.

- a. Inspect heat shield (5) for excessive burning or damage.
- b. Replace any damaged or missing parts.

4.9.2.3 Installation.

- a. Position heat shield (5) over muffler and exhaust pipe such that cutout in heat shield is over exhaust pipe.
- b. Install one spacer (4), three bolts (3), lockwashers (2), and nuts (1).
- c. Tighten nuts (1).

4.10 ENGINE ASSEMBLY.

4.10.1 Exhaust Manifold Maintenance.

This task covers:	4.10.1.1 Removal	4.10.1.4 Reassembly
	4.10.1.2 Disassembly	4.10.1.5 Installation
	4.10.1.3 Repair	

INITIAL SETUP

Tool S

General Mechanic's Tool Kit (appendix B, Section III, Item 1)

Material/Parts

Lockwashers (TM 10-4320-226-24P)
Gaskets (TM 10-4320-226-24P)

Equipment Conditions

Equipment shut down, paragraph 2.5.2.

Remove spark arrestor, paragraph 4.9.1.

General Safety Instructions

To prevent rolling or sliding, do not work on equipment that is not securely stabilized.

Do not touch exhaust system after shutting down engine. Allow time for exhaust to cool.

do not work on equipment without following standard shop safety precautions

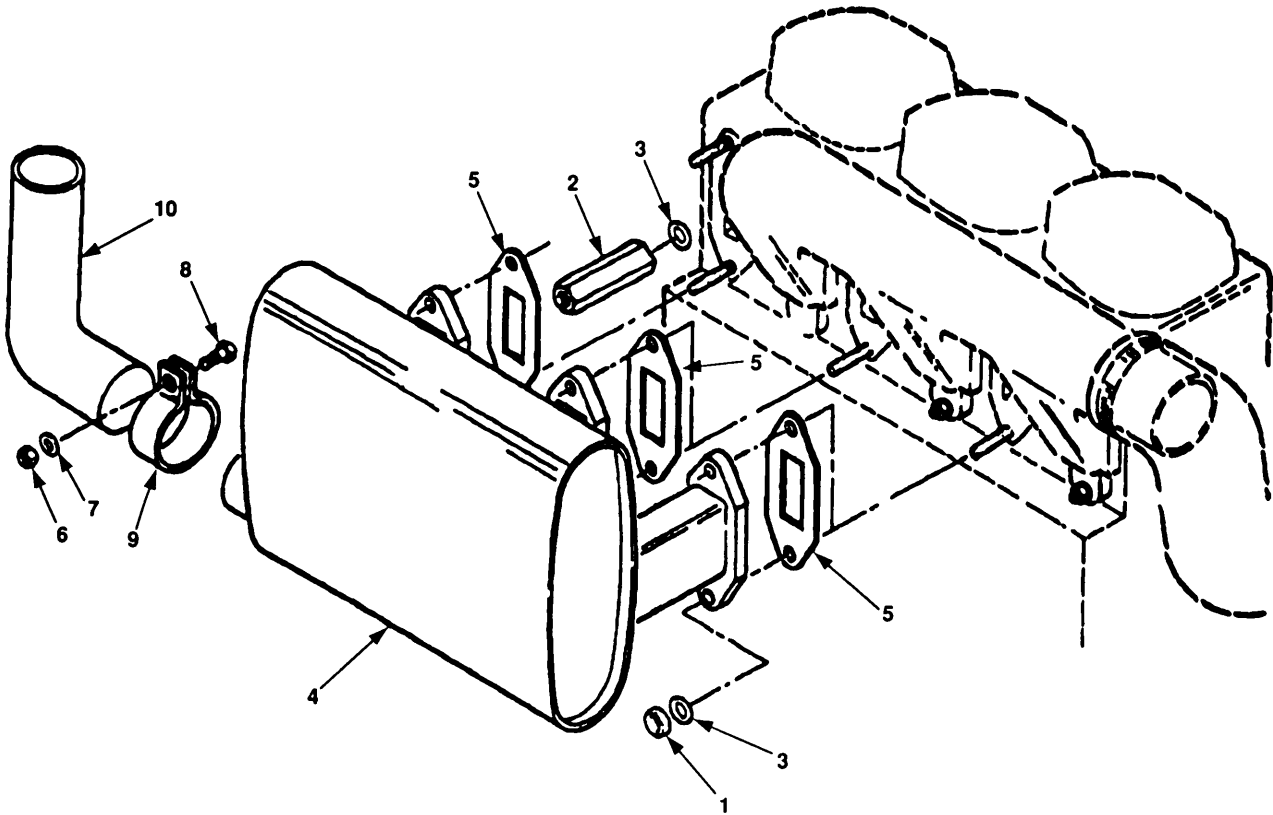

Figure 4-4. Exhaust Pipe Maintenance.

4.10.1.1 Removal.



- To prevent rolling or sliding, do not work on equipment that is not securely stabilized. Ensure both wheels are secure.
 - Do not touch exhaust system after equipment operation. Exhaust systems become very hot and can cause serious burns.
 - Failure to obey these warnings may result in serious personal injury.
- a. Remove five nuts (figure 4-4, 1), one post (2) and six washers (3) that secure muffler (4) to engine. Retain all parts removed.
 - b. Carefully remove muffler (4) from studs.
 - c. Remove and discard three gaskets (5).

4.10.1.2 Disassembly.

- a. Loosen nut (figure 4-4, 6), lockwasher (7) and bolt (8) that secures clamp (9).
- b. Remove exhaust pipe (10) and clamp (9) from muffler (4).

4.10.1.3 Repair.

- a. Inspect muffler for holes or cracks.
- b. Check to ensure internal components are not burned out.
- c. Replace any damaged or missing parts.

4.10.1.4 Reassembly.

- a. Position clamp (9) over the muffler (4) and position open end of exhaust pipe upward.
- b. Install exhaust pipe (10) into muffler (4) and position as shown.
- c. Tighten nut (6) until exhaust pipe (10) is secure.

4.10.1.5 Installation.

- a. Install three gaskets (5) over studs.
- b. Carefully install muffler (4) over studs with exhaust pipe.
- c. Install six lock washers (3), five nuts (1) and one post (2) and tighten.

4.10.2 Cold Start Aid Handpump Maintenance. (Not used on Model 350 PAWN)

This task covers: 4.10.2.1 Removal 4.10.2.2 Installation

INITIAL SETUP

Tools

General Mechanic's Tool Kit (Appendix B, Section III, Item 1)

Equipment Conditions

Engine shutdown, refer to paragraph 2.5.1.2 or 2.5.2.2

General Safety Instructions

To prevent rolling or sliding, do not work on equipment that is not securely stabilized.

Do not work on equipment without following standard shop safety precautions.

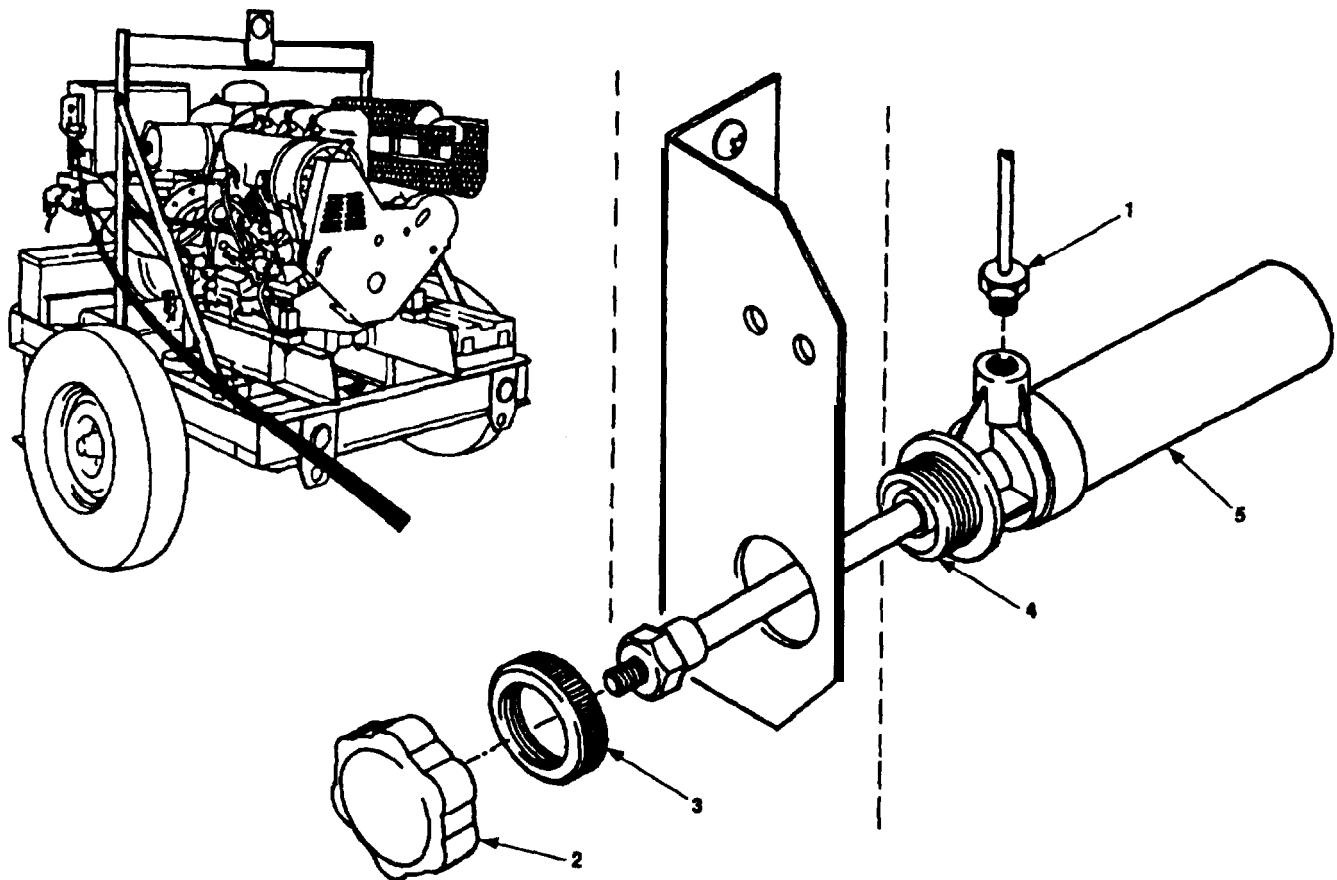

Figure 4-5. Starting Aid Handpump Maintenance (Models 350 PAW and W-8712).

4.10.2.1 **Removal.**



To prevent rolling or sliding, do not work on equipment that is not securely stabilizes. Ensure both wheels are chocked.

Failure to obey these warnings could result in serious injury.

- a. Disconnect hose (1) from pump.
- b. Pull handle of pump out and remove knob (2).
- c. Remove nut (3) from threads (4).
- d. Remove pump (5) from bracket.

4.10.2.2 **Installation.**

- a. Position pump (5) in bracket so that hose connection is pointing down
- b. Thread nut (3) on threads (4) and tighten.
- c. Pull out pump shaft and thread knob (2) on end of pump shaft.
- d. Connect tube (1) to pump.

4.10.3 Cold Start Aid Reservoir Maintenance. (Not used on Model 350 PAWN)

This task covers:	4.10.3.1	Removal	4.10.3.3	Installation
	4.10.3.2	Repair		

INITIAL SETUPTools

General Mechanic's Tool Kit (Appendix B, Section III, Item 1)

Materials/Parts

Tags (Appendix E, Section II, Item 12)

Equipment Conditions

Equipment shut down, paragraph 2.5.2.

General Safety Instructions

To prevent rolling or sliding, do not work on equipment that is not securely stabilized.

Do not work on equipment without following standard shop safety precautions.

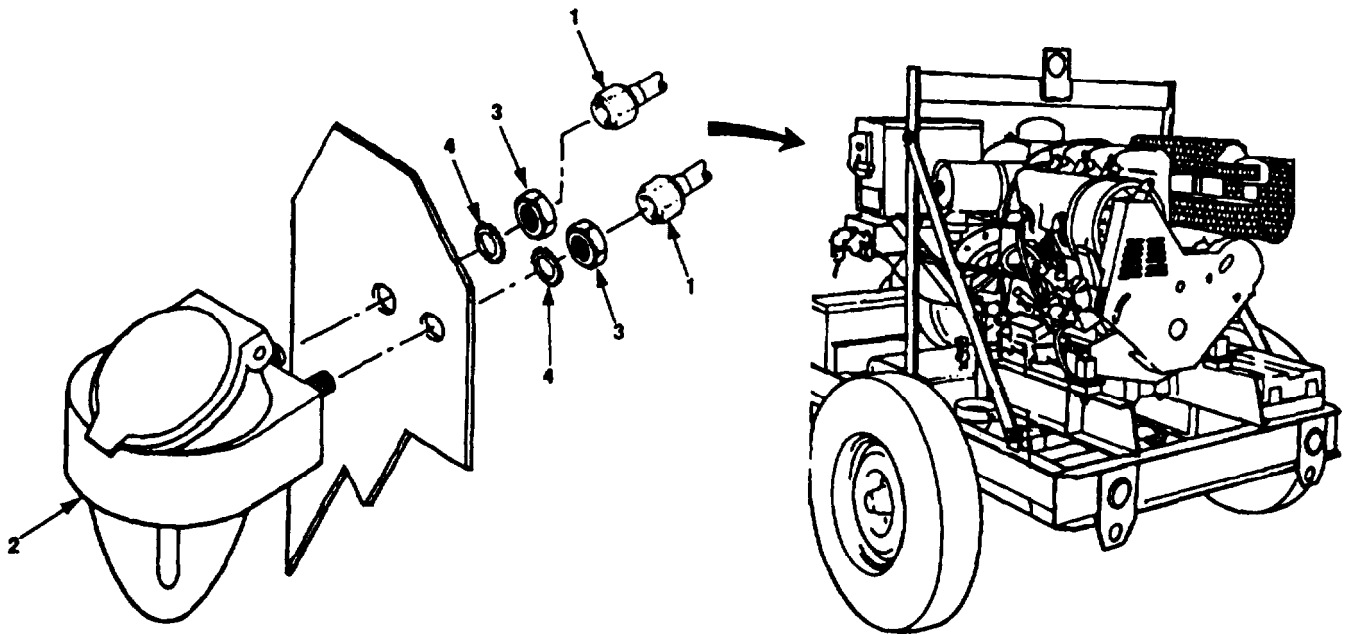

Figure 4-6. Starting Aid Reservoir Maintenance (Models 350 PAW and W-87012).

4.10.3.1 Removal.



To prevent rolling or sliding, do not work on equipment that is not securely stabilized. Ensure both wheels are secure. Failure to obey this warning may result in serious personal injury.

- a. Tag and disconnect two hoses (figure 4-6, 1) from reservoir (2).
- b. Remove two nuts (3) and external tooth lockwashers (4) .
- c. Remove reservoir (2).

4.10.3.2 Repair.

- a. Disconnect other end of hose from ether cold start pump or cold start nozzle.
- b. Manufacture new hose in accordance with appendix F.
- c. Connect new hose to cold start pump or cold start nozzle.

4.10.3.3 Installation.

- a. Position reservoir (2) in bracket with lid pointed upward.
- b. Install two external tooth lockwashers (4) and thread nuts (3) on reservoir (2) .
- c. Tighten two nuts (3).

NOTE

Connect pump hose to inner connection of reservoir.

- d. Connect two hoses (1) to reservoir (2).

4.10.3.4.3. Installation. (Refer to Figure 4-6.1)

NOTE

The blockor has left hand threads.

- a. Install blockor (5) in bottom of valve assembly(3).
- b. Position valve assembly(3) on side of engine and secure with flat washers (18), lockwashers (17) and screws (16).
- c. Secure terminal ring(15) to engine block.
- d. Install temperature switch(9) on side of engine with screw(13), and flat washer(14).
- e. Install new connector(11) on wire(12) and secure terminal ring(10) onto starter solenoid.
- f. Install new connectors(7) on wire(8) between temperature switch(9) and valve assembly(3).
- g. Install atomizer(6) into engine manifold and connect tubing(4) to blockor(5).
- h. Install a serviceable can of starting fluid(2) in valve assembly(3) and tighten clamp(1).

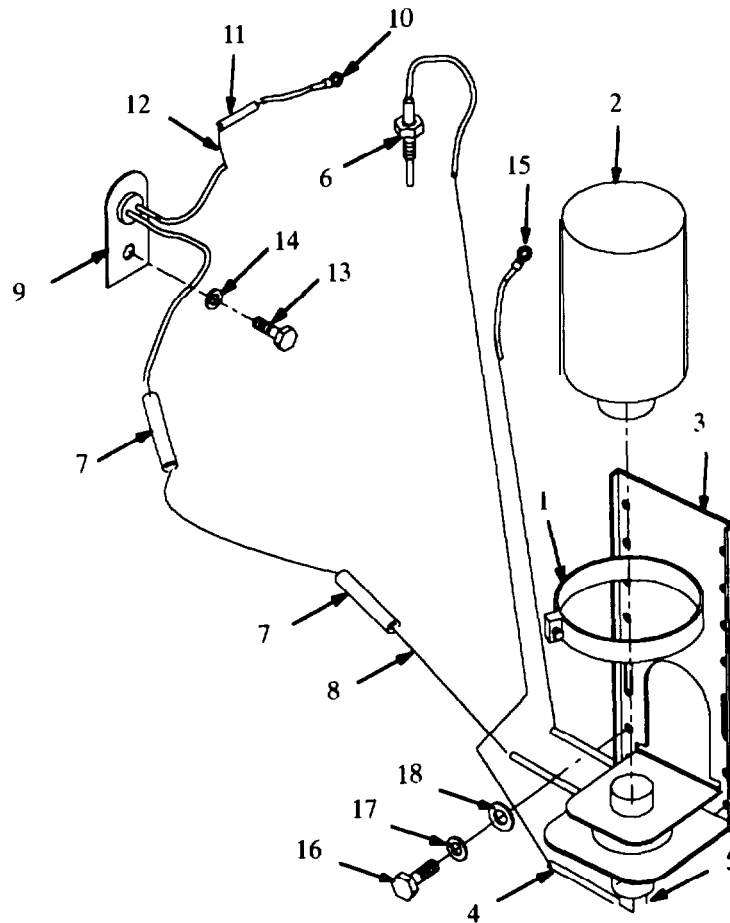

Figure 4-6.1. Starting Aid Solenoid Maintenance (Model 350 PAWN).

4.10.3.5. Temperature Switch Maintenance. (Model 350 PAWN)

This task covers: 4.10.3.5.1 Removal 4.10.3.5.2 Installation

INITIAL SETUP

Tools

General Mechanic' s Tool Kit (Appendix B, Section III, Item 1)

Material/Parts

Tags (Appendix E, Section II, Item 12)

Equipment Conditions

Equipment shut down, paragraph 2.5.2.

General Safety Instructions

To prevent rolling or sliding, do not work on equipment that is not securely stabilized.

Do not work on equipment without following standard shop safety precautions.

4.10.3.5.1. Removal. (Refer to figure 4-6.2)

- a. Tag and disconnect wire between cold start solenoid valve assembly and temperature switch (1).
- b. Tag and disconnect wire between temperature switch (1) and starter solenoid.
- c. Remove screw (2), lockwasher (3), flat washer (4) and switch (1).

4.10.3.5.2. Installation. (Refer to figure 4-6.2)

- a. Position temperature switch (1) on side of engine and secure with flat washer (4), lockwasher (3) and screw (2).
- b. Connect wires as tagged.

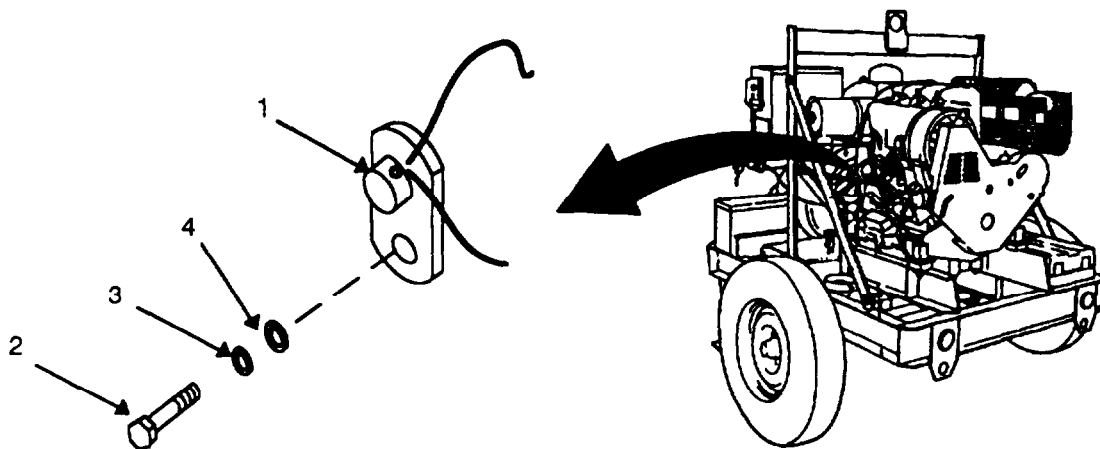

Figure 4-6.2. Starting Aid Temperature Switch (Model 350 PAWN).

4.10.4. Cold Start Aid Nozzle Maintenance. (Not used on Model 350 PAWN)

This task covers: 4.10.4.1 Removal 4.10.4.2 installation

INITIAL SETUP
Tools

General Mechanic's Tool Kit (appendix B, Section iii, Item 1)

Equipment Conditions

Equipment shut down, refer to paragraph 2.5.2.

General Safety Instructions

To prevent rolling or sliding, do not work on equipment that is not securely stabilized.

Do not work on equipment without following standard shop safety precautions.

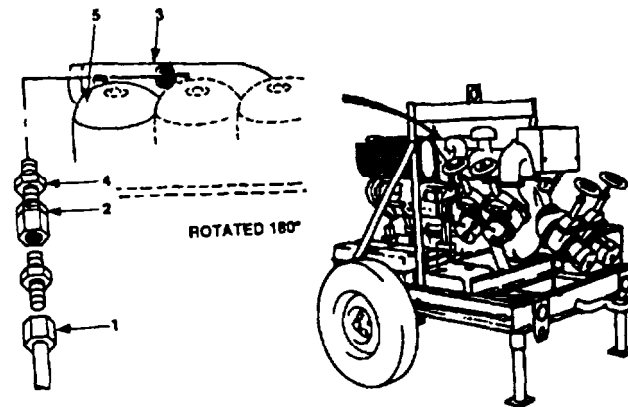

Figure 4-7. Starting Aid Nozzle Maintenance (Models 350 PAW and W-87012).

4.10.4.1 Removal.

To prevent roiling or sliding, do not work on equipment that is not securely stabilized. Ensure both wheels are secure. Failure to obey these warnings could result in serious personal injury.

- a. Disconnect hose (1, figure 4-7) from nozzle (2).
- b. Remove nozzle (2) from intake manifold (3).

4.10.4.2 installation.

- a. If arrow is not visible, hold nozzle as if being installed, and mark top flat of nozzle, so that ether would be injected toward airflow.
- b. Thread jam nut (4) three quarters of the way on the nozzle (2).
- c. Thread nozzle (2) into intake manifold (3) approximately half way.
- d. Continue to thread until arrow on nozzle points towards number 1 cylinders (5).
- e. Tighten jam nut (4) to secure nozzle (2) and connect hose (1).

4.10.4.3. Cold Start Aid Nozzle Maintenance (Used on Model 350 PAWN)

This task covers: 4.10.4.3.1 Removal 4.10.4.3.2 Installation

INITIAL SETUP

Tools

General Mechanic' s Tool Kit (Appendix B, Section III, Item 1)

Equipment Conditions

Equipment shut down, paragraph 2.5.2.

General Safety Instructions

To prevent rolling or sliding, do not work on equipment that is not securely stabilized.

Do not work on equipment without following standard shop safety precautions.

4.10.4.3.1. Removal. (Refer to figure 4-6.3)

- a. Unscrew nut of tubing (1) from nozzle (2).
- b. Remove nozzle (2) from intake manifold (3) of engine.

4.10.4.3.2. Installation. (Refer to figure 4-6.3)

- a. Install nozzle (2) on manifold (3) of engine in a manner that blue dot on nozzle is positioned to the left of the installer and is tight. When installed this will inject starting fluid into the manifold against the air stream for optimum atomization.
- b. Connect tubing (1).

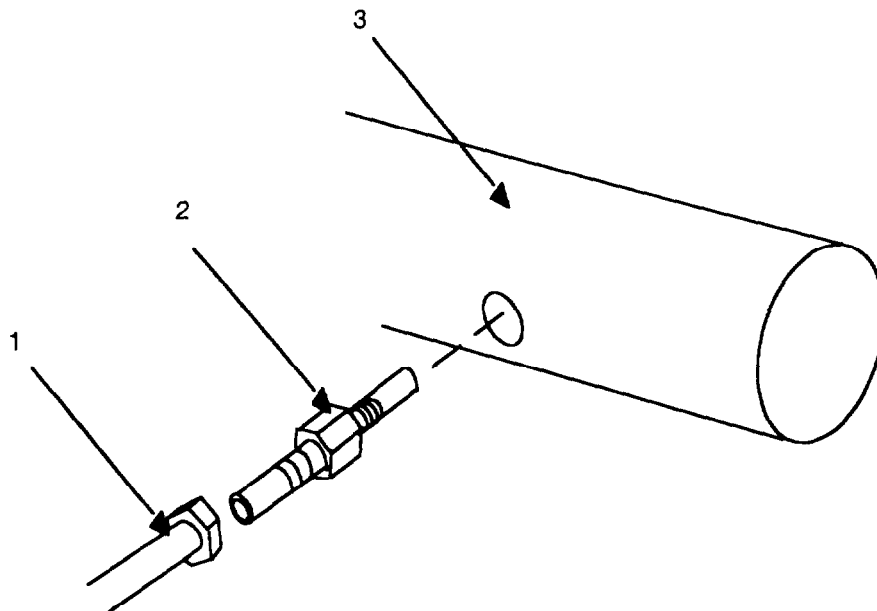

Figure 4-6.3. Starting Aid Nozzle Maintenance (Model 350 PAWN).

4.10.5 Air Cleaner Maintenance.

This task covers: 4.10.5.1 Removal 4.10.5.4 Reassembly
4.10.5.2 Disassembly 4.10.5.5 Installation
4.10.5.3 Repair

INITIAL SETUP

Tools

General Mechanics Tool Box (appendix B, Section III, Item 1)

Material/Parts

Lockwashers (TM 10-4320-226-24P)
Washers (TM 10-4320-226-24P)

Equipment Conditions

Equipment shut down, paragraph 2.5.2.

General Safety Instructions

To prevent rolling or sliding, do not work on equipment that is not securely stabilized.

Do not work on equipment without following standard shop safety precautions.

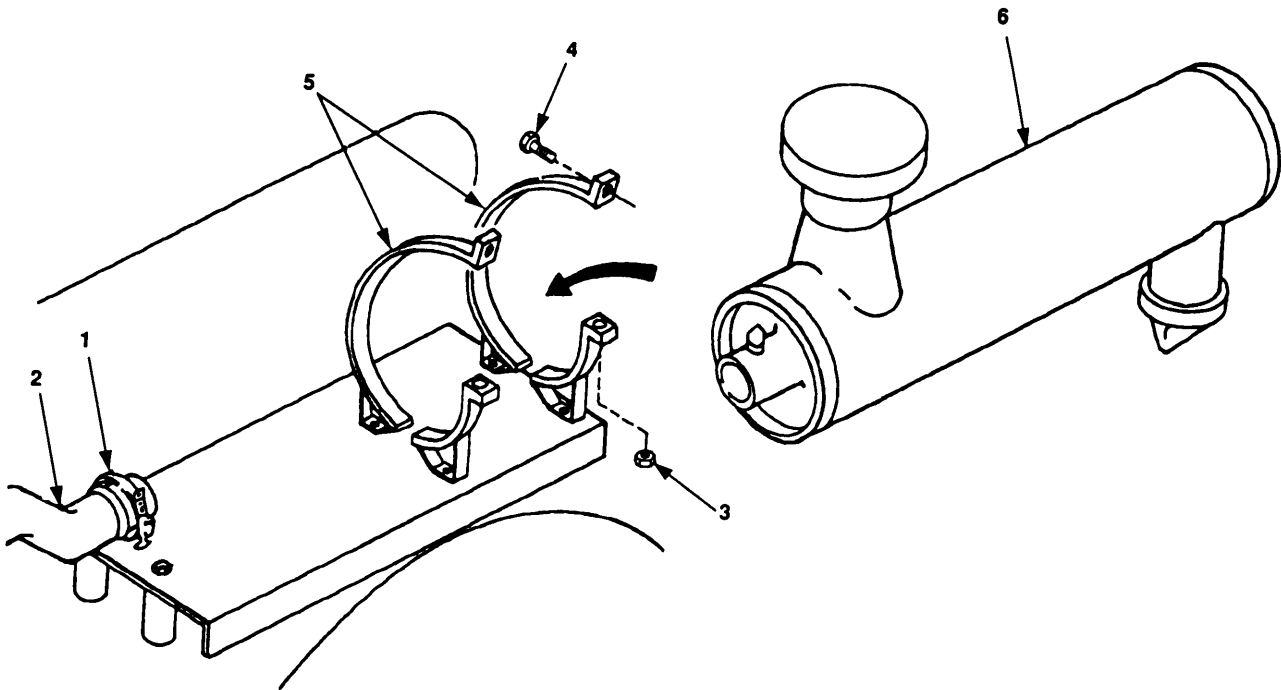

Figure 4-8. Air Cleaner Removal and Installation.



To prevent rolling or sliding, do not work on equipment that is not securely stabilized. Ensure both wheels are secure. Failure to obey this warning may result in serious personal injury.

4.10.5.1 Removal.

- a. Loosen clamp (figure 4-8, 1) from manifold and remove hose (2).

- b. Remove nuts (3) and screws (4) securing the clamps (5).
- c. Open the clamps (5) and remove air cleaner assembly (6).

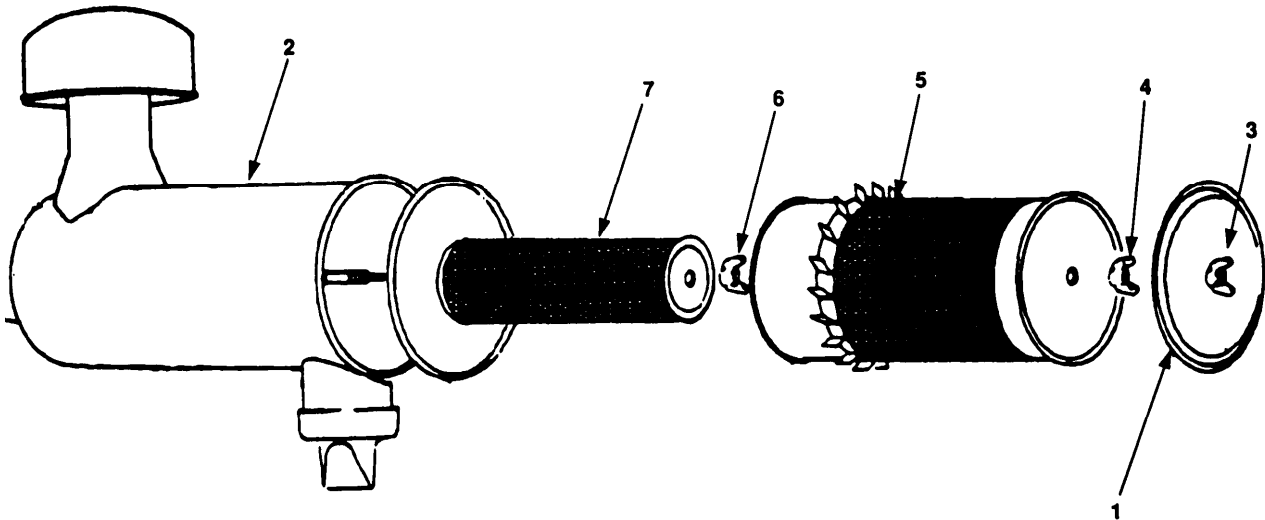

Figure 4-9. Air Cleaner Disassembly.

4.10.5.2 Disassembly.

- a. Remove cover (figure 4-9, 1) from air cleaner housing (2) by turning wing nut (3).
- b. Remove wing nut (4) that secures primary filter (5).
- c. Remove primary filter (5) from air cleaner housing (2).
- d. Remove wing nut (6) from air cleaner housing (2) that secures secondary filter (7).
- e. Remove secondary filter (7) from air cleaner housing (2).

4.10.5.3 Repair.

- a. Replace filters as necessary.

- b. Replace damaged or missing parts.

4.10.5.4 Reassembly.

- a. Install secondary filter (7) into air cleaner housing (2).
- b. Thread wing nut (6) on to shaft and tighten.
- c. Install primary filter (5) into air cleaner housing (2).
- d. Thread wing nut (4) on to shaft and tighten.
- e. Install cover (1) tighten wing nut (3).

4.10.5.5 Installation.

- a. Open clamps (figure 4-8, 5) and position air cleaner assembly (6).
- b. Position clamps (5) around air cleaner assembly (6) and install screws (4) and nuts (3).
- c. Position hose (2) and clamp (1) on air cleaner assembly (6).
- d. Tighten clamp (1) to secure hose (2) to manifold.
- e. Tighten nuts (3) to secure air cleaner assembly (6).

4.10.6 V-Belt Guard Maintenance.

This task covers: 4.10.6.1 Removal

4.10.6.2 Installation

INITIAL SETUP

Tools

General Mechanic's Tool Kit (appendix B, Section III, Item 1)

Material/Parts

LockWashers (TM 10-4320-226-24P)
Washers (TM 10-4320-226-24P)

Equipment Conditions

Equipment shut down, refer to paragraph 2.5.1.2 or 2.5.2.2.

General Safety Instructions

To prevent rolling or sliding, do not work on equipment that is not securely stabilized.

Do not work on equipment without following standard shop safety Precautions.

4.10.6.1 Removal.

WARNING

To prevent rolling or sliding, do not work on equipment that is not securely stabilized. Ensure both wheels are secure. Failure to obey this warning may result in serious personal injury.

- a. Remove bolt (figure 4-10, 1), washer (2), and spacer (3).
- b. Remove bolt (4), washer (5), lockwashers (6), and spacer (7).
- c. Remove two bolts (8), lockwashers (9), and washers (10).
- d. Remove nut (11), lockwasher (12), spacer (13), washer (14), and bolt (15).
- e. Remove V-belt guard (16).

NOTE

Engine pulley guard does not come with the original manufacturer's V-belt guard.

- f. Remove and retain nuts (17), washers (18), bolts (19), and engine pulley guard (20).

4.10.6.2 Installation.

- a. Position engine pulley guard (20) in place on V-belt guard (16).
- b. Install bolts (19), washers (18), and nuts (17) that secure engine pulley guard (20).
- c. Position V-belt guard (16) in place on engine.
- d. Install bolt (15) using washer (14), spacer (13), lockwasher (12), and nut (11).
- e. Install two washers (10), lockwashers (9), and bolts (8).
- f. Install spacer (7), washers (5), lockwashers (6), and bolt (4).
- g. Install spacer (3), washer (2), and bolt (1).

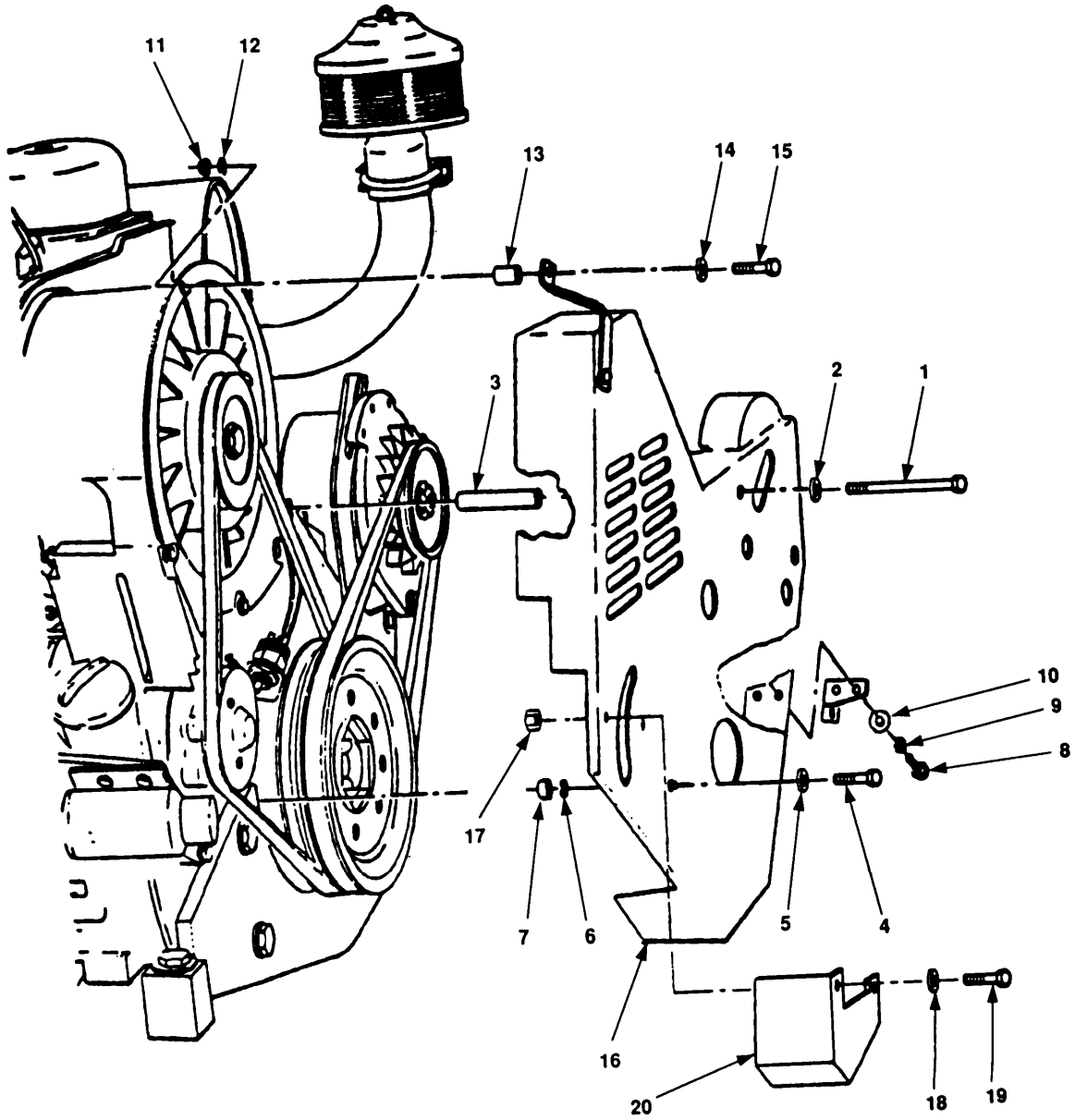

Figure 4-10. V-Belt Guard Removal.

4.10.7 Alternator Belt Maintenance.

This task covers:	4.10.7.1 Adjust	4.10.7.3 Installation
	4.10.7.2 Removal	

INITIAL SETUP**Tools**

General Mechanic's Tool Kit (appendix B, Section III, Item 1)

Equipment Conditions

Equipment shut down, refer to paragraph 2.5.1.2 or 2.5.2.2.

V-belt guard removed (paragraph 4.10.6).

General Safety Instructions

To prevent rolling or sliding, do not work on equipment that is not securely stabilized.

Do not work on equipment without following standard shop safety precautions.

4.10.7.1 Adjust.

To prevent rolling or sliding, do not work on equipment that is not securely stabilized. Ensure both wheels are secure. Failure to obey this warning may result in serious personal injury.

- a. Measure belt deflection as shown in figure 4-11. Deflection should be 1/4 inch.
- b. Loosen bolts (1 and 2) and reposition alternator to obtain desired belt deflection of 1/4 inch.
- c. Hold alternator in place and ensure belt deflection is maintained at 1/4 inch. Tighten bolts (1 and 2).
- d. Repeat steps a, b and c until proper deflection is obtained.

4.10.7.2 Removal.

- a. Loosen bolts (1 and 2).
- b. Push alternator (3) towards engine and remove V-belt (4).

4.10.7.3 Installation.

- a. Position alternator V-belt (4) on alternator pulley (5) and crankshaft pulley (6).
- b. Move alternator (3) away from engine to tighten V-belt for 1/4 inch (6mm) deflection.
- c. Hold alternator (3) in place and ensure belt deflection is maintained. Tighten bolts (1 and 2).
- d. Measure belt deflection as shown in figure 4-11. Repeat steps b and c until proper deflection is obtained.

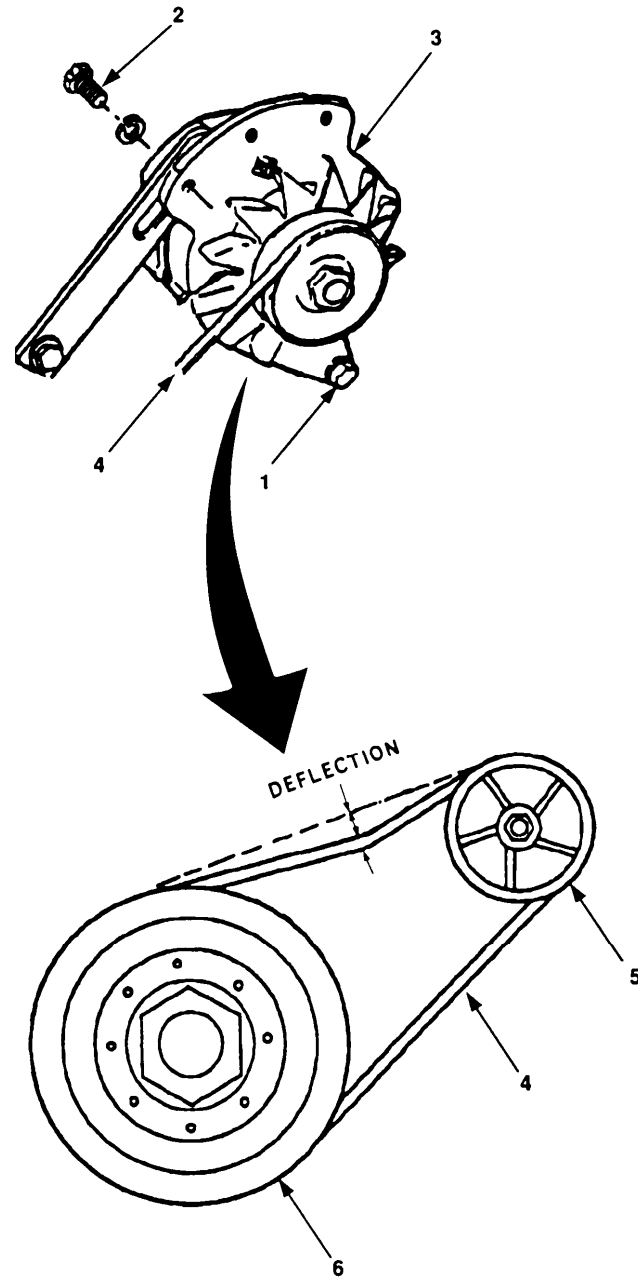

Figure 4-11. Alternator Belt Maintenance.

4.10.8 Cooling Fan Belt Maintenance.

This task covers: 4.10.8.1 Removal

4.10.8.2 Installation

INITIAL SETUP

Tools

General Mechanic's Tool Kit (appendix B, Section III, Item 1)

Equipment Conditions

Equipment shut down, refer to paragraph 2.5.1.2 or 2.5.2.2.

Alternator V-belt removed (paragraph 4.10.7).

General Safety Instructions

To prevent rolling or sliding, do not work on equipment that is not securely stabilized.

Do not work on equipment without following standard shop safety precautions.

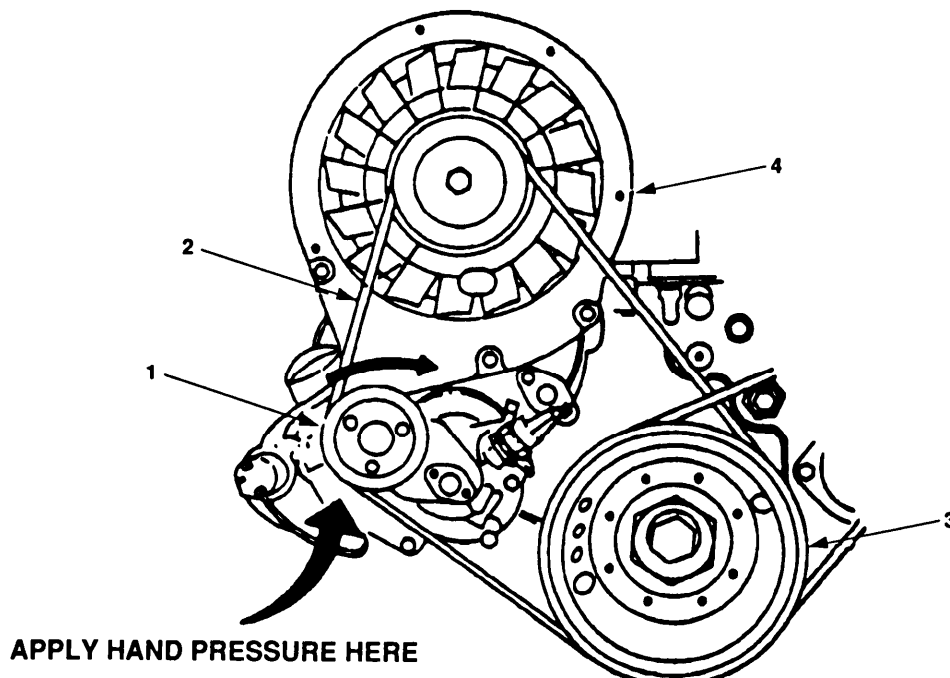

Figure 4-12. Cooling Fan Belt Maintenance.

4.10.8.1 Removal.



To prevent rolling or sliding, do not work on equipment that is not securely stabilized. Ensure both wheels are secure. Failure to obey this warning may result in serious personal injury.

- a. Apply pressure to idler pulley (figure 4-12, 1) and push upward.
- b. Remove V-belt (2) while holding idler pulley (1).
- c. Slowly release pressure from idler pulley (1).

4.10.8.2 Installation.

- a. Install cooling fan V-belt (2) on inner groove of crankshaft pulley (3) and cooling fan pulley (4), then apply pressure to idler pulley (1) and push upward.
- b. While holding idler pulley (1), install cooling fan V-belt (2) on idler pulley (1).
- c. Release idler pulley (1). Ensure cooling fan V-belt is on cooling fan pulley (4), idler pulley (1), and inner groove crankshaft pulley (3).

4.10.9 V-belt Contact Switch Test.

 This task covers: Test

INITIAL SETUPTest Equipment

Multimeter (appendix B, Section III, item 2)

Equipment Conditions

Equipment shut down, refer to paragraph 2.5.1.2 or 2.5.2.2.

Cooling fan V-belt removed (paragraph 4.10.8)

General Safety Instructions

To prevent rolling or sliding, do not work on equipment that is not securely stabilized.

Do not work on equipment without following standard shop safety precautions.

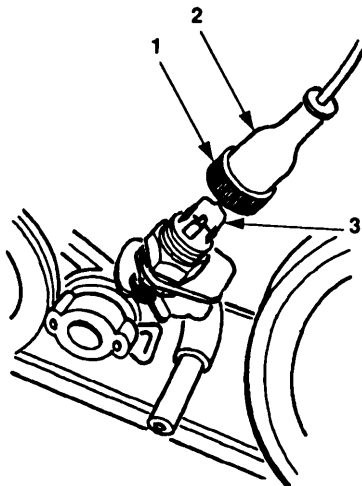

Figure 4-13. V-Belt Contact Switch Test.

WARNING

To prevent rolling or sliding, do not work on equipment that is not securely stabilized. Ensure both wheels are secure. Failure to obey this warning may result in serious personal injury.

- a. Loosen nut (figure 4-13, 1) securing boot (2), and slide up harness.
- b. Disconnect wires from V-belt contact switch terminals (3).
- c. Using multimeter set for continuity, measure resistance of V-belt contact switch terminals (3) for open.
- d. Press in on V-belt contact switch. Resistance now reads a short.

NOTE

Wires must be connected to direct opposite terminals of V-belt contact switch.

- e. Connect wires to V-belt contact switch terminals (3), slide boot (2) down harness and secure with nut (1).

4.10.10 V-belt Contact Switch Maintenance.

This task covers: 4.10.10.1 Removal

4.10.10.2 Installation

INITIAL SETUP

Tools

General Mechanic's Tool Kit (appendix B, Section III, item 1)

Material/Parts

Tags (appendix E, Section II, Item 12)

Equipment Conditions

Equipment shut down, (paragraph 2.5.1.2 or 2.5.2.2).

Cooling fan V-belt removed (paragraph 4.10.8)

General Safety Instructions

Do not work on equipment without following standard shop safety precautions.

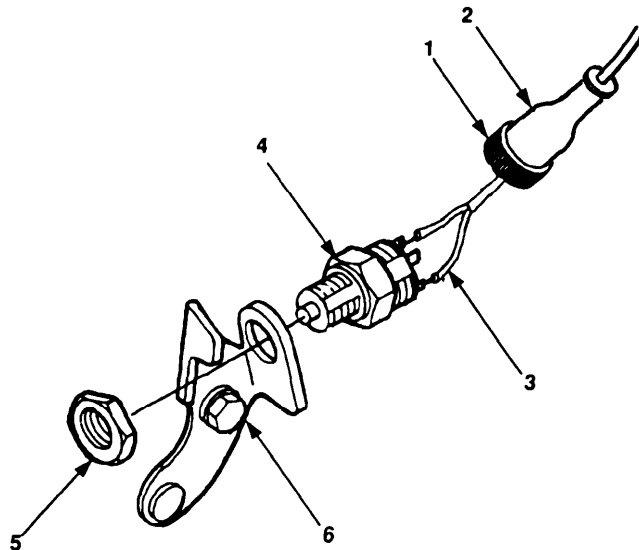

Figure 4-14. V-Belt Contact Switch Replacement.

4.10.10.1 Removal.

- a. Loosen nut (figure 4-14, 1) securing boot (2), and slide up harness.
- b. Tag and disconnect wires (3) from V-belt contact switch (4).
- c. Remove nut (5) and V-belt contact switch (4) from bracket (6).

4.10.10.2 Installation.

- a. Position V-belt contact switch (4) to bracket (6) and install nut (5), then tighten.

NOTE

Wires must be connected to direct opposite terminals of V-belt contact switch.

- b. Connect wires (3) to V-belt contact switch (4), slide boot (2) down harness and secure with nut (1).

4.10.11 Alternator Assembly Test.

INITIAL SETUP

Test Equipment

Multimeter (appendix B, Section III, Item 2)

General Safety Instructions

To prevent rolling or sliding, do not work on equipment that is not securely stabilized.

Do not work on equipment that is operating.

Do not touch exhaust system after equipment operation.

Do not work on equipment without following standard shop safety precautions.

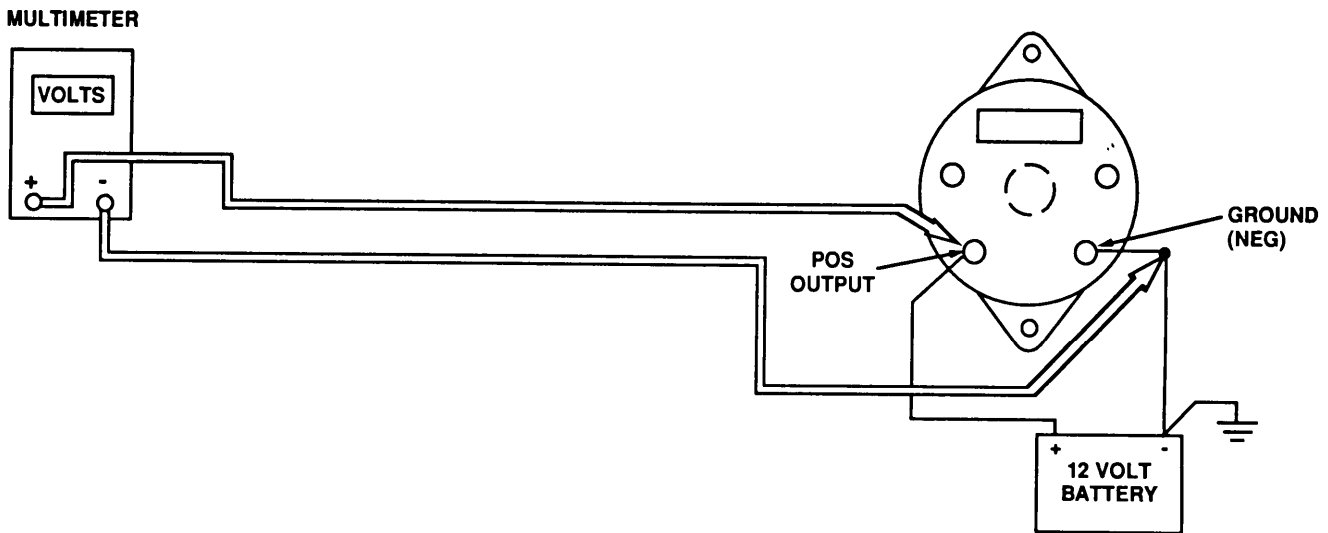

Figure 4-15. Alternator Test Configuration.

WARNING

- Do not work on equipment that is operating.
 - Do not touch exhaust system after equipment operation. Exhaust systems become very hot and can cause serious burns.
 - Failure to obey this warning could result in personal injury.
- a. If equipment is operating, shut down engine (paragraph 2.5.1.2 or 2.5.2.2).
 - b. Refer to figure 4-15 and connect multimeter as follows:

CAUTION

Do not position test equipment in path of moving parts of engine. Failure to obey this caution may result in equipment damage.

- (1) Connect positive lead of multimeter to Positive Output (largest terminal) of alternator.
 - (2) Connect negative lead of multimeter to ground.
- c. Ensure that leads of multimeter are not around moving parts and that leads are secure on alternator terminals.

CAUTION

Do not operate the 350 GPM Pumping Assembly without fuel source and destinations connected. Failure to obey this caution may result in equipment damage.

- d. Refer to paragraph 2.5.1 and start engine until 2000 RPM is achieved.
- e. Observe multimeter reading. Reading must be between 13.8 and 14.8 V dc.
- f. Refer to paragraph 2.5.1.2 or 2.5.2.2 and stop engine.
- g. Disconnect multimeter from alternator terminals.
- h. When reading is not between 13.8 and 14.8 V dc, refer to paragraph 4.10.12 and replace alternator.

4.10.12 Alternator Maintenance.

 This task covers: 4.10.12.1 Removal 4.10.12.2 Installation

INITIAL SETUPTools

General Mechanic's Tool Kit (appendix B, Section III, Item 1)

Material/Parts

Lockwashers (TM 10-4320-226-24P)
 Washers (TM 10-4320-226-24P)
 Tags (appendix E, Section II, Item 12)

Equipment Conditions

Equipment shut down, refer to paragraph 2.5.1.2 or 2.5.2.2.

Alternator V-belt removed (paragraph 4.10.7).

General Safety Instructions

To prevent rolling or sliding, do not work on equipment that is not securely stabilized.

Do not work on equipment without following standard shop safety precautions.

4.10.12.1 Removal.

- To prevent rolling or sliding, do not work on equipment that is not securely stabilized. Ensure both wheels are secure.
 - Do not work on alternator with negative battery cable connected.
 - Failure to obey these warnings may result in serious personal injury.
- a. Disconnect negative battery cable.
 - b. Tag and disconnect alternator quick disconnect lead (figure 4-16, 1).
 - c. Remove nut (2). Tag and disconnect wire (3).
 - d. Remove nut (4) and lockwasher (5). Tag and disconnect wire (6).
 - e. Remove bolt (7), lockwasher (8), washer (9), bolt (10), lockwasher (11), washer (12) and alternator (13).

4.10.7.2 Installation.

- a. Position alternator (13) in place on engine.
- b. Install, but do not fully tighten, washer (12), lockwasher (11), bolt (10), washer (9), lockwasher (8), and bolt (7).
- c. Install wire (6), lockwasher (5) and nut (4). Remove tag.
- d. Install wire (3) and nut (2). Remove tag.
- e. Connect alternator quick disconnect lead (1). Remove tag.
- f. Connect negative battery cable.

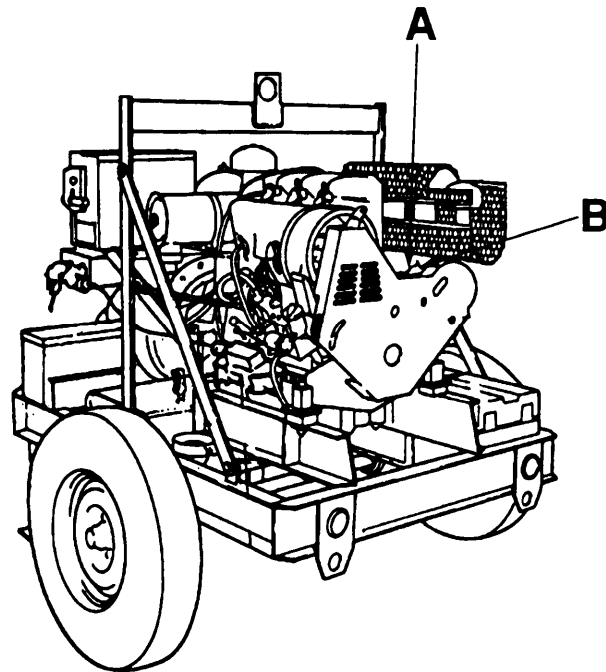
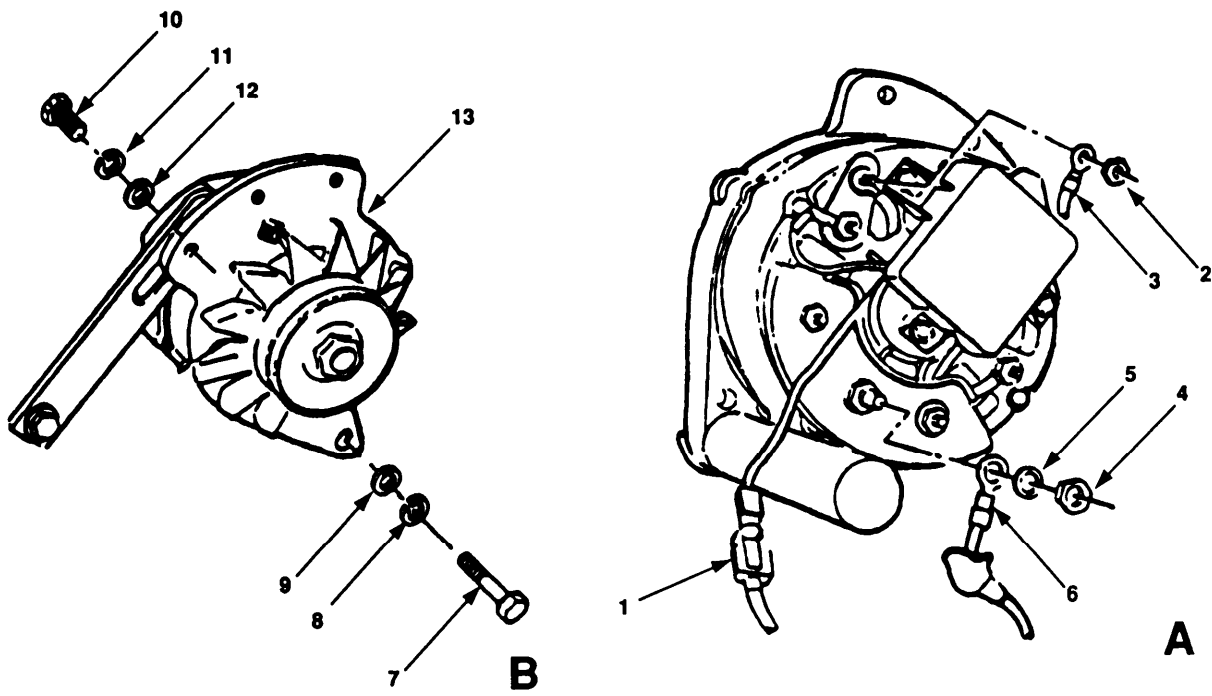

Figure 4-16. Alternator Maintenance.

4.10.13. Starter Assembly Maintenance.

This task covers: 4.10.13.1 Removal

4.10.13.2 Installation

INITIAL SETUP

Tools

General Mechanic's Tool Kit (Appendix B, Section III, Item 1)

Materials/Parts

Lockwashers (TM 10-4320-226-24P)
 Washer (TM 10-4320-226-24P)
 Tags (Appendix E, Section II, Item 12)

Equipment Conditions

Equipment shut down, refer to paragraph 2.5.1.2 or 2.5.2.2.

General Safety Instructions

To prevent rolling or sliding, do not work on equipment that is not securely stabilized.

Do not work on equipment without following standard shop safety precautions.

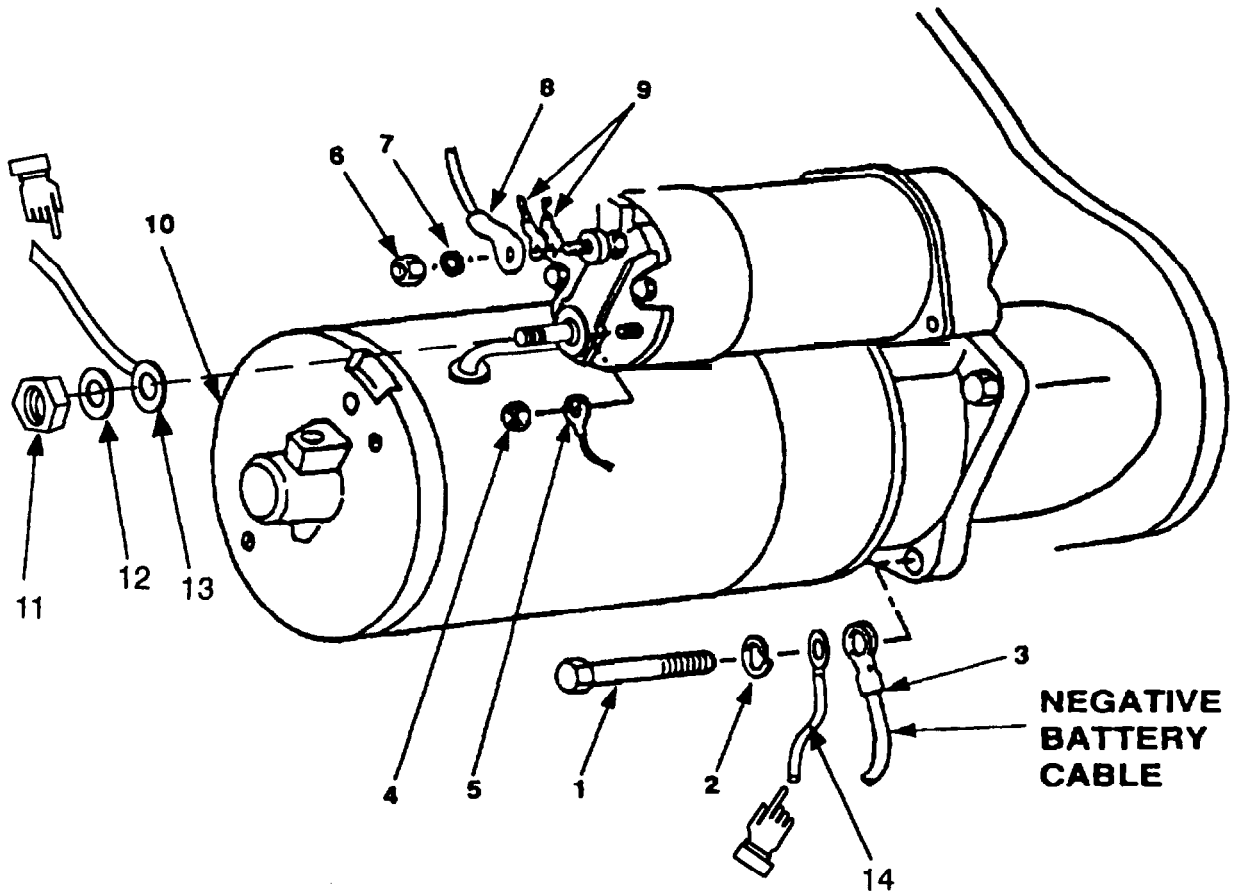

Figure 4-17. Starter Assembly Replacement.

4.10.13.1 Removal.

WARNING

Do not work on starter assembly with negative battery terminal connected.

To prevent rolling or sliding, do not work on equipment that is not securely stabilized. Ensure both wheels are secure.

Failure to obey these warnings may result in serious injury.

- a. Remove bolt (figure 4-17, 1), lockwasher (2) and negative (-) battery cable (3).
- b. Remove nut (4). Tag and disconnect wire (5).
- c. Remove nut (6) and washer (7).
- d. Tag positive (t) battery cable (8) and wires (9).
- e. On Model 350 PAWN only, remove nut (11), washer (12) and wires (13). Tag wires.
- f. Remove remaining two bolts (1) and lockwashers (2) that secure starter (10) to engine.
- g. Carefully separate starter (10) from engine.

4.10.13.2 Installation.

- a. Position starter (10) on engine so that drive gear mates with teeth on flywheel.
- b. Install two lock-washers (2) and bolts (1) in starter leaving bottom bolt (1) to connect negative battery cable (3).
- c. Install wires (9), positive (t) battery cable (8), washer (7), and nut (6). Remove tags.
- d. Install wire (5) and nut (4). Remove tag.
- e. Install negative (-) battery cable (3), lockwasher (2), and bolt (1).
- f. Tighten bolt (1).
- g. On Model 350 PAWN only, install wires (13), washer (12) and nut (11). Remove tags.

4.10.14. Shutdown Solenoid Test. (Not used on Model 350 PAWN)INITIAL SETUPTest Equipment

Multimeter (appendix B, Section III, Item 2)

Tools

General Mechanic's Tool Kit (appendix B, Section III, Item 1)

Equipment Conditions

Engine shut down, paragraph 2.5.1.2 or 2.5.2.2.

General Safety Instructions

To prevent rolling or sliding, do not work on equipment that is not securely stabilized.

Do not work on equipment without following standard shop safety precautions.

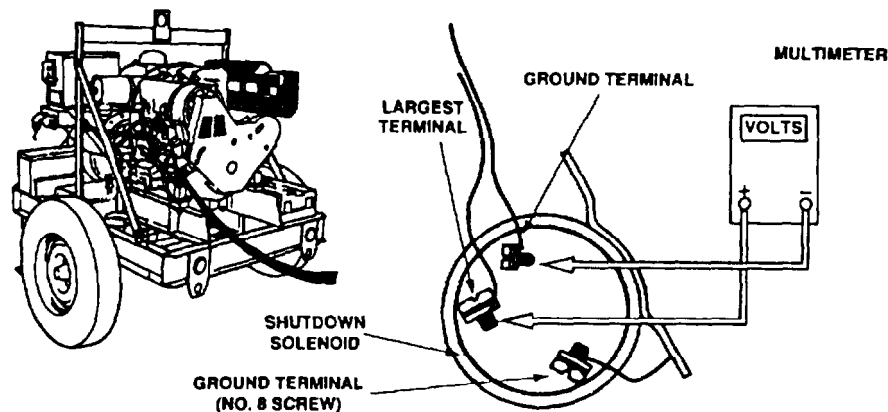
**Figure 4-18. Shutdown Solenoid Test (Models 350 PAW and W-87012).**

To prevent rolling or sliding, do not work on equipment that is not securely stabilized. Ensure both wheels are secure. Failure to obey this warning may result in serious personal injury.

WARNING

- a. Pull out start/stop switch (figure 2-1, 1).
- b. Connect multimeter to largest terminal and ground terminal as shown in figure 4-18.

CAUTION

Release oil pressure bypass switch within 30 seconds, if voltage is not indicated (by multimeter) at the auxiliary terminal.

- c. Depress oil pressure bypass switch and monitor that solenoid rod is retracting and observe multimeter for +12 Vdc.
- d. If the solenoid rod does not retract or multimeter does not indicate + 12Vdc, replace shutdown solenoid (paragraph 4.10.15).

4.10.14.1 Engine Shutdown Solenoid Test. (Used on Model 350 PAWN only)

INITIAL SETUP

Tools

General Mechanic' s Tool Kit (Appendix B, Section III, Item 1)

General Safety instructions

To prevent rolling or sliding, do not work on equipment that is not securely stabilized.

Equipment Conditions

Equipment shut down, paragraph 2.5.2.

Do not work on equipment without following standard shop safety precautions.

- a. Check for a good ground connection between black wire (figure 4-18.1,1) of solenoid (2) and engine. If in doubt, also check continuity between engine ground and battery return to insure a good ground.
- b. Remove sleeving from red and white wires (3 and 4), and disconnect spade connectors.
- c. Apply 12 V dc to red wire (3) of solenoid (2).

CAUTION

Red wire is connected to a hold-in coil while white wire is connected to a pull-in coil. Because pull in coil draws a large amount of current, coil may be damaged if power is applied for too long.

- d. Briefly apply 12 Vdc to the white wire (4) and note that plunger (5) retracts, pulls up fuel lever (6) on the engine to open the fuel valve, and stays retracted when power is disconnected from white wire as long as power remains applied to the red wire.

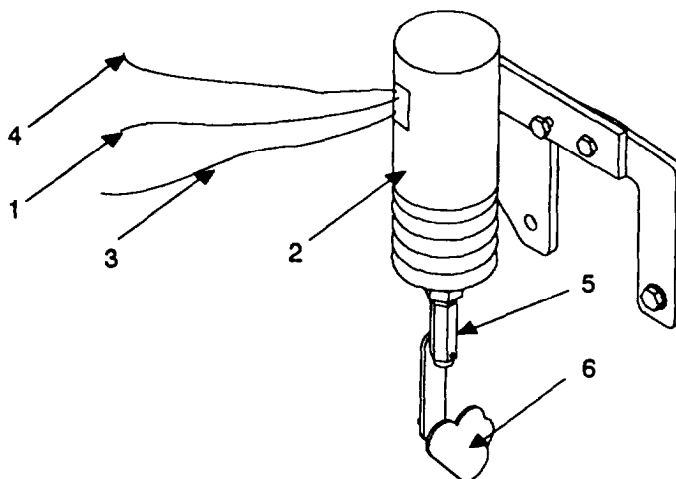

Figure 4-18.1. Shutdown Solenoid Test (Model 350 PAWN).

4.10.15.1 Shutdown Solenoid Maintenance. (Used on Model 350 PAWN)

This task covers: 4.10.15.1 Removal 4.10.15.2 Installation

INITIAL SETUPTools

General Mechanic' s Tool Kit (Appendix B, Section III, Item 1)

General Safety Instructions

To prevent rolling or sliding, do not work on equipment that is not securely stabilized.

Material/Parts

Tags (Appendix E, Section II, Item 12)

Do not work on equipment without following standard shop safety precautions.

Equipment ConditionsEquipment shut down, paragraph 2.5.2.

4.10.15.1.1. Removal

- a. Tag and disconnect wires from solenoid (1)
- b. Remove bolt (2) and lockwasher(3) from injection pump.
- c. Remove two bolts(4) and two lockwashers(5) from injection pump.
- d. Lift assembled solenoid(l) from between injection pump and engine.
- e. Remove two cotter pins(6), linkage plate(7) and fuel lever(8) from assembled solenoid(l).
- f. Remove two bolts(9), two locknuts(10) and bracket(11) from solenoid(l).
- g. Remove spacer(12) and jam nut(13) from plunger on solenoid(l).

4.10.15.1.2. Installation

- a. Spacer(12) and jam nut(13) is installed on solenoid(l) and preset at the factory. No linkage adjustment arequired.

NOTE

When the solenoid and attaching parts are received from the manufacturer they are normally assembled and the linkage preset.

- b. Install two bolts(9), locknuts(10) and bracket(11) on solenoid(l).
- c. Insert pins on linkage plate(7) through holes in spacer(12) and fuel lever(8) and secure with two cotter pins(6).
- d. Position assembled solenoid(l) into position between injection pump and engine.
- e. Loosely install two bolts(4) and two lockwashers(5) to attach assembled solenoid(l) to injection pump.

- f. Position fuel lever(8) with half-moon notch pointing up and aligned with stop pin on injection pump and install bolt(2) and lockwasher(3).

NOTE

The fuel lever has a half-moon shaped notch cut into it which is an indicator and when properly installed the notch points up. Ensure the solenoid plunger is fully retracted(pushes all way in) into solenoid when installing.

- g. Tighten two bolts(4) to secure assembled solenoid(l) to injection pump.
- h. Connect wires and remove tags.

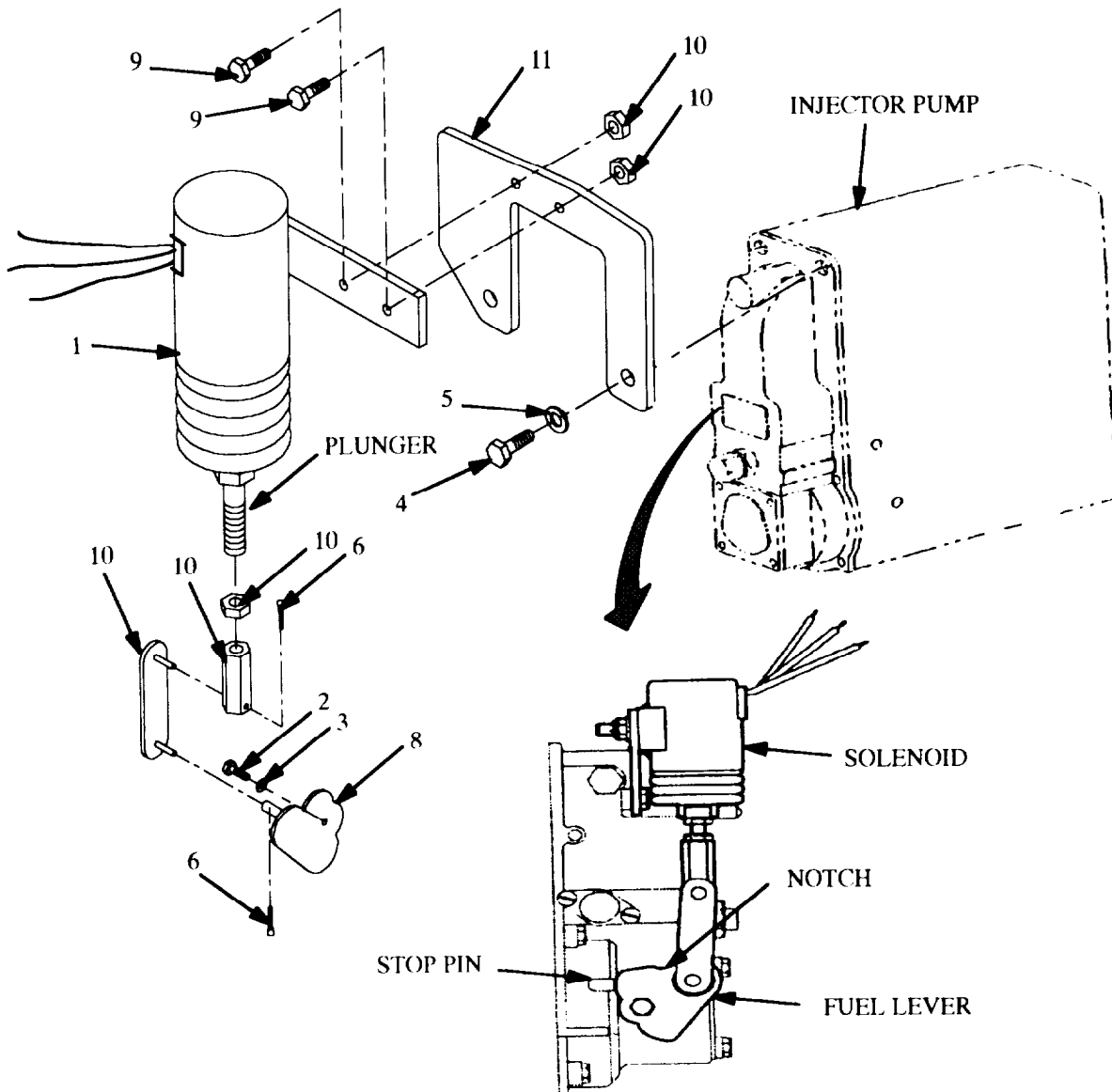

Figure 4-19. Shutdown Solenoid Maintenance (Model 350 PAWN).

WARNING

To prevent rolling or sliding, do not work on equipment that is not securely stabilized. Ensure both wheels are secure. Failure to obey this warning may result in serious personal injury.

4.10.15.1 Removal.

- a. Tag and disconnect wires (figure 4-19, 1, 2, and 3).
- b. Remove nut (4), lockwasher (5) and spacer (6).
- c. Remove nuts (7), lockwashers (8), clamp (9) and bolts (10).
- d. Remove shutdown solenoid assembly (11) with linkage.

4.10.15.2 Service.**WARNING**

Do not use dry cleaning solvent without proper ventilation and clothing. Do not smoke or use near open flame or excessive heat. Dry cleaning solvent is potentially dangerous to personnel and property. Clean parts in a well-ventilated area. Avoid inhalation of solvent fumes. Wear goggles and rubber gloves to protect eyes and skin. Wash exposed skin thoroughly. Flash point of solvent is 100°F to 138°F (38°C to 59°C). Failure to obey this warning may result in personal injury or death.

- a. Clean all metal surfaces with clean cloth moistened with solvent.
- b. Wipe rubber boot around solenoid rod with clean cloth.
- c. Dry thoroughly.
- d. Inspect electrical terminals for cracks, corrosion and looseness.
- e. Inspect solenoid housing and linkage for cracks or any other damage.
- f. Inspect stud (15) and control lever (16) for damage.

4.10.15.3 Adjust.

- a. Loosen nuts (12, 13, and 14).
- b. Pull EMERGENCY STOP switch to RESET position.
- c. Push control lever (16) away from dipstick until stop is reached, and adjust rod end length until stud (15) aligns with top hole in control lever (16).
- d. Position spacer (6) on stud (15) and insert stud through top hole in lever (16).
- e. Install lockwasher (5) and nut (4).
- f. Tighten nuts (12, 13, and 14).

4.10.15.4 Repair.

Replace all damaged or missing parts.

4.10.15.5 Installation.

- a. Position complete shutdown solenoid assembly (11) on mounting bracket.
- b. Install bolts (10), clamp (9), lockwashers (8), and nuts (7).
- c. Install spacer (6) on stud (15) and insert stud through control lever (16).
- d. Install lockwasher (5) and nut (4) on stud (15).
- e. Connect wires (1, 2, and 3) as tagged. Remove tags.
- f. Adjust in accordance with paragraph 4.10.15.3.

4.10.16 Fuel Line Hoses and Fittings Maintenance.

This task covers:	4.10.16.1 Removal	4.10.16.3 Installation
	4.10.16.2 Repair	4.10.16.4 Servicing

INITIAL SETUP

Tools

General Mechanic's Tool Kit (appendix B, Section III, Item 1)

Equipment Conditions

Equipment shut down, refer to paragraph 2.5.1.2 or 2.5.2.2.

Material/Parts

Washers (TM 10-4320-226-24P)
 Gaskets (TM 10-4320-226-24P)
 Tags (appendix E, Section II, Item 12)
 Dry Cleaning Solvent (appendix E, Section II, Item 11)
 Cloth, (appendix E, Section II, Item 4)

General Safety Instructions

To prevent rolling or sliding, do not work on equipment that is not stabilized

Do not smoke or use open flames around fuel.

do not use dry cleaning solvent without proper ventilation and clothing.

do not work on equipment without following standard shop safety precautions.

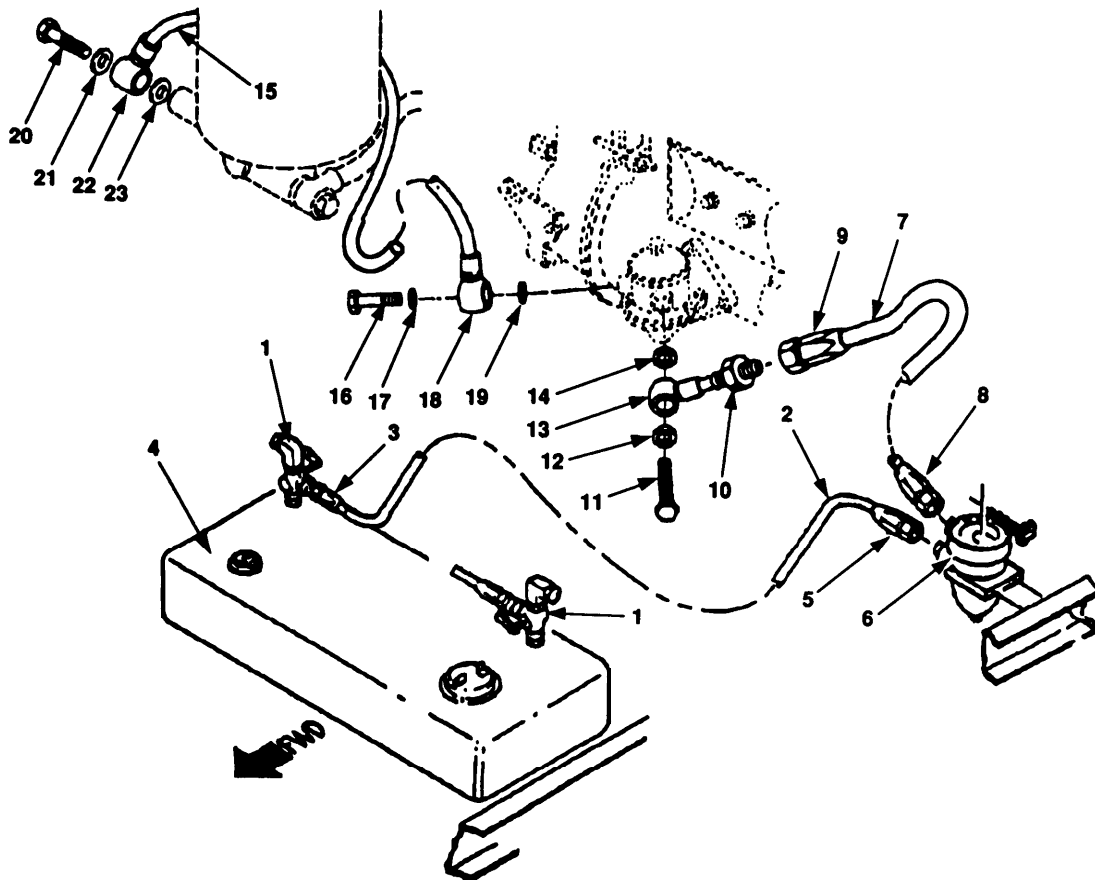

Figure 4-20. Low Pressure Fuel Lines.

4.10.16.1 Removal.

WARNING

- To prevent rolling or sliding, do not work on equipment that is not securely stabilized. Ensure both wheels of equipment have chocks that are secure.
- Do not smoke or use open flames around fuel. Ensure container is used to catch fuel and fuel is disposed of properly.
- Failure to obey these warnings may result in personal injury or death.

NOTE

Some models have clamps.

- a. Set both source selector valves (figure 4-20, 1) to the off position.
- b. Disconnect fuel supply line (2) as follows:
 - (1) Tag and disconnect fuel supply line connection (3) at source selector valve (1) on fuel tank (4).
 - (2) Tag and disconnect fuel supply line connection (5) at water separator (6) inlet fitting. Disconnect clamps as required.
 - (3) Remove fuel supply line (2) and cover openings.
- c. Disconnect fuel feed pump line (7) as follows:
 - (1) Tag and disconnect fuel pump line connection (8) at water separator (6) discharge fitting.
 - (2) Tag and disconnect fuel pump line connection (9) at adapter (10).
 - (3) Remove fuel pump line (7) and cover openings.
 - (4) Remove adapter (10).
 - (5) Remove banjo bolt (11), washer (12), banjo connector (13) and washer (14) from fuel pump. Cover openings.
- d. Tag and disconnect fuel filter line (15) as follows:
 - (1) Remove banjo bolt (16), washer (17), banjo connector (18) and washer (19) from fuel pump.
 - (2) Remove banjo bolt (20), washer (21), banjo connector (22) and washer (23) from fuel filter inlet.
 - (3) Remove fuel filter line (15) and cover openings.
- e. Tag and disconnect fuel filter outlet (figure 4-21, 1) as follows:
 - (1) Remove banjo bolt (2), washer (3), banjo connector (4) and washer (5) from fuel filter.
 - (2) Remove banjo bolt (6), washer (7), banjo connector (8) and washer (9) from fuel injector inlet.
 - (3) Remove filter outlet line (1) and cover openings.

4.10.16 Fuel Line Hoses and Fittings Maintenance. (continued)

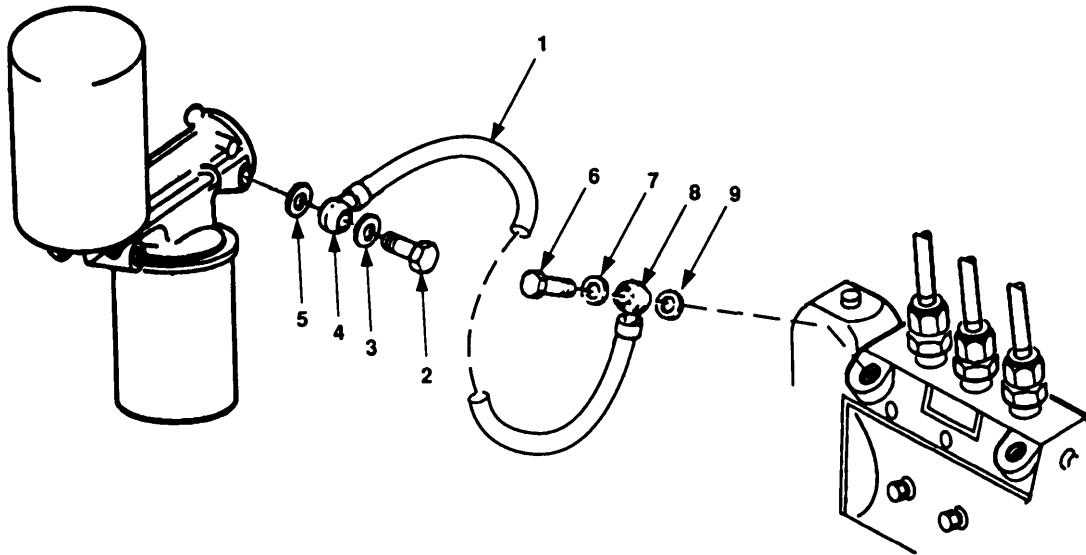

Figure 4-21. Fuel Filter Outlet Line.

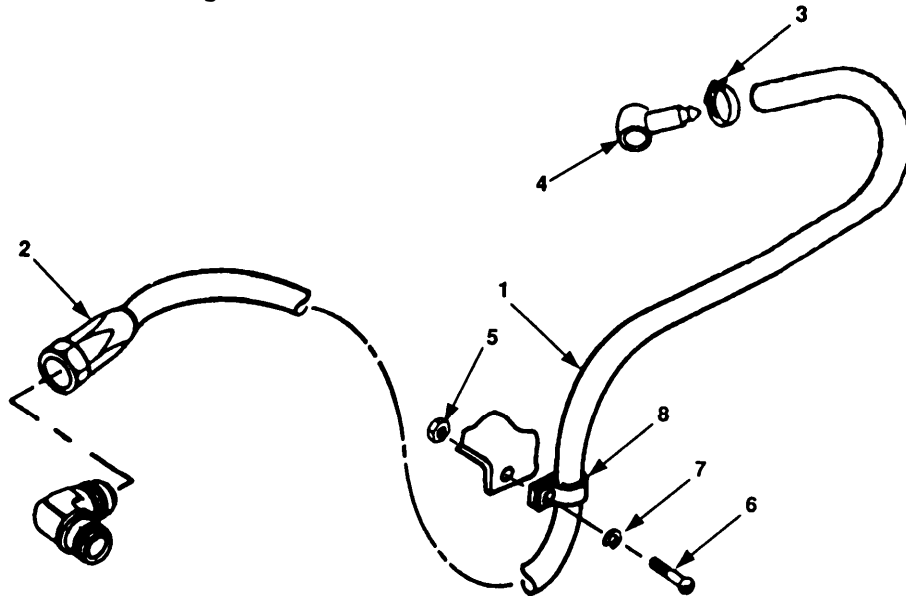

Figure 4-22. Fuel Overflow Line.

- f. Tag and disconnect fuel overflow line (figure 22, 1) as follows:
- (1) Disconnect fuel overflow line connection (2) from selector valve fitting.
 - (2) Loosen and remove clamp (3) with fuel overflow line (1) from banjo connector (4).
 - (3) Remove nut (5), screw (6), lockwasher (7) and clamp (8).
 - (4) Remove overflow line (1) and cover openings.

4.10.16 Fuel Line Hoses and Fittings Maintenance. (continued)

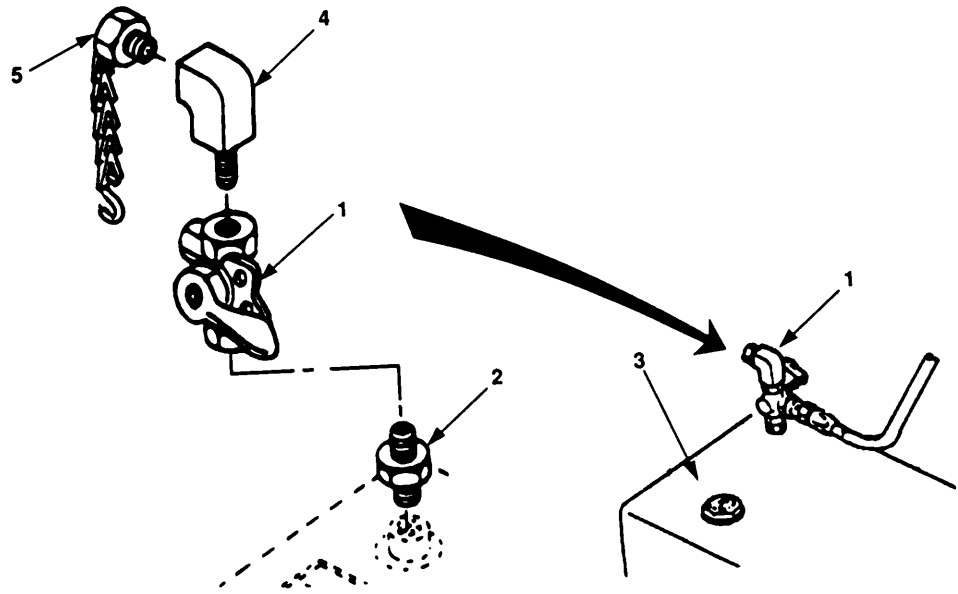

Figure. 4-23. Selection Valve Fitting.

- g. Remove selection valve fitting (figure 23, 1) as follows:
- (1) Remove adapter (2) with attaching parts from fuel tank (3).
 - (2) Remove elbow (4) from selector valve fitting (1).
 - (3) Remove plug (5) from elbow (4).

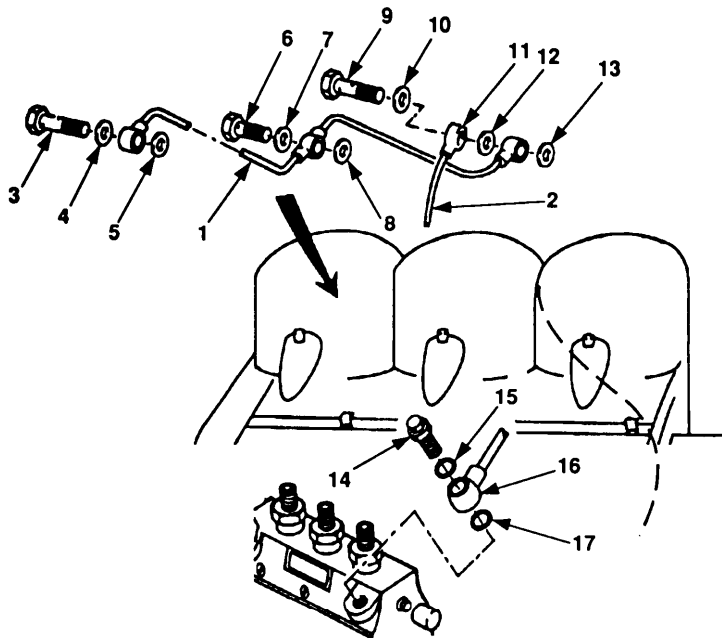

Figure 4-24. Engine Return Lines.

- h. Remove engine return lines (figure 4-24, 1 and 2).
- (1) Remove banjo bolt (3), washer (4), and washer (5).

4.10.16 Fuel Line Hoses and Fittings Maintenance. (continued)

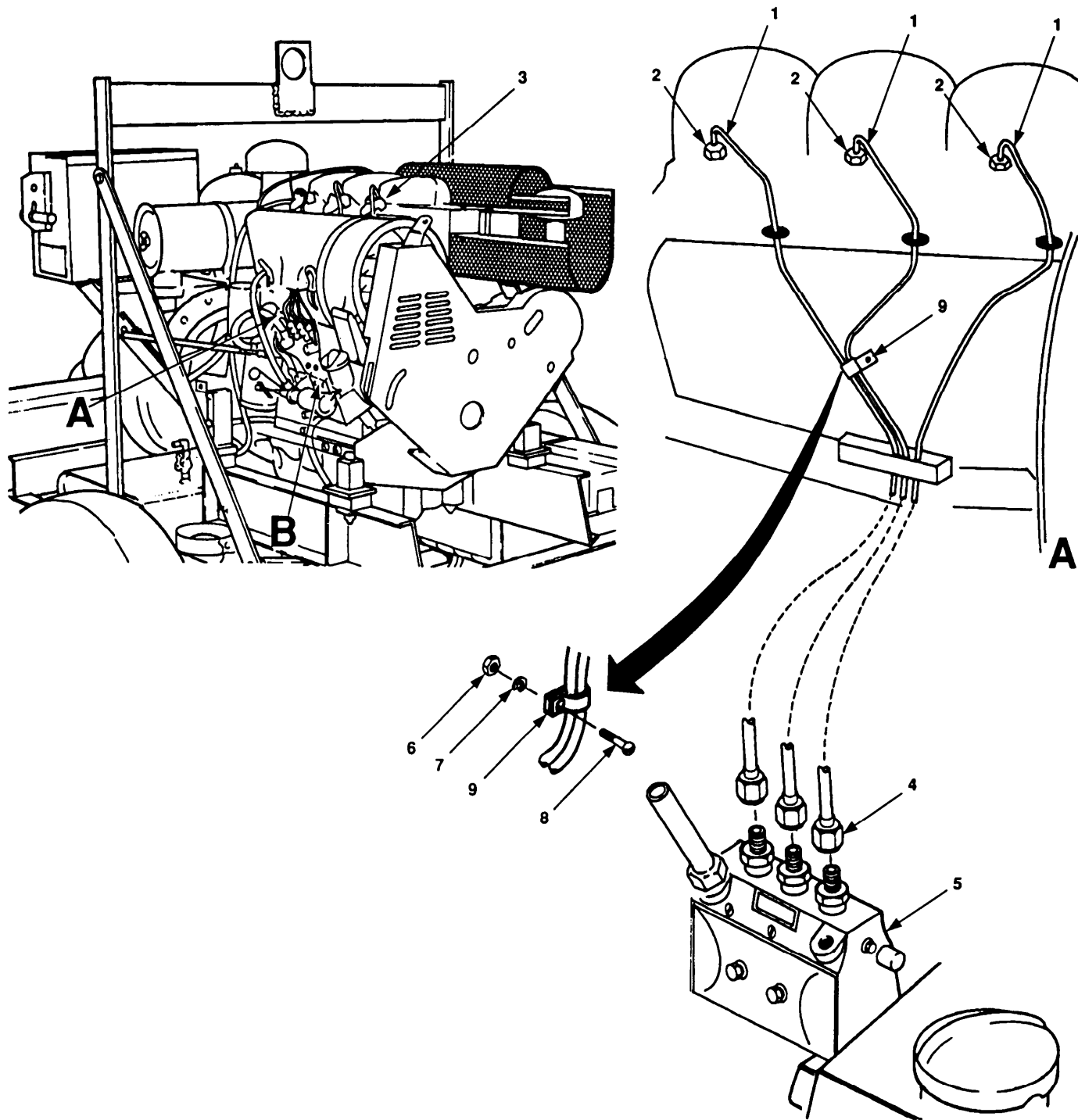

Figure 4-25. High Pressure Fuel Lines.

4.10.16 Fuel Line Hoses and Fittings Maintenance. (continued)

- (2) Remove banjo bolt, (6), washer (7), and washer (8).
 - (3) Remove banjo bolt, (9), washer (10), connector (11), washer (12), washer (13) and return line (1).
 - (4) Remove fluid restriction bolt (14), washer (15), connector (16), washer (17), and return line (2).
- i. Remove high pressure fuel lines (figure 4-25, 1) as follows:
- (1) Tag the three high pressure fuel lines (1).
 - (2) Remove three nuts (2) at fuel injection nozzles (3).
 - (3) Remove three nuts (4) at fuel injection pump (5).
 - (4) Remove nut (6), lockwasher (7), bolt (8) and clamp (9).
 - (5) Remove high pressure fuel lines (1) from engine.

4.10.16.2 Repair.



Do not use dry cleaning solvent without proper ventilation and clothing. Do not smoke or use near open flame or excessive heat. Dry cleaning solvent is potentially dangerous to personnel and property. Clean parts in a well ventilated area. Avoid inhalation of solvent fumes. Wear goggles and rubber gloves to protect eyes and skin. Wash exposed skin thoroughly. Flash point of solvent is 100°F to 138°F (38°C to 59°C). Failure to obey this warning may result in personal injury or death.

- a. Clean all fittings and lines (exterior) with clean cloth moistened with solvent.
- b. Inspect lines for cracks, chafing, and defective connectors. Replace if defective.
- c. Inspect fittings for cracks and thread distortions. Replace if defective.

4.10.16.3 Installation.



Do not smoke or use open flames around fuel. Ensure container is used to catch fuel and fuel is disposed of properly. Failure to obey this warning may result in personal injury or death.

Prior to installation of fuel lines, hoses or fittings, remove plugs and caps installed to prevent contamination.

- a. Install high pressure fuel lines (figure 4-25, 1) as follows:
 - (1) Position high pressure fuel lines (1) on engine.
 - (2) Install clamp (9), bolt (8), lockwasher (7) and nut (6).
 - (3) Install three nuts (4) on fuel injection pump (5).
 - (4) Install three nuts (2) on fuel injection nozzles (3) and remove tags.

4.10.16 Fuel Line Hoses and Fittings Maintenance. (continued)

- b. Install engine return lines (figure 4-24, 1 and 2).
 - (1) Install return line (2), washer (17), connector (16), washer (15) and fluid restriction bolt (14).
 - (2) Install return line (1), washer (13), washer (12) connector (11), washer (10), and banjo bolt (9).
 - (3) Install washer (8), washer (7), and banjo bolt (6).
 - (4) Install washer (5), washer (4), and banjo bolt (3).
- c. Install selection valve fitting (figure 23, 1) as follows:
 - (1) Install plug (5) into elbow (4).
 - (2) Install elbow (4) into source selector valve fitting (1).
 - (3) Install fitting (1) into adapter (2).
 - (4) Install adapter (2) with attaching parts into fuel tank (3).
- d. Install fuel overflow line (figure 22, 1) as follows:
 - (1) Remove covers from openings and position overflow line (1) on engine.
 - (2) Install clamp (8), lockwasher (7), screw (6) and nut (5).
 - (3) Tighten clamp (3) to secure fuel overflow line (1) in banjo connector (4).
 - (4) Connect fuel overflow line connection (2) into selector valve fitting.
- e. Install fuel filter outlet (figure 4-21, 1) as follows:
 - (1) Remove covers from openings and position filter outlet line (1) in place.
 - (2) Install washer (9), banjo connector (8), washer (7), and banjo bolt (6) into fuel injector inlet.
 - (3) Install washer (5), banjo connector (4), washer (3), and banjo bolt (2) into fuel filter.
- f. Install fuel filter line (figure 4-20, 15) as follows:
 - (1) Remove covers from openings and position fuel filter line (15) in place.
 - (2) Install washer (23), banjo connector (22), washer (21), and banjo bolt (20) from fuel filter inlet.
 - (1) Install banjo bolt (16), washer (17), banjo connector (18) and washer (19) from fuel pump.
- g. Install fuel feed pump line (7) as follows:
 - (1) Remove covers from openings. Install washer (14), banjo connector (13), washer (12) and banjo bolt (11) to fuel pump.
 - (2) Install adapter (10).
 - (3) Remove covers from openings and install fuel pump line (7).
 - (4) Connect fuel pump line connection (9) to adapter (10) and remove tags.

4.10.16 Fuel Line Hoses and Fittings Maintenance. (continued)

(5) Connect fuel pump line connection (8) to water separator (6) discharge fitting and remove tags.

h. Install fuel supply line (2) as follows:

(1) Remove covers from openings and position fuel supply line (2) in place.

(2) Install fuel supply line connection (5) to water separator (6) inlet fitting. Connect clamps as required.

(3) Connect fuel supply line connection (3) to source selector fitting (1) on fuel tank (4).

i. Set both source selector valves (1) to the TANK position.

4.10.16.4 Servicing.

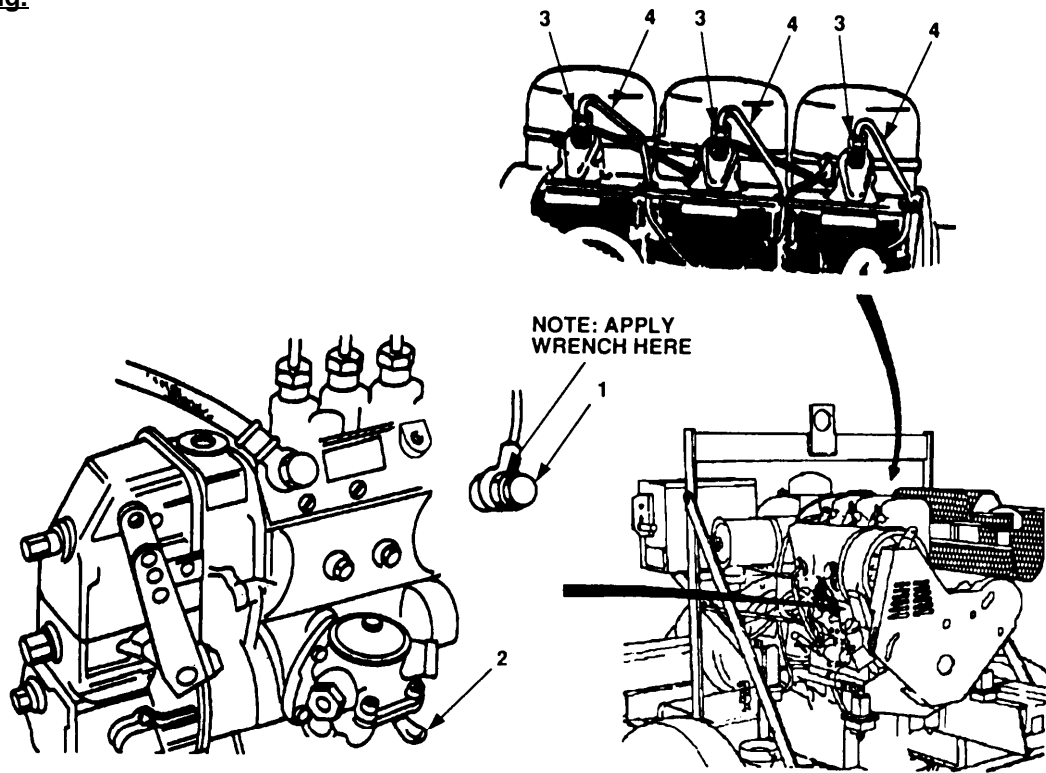

Figure 4-26 Bleeding Fuel Lines.

NOTE

Loosen overflow valve by the larger hexagon fitting (19mm) next to banjo fitting.

a. Bleed Fuel System (figure 4-26) as follows:

(1) Loosen overflow valve (1) by two or three turns.

(2) If fuel feed pump lever (2) does not have resistance while pressing down on fuel feed pump lever, rotate engine 180°.

(3) Operate fuel feed pump lever (2) by pressing down until fuel, free of air bubbles, emerges at the loosened overflow valve (1).

4.10.16 Fuel Line Hoses and Fittings Maintenance. (continued)

- (4) Tighten overflow valve (1).
 - (5) Start engine and check for leaks.
- b. Bleed Injection Lines as follows:
- (1) Loosen fuel injection line fittings (3) approximately two turns at injection nozzle end of each high pressure fuel line (4).
 - (2) Set throttle to wide open position.

CAUTION

Crank engine no longer than ten-seconds cycles, with one and one-half minute between first two cycles. After this wait five minutes between cycles.

- (3) Crank engine until fuel leakage at injection line fittings (3) are free of air bubbles.
- (4) Tighten all injection line fittings (3).
- (5) Start engine and check for leaks.

4.10.17.1 Removal.

- To prevent rolling or sliding, do not work on equipment that is not securely stabilized. Ensure both wheels are secure.
 - Do not smoke or use open flames around fuel. Ensure container is used to catch fuel and fuel is disposed of properly.
 - Failure to obey these warnings may result in personal injury or death.
- a. Remove banjo bolt (figure 4-26, 1), washer (2), hose (3) and washer (4). Place hose (3) out of the way.
 - b. Remove banjo bolt (5) and washers (6), and place hose (7) out of the way.
 - c. Remove three nuts (8) and lockwashers (9); then carefully remove fuel feed pump (10) and preformed packing (11).

4.10.17.2 Servicing.

- a. Remove bolt (12), washer (13), cover (14), and gasket (15).
- b. Remove strainer (16) from fuel feed pump (10).
- c. Using clean fuel, thoroughly clean strainer (16).
- d. Install strainer (16) in fuel feed pump (10).
- e. Install gasket (15) and cover (14).
- f. Install washer (13) and bolt (12).

4.10.17.3 Installation.

- a. Position new preformed packing (11) and fuel feed pump (10) to injection pump.
- b. Install three washers (9) and nuts (8).
- c. Position hose (7) to fuel feed pump and install washers (6) and banjo bolt (5).
- d. Position hose (3) to fuel feed pump and install washers (4 and 2) and secure with banjo bolt (1).
- e. Refer to paragraph 4.10.16.4 and bleed fuel system.



Do not operate equipment in enclosed area unless exhaust gases are piped to outside and adequate ventilation is provided. Avoid inhalation of exhaust fumes. Failure to obey this warning may result in personal injury or death.

- f. Start engine and check for leaks.

This task covers: Servicing

INITIAL SETUP

Tools

General Mechanic's Tool Kit (appendix B, Section III, Item 1)

Equipment Conditions

Equipment shut down, refer to paragraph 2.5.1.2 or 2.5.2.2.

General Safety Instructions

To prevent rolling or sliding, do not work on equipment that is not securely stabilized.

General Safety Instructions (continued)

Do not smoke or use open flames around fuel.

Do not operate equipment in enclosed area unless exhaust gases are piped to outside and adequate ventilation is provided.

Do not work on equipment without following standard shop safety precautions.

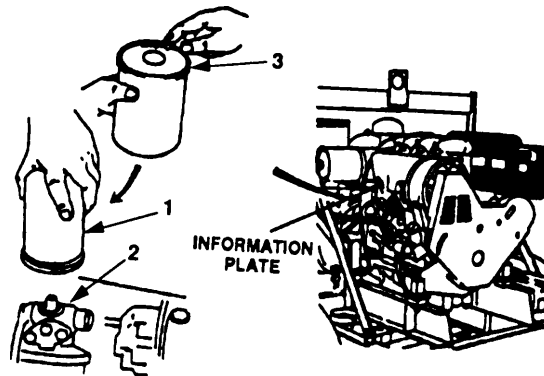

Figure 4-28. Fuel Filter Maintenance.

WARNING

- To prevent rolling or sliding, do not work on equipment that is not securely stabilized. Ensure both wheels are secure.
 - Do not smoke or use open flames around fuel. Ensure container is used to catch fuel and fuel is disposed of properly.
 - Do not operate equipment in enclosed area unless exhaust gases are piped to outside and adequate ventilation is provided. Avoid inhalation of exhaust fumes.
 - Failure to obey these warnings may result in personal injury or death.
- a. Unscrew expendable filter (figure 4-28, 1) and discard.
 - b. Clean seat (2).
 - c. Lightly oil rubber seal (3), then screw in new filter (1) until seated.
 - d. Turn filter (1) a final half turn.
 - e. Refer to paragraph 4.10.16.4 and bleed fuel system.
 - f. Refer to paragraph 2.5 and start engine and check fuel filter for leaks.

4.10.19 Low Oil Pressure Switch and Sending Unit Maintenance.

This task covers: 4.10.19.1 Removal

4.10.19.2 Installation

INITIAL SETUPTools

General Mechanic's Tool Kit (appendix B, Section III, Item 1)

Material/PartsTags (appendix E, Section II, Item 12)
Antiseizing tape (appendix E, Section II, Item 13)Equipment Conditions

Equipment shut down, refer to paragraph 2.5.1.2 or 2.5.2.2.

General Safety Instructions

To prevent rolling or sliding, do not work on equipment that is not securely stabilized.

Do not work on equipment without following standard shop safety precautions.

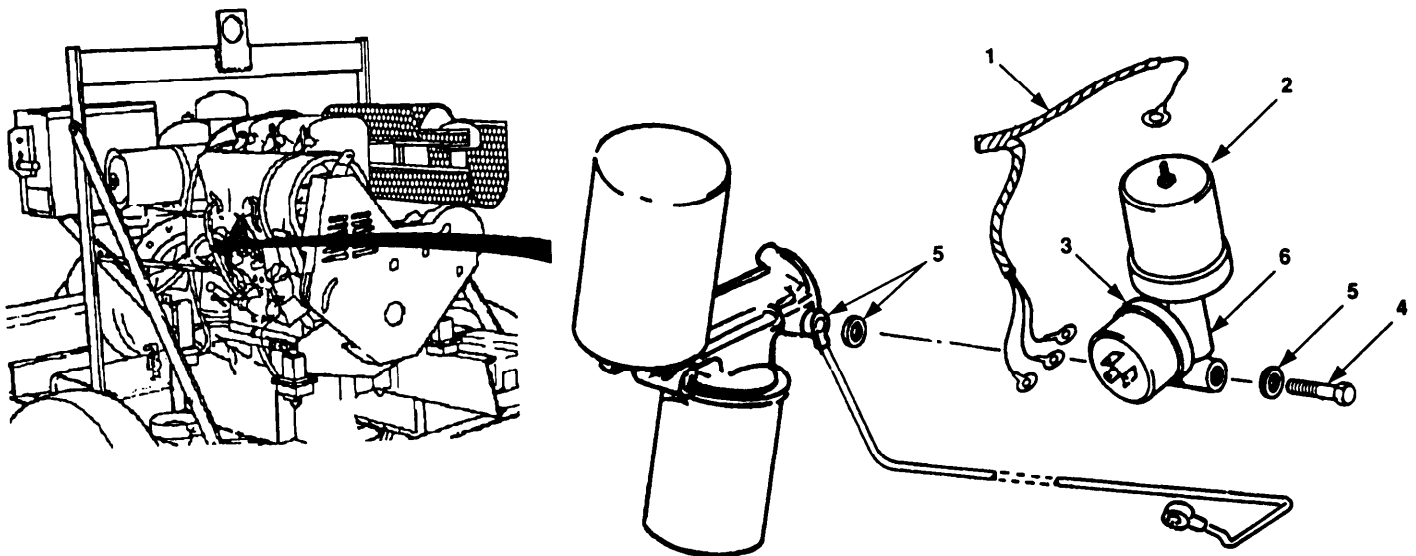

Figure 4-29. Low Pressure Switch and Oil Pressure Sending Unit Maintenance.

4.10.19.1 Removal.**WARNING**

To prevent rolling or sliding, do not work on equipment that is not securely stabilized. Ensure both wheels are secure. Failure to obey this warning may result in serious personal injury.

- a. Tag and disconnect wires (figure 4-29, 1) from low oil pressure switch (2) and oil pressure sending unit (3).
- b. Remove banjo bolt (4) and washers (5).
- c. Remove low oil pressure switch (2) and oil pressure sending unit (3) assembly.

- d. Remove low oil pressure switch (2) from tee (6).
- e. Remove low oil pressure sending unit (3) from tee (6).

4.10.19.2 Installation.

- a. Wrap all male fittings with antisieze tape before installing.
- b. Install low oil pressure sending unit (3) to tee (6).
- c. Install low oil pressure switch (2) to tee (6).
- d. Using washers (5) and banjo bolt (4), install oil pressure assembly.
- e. Connect wires (1) to low oil pressure switch (2) and oil pressure sending unit (3). Remove tags.

4.10.20 Oil Line Maintenance.

This task covers: 4.10.20.1 Removal

4.10.20.2 Installation

INITIAL SETUPTools

General Mechanic's Tool Kit (appendix B, Section III, Item 1)

Equipment Conditions (continued)

Fuel feed pump removed (paragraph 4.10.10.17).

Low oil pressure switch and sending unit, removed (paragraph 4.10.19) .

General Safety Instructions

To prevent rolling or sliding, do not work on equipment that is not securely stabilized.

Do not work on equipment without following standard shop safety precautions.

Equipment Conditions

Equipment shut down, refer to paragraph 2.5.1.2 or 2.5.2.2.

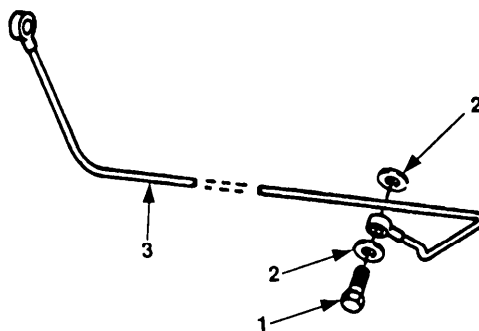

Figure 4-30. Oil Line Maintenance.

4.10.20.1 Removal.

To prevent rolling or sliding, do not work on equipment that is not securely stabilized. Ensure both wheels are secure. Failure to obey this warning may result in serious personal injury.

- a. Remove banjo bolt (1) and washers (2).
- b. Remove oil line (3).

4.10.20.2 Installation.

- a. Position oil line (3) between oil and fuel filter housing and injection pump.
- b. Install washers (2) and banjo bolt (1).

4.10.21 Cooling Fan Maintenance.

This task covers: 4.10.21.1 Removal 4.10.21.2 Installation

INITIAL SETUP

Tools

General Mechanic's Tool Kit (appendix B, Section III, Item 1)

Equipment Conditions

Equipment shut down, refer to paragraph 2.5.1.2 or 2.5.2.2.

Cooling fan belt removed (paragraph 4.10.8).

General Instructions

Do not work on equipment without following standard shop safety precautions.

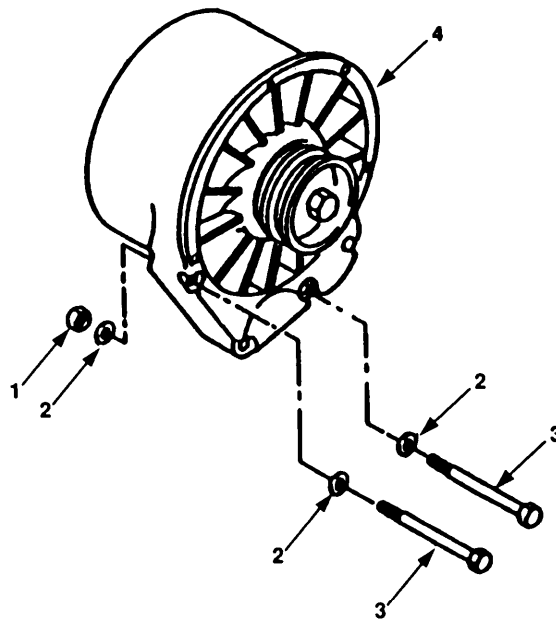

Figure 4-31. Cooling Fan Maintenance.

4.10.21.1 Removal.

- a. Remove one nut (figure 4-31, 1), five washers (2), and four bolts (3).
- b. Remove cooling fan (4).

4.10.21.2 Installation.

- a. Position cooling fan assembly (4) on engine.
- b. Install four bolts (3), five washers (2) and one nut (1).

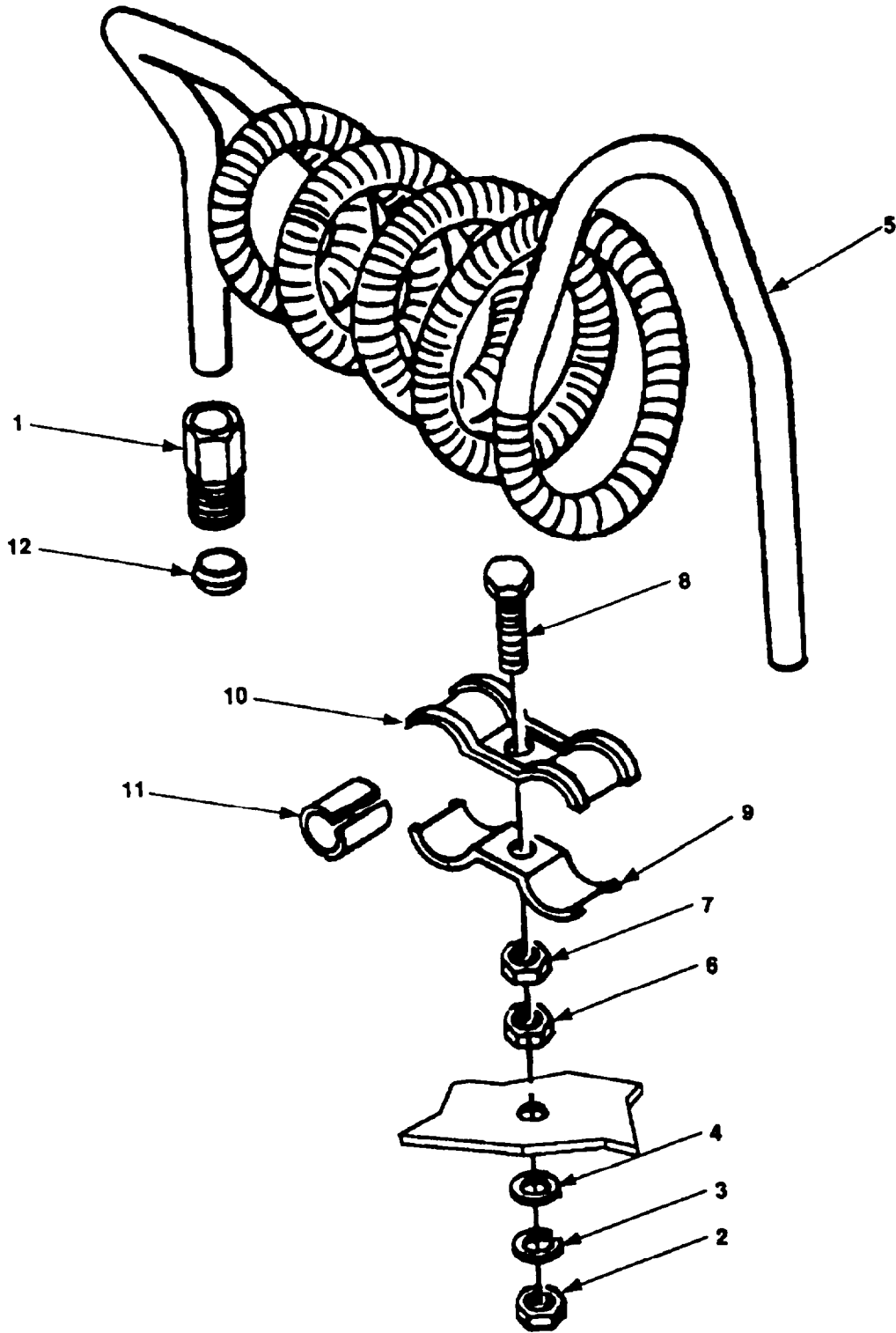

Figure 4-32. Cooling Coil Maintenance (Models 350 PAW and W-87012).

4.10.22.1. Cooling Coil Maintenance. (Used on Model PAWN 350 only)

This task covers: 4.10.22.1 Removal

4.10.22.2 Installation

INITIAL SETUPTools

General Mechanic' s Tool Kit (Appendix B, Section III, item 1)

Equipment Conditions

Equipment shut down, paragraph 2.5.2.
Fuel injector and return lines removed, paragraph 4.10.16.

General Safety Instructions

To prevent rolling or sliding, do not work on equipment that is not securely stabilized.

Do not work on equipment without following standard shop safety precautions.

4.10.22.1.1. Removal.

- a. Remove bolts (figure 4-32.1, 1) and flatwashers(2 and 3).
- b. Loosen union nuts (4) and slid up tubing.
- c. Remove oil cooler (6) with union nuts (4), duplex rings (5) and seal ring(7) from engine.

4.10.22.1.2. installation.

- a. Install union nuts (4) and duplex rings (5) tubing on oil cooler (6).
- b. Position cushion (7) and install oil cooler (6) on engine. and line up fittings.
- c. Align tubing with fittings and tighten union nuts(4).
- d. Install bolts(l) and flat washers (2 and 3).

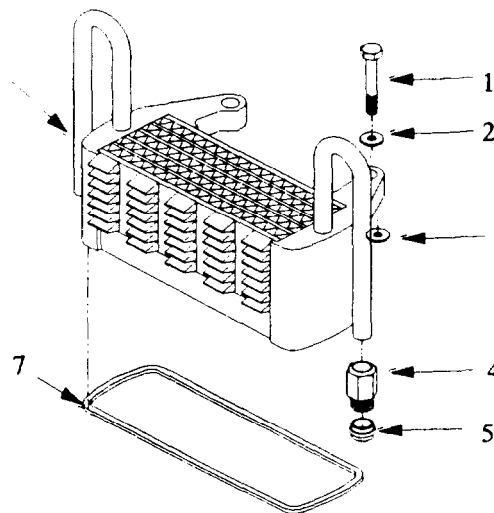

Figure 4-32.1. Cooling Coil Maintenance (Model 350 PAWN).

4.10.23 Valve Clearance Adjustment.

 This task covers: Valve Clearance Adjustment

INITIAL SETUPTools

General Mechanic's Tool Kit (appendix B, Section III, Item 1)

Material/Parts

Washers (TM 10-4320-226-24P)
 Gaskets (TM 10-4320-226-24P)
 Sealant Adhesive (appendix E, Section II, Item 2)

Equipment Conditions

Equipment shut down, refer to paragraph 2.5.1.2 or 2.5.2.2.

V-belt guard removed, paragraph 4.10.6.

General Safety Instructions

To prevent rolling or sliding, do not work on equipment that is not securely stabilized.

Do not work on equipment without following standard shop safety precautions.

WARNING

To prevent rolling or sliding, do not work on equipment that is not securely stabilized. Ensure both wheels are secure. Failure to obey this warning may result in serious personal injury.

- a. Remove bolts (figure 4-33, 1), washers (2), covers (3), and gaskets (4).
- b. Turn crankshaft (5) in direction of rotation until valves of number 1 cylinder (6) overlap (pushrods move freely).
- c. Adjust cylinder number 2 intake valve (7) and cylinder number 3 exhaust valve (8) as follows:
 - (1) Loosen slotted adjusting screw locknut (9).
 - (2) Adjust rocker arm/valve stem clearance to 0.006 in (015mm) by turning slotted adjusting screw.
 - (3) While holding slotted adjusting screw, tighten locknut (9).
 - (4) Recheck clearance and readjust if necessary.
- d. Rotate crankshaft one complete revolution (360°).
- e. Adjust remaining valves as in step c.
- f. Apply adhesive sealant to new gaskets (4) and place into position on cover (3).
- g. Install covers (3), washers (2), and bolts (1).

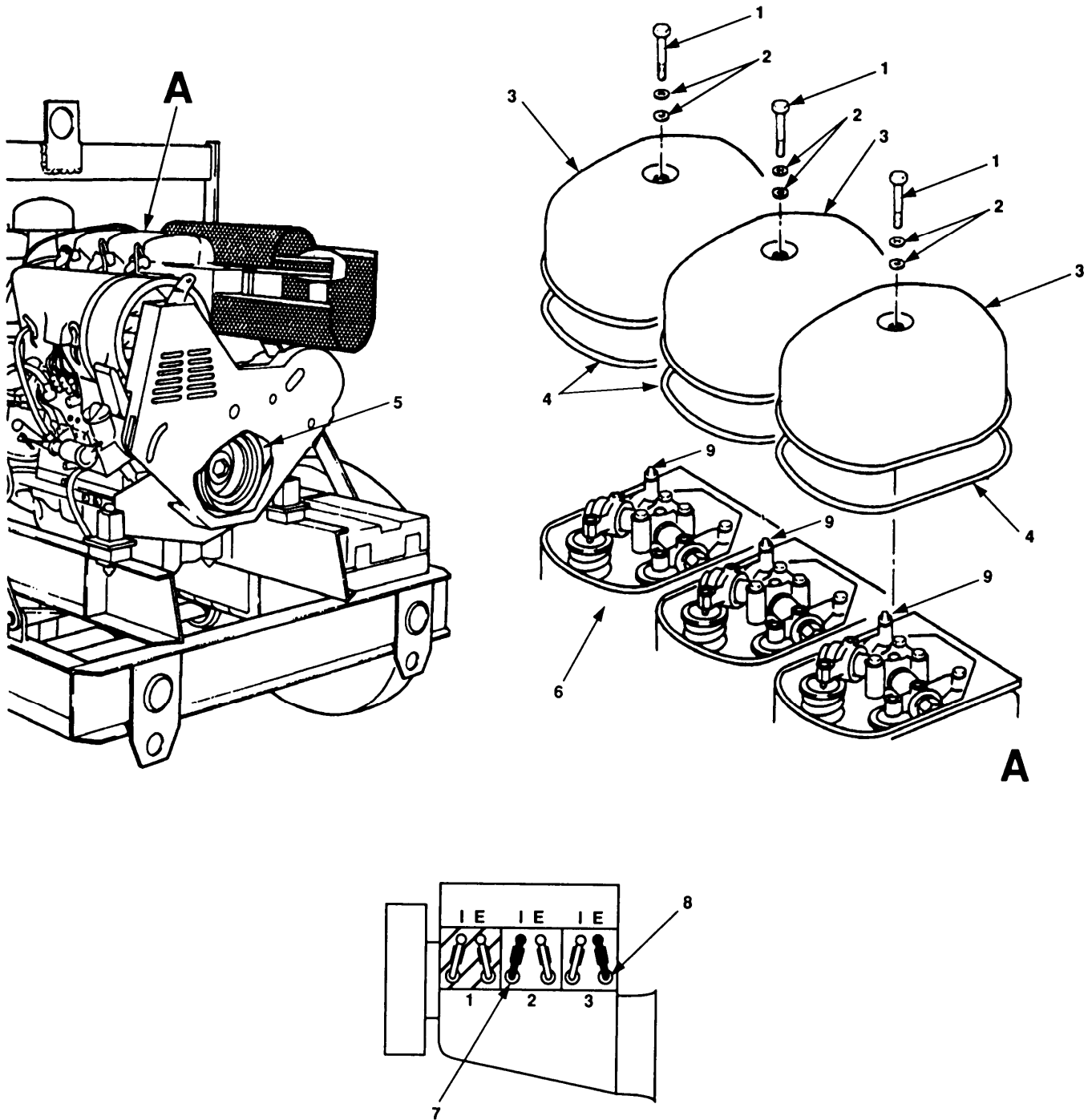

Figure 4-33. Engine Valve Clearance Adjustment.

4.10.24 Idler Pulley Assembly Maintenance.

This task covers: 4.10.24.1 Removal

4.10.24.2 Installation

INITIAL SETUP

Tools

General Mechanic's Tool Kit (appendix B, Section III, Item 1)

General Safety Instructions

To prevent rolling or sliding, do not work on equipment that is not securely stabilized.

Material/Parts

Lockwashers (TM 10-4320-226-24P)
 Tags (appendix E, Section II, Item 12)
 Preformed Packing (TM 10-4320-226-24P)

Do not work on equipment without following standard shop safety precautions.

Equipment Conditions

Equipment shut down, refer to paragraph 2.5.1.2 or 2.5.2.2.

Cooling fan belt removed, paragraph 4.10.8.

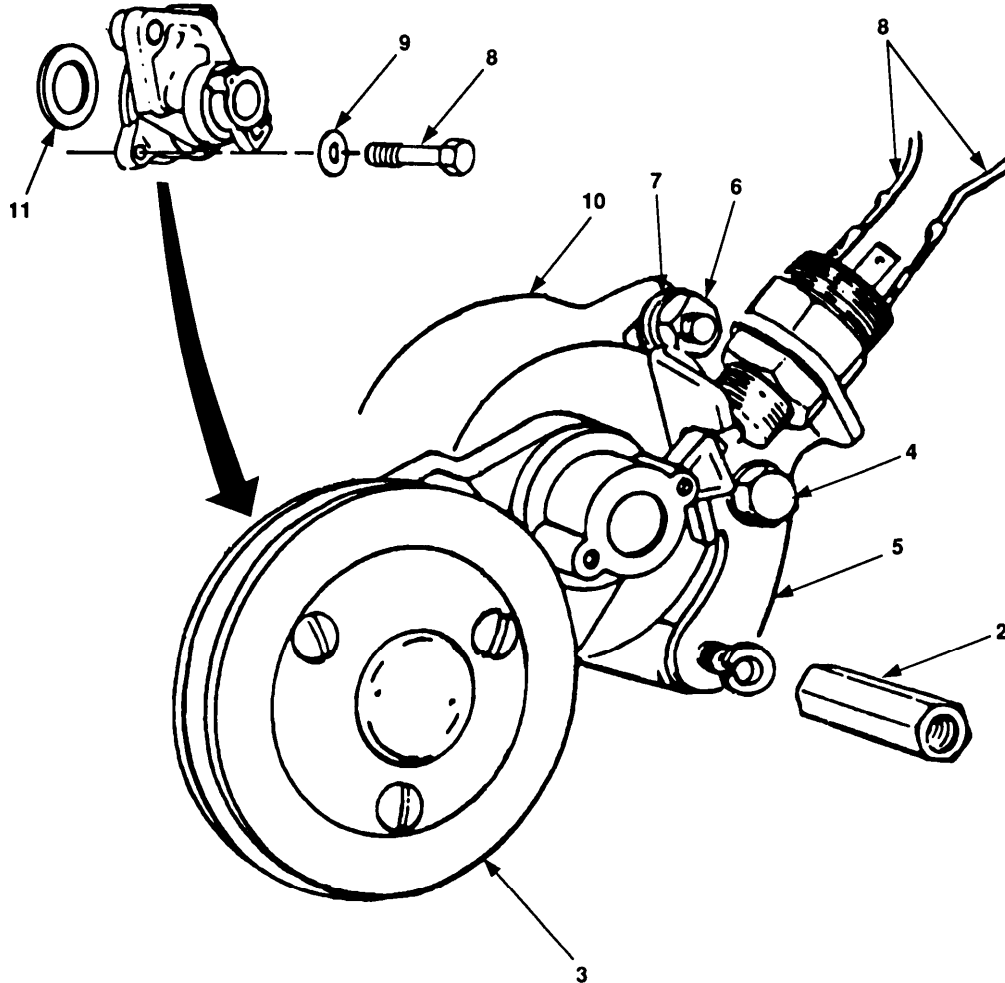

Figure 4-34. Idler Pulley Assembly Maintenance.

4.10.24.1 Removal.



To prevent rolling or sliding, do not work on equipment that is not securely stabilized. Ensure both wheels are secure. Failure to obey this warning may result in serious personal injury.

- a. Tag and disconnect V-belt contact switch wires (figure 4-34, 1).
- b. Remove spacer (2).
- c. Hold pulley (3) and remove bolt (4) and contact switch bracket (5).
- d. Remove nut (6), washer (7), bolt (8), washer (9) and idler pulley assembly (10).
- e. Remove and discard preformed packing (11).

4.10.24.2 Installation.

- a. Install new preformed packing (11).
- b. Position idler pulley assembly (10) in place on engine and install washer (9), bolt (8), washer (7), and nut (6).
- c. Raise pulley (3) and install contact switch bracket (5) with bolt (4).
- d. Install spacer (2).
- e. Connect V-belt contact switch wires (1).

4.11 Throttle Control Assembly Maintenance.

This task covers:	4.11.1	Removal	4.11.3	Assembly
	4.11.2	Disassembly	4.11.5	Installation
	4.11.3	Repair		

Tools

General Mechanic's Tool Kit (appendix Section III, Item 1)

Material/Parts

Cotter pin (TM 10-4320-226-24P)

Equipment Conditions

B, Engine shutdown, refer-to paragraph 2.5.1.2 or 2.5.2.2.

General Safety Instructions

To prevent rolling or sliding, do not work on equipment that is not securely stabilized.

Do not work on equipment without following standard shop safety precautions.

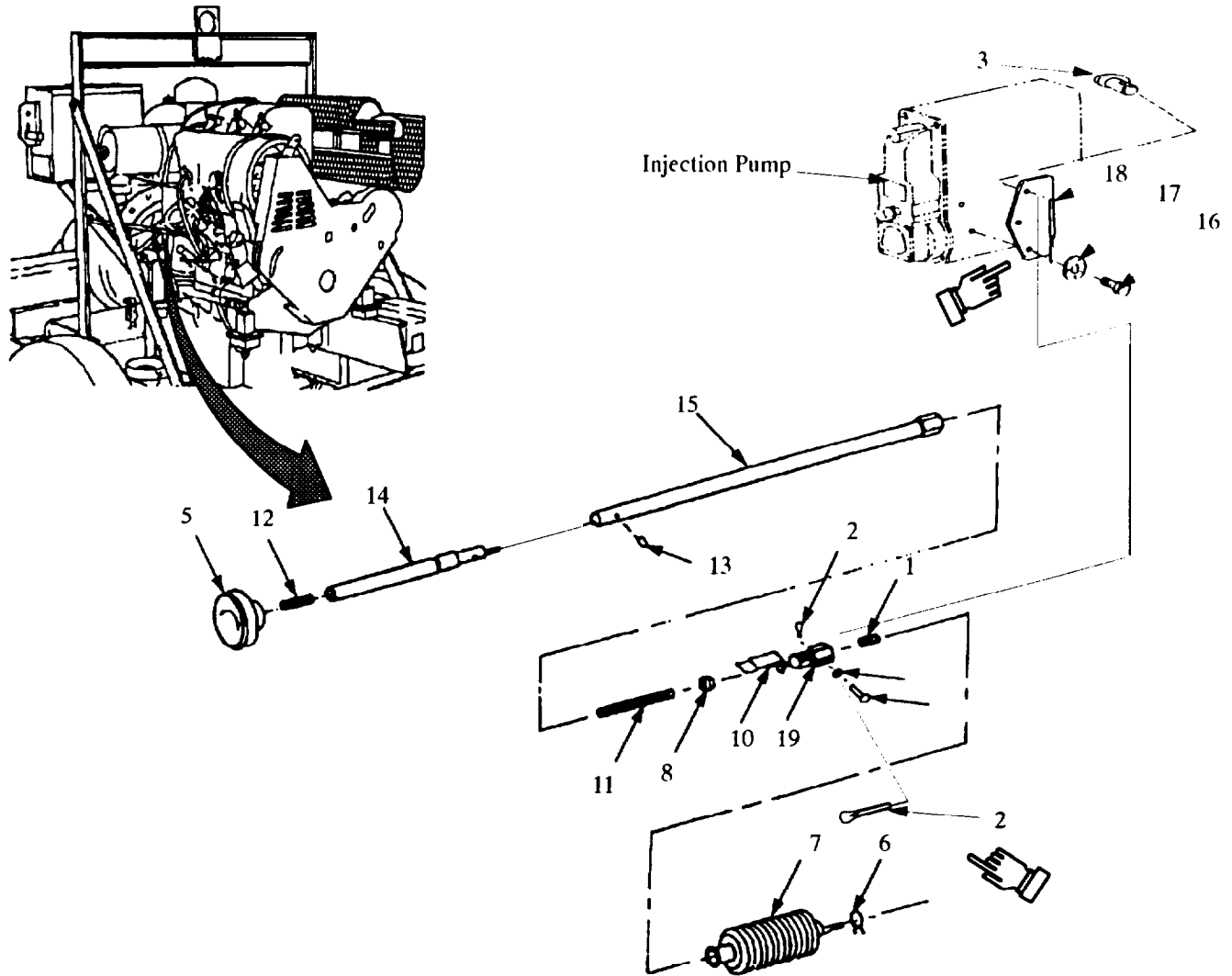

Figure 4-35. Throttle Control Assembly Maintenance(All Models).

4.11.1 **Removal.** Refer to Figure 4-35 and proceed as follows:

WARNING

To prevent rolling or sliding, do not work on equipment that is not securely stabilizes. Ensure both wheels are chocked. Failure to obey this warning could result in serious injury.

- a. Remove set screw (1), cotter pin (2), pin (3), and spacer (4). Cotter pin (2) and pin (3) installed through throttle extension (18) on Model 350 PAWN.
- b. Remove knob (5) and throttle control assembly.

4.11.2 **Disassembly.** Refer to Figure 4-35 and proceed as follows:

- a. Squeeze ends of clamp (6) and remove bellows (7).
- b. Loosen lock nut (8) and remove coupling nut (9), retaining spring (10), lock nut (8), and clamp (6).
- c. Remove threaded rod (11), threaded rod (12), set screw (13), rod (14), and extension rod (15).
- d. Remove bolts(16), lockwashers(17) and throttler extension(18) from injection pump(Model 350 PAWN only).

4.11.3 **Repair.** Refer to Figure 4-35 and proceed as follows:

NOTE

Units without bellows may have a longer extension rod and shorter coupling nut than those units with bellows. If replacement of either of these parts is required, they must be replaced as a set in order to obtain the required length.

Replace any damaged or missing parts.

4.11.4 **Assembly.** Refer to Figure 4-35 and proceed as follows:

- a. Position rod (14) on extension rod (15) and secure with set screw (13).
- b. Install threaded rod (12) on knob (5).
- c. Install threaded rod (11) on hex end of extension rod approximately one third of the way.

NOTE

Ensure locking nut is secure against coupling nut. The adjusts throttle control assembly to proper length.

- d. Install lock nut (8), retaining spring (10), clamp (6), coupling nut (9), and bellows (7).
- e. Squeeze end of clamp (6) and install on bellows (7).

4.11.5 **Installation.** Refer to Figure 4-35 and proceed as follows:

- a. Feed throttle control assembly through throttle bracket and install knob (5).
- b. Install spacer (4) and pin (3) through coupling nut and control arm and install cotter pin (2) through pin (3). Cotter pin (2) and pin (3) are installed through throttle extension (18) on Model 350 PAWN.
- c. Install set screw (1).

4.12 ELECTRICAL SYSTEM MAINTENANCE.

4.12.1 Battery Test.

INITIAL SETUP

Test Equipment

Multimeter (appendix B, Section III, Item 2).

Equipment Conditions

Equipment shut down, refer to paragraph 2.5.1.2 or 2.5.2.2.

Tools

General Mechanic's Tool Kit (appendix B, Section III, Item 1)

Battery cover removed, paragraph 3.4.

General Safety Instructions

do not work on battery with negative terminal connected.

Do not work on equipment without following standard shop safety precautions.



- Do not work on battery with negative terminal connected.
 - To prevent rolling or sliding, do not work on equipment that is not securely stabilized. Ensure both wheels of equipment have chocks that are secure.
 - Failure to obey these warnings may result in serious personal injury.
- a. Loosen nuts (figure 4-36, 1) and remove negative connectors (2) from batteries.
 - b. Loosen nuts (3) and remove positive connectors (4) from batteries.
 - c. Using battery tester, test state of charge. Recharge battery as required. If battery cannot be recharged, replace battery, paragraph 4.12.2.
 - d. Set multimeter to read continuity, and perform following:
 - (1) Remove nut (5) and terminal (6) from positive solenoid terminal (7).
 - (2) Check continuity from positive connector (4) to terminal (6).
 - (3) Check continuity from negative terminal connector (2) to starter ground terminal (8).
 - (4) If either cable does not read continuity, replace cable (paragraph 4.12.3).
 - (5) Install nut (5) to positive solenoid terminal (7).
 - e. Install positive connectors (4) on positive terminals (9).
 - f. Install negative connectors (2) on negative terminals (10).

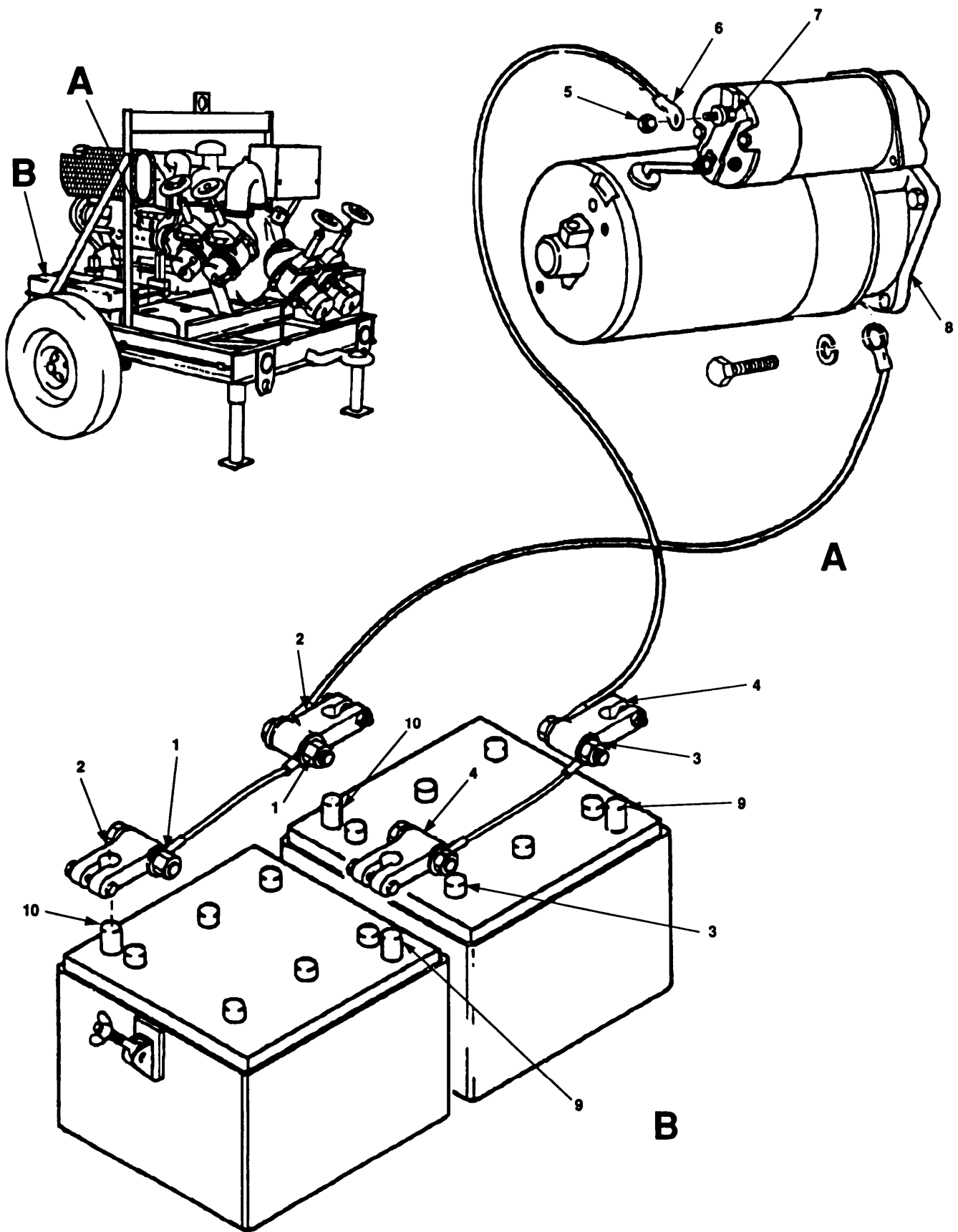

Figure 4-36. Battery Test.

4.12.2.1 Removal.

WARNING

To prevent rolling or sliding, do not work on equipment that is not securely stabilized. Ensure both wheels are secure.

Do not work on battery with negative terminal connected.

Failure to obey these warnings may result in serious personal injury.

- a. Loosen nuts (figure 4-37, 1 and 2) and remove negative battery terminals (3 and 4) from posts (5 and 6).
- b. Loosen nuts (7 and 8) and remove positive battery terminals (9 and 10) from posts (11 and 12).
- c. Remove batteries (13 and 14).

4.12.2.2 Servicing.

Clean terminals (3, 4, 9 and 10) and posts (5, 6, 11, and 12) with standard battery cable and post cleaning brush.

4.12.2.3 Installation.

- a. Install batteries (13 and 14).
- b. Install positive battery terminals (10 and 9) and tighten nuts (8 and 7).
- c. Install negative battery terminals (4 and 3) and tighten nuts (2 and 1).
- d. Coat battery terminals (10, 9, 4, and 3) with a light coat of grease.

4.12.3 Battery Cable Maintenance.

This task covers:	4.12.3.1 Removal	4.12.3.3 Installation
	4.12.3.2 Repair	

INITIAL SETUP**Tools**

General Mechanic's Tool Kit (appendix B, Section III, Item 1)

General Safety Instructions

To prevent rolling or sliding, do not work on equipment that is not securely stabilized.

Material/Parts

Grease (appendix E, Section II, Item 5)

Do not set tools on battery or battery case.

Equipment Conditions

Equipment shut down, refer to paragraph 2.5.1.2 or 2.5.2.2.

do not work on battery with negative terminal connected.

Battery cover removed, paragraph 3.4.

Do not work on equipment without following standard shop safety precautions.

4.12.3.1 Removal.**WARNING**

- To prevent rolling or sliding, do not work on equipment that is not securely stabilized. Ensure both wheels are secure.
 - Do not work on battery with negative terminal connected.
 - Failure to obey these warnings may result in serious personal injury.
- a. Remove two nuts (figure 4-38, 1) washers (2), one wire (3), two bolts (4) and one wire (5) from two terminals (6).
 - b. Remove two nuts (7), washers (8), one wire (9), two bolts (10), and one wire (11) from two terminals (12).
 - c. Remove bolt (13), lockwasher (14), and terminal lug (15) from starter.
 - d. Remove nut (16) and terminal lug (17) from starter solenoid.

4.12.3.2 Repair.

Replace damaged or missing parts.

4.12.3.3 Installation.

- a. Install terminal lug (17) and nut (16) to starter solenoid.
- b. Install terminal lug (15), lockwasher (14), and bolt (13).
- c. Install one wire (11), two bolts (10), one wire (9), washer (8), and nuts (7) to two terminals (12).
- d. Install one wire (5), two bolts (4), one wire (3), two washers (2), and nuts (1) to two terminals (6).

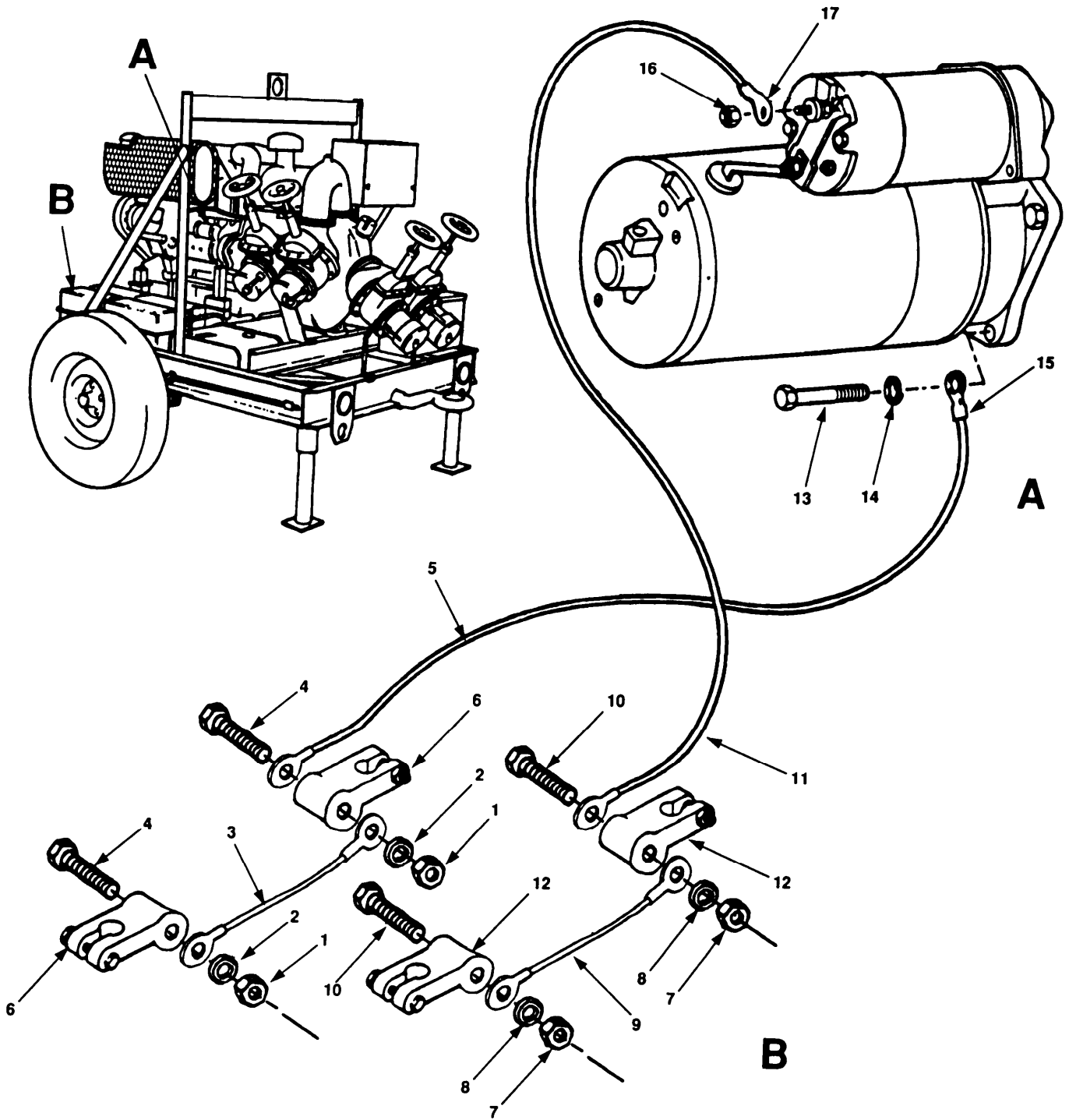

Figure 4-38. Battery Cable Maintenance.

4.12.4.1. System Wiring Testing. (Used on Model 350 PAWN)

INITIAL SETUPTools

General Mechanic' s Tool Kit (Appendix B, Section III, Item 1)

General Safety Instructions

To prevent rolling or sliding, do not work on equipment that is not securely stabilized.

Material/Parts

Tags (Appendix E, Section II, Item 12)

Do not work on equipment without following standard shop safety precautions.

Equipment Conditions

Equipment shut down, paragraph 2.5.2.

WARNING

Do not work on wiring harness with negative battery terminal connected.

To prevent rolling or sliding, do not work on equipment that is not securely stabilized. Ensure both wheels are secure.

Failure to obey these warnings may result in serious personnel injury.

- a. Remove screws (figure 4-39 sheet 1, 1), lockwashers (2) and flatwashers(3) that secure control panel cover (4) to control panel.
- b. Remove control panel cover (4).
- c. Tag and disconnect wires from terminal (5) as necessary.
- d. Using multimeter, check continuity of wires using figure 4-39 sheet 2 as a guide.
- e. If any wire does not show continuity, refer to paragraph 4.12.5 and replace wiring harness or individual defective wire.
- f. Position cover (sheet 1,4) on control panel panel.
- g. Secure cover (4) to control panel with flatwashers (3), lockwashers (2) and screws (1).

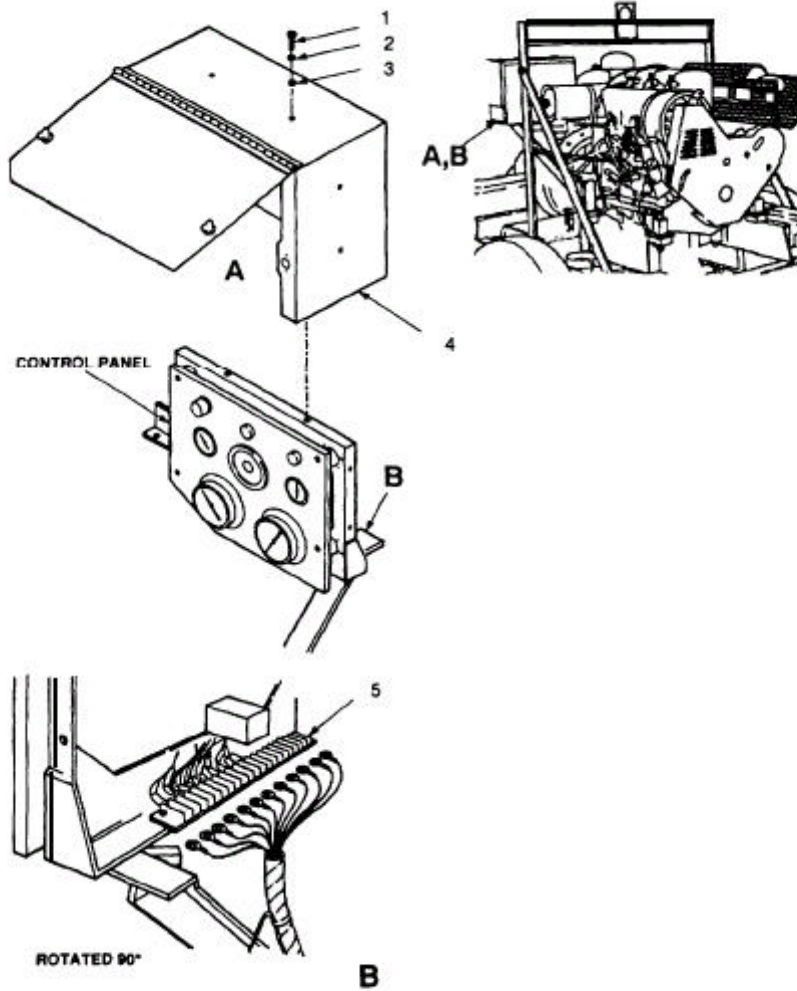

■ Figure 4-39. Wiring Harness Testing (Sheet 1 of 2) (Model 350 PAWN).

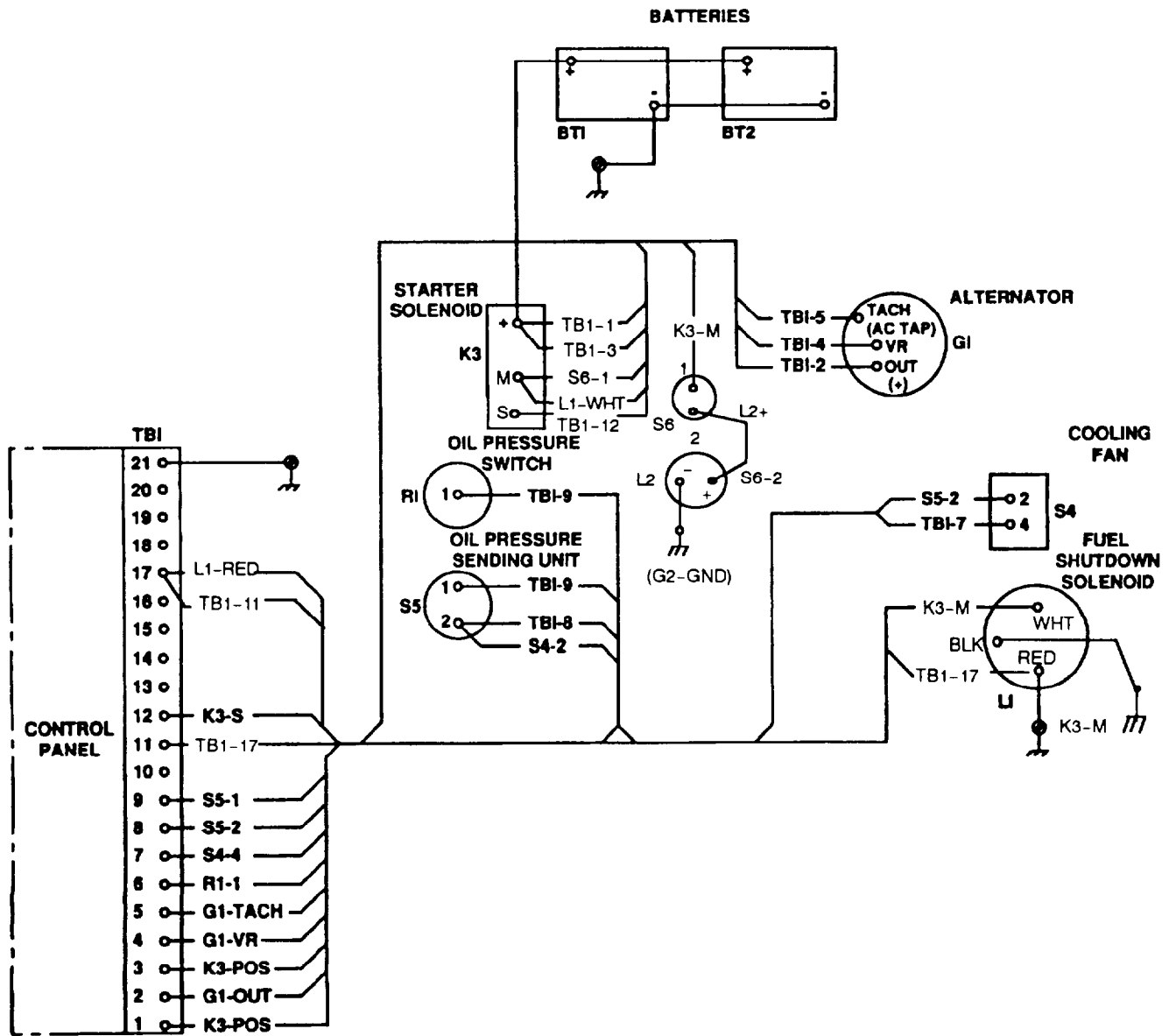

Figure 4-39. Wiring Harness Testing (Sheet 2 of 2) (Model 350 PAWN).

4.12.4. Wiring Harness Testing. (Not used on Model 350 PAWN)

INITIAL SETUPTest Equipment

Multimeter (Appendix B, Section III, Item 2)

Tools

General Mechanic' s Tool Kit (Appendix B, Section III, Item 1)

Equipment Conditions

Equipment shut down, refer to paragraph 2.5.1.2 or 2.5.2.2

Battery cover removed, paragraph 3.4.

Battery disconnected, paragraph 4.12.2.

V-belt guard removed, paragraph 4.10.6.

General Safety Instructions

To prevent rolling or sliding, do not work on equipment that is not securely stabilized.

Do not work on equipment without following standard shop safety precautions.

WARNING

Do not work on wiring harness with negative battery terminal connected. Failure to obey this warning may result in serious personal injury.

To prevent rolling or sliding, do not work on equipment that is not securely stabilized. Ensure both wheels are secure. Failure to obey this warnings may result in serious personal injury.

- a. Disconnect and tag two lines (figure 4-39.1, sheet 1, view D, 1 and 2) from cold start reservoir.
- b. Remove screws (view C, 3), lockwashers (4), washer (5) and cold weather start kit (6).
- c. Remove remaining four screws (view A, 3), lockwasher (4) and washers (5) that secure control panel cover (7).
- d. Remove control panel (7).
- e. Using multimeter set for continuity, refer to figure 4-39.1, sheet 2 and check continuity of wires.
- f. If any wire does not give continuity, refer to paragraph 4.12.5 and replace wiring harness.
- g. Install control panel cover (sheet 1, view A, 7).
- h. Install cold weather start kit (view C, sheet 1, 6) using washers (5), lockwashers (4) and screws (3).
- i. Install remaining washers (view A, 5), lockwashers (4) and screws (3).
- j. Connect two lines (view D, 1 and 2) to cold start reservoir.

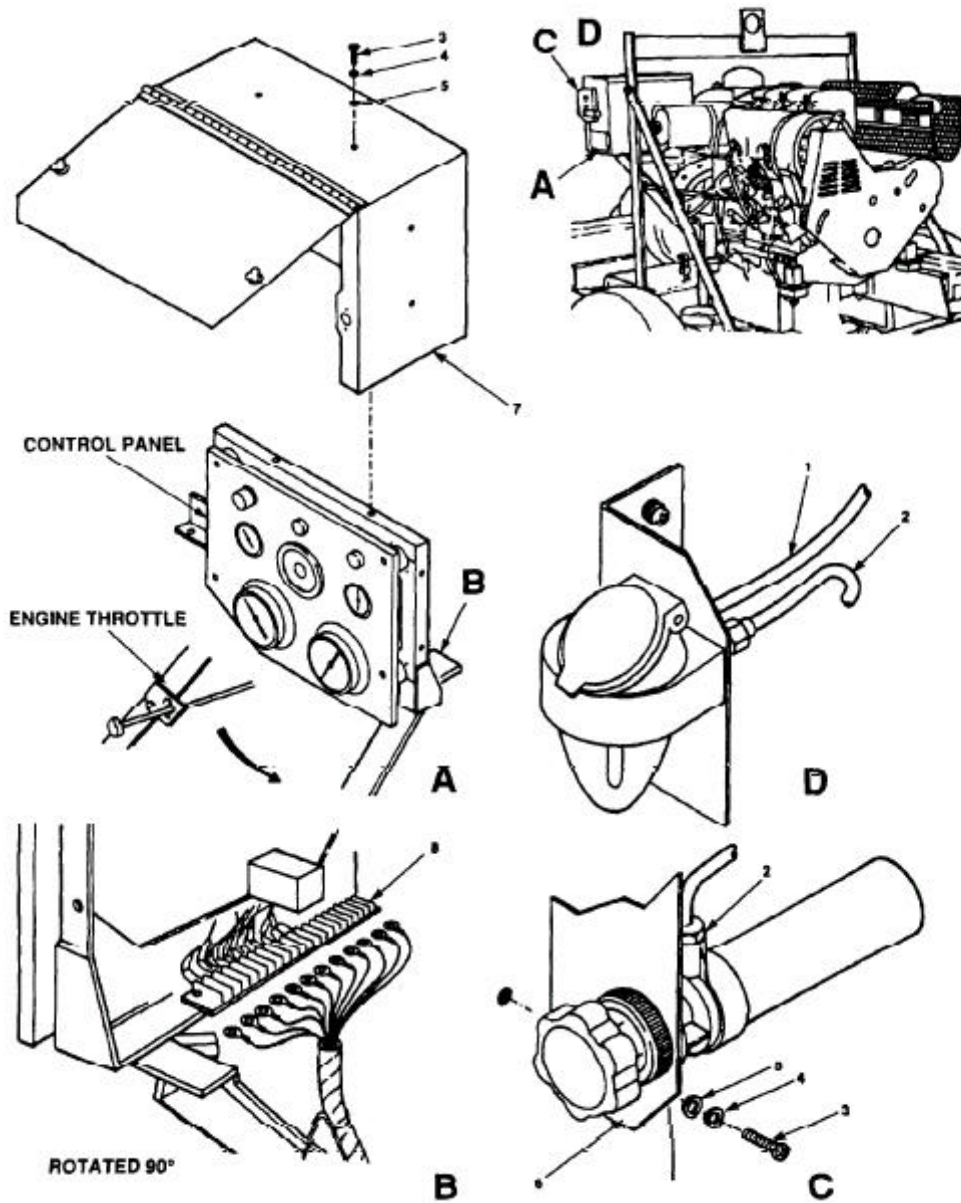

■ Figure 4-39.1. Wiring Harness Testing (Models 350 PAW and W-87012). (sheet 1 of 2)
4-74 Change 2

NOTE: FOR REGULATED PUMP,
REFER TO CONTROL PANEL
WIRING HARNESS AND
REGULATOR WIRING HARNESS

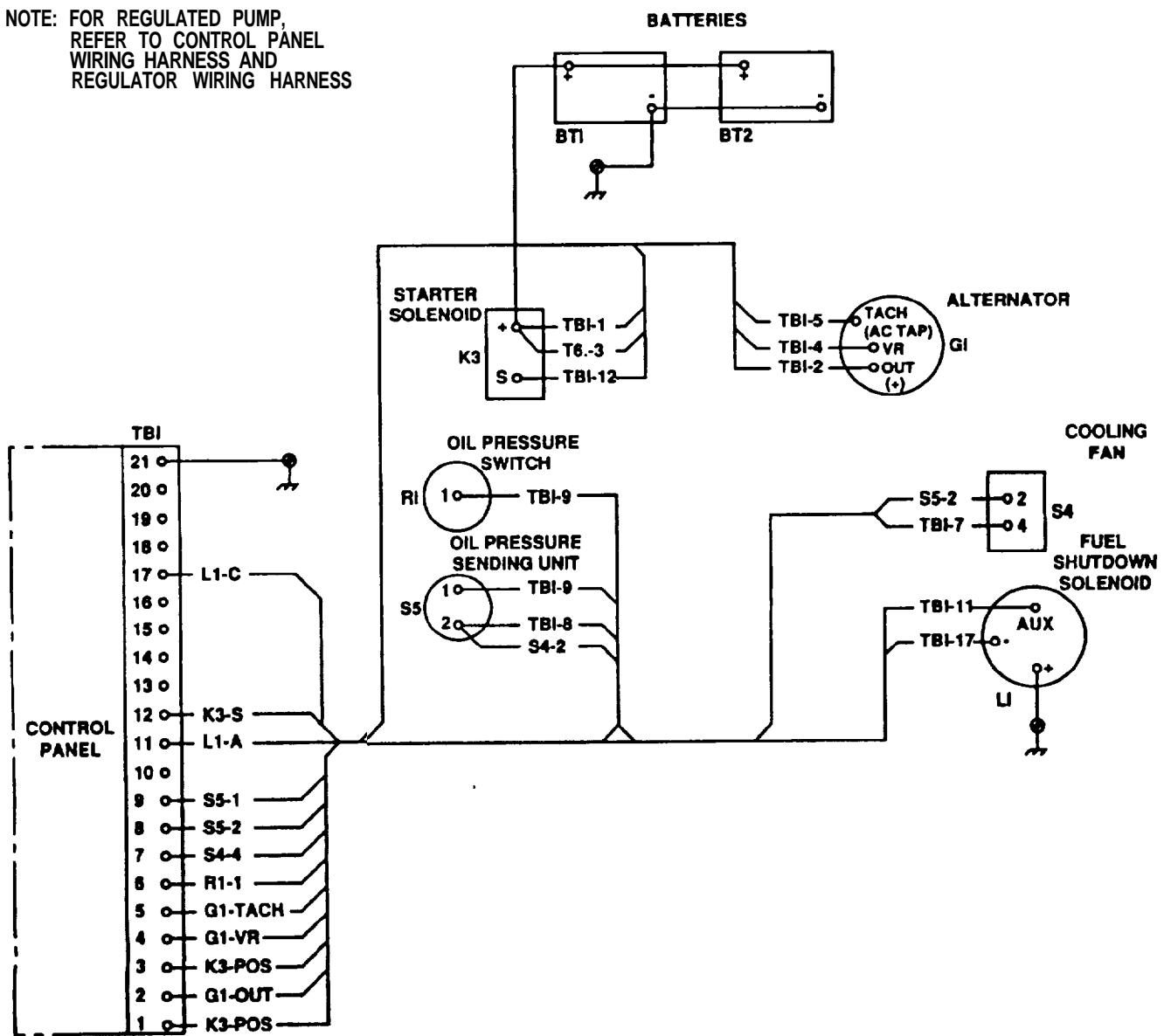
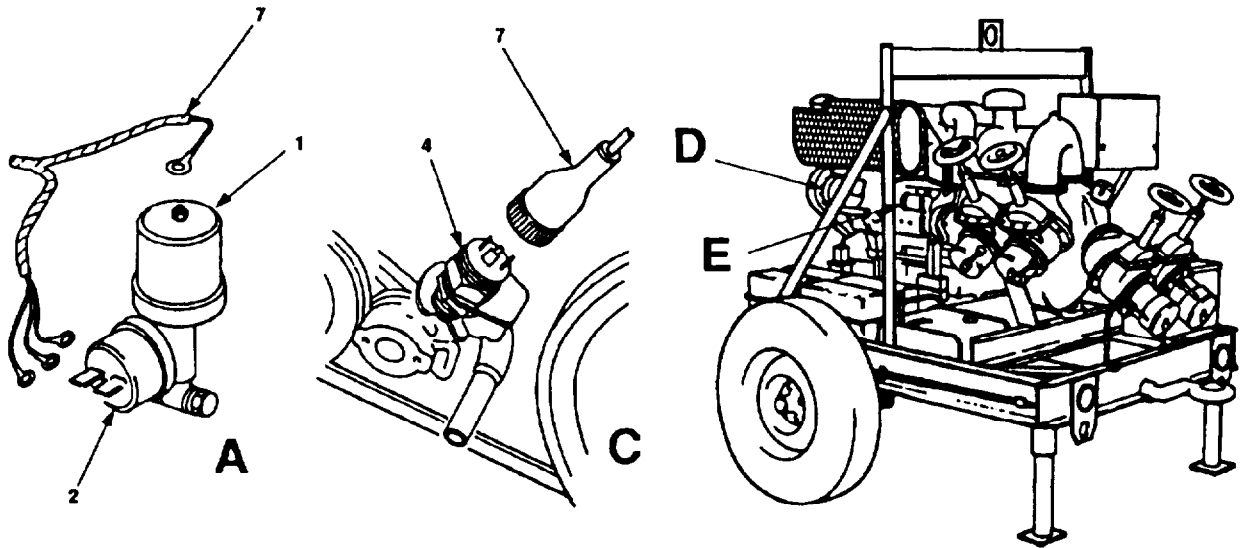
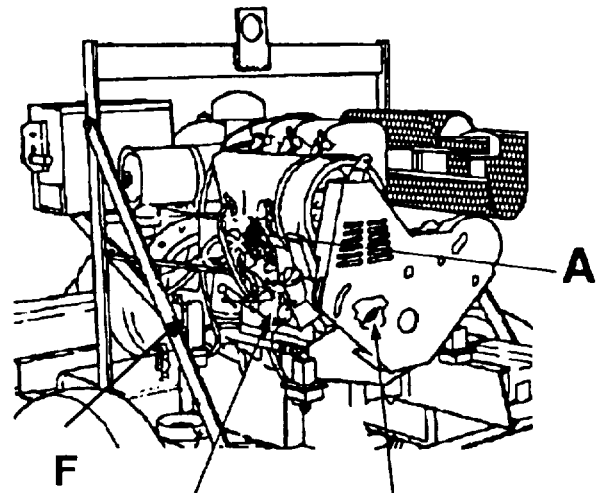
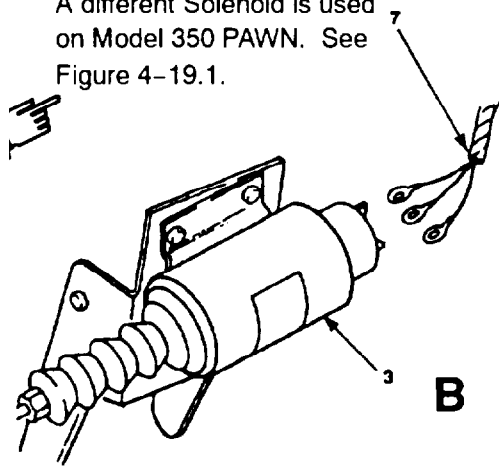

Figure 4-39.1 Wiring Harness Testing (Models 350 PAW and W-87012). (sheet 2)



A different Solenoid is used on Model 350 PAWN. See Figure 4-19.1.



Used on Model 350 PAWN only.

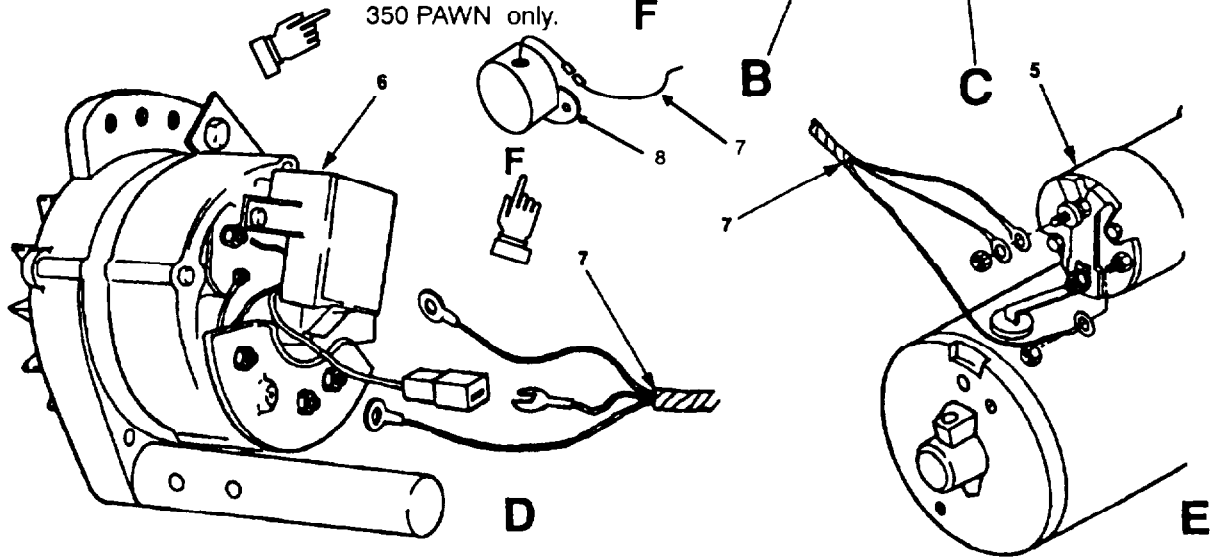

Figure 4-40. Wiring Harness Replacement (All Models).

- (3) Wires connected to low oil pressure switch (2).
 - (4) Wires connected fuel shut-off solenoid (view B, 3). On Model 350 PAWN, only the red and green wires need to be disconnected. Disconnect them at the in-line spade connectors.
 - (5) Wires connected to V-belt contact switch (view C, 4).
 - (6) Wires connected to starter solenoid (view E, 5). On Model 350 PAWN, there are two additional wires that must be disconnected.
 - (7) Wires connected to alternator (view D, 6).
 - (8) On Model 350 PAWN, wires connected to starting aid temperature switch (view F, 8).
- f. Remove cable clamps as necessary.
 - g. Remove harness assembly (7).

4.12.5.2 Repair.

- a. When repair of wiring harness is required, perform the following:
 - (1) Remove defective terminal.
 - (2) Strip wire approximately 1/8 of an inch back.
 - (3) Ensure that no strands of the wire are cut.
 - (4) Install terminal lug on wire by crimping terminal lug on wire.
- b. When a defective wire is found, refer to Appendix F to manufacture replacement wire.

4.12.5.3 Installation.

- a. Position harness assembly (7') to engine with clamps and connect the following wires:
 - (1) Connect wires to alternator (view D, 6) and remove tags.
 - (2) Connect wires to starter solenoid (view E, 5) and remove tags, Note that Model 350 PAWN uses two more wires than other models.
 - (3) Connect wires to V-belt contact switch (view C, 4) and remove tags.
 - (4) Connect wires to fuel shutdown solenoid (view B, 3) and remove tags. On Model 350 PAWN wires are connected to corresponding spade connectors.
 - (5) Connect wires to low oil pressure switch (view A, 2) and remove tags.
 - (6) Connect wires to oil sending unit (1) and remove tags.
 - (7) On Model 350 PAWN only, connect wires to starting aid temperature switch (view F, 8) and remove tags,
- b. Connect wires to terminal board (figure 4-39, sheet 1, view B, 8) and remove tags.
- c. Install control panel cover (view A, 7) and secure with washers (5), lockwashers (4) and screws (3) not used to install cold weather start kit (view C, 6).
- d. Install cold weather start kit (view C, 6) using washers (5), lock-washers (4) and screws (3).
- e. Connect two lines (view D, 1 and 2) to cold start reservoir.

4.13 CONTROL PANEL ASSEMBLY MAINTENANCE.

4.13.1 Control Panel Removal and Installation.

This task covers: 4.13.1.1 Removal

4.13.1.2 Installation

INITIAL SETUP

Tools

General Mechanic's Tool Kit (appendix B, Section III, Item 1)

Material/Parts

Washers (TM 10-4320-226-24P)
 Lockwashers (TM 10-4320-226-24P)
 Tags (appendix E, Section II, Item 12)

Equipment Conditions

Equipment shut down, refer to paragraph 2.5.1.2 or 2.5.2.2.

Battery cover removed, paragraph 3.4.

Battery disconnected, paragraph 4.12.2.

Control panel cover removed, paragraph 4.12.4.

General Safety Instructions

To prevent rolling or sliding, do not work on equipment that is not securely stabilized.

Do not work on equipment without following standard shop safety precautions.

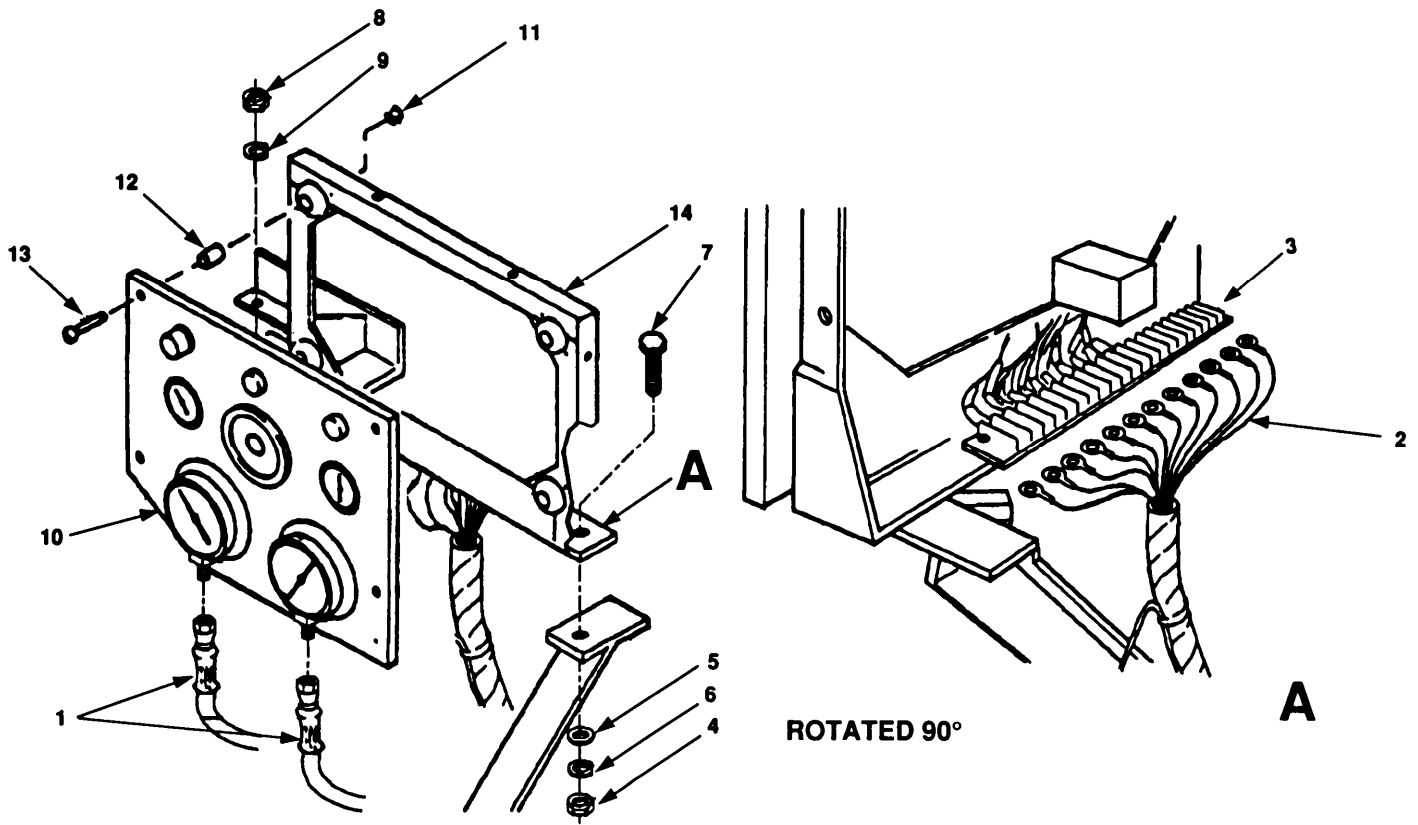

Figure 4-41. Control Panel Removal and Installation.

4.13.1.1 Removal.



- To prevent rolling or sliding, do not work on equipment that is not securely stabilized. Ensure both wheels are secure.
 - Disconnect negative cables from batteries.
 - Failure to obey these warnings may result in serious personal injury.
- a. Tag and disconnect two hoses (figure 4-41, 1).
 - b. Tag and disconnect all wires (2) from terminal board (3).
 - c. Remove nut (4), lockwasher (5), washer (6) and bolt (7).
 - d. Remove two nuts (8) and lockwashers (9).
 - e. Remove control panel assembly (10).
 - f. Remove four lock nuts (11), spacers (12), screws (13) and control panel assembly (10) from support bracket (14).

4.13.1.2 Installation.

- a. Install control panel assembly (10) on support bracket (14) using screws (13), spacers (12), and lock nuts (11).
- b. Set control panel assembly (10) with support bracket (14) on pump housing.
- c. Install two lockwashers (9) and nuts (8).
- d. Install bolt (7), washer (6), lockwasher (5) and nut (4).
- e. Connect all wires (2) to terminal board (3). Remove tags.
- f. Connect hoses (1) to gauges and remove tags.

4.13.2. Control Panel Test. (Not used on Model 350 PAWN)

INITIAL SETUPTest Equipment

Multimeter (appendix B, Section III, Item 2)

Tools

General Mechanic' s Tool Kit (appendix B, Section III, item 1)

Equipment Conditions

Equipment shut down, refer to paragraph 2.5.1.2 or 2.5.2.2.

Control panel cover removed, paragraph 4.13.1.

General Safety Instructions

To prevent rolling or sliding, do not work on equipment that is not securely stabilized.

Do not work on equipment without following standard shop safety precautions.



To prevent rolling or sliding, do not work on equipment that is not securely stabilized.
Ensure both wheels are secure.

Disconnect negative cables from batteries.

Failure to obey these warnings may result in serious personal injury.

- a. Disconnect lead from terminal 2 of K1 and measure resistance between terminals 2 and 7. Resistance should be approximately 116 Ohms.
- b. Re-connect lead to terminal 2 of K1.
- c. With Emergency Stop Switch (S1) pushed in, connect multimeter between contacts 3 and 4 of S1. Measure for open circuit.
- d. Pull S1 out, multimeter should indicate closed circuit.
- e. Connect multimeter across Push to Start switch (S2) contacts 2 and 1. Multimeter should indicate open circuit.
- f. Depress switch (S2), multimeter should indicate closed circuit.
- g. Repeat steps e and f for Oil Pressure Bypass switch (S3)
- h. Measure resistance between terminal 1 and 2 of K2. Resistance should be approximately 70 Ohms
- i. Using multimeter set for continuity, refer to figure 4-42 and check wiring.

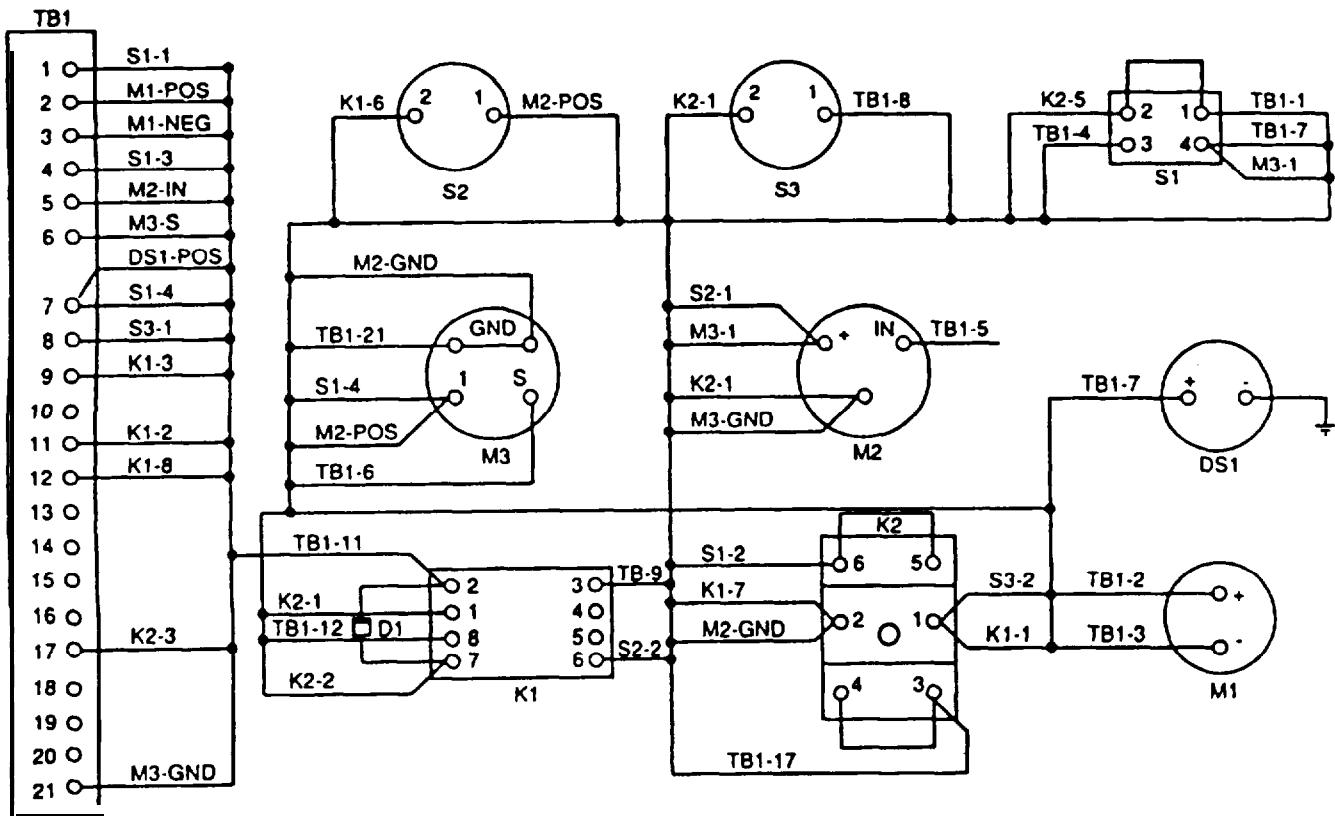

Figure 4-42. Control Panel Wiring Diagram (Models 350 PAW and W-87012).

4.13.2.1. Control Panel Test. (Used on Model 350 PAWN only)

INITIALSETUPTools

General Mechanics Tool Kit (appendix B
Section III, Item 1)

General Safety Instructions

To prevent rolling or sliding, do not work on equipment that is not securely stabilized.

Materials/Parts

Tags (appendix E, Section II, Item 12)

Do not work on equipment without following standard shop safety precautions.

Equipment Conditions

Equipment shut down, paragraph 2.5.2.

WARNING

Do not work on wiring harness with negative battery terminal connected.

To prevent rolling or sliding, do not work on equipment that is not securely stabilized. Ensure both wheels are secure.

Failure to obey these warning may result in serious personnel injury.

NOTE

All electrical checks, should be done with both battery cables disconnected. For testing pressure gauges, ammeter, hourmeter/tachometer system must be operating.

- a. Wiring Harness. Refer to figure 4-42.1 and check for continuity of wiring(may have to disconnect wires).
- b. Switch S1.
 - (1) Close switch (pulled out) and check for continuity between contacts 1/4 and 2/3.
 - (2) Open switch (pushed in) and check for open circuit between contacts 1/4 and 2/3.
- c. Switch S2.
 - (1) Close switch (pressed in) and check for continuity between its contacts (no numbers).
 - (2) Open switch (released) and check for open circuit between its contacts.
- d. Switch S3.
 - (1) Close switch (pressed in) and check for continuity between contacts 1/2.
 - (2) Open switch (released) and check for open circuit between its contacts 1/2.
- e. Relay K1.
 - (1) Apply 12 V dc to contacts 2 and 7 (ground) and check for continuity between its contacts 1/3 and 6/8.
 - (2) Disconnect 12 V dc and measure for open circuit between its contacts 1/3 and 6/8.
- f. Relay K2.

- (1) Apply 12 V dc to contacts 1 and 2 (ground) and check for continuity between its contacts 3/5 and 4/6.
- (2) Disconnect 12 V dc and measure for open circuit between its contacts 3/5 and 4/6

g. Switch (Rheostat) R2.

- (1) Measure for open circuit between contacts 1 and 2 when switch is turned to the off position (fully counterclockwise).
- (2) Turn switch on (clockwise) and attach multimeter leads to contacts 1 and 2. Note that resistance increases from 0 to 100 Ohms as switch knob is turned from off to fully on position.

h. Panel Lights (DS1 through DS5).

- (1) Briefly touch a 12 V dc source to terminal of each light assembly. All lamps should illuminate.

i. As required, operate start system and check pressure gauges, ammeter and hourmeter/tachometer for correct operations.

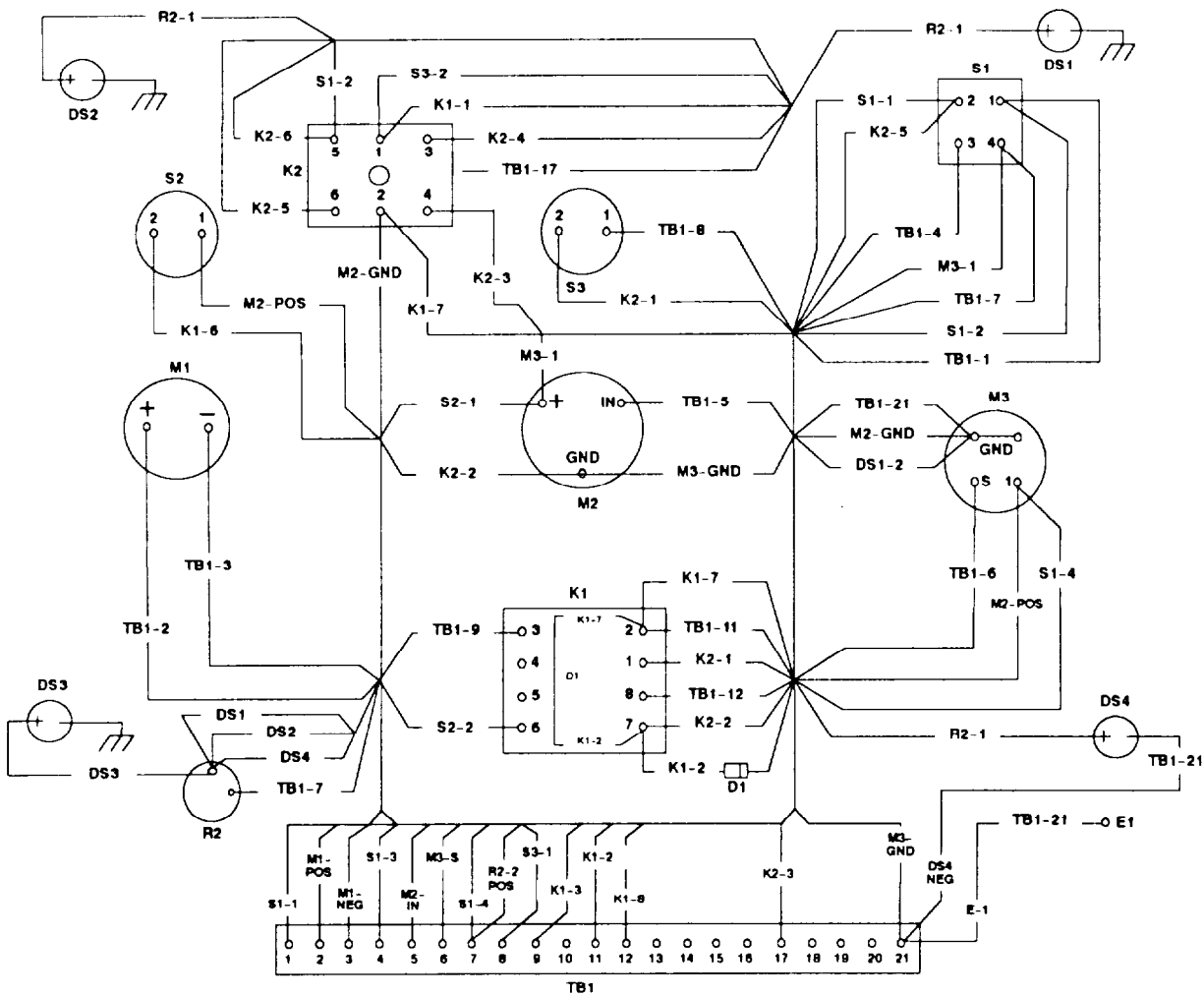

Figure 4-42.1. Control Panel Wiring Harness (Model 350 PAWN).

4.13.3 Emergency Stop Switch (S1) Replacement.

 This task covers: 4.13.3.1 Removal 4.13.3.2 Installation

INITIAL SETUPTools

General Mechanic's Tool Kit (appendix B, Section III, Item 1)

Materials/Parts

Tags (appendix E, Section II, Item 12)

Equipment Conditions

Equipment shut down, refer to paragraph 2.5.1.2 or 2.5.2.2.

Equipment Conditions (continued)

Control Panel Cover removed, paragraph 4.13.1.

General Safety Instructions

To prevent rolling or sliding, do not work on equipment that is not securely stabilized.

Do not work on equipment without following standard shop safety Precautions.

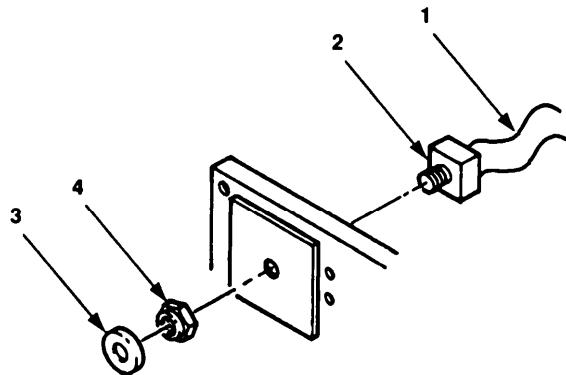

Figure 4-43. Emergency Stop Switch S1 Removal and Installation.

4.13.3.1 Removal.

- To prevent rolling or sliding, do not work on equipment that is not securely stabilized. Ensure both wheels are secure.
 - Disconnect negative cables from batteries.
 - Failure to obey these warnings may result in serious personal injury.
- a. Disconnect negative battery cable.
 - b. Tag and disconnect wires (figure 4-43, 1) from switch (2).
 - c. Unscrew knob (3) from shaft.
 - d. Remove nut (4) from switch (2).
 - e. Remove switch (2) from control panel.

4.13.3.2 Installation.

- a. Install switch (2) into control panel.

- c. Thread knob (3) on shaft.
- d. Connect wires (1) on switch (2) and remove tags.
- e. Connect negative battery cables.

4.13.4 011 Pressure Bypass (S2) and Push to Start (S3) Switch Replacement.

This task covers: 4.13.4.1 Removal 4.13.4.2 Installation

INITIAL SETUP

Tools

General Mechanic's Tool Kit (appendix B, Section III, Item 1)

Materials/Parts

Tags (appendix E, Section II, Item 12)

Equipment Conditions

Equipment shut down, refer to paragraph 2.5.1.2 or 2.5.2.2.

Equipment Conditions (continued)

Control Panel Assembly Cover removed, paragraph 4.13.1.

General Safety Instructions

To prevent rolling or sliding, do not work on equipment that is not securely stabilized.

Do not work on equipment without following standard shop safety precautions.

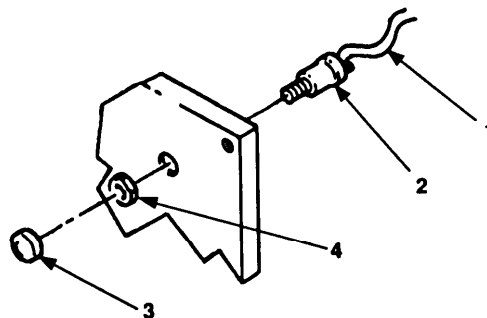

Figure 4-44. Oil Pressure Bypass and Push to Start Switch Replacement.

4.13.4.1 Removal.



- To prevent rolling or sliding, do not work on equipment that is not securely stabilized. Ensure both wheels are secure.
 - Disconnect negative cables from batteries.
 - Failure to obey this warning may result in serious personal injury.
- a. Tag and disconnect wires (figure 4-44, 1) from switch (2).
 - b. Unscrew boot (3) from switch (2).
 - c. Remove nut (4) from switch (2).
 - d. Remove switch (2).

4.13.4.2 Installation.

- a. Install switch (2).
- b. Install nut (4) on switch (2).
- c. Thread boot (3) on switch (2).
- d. Connect wires (1) on switch (2) and remove tags.

4.13.5 Oil Pressure (M1), Ammeter (M2), and Tachometer/Hourmeter (M3) Replacement.

This task covers: 4.13 .5.1 Removal 4.13 .5.2 Installation

INITIAL SETUP

Tools

General Mechanic's Tool Kit (appendix B, Section III, Item 1)

Materials/Parts

Tags (appendix E, Section II, Item 12)

Equipment Conditions

Equipment shut down, refer to paragraph 2.5.1.2 or 2.5.2.2.

Equipment Conditions (continued)

Control Panel Assembly Cover removed, paragraph 4.13.1.

General Safety Instructions

To prevent rolling or sliding, do not work on equipment that is not securely stabilized.

Do not work on equipment without following standard shop safety precautions.

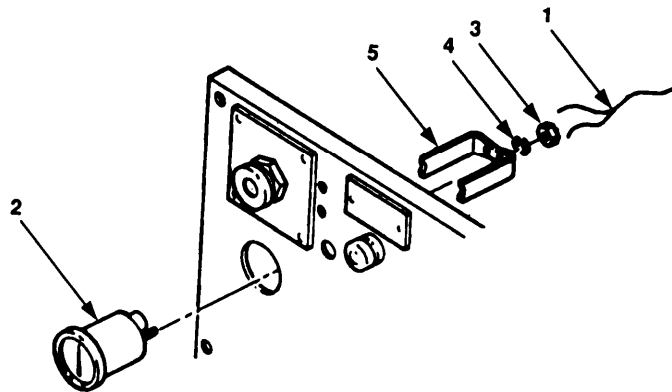

Figure 4-45. Oil Pressure, Ammeter, and Tachometer/Hourmeter Replacement.

4.13.5.1 Removal.



To prevent rolling or sliding, do not work on equipment that is not securely stabilized. Ensure both wheels are secure. Failure to obey this warning may result in serious personal injury.

- a. Tag and disconnect wires (figure 4-45, 1) from gauge (2).
- b. Remove two nuts (3), lockwashers (4), and retaining bracket (5) from gauge at back of control panel.
- c. Remove gauge (2) from front of control panel.

4.13.5.2 Installation.

- a. Install gauge (2) through front of control panel.
- b. Install retainer bracket (5) and lockwashers (4) on gauge at back of control panel.

- c. Install nuts (3) on to gauge (2) and tighten.

NOTE

Lamps to meters are no longer required.

- d. If lamp is connected to meter, clip and remove lamp wire to meter.
- e. Connect wires (1) to gauge (2) as indicated by tags.

4.13.6 Suction Gauge (M4) and Discharge Gauge (M5) Replacement.

This task covers: 4.13.6.1 Removal 4.13.6.2 Installation

INITIAL SETUP

Tools

General Mechanic's Tool Kit (appendix B, Section III, Item 1)

Materials/Parts

Tags (appendix E, Section II, Item 12)

Equipment Conditions

Equipment shut down, refer to paragraph 2.5.1.2 or 2.5.2.2.

Equipment Conditions (continued)

Control Panel Assembly Cover removed, paragraph 4.13.1.

General Safety Instructions

To prevent rolling or sliding, do not work on equipment that is not securely stabilized.

Do not work on equipment without following standard shop safety precautions.

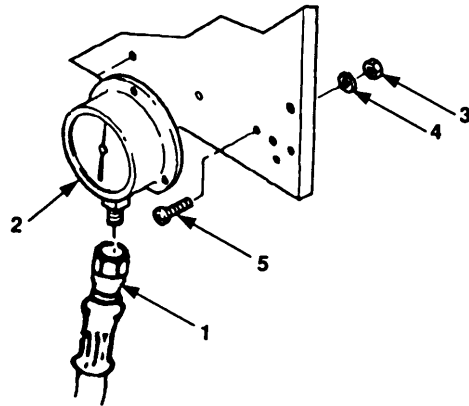

Figure 4-46. Suction Gauge (M4) and Discharge Gauge (M5) Replacement.

4.13.6.1 Removal.



To prevent rolling or sliding, do not work on equipment that is not securely stabilized. Ensure both wheels are secure. Failure to obey this warning may result in serious personal injury.

- a. Tag and disconnect hose (figure 4-46, 1) from gauge (2).
- b. Remove three nuts (3), lockwashers (4), and screws (5) from gauge (2).
- c. Remove gauge (2) from front of control panel.

4.13.6.2 Installation.

- a. Install gauge (2) through front of control panel.
- b. Install three screws (5), lockwashers (4), and nuts (3) on gauge (2).
- c. If snubber is installed between hose and gauge, remove and discard snubber, adapter, and elbow.
- d. Connect hoses (1) to gauge (2) and remove tags.

4.13.7 Safety Relay K1 Replacement.

This task covers: 4.13.7.1 Removal 4.13.7.2 Installation

INITIAL SETUPTools

General Mechanic's Tool Kit (appendix B, Section III, Item 1)

Equipment Conditions

Equipment shut down, refer to paragraph 2.5.1.2 or 2.5.2.2.

Control Panel Assembly Cover removed, paragraph 4.13.1.

General Safety Instructions

To prevent rolling or sliding, do not work on equipment that is not securely stabilized.

Do not work on equipment without following standard shop safety precautions.

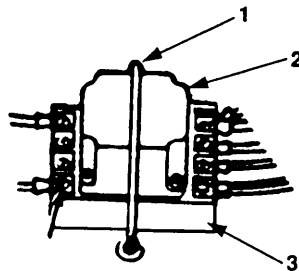

Figure 4-47. Safety Relay (K1) Replacement .

4.13.7.1 Removal.

To prevent rolling or sliding, do not work on equipment that is not securely stabilized. Ensure both wheels are secure. Failure to obey this warning may result in serious personal injury.

- a. Remove retainer clip (figure 4-47, 1) from relay (2).
- b. Remove relay (2) from socket (3).

4.13.7.2 Installation.

- a. Install relay (2) into socket (3).
- b. Secure relay (2) by lifting retainer clip (1) over relay (2).

4.13.8 Safety Relay (K1) Base Replacement.

This task covers: 4.13.8.1 Removal 4.13.8.2 Installation

INITIAL SETUP

Tools

General Mechanic's Tool Kit (appendix B, Section III, Item 1)

Materials/Parts

Tags (appendix E, Section II, Item 12)

Equipment Conditions

Equipment shut down, refer to paragraph 2.5.1.2 or 2.5.2.2.

Equipment Conditions (continued)

Control Panel Assembly Cover removed, paragraph 4.13.1.

General Safety Instructions

To prevent rolling or sliding, do not work on equipment that is not securely stabilized.

Do not work on equipment without following standard shop safety precautions.

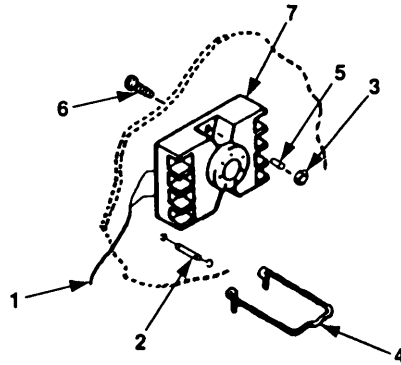

Figure 4-48. Safety Relay (K1) Base Replacement.

4.13.8.1 Removal.



To prevent rolling or sliding, do not work on equipment that is not securely stabilized. Ensure both wheels are secure. Failure to obey this warning may result in serious personal injury.

- a. Tag wires (figure 4-48, 1) and diode (2) on terminals 2 and 7.
- b. Remove terminal screws, wires (1) and diode (2) from terminals 2 and 7.

NOTE

Keep diode in safe place.

- c. Tag and disconnect remaining wires (1) .
- d. Remove two nuts (3) retaining clip (4), spacers (5), screws (6) and base (7).

4.13.8.2 Installation.

- a. Install base (7), screws (6), spacers (5), retaining clip (4) and nuts (3).
- b. Connect wires (1) removed in step b of removal and remove tags.
- c. Connect wires (1) and install diode (2) to terminals (2 and 7).

4.13.9. Run Relay (K2) Replacement

This task covers: 4.13.9.1 Removal 4.13.9.2 Installation

INITIAL SETUP

Tools

General Mechanic' s Tool Kit (Appendix B, Section III, Item 1)

Materials/Pa@

Tags (Appendix E, Section II, Item 12)

Equipment Conditions

Engine shutdown (refer to paragraph 2.5.1.2 or 2.5.2.2)

General Safety Instructions

To prevent rolling or sliding, do not work on equipment that is not securely stabilized.

Do not work on equipment without following standard shop safety precautions.

4.13.9.1 Removal. Refer to Figure 4-49 and proceed as follows:

WARNING

To prevent rolling or sliding, do not work on equipment that is not securely stabilizes. Ensure both wheels are chocked. Failure to obey these warnings may result in serious injury.

- a. Tag and disconnect wires (1) from relay (2).
- b. Remove two screws (3) and nuts (4) from front of control panel.
- c. Remove relay (2) from control panel.

4.13.9.2 Installation. Refer to Figure 4-49 and proceed as follows:

- a. Position relay (2) in place on back of control panel.
- b. Install two nuts (4) and screws (3) into relay (2) through front of control panel.
- c. Connect wires (1) to relay (2) and remove tags.

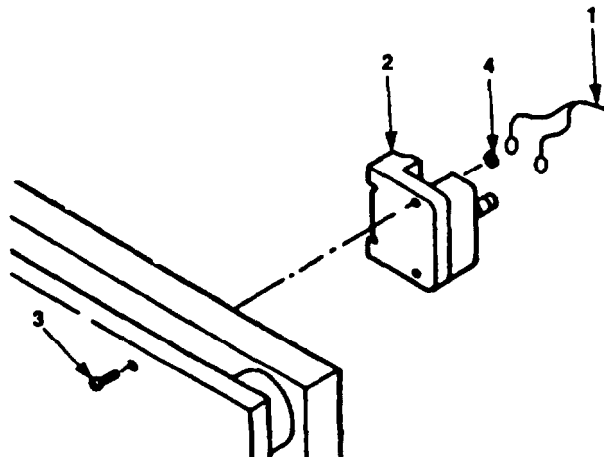

Figure 4-49. Run Relay (K2) Replacement.

4.13.10 Panel Light Replacement. (Not used on Model 350 PAWN)

This task covers: 4.13.10.1 Removal 4.13.10.2 Repair 4.13.10.3 Installation

INITIAL SETUP

Tools

General Mechanic' s Tool Kit, appendix B, Section III, Item 1

Materials/Parts

Tags (Appendix E, Section II, Item 12)

Equipment Conditions

Engine shutdown (Paragraph 2.5.1.2 or 2.5.2.2)
Control panel removed (Paragraph 4.13.1)

General Safety Instructions

To prevent rolling or sliding, do not work on equipment that is not securely stabilized.

Do not work on equipment without following standard shop safety precautions.

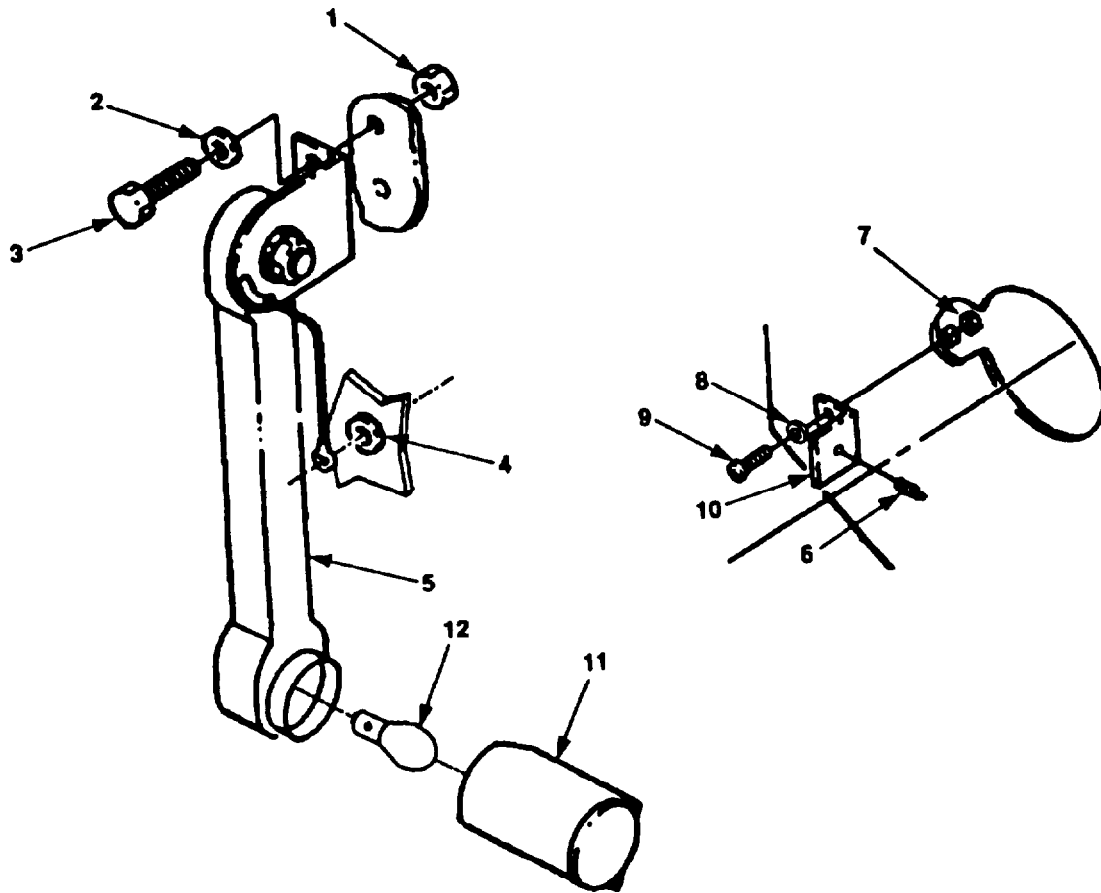

Figure 4-50. Panel Light Replacement(Except on Model 350 PAWN).

4.13.10.1 Removal.

Refer to Figure 4-50 and proceed as follows:



To prevent rolling or sliding, do not work on equipment that is not securely stabilizes. Ensure both wheels are chocked. Failure to obey these warnings may result in serious injury.

- a. Remove nuts (1), washers (2), screws (3) and grommet (4).
- b. Disconnect panel light (5) from TB1-7 and remove panel light (5).
- c. Remove threaded spring plunger (6).
- d. Remove nuts (7), washers (8), screws (9) and spring plunger bracket (10).

4.13.10.2 Repair.

Refer to Figure 4-50 and proceed as follows:

- a. Remove lens cover (11).
- b. Replace lamp (12).
- c. Install lens cover (11).

4.13.10.3 Installation.

Refer to Figure 4-50 and proceed as follows:

- a. Install spring plunger bracket (10), screws (9), washers (8) and nuts (7).
- b. Install threaded spring plunger (6).
- c. Route wire through opening in control panel and connect wire to TB1-7.
- d. Position panel light (5), secure with screws (3), washers (2) and nuts (1).
- e. Install grommet (4).

4.13.10.4 Panel Lights/Rheostat Replacement (Model 350 PAWN only)

This task covers: 4.13.10.5 Removal
4.13.10.6 Repair
4.13.10.7 Installation

INITIAL SETUP

Tools

General Mechanic's Tool Kit (Appendix B, Section III, Item 1)

Materials/Parts

Tags (Appendix E, Section II, Item 12)

Equipment Conditions

Engine shutdown, refer to paragraph 2.5.2.2
Control panel removed paragraph 4.13.1

General Safety Instructions

To prevent rolling or sliding, do not work on equipment that is not securely stabilized.

Do not work on equipment without following standard shop safety precautions.

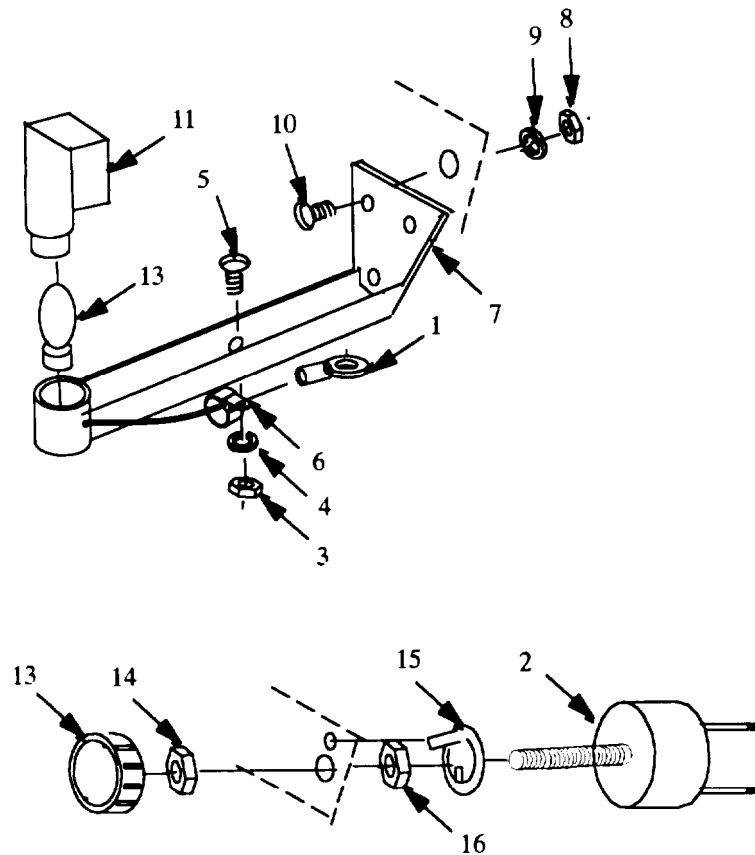

Figure 4-50.1. Panel Light/Rheostat Replacement (Model 350 PAWN).

4.13.10.5 Removal. (Refer to figure 4-50.1)**WARNING**

To prevent rolling or sliding, do not work on equipment that is not securely stabilized. Ensure both wheels are chocked. Failure to obey these warnings may result in serious injury.

- a. Disconnect wire (1) from rheostat(2) behind control panel.
- b. Remove nut(3), lockwasher(4), and screw(5) and clamp(6) from bracket support(7).
- c. Remove nuts(8), lockwashers(9), screws(10) and bracket support(7) from control panel.
- d. Remove hood(11) and incandescent light(12) from bracket support(7).
- e. Disconnect wires from rheostat(2).
- f. Loosen setscrew in knob(13) and remove knob from rheostat(2).
- g. Remove nut(14) and pull rheostat(2) from back of control panel.
- h. Remove locating washer(15) and nut(16) from rheostat(2).

4.13.10.6 Repair. (Refer to figure 4-50.1)

Repair limited a to replacing defective components,

4.13.10.7 Installation. (Refer to figure 4-50.1)

- a. Install locating washer(15) and nut(16) on rheostat. Tab on locating washer must point away from rheostat.
- b. Align tap on locating washer(15) with hole on control panel and push rheostat(2) through control panel.
- c. Install nut(14) on shaft of rheostat(2) and secure rheostat to control panel.
- d. Position knob(13) on shaft of rheostat(2) and tighten setscrew in knob.
- e. Position and secure bracket support(7) onto control panel with nuts(8), lockwashers(9) and screws(10.)
- f. Place wire through clamp(6) and secure clamp on bracket support(7) with nut(3), lockwasher(4), and screw(5).
- g. Install incandescent light(12) and hood(11) on bracket support(7).
- h. Connect wires to rheostat(2).

4.14 PUMP ASSEMBLY MANIFOLDS MAINTENANCE.

4.14.1 Coupling Half Maintenance

This task covers: 4.14.1.1 Removal 4.14.1.2 Installation

INITIAL SETUP

Tools

General Mechanic' s Tool Kit (Appendix B, Section III, Item 1)

Material/Parts

Lo&washers (TM 10-4320-226-24P)
Gasket (TM 10-4320-226-24P)

Equipment Conditions

Engine shut down (Paragraph 2.5.1.2 or 2.5.2.2)

Equipment Conditions

Suction discharge valves drained into suitable container.

General Safety Instructions

To prevent rolling or sliding, do not work on equipment that is not securely stabilized.

Do not work on equipment without following standard shop safety precautions.

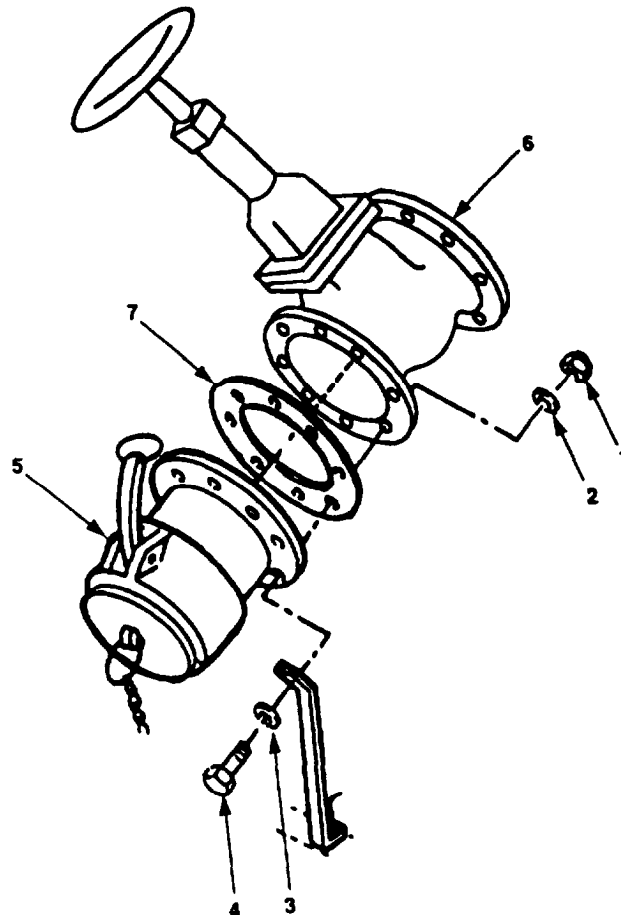

Figure 4-51. Coupling Half Maintenance.

4.14.1.1 Removal.



To prevent rolling or sliding, do not work on equipment that is not securely stabilized. Ensure both wheels are secure. Failure to obey this warning may result in serious personal injury.

NOTE

Bolt securing coupling half is longer and has a washer and lockwasher.

- a. Remove eight nuts (figure 4-51, 1), lockwashers (2), one washer (3) and eight bolts (4) securing coupling half (5) to gate valve (6).
- b. Remove coupling half (5).
- c. Remove and discard gasket (7).

4.14.1.2 Installation.

- a. Install new gasket (7) on gate valve (6).
- b. Position coupling half (5) against gate valve (6) and align mounting holes.
- c. Insert eight bolts (4) through holes in gate valve (6) and coupling half (5).
- d. Install one washer (3), eight new lockwashers (2) and nuts (1).

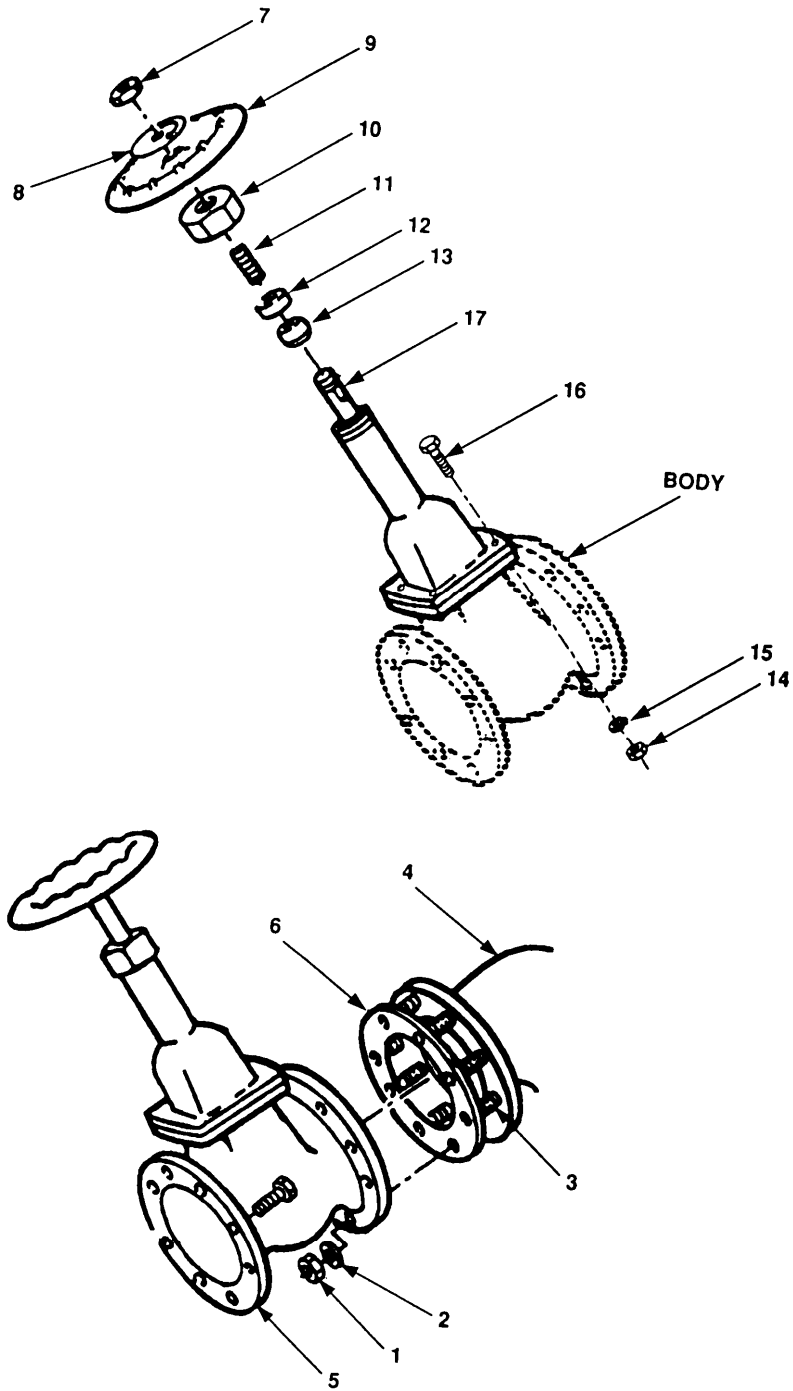

Figure 4-52. Gate Valve Maintenance.

- d. Slide packing gland (12) onto stem (17).
- e. Position spring (11) over gland and install packing nut (10).
- f. Place hand wheel (9) and plate (8) on stem (17) and secure with nut (7).

4.14.2.3 Installation.

- a. Install new gasket (6) on studs (3) of manifold (4).
- b. Install gate valve (5) on studs (3) of manifold (4).
- c. Install eight lockwashers (2) and thread eight nuts (1) on studs (3) of manifold (4).

4.14.3 Suction Manifold Maintenance.

This task covers: 4.14.3.1 Removal

4.14.3.2 Installation

INITIAL SETUP

Tools

General Mechanic's Tool Kit (appendix B, Section III, Item 1)

Material/Parts

LockWashers (TM 10-4320-226-24P)
 Gaskets (TM 10-4320-226-24P)
 Antiseizing tape (appendix E, Section II, Item 13)

Equipment Conditions

Equipment shut down, refer to paragraph 2.5.1.2 or 2.5.2.2.

Coupling half removed, paragraph 4.14.1.

General Safety Instructions

To prevent rolling or sliding, do not work on equipment that is not securely stabilized.

Do not work on equipment without following standard shop safety precautions.

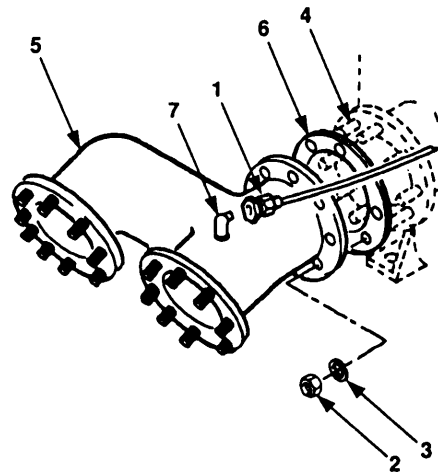

Figure 4-53. Suction Manifold Maintenance.

4.14.3.1 Removal.



To prevent rolling or sliding, do not work on equipment that is not securely stabilized. Ensure both wheels are secure. Failure to obey this warning may result in serious personal injury.

- a. Disconnect gauge hose(s) (figure 4-53, 1).
- b. Remove eight nuts (2) and lockwashers (3) from studs (4) of centrifugal pump.
- c. Remove suction manifold (5) from centrifugal pump.
- d. Remove and discard gasket (6).
- e. Remove fitting(s) (7) from suction manifold.

4.14.3.2 Installation.

- a. Wrap fitting(s) (7) with antiseizing tape and install on suction manifold.
- b. Install gasket (6) over studs of centrifugal pump.
- c. Install suction manifold (5) on studs (4) of centrifugal pump.
- d. Install eight lockwashers (3) and nuts (2).
- e. Connect suction gauge hose(s) (1).

4.14.4 Discharge Manifold Maintenance.

This task covers: 4.14.4.1 Removal 4.14.4.2 Installation

INITIAL SETUP

Tools

General Mechanic's Tool Kit (appendix B, Section III, Item 1)

Material/Parts

Lockwashers (TM 10-4320-226-24P)
Gaskets (TM 10-4320-226-24P)

Equipment Conditions

Equipment shut down, refer to paragraph 2.5.1.2 or 2.5.2.2.

Gate Valves removed, paragraph 4.14.2.

General Safety Instructions

To prevent rolling or sliding, do not work on equipment that is not securely stabilized.

Do not work on equipment without following standard shop safety precautions.

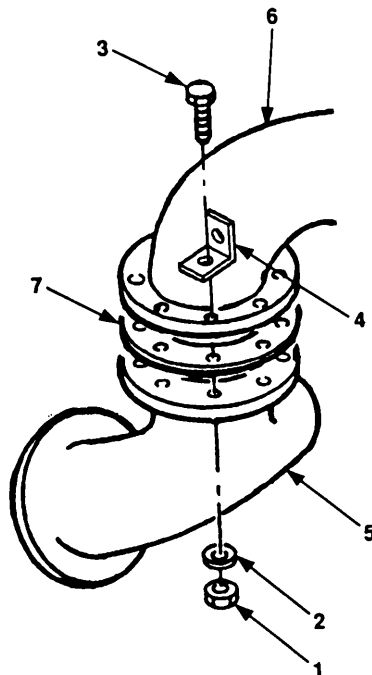

Figure 4-54. Discharge Manifold Maintenance.

4.14.4.1 Removal.



To prevent rolling or sliding, do not work on equipment that is not securely stabilized. Ensure both wheels are secure. Failure to obey this warning may result in serious personal injury.

- a. Remove eight nuts (figure 4-54, 1), lockwashers (2) bolts (3) and one bracket (4).
- b. Remove discharge manifold (5) from discharge connection (6).
- c. Remove and discard gasket (7).

4.14.4.2 Installation.

- a. Install new gasket (7).
- b. Position discharge manifold (5) against discharge connection (6) and align mounting holes.
- c. Install bracket (4), eight bolts (3), new lockwashers (2) and nuts (1).

4.14.5 Discharge Connection Maintenance.

This task covers: 4.14.5.1 Removal

4.14.5.2 Installation

INITIAL SETUP

Tools

General Mechanic's Tool Kit (appendix B, Section III, Item 1)

Material/Parts

Lockwashers (TM 10-4320-226-24P)
 Gaskets (TM 10-4320-226-24P)
 Antiseizing tape (appendix E, Section II, Item 13)

Equipment Conditions

Equipment shut down, refer to paragraph 2.5.1.2 or 2.5.2.2.

Control panel assembly removed, paragraph 4.13.1.

Equipment Conditions (continued)

Discharge Manifold removed, paragraph 4.14.4.

General Safety Instructions

To prevent rolling or sliding, do not work on equipment that is not securely stabilized.

Do not work on equipment without following standard shop safety precautions.

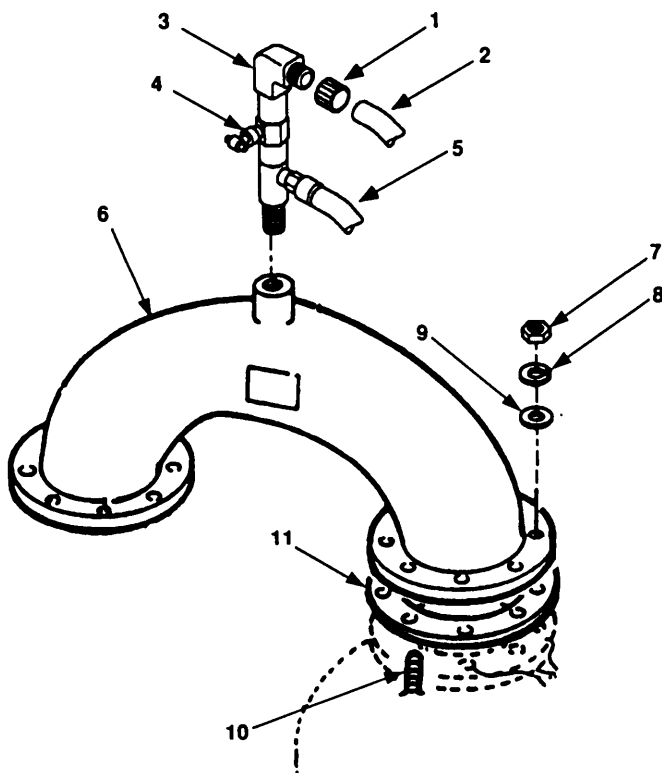

Figure 4-55. Discharge Connection Maintenance.

4.14.5.1 Removal.



To prevent rolling or sliding, do not work on equipment that is not securely stabilized. Ensure both wheels are secure. Failure to obey this warning may result in serious personal injury.

- a. Loosen clamp (figure 1-55, 1) and disconnect hose (2).
- b. Remove elbow (3) and vent valve (4).
- c. Disconnect discharge pressure hose(s) (5).
- d. Support discharge connection (6) and disconnect it from pump and control panel brackets by removing remaining five nuts (7), lockwashers (8), and washers (9) from studs (10) on centrifugal pump.
- e. Remove and discard gasket (11).

4.14.5.2 Installation.

- a. Install gasket (11) on studs (10) of centrifugal pump.
- b. Install discharge connection (6) on studs (10) of centrifugal pump.
- c. Install five washers (9) and lockwashers (8).
- d. Thread five nuts (7).
- e. Connect discharge pressure gauge hose(s) (5).
- f. Install elbow (3) and vent valve (4).
- g. Connect hose (2) and tighten clamp (1).

4.15. Water Separator Maintenance. (Not used on Model 350 PAWN)

This task covers: 4.151 Removal 4.15.2 Installation

INITIAL SETUPTools

General Mechanic's Tool Kit (appendix B, Section III, Item 1)

Material/Parts

Lockwashers (TM 10-4320-226-24P)
 Element kit (TM 10-4320-226-24P)
 Cleaning solvent (appendix B, Section II, Item 11)
 Tags (appendix E, Section II, Item 12)
 Suitable container

Equipment Conditions

Equipment shut down, refer to paragraph 2.5.1.2 or 2.5.2.2.

General Safety Instructions

To prevent rolling or sliding, do not work on equipment that is not securely stabilized.

Do not smoke or use open flames around fuel.

Do not work on equipment without following standard shop safety precautions.

4.151 Removal.

To prevent rolling or sliding, do not work on equipment that is not securely stabilized. Ensure both wheels are chocked.

Do not smoke or use open flames around fuel. Ensure container is used to catch fuel and fuel is disposed of properly.

Failure to obey this warning could result in serious injury.

- a. Remove drain plug (1) and drain contents of water separator (2) into suitable container. Install drain plug.
- b. Tag and disconnect fuel inlet line (3) and outlet line (4) from water separator (2). Cover openings.
- c. Remove two nuts (5), washers (6), lockwashers (7), bolts (8) and water separator (2).
- d. Remove retaining clamp (9), lid (10) and element (11). Discard element.
- e. Remove upper lid preformed packing (12) and lower lid preformed packing (13) and discard.

4.152 Installation.

- a. Install new upper lid preformed packing (12) on filter body.
- b. Install new lower lid preformed packing (13) on lid (10).
- c. Install new element (11) on lid (10).
- d. Install lid (10) onto filter body and secure with retaining clamp (9).
- e. Attach water separator (2) to frame with two bolts (8), washer (7), lockwashers (6) and nuts (5).

- f. Attach fuel outlet line (4), inlet line (3) and remove tags.
- g. Bleed fuel system. (Paragraph 4.10.16.).

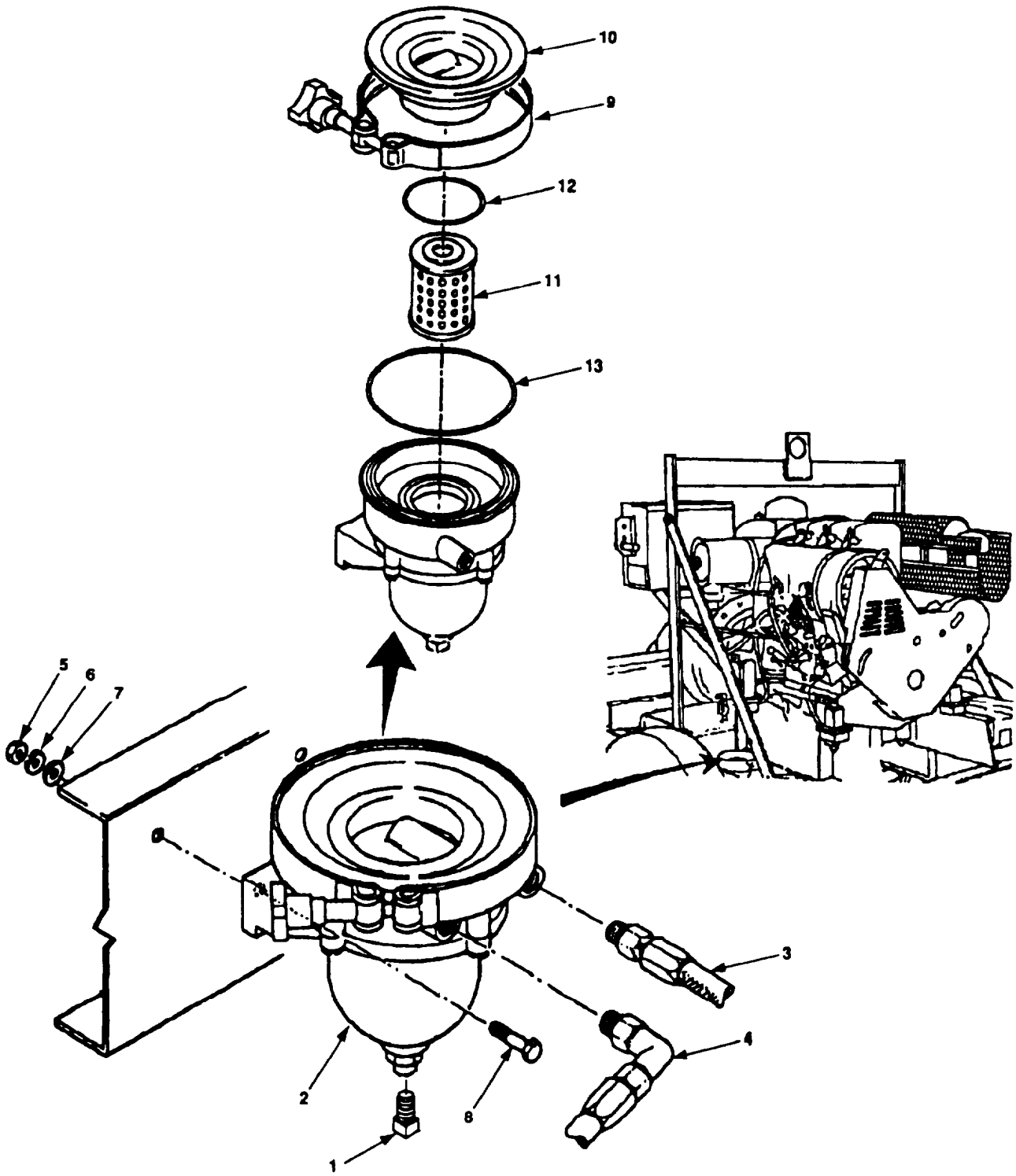

Figure 4-56. Water Separator Maintenance (Models 350 PAW and W-87012).

4.15.3. WATER/FILTER SEPARATOR MAINTENANCE. (Used on Model 350 PAWN only)

This task covers 4.15.3.1 Removal 4.15.3.2 Repair 4.15.3.3 Installation.

INITIAL SETUP

Tools

General Mechanics Tool Kit (appendix B
Section III(Item 1)

General Safety Instructions

To prevent rolling or sliding, do not work on equipment that is not securely stabilized.

Equipment Conditions

Equipment shut down, refer to paragraph 2.52.

Do not work on equipment without following standard shop safety precautions.

WARNING

Do not work on wiring harness with negative battery terminal connected.

To prevent rolling or sliding, do not work on equipment that is not securely stabilized.
Ensure both wheels are secure.

Failure to obey these warnings may result in serious personnel injury.

4.15.3.1. Removal

- a. Disconnect fuel lines from elbow (figure 4-56.1, 1) and fitting (2).
- b. Remove nuts (3), lockwashers (4), flat washers (5), bolts (6) and filter/separator from 350 GPM Pumping Assembly.
- c. Remove elbow (1) and fitting (2) and from head (7).

4.15.3.2. Repair

- a. Remove base (8), gasket (9), filter (10) and packing (11).
- b. Remove plug (12), packing (13), valve (14) and packing (15).
- c. Remove plug (16).
- d. Remove plug (17), packing (18) and ball (19).
- e. Remove plug (20) and packing (21).
- f. Remove priming pump as follows:
 - (1) Unscrew stem (22) from head (7) and pull it out hard until a snap is heard. This separates packing (23) and packing retainer (24) from stem.
 - (2) Push stem (22) into head (7).
 - (3) Remove packing (23), retainer (24), stem (22) and packing (25).
- g. Install priming pump as follows:
 - (1) Position packing (25) on stem (22) and insert stem through head (7).
 - (2) Install packing retainer (24 and packing (23).
- h. Install plug (16).

- i. Install packing (21) and plug (20).
- j. Install ball (19), packing (18) and plug (17).
- k. Install packing (11), filter (10), packing (9) and base (8)
- l. Install packing (15) and valve (14).
- m. Install packing (13) and plug (12).

4.15.3.3. Installation

- a. Install fitting (2) and elbow (1) on head (7).
- b. Position filter/separator on 350 CPM Pump Assembly and secure with bolts (6), lockwashers (4), flat washers (5) and nuts (3).
- c. Connect fuel lines to elbow (1) and fitting (2).
- d. Loosen fuel fitting between fuel pump and fuel filter on engine at pump outlet and operate stem (22) of priming pump (moving it up and down) until fuel comes out at loose connection.
- e. Tighten connection.

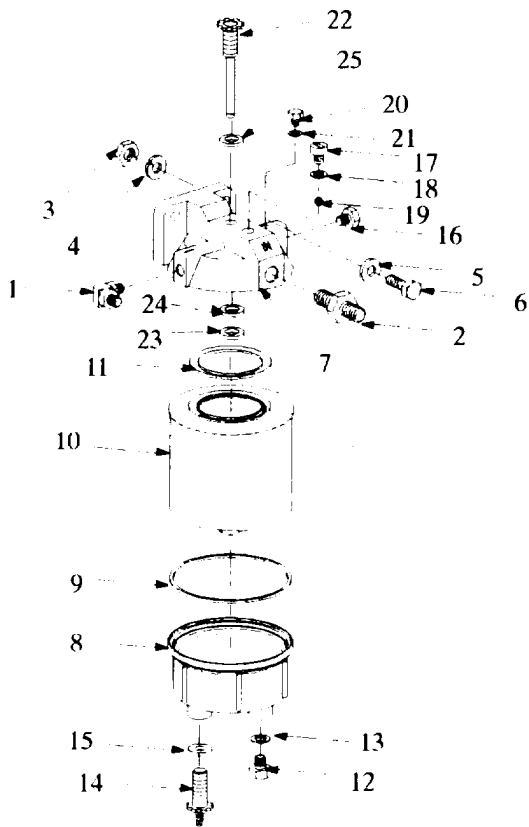

Figure 4-56.1. Water/Filter Separator Maintenance (Model 350 PAWN).

4.16 WHEEL MOUNTED FRAME ASSEMBLY MAINTENANCE.

4.16.1 Tire Maintenance.

This task covers: 4.16.1.1 Removal

4.16.1.2 Installation

INITIAL SETUP

Tools

General Mechanic's Tool Kit (appendix B, Section III, Item 1)

Jack (appendix B, Section III, Item 2)

Equipment Conditions

Equipment shut down, refer to paragraph 2.5.1.2 or 2.5.5.2.

General Safety Instructions

To prevent rolling or sliding, do not work on equipment that is not securely stabilized.

Do not work on equipment without following standard shop safety precautions.

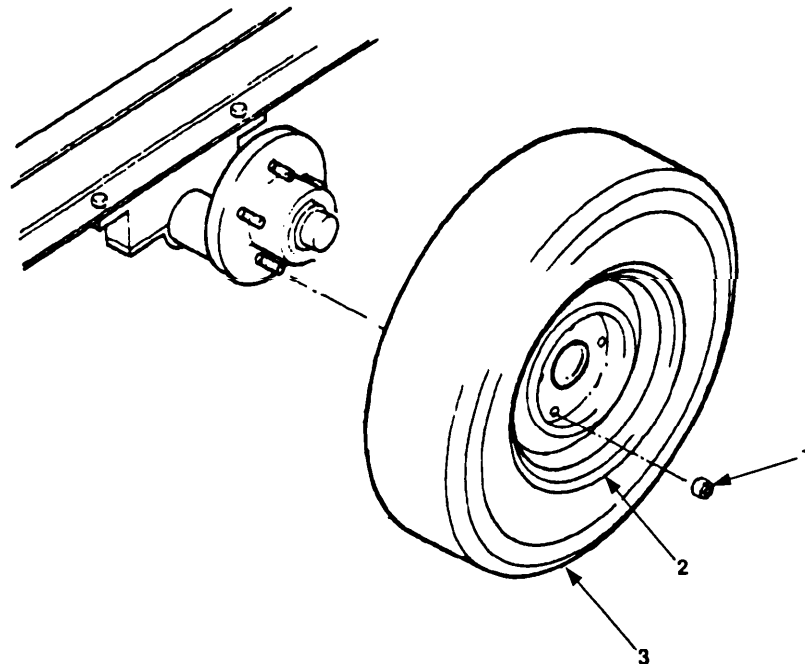

Figure 4-57. Tire Maintenance.

4.16.1.1 Removal.



To prevent rolling or sliding, do not work on equipment that is not securely stabilized. Ensure both wheels are secure. Failure to obey this warning may result in serious personal injury.

- a. Loosen five lug nuts (figure 4-66, 1).
- b. Using jack, raise wheel clear of ground.
- c. Remove five lug nuts (1).
- d. Remove wheel (2) and tire (3) from axle assembly.

4.16.1.2 Installation.

- a. With axle assembly in raised position, position wheel (2) and tire (3) on axle assembly.
- b. Install and snug nuts (1).
- c. Lower axle assembly.
- d. Tighten five lug nuts (1).
- e. Remove jack.

4.16.2 Wheel Bearing Maintenance.

This task covers: 4.16.2.1 Removal
4.16.2.2 Repair

4.16.2.3 Installation

INITIAL SETUP

Tools

General Mechanic's Tool Kit (appendix B, Section III, Item 1)

Material/Parts

Grease (appendix E, Section II, Item 6)

Equipment Conditions

Equipment shut down, refer to paragraph 2.5.1.2 or 2.5.2.2.

Tire removed, paragraph 4.16.1.

General Safety Instructions

To prevent rolling or sliding, do not work on equipment that is not securely stabilized.

Do not work on equipment without following standard shop safety precautions.

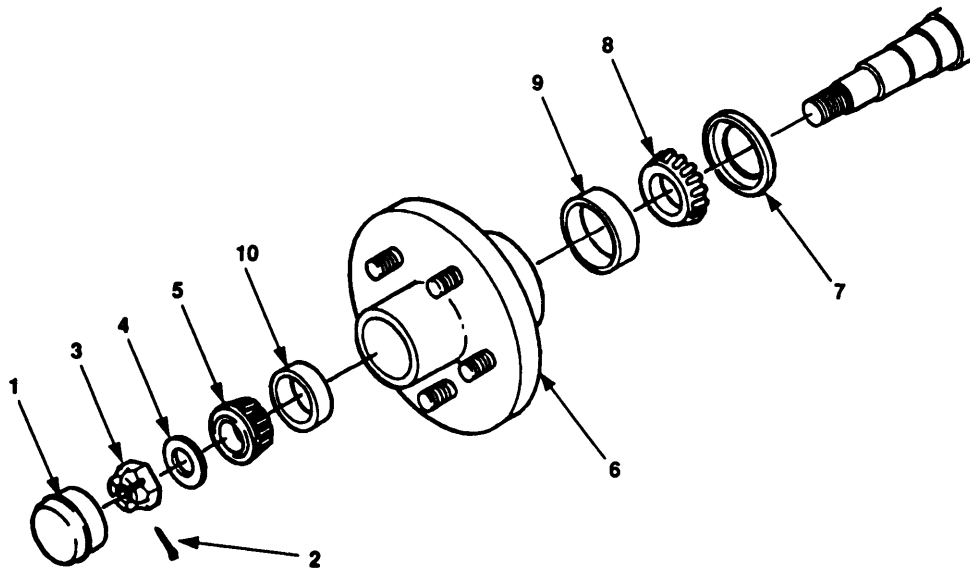

Figure 4-58. Wheel Bearing Maintenance.

4.16.2.1 Removal.



To prevent rolling or sliding, do not work on equipment that is not securely stabilized. Ensure both wheels are secure. Failure to obey this warning may result in serious personal injury.

- a. Remove dust cap (1, figure 4-58).
- b. Remove cotter pin (2), castle nut (3), and washer (4).

- c. Remove outer bearing cone (5).
- d. Remove hub (6); then remove seal (7), inner bearing cone (8), inner cup (9), and outer cup (10).

4.16.2.2 Repair.

Clean and inspect parts. Replace damaged or missing parts.

4.16.2.3 Installation.

- a. Repack bearings.
- b. Install inner cup (9) and inner cone (8) and seal (7) in hub (6).
- c. Install hub (6).
- d. Install outer cup (10) and outer bearing cone (5).
- e. Install washer (4).
- f. While rotating hub, install castle nut (3) until drag is felt.
- g. Back off castle nut until cotter pin (2) can be installed.
- h. Install cotter pin (2) and dust cap (1).

4.16.3 Reflector Maintenance.

 This task covers: 4.16.3.1 Removal 4.16.3.2 Installation

INITIAL SETUPTools

General Mechanic's Tool Kit (appendix B, Section III, Item 1)

Equipment Conditions

Equipment shut down, refer to paragraph 2.5.1.2 or 2.5.2.2.

Material/Parts

Lockwashers (TM 10-4320-226-24P)

General Instructions

Do not work on equipment without following standard shop safety precautions.

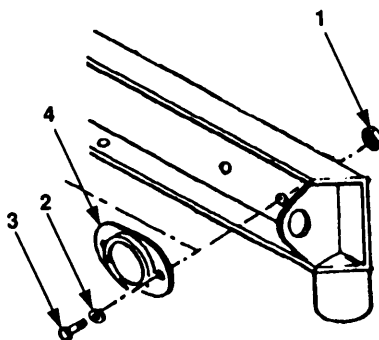

Figure 4-59. Reflector Maintenance.

4.16.3.1 Removal.

To prevent rolling or sliding, do not work on equipment that is not securely stabilized. Ensure both wheels are secure. Failure to obey this warning may result in serious personal injury.

- a. Remove nuts (1, figure 4-59), lockwashers (2), and bolts (3).
- b. Remove reflectors (4).

4.16.3.2 Installation.

Install reflector (4) with bolts (3), lockwashers (2), and nuts (1).

4.16.4 Tow Bar Maintenance.

This task covers: 4.16.4.1 Removal 4.16.4.2 Installation

INITIAL SETUP

Tools

General Mechanic's Tool Kit (appendix B, Section III, Item 1)

General Instructions

To prevent rolling or sliding or sliding, do not work on equipment that is not securely stabilized.

Equipment Conditions

Equipment shut down, refer to paragraph 2.5.1.2 or 2.5.2.2.

Do not work on equipment without following standard shop safety precautions.

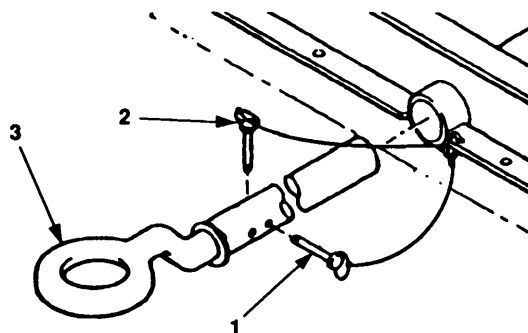

Figure 4-60. Tow Bar Maintenance.

4.16.4.1 Removal.



To prevent rolling or sliding, do not work on equipment that is not securely stabilized. Ensure both wheels are secure. Failure to obey this warning may result in serious personal injury.

- a. Remove retaining pin (figure 4-60, 1).
- b. Remove anchor pin (2).
- c. Remove tow bar (3).

4.16.4.2 Installation.

- a. Install tow bar (3) and align anchor pin holes.
- b. Install anchor pin (2) and retaining pin (1).

4.16.5 Support Leg Maintenance.

This task covers: 4.16.5.1 Removal 4.16.5.2 Installation

INITIAL SETUP

Tools

General Mechanic's tool kit, (appendix B, Section III, Item 1).
 Jack (appendix B, Section III, Item 2)

General Instructions

To prevent rolling or sliding, do not work on equipment that is not securely stabilized.

Do not lift heavy assemblies without lifting device.

Equipment Conditions

Equipment shut down, refer to paragraph 2.5.1.2 or 2.5.2.2.

Do not work on equipment without following standard shop safety precautions.

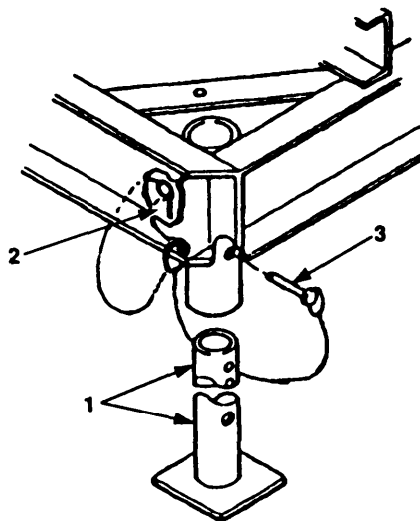

Figure 4-61. Support Leg Maintenance.

4.16.5.1 Removal.

- To prevent rolling or sliding, do not work on equipment that is not securely stabilized. Ensure both wheels are secure.
 - Do not lift heavy assemblies without lifting device.
 - Failure to obey these warnings may result in personal injury or death.
- a. Stabilize trailer.
 - b. Using jack, carefully tilt entire assembly until enough clearance is attained to remove support leg (figure 4-61, 1).
 - c. Position two jack stands directly behind support leg housing. Remove jack.
 - d. Remove retaining pin (2).
 - e. While holding support leg (1), remove anchor pin (3).
 - f. Remove support leg (1).

4.16.5.2 Installation.

- a. Position support legs (1), align anchor pin holes, insert anchor pins (3).
- b. Install retaining pins (2).
- c. Using jack, raise until jack stands can be removed.
- d. Remove jackstands.
- e. Lower assembly until support legs (1) are fully down. Remove jack.

4.16.6 Tool Box Maintenance.

This task covers: 4.16.6.1 Removal 4.16.6.2 Installation

INITIAL SETUP

Tools

General Mechanic's Tool Kit (appendix B, Section III, Item 1)

Material/Parts

Lockwashers (TM 10-4320-226-24P)

Equipment Conditions

Equipment shut down, refer to paragraph 2.5.1.2 or 2.5.2.2.

General Instructions

To prevent rolling or sliding, do not work on equipment that is not securely stabilized.

Do not lift heavy assemblies without lifting device.

Do not work on equipment without following standard shop safety precautions.

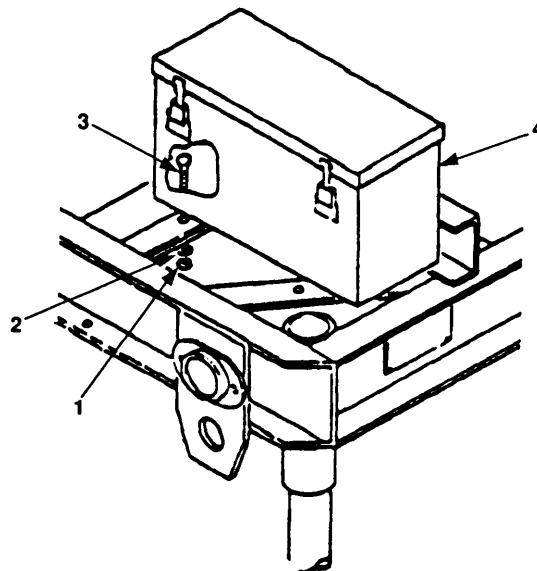

Figure 4-62. Tool Box Maintenance.

4.16.6.1 Removal.



- To prevent rolling or sliding, do not work on equipment that is not securely stabilized. Ensure both wheels are secure.
 - Do not lift heavy assemblies without lifting device.
 - Failure to obey these warnings may result in personal injury or death.
- a. Open lid of tool box (4).
 - b. Remove three nuts (figure 4-62, 1), lockwashers (2), and bolts (3) that secure tool box (4).
 - c. Remove tool box (4).

4.16.6.2 Installation.

- a. Open tool box (4) and align mounting holes.
- b. Insert three bolts (3) through mounting holes.
- c. Install lockwasher (2) and nut (1) on each bolt (3).

4.16.7 Data Plate Maintenance.

This task covers: 4.16.5.1 Removal 4.16.5.2 Installation

INITIAL SETUP

Tools

General Mechanic's Tool Kit (appendix B, Section III, Item 1)

Rivet Gun Blind (appendix B, Section III, Item 2)

Material/Parts

Rivets (TM 10-4320-226-24P)

Equipment Conditions

Equipment shut down, refer to paragraph 2.5.1.2 or 2.5.2.2.

General Instructions

To prevent rolling or sliding, do not work on equipment that is not securely stabilized.

Do not lift heavy assemblies without lifting device.

Do not work on equipment without following standard shop safety precautions.

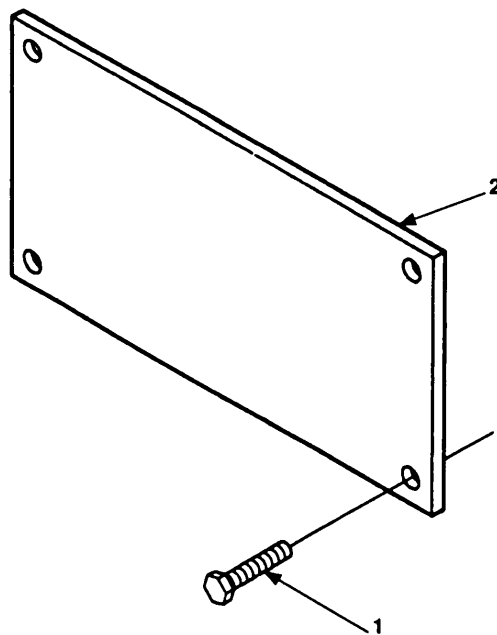

Figure 4-63. Data Plate Maintenance.

4.16.7.1 Removal.



To prevent rolling or sliding, do not work on equipment that is not securely stabilized. Ensure both wheels are secure. Failure to obey this warning may result in personal injury.

- a. Remove retaining hardware (figure 4-63, 1) from data plate (2).
- b. Remove data plate (2).

4.16.7.2 Installation.

- a. Position data plate (2) in place.
- b. Use pop rivets to secure new data plate (2).

SECTION VI. PREPARATION FOR SHIPMENT AND STORAGE

4.17 PRESERVATION PROCEDURES.

No special preservation procedures are required for the 350 gpm Pumping Assembly.

4.18 PACKING.

No special packing procedures are required for the 350 gpm Pumping Assembly.

4.19 MARKING.

Refer to MIL-STD-129 for information on marking.

4.20 STORAGE.

- a. Store equipment so as to provide maximum protection from the elements and to provide access for inspection, maintenance, and servicing.

CAUTION

Do allow water remain in the water pump undrained while in storage. Failure to obey this caution could result in equipment damage from water freezing or sludging(deposits forming).

- b. Take into account environmental conditions, such as extreme cold or heat, high humidity, blowing snow, earthquakes, or combinations thereof, and take adequate precautions. Open the drain valve or remove plug on bottom of pump housing and drain the water to prevent the pump from freezing or sludging(deposits forming),
- c. Placement of equipment in administrative storage should be for short periods of time when a shortage of maintenance effort exists. Items should be in mission readiness within 24 hours or within the time factors as determined by the directing authority. During the storage period appropriate maintenance records shall be kept.
- d. Before placing equipment in administrative storage, current preventive maintenance checks and services should be completed, shortcomings and deficiencies should be corrected, and all modification work orders (MWO' s) should be applied.

CHAPTER 5

DIRECT SUPPORT MAINTENANCE INSTRUCTIONS

SUBJECT INDEX	PAGE
SECTION I. REPAIR PARTS; SPECIAL TOOLS; TEST, MEASUREMENT, AND DIAGNOSTIC EQUIPMENT (TMDE); AND SUPPORT EQUIPMENT	5-2
5.1 COMMON TOOLS AND EQUIPMENT	5-2
5.2 SPECIAL TOOLS AND SUPPORT EQUIPMENT	5-2
5.3 REPAIR PARTS	5-2
SECTION II. DIRECT SUPPORT TROUBLESHOOTING	5-3
5.4 TROUBLESHOOTING	5-3
SECTION III. DIRECT SUPPORT MAINTENANCE PROCEDURES	5-5
5.5 ENGINE ASSEMBLY MAINTENANCE	5-5
5.6 PUMPING ASSEMBLY MAINTENANCE	5-31
5.7 FUEL TANK MAINTENANCE	5-45
5.8 AXLE ASSEMBLY Maintenance	5-47

SECTION I. REPAIR PARTS; SPECIAL TOOLS; TEST, MEASUREMENT, AND DIAGNOSTIC EQUIPMENT (TMDE); AND SUPPORT EQUIPMENT

5.1 COMMON TOOLS AND EQUIPMENT.

For Authorized common tools and equipment refer to the Modified Table of Organization and Equipment (MTOE), Common Table of Allowances (CTA) 50-970 or CTA 8-100 as applicable to your unit.

5.2 SPECIAL TOOLS AND SUPPORT EQUIPMENT.

Special tools are listed and illustrated in the Repair Parts and Special Tools List (RPSTL), TM 10-4320-226-24P, covering unit, direct support, and general support maintenance for this equipment.

5.3 REPAIR PARTS.

Repair parts are listed and illustrated in the RPSTL, TM 10-4320-226-24P, covering unit, direct support, and general support maintenance for this equipment.

SECTION II. DIRECT SUPPORT TROUBLESHOOTING

5.4 TROUBLESHOOTING.

Use the malfunction index to locate specific troubleshooting procedures contained in table 5-1. After locating the listed malfunction, perform the test/inspections and corrective actions in the order listed in table 5-1. The malfunction index and Table 5-1 cannot list all the malfunctions that may occur, all the test and inspections needed to find the fault, or all the corrective actions needed to correct the fault. If the equipment malfunction is not listed or actions listed do not correct the fault, notify your supervisor.

MALFUNCTION INDEX

	Malfunction Number in Table 5-1
Engine will not start.	1
Engine starts and runs erratically after warmup	2
No or low suction or discharge pressure	3
Pump noisy	4

Table 5-1. Direct Support Troubleshooting Table.

MALFUNCTION
TEST OR INSPECTION
CORRECTIVE ACTION
<p>1. ENGINE WILL NOT START.</p> <p style="margin-left: 40px;">Step 1. Check injection pump gear alignment. (Bolts should not be against side of slot).</p> <p style="margin-left: 80px;">a. Time injection pump by removing and installing fuel injection pump (paragraph 5.5.5).</p> <p style="margin-left: 80px;">b. Replace engine (paragraph 5.5.1).</p> <p style="margin-left: 40px;">Step 2. Test nozzles (paragraph 5.5.6)</p> <p style="margin-left: 80px;">Replace defective nozzles (paragraph 5.5.7).</p> <p style="margin-left: 40px;">Step 3. Remove Idler Pulley and inspect fuel injection timing gear for slippage.</p> <p style="margin-left: 80px;">Time fuel injection pump (paragraph 5.5.2)</p> <p style="margin-left: 40px;">Step 4. Check compression (paragraph 5.5.3).</p> <p style="margin-left: 80px;">Replace engine (paragraph 5.5.1).</p>

Table 5-1. Direct Support Troubleshooting Table.

MALFUNCTION	TEST OR INSPECTION	CORRECTIVE ACTION
2. ENGINE STARTS AND RUNS ERRATICALLY AFTER WARMUP.	Step 1. Test fuel injection nozzles (paragraph 5.5.6).	Replace fuel injection nozzles (paragraph 5.5.7).
	Step 2. Check compression (paragraph 5.5.3).	Replace engine (paragraph 5.5.1).
3. NO OR LOW SUCTION OR DISCHARGE PRESSURE.	Step 1. Inspect impeller.	Replace impeller (paragraph 5.6.2).
	Step 2. Inspect flexible coupling.	Replace flexible coupling (paragraph 5.6.3).
	Step 3. Inspect sleeve and rotating assembly.	a. Repair sleeve and rotating assembly (paragraph 5.6.4).
		b. Replace centrifugal pump assembly (paragraph 5.6.1).
4. CENTRIFUGAL PUMP NOISY.	Step 1. Inspect impeller.	Replace impeller (paragraph 5.6.2).
	Step 2. Inspect flexible coupling.	Replace flexible coupling (paragraph 5.6.3).
	Step 3. Inspect sleeve and rotating assembly.	a. Repair sleeve and rotating assembly (paragraph 5.6.4).
		b. Replace centrifugal pump assembly (paragraph 5.6.1).

SECTION III. DIRECT SUPPORT MAINTENANCE PROCEDURES.

5.5 ENGINE ASSEMBLY MAINTENANCE.

5.5.1 Engine Replacement.

This task covers: 5.5.1.1 Removal 5.5.1.2 Installation

INITIAL SETUP

Tools

Engine Stand (appendix B, Section III, Item 3)

Engine Sling (appendix B, Section III, Item 3)

General Mechanics Tool Kit (appendix B, Section III, item 1)

Two lifting eyes (appendix B, Section III, Item 4)

Material/Parts

Lock nuts (TM 10-4320-226-24P)
Lockwashers (TM 10-4320-226-24P)

Personnel Required

2

Equipment Conditions

Equipment shut down, refer to paragraph 2.5.1.2 or 2.5.2.2.

Batteries disconnected, paragraph 4.12.3.

Cold Start Aid Nozzle removed, paragraph 4.10.4.

Throttle control removed, paragraph 4.11 (Non-regulated pump only)

Actuator removed paragraph 4.14.5, (Regulated pump only)

Main Wiring Harness disconnected from engine (paragraph 4.12.5)

General Instructions

Do not lift heavy assemblies without lifting device.

Do not work on equipment without following standard shop safety precautions.

5.5.1.1 Removal.

- a. Disconnect overflow line (figure 5-1, 1) from injector nozzle to fuel tank.
- b. Remove banjo bolt (view A, 2), washers (3), and hose (4) from fuel pump. Cover hose and fuel pump port to prevent entrance of foreign material into fuel system.
- c. Remove twelve bolts (view B, 5) lockwashers (6), four washers (7) and two shields (8) .
- d. Remove six lock nuts (view C, 9), twelve washers (10), six beveled washers (11), and bolts (12) securing engine assembly to mounts.
- e. Remove and retain two plugs (view D, 13) from lifting eye holes.

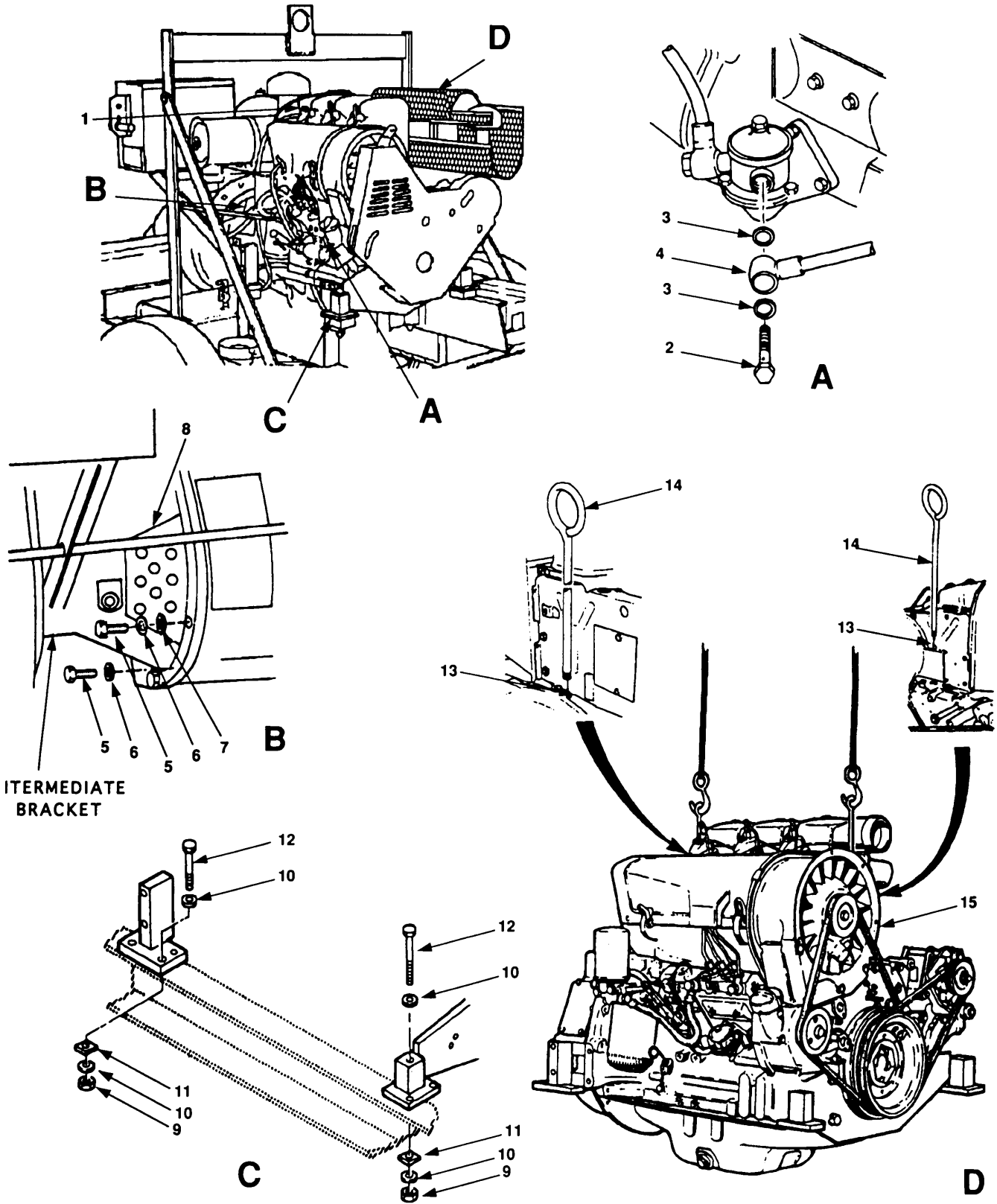

Figure 5-1. Engine Replacement.

WARNING

Do not lift heavy assemblies without lifting device. Failure to obey this warning may result in personal injury or death.

CAUTION

Do not install lifting eyes until mounting holes have been inspected and cleaned. Failure to obey this caution could result in equipment damage.

NOTE

Two personnel are required to remove engine.

- f. Install two lifting eyes (14) and attach engine sling.
- g. Slowly raise engine sling until engine assembly (15) just clears mounts.
- h. Move engine assembly (15) back, away from pump, until flexible coupling disengages from pump connection ring.
- i. Move engine assembly (15) completely clear of lifting bail of 350 GPM Pumping Assembly frame.
- j. Position engine assembly (15) on engine stand.
- k. Remove two lifting eyes (14) and install plugs (13).

5.5.1.2 Installation.**WARNING**

Do not lift heavy assemblies without lifting device. Failure to obey this warning may result in personal injury or death.

CAUTION

Do not install lifting eyes until mounting holes have been inspected and cleaned. Failure to obey this caution could result in equipment damage.

NOTE

Two personnel are required to remove engine.

- a. Remove two plugs (view D, 13) and install lifting eyes (14).
- b. Attach engine sling to two lifting eyes (14).
- c. Move engine assembly (15) clear of stand and position over frame.
- d. Lower engine assembly (15) and position below lifting bail and move toward pump assembly.
- e. Align flexible coupling of pump with pump connecting ring. This requires slow movement of engine assembly (15).

- f. When coupling and rings are aligned, push engine assembly forward until coupling completely engages. Ensure studs of intermediate bracket align with holes on engine assembly.
- g. Install six bolts (view C, 12), beveled washers (11), twelve washers (10) and six lock nuts (9).
- h. Install two shields (view B, 8), four washers (7), twelve lockwashers (6) and bolts (5).

CAUTION

Do not leave mounting holes for lifting eyes uncovered. Failure to obey this caution could result in equipment damage.

- i. Remove engine sling and two lifting eyes (view D, 14) and install two plugs (13).
- j. Uncover hose (view A, 4) and fuel pump port.
- k. Position hose (4) to fuel pump and install washers (3) and banjo bolt (2).
- l. Connect overflow line (1) from injector nozzle to fuel tank.

5.5.2 Fuel Injection Pump Timing.

INITIAL SETUP

Tools

General Mechanics Tool Kit (appendix B, Section III, item 1)
 Position Pointer (appendix B, Section III, Item 5)
 Injection Timing Pump (appendix B, Section III, Item 6)

Material/Parts

Lockwashers (TM 10-4320-226-24P)
 Gaskets (TM 10-4320-226-24P)
 Seals (TM 10-4320-226-24P)

Equipment Conditions

Equipment shut down, refer to paragraph 2.5.1.2 or 2.5.2.2.

Batteries disconnected, paragraph 4.12.3.

No. 1 Cylinder Head Cover removed paragraph 4.10.23

Idler pulley assembly removed (paragraph 4.10.24)

General Instructions

To prevent rolling or sliding, do not work on equipment that is not securely stabilized.

Do not smoke or use open flames around fuel.

Do not work on equipment without following standard shop safety precautions .

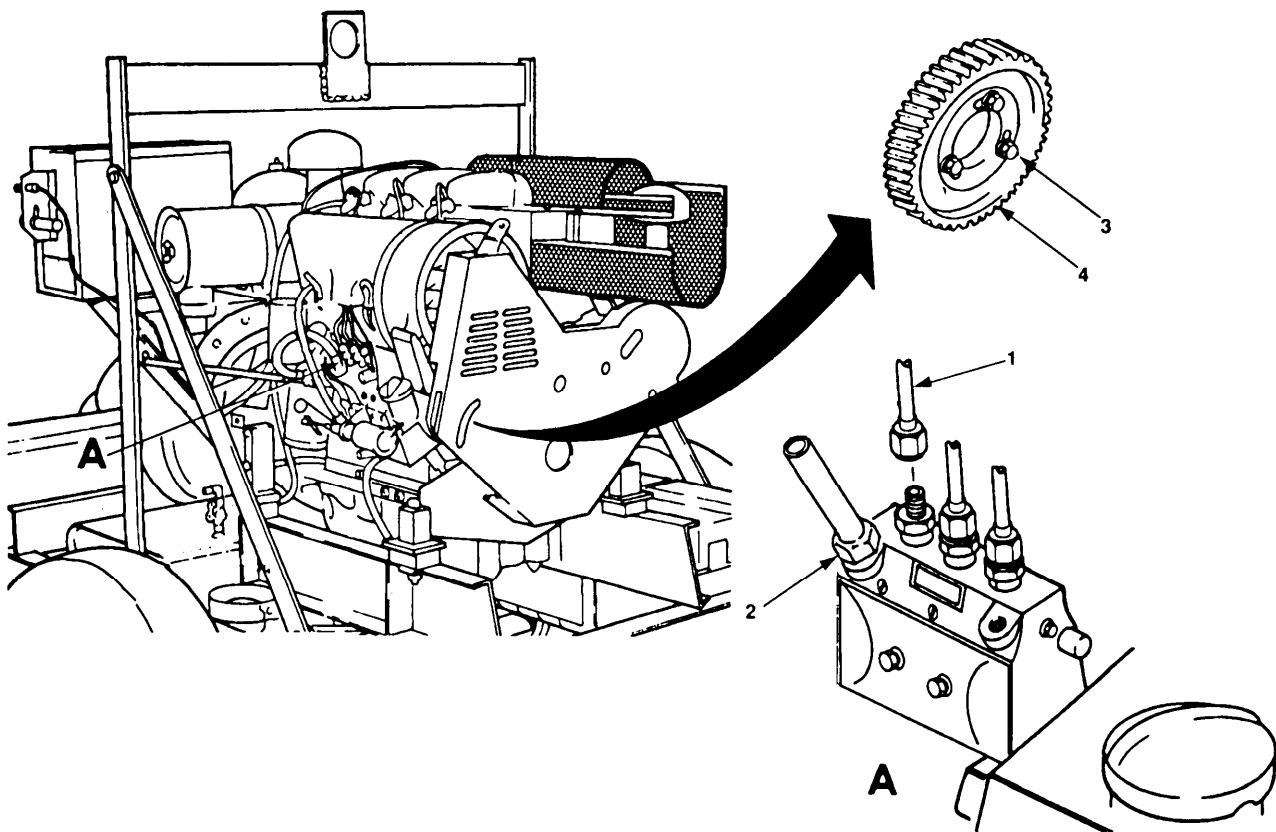

Figure 5-2. Fuel Injection Pump Timing.



- To prevent rolling or sliding, do not work on equipment that is not securely stabilized. Ensure both wheels of equipment have chocks that are secure.
 - Do not smoke or use open flames around fuel. Ensure container is used to catch fuel and fuel is disposed of properly. Failure to obey this warning may result in personal injury or death.
 - Failure to obey these warnings could result in serious personal injury.
- a. Remove Number 1 injection line (figure 5-2, 1) from fuel injection pump and install spill pipe in its place.
 - b. Disconnect main fuel supply line (2) from fuel injection pump and connect high pressure line of high pressure hand pump in its place.
 - c. Turn crankshaft pulley 1/4 turn clockwise to remove gear backlash.
 - d. Install position pointer.
 - e. Rotate crankshaft pulley counterclockwise until timing mark is exactly aligned with position pointer and number 1 cylinder is traveling toward TDC compression stroke.
 - f. Loosen three bolts (3) that secure fuel injection pump drive gear (4).
 - g. While operating high pressure hand pump, slowly turn fuel injection pump drive gear counter clockwise within its mounting slots until stream from spill pipe turns to droplets.
 - h. Holding gear in position, tighten three bolts (3) that secure fuel injection pump drive gear (4).
 - i. Check timing by turning front pulley 1/4 turn clockwise. Start operating fuel injection timing pump while turning crankshaft pulley slowly counterclockwise until stream from spill pipe turns to droplets.

Check that timing mark is aligned with position pointer \pm 1 degree. If not aligned, turn crankshaft pulley 1/4 turn clockwise and repeat steps e through j.
 - k. Disconnect high pressure line of high pressure hand pump from fuel injector pump and connect main fuel supply line (2).
 - l. Remove spill pipe and install number 1 fuel injection line (1).

5.5.3 Engine Compression Pressure Check.

INITIAL SETUP

Tools

General Mechanic's Tool Kit (appendix B, Section III, Item 1)
 Nozzle Puller (appendix B, Section III, Item 7)
 Compression Gauge Assembly (appendix B, Section III, Item 8)

Material/Parts

Washers (TM 10-4320-226-24P)

Equipment Conditions

Equipment shut down, refer to paragraph 2.5.1.2 or 2.5.2.2.

Shutdown solenoid rod disconnected (Non-regulated pump only, paragraph 4.10.15).

Actuator Rod disconnected (Regulated pump only, paragraph 4.14.6)

General Safety Instructions

To prevent rolling or sliding, do not work on equipment that is not securely stabilized.

Do not operate equipment in enclosed area unless exhaust gases are piped to outside and adequate ventilation is provided.

Do not touch exhaust system after shutting down engine.

Do not smoke or use open flames around fuel.

Do not work on equipment without following standard shop safety Precautions.

WARNING

- To prevent rolling or sliding, do not work on equipment that is not securely stabilized. Ensure both wheels of equipment have chocks that are secure.
- Do not touch exhaust system after equipment operation. Exhaust systems become very hot and can cause serious burns.
- Do not smoke or use open flames around fuel. Ensure container is used to catch fuel and fuel is disposed of properly. Failure to obey this warning may result in personal injury or death.
- Failure to obey these warnings could result in serious personal injury.

CAUTION

Handle fuel injection nozzles with care to prevent damage. Cap inlet port and plug overflow port to prevent entry of foreign matter. Failure to obey this caution may result in equipment damage.

a. Remove injection nozzle as follows:

- (1) Remove nut (figure 5-3, 1) and injection nozzle yoke (2).
- (2) Remove injection nozzle (3).
- (3) Using nozzle puller, remove injection nozzle washer (4) from cylinder and discard.

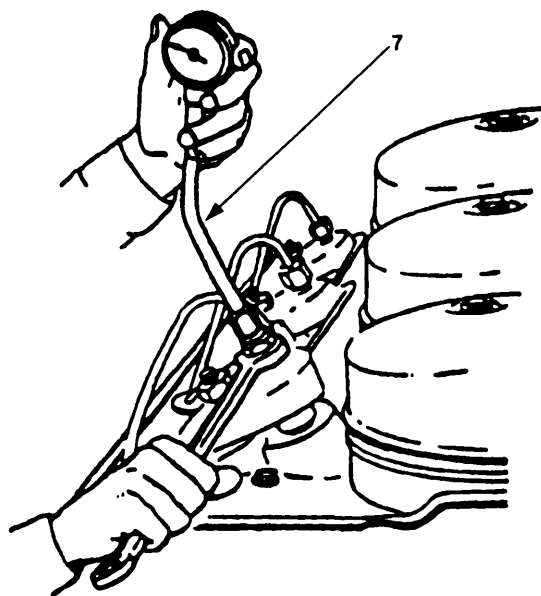
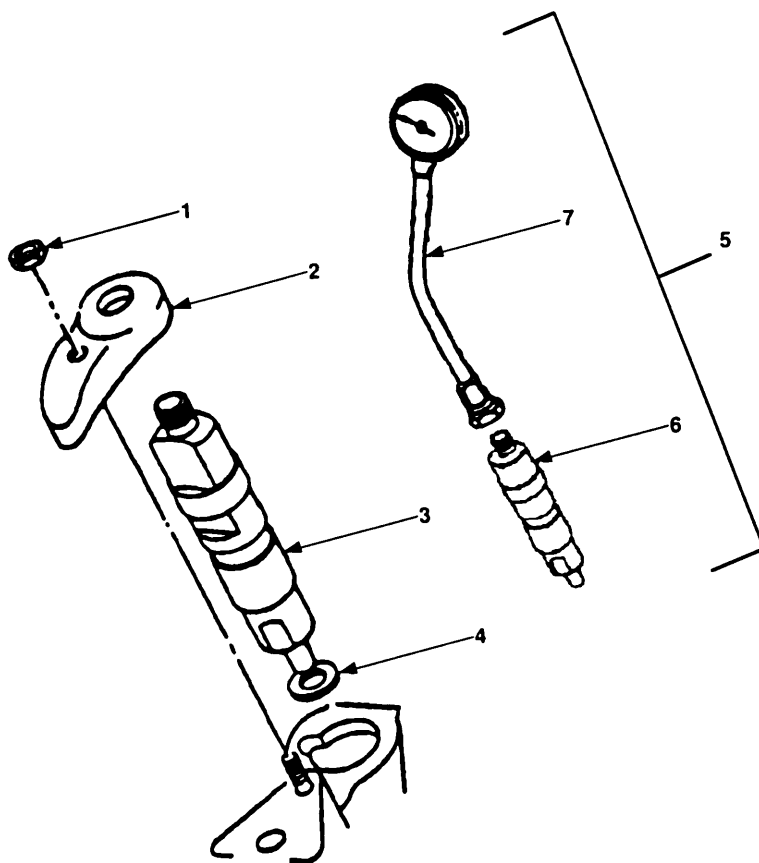

Figure 5-3. Compression Gauge Installation.

- b. Attach compression gauge (5) as follows:
- (1) Remove gauge adapter (6) from gauge (7).
 - (2) Install new injection nozzle washer (4) with metal surface down.
 - (3) Install gauge adapter (6) and injection nozzle yoke (2).
 - (4) Install nut (1).
 - (5) Attach gauge (7) to compression gauge adapter (6). Ensure all connections are tight.
- c. Record compression reading as follows:
- (1) Pull EMERGENCY STOP SWITCH out.
 - (2) Push oil pressure bypass switch and start switch simultaneously for approximately three seconds.
 - (3) Observe compression gauge installed in step d and record compression reading.
 - (4) Release start switch, oil pressure bypass switch and place run switch OFF.
- d. Remove compression gauge (5) as follows:
- (1) Remove gauge (7) from gauge adapter (6).
 - (2) Remove nut (1) and injection nozzle yoke (2).
 - (3) Remove gauge adapter (6).
 - (4) Using puller, remove injection nozzle washer (4) and discard.
 - (5) Attach gauge adapter (6) to to gauge (7).
- e. Install injection nozzle as follows:
- (1) Install new injection nozzle washer (4) with metal side down.
 - (2) Install injection nozzle (3).
 - (3) Install injection nozzle yoke (2) and nut (1).
- f. Perform steps a through e on remaining cylinders.
- g. Compare compression readings for all cylinders. Pressure reading differential must not exceed 58 psi (4 bars) within the allowable 284 psi (20 bars) and 397 psi (28 bars) compression range.

5.5.4 Intake Manifold Maintenance.

This task covers: 5.5.4.1 Removal 5.5.4.2 Installation

INITIAL SETUP

Tools

General Mechanics Tool Kit (appendix B, Section III, Item 1)

Material/Parts

Gaskets (TM 10-4320-226-24P)

Equipment Conditions

Equipment shut down, refer to paragraph 2.5.1.2 or 2.5.2.2.

Muffler removed, paragraph 4.10.1.

Cold Start Aid Nozzle removed, paragraph 4.10.4

General Instructions

To prevent rolling or sliding, do not work on equipment that is not securely stabilized.

do not work on equipment without following standard shop safety precautions.

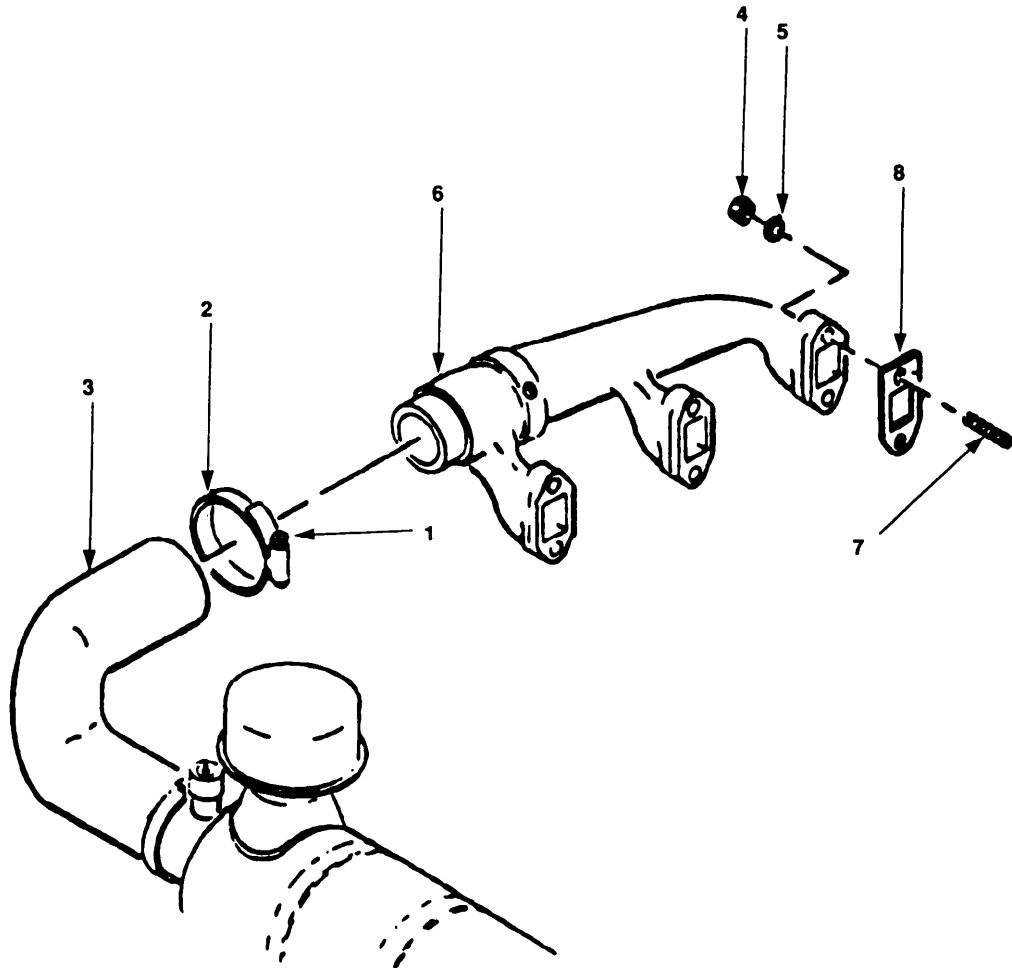

Figure. 5-4 Intake. Manifold Maintenance.

5.5.4.1 Removal.

To prevent rolling or sliding, do not work on equipment that is not securely stabilized. Ensure both wheels are secure. Failure to obey these warnings may result in serious personal injury.

- a. Loosen screw (figure 5-4, 1) of clamp (2) on airduct hose (3).
- b. Slide clamp (2) over airduct hose (3).
- c. Remove six nuts (4) and washers (5).
- d. Pull intake manifold (6) away from studs (7) and withdraw intake manifold (6) from airduct hose (3).
- e. Remove gaskets (8) and discard.

5.5.4.2 Installation.

- a. Install gaskets (8) on studs (7).
- b. Insert intake manifold (6) in airduct hose(3).
- c. Position intake manifold (6) on studs (7) and install washers (5).
- d. Install nuts (4) on studs (7).
- e. Slide clamp (2) until positioned over airduct hose (3) and intake manifold (6), then tighten screw (1).

5.5.5 Injection Pump Maintenance.

This task covers: 5.5.5.1 Removal 5.5.5.2 Installation

INITIAL SETUP

Tools

General Mechanics Tool Kit (appendix B, Section III, Item 1)

Equipment Conditions (continued)

Actuator removed paragraph 4.14.6 (Regulated pump only).

Engine at TDC, paragraph 5.5.9.

Material/Parts

Lockwashers (TM 10-4320-226-24P)
 Gaskets (TM 10-4320-226-24P)
 Preformed packing (TM 10-4320-226-24P)
 Tags (appendix E, Section II, Item 12)

Fuel lines removed from regulator pump (paragraph 4.10.16).

General Instructions

Personnel Required

2

To prevent rolling or sliding, do not work on equipment that is not securely stabilized.

Equipment Conditions

Equipment shut down, refer to paragraph 2.5.1.2 or 2.5.2.2.

Do not smoke or use open flames around fuel. Ensure container is used to catch fuel and fuel is disposed of properly.

Throttle Control Rod removed, paragraph 4.11. (Non regulated pump only).

do not work on equipment without following standard shop safety precautions.

WARNING

- To prevent rolling or sliding, do not work on equipment that is not securely stabilized. Ensure both wheels are secure.
- Do not smoke or use open flames around fuel. Ensure container is used to catch fuel and fuel is disposed of properly.
- Failure to obey these warnings may result in personal injury or death.

CAUTION

Do not drop cap screws or washers into timing cover. Failure to obey this caution may cause equipment damage.

NOTE

Upon removal of any fuel line, hose or fittings, plug all open ports and place caps over all fuel lines and hoses to prevent contamination of fuel system.

5.5.5.1 Removal.

- a. Place clean shop rag inside gear housing, so that rag is against fuel injection pump drive gear (figure 5-5, 1) and prevents objects from falling into gear hose.
- b. Remove two of three bolts (2), washers (3) and spacers (4) that secure fuel injection pump drive gear (1) to fuel injection pump (5).

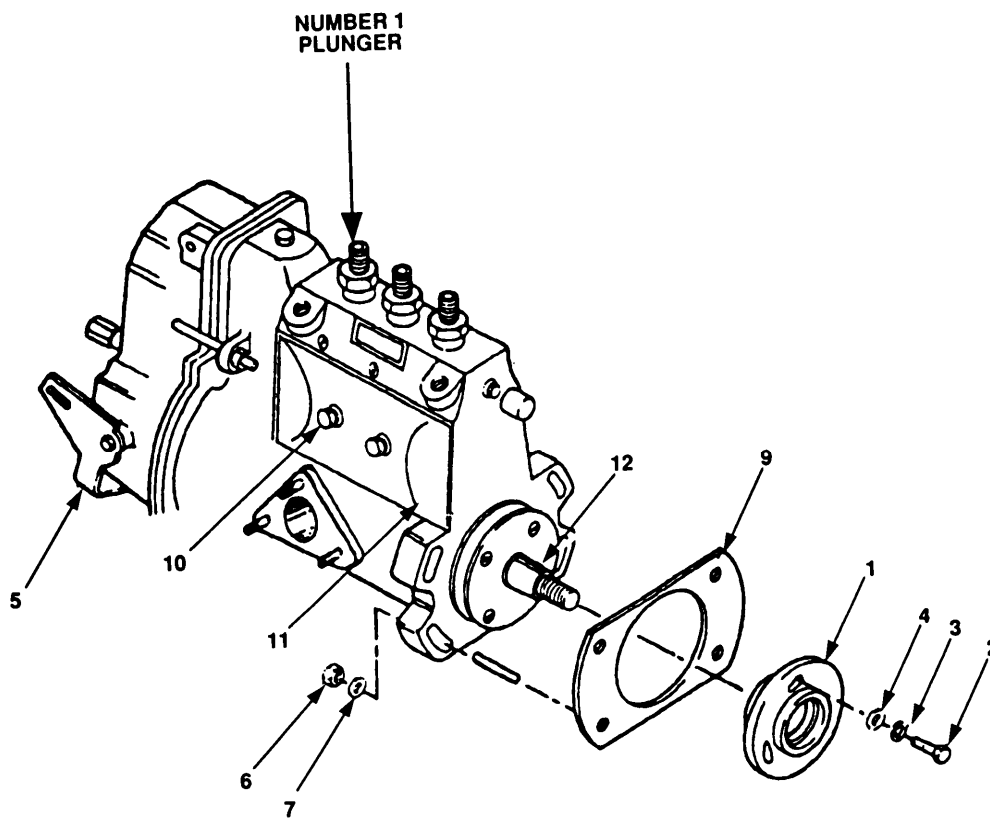

Figure 5-5 Fuel Injection Pump Maintenance.

- c. Remove three of four nuts (6) and washers (7) from fuel injection pump mounting studs.
- d. Mark gear teeth on fuel injection pump drive gear (1) and idler gear in case fuel injection pump drive gear falls out of position.
- e. Remove remaining bolt (2), flat washer (3) and spacer (4) that secure fuel injection pump drive gear (1) to fuel injection pump (5).

NOTE

To prevent difficulty in installing fuel injection pump while fuel injection pump drive gear is disconnected, do not turn crankshaft.

- f. While one person holds drive fuel injection drive gear (1) in place, remove remaining nut (6), washer (7) and injection pump (5).
- g. Remove and discard gasket (9).

5.5.5.2 Installation.

- a. Remove two bolts (10), with preformed packing, and one plate (11) with gasket.
- b. Turn fuel injection pump drive shaft (12) on new fuel injection pump clockwise until Number 1 plunger just starts to move upward.
- c. Install plate (11) with gasket, and two bolts (10) with preformed packing.
- d. Install gasket (9) on mounting studs.

NOTE

Before installation of fuel injection pump, check that marks on fuel injection pump drive gear and idler gear are aligned. Check that engine is still at TDC for number 1 cylinder.

- e. While one person holds fuel injection pump drive gear (1) in place, install fuel injection pump (5) on mounting studs.
- f. Install four washers (7) and nuts (6) on mounting studs, but do not tighten.
- g. Install three spacers (4), washers (3) and bolts (2) to secure fuel injection pump drive gear (1). Check to ensure mark on fuel injection gear (1) and idler gear (8) are aligned.
- h. Connect fuel injection lines to fuel injection pump.
- i. Tighten nuts.
- j. Remove rag.
- k. Connect fuel lines to fuel supply pump.
- l. Set the injection pump timing in accordance with paragraph 5.5.2.

5.5.6 Injection Nozzle Testing.

INITIAL SETUP

Test Equipment

Injection Pump Tester gauge (appendix B, Section III, Item 9).

Tools

General Mechanics Tool Kit (appendix B, Section III, Item 1)

Equipment Conditions

Equipment shut down, refer to paragraph 2.5.2.

Injection nozzle removed, paragraph 5.5.3 step a.

General Instructions

To prevent rolling or sliding, do not work on equipment that is not securely stabilized.

do not smoke or use open flames around fuel. Ensure container is used to catch fuel and fuel is disposed of properly.

do not allow body parts to come in contact with fuel during test. Fuel under test is under extremely high pressure and may cut through skin.

Do not work on equipment without following standard shop safety precautions.

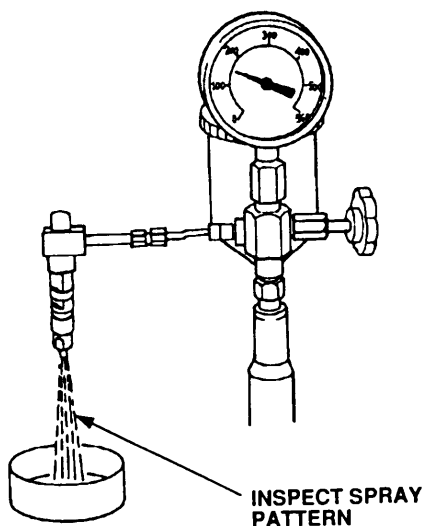

Figure 5-6. Injection Nozzle Testing.

WARNING

- To prevent rolling or sliding, do not work on equipment that is not securely stabilized. Ensure both wheels are secure.
 - Do not smoke or use open flames around fuel. Ensure container is used to catch fuel and fuel is disposed of properly.
 - Do not allow body parts to come in contact with fuel during test. Fuel under test is under extremely high pressure and may cut through skin.
 - Failure to obey these warnings may result in personal injury or death.
- a. Connect injection nozzle to injection timing pump (figure 5-6).
 - b. With pressure gauge cut in, press nozzle tester pump lever several times.

- c. Read opening pressure and inspect spray pattern.

NOTE

Readings should be 2537-2653 psi (175-183 bar) for used nozzle. Readings should be 2610-2726 psi (180-188 bar) for new nozzle, or new spring in nozzle. The jet pattern must be solid without surrounding mist.

- d. Reduce pressure to 362.5-435 pounds (25-30 bar) below specified opening pressure, check that no fuel dribbles from nozzle.
- e. Adjust injector nozzle opening pressure by adding shims to increase or removing shims to decrease (paragraph 5.5.7).
- f. Repeat test as required, then remove injection nozzle from nozzle tester.

5.5.7 Injection Nozzle Maintenance.

This task covers: 5.5.7.1 Removal 5.5.7.3 Installation
 5.5.7.2 Repair

INITIAL SETUP

Tools

General Mechanics Tool Kit (appendix B, Section III, Item 1)

Injector Pump Tester gauge (appendix B, Section III, Item 9)

Equipment Conditions

Equipment shut down, refer to paragraph 2.5.1.2 or 2.5.2.2.

Injection nozzle removed, paragraph 5.5.3 step a.

General Instructions

To prevent rolling or sliding, do not work on equipment that is not securely stabilized.

Do not smoke or use open flames around fuel. Ensure container is used to catch fuel and fuel is disposed of properly.

Do not work on equipment without following standard shop safety precautions.

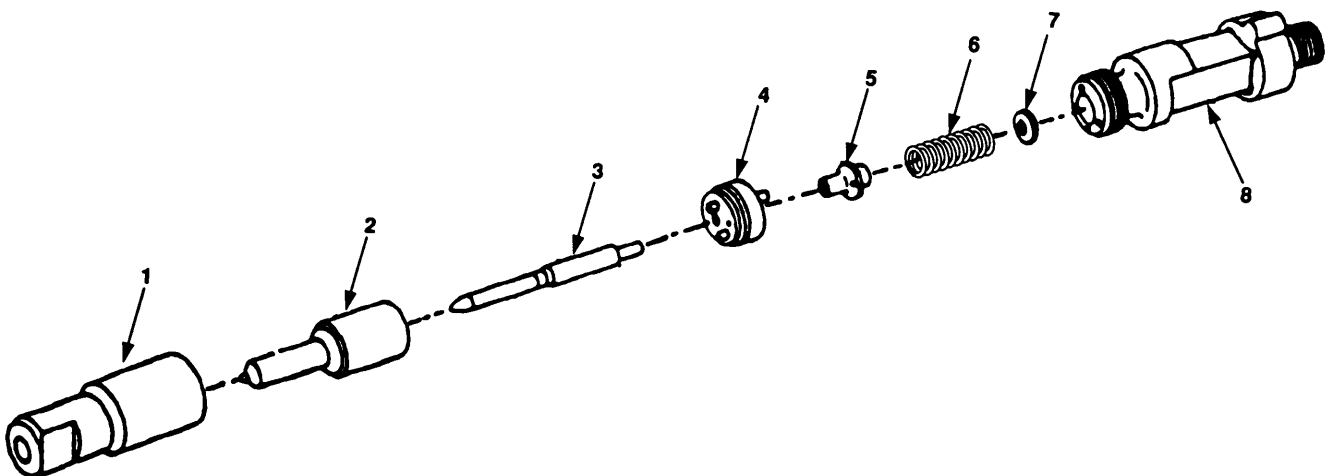

Figure 5-7. Injection Nozzle Maintenance.



- To prevent rolling or sliding, do not work on equipment that is not securely stabilized. Ensure both wheels are secure.
- Do not smoke or use open flames around fuel. Ensure container is used to catch fuel and fuel is disposed of properly.
- Failure to obey these warnings may result in personal injury or death.

5.5.7.1 Removal.

- a. Unscrew cap (figure 5-7, 1) and remove body (2), needle (3), and intermediate piece (4).

- b. Remove plunger (5), spring (6), shims (7) from holder (8).



Compressed *air is* under extreme pressure, keep your hands and arms away from the compressed *air*. Failure to obey this warning may result in personal injury.

5.5.7.2 Repair.

- a. Wash all parts in clean diesel fuel and blow out with compressed air.
- b. Inspect for obvious defects and replace damaged parts.

5.5.7.3 Installation.

- a. Install shims (7), spring (6) in holder (8), and plunger (5) with shoulder next to spring.
- b. Insert intermediate piece (4) with guide pins into holes in holder. Insert needle (3) in body (2). Align body holes with guide pins on intermediate piece (4) and insert guide pins, then install cap (1).
- c. Test injection nozzle in accordance with paragraph 5.5.6.

5.5.8 Engine Cowlings Maintenance.

This task covers: 5.5.8.1 Removal 5.5.8.2 Installation

INITIAL SETUPTools

General Mechanic's Tool Kit (appendix B, Section III, Item 1)

Equipment Conditions

Oil cooling coil removed, paragraph 4.10.22.

Material/Parts

Lockwashers (TM 10-4320-226-24P)

Fuel lines from fuel injection pump removed, paragraph 4.10.16.

General InstructionsEquipment Conditions

Equipment shut down, refer to paragraph 2.5.1.2 or 2.5.2.2.

To prevent rolling or sliding, do not work on equipment that is not securely stabilized.

Muffler removed, paragraph 4.10.4.

Do not work on equipment without following standard shop safety precautions.

5.7.4.1 Removal.

- a. Remove three bolts (figure 5-8, 1), lockwashers (2), and washers (3) from forward vertical cowling (4).
- b. Remove bolt (5) and washer (6) securing forward vertical cowling (4) to engine.
- c. Remove nut (7), bolt (8), lockwasher (9), and washer (10) securing forward vertical cowling (4) to lower cowling (11).
- d. Remove forward vertical cowling (4).
- e. Remove three bolts (12) and washers (13) attaching lower cowling (11) to engine.
- f. Remove nut (14), lockwasher (15), washer (16), and bolt (17), attaching lower cowling (11) to rear vertical cowling (18) .
- g. Remove lower cowling (11).
- h. Remove bolt (19), lockwasher (20), and washer (21) from rear vertical cowling (18).
- i. Remove three bits (22), washers (23), and lockwashers (24).
- j. Remove six bolts (25), one washer (26) and six washers (27) from cylinder cowling (28).
- k. Remove cylinder cowling (28) and rear vertical cowling (18).
- l. Remove two bolts (29), lockwashers (30), washers (31), and two brackets (32).
- m. Remove exhaust cowling (33).

5.7.4.2 Installation.

- a. Position exhaust cowling (33) on engine and install two brackets (32), washers (31), lockwashers (30) and bolts (29).
- b. Position rear vertical cowling (18) and cylinder cowling (28) on engine.

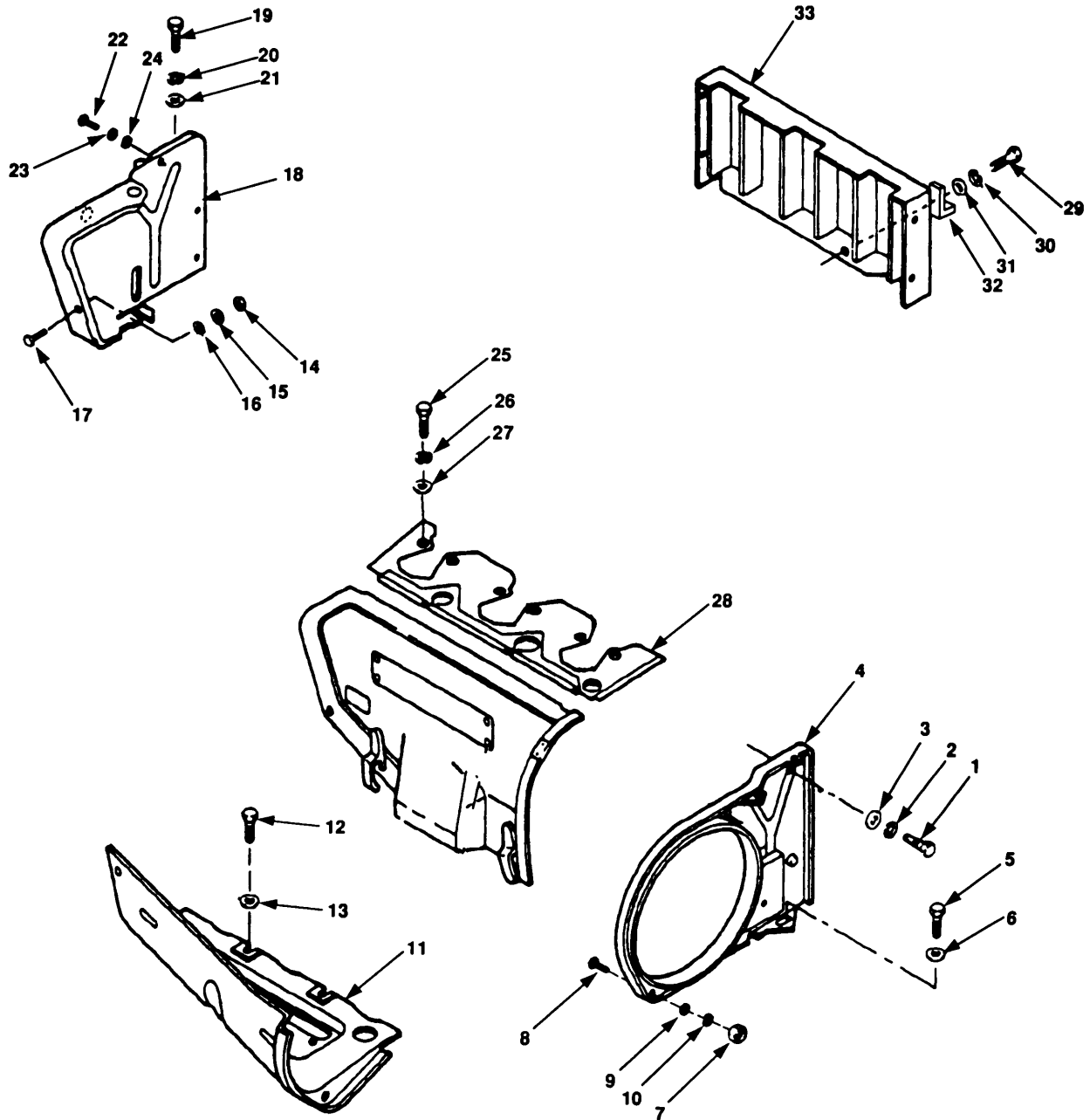

Figure 5-8. Engine Cowlings Maintenance.

- c. Install six washers (27), one washer (26) and six bolts (25).
- d. Install three washer (23), lockwashers (24), and bolts (22).
- e. Install washers (21), lockwashers (20), and bolt (19) to rear vertical cowling (18).
- f. Position lower cowling (11) in place.
- g. Install bolt (17), washer (16), lockwasher (15), and nut (14)-
- h. Install three washers (13) and bolts (12).
- i. Position forward vertical cowling (4) in place.
- j. Install washer (10), lockwasher (9), bolt (8), and nut (7).
- k. Install washer (6) and bolt (5).
- l. Install three washers (3), lockwashers (2), and bolts (1).

5.5.9 Top Dead Center.

INITIAL SETUP

Test Equipment

36 mm Socket (appendix B, Section III, Item 3)
Position pointer (appendix B, Section III, Item 5)
Timing mark and bolt Scale (appendix B, Section III, Item 10)

Tools

General Mechanic's Tool Kit (appendix B, Section III, Item 1)

Equipment Conditions

Equipment shut down, refer to paragraph 2.5.1.2 or 2.5.2.2.
V-belt guard removed, paragraph 4.10.6.
Negative battery cable disconnected, paragraph 4.12.3.

General Instructions

do not work on engine with negative battery cable connected.

Do not work on equipment without following standard shop safety precautions.

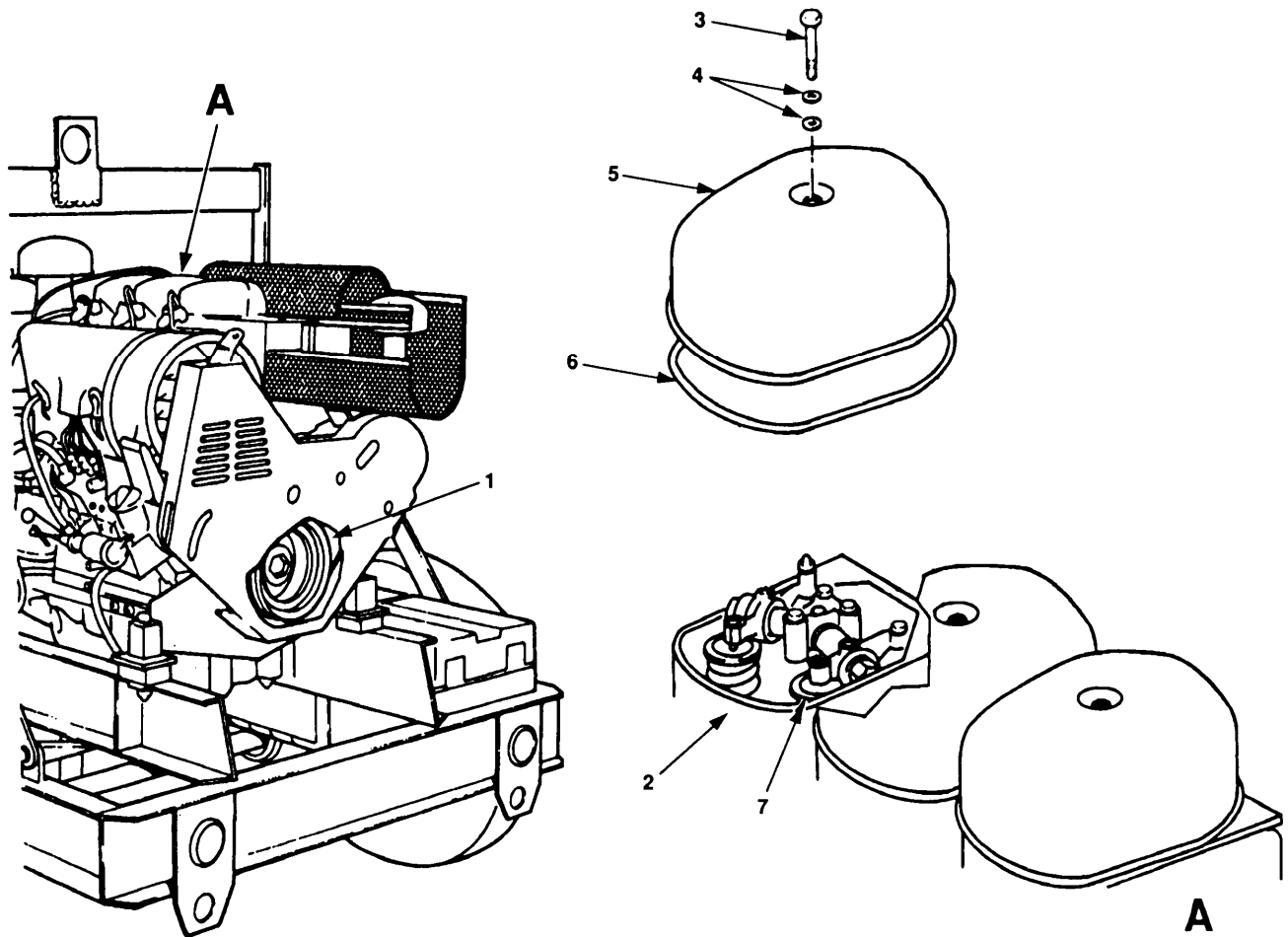

Figure 5-9. Marking of Top Dead Center (TDC).

- a. Install position pointer so that pointed end almost contacts outside edge of crankshaft pulley (figure 5-9, 1).
 - b. Locate number 1 cylinder (2).
 - c. Remove bolt (3), washers (4), cover (5), and gasket (6).
 - d. Rotate crankshaft pulley (1) counterclockwise until valves on number 1 cylinder (2) overlap.
 - c. Turn crankshaft pulley 360° (one complete turn).
 - d. Rotate crankshaft pulley 1/4 turn.
 - e. Depress exhaust valve (7) of number 1 cylinder down. Install 0.006 (6 mm) keystone between exhaust valve stem face and rocker arm.
 - f. Rotate crankshaft pulley (1) clockwise until piston lightly contacts open exhaust valve (7). Scribe mark even with pointer on front pulley.
 - g. Rotate crankshaft pulley counterclockwise 1/4 turn and remove keystone.
 - h. Rotate crankshaft pulley (1) clockwise 1/2 turn and install 0.006 (6 mm) keystone between number 1 cylinder (2) exhaust valve (7) stem face and rocker arm.
 - i. Rotate crankshaft pulley (1) counterclockwise until piston lightly contacts open exhaust valve (7). Scribe mark even with position pointer on front of crankshaft pulley (1).
- Rotate crankshaft pulley (1) 1/4 turn clockwise and remove keystone.
- Place mark exactly in center of two marks on crankshaft pulley (1). Center mark is TDC.
- l. Use timing mark and bolt scale, and scribe a mark 32° clockwise from TDC mark on crankshaft pulley (1). This mark is 32° Before TDC (BTDC) and is the fuel injection timing mark. Be sure mark is considering pulley rotation.
 - m. Install bolt (3), washers (4), cover (5), and new gasket (6).
 - n. Remove position pointer.

5.5.10 Crankshaft Pulley and Seal Maintenance.

This task covers: 5.5.10.1 Removal 5.5.10.2 Installation

INITIAL SETUP

Tools

General Mechanic's Tool Kit (appendix B, Section III, Item 1)
 36 mm Socket (appendix B, Section III, Item 3)
 Torque Wrench 0-175 ft lbs (appendix B, Section III, Item 3)
 Angle Turn Indicator Tool (appendix B, Section III, Item 11)
 Seal Removing Tool (appendix B, Section III, Item 12)
 Crankshaft seal installer (appendix B, Section III, Item 13)

Equipment Conditions

Equipment shut down, refer to paragraph 2.5.1.2 or 2.5.2.2.
 V-belt guard removed, paragraph 4.10.6.

General Safety Instructions

To prevent rolling or sliding, do not work on equipment that is not securely stabilized.

do not work on equipment without following standard shop safety precautions.

Materials/Parts

Seal (TM 10-4320-226-24P)
 Grease (appendix E, Section II, item 5)

5.5.10.1 Removal.



To prevent rolling or sliding, do not work on equipment that is not securely stabilized. Ensure both wheels are secure. Failure to obey this warning may result in serious personal injury.

NOTE

Bolt securing pulley to crankshaft has left hand threads.

- a. Using 36 mm socket turn bolt (figure 5-10, 1) clockwise while restraining pulley and remove bolt (1), washer (2), and pulley (3).
- b. Install bolt (1).
- c. Using seal removing tool, remove crankshaft seal (4) and discard.
- d. Remove bolt (1).

5.5.10.2 Installation.

- a. Lightly lubricate new seal with grease.
- b. Position crankshaft seal (4) to engine (lip inward). Press on crankshaft seal using front crankshaft seal installer.

NOTE

Check crankshaft for uneven seal contact. If seal contact with crankshaft is uneven, carefully reposition seal.

- c. Align locating hole in crankshaft pulley with locating pin in crankshaft gearwheel and slide pulley (3) into position.
- d. Install washer (2) and bolt (1).

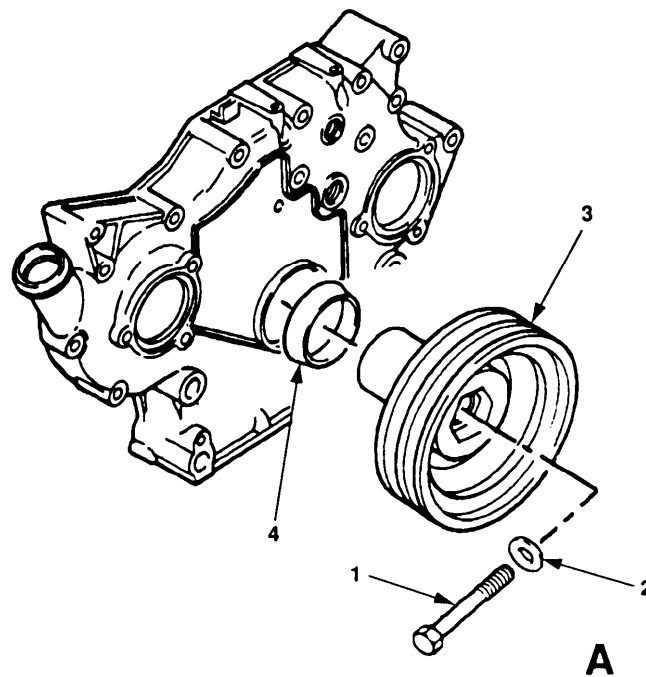
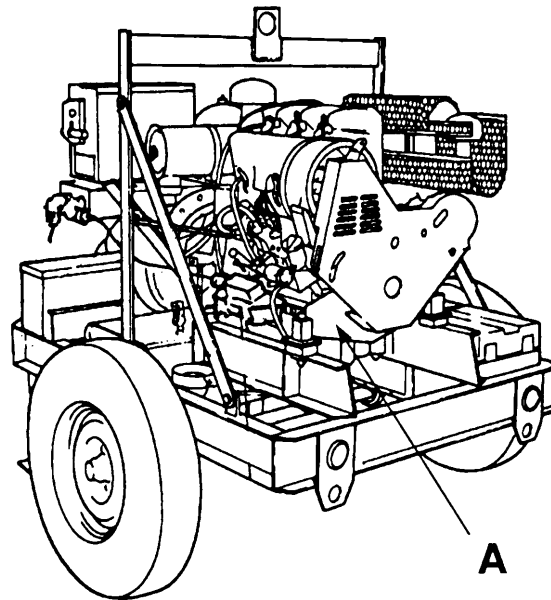

Figure 5-10. Crankshaft Pulley and Seal Maintenance.

- e. While holding pulley in place, use angle of turn indicator tool to torque bolt (1) in accordance with appendix G.
- f. If crankshaft pulley is replaced, mark TDC paragraph 5.5.9.
 - (1) Install position pointer so that pointed end almost contacts outside edge of crankshaft pulley (figure 5-9, 1).
 - (2) Locate number 1 cylinder (2).
 - (3) Remove bolt (3), washers (4), cover (5), and gasket (6).
 - (4) Rotate crankshaft pulley (1) counterclockwise until valves on number 1 cylinder (2) overlap.
 - (5) Turn crankshaft pulley 360° (one complete turn).
 - (6) Rotate crankshaft pulley 1/4 turn.
 - (7) Depress exhaust valve (7) of number 1 cylinder down. Install 0.006 (6 mm) keystone between exhaust valve stem face and rocker arm.
 - (8) Rotate crankshaft pulley (1) clockwise until piston lightly contacts open exhaust valve (7). Scribe mark even with pointer on front pulley.
 - (9) Rotate crankshaft pulley counterclockwise 1/4 turn and remove keystone.
 - (10) Rotate crankshaft pulley (1) clockwise 1/2 turn and install 0.006 (6 mm) keystone between number 1 cylinder (2) exhaust valve (7) stem face and rocker arm.
 - (11) Rotate crankshaft pulley (1) counterclockwise until piston lightly contacts open exhaust valve (7). Scribe mark even with position pointer on front of crankshaft pulley (1).
 - (12) Rotate crankshaft pulley (1) 1/4 turn clockwise and remove keystone.
 - (13) Place mark exactly in center of two marks on crankshaft pulley (1). Center mark is TDC.
 - (14) Use timing mark and bolt scale, and scribe a mark 32° clockwise from TDC mark on crankshaft pulley (1). This mark is 32° Before TDC (BTDC) and is the fuel injection timing mark. Be sure mark is considering pulley rotation.
 - (15) Install bolt (3), washers (4), cover (5), and new gasket (6).
 - (17) Remove position pointer.

5.6 PUMPING ASSEMBLY MAINTENANCE

5.6.1 Centrifugal Pump Replacement.

This task covers: 5.6.1.1 Removal 5.6.1.2 Installation

INITIAL SETUP

Tools

General Mechanic's Tool Kit (appendix B, Section III, Item 1)
 Torque Wrench 0-175 ft lbs (appendix B, Section III, Item 3)
 Engine Sling (appendix B, Section III, Item 3)
 Jack stands (appendix B, Section III, Item 3)
 Angle of Turn Indicator Tool (appendix B, Section III, Item 11)

Material/Parts

Locknuts (TM 10-4320-226-24P)
 Lockwashers (TM 10-4320-226-24P)
 Gaskets (TM 10-4320-226-24P)
 Oil (appendix E, Section II, Item 8)
 Tags (appendix E, Section II, Item 12)

References

LO 10-4320-226-12

Equipment Conditions

Equipment shut down, refer to paragraph 2.5.1.2 or 2.5.2.2.
 Control panel removed, paragraph 4.13.1.
 Suction manifold removed, paragraph 4.15.3.
 Discharge connection removed, paragraph 4.15.5.
 Tool Box removed paragraph 4.17.6.

General Instructions

Do not lift heavy assemblies without lifting device.
 To prevent rolling or sliding, do not work on equipment that is not securely stabilized.
 Do not work on trailer with pump assembly removed without jackstands at the rear of the trailer.
 Do not work on equipment without following standard shop safety precautions.

5.6.1.1 Removal.



- To prevent rolling or sliding, do not work on equipment that is not securely stabilized. Ensure both wheels are secure.
 - Do not work on trailer with pump assembly removed without jackstands at the rear of the trailer. The trailer will tip to the rear without rear jackstands.
 - Do no lift heavy assemblies without lifting device.
 - Failure to obey these warnings may result in personal injury or death.
- a. Remove twelve bolts (figure 5-11, 1), lockwashers (2), four washers (3), and two intermediate bracket covers (4).
 - b. Remove two lock nuts (5), beveled washers (6), bolts (7), and washers (8).
 - c. Remove nut (9) and lockwasher (10) and position bracket (11) clear of centrifugal pump (12).

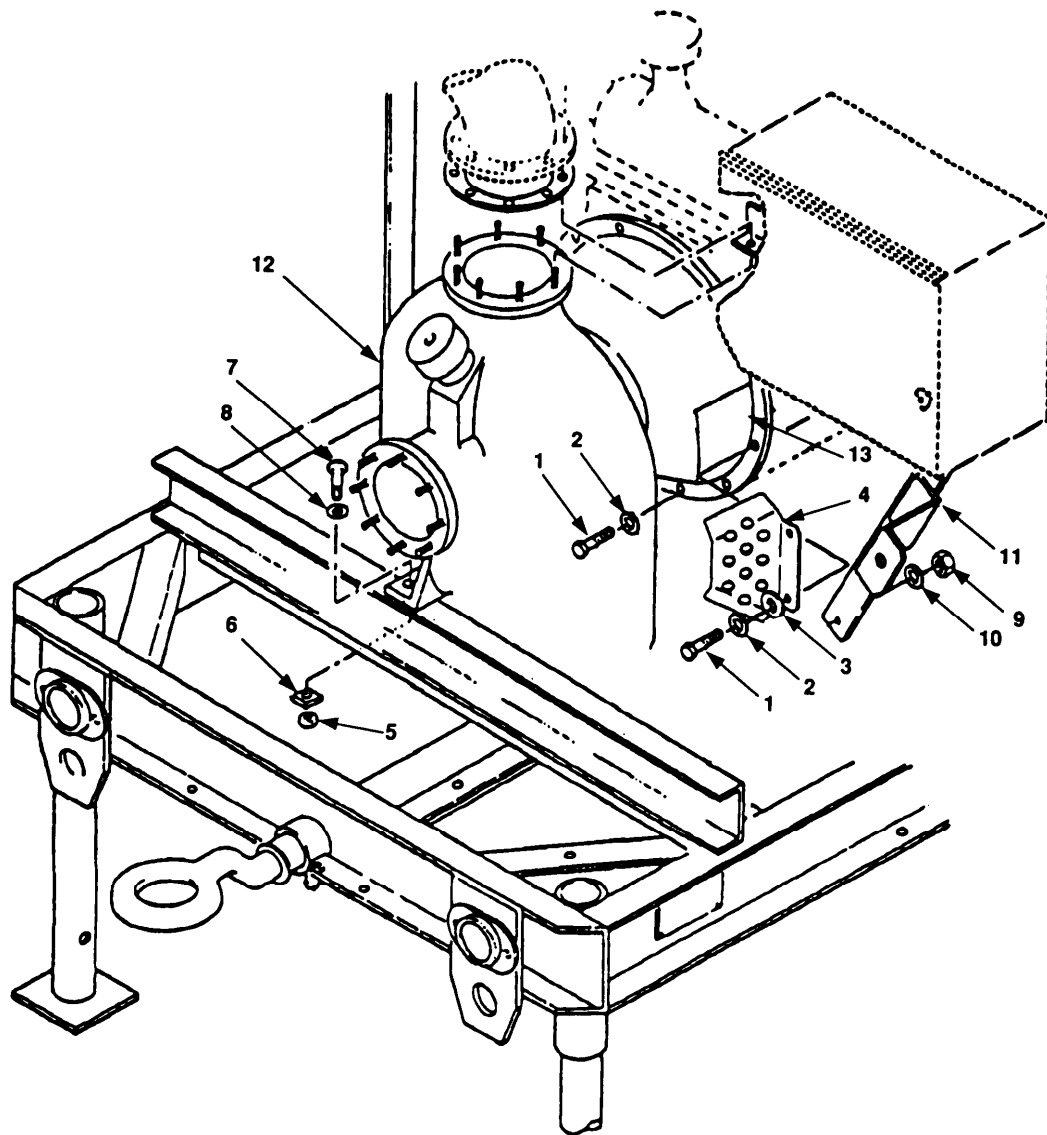

Figure 5-11. Centrifugal Pump Maintenance.

WARNING

Do not lift heavy assemblies without lifting device. Failure to obey this warning may result in personal injury or death.

- d. Place sling of adequate size around centrifugal pump (12) and attach engine sling.
- e. Place a jackstand under each side of the rear trailer frame for support.
- f. With weight of centrifugal pump (12) on engine sling, slowly and carefully pull centrifugal pump (12) back until flexible coupling disengages from connection ring.
- g. Pull centrifugal pump (12) completely clear of engine.
- h. Carefully remove centrifugal pump (12) clear of frame.
- i. Tag and remove any shims. Retain shims for installation.

5.6.1.2 Installation.**WARNING**

Do not lift heavy assemblies without lifting device. Failure to obey this warning may result in personal injury or death.

- a. Place lifting strap of adequate size around centrifugal pump (12) and connect engine sling.
- b. Raise centrifugal pump (12) and position over frame.
- c. Slowly lower centrifugal pump (12), aligning flexible coupling with connection ring observed through openings (13) on either side of intermediate bracket.
- d. Push centrifugal pump (12) toward engine and guide flexible coupling until coupling engages with coupling on engine.
- e. Secure centrifugal pump (12) as follows:
 - (1) Install shims between pump and frame. Remove tags.
 - (2) Install two bolts (7), washers (8), beveled washers (6), and lock nuts (5). Do not tighten.
 - (3) Install four bolts (1), lockwashers (2), and washers (3) to secure two intermediate bracket covers (4).
 - (4) Install remaining eight bolts (1), and lockwashers (2).
 - (5) Install bracket (11), lockwasher (10), and nut (9).
 - (6) Torque all hardware installed in accordance with Appendix G.
- f. Remove jackstands at rear of trailer.
- h. Refer to LO 10-4320-226-12 and add oil as necessary.

5.6.2 Impeller Replacement.

This task covers: 5.6.2.1 Removal 5.6.2.2 Installation

INITIAL SETUP

Tools

General Mechanic's Tool Kit (appendix B, Section III, Item 1)
 Caliper Vernier (appendix B, Section III, Item 3)
 Two 3 1/2 inch (76.2 mm) long screws (appendix E, Section II, Item 15)
 Torque wrench 0-175 ft lbs (appendix B, Section III, Item 3)
 Two steel bars, 1 1/4 inch (31.75mm) x 3/8 inch (9.525mm) x 14 inches (355.6mm)

Equipment Conditions

Equipment shut down, refer to paragraph 2.5.1.2 or 2.5.2.2.
 Pump assembly removed, paragraph 5.6.1.

General Instructions

do not work on equipment without following standard shop safety precautions.

Material/Parts

Gasket (TM 10-4320-226-24P)
 Lockwasher (TM 10-4320-226-24P)
 Seals (TM 10-4320-226-24P)
 Oil (appendix E, Section II, Item 8)

5.6.2.1 Removal.

- a. Scribe a mark on intermediate housing (figure 5-12, 1) and volute housing (2).
- b. Remove nuts (3), lockwashers (4), and intermediate housing (1) from volute housing (2).
- c. Remove and discard gasket (5).
- d. Remove and retain two screws (6) and lockwashers (7) diagonally opposite each other.
- e. Install two 3-inch (76.2mm) long screws into threaded holes.
- f. Place steel bar (8), 1 1/4 inch (31.75mm) x 3/8 inch (9.525mm) x 14 inches (355.6mm), between screws as shown in figure 5-21 view A.
- g. Place a second steel bar (9) into impeller between vanes as shown.

CAUTION

Ensure that steel bar (9) is held rigid while striking with hammer. Impeller is made of brass and damage to vanes may occur. Failure to obey this caution may cause damage to impeller.

- h. While holding steel bar (8) at coupling securely in position, and steel bar (9) at impeller end rigid, firmly strike steel bar (9) at impeller end in counterclockwise direction while facing impeller (10) until impeller breaks loose from shaft.
- i. Remove impeller (10), holding bar (8) and striking bar (9).
- j. Remove spacer shims (11), spring centering washer (12), and spring (13) from shaft.

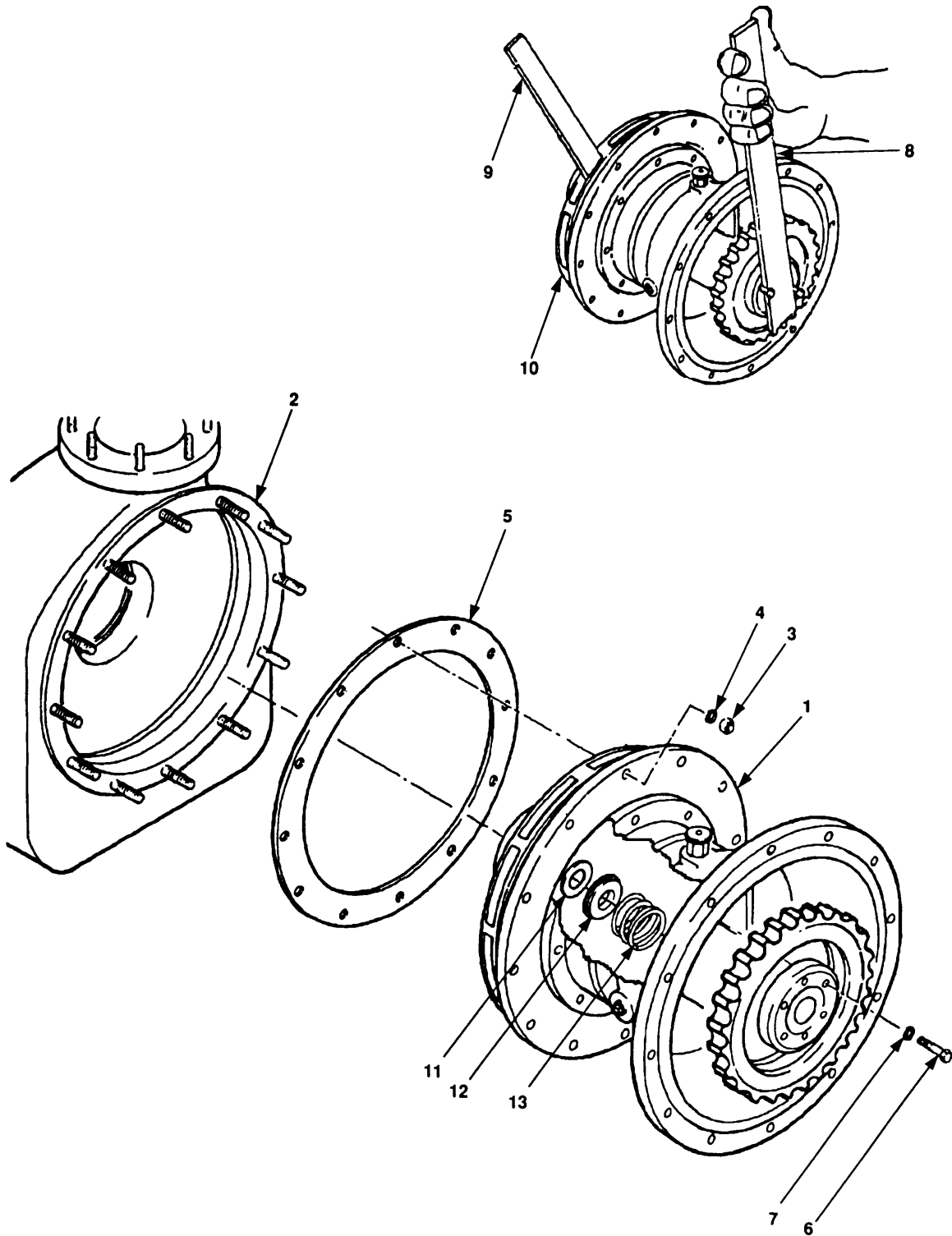

Figure 5-12. Impeller Maintenance. (Sheet 1 of 2)

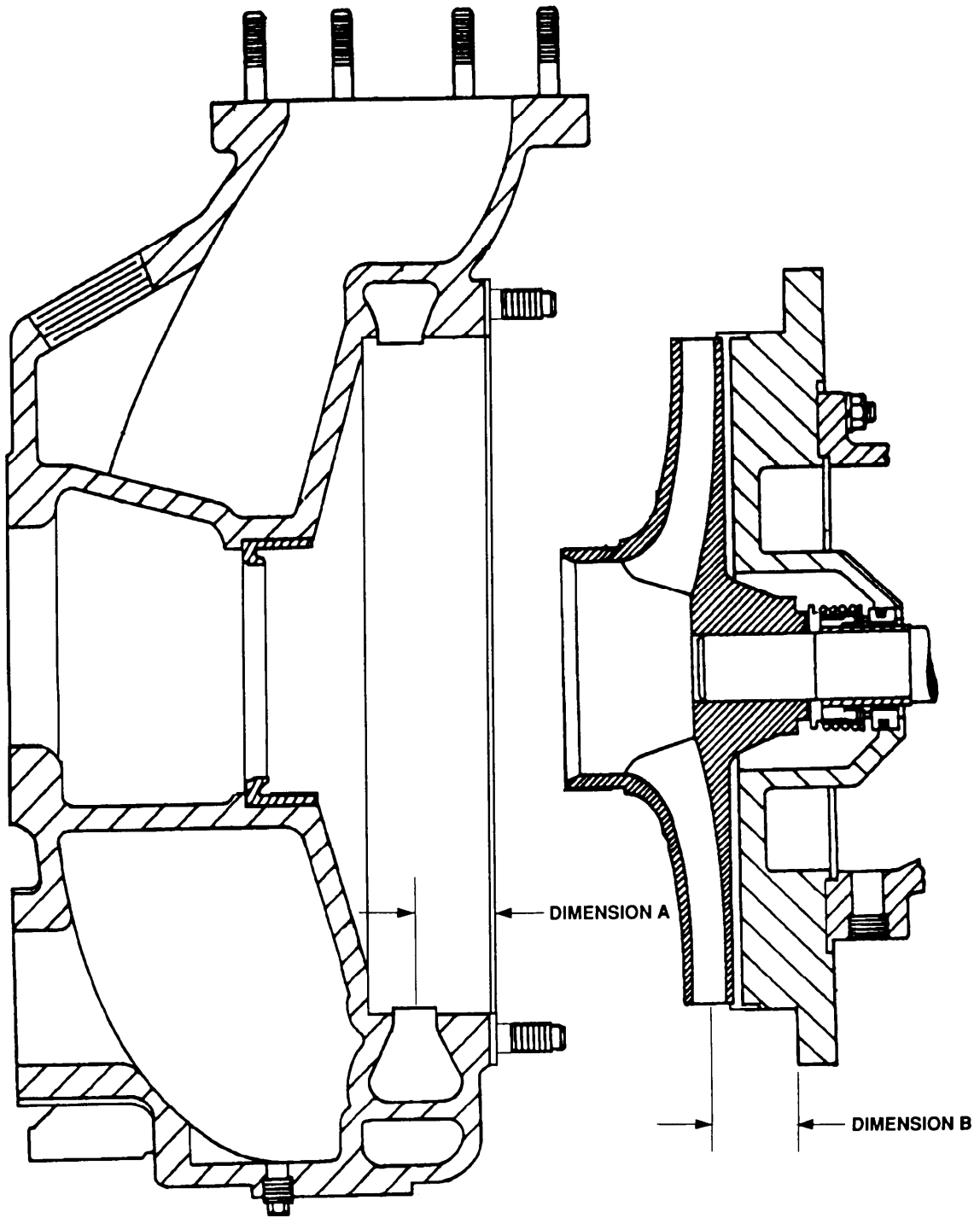

Figure 5-12. Impeller Maintenance. (sheet 2)

5.6.2.2 Installation.**CAUTION**

When installing impeller, ensure that spring remains centered on spring centering washer.

- a. Install spring (13), spring centering washer (12), and spacer shims (11) on shaft.
- b. With large end of intermediate bracket on clean work surface, and threaded (impeller) end of shaft up, install impeller (10) onto shaft by rotating clockwise, until all main shaft, sleeve, and impeller hub mating surfaces are a snug fit. No torquing is required. Impeller tightens itself during pump operation.
- c. Place gasket (5) on volute housing (2) near flange.
- d. With vernier caliper, determine dimension A from rear of gasket on flange of volute to center of discharge opening inside volute as shown in figure 5-12, sheet 2.
- e. Measure dimension B from front flange of seal plate to center of impeller opening as shown in figure 5-12 sheet 2.
- f. Determine the difference between dimensions A and B.

CAUTION

When the difference between A and B is greater or less than 1/32 inch (0.794mm), do not install impeller. Failure to obey this caution may result in equipment damage.

- g. When difference is greater or less than 1/32 inch (0.794 mm), remove impeller and add or remove shims as required.
- h. Tap out suction wear ring.
- i. Install new suction wear ring with widest face towards suction outlet.
- j. Assemble volute housing (figure 5-12, sheet 1, 2) and intermediate housing (1), making certain that scribe marks made in paragraph 5.2.2.1, step a, are aligned.
- k. Secure volute housing (2) and intermediate bracket (1) together with lockwashers (4) and nuts (3). Torque nuts as indicated in appendix G.
- l. Install lockwashers (7) and screws (6).

5.6.3 Flexible Coupling Maintenance.

This task covers: 5.6.3.1 Removal 5.6.3.2 Installation

INITIAL SETUP

Tools

General Mechanic's Tool Kit (appendix B, Section III, Item 1)
Vernier Caliper (appendix B, Section III, Item 3)
Two 3 1/2 inch screws (appendix E, Section II, Item 15)

Equipment Conditions

Equipment shut down, refer to paragraph 2.5.1.2 or 2.5.2.1.

pump assembly removed, paragraph 5.6.1.

General Instructions

Material/Parts

Lockwashers (TM 10-4320-226-24P)

Do not work on equipment without following standard shop safety precautions.

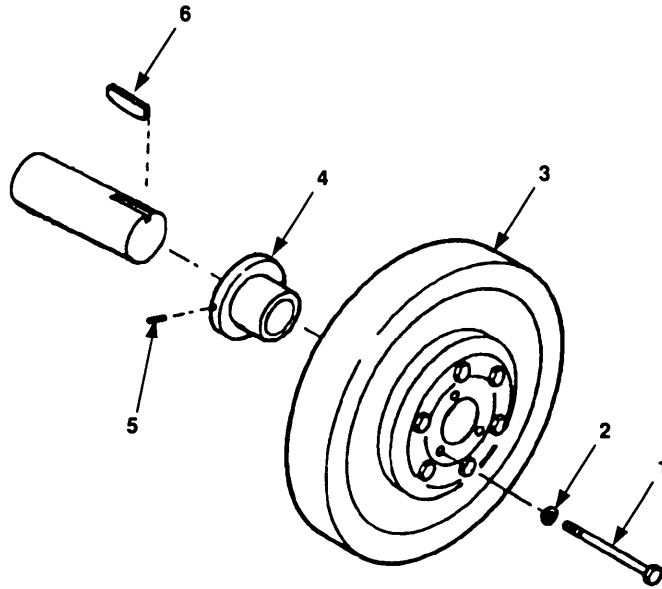

Figure 5-13. Taper Lock Hub Coupling Maintenance.

5.6.3.1 Removal.

- a. Using vernier calipers, measure distance from oil seal to back of flexible coupling.
- b. Record measurement.
- c. Remove three screws (figure 5-13, 1) and lockwashers (2) from mounting holes.
- d. Thread two 3 1/2 inch screws into mounting holes where screws (1) were removed.
- e. Tighten screws until flexible coupling (3) is evenly pressed off bushing (4). Remove screws.
- f. Remove flexible coupling (3).
- g. Loosen set screw (5) and remove taper bushing (4) from shaft.

5.6.3.2 Installation.

- a. Install bushing (4) to measurement recorded in step b of paragraph 5.6.3.1.
- b. Tap key (6) until it is even with set screw (5), then tighten.
- c. Align flexible coupling (3) on taper bushing (4) with holes in flange end.
- d. Install lockwashers (2) and screws (1). Evenly tighten screws to secure flexible coupling (3) to taper bushing (4).

5.6.4 Sleeve and Rotating Assembly Maintenance.

This task covers:	5.6.4.1 Removal	5.6.4.3 Repair
	5.6.4.2 Inspection	5.6.4.4 Installation

INITIAL SETUP

Tools

General Mechanic's Tool Kit (appendix B, Section III, Item 1)
 Torque Wrench (appendix B, Section III, Item 3)
 Arbor press (appendix B, Section III, Item 3)

Equipment Conditions

Equipment shut down, refer to paragraph 2.5.1.2 or 2.5.2.2.
 Impeller removed, paragraph 5.6.2.
 Flexible coupling removed paragraph 5.6.3.

Material/Parts

Lockwasher (TM 10-4320-226-24P)
 Gaskets (TM 10-4320-226-24P)
 Front seal (TM 10-4320-226-24P)
 Rear seal (TM 10-4320-226-24P)
 Oil (appendix E, Section II, Item 8)
 Suitable container

General Instructions

Do not work on equipment without following standard shop safety precautions.

5.6.4.1 Removal.

NOTE

Two different type drive couplings are used. One has a taper lock hub with two circles of bolts around hub. The other is a solid hub with two threaded holes opposite each other.

- a. Remove oil drain plug (figure 5-14, 1) and drain oil into suitable container.
- b. Disassemble intermediate housing as follows:
 - (1) Scribe a mark across seal plate (2) and intermediate bracket (3).
 - (2) Remove eight nuts (4) and lockwashers (5).
 - (3) Remove seal plate (2) with rotating seal assembly (6) and sleeve (7).
 - (4) Remove rotating seal assembly (6) and sleeve (7) from seal plate (2).
 - (5) Apply finger pressure to push sleeve (7) out of rotating sleeve assembly (6).
- c. Remove shaft as follows:
 - (1) Remove screws (8) and lockwashers (9) from intermediate bracket (3) and discard lockwashers.
 - (2) Remove bearing cap (10).
 - (3) Remove bearing cap gasket (11) and discard.
 - (4) Remove front oil seal (12) and discard.
 - (5) Remove shaft assembly (13) as a single unit.
 - (6) Tap rear oil seal (14) out of intermediate bracket (3) and discard.

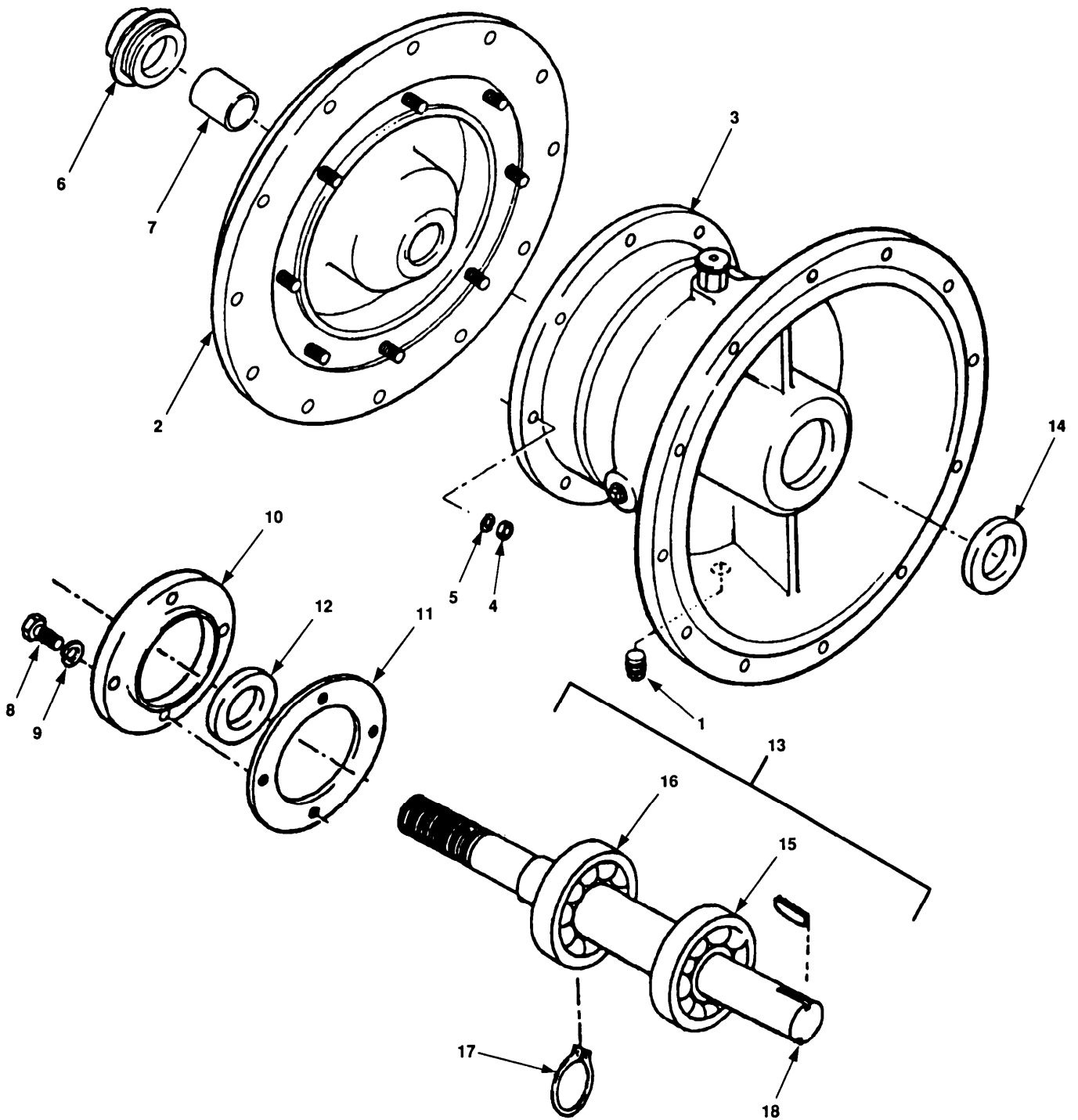

Figure 5-14. Sleeve and Rotating Assembly Maintenance.

5.6.4.2 Inspection.



Do not use dry cleaning solvent without proper ventilation and clothing. Do not smoke or use near open flame or excessive heat. Dry cleaning solvent is potentially dangerous to personnel and property. Clean parts in a well-ventilated area. Avoid inhalation of solvent fumes. Wear goggles and rubber gloves to protect eyes and skin. Wash exposed skin thoroughly. Flash point of solvent is 100°F to 138°F (38°C to 59°C). Failure to obey this warning may result in personal injury or death.

- a. Clean all parts. Dry with compressed air.
- b. Rotate bearings (15 and 16) on shaft assembly (13) Ensure that bearings do not feel rough, gritty or loose.
- c. Inspect shaft for deformation of shaft journals or other evidence of damage.
- d. Check impeller vane tip. A slight deformation may have occurred from use of steel bar during removal. If so, use a file to remove burrs. Ensure that no filings fall into impeller.

5.6.4.3 Repair.

- a. Remove retaining ring (17).
- b. Using arbor press, press front bearing (15) and rear bearing (16) off shaft (18).
- c. Lightly oil the shaft (18).

NOTE

Rear bearing contains eight balls. Check to make certain bearing is correct one.

- d. Center rear bearing (16) on shaft and press on with pressure applied to inner race only. Ensure that inner race seats against shaft shoulder.
- e. Turn shaft over with threaded (impeller) end facing upward and retain in press.
- f. Lightly oil shaft (18).



Front bearing must be installed with "THRUST HERE". marking on outer race facing upward toward threaded (impeller) end of shaft.

Front bearing contains twelve balls. Check to make certain bearing is correct one.

- g. With 'THRUST HERE' marking facing toward threaded (impeller) end of shaft (18), and front bearing (15) centered over threaded end, press bearing onto shaft.
- h. Install bearing retaining ring (17) into groove of shaft.

5.6.4.4 Installation.

CAUTION

Ensure that intermediate bracket bearing cavity is free from dirt, dust, or other contamination.

- a. Place intermediate bracket (3) on clean surface with large end facing upward.
- b. Install shaft assembly (13) as follows:
 - (1) Install new rear oil seal (14), with narrow lip of rear oil seal facing inward, into intermediate bracket (3). Tap rear oil seal into place.
 - (2) Turn intermediate bracket (3) over. Lightly oil both bearings (15 and 16) outer races with pump oil.
 - (3) Position shaft assembly (13) with rear bearing (16) pointed toward intermediate bracket (3).
 - (4) Slide shaft assembly (13) into intermediate bracket (3) from impeller end.
 - (5) Press shaft assembly (13) into position, being careful not to cock shaft, creating bearing bind. Ensure that rear bearing (16) is fully seated in intermediate bracket (3).
 - (6) Position new front oil seal (12), with narrow lip of front oil seal facing inward, into bearing cap (10). Tap front oil seal into place. Front oil seal must be flush with bearing cap face when properly installed.
 - (7) Install new bearing cap gasket (11) on bearing cap (10) face.
 - (8) Install bearing cap (10) over shaft assembly (13) onto intermediate bracket (3).
 - (9) Install lockwashers (9) and screws (8).
 - (10) Torque screws to 21 foot pounds (28.25 NM).
- c. Assemble intermediate housing as follows:
 - (1) Push sleeve (7) into rotating sleeve assembly (6).
 - (2) Install sleeve (7) and rotating sleeve assembly (6) into seal plate (2).
 - (3) With large end of intermediate bracket (3) setting on clean work surface and threaded end of shaft assembly (13) up, carefully slide seal plate (2) over shaft assembly.
 - (4) Check that scribe marks on intermediate bracket (3) and seal plate (2) are aligned.
 - (5) Install eight lockwashers (5) and nuts (4) on studs of seal plate (2).
 - (7) Torque nuts (4) in accordance with appendix G.
- d. Install and tighten oil drain plug (1).
- e. Refill oil (LO 10-4320-226-12).

5.6.5 Coupling Flange Maintenance.

This task covers: 5.6.5.1 Removal 5.6.5.2 Installation

INITIAL SETUP

Tools

General Mechanic's Tool Kit (appendix B, Section III, Item 1)

Material/Parts

Lockwashers (TM 10-4320-226-24P)
Gaskets (TM 10-4320-226-24P)
Oil (appendix E, Section II, Item 8)

Equipment Conditions

Equipment shut down, refer to paragraph 2.5.1.2 or 2.5.2.2.

Pump assembly removed, paragraph 5.6.1.

General Instructions

Do not work on equipment without following standard shop safety precautions.

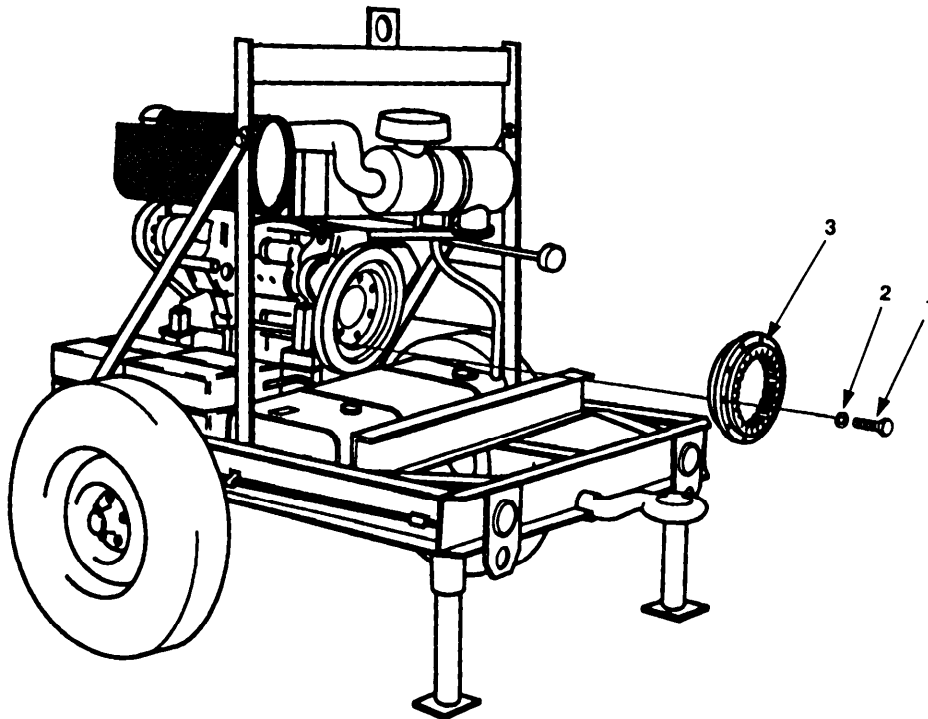

Figure 5-15. Coupling Flange Maintenance.

5.6.5.1 Removal.

- a. Remove ten bolts (figure 5-15, 1) and lockwashers (2).
- b. Remove coupling flange (3).

5.6.5.2 Installation.

- a. Hold coupling flange (3) against engine fly wheel.
- b. Install ten lockwashers (2) and bolts (1).

5.7 FUEL TANK MAINTENANCE.

This task covers: 5.7.1 Removal
5.7.2 Inspect

5.7.3 Repair
5.7.4 Installation

INITIAL SETUP

Tools

General Mechanic's Tool Kit (appendix B, Section III, Item 1)

Material/Parts

Lockwashers (TM 10-4320-226-24P)
Gaskets (TM 10-4320-226-24P)
Adhesive (appendix E, Section II, Item 2)
Cleaning solvent (appendix E, Section II, Item 11)
Tags (appendix E, Section II, Item 12)
Antiseize tape (appendix E, Section II, Item 13)

References

TM 9-237

Equipment Conditions

Equipment shut down, refer to paragraph 2.5.1.2 or 2.5.2.2.

Fuel lines removed from tank paragraph 4.10.16.

pump Assembly removed, paragraph 5.6.1.

General Safety Instructions

To prevent rolling or sliding, do not work on equipment that is not securely stabilized.

Do not smoke, use open flames, or excessive heat while working with fuel. Avoid inhalation of fumes from fuel.

Do not work on equipment without following standard shop safety precautions.

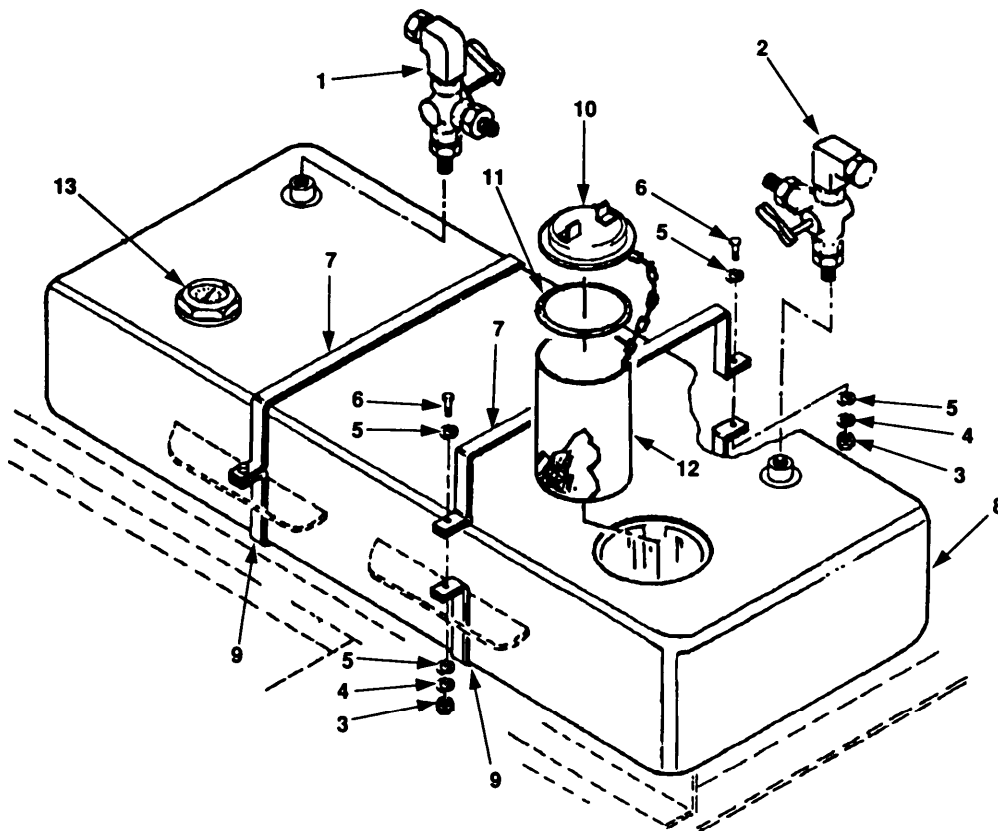

Figure 5-16. Fuel Tank Maintenance.

5.7.1 Removal.



- To prevent rolling or sliding, do not work on equipment that is not securely stabilized. Ensure both wheels are secure.
 - Do not smoke, use open flames, or excessive heat while working with fuel. Avoid inhalation of fumes from fuel.
 - Failure to obey these warnings may result in personal injury or death.
- a. Drain fuel tank into suitable container.
 - b. Remove three-way fuel selector valves (figure 5-16, 1 and 2).
 - c. Remove four nuts (3), lockwashers (4), eight washers (5), and four bolts (6).
 - d. Remove top two straps (7).
 - e. Remove fuel tank (8) and bottom two straps (9) from frame.

5.7.2 Inspection.

- a. Clean exterior of fuel tank (8) with solvent.
- b. Flush interior of fuel tank (8) with solvent.
- c. Purge fuel tank (8) with continuous flow of clean water.
- d. Inspect fuel tank (8) for leakage.
- e. Remove filler cap (10).
- f. Inspect filler cap gasket (11) and strainer (12) for damage.
- g. Inspect fuel gauge (13) for broken or cracked face glass and glass frame screws for looseness.
- h. Inspect straps for damage to anti-chaffing material.

5.7.3 Repair.

- a. Replace any missing or damaged parts.
- b. Weld fuel tank (8) in accordance with TM 9-237.

5.7.2 Installation.

- a. Position two bottom straps (9) and fuel tank (8) on frame.
- b. Install two top straps (7).
- c. Install four bolts (6), eight washers (5), four lockwashers (4) and nuts (3).
- d. Install three-way fuel selector valves (1 and 2).

5.8 AXLE ASSEMBLY MAINTENANCE.

This task covers: 5.8.1 Removal 5.8.2 Installation

INITIAL SETUP

Tools

General Mechanic's Tool Kit (appendix B, Section III, Item 1)
 Jack stands (appendix-B, Section III, Item 3)

Equipment Conditions

Equipment shut down, refer to paragraph 2.5.1.2 or 2.5.2.2.
 Wheels and tires removed, paragraph 4.17.1.

Material/Parts

Lockwashers (TM 10-4320-226-24P)

General Instructions

Do not work on equipment without following standard shop safety precautions.

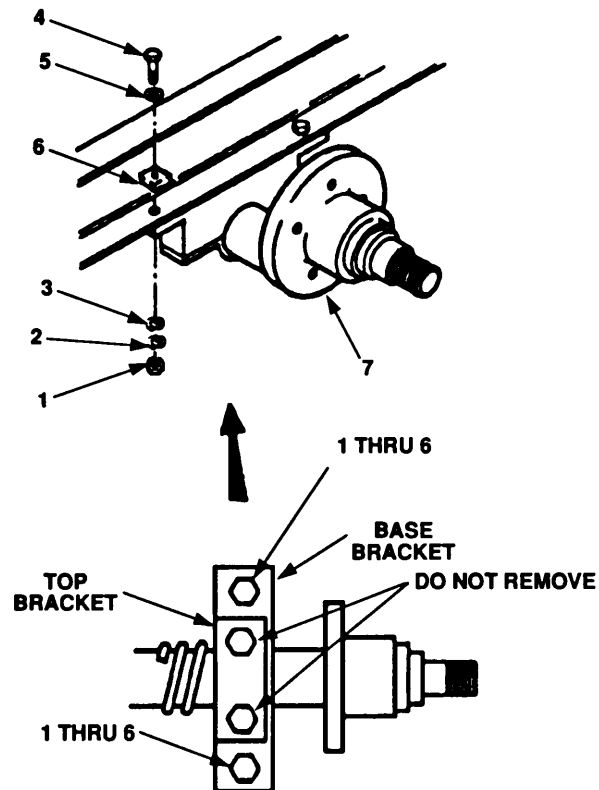

Figure 5-17. Axle Assembly Maintenance.

5.8.1 Removal.



To prevent rolling or sliding, do not work on equipment that is not securely stabilized. Ensure both wheels are secure. Failure to obey this warnings may result in serious personal injury.

- a. Raise unit clear of ground and adequately support with jack stands.
- b. Adequately support axle assembly to prevent it from dropping when attaching hardware is removed.



Do not remove bolts securing top bracket to base bracket. Coil springs are under high tension. Failure to obey this warnings may result in serious personal injury.

- c. Remove four nuts (figure 5-17, 1) lockwashers (2), washers (3), bolts (4), washers (5) and beveled washers (6).
- d. Axle assembly (7) is now free from frame. Remove axle assembly (7) from supports and move free of frame.

5.10.2.2 Installation.

- a. With frame positioned on assembly stand, raise axle assembly (7) into position under frame.
- b. Install beveled washers (6), washers (5), bolts (4), washers (3), lockwashers (2), and nuts (1).

CHAPTER 6

GENERAL SUPPORT MAINTENANCE INSTRUCTIONS

SUBJECT INDEX	PAGE
SECTION I REPAIR PARTS; SPECIAL TOOLS; TEST, MEASUREMENT, AND DIAGNOSTIC EQUIPMENT (TMDE); AND SUPPORT EQUIPMENT	6-2
6.1 COMMON TOOLS AND EQUIPMENT	6-2
6.2 SPECIAL TOOLS AND SUPPORT EQUIPMENT	6-2
6.3 REPAIR PARTS	6-2
SECTION II GENERAL SUPPORT MAINTENANCE PROCEDURES	6-3
6.4 TORQUING INSTRUCTIONS	6-3
6.5 WEAR LIMITS	6-3
6.6 ENGINE ASSEMBLY MAINTENANCE	6-7

SECTION I. REPAIR PARTS; SPECIAL TOOLS; TEST, MEASUREMENT, AND DIAGNOSTIC EQUIPMENT (TMDE); AND SUPPORT EQUIPMENT

6.1 COMMON TOOLS AND EQUIPMENT.

For Authorized common tools and equipment refer to the Modified Table of Organization and Equipment (MTOE), Common Table of Allowances (CTA) 50-970 or CTA 8-100 as applicable to your unit.

6.2 SPECIAL TOOLS AND SUPPORT EQUIPMENT.

Special tools are listed and illustrated in the Repair Parts and Special Tools List (RPSTL), TM 10-4320-226-24P, covering unit, direct support, and general support maintenance for this equipment.

6.3 REPAIR PARTS.

Repair parts are listed and illustrated in the RPSTL, TM 10-4320-226-24P, covering unit, direct support, and general support maintenance for this equipment.

SECTION II. GENERAL SUPPORT MAINTENANCE PROCEDURES

6.4 TORQUING INSTRUCTIONS.

Torquing instructions are located in Appendix G.

6.5 WEAR LIMITS.

Refer to Table 6-1 for wear limits, fits, and tolerances for use throughout maintenance procedures.

Table 6-1. Wear Limits, Fits and Tolerances.

Component	Minimum	Maximum
Intake Valves:		
Head Diameter	1.6890 in. (42.90 mm)	1.6969 in. (43.10 mm)
Stem Diameter	0.3128 in. (7.945 mm)	0.3134 in. (7.960 mm)
Stem-to-guide normal clearance	0.0016 in. (0.04 mm)	0.0028 in. (0.07 mm)
Stem-to-guide maximum clearance		0.0118 in. (0.30 mm)
Seat bore diameter in head-nominal	1.7913 in. (45.50 mm)	1.7923 in. (45.525 mm)
Seat outside diameter	1.7969 in. (45.64 mm)	1.7976 in. (45.66 mm)
Valve seat width	0.0591 in. (1.50 mm)	0.0787 in. (2.0 mm)
Seat angle	45	
Valve rim thickness	0.0197 in. (0.50 mm)	0.0394 in. (1.00 mm)
Valve recessed below cylinder head deck	0.1999 in. (5.078 mm)	0.2205 in. (5.681 mm)
Exhaust Valves:		
Head diameter	1.4527 in. (36.90 mm)	1.4606 in. (37.10 mm)
Stem diameter	0.3118 in. (7.920 mm)	0.3125 in. (7.940 mm)
Stem-to-guide normal clearance	0.0023 in. (0.06 mm)	0.0037 in. (0.095 mm)
Stem-to-guide maximum clearance		0.0197 in. (0.50 mm)
Seat bore diameter in head-nominal	1.5748 in. (40.0 mm)	1.5757 in. (40.025 mm)
Seat outside diameter	1.5803 in. (40.14 mm)	1.5811 in. (40.16 mm)
Valve seat width	0.0591 in. (1.50 mm)	0.0787 in. (2.0 mm)
Seat angle	45	
Valve rim thickness nominal	0.0197 in. (0.50 mm)	0.0591 in. (1.50 mm)
Valve recessed below cylinder head deck	0.1999 in. (5.078 mm)	0.2205 in. (5.681 mm)

Table 6-1. Wear Limits, Fits and Tolerances. (continued)

Component	Minimum	Maximum
Valve guides:		
Outside diameter - normal	0.5923 in. (15.45 mm)	0.5927 in. (15.056 mm)
Bore in cylinder head diameter	0.5905 in. (15.00 mm)	0.5909 in. (15.011 mm)
Pressed in inside diameter	0.3149 in. (8.00 mm)	0.3155 in. (8.015 mm)
Valve Springs:		
Total coils	7	
Normal length	2.2480 in. (57.1 mm)	2.23976 in. (60.9 mm)
Minimum length	2.2047 in. (56.0 mm)	
Cylinder Head:		
Distance between cylinder head bottom and cylinder head joint w/o shim bolts	0.2283 in. (5.8 mm)	0.2480 in. (6.3 mm)
Nominal length	8.287 in. (210.50 mm)	8.326 in. (211.5 mm)
Maximum length		8.3661 in. (212.5 mm)
Cylinders:		
Bore diameter - normal	3.937 in. (100.00 mm)	3.937 in. (100.022 mm)
Bore wear maximum		0.0079 in. (0.2 mm)
Pistons:		
Diameter, normal	3.9331 in. (99.901 mm)	3.9338 in. (99.919 mm)
Diameter of bore for connecting rod pin	1.3779 in. (35.0 mm)	1.3781 in. (35.0 mm)
Connecting rod pin diameter	1.3777 in. (34.994 mm)	1.3779 in. (35.0 mm)
1st ring groove width	0.0907 in. (2.305 mm)	0.0915 in. (2.325 mm)
2nd and 3rd ring groove widths	0.0984 in. (2.50 mm)	0.1020 in. (2.590 mm)
4th ring groove width	0.1969 in. (5.00 mm)	0.1980 in. (5.03 mm)
Piston Rings:		
1st ring clearance in groove	0.0031 in. (0.079 mm)	0.0046 in. (0.119 mm)
1st ring maximum clearance in groove		0.0196 in. (0.50 mm)
2nd ring clearance in groove	0.0039 in. (0.10 mm)	0.0051 in. (0.132 mm)
2nd ring maximum clearance in groove		0.0118 in. (0.30 mm)
3rd ring clearance in groove	0.0039 in. (0.10 mm)	0.0051 in. (0.132 mm)
3rd ring maximum clearance in groove		0.0118 in. (0.30 mm)
4th ring clearance in groove	0.0015 in. (0.04 mm)	0.0028 in. (0.072 mm)
4th ring maximum clearance in groove		0.0059 in. (0.15 mm)
Gap, 1st, 2nd, and 3rd rings, normal	0.0137 in. (0.350 mm)	0.0216 in. (0.550 mm)
Gap, 1st, 2nd, and 3rd rings, maximum		0.1574 in. (4.0 mm)
Gap, 4th ring, normal	0.0098 in. (0.250 mm)	0.0157 in. (0.40 mm)
Gap, 4th ring, maximum		0.0984 in. (2.50 mm)

Table 6-1. Wear Limits, Fits and Tolerances. (continued)

Component	Minimum	Maximum
Connecting Rods:		
Hole for connecting rod pin bushing	1.496 in. (38.0 mm)	1.4966 in. (38.016 mm)
Rod bearing bore diameter, less bearing	2.5196 in. (64.0 mm)	2.5204 in. (64.019 mm)
Rod bearing inside diameter	2.3622 in. (60.00 mm)	2.3627 in. (60.039 mm)
Rod pin bushing outside diameter	1.498 in. (38.050 mm)	1.4992 in. (38.080 mm)
Rod pin bushing inside diameter, pressed in	1.3795 in. (35.040 mm)	1.3813 in. (35.086 mm)
Rod pin to bushing clearance	0.0015 in. (0.040 mm)	0.0035 in. (0.091 mm)
Rod pin to bushing maximum clearance		0.0098 in. (0.250 mm)
Rod bearing width	0.9763 in. (24.80 mm)	0.9842 in. (25.00 mm)
Rod width	1.3172 in. (33.458 mm)	1.3196 in. (33.52 mm)
Rod bearing to crankshaft clearance	0.0015 in. (0.040 mm)	0.0038 in. (0.098 mm)
Rod bearing to crankshaft maximum clearance		0.0059 in. (0.150 mm)
Idler Gear and Journals:		
Bearing bush internal diameter, pressed in	1.5606 in. (40.000 mm)	1.5757 in. (40.025 mm)
Journal diameter	1.5744 in. (39.991 mm)	1.5748 in. (40.00 mm)
Journal clearance in bushing	0.0013 in. (0.034 mm)	0.0026 in. (0.066 mm)
Journal to bushing maximum clearance		0.0079 in. (0.2 mm)
Crankshaft:		
Connecting rod journal diameter, normal	2.3606 in. (59.960 mm)	2.3610 in. (59.970 mm)
Connecting rod journal out-of-round maximum		0.0004 in. (0.01 mm)
Main bearing journal diameter, normal	2.7555 in. (69.99 mm)	2.7556 in. (70.00 mm)
Main bearing journal out-of-round, maximum		0.001 in. (0.02 mm)
Main bearing journal length	1.4567 in. (37.00 mm)	1.4606 in. (37.460 mm)
Main Bearings, Numbers 2, 3, and 4:		
Main bearing bore diameter, less bearings	2.933 in. (74.50 mm)	2.9338 in. (74.519 mm)
Main bearing inside diameter, normal	2.7574 in. (70.07 mm)	2.7591 in. (70.081 mm)
Main bearing inside diameter, minimum	2.6984 in. (68.54 mm)	2.7001 in. (68.583 mm)
Main bearing to crankshaft journal clearance, normal	0.0019 in. (0.05 mm)	0.0043 in. (0.11 mm)
Main bearing to crankshaft journal clearance, maximum		0.0059 in. (0.15 mm)

Table 6-1. Wear Limits, Fits and Tolerances. (continued)

Component	Minimum	Maximum
Main Thrust Bearing, Number 1:		
Thrust bearing journal diameter, normal	2.7548 in. (69.971 mm)	2.7555 in. (69.99 mm)
Thrust bearing journal out-of-round maximum		0.001 in. (0.02 mm)
Thrust bearing journal length	1.4566 in. (37.00 mm)	1.4576 in. (37.025 mm)
Thrust bearing bore diameter	2.9330 in. (74.50 mm)	2.9338 in. (74.519 mm)
Thrust bearing nominal thickness	0.0873 in. (2.219 mm)	0.0877 in. (2.229 mm)
Thrust bearing inside diameter normal	2.7574 in. (70.04 mm)	2.7591 in. (70.083 mm)
Thrust bearing to journal normal clearance	0.0019 in. (0.05 mm)	0.0043 in. (0.11 mm)
Thrust bearing to journal to maximum clearance		0.0018 in. (0.30 mm)
Thrust half-rings (blower side) inside diameter, normal	3.1102 in. (79.00 mm)	3.1114 in. (79.03 mm)
Thrust half-rings (blower side) outside diameter, normal	3.7249 in. (94.614 mm)	3.7387 in. (94.964 mm)
Thrust half-rings (flywheel side) inside diameter, normal	3.1102 in. (79.00 mm)	3.1114 in. (79.30 mm)
Thrust half-rings (flywheel side) outside diameter, normal	4.0005 in. (101.614 mm)	4.0143 in. (101.96 mm)
Thrust half-rings thickness	0.1155 in. (2.935 mm)	0.1175 in. (2.985 mm)
Side clearance, normal	0.0059 in. (0.150 mm)	0.1236 in. (0.314 mm)
Side clearance, maximum		0.0157 in. (0.4 mm)
Outside distance across Thrust Rings	1.4433 in. (36.661 mm)	1.4507 in. (36.85 mm)
Camshaft:		
Camshaft to bushing maximum clearance		0.0079 in. (0.20 mm)
Camshaft bushing inside diameter nominal	1.8889 in. (47.980 mm)	1.8911 in. (48.034 mm)

6.6 ENGINE ASSEMBLY MAINTENANCE.**6.6.1 Cylinder Head Maintenance.**

This task covers: 6.6.1.1 Removal 6.6.1.3 Installation
 6.6.1.2 Adjustment

INITIAL SETUP**Tools**

General Mechanic's Tool Kit (appendix B, Section III, Item 1)

Angle of Turn Indicator Tool
(appendix B, Section III, Item 11)

Pushrod Tube Spring Compressor
(appendix B, Section III, Item 14)

Vernier Calipers (appendix B, Section III, item 3)

Torque Wrench (appendix B, Section III, item 3)

Equipment Conditions

Equipment shut down, refer to paragraph 2.5.1.2 or 2.5.2.2.

Air Cleaner removed,
paragraph 4.10.5

Alternator removed,
paragraph 4.10.12

Starter removed, paragraph 4.10.13

Engine removed, paragraph 5.5.1

Material/Parts

Lockwashers (TM 10-4320-226-24P)

Washers (TM 10-4320-226-24P)

Gaskets (TM 10-4320-226-24P)

Solder (appendix E, Section II, Item 10)

Grease (appendix E, Section II, item 6)

Injection Pump removed,
paragraph 5.5.5

Engine Cowlings removed,
paragraph 5.5.8

General Instructions

Do not work on equipment without following standard shop safety precautions.

6.6.1.1 Removal.

- a. Remove rocker cover bolt (figure 6-1, 1), lockwasher (2) and washer (3).
- b. Remove rocker cover (4) and rocker cover gasket (5).
- c. Remove three nuts (6) and rocker arm assembly (7).
- d. Remove two cover plugs (8) and gaskets (9).
- e. Remove two pushrods (10).
- f. Remove four cylinder head bolts (11) and washers (12).
- g. slowly lift cylinder head (13) from cylinder while keeping Pushrod cover tube assemblies (14) steady; then remove the pushrod cover tube assemblies.
- h. Remove washer (15), pushrod cover tube (16), spring (17), cap (18), and washer (19) from each pushrod cover tube assembly.
- i. Remove intermediate ring (20).

6.6.1.2 Adjustment.

- a. Coat a piece of 2mm resin core solder with grease and place it in position on piston crown at right-angles to center line of engine, as shown in figure 6-1, view A, but not on any stenciling on piston.

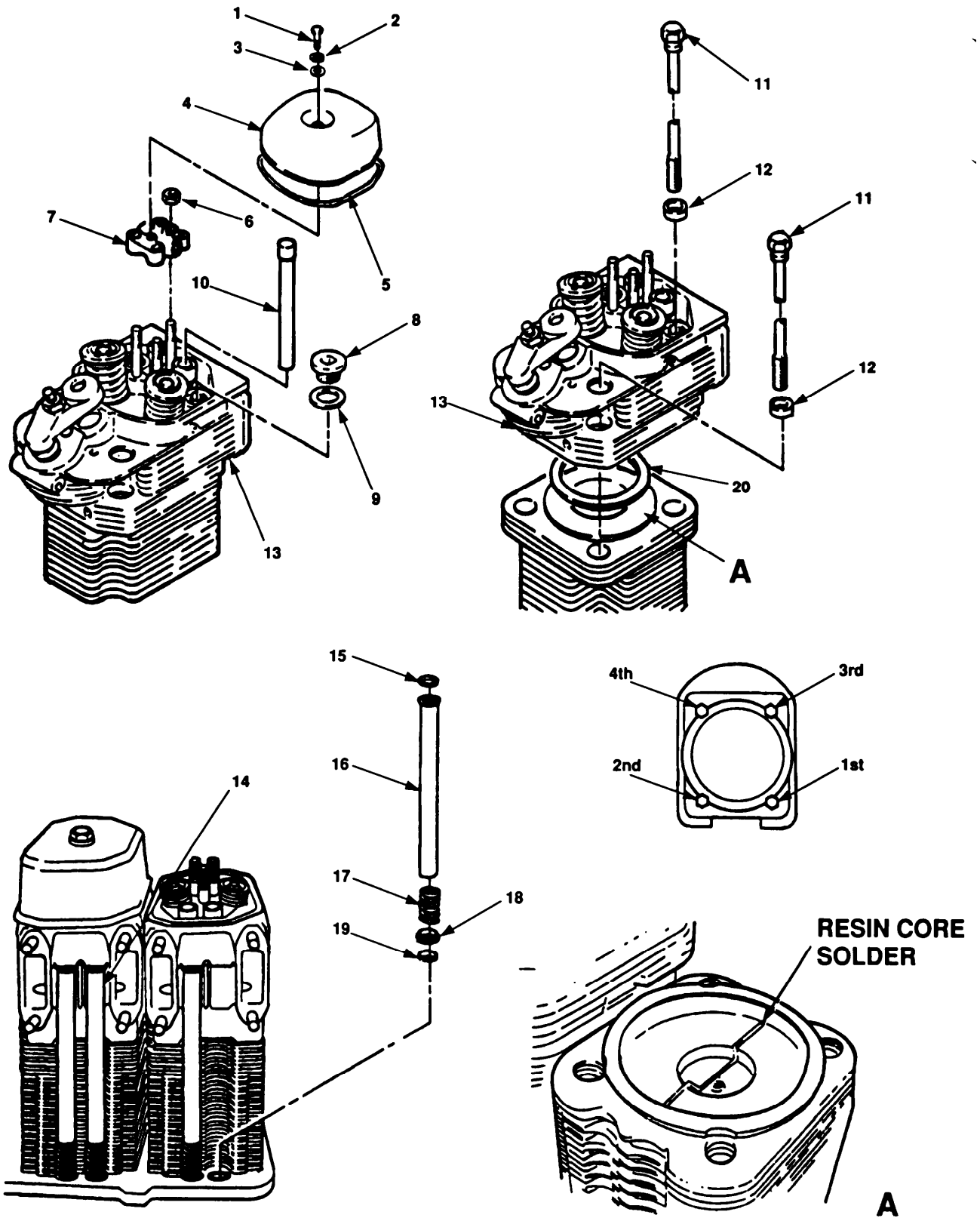

Figure 6-1. Cylinder Head Removal and Installation.

- b. Measure length of each cylinder head bolt (11).
- c. With piston positioned a little before TDC, perform following:
 - (1) Install intermediate ring (20) on block.
 - (2) Install cylinder head (13) on cylinder.
 - (3) Install washers (12) and cylinder head bolts (11), then slightly tighten cylinder head bolts.
- d. Using straight edge, align inlet and exhaust flanges of cylinder heads.
- e. Tighten head bolts in sequence, as shown in figure 6-1, through first stage 45° angle.
- f. Turn crankshaft through 360° in direction of engine rotation.
- g. Remove cylinder head (13), and measure the thickness of the resin core solder at its smallest point.
- h. When thickness is not between 0.40 and 0.48 inches (1.0 and 1.2 mm), add shims at bottom of cylinder (paragraph 6.6.2) and repeat adjustment. When thickness is correct, install cylinder head (13).

6.6.1.3 Installation.

- a. Install intermediate ring (20).
- b. Install cylinder head (13), four washers (12) and cylinder head bolts (11).
- c. Tighten head bolts in sequence shown in figure 6-1 and torque in accordance with appendix G.
- d. Install new gaskets (9) and cover plugs (8), then torque plugs in accordance with Appendix G.
- e. Using spring tensioning tool, assemble and compress spring (17) on pushrod cover tube (16).
- f. Install cap (18) with open side towards spring.
- g. Install new washer (19), with wide end face toward end of pushrod cover tube (16).
- h. Install new washer (15), with wide end face toward upper shoulder on pushrod cover tube (16).
- i. Insert spring end of pushrod cover tube (16) in crankcase hole. Position upper end of pushrod cover tube (16) with cone in cylinder head (13).
- j. Slowly remove spring tensioning tool, while guiding upper end of pushrod cover tube (16) into cylinder head (13).
- k. Repeat steps e through j for the other tube assembly.
- l. Check that upper and lower cover tube washers are properly seated.
- m. Install pushrods (10) with cup ends up.
- n. Install rocker arm assembly (7) and three nuts (6).
- o. Adjust valve clearance, paragraph 4.10.23.

- p.- Remove all old gasket material from cylinder head and rocker cover.
- q. Install new rocker cover gasket (5) using gasket sealer.
- r. Install rocker cover (4) with bolt (1), lockwasher (2), and washer (3).

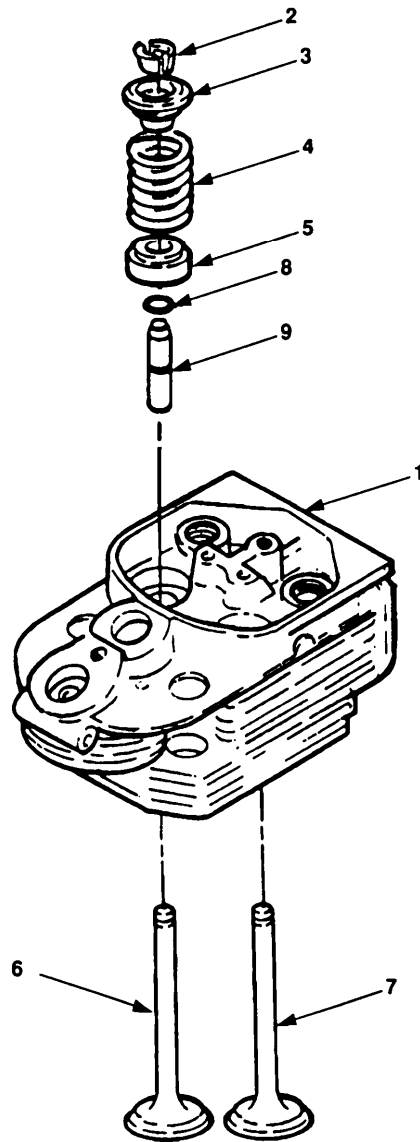

Figure 6-2. Cylinder Head Disassembly.

6.6.2 Cylinder Head Repair. (continued)

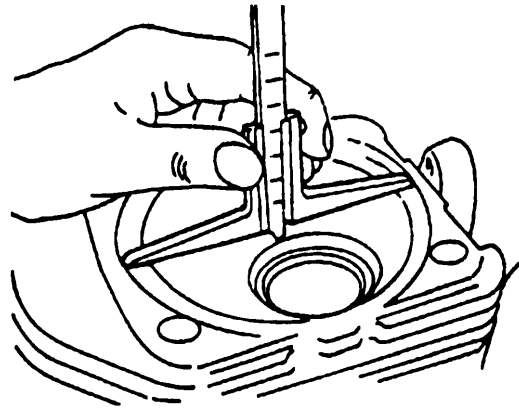

Figure 6-3. Checking Cylinder Head Seating Surface.

- e. Check that cylinder head seating surface (figure 6-3) is flat and square. Slight damage to seating surface can be ground.
- f. After reworking, measure clearance between cylinder head bottom and cylinder head seating surface. The measured value may not be lower than 0.23 inch (5.8 m).
- g. Insert valve in seat and measure distance from crown of valve to cylinder head seating surface (figure 6-4). If distance exceeds specifications on either valve, (table 6-1), seat must be replaced.

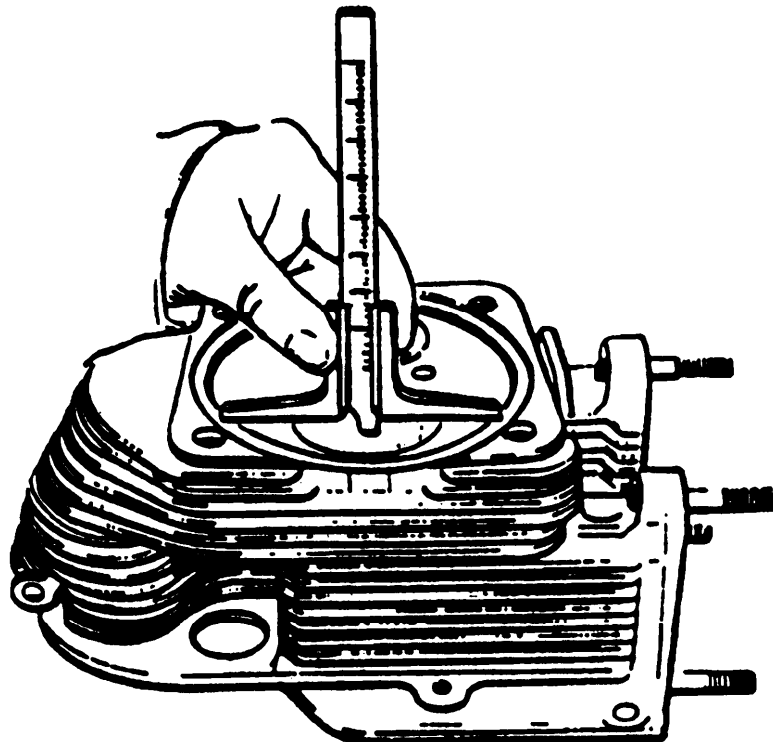

Figure 6-4. Valve Depth Measurement.

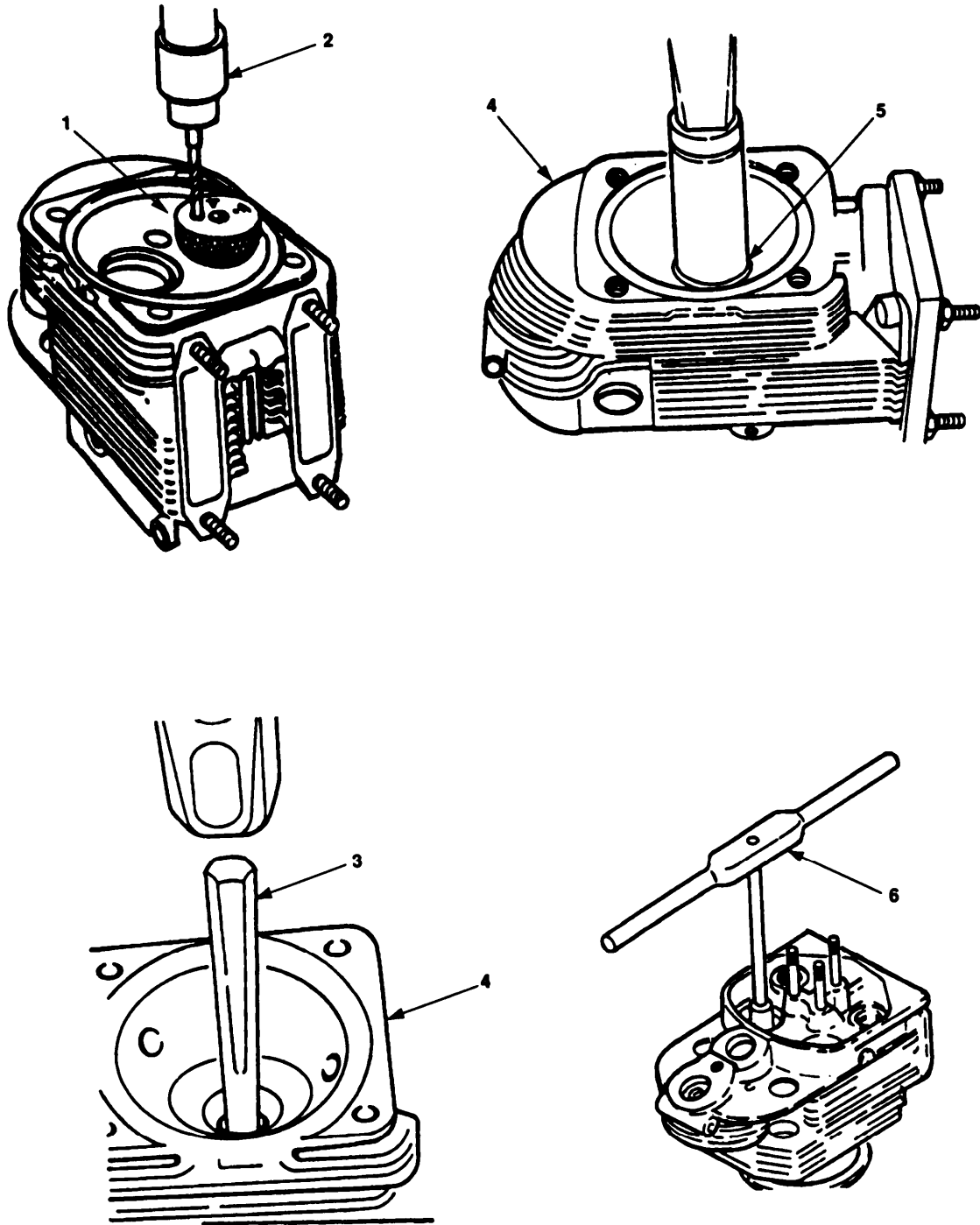

Figure 6-5. Valve Seat Drilling.

6.6.2 Cylinder Head Repair. (continued)

- h. Check clearance of valve stems in guides of both valves. If it exceeds .0016 inch (.04 mm) inlet valve, or .0024 (.06 mm) exhaust valve, replace guides.

NOTE

Mandrels (intake and exhaust) come in two sizes. One will fit exhaust valve seat and other will fit intake valve seat.

- i. Remove valve seat as follows:

- (1) Place mandrel (figure 6-5, 1) on valve seat and insert guide through mandrel into valve stem. Tighten guide so that mandrel is firmly in place.

CAUTION

Do not drill into cylinder head. Failure to obey this caution may result in equipment damage.

- (2) Insert drill (2) into mandrel (1) and drill through valve seat at two positions 180° apart.
- (3) Remove guide and mandrel (1).
- (4) Carefully remove drilled seat.
- (5) Measure diameter of valve seat bore in cylinder head.

NOTE

Intake valve seats have larger outside diameter than exhaust valve seats.

- (6) Measure outside diameter of new valve seat. Subtract the diameter of bore from diameter of seat. Difference must not be less than 0.003 inch (0.076 mm).

CAUTION

Heating cylinder head for more than 30 minutes or at a higher temperature than 430° F (220° C) may cause cylinder head to warp. Failure to obey this caution could result in equipment damage.

- j. Heat cylinder head in oven to a temperature of 430° F (220° C). Do not heat head more than 30 minutes.

WARNING

Do not touch cylinder head while it is hot without protective gloves. Exercise care when working around hot cylinder head. Severe burns can result if protective measures are not taken. Failure to obey this warning may result in personal injury.

- k. Remove head from oven.

6.6.2 Cylinder Head Repair. (continued)

NOTE

If valve guides are in need of replacement. Replace at this time.

- l. Insert Mandrel (3) into chamber side of valve guide and drive guide out of cylinder head (4).
- m. Place new locating ring on valve guide and drive longer end of guide into bore from the rocker arm side. Drive in until locating ring seats in guide bore.
- n. Place new valve seat (5) on drift with chamfered side up and drive seat into recess of cylinder head (4). Ensure that seal is fully inserted.
- o. After head cools, reem valve guides using special 8.0 mm (0.3149 in) reemer (6).
- p. Reseat valve seats.

6.6.2.3 Assembly.

- a. Install valve guides (figure 6-2, 9) and locating rings (8).
- b. Install valves (6 and 7) into cylinder head (1).
- c. Install valve rotor or spring seat (5).
- d. Install two springs (4).
- e. Install two spring caps (3).
- f. Install two tapered valve spring keepers (2).

- d. Remove two thrust pads (8).
- e. Remove two studs (9) from rocker bracket (10).

6.6.3.2 Repair.

WARNING

Do not use dry cleaning solvent without proper ventilation and clothing. Do not smoke or use near open flame or excessive heat. Dry cleaning solvent is potentially dangerous to personnel and property. Clean parts in a well-ventilated area. Avoid inhalation of solvent fumes. Wear goggles and rubber gloves to protect eyes and skin. Wash exposed skin thoroughly. Flash point of solvent is 100°F to 138°F (38°C to 59°C). Failure to obey this warning may result in personal injury or death.

- a. Clean parts in solvent.
- b. Inspect bushings (3 and 4) for excessive wear. Replace if defective.
- c. Inspect studs (7 and 9) for damage. Replace if defective.
- d. Inspect thrust pads (8) for defects. Replace if defective.

6.6.3.3 Assembly.

- a. Install two studs (9) in rocker bracket (10).
- b. Install two thrust pad (8).
- c. Install two studs (7) and lock nuts (6).

CAUTION

Oil holes in bushing must align with oil holes in rocker arm. Failure to obey this warning may cause equipment damage.

- d. Install press bushing (4) in each rocker arm (5).
- e. Install two bushings (3), rocker arms (5), washers (2), and nuts (1).

6.6.4 Engine MAINTENANCE.

This task covers:	6.6.4.1 Disassembly	6.6.4.3 Assembly
	6.6.4.2 Repair	

INITIAL SETUPTools

General Mechanic's Tool Box (appendix B, Section III, Item 1)
 Inside micrometer (appendix B, Section III, Item 3)
 Micrometer (appendix B, Section III, Item 3)
 Torque wrench, 0 - 150 ft lbs (appendix B, Section III, Item 3)
 Angle of Turn Indicator (appendix B, Section III, Item 10)
 Crankshaft Seal Installer (appendix B, Section III, Item 13)
 Refacing Device (appendix B, Section III, Item 24)
 Bolt Degree Gauge (appendix B, Section III, Item 23)
 Gasket Extractor (appendix B, Section III, Item 25)
 Crankshaft Seal Installer (appendix B, Section III, Item 26)

Material/Parts

Lockwashers (TM 10-4320-226-24P)
 Gaskets (TM 10-4320-226-24P)

Reference

LO 10-4320-226-12

Equipment Conditions

Air cleaner removed, paragraph 4.10.5.
 Alternator removed, paragraph 4.10.12.
 Starter Assembly removed, paragraph 4.10.13.
 V-belt contact switch removed, paragraph 4.12.9.
 Shutdown solenoid removed, paragraph 4.10.14.
 Fuel lines, hoses and fittings removed, paragraph 4.13.4.
 Crankshaft pulley removed paragraph 5.5.10.
 Injection pump removed, paragraph 5.5.5.
 Cooling fan removed, paragraph 5.7.2.
 Engine cowlings removed, paragraph 5.5.8.
 Cylinder head removed, paragraph 6.6.1.
 Engine removed paragraph 5.5.1 and placed on engine stand.
 Oil drained, LO 10-4320-226-12

General Safety Instructions

Do not use dry cleaning solvent without proper ventilation and clothing.

Do not work on equipment without following standard shop safety precautions.

6.6.4.1 Disassembly.

- a. Remove four bolts (figure 6-7, 1), washers (2), one motor mount (3) and four washers (4).

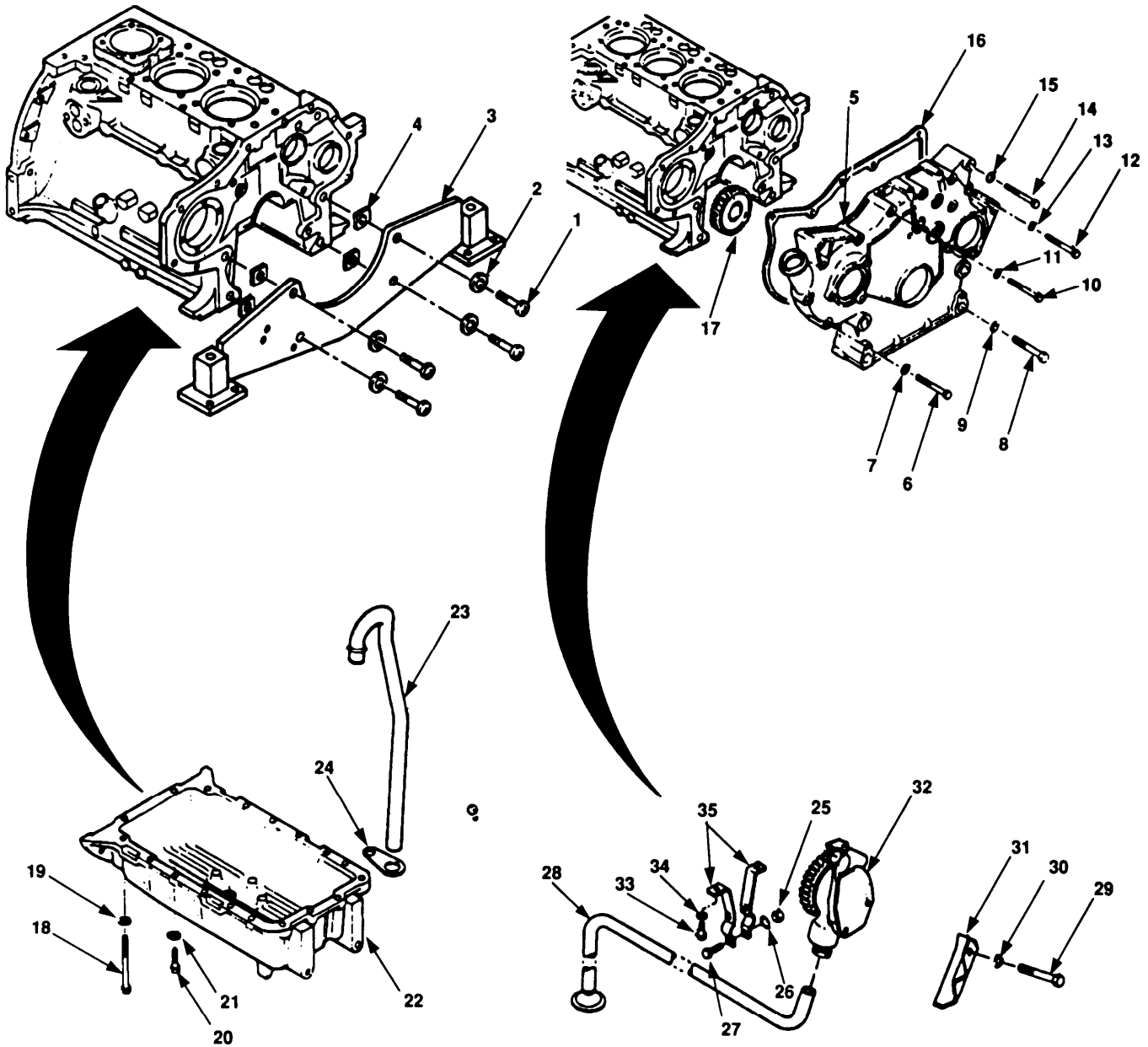

Figure 6-7. Engine Mount, Front Cover, and Oil Pump Removal.

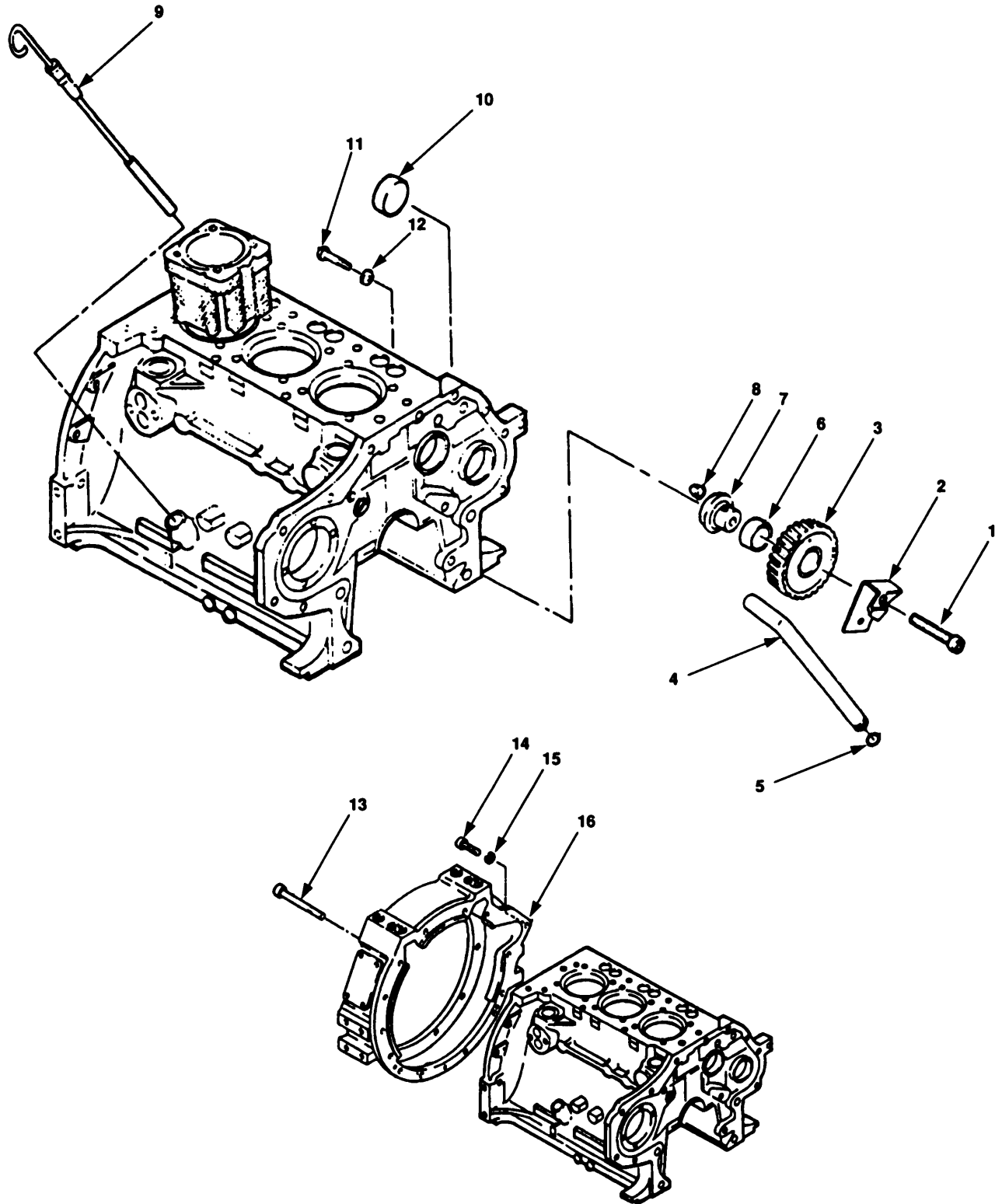

Figure 6-8. Idler Gear and Housing Adaptor Removal.

6.6.4 Engine Maintenance (continued)

CAUTION

Use care in removing front cover to prevent damage to injection pump gear which could fall when front cover is removed. Failure to obey this caution may result in equipment damage.

- b. Remove front cover (5) as follows:
 - (1) Remove two bolts (6) and washers (7).
 - (2) Remove four bolts (8) and lockwashers (9).
 - (3) Remove bolt (10) and lockwasher (11).
 - (4) Remove bolt (12) and washer (13).
 - (5) Remove three bolts (14) and washers (15).
 - (6) Remove front cover (5).
 - (7) Remove and discard gasket (16).
 - (8) Remove injection pump gear (17).
- c. Carefully rotate engine over on injection pump side.
- d. Remove oil sump as follows:
 - (1) Remove three bolts (18) and washers (19).
 - (2) Remove sixteen bolts (20) and washers (21).
 - (3) Remove oil sump (22).
- e. Remove oil pump as follows:
 - (1) Remove breather pipe (23) and bracket (24).
 - (2) Remove two nuts (25), washers (26), and bolts (27).
 - (3) Remove suction pipe (28).
 - (4) Remove two bolts (29), washers (30), shield (31), and oil Pump (32).
 - (5) Remove two screws (33), washers (34), and brackets (35).
- f. Remove cap screw (figure 6-8, 1) bracket (2) and idler gear (3).
- g. Remove tube (4) and seal (5) from bracket (2).
- h. Remove bushing (6) from idler gear (3).
- i. Remove journal (7) and bushing (8).
- j. Remove dip stick (9).
- k. Remove cover (10), screw (11) and sealing ring (12).
- l. Remove three long bolts (13), eleven short bolts (14), lockwashers (15), and one housing adapter (16).

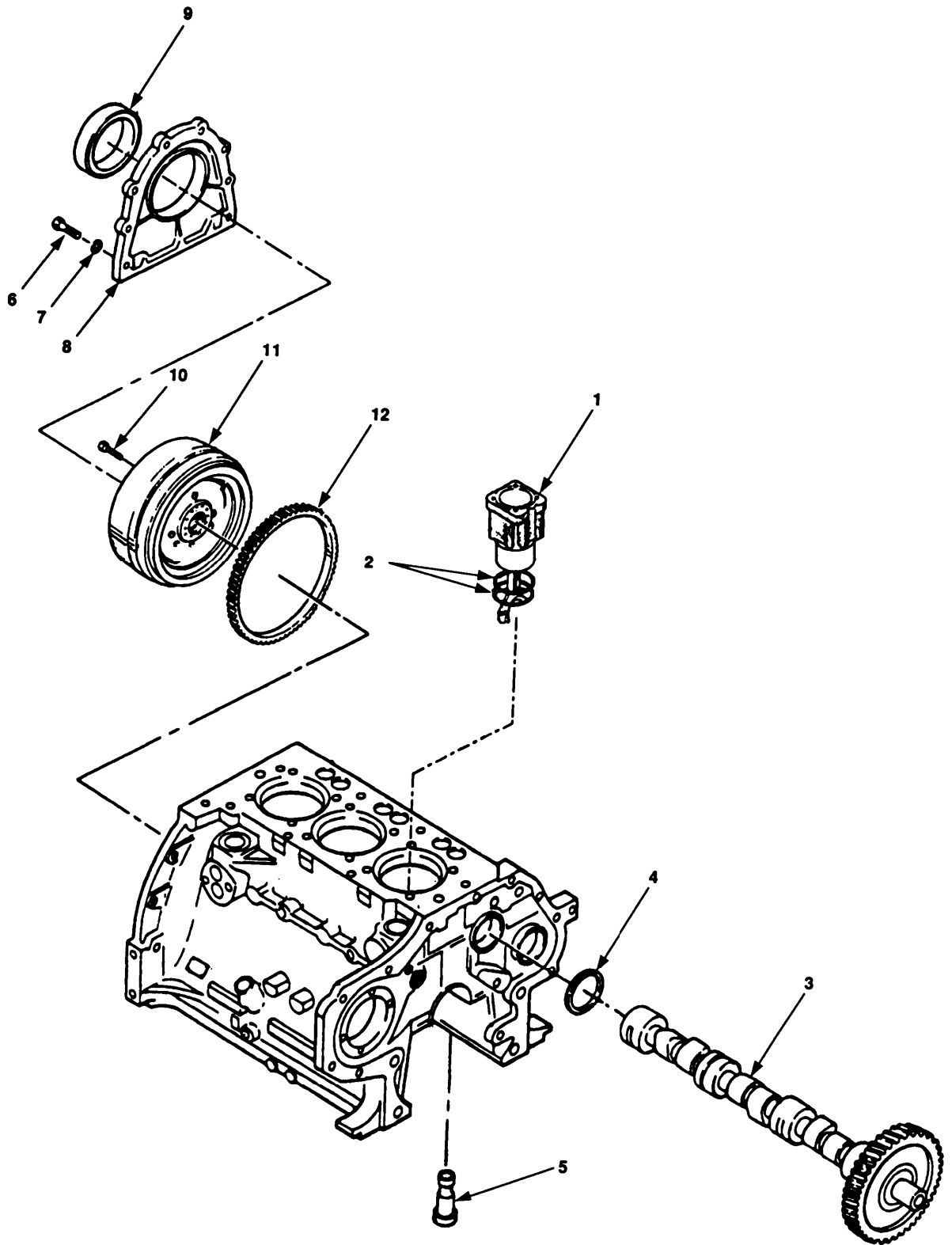

Figure 6-9. Cylinders Camshaft and Flywheel Removal.

6.6.4 Engine Maintenance: (continued)

- m. Remove cylinders (figure 6-9, 1) and shims (2).
- n. Carefully remove camshaft (3), washer (4) and valve tappets (5).
- o. Remove flywheel assembly as follows:
 - (1) Remove eight bolts (6), washers (7), and rear end cover (8).
 - (3) Press seal (9) out of rear end cover (8).
 - (3) Remove bolts (10) and flywheel (11), if ring gear (12) needs to be replaced, cut through it with a hard chisel and remove it.

NOTE

Mark connecting rod caps and corresponding rods.

- p. Remove connecting rod bolts (figure 6-10, 1) and connecting rod caps (2).
- q. Remove pistons (3).

NOTE

Identify main bearing caps, mark for location.

- r. Remove bolts (4), washers (5), and main bearing caps (6) and (7).
- s. Remove eight dowel busings (8).

NOTE

Mark bearing halves on back corresponding with crankshaft and bearing caps.

- t. Remove crankshaft (9), bearing halves (10), and stop rings (11 and 12).
- u. Remove two plugs (figure 6-11, 1), and washers (2).
- v. Remove plug (3), washer (4), plug (5), nozzle (6), washer (7), and plug (8).
- w. Remove sleeve bearing (9), notched nail (10) and deflector plate (11).

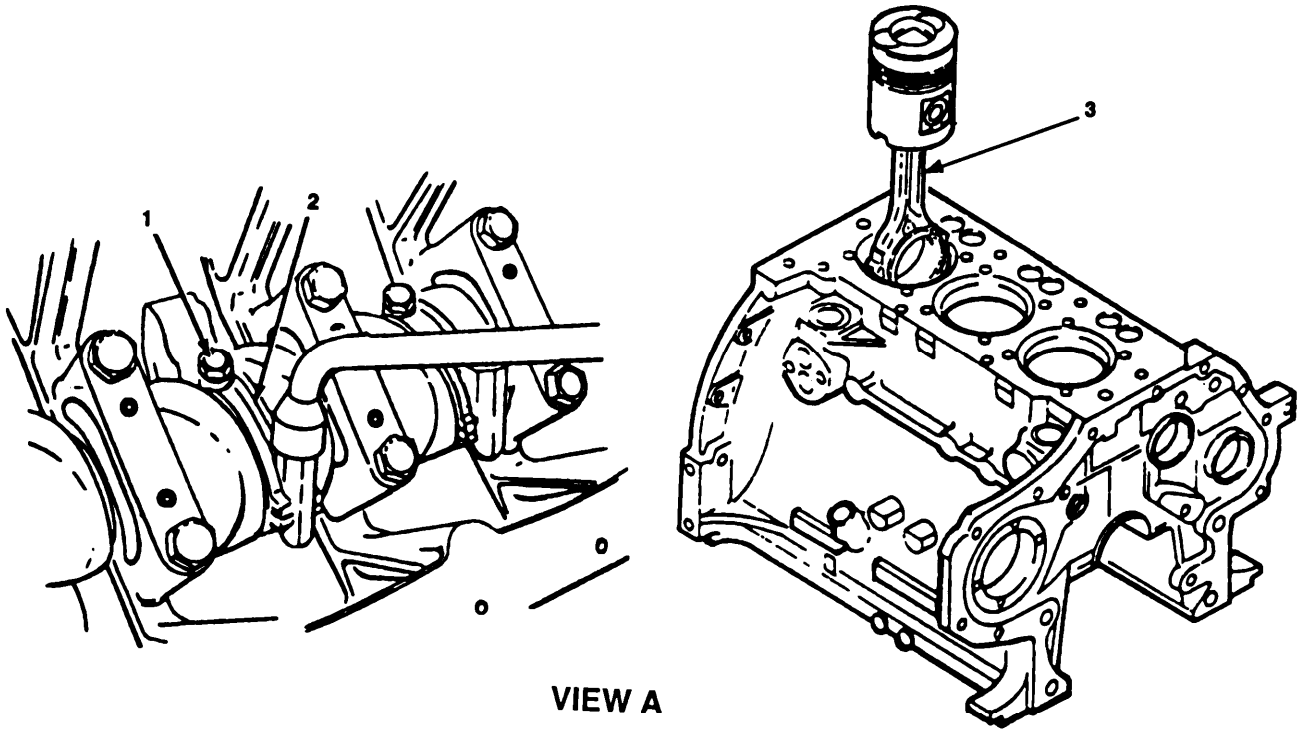

VIEW A

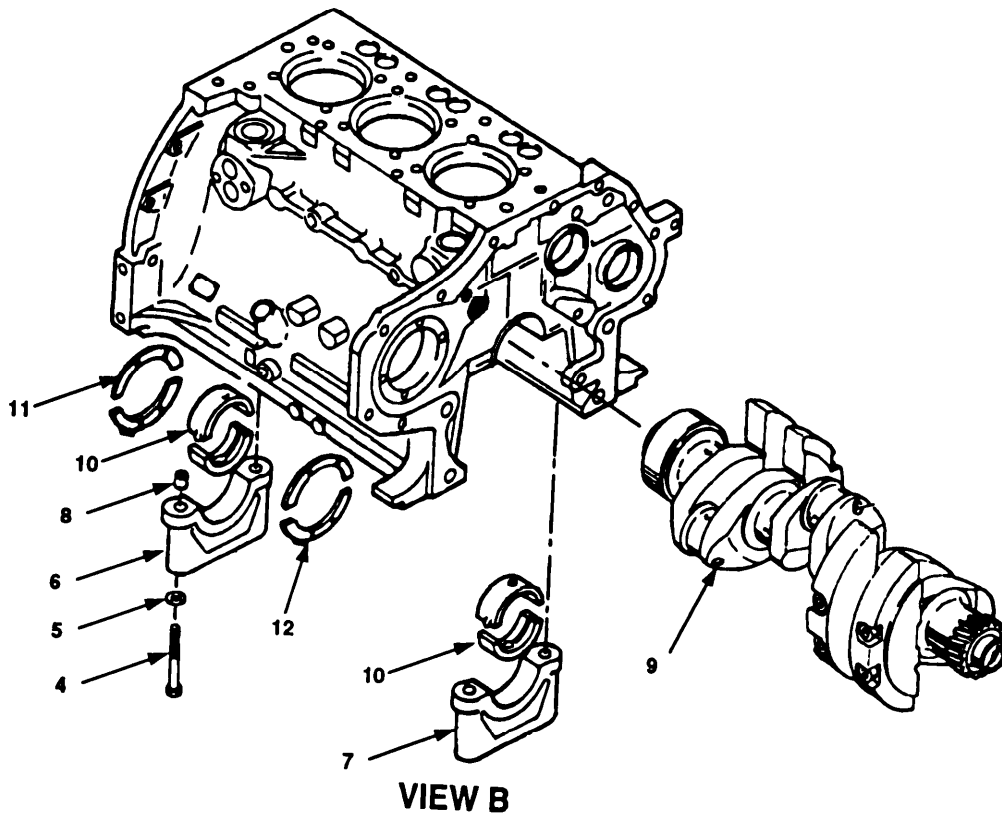

VIEW B

Figure 6-10. Piston and Crankshaft Removal.

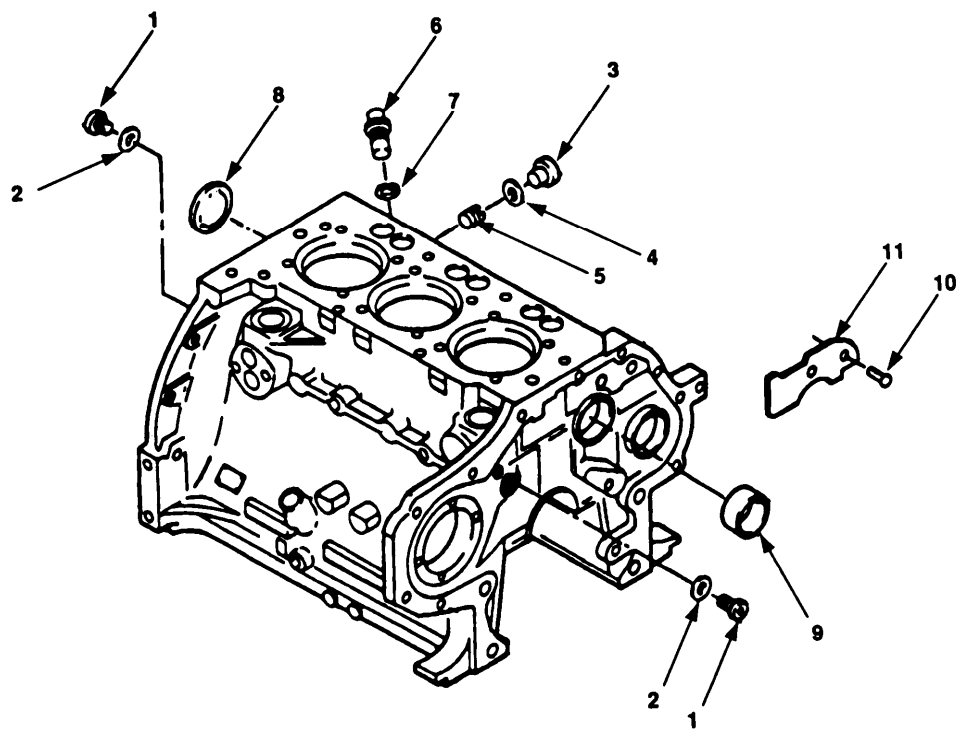

Figure 6-11. Crankcase Disassembly.

6.6.4 Engine Maintenance. (continued)

6.6.4.2 Repair.

a. Inspect and repair crankshaft as follows:

- (1) Using micrometer, measure all journal diameters at points (figure 6-12, 1, 2, and 3), in the vertical and horizontal, as indicated by "a" and "b".

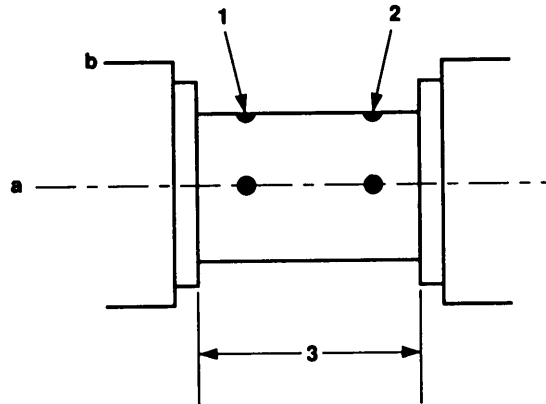

Figure 6-12. Checking Crankshaft Journals.

- (2) Note measurements and compare with table 6-2.

Table 6-2 Crankshaft Measurements.

Item to be Checked	Measurement
Crankshaft bearing diameter	2.75 inches (70 mm).
Crankshaft center locating bearing	2.75 inches (70 mm).
Width of journal	1.46 inches (37 mm).

- (3) Wear limit for ovality is 0.0008 inch (0.01 mm).

- (4) Using a micrometer, check other journals for out-of-round.

- (5) Replace crankshaft if it is defective.

b. Measure camshaft bearing journal outside diameter. Record journal diameter.

c. Measure inside diameter of bearing. Subtract journal diameter from its bearing inside diameter. Replace bearing if difference (clearance) is more than 0.0079 inch (0.20 mm).

NOTE

Use removal and installation tool to replace bearing. Bearing is removed by pressing out in direction of flywheel and installed by aligning oil holes with crankcase holes and pressing in from front side.

6.6.4 Engine Maintenance. (continued)

WARNING

Do not use dry cleaning solvent without proper ventilation and clothing. Do not smoke or use near open flame or excessive heat. Dry cleaning solvent is potentially dangerous to personnel and property. Clean parts in a well-ventilated area. Avoid inhalation of solvent fumes. Wear goggles and rubber gloves to protect eyes and skin. Wash exposed skin thoroughly. Flash point of solvent is 100°F to 138°F (38°C to 59°C). Failure to obey this warning may result in personal injury or death.

- d. Clean all parts with solvent.
- e. Clean all tapped holes in crankcase.
- f. Inspect crankcase for cracks. Replace cracked crankcase.

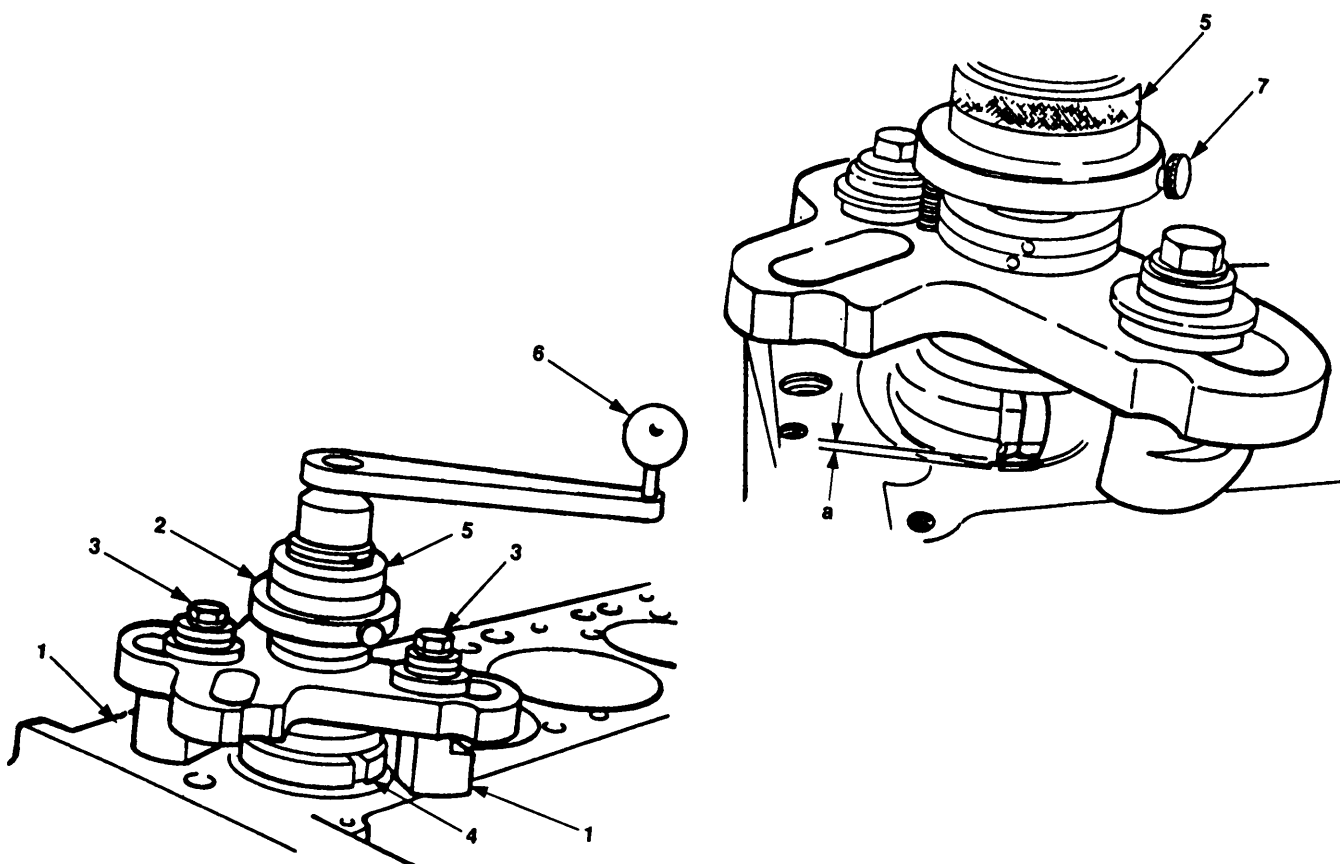

Figure 6-13. Cylinder Lining Rework.

- g. If grooved, rework cylinder liner seating on crankcase as follows:
 - (1) Clean seating area.
 - (2) Place support bracket (figure 6-13, 1) in position, mount turning fixture (2), and tighten retaining bolts (3) in such a manner that turning fixture is still movable.
 - (3) Center refacing device and tighten bolts (3).

6.6.4 Engine Maintenance. (continued)

- (4) Withdraw centering finger and slide tool holder (4) out to diameter of cylinder seating face.

CAUTION

Do not turn spindle counterclockwise when reworking surface. Adjust feed carefully. A full turn (360°) of knurled nut feeds tool holder 1 inch (1.5 mm). Failure to obey this caution may result in equipment damage.

- (5) By means of knurled nut (5), turn spindle (6) of turning device clockwise and adjust tool holder (4) to face to be reworked.
- (6) Move tool holder (4) towards middle of bore.
- (7) Using knurled nut (5) set tool over and slightly beyond distance "a" to permit satisfactory refacing as shown in figure 6-13.

NOTE

Selected cutting depth should not exceed inch (0.2 mm). This feed corresponds to 1/8th turn (45°) of knurled nut.

- (8) Tighten setscrew (7) and turn spindle (6) to rework seating area until smooth and/or flush with top of crankcase surface.
- (9) Set back tool holder and remove turning device.
- (10) Clean crankcase thoroughly.

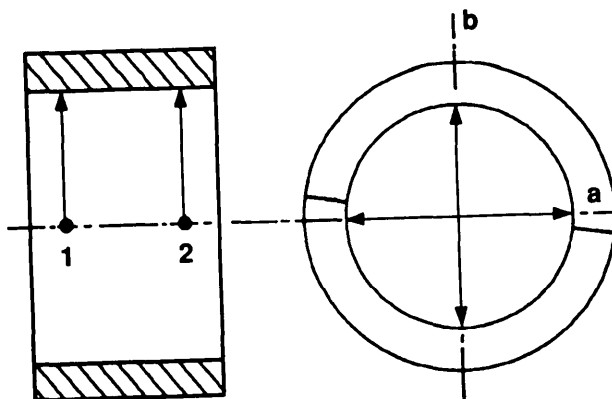

Figure 6-14. Checking Pre-loading of Engine Bearing Bores.

6.6.4 Engine Maintenance. (continued)

The main bearings are of the thin-shell type. Their proper installation requires that webs in crankcase be in alignment and for bearing bores to be preloaded. No attempt should be made to adjust or recondition bearing shells.

h. Check bearing bores as follows:

- (1) position bearing caps, making sure that their identification numbers match with those stamped in crankcase. Torque down bolts in accordance with appendix G.
- (2) Using inside micrometer, measure each main bearing base at points 1 and 2 in plan "a", then in the same manner in plane "b" offset by 90 degrees (see figure 6-14), in order to determine any contraction, out-of-roundness or conicity. See table 6-1 for wear limits.
- (3) Install new bearings.
- (4) Position bearing cap, then preload and torque according to instructions given in Table 6-1.
- (5) Using inside micrometer, measure each bearing bore and compare measurements to table 6-1.

6.6.4.3 Assembly.

- a. Install deflector plate (figure 6-11, 11), notched nail (10) and sleeve bearing (9).
- b. Install plug (8), washer (7), nozzle (6), plug (5), washer (4), and plug (3).
- c. Install two washers (2) and plugs (1).
- d. Install crankshaft (figure 6-10, 9) as follows:
 - (1) Check locating pin in crankcase gearwheel. It should project 0.67 inch (17mm) from side opposite bearing identification mark. If necessary install new locating pin.
 - (2) Install crankcase gearwheel with face bearing identification mark directed away from crankshaft (9).
 - (3) Install bearing halves (10) and bearing caps (6 and 7), making sure that identification marks are correct.
 - (4) Coat ring stops (11 and 12) with grease and stick them by their smooth faces to first bearing web and first bearing cap.
 - (5) Install eight dowel bushings (8).
 - (6) Using oil, lubricate crankshaft journals and install crankshaft (9) with crankshaft gear match mark positioned.
 - (7) Ensure bearing shells are seated in main bearing caps and bearing webs.

6.6.4 Engine Maintenance. (continued)

NOTE

Start by tightening middle bearing cap and those on either side, finish with bearing caps at ends. The crankshaft must be able to rotate freely.

- e. Install bearing caps (7) and (6), with their identification number corresponding to and in same direction as that stamped on crankcase. Install washers (5) and bolts (4). Torque in accordance with appendix G.
- f. Install pistons (3).
- g. Install connecting rod caps (2) and connecting rod bolts (1). Torque in accordance to appendix G.
- h. Assembly flywheel assembly as follows:
 - (1) If ring gear (figure 6-9, 12) has been removed, heat new ring gear to a temperature of 248° F (120°C) and position it on flywheel (11) and tap it into position so it seats against shoulder.
 - (2) Install flywheel (11) with bolts (10). Torque in accordance with appendix G.

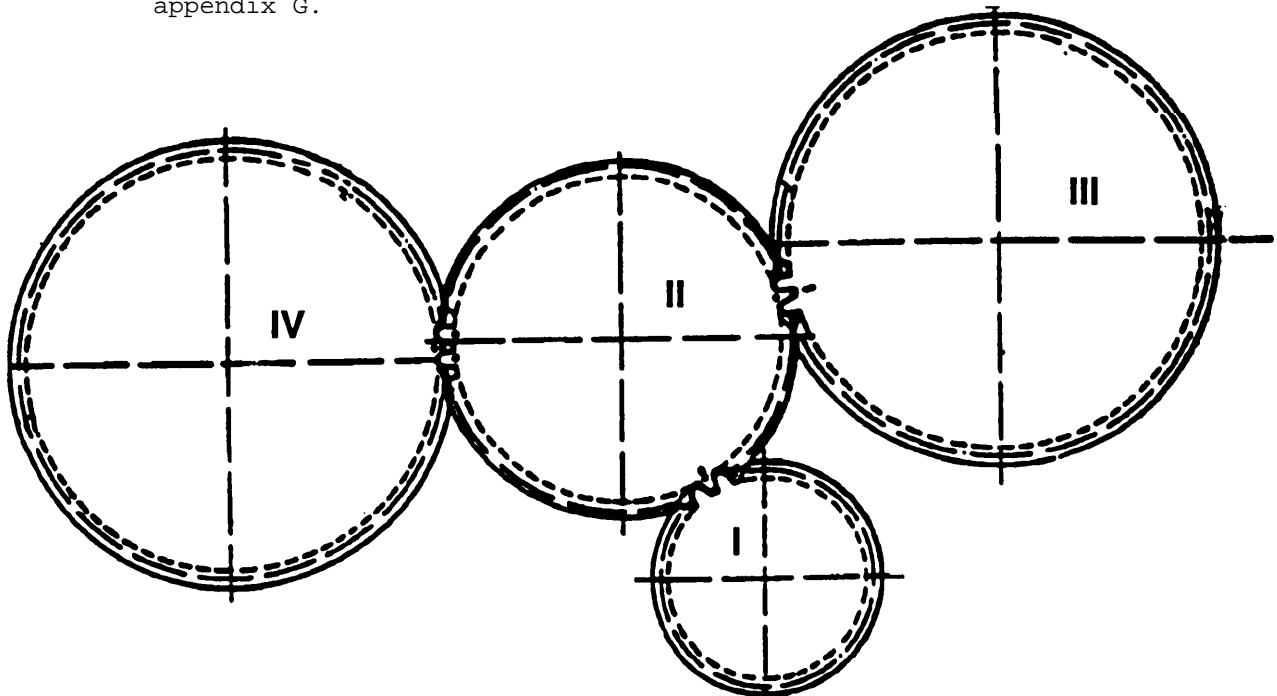

- I - CRANKSHAFTGEAR
- II - IDLERGEAR
- III - CAMSHAFTGEAR
- IV - INJECTION PUMP GEAR

Figure 6-15. Timing Gears Layout with Match Marks.

6.6.4 Engine Maintenance. (continued)

- (3) Press seal (9) into rear end cover (8).
- (4) Install rear end cover (8), eight washers (7), and bolts (6).
- i. Check valve tappets (5) for excessive wear (contacting face must be convex) and oil hole is not obstructed. Oil valve tappets and install them in crankcase.
- j. Assemble washer (4) to camshaft (3). Oil camshaft journals and install camshaft with camshaft gear positioned as shown in figure 6-15.
- k. Oil working surface of cylinder and piston. Apply grease to preformed packing groove in cylinder and cylinder liner. Place shims (2) that are 0.0197 inch (0.5 mm) and 0.0079 inch (0.2 mm) thick on cylinder liner. Install cylinders (1).
- l. Install housing adapter (figure 6-8, 16), eleven lockwashers (15), short bolts (14) and three long bolts (13).
- m. Install sealing ring (12), screw (11), and cover (10).
- n. Install dipstick (9).
- o. Install bushing (8) and journal (7).
- p. Install bushing (6) into idler gear (3).
- q. Install seal (5) and tube (4) on bracket (2).
- r. Install idler gear (3) bracket (2), cap screw (1). Torque in accordance with appendix G.
- s. Install oil pump as follows:
 - (1) Install two brackets (figure 6-7, 35), washers (34), and screws (33).
 - (2) Install oil pump (32), two shields (31), washers (30) and bolts (29).
 - (3) Install suction pipe (28).
 - (4) Install two bolts (27), washers (26), and nuts (25).
 - (5) Install bracket (24) and breather pipe (23).
- t. Install oil sump as follows:
 - (1) Position oil sump (22) in place.
 - (3) Install sixteen washers (21) and bolts (20).
 - (4) Install three washers (19) and bolts (18).
- u. Install front cover as follows:
 - (1) Install injection pump gear (17).
 - (2) Install new gasket (16).
 - (3) Align all match marks for timing gears as shown in figure 6-15) then position front cover (figure 6-7, 5) in place.
 - (4) Install three washers (15) and bolts (14).

6.6.4 Engine Maintenance. (continued)

- (5) Install washer (13) and bolt (12).
 - (6) Install lockwasher (11) and bolts (10).
 - (7) Install four lockwashers (9) and bolts (8).
 - (8) Install two washers (7) and bolts (6).
 - (9) Tighten all bolts in accordance with appendix G.
- v. Install four washers (4), one motor mount (3), four washers (2), and bolts (1).

6.6.5 Piston Repair.

This task covers: 6.6.5.1 Disassembly 6.6.5.3 Installation
 6.6.5.2 Repair

INITIAL SETUP

Tools

General Mechanic's Tool Kit (appendix B, Section III, Item 1)

Piston ring expander (appendix B, Section III, Item 3)

Inside micrometer (appendix B, Section III, Item 3)

Equipment Conditions

Engine disassembled, paragraph 6.6.4.

General Safety Instructions

Do not touch piston without wearing gloves to protect against burns.

Do not work on equipment without following standard shop safety precautions.

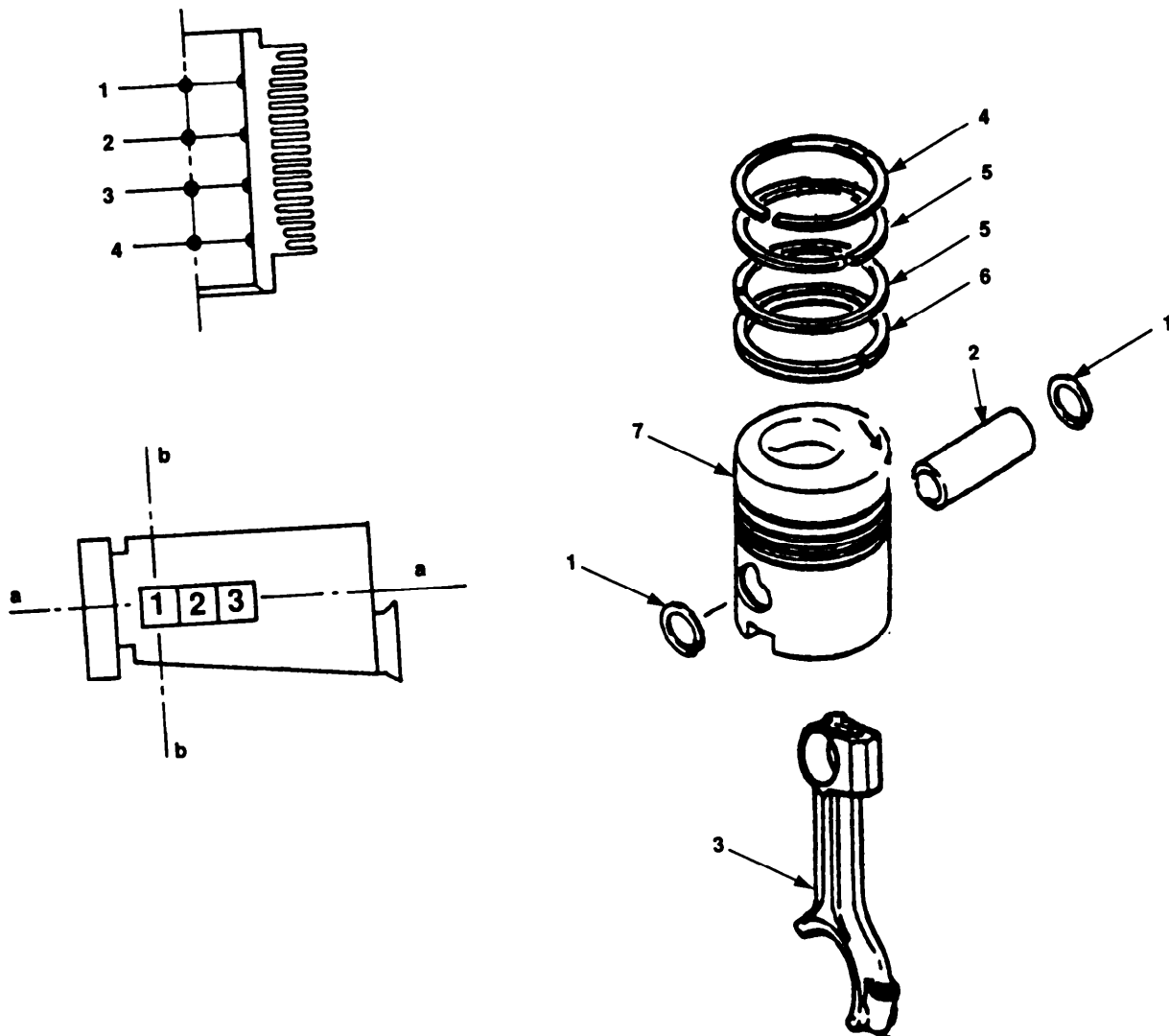

Figure 6-16. Piston Disassembly.

6.6.5.1 Disassembly.

- a. Remove retaining rings (figure 6-16, 1) and withdraw piston pin (2).
- b. Remove piston and rings from connecting rod (3).
- c. Using piston-ring expander, remove trapezoidal ring (4) and two taper piston rings (5).
- d. open and remove oil control ring (6) from piston (7).

6.6.5.2 Repair.

- a. Inspect piston for damage or visible wear, including bosses.
- b. Using standard measuring tools, refer to table 6-1 and ensure axial piston ring clearance.
- c. Insert all piston rings one at a time in cylinder and press down with piston to a distance of 1.18 inches (30 mm) from cylinder head contacting surface. Refer to table 6-1 and measure gap clearance of piston ring.
- d. Replace defective pistons together with piston pin and rings.
- e. Install expander spring for bevelled scraper ring in bottom groove on piston (7).
- f. Using piston-ring expander, perform the following:
 - (1) Install oil-control ring (6).
 - (2) Install two taper piston rings (5) with face marked "top" upwards.
 - (3) Install trapezoidal ring (4) with face marked "top" upwards.
- g. Install one retaining ring (1) into boss of piston.
- h. Oil piston pin (2) and piston pin bushing.
- i. Place piston on small end of connecting rod (3) so that exhaust air side of piston (marked on piston crown) is in same direction as open side of connecting rod bearing.
- j. Secure opposite end of piston pin (2) in position.

6.6.5.3 Assembly.

- a. Press piston pin (2) into piston bosses and small end of connecting rod (3).
- b. Install second retaining ring (1) to secure piston pin (2).
- c. Inspect cylinder liner as follows:
 - (1) Using inside micrometer, gauge cylinder bore at levels 1 to 4 of engine center line "a" as well as cross-line "b", see figure 6-16.
 - (2) Readings should be 3.937 inches (100 mm). If not within plus 0.0079 inch (0.2 mm) replace parts concerned.
- d. Check that cylinder top and bottom joint faces are flat. Replace cylinders as needed.
- e. Using micrometer and an internal dial gauge, check diameter of piston pin and gauge bore of piston pin bushing for reading of 0.0015 inch (0.04 mm) and 0.0035 inch (0.091 nun). Replace piston pin bushing if required.

APPENDIX A

REFERENCES

A.1 SCOPE.

Appendix A list publications that are related to the equipment. Since publications are updated the military publication indexes listed in this paragraph should be consulted frequently for latest changes or revisions of references given relating to material covered in this publication.

Military Publication Indexes.

Consolidated Index of Army Publications and Forms DA PAM 25-30

A.2 FORMS.

Refer to DA PAM 738-750, the Army Maintenance Management System (TAMMS), for instructions on the use of maintenance forms pertaining to the equipment.

Equipment Inspection and Maintenance Worksheet	DA Form 2024
Recommended Changes to Publications and Blank Forms	DA Form 2028
Recommended Changes to Equipment Technical Publications	DA Form 2028-2
Depreservation Guide for Vehicles and Equipment	DA Form 2258
Product Quality Deficiency Report	SF 368
Report of Discrepancy	SF 361

A.3 Field Manuals.

The following field manuals contain information pertinent to the equipment.

Camouflage	FM 5-20
Basic Cold Weather Manual	FM 31-70
Manual for Wheel Vehicle Driver	FM 21-305
Army Motor Transport Units and operation	FM 55-30
Northern Operations.	FM 31-71
Operation and Maintenance of Ordnance	
Material in Cold Weather 0° to 65°	FM 9-207
NBC Contamination Avoidance	FM 3-3
NBC Protection	FM 3-4
NBC Decontamination	FM 3-5
First Aid for Soldiers	FM 21-11

A.4 TECHNICAL MANUAL.

The following technical manuals contain information pertinent to the equipment.

Care, Maintenance and Repair of	
Pneumatic Tires and Inner Tubes	TM 9-2610-200-24
Inspection, Care and Maintenance of Antifriction Bearings	TM 9-214
Materials Used for Cleaning, Preserving, Abrading,	
and Cementing Ordnance Material and Related	
Materials Including Chemicals	TM 9-247
Welding Theory and Application	TM 9-237
Lubrication Order	LO 10-4320-226-12
Procedures for Destruction of Equipment to	
Prevent Enemy Use (Mobility Equipment Command)	TM 750-244-3

A.5 MISCELLANEOUS PUBLICATIONS.

The following miscellaneous publications contain information pertinent to the equipment.

Army Maintenance Management System (TAMMS)	DA Pam 738-750
Army Maintenance Management System-Aviation (TAMMS-A)	DA Pam 738-751
Description, Use, Bonding Techniques, and Properties of Adhesives	TB ORD1032

APPENDIX B MAINTENANCE ALLOCATION CHART (MAC)

SECTION I. INTRODUCTION

B.1 THE ARMY MAINTENANCE SYSTEM MAC.

B.1.1 Introduction. This introduction (Section I) provides a general explanation of all levels of maintenance and repair functions authorized at various maintenance levels under the standard Army Maintenance System concept.

B.1.2 Maintenance Allocation Chart Section II. The Maintenance Allocation Chart (MAC) in section II designates overall authority and responsibility for the performance of maintenance functions on the identified end item or component. The application of the maintenance functions to the end item or component will be consistent with the capacities and capabilities of the designated maintenance levels, which are shown on the MAC in column (4) as:

Unit - includes two subcolumns, C (operator/crew) and O (unit) maintenance

Direct support - includes an F subcolumn

General support - includes an H subcolumn

Depot - includes a D subcolumn

B.1.3. Tools and Test Equipment Introduction. Section III lists the tools and test equipment (both special tools and common tool sets) required for each maintenance function as referenced from section II.

B.1.4 Supplemental Instructions Introduction. Section IV contains supplemental instructions and explanatory notes for a particular maintenance function.

B.2 MAINTENANCE FUNCTIONS.

Maintenance functions are limited to and defined as follows:

B.2.1 Inspect. To determine the serviceability of an item by comparing its physical, mechanical, and/or electrical characteristics with established standards through examination (e.g., by sight, sound, or feel).

B.2.2 Test. To verify serviceability by measuring the mechanical, pneumatic, hydraulic, or electrical characteristics of an item and comparing those characteristics with prescribed standards.

B.2.3 Service. Operations required periodically to keep an item in proper operating condition i.e., to clean (includes decontaminate, when required), to preserve, to drain, to paint, or to replenish fuel, lubricants, chemical fluids, or gases.

B.2.4 Adjust. To maintain or regulate, within prescribed limits, by bringing into proper or exact position, or by setting the operating characteristics to specified parameters.

B.2.5 Align. To adjust specified variable elements of an item to bring about optimum or desired performance.

B.2.6 Calibrate. To determine and cause corrections to be made or to be adjusted on instruments or test, measuring, and diagnostic equipment used in precision measurement. Consists of comparisons of two instruments, one of which is a certified standard of known accuracy, to detect and adjust any discrepancy in the accuracy of the instrument being compared.

B.2.7 Remove/Install. To remove and install the same item when required to perform service or other maintenance functions. Install may be the act of emplacing, seating, or fixing into position a spare, repair part, or module (component or assembly) in a manner to allow the proper functioning of an equipment or system.

B.2.8 Replace. To remove an unserviceable item and install a serviceable counterpart in its place. "Replace" is authorized by the MAC and assigned maintenance level is shown as the 3d position code of the SMR code.

B.2.9 Repair. The application of maintenance services¹, including fault location/troubleshooting², removal/installation, and disassembly/assembly³ procedures, and maintenance actions⁴ to identify troubles and restore serviceability to an item by correcting specific damage, fault, malfunction, or failure in a part, subassembly, module (component or assembly), end item, or system.

B.2.10 Overhaul. That maintenance effort (service/action) prescribed to restore an item to a completely serviceable/operational condition as required by maintenance standards in appropriate technical publication (i.e., DMWR). Overhaul is normally the highest degree of maintenance performed by the Army. Overhaul does not normally return an item to like new condition.

B.2.11 Rebuild. Consists of those services/actions necessary for the restoration of unserviceable equipment to a like new condition in accordance with original manufacturing standards. Rebuild is the highest degree of materiel maintenance applied to Army equipment. The rebuild operation includes the act of returning to zero those age measurement (e.g., hour/miles) considered in classifying Army equipment /components.

B.3 EXPLANATION OF COLUMNS IN THE MAC, SECTION II.

B.3.1 Column 1, Group Number. Column 1 lists functional group code numbers, the purpose of which is to identify maintenance significant components, assemblies, subassemblies, and modules with the next higher assembly.

B.3.2 Column 2, Component/Assembly. Column 2 contains the item names of components, assemblies, subassemblies, and modules for which maintenance is authorized.

B.3.3 Column 3, Maintenance Function. Column 3 lists the functions to be performed on the item listed in Column 2. (For detailed explanation of these functions, see paragraph B.2.)

B.3.4 Column 4, Maintenance Level. Column 4 specifies each level of maintenance authorized to perform each function listed in Column 3, by indicating work-time required (expressed as man-hours in whole hours or decimals) in the appropriate subcolumn. This work-time figure represents the active time required to perform that maintenance function at the indicated level of maintenance. If the number or

¹Service8 - inspect, test, service, adjust, align, calibrate, and/or replace.

²Fault location/troubleshooting - The process of investigating and detecting the cause of equipment malfunctioning; the act of isolating a fault within a system or unit under test (UUT).

³Disassembly/assembly - The step-by-step breakdown (taking apart) of a spare/functional group coded item to the level of its least component that is assigned an SMR code for the level of maintenance under consideration (i.e., identified as maintenance significant).

⁴Actions - welding, grinding, riveting, straightening, facing, machining, and/or resurfacing.

complexity of the tasks within the listed maintenance function vary at different maintenance levels, appropriate work-time figures are to be shown for each level. The work-time figure represents the average time required to restore an item (assembly, subassembly, component, module, end item, or system) to a serviceable condition under typical field operating conditions. This time includes preparation time (including any necessary disassembly/assembly time), troubleshooting/fault location time, and quality assurance time in addition to the time required to perform the specific tasks identified for the maintenance functions authorized in the maintenance allocation chart. The symbol designations for the various maintenance levels are as follows:

- C Operator or crew maintenance
- O Unit maintenance
- F Direct Support maintenance
- H General support maintenance
- L Specialized Repair Activity (SRA)⁵
- D Depot maintenance

B.3.5. Column 5, Tools and Test Equipment Reference Code. Column 5 specifies, by code, those common tool sets (not individual tools) , common TMDE, and special tools, special TMDE, and special support equipment required to perform the designated function. Codes are keyed to tools and test equipment in Section III.

B.3.6 Column 6, Remarks. When applicable, this column contains a letter code, in alphabetic order, which is keyed to the remarks contained in Section IV.

B.4 EXPLANATION OF COLUMNS IN TOOL AND TEST EQUIPMENT REQUIREMENTS, SECTION III.

B.4.1 Column 1, Reference Code. The tool and test equipment reference code correlates with a code used in the MAC, Section II, Column 5.

B.4.2 Column 2, Maintenance Level. The lowest level of maintenance authorized to use the tool or test equipment.

B.4.3 Column 3, Nomenclature. Name or identification of the tool or test equipment.

B.4.4 Column 4, National Stock Number. The National Stock Number of the tool or test equipment.

B.4.5 Column 5, Tool Number. The manufacturer's part number, model number, or type number.

B.5 EXPLANATION OF COLUMNS IN REMARKS, SECTION IV.

B.5.1 Column 1, Remarks Code. The code recorded in Column 6, Section II.

B.5.2 Column 2, Remarks. This column lists information pertinent to the maintenance function being performed as indicated in the MAC, Section II.

⁵This maintenance category is not included in Section II, column (4) of the Maintenance Allocation Chart. To identify functions to this category of maintenance, enter a work time figure in the "H" column of Section II, column (4), and use an associated reference code in the Remarks column (6). Key the code to Section IV, Remarks, and explain the SRA complete repair application there. The explanatory remark(s) shall reference the specific Repair Parts and Special Tools List (RPSTL) TM which contains additional SRA criteria and the authorized spare/repair parts.

**SECTION II. MAINTENANCE ALLOCATION CHART
FOR
350 GALLONS PER MINUTE PUMP (WATER)**

(1) Group Number	(2) Component/Assembly	(3) Maintenance Function	(4) Maintenance Level					(5) Tools and Equipment Ref Code	(6) Remarks Code
			Unit		Direct Support	General Support	Depot		
			C	O	F	H	D		
00	350 GPM Pump Assembly								
01	Exhaust System								A
0101	Spark Arrestor	Inspect Service Replace	0.1	0.1 0.4				1 1	
0102	Exhaust Heat Shield	Inspect Replace		0.1 0.4				1 1	
02	Engine Assembly	Test Inspect Replace Repair Service	0.1		1.0 4.0 0.5		60.0	1, 7, 8 1, 3, 4 3, 10, 13, 23, 24, 25, 26 1	A, B, C, D
0201	Engine Manifolds								
020101	Exhaust Manifolds	Inspect Replace Repair	0.1	0.4 0.2				1 1	A, E
020102	Intake Manifold	Inspect Replace			0.1 1.0			1 1	
020103	Starting Aid Assembly	Inspect Replace Repair	0.1	0.4 0.2				1 1	
0202	Air Cleaner	Inspect Replace Repair		0.1 0.4 0.1				1 1	A, E, F
0203	V-Belt Guard Assembly and belts.	Inspect Replace	0.2	0.6				1	

**SECTION II. MAINTENANCE ALLOCATION CHART
FOR
350 GALLONS PER MINUTE PUMP (WATER) (continued)**

(1) Group Number	(2) Component/Assembly	(3) Maintenance Function	(4) Maintenance Level					(5) Tools and Equipment Ref Code	(6) Remarks Code
			Unit		Direct Support	General Support	Depot		
			C	O	F	H	D		
020301	Alternator V-belt	Inspect		0.1					
		Replace		0.2				1	
		Adjust		0.1				1	A, G
020302	Cooling Fan V-belt	Inspect		0.1					
		Replace		0.2				1	
020303	V-belt Contact Switch	Test		0.1				1, 2	
		Replace		0.6				1	
0204	Alternator	Test		0.2				1, 2	A, H, I
		Replace		0.6				1	
0205	Starter	Replace		0.6				1	
0207	Fuel System								
020701	Shutdown Solenoid	Test		0.4				2	A, I
		Replace		1.0				1	
		Service		0.2				1	
		Adjust		0.2				1	
		Repair		0.4				1	
020702	Fuel Lines and Fittings	Inspect		0.5					
		Replace		2.0				1	
		Service		0.5				1	A, J
		Repair		1.5				1	
020703	Fuel Feed Pump	Replace		1.0				1	
		Service		0.2					
020704	Fuel Injection Pump and Injectors	Test			1.0			1, 3, 5, 6, 7, 9	
		Replace			2.5			1, 7	A, K, L
		Service			1.0			1, 7, 9	
		Repair			1.5			1	
0208	Filters and Oil Sending Units	Inspect		0.2				1	
		Replace		1.0				1	
		Service		0.7				1	
0209	Cooling Fan and Cooling Coil Assembly	Replace		1.6				1	

**SECTION II. MAINTENANCE ALLOCATION CHART
FOR
350 GALLONS PER MINUTE PUMP (WATER) (continued)**

(1) Group Number	(2) Component/Assembly	(3) Maintenance Function	(4) Maintenance Level					(5) Tools and Equipment Ref Code	(6) Remarks Code
			Unit		Direct Support	General Support	Depot		
			C	O	F	H	D		
0210	Cylinder Heads and Valves	Adjust		0.5				1, 3, 5, 10, 14	
021001	Valves	Adjust Replace Repair		0.5		2.5 2.5		1 1, 3 1, 3, 15, 16, 17, 18, 19, 20, 21, 22, 1, 3	A, M
021002	Cylinder Head	Replace Adjust Repair				1.5 2.0 3.0		1 1 1	
021003	Rocker Arm Assembly	Replace Repair				2.0 1.0		1 1	A, E
0211	Front Cover Assembly	Replace				2.0		3	
021101	Idler Pulley Assembly	Replace		1.0				1, 11, 12, 13	
0212	Oil Pan and Oil Pump.	Replace				2.0		1	
0213	Camshaft and Bearing	Replace Inspect				6.0 1.0		1, 3 1	
0215	Block and Main Bearings	Replace Inspect				3.5 1.0		1, 24 1	
0216	Crankshaft	Replace Inspect				3.0 1.0		1, 24, 25, 26 1	
0217	Connecting Rods and Pistons	Replace Repair				6.0 2.0		1 1	
03	Throttle Control Assembly	Replace Repair		0.8 0.5				1 1	N, E

**SECTION II. MAINTENANCE ALLOCATION CHART
FOR
350 GALLONS PER MINUTE PUMP (WATER) (continued)**

(1) Group Number	(2) Component/Assembly	(3) Maintenance Function	(4) Maintenance Level					(5) Tools and Equipment Ref Code	(6) Remarks Code
			Unit		Direct Support	General Support	Depot		
			C	O	F	H	D		
04	Electrical System								A, E
0401	Batteries and Cables	Inspect Service Test Replace	0.1 0.1 0.3 0.5					1, 2 1	A, I, O
0402	Main Wiring Harness	Inspect Test Replace Repair	0.2 0.2 1.0 0.5 2.0					1, 2 1 1, 2	A, P, Q
0403	Control Panel Assembly	Inspect Test Replace Repair	0.2 1.0 2.0 4.0					1, 2 1 1, 2	A, E, P
040301	Control Panel Wiring Harnesses	Inspect Replace Repair	0.5 2.0 1.5					1 1	
05	Pump Manifolds and Valves	Inspect Repair Replace	0.1 0.5 1.0					1 1 1	A, S, R
06	Pump Assembly	Service Replace	0.2		2.0			1, 3, 11 1, 3, 11	
0601	Volute	Replace			4.0			1	
07	Water Separator	Service Replace	0.1 0.4					1 1	A, E
08	Fuel Tank	Service Replace Repair	0.2		1.0 2.0			1 1 1	A, E, T
09	Wheel Mounted Frame Assembly	Inspect Repair	0.2		3.0			1, 2	
0901	Wheels and Tires	Inspect Service Replace Repair	0.2 1.0 2.0 1.0					1, 2 1, 2 1, 2	A, E, U
0902	Axle	Replace			4.0			1	A, E

**SECTION II. MAINTENANCE ALLOCATION CHART
FOR
350 GALLONS PER MINUTE PUMP (WATER) (continued)**

(1) Group Number	(2) Component/Assembly	(3) Maintenance Function	(4) Maintenance Level					(5) Tools and Equipment Ref Code	(6) Remarks Code
			Unit		Direct Support	General Support	Depot		
			C	O	F	H	D		
09	Wheel Mounted Frame Assembly	Inspect Repair	0.2		3.0			1,2	
0901	Wheels and Tires	Inspect Service Remove Repair Install	0.2	1.0 1.0 1.0 1.0				1,2 1,2 1,2 1	D,T
0902	Axle	Remove Install			2.0 2.0			1,1 1,1	D

**SECTION III. TOOL AND TEST EQUIPMENT REQUIREMENTS
FOR
350 GALLONS PER MINUTE PUMP (WATER)**

(1) TOOL OR TEST EQUIPMENT REF CODE	(2) MAINTENANCE LEVEL	(3) NOMENCLATURE	(4) NATIONAL/NATO STOCK NUMBER	(5) TOOL NUMBER
1	O	Tool Kit, General Mechanics Automotive	5180-00-177-7033	
2	O	Shop Equipment Automotive Maintenance and Repair Common Number 1.	4910-00-754-0654	
3	F	Shop Set, Automotive Repair Field Maintenance Basic	4910-00-754-0705	
4	F	Eye/Lug		336-8621
5	F	Position Pointer		003-0678
6	F	Injection Timing Pump		J-33342
7	O	Puller		003-0463
8	O	Compression Gauge Assembly		J-33336
9	F	Injection Pump Tester Gauge		J-34006
10	F	Timing Mark and Bolt Scale		J-33146
11	F	Angle of Turn Indicator Tool		J-33339
12	F	Seal Removing Tool		
13	F	Crankshaft Seal Installer		J-33348
14	H	Push Rod Tube Spring Compressor		J-33346
15	H	Valve Spring Compressor		J-33345
16	H	Cutting Device		003-0426
17	H	Reemer		003-0452
18	H	Mandrel (Intake)		003-0620
19	H	Mandrel (Exhaust)		003-0441
20	H	Mandrel		003-0453
21	H	Cutter		003-0652
22	H	Pilot Pin		003-0650
23	H	Bolt Degree Gauge		003-1102
24	H	Refacing Device		003-1133
25	F	Gasket Extractor		003-0733
26	H	Crankshaft Seal Installer		J-33347

**SECTION IV. REMARKS
FOR
350 GALLONS PER MINUTE PUMP (WATER)**

(1) REFERENCE CODE	(2) REMARKS
A	Repair includes replacing bearings and gears.
B	Repair includes replacing rings and rod bearings.
C	Repair includes crankshaft grinding.
D	Repair by replacing defective components.
E	Replace element(s).
F	Adjust belt tension.
G	Operational test.
H	Test for known voltage.
I	Replace assembly only.
J	Test timing and pressure output.
K	Return to Depot. Depot is to retain and return to manufacturer for repair
L	Includes replacing valve seats, guides.
M	Non-regulated pumping assemblies only.
N	Check specific gravity of each cell.
O	Test for opens, grounds and shorts.
P	Repair by replacing defective wire.
Q	Regulated pump assembly only.
R	Replace gate valve seals.
S	Weld
T	Pack wheel bearings

APPENDIX C
COMPONENTS OF END ITEM AND BASIC ISSUE ITEMS LISTS

SECTION I
INTRODUCTION

C.1 **SCOPE.** This appendix lists components of the end item and basic issue items for the pump to help you inventory the items for safe and efficient operation of the equipment.

C.2 **GENERAL.** The Components of End Item (COEI) and Basic Issue Items (BII) Lists are divided into the following sections:

C.2.1 **Section II. Components of End Item.** This listing is for information purposes only, and is not authority to requisition replacements. These items are part of the 350 GPM pump. As part of the end item, these items must be with the end item whenever it is issued or transferred between property accounts. Items of COEI are removed and separately packaged for transportation or shipment only when necessary. Illustrations are furnished to help you find and identify the items.

C.2.2 **Section III. Basic Issue Items.** These essential items are required to place the 350 GPM pump in operation, operate it, and to do emergency repairs. Although shipped separately packaged, BII must be with the 350 GPM pump during operation and when it is transferred between property accounts. This list is your authority to request/requisition them for replacement based on authorization of the end item by the TOE/MTOE. Illustrations are furnished to help you find and identify the items.

C.3 **EXPLANATION OF COLUMNS.**

C.3.1 **Column (1).** The first column, Illus Number, gives you the number of the item illustrated.

C.3.2 **Column (2).** The second column, National Stock Number, identifies the stock number of the item to be used for requisitioning purposes,

C.3.3 **Column (3).** The third column, Description and Usable On Code, identifies the Federal item name (in all capital letters) followed by the minimum description when needed. The last line below the description is the Commercial and Government Entity Code (CAGEC) (in parentheses) and the part number. If the item you need is not the same for difference models of the equipment, a Usable On Code will appear on the right side of the description column on the same line as the part number. These codes are identified below:

CODE	U S E D
DRH	Model 350PAW
EKR	Model W-87012
FQF	Model 350 PAWN

C.3.4 **Column (4).** The fourth column, U/I (unit of issue), indicates how the item is issued for the National Stock Number shown in Column 2.

C.3.5 **Column (5).** The fifth column, Qty Rqd, indicated the quantity required.

C.3.6 **Column 6. Remarks.** When applicable, this column contains a letter code, in alphabetic order, which is keyed to the remarks contained in Section III.

SECTION II. COMPONENTS OF END ITEM

Not applicable.

**SECTION III
BASIC ISSUE ITEMS**

***TM 10-4320-226-14**

TECHNICAL MANUAL
OPERATOR, UNIT, DIRECT SUPPORT, AND GENERAL SUPPORT
MAINTENANCE MANUAL

FOR
WATER PUMPING ASSEMBLY, DIESEL ENGINE DRIVEN
WHEEL MOUNTED, 350 GALLONS PER MINUTE (GPM),
275 FOOT HEAD, MODELS:
350 PAW (NSN 4320-01-158-2954),
W-87012 (NSN 4320-01-265-2168)
AND
350 PAWN (NSN 4320-01-436-0188)

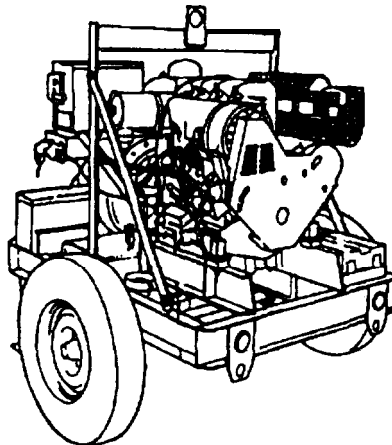

EQUIPMENT DESCRIPTION	
OPERATING INSTRUCTIONS	
OPERATOR PREVENTIVE MAINTENANCE CHECKS AND SERVICES (PMCS)	
OPERATOR MAINTENANCE PROCEDURES	
UNIT PREVENTIVE MAINTENANCE CHECKS AND SERVICES (PMCS)	
UNIT MAINTENANCE PROCEDURES	
DIRECT SUPPORT MAINTENANCE PROCEDURES	
GENERAL SUPPORT MAINTENANCE PROCEDURES	
MAINTENANCE ALLOCATION CHART	
GLOSSARY	
INDEX	

This manual, together with TM 10-4320-343-14, supersedes TM 5-4320-226-14.15 August 1984

1

**HEADQUARTERS, DEPARTMENT OF THE ARMY
31 AUGUST 1993**

(1) Illus Number	(2) National Stock Number	(3) Description CAGEC and Part Number	(4) Usable On Code U/I	(5) Qty Rqr
1		Technical Manual, TM 10-4320-226-14	DRH, EKR, FPT EA.	1

**APPENDIX D
ADDITIONAL AUTHORIZATION LIST**

Not applicable.

APPENDIX E EXPENDABLE AND DURABLE ITEMS LIST

SECTION I. INTRODUCTION

E.1 SCOPE

This appendix lists expendable and durable items that you will need to maintain the 350 Gallon Per Minute (GPM) pump. This listing is for informational purposes only and is not authority to requisition the listed items. These items are authorized to you by CTA 50-970, expendable items (except medical, class V repair parts, and Heraldic Items).

E.2 EXPLANATION OF COLUMNS

E.2.1 Column (1) - Item Number. This number is assigned to the entry in the listing referencing when required.

E.2.2 Column (2) - Level. This column identifies the lowest level of maintenance that requires the listed item.

C	- Operator/Crew
O	- Unit Maintenance
F	- Direct Support Maintenance
H	- General Support Maintenance

E.2.3 Column (3) - National Stock Number. This is the national stock number assigned to the item; use it to request or requisition the item.

E.2.4 Column (4) - Description. Indicates the federal item name and, if required, a description to identify the item. The last line for each item indicates the Commercial and Government Entity Code (CAGEC) parentheses followed by the part number.

E.2.5 Column (5) - Unit of Measure (UM)/Unit of Issue (UI). This measure is expressed by a two character alphabetical abbreviation (eg., EA, IN, PR). If the unit of measure differs from the unit of issue as shown in the Army Master Data File (AMDF) requisition the lowest unit of issue that will satisfy your requirements.

SECTION II EXPENDABLE AND DURABLE ITEMS LIST

(1) Item Number	(2) Level	(3) National Stock Number	(4) Description	(5) U/M U/I
1	F	8040-00-266-0824	Adhesive, MM-A-122	tube
2	F	8040-00-995-0590	Adhesive, Sealant, Silicone, FTV, General Purpose, MIL-A-46106A, 108	tube
3	O	7920-01-067-6190	Brush, plater's hand (81384) HB 178/2-3	ea
4	O		Cloth, lint free	
5	C	9150-00-190-0907	Grease, Automotive and Artillery, MIL-L-10924	gl
6	O	9150-00-754-2595	Grease, Ball and Roller Bearing, MIL-G-18709	lb
7	C	9150-00-186-6627	Lubricating Oil, Internal combustion engine, tactical service, MIL-L-2104C (OE/HDO 10)	gl
8	C	9150-00-186-6681	Lubricating Oil, Internal combustion engine, tactical service, MIL-L-2104C (OE/HDO 10)	qt
9	O	8010-01-149-4784	Primer, Paint, TTT-P-664	qt
10	O	3439-01-036-5762	Solder, Tin Alloy SN60WRAP2 0.125 1 LB	spool
11	O	6850-00-664-5685	Solvent, Dry Cleaning, AA711 Type I and II	gl
12	O	9905-00-111-0671	Tags, identification, UU-T-81	ea
13	O	8030-00-761-1584	Tape, Antiseizing, MIL-T-27730	ea
14	O	7510-01-128-1187	Tape, Pressure Sensitive, PP-T-60	ea
15	F		Screw, Grade 5, coarse thread, 3 1/2 inches long	

APPENDIX F ILLUSTRATED LIST OF MANUFACTURED ITEMS

F.1 INTRODUCTION.

This appendix includes complete instructions for making items authorized to be manufactured or fabricated at unit maintenance level and direct support maintenance level.

All bulk materials needed for manufacture of an item are listed by part number or specification number in a tabular list on the illustration.

F.2 ITEMS PART NUMBER INDEX.

Refer to TM 10-4320-226-24P for index of part numbers.

F.3 MANUFACTURE OF MAIN WIRING HARNESS WIRES.

- a. Refer to Figures F-1 and F-1.1 for type of wire and terminals required. ■
- b. Cut wire to length.
- c. Install terminal lugs on each end of wire,

F.4 ASSEMBLY OF MAIN WIRING HARNESS.

- a. Refer to Paragraph F-3 and manufacture wires.
- b. Refer to Figures F-1 and F-1.1 to assembly wiring harness. ■

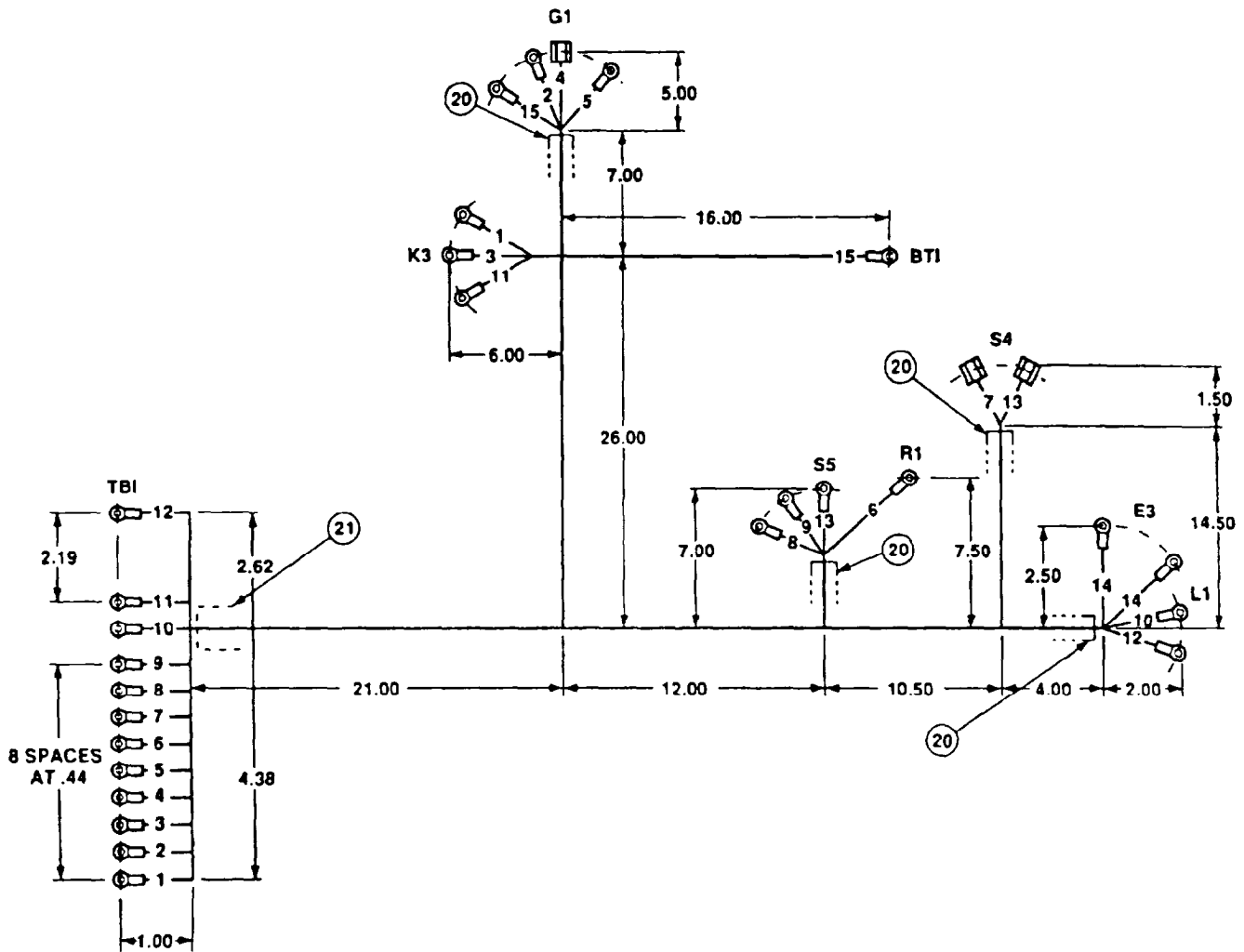

NOTES

1. INSTALLED TERMINALS, FIND 12-19, SHALL MEET THE PERFORMANCE REQUIREMENTS OF MIL-T-7928.
2. WIRING SHALL BE BUNDLED IN ACCORDANCE WITH REQUIREMENT 69 OF MIL-STD-454 AND COVERED WITH TUBING, FIND NO. 20 AND 21.
3. MARK "97403 - 13225E9054" IN ACCORDANCE WITH MIL-STD-130.
4. EACH WIRE SHALL BE MARKED ON BOTH ENDS WITH APPROPRIATE WIRE NUMBERS AS SHOWN IN TABULATION BLOCK.

EXAMPLE: TB - 1 ↔ K3 - POS

PERMANENCY LEGIBILITY AND TYPE OF LETTERING SHALL BE IN ACCORDANCE WITH MIL-STD-130.

Figure F-1. Pump Wiring Harness Assembly (Models 350 PAW and W-87012) (Sheet 1 of 2).

MAIN WIRING RUNNING LIST						
WIRE NO.	TERMINATION		TERMINATION		WIRE LENGTH (REF)	WIRE FIND NO.
	FROM	FIND NO.	TO	FIND NO.		
1	TB1-1	13	K3-POS	16	59.00	2
2	TB1-2	13	G1-OUT	19	64.00	1
3	TB1-3	13	K3-POS	16	58.00	2
4	TB1-4	14	G1-VR	12	63.50	7
5	TB1-5	14	G1-TACH	1 5	63.00	10
6	TB1-6	14	R1-1	15	44.50	5
7	TB1-7	14	S4-4	12	65.00	8
8	TB1-8	14	S5-2	1 5	42.75	9
9	TB1-9	14	S5-1	1 5	54.50	11
10	TB1-11	14	L1-AUX	1 4	54.50	6
11	TB1-12	13	K3-S	17	56.50	3
12	TB1-17	13	L1-NEG	18	60.00	4
13	S4-2	12	S5-2	15	35.00	9
14	L1-POS	18	E3	19	- - -	22
15	G1-GND	17	BT1	16	28.00	22

FACT OR MAIN WIRING HARNESS PARTS LIST						
FIND NO.	FSCM	DWG SIZE	IDENTIFICATION NO.	QTY	NOMENCLATURE OR DESCRIPTION	SPECIFICATION MATERIAL
1			MW-C12(65)U0	REQD		
2			MW-C12(65)U2	AR	WIRE. ELEC. 12 AWG, BLK	MIL-W-76
3			MW-C12(65)U6	AR	WIRE. ELEC. 12 AWG, RED	MIL-W-76
				AR	WIRE. ELEC. 12 AWG, BLU	MIL-W-76
4			MW-C12(65)U8	AR	WIRE, ELEC. 12 AWG, GRA	MIL-W-76
5			MW-C14(41)U1	AR	WIRE, ELEC. 14 AWG, BRN	MIL-W-76
6			MW-C14(41)U2	AR	WIRE. ELEC. 14 AWG, RED	MIL-W-76
7			MW-C14(41)U3	AR	WIRE. ELEC. 14 AWG, ORN	MIL-W-76
8			MW-C14(41)U4	AR	WIRE. ELEC. 14 AWG, YEL	MIL-W-76
9			MW-C14(41)U6	AR	WIRE. ELEC. 14 AWG, BLU	MIL-W-76
10			MW-C14(41)U7	AR	WIRE. ELEC. 14 AWG, VIO	MIL-W-76
11			MW-C14(41)U8	AR	WIRE. ELEC. 14 AWG, GRA	MIL-W-76
12		C	13226E0095-2	3	TERMINAL. DISCONNECT. 16- 14 AWG, .250 TAB	
13		C	13226E0107-18	5	TERMINAL. LUG, 12-10 AWG, .138 STUD	
14		C	13226E0107-11	8	TERMINAL, LUG, 16-14 AWG, .138 STUD	
15			MS25036-108	5	TERMINAL, LUG, 16-14 AWG, .190 STUD	
16			MS25036-114	3	TERMINAL, LUG, 12-10 AWG, .375 STUD	
17			MS25036-112	2	TERMINAL, LUG, 12-10 AWG, .190 STUD	
18			MS25036-156	2	TERMINAL, LUG, 12-10 AWG, .164 STUD	
19			MS25036-157	2	TERMINAL. LUG, 12-10 AWG, .250 STUD	
20		C	13226E0099-3	AR	TUBING, SPIRAL WRAP, .375 OD NOM	
21		C	13226E0099-4	AR	TUBING. SPIRAL WRAP, .500 OD NOM	
22			MW-C12(65)U5	AR	WIRE. ELEC. 12 AWG, GRN	MIL-W-76

Figure F-I. Pump Wiring Harness Assembly (Models 350 PAW and W-87012) (Sheet 2 of 2).

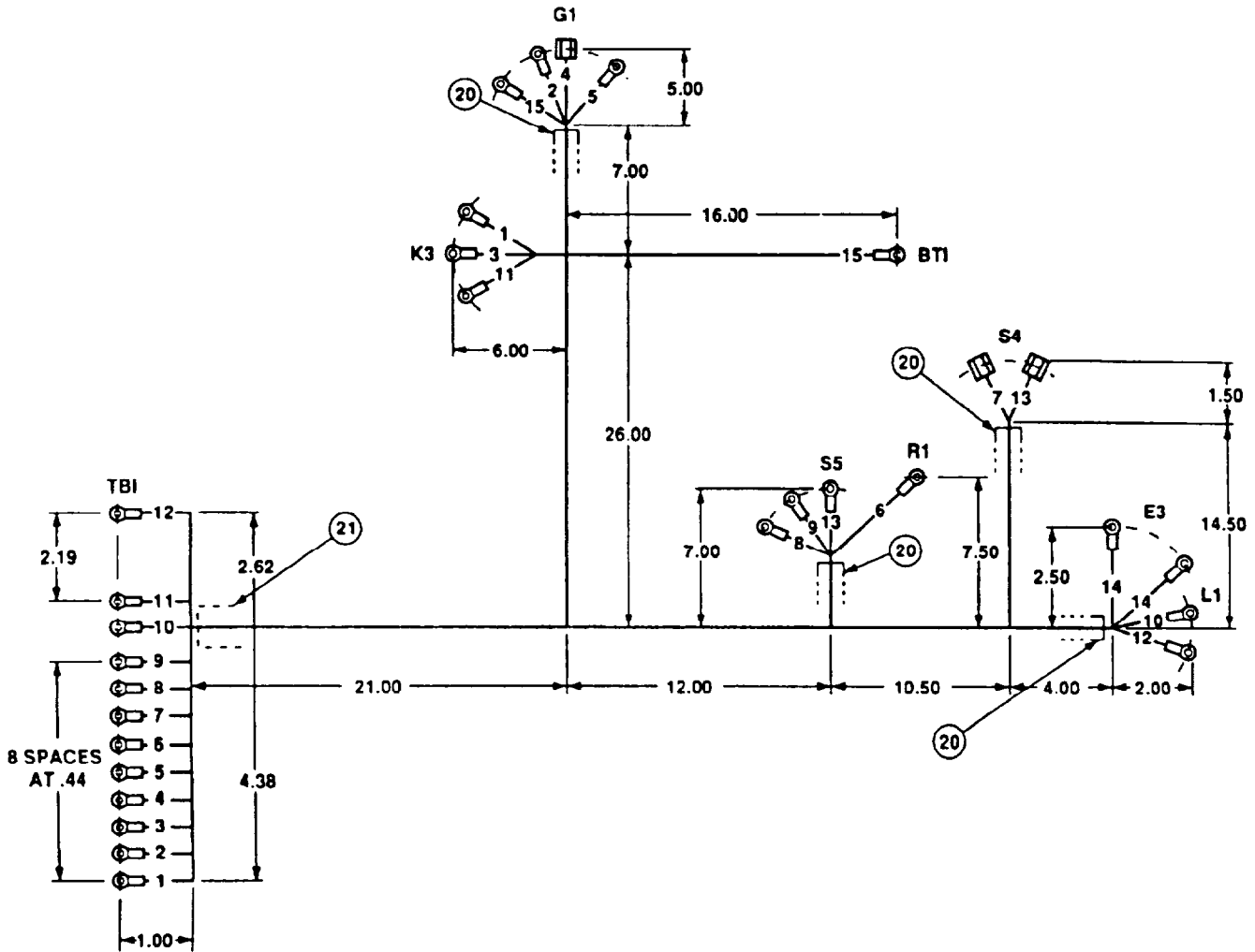

NOTES

1. INSTALLED TERMINALS, FIND 12-19, SHALL MEET THE PERFORMANCE REQUIREMENTS OF MIL-T-7928.
2. WIRING SHALL BE BUNDLED IN ACCORDANCE WITH REQUIREMENT 69 OF MIL-STD-454 AND COVERED WITH TUBING. FIND NO. 20 AND 21.
3. MARK "97403 - 13225E9054" IN ACCORDANCE WITH MIL-STD-130.
4. EACH WIRE SHALL BE MARKED ON BOTH ENDS WITH APPROPRIATE WIRE NUMBERS AS SHOWN IN TABULATION BLOCK.

EXAMPLE: TB - 1 - K3 - POS

PERMANENCY LEGIBILITY AND TYPE OF LETTERING SHALL BE IN ACCORDANCE WITH MIL-STD-130.

Figure F-1.1. Pump Wiring Harness Assembly (Model 360 PAWN) (Sheet 1 of 2).

MAIN WIRING RUNNING LIST						
WIRE NO.	TERMINATION		TERMINATION		WIRE LENGTH (REF)	WIRE FIND NO.
	FROM	FIND NO.	TO	FIND NO.		
1	TBI-1	13	KS-PO.5	16	59.00	2
2	TBI-2	13	G1-OUT	19	64.00	1
3	TB-3	13	K3-POS	16	58.00	2
4	TBI-4	14	G1-VR	12	63.50	7
S	TBI-5	14	G1-TACH	15	63.00	10
6	TBI-6	14	R1-1	1s	44.50	5
7	TBI-7	14	S4-4	12	65.00	8
8	TBI-8	14	SS-2	1S	42.7s	9
9	TBI-9	14	S5-1	15	54.50	11
10	TBI-11	14	LI-AUX	14	54.50	6
11	TBI-12	13	K3-S	17	56.50	3
12	TBI-17	13	L-NEG	18	60.00	4
13	S4-2	12	S5-2	15	35.00	9
14	L1-POS	18	E3	19	----	22
15	GI-GND	17	BTI	16	28.00	22
16	TB-21	13	GI-GND	16	62.00	22
17	G1-GND	19	E3	16	62.00	22
18	GI-GND	16	E4	16	62.00	22

MAIN WIRING HARNESS PARTS LIST							
FIND NO.	FSCM	DWG SIZE	FACT OR IDENTIFICATION NO.	QTY REQD	NOMENCLATURE OR DESCRIPTION	SPECIFICATION	MATERIAL
1			MW-C12 (65) U0	AR	WIRE, ELEC, 12 AWG, BLK	MIL-W-76	
2			MW-C12 (65) U2	AR	WIRE, ELEC, 12 AWG, RED	MIL-W-76	
3			MW-C12 (65) U6	AR	WIRE, ELEC, 12 AWG, BLU	MIL-W-76	
4			MW-C12 (65) U8	AR	WIRE, ELEC, 12 AWG, GRA	MIL-W-76	
5			MW-C14 (41) U1	AR	WIRE, ELEC, 14 AWG, BRN	MIL-W-76	
6			MW-C14 (41) U2	AR	WIRE, ELEC, 14 AWG, RED	MIL-W-76	
7			MW-C14 (41) U3	AR	WIRE, ELEC, 14 AWG, ORN	MIL-W-76	
8			MW-C14 (41) U4	AR	WIRE, ELEC, 14 AWG, YEL	MIL-W-76	
9			MW-C14 (41) U6	AR	WIRE, ELEC, 14 AWG, BLU	MIL-W-76	
10			MW-C14 (41) U7	AR	WIRE, ELEC, 14 AWG, VIO	MIL-W-76	
11			MW-C14 (41) U8	AR	WIRE, ELEC, 14 AWG, GRA	MIL-W-76	
12		C	13226E0095-2	3	TERMINAL, DISCONNECT, 16-14 AWG, .250 TAB		
13		C	13226E0107-18	5	TERMINAL, LUG, 12-10 AWG, .138 STUD		
14		C	13226E0107-11	8	TERMINAL, LUG, 16-14 AWG, .138 STUD		
15			MS25036-108	5	TERMINAL, LUG, 16-14 AWG, .190 STUD		
16			MS25036-114	3	TERMINAL, LUG, 12-10 AWG, .375 STUD		
17			MS25036-112	2	TERMINAL, LUG, 12-10 AWG, .190 STUD		
18			MS25036-156	2	TERMINAL, LUG, 12-10 AWG, .164 STUD		
19			MS25036-157	2	TERMINAL, LUG, 12-10 AWG, .250 STUD		
20		C	13226E0099-3	AR	TUBING, SPIRAL WRAP, .375 OD NOM		
21		C	13226E0099-4	AR	TUBING, SPIRAL WRAP, .500 OD NOM		
22			MW-C12(65)U5	AR	WIRE, ELEC, 12 AWG, GRN	MIL-W-76	

Figure F-1.1. Pump Wiring Harness Assembly (Model 350 PAWN) (Sheet 2 of 2).

F.5 MANUFACTURE OF CONTROL PANEL WIRING HARNESS WIRES.

- a. Refer to Figures F-2 and F-2.1 for type of wire and terminals required.
- b. Cut wire to length.
- c. install terminal lugs on each end of wire.

F.6 ASSEMBLY OF MAIN WIRING HARNESS.

- a. Refer to Paragraph F.5 and manufacture wires.
- b. Refer to Figures F-2 and F-2.1 to assembly wiring harness.

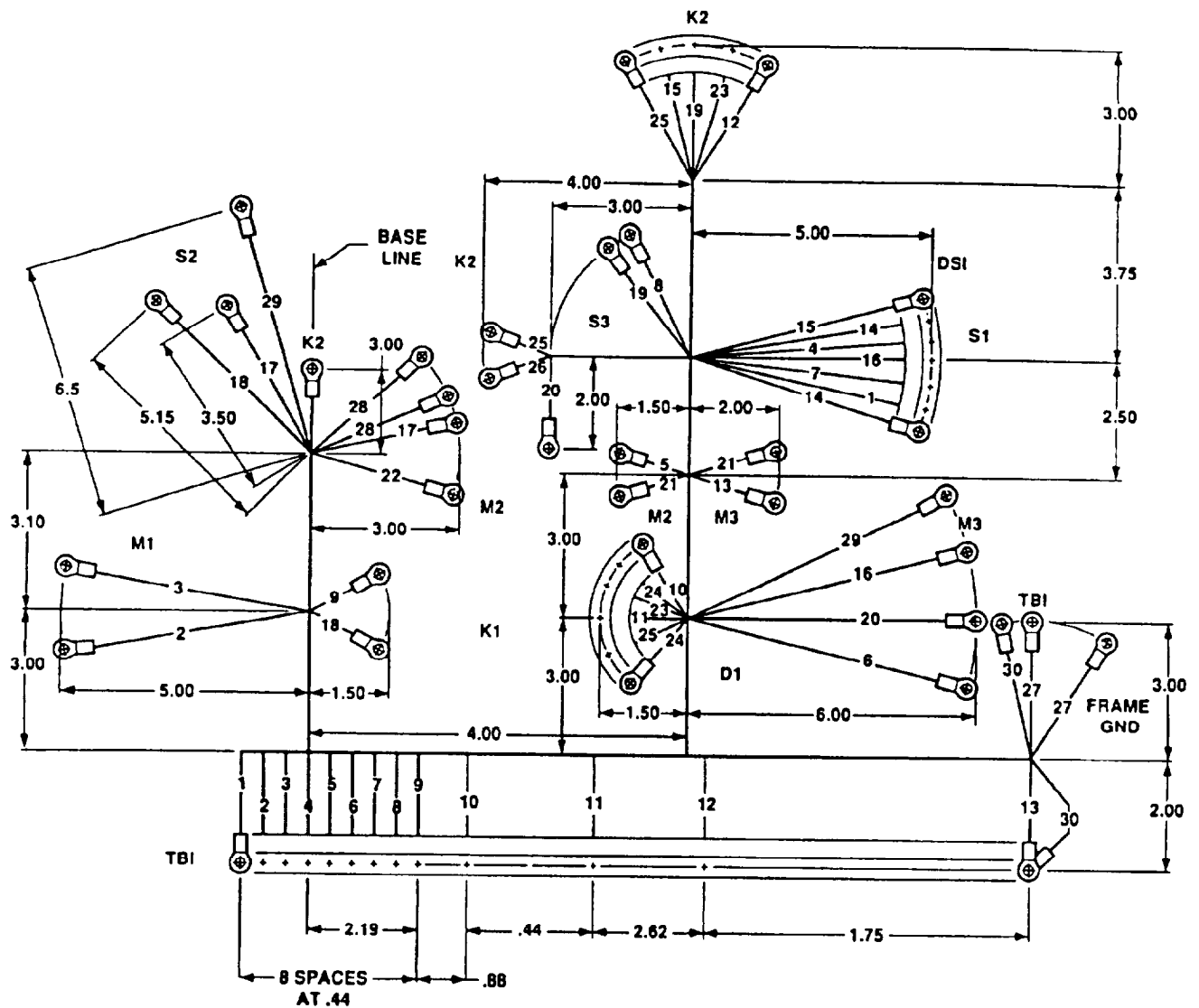

NOTES

1. EACH WIRE SHALL BE MARKED ON BOTH ENDS WITH APPROPRIATE WIRE NO. AS SHOWN IN TABULATION BLOCK.
 EXAMPLE: TB1 ↔ S1-1
 PERMANENCY LEGIBILITY AND TYPE OF LETTERING SHALL BE IN ACCORDANCE WITH MIL-STD-130.
2. ROUTING CHANGES MAY BE MADE TO FACILITATE INSTALLATION.
3. WIRING SHALL BE BUNDLED IN ACCORDANCE WITH REQUIREMENT 69 OF MIL-STD-454.
4. INSTALLED TERMINALS, FIND NO. 16-22, SHALL MEET THE PERFORMANCE REQUIREMENTS OF MIL-T-454, REQUIREMENT 19.
5. BUNDLE CABLE AND TIE WRAP USING STRAP FIND NO. 25 AS REQUIRED.
6. MARK HARNESS IN ACCORDANCE WITH MIL-STD-130.

Figure F-2. Control Panel Wiring Harness Assembly (Model 350 PAW and W-87012) (Sheet 1 of 3).

CONTROL PANEL PARTS LIST							
FIND NO	FSCM	DWN SIZE	FACT OR IDENTIFICATION NO.	QTY REQD	NOMENCLATURE OR DESCRIPTION	SPECIFICATION	MATERIAL
1	.		MW-C14 (65) U0	AR	WIRE, ELEC, 12 AWG	MIL-W-76	
2			MW-C14 (65) U2	AR	WIRE, ELEC, 12 AWG	MIL-W-76	
3			MW-C14 (65) U4	AR	WIRE, ELEC, 12 AWG	MIL-W-76	
4			MW-C14 (65) U6	AR	WIRE, ELEC, 12 AWG	MIL-W-76	
5			MW-C14 (65) U8	AR	WIRE, ELEC, 12 AWG	MIL-W-76	
6			MW-C14 (65) U9	AR	WIRE, ELEC, 12 AWG	MIL-W-76	
7			MW-C14 (65) U0	AR	WIRE, ELEC, 12 AWG	MIL-W-76	
8			MW-C14 (41) U1	AR	WIRE, ELEC, 14 AWG	MIL-W-76	
9			Mw-C14 (41) U2	AR	WIRE, ELEC, 14 AWG	MIL-W-76	
10			MW-C14 (41) U3	AR	WIRE, ELEC, 14 AWG	MIL-W-76	
12			MW-C14 (41) U5	AR	WIRE, ELEC, 14 AWG	MIL-W-76	
13			MW-C14 (41) U5	AR	WIRE, ELEC, 14 AWG	MIL-W-76	
14			Mw-C14 (41) u7	AR	WIRE, ELEC, 14 AWG	MIL-W-76	
15			MW-C14 (41) U8	AR	WIRE, ELEC, 14 AWG	MIL-W-76	
16			13226E0107-3	2	TERMINAL, LUG, 22-18 AWG, .138 STUD SIZE		
17			13226E0107-11	17	TERMINAL, LUG, 16-14 AWG, .138 STUD SIZE		
18			13226E0107-18	6	TERMINAL, LUG, 12-10 AWG, .138 STUD SIZE		
20			13226E0107-20	3	TERMINAL, LUG, 12-10 AWG, .190 STUD SIZE		
21			13226E0107-12	9	TERMINAL, LUG, 16-14 AWG, .164 STUD SIZE		
22			13226E0107-19	7	TERMINAL, LUG, 12-10 AWG, .164 STUD SIZE		
23			IN5552	11	SEMICONDUCTOR DEVICE, DIODE, SILICON	MIL-S-19500/420	
24			13226E0107-14	1	TERMINAL, LUG, 22-18 AWG, .138 STUD SIZE		
25			MS3367-1-0	AR	STRAP, TIEDOWN, ELECTRICAL		1

Figure F-2. Control Panel Wiring Harness Assembly (Model 350 PAW and W-87012) (Sheet 2 of 3).

CONTROL PANEL WIRE RUNNING LIST						
WIRE NO.	TERMINATION		TERMINATION		WIRE LENGTH (REF)	WIRE FIND NO.
	FROM	FIND NO.	TO	FIND NO.		
1	TB1-1	19	S1-1	19	18.82	3
2	TB1-2	19	MI-F'OS	20	8.88	1
3	TB1-3	19	MI-NEG	20	8.44	2
4	TB1-4	17	S1-3	17	22.50	10
5	TB1-5	17	M2-IN	19	11.06	14
6	TB1-6	17	M3-S	18	17.62	8
7	TB1-7	17	S1-4	17	16.111	11
8	TB1-8	17	S3-1	21	15.75	13
9	TB1-9	17	K1-3	17	6.70	15
10	TB1-11	17	K1-2	17	5.42	9
11	TB1-12	19	K1-8	19	7.44	4
12	TB1-17	19	K2-3	22	19.38	5
13	TB1-21	17	M3-GND	18	13.88	12
14	S1-1	19	S1-2	19	10.00	3
15	S1-2	19	K2-5	22	11.75	3
16	S1-4	17	M3-1	18	16.50	11
17	S2-1	21	M2-POS	21	11.00	11
18	S2-2	22	K1-6	19	9.75	6
19	S3-2	21	K2-1	21	9.75	7
20	M2-POS	21	M3-1	18	16.50	11
21	M2-GND	19	M3-GND	18	12.00	12
22	M2-GND	17	K2-2	21	8.00	12
23	K1-1	17	K2-1	21	13.75	7
24	D1-K	16	K1-2	23	----	----
	D1-A	16	K1-7			
25	K1-7	17	K2-2	21	11.00	12
26	K2-3	22	K2-4	22	10.75	5
27	TB1-21	17	E-1	24	6.00	12
28	K2-5	22	K2-6	22	6.00	3
29	TB1-7	19	R2-2	18	16.50	11
30	TB1-21	19	DS1-4	20	6.00	12

Figure F-2. Control Panel Wiring Harness Assembly (Model 350 PAW and W-87012) (Sheet 3 of 3).

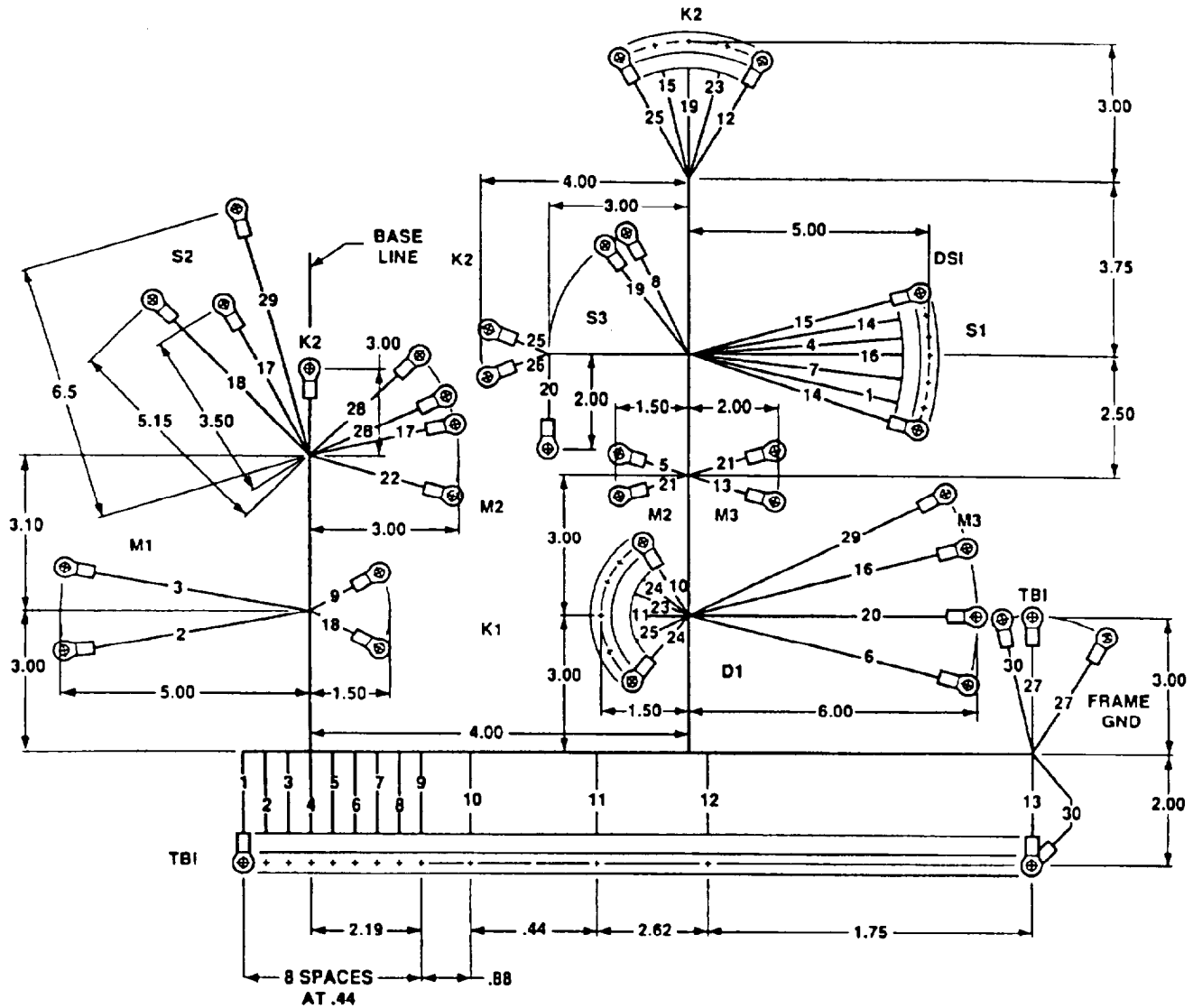

NOTES

1. EACH WIRE SHALL BE MARKED ON BOTH ENDS WITH APPROPRIATE WIRE NO. AS SHOWN IN TABULATION BLOCK.
 EXAMPLE: TB1 ↔ S1-1
 PERMANENCY LEGIBILITY AND TYPE OF LETTERING SHALL BE IN ACCORDANCE WITH MIL-STD-130.
2. ROUTING CHANGES MAY BE MADE TO FACILITATE INSTALLATION.
3. WIRING SHALL BE BUNDLED IN ACCORDANCE WITH REQUIREMENT 69 OF MIL-STD-454.
4. INSTALLED TERMINALS, FIND NO. 16-22. SHALL MEET THE PERFORMANCE REQUIREMENTS OF MIL-T-454, REQUIREMENT 19.
5. BUNDLE CABLE AND TIE WRAP USING STRAP FIND NO. 25 AS REQUIRED.
6. MARK HARNESS IN ACCORDANCE WITH MIL-STD-130.

Figure F-2.1. Control Panel Wiring Harness Assembly (Model 350 PAWN) (Sheet 1 of 3).

CONTROL PANEL PARTS LIST							
FIND NO.	FSCM	DWG SIZE	FACT OR IDENTIFICATION NO.	QTY REQD	NOMENCLATURE OR DESCRIPTION	SPECIFICATION	MATERIAL
1			MW-C14 (65) U0	AR	WIRE, ELEC, 12 AWG	MIL-W-76	
2			MW-C14 (65) U2	AR	WIRE, ELEC, 12 AWG	MIL-W-76	
3			MW-C14 (65) U4	AR	WIRE, ELEC, 12 AWG	MIL-W-76	
4			MW-C14 (65) U6	AR	WIRE, ELEC, 12 AWG	MIL-W-76	
5			MW-C14 (65) U8	AR	WIRE, ELEC, 12 AWG	MIL-W-76	
6			MW-C14 (65) U9	AR	WIRE, ELEC, 12 AWG	MIL-W-76	
7			MW-C14 (65) U0	AR	WIRE, ELEC, 12 AWG	MIL-W-76	
8			MW-C14 (41) U1	AR	WIRE, ELEC, 14 AWG	MIL-W-76	
9			MW-C14 (41) U2	AR	WIRE, ELEC, 14 AWG	MIL-W-76	
10			MW-C14 (41) U3	AR	WIRE, ELEC, 14 AWG	MIL-W-76	
11			MW-C14 (41) U4	AR	WIRE, ELEC, 14 AWG	MIL-W-76	
12			MW-C14 (41) U5	AR	WIRE, ELEC, 14 AWG	MIL-W-76	
13			MW-C14 (41) U5	AR	WIRE, ELEC, 14 AWG	MIL-W-76	
14			MW-C14 (41) U7	AR	WIRE, ELEC, 14 AWG	MIL-W-76	
15			MW-C14 (41) U8	AR	WIRE, ELEC, 14 AWG	MIL-W-76	
16			13226E0107-3	2	TERMINAL, LUG, 22-18 AWG, .138 STUD SIZE		
17			13226E0107-11	17	TERMINAL, LUG, 16-14 AWG, .138 STUD SIZE		
18			13226E0107-13	6	TERMINAL, LUG, 16-14 AWG, .190 STUD SIZE		
19			13226E0107-18	15	TERMINAL, LUG, 12-10 AWG, .138 STUD SIZE		
20			13226E0107-20	3	TERMINAL, LUG, 12-10 AWG, .190 STUD SIZE		
21			13226E0107-12	9	TERMINAL, LUG, 16-14 AWG, .164 STUD SIZE		
22			13226E0107-19	7	TERMINAL, LUG, 12-10 AWG, .164 STUD SIZE		
23			IN5552	11	SEMICONDUCTOR DEVICE, DIODE, SILICON	MIL-S-19500/420	
24			13226E0107-14	1	TERMINAL, LUG, 22-18 AWG, .138 STUD SIZE		

Figure F-2.1. Control Panel Wiring Harness Assembly (Model 350 PAWN) (Sheet 2 of 3).

CONTROL PANEL WIRE RUNNING LIST						
W I R E NO.	TERMINATION		TERMINATION		WIRE LENGTH (REF)	WIRE FIND NO.
	FROM	FIND NO.	TO	FIND NO.		
1	TB1-1	19	S1-1	19	18.82	3
2	TB1-2	19	M1-POS	20	8.88	1
3	TB1-3	19	M1-NEG	20	8.44	2
4	TB1-4	17	S1-3	17	22.50	10
5	TD1-5	17	M2-IN	19	11.06	14
6	TB1-6	17	M3-S	18	17.62	8
7	TB1-7	17	S1-4	17	16.18	11
8	TB1-8	17	S3-1	21	15.75	13
9	TB1-9	17	K1-3	17	6.70	15
10	TB1-11	17	K1-2	17	5.42	9
11	TB1-12	19	K1-8	19	7.41	4
12	TB1-17	19	K2-3	22	19.38	5
13	TB1-21	17	M3-GND	18	13.88	12
14	S1-1	19	SI-2	19	10.00	3
15	S1-2	19	K2-5	22	11.75	3
16	S1-4	17	M3-1	18	16.50	11
17	S2-1	21	M2-POS	21	11.00	11
18	S2-2	22	K1-6	19	9.75	6
19	S3-2	21	K2-1	21	9.75	7
20	M2-POS	21	M3-1	18	16.50	11
21	M2-GND	19	M3-GND	18	12.00	12
22	M2-GND	17	K2-2	21	8.00	12
23	K1-1	17	K2-1	21	13.75	7
24	DI-K	16	K1-2	23	----	----
	DI-A	16	K1-7			
25	K1-7	17	K2-2	21	11.00	12
26	K2-3	22	K2-4	22	10.75	5
27	TB1-21	17	E-1	24	6.00	12
28	K2-5	22	K2-6	22	6.00	3

Figure F-2.1. Control Panel Wiring Harness Assembly (Model 350 PAWN) (Sheet 3 of 3).

F.6 ASSEMBLY OF COLD START HOSES.

- a. Refer to Figure F-3 and obtain materials.
- b. Cut hose to length,
- c. Put nut on each end of hose.
- d. Put ferrules on each end of hose.
- e. Install hose assembly (Paragraph 4.10.3.3).

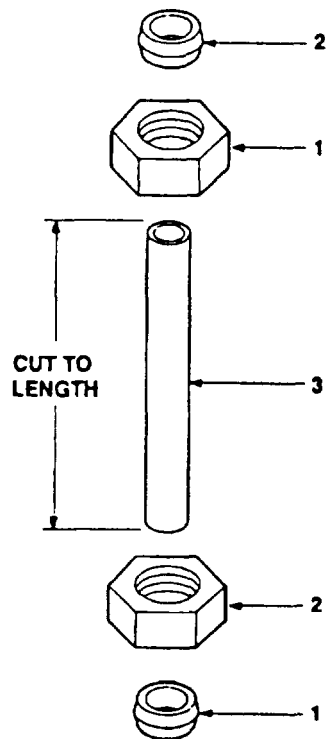

Figure F-3. Hose Assembly.

APPENDIX G TORQUE LIMITS

G.1 SCOPE.

This appendix lists torque specifications and torquing instructions for specific engine nuts and bolts.

G.2 TORQUE SPECIFICATIONS.

This application, preloading and torque angles in degrees are listed in table G-1.

G.4 ENGINE TORQUING INSTRUCTIONS.

Preloading is applied with a torque wrench that is calibrated in foot pounds (ft. lbs) or Newton meters (N • m). Preloading is applied before angle torques. All angle torques listed in table G-1 and table G-2 are accomplished by turning the bolt or nut a specific number of degrees from a zero reference point as shown in figure G-1. Torquing of two or more bolts securing one assembly should be accomplished in an alternating fashion to ensure assembly seating and equal load distribution. For example, if angle torque specified is 30° initial then 30° final, proceed as follows:

- a. Coat bolt and surface under bolt head with engine oil MIL-L2104C.
- b. Set bolts squarely to ensure assembly seating.
- c. Apply specified preload with torque wrench.

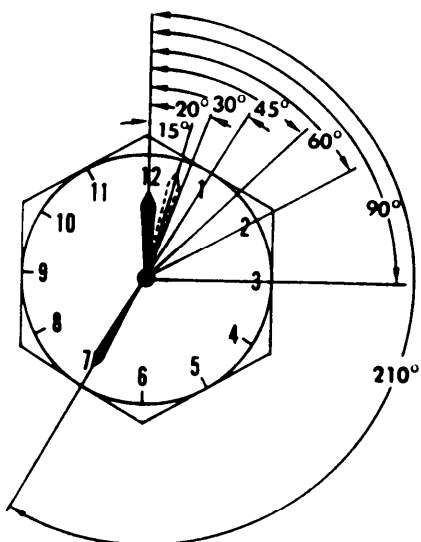

Figure G-1. Torque Instructions.

- d. With angle turning tool, apply 30° initial torque to bolt 1.
- e. Apply 30° initial torque to bolt 2.
- f. Apply 30° initial torque to bolt 1.
- g. Apply 30° initial torque to bolt 2.

Table G-1. Torque Specifications for Pump Assembly.

Application	Preloading		Angle in Degrees			Degrees Total	Note
	ft. lbs	N •m	Initial stage	Interstage	Final stage		
Volute to seal plate	45	61	-	-	-	-	
Seal plate to intermediate housing.	20	27	-	-	-	-	
Bearing cap bolts	20	27	-	-	-	-	
Intermediate bracket to engine bolts	17	23	-	-	-	-	
Drive ring mounting bolts.	17	23	-	-	-	-	
Pump mounting bolts.	22	30	15°	-	60°	75°	

Table G-2. Torque Specifications for Engine.

Application	Preloading		Angle in Degrees			Degrees Total	Note
	ft. lbs	N •m	Initial stage	Interstage	Final stage		
Cylinder head	22	30	45°	45°	45°	165°	Add 30° to 4 th stage
Connecting rod	22	30	30°	30°	-	90°	
Bearing cap	22	30	45°	60°	-	105°	
Idler gear	22	30	60°	-	-	60°	
Balance weight	22	30	30°	30°	-	60°	
Main bearing bolts	22	30	30°	60°	-	105°	
Flywheel	22	30	30°	30°	-	60°	
Injection nozzle	19	2.6	-	-	-	-	
V-belt pulley	22	3	210°	-	-	210°	
Cooling blower	22	30	30°	60°	-	90°	
Filter carrier	22	30	30°	60°	60°	150°	
Alternator	22	30	180°	-	-	180°	

Table G-2. Torque Specifications for Engine. (continued)

Application	Preloading		Angle in Degrees			Degrees Total	Note
	ft. lbs	N •m	Initial stage	Interstage	Final stage		
Idler pulley	3	30	45°	-	-	45°	8 + 1 mkp
Engine suspension	22	30	45°	60°	-	105°	
Advance retard unit	-	-	-	-	-	-	

GLOSSARY

SECTION I ABBREVIATIONS

COMMON ABBREVIATIONS.

The common abbreviations used in this manual are in accordance with MIL-STD-12D

SPECIAL OR UNIQUE ABBREVIATIONS.

The following are abbreviations and symbols that are used in this manual and not listed in MIL-STD-12D.

ABBREVIATION	DEFINITION
BDC	bottom dead center
cm	centimeters
Kg	kilograms
kPa	kilopascals
mm	millimeters
nm	newton meters
TDC	top dead center
"HG"	inches of mercury



SECTION II DEFINITION OF UNUSUAL TERMS

UNUSUAL TERMS.

There are no unusual terms that are not listed in the dictionary (AR 310-25) used in this manual.

ALPHABETICAL INDEX

Subject, Para	Subject, Para
	C (continued)
A	
Abbreviations/acronyms, list of, 1.8	Control panel test, 4.13.2
Actuating rod and actuator level maintenance 4.14.6	Control panel test (Model 350 PAWN), 4.13.2.1
Actuator and bracket maintenance, 4.105	Oil Pressure (MI) replacement, 4.13.5
Air cleaner maintenance, 4.105	Panel light replacement, 4.13.10
Alternator assembly test, 4.10.11	Run relay (K2) replacement, 4.13.9
Alternator belt maintenance, 4.10.7	Safety relay (K1) base replacement, 4.13.8
Alternator maintenance, 4.10.12	Safety relay K1 replacement, 4.13.7
Ammeter (6), 2.1.6	Suction gauge (M4) and discharge gauge (M5) replacement, 4.13.6
Ammeter (M2) replacement, 4.13.5	Switch emergency stop (S1) replacement, 4.13.3
Army material destruction to prevent enemy use, 1.4	Tachometer/hourmeter (M3) replacement, 4.13.5
Assembly and preparation for use, 2.3	Control panel removal and installation, 4.13.1
Axle assembly maintenance, 5.8	Control panel test, 4.13.2
	Controls and indicators
B	Ammeter (6) 2.1.6
Batteries and cables maintenance, 3.4	Discharge (8), 2.1.8
Battery cable maintenance, 4.12.3	Emergency stop (I), 2.1.1
Battery maintenance, 4.12.2	Handpump (9), 2.1.9
Battery testing, 4.12.1	Manual speed control (II), 2.1.11
Biological decontamination, 2.11	Mode selector (12),2.1.12
	Oil pressure (4), 2.1.4
C	Oil pressure bypass (3) 2.1.3
Centrifugal pump maintenance, 5.6.1	Operator controls and indicators, 2.1
Characteristics, capabilities, and features, 1.10	Push to start (2), 2.1.2
Checking unpacked equipment, 4.4.1	Suction (7) 2.1.7
Chemical decontamination, 2.11	Tachometer/hourmeter (5). 2.1.5
Cold start aid handpump maintenance, 4.10.2	Throttle(10),2.1.10
Cold start aid nozzle maintenance, 4.10.4	Cooling coil maintenance, 4.10.22
Cold start aid reservoir maintenance, 4.10.3	Cooling fan belt maintenance, 4.10.8
Cold start aid solenoid maintenance 4.10.3.1	Corrosion prevention and control (CPC), 1.3
Cold start system, 2.8.1	Coupling flange maintenance, 5.6.5
Cold start systems, 1.14.2.4.1	Coupling half maintenance, 4.15.1
Common tools and equipment, 4.1,5.1,6.1	Crankshaft pulley and seal maintenance, 5.5.10
xControl box test, 4.14.4	Cross reference list for nomenclature, 1.7
Control panel assembly maintenance	Cylinder head maintenance, 6.6.1
Ammeter (M2) replacement, 4.13.5	Cylinder head repair, 6.6.2
Control panel assembly maintenance, 4.13	
Control panel removal and installation, 4.13.1	

Subject, Para

Data plate maintenance, 4.17.7
 Data, equipment, 1.13
 Decals and instruction plates, 2.6
 Decontamination, 2.11
 Description and location of major components, 1.11
 Description, functional, 1.14
 Destruction of Army material to prevent enemy use, 1.4
 Differences between models, 1.12
 Direct support maintenance
 Axle assembly maintenance, 5.8
 Centrifugal pump maintenance, 5.6.1
 Coupling flange maintenance, 5.6.5
 Crankshaft pulley and seal maintenance, 5.5.10
 Engine assembly maintenance, 5.5
 Engine compression pressure check, 5.5.3
 Engine cowlings maintenance, 5.5.8
 Engine replacement, 5.5.1
 Fuel injection pump timing, 5.5.2
 Fuel tank maintenance 5.7
 Impeller maintenance, 5.6.2
 Injection nozzle testing, 5.5.6
 Injection pump maintenance, 5.5.5
 Intake manifold maintenance, 5.5.4
 Pumping assembly maintenance, 5.6
 Sleeve and rotating assembly maintenance, 5.6.4
 Top dead center, 5.5.9
 Direct support troubleshooting, 5.4
 Discharge (a), 2.1.8
 Discharge connection maintenance, 4.15.5
 Discharge Gauge (M5) Replacement, 4.136
 Discharge manifold maintenance, 4.15.4

E

Electrical system maintenance
 Battery cable maintenance, 4.12.3
 Battery maintenance, 4.12.2
 Battery testing, 4.12.1
 Battery testing, 4.12.1

Subject, Para

E (continued)

Wiring harness maintenance, 4.12.5
 Wiring harness testing, 4.12.4
 Emergency procedures, 2.10
 Emergency stop (1), 2.1.1
 Engine assembly
 Air cleaner maintenance, 4.10.5
 Alternator assembly test, 4.10.11
 Alternator belt maintenance 4.10.7
 Alternator maintenance, 4.10.12
 Cold start aid handpump maintenance, 4.10.2
 Cold start aid nozzle maintenance, 4.10.4
 Cold start aid reservoir maintenance, 4.10.3
 Cooling fan belt maintenance, 4.10.8
 Cooling fan maintenance, 4.10.21
 Crankshaft pulley and seal maintenance, 5.5.10
 Cylinder head maintenance 6.6.1
 Cylinder head repair, 6.6.2
 Engine assembly maintenance, 4.10, 5.5, 6.1
 Engine compression pressure check, 5.5.3
 Engine cowling maintenance, 5.5.8
 Engine disassembly, 6.6.4
 Engine replacement, 5.5.1
 Exhaust manifold maintenance, 4.10.1
 Fuel feed pump maintenance, 4.10.17
 Fuel filter servicing, 4.10.18
 Fuel injection pump timing, 5.5.2
 Fuel injection pump timing, 5.5.2
 Injection nozzle maintenance 5.5.7
 Injection nozzle testing, 5.5.6
 Intake manifold maintenance, 5.5.4
 Low oil pressure switch and sending unit maintenance, 4.10.19
 Oil line maintenance, 4.10.20
 Piston repair, 6.6.5
 Rocker arm assembly repair, 6.6.3
 Shutdown solenoid maintenance, 4.10.15
 Shutdown solenoid test, 4.10.14
 Starter assembly maintenance, 4.10.13

Subject, Para

Engine Assembly (continued)

- Top dead center, 5.5.9
- V-belt contact switch maintenance, 4.10.10
- V-belt contact switch test, 4.10.9
- V-belt guard maintenance, 4.10.6
- Valve clearance adjustment, 4.10.23

- Engine assembly maintenance, 3.3
- Engine assembly, 4.10
- Engine compression pressure check, 5.5.3
- Engine cowlings maintenance, 5.5.8
- Engine Disassembly, 6.6.4
- Engine replacement, 5.5.1
- Equipment and tools, common, 4.1.5,1.6.1
- Equipment characteristics, capabilities, and features, 1.10
- Equipment data, 1.13
- Equipment improvement recommendation (EIR), 1.5
- Equipment, checking unpacked, 4.4.1
- Equipment, processing unpacked, 4.4.2
- Equipment, processing unpacked, 4.4.2
- Exhaust manifold maintenance, 4.10.1

F

- Features, characteristics, and capabilities, 1 .10
- flexible coupling maintenance, 5.6.3
- Fording, 2.9
- Forms, maintenance, 1.2
- Fuel feed pump maintenance, 4.10.17
- Fuel Fitter Servicing, 4.10.18
- Fuel injection pump timing, 5.5.2
- Fuel line hoses and fittings maintenance, 4.10.16
- Fuel tank maintenance, 5.7
- Fuel tank servicing, 3.7
- Functional description for operator
 - Air cleaner, 1.14.1.2
 - Control panel assembly, 1.14.1.6
 - Electrical system, 1.14.1.3
 - Engine assembly, 1.14.1.5

Subject, Para

Functional description for operator (continued)

- Exhaust system, 1.14.1.1
- Fuel system, 1.14.1.4
- Fuel tank, 1.14.1.9
- Functional description for operator, 1.14.1
- Pump assembly, 1.14.1.8
- Pump assembly, 1.14.1.8
- Wheel mounted frame assembly, 1.14.1.10

Functional description for unit

- Actuator, 1.14.2.7.4
- Air cleaner, 1.14.2.2
- Camshaft and timing gears, 1.14.2.5.6
- Charging Circuit, 1.14.2.3.1.4
- Cold start System, 1.14.2.3.1.6
- Control box, 1.14.2.7.3
- Control panel assembly, 1.14.2.6
- Cooling fan, 1.14.2.5.3
- Crankshaft and flywheel, 1.14.2.5.8
- Crankshaft block, 1.14.2.5.5
- Cylinder head and valves, 1.14.2.5.4
- Electrical and control signals, 1.14.2.6.1
- Electrical system with regulator, 1.14.2.3.2
- Electrical system with regulator (Model 350 PAWN), 1.14.2.3.3
- Electrical system without regulator, 1.14.2.3.1
- Electrical system, 1.14.2.3
- Electrical system(350 PAWN), 1.14.2.3.1
- Engine assembly, 1.14.2.5
- Engine operation overview, 1.14.2.5.1
- Exhaust system, 1.14.2.1
- Fuel system, 1.14.2.4
- Fuel tank, 1.14.2.9
- Functional description for unit, 1.14.2
- tight Circuits, 1.14.2.3.1.2
- Lubrication system, 1.14.2.5.2
- Magnetic pick-up, 1.14.2.7.2
- Pistons and connecting rods, 1.14.2.5.7
- Pressure and compound gauge, 1.14.2.6.2
- Pressure controller, 1.14.2.7.1

Subject, Para
 Pump assembly, 1.14.2.8
 Regulator assembly, 1.14.2.7
 Start Circuits, 1.14.2.3.1.1
 Stop Circuits, 1.14.2.3.1.2
 Wheel mounted frame assembly, 1.14.2.10
 Functional description, 1.14

G

Gate valve maintenance, 4.15.2
 General support maintenance
 Cylinder head maintenance, 6.6.1
 Cylinder head repair, 6.6.2
 Engine assembly maintenance, 6.6
 Engine disassembly, 6.6.4
 Piston repair, 6.6.5
 Rocker arm assembly repair, 6.6.3

H

Glossary, 1.9
 Handpump (9), 2.1.9

I

Idler pulley assembly maintenance, 4.10.24
 Impeller maintenance, 5.6.2
 Improvement recommendation for equipment, 1.5
 Indicators and controls
 Ammeter (6), 2.1.6
 Discharge (8), 2.1.8
 Emergency stop (1), 2.1.1
 Handpump (9), 2.1.9
 Manual speed control (II), 2.1.11
 Modeselector (12), 2.1.12
 Oil pressure (4), 2.1.4
 Oil pressure bypass (3), 2.1.3
 Operator controls and indicators, 2.1
 Panel Lights, 2.1.11
 Push to start (2), 2.1.2
 Rheostat Switch, 2.1.12
 Suction (7), 2.1.7
 Tachometer/hourmeter (5), 2.1.5

Subject, Para
 Throttle (10), 2.1.10
 Initial adjustments, checks, and self test, 2.4
 Injection nozzle maintenance, 5.5.7
 Injection nozzle testing, 5.5.6
 Injection pump maintenance, 5.5.5
 Installation

 Assembly and preparation for use, 2.3

I (continued)

 Initial adjustments, checks, and self test, 2.4
 Installation instructions, 4.5.2
 Test equipment, and materials required for installation, 4.5.1
 Tools required for installation, 4.5.1
 Instruction plates and decals, 2.6
 Instructions, installation, 4.5
 Instructions, torquing, 6.4
 Intake manifold maintenance, 5.5.4

J

K

L

Limits, wear, 6.5
 List cross reference of nomenclature, 1.7
 List of abbreviations/acronyms, 1.8
 Location and description of major components, 1.11
 Low oil pressure switch and sending unit maintenance, 4.10.19
 Lubrication, 3.1
 Lubrication, pump assembly, 4.6

M

Magnetic pickup maintenance, 4.14.3
 Maintenance forms, and procedures, 1.2
 Maintenance, direct support
 Axle assembly maintenance, 5.8
 Axle assembly maintenance, 5.8

Subject, Para

- Centrifugal pump maintenance, 5.8
- Coupling flange maintenance, 5.6.5
- Crankshaft pulley and seal maintenance, 5.5.10
- Engine assembly maintenance, 5.5
- Engine compression pressure check, 5.5.3
- Engine cowlings maintenance, 5.5.8
- Engine replacement, 5.5.1

M (continued)

- Fuel injection pump timing, 5.5.2
- Fuel tank maintenance, 5.7
- Impeller maintenance, 5.6.2
- Injection nozzle maintenance, 5.5.7
- Injection nozzle testing, 5.5.6
- Injection pump maintenance 5.5.5
- Intake manifold maintenance 5.5.4
- Pumping assembly maintenance, 5.6
- Sleeve and rotating assembly maintenance, 5.6.4
- Top dead center, 5.5.9

Maintenance, general support

- Cylinder head maintenance, 6.6.1
- Cylinder head repair, 6.6.2
- Engine assembly maintenance, 6.6
- Engine disassembly, 6.6.4
- Piston repair, 6.6.5
- Rocker arm assembly repair, 6.6.3

Maintenance, operator

- Batteries and cables maintenance, 3.4
- Engine assembly maintenance, 3.3
- Fuel tank servicing, 3.7
- Lubrication, 3.1
- Pump assembly maintenance, 3.6
- Water separator servicing, 3.5

Maintenance, unit

- Actuating rod and actuator level maintenance 4.14.6
- Actuator and bracket maintenance, 4.14.5
- Air cleaner maintenance, 4.10.5
- Alternator assembly test, 4.10.11
- Alternator belt maintenance, 4.10.7

Subject, Para

- Alternator maintenance, 4.10.12
- Ammeter (M2) replacement, 4.13.5
- Battery cable maintenance, 4.12.3
- Battery maintenance, 4.12.2
- Battery testing, 4.12.1
- Cold start aid handpump maintenance, 4.10.2
- Cold start aid nozzle maintenance, 4.10.4

M (continued)

- Cold start aid nozzle maintenance (Model 350 PAWN), 4.10.4.3
- Cold start aid reservoir maintenance, 4.10.3
- Control box test, 4.14.4
- Control panel assembly maintenance, 4.13
- Control panel removal and installation 4.13.1
- Control panel test, 4.13.2
- Cooling coil maintenance, 4.10.22
- Cooling fan belt maintenance, 4.10.8
- Cooling fan maintenance, 4.10.21
- Coupling half maintenance, 4.15.1
- Data plate maintenance, 4.17.7
- Discharge connection maintenance, 4.15.5
- Discharge manifold maintenance, 4.15.4
- Electrical system maintenance, 4.12
- Engine assembly, 4.10
- Exhaust heat shield maintenance, 4.9.2
- Exhaust manifold maintenance, 4.10.1
- Water/Filter separator maintenance (Model 350 PAWN), 4-16.1
- Flexible coupling maintenance. 5.6.3
- Fuel feed pump maintenance, 4.10.17
- Fuel filter servicing, 4.10.18
- Fuel line hoses and fittings maintenance, 4.10.16
- Gate valve maintenance, 4.15.2
- Idler pulley assembly maintenance, 4.10.24
- Low oil pressure switch and sending unit maintenance, 4.10.9
- Magnetic pickup maintenance, 4.14.3
- Oil line maintenance, 4.10.20
- Oil pressure (MI) replacement, 4.13.5

Subject, Para

Panel light replacement, 4.13.10
Panel light replacement (Model 350 PAWN),
4.13.10.1
Pressure controller removal, 4.14.2
Pressure regulator cable assemblies
maintenance, 4.14.1
Pump assembly manifolds maintenance, 4.15
Reflector maintenance, 4.17.3

M (continued)

Regulator assembly maintenance, 4.14
Run relay (K2) replacement, 4.13.9
Run relay K2 replacement, 4.13.11
Safety relay (K1) replacement, 4.13.8
Safety relay K1 replacement, 4.13.7
Shutdown solenoid maintenance, 4.10.15
Shutdown solenoid test, 4.10.14
Spark arrestor maintenance, 4.9.1
Starter assembly maintenance, 4.10.13
Suction gauge (M4) and discharge gauge (M5)
replacement, 4.13.6
Suction manifold maintenance, 4.15.3
Support leg maintenance 4.17.5
Switch emergency stop (St) replacement, 4.13.3
Tachometer/hourmeter (M3) replacement, 4.13.5
Temperature switch maintenance (Model 350 PAWN)
4.10.4.1
Throttle control assembly maintenance, 4.11
Tire maintenance, 4.17.1
Tool box maintenance, 4.17.6
Tow bar maintenance, 4.17.4
V-belt contact switch maintenance, 4.10.10
V-Belt guard maintenance, 4.10.6
Valve clearance adjustment, 4.10.23
Water separator maintenance, 4.16
Wheel bearing maintenance, 4.17.2
Wheel mounted frame assembly maintenance,
4.17
Wiring harness maintenance, 4.12.5
Wiring harness testing, 4.12.4

Major components, location and description, 1.11

Manual speed control (II), 2.1.11

Subject, Para

Marking, 4.20

Material, service upon receipt of, 4.4

Mode selector (12), 2.1.12

Models, differences between 1,12

Subject, Para

N

Nomenclature, cross reference list, 1.7
 Nonregulated pumping assembly operation
 Shutdown for nonregulated models, 2.5.1.2
 Starting for nonregulated models, 2.5.1.1
 Nuclear, biological, and chemical (NBC)
 decontamination, 2.11

O

Oil line maintenance, 4.10.20
 Oil pressure (4), 2.1.4
 Oil pressure (MI) replacement, 4.13.5
 Oil pressure bypass (3), 2.1.3
 Operating procedures
 Cold start system, 2.8.1
 Operating procedures, 2.5
 Operation at high altitudes, 2.8.6
 Operation in damp or muddy areas, 2.8.4
 Operation in dusty or sandy areas, 2.8.3
 Operation in extreme heat, 2.8.2
 Operation in salt water areas, 2.8.5
 Shutdown for nonregulated model 2.5.1.2
 Shutdown for regulated models, 2.5.2.2
 Starting and shutdown for nonregulated
 pumps, 2.5.1
 Starting and shutdown for regulated model
 (ADC1500), 2.5.2
 Starting for nonregulated models, 2.5.1.1
 Starting for regulated model (ADCKOO), 2.5.2.1
 Unusual environmental/weather, 2.8
 Operation at high altitudes, 2.8.6
 Operation in damp or muddy areas, 2.8.4
 Operation in dusty or sandy areas, 2.8.3
 Operation in extreme heat, 2.8.2
 Operation in salt water areas, 2.8.5
 Operator controls and indicators
 Ammeter (6), 2.1.6
 Discharge (8), 2.18
 Emergency stop (I), 2.1.1
 Handpump (9), 2.1.9

Subject, Para

O (continued)

Manual speed control (II), 2.1.11
 Modeselector (12),2.1.12
 Oil pressure (4), 2.1.4
 Operator controls and indicators (continued)
 Oil pressure bypass (3), 2.1.3
 Operator controls and indicators, 2.1
 Push to start (2), 2.1.2
 Suction (7), 2.1.7
 Tachometer/hourmeter (5), 2.1.5
 Throttle (10),2.1.10
 Operator controls and indicators, 2.1
 Operator maintenance
 Batteries and cables maintenance, 3.4
 Engine assembly maintenance, 3.3
 Fuel tank servicing, 3.7
 Lubrication, 3.1
 Pump assembly maintenance, 3.6
 Water separator servicing, 3.5
 Operator PMCS
 Explanation of table entries, 2.2.2
 General, 2.2
 Interval column, 2.2.2.2
 Item no. column, 2.2.2.1
 Leakage classification and definitions, 2.2.:
 Location, item to check/service column, 2.2.2.3
 Not fully mission capable if: column, 2.2.2.5
 Other table entries, 2.2.3
 Procedure column, 2.2.2.4
 Special instructions, 2.2.4
 Warnings, cautions, and notes, 2.2.1
 Operator troubleshooting, 3.2

P

Packing, 4.19
 Panel light replacement, 4.13.10
 Parts, repair 4.3, 5.3, 6.3
 Subject, Para

Subject, Para

P (continued)

Piston repair, 6.6.5

PMCS, operator

- Explanation of table entries, 2.2.2
- General, 2.2
- Interval column, 2.2.2.2
- Item no. column, 2.2.2.1
- Leakage classification and definitions, 2.2.5
- Location, item to check/service column, 2.2.2.3
- Not fully mission capable if: column, 2.2.2.5
- Other table entries, 2.2.3
- Procedure column, 2.2.2.4
- Special instructions, 2.2.4
- Warnings, cautions, and notes, 2.2.1

PMCS, Unit

- Explanation of table entries, 4.7.2
- General, 4.7
- Interval column, 4.7.2.2
- Item no. Column, 4.7.2.1
- Item to be inspected column, 4.7.2.3
- Not fully mission capable if: column, 4.7.2.5
- Other table entries, 4.7.3
- Procedure column, 4.7.2.4
- Warnings, cautions, and notes, 4.7.1

Preparation for movement

- Preparation for movement at worksite, 2.7.1
- Preparation for movement to new worksite, 2.7.2
- Preparation for movement, 2.7

Preparation for movement to new worksite, 2.7.2

Preparation for storage, 1.6

Preparation for use and assembly, 2.3

Preparation for storage, 1.6

Preparation for use and assembly, 2.3

Pressure controller removal, 4.14.2

Pressure regulator cable assemblies maintenance, 4.14.1

Prevention and control of corrosion 1.3

Subject, Para

Subject, Para

P (continued)

Prevention of enemy use, 1.4

Procedures, emergency, 2.10

Procedures, operating

- Cold start system, 2.8.1
- Operation at high altitudes, 2.8.6
- Operation in damp or muddy areas, 2.8.4
- Operation in dusty or sandy areas, 2.8.3
- Operation in extreme heat, 2.8.2
- Operation in salt water areas 2.8.5
- Shutdown for nonregulated models, 2.5.1.2
- Shutdown for regulated model (ADC1500), 2.5.2.2
- Starting and shutdown for nonregulated pumps, 2.5.1
- Starting and shutdown for regulated model (ADC1500), 2.5.2
- Starting for nonregulated models, 2.5.1.1
- Starting for regulated model (ADC1500), 2.5.2.1
- Unusual environmental/weather, 2.8

Procedures, preservation, 4.18

Processing unpacked equipment, 4.4.2

Pump assembly lubrication, 4.6

Pump assembly maintenance, 3.6

Pump assembly manifolds maintenance

- Coupling half maintenance, 4.15.1
- Discharge connection maintenance, 4.15.5
- Discharge manifold maintenance, 4.15.4
- Gate valve maintenance, 4.15.2
- Pump assembly manifolds maintenance, 4.15
- Suction manifold maintenance, 4.15.3
- Centrifugal pump maintenance, 5.6.1
- Coupling flange maintenance, 5.6.5
- Flexible Coupling Maintenance, 5.6.3
- Impeller maintenance, 5.6.2

Pumping assembly maintenance (continued)

- Sleeve and rotating assembly maintenance, 5.6.4

Push to start (2), 2.1.2

Subject, Para

Q

R

Receipt of material, service upon 4.4
 Recommendation of equipment improvement, 1.5
 Reflector maintenance, 4.17.3
 Regulated pump maintenance
 Actuating rod and actuator level maintenance 4.14.6
 Actuator and bracket maintenance, 4.14.5
 Control box test, 4.14.4
 Magnetic pickup maintenance, 4.14.3
 Pressure controller removal, 4.14.2
 Pressure regulator cable assemblies maintenance, 4.14.1
 Regulator assembly maintenance, 4.14
 Run relay K2 replacement, 4.13.11
 Regulated pumping assembly operation
 Shutdown for regulated model (ADC1500), 2.5.2.2
 Starting and shutdown for regulated model (ADC1500)m 2.5.2
 Starting for regulated model (ADC1506), 2.5.2.1
 Regulator assembly maintenance
 Actuating rod and actuator level maintenance, 4.14.6
 Actuator and bracket maintenance, 4.14.5
 Control box test, 4.14.4
 Magnetic pickup maintenance, 4.14.3
 Pressure controller removal, 4.14.2
 Regulator assembly maintenance (continued)
 Regulator assembly maintenance, 4.14
 Repair parts, 4.3, 5.3,6.3
 Rocker arm assembly repair, 6.6.3
 Run relay (K2) replacement, 4.13.9
 Run relay W replacement, 4.13.11

Subject, Para

S

T

Safety relay (K1) base replacement, 4.13.8
 Safety relay K1 replacement, 4.13.7
 Scope, 1.1
 Service upon receipt of material, 4.4
 Shutdown for nonregulated models, 2.5.1.2
 Shutdown for regulated model (ADC1500), 2.5.2.2
 Shutdown solenoid maintenance, 4.10.15
 Shutdown solenoid test, 4.10.14
 Sleeve and rotating assembly maintenance, 5.6.4
 Spark arrestor maintenance, 4.9.1
 Special tools and support equipment, 4.2,5.2,6.2
 Starter assembly maintenance, 4.10.13
 Starting and shutdown for nonregulated pumps, 2.5.1
 Starting and shutdown for regulated model (ADC1500), 2.5.2
 Starting for nonregulated models, 2.5.1.1
 Starting for regulated model (ADC1500) 2.5.2.1
 Storage preparation, 1.6
 Storage, 4.21
 Suction (7), 2.1.7
 Suction gauge (M4), 4.13.6
 Suction manifold maintenance, 4.15.3
 Support equipment and tools, special 4.2, 5.2,6.2
 Support leg maintenance, 4.17.5
 Switch emergency stop (St) replacement, 4.13.3
 Tachometer/hourmeter (5) 2.1.5
 Tachometer/hourmeter (M3), replacement
 Test equipment, and materials, required for installation, 4.5.1
 Throttle (10),2.1.10
 Throttle control assembly maintenance, 4.11
 Tire maintenance, 4.17.1
 Tool box maintenance, 4.17.6
 Tools and equipment, common 4.1, 5. 1.6.1
 Tools and support equipment, special 4.2, 5.2, 6.2
 Tools installation, 4.5.1
 Top dead center, 5.5.9

Subject, Para

T (continued)

Torquing instructions, 6.4
Tow bar maintenance, 4.17.4

U

Unit maintenance

Actuating rod and actuator level maintenance 4.14.6
Actuator and bracket maintenance, 4.14.5
Air cleaner maintenance, 4.10.5
Alternator assembly test, 4.10.11
Alternator belt maintenance, 4.10.7
Alternator maintenance, 4.10.12
Ammeter (M2) replacement, 4.13.5
Battery cable maintenance, 4.12.3
Battery maintenance, 4.12.2
Battery testing, 4.12.1
Cold start aid handpump maintenance, 4.10.2
Cold start aid nozzle maintenance, 4.10.4
Cold start aid reservoir maintenance, 4.10.3
Control box test 4.14.4
Control panel assembly maintenance, 4.13
Control box removal and installation, 4.13.1
Control panel test, 4.13.2
Cooling coil maintenance, 4.10.22
Cooling fan belt maintenance, 4.10.8
Cooling fan maintenance, 4.10.21
Coupling half maintenance, 4.15.1
Data plate maintenance, 4.17.7
Discharge connection maintenance (unregulated pumps), 4.15.5
Discharge connection maintenance (regulated pumps), 4.15.5.1
Discharge manifold maintenance, 4.15.4
Electrical system maintenance, 4.9.2
Engine assembly, 4.10
Exhaust heat shield maintenance, 4.9.2
Exhaust manifold maintenance, 4.10.1

Subject, Para

Unit maintenance (continued)

Flexible coupling maintenance, 5.6.3
Fuel feed pump maintenance, 4.10.17
Fuel filter servicing, 4.10.18
Fuel line hoses and fittings maintenance, 4.10.16
Gate valve maintenance, 4.15.2
Idler pulley assembly maintenance, 4.10.24
Low oil pressure switch and sending unit maintenance, 4.10.19
Magnetic pickup maintenance, 4.14.3
Oil line maintenance, 4.10.20
Oil pressure (MI) replacement, 4.13.5
Panel light replacement, 4.13.5
Regulator assembly maintenance, 4.14
Run relay (K2) replacement, 4.13.9
Run relay K2 replacement, 4.13.11
Safety relay (K1) base replacement, 4.13.8
Safety relay K1 replacement, 4.13.11
Shutdown solenoid maintenance, 4.10.15
Shutdown solenoid test, 4.10.14
Spark arrestor maintenance, 4.9.1
Starter assembly maintenance, 4.10.13
Suction gauge (M4) and discharge gauge (M5) replacement, 4.13.6
Suction manifold maintenance, 4.15.3
Support leg maintenance, 4.17.5
Switch emergency stop (St) replacement, 4.13.3
Tachometer/hourmeter (M3) replacement, 4.13.5
Throttle control assembly maintenance, 4.11
Tire maintenance, 4.17.1
Tool box maintenance, 4.17.4
Tow bar maintenance, 4.17.4
V-belt contact switch maintenance, 4.10.10
V-Belt guard maintenance, 4.10.6
Valve clearance adjustment, 4.10.23
Water separator maintenance, 4.16
Water separator maintenance (Model 350 PAWN) 4.16.1 .

Subject, Para

Wheel bearing maintenance, 4.17.2

Wheel mounted frame assembly maintenance, 4.17

Wiring harness maintenance, 4.12.5

Wiring harness testing, 4.12.4

Unit PMCS

General, 4.7

Interval column, 4.7.2.2

Item no. column, 4.7.2.1

Item to be inspected column, 4.7.2.3

Not fully mission capable if: column, 4.7.2.5

Other table entries, 4.7.3

Procedure column 4.7.2.4

Warnings, cautions, and notes 4.7.1

Unit troubleshooting, 4.8

Unit troubleshooting (Model 350 PAWN only), 4.8.1

Unpacked equipment, checking, 4.4.1

Unpacked equipment, processing, 4.4.2

Unusual environmental/weather, 2.8

V

V-belt contact switch maintenance, 4.10.10

Subject, Para

V-belt contact switch test, 4.10.9

V-Belt guard maintenance, 4.10.6

Valve clearance adjustment, 4.10.23

W

Water separator maintenance, 4.16

Water separator servicing, 3.5

Wear limits, 6.5

Wheel bearing maintenance, 4.17.2

Wheel mounted frame assembly maintenance

Data plate maintenance, 4.17.7

Reflector maintenance, 4.17.3

Tire maintenance, 4.17.1

Tool box maintenance, 4.17.6

Tow bar maintenance, 4.17.4

Wheel mounted frame assembly maintenance, 4.17

Wheel mounted maintenance

Wheel bearing maintenance, 4.17.2

Wiring harness maintenance (Model 350 PAWN), 4.12.5.1

Wiring harness testing, 4.12.4

Wiring harness testing (Model 350 PAWN), 4.12.4.1

By Order of the Secretary of the Army:

Official:

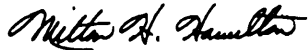

MILTON H. HAMILTON
*Administrative Assistant to the
Secretary of the Army*

05096

GORDON R. SULLIVAN
*General, United States Army
Chief of Staff*

DISTRIBUTION:

To be distributed in accordance with DA Form 12-25-E, block no. 6154, requirements for
TM 10-4320-226-14.

RECOMMENDED CHANGES TO EQUIPMENT TECHNICAL PUBLICATIONS



SOMETHING WRONG WITH THIS PUBLICATION?

THEN... JOT DOWN THE DOPE ABOUT IT ON THIS FORM. CAREFULLY TEAR IT OUT, FOLD IT AND DROP IT IN THE MAIL!

FROM: (PRINT YOUR UNIT'S COMPLETE ADDRESS)

PFC JOHN DOE
COA, 3d ENGINEER BN
FT. LEANARDWOOD, MA 63108

DATE SENT

PUBLICATION NUMBER

TM 10-4320-226-14

PUBLICATION DATE

31 Aug 93

PUBLICATION TITLE

WATER PUMPING ASSEMBLY

BE EXACT. PIN-POINT WHERE IT IS

PAGE NO	PARA-GRAPH	FIGURE NO	TABLE NO
6	2-1 a		
B1		4-3	
125	line 20		

IN THIS SPACE TELL WHAT IS WRONG AND WHAT SHOULD BE DONE ABOUT IT:

In line 6 of paragraph 2-1a the manual states the engine has 6 cylinders. The engine on my set only has 4 cylinders. Change the manual to show 4 cylinders.

Callout 16 on figure 4-3 is pointing at a bolt. In key to figure 4-3, item 16 is called a shim - Please correct one or the other.

I ordered a gasket, item 19 on figure B-16 by NSN 2 910-00-762-3001. I got a gasket but it doesn't fit. Supply says I got what I ordered, so the NSN is wrong. Please give me a good NSN

PRINTED NAME, GRADE OR TITLE, AND TELEPHONE NUMBER

JOHN DOE, PFC (263) 317-7111

SIGN HERE

JOHN DOE

DA FORM 2028-2
1 JUL 79

PREVIOUS EDITIONS ARE OBSOLETE.

DRSTS-M Overprint 1, 1 Nov 80

PS--IF YOUR OUTFIT WANTS TO KNOW ABOUT YOUR RECOMMENDATION MAKE A CARBON COPY OF THIS AND GIVE IT TO YOUR HEADQUARTERS.

TEAR ALONG PERFORATED LINE

1 Nov 80

FILL IN YOUR
UNITS ADDRESS



FOLD BACK

DEPARTMENT OF THE ARMY

OFFICIAL BUSINESS

COMMANDER
U.S. ARMY AVIATION AND TROOP COMMAND
ATTN: AMSAT-I-MP
4300 GOODFELLOW BOULEVARD
ST. LOUIS, MO 63120-1798

TEAR ALONG PERFORATED LINE

1 Nov 80

FILL IN YOUR
UNITS ADDRESS



FOLD BACK

DEPARTMENT OF THE ARMY

OFFICIAL BUSINESS

COMMANDER
U.S. ARMY AVIATION AND TROOP COMMAND
ATTN: AMSAT-I-MP
4300 GOODFELLOW BOULEVARD
ST. LOUIS, MO 63120-1798

TEAR ALONG PERFORATED LINE

The Metric System and Equivalents

Linear Measure

1 centimeter = 10 millimeters = .39 inch
 1 decimeter = 10 centimeters = 3.94 inches
 1 meter = 10 decimeters = 39.37 inches
 1 dekameter = 10 meters = 32.8 feet
 1 hectometer = 10 dekameters = 328.08 feet
 1 kilometer = 10 hectometers = 3,280.8 feet

Weights

1 centigram = 10 milligrams = .15 grain
 1 decigram = 10 centigrams = 1.54 grains
 1 gram = 10 decigrams = .035 ounce
 1 dekagram = 10 grams = .35 ounce
 1 hectogram = 10 dekagrams = 3.52 ounces
 1 kilogram = 10 hectograms = 2.2 pounds
 1 quintal = 100 kilograms = 220.46 pounds
 1 metric ton = 10 quintals = 1.1 short tons

Liquid Measure

1 centiliter = 10 milliliters = .34 fl. ounce
 1 deciliter = 10 centiliters = 3.38 fl. ounces
 1 liter = 10 deciliters = 33.81 fl. ounces
 1 dekaliter = 10 liters = 2.64 gallons
 1 hectoliter = 10 dekaliters = 26.42 gallons
 1 kiloliter = 10 hectoliters = 264.18 gallons

Square Measure

1 sq. centimeter = 100 sq. millimeters = .155 sq. inch
 1 sq. decimeter = 100 sq. centimeters = 15.5 sq. inches
 1 sq. meter (centare) = 100 sq. decimeters = 10.76 sq. feet
 1 sq. dekameter (are) = 100 sq. meters = 1,076.4 sq. feet
 1 sq. hectometer (hectare) = 100 sq. dekameters = 2.47 acres
 1 sq. kilometer = 100 sq. hectometers = .386 sq. mile

Cubic Measure

1 cu. centimeter = 1000 cu. millimeters = .06 cu. inch
 1 cu. decimeter = 1000 cu. centimeters = 61.02 cu. inches
 1 cu. meter = 1000 cu. decimeters = 35.31 cu. feet

Approximate Conversion Factors

To change	To	Multiply by	To change	To	Multiply by
inches	centimeters	2.540	ounce-inches	newton-meters	.007062
feet	meters	.305	centimeters	inches	.394
yards	meters	.914	meters	feet	3.280
miles	kilometers	1.609	meters	yards	1.094
square inches	square centimeters	6.451	kilometers	miles	.621
square feet	square meters	.093	square centimeters	square inches	.155
square yards	square meters	.836	square meters	square feet	10.764
square miles	square kilometers	2.590	square meters	square yards	1.196
acres	square hectometers	.405	square kilometers	square miles	.386
cubic feet	cubic meters	.028	square hectometers	acres	2.471
cubic yards	cubic meters	.765	cubic meters	cubic feet	35.315
fluid ounces	milliliters	29.573	cubic meters	cubic yards	1.308
pints	liters	.473	milliliters	fluid ounces	.034
quarts	liters	.946	liters	pints	2.113
gallons	liters	3.785	liters	quarts	1.057
ounces	grams	28.349	liters	gallons	.264
pounds	kilograms	.454	grams	ounces	.035
short tons	metric tons	.907	kilograms	pounds	2.205
pound-feet	newton-meters	1.356	metric tons	short tons	1.102
pound-inches	newton-meters	.11296			

Temperature (Exact)

°F Fahrenheit temperature 5/9 (after subtracting 32) Celsius temperature °C

This fine document...

Was brought to you by me:



[Liberated Manuals -- free army and government manuals](#)

Why do I do it? I am tired of sleazy CD-ROM sellers, who take publicly available information, slap “watermarks” and other junk on it, and sell it. Those masters of search engine manipulation make sure that their sites that sell free information, come up first in search engines. They did not create it... They did not even scan it... Why should they get your money? Why are not letting you give those free manuals to your friends?

I am setting this document FREE. This document was made by the US Government and is NOT protected by Copyright. Feel free to share, republish, sell and so on.

I am not asking you for donations, fees or handouts. If you can, please provide a link to liberatedmanuals.com, so that free manuals come up first in search engines:

<A HREF=<http://www.liberatedmanuals.com/>>Free Military and Government Manuals

- Sincerely
Igor Chudov
<http://igor.chudov.com/>
- [Chicago Machinery Movers](#)