

OPERATOR'S ,UNIT,  
 DIRECT SUPPORT AND  
 GENERAL SUPPORT  
 MAINTENANCE MANUAL

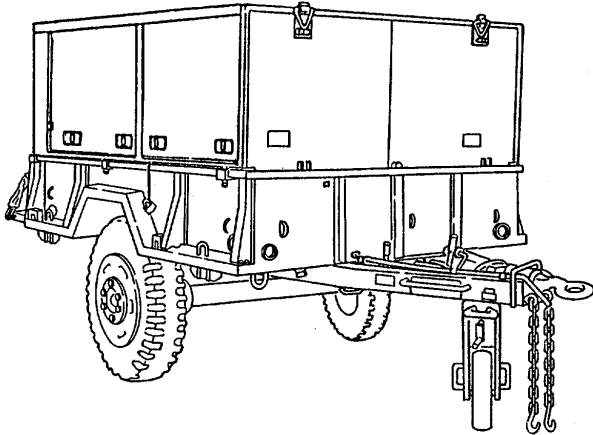

OPERATING INSTRUCTIONS	2-1
OPERATOR MAINTENANCE INSTRUCTIONS	3-1
UNIT MAINTENANCE INSTRUCTIONS	4-1
UNIT TROUBLESHOOTING	4-30
DIRECT SUPPORT MAINTENANCE INSTRUCTIONS	5-1
GENERAL SUPPORT MAINTENANCE INSTRUCTIONS	6-1

This copy is a reprint which includes current pages from Changes 1.

CLOTHING REPAIR SHOP

TRAILER MOUNTED

MODEL CRS-100, NSN: 3530-01-346-7265

DISTRIBUTION STATEMENT A: Approved for public release; distribution is unlimited.

**WARNING**

**CARBON MONOXIDE (EXHAUST GAS) CAN KILL YOU**

Carbon monoxide is without color or smell, but can kill you. Breathing carbon monoxide produces symptoms of headache, dizziness, loss of muscular control, a sleepy feeling, and coma. Brain damage or death can result from heavy exposure. Carbon monoxide occurs in the exhaust fumes of fuel-burning heaters and internal combustion engines. Carbon monoxide can become dangerously concentrated under conditions of no ventilation.

Precautions must be followed to ensure operator's safety when the Clothing Repair Shop is in operation.

1. DO NOT operate Clothing Repair Shop in an enclosed area without proper ventilation.
2. BE ALERT at all times during operating procedures for carbon monoxide poisoning. If exposure is present, IMMEDIATELY evacuate personnel to fresh air.
3. BE AWARE the field protection mask used for nuclear-biological-chemical attack WILL NOT protect you from carbon monoxide poisoning.

THE BEST DEFENSE AGAINST CARBON MONOXIDE POISONING IS GOOD VENTILATION.

**WARNING**

**JEWELRY**

Remove rings, bracelets, wristwatches, and neck chains before working around or on the Clothing Repair Shop. Jewelry can catch on equipment and cause injury, or may short across an electrical circuit and cause severe burns or electrical shock.

**WARNING**

**DURING OPERATION**

Do not make or change electrical connections while the unit is in operation. The voltage generated by the generator set can cause death by electrocution. Keep moisture away from the generator set and keep the surrounding area dry when operating the unit. Failure to observe this warning may result in death by electrocution. Do not service the unit with fuel while the unit is in operation. Failure to observe this warning may result in serious injury or death to personnel.

**WARNING**

Do not touch cold metal parts with bare hands. Frostbite can cause permanent injury.

**WARNING**

**MOVING PARTS**

Be careful not to come in contact with rotating belts or other moving parts. To do so will cause serious injury. If you are injured, obtain medical aid immediately.

**WARNING**

**FLAMMABLE FUELS**

Fuels are toxic and flammable. Wear protective goggles and refuel only in a well ventilated area. Avoid contact with skin, eyes, and clothes and don't breathe vapors. Do not use near open flame or excessive heat. If you become dizzy, get fresh air immediately and get medical aid. If contact with eyes or skin is made, flush with clean water and get medical aid for eyes immediately.

**WARNING**

**ELECTRIC SHOCK**

Death or serious injury could occur if precautions are not taken when maintaining this equipment. Be sure that any power cables are unplugged/disconnected; that circuit breakers are set to OFF; that generators are OFF; that generator cables are unplugged/disconnected. Be sure that the equipment is properly grounded. Always have another person standing by who is trained in electric shock first aid.

**WARNING**

The generator set weighs approximately 285 lbs. To avoid injury to personnel, four persons are required to remove the generator.

**WARNING**

**ELECTRICAL HIGH VOLTAGE CAN KILL YOU**

Electrical high voltage cannot be seen but it can kill you. Electricity is unlike most other dangerous things you can come in contact with because it gives no warning and no symptoms to be wary of. Its effect is immediate. It can kill you, render you unconscious, or severely burn you. To ensure your safety and that of other maintenance personnel, always observe the following precautions:

- DO NOT perform any maintenance on electrical equipment unless all power is removed.
- BE CERTAIN that there is someone assisting you who can remove power immediately.
- ALWAYS place POWER OFF warning tags on power supply switches so that no one will apply power while you are performing maintenance.
- FOR ARTIFICIAL RESPIRATION, REFER TO FM 21-11.

**WARNING**

Do not operate the generator in an enclosed area unless the exhaust gases are piped to the outside. Inhalation of fumes will result in serious illness or death.

**WARNING**

Serious burns will result from touching a hot exhaust pipe.

**WARNING**

Refer to TM 5-6115 271-14 for the generator set for grounding techniques for that particular set. Failure to ground generator set properly could cause severe injury or death to operating personnel. Be sure the generator set is off before making the below connections.

**WARNING**

To prevent injury to personnel and damage to equipment, use dry cleaning solvent only in well ventilated areas. Avoid repeated or prolonged contact with skin. Do not use near sparks, open flame or excessive heat.

**WARNING**

Remove paint before welding. Burnt paint will emit toxic fumes.

**WARNING**

Cleaning solvent, Federal Specification P-D-680, is both toxic and flammable. Keep off skin. Use only in a well-ventilated area and avoid prolonged breathing of vapors. Keep away from open flame.

**d**

CHANGE

NO. 1

HEADQUARTERS  
DEPARTMENT OF THE ARMY  
WASHINGTON, D.C., 4 APRIL 1994

Operator's, Unit, Direct Support and  
General Support Maintenance Manual

**CLOTHING REPAIR SHOP  
TRAILER MOUNTED  
MODEL CRS-100, NSN: 3530-01-346-7256**

DISTRIBUTION STATEMENT A: Approved for public release; distribution is unlimited

TM 10-3530-207-14, 28 May 1993, is changed as follows:

1. Cover, Clothing Repair Shop, Trailer Mounted, Model CRS-100, NSN: 3530-01-346-7265 should be corrected to read: NSN: 3530-01-346-7256.
2. Remove and insert pages as indicated below. New or changed text material is indicated by a vertical bar in the margin. An illustration change is indicated by a miniature pointing hand.

Remove pages	Insert pages
i and ii F-1 and F-2	i and ii F-1 and F-2

3. Retain this sheet in front of manual for reference purposes.

By Order of the Secretary of the Army:

Official:

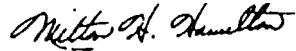

**MILTON H. HAMILTON**  
*Administrative Assistant to the  
Secretary of the Army*

06547

**GORDON R. SULLIVAN**  
*General, United States Army  
Chief of Staff*

**DISTRIBUTION:**

To be distributed in accordance with DA Form 12-25-E, block no. 6057, requirements for TM 10-3530-207-14.

TECHNICAL MANUAL

NO. 10-3530-207-14

HEADQUARTERS  
DEPARTMENT OF THE ARMY  
WASHINGTON D.C., 28 MAY 1993

TECHNICAL MANUAL

OPERATOR'S, UNIT, DIRECTOR SUPPORT AND  
GENERAL SUPPORT MAINTENANCE MANUAL

CLOTHING REPAIR SHOP  
TRAILER MOUNTED  
MODEL CRS-100, NSN: 3530-01-346-7256

**REPORTING ERRORS AND RECOMMENDING IMPROVEMENTS**

You can help improve this manual. If you find any mistakes or if you know of a way to improve these procedures, please let us know. Mail your letter or DA Form 2028 (Recommended Changes to Publications and Blank Forms), or DA Form 2028-2 located in the back of this manual directly to: Commander, US Army Aviation and Troop Command, ATTN: AMSAT-I-MP, 4300 Goodfellow Blvd., St. Louis, MO 63120-1798. A reply will be furnished directly to you.

DISTRIBUTION STATEMENT A: Approved for public release; distribution is unlimited.

**TABLE OF CONTENTS**

		PAGE
CHAPTER 1	INTRODUCTION .....	1-1
Section I	General Information .....	1-1
Section II	Equipment Description and Data .....	1-3
Section III	Principles of Operation.....	1-12
CHAPTER 2	OPERATING INSTRUCTIONS .....	2-1
Section I	Description and Use of Operator's Controls and Indicators .....	2-1
Section II	Operator's Preventive Maintenance Checks and Services (PMCS) .....	2-13
Section III	Operation Under Usual Conditions .....	2-36
Section IV	Operation Under Unusual Conditions .....	2-118
CHAPTER 3	OPERATOR MAINTENANCE INSTRUCTIONS .....	3-1
Section I	Lubrication Instructions .....	3-1
Section II	Operator troubleshooting.....	3-7
Section III	Maintenance Procedures.....	3-34

TABLE OF CONTENTS - continued

		PAGE
<b>CHAPTER 4</b>	<b>UNIT MAINTENANCE INSTRUCTIONS</b>	4-1
Section I	Repair Parts, Special Tools, TMDE, and Support Equipment .....	4-3
Section II	Service Upon Receipt .....	4-4
Section III	Unit Preventive Maintenance Checks and Services (PMCS) .....	4-6
Section IV	Unit Troubleshooting .....	4-30
Section V	Unit Maintenance Procedures .....	4-39
Section VI	Preparation For Storage or Shipment .....	4-164
<b>CHAPTER 5</b>	<b>DIRECT SUPPORT MAINTENANCE INSTRUCTIONS</b> .....	5-1
Section I	Repair Parts, Special Tools, TMDE, and Support Equipment .....	5-3
Section II	Maintenance Procedures.....	5-4
<b>CHAPTER 6</b>	<b>GENERAL SUPPORT MAINTENANCE INSTRUCTIONS</b> .....	6-1
Section I	Repair Parts, Special Tools, TMDE, and Support Equipment .....	6-1
Section II	Maintenance of Cabinet Assembly .....	6-2
<b>APPENDIX A</b>	<b>REFERENCES</b> .....	A-1
<b>APPENDIX B</b>	<b>MAINTENANCE ALLOCATION CHART</b> .....	B-1
<b>APPENDIX C</b>	<b>COMPONENTS OF END ITEM (COEI) AND BASIC ISSUE ITEMS LISTS (BII)</b> .....	C-1
<b>APPENDIX D</b>	<b>ADDITIONAL AUTHORIZATION LIST (AAL)</b> .....	D-1
<b>APPENDIX E</b>	<b>NOT APPLICABLE</b> .....	E-1
<b>APPENDIX F</b>	<b>EXPENDABLE/DURABLE SUPPLIES AND MATERIALS LIST (EDSML)</b> .....	F-1
<b>INDEX</b>	<b>ALPHABETICAL</b> .....	INDEX 1

## HOW TO USE THIS MANUAL

*Be sure to read all Warnings before using your equipment.*

This manual contains operating and maintenance instructions for the operator of the Clothing Repair Shop.

- Chapter 1 Introduces you to the equipment and gives you information such as weight, height, length, generally used abbreviations and information on how the unit works. The chapter is preceded by a full page illustration of the equipment.
- Chapter 2 Provides information necessary to identify and use the equipment's operating controls. Operating instructions in this chapter tell you how to use the equipment in both usual and unusual weather conditions. In addition, preventive maintenance instructions provide information needed to inspect and service the Clothing Repair Shop.
- Chapter 3 Provides operator troubleshooting procedures for identifying equipment malfunctions and maintenance instructions for performing operator maintenance tasks.
- Chapter 4 Provides unit maintenance instructions for equipment and supplies used with the Clothing Repair Shop.
- Chapter 5 Provides direct support maintenance instructions for equipment and supplies used with the Clothing Repair Shop.
- Chapter 6 Provides general support maintenance instructions for equipment and supplies used with the Clothing Repair Shop.
- Appendix A gives you a list of frequently used forms and publications referenced or used in this manual.
- Appendix B provides the Maintenance Allocation Chart (MAC) which designates overall authority and responsibility for performance of maintenance functions on the identified end item or component. A list of tools and test equipment is also provided.
- Appendix C lists additional equipment authorized for your unit for use with the Clothing Repair Shop, but which are not supplied as part of the system.
- Appendix D lists components that are not mounted on the equipment, but are required to make the unit functional. All components in the Components of End Item and Basic Issue Items Lists are illustrated for easy identification.
- Appendix E not used.
- Appendix F provides you with information about expendable supplies such as sealants, lubricants, chemicals, etc. that are used when operating or maintaining equipment.

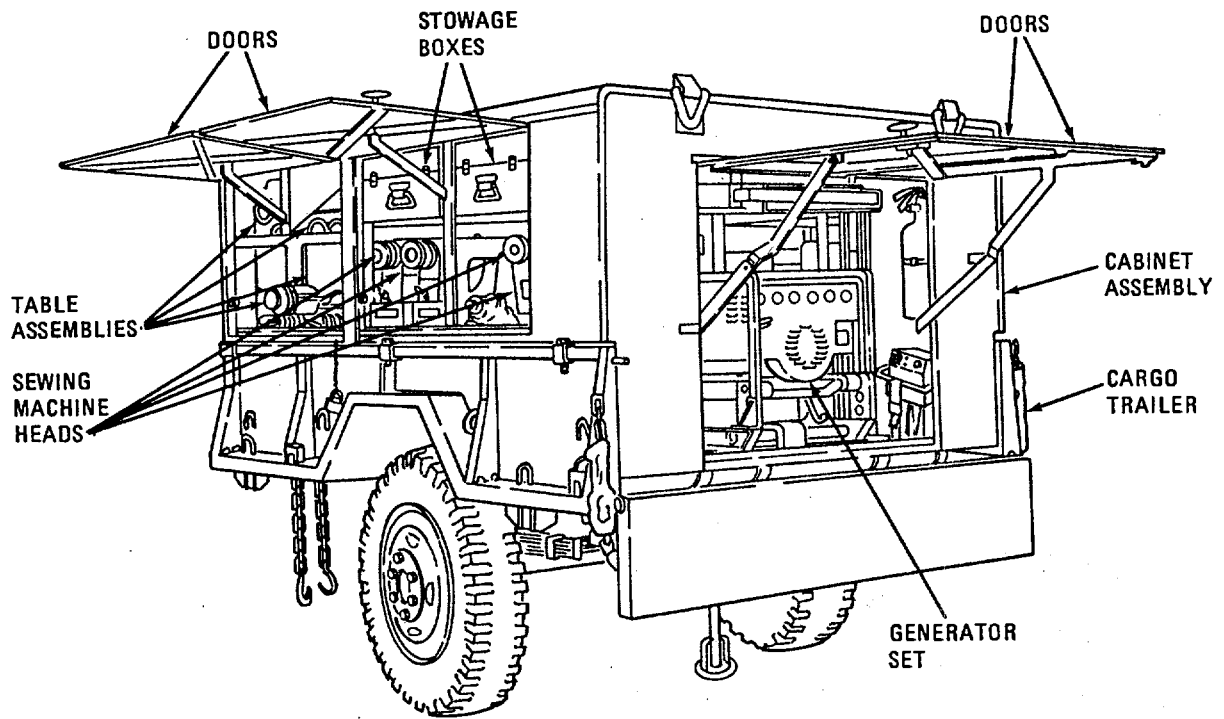

STREET SIDE

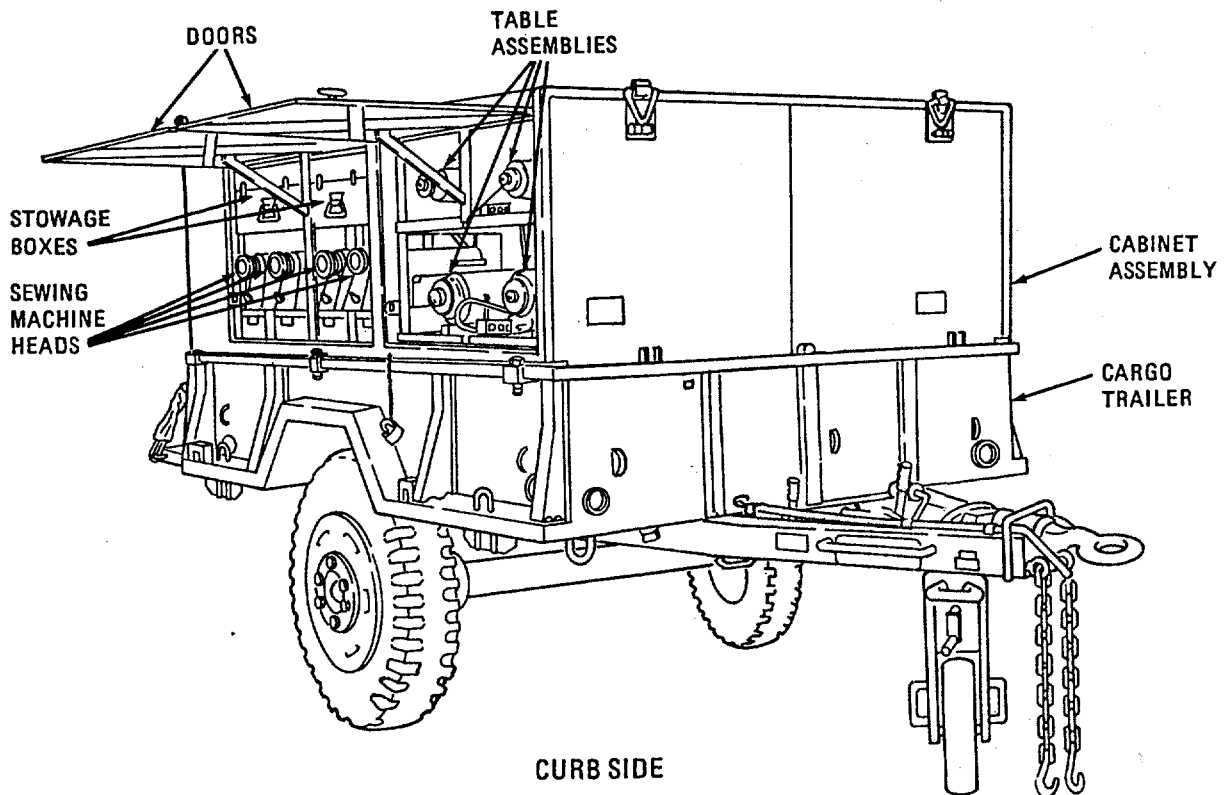

CURB SIDE

Figure 1-0. Clothing Repair Shop, Trailer Mounted

**CHAPTER 1**  
**INTRODUCTION**

<b>Paragraph</b>		<b>Page</b>
<b>Section I. General Information</b>		1-1
1-1.	Scope.....	1-1
1-2.	Maintenance Forms, Records and Reports .....	1-1
1-3.	Destruction of Army Materiel to Prevent Enemy Use .....	1-1
1-4.	Corrosion Prevention and Control (CPC) .....	1-1
1-5.	Reporting of Equipment Improvement Recommendations (EIR).....	1-2
1-6.	Nomenclature Cross Reference List .....	1-2
1-7.	List of Abbreviations.....	1-2
<b>Section II. Equipment Description and Data.....</b>		<b>1-3</b>
1-8.	Equipment Characteristics and Features .....	1-3
1-9.	Location and Description of Major Components.....	1-4
1-10.	Equipment Data.....	1-10
<b>Section III. Principles of Operation .....</b>		<b>1-12</b>
1-11.	System Technical Principles of Operation .....	1-12
1-12.	Component Technical Principles of Operation .....	1-12

**Section I. GENERAL INFORMATION**

**1-1. SCOPE.**

This manual covers Operating Instructions and Unit, Direct Support, and General Support maintenance procedures required to operate and maintain the Clothing Repair Shop. The Clothing Repair Shop is trailer mounted (figure 1-0) and is complete with all equipment necessary for the repair of clothing, and is designed for field use where it is normally set up in tents or temporary shelters.

**1-2. MAINTENANCE FORMS, RECORDS, AND REPORTS.**

Department of the Army Forms and procedures used for equipment maintenance will be those prescribed by DA Pam 738-750 The Army Maintenance Management System (TAMMS).

**1-3. DESTRUCTION OF ARMY MATERIEL TO PREVENT ENEMY USE.**

Methods and procedures for destruction of Army materiel to prevent enemy use are covered in TM 750-244-3.

**1-4. CORROSION PREVENTION AND CONTROL.**

- a. Corrosion Prevention and Control (CPC) of Army Materiel is a continuing concern. It is important that any corrosion problems with this item be reported so that the problem can be corrected and improvements can be made to prevent the problem in future items.

**1-4. CORROSION PREVENTION AND CONTROL - continued.**

- b. While corrosion is typically associated with rusting of metals, it can also include deterioration of other materials, such as rubber and plastic. Unusual cracking, softening, swelling or breaking of the materials may be a corrosion problem.
- c. If a corrosion problem is identified, it can be reported using Standard Form 368, Product Quality Deficiency Report. Using key words such as "rust", "deterioration", or "cracking" will insure that the information is identified as a CPC problem. The form should be submitted to the address specified in DA Pam 738-750.

**1-5. REPORT EQUIPMENT IMPROVEMENT RECOMMENDATIONS (EIRs).**

If your Clothing Repair Shop needs improvement, let us know. Send us an EIR. You, the user, are the only one who can tell us what you don't like about your equipment. Put it on an SF 368 (Quality Deficiency Report). Mail it to us at: Commander, U.S. Army Aviation and Troop Support Command, ATTN: AMSAT-I-MDO, 4300 Goodfellow Boulevard, St. Louis, MO 63120-1798. We'll send you a reply.

**1-6. NOMENCLATURE CROSS REFERENCE LIST.**

<b>Common Name</b>	<b>Official Nomenclature</b>
Grommet Press	Press, Grommet and Eyelet Attaching Machine
Button Attaching Machine	Press, Grommet and Eyelet Hand Operated
Clothing Repair Shop	Trailer Mounted Clothing Repair Shop
CONSEW	Consolidated Sewing Machine Corporation

**1-7. LIST OF ABBREVIATIONS.**

<b>Abbreviation</b>	<b>Nomenclature</b>
AAL	Additional Authorization List
BII	Basic Issue Items
FM	Field Manual
Hz	Hertz
ID	Identification
LO	Lubrication Order
MAC	Maintenance Allocation Chart
max	Maximum
NSN	National Stock Number
PMCS	Preventive Maintenance Checks and Services
qty	Quantity
Vac	Volts alternating current
wt	weight

---

**Section II. EQUIPMENT DESCRIPTION AND DATA**

**1-8. EQUIPMENT CHARACTERISTICS, CAPABILITIES AND FEATURES.**

a. Characteristics.

- (1) Self contained unit.
- (2) Easily transportable on cargo trailer.
- (3) Clothing Repair Shop may be quickly dismantled from trailer.

b. Capabilities.

- (1) Stand alone operation when equipped with generator set.
- (2) Operates from a 208 Vac, 60 Hz, generator set or external 208 Vac, 60 Hz commercial power sources.

c. Features.

- (1) Equipment housed in weather proof cabinet.

**1-9. LOCATION AND DESCRIPTION OF MAJOR COMPONENTS.**

- a. Cabinet Assembly. The weather-proofed aluminum cabinet assembly (1, fig. 1-1 and 1, fig. 1-2) is designed to house and transport all of the equipment required for the operation of the clothing repair shop. It has two swing up doors (2, fig. 1-1 and 2, fig. 1-2) on both the curb and street sides, and one swing up door in the rear (3, fig. 1-2) for easy access to the equipment in the cabinet. The cabinet assembly is mounted in the bed of a 1-1/2 ton utility cargo trailer (3, fig. 1-1) and is secured to the trailer bed frame by six holddown clamp assemblies (4, fig. 1-1 and 4, fig. 1-2). The cabinet contains the following:

**NOTE**

Throughout this manual the term "curb side" means the right side, while the term "street side" means the left side of the clothing repair shop as viewed from the rear of the trailer.

- (1) Four compartments (two on the curb side and two on the street side) for the stowage boxes (5, fig 1-1 and 5, fig. 1-2), which are used for storing the grommet press, tack button attaching machine, spare parts, hardware accessories and attachments necessary for operation of the Clothing Repair Shop.
- (2) Eight wooden tray assemblies for stowing the sewing machine heads (6, fig. 1-1 and 6, fig. 1-2).
- (3) Eight compartments for the machine table assemblies (7, fig. 1-1 and 7, fig. 1-2).
- (4) Four lower compartments, two on each side under the table assemblies for the holding stands (1, fig. 1-4).
- (5) One compartment (rear) for the two table assemblies (8, fig. 1-2)
- (6) Two slide tracks (1, fig. 1-3) on the sides of the generator set (2, fig. 1-3).
- (7) Space on the rear curb side of the cabinet for fire extinguisher (9, fig. 1-2) and heat sealer (10, fig. 1-2).
- (8) Space in the rear street side, front street side and front curb side for the folding chairs (11, fig. 1-2).
- (9) Space on rear floor for four folding stands (12, fig. 1-2).

1-9. LOCATION AND DESCRIPTION OF MAJOR COMPONENTS- continued.

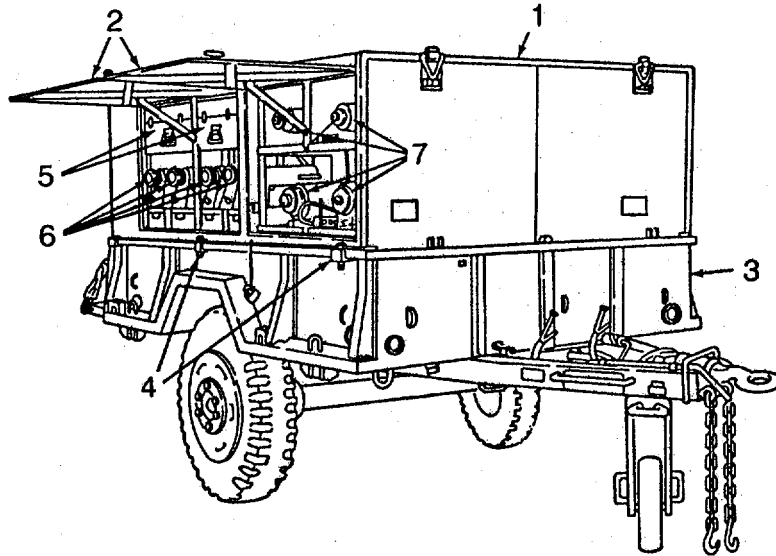

Figure 1-1

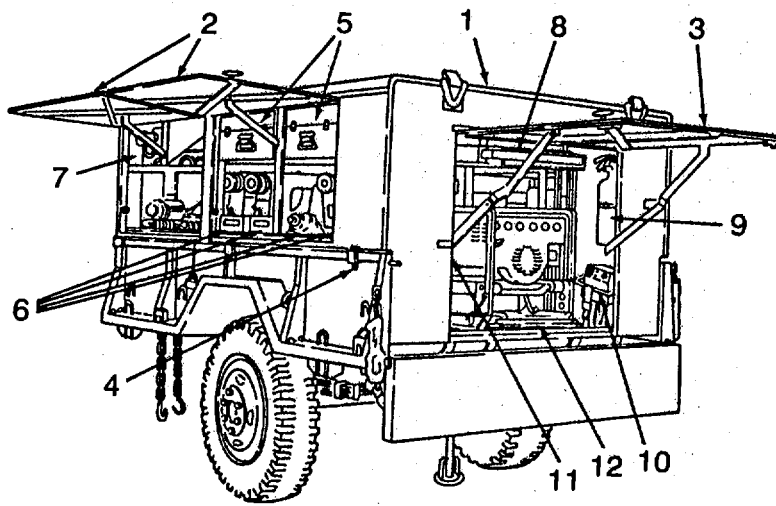

Figure 1-2

1-9. LOCATION AND DESCRIPTION OF MAJOR COMPONENTS - continued.

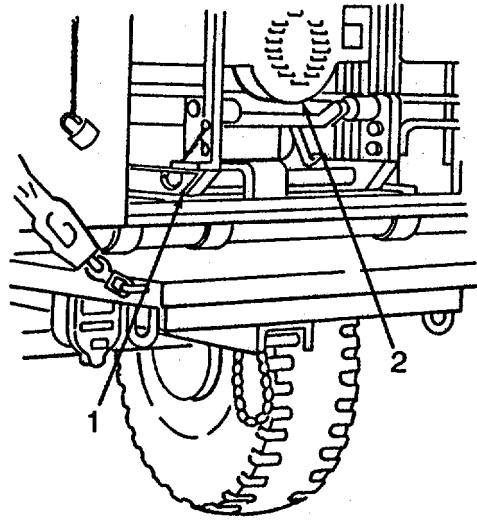

Figure 1-3

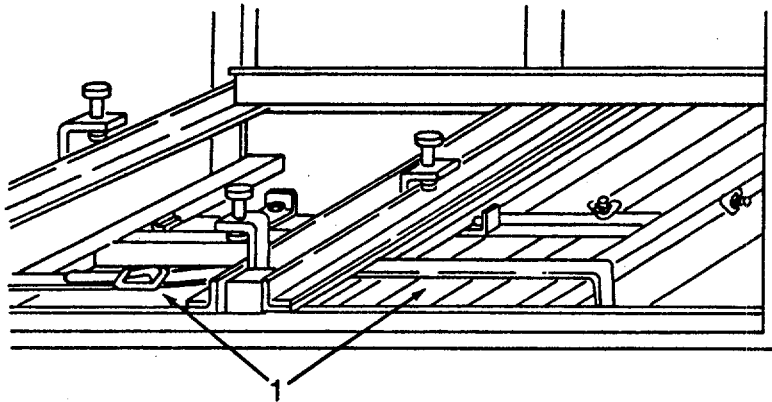
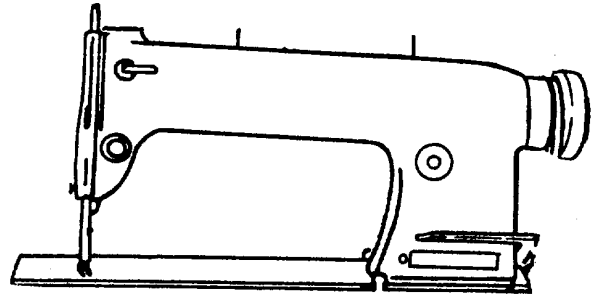

Figure 1-4

**1-9. LOCATION AND DESCRIPTION OF MAJOR COMPONENTS - continued.**

- b. Clothing Sewing Machine. The clothing sewing machine is a single needle, oscillating shuttle, lockstitch sewing machine, designed for general duty tailoring.



- c. Darning Sewing Machine. The darning sewing machine is a single needle heavy duty, cylinder arm, lockstitch machine with a vertical axis rotary sewing hook.

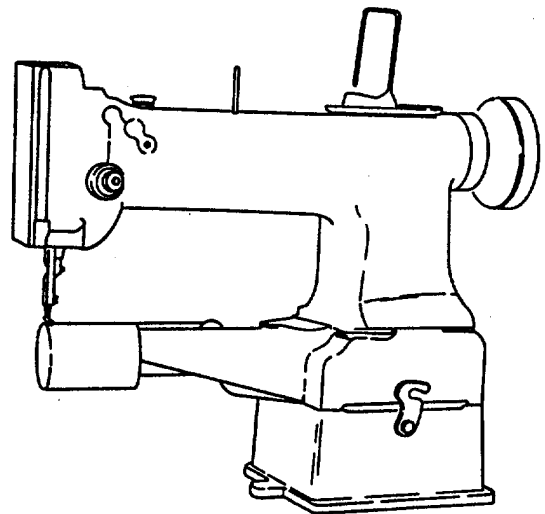

- d. Button Sewing Machine. The button sewing machine makes a single-thread chain stitch and sews on buttons with sixteen stitches, including a cross-over stitch and a knotting stitch.

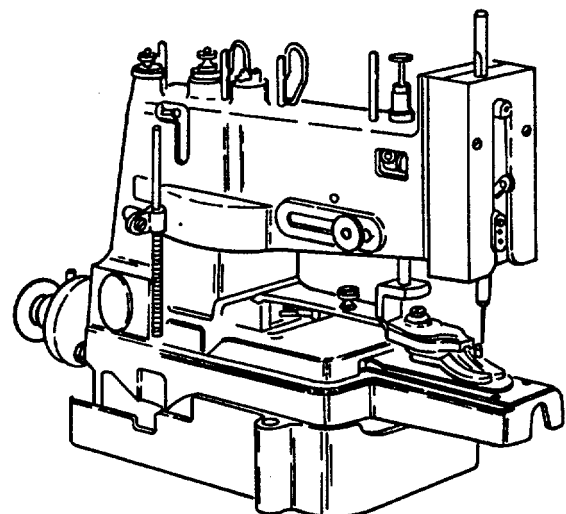

1-9. LOCATION AND DESCRIPTION OF MAJOR COMPONENTS - continued.

e. Grommet Press. The grommet press is used to attach grommets and snap fasteners.

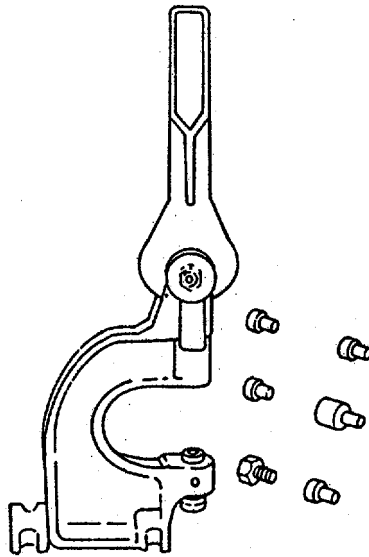

f. Tack-Button Attaching Machine. The tack button attaching machine is used to attach tack buttons.

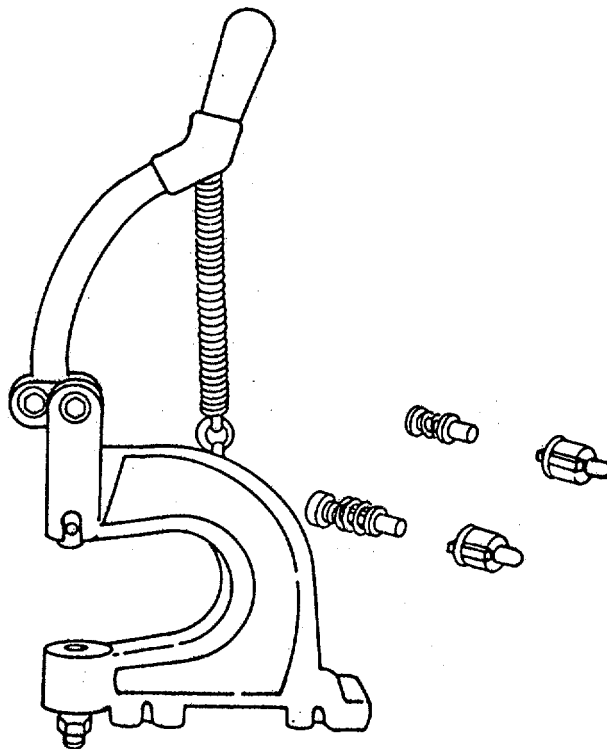

1-9. LOCATION AND DESCRIPTION OF MAJOR COMPONENTS - continued.

- g. Heat Sealer.  
The heat sealer is used to apply heat activated materials.

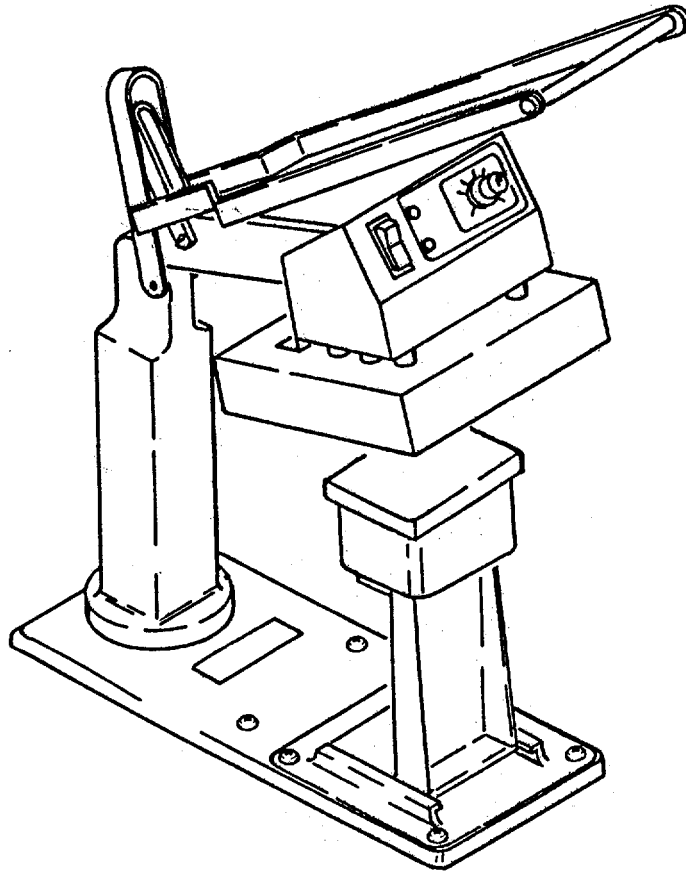

**1-10. EQUIPMENT DATA.**

Equipment Data Listing. Refer to table 1-1 for a tabulated equipment data on the clothing repair shop.

**Table 1-1. Equipment Data**

---

**CLOTHING REPAIR SHOP**

General Information:

Manufacturer	Engineered Air Systems, Inc. 1270 N. Price Road St. Louis, MO -63132
--------------	--

Manufacture Model Number	CRS-100
--------------------------	---------

National Stock Number	3530-01-346-7256
-----------------------	------------------

Dimensions and Weights:

Height	88 1/2 ,inches
--------	----------------

Length	165 1/2 inches
--------	----------------

Width	83 inches
-------	-----------

Weight	5;395 pounds
--------	--------------

1-10. EQUIPMENT DATA - continued.

Table 1-1. Equipment Data

CLOTHING SEWING MACHINE

General Information:

Manufacturer	Consolidated Sewing Machine Corp. 56-65 Rust Street Maspeth, NY 11378-7811
Model Number	CN3115R
Motor	
Input Power	115 V 60 hertz
Horsepower	1/2 hp. (373 w.)
Speed	1725 rpm

DARNING SEWING MACHINE

General Information:

Manufacturer	Consolidated Sewing Machine Corp. 56-65 Rust Street Maspeth, NY 11378-7811
Model Number	207
Motor	
Input Power	115 V 60 hertz
Horsepower	1/2 hp. (373 w.)
Speed	1725 rpm

BUTTON SEWING MACHINE

General Information:

Manufacturer	Consolidated Sewing Machine Corp. 56-65 Rust Street Maspeth, NY 11378-7811
Model Number	261-2
National stock Number	3530-00-570-5445
Motor	
Input Power	115 V 60 hertz
Horsepower	1/3 hp. (249 w.)
Speed	1725 rpm

### Section III. PRINCIPLES OF OPERATION

#### 1-11. SYSTEM TECHNICAL PRINCIPLES OF OPERATION.

The Clothing Repair Shop is trailer mounted (figure 1-0) and is complete with all equipment necessary for the repair of clothing, and is designed for field use where it is normally set up in tents or temporary shelters. The clothing repair shop is rated for 208 Vac, 60 Hertz input power. Individual components are all rated for 105 Vac to 120 Vac, 60 Hertz input power.

#### 1-12. COMPONENT PRINCIPLES OF OPERATION.

a. Clothing Sewing Machine.

The clothing sewing machine is designed for stitching clothing, coats, suits, skirts, and shirts. Each time the arm shaft rotates, the oscillating shuttle catches the needle thread, loops it around the bobbin thread, and forms a lockstitch. The clutch allows the operator to control the speed.

b. Button Sewing Machine.

The button sewing machine makes a single -thread chain stitch and sews on buttons with sixteen stitches, including a cross-over stitch and a knotting stitch. It can be adjusted for buttons with holes 7/64 inch to 7/32 inch apart from center. It is equipped with a vibrating needle bar, and is equipped with a clamp for sewing two hole and four hole flat buttons, from 20 to 45 ligne, close to the material, with through and through stitching.

c. Darning Sewing Machine.

The darning sewing machine is a single needle heavy duty, cylinder arm, lockstitch machine with a vertical axis rotary sewing hook. It is designed for darning and mending all types of medium to heavy weight materials, including cloth, vinyl, leather, canvas, denim and various coated and laminated materials. It is suitable for repairing such products as overalls, work shirts, uniforms, tents, tarpaulins, marine and truck covers and numerous other articles. Tubular and curved articles such as sleeves and pants legs are easily handled on the cylindrical bed of the machine.

d. Grommet Press.

The grommet press is a small, hand operated machine consisting of a metal frame that houses the plunger. The press comes equipped with assorted sets of chucks and dies that are easily interchanged. The chucks are installed in the plunger and dies are installed in the lower portion. When the hand lever is pushed down, the chuck presses upon the die, molding the separate metal snap fastener parts into the finished fastener and attaching the fastener to the material.

e. Tack-Button Attaching Machine.

The tack-button attaching machine is a small, hand operated machine consisting of a plunger housed in a metal frame. With a set of dies installed that match the tack-button, the handle is pushed down. The dies press upon the separate button parts into a finished tack and attach the fastener to the material.

f. Heat Sealing Machine.

The heat sealing machine is designed to handle any type of transfer and fusing operation from plastisol and ink transfers to sublimation and heat activated embroidery.

**CHAPTER 2**

**OPERATING INSTRUCTIONS**

Paragraph		Page
Section I.	Description and Use of Operator's Controls and Indicators.....	2-1
2-1.	Clothing Sewing Machine .....	2-2
2-2.	Darning Sewing Machine .....	2-8
2-3.	Button Sewing Machine .....	2-10
Section II.	Operator's Preventive Maintenance Checks and Services (PMCS) .....	2-13
2-4.	General .....	2-13
2-5.	Warnings and Cautions .....	2-13
2-6.	PMCS Table .....	2-13
Section III.	Operation Under Usual Conditions .....	2-36
2-7.	General .....	2-36
2-8.	Assembly and Preparation for Use .....	2-36
2-9.	Operating Instructions For Clothing Repair Shop .....	2-57
2-10.	Operating Procedures For Fire Extinguisher .....	2-57
2-11.	Operating Procedures For Clothing Sewing Machine.....	2-58
2-12.	Operating Procedures For Darning Sewing Machine .....	2-70
2-13.	Operating Procedures For Button Sewing Machine .....	2-80
2-14.	Operating Procedures For Grommet Press .....	2-95
2-15.	Operating Procedures For Tack Button Attaching Machine.....	2-98
2-16.	Operating Procedures For Heat Sealing Machine.....	2-100
2-17.	Decals and Instruction Plates.....	2-101
2-18.	Preparation for Movement .....	2-104
Section IV.	Operation Under Unusual Conditions .....	2-118
2-19.	General.....	2-118
2-20.	Operation in Extreme Heat and Cold .....	2-118
2-21.	Operation in Sandy and Dusty Areas .....	2-118

**Section I. DESCRIPTION AND USE OF OPERATOR'S CONTROLS AND INDICATORS**

This section provides the operator with information needed to locate, identify, and use the controls and indicators on the clothing repair shop.

Refer to TM 5-6115-271-14 for description and use of operator's controls and indicators for the Generator Set.

Refer to TM 9-2330-213-14 for description and use of Cargo Trailer.

2-1. CLOTHING SEWING MACHINE.

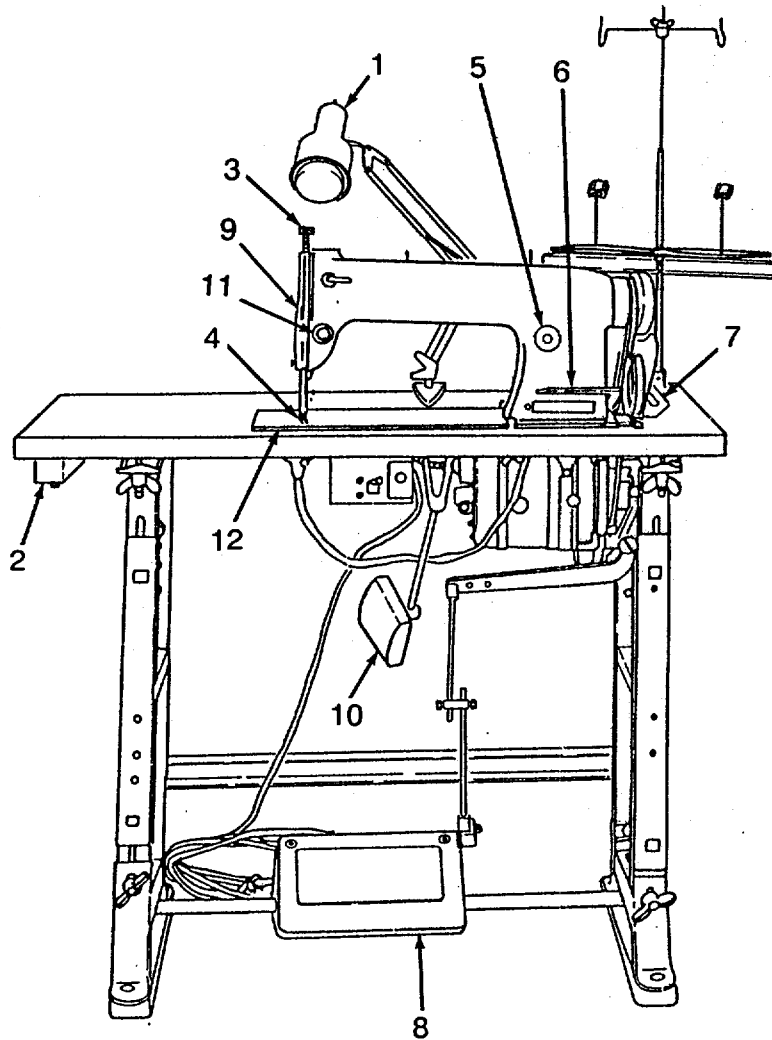

1. **Lamp Assembly ON-OFF Switch.**  
Turns the lamp assembly on and off.
2. **Motor Switch.**  
The motor switch applies power to the motor.

## 2-1. CLOTHING SEWING MACHINE - continued.

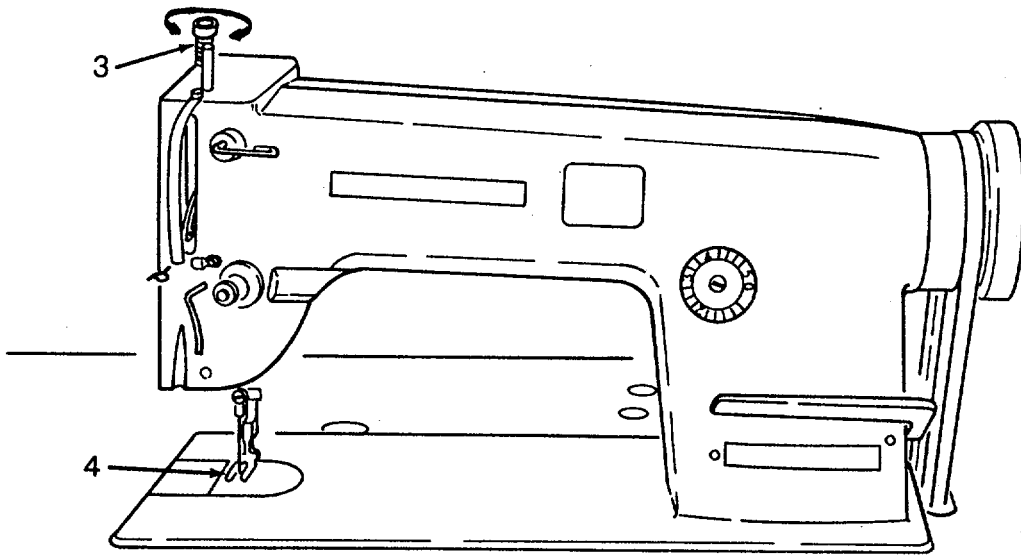
**3. Regulator Screw.**

The pressure of the presserfoot (4) on the material is regulated by the regulator screw (3) on top of the machine. Turn this regulator to the left to decrease it. Do not employ more foot pressure than is required to feed the material properly.

**4. Presser Foot.**

The presser foot adds pressure to hold the material down.

## 2-1. CLOTHING SEWING MACHINE .continued.

## 5. Feed Regulator Dial.

The stitch length is regulated by turning dial (5) at the front of the machine. When number "0" on the dial appears uppermost, the machine does not feed. Turning the dial to the left will gradually increase the stitch length to its maximum (1 to 5), when "5" is at the top. As the stitch length is increased it can be noticed that the reverse feed lever (6) slowly moves in upward direction.

When shortening the stitch length, it will be found of advantage to depress lever (6) slightly as dial (5) is being turned to the right. To do tacking for the purpose of locking the ends of seams, rapidly depress and release lever (6) as the needle approaches the edge of the material.

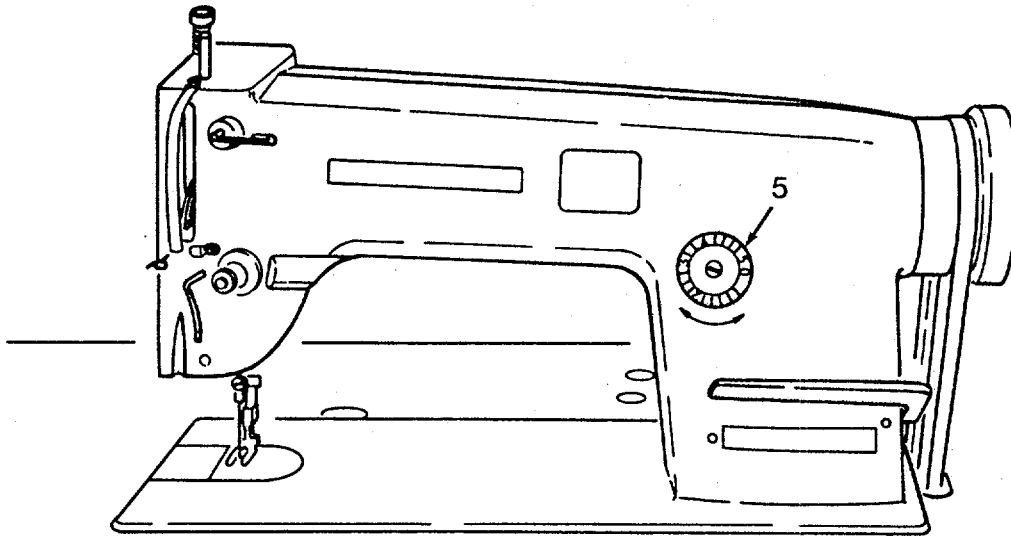

## 6. Reverse Feed Lever.

The reverse lever reverses the direction of feed. For reverse sewing, push and hold the feed lever all the way down. When released, a spring returns the lever to its normal forward stitching position.

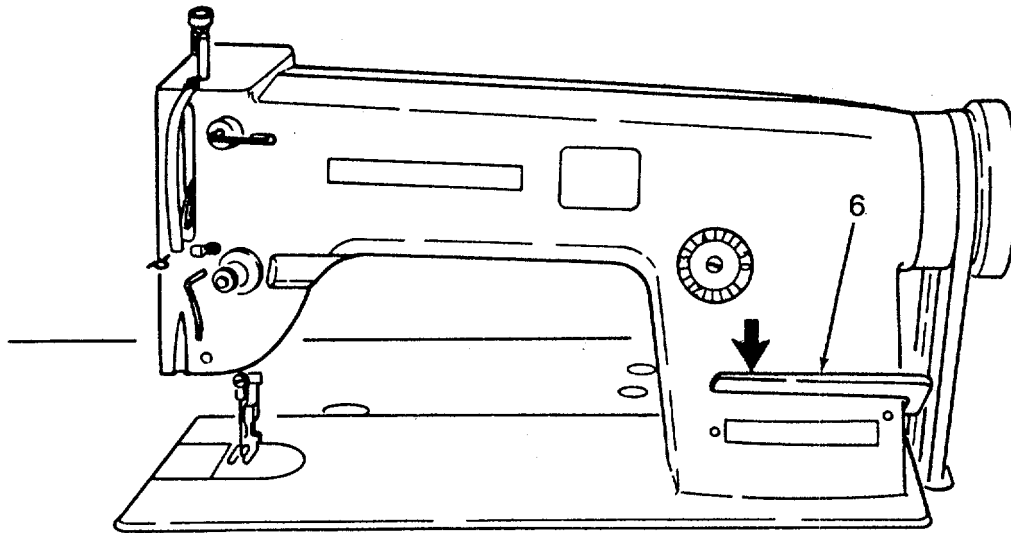

2-1. CLOTHING SEWING MACHINE - continued.

7. **Bobbin Winder.**

The bobbin winder is used to wind bobbins.

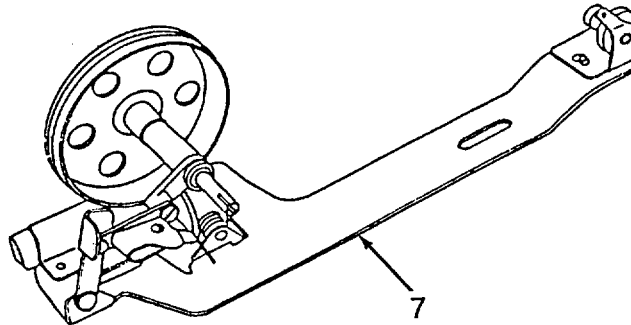

8. **Foot Treadle.**

The foot treadle engages and disengages the clutch between the motor and the motor driving pulley. Depress the treadle slowly for smooth clutch engagement. After clutch engagement, depress the treadle further until the desired speed is reached.

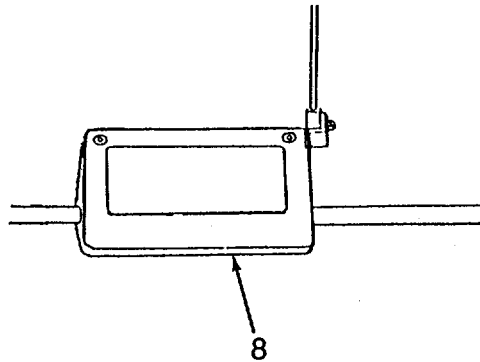

9. **Presser Bar Hand Lifter.**

The presser foot may also be lifted and locked in it's raised position by raising the hand lever to it's highest position. After the presser foot has been locked in it's raised position, it may be released by pressing the knee lifter to the right.

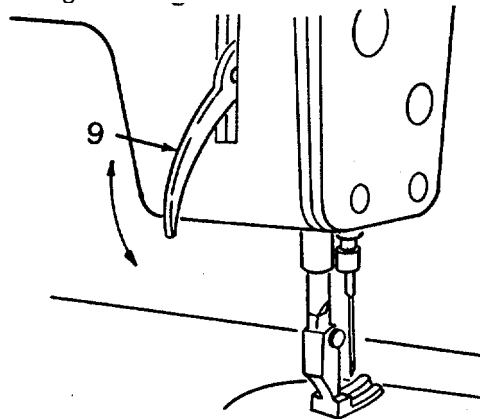

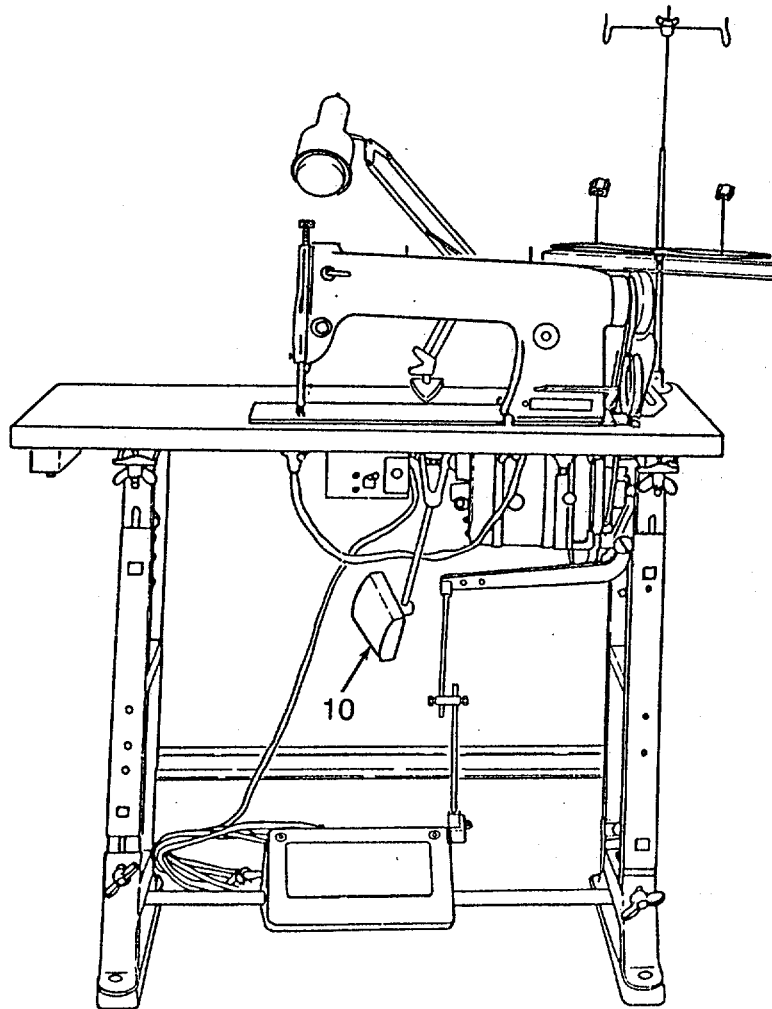
**2-1. CLOTHING SEWING MACHINE - continued.****10. Knee Lifter Lever.**

The presser foot can be raised by moving the knee lifter to the right. This allows use of both hands to work material. This knee lifter connects with a knee lifting lever on the bottom of the head of the machine. A knee lifting lever push rod runs up and behind the arm of the machine to the presser foot.

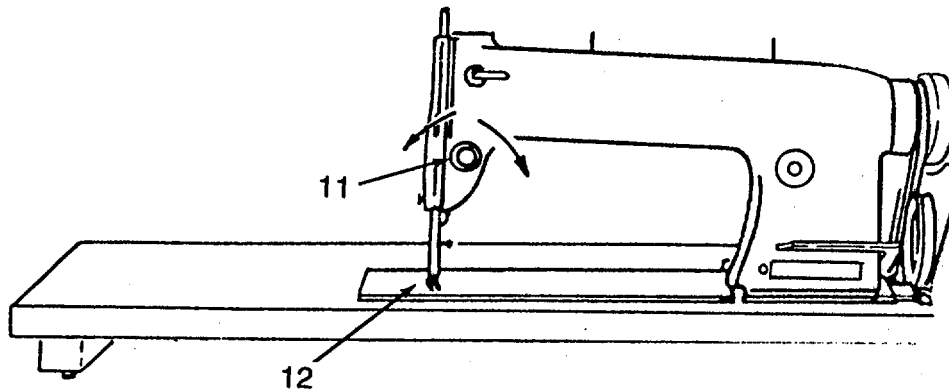
**2-1. CLOTHING SEWING MACHINE - continued.****11. Needle Upper Thread Tension Adjustment.**Tension of the Upper (Needle) Thread

Before adjusting the tension of the upper thread, be certain that the presser foot is let down and not in the lifted position. Turning the nut to the right (clockwise) increases needle tension. Turning the nut to the left (counterclockwise) decreases needle tension.

**12. Needle Lower Thread Tension Adjustment.**Tension of the Lower (Bobbin) Thread.

The tension of the lower thread is regulated by screw on the bobbin case tension spring. Tighten the screw slightly to increase the tension, or loosen it to slacken the tension.

## 2-2. DARNING SEWING MACHINE.

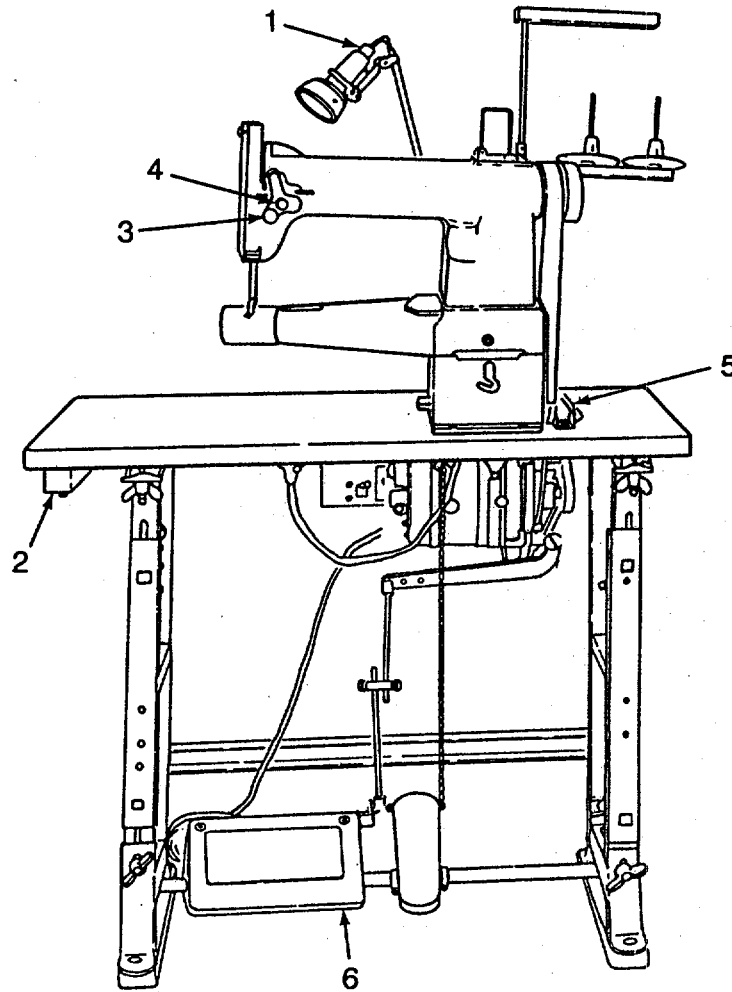
**1. Lamp Assembly ON-OFF Switch.**

Turns the lamp assembly on and off.

**2. Motor Switch.**

The motor switch applies power to the motor.

**3. Thread Controller Spring.**

The function of the thread controller spring is to hold back the slack of the needle threads until the eye of each needle reaches the goods in its descent, as without this controlling action of the spring, the slack thread will sometimes be penetrated by the point of the needle as the needle is descending. For more controller action on the thread, loosen the stop screw at the right of the tension and set the stop lower. For less action, set the stop higher.

**2-2. DARNING SEWING MACHINE - continued.****4. Needle Thread Tension Adjust Nut.**

Ideal stitches are formed when the needle thread and the bobbin thread are perfectly interlocked. The tension exerted on the needle thread can be set by the adjust nut. Turning the nut to the right (clockwise) increases the needle thread tension. Turning the nut to the left (counterclockwise) decreases the needle thread tension.

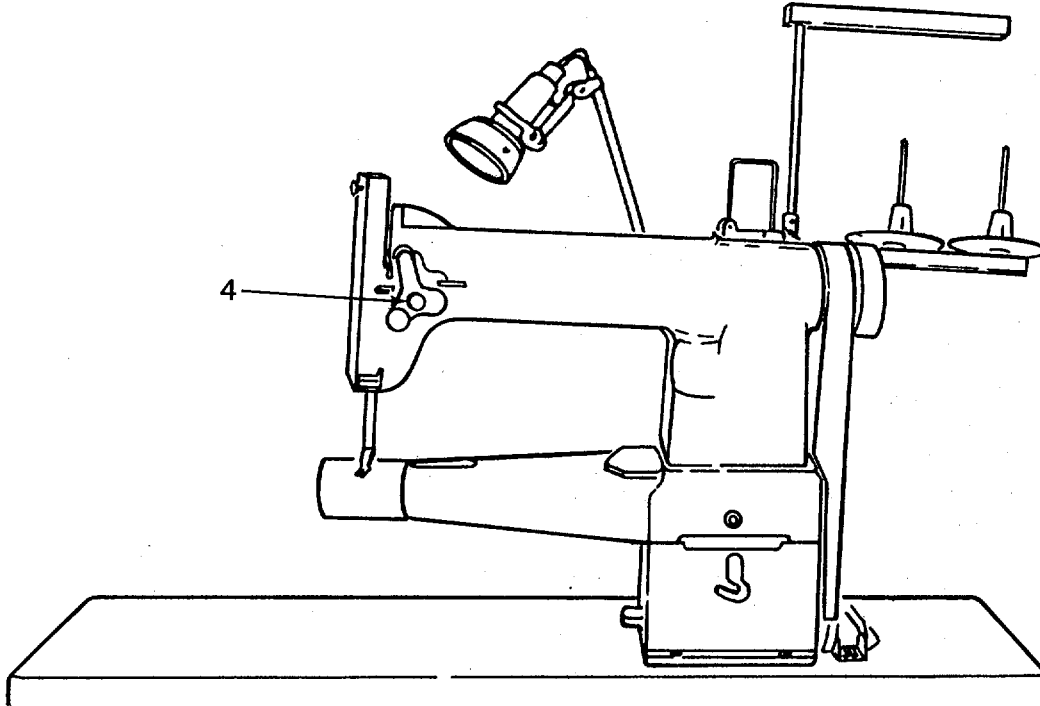
**5. Bobbin Winder.**

The bobbin winder is used to wind bobbins.

**6. Foot Treadle.**

The foot treadle engages and disengages the clutch between the motor and the motor driving pulley. Depress the treadle slowly for smooth clutch engagement. After clutch engagement, depress the treadle further until the desired speed is reached.

2-3. BUTTON SEWING MACHINE.

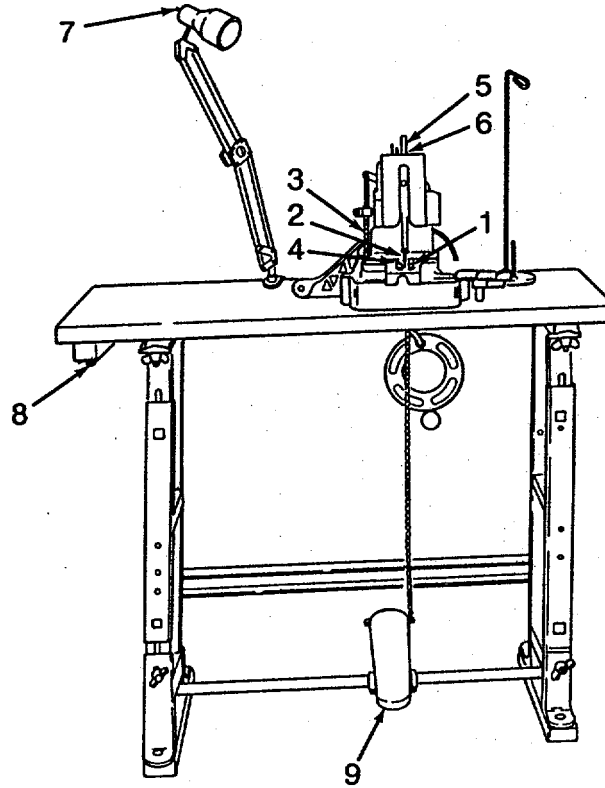

1. **Button Clamp.**

Holds the button for sewing. The lever (1) spreads the button clamp to receive the button and is locked in position by the thumbscrew(2).

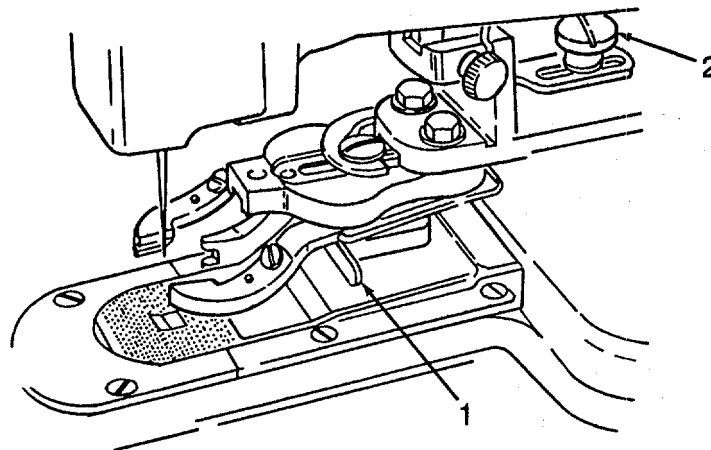

2. **Thumbscrew.**

Locks button clamp into position.

## 2-3. BUTTON SEWING MACHINE - continued.

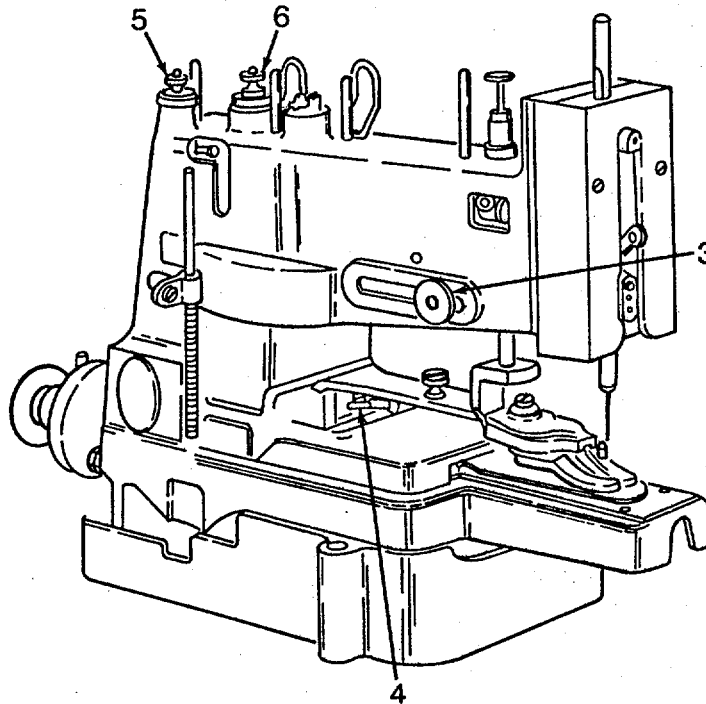

3. **Button Clamp Vibration Regulator.**  
Regulates the distance the button clamp will move from left to right. Calibrated in inches (1/16 inch divisions). Lock thumbnut after setting distance.
4. **Two-Hole or Four-Hole Regulator Hinge Pin.**  
Selects two-hole or four-hole button clamp travel of vibration.
5. **Thread Lock Timing Thumbnut.**  
The thread lock timing thumbnut provides an indication to the operator that the timing plunger is operating. It locks the thread when the sewing cycle is complete.
6. **Front Thread Tension Adjust Knob.**  
Tightness of the stitch is regulated by the front tension adjust knob. If the adjustment is too tight, the looper will snap the thread, if it is too loose, the knots on the under side of the button will be loose. Turning the knob to the right increases thread tension, turning it to the left decreases tension.

2-3. **BUTTON SEWING MACHINE - continued.**

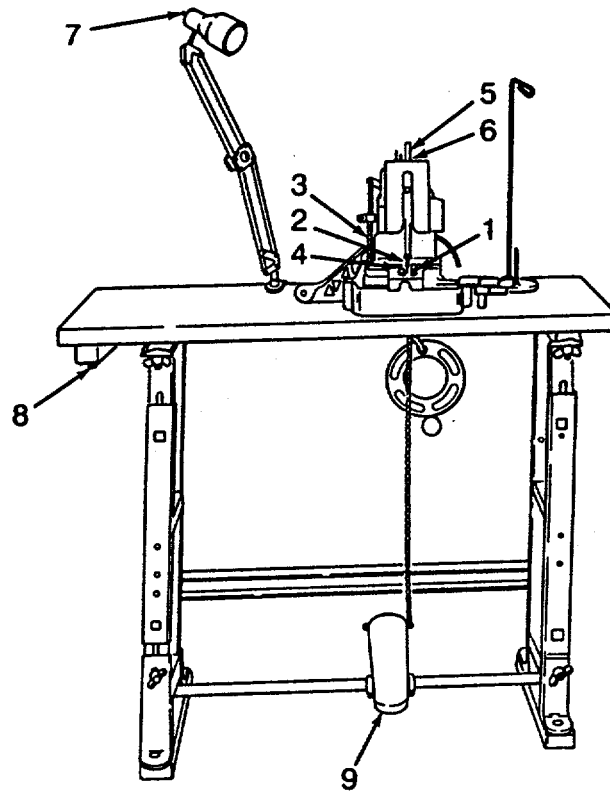

**7. Lamp Assembly ON-OFF Switch.**

Turns the lamp assembly on and off.

**8. Motor Switch.**

The motor switch applies power to the motor.

**9. Foot Pedal.**

The foot pedal engages the button machine to run through a complete cycle.

---

**Section II. OPERATOR PREVENTIVE MAINTENANCE CHECKS AND SERVICES (PMCS) FOR THE CRS-100 CLOTHING REPAIR SHOP****2-4. GENERAL.**

- a. The Preventive Maintenance Checks and Services presented in Table 2-1 list the inspections and care of your equipment required to keep it in good operating condition and ready for its primary mission.
- b. When a check and service procedure is required for both weekly and before intervals, it is not necessary to do the procedure twice if the equipment is operated during the weekly period.

**2-5. WARNINGS AND CAUTIONS.**

Always observe the WARNINGS and CAUTIONS appearing in the PMCS table. Warnings and cautions appear before applicable procedures. You must observe WARNINGS and CAUTIONS to prevent serious injury to yourself and others or prevent your equipment from being damaged.

**2-6. PMCS TABLE.**

- a. Refer to Table 2-1 for Preventive Maintenance Checks and Services.

**NOTE**

Be sure to observe all special information and notes that appear in your table.

- b. Explanation of Table Entries:

- (1) Item Number Column. Numbers in this column are for reference. When completing DA Form 2404 (Equipment Maintenance and Inspection Worksheet), include the item number for the check/service indicating a fault. Item numbers also appear in the order that you must do checks and services for the intervals listed.
- (2) Interval Column. This column tells you when you must do the procedure in the procedure column. BEFORE procedures must be done before you operate or use the equipment for its intended mission. DURING procedures must be done during the time you are operating or using the equipment for its intended mission. AFTER procedures must be done immediately after you have operated or used the equipment.
- (3) Location, Check/Service Column. This column provides the location and the item to be checked or serviced. The item location is underlined.
- (4) Procedure Column. This column gives the procedure you must do to check or service the item listed in the Check/Service column to know if the equipment is ready or available for its intended mission or for operation. You must do the procedure at the time stated in the interval column.

**2-6. PMCS TABLE- continued.**

- (5) Not Fully Mission Capable If: Column. Information in this column tells you what faults will keep your equipment from being capable of performing its mission. If you make check and service procedures that show faults listed in this column, do not operate the equipment. Follow standard operating procedures for maintaining the equipment or reporting equipment failure.

**Table 2-1. Operator Preventive Maintenance Checks and Services**

**NOTE**

If the equipment must be kept in continuous operation, do only the procedures that can be done without disturbing operation. Make complete checks and services when the equipment is shut down.

**Table 2-1. Operator Preventive Maintenance Checks and Services**

ITEM NO.	INTERVAL	LOCATION ITEM TO CHECK/ SERVICE	PROCEDURE	NOT FULLY MISSION CAPABLE IF:
1	Before	<b>CABINET ASSEMBLY</b> Padlocks	Inspect for missing or damaged padlock (1). Check that padlock keys are not bent and will unlock padlocks. Check that padlocks will open and close without binding or sticking.	

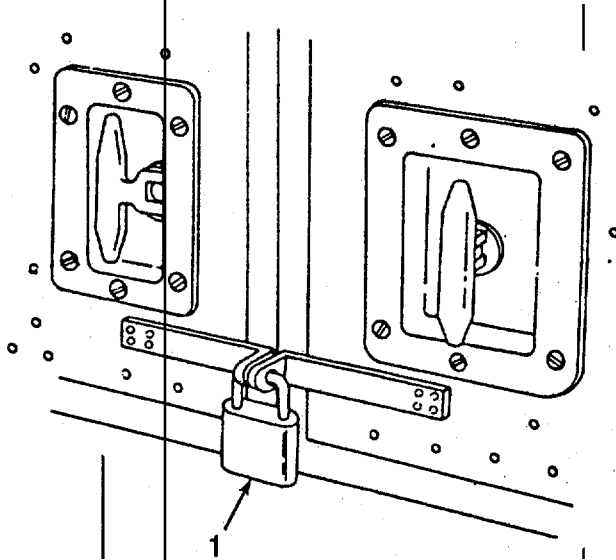
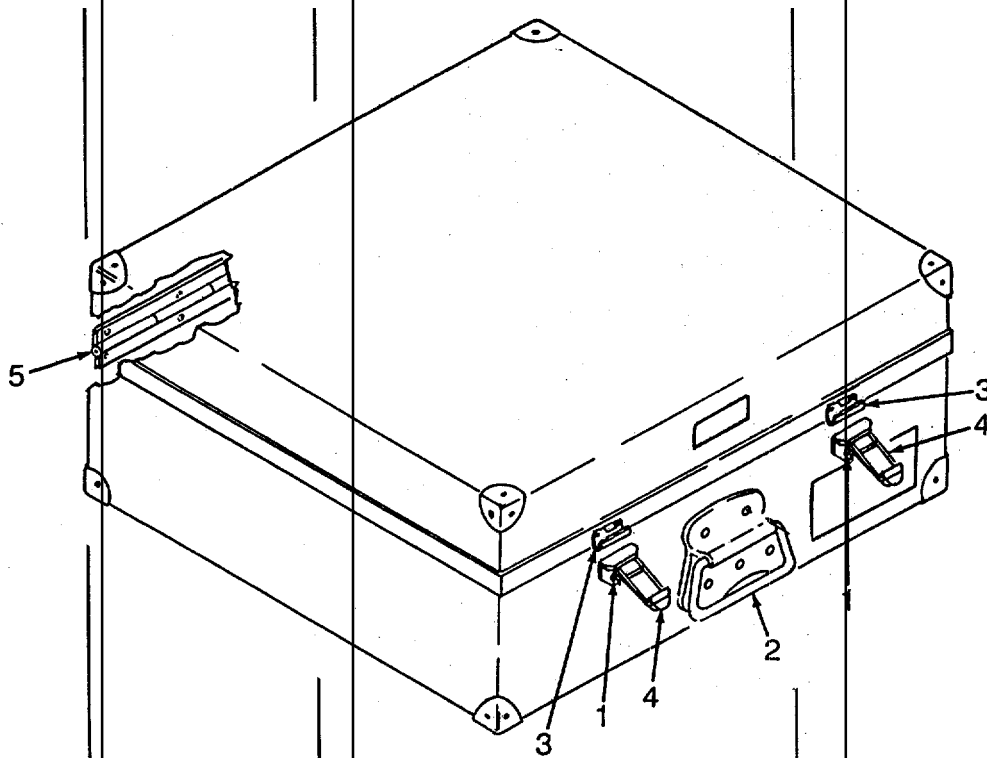

Table 2-1. Operator Preventive Maintenance Checks and Services

ITEM NO.	INTERVAL	LOCATION ITEM TO CHECK/ SERVICE	PROCEDURE	NOT FULLY MISSION CAPABLE IF:
2	Before	<p><b>CABINET ASSEMBLY - continued</b></p> <p>Stowage Box</p>	<p>a. Inspect the stowage box for cut, dented, or broken surfaces.</p> <p>b. Check for loose or missing rivets (1), bent broken or loose handles (2), hooks (3), latches (4), and hinges (5).</p> <p>c. Make certain the hooks and latches will lock and unlock, and hinges operate without binding.</p>	



**Table 2-1. Operator Preventive Maintenance Checks and Services**

ITEM NO.	INTERVAL	LOCATION ITEM TO CHECK/ SERVICE	PROCEDURE	NOT FULLY MISSION CAPABLE IF:
3	Before	<b>CABINET ASSEMBLY - continued</b>  Sewing Machine Tray Assemblies	a. Inspect the tray assemblies for chipped, cracked, warped or broken wood.  b. Check for bent or broken holddown straps and pulls.  c. Check for loose or missing screws.  d. Check for missing or worn felt and rubber shock absorber.	

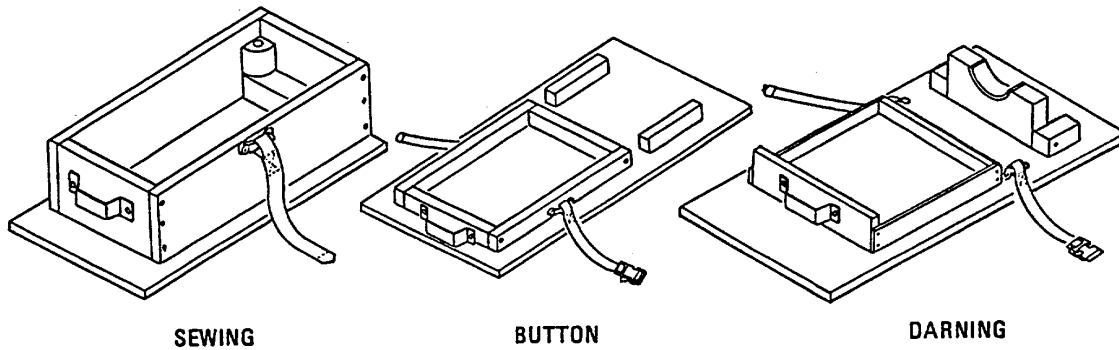
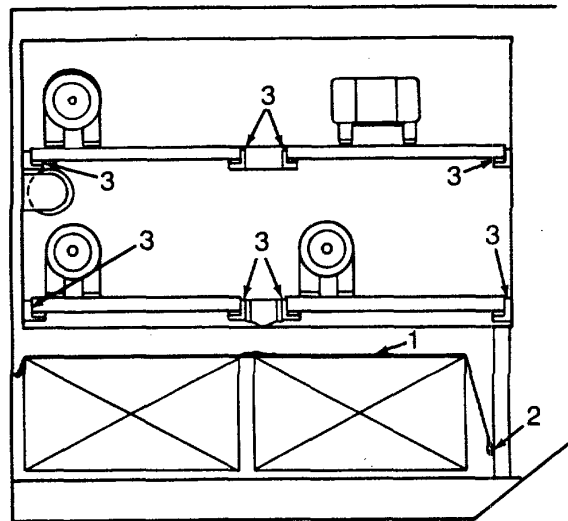

Table 2-1. Operator Preventive Maintenance Checks and Services

ITEM NO.	INTERVAL	LOCATION ITEM TO CHECK/ SERVICE	PROCEDURE	NOT FULLY MISSION CAPABLE IF:
4	Before	<p><b>CABINET ASSEMBLY - continued</b></p> <p>Sewing Machine Folding Stand Container Assemblies</p>	<p>a. Inspect the folding stand holddown strap assemblies (1) for cracked, broken, loose or missing footman loops (2), for loose or missing rivets, for cut, torn, or frayed webbing straps, for loose or damaged strap buckles, and for loose mounting.</p> <p>b. Inspect table supports (3) for damaged holddown clamps, and damaged or missing hardware.</p>	



**Table 2-1. Operator Preventive Maintenance Checks and Services**

ITEM NO.	INTERVAL	LOCATION ITEM TO CHECK/ SERVICE	PROCEDURE	NOT FULLY MISSION CAPABLE IF:
5	Before	<b>CLOTHING SEWING MACHINE</b>  Table Assembly	Inspect for cut, cracked, warped and dirty table top. Inspect for loose or missing bolts, nuts or inserts and for bent or broken components. Make certain table assembly is placed on a level surface.	Loose or missing bolts, nuts or inserts.

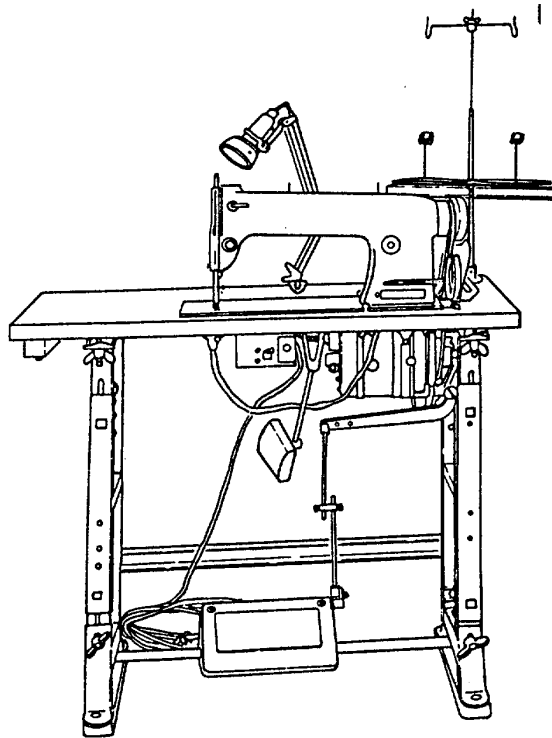
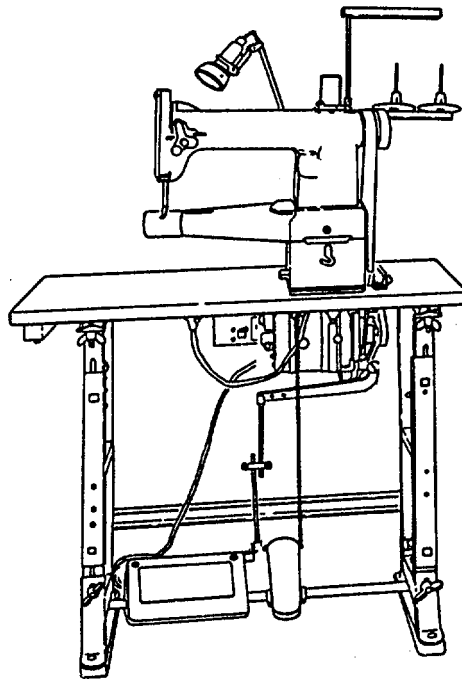

**Table 2-1. Operator Preventive Maintenance Checks and Services**

ITEM NO.	INTERVAL	<u>LOCATION</u> ITEM TO CHECK/ SERVICE	PROCEDURE	NOT FULLY MISSION CAPABLE IF:
6	Before	<p><b>CLOTHING SEWING MACHINE - continued</b></p> <p>Knee Lifter</p>	<p>Inspect for loose mounting and for bent or broken knee lifter. Make certain the lifter raises and lowers the presser foot.</p>	<p>Lifter does not raise or lower the presser foot.</p>
7	Before	<p>Machine Service</p>	<p>a. Inspect the sewing machine for dirt, lint, and other debris.</p> <p>b. Inspect for proper adjustments and operation.</p>	<p>Sewing machine is out of adjustment or fails to operate.</p>

**Table 2-1. Operator Preventive Maintenance Checks and Services**

ITEM NO.	INTERVAL	LOCATION ITEM TO CHECK/ SERVICE	PROCEDURE	NOT FULLY MISSION CAPABLE IF:
8	Before	<b>DARNING SEWING MACHINE</b>  Table Assembly	Inspect for cut, cracked, warped and dirty table top. loose or missing bolts, nuts or inserts and for bent or broken components. Make certain table assembly is placed on a level surface.	Loose or missing bolts, Inspect for nuts or inserts.

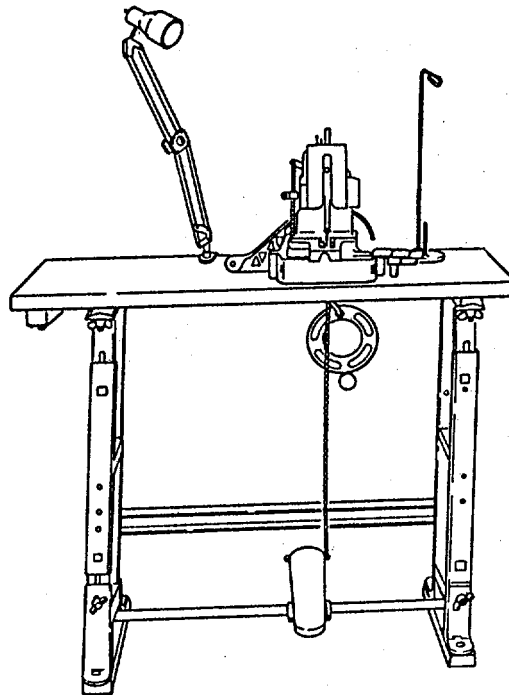

**Table 2-1. Operator Preventive Maintenance Checks and Services**

ITEM NO.	INTERVAL	<u>LOCATION</u> ITEM TO CHECK/ SERVICE	PROCEDURE	NOT FULLY MISSION CAPABLE IF:
9	Before	<p><b>DARNING SEWING MACHINE - continued</b></p> <p>Machine Service</p>	<p>a. Inspect the sewing machine for dirt, lint, and other debris.</p> <p>b. Inspect for proper adjustments and operation.</p>	<p>Sewing machine is out of adjustment or fails to operate.</p>

**Table 2-1. Operator Preventive Maintenance Checks and Services**

ITEM NO.	INTERVAL	LOCATION ITEM TO CHECK/ SERVICE	PROCEDURE	NOT FULLY MISSION CAPABLE IF:
10	Before	<b>BUTTON SEWING MACHINE</b>  Table Assembly	Inspect for cut, cracked, warped and dirty table top. Inspect for loose or missing bolts, nuts or inserts and for bent or broken components. Make certain table assembly is placed on a level surface.	Loose or missing bolts, nuts or inserts

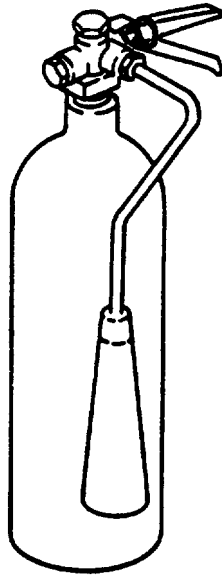

**Table 2-1. Operator Preventive Maintenance Checks and Services**

ITEM NO.	INTERVAL	<u>LOCATION</u> ITEM TO CHECK/ SERVICE	PROCEDURE	NOT FULLY MISSION CAPABLE IF:
11	Before	<b>BUTTON SEWING MACHINE - continued</b>  Machine Service	a. Inspect the sewing machine for dirt, lint, and other debris.  b. Inspect for proper adjustments and operation.	Sewing machine is out of adjustment or fails to operate.

**Table 2-1. Operator Preventive Maintenance Checks and Services**

ITEM NO.	INTERVAL	<u>LOCATION</u> ITEM TO CHECK/ SERVICE	PROCEDURE	NOT FULLY MISSION CAPABLE IF:
12	Before	<b>FIRE EXTINGUISHER</b>  Fire Extinguisher	Inspect the fire extinguisher for broken wire seal. Recharge the fire extinguisher immediately after it has been used or if the loss of gas exceeds one-half of a pound.	Not charged.



**Table 2-1. Operator Preventive Maintenance Checks and Services**

ITEM NO.	INTERVAL	LOCATION ITEM TO CHECK/ SERVICE	PROCEDURE	NOT FULLY MISSION CAPABLE IF:
13	During	<b>CLOTHING SEWING MACHINE</b>  Machine Service	a. Inspect the sewing machine for dirt, lint, and other debris.  b. Inspect for proper adjustments and operation. operate.	Sewing machine is out of adjustment or fails to operate.

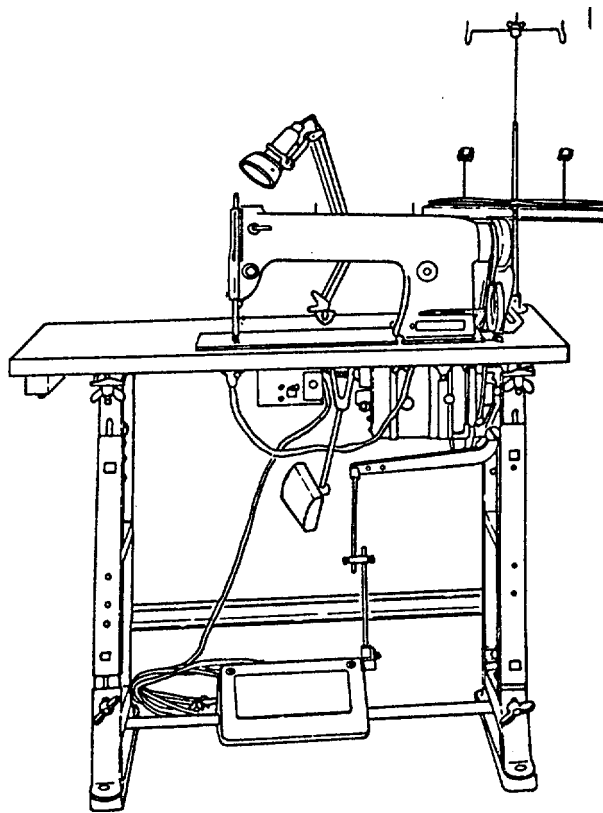

**Table 2-1. Operator Preventive Maintenance Checks and Services**

ITEM NO.	INTERVAL	<u>LOCATION</u> ITEM TO CHECK/ SERVICE	PROCEDURE	NOT FULLY MISSION CAPABLE IF:
14	During	<b>DARNING SEWING MACHINE</b>  Machine Service	a. Inspect the sewing machine for dirt, lint, and other debris.  b. Inspect for proper adjustments and operation.	Sewing machine is out of adjustment or fails to operate.

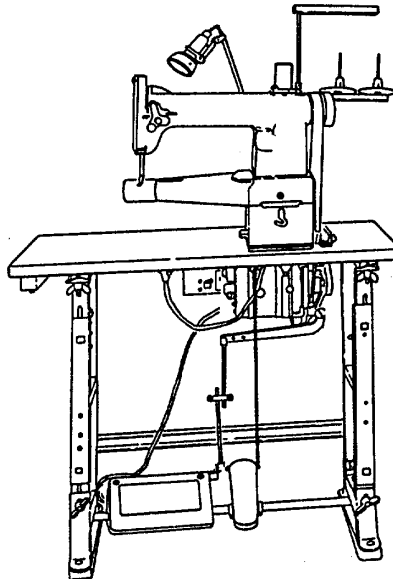

**Table 2-1. Operator Preventive Maintenance Checks and Services**

ITEM NO.	INTERVAL	LOCATION ITEM TO CHECK/ SERVICE	PROCEDURE	NOT FULLY MISSION CAPABLE IF:
15	During	<b>BUTTON SEWING MACHINE</b>  Machine Service	a. Inspect the sewing machine for dirt, lint, and other debris.  b. Inspect for proper adjustments and operation.	Sewing machine is out of adjustment or fails to operate.

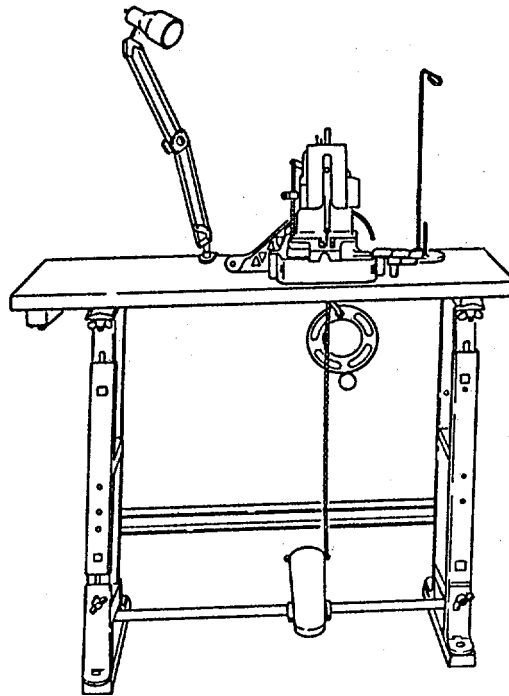

**Table 2-1. Operator Preventive Maintenance Checks and Services**

ITEM NO.	INTERVAL	LOCATION ITEM TO CHECK/ SERVICE	PROCEDURE	NOT FULLY MISSION CAPABLE IF:
16	After	<b>CABINET ASSEMBLY</b>  Sewing Machine Tray Assemblies	a. Inspect the tray assemblies for chipped, cracked, warped or broken wood.  b. Check for bent or broken holddown straps and pulls.  c. Check for loose or missing screws.  d. Check for missing or worn felt and rubber shock absorber.	

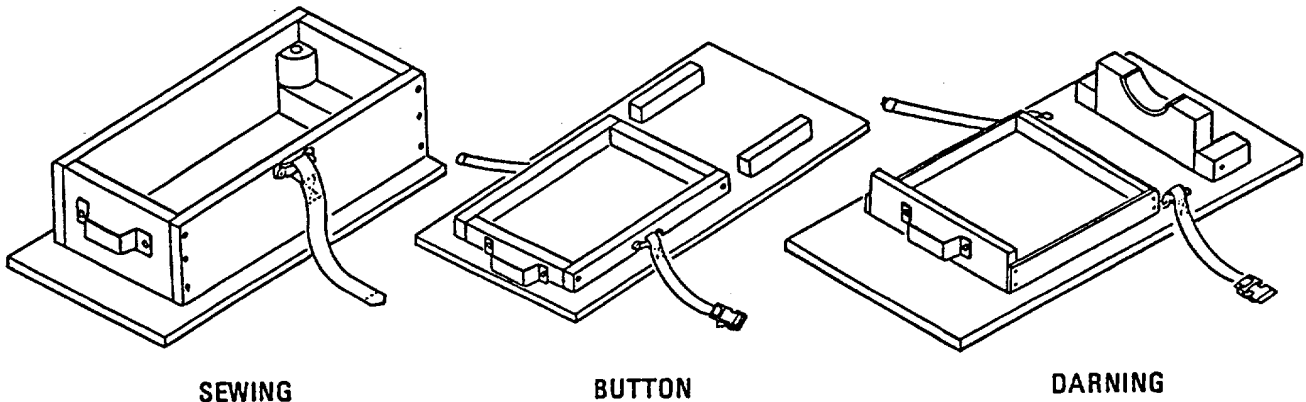

**SEWING**

**BUTTON**

**DARNING**

**Table 2-1. Operator Preventive Maintenance Checks and Services**

ITEM NO.	INTERVAL	LOCATION ITEM TO CHECK/ SERVICE	PROCEDURE	NOT FULLY MISSION CAPABLE IF:
17	After	CABINET ASSEMBLY - continued  Sewing Machine Folding Stand Container Assemblies	a. Inspect the folding stand holddown strap assemblies (1) for cracked, broken, loose or missing footman loops (2), for loose or missing rivets, for cut, torn, or frayed webbing straps, for loose or damaged strap buckles, and for loose mounting.  b. Inspect table supports (3) for damaged holddown clamps, and damaged or missing hardware.	

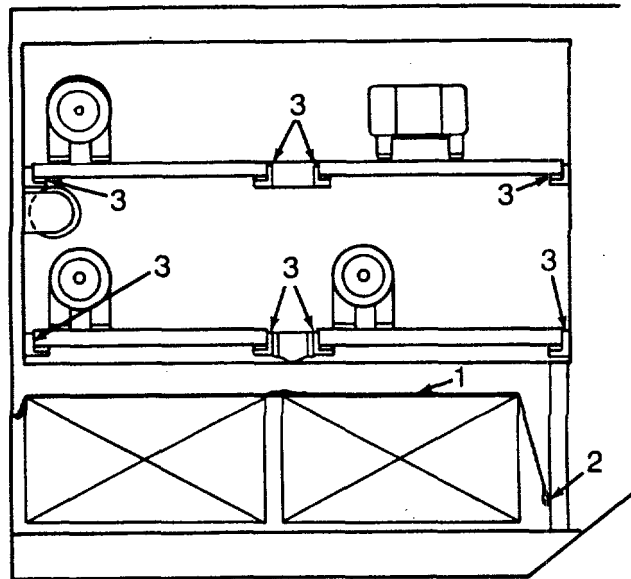

**Table 2-1. Operator Preventive Maintenance Checks and Services**

ITEM NO.	INTERVAL	<u>LOCATION</u> ITEM TO CHECK/ SERVICE	PROCEDURE	NOT FULLY MISSION CAPABLE IF:
18	After	<p><b>CLOTHING SEWING MACHINE</b></p> <p>Table Assembly</p>	<p>Inspect for cut, cracked, warped and dirty table top. Inspect for loose or missing bolts, nuts or inserts and for bent or broken components. Make certain table assembly is placed on a level surface.</p>	<p>Loose or missing bolts, nuts or inserts.</p>

**Table 2-1. Operator Preventive Maintenance Checks and Services**

ITEM NO.	INTERVAL	LOCATION ITEM TO CHECK/ SERVICE	PROCEDURE	NOT FULLY MISSION CAPABLE IF:
19	After	<b>CLOTHING SEWING MACHINE - continued</b>  Knee Lifter	Inspect for loose mounting and for bent or broken knee lifter. Make certain the lifter raises and lowers the presser foot.	Lifter does not raise or lower the presser foot.
20	After	Machine Service	a. Inspect the sewing machine or dirt, lint, and other debris.  b. Inspect for proper adjustments and operation. to operate.	Sewing machine is out of adjustment or fails

**Table 2-1. Operator Preventive Maintenance Checks and Services**

ITEM NO.	INTERVAL	LOCATION ITEM TO CHECK/ SERVICE	PROCEDURE	NOT FULLY MISSION CAPABLE IF:
21	After	<b>DARNING SEWING MACHINE</b>  Table Assembly	Inspect for cut, cracked, warped and dirty table top. Inspect for loose or missing bolts, nuts or inserts and for bent or broken components. Make certain table assembly is placed on a level surface.	Loose or missing bolts, nuts or inserts.

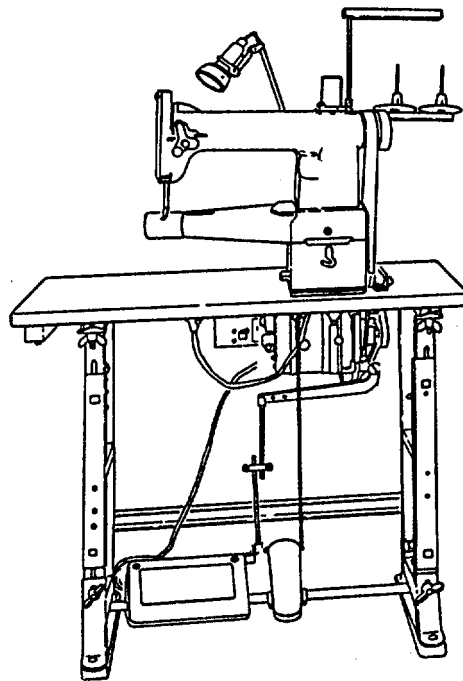
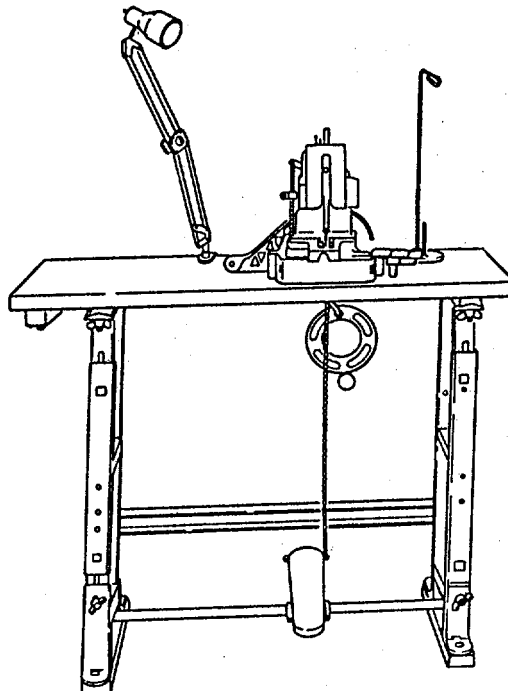

**Table 2-1. Operator Preventive Maintenance Checks and Services**

ITEM NO.	INTERVAL	<u>LOCATION</u> ITEM TO CHECK/ SERVICE	PROCEDURE	NOT FULLY MISSION CAPABLE IF:
22	After	<b>DARNING SEWING MACHINE - continued</b>  Machine Service	a. Inspect the sewing machine for dirt, lint, and other debris.  b. Inspect for proper adjustments and operation.	Sewing machine is out of adjustment or fails to operate.

**Table 2-1. Operator Preventive Maintenance Checks and Services**

ITEM NO.	INTERVAL	LOCATION ITEM TO CHECK/ SERVICE	PROCEDURE	NOT FULLY MISSION CAPABLE IF:
23	After	<b>BUTTON SEWING MACHINE</b>  Table Assembly	Inspect for cut, cracked, warped and dirty table top. Inspect for loose or missing bolts, nuts or inserts and for bent or broken components. Make certain table assembly is placed on a level surface.	Loose or missing bolts, nuts or inserts



**SECTION III. OPERATION UNDER USUAL CONDITIONS**

**2-7. GENERAL.**

The instructions in this section are for the guidance of operator/crew personnel in the successful operation of the Clothing Repair Shop.

**2-8. ASSEMBLY AND PREPARATION FOR USE.**

The following paragraphs give you general information concerning site selection and shelter requirements for the fielded clothing repair shop. Specific instructions are given to assist you in the unloading, inspection, set up, and service of the Clothing Repair Shop equipment before placing it into operation. Refer to table 2-2 for an inventory of the items contained in each of the stowage boxes.

**Table 2-2. Stowage Box Inventory List**

STOWAGE BOX	ITEM
1	Electric Iron Grommet Press with Dies Tack Button Attaching Press with Dies Darning Sewing Machine Needles Clothing Sewing Machine Needles Button Sewing Machine Needles Darning Sewing Machine Bobbins Clothing Sewing Machine Bobbins Darning Machine Base Darning Bobbin Winders Button Tray Button Machine Base Darning Thread Stand Darning Thread Guide Pin Darning Belt Guard Darning Thread Unwinder Darning Accessories Box Darning Mounting Hardware Looper

2-8. ASSEMBLY AND PREPARATION FOR USE - continued.

Table 2-2. Stowage Box Inventory List - continued

STOWAGE BOX	ITEM
1 - continued	Needle Threaders Button Belt Guard Belt Guard Pin Eye Guard Assembly Button Thread Unwinder Button Accessories Box Button Mounting Hardware Screwdriver Set Electric Distribution Box
2	Drop Lights Spare Lamp Bulbs for Drop Lights Ground Wire Sewing Lights Lamp Bulbs for Sewing Lights
3	Electric Distribution Box Sewing Head Rest Pins Clothing Repair Thread Unwinder Assemblies Bobbin Winders Belt Guard Assemblies Oil Cans Button Machine Pedal and Clips Darning Machine Pedal and Clips Scissors Clothing Punch Pliers Screwdrivers Adjustable Crescent Wrench Thimbles Belt Hooks Treadles

2-8. ASSEMBLY AND PREPARATION FOR USE - continued.

Table 2-2. Stowage Box Inventory List - continued

STOWAGE BOX	ITEM
3 - continued	Treadle Clips Treadle Extension Treadle Linkage Rod Presser Bar Needle Bar Thread Guide Needle Bar Thread Guide Screw Needle Clamps Throat Plate Throat Plate Screw Feed Dog Screw Tension Assembly Face Plate Screw Face Plate Thumb Screw Presser Bar Lifting Lever Bed Slide Plate Spring Thread Guide Set Hinged Presser Foot Shuttle and Race Assembly Thread Take-up Spring Shuttle Race Screw Clothing Hinge Pins Clothing Accessories Box Mounting Screws Vertical Access Rotary Hook Shank Button Accessories Stay Button Attachment
4	Power Supply Box Electric Distribution Box Button Machine Lifter Chains Belting Ironing Board With Pad and Cover

**2-8. ASSEMBLY AND PREPARATION FOR USE - continued.**

- a. Shelter Requirements. General purpose tent will provide adequate shelter for the equipment of the clothing repair shop.
- b. Site Selection. When making a selection for a site, keep the following in mind.
  - (1) Select a site with a minimum of 42 x 26 ft. unobstructed area (tent dimensions are approximately 32 x 16 ft.).
  - (2) Select a dry, dust free and level site that slopes on all sides for water drainage.
  - (3) Clear the site of sharp stones, roots, glass and any other undesirable matter.
  - (4) Remove overhanging tree branches that could snag the tent.
- c. Disconnecting Trailer From Towing Vehicle. Select a dry, flat area as near as possible to the clothing repair shop shelter for parking the trailer. Proceed as follows to disconnect the cargo trailer from the towing vehicle.

- (1) Set both handbrakes (1) by pulling the handbrakes forward to set the brakes.
- (2) Pull up on handle (2) and lower caster (3) into position. Release handle and check that the caster locked in the down position.
- (3) Crank castor (3) down/up using handle (4) as necessary to level the unit.
- (4) Disconnect the intervehicular electrical cable (5) from the towing vehicle. Place cable in the bracket.
- (5) Close the towing vehicle air shut-off valve. Disconnect the intervehicular air hose (6) from the towing vehicle and place in the bracket.
- (6) Unhook safety chains (7) from the towing vehicle and hook them to the lifting bars (8).
- (7) Unlatch the pintle and lift the drawbar coupler (9) from the towing vehicle pintle.

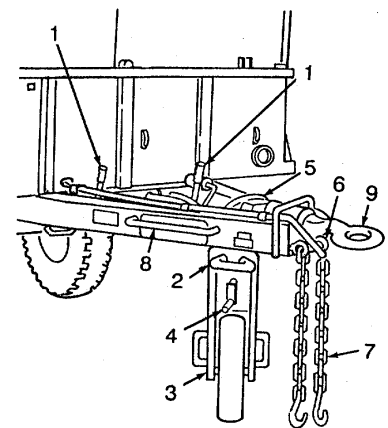

**2-8. ASSEMBLY AND PREPARATION FOR USE - continued.**

c. Disconnecting Trailer From Towing Vehicle continued.

- (8) Push up on rear support leg (1) slightly and at the same time push up on lever (2).
- (9) Lower leg (1) and screw out base plate to make firm contact with ground.

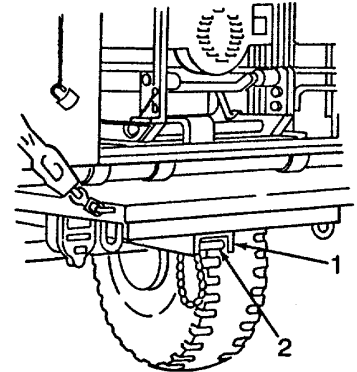

d. Opening Up The Trailer. Proceed as follows to open the trailer.

- (1) Unlock and remove four padlocks (1).
- (2) Turn both latch handles (2) on each side door (3) to unlock doors.
- (3) Raise doors (3) and make sure door stays (4) latch to hold doors (3) in the open position.

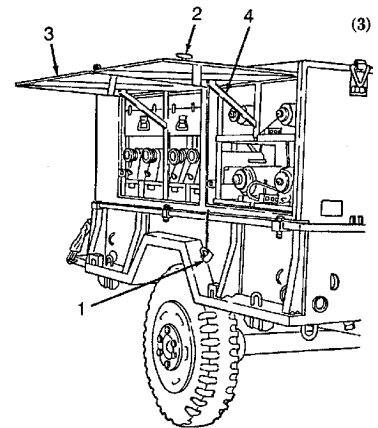

**2-8. ASSEMBLY AND PREPARATION FOR USE - continued.**

d. Opening Up The Trailer continued.

- (4) Unhook trailer end gate chains (1) and lower trailer end gate (2).
- (5) Open rear door (3) and make sure rear door stays (4) hold the door open.

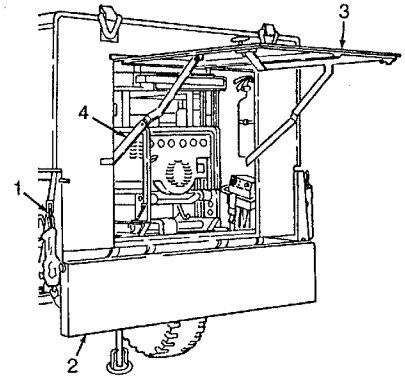

**NOTE**

As the cabinet assembly is unloaded, check the equipment against the Components of End Item List (COEIL) contained in Appendix C of this manual to insure that the clothing repair shop is complete.

- e. Folding Table Assemblies. There are two folding table assemblies: one is used for the installation and operation of the heat sealer during operation of the Clothing Repair Shop and one is used for the installation and operation of the grommet press at one end, the tack-button machine at the other end and the ironing board in the middle.

- (1) Remove two locking pins (5) and remove the two table assemblies (6) from the slides in the rear of the cabinet.

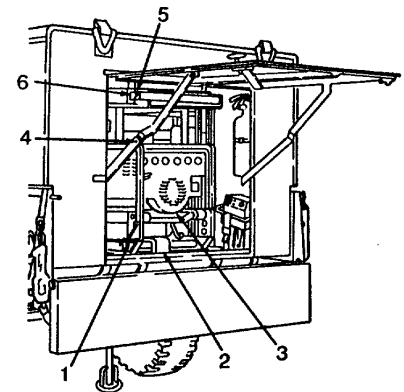

**NOTE**

The table assemblies may be snug and not slide freely. If so, gently pry out from front.

- (2) Unfold the legs and lock them in place by sliding the locks downward into position to set up the tables.

**2-8. ASSEMBLY AND PREPARATION FOR USE - continued.**

- f. Sewing Machine Table Assemblies, Folding Stands and Stowage Boxes.

**NOTE**

The swivel foot of the locking clamps have left hand threads.

- (1) Unscrew and remove the locking clamps and then slide the eight sewing machine table (top) assemblies (1) from their slide racks and out of the cabinet.
- (2) Set table top assemblies on the folding tables.

**NOTE**

The sewing machine tables must be removed to gain access to the folding stands that are located in the compartments under the table assemblies. The folding stands are used to support the table assemblies, which in turn support the sewing machine heads.

- (3) Unfasten holddown straps (1).
- (4) Remove folding stands (2) from the compartments.
- (5) Repeat steps (3) through (4) for the other side and rear of unit.

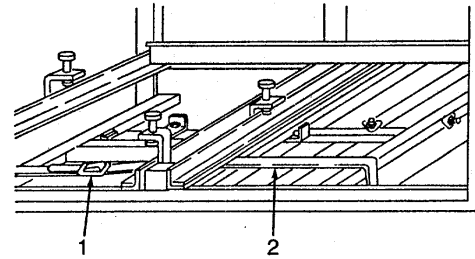
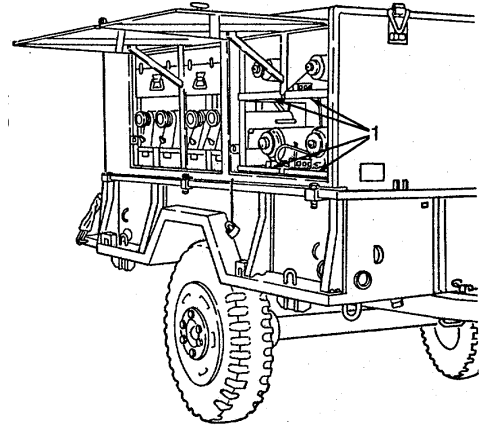

**2-8. ASSEMBLY AND PREPARATION FOR USE - continued.**

f. Sewing Machine Table Assemblies, Folding Stands and Stowage Boxes - continued.

(6) Slide stowage boxes (1) out of cabinet.

g. Unloading Generator Set Proceed as follows to unload the generator.

(1) Unstrap and remove folding chairs (1) from cabinet assembly.

(2) Unstrap and remove heat sealer (2) from cabinet assembly.

(3) Remove two locking pins (3) that secure the generator set holddown bracket (4).

(4) Remove holddown bracket (4).

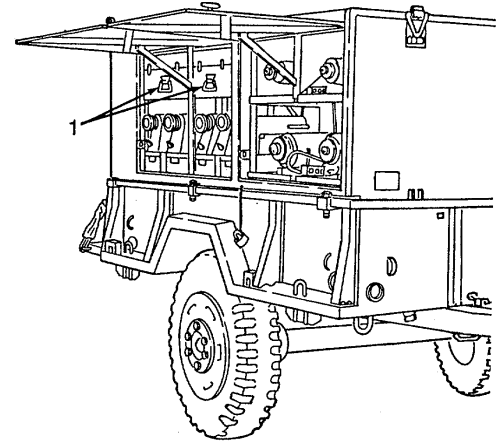

**WARNING**

The generator set weighs approximately 285 lbs. To avoid injury to personnel, four persons are required to remove the generator.

(5) Carefully slide generator set (5) rearward and lift it from the slide tracks and out of the cabinet.

(6) Reinstall bracket (4) and two locking pins (3).

**WARNING**

Do not operate the generator in an enclosed area unless the exhaust gases are piped to the outside. Inhalation of fumes will result in serious illness or death.

**WARNING**

Serious burns will result from touching a hot exhaust pipe.

(7) Place the generator set in a convenient location to furnish the power for the lights and for operating the machines. If it is to be used indoors, install a gas-tight exhaust line to pipe the exhaust gases outdoors. Provide metal shields for the exhaust line if it passes through flammable walls.

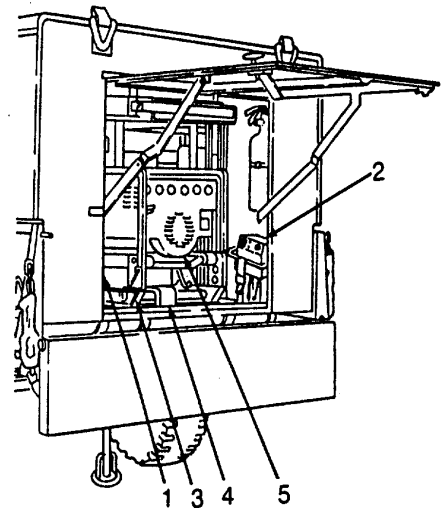

**2-8. ASSEMBLY AND PREPARATION FOR USE - continued.**

h. Assembly of Clothing Sewing Machine Table.

- (1) Remove strap from folding stand (2).
- (2) Loosen wingnuts (1) at each corner of folding stand (2).
- (3) Remove two wingnuts (3), two lockwashers (4), two flatwashers (5), two bolts (6) and cross brace (7).
- (4) Raise the ends of stand (2) to the vertical position.
- (5) Press down on the ends of stand until the bottom comes in contact with top of foot section (8).
- (6) Install cross brace (7) on rear of stand and secure with two bolts (6), two flatwashers (5), two lockwashers (4) and two wingnuts (3).
- (7) Tighten wingnuts (1) securely.

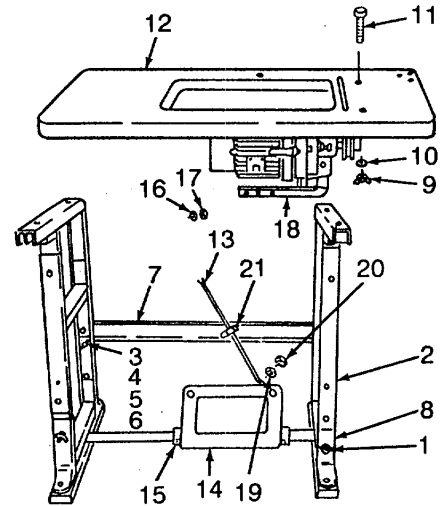

**CAUTION**

To avoid pinching electrical wiring use extreme care when placing the table top on the folding stand.

- (8) Remove four wingnuts (9) and four flatwashers (10) from four carriage bolts (11).
- (9) Install sewing table top (12) on stand (2).
- (10) Install four flatwashers (10), four wingnuts (9) on the four carriage bolts (11). Tighten wingnuts (9).
- (11) Install foot treadle linkage rod (13) from Box No. 3 to clutch arm (18) and secure with lockwasher (16) and nut (17).

**NOTE**

Clutch engagement speed is variable by the placement of the treadle rod end into the clutch arm. For slower clutch engagement, install the rod end in the outer clutch arm hole.

- (12) Remove foot treadle (14) from Box No. 3, attach bracket with two screws and square nuts.

**2-8. ASSEMBLY AND PREPARATION FOR USE - continued.**

h. Assembly of Clothing Sewing Machine Table - continued.

(13) Install foot treadle (14) on round bar of folding stand (2) using two clips (15).

(14) Connect other end of foot treadle rod (13) to foot treadle bracket (14) and secure with lockwasher (19) and nut (20).

**NOTE**

Foot treadle can be moved for the convenience of the operator.

(15) If necessary, adjust the treadle (14) to a comfortable height by loosening the lockscrews (21), telescoping the rods (13) out or in, and retightening lockscrews (21).

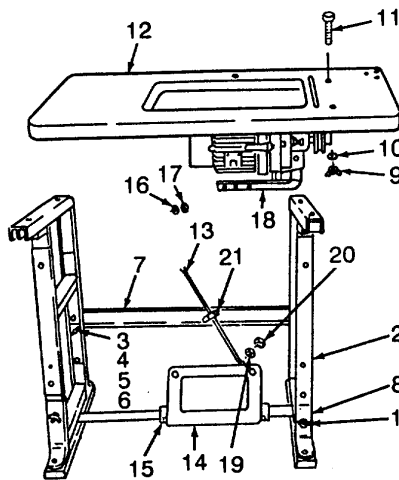

**2-8. ASSEMBLY AND PREPARATION FOR USE - continued.**

h. Assembly of Clothing Sewing Machine Table - continued.

- (16) Unfasten strap and lift sewing machine head (2) out of the tray.
- (17) Install hinge pins (1) from box No. 3 into sewing machine head (2). Install sewing machine (2) to table (3) by meshing the hinge pins (1) with the hinge plates on the table (3).
- (18) Remove light assembly (4) from box No. 2 and secure to table top (3). Be sure the felt on the clamp is on the table top (3) and the thumbscrew is on the bottom.
- (19) Install the pulley belt (5) to the motor pulley.
- (20) Install head pin (26) into table top (3).
- (21) Install the other end of the pulley belt to the machine pulley by tilting the head back, installing the belt (5) and then returning the sewing machine head (2) to the upright position.

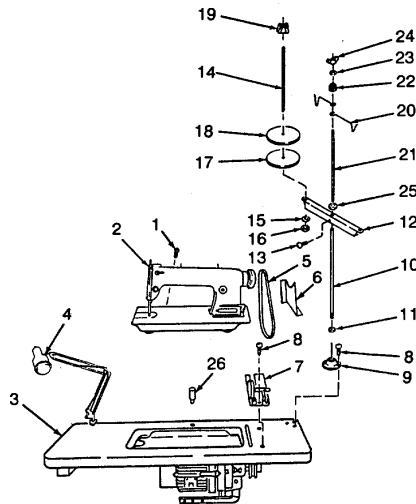

**2-8. ASSEMBLY AND PREPARATION FOR USE - continued.**

h. Assembly of Clothing Sewing Machine Table - continued.

- (22) Adjust the belt so that it is not stretched but yet not so loose that the machine does not operate. Refer to paragraph 3-10 for belt adjustment procedures.

**NOTE**

The belt guard is placed below the bobbin winder and is held on by one machine screw.

- (23) Install belt guard (6), bobbin winder (7) to table (3) and secure with two machine screws (8). Adjust for 1/8 inch (3 mm) clearance between bobbin winder pulley and belt (5).
- (24) Install thread unwinder base (9) to table (3) and secure with three machine screws (8).
- (25) Install rod (10) and nut (11) to thread underwinder base (9).
- (26) Install cone rest (12) on rod (10). Secure cone rest (12) by tightening setscrew (13).
- (27) Install two posts (14), two lockwashers (15) and two nuts (16) to cone rest (12).
- (28) Install two pads (17), two felts (18) and two thread clips (19) to posts (14).
- (29) Install thread guides (20) to top post (21) and secure with clip (22), washer (23) and wingnut (24).
- (30) Install top post (21) to rod (10) and secure by tightening nut (25).

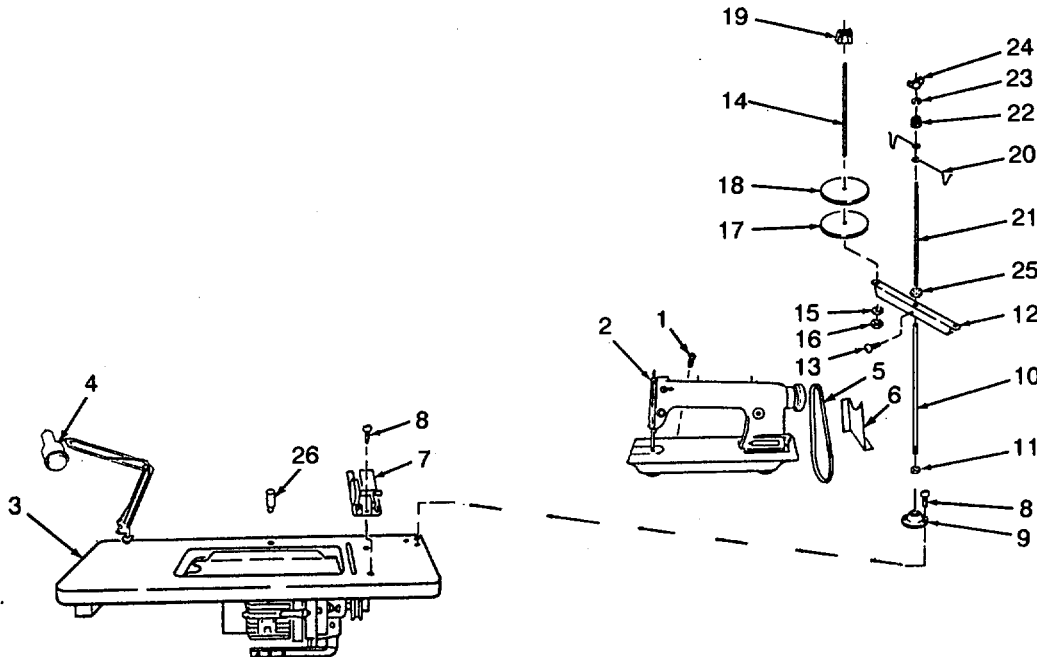

**2-8. ASSEMBLY AND PREPARATION FOR USE - continued.**

i. Assembly of Darning Sewing Machine

- (1) Assemble the stand in accordance with paragraph 2-8h steps (1) through (15).
- (2) Install foot pedal (1) and two clips (2) on round bar (3).
- (3) Remove darning machine base (4) from box No. 1 and install on table top (5) with four bolts (6), four washers (7) and four nuts (8).
- (4) Unfasten strap and lift darning machine head (9) out of the tray and install on machine base (4) using three hinge screws (10).
- (5) Attach bed clamp (11), flatwasher (12) and thumbscrew (13) to machine head (9).
- (6) Remove lifter chain (14) from box No. 4.

**NOTE**

"S" hook on lifter chain will need to be removed for assembly.

- (7) Install lifter chain (14) to machine head lever and feed chain through hole in machine head (9) and table top (5) and attach to foot pedal (1).

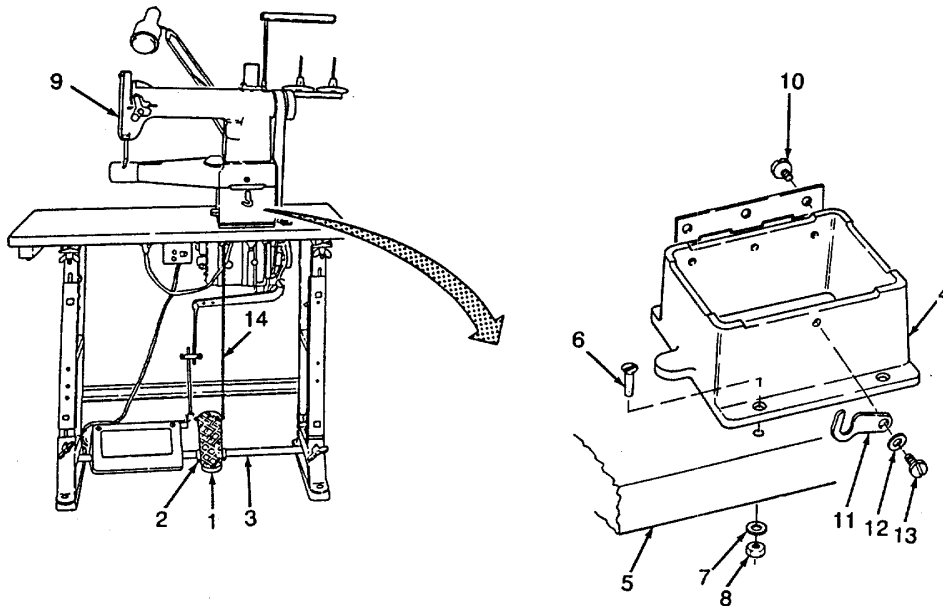

**2-8. ASSEMBLY AND PREPARATION FOR USE - continued.**

i. Assembly of Darning Sewing Machine - continued.

(8) Remove light assembly (1) from box No. 2 and secure to table top (3). Be sure the felt on the clamp is on the table top and the thumbscrew is on the bottom.

(9) Install bobbin winder (2) to table (3) and secure with two machine screws (4).

(10) Install thread unwinder base (5) to table (3) and secure with three machine screws (4).

(11) Install bottom post (6) to unwinder base (5). Secure by tightening two setscrews (7).

(12) Install two posts (8), two lockwashers (9), two nuts (10) two pads (11), and two cushions (12) to cone rest (13).

(13) Install cone rest (13) on bottom post (6). Secure cone rest (13) with screw (14), lockwasher (15) and nuts (16).

(14) Install top post (17) to bottom post (6) and secure by tightening two screws (14), two lockwashers (15) and nuts (16).

(15) Install thread guide (18) to top post (17). and secure with screw (14), lockwasher (15) and nut (16).

(16) Install two thread clips (19) on posts (8).

(17) Install rubber cap (20) on top post (17).

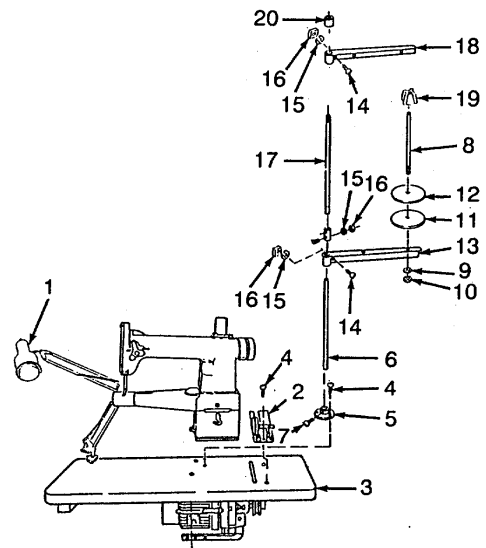

**2-8. ASSEMBLY AND PREPARATION FOR USE - continued.**

i. Assembly of Darning Sewing Machine continued.

- (18) Remove pulley (1) by removing shaft screw (2) and loosening flat setscrew (3) and pointed setscrew (4).
- (19) Remove screw (5) under pulley.
- (20) Install belt guard (6), secure with three screws (7).
- (21) Install screw (5).

**NOTE**

Pointed setscrew must be placed in groove of shaft.

- (22) Slide pulley (1) in place and ensure setscrews (3) and (4) are lined up with the flats of the shaft.
- (23) Lightly tighten setscrews. Pull pulley (1) to the right as far as it will go ensuring setscrews are still on flats of shaft.
- (24) Install shaft screw (2).
- (25) Tighten setscrews (3) and (4).
- (26) Install the pulley belt (10) through the top of the belt guard and attach to the motor pulley.
- (27) Install the other end of the pulley belt (10) to the machine pulley by tilting the machine head back, installing the belt and then returning the machine head to the upright position. Lock head in place by tightening thumbscrew.
- (28) Adjust the belt so that it is not stretched but yet not so loose that the machine does not operate. Refer to paragraph 3-10 for belt adjustment procedure.
- (29) Place belt guard top (8) in place securing with two screws (9).
- (30) Adjust belt guard (8) as needed to prevent rubbing on pulley (1).
- (31) Adjust for 1/8 inch (3 mm) clearance between bobbin winder pulley and belt (10).

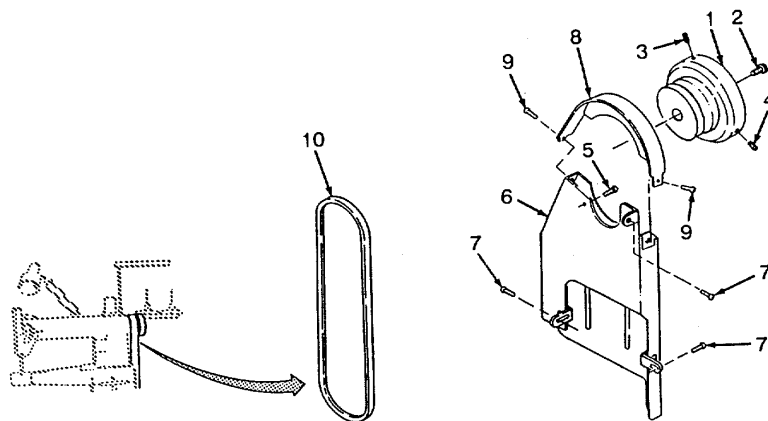

**2-8. ASSEMBLY AND PREPARATION FOR USE - continued.**

j. Assembly of Button Machine Table.

- (1) Assemble the stand in accordance with paragraph 2-8h, steps (1) through (10).

**CAUTION**

To avoid pinching electrical wiring use extreme care when placing the table top on the folding stand.

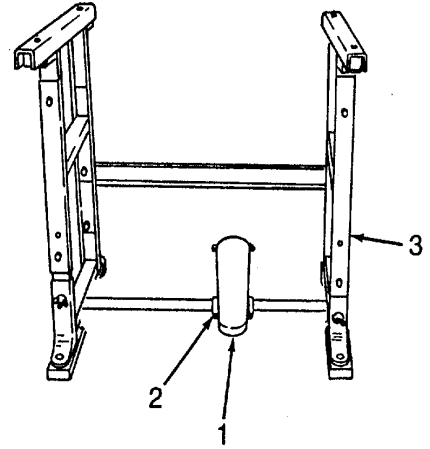

- (2) Remove foot pedal (1), and two clips (2) from Box No. 3 and install on round bar of foldingstand (3).
- (3) Remove button base (4) out of Box No. 1 and install on table top (5) with four machine screws (6)
- (4) Remove chain (7) for Box No. 4 and install on hook lever inside button base (4). (5). Connect chain (7) from the machine to foot pedal (1). Adjust chain (7) so that foot pedal (1) is full up without moving the lever in the button base (4).
- (6) Unfasten strap and lift button machine head (8) out of the tray and loosen the lock thumbscrew (9) and carefully tilt machine head (8) into base (4).
- (7) Remove light assembly (10) from box No. 2 and secure to table top (5). Be sure the felt on the clamp is on the table top and the thumbscrew is on the bottom.
- (8) Install the pulley belt (11) on the motor pulley.

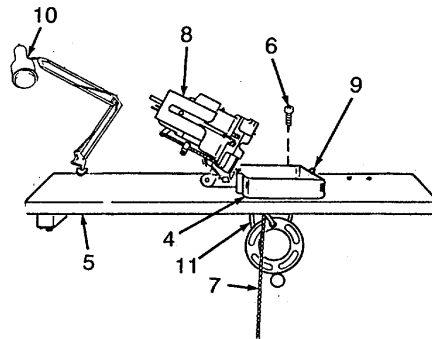

**2-8. ASSEMBLY AND PREPARATION FOR USE - continued.**

j. Assembly of Button Machine Table - continued.

**NOTE**

Pulley belt (11) may be already attached to the machine head (8).

- (9) Install the other end of the pulley belt (11) to the machine pulley by tilting the head back and installing the pulley belt (11). To attach the belt (11) to the machine head (8), loosen the two screws (21) on the slide starting bracket plate (22). Rotate the slide plate up in order to slide the belt (11) on. Rotate the slide plate (22) to the original position so it just contacts the ball on the clutch, enough to keep the large ball from falling out and the drive pulley (23) should be 1/16" away from the clutch wheel. Return the machine head (8) to the upright position.

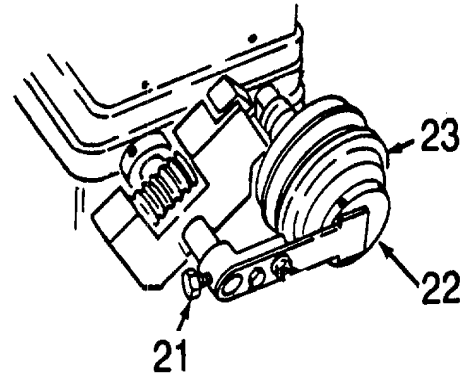

- (10) Secure machine head (8) using lock thumbscrew (9).
- (11) Adjust the belt (11) so that it is not stretched but yet not so loose that the machine does not operate. Refer to paragraph 3-10 for belt adjustment procedure.
- (12) Install thread unwinder base (12) to table (5) and secure with two machine screws (6).
- (13) Install post (13), to base (12) and secure with setscrew (14).
- (14) Install center pin (15) into base (12) by lightly tapping with rubber mallet.

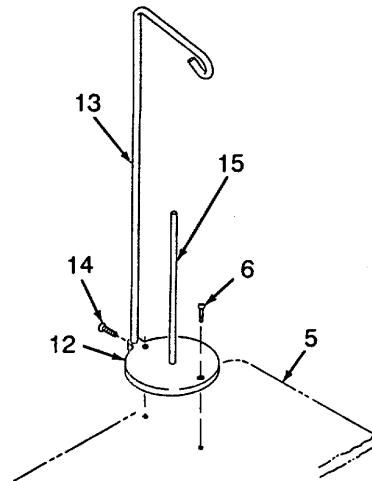

**2-8. ASSEMBLY AND PREPARATION FOR USE - continued.**

- (15) Install belt guard pin (16) to table top (5) using two machine screws (6).
- (16) Slide belt guard (17) onto belt guard pin (16) and secure with cotter pin (18).
- (17) Install three pins (19) into the button tray (20) and place on the table (5) or place in button machine base (4).

k. Grommet Press.

- (1) Remove the grommet press (1) from the stowage box no. 1.
- (2) Remove four nuts (2), four flatwashers (3), four bolts (4) and four flatwashers (5) from the folding table assembly (6).
- (3) Install grommet press (1) over mounting holes.
- (4) Secure with four flatwashers (5), four bolts (4), four flatwashers (3) and four nuts (2)

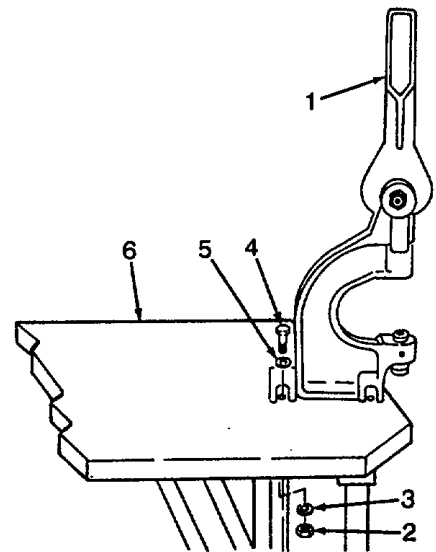
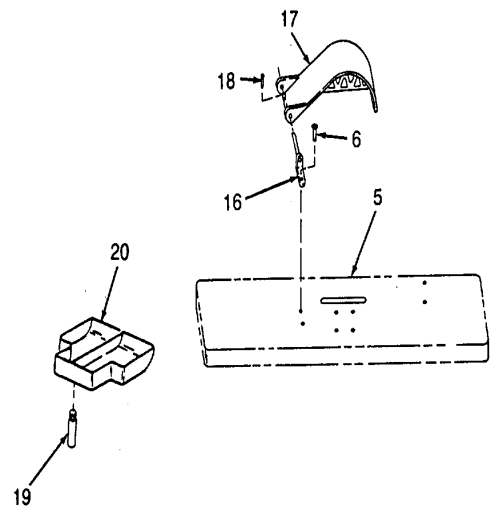

**2-8. ASSEMBLY AND PREPARATION FOR USE - continued.**

**I. Tack-Button Attaching Machine.**

- (1) Remove the tack-button attaching machine (1) from the stowage box no. 1.
- (2) Remove four nuts (2), four flatwashers (3), four bolts (4) and four flatwashers (5) from the folding table assembly (6).
- (3) Install tack-button attaching machine (1) over mounting holes.
- (4) Secure with four flatwashers (5), four bolts (4), four flatwashers (3) and four nuts (2)

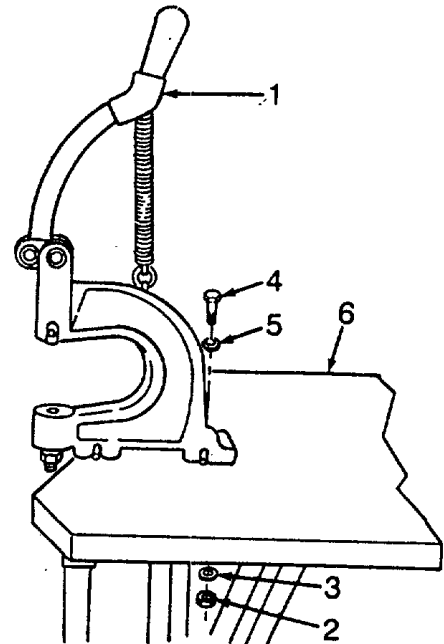

**m. Heat Sealer.**

- (1) Remove the heat sealer (1) from the rear of the unit.
- (2) Remove two nuts (2), two flatwashers (3), two bolts (4), and two flatwashers (5) from the folding table assembly (6).
- (3) Install heat sealer (1) over mounting holes.
- (4) Secure with two flatwashers (5), two bolts (4), two flatwashers (3) and two nut (2).

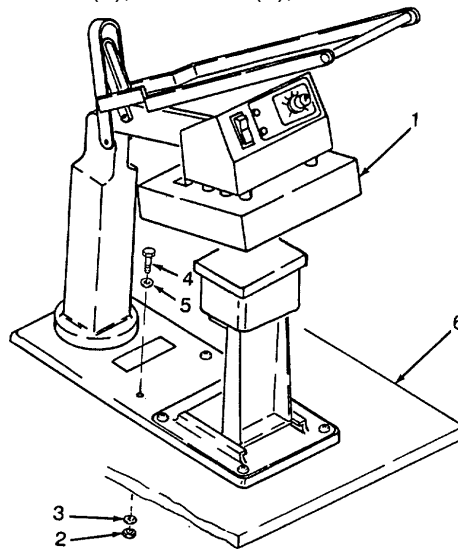

**2-8. ASSEMBLY AND PREPARATION FOR USE - continued.**n. Power Cables and Light Cords.**WARNING**

Refer to TM 5-6115-271-14 on the generator set for grounding techniques for that particular set. Failure to ground generator set properly could cause severe injury or death to operating personnel. Be sure the generator set is off before making the connections below.

- (1) Ground generator for proper operation per TM 5-6115-271-14.
- (2) Remove grounding wire that comes with the generator.
- (3) Install grounding wire from stowage box #2.
- (4) Remove power cable and three distribution boxes from stowage boxes, Nos. 1, 3, and 4.
- (5) Connect the white wire to L0, the blue wire to L1, the black wire to L2, and the red wire to L3 terminals on the generator set. Connect the green wire to the ground leg.

**2-8. ASSEMBLY AND PREPARATION FOR USE - continued.**

n. Power Cables and Light Cords - continued.

(6) Connect the sewing machines to the outlets marked M or M/L on the distribution boxes.

(7) Connect the lights to the outlets marked L or M/L on the distribution boxes.

(8) If the heat sealer or iron is to be used, disconnect one of the sewing machines and plug into that location.

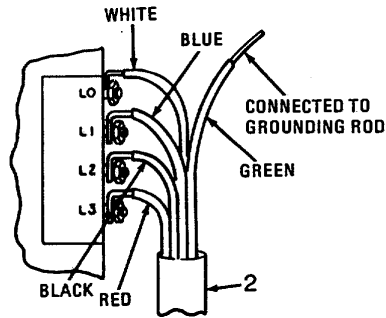

**LEGEND:**

1. GENERATOR SET
2. POWER CABLE
3. CLOTHING MACHINE
4. LIGHT CORDS
5. BUTTON MACHINE
6. DARNING MACHINE
7. DISTRIBUTION CABLE (-1)
8. DISTRIBUTION CABLE (-2)
9. DISTRIBUTION CABLE (-3)

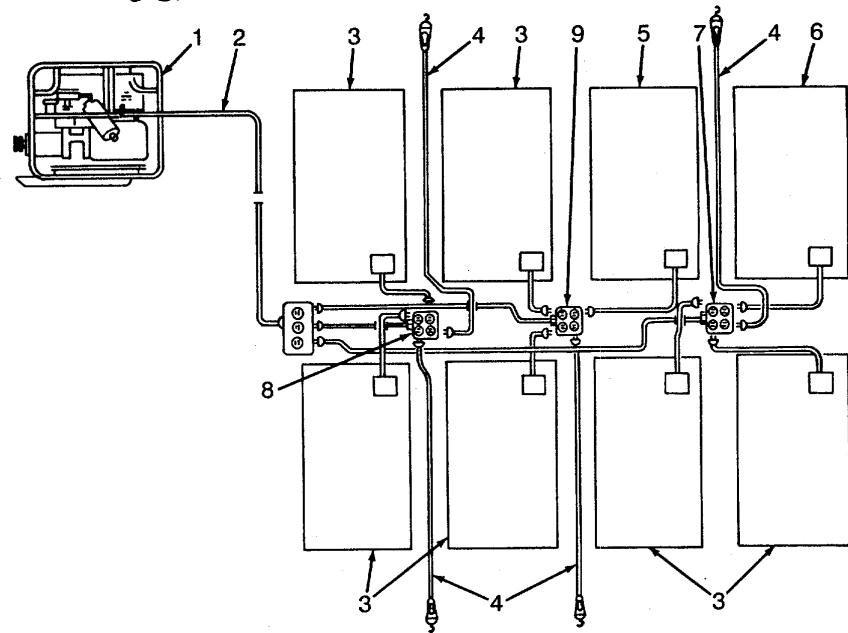

**2-8. ASSEMBLY AND PREPARATION FOR USE - continued.**o. Fire Extinguisher.

Open the fire extinguisher bracket and remove the 5-pound carbon dioxide (CO<sub>2</sub>) fire extinguisher from the cabinet. Place fire extinguisher in a convenient location near the work area.

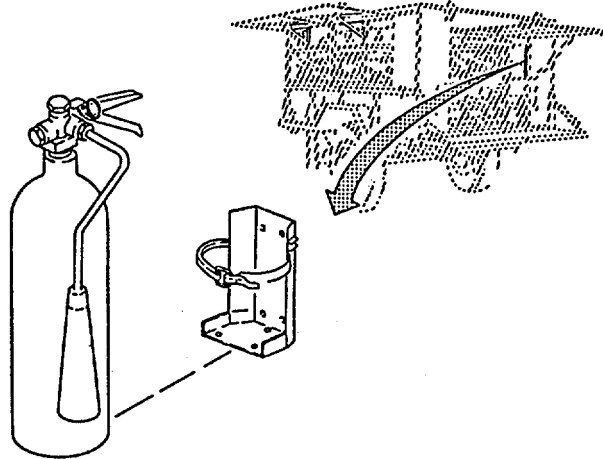
**2-9. OPERATING INSTRUCTIONS FOR CLOTHING REPAIR SHOP.**

The following paragraphs are presented to provide guidance and assist you in getting the best performance from the equipment. You, the operator, must know how to perform every operation of which the equipment is capable. Before operating the equipment, read the operating procedures that apply to the equipment you are to operate. This will give you an overall feel for what is to be done.

**2-10. OPERATING PROCEDURES FOR FIRE EXTINGUISHER.**

Operation. Operate the fire extinguisher by following the procedures in the order in which they are listed below.

1. Carry the fire extinguisher by the handle to the fire.
2. Pull out the safety pin, breaking the wire seal, and swing the horn toward the base of the fire.

**WARNING**

Do not let eyes, hands, or body come directly in contact with the fog, as frostbite or freezing may result.

3. Depress the operating lever to open the valve, and direct the discharge or fog toward the base of the fire.

**2-11. OPERATING PROCEDURES FOR CLOTHING SEWING MACHINE.**a. Selecting Needle.**CAUTION**

Always perform the "BEFORE" preventive maintenance checks and services (PMCS, Section II) before you use the equipment. Also perform the lubrication instructions, contained in paragraphs 3-2, and 3-3 before operating equipment. Damage to equipment could result if these maintenance services are not done.

- (1) The Model CN3115R sewing machine is set up to use standard type 16 x 87 needles in sizes ranging from 11 to 22. Select the needle of the correct size, class and variety from the Component of End Item (COEI) List of Appendix C of this manual.
- (2) The thickness of the sewing thread, which must pass through the eye of the needle, determines the size of the needle.

**NOTE**

Uneven, knotted or rough thread impairs the satisfactory sewing performance of your machine.



*LEFT TWIST THREAD*

- (3) Use left twist thread only in the needle. To test for twist hold a length of thread between thumbs and index fingers of your hands. Turn thread counterclockwise, if it will twist tighter, it has a left twist. If it unravels it has a right twist. The bobbin can be wound with either left or right twist thread.

**2-11. OPERATING PROCEDURES FOR CLOTHING SEWING MACHINE - continued.**

a. Selecting Needle - continued.

(4) Needle selection is based on the following:

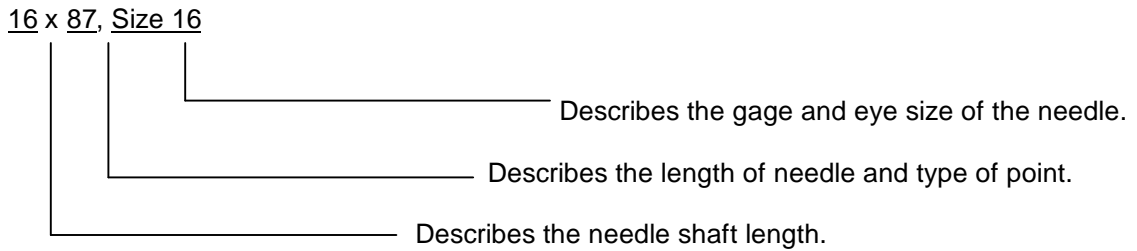

**WARNING**

Be sure that power is turned off.

b. Installing the Needle.

**NOTE**

Never use a bent needle or one with the point blunted or turned.

(1) Select a good needle of the proper size as explained in paragraph 2-11a. Set the needle with the long groove to the left.

**CAUTION**

Always rotate the machine hand pulley wheel towards you. Timing the hand wheel away from you will break or bend needles or damage bobbin case or oscillating shuttle.

- (2) To set needle (3), turn the hand wheel toward you until needle bar (1) moves up to its highest point.
- (3) Loosen needle clamp screw (2), put the shank of needle (3) up into the clamp as far as it will go, and turn the long groove of needle (3) so that it faces to the left and is directly in line with the arm of the machine.
- (4) Tighten needle clamp screw (2). If screw (2) is too loose, needle (3) will turn or slip.

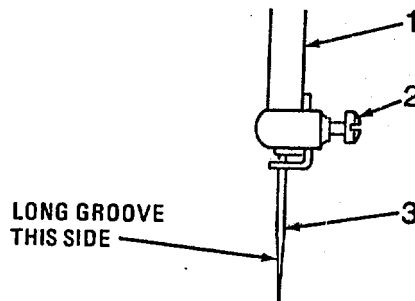

**2-11. OPERATING PROCEDURES FOR CLOTHING SEWING MACHINE - continued .**

c. Threading Needle. To thread the machine perform the following steps:

- (1) Pass the thread from right to left through the holes of the thread retainer (1).
- (2) Continue to pass the thread down between the tension disks (2), with the thread running from right to left up and over the tension controller spring (3).
- (3) Continue to pass the thread from right to left under hook (4).
- (4) Continue to pass the thread through the thread guide (5).
- (5) Continue to pass the thread up and from right to left through the hole in the end of the thread take up lever (6).
- (6) Continue to pass the thread down through the thread guide (7). (7) Continue to pass the thread down through the bottom thread eyelet (8) below faceplate.
- (8) Continue to pass the thread down through the thread guide on the needle bar thread guard (9)
- (9) Continue to pass the thread from left to right through the eye of the needle. Leave about four inches of thread through the eye of the needle.

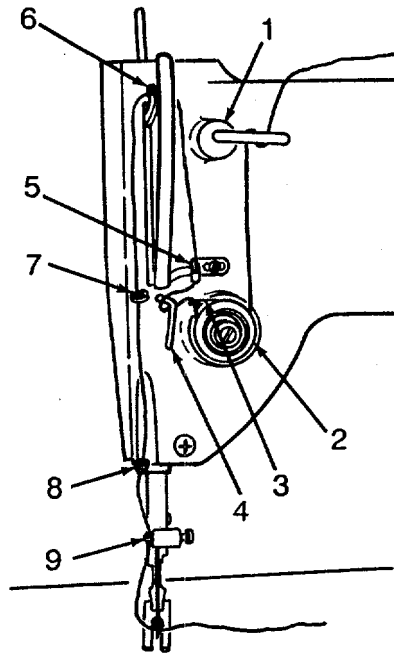

**2-11. OPERATING PROCEDURES FOR CLOTHING SEWING MACHINE - continued.**d. Removing Bobbin Case and Bobbin**CAUTION**

Always rotate the machine hand wheel towards you. Turning the hand wheel away from you will break or bend needles or damage bobbin case or oscillating shuttle.

- (1) Depress foot treadle and turn the hand wheel toward you until the needle bar moves up to its highest point.
- (2) Open side plate (1) from the machine bed (2).
- (3) Reach under the machine. Open latch (3) on bobbin case (4) and holding bobbin case (4) by latch (3), lift it to the left and out of shuttle race (5).
- (4) As long as latch (3) is held open, a sliding lug inside bobbin case (4) holds bobbin (6) inside the case. When the bobbin case is turned open-side down and the latch is released, the bobbin will drop out. Do not try to force bobbin (6) out of case (4) while latch (3) is open.

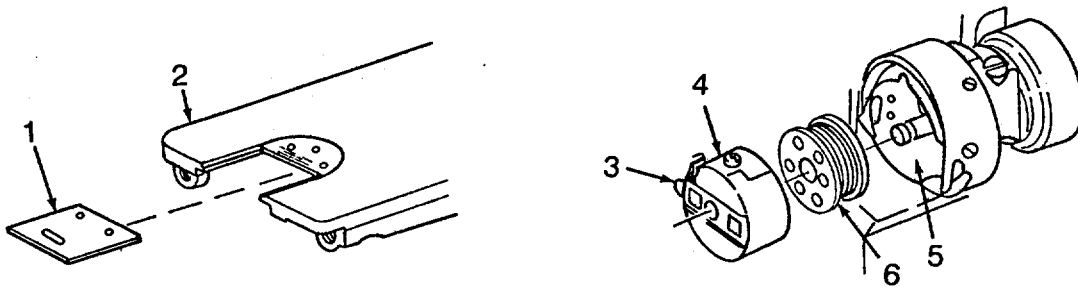

2-11. OPERATING PROCEDURES FOR CLOTHING SEWING MACHINE - continued.

e. Winding Bobbin.

- (1) Place an empty bobbin (1) on the bobbin winder spindle (2) and push it on as far as it will go.
- (2) Pass the thread (3) from the thread stand bobbin spool, up through thread stand hook, down through the hole in the tension bracket (4) and down between the bobbin winder tension disks (5).
- (3) Pass the thread from the lower side of the tension disks (5) to bobbin (1).
- (4) Pass the thread around the bottom side of the bobbin and wind it around the bobbin a few times.
- (5) Push thumb lever (6) until it latches and holds the winder pulley (7) against the drive belt (8).

**NOTE**

The bobbin may be wound while the machine is in operation. However, if no material is under the needle, pull the thread from the needle to prevent it from catching the bobbin thread and balling up under the throat plate, and also raise the presser foot to prevent undue wear on the feed dog.

- (6) Press the ON button to start the motor and depress the foot treadle to wind the bobbin until the bobbin is fully wound. If properly adjusted by the stop latch adjusting screw (10), the automatic stop latch (9) will operate and throw the bobbin winder pulley (7) away from the machine belt when thread is 1/16 inch below the spool lip.

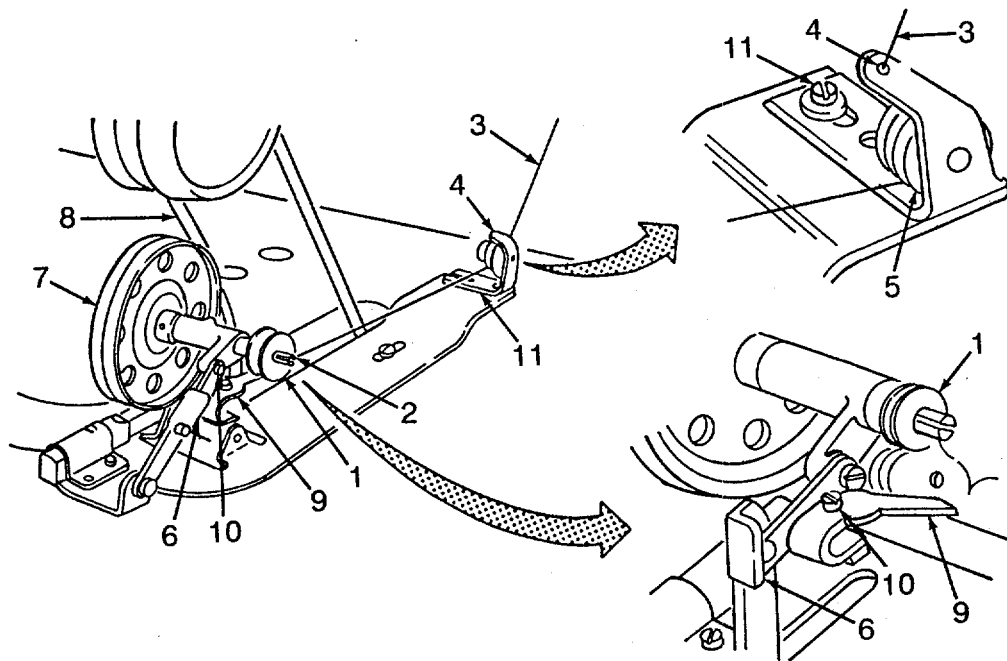

**2-11. OPERATING PROCEDURES FOR CLOTHING SEWING MACHINE - continued.**e. Winding Bobbin - continued

- (7) Regulate the amount of thread wound on the bobbin (1/16 inch) below spool lip by adjusting the bobbin winder stop latch screw (10). To wind more thread on the bobbin, turn the screw clockwise. To wind less thread on the bobbin, turn the screw counterclockwise.
- (8) If the thread fails to wind evenly on the bobbin or piles up on one side of the bobbin, loosen the screw (11) which holds tension bracket (4) to the base and move the tension bracket to the right or the left, as required, then tighten the screws evenly.

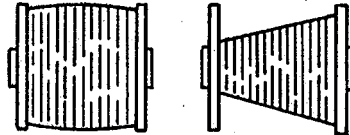

- (9) When bobbin is properly filled, release foot treadle and push the OFF button.
- (10) Cut thread and remove thread from the bobbin winder.

**2-11. OPERATING PROCEDURES FOR CLOTHING SEWING MACHINE - continued.**f. Installing the Bobbin Case and Bobbin**CAUTION**

Always rotate the hand wheel towards you. Turning the hand wheel away from you will break or bend needles or damage bobbin case or oscillating shuttle.

- (1) Depress foot treadle and turn the machine hand wheel toward you until the needle travels to its highest point.
- (2) Open slide plate (1) from machine bed (2).
- (3) Hold the threaded bobbin case (3) with latch (4) out so the bobbin will not drop out of the case.
- (4) Place the bobbin case on the center stud (5) of the rotary sewing hook so that the position finger (7) on the bobbin case is opposite notch (8) at the top of oscillating shuttle (6).
- (5) Press bobbin case (3) onto the stud (5) until the latch snaps into the groove near the end of the stud (5). Be sure position finger (7) on bobbin case (3) is in the notch (8) at top of oscillating shuttle (6). About 3 inches of thread should be left hanging down from the bobbin case.
- (6) Close slide plate (1).

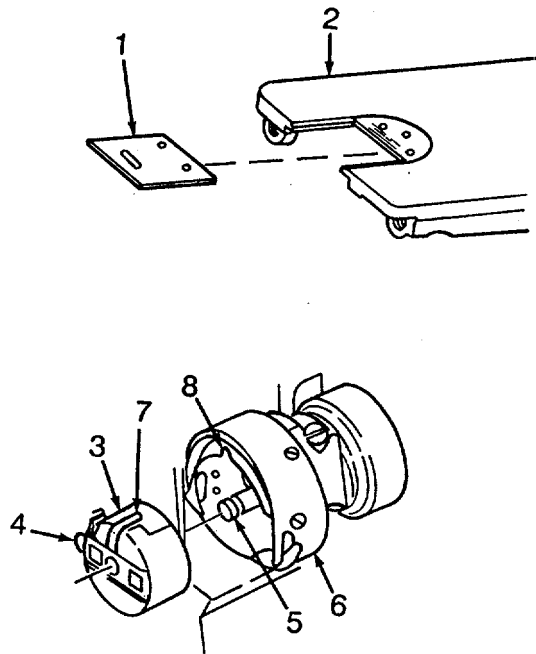

**2-11. OPERATING PROCEDURES FOR CLOTHING SEWING MACHINE - continued.**g. Catching the Bobbin Thread

- (1) Raise the presser bar hand lifter (1) to lock the presser foot (2) in its raised position.
- (2) Hold the end of the needle thread (3) with a little slack. Turn the hand wheel toward you until the needle moves from its highest position down and back up to its highest position. If the needle thread (3) is correctly timed, it will catch the bobbin thread (4).
- (3) Draw up the needle thread (3), and the bobbin thread (4) will come up with it through the hole in the throat plate.
- (4) Pull the end of the bobbin thread (4) entirely through the hole. Lay both threads back under the presser foot (2).

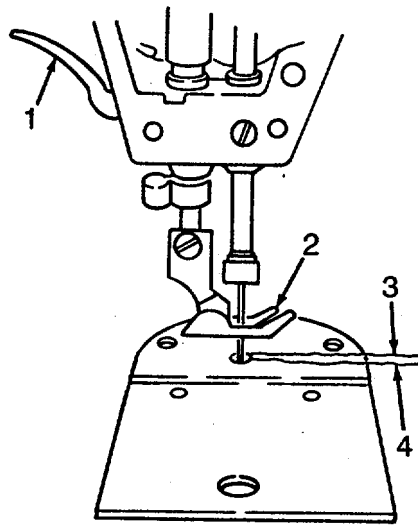

**2-11. OPERATING PROCEDURES FOR CLOTHING SEWING MACHINE - continued.**h. Adjusting Stitch Length.

- (1) The stitch length is regulated by turning dial (1) at the front of the machine. When number "0" on the dial appears uppermost, the machine does not feed. Turning the dial to the left will gradually increase the stitch length to its maximum ( 1 to 5 ), when "5" is at the top. As the stitch length is increased, it can be noticed that the tacking lever (2) slowly moves in an upward direction.
- (2) When shortening the stitch length, it will be an advantage to depress lever (2) slightly as dial (1) is being turned to the right. To do tacking for the purpose of locking the ends of seams, rapidly depress and release lever (2) as the needle approaches the edge of the material.

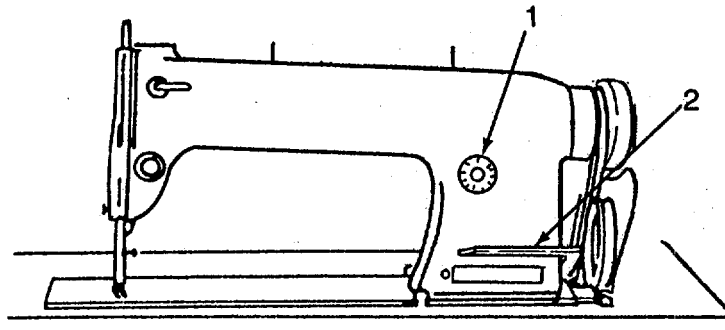

- i. Operating the Clothing Sewing Machine. After the machine has been prepared for operation, operate as follows using excess cloth. Make all thread and presser foot adjustments before starting repairs.

**CAUTION**

Always rotate the machine hand wheel towards you. Turning the hand wheel away from you will break or bend needles or damage bobbin case or oscillating shuttle.

**NOTE**

Before making clothing repairs, make sure of the adjustments by using a piece of scrap cloth.

**2-11. OPERATING PROCEDURES FOR CLOTHING SEWING MACHINE - continued.**i. Operating the Clothing Sewing Machine - continued.

(1) To insert material into the machine perform the following:

- (a) Lift the presser bar hand lifter (1) to raise the presser foot (2) which should now have about 3 inches of bobbin thread (3) and needle thread (4) under and behind it.

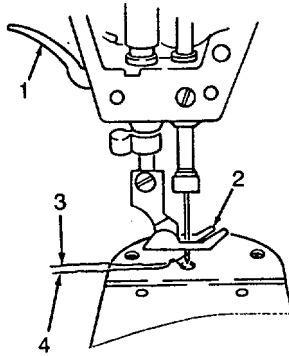

- (b) Place the edge of the material under the presser foot (2) and the needle thread (4), at the same time hand-turn the pulley wheel toward you until the needle is in the material at the desired starting point.
- (c) Place the end of the needle thread (3) toward the rear of the presser foot (2), and then lower the presser foot on the needle and thread.

(2) Set motor switch to the ON position.

(3) To sew material perform the following:

**CAUTION**

While you are sewing hold the work flat, but do not push or pull on the material. Let the feed dog carry the work evenly under the presser foot and needle. If the operator pulls on the fabric, the needle bends, strikes the throat plate, and is either dulled or, more likely, broken. When the needle is about to cross a seam or other unusually thick or uneven place in the work, disengage the clutch, and hand-turn the machine over the rough place; otherwise, the needle may be broken or thrown out of time.

- (a) Hand-turn the machine hand wheel toward you and simultaneously hold the needle and bobbin threads until a few stitches are made. Press the foot treadle slowly to engage the clutch with motor. Let the feed dog carry the material evenly under the presser foot and needle.
- (b) If the material is unusually thick, as a comforter for example, decrease the tension on the presser foot by turning the tension assembly thumbscrew counterclockwise.

**2-11. OPERATING PROCEDURES FOR CLOTHING SEWING MACHINE - continued.**

i. Operating the Clothing Sewing Machine - continued.

(4) To remove material from the machine proceed as follows:

- (a) Release the foot treadle to stop the machine.
- (b) Hand-turn the pulley wheel toward you until the needle bar is at its highest point and raise the presser foot.
- (c) Draw the material straight behind the presser foot, and break or cut the needle and bobbin threads so that about four inches will remain under and behind the presser foot.

j. Adjusting Tension on Bobbin and Needle Threads.

- (1) Proper tension locks the bobbin and needle threads in the center of the material. If needle thread tension is too tight, or if bobbin tension is too loose, the needle thread will pull to the upper surface of the material. If bobbin thread tension is too tight, or if needle thread is too loose, the bobbin thread will pull to the underside of the material. If both threads are too tight, the material will be puckered and drawn together by the stitches and the threads will break. Adjust the tensions as follows:
- (2) Remove the bobbin case (paragraph 2-1 lid). Adjust the bobbin thread tension with the adjusting screw (1) Turn screw (1) clockwise to increase the tension and counterclockwise to decrease tension.
- (3) Lower the presser foot onto the feed dog to close the tension disks. Adjust the needle thread tension with the tension thumb nut (2). Turn thumb nut (2) clockwise to increase tension and counterclockwise to decrease tension.

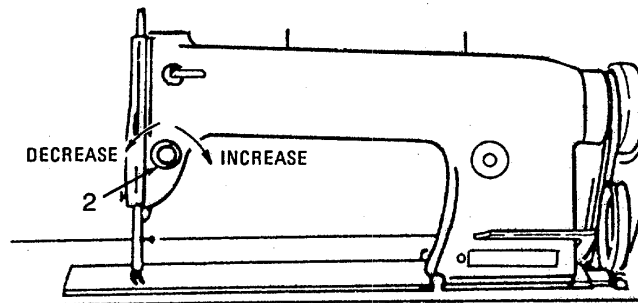
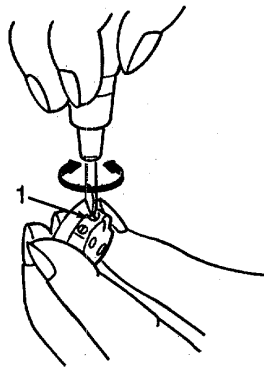

**2-11. OPERATING PROCEDURES FOR CLOTHING SEWING MACHINE - continued.**k. Adjusting Pressure on Foot Presser**NOTE**

Tension should be adjusted or regulated only when the presser foot is down.

- (1) For the needle to make a even stitch, the material must move forward at a uniform speed. The correct presser foot pressure on the material enables the feed dog to push the material forward each time the needle goes up. If the pressure is too light, the feed dog will not feed the material, the needle will hit in one place on the material, and the bobbin thread will knot or ball up. If the pressure is too great, the feed dog will wear unnecessarily and feed the bottom material (fabric or cloth) faster than the upper material.
- (2) Turn the pressure regulator thumbscrew (1) on top of the machine clockwise to increase the pressure or counterclockwise to decrease the pressure.

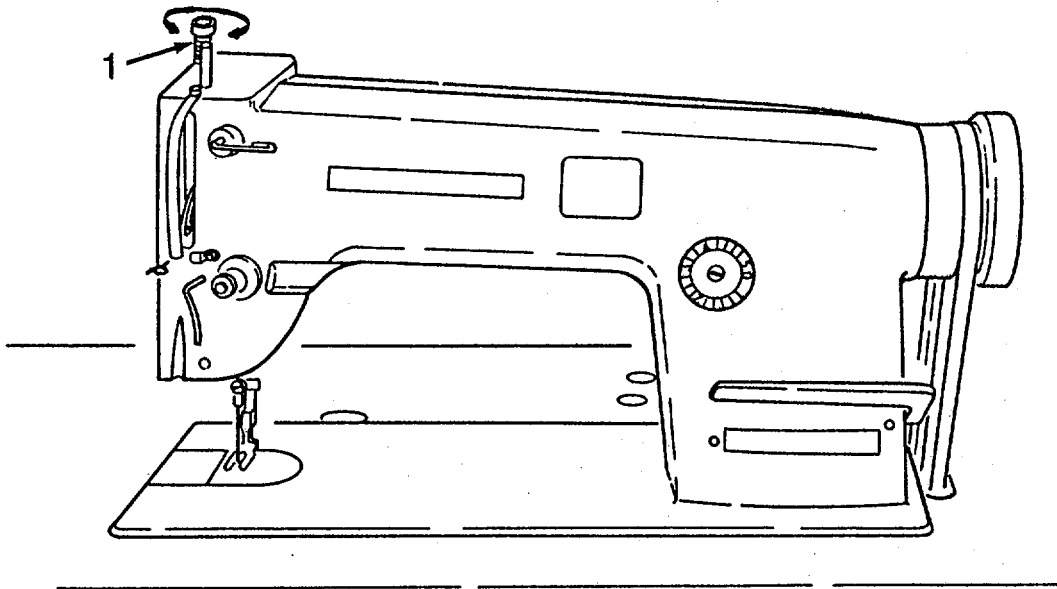

**2-12. OPERATING PROCEDURES FOR DARNING SEWING MACHINE .****CAUTION**

Always perform the "BEFORE" preventive maintenance checks and services (PMCS, Section II) before you use the equipment. Also perform the lubrication instructions contained in paragraph 3-2 and 3-5, before operating equipment. Damage to equipment could result if these maintenance services are not done.

a. Selecting Needle.

- (1) The Model 207 DARNING machine is set up to use standard type 126 x 3 needles in sizes ranging from 10 to 24. Select the needle of the correct size, class and variety from the Component of End Item (COEI) List of Appendix C of this manual.
- (2) The thickness of the sewing thread, which must pass through the eye of the needle, determines the size of the needle.

**NOTE**

Uneven, knotted or rough thread impairs the satisfactory sewing performance of your machine.



*LEFT TWIST THREAD*

- (3) Use left twist thread only in the needle. To test for twist hold a length of thread between thumbs and index fingers of your hands. Turn thread counterclockwise, if it will twist tighter, it has a left twist. If it unravels it has a right twist. The bobbin can be wound with either left or right twist thread.

2-12. OPERATING PROCEDURES FOR DARNING SEWING MACHINE - continued.

a. Selecting Needle - continued.

(4) Needle selection is based on the following:

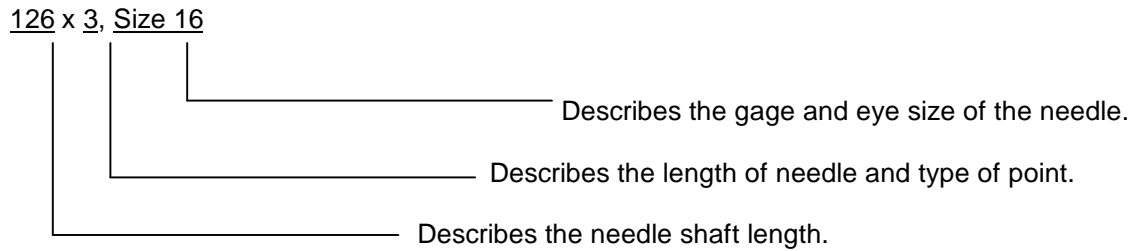

**WARNING**

Be sure that power is turned off.

b. Installing the Needle.

**NOTE**

Never use a bent needle or one with the point blunted or turned.

(1) Select a good needle of the proper size as explained in paragraph 2-12a. Set the needle with the long groove to the left.

**CAUTION**

Always rotate the machine hand wheel towards you. Turning the hand wheel away from you will break or bend needles or damage bobbin case or rotating sewing hook.

(2) To set needle (3), turn the hand wheel toward you until needle bar (1) moves up to its highest point.

(3) Loosen the needle set screw (2), about one turn, put the shank of needle (3) up into the clamp as far as it will go, and turn the long groove of needle (3) so that it faces to the left with the eye of the needle going from left to right.

(4) Tighten needle set screw (2). If screw (2) is too loose, the needle will turn or slip.

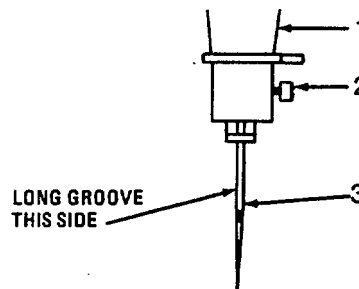

**2-12. OPERATING PROCEDURES FOR DARNING SEWING MACHINE - continued.**

c. Threading Needle. To thread the machine perform the following steps:

- (1) Lead the thread from right to left through the upper guide hole in pin (1).
- (2) From the thread stand lead the thread from back to front through the lower guide hole pin (1) on top of the machine arm.
- (3) Pass thread in weaving fashion through the three holes in thread guide (2).
- (4) Pass thread from right to left over and between the tension disc (3).
- (5) Pull thread downward and from right to left beneath and around thread controller (4), continue to pull thread upward against the pressure of the wire spring into fork in the thread controller (4).
- (6) Guide thread upward through thread guide (5) and from right to left through the eye at the tip of take-up lever (6).
- (7) Continue to pass thread down through thread guide (5) again and then through (7), (8) and (9), then from left to right through the eye of needle (10).

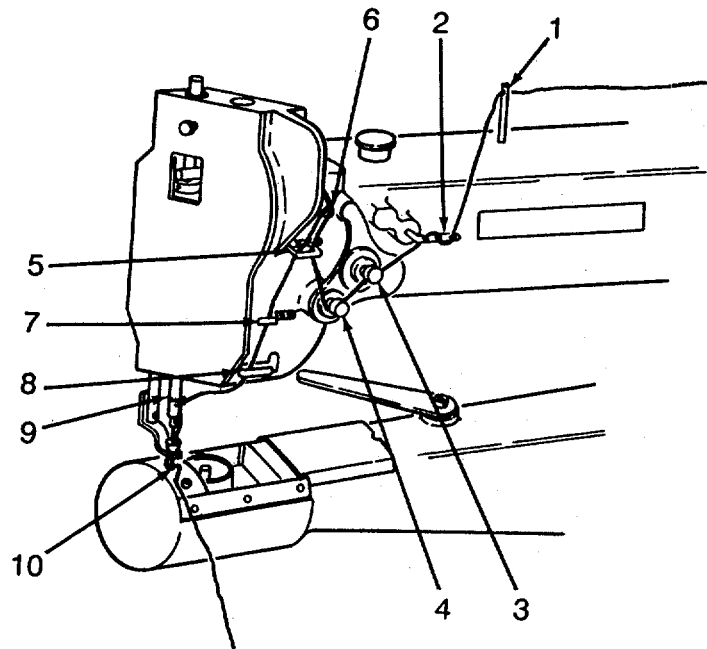

**2-12. OPERATING PROCEDURES FOR DARNING SEWING MACHINE - continued.**d. Removing Bobbin.**CAUTION**

Always rotate the machine hand wheel towards you. Turning the hand wheel away from you will break or bend needles or damage bobbin case or rotating sewing hook.

- (1) Turn the hand wheel toward you until the needle bar moves up to its highest point.
- (2) Insert the fingernail of the forefinger under latch (1), raise latch (1) and lift out bobbin (2).

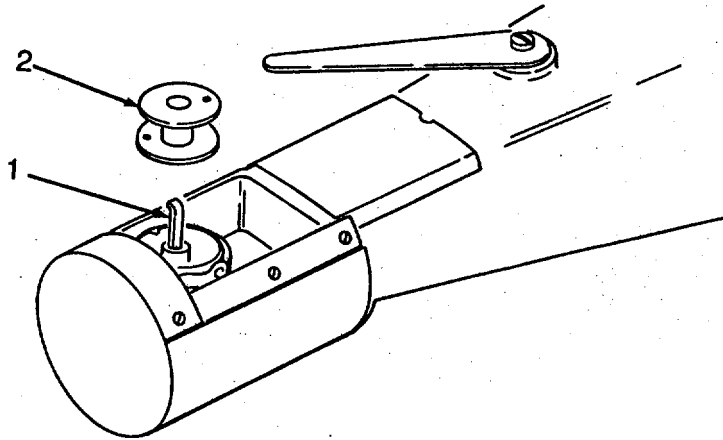

2-12. OPERATING PROCEDURES FOR DARNING SEWING MACHINE - continued.

e. Winding Bobbin.

- (1) Place an empty bobbin (1) on the bobbin winder spindle (2) and push it on as far as it will go.
- (2) Pass the thread (3) from the thread stand bobbin spool up through thread stand hook, down through the hole in the tension bracket (4) and down between the bobbin winder tension disks (5).
- (3) Pass the thread (3) from the lower side of the tension disks (5) to bobbin (1).
- (4) Pass the thread (3) around the bottom side of the bobbin (1) and wind it around the bobbin a few times.
- (5) Push thumb lever (6) until it latches and holds the winder pulley (7) against the drive belt (8).

**NOTE**

The bobbin may be wound while the machine is in operation. However, if no material is under the needle, pull the thread from the needle to prevent it from catching the bobbin thread and balling up under the throat plate, and also raise the presser foot to prevent undue wear on the feed dog.

- (6) Press the ON button to start the motor and depress the foot treadle to wind the bobbin (1) until the bobbin is fully wound. If properly adjusted by the stop latch adjusting screw (10), the automatic stop latch (9) will operate and throw the bobbin winder pulley (7) away from the machine belt when thread is 1/16 inch below the spool lip.

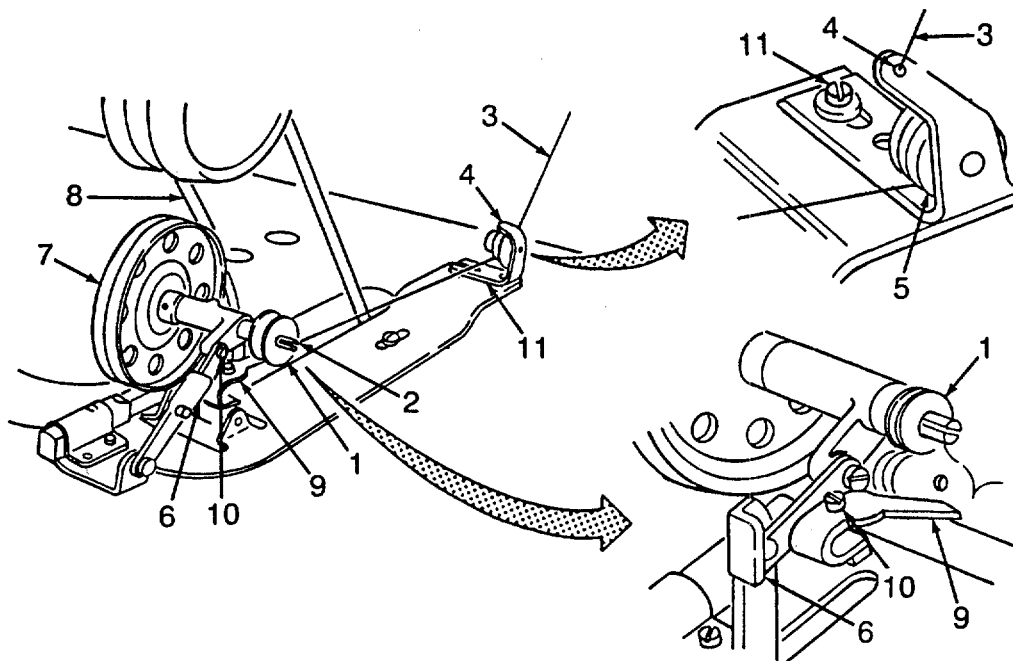

**2-12. OPERATING PROCEDURES FOR DARNING SEWING MACHINE - continued.**e. Winding Bobbin - continued

- (7) Regulate the amount of thread wound on the bobbin (1/16 inch) below spool lip by adjusting the bobbin winder stop latch screw (10). To wind more thread on the bobbin, turn the screw clockwise. To wind less thread on the bobbin, turn the screw counterclockwise.
- (8) If the thread fails to wind evenly on the bobbin or piles up on one side of the bobbin, loosen screw (11) which holds tension bracket (4) to the base and move the tension bracket to the right or the left, as required, then tighten the screws evenly.

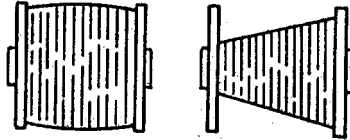

- (9) When bobbin is properly filled, release foot treadle and push the OFF button.
- (10) Cut thread and remove thread from the bobbin winder.

**2-12. OPERATING PROCEDURES FOR DARNING SEWING MACHINE - continued.**f. Installing Bobbin.**CAUTION**

Always rotate the machine hand wheel towards you. Turning the hand wheel away from you will break or bend needles or damage bobbin case or rotating sewing hook.

- (1) Using your hand, turn the machine hand wheel toward you until the needle bar travels to its highest point.
- (2) Open the latch (1) on the bobbin case.
- (3) Install bobbin (2) over the center stud, ensuring the thread is going counterclockwise. Draw thread end out at least five inches.
- (4) Close latch (1).
- (5) Pull thread into slot (3).

**NOTE**

Thread must engage behind the tension spring.

- (6) Pull thread strongly to the left in back of the tension spring.
- (7) At least five inches of thread should be left hanging down from the case.

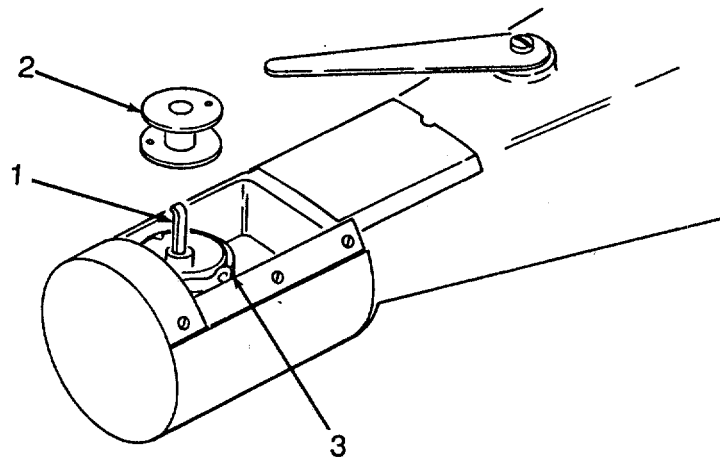

**2-12. OPERATING PROCEDURES FOR DARNING SEWING MACHINE - continued.**g. Catching the Bobbin Thread.

- (1) Raise the presser foot (1) by depressing foot pedal (2) to its raised position.
- (2) With the left hand, hold the end of the needle thread with a little slack.
- (3) With the right hand, turn the hand wheel down toward you until the needle moves from its highest position down and back up to its highest position. If the needle thread is correctly timed, it will catch the bobbin thread.
- (4) Draw up the needle thread, and the bobbin thread will come up with it through the hole in the throat plate.
- (5) Pull the end of the bobbin thread entirely through the hole. Lay both threads back under the presser foot (1).
- (6) Release presser foot (1) by releasing foot pedal (2).

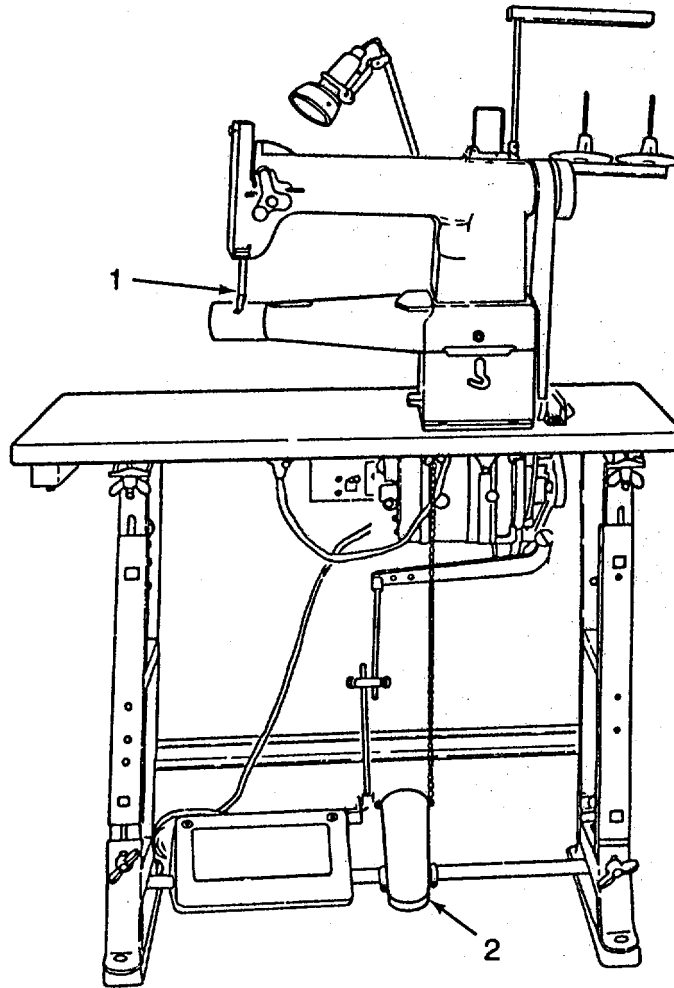

**2-12. OPERATING PROCEDURES FOR DARNING SEWING MACHINE - continued.**

- h. Operating the Darning Sewing Machine After the machine has been prepared for operation, operate as follows using excess cloth. Make all thread and presser foot adjustments before starting repairs.

**CAUTION**

Always rotate the machine hand wheel towards you. Turning the hand wheel away from you will break or bend needles or damage bobbin case or rotating sewing hook.

**NOTE**

Before making clothing repairs, make sure of the adjustments by using a piece of scrap cloth.

- (1) Turn the switch on under the table.
- (2) To insert material into the machine perform the following:
  - (a) Lift the presser bar hand lifter to raise the presser foot which now should have about five inches of bobbin and needle threads under and behind it.
  - (b) Place the edge of the material under the presser foot , having the unworn part of the work near the hole under the needle. Hold the needle thread until the first two stitches are completed, then commence the darning by making a line of stitches across the hole a little longer than the width of the hole. Continue making parallel lines of stitches across the hole, moving the work backward and forward and at the same time gradually moving the work sidewise until the hole is covered with lines of stitches running across the hole. Then commence as before and move the work lengthwise of the hole until the stitches across the hole are completely covered and the darn is finished.
- (3) To remove material from the machine proceed as follows:
  - (a) Release the foot treadle to stop the machine.
  - (b) Hand-turn the hand wheel toward you until the needle bar is at its highest point, and raise the presser foot.
  - (c) Draw the material straight behind the presser foot, and break or cut the needle and bobbin threads so that about four inches will remain under and behind the presser foot.

**2-12. OPERATING PROCEDURES FOR DARNING SEWING MACHINE - continued.**

i. Adjusting Tension on Bobbin and Needle Threads.

- (1) Proper tension locks the bobbin and needle threads in the center of the material. If needle thread tension is too tight, or if bobbin tension is too loose, the needle thread will pull to the upper surface of the material. If bobbin thread tension is too tight, or if needle thread is too loose, the bobbin thread will pull to the underside of the material. If both threads are too tight, the material will be puckered and drawn together by the stitches and the threads will break. Adjust the tensions as follows:
- (2) Turn the machine pulley until tension screw is accessible.

**NOTE**

Tension on threads should be as sufficiently tight as possible while still sufficient to set stitch in material without breaking the thread.

- (3) Adjust the bobbin thread tension with the adjusting screw (1) in the center of the tension spring on the outside of the bobbin case. Turn screw (1) clockwise to increase the tension and counterclockwise to decrease tension. Check for lint or dirt under the tension spring.

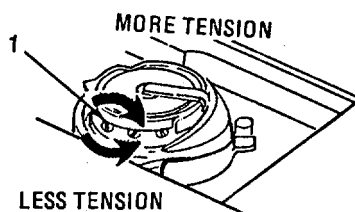

- (4) Lower the presser foot to close the tension disks. Adjust the needle thread tension by turning the serrated nuts (1) clockwise to increase tension and counterclockwise to decrease tension.

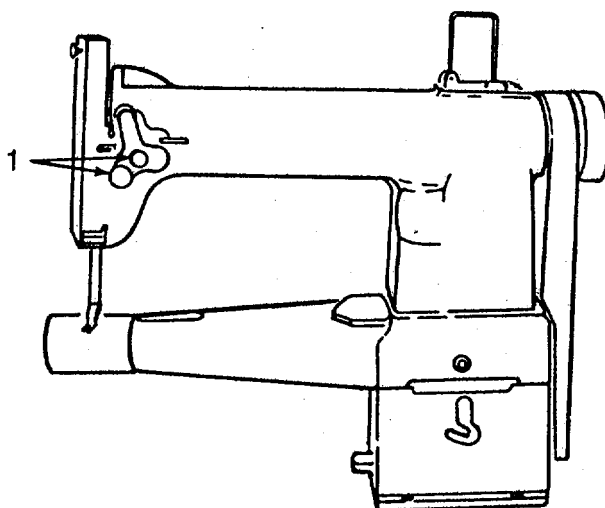

**2-13. OPERATING PROCEDURES FOR BUTTON SEWING MACHINE.****CAUTION**

Always perform the "BEFORE" preventive maintenance checks and services (PMCS, Section II) before you use the equipment. Also perform the lubrication instructions contained in paragraph 3-2 and 3-4, before operating equipment. Damage to equipment could result if these maintenance services are not done.

**a. Selecting Needle.**

- (1) The Model 261-2 Button machine is set up to use standard type 175 x 7 needles in sizes ranging from 16 to 22. Select the needle of the correct size, class and variety from the Component of End Item (COEI) List of Appendix C of this manual.
- (2) The thickness of the sewing thread, which must pass through the eye of the needle, determines the size of the needle.

**NOTE**

Uneven, knotted or rough thread impairs the satisfactory sewing performance of your machine.

**LEFT TWIST THREAD**

- (3) Use left twist thread only in the needle. To test for twist hold a length of thread between thumbs and index fingers of your hands. Turn thread counterclockwise, if it will twist tighter, it has a left twist. If it unravels it has a right twist.

**2-13. OPERATING PROCEDURES FOR BUTTON SEWING MACHINE - continued.**

a. Selecting Needle - continued.

(4) Needle selection is based on the following:

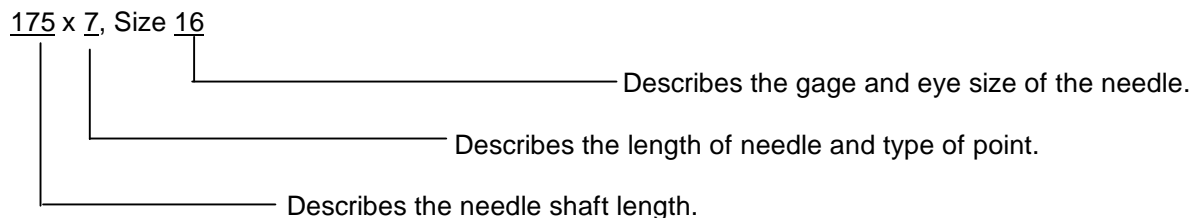

**WARNING**

Be sure that power is turned off.

b. Installing the Needle.

- (1) Select a good needle of the proper size as explained in paragraph a. Never use a bent needle or one with the point blunted or turned.
- (2) To set needle (2), turn the hand wheel clockwise until needle bar (4) moves up to its highest point.
- (3) Loosen needle set screw (1) about one turn, put the shank of the needle up into the clamp as far as it will go, and turn the long groove (3) of the needle to the front.
- (4) Tighten needle set screw (1). If screw (1) is too loose, the needle will turn or slip.

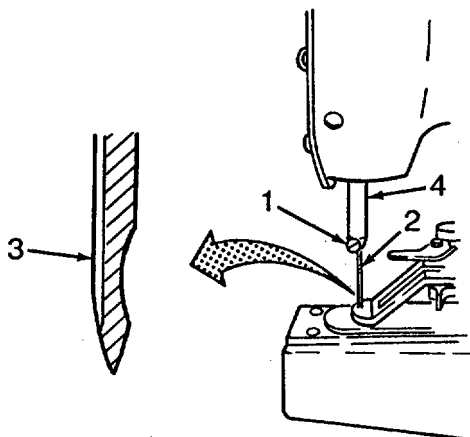

**2-13. OPERATING PROCEDURES FOR BUTTON SEWING MACHINE - continued.**

c. Threading Needle. To thread the machine perform the following steps:

- (1) Pass the thread from the thread winder and from right to left, through guide (2).
- (2) Continue to pass the thread from right to left through the guide (3).
- (3) Continue to pass the thread around the left hand side of, and between, disks, inside the post of the automatic tension assembly (4).
- (4) Continue to pass the thread forward and to the right hand side of, and between the tension disc (5).
- (5) Continue to pass the thread forward through guide (6), then forward through guide posts (7).
- (6) Loosen thread nipper releasing thumbscrew (1), releasing the thread from the grip of the thread nipper (8).
- (7) Continue to pass the thread under thread nipper (8) to the right of guide post (9).
- (8) Continue to pass the thread forward and through guide (10), forward through guide (11) and forward through guide (12) at top of face plate.
- (9) Continue to pass the thread down and from left to right through roller guide (13) at lower end of face plate.
- (10) Continue to pass the thread up and from left to right through thread take-up (14).
- (11) Continue to pass the thread down through face plate thread retainer (15) at bottom of face plate and down and from front to back through eye of needle (16).

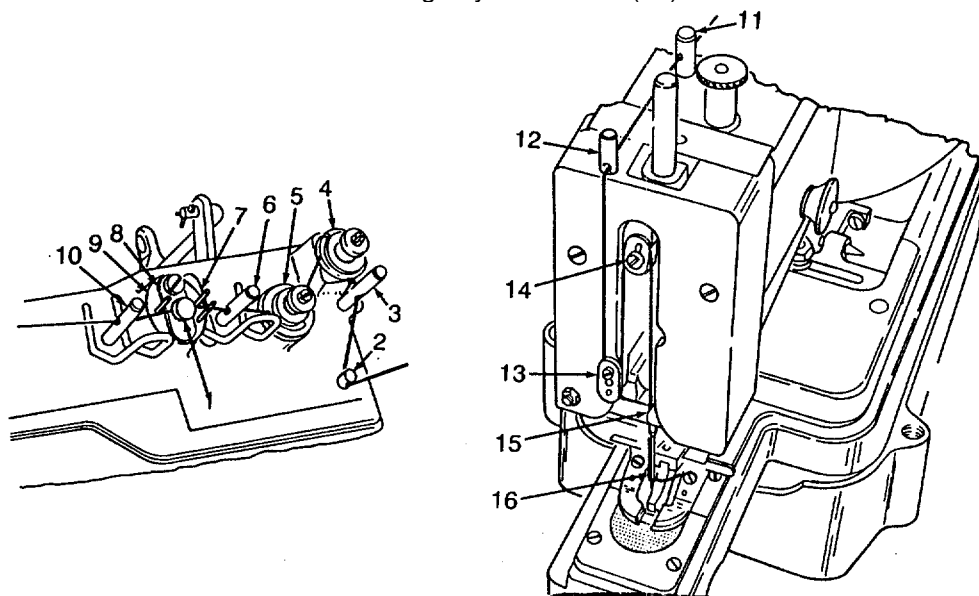

**2-13. OPERATING PROCEDURES FOR BUTTON SEWING MACHINE - continued.**

d. To Regulate the Thread Tension.

- (1) To increase thread tension, turn thumb nut (1) clockwise. To decrease thread tension turn thumb nut (1) counterclockwise.

**NOTE**

Ensure setscrew (7) is on the flat of the retainer.

- (2) Face plate thread retainer (2) is adjustable. Remove screw (3) and nut (4), then loosen setscrew (7), and move retainer (2) to the left for more tension; or to the right for less tension. Tighten setscrew (7). Install screw (3) and nut (4).

e. To Adjust Pressure on the Button Clamp.

- (1) Loosen nut (5) and turn screw (6) clockwise to increase the pressure; or counterclockwise to decrease the pressure on the button clamp.
- (2) Tighten nut (5).

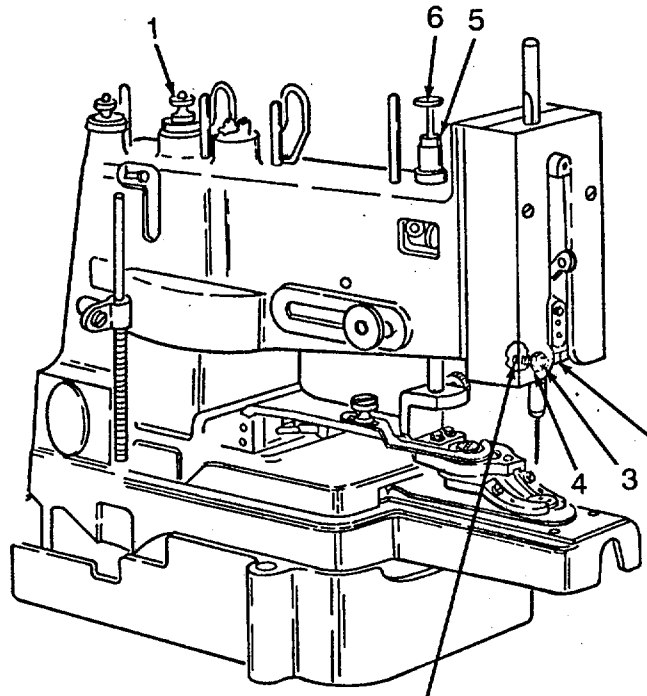

f. To Adjust Button Clamp Opening.

**NOTE**

Orientation of button holes should be parallel to the front edge of the machine head.

- (1) By means of the button clamp opener (1), open the button clamp and place in the clamp jaws a button (2) the size to be sewn.
- (2) Loosen thumb screw (3) and move the adjusting lever (4) to a point where it just clears button stop screw (5).
- (3) After adjustment, tighten thumb screw (3).

**2-13. OPERATING PROCEDURES FOR BUTTON SEWING MACHINE - continued.**

g. To Regulate Needle Bar Vibration.

- (1) To change the extent of needle bar vibration, loosen nut (6) and by means of nut (6), move slide toward the needle to decrease the width of vibration, or away to increase the width of vibration.
- (2) Tighten nut (6).

h. To Regulate Forward and Backward Motion Of Button Clamp.

- (1) The forward and backward motion of the button clamp (1), which is utilized when the machine is sewing four-hole buttons, is regulated by means of the feed plate carrier regulating nut (7).
- (2) This regulating nut (7) is provided with four holes for its handle. Screw the handle into whichever one of the four holes will bring the handle into the most accessible position.
- (3) By means of the handle on nut (7), loosen nut and move it to the left to increase the movement of the button clamp, or move it to the right to decrease movement of the clamp.
- (4) Rotate machine by hand to verify adjustment. When proper adjustment is obtained, securely tighten nut (7).

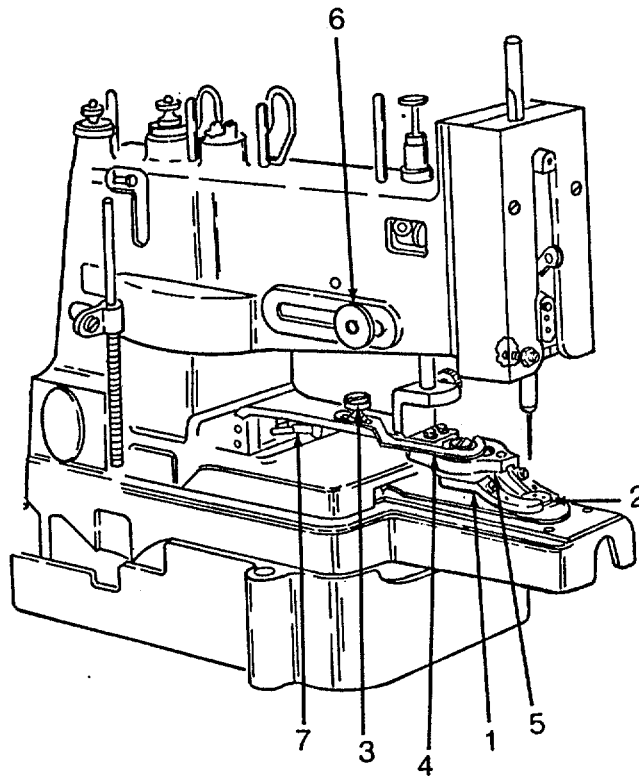

**2-13. OPERATING PROCEDURES FOR BUTTON SEWING MACHINE - continued.**i. To Adjust Feed Plate for Double Stay Work for Two-hole Buttons.

- (1) Make certain that the hinge pin (1) is in upper hole (2).
- (2) To regulate the spread of the Double stay stitch, loosen nut (3) and move it to left or to right until the desired spread of stitch is obtained, then securely tighten nut (3).

j. To Adjust for Two-hole and Four-hole Flat Buttons.

- (1) To change adjustment from four-hole to two-hole buttons, remove hinge pin (1), and insert this pin in hole (2) immediately above.
- (2) To change from two-hole to four-hole buttons, reverse the operation, inserting pin (1) in the lower hole.

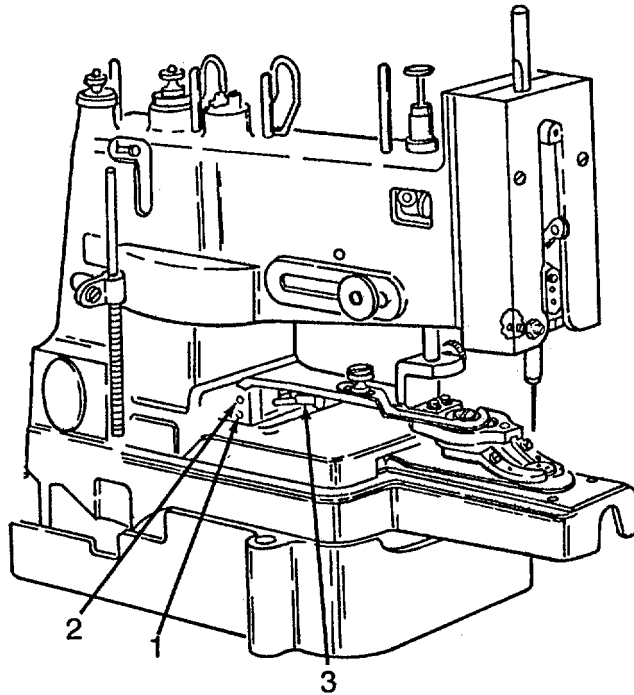

**2-13. OPERATING PROCEDURES FOR BUTTON SEWING MACHINE - continued.**

k. To Adjust Button Clamp for Flat Buttons to Center Needle in Needle Holes in Button.

- (1) Should adjustment become necessary, loosen two screws (1).
- (2) Adjust forward, backward, to the left or right as may be required.
- (3) Securely tighten screws (1).

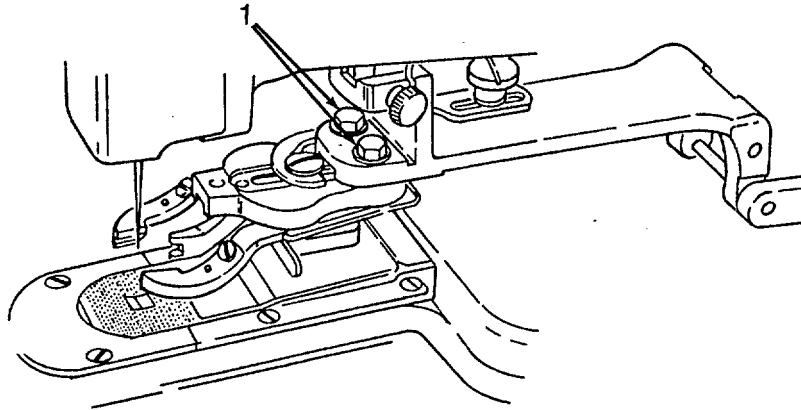

l. Through and Through Stitching Flat Buttons Close to the Material.

Install the button in the clamp jaws (1) and in notch (2) in button stop. (See instructions to adjust button clamp opening, paragraph 2-13f).

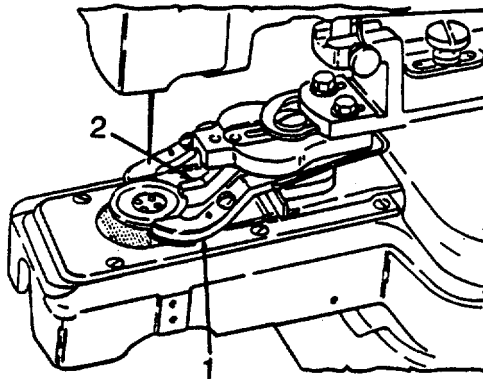

**2-13. OPERATING PROCEDURES FOR BUTTON SEWING MACHINE - continued.**

m. Through and Through Stitching Flat Buttons Close to the Material With Stay Buttons.

- (1) The figure below shows a 22-ligne, 4-hole flat button in clamp with a 22-ligne stay button in stay button holder for through and through stitching with stay buttons, close to the material.
- (2) The stay button holder (1) is attached to the machine as instructed in paragraph 2-13o.

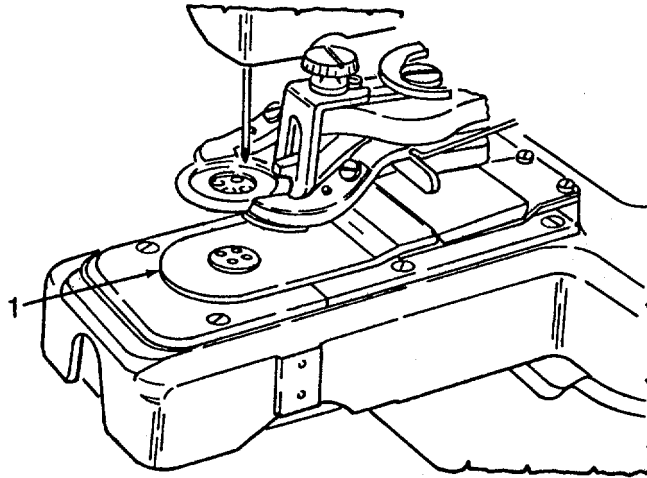

**2-13. OPERATING PROCEDURES FOR BUTTON SEWING MACHINE - continued.**n. To Change the Feed Plate.

- (1) When both button clamp and feed plate are to be changed, remove button clamp (para. 2-13o) before removing feed plate (3).
- (2) When only feed plate is to be changed, first raise button clamp, then insert fingernail beneath chamfered end of feed plate (3), raising it sufficiently so that feed plate (3), can be grasped with the fingers, and withdraw feed plate (3).

**CAUTION**

Never pry up spring (4) as this would probably injure the spring or render it useless.

- (3) To replace, insert feed plate (3) all the way back beneath spring (4) to insure that the two shallow studs, on the under side of feed plate (3), engage the holes beneath spring (4).

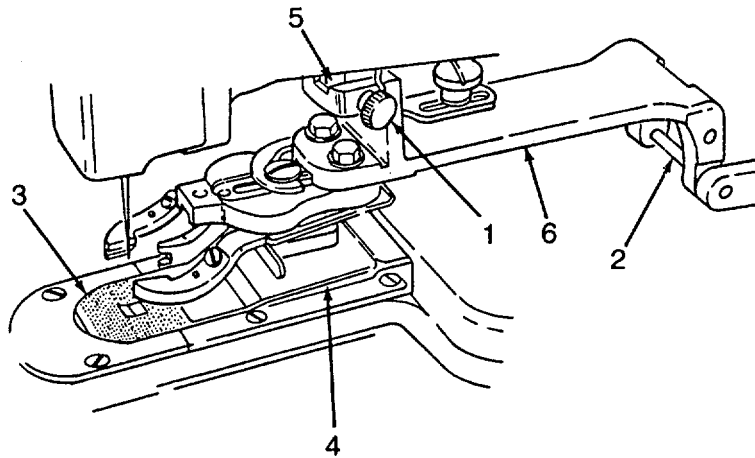

**2-13. OPERATING PROCEDURES FOR BUTTON SEWING MACHINE - continued.**

o. To Change the Button Clamp.

- (1) Unscrew thumb screw (1).
- (2) Remove hinge pin (2).
- (3) Slightly raise pressure bar (5) to relieve pressure on clamp, and remove clamp from machine.

**NOTE**

When installing the shank button attachment, the hinge pin can only be placed in the upper pin holder.

- (4) To replace, first inserting hinge pin (2) in either upper or lower pin hole, depending upon whether two-hole or four-hole button is used. Replace and tighten the thumbscrew (1).
- (5) Replace and tighten thumb screw (1).
- (6) See instructions "To Adjust for Two-hole and Four-hole Button," paragraph 2-13j.

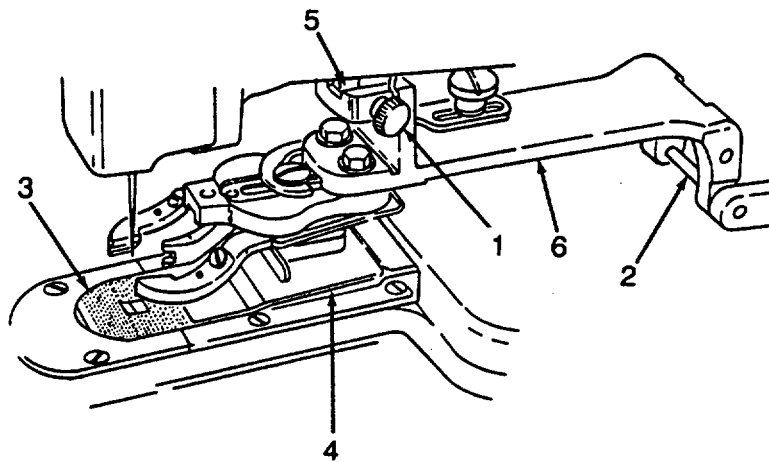

**2-13. OPERATING PROCEDURES FOR BUTTON SEWING MACHINE - continued.**

- p. To adjust shank button clamp for through and through stitching shank buttons. To center needle in needle hole in button shank.

Adjustment is the same as for the flat button clamp (para. 2-13k), except that, in this case, the two adjusting screws (1) are located at the rear of the clamp arm.

- q. To adjust shank button clamp for blind stitching shank buttons and center needle in needle hole in button shank.

- (1) Loosen the two adjusting screws (1) at rear end of clamp arm.
- (2) Also loosen hinge screw (2) and clamping screw (3) in adjustable pressure bar seat (4) and set the clamp to insure that the needle will center in hole in button shank.
- (3) Tighten screws (1), (2) and (3).

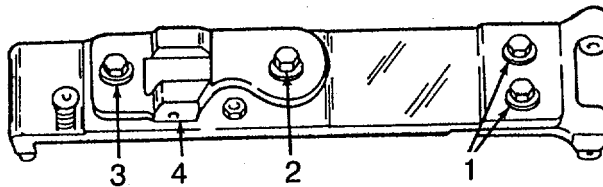

**2-13. OPERATING PROCEDURES FOR BUTTON SEWING MACHINE - continued.**r. Through and Through Stitching Metal Shank Buttons.**NOTE**

Stop the motion of the feed carrier plate, as instructed in paragraph 2-13s.

- (1) The figure below shows a metal shank button held in place in button holder and button finger with work support for through and through stitching of metal shank buttons.
- (2) Attach button holder (1) with screw (2). Set it with its opening coinciding accurately with the shank of the button which is held in place by button finger (3).
- (3) Button finger (3) is adjustable to left or right by means of thumb nut (4), and must be set to hold the button shank firmly in its opening in the button holder. The self-shank button must be held by the button finger (3) and button holder (1) in such position that the needle, on its left hand vibration, will center in the needle hole of the button shank.
- (4) Install work support (5) and secure with pin (6) and wingnut (7). Adjust button holder (1) over work support (5) and adjust for proper height using screw (2).
- (5) Adjust pin on work support (5) using screw (8) for proper position, if needed.
- (6) When this machine is to be used for through and through stitching metal shank buttons with short eyelets, button holder spring (9) is used.
- (7) The spring (9) is fitted over the button holder which together, are attached to the clamp by means of the screw (2).

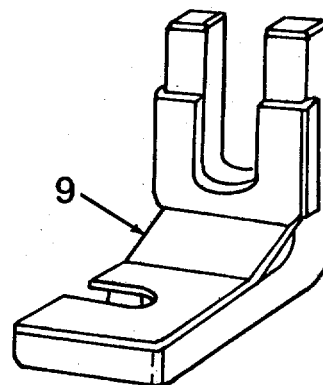
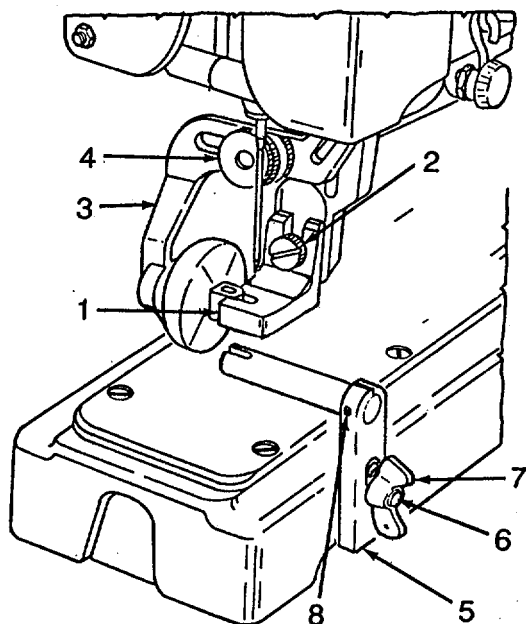

**2-13. OPERATING PROCEDURES FOR BUTTON SEWING MACHINE - continued.**

- r. Through and Through Stitching Metal Shank Buttons - continued.

**NOTE**

The button shown in the above figure has a large eyelet and therefore does not require the use of button holder spring (9).

- (8) The function of the button holder spring (9) is to lend added security in holding metal shank buttons with short eyelets, for through and through stitching; also to compensate for any slight inequalities in the thickness of the wire of which the button shanks are constructed.

**2-13. OPERATING PROCEDURES FOR BUTTON SEWING MACHINE - continued.**

- s. To Stop the Forward and Backward Motion of the Feed Plate.

To stop the forward and backward motion of the feed plate, when sewing shank buttons, position nut (1) as far as it will go to the right (as when sewing two-hole flat buttons).

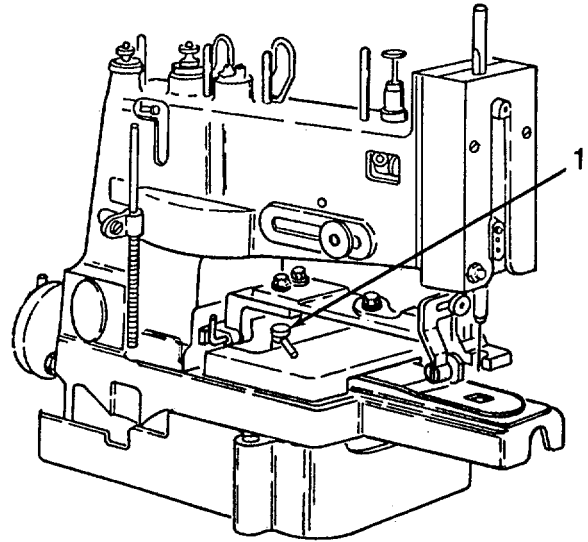

- t. Through and Through Stitching Leather Shank Buttons.

**NOTE**

Stop the motion of the feed carrier plate, as instructed in paragraph 2-13s.

- (1) The figure shows a leather shank button held in place in button holder (1) and button finger (2) and is the work support for through and through stitching of leather shank buttons.
- (2) Button holder (1) is attached and adjusted as instructed in paragraph 2-13r.
- (3) Button finger (2) is adjusted as instructed in paragraph 2-13r.

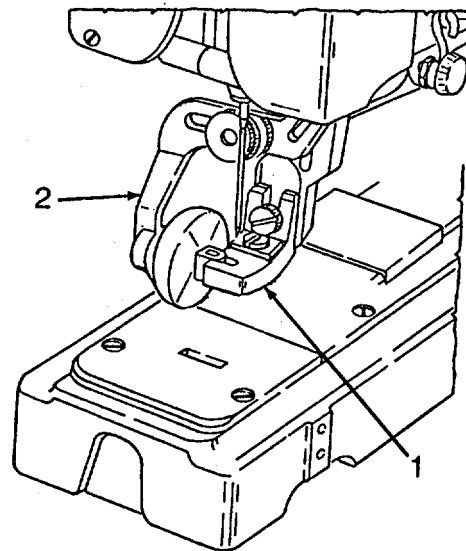

**2-13. OPERATING PROCEDURES FOR BUTTON SEWING MACHINE - continued.**

u. Through and Through Stitching Metal Shank Buttons With Stay Buttons.

- (1) Stop the motion of the feed carrier plate, as instructed in paragraph 2-13s.

**NOTE**

The figure below shows a large eyelet metal shank button held in place in button holder and button finger with a 22-ligne stay button holder for through and through stitching metal shank buttons with stay buttons.

- (2) Button holder (1), for large eyelet buttons, is provided. To adjust, see instructions in paragraph 2-13r.
- (3) Button finger (3) is adjusted as instructed in paragraph 2-13r.
- (4) Install stay button feed plate (4) as instructed in paragraph 2-13n.

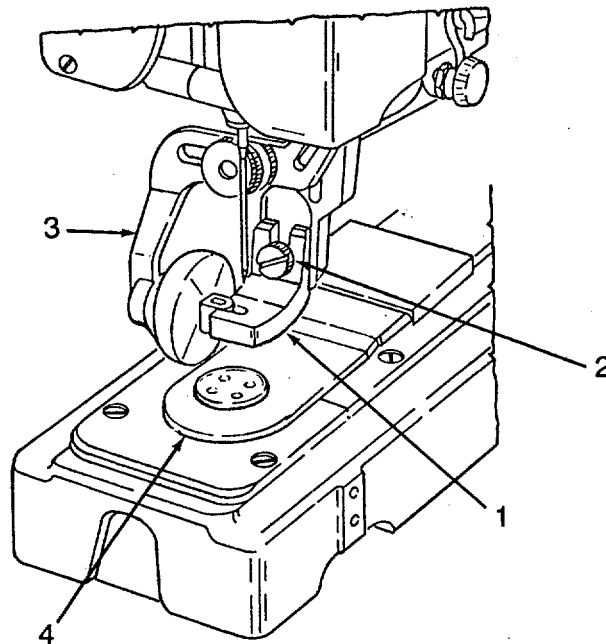

**2-14. OPERATING PROCEDURES FOR GROMMET PRESS.**

a. Punching Holes.

Use a hammer and a punch to punch holes through the material or cloth for insertion of the snap fastener parts. A flat piece of wood placed under the cloth will provide the solid surface needed in using the punch.

b. Selecting Chucks and Dies.

Select the proper chuck and die to fit the particular snap fastener set being used.

c. Inserting Chucks and Dies. Perform the following:

**NOTE**

All chucks and dies are inserted in same manner.

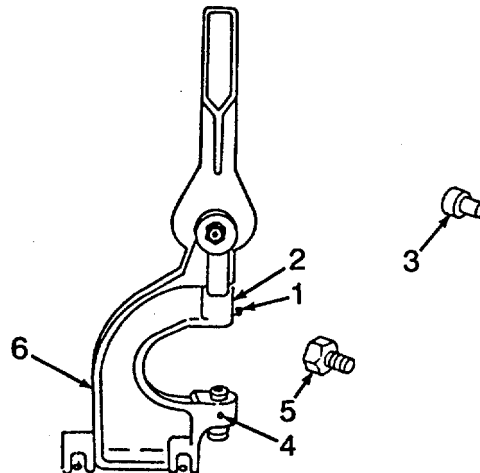

(1) Installing Chuck.

- (a) Loosen chuck setscrew (1) in plunger (2).
- (b) Insert chuck (3) all the way into plunger (2) with the flat side of the chuck shaft facing setscrew (1). Tighten the setscrew (1).

**NOTE**

When the flat side of the chuck is facing setscrew (1), the numerals on the chuck will face the operator.

(2) Installing Die.

- (a) Loosen die setscrew (4) in the lower part of grommet press (6).
- (b) Drop die (5) into position with the flat side of the die toward or facing setscrew (4).

**NOTE**

When flat side of the die shaft is facing the setscrew, the numerals on the die will face the operator.

- (c) Tighten die setscrew (4) securely.

**2-14. OPERATING PROCEDURES FOR GROMMET PRESS - continued.**

d. Inserting Snap Fastener Set in Chuck and Die.

A snap fastener set consists of a socket assembly (1) (female portion) and a stud assembly (2) (male portion). The female portion consists of socket (2) (or cap) and a clinch plate (1) (or socket). The male portion consists of a stud (3) and a washer (4) (or post) depending upon the style of the snap fastener set. Either the female portion or the male portion may be installed or fastened in material separately or independently of the other portion.

- (1) To install the female portion, insert or snap the appropriate socket (2) (or cap) firmly into the chuck. The socket should fit snugly in the chuck. Place the appropriate clinch plate (1) (or socket) in the die so the prongs on the clinch plate point upward.

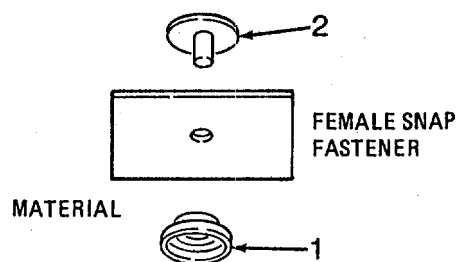

- (2) To install the male portion insert or snap the appropriate stud (3) up into the chuck. Place appropriate washer (4) (or post) in the die.

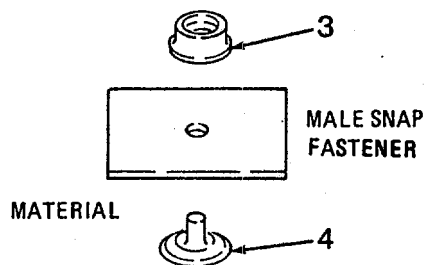

**2-14. OPERATING PROCEDURES FOR GROMMET PRESS - continued.**e. Operating the Grommet Press.

After the grommet press has been prepared for operation including installation of the appropriate die and chuck and snap fastener parts, proceed as follows to operate the grommet press.

- (1) Place the material or cloth over the die and under the chuck with the snap fastener parts in them. The hole or holes in the material should coincide exactly with the hole or holes in the snap fastener parts. Position the hole in the material over the center of the washer or over the stem of the post for the male portions of the snap fastener sets. Be sure to keep the hand lever all the way up whenever inserting material in the grommet press.
- (2) Depress the hand lever firmly to apply pressure to attach the snap fastener parts to the material securely.

f. Removal of Material, Chuck and Die.

- (1) To remove material, raise the hand lever, and remove the material (with snap fastener parts) from the grommet press.
- (2) Remove the chuck by loosening the setscrew in the plunger, and lifting the chuck from the plunger. Tighten the setscrew securely.
- (3) Remove the die by loosening the setscrew in the lower part of the grommet press, and lift the die from the grommet press. Tighten the setscrew securely.

**2-15. OPERATING PROCEDURES FOR TACK-BUTTON ATTACHING MACHINE.**a. Die Selection.

Select the appropriate upper die (1) either for the closed-top button or the open-top button. Use the appropriate lower die (2), depending upon the diameter of the tackhead being used.

- (1) Loosen screw (3) in the plunger (4) and insert the appropriate upper die (1) into plunger (4) with the flat side facing screw (3). Tighten screw (3) securely.
- (2) Loosen lower die screw (5) and drop or insert the appropriate lower die (2) into hole (6) in frame (7). Do not fasten the lower die in position until the pinch has been adjusted properly as described in paragraph 2-15b.

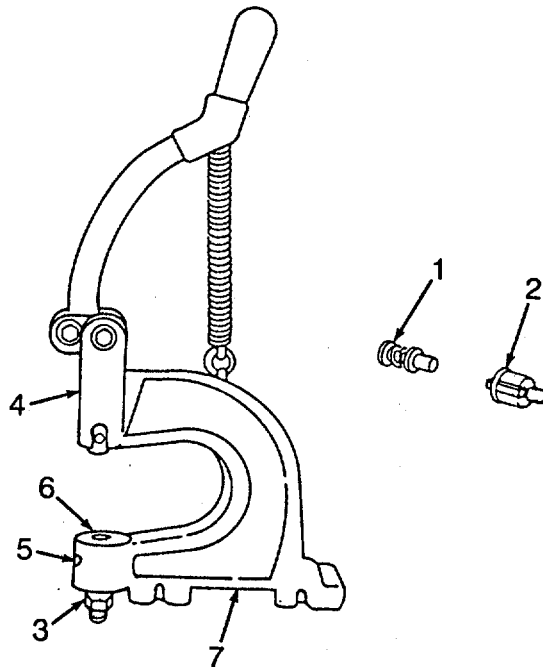

**2-15. OPERATING PROCEDURES FOR TACK-BUTTON ATTACHING MACHINE - continued**b. Adjusting Pinch.

Use and insert sample testing material in the tack-button attaching machine and adjust the pinch as follows:

- (1) Turn the screw in the base of the machine to obtain the proper pinch on the material. Adjust the pinch until the button is just tight on the material. Test the pinch by operating the tack-button attaching machine.

**CAUTION**

If the pinch is too tight, the material will be cut.

- (2) Tighten the lower die screw holding the lower die in the machine when the pinch has been adjusted properly.

c. Operating the Tack-Button Attaching Machine

After the tack-button-attaching machine has been prepared for operation, operate it as follows:

- (1) Raise the hand lever (1) and slip the closed-top button into the upper die so that the wires on the die fit and snap firmly over the button edge.

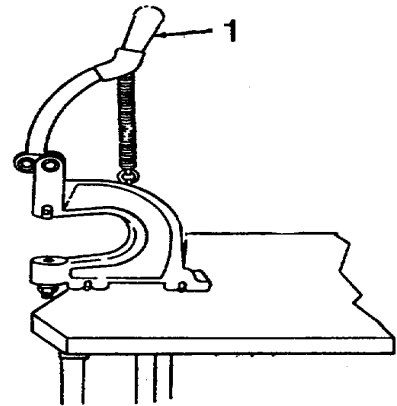

- (2) Drop the tack into the lower die with the tack prong pointed toward the upper die. When using the double-pronged tack, align the prongs so that when hand lever (1) is depressed, the prongs will pass freely into the holes in the bottom.
- (3) Place cloth or material over the lower die and the tack.
- (4) Depress the hand lever (1) firmly, clamping the button (that is in the upper die) upon the tack (that is in the lower die) on the material.

**2-16. OPERATING PROCEDURES FOR HEAT SEALING MACHINE .**

a. Pre-heating Heat Sealing Machine

- (1) Pre-heat machine to the temperature indicated on the chart for fabric to be printed.

**NOTE**

Once you turn the machine on (green light will come on followed immediately by red heating light), it will take approximately 15 minutes to warm up. There is a visual thermometer and a manual temperature adjustment knob.

- (2) The knob is marked at 350° F (390° F for sublimation transfers) and can be adjusted up or down by turning the knob.
- (3) Once the proper temperature is reached, the green light will come on.
- (4) Do not adjust the knob unless you are working with a fabric requiring a different setting.

b. Operation.

- (1) Center the item to be printed on the rubber pad and smooth out all wrinkles.
- (2) Lay the transfer or letters, ink surface down against the item being imprinted.
- (3) Position timer and pressure to desired settings.
- (4) Lower handle of machine slowly and lock into place.
- (5) After the appropriate number of seconds, the buzzer will sound. Raise handle (and heater block) to the full upright position.
- (6) Let printed work cool for 20 to 30 seconds, before removing transfer paper. Take a cloth and rub over the transfer paper for 5 seconds while it is cooling. This will assist the release of the ink from the paper and cure it into the fabric.

**TEMPERATURE AND TIME CHART**

<b>MATERIAL</b>	<b>TEMPERATURE</b>	<b>TIME (SEC.)</b>
Cotton	350° F.	08 - 12
65-35 Cotton / Polyester	350° F.	08 - 12
100% Polyester	375° F.	08 - 12
Cotton Twill	375° F.	12 - 15
Nylon	400° F.	12 - 15

2-17. DECALS AND INSTRUCTION PLATES.

- a. Instruction plates and stencils are used on the clothing repair shop to advise the operator of proper operating procedures, additional operating information, and cautions to be observed during use of the equipment. The following illustrations show where identification plates and stencils are located on the clothing repair shop.

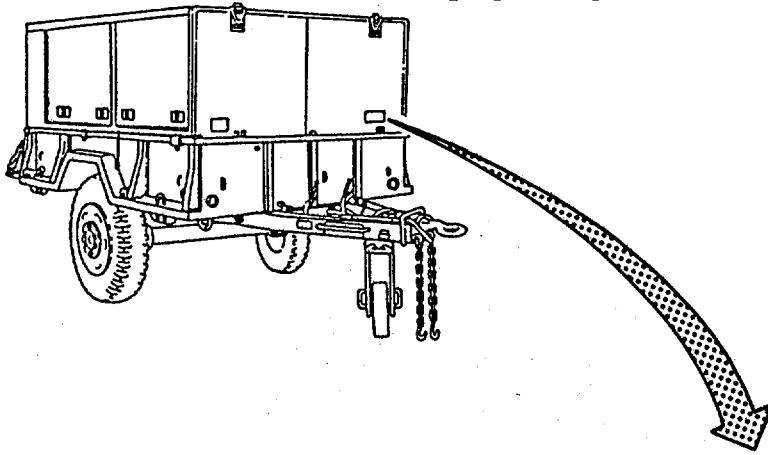

<p><b>CLOTHING REPAIR SHOP TRAILER MOUNTED</b>  <b>NATIONAL STOCK NUMBER 3530-01-346-7256</b>  <b>SPECIFICATION NO. MIL - C - 40153</b>  <b>MFD BY ENGINEERED AIR SYSTEMS, INC.</b>  <b>MFG SERIAL NO</b>  <b>MFG MODEL CRS-100</b>  <b>CONT., ACT NO. DAAK01-91-C-0272</b></p>	<p>C. G. LOADED C. G. EMPTY</p>																				
<p><b>PUBLICATIONS</b>  <b>PARTS LIST TM 10-3530-207-24P</b>  <b>TECHNICAL MANUAL TM 10-3530-207-14</b>  <b>LUBRICATION ORDER</b></p>	<table border="1"> <thead> <tr> <th>WEIGHTS</th> <th>SHIPPING</th> <th>CROSS COUNTRY</th> <th>HIGHWAY</th> </tr> </thead> <tbody> <tr> <td>P/L &amp; BODY</td> <td></td> <td></td> <td></td> </tr> <tr> <td>ON WHEELS</td> <td>4940</td> <td></td> <td></td> </tr> <tr> <td>ON GEAR</td> <td>455</td> <td></td> <td></td> </tr> <tr> <td>TOTAL</td> <td>5395</td> <td></td> <td></td> </tr> </tbody> </table>	WEIGHTS	SHIPPING	CROSS COUNTRY	HIGHWAY	P/L & BODY				ON WHEELS	4940			ON GEAR	455			TOTAL	5395		
WEIGHTS	SHIPPING	CROSS COUNTRY	HIGHWAY																		
P/L & BODY																					
ON WHEELS	4940																				
ON GEAR	455																				
TOTAL	5395																				
<p><b>DELIVERY DATE</b> <input type="checkbox"/> <b>INSPECTED</b> <input type="checkbox"/></p>	<p><b>SHIPPING CUBAGE 720</b></p>																				

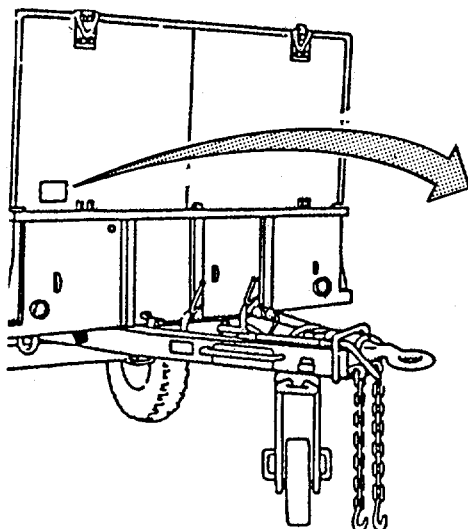

**LIFTING INSTRUCTIONS**  
**(A) SLING(CHAIN OR CABLE) 2 REQ'D**

2-17. DECALS AND INSTRUCTION PLATES - continued.

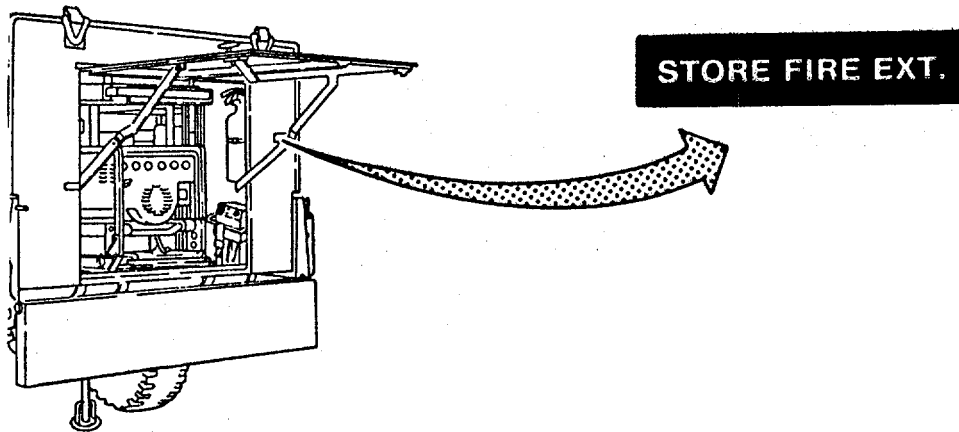

**INSTRUCTIONS FOR OPERATION**

1. POSITION GENERATOR SWITCHES TO 120/208 VOLT 3 PHASE POSITION
2. CONNECT WIRES TO L<sub>1</sub>, L<sub>2</sub>, L<sub>3</sub>, ON GENERATOR, GREEN TO GROUND.
3. PLUG 3 TWIST LOCK CONNECTORS TO THIS BOX.
4. BALANCE LOAD ON DISTRIBUTION BOXES (M-MACHINE, L-LIGHT)
5. AMMETER WILL READ IN RED DURING 3 PHASE FULL LOAD OPERATION (OK)

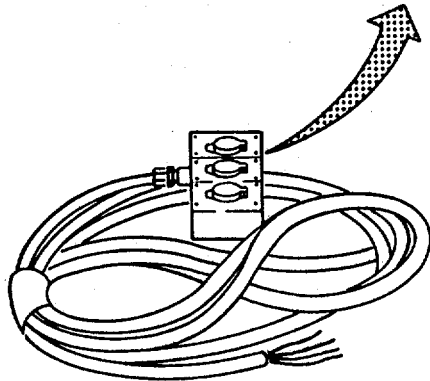

2-17. DECALS AND INSTRUCTION PLATES - continued.

**BOX NO. 1**

STORE FOLLOWING ITEMS  
IN THIS BOX

BUTTON ATTACHING MACHINE WITH DIES  
GROMMET PRESS WITH CHUCKS AND DIES  
1 - ELECTRIC DISTRIBUTION BOX  
NEEDLES, BOBBINS AND HAND IRON

**BOX NO. 2**

STORE FOLLOWING ITEMS  
IN THIS BOX

4 DROP LIGHTS  
8 SPARE BULBS  
GROUND WIRE, 20 FT. NO. 10 WIRE

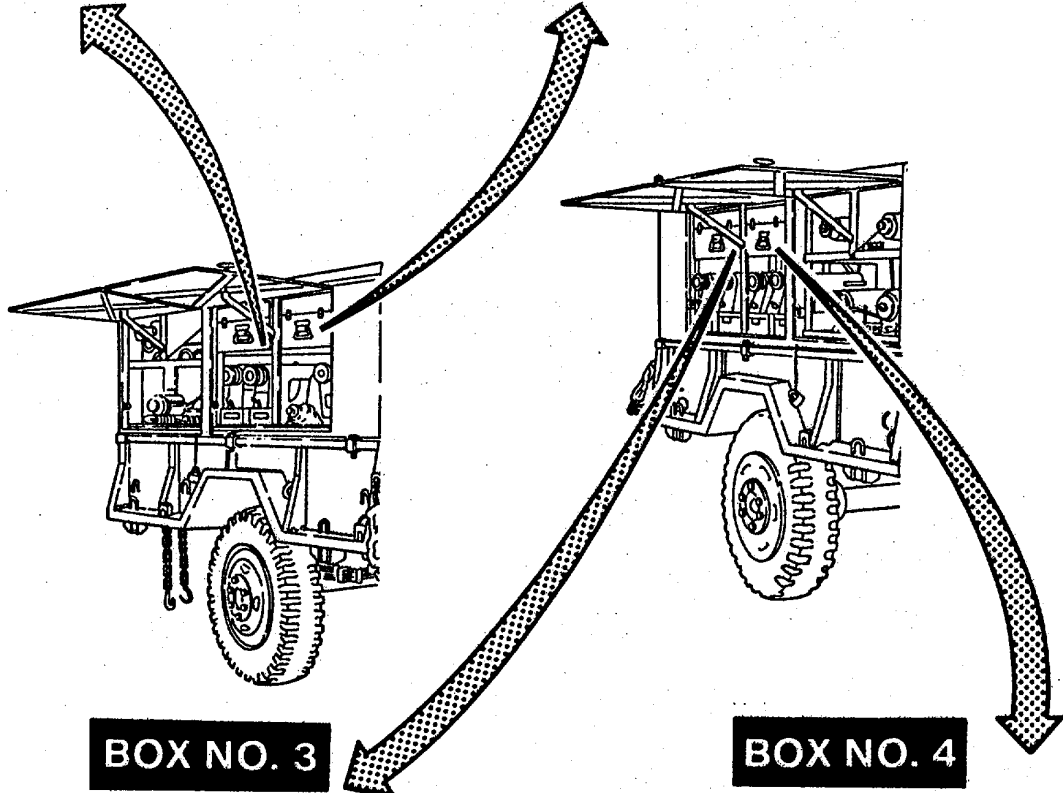

**BOX NO. 3**

STORE FOLLOWING ITEMS  
IN THIS BOX

1 ELECTRIC DISTRIBUTION BOX  
REST PINS  
DOUBLE THREAD UNWINDER ASSEMBLIES  
SINGLE THREAD UNWINDER ASSEMBLY  
BASE THREAD UNWINDERS  
BOBBIN WINDERS  
BUTTON TRAY  
BELT ASSEMBLIES  
ACCESSORIES BOX  
OIL CANS  
TREADLES  
SET OF INSTRUCTION MANUALS

**BOX NO. 4**

STORE FOLLOWING ITEMS  
IN THIS BOX

1 ELECTRIC POWER SUPPLY BOX  
1 ELECTRIC DISTRIBUTION BOX  
2 LIFTER CHAIN ASSEMBLIES  
1 ROLL OF LEATHER BELTING  
1 SLEEVE BOARD AND COVER

**2-18. PREPARATION FOR MOVEMENT.**a. Fire Extinguisher.

Place the fire extinguisher into its storage bracket and close the bracket.

b. Power Cables and Light Cords

Turn off generator set in accordance with TM 5-6115-271-14. Disconnect all power cables and light cords and stow in the proper stowage boxes (Boxes 1, 2, 3, and 4).

c. Heat Sealer.

- (1) Remove two nuts (2), two flatwashers (3), two bolts (4), and two flatwashers (5).
- (2) Remove the heat sealer (1) and stow in the rear of the unit.
- (3) Reinstall two flatwashers (5), two bolts (4), two flatwashers (3), and two nuts (2) into mounting holes in table.

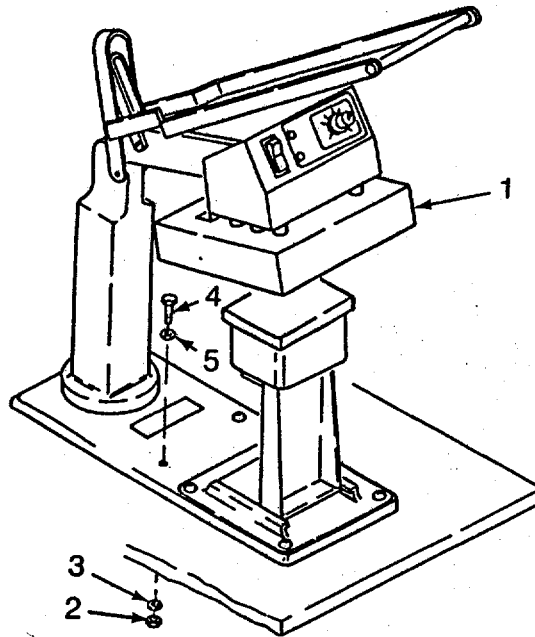

**2-18. PREPARATION FOR MOVEMENT - continued.**

d. Tack-Button Attaching Machine.

- (1) Remove four nuts (2), four washers (3), four bolts (4), and four washers (5).
- (2) Remove the tack-button machine (1) and stow in stowage box No. 1.
- (3) Reinstall four washers (5), four bolts (4), four washers (3), and four nuts (2) into the mounting holes in folding table assembly (6).

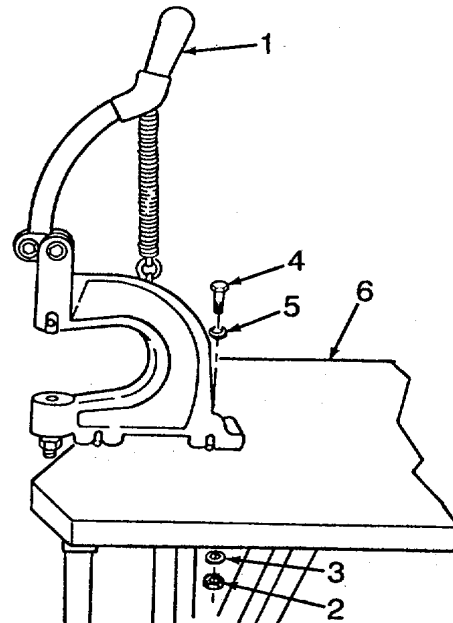

e. Grommet Press.

- (1) Remove four nuts (2), four flatwashers (3), four bolts (4), and four flatwashers (5).
- (2) Remove grommet press (1) and stow in stowage box No. 1.
- (3) Reinstall four flatwashers (5), four bolts (4), four flatwashers (3) and four nuts (2) into the mounting holes in the folding table assembly(6).

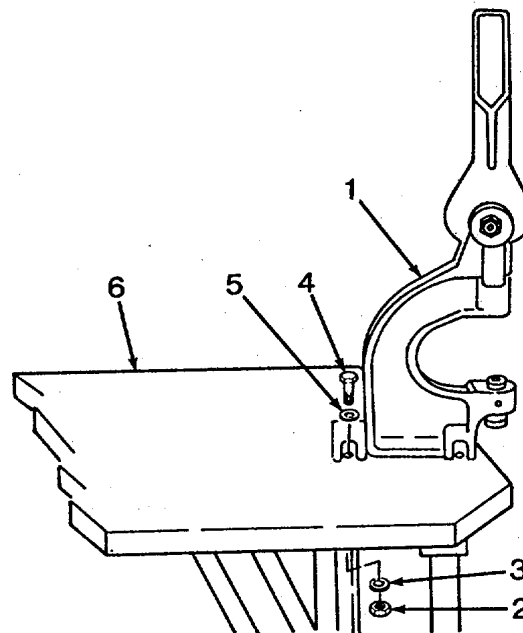

**2-18. PREPARATION FOR MOVEMENT - continued.**

f. Disassembly of Button Sewing Machine

- (1) Remove the button tray (20) from the table (5) or from the machine base (4).
- (2) Remove three pins (19) from the button tray (20).
- (3) Remove cotter pin (18) and slide belt guard (17) off of the belt guard pin (16).
- (4) Remove two machine screws (6) and belt guard pin (16) from table top (5).
- (5) Remove center pin (15) from base (12).
- (6) Loosen setscrew (14) and remove post (13) from base (12).
- (7) Remove thread unwinder base (12) from table (5) by removing two machine screws (6). Stow thread unwinder in storage box No. 3.

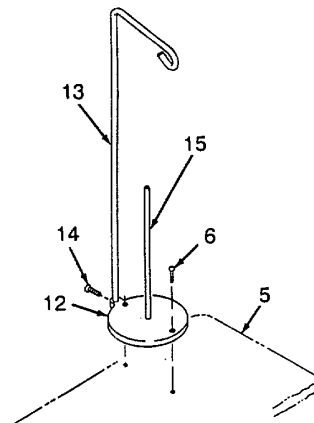
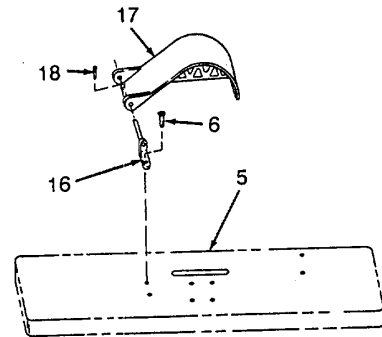
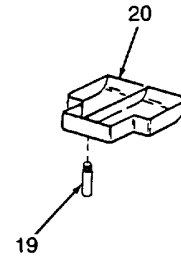

**2-18. PREPARATION FOR MOVEMENT - continued**f. Disassembly of Button Sewing Machine - continued

- (8) Remove belt (11) from the motor under the table by tilting the machine head (8) back lowering the pulley and removing the belt (11)
- (9) Remove the light assembly (10) from the table top (5) by loosening the thumbscrew on the bottom of the clamp. Stow the light assembly in box No. 2.

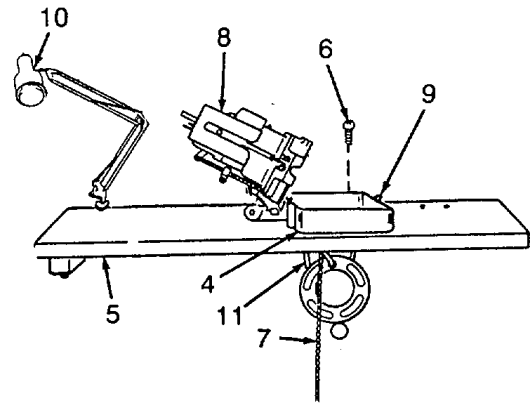
**CAUTION**

When sliding the button machine tray, do not allow needle bar to hit the bottom of the stowage box.

- (10) Carefully remove machine head (8) with belt and install in the tray marked 261-2. The pulley on the machine head (8) should be on the back of the tray. Secure with strap. Slide tray into unit where marked 261-2.
- (11) Disconnect chain (7) from the pedal and the hook/lever inside the machine base (4). Stow chain (7) in stowage box No. 4.
- (12) Remove four machine screws (6) and machine base (4) from table (5). Stow machine base (4) in box No. 1.

**2-18. PREPARATION FOR MOVEMENT - continued.**

f. Disassembly of Button Sewing Machine - continued.

- (13) Remove foot pedal (1) and two clips (2) from round bar of folding stand (3). Stow in box No. 3.
- (14) Loosen wingnuts (4) and remove table (5) from the stand assembly (6). Tighten wingnuts (4) on carriage bolt (13) with flatwasher (14) installed. Stow table (5) into unit where marked 261-2.
- (15) Loosen wingnuts (7) at each corner of the stand assembly.
- (16) Remove cross brace (8) on rear of stand and secure to base with two bolts (9), two flatwashers (10), two lockwashers (11) and two wingnuts (12).
- (17) Press in on the sides of the stand and fold the stand down. Secure with strap.

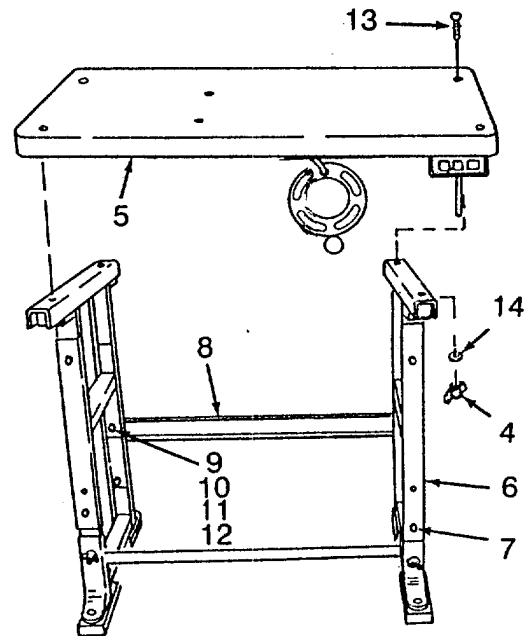
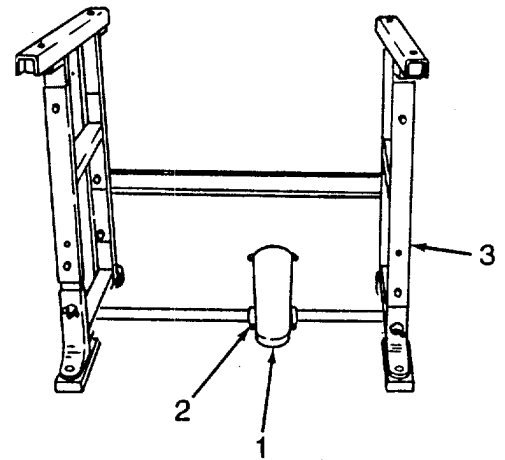

**2-18. PREPARATION FOR MOVEMENT - continued.**g. Disassembly of Darning Sewing Machine

- (1) Remove two screws (9) and belt guard top (8).
- (2) Unlock hook by loosening thumbscrew. Remove the pulley belt (10) to the machine pulley by tilting the head back, installing the belt and then returning the machine head to the upright position.
- (3) Remove the pulley belt (10) through the top of the belt guard.
- (4) Remove pulley (1) by removing shaft screw (2), loosening flat setscrew (3) and pointed setscrew (4).
- (5) Remove screw (5) under pulley.
- (6) Remove three screws (7) and belt guard (6).
- (7) Install screw (5).
- (8) Slide pulley (1) in place and ensure setscrews (3) and (4) are lined up with the flats of the shaft.
- (9) Tighten setscrews (3) and (4).

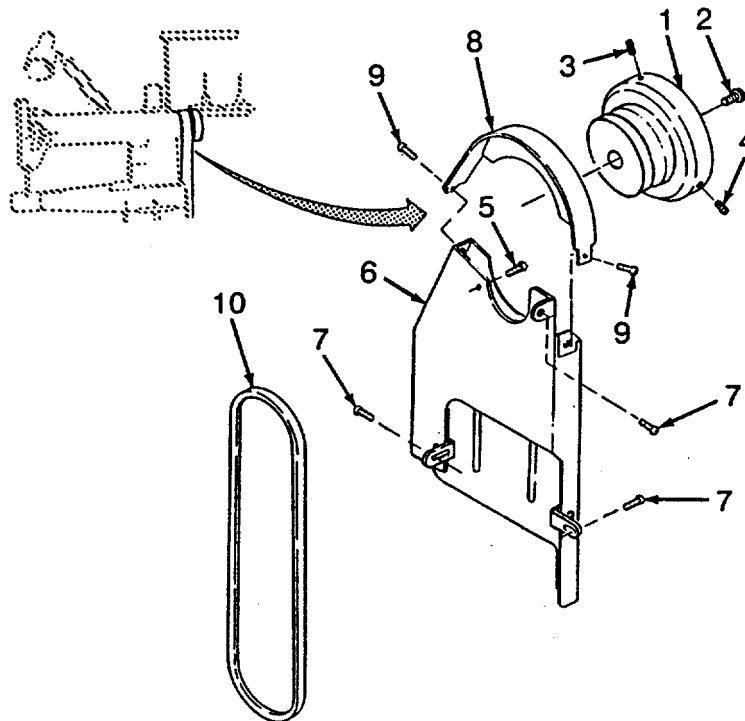

**2-18. PREPARATION FOR MOVEMENT - continued.**

g. Disassembly of Darning Sewing Machine - continued

- (10) Remove rubber cap (20) from the top post (17).
- (11) Remove two thread clips (19) on posts (8).
- (12) Remove screw (14), lockwasher (15), nut (16), and thread guides (18) from top post (17).
- (13) Remove two screws (14), two lockwashers (15), two nuts (16) and top post (17) from bottom post (16).
- (14) Remove screw (14), lockwasher (15), nuts (16) and cone rest (13).
- (15) Remove two cushions (12), two pads (11), two nuts (10), two lockwashers (9), and two posts (8) from the cone rest (13).
- (16) Loosen two setscrews (7) and remove bottom post (6) from unwinder base (5).
- (17) Remove three machine screws (4) and the threadunwinder base (5) from table (3).
- (18) Remove two machine screws (4) and bobbin winder (2) from table (3).
- (19) Remove the light assembly (1) from the table top by loosening the thumbscrew on the bottom of the clamp. Stow the light assembly in box No. 2.

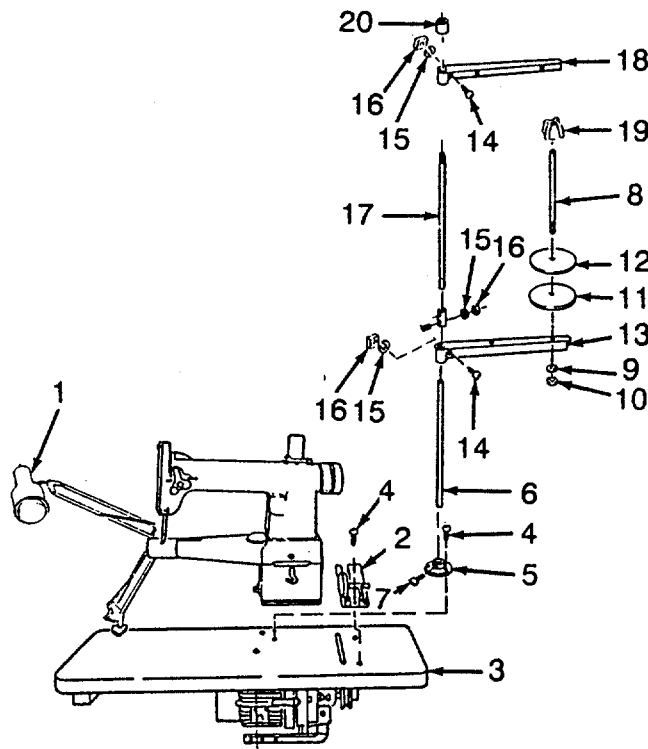

**2-18. PREPARATION FOR MOVEMENT- continued.**

g. Disassembly of Darning Sewing Machine - continued

**NOTE**

"S" hook on lifter chain will need to be removed for disassembly.

- (20) Remove lifter chain (14) from machine head lever and foot pedal (1). Stow lifter chain (14) in box No. 4.
- (21) Remove three hinge screws (10) from the darning machine head (9). Place darning machine head (9) in the tray marked 207. Secure with strap. Slide into the unit where marked by 207.
- (22) Remove four bolts (6), four washers (7), four nuts (8) and darning machine base (4) from table top (5) and stow in box No. 1.
- (23) Remove pedal (1) and clips (2) from the round bar on the stand (3). Stow in storage box No. 3.
- (24) Disconnect one end of foot treadle rod (15) to the foot treadle (16) by removing flatwasher (17) and nut (18).
- (25) Remove foot treadle rod (15) from clutch arm (19) by removing flatwasher (20) and nut (21).
- (26) Remove treadle (16) and two clips (22) from the round bar (3) of the stand. Stow in storage box No. 3.
- (27) Disassemble the stand in accordance with paragraph 2-18f, steps (15) through (17).

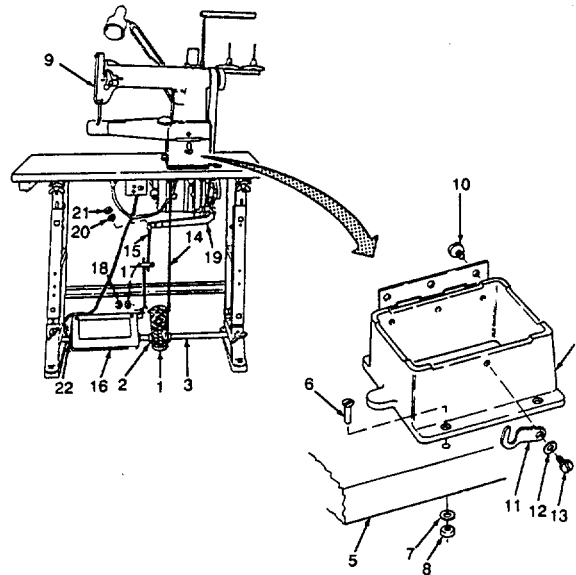

2-111

**2-18. PREPARATION FOR MOVEMENT - continued.**

h. Disassembly of Clothing Sewing Machine.

- (1) Remove tightening nut (25) and top post (21) from bottom post (10).
- (2) Remove wingnut (24) washer (23), clip (22), thread guides (20) from top post (21).
- (3) Remove two thread clips (19), two cushions (18), two pads (17).
- (4) Remove cone rest (12), two nuts (16), two lockwashers (15) and two posts (14).
- (5) Loosen setscrew (13) and remove cone rest (12) from bottom post (10).
- (6) Remove nut (11) and post (10) from thread underwinder base (9).
- (7) Remove three machine screws (8) and thread unwinder base (9) from table (3).
- (8) Remove bobbin winder (7) and belt guard (6) from table (3) by removing two machine screws (8).
- (9) Remove belt (5) from motor pulley by tilting the machine head (2) back.
- (10) Remove head pin (26) from table top (3).
- (11) Remove the light assembly (4) from the table top (3) by loosening the thumbscrew on the bottom of the clamp. Stow the light assembly in box No. 2.
- (12) Remove hinge pins (1) from the sewing machine head (2). Stow hinge pins in box No. 3.
- (13) Remove sewing machine head (2) with belt (5) from table (3).
- (14) Place Clothing Repair machine head (2) into tray marked CN3115R. Secure with strap. Slide into the unit marked for CN3115R.

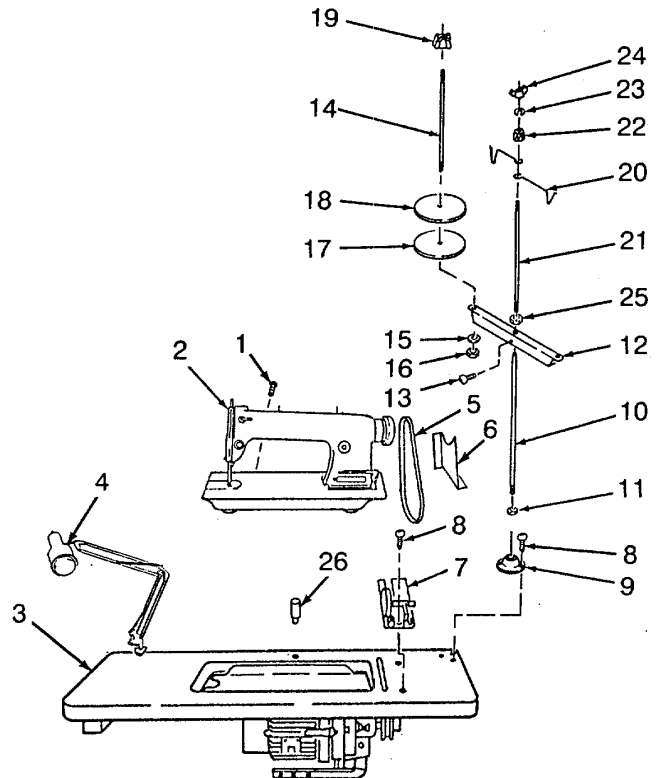

**2-18. PREPARATION FOR MOVEMENT - continued.**h. Disassembly of Clothing Sewing Machine - continued

- (15) Disconnect the foot treadle rod (1) from foot treadle (2) by removing lockwasher (3) and nut (4).
- (16) Remove foot treadle rod (1) from clutch arm (5) by removing flatwasher (6) and nut (7).
- (17) Remove treadle (2) and two clips (8) from the round bar of the stand (9). Stow in stowage box No. 3.
- (18) Loosen wingnuts (10) at each corner of the stand (9). Remove table (11) from stand (9). Tighten wingnuts (10) on carriage bolt (13) with flatwasher (12) installed.
- (19) Disassemble the stand in accordance with paragraph 2-18f, steps (15) through (17).

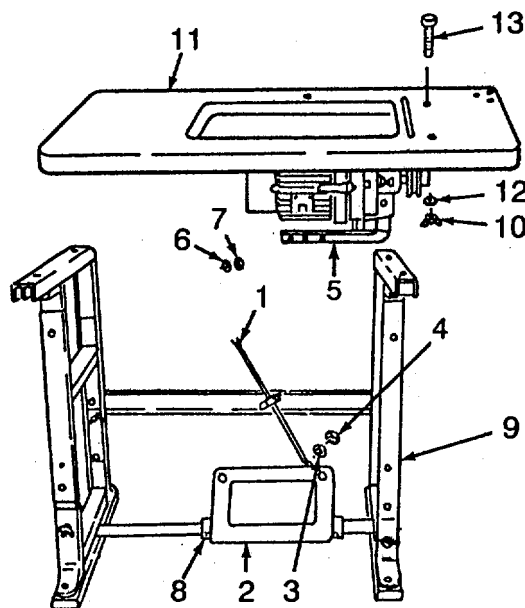

**2-18. PREPARATION FOR MOVEMENT - continued.**

i. Sewing Machine Table Assemblies, Folding Stands and Stowage Boxes

- (1) Slide stowage boxes (1) into cabinet.

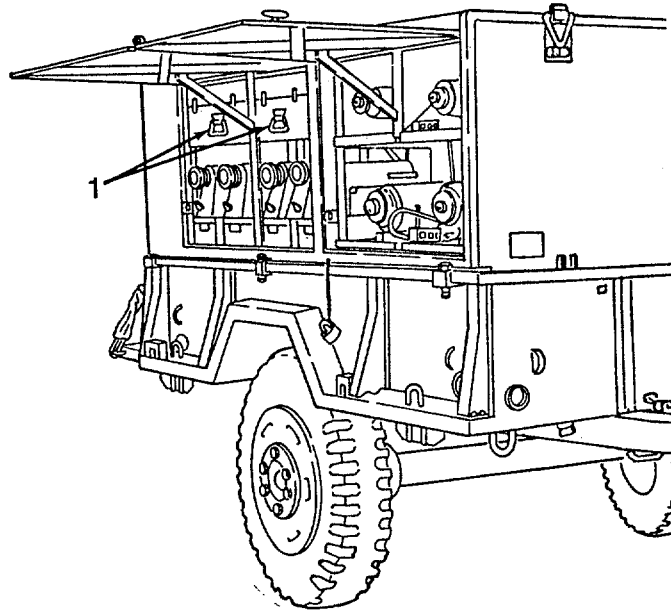

- (2) Stow folding stands (2). Secure with holddown straps (1).
- (3) Repeat step 2 for other side and rear of unit.

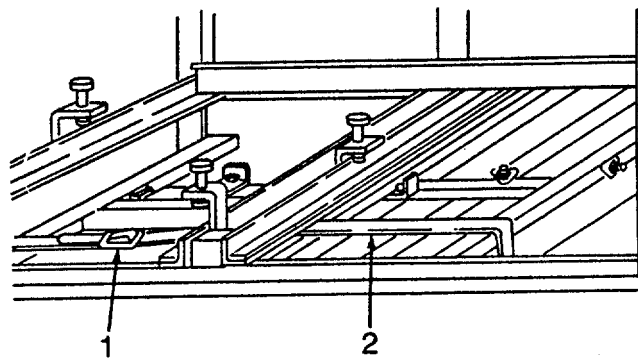

**2-18. PREPARATION FOR MOVEMENT- continued.**

i. Sewing Machine Table Assemblies, Folding Stands and Stowage Boxes - continued

- (4) Slide the eight sewing machine table assemblies (1) into their respective slide racks inside the cabinet.

**NOTE**

Swivel foot of the locking clamps have left hand threads.

- (5) Insert and screw the locking clamps into place.

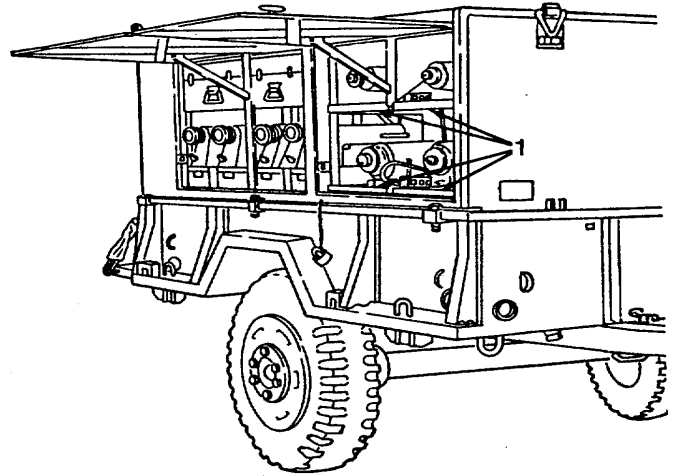

j. Folding Table Assemblies.

- (1) Fold the table legs up and lock them in place by sliding the locks upward and swiveling the clamp and tightening on the wingnut.
- (2) Slide the two table assemblies (6) into the rear of the cabinet. Secure with the two locking pins (5).

k. Loading Generator Set Proceed as follows if generator needs to be loaded.

- (1) Remove holddown bracket (2) by removing both locking pins (1).

**WARNING**

The generator set weighs approximately 285 lbs. To avoid injury to personnel, four persons are required to move the generator.

- (2) Carefully slide the generator set (3) forward and lift it onto the slide tracks and into the cabinet. Avoid hitting the rear door stays (4). Slide generator set (3) all the way forward.
- (3) Reinstall bracket (2) and two locking pins (1).

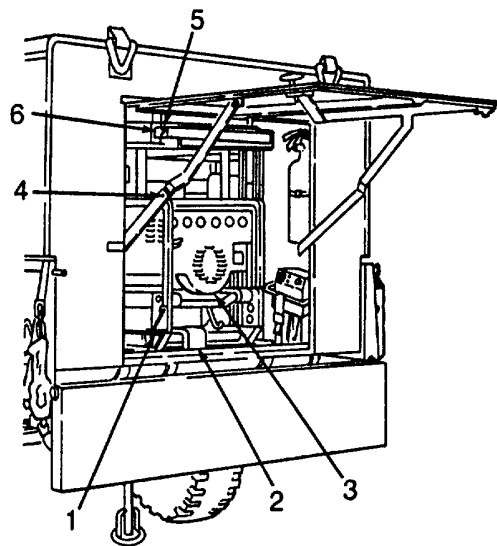

**2-18. PREPARATION FOR MOVEMENT - continued.**

k. Loading Generator Set - continued

- (4) Install four folding chairs (5) and secure with strap.
- (5) Install heat sealer (6) into the cabinet assembly and secure with strap.

1. Closing Up the Trailer. Proceed as follows to close the trailer.

- (1) Lower rear door (3) by lifting rear door stays (4) and close the door.
- (2) Turn both latch handles to the closed position.

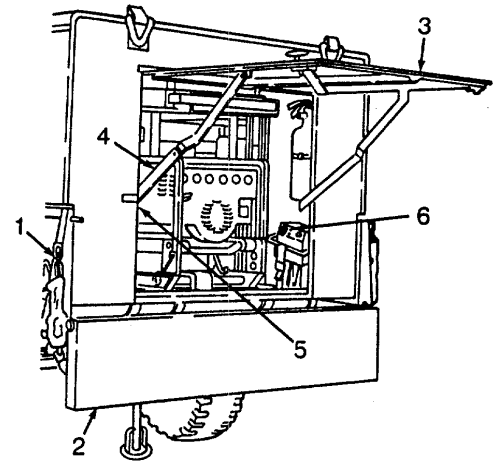

**CAUTION**

Door must be securely shut to ensure water does not get inside the unit.

- (3) Raise the trailer end gate (2) and hook trailer end gate chains (1).

- (4) Lower doors (3) by raising door stays (4).
- (5) Turn both latch handles (2) to lock doors (3).
- (6) Install and lock four padlocks (1).

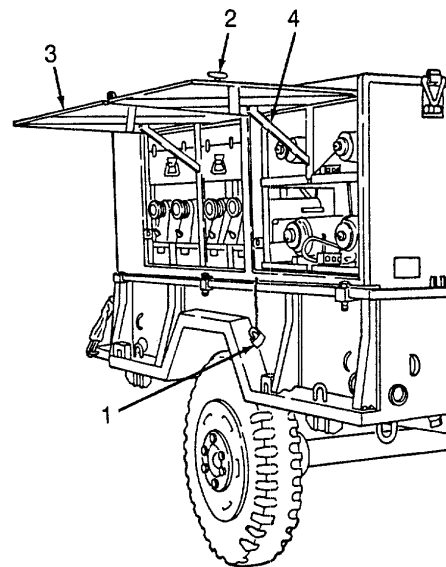

**12-18. PREPARATION FOR MOVEMENT - continued.**

m. Connecting Trailer to Towing Vehicle.

(1) Screw in base plate to raise leg (1).

(2) Swivel leg (1) up until the lever (2) is locked into position.

(3) Lift the drawbar coupler (9) to the towing vehicle pintle and latch the pintle.

(4) Unhook safety chain (7) from the lifting bars (8) and hook safety chains (7) to the towing vehicle.

(5) Connect the intervehicular air hose (6) to the towing vehicle. Open the towing vehicle air shut-off valve.

(6) Connect the intervehicular electrical cable (5) to the towing vehicle.

(7) Crank caster (3) up using handle (4) as necessary to connect trailer to unit.

(8) Raise caster (3) into position by pulling lever (2). Check that the caster (3) is locked in the up position.

(9) Release both handbrakes (1) by pushing the handbrakes back.

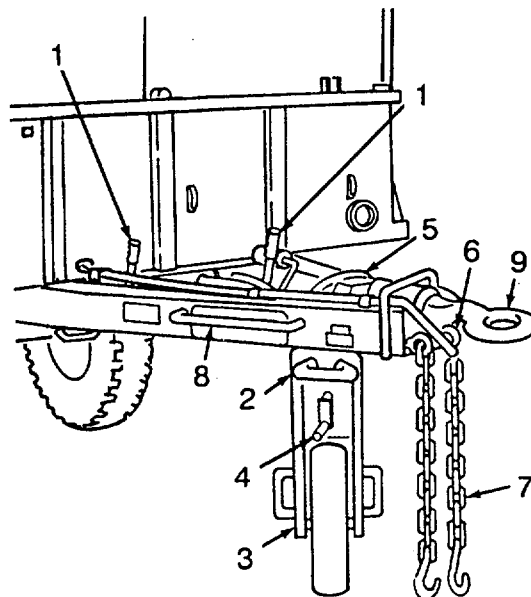
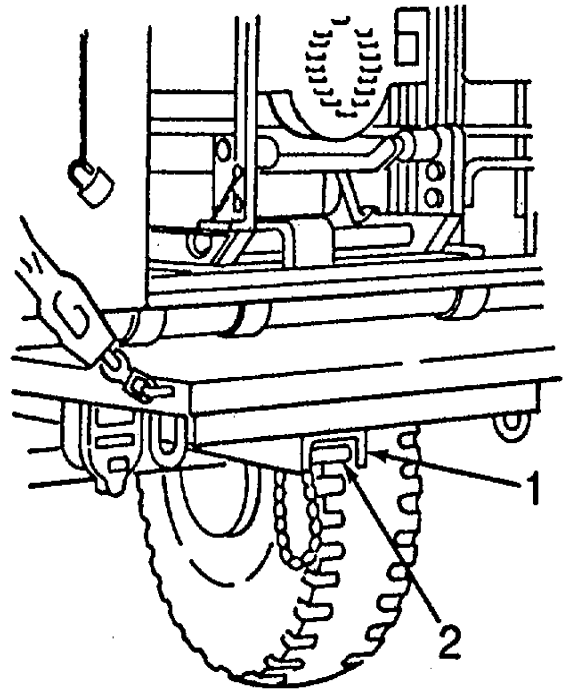

---

**Section IV. OPERATION UNDER UNUSUAL CONDITIONS****2-19. GENERAL.**

This section covers the operating instructions, in addition to those previously covered, that are necessary for the components of the clothing repair shop to function properly under unusual conditions, such as in extreme heat and cold and in dusty and sandy areas.

**2-20. OPERATION IN EXTREME HEAT AND COLD AREAS .**

Extremes of heat and cold have little or no effect upon the operation of the clothing repair shop. Extremes of humidity require the sewing machines to be lubricated (Chapter 3, Section I) more frequently because even ordinary humidity will cause the machines to rust or to corrode unless they are kept thoroughly oiled. Also, extremes of humidity will cause the thread to deteriorate and break easily during operation. All possible precautions should be taken to keep the thread dry.

**2-21. OPERATION IN SANDY AND DUSTY AREAS.**

In extremely sandy and dusty areas, the working parts of the sewing machines will require more frequent cleaning and lubrication (Chapter 3, Section I). Be sure to remove all sand or grit from the material to be stitched; sand or grit will work into the parts of the sewing machines and cause unnecessary wear and possible damage to the sewing machines.

**CHAPTER 3  
OPERATOR MAINTENANCE INSTRUCTIONS**

Paragraph	Page
<b>Section I.</b>	
Lubrication Instructions .....	3-1
3-1. Introduction .....	3-1
3-2. Detailed Lubrication Instructions.....	3-1
3-3. Lubrication Instructions for the Clothing Sewing Machine .....	3-2
3-4. Lubrication Instructions for the Button Sewing Machine.....	3-3
3-5. Lubrication Instructions for the Darning Sewing Machine.....	3-6
<b>Section II.</b>	
Operator Troubleshooting.....	3-7
3-6. Introduction .....	3-7
3-7. Malfunction Index.....	3-7
3-8. Troubleshooting Table .....	3-9
<b>Section III.</b>	
Maintenance Procedures.....	3-34
3-9. General .....	3-34
3-10. Belt Adjustment .....	3-34
3-11. Padlock Replacement .....	3-36
3-12. Lamp Assembly Replacement .....	3-38

**Section I. LUBRICATION INSTRUCTIONS**

**3-1. INTRODUCTION.**

- a. Lubrication instructions for the generator set are contained in TM 5-6115-271-14.
- b. Lubrication instructions for the cargo trailer are contained in TM 9-2330-213-14.
- c. Lubricate or oil the latches, hinges, and pivot points of the cabinet assembly, storage boxes, folding chairs, and tables when and if they become difficult to operate.

**3-2. DETAILED LUBRICATION INSTRUCTIONS.**

- a. These lubrication instructions are mandatory.
- b. Keep all lubricants in closed containers and store them in a clean, dry place away from external heat. Do not allow lint, dust, dirt, or other foreign matter to mix with lubricants. Keep all lubrication equipment clean and ready for use.
- c. Keep all external parts that do not require lubrication free of lubricants. Before lubricating, clean lint, dust, or grease from the lubrication points.
- d. Operate the machines immediately after lubrication to distribute the oil to all moving parts. It is important that the machines are lubricated as instructed.

3-3. LUBRICATION INSTRUCTIONS FOR THE CLOTHING SEWING MACHINE.

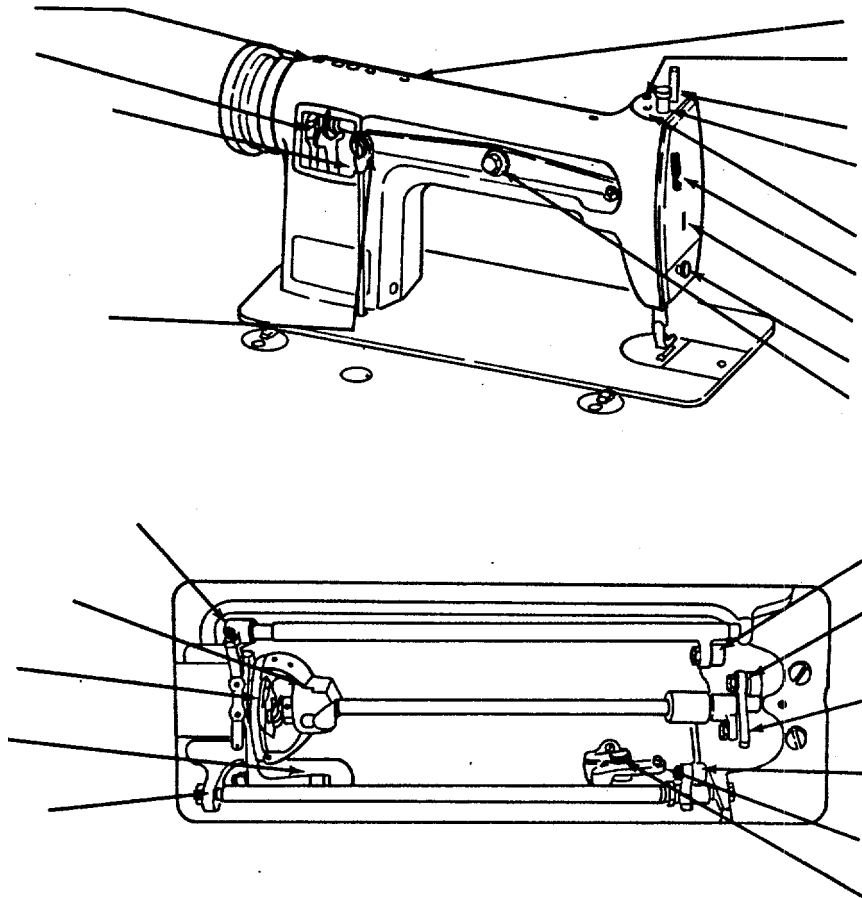

**CAUTION**

Do not flood these moving parts with oil nor ignore the four hour lubricating interval.

The clothing sewing machine should be oiled twice a day (4 hour intervals) by applying from one to three drops of lubricating oil to each of the oil points indicated above by an arrow.

3-4. LUBRICATION INSTRUCTIONS FOR THE BUTTON SEWING MACHINE. I

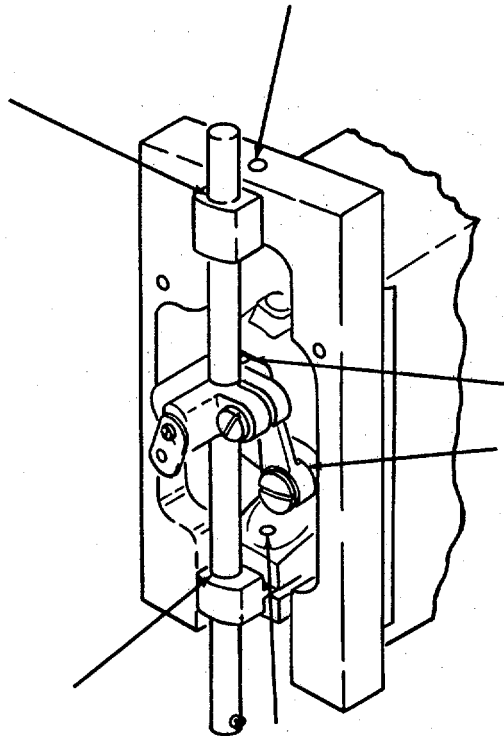

- a. The button sewing machine should be oiled at least once a day (8 hour intervals) to insure easy running and prevent unnecessary wear of the parts which are in movable contact.
- b. Remove the two face plate screws and remove the face plate.
- c. Apply a drop or two of oil to the oil holes indicated.
- d. Remove the two knurled thumb nuts which retain the arm side cover, and remove the arm side cover.

**3-4. LUBRICATION INSTRUCTIONS FOR THE BUTTON SEWING MACHINE - continued.**

- e. Apply a drop or two of oil to the oil holes indicated.

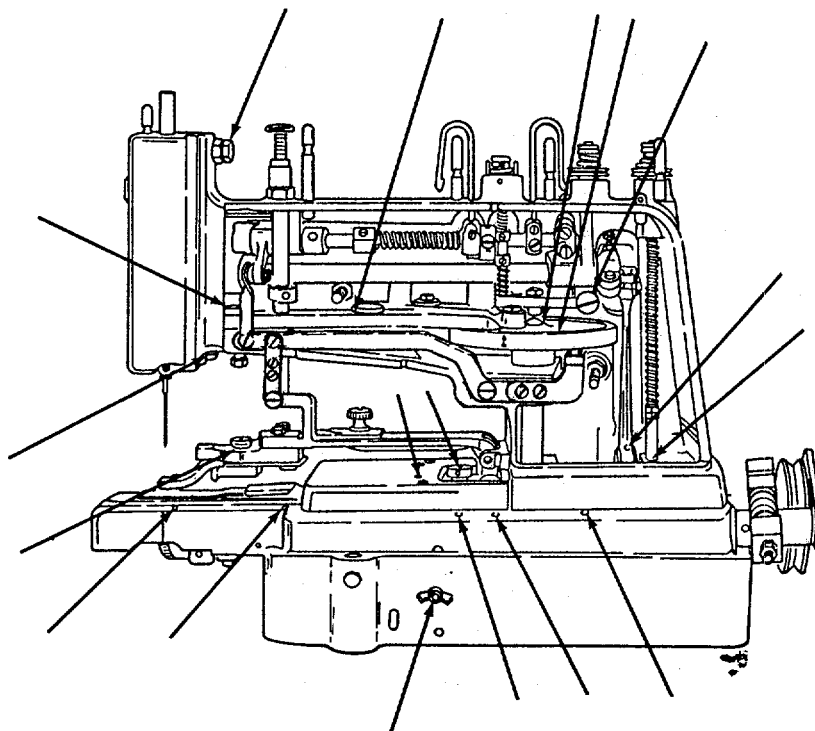

- f. Apply a drop or two of oil to the oil holes at the left side and rear of the machine.

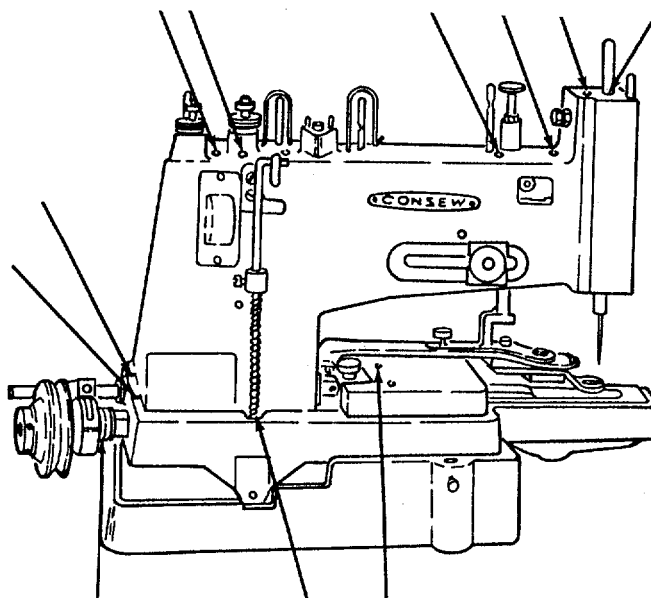

**13-4. LUBRICATION INSTRUCTIONS FOR THE BUTTON SEWING MACHINE - continued.**

- g. Loosen the wing nut and lay the machine back, to the left.
- h. Apply a drop or two of oil to the oiling points indicated.

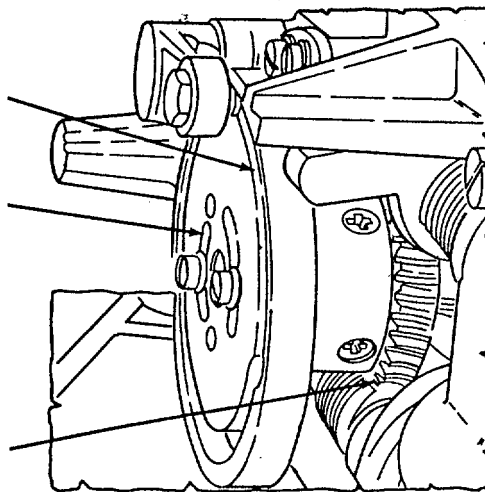
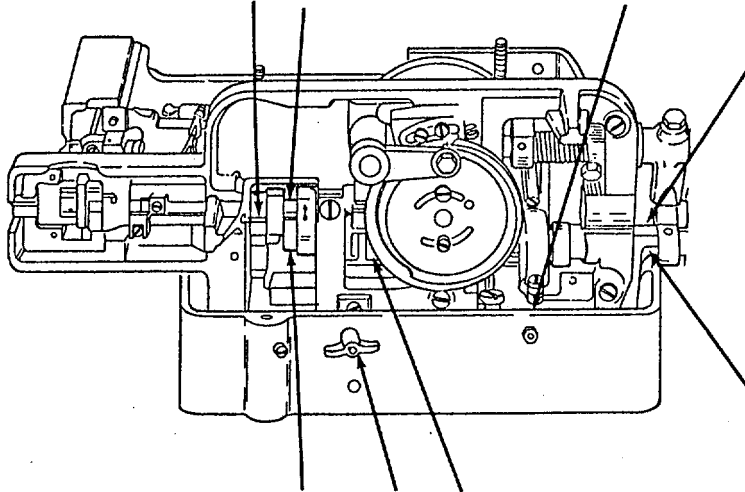

- i. Apply a drop or two of oil to the hinge of the machine starting lever inside the machine base.
- j. When the oiling is completed, turn the machine down onto its base and firmly tighten the wing nut.

**3-5. LUBRICATION INSTRUCTIONS FOR THE DARNING SEWING MACHINE.**

- a. The darning sewing machine should be oiled at least twice daily (4 hour intervals) to insure easy running and prevent unnecessary wear of the parts which are in movable contact.

**NOTE**

During the breaking-in period, a new machine should be oiled more frequently.

- b. Remove the face plate screw and remove the face plate.
- c. Apply a drop or two of oil as indicated.

**NOTE**

Most oil holes are ringed in red.

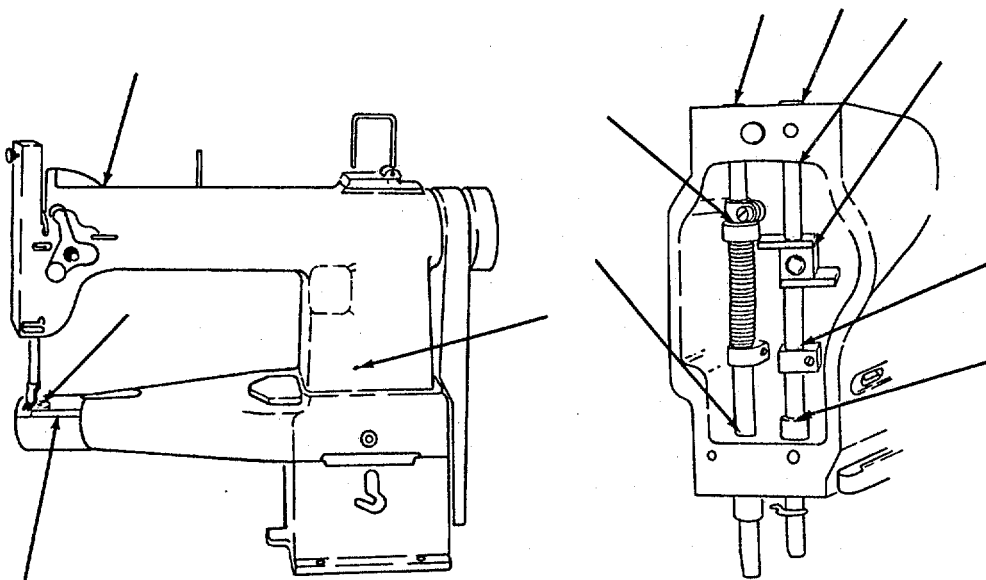

**Section II. OPERATOR TROUBLESHOOTING**

**13-6. INTRODUCTION.**

- a. The troubleshooting table lists the common malfunctions which you may find during operation of the Clothing Repair Shop. You should perform the tests, inspections and corrective actions in the order they appear in the table.
- b. This table cannot list all the malfunctions that may occur, all the tests or inspections needed to find the fault, or all the corrective actions needed to correct the fault. If the equipment malfunction is not listed or actions listed do not correct the fault, notify your supervisor.
- c. To troubleshoot the generator set, refer to TM 5-6115-271-14. To troubleshoot the cargo trailer, refer to TM 9-2330-213-14.

**3-7. MALFUNCTION INDEX.**

	<b>MALFUNCTION</b>	<b>PAGE</b>
<b><u>CABINET ASSEMBLY</u></b>		
1.	Holddown clamp assembly loose .....	3-9
2.	Rear door or any side door cannot be opened.....	3-9
3.	Rear door or any side door does not close.....	3-10
4.	Rear door or any side door will not stay in open position .....	3-10
5.	Sewing machine head is loosely mounted in tray.....	3-10
6.	Stowage box does not close securely.....	3-10
7.	Generator is loosely mounted on slides .....	3-10
<b><u>CLOTHING SEWING MACHINE</u></b>		
8.	Needle breaks.....	3-11
9.	Needle thread breaks .....	3-12
10.	Bobbin thread breaks .....	3-14
11.	Stitches skip or fail to lock.....	3-15
12.	Seams draw.....	3-16
13.	Thread snarls at beginning of seam.....	3-16
14.	Thread snarls during stitching.....	3-16
15.	Thread snarls at end of seam.....	3-17
16.	Bobbin thread cannot be raised through hole in throat plate.....	3-17
17.	Feed dogs strike throat plate .....	3-17
18.	Presser foot pressure regulator thumbscrew is hard to adjust.....	3-18
19.	Machine vibrates.....	3-18
20.	Lamp does not light .....	3-18

<b>MALFUNCTION</b>		<b>PAGE</b>
<b>CLOTHING SEWING MACHINE - continued</b>		
21.	Motor does not start .....	3-19
22.	Unusual noise in motor .....	3-20
23.	Motor does not pull load.....	3-20
<b>DARNING SEWING MACHINE</b>		
24.	Needle breaks .....	3-20
25.	Needle thread breaks .....	3-21
26.	Bobbin thread breaks .....	3-22
27.	Stitches skip or fail to lock.....	3-23
28.	Seams draw .....	3-24
29.	Thread snarls at beginning of darn .....	3-24
30.	Thread snarls during darn.....	3-25
31.	Thread snarls at end of darn.....	3-25
32.	Bobbin thread cannot be raisedthrough hole in throat plate .....	3-25
33.	Presser foot pressure regulator thumbscrew is hard to adjust.....	3-26
34.	Machine vibrates.....	3-26
35.	Lamp does not light.....	3-26
36.	Motor does not start.....	3-27
37.	Unusual noise in motor.....	3-28
38.	Motor does not pull load .....	3-28
<b>BUTTON SEWING MACHINE</b>		
39.	Needle breaks.....	3-28
40.	Thread breaks .....	3-29
41.	Lamp does not light.....	3-30
42.	Motor does not start .....	3-31
43.	Unusual noise in motor .....	3-31
44.	Motor does not pull load.....	3-31
<b>GROMMET PRESS</b>		
45.	Handlever sticks on downstroke .....	3-32
46.	Fasteners are loose .....	3-32
47.	Machine cuts material .....	3-32
<b>TACK-BUTTON ATTACHING MACHINE</b>		
48.	Handlever sticks on downstroke.....	3-32
49.	Upper die does not hold button firmly .....	3-32
50.	Double pronged tack does not fit properly into holes in button.....	3-33
51.	Machine cuts material .....	3-33
52.	Shank of lower die binds.....	3-33
<b>HEAT SEALING MACHINE</b>		
53.	Machine does not heat .....	3-33

**3-8. TROUBLESHOOTING TABLE.**

Refer to Table 3-1.

**Table 3-1. Operator Troubleshooting**

**WARNING**

Be sure to read all Warnings in front of manual before troubleshooting.

**NOTE**

Before you use the troubleshooting tables, be sure you have performed all applicable operating checks and verified that a malfunction exists. When a corrective action is performed, verify that the action has corrected the malfunction. All malfunction deferred to the next higher level of maintenance must be reported according to the instructions given in DA PAM 738-750.

---

<b>MALFUNCTION</b>
<b>TEST OR INSPECTION</b>
<b>CORRECTIVE ACTION</b>

---

**CABINET ASSEMBLY**

**1. HOLDDOWN CLAMP ASSEMBLY LOOSE.**

Check capscrew, clamp arm, and machine screws.

If capscrew, clamp arm, machine screws or nuts are loose or obviously damaged, notify next higher level of maintenance.

**2. REAR DOOR OR A SIDE DOOR CANNOT BE OPENED.**

Step 1. Inspect door for dirty, cut, broken, or dented surfaces; broken welds; and a bad door gasket.

- a. Clean dirty surfaces using soap and water.
- b. Notify next higher level of maintenance for cut, broken, dented surfaces or welds, and bad door gasket.

Step 2. Check that folding handle lock is not bent, broken, loosely mounted or missing. If folding hand lock is defective or missing, notify next higher level of maintenance.

Step 3. Check that door hinge is not broken or bent. If door hinge is broken or bent, notify next higher level of maintenance.

Table 3-1. Operator Troubleshooting - continued.

MALFUNCTION	TEST OR INSPECTION	CORRECTIVE ACTION
<b>CABINET ASSEMBLY</b>		
<b>3. REAR DOOR OR SIDE DOOR DOES NOT CLOSE.</b>	Inspect door for the same defects as malfunction No. 2.	
<b>4. REAR OR SIDE DOOR WILL NOT STAY IN OPEN POSITION.</b>	Check door stays for mechanical binding and loose or missing door stay mounting brackets.	Notify next higher level of maintenance if door stays will not lock into position due to binding or loose or missing mounting brackets.
<b>5. SEWING MACHINE HEAD IS LOOSELY MOUNTED IN TRAY.</b>	Step 1. Check that tray strap assembly hold down strap is tight. Tighten strap.	Step 2. Check that tray strap footman loop (on tray) is not loosely mounted. If strap footman loop is loose, notify next higher level of maintenance.
<b>6. STOWAGE BOX DOES NOT CLOSE SECURELY.</b>	Step 1. Check that stowage box hinge is not bent or broken. If hinge is bent or broken, notify next higher level of maintenance.	Step 2. Check that stowage box latch and latch hook are not deformed or broken. If latch or latch hook are deformed or broken, notify next higher level of maintenance.
<b>7. GENERATOR IS LOOSELY MOUNTED ON SLID ES.</b>	Step 1. Check that the rear generator holddown bracket is in place and secure. Install rear holddown bracket.	Step 2. Check that the front generator holddown is not cracked or broken. If holddown is damaged, notify next higher level of maintenance.

Table 3-1. Operator Troubleshooting - continued .

MALFUNCTION	TEST OR INSPECTION	CORRECTIVE ACTION
-------------	--------------------	-------------------

**CLOTHING SEWING MACHINE**

**8. NEEDLE BREAKS.**

Step 1. Needle might have become bent or blunted and hit presser footand/or throat plate.

Replace broken needle with new needle of correct size, class, and variety (paras.2-11a and 2-11b).

Step 2. Needle may have had a burr on the point or the eye may have become very dirty.

Replace broken needle with new needle of correct size, class, and variety (paras.2-11a and 2-11b).

Step 3. Needle may have been too fine (wrong size or variety) for the fabric being sewed or the job being done.

Replace broken needle. Be sure it is of the correct size, class, and variety for he fabric being worked and the job to be done (paras.2-11a and 2-11b).

Step 4. You may have inserted the needle incorrectly.

Replace broken needle with new needle of correct size, class, and variety (paras.2-11a and 2-11b). Be sure needle is inserted into the needle bar correctly (para.2-11b).

Table 3-1. Operator Troubleshooting - continued.

<b>MALFUNCTION</b>	<b>TEST OR INSPECTION</b>	<b>CORRECTIVE ACTION</b>
--------------------	---------------------------	--------------------------

### CLOTHING SEWING MACHINE

Step 5. Check machine settings.

- a. Machine settings may have accidentally changed during stitching. Check machine settings and make sure they are correct by following operating instructions of paras. 2-11j and 2-11k.
- b. Replace broken needle with new needle of correct size, class, and variety (paras. 2-11a and 2-11b).

Step 6. Presser foot may have become loose or the throat plate may have moved from full in position.

- a. Replace broken needle with new needle of correct size, class, and variety (paras. 2-11a and 2-11b).
- b. If presser foot is loose, notify next higher level of maintenance.

Step 7. You may have pulled too hard on the fabric while stitching.

- a. Do not pull on fabric while stitching. Allow the feed dogs to pull the fabric while stitching. Follow operating instructions para. 2-11i.
- b. Replace broken needle with new needle of correct size, class, and variety (paras. 2-11a and 2-11b).

## 9. NEEDLE THREAD BREAKS.

Step 1. Check that needle is not installed backward or needle eye is not threaded backward. Check that threading is correct.

- a. If needle is installed backward, reinstall needle correctly in needle bar clamp (para. 2-11b).
- b. Needle should be threaded from left to right through the needle eye and machine must be threaded correctly (para. 2-11 c).

Table 3-1. Operator Troubleshooting continued.

MALFUNCTION	TEST OR INSPECTION	CORRECTIVE ACTION
<b>CLOTHING SEWING MACHINE</b>		
	Step 2. Check that thread is not caught in spool notch or wrapped around spool spindle.	<ul style="list-style-type: none"> <li>a. Clear the wrap-around thread from spindle if necessary and rethread machine (para 2-11c).</li> <li>b. If notch is burred or damaged, notify next higher level of maintenance.</li> </ul>
	Step 3. Check for rough or burred places on thread guides, presser foot, or throat plate hole. If rough or burred places are found, notify next higher level of maintenance.	
	Step 4. Check for bent needle, blunted needle point, or burred needle eye. Discard bent or blunted needle and replace with a new needle of correct size, class and variety (paras. 2-11a and 2-11b).	
	Step 5. Check that the needle is all the way up in needle bar and the needle bar is tight. Insert needle all the way up into needle bar and tighten needle bar clamp (para 2-11b).	
	Step 6. Check for sharp, rough or burred edges on shuttle hook, bobbin case, or tension controls.	If defective parts are found, notify next higher level of maintenance.
	Step 7. Check thread size against needle size.	<ul style="list-style-type: none"> <li>a. Be sure you have selected the right thread weight for the needle being used. It maybe too heavy.</li> <li>b. If the wrong thread is being used, remove thread and rethread machine with the correct weight thread.</li> </ul>
	Step 8. Check that thread is left-twist thread. If thread is right-twist thread, remove thread and replace with left-twist thread. Rethread machine (para. 2-11c).	

Table 3-1. Operator Troubleshooting - continued.

MALFUNCTION	TEST OR INSPECTION	CORRECTIVE ACTION
<b>CLOTHING SEWING MACHINE</b>		
<b>10. BOBBIN THREAD BREAKS.</b>		
	Step 1. Check that bobbin case is threaded correctly and installed correctly.	Thread and install bobbin case correctly (paras. 2-11d through 2-11g).
	Step 2. Check bobbin to see that it is not so full of thread as to keep it from revolving freely in the bobbin case.	Remove excess thread until rounds of thread are even with the rim of the bobbin (para. 2-11e).
	Step 3. Check that rounds of thread on bobbin are not lapped over one another and check that rounds of thread are evenly wound across the bobbin (no - ridges or valleys in the rounds).	Use a correctly wound bobbin or remove thread and rewind bobbin correctly with proper thread (para. 2-11e).
<b>NOTE</b>		
In steps 2 and 3 above, the problem could be misadjustment of bobbin winder.		
	Step 4. Check that bobbin case tension is not too tight.	Adjust bobbin case for correct tension (para. 2-11j).
	Step 5. Check that bobbin case is not sticky with oil and lint.	If bobbin case is sticky, notify next higher level of maintenance.
	Step 6. Check that rough, sharp, or burred edges on oscillating shuttle, bobbin, and bobbin case.	If defects are found, notify next higher level of maintenance.
	Step 7. Check that thread being used is not damp, old, or dried out.	Discard damp, old, or dried out thread. Rewind bobbin with fresh, dry, smooth thread of the correct weight (para. 2-11e).

Table 3-1. Operator Troubleshooting - continued.

MALFUNCTION	TEST OR INSPECTION	CORRECTIVE ACTION
-------------	--------------------	-------------------

### CLOTHING SEWING MACHINE

#### 11. STITCHES SKIP OR FAIL TO LOCK.

##### NOTE

The most common cause of fail-to-lock or skipped stitches is using the wrong needle for the fabric being sewed. Always use the correct size, class, and variety needle recommended for the fabric being worked.

Step 1. Check that needle size, class, and variety is right for the fabric being worked.

If needle is incorrect, replace needle with new needle of correct size, class and variety (paras. 2-11a and 2-11b).

Step 2. There may not be enough pressure on the presser foot for the fabric being worked.

Vary pressure of presser foot using pressure regulator to try and correct trouble:

Step 3. You may be pulling on the fabric while stitching.

Do not pull on fabric while stitching. Let the feed dogs move the fabric under the needle. You should only guide the fabric while stitching.

Step 4. Check that needle is not blunted or bent.

If blunted or bent, replace needle with a new needle of correct size, class, and variety (paras. 2-11a and 2-11b).

##### NOTE

Even if you see nothing wrong with the needle, it may have accumulated lint or sizing from the fabric. This can happen with certain synthetics and permanent press fabrics or in stitching through adhesives. Clean the needle or change it if this problem is suspected.

Step 5. Needle bar is out of adjustment.

Notify next higher level of maintenance.

Table 3-1. Operator Troubleshooting - continued.

MALFUNCTION	TEST OR INSPECTION	CORRECTIVE ACTION
<b>CLOTHING SEWING MACHINE</b>		
<b>12. SEAMS DRAW.</b>		
	Step 1. Needle thread or bobbin thread tension too tight.	Adjust needle thread and bobbin thread to correct tension (para. 2-11j).
	Step 2. Stitches are too long for the fabric(s) being worked.	Vary stitch length by turning the feed regulator dial to correct this problem. (para.2-11h).
<b>13. THREAD SNARLS AT BEGINNING OF SEAM.</b>		
	<b>NOTE</b>	
	Snarls at the start of a seam can usually be prevented by manually placing needle into fabric before lowering presser foot. Be sure you have both needle and bobbin threads under the presser foot and drawn to the rear. Hold both thread ends for the first two sew stitches.	
	Thread and/or fabric are probably pulled down into the bobbin area.	
	a. To release snarl, turn hand wheel back and forth a few times to loosen the caught material. Remove the material and snarled thread and observe the note above before resuming work.	
	b. Check that machine is threaded correctly. Rethread machine if necessary (para. 2-11c).	
<b>14. THREAD SNARLS DURING STITCHING.</b>		
	Step 1. Lint from the bobbin area may be caught in the stitching.	Clean bobbin area of lint.
	Step 2. Bobbin thread may be running out.	Replace bobbin with one fully wound (paras. 2-11d through 2-11g).
	Step 3. Needle thread or bobbin thread tensions may be incorrect.	

Table 3-1. Operator Troubleshooting - continued.

MALFUNCTION	TEST OR INSPECTION	CORRECTIVE ACTION
<b>CLOTHING SEWING MACHINE</b>		
		Adjust needle thread and bobbin thread to correct tension (para. 2-11j).
	Step 4. Machine timing may be off.	Notify next higher level of maintenance.
<b>15. THREAD SNARLS AT END OF SEAM.</b>		
		<b>NOTE</b>
		As a general rule, it is not a good practice to stitch off the fabric. This can cause thread knotting in the bobbin area and snarls at the end of the seam.
	Step 1. Fabric and thread are being pushed into the bobbin area causing knots.	Turn the hand wheel back and forth a few times to loosen snarl; then remove snarl.
	Step 2. Check all machine adjustments and readjust as necessary.	If trouble still persists, notify next higher level of maintenance.
<b>16. BOBBIN THREAD CANNOT BE RAISED THROUGH HOLE IN THROAT PLATE.</b>		
	Step 1. Check bobbin case threading.	Rethread bobbin case (para. 2-11g).
	Step 2. Check that bobbin case is seated in rotary-sewing hook correctly.	Seat bobbin case correctly (para. 2-11f).
<b>17. FEED DOGS STRIKE THROAT PLATE.</b>		
	Check that throat plate is in the full in position.	If throat plate is in the full in position but trouble persists, notify next higher level of maintenance.

**Table 3-1. Operator Troubleshooting - continued.**

<b>MALFUNCTION</b>
<b>TEST OR INSPECTION</b>
<b>CORRECTIVE ACTION</b>
<b>CLOTHING SEWING MACHINE</b>
<b>18. PRESSER FOOT PRESSURE REGULATOR THUMBSCREW IS HARD TO ADJUST.</b>
Presser foot may have been lowered before change was made in the pressure setting.
<ul style="list-style-type: none"> <li>a. Raise presser foot with hand lifter. Decrease pressure on presser foot by turning the pressure adjusting thumbscrew counterclockwise. Lower presser foot and adjust presser foot to the desired pressure for the fabric being worked.</li> <li>b. If presser foot pressure cannot be increased or decreased, notify next higher level of maintenance.</li> </ul>
<b>19. MACHINE VIBRATES .</b>
Step 1 Check that hinge plate mounting screws are tight and check that table is on a flat hard surface.
<ul style="list-style-type: none"> <li>a. If any screws are loose, tighten.</li> <li>b. Relocate table to flat, hard surface, if necessary.</li> </ul>
Step 2. Check that all four felt pads are installed in the table tops.
If any felt pads are missing, notify next higher level of maintenance.
Step 3. Machine motor drive belt is probably too tight.
Adjust belt (paragraph 3-10).
Step 4. Machine drive pulley or balance wheel is out of balance, loose, or installed wrong.
Notify next higher level of maintenance.
<b>20. LAMP DOES NOT LIGHT.</b>
Step 1. Check lamp ON-OFF switch.
Set lamp ON-OFF switch to the ON position.
Step 2. Check that lamp light cord is plugged into power outlet.
Plug in light cord into power outlet.

Table 3-1. Operator troubleshooting - continued

MALFUNCTION	TEST OR INSPECTION	CORRECTIVE ACTION
<b>CLOTHING SEWING MACHINE</b>		
Step 3. Check that light bulb is not broken, burned out, or missing.	If light bulb is burned out, missing, or broken, replace light bulb.	
Step 4. Unplug light cord from outlet and check cord and plug for frayed or broken insulation and wires.	If defective insulation, wiring, or plug is found, notify next higher level of maintenance.	
Step 5. Lamp assembly or lamp ON-OFF switch may be defective.	Replace lamp assembly (para. 3-12).	
Step 6. Electrical power outlet receptacle may be defective.	Notify next higher level of maintenance.	
<b>21. MOTOR DOES NOT START.</b>		
Step 1. Check motor ON/OFF switch.	Set motor ON/OFF switch to ON position.	
Step 2. Check that motor power cable is plugged into distribution power outlet.	Plug power cable into distribution power outlet, (para 2-8n).	
Step 3. Motor ON/OFF switch may be defective.	Notify next higher level of maintenance.	
Step 4. Motor may be defective.	Notify next higher level of maintenance.	

Table 3-1. Operator troubleshooting - continued

MALFUNCTION	TEST OR INSPECTION	CORRECTIVE ACTION
<b>CLOTHING SEWING MACHINE</b>		
<b>22. UNUSUAL NOISE IN MOTOR.</b>	Motor may be defective.	Turn off machine and notify next higher level of maintenance.
<b>23. MOTOR DOES NOT PULL LOAD.</b>	Step 1. Check to see if motor to sewing machine drive belt is loose, slipping, frayed, or deteriorated.	Turn off motor and adjust and/or replace belt (para. 3-10).
	Step 2. Input voltage to motor may be low or motor may be faulty.	Turn off motor and notify next higher level of maintenance.
<b>DARNING SEWING MACHINE</b>		
<b>24. NEEDLE BREAKS.</b>	Step 1. Needle might have become bent or blunted and hit presser foot.	Replace broken needle with new needle of correct size, class, and variety (paras 2-12a and 2-12b).
	Step 2. Needle may have had a burr on the point or the eye may have become very dirty.	Replace broken needle with new needle of correct size, class, and variety (paras 2-12a and 2-12b).
	Step 3. Needle may have been too fine (wrong size, class, and variety) for the fabric being darned or the job being done.	Replace broken needle. Be sure it is of the correct size, class, and variety for the fabric being worked and the job to be done (paras 2-12a and 2-12b).
	Step 4. You may have installed the needle incorrectly.	Replace broken needle with new needle of correct size, class, and variety (paras 2-12a and 2-12b). Be sure needle is inserted into the needle bar correctly.

Table 3-1. Operator troubleshooting - continued

MALFUNCTION	TEST OR INSPECTION	CORRECTIVE ACTION
<b>DARNING SEWING MACHINE</b>		
	Step 5. Check machine settings.	<ul style="list-style-type: none"> <li>a. Machine settings may be wrong or they have accidentally changed during mending. Check machine settings and make sure they are correct by following operating instructions of para. 2-12i.</li> <li>b. Replace broken needle with new needle of correct size, class, and variety (paras 2-12a and 2-12b).</li> </ul>
<b>25. NEEDLE THREAD BREAKS.</b>		
	Step 1. Check that needle is not installed backward or needle eye is not threaded backward. Check that threading is correct.	<ul style="list-style-type: none"> <li>a. If needle is installed backward, reinstall needle correctly in needle bar clamp (para. 2-12b).</li> <li>b. Needle should be threaded from left to right through the needle eye and machine must be threaded correctly (para. 2-12c).</li> </ul>
	Step 2. Check that thread is not caught in spool notch or wrapped around spool spindle.	Smooth notch in spool or change spools as necessary.
	Step 3. Check for rough or burred places on thread guides, presser foot, and latch guard hole.	If rough or burred places are found, notify next higher level of maintenance.
	Step 4. Check for bent needle, blunted needle point or rough/burred needle eye.	Discard bent or blunted needle and replace with a new needle of correct size, class, and variety (paras. 2-12a and 2-12b).
	Step 5. Check that needle is all the way up in needle bar and the needle bar clamp is tight.	Insert needle all the way up into needlebar and tighten needle bar clamp (para. 2-12b).

Table 3-1. Operator troubleshooting - continued

MALFUNCTION	TEST OR INSPECTION	CORRECTIVE ACTION
<b>DARNING SEWING MACHINE</b>		
	Step 6. Check for sharp, rough, or burred edges on rotary-sewing hook, bobbin case, or tension controls.	If defective parts are found, notify next higher level of maintenance.
	Step 7. Check thread size against needle size, variety, and class.	<ul style="list-style-type: none"> <li>a. Be sure you have selected the right thread weight for the needle being used (It may be too heavy).</li> <li>b. If the wrong thread is being used, remove thread and rethread machine with the correct weight thread.</li> </ul>
	Step 8. Check that thread is left-twist thread.	If thread is right-twist thread, remove thread and replace with left-twist thread. Rethread machine (para 2-12c).
	Step 9. Check that thread being used is not damp, old, or dried out.	Discard damp, old, or dried out thread. Rethread machine with fresh, dry, smooth, left-twist thread of the correct weight (para 2-12c).
<b>26. BOBBIN THREAD BREAKS.</b>		
	Step 1. Check that bobbin case is threaded correctly and installed correctly.	Thread and install bobbin case correctly (paras 2-12d through 2-12g).
	Step 2. Check bobbin to see that it is not so full of thread as to keep it from revolving freely in the bobbin case.	Remove excess thread until rounds of thread are even with the rim of the bobbin (para. 2-12e).
	Step 3. Check that rounds of thread on bobbin are not lapped over one another and check that rounds of thread are evenly wound across the bobbin (no ridges or valleys in the rounds).	Use a correctly wound bobbin, or remove thread and rewind bobbin correctly with proper thread (paras 2-12d through 2-12g).

Table 3-1. Operator troubleshooting - continued

MALFUNCTION	TEST OR INSPECTION	CORRECTIVE ACTION
<b>DARNING SEWING MACHINE</b>		
	Step 4. Check that bobbin case tension is not too tight.	Adjust bobbin case for correct tension (para 2-12i).
	Step 5. Check that bobbin case is not sticky with oil and lint.	If bobbin case is sticky, notify next higher level of maintenance.
	Step 6. Check for rough, sharp, or burred edges on rotary-sewing hook, bobbin, and bobbin case.	If defects are found, notify next higher level of maintenance.
	Step 7. Check that thread being used is not damp, old, or dried out.	Discard damp, old, or dried out thread. Rewind bobbin with fresh, dry, smooth thread of the correct weight (paras 2-12d through 2-12g).

**27. STITCHES SKIP OR FAIL TO LOCK.****NOTE**

The most common cause of fail-to-lock or skipped stitches, is using the wrong needle for the fabric being mended. Always use the correct size, class, and variety needle recommended for the fabric being worked.

Step 1. Check that needle size, class, and variety is right for the fabric in work.

If needle is incorrect, replace needle with new needle of correct size, class, and variety (paras. 2-12a and 2-12b).

Step 2. There may not be enough pressure on the presser foot for the fabric being worked.

Vary pressure of presser foot using pressure regulator to try and correct trouble.

Step 3. Check that needle is not blunted or bent.

If blunted or bent, replace needle with a new needle of correct size, class, and variety (paras. 2-12a and 2-12b).

Table 3-1. Operator troubleshooting - continued

MALFUNCTION	TEST OR INSPECTION	CORRECTIVE ACTION
-------------	--------------------	-------------------

### DARNING SEWING MACHINE

#### NOTE

Even if you see nothing wrong with the needle, it may have accumulated lint or sizing from the fabric. This can happen with certain synthetics and permanent press fabrics or in stitching through adhesives. Clean the needle or change it if this problem is suspected.

Step 4. Needle bar is out of adjustment.

Notify next higher level of maintenance.

#### 28. SEAMS DRAW.

Needle thread or bobbin thread tension too tight.

Adjust needle thread and bobbin thread to correct tension (para. 2-12i).

#### 29. THREAD SNARLS AT BEGINNING OF DARN.

#### NOTE

Snarls at the start of a mend can usually be prevented by manually placing needle into fabric before lowering pressure foot. Be sure you have both needle and bobbin threads under the presser foot and drawn to the rear. Hold both thread ends for the first two sew stitches.

Thread and/or fabric are probably pulled down into the bobbin area.

- a. To release snarl, turn handwheel back and forth a few times to loosen the caught material. Remove the material and snarled thread and observe the note above before resuming work.
- b. Check that machine is threaded correctly. Rethread machine if necessary (para. 2-12c).

Table 3-1. Operator troubleshooting - continued

MALFUNCTION	TEST OR INSPECTION	CORRECTIVE ACTION
<b>DARNING SEWING MACHINE</b>		
<b>30. THREAD SNARLS DURING DARNING.</b>		
	Step 1. Lint from the bobbin area may be caught in the stitching.	Clean bobbin area of lint.
	Step 2. Bobbin thread may be running out.	Replace with a fully wound bobbin (paras 2-12d through 2-12g).
	Step 3. Needle thread or bobbin thread tensions may be incorrect.	Adjust needle thread and bobbin thread to correct tension (para 2-12i).
	Step 4. Machine timing may be off.	Notify next higher level of maintenance.
<b>31. THREAD SNARLS AT END OF DARN.</b>		
	<b>NOTE</b>	
	As a general rule, it is not a good practice to mend off the fabric. This can cause thread knotting in the bobbin area and snarls at the end of the mend.	
	Step 1. Fabric and thread are being pushed into the bobbin area causing knots.	Turn the handwheel back and forth a few times to loosen snarl; then remove snarl.
	Step 2. Check all machine adjustments and readjust as necessary.	If trouble still persists, notify next higher level of maintenance.
<b>32. BOBBIN THREAD CANNOT BE RAISED THROUGH HOLE IN LATCH PLATE .</b>		
	Step 1. Check bobbin case threading.	Rethread bobbin case (para 2-12e).

Table 3-1. Operator troubleshooting - continued

MALFUNCTION	TEST OR INSPECTION	CORRECTIVE ACTION
<b>DARNING SEWING MACHINE</b>		
	Step 2. Check that bobbin case is seated in rotary-sewing hook correctly.	Seat bobbin case correctly (para 2-12f).
<b>33. PRESSER FOOT PRESSURE REGULATOR THUMBSCREW IS HARD TO ADJUST .</b>		Presser foot may have been lowered before change was made in the pressure setting.
	a. Raise presser foot with hand lifter. Decrease pressure on presser foot by tuning the pressure adjusting thumbscrew counterclockwise. Lower presser foot and adjust presser foot to the desired pressure for the fabric being worked.	
	b. If presser foot pressure cannot be increased or decreased, notify next higher level of maintenance.	
<b>34. MACHINE VIBRATES.</b>		Step 1. Check that machine-to-table mounting screws are tight and check that table is on a flat hard surface.
	a. If mounting screws are loose, notify next higher level of maintenance.	
	b. Relocate table to flat, hard surface, if necessary.	
	Step 2. Machine motor drive belt is too tight.	Adjust belt (paragraph 3-10).
	Step 3. Machine drive pulley or balance wheel out-of-balance, loose, or installed wrong.	Notify next higher level of maintenance.
<b>35. LAMP DOES NOT LIGHT.</b>		Step 1. Check lamp ON/OFF switch.
		Set lamp ON/OFF switch to the ON position.
	Step 2. Check that lamp light cord is plugged into input power outlet.	Plug in light cord into power outlet, if necessary.

Table 3-1. Operator troubleshooting - continued

MALFUNCTION	TEST OR INSPECTION	CORRECTIVE ACTION
<b>DARNING SEWING MACHINE</b>		
	Step 3. Check that light bulb is not broken, burned out, or missing.	If light bulb is burned out, missing, or broken, replace light bulb.
	Step 4. Unplug light cord from outlet and check cord and plug for frayed or broken insulation and wires.	If defective insulation, wiring, or plug is found, notify next higher level of maintenance.
	Step 5. Lamp assembly or lamp ON/OFF switch may be defective.	Replace lamp assembly. (para. 3-12).
	Step 6. Electrical power outlet receptacle may be defective.	Notify next higher level of maintenance.
<b>36. MOTOR DOES NOT START.</b>	Step 1. Check motor ON/OFF switch.	Set motor ON/OFF switch to ON position.
	Step 2. Check that motor power cable is plugged into distribution power outlet.	Plug power cable into distribution power outlet, (para 2-8n).
	Step 3. Motor ON/OFF switch may be defective.	Notify next higher level of maintenance.
	Step 4. Motor may be defective.	Notify next higher level of maintenance.

Table 3-1. Operator troubleshooting - continued

MALFUNCTION	TEST OR INSPECTION	CORRECTIVE ACTION
<b>DARNING SEWING MACHINE</b>		
<b>37. UNUSUAL NOISE IN MOTOR.</b>		<p>Motor may be defective.</p> <p>Turn off motor and notify next higher level of maintenance.</p>
<b>38. MOTOR DOES NOT PULL LOAD.</b>		<p>Step 1. Check to see if motor to sewing machine drive belt is loose, slipping, frayed, or deteriorated.</p> <p>Turn off motor, adjust and/or replace belt (para 3-10).</p> <p>Step 2. Input voltage to motor may be low or motor may be faulty.</p> <p>Turn off motor and notify next higher level of maintenance.</p>
<b>BUTTON SEWING MACHINE</b>		
<b>39. NEEDLE BREAKS.</b>		<p>Step 1. Needle may have been wrong size, class, and variety. Check needle size.</p> <p>Replace broken needle with new needle of correct size, class, and variety (paras 2-13a and 2-13b).</p> <p>Step 2. Needle may have become bent or has a blunt point.</p> <p>Replace broken needle with new needle of correct size, class, and variety (paras 2-13a and 2-13b).</p> <p>Step 3. Button was not aligned firmly and correctly in button clamp.</p> <p>a. Replace broken needle with new needle of correct size, class, and variety (paras 2-13a and 2-13b).</p> <p>b. Align button firmly and correctly in button clamp (paras 2-13e and 2-13f)..</p> <p>Step 4. Make sure you are not stepping on motor starting treadle before lowering button clamp on material firmly with button clamp treadle.</p> <p>Be sure button clamp is firmly down on material before starting machine with motor starting treadle.</p>

Table 3-1. Operator troubleshooting - continued

MALFUNCTION	TEST OR INSPECTION	CORRECTIVE ACTION
<b>BUTTON SEWING MACHINE</b>		
	Step 5. Two-hole or four-hole regulator is not set to correspond with number of holes in button.	<ul style="list-style-type: none"> <li>a. Replace broken needle with new needle of correct size, class, and variety (paras. 2-13a and 2-13b).</li> <li>b. Set two-hole or four-hole regulator to the position corresponding to the number of holes in the button (para 2-13j). Lock button clamp in position with thumbscrew (para. 2-13f).</li> </ul>
	Step 6. Button clamp is out of adjustment.	Adjust (refer to para. 2-13k).
	Step 7. Looper is out of adjustment.	Notify next higher level of maintenance.
<b>40. THREAD BREAKS.</b>		
	Step 1. Check that machine is threaded correctly.	Rethread machine in accordance with para. 2-13c.
	Step 2. Check needle size, class and variety.	Install new needle of correct size, class, and variety (paras 2-13a and 2-13b).
	Step 3. Check needle point.	Install new needle of correct size, class, and variety if needle point is blunt, blurred, or broken (paras. 2-13a and 2-13b).
	Step 4. Check thread tension.	Adjust thread tension if tension is too tight or too loose (para 2-13d).

Table 3-1. Operator troubleshooting - continued

MALFUNCTION	TEST OR INSPECTION	CORRECTIVE ACTION
<b>BUTTON SEWING MACHINE</b>		
	Step 5. Check quality and condition of thread.	Replace thread if damp or defective (para. 2-13c).
	Step 6. Check twist of thread.	Thread must be left-twist thread. Replace thread (para. 2-13c) if right-twist thread is being used.
	Step 7. Check thread size.	Use correct size thread.
	Step 8. Check looper.	If looper has rough edges or point is bent, notify next higher level of maintenance.
	Step 9. Rear thread tension disks out of adjustment.	Do not attempt to adjust rear thread tension disks, notify next higher level of maintenance.
<b>41. LAMP DOES NOT LIGHT.</b>	Step 1. Check lamp ON/OFF switch.	Set lamp ON/OFF switch to the ON position.
	Step 2. Check that lamp light cord is plugged into input power outlet.	Plug in light cord into power outlet.
	Step 3. Check that light bulb is not broken, burned out, or missing.	If light bulb is burned out, missing, or broken, replace light bulb.
	Step 4. Unplug light cord from outlet and check cord and plug for frayed or broken insulation and wires.	If defective insulation, wiring, or plug is found, replace lamp assembly (para. 3-12).

Table 3-1. Operator troubleshooting - continued

MALFUNCTION	TEST OR INSPECTION	CORRECTIVE ACTION
<b>BUTTON SEWING MACHINE</b>		
	Step 5. Lamp assembly or lamp ON/OFF switch may be defective.	Replace lamp assembly (para. 3-12).
	Step 6. Electrical power outlet receptacle may be defective.	Notify next higher level of maintenance.
<b>42. MOTOR DOES NOT START.</b>	Step 1. Check motor ON/OFF switch.	Set motor ON/OFF switch to the ON position.
	Step 2. Check that motor power cable is plugged into input power outlet.	Plug power cable into input power outlet, if necessary.
	Step 3. Motor ON/OFF switch may be defective.	Notify next higher level of maintenance.
	Step 4. Motor may be defective.	Notify next higher level of maintenance.
<b>43. UNUSUAL NOISE IN MOTOR.</b>	Motor may be defective.	Turn off motor and notify next higher level of maintenance.
<b>44. MOTOR DOES NOT PULL LOAD.</b>	Step 1. Check to see if motor to sewing machine drive belt is loose, has slipped, frayed or deteriorated.	Turn off motor and adjust and/or replace belt (para 3-10).
	Step 2. Input voltage to motor may be low or motor may be faulty.	Turn off motor and notify next higher level of maintenance.

Table 3-1. Operator troubleshooting - continued

MALFUNCTION	TEST OR INSPECTION	CORRECTIVE ACTION
<b>GROMMET PRESS</b>		
<b>45. HANDLEVER STICKS ON DOWNSTROKE.</b>	Check frame and handlever pivot for dirt or other obstruction.	Clean inside of frame and pivot.
<b>46. FASTENERS ARE LOOSE.</b>	Step 1. Be sure you are using enough downward hand pressure on lever.	Apply hand pressure on lever more firmly.
	Step 2. Check that snap fastener parts are inserted properly.	Insert snap fastener parts properly in chucks and dies (para. 2-14d).
<b>47. MACHINE CUTS MATERIAL</b>	Pressure is too great on hand lever.	Decrease pressure on hand lever.
<b>TACK-BUTTON ATTACHING MACHINE</b>		
<b>48. HANDLEVER STICKS ON DOWNSTROKE.</b>	Check frame and handlever pivot for dirt or other obstruction.	Clean inside frame and pivot.
<b>49. UPPER DIE DOES NOT HOLD BUTTON FIRMLY.</b>	Inspect upper die wires.	If upper die wires are loose or broken, replace die.

Table 3-1. Operator troubleshooting - continued

MALFUNCTION	TEST OR INSPECTION	CORRECTIVE ACTION
<b>TACK-BUTTON ATTACHING MACHINE</b>		
<b>50. DOUBLE-PRONGED TACK DOES NOT FIT PROPERLY INTO HOLES IN BUTTON.</b>	Check that tack is properly installed in lower die.	Install tack in lower die properly.
<b>51. MACHINE CUTS MATERIAL.</b>	Check pinch adjustment.	Pinch adjusted too tight. Adjust pinch properly (para. 2-15b).
<b>52. SHANK OF LOWER DIE BINDS.</b>	Pin on lower die is interfering with spring.	Notify next higher level of maintenance.
<b>HEAT SEALING MACHINE</b>		
<b>53. MACHINE DOES NOT HEAT.</b>	Step 1. Check ON/OFF switch.	Set ON/OFF switch to the ON position (para. 2-16a).
	Step 2. Be sure unit is plugged in.	Plug heat sealer into the outlet (para. 2-8n).
	Step 3. Unplug heat sealer from outlet and check cord and plug for frayed or broken insulation and wires.	If defective insulation, wiring, or plug is found, notify next higher level of maintenance.
	Step 4. Heat sealing machine or ON/OFF switch may be defective.	Notify next higher level of maintenance.

---

### Section III. OPERATOR MAINTENACE PROCEDURES

#### 3-9. GENERAL

This section contains information on the adjustment of the various items that are maintainable at the Crew/Operator Level.

#### 3-10. DRIVE BELT ADJUST AND REPLACE.

---

This task consists of: (a) Drive Belt Adjustment (b) Drive Belt Replacement

---

##### INITIAL SET-UP:

##### Tools:

Wrench, Adjustable

##### Equipment Condition:

Electrical power removed (para. 2-18).  
Sewing Tables Set-Up and Machines Installed (para. 2-8).

##### Belt Adjustment

##### (1) Belt Tightening.

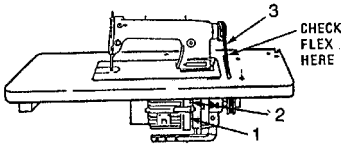

(a) Loosen lower nut (1).

(b) Turn upper nut (2) counterclockwise to tighten belt (3).

(c) Tighten upper nut (2) until belt flex is 1/2 inch (1.27 cm.) at center of belt (3).

(d) Tighten lower nut (1).

##### (2) Belt Loosening.

(a) Loosen upper nut (2) clockwise until belt flex is 1/2 inch (1.27 cm) at center of belt (3).

(b) Tighten lower nut (1).

**3-10. DRIVE BELT ADJUST AND REPLACE - continued.**

Belt Replacement

- (1) Remove old belt as instructed in paragraph 2-18.
- (2) Install new belt as instructed in paragraph 2-8.

**3-11 PADLOCK REPLACEMENT.**

This task consists of: (a) Removal

(b) Installation

**INITIAL SET-UP:****Tools:**

General Mechanics Tool Kit (Appendix B, Item 1)

**Materials/Parts:**

Wiping rag (Appendix F, Item 2)

Sealing Compound (Appendix F, Item 7)

Washers, Lock

**Equipment Condition:**

Doors Unlocked (para 2-8).

Removal

- (1) Remove screw (1), nut (2), lock washer (3) and padlock set (4).
- (2) Remove old sealing compound from hardware.

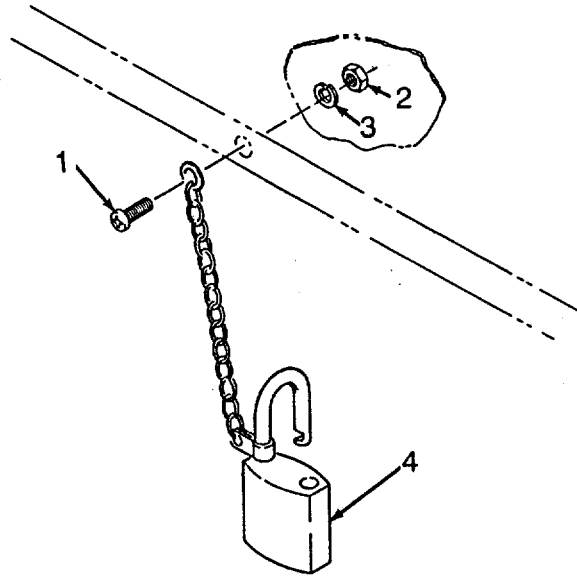

3-36

**3-11 PADLOCK REPLACEMENT - continued.**Installation**NOTE**

All padlocks in a padlock set are keyed to the same key.

- (1) Place sealing compound (Appendix F, Item 7) around base of the head of screw (1).
- (2) Install padlock set (2). Secure with screw (1), lock washer (3), nut (4).
- (3) Wipe excessive sealing compound away using a wiping rag (Appendix F, Item 2).

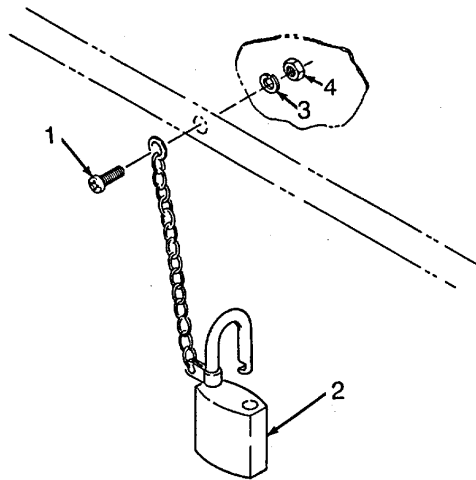

**3-12. LAMP ASSEMBLY REPLACEMENT.**

---

This task consists of: (a) Removal (b) Installation

---

**INITIAL SET-UP:****Tools:**

General Mechanics Tool Kit (Appendix B, Item 1).

**Equipment Condition:**

Operational Condition (para. 2-8).

Removal

Unplug and remove lamp assembly from the table top (para. 2-18).

Installation

- (1) Install new lamp assembly on the table top (para 2-8). Be sure the felt on the clamp is on the table top and the thumbscrew is on the bottom.
- (2) Plug lamp assembly into the receptacle under the table top.

**CHAPTER 4**  
**UNIT MAINTENANCE INSTRUCTIONS**

<b>Paragraph</b>		<b>Page</b>
<b>Section I.</b>	<b>Repair Parts, Special Tools, TMDE, and Support Equipment .....</b>	<b>4-3</b>
4-1.	Common Tools and Equipment.....	4-3
4-2.	Special Tools, TMDE and Support Equipment.....	4-3
4-3.	Repair Parts .....	4-3
<b>Section II.</b>	<b>Service Upon Receipt.....</b>	<b>4-4</b>
4-4.	Site and Shelter Requirements.....	4-4
4-5.	Service Upon Receipt of New or Replacement Equipment.....	4-4
4-6.	Service Upon Receipt of Complete Clothing Repair Shop.....	4-5
<b>Section III.</b>	<b>Unit Preventive Maintenance Checks and Services (PMCS).....</b>	<b>4-6</b>
4-7.	General .....	4-6
4-8.	Warnings and Cautions.....	4-6
4-9.	PMCS Table.....	4-7
<b>Section IV.</b>	<b>Unit Troubleshooting .....</b>	<b>4-30</b>
4-10.	Introduction .....	4-30
4-11.	Troubleshooting.....	4-30
4-12.	Malfunction Index.....	4-30
4-13.	Unit Troubleshooting Table.....	4-31
<b>Section V.</b>	<b>Unit Maintenance Procedures.....</b>	<b>4-39</b>
4-14.	General .....	4-39
4-15.	Personal Safety.....	4-39
4-16.	Proper Equipment.....	4-39
4-17.	Lifting Eye Assembly Maintenance.....	4-40
4-18.	Clothing Sewing Machine Tray Maintenance.....	4-42
4-19.	Clothing Sewing Machine Thread Unwinder Maintenance.....	4-45
4-20.	Clothing Sewing Machine Lever Guard and Thread Guard Maintenance.....	4-46
4-21.	Clothing Sewing Machine Thread Guides Maintenance.....	4-48
4-22.	Clothing Sewing Machine Face Plate and Oil Cover Maintenance.....	4-51
4-23.	Clothing Sewing Machine Thread Tensioner Maintenance.....	4-54
4-24.	Clothing Sewing Machine Belt Guard Maintenance.....	4-58
4-25.	Clothing Sewing Machine Table Top Assembly Maintenance.....	4-59
4-26.	Bobbin Winder Maintenance.....	4-61
4-27.	Clothing Sewing Machine Knee Lever Assembly Maintenance.....	4-62
4-28.	Clothing Sewing Machine Clutch and Motor Assembly Maintenance.....	4-65
4-29.	Clothing Sewing Machine Clutch and Motor Belt Guard Maintenance.....	4-66
4-30.	Clothing Sewing Machine Treadle Rod Assembly Maintenance.....	4-68
4-31.	Clothing Sewing Machine Treadle Pipe Maintenance.....	4-69
4-32.	Clothing Sewing Machine Stand Assembly Maintenance.....	4-70
4-33.	Darning Sewing Machine Tray Maintenance.....	4-75
4-34.	Darning Sewing Machine Thread Unwinder Stand Maintenance.....	4-79
4-35.	Darning Sewing Machine Belt Guard Maintenance.....	4-80
4-36.	Darning Sewing Machine Thread Guides Maintenance.....	4-81
4-37.	Darning Sewing Machine Slide, Needle and Guide Plates Maintenance.....	4-86
4-38.	Darning Sewing Machine Presser Foot, Needle Guards and Guide Maintenance.....	4-89
4-39.	Darning Sewing Machine Table Top Assembly Maintenance.....	4-91
4-40.	Darning Sewing Machine Machine Foot Pedal Maintenance.....	4-92

<b>Paragraph</b>		<b>Page</b>
<b>Section V.</b>	<b>Unit Maintenance Procedures (Continued)</b>	
4-41.	Darning Sewing Machine Clutch and Motor Assembly Maintenance.....	4-93
4-42.	Darning Sewing Machine Clutch and Motor Belt Guard Maintenance.....	4-94
4-43.	Darning Sewing Machine Treadle Rod Assembly Maintenance.....	4-96
4-44.	Darning Sewing Machine Treadle Pipe Maintenance.....	4-97
4-45.	Darning Sewing Machine Stand Assembly Maintenance.....	4-98
4-46.	Button Sewing Machine Tray Maintenance.....	4-103
4-47.	Button Sewing Machine Single Thread Stand Maintenance.....	4-106
4-48.	Button Sewing Machine Foot Pedal Maintenance.....	4-107
4-49.	Button Sewing Machine Adjustment Procedures.....	4-108
4-50.	Button Sewing Machine Table Top Assembly Maintenance.....	4-122
4-51.	Button Sewing Machine Belt Guard Maintenance.....	4-123
4-52.	Button Sewing Machine Bed Assembly Maintenance.....	4-124
4-53.	Button Sewing Machine Motor Belt Guard Maintenance.....	4-127
4-54.	Button Sewing Machine Stand Assembly Maintenance.....	4-129
4-55.	Stowage Box Assembly Maintenance.....	4-134
4-56.	Folding Table Maintenance .....	4-136
4-57.	Heat Sealer Base Maintenance.....	4-139
4-58.	Heat Sealer Console Maintenance.....	4-142
4-59.	Heat Sealer Block Assembly Maintenance.....	4-146
4-60.	Distribution Box Maintenance.....	4-149
4-61.	Power Box Assembly Maintenance.....	4-154
4-62.	Ironing Board Maintenance.....	4-159
4-63.	Hand Tack Machine Maintenance.....	4-162
4-64.	Grommet Press Maintenance.....	4-163
<b>Section VI.</b>	<b>Preparation For Storage or Shipment .....</b>	<b>4-164</b>
4-65.	Security Procedures.....	4-164
4-66.	Administrative Storage .....	4-164

**Section I. REPAIR PARTS, SPECIAL TOOLS, TMDE,  
AND SUPPORT EQUIPMENT**

**4-1. COMMON TOOLS AND EQUIPMENT.**

For authorized common tools and equipment refer to the Modified Table of Organization and Equipment (MTOE) applicable to your unit.

**4-2. SPECIAL TOOLS, TMDE, AND SUPPORT EQUIPMENT**

No special tools, TMDE, or support equipment is authorized for the maintenance of the clothing repair shop.

**4-3. REPAIR PARTS.**

Repair parts are listed and illustrated in the repair parts and special tools list TM 10-3530-207-24P covering unit, direct support, general support, and depot maintenance for this equipment.

---

## Section II. SERVICE UPON RECEIPT

### 4-4. SITE AND SHELTER REQUIREMENTS.

#### a. Fixed Site.

When operating the clothing repair shop at a fixed site, select an area that is flat and level, and provides good water drainage away from clothing repair shop.

#### b. Shelter Requirements.

The clothing repair shop does not require special sheltering. If shelter is available, storing the clothing repair shop under cover will minimize routine maintenance. When operating the clothing repair shop, adequate shelter will need to be provided to protect the contents from the elements.

### 4-5. SERVICE UPON RECEIPT OF NEW OR REPLACEMENT EQUIPMENT.

When new or replacement items of equipment are received by the using organization, they must be unpacked and inspected before they are fielded as part of the clothing repair shop. The services performed are the responsibility of unit personnel as described below:

#### a. Unpacking New or Replacement Equipment

#### **CAUTION**

Use caution when unpacking the equipment from the original shipping containers. The use of screwdrivers and prybars to open shipping containers can cause damage to equipment if not used properly. Observe all precautions noted on the shipping tag.

- (1) Remove and discard all tape and materials used in packing the equipment.
- (2) Remove and discard any desiccant packages that may have been used in the packaging.
- (3) Remove any preservative compounds that may have been sprayed on metal surfaces prior to packaging. Because these compounds are not lubricants, take special care to remove them from all wearing surfaces.

**4-5. SERVICE UPON RECEIPT OF NEW OR REPLACEMENT EQUIPMENT continued.**

- b. Checking Unpacked New Equipment or Replacement Equipment Check unpacked items of equipment as follows:
- (1) Inspect the equipment for damage incurred during shipment. If the equipment has been damaged, report the damage on DD Form 6, Packaging Improvement Report.
  - (2) Check the equipment against the packing slip to see if the shipment is complete. Report all discrepancies in accordance with the instructions contained in DA PAM 738-750.
  - (3) Check to see whether the equipment has been modified. If equipment has been modified, check equipment decals to insure that the Modification Work Order has been completed and dated.

**4-6. SERVICE UPON RECEIPT OF COMPLETE CLOTHING REPAIR SHOP.**

When either a new or used clothing repair shop is received by a unit, the unit personnel must inspect and service each component to prepare it for operation. The operator will assist the unit personnel when he is directed to do so.

- a. Unpacking and Unloading of Equipment From Cabinet Assembly

**CAUTION**

Use caution when unpacking the equipment from the original shipping containers. The use of screwdrivers and prybars to open shipping containers can cause damage to equipment if not used properly. Observe all precautions noted on the shipping tag.

- (1) Remove the equipment from the cabinet assembly and set it up in accordance with the instructions contained in Chapter 2, Section III of this manual.
  - (2) Remove and discard all protective tape and packing material.
  - (3) As the cabinet assembly is unloaded, check the equipment against the Components of End Item List (COEIL), contained in Appendix C of this manual to ensure that all items of the clothing repair shop are accounted for.
- b. Inspection and Servicing of Unpacked Equipment
- (1) Carry out a complete visual inspection of the clothing repair shop equipment, taking special notice of any damaged or missing parts which might have been sustained in transit. Read any warnings on the shipping tag to determine the condition in which the clothing repair shop was shipped. Observe all precautions noted on the shipping tag.

**4-6. SERVICE UPON RECEIPT OF COMPLETE CLOTHING EQUIPMENT - continued.**

- b. Inspection and Servicing of Unpacked Equipment - continued
  - (2) Perform the preventive maintenance checks and services (PMCS) described in Section III of this chapter.
  - (3) Perform the lubrication services contained in Chapter 3, Section I of this manual.
  - (4) Perform PMCS and lubrication services for the generator set as described in TM 5-6115-271-14.
  - (5) Perform the PMCS and lubrication services for the cargo trailer as described in TM 9-2330-213-14.

**NOTE**

The services performed at this time will begin the cycle of regularly scheduled quarterly preventive maintenance services.

---

**Section III. UNIT PREVENTIVE MAINTENANCE CHECKS AND SERVICES (PMCS)****4-7. GENERAL**

- a. The Preventive Maintenance Checks and Services presented in Table 4-1 list the inspections and care of your equipment required to keep it in good operating condition and ready for its primary mission.
- b. When a check and service procedure is required for both weekly and monthly intervals, it is not necessary to do the procedure twice if the equipment is operated during the weekly period.

**4-8. WARNINGS AND CAUTIONS.**

Always observe the WARNINGS and CAUTIONS appearing in the PMCS table. Warnings and cautions appear before applicable procedures. You must observe WARNINGS and CAUTIONS to prevent serious injury to yourself and others or prevent your equipment from being damaged.

**4-9. PMCS TABLE.**

Refer to Table 4-1 for Preventive Maintenance Checks and Services.

Explanation of entries:

- a. Item Number Column. Numbers in this column are for reference. When completing DA Form 2404 (Equipment Maintenance and Inspection Worksheet), include the item number for the check/service indicating a fault. Item numbers also appear in the order that you must do checks and services for the intervals listed.
- b. Interval Columns. This column tells you when you must do the procedure in the procedure column. WEEKLY procedures must be done during the seven day operating period. MONTHLY procedures must be done during the time you are operating or using the equipment for its intended mission.
- c. Location, Item to Check/Service Column. This column provides the location and the item to be checked or serviced. The item location is underlined.
- d. Procedure Column. This column gives the procedure you must do to check or service the item listed in the Check/Service column to know if the equipment is ready or available for its intended mission or for operation. You must do the procedure at the time stated in the interval column.
- e. Not Fully Mission Capable If: Column. Information in this column tells you what faults will keep you equipment from being capable of performing its mission. If you make check and service procedures that show faults listed in this column, do not operate the equipment. Follow standard operating procedures for maintaining the equipment or reporting equipment failure.

**Table 4-1. Unit Preventive Maintenance Checks and Services for Clothing Repair Shop.**

**NOTE**

If the equipment must be kept in continuous operation, do only the procedures that can be done without disturbing operation. Make complete checks and services when the equipment is shut down.

ITEM NO.	INTERVAL	<u>LOCATION</u> ITEM TO CHECK/ SERVICE	PROCEDURE	NOT FULLY MISSION CAPABLE IF:
1	Weekly	<b>CABINET ASSEMBLY</b>  Doors and hinges	a. Inspect the rear and side door for broken welds, dented surfaces or deteriorated gasket.  b. Inspect the hinges for loose or missing rivets and make certain doors will open and close without binding.	Broken welds or binding  Parts are loose, missing or damaged or if doors bind

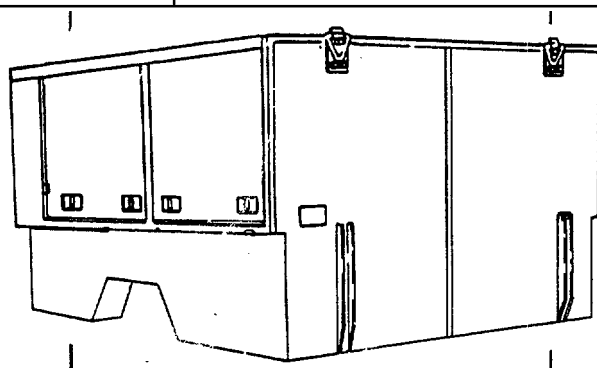

**Table 4-1. Unit Preventive Maintenance Checks and Services for Clothing Repair Shop.**

ITEM NO.	INTERVAL	LOCATION ITEM TO CHECK/ SERVICE	PROCEDURE	NOT FULLY MISSION CAPABLE IF:
2	Weekly	<p><b>CABINET ASSEMBLY - continued</b></p> <p>Door and panel latches</p>	<p>a. Inspect for bent or broken door and panel latches. Check the latches for binding, broken welds or loose mounting.</p> <p>b. Check operation of the handles to see that they lock and unlock the doors. fail to function.</p>	<p>Loose or broken welds</p> <p>Broken</p>
3	Weekly	Door stays	Inspect for bent or broken rear and side door stays. Be sure the stays will lock and hold the door in the open position.	Stay is missing or broken or door will not lock open
4	Weekly	Lifting eyes	Inspect for loose hardware and bent, cracked, or damaged loops.	Loose or cracked
5	Weekly	Fire extinguisher	<p>a. Check that handle and trigger assembly is not damaged and that nozzle is not bent or broken. Replace fire extinguisher if required.</p> <p>b. Inspect fire extinguisher mounting bracket for bent or broken frame. Check that locking latch operates properly and that bracket is securely mounted to cabinet frame. Replace fire extinguisher mounting bracket if required.</p>	Bent or broken

**Table 4-1. Unit Preventive Maintenance Checks and Services for Clothing Repair Shop.**

ITEM NO.	INTERVAL	<u>LOCATION</u> ITEM TO CHECK/ SERVICE	PROCEDURE	NOT FULLY MISSION CAPABLE IF:
6	Weekly holddown	<p><b>CABINET ASSEMBLY - continued</b></p> <p>Cabinet missing. clamp assembly</p>	<p>Check that no holddown clamps are broken or threads are not stripped on knurled clamp screws or clamping bracket. Check that holddown clamp assemblies are tight, and securely clamp the cabinet assembly to the trailer. Tighten as required.</p>	<p>Loose or broken parts</p>

**Table 4-1. Unit Preventive Maintenance Checks and Services for Clothing Repair Shop.**

ITEM NO.	INTERVAL	LOCATION ITEM TO CHECK/ SERVICE	PROCEDURE	NOT FULLY MISSION CAPABLE IF:
7	Weekly	<p><b>CLOTHING SEWING MACHINE</b></p> <p>Needle, thread guide and clamp</p>	<p>Inspect needle for broken or worn point and for bent or broken shaft. Make certain needle is installed properly. Inspect for broken, bent, or improperly installed thread guide and clamp. Refer to paragraph 2-11 for needle replacement.</p>	<p>Missing or broken</p>

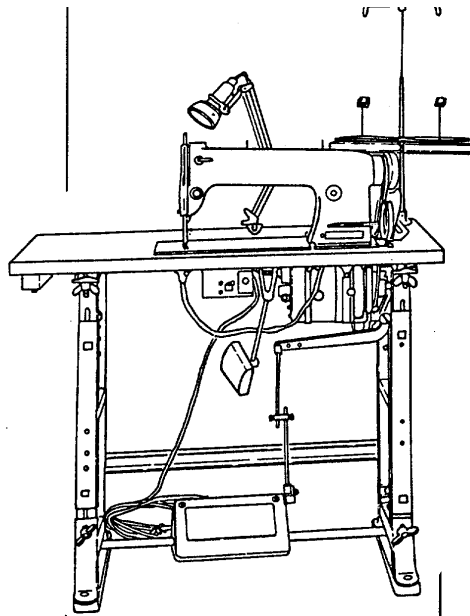

4-11

**Table 4-1. Unit Preventive Maintenance Checks and Services for Clothing Repair Shop.**

ITEM NO.	INTERVAL	LOCATION ITEM TO CHECK/ SERVICE	PROCEDURE	NOT FULLY MISSION CAPABLE IF:
8	Weekly	<b>CLOTHING SEWING MACHINE - continued</b> Lamp assembly	Inspect lamp assembly and bracket for loose or missing bolts, nuts, and screws. Inspect electrical cord for frayed insulation and broken wiring. Inspect for broken bulb switch and for broken or burned out lamp. Replace a defective bulb.	Light fails
9	Weekly	Drive belt and pulleys	Inspect for broken, frayed, and excessively worn drive belt. Inspect belt for loose mounting on the pulleys. Inspect pulleys for cracked, chipped, or broken edges. Check for a 1/2 inch deflection of belt (para. 3-10) midway between pulleys,	Broken, loose or too tight belt
10	Weekly	Bobbin winder broken,	Inspect bobbin winder for bent, loose or missing components. Inspect for excessively worn belt brake, for incorrect tension of thread tension spring, and for improper tension of the pulley with the drive belt. Replace damaged bobbin winder. Adjust bobbin winder (para. 2-11) if out of adjustment. If drive belt tension is improper, adjust belt (para. 3-10).	Bent or broken

**Table 4-1. Unit Preventive Maintenance Checks and Services for Clothing Repair Shop.**

ITEM NO.	INTERVAL	LOCATION ITEM TO CHECK/ SERVICE	PROCEDURE	NOT FULLY MISSION CAPABLE IF:
11	Weekly	<p><b>CLOTHING SEWING MACHINE - continued</b></p> <p>Motor clutch, rod and treadle</p>	<p>Inspect motor clutch, rod, and treadle for bent, broken, or loose components. Operate treadle and see that the clutch engages the motor drive pulley with the drive when the treadle is depressed. Make certain the pulley brake lever disengages the stops and pulley when the treadle is released. Adjust clutch and motor assembly per paragraph 4-29.</p>	<p>Bent, broken, or loose components</p>
12	Weekly	<p>Electrical motor and switch</p>	<p>Inspect electrical motor for dirty surfaces and grease deposits; for bent, cracked, or broken housing; for loose or missing bolts; for loose electrical connections; for frayed insulation and broken wiring; for loose mounting. Inspect for broken motor switch. Inspect for loose mounting in the switch-box. Clean a dirty motor and switch by wiping with a dry wiping rag (Appendix F, Item 2). Tighten loose mounting hardware.</p>	<p>Cracked, bent or loose electrical connections</p>
13	Weekly	<p>Thread tension stud, thumb nut, and thread control spring</p>	<p>Inspect thread control spring for broken, bent, or corroded coils and incorrect tension. Inspect thread tension and stud and thumb nut for stripped threads, and make certain thumb nut turns on stud. Replace or repair the thread tension per paragraph 4-23.</p>	<p>Broken or bent</p>

**Table 4-1. Unit Preventive Maintenance Checks and Services for Clothing Repair Shop.**

ITEM NO.	INTERVAL	<u>LOCATION</u> ITEM TO CHECK/ SERVICE	PROCEDURE	NOT FULLY MISSION CAPABLE IF:
14	Weekly	<p><b>CLOTHING SEWING MACHINE - continued</b></p> <p>Throat plate and feed dog</p>	<p>Inspect for broken, bent, and improperly installed throat plate. Inspect plate for nicked or corroded surface. Inspect feed dog for excessively worn or broken teeth. Make certain teeth show their full length above the throat plate when needle is in the up position.</p>	<p>Broken or bent</p>

**Table 4-1. Unit Preventive Maintenance Checks and Services for Clothing Repair Shop.**

ITEM NO.	INTERVAL	LOCATION ITEM TO CHECK/ SERVICE	PROCEDURE	NOT FULLY MISSION CAPABLE IF:
15	Weekly	<p><b>DARNING SEWING MACHINE</b></p> <p>Table assembly</p>	<p>Inspect table for cut, cracked, broken, warped, or dirty tabletop; for loose or missing bolts, nuts and inserts, and for loose mounting to the folding stand. Clean a dirty table top with a wiping rag (Appendix F, Item 2). Refer to paragraph 4-25 for repair of the table top.</p>	<p>Missing hardware</p>
16	Weekly	<p>Lamp</p>	<p>Inspect lamp assembly and bracket assembly for loose or missing bolts, nuts, and screws. Inspect electrical cord for frayed insulation and broken wiring. Inspect for broken bulb switch and for broken or burned out lamp. Replace defective bulb. Replace lamp assembly per paragraph 3-12.</p>	<p>Light fails</p>

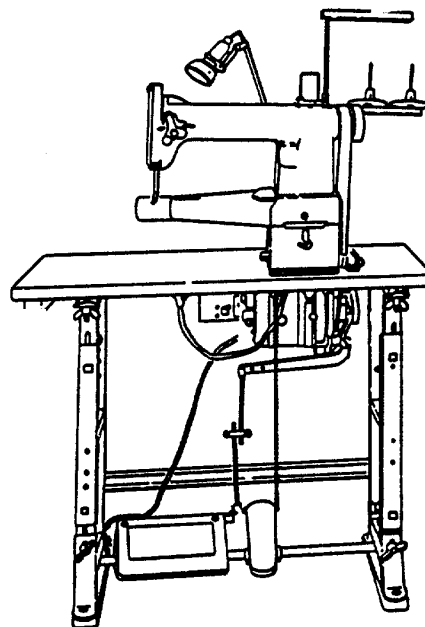

**Table 4-1. Unit Preventive Maintenance Checks and Services for Clothing Repair Shop.**

ITEM NO.	INTERVAL	LOCATION ITEM TO CHECK/ SERVICE	PROCEDURE	NOT FULLY MISSION CAPABLE IF:
17	Weekly	<b>DARNING SEWING MACHINE - continued</b> Thread	Inspect thread unwinder for loose or unwinder missing bolts, nuts, and screws; for bent or broken components and for loose mounting. Replace defective parts, as required.	Missing or broken components
18	Weekly	Drive belt and pulleys	Inspect for broken, frayed, and excessively worn drive belt. Inspect belt for loose mounting on the pulleys. Inspect pulleys for cracked, chipped, or broken edges. Check for a 1/2 inch deflection of belt (para. 3-10) midway between pulleys.	Broken, loose or tight belt
19	Weekly	Bobbin winder	Inspect bobbin winder for bent, broken, loose or missing components. Inspect for excessively worn leather brake, for incorrect tension of thread tension spring, and for improper tension of the pulley with the drive belt. Replace damaged bobbin winder. Adjust bobbin winder (para. 2-12) if out of adjustment. If drive belt tension is improper, adjust belt (para. 3-10).	Bent or broken

**Table 4-1. Unit Preventive Maintenance Checks and Services for Clothing Repair Shop.**

ITEM NO.	INTERVAL	LOCATION ITEM TO CHECK/ SERVICE	PROCEDURE	NOT FULLY MISSION CAPABLE IF:
20	Weekly	<b>DARNING SEWING MACHINE - continued</b> Base	Inspect base for cracked or rough surface.	Cracked or burred surface
21	Weekly	Thread tension stud, thumb nut, and thread control spring	Inspect thread control spring for broken, bent, or corroded coils and for incorrect tension. Inspect thread tension stud and thumb nut for stripped threads and make certain the thumb nut turns on the stud.	Broken or bent
22	Weekly	Motor clutch, rod, and treadle	Inspect motor clutch, rod, and treadle for bent, broken, or loose components. Operate treadle fully and see that the clutch fully engages the motor drive pulley with the drive motor. Make certain the pulley brake lever disengages and stops the drive pulley when the treadle is released. Adjust clutch and motor assembly per paragraph 4-41.	Bent, broken, or loose components

**Table 4-1. Unit Preventive Maintenance Checks and Services for Clothing Repair Shop.**

ITEM NO.	INTERVAL	LOCATION ITEM TO CHECK/ SERVICE	PROCEDURE	NOT FULLY MISSION CAPABLE IF:
23	Weekly	<p><b>DARNING SEWING MACHINE - continued</b></p> <p>Electric motor</p>	<p>Inspect electric motor for dirty surfaces and grease deposits, for bent, cracked or broken housing; for loose or missing bolts and nuts, for loose electrical connections, for frayed insulation and broken wiring, and for loose mounting. Clean a dirty motor by wiping with a dry wiping rag (Appendix F, Item 2). Tighten loose mounting hardware.</p>	Cracked or bent
24	Weekly	Receptacle switch	<p>Inspect for a broken receptacle switch. Inspect for loose mounting in the switchbox. Check for loose electrical connections or broken wiring at the switchbox. Check the switch for improper operation.</p>	Loose electrical connections

**Table 4-1. Unit Preventive Maintenance Checks and Services for Clothing Repair Shop.**

ITEM NO.	INTERVAL	LOCATION ITEM TO CHECK/ SERVICE	PROCEDURE	NOT FULLY MISSION CAPABLE IF:
25	Weekly	<b>BUTTON SEWING MACHINE'</b> Table assembly	Inspect table for cut, cracked, broken, warped, or dirty tabletop; for loose or missing bolts, nuts and inserts, and for loose mounting to the folding stand. Clean a dirty table top with a wiping rag (Appendix F, Item 2). Refer to paragraph 4-50 for replacement or repair of damaged parts.	Missing hardware
26	Weekly	Lamp assembly screws.	Inspect lamp assembly and bracket for loose or missing bolts, nuts, and inspect electrical cord for frayed insulation and broken wiring. Inspect for broken bulb switch and for broken or burned out lamp. Replace a defective bulb. Replace lamp assembly per paragraph 3-12.	Light fails

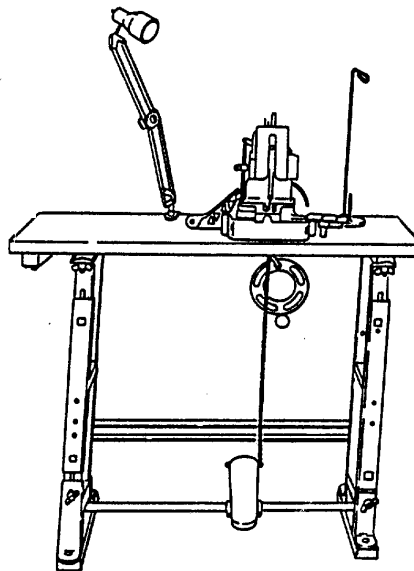

**Table 4-1. Unit Preventive Maintenance Checks and Services for Clothing Repair Shop.**

ITEM NO.	INTERVAL	<u>LOCATION</u> ITEM TO CHECK/ SERVICE	PROCEDURE	NOT FULLY MISSION CAPABLE IF:
27	Weekly	<b>BUTTON SEWING MACHINE - continued</b>  Button machine head	Inspect button machine head for dirty surface and grease deposits, for bent, broken, loose, or missing components; and for loose mounting. Inspect needle for broken or excessively worn point and for bent or broken shaft. Refer to paragraph 2-13 to replace a defective needle.	Broken or missing
28	Weekly	Thread unwinder	Inspect thread unwinder for loose or missing bolts, nuts, and screws and for bent or broken components. Replace defective parts, as required (para. 2-8 and 2-18).	Missing or broken components
29	Weekly	Drive belt and pulley	Inspect for broken, frayed, and excessively worn drive belt. Inspect belt for loose mounting on the pulleys. Inspect pulleys for cracked, chipped, or broken edges and for loose mounting. Check for a 1/2 inch deflection of the belt midway between the pulleys (para. 3-10).	Broken, loose or too tight belt
30	Weekly	Looper	Tilt machine head on one side and inspect for broken looper point. Inspect looper, needle guide, and thread finger for improper adjustment (para. 4-49).	Broken

**Table 4-1. Unit Preventive Maintenance Checks and Services for Clothing Repair Shop.**

ITEM NO.	INTERVAL	LOCATION ITEM TO CHECK/ SERVICE	PROCEDURE	NOT FULLY MISSION CAPABLE IF:
31	Weekly	<p><b>BUTTON SEWING MACHINE - continued</b></p> <p>Receptacle switch</p>	<p>Inspect for broken receptacle switch. Inspect it for loose mounting in the switchbox and make certain it turns the motor on and off. Check for loose electrical connections or broken wiring at switchbox.</p>	<p>Loose or broken</p>
32	Weekly	<p>Starting chain</p>	<p>Inspect starting chain for bent or broken links and loose mounting to the pulley shifter or the starting treadle. Press pedal and make certain pulley shifter engages with the machine drive pulley. Adjust chain or replace it if any of the above conditions exist.</p>	<p>Disconnected</p>
33	Weekly	<p>Electric motor</p>	<p>Inspect motor for dirty surfaces and grease deposits, for bent, cracked, or broken housing; for loose or missing bolts and nuts, for loose electrical connections, for frayed insulation and broken wiring, and for improper and loose mounting. Clean a dirty motor by wiping with a dry wiping rag (Appendix F, Item 2). Tighten loose mounting hardware.</p>	<p>Cracked, bent or loose electrical connections</p>

Table 4-1. Unit Preventive Maintenance Checks and Services for Clothing Repair Shop.

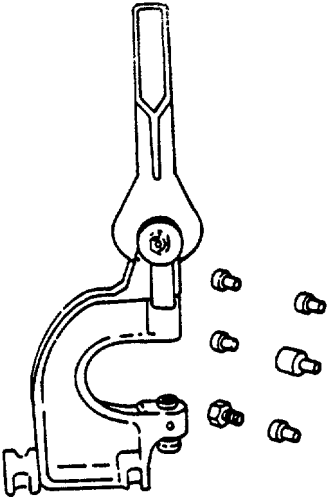
ITEM NO.	INTERVAL	<u>LOCATION</u> ITEM TO CHECK/ SERVICE	PROCEDURE	NOT FULLY MISSION CAPABLE IF:
34	Weekly	GROMMET PRESS		Cracked or broken
		Hand Lever		
35	Weekly	Pivot pin	Inspect for bent, broken, loose, or missing pivot pin. Replace the grommet press if any of the above conditions exist (para. 2-18).	Bent, broken, loose or missing

**Table 2-1. Operator Preventive Maintenance Checks and Services for Clothing Repair Shop.**

ITEM NO.	INTERVAL	LOCATION ITEM TO CHECK/ SERVICE	PROCEDURE	NOT FULLY MISSION CAPABLE IF:
36	Weekly	<p><b>GROMMET PRESS-continued</b></p> <p>Plunger</p>	<p>Inspect plunger for burred, nicked, or corroded surfaces; for mechanical binding, and for loose mounting. Replace the grommet press if any of the above conditions exist (para. 2-18).</p>	<p>Burred, nicked or binding</p>
37	Weekly	<p>Upper and lower dies</p>	<p>Inspect the chucks and dies for dirty, nicked, burred, or corroded surfaces and for loose mounting. Make certain the chucks and dies will fit into position without mechanical binding. Clean a dirty die (para. 4-64). Replace any defective die.</p>	<p>Burred or nicked</p>
38	Weekly	<p>Frame</p>	<p>Inspect for cracked or broken frame. Inspect for dirty surfaces, for loose or missing nuts and screws, and for loose mounting to the table. Clean a dirty grommet press. Tighten loose mounting nuts (para. 2-8). Replace the grommet press if any of the other above conditions exist.</p>	<p>Cracked or broken</p>
39	Weekly	<p>Plunger return</p>	<p>Inspect the plunger return spring spring for bent or broken coils and for loose mounting. Replace the grommet press if any of the above conditions exist (para. 2-18).</p>	<p>Bent or broken</p>

Table 4-1. Unit Preventive Maintenance Checks and Services for Clothing Repair Shop.

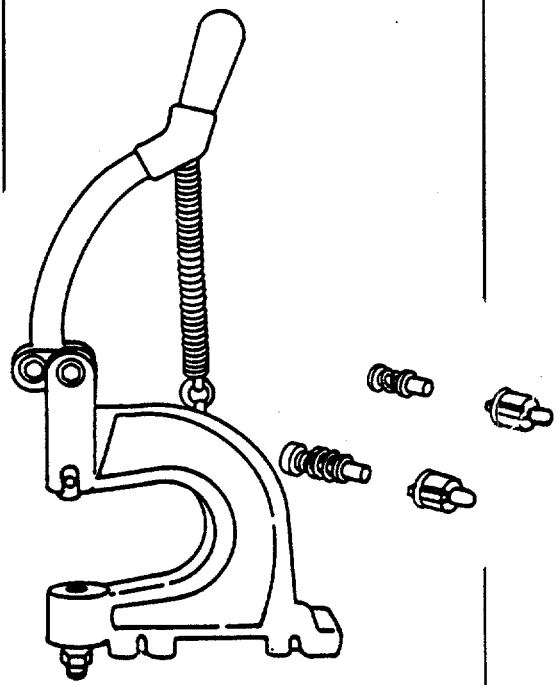
ITEM NO.	INTERVAL	LOCATION ITEM TO CHECK/ SERVICE	PROCEDURE	NOT FULLY MISSION CAPABLE IF:
		<p>TACK BUTTON ATTACHING MACHINE</p>  <p>The diagram shows a mechanical tack button attaching machine. It features a hand lever on the left side, connected to a spring mechanism. To the right of the main machine, several individual components are shown, including a spring, a lever pin, and several small pins or screws used in the assembly.</p>		
40	Weekly	Hand lever	Inspect for cracked or broken hand lever. Inspect the lever for loose mounting and mechanical binding. Replace the tack button attaching machine if any of the above conditions exist (para. 2-18).	Cracked or broken
41	Weekly	Hand lever spring broken	Inspect the spring for bent or coils. Replace the tack button attaching machine if any of the above conditions exist (para.2-18).	Bent or broken

**Table 4-1. Unit Preventive Maintenance Checks and Services for Clothing Repair Shop.**

ITEM NO.	INTERVAL	LOCATION ITEM TO CHECK/ SERVICE	PROCEDURE	NOT FULLY MISSION CAPABLE IF:
42	Weekly	<p style="text-align: center;"><b>TACK BUTTON ATTACHING MACHINE - continued</b></p> <p>Frame</p>	<p>Inspect for cracked or broken frame. Inspect for dirty surfaces, for loose or missing nuts and screws, and for loose mounting to the table. Clean a dirty tack button attaching machine (para. 4-63). Tighten loose mounting nuts. Replace the tack button attaching machine if any of the other above conditions exist (para. 2-18).</p>	Cracked or broken
43	Weekly	Mounting	<p>Inspect for cracked or broken screws mounting screws. Inspect for stripped threads. Replace the mounting screws if any of the above conditions exist.</p>	Cracked or broken
44	Weekly	<p>Dies</p> <p>binding.</p>	<p>Inspect the dies for dirty, nicked, burred, or corroded surfaces, and for bent or broken shafts and springs. Make certain the dies will fit into position without mechanical binding. Clean dirty dies (para. 4-63). Replace the dies if any of the above conditions exist.</p>	Burred or nicked
45	Weekly	Plunger	<p>Inspect the plunger for burred, nicked, or corroded surfaces; for mechanical binding, and for loose mounting. Replace the tack button attaching machine if any of the above conditions exist (para. 2-18).</p>	Burred, nicked or binding
46	Weekly	Pins and locks	<p>Inspect for bent, broken, burred, corroded loose, or missing pins or lock. Inspect the locks for loose mounting on the pins. Replace the tack button attaching machine if any of the above conditions exist M-W (para. 2-18).</p>	Bent, broken or burred

**Table 4-1. Unit Preventive Maintenance Checks and Services for Clothing Repair Shop.**

ITEM NO.	INTERVAL	LOCATION ITEM TO CHECK/ SERVICE	PROCEDURE	NOT FULLY MISSION CAPABLE IF:
47	Monthly	<p><b>CABINET ASSEMBLY</b></p> <p>Chair holddown straps</p>	<p>Inspect chair holddown assemblies for cracked, broken, loose, or missing footman loops. Check that strap webbing does not show signs of cuts, tears, or excessive fraying. Check for loose or broken buckles and for loose mounting.</p>	<p>Missing or broken loops or straps</p>
48	Monthly	<p>Cabinet assembly framework</p>	<p>Inspect overall cabinet framework for cracked, broken, or bent stiffeners. Inspect for broken welds on stiffeners and check for loose rivets attaching sheet metal to stiffeners.</p>	<p>Cracked, broken or bent</p>

**Table 4-1. Unit Preventive Maintenance Checks and Services for Clothing Repair Shop.**

ITEM NO.	INTERVAL	<u>LOCATION</u> ITEM TO CHECK/ SERVICE	PROCEDURE	NOT FULLY MISSION CAPABLE IF:
49	Monthly	<p><b>CABINET ASSEMBLY - continued</b></p> <p>Panels</p>	<p>a. Inspect panels and exterior of cabinet for dirt. Clean dirty surfaces with general purpose detergent (Appendix F, Item 11) and water.</p> <p>b. Check for cut, broken, or dented surfaces. Check for broken welds, loose or missing rivets and loose mountings. Notify next higher level of maintenance if any of these conditions exist.</p>	Cut, loose or broken
50	Monthly	Generator holddown assembly	Check for cracked, bent, or broken tracks, stops, and holddowns. Check for broken welds and loose mounting of holddown assembly to floor. Check for missing pins. Notify next higher level of maintenance for defective parts.	Cracks or missing pins
51	Monthly	Folding table slides	Check slides for broken welds or missing pins. Notify next higher level of maintenance if any of these conditions exist.	Broken welds or missing pins
52	Monthly	Stowage boxes	Inspect for dirty, cut, dented, and broken surfaces. Check for loose or missing rivets and for bent, broken, or loose handles, hooks, latches, and hinges. Make certain the hooks and latches will lock and unlock, and hinges operate without binding. Repair stowage box as required (para. 4-55) for any of the above conditions.	Broken

**Table 4-1. Unit Preventive Maintenance Checks and Services for Clothing Repair Shop.**

ITEM NO.	INTERVAL	LOCATION ITEM TO CHECK/ SERVICE	PROCEDURE	NOT FULLY MISSION CAPABLE IF:
53	Monthly	<p><b>CABINET ASSEMBLY - continued</b></p> <p>Sewing machine tray assemblies</p>	<p>Inspect the tray assemblies for any cracks longer than 2 inches extending through the full thickness of the wood or any cracks in the holddown areas. Check for missing or broken holddown straps and tray pulls. Check for cut, torn or frayed webbing straps. Check for missing or loose screws throughout. Check that felt shock absorbers are not worn or missing, and that rubber bumpers are not deteriorated or badly worn. Refer to paragraphs 4-18, 4-33 or 4-46 for replacement of damaged parts.</p>	<p>Missing or broken straps</p>
54	Monthly	<p>Sewing machine folding stand straps</p>	<p>Inspect the sewing machine folding stand holddown strap assemblies for cracked, broken, loose, or missing footman loops; for missing, loose, or damaged screws; for cut, torn, or frayed retaining straps; for loose or damaged strap buckles, and for loose mounting. Notify next higher level of maintenance if any of these conditions exist. Repair folding stand (para. 4-32).</p>	<p>Missing or broken straps</p>
55	Monthly	<p>Machine table slides</p>	<p>Inspect the sewing machine table assembly slides for broken welds, and missing swivel screws. Replace swivel screws if missing. Notify next higher level of maintenance if table slides are broken.</p>	<p>Broken or missing swivel screws</p> <p>Notify</p>

**Table 4-1. Unit Preventive Maintenance Checks and Services for Clothing Repair Shop.**

ITEM NO.	INTERVAL	<u>LOCATION</u> ITEM TO CHECK/ SERVICE	PROCEDURE	NOT FULLY MISSION CAPABLE IF:
56	Monthly	<p align="center"><b>CLOTHING SEWING MACHINE</b></p> <p>Table assembly</p>	<p>Inspect table for cut, cracked, broken, warped, or dirty tabletop; for loose or missing bolts, nuts and inserts, and for loose mounting to the folding stand. Clean a dirty table top with a wiping rag (Appendix F, Item 2). Refer to paragraph 4-25 for replacement or repair of damaged parts.</p>	<p>Missing hardware</p>
57	Monthly	<p>Machine pulley wheel</p>	<p>Inspect machine pulley wheel for loose mounting. Turn machine pulley wheel toward front of machine and check the wheel for mechanical binding. Notify next higher level of maintenance if any of the above conditions exist.</p>	<p>Binding</p>
58	Monthly	<p>Thread unwinder</p>	<p>Inspect for loose or missing bolts, nuts, and screws; bent or broken components and for loose mounting. Replace defective or missing parts.</p>	<p>Missing or broken components</p>

**Section IV. UNIT TROUBLESHOOTING**

**4-10. INTRODUCTION.**

This section provides the troubleshooting information for the Clothing Repair Shop at the Unit Maintenance level. It consists of the symptom index, listing the most common malfunction symptoms, and the troubleshooting table, Table 4-2. This table repeats the malfunctions, and provides the procedural steps and corrective actions necessary to return the system to operational readiness.

**4-11. TROUBLESHOOTING.**

- a. The troubleshooting table lists the common malfunctions which you may find during operation of the Clothing Repair Shop. You should perform the tests, inspections and corrective actions in the order they appear in the table.
- b. This table cannot list all the malfunctions that may occur, all the tests or inspections needed to find the fault, or all the corrective actions needed to correct the fault. If the equipment malfunction is not listed or actions listed do not correct the fault, notify your supervisor.
- c. To troubleshoot the generator set, refer to TM 5-6115-271-14. To troubleshoot the cargo trailer, refer to TM 9-2330-213-14.

**4-12. MALFUNCTION INDEX.**

<b>MALFUNCTION</b>	<b>PAGE</b>
<b><u>CABINET</u></b>	
1. Holddown clamp assembly loose .....	4-32
2. Rear door or any side door cannot be opened .....	4-32
3. Rear door or any side door does not close securely.....	4-32
4. Rear door or any side door will not stay in open position .....	4-33
5. Sewing machine head is loose in tray .....	4-33
6. Stowage box does not close securely .....	4-33
7. Folding chair rocks .....	4-33
<b><u>CLOTHING SEWING MACHINE</u></b>	
8. Needle breaks .....	4-34
9. Feed dogs strike throat plate.....	4-34
10. Machine vibrates .....	4-34
11. Lamp does not light.....	4-34
12. Motor does not start .....	4-35

**4-12. MALFUNCTION INDEX - continued.**

**MALFUNCTION PAGE**

**CLOTHING SEWING MACHINE - continued.**

13. Unusual noise in motor.....	4-35
14. Motor does not pull load .....	4-35

**DARNING SEWING MACHINE**

15. Needle breaks .....	4-36
16. Machine vibrates .....	4-36
17. Lamp does not light .....	4-36
18. Motor does not start .....	4-36
19. Unusual noise in motor.....	4-37
20. Motor does not pull load .....	4-37

**BUTTON SEWING MACHINE**

21. Lamp does not light .....	4-38
22. Motor does not start .....	4-38
23. Unusual noise in motor.....	4-38
24. Motor does not pull load .....	4-38

**4-13. UNIT TROUBLESHOOTING TABLE.**

Refer to Table 4-2, Unit Troubleshooting.

**NOTE**

Before you use the troubleshooting tables, be sure you have performed all applicable operating checks and verified that a malfunction exists. When a corrective action is performed, verify that the action has corrected the malfunction. All malfunctions deferred to the next higher level of maintenance must be reported according to the instructions given in DA PAM 738-750.

Table 4-2. Unit Troubleshooting

---

**MALFUNCTION**  
**TEST OR INSPECTION**  
**CORRECTIVE ACTION**

---

**CABINET ASSEMBLY**

**1. HOLDDOWN CLAMP ASSEMBLY LOOSE.**

Step 1. Check for loose, missing, or damaged hardware and clamp.

If hardware is missing or clamp is damaged, notify next higher level of maintenance.

Step 2. Check for damaged trailer or cabinet assembly.

If trailer is damaged, refer to TM 9-2330-213-14.

If cabinet assembly is damaged, notify next higher level of maintenance.

**2. REAR DOOR OR ANY SIDE DOOR CANNOT BE OPENED.**

Step 1. Inspect door for dirty, cut, broken, or dented surfaces, broken welds, or a bad door gasket.

a. Clean dirty surfaces with general purpose detergent (Appendix F, Item 11) and water.

b. Notify next higher level of maintenance for cut, broken, dented surfaces or welds, and bad door gasket.

Step 2. Check that handle lock is not bent, broken, loosely mounted or missing.

Notify next higher level of maintenance if any of the above conditions exist.

Step 3. Check that door hinge is not broken or bent.

Notify next higher level of maintenance if any of the above conditions exist.

**3. REAR DOOR OR ANY SIDE DOOR DOES NOT CLOSE SECURELY.**

Inspect door for the same defects as malfunction 2.

Table 4-2. Unit Troubleshooting - continued

---

<b>MALFUNCTION</b>	<b>TEST OR INSPECTION</b>	<b>CORRECTIVE ACTION</b>
--------------------	---------------------------	--------------------------

---

**CABINET ASSEMBLY - continued.**

**4. REAR OR SIDE DOOR WILL NOT STAY IN OPEN POSITION.**

Check door stays for mechanical binding and loose or missing door stay mounting brackets.

Notify next higher level of maintenance if any of the above conditions exist.

**5. SEWING MACHINE HEAD IS LOOSE IN TRAY.**

Check that tray strap loop is not loose.

If tray strap loop is loose, replace or repair tray (para. 4-18, 4-33 or 4-46).

**6. STOWAGE BOX DOES NOT CLOSE SECURELY.**

Step 1. Check that stowage box hinge is not bent or broken.

If hinge is bent or broken, replace stowage box.

Step 2. Check that stowage box latch and latch hook are not deformed or broken.

If latch or latch hook is deformed or broken, refer to next higher level of maintenance.

**7. FOLDING CHAIR ROCKS**

Step 1. Check if chair is bent or broken.

If chair is bent or broken, replace chair.

Table 4-2. Unit Troubleshooting - continued

**MALFUNCTION****TEST OR INSPECTION****CORRECTIVE ACTION****CLOTHING SEWING MACHINE continued.****8. NEEDLE BREAKS.**

Check for loose presser foot.

If presser foot is loose, notify next higher level of maintenance.

**9. FEED DOGS STRIKE THROAT PLATE.**

Check that throat plate is fully into position.

If throat plate is in the full in position, notify next higher level of maintenance.

**10. MACHINE VIBRATES.**

Step 1. Check that hinge plate mounting screws are tight.

If any screws are loose, tighten screws.

Step 2. Check felt pads are installed in the table tops.

If all four felt pads are not located on table, install felt (para. 4-25).

Step 3. Check for 1/2-inch deflection at mid-point of drive belt.

If drive belt is out of adjustment, adjust belt (para. 3-10).

Step 4. Check for loose or damaged drive pulley or machine pulley.

Notify next higher level of maintenance if any of the above conditions exist.

**11. LAMP DOES NOT LIGHT.**

Step 1. Check that light bulb is broken.

If light bulb is broken, unplug power cord from outlet, remove old bulb and replace.

Step 2. Unplug power cord from outlet and inspect for frayed or broken insulation and wires.

If cord is frayed or broken, replace lamp (para. 3-12).

Table 4-2. Unit Troubleshooting - continued

---

<b>MALFUNCTION</b>	<b>TEST OR INSPECTION</b>	<b>CORRECTIVE ACTION</b>
--------------------	---------------------------	--------------------------

---

**CLOTHING SEWING MACHINE - continued.**

**12. MOTOR DOES NOT START.**

Use a multimeter and check for 110 Vac at power outlet box on the table tops.

- a. If power is not present, the power or distribution cable may be defective. Test cables (para. 4-60 and 4-61).
- b. If power is present, notify next higher level of maintenance that motor or switch may be defective.

**13. UNUSUAL NOISE IN MOTOR.**

Notify next higher level of maintenance of defective motor.

**14. MOTOR DOES NOT PULL LOAD.**

Step 1. Check for loose, slipping, frayed or deteriorated drive belt.

Replace drive belt (para. 2-8 and 2-18).

Step 2. Use a multimeter and check that input voltage at power outlet is 110 Vac.

If voltage is low, check generator set for proper power output.

Step 3. Rotate handwheel toward operator, check sewingmachine for binding.

If sewing machine is not binding, notify next higher level of maintenance of a possible defective motor.

Table 4-2. Unit Troubleshooting - continued

MALFUNCTION	TEST OR INSPECTION	CORRECTIVE ACTION
<b>DARNING SEWING MACHINE</b>		
<b>15. NEEDLE BREAKS.</b>	Check for loose presser foot.	If presser foot is loose, tighten (para. 4-38).
<b>16. MACHINE VIBRATES.</b>	Step 1. Check that machine-to-table mounting screws are tight.	If any screws are loose, tighten screws (para. 2-8).
	Step 2. Check for Finch deflection at mid-point of drive belt.	If drive belt is out of adjustment, adjust sewing machine (para. 3-10).
	Step 3. Check for loose or damaged drive pulley or machine pulley.	Notify next higher level of maintenance if any of the above conditions exist.
<b>17. LAMP DOES NOT LIGHT.</b>	Step 1. Check that light bulb is broken.	If light bulb is broken, unplug power cord from outlet, remove old bulb and replace.
	Step 2. Unplug power cord from outlet and inspect for frayed or broken insulation and wires.	If cord is frayed or broken, replace lamp (para. 3-12).
<b>18. MOTOR DOES NOT START.</b>	Use a multimeter and check for 110 Vac at power outlet.	
	a. If power is not present, the power or distribution cable may be defective. Test cables (para. 4-60 and 4-61).	
	b. If power is present, notify next higher level of maintenance that motor or switch may be defective.	

Table 4-2. Unit Troubleshooting - continued

---

<b>MALFUNCTION</b>	<b>TEST OR INSPECTION</b>	<b>CORRECTIVE ACTION</b>
--------------------	---------------------------	--------------------------

---

**DARNING SEWING MACHINE - continued.****19. UNUSUAL NOISE IN MOTOR.**

Notify next higher level of maintenance of defective motor.

**20. MOTOR DOES NOT PULL LOAD.**

Step 1. Check for loose, slipping, frayed or deteriorated drive belt.

Replace drive belt.

Step 2. Use a multimeter and check that input voltage at power outlet is 110 Vac.

If voltage is low, check generator set for proper power output.

Step 3. Rotate handwheel toward operator, check sewing machine for binding.

If sewing machine is not binding, notify next higher level of maintenance of possible defective motor.

Table 4-2. Unit Troubleshooting - continued

MALFUNCTION	TEST OR INSPECTION	CORRECTIVE ACTION
<b>BUTTON SEWING MACHINE</b>		
<b>21. LAMP DOES NOT LIGHT.</b>	Step 1. Check that light bulb is broken.	If light bulb is broken, unplug power cord from outlet, remove old bulb and replace.
	Step 2. Unplug power cord from outlet and inspect for frayed or broken insulation and wires.	If cord is frayed or broken, replace lamp (para. 3-12).
<b>22. MOTOR DOES NOT START.</b>	a. If power is not present, the power or distribution cable may be defective. Test cables (para. 4-60 and 4-61).	b. If power is present, notify next higher level of maintenance that motor or switch may be defective.
<b>23. UNUSUAL NOISE IN MOTOR.</b>	Notify next higher level of maintenance of defective motor.	
<b>24. MOTOR DOES NOT PULL LOAD.</b>	Step 1. Check for loose, slipping, frayed or deteriorated drive belt.	Replace drive belt (para. 2-8).
	Step 2. Use a multimeter and check that input voltage at power outlet is 110 Vac.	If voltage is low, check generator set for proper power output.
	Step 3. Rotate handwheel toward operator, check sewing machine for binding.	If sewing machine is not binding, notify next higher level of maintenance of a possible defective motor.

---

## Section V. UNIT MAINTENANCE PROCEDURES

### 4-14. GENERAL.

This section contains instructions for performing unit level maintenance on the clothing repair shop.

### 4-15. PERSONAL SAFETY.

To ensure safety of personnel, proper care should be used when handling assemblies and parts. Many assemblies are heavy. The assistance of another person, lifting device, or other support equipment may be required to move or position heavy items.

Personnel must remove all items of jewelry ( rings, bracelets, watches, necklaces etc) and loose clothing before working on the equipment. Jewelry and loose clothing can get caught in moving equipment and result in injury to personnel. Jewelry can cause electrical shorts or severe injury when working around electrical equipment.

### 4-16. PROPER EQUIPMENT.

Obtain proper equipment before beginning maintenance. This includes hand tools and/or special tools, receptacles for storing small parts, and expendable materials required by the maintenance task.

**4-17. LIFTING EYE ASSEMBLY MAINTENANCE.**

This task consists of: a. Inspection b. Removal c. Cleaning  
 d. Repair e. Installation

INITIAL SET-UP:	
<b>Tools:</b>	<b>Material/Parts:</b>
General Mechanics Tool Kit (Appendix B, Item 1)	Detergent, General Purpose (Appendix F, Item 11)
	Washer, Lock

Inspection.

- (1) Inspect for loose or missing hardware.
- (2) Inspect for cracks, broken parts, rust and corrosion.

Removal.

- (1) From inside the cabinet, remove three nuts (1) , three lock washers (2), and backing plate (3).
- (2) From outside the cabinet, remove three bolts (4), and lifting eye assembly (5).

Cleaning.

- (1) Wash the lifting eyes with a solution of detergent, general purpose (Appendix F, Item 11) and water.
- (2) Rinse thoroughly with clean water.
- (3) Allow to dry.

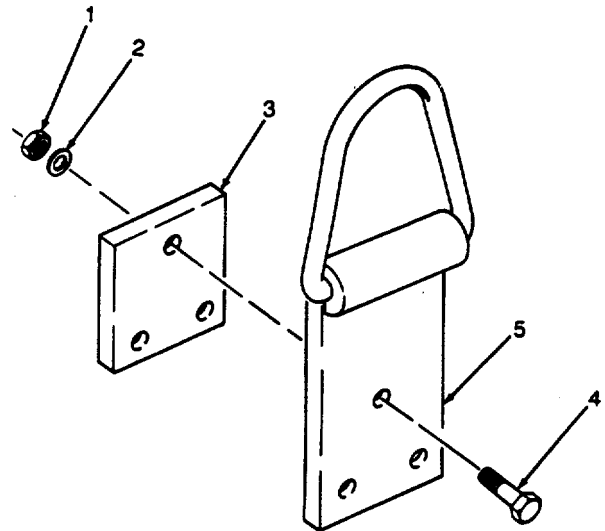

**14-17. LIFTING EYE ASSEMBLY MAINTENANCE - continued.**

Repair.

Repair of the lifting eye is limited to the replacement of defective parts.

Installation.

- (1) Install lifting eye assembly (1) into position.
- (2) Install three bolts (2), backing plate (3), three lock washers (4) and three nuts (5).

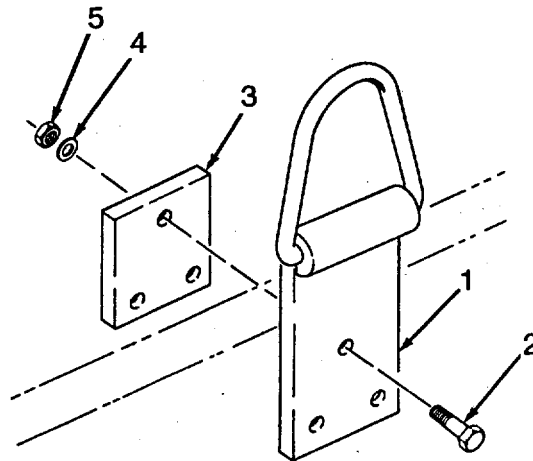

**14-18. CLOTHING SEWING MACHINE TRAY MAINTENANCE.****This task covers:****a. Inspection****b. Cleaning****c. Repair****INITIAL SETUP:****Tools:**

General Mechanics Tool Kit (Appendix B, Item 1)

**Material/Parts:**

Coating, Clear, Polyurethane (Appendix F, Item 10)

Rag, Wiping (Appendix F, Item 2)

Wood Glue (Appendix F, Item 13)

**Equipment Condition:**

Sewing machine removed (para. 2-8)

Inspection.

- (1) Inspect for damaged wood.
- (2) Inspect for damaged holddown straps and pulls.
- (3) Inspect for loose or missing hardware.
- (4) Inspect for damaged rubber bumper.

Cleaning.

- (1) Clean the tray assembly with a clean damp rag (Appendix F, Item 2)
- (2) Allow to dry.

Repair. Repair is limited to the following:

- (1) Refinishing of damaged or scuffed tray using coating, clear, polyurethane (Appendix F, Item 10).
- (2) Replacement of the holddown strap as follows:
  - (a) Remove two screws (1), loop (2), and holddown strap (3) from tray (4).
  - (b) Install holddown strap (3), loop (2) and secure with two screws (1). Repeat for other side.

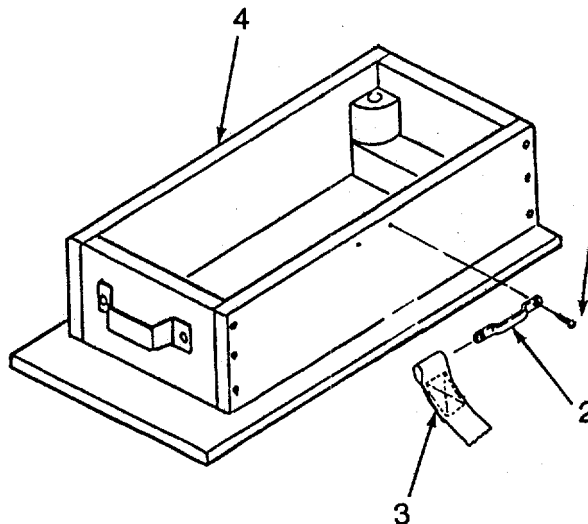

**4-18. CLOTHING SEWING MACHINE TRAY MAINTENANCE - continued.**

(3) Replacement of the rubber bumpers as follows:

- (a) Remove screw (1) and rubber bumper (2) from tray (3).
- (b) Install rubber bumper (2) and screw (1).

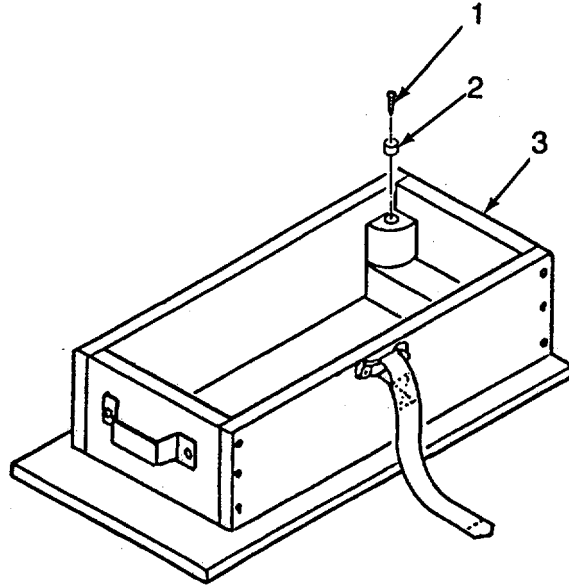

(4) Replacement of the handle.

- (a) Remove two screws (1) and handle (2) from tray (3).
- (b) Install new handle (2) and secure with two screws (1).

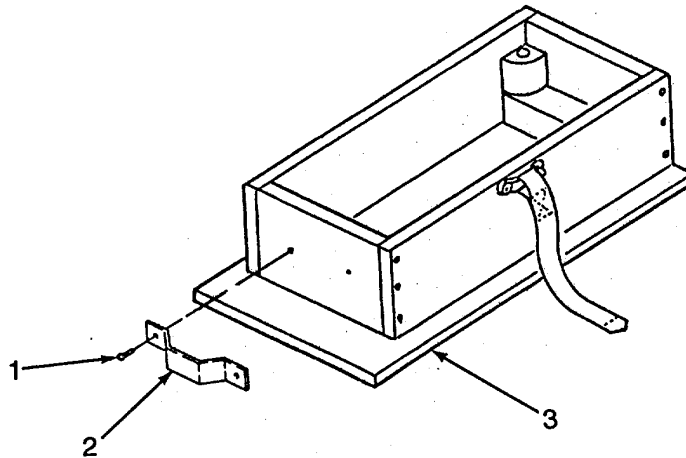

**4-18. CLOTHING SEWING MACHINE TRAY MAINTENANCE - continued.**

(5) Replacement of ID Plate.

(a) Remove four screws (1) and ID plate (2) from the clothing machine tray (3).

**NOTE**

ID Plate reads "CN3115R."

(b) Install new ID plate (2) and secure with four screws (1).

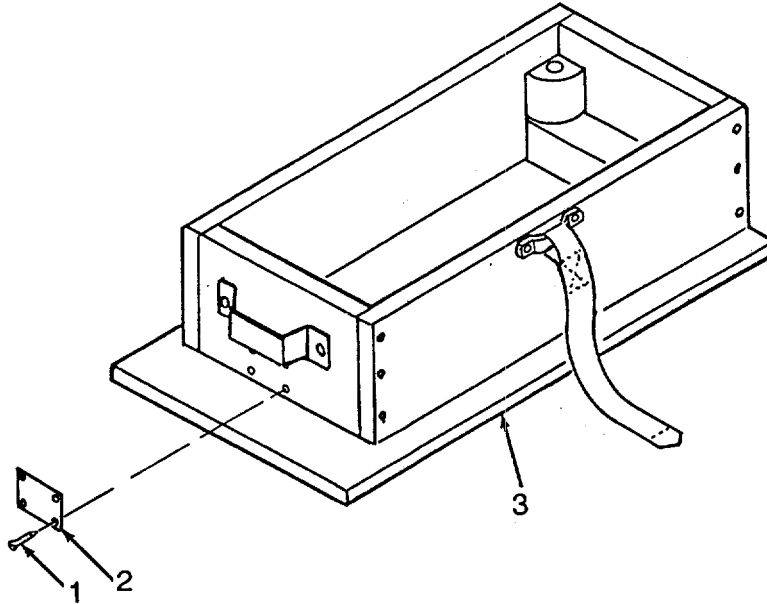

(6) Repair wooden cracks and breaks.

(a) Spread wood glue on cracked areas and clamp securely.

(b) Wipe off excess wood glue (Appendix F, Item 13).

(c) Allow to dry.

**14-19. CLOTHING SEWING MACHINE THREAD UNWINDER MAINTENANCE.**

---

This task covers:

- |            |                 |             |
|------------|-----------------|-------------|
| a. Removal | b. Inspection   | c. Cleaning |
| d. Repair  | e. Installation |             |
- 

**INITIAL SETUP:****Tools:**

General Mechanics Tool Kit (Appendix B, Item 1)

**Material/Parts:**

Rag, wiping (Appendix F, Item 2)

**Equipment Condition:**

Thread removed from stand.

Removal. Refer to paragraph 2-18.

Inspection.

- (1) Inspect for damaged parts.
- (2) Inspect for loose or missing hardware.
- (3) Inspect for corrosion on thread hook.

Cleaning.

- (1) Clean the thread unwinder with a clean damp wiping rag (Appendix F, Item 2)
- (2) Allow to dry.

Repair. Repair is limited to replacement of the defective components.

Installation. Refer to paragraph 2-8.

**4-20. CLOTHING SEWING MACHINE LEVER GUARD AND THREAD GUARD MAINTENANCE.**

---

**This task covers:**

- |            |                 |               |
|------------|-----------------|---------------|
| a. Removal | b. Cleaning     | c. Inspection |
| d. Repair  | e. Installation | f. Adjustment |
- 

**INITIAL SETUP:****Tools:**

General Mechanics Tool Kit (Appendix B, Item 1)

**Materials/Parts:**

Rag, wiping (Appendix F, Item 2)

**Equipment Condition:**

Sewing machine removed (para. 2-18).  
Needle and thread removed (para. 2-8).

**Removal.**

- (1) Remove two screws (1).
- (2) Remove thread guard (3) and lever guard (2).

**Cleaning.**

Clean parts using a clean, dry wiping rag (Appendix F, Item 2).

**Inspection.**

- (1) Inspect hardware for damage.
- (2) Inspect thread guard for damage and burrs.
- (3) Inspect lever guard for damage.

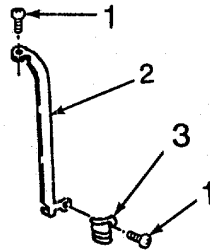

**4-20. CLOTHING SEWING MACHINE LEVER GUARD AND THREAD GUARD MAINTENANCE - continued.**

Repair. Repair of the lever and thread guides is limited to the replacement of defective components.

Installation.

Install thread guard (1) and the lever guard (2) using two screws (3).

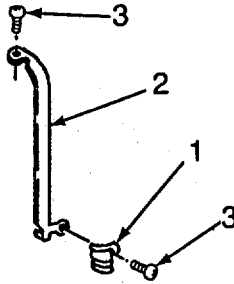

Adjustment.

Rotate pulley (1) toward the front of the unit to ensure the take up lever does not interfere with the lever guard. Adjust lever guard, as needed to prevent interference.

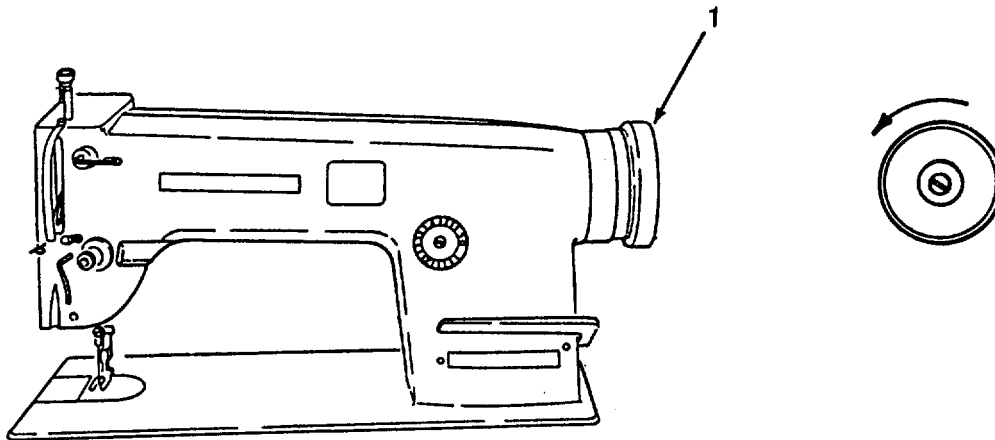

**4-21. CLOTHING SEWING MACHINE THREAD GUIDES MAINTENANCE.**

This task covers:

- |            |                 |               |
|------------|-----------------|---------------|
| a. Removal | b. Cleaning     | c. Inspection |
| d. Repair  | e. Installation | f. Adjustment |

**INITIAL SETUP:****Tools:**

General Mechanics Tool Kit (Appendix B, Item 1)

**Materials/Parts:**

Cleaning Solvent (Appendix F, Item 8)  
Rag, wiping (Appendix F, Item 2)  
Brush, Medium Bristle (Appendix F, Item 1)

**Equipment Condition:**

Sewing machine removed (para. 2-18).  
Needle and thread removed (para. 2-8).

**Removal.**

- (1) Remove thread pin (1).
- (2) Remove setscrew (2) and slide the thread retainer (3) out.
- (3) Loosen nut (4) and remove thread guide (5).
- (4) Remove screw (6), and thread eyelet (7).

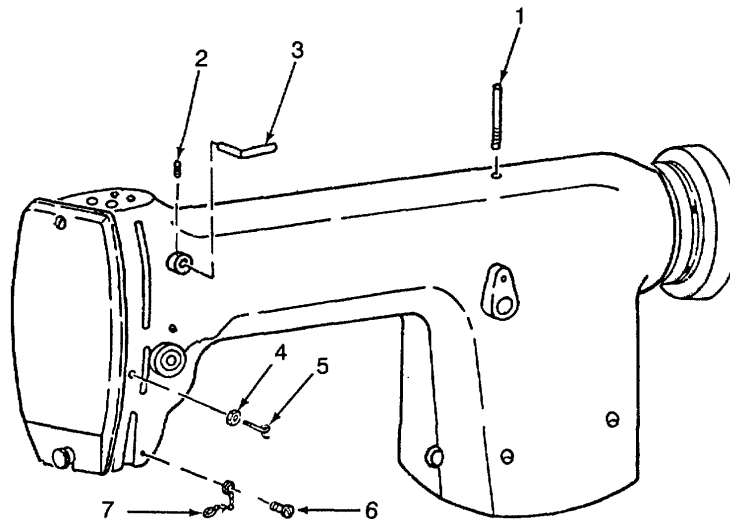

**4-21. CLOTHING SEWING MACHINE THREAD GUIDES MAINTENANCE - continued.**

Cleaning.

- (1) Remove all buildup of grease, dirt, etc. by wiping with a rag, wiping (Appendix F, Item 2).

**WARNING**

Cleaning solvent, Federal Specification P-D-680, is both toxic and flammable. Keep off skin. Use only in a well-ventilated area and avoid prolonged breathing of vapors. Keep away from open flame.

- (2) If needed, clean using cleaning solvent (Appendix F, Item 8) and either a rag, wiping (Appendix F, Item 2) or a medium bristle brush (Appendix F, Item 1).
- (3) Allow to dry.

Inspection.

- (1) Inspect hardware for damage.
- (2) Inspect the thread retainer for damage.
- (3) Inspect the thread guide for damage.
- (4) Inspect the thread eyelet for damage.

Repair. Repair of the thread guides is limited to the replacement of defective components.

4-21. CLOTHING SEWING MACHINE THREAD GUIDES MAINTENANCE - continued.

Installation.

- (1) Install thread eyelet (1), using screw (2).
- (2) Install thread guide (3) and tighten nut (4).
- (3) Install thread retainer (5) and secure with setscrew (6).
- (4) Install thread pin (7).

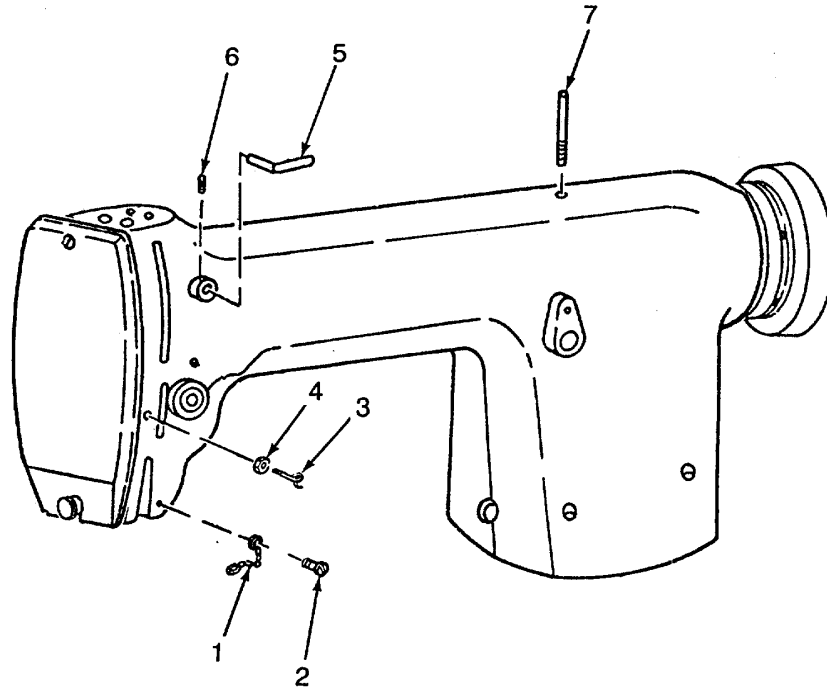

**4-22. CLOTHING SEWING MACHINE FACE PLATE AND OIL COVER MAINTENANCE.**

---

This task covers:

- |            |                 |               |
|------------|-----------------|---------------|
| a. Removal | b. Cleaning     | c. Inspection |
| d. Repair  | e. Installation |               |
- 

**INITIAL SETUP:****Tools:**

General Mechanics Tool Kit (Appendix B, Item 1)

**Equipment Condition:**

Sewing machine removed (para. 2-18).

**Materials/Parts:**

Cleaning Solvent (Appendix F, Item 8)

Rag, wiping (Appendix F, Item 2)

**Removal.**

- (1) Remove screw (1) and thumbscrew (2).
- (2) Remove face plate (3).

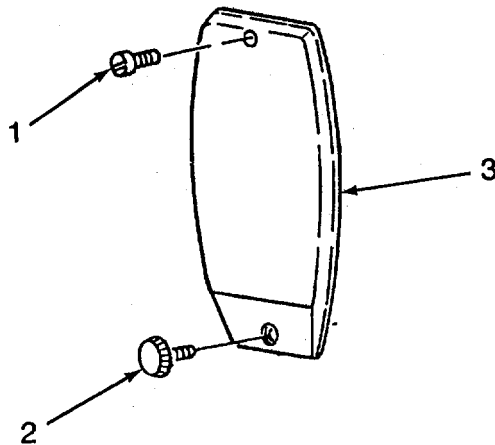

**4-22. CLOTHING SEWING MACHINE FACE PLATE AND OIL COVER MAINTENANCE - continued.**

- (3) Remove screw (3) and side oil cover (4).

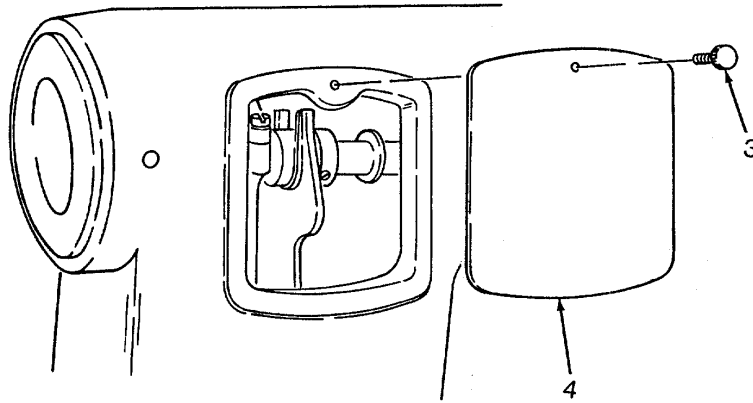
**Cleaning.**

- (1) Remove all buildup of grease, dirt, etc., by wiping with a rag, wiping (Appendix F, Item 2).

**WARNING**

Cleaning solvent, Federal Specification P-D-680, is both toxic and flammable. Keep off skin. Use only in a well-ventilated area and avoid prolonged breathing of vapors. Keep away from open flame.

- (2) If needed, clean using cleaning solvent (Appendix F, Item 8) and either a soft, clean cloth (Appendix F, Item 2) or a medium bristle brush (Appendix F, Item 1).
- (3) Allow to dry.

**4-22. CLOTHING SEWING MACHINE FACE PLATE AND OIL COVER MAINTENANCE - continued.**

Inspection.

- (1) Inspect hardware for damage.
- (2) Inspect face plate for damage.
- (3) Inspect side oil cover for damage.

Repair. Repair of the face plate and oil cover is limited to the replacement of defective components.

Installation.

- (1) Install face plate (1) and secure with screw (2) and thumbscrew (3).

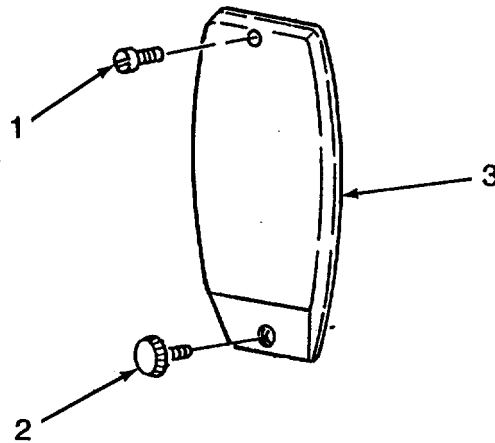

- (2) Install side oil cover (4) and secure with screw (5).

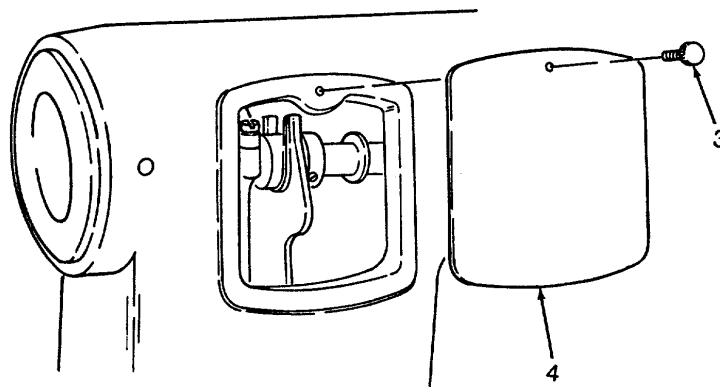

**4-23. CLOTHING SEWING MACHINE THREAD TENSIONER MAINTENANCE.**

---

This task covers:

- |                 |                |             |
|-----------------|----------------|-------------|
| a. Removal      | b. Disassembly | c. Cleaning |
| d. Inspection   | e. Repair      | f. Assembly |
| g. Installation |                |             |
- 

**INITIAL SETUP:**

**Tools:**

General Mechanics Tool Kit (Appendix B, Item 1)

**Equipment Condition:**

Sewing machine removed (para. 2-18).

**Materials/Parts:**

Cleaning Solvent (Appendix F, Item 8)  
 Rag, wiping (Appendix F, Item 2)

Removal.

Remove setscrew (1) and thread tensioner assembly (2).

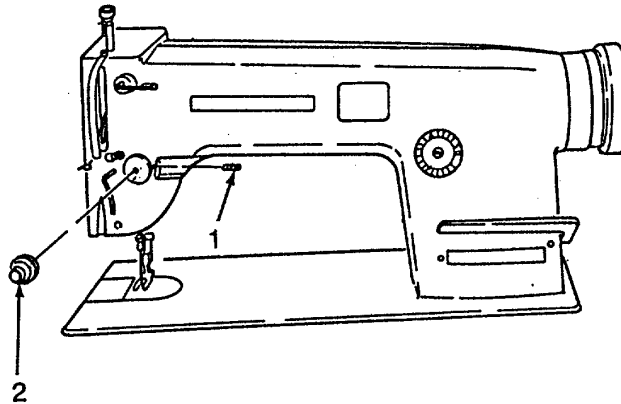

**4-23. CLOTHING SEWING MACHINE THREAD TENSIONER MAINTENANCE - continued.**

Disassembly.

**CAUTION**

Be careful when removing the spring.

- (1) Remove tension nut (1) and spring (2).
- (2) Slide off release disc (3), two tension discs (4), and tension pin (5) from the tension stud (6).

**NOTE**

Some models may have setscrews.

- (3) Unscrew tension stud (6) from spring regulator (7) and remove spring (8).

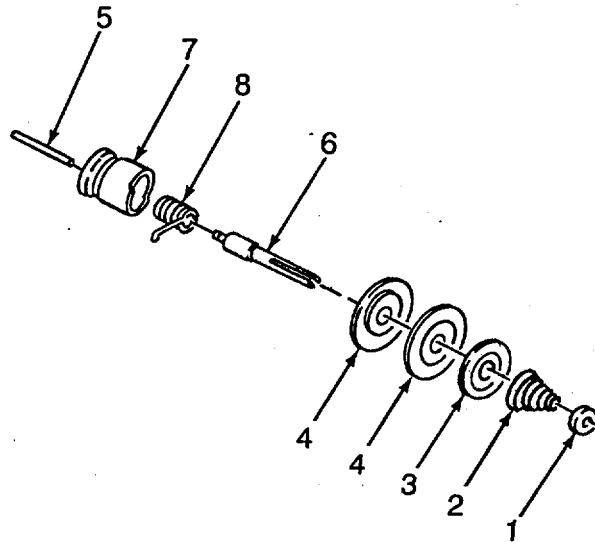

Cleaning.

- (1) Remove all buildup of grease, dirt, etc., by wiping with a rag, wiping (Appendix F, Item 2).

**WARNING**

Cleaning solvent, Federal Specification P-D-680, is both toxic and flammable. Keep off skin. Use only in a well-ventilated area and avoid prolonged breathing of vapors. Keep away from open flame.

- (2) If needed, clean using cleaning solvent (Appendix F, Item 8) and either a soft, clean cloth (Appendix F, Item 2).
- (3) Allow to dry.

**4-23. CLOTHING SEWING MACHINE THREAD TENSIONER MAINTENANCE - continued.**Inspection.

- (1) Inspect hardware for damage.
- (2) Inspect the spring for damage.
- (3) Inspect discs for damage.
- (4) Inspect pin for damage.
- (5) Inspect tension stud for damage.

Repair. Repair of the thread tensioner is limited to the replacement of defective components.

Assembly.

- (1) Slide spring (1) onto tension stud (2) and install tension stud (2) onto spring regulator (3), the two tension discs (4), and the release disc (5) onto the tension stud (2).

**CAUTION**

Be careful when removing the spring.

- (2) Install the spring (6) and secure with tension nut (7).
- (3) Insert the tension pin (8) into the assembly.

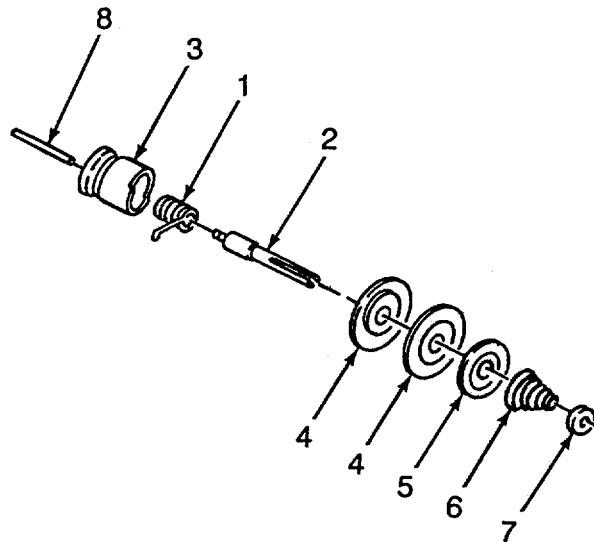

**4.23. CLOTHING SEWING MACHINE THREAD TENSIONER MAINTENANCE - continued.**

Installation.

Install thread tensioner assembly (1) and secure with setscrew (2).

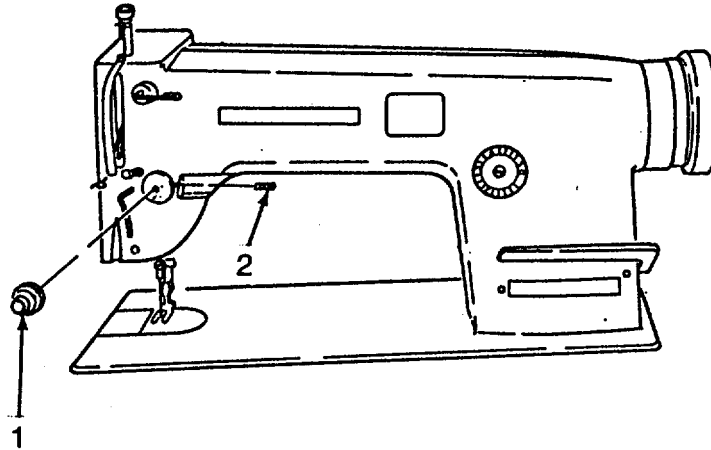

**4-24. CLOTHING SEWING MACHINE BELT GUARD MAINTENANCE.**

---

This task covers:

- |                 |             |               |
|-----------------|-------------|---------------|
| a. Removal      | b. Cleaning | c. Inspection |
| d. Installation |             |               |
- 

**INITIAL SETUP:****Tools:**

General Mechanics Tool Kit (Appendix B, Item 1)

**Material/Parts:**

Rag, wiping (Appendix F, Item 2)

**Equipment Condition:**

Power disconnected

Removal. Refer to paragraph 2-18.

Cleaning. Clean parts with a clean dry wiping rag (Appendix F, Item 2).

Inspection.

- (1) Inspect belt guard for damage.
- (2) Inspect hinge for proper movement.

Installation. Refer to paragraph 2-8.

**4-25. CLOTHING SEWING MACHINE TABLE TOP ASSEMBLY MAINTENANCE.**

---

This task covers:

- |                 |             |           |
|-----------------|-------------|-----------|
| a. Removal      | b. Cleaning | c. Repair |
| d. Installation |             |           |
- 

**INITIAL SETUP:****Tools:**

General Mechanics Tool Kit (Appendix B, Item 1)

**Material/Parts**

Adhesive  
Coating, Clear, Polyurethane (Appendix F, Item 10)  
Rag, wiping (Appendix F, Item 2)  
Nails

**Equipment Condition:**

Sewing machine removed (para. 2-18)  
Electrical power removed (para. 2-18)

Removal. Refer to paragraph 2-18.

Cleaning.

- (1) Clean the table top assembly with a clean damp rag (Appendix F, Item 2)
- (2) Allow to dry.

Repair. Repair is limited to the following:

- (1) Refinishing of damaged or scuffed table top.
  - (a) Sand surfaces, as required.
  - (b) Clean surface of wooden table top.
  - (c) Apply a coating of clear, polyurethane (Appendix F, Item 10) to the effected wooden surface.
  - (d) Allow to dry.

**4-25. CLOTHING SEWING MACHINE TABLE TOP ASSEMBLY MAINTENANCE - continued.**

- (2) Replacement of the oil drip pan.
  - (a) Remove four nails (1) and oil drip pan (2).
  - (b) Inspect and then replace oil drip pan as required.
  - (c) Install oil drip pan (2) with four new nails (1).

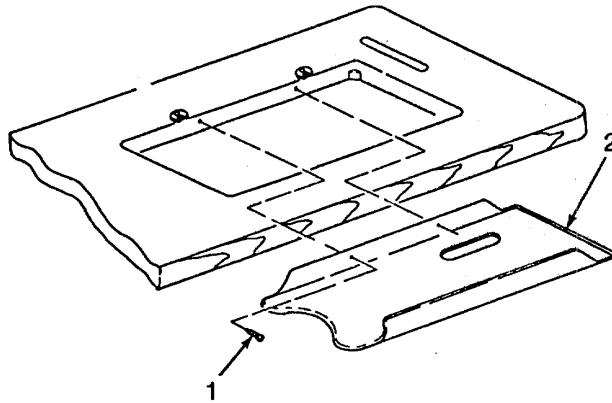

- (3) Replacement of the felt.
  - (a) Remove nail (1) and scrape off felt pad (2) off of table (3).
  - (b) Install new felt pad (2) by using adhesive (Appendix F, Item 12).
  - (c) Install new nail (1) through felt pad (2) into the table (3).

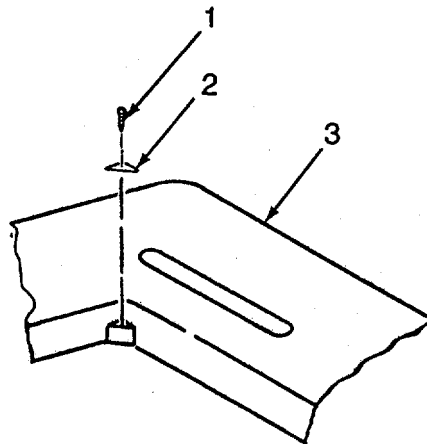

Installation.

- (1) Refer to paragraph 2-8.

**4-26. BOBBIN WINDER MAINTENANCE.**

---

**This task consists of:**

- a. Removal
- d. Installation

**b. Inspection****c. Cleaning****INITIAL SETUP:****Tools:**

General Mechanics Tool Kit (Appendix B, Item 1)

**Material/Parts:**

Rag, wiping (Appendix F, Item 2)

**Equipment Condition:**

Bobbin removed from bobbin winder.

Removal. Refer to paragraph 2-18.

Inspection.

- (1) Inspect for rust/corrosion and damaged parts.
- (2) Inspect for lost or missing parts.
- (3) Inspect for free spinning pulley wheel when engagement lever is extended.
- (4) Inspect for metal cracks on the bobbin retainer.
- (5) Inspect for cracked or missing pulley wheel stop.

Cleaning. Clean bobbin winder with a clean dry wiping rag (Appendix F, Item 2).

Installation. Refer to paragraph 2-8.

## 4-27. CLOTHING SEWING MACHINE KNEE LEVER ASSEMBLY MAINTENANCE.

This task consists of:

- |                 |                |               |
|-----------------|----------------|---------------|
| a. Removal      | b. Disassembly | c. Inspection |
| d. Cleaning     | e. Repair      | f. Assembly   |
| g. Installation |                |               |

**INITIAL SET-UP:****Tools:**

General Mechanics Tool Kit (Appendix B, Item 1)

**Equipment Condition:**

Sewing machine removed (para. 2-18)  
 Remove table from folding stand (para. 2-8)  
 Electrical power removed (para. 2-18)

**Material/Parts:**

Brush (Appendix F, Item 1)  
 Cleaning Solvent (Appendix F, Item 8)  
 Rag, wiping (Appendix F, Item 2)

Removal.

- (1) Remove four screws (1), and brackets (2).
- (2) Remove knee lifter assembly (3).

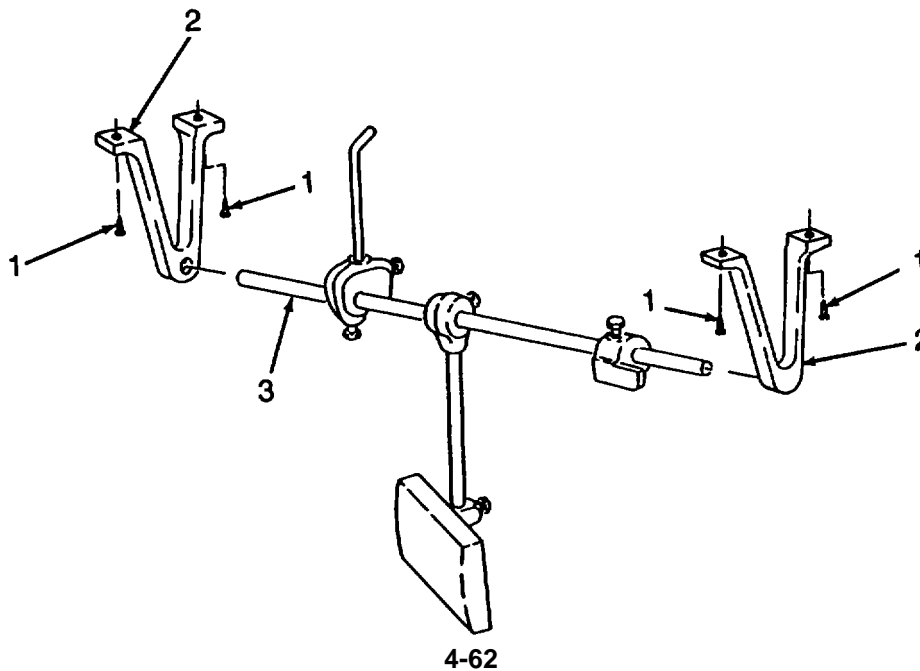

## 4-27. CLOTHING SEWING MACHINE KNEE LEVER ASSEMBLY MAINTENANCE -continued.

### Disassembly.

- (1) Remove five setscrews (1).
- (2) Remove shaft crank (2) and stop bracket (3) from horizontal shaft (4).
- (3) Remove shaft stop (5) from horizontal shaft (4).
- (4) Remove knee plate (6) from rod (7).
- (5) Unscrew rod (7) from joint crank (8).

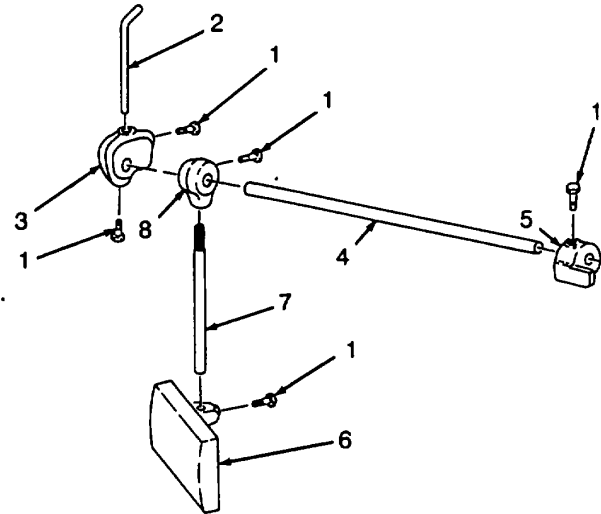

### Inspection.

- (1) Inspect for rust /corrosion and damaged parts.
- (2) Inspect for loose or missing hardware.
- (3) Inspect for cracked or missing knee pad.

### Cleaning.

- (1) Remove all buildups of grease, dirt, etc. by wiping with a wiping rag.

### **WARNING**

To prevent injury to personnel and damage to equipment, use dry cleaning solvent only in well ventilated areas. Avoid repeated or prolonged contact with skin. Do not use near sparks, open flame or excessive heat.

- (2) Clean using cleaning solvent (Appendix F, Item 8) and either a brush (Appendix F, Item 1) or a wiping rag (Appendix F, Item 2). Do not use cleaning solvent on knee pad.
- (3) Allow to dry.

**4-27. CLOTHING SEWING MACHINE KNEE LEVER ASSEMBLY MAINTENANCE-continued.**

Repair. Repair of the knee lifter assembly is limited to the replacement of defective parts.

Assembly.

- (1) Position rod (1) into joint crank (2).
- (2) Place knee plate (3) onto rod (1). Secure with set screw (4).
- (3) Position shaft stop (5) onto horizontal shaft (6). Secure with setscrew (7).
- (4) Place joint crank (2) onto horizontal shaft (6). Secure with setscrew (8).
- (5) Assemble shaft stop (9) onto stop bracket (10) and secure with two setscrews (11).
- (6) Assemble stop bracket (10) onto horizontal shaft (6).

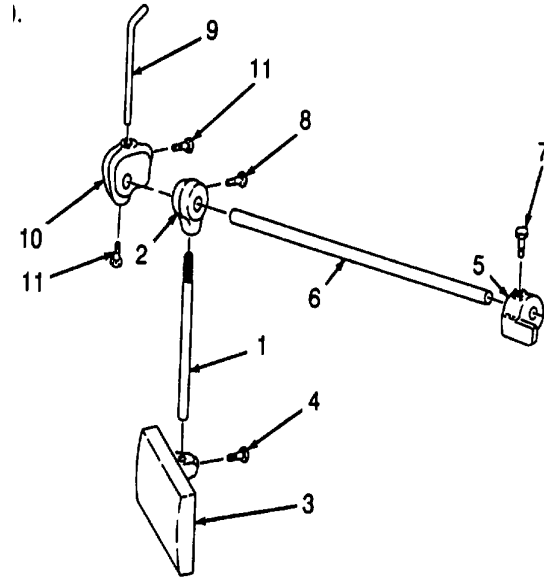

Installation.

- (1) Place knee lifter assembly (1) into position through brackets (2).
- (2) Install brackets (2) and secure with four screws (3).

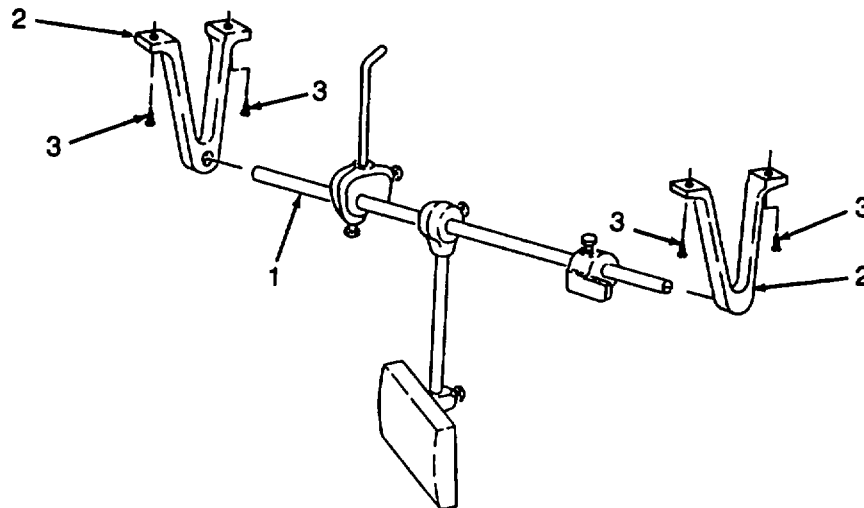

**4-28. CLOTHING SEWING MACHINE CLUTCH AND MOTOR ASSEMBLY ADJUSTMENT.**

**This task covers: Adjustment**

**INITIAL SETUP:**

**Tools:**

General Mechanics Tool Kit (Appendix B,  
Item 1)

**Equipment Condition:**

Operational configuration (para 2-8)

Adjustment.

Adjust clutch with adjustment wing nut (1) for proper clutch engagement.

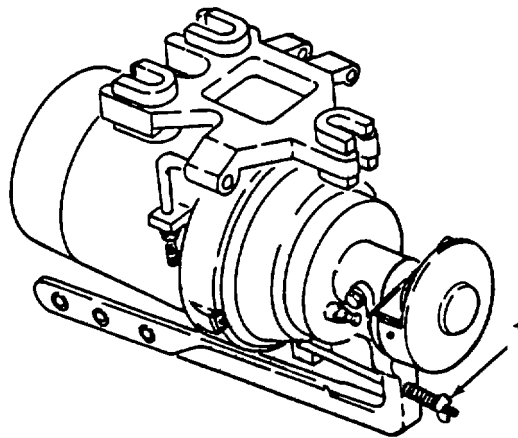

4-65

#### 4-29. CLOTHING SEWING MACHINE CLUTCH AND MOTOR BELT GUARD MAINTENANCE.

This task consists of:

- |            |                 |               |
|------------|-----------------|---------------|
| a. Removal | b. Cleaning     | c. Inspection |
| d. Repair  | e. Installation | f. Adjustment |

##### INITIAL SET-UP:

##### Tools:

General Mechanics Tool Kit (Appendix B, Item 1)

##### Materials/Parts:

Detergent, General Purpose (Appendix F, Item 11)

##### Equipment Condition:

Power Removed (para 2-18)

##### Removal.

- (1) Remove two screws (1), two lockwashers (2), and two flatwashers (3).
- (2) Remove guard cover (4).

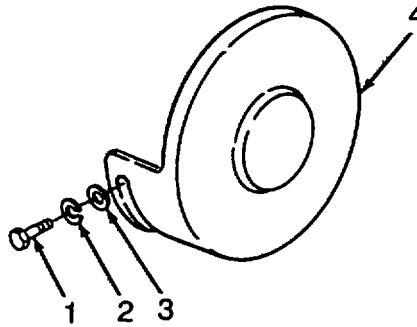

##### Cleaning.

- (1) Wash the belt guard with a solution of detergent, general purpose (Appendix F, Item 11) and water.
- (2) Rinse thoroughly with clean water.
- (3) Allow to dry.

**4-29. CLOTHING SEWING MACHINE CLUTCH AND MOTOR  
BELT GUARD MAINTENANCE-continued.**

Inspection.

- (1) Inspect hardware for damage.
- (2) Inspect guard cover for cracks.

Repair. Repair is limited to the replacement of defective components with serviceable ones.

Installation. Install guard cover (1). Secure with two screws (2), two lockwashers (3), and two flatwashers (4).

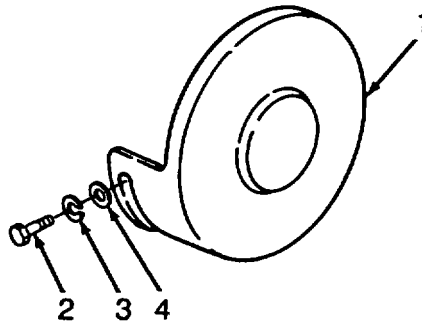

Adjustment.

- (1) Loosen the two screws securing the guard cover onto the clutch and motor assembly.
- (2) Rotate the guard cover so it does not interfere with the belt.
- (3) Tighten the two screws securing the guard cover in place.

**4-30. CLOTHING SEWING MACHINE TREADLE ROD ASSEMBLY MAINTENANCE.**

**This task consists of:**

- |                   |                        |                      |
|-------------------|------------------------|----------------------|
| <b>a. Removal</b> | <b>b. Cleaning</b>     | <b>c. Inspection</b> |
| <b>d. Repair</b>  | <b>e. Installation</b> |                      |

<p><b>INITIAL SET-UP:</b></p> <p><b>Tools:</b>                  General Mechanics Tool Kit (Appendix B, Item 1)</p> <p><b>Equipment Condition:</b>                  Power removed (para. 2-18)</p>	<p><b>Materials/Parts:</b>                  Rag, wiping (Appendix F, Item 2)                  Adhesive (Appendix F, Item 12)</p>
--	--

Removal. Refer to paragraph 2-18.

Cleaning.

- (1) Clean the treadle assembly with a clean damp wiping rag (Appendix F, Item 2).
- (2) Allow to dry.

Inspection.

- (1) Inspect for damaged parts.
- (2) Inspect for loose or missing hardware.
- (3) Inspect for loose or missing cork on the pipe treadle.

Repair. Repair is limited to the replacement of defective parts.

Installation. Refer to paragraph 2-8.

**4-31. CLOTHING SEWING MACHINE TREADLE PIPE MAINTENANCE.**

**This task consists of:**

- |            |                 |               |
|------------|-----------------|---------------|
| a. Removal | b. Cleaning     | c. Inspection |
| d. Repair  | e. Installation |               |

<p><b>INITIAL SET-UP:</b></p> <p><b>Tools:</b> General Mechanics Tool Kit (Appendix B, Item 1)</p> <p><b>Equipment Condition:</b> Power removed (para. 2-18)</p>	<p><b>Materials/Parts:</b> Rag, wiping (Appendix F, Item 2) Adhesive (Appendix F, Item 12)</p>
--	--

Removal. Refer to paragraph 2-18.

Cleaning.

- (1) Clean the pipe treadle with a clean damp wiping rag (Appendix F, Item 2).
- (2) Allow to dry.

Inspection.

- (1) Inspect for damaged parts.
- (2) Inspect for missing or cracked clamps.
- (3) Inspect for loose or missing cork.

Repair. Repair is limited to the following:

Replace damaged or missing cork.

- (1) Remove old cork (1) from pipe treadle (2).
- (2) Using adhesive (Appendix F, Item 12), replace the cork (1) on the pipe treadle (2).

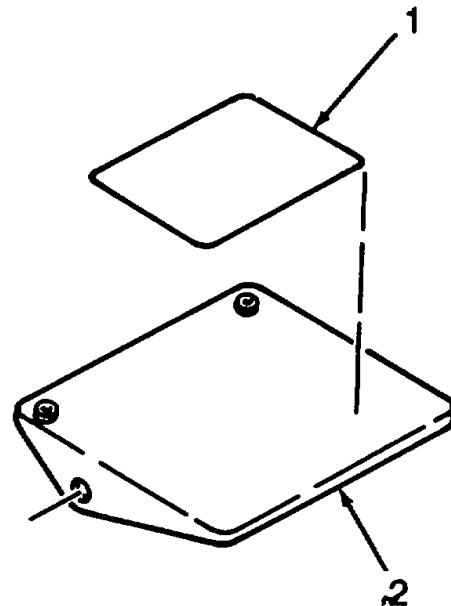

Installation. Refer to paragraph 2-8.

**4-32. CLOTHING SEWING MACHINE STAND ASSEMBLY MAINTENANCE.**

This task consists of:

- |            |                |                 |
|------------|----------------|-----------------|
| a. Removal | b. Disassembly | c. Cleaning     |
| d. Repair  | e. Assembly    | f. Installation |

**INITIAL SET-UP:**

**Tools:**

General Mechanics Tool Kit (Appendix B, Item 1)

**Equipment Condition:**

Power removed (paragraph 2-18)

**Materials/Parts:**

Detergent, General Purpose (Appendix F, Item 11)

Removal. Refer to paragraph 2-18.

Disassembly.

- (1) Remove strap (1), if not already removed.
- (2) Remove two wing nuts (2), two lock washer (3), two flat washers (4), two bolts (5) and the rear cross member (6).

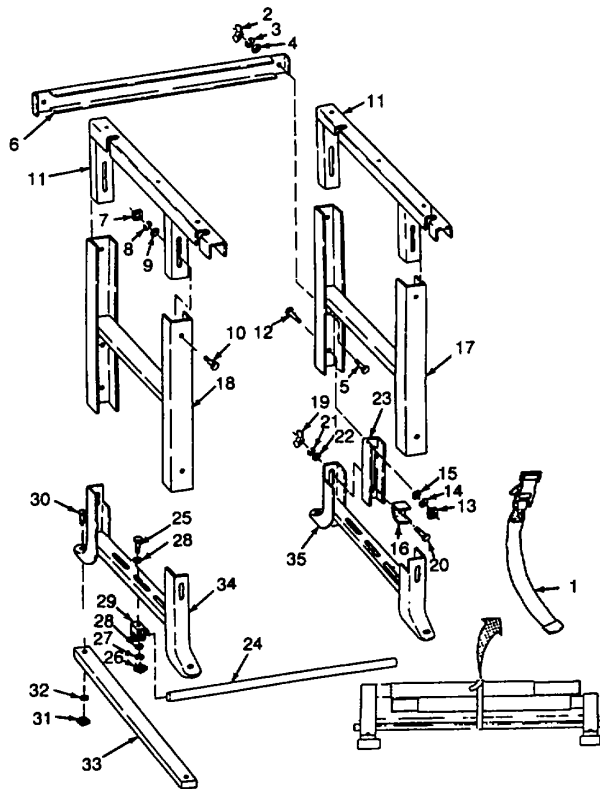

**4-32. CLOTHING SEWING MACHINE STAND ASSEMBLY MAINTENANCE-continued.**

Disassembly-continued.

- (3) Remove four square nuts (7), four lock washers (8), four flat washers (9), four bolts (10) and two top rail assemblies (11).
- (4) Remove four bolts (12), four square nuts (13), four lock washers (14), four flat washers (15), four bolt retainers (16), left leg assembly (17) and right leg assembly (18).
- (5) Remove four wing nuts (19), four bolts (20), four lock washers (21), four flat washers (22), and four folding clips (23).
- (6) Remove treadle support (24).
- (7) Remove two bolts (25), two square nuts (26), two lock washers (27), four flat washers (28) and two pipe supports (29).
- (8) Remove two bolts (30), two square nuts (31), two flat washers (32) and a base (33) from the lower left leg (34) and lower right leg (35).

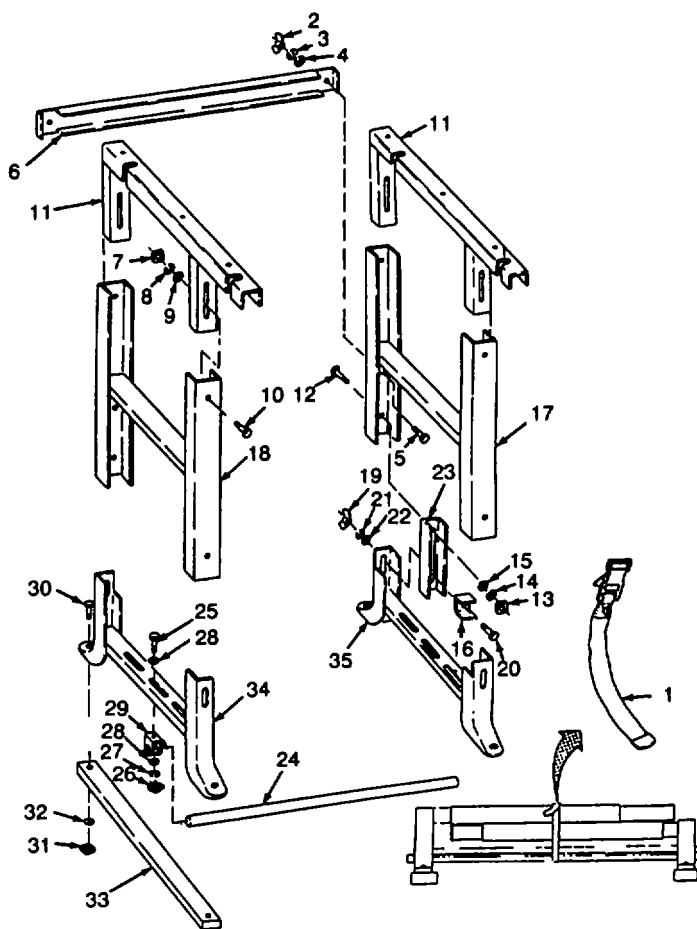

**4-32. CLOTHING SEWING MACHINE STAND ASSEMBLY MAINTENANCE-continued.**

Cleaning.

- (1) Clean the stand with a solution of detergent (Appendix F,Item 11) and water.
- (2) Rinse thoroughly with clean water.
- (3) Allow to dry.

Inspection.

- (1) Inspect hardware for damage.
- (2) Inspect treadle support for damage and straightness.
- (3) Inspect retaining strap for frayed areas or damaged strap buckles.
- (4) Inspect clips for damage.
- (5) Inspect legs for damage.

Repair. Repair is limited to the replacement of defective parts.

**4-32. CLOTHING SEWING MACHINE STAND ASSEMBLY MAINTENANCE-continued.**

Assembly.

- (1) Install base (1) onto the lower left leg (2) and the lower right leg (3). Secure with two bolts (4), two flat washers (5) and two square nuts (6).
- (2) Install the pipe support (7) onto the lower left leg (2). Secure with bolt (8), two flat washers (9), lock washer (10) and a square nut (11).
- (3) Install the pipe support (7) onto the lower right leg (3). Secure with bolt (8), two flat washers (9), lock washer (10) and a square nut (11).
- (4) Slide and install the treadle support (12) through both pipe supports (7). Position the lower left leg assembly (2) and the lower right leg assembly (3) and the ends of the pipe.
- (5) Install four folding clips (13). Secure with four bolts (14), four flat washers (15), four lock washers (16) and four wing nuts (17).

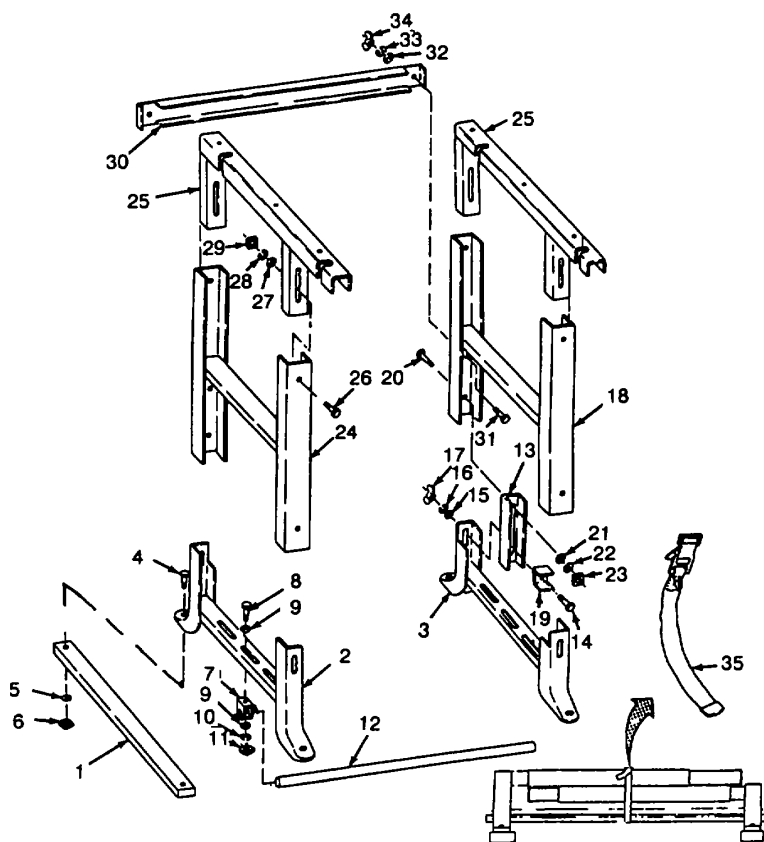

**4-32. CLOTHING SEWING MACHINE STAND ASSEMBLY MAINTENANCE-continued.**

- (6) Install right leg assembly (18). Secure with two bolt retainers (19), two bolts (20), two flat washers (21), two lock washers (22), two square nuts (23).
- (7) Install left leg assembly (24). Secure with two bolt retainers (19), two bolts (20), two flat washers (21), two lock washers (22), two square nuts (23).
- (8) Install two top rail assemblies (25). Secure with four bolts (26), four flat washers (27), four lock washers (28) and four square nuts (29).
- (9) Install the rear cross member (30). Secure with two bolts (31), two flat washers (32), two lock washers (33) and two wing nuts (34).
- (10) Install strap (35) around stand assembly if the stand is to be returned to the folded position.

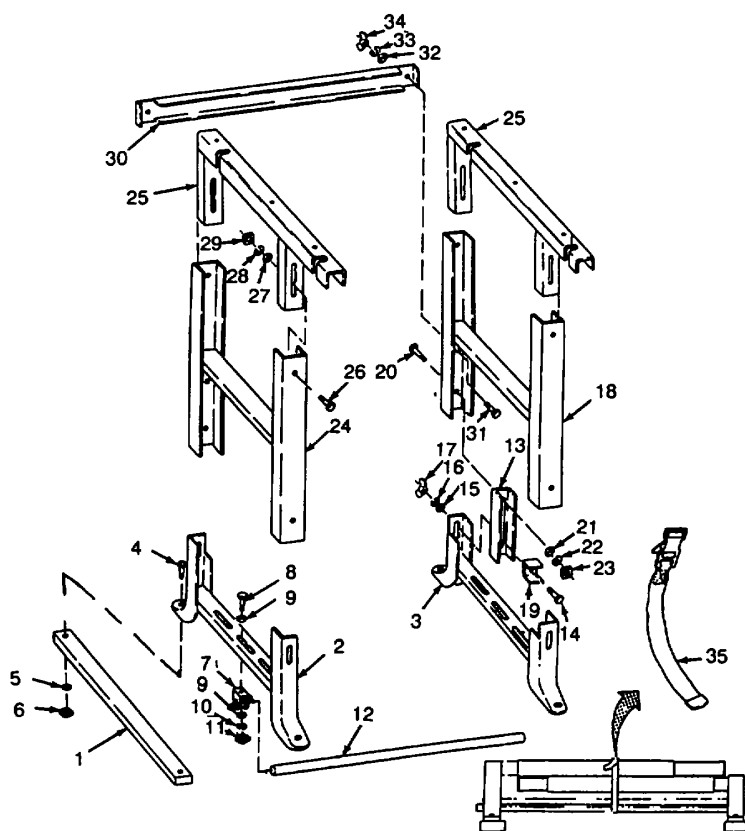

Installation. Refer to paragraph 2-8.

**4-33. DARNING SEWING MACHINE TRAY MAINTENANCE.****This task consists of:****a. Inspection****b. Cleaning****c. Repair****INITIAL SET-UP:****Tools:**

General Mechanics Tool Kit (Appendix B, Item 1)

**Equipment Condition:**Sewing machine removed (para. 2-8)  
Wood Glue (Appendix F, Item 13)**Material/Parts:**Adhesive (Appendix F, Item 12)  
Coating, Clear, Polyurethane (Appendix F, Item 10)  
Rag, Wiping (Appendix F, Item 2)Inspection.

- (1) Inspect for damaged wood.
- (2) Inspect for damaged holddown straps and handles.
- (3) Inspect for loose or missing hardware.
- (4) Inspect for damaged or deteriorated felt absorbers.

Cleaning.

- (1) Clean the tray assembly with a clean damp rag (Appendix F, Item 2).
- (2) Rinse thoroughly with clean water.
- (3) Allow to dry.

Repair. Repair is limited to the following:

- (1) Refinishing of damaged or scuffed table top.
  - (a) Sand surface, as required.
  - (b) Clean surface of wooden table top.
  - (c) Apply a coating of coating, clear, polyurethane (Appendix F, Item 10) to the effected wooden surface.
  - (d) Allow to dry.
- (2) Replacement of the holddown strap as follows:
  - (a) Remove two screws (1), loop (2) and holddown strap (3) from tray (4).

**4-33. DARNING SEWING MACHINE TRAY MAINTENANCE-continued.**

(b) Install holddown strap (3), loop (2) and secure with two screws (1). Repeat for other side.

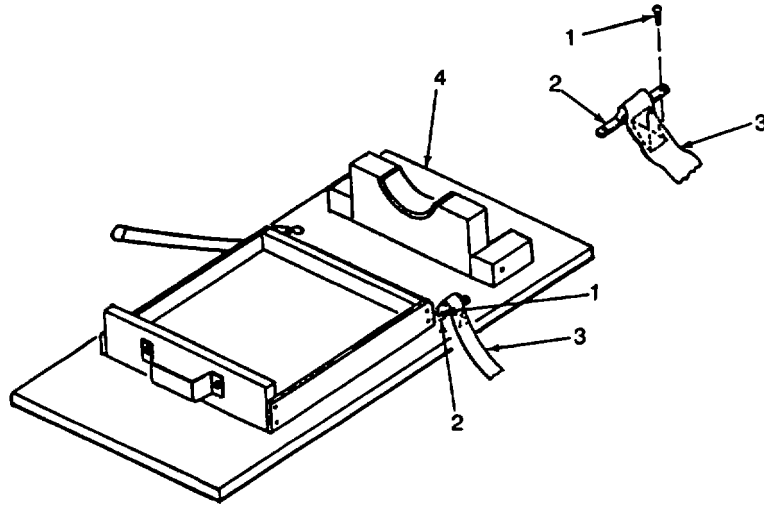

(3) Replacement of the felt shock absorbers is as follows:

(a) Scrape off old felt (1 or 2) from tray (3), as required.

(b) Install new felt (1 or 2) to tray (3) using adhesive (Appendix F, Item 12).

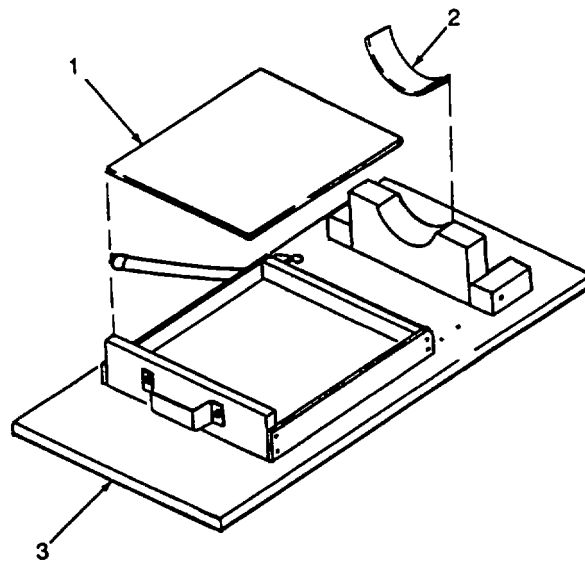

4-33. DARNING SEWING MACHINE TRAY MAINTENANCE-continued.

(4) Replacement of the handle.

- (a) Remove two screws (1) and handle (2) from tray (3).
- (b) Install new handle (2) and secure with two screws (1).

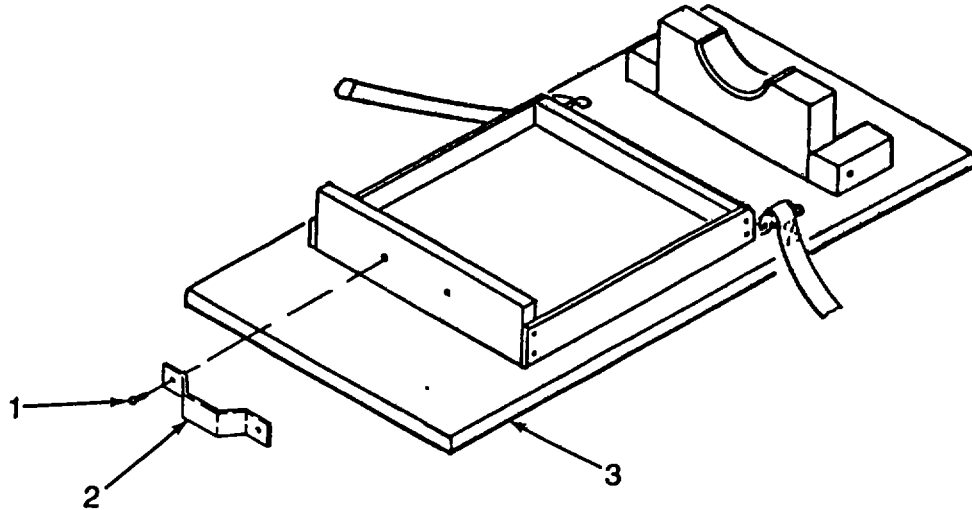

(5) Replacement of ID Plate

- (a) Remove four screws (1) and ID plate (2) from the clothing machine tray (3).

**NOTE**

ID plate reads "207".

- (b) Install new ID plate (2) and secure with four screws (1).

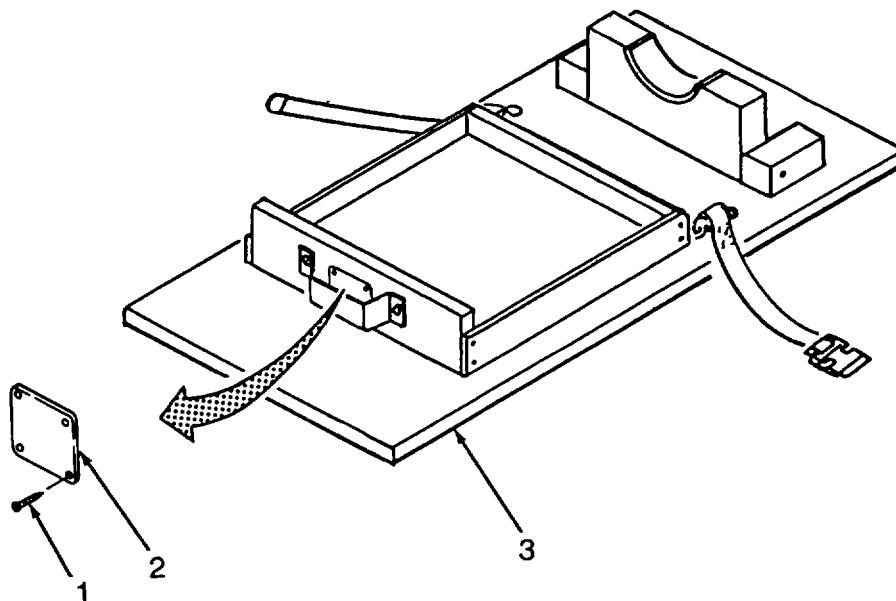

**4-33. DARNING SEWING MACHINE TRAY MAINTENANCE-continued.**

- (6) Repair wooden cracks and breaks.
  - (a) Spread wood glue (Appendix F, Item 13) on cracked areas and clamp securely.
  - (b) Wipe off excess wood glue.
  - (c) Allow to dry.

**4-34. DARNING SEWING MACHINE THREAD UNWINDER STAND MAINTENANCE.****This task consists of:**

- |            |                 |             |
|------------|-----------------|-------------|
| a. Removal | b. Inspection   | c. Cleaning |
| d. Repair  | e. Installation |             |

**INITIAL SET-UP:****Tools:**

General Mechanics Tool Kit (Appendix B, Item 1)

**Material/Parts:**

Rag, wiping (Appendix F, Item 2)

**Equipment Condition:**

Thread removed from stand.

Removal. Refer to paragraph 2-18.

Inspection.

- (1) Inspect for damaged parts.
- (2) Inspect for loose or missing hardware.
- (3) Inspect for corrosion on thread hook.

Cleaning.

- (1) Clean the thread unwinder with a clean damp wiping rag (Appendix F, Item 2)
- (2) Allow to dry.

Repair. Repair is limited to replacement of the defective components.

Installation. Refer to paragraph 2-8.

**4-35. DARNING SEWING MACHINE BELT GUARD MAINTENANCE.**

---

**This task consists of:**

a. Removal  
d. Repair

b. Cleaning  
e. Installation

c. Inspection

**INITIAL SET-UP:****Tools:**

General Mechanics Tool Kit (Appendix B, Item 1)

**Material/Parts:**

Rag, wiping (Appendix F, Item 2)

**Equipment Condition:**

Power disconnected (para. 2-18)

Removal. Refer to paragraph 2-18.

Cleaning. Clean parts with a clean dry wiping rag (Appendix F, Item 2).

Inspection.

- (1) Inspect hardware for damage.
- (2) Inspect belt guard for damage.

Repair. Repair is limited to replacement of defective components.

Installation. Refer to paragraph 2-8.

**4-36. DARNING SEWING MACHINE THREAD GUIDES MAINTENANCE.**

**This task consists of:**      a. Removal      b. Disassembly      c. Cleaning      d. Inspection  
    e. Repair      f. Assembly      g. Installation

**INITIAL SET-UP:**

**Tools:**

General Mechanics Tool Kit (Appendix B, Item 1)

**Equipment Condition:**

Thread removed (para. 2-12).

**Materials/Parts:**

Rag, wiping (Appendix F, Item 2)  
 Cleaning Solvent (Appendix F, Item 8)  
 Brush, Medium Bristle (Appendix F, Item 1)

Removal.

**NOTE**

Thread stand (3) is an accessory and may or may not be mounted on the machine head.

(1) Remove screw (1), nut (2) and thread stand (3).

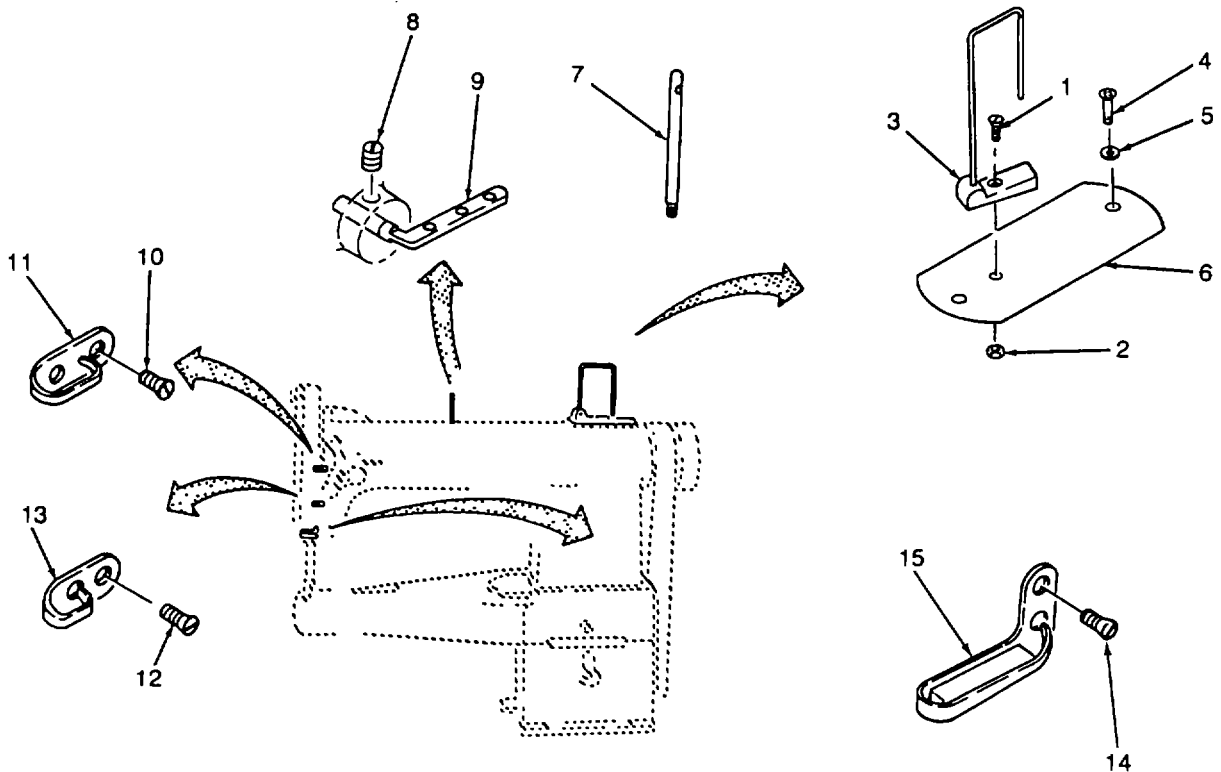

4-36. DARNING SEWING MACHINE THREAD GUIDES MAINTENANCE - continued. |

- (2) Remove screw (4), flat washer (5) and plate (6).
- (3) Remove spool pin (7).
- (4) Remove setscrew (8) and remove thread retainer (9).
- (5) Remove screw (10) and upper thread guide (11).
- (6) Remove screw (12) and lower thread guide (13).
- (7) Remove screw (14) and thread guide assembly (15).

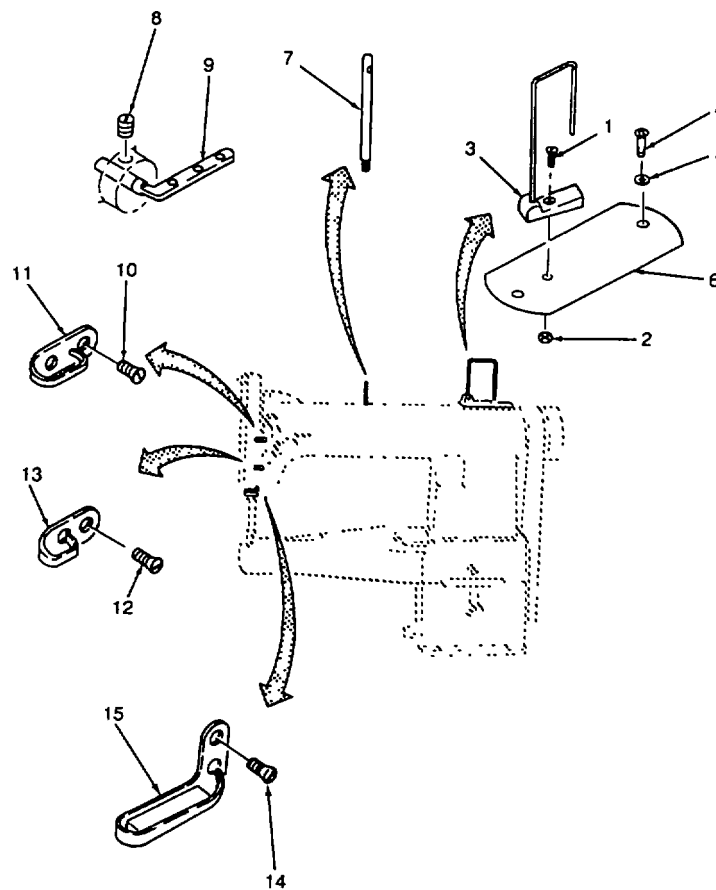

**4-36. DARNING SEWING MACHINE THREAD GUIDES MAINTENANCE - continued .**

Disassembly. Remove thread guide felt (1) from thread guide (2).

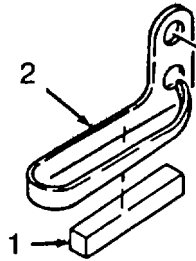
**Cleaning.**

- (1) Remove all buildups of grease, dirt, etc., by wiping with a wiping rag (Appendix F, Item 2).

**WARNING**

Cleaning solvent, Federal Specification P-D-680, is both toxic and flammable. Keep off skin. Use only in a well-ventilated area and avoid prolonged breathing of vapors. Keep away from open flame.

- (2) Clean using cleaning solvent (Appendix F, Item 8) and either a wiping rag (Appendix F Item 2) or a medium bristle brush (Appendix F, Item 1). Do not clean thread guide felt.
- (3) Allow to dry.

**4-36. DARNING SEWING MACHINE THREAD GUIDES MAINTENANCE - continued .**

Inspection

- (1) Inspect hardware for damage.
- (2) Inspect thread stand for damage.
- (3) Inspect spool pin for damage.
- (4) Inspect thread retainer for damage.
- (5) Inspect upper thread guide for damage.
- (6) Inspect lower thread guide for damage.
- (7) Inspect thread guide felt for damage (may be inspected without disassembly).

Repair. Repair of the thread guides is limited to the replacement of defective components

Assembly. Install thread guide felt (1) in thread guide (2).

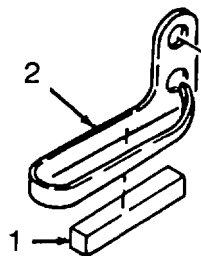

Installation.

- (1) Install thread guide assembly (1) and secure with screw (2).
- (2) Install lower thread guide (3) and secure with screw (4)
- (3) Install upper thread guide (5) and secure with screw (6).
- (4) Install thread retainer (7) and secure with setscrew (8).
- (5) Screw spool pin (9) into place.

4-36. DARNING SEWING MACHINE THREAD GUIDES MAINTENANCE - continued. |

(6) Install plate (10), flatwasher (11) and secure loosely with screw (12).

(7) Install thread stand (13) Secure with screw (14) and nut (15).

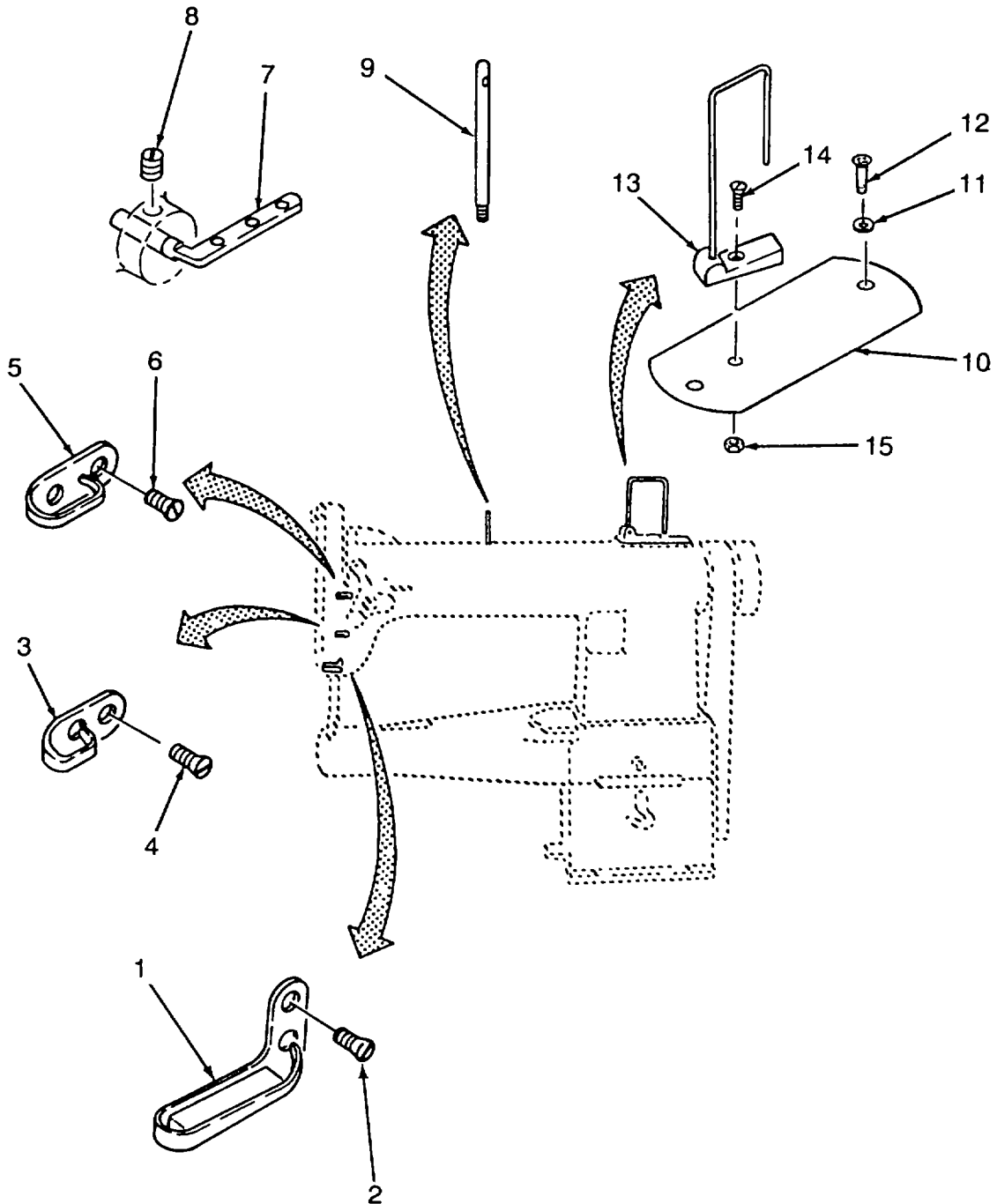



**4-37. DARNING SEWING MACHINE SLIDE, NEEDLE AND GUIDE PLATES MAINTENANCE - continued.**

Cleaning.

- (1) Remove all buildups of grease, dirt, etc., by wiping with a wiping rag (Appendix F, Item 2)

**WARNING**

**Cleaning solvent, Federal Specification P-D-680, is both toxic and flammable. Keep off skin Use only in a well-ventilated area and avoid prolonged breathing of vapors. Keep away from open flame.**

- (2) Clean using cleaning solvent (Appendix F, Item 8) and either a wiping rag (Appendix F Item 2) or a medium bristle brush (Appendix F, Item 1).
- (3) Allow to dry.

Inspection.

- (1) Inspect hardware for damage.
- (2) Inspect cylinder for burrs and damage.
- (3) Inspect slide plate for burrs and damage.
- (4) Inspect slide plate stop for burrs and damage.
- (5) Inspect needle plate for burrs and damage.

Repair. Repair of the slide, needle and guide plates is limited to deburring and the replacement of defective components.

4-37. DARNING SEWING MACHINE SLIDE, NEEDLE AND GUIDE PLATES MAINTENANCE - continued .

**Installation**

- (1) Install slide plate stop (1). Secure with screw (2) and washer (3).
- (2) Install needle plate (4). Secure with two screws (5)
- (3) Install side plate (6) Secure with two screws (7).
- (4) Install side plate (8). Secure with two screws (7).
- (5) Install slide plate (9). Rotate slide plate stop (1) over slide plate
- (6) Slide cylinder (10) onto machine

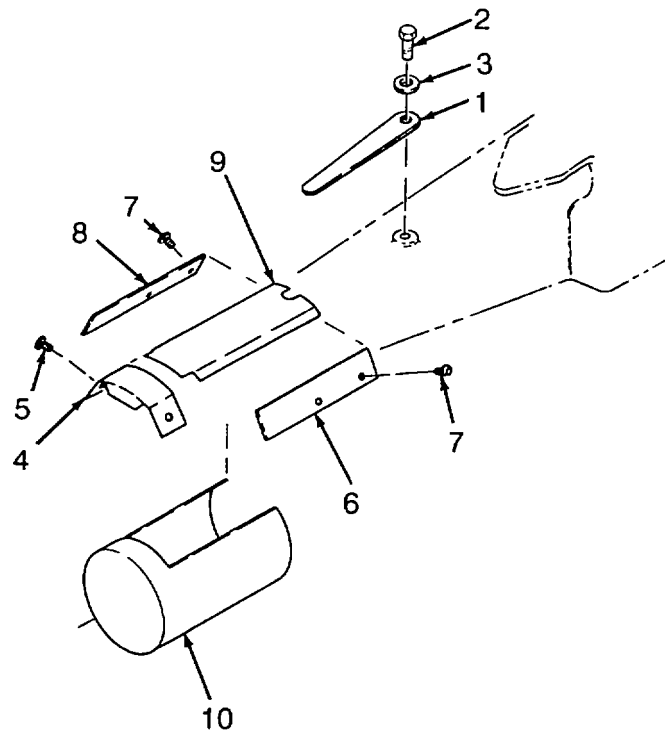

**4-38. DARNING SEWING MACHINE PRESSER FOOT, NEEDLE GUARDS AND GUIDE MAINTENANCE.**

**This task consists of:**      a. Removal    b. Inspection  
    c. Repair      d. Installation

**INITIAL SET-UP:**

**Tools:**

General Mechanics Tool Kit (Appendix B, Item 1)

**Equipment Condition:**

Power removed (para. 2-18)  
 Thread and Needle removed (para. 2-12)

Removal.

(1) Remove screw (1), guard (2), and presser foot (3)

(2) Remove screw (4) and presser spring (5) from presser foot (3).

(3) Remove thread guide (6) from needle bar bushing (7).

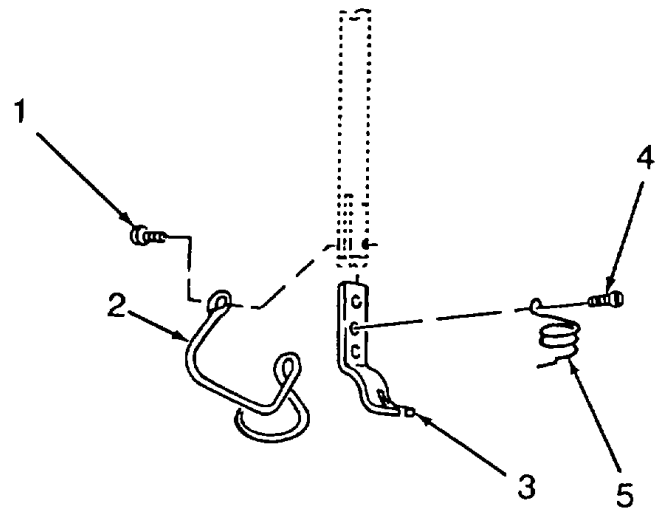

Inspection.

- (1) Inspect hardware for damage.
- (2) Inspect presser foot for damage.
- (3) Inspect guard for damage.
- (4) Inspect presser spring for damage.

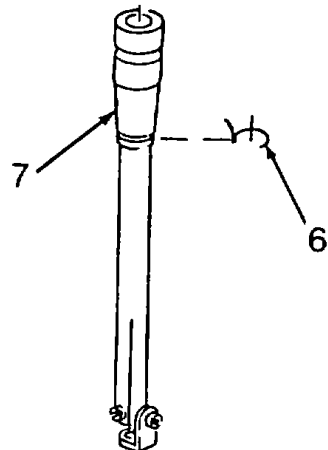

**4-38. DARNING SEWING MACHINE PRESSER FOOT, NEEDLE GUARDS AND GUIDE MAINTENANCE - continued.**

Repair Repair is limited to replacement of the defective components.

Installation.

- (1) Install thread guide (1) on needle bar bushing (2).

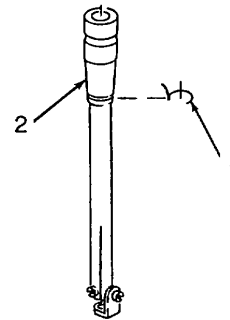

- (2) Install presser spring (3) on presser foot (4). Secure with screw (5).

- (3) Install presser foot (4) and guard (6). Secure with screw (7).

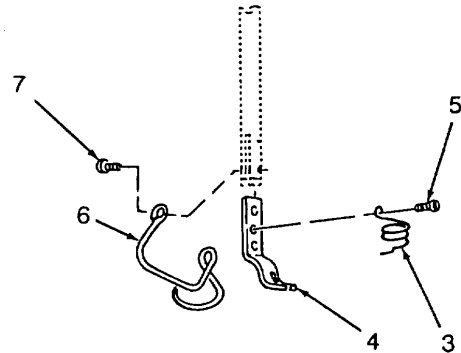

**4-39. DARNING SEWING MACHINE TABLE TOP ASSEMBLY MAINTENANCE. I**

**This task consists of:**

<b>a. Removal</b>	<b>b. Cleaning</b>
<b>c. Repair</b>	<b>d. Installation</b>

**INITIAL SET-UP:**

**Tools:**

General Mechanics Tool Kit (Appendix B, Item 1)

**Materials/Parts:**

Coating, Clear, Polyurethane (Appendix F, Item 10)

**Equipment Condition:**

Sewing machine removed (para. 2-18)  
Electrical power removed (para 2-18)

Rag, wiping (Appendix F, Item 2)

Removal.

**Refer to paragraph 2-18.**

Cleaning

- (1) Clean the table top assembly with a clean damp wiping rag (Appendix F, Item 2).
- (2) Rinse thoroughly with clean water.
- (3) Allow to dry.

Repair. **Repair is limited to the following:**

- (1) Refinishing of damaged or scuffed table top
  - (a) Sand surface, as required.
  - (b) Clean surface of wooden table top.
  - (c) Apply a coating of coating, clear, polyurethane (Appendix F, Item 10) to the effected wooden surface
  - (d) Allow to dry.

Installation. Refer to paragraph 2-8

**4-40. DARNING SEWING MACHINE FOOT PEDAL MAINTENANCE.**

This task consists of:           a. Removal   b. Inspection   c. Repair  
  d. Installation

**INITIAL SET-UP:**

**Tools:**

General Mechanics Tool Kit (Appendix B,  
Item 1)

**Equipment Condition:**

Power Removed (para. 2-18)

Removal. Refer to paragraph 2-18

Inspection.

- (1) Inspect for cracked or damaged parts
- (2) Inspect for lost or missing clamps.

Repair. Repair is limited to replacement of the defective components.

Installation. Refer to paragraph 2-8.

**4-41. DARNING SEWING MACHINE CLUTCH AND MOTOR ASSEMBLY ADJUSTMENT.**

**This task covers:**      **Adjustment**

**INITIAL SET-UP:**

**Tools:**

General Mechanics Tool Kit (Appendix B,  
Item 1)

**Equipment Condition:**

Operational configuration (para 2-18)

Adjustment

Adjust clutch with adjustment wing nut (1) for proper clutch engagement.

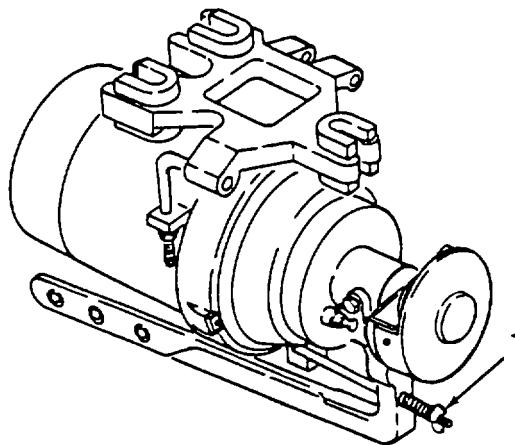

**4-42. DARNING SEWING MACHINE CLUTCH AND MOTOR BELT GUARD MAINTENANCE.**

**This task covers:**                    a. Removal      b. Cleaning      c. Inspection  
    d. Repair        e. Installation   f. Adjustment

**INITIAL SET-UP:**

**Tools:**

General Mechanics Tool Kit (Appendix B, Item 1)

**Equipment Condition:**

Power Removed (para 2-18)

**Materials/Parts:**

Detergent, General Purpose (Appendix F, Item 11)

Removal.

- (1) Remove two screws (1), two lockwashers (2), and two flatwashers (3).
- (2) Remove guard cover (4).

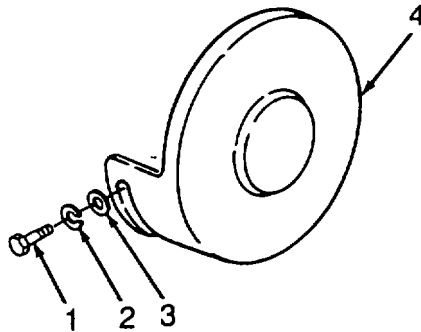

Cleaning.

- (1) Wash the belt guard with a solution of detergent, general purpose (Appendix F, Item 11) and water.
- (2) Rinse thoroughly with clean water.
- (3) Allow to dry.

**4-42. DARNING SEWING MACHINE CLUTCH AND MOTOR BELT GUARD MAINTENANCE - continued.**

Inspection.

- (1) Inspect hardware for damage.
- (2) Inspect guard cover for cracks.

Repair. Repair is limited to the replacement of defective components with serviceable ones.

Installation. Install guard cover (1). Secure with two screws (2), two lockwashers (3), and two flatwashers (4).

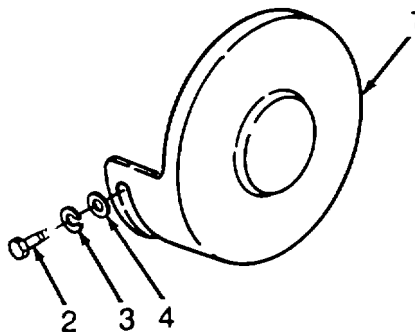

Adjustment.

- (1) Loosen the two screws securing the guard cover onto the clutch and motor assembly
- (2) Rotate the guard cover so it does not interfere with the belt.
- (3) Tighten the two screws securing the guard cover in place.

**4-43. DARNING SEWING MACHINE TREADLE ROD ASSEMBLY MAINTENANCE. I**

**This task consists of:**            **a. Removal**    **b. Cleaning**    **c. Inspection**  
   **d. Repair**       **e. Installation**

**INITIAL SET-UP:**

**Tools:**

General Mechanics Tool Kit (Appendix B, Item 1)

**Materials/Parts:**

Rag, wiping (Appendix F, Item 2)

**Equipment Condition:**

Power removed (para 2-18)

Removal. Refer to paragraph 2-18

Cleaning.

(1) Clean the treadle rod assembly with a clean damp wiping rag (Appendix F, Item 2).

(2) Allow to dry.

Inspection.

(1) Inspect for loose or missing hardware.

(2) Inspect treadle rod assembly for damage.

Repair. Repair is limited to the replacement of defective parts.

Installation. Refer to paragraph 2-8.

4-44. DARNING SEWING MACHINE TREADLE PIPE MAINTENANCE . I

This task consists of:            a. Removal      b. Cleaning      c. Inspection  
    d. Repair        e. Installation

**INITIAL SET-UP:**

**Tools:**

General Mechanics Tool Kit (Appendix B, Item 1)

**Materials/Parts:**

Rag, wiping (Appendix F, Item 2)  
 Adhesive (Appendix F, Item 12)

**Equipment Condition:**

Power removed (para. 2-18)

**Removal.** Refer to paragraph 2-18

**Cleaning.**

- (1) Clean the pipe treadle with a clean damp wiping rag (Appendix F, Item 2).
- (2) Allow to dry.

**Inspection.**

- (1) Inspect for damaged parts.
- (2) Inspect for missing or cracked clamps.
- (3) Inspect for loose or missing cork.

Repair. Repair is limited to the following:

Replace damaged or missing cork.

- (2) Remove old cork (1) from pipe treadle (2).
- (3) Using adhesive (Appendix F, Item 12), replace the cork (1) on the pipe treadle (2).

**Installation.** Refer to paragraph 2-8.

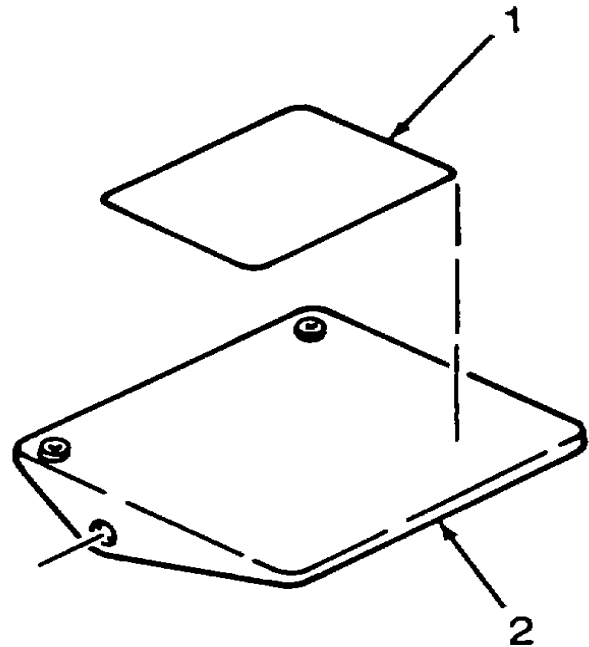

4-45. DARNING SEWING MACHINE STAND ASSEMBLY.

This task consists of:      a. Removal      b. Disassembly      c. Cleaning      d. Inspection  
    e. Repair      f. Assembly      g. Installation

INITIAL SET-UP:

**Tools:**

General Mechanics Tool Kit (Appendix B, Item 1)

**Materials/Parts:**

Detergent, General Purpose (Appendix F, Item 11)

**Equipment Condition:**

Power removed (paragraph 2-18)

Removal. Refer to paragraph 2-18.

Disassembly.

- (1) Remove strap (1), if not already removed.
- (2) Remove two wing nuts, two lock washer (3), two flat washers (4), two bolts (5) and the rear cross member (6).

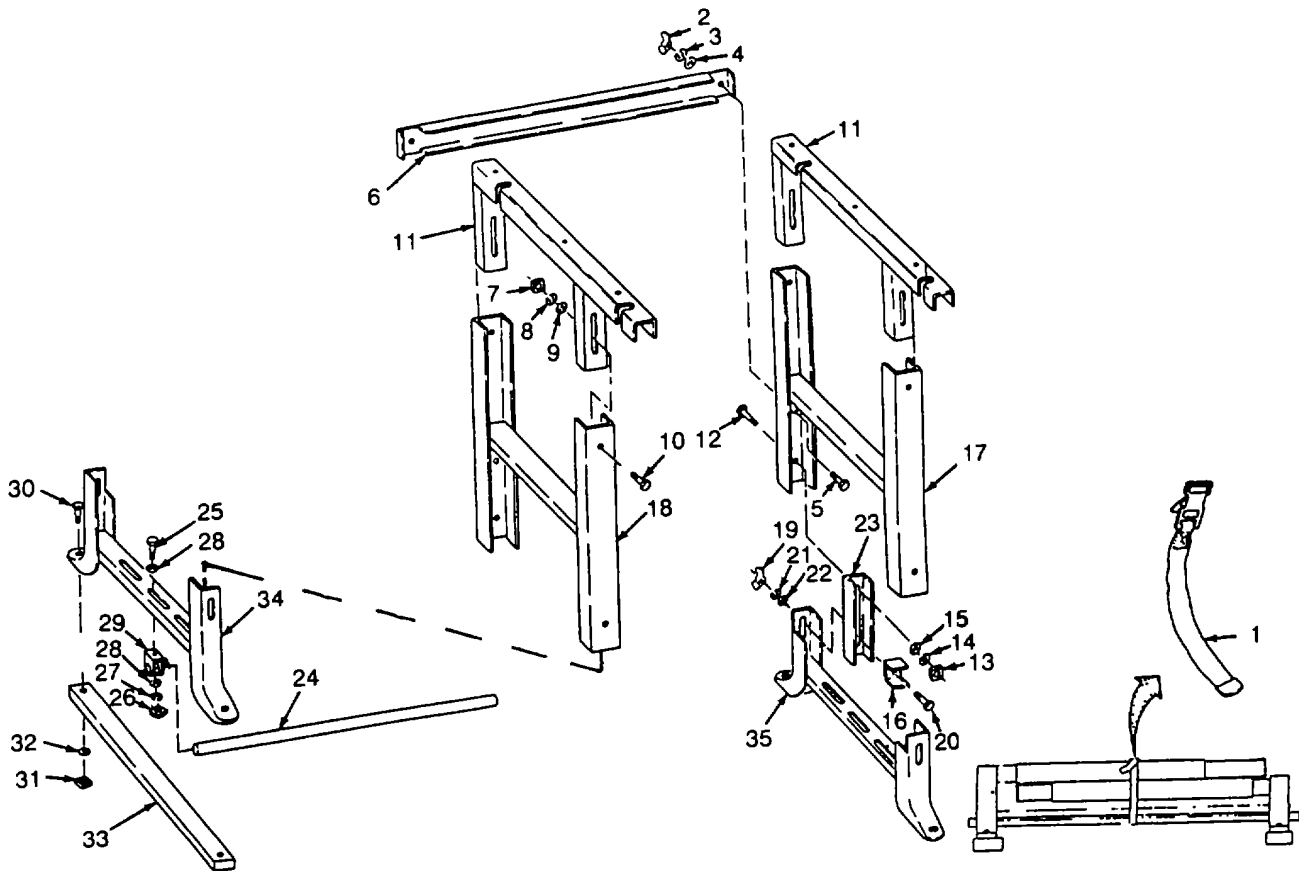

4-45. DARNING SEWING MACHINE STAND ASSEMBLY - continued.

Disassembly - continued.

- (3) Remove four square nuts (7), four lock washers (8), four flat washers (9), four bolts (10) and two top rail assemblies (11).
- (4) Remove four bolts (12), four square nuts (13), four lock washers (14), four flat washers (15), four bolt retainers (16), left leg assembly (17) and right leg assembly (18).
- (5) Remove four wing nuts (19), four bolts (20), four lock washers (21), four flat washers (22) and four folding clips (23).
- (6) Remove treadle support (24).
- (7) Remove two bolts (25), two square nuts (26), two lock washers (27), four flat washers (28) and two pipe supports (29).
- (8) Remove two bolts (30), two square nuts (31), two flat washers (32) and a base (33) from the lower left leg (34) and lower right leg (35).

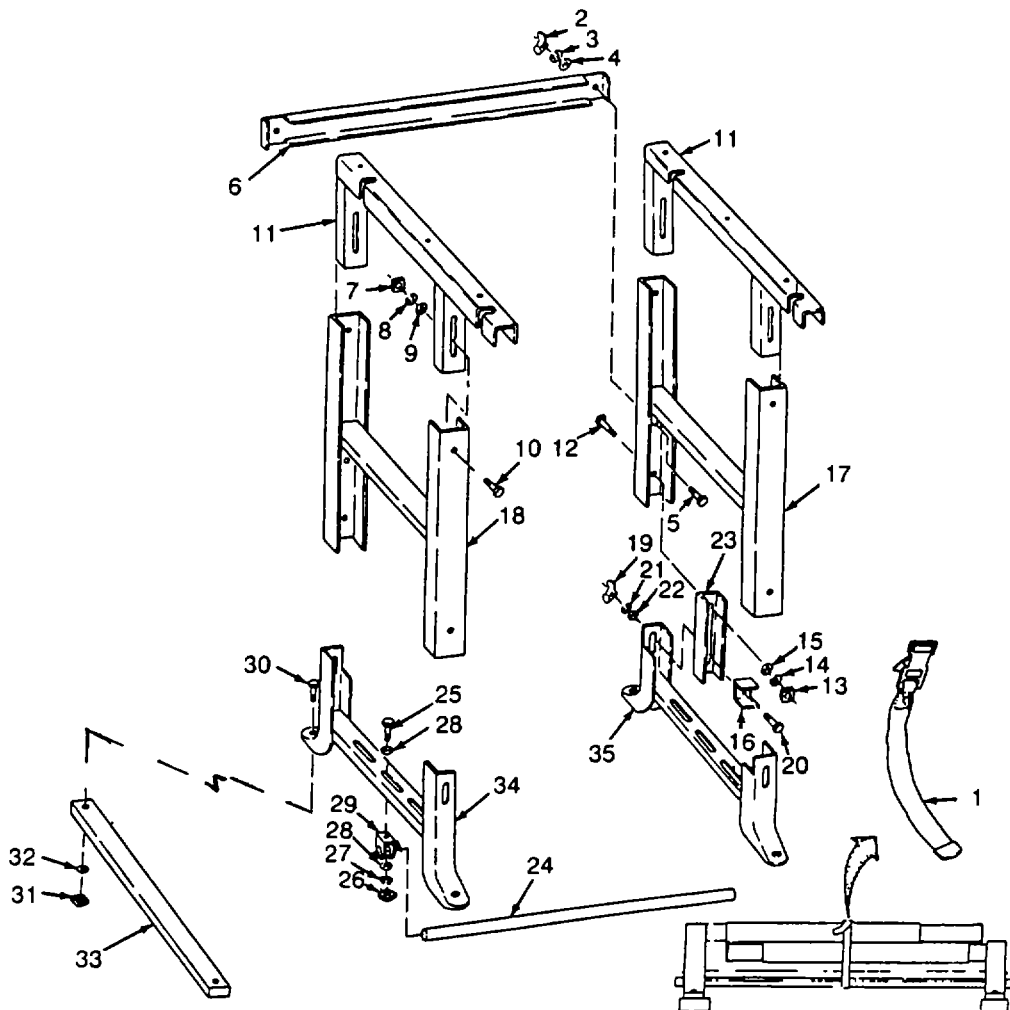

**4-45. DARNING SEWING MACHINE STAND ASSEMBLY - continued.**

Cleaning

- (1) Clean the stand with a solution of detergent (Appendix F, Item 11) and water
- (2) Rinse thoroughly with clean water.
- (3) Allow to dry.

Inspection.

- (1) Inspect hardware for damage.
- (2) Inspect treadle support for damage and straightness.
- (3) Inspect retaining strap for frayed areas or damaged strap buckles.
- (4) Inspect clips for damage.
- (5) Inspect legs for damage.

Repair. Repair is limited to the replacement of defective parts

**4-45. DARNING SEWING MACHINE STAND ASSEMBLY - continued.**

Assembly.

- (1) Install base (1) onto the lower left leg (2) and the lower right leg (3). Secure with two bolts (4), two flat washers (5) and two square nuts (6).
- (2) Install the pipe support (7) onto the lower left leg (2). Secure with bolt (8), two flat washers (9), lock washer (10) and a square nut (11).
- (3) Install the pipe support (7) onto the lower right leg (3). Secure with bolt (8), two flat washers (9), lock washer (10) and a square nut (11).
- (4) Slide and install the treadle support (12) through both pipe supports (7). Position the lower left leg (2) and the lower right leg assembly (3) and the ends of the pipe.
- (5) Install four folding clips (13). Secure with four bolts (14), four flat washers (15), four lock washers (16) and four wing nuts (17).

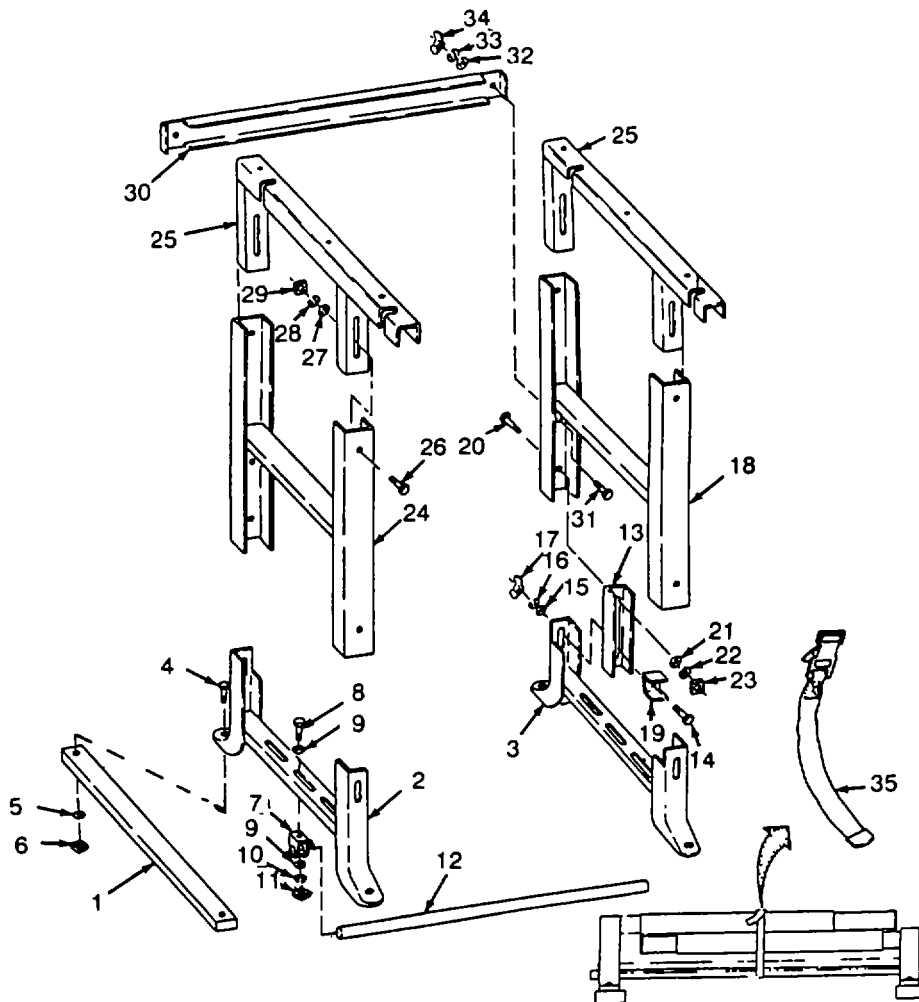

**4-45. DARNING SEWING MACHINE STAND ASSEMBLY - continued.**

- (6) Install right leg assembly (18). Secure with two bolt retainers (19), two bolts (20), two flat washers (21), two lock washers (22), two square nuts (23)
- (7) Install left leg assembly (24). Secure with two bolt retainers (19), two bolts (20), two flat washers (21), two lock washers (22), two square nuts (23).
- (8) Install two top rail assemblies (25). Secure with four bolts (26), four flat washers (27), four lock washers (28) and four square nuts (29).
- (9) Install the rear cross member (30). Secure with two bolts (31), two flat washers (32), two lock washers (33) and two wing nuts (34).
- (10) Install strap (35) around stand assembly if the stand is to be returned to the folded position.

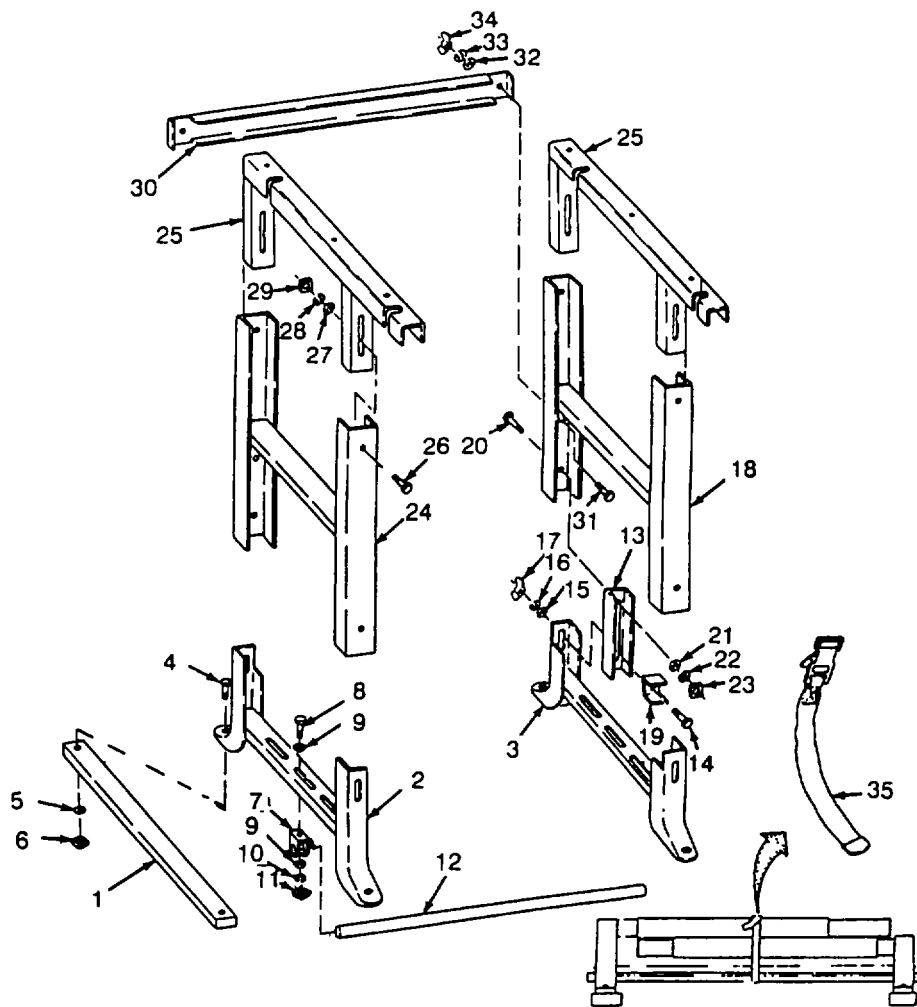

Installation. Refer to paragraph 2-8.

**4-46. BUTTON SEWING MACHINE TRAY MAINTENANCE.**

---

This task consists of a. Inspection                      b. Cleaning                      c. Repair

---

**INITIAL SET-UP:****Tools:**

General Mechanics Tool Kit (Appendix B, Item 1)

**Equipment Condition :**

Sewing machine removed (para 2-18)

**Material/Parts:**

Adhesive (Appendix F, Item 12)  
 Coating, Clear, Polyurethane (Appendix F, Item 10)  
 Rag, wiping (Appendix F, Item 2)  
 Wood Glue (Appendix F, Item 13)

*Inspection.*

- (1) Inspect for damaged wood.
- (2) Inspect for damaged holddown straps and tray pulls.
- (3) Inspect for loose or missing hardware.
- (4) Inspect for damaged or deteriorated felt absorbers.

Cleaning.

- (1) Clean the tray assembly with a clean damp wiping rag (Appendix F, Item 2).
- (2) Rinse thoroughly with clean water.
- (3) Allow to dry.

Repair. Repair is limited to the following:

- (1) Refinishing of damaged or scuffed table top.
  - (a) Sand surface, as required.
  - (b) Clean surface of wooden table top.
  - (c) Apply a coating of coating, clear, polyurethane (Appendix F, Item 10) to the affected wooden surface.
  - (d) Allow to dry.

**4-46. BUTTON SEWING MACHINE TRAY MAINTENANCE - continued.**

(2) Replacement of the holddown straps as follows:

- (a) Remove two screws (1), loop (2) and holddown strap (3) from tray (4).
- (b) Install holddown strap (3), loop (2) and secure with two screws (1). Repeat for other side.

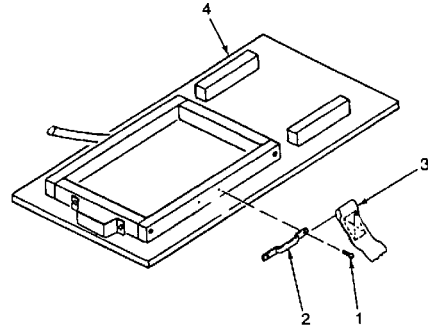

(3) Replacement of the felt shock absorbers is as follows:

- (a) Scrape off old felt (1) from tray (2) as required
- (b) Install new felt (1) to tray (2) using adhesive (Appendix F, Item 12).

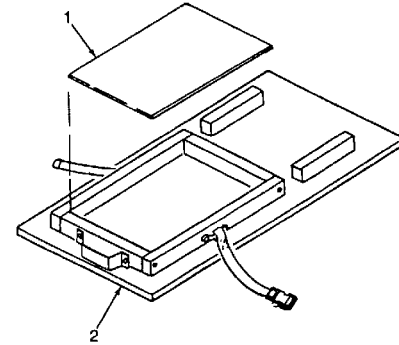

(4) Replacement of the handle.

- (a) Remove two screws (1) and handle (2) from tray (3)
- (b) Install new handle (2) and secure with two screws (1).

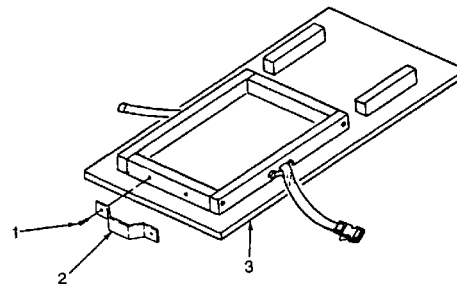

**4-46. BUTTON SEWING MACHINE TRAY MAINTENANCE - continued.**

- (5) Replacement of ID Plate.

**NOTE**

ID plate reads: "261-2."

- (a) Remove four screws (1) and ID plate (2) from the button machine tray (3).  
(b) Install new ID plate (2) and secure with four screws (1).

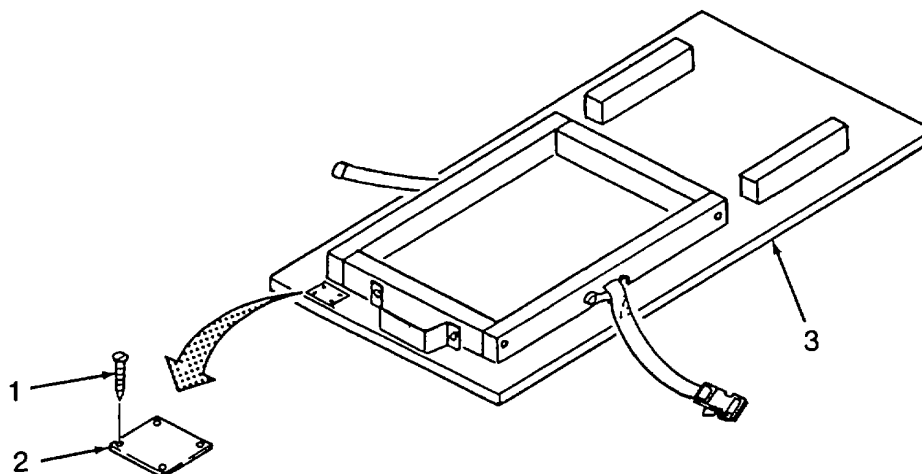

- (6) Repair wooden cracks and breaks

- (a) Spread wood glue (Appendix F, Item 13) on cracked areas and clamp securely.  
(b) Wipe off excess wood glue.  
(c) Allow to dry.





**4-49. BUTTON SEWING MACHINE MAINTENANCE ADJUSTMENT PROCEDURES.**

---

This task consists of: a. Removal                      b. Adjustment                      c. Installation

---

**INITIAL SET-UP:****Tools:**

General Mechanics Tool Kit (Appendix B,  
Item 1)

**Equipment Condition:**

Power Removed (para 2-18)

Removal.

Remove two cover nuts and right side cover.

Adjustment.

- a. To adjust the stop motion.

**NOTE**

When the machine is operated at recommended speed (not in excess of 1000 R.P.M.) it should come to a stop with the stop mechanism in locked position, and with the needle bar resting at the high point of its stroke.

- (1) If the machine stops too early or too late, loosen two screws (1) and move the stop motion trip (2) to the left for an earlier stop, or to the right for a later stop
- (2) When the required adjustment is made, securely tighten two screws (1).

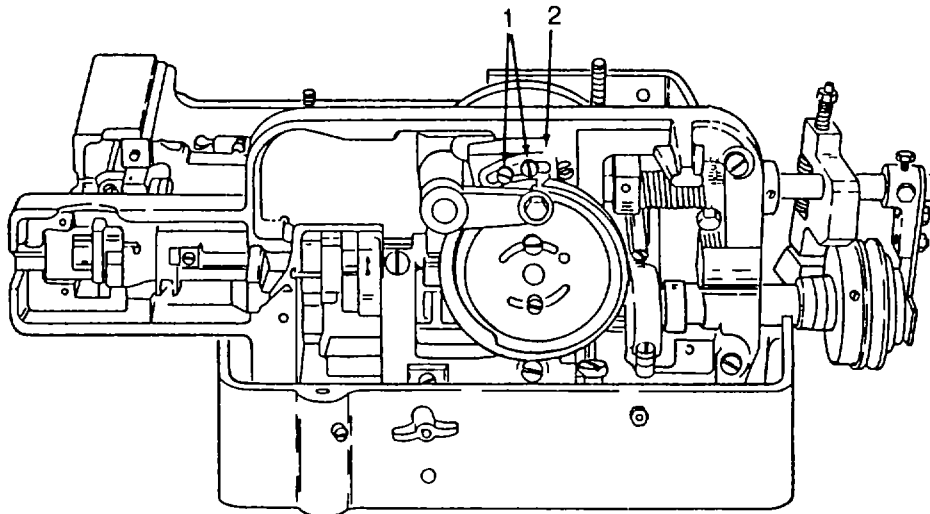

**4-49. BUTTON SEWING MACHINE MAINTENANCE ADJUSTMENT PROCEDURES - continued.**

- b. To adjust spring tension of stop motion shaft.

**NOTE**

Not enough tension will not let the stop brake go down and lock. Too much tension will stop the pulley and rotation prematurely.

Loosen hexagon screw (3) and by means of screw (3) turn collar (4) downward for greater tension, or upward for less tension, then securely tighten screw (3).

- c. To time the looper shaft crank and the looper driving shaft crank.

- (1) Cranks (5 and 6) must be set with the arrow on the rim of each in exact alignment with the arrow on the machine casting at (7) when the machine is in its stopped or locked position.
- (2) To align these cranks, loosen clamping screw (14) which holds the shaft bushing (15) in the machine bed. Turn this bushing (which is eccentric) upward toward the bed of the machine. This will unmesh the gears and permit turning the cranks to required position. After the arrows on these cranks are aligned with the arrow at (7), turn bushing (15) downward to again mesh the gears, then tighten clamping screw (14).
- (3) Looper shaft link (16), which connects cranks (5 and 6) should be attached so that the large crank (6) will PULL the looper shaft link (16). If it is attached so that it is pushed by crank (6), the machine will not function properly.

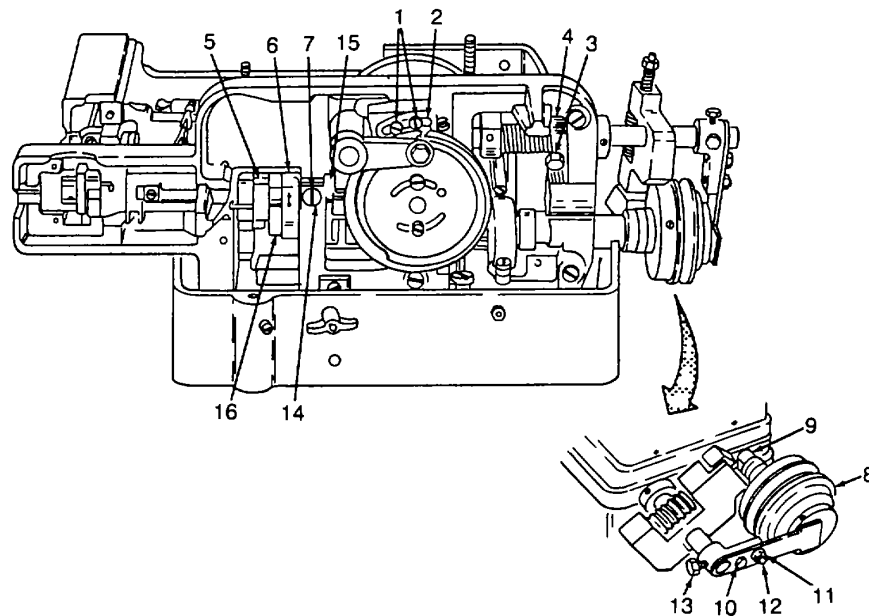

**4-49. BUTTON SEWING MACHINE MAINTENANCE ADJUSTMENT PROCEDURES - continued.**d. To adjust stop motion pulley shifter.

- (1) The pulley (8) should be set approximately 1/16" to 1/8" from the stop motion clutch wheel (9).
- (2) To adjust, loosen clamping screw (10), and stopper set screw nut (11), turn set screw (12) clockwise to increase the distance, counterclockwise to decrease the distance.
- (3) When desired distance is obtained, securely tighten clamping screw (10) and stopper set screw nut (11).

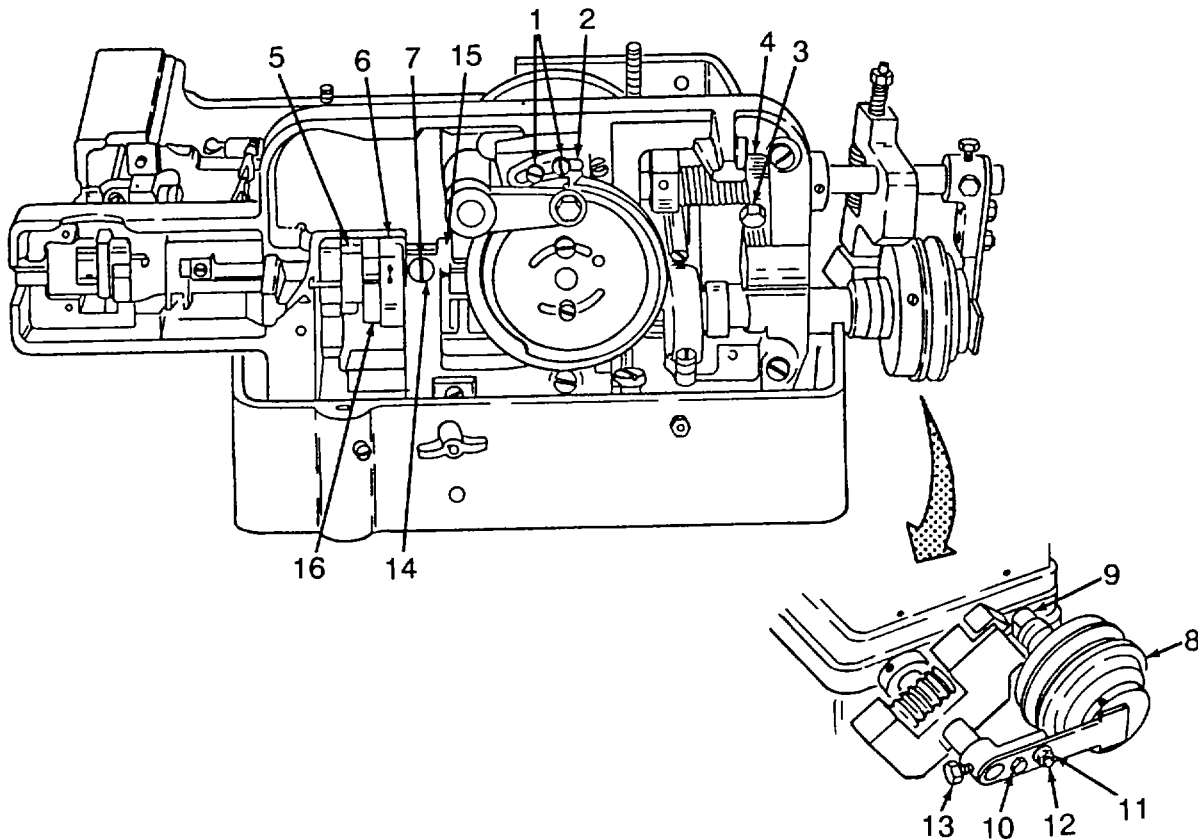

**4-49. BUTTON SEWING MACHINE MAINTENANCE ADJUSTMENT PROCEDURES - continued .**e. To set needle bar at correct height.

- (1) Take out the two face plate screws (1) and remove the face plate (2). Insert needle (3) of correct size in the needle bar (4), making sure that it is up into the needle bar (4) as far as it will go.
- (2) Turn machine hand wheel, by hand, to bring the needle bar (4) to its highest position. Loosen clamping screw (5) which fastens needle bar connecting link hinge stud (6) to the needle bar; then, while the needle bar is still at the highest point of its stroke, move needle bar up or down to bring the top of the needle eye  $1\text{-}5/16$  inch above the top surface of the needle plate. To check this adjustment, see that the needle point does not protrude through the needle hole in the looper when the needle bar is at the bottom of its stroke. This check can be made only after the looper is adjusted and timed as instructed in paragraph 4-49h.

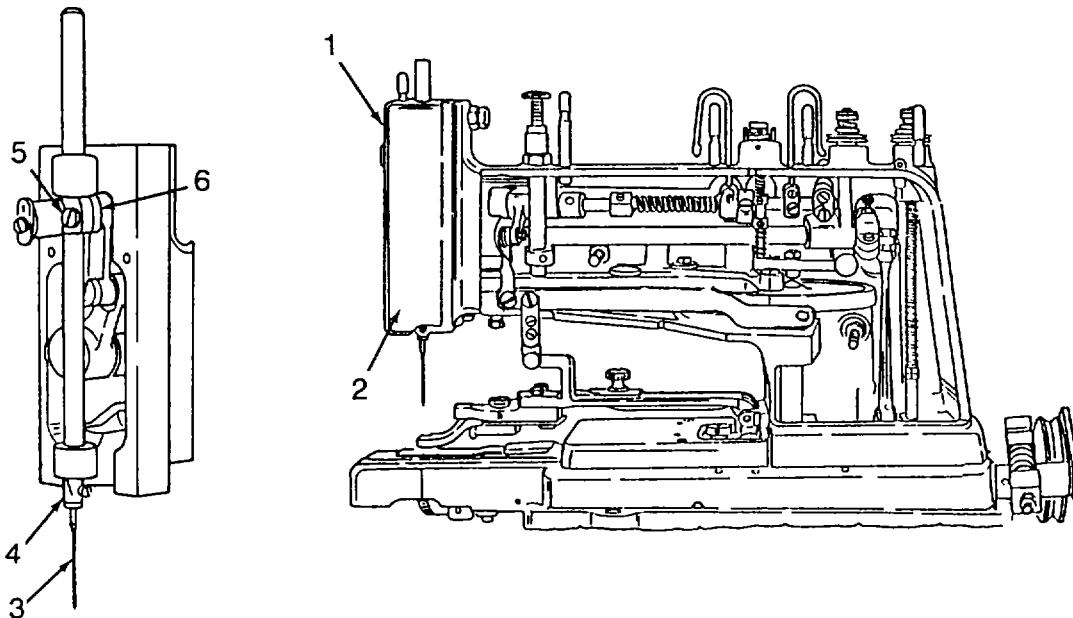

4-49. BUTTON SEWING MACHINE MAINTENANCE ADJUSTMENT PROCEDURES - continued.

f. To time the needle bar vibration (With machine at stop locked position).

- (1) Set cam (1) to bring the arrow on its rim in alignment with arrow on needle bar vibrating lever arm (2). With cam (1) in proper time, needle bar vibration will start about ½ inch from top of upward stroke of needle bar.

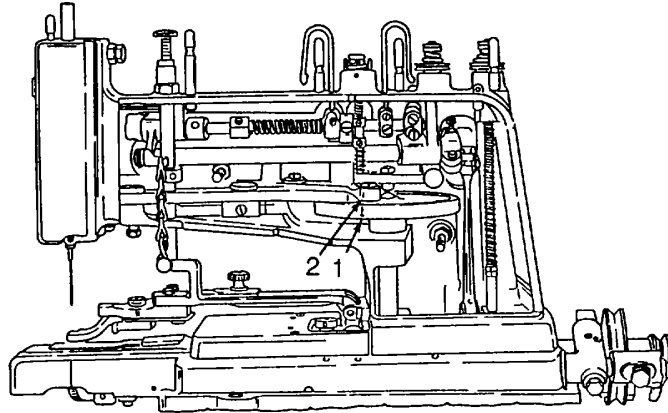

- (2) To adjust, loosen the two screws (1) in worm gear (2). These screws are located between the under side of machine bed and the large cam (3) (underneath the machine bed).

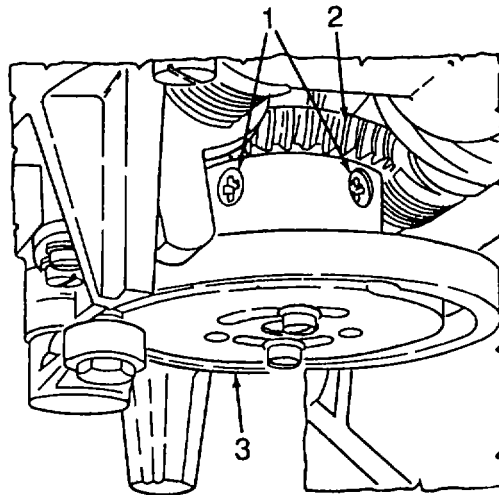

**4-49. BUTTON SEWING MACHINE MAINTENANCE ADJUSTMENT PROCEDURES - continued.**

- g. To adjust needle bar vibration centrally with looper shaft and with relation to the needle slot in the needle plate.

**NOTE**

When adjusting, make sure that needle clears the left hand and right hand ends of the slot in needle plate

- (1) Remove feed plate or stay button holder (para. 2-13), needle plate and looper. In place of the looper, insert a stud or pin in looper stem opening in looper shaft. This pin should be of proper size to fit snugly in looper shaft (a size 20 drill will serve the purpose).
- (2) Loosen hexagon head screw (1) and move lever arm (2) to right or left using the belt pulley until the needle, on both vibrations, just touches both sides of the projecting stud, pin or drill, then tighten screw (1).

**NOTE**

By this method, It is possible to determine accurately whether both vibrations are exactly equal distance from the center of the looper shaft.

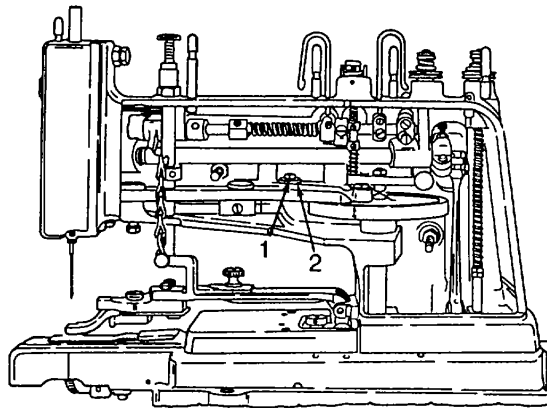

**4-49. BUTTON SEWING MACHINE MAINTENANCE ADJUSTMENT PROCEDURES - continued.**

h. To adjust the looper with relation to the needle.

- (1) Loosen the looper set screw (1) and set the looper as close as possible to the needle, but without actually touching it.
- (2) Be sure that the set screw (1) engages the "flat" of the looper shank when this screw is tightened.

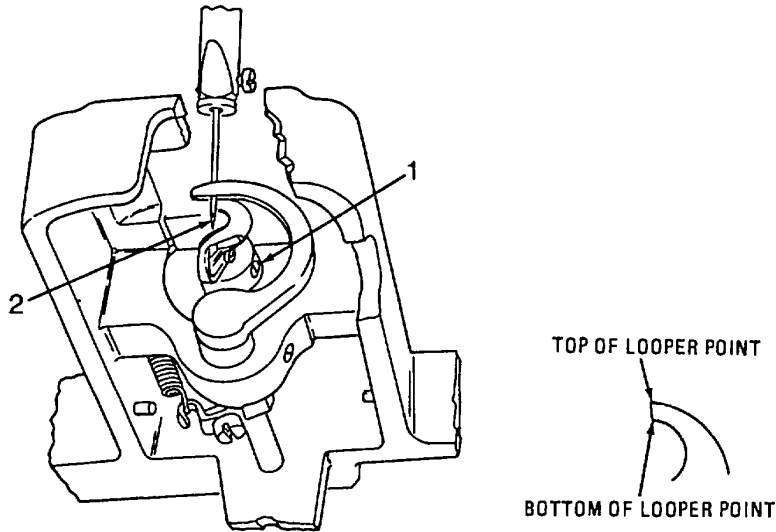

**4-49. BUTTON SEWING MACHINE MAINTENANCE ADJUSTMENT PROCEDURES - continued.**i. To time the looper.

- (1) With the needle bar set at correct height, as instructed in paragraph 4-49e, turn the machine hand wheel, by hand, to bring the needle bar to the bottom of its LEFT HAND STROKE. Continue to turn the machine-driving pulley until, as the needle bar rises, the TOP of the looper point reaches the center of the needle.
- (2) With the TOP of the looper point at the center of the needle, the BOTTOM of the looper point should be exactly at the top of the needle eye (2), on the left hand stroke of the needle bar.
- (3) If the BOTTOM of the looper point is not exactly at the top of the needle eye when the TOP of the looper point is at the center of the needle, on the LEFT HAND STROKE of the needle bar, make adjustment as follows'
- (4) Loosen the two set screws in the crank (1). Turn the looper shaft until the BOTTOM of the looper point is exactly at the top of the needle eye when the TOP of the looper point is at the center of the needle on the LEFT HAND STROKE of the needle bar and the needle bar has risen slightly from its lowest position. Then securely tighten two set screws in crank (1).

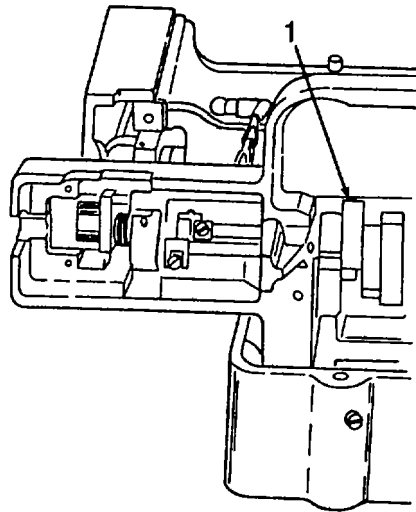
**NOTE**

When the looper point is correctly set with relation to the needle on the LEFT HAND STROKE of the needle bar, the looper point will be in proper relationship to the needle on the RIGHT HAND STROKE of the needle bar.

**4-49. BUTTON SEWING MACHINE MAINTENANCE ADJUSTMENT PROCEDURES - continued.**

i. To time the looper - continued.

- (5) The above setting must be made for each variation in the distance between holes in the button as the distances between holes increase; that is, if the looper is timed for a button with holes  $7/64$  inch apart, it must be reset for a button with the holes farther apart.
- (6) However, if the looper is timed to handle a button with the holes  $7/32$  inch apart, it is not necessary to retime the looper for every button having the same or lesser distances between the holes.

To time the needle guide.

- (1) Remove button clamp and needle plate before adjusting.
- (2) The guide (1) is generally timed so that it starts to move back (toward the right) when the needle bar, on its upward stroke and has risen approximately  $13/16$  inch.
- (3) To adjust, loosen the screw (2) in the cam (3) on the looper shaft. Turn the cam (3) to the required position, then tighten the screw (2).
- (4) Rotate machine by hand to check adjustment per paragraph 4-49i.

**NOTE**

It is sometimes necessary to vary slightly the timing of the needle guide, depending upon the nature of the material to which the button is sewn and the distance between the holes in the button.

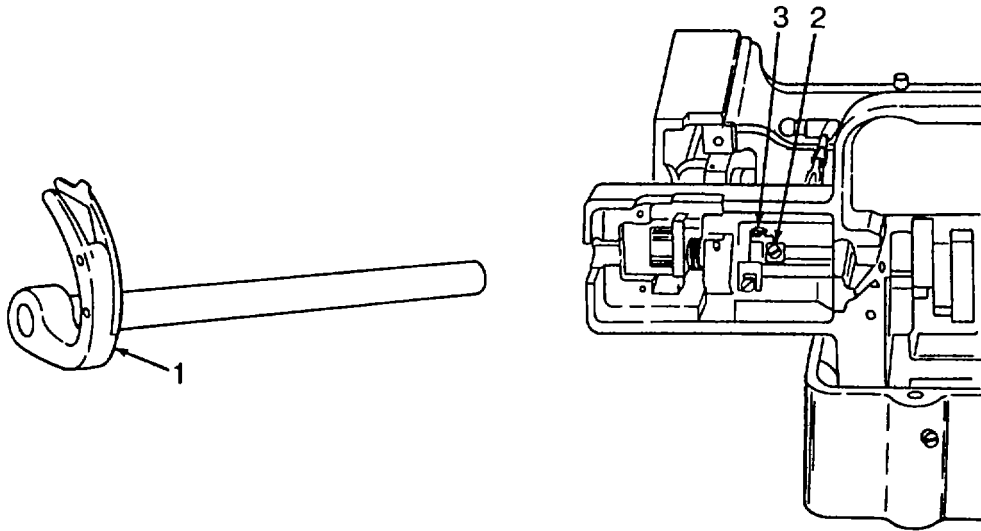

**4-49. BUTTON SEWING MACHINE MAINTENANCE ADJUSTMENT PROCEDURES - continued.**

k. To time the button clamp feed cam.

- (1) The button clamp feed cam (1) should be timed so that the arrow on its rim is in alignment with the arrow on the button clamp carrier driving arm (2) when the machine is in its stopped or locked position.
- (2) To adjust, loosen the two screws (3) and set cam (1) so that the arrows are in alignment with each other at (4) then tighten the screws (3).

l. To time the automatic tension.

- (1) Depending upon the type of button and material being sewn, the needle bar should move from about 3/8 inch to about 5/8 inch to complete its upward stroke after the automatic tension has released the thread.

**NOTE**

Note that this cam also serves as an end thrust collar for the main shaft; therefore, make certain that it is in contact with the shaft bearing in the machine bed, then securely tighten the two screws (5)

- (2) To adjust, loosen the two screws (5) and turn the cam (6) to the position required to get the 3/8" to 5/8" movement.

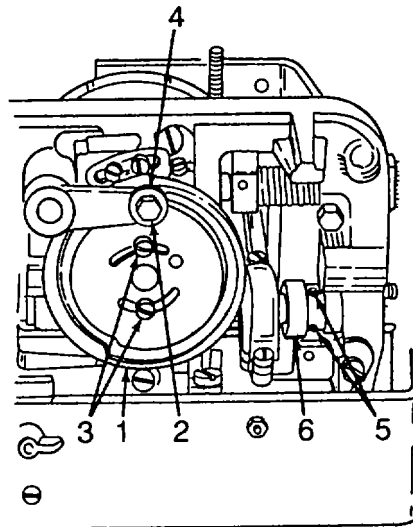

**4-49. BUTTON SEWING MACHINE MAINTENANCE ADJUSTMENT PROCEDURES - continued.**

m. To adjust as a needle guide.

- (1) The front prong (1) is the needle guide and should be adjusted with its inside surface just clearing the needle.
- (2) To adjust, loosen the set screw (2) which holds the needle guide shaft bushing in which the needle guide shaft has its bearing. Move this bushing endwise in the desired direction. Then securely tighten the set screw (2) The needle guide shaft bushing is concealed by the coil spring (3).

n. To adjust for thread control

**NOTE**

Time the machine before making the following adjustment per paragraph 4-49i.

- (1) The needle guide thread finger (4) which forms the rear prong of the guide (5), is the thread controlling portion. It should be adjusted so that the point of the needle, on its downward stroke, clears the inside of the thread finger at (6) by about 1/32 inch when the needle bar is on its left hand vibration, or throw
- (2) To adjust, loosen clamping screw (7) in the needle guide oscillating crank (8). Turn the needle guide (5) to the required position and securely tighten the screw (7).

**NOTE**

The above adjustment, to provide a clearance of about 1/32 inch, must be made for each variation in the distance between the holes in the button.

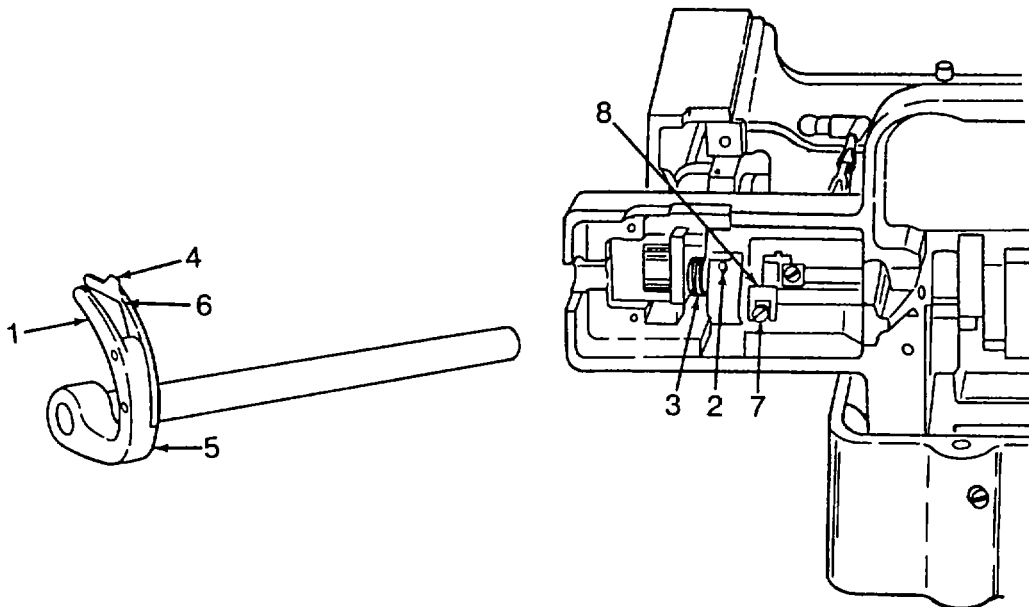

**4-49. BUTTON SEWING MACHINE MAINTENANCE ADJUSTMENT PROCEDURES - continued.**

o. To regulate the height of lift of the button clamp

- (1) The height to which the button clamp is raised is controlled by the position of the button clamp lifting rod arm stop plate (1).
- (2) To adjust, loosen the two screws (2) and move the stop (1) downward to raise the button clamp higher, or move the stop (1) upward to lessen the height of the button clamp lift. When the desired adjustment is obtained, securely tighten the two screws (2).

p. To adjust the automatic tension.

- (1) When the automatic tension (3) is closed (without thread being between the discs) there should be about 1/64 inch between the upper end of the automatic tension rod (4) and the tension release disc (5).
- (2) To adjust, loosen the nuts (6) and turn the rod (4) up or down until the proper end play is obtained, then securely tighten the nuts (6).

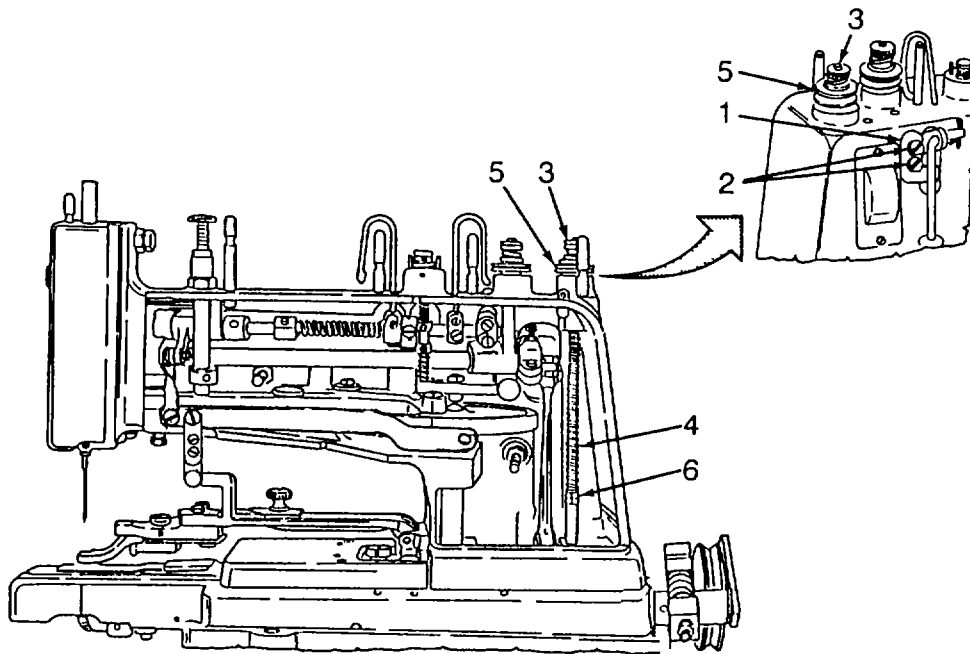

**4-49. BUTTON SEWING MACHINE MAINTENANCE ADJUSTMENT PROCEDURES - continued.**q. To adjust the tension of the thread pull-off (front).

Should it become necessary to adjust the tension of the thread pull-off (front) (1) loosen set screw (2) and turn the hexagon nut (3) up to tighten the spiral spring (4) thus increasing the tension of the thread pull-off (front) (1), or turn the hexagon nut (3) down to decrease the tension. When the tension is correctly set, securely tighten screw (2).

r. To adjust the thread pull-off (back).

- (1) Thread pull-off (back) (5) should move back toward the left of the thread post (6) about ½inch when the button clamp is lifted to its highest position
- (2) To adjust, loosen screw (7) and move the thread pull-off (back) (5) backward or forward (left or right), as required, to set as stated, then securely tighten screw (7).

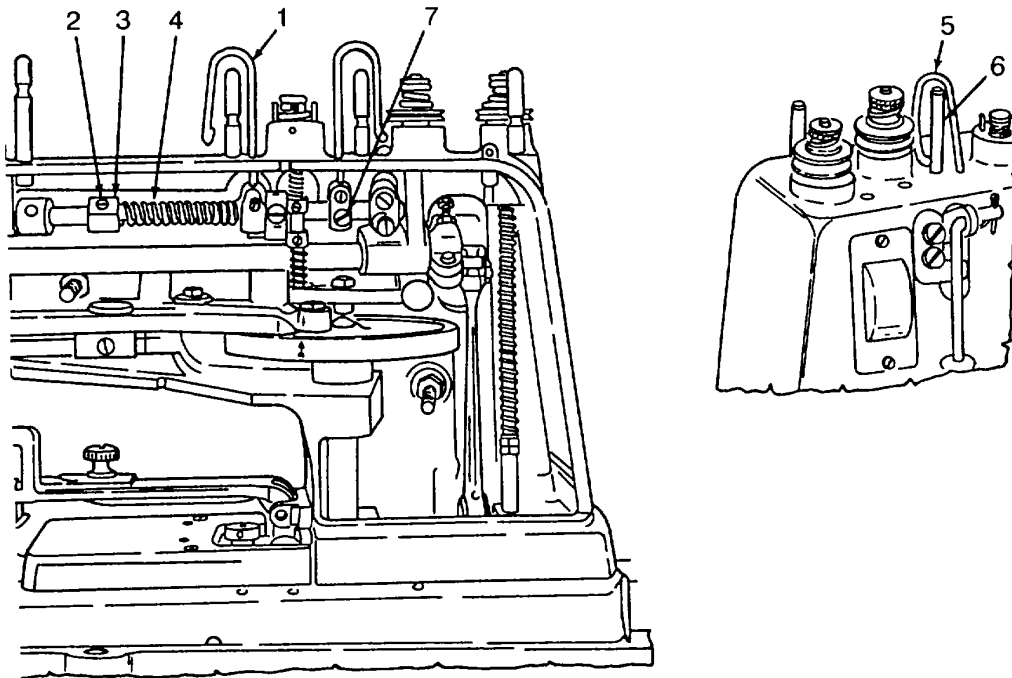

**4-49. BUTTON SEWING MACHINE MAINTENANCE ADJUSTMENT PROCEDURES - continued.**

- s. To adjust the tension of the thread nipper.

**NOTE**

Decreasing the tension may be required when operating with heavier material.

- (1) The thread nipper (1) should hold the thread tightly while the machine is in its stopped position.
  - (2) Should adjustment be necessary, loosen screw (2) in the collar (3) and move the collar (3) downward for tighter thread nipping or upward for less thread grip. When the required adjustment is obtained, securely tighten screw (2).
- t. To adjust the timing of the thread nipper.
- (1) When the machine is in its stopped or locked position, the stud (4) on the underside of the thread nipper, releasing lever (8), should rest upon the center of the stud (5) on the top surface of the cam (6).
  - (2) To adjust, loosen the nut (7) at the upper side of the thread nipper (1) releasing lever (8). By means of nut (7), move the stud (4) forward or backward. When correct adjustment is made, securely tighten the nut (7).

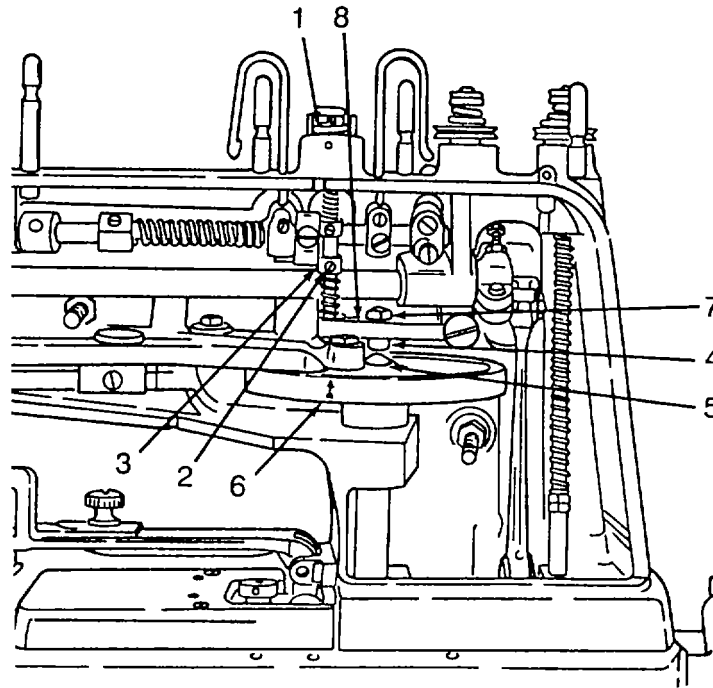

**4-50. BUTTON SEWING MACHINE TABLE TOP ASSEMBLY MAINTENANCE.**

---

**This task covers:**

- |            |                 |
|------------|-----------------|
| a. Removal | b. Cleaning     |
| c. Repair  | d. Installation |
- 

**INITIAL SET-UP:****Tools:**

General Mechanics Tool Kit (Appendix B, Item 1)

**Equipment Condition:**

Sewing machine removed (para. 2-18)

**Material/Parts:**

Coating, Clear, Polyurethane (Appendix F, Item 10)

Rag, wiping (Appendix F, Item 2)

**Removal.**

Remove button table top from stand assembly (para. 2-18).

**Cleaning.**

- (1) Clean the table top assembly with a damp wiping rag (Appendix F, Item 2).
- (2) Allow to dry.

**Repair**

Repair at the unit level is limited to the following:

Refinishing of damaged or scuffed table top.

- (1) Sand surface, as required.
- (2) Clean surface of wooden table top.
- (3) Apply a coating of coating, clear, polyurethane (Appendix F, Item 10) to the affected wood surface.
- (4) Allow to dry.

**Installation.**

Refer to paragraph 2-8.

4-51. BUTTON SEWING MACHINE BELT GUARD MAINTENANCE.

This task covers:

- |            |                 |               |
|------------|-----------------|---------------|
| a. Removal | b. Cleaning     | c. Inspection |
| d. Repair  | e. Installation |               |

**INITIAL SET-UP:**

**Tools:**

General Mechanics Tool Kit (Appendix B, Item 1)

**Material/Parts:**

Rag, wiping (Appendix F, Item 2)

**Equipment Condition:**

Power disconnected (para. 2-18)

**Removal.**

- (1) Remove cotter pin (4).
- (2) Slide belt guard (1) off.
- (3) Remove pin (2) by removing two screws (3).

**Cleaning.** Clean parts with a clean dry wiping rag (Appendix F, Item 2).

**Inspection.**

- (1) Inspect belt guard for damage.
- (2) Inspect screws for damaged threads.
- (3) Inspect pin for damage.

**Repair.** Repair is limited to replacement of defective components

**Installation.**

- (1) Install pin (1) by securing screws (2).
- (2) Slide belt guard (3) on.
- (3) Install cotter pin (4).

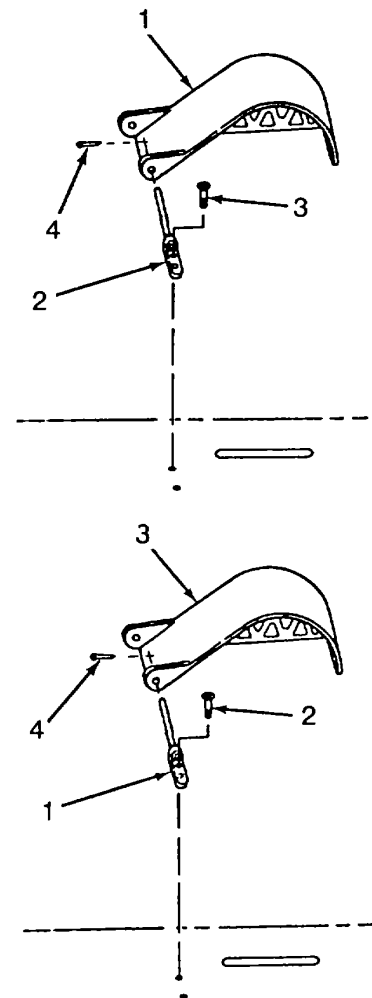

4-52. BUTTON SEWING MACHINE BED ASSEMBLY MAINTENANCE.

This task covers:

- |                 |                |             |
|-----------------|----------------|-------------|
| a. Removal      | b. Disassembly | c. Cleaning |
| d. Inspection   | e. Repair      | f. Assembly |
| g. Installation | h. Adjustment  |             |

**INITIAL SET-UP:**

**Tools:**

General Mechanics Tool Kit (Appendix B, Item 1)

**Equipment Condition:**

Button machine head removed (para. 2-18)

**Material/Parts:**

Rag, wiping (Appendix F, Item 2)  
 Cleaning Solvent (Appendix F, Item 8)  
 Brush, Medium Bristle (Appendix F, Item 1)

**Removal.** Remove Button Machine Bed from table top (para. 2-18).

**Disassembly**

- (1) Remove machine screw (1) from base (2).
- (2) Remove two screws (3) from base (2).
- (3) Remove wing nut (4), washer (5), spring (6) and lock (7).
- (4) Remove start/stop screw (8) and nut (9).
- (5) Remove screw (10), starting pin (11), starting lever (12), starting spring (13).

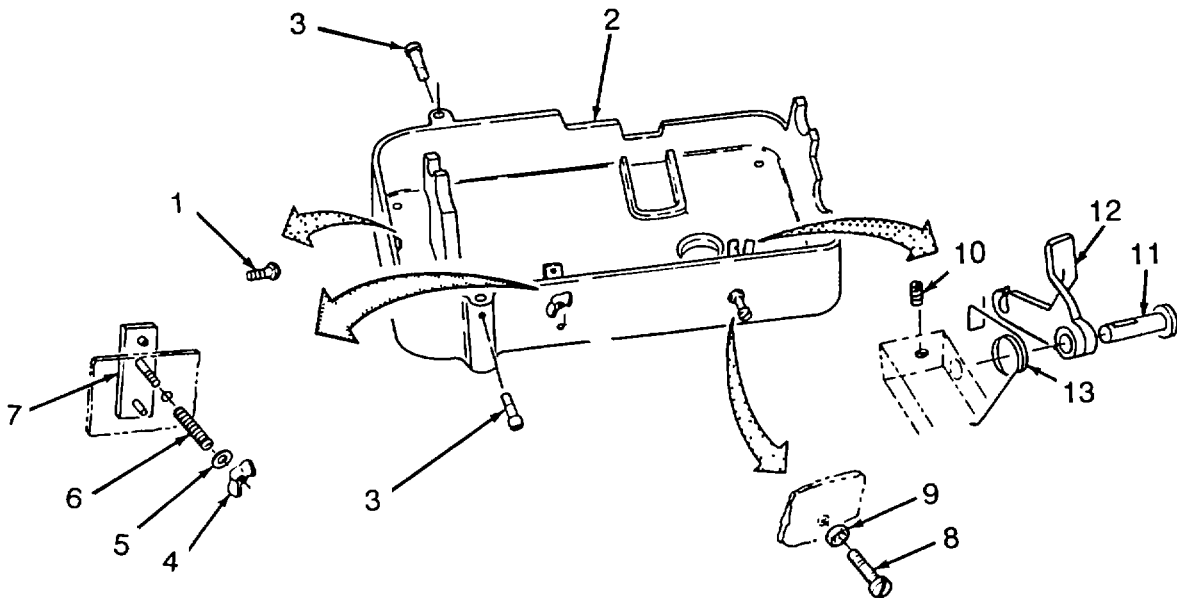

**4-52. BUTTON SEWING MACHINE BED ASSEMBLY MAINTENANCE - continued.****Cleaning.**

- (1) Remove all buildups of grease, dirt, etc, by wiping with a wiping rag (Appendix F, Item 2).

**WARNING**

Cleaning solvent, Federal Specification P-D-680, is both toxic and flammable. Keep off skin. Use only in a well-ventilated area and avoid prolonged breathing of vapors. Keep away from open flame.

- (2) Clean using cleaning solvent (Appendix F, Item 8) and either a wiping rag (Appendix F, Item 2) or a medium bristle brush (Appendix F, Item 1).
- (3) Allow to dry.

**Inspection.**

- (1) Inspect hardware for damage.
- (2) Inspect spring for damage and corrosion.
- (3) Inspect starting pin for damage.

**Repair.** Repair of the button machine bed assembly is limited to the replacement of defective components.

**Assembly.**

- (1) Assemble starting spring (1), starting lever (2), starting pin (3) in the base (4) and secure with screw (5).
- (2) Assemble start/stop screw (6) and lever stop nut (7).
- (3) Install lock (8) on base (4) and secure with spring (9), washer (10) and wingnut (11).
- (4) Assemble two screws (12) into the base (4).

**4-52. BUTTON SEWING MACHINE BED ASSEMBLY MAINTENANCE - continued.**

(5) Assemble machine screw (13) into the base (4).

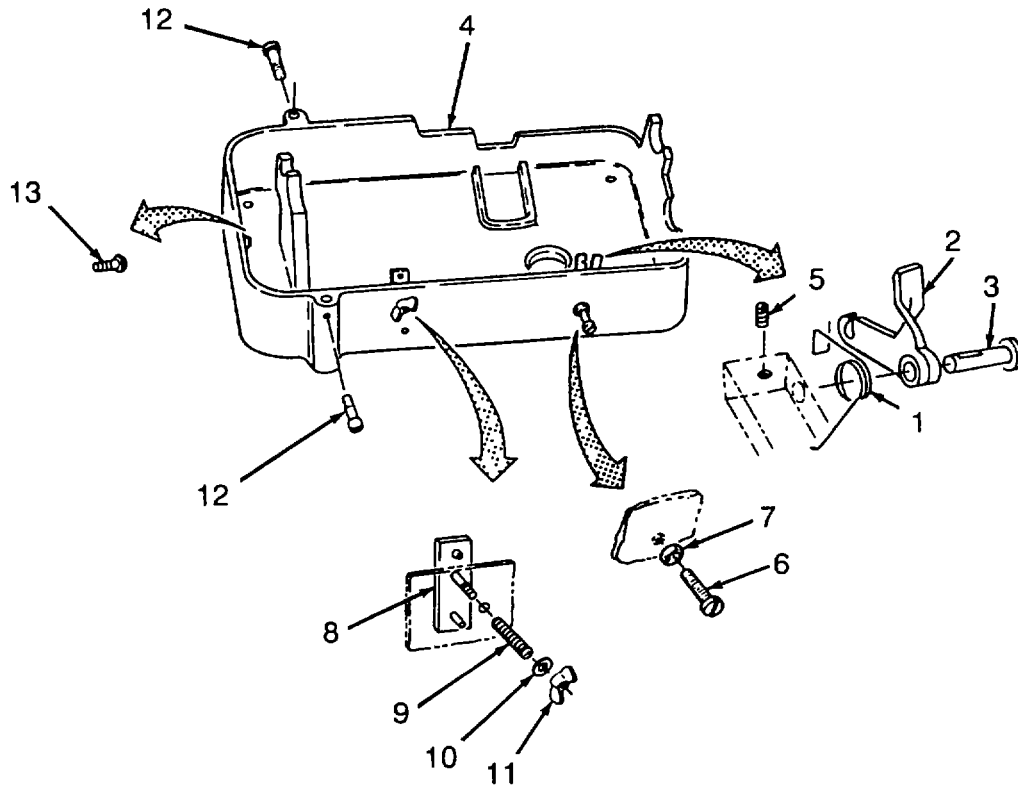

**Installation.**

Install Button Machine Bed onto the table top (para. 2-8).

**Adjustment.**

To tighten or loosen starting lever, adjust start/stop screw (6).

**4-53. BUTTON MOTOR BELT GUARD MAINTENANCE.****This task covers:**

a. Removal  
d. Repair

b. Cleaning  
e. Installation

c. Inspection  
f. Adjustment

**INITIAL SETUP:****Tools:**

General Mechanics Tool Kit (Appendix B, Item 1)

**Equipment Condition:**

Power Removed (para 2-18)

**Materials/Parts:**

Detergent, General Purpose (Appendix F, Item 11)

**Removal.**

- (1) Remove two screws (1), two lockwashers (2), and two flatwashers (3).
- (2) Remove guard cover (4).

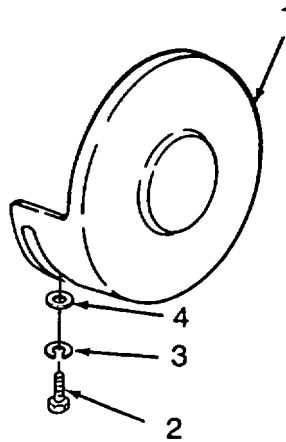
**Cleaning.**

- (1) Wash the belt guard with a solution of detergent, general purpose (Appendix F, Item 11) and water.
- (2) Rinse thoroughly with clean water.
- (3) Allow to dry.

**4-53. BUTTON MOTOR BELT GUARD MAINTENANCE - continued.****Inspection.**

- (1) Inspect hardware for damage
- (2) Inspect guard cover for cracks.

**Repair.** Repair is limited to the replacement of defective components with serviceable ones.

**Installation.** Install guard cover (1). Secure with two screws (2), two lockwashers (3) and two flatwashers (4).

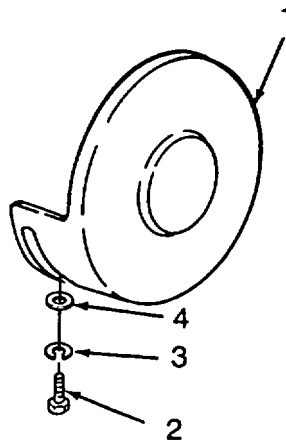
**Adjustment.**

- (1) Loosen the two screws securing the guard cover onto the clutch and motor assembly.
- (2) Rotate the guard cover so it does not interfere with the belt.
- (3) Tighten the two screws securing the guard cover in place.

4-54. BUTTON SEWING MACHINE STAND ASSEMBLY MAINTENANCE.

This task covers:

- |            |                |                 |               |
|------------|----------------|-----------------|---------------|
| a. Removal | b. Disassembly | c. Cleaning     | d. Inspection |
| e. Repair  | f. Assembly    | g. Installation |               |

**INITIAL SETUP:**

**Tools:**

General Mechanics Tool Kit (Appendix B, Item 1)

**Materials/Parts:**

Detergent, General Purpose (Appendix F, Item 11)

**Equipment Condition:**

Power removed (paragraph 2-18)

**Removal.** Refer to paragraph 2-18.

**Disassembly.**

- (1) Remove strap (1), if not already removed.
- (2) Remove two wing nuts (2), two lock washer (3), two flat washers (4), two bolts (5) and the rear cross member (6).

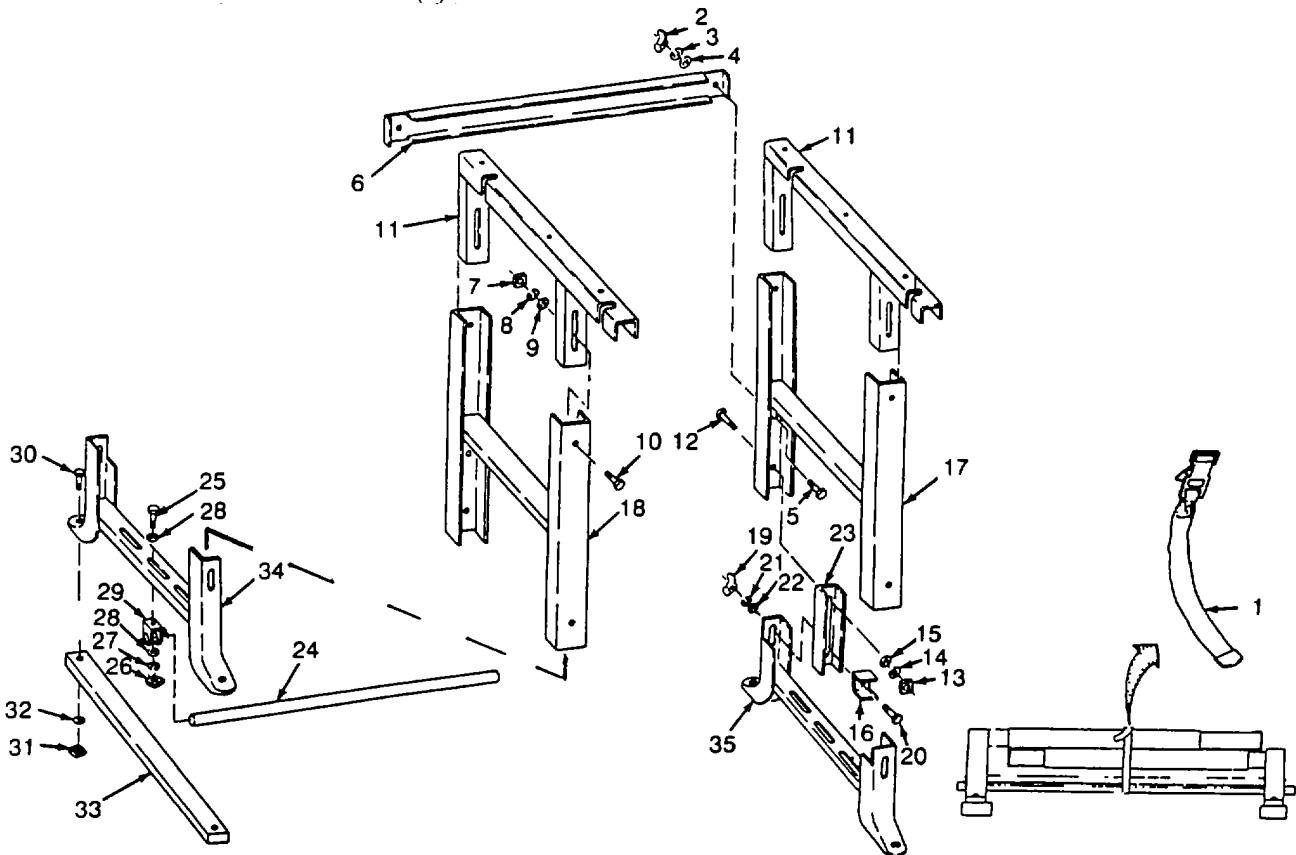

4-54. BUTTON SEWING MACHINE STAND ASSEMBLY MAINTENANCE - continued.

Disassembly - continued.

- (3) Remove four square nuts (7), four lock washers (8), four flat washers (9), four bolts (10) and two top rail assemblies (11).
- (4) Remove four bolts (12), four square nuts (13), four lock washers (14), four flat washers (15), four bolt retainers (16), left leg assembly (17) and right leg assembly (18).
- (5) Remove four wing nuts (19), four bolts (20), four lock washers (21), four flat washers (22) and four folding clips (23).
- (6) Remove treadle support (24).
- (7) Remove two bolts (25), two square nuts (26), two lock washers (27), four flat washers (28) and two pipe supports (29).
- (8) Remove two bolts (30), two square nuts (31), two flat washers (32) and a base (33) from the lower left leg (34) and lower right leg (35).

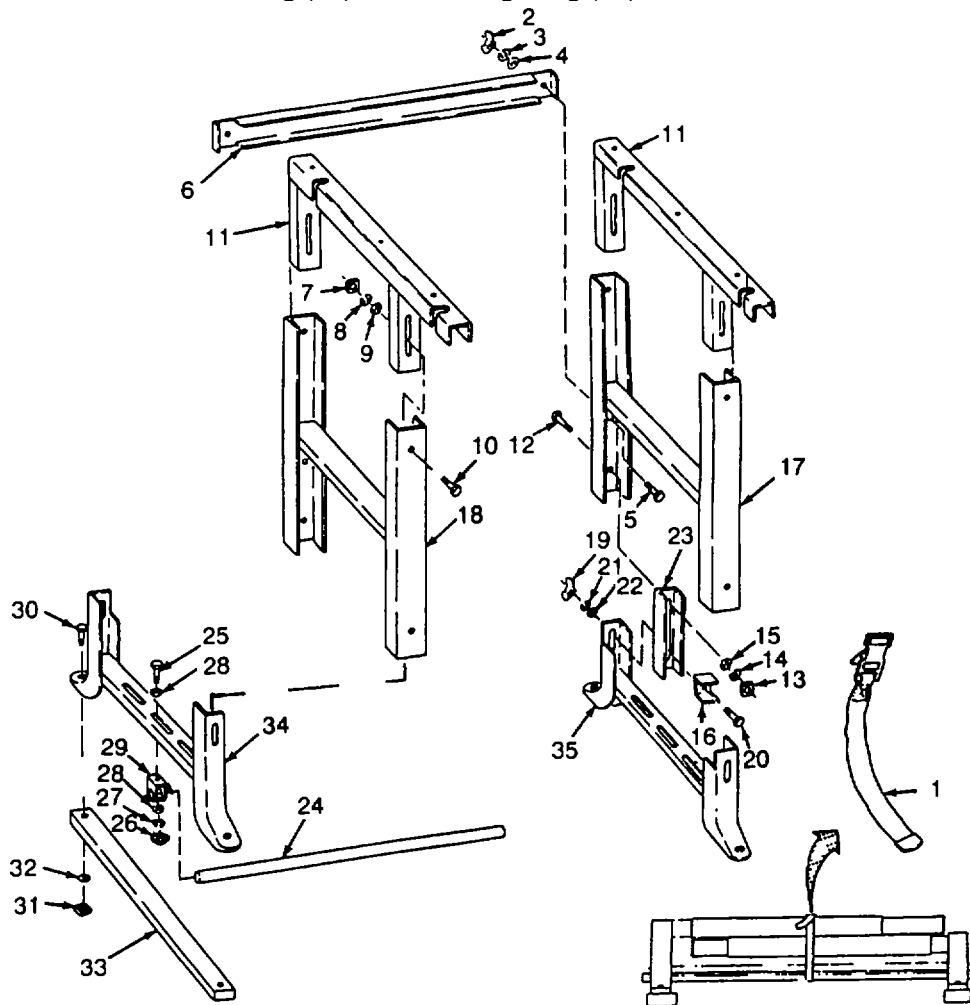

**4-54. BUTTON SEWING MACHINE STAND ASSEMBLY MAINTENANCE - continued.**

**Cleaning.**

- (1) Clean the stand with a solution of detergent (Appendix F, Item 11) and water.
- (2) Rinse thoroughly with clean water.
- (3) Allow to dry.

**Inspection.**

- (1) Inspect hardware for damage.
- (2) Inspect treadle support for damage and straightness.
- (3) Inspect retaining strap for damage.
- (4) Inspect clips for damage.
- (5) Inspect legs for damage.

**Repair.** Repair is limited to the replacement of defective parts.

4-54. BUTTON SEWING MACHINE STAND ASSEMBLY MAINTENANCE - continued.

**Assembly.**

- (1) Install base (1) onto the lower left leg (2) and the lower right leg (3). Secure with two bolts (4), two flat washers (5) and two square nuts (6).
- (2) Install the pipe support (7) onto the lower left leg (2). Secure with bolt (8), two flat washers (9), lock washer (10) and a square nut (11).
- (3) Install the pipe support (7) onto the lower right leg (3). Secure with bolt (8), two flat washers (9), lock washer (10) and a square nut (11).
- (4) Slide and install the treadle support (12) through both pipe supports (7). Position the lower left leg assembly (2) and the lower right leg assembly (3) and the ends of the pipe.
- (5) Install four folding clips (13). Secure with four bolts (14), four flat washers (15), four lock washers (16) and four wing nuts (17).

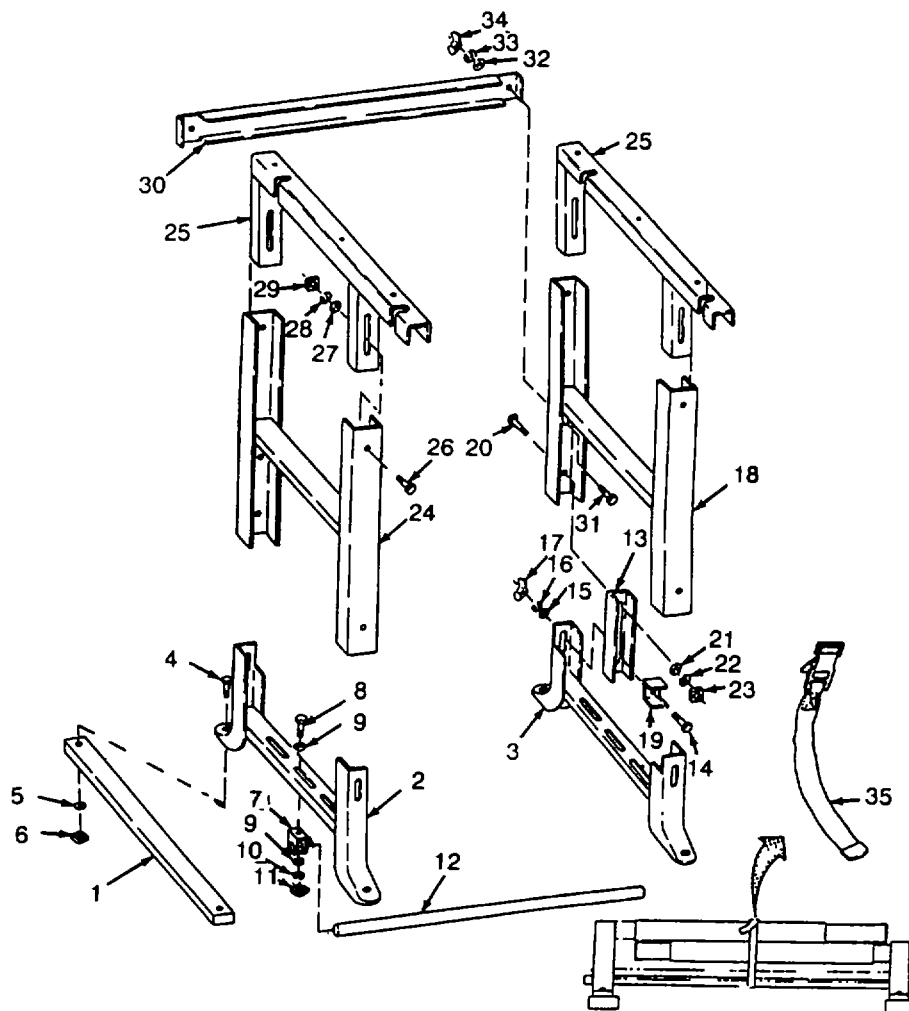

**4-54. BUTTON SEWING MACHINE STAND ASSEMBLY MAINTENANCE - continued.**

- (6) Install right leg assembly (18). Secure with two bolt retainers (19), two bolts (20), two flat washers (21), two lock washers (22), two square nuts (23).
- (7) Install left leg assembly (24). Secure with two bolt retainers (19), two bolts (20), two flat washers (21), two lock washers (22), two square nuts (23).
- (8) Install two top rail assemblies (25). Secure with four bolts (26), four flat washers (27), four lock washers (28) and four square nuts (29).
- (9) Install the rear cross member (30). Secure with two bolts (31), two flat washers (32), two lock washers (33) and two wing nuts (34).
- (10) Install strap (35) around stand assembly if the stand is to be returned to the folded position.

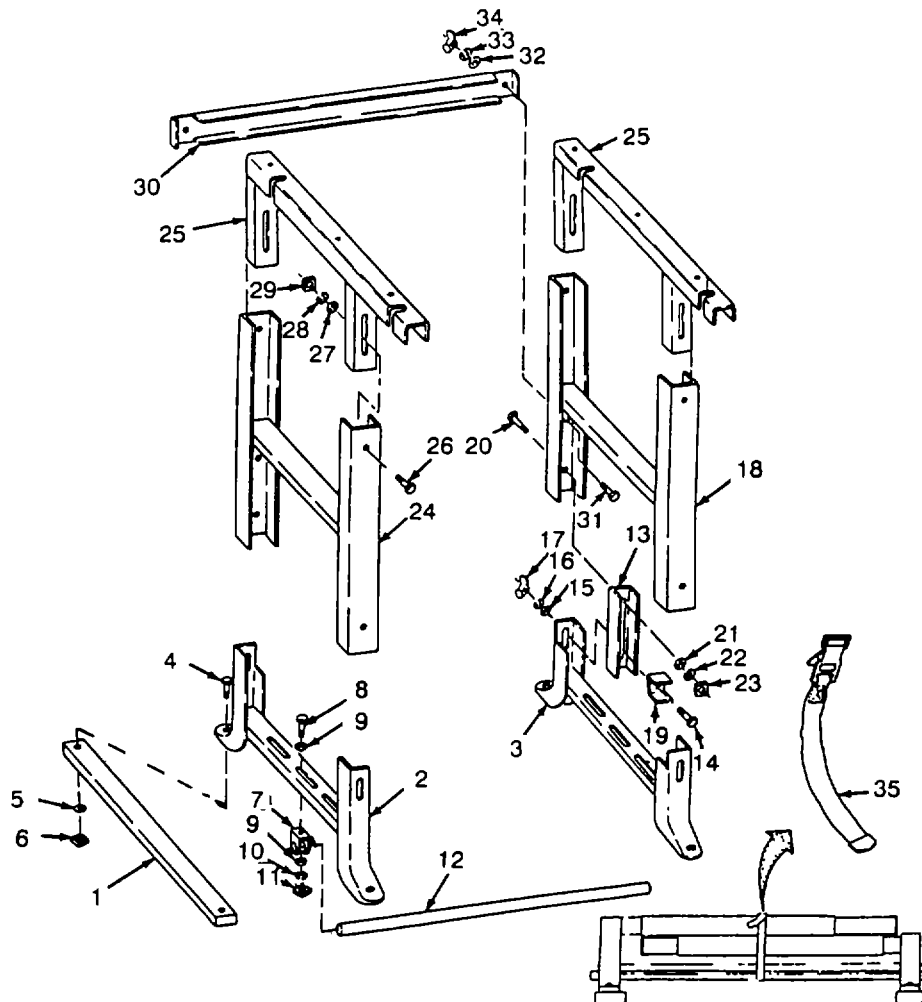

**Installation.** Refer to paragraph 2-8.

**4-55. STOWAGE BOX ASSEMBLY MAINTENANCE.**

---

**This task covers:****a. Inspection****b. Cleaning****c. Repair**

---

**INITIAL SETUP:****Tools:**

Shop Equipment (Appendix B, Item 2)  
Riveting Tool Set (Appendix B, Item 5)

**Equipment Condition:**

Stowage Box Removed From Cabinet  
(para 2-8) and empty

**Material/Parts:**

Detergent, General Purpose (Appendix F, Item  
11)

Rivets

**Inspection**

- (1) Inspect for loose or missing hardware.
- (2) Inspect hinge for rust, corrosion and damage.
- (3) Inspect for missing rubber mat inside the box.
- (4) Inspect for missing labels.
- (5) Inspect for missing or damaged latch.

**Cleaning.**

- (1) Clean the door with a solution of detergent (Appendix F, Item 11) and water.
- (2) Rinse thoroughly with clean water.
- (3) Allow to dry.

**4-55. STOWAGE BOX ASSEMBLY MAINTENANCE - continued.**

**Repair.** Repair is limited to the following:

(1) Replace a hinge as follows:

- (a) Remove ten rivets (1) and hinge (2) from the stowage box (3).
- (b) Inspect and then replace parts as required.
- (c) Install hinge (2) using ten rivets (1).

(2) Replace catch/with strike as follows:

- (a) Remove four rivets (4) and catch/with strike (5) from the stowage box (3).
- (b) Inspect and then replace parts as required.
- (c) Install catch/with strike (5) using four rivets (4). Repeat for other side.

(3) Replace handle as follows:

- (a) Remove five rivets (6) and handle (7).
- (b) Inspect and then replace parts as required.
- (c) Install handle (7) using five rivets (6). Repeat for other side.

(4) Replace instruction plate and ID Plate as follows:

- (a) Remove damaged instruction plate (8) and ID Plate (9).
- (b) Clean adhesive surface of stowage box using a solution of detergent (Appendix F, Item 11) and water.
- (c) Rinse thoroughly with clean water.
- (d) Allow to dry.

**NOTE**

Instruction and ID plates are self-adhesive.

- (e) Install new instruction plate (8) and ID Plate (9).

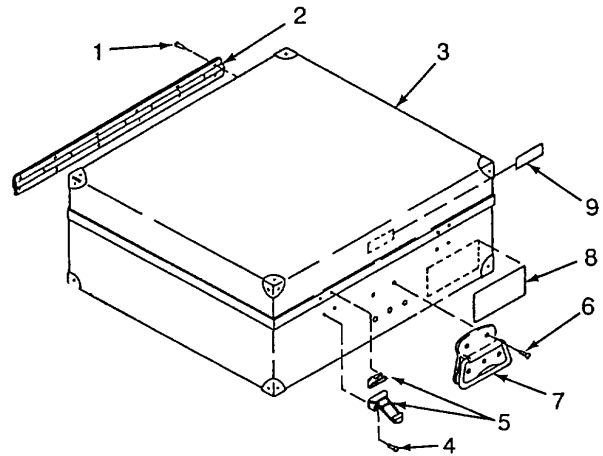

**4-56. FOLDING TABLE MAINTENANCE.**

---

**This task covers:**

**a. Inspection**

**b. Cleaning**

**c. Repair**

---

**INITIAL SETUP:****Tools:**

General Mechanics Tool Kit (Appendix B, Item 1)

**Equipment Condition:**

Table removed from cabinet and set-up (para. 2-8)

**Material/Parts:**

Detergent, General Purpose (Appendix F, Item 11)  
Coating, Clear, Polyurethane (Appendix F, Item 10)  
Washer, Lock

**Inspection.**

- (1) Inspect for damaged hardware.
- (2) Inspect for damage to the leg latch assembly.
- (3) Inspect for rust, corrosion or damage to the legs.
- (4) Inspect the top stiffener for damage.
- (5) Inspect top for cracks, splits, warping and other damage.

**Cleaning.**

- (1) Clean folding table with a solution of detergent and water.
- (2) Rinse thoroughly with clean water.
- (3) Allow to dry.

**4-56. FOLDING TABLE MAINTENANCE - continued.**

**Repair.** Repair is limited to the following.

- (1) Refinishing of a damaged or scuffed top using coating, clear, polyurethane (Appendix F, Item 10).
- (2) Replacement of defective leg latch assembly as follows:
  - (a) Remove wing nut (1), lockwasher (2) and latch (3). Repeat for other latch
  - (b) Remove eight screws (4), and base plate (5).
  - (c) Inspect and then replace parts as required.
  - (d) Install base plate (5) and eight screws (4).
  - (e) Install latch (3), lockwasher (2) and wing nut (1). Repeat for other latch.

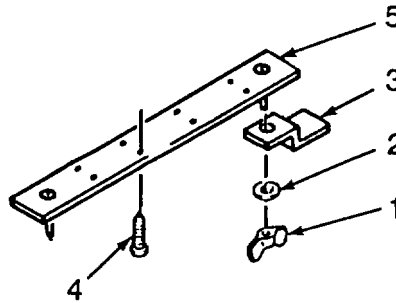

**4-56. FOLDING TABLE MAINTENANCE - continued.**

- (3) Replace a defective top stiffener as follows:
- (a) Remove five screws (1), and stiffeners (2).
  - (b) Inspect and then replace parts as required.
  - (c) Install stiffeners (2), and five screws (1). Repeat for other side.

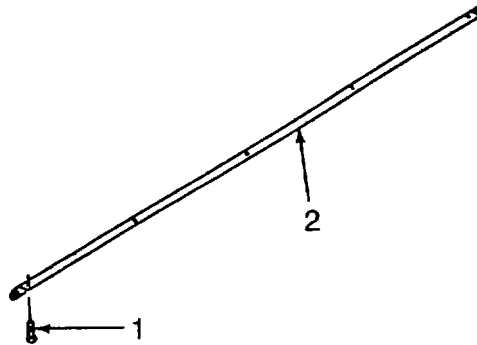

- (4) Replace table edging as follows:
- (a) Remove twenty-nine screws (1) and table edging (2).
  - (b) Inspect and then replace parts as required.
  - (c) Install edging (2) and twenty-nine screws (1). Repeat for other side.

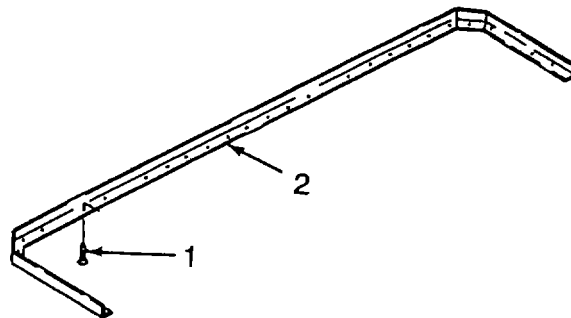

4-57. HEAT SEALER BASE MAINTENANCE.

This task covers:

- |            |                |                 |               |
|------------|----------------|-----------------|---------------|
| a. Removal | b. Disassembly | c. Cleaning     | d. Inspection |
| e. Repair  | f. Assembly    | g. Installation |               |

**INITIAL SETUP:**

**Tools:**

General Mechanics Tool Kit (Appendix B, Item 1)

**Equipment Condition:**

Heat Sealer unplugged

**Materials/Parts:**

Rag, wiping (Appendix F, Item 2)  
 Polychloroprene Cement

**Removal.**

Remove heat sealer from the table (para. 2-18).

**Disassembly.**

- (1) Remove or backoff thumb screw (1), remove stop screw (2) base stand (3) from the base assembly (4).
- (2) Remove bottom form (5) from base stand (3).
- (3) If bottom pad (6) is damaged, remove bottom pad (6) from bottom form (5).
- (4) Remove two locating nuts (7), and two locating pins (8).

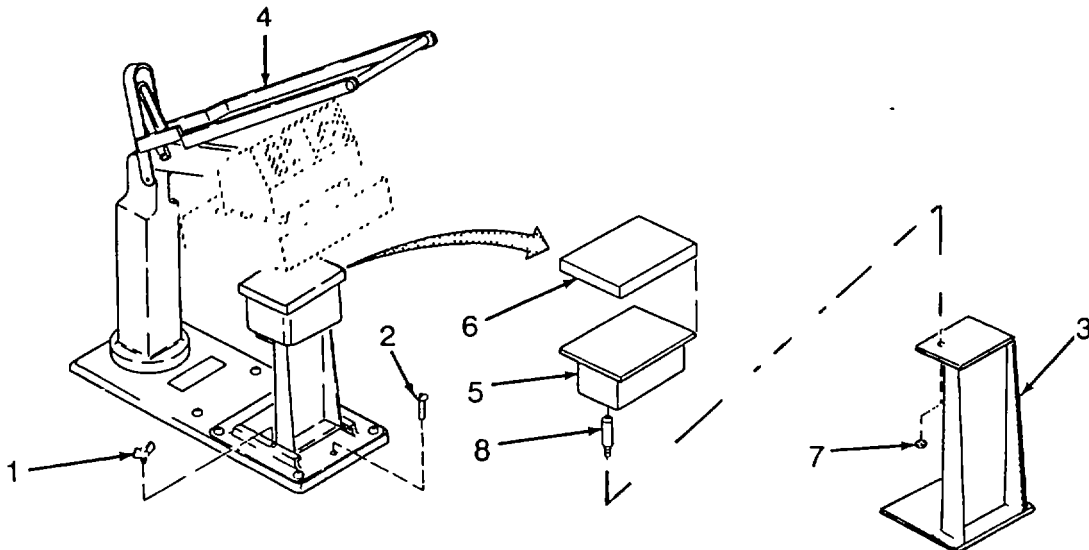

**4-57. HEAT SEALER BASE MAINTENANCE - continued.****Cleaning.**

- (1) Wipe parts with a damp wiping rag (Appendix F, Item 2).
- (2) Allow to dry.

**Inspection.**

- (1) Inspect hardware for damage
- (2) Inspect base stand for damage.
- (3) Inspect bottom form for damage.
- (4) Inspect bottom pad for damage or excessive wear.

**Repair.**

Repair is limited to the replacement of defective components with serviceable ones.

**Assembly.**

- (1) Position two locating pins (1), two locating nuts (2) into the base stand.
- (2) Place bottom pad (4) onto the bottom form (5) using two coats of polychloroprene cement.
- (3) Place bottom form (5) onto the locating pins (1).
- (4) Install the base stand (3) onto the heat sealer (6). Secure with thumbscrew (7).
- (5) Install stop screw (8).

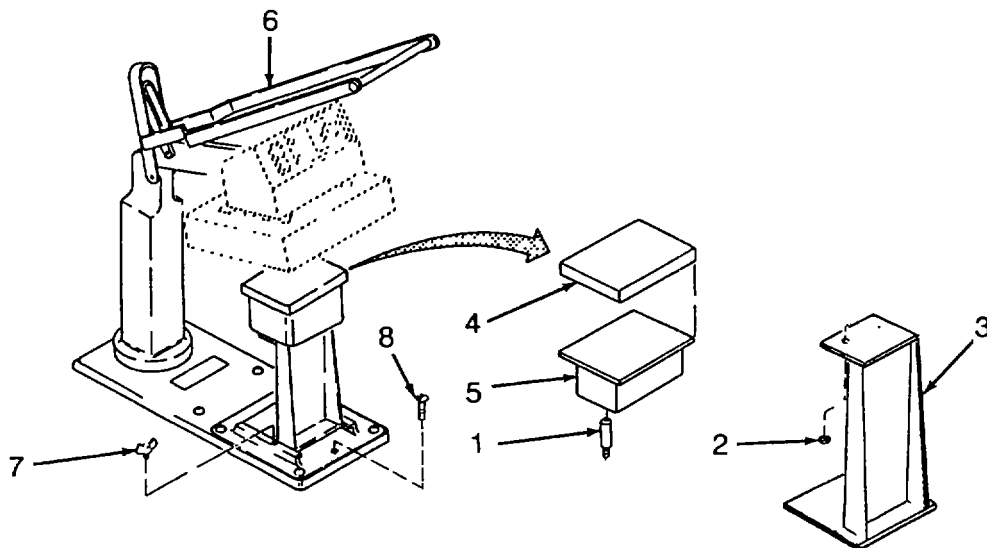

**4-57. HEAT SEALER BASE MAINTENANCE - continued.**

Installation.

Install heat sealer back on the table (para. 2-8).

**4-58. HEAT SEALER CONSOLE MAINTENANCE.**

---

This task consists of: a. Removal      b. Disassembly      c. Cleaning      d. Inspection  
   e. Repair              f. Assembly        g. Installation

---

**INITIAL SET-UP:****Tools:**

General Mechanics Tool Kit (Appendix B, Item 1)

**Equipment Condition:**

Heat Sealer unplugged.

**Materials/Parts:**

Rag, wiping (Appendix F, Item 2)  
Ring Terminals

Removal.

- (1) Remove heat sealer from the table (para. 2-18).
- (2) Remove clamp screw (1) and cord clamp (2).
- (3) Rotate handle (3) counterclockwise until the heat sealer assembly (4) is free. Remove heat sealer assembly (4).

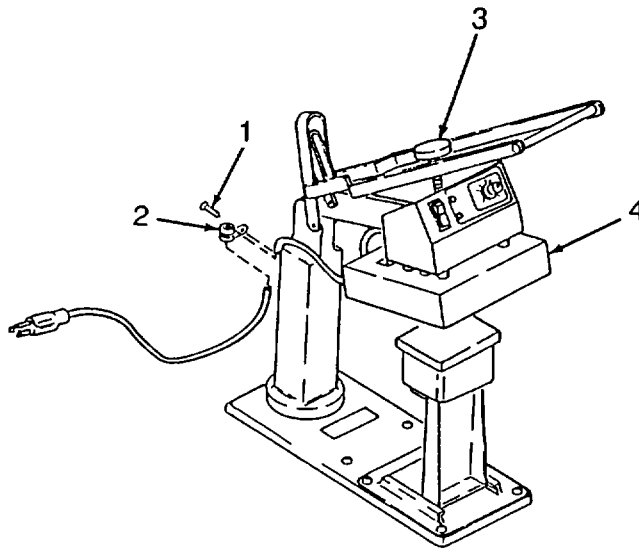

**4-58. HEAT SEALER CONSOLE MAINTENANCE - continued.**

Disassembly.

- (1) Remove four panel screws (1) and two cover screws (2) from the back console panel (3).
- (2) Tag two wires at switch (4), then gently pull off wires from the circuit breaker (4) back.
- (3) Push circuit breaker (4) locking tabs into the circuit breaker assembly, then pull circuit breaker (4) out from the front of console assembly.

**NOTE**

One wire from each light ties together at crimped terminal ring.

- (4) Tag and identify wires on the green light (5) and red light (6).
- (5) Remove the three ring terminals (7) from the terminal studs inside the console assembly
- (6) If lights are to be removed, then cut off the ring terminals (7) from the lights.
- (7) Fold mounting tabs on light lens so that the green light (5) and the red light (6) can be removed out the front of the console assembly.
- (8) Remove set screw (8) and potentiometer knob (9).

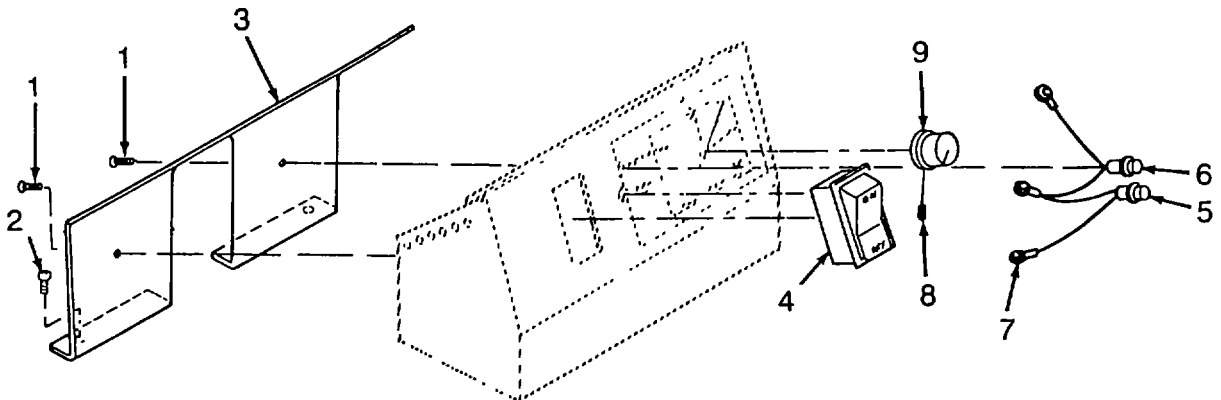

**4-58. HEAT SEALER CONSOLE MAINTENANCE - continued.**Cleaning.

Wipe parts with a wiping rag (Appendix F, Item 2).

Inspection.

- (1) Inspect hardware for damage.
- (2) Inspect electrical parts damage.
- (3) Inspect for missing back panel console

Repair.

Repair is limited to the replacement of defective components with serviceable ones.

Assembly.

- (1) Install potentiometer knob (1). Secure with setscrew (2).
- (2) Insert the red light (3) into the bottom hole and the green light (4) into the top hole.
- (3) Strip light wires and crimp ring terminals (5) onto the light wires.
- (4) Connect light wires to proper studs as previously marked or tagged.
- (5) Install circuit breaker (6) into the console assembly.
- (6) Attach wires to the circuit breaker (6) terminals as previously marked or tagged.
- (7) Install back console (7) into the console assembly. Secure with panel, four panel screws (8) and two cover screws (9).

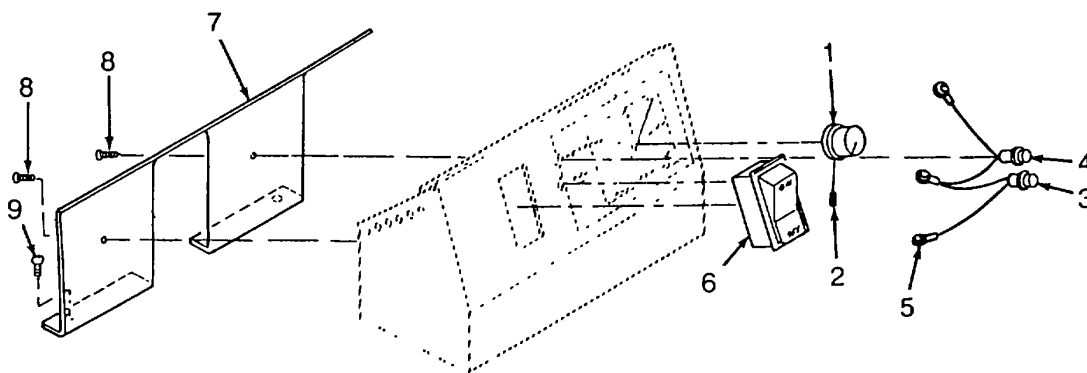

**4-58. HEAT SEALER CONSOLE MAINTENANCE - continued.**Installation.

- (1) Place heat sealer assembly (1) into the stand so that it contacts the handle (2).
- (2) Rotate handle (2) clockwise until the heat sealer assembly (1) is supported
- (3) Install cord clamp (3) and secure with the clamp screw (4).
- (4) Install heat sealer onto the table (para. 2-8).

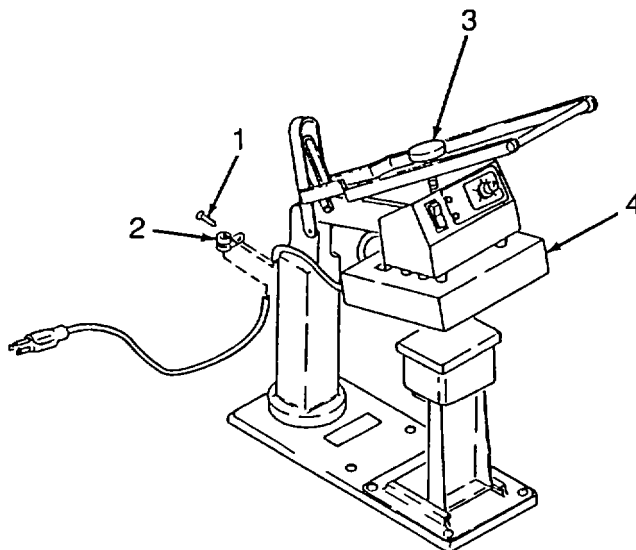

**4-59. HEAT SEALER BLOCK ASSEMBLY MAINTENANCE.**

---

This task consists of: a. Removal      b. Disassembly      c. Cleaning      d. Inspection  
                                 e. Repair              f. Assembly        g. Installation

---

**INITIAL SET-UP:****Tools:**

General Mechanics Tool Kit (Appendix B, Item 1)

**Equipment Condition:**

Heat Sealer unplugged.

**Materials/Parts:**

Rag, wiping (Appendix F, Item 2)

Removal.

- (1) Remove heat sealer from the table (para. 2-18).
- (2) Remove screw clamp (1) and cord clamp (2).
- (3) Rotate handle (3) counterclockwise until the heat sealer assembly (4) is free. Remove heat sealer assembly (4).

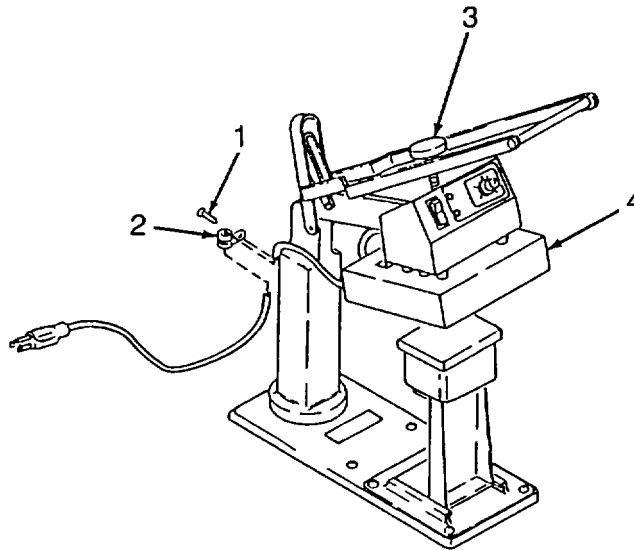

**4-59. HEAT SEALER BLOCK ASSEMBLY MAINTENANCE - continued.**Disassembly.

- (1) Remove eight bar wrap screws (1), two wrap bars (2) and teflon wrap (3).
- (2) Remove setscrew (4) and thermostat knob (5).

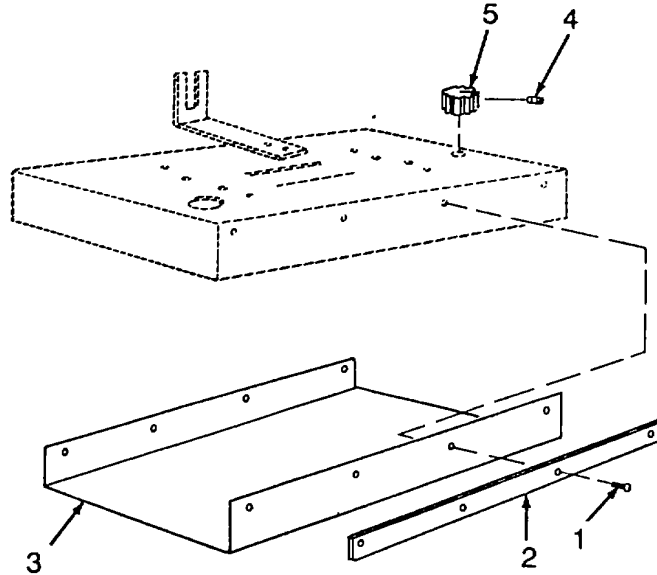
Cleaning.

- (1) Clean items with damp wiping rag (Appendix F, Item 2).
- (2) Allow to dry.

Inspection.

- (1) Inspect hardware for damage.
- (2) Inspect wrap bars for burrs or damage.
- (3) Inspect teflon wrap for damage or excessive wear.

Repair.

Repair is limited to the replacement of defective components with serviceable ones.

**4-59. HEAT SEALER BLOCK ASSEMBLY MAINTENANCE - continued.**Assembly.

- (1) Install thermostat knob (1) and secure with set screw (2).
- (2) Install teflon wrap (3). Secure with two wrap bars (4) and eight bar wrap screws (5).

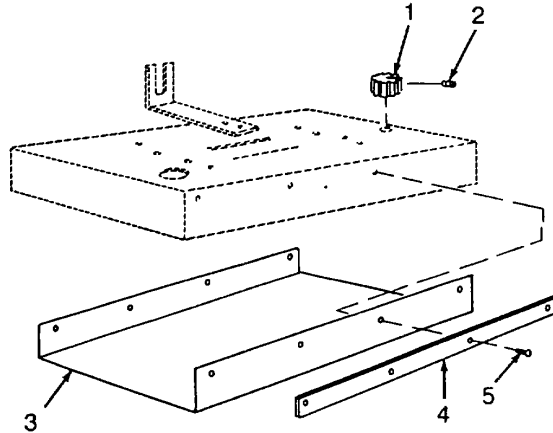
Installation.

- (1) Place heat sealer assembly (1) into the stand so that it contacts the handle (2).
- (2) Rotate handle (2) clockwise until the heat sealer assembly (1) is supported.
- (3) Install cord clamp (3) and secure with the clamp screw (4).
- (4) Install Heat Sealer onto the table (para 2-8).

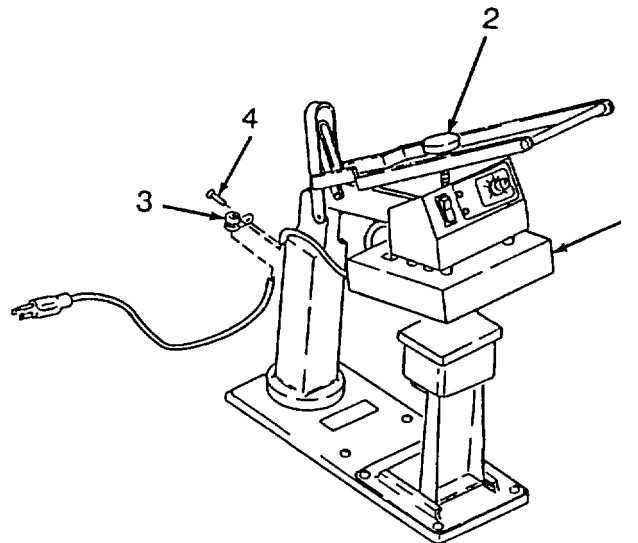

**4-60. DISTRIBUTION BOX MAINTENANCE.**

**This task consists of:** a. Removal      b. Disassembly      c. Cleaning      d. Inspection  
                                  e. Repair              f. Assembly        g. Installation

**INITIAL SET-UP:**

**Tools:**

General Mechanics Tool Kit (Appendix B, Item 1)

**Test Equipment:**

Multimeter (Appendix B, Item 2)

**Equipment Condition:**

Power disconnected.

**Materials/Parts:**

Rag, wiping (Appendix F, Item 2)

Inspection.

**WARNING**

Disconnect the power cable from all equipment prior to beginning any cleaning or testing.

- (1) Inspect for broken wires, cracked or frayed insulation, and burnt or charred insulation.
- (2) Inspect distribution boxes for cracks, dents, holes, corrosion, and signs of burning or charring.
- (3) Inspect cover for missing, broken or misaligned flip top covers.
- (4) Inspect all parts for proper connections.

Cleaning.

**WARNING**

Disconnect the power cable from all equipment prior to beginning any cleaning or testing.

- (1) Remove all dirt, debris, etc., by wiping with a damp rag (Appendix F, Item 2).
- (2) Allow to dry.

4-60. DISTRIBUTION BOX MAINTENANCE - continued.

Test.

**NOTE**

The dash number is located on the top center of each distribution box.

Perform a continuity test using the multimeter (Appendix B, Item 2) Refer to the schematic below

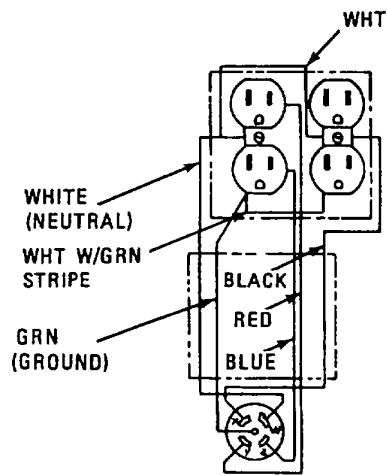

-1 Configuration

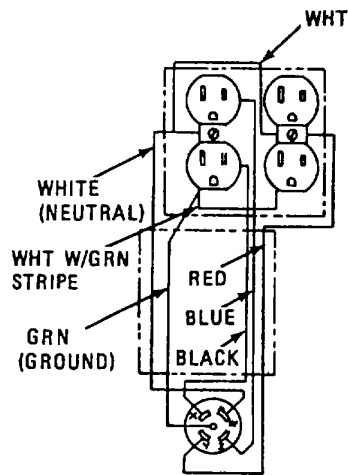

-2 Configuration

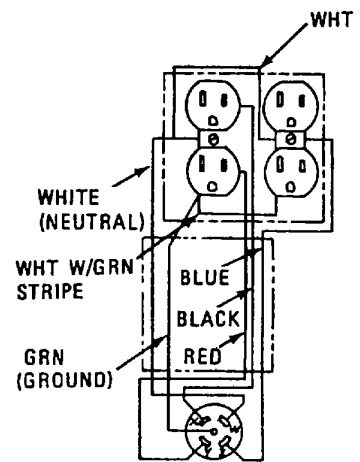

-3 Configuration

**4-60. DISTRIBUTION BOX MAINTENANCE - continued.**Removal.**WARNING**

Disconnect the power cable from all equipment prior to beginning any cleaning or testing.

- (1) Remove four topping screws (1) and the receptacle cover (2).
- (2) Tag and disconnect all internal wiring (3) to the receptacles (4)
- (3) Unscrew and loosen the connector (5).
- (4) Remove the cable (6) from the electrical box (7).
- (5) Remove the male plug (8) from the cable (6).

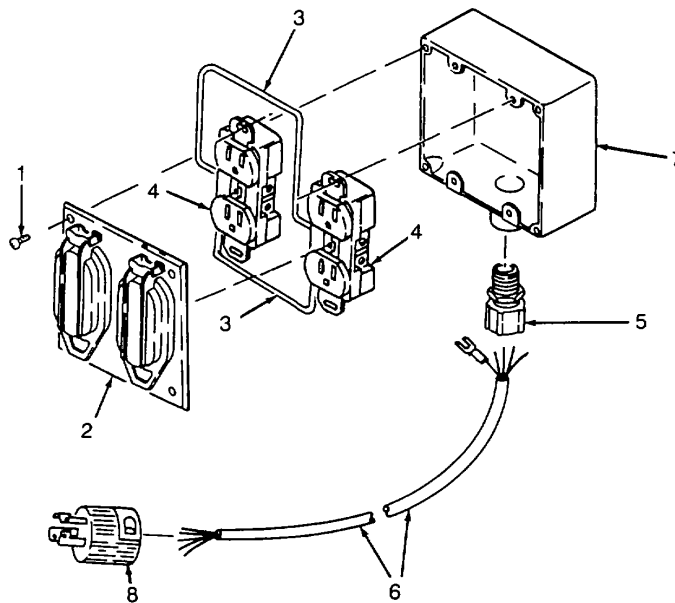

**4-60. DISTRIBUTION BOX MAINTENANCE - continued.**Inspection.

- (1) Inspect for broken wires, cracked or frayed insulation, and burnt or charred insulation.
- (2) Inspect distribution boxes for cracks, dents, holes, corrosion, and signs of burning or charring.
- (3) Inspect cover for missing, broken or misaligned flip top covers.
- (4) Inspect all parts for proper connection.

Repair. Repair is limited to the replacement of defective parts and the following:

## Lug Terminal Replacement.

- (1) Crimp lug terminal (1) on both ends of the white/green wire (2).
- (2) Replace lug terminal (3) on the green wire on the cable (4).

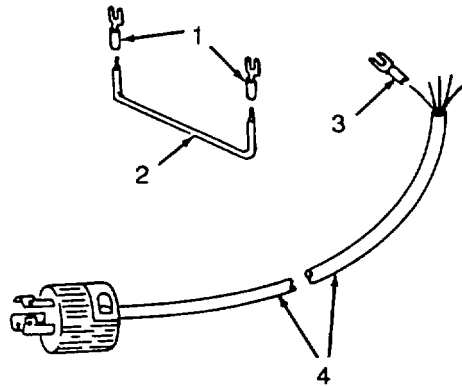

**4-60. DISTRIBUTION BOX MAINTENANCE - continued.**

Installation.

- (1) Install the male plug (1) onto the cable (2).
- (2) Install the cable (2) through the connector (3) and into the electrical box (4). Tighten connector (3).

**CAUTION**

For wiring connections, refer to the same schematic as marked on the front of the receptacle cover (7).

- (3) Connect all internal wiring (5) to the receptacles (6) and install the receptacles (6) into the electrical box (4).
- (4) Install the receptacle cover (7) on the electrical box (4) and secure with four topping screws (8).

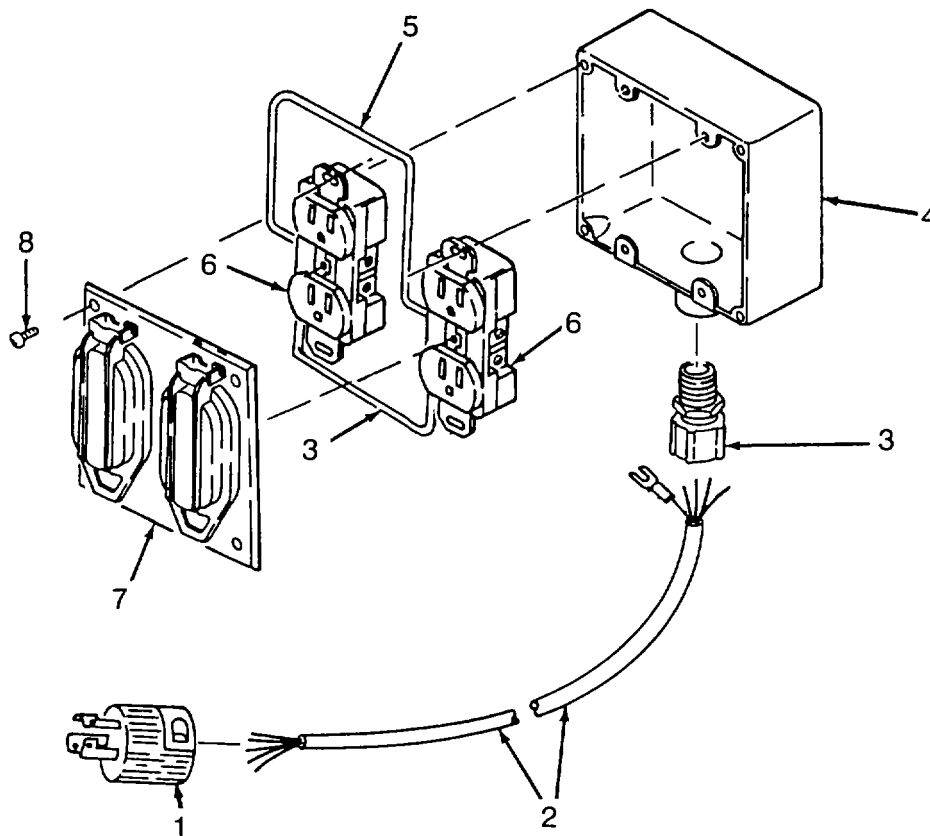

**4-61. POWER BOX ASSEMBLY MAINTENANCE.**

---

**This task consists of:** a. Removal      b. Disassembly      c. Cleaning      d. Inspection  
                                  e. Repair              f. Assembly        g. Installation

---

**INITIAL SET-UP:****Tools:**

General Mechanics Tool Kit (Appendix B, Item 1)

**Test Equipment:**

Multimeter (Appendix B, Item 2)

**Equipment Condition:**

Power disconnected.

**Materials/Parts:**Rag, wiping (Appendix F, Item 2)  
Detergent, General Purpose  
(Appendix F, Item 11)Inspection.**WARNING**

Disconnect the power cable from all equipment prior to beginning any cleaning or testing.

- (1) Inspect for broken wires, cracked or frayed insulation, and burnt or charred insulation.
- (2) Inspect power box for cracks, dents, holes, corrosion, and signs of burning or charring.
- (3) Inspect power box covers for missing, broken or misaligned flip top covers.
- (4) Inspect all parts for proper connection.

Cleaning.**WARNING**

Disconnect the power cable from all equipment prior to beginning any cleaning or testing.

- (1) Remove all dirt, debris, etc., by wiping with a damp rag (Appendix F, Item 2).
- (2) Allow to dry.

4-61. POWER BOX ASSEMBLY MAINTENANCE - continued.

Test.

Perform a continuity test using the multimeter (Appendix B, Item 2). Refer to the following schematic.

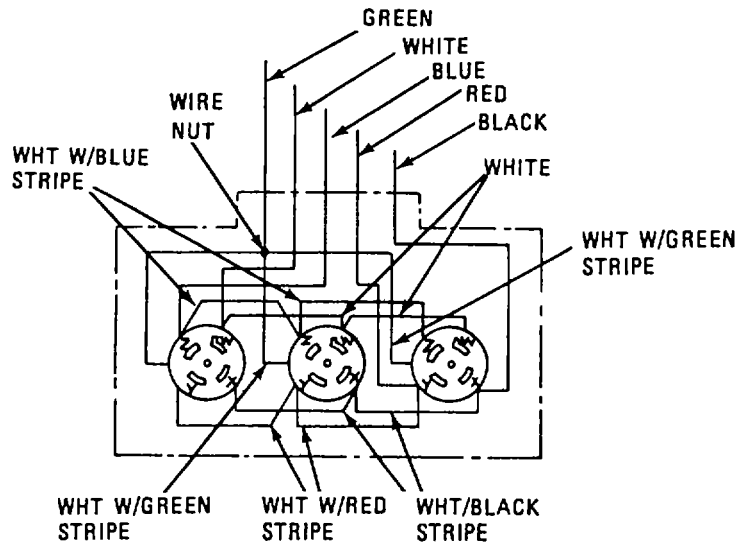

**4-61. POWER BOX ASSEMBLY MAINTENANCE - continued.**

Removal.

**WARNING**

Disconnect the power cable from all equipment prior to beginning any cleaning or testing.

- (1) Remove twelve machine screws (1), twelve flat washers (2) and the three covers with gasket (3) from the electrical box (4).
- (2) Remove wingnut (5) from the wiring.
- (3) Tag and disconnect all internal wiring (6) to the three receptacles (7).
- (4) Remove six machine screws (8), six flat washers (9) and three receptacles (7) from the three covers (3).
- (5) Unscrew and loosen the connector (10).
- (6) Remove the cable (11) from the electrical box (4).

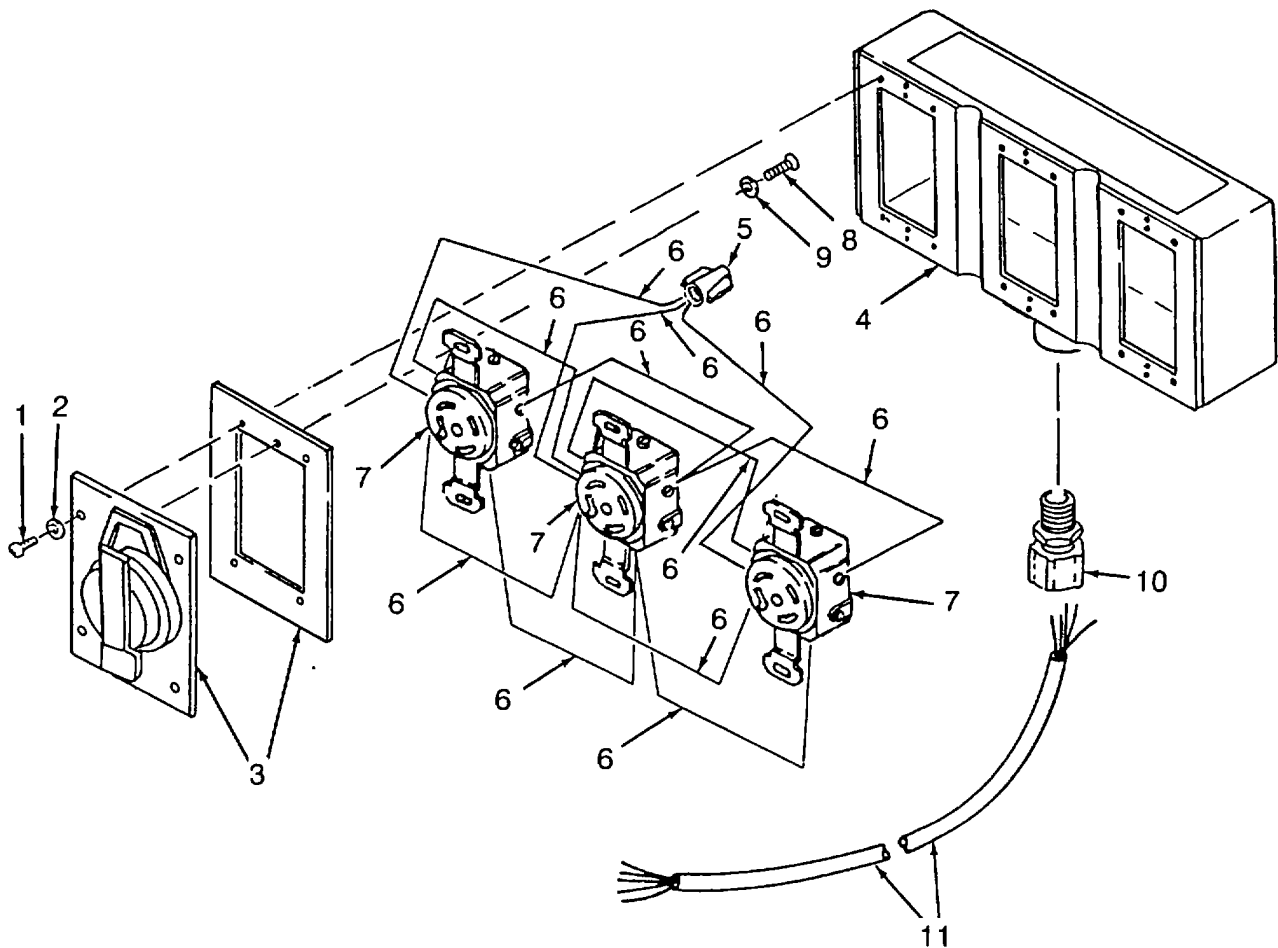

**4-61. POWER BOX ASSEMBLY MAINTENANCE - continued.**Inspection.

- (1) Inspect for broken wires, cracked or frayed insulation, and burnt or charred insulation.
- (2) Inspect power box for cracks, dents, holes, corrosion, and signs of burning or charring.
- (3) Inspect covers for missing, broken or misaligned flip top covers.
- (4) Inspect all parts for proper connection.

Repair. Repair is limited to the replacement of defective parts and the following:

## Instruction Plate Replacement

- (1) Remove old instruction plate (1) from the electrical box (2).

**NOTE**

A mild detergent (Appendix F, Item 11) may be used.

- (2) Remove any excess adhesive from the electrical box (2). See above cleaning procedures.

**NOTE**

Electrical box must be free of dust and dirt and completely dry.

- (3) Install new instruction plate (1) onto the electrical box (2).

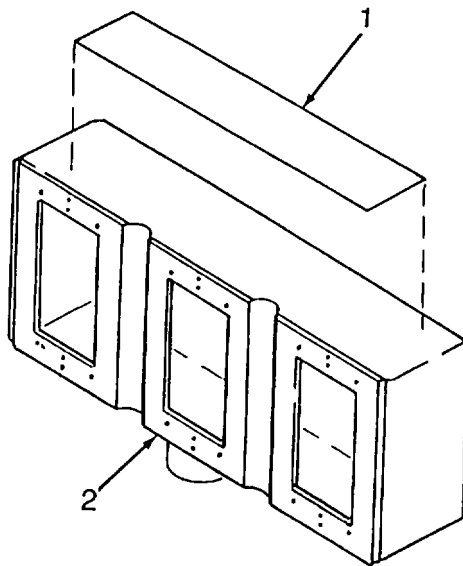

**4-61. POWER BOX ASSEMBLY MAINTENANCE - continued.**

Installation.

- (1) Install the cable (1) through the connector (2) and into the electrical box (3). Tighten connector (2).
- (2) Connect all internal wiring (4) to the receptacles (5).
- (3) Install the three receptacles (5) to the three covers with gasket (6) and secure with six machine screws (7) and six flat washers (8).
- (4) Install wingnut (9).
- (5) Install three covers (6) and secure with twelve flat washers (10) and twelve machine screws (11).

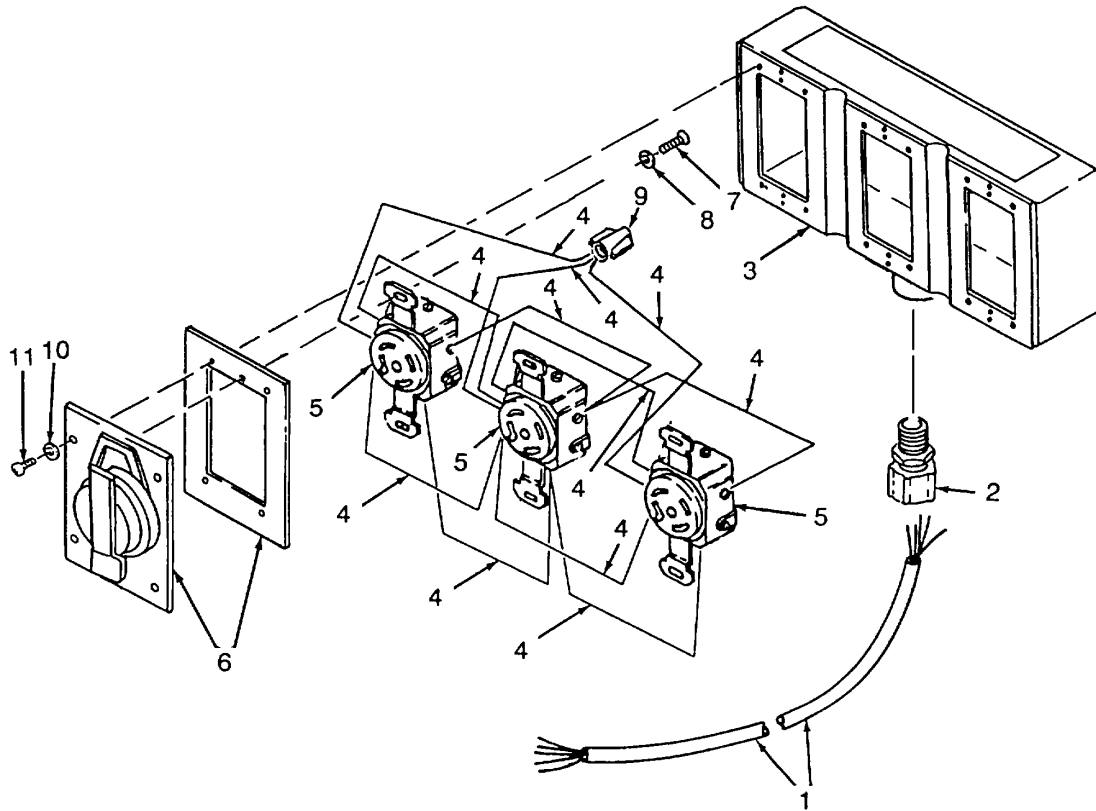

**4-62. IRONING BOARD MAINTENANCE.**

**This task consists of:** a. Removal      b. Disassembly      c. Cleaning      d. Inspection  
                                  e. Repair              f. Assembly              g. Installation

**INITIAL SET-UP:**

**Tools:**

General Mechanics Tool Kit (Appendix B, Item 1)

**Equipment Condition:**

Removed from Stowage Box, placed on folding table.

**Equipment Condition:**

Rag, Wiping (Appendix F, Item 2)  
 Detergent, General Purpose (Appendix F, Item 11)

Removal. Remove Ironing Board Assembly from the grommet and hand tack folding table.

Disassembly.

- (1) Remove pad (1) and cover (2) from ironing board (3).
- (2) Remove two caps (4) from ironing board (3).

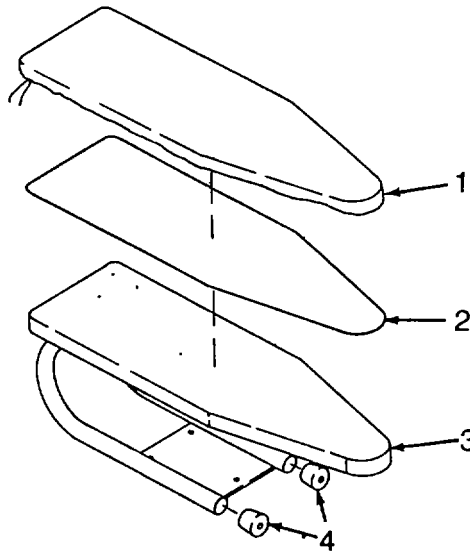

**4-62. IRONING BOARD MAINTENANCE - continued.**

Cleaning.

- (1) Wash the Ironing Board with a solution of general purpose detergent (Appendix F, Item 11) and water.
- (2) Rinse thoroughly with clean water.
- (3) Allow to dry.

**NOTE**

If needed, cover and pad may be washed in cold water.

- (4) Clean top of the cover with a damp wiping rag (Appendix F, Item 2).

Inspection.

- (1) Inspect ironing board for damage.
- (2) Inspect cover for damage or excessive wear.
- (3) Inspect pad for damage.
- (4) Inspect for missing caps.

Repair. Repair of the ironing board is limited to the replacement of defective components.

**4-62. IRONING BOARD MAINTENANCE - continued.**

Assembly.

(1) Assemble two caps (1) onto ironing board (2).

**NOTE**

Pad (3) is placed under the cover (4).

(2) Assemble pad (3) and cover (4) onto ironing board (2). Gently secure using drawstrings on cover (4).

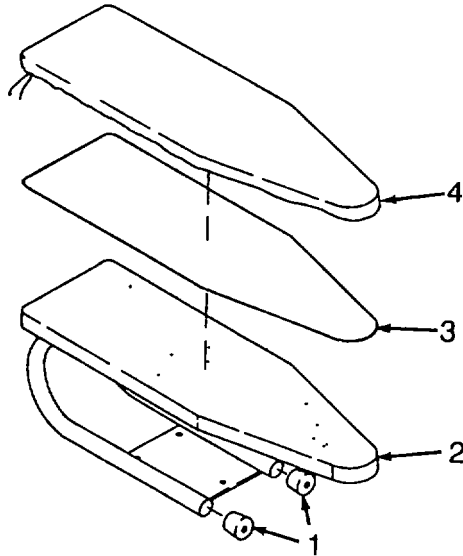

Installation. Return ironing board to the center of the grommet and hand tack folding table.

**4-63. HAND TACK MACHINE MAINTENANCE.**

---

**This task consists of:**      **a. Removal**                      **b. Cleaning**                      **c. Inspection**  
    **d. Installation**

---

**INITIAL SET-UP:**

**Tools:**

General Mechanics Tool Kit (Appendix B, Item 1)

**Equipment Condition:**

Tack Button machine mounted to table (para. 2-8)

**Material/Parts:**

Brush (Appendix F, Item 1)  
 Cleaning Solvent (Appendix F, Item 8)  
 Rag, wiping (Appendix F, Item 2)

Removal. Refer to paragraph 2-18.

Cleaning.

- (1) Remove all buildups of grease, dirt, etc. by wiping with a wiping rag (Appendix F, Item 2).

**WARNING**

To prevent injury to personnel and damage to equipment, use dry cleaning solvent only in well ventilated areas. Avoid repeated or prolonged contact with skin. Do not use near sparks, open flame or excessive heat.

- (2) Clean using cleaning solvent (Appendix F, Item 8) and either a brush (Appendix F, Item 1) or a wiping rag (Appendix F, Item 2).
- (3) Allow to dry.

Inspection.

- (1) Inspect for rust / corrosion and damaged parts.
- (2) Inspect for loose or missing hardware.

Installation. Refer to paragraph 2-8.

**4-64. GROMMET PRESS MAINTENANCE.**

<b>This task consists of</b>	<b>a. Removal d. Installation</b>	<b>b. Cleaning</b>	<b>c. Inspection</b>
------------------------------	---------------------------------------	--------------------	----------------------

**INITIAL SET-UP:**

**Tools:**

General Mechanics Tool Kit (Appendix B, Item 1)

**Equipment Condition:**

Grommet Press mounted to table (para 2-8).

**Material/Parts:**

Brush (Appendix F, Item 1)  
 Cleaning Solvent (Appendix F, Item 8)  
 Rag, wiping (Appendix F, Item 2)

Removal. Refer to paragraph 2-18.

Cleaning.

- (1) Remove all buildups of grease, dirt, etc. by wiping with a wiping rag (Appendix F, Item 2).

**WARNING**

To prevent injury to personnel and damage to equipment, use dry cleaning solvent only in well ventilated areas. Avoid repeated or prolonged contact with skin. Do not use near sparks, open flame or excessive heat.

- (2) Clean using cleaning solvent (Appendix F, Item 8) and either a brush (Appendix F, Item 1) or a wiping rag (Appendix F, Item 2).
- (3) Allow to dry.

Inspection.

- (1) Inspect for rust / corrosion and damaged parts.
- (2) Inspect for loose or missing hardware.

Installation. Refer to paragraph 2-8.

---

**SECTION VI. PREPARATION FOR STORAGE OR SHIPMENT****4-65. SECURITY PROCEDURES.**

Refer to AR 190-11 or AR 190-13.

**4-66. ADMINISTRATIVE STORAGE.**

- a. Placement of equipment in administrative storage should be for short periods of time when a shortage of maintenance effort exists. Items should be mission ready within 24 hours or within the time factors as determined by the directing authority. During the shortage period, appropriate maintenance records will be kept.
- b. Before placing equipment in administrative storage, current maintenance services and Preventive Maintenance Checks and Services (PMCS) evaluations should be completed, shortcomings and deficiencies should be corrected, and all modification work orders (MWOs) should be applied.
- c. If clothing repair shop was used in a salt air environment, wash exterior with detergent and fresh water. Rinse with clean water and allow to dry.
- d. Storage Site Section. Inside storage is preferred for items selected for administrative storage. If inside storage is not available, keep clothing repair shop away from the corrosive materials, such as saltwater spray.

## CHAPTER 5

## DIRECT SUPPORT MAINTENANCE INSTRUCTIONS

Paragraph		Page
Section I.	Repair Parts, Special Tools, TMDE, and Support Equipment.....	5-3
5-1.	Common Tools and Equipment .....	5-3
5-2.	Special Tools, TMDE, and Support Equipment .....	5-3
5-3.	Repair Parts .....	5-3
Section II.	Maintenance Procedures.....	5-4
5-4.	General.....	5-4
5-5.	Holddown Clamp Assembly Replacement.....	5-4
5-6.	Cabinet Assembly Maintenance.....	5-6
5-7.	Side Door Assembly Maintenance.....	5-10
5-8.	Side Door Stay Maintenance .....	5-14
5-9.	Rear Door Assembly Maintenance.....	5-15
5-10.	Rear Door Stay Assembly Maintenance .....	5-19
5-11.	Heat Sealer Mounting Plate Maintenance .....	5-20
5-12.	Retaining Strap Maintenance .....	5-21
5-13.	Generator Support Rail Maintenance.....	5-23
5-14.	Clothing Sewing Machine Presser Foot and Throat Plate Maintenance.....	5-26
5-15.	Clothing Sewing Machine Bobbin Assembly Maintenance.....	5-29
5-16.	Clothing Sewing Machine Presser Bar Mechanism Maintenance.....	5-31
5-17.	Clothing Sewing Machine Lifting Lever Maintenance .....	5-33
5-18.	Clothing Sewing Machine Needle Bar and Thread Take-up Maintenance .....	5-36
5-19.	Clothing Sewing Machine Tension Retaining Lever Maintenance .....	5-40
5-20.	Clothing Sewing Machine Slide Rail Maintenance .....	5-42
5-21.	Clothing Sewing Machine Arm Shaft and Vertical Shaft Maintenance.....	5-44
5-22.	Clothing Sewing Machine Crank Rod Maintenance.....	5-50
5-23.	Clothing Sewing Machine Connecting Rod Maintenance .....	5-53
5-24.	Clothing Sewing Machine Stitch Length Regulator Maintenance .....	5-56
5-25.	Clothing Sewing Machine Feed and Feed Lifting Mechanism Maintenance .....	5-59
5-26.	Clothing Sewing Machine Rotation Shuttle Maintenance .....	5-62
5-27.	Clothing Sewing Machine Front Bushing Maintenance.....	5-65
5-28.	Clothing Sewing Machine Timing.....	5-68
5-29.	Clothing Sewing Machine Receptacle Assembly Maintenance.....	5-71
5-30.	Clothing Sewing Machine Clutch and Motor Assembly Maintenance.....	5-73
5-31.	Darning Sewing Machine Rotating Hook Maintenance.....	5-81
5-32.	Darning Sewing Machine Needle Bar and Presser Bar Assembly Maintenance....	5-84
5-33.	Darning Sewing Machine Oil Guard, Needle Bar Crank Maintenance .....	5-90
5-34.	Darning Sewing Machine Hook Driving Shaft Maintenance.....	5-95
5-35.	Darning Sewing Machine Lifting Lever Maintenance .....	5-98
5-36.	Darning Sewing Machine Tension Assembly Maintenance.....	5-100
5-37.	Darning Sewing Machine Rear Shaft Bearing Maintenance .....	5-104
5-38.	Darning Sewing Machine Front Shaft Bearing Maintenance.....	5-107
5-39.	Darning Sewing Machine Timing .....	5-110
5-40.	Darning Sewing Machine Receptacle Assembly Maintenance .....	5-111
5-41.	Darning Sewing Machine Clutch and Motor Assembly Maintenance .....	5-113
5-42.	Button Sewing Machine Side Cover and Thread Guides Maintenance.....	5-121
5-43.	Button Sewing Machine Face Plate and Eye Guard Maintenance.....	5-124
5-44.	Button Sewing Machine Automatic Thread Tension Disks and Release Disk, Spring, and Studs .....	5-127
5-45.	Button Sewing Machine Needle Bar Maintenance.....	5-129

Paragraph		Page
<b>Section II.</b>	<b>Maintenance Procedures (continued)</b>	
5-46.	Button Sewing Machine Crank and Needle Guide With Shaft and Bushing Maintenance.....	5-131
5-47.	Button Sewing Machine Thread Looper Shaft, Link, Cam, and Crank Maintenance .....	5-135
5-48.	Button Sewing Machine Presser Bar Maintenance.....	5-138
5-49.	Button Sewing Machine Thread Tension Rod Assembly Maintenance.....	5-141
5-50.	Button Sewing Machine Thread Release and Nipper Maintenance.....	5-144
5-51.	Button Sewing Machine Arm Clamp and Spreader Maintenance.....	5-147
5-52.	Button Sewing Machine Lifting Lever Maintenance.....	5-150
5-53.	Button Sewing Machine Pulley Starter and Trip Block Maintenance.....	5-154
5-54.	Button Sewing Machine Drive Pulley Clutch Maintenance .....	5-158
5-55.	Button Sewing Machine Feed and Needle Plate Maintenance.....	5-162
5-56.	Button Sewing Machine Vibrating Lever Maintenance.....	5-166
5-57.	Button Sewing Machine Lifting Arm and Thread Pulloff Maintenance.....	5-170
5-58.	Button Sewing Machine Cam and Drive Shaft Maintenance.....	5-173
5-59.	Button Sewing Machine Stop Motion Shaft Maintenance.....	5-176
5-60.	Button Sewing Machine Arm Rock Shaft Maintenance.....	5-180
5-61.	Button Sewing Machine Eccentric, Drive Shaft, Looper Cam and Crank Maintenance.....	5-183
5-62.	Button Sewing Machine Motor Assembly Maintenance.....	5-188
5-63.	Button Sewing Machine Receptacle Assembly Maintenance.....	5-192
5-64.	Stowage Box Assembly Maintenance.....	5-194

**Section I. REPAIR PARTS, SPECIAL TOOLS, TMDE, AND SUPPORT EQUIPMENT**

**5-1. COMMON TOOLS AND EQUIPMENT.**

For authorized common tools and equipment, refer to the Modified Table of Organization and Equipment (MTOE) applicable to your unit.

**5-2. SPECIAL TOOLS, TMDE, AND SUPPORT EQUIPMENT.**

For the special tools, TMDE, or support equipment authorized for the maintenance of the Clothing Repair Shop, refer to Appendix B, Maintenance Allocation Chart.

**5-3. REPAIR PARTS.**

Repair parts are listed and illustrated in the repair parts and special tools list TM 10-3530-207-24P covering organizational, direct support and general support, and depot maintenance for this equipment.



**5-5 HOLDDOWN CLAMP ASSEMBLY REPLACEMENT - continued.**

Cleaning.

- (1) Clean the holddown clamp assembly with a solution of detergent (Appendix F, Item 11) and water.
- (2) Rinse thoroughly with fresh water.
- (3) Allow to dry.

Installation.

- (1) Place outside bracket (1) and inside plate (2) into position.
- (2) Lower cabinet (para. 5-6).
- (3) Install three screws (3), three washers (4), and three nuts (5).
- (4) Install clamp arm (6), washer (7), and bolt (8).
- (5) Install pin (9).

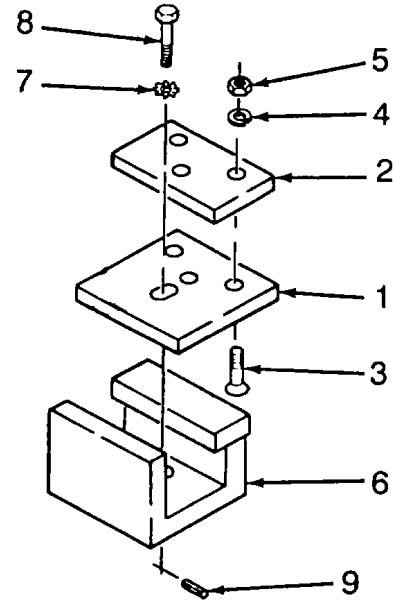



**5-6. CABINET ASSEMBLY MAINTENANCE - continued.**

Removal.

- (1) Raise the four lifting loops (1) up.
- (2) Attach a chain (2) to each lifting loop (1) and to the hoist (3) Be sure the chains are all of equal length.
- (3) Attach a cargo strap (4) to each of the four lifting loops (1).
- (4) Remove pin (5), screw (6), washer (9) on each of the six holddown clamp assemblies (7).
- (5) Remove six clamp arm pads (8) from the trailer ledge.

**WARNING**

Be sure that all personnel are standing clear of the cabinet. Do not allow anyone near the cabinet while it is off the trailer or the ground.

- (6) Have one person hold the end of each of the four 15 foot cargo straps (4).
- (7) With four persons steadying the cabinet by using the four cargo straps (4), slowly lift the cabinet off the trailer.
- (8) When the cabinet assembly is clear of the trailer, move the cabinet assembly to a suitable area, (such as wooden pallets or jack stands).
- (9) Disconnect the chains and hoist from the lifting eyes (1).

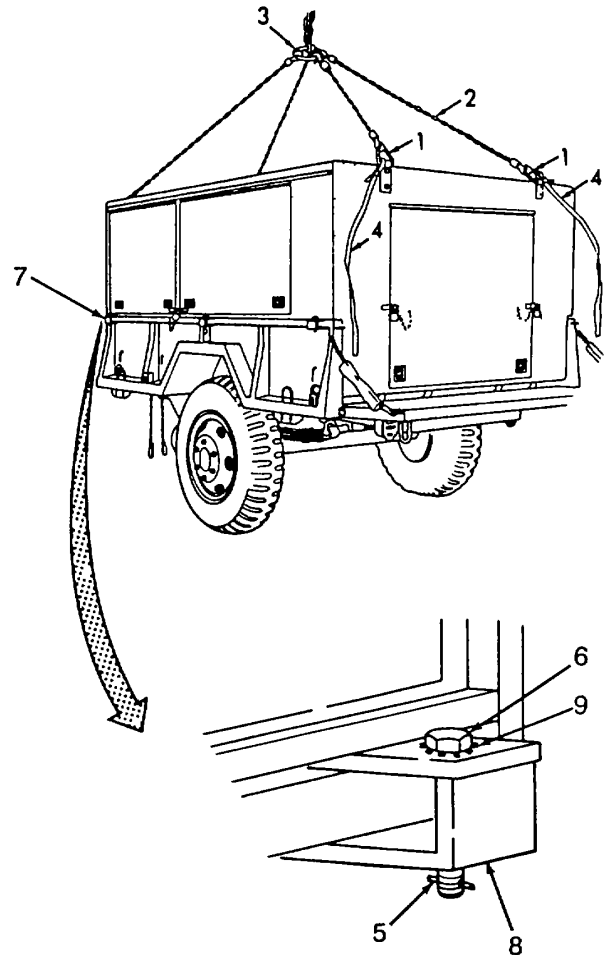

Cleaning

- (1) Clean the cabinet assembly with a solution of mild soap and water.
- (2) Rinse thoroughly with clean water.
- (3) Allow to dry.

**5-6. CABINET ASSEMBLY MAINTENANCE - continued.**

Inspection.

- (1) Inspect for loose, missing, or damaged hardware.
- (2) Inspect the door, panels, and other parts for damage.
- (3) Inspect the frame for damage.

Repair. Repair is limited at this maintenance level to the replacement of defective components with serviceable ones.

Installation

- (1) Pull the four lifting loops (1) up.
- (2) Attach a chain (2) to each loop (1) and the hoist (3). Be sure the chains are of equal length
- (3) Attach a cargo strap (4) to each lifting loop

**WARNING**

Be sure that all personnel are standing clear of the cabinet. Do not allow anyone near the cabinet while it is off the trailer or the ground.

- (4) Have one person operate the hoist.
- (5) With the four persons using the cargo straps (4) to steady the cabinet, slowly lift the cabinet assembly up and onto the trailer.
- (6) Disconnect the chains (2) and hoist (3) from the lifting loops (1).
- (7) Disconnect the cargo straps (4) from the lifting loops (1).

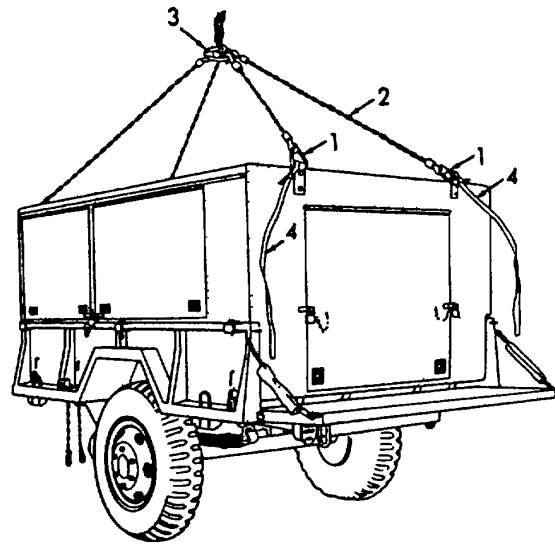

**5-6. CABINET ASSEMBLY MAINTENANCE - continued.**Installation - continued

- (8) Position the clamp arm pad (i) under the trailer ledge.
- (9) Install screw (2), washer (5) on each of the six holddown clamp assemblies (3) securely.
- (10) Install pin (4) on each of the six holddown clamp assemblies (3).
- (11) Load the cabinet assembly as required (para. 2-16).

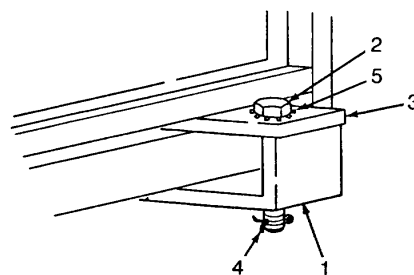

**5-7. SIDE DOOR ASSEMBLY MAINTENANCE.**

**This Task consists of** a. Installed Item Inspection b. Removal c. Cleaning  
 d. Repair e. Installation

**INITIAL SET-UP:**

**Tools:**

- Master Mechanics Tool Kit (Appendix 13, Item 2)
- Riveting Tool Set (Appendix B, Item 4)
- Rag, Wiping (Appendix F, Item 2)

**Personnel Required:**

2 Persons

**Equipment Condition:**

Equipment removed from compartment (para. 2-8)

**Materials/Parts:**

- Sealing Compound (Appendix 1,, Item 7)
- Rivets
- Washers, Lock
- Gasket
- Detergent, General Purpose (Appendix F, Item 11)

Installed Item Inspection.

- (1) Inspect for loose or missing hardware
- (2) Inspect hinge for rust, corrosion, damage, and loose fit to door.
- (3) Inspect gasket for damage, deterioration.
- (4) Inspect latches for rust, corrosion, damage, and loose fit to door.
- (5) Inspect hasps for rust, corrosion, damage, and loose fit to door.
- (6) Inspect door for damage, rust, and corrosion.

Removal.

- (1) Drill out and remove rivets (1) that secure the door assembly (2). Do not allow the door (3) to fall.
- (2) Remove the door assembly (2).

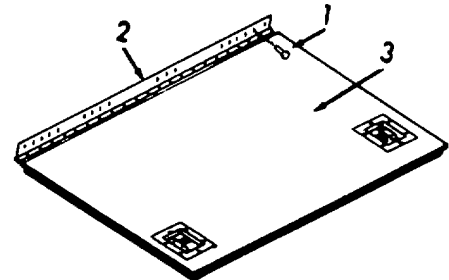

**5-7. SIDE DOOR ASSEMBLY MAINTENANCE - continued.**Cleaning

- (1) Clean the door with a solution of detergent (Appendix F, Item 11 ) and water.
- (2) Rinse thoroughly with clean water.
- (3) Allow to dry.

Repair. Repair of side door is limited to

- (1) Replacement of gasket.
  - (a) Drill out and remove the rivets (1) securing the outside edge of the channel (2).
  - (b) Remove the nuts (3), washers (4), screws (5), and gasket retainer (6).
  - (c) Remove gasket (7) and clean the gasket mounting area with a dry wiping rag (Appendix F, Item 2)
  - (d) Install new gasket (7) into position Make sure gasket slips under outside edge of channel (2).
  - (e) Drill a 3/16 inch hole through the gasket using the retainer (6) and the channel (2) as a template.
  - (f) Install gasket retainers (6), screws (5), washers (4), and nuts (3). Tighten hardware securely.

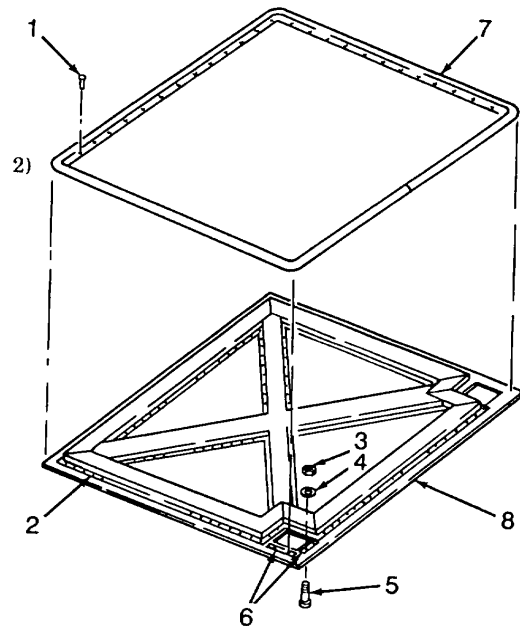

**5-7. SIDE DOOR ASSEMBLY MAINTENANCE - continued.**

Repair - continued

(g) Install rivets (1) using the rivet tool kit (Appendix B, Item 4) to secure outside edge of the channel (2) to door panel (8).

(2) Replacement of latches.

(a) Remove six nuts (1), six washers (2), and screws (3).

(b) Remove latch assembly (4) and scrape off old sealing compound.

(c) Apply sealing compound (Appendix F, Item 7) to the flange of the new latch (4).

(d) Install new latch assembly (4) to door (5).

(e) Secure latch (4) with six screws (3), six washers (2), and six nuts (1).

(f) Wipe excessive sealing compound away using a wiping rag (Appendix i, Item 2).

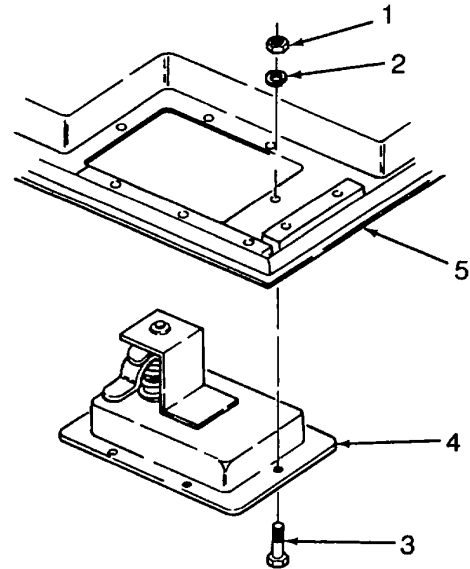

(3) Replacement of hasp.

(a) Drill out and remove the five rivets (1) that secure the hasp (2) to the door (3).

(b) Remove the hasp (2).

(c) Install a new hasp (2) into position.

(d) Install five new rivets (1) using the rivet tool set (Appendix B, Item 4) to secure hasp (2) to door (3).

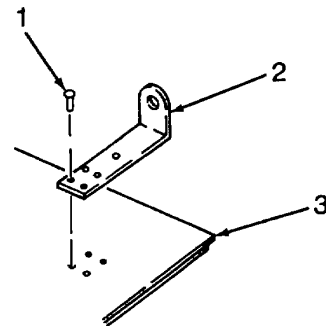

**5-7. SIDE DOOR ASSEMBLY MAINTENANCE - continued.**Installation.

- (1) Center door (1) into place in closed position.
- (2) Secure hinge (2) to cabinet with rivets (3) using the rivet tool kit.

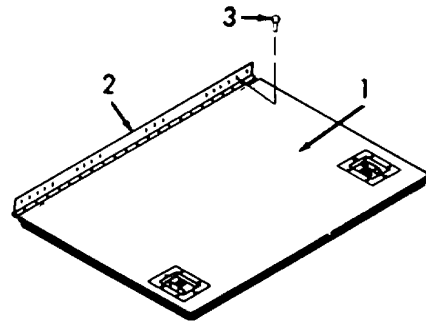

**5-8. SIDE DOOR STAY MAINTENANCE.**

This task consists of a. Removal                      b. Cleaning                      c. Installation

**INITIAL SET-UP**

**Tools:**

General Mechanics Tool Kit (Appendix B, Item 1)

**Materials/Parts:**

Detergent, General Purpose (Appendix F, Item 11)

**Equipment Condition:**

Padlock unlocked (para. 2-8).

Removal

- (1) Remove nut (1), washer (2), screw (3), and door stay (4) from the door (5).

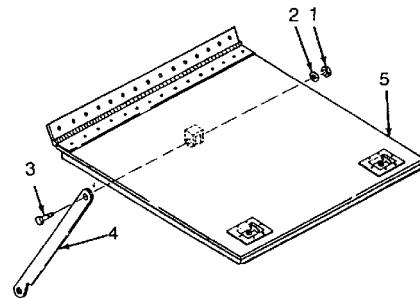

Cleaning

- (1) Clean the side door stay with a solution of detergent (Appendix F, Item 11) and water.
- (2) Rinse thoroughly with clean water.
- (3) Allow to dry.

Installation

Install door stay (1) to the side door (2) Secure with screw (3), washer (4), and nut (5).

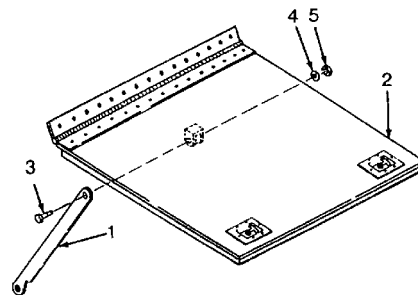

**5-9. REAR DOOR ASSEMBLY MAINTENANCE.**

---

**This task consists of**    **a. Installed Item Inspection**    **b. Removal**    **c. Cleaning**  
    **d. Repair**     **e. Installation**

---

**INITIAL SET-UP:**

**Tools:**

- Master Mechanics Tool Kit (Appendix 13, Item 2)
- Riveting Tool Set (Appendix B, Item 4)
- Rag, Wiping (Appendix F, Item 2)

**Personnel Required:**

2 Persons

**Equipment Condition:**

Equipment removed from compartment (para. 2-8)

**Materials/Parts:**

- Sealing Compound (Appendix 1,, Item 7)
- Rivets
- Washers, Lock
- Gasket
- Detergent, General Purpose (Appendix F, Item 11)
- Washer, Lock
- Gasket

Installed Item Inspection.

- (1) Inspect for loose or missing hardware.
- (2) Inspect hinge for rust, corrosion, damage, and loose fit to door.
- (3) Inspect gasket for damage and deterioration.
- (4) Inspect latches for rust, corrosion, damage, and loose fit to door.
- (5) Inspect hasps for rust, corrosion, damage, and loose fit to door.
- (6) Inspect door for damage, rust, and corrosion.

Removal

- (1) Remove nut (1), washer (2), and screw (3) that secures the stay (4) to the cabinet.
- (2) Swing the stay (4) away from the cabinet.
- (3) Remove other stay per steps (1) and (2) above.
- (4) Remove the rivets (6) that secure the door hinge (7) to the cabinet Do not allow the door (5) to fall.
- (5) Remove the door (5).

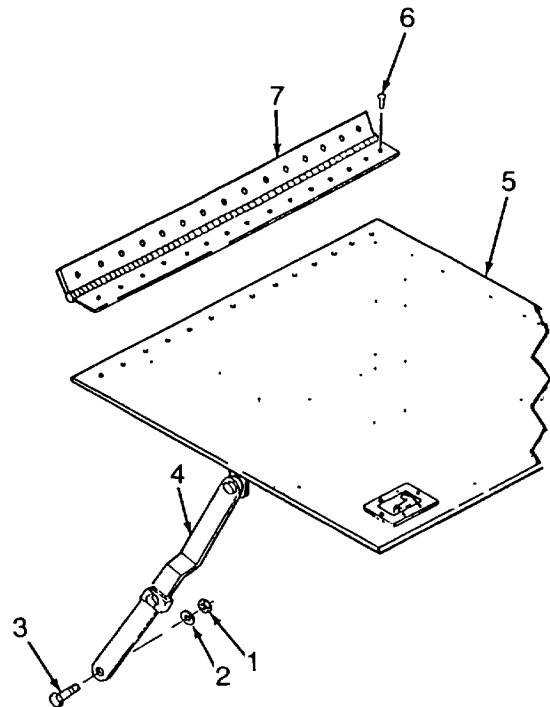

**5-9. REAR DOOR ASSEMBLY MAINTENANCE - continued.**Cleaning

- (1) Clean the door with a solution of mild soap and water.
- (2) Rinse thoroughly with clean water.
- (3) Allow to dry.

Repair. Repair of the rear door is limited to the following.

- (1) Replacement of gasket.
  - (a) Drill out and remove the rivets (1) securing the outside edge of the channel (2).
  - (b) Remove the nuts (3), washers (4), screws (5), and gasket retainer (6).
  - (c) Remove gasket (7) and clean the gasket mounting area.
  - (d) Install new gasket (7) into position. Make sure gasket slips under outside edge of channel (2).
  - (e) Drill a 3/16 inch hole through the gasket using the retainer (6) and the channel (2) as a template.
  - (f) Install gasket retainers (6), screws (5), washers (4), and nuts (3). Tighten hardware securely.

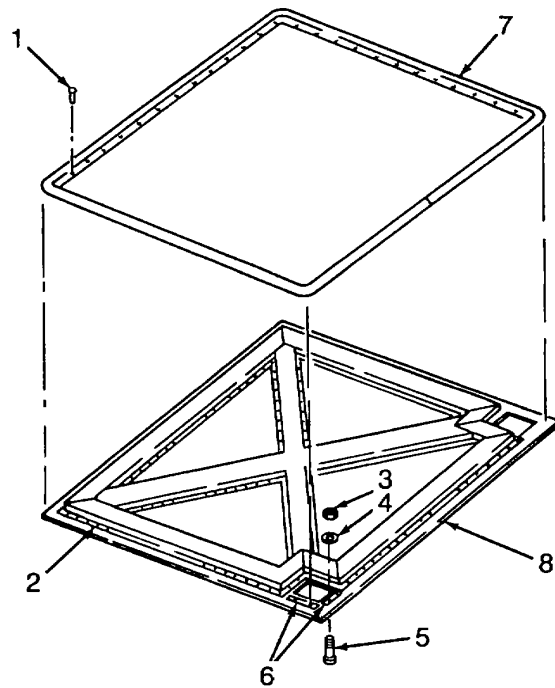

**5-9. REAR DOOR ASSEMBLY MAINTENANCE - continued.**

- (g) Install rivets (1) using the rivet tool kit (Appendix B, Item 4) to secure outside edge of the channel (2) to door panel (8).

(2) Replacement of latches.

- (a) Remove six nuts (1), six washers (2), and screws (3).
- (b) Remove latch assembly (4) and scrape off old sealing compound.
- (c) Apply sealing compound (Appendix F, Item 7) to the flange of the new latch (4).
- (d) Install new latch assembly (4) to door (5).
- (e) Secure latch (4) with six screws (3), six washers (2), and six nuts (1).
- (f) Wipe excessive sealing compound away using a wiping rag (Appendix F, Item 2).

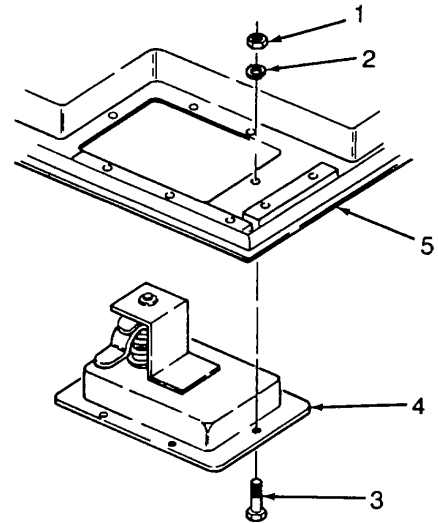

(3) Replacement of hasp.

- (a) Drill out and remove the five rivets (1) that secure the hasp (2) to the door (3).
- (b) Remove the hasp (2).
- (c) Install a new hasp (2) into position.
- (d) Install five new rivets (1) using the rivet tool set (Appendix B, Item 4) to secure hasp (2) to door (3).

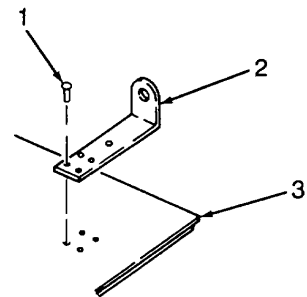

**5-9. REAR DOOR ASSEMBLY MAINTENANCE - continued.**

Installation

- (1) Center door (1) into place in closed position.
- (2) Secure hinge (2) to cabinet with rivets (3) using riveting tool kit.
- (3) Place stay (4) into position.
- (4) Install screw (5), washer (6) and nut (7) to secure stay (4) to door (1).
- (5) Repeat steps (3) and (4) above for other stay.

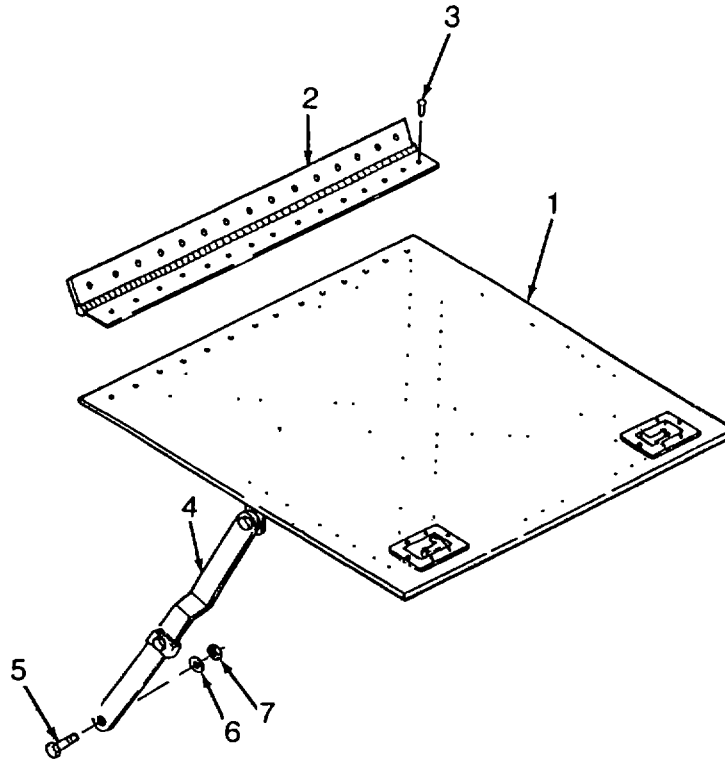

**5-10. REAR DOOR STAY ASSEMBLY MAINTENANCE.**

This task covers:

a. Removal

b. Cleaning

c. Installation

**INITIAL SETUP:****Tools:**

General Mechanics Tool Kit (Appendix I1, Item I)

**Equipment Condition:**

Tailgate lowered (para 2-8)

Padlocks unlocked (para 2-8)

**Materials/Parts:**

Detergent, General Purpose (Appendix F, Item 11 )

**Removal.**

- (1) Remove nut (1), washer (2), screw (3), and arm stay (4) from the door (5).
- (2) Repeat step 1 for the other side.

**Cleaning.**

- (1) Clean the rear door stay with a solution of detergent (Appendix F, Item 11) and water.
- (2) Rinse thoroughly with clean water.
- (3) Allow to dry.

**Installation.**

- (1) Install arm stay (1) to the door (2). Secure with screw (3), washer (4), and nut (5).
- (2) Repeat step 1 for the other side.

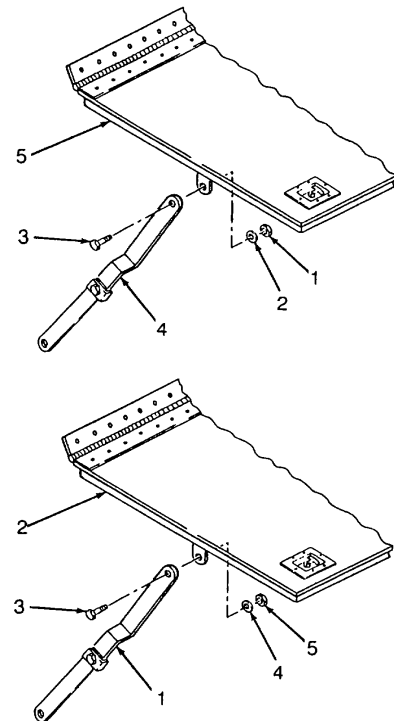

**5-11. HEAT SEALER MOUNTING PLATE MAINTENANCE.****This task covers:****a. Inspection.****b. Repair****INITIAL SETUP:****Tools:**

General Mechanics Tool Kit (Appendix B, Item 1)

Drill, (Electric or Pneumatic)

Set, Drill Bits

Riveting Tool Set (Appendix B, Item 4)

**Equipment Condition :**

Heat sealer removed from compartment (para 2-8).

**Materials/Parts:**

Blind Rivet

Blind Nut

**Inspection.**

- (1) Inspect for missing or damaged hardware.
- (2) Inspect for missing or damaged straps.
- (3) Inspect for spinning blind nut.

**Repair.** Repair is limited to the following:

- (1) Replacement of blind nuts.
  - (a) Drill out and remove damaged blind nuts (1).
  - (b) Install a new blind nut (1) into position.
- (2) Replacement of straps.
  - (a) Remove two blind rivets (1) and strip (2).
  - (b) Separate retainer (3) from strap (2).
  - (c) Repeat above steps for other strap (4).

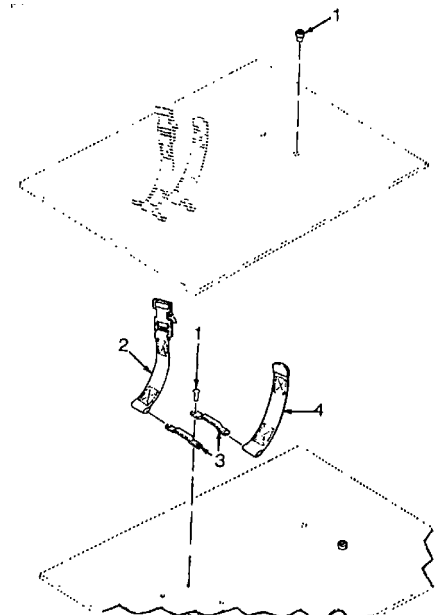

**5-12. RETAINING STRAP MAINTENANCE.****This task covers:**

- a. Inspection
- d. Repair

- b. Removal
- e. Installation

- c. Cleaning

**INITIAL SETUP:****Tools:**

General Mechanics Tool Kit (Appendix B Item 1)

Riveting Tool Set (Appendix 13, Item 4)

**Material/Parts:**

Detergent, General Purpose (Appendix F, Item 11)

Rag, wiping (Appendix F, Item 2)

Thread

Rivets

**Equipment Condition:**

Generator removed from cabinet (para 2-8)

Chairs removed from cabinet (para 2-8)

Table tops removed from cabinet (para 2-8)

Folding stands removed from cabinet (para 2-8)

**Inspection.**

- (1) Inspect for loose or missing hardware.
- (2) Inspect for torn, ripped, or deteriorated strap webbing.
- (3) Inspect for missing or damaged buckles.

**Removal.**

- (1) Remove two rivets (1), strap (2) and retainer (3).
- (2) Separate retainer (3) from strap (2).
- (3) Repeat steps (1) and (2) for the other strap.

**Cleaning.**

- (1) Wash the straps with a solution of detergent (Appendix F, Item 11) and water.
- (2) Rinse thoroughly with clean water.
- (3) Wipe dry with a clean cloth (Appendix F, Item 2).

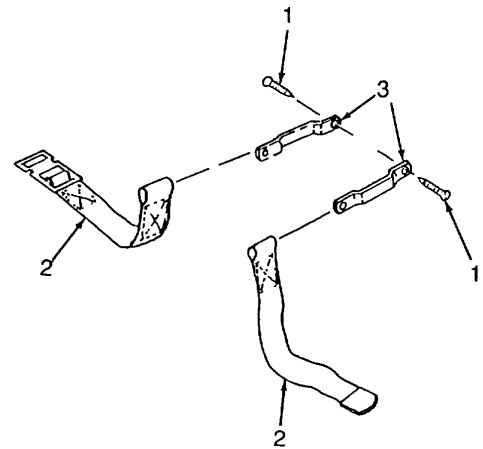

**5-12. RETAINING STRAIP MAINTENANCE - continued.**

Repair Repair is Limited to the replacement of defective items with the following exception:

- (1) Resew the strap (2), using thread (4) to form a loop as shown. Sew material six to eight threads per inch.

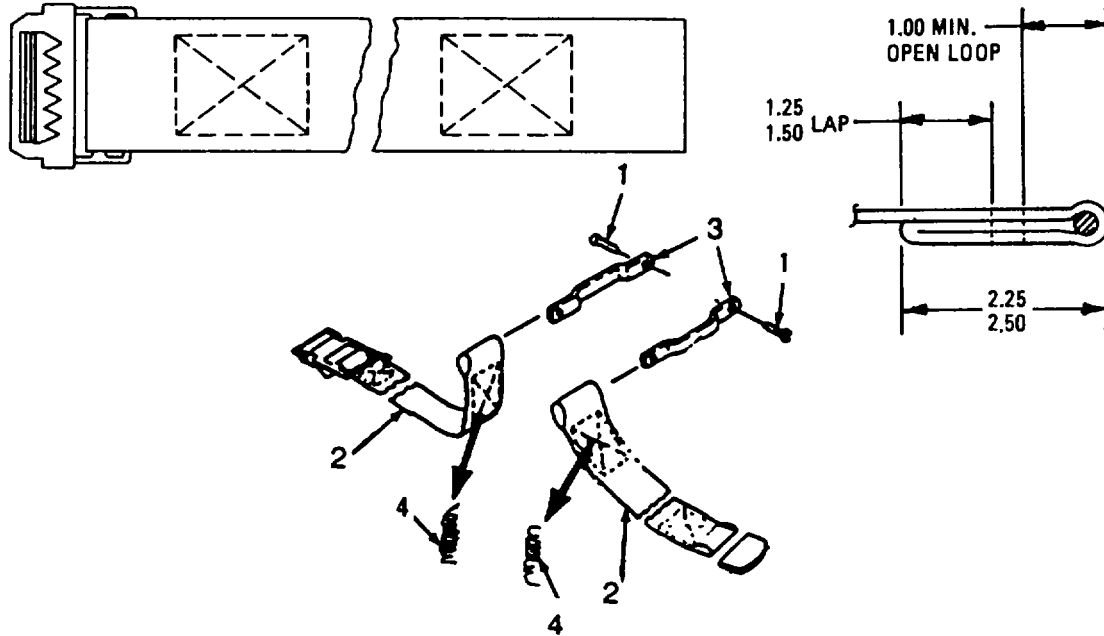

Installation.

- (1) Install retainer (1) into loop on strap (2).
- (2) Install retainer (1) into position using two rivets (3) to secure the holddown to the cabinet. Repeat steps (1 and 2) for other straps.

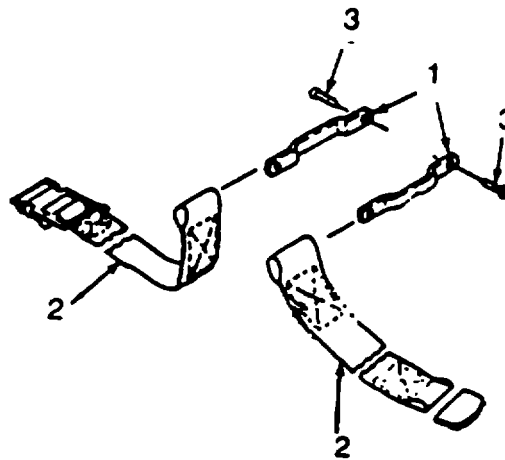

**5-13. GENERATOR SUPPORT RAIL MAINTENANCE.**

This task covers:

- |                              |            |                 |
|------------------------------|------------|-----------------|
| a. Installed Item Inspection | b. Removal | c. Cleaning     |
| d. Inspection                | e. Repair  | f. Installation |

**INITIAL SETUP:****Tools:**

General Mechanics Tool Kit (Appendix 13, Item 1)  
Riveting Tool Set (Appendix 13, Item 4)

**Equipment Condition :**

Tailgate lowered (para 2-8).  
Generator removed (para 2-8.)

**Material:**

Detergent, General Purpose (Appendix F, Item 11)  
Rivet

**Installed Item Inspection.**

- (1) Inspect for loose or missing hardware.
- (2) Inspect for cracks, broken parts, rust and corrosion.

**Removal.**

- (1) Disconnect two pins (1) and remove generator clamp (2).
- (2) Remove six screws (3) on each track (4).
- (3) Remove both tracks.(4)

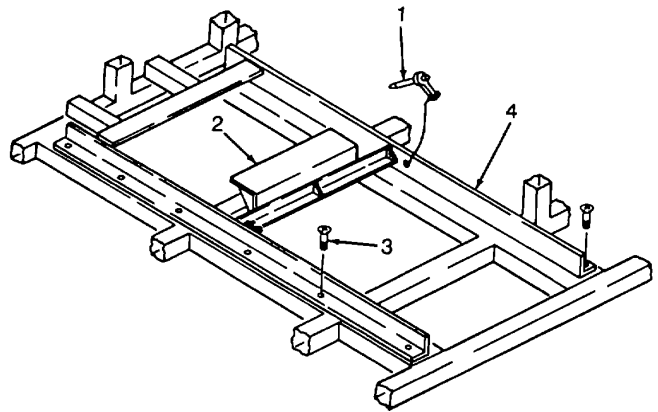
**Cleaning.**

- (1) Wash the generator track and holddown assembly with a solution of detergent (Appendix F, Item 11) and water.
- (2) Rinse thoroughly with clean water.
- (3) Allow to dry.

**Inspection.**

- (1) Inspect for missing or damaged hardware.

**5-13. GENERATOR SUPPORT RAIL MAINTENANCE - continued.**Inspection - continued

- (2) Inspect holddown for cracks, elongated holes, and rust/corrosion.
- (3) Inspect track for cracks, elongated holes, and rust/corrosion.
- (4) Inspect pin on track for function, cracks, and rust/corrosion.

Repair Repair of the generator track is limited to the following:

Replacement of the damage pin as follows:

- (1) Drill out and remove rivet (1) securing the pin (2) to the generator track (3).
- (2) Install new pin assembly (2) with a new rivet (1) and secure it to track (3).

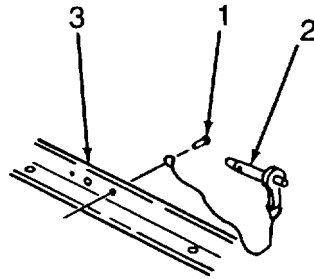

**5-13. GENERATOR SUPPORT HAIL MAINTENANCE - continued.**Installation.

- (1) Place generator track (1) into position. Secure with six screws (2).
- (2) Repeat step 1 for the other side.
- (3) Install generator clamp (3) with pins (4) through generator track (1).

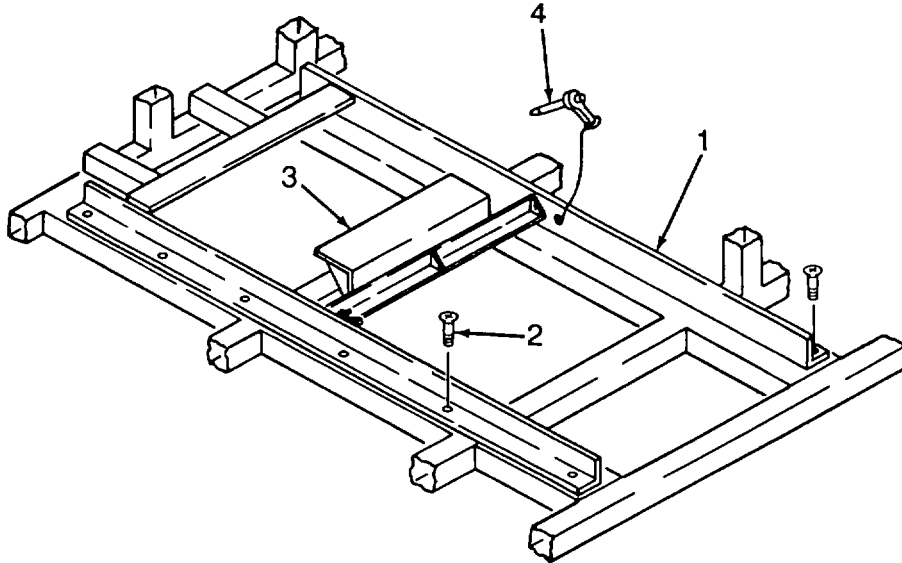

**5-14. CLOTHING SEWING MACHINE PRESSER FOOT AND THROAT PLATE MAINTENACE**

This task covers:

- |            |                |                 |
|------------|----------------|-----------------|
| a. Removal | b. Disassembly | c. Inspection   |
| d. Repair  | e. Assembly    | f. Installation |

**INITIAL SETUP:****Tools:**

General Mechanics Tool Kit (Appendix B, Item 1)

**Materials/Parts:**

Rag, wiping (Appendix F, Item 2)

**Equipment Condition :**

Sewing machine removed (para. 2-8).

Needle and thread removed (para. 2-8).

**Removal.**

- (1) Remove screw (1).

**NOTE**

Some machines may not have a guard.

- (2) Remove presser foot guard (2).
- (3) Slide presser foot (3) off of presser bar (4).

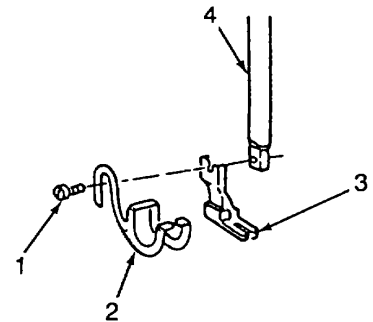

- (3) Remove slide plate (5) by sliding it away from the machine.
- (4) Remove two screws (6) and the throat plate (7).

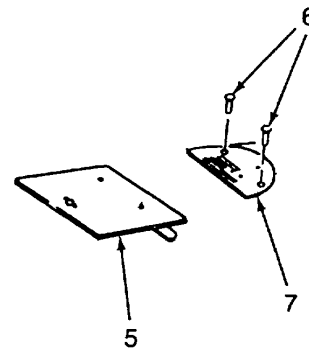

**5-14. CLOTHING SEWING MACHINE PRESSER FOOT AND THROAT PLATE  
MAINTENANCE - continued.**

Disassembly.

- (1) Remove two screws (1) and slide spring (2).

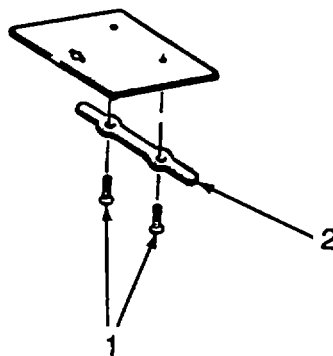

**5-14. CLOTHING SEWING MACHINE PRESSER FOOT AND THROAT PLATE MAINTENANCE - continued.**

Inspection.

- (1) Inspect hardware for damage.
- (2) Inspect clip for damage.
- (3) Inspect slide for burrs or damage
- (4) Inspect throat plate for burrs or damage.
- (5) Inspect presser foot for damage.

Repair. Repair of the presser foot and throat plate is limited to the replacement of defective components.

Assembly.

- (1) Install two screws (1) and slide spring (2).

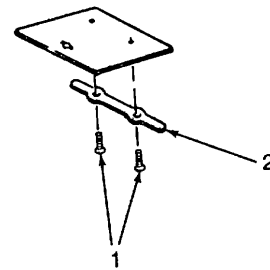

Installation.

- (1) Install throat plate (1). Secure with two screws (2).
- (2) Install slide plate (3) by sliding it onto the machine.

**NOTE**

Some machines may not have a guard.

- (3) Slide presser foot (4) and guard (5) onto the presser bar (6). Secure with screw (7).

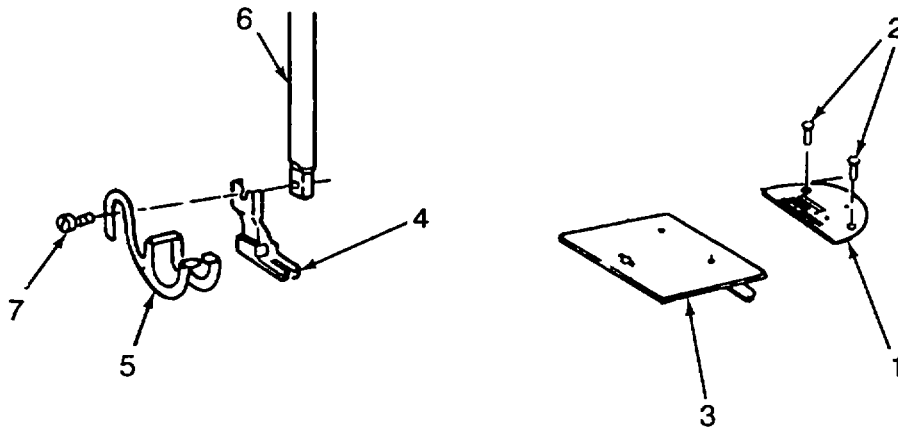

**5-15. CLOTHING SEWING MACHINE BOBBIN ASSEMBLY MAINTENANCE**

This task covers:

- |                 |                |             |
|-----------------|----------------|-------------|
| a. Removal      | b. Disassembly | c. Cleaning |
| d. Inspection   | e. Repair      | f. Assembly |
| g. Installation |                |             |

**INITIAL SETUP:**

**Tools:**

General Mechanics Tool Kit (Appendix B, Item 1)

**Materials/Parts:**

- Rag, wiping (Appendix F, Item 2)
- Cleaning Solvent (Appendix F, Item 8)
- Medium Bristle Brush (Appendix F, Item 1)

**Equipment Condition :**

- Sewing machine removed (para. 2-8).
- Needle and thread removed (para. 2-8).
- Bobbin and bobbin case removed (para. 2-11).
- Presser foot and throat plate removed (para. 5-14).

Removal. Place machine on its side.

**NOTE**

Needle bar must be fully up.

- (1) Remove two screws (1).
- (2) Remove race shuttle assembly (2) from the sewing machine.

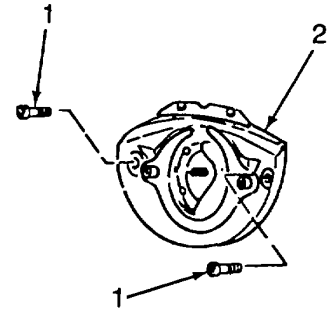

Disassembly.

- (1) Remove two screws (1) and race ring (2).
- (2) Remove screw (3), race back (4), race ring back (5) and shuttle hook (6) from race body cap (7).

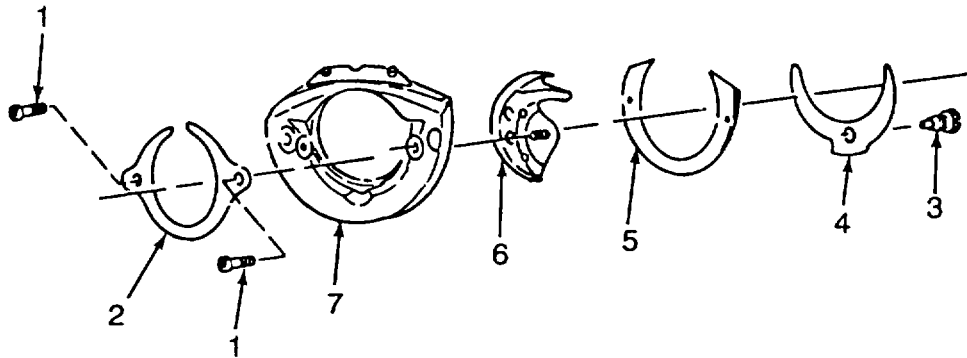

**5-15. CLOTHING SEWING MACHINE BOBBIN ASSEMBLY MAINTENANCE - continued.**

Cleaning.

- (1) Remove all buildups of grease, dirt, etc., by wiping with a wiping rag (Appendix F, Item 2).

**WARNING**

Cleaning solvent, Federal Specification P-D-680, is both toxic and flammable. Keep off skin. Use only in a well ventilated area and avoid prolonged breathing of vapors. Keep away from open flame.

- (2) Clean using cleaning solvent (Appendix F, Item 8) and either a wiping rag (Appendix F, Item 2) or a medium bristle brush (Appendix F, Item 1).
- (3) Allow to dry.

Inspection.

- (1) Inspect hardware for damage
- (2) Inspect the rotary hook assembly for damage.

Repair. Repair of the bobbin assembly components is limited to the replacement of defective parts.

Assembly.

- (1) Install shuttle hook (1), race ring back (2), race back (3) and secure with screw (4) on race body cap (5).
- (2) Install race ring (6) securing with two screws (7).

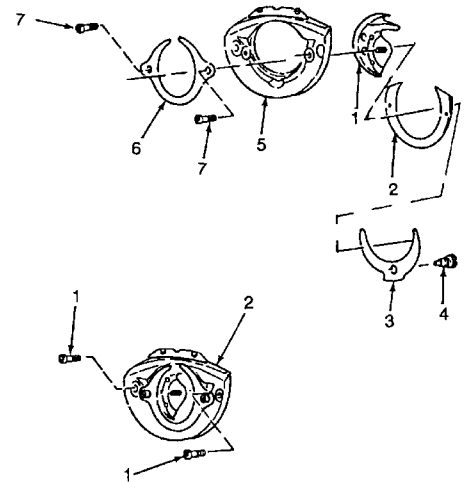

Installation.

**NOTE**

Needle bar must be fully up.

- (1) Install race shuttle assembly (2) and secure with two screws (1).

**5-16. CLOTHING SEWING MACHINE PRESSER BAR MECHANISM MAINTENANCE**

This task covers:

- |            |                 |               |
|------------|-----------------|---------------|
| a. Removal | b. Cleaning     | c. Inspection |
| d. Repair  | e. Installation | f. Adjustment |

**INITIAL SETUP:**

**Tools:**

General Mechanics Tool Kit (Appendix B, Item 1)

**Materials/Parts:**

Rag, wiping (Appendix F, Item 2)  
 Cleaning Solvent (Appendix F, Item 8)  
 Brush, Medium Bristle (Appendix F, Item 1)

**Equipment Condition :**

Sewing machine removed (para. 2-8).  
 Needle and thread removed (para. 2-8).  
 Presser foot removed (para. 5-14).  
 Face plate removed (para. 4-22).

Removal.

- (1) Remove screw (1) and the thread guide (2).
- (2) Unscrew thumb screw (3) and remove spring (4).
- (3) Loosen setscrew (5), remove presser bar (6), lifting bracket (7), lifter lever assembly (8).

Cleaning.

- (1) Remove all buildups of grease, dirt, etc., by wiping with a wiping rag (Appendix F, Item 2).

**WARNING**

Cleaning solvent, Federal Specification P-D-680, is both toxic and flammable. Keep off skin. Use only in a well-ventilated area and avoid prolonged breathing of vapors. Keep away from open flame.

- (2) Clean using cleaning solvent (Appendix F, Item 8) and either a rag, wiping (Appendix F, Item 2) or a medium bristle brush (Appendix F, Item 1).

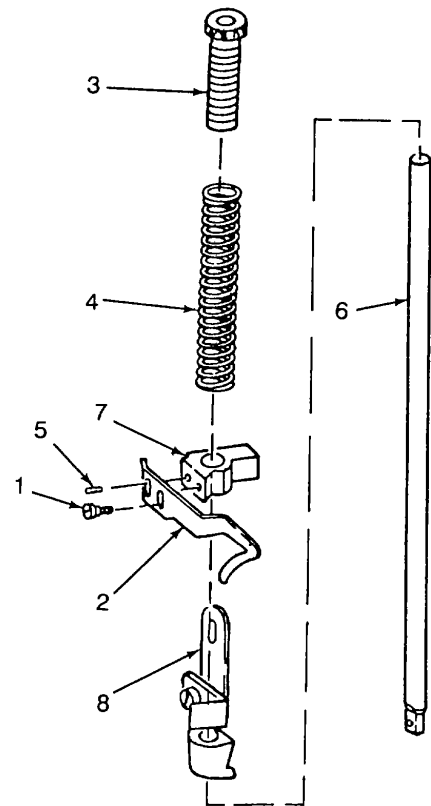

**5-16. CLOTHING SEWING MACHINE PRESSER BAR MECHANISM MAINTENANCE - continued.**

Cleaning - continued.

- (3) Allow to dry.

Inspection.

- (1) Inspect hardware for damage.
- (2) Inspect presser bar for damage.
- (3) Inspect thread guide for damage.
- (4) Inspect spring for damage
- (5) Inspect lifting bracket for damage
- (6) Inspect lifter lever assembly for damage

Repair. Repair is limited to the replacement of defective parts

Installation.

- (1) Install presser bar (6), lifting bracket (7) and lifter lever assembly (8). Secure with setscrew (5).
- (2) Insert spring (4) and install thumbscrew (3).
- (3) Install thread guide (2). Secure with screw (1).

Adjustment.

Adjust pressure on presser foot (para. 2-11).

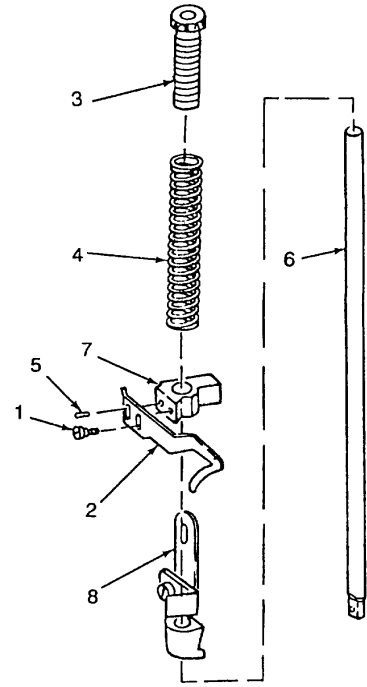

**5-17. CLOTHING SEWING MACHINE LIFTING LEVER MAINTENANCE**

This task covers:

- |            |                 |               |
|------------|-----------------|---------------|
| a. Removal | b. Cleaning     | c. Inspection |
| d. Repair  | e. Installation | f. Adjustment |

**INITIAL SETUP:**

**Tools:**

General Mechanics Tool Kit (Appendix B, Item 1)

**Materials/Parts:**

Rag, wiping (Appendix F, Item 2)  
 Cleaning Solvent (Appendix F, Item 8)  
 Brush, Medium Bristle (Appendix F, Item 1)

**Equipment Condition :**

Face Plate removed (para. 4-22)  
 Thread tensioner removed (para. 4-23).  
 Presser bar mechanism removed (para. 5-16).

Removal.

- (1) Remove screw (1), connecting rod joint (2), nut (3) and connecting rod (4).
- (2) Remove screw (5) and lever (6).
- (3) Remove setscrew (7) and pin (8) from lever (6).
- (4) Remove mounting base (9) and two screws (10).
- (5) Remove nut (11), screw (12) and presser lifter bar (13).

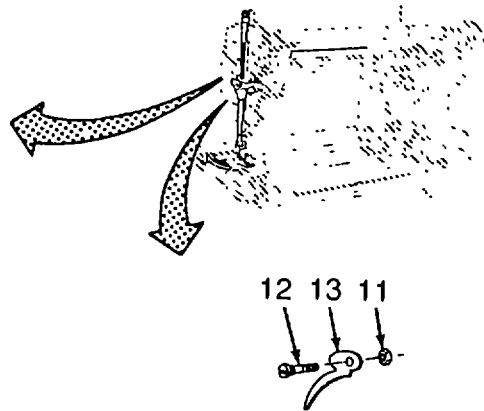
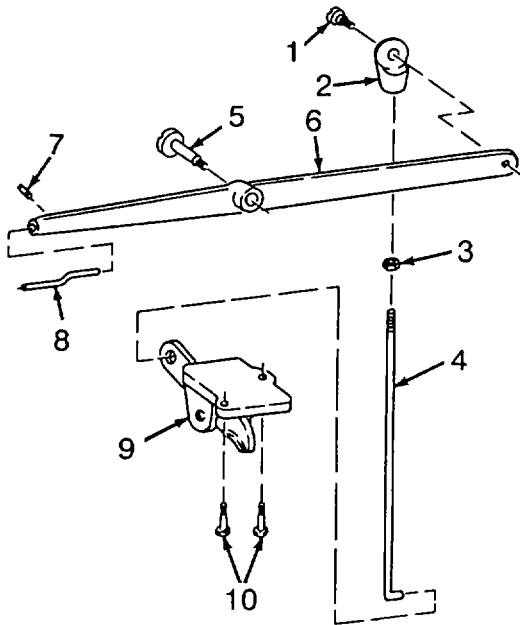

**5-17. CLOTHING SEWING MACHINE LIFTING LEVER MAINTENANCE - continued.**

Cleaning.

- (1) Remove all buildups of grease, dirt, etc., by wiping with a wiping rag (Appendix F, Item 2).

**WARNING**

Cleaning solvent, Federal Specification P-D-680, is both toxic and flammable. Keep off skin. Use only in a well ventilated area and avoid prolonged breathing of vapors. Keep away from open flame.

- (2) Clean using cleaning solvent (Appendix F, Item 8) and either a wiping rag (Appendix F, Item 2) or a medium bristle brush (Appendix F, Item 1).
- (3) Allow to dry.

Inspection.

- (1) Inspect hardware for damage.
- (2) Inspect connecting rod for straightness and damage.
- (3) Inspect presser bar lifter for damage.
- (4) Inspect lifting lever for damage.

Repair. Repair is limited to the replacement of defective parts.

**5-17. CLOTHING SEWING MACHINE LIFTING LEVER MAINTENANCE - continued.**

Installation.

- (1) Install lower case. Presser lifter bar (1) and secure with nut (2) and screw (3).
- (2) Install mounting base (4) and secure with two screw (5).
- (3) Install pin (6) into the lever (7) securing with setscrew (8).
- (4) Install lever (7) and secure screw (9).
- (5) Install connecting rod (10), connecting rod joint (11) and nut (13). Secure with screw (12).

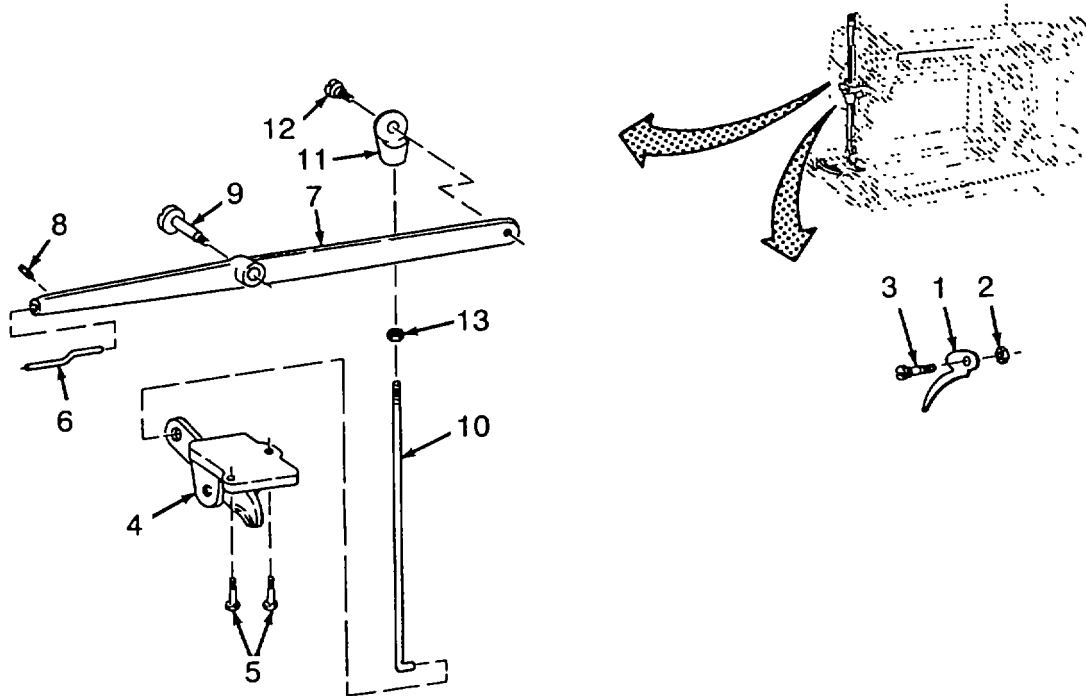

**5-18. CLOTHING SEWING MACHINE NEEDLE BAR AND THREAD TAKE-UP MAINTENANCE.**

This task covers:

- |            |                 |               |
|------------|-----------------|---------------|
| a. Removal | b. Cleaning     | c. Inspection |
| d. Repair  | e. Installation | f. Adjustment |

**INITIAL SETUP:****Tools:**

General Mechanics Tool Kit (Appendix B, Item 1)

**Materials/Parts:**

Rag, wiping (Appendix F, Item 2)

Cleaning Solvent (Appendix F, Item 8)

Brush, Medium Bristle (Appendix F, Item 1)

**Equipment Condition :**

Remove lifting lever (para. 5-17)

**Removal.**

- (1) Remove lifting lever guard plate.
- (2) Remove needle screw (1) and the needle clamp (2).
- (3) Loosen setscrew (3) and remove needle bar (4), connecting stud (5), slide block (6).
- (4) Loosen setscrew (7) through casing and pull the connecting link (8) out using pliers.

**NOTE**

Screw (9) has left hand threads. Turn the screw clockwise to loosen.

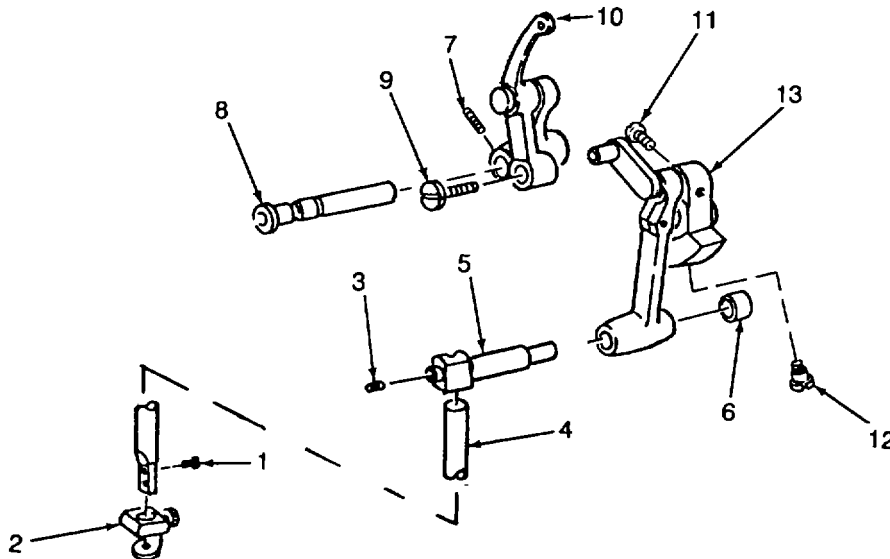

5-36

**5-18. CLOTHING SEWING MACHINE NEEDLE BAR AND THREAD TAKE-UP MAINTENANCE - continued.**Removal - continued.

- (5) Remove screw (9) and remove level take up assembly (10).
- (6) Remove setscrew (11) and shoulder screw (12) and remove crank assembly (13).

Cleaning.

- (1) Remove all buildups of grease, dirt, etc., by wiping with a soft, clean cloth.

**WARNING**

Cleaning solvent, Federal Specification P-D-680, is both toxic and flammable. Keep off skin Use only in a well ventilated area and avoid prolonged breathing of vapors Keep away from open flame.

- (2) Clean using cleaning solvent (Appendix F, Item 8) and either a wiping rag (Appendix F, Item 2) or a medium bristle brush (Appendix F, Item 1).
- (3) Allow to dry.

Inspection.

- (1) Inspect hardware for damage.
- (2) Inspect needle clamp for damage.
- (3) Inspect needle bar for damage.
- (4) Inspect connecting stud for damage.
- (5) Inspect slide block for damage and uneven wear.
- (6) Inspect connecting link for damage.
- (7) Inspect crank assembly for damage.

**5-18. CLOTHING SEWING MACHINE NEEDLE BAR AND THREAD TAKE-UP MAINTENANCE - continued.**

Repair. Repair is limited to the replacement of defective parts.

Installation.

**NOTE**

Ensure that shoulder screw is placed over shaft alignment hole.

- (1) Install crank assembly (1). Secure with shoulder screw (2) and setscrew (3).
- (2) Replace the slide block (4) by placing the connecting stud (5) through the crank assembly (1) making sure the slide block (4) is in the groove and slides freely.

**NOTE**

Screw (9) has left hand threads. Turn the screw counterclockwise to tighten.

- (3) Install lever take up assembly (7) and secure with screw (9).
- (4) Install connecting link (6) through take up assembly (7) and secure with setscrew (8) through casing. Make sure the connecting link (6) is not placed in too far to inhibit free movement. Make sure that setscrew (8) sits onto flat surface of connecting link (6).
- (5) Install needle bar (10) through top and through connecting stud (5). Rotate needle bar so flat is on left side of machine. Secure with setscrew (11).
- (6) Install the needle clamp (12) with needle screw (13).

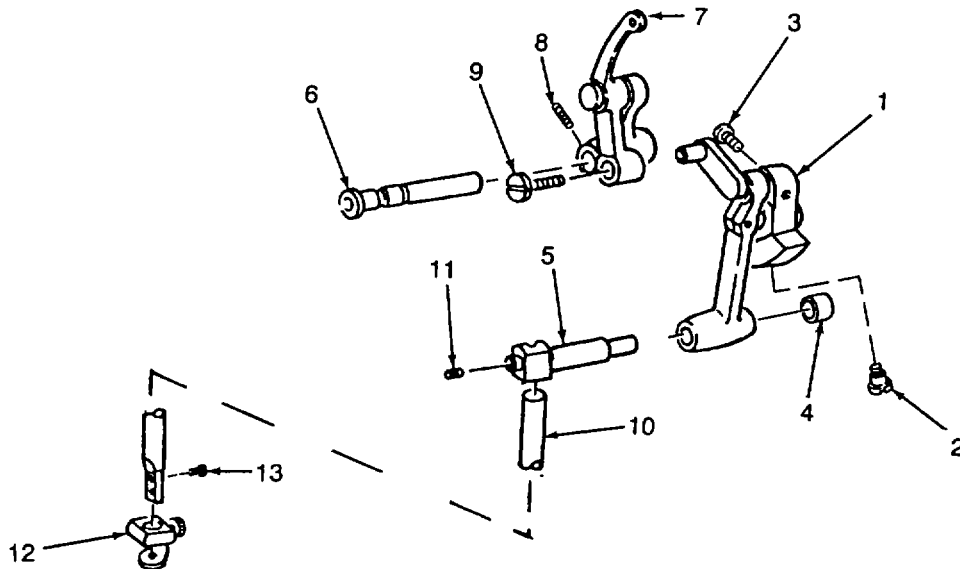

- (7) Install lifting lever guard plate.

**5-18. CLOTHING SEWING MACHINE NEEDLE BAR AND THREAD TAKE-UP MAINTENANCE - continued.**

Adjustment.

Rotate pulley toward the front of the unit to ensure the needle clamp does not hit the sewing machine casing at the top of the stroke. Adjust height of needle bar as required

**5-19. CLOTHING SEWING MACHINE TENSION RETAINING LEVER MAINTENANCE.**

This task covers:

- |            |                 |               |
|------------|-----------------|---------------|
| a. Removal | b. Cleaning     | c. Inspection |
| d. Repair  | e. Installation |               |

**INITIAL SETUP:****Tools:**

General Mechanics Tool Kit (Appendix B, Item 1)

**Equipment Condition:**

Needle bar and thread take-up removed (para 5-18).

**Materials/Parts:**

Rag, wiping (Appendix F, Item 2)  
 Cleaning Solvent (Appendix F, Item 8)  
 Brush, Medium Bristle (Appendix F, Item 1)

Removal. Drive pin (1) out and remove lever (2) and spring (3).

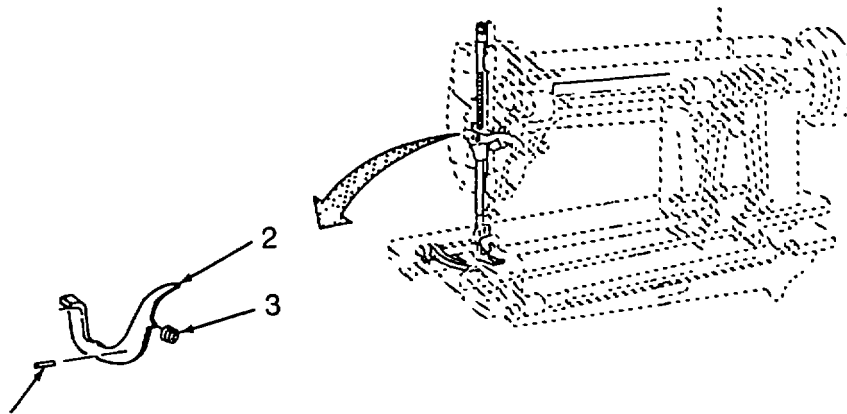

Cleaning.

(1) Remove all buildups of grease, dirt, etc., by wiping with a wiping rag (Appendix F, Item 2).

**WARNING**

Cleaning solvent, Federal Specifications P-D-680, is both toxic and flammable. Keep off skin. Use only in a well-ventilated area and avoid prolonged breathing of vapors. Keep away from open flame

(2) Clean using cleaning solvent (Appendix F, Item 8) and either a wiping rag (Appendix F, Item 2) or a medium bristle brush (Appendix F, Item 1)

(3) Allow to dry.

**5-19. CLOTHING SEWING MACHINE TENSION RETAINING LEVER MAINTENANCE - continued.**

Inspection.

- (1) Inspect spring for corrosion and damage.
- (2) Inspect lever for damage.
- (3) Inspect pin for straightness and damage.

Repair. Repair is limited to the replacement of defective parts.

**NOTE**

Install the tapered end of pin (3) first.

Installation. Install lever (1), spring (2) and pin (3)

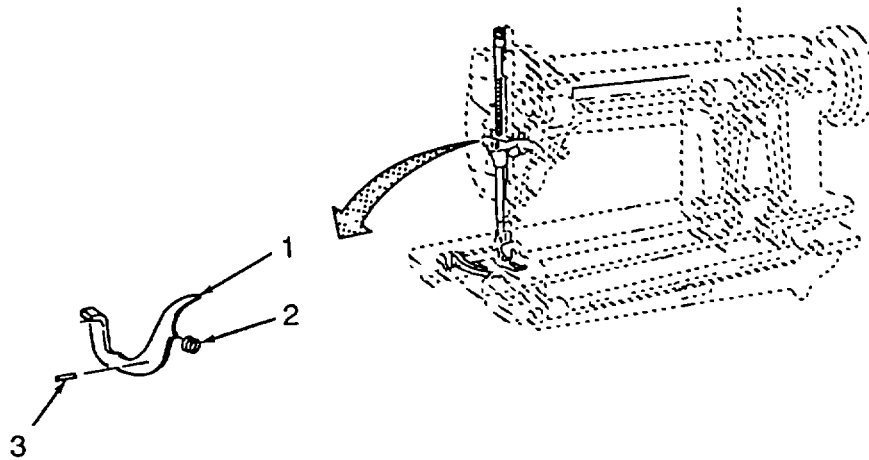

**5-20. COTHING SEWING MACHINE SLIDE RAIL MAINTENANCE.****This task covers:**

- a. Removal
- d. Repair

- b. Cleaning
- e. Installation

- c. Inspection

**INITIAL SETUP:**

Tools:

General Mechanics Tool Kit (Appendix B,  
Item 1)

Materials/Parts:

Rag, wiping (Appendix F, Item 2)  
Cleaning Solvent (Appendix F, Item 8)  
Brush, Medium Bristle (Appendix F, Item 1)

Equipment Condition:

Needle bar and thread take-up removed (para. 5-18)

**Removal.**

Remove two screws (1) and slide rail (2).

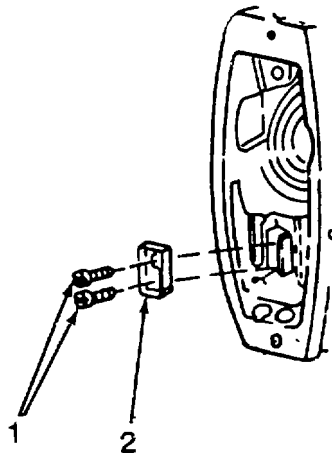
**Cleaning.**

(1) Remove all buildups of grease, dirt, etc., by wiping with a wiping rag (Appendix F, Item 2).

**WARNING**

Cleaning solvent, Federal Specification P-D-680, is both toxic and flammable. Keep off skin Use only in a well ventilated area and avoid prolonged breathing of vapors. Keep away from open flame.

(2) Clean using cleaning solvent (Appendix F, Item 8) and either a wiping rag (Appendix F, Item 2) or a medium bristle brush (Appendix F, Item 1).

(3) Allow to dry.

**5-20. CLOTHING SEWING MACHINE SLIDE RAIL MAINTENANCE - continued.**

Inspection.

- (1) Inspect hardware for damage.
- (2) Inspect slide rail for damage or uneven wear.

Repair. Repair is limited to the replacement of defective parts.

Installation.

**NOTE**

Install bevel side of slide rail (2) down.

Install slide rail (2) with two screws (1).

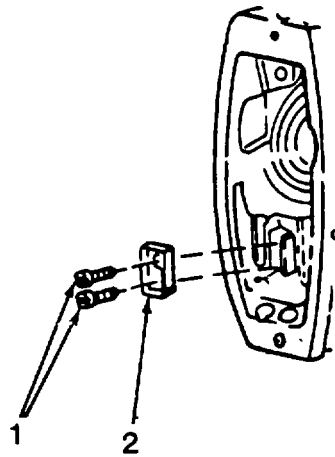

**5-21. CLOTHING SEWING MACHINE ARM SHAFT AND VERTICAL SHAFT MAINTENANCE.**

This task covers:

- |               |                |                 |
|---------------|----------------|-----------------|
| a. Removal    | b. Disassembly | c. Cleaning     |
| d. Inspection | e. Repair      | f. Assembly     |
|               |                | g. Installation |

**INITIAL SETUP:****Tools:**

General Mechanics Tool Kit (Appendix B, Item 1)

**Equipment Condition :**

Needle bar and thread take-up removed (para 5-18)

**Materials/Parts:**

Rag, wiping (Appendix F, Item 2)  
 Cleaning Solvent (Appendix F, Item 8)  
 Brush, Medium Bristle (Appendix F, Item 1)

**Removal.**

- (1) Loosen setscrew (1) and remove shuttle shaft (2).
- (2) Remove top half of crank rod (3) by removing two screws (4).
- (3) Remove shaft shuttle and arm assembly (5).

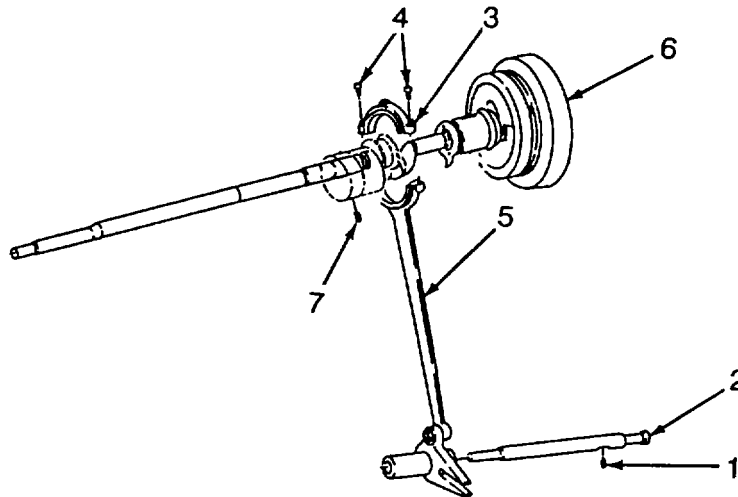
**NOTE**

Loop of crankshaft must match outline of casting hole in order to remove.

- (5) Remove crankshaft pulley assembly (6) by loosening setscrew (7) from feed cam and placing a piece of wood or other soft material on the end of the shaft and gently tapping it out.

5-21. CLOTHING SEWING MACHINE ARM SHAFT AND VERTICAL SHAFT MAINTENANCE - continued.

Disassembly.

(1) Remove nut (1), screw (2), shuttle shaft (3) and crank arm (4).

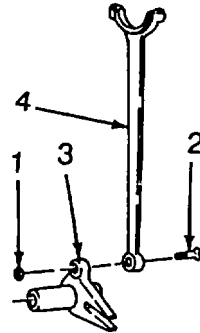

(2) Remove two setscrews (1) and screw (2) and slide pulley (3) off crankshaft (4).

(3) Slide bearing assembly (5) off camshaft (4)

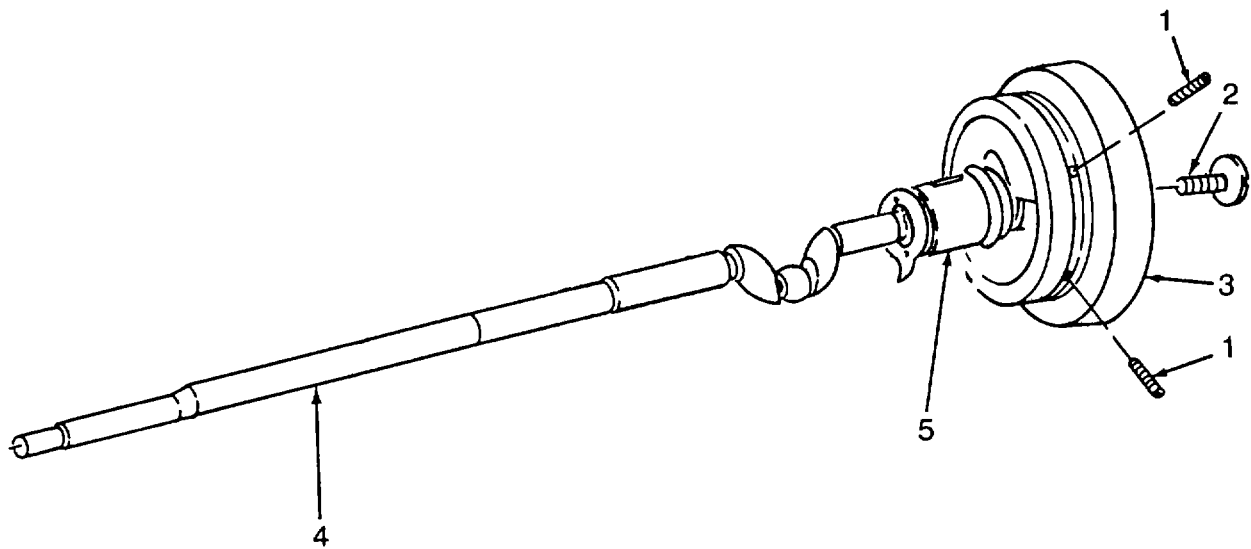

**5-21. CLOTHING SEWING MACHINE ARM SHAFT AND VERTICAL SHAFT MAINTENANCE - continued.**

Cleaning.

- (1) Remove all buildups of grease, dirt, etc., by wiping with a wiping rag (Appendix F, Item 2).

**WARNING**

Cleaning solvent, Federal Specification P-D-680, is both toxic and flammable. Keep off skin. Use only in a well ventilated area and avoid prolonged breathing of vapors. Keep away from open flame.

- (2) Clean using cleaning solvent (Appendix F, Item 8) and either a wiping rag (Appendix F, Item 2) or a medium bristle brush (Appendix F, Item 1).
- (3) Allow to dry.

Inspection.

- (1) Inspect hardware for damage.
- (2) Inspect shuttle shaft for damage.
- (3) Inspect crank arm for damage.
- (4) Inspect slide pulley for damage.
- (5) Inspect crankshaft for damage.
- (6) Inspect slide bar for damage.
- (7) Inspect oil wick for damage.

Repair. Repair is limited to the replacement of defective parts and the removal of burrs.

**5-21. CLOTHING SEWING MACHINE ARM SHAFT AND VERTICAL SHAFT MAINTENANCE - continued.**

**NOTE**

Do not overtighten screw (1) and nut (4). Allow free movement with minimal side play.

Assembly. Install screw (1) through crank arm (2) and shuttle shaft (3) and secure with nut (4).

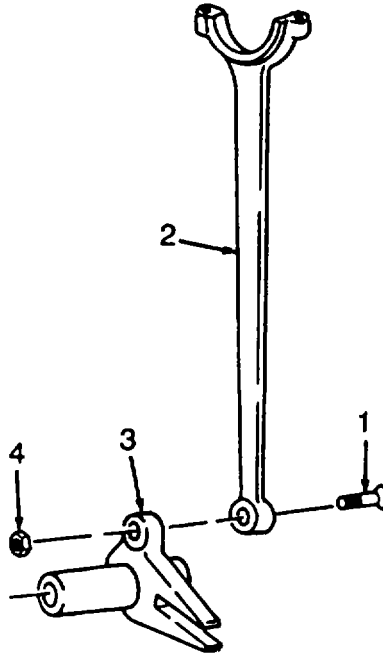

Installation.

**NOTE**

Make sure to rotate so the loop of the crankshaft (1) matches the cutout in the casting.

(1) Replace crankshaft (1).

**NOTE**

Bearing assembly will need to be tapped in.

(2) Install bearing assembly (2) with flat over setscrew hole.

**5-21. CLOTHING SEWING MACHINE ARM SHAFT AND VERTICAL SHAFT MAINTENANCE - continued.**

Installation - continued.

- (3) Install setscrew (3) to secure bearing assembly

**CAUTION**

Pulley must be installed with the setscrews over the flats of the shaft or the machine will be out of balance during operation.

**NOTE**

Secure setscrew (5) and screw (6), but do not tighten until further adjustments are made on the crankshaft assembly.

- (4) Install pulley (4) and secure with screw (6) and setscrews (5) located over the flats of the crankshaft (1).

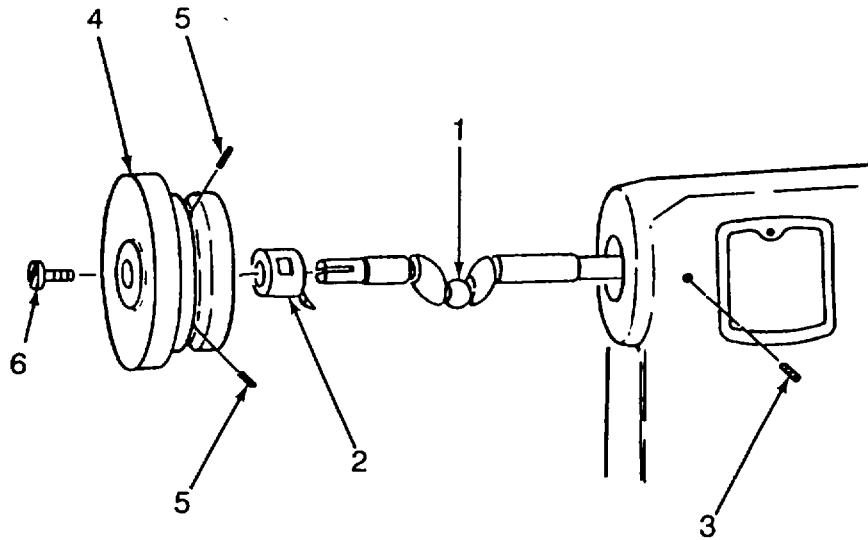

**5-21. CLOTHING SEWING MACHINE ARM SHAFT AND VERTICAL SHAFT MAINTENANCE - continued.**

Installation - continued.

- (5) Install shaft shuttle arm assembly (1) into machine head..

**NOTE**

Ensure top half of crank rod is installed so the markings line up with the bottom half

- (6) Install top half of crank rod (2) and secure with two screws (3)
- (7) Slide shaft arm assembly (1) slot on the suspension driver block. Ensure the oil hole in suspension driver block is up.
- (8) Replace shuttle shaft (4) and tighten setscrew (5) Ensure shuttle shaft (4) flats are over setscrew (5).

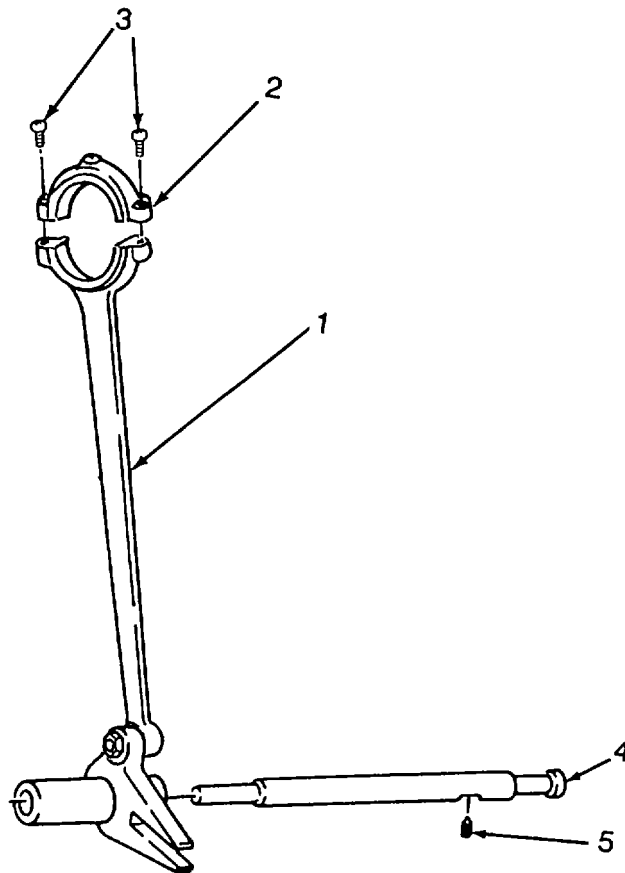

**5-22. CLOTHING SEWING MACHINE CRANK ROD MAINTENANCE.****This task covers:**

- |            |                |                 |               |
|------------|----------------|-----------------|---------------|
| a. Removal | b. Disassembly | c. Cleaning     | d. Inspection |
| e. Repair  | f. Assembly    | g. Installation |               |

**INITIAL SETUP:****Tools:**

General Mechanics Tool Kit (Appendix B, Item 1)

**Equipment Condition:**

Arm shaft and vertical shaft removed (para. 5-21)

**Materials/Parts:**

Rag, wiping (Appendix F, Item 2)

Cleaning Solvent (Appendix F, Item 8)

Brush, Medium Bristle (Appendix F, Item 1)

Removal. Slide crank rod assembly off of the connecting rod and remove.

Disassembly.

- (1) Remove top of crank rod (1) by removing two screws (2) from crank rod (3).
- (2) Remove screw (6) and nut (7).
- (3) Remove feed cam (4) and slide fork slide block (5) off.

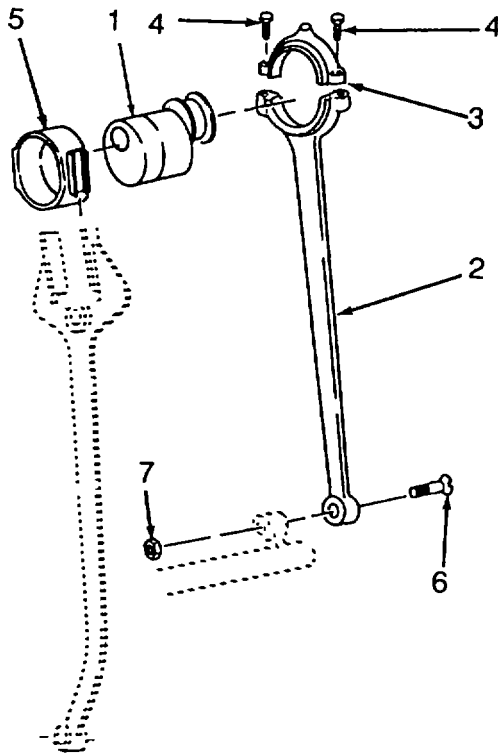

**5-22. CLOTHING SEWING MACHINE CRANK ROD MAINTENANCE - continued.**

Cleaning.

- (1) Remove all buildups of grease, dirt, etc., with a wiping rag (Appendix F, Item 2).

**WARNING**

Cleaning solvent, Federal Specification P-D-680, is both toxic and flammable. Keep off skin. Use only in a well ventilated area and avoid prolonged breathing of vapors. Keep away from open flame.

- (2) Clean using cleaning solvent (Appendix F, Item 8) and either a wiping rag (Appendix F, Item 2) or a medium bristle brush (Appendix F, Item 1).

- (3) Allow to dry.

Inspection.

- (1) Inspect hardware for damage.
- (2) Inspect crank rod for damage.
- (3) Inspect feed cam for damage
- (4) Inspect slide fork slide block for damage

Repair. Repair is limited to the replacement of defective components.

**5-22. CLOTHING SEWING MACHINE CRANK ROD MAINTENANCE - continued.**Assembly.**NOTE**

Make sure top of crank rod lines marks line up with the markings on the crank bottom.

- (1) Install crank rod (2) onto feed cam (1) and secure with top of crank rod (3) and two screws (4).
- (2) Install slide block (5) onto feed cam (1). The flat cheek of the slide block (5) should be oriented toward the crank rod (2).
- (3) Secure crank rod (2) with screw (6) and nut (7).

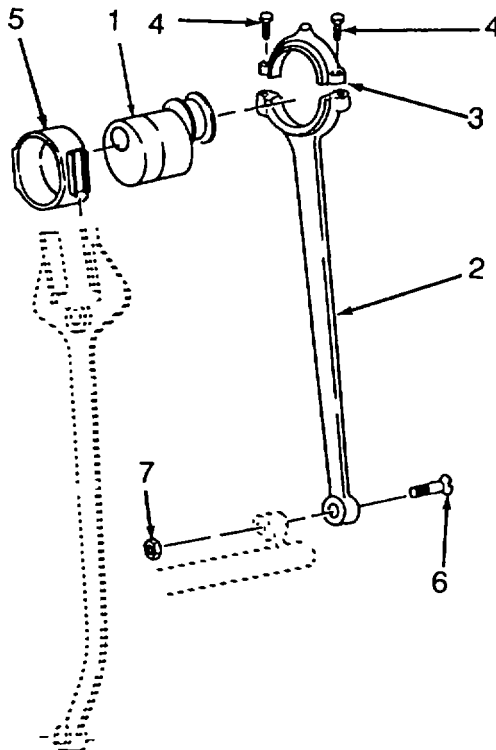

Installation. Install assembly onto the forks of the connecting rod.

**5-23. CLOTHING SEWING MACHINE CONNECTING ROD MAINTENANCE.**

This task covers:

- |            |                 |               |
|------------|-----------------|---------------|
| a. Removal | b. Cleaning     | c. Inspection |
| d. Repair  | e. Installation |               |

**INITIAL SETUP:**

**Tools:**

General Mechanics Tool Kit (Appendix B, Item 1)

**Equipment Condition :**

Crank rod assembly removed (para. 5-22).

**Materials/Parts:**

Rag, wiping (Appendix F, Item 2)

Cleaning Solvent (Appendix F, Item 8)

Brush, Medium Bristle (Appendix F, Item 1)

Removal.

- (1) Remove screw (1) and nut (2).
- (2) Remove screw (3) from the feed regulator (4)
- (2) Remove pin (5) from connecting link (6) and connecting rod (7).
- (3) Remove screw (8), nut (9) and connecting link (6) from connecting rod (7)
- (5) Remove setscrew (10) through machine and pin (11) from the feed regulator (4).

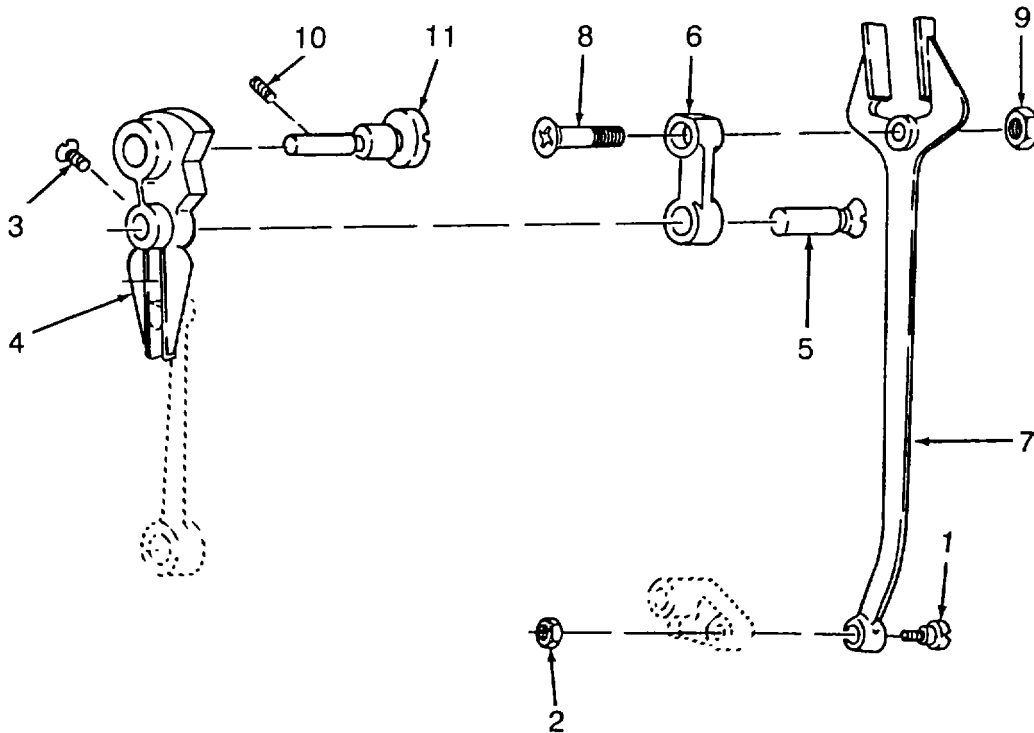

**5-23. CLOTHING SEWING MACHINE CONNECTING ROD MAINTENANCE - continued.**

Cleaning.

- (1) Remove all buildups of grease, dirt, etc., with a wiping rag (Appendix F, Item 2).

**WARNING**

Cleaning solvent, Federal Specification P-D-680, is both toxic and flammable. Keep off skin. Use only in a well ventilated area and avoid prolonged breathing of vapors. Keep away from open flame.

- (2) Clean using cleaning solvent (Appendix F, Item 8) and either a wiping rag (Appendix F, Item 2) or a medium bristle brush (Appendix F, Item 1).
- (3) Allow to dry.

Inspection.

- (1) Inspect hardware for damage.
- (2) Inspect pin for damage.
- (3) Inspect connecting link for damage.
- (4) Inspect feed regulator for damage.

Repair. Repair is limited to the replacement of defective components and the removal of burrs.

**5-23. CLOTHING SEWING MACHINE CONNECTING ROD MAINTENANCE - continued.**

Installation.

**NOTE**

Flat on pin (1) must line up with setscrew (2).

- (1) Install pin (1) through feed regulator (3) and secure with setscrew (2).
- (2) Install connecting link (4) to connecting rod (5) and secure with screw (6) and nut (7).

**NOTE**

Feed regulator must be positioned over crank.

- (3) Install connecting link (4) and connecting rod (5) to feed regulator (3) and secure with pin (8) and screw (9).
- (4) Secure connecting rod (5) to shaft with screw (10) and nut (11).

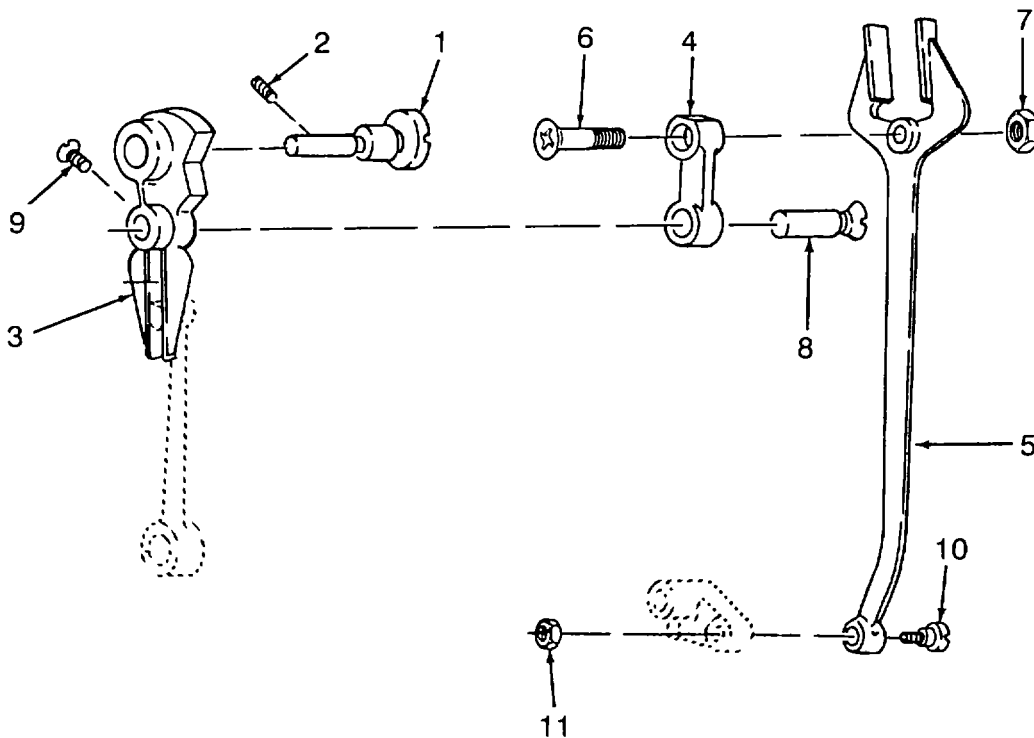

**5-24. CLOTHING SEWING MACHINE STITCH LENGTH REGULATOR MAINTENANCE.**

This task covers:

- |            |                 |               |
|------------|-----------------|---------------|
| a. Removal | b. Cleaning     | c. Inspection |
| d. Repair  | e. Installation |               |

**INITIAL SETUP:**

**Tools:**

General Mechanics Tool Kit (Appendix B, Item 1)

**Materials/Parts:**

Rag, wiping (Appendix F, Item 2)  
 Cleaning Solvent (Appendix F, Item 8)  
 Brush, Medium Bristle (Appendix F, Item 1)

**Equipment Condition :**

Lifting lever removed (para. 5-17)  
 Arm shaft removed (para. 5-21)  
 Connecting Rod less feed regulator removed (para. 5-23)

Removal.

- (1) Remove screw (1), dial (2), pin (3), spring (4).
- (2) Unscrew and remove feed regulator screw (5).
- (3) Unhook spring (6) from bracket (7). Remove two screws (8) and bracket (7).
- (4) Remove screw (9).
- (5) Pull lever (10) and shaft (11) out enough to gain access to setscrews (12). Loosen both setscrews (12) enough to allow shaft (11) to be removed from crank (13) and bracket (14) as they slide off the shaft (11).
- (6) Remove shaft screw (17). Loosen setscrew (15) and screw (16). Remove shaft screw (17) and lever (10).
- (7) Remove spring (6) from bracket (14).

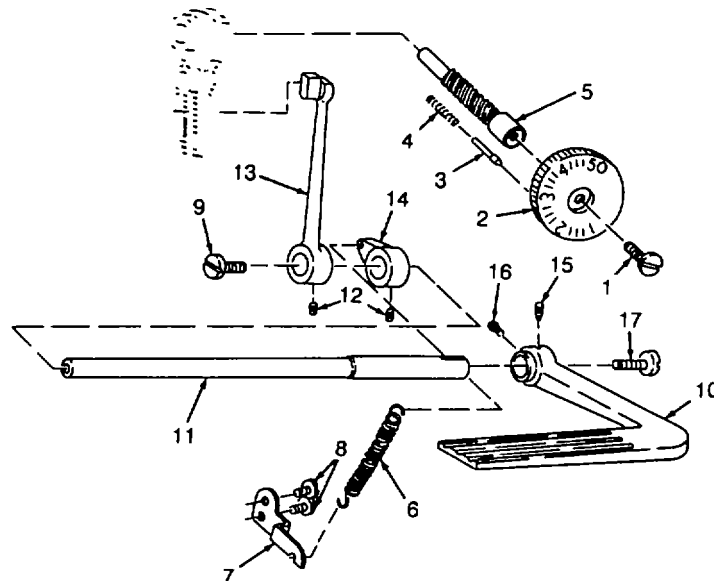

**5-24. CLOTHING SEWING MACHINE STITCH LENGTH REGULATOR MAINTENANCE - continued.**

Cleaning.

- (1) Remove all buildups of grease, dirt, etc., by wiping with a wiping rag (Appendix F, Item 2).

**WARNING**

Cleaning solvent, Federal Specification P-D-680, is both toxic and flammable. Keep off skin. Use only in a well-ventilated area and avoid prolonged breathing of vapors. Keep away from open flame.

- (2) Clean using cleaning solvent (Appendix F, Item 8) and either a wiping rag (Appendix F, Item 2) or a medium bristle brush (Appendix F, Item 1).
- (3) Allow to dry.

Inspection.

- (1) Inspect hardware for damage.
- (2) Inspect dial for damage.
- (3) Inspect spring for damage.
- (4) Inspect pin for damage.
- (5) Inspect feed regulator screw for damage.
- (6) Inspect bracket for damage.
- (7) Inspect lever for damage.
- (8) Inspect shaft for damage.
- (9) Inspect handle for damage.

Repair. Repair is limited to the replacement of defective parts and the removal of burrs.

Installation.

**NOTE**

Make sure that the pointed set screw (3) lines up with "v" groove in shaft.

- (1) Install lever (1) onto shaft (2) securing with setscrew (3) and screw (4).
- (2) Install shaft screw (5) on the end of shaft (2).

**5-24. CLOTHING SEWING MACHINE STITCH LENGTH REGULATOR MAINTENANCE - continued.**

Installation - continued.

- (3) Install spring (6) in small hole of bracket (7).
- (4) Slide lever (1) and shaft (2) into the machine head. Slide bracket (7) and crank (8) onto shaft (2). Secure with setscrews (9) on the respective flat spots on the shaft (2).
- (5) Continue to slide shaft (2) into the machine head making sure that crank (8) fits into the feed regulator fork and the end of shaft (2) fits into the hole in the machine head.
- (6) Install screw (10).
- (7) Install bracket (11) securing with two screws (12).
- (8) Attach spring (6) onto bracket (11).
- (9) Screw feed regulator screw (13) into the machine. Make sure it bottoms out against the notched area of feed regulator fork.
- (10) Install pin (14) and spring (15).

**NOTE**

Make sure the pin on the back of the dial (16) is pressed against the left side of pin (14) before tightening screw (17).

- (11) Install dial (16) onto feed regulating screw (13) and secure with screw (17).

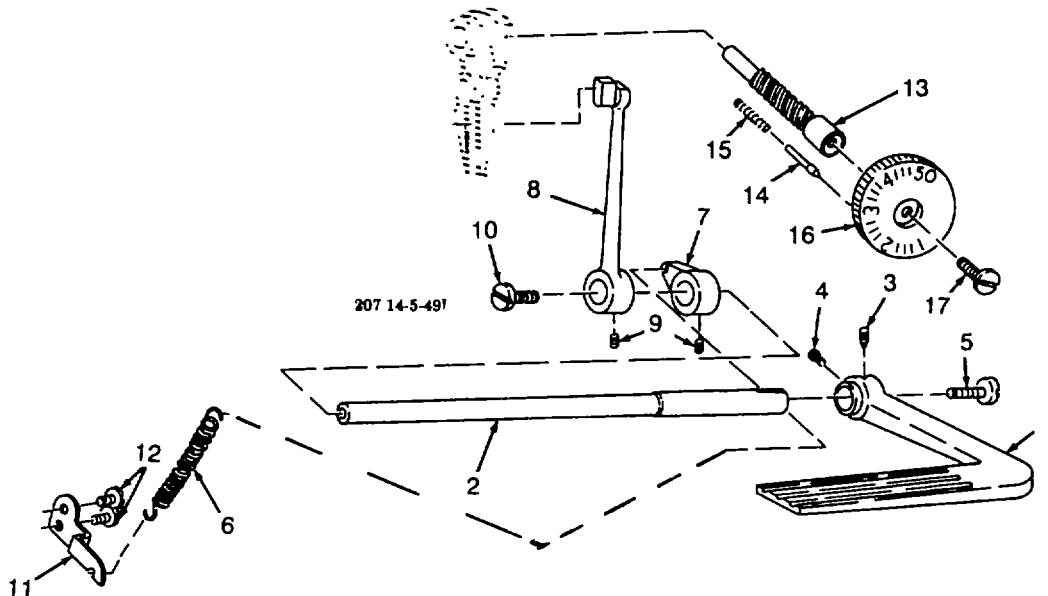

**5-25. CLOTHING SEWING MACHINE FEED AND FEED LIFTING MECHANISM MAINTENANCE.**

**This task covers:**

- |            |                 |               |
|------------|-----------------|---------------|
| a. Removal | b. Cleaning     | c. Inspection |
| d. Repair  | e. Installation |               |

**INITIAL SETUP:**

**Tools:**

General Mechanics Tool Kit (Appendix B, Item 1)

**Equipment Condition:**

Stitch length regulating assembly removed (para. 5-24).  
Race Shuttle assembly removed (para. 5-15)

**Materials/Parts:**

Rag, wiping (Appendix F, Item 2)  
Cleaning Solvent (Appendix F, Item 8)  
Brush, Medium Bristle (Appendix F, Item 1)

Removal

**NOTE**

Screws and nuts are located on opposite ends of the shaft.

- (1) Remove two shaft screws (1), two nuts (2) and shaft (3).
- (2) Mark the location of the crank (4) on shaft (3).
- (3) Loosen screw (5) and remove crank (4).

**NOTE**

Screws and nuts are located on opposite ends of the shaft

- (4) Remove two shaft screws (6) and two nuts (7) and shaft (8).
- (5) Remove two bar screws (9), two nuts (10) and feed bar (11).
- (6) Remove two screws (12) and feed dog (13) from feed bar (11).

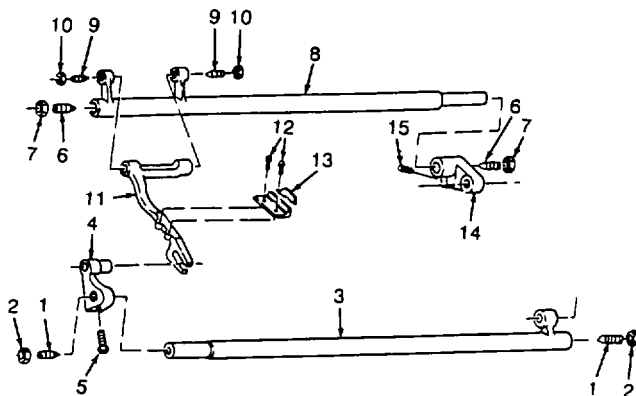

**5-25. CLOTHING SEWING MACHINE FEED AND FEED LIFTING MECHANISM MAINTENANCE - continued.**

(7) Mark the location of the crank (14) on shaft (8). Remove setscrew (15) and crank (14).

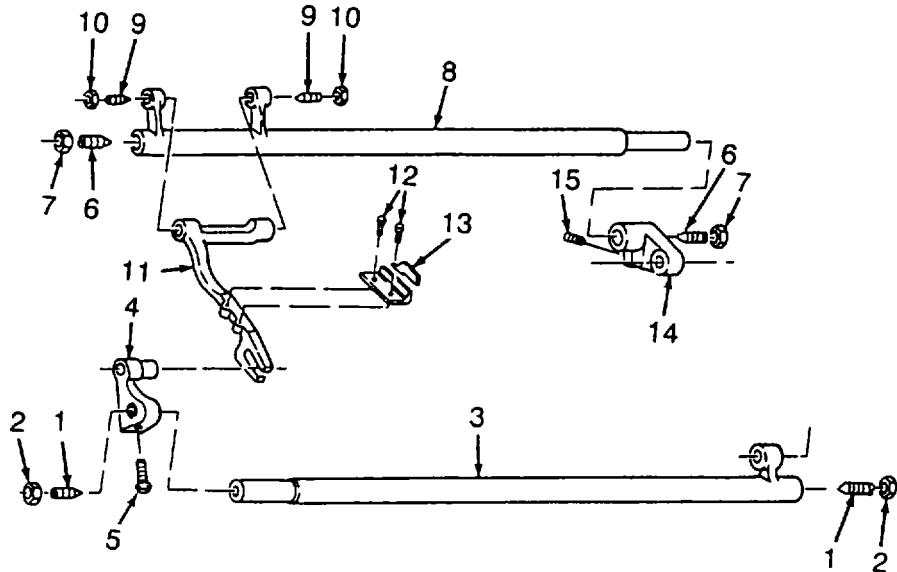

Cleaning.

(1) Remove all buildups of grease, dirt, etc., with a wiping rag (Appendix F, Item 2).

**WARNING**

Cleaning solvent, Federal Specification P-D-680, is both toxic and flammable. Keep off skin. Use only in a well-ventilated area and avoid prolonged breathing of vapors. Keep away from open flame.

(2) Clean using cleaning solvent (Appendix F, Item 8) and either a wiping rag (Appendix F, Item 2) or a medium bristle brush (Appendix F, Item 1).

(3) Allow to dry.

Inspection.

- (1) Inspect hardware for damage.
- (2) Inspect shaft for damage.
- (3) Inspect crank for damage.
- (4) Inspect feed dog for damage or excessive wear.
- (5) Inspect feed bar for damage.

Repair. Repair is limited to the replacement of defective components.

**5-25. CLOTHING SEWING MACHINE FEED AND FEED LIFTING MECHANISM MAINTENANCE - continued.**

Installation.

- (1) Install crank (1) onto shaft (2). Ensure that the crank (1) is in the proper location, as previously marked. Secure with setscrew (3).
- (2) Install feed dog (4) on feed bar (5) and secure with two screws (6).
- (3) Install feed bar (5) on shaft (2) with two screws (8) and two nuts (9).
- (4) Adjust screws (8) to make sure that the feed bar (5) rotates freely, and is centered, but with no side-to-side play. Tighten nuts (9).
- (5) Install shaft (2) into machine within two shaft screws (10) and two nuts (11). Do not tighten.
- (6) Adjust screws (10) to center shaft (2). Tighten nuts (11) ensuring the shaft does not bend.
- (7) Install crank (13) onto shaft (14). Ensure that the crank (13) is in the proper location, as previously marked. Secure with screw (15).
- (8) Install shaft (14) into machine with two shaft screws (16) and two nuts (17). Do not tighten. Ensure the roller tab of crank (13) fits into feed bar (5).
- (9) Adjust screws (16) to maintain alignment with feed bar (5). Tighten nuts (17) ensuring shaft does not bind.
- (10) Adjust feed dog timing (para. 5-28), if necessary

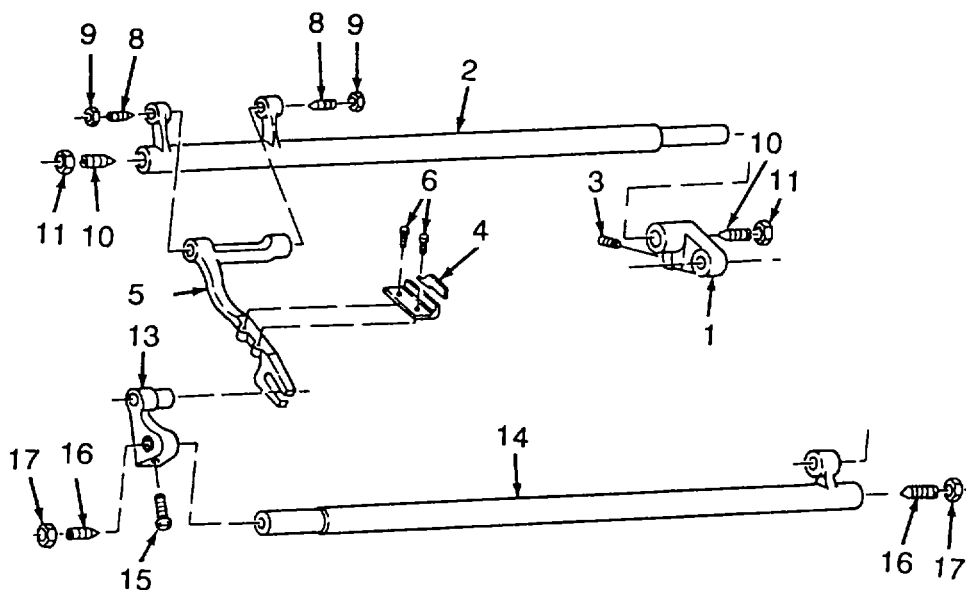

## 5-26. CLOTHING SEWING MACHINE ROTATING SHUTTLE MAINTENANCE.

This task covers:

- |            |                 |               |
|------------|-----------------|---------------|
| a. Removal | b. Cleaning     | c. Inspection |
| d. Repair  | e. Installation |               |

### INITIAL SETUP:

#### **Tools:**

General Mechanics Tool Kit (Appendix B, Item 1)

#### **Equipment Condition:**

Connecting Rod assembly removed (para. 5-23)  
Shuttle arm shaft assembly removed (para. 5-21)  
Race shuttle assembly removed (para. 5-15)

#### **Material/Parts:**

Cleaning Solvent (Appendix F, Item 8)  
Brush, Medium Bristle (Appendix F, Item 1)  
Rag, wiping (Appendix F, Item 2)

### Removal.

#### **NOTE**

Pin (4) is tapered and can only be removed from one side.

- (1) Mark location of crank (1) on shuttle (2). Remove setscrew (3), pin (4) and crank (1) from shuttle (2).
- (2) Remove nut (5) and driver (6).
- (3) Mark location of carrier (8) on the shuttle (2).
- (4) Remove two setscrews (7) and carrier (8).

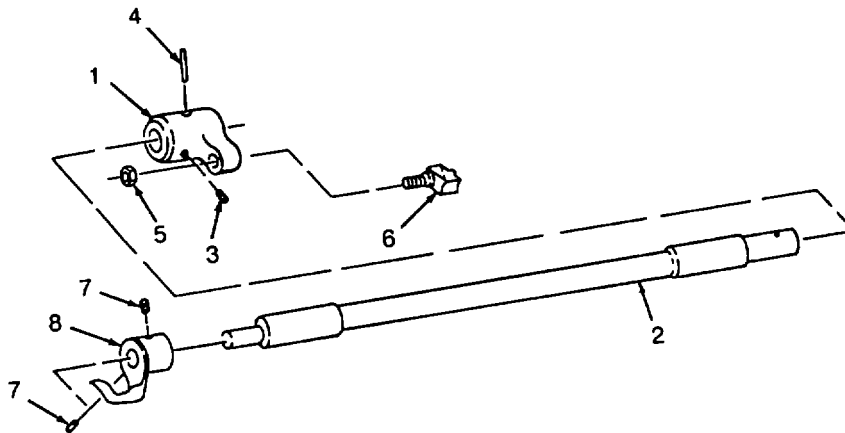

### Cleaning.

- (1) Remove all buildups of grease, dirt, etc., by wiping with a wiping rag (Appendix F, Item 2).

**5-26. CLOTHING SEWING MACHINE ROTATING SHUTTLE MAINTENANCE - continued.**

**WARNING**

Cleaning solvent, Federal Specification P-D-680, is both toxic and flammable. Keep off skin. Use only in well-ventilated area and avoid prolonged breathing of vapors. Keep away from open flame.

- (2) Clean using cleaning solvent (Appendix F, Item 8) and either a wiping rag (Appendix F, Item 2) or a medium bristle brush (Appendix F, Item 1).
- (3) Allow to dry.

**Inspection.**

- (1) Inspect hardware for damage.
- (2) Inspect crank for damage.
- (3) Inspect shuttle for damage and straightness.
- (4) Inspect stud for damage.
- (5) Inspect driver for damage.
- (6) Inspect carrier for damage.

**Repair.** Repair is limited to the replacement of defective parts and the removal of burrs.

**5-26. CLOTHING SEWING MACHINE ROTATING SHUTTLE MAINTENANCE - continued.**

Installation

- (1) Align carrier marking (1) with marking on shuttle (2). Install carrier (1) onto shuttle (2) and secure with two screws (3).
- (2) Install shuttle (2) into machine head.
- (3) Install crank (4) onto driver (5) and secure with nut (6).

**NOTE**

Make sure crank is oriented properly on the shuttle before installing pin.

**NOTE**

Pin (7) is tapered and can only be installed from one side.

- (4) Install shuttle (2) into crank (4) and secure with pin (7) and screw (8).

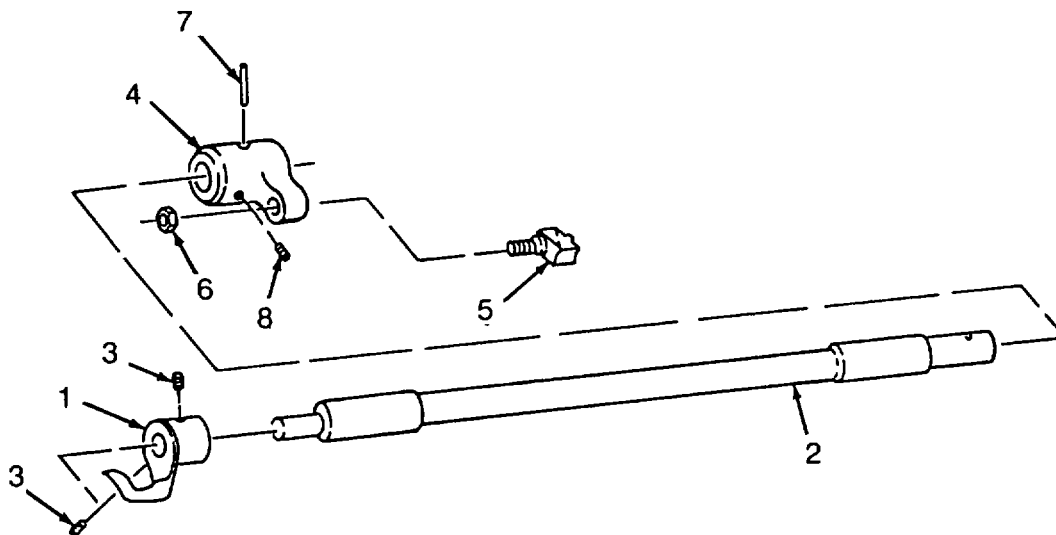

**5-27. CLOTHING SEWING MACHINE FRONT BUSHING MAINTENANCE.**

**This task covers:**

- |   |  |   |
|---|--|---|
| <ul style="list-style-type: none"> <li>a. Removal</li> <li>d. Repair</li> </ul> | <ul style="list-style-type: none"> <li>b. Cleaning</li> <li>e. Installation</li> </ul> | <ul style="list-style-type: none"> <li>c. Inspection</li> </ul> |
|---|--|---|

**INITIAL SETUP:**

**Tools:**

General Mechanics Tool Kit (Appendix B, Item 1)

**Equipment Condition:**

Crank Rod assembly removed (para. 5-22)

**Material/Parts:**

Cleaning Solvent (Appendix F, Item 8)  
 Brush, Medium Bristle (Appendix F, Item 1)  
 Rag, wiping (Appendix F, Item 2)

Removal.

- (1) Remove setscrews (1 and 2) through machine casing (4).
- (2) Using long brass punch, tap bushing (3) out of the machine casing (4).

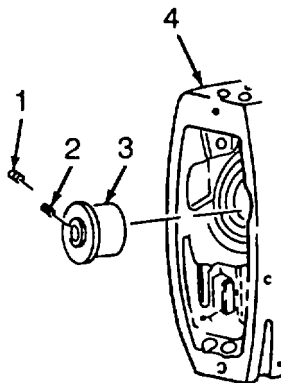

**5-27. CLOTHING SEWING MACHINE BUSHING MAINTENANCE - continued.**

Cleaning.

**NOTE**

Do not clean oil pad.

- (1) Remove all buildups of grease, dirt, etc., by wiping with a wiping rag (Appendix F, Item 2).

**WARNING**

Cleaning solvent, Federal Specification P-D-680, is both toxic and flammable. Keep off skin. Use only in well-ventilated area and avoid prolonged breathing of vapors. Keep away from open flame.

- (2) Clean using cleaning solvent (Appendix F, Item 8) and either a wiping rag (Appendix F, Item 2) or a medium bristle brush (Appendix F, Item 1).
- (3) Allow to dry.

Inspection.

- (1) Inspect hardware for damage.
- (2) Inspect bushings for damage.
- (3) Inspect pad for excessive wear.

Repair. Repair is limited to the replacement of defective parts and the removal of burrs.

5-27. CLOTHING SEWING MACHINE BUSHING MAINTENANCE - continued.

Installation.

**NOTE**

Lube hole must be located on the top side.

Install bushing (1) into machine arm (2) and secure with setscrews (3 and 4).

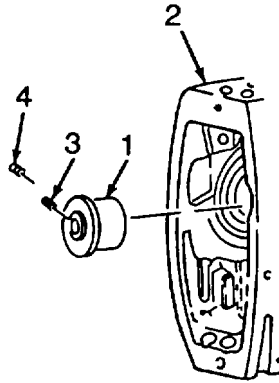

## 5-28. CLOTHING SEWING MACHINE TIMING.

This task covers:

- a. Needle and Shuttle Timing
- b. Feed Dog with Needle Timing
- c. Feed Dog Height

### INITIAL SETUP:

#### Tools:

General Mechanics Tool Kit (Appendix B, Item 1)

#### Equipment Condition:

Sewing machine removed (para. 2-18).  
Thread removed (para. 2-8).  
Presser foot and throat plate removed (para. 5-14).

### Needle and Shuttle Timing.

#### NOTE

Needle must be all the way up and the long groove must be facing out.

- (1) Bring the needle to its lowest position and then raise the needle 2 mm (5/64 inch) by rotating the pulley, toward the front of the machine.
- (2) Check that the point of the sewing hook is at the top of needle eye in the center of the needle. If it is not, remove the face plate (para. 4-23) and loosen the needle bar clamp screw. Move the needle bar, as necessary, and retighten the screws.
- (3) Check that the rotary hook point is at the center line of the needle. Loosen the two setscrews going into the shaft and rotate the rotary hook assembly as needed.
- (4) Tighten the rotary hook setscrew and recheck all settings.
- (5) Rotate pulley toward the front of the unit to ensure there is no interference or binding.

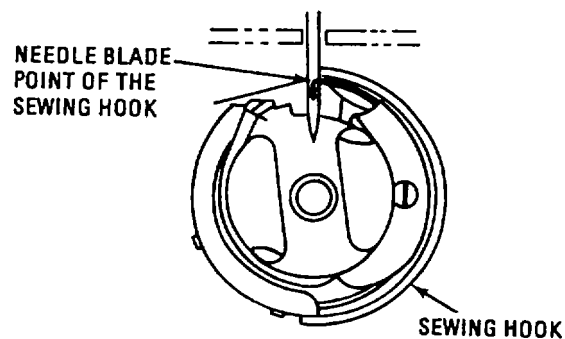

**5-28. CLOTHING SEWING MACHINE TIMING - continued.**Feed Dog and Needle Timing.

- (1) If the needle is correctly timed with the shuttle, the feed dog should be on its downstroke and level with the throat plate when the point of the needle reaches the material. If the balance wheel is turned toward the front of the machine, the needle should enter the material and come back up. After the needle on its upstroke has cleared the material, the feed dog should then rise above the throat plate and push the material forward the distance of one stitch.

**NOTE**

If the machine is not timed correctly, adjust per the following steps.

- (2) Rotate the feed regulator dial to its highest setting (five). The machine will then make its longest stitch.
- (3) Open the cover plate on the side of the machine head.
- (4) Loosen the feed eccentric setscrew (1). If the screw is loosened, the feed dog can move without moving the needle.
- (5) Install throat plate without mounting screws.
- (6) Turn the eccentric by hand until the feed dog is just ready to move below the top of the throat plate and begin its returning motion (toward the front of the machine).
- (7) Holding the eccentric in that position, turn the balance wheel toward the front of the machine until the needle on its upstroke is even with the top of the throat plate. Then tighten the eccentric setscrew (1).

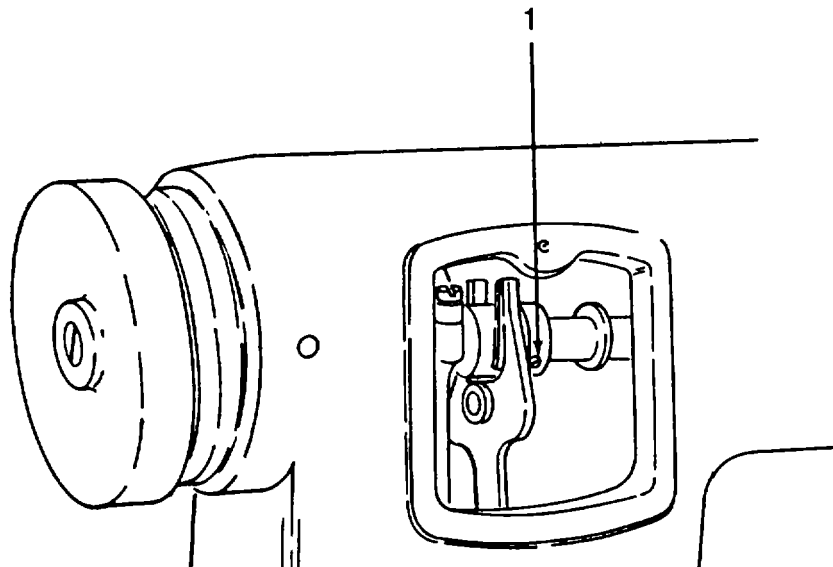

**5-28. CLOTHING SEWING MACHINE TIMING - continued.**Feed Dog Height.**NOTE**

The feed dog is normally adjusted for sewing fabrics of light and medium weight.

- (1) When correctly adjusted, the feed dog rises just enough for the teeth to show their full length above the throat plate.

**NOTE**

If the feed dog height is not properly set adjust per the following steps.

- (2) Loosen screw (1) and move the crank up or down as necessary.
- (3) Tighten the screw and test the adjustment by hand-turning the balance wheel forward.
- (4) A change in the height of the feed dog may throw the needle and feed dog out of time. Therefore, check and adjust the timing of the feed dog and needle timing as necessary.

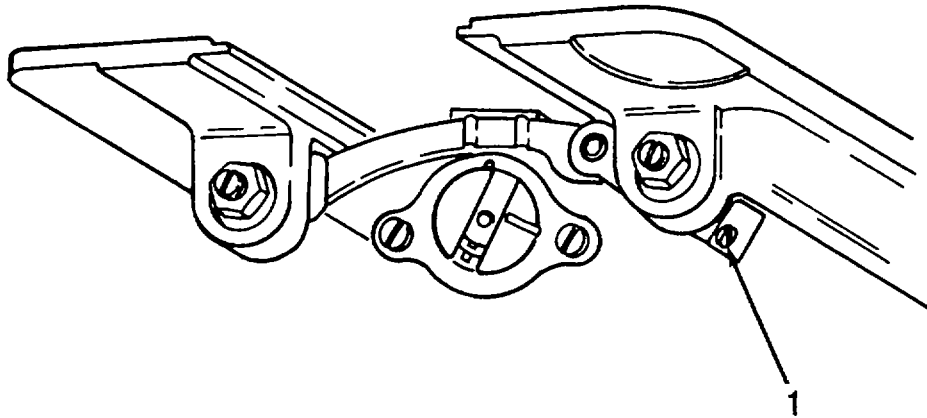

5-29. CLOTHING SEWING MACHINE RECEPTACLE ASSEMBLY MAINTENANCE.

This task covers:

- |            |                 |               |
|------------|-----------------|---------------|
| a. Removal | b. Cleaning     | c. Inspection |
| d. Repair  | e. Installation |               |

**INITIAL SETUP:**

**Tools:**

General Mechanics Tool Kit (Appendix B, Item 1)

**Materials/Parts:**

Rag, wiping (Appendix F, Item 2)

**Equipment Condition:**

- Power removed (para. 2-18)
- Table removed from stand (para. 2-18)
- Machine removed (para. 2-18)
- Bobbin removed (para. 2-18)
- Thread unwinder removed (para. 2-18)
- Light assembly removed (para. 2-18)

Removal.

- (1) Loosen four screws on both box cords (1).
- (2) Remove cover (2).
- (3) Remove receptacle (3).
- (4) Tag and disconnect wiring.
- (5) Remove two wood screws (4) and electrical box (5) from clothing table top.
- (6) Remove box cords (1).

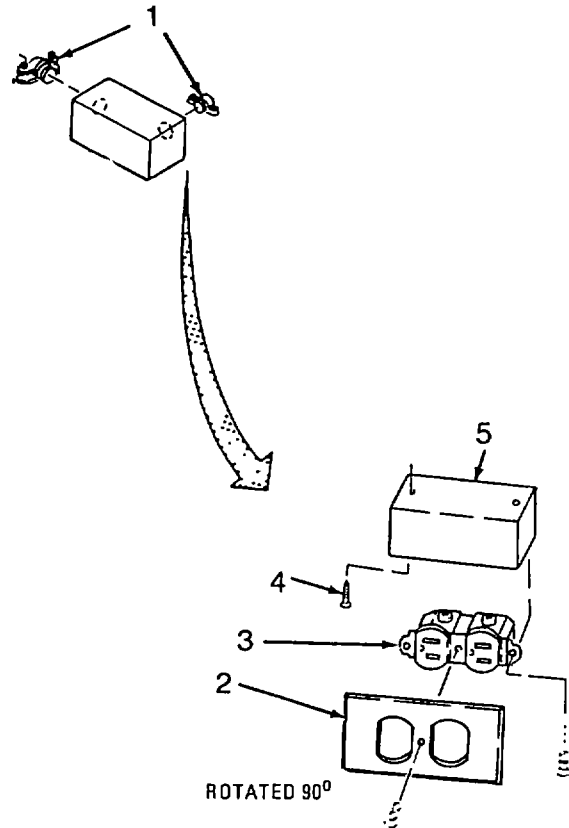

Cleaning.

- (1) Wipe parts with a damp wiping rag (Appendix F, Item 2).
- (2) Allow to dry.

Inspection.

- (1) Inspect hardware for damage.
- (2) Inspect for broken or burnt wires.
- (3) Inspect receptacle for damage.
- (4) Inspect electrical box for damage.

**5-29. CLOTHING SEWING MACHINE RECEPTACLE ASSEMBLY MAINTENANCE - continued.**

Repair. Repair is limited to the replacement of defective components with serviceable ones.

Installation.

- (1) Install two box cords (5) in the electrical box (1).
- (2) Install electrical box (1) on the clothing table top. Secure with two wood screws (2).
- (3) Connect wiring as tagged.
- (4) Install receptacle (3).
- (5) Install cover (4).

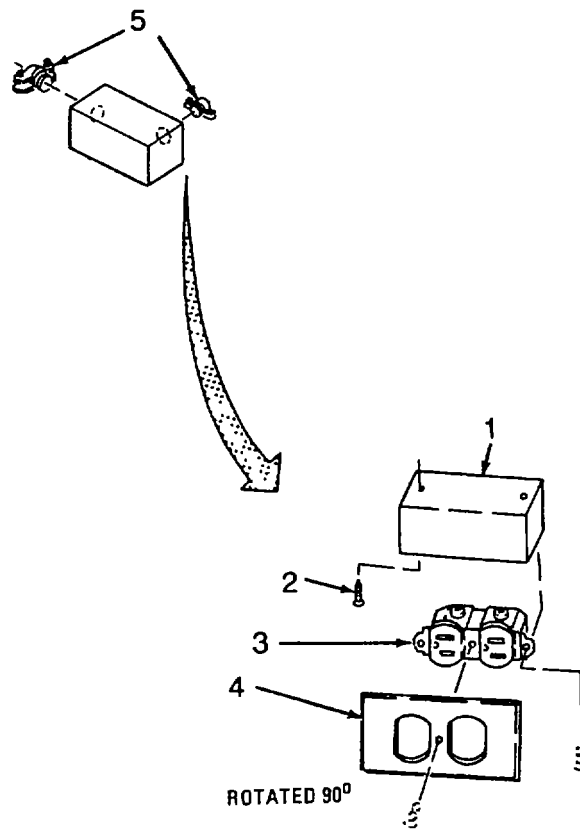

## 5-30. CLOTHING SEWING MACHINE CLUTCH AND MOTOR ASSEMBLY MAINTENANCE.

This task covers:

- |            |                |                 |               |
|------------|----------------|-----------------|---------------|
| a. Removal | b. Disassembly | c. Cleaning     | d. Inspection |
| e. Repair  | f. Assembly    | g. Installation | h. Adjustment |

### INITIAL SETUP:

#### **Tools:**

General Mechanics Tool Kit (Appendix B, Item 1)

#### **Materials/Parts:**

Rag, wiping (Appendix F, Item 2)  
Grease

#### **Equipment Condition:**

Table removed from stand assembly (para. 2-18).  
Power removed (para. 2-18).

### Removal.

- (1) Remove two screws (1) on the clamp connector (2).
- (2) Remove two screws (9) that hold the motor back cover on.
- (3) Tag and disconnect switch wires.
- (4) Remove three flat washers (3), three lock washers (4), and three nuts (5) from the carriage bolts (6).
- (5) Remove clutch and motor (7) from the clothing table top (8).

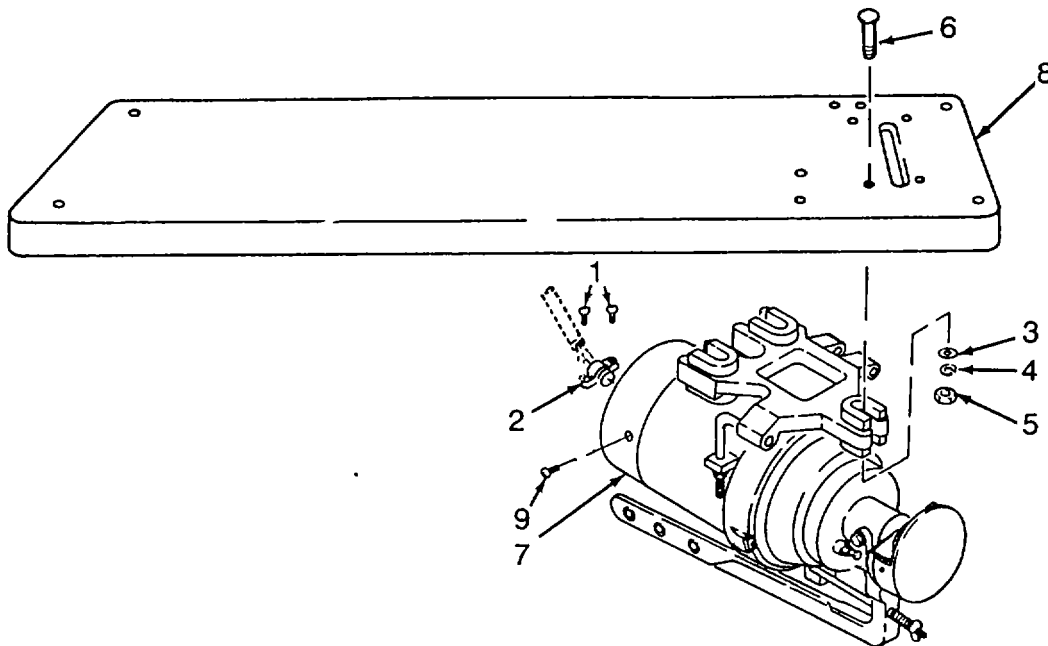

**5-30. CLOTHING SEWING MACHINE CLUTCH AND MOTOR ASSEMBLY MAINTENANCE - continued.**

Disassembly.

- (1) Remove two screws (1), two lock washers (2) and guard cover (3).
- (2) Remove two screws (4), two lock washers (5) and guard cover (6).
- (3) Remove setscrew (7), pulley (8) and key (9).

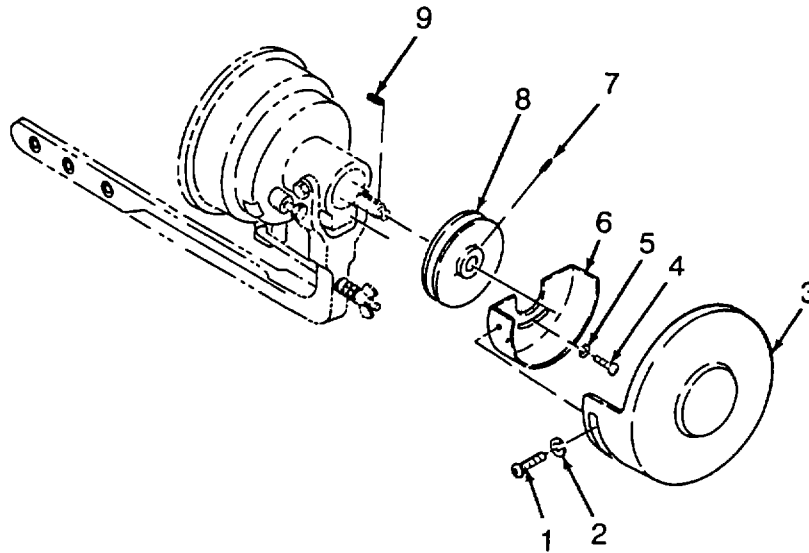

Cleaning.

- (1) Use a dry wiping rag (Appendix F, Item 2) to clean only the external surfaces of the electric motor.

Inspection.

- (1) Inspect hardware for damage.
- (2) Inspect for missing guard cover.
- (3) Inspect pulley for damage.
- (4) Inspect key for damage.

**5-30. CLOTHING SEWING MACHINE CLUTCH AND MOTOR ASSEMBLY MAINTENANCE - continued.**

Repair. Repair is limited to the replacement of defective parts and the following:

- (1) Repair of the clutch lever and adjusting rod
  - (a) Remove wing nut (1), washer (2) and spring (3).
  - (b) Remove retainer ring (4), lever pin (5), clutch lever (6) and adjusting rod (7).
  - (c) Replace with new parts as required.
  - (d) Install adjusting rod (7), clutch lever (6), lever pin (5) and retainer ring (4).
  - (e) Install spring (3), washer (2) and wing nut (1) to adjusting rod (7).

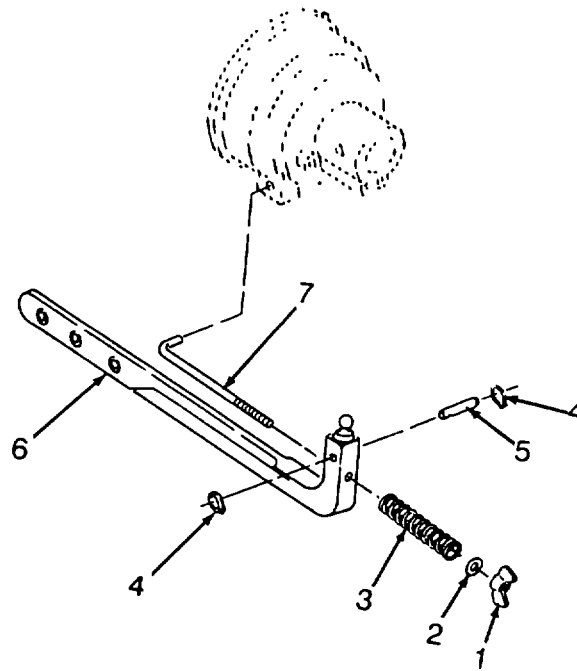

**5-30. CLOTHING SEWING MACHINE CLUTCH AND MOTOR ASSEMBLY MAINTENANCE - continued.**

## (2) Repair of clutch housing

- (a) Remove three screws (18), lock washer (19) and retaining bracket (20).
- (b) Remove clutch housing (1) from motor assembly.
- (c) Slide clutch housing (1) from shaft (2).
- (d) Remove adjustment bolt (3), nut (4), brake block (5).
- (e) Remove four hex head screws (6), four lock washers (7) and clutch disk (8).
- (f) Bend tab down on lock washer (9) Remove nut (10), lock washer (9), clutch plate (11) and key (12).
- (g) Press shaft (2) through ball bearing (13), neoprene washer (14), spacer (15), ball bearing (16) and clutch sleeve (17).
- (h) Press ball bearing (13) and ball bearing (16) from clutch sleeve (17). Remove neoprene washer (14).
- (i) Replace with new parts, as required.
- (j) Install neoprene washer (14) and ball bearing (13) into clutch sleeve (17). Make sure it is placed in the end opposite the side hole.
- (k) Install spacer (15) and press ball bearing (16) into clutch sleeve (17).
- (l) Press shaft (2) into ball bearing (16), clutch sleeve (17), spacer (15), neoprene washer (14) and ball bearing (13).

**NOTE**

Make sure that small tab on lock washers (9) fits into keyway.

- (m) Install key (12), clutch plate (11), lock washer (9), and nut (10). Tighten nut (10) and bend washer (9) up against nut (10).
- (n) Install clutch disk (8). Secure with four hex head screws (6) and four lock washers (7).

**5-30. CLOTHING SEWING MACHINE CLUTCH AND MOTOR ASSEMBLY MAINTENANCE - continued.**

(2) Repair of clutch housing - continued.

**NOTE**

It may be necessary to remove and install locking screw (21) to install brake block (5).

- (o) Install brake block (5) into the clutch housing (1) Secure with adjustment bolt (3) and nut (4).
- (p) Apply a small amount of grease to clutch sleeve (17).

**NOTE**

Hole in clutch sleeve (17) must be aligned with hole in the clutch housing (1).

- (q) Press clutch housing (1) onto the shaft (2) and clutch sleeve (17).
- (r) Install clutch housing (1) to motor with three retaining brackets (20), three lock washers (19) and three screws (18).

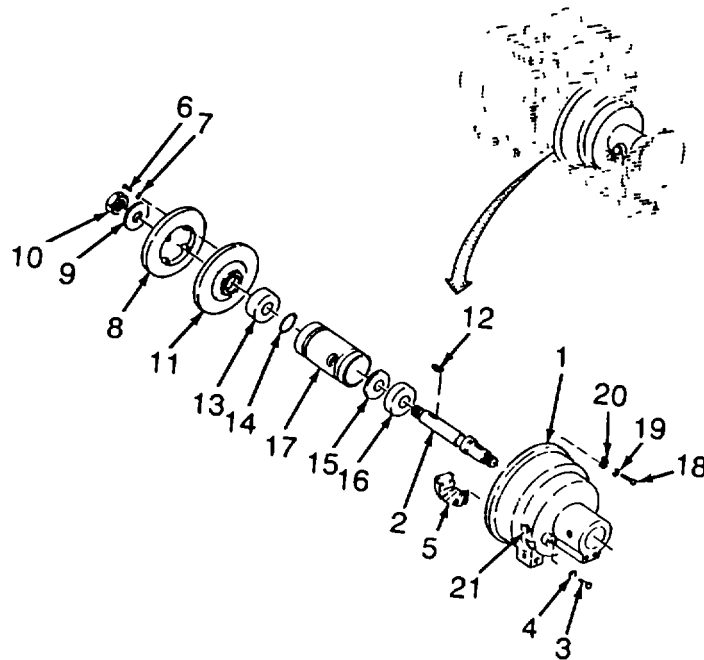

**5-30. CLOTHING SEWING MACHINE CLUTCH AND MOTOR ASSEMBLY MAINTENANCE - continued.**

- (3) Replacement of clutch motor fly wheel and electric motor.
  - (a) Bend tab flat on washer (1).
  - (b) Remove nut (2), flywheel (3) and key (4) from electric motor (5).
  - (c) Replace with new parts, as required.

**NOTE**

Small tab on washer fits into shaft keyway.

- (d) Install key (4), flywheel (3), washer (1) and loosely install nut (2) onto the electric motor (5).
- (e) Tighten nut (2) and bend washer up against nut (2) to prevent nut (2) from rotating.

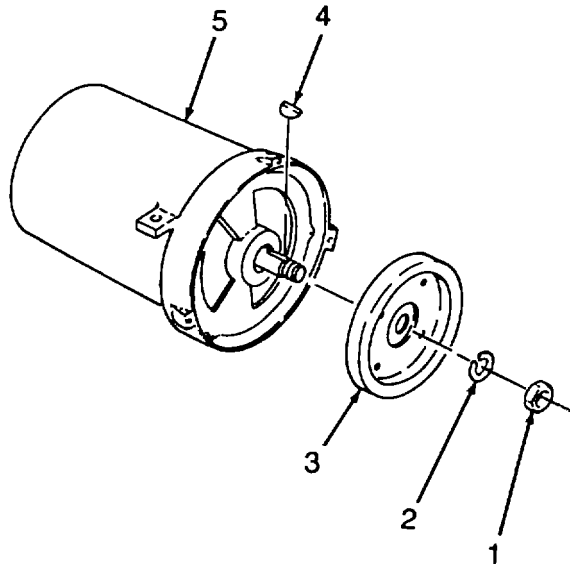

**5-30. CLOTHING SEWING MACHINE CLUTCH AND MOTOR ASSEMBLY MAINTENANCE - continued.**

- (4) Replacement of belt tightener.
  - (a) Remove two nuts (1), two lock washers (2) and adjusting rod (3).
  - (b) Remove retaining ring (4), hinge pin (5), and belt tightener (6).
  - (c) Remove three vibration insulators (7)
  - (d) Replace with new parts, as required.
  - (e) Install three vibration insulators (7).
  - (f) Install retaining ring (4), hinge pin (5) and belt tightener (6).
  - (g) Install adjusting rod (3). Secure with two nuts (1) and two lock washers (2).

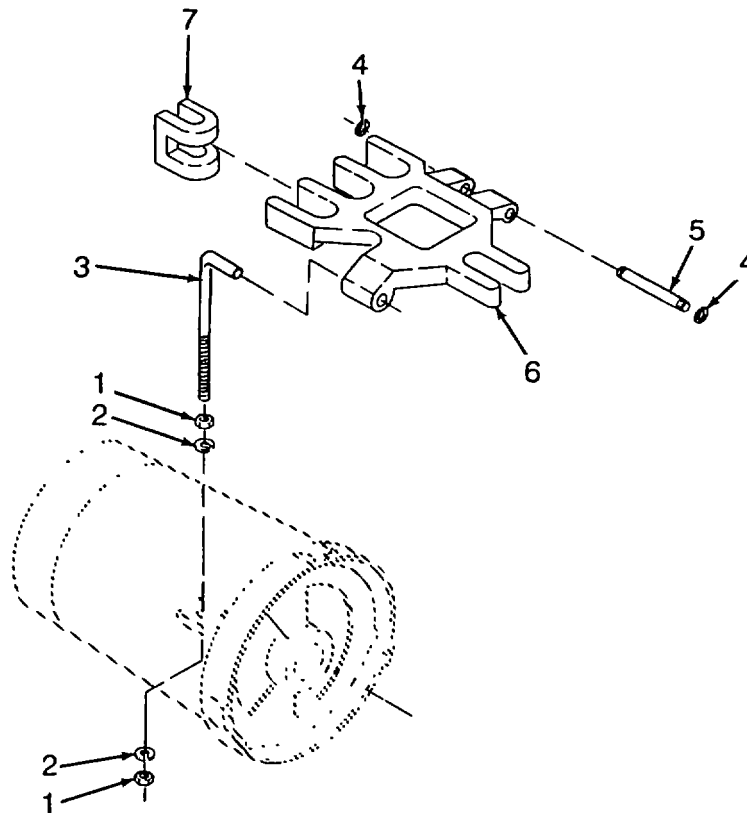

**5-30. CLOTHING SEWING MACHINE CLUTCH AND MOTOR ASSEMBLY MAINTENANCE - continued.**

Assembly.

- (1) Install key (1), and pulley (2). Secure with setscrew (3). Make sure pulley (2) is against the wall of the shaft.
- (2) Install guard cover (4). Secure with two lock washers (5) and two screws (6).
- (3) Install guard cover (7) Secure with two lock washers (8) and two screws (9).

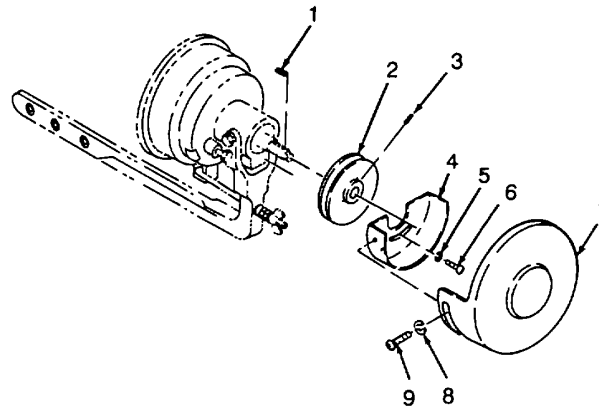

Installation.

- (1) Install clutch and motor (1) onto the sewing table top (2). Secure with three carriage bolts (3), three flatwashers (4), three lock washers (5) and three nuts (6).
- (2) Connect wires to motor as previously tagged
- (3) Hold the motor back cover in place with two screws (9).
- (4) Tighten two screws (8) on the clamp connect (7).

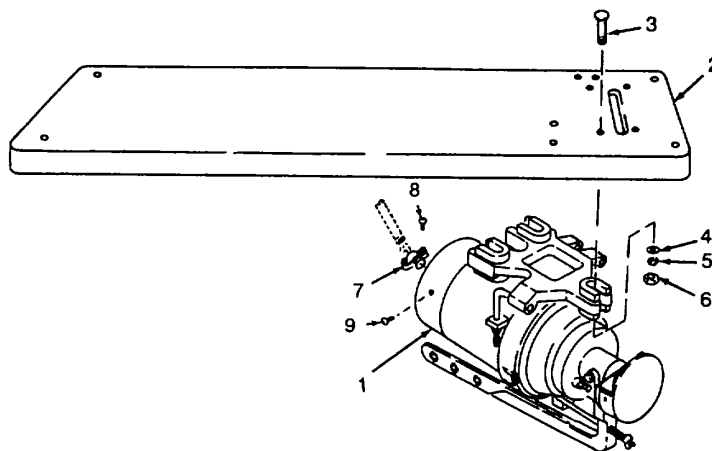

Adjustment. Adjust clutch with adjustment wing nut for proper clutch engagement (para 4-29)

**5-31. DARNING SEWING MACHINE ROTATING HOOK MAINTENANCE.**

This task consist of:

- |            |                 |               |
|------------|-----------------|---------------|
| a. Removal | b. Cleaning     | c. Inspection |
| d. Repair  | e. Installation | f. Adjustment |

**INITIAL SETUP:**

**Tools:**

General Mechanics Tool Kit (Appendix B, Item 1)

**Materials/Parts:**

Rag, wiping (Appendix F, Item 2)  
 Cleaning Solvent (Appendix F, Item 8)  
 Brush, Medium Bristle (Appendix F, Item 1)

**Equipment Condition :**

Thread and needle removed (para. 2-12).  
 Cylinder and slide plates removed (para. 4-37).

Removal.

- (1) Remove bobbin (1) by moving the handle up on the bobbin case (2).
- (2) Remove two screws (3) and hook gib set (4).
- (3) Remove bobbin case (2).
- (4) Remove rotating hook (5) by unscrewing screw (6).
- (5) Remove bobbin case opener (7), hook washer (8) and bobbin case lever eccentric (9)
- (6) Remove hook saddle (10) by unscrewing screws (11) and removing flat washer (12).
- (7) Remove gear (13).
- (8) Remove fulcrum and stud (14) from hook saddle (10) by removing screw (15).
- (9) Remove oil wick (16) from hook saddle (10).

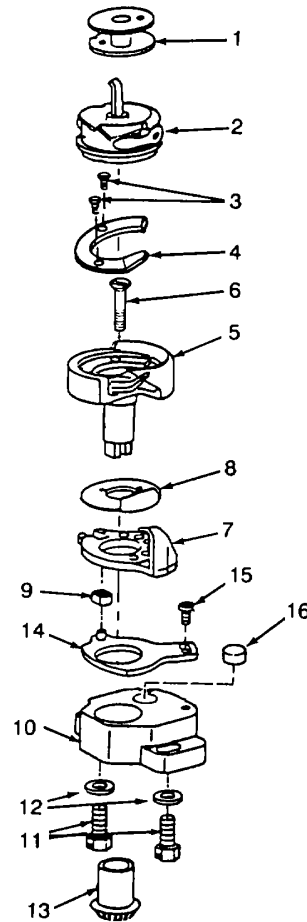

**5-31. DARNING SEWING MACHINE ROTATING HOOK MAINTENANCE - continued.**

Cleaning.

- (1) Remove all buildups of grease, dirt, etc , by wiping with a wiping rag (Appendix F, Item 2)

**WARNING**

Cleaning solvent, Federal Specification P-D-680, is both toxic and flammable. Keep off skin. Use only in a well ventilated area and avoid prolonged breathing of vapors. Keep away from open flame.

- (2) Clean using cleaning solvent (Appendix F, Item 8) and either a wiping rag(Appendix F, Item 2) or a medium bristle brush (Appendix F, Item 1).
- (3) Allow to dry.

Inspection.

- (1) Inspect hardware for damage.
- (2) Inspect bobbin for damage.
- (3) Inspect the bobbin case for damage.
- (4) Inspect the rotating hook for damage.
- (5) Inspect hook saddle for damage.
- (6) Inspect gear for damage.

Repair. Repair of the hook shaft assembly is limited to the replacement of defective components.

**5-31. DARNING SEWING MACHINE ROTATING HOOK MAINTENANCE - continued**

Installation.

- (1) Install oil wick (1) into hook saddle (2).
- (2) Install fulcrum and stud (3) on hook saddle (2).  
Secure with screw (4)
- (3) Install gear (5) into hook saddle (2).
- (4) Install hook saddle (2) and secure with screws (6) and flat washer (7). Position to ensure proper gear meshing.
- (5) Install bobbin case opener (8), and bobbin case lever eccentric (9).
- (6) Fit hook washer (10) to rotating hook (11). Make sure dimple on hook washer (10) fits into hole in the rotating hook (11).
- (7) Install rotating hook (11). Make sure tab on rotating hook (11) fits into slot on gear (5). Secure with screw (12).
- (8) Install bobbin case (13), hook gib (14) with two screws (15).
- (9) Install bobbin (16) and snap handle down.

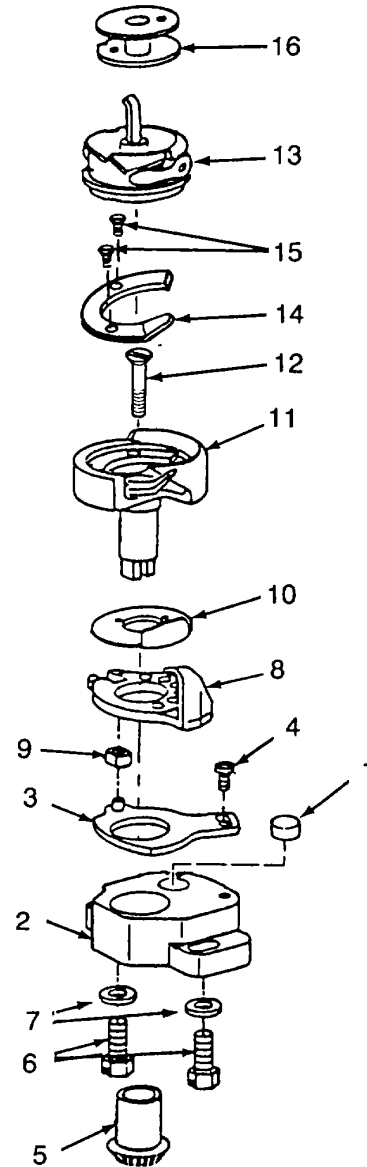

Adjustment.

Time darning machine according to paragraph 5-39.

**5-32. DARNING SEWING MACHINE NEEDLE BAR AND PRESSER BAR ASSEMBLY MAINTENANCE.**

---

This task consist of:

- |            |                 |               |
|------------|-----------------|---------------|
| a. Removal | b. Cleaning     | c. Inspection |
| d. Repair  | e. Installation |               |

---

**INITIAL SETUP:****Tools:**

General Mechanics Tool Kit (Appendix B, Item 1)

**Materials/Parts:**

Rag, wiping (Appendix F, Item 2)  
Cleaning Solvent (Appendix F, Item 8)  
Brush, Medium Bristle (Appendix F, Item 1)

**Equipment Condition:**

Thread and needle removed (para. 2-12)  
Pressor foot and needle guard removed (para. 4-38)  
Rotating hook removed (para. 5-31)

**Removal.**

- (1) Remove needle bar (1) by loosening screw (2).
- (2) Remove screw (2), connecting stud (3) and oil wick (4).

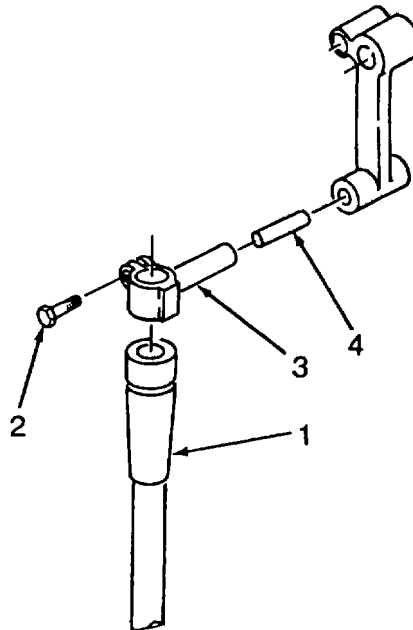

**5-32. DARNING SEWING MACHINE NEEDLE BAR AND PRESSER BAR ASSEMBLY MAINTENANCE - continued.**

Removal - continued.

- (3) Loosen screws (1), (2) and (3)
- (4) Remove pressure bar (4) through the top of the head.
- (5) Remove lifting bracket (5), lifting bracket (6), spring (7) and lifting bracket (8).

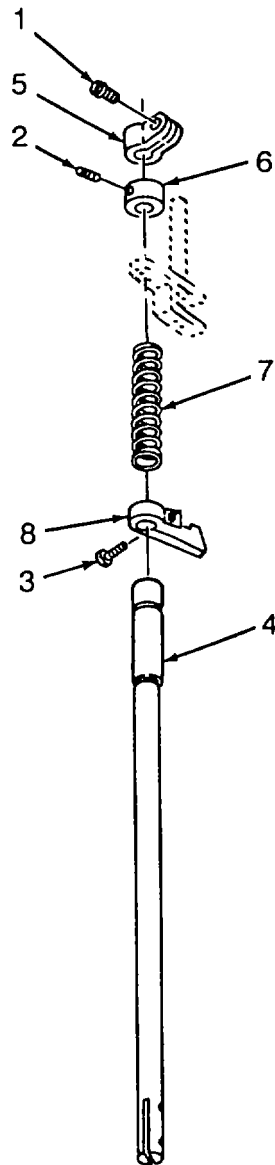

**5-32. DARNING SEWING MACHINE NEEDLE BAR AND PRESSER BAR ASSEMBLY MAINTENANCE - continued.**

Removal - continued.

- (6) Loosen setscrew (1) and remove bushing (2), presser bar (3) and thread take-up block (4).

**NOTE**

Use soft metal or wooden block with a rubber mallet.

- (7) Loosen setscrew (5) and drive out hinged stud (6) from the oil hole access.  
 (8) Remove oil wick (9) from hinged stud (6).  
 (9) Remove thread take-up lever (7) and driving stud (10) from connecting link (8).

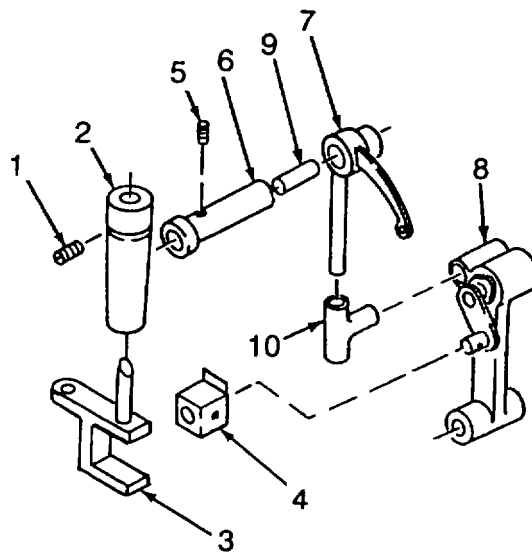

**5-32. DARNING SEWING MACHINE NEEDLE BAR AND PRESSER BAR ASSEMBLY MAINTENANCE - continued.**

Cleaning.

- (1) Remove all buildups of grease, dirt, etc., by wiping with a wiping rag (Appendix F, Item 2)

**WARNING**

Cleaning solvent, Federal Specification P-D-680, is both toxic and flammable. Keep off skin. Use only in a well ventilated area and avoid prolonged breathing of vapors. Keep away from open flame.

- (2) Clean using cleaning solvent (Appendix F, Item 8) and either a wiping rag (Appendix F, Item 2) or a medium bristle brush (Appendix F, Item 1).
- (3) Allow to dry

Inspection

- (1) Inspect hardware for damage.
- (2) Inspect needle bar for damage
- (3) Inspect connecting stud for damage
- (4) Inspect oil wick for damage.
- (5) Inspect presser bar for damage.
- (6) Inspect lifting brackets for damage.
- (7) Inspect spring for damage or weakness.
- (8) Inspect stud for damage.

Repair. Repair is limited to the replacement of defective components.

## 5-32. DARNING SEWING MACHINE NEEDLE BAR AND PRESSER BAR ASSEMBLY MAINTENANCE - continued.

### Installation.

- (1) Install thread take-up lever (1) and driving stud (2) into connecting link (3).
- (2) Install oil wick (4) into hinged stud (5).
- (2) Install hinged stud (5) and setscrew (6). Ensure flat side is up so setscrew (6) will sit on flat. Do not place hinged stud (4) too deep into the thread take-up lever (1).
- (3) Place thread take-up block (7) onto connecting link (3).
- (4) Slide presser bar (8) over thread take-up block (7).
- (5) Install bushing (9).
- (6) Install setscrew (10). Ensure setscrew (10) is over groove in bushing (9).

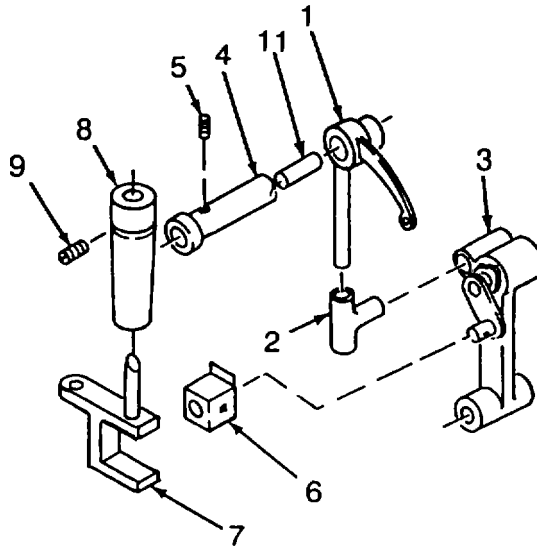

**5-32. DARNING SEWING MACHINE NEEDLE BAR AND PRESSER BAR ASSEMBLY MAINTENANCE - continued.**

Installation - continued.

(6) Place pressure bar (1) through top of head.

**NOTE**

Lifting bracket (2) must stay above the lifting lever.

(7) Install lifting brackets (2, 3, and 4) and spring (5)

(8) Lightly tighten setscrews, (6, 7, and 8).

(9) Install oil wick (1) into the connecting stud (2).

(10) Install needle bar (3) and secure with screw (4).

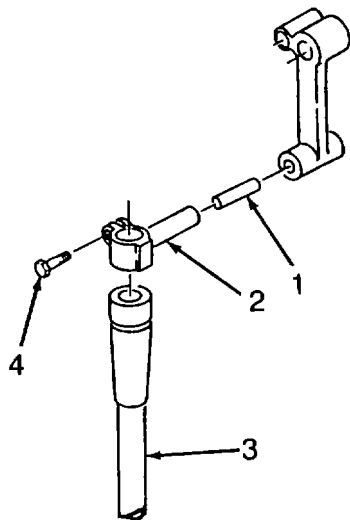
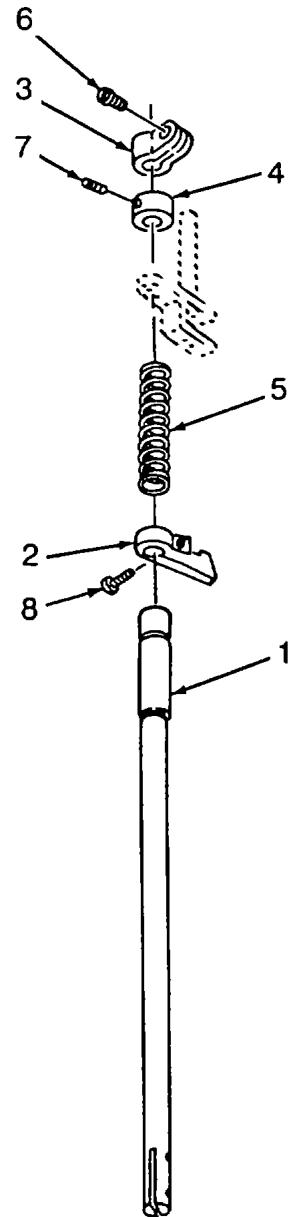

**5-33. DARNING SEWING MACHINE OIL GUARD, NEEDLE BAR CRANK MAINTENANCE.**

This task consist of:

- |               |                |                 |
|---------------|----------------|-----------------|
| a. Removal    | b. Disassembly | c. Cleaning     |
| d. Inspection | e. Repair      | f. Installation |

**INITIAL SETUP:****Tools:**

General Mechanics Tool Kit (Appendix B, Item 1)

**Equipment Condition:**

Needle bar and presser bar removed (para. 5-32).

**Materials/Parts:**

Rag, wiping (Appendix F, Item 2)

Cleaning Solvent (Appendix F, Item 8)

Brush, Medium Bristle (Appendix F, Item 1)

Removal.

- (1) Remove setscrews (1 and 2). Scribe a line on the end of the shaft to show where the setscrew is placed.
- (2) Remove belt from lower and upper pulley wheel by rotating wheel.
- (3) Remove setscrews (3, 4, and 5).
- (4) Remove setscrew (6) through the machine housing.
- (5) Drive shaft pulley assembly (8) out and remove needle bar crank assembly (9), pulley (10) and washer (11).

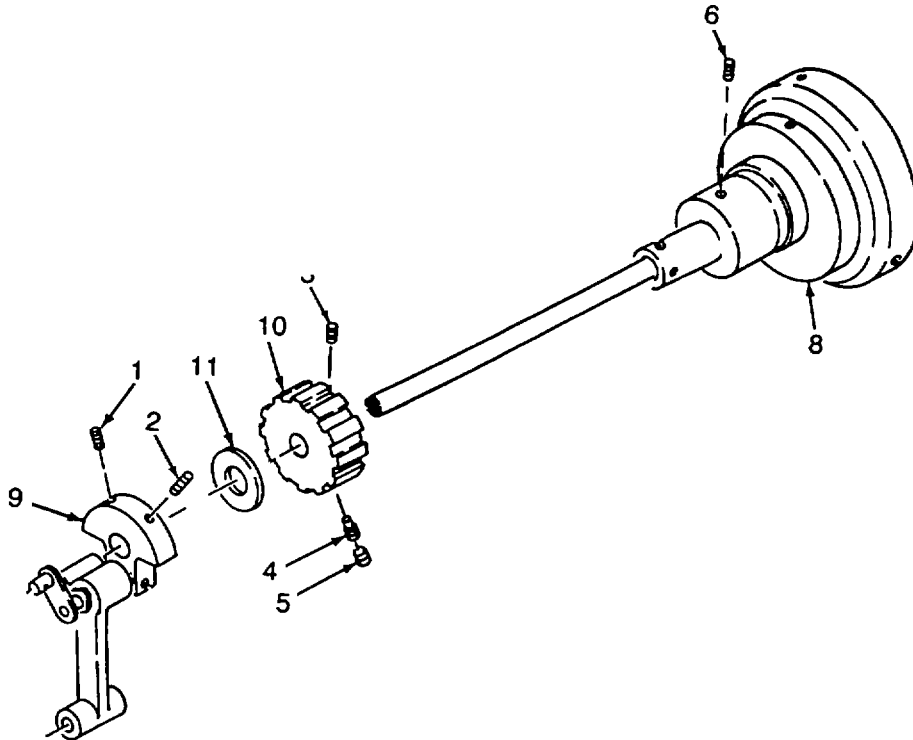

**5-33. DARNING SEWING MACHINE O[L GUARD, NEEDLE BAR CRANK MAINTENANCE - continued.**

Disassembly.

- (1) Remove screw (1).
- (2) Loosen setscrews (2 and 3) and slide pulley (4) off.
- (3) Remove screw (5) and indicator ring (6).
- (4) Remove two setscrews (12).
- (5) Remove bearing assembly (7-10) and remove from shaft (11).
- (6) Remove retaining washer (7), shaft arm bearing (8), adapter bearing (9) and adapter sleeve (10).

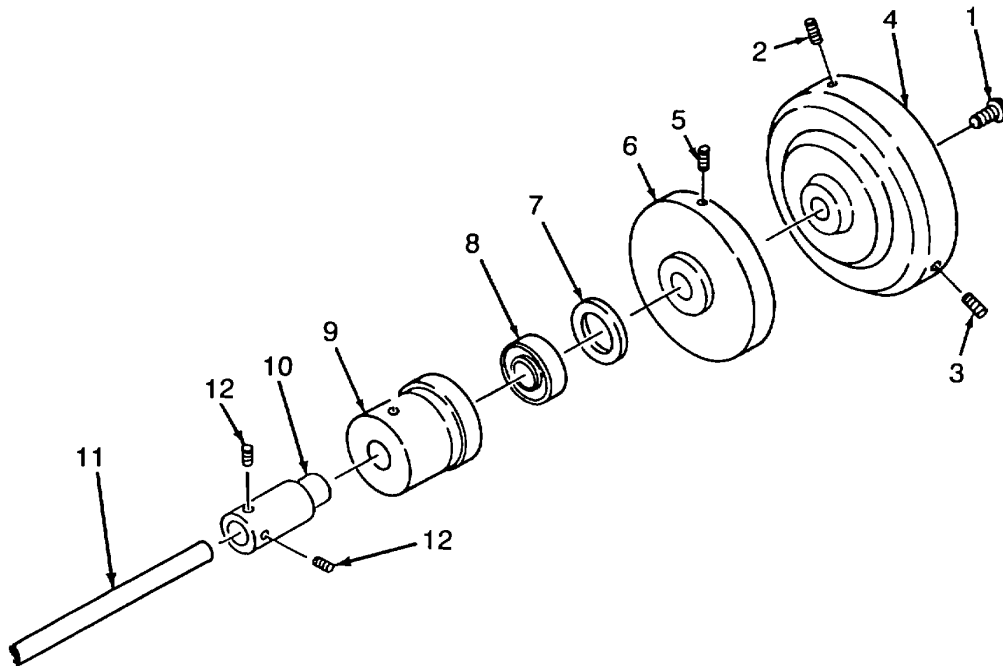

- (7) Loosen setscrews (13 and 14) from needle bar crank (15). Drive take-up crank (16) from connecting link (17) and needle bar crank (15)

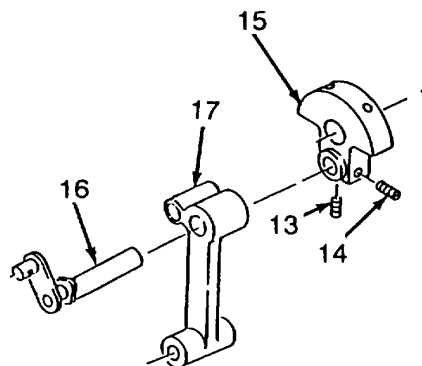

**5-33. DARNING SEWING MACHINE OIL GUARD, NEEDLE BAR CRANK MAINTENANCE - continued.**Cleaning.

- (1) Remove all buildups of grease, dirt, etc., with a wiping rag (Appendix F, Item 2).

**WARNING**

Cleaning solvent, Federal Specification P-D-680, is both toxic and flammable. Keep off skin. Use only in a well ventilated area and avoid prolonged breathing of vapors. Keep away from open flame.

- (2) Clean using cleaning solvent (Appendix F, Item 8) and either a wiping rag (Appendix F, Item 2) or a medium bristle brush (Appendix F, Item 1).
- (3) Allow to dry.

Inspection.

- (1) Inspect hardware for damage.
- (2) Inspect belt for damage or excessive wear.
- (3) Inspect needle bar crank assembly for damage.
- (4) Inspect pulley for damage.
- (5) Inspect shaft arm bearing for damage.
- (6) Inspect indicator ring for damage.
- (7) Inspect adapter bearing for damage.
- (8) Inspect shaft for damage.

Repair. Repair is limited to the replacement of defective components.

5-33. DARNING SEWING MACHINE OIL GUARD, NEEDLE BAR CRANK MAINTENANCE - continued.

Assembly.

**NOTE**

Flat area on take-up crank (1) must line up with setscrew (5).

- (1) Install take-up crank (1) into connecting link (2) and needle bar crank (3).
- (2) Tighten setscrews (4 and 5) in needle bar crank (3).

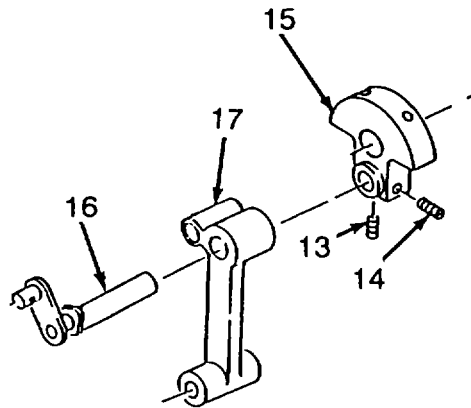

- (3) Assemble onto shaft (6), indicator ring (7), and secure with screw (8).

**NOTE**

Be sure that the flat tipped setscrew is in the flat of the shaft (6) and the pointed setscrew is on the groove of the shaft (6).

- (4) Slide pulley (9) on and install setscrews (10 and 11).
- (5) Install screw (12).

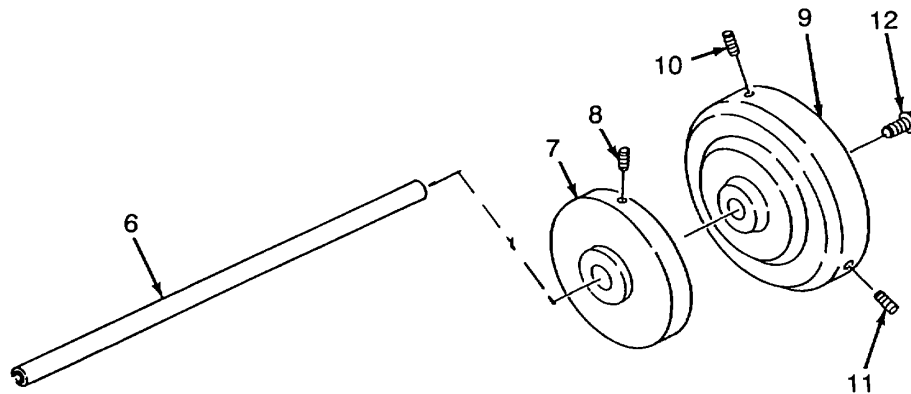

**5-33. DARNING SEWING MACHINE OIL GUARD, NEEDLE BAR CRANK MAINTENANCE - continued.**

Installation.

- (1) Install washer retaining (1), arm shaft bearing (2), adapter bearing (3) and adapter sleeve (4) into machine housing.
- (2) Place pulley (5) onto the belt and slide belt and pulley (5) into access hole. Position pulley (5) with flat side to the rear. Slide shaft assembly (6) through pulley (5) and into the arm shaft bearing (7). Secure with screw (8). Ensure screw (8) goes into hole in the shaft (3) and shaft (3) goes through the loose belt.
- (2) Install setscrew (9) over screw (8).
- (3) Install setscrew (10).
- (4) Loosely install two setscrews (11).
- (5) Install setscrew (12) through machine housing.
- (6) Slide belt onto top pulley (5). Ensure belt is on the top pulley first then walk the belt onto the bottom pulley.
- (7) Install washer (13), needle bar crank assembly (14) on the end of the shaft assembly (6). Secure with setscrews (15 and 16). Ensure that the "s" is over the marking you placed on the shaft previously. Lightly tap on both sides to ensure that there is no side-to-side movement.

**NOTE**

Setscrew (11) lines up with the "S" mark and ensure it goes in hole of shaft.

- (8) Tighten two setscrews (11).

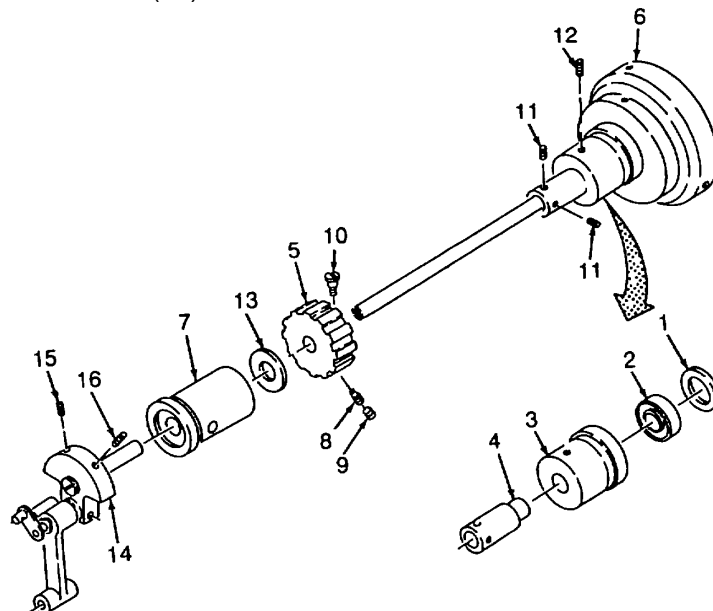

**5-34. DARNING SEWING MACHINE HOOK DRIVING SHAFT.**

This task covers:

- |             |             |             |
|-------------|-------------|-------------|
| a. FUNCTION | b. FUNCTION | c. FUNCTION |
| d. FUNCTION | e. FUNCTION | f. FUNCTION |

**INITIAL SETUP:**

**Tools:**

General Mechanics Tool Kit (Appendix B, Item 1)

**Equipment Condition:**

Rotating hook assembly removed (para 5-31)

**Materials/Parts:**

Rag, wiping (Appendix F, Item 2)  
 Cleaning Solvent (Appendix F, Item 8)  
 Brush, Medium Bristle (Appendix F, Item 1)

Removal.

- (1) Slide belt off of pulley (7).
- (2) Loosen three setscrews (1) and remove gear (2).
- (3) Loosen two setscrews (3) and two setscrews (4). Pull shaft (5) out from the front of the machine, through collar (6). Remove pulley (7).
- (4) Remove screw (8) and bushing (9) from hook drive shaft (5).
- (5) Remove screw (10) and bushing (11).

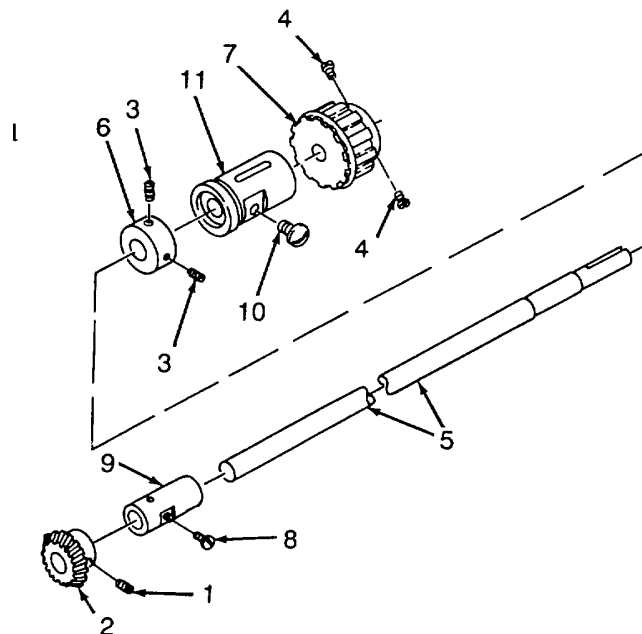

**5-34. DARNING SEWING MACHINE HOOK DRIVING SHAFT - continued.**Cleaning.

- (1) Remove all buildups of grease, dirt, etc., by wiping with a wiping rag (Appendix F, Item 2).

**WARNING**

Cleaning solvent, Federal Specification P-D-680, is both toxic and flammable. Keep off skin. Use only in a well ventilated area and avoid prolonged breathing of vapors. Keep away from open flame.

- (2) Clean using cleaning solvent (Appendix F, Item 8) and either a wiping rag (Appendix F, Item 2) or a medium bristle brush (Appendix F, Item 1). Do not clean thread guide felt.
- (3) Allow to dry.

Inspection.

- (1) Inspect hardware for damage.
- (2) Inspect shaft for straightness and damage.
- (3) Inspect collar for damage.
- (4) Inspect bushing for damage.
- (5) Inspect gear for damage.

Repair. Repair is limited to the replacement of defective parts and the removal of burrs.

Installation.

- (1) Install bushing (1) into the machine. Make sure the flat of the bushing lines up with setscrew (2). Center the bushing then secure with setscrew (2).

**NOTE**

The oil hole faces up.

- (2) Install bushing (3) into the machine. Make sure the flat spot on the bushing lines up with the setscrew (4). Let bushing extend about 3/8" from casting, tighten setscrew (4).
- (3) Slide shaft (5) through bushing (3), collar (6) and bushing (1).
- (4) Install pulley (7). Make sure one setscrew (8) lines up with groove on shaft (5). Let pulley come to a rest on shaft (5) and tighten both setscrews (8).
- (5) Tighten two setscrews (9) on collar (6).

**5-34. DARNING SEWING MACHINE HOOK DRIVING SHAFT - continued.**

Installation

**NOTE**

Do not tighten setscrews (10). Tighten when the machine is being timed.

(6) Install three setscrews (10) and gear (11) onto shaft (5).

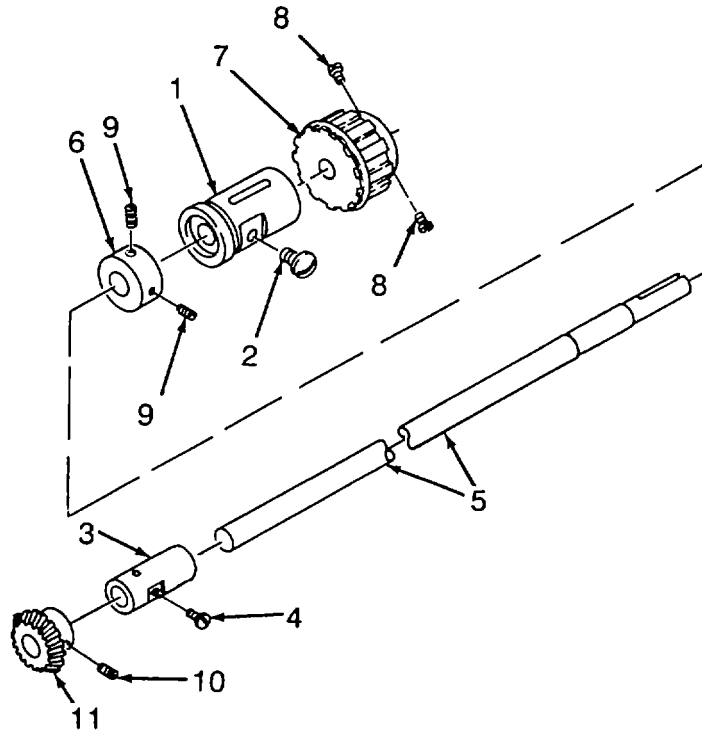

Adjustment.

Time darning machine according to paragraph 5-37.

5-35. DARNING SEWING MACHINE LIFTING LEVER MAINTENANCE..

This task consists of

- |            |                 |               |
|------------|-----------------|---------------|
| a. Removal | b. Cleaning     | c. Inspection |
| d. Repair  | e. Installation |               |

INITIAL SET-UP:

Tools:

General Mechanics Tool Kit (Appendix B, Item 1)

Material/Parts:

Cleaning Solvent (Appendix F, Item 8)  
Brush, Medium Bristle (Appendix F, Item 1)

Equipment Condition:

Chain removed (para 2-18)

Rag, wiping (Appendix F, Item 2)

Removal.

- (1) Remove screw (1) and lifting lever (2).
- (2) Remove two nuts (3), spring (4), stop lever (5) and stud (6).

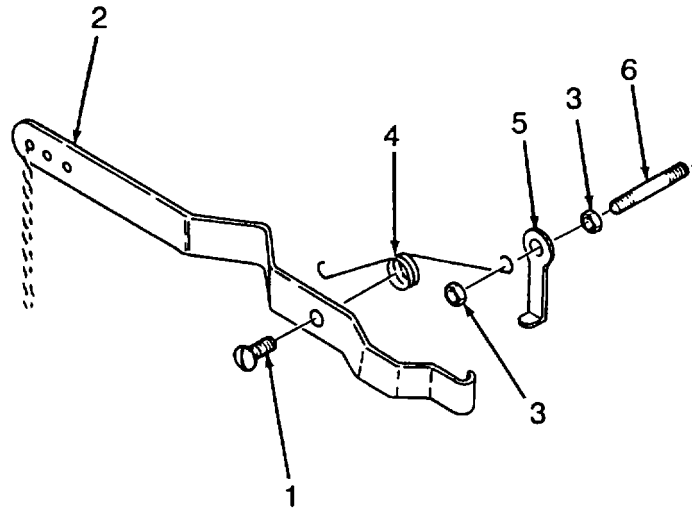

Cleaning.

- (1) Remove all buildups of grease, dirt, etc., by wiping with a wiping rag (Appendix F, Item 2).

**WARNING**

Cleaning solvent, Federal Specification P-D-680, is both toxic and flammable. Keep off skin. Use only in a well ventilated area and avoid prolonged breathing of vapors. Keep away from open flame.

- (2) Clean using cleaning solvent (Appendix F, Item 8) and either a wiping rag (Appendix F, Item 2) or a medium bristle brush (Appendix F, Item 1).
- (3) Allow to dry.

**5-35. DARNING SEWING MACHINE LIFTING LEVER MAINTENANCE.**

Inspection.

- (1) Inspect hardware for damage.
- (2) Inspect spring for corrosion or broken coils.
- (3) Inspect lifting lever for damage.
- (4) Inspect stop lever for damage.
- (5) Inspect stud for damage.

Repair. Repair is limited to the replacement of defective components.

Installation.

- (1) Install stud (1), two nuts (2), stop lever (3) and spring (4).
- (2) Install screw (5) through lifting lever (6) and spring (4).

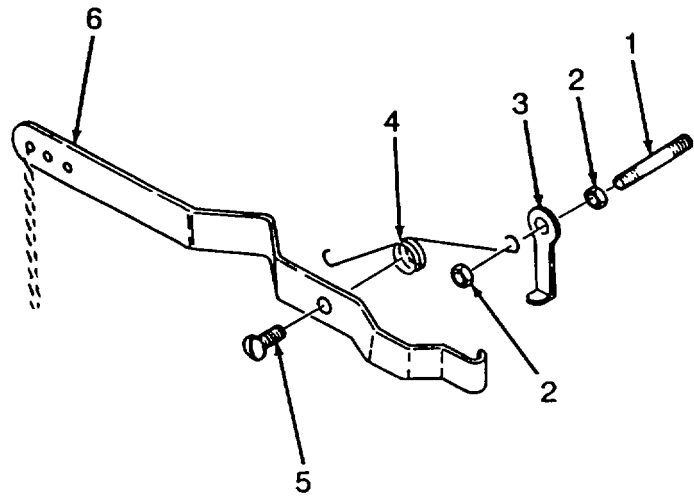

**5-36. DARNING SEWING MACHINE TENSION ASSEMBLY MAINTENANCE.****This task consists of**

- |            |                |                 |               |
|------------|----------------|-----------------|---------------|
| a. Removal | b. Disassembly | c. Cleaning     | d. Inspection |
| e. Repair  | f. Assembly    | g. Installation |               |

**INITIAL SET-UP:****Tools:**

General Mechanics Tool Kit (Appendix B, Item 1)

**Material/Parts:**

Cleaning Solvent (Appendix F, Item 8)  
Brush, Medium Bristle (Appendix F, Item 1)

**Equipment Condition :**

Face plate removed

Rag, wiping (Appendix F, Item 2)

Removal.

- (1) Remove screw (1) and screw (2).
- (2) Remove tension assembly from the darning machine.

Disassembly.

- (1) Unscrew and remove thumb nut (3).
- (2) Remove screw (4), disc (5), spring (6) and stud (7).
- (3) Unscrew and remove thumb nut (8), washer (9), spring (10), washer (11), and two discs (12), pin (13) from bracket (14).
- (4) Remove two screws (15) from bracket (16).
- (5) Remove lever pin (17).

**5-36. DARNING SEWING MACHINE TENSION ASSEMBLY MAINTENANCE - continued.**

- (6) Remove screw (18) and stop spring (19).

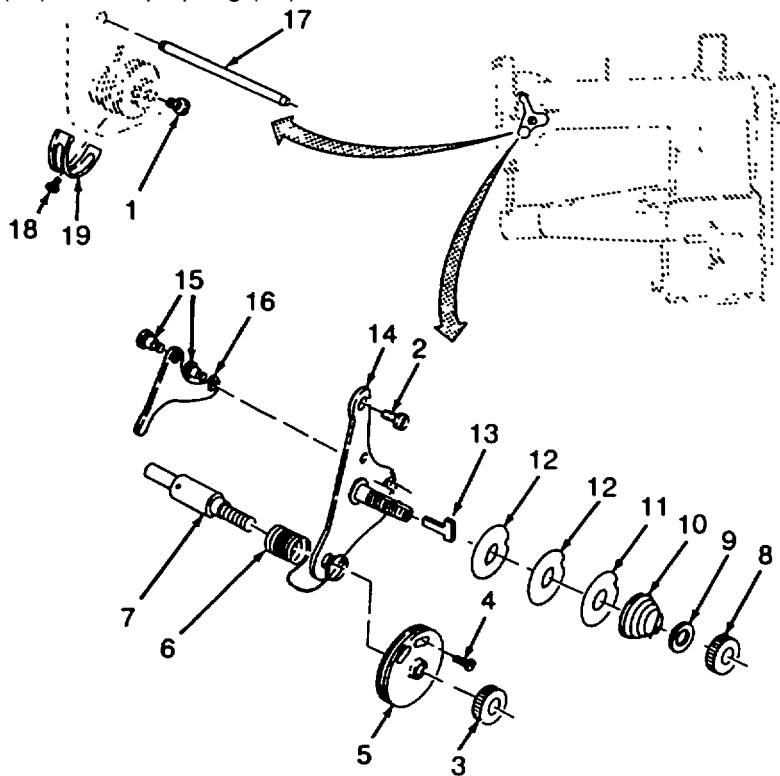

Cleaning.

- (1) Remove all buildups of grease, dirt, etc., by wiping with a wiping rag (Appendix F, Item 2).

**WARNING**

Cleaning solvent, Federal Specification P-D-680, is both toxic and flammable. Keep off skin. Use only in well-ventilated area and avoid prolonged breathing of vapors. Keep away from open flame.

- (2) Clean using cleaning solvent (Appendix F, Item 8) and either a wiping rag (Appendix F, Item 2) or a medium bristle brush (Appendix F, Item 1).
- (3) Allow to dry.

Repair. Repair is limited to the replacement of defective components.

**5-36. DARNING SEWING MACHINE TENSION ASSEMBLY MAINTENANCE - continued**

Assembly.

- (1) Assemble bracket (1) to bracket (2) and secure with two screws (3).
- (2) Install pin (4) on thread stud on bracket (2).

**NOTE**

Discs together should look like a pulley.

- (3) Install two discs (6), washer (7), spring (8), washer (9), and thumb nut (10).

**NOTE**

Spring (11) clips into hole in shaft (12).

- (4) Install spring (11) on shaft (12) and slide through the back of bracket (2). Secure shaft (12) using controller disc (13), thumb nut (14) and screw (15).

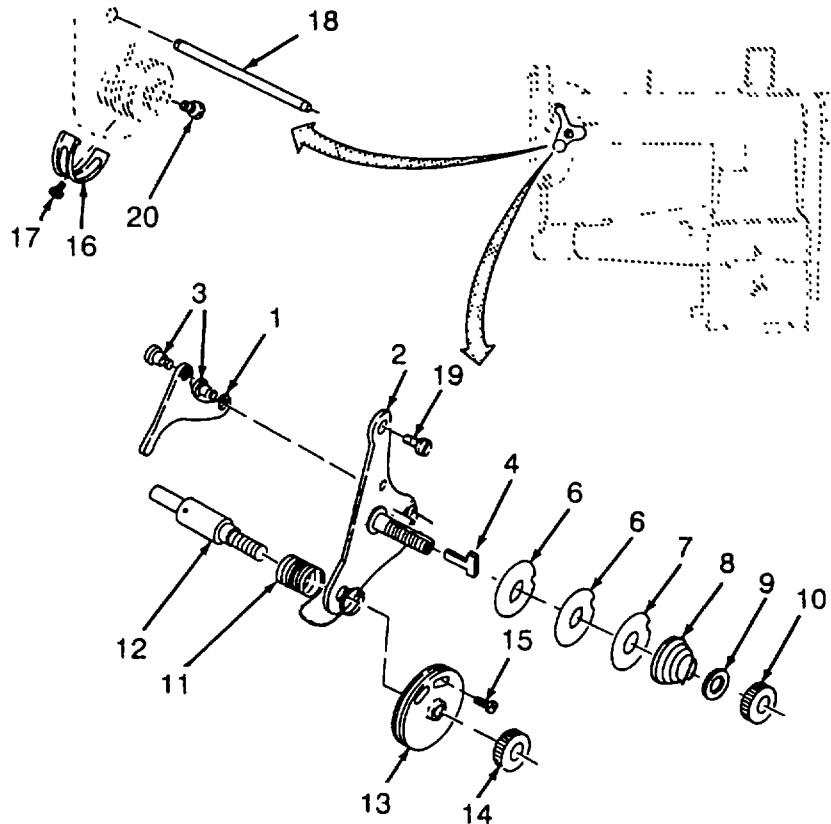

**5-36. DARNING SEWING MACHINE TENSION ASSEMBLY MAINTENANCE - continued.**

Installation.

- (1) Install stop spring (16) and secure with screw (17).
- (2) Install pin (18).
- (3) Install tension assembly onto the machine and secure with screw (19) and screw (20).

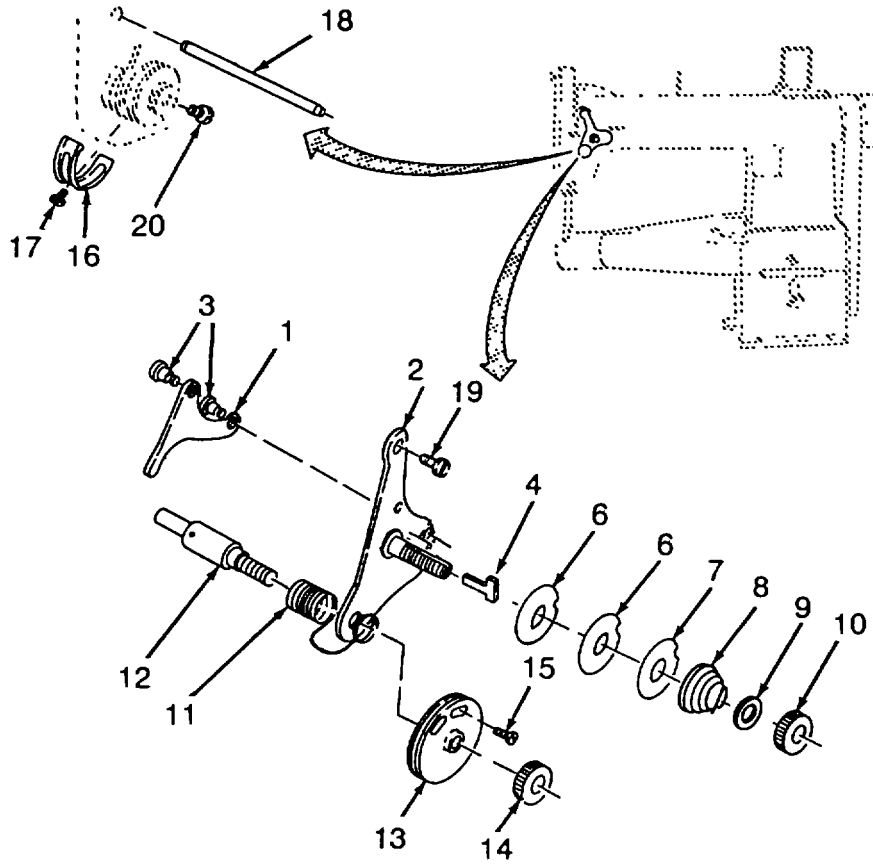

**5-37. DARNING SEWING MACHINE REAR SHAFT BEARING MAINTENANCE.**

This task consists of:

- |            |                 |               |
|------------|-----------------|---------------|
| a. Removal | b. Cleaning     | c. Inspection |
| d. Repair  | e. Installation |               |

**INITIAL SET-UP:****Tools:**

General Mechanics Tool Kit (Appendix B, Item d)

**Material/Parts:**

Cleaning Solvent (Appendix F, Item 8)  
Brush, Medium Bristle (Appendix F, Item 1)

**Equipment Condition :**

Lifting lever removed (para.5-35)  
Needle bar shaft assembly removed  
(para 5-32)

Rag, wiping (Appendix F, Item 2)

Removal

- (1) Remove setscrew (1), through housing.
- (2) Press apart bearing adapter (2), sleeve (3), washer (4) and bearing (5).

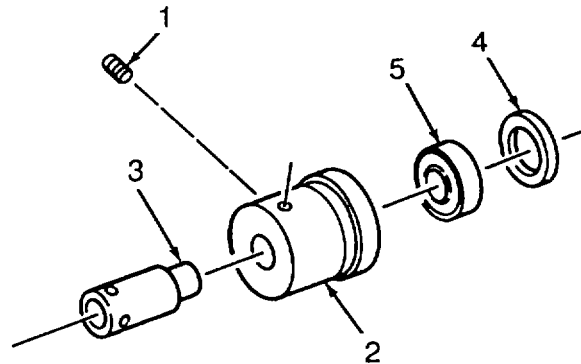

5-104

**5-37. DARNING SEWING MACHINE REAR SHAFT BEARING MAINTENANCE - continued.**

Cleaning.

- (1) Remove all buildups of grease, dirt, etc., by wiping with a wiping rag (Appendix F, Item 2).

**WARNING**

Cleaning solvent, Federal Specification P-D-680, is both toxic and flammable. Keep off skin Use only in well-ventilated area and avoid prolonged breathing of vapors. Keep away from open flame.

- (2) Clean using cleaning solvent (Appendix F, Item 8) and either a wiping rag (Appendix F, Item 2) or a medium bristle brush (Appendix F, Item 1).
- (3) Allow to dry.

Inspection.

- (1) Inspect hardware for damage.
- (2) Inspect bearing for damage.
- (3) Inspect washer for damage.
- (4) Inspect sleeve for damage.

Repair. Repair is limited to the replacement of defective parts and the removal of burrs.

**5-37. DARNING SEWING MACHINE REAR SHAFT BEARING MAINTENANCE - continued.**Installation.**NOTE**

Flat spot on bearing adapter (4) must line up with setscrew (5).

- (1) Install sleeve (1), washer (2), bearing (3) onto the bearing adapter (4) and into the machine.
- (2) Install setscrew (5) through housing.

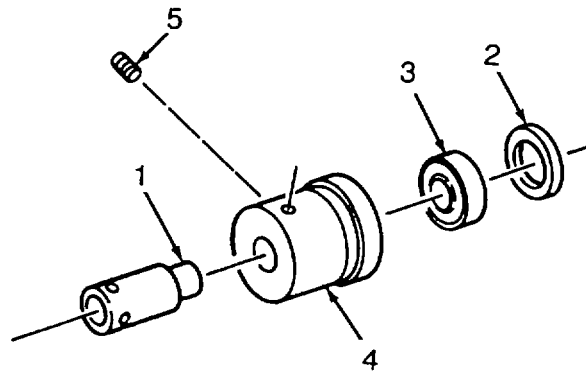

5-106

**5-38. DARNING SEWING MACHINE FRONT SHAFT BEARING MAINTENANCE**

---

This task consists of

- a. Removal
- d. Repair

- b. Cleaning
- e. Installation

- c. Inspection

**INITIAL SET-UP:****Tools:**

General Mechanics Tool Kit (Appendix B, Item 1)

**Material/Parts:**

Cleaning Solvent (Appendix F, Item 8)  
Brush, Medium Bristle (Appendix F, Item 1)

**Equipment Condition:**

Lifting lever removed (para.5-35)  
Needle bar shaft assembly removed (para.5-33)

Rag, wiping (Appendix F, Item 2)

Removal.

- (1) Remove setscrew (1) from bushing.
- (2) Using a brass (or other soft material) rod, tap bearing (2) out of the front of the machine.
- (3) Remove oil wick (3) and oil wick (4).

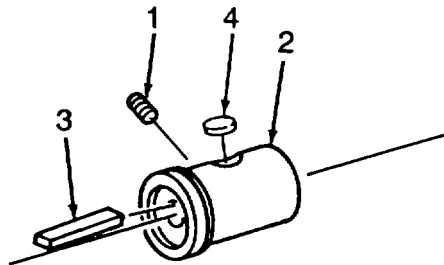

5-107

**5-38. DARNING SEWING MACHINE FRONT SHAFT BEARING MAINTENANCE - continued.**

Cleaning.

- (1) Remove all buildups of grease, dirt, etc., by wiping with a wiping rag (Appendix F, Item 2).

**WARNING**

Cleaning solvent, Federal Specification P-D-680, is both toxic and flammable. Keep off skin. Use only in well-ventilated area and avoid prolonged breathing of vapors. Keep away from open flame.

- (2) Clean using cleaning solvent (Appendix F, Item 8) and either a wiping rag (Appendix F, Item 2) or a medium bristle brush (Appendix F, Item 1).
- (3) Allow to dry.

Inspection.

- (1) Inspect hardware for damage.
- (2) Inspect bearing for damage or excessive wear.
- (3) Inspect oil wick for damage or excessive wear.

Repair. Repair is limited to the replacement of defective parts and the removal of burrs.

**5-38. DARNING SEWING MACHINE FRONT SHAFT BEARING MAINTENANCE - continued.**

Installation.

- (1) Install oil wicks (1) and (2) into bearing (3).

**NOTE**

Groove in outside diameter of bearing must line up with the setscrew (4).

- (2) Install bearing (3) using a soft rod or wood, tap the bearing into place.
- (2) Install setscrew (4).

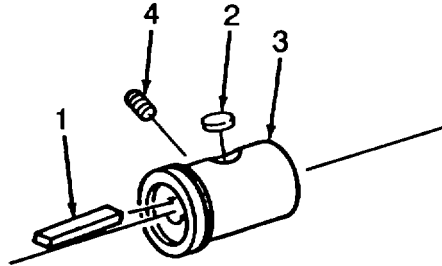

5-109

**5-39. DARNING SEWING MACHINE TIMING.**

**This task consists of: Machine Timing**

**INITIAL SET-UP:****Tools:**

General Mechanics Tool Kit (Appendix B, Item 1)

**Equipment Condition:**

Machine removed from table (para. 2-18).  
Thread, presser foot and needle guards removed (para. 4-38).  
Cylinder, needle plate and slide plate removed (para. 4-37).

Machine Timing.

- (1) Make sure needle is correctly inserted into needle bar as far as possible. Rotate machine pulley toward you, by hand, to ensure that needle goes to its lowest point.
- (2) Time the machine by placing the needle at its lowest point and raising 2 mm (.08 in.) by rotating the pulley toward you. Needle (1) and hook on the bobbin case (2) should be positioned so the hook is at the top of the needle hole as shown.
- (3) If the needle bar height is not correct, adjust needle bar accordingly.

**NOTE**

Make sure gear teeth are meshed properly.

- (4) If hook is not positioned properly, loosen screw on pinion. Rotate pinion and tighterscrew. Repeat steps 2 through 4 until machine is properly timed.

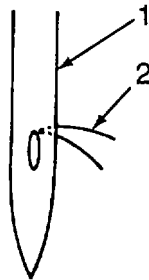

**5-110**

**5-40. DARNING SEWING MACHINE RECEPTACLE ASSEMBLY MAINTENANCE.**

**This task consists of**

- |   |  |   |
|---|--|---|
| <ul style="list-style-type: none"> <li>a. Removal</li> <li>d. Repair</li> </ul> | <ul style="list-style-type: none"> <li>b. Cleaning</li> <li>e. Installation</li> </ul> | <ul style="list-style-type: none"> <li>c. Inspection</li> </ul> |
|---|--|---|

**INITIAL SET-UP:**

**Tools:**

Shop Equipment (Appendix B, Item 2)

**Materials/Parts:**

Rag, wiping (Appendix F, Item 2)

**Equipment Condition:**

- Power removed (para.2-18)
- Table removed from stand (para. 2-18)
- Machine removed (para.2-18)
- Thread unwinder removed (para.2-18)
- Light assembly removed (para.2-18)

Removal.

- (1) Loosen four screws on both box cords (1).
- (2) Remove cover (2).
- (3) Remove receptacle (3).
- (4) Tag and disconnect wiring.
- (5) Remove two wood screws (4) and electrical box (5) from darning table top.
- (6) Remove box cords (1).

Cleaning.

- (1) Wipe parts with a damp wiping rag (Appendix F, Item 2).
- (2) Allow to dry.

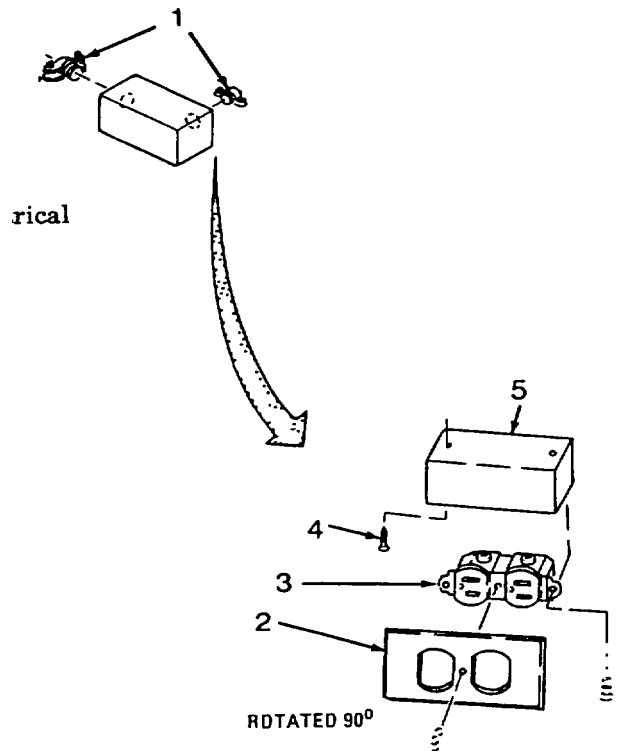

**5-40. DARNING SEWING MACHINE RECEPTACLE ASSEMBLY MAINTENANCE - continued.**Inspect.

- (1) Inspect hardware for damage.
- (2) Inspect for broken or burnt wires.
- (3) Inspect receptacle for damage.
- (4) Inspect electrical box for damage.

Repair. Repair is limited to the replacement of defective components with serviceable ones.

Installation.

- (1) Install two cords (5) in the electrical box (1).
- (2) Install electrical box (1) on the darning table top. Secure with two wood screws (2).
- (3) Connect wiring as tagged.
- (4) Install receptacle (3).
- (5) Install cover (4).

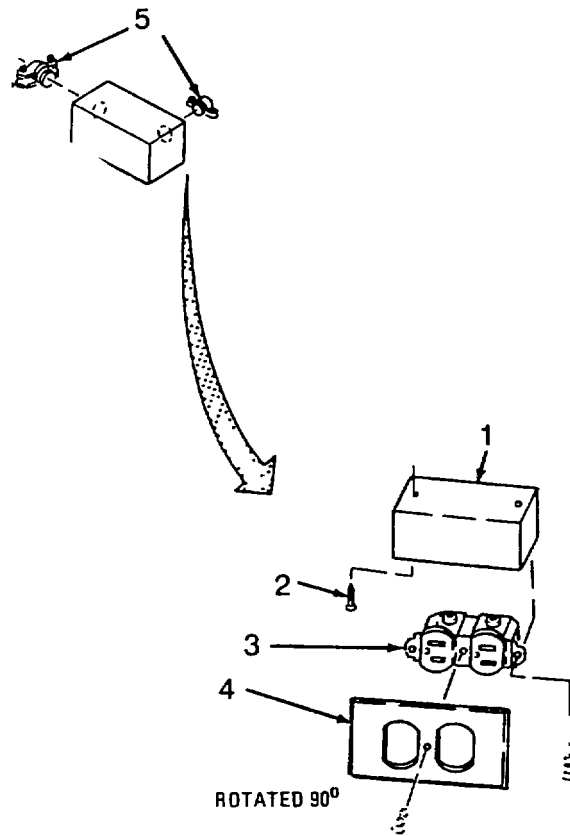

## 5-41. DARNING SEWING MACHINE CLUTCH AND MOTOR ASSEMBLY MAINTENANCE.

This task consists of

- |            |                |                 |               |
|------------|----------------|-----------------|---------------|
| a. Removal | b. Disassembly | c. Cleaning     | d. Inspection |
| e. Repair  | f. Assembly    | g. Installation | h. Adjustment |

INITIAL SET-UP:

**Tools:**

General Mechanics Tool Kit (Appendix B, Item 1)

**Equipment Condition:**

Table removed from stand assembly (para. 2-18).  
Power removed (para. 2-18).

**Materials/Parts:**

Rag, wiping (Appendix F, Item 2)  
Grease

**Removal**

- (1) Remove two screws (1) on the clamp connector (2).
- (2) Remove two screws (9) that hold the motor back cover on.
- (3) Tag and disconnect switch wires.
- (4) Remove three flat washers (3), three lockwashers (4), and three nuts (5) from the carriage bolts (6).
- (5) Remove clutch and motor (7) from the darning table top (8).

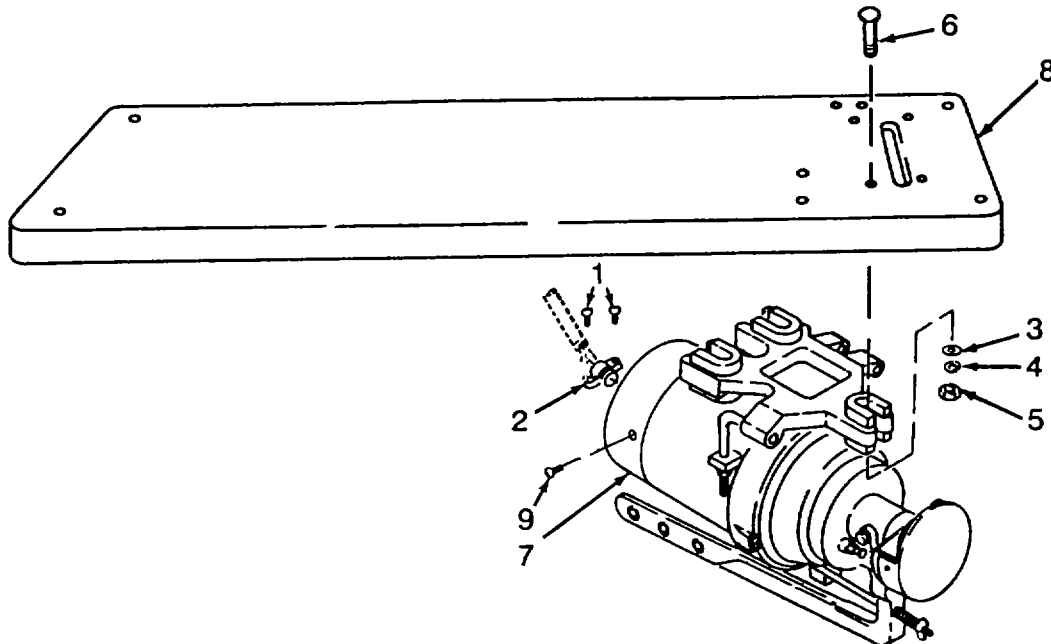

**5-41. DARNING SEWING MACHINE CLUTCH AND MOTOR ASSEMBLY MAINTENANCE -continued.**Disassembly.

- (1) Remove two screws (1), two lockwashers (2) and guard cover (3).
- (2) Remove two screws (4), two lockwashers (5) and guard cover (6).
- (3) Remove setscrew (7), pulley (8) and key (9).

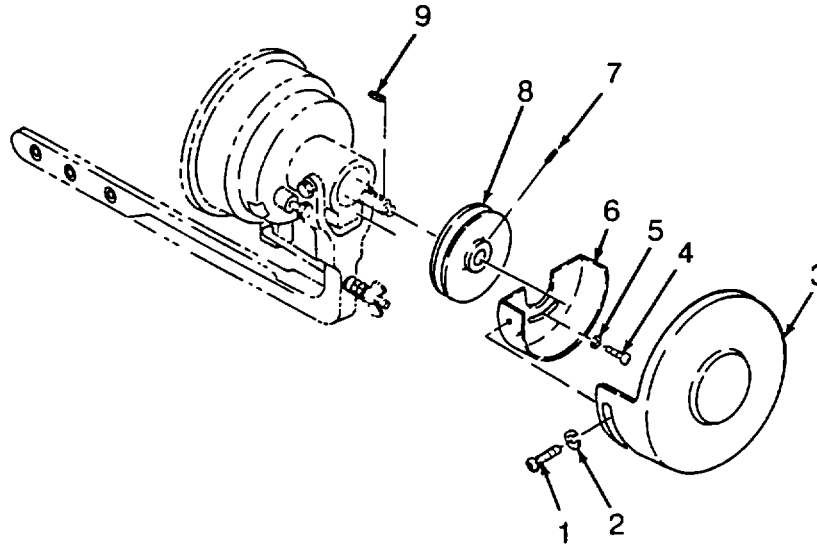
Cleaning.

- (1) Use a dry wiping rag (Appendix F, Item 2) to clean only the external surfaces of the electric motor.

Inspection.

- (1) Inspect hardware for damage.
- (2) Inspect for missing guard cover.
- (3) Inspect pulley for damage.
- (4) Inspect key for damage.

**5-41. DARNING SEWING MACHINE CLUTCH AND MOTOR ASSEMBLY MAINTENANCE - continued.**

Repair. Repair is limited to the replacement of defective parts and the following:

- (1) Repair of the clutch lever and adjusting rod.
- (a) Remove wing nut (1), washer (2) and spring (3).
- (b) Remove retainer ring (4), lever pin (5), clutch lever (6) and adjusting rod (7).
- (c) Replace with new parts as required.
- (d) Install adjusting rod (7), clutch lever (6), lever pin (5) and retainer ring (4).
- (e) Install spring (3), washer (2) and wing nut (1) to adjusting rod (7).

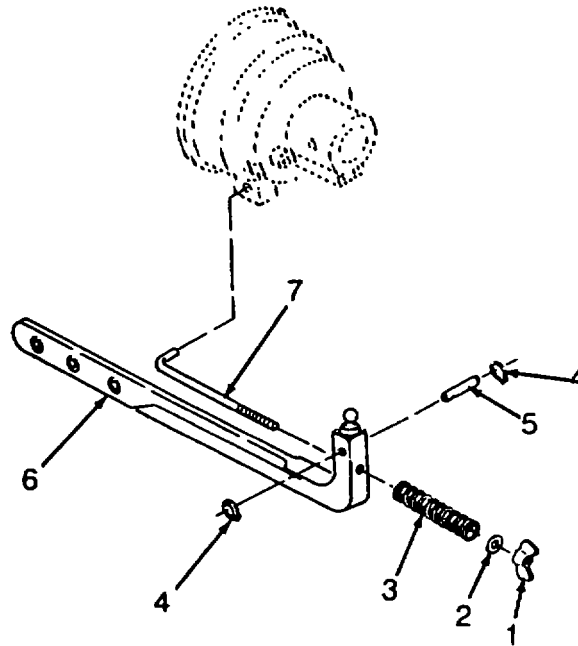

**5-41. DARNING SEWING MACHINE CLUTCH AND MOTOR ASSEMBLY MAINTENANCE -continued.**

- (2) Repair of clutch housing.
  - (a) Remove three screws (18), lockwasher (19) and retaining bracket (20).
  - (b) Remove clutch housing (1) from motor assembly.
  - (c) Slide clutch housing (1) from shaft (2).
  - (d) Remove adjustment bolt (3), nut (4), brake block (5).
  - (e) Remove four screws (6), four lockwashers (7) and clutch disk (8).
  - (f) Bend tab down on lockwasher (9). Remove nut (10), lockwasher (9), clutch plate (11) and key (12).
  - (g) Press shaft (2) through ball bearing (13), neoprene washer (14), spacer (15), ball bearing (16) and clutch sleeve (17).
  - (h) Press ball bearing (13) and ball bearing (16) from clutch sleeve (17). Remove neoprene washer (14).
  - (i) Replace with new parts, as required.
  - (j) Install neoprene washer (14) and ball bearing (13) into clutch sleeve (17). Make sure it is placed in the end opposite the side hole.
  - (k) Install spacer (15) and press ball bearing (16) into clutch sleeve (17).
  - (l) Press shaft (2) into ball bearing (16), clutch sleeve (17), spacer (15), neoprene washer (14) and ball bearing (13).

**NOTE**

Make sure that small tab on lockwasher (9) fits into keyway.

- (m) Install key (12), clutch plate (11), lockwasher (9) and nut (10). Tighten nut (10) and bend washer (9) up against nut (10).
- (n) Install clutch disk (8). Secure with four hex head screws (6) and four lockwashers (7).

**5-41. DARNING SEWING MACHINE CLUTCH AND MOTOR ASSEMBLY MAINTENANCE - continued.**

Repair - continued.

**NOTE**

It may be necessary to remove and reinstall locking screw (21) to install brake block (5).

- (o) Install brake block (5) into the clutch housing (1). Secure with adjustment bolt (3) and nut (4).
- (p) Apply a small amount of grease to clutch sleeve (17).

**NOTE**

Hole in clutch sleeve (17) must align with hole in clutch housing (1).

- (q) Press clutch housing (1) onto the shaft (2) and clutch sleeve (17).
- (r) Install clutch housing (1) to motor with three retaining brackets (20), three lockwashers (19) and three screws (18).

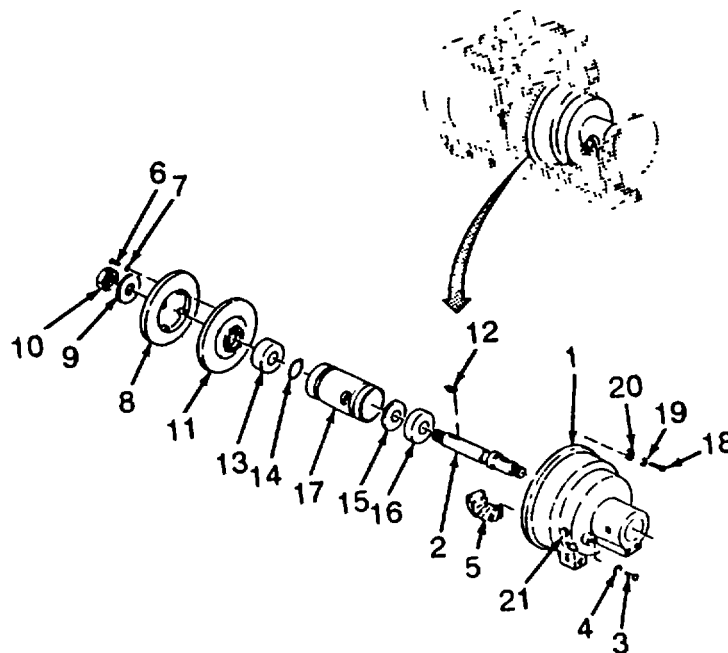

**5-41. DARNING SEWING MACHINE CLUTCH AND MOTOR ASSEMBLY MAINTENANCE - continued.**Repair - continued.

- (3) Replacement of clutch motor flywheel and electric motor.
  - (a) Bend tab flat on washer (2).
  - (b) Remove nut (1), flywheel (3) and key (4) from electric motor (5).
  - (c) Replace with new parts, as required.

**NOTE**

Small tab on washer fits into shaft keyway.

- (d) Install key (4), flywheel (3), washer (2) and loosely install nut (1) onto the electric motor (5).
- (e) Tighten nut (1) and bend washer (2) up against nut (1) to prevent nut (1) from rotating.

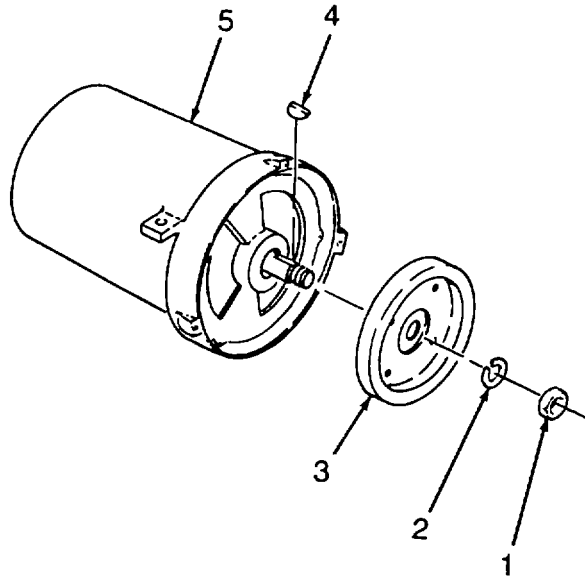

**5-41. DARNING SEWING MACHINE CLUTCH AND MOTOR ASSEMBLY MAINTENANCE - continued.**

Repair - continued.

(4) Replacement of belt tightener.

- (a) Remove two nuts (1), two lockwashers (2) and adjusting rod (3).
- (b) Remove retaining ring (4), hinge pin (5) and belt tightener (6).
- (c) Remove three vibration insulators (7).
- (d) Replace with new parts, as required.
- (e) Install three vibration insulators (7).
- (f) Install retaining ring (4), hinge pin (5) and belt tightener (6).
- (g) Install adjusting rod (3). Secure with two nuts (1) and two lockwashers (2).

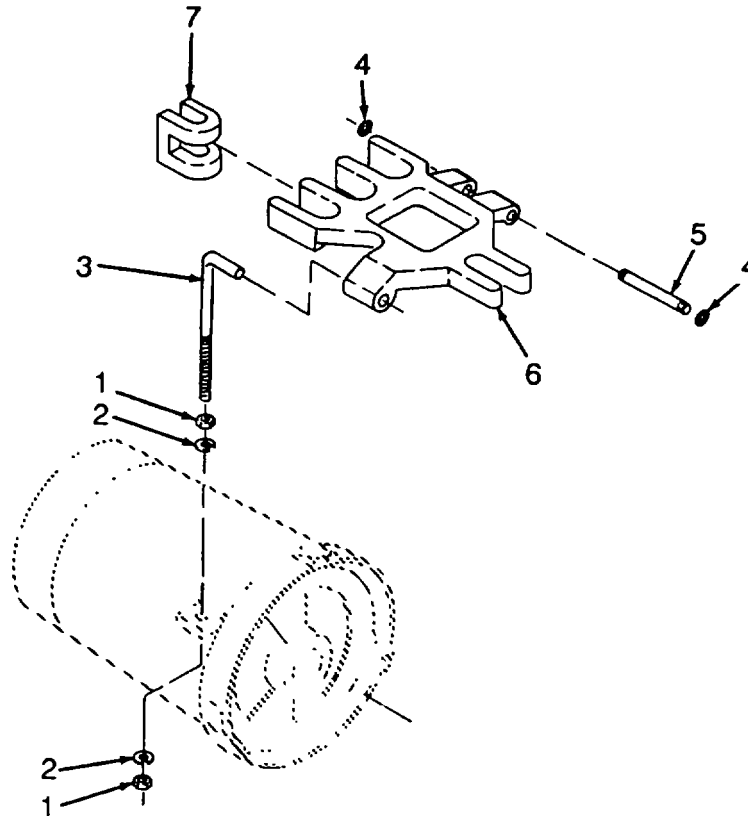

**5-41. DARNING SEWING MACHINE CLUTCH AND MOTOR ASSEMBLY MAINTENANCE - continued.**

Assembly.

- (1) Install key (1), and pulley (2). Secure with setscrew (3). Make sure pulley (2) is against the wall of the shaft.
- (2) Install guard cover (4). Secure with two lockwashers (5) and two screws (6).
- (3) Install guard cover (7). Secure with two lockwashers (8) and two screws (9).

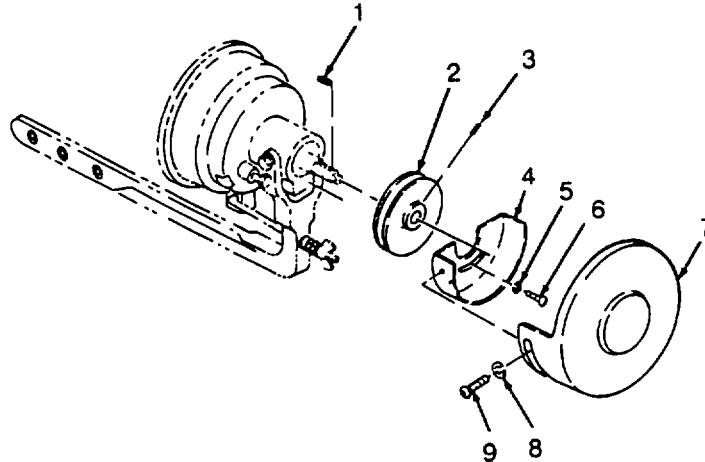

Installation.

- (1) Install clutch and motor (1) onto the sewing table top (2). Secure with three carriage bolts (3), three flat washers (4), three lockwashers (5) and three nuts (6).
- (2) Connect wires to motor as previously tagged.
- (3) Hold the motor back cover in place with two screws (9).
- (4) Tighten two screws (8) on the clamp connect (7).

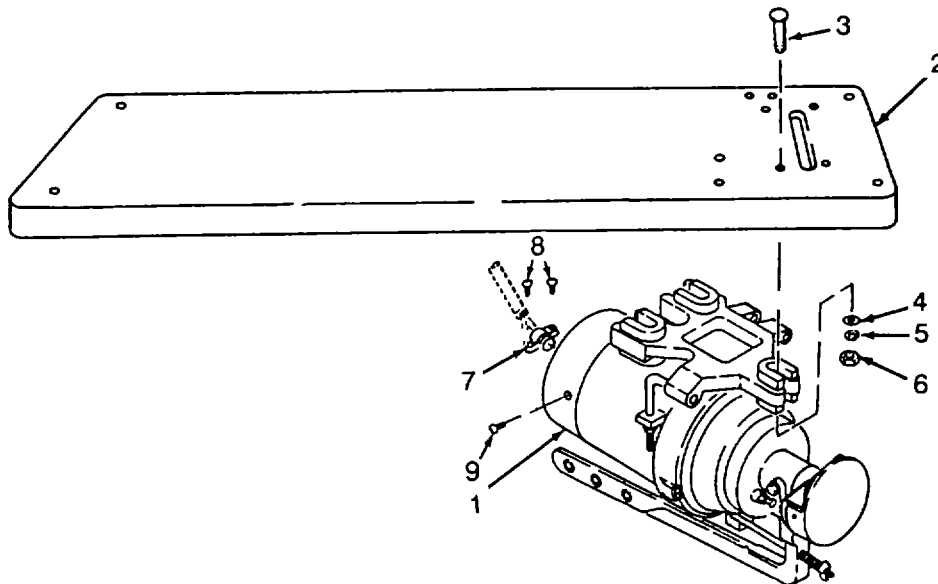

Adjustment. Adjust clutch with adjustment wing nut for proper clutch engagement.

**5-42. BUTTON SEWING MACHINE SIDE COVER AND THREAD GUIDES MAINTENANCE.**

This task covers:

- |            |                 |               |
|------------|-----------------|---------------|
| a. Removal | b. Cleaning     | c. Inspection |
| d. Repair  | e. Installation |               |

**INITIAL SETUP:**

**Tools:**

General Mechanics Tool Kit (Appendix B, Item 1)

**Equipment Condition :**

Thread removed (para. 2-13)

**Materials/Parts:**

Rag, wiping (Appendix F, Item 2)

Removal.

**NOTE**

Location of thread holes for proper installation.

- (1) Remove thread guide pins (1, 2, 3, 4, 5 and 6) with punch.
- (2) Remove two cover nuts (7) and right side cover (8).

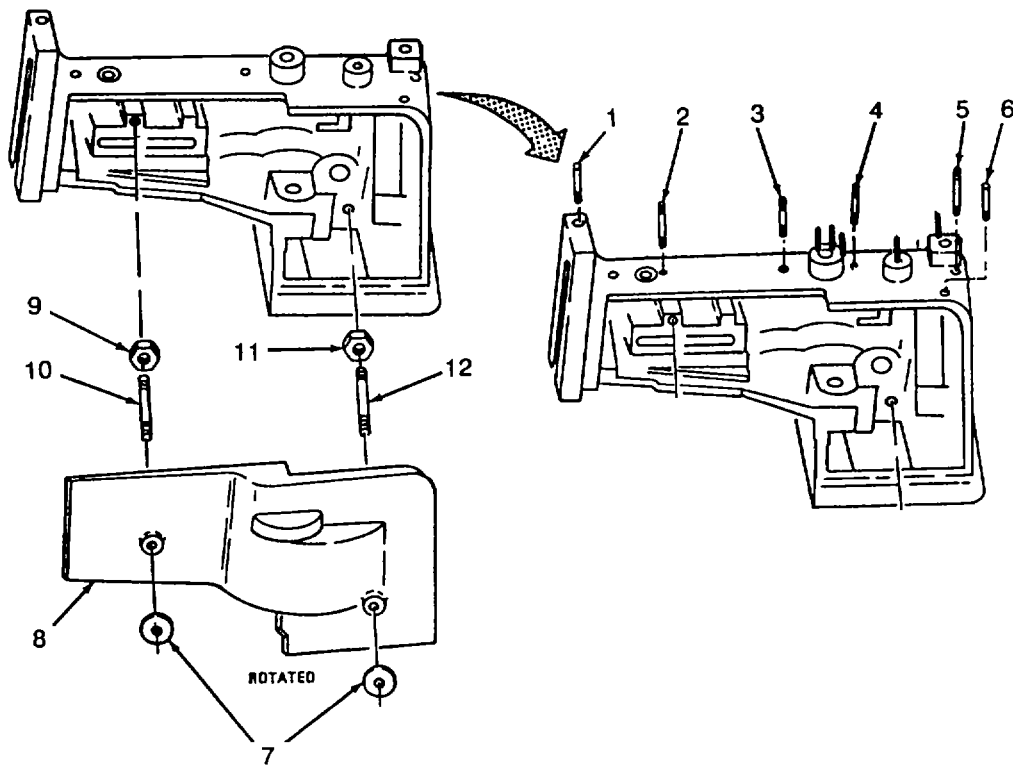

**5-42. BUTTON SEWING MACHINE SIDE COVER AND THREAD GUIDES MAINTENANCE - continued.**Removal - continued.

- (4) Loosen locknut (11) and remove long stud (12).
- (3) Loosen locknut (9) and remove short stud (10).

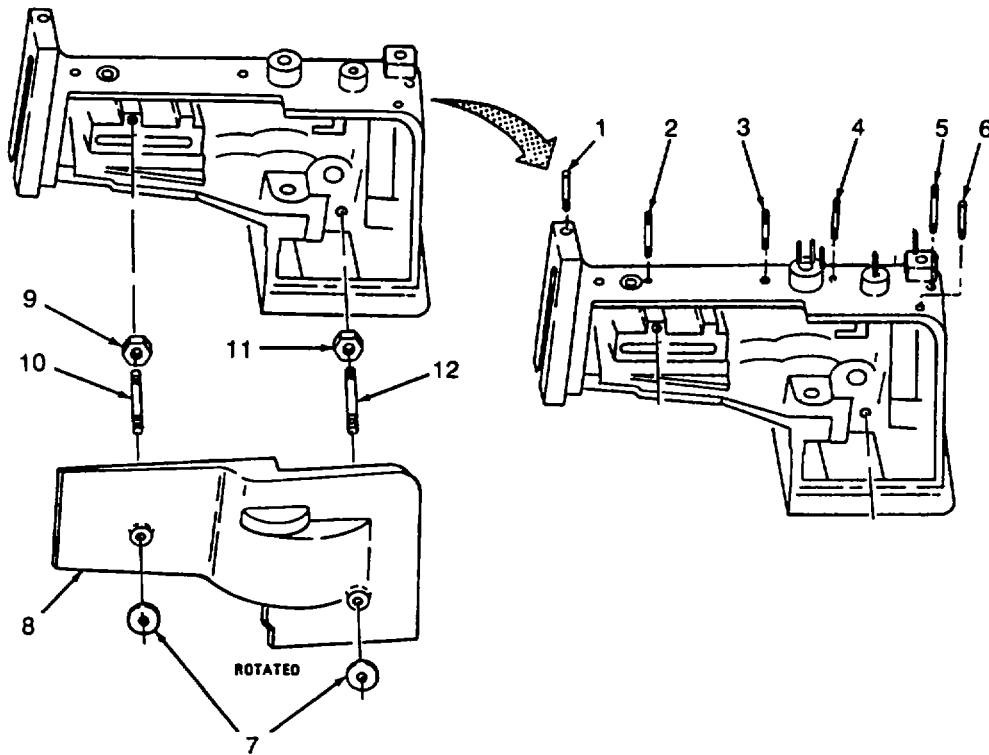
Cleaning.

Wipe all parts clean using a dry wiping rag (Appendix F, Item 2).

Inspection.

- (1) Inspect hardware for damage.
- (2) Inspect guide pins for damage.
- (3) Inspect right side cover for damage.
- (4) Inspect short stud for damage.
- (5) Inspect long stud for damage.

**5-42. BUTTON SEWING MACHINE SIDE COVER AND THREAD GUIDES MAINTENANCE - continued.**

Repair. Repair of the guide pins and side cover is limited to the replacement of defective components.

Installation.

- (1) Install thread guide pins (1, 2, 3, 4, 5 and 6).
- (2) Install short stud (7) and locknut (8). Secure by tightening locknut (8).
- (3) Install long stud (9) and locknut (10). Secure by tightening locknut (10).
- (4) Install right side cover (11). Secure by tightening two cover nuts (12).

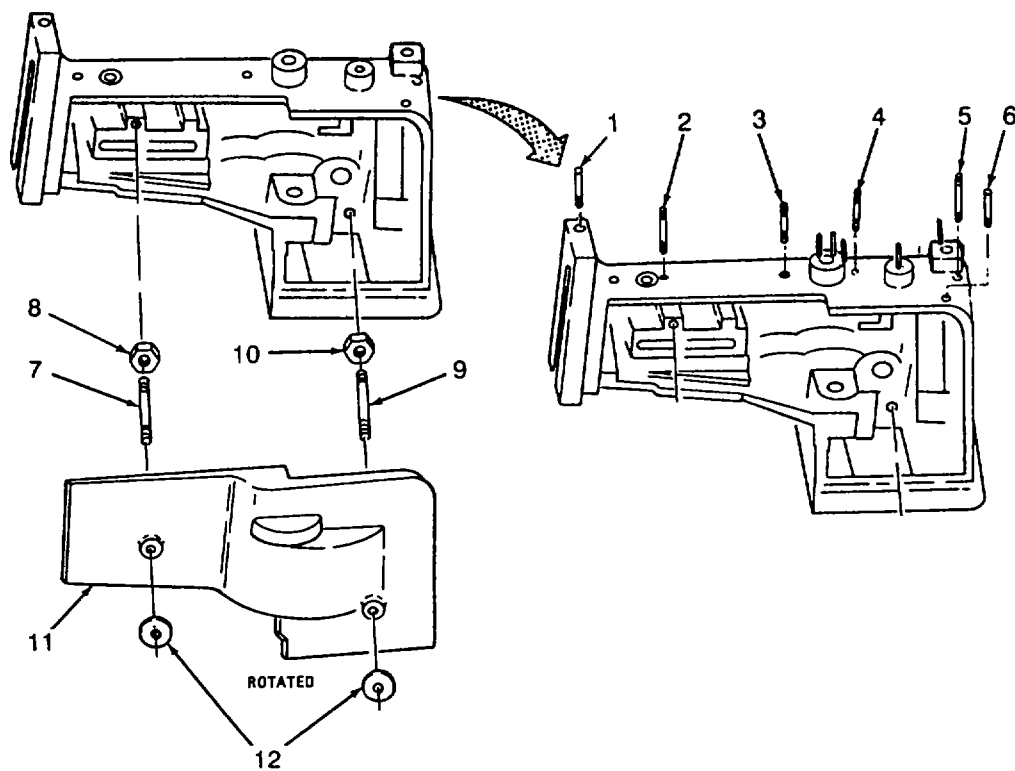

**5-43. BUTTON SEWING MACHINE FACE PLATE AND EYE GUARD MAINTENANCE.**

This task covers:

- |            |                |                 |               |
|------------|----------------|-----------------|---------------|
| a. Removal | b. Disassembly | c. Cleaning     | d. Inspection |
| e. Repair  | f. Assembly    | g. Installation |               |

**INITIAL SETUP:**

**Tools:**

General Mechanics Tool Kit (Appendix B, Item 1)

**Equipment Condition :**

Thread removed (para. 2-13).

**Materials/Parts:**

Rag, wiping (Appendix F, Item 2)

Detergent, General Purpose (Appendix F, Item 11)

Removal.

(1) Remove screw (1), jam nut (2) and eye guard (3), if installed

(2) Remove two screws (4).

(3) Remove face plate (5).

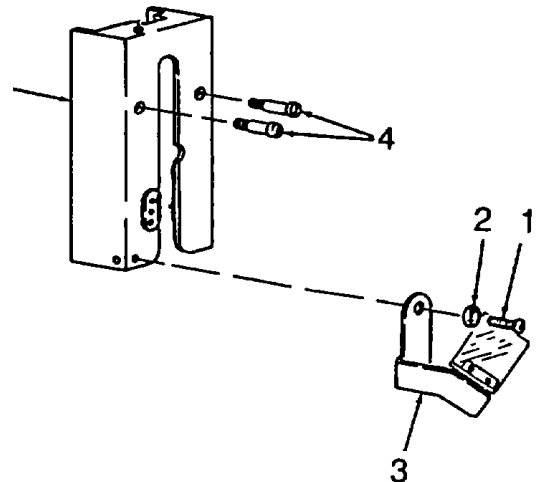

Disassembly.

(1) Remove lower guide screw (1), lower guide plate (2), plate pin (3), lower guide roller (4) and lower thread collar (5) from face plate (6).

(2) Remove setscrew (7).

(3) Remove thread stud (8), thread sleeve (9) and thread spring (10) from face plate (6).

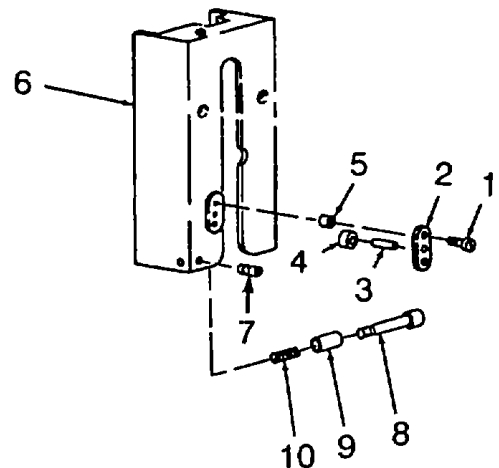

**5-43. BUTTON SEWING MACHINE FACE PLATE AND EYE GUARD MAINTENANCE - continued.**

**Cleaning.**

- (1) Wipe all parts using a wiping rag (Appendix F, Item 2).
- (2) If eye guard is dirty or oily, wash with general purpose detergent (Appendix F, Item 11) and warm water.
- (3) Allow to dry.

Inspection.

- (1) Inspect hardware for damage.
- (2) Inspect eye guard for cracks or other damage.
- (3) Inspect face plate for damage.
- (4) Inspect lower guide plate for damage.
- (5) Inspect plate pin for damage.
- (6) Inspect lower guide roller for damage.
- (7) Inspect lower thread collar for damage.

Repair. Repair is limited to the replacement of defective components.

**5-43. BUTTON SEWING MACHINE FACE PLATE AND EYE GUARD MAINTENANCE - continued.**

Assembly.

- (1) Assemble thread stud (1), thread sleeve (2) and thread spring (3) onto face plate (4). Secure with setscrew (5).
- (2) Assemble plate pin (6), lower guide roller (7), lower thread collar (8) and lower guide plate (9), onto face plate (4). Secure with lower guide screw (10).

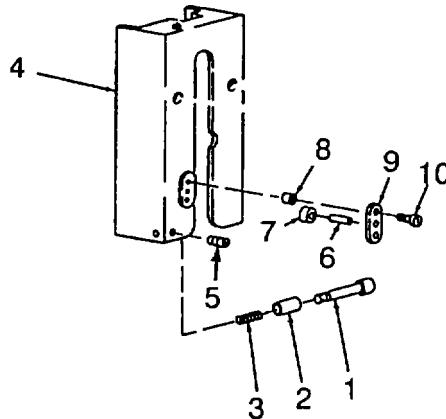

Installation.

- (1) Install face plate (1). Secure with two screws (2).
- (2) Install eye guard (3) and secure with screw (4) and jam nut (5).

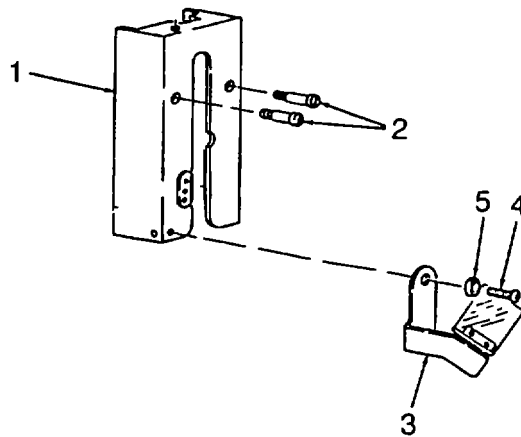

**5-44. BUTTON SEWING MACHINE AUTOMATIC THREAD TENSION DISKS AND RELEASE DISK, SPRING, AND STUDS ..**

**This task covers:**

- |            |                 |               |
|------------|-----------------|---------------|
| a. Removal | b. Cleaning     | c. Inspection |
| d. Repair  | e. Installation | f. Adjustment |

**INITIAL SETUP:**

**Tools:**

General Mechanics Tool Kit (Appendix B, Item 1)

**Equipment Condition:**

Thread removed (para. 2-13).

**Materials/Parts:**

Rag, wiping (Appendix F, Item 2)  
 Cleaning Solvent (Appendix F, Item 8)  
 Brush, Medium Bristle (Appendix F, Item 1)

Removal.

- (1) Remove tension stud thumb nuts (1).
- (2) Lift the spring (2), the release disk (3) and the two thread tension disks (4) from the stud (5).
- (3) Lift the spring (6) and the two tension disks (7) from the stud (8).
- (4) Turn the studs (5 and 8) counterclockwise and remove them from the machine arm.

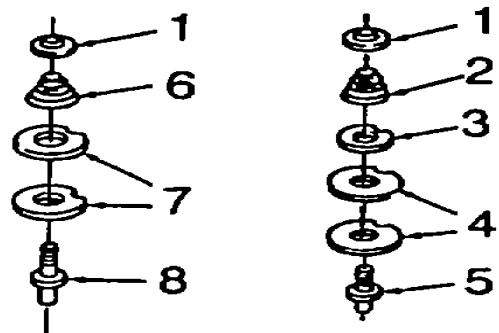

Cleaning.

- (1) Remove all buildups of grease, dirt, etc., by wiping with a wiping rag (Appendix F, Item 2).

**WARNING**

Cleaning solvent, Federal Specification P-D-680, is both toxic and flammable. Keep off skin. Use only in a well ventilated area and avoid prolonged breathing of vapors. Keep away from open flame.

- (2) Clean using cleaning solvent (Appendix F, Item 8) and either a wiping rag (Appendix F, Item 2) or a medium bristle brush (Appendix F, Item 1).
- (3) Allow to dry.

**5-44. BUTTON SEWING MACHINE AUTOMATIC THREAD TENSION DISKS AND RELEASE DISK, SPRING, AND STUDS - continued .**

Inspection.

- (1) Inspect hardware for damage.
- (2) Inspect spring for broken coils and corrosion.
- (3) Inspect disks for damage.
- (4) Inspect studs for damage.

Repair. Repair is limited to the replacement of defective components with serviceable ones.

Installation.

- (1) Turn the studs (1 and 2) clockwise and install them into the machine arm.

**NOTE**

Facing tension disk shall form a pulley.

- (2) Install the two tension disks (3) and the spring (4) over the stud (1).
- (3) Install the two thread tension disks (5), the release disk (6) and the spring (7) over the stud (2).
- (4) Install the tension stud thumb nuts (8).

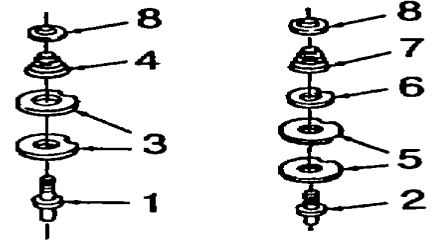

Adjustment.

Refer to paragraph 4-49p to adjust the automatic thread tension.

**5-45. BUTTON SEWING MACHINE NEEDLE BAR MAINTENANCE.**

This task covers:

- |            |                 |               |
|------------|-----------------|---------------|
| a. Removal | b. Cleaning     | c. Inspection |
| d. Repair  | e. Installation | f. Adjustment |

**INITIAL SETUP:**

**Tools:**

General Mechanics Tool Kit (Appendix B, Item 1)

**Materials/Parts:**

Rag, wiping (Appendix F, Item 2)  
 Cleaning Solvent (Appendix F, Item 8)  
 Brush, Medium Bristle (Appendix F, Item 1)

**Equipment Condition:**

Face Plate removed (para. 5-43)  
 Thread removed (para. 2-13).  
 Needle removed (para. 2-13).

Removal.

- (1) Loosen the hinge stud screw(1) that secures the needle bar to the connecting stud.
- (2) Remove needle setscrew (2).
- (3) Slide the needle bar (3) from the connecting link stud and from the top of the machine.

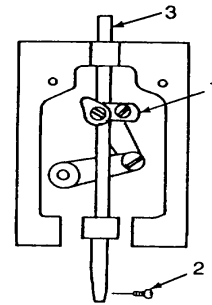

Cleaning.

- (1) Remove all buildups of grease, dirt, etc., by wiping with a wiping rag, (Appendix F, Item 2).

**WARNING**

Cleaning solvent, Federal Specification P-D-680, is both toxic and flammable. Keep off skin. Use only in a well ventilated area and avoid prolonged breathing of vapors. Keep away from open flame.

- (2) Clean using cleaning solvent (Appendix F, Item 8) and either a wiping rag (Appendix F, Item 2) or a medium bristle brush (Appendix F, Item 1).

- (3) Allow to dry.

**5-45. BUTTON SEWING MACHINE NEEDLE BAR MAINTENANCE - continued.**Inspection.

- (1) Inspect screw for damage.
- (2) Inspect needle bar for bending and other damage.

Repair. Repair is limited to the replacement of defective items.

Installation.

- (1) Slide the needle bar (1) into the connecting link stud through the top of the machine.
- (2) Secure needle bar with screw (2)
- (3) Install needle setscrew (3).

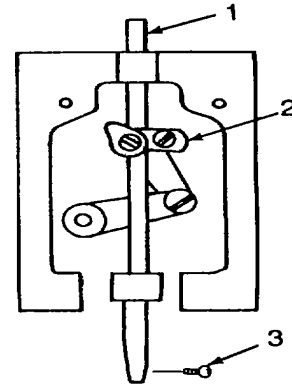
Adjustment.

- (1) Install needle per paragraph 2-13. Make sure the needle is as far up as it will go into the needle bar.
- (2) Engage clutch and hand-turn the drive pulley to bring the needle bar to its highest position.
- (3) Loosen the hinge stud screw that holds the needle bar connecting link stud to the needle bar (1).
- (4) Hold the needle bar connecting link stud at the highest point of its stroke, and move the needle bar (1) up or down to bring the top of the needle eye 1-5/16 inch above the top surface of the needle plate and tighten screw (2).
- (5) Check this adjustment to see that the needle point does not protrude through the needle hole in the looper when the needle bar is at the bottom of its stroke. This check cannot be made until the looper is adjusted or timed correctly (para. 2-13).

**5-46. BUTTON SEWING MACHINE CRANK AND NEEDLE BAR GUIDE WITH SHAFT AND BUSHING.**

This task covers:

- |            |                |                 |               |
|------------|----------------|-----------------|---------------|
| a. Removal | b. Disassembly | c. Cleaning     | d. Inspection |
| e. Repair  | f. Assembly    | g. Installation | h. Adjustment |

**INITIAL SETUP:**

**Tools:**

General Mechanics Tool Kit (Appendix B, Item 1)

**Materials/Parts:**

- Rag, wiping (Appendix F, Item 2)
- Cleaning Solvent (Appendix F, Item 8)
- Brush, Medium Bristle (Appendix F, Item 1)

**Equipment Condition :**

Thread removed (para. 2-13).

Removal.

- (1) Place the machine on its side to gain access to its bottom. Remove end cover.
- (2) Loosen the screw (1) from the crank (2).
- (3) Slide the needle guide shaft assembly (3) and the spring (4) from the crank (2).
- (4) Remove the crank (2) from the machine.
- (5) Remove the spring (4) from the needle guide (3).
- (6) Remove the setscrew (5) that secures the bushing (6) to the machine, and remove the bushing from the machine.

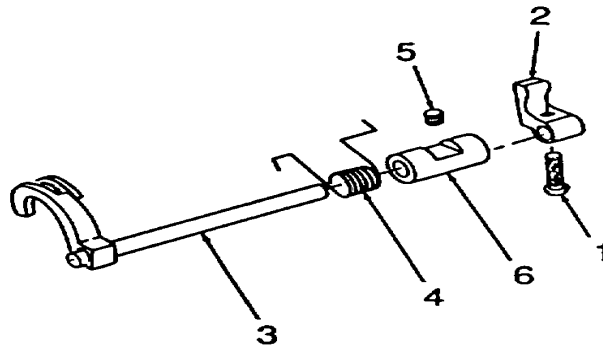

Disassembly.

Remove the two screws (1) that secure the finger (2) to the needle guide (3) and remove the finger (2) from the needle guide (3).

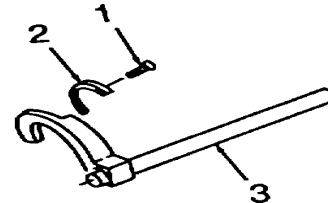

**5-46. BUTION SEWING MACHINE CRANK AND NEEDLE GUIDE WITH SHAFT AND BUSHING - continued.**Cleaning.

- (1) Remove all buildups of grease, dirt, etc., by wiping with a wiping rag (Appendix F, Item 2).

**WARNING**

Cleaning solvent, Federal Specification P-D-680, is both toxic and flammable. Keep off skin. Use only in a well ventilated area and avoid prolonged breathing of vapors. Keep away from open flame.

- (2) Clean using cleaning solvent (Appendix F, Item 8) and either a wiping rag (Appendix F, Item 2) or a medium bristle brush (Appendix F, Item 1).
- (3) Allow to dry.

Inspection.

- (1) Inspect screws for damage.
- (2) Inspect finger for damage.
- (3) Inspect needle guide for damage.

Repair. Repair is limited to the replacement of defective items.

Assembly.

Install the finger (1) to the needle guide (2). Secure with two screws (3). Ensure that a thread can pass between the end of the finger (1) and the sharp edge of the needle guide (2).

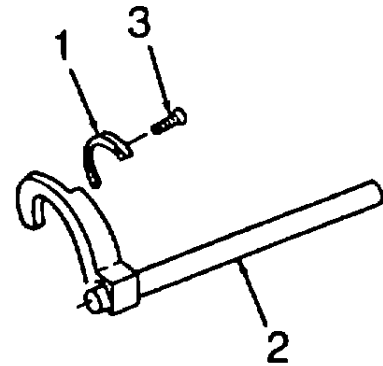

**5-46. BUTTON SEWING MACHINE CRANK AND NEEDLE GUIDE WITH SHAFT AND BUSHING - continued.**Installation**NOTE**

Bushing (1) has an oil hole that must face the top.

- (1) Install the bushing (1) into the machine and secure with setscrew (2).
- (2) Install the spring (3) onto the needle guide shaft (4).
- (3) Install the crank (5) onto the machine.
- (4) Slide the needle guide shaft assembly (4) through bushing (1) and through the crank (5). Secure with screw (6).

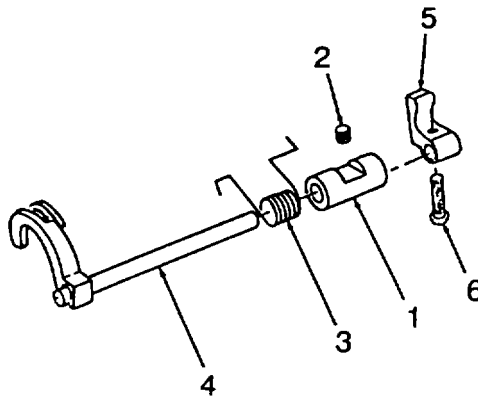

**5-46. BUTTON SEWING MACHINE CRANK AND NEEDLE GUIDE WITH SHAFT AND BUSHING - continued.**

Adjustment.

Adjust the needle guide and the finger separately and also adjust otime them together as a unit.

(1) Adjust the needle guide so that its inside surface just clears the needle. Loosen the setscrew (2) that holds the needle guide shaft bushing (1), move the bushing enough to make the inside of the guide just clear the needle, and then tighten the setscrew (2).

(2) Adjust the needle guide thread finger (3) so that the point of the needle on its left-hand downstroke clears the inside of the finger (3) by about 1/32 inch. Hand-turn the drive pulley until the eye of the needle on its left-hand downstroke passes the finger. Loosen the screw (4), turn the needle guide until the needle clears the guide by about 1/32 inch, and tighten the screw securely.

(3) Adjust the needle guide and finger (3) together as a unit. Hand-turn the drive pulley until the needle bar has reached its lowest position and has risen about 13/16 inch. Loosen the screw in the cam on the looper shaft and then turn the cam until the needle guide starts to move back to the right. Tighten the screw.

**NOTE**

The nature of the material to which buttons are to be sewed may make it necessary to vary slightly from the needle guide and finger adjustment described above.

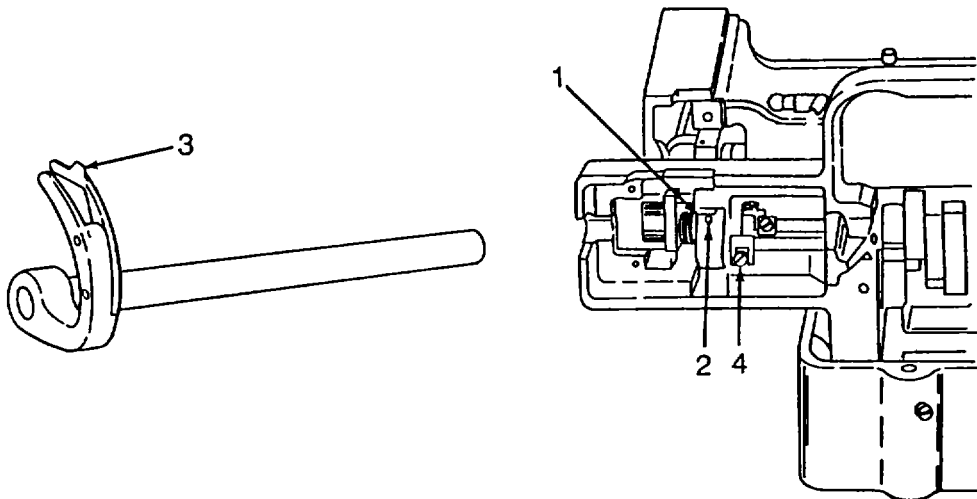

**5-46. BUTTON SEWING MACHINE THREAD LOOPER SHAFT, LINK, CAM, AND CRANK MAINTENANCE**

This task covers:

- |            |             |               |
|------------|-------------|---------------|
| a. Removal | b. Cleaning | c. Inspection |
| d. Repair  | e. Assembly | f. Adjustment |

**INITIAL SETUP:****Tools:**

General Mechanics Tool Kit (Appendix B, Item 1)

**Materials/Parts:**

Wiping rag (Appendix F, Item 2)  
 Cleaning Solvent (Appendix F, Item 8)  
 Brush, Medium Bristle (Appendix F, Item 1)

**Equipment Condition:**

Needle guide removed except for bushing (para. 5-46).

Thread and needle removed (para. 2-13).

**Removal.**

- (1) Remove the setscrew (1) and the looper from the shaft (3).
- (2) Remove the two setscrews (4) from the needle guide cam (5).
- (3) Remove the two setscrews (6) from the crank (7).
- (4) Remove the shaft (3) out through the front of the machine.
- (5) Remove the crank (7) with stud (8), cam (5), and the link (9) from the machine.

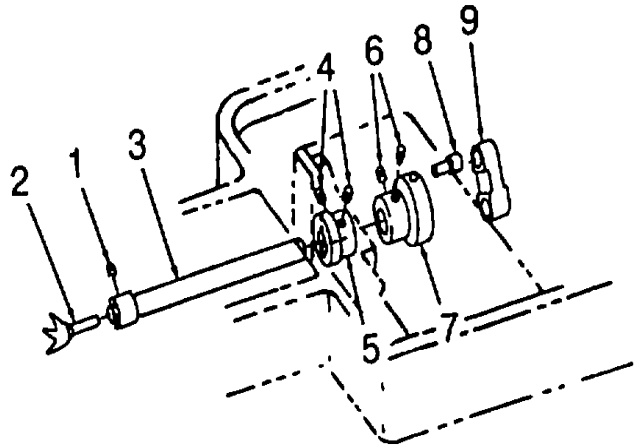

**5-47. BUTTON SEWING MACHINE THREAD LOOPER SHAFT, LINK, CAM, AND CRANK MAINTENANCE - continued.**Cleaning.

- (1) Remove all buildups of grease, dirt, etc., with a wiping rag (Appendix F, Item 2).

**WARNING**

Cleaning solvent, Federal Specification P-D-680, is both toxic and flammable. Keep off skin. Use only in a well ventilated area and avoid prolonged breathing of vapors. Keep away from open flame

- (2) Clean using cleaning solvent (Appendix F, Item 8) and either a wiping rag (Appendix F, Item 2) or a medium bristle brush (Appendix F, Item 1).
- (3) Allow to dry.

Inspection.

- (1) Inspect hardware for damage.
- (2) Inspect looper for damage.
- (3) Inspect needle guide cam for damage.
- (4) Inspect shaft for straightness and for damage.
- (5) Inspect crank for damage.
- (6) Inspect cam for damage and excessive wear.
- (7) Inspect link for damage

Repair. Repair is limited to the replacement of defective parts.

**5-47. BUTTON SEWING MACHINE THREAD LOOPER SHAFT, LINK, CAM, AND CRANK MAINTENANCE - continued.**

Installation.

- (1) Install the crank (1) with stud (2), and the link (4) into the machine.
- (2) Install the shaft (5) through the front of the machine, cam (3) and crank (1).
- (3) Install the crank (1). Secure with two setscrews (6) and two setscrews (7).
- (4) Install looper (8) and secure with setscrew (9).

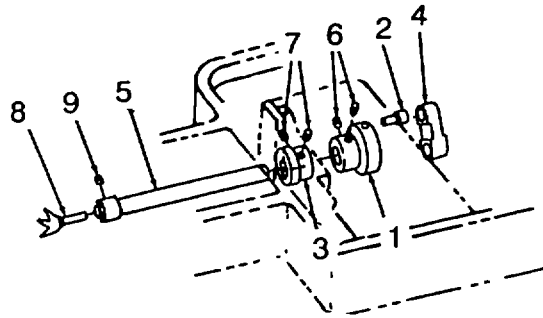

Adjustment

Time the looper with respect to the needle according to paragraph 4-49.

**5-48. BUTTON SEWING MACHINE PRESSER BAR MAINTENANCE.**

This task covers:

- |            |                 |               |
|------------|-----------------|---------------|
| a. Removal | b. Cleaning     | c. Inspection |
| d. Repair  | e. Installation |               |

**INITIAL SETUP:**

**Tools:**

General Mechanics Tool Kit (Appendix B, Item 1)

**Equipment Condition:**

Side cover removed (para. 5-42)

**Material/Parts:**

Cleaning Solvent (Appendix F, Item 8)  
 Brush, Medium Bristle (Appendix F, Item 1)  
 Rag, wiping (Appendix F, Item 2)

Removal.

- (1) Loosen locknut (1). Remove thumb screw (2) and locknut (1).
- (2) Remove presser bar screw (3) and presser bar spring (4).
- (3) Loosen setscrew (5).
- (4) Pull shaft (6) out of the top of the machine.
- (5) Remove collar (7)

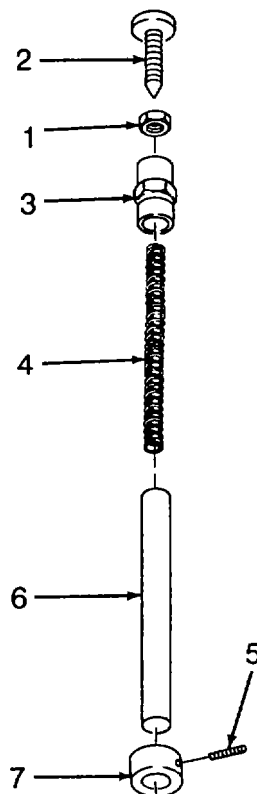

**5-48. BUTTON SEWING MACHINE PRESSER BAR MAINTENANCE - continued.**

Cleaning.

- (1) Remove all buildups of grease, dirt, etc., by wiping with a wiping rag (Appendix F, Item 2).

**WARNING**

Cleaning solvent, Federal Specification P-D-680, is both toxic and flammable. Keep off skin. Use only in well-ventilated area and avoid prolonged breathing of vapors. Keep away from open flame.

- (2) Clean using cleaning solvent (Appendix F, Item 8) and either a wiping rag (Appendix F, Item 2) or a medium bristle brush (Appendix F, Item 1).
- (3) Allow to dry.

Inspection.

- (1) Inspect hardware for damage.
- (2) Inspect spring for broken coils and corrosion.
- (3) Inspect shaft for damage.
- (4) Inspect collar for damage.

Repair. Repair is limited to the replacement of defective components with serviceable ones.

**5-48. BUTTON SEWING MACHINE PRESSER BAR MAINTENANCE - continued.**Installation.**NOTE**

Button arm clamp assembly must be set for four hole buttons.

- (1) Slide shaft (1) through machine and collar (2). Let shaft (1) come to rest onto button arm clamp assembly.
- (2) Position collar (2) so that it is just above the needle bar lever. Tighten with setscrew (3).
- (3) Install presser bar spring (4), presser bar screw (5). Secure through the outside with the locknut (6) and thumbscrew (7).

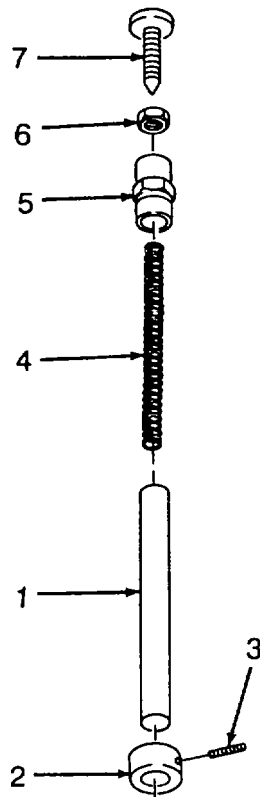

5-140

**5-49. BUTTON SEWING MACHINE THREAD TENSION ROD ASSEMBLY MAINTENANCE.**

This task covers:

- |            |                 |               |
|------------|-----------------|---------------|
| a. Removal | b. Cleaning     | c. Inspection |
| d. Repair  | e. Installation | f. Adjustment |

**INITIAL SETUP:**

**Tools:**

General Mechanics Tool Kit (Appendix B, Item 1)

**Equipment Condition:**

Automatic thread tension disk spring and stud removed (para. 5-44)  
Side cover removed (para. 5-42)

**Material/Parts:**

Cleaning Solvent (Appendix F, Item 8)  
Brush, Medium Bristle (Appendix F, Item 1)  
Rag, wiping (Appendix F, Item 2)

Removal

- (1) Loosen both rod adjustment nuts (1).
- (2) Using a pair of pliers, grip the thread tension rod (2) at the rod adjustment nuts (1) and push up to overcome the thread tension spring (3) enough to remove the thread tension sleeve (4)
- (3) Remove two rod adjustment nuts (1).
- (4) Remove the thread tension rod (2) out of the top of the machine
- (5) Remove thread tension spring (3).

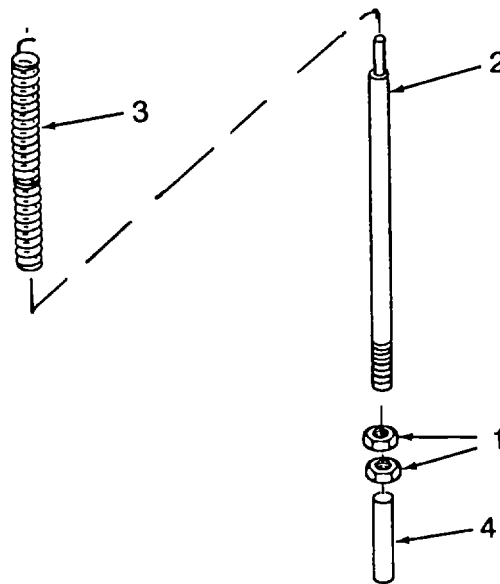

**5-49. BUTTON SEWING MACHINE THREAD TENSION ROD ASSEMBLY MAINTENANCE - continued.**

Cleaning.

- (1) Remove all buildups of grease, dirt, etc., by wiping with a wiping rag (Appendix F, Item 2).

**WARNING**

Cleaning solvent, Federal Specification P-D-680, is both toxic and flammable. Keep off skin. Use only in well-ventilated area and avoid prolonged breathing of vapors. Keep away from open flame.

- (2) Clean using cleaning solvent (Appendix F, Item 8) and either a wiping rag (Appendix F, Item 2) or a medium bristle brush (Appendix F, Item 1).
- (3) Allow to dry.

Inspection.

- (1) Inspect hardware for damage.
- (2) Inspect spring for broken coils and corrosion.
- (3) Inspect rod for damage.
- (4) Inspect sleeve for damage.

Repair. Repair is limited to the replacement of defective components with serviceable ones.

**5-49. BUTTON SEWING MACHINE THREAD TENSION ROD ASSEMBLY MAINTENANCE - continued.**Installation.

- (1) Slide the thread tension rod (1) into the machine from the top.
- (2) Slip the thread tension spring (2) over the thread tension rod (1).
- (3) Thread both rod adjustment nuts (3) all the way up the threaded area of the thread tension rod (1).
- (4) Grab the rod adjustment nuts (3) with a pair of pliers and push up to compress the spring. Install the thread tension sleeve (4) into the machine with the hollow end up. Insert the thread tension rod (1) into the thread tension sleeve.

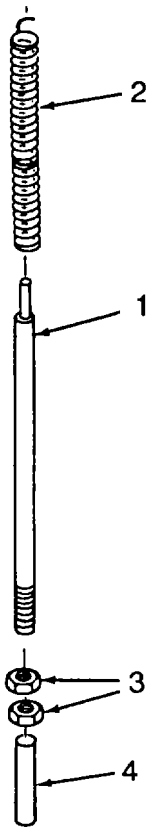
Adjustment.

- (1) Rotate machine and observe thread tension rod travel to the highest point.
- (2) Make sure that the automatic tension assembly will thread in place.
- (3) Adjust rod adjustment nuts to lower thread tension rod.

**5-50. BUTTON SEWING MACHINE THREAD RELEASE AND NIPPER MAINTENANCE.**

This task covers:

- |            |                 |               |
|------------|-----------------|---------------|
| a. Removal | b. Cleaning     | c. Inspection |
| d. Repair  | e. Installation | f. Adjustment |

**INITIAL SETUP:**

**Tools:**

General Mechanics Tool Kit (Appendix B, Item 1)

**Equipment Condition:**

Side covers removed (para 5-42)  
Thread removed (para 2-13)

**Material/Parts:**

Cleaning Solvent (Appendix F, Item 8)  
Brush, Medium Bristle (Appendix F, Item 1)  
Rag, wiping (Appendix F, Item 2)

Removal.

- (1) Remove the thread nipper screw (1), plate screw (2), thread nipper plate (3), and the plate washer (4).
- (2) Loosen two setscrews (5). Remove thread release head (6) with thread rod (7), lower spring (8), spring washer (9), two thread collars (10) and the thread release spring (11).
- (3) Remove thread release head (6) from thread rod (7).
- (4) Remove hinge lever screw (12) and thread release lever (13).
- (5) Remove thread nipper stud (14), stud washer (15) and stud nut (16) from thread release lever (13).

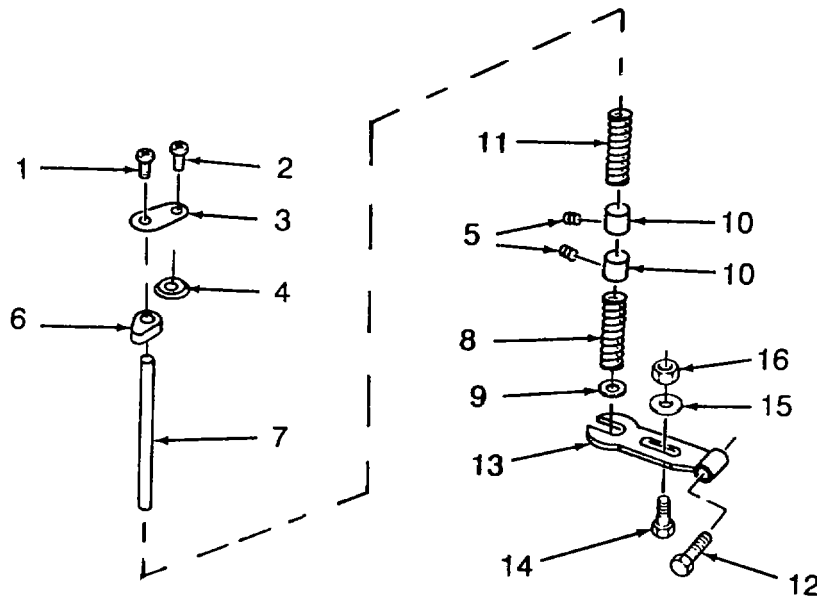

**5-50. BUTTON SEWING MACHINE THREAD RELEASE AND NIPPER MAINTENANCE - continued.**

Cleaning.

- (1) Remove all buildups of grease, dirt, etc., by wiping with a wiping rag (Appendix F, Item 2).

**WARNING**

Cleaning solvent, Federal Specification P-D-680, is both toxic and flammable. Keep off skin Use only in well-ventilated area and avoid prolonged breathing of vapors. Keep away from open flame.

- (2) Clean using cleaning solvent (Appendix F, Item 8) and either a wiping rag (Appendix F, Item 2) or a medium bristle brush (Appendix F, Item 1).
- (3) Allow to dry.

Inspection

- (1) Inspect hardware for damage.
- (2) Inspect thread nipper plate for damage.
- (3) Inspect springs for broken coils and corrosion
- (4) Inspect thread rod for damage.
- (5) Inspect thread release lever for damage

Repair. Repair is limited to the replacement of defective components with serviceable ones.

**5-50. BUTION SEWING MACHINE THREAD RELEASE AND NIPPER MAINTENANCE - continued.**

Installation.

- (1) Install thread nipper stud (1), stud washer (2) onto thread release lever (3) and secure with nut (4).
- (2) Install the thread release lever (3) to the machine and secure with the hinge lever screw (5).
- (3) Screw thread release head (6) onto the thread release rod (7).
- (4) Install the thread release head (6) and the thread rod (7) into the machine from the top.

**NOTE**

The thread release spring is a lighter gauge material than the lower spring is.

- (5) Slide the thread release spring (8), two thread collars (9), lower spring (10), and the spring washer (11) onto the thread release rod (7).
- (6) Tighten two setscrews (12).

**NOTE**

Plate washer is installed with bevel side up.

- (7) Install the thread nipper plate (13) and the plate washer (14). Secure with the thread screw (15) and the plate screw (16).

Adjustment. Refer to paragraph 4-49 for thread release and nipper adjustment.

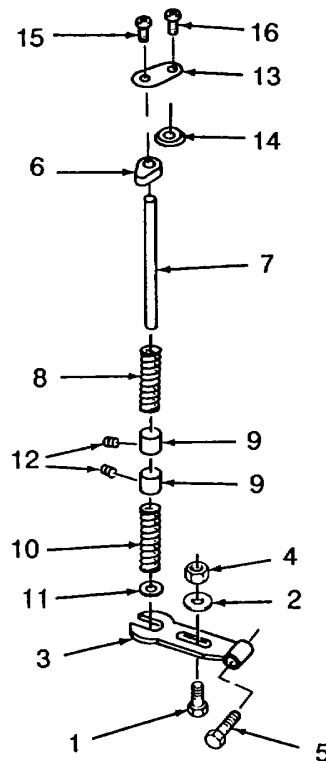

**5-51. BUTTON SEWING MACHINE ARM CLAMP AND SPREADER MAINTENANCE.**

This task covers:

- |                 |                |             |
|-----------------|----------------|-------------|
| a. Removal      | b. Disassembly | c. Cleaning |
| d. Inspection   | e. Repair      | f. Assembly |
| g. Installation |                |             |

**INITIAL SETUP:**

**Tools:**

General Mechanics Tool Kit (Appendix B, Item 1)

**Equipment Condition:**

Thread removed (para. 2-13)

**Material/Parts:**

Cleaning Solvent (Appendix F, Item 8)  
 Brush, Medium Bristle (Appendix F, Item 1)  
 Rag, wiping (Appendix F, Item 2)

Removal. Remove button clamp assembly (para 2-13).

Disassembly

- (1) Remove thumbscrew (1), washer (2), and clamp lever (3).
- (2) Remove two spreader screws (4), two washers (2) from the arm hinge pin (5).
- (3) Remove closing spring (6).
- (4) Remove spreader screw (7), spreader screw nut (8), screw (20), screw (17), and bottom spreader (9).
- (5) Remove two spreader screws (13) and spreader handle (14).
- (6) Remove hinge screw (18) from left button clamp (11) and right button clamp (12).
- (7) Remove spring screw (15), spring (16), screw (17), and the clamp hinge screw (18) from the right button clamp (12).
- (8) Remove spring screw (15), spring (19) from the left button clamp (11).

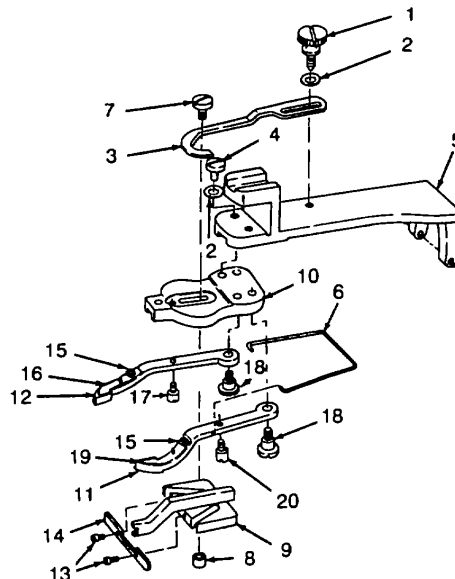

**5-51. BUTITON SEWING MACHINE ARM CLAMP AND SPREADER MAINTENANCE - continued.**Cleaning.

- (1) Remove all buildups of grease, dirt, etc., by wiping with a wiping rag (Appendix F, Item 2).

**WARNING**

Cleaning solvent, Federal Specification P-D-680, is both toxic and flammable. Keep off skin. Use only in well-ventilated area and avoid prolonged breathing of vapors. Keep away from open flame.

- (2) Clean using cleaning solvent (Appendix F, Item 8) and either a wiping rag (Appendix F, Item 2) or a medium bristle brush (Appendix F, Item 1).
- (3) Allow to dry.

Inspection.

- (1) Inspect hardware for damage.
- (2) Inspect closing spring for damage.
- (3) Inspect left button clamp for damage.
- (4) Inspect right button clamp for damage.
- (5) Inspect springs for corrosion and broken coils.

Repair. Repair is limited to the replacement of defective components with serviceable ones.

Installation.

- (1) Install spring (1) and spring screw (4) onto left button clamp (3).
- (2) Install spring (5) and spring screw (4) onto right button clamp (7).
- (3) Install the left button clamp (3) to the spreader base (8). Secure with the clamp hinge screw (9).
- (4) Install the right button clamp (7) to the spreader base (8). Secure with the clamp hinge screw (9).
- (5) Install spreader handle (10) and secure with two spreader screws (11).
- (6) Install bottom spreader (12) to the spreader base (8). Secure using spreader screw (13) and spreader screw nut (14)

**5-51. BUTTON SEWING MACHINE ARM CLAMP AND SPREADER MAINTENANCE - continued.**

- (7) Install screw (2) to left button clamp (3) and screw (6) to right button clamp (7).
- (8) Install closing spring (15)
- (9) Install the spreader base (8) to the arm hinge pin (16). Secure with two spreader screws (17) and two washers (18).
- (10) Install the clamp lever (19) to the arm hinge pin (16). Secure using thumbscrew (20) and washer (21).

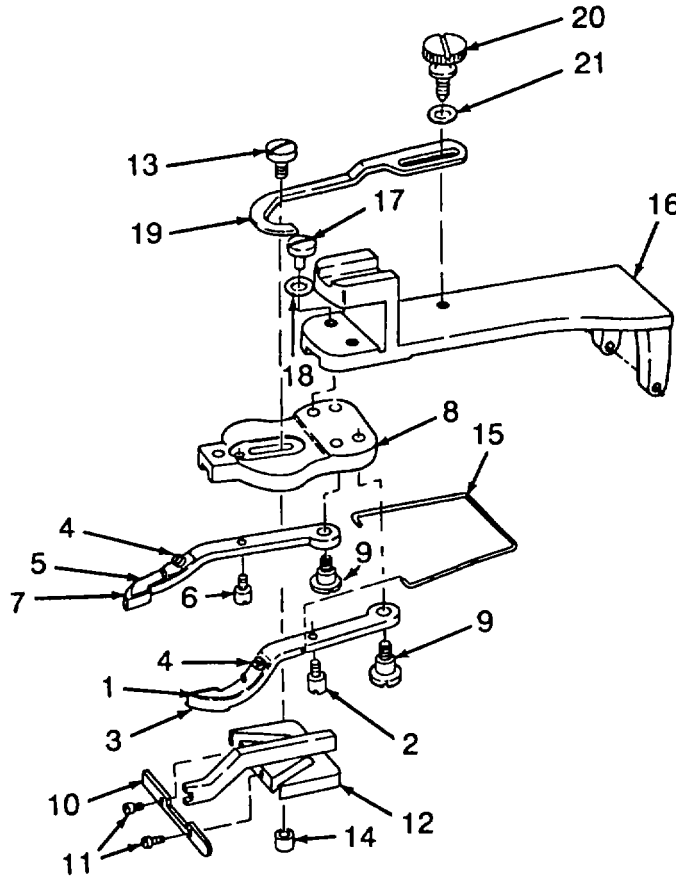

Installation. Install button clamp assembly (para 2-13).

**5-52. BUTTON SEWING MACHINE LIFTING LEVER MAINTENANCE..**

This task covers:

- |            |                 |               |
|------------|-----------------|---------------|
| a. Removal | b. Cleaning     | c. Inspection |
| d. Repair  | e. Installation | f. Adjustment |

**INITIAL SETUP:**

**Tools:**

General Mechanics Tool Kit (Appendix B, Item 1)

**Equipment Condition:**

Button clamp assembly removed (2-13)  
 Side panel removed (5-42)  
 Face plate removed (5-43)

**Material/Parts:**

Cleaning Solvent (Appendix F, Item 8)  
 Brush, Medium Bristle (Appendix F, Item 1)  
 Rag, wiping (Appendix F, Item 2)

Removal.

- (1) Remove two screws (1), and screw (2).
- (2) Remove screw (3) and connection lever (4).
- (3) Remove two screws (5) and two washers (6) and lower plate (7).
- (4) Remove screws (8) and upper plate (9).
- (5) Remove nut (10) and screw (11).
- (6) Remove two screws (12), two washers(13) and lifting holder (14) from lifting lever (15).

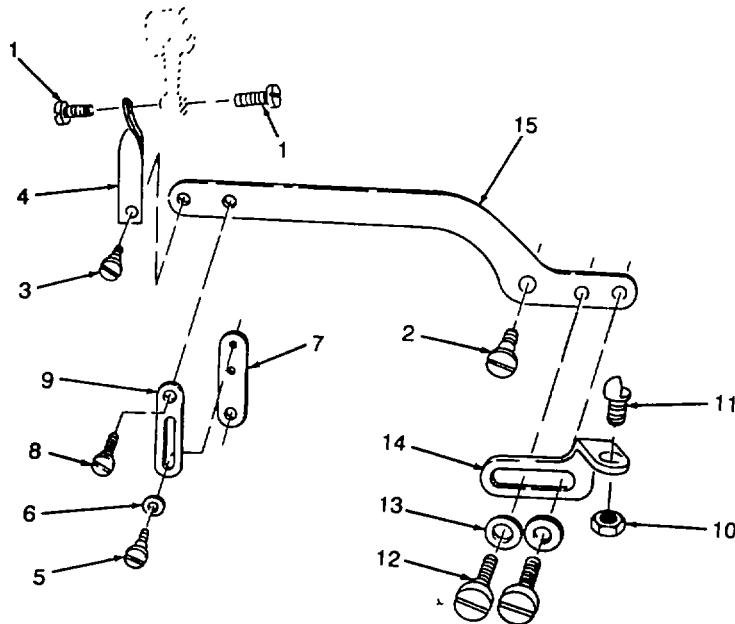

**5-52. BUTTON SEWING MACHINE LIFTING LEVER MAINTENANCE - continued.**

Cleaning.

- (1) Remove all buildups of grease, dirt, etc., by wiping with a wiping rag (Appendix F, Item 2).

**WARNING**

Cleaning solvent, Federal Specification P-D-680, is both toxic and flammable. Keep off skin. Use only in well-ventilated area and avoid prolonged breathing of vapors. Keep away from open flame

- (2) Clean using cleaning solvent (Appendix F, Item 8) and either a wiping rag (Appendix F, Item 2) or a medium bristle brush (Appendix F, Item 1).
- (3) Allow to dry.

Inspection.

- (1) Inspect hardware for damage.
- (2) Inspect lower and upper plate for damage.
- (3) Inspect lifting holder for damage.
- (4) Inspect lifting lever for damage.
- (5) Inspect connecting lever for damage.

Repair. Repair is limited to the replacement of defective components with serviceable ones.

**5-52. BUTTON SEWING MACHINE LIFTING LEVER MAINTENANCE - continued.**

Installation.

- (1) Install lifting holder (1) onto the lifting lever (2). Secure with two screws (3) and two washers (4). Do not tighten the screws (3).

**NOTE**

Be sure that screw (5) has head installed as illustrated.

- (2) Install screw (5) into the lifting holder (1) and secure with nut (6).
- (3) Assemble lower plate (7) to the upper plate (8) with two screws (9) and two washers (10). Do not tighten the screws.
- (4) Install the upper plate (8) onto the lifting lever (2) and secure with screw (11)
- (5) Install connection lever (12) onto the lifting lever (2) and secure with screw (13).
- (6) Install lever assembly on the machine with screw (14), two screws (15)
- (7) Tighten screw (15) so that the connection on lever (12) rotates freely.

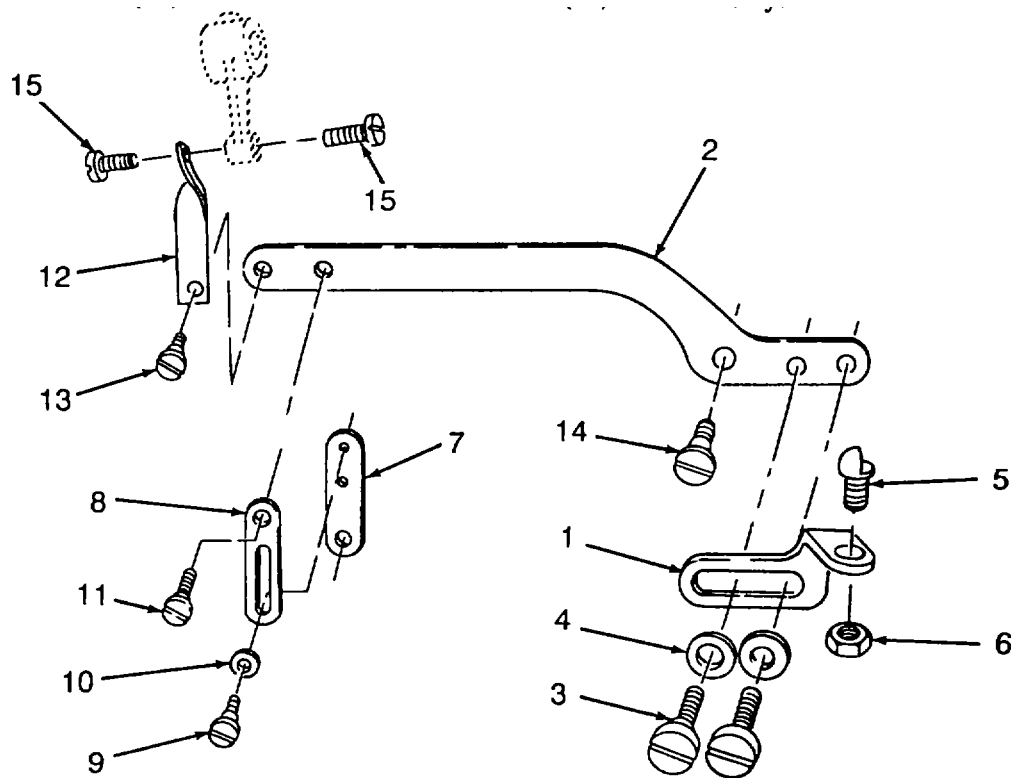

5-52. BUTTON SEWING MACHINE LIFTING LEVER MAINTENANCE - continued.

Adjustment

**NOTE**

Machine should be in the stopped and locked position.

- (1) The tip of screw (5) on lifting holder (1) should contact tip of screw on cam. Tighten screws (3) after adjusting. Adjust upper plate to lift clamp assembly to desired height. Tighten screws (9) after adjusting.

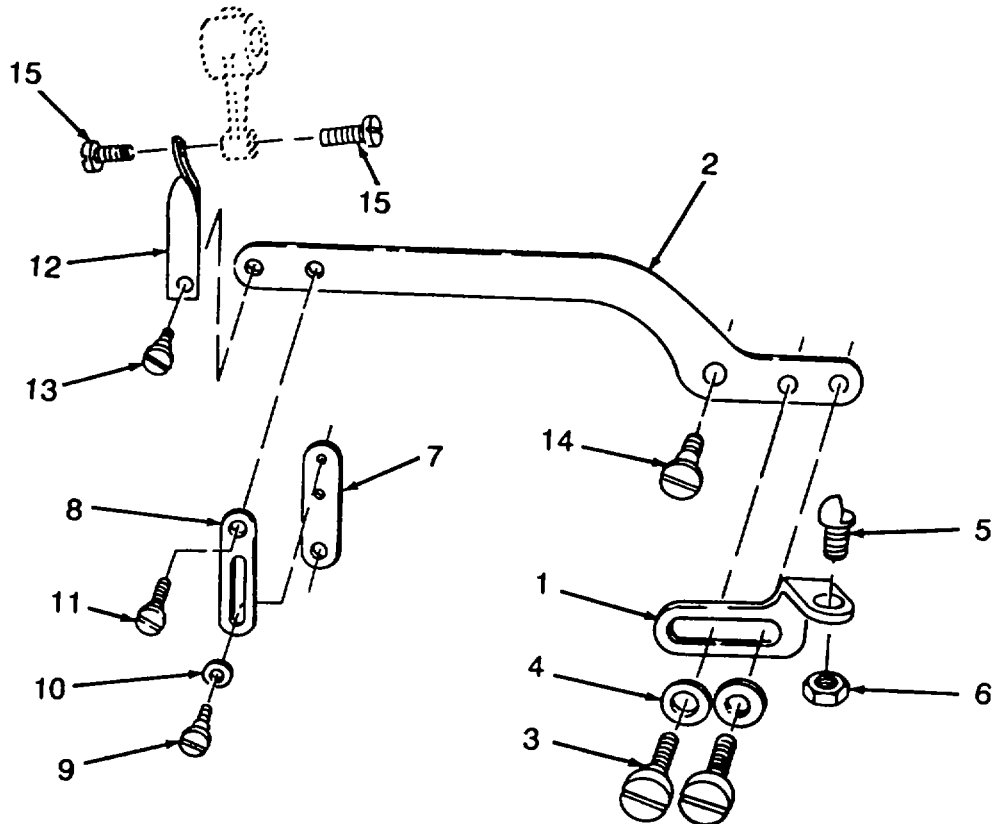

**5-53. BUTTON SEWING MACHINE PULLEY STARTER AND TRIP BLOCK MAINTENANCE.**

---

**This task covers:**

- |                   |                        |                      |
|-------------------|------------------------|----------------------|
| <b>a. Removal</b> | <b>b. Cleaning</b>     | <b>c. Inspection</b> |
| <b>d. Repair</b>  | <b>e. Installation</b> |                      |
- 

**INITIAL SETUP:****Tools:**

General Mechanics Tool Kit (Appendix B, Item 1)

**Equipment Condition :**

Thread and Belt removed (para 2-13)  
 Machine Stopped and in locked position (para. 2-13)  
 Power removed (para 2-18)

**Material/Parts:**

Cleaning Solvent (Appendix F, Item 8)  
 Brush, Medium Bristle (Appendix F, Item 1)  
 Rag, wiping (Appendix F, Item 2)

Removal.

- (1) Remove starting screw (1) and washer (2).
- (2) Remove screw nut (3), setscrew (4) and starting plate (5).

**NOTE**

Mark position of starting bracket (7) and drive shaft.

- (3) Remove two arm screws (6) and slide starting bracket (7) off the drive shaft.

**NOTE**

The flat on the shaft lines up arm screw (8) and screw (9).

- (4) Remove arm screw (8) and screw (9).
- (5) Slide as an assembly the shaft stop arm (10) off the drive shaft.
- (6) Remove two arm bolt nuts (11) and arm spring (12), twenty-two spring discs (13), stop block (14) and the arm bolt (15) from the shaft stop arm (10).

**5-53. BUTTON SEWING MACHINE PULLEY STARTER AND TRIP BLOCK MAINTENANCE - continued.**

- (7) Remove two collar setscrews (16) and the shaft collar (17) from the shaft.

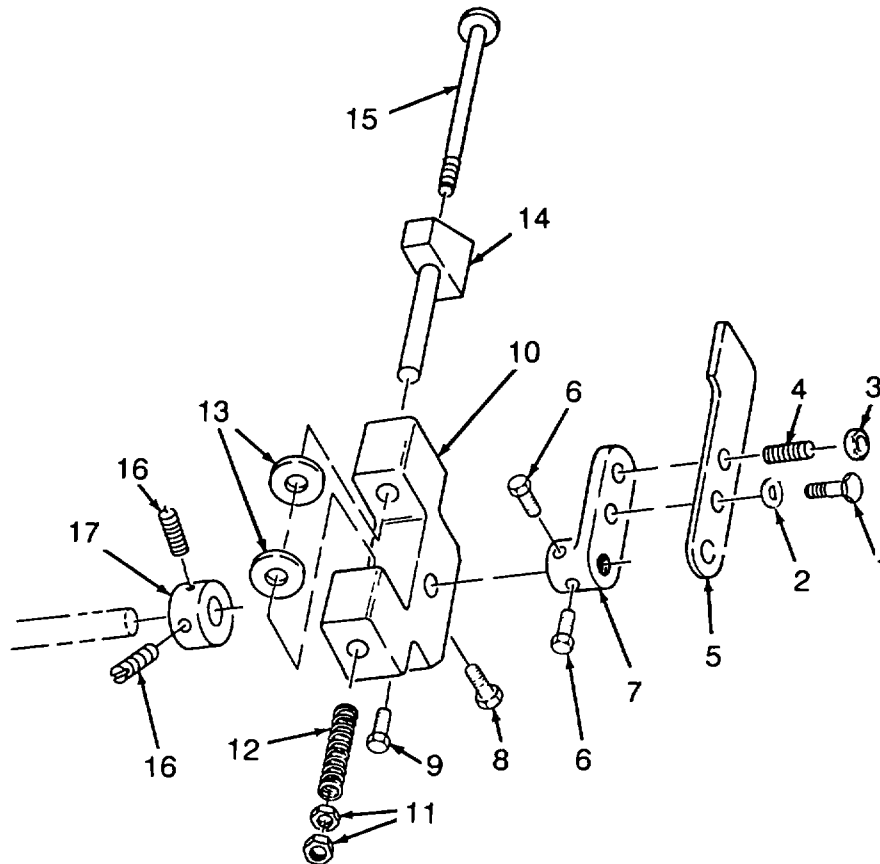
**Cleaning.**

- (1) Remove all buildups of grease, dirt, etc., by wiping with a wiping rag (Appendix F, Item 2).

**WARNING**

Cleaning solvent, Federal Specification P-D-680, is both toxic and flammable. Keep off skin. Use only in well-ventilated area and avoid prolonged breathing of vapors. Keep away from open flame.

- (2) Clean using cleaning solvent (Appendix F, Item 8) and either a wiping rag (Appendix F, Item 2) or a medium bristle brush (Appendix F, Item 1).
- (3) Allow to dry.

**5-53. BUTTON SEWING MACHINE PULLEY STARTER AND TRIP BLOCK MAINTENANCE - continued.**

Inspection.

- (1) Inspect hardware for damage.
- (2) Inspect slide starting bracket for damage.
- (3) Inspect shaft stop arm for damage.
- (4) Inspect arm spring for broken coils and corrosion.
- (5) Inspect starting plate for damage.

Repair. Repair is limited to the replacement of defective components with serviceable ones.

Installation.

- (1) Install arm bolt (1) through stop block (2) and into shaft stop arm (3). Place twenty-two spring discs (4) onto the arm bolt (1) with each one paired off with another spring disc (4), concave side facing each other.
- (2) With the arm bolt (1) fully installed Secure with arm spring (5) and two arm bolt nuts (6).
- (3) Install the shaft (7) and secure with two collar setscrews (8).
- (4) Install drive arm screw (9) and screw (10) lightly into shaft stop arm (3). Slide shaft stop arm (3) onto the drive shaft
- (5) The point of stop block (2) should fit into the clutch wheel.
- (6) The slide starting bracket (11) should be rotated so that the side plate (13) just contacts the ball on the clutch, enough to keep the large ball from falling out and drive pulley should be 1/16" from clutch wheel.
- (7) Line up screw (10) with the flat on the drive shaft. Tighten drive arm screw (9) and screw (10).

**5-53. BUTTON SEWING MACHINE PULLEY STARTER AND TRIP BLOCK MAINTENANCE continued.**

- (8) Install starting plate (13). Secure with starting screw (14), washer (15), setscrew (16) and screw nut (17).
- (9) Slide starting bracket (11) onto the drive shaft. Secure with two bolts (12). Line up markings and secure with two bolts (12).

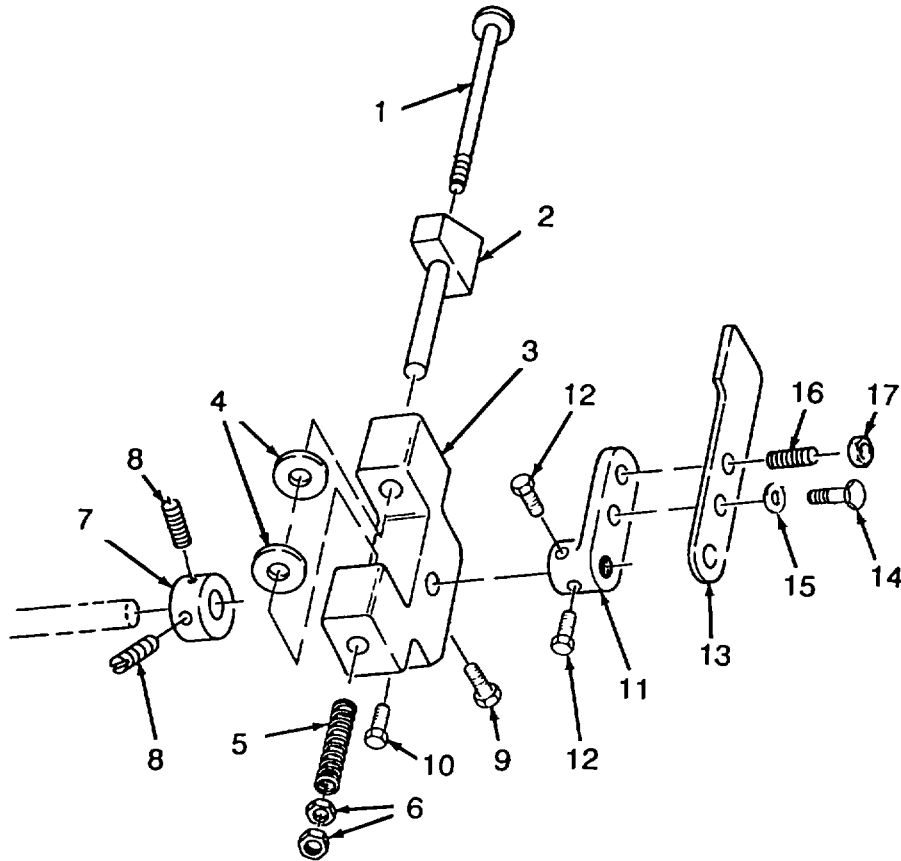

**5-54. BUTTON SEWING MACHINE DRIVE PULLEY CLUTCH MAINTENANCE.**

---

**This task consists of:**

- |                   |                        |                      |
|-------------------|------------------------|----------------------|
| <b>a. Removal</b> | <b>b. Cleaning</b>     | <b>c. Inspection</b> |
| <b>d. Repair</b>  | <b>e. Installation</b> |                      |
- 

**INITIAL SETUP:****Tools:**

General Mechanics Tool Kit (Appendix B, Item 1)

**Equipment Condition:**

Pulley starter and trip block removed (para. 5-53)

**Material/Parts:**

Cleaning Solvent (Appendix F, Item 8)  
 Brush, Medium Bristle (Appendix F, Item 1)  
 Rag, wiping (Appendix F, Item 2)  
 Grease

Removal.

- (1) Remove large ball (1).
- (2) Slide drive pulley (2) off the shaft
- (3) Remove spring (3) and small ball (4).
- (4) Remove set screws (5) and ball bracket base (6).
- (5) Remove bearing (7).

**NOTE**

Be careful not to get any oil or grease on the friction cork (10).

- (6) Remove two screws (8), two nuts (9), and friction cork (10).
- (7) Remove screw (11), nut (12), reverse stopper (13) and stopper spring (14).
- (8) Remove setscrew (15), setscrew (16), clutch wheel (17), and key (18).

**5-54. BUTTON SEWING MACHINE DRIVE PULLEY CLUTCH MAINTENANCE continued.**

- (9) Remove thrust washer (19) and thrust bearing (20)

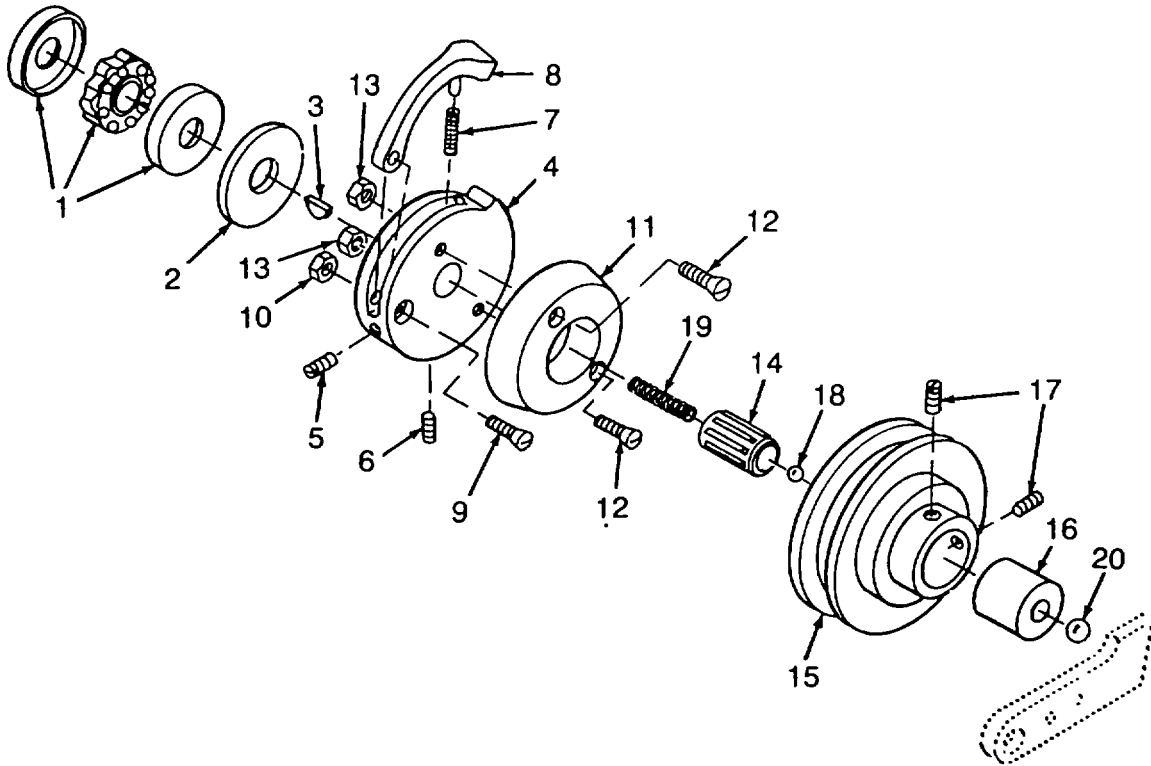
Cleaning.

- (1) Remove all buildups of grease, dirt, etc., by wiping with a wiping rag (Appendix F, Item 2).

**WARNING**

Cleaning solvent, Federal Specification P-D-680, is both toxic and flammable. Keep off skin. Use only in well-ventilated area and avoid prolonged breathing of vapors. Keep away from open flame.

- (2) Clean using cleaning solvent (Appendix F, Item 8) and either a wiping rag (Appendix F, Item 2) or a medium bristle brush (Appendix F, Item 1)
- (3) Allow to dry.

Inspection.

- (1) Inspect hardware for damage.
- (2) Inspect arm spring for broken coils and corrosion

**5-54. BUTTON SEWING MACHINE DRIVE PULLEY CLUTCH MAINTENANCE continued.**

- (3) Inspect drive pulley for damage
- (4) Inspect drive bearings for damage
- (5) Inspect friction cork for excessive wear and oil or grease deposits.

Repair. Repair is limited to to the replacement of defective components with serviceable ones

Installation.

- (1) Install thrust bearing (1) and thrust washer (2).

**NOTE**

Setscrew (6) has a point that fits in V-groove of shaft.

- (2) Install key (3) and clutch wheel (4). Slide clutch wheel (4) up against the thrust washer (2). Secure with setscrew (5) and setscrew (6)
- (3) Install the stopper spring (7) and the reverse stopper (8) into the clutch wheel (4) Make sure the stopper spring (7) fits into the hole in the clutch wheel (4)

**NOTE**

Make sure the reverse stopper moves freely.

- (4) Install screw (9) and nut (10).
- (5) Install friction cork (11) and secure with two screws (12) and two nuts (13).
- (6) Install bearing (14) into the drive pulley (15).

**NOTE**

Large dimple on ball bracket base (16) faces out.

- (7) Install ball bracket base (16) flush with the drive pulley (15). Secure with two setscrews (17).
- (8) Place small ball (18) into the drive pulley (15). Make sure the small ball (18) fits into the dimple. Hold in place with grease.
- (9) Place small end of ball push spring (19) into hollow end of shaft

**5-54. BUTTON SEWING MACHINE DRIVE PULLEY CLUTCH MAINTENANCE continued.**

- (10) Slide drive pulley (15) on shaft. Make sure the small ball (18) does not drop out of the dimple.
- (11) Install large ball (20) in the dimple in ball bracket base (17), hold in place with grease.

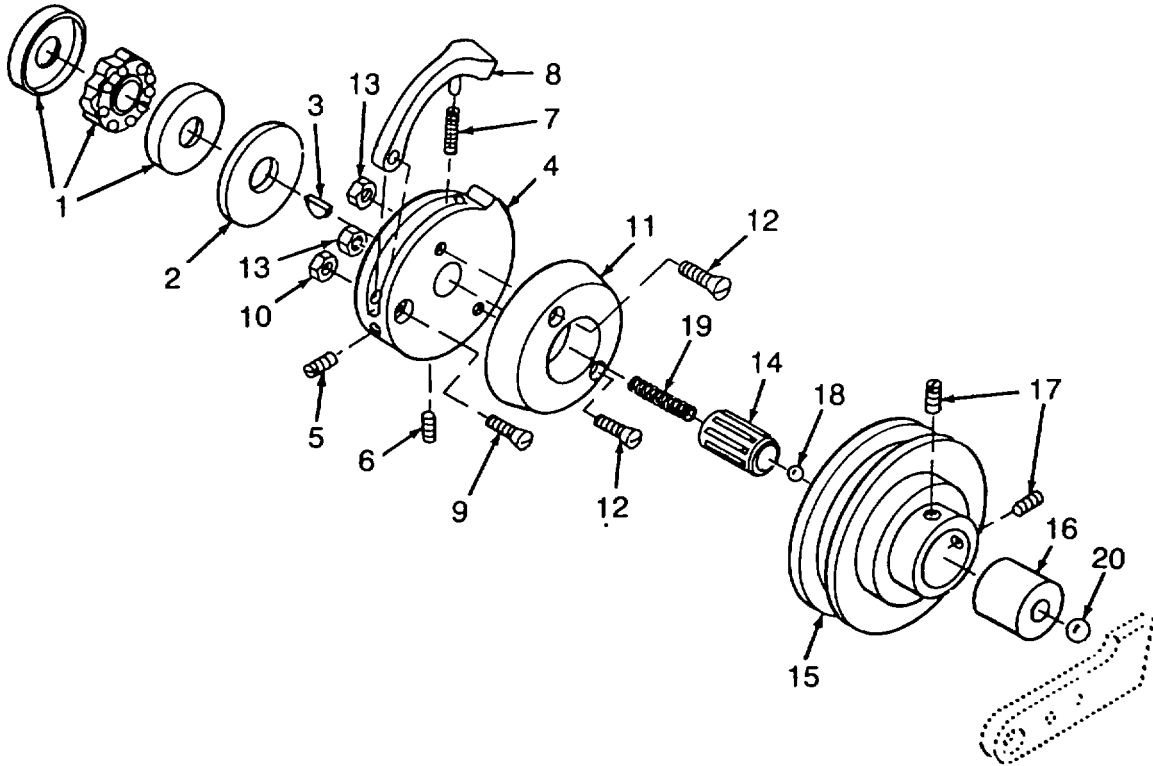

**5-55. BUTTON SEWING MACHINE FEED AND NEEDLE PLATE MAINTENANCE.**

---

This task consists of:

- |            |                 |               |
|------------|-----------------|---------------|
| a. Removal | b. Cleaning     | c. Inspection |
| d. Repair  | e. Installation |               |
- 

**INITIAL SETUP:**

**Tools:**

General Mechanics Tool Kit (Appendix B, Item 1)

**Equipment Condition:**

Arm Clamp and Spreader removed (para. 2-13)

**Material/Parts:**

Cleaning Solvent (Appendix F, Item 8)  
 Brush, Medium Bristle (Appendix F, Item 1)  
 Rag, wiping (Appendix F, Item 2)

Removal

- (1) Remove two screws (1) and the rear top cover (2).
- (2) Remove two screws (3), hinge pin bracket (4) and the bracket shims (5).
- (3) Remove two screws (6), feed plate spring (7), feed plate (8), and the feed plate holder (9).
- (4) Remove two screws (10) and the needle plate (11).
- (5) Remove four screws (12) and the front top cover (13).
- (6) Remove two screws (14) and guide block (15).
- (7) Remove two screws (14) and feed plate block (16).
- (8) Remove slide block nut (17), washer (18), and the feed carrier plate (19).
- (9) Remove stud nut handle (20) from side block nut (17).
- (10) Remove slide block stud (21) and the feed plate block (22).
- (11) Loosen setscrew (23).

**NOTE**

Make sure that the small end is driven out to the large end.

- (12) Drive arm pin (24) out of carrier arm (25) Remove carrier arm (25)
- (13) Remove screw (26), roller (27) and stud (28).

**5-55. BUTTON SEWING MACHINE FEED AND NEEDLE PLATE MAINTENANCE continued.**

- (14) Remove spring screw (31) regulator feed plate (29), feed plate spring (30), and regulator screw (32).

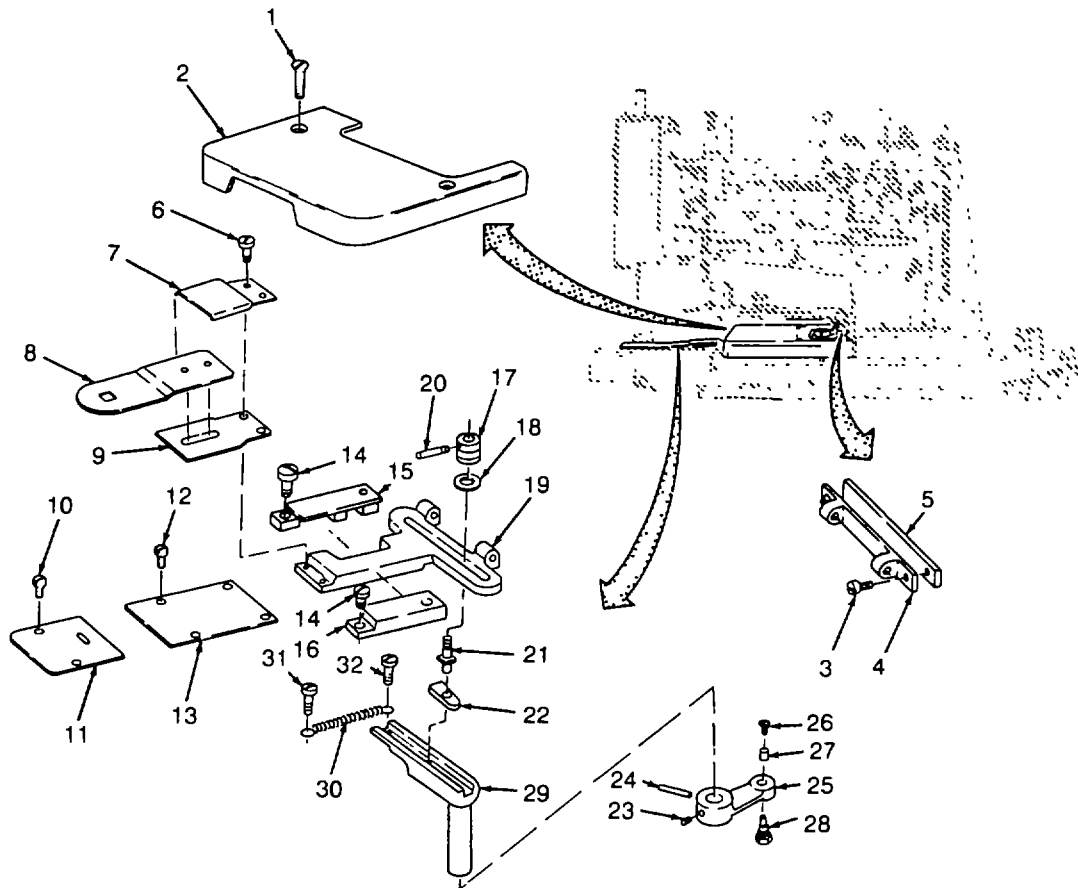

Cleaning.

- (1) Remove all buildups of grease, dirt, etc., by wiping with a wiping rag (Appendix F, Item 2).

**WARNING**

Cleaning solvent, Federal Specification P-D-680, is both toxic and flammable. Keep off skin Use only in well-ventilated area and avoid prolonged breathing of vapors. Keep away from open flame.

- (2) Clean using cleaning solvent (Appendix F, Item 8) and either a wiping rag (Appendix F, Item 2) or a medium bristle brush (Appendix F, Item 1).
- (3) Allow to dry.

**5-55. BUTTON SEWING MACHINE FEED AND NEEDLE PLATE MAINTENANCE continued.**Inspection.

- (1) Inspect hardware for damage.
- (2) Inspect feed plate spring for broken coils and corrosion.
- (3) Inspect regulator plate for damage.
- (4) Inspect feed plate block for damage.
- (5) Inspect feed carrier plate for damage.
- (6) Inspect block guide for damage.
- (7) Inspect feed plate block for damage.

Repair. Repair is limited to to the replacement of defective components with serviceable ones

Installation.

- (1) Install regulator feed plate (1), feed plate spring (2), regulator screw (4) and spring screw (3).
- (2) Install screw (5), roller (6), and stud (7).

**NOTE**

Make sure that the large end of the tapered hole in the lever and the regulator feed plate line up.

- (3) Install carrier arm (10), secure by driving arm pin (9) through carrier arm (10) and the regulator feed plate (1).
- (4) Install set screw (11) into the carrier arm (10).
- (5) Install stud nut handle (17) into the side block nut (16).
- (6) Install the feed plate block (12), slide block stud (13), feed plate carrier (14). Secure with washer (15) and slide block nut (16).
- (7) Install feed plate block (18) and guide block (19). Secure with four screws (20).
- (8) Install front top cover (21) and the needle plate (22). Secure with six screws (23).

**5-55. BUTTON SEWING MACHINE FEED AND NEEDLE PLATE MAINTENANCE continued.**

- (9) Install feed plate holder (24), feed plate (25), and the feed plate spring (26). Secure with two screws (27).
- (10) Install hinge pin bracket (28) and bracket shim(s) (29). Secure with two screws (30).
- (11) Install cover (31) and secure with the two rear top screws (32).

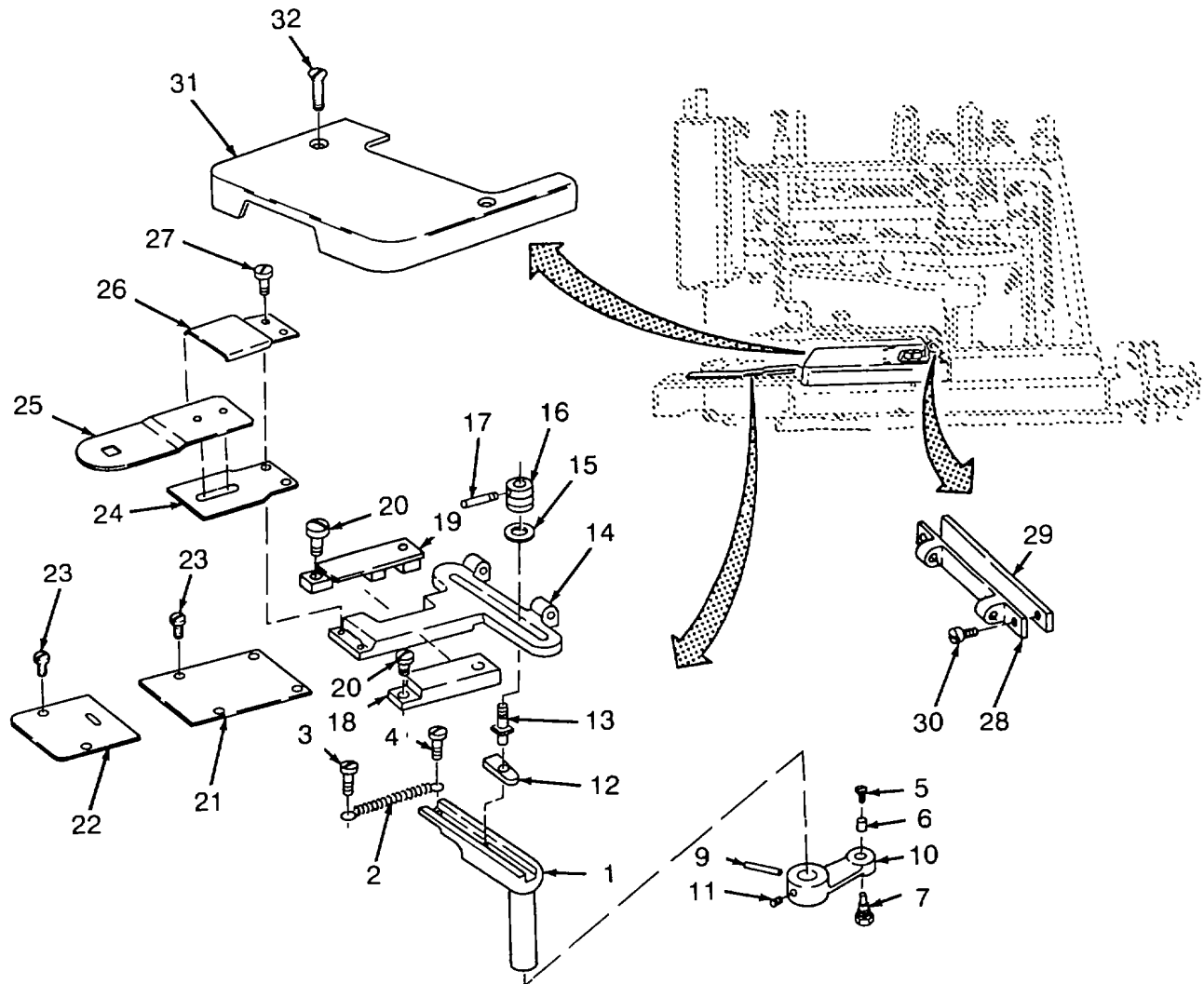

**5-56. BUTTON SEWING MACHINE VIBRATING LEVER MAINTENANCE.**

---

**This task consists of:**

- |                   |                        |                      |
|-------------------|------------------------|----------------------|
| <b>a. Removal</b> | <b>b. Cleaning</b>     | <b>c. Inspection</b> |
| <b>d. Repair</b>  | <b>e. Installation</b> |                      |
- 

**INITIAL SETUP:****Tools:**

General Mechanics Tool Kit (Appendix B, Item 1)

**Equipment Condition:**

Needle bar removed (para. 5-45)  
 Presser bar removed (para. 5-48).  
 Automatic lifting lever removed (para. 5-51).

**Materials/Parts:**

Rag, wiping (Appendix F, Item 2)  
 Cleaning Solvent (Appendix F, Item 8)  
 Brush, Medium Bristle (Appendix F, Item 1)

**Removal.**

- (1) Remove knob (1) and clip (2).
- (2) Remove setscrew (3).
- (3) Remove lever hinge screw (4).
- (4) Remove needle bar lever (5).
- (5) Remove setscrew (6), bracket hinge stud (7), two needle bar slides (8), needle bar bracket (9), setscrew (10) and bracket stud (11) from the needle bar lever (5).
- (6) Remove connecting stud locknut (12), connecting stud nut (13, connecting stud washer (14), and lower needle stud (15).
- (7) Remove stud (16), roller (17), and screw (18).

5-56. **BUTTON SEWING MACHINE VIBRATING LEVER MAINTENANCE - continued.**

- (8) Remove guide play roller (19), lever arm screw (20), the lockwasher (21), washer (23) from the vibrating lever arm (22).

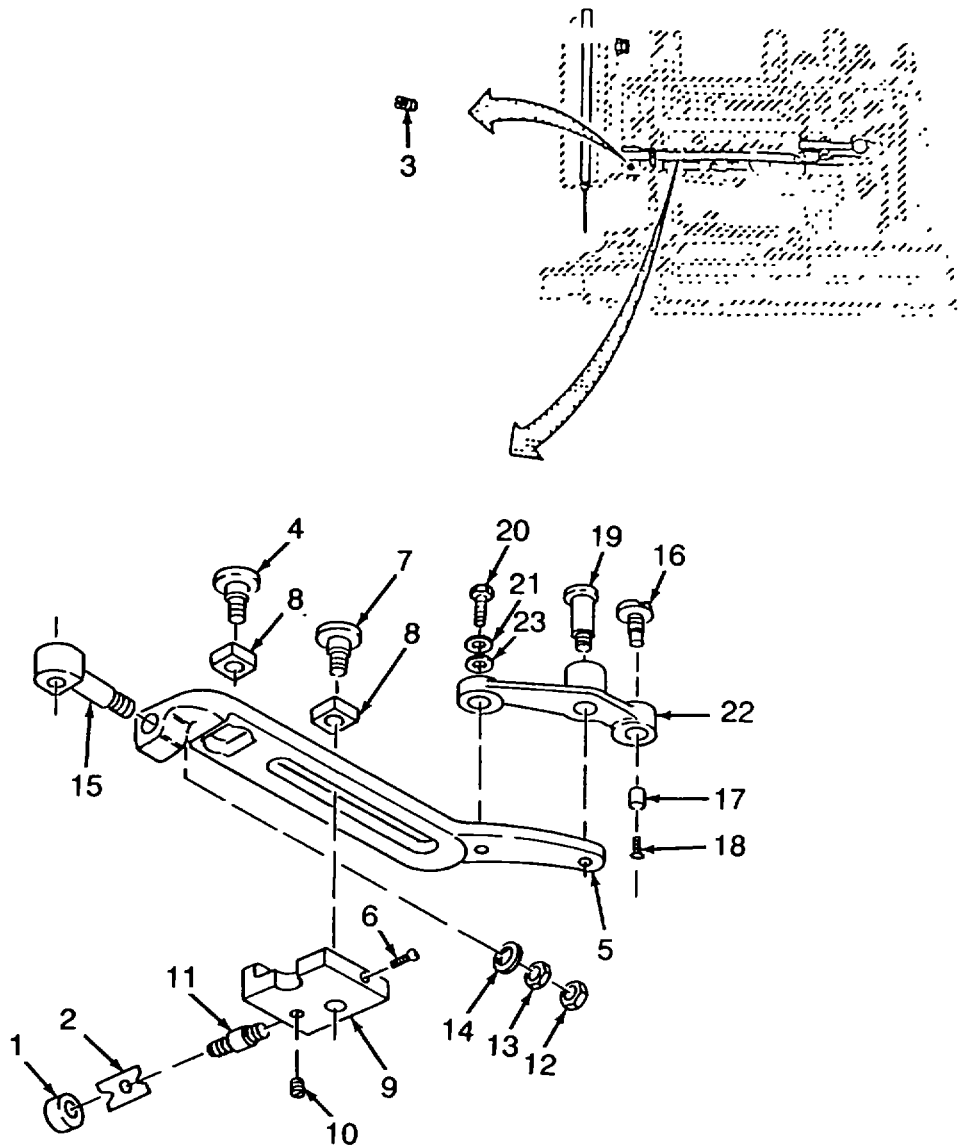

**5-56. BUTTON SEWING MACHINE VIBRATING LEVER MA INTENANCE continued.**Cleaning

- (1) Remove all buildups of grease, dirt, etc, by wiping with a wiping rag (Appendix F, Item 2).

**WARNING**

Cleaning solvent, Federal Specification P-D-680, is both toxic and flammable. Keep off skin Use only in a wellventilated area and avoid prolonged breathing of vapors. Keep away from open flame.

- (2) Clean using cleaning solvent (Appendix F, Item 8) and either a wiping rag (Appendix F, Item 2) or a medium bristle brush (Appendix F, Item 1).
- (3) Allow to dry.

Inspection

- (1) Inspect hardware for damage.
- (2) Inspect needle bar lever for damage.
- (3) Inspect vibrating lever arm for damage.
- (4) Inspect needle bar slides for damage or excessive wear.
- (5) Inspect lower needle stud for damage

Repair. Repair is limited to deburring and the replacement of defective components.

Installation.

- (1) Install the vibrating lever arm (1) into the needle bar lever (2). Secure with guide play roller (3), lever arm screw (4) and the lockwasher (5)and washer (24).
- (2) Install stud (6), roller (7) and screw (8).
- (3) Install bracket stud (9) into the needle bar bracket (10) and secure with setscrew (11).
- (4) Install needle bar bracket (10), needle bar slide (12), bracket hinge stud (13), and setscrew (14). Make sure the flat on the bracket hinge stud (13) lines up with setscrew (14). Tighten setscrew (14).

5-56. BUTTON SEWING MACHINE VIBRATING LEVER MAINTENANCE continued.

NOTE

Tighten the connecting stud nut (17) and the connecting stud locknut (18) so that the lower needle stud (15) moves freely with minimum end play.

- (5) Install lower needle stud (15). Secure with connecting stud washer (16), connecting stud nut (17), connecting stud locknut (18).
- (6) Install the needle bar lever (2) into the machine head. Secure with needle bar slide (19) and lever hinge screw (20).
- (7) Install setscrew (21)
- (8) Install clip (22) and knob (23).

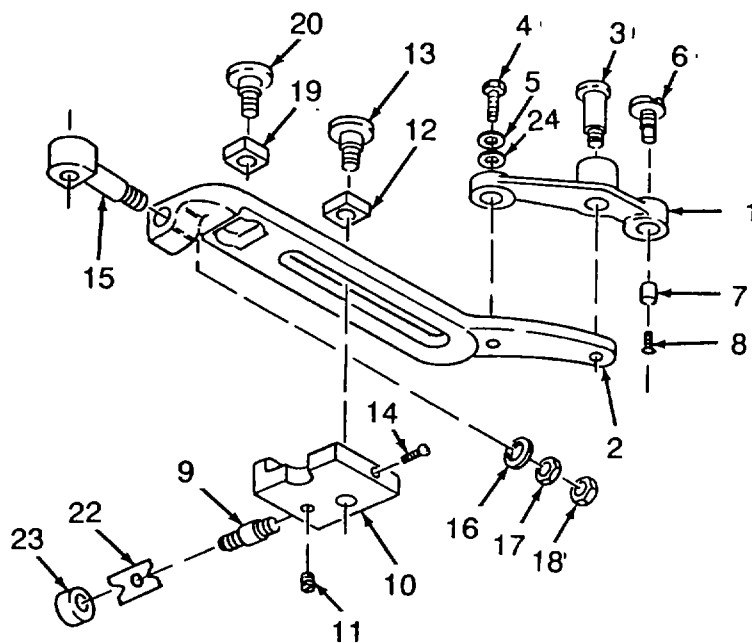
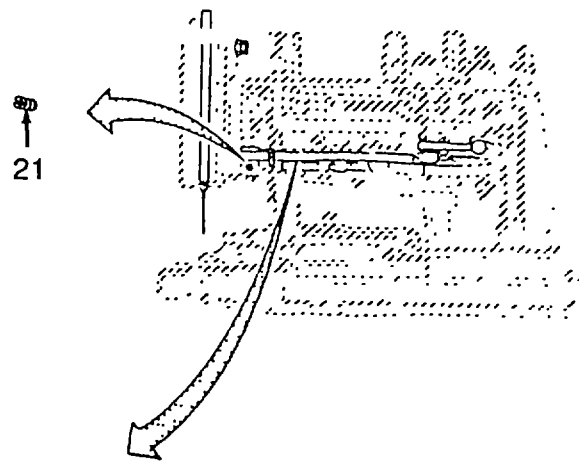

**5-57. BUTTON SEWING MACHINE LIFTING ARM AND THREAD PULLOFF MAINTENANCE.**

This task consists of:

- |            |                 |               |
|------------|-----------------|---------------|
| a. Removal | b. Cleaning     | c. Inspection |
| d. Repair  | e. Installation | f. Adjustment |

**INITIAL SETUP:**

**Tools:**

General Mechanics Tool Kit (Appendix B, Item 1)

**Materials/Parts:**

Rag, wiping (Appendix F, Item 2)  
 Cleaning Solvent (Appendix F, Item 8)  
 Brush, Medium Bristle (Appendix F, Item 1)

**Equipment Condition:**

Thread removed (para. 2-13)  
 Side cover removed (para. 5-42)  
 Presser bar removed (para. 5-48)  
 Lifting lever removed (para. 5-52)  
 Face plate removed (para. 5-43)

Removal.

- (1) Remove cotter pin and lifting rod from lifting rod arm (1).
- (2) Remove setscrew (2) and lifting arm (3).
- (3) Loosen two screws (4) Remove front pulloff (5) and rear pulloff (6).
- (4) Loosen two setscrews (7), three screws (8), and remove screw (9).
- (5) Drive clamp lift shaft (10) through machine from the back to the front. Remove two thread collars (11) and (12), thread spring (13), rear thread holder (14), thread collar (15), rear thread holder (16), and lifting rod arm (1).

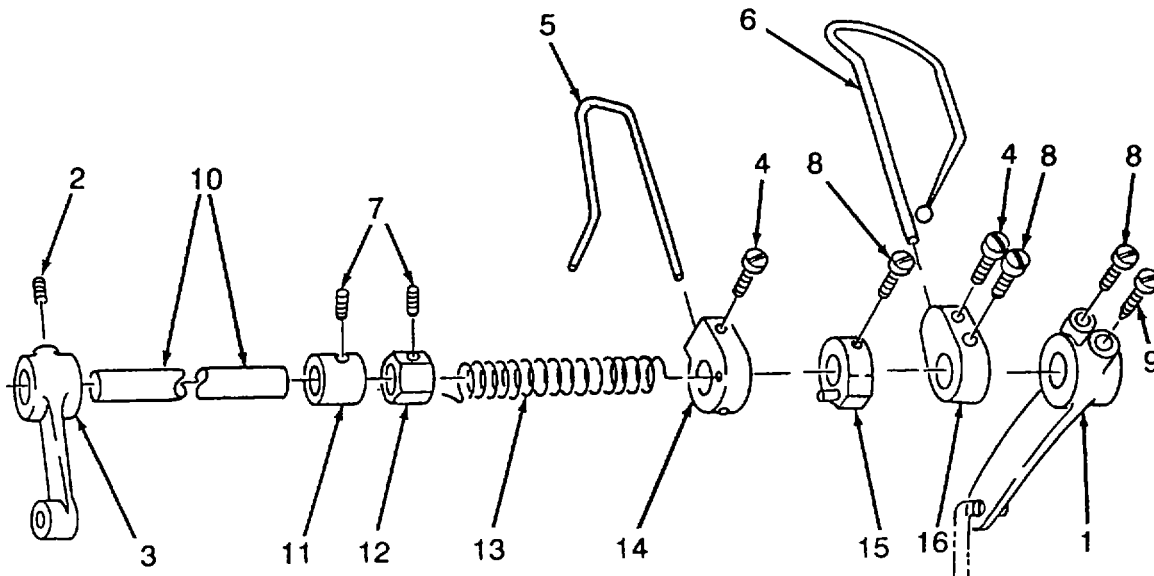

**5-57. BUTTON SEWING MACHINE LIFTING ARM AND THREAD PULLOFF**Cleaning

- (1) Remove all buildups of grease, dirt, etc., by wiping with a wiping rag (Appendix F, Item 2).

**WARNING**

Cleaning solvent, Federal Specification P-D-680, is both toxic and flammable. Keep off skin. Use only in a wellventilated area and avoid prolonged breathing of vapors. Keep away from open flame.

- (2) Clean using cleaning solvent (Appendix F, Item 8) and either a wiping rag (Appendix F, Item 2) or a medium bristle brush (Appendix F, Item 1).
- (3) Allow to dry

Inspection

- (1) Inspect hardware for damage.
- (2) Inspect lifting arm for damage
- (3) Inspect front pulloff for damage.
- (4) Inspect rear pulloff for damage.
- (5) Inspect clamp lift shaft for damage and straightness.
- (6) Inspect thread spring for corrosion and broken coils.
- (7) Inspect lifting rod arm for damage

Repair. Repair is limited to the replacement of defective components.

Installation.**NOTES**

Flat on clamp lift shaft (1) goes toward front of the machine.

Thread collar (3) has four holes drilled in one side, make sure this side faces spring (4).

Be sure end of thread spring (4) is placed in holes of thread collar (3) and rear thread holder (5).

**5-57. BUTTON SEWING MACHINE LIFTING ARM AND THREAD PULL OFF MAINTENANCE continued.**

Installation-continued.

- (1) Slide clamp lift shaft (1) into the front of the machine head through thread collar (2), thread collar (3), thread spring (4), rear thread holder (5), thread collar (6), rear thread holder (7), and lifting rod arm (8).
- (2) Install lifting arm (9). Make sure setscrew (10) lines up with the flat of the clamp lift shaft (1), flush with the end of the clamp lift shaft (1).
- (3) Install screw (11) making sure that the dimple lines up with the point of screw (11). Tighten screw (11) and three screws (7).
- (4) Slide thread collar (2), thread collar (3), and tighten the two setscrews (12) so that the clamp lift shaft (1) rotates freely with minimum side play.
- (5) Install rear pulloff (13) and front pulloff (14). Secure with two setscrews (15). Make sure flats on the rear pull off (13) and front pulloff line up with setscrews (15).
- (6) Attach lift rod arm (8) to lifting rod and secure with cotter pin

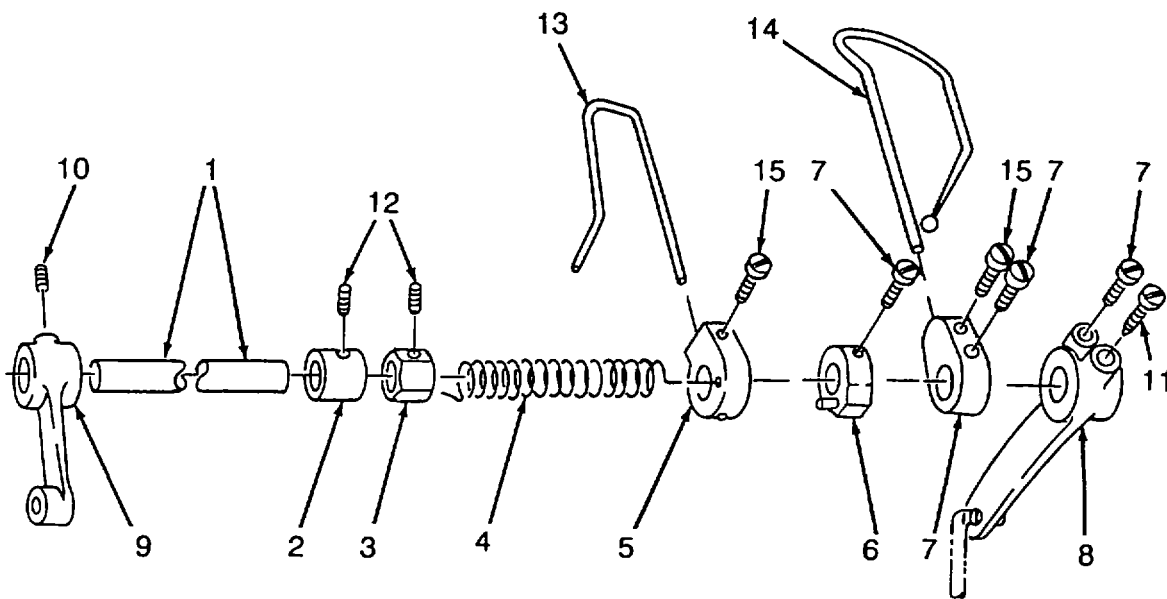

Adjustment.

- (1) Adjust the tension of the thread pulloff (para. 2-13).

**5-58. BUTTON SEWING MACHINE CAM AND DRIVE SHAFT MAINTENANCE**

This task consists of:

- |            |                 |               |
|------------|-----------------|---------------|
| a. Removal | b. Cleaning     | c. Inspection |
| d. Repair  | e. Installation | f. Adjustment |

**INITIAL SETUP:****Tools:**

General Mechanics Tool Kit (Appendix B, Item 1)

**Materials/Parts:**

Rag, wiping (Appendix F, Item 2)  
 Cleaning Solvent (Appendix F, Item 8)  
 Brush, Medium Bristle (Appendix F, Item 1)

**Equipment Condition:**

Vibrating Lever removed (para. 5-56).  
 Lifting Lever removed (para 5-52).  
 Thread tension rod assembly removed (para. 5-49).  
 Carrier arm removed (para 5-55).

**Removal.**

- (1) Mark the location of the feed cam (1) to feed cam wheel (2).
- (2) Remove two screws (3), two washers (4), and the feed cam (1).
- (3) Drive out tapered cam pin (5). Remove needle bar cam (6), feed cam shaft (7) and feed cam wheel (2)
- (4) Mark on feed cam wheel (2), the location to the feed cam shaft (7). Remove two setscrews (8), wheel trip point (9), and the feed cam wheel (2).

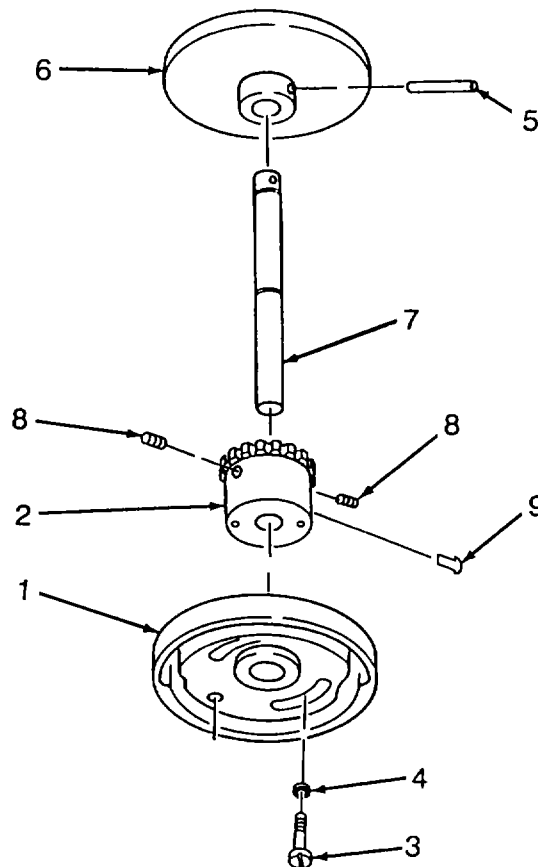

**5-58. BUTTON SEWING MACHINE CAM AND DRIVE SHAFT MAINTENANCE continued.**Cleaning.

- (1) Remove all buildups of grease, dirt, etc., by wiping with a wiping rag (Appendix F, Item 2).

**WARNING**

Cleaning solvent, Federal Specification P-D-680, is both toxic and flammable. Keep off skin. Use only in a wellventilated area and avoid prolonged breathing of vapors. Keep away from open flame.

- (2) Clean using cleaning solvent (Appendix F, Item 8) and either a wiping rag (Appendix F, Item 2) or a medium bristle brush (Appendix F, Item 1).
- (3) Allow to dry.

Inspection.

- (1) Inspect hardware for damage.
- (2) Inspect feed cam for damage.
- (3) Inspect feed cam wheel for damage.
- (4) Inspect needle bar cam damage.
- (5) Inspect feed cam shaft for damage.
- (6) Inspect wheel trip point for damage.

Repair. Repair is limited to deburring and the replacement of defective components.

Installation.**NOTE**

The machine should be stopped and locked.

- (1) Install wheel trip point (1).
- (2) Slide feed cam wheel (2) onto the feed cam shaft (3). Make sure it is oriented as previously marked. Install two setscrews (4), but do not tighten.
- (3) Make sure that the looper crank arrows are lined up with the markings on the housing.
- (4) Slide feed cam shaft (3), into the machine head from the bottom so that the wheel trip point (1) contacts the point on the stop motion plate.

**5-58. BUTTON SEWING MACHINE CAM AND DRIVE SHAFT MAINTENANCE continued.**

- (5) Install needle bar cam (5). Line up the large end of the tapered hole in the needle bar cam (5) with the large hole in the feed cam shaft (3). Secure with tapered cam pin (6)
- (6) Push needle bar cam (5) and feed cam wheel (2) together enough to eliminate side play, but not too much to cause binding. Check feed cam shaft (3) and feed cam wheel (2) with previous marks. Tighten setscrews (4).
- (7) Install feed cam (7). Line up with previous marks on feed cam wheel (2). Secure with two screws (9) and two washers (8).

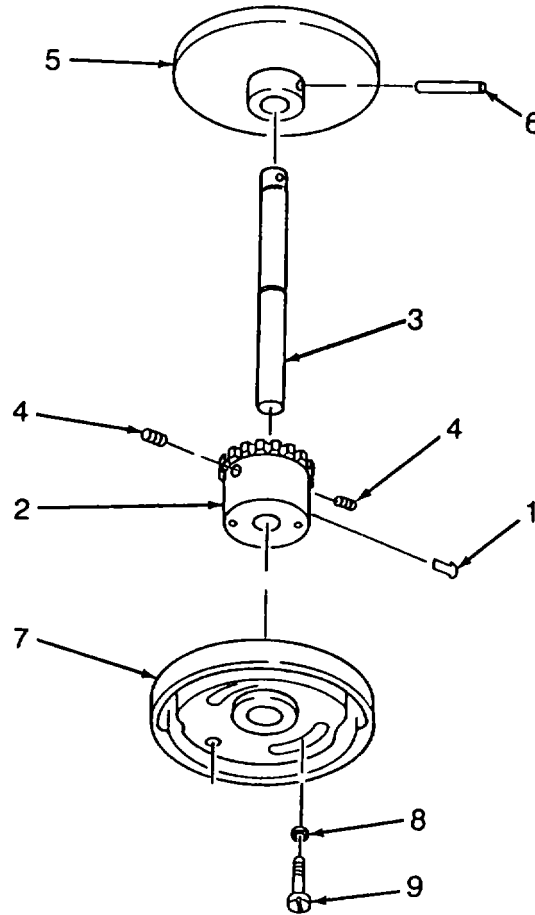
Adjustment.

Time the button clamp feed cam (para. 2-13).

**5-59. BUTTON SEWING MACHINE STOP MOTION SHAFT MAINTENANCE.**

---

This task consists of:

- |            |                 |               |
|------------|-----------------|---------------|
| a. Removal | b. Cleaning     | c. Inspection |
| d. Repair  | e. Installation | f. Adjustment |
- 

**INITIAL SETUP:**

**Tools:**

General Mechanics Tool Kit (Appendix B, Item 1)

**Materials/Parts:**

Rag, wiping (Appendix F, Item 2)  
 Cleaning Solvent (Appendix F, Item 8)  
 Brush, Medium Bristle (Appendix F, Item 1)

**Equipment Condition:**

Trip block removed (para. 5-53).  
 Pulley starter removed (para. 5-53).  
 Feed cam removed (para. 5-58).

Removal.

- (1) Loosen two setscrews (1) and remove shaft collar (2).
- (2) Remove crank adjustment screw (5) and adjusting screw nut (6).
- (3) Remove setscrew (3) from stop motion collar (4).

**NOTE**

Pin must be removed from large end.

- (4) Loosen collar screw (9) and note which hole in the collar (10) that the stop motion spring (11) is placed in.
- (5) Drive crank tapered pin (7) from starting crank (8).
- (6) Pull stop motion shaft (12) out of the machine head.
- (7) Remove stop motion collar (4), starting crank (8), stop motion spring (11) and collar (10).
- (8) Remove two screws (13), two washers (14), and the stop motion plate (15).
- (9) Remove block hinge screw (16), nut (17), and the stop motion block (18).

**5-59. BUTTON SEWING MACHINE STOP MOTION SHAFT MAINTENANCE-continued.**Removal-continued.

- (10) Remove setscrew (19) and remove the collar stud (20).

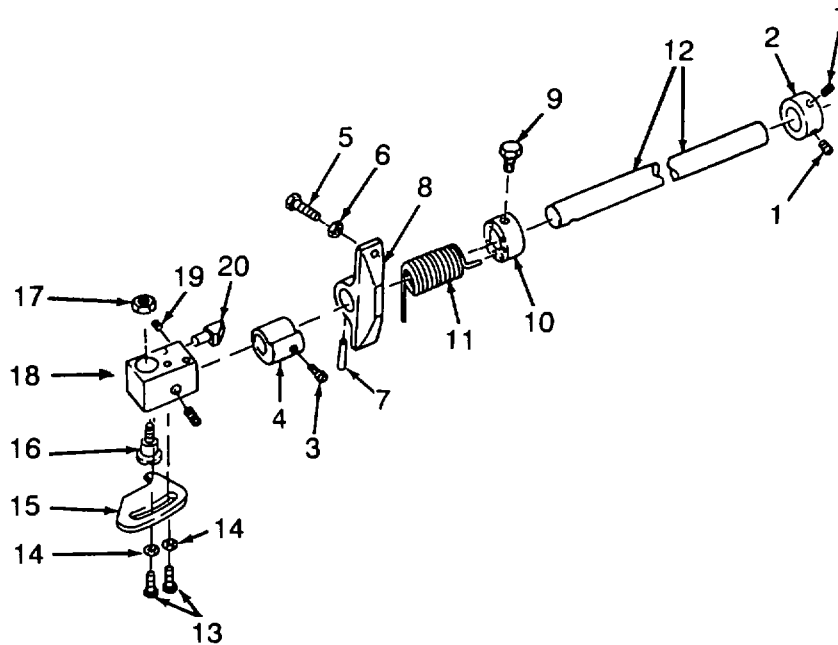
Cleaning.

- (1) Remove all buildups of grease, dirt, etc., with a wiping rag (Appendix F, Item 2).

**WARNING**

Cleaning solvent, Federal Specification P-D-680, is both toxic and flammable. Keep off skin. Use only in a well-ventilated area and avoid prolonged breathing of vapors. Keep away from open flame.

- (2) Clean using cleaning solvent (Appendix F, Item 8) and either a wiping rag (Appendix F, Item 2) or a medium bristle brush (Appendix F, Item 1).
- (3) Allow to dry.

Inspection.

- (1) Inspect hardware for damage.
- (2) Inspect shaft collar for damage.
- (3) Inspect starting crank for damage.
- (4) Inspect stop motion shaft for damage.
- (5) Inspect stop motion spring for corrosion or broken coils.

**5-59. BUTTON SEWING MACHINE STOP MOTION SHAFT MAINTENANCE-continued.**Inspection-continued.

- (6) Inspect stop motion block for damage.
- (7) Inspect collar stud for damage and for missing spring. Glue in place.

Repair. Repair is limited to deburring and the replacement of defective components.

Installation.

- (1) Install collar stud (1). Secure with setscrew (2) and make sure setscrew seats on the collar stud flat.
- (2) Install stop motion block (3). Secure with block hinge screw (4) and block hinge nut (5).
- (3) Install stop motion plate (6). Secure with two screws (7) and two washers (8).

## NOTES

Make sure spring (11) is in correct hole of the collar (10). Hole is opposite of collar screw (18)  
Collar stud (1) should be rotated clockwise until it clears stop motion collar (13).

- (4) Slide stop motion shaft (9) into the rear of machine head through collar (10), stop motion spring (11), starting crank (12) and stop motion collar (13).
- (5) Install tapered pin starting crank (12) to stop motion shaft (9). Secure with crank pin (14) through large hole in starting crank (12) and the stop motion shaft (9).
- (6) Install setscrew (15) into the stop motion collar (13). Rotate stop motion collar (13) so that the holes line up with the threaded hole in the stop motion shaft (9). Tighten setscrew (15).

## NOTE

Small end of shaft collar (16) faces the machine.

- (7) Slide shaft collar (16) onto the stop motion shaft (9) far enough to eliminate any side play. Secure with two setscrews (17). Make sure that the stop motion shaft (9) does not bind.
- (8) Install collar screw (18) into the collar (10). Rotate collar (10) to tighten stop motion spring (11). Make sure the stop motion collar (13) is up against machine, then tighten collar screw (18).

**5-59. BUTTON SEWING MACHINE STOP MOTION SHAFT MAINTENANCE-continued.**

Installation-continued.

- (9) Loosely install crank adjustment screw (19) and adjusting screw nut (20). Set crank adjustment screw (19) so that it does not stop the starting crank (12) and stop motion collar (13) from rotating far enough to allow collar stud (1) from falling into the groove on starting crank (12). Tighten adjusting screw nut (20).

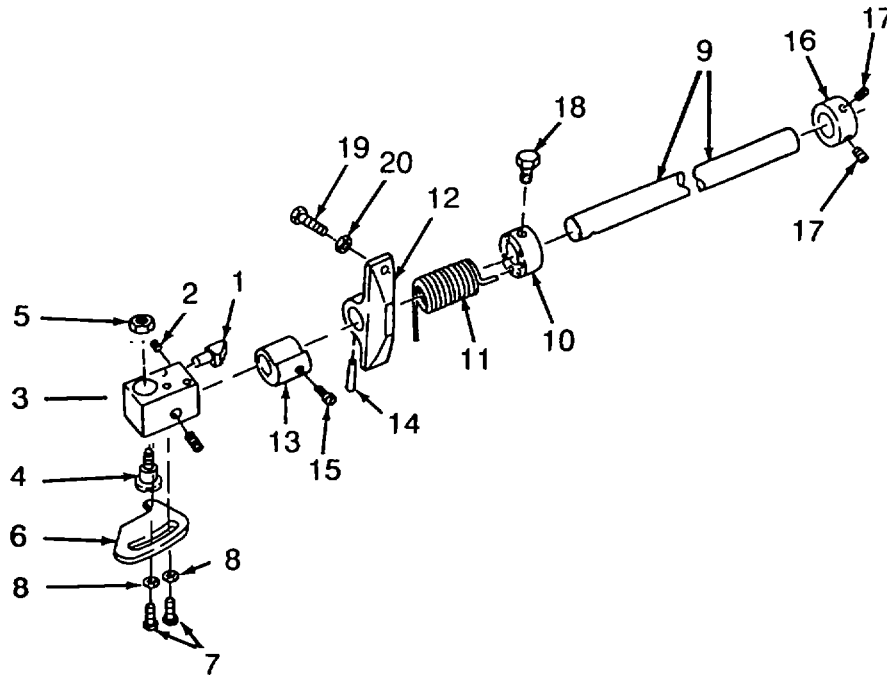

Adjustments.

Set timing (para. 4-49).

**5-60. BUTTON SEWING MACHINE ARM ROCKSHAFT MAINTENANCE.**

---

**This task covers:**

- |                   |                        |                      |
|-------------------|------------------------|----------------------|
| <b>a. Removal</b> | <b>b. Cleaning</b>     | <b>c. Inspection</b> |
| <b>d. Repair</b>  | <b>e. Installation</b> |                      |

**INITIAL SETUP:****Tools:**

General Mechanics Tool Kit (Appendix B, Item 1)

**Equipment Condition:**

Needle bar removed (para 5-45).

**Materials/Parts:**

Rag, wiping (Appendix F, Item 2)  
 Cleaning Solvent (Appendix F, Item 8)  
 Brush, Medium Bristle (Appendix F, Item 1)

Removal

- (1) Remove link hinge screw (1), nut (2) and needle bar link (3).
- (2) Remove two setscrews (4).
- (3) Remove crank screw (5) and rod screw nut (6).

## NOTE

A small access plate on the back side of the machine may need to be removed to have access to crank screw (7).

- (4) Loosen crank screw (7).
- (5) Carefully drive rockshaft (10) through rockshaft crank (11) and collar (19) out through the front of the machine head.
- (6) Remove two cap screws (8), bottom half of needle bar rod (9), upper half of needle bar rod (18), and rockshaft crank (11).
- (7) Mark on rockshaft (10) position of rockshaft crank (12). Drive tapered pin (13) through rockshaft crank (12) and rockshaft (10).
- (8) Remove hinge screw nut (14), rod screw (15) and rockshaft crank (11) from upper needle bar rod (18).
- (9) Loosen rod screw nut (16) and remove hinge screw (17) from the upper half of needle bar rod (18).

**5-60. BUTTON SEWING MACHINE ARM ROCKSHAFT MAINTENANCE-continued.**Removal-continued.

- (10) Remove collar (19) from rockshaft (10).

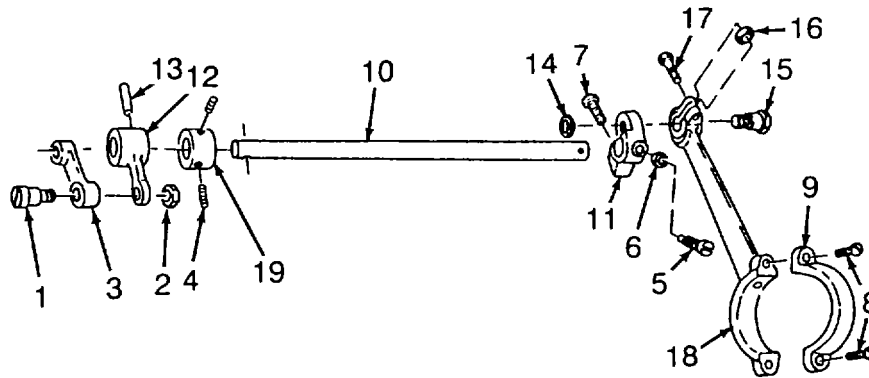
Cleaning.

- (1) Remove all buildups of grease, dirt, etc, with a wiping rag (Appendix F, Item 2)

**WARNING**

Cleaning solvent, Federal Specification P-D-680, is both toxic and flammable. Keep off skin. Use only in a well-ventilated area and avoid prolonged breathing of vapors. Keep away from open flame.

- (2) Clean using cleaning solvent (Appendix F, Item 8) and either a wiping rag (Appendix F, Item 2) or a medium bristle brush (Appendix F, Item 1).
- (3) Allow to dry.

Inspection.

- (1) Inspect hardware for damage.
- (2) Inspect needle bar link for damage
- (3) Inspect needle bar rod for damage.
- (4) Inspect rockshaft crank for damage.
- (5) Inspect rockshaft for damage.

Repair. Repair is limited to deburring and the replacement of defective components.

**5-60. BUTTON SEWING MACHINE ARM ROCKSHAFT MAINTENANCE-continued.**Installation.

- (1) Install rockshaft crank (1) onto rockshaft (2). Make sure rockshaft crank (1) is in the correct position as previously marked. Secure with tapered pin (3).

## NOTE

The rod screw nut (5) sits inside the tangs of the lower half of the needle bar rod (6).

- (2) Loosely install the hinge screw (4) on rod screw nut (5) in the upper half of needle bar rod (6).
- (3) Install rod screw (20), rockshaft crank (8) and hinge screw nut (21). Make sure rockshaft crank (8) smooth side faces the upper half of the needle bar rod (6). Tighten hinge screw nut (21) so that the rockshaft crank (8) rotates freely.
- (4) Tighten hinge screw (4) and rod screw nut (5) in the upper half of needle bar rod (6). Make sure that the rockshaft crank (8) rotates freely.
- (5) Position upper needle bar rod (6) into machine.
- (6) Slide rockshaft (2) into the front of the machine through collar (15) into the rockshaft crank (8). Make sure that the dimple on the rockshaft (2) lines up with the hole for crank screw (10).
- (7) Install rod screw nut (11) and crank screw (10).
- (8) Tighten crank screw (12).
- (9) Install bottom half of needle bar rod (13). Secure with two cap rod screws (14).
- (10) Adjust collar (15) to maintain minimum side play without binding rockshaft (2). Secure with two setscrews (16).
- (11) Install needle bar link (17). Secure with link hinge screw (18) and nut (19).

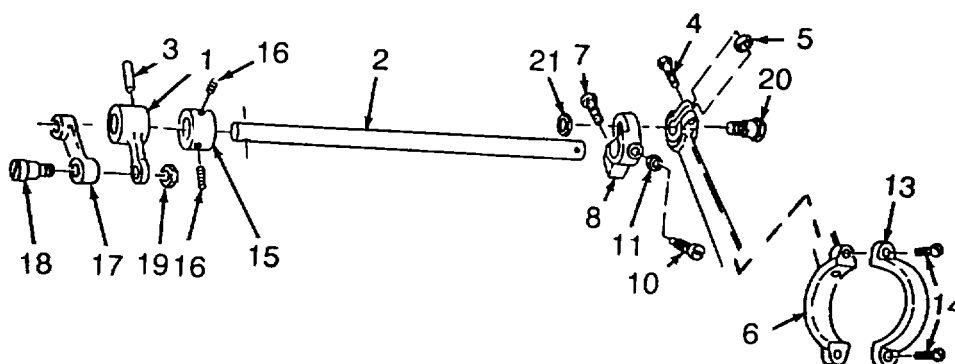

**5-61. BUTTON SEWING MACHINE ECCENTRIC, DRIVE SHAFT, LOOPER CAM AND CRANK MAINTENANCE.**

This task covers:

- |            |                 |               |
|------------|-----------------|---------------|
| a. Removal | b. Cleaning     | c. Inspection |
| d. Repair  | e. Installation | f. Adjustment |

**INITIAL SETUP:**

**Tools:**

General Mechanics Tool Kit (Appendix B, Item 1)

**Materials/Parts:**

Rag, wiping (Appendix F, Item 2)  
 Cleaning Solvent (Appendix F, Item 8)  
 Brush, Medium Bristle (Appendix F, Item 1)

**Equipment Condition:**

Pulley clutch removed (para. 5-54).  
 Feed cam removed (para 5-58)  
 Bottom needle bar rod removed (para. 5-45).

Removal.

- (1) Loosen clamp screw (11), rotate looper drive gear eccentric to clear gears.
- (2) Loosen two setscrews (1) and setscrew (2).

NOTE

Pins (3), (4) and (5) are tapered and are different in size.

- (3) Drive out gear pin (3), gear pin (4) and pin (5).

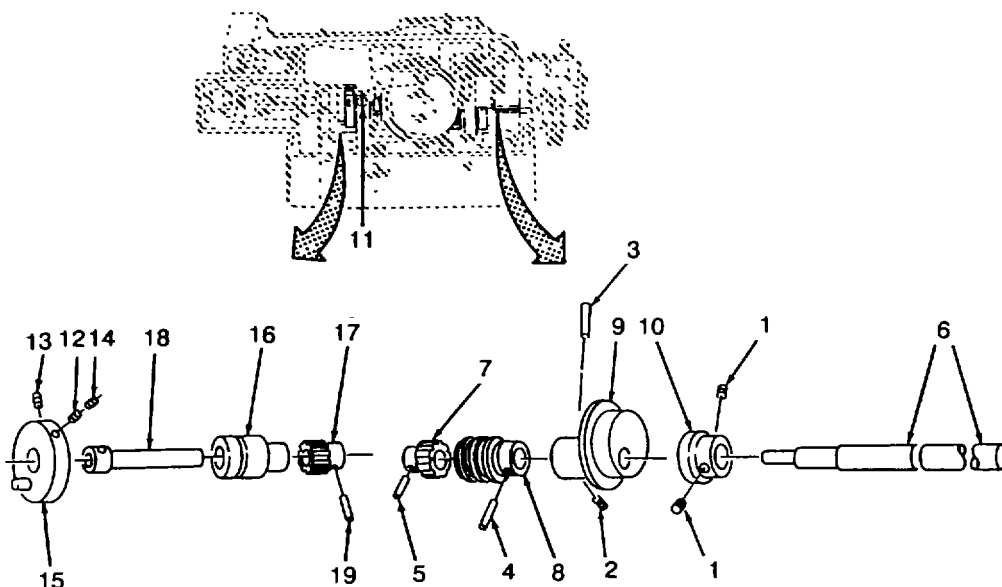

**5-61. BUTTON SEWING MACHINE ECCENTRIC, DRIVE SHAFT, LOOPER CAM AND CRANK MAINTENANCE-continued.**

- (4) Pull drive shaft (6) out through left rear of machine head. Remove pulley shaft gear (7), drive gear (8), needle eccentric (9), and thread tension cam (10).

**NOTE**

Setscrew (12) is lined up with dimple on shaft.

- (5) Remove setscrew (13), setscrew (14) and setscrew (12).

**NOTE**

It may be necessary to tighten clamp screw (11) to pry crank (15).

- (6) Remove drive shaft crank (15). Remove (16), (17), and (18) as an assembly.  
 (7) Drive thread looper pin (14) out Remove the thread loop gear (17) and thread bushing (16) from the thread loop shaft (18).

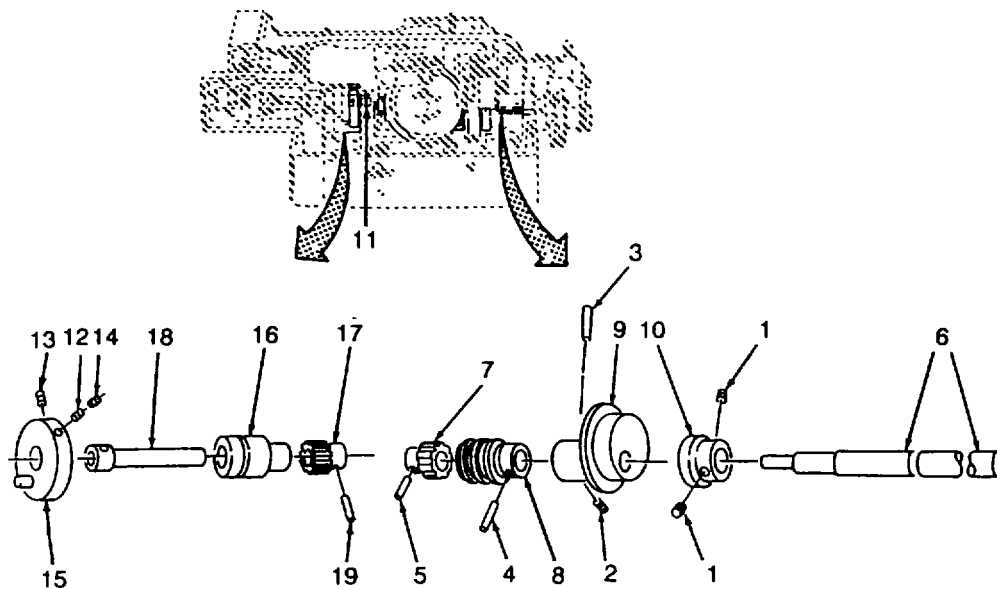

**5-61. BUTTON SEWING MACHINE ECCENTRIC, DRIVE SHAFT, LOOPER CAM AND CRANK MAINTENANCE-continued.**Cleaning

- (1) Remove all buildups of grease, dirt, etc, by wiping with a wiping rag (Appendix F, Item 2).

**WARNING**

Cleaning solvent, Federal Specification P-D-680, is both toxic and flammable. Keep off skin. Use only in a well-ventilated area and avoid prolonged breathing of vapors. Keep away from open flame.

- (2) Clean using cleaning solvent (Appendix F, Item 8) and either a wiping rag (Appendix F, Item 2) or a medium bristle brush (Appendix F, Item 1).
- (3) Allow to dry.

Inspection.

- (1) Inspect hardware for damage.
- (2) Inspect drive shaft for damage and straightness.
- (3) Inspect thread looper pin for damage.
- (4) Inspect bushing for damage.
- (5) Inspect thread loop gear for damage.
- (6) Inspect shaft gear for damage.
- (7) Inspect drive worm for damage.
- (8) Inspect needle eccentric for damage.
- (9) Inspect thread tension cam for damage.

Repair. Repair is limited to deburring and the replacement of defective components.

**5-61. BUTTON SEWING MACHINE ECCENTRIC, DRIVE SHAFT, LOOPER CAM AND CRANK MAINTENANCE-continued.**Installation.

- (1) Slide thread bushing (1) and thread loop gear (2) onto the thread loop shaft (3).
- (2) Locate large end on holes in the thread loop gear (2) and the thread loop shaft (3). Line up large end of tapered holes and drive thread looper pin (4) through parts.
- (3) Install thread loop shaft (3), thread bushing (1) and thread loop gear (2) into machine head. Slide thread bushing (1) until the front [opposite of the thread loop gear (2)] side is flushed with machine.

## NOTE

If gear (14) does not clear gear (2), rotate bushing (1) until it does clear.

- (4) Slide drive shaft (10) from rear side of machine head through thread tension cam (11), needle eccentric (12), drive worm gear (13), and pulley shaft gear (14).
- (5) Line up large end of tapered holes in the needle eccentric (12) and drive shaft (10). Drive pin (15) through large end of holes. Tighten setscrew (16).
- (6) Repeat step 2 with drive worm gear (13) and worm gear pin (17).
- (7) Repeat step 2 with pulley shaft gear (14) and gear pin (18).
- (8) Slide thread tension cam (11) against machine head Install and tighten two setscrews (19).
- (9) Rotate thread bushing (6) so that thread loop gear (2) engages with pulley shaft gear (14).
- (10) Tighten clampscrew (5).

5-61. **BUTTON SEWING MACHINE ECCENTRIC, DRIVE SHAFT, LOOPER CAM AND CRANK MAINTENANCE-continued.**

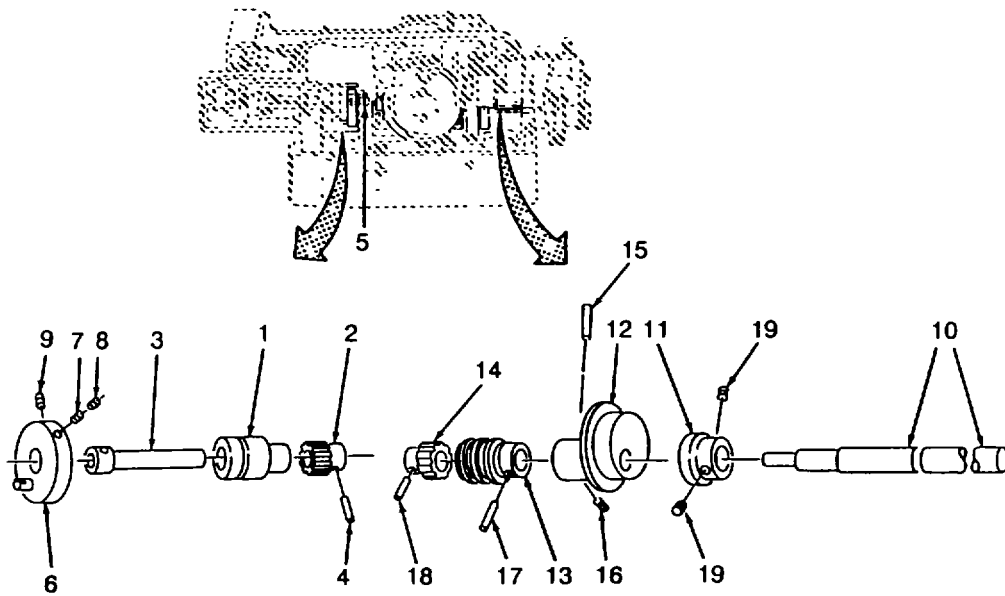

Adjustment.

Set automatic tension timing (para. 4-49).

**5-62. BUTTON SEWING MACHINE MOTOR ASSEMBLY MAINTENANCE.**

---

This task covers:

- |            |                |                 |               |
|------------|----------------|-----------------|---------------|
| a. Removal | b. Disassembly | c. Cleaning     | d. Inspection |
| e. Repair  | f. Assembly    | g. Installation |               |

**INITIAL SETUP:****Tools:**

Shop Equipment (Appendix B, Item 2)

**Equipment Condition:**

Table removed from stand assembly (para. 2-18)

Power removed (para. 2-18)

**Materials/Parts:**

Rag, wiping (Appendix F, Item 2)

**Removal.**

- (1) Remove motor electrical box cover. Tag and identify wires. Remove wires from motor.
- (2) Remove four nuts (1), four lockwashers (2), four flat washers (3) from four carriage bolts (4) and remove motor assembly (5) from the button table top (6).

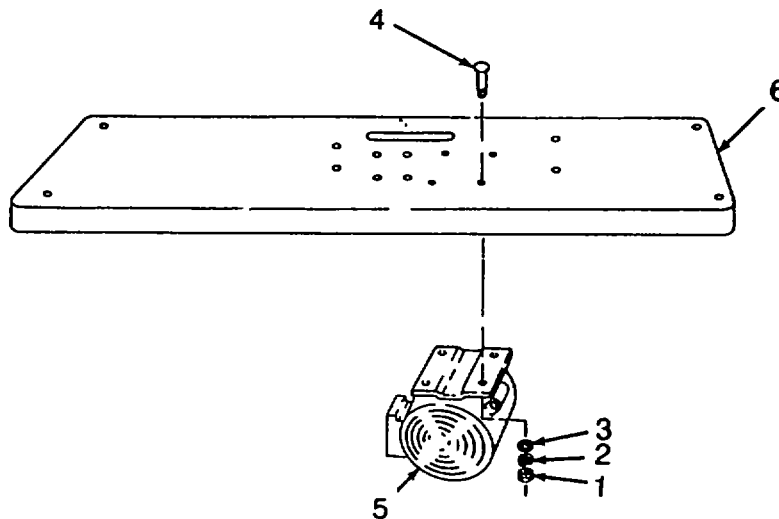

**5-62. BUTTON SEWING MACHINE MOTOR ASSEMBLY MAINTENANCE-continued.**

Disassembly.

- (1) Remove two nuts (1), Two lockwashers (2) and adjusting bolt (3).
- (2) Remove two retaining rings (4), base pin (5) and slide base (6).
- (3) Remove four vibration insulators (7) from slide base (6).

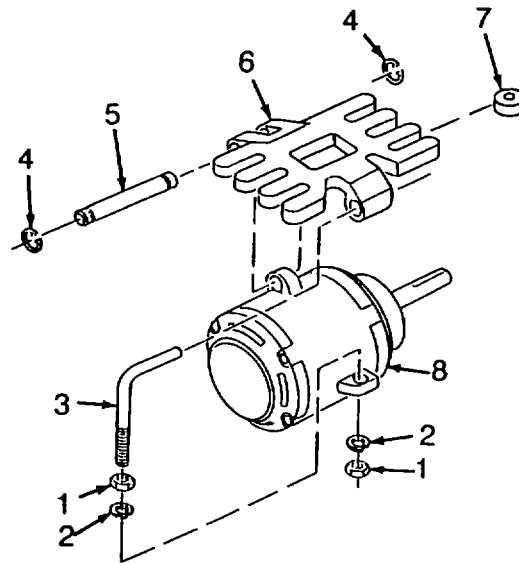

**5-62. BUTTON SEWING MACHINE MOTOR ASSEMBLY MAINTENANCE-continued.**

Cleaning. Use a dry wiping rag (Appendix F, Item 2) to clean only the external surfaces of the electric motor.

Inspection.

- (1) Inspect hardware for damage.
- (2) Inspect motor assembly for damage.
- (3) Inspect adjusting rod for damage.

Repair. Repair is limited to the replacement of defective parts and the following:

- (1) Remove two screws (1), two washers (2) and guard cover (3).
- (2) Remove two screws (4), two washers (5) and guard cover (6).
- (3) Remove setscrew (7), pulley (8) and key (9) from electric motor (10).
- (4) Replace with new parts as required.
- (5) Install key (9) and pulley (8). Secure with setscrew (7).
- (6) Install guard cover (6). Secure with two screws (4) and two washers (5).
- (7) Install guard cover (3). Secure with two washers (2) and two screws (1).

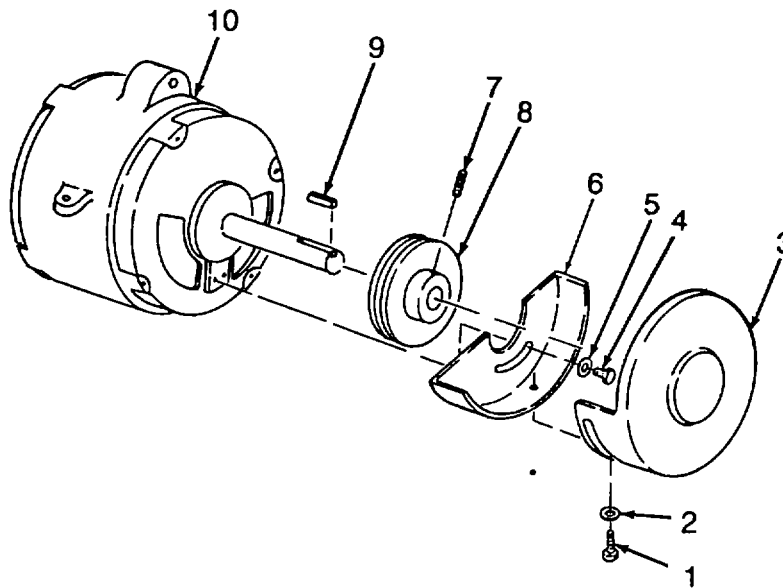

**5-62. BUTTON SEWING MACHINE MOTOR ASSEMBLY MAINTENANCE-continued. I**

Assembly.

- (1) Assemble four vibration insulators (1) onto the slide base (2).
- (2) Assemble base pin (3) to slide base (2) and secure with two retaining rings (4).
- (3) Install adjusting bolt (5) to electric motor (6) and secure with two lockwashers (7) and two nuts (8).

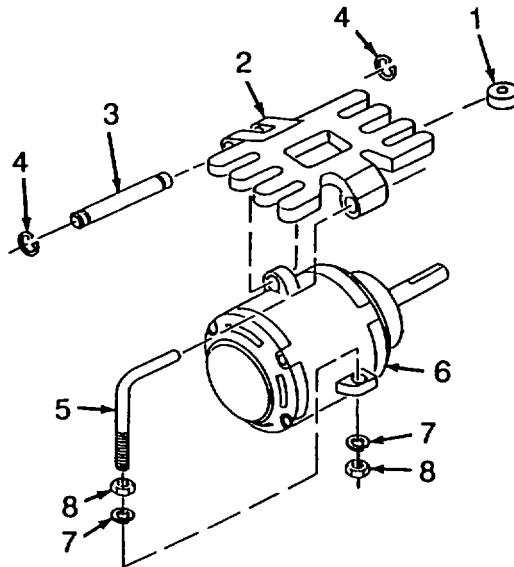

Installation.

- (1) Install motor assembly (1) to the button table top (2). Secure with four flat washers (3), four lockwashers (4) and four nuts (5) onto the four carriage bolts (6).
- (2) Connect wires to the motor, as previously tagged. Install motor electrical box cover.

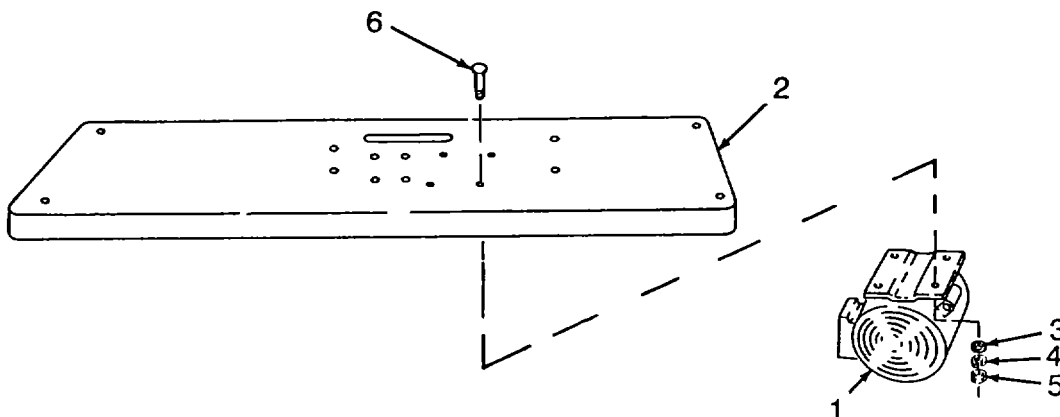

**5-63. BUTTON SEWING MACHINE RECEPTACLE ASSEMBLY MAINTENANCE.**

**This task covers:**

- |   |  |   |
|---|--|---|
| <ul style="list-style-type: none"> <li>a. Removal</li> <li>d. Repair</li> </ul> | <ul style="list-style-type: none"> <li>b. Cleaning</li> <li>e. Installation</li> </ul> | <ul style="list-style-type: none"> <li>c. Inspection</li> </ul> |
|---|--|---|

**INITIAL SETUP:**

**Tools:**

Shop Equipment (Appendix B, Item 2)

**Materials/Parts:**

Rag, wiping (Appendix F, Item 2)

**Equipment Condition:**

- Power removed (para 2-18)
- Table removed from stand (para. 2-18)
- Machine removed (para. 2-18)
- Bobbin removed (para. 2-18)
- Thread unwinder removed (para. 2-18)
- Light assembly removed (para. 2-18)

Removal.

- (1) Loosen four screws on both box cords (1).
- (2) Remove cover (2).
- (3) Remove receptacle (3).
- (4) Tag and disconnect wiring.
- (5) Remove two wood screws (4) and electrical box (5) from button table top.
- (6) Remove box cords (1).

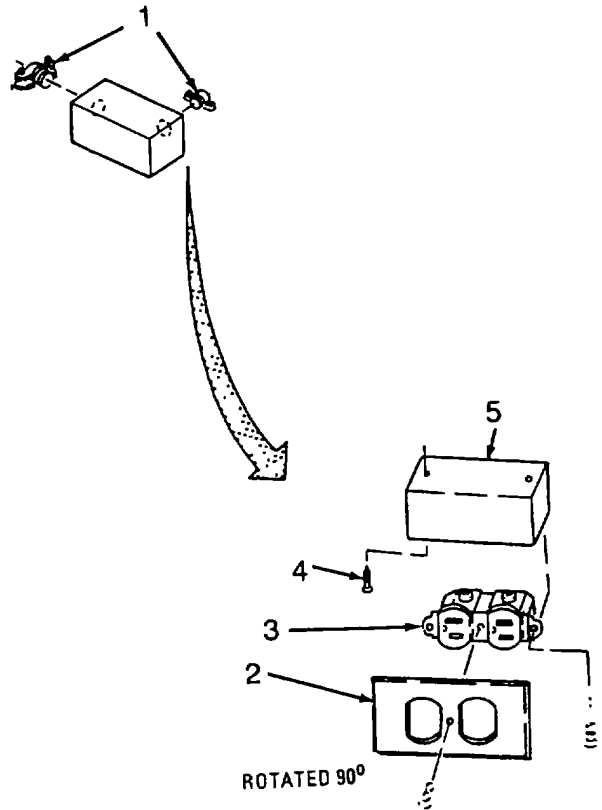

Cleaning.

- (1) Wipe parts with a dry wiping rag (Appendix F, Item 2).
- (2) Allow to dry.

Inspect.

- (1) Inspect hardware for damage.
- (2) Inspect for broken or burnt wires.
- (3) Inspect receptacle for damage.
- (4) Inspect electrical box for damage.

**5-63. BUTTON SEWING MACHINE RECEPTACLE ASSEMBLY MAINTENANCE-continued.**

Repair. Repair is limited to the replacement of defective components with serviceable ones.

Installation.

- (1) Install two box cords (5) in the electrical box (1).
- (2) Install electrical box (1) on the button table top. Secure with two wood screws (2).
- (3) Connect wiring as tagged.
- (4) Install receptacle (3).
- (5) Install cover (4).

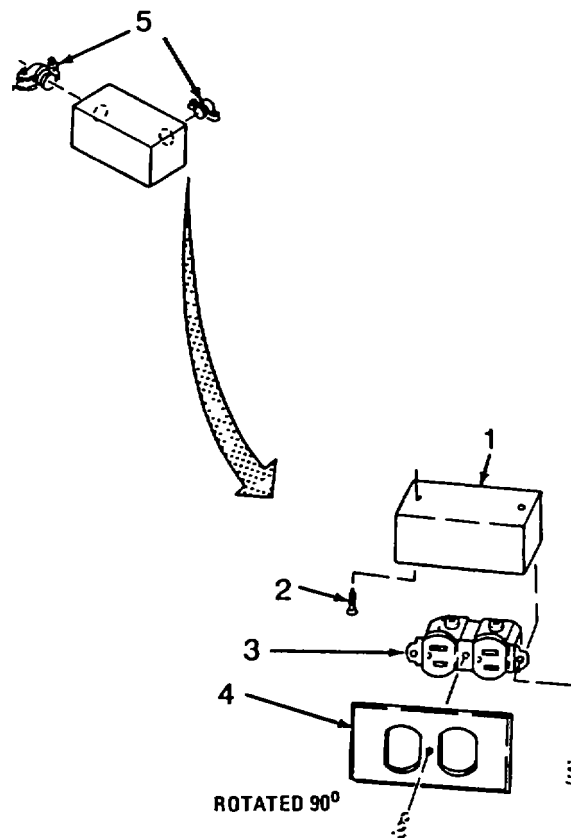

**5-64. STOWAGE BOX ASSEMBLY MAINTENANCE.**

---

**This task covers:****a. Inspection****b. Cleaning****c. Repair****INITIAL SETUP:****Tools:**

Shop Equipment (Appendix B, Item 2)  
Riveting Tool Set (Appendix B, Item 4)  
Welding Set (for Aluminum)  
Paint Spraying Equipment

**Equipment Condition:**

Stowage Box Removed From Cabinet (para 2-8)  
and emptied

**Materials/Parts:**

Detergent, General Purpose (Appendix F,  
Item 11)  
Rivets  
Aluminum Sheet Metal (Patches)  
Primer, Zinc Chromate (Appendix F,  
Item 6)  
Paint, Olive Drab (Appendix F, Item 3)  
Sealing Compound (Appendix F, Item 7)

**Inspection.**

- (1) Inspect for cracked or broken welds.
- (2) Inspect for rust, corrosion and damage.
- (3) Inspect for dents or hole in stowage box.

**Cleaning.**

- (1) Clean the door with a solution of detergent (Appendix F, Item 11) and water.
- (2) Rinse thoroughly with clean water.
- (3) Allow to dry.

**Repair. Repair is limited to the following.**

- (1) Repair of Dents.
  - (a) Push out all dents. If damage is too great to push out, treat as if it were a hole.
  - (b) Sand area with sandpaper and refinish with primer (Appendix F, Item 6) and olive drab paint (Appendix F, Item 3). Refer to TM 43-0139 for proper painting instructions. Allow paint to dry.

**5-64. STOWAGE BOX ASSEMBLY MAINTENANCE-continued.**

## (2) Repair of Holes.

- (a) Cut away the affected areas to remove all jagged edges. If metal is bent, straighten.
- (b) Sand both sides of the area with sandpaper to remove all sharp edges.
- (c) Apply one coat of primer (Appendix F, Item 6) to both sides of the sheet metal Refer to TM 43-0139 for proper painting instructions Allow primer to dry.
- (d) Cut two patches that are alike. Be sure that they extend at least 1 inch (2.54 cm) over the edges of the hole all the way around.
- (e) Place the patches in position and drill holes not further than 14 inches (3.81 cm) apart for mounting the rivets.
- (f) Apply one coat of primer (Appendix F, Item 6) to both sides of the patches and allow to dry.
- (g) Refinish both the inside and outside of the primed and patched area with olive drab paint (Appendix F, Item 3). Allow paint to dry.

**CAUTION**

Paint before applying sealant. Paint will not adhere if applied after sealant is used.

- (h) Apply sealing compound (Appendix F, Item 7) between both patches and the sheet metal.
- (i) Install the patches with rivets.
- (j) Wipe off excess sealing compound using wiping rag (Appendix F, Item 2).

## (3) Repair of Welds.

- (a) Remove all paint from at least 4 inches (10.2 cm) on each side of the damaged area.

**WARNING**

Remove paint before welding. Burnt paint will emit toxic fumes.

- (b) Weld the crack using aluminum welding techniques. Refer to TM 9-237 for proper welding technique.
- (c) Refinish the repaired area with one coat of primer (Appendix F, Item 6). Allow primer to dry.
- (d) Refinish area with olive drab paint (Appendix F, Item 3). Refer to TM 43-0139 for proper painting instructions. Allow paint to dry.

CHAPTER 6

GENERAL SUPPORT MAINTENANCE INSTRUCTIONS

<b>Section I.</b>	<b>Repair Parts, Special Tools, TMDE, and Support Equipment .....</b>	<b>6-1</b>
6-1.	Common Tools and Equipment.....	6-1
6-2.	Special Tools, TMDE, and Support Equipment.....	6-1
6-3.	Repair Parts.....	6-1
<b>Section II.</b>	<b>Maintenance of Cabinet Assembly .....</b>	<b>6-2</b>
6-4.	General.....	6-2
6-5.	Door Assembly Maintenance.....	6-2
6-6.	Panel, Rack and Wheel Well Maintenance.....	6-3

**Section I. REPAIR PARTS, SPECIAL TOOLS, TMDE, AND SUPPORT EQUIPMENT**

**6-1. COMMON TOOLS AND EQUIPMENT.**

For authorized common tools and equipment, refer to the Modified Table of Organization and Equipment (MTOE) applicable to your unit.

**6-2. SPECIAL TOOLS, TMDE, AND SUPPORT EQUIPMENT.**

No special tools, TMDE, or support equipment is authorized for the maintenance of the Clothing Repair Shop.

**6-3. REPAIR PARTS.**

Repair parts are listed and illustrated in the repair parts and special tools list TM 10-3530-207-24P, covering organizational, direct support and general support, and depot maintenance for this equipment.

---

**Section II. MAINTENANCE OF CABINET ASSEMBLY****6-4. GENERAL**

This section contains information on the repair of the cabinet assembly, which includes doors, panels, wheel wells and the frame.

**6-5. DOOR ASSEMBLY MAINTENANCE.**

---

**This task covers:**

**a. Repair of Dents in Door Panel**

---

**INITIAL SETUP:****Tools:**

Shop Equipment (Appendix B, Item 2)  
Welding Set (for Aluminum)

**Materials/Parts:**

Primer, Zinc Chromate (Appendix F, Item 6)  
Paint, Olive Drab (Appendix F, Item 3)

**Equipment Condition:**

Remove door from cabinet (para. 5-7 or 5-9)

---

**Repair of Dents in Door Panel.**

- (1) Push or bang out all dents.

**WARNING**

Remove paint before welding. Burnt paint will emit toxic fumes.

**CAUTION**

Do not paint gasket. Gasket will not seal properly if painted.

- (2) Sand area with sandpaper and refinish with zinc chromate primer (Appendix F, Item 6) and olive drab paint (Appendix F, Item 3) Refer to TM 43-0139 for proper painting instructions.
- (3) Allow paint to dry.

**6-6. PANEL, RACK AND WHEELWELL MAINTENANCE.**

---

**This task covers:**

- |                                 |  |
|---------------------------------|--|
| a. Removal                      | b. Repair of Holes and Dents in Panels and Wheel Wells |
| c. Repair of Framework and Rack | d. Installation  |
- 

**INITIAL SETUP:****Tools:**

Riveting Tool Set (Appendix B, Item 4)  
 Welding Set (for Aluminum)  
 Paint Spraying Equipment

**Materials/Parts:**

Rivets  
 Aluminum Sheet Metal (Patches)  
 Primer, Zinc Chromate (Appendix F, Item 6)  
 Paint, Olive Drab (Appendix F, Item 3)  
 Sealing Compound (Appendix F, Item 7)

**Equipment Condition:**

All equipment removed from cabinet (para. 2-8)

---

Removal. Remove cabinet from trailer (para. 5-6) if access to repair is restricted.

Repair of Holes and Dents in Panels and Wheel Wells.

## (1) Dents.

- (a) Push out all dents. If damage is too great to push out, treat as if it were a hole.
- (b) Sand area with sandpaper and refinish with zinc chromate primer (Appendix F, Item 6) and olive drab paint (Appendix F, Item 3). Refer to TM 43-0139 for proper painting instructions. Allow paint to dry.

## (2) Holes.

- (a) Cut away the affected areas to remove all jagged edges. If metal is bent, straighten.
- (b) Sand both sides of the area with sandpaper to remove all sharp edges.
- (c) Apply one coat of primer (Appendix F, Item 6) to both sides of the sheet metal. Refer to TM 43-0139 for proper painting instructions. Allow paint to dry.
- (d) Cut two patches that are alike. Be sure that they extend at least 1 inch (2.54 cm) over the edges of the hole all the way around.
- (e) Place the patches in position and drill holes not further than 1½ inches (3.81 cm) apart for mounting the rivets.
- (f) Apply one coat of primer (Appendix F, Item 6) to both sides of the patches and allow to dry.

**6-6. PANEL, RACK AND WHEELWELL MAINTENANCE - c ontinued.**Repair of Holes and Dents in Panels and Wheel Wells - continued

(2) Holes - continued.

- (g) Refinish both the inside and outside of the primed and patched area with olive drab paint (Appendix F, Item 3). Allow primer to dry.

**CAUTION**

Paint before applying sealant. Paint will not adhere if applied after sealant is used.

(h) Apply sealing compound (Appendix F, Item 7) between both patches and the sheet metal.

(i) Install the patches with rivets.

(j) Wipe off excess sealing compound using wiping rag (Appendix F, Item 2).

Repair of Framework and Rack.

(1) Remove all paint from at least 4 inches (10.2 cm) on each side of the damaged area.

(2) Cut away the damaged area if bent or twisted. Cut away several inches away from a break. If the frame is cracked, the area does not have to be cut away.

(3) Cut a new piece of material of the same size and shape as the frame piece to be repaired.

**WARNING**

Remove paint before welding. Burnt paint will emit toxic fumes.

(4) Place the new piece into position and weld into place. If frame was cracked, weld the crack using aluminum techniques. Refer to TM 9-237 for proper welding technique.

(5) Refinish the repaired area with one coat of zinc chromate primer (Appendix F, Item 6). Allow primer to dry.

(6) Refinish area with olive drab paint (Appendix F, Item 3). Refer to TM 43-0139 for proper painting instructions. Allow paint to dry.

Installation. If cabinet was removed, install cabinet on the trailer (para 5-6).

**APPENDIX A**  
**REFERENCES**

---

**A-1. SCOPE.**

This appendix lists all forms, field manuals, technical manuals, and other miscellaneous publications referenced in this manual. Also listed are those publications that should be consulted for additional information about the Clothing Repair Shop and its major components.

**A-2. FORMS.**

Recommended Changes to Publications and Blank Forms.....	DA FORM 2028
Recommended Changes to Equipment Technical Publications.....	DA FORM 2028-2
Equipment Inspection and Maintenance Worksheet.....	DA FORM 2404
Maintenance Request.....	DA FORM 2407
Equipment Log Assembly (Records).....	DA FORM 2408-9
Quality Deficiency Report.....	SF 368

**A-3. TECHNICAL MANUALS.**

Destruction Procedures for TSARCOM Equipment.....	TM 750-244-3
Generator Set, GED.....	TM 5-6115-271-14
Trailer, Chassis, Cargo.....	TM 9-2330-213-14
Painting Instructions for Field Equipment.....	TM 43-0139
Operator's Manual: Welding Theory and Application.....	TM 9-237

**A-4. FIELD MANUAL.**

First Aid for Soldiers ..... FM 21-11

**A-5. OTHER PUBLICATIONS.**

Army Maintenance Management System (TAMMS)..... DA Pam 738-750

Physical Security of Arm, Ammunition and Explosives ..... AR 190-11

Army Physical Security Program ..... AR 190-13

## APPENDIX B

MAINTENANCE ALLOCATION CHART

---

## Section I. INTRODUCTION

## B-1. GENERAL.

- a. This section provides a general explanation of all maintenance and repair function authorized at various maintenance categories.
- b. The Maintenance Allocation Chart (MAC) in Section II designates overall authority and responsibility for performance of maintenance functions on the identified end item or component. The application of the maintenance functions to the end item or component will be consistent with the capacities and capabilities of the designated maintenance categories.
- c. Section III lists the tools and test equipment (both special tools and common tool sets) required for each maintenance function as referenced from Section II.
- d. Section IV contains supplemental instructions and explanatory notes for a particular maintenance function.

## B-2. MAINTENANCE FUNCTIONS.

Maintenance functions will be limited to and are defined as follows:

- a. Inspect. To determine the serviceability of an item by comparing its physical, mechanical, and/or electrical characteristics with established standards through examination (e g, by sight, sound, or feel).
- b. Test. To verify serviceability by measuring the mechanical, pneumatic, hydraulic, or electrical characteristics of an item and comparing those characteristics with prescribed standards.
- c. Service. Operations required periodically to keep an item in proper operating condition, i.e., to clean (includes decontaminate, when required), to preserve, to drain, to paint, or to replenish fuel, lubricants, chemical fluids, or gases.
- d. Adjust. To maintain or regulate, within prescribed limits, by bringing into proper or exact position, or by setting the operating characteristics to specified parameters.
- e. Align. To adjust specified variable elements of an item to bring about a optimum performance.
- f. Calibrate. To determine and cause corrections to be made or to be adjusted on instruments or test, measuring, and diagnostic equipments used in precision measurement. Consists of comparisons of two instruments, one of which is a certified standard of known accuracy, to detect and adjust any discrepancy in the accuracy of the instrument being compared.

**B-2. MAINTENANCE FUNCTIONS - continued.**

- g. Remove/Install. To remove and install the same item when required to perform service or other maintenance functions. Install may be the act of emplacing, seating, or fixing into position a spare, repair part, or module (component or assembly) in a manner to allow the proper functioning of an equipment or system.
  - h. Replace. To remove an unserviceable item and install a serviceable counterpart in its place. "Replace" is authorized by the MAC and is shown as the 3rd position code of the SMR code.
  - i. Repair. The application of maintenance services, including fault location/troubleshooting, removal/installation, and disassembly/assembly procedures, and maintenance actions to identify troubles, and restore serviceability to an item by correcting specific damage, fault, malfunction, or failure in a part, subassembly, module (component or assembly) end item, or system.
  - j. Overhaul. That maintenance effort (service/action) prescribed to restore an item to a completely serviceable/operational condition as required by maintenance standards in appropriate technical publications (i.e., DMWR). Overhaul is normally the highest degree of maintenance performed by the Army. Overhaul does not normally return an item to like new condition.
  - k. Rebuild. Consists of those services/actions necessary for the restoration of unserviceable equipment to a like new condition in accordance with original manufacturing standards. Rebuild is the highest degree of material maintenance applied to Army equipment. The rebuild operation includes the act of returning to zero those age measurements (hours/miles, etc.) considered in classifying Army equipment/components.
- 

**B-3. EXPLANATION OF COLUMNS IN THE MAC - SECTION II.**

- a. Column 1, Group Number Column 1. lists functional group code numbers, the purpose of which is to identify maintenance significant components, assemblies, subassemblies, and modules with the next higher assembly. End item group numbers are "00".
- b. Column 2, Component/Assembly. Column 2 contains the names of components, assemblies, subassemblies, and modules for which maintenance is authorized.
- c. Column 3, Maintenance Function. Column 3 lists the functions to be performed on the item listed in Column 2. (For a detailed explanation of these functions, see paragraph B-2).
- d. Column 4, Maintenance Level. Column 4 specifies, by the listing of a work time figure (expressed as man-hours shown as whole hours or decimals) in the appropriate subcolumn(s), the level of maintenance authorized to perform the function listed in Column (3). This figure represents the active time required to perform that maintenance function at the indicated level of maintenance. If the number or the complexity of the tasks within the listed maintenance function vary at different maintenance levels, appropriate work time figures will be shown for each level. The work time figure represents the average time required to restore an item (assembly, subassembly, component, module, end item, or system) to a serviceable condition under typical field operating conditions. This time includes preparation item including any necessary disassembly/assembly time), troubleshooting/fault location time, and quality assurance/quality control time in addition to the time required to perform

**B-3. EXPLANATION OF COLUMNS IN THE MAC - SECTION II - continued.**

the specific tasks identified for the maintenance functions authorized in the maintenance allocation chart. The system designations for the various maintenance levels are shown on the following page.

- C ..... Operator or crew
- O ..... Unit Maintenance
- F ..... Direct Support Maintenance
- H ..... General Support Maintenance
- D ..... Depot Maintenance

- e. Column 5, Tools and Equipment. Column 5 specifies, by code, those common tool sets (not individual tools) common TMDE, and special tools, special TMDE, and support equipment required to perform the designated function.
- f. Column 6, Remarks. This column, when applicable, contains a letter code, in alphabetic order, which is keyed to the remarks contained in Section IV.

**B-4. EXPLANATION OF COLUMNS IN TOOL AND TEST EQUIPMENT REQUIREMENTS, SECTION III.**

- a. Column 1, Reference Code. The tool and test equipment reference code correlates with a code used in the MAC, Section II, Column 5.
- b. Column 2, Maintenance Level. The lowest category of maintenance authorized to use the tool or test equipment.
- c. Column 3, Nomenclature. Name or identification of the tool or test equipment.
- d. Column 4, National Stock Number. The national stock number of the tool or test equipment
- e. Column 5, Tool Number. The manufacturer's part number.

**B-5. EXPLANATION OF COLUMNS IN REMARKS, SECTION IV.**

- a. Column 1, Reference Code. The code recorded in column 6, Section II.
- b. Column 2, Remarks. This column lists information pertinent to the maintenance function being performed as indicated in the MAC, Section II.

Section II. MAINTENANCE ALLOCATION CHART								
(1) GROUP NUMBER	(2) COMPONENT/ASSEMBLY	(3) MAINTENANCE FUNCTION	(4) MAINTENANCE LEVEL				(5) TOOLS & EQPT	(6) REMARKS
			UNIT		DS	GS		
			C	O	F	H		
00	CLOTHING REPAIR SHOP TRAILER MOUNTED							
01	TRAILER, CARGO	INSPECT SERVICE REPLACE REPAIR	0.5	0.5 1.0	4.0		1 2,5	E
02	SUPPORT LEG ASSEMBLY	INSPECT REPLACE REPAIR	0.5	1.0 1.0			1 1	E
03	HOLDDOWN CLAMP ASSEMBLY	INSPECT REPLACE		0.5	0.5		1	
04	CABINET ASSEMBLY	INSPECT REPLACE REPAIR		0.2	2.0 14.0	15.0	2 2,3,4	AB
0401	*LIFTING EYE	INSPECT REPLACE		0.5 1.0			1	D
0402	*PADLOCKS	INSPECT REPLACE	0.2 0.5				1	D
0403	*DOOR ASSEMBLIES	INSPECT REPLACE REPAIR		0.5	2.0 1.0	2.0	2 1, 2, 5	A
040301	**DOOR STAY ASSY	INSPECT REMOVE REPLACE		0.5	2.0 2.0		1 1	D D
0404	*PANELS	INSPECT REPLACE REPAIR		0.5	2.0 6.0		2,5	A
0405	*DOOR/RACK ASSEMBLY	INSPECT REPLACE REPAIR		0.5		1.0 2.0 8.0	2,4 2,4	A
040501	**WHEEL WELL ASSEMBLY	INSPECT REPLACE REPAIR		0.5		1.0 1.0	2 2,4	A

Section II. MAINTENANCE ALLOCATION CHART								
(1) GROUP NUMBER	(2) COMPONENT/ASSEMBLY	(3) MAINTENANCE FUNCTION	(4) MAINTENANCE LEVEL				(5) TOOLS & EQPT	(6) REMARKS
			UNIT		DS	GS		
			C	O	F	H		
040502	**HEAT SEALER MOUNTING PLATE	INSPECT REPAIR		0.2	1.0		1	D
040503	**RETAINING STRAPS	INSPECT REPLACE		0.5	0.5		1	D
040504	**GENERATOR SUPPORT RAIL	INSPECT REPLACE REPAIR		0.5	0.5 1.0		1 2	
040505	**FRAME	INSPECT REPAIR		0.5		1.0 3.0	3,4,5	B
05	CLOTHING MACHINE TRAY ASSEMBLY	INSPECT REPLACE REPAIR	0.2				1	D
06	CLOTHING SEWING MACHINE ASSEMBLY	INSPECT SERVICE ADJUST REPLACE REPAIR	0.5		1.0 1.5 1.0 9.0	1.0 2.5	1 1 1,2	
0601	*LAMP ASSEMBLY	INSPECT REPLACE	0.2 0.5				1	D
0602	*CLOTHING SEWING MACHINE HEAD ASSEMBLY	INSPECT SERVICE ADJUST REPLACE REPAIR	0.5		0.5 0.5 1.0 1.0	0.5 1.0	1 1 1,2	
060201	**THREAD UNWINDER	INSPECT REPLACE REPAIR	0.2		0.5 1.0		1 1	D
060202	**CLOTHING MACHINE HEAD	INSPECT SERVICE ADJUST REPLACE REPAIR	0.5		0.5 0.5 1.0 1.0	0.5 1.0	1 1	

Section II. MAINTENANCE ALLOCATION CHART								
(1) GROUP NUMBER	(2) COMPONENT/ASSEMBLY	(3) MAINTENANCE FUNCTION	(4) MAINTENANCE LEVEL				(5) TOOLS & EQPT	(6) REMARKS
			UNIT		DS	GS		
			C	O	F	H		
06020201	***TENSION ASSEMBLY	INSPECT	0.2					
		REPLACE		0.3			1	
		REPAIR		0.5			1	D
060203	**BELT GUARD	INSPECT	0.2					
		REPLACE		0.3				
0603	*TABLE TOP ASSEMBLY	INSPECT	0.5					
		REPLACE		1.0			1	
		REPAIR		2.0			1,2	
060301	**BOBBIN WINDER	INSPECT	0.2					
		REPLACE		0.5			1	D
060302	**LIFT KNEE LEVER ASSEMBLY	INSPECT	0.2					
		REPLACE		0.5			1	
		REPAIR		1.0			1	D
060303	**CLUTCH MOTOR ASSEMBLY	INSPECT	0.5					
		REPLACE			1.0		1	
		EPAIR			2.0		1	
06030301	***RECEPTACLE ASSEMBLY	INSPECT	0.2					
		REPLACE			0.5		1,2	
		REPAIR			1.0		1,2	D
06030302	***CLUTCH AND MOTOR ASSEMBLY	INSPECT	0.5					
		ADJUST		0.5	0.5		1	
		REPLACE			1.0		2	
0603030201	****BELT GUARD	INSPECT	0.2					
		ADJUST		0.2			1	
		REPLACE		0.5			1	
0603030202	****ELECTRIC MOTOR	REPAIR		0.5				D
		INSPECT	0.5					
		ADJUST	0.5			1.0	2	D

Section II. MAINTENANCE ALLOCATION CHART								
(1) GROUP NUMBER	(2) COMPONENT/ASSEMBLY	(3) MAINTENANCE FUNCTION	(4) MAINTENANCE LEVEL				(5) TOOLS & EQPT	(6) REMARKS
			UNIT		DS	GS		
			C	O	F	H		
0604	**TREADLE ASSEMBLY	INSPECT	0.5					
		REPLACE		0.5			1	
		REPAIR		1.0			1	
0605	**TREADLE PIPE	INSPECT	0.5					
		REPLACE		0.5			1	
		REPAIR		1.0			1	
0606	*CLOTHING MACHINE STAND ASSEMBLY	INSPECT	0.5					
		REPLACE		0.5			1	
		REPAIR		1.0			1	
07	DARNING MACHINE TRAY ASSEMBLY	INSPECT	0.5					
		REPLACE		0.5			1	
		REPAIR		1.0			1	
08	DARNING SEWING MACHINE ASSEMBLY	INSPECT	0.5					
		SERVICE		0.5	1.0		1	
		ADJUST		0.5	1.0			
		REPLACE		1.0			1	
		REPAIR		1.0	6.0		1,2	
0801	*LAMP ASSEMBLY	INSPECT	0.2					
		REPLACE	0.5				1	
0802	*DARNING MACHINE HEAD ASSEMBLY	INSPECT	0.5					
		SERVICE		0.5				
		ADJUST		0.5	1.0		1	
		REPLACE		1.0			1	
		REPAIR		1.0	6.0		1,2	
080201	**THREAD STAND	INSPECT	0.2					
		REPLACE		0.5			1	
		REPAIR		1.0			1	
080202	**BELT GUARD	INSPECT	0.2					
		REPLACE		0.5			1	
		REPAIR		1.0			1	
080203	**DARNING MACHINE HEAD	INSPECT	0.5					
		SERVICE		0.5	1.0		1	
		ADJUST			1.0			
		REPLACE		1.0			1	
		REPAIR		1.0	6.0		1,2	

Section II. MAINTENANCE ALLOCATION CHART								
(1) GROUP NUMBER	(2) COMPONENT/ASSEMBLY	(3) MAINTENANCE FUNCTION	(4) MAINTENANCE LEVEL				(5) TOOLS & EQPT	(6) REMARKS
			UNIT		DS	GS		
			C	O	F	H		
0803	*DARNING MACHINE TABLE TOP ASSEMBLY	INSPECT REPLACE REPAIR	0.5	1.0 2.0			1 1,2	
080301	**FOOT PEDAL	INSPECT REPLACE REPAIR	0.2	0.5 0.5			1 1	D D
080302	**CLUTCH MOTOR ASSEMBLY	INSPECT ADJUST REPLACE REPAIR	0.5	0.5	0.5 1.0 2.0		1 2 2	D
08030201	***RECEPTACLE ASSEMBLY	INSPECT REPLACE REPAIR	0.2		0.5 1.0		2 2	D
08030202	***CLUTCH ASSEMBLY	INSPECT ADJUST REPLACE REPAIR	0.5	0.5	0.5 1.0 2.0		2 2 2	
0803020201	****BELT GUARD	INSPECT ADJUST REPLACE REPAIR	0.2	0.2 0.5 0.5			1 1 1	D
0803020202	****ELECTRIC MOTOR	INSPECT REPLACE	0.5		1.0		2	D
0804	*TREADLE ASSEMBLY	INSPECT REPLACE REPAIR	0.2	0.5 1.0			1 1	D
0805	**TREADLE PIPE	INSPECT REPLACE REPAIR	0.2	0.5 0.5			1 1	D
0806	*DARNING STAND ASSEMBLY	INSPECT REPLACE REPAIR	0.5	0.5 1.0			1 1	D

Section II. MAINTENANCE ALLOCATION CHART								
(1) GROUP NUMBER	(2) COMPONENT/ASSEMBLY	(3) MAINTENANCE FUNCTION	(4) MAINTENANCE LEVEL				(5) TOOLS & EQPT	(6) REMARKS
			UNIT		DS	GS		
			C	O	F	H		
09	BUTTON MACHINE TRAY ASSEMBLY	INSPECT REPLACE REPAIR	0.2	0.2 1.0			1 D	
10	BUTTON SEWING MACHINE ASSEMBLY	INSPECT SERVICE ADJUST REPLACE REPAIR	0.5	0.5 0.5 1.0	1.0 1.0 9.0		1 1,2 D	
1001	*LAMP ASSEMBLY	INSPECT REPLACE	0.2 0.5				1 D	
1002	*BUTTON SEWING MACHINE HEAD ASSEMBLY	INSPECT SERVICE ADJUST REPLACE REPAIR	0.5	0.5 0.5 1.0	0.5 9.0		1 1,2 D	
100201	**THREAD STAND	INSPECT REPLACE REPAIR	0.2	0.5 0.5			1 1 D	
100202	**FOOT PEDAL	INSPECT REPLACE REPAIR	0.2	0.5 0.5			1 1 D D	
100203	**BUTTON MACHINE HEAD	INSPECT SERVICE ADJUST REPLACE REPAIR	0.5	0.5 0.5	0.5 1.0 1.0 9.0		2 1,2 D	
1003	*BUTTON MACHINE TABLE TOP ASSEMBLY	INSPECT REPLACE REPAIR	0.5	1.0 2.0			1 2 D	
100301	**BELT GUARD	INSPECT REPLACE REPAIR	0.5	1.0 1.0			1 1 D	

Section II. MAINTENANCE ALLOCATION CHART								
(1) GROUP NUMBER	(2) COMPONENT/ASSEMBLY	(3) MAINTENANCE FUNCTION	(4) MAINTENANCE LEVEL				(5) TOOLS & EQPT	(6) REMARKS
			UNIT		DS	GS		
			C	O	F	H		
100302	**BASE BED ASSEMBLY	INSPECT REPLACE REPAIR	0.2	0.5 1.0			1 1	D
100303	**MOTOR ASSEMBLY WITH PULLEY	INSPECT REPLACE REPAIR	0.5		1.0 1.0		2	D
10030301	***RECEPTACLE ASSEMBLY	INSPECT REPLACE REPAIR	0.2		1.0 1.0		2 2	D
10030302	***BELT GUARD	INSPECT ADJUST REPLACE REPAIR	0.2	0.2 0.5 0.5			1 1 1	D
10030303	***ELECTRIC MOTOR	INSPECT REPLACE	0.5		1.0		2	D
1004	*BUTTON STAND ASSEMBLY	INSPECT REPLACE REPAIR	0.5	0.5 1.0			1 1	D
11	STOWAGE BOX ASSEMBLY (I, IL m, ANDIV)	INSPECT REPLACE REPAIR	0.5	0.5 0.5	2.0		2,4	A
12	FOLDING CHAIR	INSPECT REPLACE	0.2 0.2				1	D
13	GROMMET/IANDTACK AND HEAT SEALER FOLDING TABLES	INSPECT REPLACE REPAIR	0.5	0.5 2.0			1	D
14	HEAT SEALER	INSPECT REPLACE REPAIR	0.5	0.5 0.5			1,2	D
1401	*BASE ASSEMBLY	INSPECT REPLACE REPAIR	0.5	0.5 1.0			1	D

Section II. MAINTENANCE ALLOCATION CHART								
(1) GROUP NUMBER	(2) COMPONENT/ASSEMBLY	(3) MAINTENANCE FUNCTION	(4) MAINTENANCE LEVEL				(5) TOOLS & EQPT	(6) REMARKS
			UNIT		DS	GS		
			C	O	F	H		
1402	*CONSOLE ASSEMBLY	INSPECT REPLACE REPAIR	0.5	1.0 2.0			2	D
1403	*BLOCK ASSEMBLY	INSPECT REPLACE REPAIR	0.2	0.5 1.0			2	D
15	DISTRIBUTION BOX ASSEMBLY (-1, -2, & -3)	INSPECT TEST REPLACE REPAIR	0.5	0.5 0.5 1.0			2 2	D
16	POWER BOX ASSEMBLY	INSPECT TEST REPLACE REPAIR	0.5	0.5 0.5 1.0			2 2	D
17	IRONING BOARD	INSPECT REPLACE REPAIR	0.2	0.2 0.5				D
18	HAND TACK AND DIES	INSPECT REPLACE	0.5	0.5				D
19	GROMMET PRESS AND DIES	INSPECT REPLACE	0.5	0.5				D
20	TROUBLE LIGHT	INSPECT REPLACE	0.5 0.5				1	
21	FIRE EXTINGUISHER	INSPECT SERVICE REPLACE	0.2	0.5 0.5			1	D
22	GENERATOR CLAMP ASSEMBLY	INSPECT REPLACE	0.5		0.5		1	D
23	GROUND WIRE	INSPECT REPLACE	0.5 0.5				1	D

**Section III. TOOLS AND TEST EQUIPMENT REQUIREMENTS**

(1) REFERENCE CODE	(2) MAINTENANCE CATEGORY	(3) NOMENCLATURE	(4) NATIONAL STOCK NUMBER (NSN)	(5) TOOL NUMBER
1	0	TOOL KIT (1) GENERAL MECHANICS	5180-00-177-7033	SC5180-90-N26
2	0	SHOP EQUIPMENT (1), AUTOMOTIVE VEHICLE	4910-00-754-0654	SC4910-95-CL-A74
3	F	HOIST		
4	F	RIVETING TOOL SET	5120-00-017-2849	SC4910-95-A31
5	H	WELDING SHOP, TRAILER MOUNTED	3431-01-090-1231	SC3431-95-CLA04

**Section IV. REMARKS**

REFERENCE CODE	REMARKS
A	PATCH, ALUMINUM WELD, AND RIVET
B	ALUMINUM WELD AND STRAIGHTEN
C	WELD AND STRAIGHTEN
D	REPAIR LIMITED TO REPLACEMENT OF DEFECTIVE COMPONENTS
E	REFER TO TRAILER TM 9-2830-376-14&P

**APPENDIX C****COMPONENTS OF END ITEM AND BASIC ISSUE ITEMS LIST**

---

**Section I. INTRODUCTION****C-1. SCOPE**

This appendix lists components of end item and basic issue items for the Clothing Repair Shop to help you inventory items required for safe and efficient operation.

**C-2. GENERAL**

The Components of End Item and Basic Issue Items List are divided into the following sections

- a. Section II. Components of End Item. This listing is for informational purposes only, and is not authority to requisition replacements. These items are part of the end item, but are removed separately packaged for transportation or shipment. As part of the end item, these items must be with the end item whenever it is issued or transferred between property accounts. Illustrations are furnished to assist you in identifying the items.
- b. Section III. Basic Issue Items. These are the minimum essential items required to place the Clothing Repair Shop in operation, to operate it, and to perform emergency repairs. Although shipped separately packaged, BII must be with the Clothing Repair Shop during operation and whenever it is transferred between property accounts. The illustrations will assist you with hard to-identify items. This manual is your authority to request/requisition replacement BII, based on TOE/MTOE authorization of the end item.

**C-3. EXPLANATION OF COLUMNS**

The following provides an explanation of columns found in the tabular listing:

- a. Column (1) Illustration Number (Illus Number). This column indicates the number of the illustration in which the item is shown.
- b. Column (2) National Stock Number. Indicates the national stock number assigned to the item and will be used for requisitioning purposes.
- c. Column (3) Description. Indicates the Federal item and name and, if required, a minimum description to identify and locate the item. The last line for each item indicates the CAGE (in parentheses) followed by the part number.
- d. Column (4) Unit of Measure (U/M). Indicates the measure used in performing the actual operational/maintenance function. This measure is expressed by a two-character alphabetical abbreviation (e g., ea, in, pr).
- e. Column (5) Quantity required (Qty reqd). Indicates the quantity of the item authorized to be used with/on the equipment.

Section II. COMPONENTS OF END ITEM

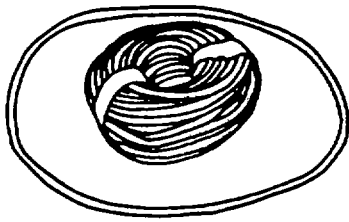

1

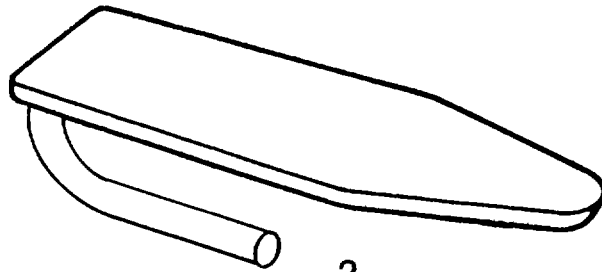

2



6



5



4



3

(1) ILLUS NUMBER	(2) NATIONAL STOCK NUMBER	(3) DESCRIPTION CAGE and Part Number	Usable on Code	(4) U/M RQD	(5) QTY.
1		Belting, V, Rubber, 100 foot per roll (90338) 33V0		RL	1
2		Board, Ironing with Cover Set (90589) 6-1-9557-28		EA	1
3		Bobbin, Clothing Machine (90338) 212		EA	15
4	3530-01-169-1786	Bobbin, Darning Machine (90338) 10656			15
5		Bobbin Case, Clothing Machine (90338) 214		EA	5
6	3530-01-192-1678	Bobbin Case, Darning Machine (90338) 13086		EA	5

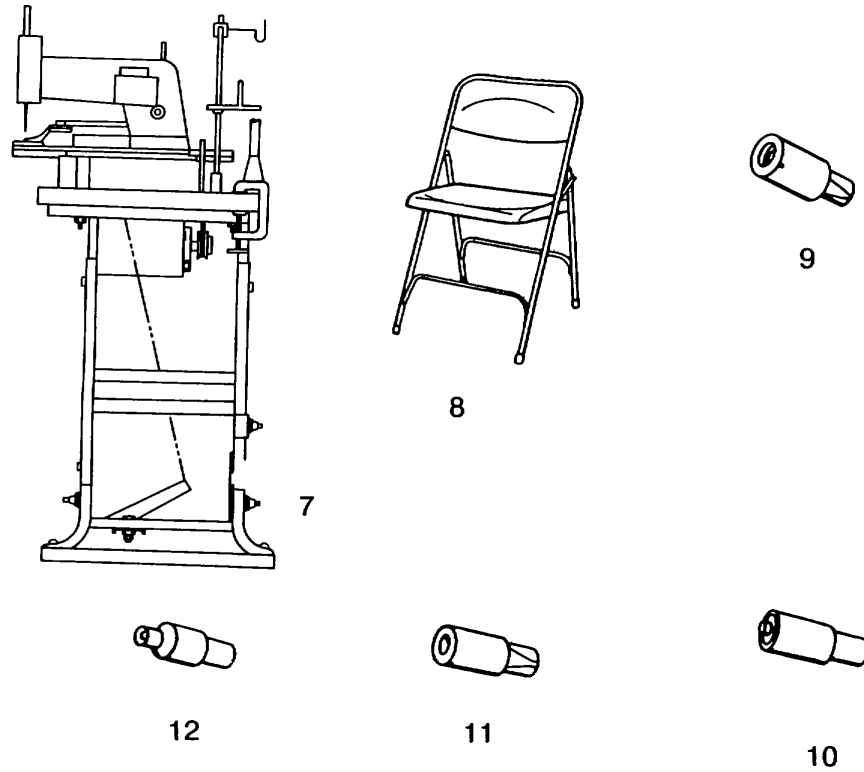

(1) ILLUS NUMBER	(2) NATIONAL STOCK NUMBER	(3) DESCRIPTION CAGE and Part Number	(4) Usable on U/M Code	(5) QTY. RQD
7		Button Sewing Machine Assembly (90338) 6-1-6388	EA	1
8		Chair, Folding, AAC291, Type I, Style A (00513) CHF01	EA	8
9	5120-00-329-3297	Chuck, Grommet Press (61864) 1486	EA	1
10	5120-00-144-2087	Chuck, Grommet Press (61864) 1580	EA	1
11	5120-00-357-5596	Chuck, Grommet Press (61864) 9219R	EA	1
12	5110-00-090-4401	Chuck, Grommet Press (61864) 9323	EA	1

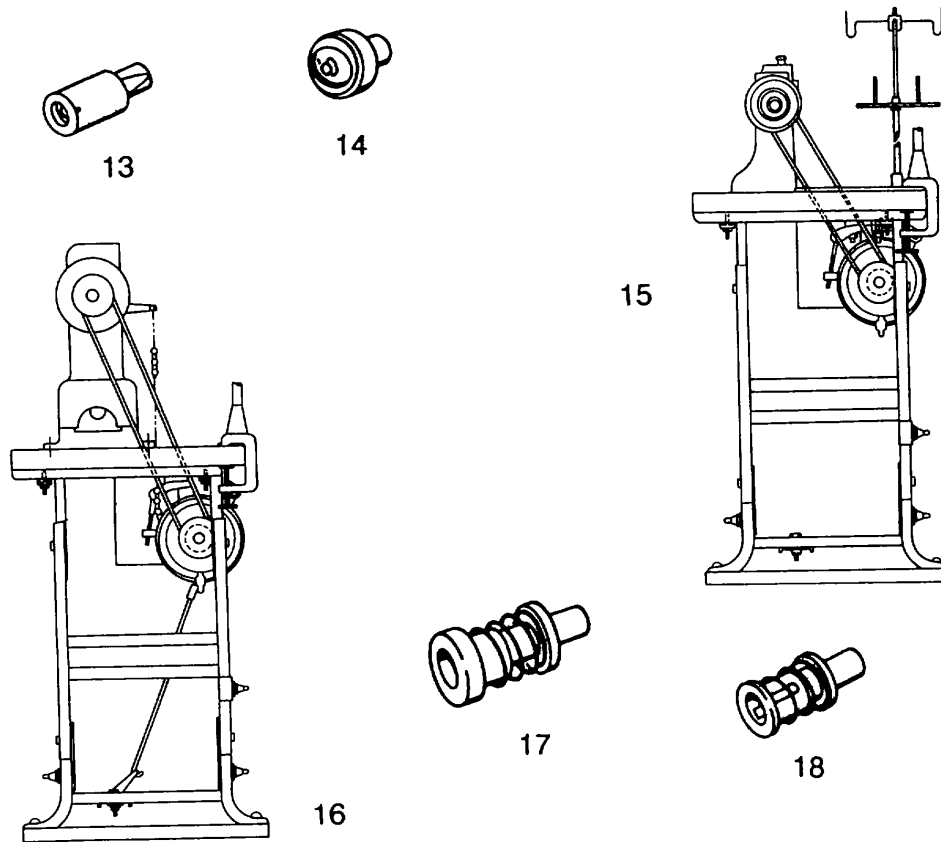

(1) ILLUS NUMBER	(2) NATIONAL STOCK NUMBER	(3) DESCRIPTION CAGE and Part Number	Usable on Code	(4) U/M	(5) QTY. RQD
13	5120-00-357-5597	Chuck, Grommet Press (61864) 9447		EA	1
14	5120-00-357-5594	Chuck, Grommet Press (61864) 9470		EA	1
15		Clothing Sewing Machine Assembly (90338) 6-1-6384		EA	6
16		Darning Sewing Machine Assembly (90338) 6-1-6385		EA	1
17	5120-00-322-6189	Die, Attaching Machine, Lower (61864) 312		EA	1
18	5120-00-322-6188	Die, Attaching Machine, Lower (61864) 351		EA	1

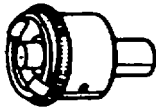

19

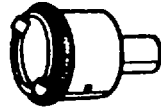

20



21



24



23



22

(1) ILLUS NUMBER	(2) NATIONAL STOCK NUMBER	(3) DESCRIPTION CAGE and Part Number	(4) Usable on Code	(5) U/M QTY. RQD
19	5120-00-322-6190	Die, Attaching Machine Upper Closed (61864) 3032	EA	1
20	5120-00-900-8324	Die, Attaching Machine Upper Open (61864) 2727	EA	1
21	5110-00-509-8062	Die, Button Fastener (61864) 1483	EA	1
22	5120-00-359-6503	Die, Button Fastener (61864)9182	EA	1
23	5120-00-449-3745	Die, Button Washer Fastener (61864)9454	EA	1
24	5120-00-357-5752	Die, Clinch Plate (61864) 9471	EA	1

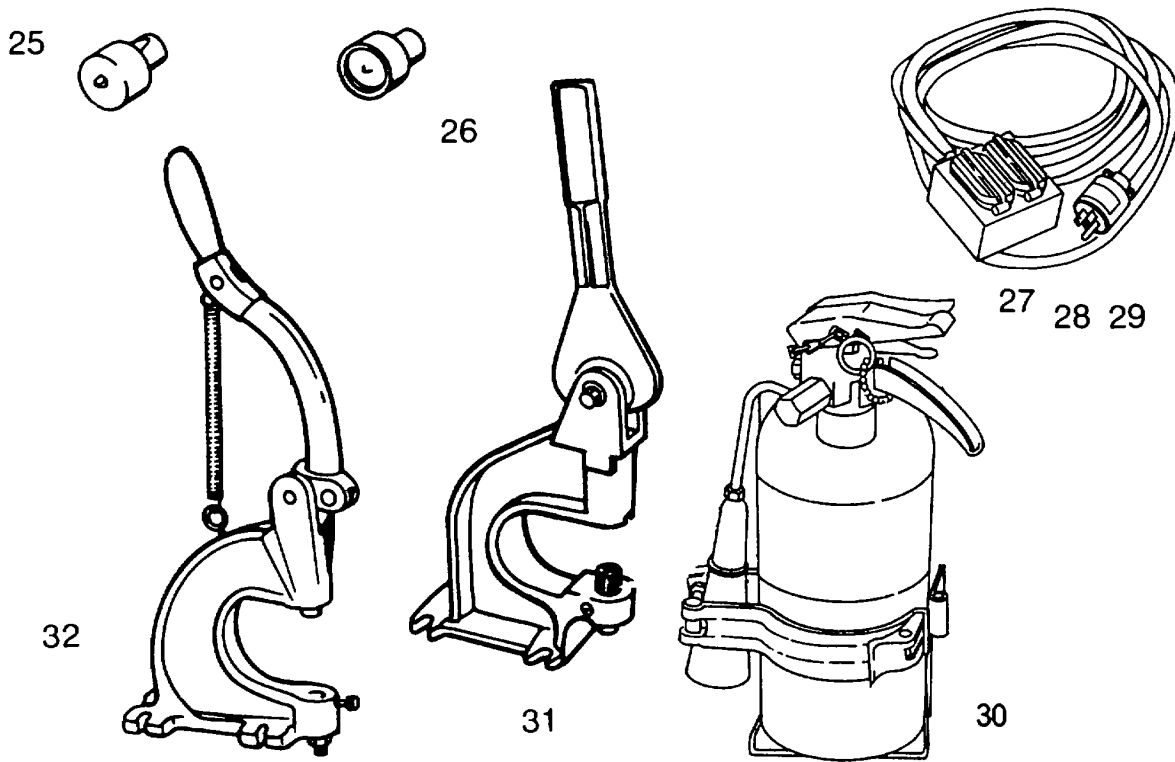

(1) ILLUS NUMBER	(2) NATIONAL STOCK NUMBER	(3) DESCRIPTION CAGE and Part Number	Usable on Code	(4) U/M	(5) QTY. RQD
25	5120-00-144-2100	Die, Eyelet (61864) 1587		EA	1
26	5120-00-449-3744	Die, Eyelet Fastener Tool (61864) 1488		EA	1
27		Distribution Box Assembly (81337) 6-1-9775-1		EA	1
28		Distribution Box Assembly (81337) 6-1-9775-2		EA	1
29		Distribution Box Assembly (81337) 6-1-9775-3		EA	1
30	4210-00-595-1777	Extinguisher, Fire, Carbon Dioxide, 5 LB. Hand Type 0-E-910, Type I, Size 5 (5N346) 79424		EA	1
31		Grommet Press (61864) 6-1-9557-30		EA	1
32		Hand Tack, Button Attaching Machine (65051) 6-1-9557-29		EA	1

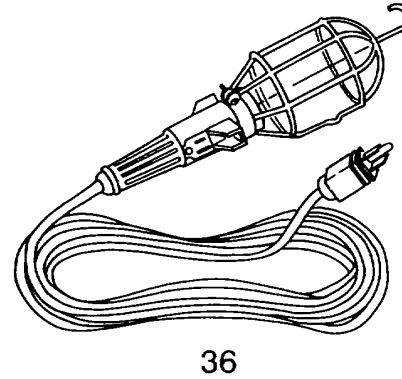
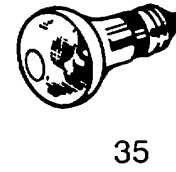
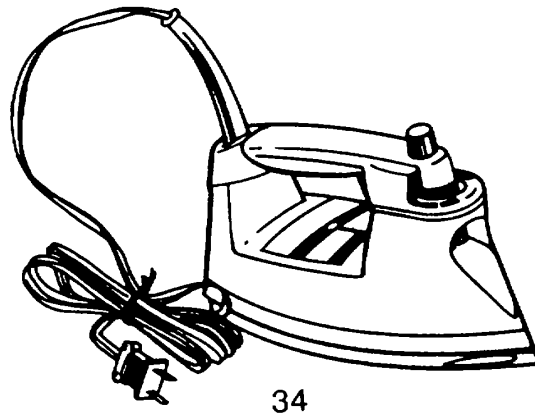
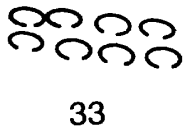

(1) ILLUS NUMBER	(2) NATIONAL STOCK NUMBER	(3) DESCRIPTION CAGE and Part Number	Usable on Code	(4) U/M	(5) QTY. RQD
33		Hooks, Belt (90338) 31B		BX	1
34		Iron, Hand Electric, Model F392 (8C244) F392		EA	1
35	6240-01-351-3889	Lamp, Incandescent, 100W, 120V, Rough Service (24446) 30R20		EA	8
36	6230-00-115-2687	Light, Extension, Electrical, 25 ft. (1G601) 05557		EA	4
37		Looper (90338) 50201		EA	1
38		Needle, Button Machine Stub Point Chromium Finish Needle (55955) 175 x 7, Size 16		EA	100

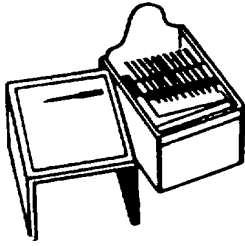

39

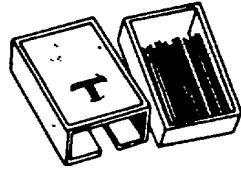

40



41

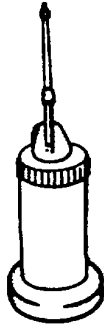

44



43



42

(1) ILLUS NUMBER	(2) NATIONAL STOCK NUMBER	(3) DESCRIPTION CAGE and Part Number	Usable on Code	(4) U/M	(5) QTY. RQD
39	3530-00-245-8001	Needle, Button Machine Stub Point Chromium Finish Needle, (55955) 175 X 7, Size 18		EA	100
40	3530-00-254-3441	Needle, Clothing Machine Round Point Needle, (55955) 16 X 87, Size 16		EA	100
41	3530-00-254-3446	Needle, Clothing Machine Round Point Needle, (55955) 16 X 87, Size 18		EA	100
42		Needle, Darning Machine Round Point Chromium Finish Needle, (55955) 126 X 3, Size 16		EA	100
43	3530-00-257-2830	Needle, Darning Machine Round Point Chromium Finish Needle, (55955) 126 X 3, Size 18		EA	100
44	4930-00-537-8977	Oiler, Hand,(81348) GGG0591		EA	4

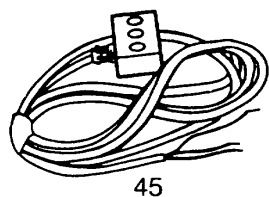

45



46



47



48

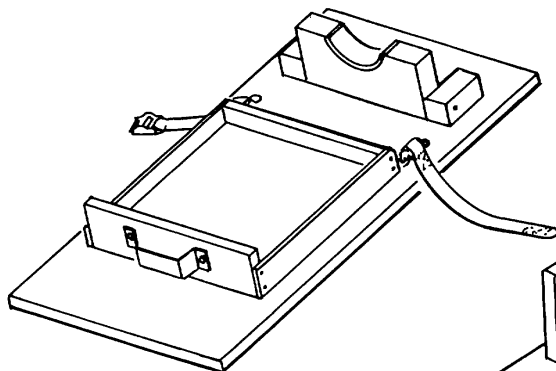

50

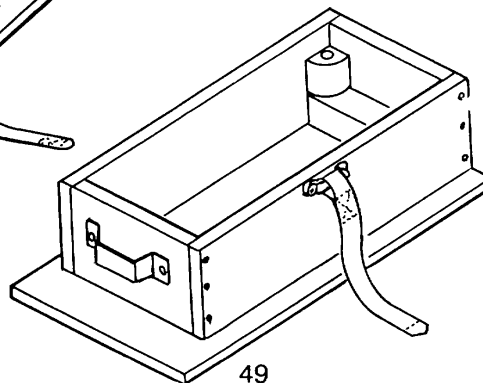

49

(1) ILLUS NUMBER	(2) NATIONAL STOCK NUMBER	(3) DESCRIPTION CAGE and Part Number	(4) Usable on Code	(5) U/M QTY. RQD
45		Power Box Assembly (81337)6-1-9779	EA	1
46		Punch, Cutting, Revolving Head (39428) 3488A1	EA	1
47		Thimble, Sewing, Solid Nickel Silver, Closed, Large Size 4536 #12 (90598) Table-III-11	EA	4
48		Thimble, Sewing, Solid Nickel Silver, Closed, Medium Size 4536 #9 (90598) Table-III-12	EA	4
49		Tray assembly Clothing Machine (90598)6-1-9758	EA	6
50		Tray assembly Darning Machine (90598)6-1-9760	EA	1

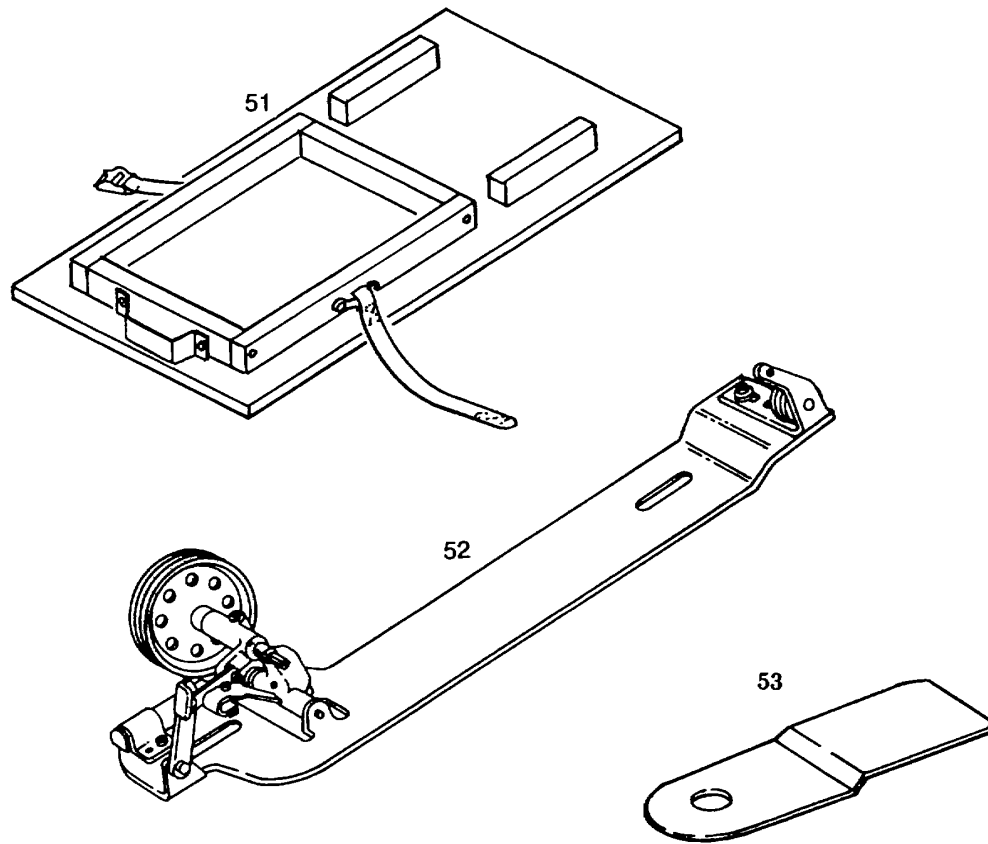

(1) ILLUS NUMBER	(2) NATIONAL STOCK NUMBER	(3) DESCRIPTION CAGE and Part Number	Usable on Code	(4) U/M	(5) QTY. RQD
51		Tray Assembly, Button (90598)6-1-9759		EA	1
52	NA	Winder, Bobbin		-	-
	3530-01-195-0679	•(81337)6-1-6386-8		EA	1
		•(81337)6-1-6383-12		EA	6
53		Stay Button Holder, 22-Ligne (90338) 175696		EA	1

Section III. BASIC ISSUE ITEMS

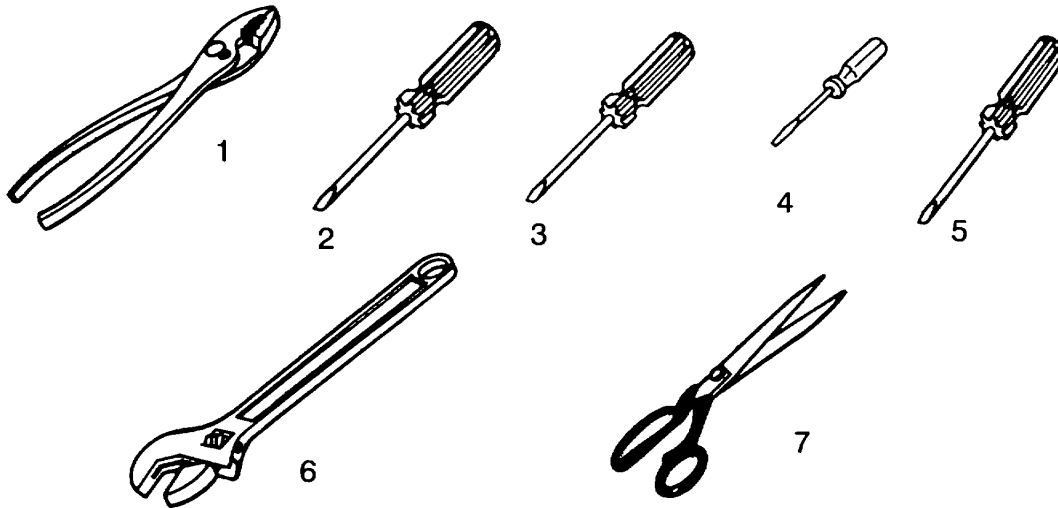

(1) ILLUS NUMBER	(2) NATIONAL STOCK NUMBER	(3) DESCRIPTION CAGE and Part Number	Usable on Code	(4) U/M	(5) QTY. RQD
1	5120-00-223-7397	Pliers, Slip Joint, Straight nose with cutter, 8 inch (81348) GGG-P-471		EA	1
2	5120-00-222-8852	Screwdriver, Flat tip. Straight side, 1/4 X 4 inch Blade, Type I, Class 5 Design A (81348) GGG-S-121 TY1CL5DEA		EA	1
3	5120-00-236-2127	Screwdriver, Flat tip. Straight side, 3/16 X 3 inch Blade, Type I, Class I Design A (81348) GGG-S-121TYICLIDEA		EA	1
4	5120-00-278-1269	Screwdriver, Flat tip. Straight side, 9/64 X 1-2 inch Blade, Type I, Class I Design A (81348) GGG-S-121 TY1CLIDEA		EA	1
5	5120-00-787-2504	Screwdriver, Flat tip. Straight side, 9/64 X 3 inch Blade, Type I, Class I Design A (81348) GGG-S-121 TYLCLIDEA		EA	1
6		Shears, 10 inch, Type I, Class 2 (81348) GGG-S-00278 TY1CL2STYA		EA	1
7	5120-00-449-8083	Wrench, Adjustable, Crescent Type, 10 inch, Type I, Class I (81348) GGG-W-613 TYICL1		EA	1

C-11/(C-12 Blank)

**APPENDIX D  
ADDITIONAL AUTHORIZATION LIST**

---

**Section I. Introduction.**

**D-1. SCOPE.**

This appendix lists additional items that are authorized for the support of the Clothing Repair Shop.

**D-2. GENERAL.**

This list identifies items that do not have to accompany the laundry unit and that do not have to be turned in with it. These items are all authorized for use by CTA, MTOE, TDA, or JTA.

**D-3. EXPLANATION OF LISTING.**

National stock number, descriptions and quantities are provided to help you identify and request the additional items required to support this equipment. The items are listed in alphabetical sequence by item name under the type document (i.e., CTA, MTOE, TRDA, or JTA) which authorizes the item(s) to you

---

**Section II. Additional Authorization Items List**

<b>NATIONAL STOCK NUMBER</b>	<b>DESCRIPTION CAGE CODE &amp; PART NUMBER</b>	<b>U/I</b>	<b>QTY RECD</b>
5120-01-013-1676	Slide Hammer, Ground (45225) P74-144 (For Ground Rod)	EA	1

**APPENDIX E**

---

**Appendix E is not used.**

**E-1/(E-2 Blank)**

**APPENDIX F**  
**EXPENDABLE/DURABLE SUPPLIES AND MATERIALS LIST**

---

**Section I. INTRODUCTION**

**F-1. SCOPE**

This appendix lists expendable/durable supplies and materials you will need to operate and maintain the Clothing Repair Shop. This listing is for informational purpose only and is not authority to requisition the listed items. These items are authorized to you by CTA 50-970, Expendable/Durable Items (Except Medical, Class V, Repair Parts, and Heraldic Items), or CTA 8-100, Army Medical Department Expendable/Durable Items.

**F-2. EXPLANATION OF COLUMNS**

a. Column 1-Item Number. This number is assigned to the entry in the listing and is referenced in the task Initial Setup instructions to identify the material; e.g., "Dry cleaning solvent (Appendix F)."

b. Column 2-Category. This column identified the lowest category of maintenance that required the listed item:

C-Operator/Crew  
O-Unit Maintenance  
F-Direct Support Maintenance  
G-General Support Maintenance

c. Column 3-National Stock Number. This is the national stock number assigned to the item; use it to request or requisition the items.

d. Column 4-Description. Indicates the federal item name and, if required, a description to identify the item. The last line for each item indicates the part number followed by the Commercial And Government Entity (CAGE) Code for Manufacturer in parentheses, if applicable.

e. Column 5-Unit of Measure (U/M). Indicates the measure used in performing the actual maintenance function. This measure is expressed by a two character alphabetical abbreviation (e.g., ea., in, pr). If the unit of measure differs from the rest of the issue, requisition the lowest unit of issue that will satisfy your requirements.

## Section II. EXPENDABLE/DURABLE SUPPLIES AND MATERIALS LIST

Item Number	Category	National Stock Number	Description	U/M
1	O	8020-00-263-3873	Brush, Medium Bristle (96906) MS16866	EA
2	O	7920-00-205-3571	Rag, Wiping (81348) DDD-R-0030	BX
3	G	8010-01-128-6957	Coating Aliphatic, Polyurethane, Chemical Agent Resisting MIL-C-46168 Type I (80244) MIL-C46168 TY 1	GL
4	C	9150-00-189-6727	Oil, Lubricating, General Purpose (81349) MIL-L-2104	QT
5	O	8010-00-161-7275	Primer Coating, Synthetic, Rust- Inhibiting Lacquer Resisting (81348) TT-P-664	CN
6	G	8010-00-297-0593	Primer Coating (81348) TT-P-1757	PT
7	F	8040-00-865-8991	Sealing Compound, Type I (81349) MIL-A-46106	KT
8	F	6850-00-281-1985	Solvent, Dry Cleaning (81348) PD-680	GL
9	O	8010-00-242-2089	Thinner, Paint (81348) TT-T-291	GL
10	O		Coating, Clear, Polyurethane (81349) TT-C-001951	GL
11	O	7930-00-985-6911	Detergent, General Purpose (81349) MIL-D-16791	GL
12	O	8040-00-6644318	Adhesive, General Purpose (80244) MMM-A-1617 TY2	PT
13	O		Adhesive, Nonstructural Lumber (01666) 40-0272	GL

## INDEX

Subject	Paragraph Figure, Table Number
<b>-A-</b>	
Abbreviations, List Of .....	1-7
Additional Authorization Items List .....	D-1
Adjustment Procedures, Button Sewing Machine (Unit) .....	4-49
Administrative Storage, Preparation For Storage or Shipment (Unit).....	4-66
Arm Clamp and Spreader Maintenance, Button Sewing Machine (Direct Support) .....	5-51
Arm Rock Shaft Maintenance, Button Sewing Machine (Direct Support).....	5-60
Arm Shaft and Vertical Shaft Maintenance, Clothing Sewing Machine (Direct Support).....	5-21
Assembly and Preparation For Use, Operation Under Usual Conditions.....	2-8
Automatic Thread Tension Disks and Release Disk, Spring, and Studs Maintenance, Button Sewing Machine (Direct Support) .....	5-44
<b>-B-</b>	
Basic Issue Items List.....	C-2
Bed Assembly Maintenance, Button Sewing Machine (Unit) .....	4-52
Belt Adjustment, (Operator) .....	3-10
Belt Guard Maintenance, Button Sewing Machine (Unit) .....	4-51
Belt Guard Maintenance, Clothing Sewing Machine (Unit) .....	4-24
Belt Guard Maintenance, Clutch and Motor, Darning Sewing Machine (Unit) .....	4-42
Belt Guard Maintenance, Darning Sewing Machine (Unit) .....	4-35
Belt Guard Maintenance, Motor, Button Sewing Machine (Unit).....	4-53
Bobbin Assembly Maintenance, Clothing Sewing Machine (Direct Support) .....	5-15
Bobbin Winder Maintenance (Unit) .....	4-26
Button Sewing Machine Maintenance See Maintenance, Button Sewing Machine	
Button Sewing Machine, (Description and Use of Operator's Controls and Indicators) .....	2-3
Button Sewing Machine, Lubrication Instructions For The (Operator).....	3-4
Button Sewing Machine, Operating Procedures For.....	2-13
<b>-C-</b>	
Cabinet Assembly Maintenance (Direct Support) .....	5-6
Cabinet Assembly, Maintenance of (General Support)	
Door Assembly Maintenance.....	6-5
General .....	6-4
Panel, Rack And Wheel Well Maintenance.....	6-6
Cam and Drive Shaft Maintenance, Button Sewing Machine (Direct Support).....	5-58

INDEX-continued

Subject	Paragraph Figure, Table Number
<b>-C-(continued)</b>	
Clothing Repair Shop	
Operating Instructions For.....	2-9
Service Upon Receipt of Complete .....	4-6
Trailer Mounted.....	F 1-0
Clothing Sewing Machine Maintenance	
See Maintenance, Clothing Sewing Machine	
Clothing Sewing Machine, (Description and Use of Operator's Controls and Indicators) .....	2-1
Clothing Sewing Machine, Lubrication Instructions For The (Operator).....	3-3
Clothing Sewing Machine, Operating Procedures For .....	2-11
Clutch and Motor Assembly Maintenance, Clothing Sewing Machine (Direct Support) .....	5-30
Clutch and Motor Assembly Maintenance, Clothing Sewing Machine (Unit).....	4-28
Clutch and Motor Assembly Maintenance, Darning Sewing Machine (Direct Support) .....	5-41
Clutch and Motor Assembly Maintenance, Darning Sewing Machine (Unit).....	4-41
Clutch and Motor Belt Guard Maintenance, Clothing Sewing Machine (Unit).....	4-29
Clutch and Motor Belt Guard Maintenance, Darning Sewing Machine (Unit).....	4-42
Cold Areas, Operation In Extreme Heat and.....	2-20
Common Tools and Equipment (General Support).....	6-1
Common Tools and Equipment, (Direct Support).....	5-1
Common Tools and Equipment, (Unit).....	4-1
Component Principles of Operation.....	1-12
Components of End Item List .....	C-2
Connecting Rod Maintenance, Clothing Sewing Machine (Direct Support).....	5-23
Controls and Indicators, See Description and Use of Operator's Controls and Indicators	
Corrosion Prevention and Control.....	1-4
Crank and Needle Guide With Shaft and Bushing Maintenance, Button Sewing Machine (Direct Support) .....	5-46
Crank Rod Maintenance, Clothing Sewing Machine (Direct Support).....	5-22
Cross Reference List, Nomenclature.....	1-6

**-D-**

Darning Sewing Machine Maintenance	
See Maintenance, Darning Sewing Machine	
Darning Sewing Machine, (Description and Use of Operator's Controls and Indicators) .....	2-2

INDEX-continued

Subject	Paragraph Figure, Table Number
<b>-D-(continued)</b>	
Darning Sewing Machine, Lubrication Instructions For The (Operator).....	3-5
Darning Sewing Machine, Operating Procedures For.....	2-12
Data, Equipment .....	1-10
Decals and Instruction Plates .....	2-17
Description and Use of Operator's Controls and Indicators	
Button Sewing Machine.....	2-3
Clothing Sewing Machine.....	2-1
Darning Sewing Machine.....	2-2
Destruction of Army Materiel To Prevent Enemy Use.....	1-3
Distribution Box Maintenance (Unit).....	4-60
Door Assembly Maintenance (General Support).....	6-5
Drive Pulley Clutch Maintenance, Button Sewing Machine (Direct Support).....	5-54
Dusty Areas, Operation In Sandy and.....	2-21
<b>-E-</b>	
Eccentric, Drive Shaft, Looper Cam and Crank Maintenance, Button Sewing Machine (Direct Support).....	5-61
Equipment Characteristics and Features.....	1-8
Equipment Data.....	1-10
Equipment Data (Table).....	T 1-1
Equipment Improvement Recommendations (EIRs), Report.....	1-5
Equipment, Proper (Unit) .....	4-16
Expendable/Durable Supplies and Materials List.....	F-1
<b>-F-</b>	
Face Plate and Eye Guard Maintenance, Button Sewing Machine (Direct Support) .....	5-43
Face Plate and Oil Cover Maintenance, Clothing Sewing Machine (Unit).....	4-22
Feed and Feed Lifting Mechanism Maintenance, Clothing Sewing Machine (Direct Support).....	5-25
Feed and Needle Plate Maintenance, Button Sewing Machine (Direct Support) .....	5-55
Field Manual.....	A-4
Fire Extinguisher, Operating Procedures For .....	2-10
Folding Table Maintenance (Unit) .....	4-56
Foot Pedal Maintenance, Button Sewing Machine (Unit).....	4-48
Forms .....	A-2
Front Bushing Maintenance, Clothing Sewing Machine (Direct Support).....	5-27
Front Shaft Bearing Maintenance, Darning Sewing Machine (Direct Support) .....	5-38

INDEX-continued

Subject	Paragraph Figure, Table Number
<b>-G-</b>	
Generator Support Rail Maintenance (Direct Support).....	5-13
Grommet Press Maintenance (Unit).....	4-64
Grommet Press, Operating Procedures For.....	2-14
Guide Maintenance, Presser Foot Needle Guards and, Darning Sewing Machine (Unit).....	4-38
Guide Plates Maintenance, Slide Needle and, Darning Sewing Machine (Unit).....	4-37
<b>-H-</b>	
Hand Tack Machine Maintenance (Unit).....	4-63
Heat and Cold Areas, Operation In Extreme.....	2-20
Heat Sealer Base Maintenance (Unit).....	4-57
Heat Sealer Block Assembly Maintenance (Unit).....	4-59
Heat Sealer Console Maintenance (Unit).....	4-58
Heat Sealer Maintenance See Maintenance, Heat Sealer	
Heat Sealer Mounting Plate Maintenance (Direct Support).....	5-11
Heat Sealing Machine, Operating Procedures For.....	2-16
Holddown Clamp Assembly Replacement (Direct Support).....	5-5
Hook Driving Shaft Maintenance, Darning Sewing Machine (Direct Support).....	5-34
<b>-I-</b>	
Inventory List, Storage Box.....	T 2-2
Ironing Board Maintenance (Unit).....	4-62
<b>-K-</b>	
Knee Lever Assembly Maintenance, Clothing Sewing Machine (Unit).....	4-27
<b>-L-</b>	
Lamp Assembly Replacement, (Operator).....	3-12
Lever Guard and Thread Guard Maintenance, Clothing Sewing Machine (Unit).....	4-20
Lifting Arm and Thread Pulloff Maintenance, Button Sewing Machine (Direct Support).....	5-57
Lifting Eye Assembly Maintenance (Unit).....	4-18
Lifting Lever Maintenance, Button Sewing Machine (Direct Support).....	5-52
Lifting Lever Maintenance, Clothing Sewing Machine (Direct Support).....	5-17
Lifting Lever Maintenance, Darning Sewing Machine (Direct Support).....	5-35
List of Abbreviations.....	1-7

INDEX - continued

Subject	Paragraph Figure, Table Number
<b>- L - (continued)</b>	
Lists	
Abbreviations.....	1-7
Additional Authorization Items.....	D-1
Basic Issue Items .....	C-2
Components of End Item .....	C-2
Expendable/Durable Supplies and Materials .....	F-1
Nomenclature Cross-Reference .....	1-6
Storage Box Inventory List .....	T2-2
Location and Description of Major Components .....	1-9
Lubrication Instructions (Operator)	
Button Sewing Machine.....	3-4
Clothing Sewing Machine .....	3-3
Darning Sewing Machine .....	3-5
Detailed Lubrication Instructions .....	3-2
Introduction .....	3-1
<b>-M-</b>	
Machine Foot Pedal Maintenance, Darning Sewing Machine (Unit).....	4-40
Maintenance	
Bobbin Winder, See Bobbin Winder Maintenance	
Button Sewing Machine, See Maintenance, Button Sewing Machine	
Clothing Sewing Machine, See Maintenance, Clothing Sewing Machine	
Darning Sewing Machine, See Maintenance, Darning Sewing Machine	
Direct Support, See Chapter 5	
Distribution Box, See Distribution Box Maintenance	
Folding Table, See Folding Table Maintenance	
General Support, See Chapter 6	
Grommet Press, See Grommet Press Maintenance	
Hand Tack Machine, See Hand Tack Machine Maintenance	
Heat Sealer, See Maintenance, Heat Sealer	
Ironing Board, See Ironing Board Maintenance	
Lifting Eye Assembly, See Lifting Eye Assembly Maintenance	
Operator, See Chapter 3	
Power Box Assembly, See Power Box Assembly Maintenance	
Stowage Box Assembly, See Stowage Box Assembly Maintenance	
Unit, See Chapter 4	
Maintenance Allocation Chart .....	B-1
Maintenance Forms, Records, and Reports .....	1-2
Maintenance Functions.....	B-2

INDEX - continued

Subject	Paragraph Figure, Table Number
<b>- M - (continued)</b>	
Maintenance Procedures, Unit	
General .....	4-14
Personal Safety .....	4-15
Proper Equipment .....	4-16
Maintenance, Button Sewing Machine (Direct Support)	
Arm Clamp and Spreader .....	5-51
Arm Rock Shaft .....	5-60
Automatic Thread Tension Disks and Release Disk, Spring, and Studs.....	5-44
Cam and Drive Shaft .....	5-58
Crank and Needle Guide With Shaft and Bushing .....	5-46
Drive Pulley Clutch .....	5-54
Eccentric, Drive Shaft, Looper Cam and Crank.....	5-61
Face Plate and Eye Guard .....	5-43
Feed and Needle Plate .....	5-55
Lifting Arm and Thread Pulloff .....	5-57
Lifting Lever.....	5-52
Motor Assembly .....	5-62
Needle Bar .....	5-45
Presser Bar .....	5-48
Pulley Starter and Trip Block .....	5-53
Receptacle Assembly .....	5-63
Side Cover and Thread Guides .....	5-42
Stop Motion Shaft .....	5-59
Thread Looper Shaft, Link, Cam, and Crank .....	5-47
Thread Release and Nipper.....	5-50
Thread Tension Rod Assembly.....	5-49
Vibrating Lever .....	5-56
Maintenance, Button Sewing Machine (Unit)	
Adjustment Procedures .....	4-49
Bed Assembly.....	4-52
Belt Guard .....	4-51
Foot Pedal .....	4-48
Motor Belt Guard .....	4-53
Single Thread Stand .....	4-47
Stand Assembly.....	4-54
Table Top Assembly .....	4-50
Tray .....	4-46

INDEX - continued

Subject	Paragraph Figure, Table Number
<b>- M - (continued)</b>	
Maintenance, Clothing Sewing Machine (Direct Support)	
Arm Shaft and Vertical Shaft .....	5-21
Bobbin Assembly .....	5-15
Clutch and Motor Assembly .....	5-30
Connecting Rod .....	5-23
Crank Rod .....	5-22
Feed and Feed Lifting Mechanism .....	5-25
Front Bushing .....	5-27
Lifting Lever .....	5-17
Needle Bar and Thread Take-up .....	5-18
Presser Bar Mechanism .....	5-16
Presser Foot and Throat Plate .....	5-14
Receptacle Assembly .....	5-29
Rotation Shuttle .....	5-26
Slide Rail .....	5-20
Stitch Length Regulator .....	5-24
Tension Retaining Lever .....	5-19
Timing .....	5-28
Maintenance, Clothing Sewing Machine (Unit)	
Belt Guard .....	4-24
Clutch and Motor Assembly.....	4-28
Clutch and Motor Belt Guard .....	4-29
Face Plate and Oil Cover .....	4-22
Knee Lever Assembly .....	4-27
Lever Guard and Thread Guard .....	4-20
Stand Assembly.....	4-32
Table Top Assembly .....	4-25
Tray .....	4-18
Thread Guides.....	4-21
Thread Tensioner .....	4-23
Thread Unwinder .....	4-19
Treadle Pipe .....	4-31
Treadle Rod Assembly.....	4-30
Maintenance, Darning Sewing Machine (Direct Support)	
Clutch and Motor Assembly .....	5-41
Front Shaft Bearing .....	5-38
Hook Driving Shaft.....	5-34
Lifting Lever .....	5-35
Needle Bar and Presser Bar Assembly.....	5-32
Oil Guard, Needle Bar Crank .....	5-33

INDEX - continued

Subject	Paragraph Figure, Table Number
<b>-M- (continued)</b>	
Maintenance, Darning Sewing Machine (Direct Support) - continued	
Rear Shaft Bearing.....	5-37
Receptacle Assembly.....	5-40
Rotating Hook .....	6-31
Tension Assembly.....	5-36
Timing .....	5-39
Maintenance, Darning Sewing Machine (Unit)	
Belt Guard.....	4-35
Clutch and Motor Assembly.....	4-41
Clutch and Motor Belt Guard.....	4-42
Machine Foot Pedal .....	4-40
Presser Foot, Needle Guards and Guide.....	4-38
Slide, Needle and Guide Plates.....	4-37
Stand Assembly.....	4-45
Table Top Assembly .....	4-39
Thread Guides.....	4-36
Thread Unwinder Stand.....	4-34
Tray .....	4-33
Treadle Pipe Assembly .....	4-44
Treadle Rod Assembly.....	4-43
Maintenance, Heat Sealer (Unit).....	
Base .....	4-57
Block Assembly.....	4-59
Console.....	4-58
Major Components, Location and Description of.....	1-9
Malfunction Index, (Unit).....	4-12
Malfunction, (Operator).....	3-7
Manufacturer .....	1-10
Materials List, Expendable/Durable Supplies and.....	F-1
Motor Assembly Maintenance, Button Sewing Machine (Direct Support).....	5-62
Motor Assembly Maintenance, Clutch and, Darning Sewing Machine (Unit).....	4-41
Motor Belt Guard Maintenance, Button Sewing Machine (Unit).....	4-53
Motor Belt Guard Maintenance, Clutch and, Darning Sewing Machine (Unit) .....	4-42
<b>- N -</b>	
Needle and Guide Plates Maintenance, Slide, Darning Sewing Machine (Unit) .....	4-37
Needle Bar and Presser Bar Assembly Maintenance, Darning Sewing Machine (Direct Support).....	5-32

INDEX - continued

Subject	Paragraph Figure, Table Number
<b>-N- (continued)</b>	
Needle Bar and Thread Take-up Maintenance, Clothing Sewing Machine (Direct Support) .....	5-18
Needle Bar Maintenance, Button Sewing Machine (Direct Support).....	5-45
Needle Guards and Guide Maintenance, Presser Foot, Darning Sewing Machine (Unit) .....	4-38
New or Replacement Equipment, Service Upon Receipt of (Unit).....	4-5
Nomenclature Cross Reference List .....	1-6
<b>-O -</b>	
Oil Cover Maintenance, Face Plate and, Clothing Sewing Machine (Unit).....	4-22
Oil Guard, Needle Bar Crank Maintenance, Darning Sewing Machine (Direct Support) .....	5-33
Operating Instructions For Clothing Repair Shop.....	2-9
Operating Procedures For	
Button Sewing Machine.....	2-13
Clothing Sewing Machine.....	2-11
Darning Sewing Machine.....	2-12
Fire Extinguisher.....	2-10
Grommet Press.....	2-14
Heat Sealing Machine.....	2-16
Tack Button Attaching Machine.....	2-15
Operation In Extreme Heat and Cold Areas.....	2-20
Operation In Sandy and Dusty Areas.....	2-21
Operation Under Unusual Conditions	
General.....	2-19
Operation In Extreme Heat and Cold Areas.....	2-20
Operation In Sandy and Dusty Areas.....	2-21
Operation Under Usual Conditions	
Assembly and Preparation For Use.....	2-8
General.....	2-7
Operation, Component Principles of.....	1-12
Operation, System Technical Principles of.....	1-11
Operator Maintenance Procedures	
General.....	3-9
Operator Preventive Maintenance Checks and Services (PMCS) For The CRS- 100 Clothing Repair Shop.....	T2-1
Operator Troubleshooting.....	T3-1
Operator Troubleshooting	
Introduction.....	3-6
Malfunction .....	3-7
Troubleshooting Table.....	3-8

INDEX - continued

Subject	Paragraph Figure, Table Number
<b>-P-</b>	
Padlock Replacement, (Operator) .....	3-11
Panel, Rack And Wheel Well Maintenance (General Support).....	6-6
Pedal Maintenance, Foot, Button Sewing Machine (Unit) .....	4-48
Pedal Maintenance, Machine Foot, Darning Sewing Machine (Unit).....	4-40
PMCS Table, (Operating Instructions).....	2-6
PMCS Table, (Unit) .....	4-9
Power Box Assembly Maintenance (Unit) .....	4-61
Preparation For Movement.....	2-18
Preparation For Storage or Shipment (Unit)	
Administrative Storage .....	4-65
Security Procedures .....	4-66
Presser Bar Maintenance, Button Sewing Machine (Direct Support).....	5-48
Presser Bar Mechanism Maintenance, Clothing Sewing Machine (Direct Support).....	5-16
Presser Foot and Throat Plate Maintenance, Clothing Sewing Machine (Direct Support).....	5-14
Presser Foot, Needle Guards and Guide Maintenance, Darning Sewing Machine (Unit) .....	4-38
Preventive Maintenance Checks and Services (PMCS) (Operator)	
General .....	2-4
Warnings and Cautions.....	2-5
Preventive Maintenance Checks and Services (PMCS) (Unit)	
General .....	4-7
Warnings and Cautions .....	4-8
Preventive Maintenance Checks and Services (PMCS) For	
The CRS-100 Clothing Repair Shop, Operator.....	T2-1
Preventive Maintenance Checks and Services for Clothing Repair Shop, Unit .....	T4-1
Principles of Operation, Component.....	1-12
Principles of Operation, System Technical .....	1-11
Publications, Other.....	A-5
Pulley Starter and Trip Block Maintenance, Button Sewing Machine (Direct Support).....	5-53
<b>-Q-</b>	
<b>-R-</b>	
Rack And Wheel Well Maintenance, Panel, (General Support) .....	6-6
Rear Door Assembly Maintenance (Direct Support).....	5-9
Rear Door Stay Assembly Maintenance (Direct Support).....	5-10
Rear Shaft Bearing Maintenance, Darning Sewing Machine (Direct Support).....	5-37
Receptacle Assembly Maintenance, Button Sewing Machine (Direct Support).....	5-63

INDEX - continued

Subject	Paragraph Figure, Table Number
<b>-R-</b>	
Receptacle Assembly Maintenance, Clothing Sewing Machine (Direct Support) .....	5-29
Receptacle Assembly Maintenance, Darning Sewing Machine (Direct Support) .....	5-40
References.....	A-1
Repair Parts (General Support) .....	6-3
Repair Parts, (Direct Support) .....	5-3
Repair Parts, (Unit) .....	4-3
Replacement Equipment, Service Upon Receipt of New or (Unit).....	4-5
Report Equipment Improvement Recommendations (EIRs) .....	1-5
Retaining Strap Maintenance (Direct Support) .....	5-12
Rotating Hook Maintenance, Darning Sewing Machine (Direct Support).....	5-31
Rotation Shuttle Maintenance, Clothing Sewing Machine (Direct Support) .....	5-26
<b>-S-</b>	
Safety, Personal (Unit) .....	4-15
Sandy and Dusty Areas, Operation In .....	2-21
Security Procedures, Preparation For Storage or Shipment (Unit) .....	4-65
Service Upon Receipt of Complete Clothing Repair Shop (Unit) .....	4-6
Service Upon Receipt of New or Replacement Equipment (Unit) .....	4-5
Side Cover and Thread Guides Maintenance, Button Sewing Machine (Direct Support) .....	5-42
Side Door Assembly Maintenance (Direct Support) .....	5-7
Side Door Stay Maintenance (Direct Support) .....	5-8
Single Thread Stand Maintenance, Button Sewing Machine (Unit) .....	4-47
Site and Shelter Requirements (Unit) .....	4-4
Slide Rail Maintenance, Clothing Sewing Machine (Direct Support) .....	5-20
Slide, Needle and Guide Plates Maintenance, Darning Sewing Machine (Unit) .....	4-37
Special Tools, TMDE, and Support Equipment (General Support).....	6-2
Special Tools, TMDE, and Support Equipment (Direct Support) .....	5-2
Special Tools, TMDE, and Support Equipment (Unit) .....	4-2
Stand Assembly Maintenance, Button Sewing Machine (Unit) .....	4-54
Stand Assembly Maintenance, Clothing Sewing Machine (Unit) .....	4-32
Stand Assembly Maintenance, Darning Sewing Machine (Unit) .....	4-45
Stitch Length Regulator Maintenance, Clothing Sewing Machine (Direct Support) .....	5-24
Stop Motion Shaft Maintenance, Button Sewing Machine (Direct Support) .....	5-59
Storage Box Inventory List .....	T2-2

INDEX - continued

Subject	Paragraph Figure, Table Number
<b>- S - (continued)</b>	
Storage, Administrative, Preparation For Storage or Shipment (Unit) .....	4-66
Stowage Box Assembly Maintenance (Direct Support) .....	5-64
Stowage Box Assembly Maintenance (Unit) .....	4-55
Supplies and Materials List, Expendable/Durable .....	F-1
Support Equipment, Special Tools, TMDE, and (Direct Support) .....	5-2
Support Equipment, Special Tools, TMDE, and (General Support) .....	6-2
Support Equipment, Special Tools, TMDE, and (Unit) .....	4-2
System Technical Principles of Operation .....	1-11
<b>-T-</b>	
Table Top Assembly Maintenance, Button Sewing Machine (Unit) .....	4-50
Table Top Assembly Maintenance, Clothing Sewing Machine (Unit) .....	4-25
Table Top Assembly Maintenance, Darning Sewing Machine (Unit) .....	4-39
Tack Button Attaching Machine, Operating Procedures For.....	2-15
Technical Manuals .....	A-3
Tension Assembly Maintenance, Darning Sewing Machine (Direct Support).....	5-36
Tension Retaining Lever Maintenance, Clothing Sewing Machine (Direct Support) .....	5-19
Thread Guard Maintenance, Lever Guard and, Clothing Sewing Machine (Unit) .....	4-20
Thread Guides Maintenance, Clothing Sewing Machine (Unit) .....	4-21
Thread Guides Maintenance, Darning Sewing Machine (Unit) .....	4-36
Thread Looper Shaft, Link, Cam, and Crank Maintenance, Button Sewing Machine (Direct Support) .....	5-47
Thread Release and Nipper Maintenance, Button Sewing Machine (Direct Support) .....	5-50
Thread Tension Rod Assembly Maintenance, Button Sewing Machine (Direct Support) .....	5-49
Thread Tensioner Maintenance, Clothing Sewing Machine (Unit) .....	4-23
Thread Unwinder Maintenance, Clothing Sewing Machine (Unit) .....	4-19
Thread Unwinder Stand Maintenance, Darning Sewing Machine (Unit) .....	4-34
Timing, Clothing Sewing Machine (Direct Support) .....	5-28
Timing, Darning Sewing Machine (Direct Support) .....	5-39
TMDE, and Support Equipment, Special Tools, (Direct Support) .....	5-2
TMDE, and Support Equipment, Special Tools, (General Support) .....	6-2
TMDE, and Support Equipment, Special Tools, (Unit) .....	4-2
Tools and Equipment, Common (Unit) .....	4-1
Tools and Equipment, Common, (Direct Support) .....	5-1
Tools and Test Equipment Requirements .....	B-4

INDEX - continued

Subject	Paragraph Figure, Table Number
<b>-T- (continued)</b>	
Trailer Mounted Clothing Repair Shop .....	F1-0
Tray Maintenance, Button Sewing Machine (Unit) .....	4-46
Tray Maintenance, Clothing Sewing Machine (Unit) .....	4-18
Tray Maintenance, Darning Sewing Machine (Unit) .....	4-33
Treadle Pipe Assembly Maintenance, Darning Sewing Machine (Unit).....	4-44
Treadle Pipe Maintenance, Clothing Sewing Machine (Unit).....	4-31
Treadle Rod Assembly Maintenance, Clothing Sewing Machine (Unit).....	4-30
Treadle Rod Assembly Maintenance, Darning Sewing Machine (Unit).....	4-43
Troubleshooting Table, (Operator) .....	3-8
Troubleshooting Table, Unit .....	4-13
Troubleshooting, (Unit) .....	4-11
Troubleshooting, Operator .....	T3-1
<b>-U-</b>	
Unit Maintenance Instructions	
Repair Parts, Special Tools, TMDE, and Support Equipment	
Common Tools and Equipment.....	4-1
Repair Parts .....	4-3
Special Tools, TMDE, and Support Equipment.....	4-2
Unit Preventive Maintenance Checks and Services for Clothing Repair Shop.....	T4-1
Unit Troubleshooting	
Introduction .....	4-10
Malfunction Index .....	4-12
Troubleshooting.....	4-11
Unit Troubleshooting Table .....	4-13
<b>-V-</b>	
Vibrating Lever Maintenance, Button Sewing Machine (Direct Support) .....	5-56
<b>-W-</b>	
Warnings and Cautions, (Operator PMCS) .....	2-5
Warnings and Cautions, (Unit PMCS) .....	4-8
Wheel Well Maintenance, Panel, Rack And (General Support) .....	6-6
<b>-X-</b>	
<b>-Y-</b>	
<b>-Z-</b>	

By Order of the Secretary of the Army:

Official:

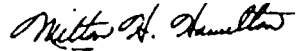

**MILTON H. HAMILTON**  
*Administrative Assistant to the  
Secretary of the Army*

04386

**GORDON R. SULLIVAN**  
*General, United States Army  
Chief of Staff*

**DISTRIBUTION:**

To be distributed in accordance with DA Form 12-25-E, block no. 6057, requirements for TM 10-3530-207-14.

RECOMMENDED CHANGES TO EQUIPMENT TECHNICAL PUBLICATIONS



THEN...JOT DOWN THE  
DOPE ABOUT IT ON THIS FORM.  
CAREFULLY TEAR IT OUT, FOLD IT  
AND DROP IT IN THE MAIL.

SOMETHING WRONG WITH PUBLICATION

FROM: (PRINT YOUR UNIT'S COMPLETE ADDRESS)

DATE SENT

PUBLICATION NUMBER

PUBLICATION DATE

PUBLICATION TITLE

BE EXACT PIN-POINT WHERE IT IS

PAGE NO.	PARA-GRAPH	FIGURE NO.	TABLE NO.
----------	------------	------------	-----------

IN THIS SPACE, TELL WHAT IS WRONG  
AND WHAT SHOULD BE DONE ABOUT IT.

TEAR ALONG PERFORATED LINE

PRINTED NAME, GRADE OR TITLE AND TELEPHONE NUMBER

SIGN HERE

## THE METRIC SYSTEM AND EQUIVALENTS

### Linear Measure

1 centimeter = 10 millimeters = .39 inch  
 1 decimeter = 10 centimeters = 3.94 inches  
 1 meter = 10 decimeters = 39.37 inches  
 1 dekameter = 10 meters = 32.8 feet  
 1 hectometer = 10 dekameters = 328.08 feet  
 1 kilometer = 10 hectometers = 3,280.8 feet

### Weights

1 centigram = 10 milligrams = .15 grain  
 1 decigram = 10 centigrams = 1.54 grains  
 1 gram = 10 decigrams = .035 ounce  
 1 dekagram = 10 grams = .35 ounce  
 1 hectogram = 10 dekagrams = 3.52 ounces  
 1 kilogram = 10 hectograms = 2.2 pounds  
 1 quintal = 100 kilograms = 220.46 pounds  
 1 metric ton = 10 quintals = 1.1 short tons

### Cubic Measure

1 cu. centimeter = 1000 cu. millimeters = .06 cu. inch  
 1 cu. decimeter = 1000 cu. centimeters = 61.02 cu. in.  
 1 cu. meter = 1000 cu. decimeters = 35.31 cu. feet

### Square measure

1 sq. centimeter = 100 sq. millimeters = .155 sq. in.  
 1 sq. decimeter = 100 sq. centimeters = 15.5 inches  
 1 sq. meter (centare) = 100 sq. decimeters = 10.76 feet  
 1 sq. dekameter (are) = 100 sq. meters = 1,076.4 sq. ft.  
 1 sq. hectometer (hectare) = 100 sq. dekameters = 2.47 acres  
 1 sq. kilometer = 100 hectometers = .386 sq. miles

### Liquid Measure

1 dekaliter = 10 liters = 2.64 gallons  
 1 hectoliter = 10 dekaliters = 26.42 gallons  
 1 kiloliter = 10 hectoliters = 264.18 gallons  
 1 liter = 10 deciliters = 33.81 fl. ounces  
 1 centiliter = 10 milliliters = .34 fl. ounce  
 1 deciliter = 10 centiliters = 3.38 fl. ounces  
 1 metric ton = 10 quintals = 1.1 short tons

### Approximate Conversion Factors

To change	To	Multiply by	To change	To	Multiply by
inches	centimeters	2.540	ounce inches	newton-meters	.0070062
feet	meters	.305	centimeters	inches	.394
yards	meters	.914	meters	feet	3.280
miles	kilometers	1.609	meters	yards	1.094
sq. inches	sq. centimeters	6.451	kilometers	miles	.621
sq. feet	sq. meters	.093	sq. centimeters	sq. inches	.155
sq. yards	sq. meters	.836	sq. meters	sq. yards	10.764
sq. miles	sq. kilometers	2.590	sq. kilometers	sq. miles	1.196
acres	sq. hectometers	.405	sq. hectometers	acres	2.471
cubic feet	cubic meters	.028	cubic meters	cubic feet	35.315
cubic yards	cubic meters	.765	milliliters	fluid ounces	.034
fluid ounces	milliliters	29.573	liters	pints	2.113
pints	liters	.472	liters	quarts	1.057
quarts	liters	.946	grams	ounces	.035
gallons	liters	3.785	kilograms	pounds	2.205
ounces	grams	28.349	metric tons	short tons	1.102
pounds	kilograms	.454	pound-feet	newton-meters	1.356
short tons	metric tons	.907			
pound inches	newton-meters	.11296			

### Temperature (Exact)

°F Fahrenheit temperature

5/9 ( after subtracting 32)

Celsius Temperature °C



This fine document...

Was brought to you by me:



## [Liberated Manuals -- free army and government manuals](#)

Why do I do it? I am tired of sleazy CD-ROM sellers, who take publicly available information, slap “watermarks” and other junk on it, and sell it. Those masters of search engine manipulation make sure that their sites that sell free information, come up first in search engines. They did not create it... They did not even scan it... Why should they get your money? Why are not letting you give those free manuals to your friends?

I am setting this document FREE. This document was made by the US Government and is NOT protected by Copyright. Feel free to share, republish, sell and so on.

I am not asking you for donations, fees or handouts. If you can, please provide a link to [liberatedmanuals.com](http://liberatedmanuals.com), so that free manuals come up first in search engines:

<A HREF=<http://www.liberatedmanuals.com/>>Free Military and Government Manuals</A>

- Sincerely  
Igor Chudov  
<http://igor.chudov.com/>
- [Chicago Machinery Movers](#)