

TECHNICAL MANUAL

**OPERATOR'S, AVIATION UNIT,
AND INTERMEDIATE
MAINTENANCE MANUAL
(INCLUDING REPAIR PARTS
AND SPECIAL TOOLS LIST)
FOR**

**TRUCK, HAND
(HIGH PRESSURE NITROGEN SERVICING CART)**

P/N FPNC-01

NSN: 1740-01-327-6831

DISTRIBUTION STATEMENT A: Approved for public release; distribution unlimited.

**Headquarters, Department of the Army
31 December 1996**

WARNINGS and CAUTIONS Page

A **WARNING** denotes a hazard. A WARNING highlights a procedure, practice, etc., which, if not correctly followed, could result in personnel injury or loss of life. Do not proceed beyond a WARNING until the indicated conditions are fully understood and met.

A **CAUTION** denotes a hazard. It calls attention to an operating procedure, practice, or the like, which, if not correctly performed or adhered to, could result in damage to or destruction of part of or all of the product. Do not proceed beyond a CAUTION until the indicated conditions are fully understood and met.

WARNING

PRESSURIZED AIR OR GAS CAN CAUSE SEVERE INJURY OR DEATH IF MISUSED. Read and understand these and manufacturer's operating instructions prior to operating the cart.

WARNING

Do not remove, tamper with, or in any way disable installed pressure relief valves.

WARNING

Always wear safety glasses.

WARNING

Remove or disconnect nitrogen tanks before maintenance. Never disconnect a pressurized line.

WARNING

The booster panel assembly weighs approximately 100 lb. This requires a two man lift to remove from the cart chassis. Protect the hands from being pinched with gloves.

WARNING

Always confirm that the pressure produced by the High Pressure Nitrogen Servicing Cart does not exceed the servicing pressures specified in the applicable aircraft technical manuals.

WARNING

Verify the correct tire inflation pressure in the aircraft manual before inflating.

WARNING

Use nitrogen from approved nitrogen tanks only for the supply gas. If shop air is used as the supply in a high pressure system, an explosion could occur.

WARNING

Depressurize and shut down the high pressure nitrogen servicing cart prior to any repair action including the tightening of fittings.

WARNING

Check the direction of the arrow stamped on the check valve before replacement. An incorrectly installed check valve may cause the connector hose to whip violently when used with only one tank of nitrogen and possibly cause serious injury to the operator.

WARNING

Inspect all four check valves. Remove and inspect only one check valve at a time on the booster pump to ensure proper reassembly. Improper assembly of the check valves or the swapping of the inlet and outlet check valves can cause very high pressures to be trapped in the booster pump. These pressures can be released suddenly and unexpectedly with any subsequent disassembly.

CAUTION

Use only a 6 point 11/16 inch socket to remove the nipple connector of the tank connector assembly. An open end wrench or 12 point socket will deform and damage this part.

CAUTION

Nitrogen tanks must be secured tightly to the hand truck's saddles. Loose or unsecured tank retention straps will allow the tanks to shift during towing. This could damage the tank connectors, hoses or tow vehicle.

CAUTION

The maximum safe towing speed for the High Pressure Nitrogen Servicing Cart is 15 miles per hour. Do not exceed this speed.

CAUTION

Do not stand on any tubing or pneumatic assemblies or place any pressure on any of the pneumatic assemblies of the panel while positioning, moving and tilting the High Pressure Nitrogen Servicing Cart.

CAUTION

Use of an air line lubricator of any kind is not recommended. Lubricating oil leaking into the compressor chamber may cause pump valve damage.

CAUTION

Before disassembly of any Cart components, relieve all air pressures in the affected section prior to disconnecting.

CAUTION

When removing or tightening a fitting to the high pressure filter, hold the filter body hex with a wrench adjacent the fitting. Tightening the filter across its body may stress the filter housing and cause leaks to develop. Extreme caution should be used to prevent contaminants such as old Teflon tape, sealant, dirt or any other matter from falling into the tubing going to the booster pump. This will cause booster pump failure.

CAUTION

DO NOT force-tighten control valves; damage will occur to the soft needle seat of the valve.

CAUTION

Verify that shop air supplies are within the limits (as specified in paragraph 1-7 Pneumatic Input Requirements) or damage may result.

CAUTION

Make sure grease, seals and bearings are in good condition before reassembly.

CAUTION

Do not set the high pressure relief valve for less than 2,300 psi since fully charged nitrogen tanks may be pressurized to that level.

CAUTION

Do not exceed 30 inch pounds of torque when connecting high pressure inflation chuck to any charging fitting.

d

TECHNICAL MANUAL
No. 1-1740-204-13&P

Headquarters
Department of the Army
Washington, DC. 31 December 1996

TECHNICAL MANUAL
OPERATOR'S, AVIATION UNIT,
AND INTERMEDIATE
MAINTENANCE MANUAL
(INCLUDING REPAIR PARTS
AND SPECIAL TOOLS LIST)

FOR
TRUCK, HAND
(HIGH PRESSURE NITROGEN SERVICING CART)
P/N FPNC-01
(NSN: 1740-01-327-6831)

REPORTING OF ERRORS AND RECOMMENDING IMPROVEMENTS You can help improve this manual. If you find any mistakes, or if you know a way to improve the procedures, please let us know. Mail your letter, DA Form 2028 (recommended Changes to Publications and Blank Forms), or DA Form 2028-2 located in the back of this manual, directly to : Commander, US. Army Aviation and Troop Command, ATTN: AMSAT-I-MP, 4300 Goodfellow Boulevard, St. Louis, MO 63120-1798. A reply will be furnished to you.

DISTRIBUTION STATEMENT A: Approved for public release; distribution unlimited.

TABLE OF CONTENTS

	Page
Warning and First Aid Data Page	
CHAPTER 1 INTRODUCTION	1-1
Section I General Information.....	1-1
Section II Equipment Description and Data.....	1-3
Section III Technical Principles of Operation	1-9
CHAPTER 2 OPERATING INSTRUCTIONS.....	2-1
Section I Description and Use of Operator's Controls and Indicators	2-1
Section II Preventive Maintenance Checks and Services (PMCS).....	2-6
Section III Operations under Usual Conditions	2-11
Section IV Operations under Unusual Conditions.....	2-14

CHAPTER 3 AVIATION UNIT MAINTENANCE - MAINTENANCE INSTRUCTIONS..... 3-1

 Section I Repair Parts, Special Tools, TMDE, and Support Equipment..... 3-2

 Section II Service Upon Receipt 3-2

 Section III Preventive Maintenance Checks (PMCS) 3-3

 Section IV Troubleshooting 3-4

 Section V Maintenance Procedures 3-11

 Section VI Preparation for Storage or Shipment 3-42

CHAPTER 4 AVIATION INTERMEDIATE MAINTENANCE - MAINTENANCE INSTRUCTIONS 4-1

 Section I Repair Parts, Special Tools, TMDE, and Support Equipment..... 4-1

 Section II Service Upon Receipt 4-2

 Section III Preventive Maintenance Checks (PMCS) 4-3

 Section IV Troubleshooting 4-4

 Section V Maintenance Procedures 4-7

 Section VI Preparation for Storage or Shipment 4-17

APPENDIX A REFERENCES A-1

APPENDIX B MAINTENANCE ALLOCATION CHART (MAC) B-1

APPENDIX C REPAIR PARTS AND SPECIAL TOOLS LIST (RPSTL) C-1

APPENDIX D EXPENDABLE SUPPLIES AND MATERIALS LIST D-1

ALPHABETICAL INDEX..... INDEX-1

HOW TO USE THIS MANUAL

1. Take a few minutes to look through this manual. We've designed this manual so that it will be easy for you to find and perform the procedures you need.
2. If the High Pressure Nitrogen Servicing Cart needs repair and you know what's wrong with it, here's what you do:
 - a. Turn to the alphabetical index and check for a paragraph on the component you want to remove and replace.
 - b. Turn to the paragraph. Under the paragraph title, you'll find the tools, materials, and equipment condition needed to perform the procedure. If there are no tools or materials needed, it will also be noted there. If there is no equipment condition needed to prepare the High Pressure Nitrogen Servicing Cart for the removal procedure, it will be noted.
 - c. To remove the bad component, perform the removal procedure. To install the new component, perform the installation procedure. Perform the leak check and confidence test procedure. The High Pressure Nitrogen Servicing Cart should now be ready to operate.
3. If the High Pressure Nitrogen Servicing Cart needs repair and you don't know what is wrong with it, go to the troubleshooting procedures. Troubleshooting procedures will direct you to the appropriate paragraph to repair your unit. Appendix C Repair Parts and Special Tools List (RPSTL) will show component relationships, provide part number information and show a illustration of the various components of the cart.

**CHAPTER 1
INTRODUCTION**

<u>CHAPTER CONTENTS</u>		<u>PAGE</u>
Section I	GENERAL INFORMATION	1-1
Section II	EQUIPMENT DESCRIPTION AND DATA	1-3
Section III	PRINCIPLES OF OPERATION	1-9

Section I. General Information

<u>SECTION CONTENTS</u>	<u>PARA</u>	<u>PAGE</u>
SCOPE	1-1	1-2
MAINTENANCE FORMS, RECORDS, AND REPORTS	1-2	1-3
DESTRUCTION OF ARMY MATERIEL TO PREVENT ENEMY USE	1-3	1-3
ADMINISTRATIVE STORAGE	1-4	1-3
REPORTING EQUIPMENT IMPROVEMENT RECOMMENDATIONS (EIRS)	1-5	1-3

1-1. SCOPE

This manual contains operation, maintenance, and illustrated parts breakdown, and repair parts list for the Hand Truck (High Pressure Nitrogen Servicing Cart), Part Number: FPNC-01 illustrated in Figure 1-1.

The High Pressure Nitrogen Servicing Cart is a mobile, self-contained piece of field support equipment suitable for use in aircraft flight line servicing of accumulators, struts and tires. The servicing cart is capable of supplying a regulated 160 psi maximum working pressure output for filling aircraft tires. A booster system is capable of providing a regulated 4000 psi maximum working pressure output for charging aircraft struts and accumulators.

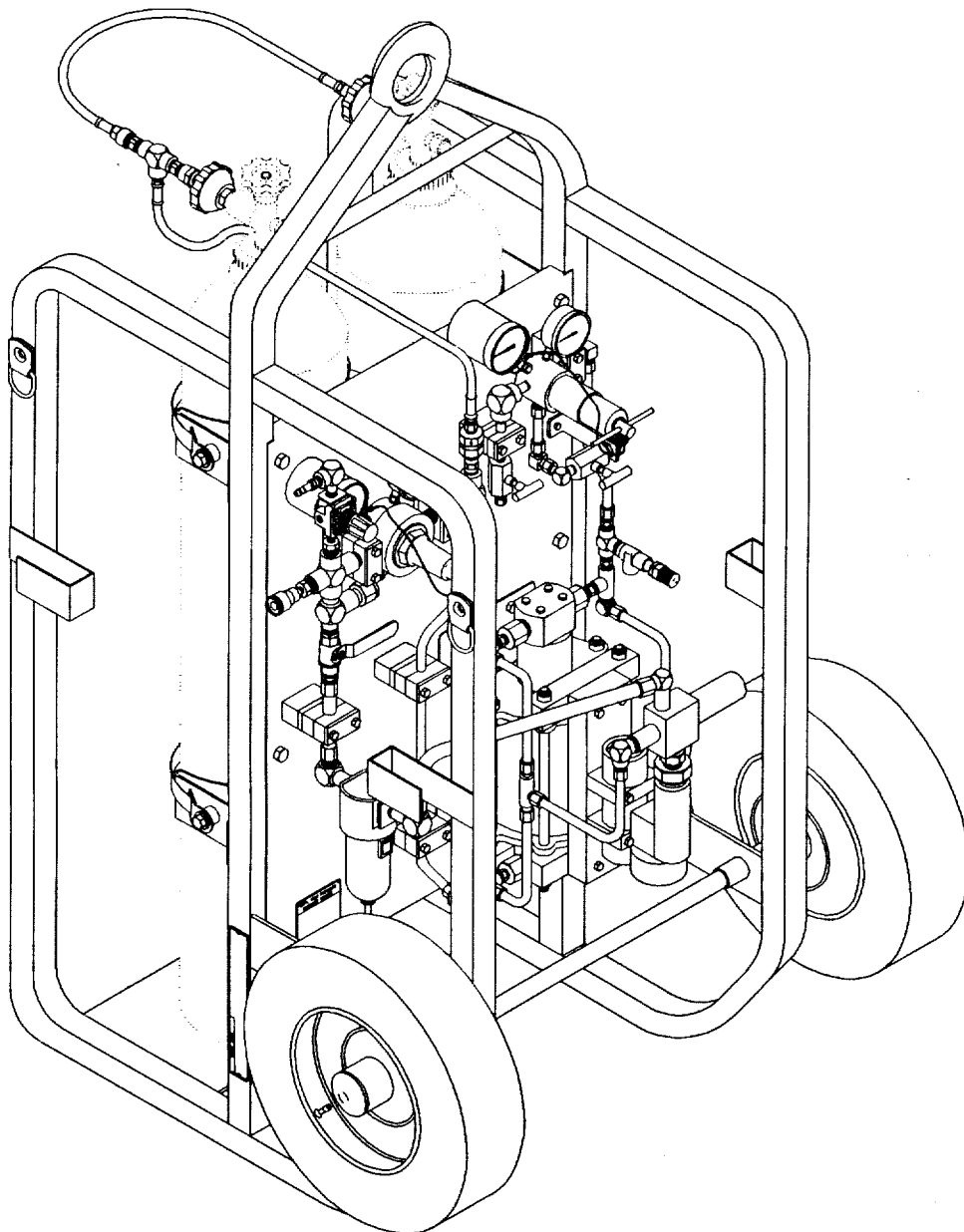

Figure 1-1. Hand Truck (High Pressure Nitrogen Servicing Cart)

1-2. MAINTENANCE FORMS, RECORDS, AND REPORTS

Department of the Army forms and procedures used for equipment maintenance will be those prescribed by DA PAM 738-751, Functional User's Manual for The Army Maintenance Management System Aviation (TAMMS-A).

1-3. DESTRUCTION OF ARMY MATERIEL TO PREVENT ENEMY USE

Refer to TM 750-244-1-4 Procedures for Destruction of Aviation Ground Support Equipment to Prevent Enemy Use.

1-4. ADMINISTRATIVE STORAGE

Storage and shipment instructions are provided in Chapter 4.

1-5. REPORTING EQUIPMENT IMPROVEMENT RECOMMENDATIONS (EIRs)

As a primary user of this equipment, your ideas to improve its design or function are valuable. If your equipment needs improvement, let us know. Send us an EIR. Put it on an SF 368 (Quality Deficiency Report). Mail it to US Army Aviation and Troop Command ATTN: AMSAT-I-MDO. Will send you a reply.

Section II. Equipment Description and Data

<u>SECTION CONTENTS</u>	<u>PARA</u>	<u>PAGE</u>
FUNCTION	1-6	1-3
PNEUMATIC INPUT REQUIREMENTS	1-7	1-3
EQUIPMENT DATA	1-8	1-4
LOCATION AND DESCRIPTION OF MAJOR COMPONENTS	1-9	1-6

1-6. FUNCTION

The High Pressure Nitrogen Servicing Cart is a two wheeled unit which includes a 30: 1 booster pump, tank carriage, hose rack and hoses suitable for use in aircraft flight line servicing of accumulators, struts and tires. The cart is towable to a maximum speed of 15 mph.

1-7. PNEUMATIC INPUT REQUIREMENTS

The High Pressure Nitrogen Servicing Cart is capable of operation in two different pneumatic input modes. One or two 230 cu ft size nitrogen tanks can be used to supply the nitrogen gas in the low regulated pressure mode. In the high pressure mode, either the tank supplied nitrogen gas or shop air can be used to operate the booster pump system to generate high nitrogen gas pressures.

TANK SUPPLY:

Gas Supply Containers: Uses one or two 230 std cu ft nitrogen tanks nominally 9 inch diameter and 50 inches in length, NSN 6830-01-028-9402; 2,000 to 2,500 psi

Gas Connector: Compressed Gas Association (CGA) 580

SHOP AIR SUPPLY:

Shop Air Coupling: 1/4" quick disconnect socket coupler compliant with MIL-C-4109

Shop Air Requirements: 90 psi minimum and 150 psi maximum with a minimum flow rate of 40 cfm

1-8. EQUIPMENT DATA

TABLE 1-1. Equipment Data

Cart Dimensions:		
Depth	36.0 inches	91.4 cm
Width	32.5 inches	82.6 cm
Height	60.0 inches	152.4 cm

Weight:		
with hoses but without tanks	241 lb.	109.3 K-gm
with full tanks and hoses	501 lb.	227.3 K-gm

The High Pressure Nitrogen Servicing Cart is capable of the specified performance under the following environmental conditions.

- a. Temperatures ranging from -20 degrees F to + 160 degrees F.
- b. Relative humidity up to 100 percent.
- c. Exposure to salt fog.
- d. Exposure to sand and dust particles as encountered in desert areas.
- e. Storage at temperatures ranging from -65 to +160 degrees F.

1-9. LOCATION AND DESCRIPTION OF MAJOR COMPONENTS

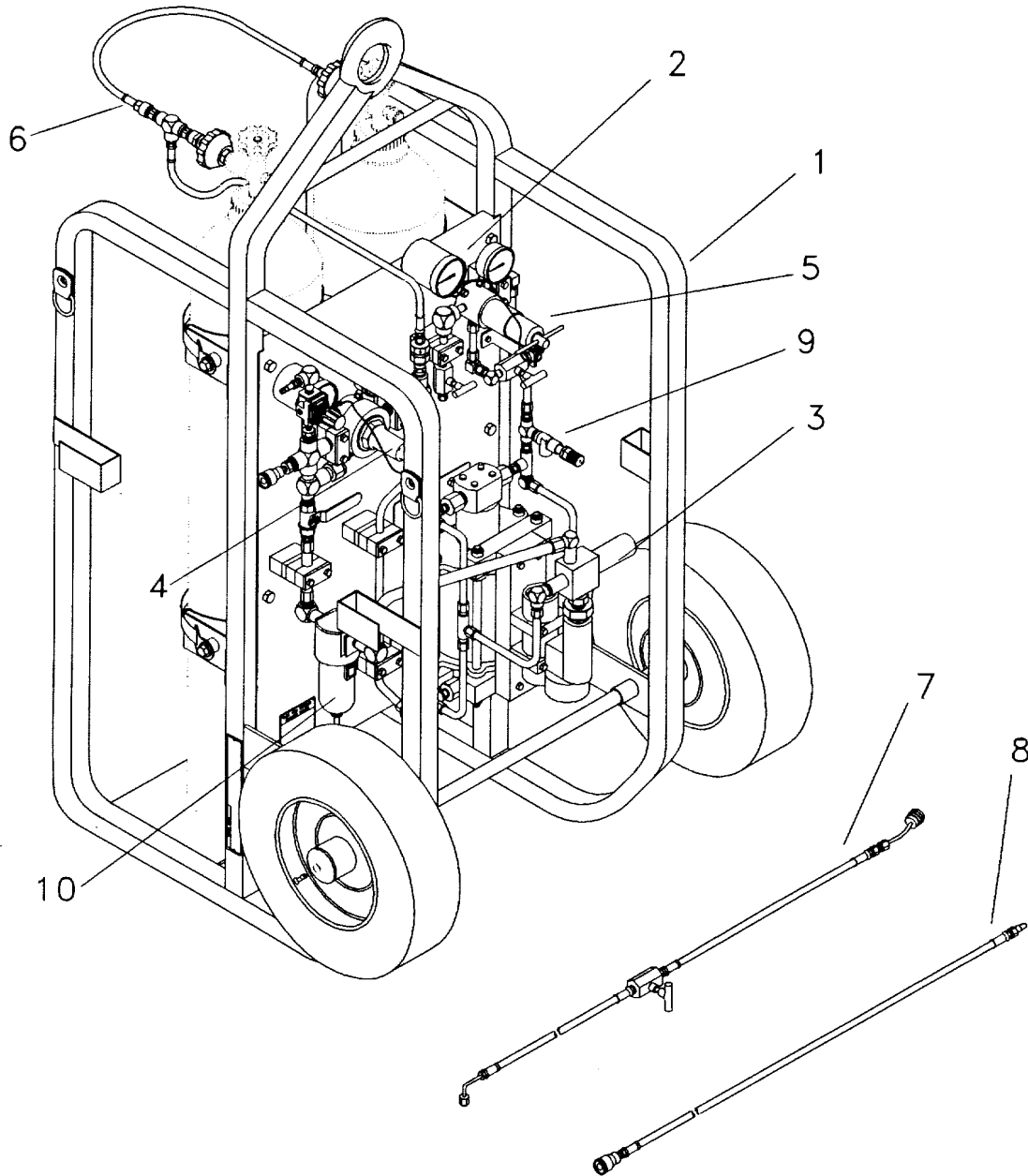

LEGEND:

- | | |
|-------------------------------------|--------------------------------|
| 1. Hand Truck | 6. Tank Connector Assembly |
| 2. Booster Panel | 7. High Pressure Charging Hose |
| 3. Booster Pump | 8. Tire Filling Hose |
| 4. Low Pressure Regulator Assembly | 9. High Pressure Relief Valve |
| 5. High Pressure Regulator Assembly | 10. Low Pressure Filter |

Figure 1-2. Major Components of the High Pressure Nitrogen Servicing Cart

a. Hand truck (1)

The hand truck (1) is fabricated of tubular steel. Its wrap around construction provides tip over protection for the booster system and tanks. Retention means for two standard 230 cu ft nitrogen tanks is provided. Means for attaching the booster panel and cleats for separately storing the tire filling and high pressure hose are provided.

The frame and axle locations provide for easy handling and tipping from the vertical to towing position. When the cart is in the towing position, the coupler is 20 inches above the pavement and the ground clearance is 5 inches.

A MS 51336 lunette coupler for towing the cart is provided. 16 inch pneumatic tires permit a maximum towing speed of 15 mph.

b. Booster Panel (2)

The components of the booster are mounted on the booster panel assembly (2) that forms an integral and easily removable system. The panel is attached to the hand truck by six mounting bolts. The regulators are mounted near the top of the panel to provide ease of operation and good visibility of the gauges. The booster pump system is mounted on the lower portion of the booster panel assembly. Labels indicate the location of controls and purpose of the gauges.

c. Booster Pump (3)

The booster pump (3) is a 30: 1 compression ratio, double acting, single stage, air driven pump with a rated system gas outlet pressure of 4000 psi and a maximum air drive operating pressure of 150 psi. The pump is capable of continuous operation at gas outlet temperatures of up to 300 degrees F.

An air pilot valve integral to the booster pump will shut off the pump when the nitrogen supply pressure is below 300 psi. Mufflers are mounted on the booster exhaust to provide noise attenuation during booster pump operation.

d. Regulators (4 and 5)

Low pressure regulator (4) sets the pressure of the tire filling output from the nitrogen tanks for tire inflation or nitrogen gas to operate the booster pump. The high pressure regulator (5) sets the pressure available at the high pressure output.

e. Tank Connector Assembly (6)

The tank connector assembly provides the means to connect one or two nitrogen tanks to the high pressure nitrogen servicing cart. In line check valves prevent nitrogen from escaping when only one tank is used.

f. Accessories (7 and 8)

A 30 foot, 1/4 inch high pressure charging hose assembly (7) consisting of 27 feet of hose followed by a soft seat needle shut off valve followed by a 3 foot length of hose terminated with a high pressure (5000 psi) inflating chuck is supplied. The high pressure hose outer rubber jacket is perforated to prevent ballooning.

A 20 foot low pressure, 1/4 inch tire filling hose (8) is supplied with a 1/4 inch quick disconnect coupling socket that mates with a quick disconnect coupling plug.

g. High Pressure Relief Valve (9)

The adjustable high pressure relief valve (9) has a range of 2,000 psi to 4,000 psi. It is provided to limit the high pressures generated in the booster pump system and has a mechanical stop limiting the maximum pressure to 4,200 psi.

h. Low Pressure Filter (10)

The low pressure filter (10) separates water and particulate contaminants from the shop air source and has an automatic mechanical drain to remove the contaminants from the filter bowl.

SECTION III. Principles of Operation

1-10. PRINCIPLES OF OPERATION.

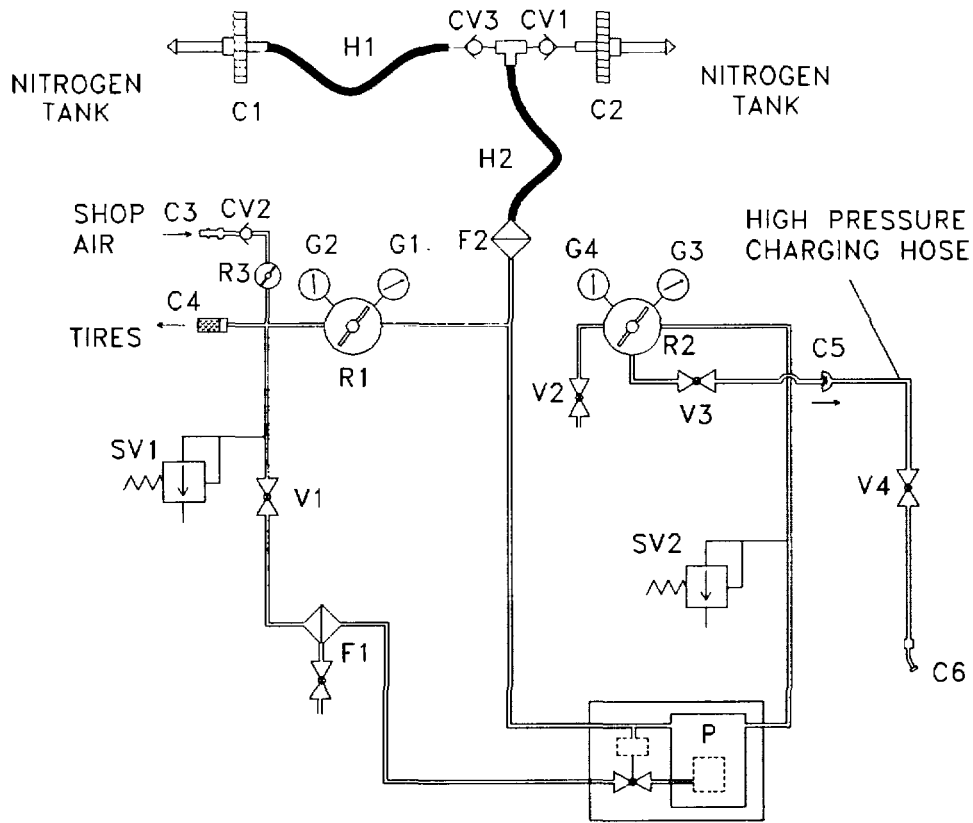

- | | | | |
|-----|-------------------------------|--------|------------------------------|
| P | Booster Pump | V3 | High Pressure Shut-Off Valve |
| R1 | Low Pressure Regulator | V4 | High Pressure Shut-Off Valve |
| R2 | High Pressure Regulator | CV1 | Tank Check Valve |
| R3 | Shop Air Regulator | CV2 | Shop Air Check Valve |
| G1 | Tank Pressure | CV3 | Tank Check Valve |
| G2 | Regulated Low Pressure Gauge | F1 | Low Pressure Filter |
| G3 | Pump Outlet Pressure Gauge | F2 | High Pressure Filter |
| G4 | Regulated High Pressure Gauge | H1, H2 | Hoses |
| SV1 | Relief Valve, Low Pressure | C1, C2 | Tank Connectors |
| SV2 | Relief Valve, High pressure | C3 | Shop Air Inlet |
| V1 | Pump Drive Valve | C4 | Tire Filling Output |
| V2 | High Pressure Vent | C5, C6 | High Pressure Output |

Figure 1-3. Schematic Diagram of High Pressure Nitrogen Servicing Cart

Refer to Figure 1-3, Schematic of the High Pressure Nitrogen Servicing Cart for the following discussion of the principles of operation. The corresponding physical location of the designated component is shown in Figure 1-4.

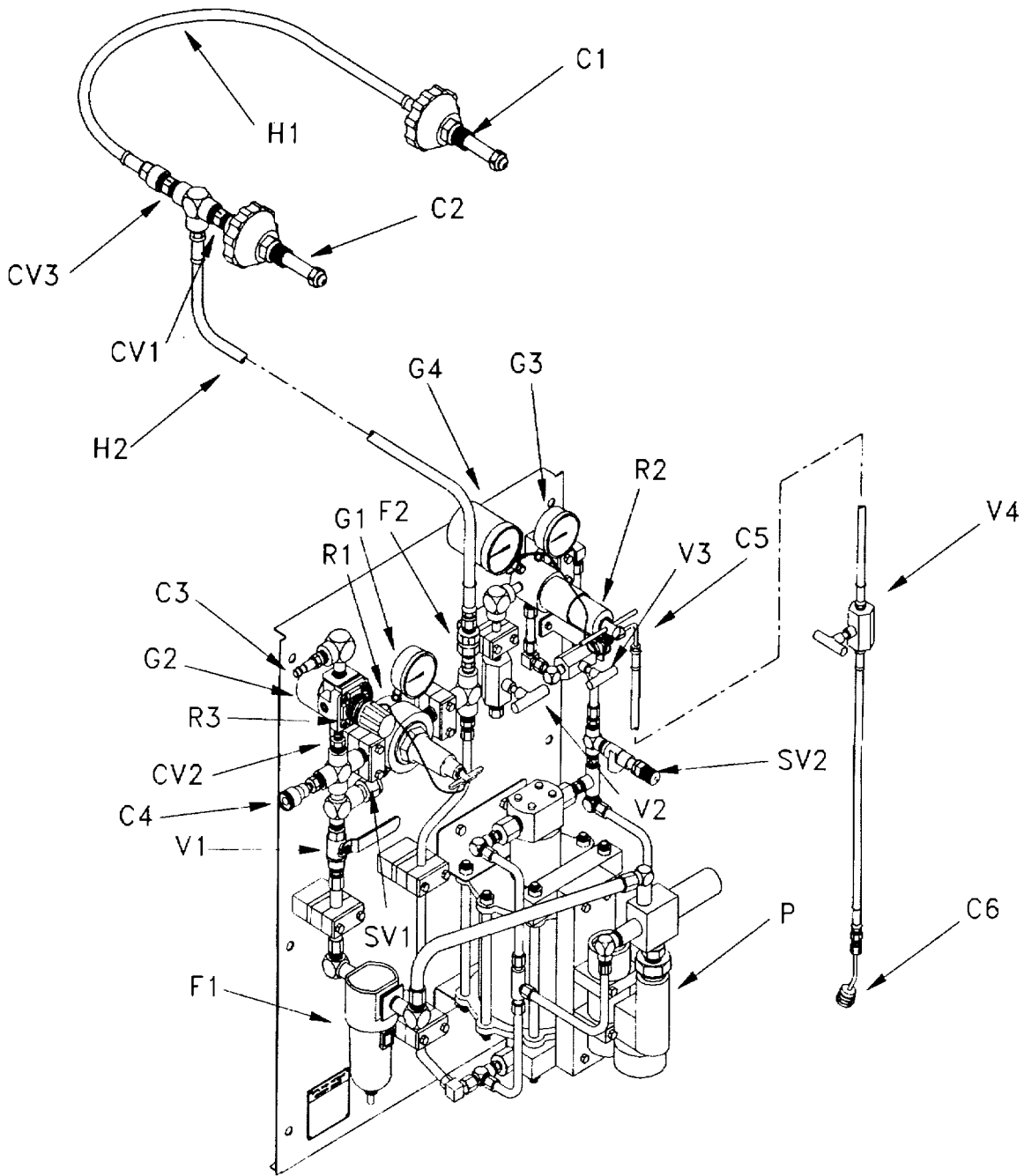

Figure 1-4. Component Location Diagram for the High Pressure Nitrogen Servicing Cart

Nitrogen gas is supplied by one or two 230 cu ft tanks via connectors C1 and C2. Nitrogen gas flows to the system from the tanks via flexible hoses, H1, H2 and filter, F2. There are also porous bronze filters located in the nipple connectors, C1 and C2. Nitrogen from the tanks pass

through the check valves CV1 and CV2. One or two nitrogen tanks may be used with the operation of the servicing cart. The check valves prevent nitrogen gas from escaping if only one tank is connected.

Gauge, G1, monitors nitrogen supply pressure available from the tanks. Low pressure regulator, R1, allows the user to adjust the available pressure to the desired pressure as measured by gauge, G2. This regulated nitrogen is available at the 1/4 inch quick disconnect coupler, C4. This output is typically used for inflating tires. A maximum of 160 psi working pressure is available at this output. This same pressure can be used to drive booster pump, P, via pump drive valve, V1.

The pump is a double acting, single stage, air or gas driven booster pump with a compression ratio of 30: 1. The booster pump is capable of continuous operation at outlet temperatures of up to 300 degrees F and the booster system can provide a 4000 psi maximum working pressure output at connector, C5, for charging aircraft struts and accumulators. The pump drive pressure can be supplied either from the tank source or shop air.

Shop air is connected to the system via quick disconnect coupler, C3. This pressure is used for driving pump, P, and is adjustable with the use of R3 located under the label designated "Shop Air Inlet". Check valve, CV2, prevents nitrogen from escaping via quick disconnect coupler, C3.

An air pilot valve integral with pump, P, monitors the tank supply pressure and will shut off the pump drive pressure when the nitrogen supply pressure is below 300 psi. The filter, F1, separates water and particulate contaminants from the shop air source and has an automatic mechanical drain to remove the contaminants from the filter bowl. The high pressure filter, F2, prevents extremely fine particulate matter and contaminants from entering the booster system.

Gauge, G3, allows the user to monitor pump output pressure and high pressure regulator, R2, permits the user to adjust the high pressure output at connector C5. The adjustable, regulated pressure output is measured by gauge, G4. Valve, V3, is the shut off valve for the high pressure output. Valve, V4, is part of the high pressure charging hose and is used to control the application of high pressure nitrogen.

High pressure vent, V2, exhausts excess nitrogen during the adjustment of high pressure regulator, R2 and is used to bleed the entire booster pump system. Relief valves, SV1 and SV2, limit the low and high pressure in the system respectively to safe levels in the case of misapplication of air sources or malfunction of the system. The low pressure relief valve, SV1, is set to crack at 175 psi to limit pneumatic pressures applied to the system and to prevent tire blow outs. SV2 is provided to limit the high pressures generated in the booster pump system and has a mechanical stop limiting the maximum pressure to 4,200 psi.

CHAPTER 2
OPERATING INSTRUCTIONS

<u>CHAPTER CONTENTS</u>		<u>PAGE</u>
Section I	DESCRIPTION AND USE OF OPERATOR CONTROLS AND INDICATORS	2-1
Section II	PREVENTIVE MAINTENANCE CHECKS AND SERVICES (PMCS)	2-6
Section III	OPERATIONS UNDER USUAL CONDITIONS	2-11
Section IV	OPERATIONS UNDER UNUSUAL CONDITIONS	2-14

Section I. Description and Use of Operator's Controls and Indicators

<u>SECTION CONTENTS</u>	<u>PARA</u>	<u>PAGE</u>
GENERAL	2-1	2-2
PRE-OPERATION PROCEDURES	2-2	2-2
CONTROLS AND INDICATORS	2-3	2-4

2-1. GENERAL

This chapter contains instructions for operating the High Pressure Nitrogen Servicing Cart. Operating personnel should be familiar with inflation of tires, accumulators and struts.

2-2. PRE-OPERATION PROCEDURES

Review the following warning and cautions before operating the equipment.

WARNING

PRESSURIZED AIR OR GAS CAN CAUSE SEVERE INJURY OR DEATH IF MISUSED. Read and understand these and manufacturers operating instructions prior to operating the cart.

WARNING

Do not remove, tamper with, or in any way disable installed pressure relief valves.

WARNING

Always wear safety glasses.

WARNING

Always confirm that the pressure produced by the High Pressure Nitrogen Servicing Cart does not exceed the servicing pressures specified in the applicable aircraft technical manuals.

WARNING

Use nitrogen from approved nitrogen tanks only for the supply gas. If shop air is used as the supply in a high pressure system, an explosion could occur.

CAUTION

Do not stand on any tubing or pneumatic assemblies or place any pressure on any of the pneumatic assemblies of the panel while positioning, moving and tilting the High Pressure Nitrogen Servicing Cart.

CAUTION

Before disassembly of any Cart components, relieve all air pressures in the affected section prior to disconnecting.

CAUTION

DO NOT force-tighten control valves; damage will occur to the soft needle seat of the valve.

CAUTION

Verify that shop air supplies are within the limits (as specified in paragraph 1-7 Pneumatic Input Requirements) or damage may result.

2-3. CONTROLS AND INDICATORS

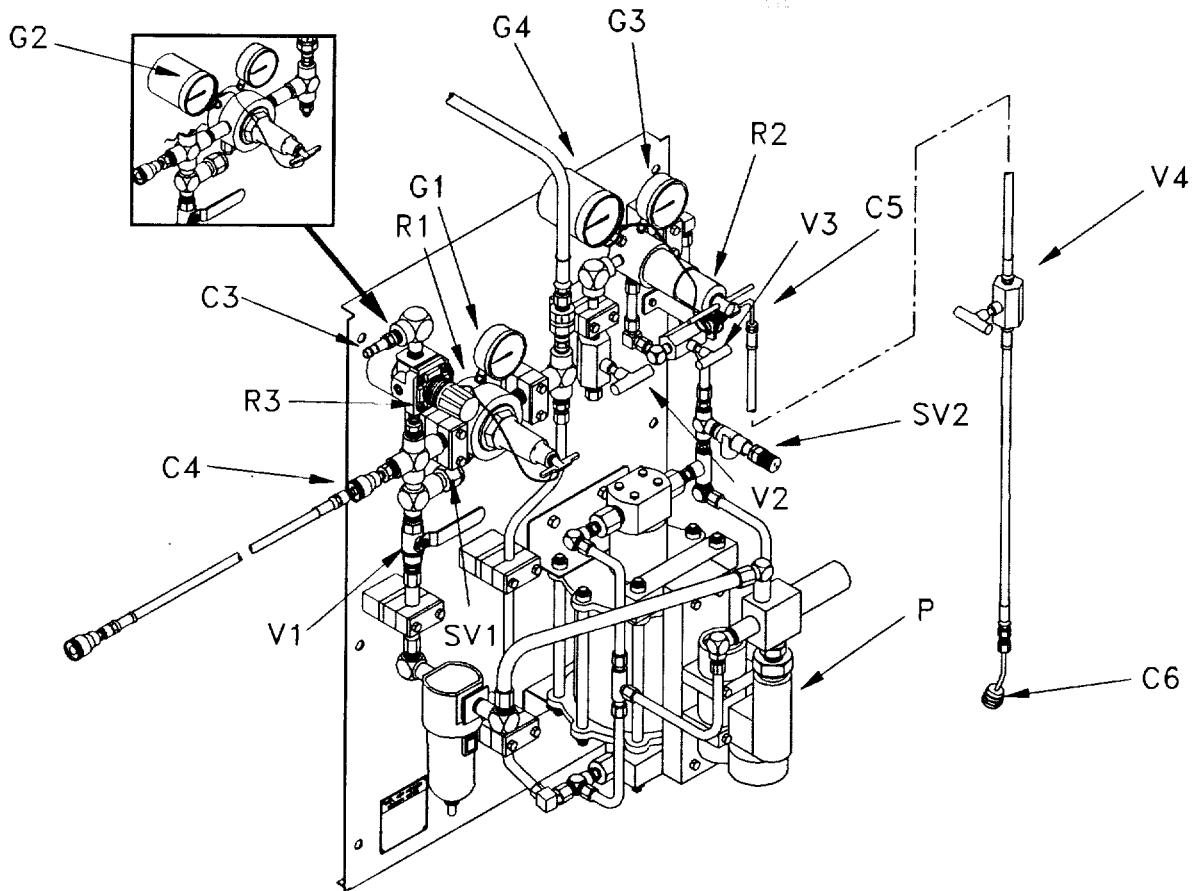

Figure 2-1. Controls and Indicators of the Booster Panel Assembly

General. Refer to Figure 2-1. This section describes the various controls and indicators provided for the proper operation of the equipment. These component designators correspond to those described in Figure 1-3 Schematic Diagram and Figure 1-4 Component Location Diagram.

- a. **R1, Low Pressure Regulator.** R1 is an adjustable regulator used to control the output pressure from the nitrogen supply tanks to connector C4 and the nitrogen drive pressure to the booster pump system. The regulator has a rated outlet working pressure of 0-300 psi. Its output pressure is read on gauge, G2.
- b. **R2, High Pressure Regulator.** R2 is an adjustable regulator that controls the output pressure to connector C5 by regulating the output pressure available from the booster pump system. The regulator has a 300 to 4500 psi delivery range.
- c. **R3, Shop Air Regulator.** R3 is an adjustable regulator that controls the shop air drive pressure for the gas booster pump. Its output pressure range is 7 to 125 psi and is read on gauge, G2.

- d. **G1, Tank Pressure Gauge.** This gauge indicates the pressure remaining in the nitrogen supply tanks. The gauge is 2-1/2 inches in diameter and has a 3,000 psi scale and 2-1/2% full scale accuracy.
- e. **G2, Regulated Low Pressure Gauge.** This gauge indicates the output pressure of regulator R1 which is provided to connector C4 and to drive the booster pump. The gauge is 2-1/2 inches in diameter and has a 300 psi scale and 1% full scale accuracy.
- f. **G3, Pump Outlet Pressure Gauge.** This gauge indicates the output pressure of the booster pump P. The gauge is 2-1/2 inches in diameter and has a 5,000 psi scale and 2-1/2% full scale accuracy.
- g. **G4, Regulated High Pressure Gauge.** This gauge indicates the output pressure of regulator R2 that is being supplied to connector C5. The gauge is 2-1/2 inches in diameter and has a 5,000 psi scale and 1% full scale accuracy.
- h. **V1, Pump Drive Valve.** This valve turns 'on' and shuts 'off' the flow of shop air applied at connector C3 or nitrogen from the tanks to the booster pump, P. Turning the handle in-line with the tubing turns the valve 'on' for flow. Turning the valve handle perpendicular to the tubing will shut 'off' flow.
- i. **V2, High Pressure Vent Valve.** This vent valve, when open, vents the line pressure contained between regulator, R2, and shut off valve, V3. This is a soft needle seat valve and is actuated by turning the handle clockwise to shut the valve and counter clockwise to open the valve.
- j. **V3, High Pressure Shut-Off Valve.** This valve turns 'on' and shuts 'off' the regulated high pressure output from the high pressure regulator, R2, to connector C5.
- k. **V4, High Pressure Shut-Off Valve.** This valve turns 'on' and shuts 'off' the regulated high pressure output at the high pressure charging hose connector, C6. It is used to control the flow when actually charging an aircraft accumulator or strut.
- l. **SV2, High Pressure Relief Valve.** The adjustable high pressure relief valve has a range of 2,000 psi to 4,000 psi. It is provided to limit the high pressures generated in the booster pump system and has a mechanical stop limiting the maximum pressure to 4,200 psi.

Section II. Preventive Maintenance Checks and Services (PMCS)

<u>SECTION CONTENTS</u>	<u>PARA</u>	<u>PAGE</u>
BEFORE YOU OPERATE	2-4	2-6
SETUP	2-5	2-7
SETTING THE HIGH PRESSURE RELIEF VALVE	2-6	2-9
SHUTDOWN PROCEDURE	2-7	2-9
LEAK CHECK AND CONFIDENCE TEST PROCEDURE	2-8	2-10

2-4. BEFORE YOU OPERATE

Always keep in mind caution and warning. Review those in the front of this manual. Handle the High Pressure Nitrogen Servicing Cart like you would any other high pressure pneumatic equipment. See Table 2-1 for normal preventive maintenance checks and services.

NOTE

Within the designated interval, these checks are to be performed in the order listed.

TABLE 2-1. Preventive Maintenance Checks and Services

Item No.	Interval	Item to be Checked or Serviced	Procedure	Not Fully Mission Capable if:
1	With each new tank	O-ring seal at tank nipple connector	Visually inspect. Then leak test with soap solution (item 8 of Appendix D) after connecting to tanks.	Deformed, cut, missing or dry.
2	90 days	Hoses	Visually inspect	Cut, leaking
3	6 mos.	Automatic mechanical drain in low pressure filter	Remove filter bowl and inspect for less than 1/4 in. Level of water. Fill bowl with water and verify valve drains water down to 1/4 in. Level.	Binding or frozen; bowl full of water or contaminants
4	6 mos.	Wheel assembly	Visually inspect tire, valve stem and wheel. Check tire pressure and inflate to 60 psi.	Tire is flat, has cuts or bruises. Wheel is bent.
5	6 mos.	Wheel bearing grease	Remove wheel assembly from axle to examine bearings. Clean and repack as necessary.	No grease, water in bearings
6	6 mos.	Gauge damping fluid in gauges G1 or G3 (see figure 2-1)	Inspect gauge face plate. Refill with glycerin (item 9 of Appendix D) via blow out plugs to within 1/4 in. From top of gauge face plate.	

TABLE 2-1. Preventive Maintenance Checks and Services (Cont'd)

Item No.	Interval	Item to be Checked or Serviced	Procedure	Not Fully Mission Capable if:
7	6 mos.	Leaks	Leak check by pressurizing system with output valves shut off. Soap bubble test per paragraph 2-8.	
8	6 mos.	High pressure relief valve	Check that valve vents at no higher than 4,200 psi per paragraph 2-6.	Relief valve does not vent.
9	6 mos.	Paint, item 7 of Appendix D	Visually inspect for corrosion, chipping and worn areas. Treat corrosion and touch up per TM 43-0139	

2-5. SETUP**CAUTION**

Nitrogen tanks must be secured tightly to the hand truck's saddles. Loose or unsecured tank retention straps will allow the tanks to shift during towing. This could damage the tank connectors, hoses or tow vehicle.

CAUTION

The maximum safe towing speed for the High Pressure Nitrogen Servicing Cart is 15 miles per hour. Do not exceed this speed.

To set up the cart, follow these procedures:

- a. Verify that the high pressure charging hose is connected to the high pressure output port labeled HIGH PRESSURE SHUT-OFF.
- b. Place one or two pressurized, 230 cu ft nitrogen tanks into the saddles of the hand truck. Roll each tank into its saddle. Adjust the upper and lower pairs of tank retention straps until they hold the tanks securely.
- c. Refer to Figure 2-2. Inspect the O-ring at the end of the nipple connector (1) for cuts and bruises. Connect each tank to its connector by inserting the nipple connector (1) into the tank connector port (2), fully seating the connector (1) and turning the knurled hand nut (3) until it is hand tight.
- d. Leave the tank valve(s) completely closed until ready for use. Refer to Figure 2-1. Before any test or operation of the unit, verify that the following controls are properly set:

-Back off both low pressure regulator, R1, and high pressure regulator, R2, by turning the T-handles counter-clockwise until they spin freely.

NOTE

The V1 shut-off valve is closed when the handle is perpendicular to the direction of gas flow.

- Close the shut-off valve, V1, and vent valves, V2 and V3, and the shut off valve, V4, on the high pressure charging hose. Rotate the valve handles clockwise to seat the needle.
- Unlock the adjustment knob of the shop air regulator, R3, by pulling the knob out. Turn the adjustment knob fully counter clockwise to set the regulator at its lowest setting.

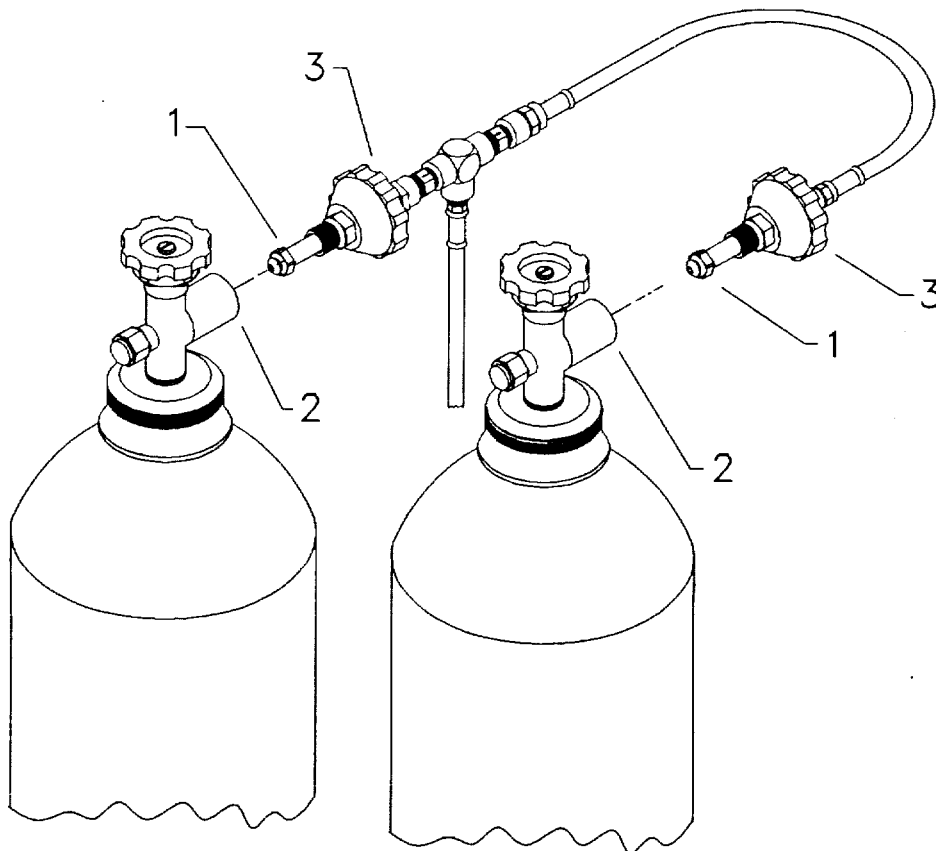

Figure 2-2. Connecting Nitrogen Tanks

2-6 SETTING THE HIGH PRESSURE RELIEF VALVE (See Fig. 2-1)

When new, the high pressure relief valve is set at the maximum setting at 4,000 to 4,200 psi for normal use. The high pressure relief valve may be set for relief at any pressure between 2,300 psi to 4,200 psi as required. The following procedure may be used to set and verify the relief valve's performance and setting.

CAUTION

Do not set the high pressure relief valve for less than 2,300 psi since fully charged nitrogen tanks may be pressurized to that level.

- a. Setup the cart per paragraph 2-5.
- b. Open both nitrogen tank valves and pump drive valve, V1.
- c. Adjust low pressure regulator, R1, T-handle clockwise slowly until the booster pump cycles and the pump outlet pressure gauge, G3, reads 4000 psi.
- d. Loosen the locknut on the knob of the high pressure relief valve, SV2, and turn the knob counterclockwise. Relief valve, SV2, will exhaust. Continue turning the knob counterclockwise until the pump outlet pressure gauge, G3, reads at the desired setting. Tighten locknut to secure the knob position.
- e. Turn the low pressure regulator, R1, T-handle fully counterclockwise until regulated low pressure gauge, G2, reads zero.
- f. Depressurize and shut down the system per paragraph 2-7.

2-7. SHUTDOWN PROCEDURE (See Fig. 2-1)

To depressurize the High Pressure Nitrogen Servicing Cart and shutdown the system, perform the following steps:

- a. Close the valves on the nitrogen tanks.
- b. If the regulated high pressure gauge, G4, reads zero psi, rotate the high pressure regulator, R2, T-handle clockwise until G4 reads 300 psi minimum. If high pressure gauge, G4, already reads pressure above 300 psi, do not adjust the regulator.
- c. Open the high pressure vent valve, V2, to bleed off the high pressure. When pressure is bled off, do not turn high pressure regulator, R2, handle at this time.
- d. Turn low pressure regulator, R1, handle clockwise until handle is free spinning. The regulated low pressure gauge, G2, will still show some pressure. Open pump drive valve, V1, to exhaust this pressure through the booster pump exhaust.
- e. The system is depressurized. Turn the valves V1, V2 and V3 clockwise to shut off valves and turn the high pressure regulator, R2, T-handle counterclockwise until handle is free spinning. The shop air regulator, R3, may be left set where it is.
- f. If the nitrogen tanks are to be removed, unbuckle the upper and lower tank retention straps of the tank to be removed. Carefully pull the tank out of its saddle and roll the tank away from the cart. Repeat with the second tank if used.

2-8 LEAK CHECK AND CONFIDENCE TEST PROCEDURE (See Fig. 2-1)**WARNING**

Depressurize and shut down the high pressure nitrogen servicing cart per paragraph 2-7 prior to any repair action including the tightening of fittings.

- a. Setup the cart per paragraph 2-5.
- b. Remove tire filling hose assembly from hose cleats.
- c. Place the quick disconnect plug end of the tire filling hose assembly into the connector, C4, labeled TIRE FILLING OUTPUT. Couple the quick disconnect socket side to the connector, C3, labeled SHOP AIR INLET.
- d. Slowly open valve(s) located on the nitrogen tanks. The tank pressure gauge, G1, and pump outlet pressure gauge, G3, on both regulator assemblies will show the tank pressure.
- e. Slowly turn low pressure regulator, R1, T-handle clockwise until the regulated low pressure gauge, G2, reads 150 psi. Slowly turn the high pressure regulator, R2, T-handle fully clockwise.
- f. Remove the high pressure charging hose from hose cleats. Open the high pressure shutoff valve, V3.

NOTE

The high pressure charging hose assembly consists of two hose assemblies connected by a shut-off valve.

- g. The system is now pressurized with nitrogen tank pressure. Soap bubble test all pressure connections.
- h. If leaks are found, depressurize and shut down the high pressure nitrogen cart using the procedure of paragraph 2-7. Refer to the applicable maintenance procedure in Chapters 3 or 4. If no leaks are found, continue.
- i. Turn the T-handle of the low pressure regulator, R1, counter clockwise until it spins freely. Disconnect the tire filling hose from the mating connectors, C3 and C4.
- j. Open the pump drive valve, VI. Slowly turn the T-handle of the low pressure regulator, R1, clockwise until the booster pump cycles and charges the pump outlet pressure gauge, G3, to read approx. 3750 psi. Do not charge the pump output pressure higher than 3900 psi or the high pressure relief valve, SV2, may open.
- k. The system is now pressurized with booster pump output pressure. Soap bubble test all pressure connections with soap solution (D8).
- l. If leaks are found, depressurize and shut down the high pressure nitrogen cart using the procedure of paragraph 2-7. Tighten loose fittings and reapply Teflon tape or sealant on pipe threads as required. If a component leaks, refer to the applicable maintenance procedure in Chapters 3 or 4 for replacement.
- m. If no leaks are found, depressurize and shut down the system per paragraph 2-7. This concludes the leak check and confidence test procedure.

Section III. Operations under Usual Conditions

<u>SECTION CONTENTS</u>	<u>PARA</u>	<u>PAGE</u>
OPERATING PROCEDURES	2-9	2-11
NITROGEN CHARGING DIRECTLY FROM THE SUPPLY TANKS	2-10	2-11
NITROGEN CHARGING USING BOOSTER PUMP	2-11	2-12

2-9. OPERATING PROCEDURES

The cart can be configured to provide nitrogen for pressurizing tires, accumulators and struts directly from the nitrogen tank when tank pressure is adequate or by increasing the nitrogen supply pressure with the booster pump. The booster pump can be driven by the supply nitrogen or by compressed air when available.

WARNING

Always confirm that the pressure produced by the High Pressure Nitrogen Servicing Cart does not exceed the servicing pressures specified in the applicable aircraft technical manuals.

WARNING

Verify the correct tire inflation pressure in the aircraft manual before inflating.

CAUTION

Do not exceed 30 inch pounds of torque when connecting high pressure inflation chuck to any charging fitting.

2-10. NITROGEN CHARGING DIRECTLY FROM THE SUPPLY TANKS (See Fig. 2-1)

a. High Pressure Servicing:

- (1) Setup the cart per paragraph 2-5. Use one or two tanks with adequate pressure to complete the charging procedure for the given accumulator or strut.
- (2) Slowly open valve(s) located on the nitrogen tanks.
- (3) Check tank pressure on the tank pressure gauge, G1, to make sure that tank pressure is higher than the required servicing pressure per the applicable aircraft manual.

NOTE

If tank pressure is not adequate for the task, nitrogen charging can be accomplished using the booster pump by proceeding to paragraph 2-11. Otherwise, replace supply tank(s).

- (4) Adjust the high pressure regulator, R2, to the required servicing pressure measured on gauge, G4. Then open high pressure shut-off valve, V3.
- (5) Connect the inflating chuck, C6, of the charging hose assembly to the inlet port of the aircraft component to be serviced. Do not over torque the inflating chuck, C6.
- (6) Refer to applicable aircraft manuals for charging procedures. Open the shut off valve, V4, in the high pressure servicing hose.
- (7) Depressurize and shut down the system per paragraph 2-7. Leave the shutoff valve, V4, in the high pressure charging hose open to vent the line.
- (8) Remove the inflating chuck, C6, from the inlet port of the aircraft component.

b. Tire Servicing:

- (1) Setup the cart per paragraph 2-5. Use one or two tanks with adequate pressure to complete the charging procedure for the tire.
- (2) Connect the tire filling hose from the tire filling output, C4, to the tire using the appropriate inflating chuck.
- (3) Slowly open valve(s) located on the nitrogen tank(s).
- (4) Verify the specified tire pressure per the applicable aircraft manual.
- (5) Adjust the T-handle of the low pressure regulator, R1, pressure as indicated on gauge, G2, to the specified tire pressure.
- (6) Depressurize and shut down the system per paragraph 2-7.

2-11. NITROGEN CHARGING USING BOOSTER PUMP (See Fig. 2-1)

a. High pressure servicing using nitrogen to drive the booster pump:

- (1) Setup the cart per paragraph 2-5. Use one or two tanks with adequate pressure to complete the charging procedure for the given accumulator or strut.
- (2) Slowly open valve(s) located on the nitrogen tank(s).

NOTE

Replace tank(s) if pressure is below 350 psi or if it will be reduced to 350 psi during the charging operation.

- (3) Read tank pressure on regulator, G1.
- (4) Open the booster shutoff valve, V1. Raise the pressure by slowly adjusting the low pressure regulator, R1, until the indicated pressure on the pump outlet pressure gauge,

G3, is 3800 psi. Reduce the pump drive by turning low pressure regulator, R1, T-handle counter clockwise if the safety relief valve, SV2, starts to exhaust.

- (5) Adjust the high pressure regulator, R2, until the required servicing pressure as shown on gauge, G4, is attained.
- (6) Open high pressure shut-off valve, V3. Connect the inflating chuck of the charging hose assembly to the inlet port of the vessel to be serviced. Do not over torque the inflating chuck, C6.
- (7) Refer to applicable aircraft manuals for charging procedures. Open the shut off valve, V4, in the high pressure servicing hose.
- (8) Depressurize and shut down the system per paragraph 2-7. Leave the shutoff valve, V4, in the high pressure charging hose open to vent the line.
- (9) Remove the inflating chuck, C6, from the inlet port of the aircraft component.

b. High pressure servicing using shop air to drive the booster pump:

- (1) Setup the cart per paragraph 2-5. Use one or two tanks with adequate pressure to complete the charging procedure for the given accumulator or strut.
- (2) Connect shop air or a portable air compressor to the shop air inlet, C3. (Make sure that the shop air is connected upstream from any air line lubricator.) Verify that the low pressure regulator, R1, has its T-handle turned fully counter clockwise since nitrogen will not be used to drive the booster pump, P.
- (3) Slowly open valve(s) located on the nitrogen tank(s).
- (4) Read tank pressure on regulator, G1. Replace tank if pressure is below 350 psi or if it will be reduced to 350 psi during the charging operation.
- (5) Open the booster shutoff valve, V1. Raise the booster pump drive pressure by slowly adjusting the shop air regulator, R3, until the indicated pressure on the pump outlet pressure gauge, G3, is 3800 psi. Reduce if SV2 starts to exhaust.

NOTE

The shop air supply may be inadequate to charge the pump outlet pressure to 3800 psi. If it is insufficient to boost the output pressure to complete the task, use the booster pump procedure in paragraph 2-11.a.

- (6) Adjust the high pressure regulator, R2, until the required servicing pressure as shown on gauge, G4, is attained.
- (7) Open high pressure shut-off valve, V3. Connect the inflating chuck of the charging hose assembly to the inlet port of the vessel to be serviced. Do not over torque the inflating chuck.
- (8) Refer to applicable aircraft manuals for charging procedures. Open the shut off valve, V4, in the high pressure servicing hose.
- (9) Depressurize and shut down the system per paragraph 2-7.
- (10) Disconnect the inflating chuck, C6, from the inlet port of the aircraft component.

Section IV. Operations under Unusual Conditions

<u>SECTION CONTENTS</u>	<u>PARA</u>	<u>PAGE</u>
UNUSUAL CONDITIONS	2-12	2-14
EXTREME ENVIRONMENTAL MAINTENANCE	2-13	2-14

2-12. UNUSUAL CONDITIONS

- a. Towing. The cart may be towed by a tow vehicle at a maximum speed of 15 miles per hour to any location on good roads. The cart has a clearance of five inches if towed over rough terrain.
- b. Extremes of heat and cold. The cart is designed to operate in temperatures ranging from -20 degrees F to +160 degrees F.
- c. Other unusual conditions.
 - (1) When operating the cart in extreme conditions of snow, ice, rain, mud, dust, salt air or similar conditions, do everything possible to prevent foreign material from entering the nitrogen tank connector nipples. This may clog in-line filters and cause reduced booster pump performance.
 - (2) After operation in extreme conditions, thoroughly clean and dry the cart and its accessories. Perform the filter inspection procedures per paragraph 3-25 "Tank Connector Assembly Inspect and Replace" and 3-26 "Tank Connector Assembly Inspecting and Replacing Components". Replace the tank connector nipples and the high pressure filter (F2) if necessary.
 - (3) Frequent over the road service or submersion requires wheel bearing maintenance.
 - (4) If the cart has been connected to contaminated shop air and performance has degraded, replace the low pressure filter (F1).

2-13. EXTREME ENVIRONMENTAL MAINTENANCE

- a. The High Pressure Nitrogen Servicing Cart is capable of the specified performance under the following conditions.
 - (1) Temperatures ranging from -20 degrees F to + 160 degrees F.
 - (2) Relative humidity up to 100 percent.
 - (3) Exposure to salt fog.
 - (4) Exposure to sand and dust particles as encountered in desert areas.
 - (5) Storage at temperatures ranging from -65 to +160 degrees F.
- b. Exposure to salt. Hose off salt frequently with fresh water. Check for chipped paint and possible corrosion. Touch up paint per TM 43-0139 Painting Operations Instructions for Field Use. Use paint item 7 of Appendix D.

CHAPTER 3
AVIATION UNIT MAINTENANCE (AVUM) MAINTENANCE
INSTRUCTIONS

<u>CHAPTER CONTENTS</u>		<u>PAGE</u>
Section I	REPAIR PARTS, SPECIAL TOOLS, TMDE AND SUPPORT EQUIPMENT	3-2
Section II	SERVICE UPON RECEIPT	3-2
Section III	PREVENTIVE MAINTENANCE CHECKS AND SERVICES (PMCS)	3-3
Section IV	TROUBLESHOOTING	3-4
Section V	MAINTENANCE PROCEDURES	3-11
Section VI	PREPARATION FOR STORAGE OR SHIPMENT	3-43

3-1. GENERAL

This chapter contains maintenance procedures that are the responsibility of the aviation unit maintenance technician as authorized by the Maintenance Allocation Chart (MAC) and Source Maintenance and Recoverability (SMR) coded items in the Repair Parts and Special Tools List (RPSTL). The maintenance procedures in this chapter are prepared in the form of summary and detailed procedures.

3-2. MAINTENANCE OPERATIONS

These instructions provide the proper technique and detailed procedures required to perform the maintenance operations. Each maintenance operation provides step-by-step instructions in the order in which the work is most logically accomplished. Any unusual or critical steps are covered in detail.

Section I. Repair Parts, Special Tools, TMDE, and Support Equipment

<u>SECTION CONTENTS</u>	<u>PARA</u>	<u>PAGE</u>
TOOLS AND TEST EQUIPMENT LIST	3-3	3-2
SPECIAL TOOLS, TMDE AND SUPPORT EQUIPMENT	3-4	3-2
REPAIR PARTS	3-5	3-2

3-3. TOOLS AND TEST EQUIPMENT LIST

Tools and test equipment required for maintenance of the High Pressure Nitrogen Servicing Cart are identified in the Maintenance Allocation Chart, Appendix B.

3-4. SPECIAL TOOLS, TMDE, AND SUPPORT EQUIPMENT

There are no special tools required for test or inspection procedures at the AVUM level.

3-5. REPAIR PARTS

Repair parts are listed in the Repair Parts and Special Tools List (RPSTL) in Appendix C of this manual.

Section II. Service Upon Receipt

3-6. GENERAL

- a. Visually check the exterior of the High Pressure Nitrogen Servicing Cart for apparent damage. Check contents to assure that all components listed in APPENDIX C (RPSTL) of this manual are enclosed and undamaged.
- b. If the equipment has been damaged, report the damage on SF 368 (REPORT OF DISCREPANCIES). Check the equipment against the packing slip to see if the shipment is complete. Report any discrepancies in accordance with the instructions of DA PMA 738-751.

Section III. Preventive Maintenance Checks (PMCS)

<u>SECTION CONTENTS</u>	<u>PARA</u>	<u>PAGE</u>
GENERAL	3-7	3-3
CLEANING	3-8	3-3
SETUP, CONFIDENCE AND LEAK TESTS	3-9	3-3

3-7. GENERAL

Preventive maintenance of the High Pressure Nitrogen Servicing Cart is covered by the following paragraphs as well as the warnings, cautions and Notes in Chapter 2, and PMCS information listed in Table 2-1. These, if followed, assure that the equipment will be used in the proper manner.

No lubrication is required for the Booster Pump. Any required lubrication internally to the pump is provided during pump rebuild.

3-8. CLEANING

- a. Keep equipment free of dirt and grease. Place a protective cover over the booster panel and tank connectors when not in use.
- b. In salt water environment, hose cart off frequently with water. Cover tank connectors and connector ports with plastic bags to prevent entry of contaminants.
- c. Use a soft cloth dampened with a solution of mild soap and water or isopropyl alcohol for cleaning.

3-9. SETUP, CONFIDENCE AND LEAK TESTS

Visually inspect the High Pressure Nitrogen Servicing Cart accessories, indicators and shut-off valves. Refer to the following paragraphs for the applicable procedures:

BEFORE YOU OPERATE	<u>PARA</u> 2-4
SETUP	2-5
SETTING THE HIGH PRESSURE RELIEF VALVE	2-6
SHUTDOWN PROCEDURE	2-7
LEAK CHECK AND CONFIDENCE TEST PROCEDURE	2-8

Section IV. Troubleshooting

<u>SECTION CONTENTS</u>	<u>PARA</u>	<u>PAGE</u>
GENERAL	3-10	3-4
TROUBLESHOOTING PROCEDURES: NOT REQUIRING BOOSTER PUMP OPERATION	3-11	3-4
TROUBLESHOOTING PROCEDURE: REQUIRING BOOSTER PUMP OPERATION	3-12	3-7
CART INSPECTION	3-13	3-8
ACCESSORY INSPECTION	3-14	3-9

3-10. GENERAL**WARNING**

Remove or disconnect nitrogen tanks before maintenance. Never disconnect a pressurized line.

Possible failures of the High Pressure Nitrogen Servicing Cart as well as probable cause and corrective action are shown in the following troubleshooting flow charts. Corrective actions, as shown in the following troubleshooting flow charts, are described in the applicable removal/installation paragraphs in the text of this manual.

Troubleshooting flow charts are grouped into two categories. Paragraph 3-11 covers the case where booster pump operation is not used and paragraph 3-12 covers troubleshooting for the case where the booster pump is required for operation.

3-11. TROUBLESHOOTING PROCEDURES: NOT REQUIRING BOOSTER PUMP OPERATION

Paragraphs 3-11.1 "No Tire Inflation (Low) Pressures" and 3-11.2 "No Nitrogen Flow to High Pressure Output" show troubleshooting flow charts for the cases where booster pump operation is not required.

Paragraph 3-11.1 is to be used for troubleshooting difficulties associated with low pressure operation such as tire inflation. The nitrogen supply pressure is obtained from the Cart's C4 connector in this case.

Paragraph 3-11.2 is to be used for troubleshooting difficulties associated with no high pressure output appearing at the High Pressure Output connector, C5, or at the high pressure fitting end of the high pressure charging hose.

See Figures 1-3 and 1-4 for the function and location of the designated components.

3-11.1 NO TIRE INFLATION (LOW) PRESSURES

This flow chart is to be used for troubleshooting difficulties associated with low pressure operation such as tire inflation. The nitrogen supply pressure is obtained from the Cart's C4 connector in this case. See Figures 1-3 and 1-4 for the function and location of the designated components.

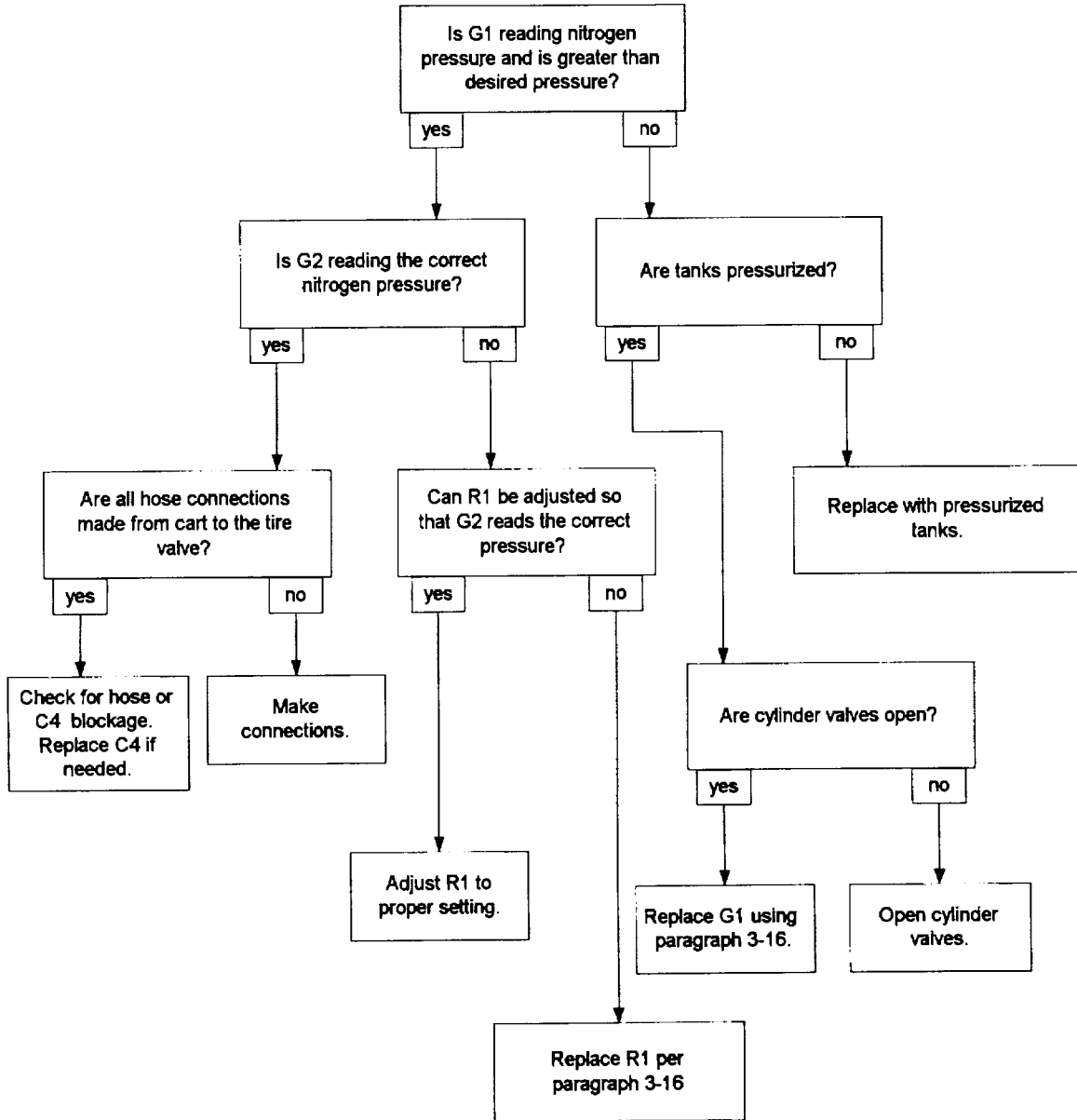

3-11.2 NO NITROGEN FLOW TO HIGH PRESSURE OUTPUT (NOT REQUIRING BOOSTER PUMP OPERATION).

This flow chart is to be used for troubleshooting difficulties associated with no high pressure output appearing at the High Pressure Output connector, C5, or at the high pressure fitting end of the high pressure charging hose. See Figures 1-3 and 1-4 for the function and location of the designated components.

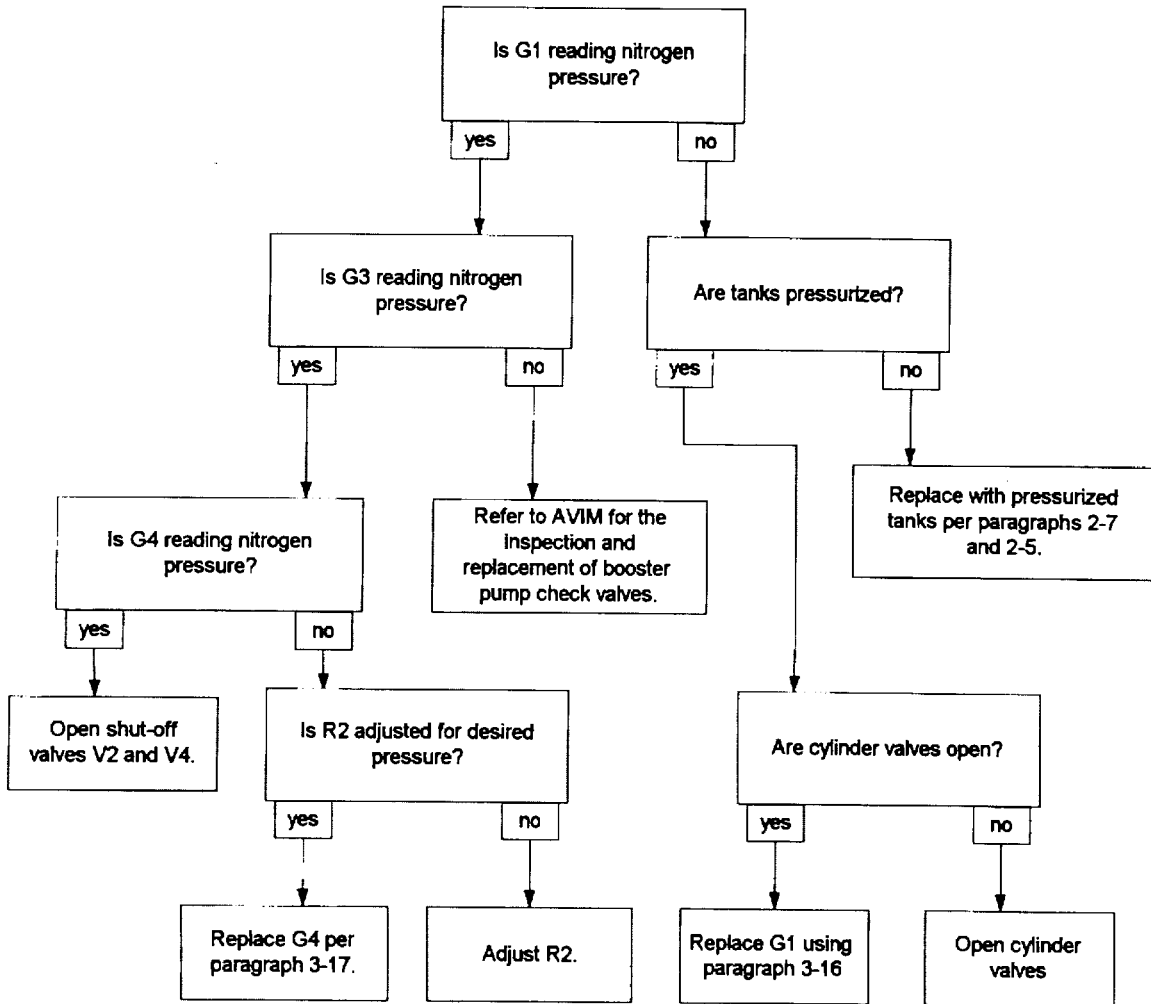

3-12. TROUBLESHOOTING PROCEDURE: REQUIRING BOOSTER PUMP OPERATION

This flow chart is to be used in troubleshooting difficulties with booster pump operation. See Figures 1-3 and 1-4 for the function and location of the designated components.

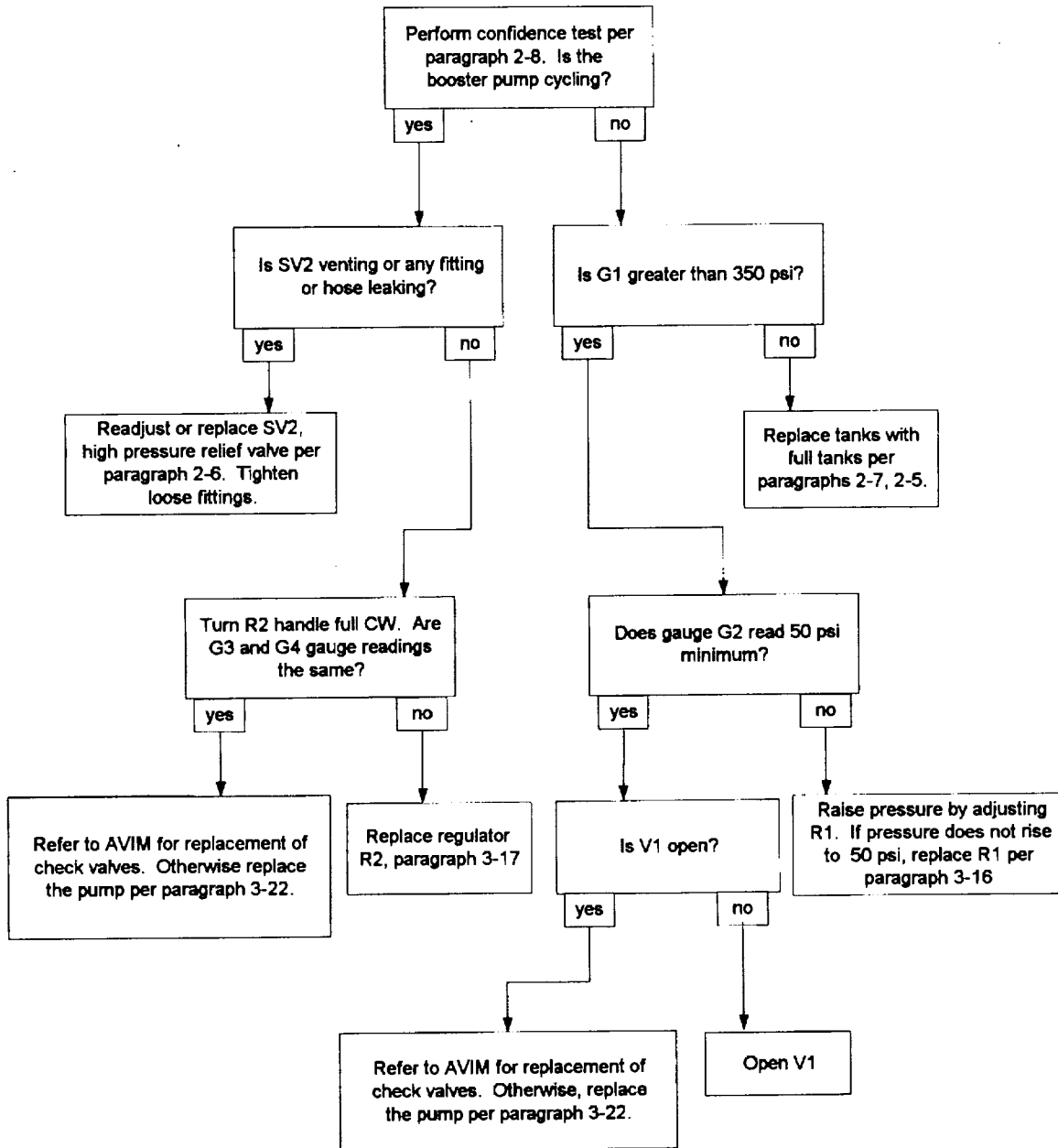

3-13. CART INSPECTION

Personnel Required:	67 Series
Material/parts:	High Pressure Nitrogen Servicing Cart, FPNC-01 Nitrogen tanks (1 or 2), 230 cu ft, NSN 6830-01-028-9402
Equipment Condition:	Cart in upright position

- a. Shut off the valves of both nitrogen tanks. Shut down the cart and bleed the booster pump system per shutdown procedure of paragraph 2-7.
- b. Disconnect both tank connectors from the tanks by turning hand nut counterclockwise. Remove nipple connector from the tank fitting. Examine the O-ring on the nipple connector as shown in the Figure 2-2 and described in paragraph 2.5.c.
- c. Inspect the items described in Preventive Maintenance Checks and Services (PMCS), Table 2-1.
- d. Check all hoses and rigid tubing. Check entire cart for bent, broken or corroded fittings and components. Examine the nipple connector of both tank connectors for nicks and flat spots.
- e. Examine the webbing of the tank retention straps for cuts and abrasions. Check the buckles for ability to adjust and to secure the tanks tightly.
- f. Check that all booster panel and accessory components are accounted for and undamaged. Check that the wire retainers for the regulator T-handles are present and in good shape. Replace all missing or broken parts. Refer to Appendix C Repair Parts and Special Tools List (RPSTL).
- g. Check the hand truck for any broken welds and corrosion of painted surfaces.
- h. Check tire for tread wear, cuts and bruises. Check the condition of the valve stem and core. Check tire pressures and inflate to 60 psi if necessary. Spin the tire by hand to check the condition of wheel bearings and freedom of wheel rotation.
- i. Leak check and confidence test the cart per the procedure in paragraph 2-8.
- j. Clean all components.

END OF TASK

3-14. ACCESSORY INSPECTION

Personnel Required: 67 Series

Material/parts: High Pressure Hose
Tire Filling Hose

Equipment Condition: Disconnect hoses from the cart

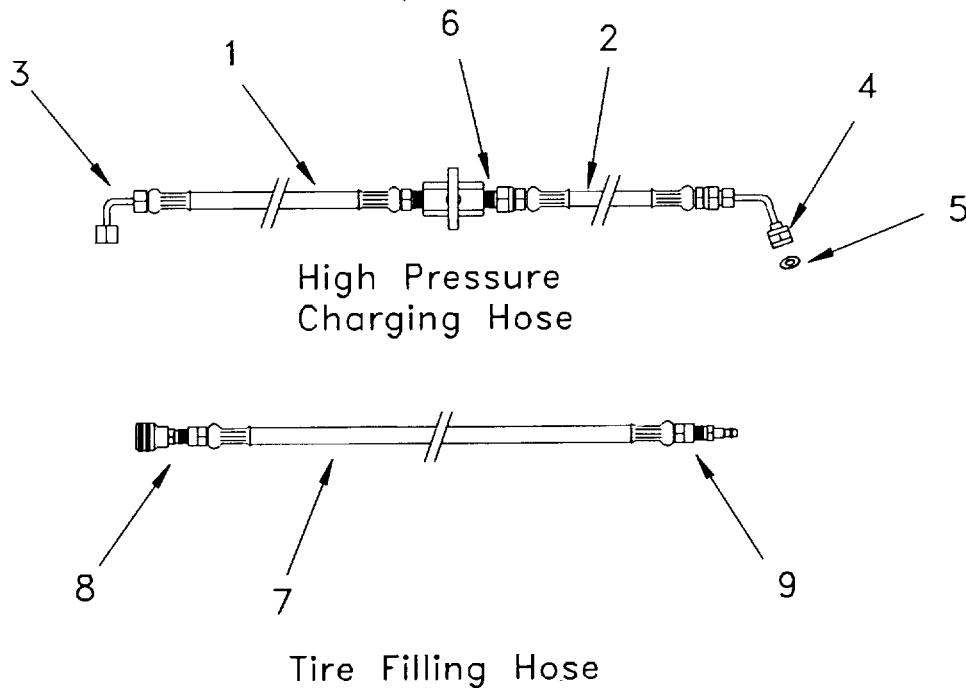

3-14.1. HIGH PRESSURE HOSE

- a. Inspect the rubber hose sections (1) and (2) of the high pressure hose for nicks, cuts and abrasions. Examine the crimps at the hose ends.
- b. Inspect high pressure fitting (3) and inflating chuck (4) for bent, distorted parts or deformed screw threads.
- c. Inspect the washer (5) in the inflating chuck (4) for wear and nicks.

CAUTION

DO NOT force-tighten control valves; damage will occur to the soft needle seat of the valve.

- d. Inspect high pressure shutoff valve (6) for smooth operation and freedom from corrosion.

GO TO NEXT PAGE

3-14.2. TIRE FILLING HOSE

- a. Inspect the rubber hose section (7) of the tire filling hose for nicks, cuts and abrasions. Examine the crimps at the hose ends.
- b. Examine both coupler (8) and plug (9) end of the quick disconnect fittings for wear.
- c. Push the male quick disconnect plug (9) into the tire filling output connector (item C4 of Figure 2-1) of the cart. Apply 90 psi of pressure using the tire servicing procedure of paragraph 2-10.b. Listen for leaks.

END OF TASK

Section V Maintenance Procedures

<u>SECTION CONTENTS</u>	<u>PARA</u>	<u>PAGE</u>
BOOSTER PANEL ASSY - REPLACE	3-15	3-12
LOW PRESSURE REGULATOR - REPLACE	3-16	3-14
HIGH PRESSURE REGULATOR - REPLACE	3-17	3-18
HIGH PRESSURE RELIEF VALVE - REPLACE	3-18	3-20
LOW PRESSURE FILTER - REPLACE	3-19	3-22
HIGH PRESSURE SHUTOFF VALVE - REPLACE	3-20	3-24
TUBE ASSEMBLIES - REPLACE	3-21	3-26
BOOSTER PUMP - REPLACE	3-22	3-28
WHEEL ASSEMBLY - REPLACE	3-23	3-30
TANK RETENTION STRAP ASSY - REPLACE	3-24	3-32
TANK CONNECTOR ASSY AND HIGH PRESSURE FILTER - REPLACE	3-25	3-34
TANK CONNECTOR ASSY - INSP. FILTERS, REPLACE COMPONENTS	3-26	3-36
HIGH PRESSURE CHARGING HOSE - REPAIR	3-27	3-39
TANK CONNECTOR O RINGS - REPLACE	3-28	3-41
TIRE FILLING HOSE - REPAIR	3-29	3-42

WARNING

Remove or disconnect nitrogen tanks before maintenance. Never disconnect a pressurized line.

When maintenance is required, removal and replacement of a part or assembly is indicated. Removal procedures are given only to the extent necessary to repair or replace authorized parts. Removal of the booster panel assembly from the hand truck is generally not necessary to remove and replace components. Most of the components are accessible with the panel on the cart.

3-15. BOOSTER PANEL ASSEMBLY - REPLACE

THIS TASK COVERS: REMOVAL AND INSTALLATION

Personnel Required: 67 Series (2)

Tools/Test and Support Equipment: Tool Kit, SC 5180-99-A01, NSN 5180-00-323-4692
Gloves

Material/parts: Booster Panel Assy, PA004
Teflon Tape (D1) or Perma Lok LM012 (D2)

Equipment Conditions: Shop air disconnected. Cart depressurized and shutdown per paragraph. 2-7. Nitrogen tanks disconnected and removed. Cart in horizontal position, booster panel side up.

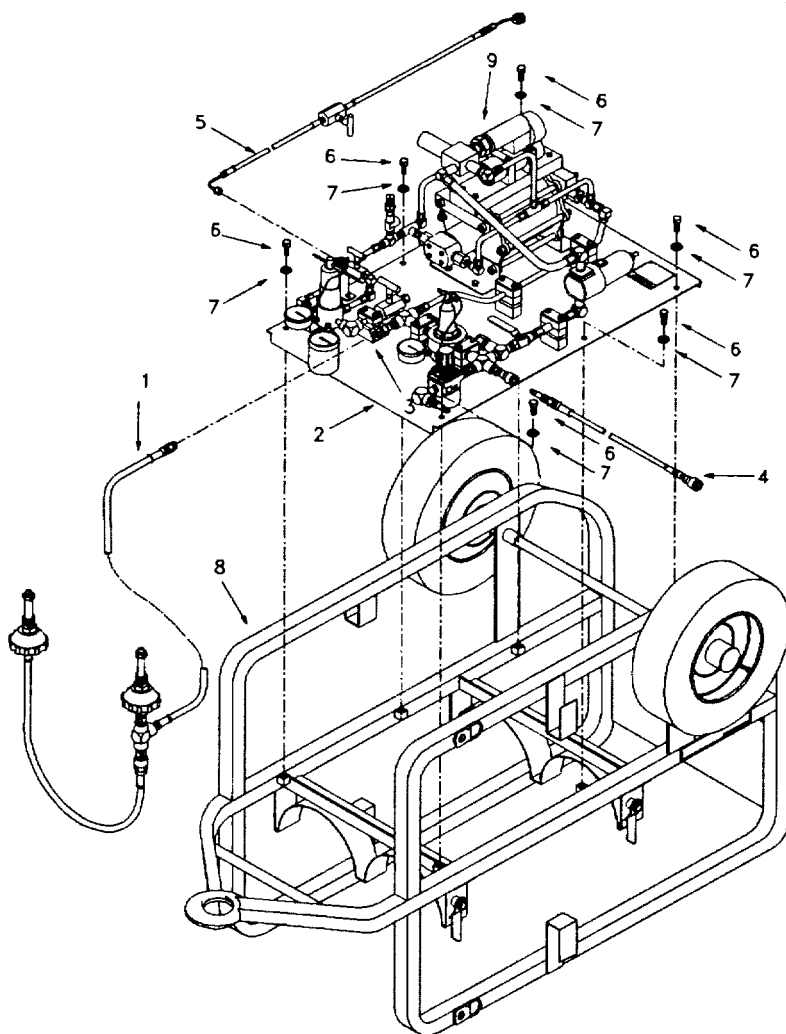

GO TO NEXT PAGE

3-15.1. REMOVAL

WARNING

The booster panel assembly weighs approximately 100 lb. This requires a two man lift to remove from the cart chassis. Protect the hands from being pinched with gloves.

CAUTION

When removing or tightening a fitting to the high pressure filter, hold the filter body hex with a wrench adjacent the fitting. Tightening the filter across its body may stress the filter housing and cause leaks to develop. Extreme caution should be used to prevent contaminants such as old Teflon tape, sealant, dirt or any other matter from falling into the tubing going to the booster pump. This will cause booster pump failure.

- a. Disconnect the Tank Connector Assembly (1) from the Booster Panel Assembly (2) at the High Pressure Filter (3).
- b. Disconnect the Tire Filling Hose (4) at the quick disconnect fitting and the High Pressure Hose Assembly (5) at the swivel fitting. Remove both hoses from the chassis.
- c. Remove the six bolts (6) and lock washers (7) that hold the Booster Panel Assembly (2) to the cart (8)
- d. Carefully lift the Booster Panel Assembly (2), tilting it sideways with the booster pump (9) side first until the panel assembly components clear the chassis (8).

3-15.2. INSTALLATION

- a. Carefully lower the Booster Panel Assembly (2) between the frame rails, tilting it so that the booster pump (9) side of the panel is lowered last. Align the panel assembly holes against the chassis mounting nut holes. Secure the panel to the chassis by inserting the mounting bolts (6) through lock washers (7) and into the six panel through holes and tightening the bolts.
- b. Remove old Teflon tape or sealant from the pipe threads of the Tank Connector Assembly (1) at the High Pressure Filter (3) while observing the caution above. Apply Teflon tape (D1) or sealant (D2) on the pipe threads. Install and tighten the Tank Connector Assembly (1) at the High Pressure Filter (3).
- c. Connect the Tire Filling Hose (4) at the quick disconnect and the High Pressure Hose Assembly (5).
- d. Perform leak check and confidence test procedure per paragraph 2-8.

END OF TASK

3-16. LOW PRESSURE AND SHOP AIR REGULATOR - REPLACE

THIS TASK COVERS: REMOVAL AND INSTALLATION

Personnel Required: 67 Series

Tools/Test and Support Equipment: Tool Kit, SC 5180-99-A01, NSN 5180-00-323-4692
 Pipe Wrench, NSN 5120-00-277-1485
 Workbench, vise

Material/parts: Low Press. Reg., SR700E-500-VIC-0797-0233
 Shop Air Reg., NAR2500-NO2
 Teflon Tape (D1) or Perma Lok LM012 (D2)

Equipment Conditions: Shop air disconnected. Cart depressurized and shutdown per paragraph. 2-7. Nitrogen tanks and accessory hoses disconnected and removed.

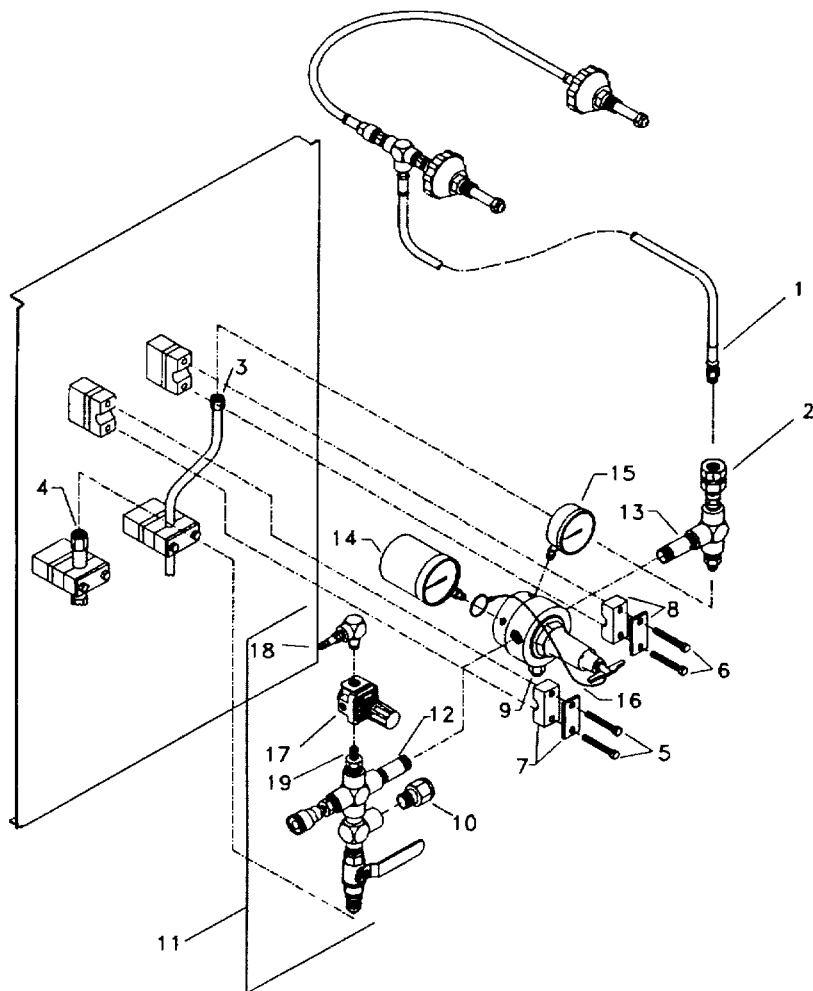

GO TO NEXT PAGE

3-16.1. REMOVAL

WARNING

Remove or disconnect nitrogen tanks before maintenance. Never disconnect a pressurized line.

CAUTION

When removing or tightening a fitting to the high pressure filter, hold the filter body hex with a wrench adjacent the fitting. Tightening the filter across its body may stress the filter housing and cause leaks to develop. Extreme caution should be used to prevent contaminants such as old Teflon tape, sealant, dirt or any other matter from falling into the tubing going to the booster pump. This will cause booster pump failure.

- a. Remove the Tank Connector Assembly (1) at the High Pressure Filter (2). Loosen tubing flare nuts at (3) and (4).
- b. Remove bolts (5) and (6) and the tube clamp assemblies (7) and (8). Disconnect the flare fittings at (3) and (4) and remove the regulator assembly.

NOTE

To remove the shop air regulator (17) only, go to step g; otherwise, proceed.

- c. With the regulator (9) mounted by the rear forged hex (part of the valve body) in a vise with non-marring jaws, remove low pressure relief valve (10). Remove the assembly (11) using a pipe wrench on the nipple (12) using care not to damage threads.
- d. Remove the tee subassembly with the High Pressure Filter (2) using a pipe wrench on nipple (13) using care not to damage threads.
- e. Remove the gauges (14) and (15) from the regulator assembly using open ended wrenches.
- f. Remove retaining wire (16) from the regulator (9) T- handle. Expand the eyelets of the retainer on the T-handle with a pair of needle nose pliers so that the wire loop can be removed from the retainer; then slip the retainer off the T-handle. This completes the removal of the low pressure regulator.
- g. To remove the shop air regulator (17), mount the assembly (11) in a non-marring vise by the T-and using a adjustable wrench, remove the quick disconnect assembly (18) by the elbow.
- h. Unscrew the shop air regulator (17) from the check valve (19).

3-16.2. INSTALLATION

- a. If the shop air regulator (17) was removed, assemble using Teflon tape (D1) or sealant (D2) but do not tighten the quick disconnect assembly (18) to the shop air regulator (17). Assemble this subassembly to the pipe threads of check valve (19) using Teflon tape (D1) or sealant (D2).

GO TO NEXT PAGE

- b. Mount the entire assembly (11) in a non-marring vise. Using an adjustable wrench, tighten and orient the quick disconnect assembly (18) and the shop air regulator (17) in the correct orientation. Using Teflon tape (D1) or sealant (D2) install low pressure relief valve (10). This reassembles the shop air regulator assembly (11).
- c. Mount the low pressure regulator (9) by the rear forged hex (part of the valve body) in a vise with non-marring jaws. Slip the end of retaining wire (16) with the large loop over the stem of gauge (14). Using Teflon tape (D1) or sealant (D2), install gauges (14) and (15) onto the regulator (9) using open end wrenches.
- d. Expand the eyelets of the small loop retainer of retainer wire (16) with a pair of needle nose pliers. Place the smaller loop retainer over the channel of the low pressure regulator (9) T-handle. Loop the wire loop over the eyelets of the retainer; then close the eyelets with a pair of needle nose pliers.
- e. Install the T-assembly with the High Pressure Filter (2) onto regulator (9) pipe fittings using Teflon tape (D1) or sealant (D2). Spin, tighten and orient the assembly (11) on the low pressure regulator (9) . Using Teflon tape (D1) or sealant (D2) install low pressure relief valve (10).
- f. Secure this assembly to the booster panel by using tube clamp assemblies (7) and (8) and bolts (5) and (6).
- g. Tighten the flare fittings of tubing assemblies (3) and (4). Install Tank Connector Assembly (1) to High Pressure Filter (2) h. Perform leak check and confidence test procedure per paragraph 2-8.

END OF TASK

3-16/(3-17 blank)

3-17. HIGH PRESSURE REGULATOR - REPLACE

THIS TASK COVERS: REMOVAL AND INSTALLATION

Personnel Required: 67 Series

Tools/Test and Support Equipment: Tool Kit, SC 5180-99-A01, NSN 5180-00-323-4692
Pipe Wrench, NSN 5120-00-277-1485
Workbench and Vise

Material/parts: High Press. Reg., SR4K-250-VIC-0797-0232
Teflon tape (D1) or Perma Lok LM012 (D2)

Equipment Conditions: Shop air disconnected. Cart depressurized and shutdown per paragraph. 2-7. Nitrogen tanks and accessory hoses disconnected and removed.

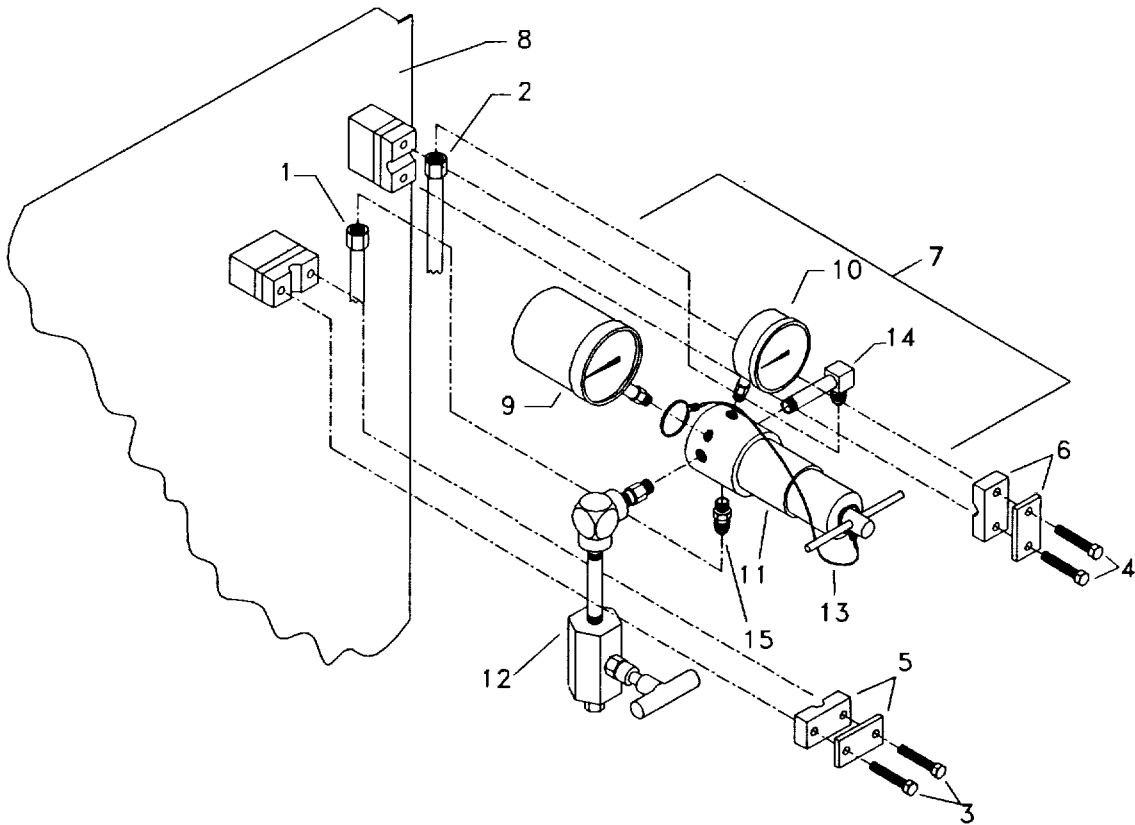

3-17.1. REMOVAL

WARNING

Remove or disconnect nitrogen tanks before maintenance. Never disconnect a pressurized line.

GO TO NEXT PAGE

- a. Loosen flare nuts (1) and (2).
- b. Remove bolts (3), (4) and the tube clamp assemblies (5), (6). Remove the high pressure regulator assembly (7) from booster panel (8).
- c. Remove gauges (9) and (10) from the regulator (11). Remove the subassembly (12) from the regulator (11). The body of the regulator (11) may be clamped in a non-marring vise lengthwise to remove fittings.
- d. Remove retaining wire (13) from the regulator (11) T-handle as follows. Expand the eyelets of the retainer on the T-handle with a pair of needle nose pliers so that the wire loop can be removed from the retainer; then slip the retainer off the T-handle.
- e. Remove elbow (14) and fitting (15).

3-17.2. INSTALLATION

- a. Using Teflon tape (D1) or sealant (D2) for pipe threads, install subassembly (12), elbow (14) and fitting (15) onto the body of the high pressure regulator (11).
- b. Expand the eyelets of the small loop retainer of retainer wire (13) with a pair of needle nose pliers. Place the smaller loop retainer over the channel of the regulator (11) T-handle. Loop the wire loop over the eyelets of the retainer; then close the eyelets with a pair of needle nose pliers.
- c. Slip one end of retaining wire (13) over the stem of gauge (9). Using Teflon tape (D1) or sealant (D2), assemble gauges (9) and (10) to the body of the regulator (11).
- d. Secure the regulator assembly to the booster panel with tube clamps (5) and (6) and bolts (3) and (4) while aligning the flare fittings at (1) and (2). Tighten the flare nuts (1) and (2).
- e. Perform leak check and confidence check procedure per paragraph 2-8.

END OF TASK

3-18. HIGH PRESSURE RELIEF VALVE - REPLACE

THIS TASK COVERS: REMOVAL AND INSTALLATION

- Personnel Required:** 67 Series
- Tools/Test and Support Equipment:** Tool Kit, SC 5180-99-A01, NSN 5180-00-323-4692
Adjustable Wrench, NSN 5120-00-264-3796
- Material/parts:** High Press. Relief Valve, RV54-1
Teflon tape (D1) or Perma Lok LM012 (D2)
- Equipment Conditions:** Shop air disconnected. Cart depressurized and shutdown per paragraph. 2-7.

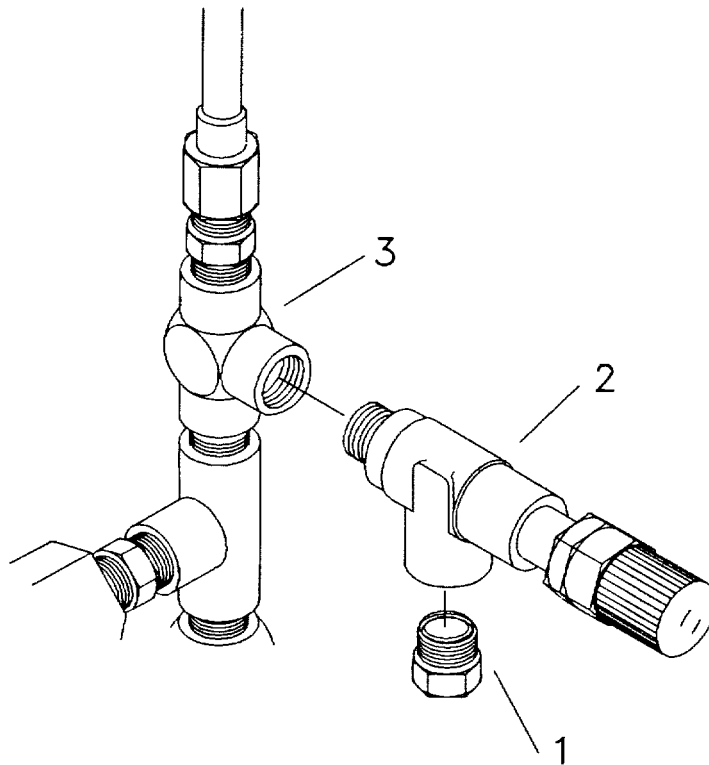

GO TO NEXT PAGE

3-18.1. REMOVAL.

WARNING

Remove or disconnect nitrogen tanks before maintenance. Never disconnect a pressurized line. Depressurize and shut down the system per paragraph 2-7.

- a. Remove vent breather (1) using an open end wrench.
- b. Grip the body of the high pressure relief valve (2) with an adjustable wrench. Turn body counterclockwise so that the pipe threads back out of fitting (3).

3-18.2. INSTALLATION

- a. Using Teflon tape (D1) or sealant (D2), install the high pressure relief valve (2) by gripping the body of the valve with an adjustable wrench and turning clockwise until seated in fitting (3).
- b. Install vent breather (1) using the open end wrench.

END OF TASK

3-19. LOW PRESSURE FILTER - REPLACE

THIS TASK COVERS: REMOVAL AND INSTALLATION

Personnel Required: 67 Series

Tools/Test and Support Equipment: Tool Kit, SC 5180-99-A01, NSN 5180-00-323-4692
 Pipe Wrench, NSN 5120-00-277-1485
 Work Bench, vise

Material/parts: Low Pressure Filter, F26-04-FMO
 Teflon tape (D1) or Perma Lok LM012 (D2)

Equipment Conditions: Shop air disconnected. Cart depressurized and shutdown per paragraph. 2-7.

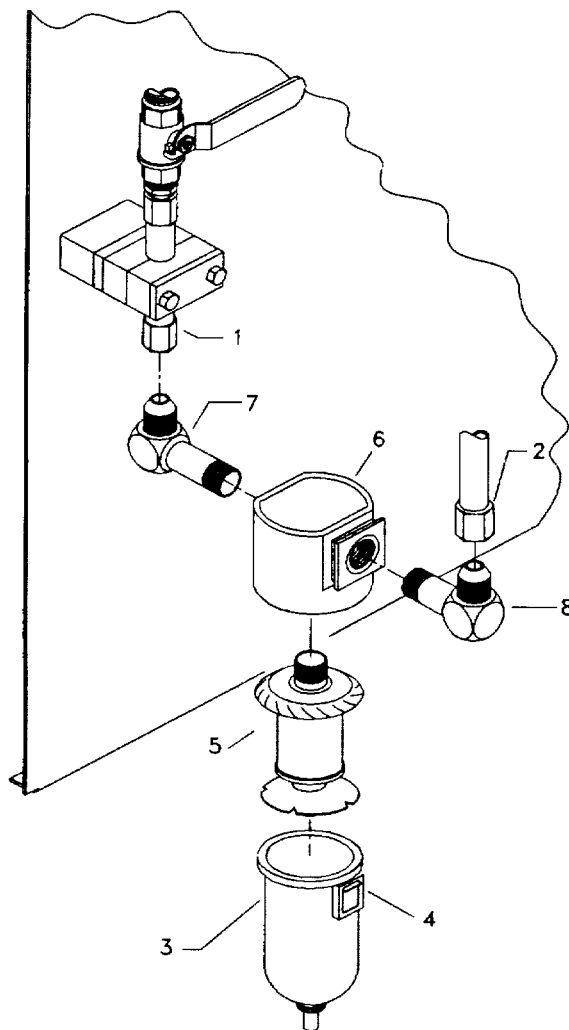

GO TO NEXT PAGE

3-19.1. REMOVAL**WARNING**

Remove or disconnect nitrogen tanks before maintenance. Never disconnect a pressurized line.

- a. Loosen and disconnect the flare fittings at the elbows (1) and (2).
- b. Remove bowl (3) by sliding latch (4) down and rotating bowl. Discard the bowl. Unscrew the filter element (5) and discard. This permits the top of the filter housing (6) to be secured in a vise.
- c. Remove both elbows (7) and (8).

3-19.2. INSTALLATION

- a. Disassemble the new filter by depressing sliding latch (4) and turning the bowl (3). Remove the bowl (3). Remove the filter element (5) by unscrewing it. Secure the top of the filter housing (6) in a bench vise by clamping its top and bottom.
- b. Install elbows (7) and (8) in the top of the filter housing (6) with Teflon tape (D1) or sealant (D2). Position the elbows so that the flare ports are vertically pointing upward as illustrated.
- c. Mount this assembly to the flare fittings of (1) elbow and tubing (2). Tighten the flare nuts.
- d. Install the filter element (5) and assemble the bowl (3) to the top of the filter housing (6) by turning the bowl (3) until latch (4) clicks.
- e. Perform leak check and confidence test procedure per paragraph 2-8.

END OF TASK

3-20. HIGH PRESSURE SHUTOFF VALVE - REPLACE

THIS TASK COVERS: REMOVAL AND INSTALLATION

Personnel Required: 67 Series

Tools/Test and Support Equipment: Tool Kit, SC 5180-99-A01, NSN 5180-00-323-4692

Material/parts: High Press. Shutoff Valve, 9698935
Teflon tape (D1) or Perma Lok LM012 (D2)

Equipment Conditions: Shop air disconnected. Cart depressurized and shutdown per paragraph. 2-7.

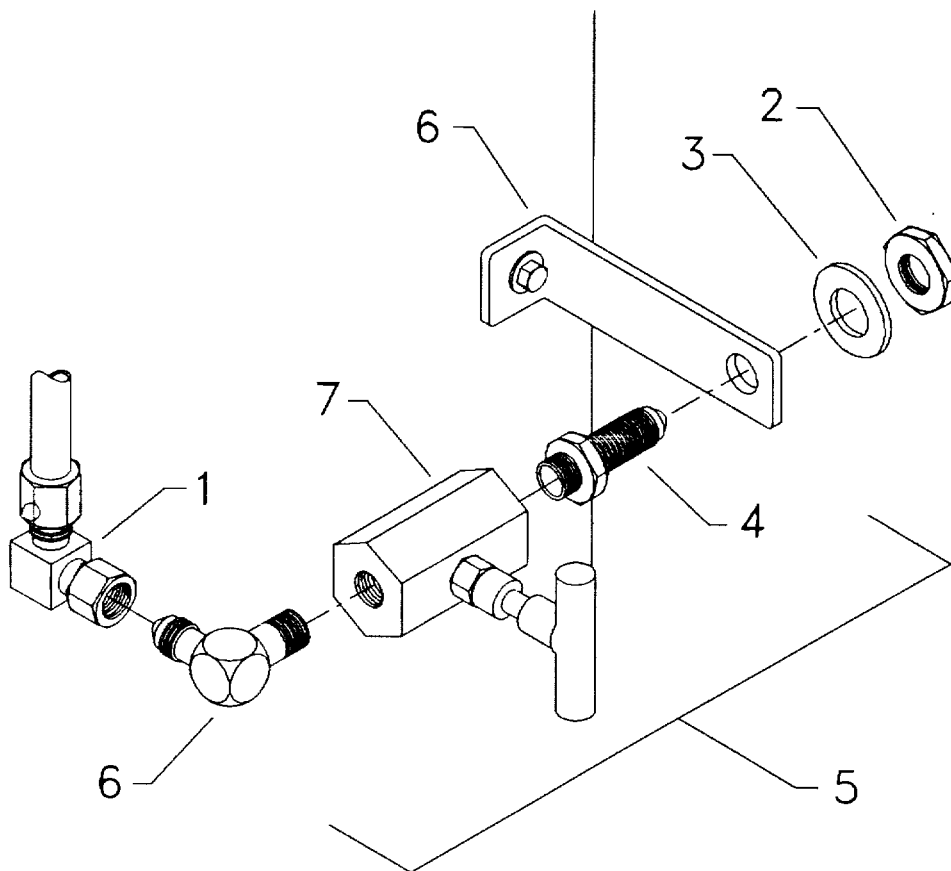

GO TO NEXT PAGE

3-20.1. REMOVAL

WARNING

Remove or disconnect nitrogen tanks before maintenance. Never disconnect a pressurized line.

- a. Loosen fitting on elbow (1).
- b. Remove nut (2) and washer (3) from hose fitting (4).
- c. Remove valve assembly (5) by disconnecting assembly from elbow (1) and mounting bracket (6).
- d. Remove hose fitting (4) and elbow (6) from the body of the high pressure shutoff valve (7).

3-20.2. INSTALLATION

- a. Using Teflon tape (D1) or sealant (D2), install hose fitting (4) and elbow (6) into the body of the high pressure shutoff valve (7).
- b. Position the assembly in the hole of mounting bracket (6) and loosely secure with nut (2).
- c. Mount the assembly by elbow (6) and tighten the flare nut on elbow (1).
- d. Tighten the nut (2) to secure the assembly to the mounting bracket (6).
- e. Perform leak check and confidence test procedure per paragraph 2-8.

END OF TASK

3-21. TUBE ASSEMBLIES - REPLACE; (TYPICAL) PA009 THROUGH PA013

THIS TASK COVERS: TYPICAL REMOVAL AND INSTALLATION, PA011 SHOWN

- Personnel Required:** 67 Series
- Tools/Test and Support Equipment:** Tool Kit, SC 5180-99-A01, NSN 5180-00-323-4692
- Material/parts:** Tube assemblies: PA009, PA010, PA011, PA012, PA013 (as required)
- Equipment Conditions:** Shop air disconnected. Cart depressurized and shutdown per paragraph. 2-7.

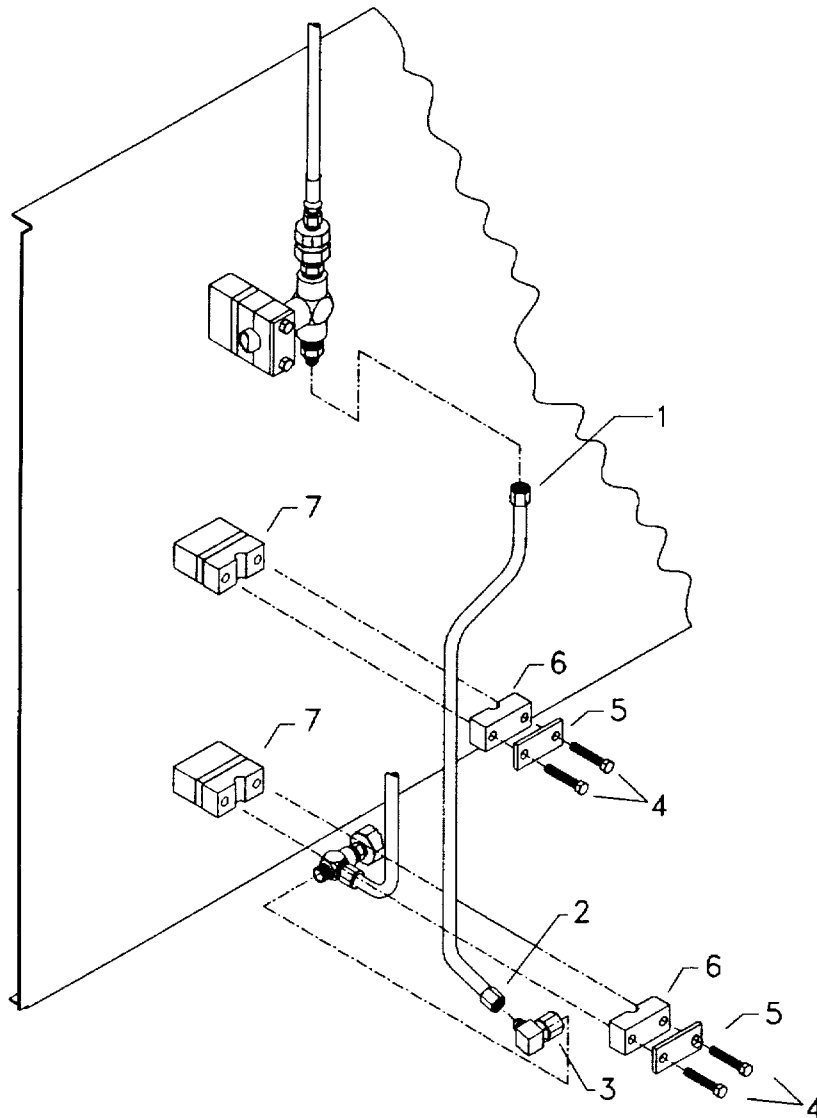

GO TO NEXT PAGE

3-21.1. REMOVAL

WARNING

Remove or disconnect nitrogen tanks before maintenance. Never disconnect a pressurized line.

- a. Loosen flare nuts (1) and (2) and fittings (3) at both ends of the tubing assembly so it can be removed.
- b. If clamp assemblies are used to secure tubing, remove bolts (4) and clamp assemblies consisting of clamp cover (5) and tube cushion (6) to permit removal of the tubing assembly.

3-21.2. INSTALLATION

- a. Position tubing assembly with flare nuts (1) and (2) loosely tightened to its mating fittings.
- b. Secure tubing assembly to the Booster Panel by sandwiching the tubing between tube cushions (6) and (7) and securing with clamp cover (5) and bolts (4).
- c. Tighten flare nuts (1) and (2) securely.
- d. Perform leak check and confidence test procedure per paragraph 2-8.

END OF TASK

3-22. BOOSTER PUMP - REPLACE

THIS TASK COVERS: REMOVAL AND INSTALLATION

Personnel Required: 67 Series

Tools/Test and Support Equipment: Tool Kit, SC 5180-99-A01, NSN 5180-00-323-4692

Material/parts: Booster Pump, 93639-11
 Teflon tape (D1) or Perma Lok LM012 (D2)
 Thread lock fluid, Loctite 241 (D3)

Equipment Conditions: Shop air disconnected. Cart depressurized and shutdown per paragraph. 2-7. Place cart in horizontal position with booster pump on top.

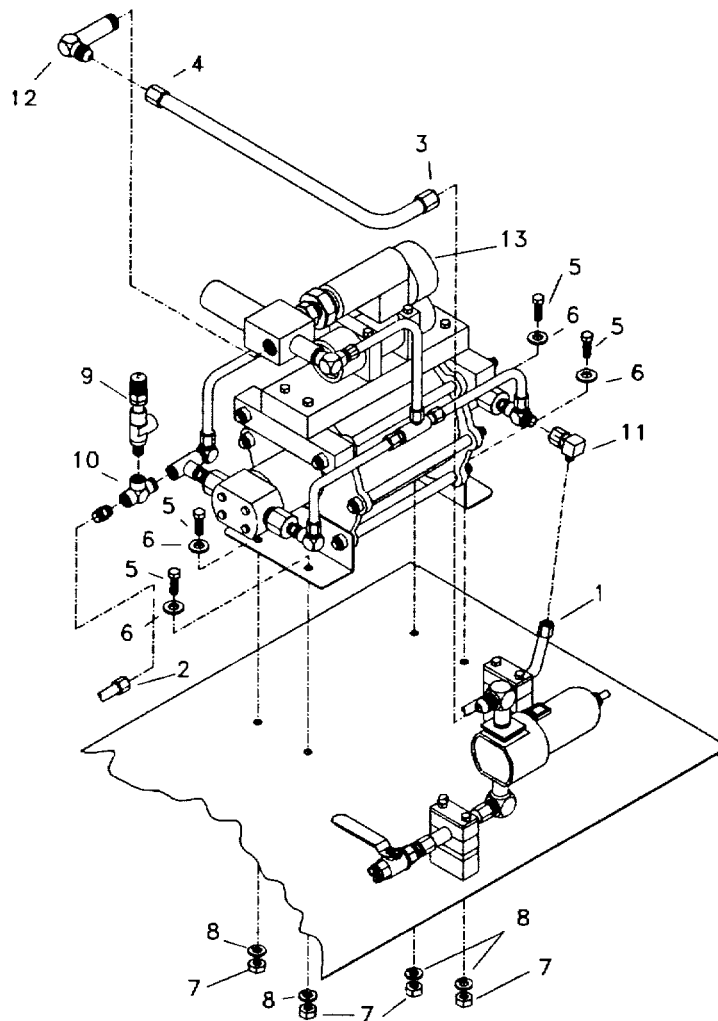

GO TO NEXT PAGE

3-22.1. REMOVAL**WARNING**

Remove or disconnect nitrogen tanks before maintenance. Never disconnect a pressurized line.

- a. Loosen and disconnect the flare fittings in the supply and output lines at (1) and (2). Loosen and disconnect the flare fittings in the pressure sense line to the air pilot valve at (3) and (4).
- b. Loosen and remove bolts (5), flat washer (6), nuts (7) and lock washers (8) at four places. The booster pump can then be removed from the booster panel.
- c. Remove high pressure relief valve (9) and T fitting (10) assembly with an adjustable wrench. Remove the elbows (11) and (12) from the booster pump (13).

3-22.2. INSTALLATION

- a. Install elbow fitting (11) on the booster pump (13) but do not tighten the flare fitting yet. Using Teflon tape (D1) or sealant (D2), install elbow fitting (12) and T fitting (10) on the booster pump (13) and orient as shown in the illustration..
- b. Using Teflon tape (D1) or sealant (D2), install high pressure relief valve (9) to T fitting (10) and orient as shown in the illustration.
- c. Mount booster pump to booster panel using four each of bolt (5), flat washer (6), nut (7) and lock washers (8). Apply a drop of thread lock fluid (D3) to the mounting bolts (5) before assembling nuts (7).
- d. Connect supply and output line flare fittings (1) and (2) and tighten. Tighten the flare nuts of elbow fitting (11). Reconnect the flare fittings in the pressure sense line to the air pilot valve at (3) and (4).
- e. Perform leak check and confidence test procedure per paragraph 2-8.

END OF TASK

3-23. WHEEL ASSEMBLY - REPLACE AND REPAIR

THIS TASK COVERS: REMOVAL AND INSTALLATION

Personnel Required: 67 Series

Tools/Test and Support Equipment: Tool Kit, SC 5180-99-A01, NSN 5180-00-323-4692
 Shop Set, SC 4920-99-890
 1-1/2 in. Adj. Wrench, NSN 5120-00-264-3796
 Brush, Wood Block

Material/parts: Wheel and tire assy, CA053
 Thread lock fluid, Loctite 241 (D3)
 Lithium Bearing Grease (D4)
 Kerosene (D5), Shop Towels (D6)

Equipment Conditions: Any position except towing position

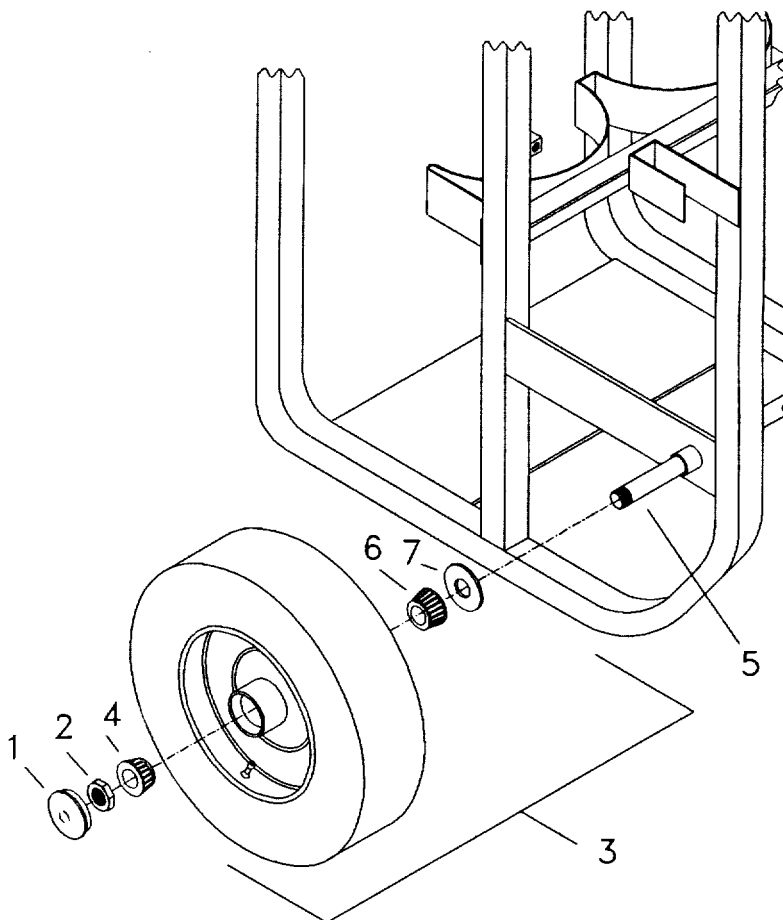

GO TO NEXT PAGE

REMOVAL:

- a. Pull off the dust cap (1). With an adjustable wrench, remove jam-nut (2).
- b. Pull wheel assembly (3) part way out and note that the outer bearing (4) is loose. Remove this bearing and wrap in a shop towel (D6) to prevent the contamination of wheel bearing grease.
- c. Then remove the wheel assembly (3) entirely from the axle spindle (5). The inner bearing (6) is retained by the grease seal (7).
- d. The wheel bearings (4) and (6) require periodic maintenance depending on severity of use. Remove the inner bearing (6) by removing and discarding the grease seal (7).

INSTALLATION:**CAUTION**

Make sure grease, seals and bearings are in good condition before reassembly.

- a. Clean the wheel bearings (4) and (6) of old grease using kerosene (D5) and kerosene soaked brush. Dry wheel bearings with shop towels and repack the wheel bearings with lithium based grease (D4).
- b. Lay the wheel and tire assembly flat on the ground with the inner hub facing up. Reassemble inner wheel bearing (6) by placing it into wheel hub and securing it with a new grease seal (6). Tap the grease seal (6) into the wheel hub using a block of wood and a hammer. Position the block of wood over the seal so that tapping with the hammer does not deform the seal.
- c. Check the tire pressures. They should be inflated to 60 psi. Align the cart spindle (5) with the grease seal (7) and inner wheel bearing (6) in the wheel assembly (3) before pushing it over the spindle (5).
- d. Insert the outer wheel bearing (4) into the wheel hub and over the spindle. Clean the grease from the threads.
- e. Place two drops of thread lock fluid on the spindle threads. Hand tighten the jam-nut (2) against the wheel bearing (4). Tighten jam-nut (2) with an adjustable wrench an additional 1/4 to 1/2 of a flat.
- f. Place dust cap (1) over the wheel hub of the wheel assembly (3).

END OF TASK

3-24. TANK RETENTION STRAP ASSEMBLY - REPLACE

THIS TASK COVERS: REMOVAL AND INSTALLATION

- Personnel Required:** 67 Series
- Tools/Test and Support Equipment:** Tool Kit, SC 5180-99-A01, NSN 5180-00-323-4692
- Material/parts:** Tank Retention Strap Assy, CA050
- Equipment Conditions:** Shop air disconnected. Cart depressurized and shutdown per paragraph. 2-7.

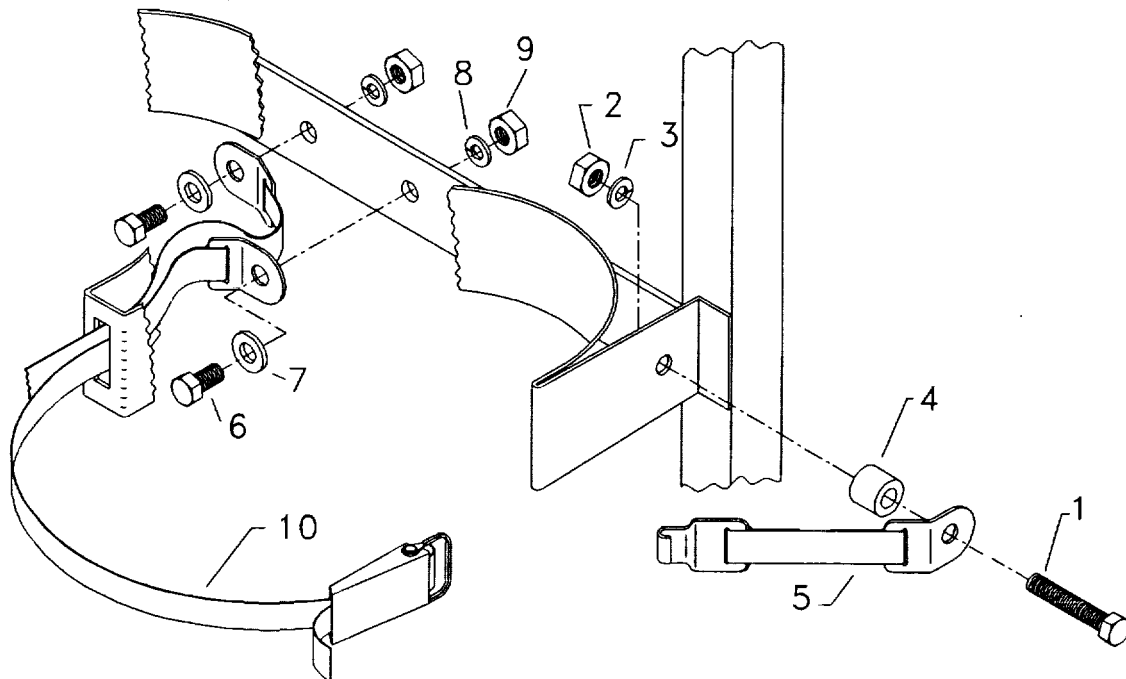

3-24.1. REMOVAL

- a. Loosen bolt (1) and remove nut (2), lock washer (3), strap mounting spacer (4) and strap (5).
- b. Loosen bolt (6) and remove washer (7), lock washer (8), nut (9) and strap (10).

3-24.2. INSTALLATION

- a. Install straps (5) and (10) ensuring the mating buckle end pieces are properly oriented and that the mounting bracket of both straps (5), (10) are properly positioned as shown.

GO TO NEXT PAGE

- b. Install bolt (1) through strap (5) mounting bracket, spacer (4) through the chassis with lock washer (3) and nut (2).
- c. Install bolt (6) through strap (10) mounting bracket, through the chassis with lock washer (8) and nut (9).

END OF TASK

3-25. TANK CONNECTOR ASSEMBLY AND HIGH PRESSURE FILTER - INSPECT AND REPLACE

THIS TASK COVERS: REMOVAL, INSPECTION OF THE FILTERS AND INSTALLATION

- Personnel Required:** 67 Series
- Tools/Test and Support Equipment:** Tool Kit, SC 5180-99-A01, NSN 5180-00-323-4692
- Material/parts:** Tank Connector Assy, HA003
High Pressure Filter, 4205T-3PP
Teflon tape (D1) or Perma Lok LM012 (D2)
- Equipment Conditions:** Shop air disconnected. Cart depressurized and shutdown per paragraph. 2-7.

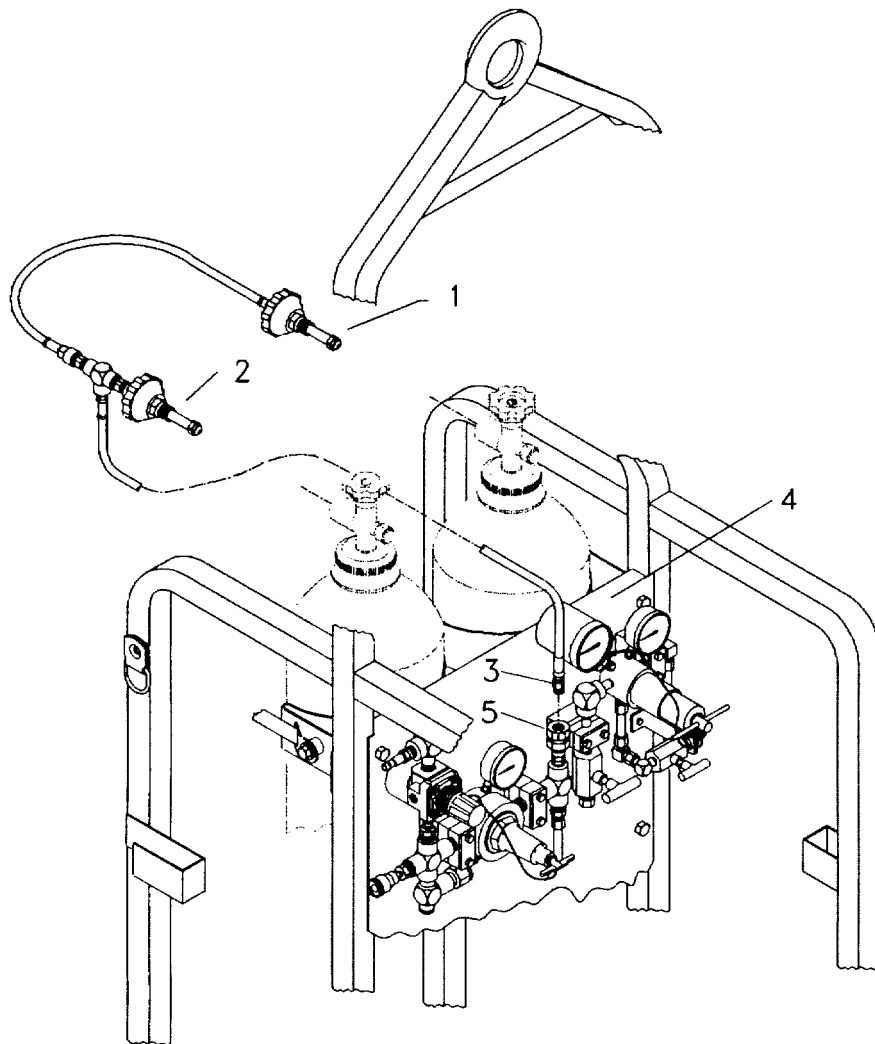

GO TO NEXT PAGE

3-25.1. REMOVAL**WARNING**

Remove or disconnect nitrogen tanks before maintenance. Never disconnect a pressurized line.

CAUTION

When removing or tightening a fitting to the high pressure filter, hold the filter body hex with a wrench adjacent the fitting. Tightening the filter across its body may stress the filter housing and cause leaks to develop. Extreme caution should be used to prevent contaminants such as old Teflon tape, sealant, dirt or any other matter from falling into the tubing going to the booster pump. This will cause booster pump failure.

- a. Verify that the valves on both nitrogen supply tanks are shut off. Remove both connectors (1) and (2) of the tank connector assembly (3) from the nitrogen supply tanks. Use the filter body hex adjacent the fitting for loosening.
- b. Disconnect the tank connector assembly (3) from the booster panel (4) at the high pressure filter (5) by loosening the fitting and removing the entire assembly.
- c. Remove the high pressure filter (5) with a wrench and observing the caution regarding the use of the hex on the filter adjacent the fitting.

3-25.2. FILTER INSPECTION PROCEDURE After removing high pressure filter (5), tap the inlet end on a solid surface. If any particles or contaminants are visible, replace the filter with a new one.

3-25.3. INSTALLATION

- a. Using Teflon tape (D1) or sealant (D2), install high pressure filter (5) while observing the caution note. The direction of the arrow on the filter MUST be pointed toward the booster pump. Using Teflon tape (D1) or sealant (D2), install the tank connector assembly (3) to the high pressure filter (5). Use the filter body hex adjacent the fitting for tightening.
- b. Connect the two tank connectors (1) and (2) to the nitrogen supply tanks.
- c. Perform leak check and confidence test procedure per paragraph 2-8.

END OF TASK

3-26. TANK CONNECTOR ASSEMBLY - INSPECT FILTERS, REPLACING COMPONENTS

THIS TASK COVERS: REMOVAL AND INSTALLATION OF NIPPLES, HOSES AND FITTINGS AND INSPECTION OF THE IN-LINE FILTERS.

Personnel Required:

67 Series

Tools/Test and Support Equipment:

Tool Kit, SC 5180-99-A01, NSN 5180-00-323-4692
 Six point socket, 11/16 inch x 3/8 sq. drive,
 NSN 5120-01-335-0320
 Vise

Material/parts:

Refer to RPSTL for component part numbers
 Teflon tape (D1) or Perma Lok LM012 (D2)

Equipment Conditions:

Shop air disconnected. Cart depressurized and shutdown per paragraph. 2-7.

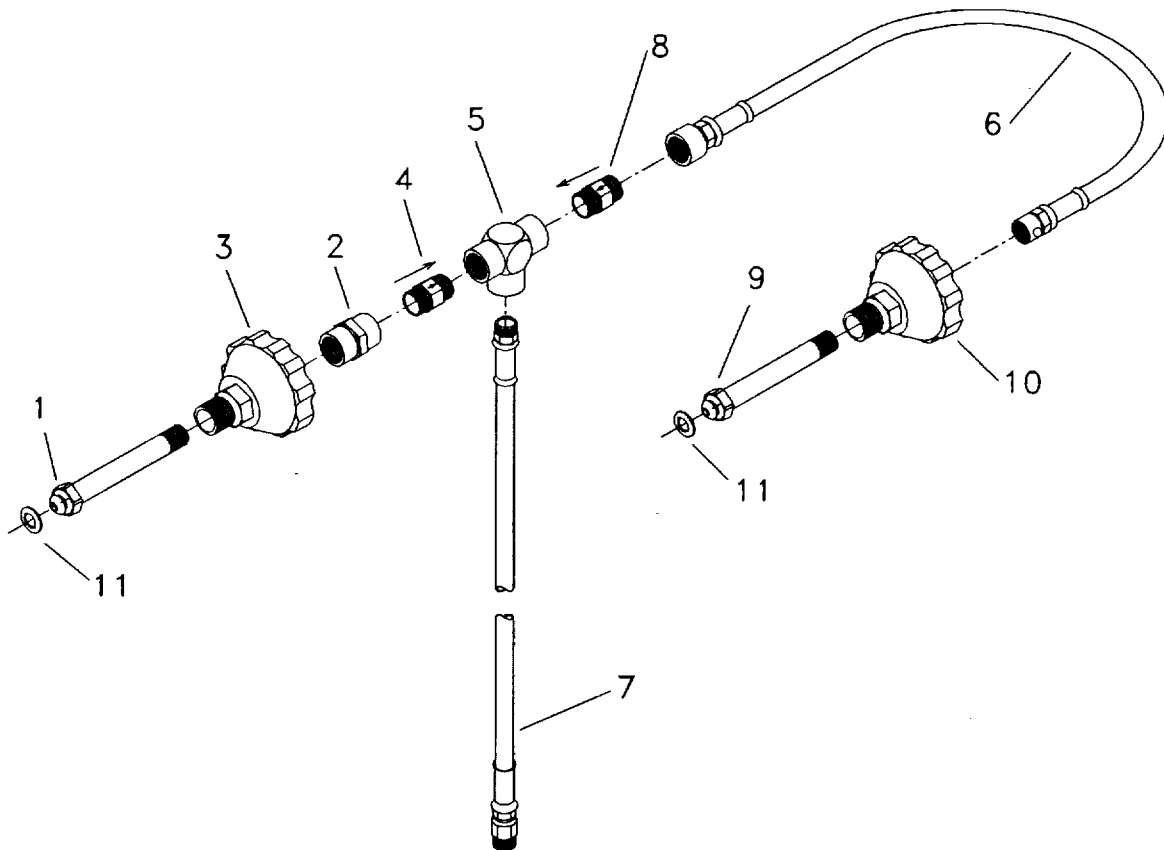

GO TO NEXT PAGE

3-26.1. REMOVAL

To remove a component of the tank connector assembly, use the following disassembly procedures.

WARNING

Remove or disconnect nitrogen tanks before maintenance. Never disconnect a pressurized line.

WARNING

Check the direction of the arrow stamped on the check valve. An incorrectly installed check valve may cause the connector hose to whip violently when used with only one tank of nitrogen and possibly cause serious injury to the operator.

CAUTION

Use only a 6 point 11/16 inch socket to remove the nipple connector of the tank connector assembly. An open end wrench or 12 point socket will deform and damage this part.

NOTE

Carefully remove old Teflon tape or sealant. Do not allow Teflon tape or dried sealant particles to fall into the components.

- a. Place a ratchet wrench with a 6 point, 11/16 inch socket over the nipple connector (1) and turn it counter clockwise while holding the reducing pipe coupling (2) with an adjustable wrench on its hex.
- b. Remove hand nut (3). Remove coupling (2) from check valve (4) by using a box wrench and an adjustable wrench on the hexes.
- c. Remove check valve (4) from pipe tee (5) by gripping pipe tee (5) in a non-marring vise.
- d. The tank hose assembly (6) and panel hose assembly (7) may be removed. Use a wrench to disconnect the hose fittings from the tee. Remove check valve (8).
- e. Place a ratchet wrench with a 6 point, 11/16 inch socket over the nipple (9) and turn it counterclockwise while holding the fitting of the tank hose assembly (6) with a wrench on the fitting hex.
- f. Remove hand nut (10). Remove O-rings (11).

GO TO NEXT PAGE

3-26.2. FILTER INSPECTION PROCEDURE Connectors (1) and (9) have a porous bronze filter on the threaded end. After removing the connector inlets (1) and (9), tap the inlet's O-ring end on a solid surface. If any particles or contaminants are visible, replace the inlets with a new one.

3-26.3. INSTALLATION

- a. Slip hand nut (10) over nipple connector (9) in the orientation as shown. Apply Teflon tape (D1) or sealant (D2) to the threaded end of the nipple connector (9). Place a ratchet wrench with a 6 point, 11/16 inch socket over the nipple connector (9) and turn it clockwise while holding the fitting of the tank hose assembly (6) with a wrench on its hex.
- b. Slip hand nut (3) over nipple connector (1) in the orientation as shown. Apply Teflon tape (D1) or sealant (D2) to the threaded end of the nipple connector (1). Place a ratchet wrench with a 6 point, 11/16 inch socket over the nipple connector (1) and turn it clockwise while holding the reducing pipe coupling (2) with a wrench on the fitting hex.
- c. Grip pipe tee (5) in a non-marring vise and, using Teflon tape (D1) or sealant (D2), assemble check valve (4) along with items (1) through (3) as shown by using a wrench on the hex of reducing pipe coupling (2).
- d. Using Teflon tape (D1) or sealant (D2), connect the tank hose assembly (6) and panel hose assembly (7) end fittings to the pipe tee (5).
- e. Using your fingers, roll the O-rings (11) over the nipple connectors (1) and (9) until they are retained by the groove on the inlet.
- f. Perform leak check and confidence test procedure per paragraph 2-8.

END OF TASK

3-27. HIGH PRESSURE CHARGING HOSE - REPAIR

- Personnel Required:** 67 Series
- Tools/Test and Support Equipment:** Tool Kit, SC 5180-99-A01, NSN 5180-00-323-4692
- Material/parts:** Washer, 2755-26
Refer to RPSTL for other part numbers
Teflon tape (D1) or Perma Lok LM012 (D2)
- Equipment Conditions:** High Pressure Charging Hose disconnected from cart.

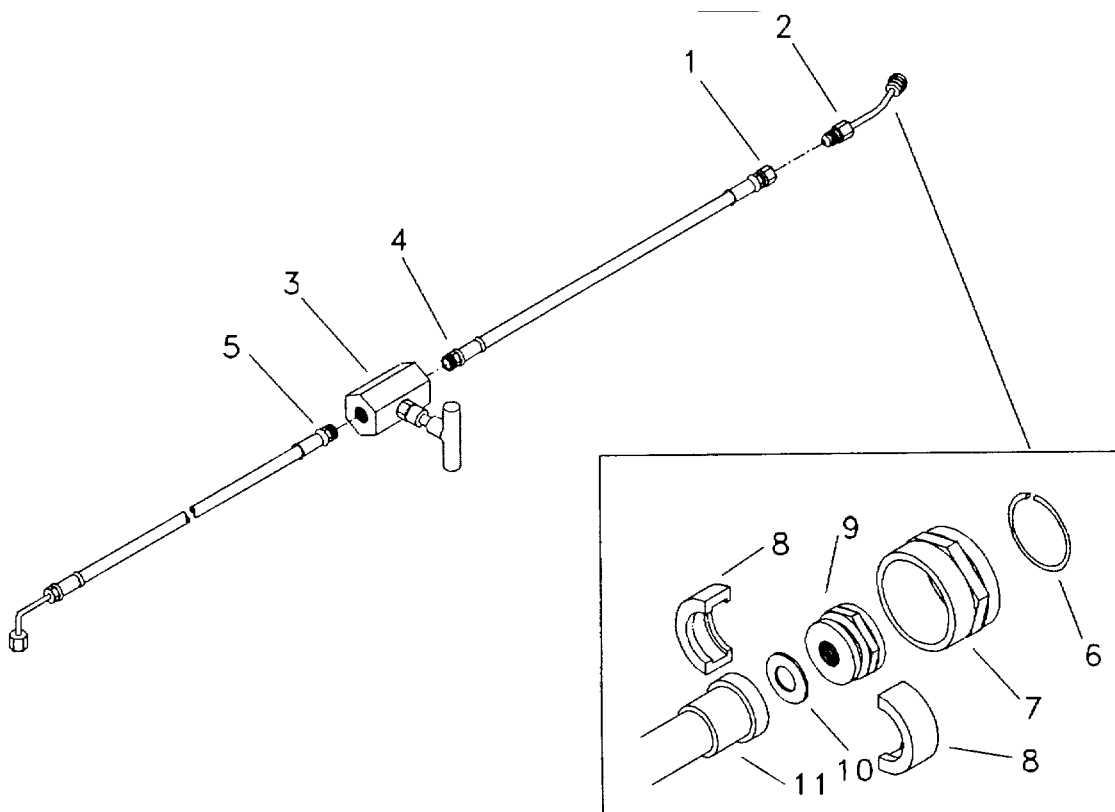

CAUTION

Do not exceed 30 inch pounds of torque when connecting high pressure inflation chuck to any charging fitting.

NOTE

A replacement copper washer is available to replace the fiber washer. Its part number is found in the RPSTL, Appendix C.

GO TO NEXT PAGE

3-27.1. REMOVAL

- a. Using two wrenches, one at the whip hose fitting (1) and one at the hex of the inflating chuck (2), remove the inflating chuck (2) from the hose fitting.
- b. Using an adjustable wrench to hold the body of the high pressure shutoff valve (3) and an open end wrench on the end fitting of the whip hose (4), remove the whip hose.
- c. Remove the high pressure hose (5) by using an open end wrench on the end fitting.

3-27.2. WASHER INSPECTION AND REPLACEMENT (see inset illustration)

- a. Remove snap ring (6) with a small, flat blade screw driver. Lift the hex shell (7) off.
- b. Remove collet halves (8). Remove the threaded washer housing (9) that holds the washer (10) against the chuck body (11).
- c. Inspect the washer (10) for nicks and wear. Replace the washer (10) if necessary.
- d. Reassemble by placing the washer (10) between the threaded washer housing (9) and the chuck body (11).
- e. Install the two collet halves (8). Slip the hex shell (7) over the collet halves (8) and secure with the snap ring (6).

3-27.3. INSTALLATION

- a. Using two wrenches, one at the whip hose fitting (1), one at the hex of the inflating chuck (2), mate the chuck threads to the flare fitting and tighten the hose flare fitting.
- b. Using Teflon tape (D1) or sealant (D2), install the whip hose (4) to the high pressure shutoff valve (3).
- c. Using Teflon tape (D1) or sealant (D2), install the high pressure hose (5) to the high pressure shutoff valve (3).
- d. Install inflating chuck (2) to the whip hose fitting (1).
- e. Perform leak check and confidence test procedure per paragraph 2-8.

END OF TASK

3-28. TANK CONNECTOR O RINGS - REPLACE

Personnel Required:	67 Series
Tools/Test and Support Equipment:	Tool Kit, SC 5180-99-A01, NSN 5180-00-323-4692
Material/parts:	O-Ring, RO-111V
Equipment Conditions:	Shop air disconnected. Cart depressurized and shutdown per paragraph. 2-7.

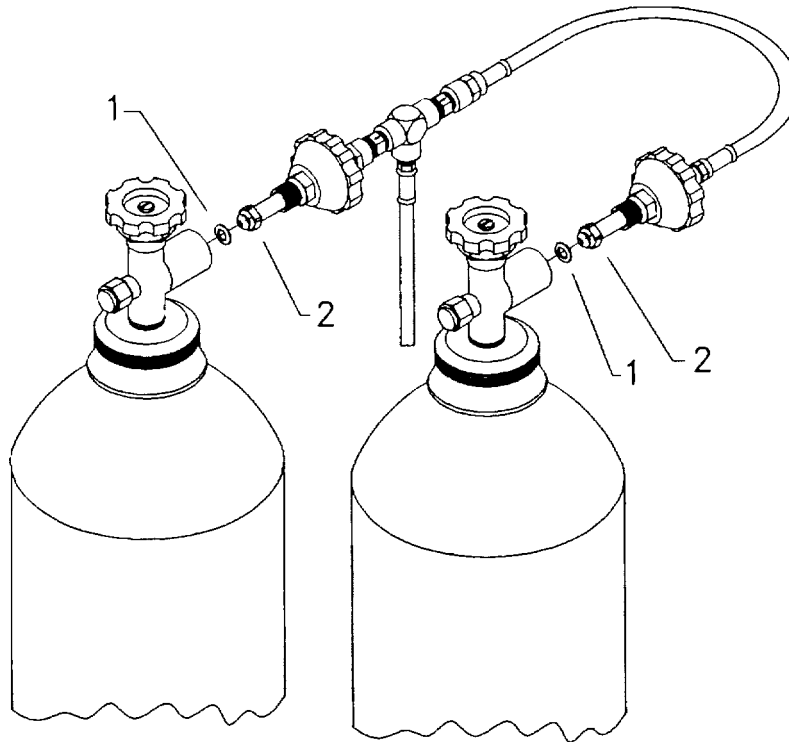

3-28.1 REMOVAL Roll the O-ring (1) off the groove of the nipple connector (2) with the thumb or a sharp object such as an awl. Be careful not to nick the brass surfaces.

3-28.2 INSTALLATION Roll the O-ring (1) onto the groove of the nipple connector (2) using the thumb or finger. Do not use any tools.

END OF TASK

3-29. TIRE FILLING HOSE - REPAIR

- Personnel Required:** 67 Series
- Tools/Test and Support Equipment:** Tool Kit, SC 5180-99-A01, NSN 5180-00-323-4692
- Material/parts:** Hose Assembly, HA056-A
Quick Disconnect Socket, DM-341
Quick Disconnect Nipple, P-341B
- Equipment Conditions:** Remove tire filling hose from cart.

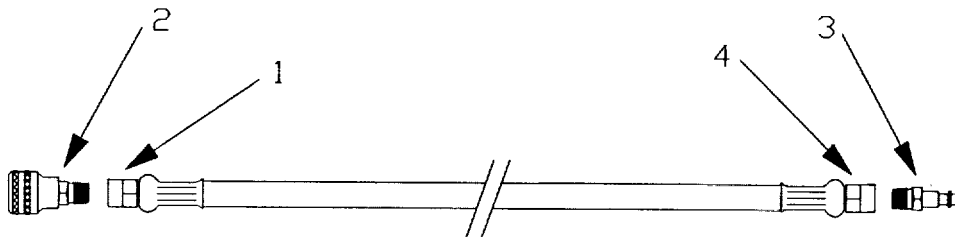

3-27.1. DISASSEMBLY

- a. Using two wrenches, one at the hose fitting (1) and one at the hex of the quick disconnect socket (2), remove the socket (2) from the hose fitting (1).
- b. Using a wrench to hold the body of the quick disconnect nipple (3) and an open end wrench on the hose fitting (4). Remove the quick disconnect nipple (3).

3-27.2. INSTALLATION

- a. Using two wrenches, one at the hose fitting (1), one at the hex of the quick disconnect socket (2), mate the socket threads to the flare fitting and tighten the hose fitting.
- b. Install the hose by using an open end wrench on the hose end fitting (4) and another one at the quick disconnect nipple (3). Mate and tighten both together.

END OF TASK

Section VI. Preparation for Storage or Shipment

<u>SECTION CONTENTS</u>	<u>PARA</u>	<u>PAGE</u>
PREPARATION FOR STORAGE	3-33	3-43
PREPARATION FOR SHIPMENT	3-34	3-43

3-33. PREPARATION FOR STORAGE

The High Pressure Nitrogen Servicing Cart may be stored using normal procedures. Instructions are provided in TM 1-1500-204-23 Series Manuals (1 through 10). Carts may NOT be stored with nitrogen tanks strapped to the cart. There are no in-storage maintenance or inspection procedures required for storage less than 12 months.

3-34. PREPARATION FOR SHIPMENT

Carts may NOT be shipped with nitrogen tanks strapped to the cart. Preservation and packaging shall be level A or Level B in accordance with MIL-STD-2073-1 or Level C in accordance with MIL-STD-1190.

3-43/(3-44 blank)

CHAPTER 4

**AVIATION INTERMEDIATE MAINTENANCE (AVIM)
MAINTENANCE INSTRUCTIONS**

<u>CHAPTER CONTENTS</u>		<u>PAGE</u>
Section I	REPAIR PARTS, SPECIAL TOOLS, TMDE AND SUPPORT EQUIPMENT	4-1
Section II	SERVICE UPON RECEIPT	4-2
Section III	PREVENTIVE MAINTENANCE CHECKS (PMCS)	4-3
Section IV	TROUBLESHOOTING	4-4
Section V	MAINTENANCE PROCEDURES	4-7
Section VI	PREPARATION FOR STORAGE OR SHIPMENT	4-17

Section I Repair Parts, Special Tools, TMDE, and Support Equipment

<u>SECTION CONTENTS</u>	<u>PARA</u>	<u>PAGE</u>
GENERAL	4-1	4-1
MAINTENANCE OPERATIONS	4-2	4-2
TOOLS AND TEST EQUIPMENT LIST	4-3	4-2
SPECIAL TOOLS, TMDE AND SUPPORT EQUIPMENT	4-4	4-2
REPAIR PARTS	4-5	4-2

4-1. GENERAL

This chapter contains maintenance procedures that are the responsibility of the Aviation Intermediate Maintenance (AVIM) technician as authorized by the Maintenance Allocation Chart (MAC) and Source, Maintenance and Recoverability (SMR) coded items in the Repair Parts and Special Tools List (RPSTL). The maintenance procedures in this chapter are prepared in the form of summary and detailed procedures.

4-2. MAINTENANCE OPERATIONS

These instructions provide the proper technique and detailed procedures required to perform the maintenance operations. Each maintenance operation provides step-by-step instructions in the order in which the work is most logically accomplished. Any unusual or critical steps are covered in detail.

4-3. TOOLS AND TEST EQUIPMENT LIST

Tools and test equipment required for maintenance of the High Pressure Nitrogen Servicing Cart are identified in the Maintenance Allocation Chart, Appendix B.

4-4. SPECIAL TOOLS, TMDE, AND SUPPORT EQUIPMENT

There are no special tools required for test or inspection procedures at the AVIM level.

4-5. REPAIR PARTS

Repair parts are listed in the Repair Parts and Special Tools List (RPSTL) in Appendix C of this manual.

Section II. Service Upon Receipt

4-6. GENERAL

- a. Visually check the exterior of the High Pressure Nitrogen Servicing Cart for apparent damage. Check contents to assure that all components listed in APPENDIX C (RPSTL) of this manual are enclosed and undamaged.
- b. If the equipment has been damaged, report the damage on SF 368 (REPORT OF DISCREPANCIES). Check the equipment against the packing slip to see if the shipment is complete. Report any discrepancies in accordance with the instructions of DA PAM 738751.

Section III. Preventive Maintenance Checks and Services (PMCS)

<u>SECTION CONTENTS</u>	<u>PARA</u>	<u>PAGE</u>
GENERAL	4-7	4-3
CLEANING	4-8	4-3
SETUP, CONFIDENCE AND LEAK TESTS	4-9	4-4

4-7. GENERAL

Preventive maintenance of the High Pressure Nitrogen Servicing Cart is covered by the following paragraphs as well as the Warnings, Cautions and Notes in Chapter 2, and PMCS information listed in Table 2-1. These, if followed, assure that the equipment will be used in the proper manner.

CAUTION

Use of an air line lubricator of any kind is not recommended. Lubricating oil leaking into the compressor chamber may cause pump valve damage.

No lubrication is required for the booster pump. Any required lubrication internally to the pump is provided during pump rebuild.

4-8. CLEANING

- a. Keep equipment free of dirt and grease. Place protective cover over tester operator panel and tank connectors when not in use.
- b. In salt water environment, hose cart off frequently with water. Cover tank connectors and ports with plastic bags to prevent entry of contaminants.
- c. Use a soft cloth dampened with a solution of mild soap and water or isopropyl alcohol for cleaning.

4-9. SETUP, CONFIDENCE AND LEAK TESTS

Visually inspect the High Pressure Nitrogen Servicing Cart accessories, indicators and shut-off valves. Refer to the tasks in Chapter 2 for applicable procedures. Refer to the following paragraphs for the applicable procedures:

BEFORE YOU OPERATE	<u>PARA</u> 2-4
SETUP	2-5
SETTING THE HIGH PRESSURE RELIEF VALVE	2-6
SHUTDOWN PROCEDURE	2-7
LEAK CHECK AND CONFIDENCE TEST PROCEDURE	2-8

Section IV. Troubleshooting

<u>SECTION CONTENTS</u>	<u>PARA</u>	<u>PAGE</u>
GENERAL	4-10	4-4
NO NITROGEN FLOW TO HIGH PRESSURE OUTPUT: NOT REQUIRING BOOSTER PUMP OPERATION	4-11	4-5
TROUBLESHOOTING PROCEDURE: REQUIRING BOOSTER PUMP OPERATION	4-12	4-6

4-10. GENERAL

Possible failures of the High Pressure Nitrogen Servicing Cart as well as probable cause and corrective action are shown in the following troubleshooting flow charts. Corrective actions, as shown in the following troubleshooting flow charts, are described in the applicable removal/installation paragraphs in the text of this manual.

In this chapter, troubleshooting flow charts are grouped into two categories. Paragraph 4-11 covers the case of high pressure operation where booster pump operation is not used and paragraph 4-12 covers troubleshooting for the case where the booster pump is required for operation. The low pressure operation troubleshooting procedure is described in Chapter 3 under paragraph 3-11.1 "No Tire Inflation (Low) Pressures".

Paragraph 4-11 is to be used for troubleshooting difficulties associated with no high pressure output appearing at the High Pressure Output connector, C5 of Figure 1-3, or at the high pressure fitting end of the high pressure charging hose. Booster pump operation is not required. Paragraph 4-12 is to be used for troubleshooting difficulties associated with booster pump operation.

See Figures 1-3 and 1-4 for the function and location of the designated components.

4-11. NO NITROGEN FLOW TO HIGH PRESSURE OUTPUT (NOT REQUIRING BOOSTER PUMP OPERATION).

This flow chart is to be used for troubleshooting difficulties associated with no high pressure output appearing at the High Pressure Output connector, C5 of Figure 1-3, or at the high pressure fitting end of the high pressure charging hose. See Figures 1-3 and 1-4 for the function and location of the designated components.

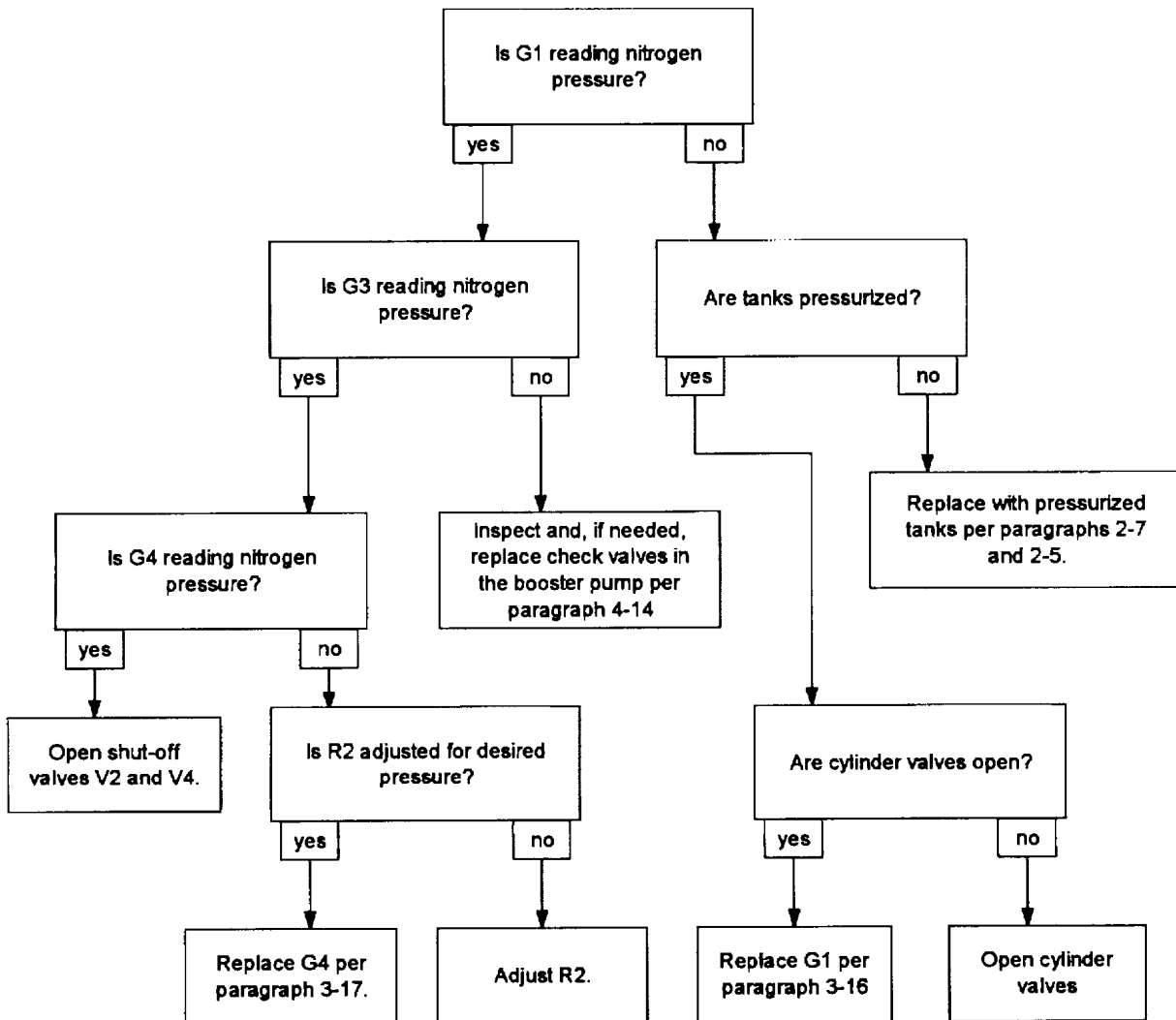

4-12. TROUBLESHOOTING PROCEDURE: REQUIRING BOOSTER PUMP OPERATION

This flow chart is to be used in troubleshooting difficulties with booster pump operation. See Figures 1-3 and 1-4 for the function and location of the designated components.

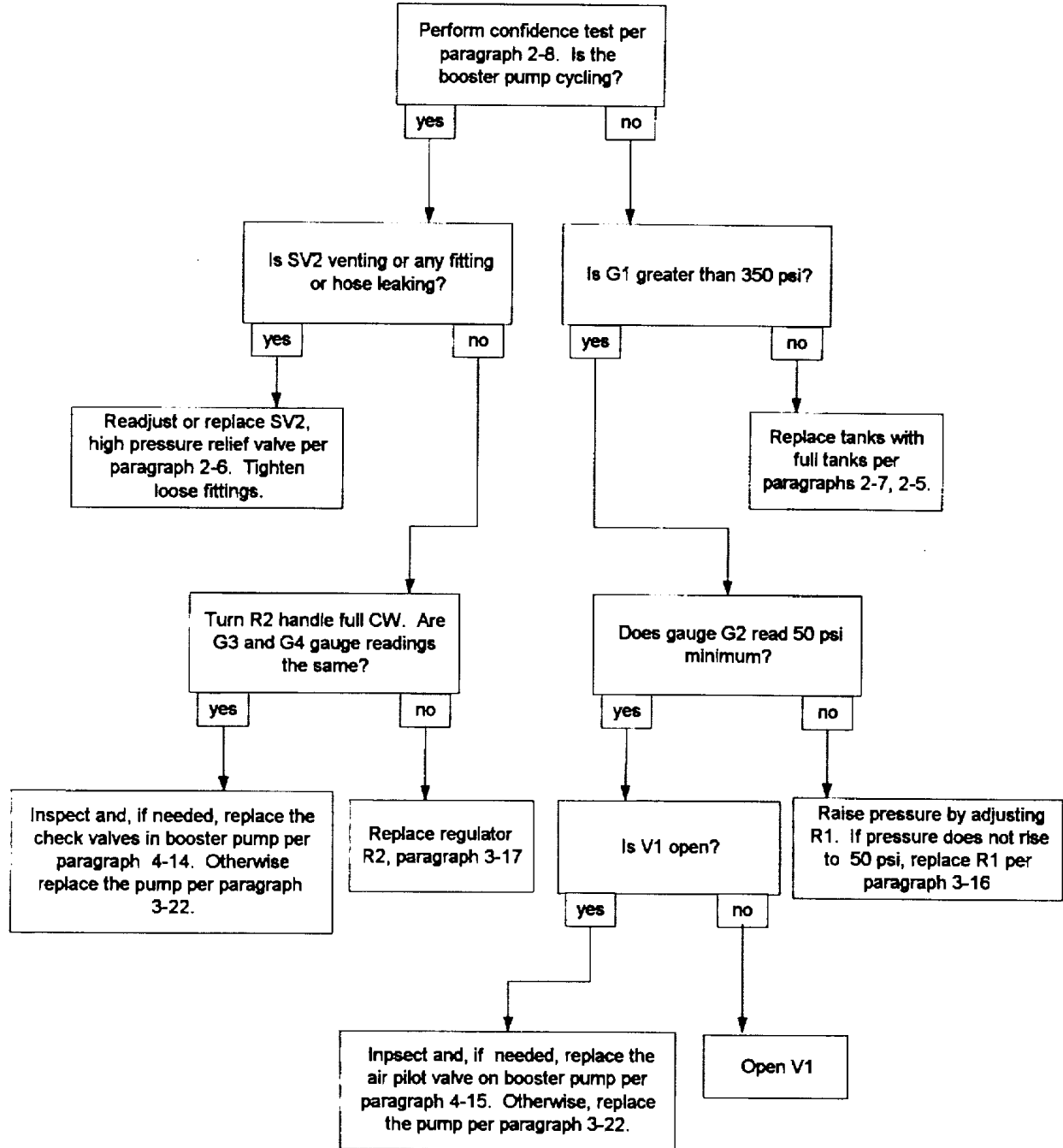

Section V Maintenance Procedures

<u>SECTION CONTENTS</u>	<u>PARA</u>	<u>PAGE</u>
MAINTENANCE PROCEDURES - GENERAL	4-13	4-7
BOOSTER PUMP CHECK VALVES - INSPECTION AND REPAIR	4-14	4-7
BOOSTER PUMP AIR PILOT VALVE - REPLACE	4-15	4-15

4-13. MAINTENANCE PROCEDURES - GENERAL

WARNING

Remove or disconnect nitrogen tanks before maintenance. Never disconnect a pressurized line.

When maintenance is required, removal and replacement of a part or assembly is indicated. Removal procedures are given only to the extent necessary to repair or replace authorized parts. In most cases, removal of the pump panel from the hand truck is not necessary because most of the components are accessible with the panel on the cart.

4-14. BOOSTER PUMP CHECK VALVES - INSPECTION AND REPAIR

THIS TASK COVERS: REMOVAL, REPAIR AND INSTALLATION

Personnel Required:	67 Series
Tools/Test and Support Equipment:	Tool Kit, SC 5180-99-A01, NSN 5180-00-323-4692
Material/parts:	Inlet Check Valve Repair Kit, 93651 Outlet Check Valve Repair Kit, 93652 Teflon tape (D1) or Perma Lok LM012 (D2)
Equipment Conditions:	Shop air disconnected. Cart depressurized and shutdown per paragraph. 2-7.

WARNING

Inspect all four check valves. Remove and inspect only one check valve at a time on the booster pump to ensure proper reassembly. Improper assembly of the check valves or the swapping of the inlet and outlet check valves can cause very high pressures to be trapped in the booster pump. These pressures can be released suddenly and unexpectedly with any subsequent disassembly.

GO TO NEXT PAGE

4-14.1 UPPER INLET CHECK VALVE

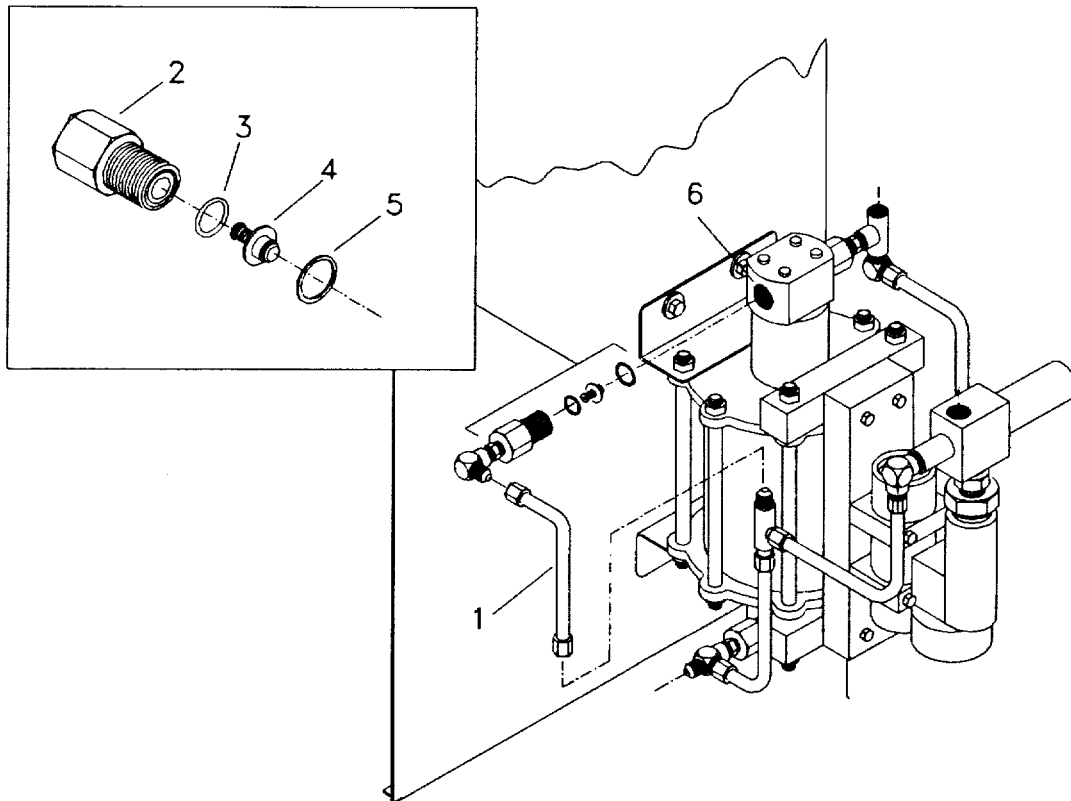

- a. Loosen the flare nuts of tubing (1) and remove the tubing.
- b. With an adjustable wrench, remove the upper inlet check valve body (2).
- c. Refer to the inset illustration for the inlet check valve.. Carefully remove the O-ring (3) from the groove in the check valve body (2). Remove check valve assembly (4).
- d. Remove the flat O-ring (5) from inside the check valve cavity of the pump body (6).
- e. Examine all rubber parts for contamination, nicks, cuts and abrasions. If necessary, replace all components with repair kit components. Refer to Appendix C RPSTL for kit part numbers.

NOTE

Complete the installation of this check valve before proceeding with the inspection of the next one.

- f. Press O-ring (3) with fingers into the groove of the check valve body (2). Insert the O-ring (5) into the check valve cavity of the pump body (6). Position check valve (4) in the check valve body (2). Thread the check valve body (2) into the pump body (6), tighten and orient assembly as illustrated..
- g. Reassemble the flare fittings of tubing (1) and tighten.

GO TO NEXT PAGE

4-14.2 LOWER INLET CHECK VALVE

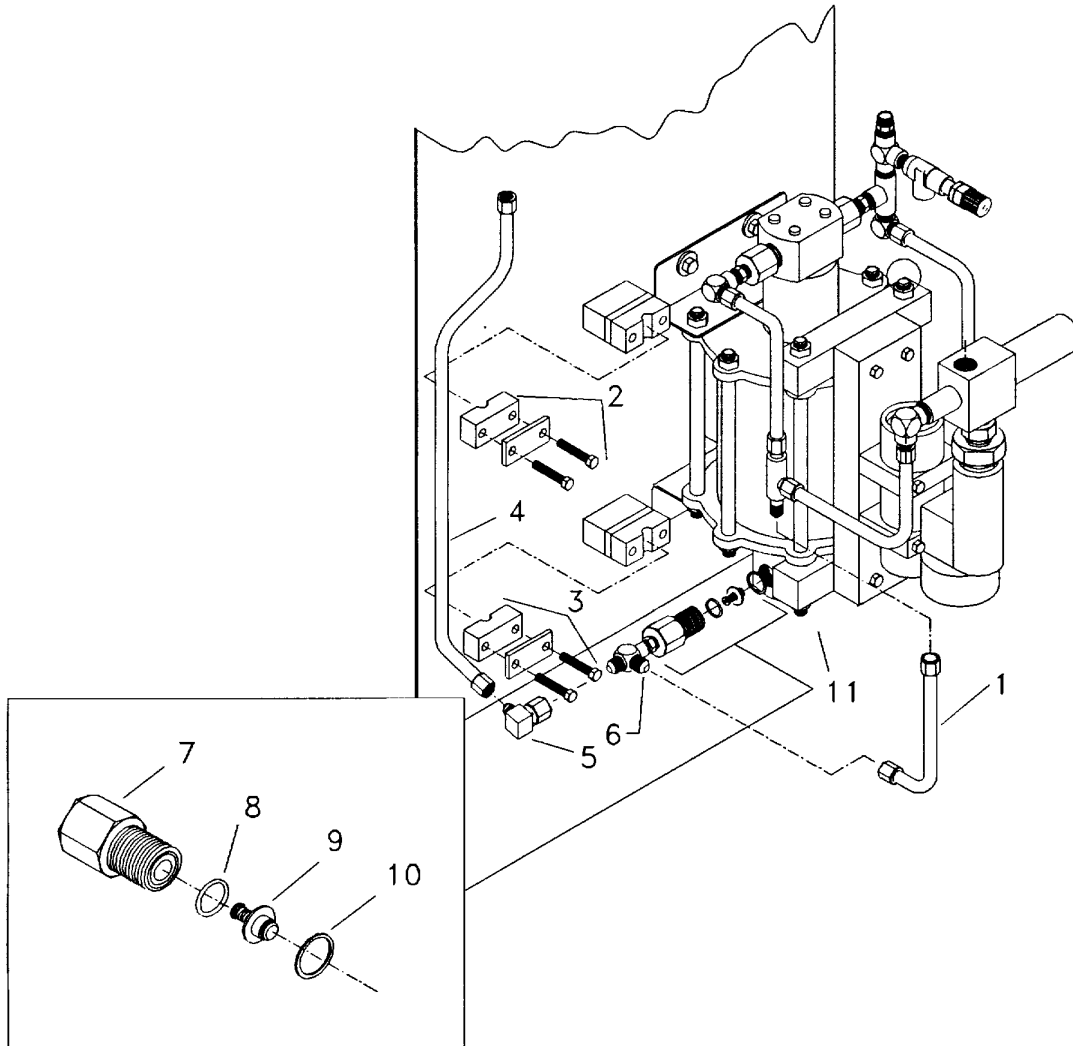

- a. Loosen the flare fittings of tubing (1) and remove the tubing.
- b. Loosen the bolts of bracket assemblies (2 and 3). Loosen the lower flare fitting of tubing (4) and the flare fitting of elbow (5). Remove elbow (5) from T-fitting (6).
- c. With an adjustable wrench, remove the lower inlet check valve body (7) with T-fitting (6) attached.
- d. Refer to the inset illustration for the inlet check valve. Carefully remove the O-ring (8) from the groove in the check valve body (7). Remove check valve assembly (9).
- e. Remove the flat O-ring (10) from inside the check valve cavity of the pump body (11).
- f. Examine all rubber parts for contamination, nicks, cuts and abrasions. If necessary, replace all components with repair kit components. Refer to Appendix C -RPSTL for kit part numbers.

GO TO NEXT PAGE

NOTE

Complete the installation of this check valve before proceeding with the inspection of the next one.

- g. Press O-ring (8) with fingers into the groove of the check valve body (7). Insert the O-ring (10) into the check valve cavity of the pump body (11). Position check valve (9) in the check valve body (7). Thread the check valve body (7) with T-fitting (6) attached into the pump body (11), tighten and orient as illustrated..
- h. Install elbow fitting (3) and tighten flare nuts. Tighten the bolts of the bracket assembly (5 and 6), if necessary.
- i. Install tubing (1) and tighten the flare fittings.

GO TO NEXT PAGE

4-14.3 UPPER OUTLET CHECK VALVE

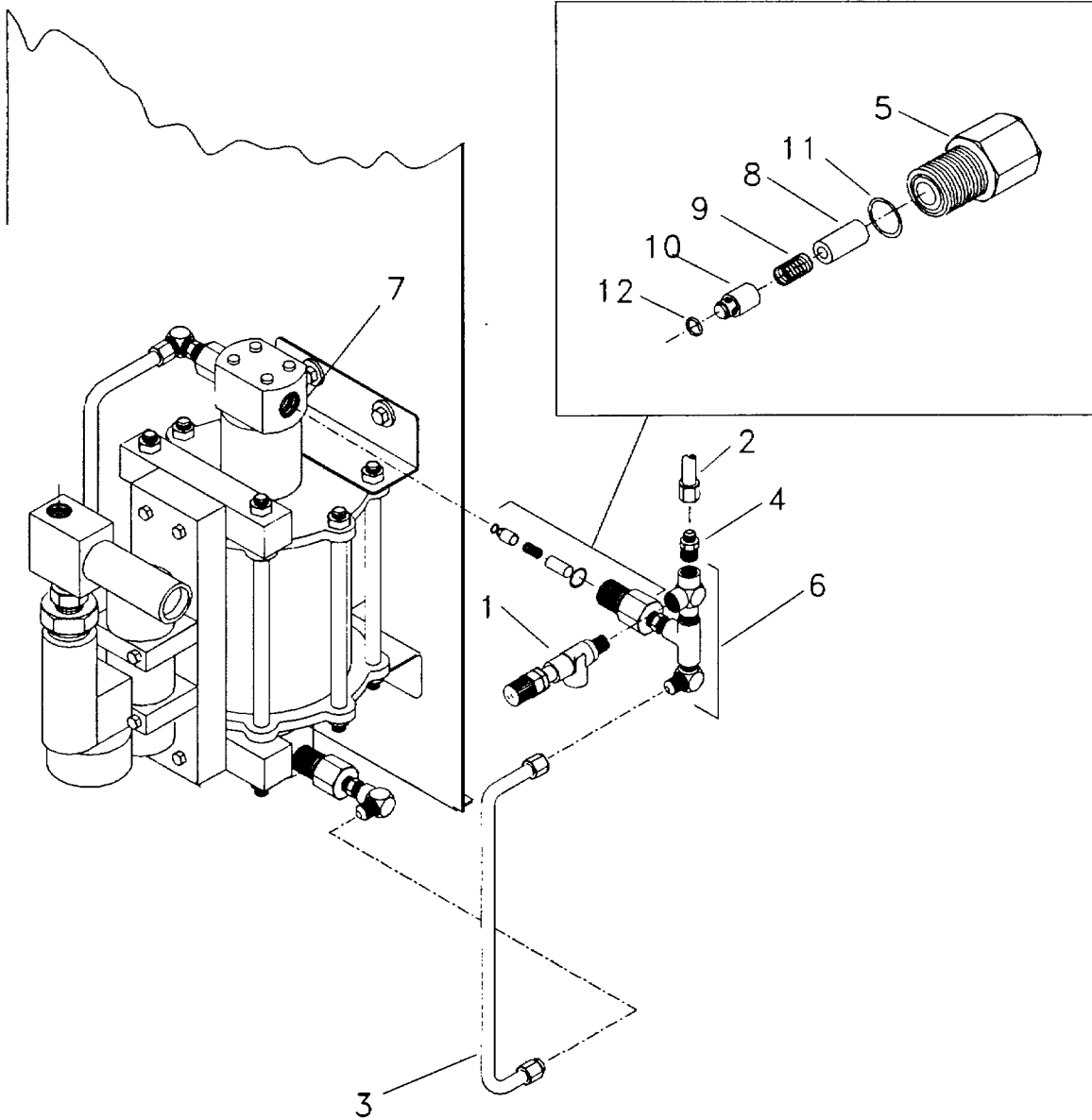

- a. Remove the high pressure relief valve (1).
- b. Loosen flare fittings of tubing (2 and 3) and remove tubing (3).
- c. Remove flare fitting (4).
- d. Remove the upper outlet check valve body (5) with tee and coupler assembly (6) attached from the pump body (7).
- e. Refer to the inset illustration of the outlet check valve. Carefully remove the spacer (8), spring (9) and the check valve poppet (10). These items could remain in the pump.

GO TO NEXT PAGE

f. Carefully remove the O-ring (11) from the groove in the check valve body (5). Remove the O-ring (12) from the end of the check valve poppet (10).

g. Examine all rubber parts for contamination, nicks, cuts and abrasions. Examine the spring. If necessary, replace all components with repair kit components. Refer to Appendix C -RPSTL for kit part numbers.

NOTE

Complete the installation of this check valve before proceeding with the inspection of the next one.

h. Assemble the check valve parts (8) through (12) as shown in the outlet check valve illustration. Press O-ring (12) onto the groove of check valve poppet (10). Press O-ring (11) with fingers into the groove of the check valve body (5). The spacer (8) slides into the cavity of the check valve body (5).

i. Insert these parts into the pump body (7) as shown. Pivot the combination tee and coupler assembly (6) with the check valve body (5) attached. Tighten and orient as illustrated.

j. Insert flare fitting (4) with Teflon tape (D1) or sealant (D2) into the tee and coupler assembly (6) and tighten.

k. Reconnect tubing (2) and tighten the flare fittings of tubing (2). Leave tubing (3) off for the lower check valve inspection in paragraph 4-14.4.

l. Reinstall the high pressure relief valve (1) with Teflon tape (D1) or sealant (D2) and orient as shown.

m. Continue with the inspection of the lower outlet check valve.

GO TO NEXT PAGE

4-14.4 LOWER OUTLET CHECK VALVE

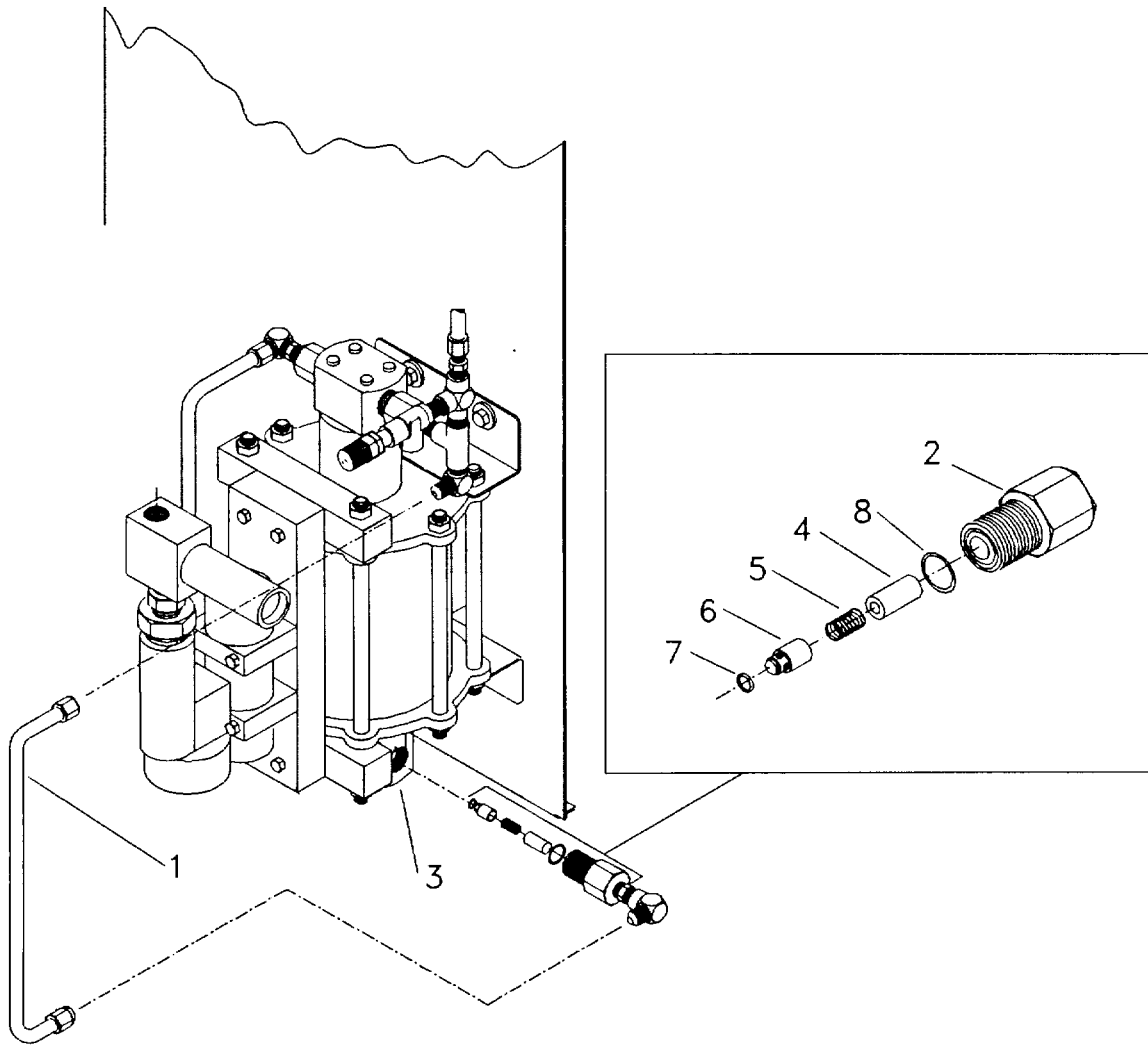
**NOTE**

Tubing (1) has already been removed from the inspection of the upper outlet check valve.

- a. With an adjustable wrench, remove the lower outlet check valve body (2) from the pump body (3).
- b. Refer to the inset illustration for the outlet check valve. Carefully remove the spacer (4), spring (5) and the check valve poppet (6). Parts may remain in the pump (3).
- c. Carefully remove the O-ring (7) from the groove in the check valve body (2). Remove the O-ring (8) from the end of the check valve poppet (6).
- d. Examine all rubber parts for contamination, nicks, cuts and abrasions. Examine the spring. If necessary, replace all components with repair kit components. Refer to Appendix C -RPSTL for kit part numbers.

GO TO NEXT PAGE

- e. Assemble the check valve parts (4) through (8) as shown in the outlet check valve illustration. Press O-ring (8) with fingers into the groove of the check valve body (2). The spacer (4) slides into the cavity of the check valve body (2).
- f. Thread the check valve assembly into the pump body (3), tighten and orient as illustrated.
- g. Align and tighten the flare fittings of tubing (1).
- h. This completes the inspection and repair of the booster pump check valves. Perform leak check and confidence test procedure per paragraph 2-8.

END OF TASK

4-15 BOOSTER PUMP AIR PILOT VALVE - REPLACE

THIS TASK COVERS: REMOVAL AND INSTALLATION

Personnel Required:

67 Series

Tools/Test and Support Equipment:

Tool Kit, SC 5180-99-A01, NSN 5180-00-323-4692
 Pipe Wrench, NSN 5120-00-277-1485 or Vise Grip, NSN 5120-00-494-1911

Material/parts:

Air Pilot Valve, 93622
 Air Valve Gasket, 91462
 Teflon tape (D1) or Perma Lok LM012 (D2)

Equipment Conditions:

Shop air disconnected. Cart depressurized and shutdown per paragraph. 2-7.

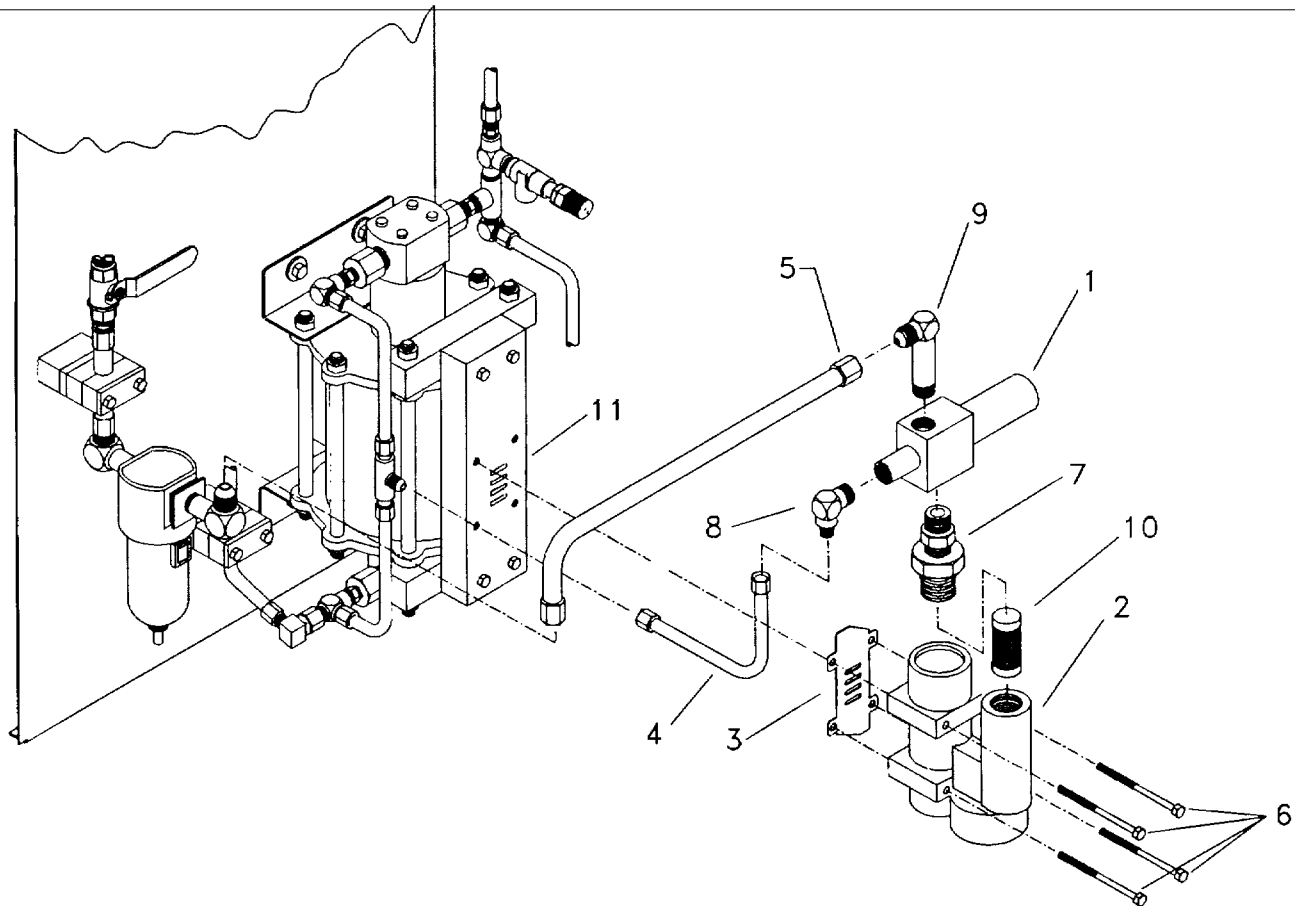

GO TO NEXT PAGE

4-15.1 REMOVAL

In order to remove and replace the air pilot valve (1), the air valve assembly (2) must be removed. Removal and replacement of the air valve assembly (2) will require the replacement of the air valve gasket (3).

- a. Loosen the flare fittings of tubing (4) and (5) and remove.
- b. Remove the air valve assembly (2) along with the air pilot valve (1) by removing the four bolts (6).
- c. Remove air valve gasket (3) and discard.
- d. Grip the air valve assembly (2) in a non-marring vise. Remove the air pilot valve (1) by pivoting it about the pipe nipple and bushing assembly (7). Remove the elbows (8) and (9) from the air pilot valve (1).
- e. Remove the nipple and bushing assembly (7) from the air pilot valve (2) and remove the filter screen (10). Inspect the filter screen (10) for contaminants and clean if necessary.

4-15.2 INSTALLATION

- a. Insert the filter screen (10) into the air valve assembly (2).
- b. Grip the air valve assembly (2) in a non-marring vise. Apply Teflon tape (D1) or sealant (D2) on the threads of pipe fittings (7), (8) and (9). Thread the pipe nipple and bushing assembly (7) onto the inlet of the air valve assembly (2). Attach the air pilot valve (1) by pivoting it about the pipe nipple and bushing assembly (7). Align the air pilot valve (1) in the orientation as shown in the illustration. Thread, tighten and position elbows (8) and (9) as shown in the illustration.
- c. Position a new gasket (3) between the air valve assembly (2) and the body of the booster pump (11). Fasten the assembly to the pump (11) with four bolts (6). Align and tighten the flare fittings of tubing (4) first and then (5). Align elbows (8) and (9) if necessary.
- d. This completes the removal and replacement of the booster pump air pilot valve. Perform leak check and confidence test procedure per paragraph 2-8.

END OF TASK

Section VI Preparation for Storage or Shipment

<u>SECTION CONTENTS</u>	<u>PARA</u>	<u>PAGE</u>
PREPARATION FOR STORAGE	4-16	4-17
PREPARATION FOR SHIPMENT	4-17	4-17

4-16. PREPARATION FOR STORAGE

The High Pressure Nitrogen Servicing Cart may be stored using normal procedures. Instructions are provided in TM 1-1500-204-23 Series. Carts may NOT be stored with nitrogen tanks strapped to the cart. There are no in-storage maintenance or inspection procedures required for storage of less than 12 months.

4-17. PREPARATION FOR SHIPMENT

Carts may NOT be shipped with nitrogen tanks strapped to the cart. Preservation and packaging shall be level A or Level B in accordance with MIL-STD-2073-1 or Level C in accordance with MIL-STD-1190.

APPENDIX A

REFERENCES

A-1. DICTIONARIES OF TERMS AND ABBREVIATIONS

AR 310-25 Dictionary of United States Army Terms

AR 310-50 Authorized Abbreviations and Brevity Codes

A-2. PUBLICATION INDEXES

DA PAM 25-30 Consolidated Index of Army Publications and Blank Forms

A-3. LOGISTICS AND STORAGE

TM 1-1500-204-23 Series (1 through 10)

TM 743-200-1 Storage and Materials Handling

A-4. MAINTENANCE OF SUPPLIES AND EQUIPMENT

AR 750-1 Army Material Maintenance Concepts and Policies

DA PAM 738-751 Functional User's Manual for The Army Maintenance Management System - Aviation (TAMMS-A)

TM 43-0139 Painting Operations Instructions for Field Use

A-5. OTHER PUBLICATIONS

AR 420-90 Fire Prevention and Protection

AR 55-38 Reporting of Transportation Discrepancies in Shipments

AR 700-58 Packaging Improvement Report

DA PAM 310-13 Posting and Filing Publications

FM 21-11 First Aid for Soldier

TB 43-180 Calibration Requirements for the Maintenance of Materiel

TM 750-244-1-4 Procedures for the Destruction of Aviation Ground Support Equipment (FSC 1740) to Prevent Enemy Use

A-1/((A2 blank))

APPENDIX B

MAINTENANCE ALLOCATION CHART

SECTION I. Introduction

B-1 GENERAL

- a. This section provides a general explanation of all maintenance and repair functions authorized at various maintenance categories.
- b. The Maintenance Allocation Chart (MAC) in Section II designates overall authority and responsibility for the performance of maintenance functions of the identified end item or component. The application of the maintenance functions to the end item or component will be consistent with the capacities and capabilities of the designated maintenance categories.
- c. Section III lists the tools and test equipment (both special tools and common tool sets) required for each maintenance function as referenced from Section II.
- d. Section IV contains supplemental instructions and explanatory notes for a particular maintenance function.

B-2 MAINTENANCE FUNCTIONS

- a. Inspect to determine the serviceability of an item by comparing its physical, mechanical, and/or electrical characteristics with established standards through examination (e.g. by sight, sound or feel).
- b. Replace to remove an unserviceable item and install a serviceable counterpart in its place. "Replace" is authorized by the MAC and is shown as the 3rd position code for the SMR code.
- c. Repair the application of maintenance services, including fault location/troubleshooting, removal/installation, and disassembly/assembly procedures, and maintenance actions to identify troubles and restore serviceability to an item by correcting specific damage, fault, malfunction, or failure in a part, subassembly, module (component or assembly), end item, or system.
- d. Calibrate to determine and cause corrections to be made or to be adjusted on instruments or test, measuring, and diagnostic equipment used in precession measurement. Consists of comparisons of two instruments, one of which is a certified standard of known accuracy, to detect and adjust any discrepancy in the accuracy of the instrument being compared.
- e. Test to verify serviceability by measuring the mechanical, pneumatic, hydraulic, or electrical characteristics of an item and comparing those characteristics with prescribed standards.

B-3 EXPLANATION OF COLUMNS IN THE MAC, SECTION II

- a. Column 1, Group Number- Column 1 lists functional group code numbers, the purpose of which is to identify maintenance significant components, assemblies, subassemblies, and modules with the next higher assembly. End item group number shall be "00".
- b. Column 2, Component/Assembly Column 2 contains the names of components assemblies, subassemblies, and modules for which maintenance is authorized.
- c. Column 3, Maintenance Function Column 3 lists the functions to be performed on the item listed in Column 2. (For detailed explanation of these functions, see paragraph B-2).
- d. Column 4, Maintenance Category
 - (1) AVUM Aviation Unit Maintenance. AVUM activities will be staffed and equipped to perform high frequency "On-Equipment" maintenance tasks required to retain or return equipment to a serviceable condition.
 - (2) AVIM Aviation Intermediate Maintenance. AVIM provides mobile, responsive "onestop" maintenance support. Authorized maintenance includes replacement and repair of module/components and end items which can be accomplished efficiently with available skills, tools, and equipment. AVIM inspects, troubleshoots, tests diagnoses, repairs, adjusts, calibrates, and aligns system modules and components.
- e. Column 5, Tools and Equipment Column 5 specifies, by code, those common tool sets (not individual tools) and special tools, TMDE, and support equipment required to perform the designated function.
- f. Column 6, Remarks This column shall, when applicable, contain a letter code, in alphabetic order, which shall be keyed to the remarks contained in Section IV.

**SECTION II. Maintenance Allocation Chart
for
High Pressure Nitrogen Servicing Cart**

(1) GROUP NUMBER	(2) COMPONENT/ ASSEMBLY	(3) MAINTENANCE FUNCTION	(4) MAINTENANCE CATEGORY		(5) TOOLS AND EQUIPMENT	(6) REMARKS
			AVUM	AVIM		
00	Servicing Cart, High Pressure Nitrogen	Inspect	1.5	2.5	1,2,3 1,2,3	A
		Service	1.5			B
		Test	0.5			E
		Repair	1.0			C
		Repair				C,F
01	Panel Assy, Booster	Inspect	0.7		1 1	A
		Replace	1.0			C,D
		Repair	2.4			C,D,E
0101	Regulator, Low Pressure	Inspect	0.5		1,2	A
		Test	0.5			E
		Replace	0.7			D,E
0102	Regulator, High Pressure	Inspect	0.5		1,2	A
		Test	0.5			D,E
		Replace	0.7			1,2
010201	Relief Valve, High Pressure	Inspect	0.5	1	1	A
		Service	0.5			B
		Replace	0.7			D,E
0103	Regulator, Shop Air	Inspect	0.5		1,2	A
		Test	0.5			D,E
		Replace	0.7			
0104	Filter,Low Pressure	Inspect	0.7		1	A
		Replace	0.7			
0105	Shutoff,High Pressure	Inspect	0.5		1	A
		Replace	0.5			
0106	Tube Assembly	Inspect	0.2		1	A
		Replace	0.5			1
0107	Pump, Booster (check valve, pilot valve)	Inspect	0.7	2.0	1 1	A
		Replace	0.7			D,E
		Repair				C,D,E
010701	Valve, Check	Inspect		1.0	1	A
		Replace		1.0	1	D,E
		Repair		2.0	1	C,D,E

**SECTION II. Maintenance Allocation Chart
for
High Pressure Nitrogen Servicing Cart (Cont.)**

(1) GROUP NUMBER	(2) COMPONENT/ ASSEMBLY	(3) MAINTENANCE FUNCTION	(4) MAINTENANCE CATEGORY		(5) TOOLS AND EQUIPMENT	(6) REMARKS
			AVUM	AVIM		
010702	Pilot Valve,Air	Inspect Replace		1.0 1.0	1	A D,E
02	Truck Assy,Hand	Inspect Repair Repair	0.5 1.0	2.5	1 1	A C F
0201	Wheel Assy	Inspect Service Replace Repair	0.5 1.0 0.5 1.0		1 1 1 1	A B C
0202	Strap,Tank Retention	Inspect Replace	0.2 0.5		1	A
03	Connector Assy,Tank	Inspect Replace Repair	0.5 0.5 0.5		1 1,2,3	A C C
0301	Nipple	Inspect Service Replace Repair	0.2 0.2 0.4 0.3		1 1,3 1	A,B C C
04	Hose Assy, Whip	Inspect Repair	0.5 0.5		1 1	A,B C
0401	Chuck,Inflating	Inspect Replace Repair	0.3 0.3 0.3		1 1	A C C
05	Hose,Tire Filling	Inspect Repair	0.3 0.3		1	A
0501	Coupler, Quick Disconnect	Inspect Replace	0.3 0.3		1	A D

SECTION III. Tools and Test Equipment Requirements

REFERENCE CODE	MAINTENANCE CATEGORY	NOMENCLATURE	NATIONAL STOCK NUMBER	TOOL SET NUMBER
1	F	Tool Kit, Aircraft Mechanic's: General	5180-00-323-4692	SC 5180-99-A01
2	O	10" Pipe Wrench or Vise Grip	5120-00-277-1485 or 5120-00-494-1911	SC 4920-99-B90
3	O	6 point socket, 11/16 x 3/8 sq drive, std length or long length	5120-01-335-0320 or 5120-01-335-0328	

SECTION IV. MAC Reference Code and Remarks

MAINTENANCE ALLOCATION CODE	
Reference Code	Remarks
A	Visual inspection only
B	Preventive Maintenance Checks and Services (PMCS)
C	Replace Components
D	Leak check
E	Performance Check
F	Re-bend Cart Tubing, Weld and Paint Cart

APPENDIX C**REPAIR PARTS AND SPECIAL TOOLS LIST**

SECTION I. Introduction**C-1 SCOPE**

This RPSTL lists and authorizes spares and repair parts; special tools; special test, measurement, and diagnostic equipment (TMDE); and other special support equipment required for performance of AVIM/AVUM maintenance of the high pressure nitrogen servicing cart. It authorizes the requisitioning, issue, and disposition of spares, repair parts and special tools as indicated by the source, maintenance and recoverability (SMR) codes.

C-2 GENERAL

In addition to Section I, Introduction, this Repair Parts and special Tools List is divided into the following sections:

- a. Section II. Repair Parts List A list of spares and repair parts authorized by the RPSTL for use in the performance of removed for replacement of the authorized parts. Parts lists are composed of functional groups in the ascending alphanumeric sequence, with the parts in each group listed in ascending item number sequence.
- b. Section III. Special Tools List a list of special tools, special TMDE, and other special support equipment authorized by this RPSTL (as indicated by Basis of Issue (BOI) information in DESCRIPTION AND USABLE ON CODE column) for the performance of maintenance.
- c. Section IV. National Stock Number and Part Number Index A list, in National Item Identification Number (NIIN) sequence of all National stock numbered items appearing in the listing, followed by a list in alphanumeric sequence of all part numbers appearing in the listings. National stock numbers and part numbers are all cross-referenced to each illustration figure and item number appearance.

C-3. EXPLANATION OF COLUMNS (SECTIONS II AND III)

- a. ITEM NO. (Column (1)) - Indicates the number used to identify items called out in the illustration.
- b. SMR CODE (Column (2)) - The Source, Maintenance, and Recoverability (SMR) code is a 5 position code containing supply/requisitioning information, maintenance category authorization criteria, and disposition instruction, as shown in the following breakout:

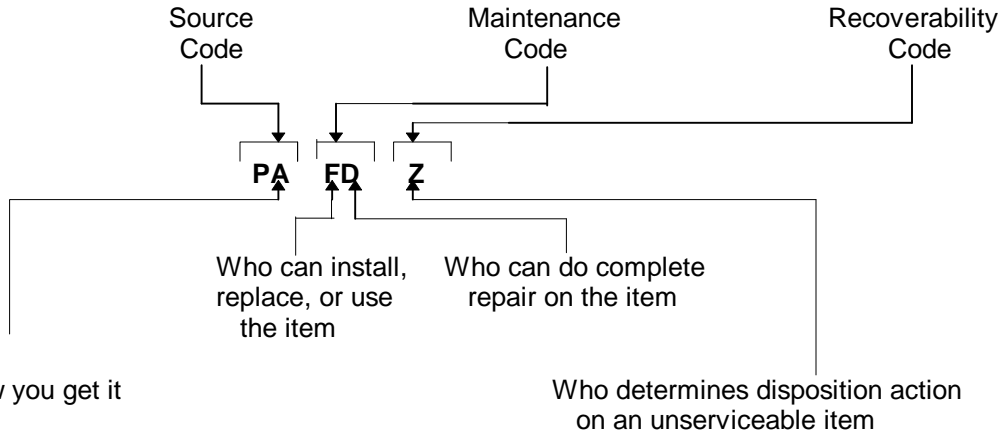

*Complete Repair: maintenance capacity, capability, and authority to perform all corrective maintenance tasks on the "Repair" function in a use/user environment in order to restore serviceability to a failed item.

(1) Source Code. The source code tells you how to get an item needed for maintenance, repair, or overhaul of an end item/equipment. Explanations of source codes follows:

Code	Explanation
PA PB PC** PD PE PF PG	Stocked items; use the applicable NSN to request/requisition items with these source codes. They are authorized to the category indicated by the code entered in the 3rd position of the SMR code. **NOTE: Items coded PC are subject to deterioration.
KD KF KB	Items with these codes are not to be requested/requisitioned individually. They are part of a kit which is authorized to the maintenance category indicated in the 3rd position of the SMR code. The complete kit must be requisitioned and applied.
KO (made at Org/AVUM level) MF (made at DS/AVIM level) MH (made at GS level) ML (made at Specialized Repair Activity (SRA)) MD (made at Depot)	Items with these codes are not to be requested/requisitioned individually. They must be made from bulk material which is identified by part number in the DESCRIPTION AND USABLE ON CODE (UOC) column and listed in the Bulk Material group of the repair parts list in this RPSTL. If the item is authorized to you by the 3rd position of the SMR code, but the source code indicates it is made at a higher level, order the item from the higher level of maintenance.

Code	Explanation
AO (assembled at Org/AVUM level) AF (assembled at DS/AVIM level) AH (assembled at GS level) AL (assembled by SRA) AD (assembled at Depot)	Items with those codes are not to be requested/requisitioned individually. The parts that make up the assembled item must be requisitioned or fabricated at the level of maintenance indicated by the source code. If the 3rd position authorizes you to replace the item but the source code indicated the item is assembled at a higher level, order the item from the higher level of maintenance.
XA	Do not requisition an "XA"-coded item. Order its next higher assembly. (Also, refer to the NOTE below).
XB	If an "XB" item is not available for salvage, order it using the CAGE and part number given.
XC	Installation drawing, diagram, instruction sheet, field service drawing, that is identified by manufacturers part number.

NOTE: Cannibalization or controlled exchange, when authorized, may be used as a source of supply for items with the above source codes, except for those source coded "XA" or those aircraft support items restricted by requirements of AR 700-42.

- (2) Maintenance Code maintenance code tells you the level (s) of maintenance authorized to USE and REPAIR support items. The maintenance codes are entered in the third and fourth positions of the SMR Code as follows:
- a. The maintenance code entered in the third position tells you the lowest maintenance level authorized to remove, replace, and use an item . The maintenance code entered in the third position will indicate authorization to one of the following levels of maintenance.

Code	Application/Explanation
C	Crew or operator maintenance done with organization or aviation unit maintenance
O	Organizational or aviation unit category can remove, replace or use the item.
F	Direct support or aviation intermediate level can remove, replace or use the item.
H	General support level can remove, replace, or use item.
L	Specialized repair activity can remove, replace or use the item.
D	Depot level can remove replace, or use the item

- b. The maintenance code entered in the fourth position tells whether or not the item is to be repaired and identifies the lowest maintenance level with the capability to do complete repair (i.e., perform all authorized repair functions,)

NOTE: Some limited repair may be done on the item at a lower level of maintenance, if authorized by the maintenance allocation Chart (MAC) and SMR codes.

The portion will contain one of the following maintenance codes:

Code	Application/Explanation
O	Organizational (or aviation unit) is the lowest level that can do complete repair on the item.
F	Direct support or aviation intermediate is the lowest level that can do complete repair on the item.
H	General support is the lowest level that can do complete repair on the item.
L	Specialized repair activity (designates the specialized repair activity) is the lowest level that can do complete repair on the item.
D	Depot is the lowest level that can do complete repair on the item.
Z	Non repairable. No repair is authorized.
B	No repair is authorized. (No parts or special tools are authorized for the maintenance of a "B"-coded item.) However, the item may be reconditioned by adjusting, lubricating, etc., at the user level.

(3) Recoverability Code Recoverability codes are assigned to items to indicate the composition action on unserviceable its. The recoverability code is entered in the fifth position of the SMR Code as follows:

Code	Application/Explanation
Z	Non repairable Item. When unserviceable, condemn and dispose of item at the level of maintenance shown in the 3rd position of the SMR code.
O	Repairable Item. When uneconomically repairable, condemn and dispose of item at organizational or aviation unit level.
F	Repairable Item. When unserviceable, condemn and dispose of item at the direct support level.
H	Repairable Item. When uneconomically repairable, condemn and dispose of item at general support level.
D	Repairable Item. When beyond lower level repair capability, return to depot. Condemnation and disposal of item not authorized below depot level.
L	Repairable Item. Condemnation and disposal not authorized below specialized repair activity.
A	Item requires special handling or condemnation procedures because of specific reasons (e.g. precious metal content, high dollar value, critical material, or hazardous material). Refer to appropriate manuals/directives for specific instructions.

- c. NSN (Column (3)). The national stock number for the item is listed in this column.
- d. CAGE (Column (4)). The commercial and Government Entity Code (CAGE) is a 5-digit alphanumeric code which is used to identify the manufacturer, distributor, or Government agency, etc., that supplies the item.
- e. PART NUMBER (Column (5)). Indicates the primary number used by the manufacturer

(individual, company, firm, corporation, or Government activity), which controls the design and characteristics of the item by means of its engineering drawings, specification standards, and inspection requirements to identify an item or range of items.

NOTE: When you use an NSN to requisition an item, the item you receive may have a different part number from the part ordered.

- f. DESCRIPTION AND USABLE ON CODE (UOC) (Column (6)). This column includes the following information:
- (1). The Federal item name and, when required, a minimum description to identify the item.
 - (2) The physical security classification of the item is indicated by the parenthetical entry (insert applicable physical security classification abbreviation, e.g., Phy Sec C1 (C) confidential, phy Sec Ca (S) Secret, Phy Sec C1 (T) Top Secret).
 - (3) Items that are included in kits and sets are listed below the name of the kit or set.
 - (4) Spare/repair parts that make up an assembled item are listed immediately following the assembled item line entry.
 - (5) Part numbers for bulk materials are referenced in this column in the line item entry for the item to be manufactured /fabricated.
 - (6) When the item is not used with all serial numbers of the same model, the effective serial numbers are shown on the last line of the description (before UOC).
 - (7) The usable on code, when applicable (see paragraph C-5, Special Information).
 - (8) In the Special Tools List section, the basis of the issue (BOI) appears as the last line(s) in the entry for each special tools, special TMDE, and other special support equipment. When density of equipment's supported exceeds density spread indicated in the basis of issue, the total authorization is increased proportionately.
 - (9) The statement "END OF FIGURE" appears just below the last item description in Column (5) for given figure in both Section II and Section III.
- g. QTY (Column (7)). The QTY (quantity per figure column) indicated the quantity of the item used in the breakout shown on the illustration figure, which is prepared for a functional group, sub function group, or an assembly. A "V" appearing in this column in lieu of a quantity indicated that the quantity is variable and the quantity may vary from application to application.

C-4 EXPLANATION OF COLUMNS (SECTION IV)

a. NATIONAL STOCK NUMBER (NSN) INDEX

- (1). STOCK NUMBER COLUMN this column lists the NSN by National Item Identification Number (NIIN) sequence. The NIIN consists of the last nine digits of the NSN.

Example: 5305-01-674-1467 NIIN

When using this column to locate an item, ignore the first 4 digits of the NSN. However, the complete NSN should be used when ordering items by stock number.

- (2) FIG. Column this column lists the number of the figure where the item is identified/located. the figures are in numerical order in Section II and Section III.
- (3) ITEM Column The item number identifies the item associated with the figure listed in the adjacent FIG. column. This item is also identified by the NSN listed on the same line.

b. PART NUMBER INDEX Part numbers in this index are listed by part number in ascending alphanumeric sequence (i.e., vertical arrangement of letter and number combination which places the first letter of digit of each group in order A through Z, followed by the numbers 0 through 9 and each following letter or digit in like order).

- (1) CAGE Column Commercial and Government Entity Code (CAGE) is a 5-digit alphanumeric code used to identify the manufacturer, distributor, or Government agency, etc. that supplies the item.
- (2) PART NUMBER Column Indicates the primary number used by the manufacturer (individual, form, corporation, or Government activity), which controls the design and characteristics of the item by means of its engineering drawings, specifications standards, and inspection requirements to identify an item or range of items.
- (3) STOCK NUMBER Column This column lists the NSN for the associated part number and manufacturer identified in the PART NUMBER and CAGE columns to the left.
- (4) FIGURE. Column This column lists the number of the figure where the item is identified/located in Section II and III.
- (5) ITEM Column The item number is that number assigned to the item as it appears in the figure referenced in the adjacent figure number column.

C-5 SPECIAL INFORMATION Use the following subparagraphs as applicable:

a. USABLE ON CODE The usable on code appears in the lower left corner of the Description column heading. Usable on codes are shown as "UOC:" in the Description Column justified left) on the first line applicable item description of the usable on codes used in the RPSTL are:

Code	Used On
N/A	N/A

- b. FABRICATION INSTRUCTIONS Bulk materials required to manufacture items are listed in the Bulk Materials functional Group of the RPSTL. Part number of bulk materials are also referenced in the description column of the line item entry for the item to be manufactured/fabricated.
- c. ASSEMBLY INSTRUCTION N/A
- d. KITS Line item entries for repair parts kits appear in a group in Section II.
- e. INDEX NUMBERS Items which are the work BULK in the figure column will have an index number shown in the item number column. This index number is a cross-reference between the National Stock Number/Part Number Index and the bulk material list in Section II.
- f. ASSOCIATED PUBLICATIONS - N/A

C-6. HOW TO LOCATE REPAIR PARTS

a. When National Stock Number or Part Number is not known:

- STEP 1 Using the table of contents, determine the assembly group or subassembly group to which the item belongs. This is necessary since figures are prepared for assembly and subassembly groups, and lists are divided into the same groups.
- STEP 2 Find the figure covering the assembly group or subassembly group to which the item belongs.
- STEP 3 Identify the item on the figure and note the item number.
- STEP 4 Refer to the Repair Parts List for the figure to find the part number for the item number noted on the figure.
- STEP 5 Refer to the Part Number Index to find the NSN, if assigned.

b. When National Stock Number or Part Number is known:

- STEP 1 Using the Index of National Stock Numbers and Part Numbers, find the pertinent National Stock Number or Part Number. The NSN index is in National Item Identification Number (NIIN) sequence. The part numbers in the Part Number Index are listed in ascending alphanumeric sequence. Both indexes cross-reference you to the illustration figure and Item Number of the item you are looking for.
- STEP 2 After finding the figure and item number, verify that the item is the one you are looking for, then locate the item number in the repair parts list for the figure.

SECTION II. Repair Parts List

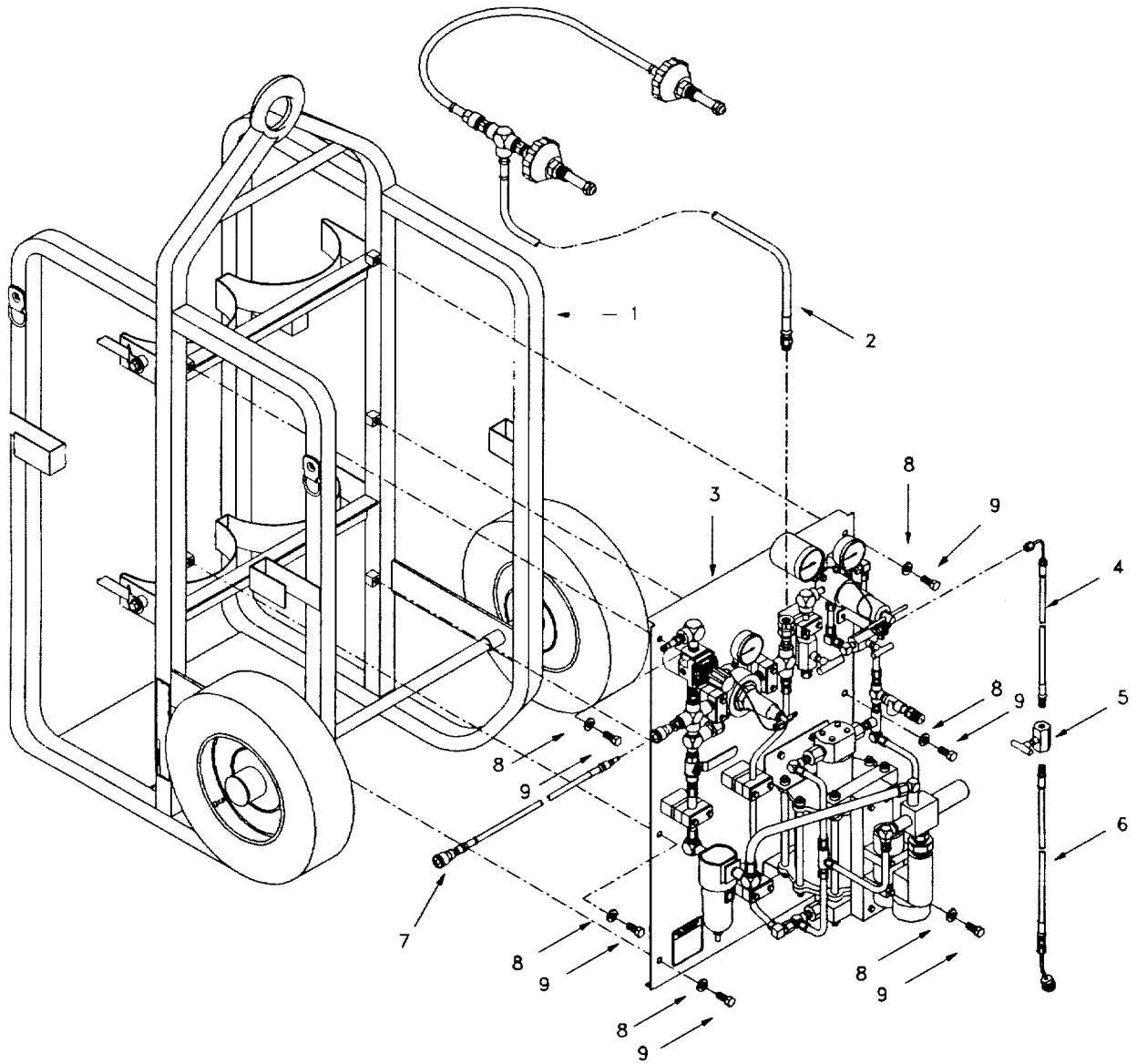

Figure C-1. HIGH PRESSURE NITROGEN SERVICING CART

(1) ITEM NO.	(2) SMR CODE QTY	(3) NSN	(4) CAGEC	(5) PART NUMBER	(6) DESCRIPTION AND USABLE ON CODE (UOC)	(7)
1	PBOFF		4G303	CA033	Assy, Hand Truck (see figure C-7)	1
2	PAOOO		4G303	HA003	Assy, Tank Connector (see figure C-9)	1
3	PBOFF		4G303	PA004	Panel Assy, Booster (see figure C-2)	1
4	PAOZZ		4G303	HA057	Assy-Hose, High Pressure	1
5	PAOZZ		61049	9698935	Valve, High Press Shut-Off	1
6	PAOOO		4G303	HA058	Hose Assy, Whip (see figure C-10)	1
7	PAOOO		4G303	HA056	Hose Assy, Tire Filling (see figure C-10)	1
8	PAOZZ		4G303	F015SP	Washer-Lock, 1/2, grd 8	6
9	PAOZZ		4G303	F005SP	Bolt-Hex, 1/2-13 x 1, grd 8	6

END OF FIGURE

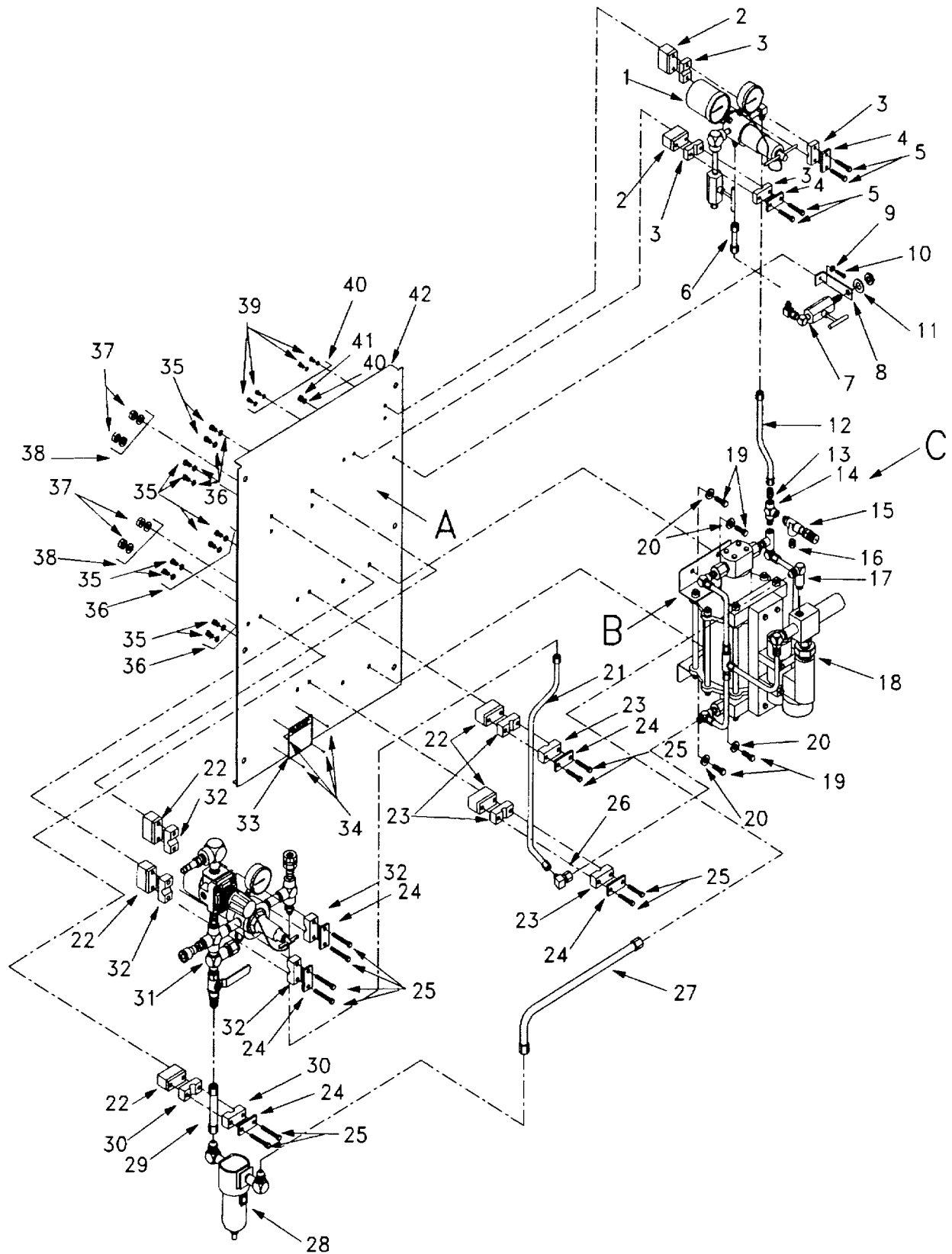

Figure C-2. BOOSTER PANEL ASSEMBLY (PA004) (1 of 4)
C-10

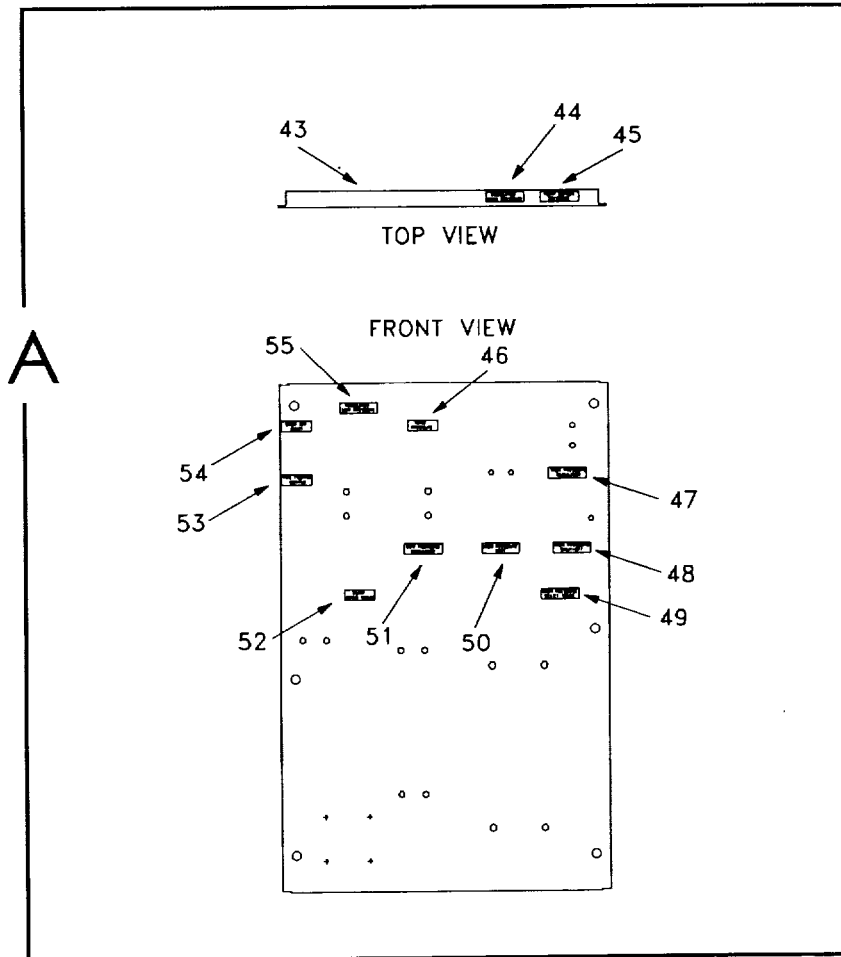

Figure C-2. BOOSTER PANEL ASSEMBLY (PA004) (2 of 4)

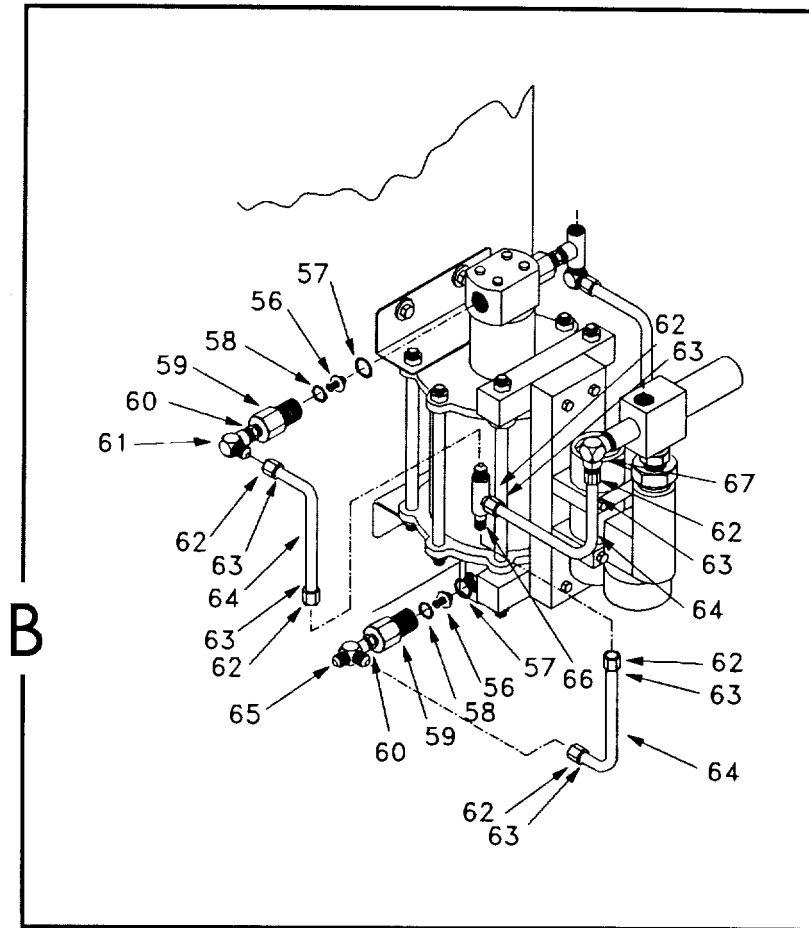

Figure C-2. BOOSTER PANEL ASSEMBLY (PA004) (3 of 4)

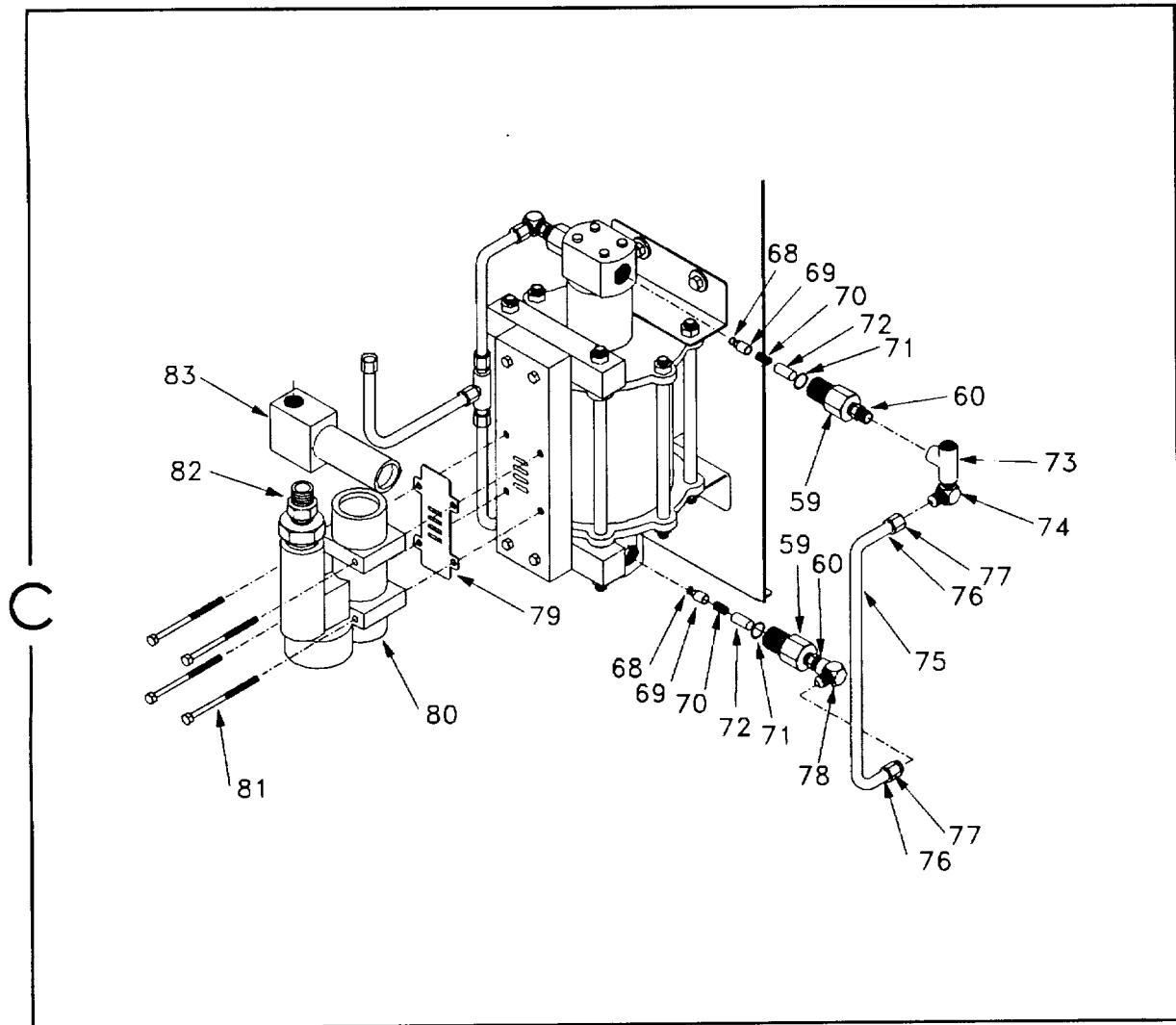

Figure C-2. BOOSTER PANEL ASSEMBLY (PA004) (4 of 4)

(1) ITEM NO.	(2) SMR CODE	(3) NSN	(4) CAGE	(5) PART NUMBER	(6) DESCRIPTION AND USABLE ON CODE (UOC)	(7) QTY
GROUP: 01 FIGURE C-2.						
PANEL ASSY, BOOSTER (PA004)						
1	PAOOO		4G303	PA006	Assy, High Pressure Regulator (see figure C-4)	1
2	PAOZZ		4G303	PA016	Clamp, Base	2
3	PAOZZ		61028	A-25P-C	Cushion, 1/4 Pipe Clamp	4
4	PAOZZ		4G303	PA016-T	Top, Clamp	2
5	PAOZZ		4G303	F018SP	Bolt, 5/16-18 x 1-1/2	4
6	PAOZZ		4G303	PA013	Tube Assy	1
7	PAOOO		4G303	PA008	Assy. High Pressure Shutoff (see figure C-6)	1
8	PAOZZ		4G303	PA017	Bracket, High Press Shut-Off	1
9	PAOZZ		40303	F007SP	Washer-Flat, 1/4, grd 8	1
10	PAOZZ		4G303	F002SP	Bolt-Hex, 1/4-20 x 3/4, grd 8	1
11	PAOZZ		4G303	F020SP	Flatwasher, 7/16	1
12	PAOZZ		4G303	PA012	Tube Assy	1
13	PAOZZ		1U339	2404-4-4SP	Fitting, Flared	1
14	PAOZZ		1U339	5602-4SP	Fitting, Pipe	1
15	PAOZZ		91816	RV54-1	Valve, High Pressure Relief	1
16	PAOZZ		OB8K7	ASP-2BV	Vent, Breather	1
17	PAOZZ		1U339	2501-LL-8-8SP	Fitting, Flared Elbow	1
18	PBOLL		86768	93639-11	Pump, Booster	1
19	PAOZZ		4G303	F004SP	Bolt-Flat, 3/8-16 x 3/4, grd 8	4
20	PAOZZ		40303	F011SP	Washer-Flat, 3/8, grd 8	4
21	PAOZZ		4G303	PA011	Tube Assy	1
22	PAOZZ		4G303	PA015	Clamp, Base	5
23	PAOZZ		61028	B-37T-C	Cushion, 3/8 Tube Clamp	4
24	PAOZZ		4G303	PA015-T	Top, Clamp	5
25	PAOZZ		4G303	F019SP	Bolt, 5/16-18x2	10
26	PAOZZ		1U339	6500-6-6SP	Fitting, Flared	1
27	PAOZZ		4G303	PA010	Tube Assy	1
28	PAOOO		4G303	PA007	Assy, Low Pressure Filter (see figure C-5)	1
29	PADZZ		4G303	PA009	Tube Assy	1
30	PAOZZ		61028	B-50T-C	Cushion, 1/2 Tube Clamp	2
31	PAOOO		4G303	PA005	Assy, Low Pressure Regulator (see figure C-3)	1
32	PAOZZ		61028	B-50P-C	Cushion, 1/2 Pipe Clamp	4
33	XDFZZ		4G303	PA018	Nameplate, Top Assy	1
34	PAOZZ		10054	MS24243	Rivet	4
35	PAOZZ		4G303	F003SP	Bolt-Hex, 5/16-18x1/2, grd 8	10
36	PAOZZ		4G303	F010SP	Washer-Lock, 5/16, grd 8	10
37	PAOZZ		4G303	F013SP	Nut-Hex, 3/8-16, grd 8	4
38	PAOZZ		4G303	F012SP	Washer-Lock, 3/8, grd 8	4
39	PAOZZ		4G303	F001SP	Bolt-Hex, 1/4-20 x 1/2, grd 8	4
40	PAOZZ		4G303	F008SP	Washer-Lock, 1/4, grd 8	5
41	PAOZZ		4G303	F009SP	Nut-Hex, 1/4-20, grd 8	1
42	XDOZZ		4G303	PA060	Panel, Steel Mtg (w/labels)	1
43	XDOZZ		4G303	PA014	.Panel, Steel Mounting	1
44	PAOZZ		40303	PA023	.Label, "Regulated High Pressure"	1
45	PAOZZ		4G303	PA024	.Label, "Pump Outlet Pressure"	1
46	PAOZZ		4G303	PA028	.Label, "Tank Pressure"	1
47	PAOZZ		4G303	PA022	.Label, "High Press. Regulator"	1
48	PAOZZ		4G303	PA026	.Label, "High Press. Shut Off"	1
49	PAOZZ		4G303	PA025	.Label, "High Press. Relief Vlive"	1

(1) ITEM NO.	(2) SMR CODE	(3) NSN	(4) CAGE	(5) PART NUMBER	(6) DESCRIPTION AND USABLE ON CODE (UOC)	(7) QTY
GROUP: 01 FIGURE C-2. PANEL ASSY, BOOSTER (PA004)						
50	PAOZZ		4G303	PA019	.Label,"High Pressure Vent"	1
51	PAOZZ		4G303	PA020	.Label,"Low Pressure Regulator"	1
52	PAOZZ		4G303	PA030	.Label,"Pump Drive Valve"	1
53	PAOZZ		4G303	PA027	.Label,"Tire Filling Output"	1
54	PAOZZ		4G303	PA029	.Label,"Shop Air Inlet"	1
55	PAOZZ		4G303	PA021	.Label,"Regulated Low Pressure"	1
REF	PBOLL		86768	93639-11	Pump,Booster	1
56	PAFZZ		86768	89780	.Subassy,Inlet Check Valve Part of Kit p/n 93651	2
57	PAFZZ		86768	91417-019	.O-ring Part of Kit p/n 93651	2
58	PAFZZ		86768	91417-016-1	.O-ring Part of Kit p/n 93651	2
59	PAFZZ		86768	90868	.Check Valve Body	4
60	PAFZZ		86768	93644	.Nipple,Male	4
61	PAFZZ		86768	93645-2	.Elbow,Male	1
62	PAFZZ		1U339	318-6SP	.Nut,3/8 Tube	6
63	PAFZZ		1U339	319-6SP	.Sleeve,3/8 Tube	6
64	PAFZZ		86768	304SS-3/8	. Tubing,3/8,304 Stnls Stl.,.049	V
65	PAFZZ		86768	93647	.Tee,Female Run	1
66	PAFZZ		86768	93648	.Tee,Union	1
67	PAFZZ		86768	93646-2	.Elbow,Female	1
68	PAFZZ		86768	79550-5-1	.O-ring Part of Kit p/n 93652	2
69	PAFZZ		86768	89297	.Poppet,Outlet Check Valve Part of Kit p/n 93652	2
70	PAFZZ		86768	5-216-63	.Spring,Outlet Check Valve Part of Kit p/n 93652	2
71	PAFZZ		86768	91417-016-1	.O-ring Part of Kit p/n 93652	2
72	PAFZZ		86768	91662	.Spacer	2
73	PAFZZ		86768	93649	.Tee,Female Pipe	1
74	PAFZZ		86768	93645-1	.Elbow,Male	1
75	PAFZZ		86768	304SS-1/4	.Tubing,1/4,304 Stnls Stl.,.035	V
76	PAFZZ		1U339	319-4SP	.Sleeve,1/4	2
77	PAFZZ		1U339	318-4SP	.Nut,1/4 Tube	2
78	PAFZZ		86768	93646-1	.Elbow,Female	1
79	PAFZZ		86768	91462	.Gasket,Air Valve	1
80	PAFZZ		86768	93622	.Air Pilot Valve	1
81	PAFZZ		86768	92124-06B18Z.	Hex. Head Screw,1/4 20 x 2 1/2	4
82	PAFZZ		86768	1/2FF-B	.Pipe Nipple	1
83	PAFZZ		86768	93622	.Valve, Air Pilot	1
	PAOZZ		86768	93651	Repair Kit,Inlet Check Valve Subassy,Inlet Check Valve O-ring O-ring	V 1 1 1
	PAOZZ		86768	93652	Repair Kit,Outlet Check Valve Poppet,Outlet Check Valve O-ring Spring,Outlet Check Valve O-ring	V 1 1 1 1

END OF FIGURE

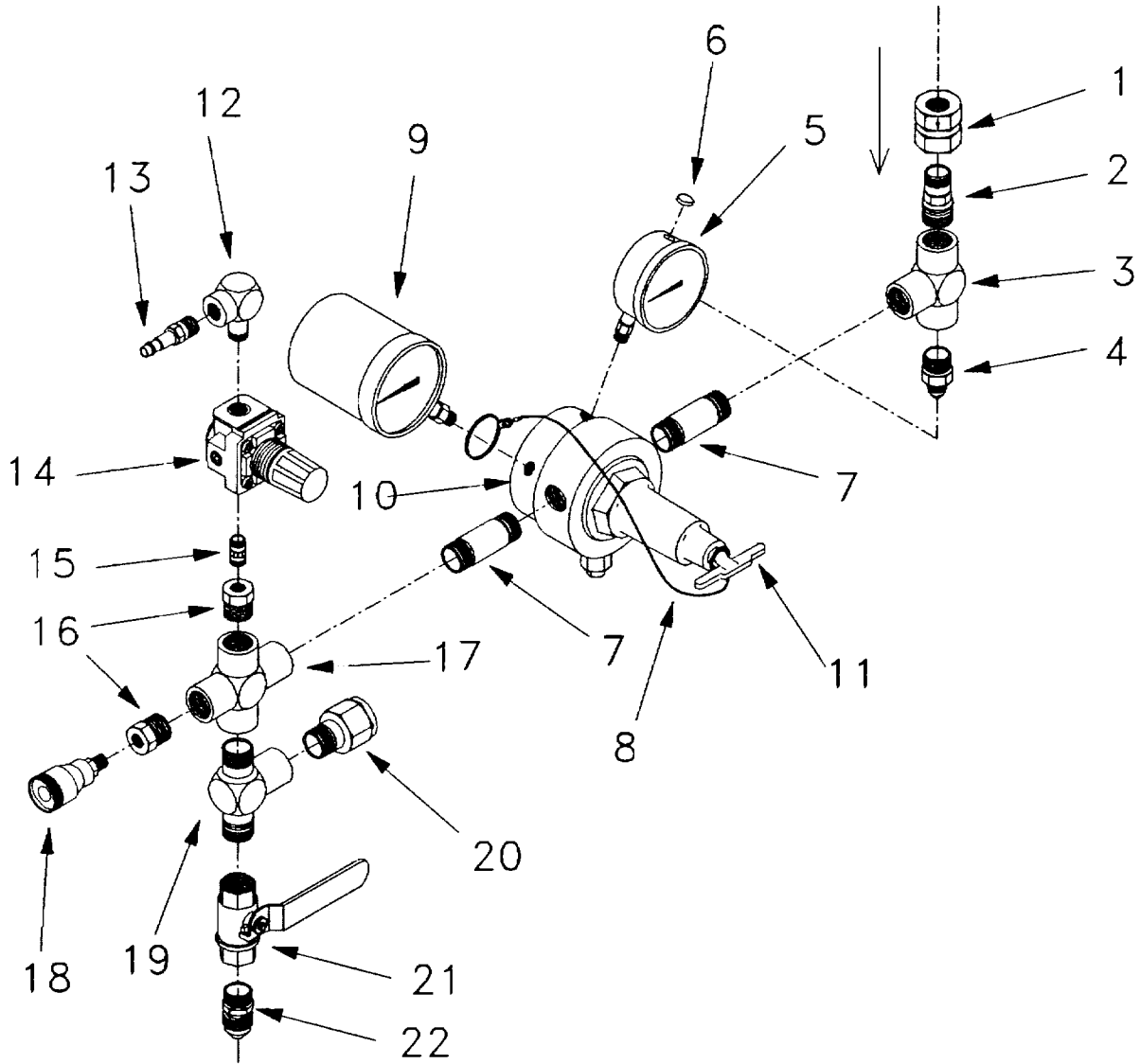

Figure C-3. LOW PRESSURE REGULATOR ASSEMBLY (PA005)

(1) ITEM NO.	(2) SMR CODE	(3) NSN	(4) CAGE	(5) PART NUMBER	(6) DESCRIPTION AND USABLE ON CODE (UOC)	(7) QTY
GROUP: 0101 FIGURE C-3. REGULATOR ASSY, LOW PRESSURE (PA005)						
1	PAOZZ		59165	4205T-3PP	Filter,High Pressure	1
2	PAOZZ		1U339	5404-8-6SP	Nipple,Reducing Pipe	1
3	PAOZZ		1U339	5605-8SP	Tee,Pipe	1
4	PAOZZ		1U339	2404-6-8SP	Fitting,Flared	1
5	PAOOO		61049	9767150	Gauge,Tank Pressure	1
6	PAOZZ		61049	534-307	.Cap,Fill	1
7	PAOZZ		1U339	5404-N-8-2.5SP	Nipple,Pipe	2
8	PAOZZ		99862	CL-51-KA-8.00-16-9R	Wire,Retention	1
9	PAOZZ		59018	123NID07A21-X	Gauge,Regulated Low Press	1
10	PAOOO		63026	SR700E-500-VIC-0797 0233	Regulator,Low Pressure	1
11	PAOZZ		63026	0750-0007	.T-Handle,Regulator	1
12	PAOZZ		1U339	5504-4SP	Elbow,Pipe	1
13	PAOZZ		60515	P-341B	Nipple,Quick Disconnect	1
14	PAOZZ		55470	NAR2500-N02	Regulator,Shop Air	1
15	PAOZZ		29771	CMM020SS2	Valve,Low Pressure Check	1
16	PAOZZ		1U339	5406-8-4SP	Bushing,Hex Pipe	2
17	PAOZZ		1U339	5652-8SP	Cross,Pipe	1
18	PAOZZ		60515	DM-341	Socket,Quick Disconnect	1
19	PAOZZ		1U339	5601-8-8-8SP	Tee. Male Run Pipe	1
20	PAOZZ		91816	RV06-43	Valve,Low Pressure Safety	1
21	PAOZZ		60515	VMH2-A9-1/2	Valve,Shut-Off Ball	1
22	PAOZZ		1U339	2404-8-8SP	Fitting,Flared Str	1

END OF FIGURE

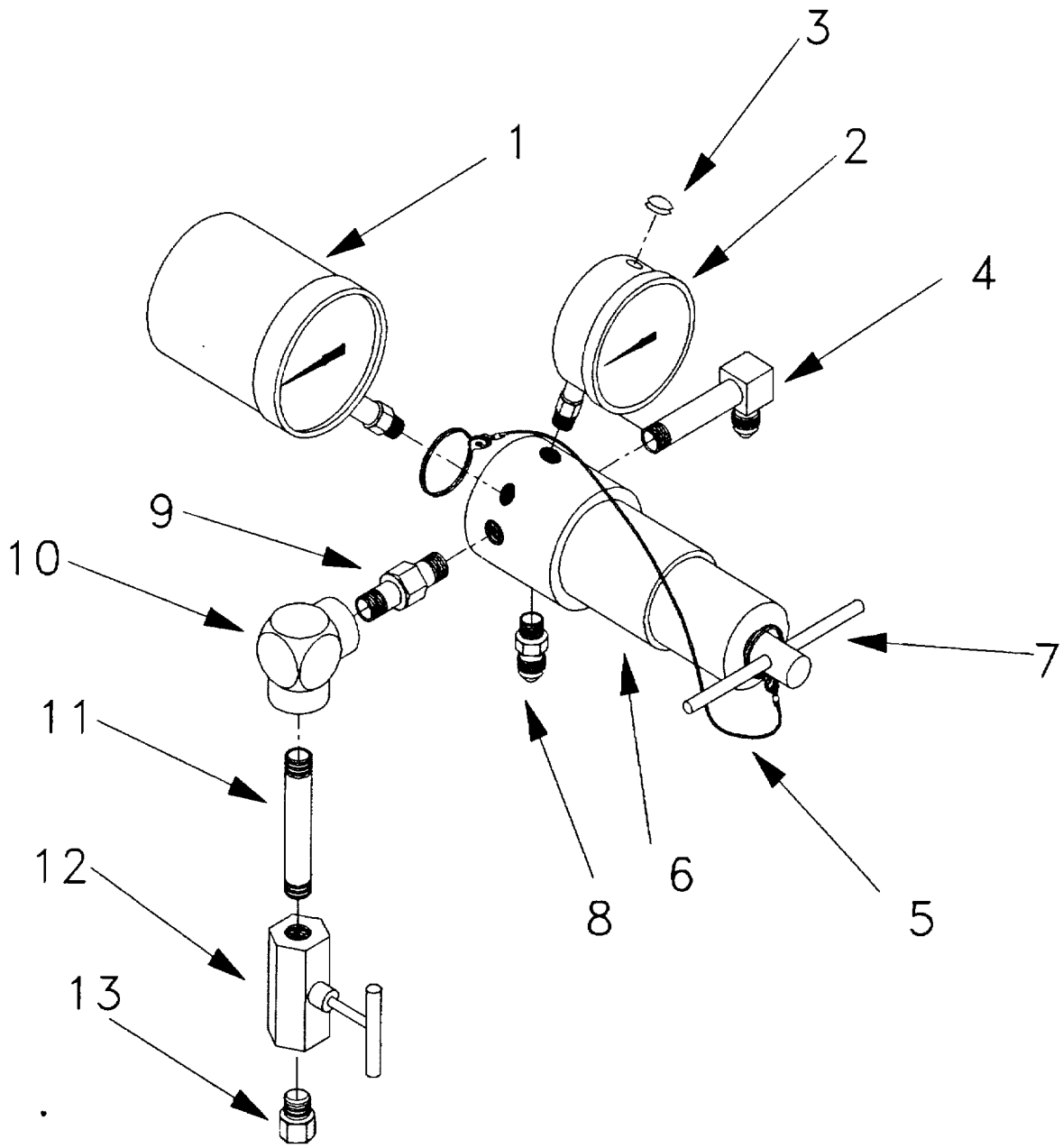

Figure C-4. HIGH PRESSURE REGULATOR ASSEMBLY (PA006)

(1) ITEM NO.	(2) SMR CODE	(3) NSN	(4) CAGE	(5) PART NUMBER	(6) DESCRIPTION AND USABLE ON CODE (UOC)	(7) QTY
GROUP: 0102 FIGURE C-4. REGULATOR ASSY, HIGH PRESSURE (PA006)						
1	PAOZZ		59018	123NID15A21-X	Gauge,Regulated High Pressure	1
2	PAOOO		61049	9767169	Gauge,Booster Output Pressure	1
3	PAOZZ		61049	534-307	.Cap,Fill	1
4	PAOZZ		1U339	2501-LL-4-4SP	Fitting,Flared Elbow	1
5	PAOZZ		99862	CL-51-KA-8.00-16-9R	Wire,Retention	1
6	PAOOO		63026	SR4K-250-VIC-0797-0232	Regulator,High Pressure	1
7	PAOZZ		63026	0750-0049	.T-Handle,Regulator	1
8	PAOZZ		1U339	2404-4-4SP	Fitting,Flared	1
9	PAOZZ		1U339	5404-4-4SP	Nipple,Pipe	1
10	PAOZZ		1U339	5504-4SP	Elbow,Pipe	1
11	PAOZZ		1U339	5404-N-4-3.0SP	Nipple,Pipe	1
12	PAOZZ		61049	9698935	Valve,High Press Shut-Off	1
13	PAOZZ		OB8K7	ASP-2BV	Vent,Breather	1

END OF FIGURE

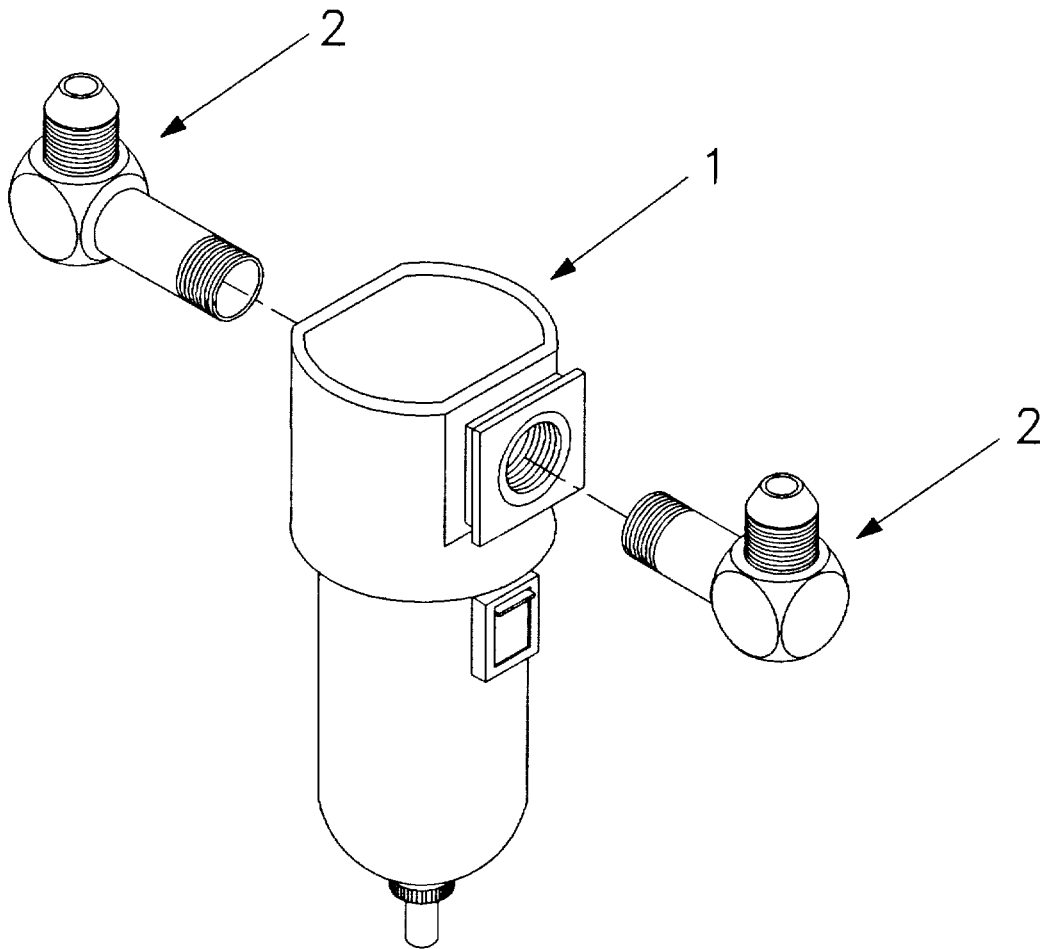

Figure C-5. LOW PRESSURE FILTER ASSEMBLY (PA007)

(1) ITEM NO.	(2) SMR CODE	(3) NSN	(4) CAGE	(5) PART NUMBER	(6) DESCRIPTION AND USABLE ON CODE (UOC)	(7) QTY
GROUP: 0103 FIGURE C-5. FILTER ASSY, LOW PRESSURE (PA007)						
1	PAOZZ		98963	F26-04-FMO	Filter,Low Pressure	1
2	PAOZZ		1U339	2501-8-8SP	Fitting,Flared Elbow	2

END OF FIGURE

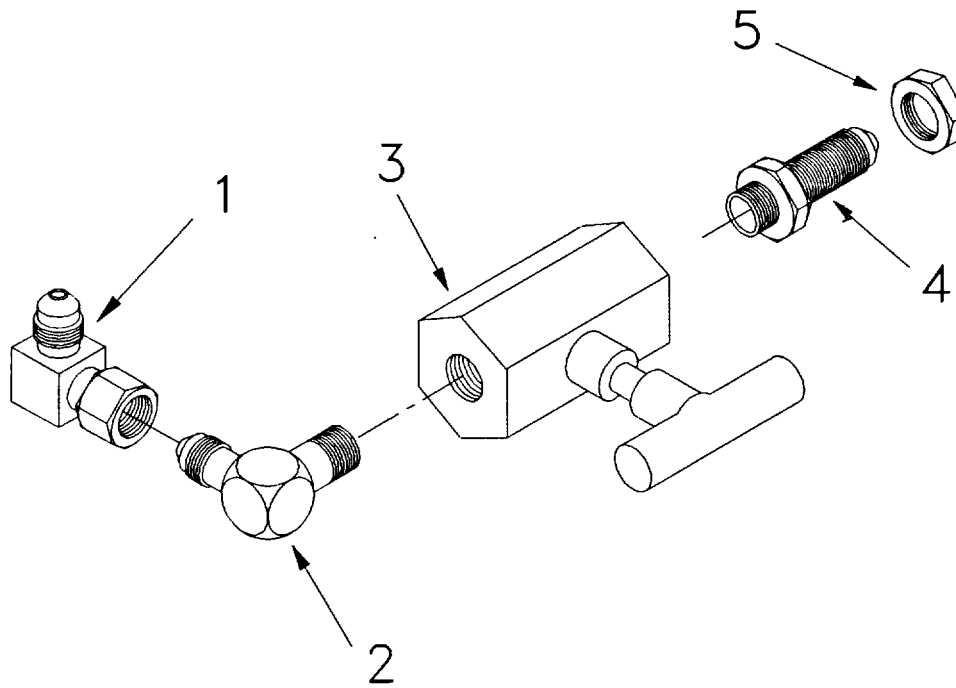

Figure C-6. HIGH PRESSURE SHUT-OFF ASSEMBLY (PA008)

(1) ITEM NO.	(2) SMR CODE	(3) NSN	(4) CAGE	(5) PART NUMBER	(6) DESCRIPTION AND USABLE ON CODE (UOC)	(7) QTY
<p>GROUP: 0104 FIGURE C-6. SHUTOFF ASSY, HIGH PRESSURE (PA008)</p>						
1	PAOZZ		1U339	6500-4-4SP	Fitting, Swivel Nut Tube	1
2	PAOZZ		1U339	2501-4-4SP	Fitting, Flared Elbow	1
3	PAOZZ		61049	9698935	Valve, High Press Shut-Off	1
4	PAOZZ		1U339	2706-4-4SP	Fitting, Flared-Bulkhead	1
5	PAOZZ		1U339	0306-4SP	Nut, Bulkhead Fitting	1

END OF FIGURE

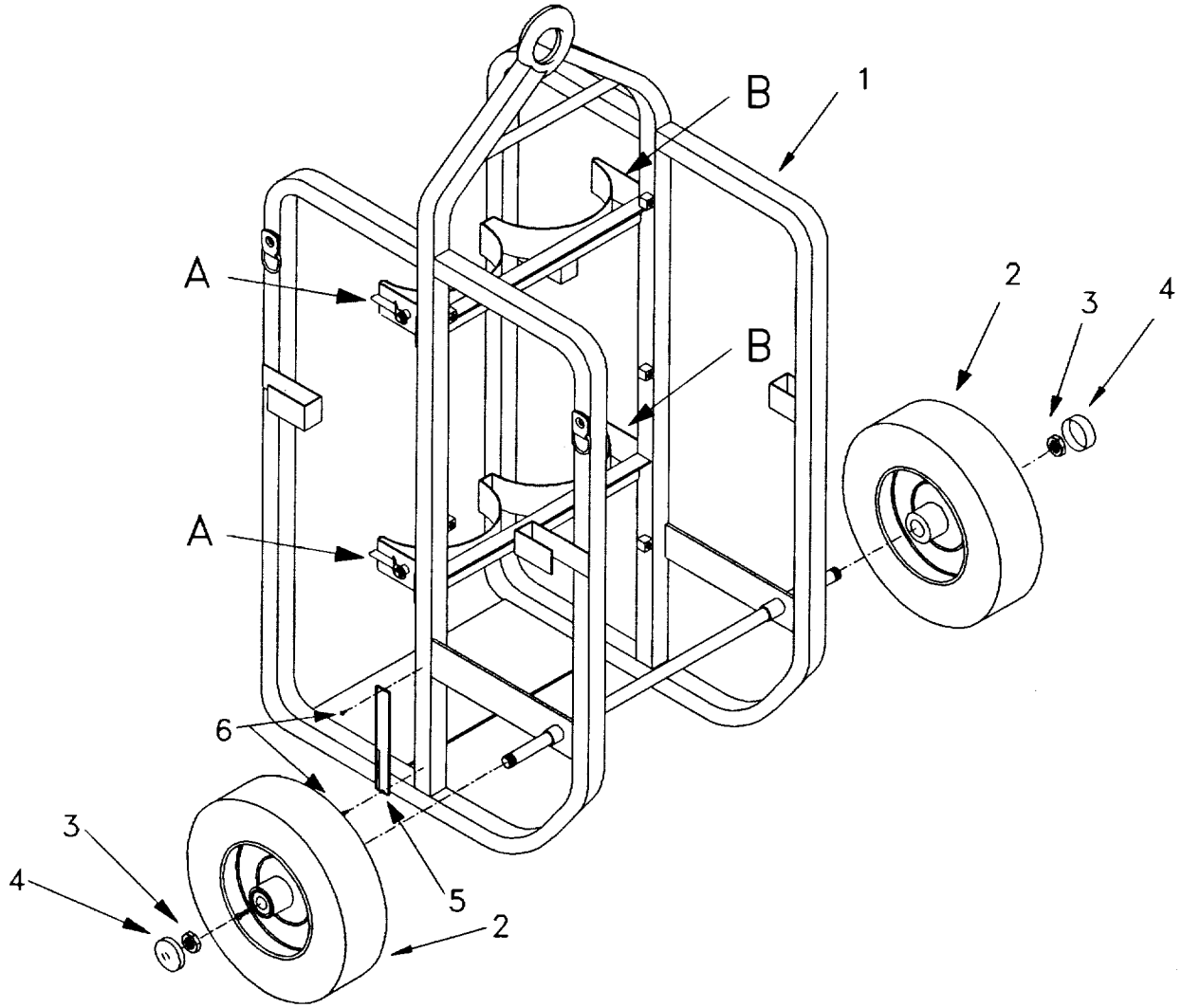

Figure C-7. HAND TRUCK ASSEMBLY (CA033) (1 of 2)

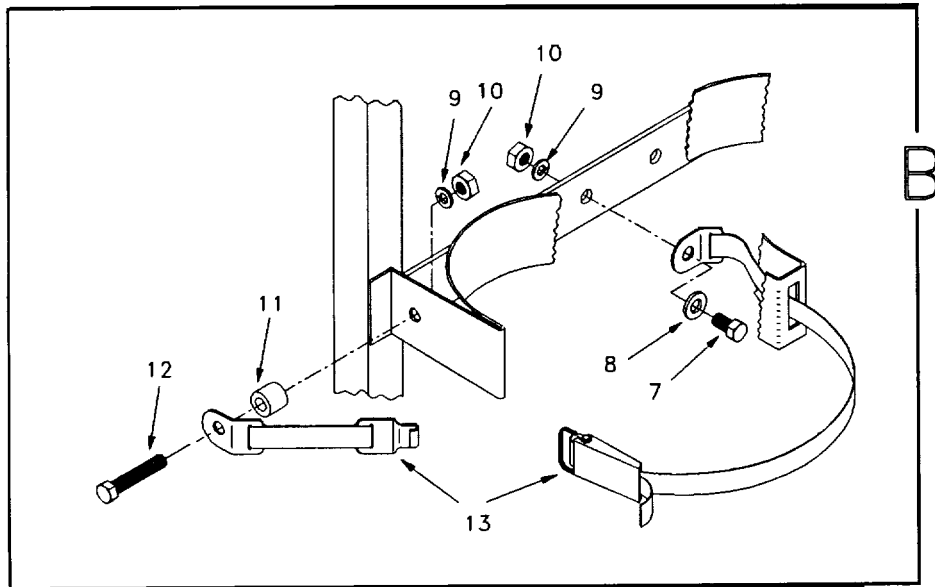
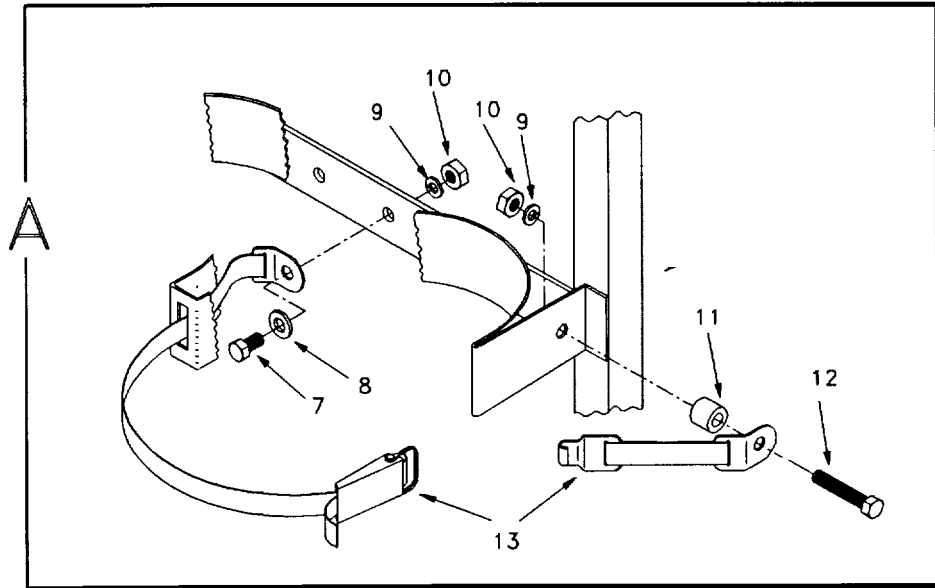

Figure C-7. HAND TRUCK ASSEMBLY (CA033) (2 of 2)

(1) ITEM NO.	(2) SMR CODE	(3) NSN	(4) CAGE	(5) PART NUMBER	(6) DESCRIPTION AND USABLE ON CODE (UOC)	(7) QTY
GROUP: 02 FIGURE C-7. TRUCK ASSY, HAND (CA033)						
1	PBOFF		4G303	CA034	Chassis,Hand Truck	1
2	PAOOO		4G303	CA053	Assy,Wheel and Tire (see figure C-8)	2
3	PAOZZ		4G303	F017SP	Jam Nut	2
4	PAOZZ		62081	2.25-1 9238-2	Dustcap, Vinyl, 2.25xl	2
5	XDFZZ		4G303	CA052	Nameplate,Hand Truck	1
6	PAOZZ		10054	MS24243	Rivet	2
7	PAOZZ		4G303	F005SP	Bolt-Hex,1/2-13 x 1,grd 8	4
8	PAOZZ		4G303	F014SP	Flat Washer	4
9	PAOZZ		4G303	F015SP	Washer-Lock,1/2,grd 8	8
10	PAOZZ		4G303	F016SP	Machine Nut	8
11	PAOZZ		4G303	CA049	Spacer,Strap Mounting	4
12	PAOZZ		4G303	F006SP	Hex Bolt	4
13	PAOZZ		4G303	CA050	Strap,Tank Retention	4

END OF FIGURE

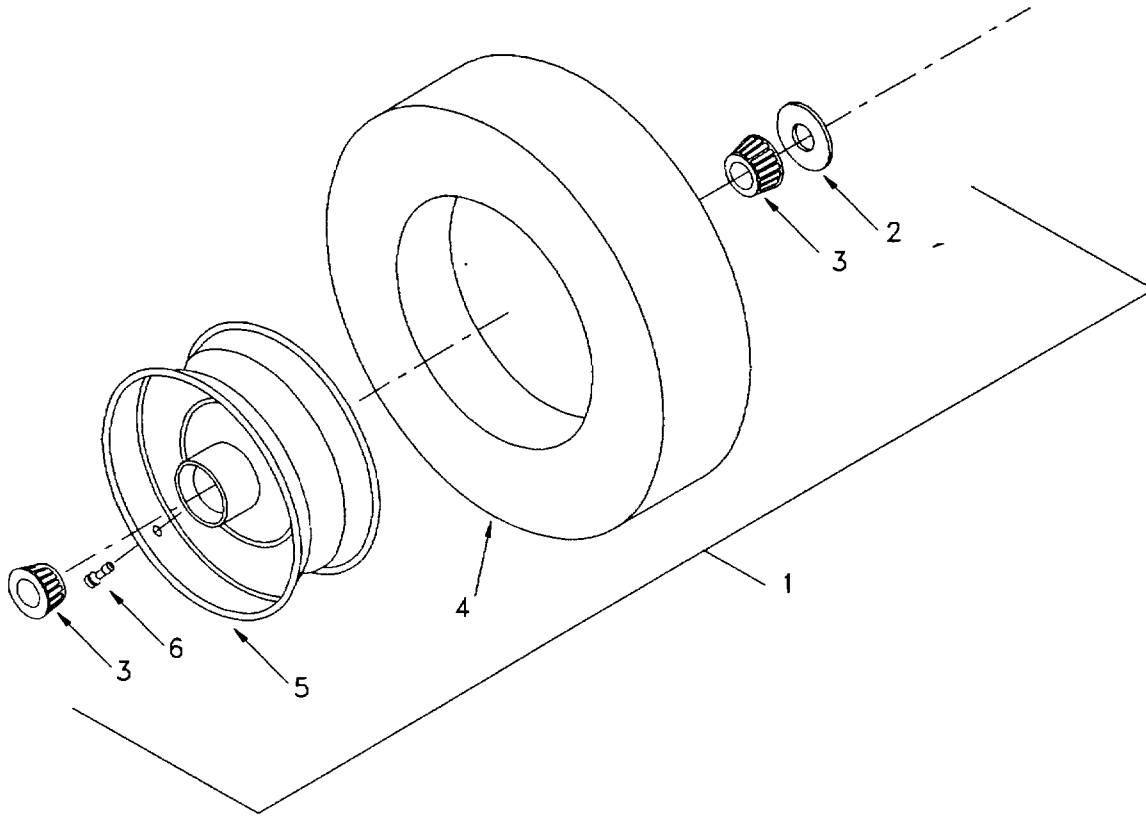

Figure C-8. WHEEL AND TIRE ASSEMBLY (CA053)

(1) ITEM NO.	(2) SMR CODE	(3) NSN	(4) CAGE	(5) PART NUMBER	(6) DESCRIPTION AND USABLE ON CODE (UOC)	(7) QTY
GROUP: 0201 FIGURE C8. WHEEL AND TIRE ASSY (CA053)						
1	PAOOO		4G303	10-0059	Assy,Wheel and Tire	1
2	PAOZZ		4G303	30-429	.Seal, Grease	1
3	PAOZZ		4G303	30-427	.Bearing	2
4	PAOZZ		4G303	10-005	.Tire, 480-8 Highway Rib	1
5	PAOZZ		4G303	30-399W	.Wheel, 8x3.75, white	1
6	PAOZZ		27783	413	.Valve Stem	1

END OF FIGURE

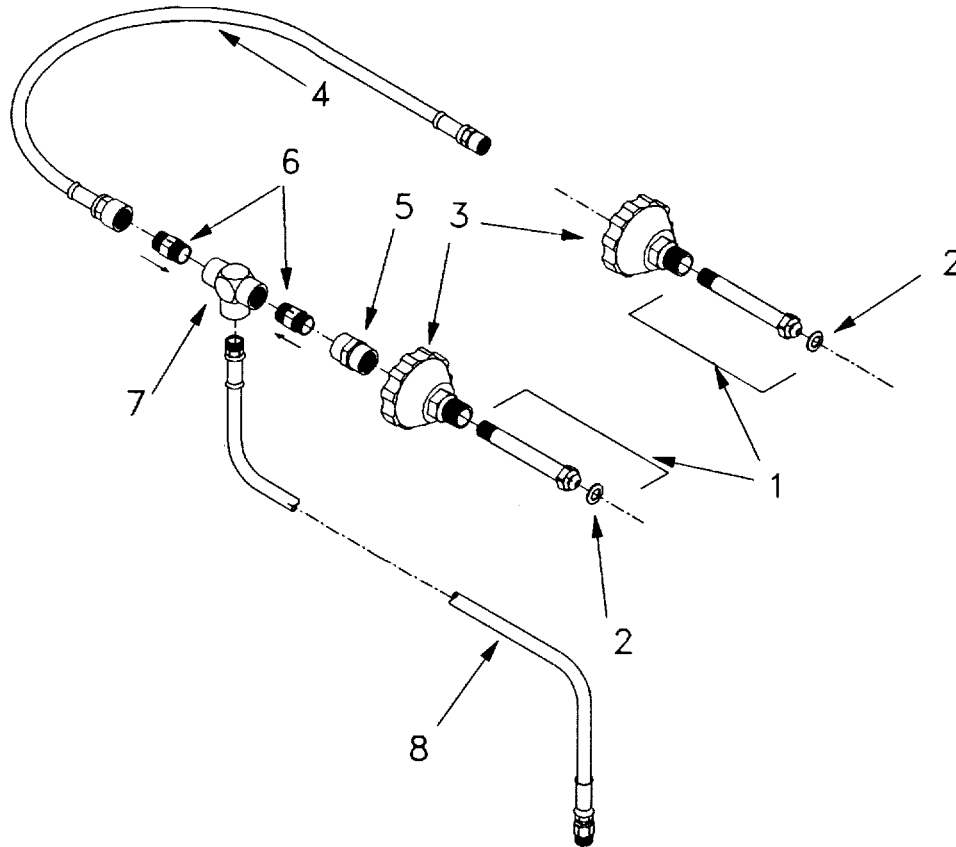

Figure C-9. TANK CONNECTOR ASSEMBLY (HA003)

(1) ITEM NO.	(2) SMR CODE	(3) NSN	(4) CAGE	(5) PART NUMBER	(6) DESCRIPTION AND USABLE ON CODE (UOC)	(7) QTY
GROUP: 03 FIGURE C-9. CONNECTOR ASSY, TANK (HA003)						
1	PAOOO		16166	615-3SF	Nipple,Connector,CGA580	2
2	PAOZZ		16166	RO-11V	.O-ring	2
3	PAOZZ	4730-01-300-3048	16166	692P	Nut,Hand Tight, CGA580	2
4	PAOZZ		4G303	RA054	Assy,Tank Hose	1
5	PAOZZ		1U339	5000-6-48P	Coupling,Reducing Pipe	1
6	PAOZZ		29771	CWI025SS	Valve,Check-High Pressure	1
7	PAOZZ		1U339	5605-6SP	Tee,Pipe	1
8	PAOZZ		4G303	HA055	Assy,Panel Hose	1

END OF FIGURE

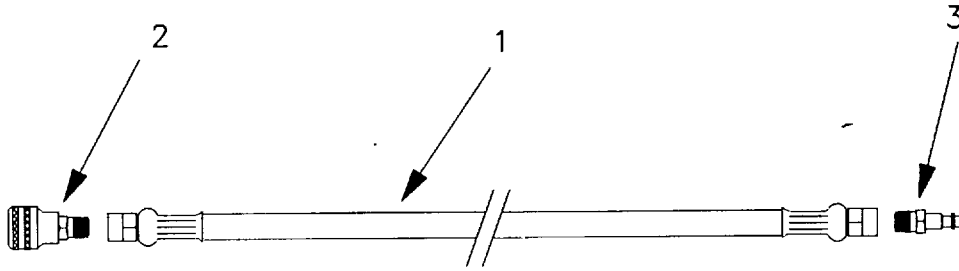

Figure C-10. TIRE FILLING HOSE (HA056)

(1) ITEM NO.	(2) SMR CODE	(3) NSN	(4) CAGE	(5) PART NUMBER	(6) DESCRIPTION AND USABLE ON CODE (UOC)	(7) QTY
GROUP: 04 FIGURE C-10. FILLING HOSE, TIRE (HA056)						
1	PAOZZ		4G303	HA056-A	Hose Assembly	1
2	PAOZZ		60515	DM-341	Socket, Quick Disconnect	1
3	PAOZZ		60515	P-341B	Nipple, Quick Disconnect	1

END OF FIGURE

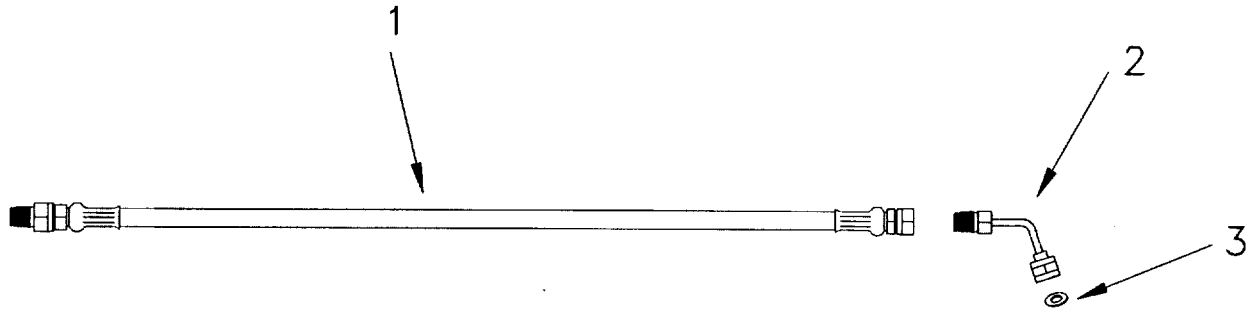

Figure C-11. WHIP HOSE (HA058)

(1) ITEM NO.	(2) SMR CODE	(3) NSN	(4) CAGE	(5) PART NUMBER	(6) DESCRIPTION AND USABLE ON CODE (UOC)	(7) QTY
GROUP: 04 FIGURE C-11. HOSE, WHIP (HA058)						
1	PAOZZ		40303	HA058-A	Hose Assy, Whip	1
2	PAOOO		27783	5784	Chuck, High Pressure Inflating	1
3	PAOZZ		27783	2755-26	.Washer,Copper replacement for fiber washer	1

END OF FIGURE

SECTION III. Special Tools List

NOT APPLICABLE

C-29

**SECTION IV. National Stock Number and
Part Number Index**

CROSS-REFERENCE INDEXES

NATIONAL STOCK NUMBER INDEX

PART NUMBER INDEX

PART NUMBER	FIG.	ITEM	PART NUMBER	FIG	ITEM
0306-4SP	C-6	5	93622	C-2	83
0750-0049	C-4	7	93639-11	C-2	18
0750-7	C-3	11	93644	C-2	60
1/2FF-B	C-2	82	93645-1	C-2	74
10-005	C-8	4	93645-2	C-2	61
10-0059	C-8	1	93646-1	C-2	78
123NID07A21-X	C-3	9	93646-2	C-2	67
123NID15A21-X	C-4	1	93647	C-2	65
2.25-1 9238-2	C-7	4	93648	C-2	66
2404-4-4SP	C-2	13	93649	C-2	73
2404-4-4SP	C-4	6	9698935	C-1	5
24046-8SP	C-3	4	9698935	C4	12
2404-68-SP	C-3	22	9698935	C-6	3
2501-4-4SP	C-6	2	9767150	C-3	5
2501-8-8SP	C-5	2	9767169	C-4	2
2501-LL-4-4SP	C-4	4	A-25P-C	C-2	3
2501-LL-8-8SP	C-2	17	ASP-2BV	C-2	16
2706-4-4SP	C-6	4	ASP-2BV	C-4	13
2755-26	C-11	3	B-37T-C	C-2	23
30-399W	C-8	5	B-50P-C	C-2	30
30-427	C-8	3	B-50T-C	C-2	32
30-429	C-8	2	CA033	C-i	1
318-4SP	C-2	77	CA034	C-7	1
318-6SP	C-2	62	CA049	C-7	11
319-4SP	C-2	76	CA050	C-7	13
319-6SP	C-2	63	CA052	C-7	5
413	C-8	5	CA053	C-7	2
4205T-3PP	C-3	1	CL-51 -KA-8.00-16-9R	C-3	8
5-216-63	C-2	70	CL-51-KA-8.00-16-9R	C-4	5
5-64SP	C-9	5	CMM020SS2	C-3	15
534307	C-3	6	CMM025SS	C-9	6
534307	C-4	3	DM-341	C-10	2
5404-4-4SP	C-4	9	DM-341	C-3	18
54048-6SP	C-3	2	F001 SP	C-2	39
5404-N-43.0SP	C-4	11	F002SP	C-2	10
5404-N-8-2.5SP	C-3	7	F003SP	C-2	35
5406-8-4SP	C-3	16	F004SP	C-2	19
55044SP	C-3	12	F005SP	C-1	9
55044SP	C-4	10	F005SP	C-7	7
5601--8-8SP	C-3	19	F006SP	C-7	12
5602-4SP	C-2	14	F007SP	C-2	9
5605-6SP	C-9	7	F008SP	C-2	40
5605-8SP	C-3	3	F009SP	C-2	41
5652-8SP	C-3	17	F010SP	C-2	36
5784	C-11	2	F011SP	C-2	20
615-3SF	C-9	1	F012SP	C-2	38
6500-4-4SP	C-6	1	F013SP	C-2	37
6500-6-6SP	C-2	26	F014SP	C-7	8
692P	C-9	3	F015SP	C-1	8
79550-5-1	C-2	68	F01 5SP	C-7	9
89297	C-2	69	F016SP	C-7	10
89780	C-2	56	F017SP	C-7	3
90868	C-2	59	F018SP	C-2	5
91417-016-1	C-2	71	F019SP	C-2	25
91417-016-1	C-2	58	F020SP	C-2	11
91417-019	C-2	57	F26-04FMO	C-5	1
91451-2	C-2	80	FPNC-01	C-1	0
91462	C-2	79	HA003	C-1	2
91662	C-2	72	HA054	C-9	4
92124-06B18Z	C-2	81	HA055	C-9	8

PART NUMBER	FIG.	ITEM	PART NUMBER	FIG	ITEM
HA056	C-1	7	PA016-T	C-2	4
HA056-A	C-10	1	PA017	C-2	8
HA057	C-1	4	PA018	C-2	33
HA058	C-1	6	PA019	C-2	50
HA058-A	C-11	1	PA020	C-2	51
MS24243	C-2	34	PA021	C-2	55
MS24243	C-7	6	PA022	C-2	47
NAR2500-NO2	C-3	14	PA023	C-2	44
P-341B	C-10	3	PA024	C-2	45
P-341B	C-3	13	PA025	C-2	49
PA004	C-1	3	PA026	C-2	48
PA005	C-2	31	PA027	C-2	53
PA006	C-2	1	PA028	C-2	46
PA007	C-2	28	PA029	C-2	54
PA008	C-2	7	PA030	C-2	52
PA009	C-2	29	PA060	C-2	42
PA010	C-2	27	RO-111V	C-9	2
PA011	C-2	21	RV06-43	C-3	20
PA012	C-2	12	RV54-1	C-2	15
PA013	C-2	6	SR4K-250-VIC-079	C-4	6
PA014	C-2	43	SR700E-500-VIC-0	C-3	10
PA015	C-2	22	TUBING,1/4	C-2	75
PA015-T	C-2	24	TUBING,3/8	C-2	64
PA016	C-2	2	VMH2-A9-1/2	C-3	21

APPENDIX D

EXPENDABLE/DURABLE SUPPLIES AND MATERIALS LIST

SECTION I. Introduction

D-1. SCOPE

This appendix lists expendable supplies and materials you will need to operate and maintain the High Pressure Nitrogen Servicing Cart. These items are authorized to you by CTA 50-970, Expendable Items (Except Medical, Class V, Repair Parts, and Heraldic Items.)

D-2. EXPLANATION OF CO1UMNS

- a. Column (1). Item Number. This number is assigned to the entry in the listing.
- b. Column (2). Level. This column identifies the lowest level of maintenance that requires the listed it
 - C- Operator/Crew
 - O - Organizational Maintenance
 - F - Direct Support Maintenance
 - H - General Support Maintenance
- c. Column (3). National Stock Number. This is the National Stock number assigned to the item; use it to request or requisition the item.
- d. Column (4). Description. Indicates the Federal item name and, if required, a description to identify the item. The last line for each parentheses followed by the part number.
- e. Column (5). Unit of Measure (U/M). Indicates the measure used in performing the actual maintenance function. This measure is expressed by a two-character alphabetical abbreviations (e.g., ea. in pr). If the unit of measure differs from the unit of issue, requisition the lowest unit of issue that will satisfy your requirements.

EXPENDABLE/DURABLE SUPPLIES AND MATERIALS LIST

(1) Item Number	(2) Level	(3) National Stock Number	(4) Description	(5) Unit of Measure U/M
1	O		Teflon Pipe Thread Tape	SP
2	O		Anaerobic Sealant. Perma Lok LM012	OZ
3	O		Thread Locker, Loctite 271	OZ
4	O		Grease, Lithium wheel bearing	OZ
5	O		Kerosene	OZ
6	O		Shop Towels	EA
7	F		Paint, Touch Up, MIL-C-46168, 383 Green	OZ
8	O		Soap Solution	OZ
9	O		Glycerin	OZ

ALPHABETICAL INDEX

	PAGE
A	
Air Valve Assy	4-16
B	
Before You Operate	2-6
Booster Panel Assembly (PA004), Figure C-2	C-10
Booster Panel Assy - Replace	3-12
Booster Pump - Replace	3-28
Booster Pump Air Pilot Valve - Replace	4-15
Booster Pump Check Valves - Inspection and Repair	4-7
C	
Cautions	a
Check Valve, Upper Inlet	4-8
Check Valve, Lower Inlet	4-9
Check Valve, Upper Outlet.....	4-11
Check Valve, Lower Outlet.....	4-13
Check Valve, Tank Connector Assy	3-37
Clamp Assemblies	3-27
Cleaning	3-3,4-3
Component Locations	1-10
Confidence Test Procedure.....	2-10
Controls and Indicators	2-4
D	
Damping Fluid, Gauge.....	2-6
Depressurizing the Cart.....	2-9
Destruction of Army Materiel.....	1-3
Dimensions	1-4
Drain, Automatic	2-6
E	
Equipment Data	1-4
Equipment Improvement Recommendations (EIRs).....	1-3
Expendable/Durable Supplies and Material List.....	D-2
Extreme Environmental Maintenance.....	2-14
F	
Filter, Porous Bronze	3-38
Filter Element	3-23
Filter Housing	3-23

ALPHABETICAL INDEX

PAGE

G

Grease Seal 3-31

H

Hand Nut..... 3-37
 Hand Truck Assembly (CA033), Figure C-7..... C-22
 High Pressure Charging Hose - Repair..... 3-39
 High Pressure Filter 3-15,3-35
 High Pressure Nitrogen Servicing Cart (FPNC-01), Figure C-1 C-8
 High Pressure Regulator- Replace 3-18
 High Pressure Regulator Assembly (PA006), Figure C-4 C-18
 High Pressure Relief Valve 3-29
 High Pressure Relief Valve - Replace 3-20
 High Pressure Relief Valve - Setting 2-9
 High Pressure Shut-Off Assembly (PA008), Figure C-6 C=21
 High Pressure Shutoff Valve 3-40
 High Pressure Shutoff Valve - Replace 3-24
 Hose, High Pressure Assy..... 3-14
 How to Use This Manual iii

I

Inflating Chuck 3-40
 Inspection, Cart 3-8
 Inspection, Accessory..... 3-9
 Inspection, In Line Filters 3-36

J

Jam Nut 3-31

L

Leak Check Procedure 2-10
 Low Pressure Filter 3-22
 Low Pressure Filter Assembly (PA007), Figure C-5 C-20
 Low Pressure Regulator 3-15
 Low Pressure Regulator- Replace 3-14
 Low Pressure Regulator Assembly (PA005), Figure C-3..... C-16
 Low Pressure Relief Valve 3-15

M

Maintenance Allocation Chart (MAC) B-3
 Maintenance Instructions, AVUM..... 3-1
 Maintenance Instructions, AVIM 4-1 -
 Maintenance Procedures, AVUM..... 3-11
 Major Components 1-6
 Mission Capable Requirements 2-6

ALPHABETICAL INDEX

	PAGE
N	
National Stock Number Index.....	C-30
Nipple Connector	3-37
Nitrogen Charging Directly from the Supply Tanks	2-11
Nitrogen Charging Using Booster Pump	2-12
No Nitrogen Flow to High Pressure Output (Not Requiring Rooster Pump Operation)	3-6
No Nitrogen Flow to High Pressure Output (Requiring Booster Pump Operation)	3-7.4-5
No Tire Inflation (Low) Pressures	3-5
O	
O-Ring Seals.....	2-6
Operating Conditions	1-4
Operating Procedures	2-11
P	
Panel Hose Assembly	3-37
Part Number Index	C-31
Pneumatic Input Requirements	1-3
Pre-Operation Procedures	2-2
Preventive Maintenance Checks and Services (PMCS), Operator	2-6
Preventive Maintenance Checks and Services (PMCS), AVUM	3-3
Principles of Operation.....	1-10
Q	
Quality Deficiency Report.....	1-3
Quick Disconnect Nipple	3-42
Quick Disconnect Socket	3-42
R	
References	A-1
Repair Parts and Special Tools List (RPSTL)	C-1
Retaining Wire	3-15,3-19
S	
Schematic Diagram, Pneumatic	1-9
Setup	2-7
Shop Air Regulator.....	3-15
Shop Air Supply Requirements	1-4
Shutdown Procedure	2-9
Storage and Shipment.....	3-43,4-17
T	
Tank Connector Assembly	3-13
Tank Connector Assembly (HA003), Figure C-9	C-26
Tank Connector Assembly - Inspect Filters, Replacing Components	3-36
Tank Connector Assy	3-35

ALPHABETICAL INDEX

	PAGE
Tank Hose Assembly	3-37
Tank Retention Strap Assy - Replace	3-32
Tank Supply Requirements	1-4
Tire Filling Hose	3-14
Tire Filling Hose (HA056), Figure C-10	C-27
Tire Filling Hose - Repair.	3-42
Tire Pressures.....	3-31
Tools and Test Equipment Requirements	B-5
Troubleshooting, AVUM	3-4
Troubleshooting, AVIM.....	4-4
Troubleshooting Procedure: Not Requiring Booster Pump Operation.....	3-4
Troubleshooting Procedure: Requiring Booster Pump Operation	4-6
Tube Assemblies - Replace.....	3-26

V

Vent Breather	3-21
---------------------	------

Warnings	a
Washer, Inspection and Replacement	3-40
Weight	1-4
Wheel and Tire Assembly (CA053), Figure C-8	C-25
Wheel Assembly - Replace and Repair	3-30
Wheel Bearings.....	3-31
Whip Hose	3-40
Whip Hose (HA058), Figure C-11	C-28

By Order of the Secretary of the Army:

Official:

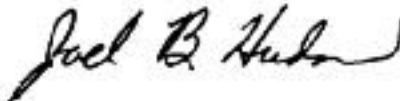

*Administrative Assistant to the
Secretary of the Army*
03149

DENNIS J. REIMER
General, United States Army
Chief of Staff

DISTRIBUTION:

To be distributed in accordance with DA Form 12-31 -E, block no. 3636, requirements for TM 1-1740-204-13&P.



THEN . . . JOT DOWN THE DOPE ABOUT IT ON THIS FORM, CAREFULLY TEAR IT OUT, FOLD IT AND DROP IT IN THE MAIL!

SOMETHING WRONG WITH THIS PUBLICATION?

FROM: (PRINT YOUR UNIT'S COMPLETE ADDRESS)
 PFC John DOE
 CO 4 3rd Engineer Bn
 Ft. Leonardwood, MD 63108

DATE SENT
 22 August 1992

PUBLICATION NUMBER TM 1-1520-250-10	PUBLICATION DATE 15 June 1992	PUBLICATION TITLE Operator's manual MH60K Helicopter
--	----------------------------------	---

BE EXACT PIN-POINT WHERE IT IS				IN THIS SPACE, TELL WHAT IS WRONG AND WHAT SHOULD BE DONE ABOUT IT:
PAGE NO	PARA-GRAPH	FIGURE NO	TABLE NO	
6	2-1 a			<p>In line 6 of paragraph 2-1a the manual states the engine has 6 cylinders. The engine on my set only has <u>4</u> cylinders. Change the manual to show 4 cylinders.</p> <p>Callout 16 in figure 4-3 is pointed to <u>bolt</u>. In key to figure 4-3, item 16 is called a <u>shim</u>. Please correct one or the other</p>
B1		4-3		

PRINTED NAME, GRADE OR TITLE, AND TELEPHONE NUMBER JOHN DOE, PFC (268) 317-7111	SIGN HERE JOHN DOE <i>John Doe</i>
--	---------------------------------------

FILL IN YOUR
UNITS ADDRESS



FOLD BACK

DEPARTMENT OF THE ARMY

OFFICIAL BUSINESS

COMMANDER
U.S. ARMY AVIATION AND TROOP COMMAND
ATTN: AMSAT-I-MP
4300 GOODFELLOW BOULEVARD
ST. LOUIS, MO 63120-1798

TEAR ALONG PERFORATED LINE

FILL IN YOUR
UNITS ADDRESS



FOLD BACK

DEPARTMENT OF THE ARMY

OFFICIAL BUSINESS

COMMANDER
U.S. ARMY AVIATION AND TROOP COMMAND
ATTN: AMSAT-I-MP
4300 GOODFELLOW BOULEVARD
ST. LOUIS, MO 63120-1798

TEAR ALONG PERFORATED LINE

FILL IN YOUR
UNITS ADDRESS



FOLD BACK

DEPARTMENT OF THE ARMY

OFFICIAL BUSINESS

COMMANDER
U.S. ARMY AVIATION AND TROOP COMMAND
ATTN: AMSAT-I-MP
4300 GOODFELLOW BOULEVARD
ST. LOUIS, MO 63120-1798

TEAR ALONG PERFORATED LINE

RECOMMENDED CHANGES TO EQUIPMENT TECHNICAL PUBLICATIONS

SOMETHING WRONG WITH THIS PUBLICATION?



THEN . . . JOT DOWN THE DOPE ABOUT IT ON THIS FORM, CAREFULLY TEAR IT OUT, FOLD IT AND DROP IT IN THE MAIL!

FROM: (PRINT YOUR UNIT'S COMPLETE ADDRESS)

DATE SENT

PUBLICATION NUMBER

TM 1-1740-204-13&P

PUBLICATION DATE

31 December 1996

PUBLICATION TITLE

Truck, Hand (Nitrogen Servicing Cart)

BE EXACT PIN-POINT WHERE IT IS

IN THIS SPACE, TELL WHAT IS WRONG AND WHAT SHOULD BE DONE ABOUT IT:

PAGE NO	PARA-GRAPH	FIGURE NO	TABLE NO

PRINTED NAME, GRADE OR TITLE, AND TELEPHONE NUMBER

SIGN HERE

DA FORM
1 JUL 79 **2028-2**

PREVIOUS EDITIONS ARE OBSOLETE.
DRSTS-M verprint2, 1 Nov 80

P.S. - IF YOUR OUTFIT WANTS TO KNOW ABOUT YOUR RECOMMENDATION, MAKE A CARBON COPY OF THIS AND GIVE TO YOUR HEADQUARTERS.

FILL IN YOUR
UNITS ADDRESS



FOLD BACK

DEPARTMENT OF THE ARMY

OFFICIAL BUSINESS

COMMANDER
U.S. ARMY AVIATION AND TROOP COMMAND
ATTN: AMSAT-I-MP
4300 GOODFELLOW BOULEVARD
ST. LOUIS, MO 63120-1798

TEAR ALONG PERFORATED LINE

The Metric System and Equivalents

Linear Measure

1 centimeter = 10 millimeters = .39 inch
 1 decimeter = 10 centimeters = 3.94 inches
 1 meter = 10 decimeters = 39.37 inches
 1 dekameter = 10 meters = 32.8 feet
 1 hectometer = 10 dekameters = 328.08 feet
 1 kilometer = 10 hectometers = 3,280.8 feet

Weights

1 centigram = 10 milligrams = .15 grain
 1 decigram = 10 centigrams = 1.54 grains
 1 gram = 10 decigrams = .035 ounce
 1 dekagram = 10 grams = .35 ounce
 1 hectogram = 10 dekagrams = 3.52 ounces
 1 kilogram = 10 hectograms = 2.2 pounds
 1 quintal = 100 kilograms = 220.46 pounds
 1 metric ton = 10 quintals = 1.1 short tons

Liquid Measure

1 centiliter = 10 milliliters = .34 fl. ounce
 1 deciliter = 10 centiliters = 3.38 fl. ounces
 1 liter = 10 deciliters = 33.81 fl. ounces
 1 dekaliter = 10 liters = 2.64 gallons
 1 hectoliter = 10 dekaliters = 26.42 gallons
 1 kiloliter = 10 hectoliters = 264.18 gallons

Square Measure

1 sq. centimeter = 100 sq. millimeters = .155 sq. inch
 1 sq. decimeter = 100 sq. centimeters = 15.5 sq. inches
 1 sq. meter (centare) = 100 sq. decimeters = 10.76 sq. feet
 1 sq. dekameter (are) = 100 sq. meters = 1,076.4 sq. feet
 1 sq. hectometer (hectare) = 100 sq. dekameters = 2.47 acres
 1 sq. kilometer = 100 sq. hectometers = .386 sq. mile

Cubic Measure

1 cu. centimeter = 1000 cu. millimeters = .06 cu. inch
 1 cu. decimeter = 1000 cu. centimeters = 61.02 cu. inches
 1 cu. meter = 1000 cu. decimeters = 35.31 cu. feet

Approximate Conversion Factors

To change	To	Multiply by	To change	To	Multiply by
inches	centimeters	2.540	ounce-inches	newton-meters	.007062
feet	meters	.305	centimeters	inches	.394
yards	meters	.914	meters	feet	3.280
miles	kilometers	1.609	meters	yards	1.094
square inches	square centimeters	6.451	kilometers	miles	.621
square feet	square meters	.093	square centimeters	square inches	.155
square yards	square meters	.836	square meters	square feet	10.764
square miles	square kilometers	2.590	square meters	square yards	1.196
acres	square hectometers	.405	square kilometers	square miles	.386
cubic feet	cubic meters	.028	square hectometers	acres	2.471
cubic yards	cubic meters	.765	cubic meters	cubic feet	35.315
fluid ounces	milliliters	29.573	cubic meters	cubic yards	1.308
pints	liters	.473	milliliters	fluid ounces	.034
quarts	liters	.946	liters	pints	2.113
gallons	liters	3.785	liters	quarts	1.057
ounces	grams	28.349	liters	gallons	.264
pounds	kilograms	.454	grams	ounces	.035
short tons	metric tons	.907	kilograms	pounds	2.205
pound-feet	newton-meters	1.356	metric tons	short tons	1.102
pound-inches	newton-meters	.11296			

Temperature (Exact)

°F Fahrenheit temperature

5/9 (after subtracting 32)

Celsius temperature

°C

PIN: 075266-000

This fine document...

Was brought to you by me:



[Liberated Manuals -- free army and government manuals](#)

Why do I do it? I am tired of sleazy CD-ROM sellers, who take publicly available information, slap “watermarks” and other junk on it, and sell it. Those masters of search engine manipulation make sure that their sites that sell free information, come up first in search engines. They did not create it... They did not even scan it... Why should they get your money? Why are not letting you give those free manuals to your friends?

I am setting this document FREE. This document was made by the US Government and is NOT protected by Copyright. Feel free to share, republish, sell and so on.

I am not asking you for donations, fees or handouts. If you can, please provide a link to liberatedmanuals.com, so that free manuals come up first in search engines:

<A HREF=<http://www.liberatedmanuals.com/>>Free Military and Government Manuals

- Sincerely
Igor Chudov
<http://igor.chudov.com/>
- [Chicago Machinery Movers](#)