

***TM 1-1730-221-23P**

TECHNICAL MANUAL

**FIELD MAINTENANCE MANUAL
INCLUDING REPAIR PARTS AND SPECIAL TOOLS LIST
FOR**

**JACK HYDRAULIC, AIRCRAFT, 10-TON TYPE A-6
PN 53D22004 NSN 1730-00-203-4697 (EIC: N/A)**

DISTRIBUTION STATEMENT A : Approved for public release; distribution is unlimited.

*This manual supersedes TM 55-1730-221-20P, dated 29 April 1977, including all changes..

**HEADQUARTERS, DEPARTMENT OF THE ARMY
24 APRIL 2009**

LIST OF EFFECTIVE PAGES/WORK PACKAGES

INSERT LATEST UPDATED PAGES/WORK PACKAGES. DESTROY SUPERSEDED DATA.

Dates of issue for original and changed pages/work packages are:

Original ..0...24 Apr 09

THE TOTAL NUMBER OF PAGES FOR FRONT AND REAR MATTER IS 15 AND THE TOTAL NUMBER OF WORK PACKAGES IN THIS MANUAL IS 4 CONSISTING OF THE FOLLOWING:

Page / WP No.	*Change No.	Page / WP No.	*Change No.	Page / WP No.	*Change No.	Page / WP No.	*Change No.
WP 0001 00	0	WP 0002 00	0	WP 0003 00	0	WP 0004 00	0

* Zero in this column indicates an original page or work package

A/B blank

HEADQUARTERS
DEPARTMENT OF THE ARMY
Washington, D.C., 24 April 2009

TECHNICAL MANUAL

FIELD MAINTENANCE MANUAL
INCLUDING REPAIR PARTS AND SPECIAL TOOLS LIST

FOR

JACK HYDRAULIC, AIRCRAFT, 10-TON TYPE A-6
PN 53D22004 NSN 1730-00-203-4697 (EIC: N/A)

REPORTING ERRORS AND RECOMMENDING IMPROVEMENTS

You can improve this manual. If you find mistakes or if you know of a way to improve procedures, please let us know. Mail your letter or DA Form 2028 (Recommended Changes to Publications and Blank Forms) located at the back of this manual, directly to: Commander, U.S. Army Aviation and Missile Command, ATTN: AMSAM-MMC-MA-NP, Redstone Arsenal, AL 35898-5000. A reply will be furnished to you. You may also provide DA Form 2028 information to AMCOM via e-mail, fax or the World Wide Web. Our fax number is: DSN 788-6546 or Commercial (256) 842-6546. Our e-mail address is 2028@redstone.army.mil. Instructions for sending an electronic 2028 may be found at the back of this bulletin immediately preceding the hard copy 2028. For the World Wide Web use: <https://amcom2028.redstone.army.mil>.

DISTRIBUTION STATEMENT A – Approved for public release; distribution is unlimited.

*This manual supersedes TM 55-1730-221-20P, dated 29 April 1977, including all changes.

TABLE OF CONTENTS

	<u>WP Sequence No.</u>
Introduction To Repair Parts And Special Tools List (RPSTL)	0001 00
Repair Parts List.....	0002 00
Group 01.....10-TON HYDRAULIC AIRCRAFT HAND JACK.....	0002 00
Part Number Index.....	0003 00
NSN Index.....	0004 00

**JACK HYDRAULIC, AIRCRAFT, 10-TON TYPE A-6
NSN 1730-00-203-4697PART NO. 53D22004**

INTRODUCTION TO REPAIR PARTS AND SPECIAL TOOLS LIST (RPSTL)

INTRODUCTION

SCOPE

This RPSTL lists and authorizes spares and repair parts, special tools, special test measurement and diagnostic equipment (TMDE) and other special support equipment required for performance of the Two-level maintenance of the B-1 Maintenance Platform. It authorizes the requisitioning, issue, and disposition of spares, repair parts, and special tools as indicated by the Source, Maintenance, and Recoverability (SMR) codes

GENERAL

In addition to the Introduction work package, this RPSTL is divided into the following work packages.

1. **Repair Parts List Work Packages.** Work packages containing lists of spares and repair parts authorized by this RPSTL for use in the performance of maintenance. These work packages also include parts which must be removed for replacement of the authorized parts. Parts lists are composed of functional groups in ascending alphanumeric sequence, with the parts in each group listed in ascending figure and item number sequence. Sending units, brackets, filters, and bolts are listed with the component they mount on. Bulk materials are listed by item name in FIG. BULK at the end of the work packages. Repair parts kits are listed separately in their own functional group and work package. Repair parts for reparable special tools are also listed in a separate work package. Items listed are shown on the associated illustrations.
2. **Special Tools List Work Packages.** Work packages containing lists of special tools, special TMDE, and special support equipment authorized by this RPSTL (as indicated by Basis of Issue (BOI) information in the DESCRIPTION AND USABLE ON CODE (UOC) column). Tools that are components of common tool sets and/or Class VII are not listed.
3. **Cross-Reference Indexes Work Packages.** There are two cross reference indexes work packages in this RPSTL: the National Stock Number (NSN) Index work package and the Part Number (P/N) Index work package. The National Stock Number Index work package refers you to the figure and item number. The Part Number Index work package refers you to the figure and item number.

EXPLANATION OF COLUMNS IN THE REPAIR PARTS LIST AND SPECIAL TOOLS LIST WORK PACKAGES

ITEM NO. (Column (1)). Indicates the number used to identify items called out in the illustration.

SMR CODE (Column (2)). The SMR code containing supply/requisitioning information, maintenance level authorization criteria, and disposition instruction, as shown in the following breakout:

Source Code	Maintenance Code		Recoverability Code
<u>XXXXX</u>	<u>XXXXX</u>	<u>XXXXX</u>	<u>XXXXX</u>
1st two positions: How to get an item.	3rd position: Who can install, replace, or use the item.	4th position: Who can do complete repair* on the item.	5th position: Who determines disposition action on unserviceable items.

*Complete Repair: Maintenance capacity, capability, and authority to perform all corrective maintenance tasks of the "Repair" function in a use/user environment in order to restore serviceability to a failed item.

Source Code. The source code tells you how you get an item needed for maintenance, repair, or overhaul of an end item/equipment. Explanations of source codes follow:

INTRODUCTION – CONTINUED

– Continued

Source Code	Application/Explanation
PA PB PC PD PE PF PG	<p style="text-align: center;">NOTE</p> <p style="text-align: center;">Items coded PC are subject to deterioration.</p> <p>Stock items; use the applicable NSN to requisition/request items with these source codes. They are authorized to the level indicated by the code entered in the 3rd position of the SMR code.</p>
KD KF KB	Items with these codes are not to be requested/requisitioned individually. They are part of a kit which is authorized to the maintenance level indicated in the 3rd position of the SMR code. The complete kit must be requisitioned and applied.
MO-Made at unit/AVUM level MF-Made at DS/AVIM level MH-Made at GS level ML-Made at SRA MD-Made at depot	Items with these codes are not to be requisitioned/requested individually. They must be made from bulk material which is identified by the P/N in the DESCRIPTION AND USABLE ON CODE (UOC) column and listed in the bulk material group work package of the RP-STL. If the item is authorized to you by the 3rd position code of the SMR code, but the source code indicates it is made at higher level, order the item from the higher level of maintenance.
AO-Assembled by unit/AVUM level AF-Assembled by DS/AVIM level AH-Assembled by GS level AL-Assembled by SRA AD-Assembled by depot	Items with these codes are not to be requested/requisitioned individually. The parts that make up the assembled item must be requisitioned or fabricated and assembled at the level of maintenance indicated by the source code. If the 3rd position of the SMR code authorizes you to replace the item, but the source code indicates the item is assembled at a higher level, order the item from the higher level of maintenance.
XA	Do not requisition an "XA" coded item. Order the next higher assembly.(Refer to NOTE below.)
XB	If an item is not available from salvage, order it using the CAGEC and P/N.
XC	Installation drawings, diagrams, instruction sheets, field service drawings; identified by manufacturer's P/N.

INTRODUCTION – CONTINUED

- Continued

Source Code	Application/Explanation
XD	Item is not stocked. Order an XD-coded item through local purchase or normal supply channels using the CAGEC and P/N given, if no NSN is available.
<p>NOTE</p> <p>Cannibalization or controlled exchange, when authorized, may be used as a source of supply for items with the above source codes except for those items source coded "XA" or those aircraft support items restricted by requirements of AR 750-1.</p>	

Maintenance Code. Maintenance codes tell you the level(s) of maintenance authorized to use and repair support items. The maintenance codes are entered in the third and fourth positions of the SMR code as follows:

Third Position. The maintenance code entered in the third position tells you the lowest maintenance level authorized to remove, replace, and use an item. The maintenance code entered in the third position will indicate authorization to the following levels of maintenance:

Maintenance Code	Application/Explanation
C-	Crew or operator maintenance done within Field Maintenance.
O-	Service/AMC maintenance can remove, replace, and use this item.
F-	Field/ASB maintenance can remove, replace, and use this item.
H-	Below depot Sustainment can remove, replace, and use this item.
L-	Specialized repair activity or TASMGM can remove, replace, and use this item.
D-	Depot can remove, replace, and use the item.

Fourth Position. The maintenance code entered in the fourth position tells you whether or not the item is to be repaired and identifies the lowest maintenance level with the capability to do complete repair (perform all authorized repair functions).

Recoverability Code. Recoverability codes are assigned to items to indicate the disposition action on unserviceable items. The recoverability code is shown in the fifth position of the SMR code as follows:

Recoverability Code	Application/Explanation
Z -	Nonreparable item. When unserviceable, condemn and dispose of the item at the level of maintenance shown in the third position of the SMR code.
O -	Reparable item. When uneconomically repairable, condemn, and dispose of the item at service/AMC level.

INTRODUCTION – CONTINUED

– Continued

Recoverability Code	Application/Explanation
F -	Reparable item. When uneconomically reparable, condemn, and dispose of the item at the Field/ASB level.
H -	Reparable item. When uneconomically reparable, condemn, and dispose of the item at the below depot Sustainment level.
D -	Reparable item. When beyond lower level repair capability, return to depot. Condemnation and disposal of item are not authorized below depot level.
L -	Reparable item. Condemnation and disposal not authorized below Specialized Repair Activity (SRA)/TASMG.
A -	Item requires special handling or condemnation procedures because of specific reasons (such as precious metal content, high dollar value, critical material or hazardous material). Refer to appropriate manuals/directives for specific instructions.

NOTE

Some limited repair may be done on the item at a lower level of maintenance, if authorized by the Maintenance Allocation Chart (MAC) and SMR codes.

Maintenance Code	Application/Explanation
O -	Service/AMC is the lowest level that can do complete repair of the item.
F -	Field/ASB is the lowest level that can do complete repair of the item.
H -	Below depot Sustainment is the lowest level that can do complete repair of the item.
L -	Specialized repair activity XXXX or TASMG is the lowest level that can do complete repair of the item.
D -	Depot is the lowest level that can do complete repair of the item.
Z -	Nonreparable. No repair is authorized.
B -	No repair is authorized. No parts or special tools are authorized for maintenance of "B" coded item. However, the item may be reconditioned by adjusting, lubricating, etc., at the user level.

NSN (Column (3)). The NSN for the item is listed in this column.

CAGEC (Column (4)). The Commercial and Government Entity Code (CAGEC) is a five-digit code which is used to identify the manufacturer, distributor, or Government agency/activity that supplies the item.

PART NUMBER (Column (5)). Indicates the primary number used by the manufacturer (individual, company, firm, corporation, or Government activity), which controls the design and characteristics of the item by means

INTRODUCTION – CONTINUED

of its engineering drawings, specifications, standards, and inspection requirements to identify an item or range of items.

NOTE

When you use an NSN to requisition an item, the item you receive may have a different P/N from the number listed.

DESCRIPTION AND USABLE ON CODE (UOC) (Column (6)). This column includes the following information:

1. The federal item name, and when required, a minimum description to identify the item.
2. P/Ns of bulk materials are referenced in this column in the line entry to be manufactured or fabricated.
3. Hardness Critical Item (HCI). A support item that provides the equipment with special protection from electromagnetic pulse (EMP) damage during a nuclear attack.
4. The statement END OF FIGURE appears just below the last item description in column (6) for a given figure in both the repair parts list and special tools list work packages.

QUANTITY (QTY) (Column (7)). The QTY (quantity per figure) column indicates the quantity of the item used in the breakout shown on the illustration/figure, which is prepared for a functional group, subfunctional group, or an assembly. A "V" appearing in this column instead of a quantity indicates that the quantity is variable and quantity may change from application to application.

EXPLANATION OF CROSS-REFERENCE INDEXES WORK PACKAGES FORMAT AND COLUMNS

1. **National Stock Number (NSN) Index Work Package.**

STOCK NUMBER Column. This column lists the NSN in National item identification number (NIIN) sequence. The NIIN consists of the last nine digits of the NSN.

NSN
(e.g., 5385- 01-574-1476)
NIIN

When using this column to locate an item, ignore the first four digits of the NSN. However, the complete NSN should be used when ordering items by stock number.

FIG. Column. This column lists the number of the figure where the item is identified/located. The figures are in numerical order in the repair parts list and special tools list work packages.

ITEM Column. The item number identifies the item associated with the figure listed in the adjacent FIG. column. This item is also identified by the NSN listed on the same line.

2. **Part Number (P/N) Index Work Package.** P/Ns in this index are listed in ascending alphanumeric sequence (vertical arrangement of letter and number combinations which places the first letter or digit of each group in order A through Z, followed by the numbers 0 through 9 and each following letter or digit in like order).

PART NUMBER Column. P/Ns in this index are listed in ascending alphanumeric sequence (vertical arrangement of letter and number combinations which places the first letter or digit of each group in order A through Z, followed by the numbers 0 through 9 and each following letter or digit in like order).

FIG. Column. This column lists the number of the figure where the item is identified/located. The figures are in numerical order in the repair parts list and special tools list work packages.

ITEM Column. The item number identifies the item associated with the figure listed in the adjacent FIG. column. This item is also identified by the NSN listed on the same line.

HOW TO LOCATE REPAIR PARTS

1. **When NSNs or P/Ns Are Not Known.**

First. Using the table of contents, determine the assembly group to which the item belongs. This is necessary since figures are prepared for assembly groups and subassembly groups, and lists are divided into the same groups.

Second. Find the figure covering the functional group or the subfunctional group to which the item belongs.

Third. Identify the item on the figure and note the number(s).

Fourth. Look in the repair parts list work packages for the figure and item numbers. The NSNs and part numbers are on the same line as the associated item numbers.

2. **When NSN Is Known.** When NSN Is Known.

First. If you have the NSN, look in the STOCK NUMBER column of the NSN index work package. The NSN is arranged in NIIN sequence. Note the figure and item number next to the NSN.

Second. Turn to the figure and locate the item number. Verify that the item is the one you are looking for.

3. **When P/N Is Known.**

First. If you have the P/N and not the NSN, look in the PART NUMBER column of the P/N index work package. Identify the figure and item number.

Second. Look up the item on the figure in the applicable repair parts list work package.

JACK HYDRAULIC, AIRCRAFT, 10-TON TYPE A-6
NSN 1730-00-203-4697PART NO. 53D22004

REPAIR PARTS LIST

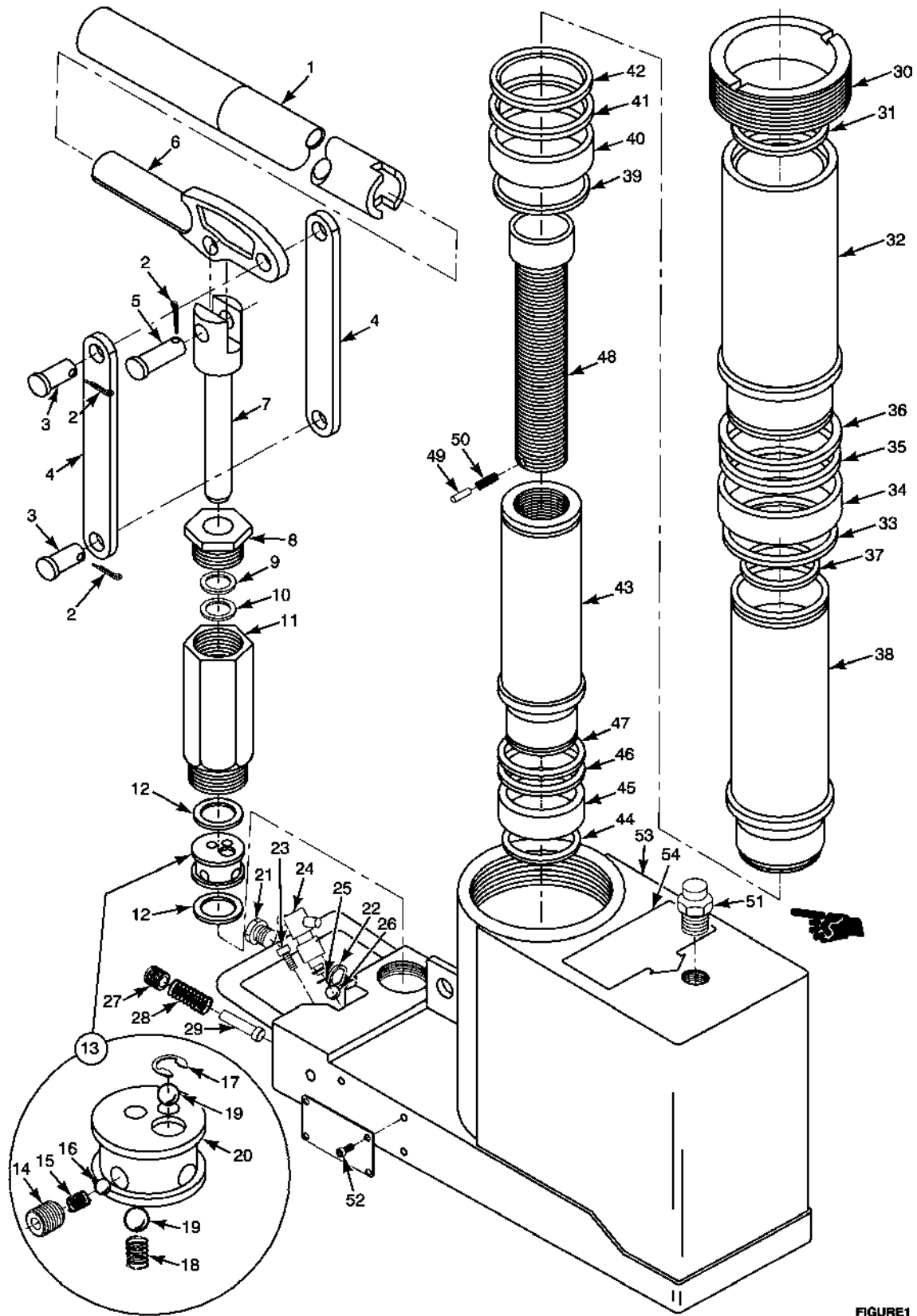

FIGURE 1

Figure 1. 10-Ton Hydraulic Aircraft Hand Jack.

(1) ITEM NO.	(2) SMR CODE	(3) NSN	(4) CAGEC	(5) PART NUMBER	(6) DESCRIPTION AND USABLE ON CODE(UOC)	(7) QTY
GROUP 01						
10-TON HYDRAULIC AIRCRAFT HAND JACK						
FIGURE 1. 10-TON HYDRAULIC AIRCRAFT						
HAND JACK						
	PBOZZ	1730-00-203-4697	80049	53D22004	10-TON HYDRAULIC JACK	1
1	PBOZZ	1730-00-629-5608	80049	53B22101	. HANDLE, PUMP	1
2	PBOZZ	5315-00-842-3044	96906	MS24665-283	. PIN, COTTER	3
3	PBOZZ	5315-00-812-3427	80205	MS20392-4C25	. PIN, COTTER	2
4	XDOZZ	3040-00-720-1014	98750	53B22097-2	. LINK, PUMP	2
5	PBOZZ	5315-00-812-3683	96906	MS20392-4C33	. PIN, STRAIGHT, HEADED	1
6	PBOZZ	1730-00-629-5637	80049	53B22091	. ROCKER ARM	1
7	PBOZZ	1730-00-629-5643	80049	53A22103	. PISTON, PUMP	1
8	PBOZZ	4730-00-720-1961	98750	53A22090	. PACKING NUT	1
9	PBOZZ	5330-00-684-5607	80049	53B22036-1	. PACKING, PREFORMED	1
10	PBOZZ	5331-00-350-9013	88044	AN6227B10	. O-RING	1
11	PBOZZ	4320-00-629-5642	80049	53A22102	. BODY, PUMP	1
12	PBOZZ	5330-00-580-1826	80049	53A22099	. GASKET	2
13	PBOOO	4820-00-932-2038	07878	53C22096	. VALVE ASSEMBLY	1
14	XDOZZ	5305-00-808-8287	88044	AN565F428H3	.. SETSCREW	1
15	PBOZZ	5360-00-790-8548	80049	53A22094	.. SPRING, HELICAL, COMPRESSION	1
16	PBOZZ	3110-00-950-4236	96906	MS19061-5	.. BALL, BEARING	1
17	PBOZZ	5325-00-775-5106	80049	53A22095	.. RING, RETAINER	1
18	PBOZZ	5360-00-809-1648	80049	53A22093	.. SPRING, HELICAL, COMPRESSION	1
19	PBOZZ	3110-00-100-6151	81346	MS150457	.. BALL BEARING	2
20	PBOZZ	4910-00-779-4353	80049	53C22092-2	.. VALVE, PUMP	1
21	PBOZZ	5365-00-727-5244	98750	53A22045	. SCREW, ADJUSTING	1
22	PBOZZ	5330-00-494-3191	00994	53A22098	. GASKET	1
23	PBOZZ	5305-00-801-0047	98750	53A22043	. SCREW, SHOULDER	1
24	PBOZZ	1730-00-629-5632	80049	53A22157	. VALVE, RELEASE	1
25	PCOZZ	5331-00-582-2133	96906	MS28775-011	. O-RING	1
26	PBOZZ	3110-00-100-6155	96906	MS150461	. BALL, BEARING	1
27	PBOZZ	4730-00-177-6324	88044	AN932-4	. PLUG, PIPE	1
28	PBOZZ	5360-00-629-5627	80049	53A22038	. SPRING, HELICAL, COMPRESSION	1
29	PBOZZ	4730-00-720-1012	80049	53A22044	. SCREEN, PUMP	1
30	PBOZZ	5120-00-629-5641	80049	53A22010	. BUSHING, HYDRAULIC	1
31	PBOZZ	5325-00-702-7515	80049	53C22035-9	. RING, RETAINING	1
32	PBOZZ	5120-00-629-3358	80049	53C22011	. RAM, FIRST STAGE	1
33	PBOZZ	5325-00-702-7514	80049	53C22035-6	. RING, RETAINING	1
34	PBOZZ	3120-00-580-4970	80049	53A22015	. BEARING, SLEEVE	1
35	PBOZZ	5331-00-194-3729	88044	AN6227B42	. O-RING	1
36	PBOZZ	5330-00-684-5614	80049	53C22069-4	. PACKING, PREFORMED	1
37	PBOZZ	5325-00-688-0311	80049	53C22035-10	. RING, RETAINING	1
38	PBOZZ	5120-00-629-3359	80049	53C22012	. RAM, SECOND STAGE	1
39	PBOZZ	5325-00-688-0310	80049	53C22035-7	. RING, RETAINING	1
40	PBOZZ	3120-00-580-4967	80049	53A22016	. BEARING, SLEEVE	1
41	PBOZZ	5331-00-194-3719	88044	AN6227B37	. O-RING	1

(1) ITEM NO.	(2) SMR CODE	(3) NSN	(4) CAGEC	(5) PART NUMBER	(6) DESCRIPTION AND USABLE ON CODE(UOC)	(7) QTY
42	PBOZZ	5330-00-684-5613	80049	53C22069-5	. PACKING, PREFORMED	1
43	PBOZZ	5120-00-629-5645	80049	53B22018	. RAM, THIRD STAGE	1
44	PBOZZ	5325-00-688-0261	80049	53C22035-8	. RING, RETAINING	1
45	PBOZZ	3120-00-580-4974	80049	53A22017	. BEARING, SLEEVE	1
46	PBOZZ	5331-00-297-9986	96906	MS28775-329	. O-RING	1
47	PBOZZ	5330-00-016-9929	98750	53C22069-6	. RETAINER, PACKING	1
48	PBOZZ	1730-00-629-5644	80049	53B22014	. SCREW, EXTENSION	1
49	PBOZZ	1730-00-253-9391	98750	53A22041	. PLUNGER, RETAINER, JACK	1
50	PBOZZ	5360-00-629-5629	80049	53A22040	. SPRING, HELICAL, COMPRESSION	1
51	PBOZZ	4320-00-212-4500	98750	50B7763	. VENT ASSEMBLY	1
52	PBOZZ	5305-00-253-5606	96906	MS21318-7	. SCREW, DRIVE	4
53	XDOZZ		98750	53D22007	. BASE ASSEMBLY, JACK	1

END OF FIGURE

**JACK HYDRAULIC, AIRCRAFT, 10-TON TYPE A-6
NSN 1730-00-203-4697PART NO. 53D22004**

PART NUMBER INDEX

PART NUMBER	FIG.	ITEM	PART NUMBER	FIG.	ITEM
50B7763	1	51			
53A22010	1	30	53C22012	1	38
53A22015	1	34	53C22035-10	1	37
53A22016	1	40	53C22035-6	1	33
53A22017	1	45	53C22035-7	1	39
53A22038	1	28	53C22035-8	1	44
53A22040	1	50	53C22035-9	1	31
53A22041	1	49	53C22069-4	1	36
53A22043	1	23	53C22069-5	1	42
53A22044	1	29	53C22069-6	1	47
53A22045	1	21	53C22092-2	1	20
53A22090	1	8	53C22096	1	13
53A22093	1	18	53D22007	1	53
53A22094	1	15	AN565F428H3	1	14
53A22095	1	17	AN6227B10	1	10
53A22098	1	22	AN6227B37	1	41
53A22099	1	12	AN6227B42	1	35
53A22102	1	11	AN932-4	1	27
53A22103	1	7	MS150457	1	19
53A22157	1	24	MS150461	1	26
53B22014	1	48	MS19061-5	1	16
53B22018	1	43	MS20392-4C25	1	3
53B22036-1	1	9	MS20392-4C33	1	5
53B22091	1	6	MS21318-7	1	52
53B22097-2	1	4	MS24665-283	1	2
53B22101	1	1	MS28775-011	1	25
53C22011	1	32	MS28775-329	1	46

**JACK HYDRAULIC, AIRCRAFT, 10-TON TYPE A-6
NSN 1730-00-203-4697PART NO. 53D22004**

NSN INDEX

STOCK NUMBER	FIG.	ITEM	STOCK NUMBER	FIG.	ITEM
1730-00-253-9391	1	49	5305-00-808-8287	1	14
1730-00-629-5608	1	1	5315-00-812-3427	1	3
1730-00-629-5632	1	24	5315-00-812-3683	1	5
1730-00-629-5637	1	6	5315-00-842-3044	1	2
1730-00-629-5643	1	7	5325-00-688-0261	1	44
1730-00-629-5644	1	48	5325-00-688-0310	1	39
3040-00-720-1014	1	4	5325-00-688-0311	1	37
3110-00-100-6151	1	19	5325-00-702-7514	1	33
3110-00-100-6155	1	26	5325-00-702-7515	1	31
3110-00-950-4236	1	16	5325-00-775-5106	1	17
3120-00-580-4967	1	40	5330-00-016-9929	1	47
3120-00-580-4970	1	34	5330-00-494-3191	1	22
3120-00-580-4974	1	45	5330-00-580-1826	1	12
4320-00-212-4500	1	51	5330-00-684-5607	1	9
4320-00-629-5642	1	11	5330-00-684-5614	1	36
4730-00-177-6324	1	27	5330-00-684-5613	1	42
4730-00-720-1012	1	29	5331-00-194-3719	1	41
4730-00-720-1961	1	8	5331-00-194-3729	1	35
4820-00-932-2038	1	13	5331-00-297-9986	1	46
4910-00-779-4353	1	20	5331-00-350-9013	1	10
5120-00-629-3358	1	32	5331-00-582-2133	1	25
5120-00-629-3359	1	38	5360-00-629-5627	1	28
5120-00-629-5645	1	43	5360-00-629-5629	1	50
5120-00-629-5641	1	30	5360-00-790-8548	1	15
5305-00-253-5606	1	52	5360-00-809-1648	1	18
5305-00-801-0047	1	23	5365-00-727-5244	1	21

By Order of the Secretary of the Army:

Official:

A handwritten signature in black ink that reads "Joyce E. Morrow". The signature is written in a cursive style with a large initial "J" and "M".

JOYCE E. MORROW
*Administrative Assistant to the
Secretary of the Army*
0907106

GEORGE W. CASEY, JR.
*General, United States Army
Chief of Staff*

Distribution:

**To be distributed in accordance with the initial distribution number (IDN) 255187,
requirements for TM 1-1730-221-23P.**

These are the instructions for sending an electronic 2028

The following format must be used if submitting an electronic 2028. The subject line must be exactly the same and all fields must be included; however only the following fields are mandatory: 1, 3, 4, 5, 6, 7, 8, 9, 10, 13, 15, 16, 17, and 27.

From: "Whomever" whomever@wherever.army.mil

To: 2028@redstone.army.mil

Subject: DA Form 2028

1 **From: Joe Smith**
2 *Unit: home*
3 **Address: 4300 Park**
4 **City:** Hometown
5 **St: MO**
6 **Zip: 77777**
7 **Date Sent:** 19--OCT--93
8 **Pub no:** 55--2840--229--23
9 **Pub Title: TM**
10 **Publication Date:** 04--JUL--85
11 *Change Number: 7*
12 *Submitter Rank: MSG*
13 **Submitter FName:** Joe
14 *Submitter MName: T*
15 **Submitter LName:** Smith
16 **Submitter Phone:** 123--123--1234
17 **Problem: 1**
18 *Page: 2*
19 *Paragraph: 3*
20 *Line: 4*
21 *NSN: 5*
22 *Reference: 6*
23 *Figure: 7*
24 *Table: 8*
25 *Item: 9*
26 *Total: 123*

27 **Text:**

This is the text for the problem below line 27.

RECOMMENDED CHANGES TO PUBLICATIONS AND BLANK FORMS For use of this form, see AR 25-30; the proponent agency is ODISC4.						Use Part II (reverse) for Repair Parts and Special Tool Lists (RPSTL) and Supply Catalogs/ Supply Manuals (SC/SM)	DATE 8/30/02
TO: (Forward to proponent of publication or form)(Include ZIP Code) Commander, U.S. Army Aviation and Missile Command ATTN: AMSAM--MMC--MA--NP Redstone Arsenal, AL 35898						FROM: (Activity and location)(Include ZIP Code) MSG, Jane Q. Doe 1234 Any Street Nowhere Town, AL 34565	
PART 1 - ALL PUBLICATIONS (EXCEPT RPSTL AND SC/SM) AND BLANK FORMS							
PUBLICATION/FORM NUMBER TM 9-1005-433-24					DATE 16 Sep 2002	TITLE Organizational, Direct Support, And General Support Maintenance Manual for Machine Gun, .50 Caliber M3P and M3P Machine Gun Electrical Test Set Used On Avenger Air Defense Weapon System	
ITEM NO.	PAGE NO.	PARA-GRAPH	LINE NO. *	FIGURE NO.	TABLE NO.	RECOMMENDED CHANGES AND REASON	
1	WP0005 PG 3		2			Test or Corrective Action column should identify a different WP number.	
EXAMPLE							
* Reference to line numbers within the paragraph or subparagraph.							
TYPED NAME, GRADE OR TITLE MSG, Jane Q. Doe, SFC					TELEPHONE EXCHANGE/ AUTOVON, PLUS EXTENSION 788-1234		SIGNATURE

TO: (Forward direct to addressee listed in publication) Commander, U.S. Army Aviation and Missile Command ATTN: AMSAM-MMC-MA-NP Redstone Arsenal, AL 35898	FROM: (Activity and location) (Include ZIP Code) MSG, Jane Q. Doe 1234 Any Street Nowhere Town, AL 34565	DATE 8/30/02
---	---	------------------------

PART II - REPAIR PARTS AND SPECIAL TOOL LISTS AND SUPPLY CATALOGS/SUPPLY MANUALS

PUBLICATION NUMBER			DATE		TITLE			
PAGE NO.	COLM NO.	LINE NO.	NATIONAL STOCK NUMBER	REFERENCE NO.	FIGURE NO.	ITEM NO.	TOTAL NO. OF MAJOR ITEMS SUPPORTED	RECOMMENDED ACTION
EXAMPLE								

PART III - REMARKS (Any general remarks or recommendations or suggestions for improvement of publications and blank forms. Additional blank sheets may be used if more space is needed.)

EXAMPLE

TYPED NAME, GRADE OR TITLE MSG, Jane Q. Doe, SFC	TELEPHONE EXCHANGE/AUTOVON, PLUS EXTENSION 788-1234	SIGNATURE
--	--	-----------

RECOMMENDED CHANGES TO PUBLICATIONS AND BLANK FORMS For use of this form, see AR 25--30; the proponent agency is ODISC4.						Use PartII(reverse) for Repair Parts and Special Tool Lists (RPSTL) and Supply Catalogs/ Supply Manuals (SC/SM)	DATE
TO: (Forward to proponent of publication or form)(Include ZIP Code) Commander, U.S. Army Aviation and Missile Command ATTN: AMSAM-MMC-MA-NP Redstone Arsenal, AL 35898						FROM: (Activity and location)(Include ZIP Code)	
PART 1 --ALL PUBLICATIONS (EXCEPT RPSTL AND SC/SM) AND BLANK FORMS							
PUBLICATION/FORM NUMBER						DATE	TITLE
ITEM NO.	PAGE NO.	PARA-GRAPH	LINE NO. *	FIGURE NO.	TABLE NO.	RECOMMENDED CHANGES AND REASON	
* Reference to line numbers within the paragraph or subparagraph.							
TYPED NAME, GRADE OR TITLE						TELEPHONE EXCHANGE/ AUTOVON, PLUS EXTENSION	SIGNATURE

TO: (Forward direct to addressee listed in publication) Commander, U.S. Army Aviation and Missile Command ATTN: AMSAM-MMC-MA-NP Redstone Arsenal, AL 35898	FROM: (Activity and location) (Include ZIP Code)	DATE
--	---	-------------

PART II --REPAIR PARTS AND SPECIAL TOOL LISTS AND SUPPLY CATALOGS/SUPPLY MANUALS

PUBLICATION NUMBER			DATE		TITLE			
PAGE NO.	COLM NO.	LINE NO.	NATIONAL STOCK NUMBER	REFERENCE NO.	FIGURE NO.	ITEM NO.	TOTAL NO. OF MAJOR ITEMS SUPPORTED	RECOMMENDED ACTION

PART III --REMARKS (Any general remarks or recommendations, or suggestions for improvement of publications and blank forms. Additional blank sheets may be used if more space is needed.)

TYPED NAME, GRADE OR TITLE	TELEPHONE EXCHANGE/AUTOVON, PLUS EXTENSION	SIGNATURE
----------------------------	--	-----------

RECOMMENDED CHANGES TO PUBLICATIONS AND BLANK FORMS For use of this form, see AR 25--30; the proponent agency is ODISC4.						Use PartII(reverse) for Repair Parts and Special Tool Lists (RPSTL) and Supply Catalogs/ Supply Manuals (SC/SM)	DATE
TO: (Forward to proponent of publication or form)(Include ZIP Code) Commander, U.S. Army Aviation and Missile Command ATTN: AMSAM-MMC-MA-NP Redstone Arsenal, AL 35898						FROM: (Activity and location)(Include ZIP Code)	
PART 1 --ALL PUBLICATIONS (EXCEPT RPSTL AND SC/SM) AND BLANK FORMS							
PUBLICATION/FORM NUMBER						DATE	TITLE
ITEM NO.	PAGE NO.	PARA-GRAPH	LINE NO. *	FIGURE NO.	TABLE NO.	RECOMMENDED CHANGES AND REASON	
* Reference to line numbers within the paragraph or subparagraph.							
TYPED NAME, GRADE OR TITLE						TELEPHONE EXCHANGE/ AUTOVON, PLUS EXTENSION	SIGNATURE

TO: <i>(Forward direct to addressee listed in publication)</i> Commander, U.S. Army Aviation and Missile Command ATTN: AMSAM-MMC-MA-NP Redstone Arsenal, AL 35898	FROM: <i>(Activity and location) (Include ZIP Code)</i>	DATE
---	--	-------------

PART II --REPAIR PARTS AND SPECIAL TOOL LISTS AND SUPPLY CATALOGS/SUPPLY MANUALS

PUBLICATION NUMBER			DATE		TITLE			
PAGE NO.	COLM NO.	LINE NO.	NATIONAL STOCK NUMBER	REFERENCE NO.	FIGURE NO.	ITEM NO.	TOTAL NO. OF MAJOR ITEMS SUPPORTED	RECOMMENDED ACTION

PART III --REMARKS *(Any general remarks or recommendations, or suggestions for improvement of publications and blank forms. Additional blank sheets may be used if more space is needed.)*

TYPED NAME, GRADE OR TITLE	TELEPHONE EXCHANGE/AUTOVON, PLUS EXTENSION	SIGNATURE
----------------------------	--	-----------

RECOMMENDED CHANGES TO PUBLICATIONS AND BLANK FORMS For use of this form, see AR 25--30; the proponent agency is ODISC4.						Use PartII(reverse) for Repair Parts and Special Tool Lists (RPSTL) and Supply Catalogs/ Supply Manuals (SC/SM)	DATE
TO: (Forward to proponent of publication or form)(Include ZIP Code) Commander, U.S. Army Aviation and Missile Command ATTN: AMSAM-MMC-MA-NP Redstone Arsenal, AL 35898						FROM: (Activity and location)(Include ZIP Code)	
PART 1 --ALL PUBLICATIONS (EXCEPT RPSTL AND SC/SM) AND BLANK FORMS							
PUBLICATION/FORM NUMBER						DATE	TITLE
ITEM NO.	PAGE NO.	PARA-GRAPH	LINE NO. *	FIGURE NO.	TABLE NO.	RECOMMENDED CHANGES AND REASON	
* Reference to line numbers within the paragraph or subparagraph.							
TYPED NAME, GRADE OR TITLE						TELEPHONE EXCHANGE/ AUTOVON, PLUS EXTENSION	SIGNATURE

TO: <i>(Forward direct to addressee listed in publication)</i> Commander, U.S. Army Aviation and Missile Command ATTN: AMSAM-MMC-MA-NP Redstone Arsenal, AL 35898	FROM: <i>(Activity and location) (Include ZIP Code)</i>	DATE
---	--	-------------

PART II --REPAIR PARTS AND SPECIAL TOOL LISTS AND SUPPLY CATALOGS/SUPPLY MANUALS

PUBLICATION NUMBER			DATE		TITLE			
PAGE NO.	COLM NO.	LINE NO.	NATIONAL STOCK NUMBER	REFERENCE NO.	FIGURE NO.	ITEM NO.	TOTAL NO. OF MAJOR ITEMS SUPPORTED	RECOMMENDED ACTION

PART III --REMARKS *(Any general remarks or recommendations, or suggestions for improvement of publications and blank forms. Additional blank sheets may be used if more space is needed.)*

TYPED NAME, GRADE OR TITLE	TELEPHONE EXCHANGE/AUTOVON, PLUS EXTENSION	SIGNATURE
----------------------------	--	-----------

The Metric System and Equivalents

Linear Measure

1 centimeter = 10 millimeters = .39 inch
 1 decimeter = 10 centimeters = 3.94 inches
 1 meter = 10 decimeters = 39.37 inches
 1 dekameter = 10 meters = 32.8 feet
 1 hectometer = 10 dekameters = 328.08 feet
 1 kilometer = 10 hectometers = 3,280.8 feet

Weights

1 centigram = 10 milligrams = .15 grain
 1 decigram = 10 centigrams = 1.54 grains
 1 gram = 10 decigrams = .035 ounce
 1 decagram = 10 grams = .35 ounce
 1 hectogram = 10 decagrams = 3.52 ounces
 1 kilogram = 10 hectograms = 2.2 pounds
 1 quintal = 100 kilograms = 220.46 pounds
 1 metric ton = 10 quintals = 1.1 short tons

Liquid Measure

1 centiliter = 10 milliliters = .34 fl. ounce
 1 deciliter = 10 centiliters = 3.38 fl. ounces
 1 liter = 10 deciliters = 33.81 fl. ounces
 1 dekaliter = 10 liters = 2.64 gallons
 1 hectoliter = 10 dekaliters = 26.42 gallons
 1 kiloliter = 10 hectoliters = 264.18 gallons

Square Measure

1 sq. centimeter = 100 sq. millimeters = .155 sq. inch
 1 sq. decimeter = 100 sq. centimeters = 15.5 sq. inches
 1 sq. meter (centare) = 100 sq. decimeters = 10.76 sq. feet
 1 sq. dekameter (are) = 100 sq. meters = 1,076.4 sq. feet
 1 sq. hectometer (hectare) = 100 sq. dekameters = 2.47 acres
 1 sq. kilometer = 100 sq. hectometers = .386 sq. mile

Cubic Measure

1 cu. centimeter = 1000 cu. millimeters = .06 cu. inch
 1 cu. decimeter = 1000 cu. centimeters = 61.02 cu. inches
 1 cu. meter = 1000 cu. decimeters = 35.31 cu. feet

Approximate Conversion Factors

To change	To	Multiply by	To change	To	Multiply by
inches	centimeters	2.540	ounce-inches	Newton-meters	.007062
feet	meters	.305	centimeters	inches	.394
yards	meters	.914	meters	feet	3.280
miles	kilometers	1.609	meters	yards	1.094
square inches	square centimeters	6.451	kilometers	miles	.621
square feet	square meters	.093	square centimeters	square inches	.155
square yards	square meters	.836	square meters	square feet	10.764
square miles	square kilometers	2.590	square meters	square yards	1.196
acres	square hectometers	.405	square kilometers	square miles	.386
cubic feet	cubic meters	.028	square hectometers	acres	2.471
cubic yards	cubic meters	.765	cubic meters	cubic feet	35.315
fluid ounces	milliliters	29.573	cubic meters	cubic yards	1.308
pints	liters	.473	milliliters	fluid ounces	.034
quarts	liters	.946	liters	pints	2.113
gallons	liters	3.785	liters	quarts	1.057
ounces	grams	28.349	grams	gallons	.264
pounds	kilograms	.454	grams	ounces	.035
short tons	metric tons	.907	kilograms	pounds	2.205
pound-feet	Newton-meters	1.356	metric tons	short tons	1.102
pound-inches	Newton-meters	.11296			

Temperature (Exact)

F	Fahrenheit temperature	5/9 (after subtracting 32)	Celsius temperature	°C
---	------------------------	----------------------------	---------------------	----

This fine document...

Was brought to you by me:



[Liberated Manuals -- free army and government manuals](#)

Why do I do it? I am tired of sleazy CD-ROM sellers, who take publicly available information, slap “watermarks” and other junk on it, and sell it. Those masters of search engine manipulation make sure that their sites that sell free information, come up first in search engines. They did not create it... They did not even scan it... Why should they get your money? Why are not letting you give those free manuals to your friends?

I am setting this document FREE. This document was made by the US Government and is NOT protected by Copyright. Feel free to share, republish, sell and so on.

I am not asking you for donations, fees or handouts. If you can, please provide a link to liberatedmanuals.com, so that free manuals come up first in search engines:

<A HREF=<http://www.liberatedmanuals.com/>>Free Military and Government Manuals

- Sincerely
Igor Chudov
<http://igor.chudov.com/>
- [Chicago Machinery Movers](#)