

TECHNICAL BULLETIN

OPERATOR'S, UNIT, INSTALLATION/REMOVAL INSTRUCTIONS, AND REPAIR PARTS AND SPECIAL TOOLS LIST (RPSTL)

FOR

TANKER BALLISTIC PROTECTION SYSTEM (TBPS/AOA/FTSS)

FOR

SEMITRAILER, TANK, FUEL, 7500-GALLON M1062P1 (NSN 2330-01-533-9904)

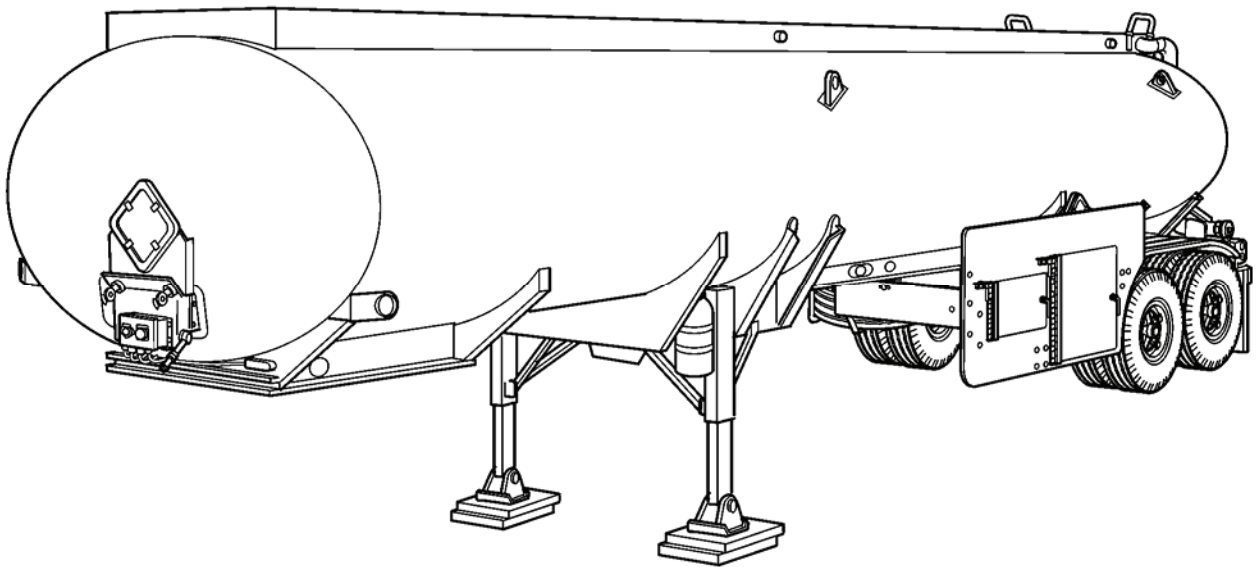

DISTRIBUTION STATEMENT A: Approved for public release; distribution is unlimited.

Headquarters, Department of the Army

APRIL 2007

WARNING SUMMARY



WARNING

Eye and hearing protection must be worn at all times when using power tools for grinding, cutting, sawing, and drilling. Failure to do so may result in injury to personnel.

Chemical Agent Resistant Coating (CARC) paint contains isocyanate (HDI), which is highly irritating to skin and respiratory system. High concentrations of HDI can produce symptoms of itching and reddening of skin, a burning sensation in throat and nose, and watering of the eyes. In extreme concentrations, HDI can cause cough, shortness of breath, pain during respiration, increased sputum production, and chest tightness. The following precautions must be taken whenever using CARC paint:

- NEVER cut CARC-coated materials without high-efficiency, air-purifying respirators in use.
- DO NOT grind or sand painted equipment without high-efficiency, air-purifying respirators in use.
- BE AWARE of CARC paint exposure symptoms; symptoms can occur a few days after initial exposure. Seek medical help immediately if symptoms are detected.



WARNING

Use caution when lifting supplemental armor. A swinging or shifting load may cause injury to personnel.

WARNING

Armor door assemblies are heavy and must be secured in place, with safety latch, when open. Failure to do so may cause injury to personnel.

WARNING SUMMARY (continued)



WARNING

Fuel is very flammable and can explode easily. To avoid serious injury or death, keep fuel away from open flame or any spark (ignition source). Keep a B-C fire extinguisher within reach when performing fuel tank repair.

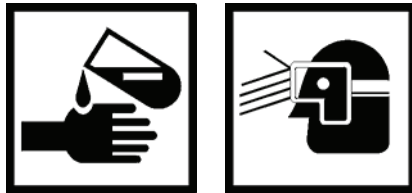

WARNING

Eye and hand protection must be worn at all times when applying FTSS Patch Kit. Failure to do so may result in injury to personnel.

LIST OF EFFECTIVE PAGES/WORK PACKAGES

Date of issue for original pages/work packages is:

06 April 2007

NOTE: The portion of text affected by the changes is indicated by a vertical line in the outer margins of the page. Changes to illustrations are indicated by miniature pointing hands.

Dates of issue for original and changed pages are:

Original .. 0 .. 06 April 2007

TOTAL NUMBER OF PAGES FOR FRONT AND REAR MATTER IS 22 AND TOTAL NUMBER OF PAGES IS 104 CONSISTING OF THE FOLLOWING:

Page Number	*Change Number
Cover	0
a and b	0
A/B blank and B blank.....	0
i/ii blank and ii blank.....	0
1-1 and 1-2.....	0
2-1/2-2 blank and 2-2 blank	0
3-1 thru 3-20	0
4-1 thru 4-20	0
5-1 and 5-2.....	0
6-1 and 6-2.....	0
7-1 and 7-2.....	0
8-1 thru 8-11	0
Figure 1 thru Figure 8	0
Kits-1 and Kits-2.....	0
I-1 and I-2/I-3 blank.....	0

*Zero in this column indicates an original page or work package.

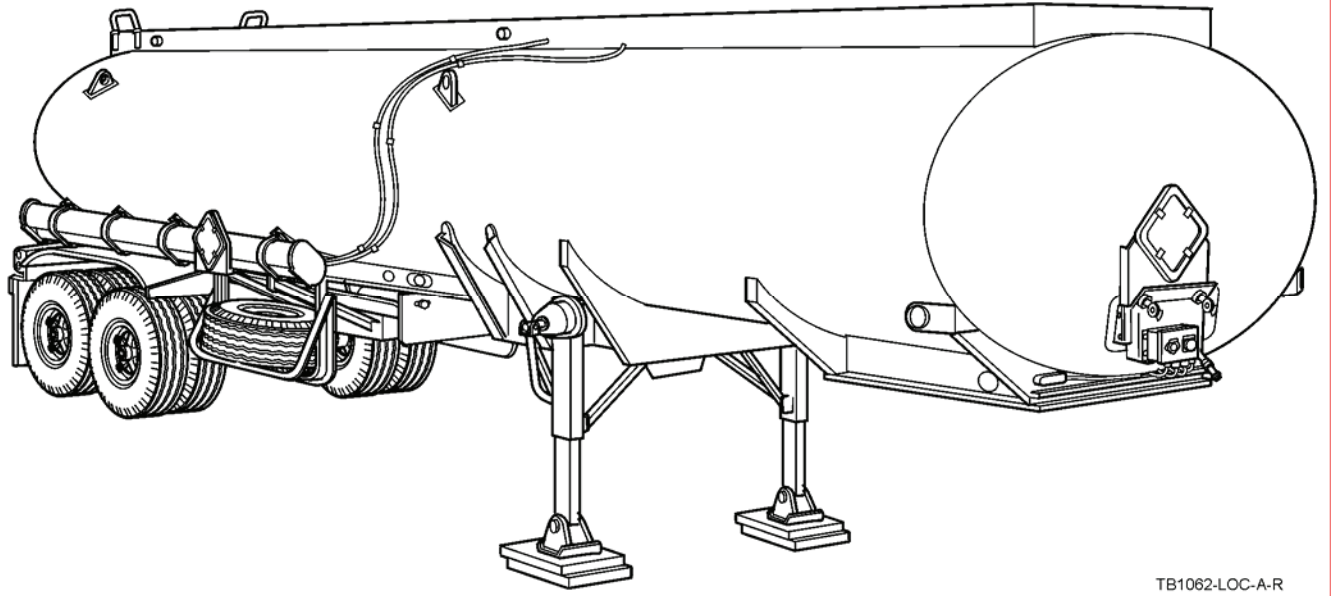

TB1062-LOC-A-R

M1062P1 RIGHT SIDE (CURBSIDE)

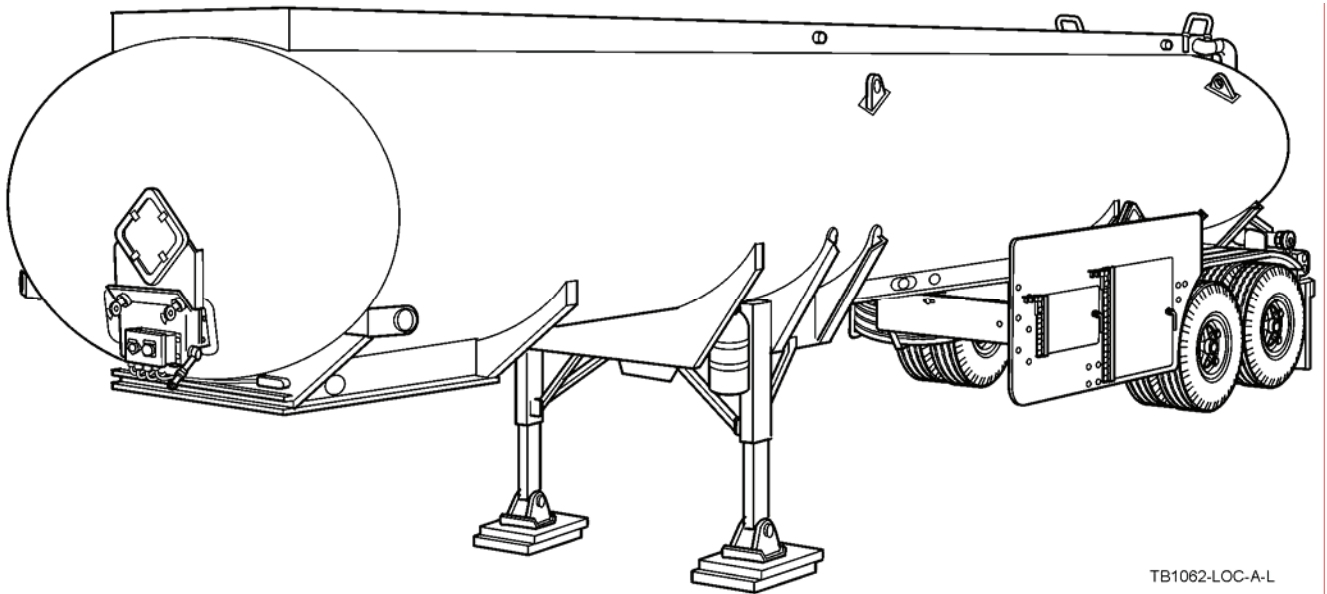

TB1062-LOC-A-L

M1062P1 LEFT SIDE (ROADSIDE)

TECHNICAL BULLETIN
OPERATOR'S, UNIT,
INSTALLATION/REMOVAL INSTRUCTIONS, AND
REPAIR PARTS AND SPECIAL TOOLS LIST (RPSTL)

FOR

TANKER BALLISTIC PROTECTION SYSTEM (TBPS/AOA/FTSS)

FOR

SEMITRAILER, TANK, FUEL, 7500-GALLON
M1062P1 (NSN 2330-01-533-9904)

REPORTING ERRORS AND RECOMMENDING IMPROVEMENTS

You can help improve this publication. If you find any mistakes or if you know of a way to improve the procedures, please let us know. Submit your DA Form 2028-2 (Recommended Changes to Equipment Technical Publications) through the Internet, on the Army Electronic Product Support (AEPS) website. The Internet address is <http://aeeps.ria.army.mil>. The DA Form 2028 is located under the PUBLIC APPLICATIONS section of the AEPS public home page. Fill out the form and click on SUBMIT. Using this form on the AEPS will enable us to respond more quickly to your comments and better manage the DA Form 2028 program. You may also mail, fax, or e-mail your letter, DA Form 2028, or DA Form 2028-2 directly to TACOM Life Cycle Management Command, ATTN: AMSTA-LC-LPIT/TECH PUBS 1 Rock Island Arsenal, Rock Island, IL 61299-7630. The e-mail address is ROCK-TACOM-TECH-PUBS@conus.army.mil. The fax number is DSN 793-0726 or Commercial (309) 782-0726. A reply will be furnished to you.

DISTRIBUTION STATEMENT A: Approved for public release; distribution is unlimited.

WARNING SUMMARY

	<u>Page Number</u>
CHAPTER 1 – GENERAL MAINTENANCE PROCEDURES	1-1
CHAPTER 2 – PRECONDITIONS	2-1
CHAPTER 3 – FUEL TANK SELF-SEALING (FTSS) SYSTEM	3-1
CHAPTER 4 – ADD-ON-ARMOR (AOA) KIT	4-1
CHAPTER 5 – DOOR HANDLE REPLACEMENT	5-1
CHAPTER 6 – FUEL TANK SELF-SEALING (FTSS) REPAIR KIT	6-1
CHAPTER 7 – QUALITY ASSURANCE AND FINAL INSPECTION	7-1
CHAPTER 8 – SUPPORT DATA AND REPAIR PARTS AND SPECIAL TOOLS LIST (RPSTL)	8-1

CHAPTER 1 GENERAL MAINTENANCE PROCEDURES

SCOPE

The purpose of this Technical Bulletin (TB) is to provide the instructions and Repair Parts and Special Tools List (RPSTL) for applying and/or replacing the Tanker Ballistic Protection System (TBPS) on M1062 series, 7500-gallon, fuel tankers. The TBPS consists of the Fuel Tank Self-Sealing (FTSS) System, Add-On-Armor (AOA) Kit, and FTSS Repair Kit, which all work in conjunction to provide the fuel tanker with ballistic protection against small arms fire.

The TBPS kit is applicable to the following:

Nomenclature	National Stock Number	Part Number
M1062	2330-01-275-7475	TKG5000

When completed, the vehicle NSN and part number will change for the end items as follows:

Nomenclature	National Stock Number	Part Number
M1062P1	2330-01-533-9904	12500848-1

ARMY KNOWLEDGE ONLINE (AKO) WEBSITE

Refer to the AKO website at <https://www.us.army.mil/suite/login/welcome.html> for the most recent updates to the kits and TB installation instructions.

MAINTENANCE FORMS, RECORDS, AND REPORTS

Department of the Army forms and procedures used for equipment maintenance will be those prescribed by DA PAM 750-8, The Army Maintenance Management System (TAMMS) Users Manual.

REPORTING EQUIPMENT IMPROVEMENT RECOMMENDATIONS (EIRs)

If your M1062P1 needs improvement, let us know. Send us an EIR. You, the user, are the only one who can tell us what you don't like about your equipment. Let us know why you don't like the design or performance. Put it on an SF 368 (Product Quality Deficiency Report). Mail it to: Commander, U.S. Army Tank-automotive and Armaments Command, ATTN: AMSTA-TR-E/PQDR, Warren, MI 48397-5000. We will send you a reply.

CORROSION PREVENTION AND CONTROL (CPC)

1. CPC of Army materiel is a continuing concern. Any corrosion problems with this item should be reported so that they can be corrected and improvements made to prevent the problem in future items.
2. While corrosion is typically associated with rusting of metals, it can also include deterioration of other materials, such as rubber and plastic. Unusual cracking, softening, swelling, or breaking of these materials may be a corrosion problem.
3. If a corrosion problem is identified, it can be reported using SF 368, Product Quality Deficiency Report. Use of key words such as "corrosion," "rust," "deterioration," or "cracking" will ensure that the information is identified as a CPC problem.
4. The form should be submitted to the address specified in DA PAM 750-8, The Army Maintenance Management System (TAMMS) Users Manual.

DESTRUCTION OF ARMY MATERIEL TO PREVENT ENEMY USE

Refer to TM 750-244-6 for procedures on destruction of military vehicles.

PREPARATION FOR STORAGE OR SHIPMENT

Refer to TM 38-470, Storage and Maintenance of Army Prepositioned Stock Material, for preservation, packaging, marking, and preparation for storage or shipment of M1062 series fuel tankers with AOA kit and/or FTSS kit installed.

LIST OF ABBREVIATIONS AND ACRONYMS

AOA	Add-On-Armor
CPC	Corrosion Prevention and Control
DA PAM	Department of the Army Pamphlet
DOT	Department of Transportation
EIR	Reporting Equipment Improvement Recommendations
FRP	Field Repair Patch
FTSS	Fuel Tank Self-Sealing
TAMMS	The Army Maintenance Management System
TB	Technical Bulletin
TBPS	Tanker Ballistic Protection System
TM	Technical Manual

CHAPTER 2 PRECONDITIONS

AOA AND FTSS VEHICLE PREPARATION

NOTE

The fuel tanker does not require purging or sniff testing prior to modification.

1. Ensure the fuel tanker has been emptied in accordance with Operator's Manual TM 9-2330-384-14&P.
2. Ensure the fuel tanker is properly grounded and all vessel openings have been properly and completely secured.

WARNING

Eye and hearing protection must be worn at all times when using power tools for grinding, cutting, sawing, and drilling. Failure to do so may result in injury to personnel.

CARC paint contains isocyanate (HDI), which is highly irritating to skin and respiratory system. High concentrations of HDI can produce symptoms of itching and reddening of skin, a burning sensation in throat and nose, and watering of the eyes. In extreme concentrations, HDI can cause cough, shortness of breath, pain during respiration, increased sputum production, and chest tightness. The following precautions must be taken whenever using CARC paint:

- **NEVER cut CARC-coated materials without high-efficiency, air-purifying respirators in use.**
 - **DO NOT grind or sand painted equipment without high-efficiency, air-purifying respirators in use.**
 - **BE AWARE of CARC paint exposure symptoms; symptoms can occur a few days after initial exposure. Seek medical help immediately if symptoms are detected.**
3. Check assembly areas for any items that could interfere with the installation of the AOA and FTSS kits, should any items be in the way, cut or hand grind to remove those items.
 4. Finish all exposed metal areas using a rust inhibitor primer and paint as specified in Table 8-4, Materials and Parts.
 5. Allow for the appropriate time for prime and paint to cure.
 6. For specific vehicle preparation, application of the FTSS System, and removal instructions for unique items, refer to Chapter 3 of this TB.
 7. For specific installation and removal instructions of the AOA kit, refer to Chapter 4 of this TB.

CHAPTER 3 FUEL TANK SELF-SEALING (FTSS) SYSTEM

SCOPE

This section provides the instructions for applying the FTSS System to M1062 fuel tankers. The FTSS System is a coating applied to the exterior surface of the fuel tank vessel that will seal a leak caused by small arms fire within twenty minutes of impact. Once sealed, the fuel tanker may continue operating under normal conditions. In the event the FTSS System does not seal a leak within twenty minutes, a repair kit is provided to patch the affected area. Refer to Chapter 6, FTSS Repair Kit, for instructions on applying the field patch assemblies. Also included are removal instructions for the unique items installed on the fuel tanker as part of the application of the FTSS System coating.

KIT PARTS AND THEIR DISPOSITION

The following lists the kit components of the FTSS kit (RPSTL Figures 4-7). This list can be used to inventory the kit for completeness.

Table 3-1. Fuel Tanker Self-Sealing (FTSS) Kit Contents List

Item No.	Nomenclature	National Stock Number	Part Number	CAGEC	QTY
	FTSS Application Procedures		14282	31902	1
	FTSS Microscopic Expansion Beads		14290	31902	1
	FTSS Polyurethane Coating		14291	31902	1
	FTSS System Application Installation Instruction		12500867	19207	1
	Technical Bulletin		TB 9-2330-384-14&P	19207	1
1	Screw, Cap, Hexagon Head	5305-00-068-0510	B1821BH038C100N	85047	24
2	Nut, Self-Locking	5310-01-542-0345	M45913/4-6CG8Z	96906	36
3	Washer, Flat	5310-00-773-7618	MS15795-814	80205	72
12	Grommet, Nonmetallic	5325-01-086-4841	FSP11-1-PK3	366L9	2
21	Plate, Placard Extension	5340-01-542-0378	12502023	19207	2
22	Screw, Cap, Hexagon Head	5305-00-725-2317	B1821BH038C150N	80204	8
23	Hazel Nut	4730-01-541-7204	14332	31902	18
24	Clip, Retaining	5340-01-542-0358	12500884-001	19207	18
25	Screw, Cap, Hexagon Head	5305-00-782-9489	B1821BH038C200N	80204	4
26	Sleeve, Lower Ladder	4710-01-541-9729	12500882	19207	2
27	Sleeve, Upper Ladder	4710-01-541-9766	12501995	19207	2

VEHICLE PREPARATION

The following list details the locations and components that must be removed to allow access to restricted areas of the fuel tanker before the FTSS System coating is applied. Once the coating has been applied, dried, and inspected, some of the components may be reinstalled. For component removal instructions, refer to TM 9-2330-384-14&P.

Front Bulkhead:

1. Remove hazardous warning placard. Discard hardware.
2. Remove nose adapter bracket with voltage control unit attached.

Curbside:

NOTE

- Steps 1 and 2 apply to curbside and roadside fenders. Curbside is shown.
 - Fender removal is a two person task.
1. Remove three hexagon head capscrews (1), three self-locking nuts (2), and six flat washers (3) from front and rear fender supports. Discard hardware.
 2. Remove six hexagon head capscrews (1), six self-locking nuts (2), and twelve flat washers (3) from fender support bracket. Remove fender and fender support bracket from tanker. Discard hardware.

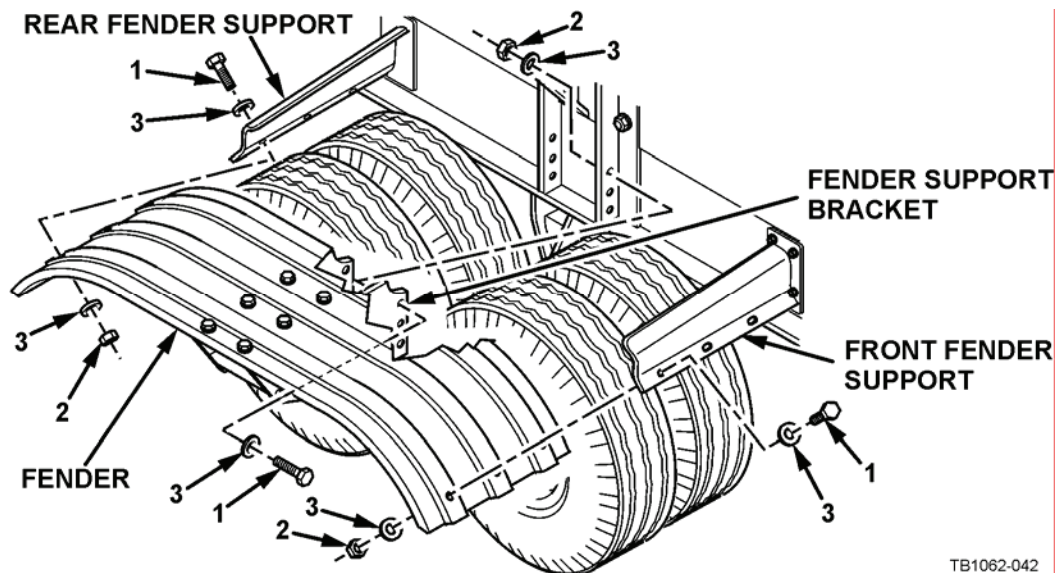

TB1062-042

3. Remove hazardous warning placard.

VEHICLE PREPARATION (continued)**Curbside (continued):****WARNING**

Eye and hearing protection must be worn at all times when using power tools for grinding, cutting, sawing, and drilling. Failure to do so may result in injury to personnel.

CARC paint contains isocyanate (HDI), which is highly irritating to skin and respiratory system. High concentrations of HDI can produce symptoms of itching and reddening of skin, a burning sensation in throat and nose, and watering of the eyes. In extreme concentrations, HDI can cause cough, shortness of breath, pain during respiration, increased sputum production, and chest tightness. The following precautions must be taken whenever using CARC paint:

- **NEVER** weld or cut CARC-coated materials without high-efficiency, air-purifying respirators in use.
 - **DO NOT** grind or sand painted equipment without high-efficiency, air-purifying respirators in use.
 - **BE AWARE** of CARC paint exposure symptoms; symptoms can occur a few days after initial exposure. Seek medical help immediately if symptoms are detected.
4. Remove emergency valve control lines and grommets. Grind retaining straps from tanker box. Discard grommets.
 5. Remove hose canister assembly.
 6. Bend three retaining clamps (4) away from tubing (5).
 7. Loosen two nuts (10), U-bolt (9), and remove cable (7) from relay switch (8).
 8. Remove nut (6) from straight adapter (11).
 9. Pull tubing (5) from grommet (12) and vehicle.
 10. Remove grommet (12) from vehicle. Discard grommet.
 11. Pull tubing (5) away from tanker body.

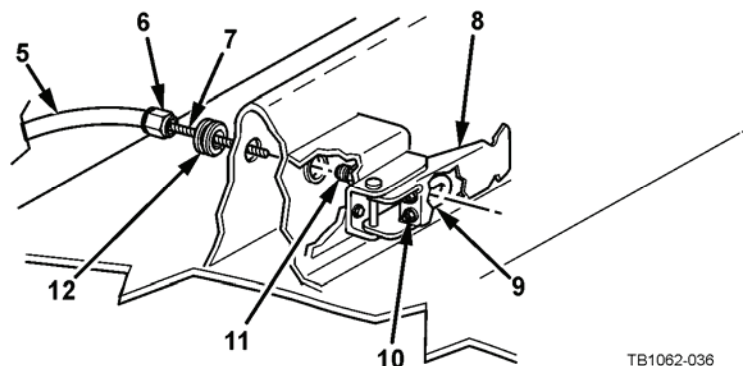
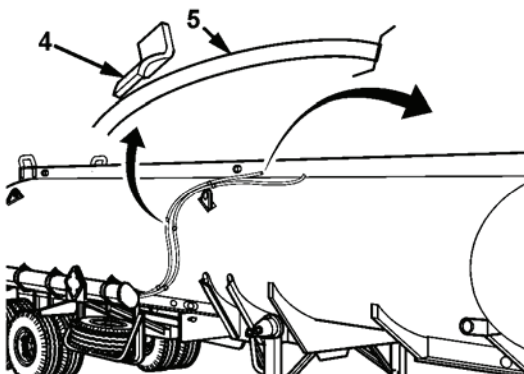

TB1062-036

VEHICLE PREPARATION (continued)

Curbside (continued):

12. Bend three retaining clamps (13) away from tubing (14).
13. Loosen nut (19) and remove cable (17) from vapor vent valve (18).
14. Remove nut (15) from straight adapter (20).
15. Pull tubing (14) from grommet (12) and vehicle.
16. Remove grommet (12) from vehicle. Discard grommet.

WARNING

Eye and hearing protection must be worn at all times when using power tools for grinding, cutting, sawing, and drilling. Failure to do so may result in injury to personnel.

CARC paint contains isocyanate (HDI), which is highly irritating to skin and respiratory system. High concentrations of HDI can produce symptoms of itching and reddening of skin, a burning sensation in throat and nose, and watering of the eyes. In extreme concentrations, HDI can cause cough, shortness of breath, pain during respiration, increased sputum production, and chest tightness. The following precautions must be taken whenever using CARC paint:

- NEVER weld or cut CARC-coated materials without high-efficiency, air-purifying respirators in use.
- DO NOT grind or sand painted equipment without high-efficiency, air-purifying respirators in use.
- BE AWARE of CARC paint exposure symptoms; symptoms can occur a few days after initial exposure. Seek medical help immediately if symptoms are detected.

17. Grind retaining clamps (4) and (13) to remove from vehicle. Ensure retaining clamps are ground smooth to surface of tank body.

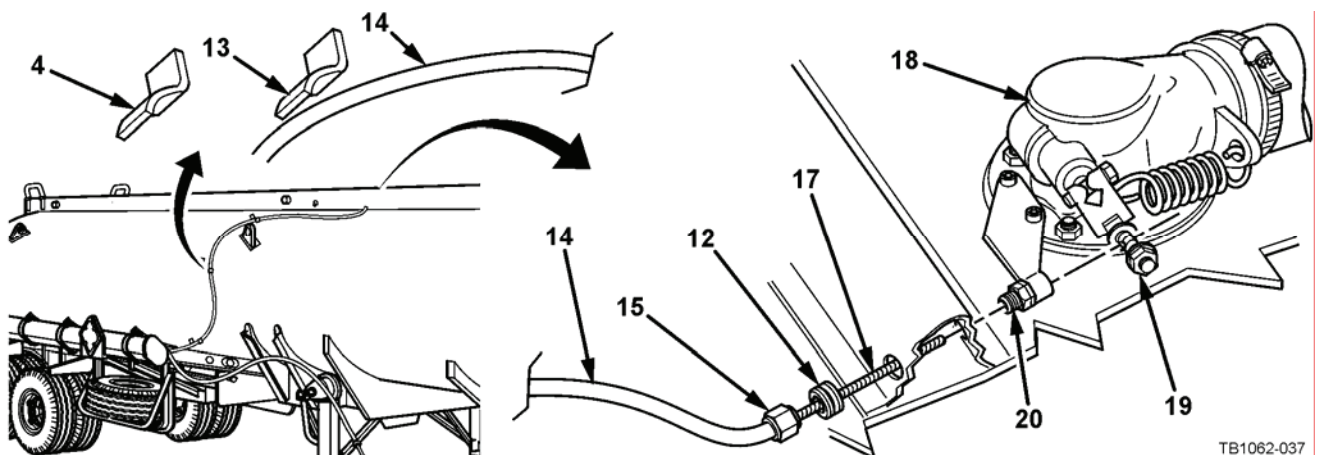

TB1062-037

VEHICLE PREPARATION (continued)**Rear Bulkhead:**

1. Remove vapor collection hose.

WARNING

Eye and hearing protection must be worn at all times when using power tools for grinding, cutting, sawing, and drilling. Failure to do so may result in injury to personnel.

CARC paint contains isocyanate (HDI), which is highly irritating to skin and respiratory system. High concentrations of HDI can produce symptoms of itching and reddening of skin, a burning sensation in throat and nose, and watering of the eyes. In extreme concentrations, HDI can cause cough, shortness of breath, pain during respiration, increased sputum production, and chest tightness. The following precautions must be taken whenever using CARC paint:

- **NEVER** weld or cut CARC-coated materials without high-efficiency, air-purifying respirators in use.
- **DO NOT** grind or sand painted equipment without high-efficiency, air-purifying respirators in use.
- **BE AWARE** of CARC paint exposure symptoms; symptoms can occur a few days after initial exposure. Seek medical help immediately if symptoms are detected.

NOTE

Do not remove left and right rear wiring conduit from tanker.

2. Remove left and right rear wiring conduit from retaining straps. Grind retaining straps from tanker box.
3. Remove wire ties, clamps, and hoses from ladder assembly, if so equipped.
4. Measure and cut legs of ladder assembly 4-inches (10 cm) from base of vehicle.

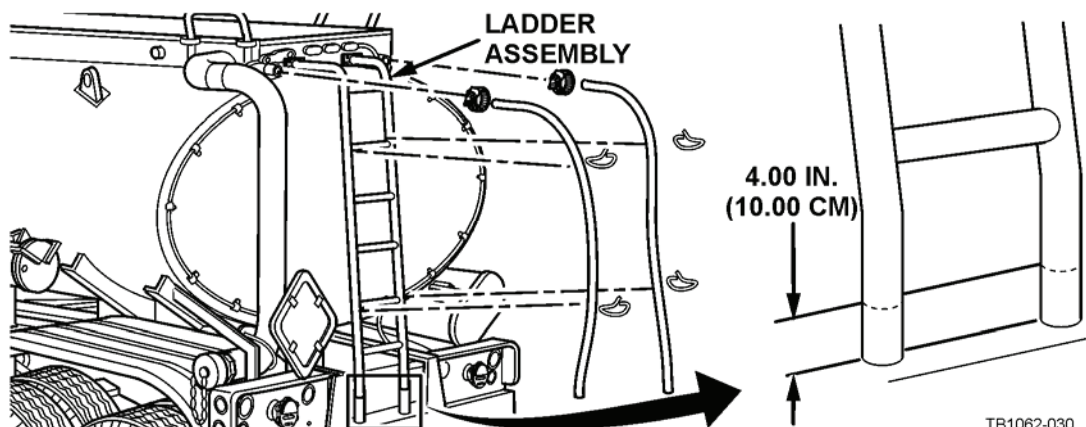

VEHICLE PREPARATION (continued)

Rear Bulkhead (continued):

5. Remove ladder mounting hardware and ladder assembly from tanker body. Discard mounting hardware.

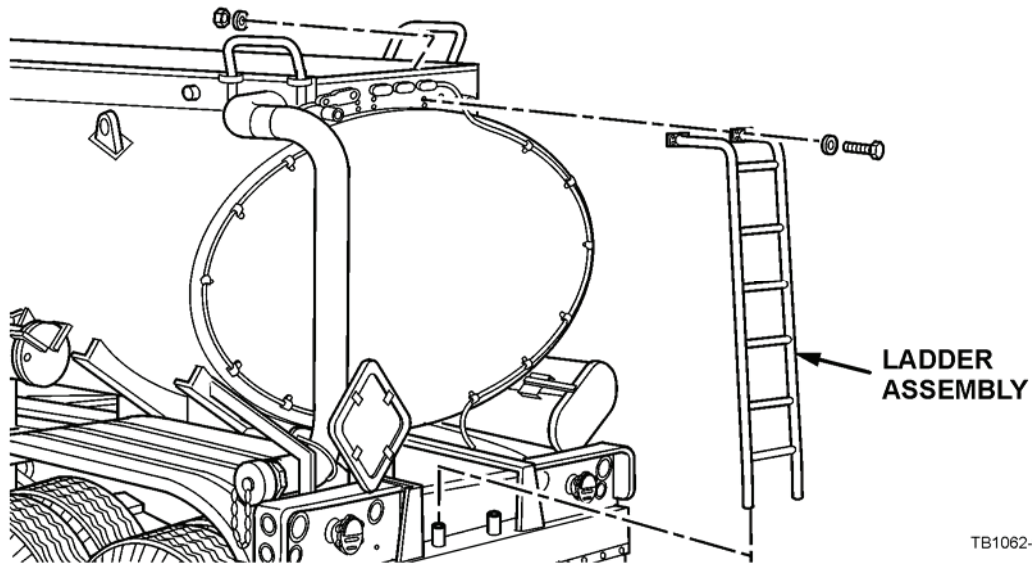

TB1062-031

VEHICLE PREPARATION (continued)

Rear Bulkhead (continued):

NOTE

Perform Step 6 if ladder assembly is welded to upper tank body.

WARNING

Eye and hearing protection must be worn at all times when using power tools for grinding, cutting, sawing, and drilling. Failure to do so may result in injury to personnel.

CARC paint contains isocyanate (HDI), which is highly irritating to skin and respiratory system. High concentrations of HDI can produce symptoms of itching and reddening of skin, a burning sensation in throat and nose, and watering of the eyes. In extreme concentrations, HDI can cause cough, shortness of breath, pain during respiration, increased sputum production, and chest tightness. The following precautions must be taken whenever using CARC paint:

- **NEVER** weld or cut CARC-coated materials without high-efficiency, air-purifying respirators in use.
- **DO NOT** grind or sand painted equipment without high-efficiency, air-purifying respirators in use.
- **BE AWARE** of CARC paint exposure symptoms; symptoms can occur a few days after initial exposure. Seek medical help immediately if symptoms are detected.

6. Cut ladder assembly approximately midway on straight run from tanker body, as shown.

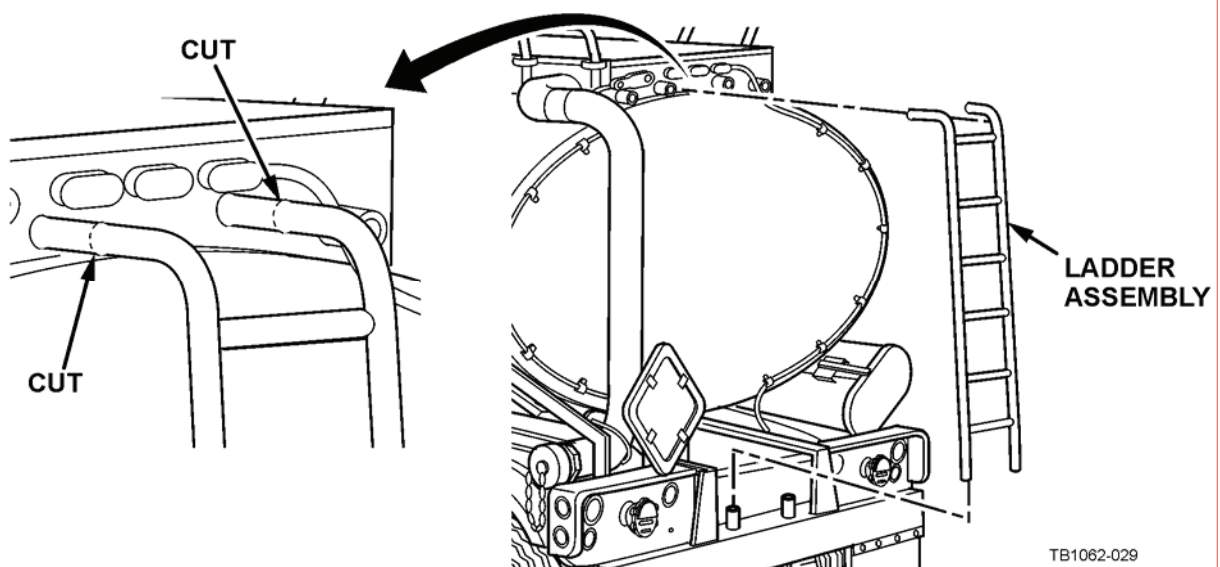

TB1062-029

VEHICLE PREPARATION (continued)

Roadside:

1. Remove fender and fender support bracket (see curbside section).
2. Remove ground rod tube assembly.
3. Locate three conduit lines between the second and third cross member on the roadside of the fuel tanker, as shown.
4. Mask the conduit lines to protect during the application of the FTSS.
5. Locate two conduit lines between the second and third cross member on the curbside of the fuel tanker, as shown.
6. Mask the conduit lines to protect during the application of the FTSS.

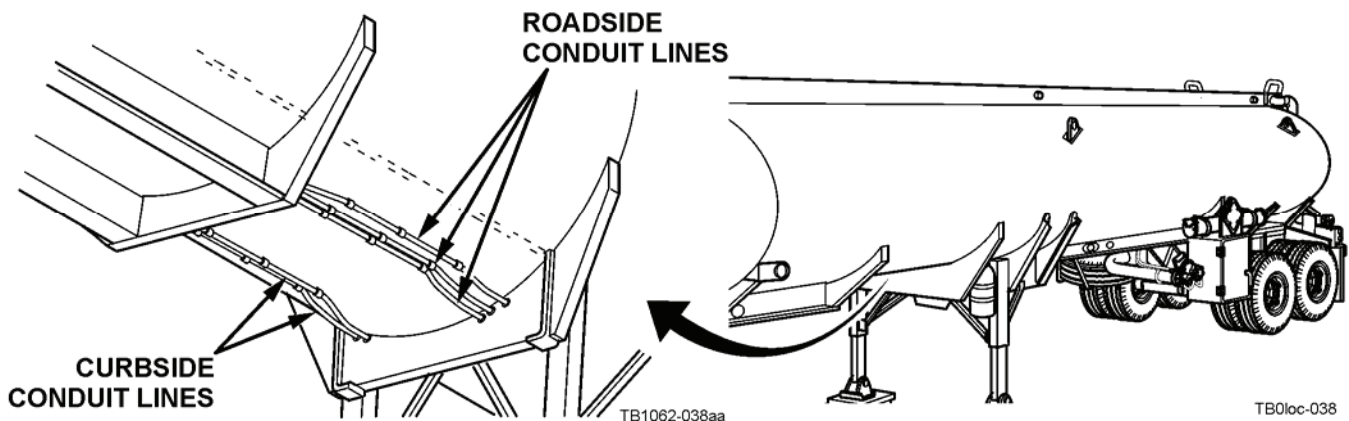

FTSS SYSTEM PROCEDURE

The source and application of the FTSS System is proprietary. For vehicle preparation, applications, and reapplication of the FTSS System, contact VSE Corporation, 2550 Huntington Avenue, Alexandria, VA 22303 or you may submit your request by phone (800) 455-4873 or fax (703) 960-2688.

FOLLOW-ON TASK

The following list details the components that are installed after the FTSS System coating has been applied, dried, and inspected. For component installation instructions, refer to TM 9-2330-384-14&P.

Front Bulkhead:

NOTE

- Two placard extension plates are required to provide clearance between FTSS coating and front placard.
 - Voltage control unit and nose adapter bracket are re-installed in Step 1.
1. Install two placard extension plates (21), nose adapter bracket, and voltage control unit on tanker with four new hexagon head capscrews (22), four new self-locking nuts (2), and eight new flat washers (3). Hand tighten self-locking nuts.

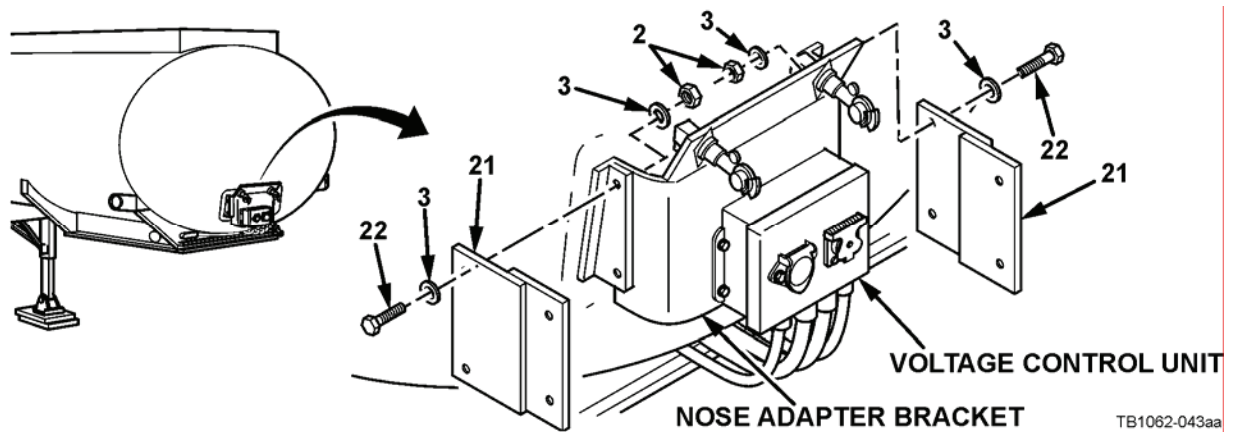

2. Install front placard on two placard extension plates (21) with four new hexagon head capscrews (22), four new self-locking nuts (2), and eight new flat washers (3). Torque eight self-locking nuts to 30-35 lb-ft (41-48 N•m).

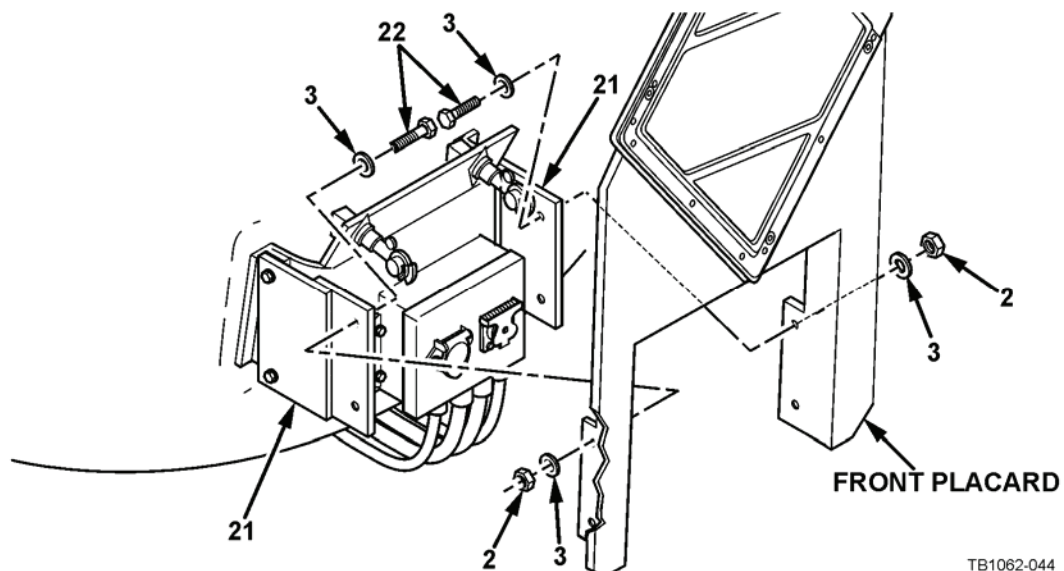

FOLLOW-ON TASK (continued)

Curbside:

1. Place new grommet (12) on tubing (14).
2. Insert cable (17) and tubing (14) through port on vehicle.
3. Insert cable (17) through straight adapter (20) and into lever of vapor vent valve (18). Ensure cable (17) rest between washers on lever.
4. Install tubing (14) on straight adapter (20) and tighten nut (15).
5. Pull cable (17) tight in lever and tighten nut (19).
6. Install tubing (14) on tanker with three new retaining clips (24) and new hazel nuts (23).
7. Check vapor vent valve operation. Adjust as necessary.

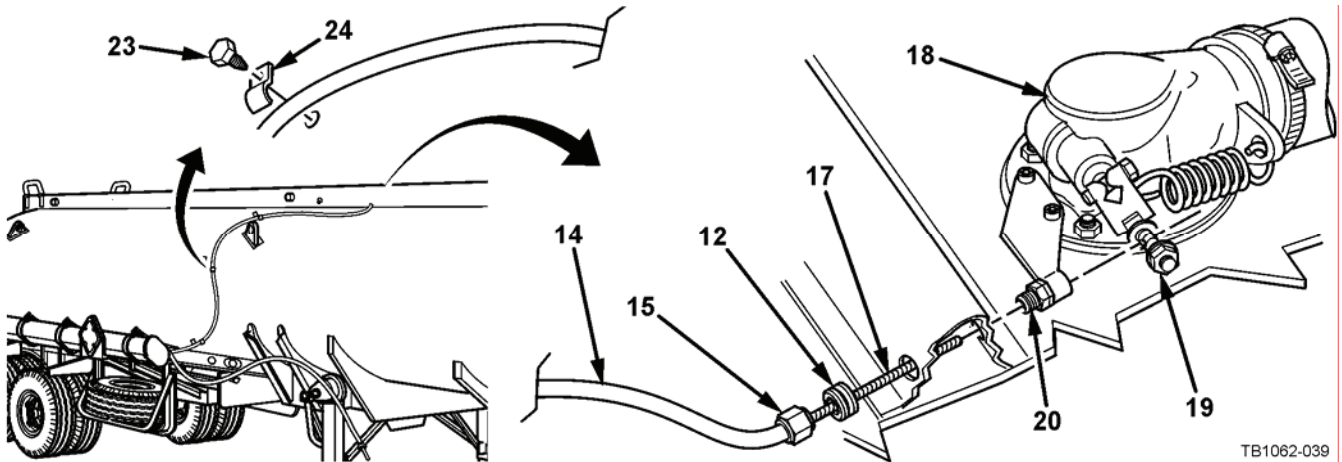

TB1062-039

FOLLOW-ON TASK (continued)**Curbside (continued):**

8. Place new grommet (12) on tubing (5).
9. Insert cable (7) and tubing (5) through port on vehicle.
10. Insert cable (7) through straight adapter (11) and U-bolt (9) on relay switch (8).
11. Install tubing (5) on straight adapter (11) and tighten nut (6).
12. Pull cable (7) tight in U-bolt (9) and tighten two nuts (10).
13. Install tubing (5) on tanker with three new retaining clips (24) and new hazel nuts (23).
14. Check relay switch operation. Adjust as necessary.

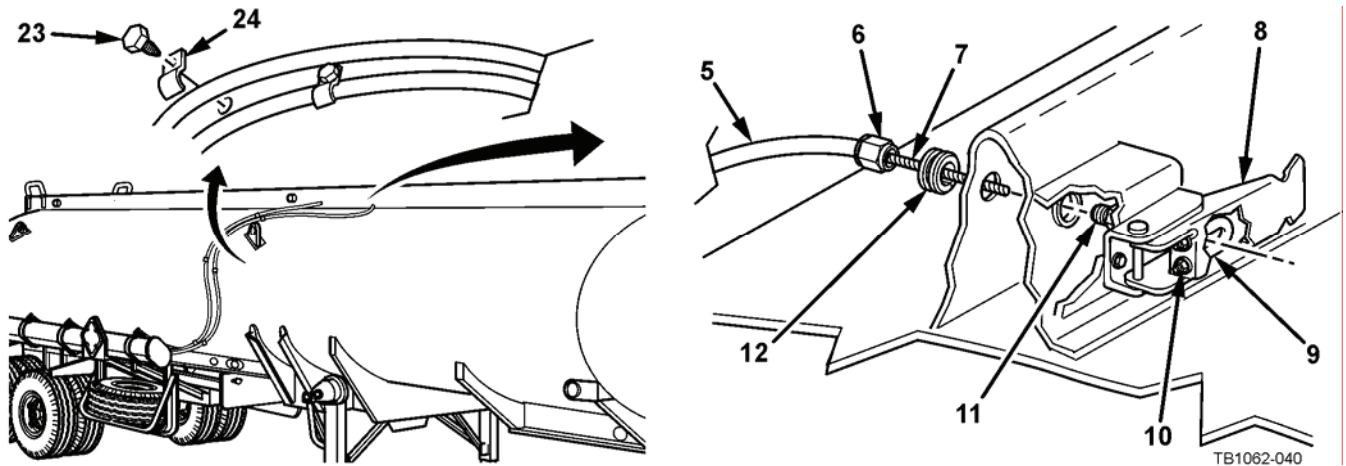

15. Install hose canister assembly.
16. Install emergency valve control lines and grommets.
17. Install hazardous warning placard.

FOLLOW-ON TASK (continued)

Curbside (continued):

NOTE

- Steps 18 and 19 apply to curbside and roadside fenders. Curbside is shown.
- Fender installation is a two person task.

18. Install fender and fender support bracket on tanker with six new hexagon head capscrews (1), six new self-locking nuts (2), and twelve new flat washers (3). Hand tighten self-locking nuts.
19. Install fender on front and rear fender supports with three new hexagon head capscrews (1), three new self-locking nuts (2), and six new flat washers (3). Torque twelve self-locking nuts to 30-35 lb-ft (41-48 N•m).

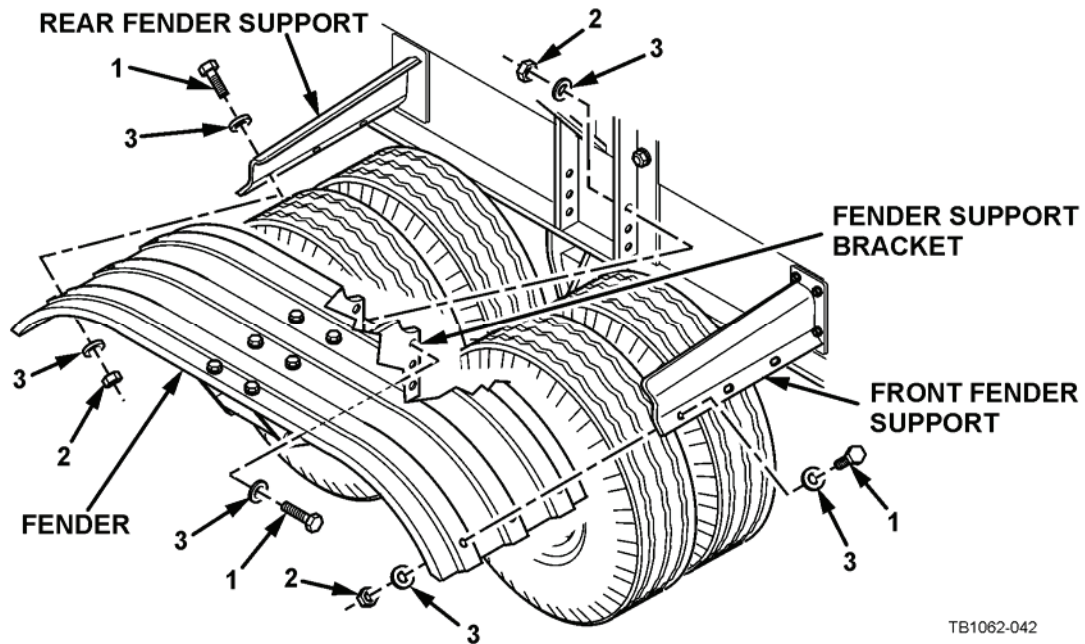

TB1062-042

FOLLOW-ON TASK (continued)**Rear Bulkhead:**

1. Install vapor collection hose.
2. Install twelve new retaining clips (24) and new hazel nuts (23) on left and right rear wiring conduit.

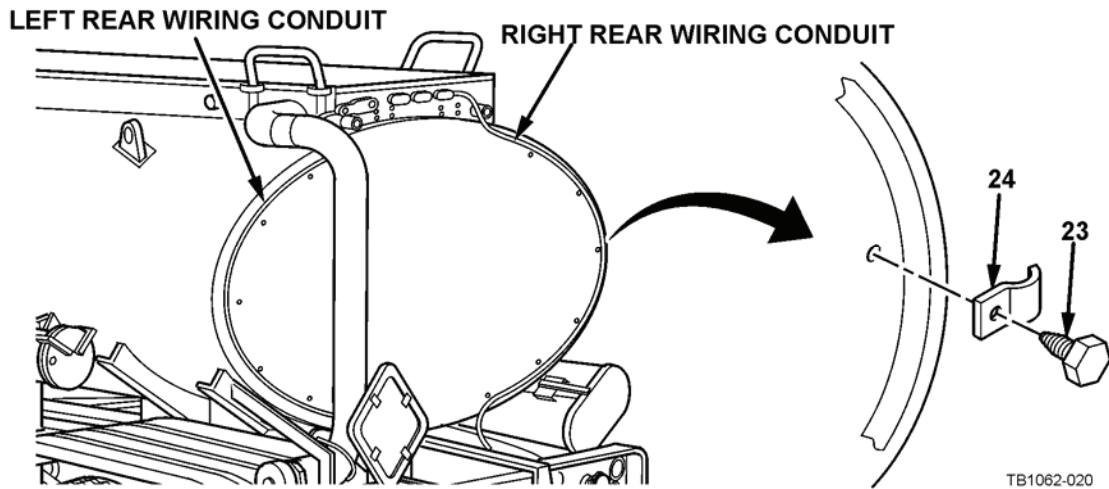
**NOTE**

If ladder was welded to upper tank assembly go to Steps 5 through 9.

3. Install ladder assembly on rear of tanker using two new sleeves (26), four new hexagon head capscrews (25), four new self-locking nuts (2), and eight new flat washers (3). Torque self-locking nuts to 30-35 lb-ft (41-48 N•m).

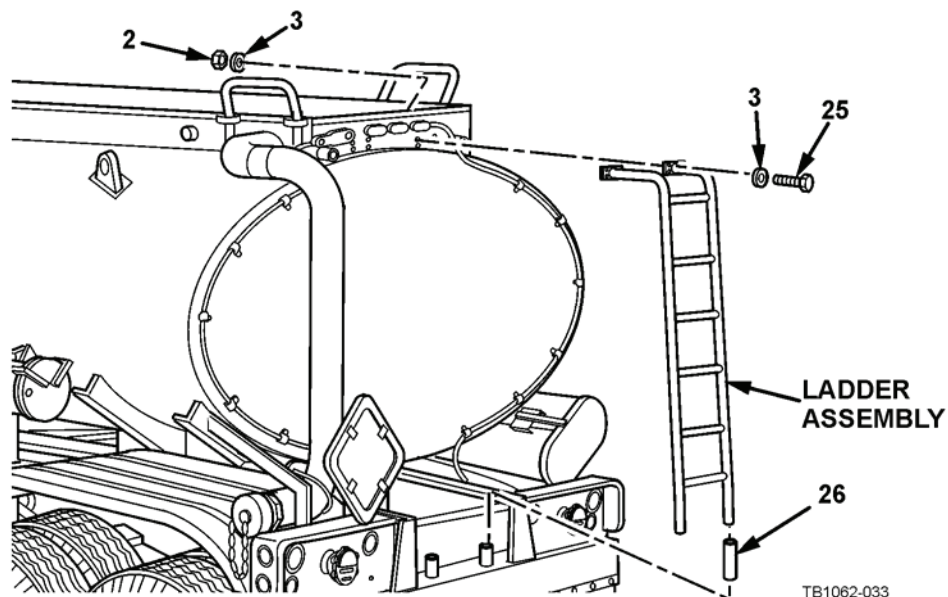

FOLLOW-ON TASK (continued)

Rear Bulkhead (continued):

4. Install two hoses on rear of tanker using two clamps and secure to ladder assembly with tiedown straps, as required.

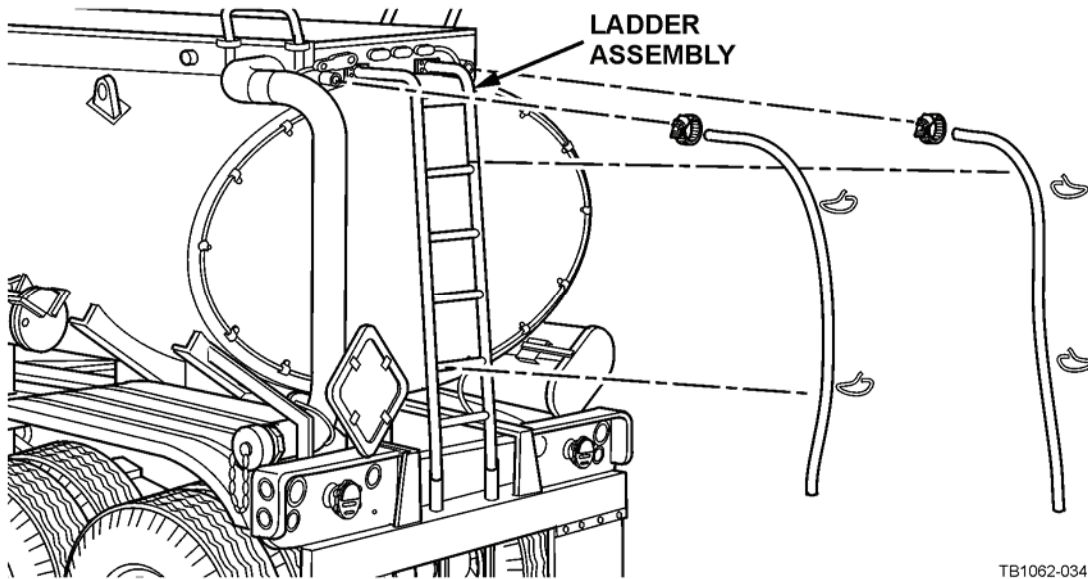

TB1062-034

FOLLOW-ON TASK (continued)**Rear Bulkhead (continued):****NOTE**

Perform Steps 5 through 9 if ladder assembly was welded to upper tank assembly.

5. Position two new upper ladder sleeves (27) over upper ladder stubs.
6. Install two new lower ladder sleeves (26) on base of tanker.
7. Insert ladder assembly into sleeves (26) and (27).
8. Align holes in upper ladder sleeves (27) vertically. Center and drill two holes through each upper sleeve using 13/32-inch drill bit.
9. Install ladder assembly and upper sleeves (27) with eight new flat washers (3), four new hexagon head capscrews (25), and four new self-locking nuts (2). Torque self-locking nuts to 30-35 lb-ft (41-48 N•m).

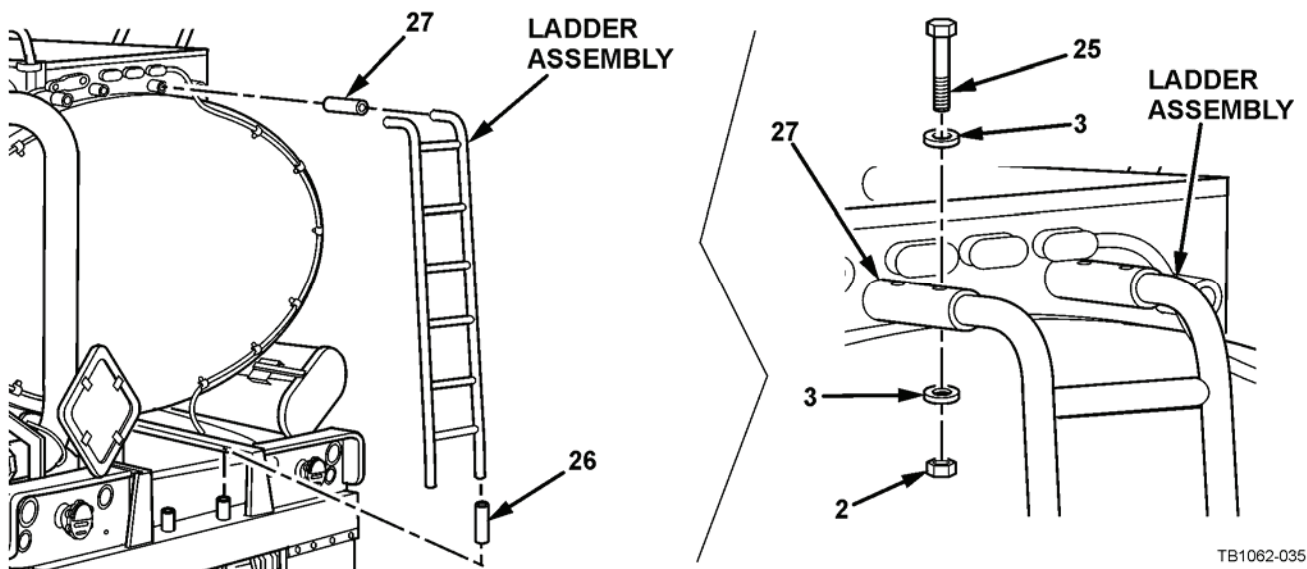

TB1062-035

FOLLOW-ON TASK (continued)

Roadside:

1. Install ground rod tube assembly.
2. Install fender and fender support bracket (see curbside section).
3. Remove masking from three roadside and two curbside conduit lines.

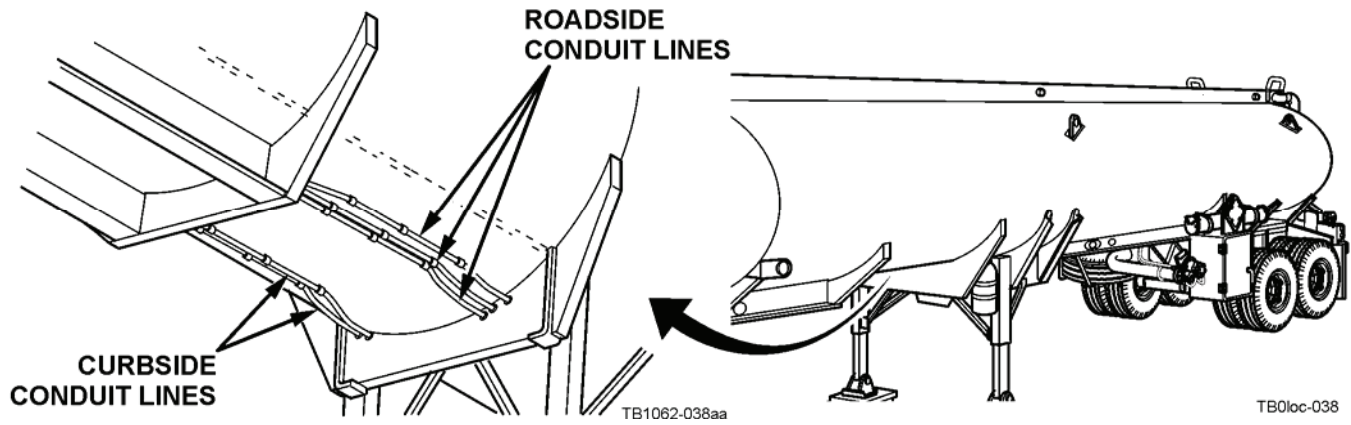

REMOVAL

The following list details the removal instructions for the unique items installed on the fuel tanker as part of the application of the FTSS System coating.

Front Bulkhead:

1. Remove four hexagon head capscrews (22), four self-locking nuts (2), eight flat washers (3), and front placard from two placard extension plates (21).

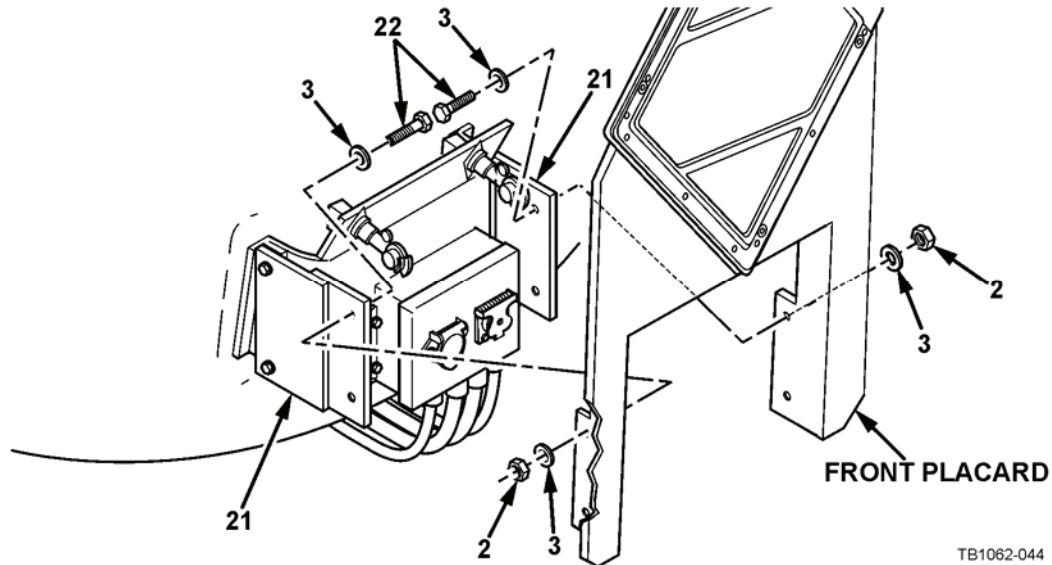

TB1062-044

NOTE

- Two placard extension plates are required to provide clearance between FTSS coating and front placard.
 - Voltage control unit and nose adapter bracket are removed in Step 2.
2. Remove four hexagon head capscrews (22), four self-locking nuts (2), and eight flat washers (3), two placard extension plates (21), nose adapter bracket, and voltage control unit from tanker.

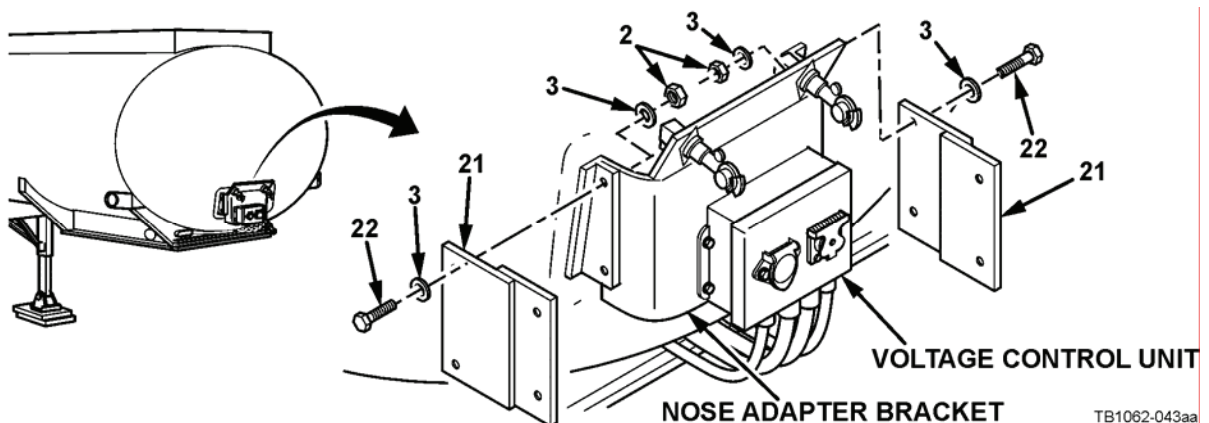

TB1062-043aa

TB 9-2330-384-14&P
REMOVAL (continued)

Curbside:

1. Remove three retaining clips (24) and hazel nuts (23) from tubing (14) on tanker.
2. Remove three retaining clips (24) and hazel nuts (23) from tubing (5) on tanker.

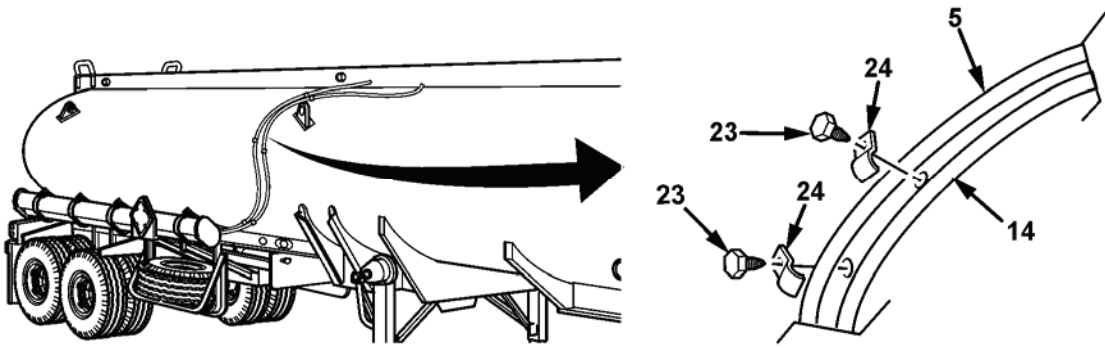

TB1062-053

REMOVAL (continued)

Rear Bulkhead:

1. Remove twelve retaining clips (24) and hazel nuts (23) from left and right rear wiring conduit.

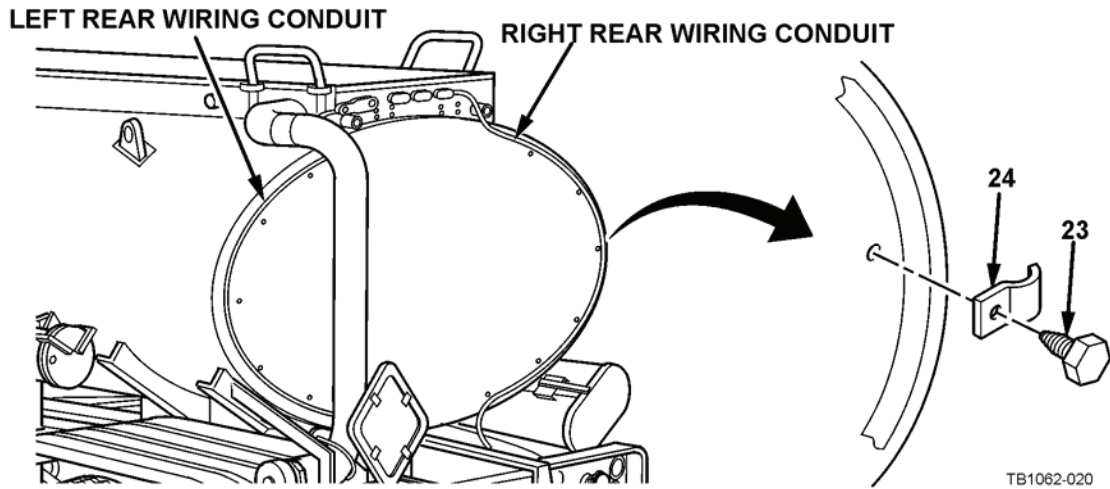

NOTE

If ladder assembly has upper and lower ladder sleeves perform Steps 4 and 5.

2. Remove two clamps, tiedown straps, and two hoses from ladder assembly.

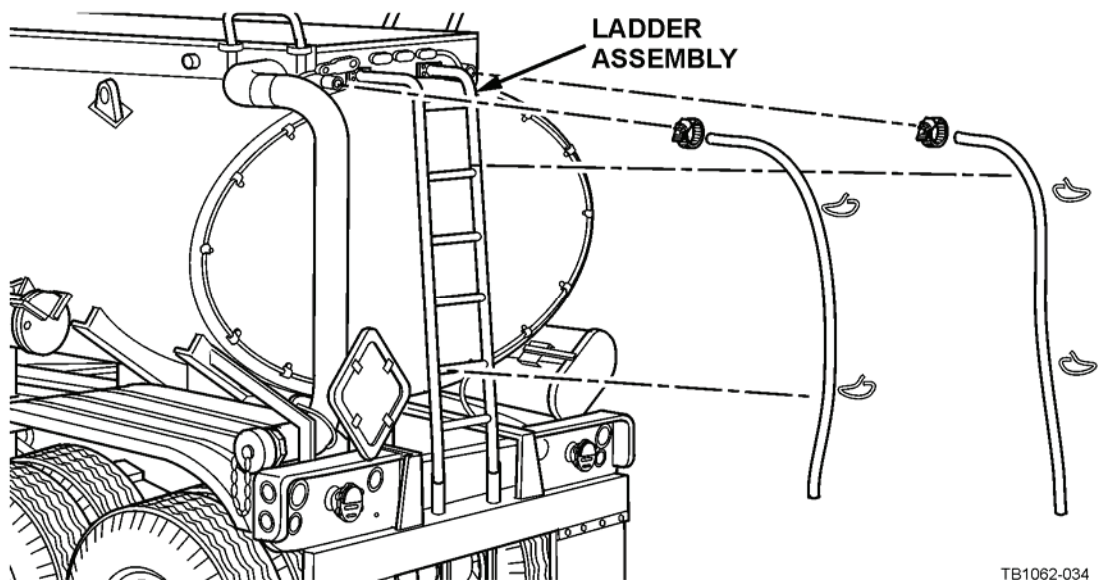

REMOVAL (continued)

Rear Bulkhead (continued):

3. Remove four hexagon head capscrews (25), four self-locking nuts (2), eight flat washers (3), two sleeves (26), and ladder assembly from rear of tanker.

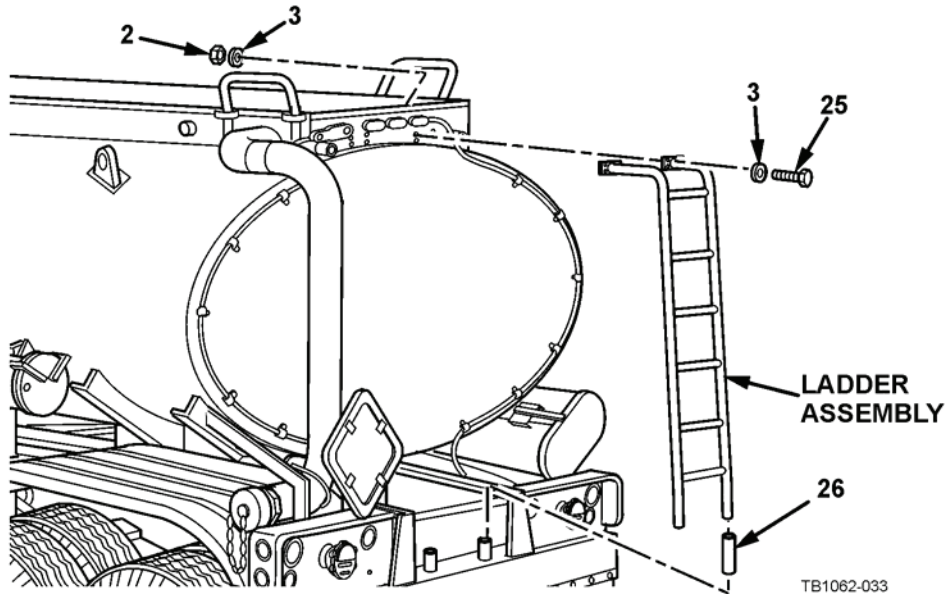

NOTE

Perform Steps 4 and 5 if ladder assembly has upper and lower ladder sleeves.

4. Remove four hexagon head capscrews (25), four self-locking nuts (2), and eight flat washers (3), from ladder assembly and upper sleeves (27).
5. Remove ladder assembly, two upper ladder sleeves (27), and two lower ladder sleeves (26) from tanker.

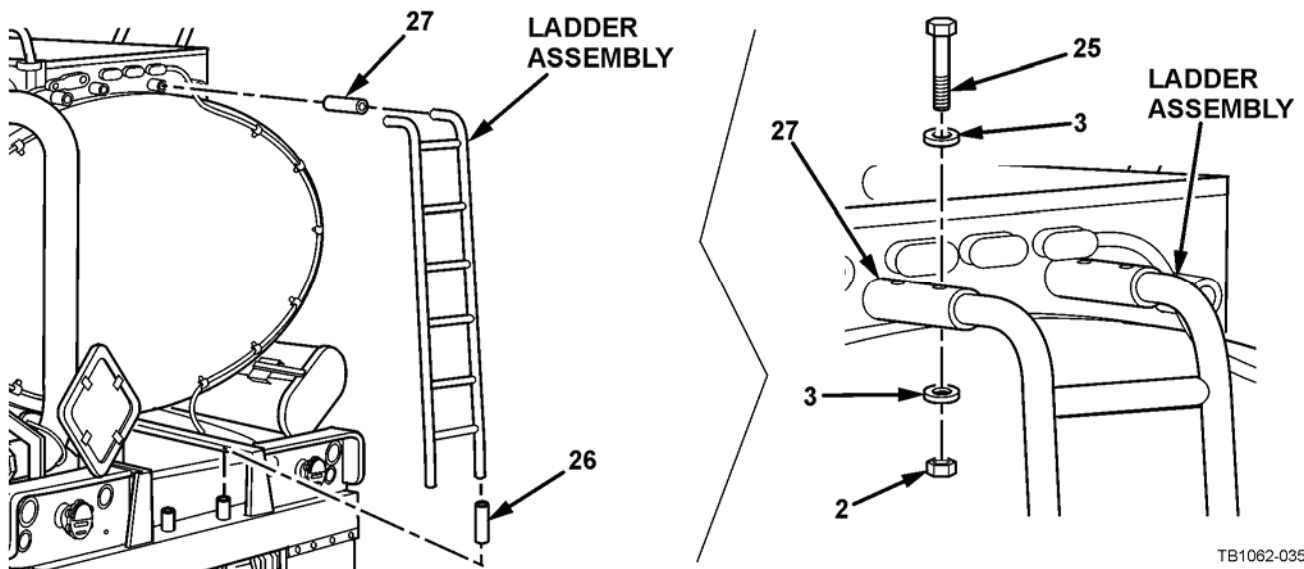

CHAPTER 4 ADD-ON-ARMOR (AOA) KIT

SCOPE

This chapter provides the parts list, installation, and removal instructions for the AOA kit.

TOOLS AND SPECIAL TOOLS

For a list of tools and special tools needed to install the AOA kit, refer to Chapter 8, Table 8-2.

NOTE

All lifting devices, lifting slings, and hydraulic jacks must have the capability to support 500 pounds (227 kg) when used to install the AOA kit.

ARMY KNOWLEDGE ONLINE (AKO) WEBSITE

Refer to the AKO website at <https://www.us.army.mil/suite/login/welcome.html> for the most recent updates to the kits and TB installation instructions.

KIT PARTS AND THEIR DISPOSITION

The following lists the kit components of the AOA kit (RPSTL Figures 1-3). This list can be used to inventory the kit for completeness.

Table 4-1. Add-On-Armor (AOA) Kit Contents List

Item No.	Nomenclature	National Stock Number	Part Number	CAGEC	QTY
	AOA Kit Assembly Drawing		12500828	19207	1
	Technical Bulletin		TB 9-2330-384-14&P	19207	1
1	Washer, Flat, 1/2, SS	5310-00-767-9425	MS15795-818	80205	60
2	Screw, Cap, Hexagon Head 1/2-13 x 2.00	5305-00-071-2071	B1821BH050C200N	80204	21
3	Support, Cross Brace	2510-01-541-8817	12500878	19207	1
4	Nut, Self-locking, Hexagon 1/2-13, SS	5310-00-411-4385	MS17830-8C	96906	30
5	Bracket, Rear Brace	5340-01-542-0420	12500880	19207	1
6	Slider, Support Bracket	2590-01-541-3759	12500852	19207	2
7	Bracket, Frame Support	5340-01-542-0388	12500881	19207	1
8	Screw, Cap, Hexagon Head 1/2-13 x 3.00	5305-00-071-2075	B1821BH050C300N	80204	4
9	Bracket, Center Brace	5340-01-542-0343	12500879	19207	1
10	Frame Panel, Roadside	2540-01-541-8802	12500875	19207	1
11	Support, Lower Bracket	5340-01-542-0366	12500883	19207	1
12	Screw, Cap, Hexagon Head 3/8-16 x 1.50	5305-00-725-2317	B1821BH038C150N	80204	7
13	Washer, Flat, 3/8, SS	5310-00-773-7618	MS15795-814	80205	38
14	Nut, Self-locking, Hexagon 3/8-16, SS	5310-01-542-0345	M45913/4-6CG8Z	96906	19

KIT PARTS AND THEIR DISPOSITION (continued)

Table 4-1. Add-On-Armor (AOA) Kit Contents List (continued)

Item No.	Nomenclature	National Stock Number	Part Number	CAGEC	QTY
15	Panel, Belly	2540-01-542-0435	12500876	19207	1
16	Screw, Cap, Hexagon Head 1/2-13 x 4.00	5305-00-071-2079	B1821BH050C400N	80204	1
17	Panel, Forward Belly	2540-01-542-1198	12500877	19207	1
18	Screw, Cap, Hexagon Head 1/2-13 x 1.50	5305-00-071-2069	B1821BH050C150N	80204	4
19	Door Assembly A	5340-01-542-0333	12500873	19207	1
20	Latch, Safety	2540-01-542-0334	12500887-001	19207	2
21	Screw, Cap, Hexagon Head 3/8-16 x 1.25	5305-00-068-0510	B1821BH038C125N	80204	12
22	Door Assembly B	5340-01-541-8481	12500874	19207	1

INSTALLATION

1. Locate existing cross member and two support beams slightly rear of the mid-point of the tanker.
2. Position cross brace support locating template on two support beams with 17-1/2 inches (44.45 cm) between front surface of cross member and back edge of template, as shown. Ensure that template is parallel with cross member and clamp in place.

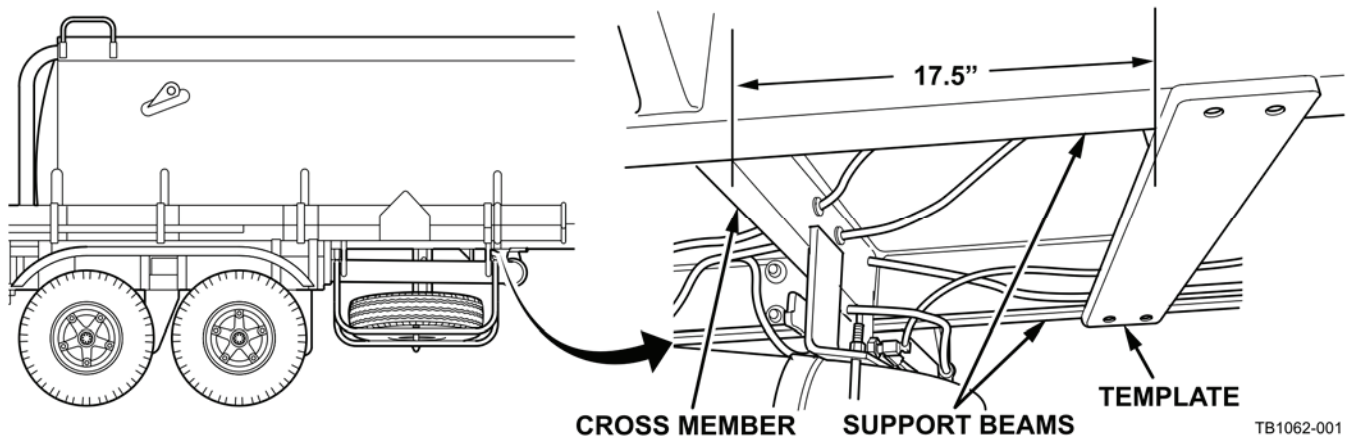

3. Using a 1/4-inch drill bit and template as a guide, drill four holes, marked A, through two support beams.
4. Remove template from two support beams.
5. Using a 19/32-inch drill bit, enlarge four holes, marked A, in two support beams.
6. Install cross brace support (3) on two support beams with four hexagon head capscrews (2), four self-locking nuts (4), and eight flat washers (1), as shown. Torque self-locking nuts to 55-65 lb-ft (75-88 N•m).

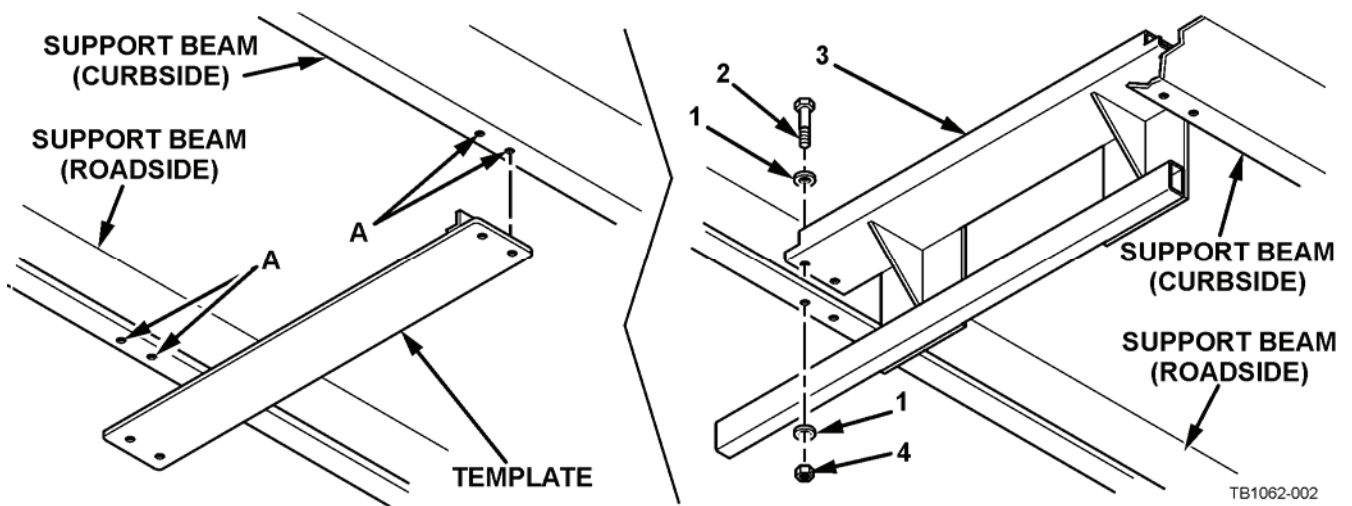

INSTALLATION (continued)

7. Measure from vehicle frame to outer edge of vehicle fender, as shown, approximately 29 inches (73.66 cm). This distance will be referred to as Measurement X.

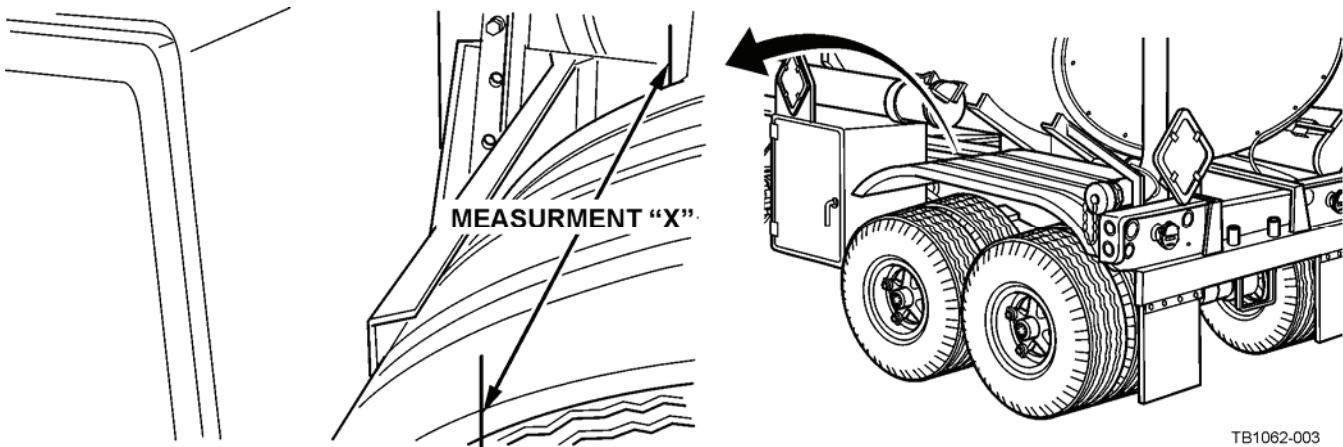

8. Install slider support bracket (6) on rear brace roadside bracket (5) and frame support bracket (7).

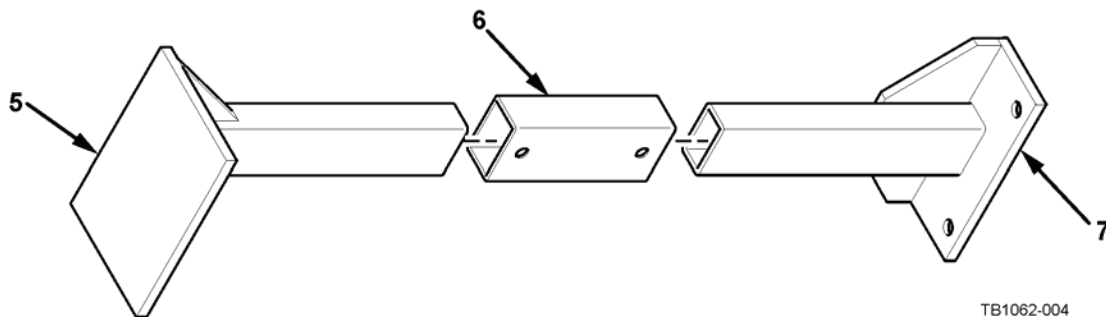

9. Adjust rear brace roadside bracket (5) and frame support bracket (7) to equal Measurement X. Measurement should be taken between outer edge of frame support bracket (7) and inner edge of rear brace roadside bracket (5), as shown.
10. Center slider support bracket (6) on rear brace roadside bracket (5) and frame support bracket (7) while maintaining measurement X, and clamp slider support bracket (6) in place.
11. Using 19/32-inch drill bit and slider support bracket (6) as a template, drill two holes, marked B, through rear brace roadside bracket (5), frame support bracket (7), and slider support bracket (6).

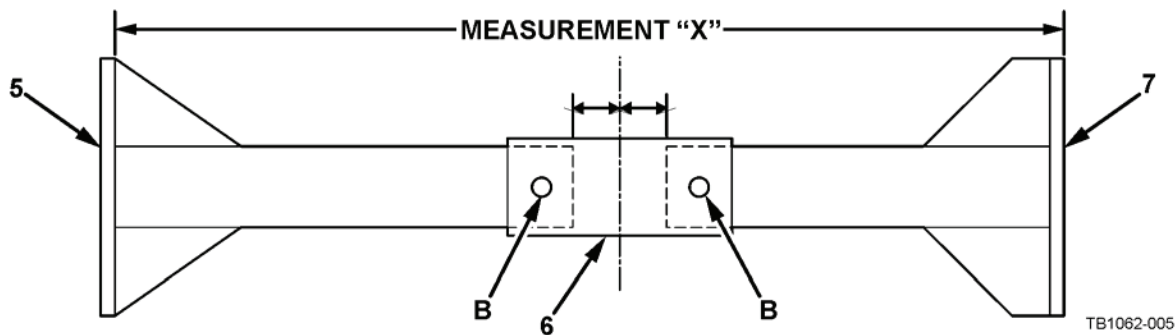

INSTALLATION (continued)

12. Install two hexagon head capscrews (8), two self-locking nuts (4), and four flat washers (1) through slider support bracket (6), rear brace roadside bracket (5), and frame support bracket (7), as shown. Torque self-locking nuts to 55-65 lb-ft (75-88 N•m).

NOTE

If vehicle frame has two existing holes for frame support bracket go to Step 15, if not perform Steps 13 and 14.

13. Position and clamp assembled slider support bracket (6), rear brace roadside bracket (5), and frame support bracket (7) on vehicle frame and mark two hole locations on frame.
14. Using 19/32-inch drill bit, drill two holes marked C through frame.

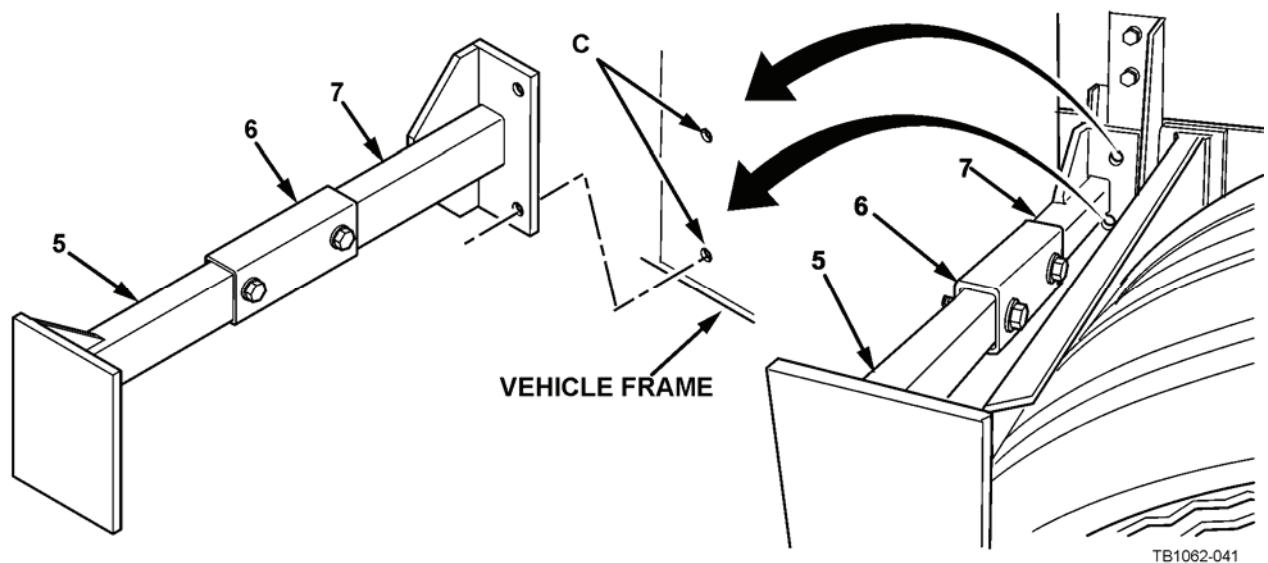

15. Install assembled slider support bracket (6), rear brace roadside bracket (5), and frame support bracket (7) on vehicle frame with two hexagon head capscrews (2), two self-locking nuts (4), and four flat washers (1), as shown. Torque self-locking nuts to 55-65 lb-ft (75-88 N•m).

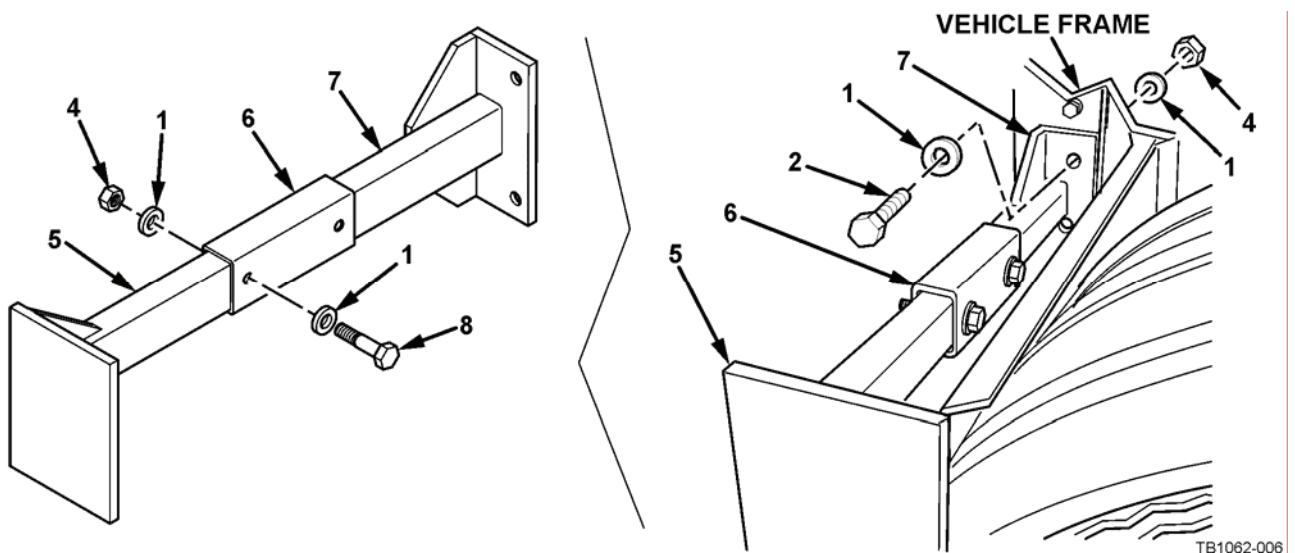

INSTALLATION (continued)

16. Install slider support bracket (6) on center brace bracket (9) and cross brace support (3). Adjust center brace bracket (9) to duplicate Measurement X. Measurement X should be taken between vehicle frame and inner edge of center brace bracket (9), as shown.
17. Center slider support bracket (6) on center brace bracket (9) and cross brace support (3) while maintaining Measurement X, and clamp slider support bracket (6) in place.
18. Using 19/32-inch drill bit and slider support bracket (6) as a template, drill two holes, marked D, through center brace bracket (9), cross brace support (3), and slider support bracket (6).

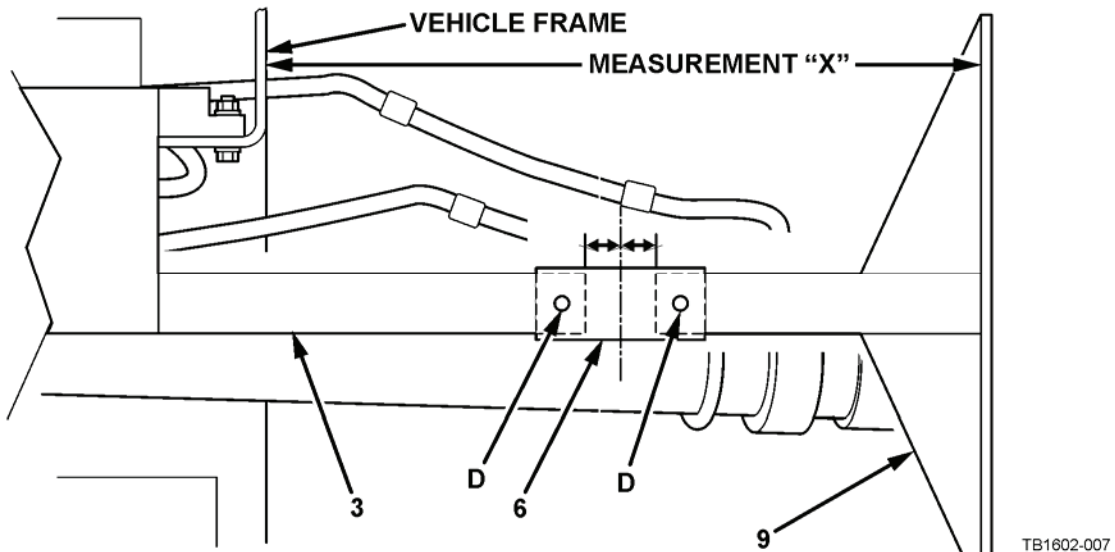

19. Install two hexagon head capscrews (8), two self-locking nuts (4), and four flat washers (1) through slider support bracket (6), center brace bracket (9), and cross brace support (3), as shown. Ensure two hexagon head capscrews (8) are installed in the direction shown. Torque self-locking nuts to 55-65 lb-ft (75-88 N•m).

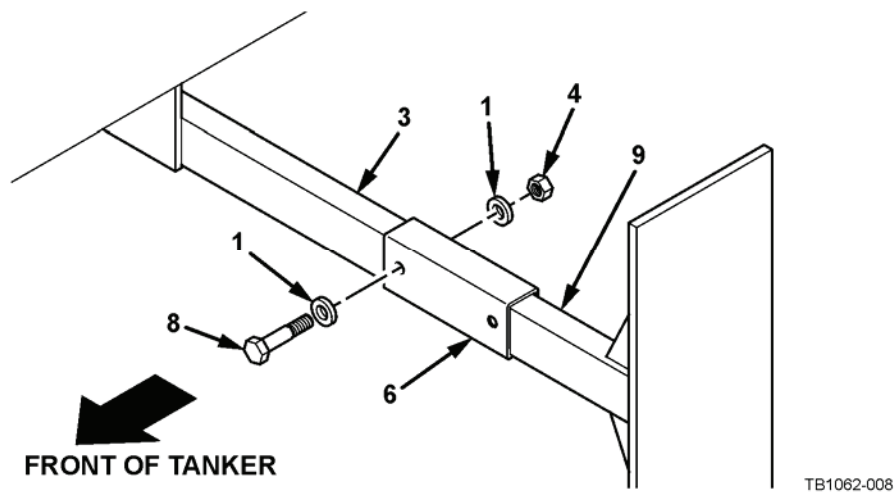

INSTALLATION (continued)**WARNING**

Use caution when lifting supplemental armor. A swinging or shifting load may cause injury to personnel.

NOTE

- Roadside frame panel may come with doors pre-installed with shipping hardware. If doors are installed, remove doors from frame panel. Set doors aside and discard hardware.
 - Correct positioning of roadside frame panel prior to drilling is critical.
20. Using dawg grips (Table 8-2), a suitable lifting sling, and suitable lifting device raise and position roadside frame panel (10) against rear brace roadside bracket (5) and center brace bracket (9). Ensure roadside frame panel (10) is level and lines up properly with rear brace roadside bracket (5) and center brace bracket (9).

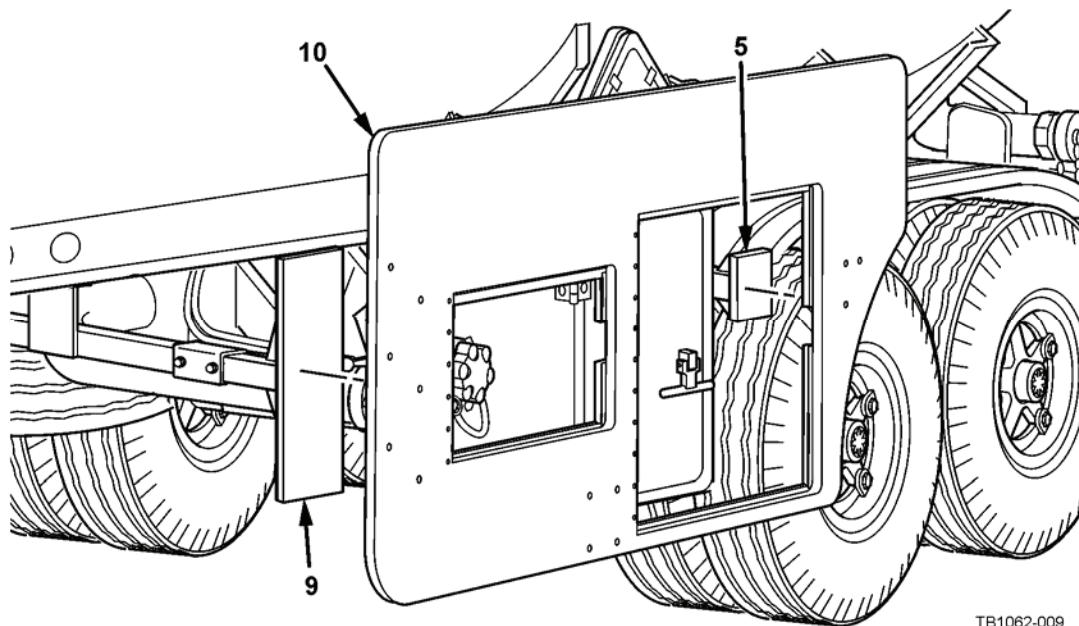

TB1062-009

INSTALLATION (continued)

21. Open door of existing accessories stowage box and ensure the rear door opening of roadside frame panel (10) is square with accessories stowage box and there is clearance for accessories stowage box door. Readjust position of roadside frame panel (10) as required.

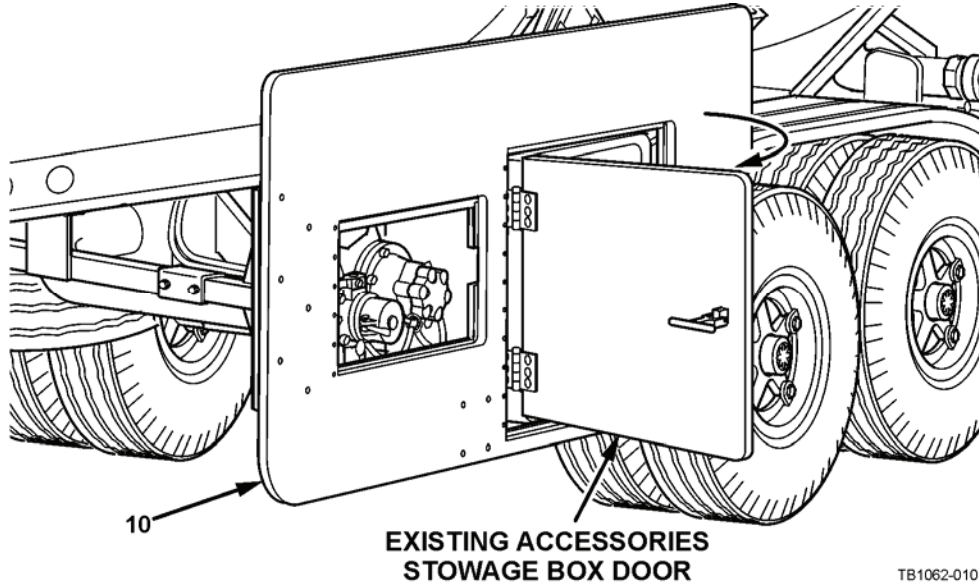

22. Clamp roadside frame panel (10) to rear brace roadside bracket (5) and center brace bracket (9).

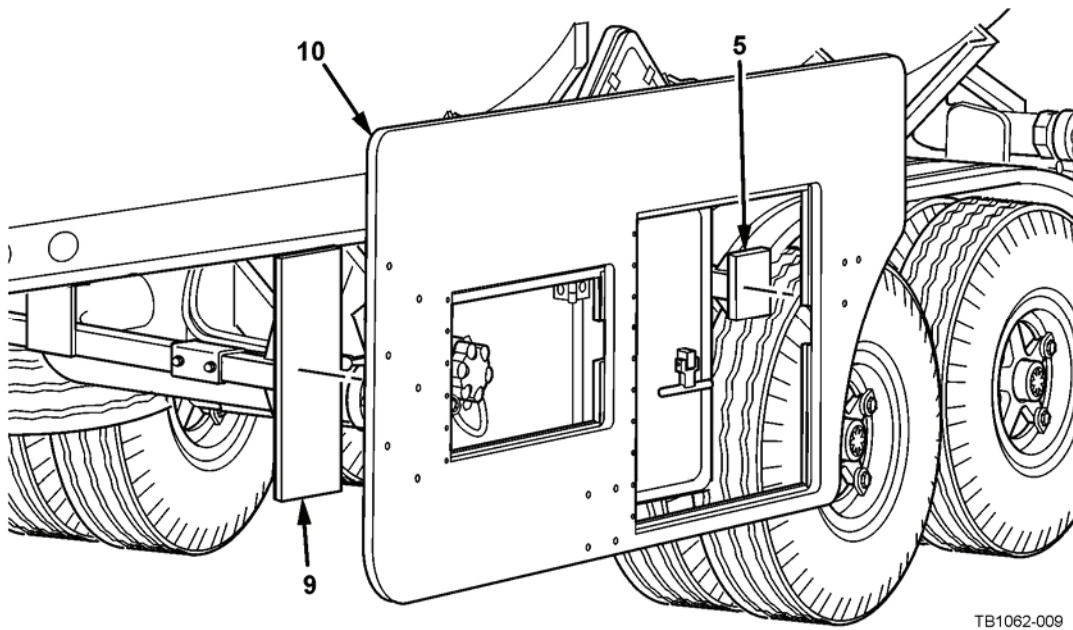

INSTALLATION (continued)

23. Using 19/32-inch drill bit and roadside frame panel (10) as a template, drill three holes, marked E, through pad of rear brace roadside bracket (5).
24. Install roadside frame panel (10) on rear brace roadside bracket (5) with three hexagon head capscrews (2), three self-locking nuts (4), and six flat washers (1), as shown. Torque self-locking nuts to 55-65 lb-ft (75-88 N•m).

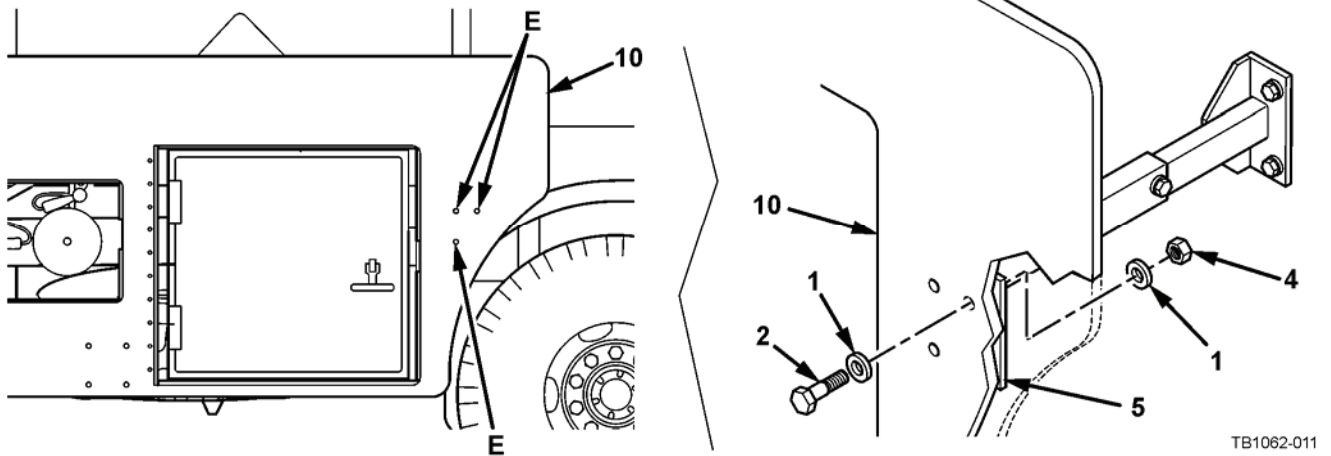

25. Using 19/32-inch drill bit and roadside frame panel (10) as a template, drill six holes, marked F, through pad of center brace bracket (9).
26. Install roadside frame panel (10) on center brace bracket (9) with six hexagon head capscrews (2), six self-locking nuts (4), and twelve flat washers (1), as shown. Torque self-locking nuts to 55-65 lb-ft (75-88 N•m).

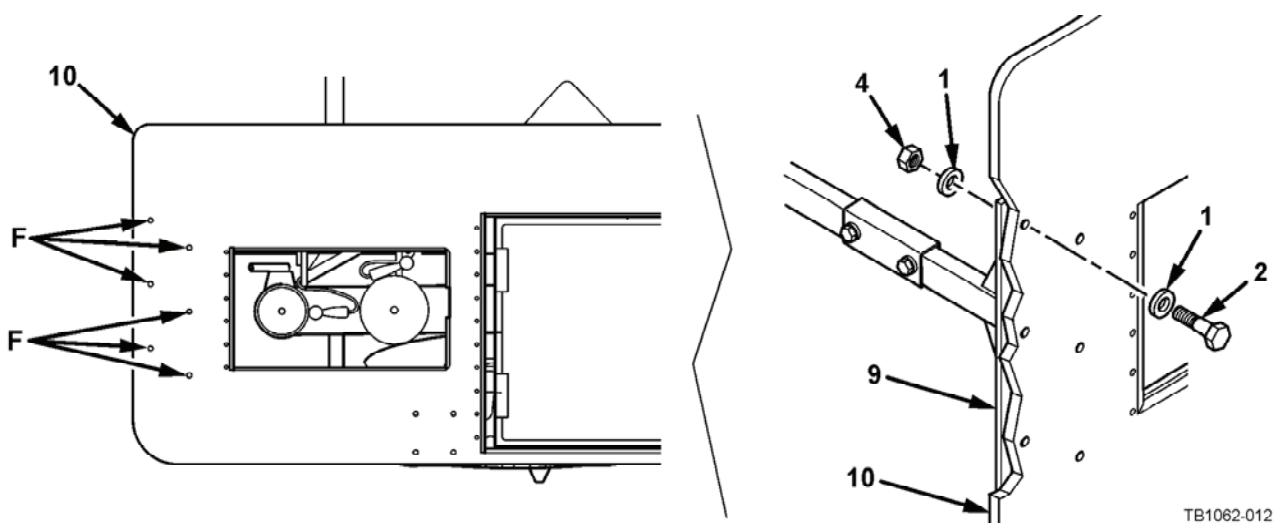

INSTALLATION (continued)

27. Position no-hole pad of lower bracket support (11) on roadside frame panel (10), even with bottom edge and lined up with four holes in roadside frame panel (10). Position 3-hole pad of lower bracket support (11) against side of accessories stowage box. Clamp lower bracket support (11) in place on roadside frame panel (10).
28. Using 19/32-inch drill bit and roadside frame panel (10) as a template, drill four holes, marked G, through pad of lower bracket support (11).

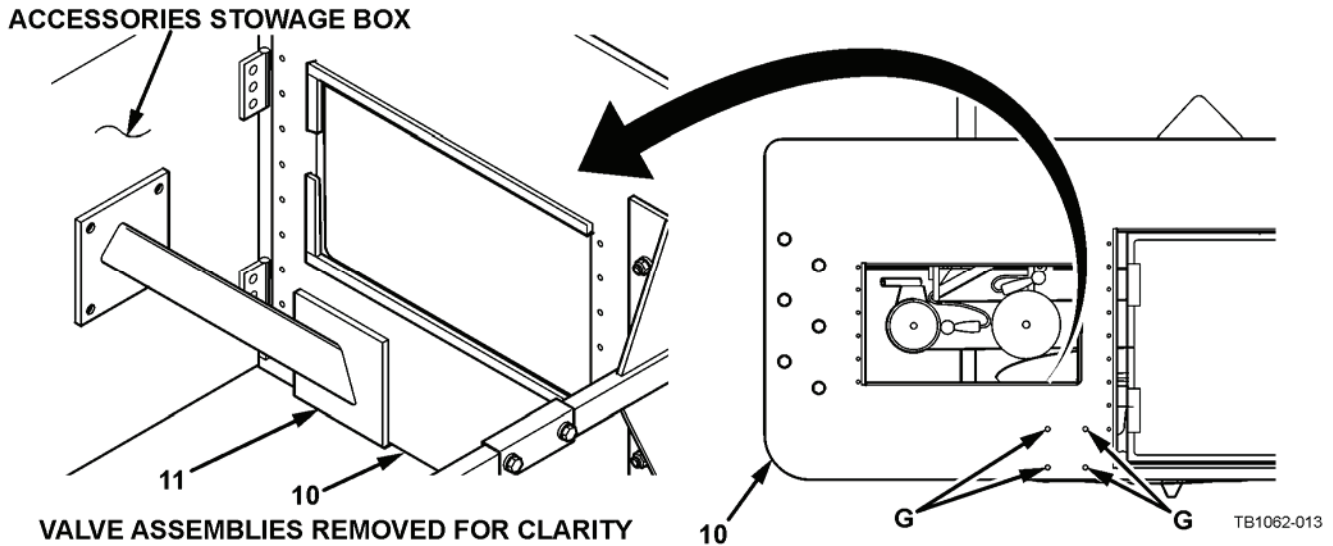

29. Install lower bracket support (11) on roadside frame panel (10) with four hexagon head capscrews (2), four self-locking nuts (4), and eight flat washers (1), as shown. Torque self-locking nuts to 55-65 lb-ft (75-88 N•m).
30. Using 13/32-inch drill bit and lower bracket support (11) as a template, drill three holes, marked H, through side of accessories stowage box.

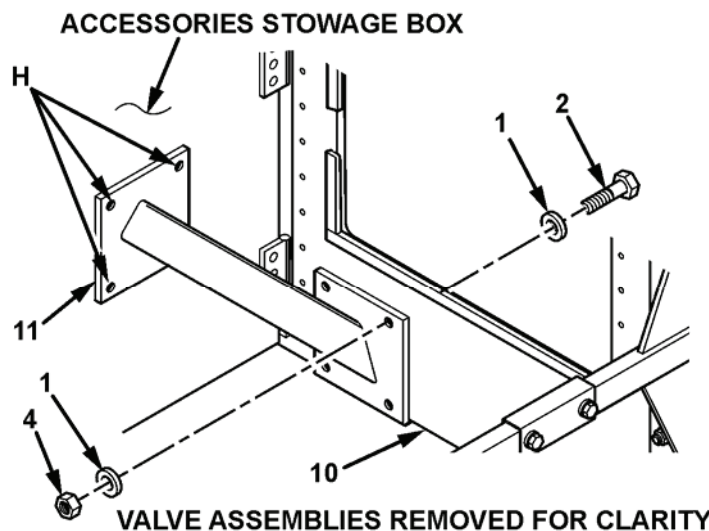

INSTALLATION (continued)

31. Install lower bracket support (11) on accessories stowage box with three hexagon head capscrews (12), three self-locking nuts (14), and six flat washers (13), as shown. Torque self-locking nuts to 30-35 lb-ft (41-48 N•m).

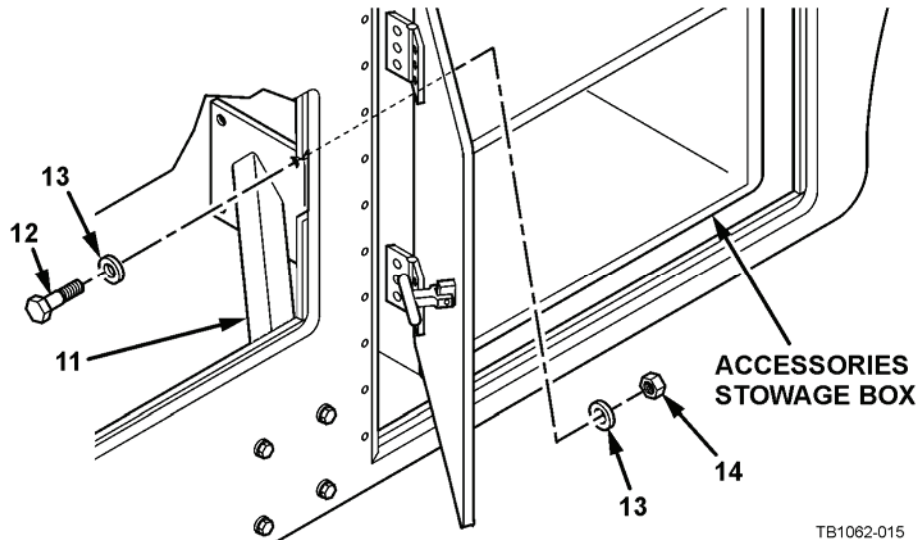

TB1062-015

32. Position belly panel (15) against cross brace support (3) with roadside edge against center brace bracket (9) and round hole centered on post of center brace bracket (9). Ensure that belly panel (15) is level and clamp in place.
33. Using 19/32-inch drill bit and belly panel (15) as a template, drill two holes, marked I, through cross brace support (3). Holes should be centered in oval cutout in belly panel (15), unless such a location would interfere with gussets at rear of cross brace support (3).

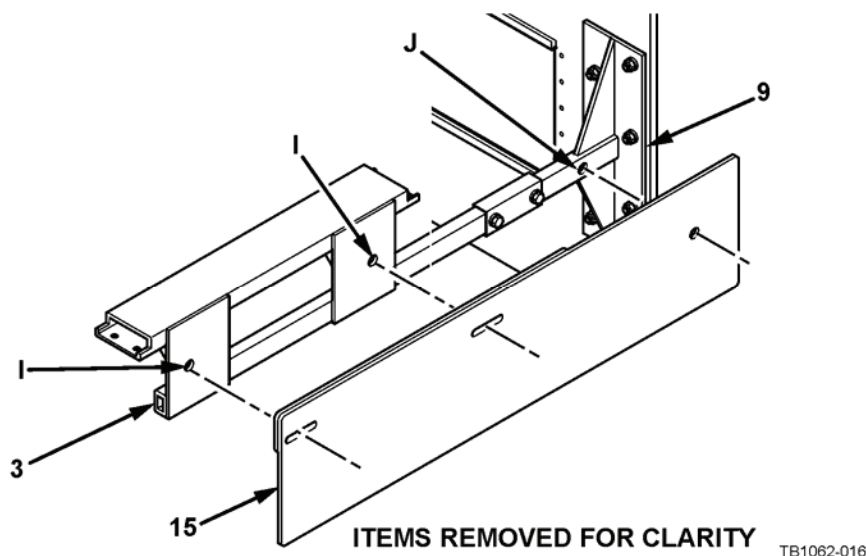

TB1062-016

INSTALLATION (continued)

34. Install belly panel (15) on cross brace support (3) with two hexagon head capscrews (2), two self-locking nuts (4), and four flat washers (1), as shown.
35. Slide belly panel (15) to far right against post center brace bracket (9).
36. Using 19/32-inch drill bit and belly panel (15) as a template, drill hole, marked J, through post of center brace bracket (9).
37. Install belly panel (15) on post center brace bracket (9) with hexagon head capscrew (16), self-locking nut (4), and two flat washers (1), as shown.
38. Torque all belly panel hardware to 55-65 lb ft (75-88 N•m).

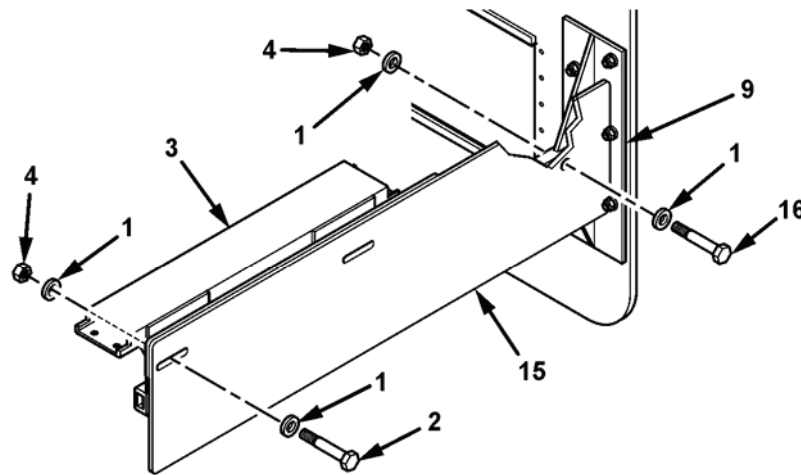

ITEMS REMOVED FOR CLARITY

TB1062-017

39. Position forward belly panel (17) on top of two existing tanker supports and the end with cutout section against cross brace support (3). Ensure that forward belly panel (17) is parallel with underside of tanker and clamp in place.
40. Using 19/32-inch drill bit and forward belly panel (17) as a template, center punch and drill four holes, marked K, through two supports.

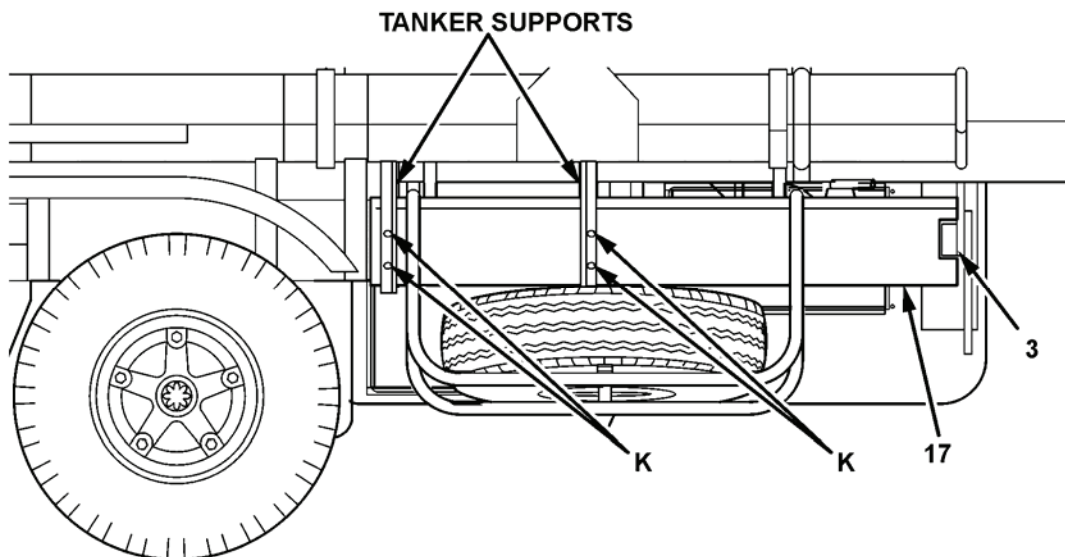

TB1062-018

INSTALLATION (continued)

41. Install forward belly panel (17) on two supports with four hexagon head capscrews (18), four self-locking nuts (4), and eight flat washers (1), as shown. Torque self-locking nuts to 55-65 lb-ft (75-88 N•m).

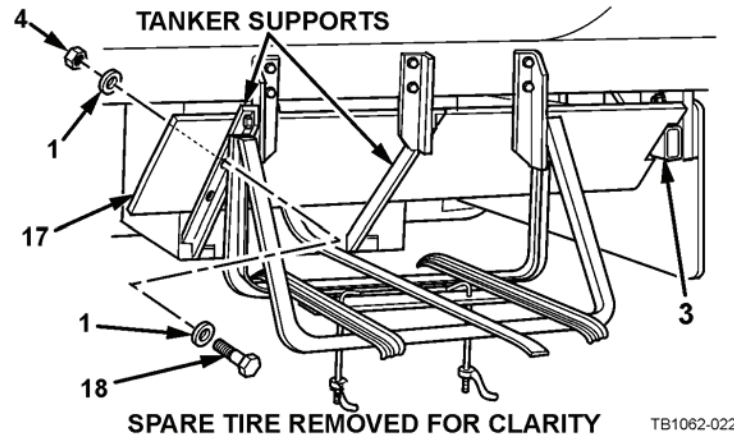
**NOTE**

- Armor door assemblies may or may not have door handles installed when shipped. If door handles are not installed they are supplied separately with each door assembly. Refer to Chapter 5 for door handle installation.
 - Ensure doors are mounted with AOA kit hardware only. Do not mount with shipping hardware.
 - Refer to Chapter 5 for door handle replacement.
42. Using four bottom holes install door assembly (19) on roadside frame panel (10) with four hexagon head capscrews (21), four self-locking nuts (14), and eight flat washers (13). Torque self-locking nuts to 30-35 lb-ft (41-48 N•m).
43. Using two top holes install safety latch (20) on door assembly (19) and roadside frame panel (10) with two hexagon head capscrews (12), two self-locking nuts (14), and four flat washers (13). Torque self-locking nuts to 30-35 lb-ft (41-48 N•m).

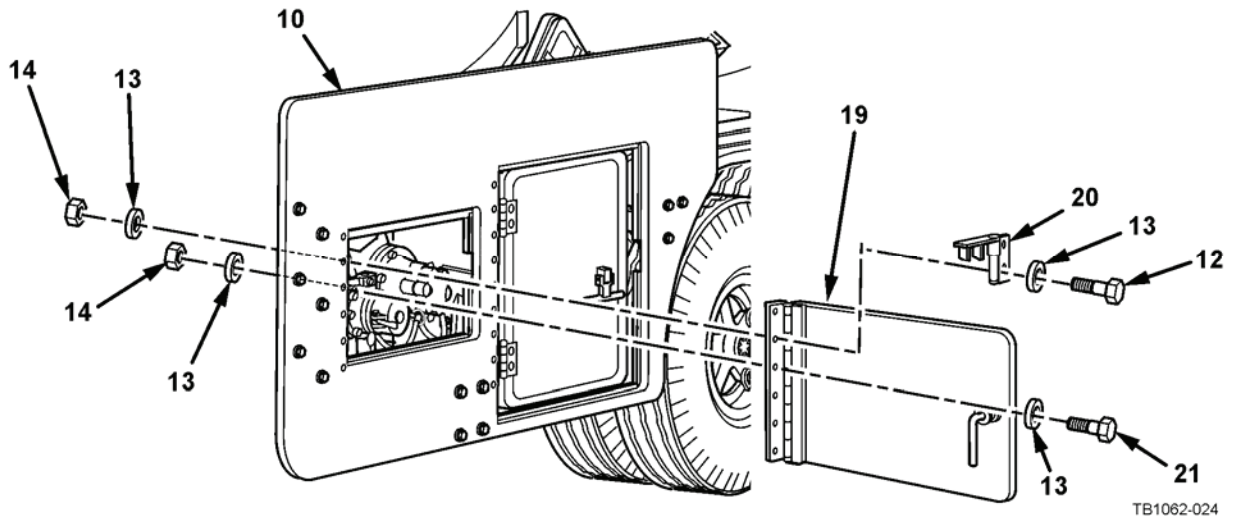

INSTALLATION (continued)

44. Using eight bottom holes install door assembly (22) on roadside frame panel (10) with eight hexagon head capscrews (21), eight self-locking nuts (14), and sixteen flat washers (13). Torque self-locking nuts to 30-35 lb-ft (41-48 N•m).
45. Using two top holes install safety latch (20) on door assembly (22) and roadside frame panel (10) with two hexagon head capscrews (12), two self-locking nuts (14), and four flat washers (13). Torque self-locking nuts to 30-35 lb-ft (41-48 N•m).

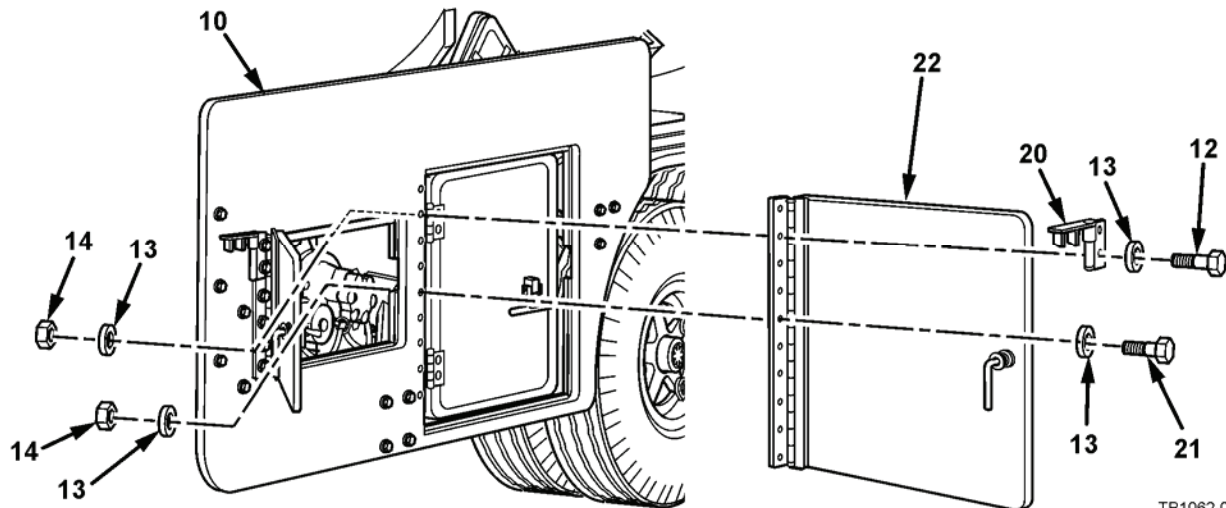

TB1062-023

FOLLOW-ON TASK

Place the FTSS repair kit and TB 9-2330-384-14&P in accessories stowage box.

REMOVAL

WARNING

Use caution when lifting supplemental armor. A swinging or shifting load may cause injury to personnel.

NOTE

Refer to Chapter 5 for door handle replacement.

1. Remove two hexagon head capscrews (12), two self-locking nuts (14), four flat washers (13) and safety latch (20) from door assembly (22) and roadside frame panel (10).
2. Remove eight hexagon head capscrews (21), eight self-locking nuts (14), sixteen flat washers (13) and door assembly (22) from roadside frame panel (10).

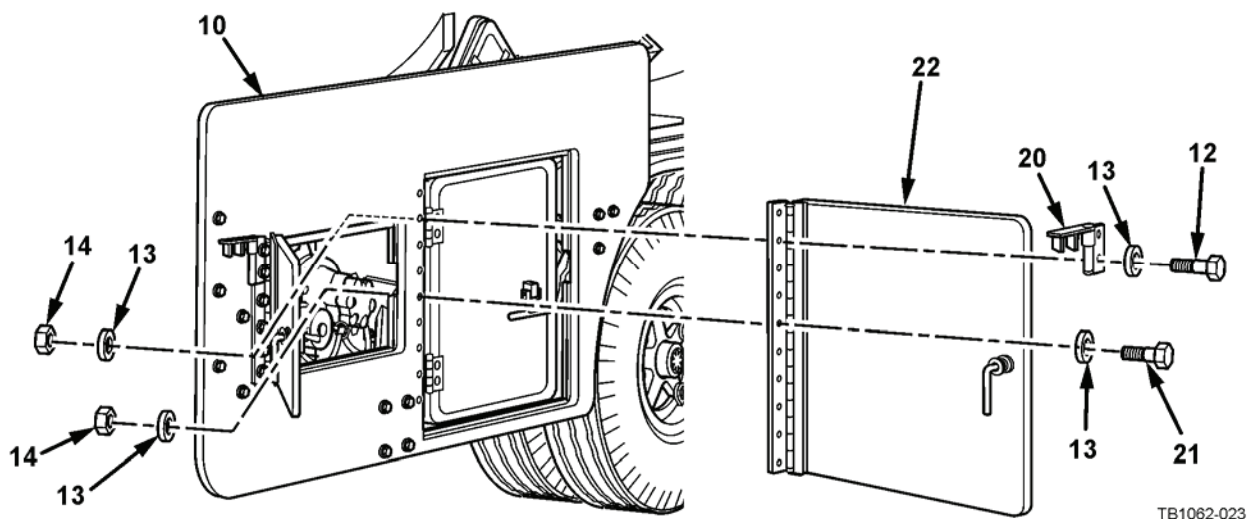

TB1062-023

3. Remove two hexagon head capscrews (12), two self-locking nuts (14), four flat washers (13), and safety latch (20) from door assembly (19) and roadside frame panel (10).
4. Remove four hexagon head capscrews (21), four self-locking nuts (14), eight flat washers (13), and door assembly (19) from roadside frame panel (10).

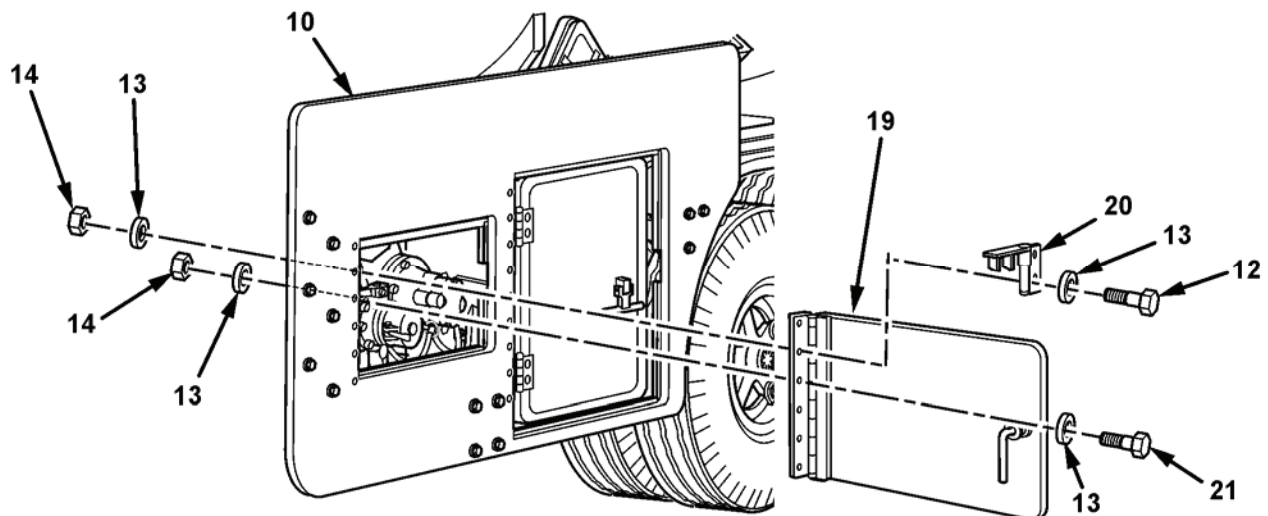

TB1062-024

REMOVAL (continued)

5. Remove four hexagon head capscrews (18), four self-locking nuts (4), eight flat washers (1), and forward belly panel (17) from two supports.

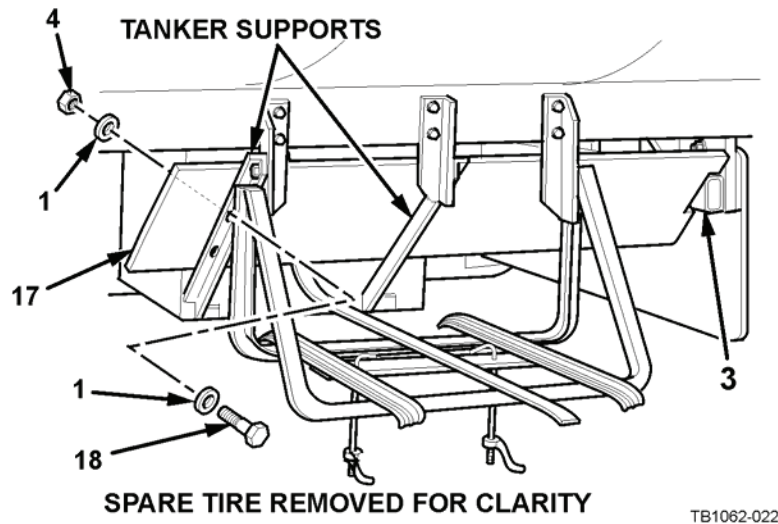

6. Remove hexagon head capscrew (16), self-locking nut (4), two flat washers (1), and belly panel (15) from post center brace bracket (9).
7. Remove two hexagon head capscrews (2), two self-locking nuts (4), four flat washers (1), and belly panel (15) from cross brace support (3).

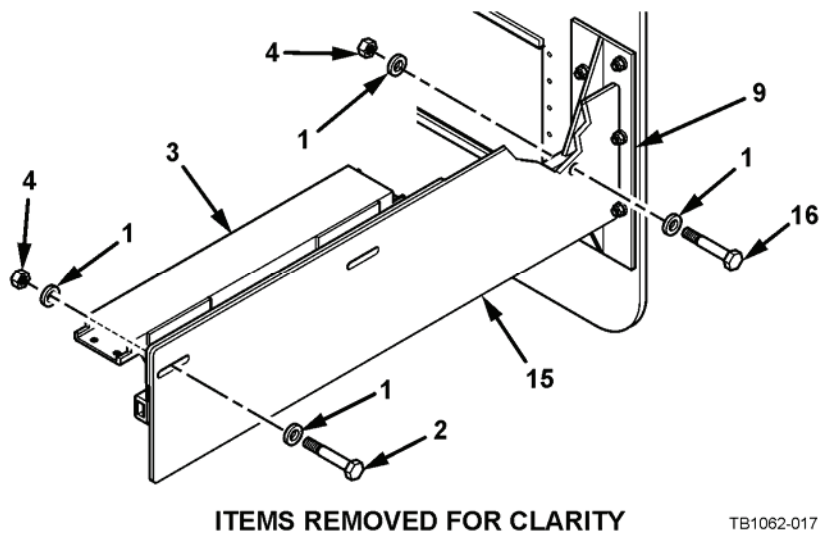

REMOVAL (continued)

8. Remove three hexagon head capscrews (12), three self-locking nuts (14), and six flat washers (13) from lower bracket support (11) on accessories storage box.

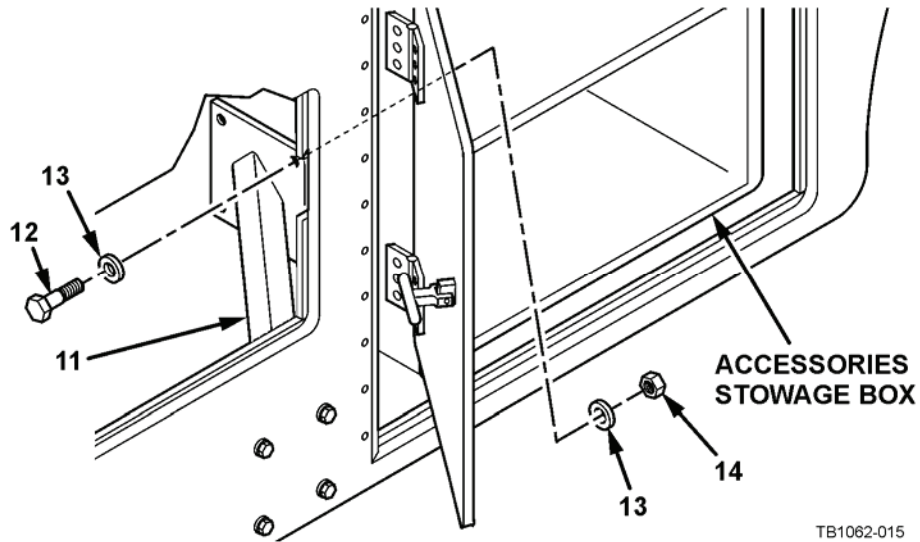

TB1062-015

9. Remove four hexagon head capscrews (2), four self-locking nuts (4), eight flat washers (1), and lower bracket support (11) from roadside frame panel (10).

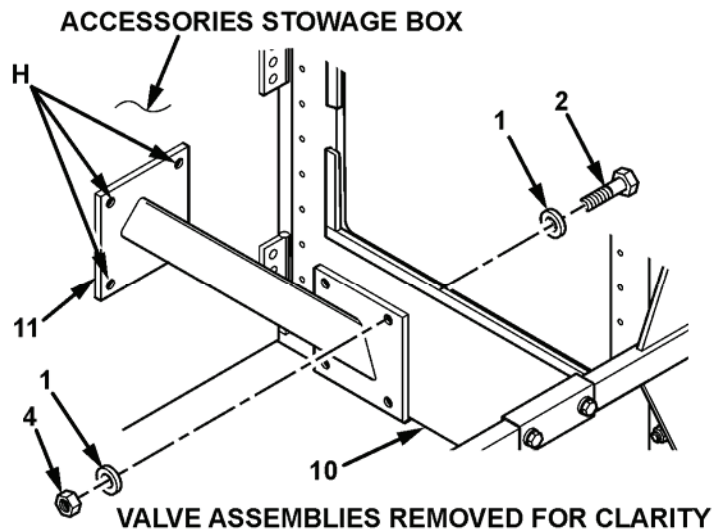

TB1062-014

REMOVAL (continued)

WARNING

Use caution when lifting supplemental armor. A swinging or shifting load may cause injury to personnel.

10. Using dawg grips (Table 8-2), a suitable lifting sling, and suitable lifting device support roadside frame panel (10) prior to removal of attaching hardware.
11. Remove six hexagon head capscrews (2), six self-locking nuts (4), and twelve flat washers (1) from roadside frame panel (10) and center brace bracket (9).
12. Remove three hexagon head capscrews (2), three self-locking nuts (4), six flat washers (1), and roadside frame panel (10) from rear brace roadside bracket (5).

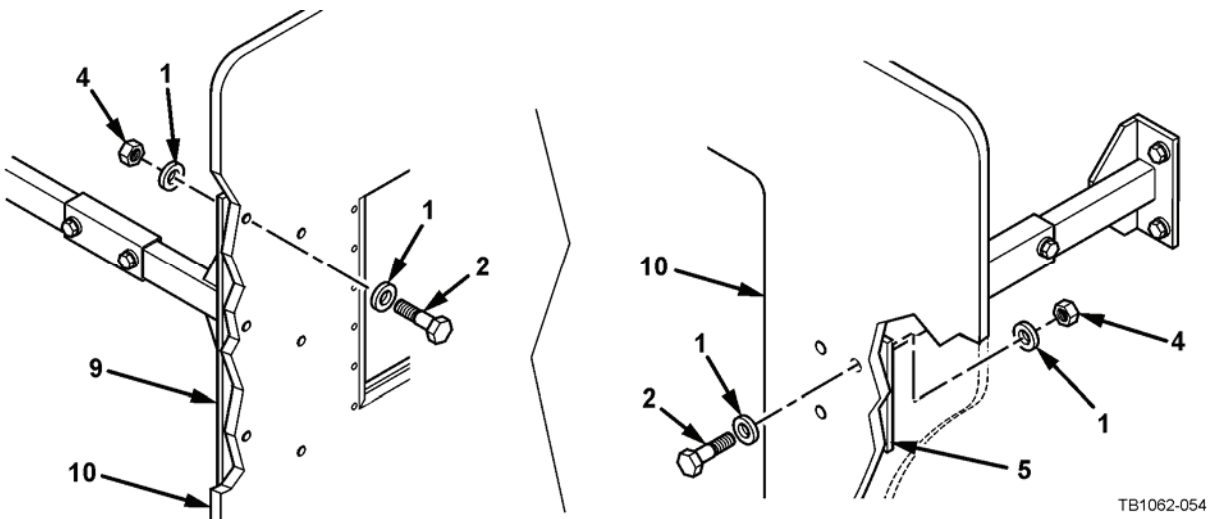

REMOVAL (continued)

13. Remove two hexagon head capscrews (8), two self-locking nuts (4), four flat washers (1), center brace bracket (9), and slider support bracket (6) from cross brace support (3).

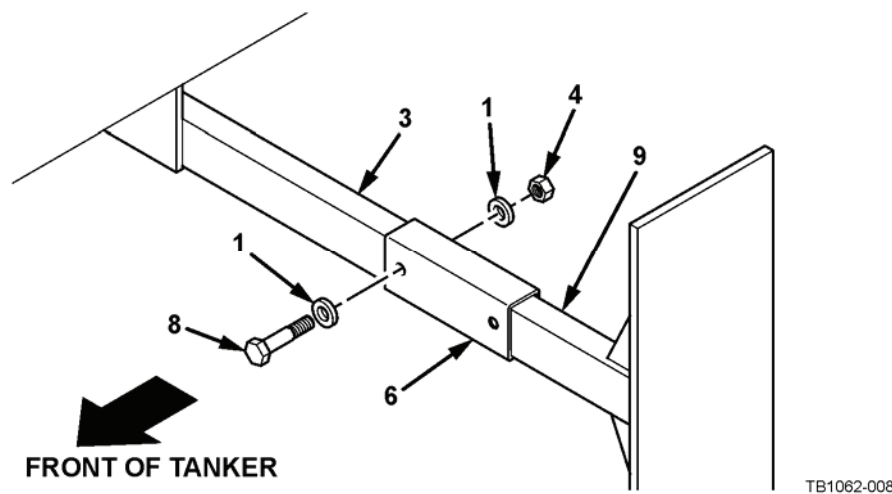

14. Remove two hexagon head capscrews (2), two self-locking nuts (4), four flat washers (1), assembled slider support bracket (6), rear brace roadside bracket (5), and frame support bracket (7) from vehicle frame.

15. Remove two hexagon head capscrews (8), two self-locking nuts (4), and four flat washers (1) from slider support bracket (6), rear brace roadside bracket (5), and frame support bracket (7).

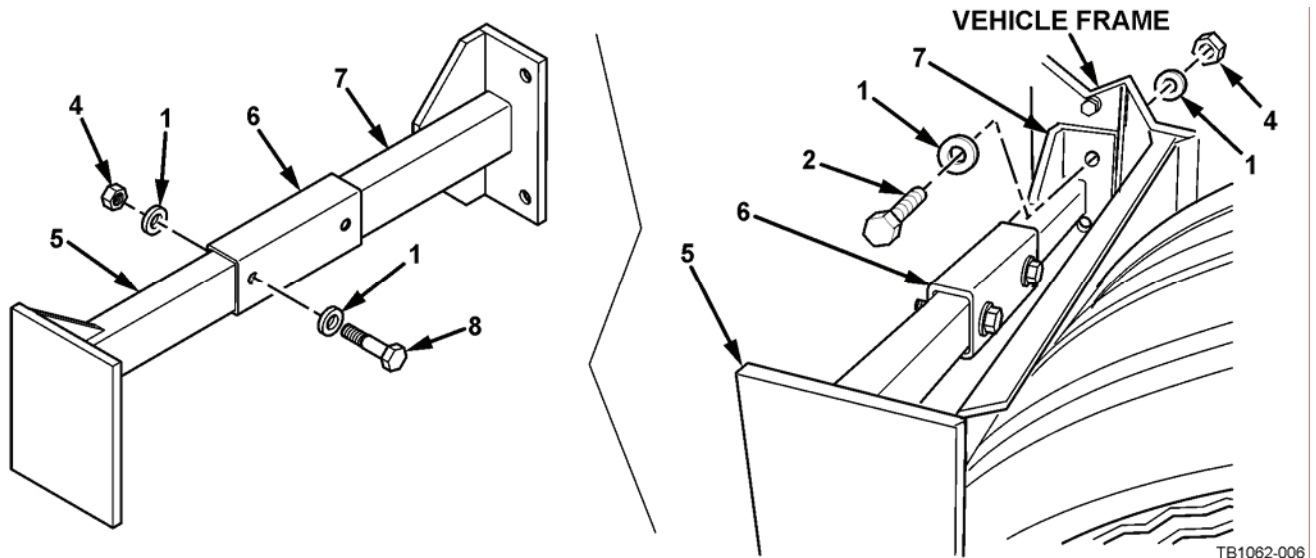

REMOVAL (continued)

16. Remove four hexagon head capscrews (2), four self-locking nuts (4), eight flat washers (1), and cross brace support (3) from two support beams.

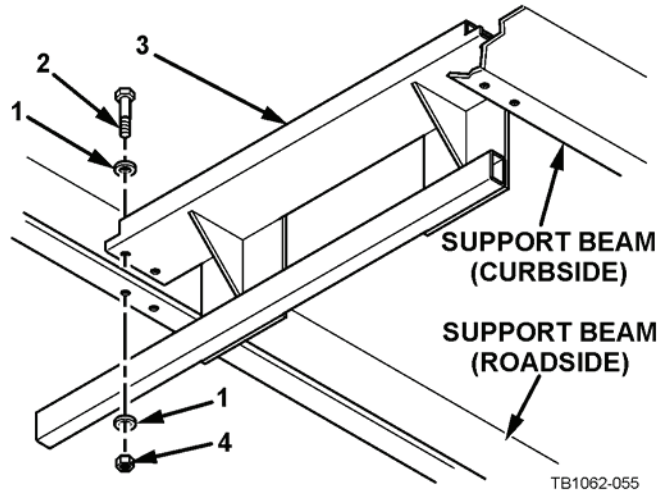

CHAPTER 5 DOOR HANDLE REPLACEMENT

SCOPE

This chapter provides the removal and installation instructions for armor door assembly handles.

REMOVAL

WARNING

Armor door assemblies are heavy and must be secured in place, with safety latch, when open. Failure to do so may cause injury to personnel.

1. Open door 90 degrees and secure door in place with safety latch.
2. Remove self-locking nut, latch, and teflon washer from threaded end of door handle. Discard self-locking nut, latch, and teflon washer.
3. Remove teflon washer and door handle from armor door assembly. Discard teflon washer and door handle.

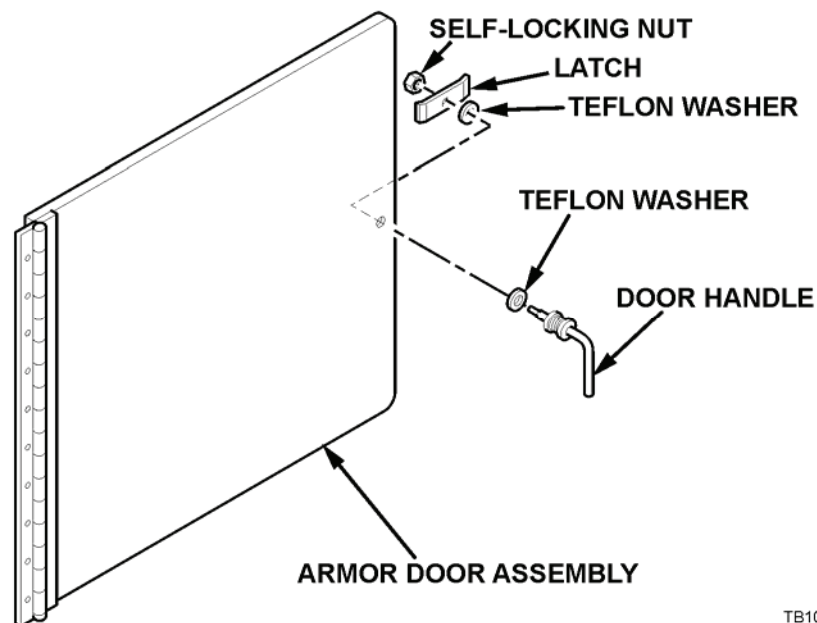

TB1062-056

INSTALLATION

WARNING

Armor door assemblies are heavy and must be secured in place, with safety latch, when open. Failure to do so may cause injury to personnel.

1. Position new Teflon washer on door handle.
2. From outside of armor door assembly, insert threaded end of new handle through hole in armor door assembly. Teflon washer must contact outside surface of armor door assembly.

NOTE

The latch must be positioned so that the bent ends of the latch point away from the armor door assembly.

3. Install new Teflon washer and latch onto threaded end of armor door assembly with new self-locking nut. Teflon washer must contact inside surface of armor door assembly.
4. Check operation of door handle.
5. Release safety latch and close armor door assembly. Rotate door handle to latched position. Handle should be in downward position. Check that armor door assembly is securely closed.

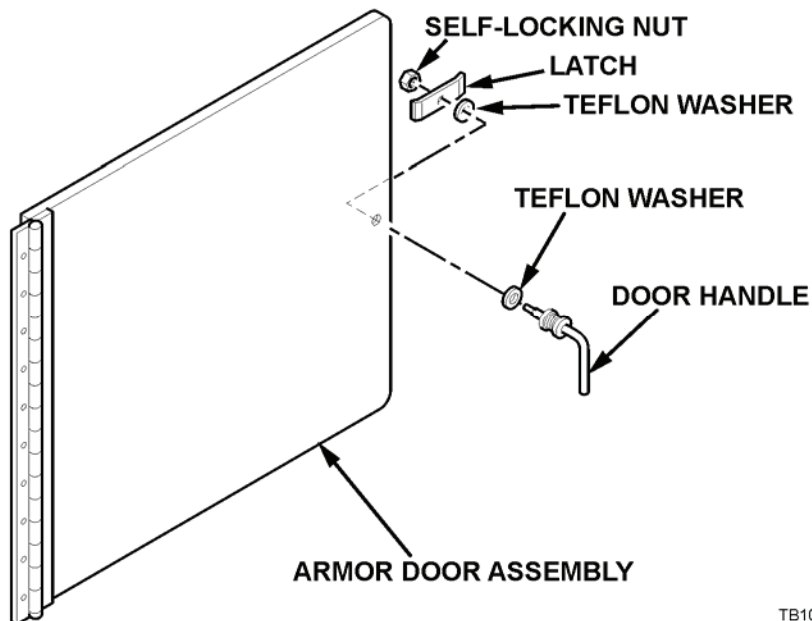

TB1062-056

CHAPTER 6

FUEL TANK SELF-SEALING (FTSS) REPAIR KIT

SCOPE

This chapter provides the kit contents and instructions for repairing a fuel tanker that has been coated with the Fuel Tank Self-Sealing (FTSS) System. The FTSS Repair Kit is used to close punctures in the tanker wall that the FTSS System does not fully seal after being ruptured. Each of the 3 and 5-inch diameter Field Repair Patch (FRP) assemblies contain an absorbent packet that will activate a gelatin process, which converts the leaking fuel into a semi-solid. The combination of the semi-solid and mechanical rubber seal of the patch form a blockage of the leaking fuel from the tanker.

FTSS REPAIR KIT

The FTSS Repair Kit (RPSTL Figure 8) consists of the following items listed in Table 6-1:

Table 6-1. FTSS Repair Kit Contents List – 57K4786

Nomenclature	NSN	Part Number	CAGE	QTY
3-inch Patch, Spill Control	4235-01-541-8511	12500859	31902	15 each
5-inch Patch, Spill Control	4235-01-541-8515	12500860	31902	5 each
Adhesive, 3 oz. Tube	5130-01-546-1739	051135-05203	OFRU4	2 each
Bag, Tool	5140-01-542-2828	2608-VSE	79623	1 each
Battery, Non-Rechargeable, AA 4-Pack	6135-01-447-0950	115A	80204	1 pkg.
Blade, Knife	5110-00-293-2867	PD5110-00-293-2865	80244	1 pkg.
Cloth, Cleaning 80 Count Alcohol Saturated	7920-01-036-4464	TX1301	21994	1 box
Extension, Socket Wrench 20-inch Extension 1/2-inch Drive	5120-00-240-8705	516059-6	80020	1 each
Flashlight, AA Battery	6230-00-635-4998	Z21P	77542	1 each
Gloves, Disposable, XL 100 Count Box	8415-01-492-0180	8415-01-492-0180	80244	1 box
Goggles, Industrial	4240-00-052-3776	3336841	45152	2 pair
Handle, Socket Wrench, 18-inch, 1/2-inch Drive	5120-00-249-1071	B107.10M TY1CL3ST1	05047	1 each
Knife, Craftsman's	5110-00-892-5071	PD5110-00-892-5071	80244	1 each
Laminated Instruction Sheet	7610-01-541-8112	12500872	19205	1 each
Laminated Parts List	7610-01-541-8159	12500888	19207	1 each
Socket, Magnetic 3/4-inch, 1/2-inch Drive	5130-01-546-1738	14394	31902	1 each

REPAIR PROCEDURES

WARNING

Fuel is very flammable and can explode easily. To avoid serious injury or death, keep fuel away from open flame or any spark (ignition source). Keep a B-C fire extinguisher within reach when performing fuel tank repair.

WARNING

Eye and hand protection must be worn at all times when applying FTSS Patch Kit. Failure to do so may result in injury to personnel.

1. Place the bolt head of the FRP assembly into the magnetic socket.
2. Position the FRP assembly within 1/2-inch (12.7 mm) of the leak by "stabbing" the patch assembly directly into the FTSS System liner.
3. Using the socket wrench handle and extension, tighten the FRP assembly screw until secure.

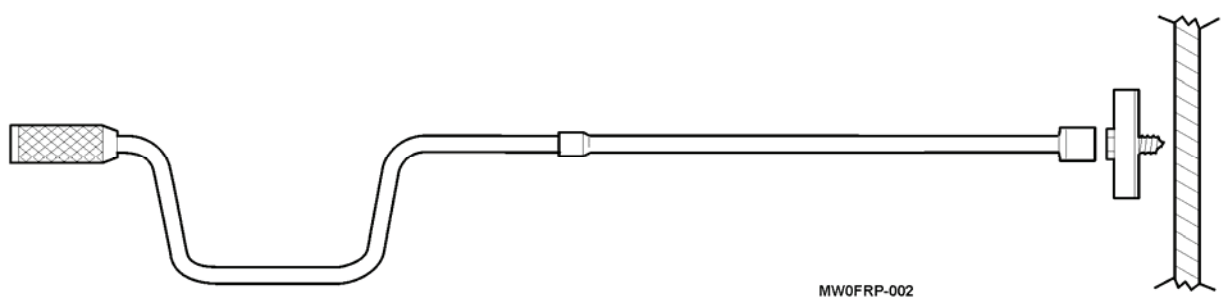
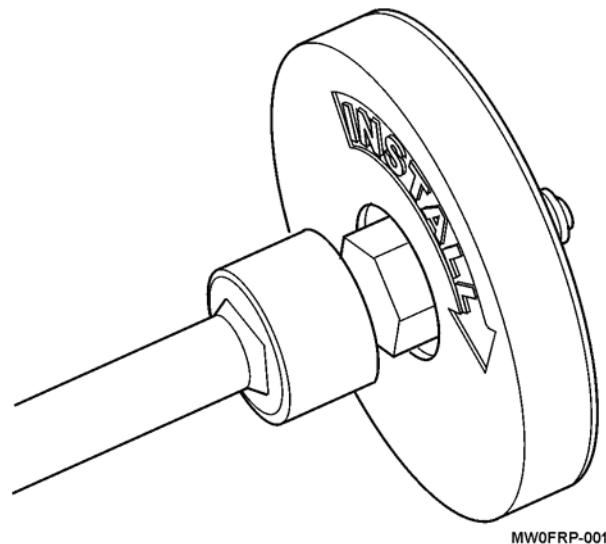

4. Observe the fuel flow. Leakage should begin to slow noticeably and stop within a few seconds. If the leak continues, remove the patch and relocate to a different position.
5. After leak has stopped, wipe any excess fuel from repaired area with a clean rag. Clean repaired area with alcohol wipes. Apply adhesive to the base of the FRP assembly to permanently seal the patch in place.
6. Using knife remove any excess adhesive, as required.
7. Report all fuel tanker vessel damage to immediate supervisor for proper repair.

CHAPTER 7

QUALITY ASSURANCE AND FINAL INSPECTION

QUALITY ASSURANCE REQUIREMENTS

The installer is responsible for compliance with quality assurance requirements specified herein. The installer is responsible for observing all quality and safety standards. These requirements and the installer's plan of inspection, or quality assurance program, constitute the minimum examinations and tests necessary to assure compliance with established requirements. The installer is responsible for following the instructions contained in this Technical Bulletin (TB) for installing the TBPS kit. Report and record the application of this TB in accordance with DA Pam 750-8 and DA Pam 738-751.

The user is required to follow maintenance and lubrication requirements.

FINAL PAINT

1. Ensure all exposed surfaces have been thoroughly cleaned by an approved chemical or mechanical method.
2. Finish all exposed metal plates, brackets, and shields using rust inhibitor primer and paint as specified in Table 8-4, Materials and Parts, in accordance with TM 43-0139, Painting Instructions for Army Materiel. Allow for the appropriate time for the primer and paint to cure.
3. Ensure all surfaces have been pretreated as soon as possible after cleaning by an approved spray or brush method.
4. Apply stencils per TM 9-2330-384-14&P in accordance with TM 43-0139 and TB 43-0209.

FINAL INSPECTION REQUIREMENTS

1. Check all armor panels, braces, brackets, and doors are properly installed and secure.
2. Check the operation of all access doors. Ensure access doors do not bind when opening and closing.
3. Ensure door latches do not bind and hold access doors securely in place.
4. Ensure that TB 9-2330-384-14&P is in accessories stowage box.

MAINTENANCE AND LUBRICATION REQUIREMENTS

1. Ensure door hinges, safety latches, and door handles are lubricated using lubricating oil weekly (Item 9, Table 8-4).
2. Ensure hexagon head capscrews and self-locking nuts are properly torqued monthly.

MARKING EQUIPMENT

After the TBPS has been installed, apply the new data plate next to the existing vehicle data plate, as shown.

UP-ARMORED VEHICLE	
MODEL :	FIELD A :
NSN :	FIELD B :
NEW LIN :	FIELD C :
OLD LIN :	FIELD D :

LIQUID and BULK TANK DIVISIONS FRUEHAUF TRAILER OPERATIONS OMAHA, NEBRASKA			
MFG. S/N		DATE	
DOT - MC 306 - AL		CERT	
PRES - DESIGN	1	PSIG AT 125 F MAX	
TEST	3	PSIG	DATE
MAT SHELL	5454 H32	HEAD	5454-0
WELD	5356	EXTR	6061
LINING	NONE		
CAP BY COMPT	FR US GAL	7500	TOTAL 7500 GAL
MAX LOAD	54000 LBS AT 72	LBS.	GAL. MAX
LIMIT - LD	1.5 PSIG UNLD	0.5 PSIG	
TKG53330			

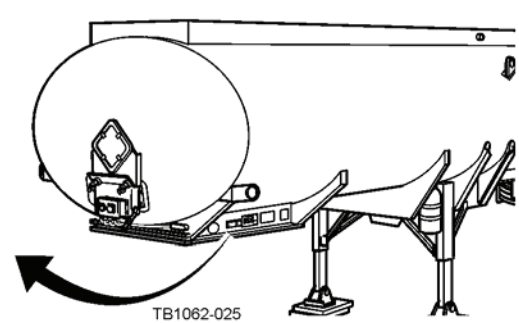

CHAPTER 8 SUPPORT DATA

INDEX

- Section 1. References
- Section 2. Special Tools; Tool Kits; and Templates Required
- Section 3. Materials and Expendables
- Section 4. Repair Parts and Special Tools List (RPSTL)

SECTION 1. REFERENCES

This section contains a list of all the publications referenced in and/or applicable to this TB.

DA Form 2028-2	Recommended Changes to Equipment Technical Publications
DA PAM 738-751	Functional User's Manual for The Army Maintenance Management System – Aviation (TAMMS-A)
DA PAM 750-8	The Army Maintenance Management System (TAMMS) User's Manual
SF 368	Product Quality Deficiency Report
TB 43-0209	Color and marking of Military Vehicles, Construction Equipment, and Materials Handling Equipment
TM 38-470	Storage and Maintenance of Army Prepositioned Stock Material
TM 43-0139	Painting Instructions for Army Materiel
TM 750-244-6	Procedures for Destruction of Tank-Automotive Equipment to Prevent Enemy Use
TM 9-2330-384-14&P	Operator's, Unit, Installation/Removal Instructions, and Repair Parts and Special Tools List (RPSTL), for Tanker Ballistic Protection System (TBPS/AOA/FTSS), for Semitrailer, Tank, Fuel, 7500-Gallon, M1062P1.

SECTION 2. SPECIAL TOOLS; TOOL KITS; AND TEMPLATES REQUIRED

The following list contains the common and special tools needed to properly install the AOA kit:

Table 8-1. Hand Tools

Nomenclature	National Stock Number	CAGEC	Part Number	QTY
Tool Kit, General Mechanics	5180-00-177-7033 or Commercial Equivalent	19204	SC5180-90-CL-N26	1
Hand Grinder	Dewalt or Commercial Equivalent	1U3E8	DW818	1
C Clamps, 8-inch	5120-00-203-6436	2V507	5027A16	3
C Clamps, 12-inch	McMaster-Carr or Commercial Equivalent	2V507	5027A25	2
Vise Grip Clamps, 8-inch	McMaster-Carr or Commercial Equivalent	2V507	5105A17	4
Vise Grip Clamps, 4-1/2-inch	McMaster-Carr or Commercial Equivalent	2V507	5105A23	4
Pads, Grinding 4-inch	McMaster-Carr or Commercial Equivalent	2V507	4655A5	2
Grinding Discs 4-1/2-inch (Package of 25)	McMaster-Carr or Commercial Equivalent	2V507	4732A12	2
Wrench, Torque 1/2-inch Drive	5120-00-640-6364	05047	B107.14M TY1CLBST1	1

Table 8-2. Common and Special Tools

Nomenclature	National Stock Number	CAGEC	Part Number	QTY
Drill Bits, 19/32 (.5938) Diameter Ex Gold Cobalt, Split Point	MCS International or Commercial Equivalent	4J007	78581055	6
Work Lights	Northern Tool or Commercial Equivalent	1LLB3	160923-1405	2
Electrical Extension Lines, 50-Foot	Northern Tool or Commercial Equivalent	1LLB3	162439-1405	4
Rigging, Material Dawg/Grippers	McMaster Carr or Commercial Equivalent	2V507	8845T74	2
Gloves, Work, Leather	McMaster Carr or Commercial Equivalent	2V507	52835T41	8
Drill Bits, 13/32 (.40625) Diameter Ex, Cobalt	MCS International or Commercial Equivalent	4J007	01324268	6

Table 8-3. Templates

IETM	Nomenclature	National Stock Number	CAGEC	Part Number	QTY
1	Cross Brace Support Locating Template		19207	12501984	1

SECTION 3. MATERIALS AND EXPENDABLES

The following list contains the bulk and expendable materials needed to apply the AOA/FTSS kit:

Table 8-4. Materials and Parts

ITEM	Nomenclature	National Stock Number	Part Number	CAGEC	QTY
1	Primer, Coating (Rust Inhibitor)	8010-00-687-8191 or Commercial Equivalent	TT-P-662	81348	1 GL
2	Rag, Wiping White	7920-00-205-3571 or Commercial Equivalent	DDD-R-0030	81348	50 LB
3	Cutting Fluid	9150-01-373-5788 or Commercial Equivalent	TAPMAGIC EP-XTRA	17781	1 PT
4	Cleaning Compound, Solvent	7930-00-177-5217 or Commercial Equivalent	7930-00-177-5217	80244	5 GL
5	Detergent, General Purpose	7930-00-985-6945 or Commercial Equivalent	7930-00-985-6945	83421	1 GL
6	Coating, Water Dispersible Aliphatic Polyurethane, Chemical Agent Resistant (Desert Tan 686A)	8010-01-519-6769 or Commercial Equivalent	M64159-2-003G-33446	81349	3 GL
7	Adhesive, Spray	8040-00-938-6860 or Commercial Equivalent	MMM-A-1058	81348	1 CN
8	Lubricating Oil	9150-00-189-6727	MIL-PRF-2104	81349	1 QT

SECTION 4. REPAIR PARTS AND SPECIAL TOOLS LIST (RPSTL)

INTRODUCTION

1. SCOPE.

This Repair Parts and Special Tools List (RPSTL) lists and authorizes spares and repair parts required for performance of Field level maintenance of the Semitrailer, Tank, Fuel, 7500-Gallon M1062P1 Tanker Ballistic Protection Systems/Add-On-Armor/Fuel Tank Self-Sealing System (TBPS/AOA/FTSS). It authorizes the requisitioning, issue, and disposition of spares and repair parts as indicated by the Source, Maintenance, and Recoverability (SMR) codes.

2. GENERAL

In addition to the Introduction, this RPSTL is divided into the following sections:

- a. Section II. Repair Parts List.** A list of spares and repair parts authorized by this RPSTL for use in the performance of maintenance. This list also includes parts which must be removed for replacement of the authorized parts. Parts lists are composed of functional groups in ascending alphanumeric sequence, with the parts in each group listed in ascending figure and item number sequence. Repair parts kits are listed separately in their own functional group. Items listed are shown on the associated illustrations.
- b. Section III. Special Tools List.** There are no special tools for the M1062P1 TBPS.
- c. Section IV. Cross-Reference Indexes.** There are two cross-reference indexes in this RPSTL: National Stock Number Index and Part Number Index.

3. EXPLANATION OF COLUMNS (SECTIONS II AND III)

- a. Item No. (Column 1).** Indicates the number used to identify items called out in the illustration.
- b. SMR Code (Column 2).** The SMR code contains supply/requisitioning information, maintenance level authorization criteria, and disposition instruction, as shown in the following breakout:

<u>Source Code</u>	<u>Maintenance Code</u>	<u>Recoverability Code</u>	<u>Demilitarization Code</u>	
xx	x	x	x	
1 st two positions: How to get an item.	3 rd position: Who can install, replace, or use an item.	4 th position: Who can complete repair* on the item.	5 th position: Who determines disposition action items on unserviceable items.	6 th position: Method and degree of demilitarizing items when required.

**Complete Repair*: Maintenance capacity, capability, and authority to perform all corrective maintenance tasks of the "Repair" function in a use/user environment in order to restore serviceability to a failed item.

SECTION 4. REPAIR PARTS AND SPECIAL TOOLS LIST (RPSTL) (continued)

3. EXPLANATION OF COLUMNS (SECTIONS II AND III) (continued)

- (1) **Source Code.** The source code tells you how to get an item needed for maintenance, repair, or overhaul of an end item/equipment. Explanations of source codes follow:

Code	Application/Explanation
PA PB PC PD PE PF PG	Stocked items; use the applicable NSN to request/requisition items with these source codes. They are authorized to the maintenance category indicated by the code entered in the third position of the SMR code. <i>Items coded PC are subject to deterioration.</i>
KD KF KB	Items with these codes are not to be requested/requisitioned individually. They are part of a kit which is authorized to the maintenance level indicated in the third position of the SMR code. The complete kit must be requisitioned and applied.
MO - Made at Unit/AVUM level MF - Made at DS/AVIM Level MH - Made at GS Level ML - Made at SRA MD - Made at Depot	Items with these codes are not to be requested/requisitioned individually. They must be made from bulk materiel which is identified by the part number in the DESCRIPTION AND USABLE ON CODE (UOC) column and listed in the bulk materiel functional group of the RPSTL. If the item is authorized to you by the third position of the SMR code, but the source code indicates it is made at a higher level, order the item from the higher level of maintenance.
AO - Assembled by Unit/ AVUM level AF - Assembled by DS/ AVIM level AH - Assembled by GS level AL - Assembled by SRA AD - Assembled by Depot	Items with these codes are not to be requested/requisitioned individually. The parts that make up the assembled item must be requisitioned or fabricated and assembled at the level of maintenance indicated by the source code. If the third position of the SMR code authorizes you to replace the item, but the source code indicates the item is assembled at a higher level, order the item from the higher level of maintenance.
XA	Do not requisition an "XA" coded item. Order the next higher assembly. (Refer to NOTE on the following page).
XB	If an item is not available from salvage, order it using the CAGEC and P/N.
XC	Installation drawings, diagrams, instruction sheets, field service drawings; identified by manufacturer's P/N.
XD	Item is not stocked. Order an XD-coded item through normal supply channels using the CAGEC and P/N given, if no NSN is available.

SECTION 4. REPAIR PARTS AND SPECIAL TOOLS LIST (RPSTL) (continued)

3. EXPLANATION OF COLUMNS (SECTIONS II AND III) (continued)

NOTE

Cannibalization of controlled exchange, when authorized, may be used as a source of supply for items with the above source codes, except for those source coded "XA" or those aircraft support items restricted by requirements of AR 750-1.

(2) Maintenance Code. Maintenance codes tell you the level(s) of maintenance authorized to use and repair support items. The maintenance codes are entered in the third and fourth positions of the SMR code as follows:

(a) Third Position. The maintenance code entered in the third position tells you the lowest maintenance level authorized to remove, replace, and use an item. The maintenance code entered in the third position will indicate authorization to one of the following levels of maintenance:

<u>Code</u>	<u>Application/Explanation</u>
C.....	Crew or Operator maintenance done within Field/AVUM maintenance.
O	Unit Level/AVUM maintenance can remove, replace, and use the item.
F	Direct Support/AVIM maintenance can remove, replace, and use the item.
H.....	General Support maintenance can remove, replace, and use the item.
L	Specialized Repair Activity (SRA) can remove, replace, and use the item.
D.....	Depot Maintenance can remove, replace, and use the item.

(b) Fourth Position. The maintenance code entered in the fourth position tells you whether or not the item is to be repaired and identifies the lowest maintenance level with the capability to do complete repair (perform all authorized repair functions).

NOTE

Some limited repair may be done on the item at a lower level of maintenance, if authorized by the SMR codes.

<u>Code</u>	<u>Application/Explanation</u>
O	Unit/AVUM is the lowest level that can do complete repair of the item.
F	Direct Support/AVIM is the lowest level that can do complete repair of the item.
H.....	General Support is the lowest level that can do complete repair of the item.
L	Specialized Repair Activity (SRA) is the lowest level that can do complete repair of the item.
D.....	Depot is the lowest level that can do complete repair of the item.
Z	Nonreparable. No repair is authorized.
B.....	No repair is authorized. No parts or special tools are authorized for the maintenance of a "B"-coded item. However, the item may be reconditioned by adjusting, lubricating, etc., at the user level.

SECTION 4. REPAIR PARTS AND SPECIAL TOOLS LIST (RPSTL) (continued)

3. EXPLANATION OF COLUMNS (SECTIONS II AND III) (continued)

- (3) **Recoverability Code.** Recoverability codes are assigned to items to indicate the disposition action on unserviceable items. The recoverability code is entered in the fifth position of the SMR code as follows:

<u>Code</u>	<u>Application/Explanation</u>
Z.....	Nonreparable Item. When unserviceable, condemn and dispose of the item at the level of maintenance shown in the third position of the SMR code.
O.....	Reparable Item. When uneconomically repairable, condemn and dispose the item at the Unit level maintenance.
F.....	Reparable Item. When uneconomically repairable, condemn and dispose of the item at Direct Support level.
H.....	Reparable Item. When uneconomically repairable, condemn and dispose of the item at General Support level.
D.....	Reparable Item. When beyond lower level repair capability, return to depot. Condemnation and disposal of item are not authorized below depot level.
L.....	Reparable Item. Condemnation and disposal of item not authorized below Specialized Repair Activity (SRA).
A.....	item requires special handling or condemnation procedures because of specific reasons (e.g., precious metal content, high dollar value, critical material, or hazardous material). Refer to appropriate manuals/directives for specific instructions.

- (4) **Demilitarization Code.** Demilitarization codes are assigned to items to indicate the method and degree of demilitarization required. The demilitarization code is entered in the sixth position of the SMR code as follows:

<u>Code</u>	<u>Application/Explanation</u>
A.....	No demilitarization required.
B.....	MLI, No demilitarization required.
C.....	MLI, removed deadly parts in accordance with DOD 4160.21-M-1.
D.....	MLI, mutilate.
E.....	MLI, burn, shred or pulp.
F.....	MLI, contact the item manager.
G.....	MLI, demil required prior to DRMO.
P.....	MLI, security classified, demilitarize sensitive markings prior to transfer to DRMO. Not used on AEDA items.
Q.....	SLI, mutilate to preclude normal use, OCONUS only.

SECTION 4. REPAIR PARTS AND SPECIAL TOOLS LIST (RPSTL) (continued)**3. EXPLANATION OF COLUMNS (SECTIONS II AND III) (continued)**

- c. **NSN - (Column 3).** The NSN for the item is listed in this column.
- d. **CAGEC (Column 4).** The Commercial and Government Entity Code (CAGEC) is a five-digit code which is used to identify the manufacturer, distributor, or Government agency/activity that supplies the item.
- e. **PART NUMBER (Column 5).** Indicates the primary number used by the manufacturer (individual, company, firm, corporation, or Government activity), which controls the design and characteristics of the item by means of its engineering drawings, specifications, standards, and inspection requirements to identify an item or range of items.

NOTE

When you use an NSN to requisition an item, the item you receive may have a different part number from the part ordered.

- f. **DESCRIPTION AND USABLE ON CODE (UOC) (Column 6).** This column includes the following information:
 - (1) The Federal item name and, when required, a minimum description to identify the item.
 - (2) Part Numbers (P/Ns) of bulk materials are referenced in this column in the line entry to be manufactured or fabricated.
 - (3) Hardness Critical Item (HCI). A support item that provides the equipment with special protection from electromagnetic pulse (EMP) damage during a nuclear attack.
 - (4) The statement END OF FIGURE appears just below the last item description in column (6) for a given figure in both the repair parts list and special tools list functional groups.
- g. **QTY (Column 7).** The QTY (quantity per figure) column indicates the quantity of the item used in the breakout shown on the illustration/figure, which is prepared for a functional group, subfunctional group, group or an assembly. A "V" appearing in this column in lieu of a quantity indicates that the quantity is variable and the quantity may vary from application to application.

SECTION 4. REPAIR PARTS AND SPECIAL TOOLS LIST (RPSTL) (continued)

4. EXPLANATION OF CROSS-REFERENCE INDEXES (SECTIONS IV)

a. National Stock Number (NSN) Index

(1) STOCK NUMBER Column. This column lists the NSN by National Item Identification Number (NIIN) sequence. The NIIN consists of the last nine digits of the NSN (i.e., NSN 5305-01-674-1467). When using this column to locate an item, ignore the first four digits of the NSN. However, the complete NSN should be used when ordering items by stock number.

(2) FIG. Column. This column lists the number of the figure where the item is identified/located. The figures are in numerical order in Section II and III.

(3) ITEM Column. The item number identifies the item associated with the figure listed in the adjacent FIG. column. This item is also identified by the NSN listed on the same line.

b. Part Number (P/N) Index. Part numbers in this index are listed in ascending alphanumeric sequence (i.e., vertical arrangement of letter and number combination which places the first letter or digit of each group in order A through Z, followed by the numbers 0 through 9 and each following letter or digit in like order).

(1) PART NUMBER Column. Indicates the P/N assigned to the item.

(2) FIG. Column. This column lists the number of the figure where the item is identified/located in the RPSTL Sections II and III.

(3) ITEM Column. The item number is the number assigned to the item as it appears in the figure referenced in the adjacent figure number column.

5. SPECIAL INFORMATION

a. Usable On Code (UOC). The UOC appears in the lower left corner of the DESCRIPTION column heading. Usable on codes are shown as "UOC:" in the Description Column (justified left) on the first line under the applicable item/nomenclature. Uncoded items are applicable to all models. Identification of the UOC's used in the RPSTL are:

<u>Code</u>	<u>Used On</u>
LP1	M1062P1

b. Associated Publication. The publication(s) listed below pertain to the Semitrailer, Tank, Fuel, 7500-Gallon (M1062).

TM 9-2330-384-14&P.....	M1062
-------------------------	-------

SECTION 4. REPAIR PARTS AND SPECIAL TOOLS LIST (RPSTL) (continued)

6. HOW TO LOCATE REPAIR PARTS

a. When National Stock Number (NSN) is Known:

- (1) **First.** If you have the NSN, look in the STOCK NUMBER column of the NSN index. The NSN is arranged in NIIN sequence. Note the figure and item number next to the NSN.
- (2) **Second.** Turn to the figure and locate the item number. Verify that the item is the one you are looking for.

b. When Part Number (P/N) is Known.

- (1) **First.** If you have the P/N and not the NSN, look in the PART NUMBER column of the P/N index. Identify the figure and item number.
- (2) **Second.** Look up the item on the figure in the applicable repair parts list figure.

7. ABBREVIATIONS

For standard abbreviations see ASME Y14.38-1999, *Abbreviations and Acronyms*.

Abbreviations Explanation

AEDA.....	Ammunition, Explosives, and Dangerous Articles
AOA.....	Add-on-Armor
AVIM.....	Aviation Intermediate Maintenance
AVUM.....	Aviation Unit Maintenance
CAGEC.....	Commercial and Government Entity Code
DOD.....	Department of Defense
DRMO.....	Defense Reutilization and Marketing Office
EMP.....	Electromagnetic Pulse
FTSS.....	Fuel Tanker Self-Sealing
MLI.....	Military List Items
NIIN.....	National Item Identification Number (consists of the last 9 digits of the NSN)
NSN.....	National Stock Number
OCONUS.....	Outside Contiguous United States
P/N.....	Part Number
RPSTL.....	Repair Parts and Special Tools Lists
SLI.....	Strategic List Items
SMR.....	Source, Maintenance, and Recoverability Code
TBPS.....	Tanker Ballistics Protection System
UOC.....	Usable On Code

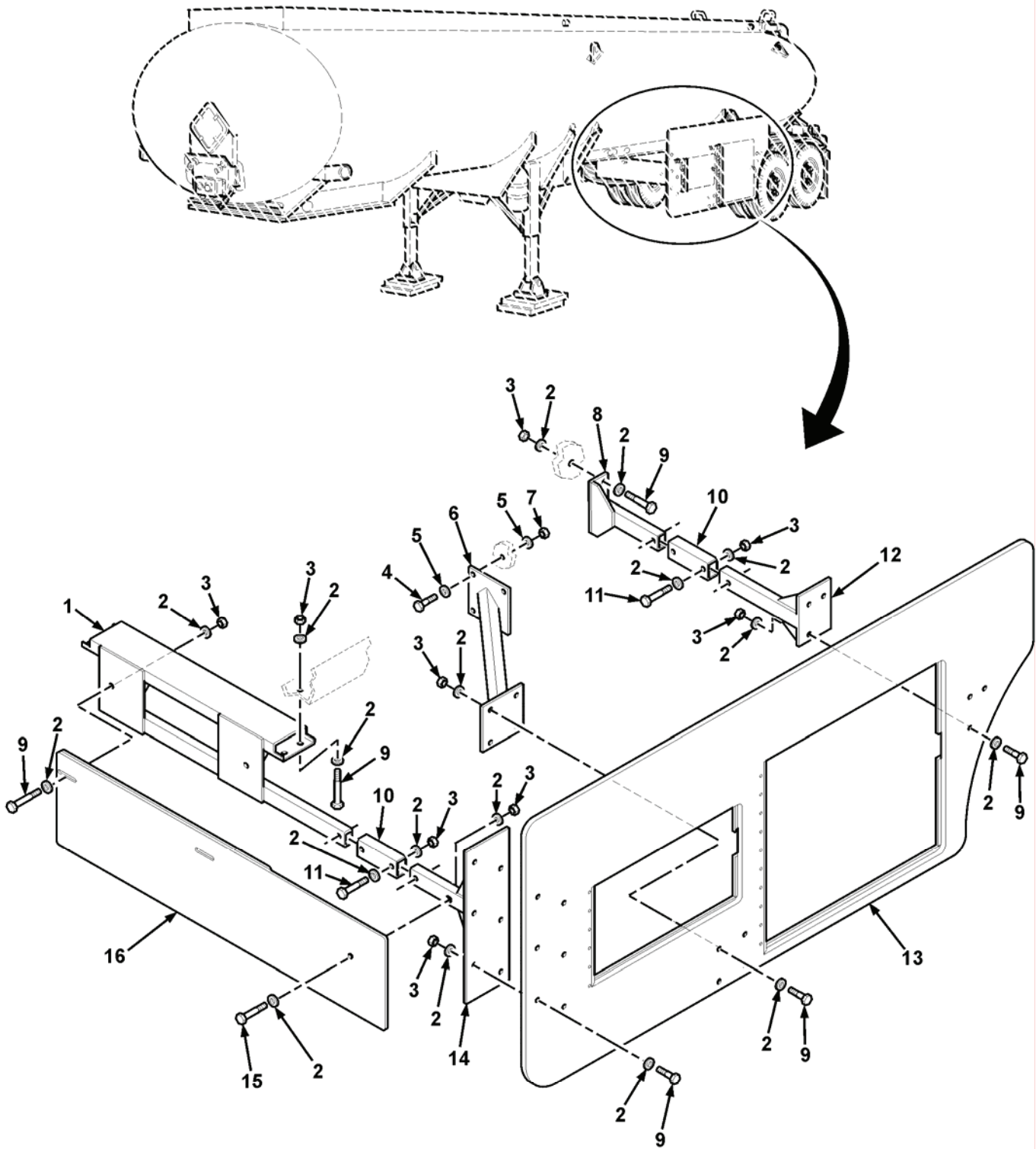
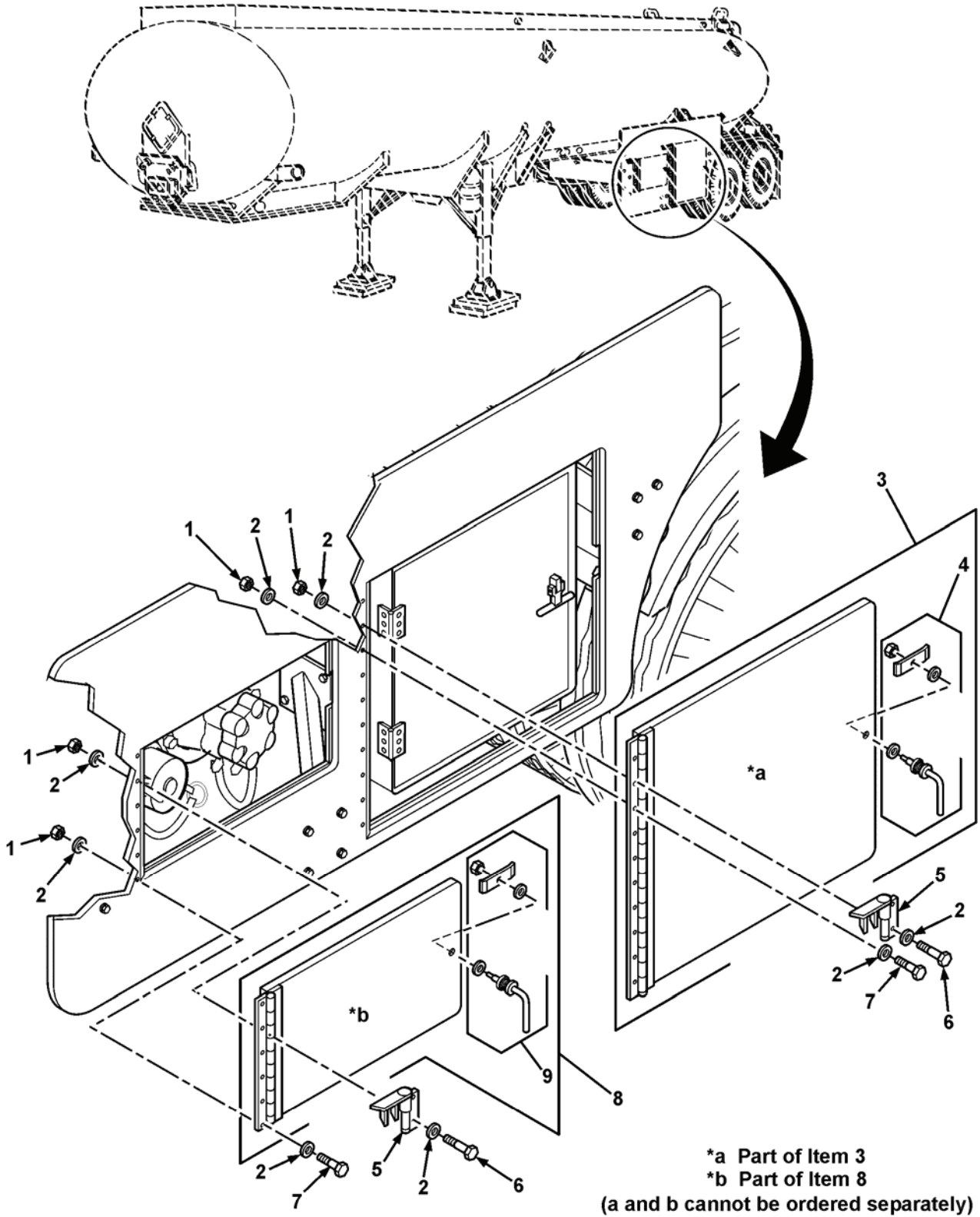

Figure 1. Armor Plates, Brackets, and Mounting Hardware

SECTION II		TB 9-2330-384-14&P			(6)	(7)
(1)	(2)	(3)	(4)	(5)	(6)	(7)
ITEM	SMR	NSN	CAGE	PART	DESCRIPTION AND	QTY
NO				NUMBER	USABLE ON CODE (UOC)	
					GROUP 33 SPECIAL PURPOSE KITS	
					GROUP 3307 SPECIAL PURPOSE KITS	
					FIG.1 ARMOR PLATES, BRACKETS, AND	
					MOUNTING HARDWARE	
1	PAOZZD	2510-01-541-8817	31902	12500878	SUPPORT,CROSS BASE PART OF KIT P/N 57K4867.....	1
2	PAOZZA	5310-00-787-9425	80205	MS15795-818	WASHER,FLAT PART OF KIT P/N 57K4867.	52
3	PAOZZA	5305-00-411-4385	96906	MS17830-8C	NUT,SELF-LOCKING HE PART OF KIT P/N 57K4867.....	26
4	PAOZZA	5305-00-725-2317	80204	B1821BH038C150N	SCREW,CAP,HEXAGON H PART OF KIT P/N 57K4867.....	3
5	PAOZZA	5310-00-773-7618	80205	MS15795-814	WASHER,FLAT PART OF KIT P/N 57K4867.	6
6	PAOZZA	5340-01-542-0366	31902	12500883	SUPPORT PART OF KIT P/N 57K4867.....	1
7	PAOZZA	5310-01-542-0395	96906	M45913/4-6CG8Z	NUT,SELF-LOCKING PART OF KIT P/N 57K4867.....	3
8	PAOZZD	5340-01-542-0388	31902	12500881	BRACKET,MOUNTING PART OF KIT P/N 57K4867.....	1
9	PAOZZA	5305-00-071-2071	80204	B1821BH050C200N	SCREW,CAP,HEXAGON H PART OF KIT P/N 57K4867.....	21
10	PAOZZD	2590-01-541-3759	31902	12500852	BRACKET,MOUNTING PART OF KIT P/N 57K4867.....	2
11	PAOZZA	5305-00-071-2075	80204	B1821BH050C300N	SCREW,CAP,HEXAGON H PART OF KIT P/N 57K4867.....	4
12	PAOZZD	5340-01-542-0420	31902	12500880	BRACKET,MOUNTING PART OF KIT P/N 57K4867.....	1
13	PBOZZD	2540-01-541-8802	31902	12500875	ARMOR,SUPPLEMENTAL PART OF KIT P/N 57K4867.....	1
14	PAOZZD	5340-01-542-0343	31902	12500879	BRACKET,MOUNTING PART OF KIT P/N 57K4867.....	1
15	PAOZZA	5305-00-071-2079	80204	B1821BH050C400N	SCREW,CAP,HEXAGON H PART OF KIT P/N 57K4867.....	1
16	PBOZZD	2540-01-542-0435	31902	12500876	ARMOR,SUPPLEMENTAL PART OF KIT P/N 57K4867.....	1

END OF FIGURE



TB1062-FIG2

Figure 2. Armor Plate Doors, Hold-Open Latches, and Mounting Hardware

SECTION II		TB 9-2330-384-14&P			(6)	(7)
(1)	(2)	(3)	(4)	(5)	(6)	(7)
ITEM NO	SMR	NSN	CAGE	PART NUMBER	DESCRIPTION AND USABLE ON CODE (UOC)	QTY
GROUP 3307 SPECIAL PUPOSE KITS						
FIG.2 ARMOR PLATE DOORS, HOLD-OPEN LATCHES, AND MOUNTING HARDWARE						
1	PAOZZA	5310-01-542-0395	96906	M45913/4-6CG8Z	NUT,SELF-LOCKING PART OF KIT P/N 57K4867.....	16
2	PAOZZA	5310-00-773-7618	80205	MS15795-814	WASHER,FLAT PART OF KIT P/N 57K4867.	32
3	PBOOD	5340-01-541-8481	31902	12500874	DOOR,ACCESS,GENERAL PART OF KIT P/N 57K4867.....	1
4	PAOZZA	2540-01-542-7383	19207	12500849	.LATCH,DOOR,VEHICULA.....	1
5	PAOZZA	2540-01-542-0334	31902	12500887-001	HANDLE,MANUAL CONTR PART OF KIT P/N 57K4867.....	2
6	PAOZZA	5305-00-725-2317	80204	B1821BH038C150N	SCREW,CAP,HEXAGON H PART OF KIT P/N 57K4867.....	4
7	PAOZZA	5305-00-068-0511	80204	B1821BH038C125N	SCREW,CAP,HEXAGON H PART OF KIT P/N 57K4867.....	12
8	PBOOD	5340-01-542-0333	31902	12500873	DOOR,ACCESS,GENERAL PART OF KIT P/N 57K4867.....	1
9	PAOZZA	2540-01-542-7383	19207	12500849	.LATCH,DOOR,VEHICULA.....	1

END OF FIGURE

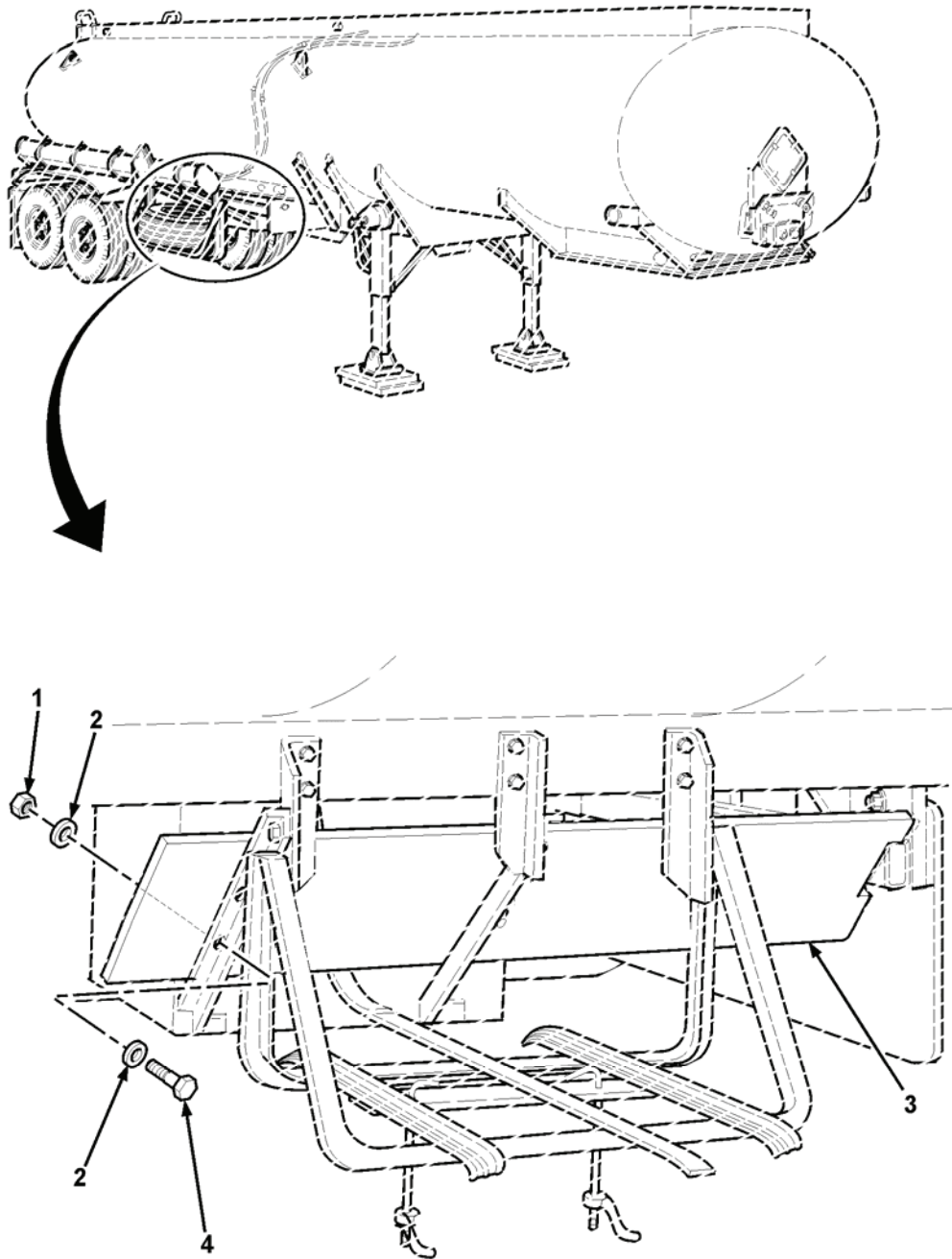

Figure 3. Armor Belly Plate and Mounting Hardware

SECTION II		TB 9-2330-384-14&P			(6)	(7)
(1)	(2)	(3)	(4)	(5)		
ITEM	SMR	NSN	CAGE	PART	DESCRIPTION AND	QTY
NO			NUMBER		USABLE ON CODE (UOC)	
					GROUP 3307 SPECIAL PURPOSE KITS	
					FIG.3 ARMOR BELLY PLATES AND	
					MOUNTING HARDWARE	
1	PAOZZA	5305-00-411-4385	96906	MS17830-8C	NUT,SELF-LOCKING HE PART OF KIT P/N	4
					57K4867.....	
2	PAOZZA	5310-00-787-9425	80205	MS15795-818	WASHER,FLAT PART OF KIT P/N 57K4867.	8
3	PBOZZD	2540-01-542-1198	31902	12500877	ARMOR,SUPPLEMENTAL PART OF KIT P/N	1
					57K4867.....	
4	PAOZZA	5305-00-071-2069	80204	B1821BH050C150N	SCREW,CAP,HEXAGON H PART OF KIT P/N	4
					57K4867.....	

END OF FIGURE

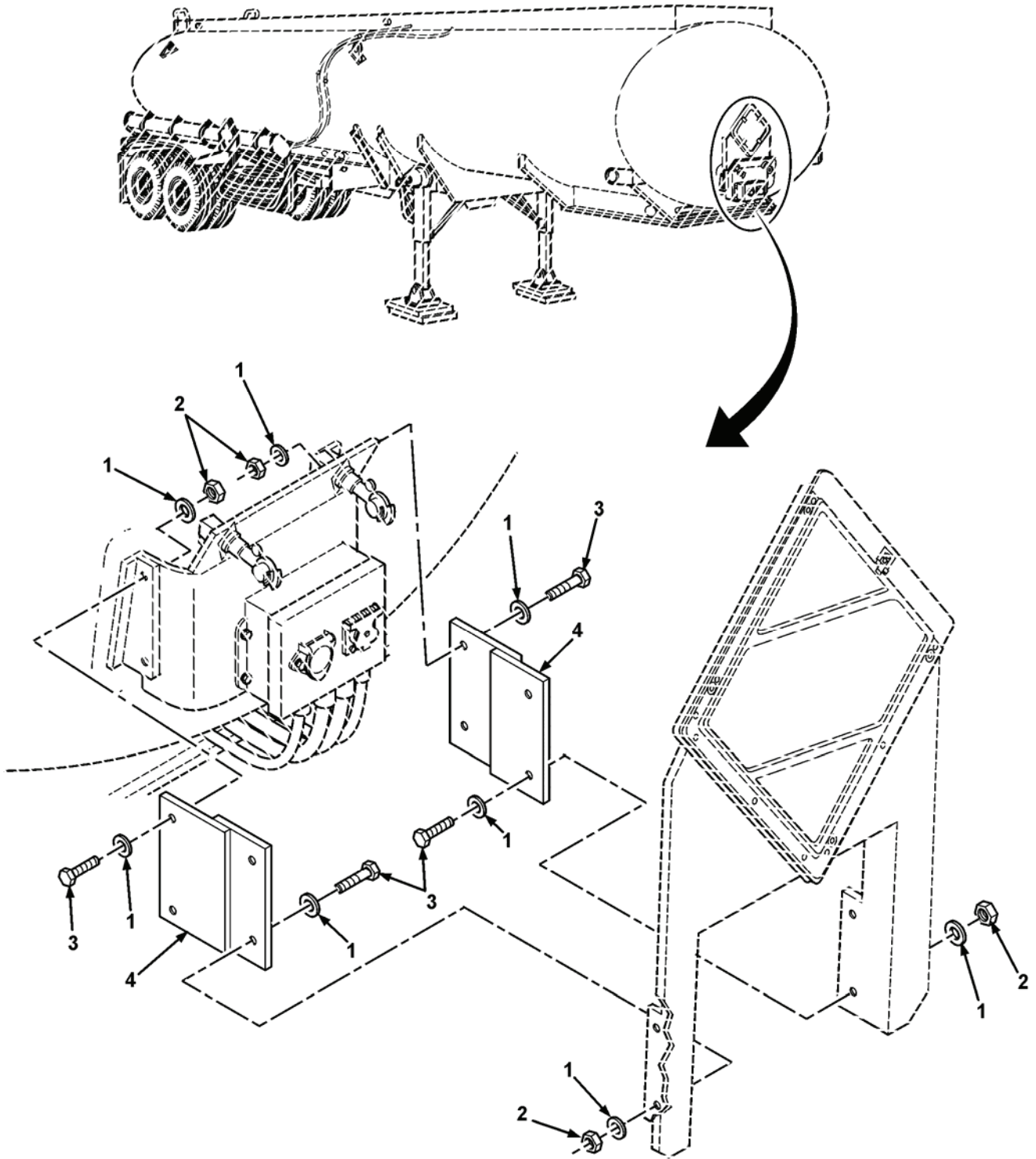

Figure 4. Plcard Extension Plates and Mounting Hardware

SECTION II		TB 9-2330-384-14&P			(6)	(7)
(1)	(2)	(3)	(4)	(5)		
ITEM	SMR	NSN	CAGE	PART	DESCRIPTION AND	QTY
NO			NUMBER		USABLE ON CODE (UOC)	
					GROUP 3307 SPECIAL PURPOSE KITS	
					FIG.4 PLACARD EXTENSION PLATES	
					AND MOUNTING HARDWARE	
1	PAOZZA	5310-00-773-7618	80205	MS15795-814	WASHER,FLAT PART OF KIT P/N 57K4866.	16
2	PAOZZA	5310-01-542-0395	96906	M45913/4-6CG8Z	NUT,SELF-LOCKING PART OF KIT P/N	8
					57K4866.....	
3	PAOZZA	5305-00-725-2317	80204	B1821BH038C150N	SCREW,CAP,HEXAGON H PART OF KIT P/N	8
					57K4866.....	
4	PAOZZA	5340-01-542-0378	31902	12502023	PLATE,EXTENSION PART OF KIT P/N	2
					57K4866.....	

END OF FIGURE

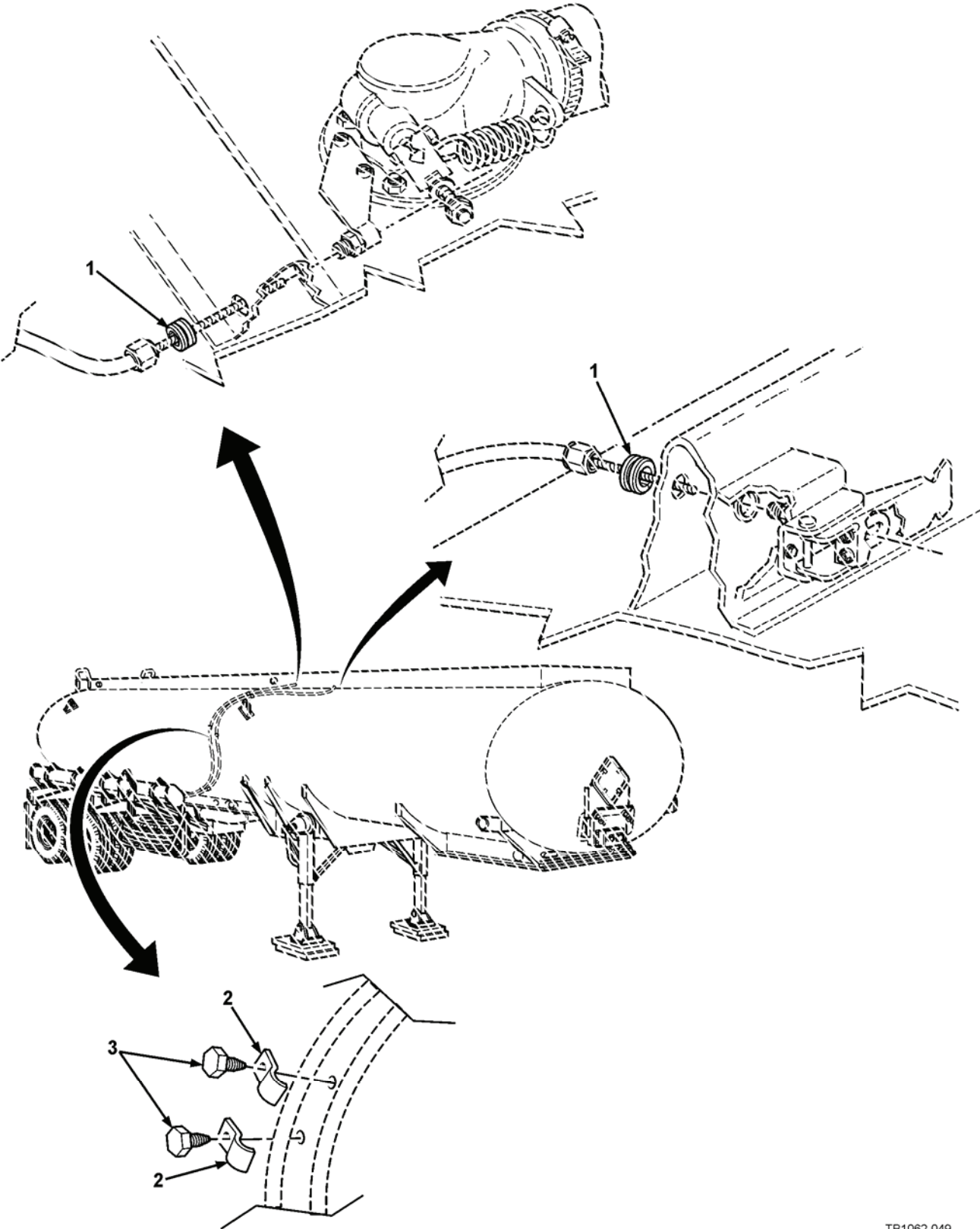

Figure 5. Curbside Pull Cable Mounting Hardware

SECTION II		TB 9-2330-384-14&P			(6)	(7)
(1)	(2)	(3)	(4)	(5)		
ITEM	SMR	NSN	CAGE	PART	DESCRIPTION AND	QTY
NO			NUMBER		USABLE ON CODE (UOC)	
					GROUP 3307 SPECIAL PURPOSE KITS	
					FIG.5 CURBSIDE PULL CABLE	
					MOUNTING HARDWARE	
1	PAOZZA	5325-01-086-4841	366L9	FSP11-1-PK3	GROMMET, NONMETALLIC PART OF KIT P/N	2
					57K4866.....	
2	PAOZZA	5340-01-542-0358	31902	12500884-001	CLIP, RETAINING PART OF KIT P/N	4
					57K4866.....	
3	PAOZZA	4730-01-541-7204	31902	14332	HAZEL NUT PART OF KIT P/N 57K4866...	4

END OF FIGURE

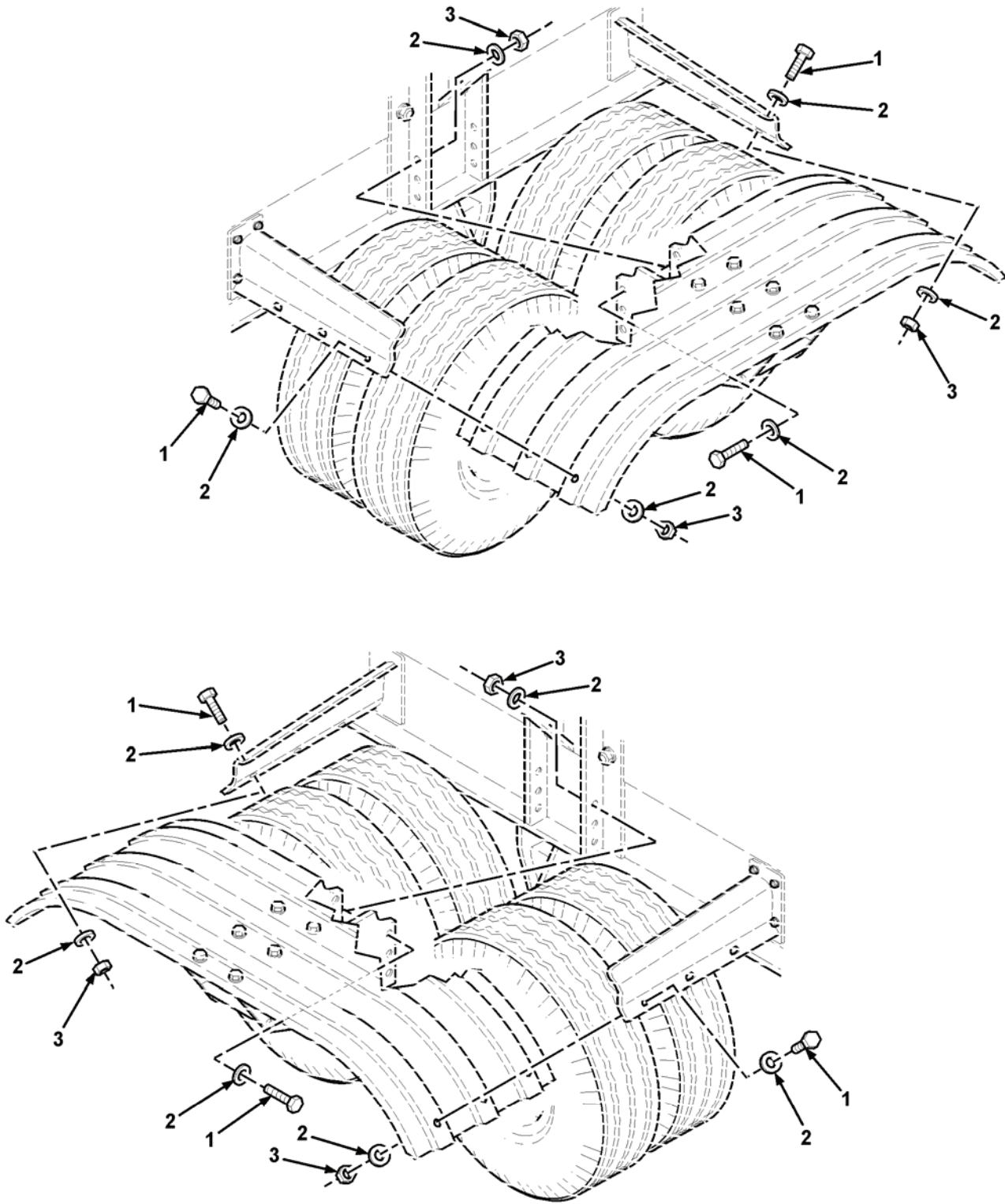
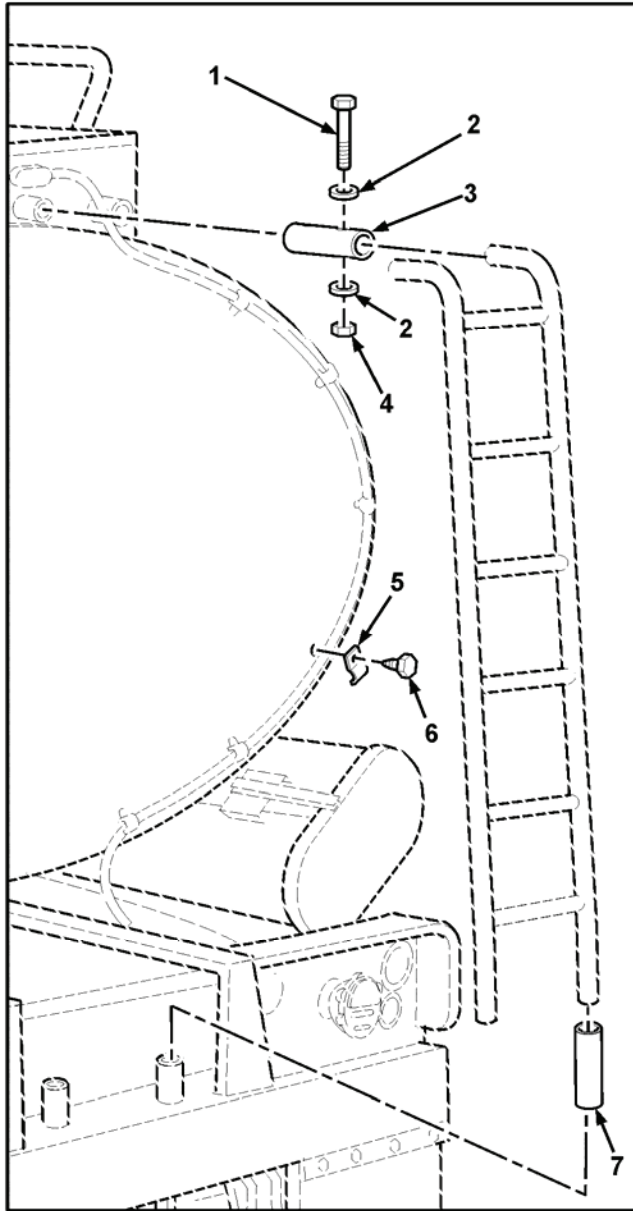

Figure 6. Right and Left Fender Mounting Hardware

SECTION II		TB 9-2330-384-14&P			(6)	(7)
(1)	(2)	(3)	(4)	(5)		
ITEM	SMR	NSN	CAGE	PART	DESCRIPTION AND	QTY
NO			NUMBER		USABLE ON CODE (UOC)	
					GROUP 3307 SPECIAL PURPOSE KITS	
					FIG.6 RIGHT AND LEFT FENDER	
					MOUNTING HARDWARE	
1	PAOZZA	5305-00-068-0510	05047	B1821BH038C100N	SCREW,CAP,HEXAGON H PART OF KIT P/N	24
					57K4866.....	
2	PAOZZA	5310-00-773-7618	80205	MS15795-814	WASHER,FLAT PART OF KIT P/N 57K4866.	48
3	PAOZZA	5310-01-542-0395	96906	M45913/4-6CG8Z	NUT,SELF-LOCKING PART OF KIT P/N	24
					57K4866.....	

END OF FIGURE



WELDED LADDER

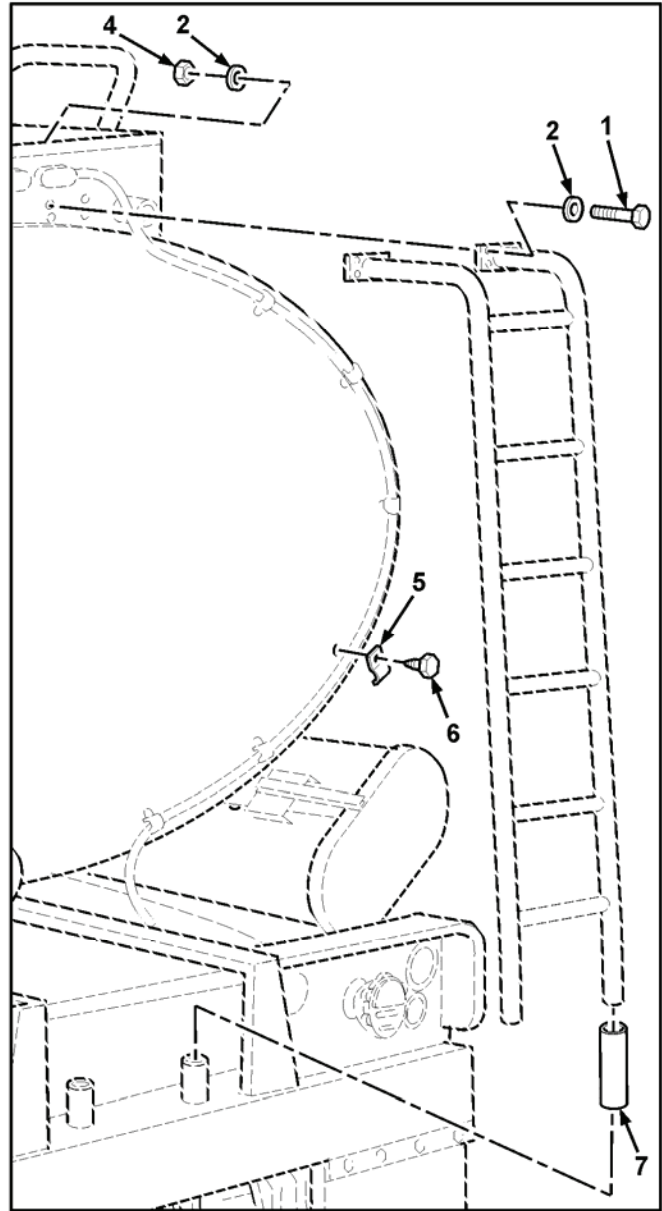

BOLT-ON LADDER

Figure 7. Rear Ladder and Cable Mounting Hardware

SECTION II		TB 9-2330-384-14&P			(6)	(7)
(1)	(2)	(3)	(4)	(5)	DESCRIPTION AND	
ITEM	SMR	NSN	CAGE	PART	USABLE ON CODE (UOC)	QTY
NO			NUMBER			
GROUP 3307 SPECIAL PURPOSE KITS						
FIG.7 REAR LADDER AND CABLE MOUNTING						
HARDWARE						
1	PAOZZA	5305-00-782-9489	80204	B1821BH038C200N	SCREW,CAP,HEXAGON H PART OF KIT P/N 57K4866.....	4
2	PAOZZA	5310-00-773-7618	80205	MS15795-814	WASHER,FLAT PART OF KIT P/N 57K4866.	8
3	PAOZZA	4710-01-541-9766	31902	12501995	SLEEVE PART OF KIT P/N 57K4866.....	2
4	PAOZZA	5310-01-542-0395	96906	M45913/4-6CG8Z	NUT,SELF-LOCKING PART OF KIT P/N 57K4866.....	4
5	PAOZZA	5340-01-542-0358	31902	12500884-001	CLIP, RETAINING PART OF KIT P/N 57K4866.....	14
6	PAOZZA	4730-01-541-7204	31902	14332	HAZEL NUT PART OF KIT P/N 57K4866...	14
7	PAOZZA	4710-01-541-9729	31902	12500882	SLEEVE PART OF KIT P/N 57K4866.....	2

END OF FIGURE

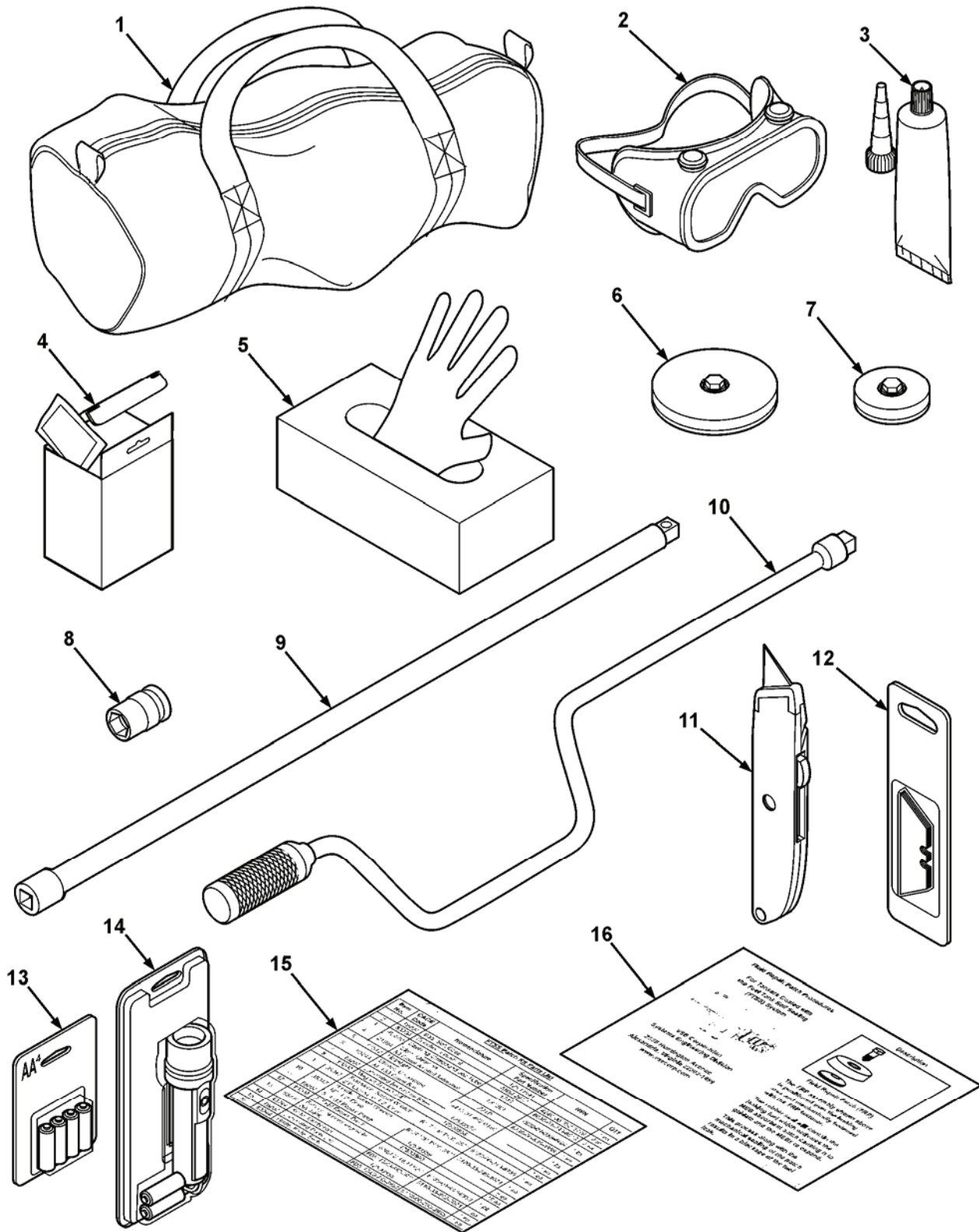

Figure 8. FTSS Repair Patch Kit, P/N 57K4786

SECTION II		TB 9-2330-384-14&P			(6)	(7)
(1)	(2)	(3)	(4)	(5)	DESCRIPTION AND	
ITEM	SMR	NSN	CAGE	PART	USABLE ON CODE (UOC)	QTY
NO				NUMBER		
					GROUP 3307 SPECIAL PURPOSE KITS	
					FIG.8 FTSS REPAIR PATCH KIT,	
					P/N 57K4786	
1	PAOZZA	5140-01-542-2828	79623	2608-VSE	BAG,TOOL PART OF KIT P/N 57K4786....	1
2	PAOZZA	4240-00-025-3776	45152	3336841	GOGGLES,INDUSTRIAL PART OF KIT P/N	2
					57K4786.....	
3	PAOZZA	5130-01-546-1739	0FRU4	051135-05203	ADHESIVE 3 OZ. TUBE PART OF KIT P/N	2
					57K4786.....	
4	PAOZZA	7920-01-036-4464	21994	TX1301	CLOTH,CLEANING 80 COUNT BOX PART OF	1
					06 N 57K4786.....	
5	PAOZZA	8415-01-492-0180	80244	8415-01-492-0180	GLOVES,DISPOSABLE SIZE XL, 100	1
					COUNT BOX PART OF KIT P/N 57K4786...	
6	PAOZZD	4235-01-541-8511	31902	12500859	PATCH,SPILL CONTROL 5 IN PART OF	5
					KIT P/N 57K4786.....	
7	PAOZZD	4235-01-541-8515	31902	12500860	PATCH,SPILL CONTROL 3 IN PART OF	15
					KIT P/N 57K4786.....	
8	PAOZZA	5130-01-546-1738	31902	14394	SOCKET,MAGNETIC 3/4 IN, 1/2 IN	1
					DRIVE PART OF KIT P/N 57K4786.....	
9	PAOZZA	5120-00-240-8705	80020	516059-6	EXTENSION,SOCKET WR 20 IN LG, 1/2	1
					IN DRIVE PART OF KIT P/N 57K4786....	
10	PAOZZA	5120-00-237-4969	05047	B107.10M TY1CL3S	HANDLE,SOCKET WRENC 18 IN LG, 1/2	1
				T1	IN DRIVE PART OF KIT P/N 57K4786....	
11	PAOZZA	5110-00-892-5071	80244	PD5110-00-892-50	KNIFE,CRAFTMANS PART OF KIT P/N	1
				71	57K4786.....	
12	PAOZZA	5110-00-293-2865	80244	PD5110-00-293-28	BLADE,KNIFE 5 BLADE PK PART OF KIT	1
				65	P/N 57K4786.....	
13	PAOZZA	6135-01-447-0950	80204	115A	BATTERY,NONRECHARG AA, 4 PK PART	1
					OF KIT P/N 57K4786.....	
14	PAOZZA	6230-00-635-4998	77542	Z21P	FLASHLIGHT PART OF KIT P/N 57K4786..	1
15	PAOZZA	7610-01-541-8159	31902	12500888	PARTS LIST PARTS LIST PART OF KIT	1
					P/N 57K4786.....	
16	PAOZZA	7610-01-541-8112	31902	12500872	SHEET TECHNICAL INSTRUCTION SHEET	1
					PART OF KIT P/N 57K4786.....	

END OF FIGURE

SECTION II		TB 9-2330-384-14&P			(6)	(7)
(1)	(2)	(3)	(4)	(5)	(6)	(7)
ITEM NO	SMR	NSN	CAGE	PART NUMBER	DESCRIPTION AND USABLE ON CODE (UOC)	QTY
					GROUP 94 REPAIR KITS	
					GROUP 9401 REPAIR KITS	
					FIG.KITS M1062P1 TBPS KITS	
1	PAOZZA	4940-01-540-2973	31902	57K4786	REPAIR KIT FTSS REPAIR PATCH PART OF KIT P/N 57K4839.....	1
					BAG, TOOL (1) 8-1	
					GOGGLES, INDUSTRIAL (2) 8-2	
					ADHESIVE (2) 8-3	
					CLOTH, CLEANING (1) 8-4	
					GLOVES, DISPOSABLE (1) 8-5	
					PATCH, SPILL CONTROL (5) 8-6	
					PATCH, SPILL CONTROL (15) 8-7	
					SOCKET, MAGNETIC (1) 8-8	
					EXTENSION, SOCKET WR (1) 8-9	
					HANDLE, SOCKET WRENCH (1) 8-10	
					KNIFE, CRAFTSMAN (1) 8-11	
					BLADE, KNIFE (1) 8-12	
					BATTERY, NONRECHARGE (1) 8-13	
					FLASHLIGHT (1) 8-14	
					PARTS LIST (1) 8-15	
					SHEET TECHNICAL (1) 8-16	
2	PFKZZD	2590-01-542-0382	31902	57K4839	MODIFICATION KIT, VE TBPS.....	1
					TEMPLATE (1)	
					DRAWING, KIT TBPS (1)	
					REPAIR KIT (1) KITS-1	
					ARMOR, SUPPLEMENTAL (1) KITS-3	
					ARMOR SET, SUPPLEMENTAL (1) KITS-4	
3	PFKZZD	4730-01-542-1628	31902	57K4866	ARMOR, SUPPLEMENTAL FTSS APPLICATION PART OF KIT P/N 57K4839.....	1
					WASHER, FLAT (72) 4-1	
					NUT, SELF-LOCKING (36) 4-2	
					SCREW, CAP, HEXAGON H (8) 4-3	
					PLATE, EXTENSION (2) 4-4	
					GROMMET, NONMETALLIC (2) 5-1	
					CLIP, RETAINING (18) 5-2	
					HAZEL NUT (18) 5-3	
					DRAWING, FTSS MEBS (1)	
					DRAWING, POLYURETHAN (1)	
					SCREW, CAP, HEXAGON H (24) 6-1	
					SCREW, CAP, HEXAGON H (4) 7-1	
					SLEEVE (2) 7-3	
					SLEEVE (2) 7-7	
					DRAWING, FTSS APPLIC (1)	
					DRAWING, FTSS APPLIC (1)	
4	PFOZZD	2540-01-542-0356	31902	57K4867	ARMOR SET, SUPPLEMENTAL AOA PART OF KIT P/N 57K4839.....	1
					SUPPORT, CROSS BASE (1) 1-1	
					WASHER, FLAT (60) 1-2	
					NUT, SELF-LOCKING HE (30) 1-3	
					SCREW, CAP, HEXAGON H (7) 1-4	
					WASHER, FLAT (38) 1-5	
					SUPPORT (1) 1-6	
					NUT, SELF-LOCKING (19) 1-7	
					BRACKET, MOUNTING (1) 1-8	
					SCREW, CAP, HEXAGON H (21) 1-9	
					BRACKET, MOUNTING (2) 1-10	

SECTION II
(1) (2)
ITEM SMR
NO

TB 9-2330-384-14&P
(3) (4) (5)
NSN PART
CAGE NUMBER

(6) (7)
DESCRIPTION AND
USABLE ON CODE (UOC) QTY

SCREW,CAP,HEXAGON H(4)	1-11
BRACKET,MOUNTING (1)	1-12
ARMOR,SUPPLEMENTAL (1)	1-13
BRACKET,MOUNTING (1)	1-14
SCREW,CAP,HEXAGON H(1)	1-15
ARMOR,SUPPLEMENTAL (1)	1-16
DOOR,ACCESS,GENERAL(1)	2-3
HANDLE,MANUAL CONTR(2)	2-5
SCREW,CAP,HEXAGON H(12)	2-7
DOOR,ACCESS,GENERAL(1)	2-8
DRAWING,ASSY AOA (1)	
ARMOR,SUPPLEMENTAL (1)	3-3
SCREW,CAP,HEXAGON H(4)	3-4

END OF FIGURE

CROSS REFERENCE INDEXES

NATIONAL STOCK NUMBER INDEX

STOCK NUMBER	FIGURE NO	ITEM NO	STOCK NUMBER	FIGURE NO	ITEM NO
4240-00-052-3776	8	2	2590-01-541-3759	1	10
5305-00-068-0510	6	1	4730-01-541-7204	5	3
5305-00-068-0511	2	7		7	6
5305-00-071-2069	3	4	7610-01-541-8112	8	16
5305-00-071-2071	1	9	7610-01-541-8159	8	15
5305-00-071-2075	1	11	5340-01-541-8481	2	3
5305-00-071-2079	1	15	4235-01-541-8511	8	6
5120-00-237-4969	8	10	4235-01-541-8515	8	7
5120-00-240-8705	8	9	2540-01-541-8802	1	13
5110-00-293-2865	8	12	2510-01-541-8817	1	1
5310-00-411-4385	1	3	4710-01-541-9729	7	7
	3	1	4710-01-541-9766	7	3
6230-00-635-4998	8	14	5340-01-542-0333	2	8
5305-00-725-2317	1	4	2540-01-542-0334	2	5
	2	6	5340-01-542-0343	1	14
	4	3	2540-01-542-0356	Kits	4
5310-00-767-9425	1	2	5340-01-542-0358	5	2
	3	2		7	5
5310-00-773-7618	1	5	5340-01-542-0366	1	6
	2	2	5340-01-542-0378	4	4
	4	1	2590-01-542-0382	Kits	2
	6	2	5340-01-542-0388	1	8
	7	2	5310-01-542-0395	1	7
5305-00-782-9489	7	1		2	1
5110-00-892-5071	8	11		4	2
7920-01-036-4464	8	4		6	3
5325-01-086-4841	5	1		7	4
6135-01-447-0950	8	13	5340-01-542-0420	1	12
8415-01-492-0180	8	5	2540-01-542-0435	1	16
4940-01-540-2973	Kits	1	2540-01-542-1198	3	3
			4730-01-542-1628	Kits	3
			5140-01-542-2828	8	1
			2540-01-542-7383	2	4
				2	9
			5130-01-546-1738	8	8
			5130-01-546-1739	8	3

CROSS REFERENCE INDEXES

PART NUMBER INDEX

PART NUMBER	FIG.	ITEM	PART NUMBER	FIG.	ITEM
051135-05203	8	3	8415-01-492-0180	8	5
115A	8	13	B107.10M TY1CL3S	8	10
12500849	2	4	T1		
	2	9	B1821BH038C100N	6	1
12500852	1	10	B1821BH038C125N	2	7
12500859	8	6	B1821BH038C150N	1	4
12500860	8	7		2	6
12500872	8	16		4	3
12500873	2	8			
12500874	2	3			
12500875	1	13	B1821BH038C200N	7	1
12500876	1	16	B1821BH050C150N	3	4
12500877	3	3	B1821BH050C200N	1	9
12500878	1	1	B1821BH050C300N	1	11
12500879	1	14	B1821BH050C400N	1	15
12500880	1	12	FSP11-1-PK3	5	1
12500881	1	8	M45913/4-6CG8Z	1	7
12500882	7	7		2	1
12500883	1	6		4	2
12500884-001	5	2		6	3
	7	5		7	4
12500887-001	2	5	MS15795-814	1	5
12500888	8	15		2	2
12501995	7	3		4	1
12502023	4	4		6	2
14332	5	3		7	2
	7	6	MS15795-818	1	2
14394	8	8		3	2
2608-VSE	8	1	MS17830-8C	1	3
3336841	8	2		3	1
516059-6	8	9	PD5110-00-293-28	8	12
57K4786	KITS	1	65		
57K4839	KITS	2	PD5110-00-892-50	8	11
57K4866	KITS	3	71		
57K4867	KITS	4	TX1301	8	4
			Z21P	8	14

RECOMMENDED CHANGES TO PUBLICATIONS AND BLANK FORMS For use of this form, see AR 310-1; the proponent agency is US Army Adjutant General Center.						Use Part II (reverse) for Repair Parts and Special Tools Lists (RPSTL) and Supply Catalogs/Supply Manuals (SC/SM)	DATE (Date You Will Fill Out This Form)
TO: (Forward to proponent of publication or form)(Include Zip Code)						FROM: (Activity and location)(Include Zip Code) (Your Mailing Address)	
PART I - ALL PUBLICATIONS (EXCEPT RPSTL AND SC/SM) AND BLANK FORMS							
PUBLICATION FORM NUMBER TB 9-2330-384-14&P					DATE XX/XX/XXXX	TITLE Technical Bulletin for M1062 Fuel Tankers	
ITEM	PAGE NO.	PARA-GRAPH	LINE NO.*	FIGURE NO.	TABLE NO.	RECOMMENDED CHANGES AND REASON <i>(Exact wording of recommended changes must be given)</i>	
	0004 00-3					Callouts on art are numbered incorrectly. Callouts 3, 4, and 5 should be 6, 7, and 8.	
SAMPLE							
<i>* Reference to line numbers within the paragraph or sub paragraph.</i>							
TYPED NAME, GRADE OR TITLE John Doe SSG				TELEPHONE EXCHANGE/AUTOVON, PLUS EXTENSION XXX-XXXX		SIGNATURE 	

TO: (Forward direct to addressee listed in publication)	FROM: (Activity and location)(Include Zip Code) (Your Mailing Address)	DATE (Date You Will Fill Out This Form)
---	---	--

PART II - REPAIR PARTS AND SPECIAL TOOLS LISTS AND SUPPLY CATALOGS/SUPPLY MANUALS

PUBLICATION NUMBER TB 9-2330-384-14&P	DATE XX/XX/XXXX	TITLE Technical Bulletin for M1062 Fuel Tankers
--	--------------------	---

PAGE NO.	COLM NO.	LINE NO.	NATIONAL STOCK NUMBER	REFERENCE NO.	FIGURE NO.	ITEM NO.	TOTAL NO. OF MAJOR ITEMS SUPPORTED	RECOMMENDED ACTION
260			4730-00-273-6772		134	4	1	Change from Hex to Socket Plug.
260-1			4730-00-273-6772			4	1	Change part Number to 12301694.

PART III - REMARKS (Any general remarks or recommendations, or suggestions for improvement of publications and blank forms. Additional blank sheets may be use dif more space is needed.)

SAMPLE

TYPED NAME, GRADE OR TITLE John Doe SSG	TELEPHONE EXCHANGE/AUTOVON, PLUS EXTENSION XXX-XXXX	SIGNATURE <i>John Doe</i>
--	--	------------------------------

RECOMMENDED CHANGES TO PUBLICATIONS AND BLANK FORMS For use of this form, see AR 310-1; the proponent agency is US Army Adjutant General Center.					Use Part II (reverse) for Repair Parts and Special Tools Lists (RPSTL) and Supply Catalogs/Supply Manuals (SC/SM)		DATE
TO: (Forward to proponent of publication or form)(Include Zip Code)					FROM: (Activity and location)(Include Zip Code)		
PART I - ALL PUBLICATIONS (EXCEPT RPSTL AND SC/SM) AND BLANK FORMS							
PUBLICATION FORM NUMBER TB 9-2330-384-14&P					DATE XX/XX/XXXX		TITLE Technical Bulletin for M1062 Fuel Tankers
ITEM	PAGE NO.	PARA-GRAPH	LINE NO.*	FIGURE NO.	TABLE NO.	RECOMMENDED CHANGES AND REASON <i>(Exact wording of recommended changes must be given)</i>	
<i>* Reference to line numbers within the paragraph or sub paragraph.</i>							
TYPED NAME, GRADE OR TITLE				TELEPHONE EXCHANGE/AUTOVON, PLUS EXTENSION		SIGNATURE	

DA FORM 1 FEB 74 **2028**

REPLACES DA FORM 2028, 1 DEC 68, WHICH WILL BE USED

TO: <i>(Forward direct to addressee listed in publication)</i>	FROM: <i>(Activity and location)(Include Zip Code)</i>	DATE
---	---	------

PART II - REPAIR PARTS AND SPECIAL TOOLS LISTS AND SUPPLY CATALOGS/SUPPLY MANUALS

PUBLICATION NUMBER TB 9-2330-384-14&P	DATE XX/XX/XXXX	TITLE Technical Bulletin for M1062 Fuel Tankers
--	--------------------	---

PAGE NO.	COLM NO.	LINE NO.	NATIONAL STOCK NUMBER	REFERENCE NO.	FIGURE NO.	ITEM NO.	TOTAL NO. OF MAJOR ITEMS SUPPORTED	RECOMMENDED ACTION

PART III - REMARKS *(Any general remarks or recommendations, or suggestions for improvement of publications and blank forms. Additional blank sheets may be use dif more space is needed.)*

TYPED NAME, GRADE OR TITLE	TELEPHONE EXCHANGE/AUTOVON, PLUS EXTENSION	SIGNATURE
----------------------------	---	-----------

RECOMMENDED CHANGES TO PUBLICATIONS AND BLANK FORMS For use of this form, see AR 310-1; the proponent agency is US Army Adjutant General Center.						Use Part II (reverse) for Repair Parts and Special Tools Lists (RPSTL) and Supply Catalogs/Supply Manuals (SC/SM)	DATE
TO: (Forward to proponent of publication or form)(Include Zip Code)						FROM: (Activity and location)(Include Zip Code)	
PART I - ALL PUBLICATIONS (EXCEPT RPSTL AND SC/SM) AND BLANK FORMS							
PUBLICATION FORM NUMBER TB 9-2330-384-14&P					DATE XX/XX/XXXX	TITLE Technical Bulletin for M1062 Fuel Tankers	
ITEM	PAGE NO.	PARA-GRAPH	LINE NO.*	FIGURE NO.	TABLE NO.	RECOMMENDED CHANGES AND REASON <i>(Exact wording of recommended changes must be given)</i>	
<i>* Reference to line numbers within the paragraph or sub paragraph.</i>							
TYPED NAME, GRADE OR TITLE				TELEPHONE EXCHANGE/AUTOVON, PLUS EXTENSION		SIGNATURE	

TO: <i>(Forward direct to addressee listed in publication)</i>	FROM: <i>(Activity and location)(Include Zip Code)</i>	DATE
---	---	------

PART II - REPAIR PARTS AND SPECIAL TOOLS LISTS AND SUPPLY CATALOGS/SUPPLY MANUALS

PUBLICATION NUMBER TB 9-2330-384-14&P	DATE XX/XX/XXXX	TITLE Technical Bulletin for M1062 Fuel Tankers
--	--------------------	---

PAGE NO.	COLM NO.	LINE NO.	NATIONAL STOCK NUMBER	REFERENCE NO.	FIGURE NO.	ITEM NO.	TOTAL NO. OF MAJOR ITEMS SUPPORTED	RECOMMENDED ACTION

PART III - REMARKS *(Any general remarks or recommendations, or suggestions for improvement of publications and blank forms. Additional blank sheets may be use dif more space is needed.)*

TYPED NAME, GRADE OR TITLE	TELEPHONE EXCHANGE/AUTOVON, PLUS EXTENSION	SIGNATURE
----------------------------	---	-----------

RECOMMENDED CHANGES TO PUBLICATIONS AND BLANK FORMS For use of this form, see AR 310-1; the proponent agency is US Army Adjutant General Center.						Use Part II (reverse) for Repair Parts and Special Tools Lists (RPSTL) and Supply Catalogs/Supply Manuals (SC/SM)	DATE
TO: (Forward to proponent of publication or form)(Include Zip Code)						FROM: (Activity and location)(Include Zip Code)	
PART I - ALL PUBLICATIONS (EXCEPT RPSTL AND SC/SM) AND BLANK FORMS							
PUBLICATION FORM NUMBER TB 9-2330-384-14&P					DATE XX/XX/XXXX	TITLE Technical Bulletin for M1062 Fuel Tankers	
ITEM	PAGE NO.	PARA-GRAPH	LINE NO.*	FIGURE NO.	TABLE NO.	RECOMMENDED CHANGES AND REASON <i>(Exact wording of recommended changes must be given)</i>	
<i>* Reference to line numbers within the paragraph or sub paragraph.</i>							
TYPED NAME, GRADE OR TITLE				TELEPHONE EXCHANGE/AUTOVON, PLUS EXTENSION		SIGNATURE	

TO: <i>(Forward direct to addressee listed in publication)</i>	FROM: <i>(Activity and location)(Include Zip Code)</i>	DATE
---	---	------

PART II - REPAIR PARTS AND SPECIAL TOOLS LISTS AND SUPPLY CATALOGS/SUPPLY MANUALS

PUBLICATION NUMBER TB 9-2330-384-14&P	DATE XX/XX/XXXX	TITLE Technical Bulletin for M1062 Fuel Tankers
--	--------------------	---

PAGE NO.	COLM NO.	LINE NO.	NATIONAL STOCK NUMBER	REFERENCE NO.	FIGURE NO.	ITEM NO.	TOTAL NO. OF MAJOR ITEMS SUPPORTED	RECOMMENDED ACTION

PART III - REMARKS *(Any general remarks or recommendations, or suggestions for improvement of publications and blank forms. Additional blank sheets may be use dif more space is needed.)*

TYPED NAME, GRADE OR TITLE	TELEPHONE EXCHANGE/AUTOVON, PLUS EXTENSION	SIGNATURE
----------------------------	---	-----------

By Order of the Secretary of the Army:

PETER J. SCHOOMAKER
General, United States Army
Chief of Staff

Official:

A handwritten signature in black ink that reads "Joyce E. Morrow". The signature is written in a cursive style with a large initial "J" and "M".

JOYCE E. MORROW
Administrative Assistant to the
Secretary of the Army
0708101

Distribution:

To be distributed in accordance with the Initial Distribution Number (IDN) 344875, requirements for TB 9-2330-384-14&P.

THE METRIC SYSTEM AND EQUIVALENTS

LINEAR MEASURE

1 Centimeter = 10 Millimeters = 0.01 Meters = 0.3937 Inch
 1 Meter = 100 Centimeters = 1000 Millimeters = 39.37 Inches
 1 Kilometer = 1000 Meters = 0.621 Mile

WEIGHTS

1 Gram = 0.001 Kilogram = 1000 Milligrams = 0.035 Ounce
 1 Kilogram = 1000 Grams = 2.2 Lb
 1 Metric Ton = 1000 Kilograms = 1 Megagram = 1.1 Short Tons

LIQUID MEASURE

1 Milliliter = 0.001 Liter = 0.0338 Fluid Ounce
 1 Liter = 1000 Milliliters = 33.82 Fluid Ounces

SQUARE MEASURE

1 Sq. Centimeter = 100 Sq. Millimeters = 0.155 Sq. Inch
 1 Sq. Meter = 10,000 Sq. Centimeters = 10.76 Sq. Feet
 1 Sq. Kilometer = 1,000,000 Sq. Meters = 0.386 Sq. Mile

CUBIC MEASURE

1 Cu. Centimeter = 1000 Cu. Millimeters = 0.06 Cu. Inch
 1 Cu. Meter = 1,000,000 Cu. Centimeters = 35.31 Cu. Feet

TEMPERATURE

$5/9 (^{\circ}\text{F} - 32) = ^{\circ}\text{C}$
 212° Fahrenheit is equivalent to 100° Celsius
 90° Fahrenheit is equivalent to 32.2° Celsius
 32° Fahrenheit is equivalent to 0° Celsius
 $9/5 (^{\circ}\text{C} + 32) = ^{\circ}\text{F}$

APPROXIMATE CONVERSION FACTORS

TO CHANGE	TO	MULTIPLY BY
Inches	Centimeters	2.540
Feet	Meters	0.305
Yards	Meters	0.914
Miles.....	Kilometers.....	1.609
Square Inches	Square Centimeters	6.451
Square Feet.....	Square Meters	0.093
Square Yards	Square Meters	0.836
Square Miles.....	Square Kilometers	2.590
Acres	Square Hectometers.....	0.405
Cubic Feet	Cubic Meters	0.028
Cubic Yards.....	Cubic Meters	0.765
Fluid Ounces	Milliliters.....	29.573
Pints.....	Liters	0.473
Quarts	Liters	0.946
Gallons	Liters	3.785
Ounces.....	Grams.....	28.349
Pounds	Kilograms.....	0.454
Short Tons	Metric Tons	0.907
Pound-Feet	Newton-Meters.....	1.356
Pounds per Square Inch	Kilopascals	6.895
Miles per Gallon.....	Kilometers per Liter	0.425
Miles per Hour	Kilometers per Hour.....	1.609

TO CHANGE	TO	MULTIPLY BY
Centimeters	Inches	0.394
Meters.....	Feet.....	3.280
Meters.....	Yards.....	1.094
Kilometers.....	Miles	0.621
Square Centimeters.....	Square Inches	0.155
Square Meters.....	Square Feet.....	10.764
Square Kilometers	Square Miles	0.386
Square Hectometers.....	Acres	2.471
Cubic Meters	Cubic Feet	35.315
Cubic Meters	Cubic Yards.....	1.308
Milliliters.....	Fluid Ounces	0.034
Liters	Pints	2.113
Liters	Quarts	1.057
Liters	Gallons	0.264
Grams.....	Ounces.....	0.035
Kilograms.....	Pounds.....	2.205
Metric Tons	Short Tons.....	1.102
Newton-Meters.....	Pound-Feet	0.738
Kilopascals	Pounds per Square Inch.....	0.145
Kilometers per Liter	Miles per Gallon.....	2.354
Kilometers per Hour.....	Miles per Hour	0.621



PIN: 083908-000

This fine document...

Was brought to you by me:



[Liberated Manuals -- free army and government manuals](#)

Why do I do it? I am tired of sleazy CD-ROM sellers, who take publicly available information, slap “watermarks” and other junk on it, and sell it. Those masters of search engine manipulation make sure that their sites that sell free information, come up first in search engines. They did not create it... They did not even scan it... Why should they get your money? Why are not letting you give those free manuals to your friends?

I am setting this document FREE. This document was made by the US Government and is NOT protected by Copyright. Feel free to share, republish, sell and so on.

I am not asking you for donations, fees or handouts. If you can, please provide a link to liberatedmanuals.com, so that free manuals come up first in search engines:

<A HREF=<http://www.liberatedmanuals.com/>>Free Military and Government Manuals

- Sincerely
Igor Chudov
<http://igor.chudov.com/>
- [Chicago Machinery Movers](#)