

TB 11-6625-928-35

DEPARTMENT OF THE ARMY TECHNICAL BULLETIN

CALIBRATION PROCEDURE FOR TEST FACILITIES KIT MK-994/AR (NSN 6625-00-802-7191)

Headquarters, Department of the Army, Washington, DC
23 February 1979

REPORTING OF ERRORS

You can help improve this publication by calling attention to errors and recommending improvements and stating your reasons for the recommendations. Your letter or DA Form 2028 (Recommended Changes to Publications and Blank Forms) should be mailed direct to Commander, US Army Communications and Electronics Materiel Readiness Command, ATTN: DRSEL-ME-MQ, Fort Monmouth NJ 07703. A reply will be furnished direct to you.

SECTION		Paragraph	Page
I.	IDENTIFICATION AND DESCRIPTION		
	Test instrument identification	1	1
	Calibration data card (DA Form 2416)	2	1
	Calibration description	3	2
II.	EQUIPMENT REQUIREMENTS		
	Equipment required	4	2
	Accessories required	5	2
III.	PRELIMINARY OPERATIONS		
	Preliminary instructions	6	3
	Assembly of test cables B3 and B4	7	3
	Visual inspection of TI	8	4
	Resistance checks of TI	9	5
IV.	CALIBRATION PROCESS		
	Tests of heading dial	10	5
	Tests of heading differential (B1-A)	11	7
	Tests of heading differential (B1-B)	12	7
	Tests of radio bearing pointer (RBP)	13	7
	Tests of steering indicator (M1)	14	9
	Tests of station approach indicator (M2)	15	9
	Tests of signal strength indicator (M3)	16	9
	Tests of compass power flag (M4)	17	9
	Tests of annunciator (M5)	18	9
	Final procedure	19	9

WARNING

Voltages up to 115 volts are present at TB1. DEATH ON CONTACT may result if personnel fail to observe safety precautions.

SECTION I. IDENTIFICATION AND DESCRIPTION

1. Test Instrument Identification. This bulletin provides instructions for calibration of the Test Facilities Kit MK-994/AR. The only equipment in the Test Facilities

Kit MK-994/AR that requires calibration is the Heading-Radio Bearing Indicator ID-1351(*). The ID-1351(*) will be referred to as the TI (test instrument).

NOTE

Heading-Radio Bearing Indicator ID-1351(*) is adjusted, repaired, and aligned at depot avionics maintenance shops only. Under no circumstances will the personnel performing the calibration break the seal on the ID-1351(*).

a. **Model Variations.** ID-1351(*) refers to ID-1351/A, ID-1351A/A or ID-1351B/A. Externally all models of ID-1351(*) are the same. Calibration of all models is identical,

b. **Time and Technique.** The time required for this calibration is approximately 3 hours, using the technique described herein.

2. Calibration Data Card (DA Form 2416). Forms, records, and reports required for calibration personnel at all levels are prescribed by TM 38-750. DA Form 2416 must be annotated in accordance with TM 38-750 for each calibration performed.

3. Calibration Description. TI parameters and performance specifications which pertain to this calibration are listed in table 1.

Table 1. Calibration Description

TI parameters	Performance specifications
Heading dial	Null voltages: 60°, 120°, 180°, 240°, and 300° ±1° 30 minutes
Heading differential	Output voltage: 0 to 10.2 Vac

Table 1. Calibration Description - Continued

TI parameters	Performance specifications
Radio bearing pointer	XMTR No. 1 at 0° Radio bearing pointer at S, ADF pointer tracks XMTR 2
Steering indicator (M1)	Mechanical alignment: When unit is horizontal M1 is aligned with center dot ± 1/64" Electrical alignment: With 75±20 μ amps M1 indicates at first dot. With 150± 12 μ amps M1 is aligned with 2nd dot.
Station approach indicator (M2)	Mechanical alignment: When unit is horizontal M2 aligns with upper dot ± 1/64 inch Electrical alignment: With 75±20 μ amps M2 indicates at center of first dot, with 150±12 μ amps M2 indicates center of second dot.
Signal strength meter (M3)	All black indication: With 22 or less volts applied Alternate black and white indication: With 0.5 volt applied.
Power warning indicator (M4)	As M4 just starts to move out of position multimeter should indicate 20 or more volts. With M4 fully out of sight multimeter indicates 36 volts ±4.

SECTION II. EQUIPMENT REQUIREMENTS

4. Equipment Required. Table 2 identifies the specific equipment used in this calibration procedure. This equipment is available in avionics repair facilities, and is to be used in performing this procedure. Alternate items may be used by the calibrating activity when the equipment listed in table 2 is not available. The items selected must be verified to perform satisfactorily prior to use and must bear evidence of current calibration. The equipment must

meet or exceed the minimum use specifications listed in table 2. The accuracies listed in table 2 provide a four to one ratio between the standard and the TI.

5. Accessories Required. The accessories required in table 2 are issued as indicated in paragraph 4 above and are to be used in this calibration procedure when necessary. These items may be substituted by equivalent items unless specifically prohibited.

Table 2. Minimum Specifications of Equipment Required

Item	Common name	Minimum use specifications	Manufacturer, model, and part number
A1	GYRO SIGNAL SIMULATOR	Must provide 2 independent synchro transmitter outputs, three-wire synchro type, adjustable through 360° and set table to 1 minute of arc.	Simulator, Gyro Compass, signal SM-486/ASN, with correction chart.
A2	VOLTMETER	Range: 0 to 26 Vac Accuracy: ±5%	Multimeter ME-30/U
A3	MULTIMETER	Range volts 0-40 Vdc amperes, 0-230 μa ohms, 0-100 k ohms Accuracy: ±5%	Multimeter AN/USM-223
A4	POWER SUPPLY	Range: volts, 0-40 Vdc amperes, 0-230 μa Accuracy: N/A	Power supply PP-4838/U

Table 3. Accessories Required

Item	Common name	Description and part number
B1	Lead ¹	AWG 20 wire cut in 12 inch lengths
B2	Stopwatch	Must measure from zero to 60 seconds in seconds
B3	Test cable No. 1	Assemble special test cable No. 1 in accordance with figure 1. Cable consists of plug Bendix PT06A-14-15S (SR) four feet 10

Table 3. Accessories Required - Continued

Item	Common name	Description and part number
		conductor cable Double pole, double throw switch 18 connection terminal board.
B4	Test cable No. 2	Test cable No. 2 consists of 30 conductor cable 4 feet long Plug Bendix PT06E-18-32S (RS) 30 connection terminal board.

¹ 16 required.

SECTION III. PRELIMINARY OPERATIONS

6. Preliminary Instructions. *a.* The instructions outlined in this section are preparatory to the calibration process. Personnel should become familiar with the entire bulletin before beginning the calibration.

b. Items of equipment used in this procedure are referenced with the text by common name and item identification number as listed in tables 2 and 3. For the identification of equipment referenced by item numbers

prefixed with A, see table 2, and prefix B, see table 3.

WARNING

HIGH VOLTAGE is used during the performance of this calibration. DEATH ON CONTACT may result if personnel fail to observe precautions.

7. Assembly of test cables B3 and B4. Fabricate the test cables as described in table 3 and figure 1.

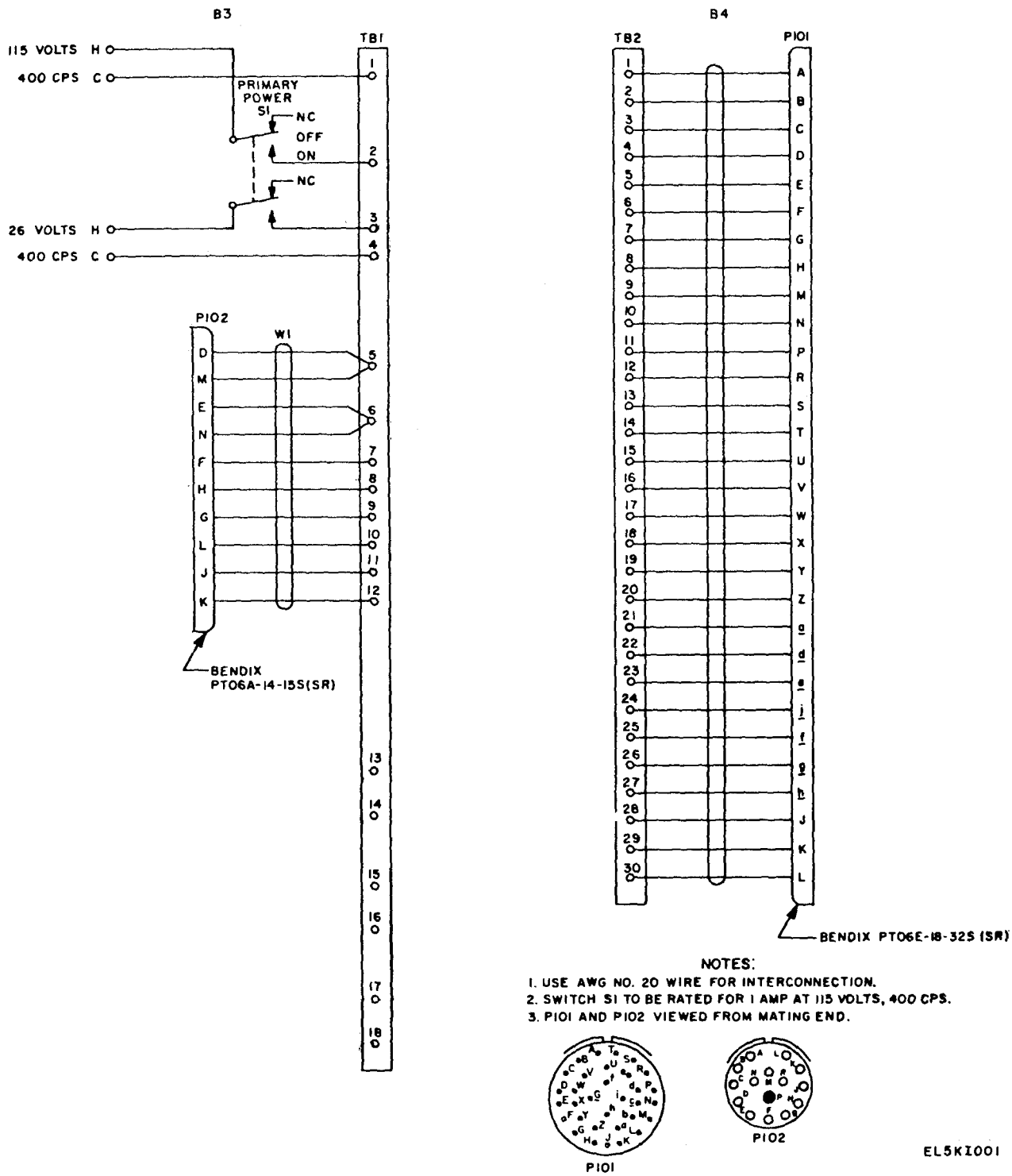
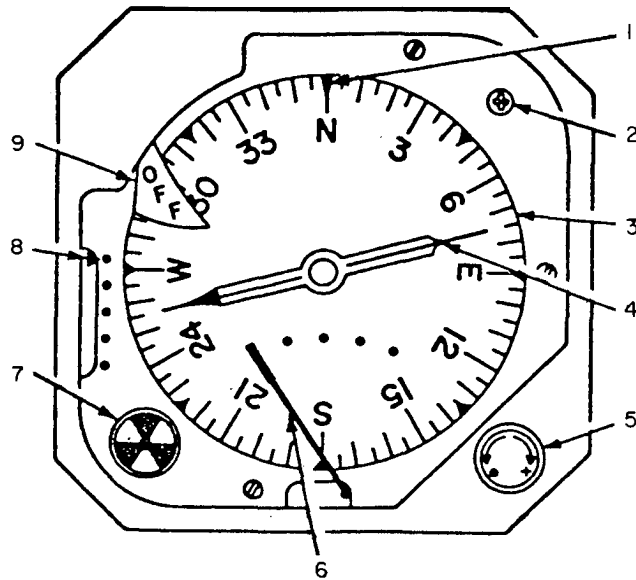

Figure 1. Test cable fabrication.

8. Visual inspection of TI. a. With TI in the normal viewing position (horizontal) observe that the various indicators (fig. 2) align as listed below:



1. MAJOR HEADING INDEX.
2. ANNUNCIATOR (M5).
3. HEADING DIAL.
4. RADIO BEARING POINTER (RBP).
5. SYNCHRONIZING KNOB.
6. STEERING INDICATOR (M1).
7. SIGNAL STRENGTH INDICATOR (M3).
8. STATION APPROACH INDICATOR (M2).
9. COMPASS POWER FLAG (M4).

EL5K1002

Figure 2. Test instrument indicator identification.

(1) Steering indicator (M1) aligns with center dot of scale $\pm 1/64$ inch.

(2) Station approach indicator (M2) aligns with upper most dot of scale $\pm 1/64$ inch.

(3) On the annunciator (M5) there will be no more than $1/64$ inch of either the dot or cross visible.

b. With the TI in any position the various indicators will align within $1/32$ inch of indications specified in a(1)

through (3) above.

9. Resistance checks of TI. *a.* Using multimeter (A3) measure the resistance between J1-j and both halves of TI case. The resistance will be no more than 5 ohms.

b. Using multimeter measure the resistance between J1-A and J1-j and between J1-B and J1-j. The resistance will be no less than 100,000 ohms.

SECTION IV. CALIBRATION PROCESS

NOTE

Unless otherwise specified, verify the results of each test and if the equipment fails to meet the test requirement, it will be returned to the depot

for repair without further testing.

10. Tests of Heading Dial. *a.* Connect equipment as shown in figure 3.

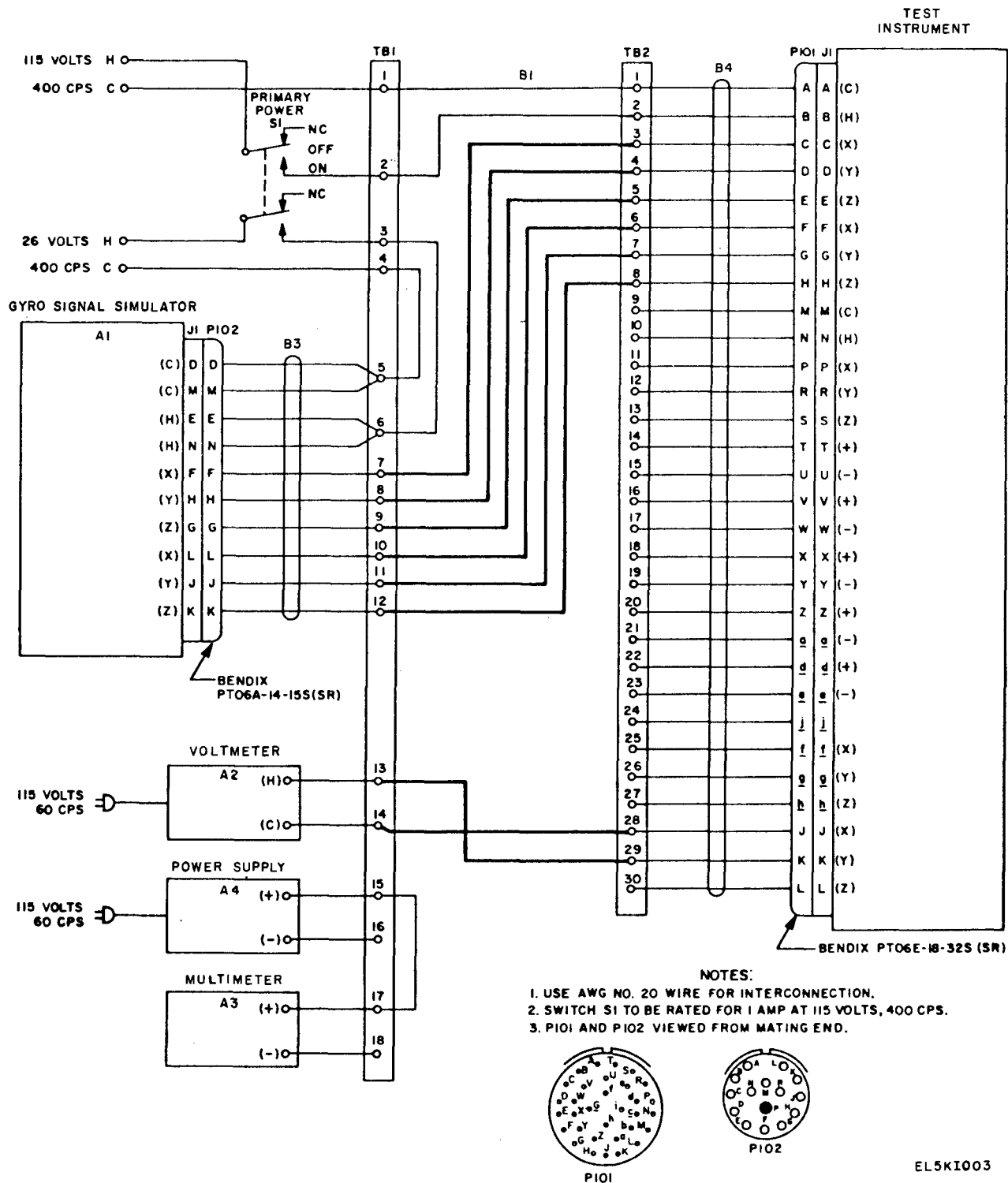

Figure 3. Heading dial setup.

- b. Set Gyro Signal Simulator (A1) COMP. Gyro # 2 switch to GYRO # 2 and adjust XMTR 1 (GYRO XMTR # 1) and XMTR 2 (COMPASS & GYRO XMTR # 2) for 0°.
- c. Set primary power S1 to ON.
- d. Adjust the TI synchronizing knob to obtain a null on

voltmeter (A2). The heading dial will be aligned with the major heading index (0°) ± 1.5°.

e. Adjust XMTR 1 for an increasing heading. The heading dial will rotate counterclockwise.

f. Adjust the TI synchronizing knob clockwise. The heading dial will rotate counterclockwise.

g. Set XMTR 1 to 0° .
 h. Adjust the TI synchronizing knob to obtain each of the voltmeter nulls listed in table 4. For each null position, the amount of rotation of XMTR 1 needed to set the heading dial to the corresponding heading will be $0^\circ \pm 1^\circ$, 30 minutes. Tap the TI prior to taking any readings. Return XMTR 1 to 0° after each step and make test connection changes as indicated.

i. Set XMTR 1 to 0° .

j. Adjust the TI synchronizing knob to align the heading dial N mark with the major index.

k. Set primary power S1 to OFF.

l. Set XMTR 1 to 170° .

m. Set primary power S1 to ON. The time required for the heading dial to come to rest at 170° as measured with stopwatch (B2) will be no more than 8 seconds.

n. Rotate XMTR 1, causing heading dial to rotate through 360° , at a rate of approximately 2-revolutions-per-minute. Any sticking or binding will not cause the heading dial to lag the XMTR 1 indication by more than 3° .

11. Tests of Heading Differential (B1-A). a. Remove the voltmeter (A2) leads from TB 2-29 and TB 2-30 and connect them to TB 2-25 and TB 2-27.

b. Set XMTR 1 to 0° . Adjust the TI synchronizing knob to align the heading dial N mark with the major heading index. The voltmeter will indicate approximately 10.8 volts.

Table 4. Heading Dial Check

Voltmeter Connection TB2	TI Heading Dial Indication
28 to 30	$60^\circ \pm 1^\circ$, 30 minutes
29 to 30	$120^\circ \pm 1^\circ$, 30 minutes
28 to 29	$180^\circ \pm 1^\circ$, 30 minutes
28 to 30	$240^\circ \pm 1^\circ$, 30 minutes
29 to 30	$300^\circ \pm 1^\circ$, 30 minutes

c. Slowly adjust XMTR 1 from 0° to 30° . The indication of the voltmeter will increase.

d. Reset XMTR 1 to 0° .

e. Slowly rotate the TI synchronizing knob approximately 1/4 turn clockwise. The indication of the voltmeter will increase.

12. Tests of Heading Differential (B1-B). a. Remove the voltmeter (A2) leads from TB 2-25 and TB 2-27 and connect them to TB 2-28 and TB 2-30.

b. Adjust the TI synchronizing knob to align the heading dial N mark with the major heading index. The voltmeter will indicate approximately 10.2 volts.

c. Slowly adjust XMTR 2 from 0° to 30° . The indication of the voltmeter will increase.

d. Reset XMTR 2 to 0° .

e. Slowly rotate the TI synchronizing knob approximately 1/4 turn clockwise. The indication of the voltmeter will decrease.

f. Set primary power S1 to OFF.

13. Tests of Radio Bearing Pointer (RBP). a. Connect equipment as shown in figure 4.

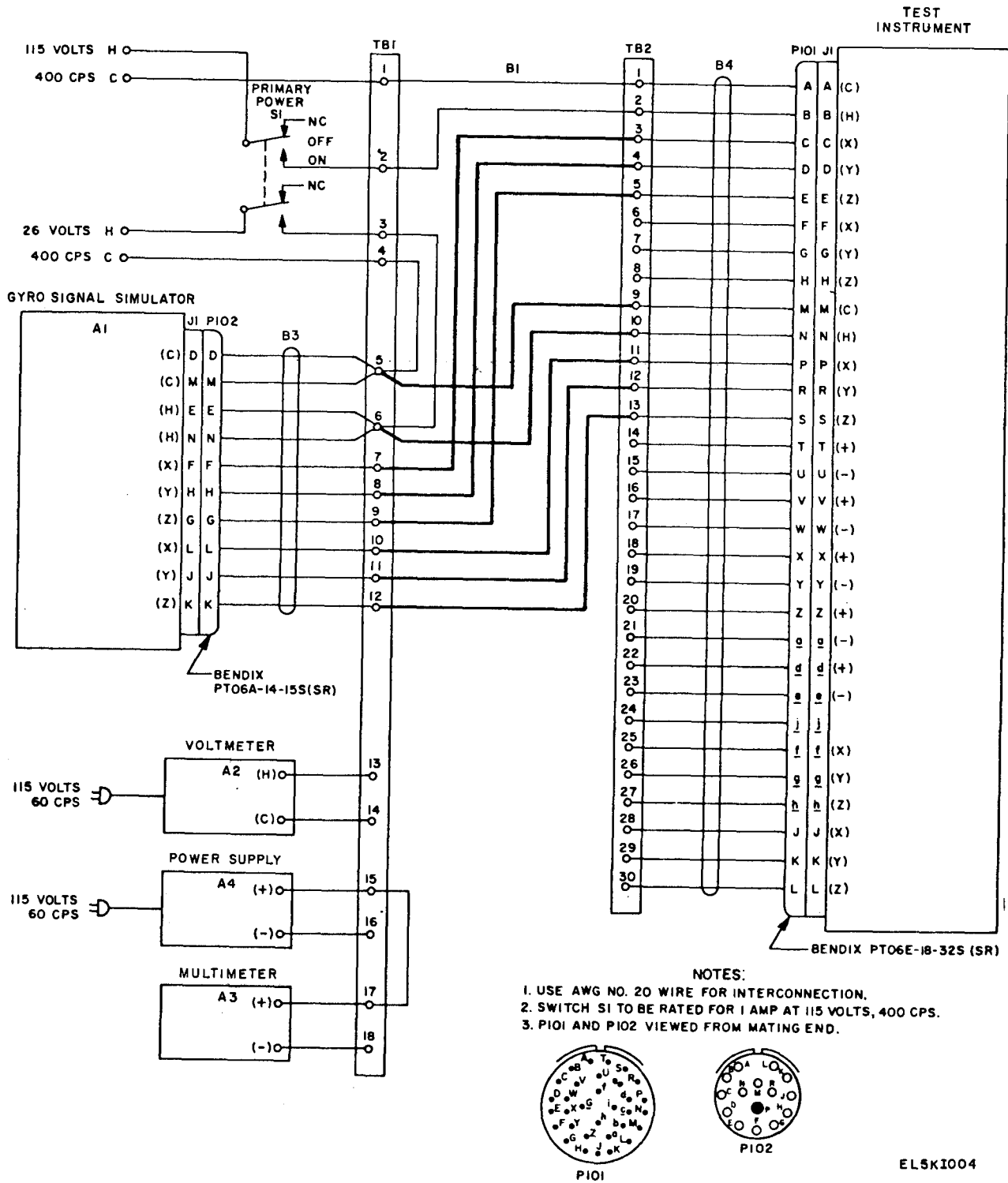

Figure 4. Radio bearing pointer test setup.

- b. Set primary power S1 to ON.
- c. Adjust XMTR 1 to set the heading dial to N.
- d. Adjust XMTR 2 to set the RBP to the heading dial S mark. XMTR 2 will indicate $0^\circ \pm 1^\circ, 15$ minutes.
- e. Adjust XMTR 2 for an increasing heading. The RBP will rotate in the direction of increasing heading.
- f. Adjust XMTR 2 to set the RBP to each of the set-

tings listed in table 5. In each case, XMTR 2 will indicate as shown.

- g. Set XMTR 2 to 180° .
- h. Set primary power S1 to OFF.
- i. Set XMTR 2 to 10° .
- j. Set primary power S1 to ON. The time required for the RBP to come to rest at 190° as measured with stop-

watch (B2) will be no more than 8 seconds.

k. Rotate XMTR 2, causing the RBP to rotate through 360° at a rate of approximately 2-revolutions-per-minute. Any sticking or binding will not cause the RBP to lag the XMTR 2 indication by more than 3° (183° including phase difference).

l. Set primary power S1 to OFF.

14. Tests of Steering Indicator (M1). a. Set multimeter (A3) to current function.

b. Energize the power supply (A4) and increase output until steering indicator (M1) aligns with the first dot clockwise from center. The multimeter will indicate between 55 and 95 µa.

Table 5. Radio Bearing Pointer Check

Test Instrument Radio Bearing Pointer Indication	Gyro Signal Simulator XMTR 2 Indication
W	90° ± 1°, 15 minutes
N	180° ± 01, 15 minutes
E	270° ± 1°, 15 minutes

c. Continue to increase the power supply output until steering indicator (M1) aligns with the second dot clockwise from center. The multimeter will indicate between 138 and 162 µa.

d. Set the power supply for a 0-volt output, and reverse the connections to TB 2-14 and TB 2-15.

e. Adjust the power supply output until steering indicator (M1) aligns with the first dot counterclockwise from center. The multimeter will indicate between 55 and 95 µa.

f. Continue to increase the power output until steering indicator (M1) aligns with the second dot counterclockwise from center. The multimeter will indicate between 138 and 162 µa.

g. Set the power supply output for 0 volt.

15. Tests of Station Approach Indicator (M2). a. Disconnect the lead (B1) connected to TB 2-14 and connect it to TB 2-17. Disconnect the lead connected to TB 2-15 and connect it to TB 2-16.

b. Adjust the power supply (A4) output until station approach indicator (M2) aligns with the center dot of the scale. The multimeter (A3) will indicate between 55 and 95 µa.

c. Adjust the power supply output until station approach indicator (M2) aligns with the bottom of the scale. The multimeter will indicate between 138 and 162 µa.

d. Set the power supply for 0-volt output.

16. Tests of Signal Strength Indicator (M3). a. Disconnect the lead (B1) connected to TB 2-16 and connect it to TB 2-19. Disconnect the lead connected to TB 2-17 and

connect it to TB 2-19. Remove the lead connected between TB 1-15 and TB 1-17. Connect a new lead between TB 1-15 and TB 2-18. Connect a new lead between TB 1-17 and TB 2-18.

b. Adjust the power supply (A4) output until signal strength indicator (M3) energizes and shows all black. The multimeter (A3) will indicate no more than 22 volts.

c. Slowly reduce the power supply output until signal strength indicator (M3) deenergizes and shows alternating black and red segments. The multimeter will indicate no less than 0.5 volts.

d. Set the power supply for a 0-volt output.

17. Tests of Compass Power Flag (M4). a. Disconnect the leads (B1) connected to TB 2-18 and connect them to TB 2-20. Disconnect the leads connected to TB 2-19 and connect them to TB 2-21.

b. Adjust the power supply output until compass power flag (M4) just begins to move toward the out-of-view position. The multimeter (A3) will indicate no less than 20 volts.

c. Increase the power supply output until compass power flag (M4) is fully out of view against the stop. The multimeter will indicate between 32 and 40 volts.

d. Set the power supply for a 0-volt output.

18. Tests of Annunciator (M5). a. Reconnect equipment as shown in figure 4.

b. Disconnect lead connected to TB 2-14 and connect it to TB 2-22. Disconnect lead connected to TB 2-15 and connect it to TB 2-23.

c. Set the multimeter (A3) to the current range.

d. Adjust the power supply (A4) output until the multimeter indicates 140 microamperes. Annunciator (M5) cross will not be in full view.

e. Increase the power supply output until annunciator (M5) cross is in full view. The multimeter will indicate between 170 and 230 µa.

f. Set the power supply for a 0-volt output, and reverse connections to TB 2-22 and TB 2-23.

g. Repeat d and e above.

h. Set power supply for a 0-volt output.

19. Final Procedure. a. Deenergize and disconnect all equipment.

b. In accordance with TM 38-750, annotate and affix DA Label 80 (US Army Calibration System) to the front of the MK-994/AR. When the TI is not within the specified tolerances, annotate and affix DA Form 2417 (Unserviceable or Limited Use) tag and return TI to the depot for repair.

By Order of the Secretary of the Army:

BERNARD W. ROGERS
General, United States Army
Chief of Staff

Official:

J. C. PENNINGTON
Major General, United States Army
The Adjutant General

DISTRIBUTION:

To be distributed in accordance with DA Form 12-36A, Calibration Procedure requirements for MK-994 ()/AR.

This fine document...

Was brought to you by me:



[Liberated Manuals -- free army and government manuals](#)

Why do I do it? I am tired of sleazy CD-ROM sellers, who take publicly available information, slap “watermarks” and other junk on it, and sell it. Those masters of search engine manipulation make sure that their sites that sell free information, come up first in search engines. They did not create it... They did not even scan it... Why should they get your money? Why are not letting you give those free manuals to your friends?

I am setting this document FREE. This document was made by the US Government and is NOT protected by Copyright. Feel free to share, republish, sell and so on.

I am not asking you for donations, fees or handouts. If you can, please provide a link to liberatedmanuals.com, so that free manuals come up first in search engines:

<A HREF=<http://www.liberatedmanuals.com/>>Free Military and Government Manuals

- Sincerely
Igor Chudov
<http://igor.chudov.com/>
- [Chicago Machinery Movers](#)