

NORMAL

MWO effective date 1 June 1992 and completion date 30 May 1994

MWO 9-2320-279-20-3

MODIFICATION WORK ORDER

MODIFICATION OF M977 SERIES HEAVY EXPANDED MOBILITY TACTICAL TRUCK (HEMTT) INSTALLATION INSTRUCTIONS FOR NATO SLAVE RECEPTACLE RELOCATION

MODEL	NSN
TRUCK, CARGO W/WINCH M977	2320-01-097-0260
TRUCK, CARGO, W/O WINCH M977	2320-01-099-6426
TRUCK, TANK, FUEL, W/WINCH M978	2320-01-097-0249
TRUCK, TANK, FUEL, W/O WINCH M978	2320-01-100-7672
TRUCK, TRACTOR, W/WINCH, W/CRANE M983	2320-01-099-6421
TRUCK, TRACTOR, W/WINCH, W/O CRANE M983	2320-01-097-0247
TRUCK, WRECKER, W/WINCH M984	2320-01-097-0248
TRUCK, WRECKER, W/WINCH M984A1	2320-01-195-7641
TRUCK, CARGO, W/WINCH M985	2320-01-097-0261
TRUCK, CARGO, W/O WINCH M985	2320-01-100-7673
TRUCK, CARGO, W/WINCH M985E1	2320-01-194-7032
TRUCK, CARGO, W/O WINCH M985E1	2320-01-194-7031

HEADQUARTERS, DEPARTMENT OF THE ARMY, WASHINGTON, DC
1 JULY 1992

REPORTING OF ERRORS AND RECOMMENDING IMPROVEMENTS

You can help improve this MWO. If you find any mistakes or if you know a way to improve the procedures, please let us know. Write a letter, or complete and mail in a DA Form 2028 (Recommended Changes to Publications and Blank Forms), direct to: Commander, U.S. Army Tank-Automotive Command, Attn: AMSTA-MB, Warren. MI 48397-5000. A reply will be furnished to you.

Approved for public release; distribution is unlimited.

CHANGE

NO. 1

HEADQUARTERS
DEPARTMENT OF THE ARMY
Washington D. C., 1 November 1992

MODIFICATION WORK ORDER
MODIFICATION OF M977 SERIES HEAVY EXPANDED MOBILITY
TACTICAL TRUCK (HEMTT)
INSTALLATION INSTRUCTIONS FOR
NATO SLAVE RECEPTACLE RELOCATION

MODEL	NSN
TRUCK, CARGO, W/WINCH, M977	2320-01-097-0260
TRUCK, CARGO, W/O WINCH, M977	2320-01-099-6426
TRUCK, TANK, FUEL, W/WINCH, M978	2320-01-097-0249
TRUCK, TANK, FUEL, W/O WINCH, M978	2320-01-100-7672
TRUCK, TRACTOR, W/WINCH, W/CRANE, M983	2320-01-099-6421
TRUCK, TRACTOR, W/WINCH, W/O CRANE, M983	2320-01-097-0247
TRUCK, WRECKER, W/WINCH M984	2320-01-097-0248
TRUCK, WRECKER, W/WINCH M984A1	2320-01-195-7641
TRUCK, CARGO, W/WINCH, M985	2320-01-097-0261
TRUCK, CARGO, W/O WINCH, M985	2320-01-100-7673
TRUCK, CARGO, W/WINCH, M985E1	2320-01-094-7032
TRUCK, CARGO, W/O WINCH, M985E1	2320-01-094-7031

MWO 9-2320-279-20-3 dated 1 July 1992, is changed as follows:

1. Remove old pages and insert new pages as indicated below.
2. New or changed information is indicated by a vertical bar in the margin of the page.
3. Minor changes to illustrations are indicated by a miniature pointing hand.
4. Illustrations that are new or that have major revisions are indicated by a vertical bar adjacent to the illustration identification number,

Remove Pages

Insert Pages

Cover and 2

Cover and 2

3. File this change sheet in front of the publication for reference purposes.

By Order of the Secretary of the Army:

GORDON R. SULLIVAN
General, United States Army
Chief Of Staff

Official:

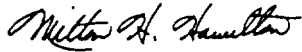

MILTON H. HAMILTON
Administrative Assistant to the
Secretary of the Army

03243

Distribution:

To be distributed in accordance with DA Form 12-38-E (Block 0867) Unit maintenance requirements for MWO 9-2320-279-20-3.

1. **PURPOSE.** The relocation of the NATO slave receptacle contained in this MWO is intended to increase its reliability by correcting inherent deficiencies, The new location will prevent moisture and contaminants from shorting out the receptacle.
2. **PRIORITY.** This modification is classified as NORMAL.
3. **END ITEM TO BE MODIFIED.** Refer to Table 1.

Table 1. End Items to be Modified

Nomenclature	NSN	PN	CAGE	Model	Serial No. Range
Truck, Cargo, w/Winch	2320-01-097-0260	XM977WW	19207	M977	} 20001-20009 20011-20055 20501-22773 22775-24667 24669-24700 24702-24731 24733-24751 24753-24769 24771-24798 24800-26720
Truck, Cargo, w/o Winch	2320-01-099-W26	XM977WOW	19207	M977	
Truck, Tank, Fuel, w/Winch	2320-01-097-0249	XM978WW	19207	M978	
Truck, Tank, Fuel, w/o Winch	2320-01-100-7672	XM978WOW	19207	M978	
Truck, Tractor, w/Winch, w/Crane	2320-01-099-EM21	XM983WC	19207	M983	
Truck, Tractor, w/Winch, w/o Crane	2320-01-097-0247	XM983WOC	19207	M983	
Truck, Wrecker, w/Winch	2320-01-097-0248	XM984WW	19207	M984	
Truck, Wrecker, w/Winch	2320-01-195-7641	XM984A1WW	19207	M984A1	
Truck, Cargo, w/Winch	2320-01-097-0261	XM985WW	19207	M985	
Truck, Cargo, w/o Winch	2320-01-100-7673	XM985WOW	19207	M985	
Truck, Cargo, w/Winch (GTM)	2320-01-194-7032	XM985E1WW	19207	M985E1	
Truck, Cargo, w/o Winch	2320-01-194-7031	XM985E1WOW	19207	M985F1	

*Serial numbers pertain to all models.

4. **MODULE (COMPONENTS, ASSEMBLIES, SUBASSEMBLIES, BOARDS, AND CARDS) TO BE MODIFIED.** Not applicable.
5. **PARTS TO BE MODIFIED.** The following item, whether installed or in depot stock, shall be modified prior to issue and shall be marked so that it can be easily determined that modification has been accomplished. Refer to Table 2.

Table 2. Parts to be Modified

NOMENCLATURE	NSN	PN	CAGE
NATO Slave Receptacle	5935-01-059-0117	11674728	19207

6. **APPLICATION.**

- a. Time Compliance Schedule. The effective date of this MWO is 1 June 1992 and its completion date is 30 May 1994.
- b. Lowest Level of Maintenance Authorized to Apply the MWO: Unit.
- c. Work Force and Man-Hour Requirements for Application of this MWO to a Single Unit, End Item or System is as follows:

REQUIREMENTS

WORK FORCE/SKILLS

MAN-HOURS

Heavy Wheeled Vehicle Mechanic
(MOS 63S) (1)

1.0

Total man-hours required for a single application of this MWO is one hour.

7. TECHNICAL PUBLICATIONS AFFECTED/CHANGED. Refer to Table 3.

Table 3. Publications Affected

Publication	Date
TM 9-2320-279-10-1	November 1986
TM 9-2320-279-20-1	April 1987
TM 9-2320-279-20-2	April 1987
TM 9-2320-279-20P	March 1988
TM 9-2320-279-34P	March 1988

8. MWO KITS/PARTS AND THEIR DISPOSITION.

a. Kits/Parts Needed to Apply this MWO.

(1) The parts listed in Table 4 are required to accomplish this MWO.

Table 4. Part and Security Classification

Nomenclature	NSN	PN	CAGE	Qty	Classification
NATO Slave Receptacle MWO Kit	4935-01-264-3172	5705741	19207		
Consists of:					
Box, electrical (Includes box, cover, gasket, four #10-32 screws)		A-40445C	00843	1	Unclassified
Battery cable, positive (+)		12357906-1	19207	1	Unclassified
Battery cable, negative (-)		12357906-2	19207	1	Unclassified
Grommet, rubber		MS35489-49	96906	2	Unclassified
Capscrew, hex		MS90725-31	96906	4	Unclassified
Nut, hex		MS51922-9	96906	4	Unclassified
Clip, cushion		MS21333-129	96906	1	Unclassified
Screw, machine, pan head		MS35206-267	96906	4	Unclassified
Washer, flat		MS27183-42	96906	4	Unclassified
Nut, hex	MS17829-3C	96906	4	Unclassified	

(2) Kit shipping data:

b. Contents of MWO Kits: Refer to Table 4.

c. Bulk and Expendable Material: Not applicable.

d. Parts Disposition: Not applicable.

9. SPECIAL TOOLS; JIGS; TEST MEASUREMENT AND DIAGNOSTIC EQUIPMENT (TMDE); AND FIXTURES REQUIRED. Not applicable.

10. MODIFICATION PROCEDURES.

a. Battery Removal.

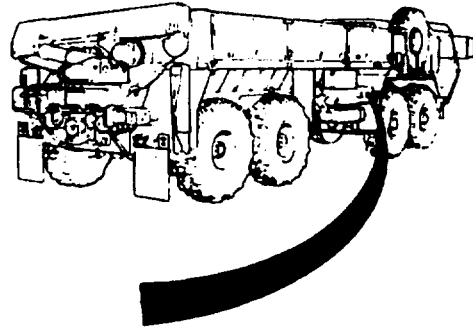
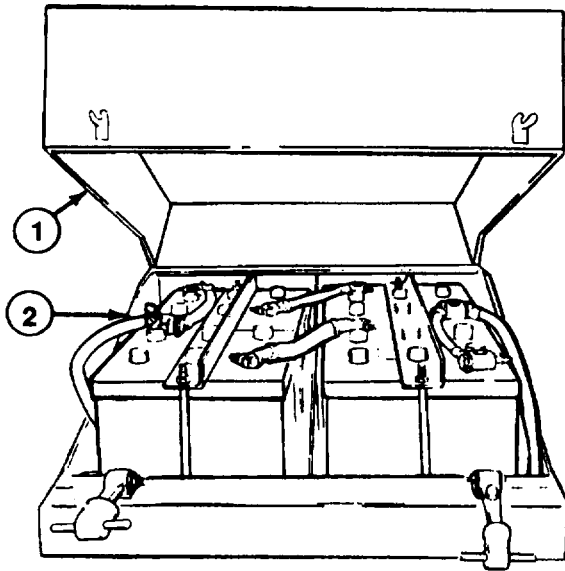

- (1) Remove battery box cover (1) from battery box (2).

WARNING

Batteries produce explosive gases. To prevent injury to personnel, keep sparks and flame away. DO NOT smoke near batteries.

- (2) Remove two nuts (3) and screws (4).

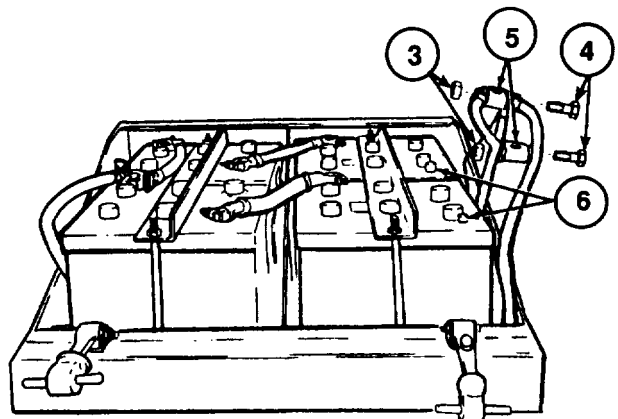

CAUTION

DO NOT pry between terminals and top of battery. Prying can cause damage to battery case. If the cable cannot be removed by hand from the post, use a terminal remover tool.

- (3) Disconnect two negative terminals (5) from battery posts (6).
- (4) Remove one nut (7), lockwasher (8), and screw (9) from rear terminal (5).
- (5) Remove three negative battery cables (10) and STE/ICE wire (11) from terminal (5).

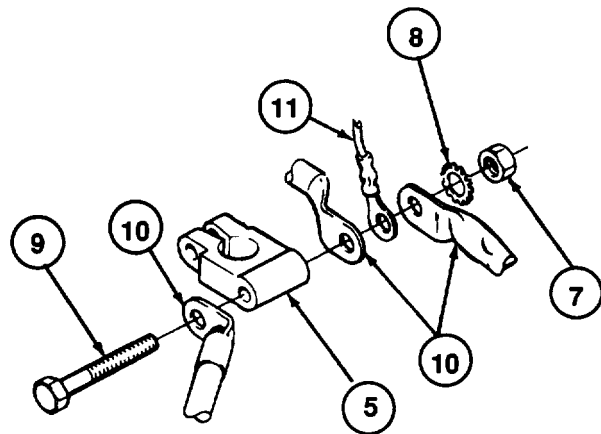

- (9) Remove three positive battery cables (19) and STE/ICE wire (20) from terminal (14).

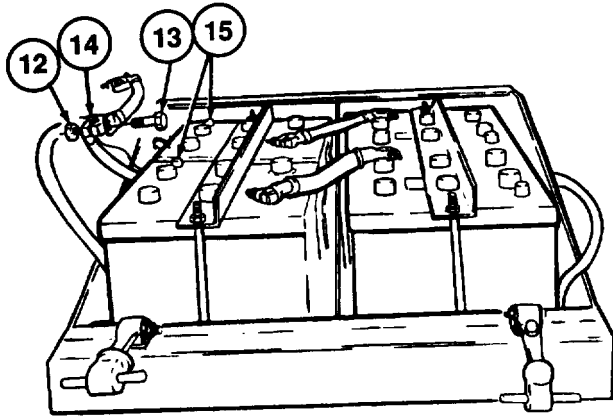

- (6) Remove two nuts (12) and screws (13).

CAUTION

DO NOT pry between terminals and top of battery. Prying can cause damage to battery case. If the cable cannot be removed by hand from the post, use a terminal remover tool.

- (7) Disconnect two positive cable terminals (14) from battery posts (15).

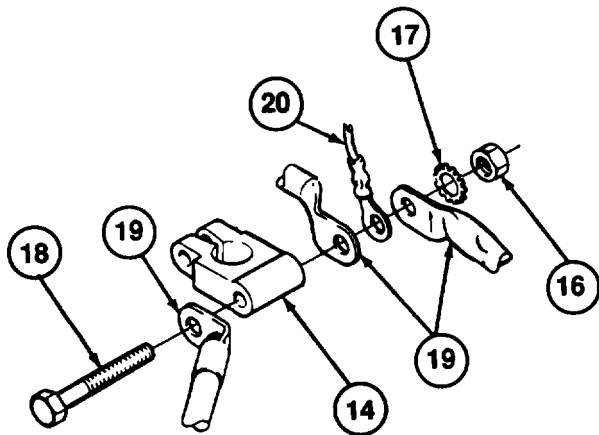

- (8) Remove one nut (16), lockwasher (17), and screw (18) from front terminal (14).

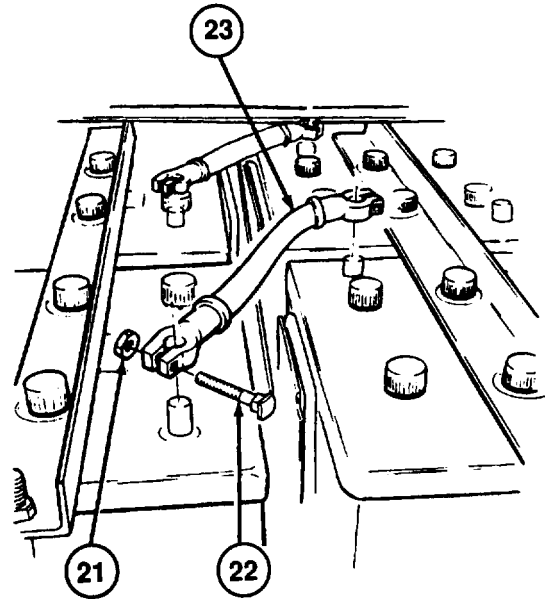

- (10) Remove two nuts (21), screws (22), and jumper cable assembly (23).

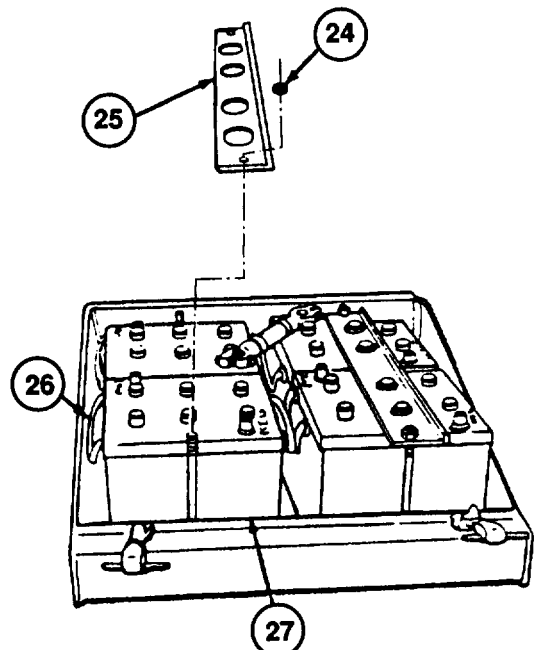

- (11) Remove two nuts (24) and one bracket (25).

- (12) Using handles (26), lift out one front battery (27).

b. NATO Receptacle Removal.

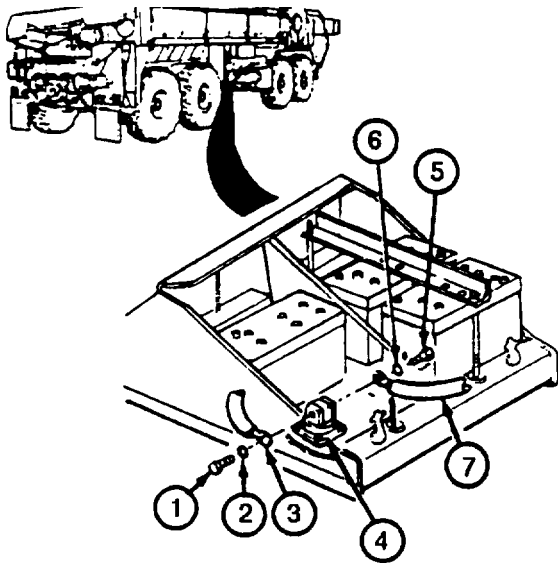

- (1) Remove screw (1), lockwasher (2), and positive battery cable (3) from NATO receptacle (4).
- (2) Remove screw (5), lockwasher (6), and negative battery cable (7) from NATO receptacle (4).
- (3) Discard positive battery cable (3) and negative battery cable (7).

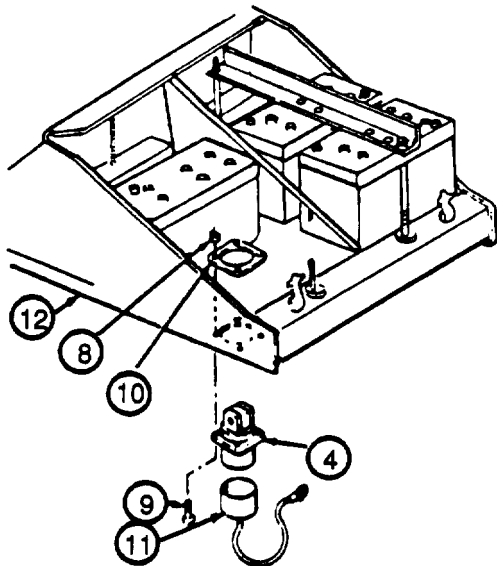

- (4) Remove four locknuts (8), screws (9), and NATO receptacle (4). Discard locknuts and screws.

- (5) Remove top plate (10) and cover (11).

c Installation of NATO Slave Box on Left Front Fender.

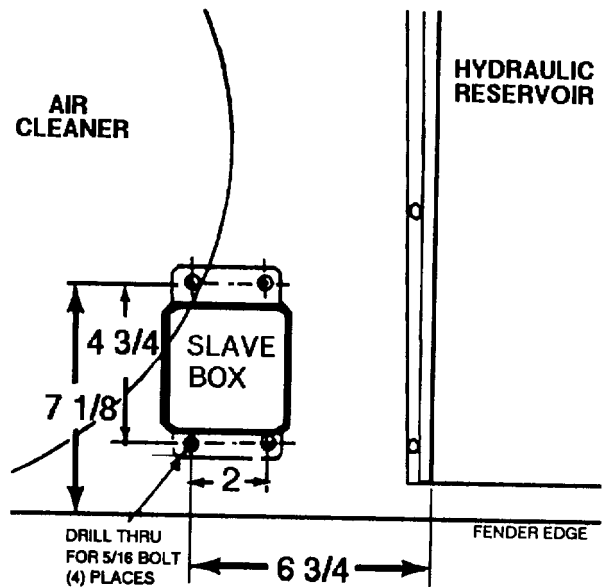
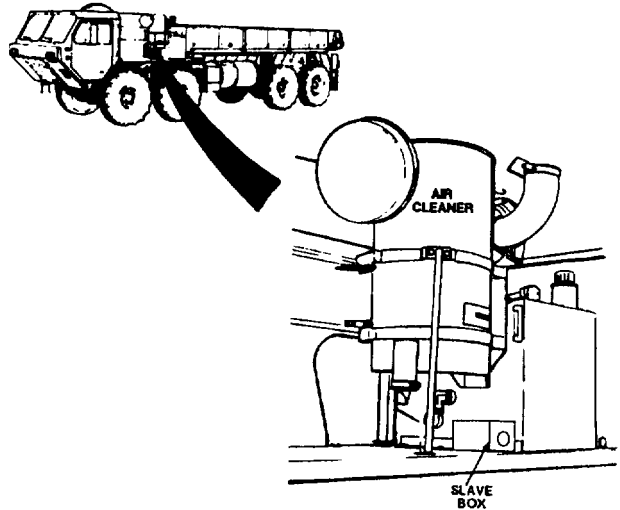

NOTE

In some models it may be easier to drill holes from the underside of the fender,

- (1) Use the slave box as a hole location template. Place It on the left front fender as shown. Mark the four mounting holes, Remove the slave box and drill four holes for 5/16 inch mounting screws.

- (2) Place the slave box back on the fender. Install the four mounting screws (5/1 6-18x5/8) and enlarge mounting holes, if required, to remove any interference. Remove the slave box for installation of cables and NATO receptacle.

d. Assembly of NATO Receptacle.

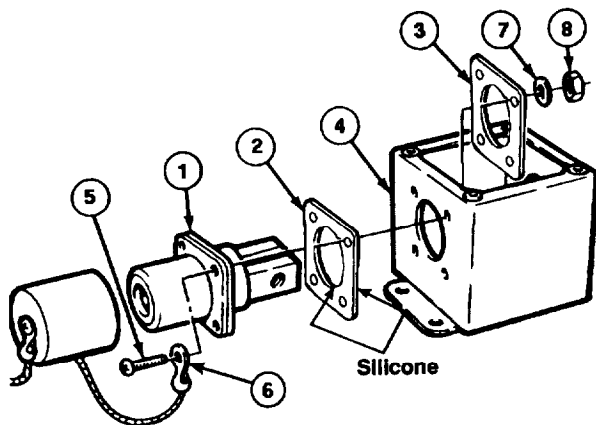

WARNING

Adhesives, solvents, and sealing compounds can burn easily, can give off harmful vapors, and are harmful to skin and clothing. To avoid injury or death, keep away from open fire and use in well-ventilated area. If adhesive, solvent, or sealing compound gets on skin or clothing, wash immediately with soap and water.

- (1) Apply silicone adhesive sealant (item 1, Table 5) to both sides of insulator (2) and install NATO receptacle (1), insulator, and plastic gasket (3) in box (4).

NOTE

Install plastic gasket (3) so that bosses on the gasket are next to the four washers (7).

- (2) Install four screws (#10-24X1) (5), one through cap assembly lead (6), four washers (7), and four locknuts (8) in NATO receptacle (1).

NOTE

When installing receptacle, make sure positive terminal (+) is on the right side of the box (viewed with the NATO receptacle facing you). Positive terminal is identified by a (+) sign.

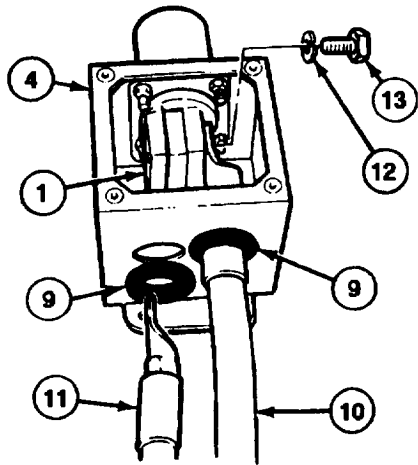

- (3) Install two grommets (9) in box (4).

TABLE 5. Supplies

ITEM	NATIONAL STOCK NUMBER	DESCRIPTION
1	8040-00-995-0590	Adhesive-Sealant, Silicone RTV, General Purpose (MIL-A-46106A)
2	9150-00-065-0029	Grease, Automotive and Artillery GAA (MIL-G-10924)
3		Ties, Cable, Plastic (MIL-S-29190)

- (4) Apply grease (item 2, Table 5) to two grommets (9). Insert negative battery cable (10) and positive battery cable (11) through grommets and into box as shown below.

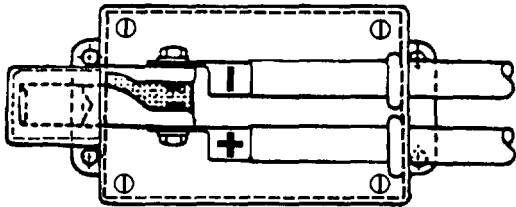

- (5) Install two battery cables (10) and (11) on receptacle (1) and secure each with lockwashers (12) and screws (13).

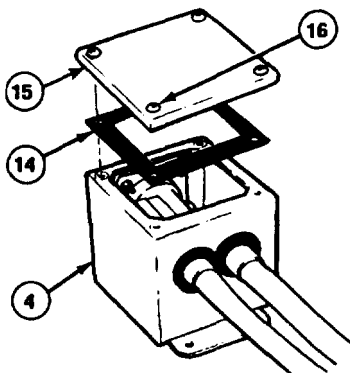

WARNING

Adhesives, solvents, and sealing compounds can burn easily, can give off harmful vapors, and are harmful to skin and clothing. To avoid injury or death, keep away from open fire and use in well-ventilated area. If adhesive, solvent, or sealing compound gets on skin or clothing, wash immediately with soap and water.

- (6) Apply silicone adhesive sealant to both sides of gasket (14) and install gasket in cover (15).

- (7) Install cover (15) on box (4) with four screws (#10-32) (16).

- e. Installation of NATO Slave Receptacle and Box.

NOTE

Install ties (item 3, Table 5) as necessary.

- (1) Open engine cover on driver's side and remove engine cover side panel.

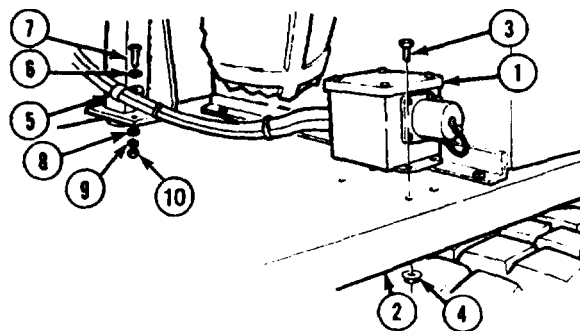
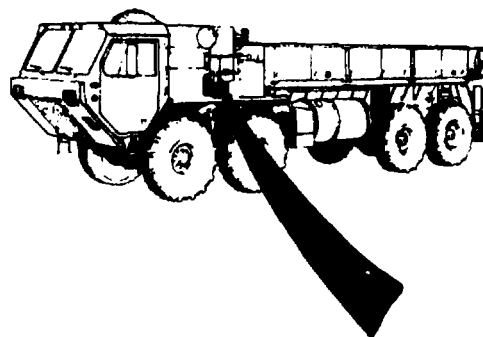

- (2) Mount slave box (1) on fender (2) with four 5/16 bolts (3) and four locknuts (4).

- (3) Install cushion clip clamp (5) (furnished with kit), washer (6), screw (7), washer (8), lockwasher (9), and nut (10).

NOTE

If equipped with 6TL (green) batteries, the batteries will be turned 90 degrees from illustration.

- (1) Install one front battery (1) in battery box (2).

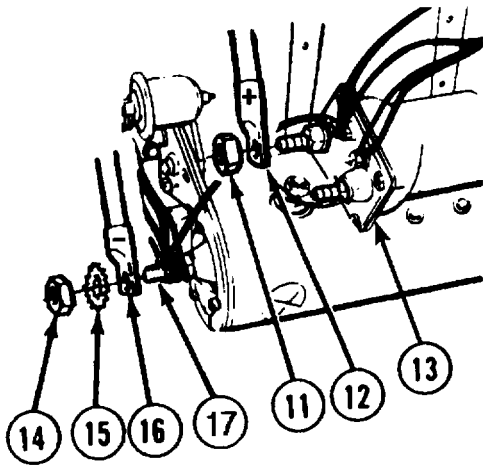

- (4) Remove nut (11) and install positive battery cable from NATO slave box (12) on solenoid (13). Reinstall nut (11).
- (5) Remove nut (14) and lockwasher (15), and install negative battery cable (16) from NATO slave box on starter (17). Reinstall lockwasher (15) and nut (14).
- (6) Install engine cover side panel and close engine cover.

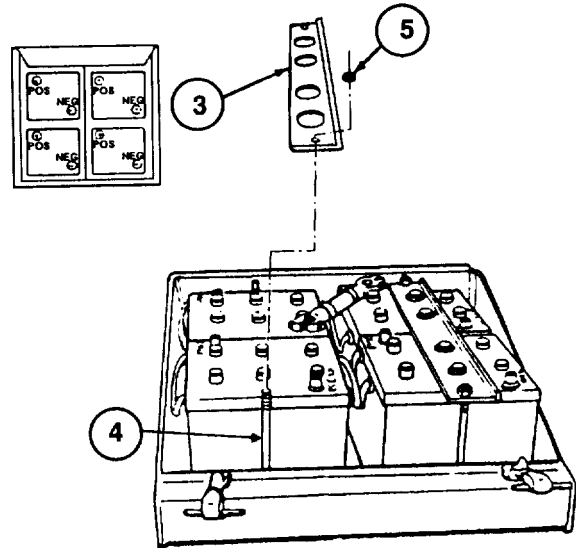

f. Installation of Battery.

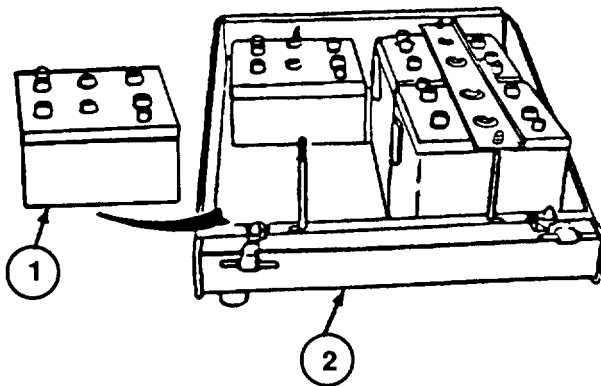

WARNING

Batteries produce explosive gases. To prevent injury to personnel, keep sparks and flame away. DO NOT smoke near batteries.

- (2) Install one bracket (3) over carriage bolts (4) with two nuts (5).

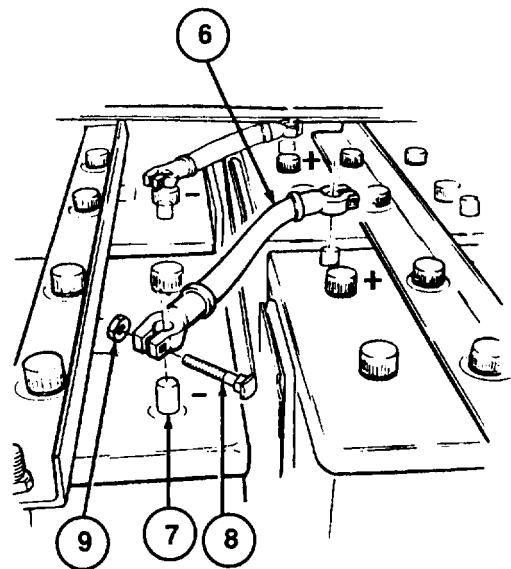

- (3) Install one jumper cable assembly (6) on two battery posts (7) with two screws (8) and nuts (9).

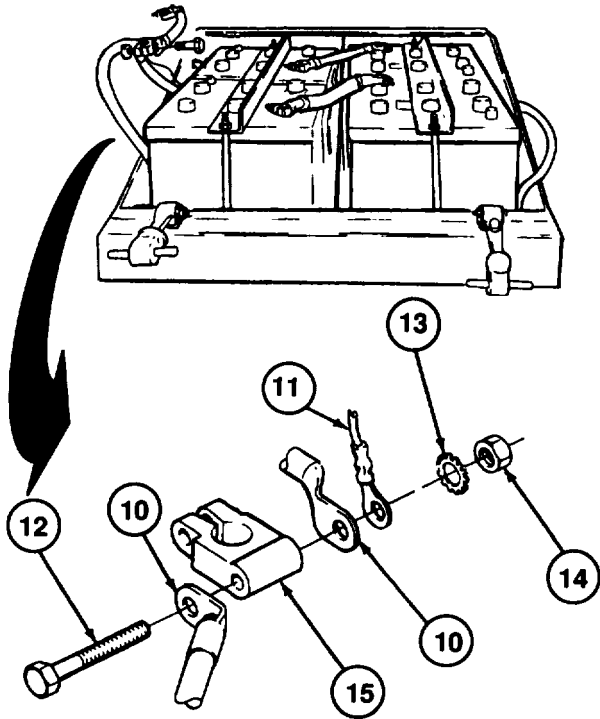

NOTE

STE/ICE wire is connected to front battery terminal. There is only one cable connected to rear terminal.

- (4) Install two positive battery cables (10) and STE/ICE wire (11) with screw (12), lockwasher (13), and nut (14) on terminal (15).

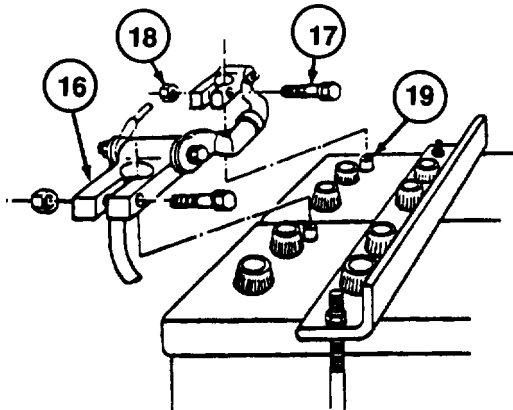

- (5) Install two terminals (16) with two screws (17) and nuts (18) on battery posts (19).

NOTE

STE/ICE wire is connected to rear battery terminal. There is only one cable connected to front terminal.

- (6) Install two negative battery cables (20) and STE/ICE wire (21) with screw (22), lockwasher (23), and nut (24) on terminal (25).

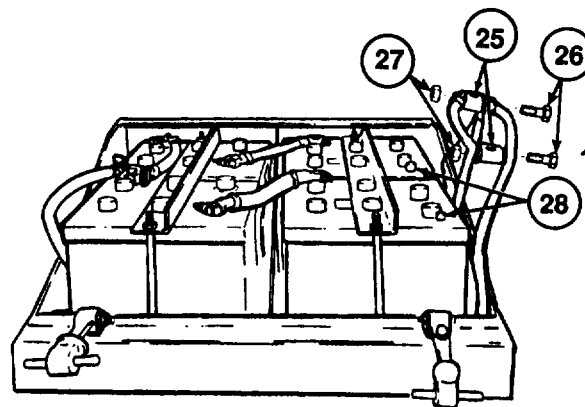
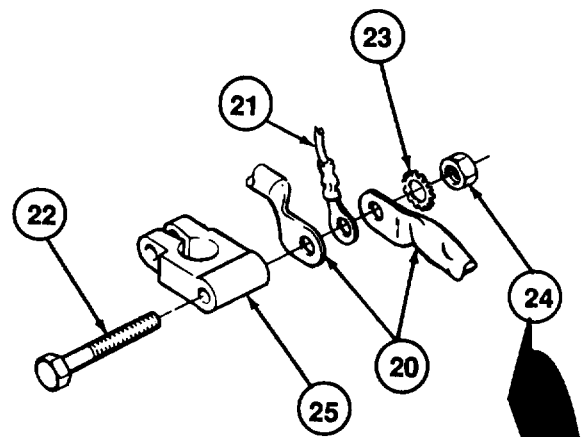

- (7) Install two terminals (25) with two screws (26) and nuts (27) on battery posts (28).

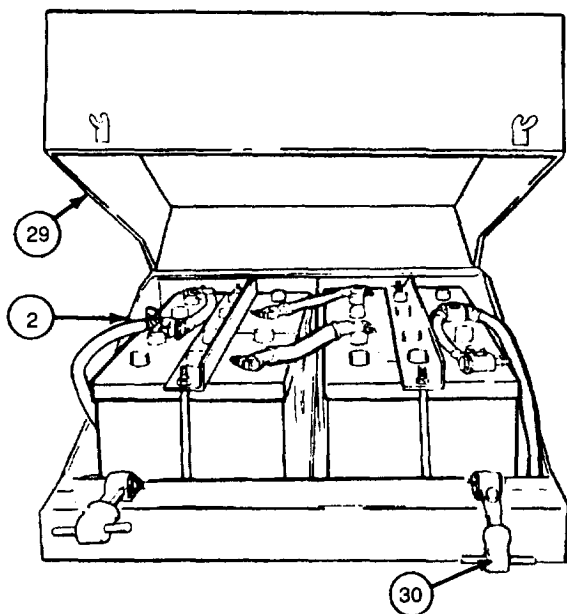

- (8) Install battery box cover (29) on battery box (2) and secure in closed position with rubber hood hooks (30).

g. Follow-on Maintenance.

- (1) Touch up installed external hardware with black CARC paint, color 37030, in accordance with TM 43-0139.

- (2) Start engine to check operation of batteries (TM 9-2320-279-10).

- (3) Shut off engine (TM 9-2320-279-10).

END OF TASK

11. CALIBRATION REQUIREMENTS. Not applicable.

12. WEIGHT AND BALANCE DATA. Weight and balance are not significantly affected.

13. QUALITY ASSURANCE REQUIREMENTS. Not Applicable.

14. RECORDING AND REPORTING OF THE MODIFICATION. Completion of this MWO will be reported on DA Form 2407 in accordance with DA Pam 738-750 and AR 750-10. In addition, block 16 of DA Form 2407 must include vehicle serial number and registration (USA) number and the date the modification was completed.

15. PRODUCT IMPROVEMENT PROPOSAL (PIP) NUMBER. This MWO is authorized by PIP number 1-86-06-4135.

16. MODIFICATION IDENTIFICATION. The NATO slave box is installed on the left front fender under the air cleaner.

By Order of the Secretary of the Army:

Official:

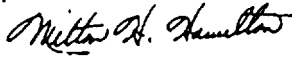

MILTON H. HAMILTON
*Administrative Assistant to the
Secretary of the Army*

01951

GORDON R. SULLIVAN
*General, United States Army
Chief of Staff*

Distribution:

To be distributed in accordance with DA Form 12-38-E (Block 0867) Unit maintenance requirements for MW09-2320-279-20-3.

RECOMMENDED CHANGES TO EQUIPMENT TECHNICAL PUBLICATIONS



THEN...JOT DOWN THE DOPE ABOUT IT ON THIS FORM. CAREFULLY TEAR IT OUT, FOLD IT AND DROP IT IN THE MAIL.

SOMETHING WRONG WITH PUBLICATION

FROM: (PRINT YOUR UNIT'S COMPLETE ADDRESS)

DATE SENT

PUBLICATION NUMBER

PUBLICATION DATE

PUBLICATION TITLE

BE EXACT PIN-POINT WHERE IT IS

PAGE NO.

PARA-GRAPH

FIGURE NO.

TABLE NO.

IN THIS SPACE, TELL WHAT IS WRONG AND WHAT SHOULD BE DONE ABOUT IT.

TEAR ALONG PERFORATED LINE

PRINTED NAME, GRADE OR TITLE AND TELEPHONE NUMBER

SIGN HERE

THE METRIC SYSTEM AND EQUIVALENTS

NEAR MEASURE

1 Centimeter = 10 Millimeters = 0.01 Meters = 0.3937 Inches
 1 Meter = 100 Centimeters = 1000 Millimeters = 39.37 Inches
 1 Kilometer = 1000 Meters = 0.621 Miles

WEIGHTS

1 Gram = 0.001 Kilograms = 1000 Milligrams = 0.035 Ounces
 1 Kilogram = 1000 Grams = 2.2 lb.
 1 Metric Ton = 1000 Kilograms = 1 Megagram = 1.1 Short Tons

LIQUID MEASURE

1 Milliliter = 0.001 Liters = 0.0338 Fluid Ounces
 1 Liter = 1000 Milliliters = 33.82 Fluid Ounces

SQUARE MEASURE

1 Sq. Centimeter = 100 Sq. Millimeters = 0.155 Sq. Inches
 1 Sq. Meter = 10,000 Sq. Centimeters = 10.76 Sq. Feet
 1 Sq. Kilometer = 1,000,000 Sq. Meters = 0.386 Sq. Miles

CUBIC MEASURE

1 Cu. Centimeter = 1000 Cu. Millimeters = 0.06 Cu. Inches
 1 Cu. Meter = 1,000,000 Cu. Centimeters = 35.31 Cu. Feet

TEMPERATURE

$5/9(^{\circ}\text{F} - 32) = ^{\circ}\text{C}$
 212° Fahrenheit is equivalent to 100° Celsius
 90° Fahrenheit is equivalent to 32.2° Celsius
 32° Fahrenheit is equivalent to 0° Celsius
 $9/5^{\circ}\text{C} + 32 = ^{\circ}\text{F}$

APPROXIMATE CONVERSION FACTORS

TO CHANGE	TO	MULTIPLY BY
Inches	Centimeters	2.540
Feet	Meters	0.305
Yards	Meters	0.914
Miles	Kilometers	1.609
Square Inches	Square Centimeters	6.451
Square Feet	Square Meters	0.093
Square Yards	Square Meters	0.836
Square Miles	Square Kilometers	2.590
Acres	Square Hectometers	0.405
Cubic Feet	Cubic Meters	0.028
Cubic Yards	Cubic Meters	0.765
Fluid Ounces	Milliliters	29.573
its	Liters	0.473
arts	Liters	0.946
allons	Liters	3.785
Ounces	Grams	28.349
Pounds	Kilograms	0.454
Short Tons	Metric Tons	0.907
Pound-Feet	Newton-Meters	1.356
Pounds per Square Inch	Kilopascals	6.895
Miles per Gallon	Kilometers per Liter	0.425
Miles per Hour	Kilometers per Hour	1.609

TO CHANGE	TO	MULTIPLY BY
Centimeters	Inches	0.394
Meters	Feet	3.280
Meters	Yards	1.094
Kilometers	Miles	0.621
Square Centimeters	Square Inches	0.155
Square Meters	Square Feet	10.764
Square Meters	Square Yards	1.196
Square Kilometers	Square Miles	0.386
Square Hectometers	Acres	2.471
Cubic Meters	Cubic Feet	35.315
Cubic Meters	Cubic Yards	1.308
Milliliters	Fluid Ounces	0.034
Liters	Pints	2.113
Liters	Quarts	1.057
ers	Gallons	0.264
ms	Ounces	0.035
ograms	Pounds	2.205
Metric Tons	Short Tons	1.102
Newton-Meters	Pounds-Feet	0.738
Kilopascals	Pounds per Square Inch	0.145
ometers per Liter	Miles per Gallon	2.354
ometers per Hour	Miles per Hour	0.621

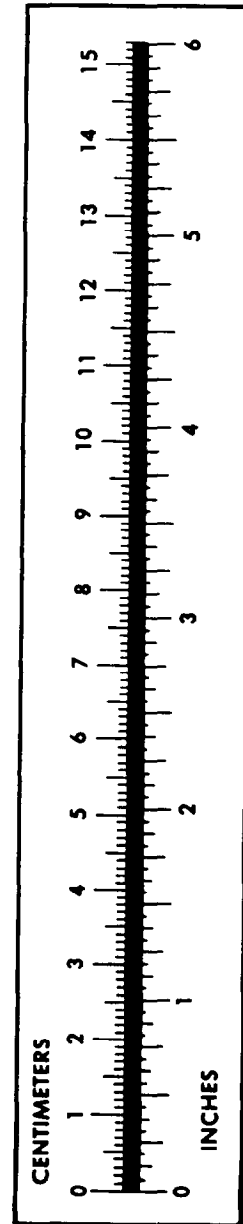

PIN: 070093-001

This fine document...

Was brought to you by me:



[Liberated Manuals -- free army and government manuals](#)

Why do I do it? I am tired of sleazy CD-ROM sellers, who take publicly available information, slap “watermarks” and other junk on it, and sell it. Those masters of search engine manipulation make sure that their sites that sell free information, come up first in search engines. They did not create it... They did not even scan it... Why should they get your money? Why are not letting you give those free manuals to your friends?

I am setting this document FREE. This document was made by the US Government and is NOT protected by Copyright. Feel free to share, republish, sell and so on.

I am not asking you for donations, fees or handouts. If you can, please provide a link to liberatedmanuals.com, so that free manuals come up first in search engines:

<A HREF=<http://www.liberatedmanuals.com/>>Free Military and Government Manuals

- Sincerely
Igor Chudov
<http://igor.chudov.com/>
- [Chicago Machinery Movers](#)