

N O R M A L

MWO effective date is 2 January 1989 and completion date is 1 February 1991

MWO 9-2320-273-20-1

M O D I F I C A T I O N W O R K O R D E R

Modification Of:

TRUCK TRACTOR, LINE HAUL,
50,000 GVWR, 6 X 4, M915 (NSN 2320-01428-4395)

TRUCK TRACTOR, LIGHT EQUIPMENT TRANSPORTER
(LET), 56,000 GVWR, 6 X 6, W/WINCH
M916 (NSN 2320-01-028-4396)

TRUCK TRACTOR, MEDIUM EQUIPMENT TRANSPORTER
(MET), 75,000 GVWR, 8 X 6, W/WINCH
M920 (NSN 2320-01-0284397)

TRUCK CHASSIS, 75/000 GVWR, 8 X 6,
FOR 20-TON DUMP TRUCK,
M917 (NSN 3805-01-028-4389)

TRUCK CHASSIS, 56,000 GVWR, 6 X 6,
FOR BITUMINOUS DISTRIBUTOR TRUCK,
M918 (NSN 3895-01-028-4390)

TRUCK CHASSIS, 75,000 GVWR, 8 X 6,
FOR CONCRETE MOBILE MIXER TRUCK,
M919 (NSN 3895-01-028-4391)

Headquarters, Department of the Army, Washington, D.C.

12 September 1989

REPORTING ERRORS AND RECOMMENDING IMPROVEMENTS

You can help improve this MWO. If you find any mistakes or if you know of a way to improve these procedures, please let us know. Write a letter or complete and mail a DA Form 2028, Recommended Changes to Publications and Blank Forms to: Commander, U.S. Army Tank-Automotive Command, ATTN: AMSTA-MB, Warren, MI 48397-50LXI A reply will be provided to you.

Approved for public release; distribution is unlimited.

1. **PURPOSE.** This modification consists of procedures to add a new air tank to the compressed air system.

2. **PRIORITY.** This modification is classified **NORMAL**.

a. Equipment in use (including equipment in supply or maintenance activity below depot level and equipment in administrative storage). Equipment in use will be modified as soon as practicable but no later than the scheduled completion date. Equipment not modified after expiration of Department of the Army Modification Work Order (DAMWO) scheduled completion date will be reported as **NOT MISSION CAPABLE** in accordance with applicable Army Regulations and will not be operated until the modification is applied.

b. Equipment in wholesale depot supply or maintenance activities. All DAMWO'S which have been incorporated into Depot Maintenance Work Requirement (DMWR), will be accomplished on serviceable materiel prior to issue and/or subsequent to scheduled completion date. Operational Project Stock stored at the Depots will be modified concurrently with Depot Stock. Issue of unmodified materiel is prohibited. The DAMWO will be applied to unserviceable materiel during the scheduled Depot Maintenance.

c. Propositioned stock, to include non-p.repositioned Materiel Configured to Unit Sets (POMCUS) operational projects will be applied at once.

3. **END ITEMS TO BE MODIFIED.**

See Table 1.

Table 1. End Items to be Modified

Nomenclature	NSN	Model No.
Truck Tractor, Line Haul, 50,000 GVWR, 6 X 4	2320-01428-4395	M915
Truck Tractor, Med Equip. Transporter (LET), 56,000 GVWR, 6 X 6, W/Winch	2320-01-028-4396	M916
TruckTractor, Med Equip. Transporter (MET), 75,000 GVWR, 8 X 6, W/Winch	2320-01-028-4397	M920
Truck Chassis, 75,000 GVWR, 8 X 6, for 20-Ton Dump Truck	3805-014284389	M917
Truck Chassis, 56,000 GVWR, 6 X 6, for Bituminous Distributor Truck	3895-01-028-4390	M918
Truck Chassis, 75,000 GVWR, 8 X 6, for Concrete Mixer Truck	3895-01-028-4391	M919

4. **MODULES (COMPONENTS, ASSEMBLIES, SUBASSEMBLIES) TO BE MODIFIED.**

The following items, whether installed or in depot stock, shall be modified. See Table 2.

Table 2. Assemblies to be Modified

Nomenclature	Model	Part Number & FSCM
Auxiliary Air System	M915	12357132 (19207)
	M916, M917, M918, M919 and M920	12368245 (19207)

5. PARTS TO BE MODIFIED.

Not applicable.

6. APPLICATION.

a. **Time Compliance Schedule** The effective date of this Modification Work Order (MWO) is 2 January 1989 and its completion date is 1 February 1991.

b. **Lowest Level of Maintenance Authorized to Apply this MWO:** Organizational.

c. **Work Force and Man-hour Requirements for Application of this MWO to a Single Unit, End Item, or System is as follows**

REQUIREMENTS**WORK FORCE/SKILLS****MAN-HOURS**

MOS 63S

3.5 hours to install either MWO kit

Contractor team

2.0 hours to install either MWO kit

Total man-hours required for a single application of this MWO at Organizational maintenance is 3.5 hours.

Total man-hours required for a single application of this MWO by contractor team is 2.0 hours.

d. **MWO'S to be Applied Prior to or Concurrently with the Application of this MWO.** Not applicable.

e. **Additional Information Deemed Necessary to Assist in the Application of this MWO** Not applicable.

7. TECHNICAL PUBLICATIONS AFFECTED/CHANGED.

See Table 3.

Table 3. Publications Affected

Publication	Date
TM 9-2320-273-10	May 1980
TM 9-2320-273-20	Nov 1980
TM 9-2320-273-34	Dec 1980
TM 9-2320-273-20P	Sept 1986
TM 9-2320-273-34P	Sept 1986

8. MWO KIT(S) /PART(S) AND THEIR DISPOSITION.

a. **Kit(s) /Part(s) Needed to Apply this MWO:** P/N 12357132, FSCM 19207 (M915); P/N 12368245, FSCM 19207 (M916, M917, M918, M919 and M920).

b. Contents of MWO Kits: See Table 4 and Table 5.

Table 4. Modification Kit (M915)

Nomenclature	NSN	Part Number & FSCM	Qty	Mod Kit Item No.
Valve Check	4820-00-115-3896	11669271 (19207)	1	1
Support, Air Tank		12357127	1	2
Clamp Assy		12357128	2	3
Tank, Air Reservoir		12357129	1	4
Install, hstructions		12357131	1	5
Hose, Non-Metallic (53" long)	4720-01-009-9058	CPR104420-4 (19207)	1	6
Hose, Non-Metallic (57" long)	4720-01-009-9058	CPR104420-4 (19207)	1	7
Strap, Tiedown	5975-00-570-9598	MS3367-7-9 (%906)	2	8
clamp, Loop	5340-00-833-3049	MS21333-127 (96906)	3	9
Washer	5310-00-080-6004	MS27183-14 (%906)	6	10
Cock, Drain	4820-00-287-4268	MS35784-2 (96906)	1	11
Nut, Self-Locking	5310-01-249-0904	MS51943-5 (96906)	6	12
Screw, Cap, Hexagon	5305-00-269-3212	MS90725-61 (96906)	6	13
Connector Assy		SAE J246 10-8 100102BA	2	14
Elbow Assy		SAE J246 10-8 100202BA	1	15
Union Assy		SAE J246 10-10 100101BA	1	16
Plug		SAEJ5146 080109B	4	17
Elbow		SAE J530 8-8 130239B	1	18
Bushing		SAE J530 12-8 130140B	3	19
MWO Data Plate	9905-00-858-5682	10930014 (19207)	1	20
Drivescrew	5305-00-253-5614	922002 (99832)	1	21

Table 5. Modification Kit (M916, M917, M918, M919 & M920)

Nomenclature	NSN	Part Number & FSCM	Qty	Mod Kit Item No.
Valve Check	4820-03-115-3896	11669271 (19207)	1	1
Clamp Assy		12357128	2	2
Tank, Air Reservoir		12357129	3	1
Support, Air Tank		12357130	4	2
Installation Instructions		12357133	5	1
Hose, Non-Metallic (11" long)	4720-01-009-9058	CPR104420-4 (19207)	6	2
Strap, Tiedown	5975-00-570-9598	MS3367-7-9 (96906)	2	8
Clamp, Loop	5340-00-833-3049	MS21333-127 (96906)	3	9
Washer	5310-00-823-8804	MS27183-9 (96906)	9	1
Washer	5310-00-080-6004	MS27183-14 (96906)	10	8
Cock, Drain	4820-00-287-4268	MS35784-2 (96906)	11	1
Nut, Self-Locking	5310-01-249-0904	MS51943-5 (96906)	12	10
Screw, Cap Hexagon	5305-00-269-3214	MS90725-64 (96906)	13	8
Plug		SAE J5146	14	4
		O80109B		
Elbow		SAE J530 8-8	15	2
Connector Assy		SAE J246 10-8	16	2
		100102BA		
Elbew Assy		SAE J246 10-8	17	1
		100202BA		
Union Assy		SAE J246 10-10	18	1
		100101BA		
Bushing		SAE J530 12-8	19	3
		130140B		
MWO Data Plate	9905-00-858-5682	10930014 (19207)	1	11
DrivesCrew	5305-00-253-5614	922002 (99832)	1	12

c. Bulk and expendable materials. See Table 6.

Table 6. Bulk and Expendable Material

Nomenclature	NSN	Part Number & FSCM	Qty
Sealing Compound	8030-01-054-0740	59231 (05972)	1/2 tube per application

NOTE

Teflon tape may be used in place of Sealing Compound

d. Parts disposition. All material removed and not reused during installation will be returned to stock for disposition in accordance with AR 725-50.

9. SPECIAL TOOLS; TOOL KITS; JIGS; TEST, MEASUREMENT AND DIAGNOSTIC EQUIPMENT (TMDE); AND FIXTURES REQUIRED.

None.

10. MODIFICATION PROCEDURES.

(M915).

a. Vehicle Preparation. (M915).

(1) Drain air system (refer to TM 9-2320-273-10).

(2) Remove plug from front of air tank as shown in figure 1.

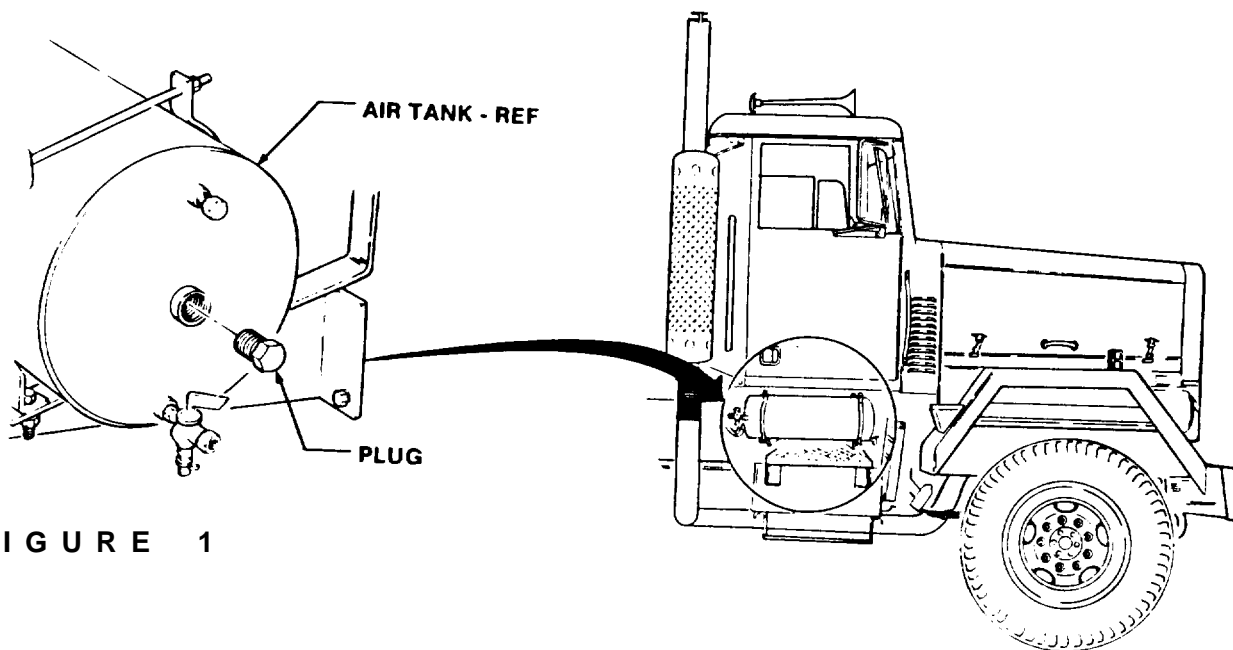

FIGURE 1

(3) Remove 5/8-inch yellow transmission air line from elbow on shuttle valve as shown in figure 2.

(4) Remove elbow from bottom port on shuttle valve as shown in figure 2.

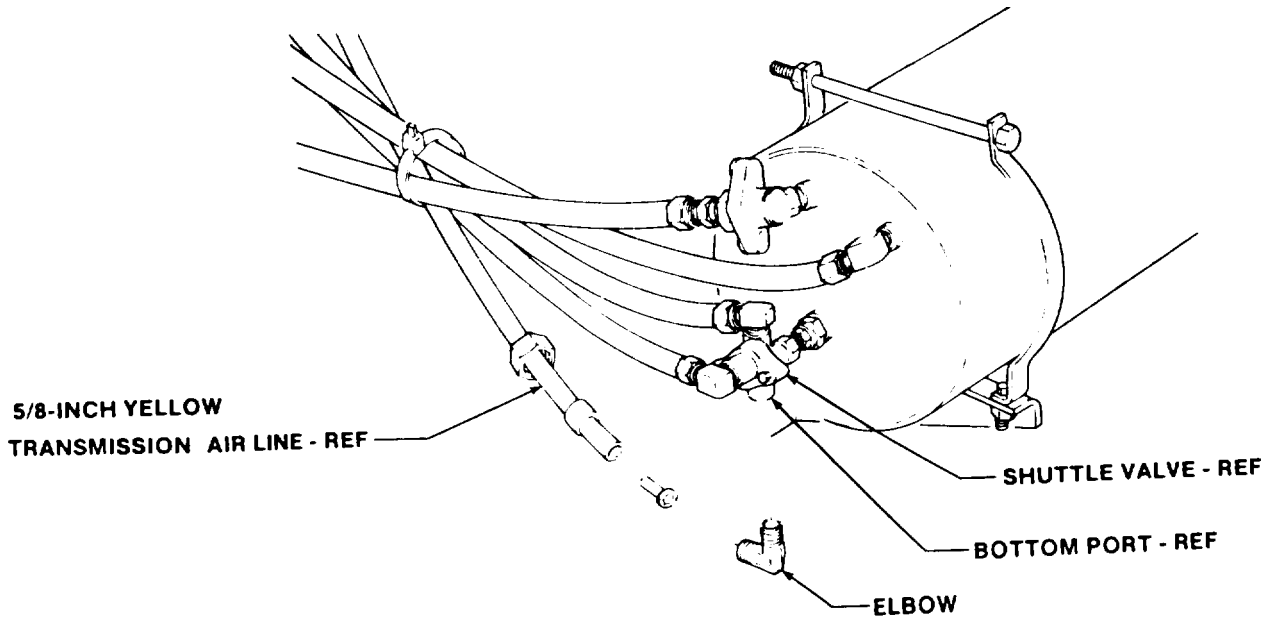

FIGURE 2

NOTE

Coat threads on plug bushing elbow, and connector assembly being installed in steps 5,6,7 and 8 with pipe sealing compound prior to installation.

(5) Install SAE J514 6 080109B plug in bottom port of shuttle valve as shown in figure 3.

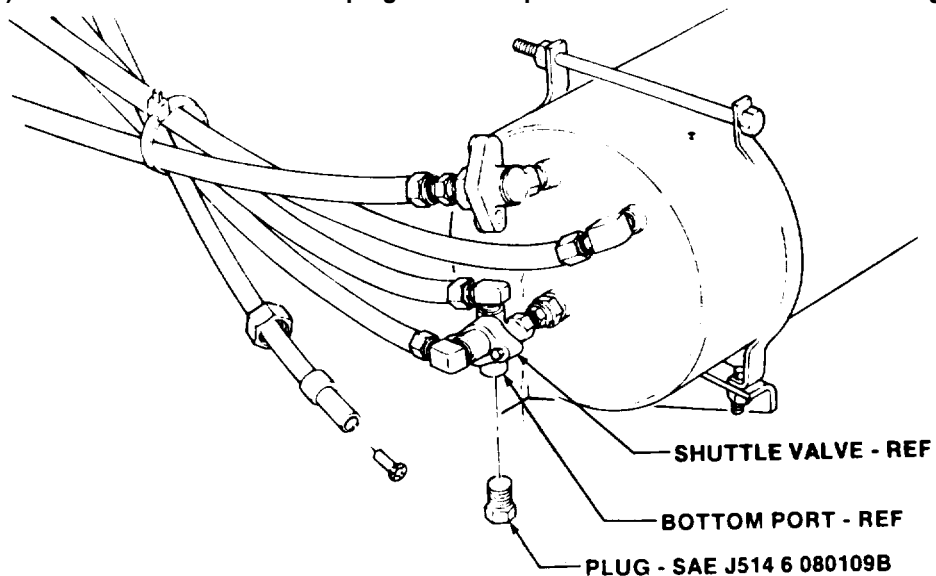

FIGURE 3

(6) Install SAE J530 12-8 130140B bushing in air tank as shown in figure 4.

(7) Install SAE J530 8-8 130239B elbow in bushing on air tank as shown in figure 4.

(8) Install SAE J246 10-8 100102BA connector assembly to elbow as shown in figure 4. Retain sleeve and nut for use in 10. b. (8).

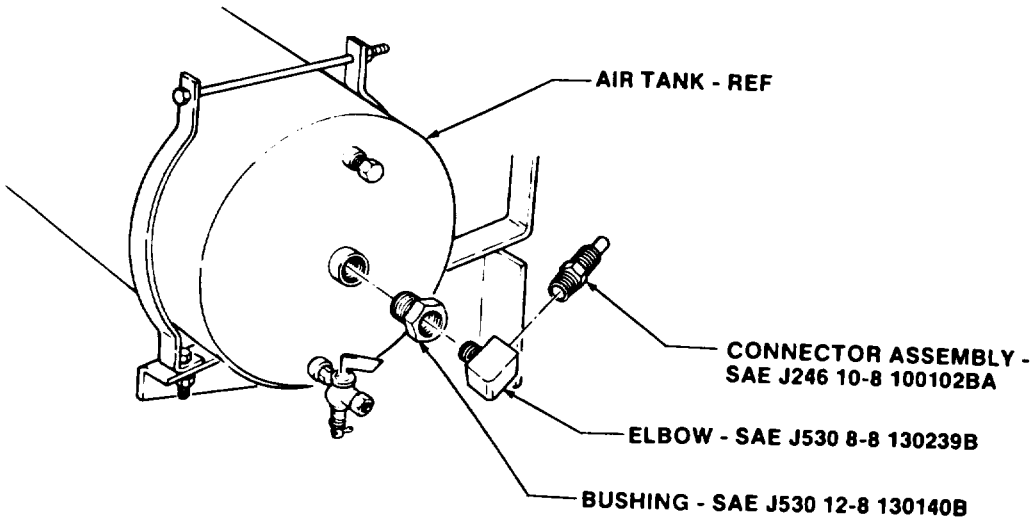

FIGURE 4

(9) Remove screw and nut from right frame rail as shown in figure 5.

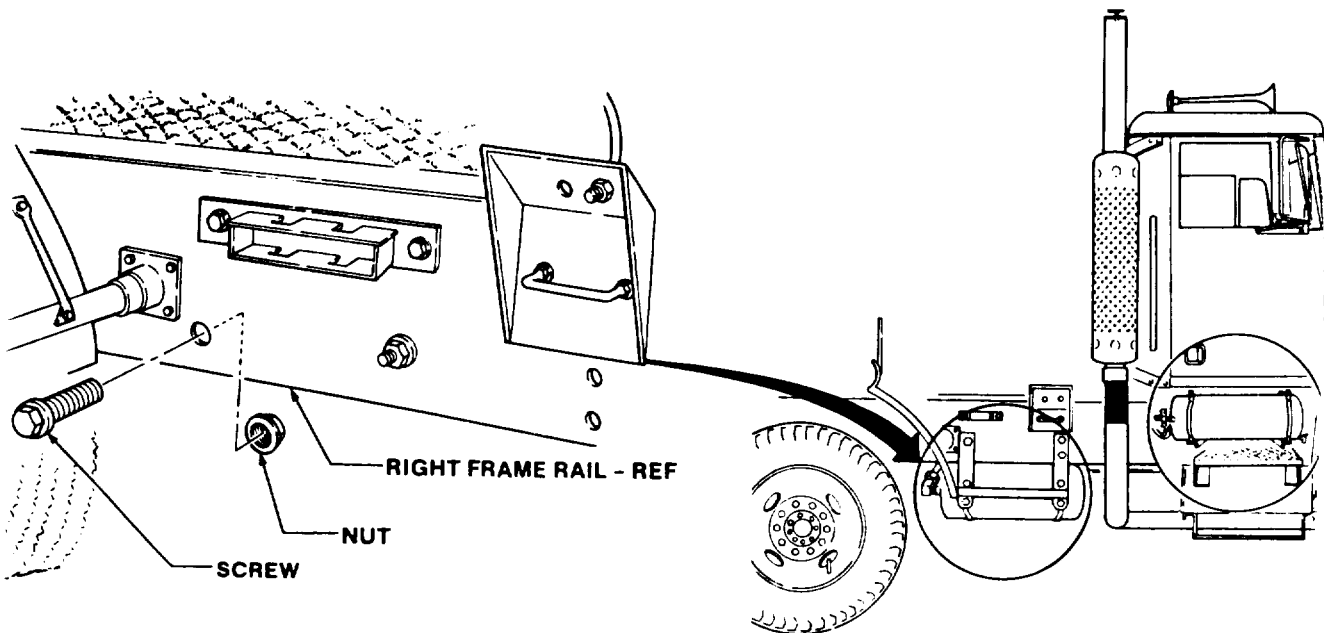

FIGURE 5

(10) Install 12357127 support bracket to right frame rail and secure with two MS90725-61 screws, MS27183-14 washers, and MS51943-5 nuts as shown in figure 6. Tighten nuts finger tight.

(11) Install screw (removed in step 9) through support bracket and right frame rail and secure with nut (removed in step 9) as shown in figure 6. Tighten nut finger tight.

(12) Tighten two screws installed in step (10) to 20 lb ft (40.7 N.m).

(13) Tighten screw installed in step (11) to 95 lb ft (128.8 N.m).

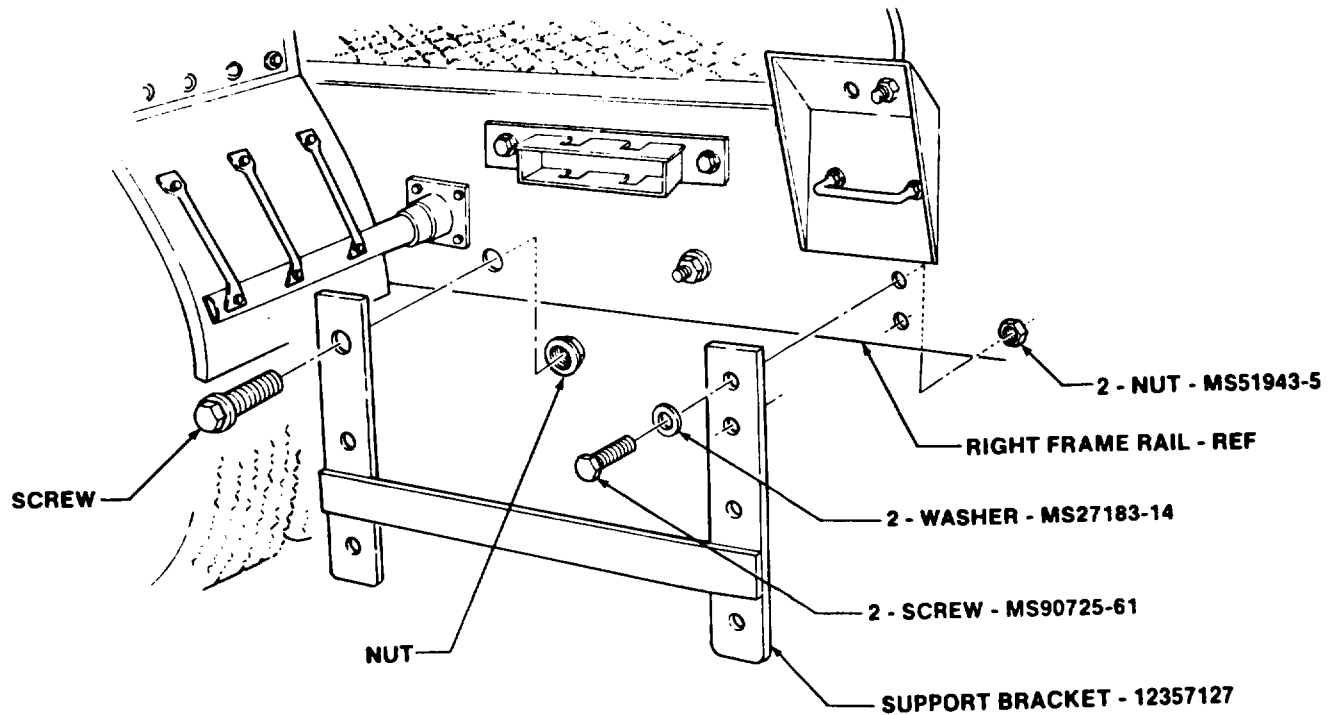

FIGURE 6

(14) Install lower half of two 12357128 clamp assemblies support bracket and secure with two MS90725-61 screws, MS27183-14 washers, and MS51943-5 nuts as shown in figure 7. Tighten screws 30 lb ft (40.7 N.m).

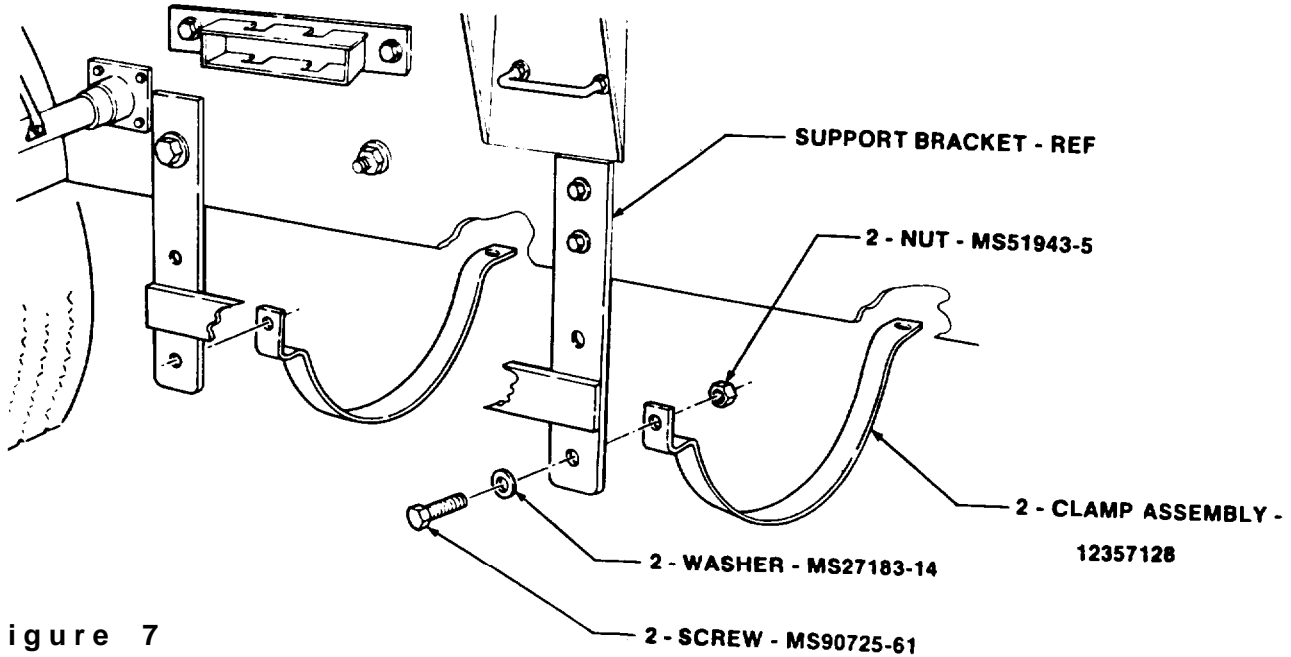

Figure 7

(15) Remove screw and nut from transmission dipstick tube clamp as shown in figure 8.

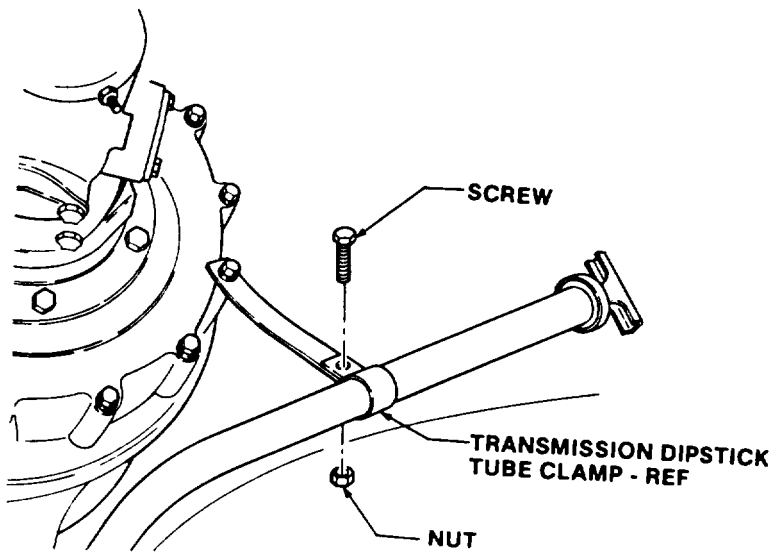
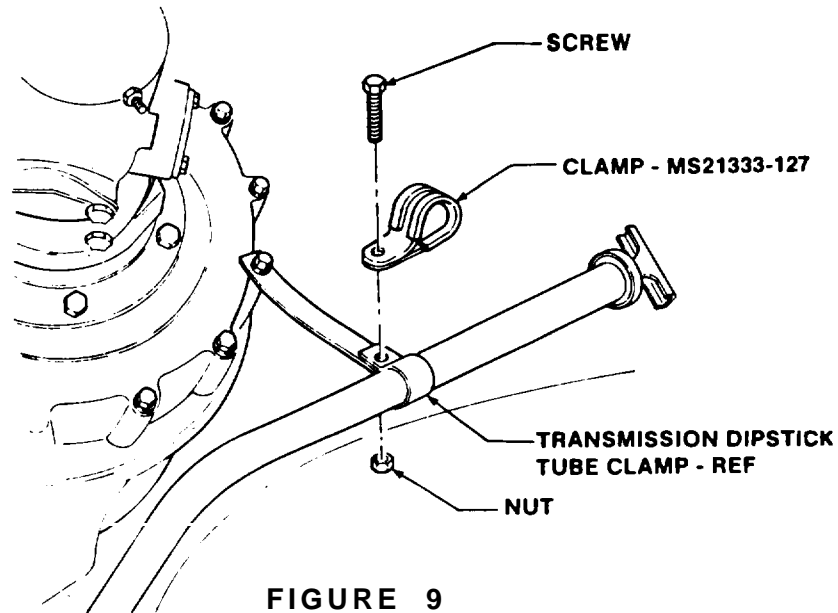

FIGURE 8

(16) Install MS21333-127 clamp on transmission dipstick tube clamp and secure with nut and screw (removed in step (15)) as shown in figure 9.



b. Air Lines and Tank Installation.

NOTE

When installing air tank on clamp, ensure air tank is positioned as shown in figure 10.

(1) Position 12357129 air tank in lower half of two clamp assemblies as shown in figure 10.

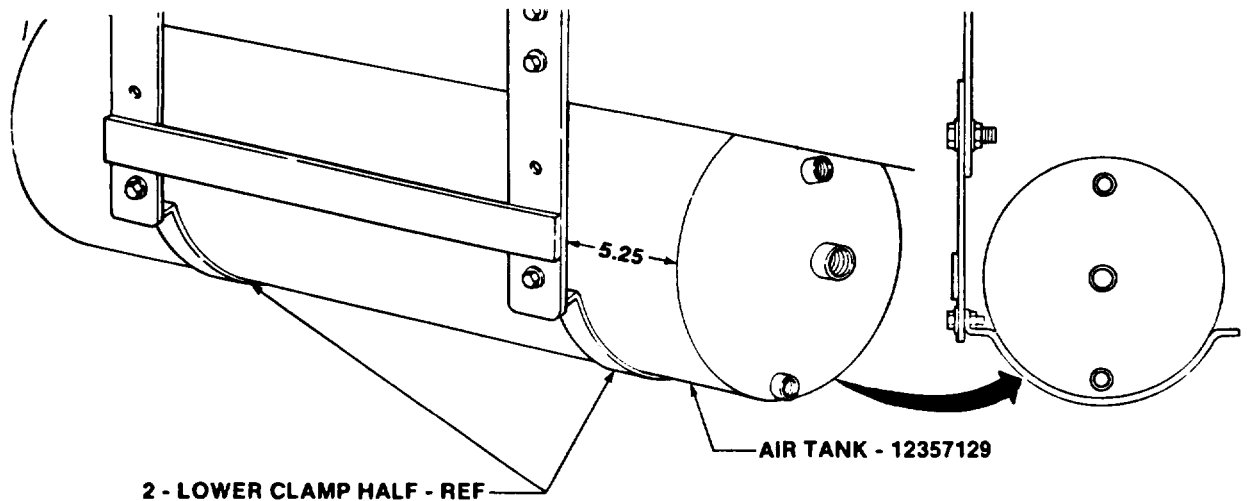

(2) Install upper half of two clamp assemblies to support bracket and secure with two MS90725-61 screws, MS27183-14 washers, and MS51943-5 nuts as shown in figure 11.

(3) Install two MS21333-127 clamps on two bolts and install bolts through upper and lower clamp halves and secure with two nuts as shown in figure 11. Tighten nuts finger tight.

NOTE

Ensure the 5.25-inch measurement is made as shown in figure 10 prior to performing step 4.

(4) Secure four screws and nuts installed in steps 2 and 3.

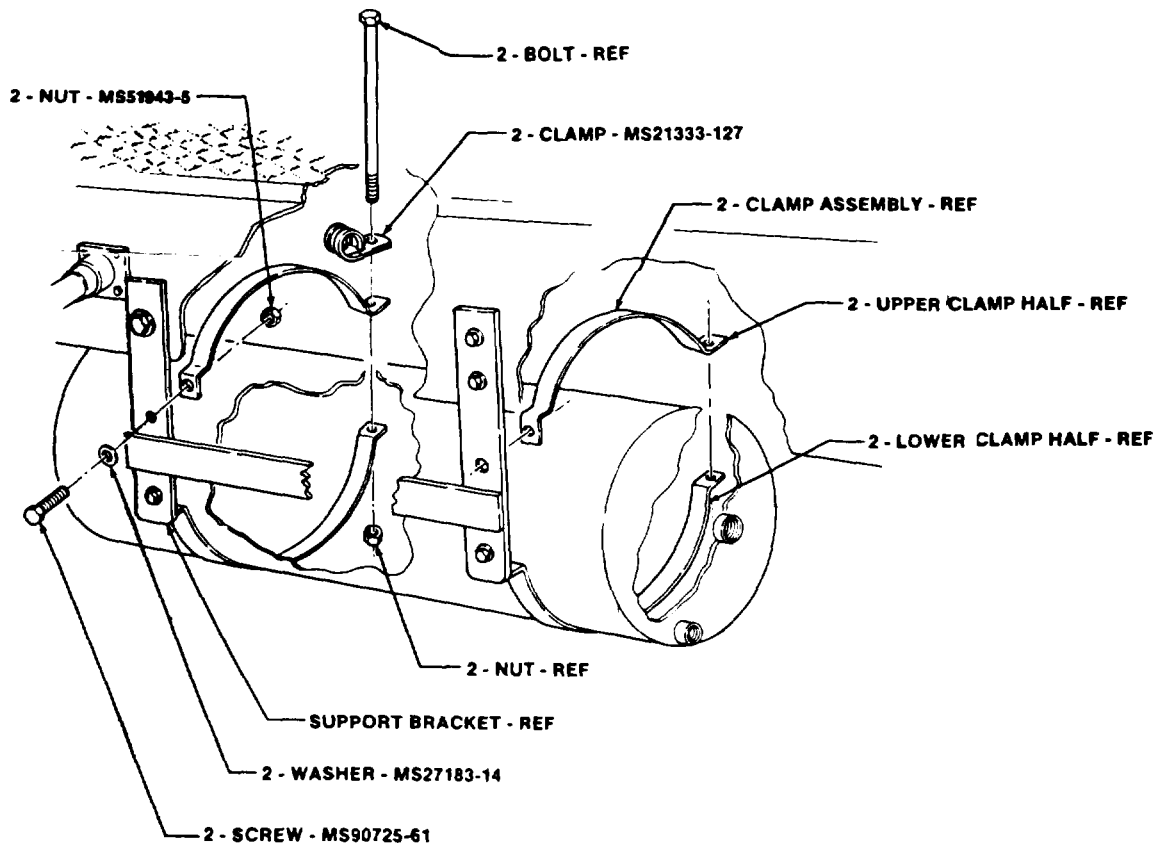

FIGURE 11

NOTE

Coat threads on bushing check valve, and connector assembly being installed in steps 5, 6 and 7 with pipe sealing compound prior to installation.

(5) Install SAE J530 12-8130140B bushing in forward end of air tank as shown in figure 12.

(6) Install 11669271 check valve in bushing on air tank as shown in figure 12.

(7) Install SAE J24610-8 100102BA connector assembly in check valve on air tank as shown in figure 12. Retain sleeve and nut for use in step 9.

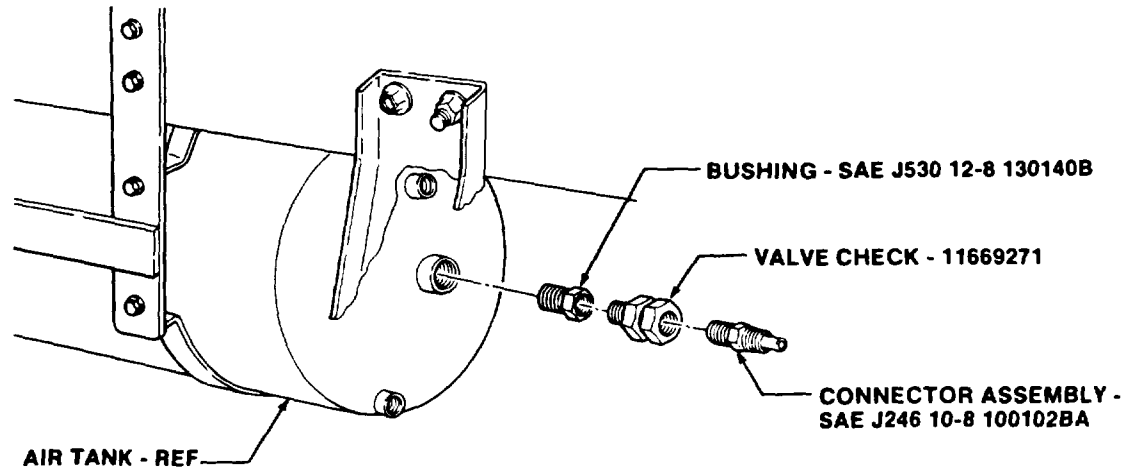

FIGURE 12

(8) Install CPR104420-4 (57 inches long) tube to connector on front of existing air tank and secure with sleeve and nut as shown in figure 13. Sleeve and nut retained from 10. a. (8).

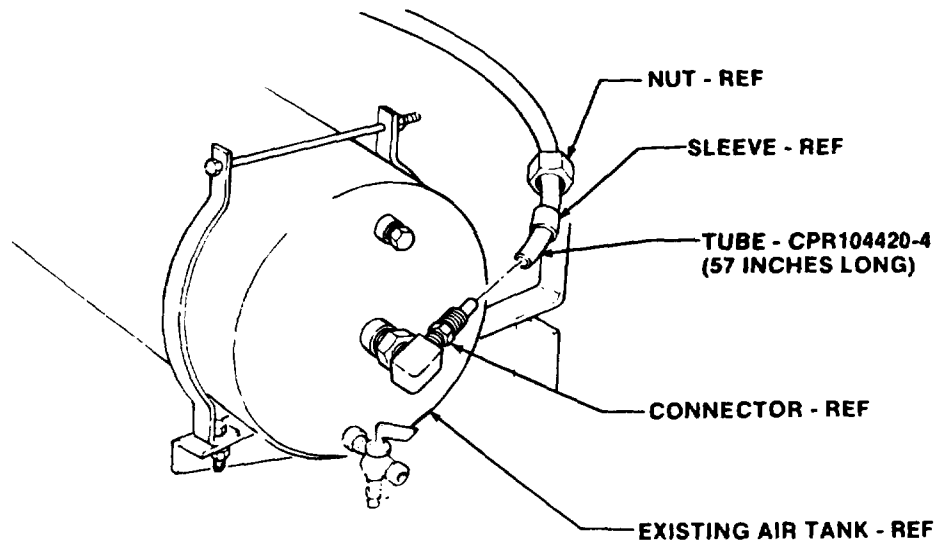

FIGURE 13

(9) Route tube through clamp to connector assembly on front of new air tank, cut tube, and secure tube to connector assembly with sleeve and nut as shown in figure 14.

NOTE

Coat threads on plugs, bushing elbow, and draincock being installed in steps 10, 11, 12, 13 and 14 with pipe sealing compound prior to installation.

(10) Install SAE J514 6 080109B plug in upper port on air tank as shown in figure 14.

(11) Install MS35784-2 draincock in lower port on air tank as shown in figure 14.

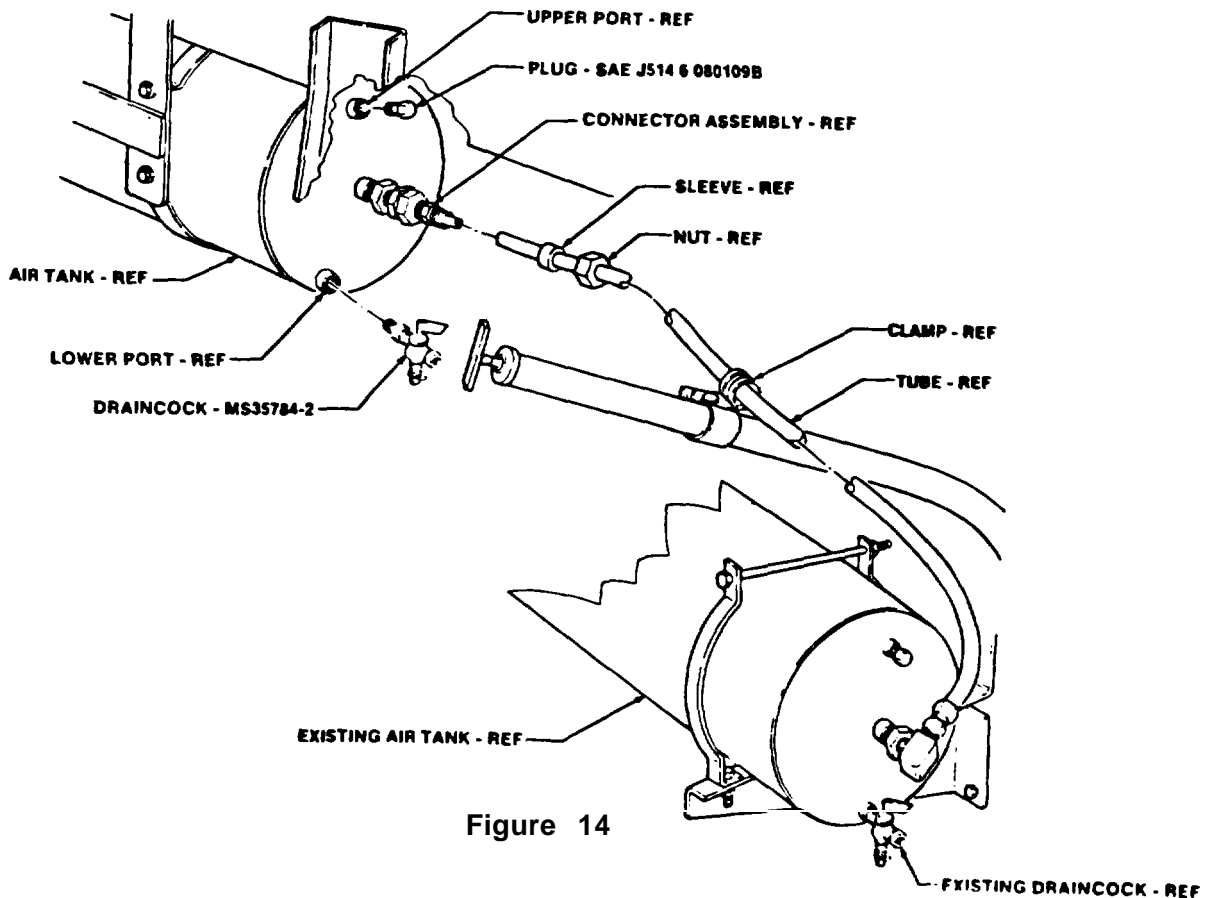

Figure 14

(12) Install two SAE J5146080109B plugs in rear upper ports on air tank as shown in figure 15.

(13) Install SAE J530 12-8130140B bushing in port on rear of air tank as shown in figure 15.

NOTE

After installing elbow, ensure elbow is positioned as shown in figure 15.

(14) Install SAE J246 10-8 100202BA elbow assembly in bushing on air tank as shown in figure 15. Retain sleeve and nut for use in step 18.

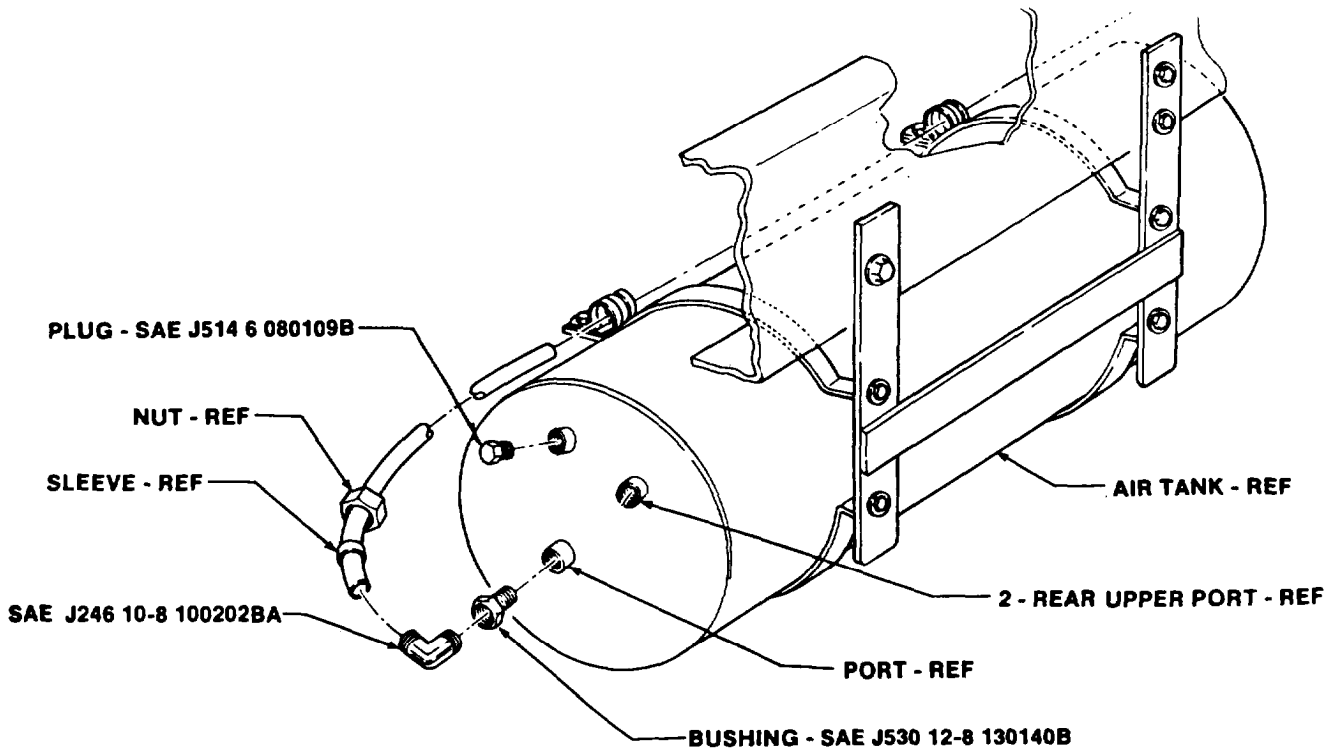

FIGURE 15

(15) Cut off one inch of existing 5/8-inch yellow transmission airline as shown in figure 16, and discard fitting.

(16) Install SAE J246 10-10100101BA union assembly on 5/8-inch yellow transmission air line and secure with sleeve and nut as shown in figure 16. Retain sleeve and nut for use within step 17.

(17) Install CPR104420-4 (53 inches long) tube on union assembly and secure with sleeve and nut as shown in figure 16.

(18) Route tube through two clamps and to elbow in rear of air tank, and install tube on elbow and secure with nut and sleeve as shown in figure 15 and 16. Sleeve and nut retained from step (14).

(19) Install two MS3367-7-9 straps around airlines as shown in figure 16.

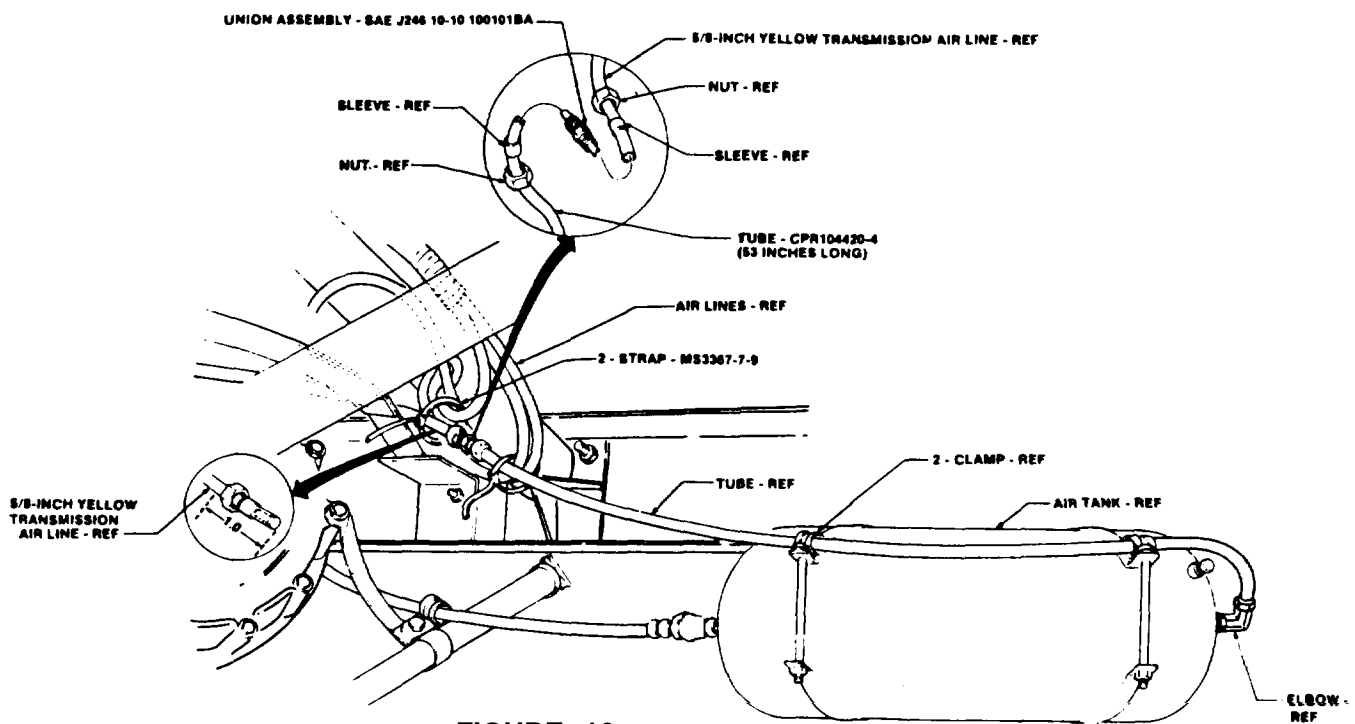

FIGURE 16

c. Vehicle Equipment.

(1) Start vehicle and build air pressure up to operating range (refer to TM 9-2320-273-10).

(2) Inspect vehicle for air leaks, loose fittings, screws, and nuts (refer to TM 9-2320-273-10).

(3) Shut off vehicle and drain air system by opening draincock on existing air tank only as shown in figure 14.

NOTE

Step 4 is performed to verify check valve installed in paragraph b., step 6 is functioning properly and air pressure (required for shifting) is maintained in the new air tank only.

- (4) Engage~ transmission air charging valve knob and shift from first gear through fifth gear ranges.
- (5) Return transmission to neutral and disengage transmission air charging valve knob.
- (6) Repeat step 1 and road test vehicle (refer to TM 9-2320-273-10).

NOTE

Spot paint as needed.

M916, M917, M918, M919 and M920.

a. Vehicle Preparation. M916, M917, M918, M919 and M920.

- (1) Drain air system (refer to TM 9-2320-273-10).
- (2) Remove plug from front of air tank as shown in figure 1.

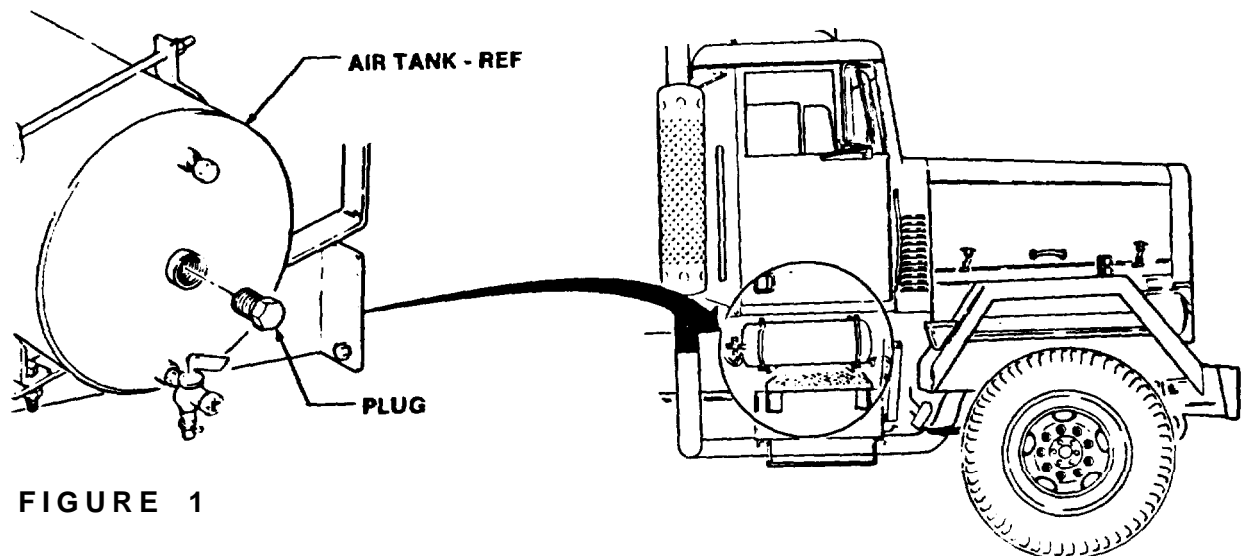

FIGURE 1

(3) Remove 5/8-inch yellow transmission air line from elbow on shuttle valve as shown in figure 2.

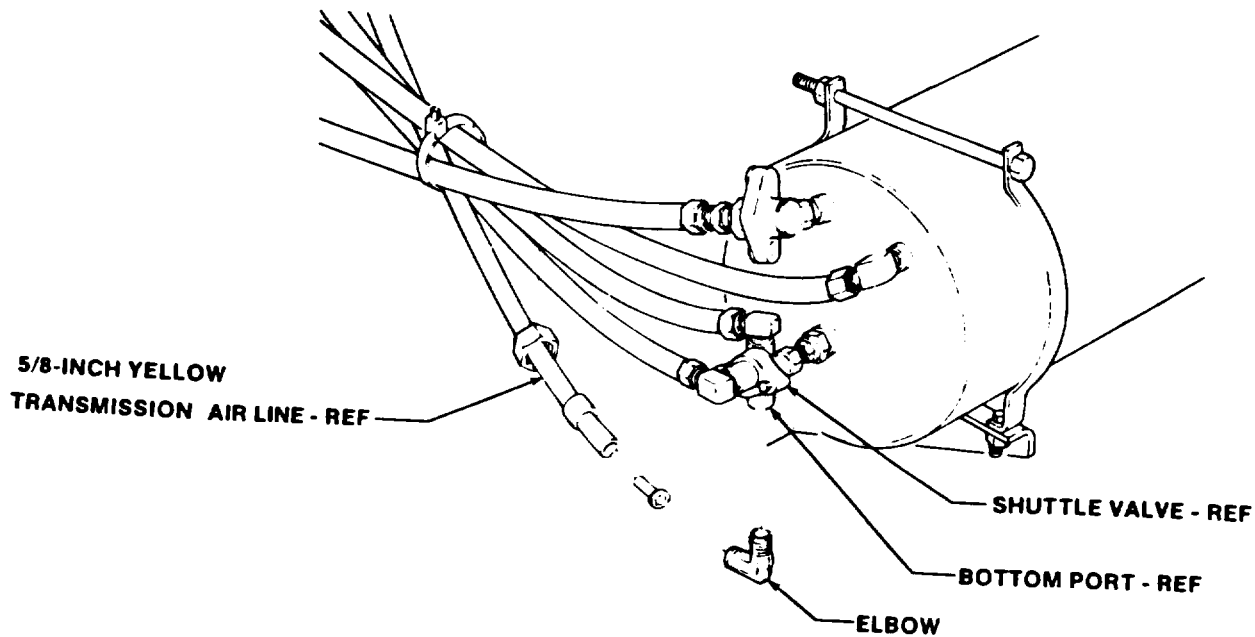

FIGURE 2

(4) Remove elbow from bottom port on shuttle valve as shown in figure 2.

NOTE

Coat threads on plug bushing, elbow, and connector being installed in steps 5,6,7 and 8 with pipe sealing compound prior to installation.

(5) Install SAE J514 6080109B plug in bottom port of shuttle valve as shown in figure 3.

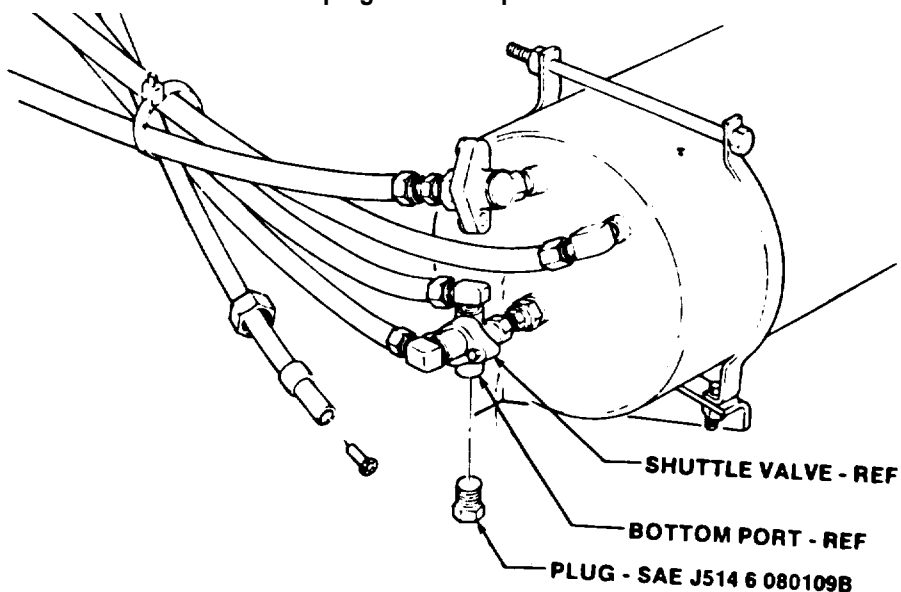

FIGURE 3

(6) Install SAE J530 12-8 130140B bushing in air tank as shown in figure 4.

(7) Install SAE J530 8-8 130239B elbow in bushing on air tank as shown in figure 4.

(8) Install SAE J246 10-8 100102BA connector assembly in elbow as shown in figure 4. Retain sleeve and nut for use in paragraph b. step 8.

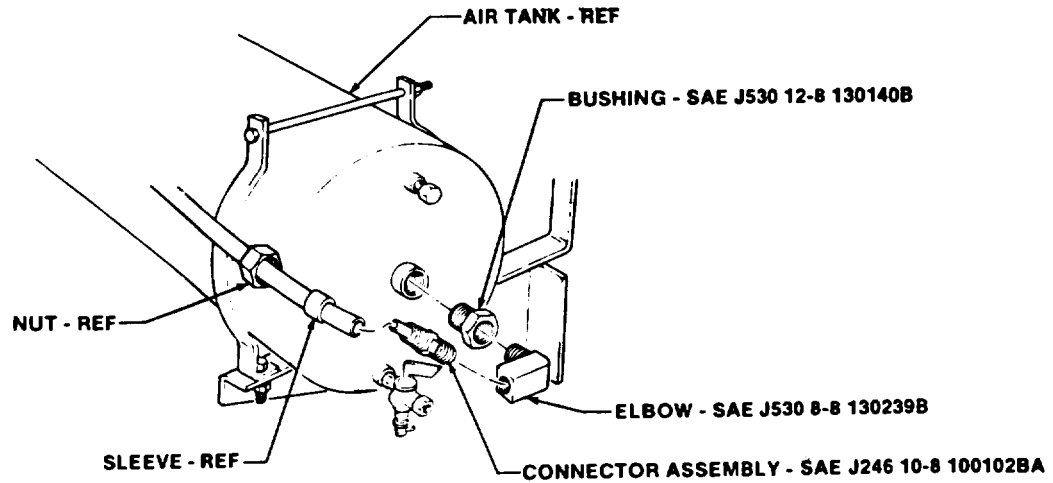

FIGURE 4

(9) Remove two nuts, washers, and screws from two clamp assemblies as shown in figure 5.

(10) Remove four nuts, washers, and screws from two clamp assemblies and remove clamp assemblies as shown in figure 5.

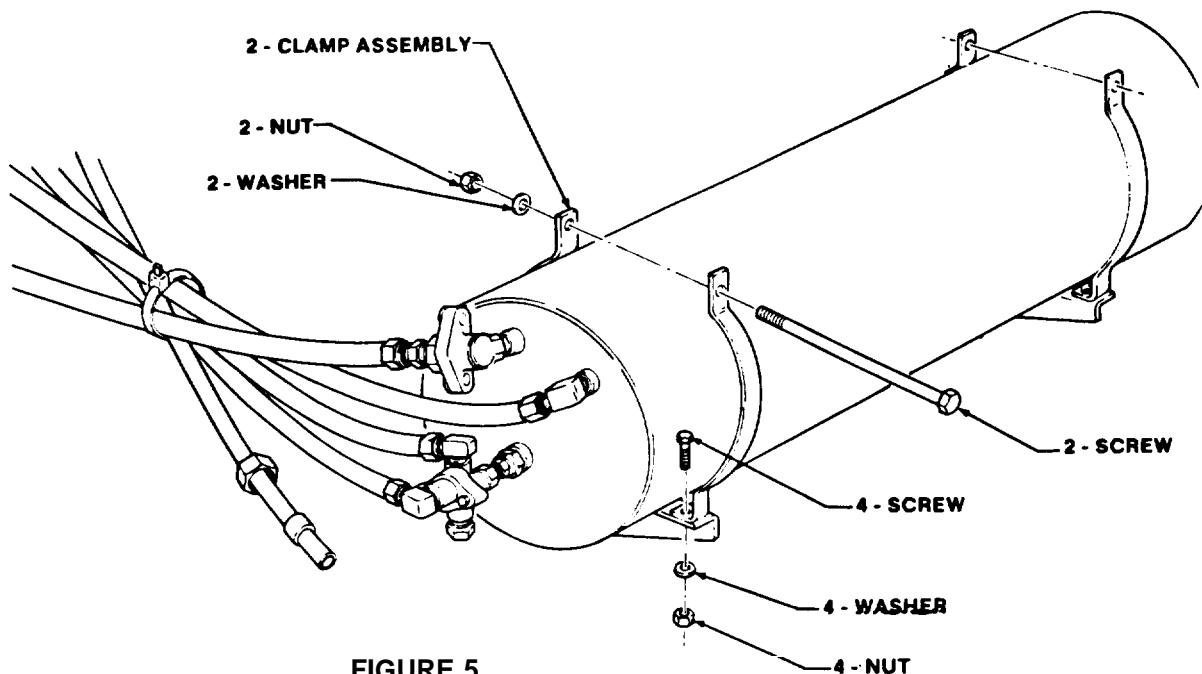

FIGURE 5

(11) Install two 12357130 supports and two existing clamp assemblies to two existing supports and secure with four MS90725-64 screws, MS27183-14 washers, and MS51943-5 nuts as shown in figure 6. Tighten nuts finger tight.

(12) Install two screws, clamps, washers (removed in step 9), and MS51943-5 nuts as shown in figure 6. Tighten nuts finger tight.

(13) Secure nuts installed in steps 11 and 12.

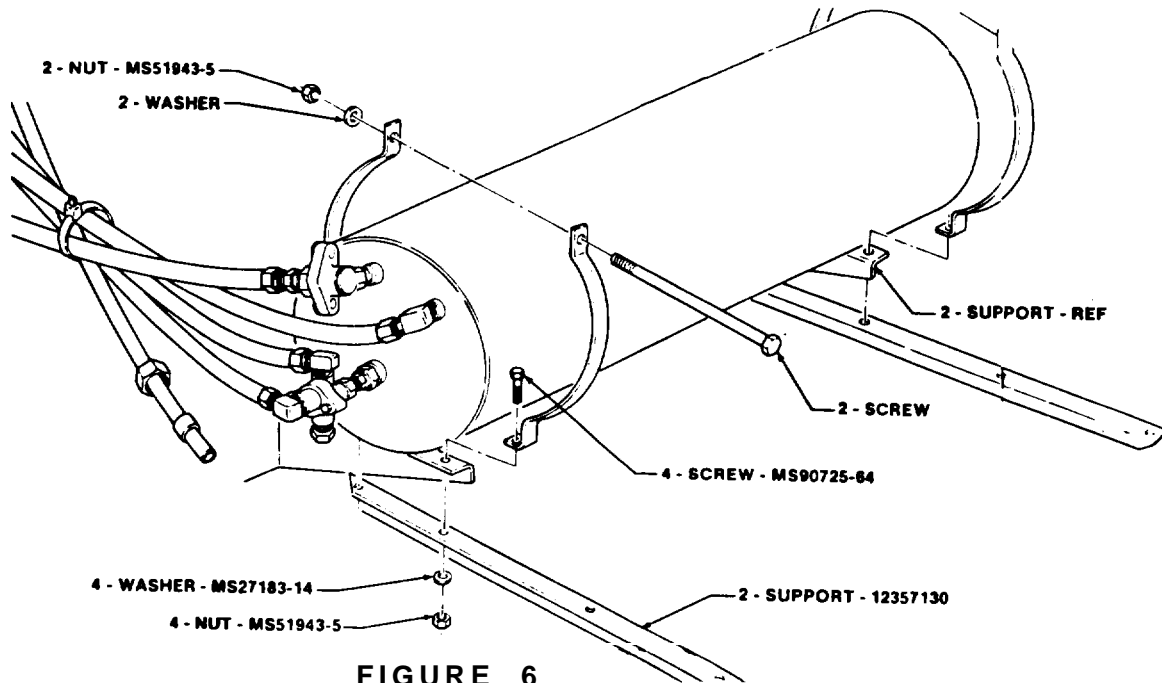

FIGURE 6

b. Air Lines and Tank Installation.

NOTE

When installing the air tank on the supports, ensure it is positioned as shown in figure 7.

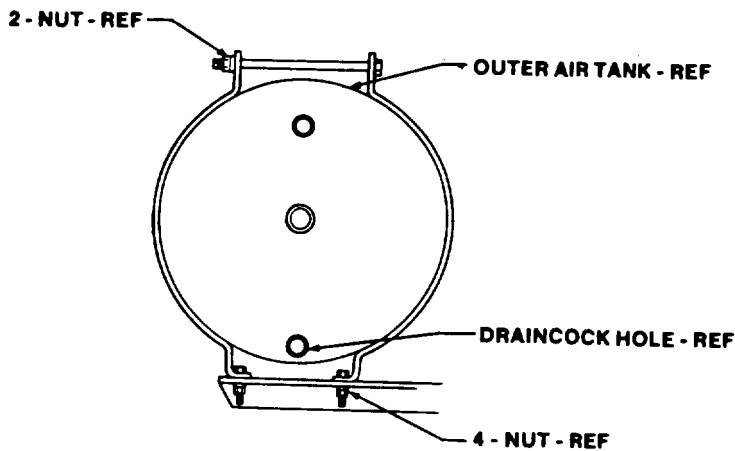

FIGURE 7

(1) Install 12357129 air tank and two 12357128 clamp assemblies to two supports and secure with four MS90725-64 screws, MS27183-14 washers, and MS51943-5 nuts as shown in figure 8. Tighten nuts finger tight.

(2) Install two screws through two clamps and secure with two washers and nuts as shown in figure 8. Tighten nuts finger tight.

(3) Ensure outer air tank is positioned as shown in figure 7 and secure nuts installed in steps 1 and 2.

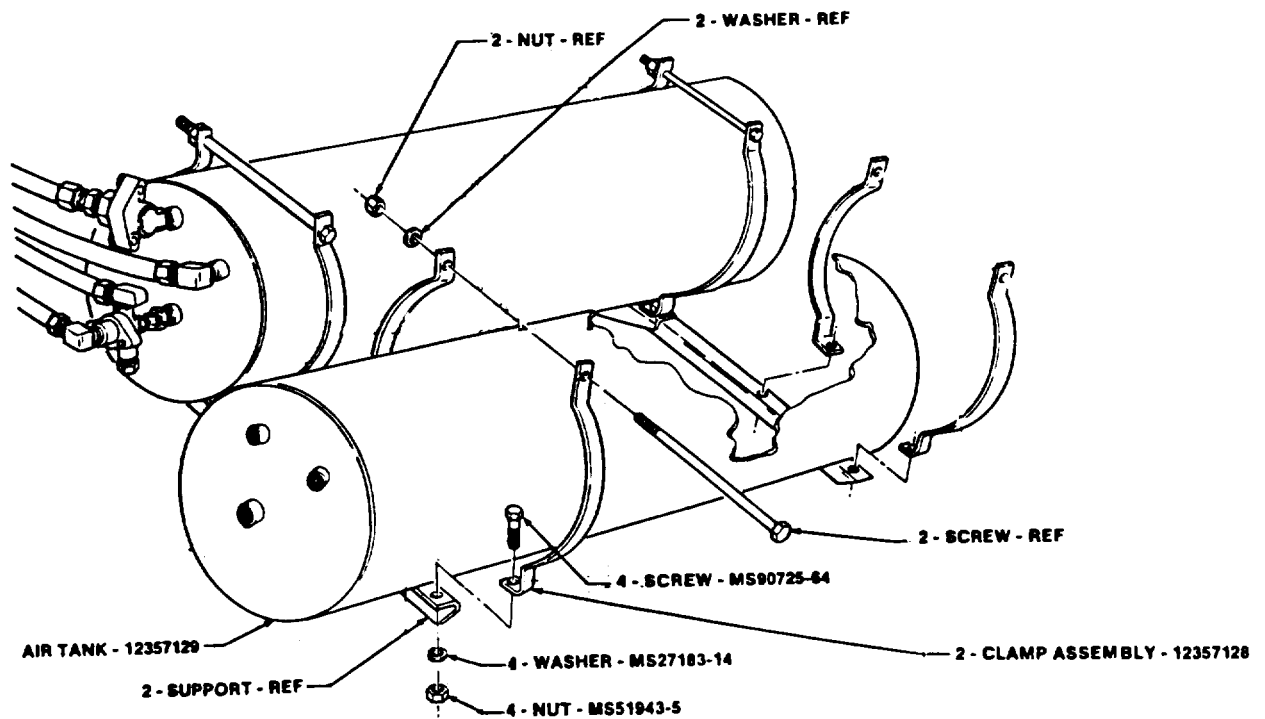

FIGURE 8

NOTE

Coat threads on bushing elbow, check valve, and connector being installed in steps 4,5,6 and 7 with pipe sealing compound prior to installation.

(4) Install SAE J530 12-8 130140B bushing in forward end of outer air tank as shown in figure 9.

(5) Install SAE J530 8-8 130239B elbow in bushing on outer air tank as shown in figure 9.

(6) Install 11669271 check valve in elbow on outer air tank as shown in figure 9.

(7) Install SAE J246 10-8 100102BA connector assembly in check valve on outer air tank as shown in figure 9. Retain sleeve and nut for use in step 8.

NOTE

Position elbows to obtain smooth bend during installation of tube.

(8) Install CPR1044204 tube to inner and outer air tanks and secure with two sleeves and nuts as shown in figure 9.

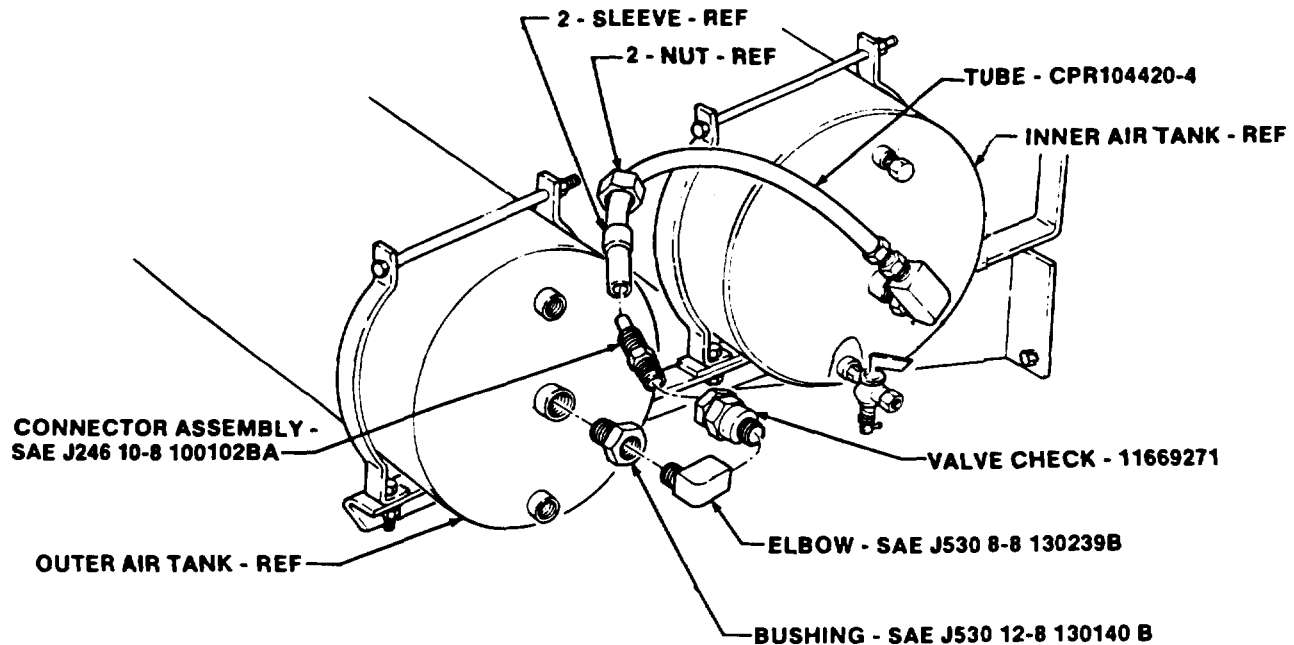

FIGURE 9

NOTE

Coat threads on plugs, bushing elbow, and draincock being installed in steps 9,10,11,12 and 13 with pipe sealing compound prior to installation.

(9) Install SAE J514 6 O80109B plug in upper port on outer air tank as shown in figure 10.

(10) Install MS35784-2 draincock in lower port on outer air tank as shown in figure 10.

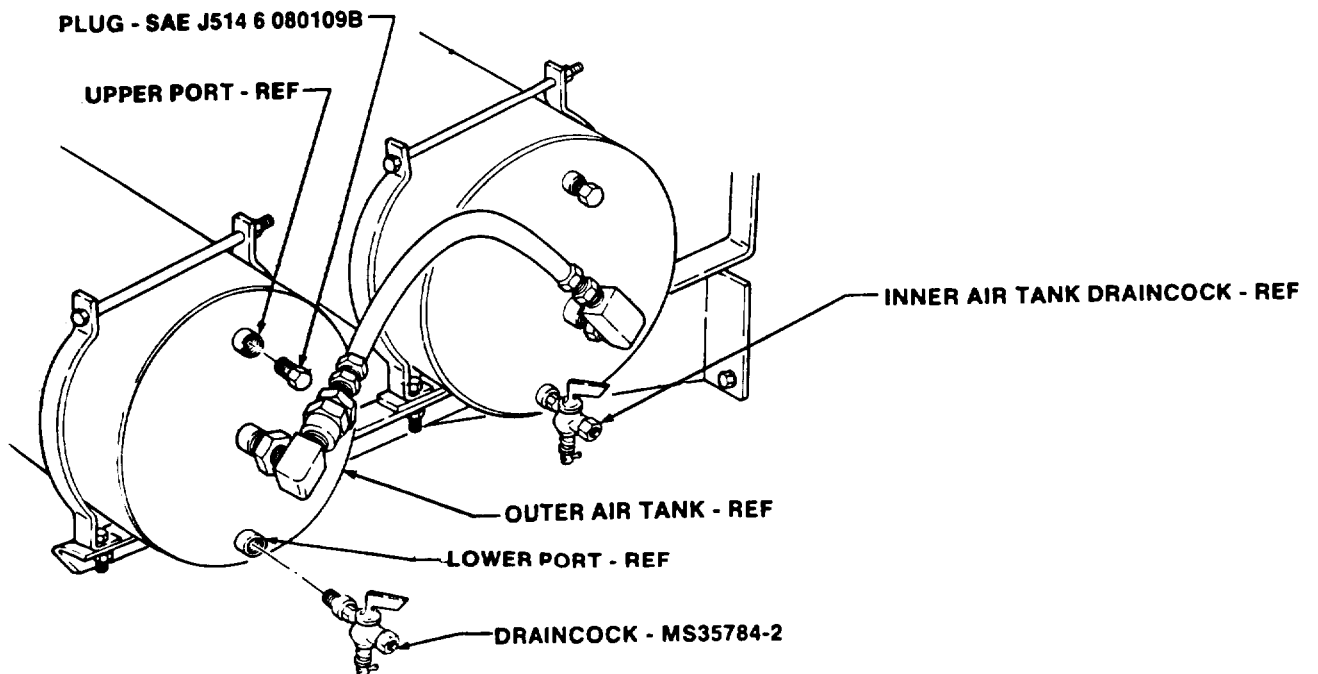

FIGURE 10

(11) Install two SAE J514 6080109B plugs in rear upper ports on outer air tank as shown in figure 11.

(12) Install SAE J530 12-8 130140B bushing in port on rear of outer air tank as shown in figure 11.

(13) Install SAE J246 10-8 100202BA elbow assembly in bushing on outer air tank as shown in figure 11. Retain sleeve and nut for use in step 17.

(14) Cut off one inch of existing 5/8-inch yellow transmission airline as shown in figure 11, and discard fitting.

(15) Install SAE 1246 10-10100101BA union assembly on 5/8-inch yellow transmission airline and secure with sleeve and nut as shown in figure 11. Retain sleeve and nut for use in step 16.

(16) Install CPR104420-4 tube on union and secure with sleeve and nut as shown in figure 11.

(17) Route tube to elbow in rear of outer tank, cut tube, and secure to elbow with nut and sleeve as shown in figures 11 and 12. Sleeve and nut retained from step (13).

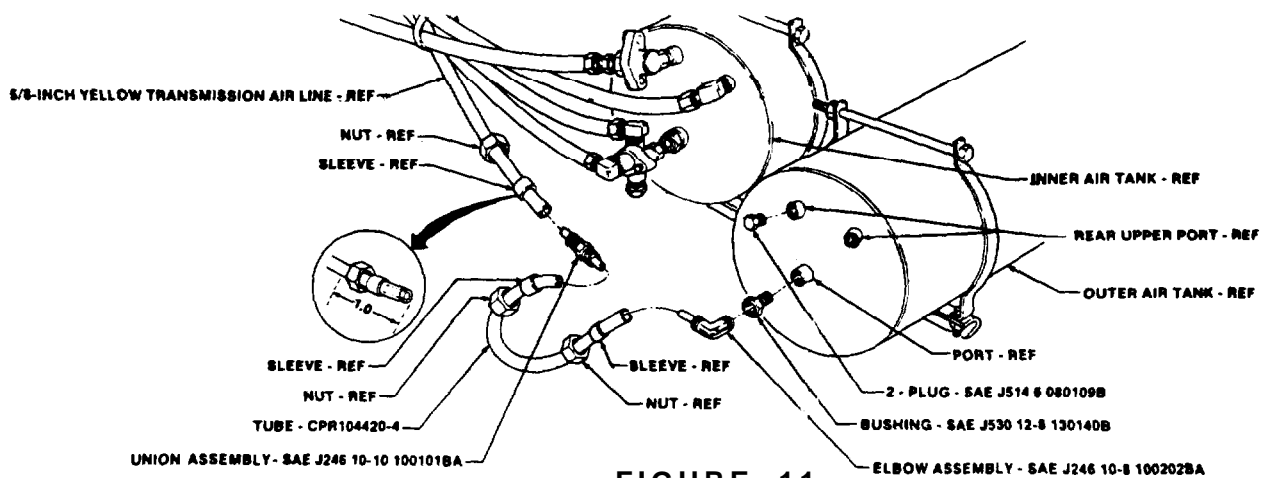

FIGURE 11

(18) Remove screw from shuttle valve and install MS21333-114 clamp around tube and secure tube to shuttle valve with screw and MS27183-9 washer as shown in figure 12.

(19) Secure 5/8-inch yellow transmission air line to air lines with MS3367-7-9 strap as shown in figure 12.

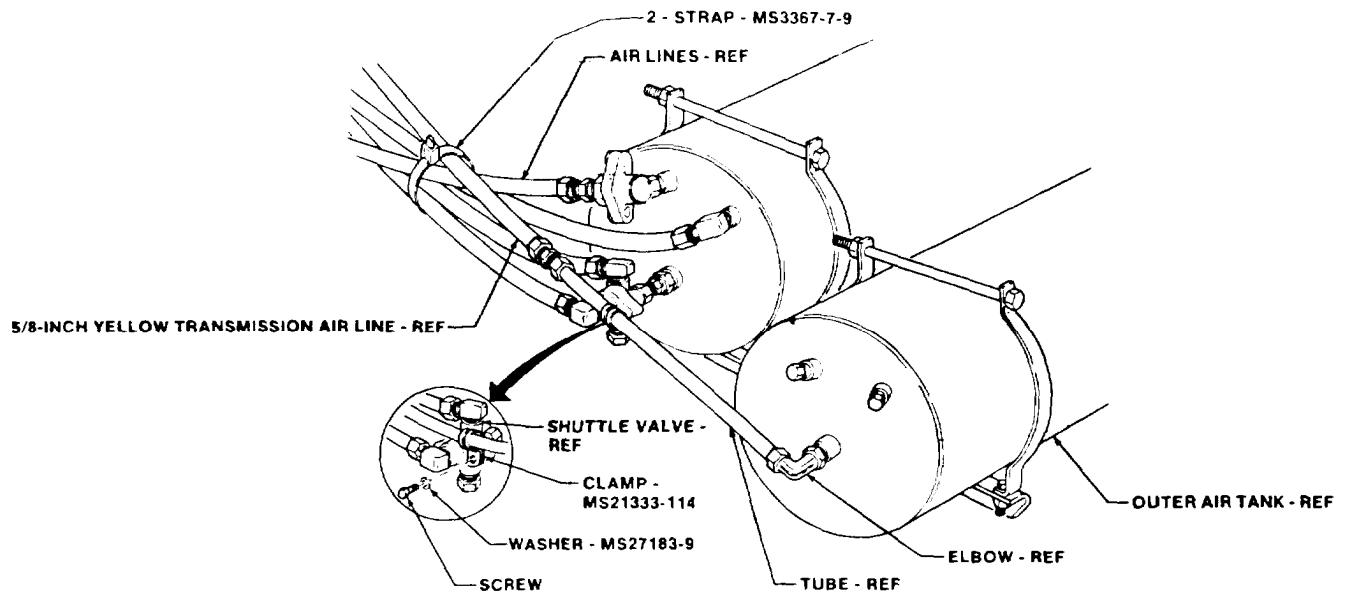

FIGURE 12

c. Vehicle Equipment.

- (1) Start vehicle and build air pressure up to operating range (refer to TM 9-2320-273-10).
- (2) Inspect vehicle for air leaks, loose fittings, screws, and nuts (refer to TM 9-2320-273-10).
- (3) Shut off vehicle, drain air system by opening draincock on inner air tank as shown in figure 10.
- (4) Engage transmission air charging valve knob and shift from first gear through fifth gear ranges.
- (5) Return transmission to neutral and disengage transmission charging valve knob.
- (6) Repeat step 1 and road test vehicle (refer to TM 9-2320-273-10)

NOTE

Spot paint as required.

11. CALIBRATION REQUIREMENTS. Not applicable.

12. WEIGHT AND BALANCE DATA. Not applicable.

11. CALIBRATION REQUIREMENTS. Not applicable.

12. WEIGHT AND BALANCE DATA. Not applicable.

13. QUALITY ASSURANCE REQUIREMENTS. Perform quality assurance inspection, including performance testing, appearance, and uniformity in accordance with TM 750-245-4.

14. RECORDING AND REPORTING OF THE MODIFICATION.

a. Records and Reports: Record the modification in accordance with AR 750-10, DA PAM 738-750, DA PAM 738-751 and TB 9-1100-803-15.

b. Marking Equipment.

(1) After the kit is installed, mark MWO Number "9-2320-273-20-1" in MWO Applied Block and date applied in Date Block on MWO Data Plate NSN 9905-00-858-5682.

(2) Install MWO date plate by drilling one 3/64 inch (#37 drill) hole in cab door and secure with drivescrew NSN 5305-00-253-5614 as shown in illustration.

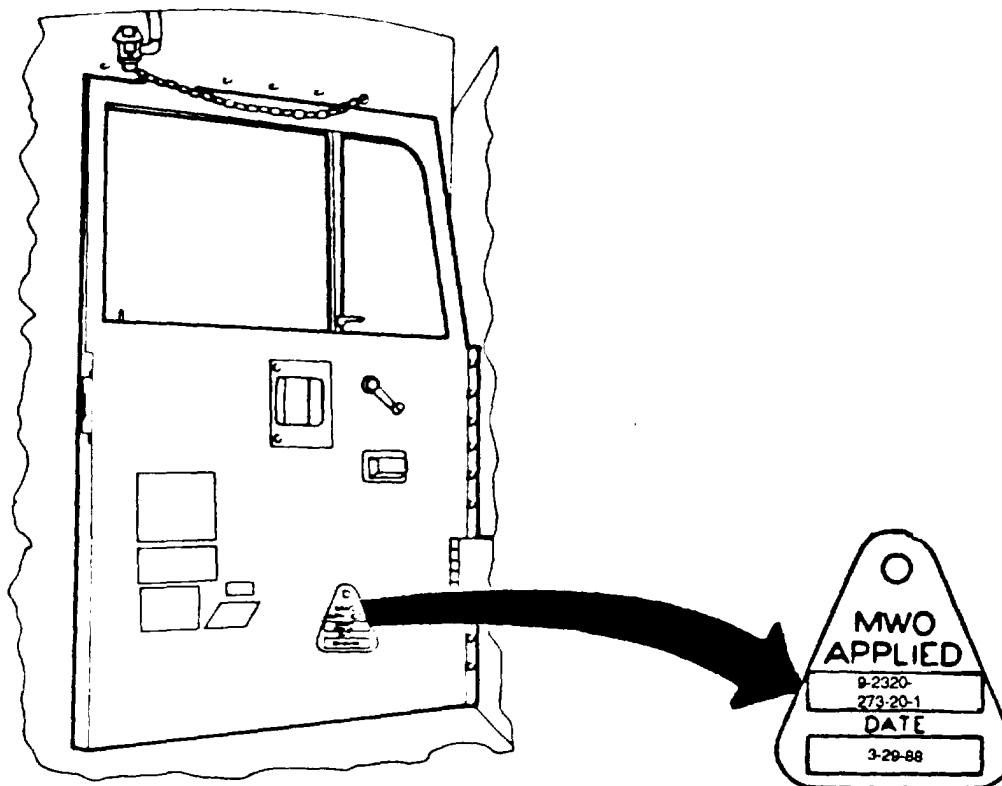

c. Identification Data: Not applicable.

15. PRODUCT IMPROVEMENT PROPOSAL. This MWO is authorized by PIP number 1-84-06-4041.

16. MODIFICATION IDENTIFICATION. Refer to paragraph 10.

By Order of the Secretary of the Army:

Official:

WILLIAM J. MEEHAN II
Brigadier General, United States Army
The Adjutant General

C A R L E . V U O N O
General, United States Army
C h i e f o f S t a f f

Distribution:

To be distributed in accordance with DA Form 12-38, Unit maintenance requirements for Truck, Tractor, Line Haul, 6x4, M915; LET, 6x6, M916; 8x6, M917; 6x6, M918; 8x6, M919; 8x6, M920.

This fine document...

Was brought to you by me:



[Liberated Manuals -- free army and government manuals](#)

Why do I do it? I am tired of sleazy CD-ROM sellers, who take publicly available information, slap “watermarks” and other junk on it, and sell it. Those masters of search engine manipulation make sure that their sites that sell free information, come up first in search engines. They did not create it... They did not even scan it... Why should they get your money? Why are not letting you give those free manuals to your friends?

I am setting this document FREE. This document was made by the US Government and is NOT protected by Copyright. Feel free to share, republish, sell and so on.

I am not asking you for donations, fees or handouts. If you can, please provide a link to liberatedmanuals.com, so that free manuals come up first in search engines:

<A HREF=<http://www.liberatedmanuals.com/>>Free Military and Government Manuals

- Sincerely
Igor Chudov
<http://igor.chudov.com/>
- [Chicago Machinery Movers](#)