

LUBRICATION ORDER  
17 September 1991

LO 9-2805-262-12  
(Supersedes LO 9-2805-203-12, 15 February 1990)

---

ENGINE, GASOLINE 6 HP,  
MILITARY STANDARD MODELS  
(MODEL 4A032-1, NSN 2805-00-776-0483)  
(MODEL 4A32-2, NSN 2805-00-068-7512)  
(MODEL 4A032-3, NSN 2805-01-139-0596)  
(MODEL 4A032-4, NSN 2805-01-276-5946)

References: TM 9-2805-262-14/andC9100-IL

#### REPORTING OF ERRORS

You can help improve this publication. If you find mistakes or if you know of a way to improve the procedures, please let us know. Your letter or DA Form 2028 (Recommended Changes to Publications and Blank Forms) should be mailed directly to: Commander, U.S. Army Troop Support Command, ATTN: AMSTR-MMTS, 4300 Goodfellow Blvd., St. Louis, MO 63120-1798. A reply will be furnished to you.

---

#### NOTES

This LO is for (C) crew/operator or organization (0) maintenance. Lube intervals (on condition or hard time) and task-hour times are based on normal hours of operation. Change the intervals if your lubricants are contaminated or if you are operating the equipment under adverse conditions. Lube more during constant use and less during inactive periods. Adequate preservation precautions must be taken during inactive periods.

#### WARNING

Drycleaning Solvent PD-680 used to clean parts is potentially dangerous to personnel and property. Avoid repeated and prolonged skin contact. Do not use near open flame or excessive heat. Flash point of solvent is 100°F-138°F (38°C-60°C).

Clean parts with drycleaning solvent PD-680 and dry before lubricating.

Before you start your lube service.

#### ALWAYS

- a. Clean parts before lubricating.
- b. Use the lubrication order as your guide

#### NEVER

- a. Use wrong type/grade lubricant.
- b. Use too much lubricant.

The 6 HP military standard engine, gasoline is not enrolled in the Army Oil Analysis Program (AOAP). HARD TIME INTERVALS APPLY.

DISTRIBUTION STATEMENT A—Approved for public release; Distribution is unlimited.

\*The time specified is the time required to perform all services at the particular interval (on condition or hard time).

| *TOTAL TASK-HR |         | *TOTAL TASK-HR |         |
|----------------|---------|----------------|---------|
| INTERVAL       | TASK-HR | INTERVAL       | TASK-HR |
| 8              | 0.1     | 500            | 0.3     |
| 50             | 0.5     |                |         |

LUBRICANT • INTERVAL

INTERVAL • LUBRICANT

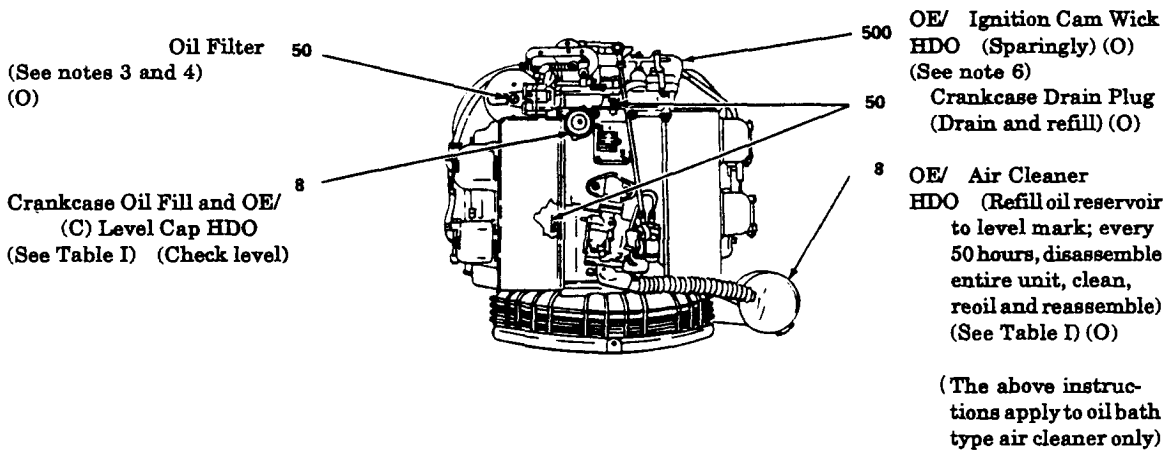

| Temperature Range              | Lubricant<br>Mil. symbol<br>(NATO Code)<br>Specification | Capacity         | Interval | TASK<br>HOUR |
|--------------------------------|--|------------------|----------|--------------|
| 0°C to +55°C (+32°F to +120°F) | OE/HDO 15/40<br>(0-1236)<br>MIL-L-2104                   | 2-1/8 qt (2.0 L) | 50 hr    | .05          |
| 5°C to -23°C (+40°F to -10°F)  | OE/HDO-10<br>(0-237)<br>MIL-2104                         | 2-1/8 qt (2.0 L) | 50 hr    | .05          |
| 18°C to -50°C (1°F to -5°F)    | OEA<br>(0-183)<br>MIL-L-46167                            | 2-1/8 qt (2.0 L) | 50 hr    | .05          |

1. **FOR OPERATION OF EQUIPMENT IN PROTRACTED COLD TEMPERATURES BELOW -10°F (-23°C).** Remove lubricants prescribed in the key for temperature above -10°F (-23°C). Clean parts with drycleaning solvent PD-680. Relubricate with lubricants specified in the key for temperatures below -10° (-23°C).
2. **OIL CAN POINTS.** Every 25 hours lubricate all exposed adjusting threads with OE/HDO.
3. **OIL FILTER-Element Type.** Every 50 hours remove filter element, clean housing, install new element.
4. **OIL FILTER-Spin-On Type.** Every 50 hours remove oil filter, clean housing, and install new oil filter.
5. **CRANKCASE-Drain crankcase when hot.** Every 50 hours drain and refill crankcase, operate engine for five minutes, check for leaks, check crankcase oil level, and bring to FULL mark.
6. **Insure cam wick is lubricated with OE/HDO (sparingly) whenever ignition contact points are replaced or adjusted.**
7. **For artic operation, refer to TM 9-207.**

**A copy of this Lubrication Order will remain with the equipment at all times; instructions contained here in are mandatory.**

**By Order of the Secretary of the Army**

**GORDON R. SULLIVAN**  
*General, United States Army*  
*Chief of Staff*

**Official:**

**PATRICIA P. HICKERSON**  
*Brigadier General, United States Army*  
*The Adjutant General*

**DISTRIBUTION**

**To be distributed in accordance with DA Form 12-25A, Operator and Unit Maintenance Requirements for Engine, Gasoline, 6HP, Models 4A0321/1213.**



This fine document...

Was brought to you by me:



## [Liberated Manuals -- free army and government manuals](#)

Why do I do it? I am tired of sleazy CD-ROM sellers, who take publicly available information, slap “watermarks” and other junk on it, and sell it. Those masters of search engine manipulation make sure that their sites that sell free information, come up first in search engines. They did not create it... They did not even scan it... Why should they get your money? Why are not letting you give those free manuals to your friends?

I am setting this document FREE. This document was made by the US Government and is NOT protected by Copyright. Feel free to share, republish, sell and so on.

I am not asking you for donations, fees or handouts. If you can, please provide a link to [liberatedmanuals.com](http://liberatedmanuals.com), so that free manuals come up first in search engines:

<A HREF=<http://www.liberatedmanuals.com/>>Free Military and Government Manuals</A>

- Sincerely  
Igor Chudov  
<http://igor.chudov.com/>
- [Chicago Machinery Movers](#)