

LUBRICATION

8 JANUARY 1971 (Supersedes LO 5-2410-227-12, dtd 16 March 1970)

ORDER

TRACTOR, FULL TRACKED; D E D; 9900 LB. DRAWBAR PULL,
 W/DOZER BLADE, BACK RIP SCARIFIER (J.I. CASE MODEL
 M-450) AND LOADER SCOOP-TYPE; W/FORK LIFT
 ATTACHMENT (J.I. CASE MODEL M-450-L)
 W/ENGINE CASE MODEL G188D

Reference: LO 5-2410-227-12-1 and C9100-IL

Intervals are based on normal hours of operation. Adjust to compensate for abnormal operation and severe conditions. During inactive periods, sufficient lubrication must be performed for adequate preservation.

Clean parts with SOLVENT, dry-cleaning, or with OIL, fuel, Diesel. Dry before lubricating.

Relubricate after washing.

Lubricate points indicated by dotted arrow shaft on both sides of equipment.

Clean fitting before lubricating,

FOLD

FOLD

LUBRICANT ● INTERVAL

INTERVAL ● LUBRICANT

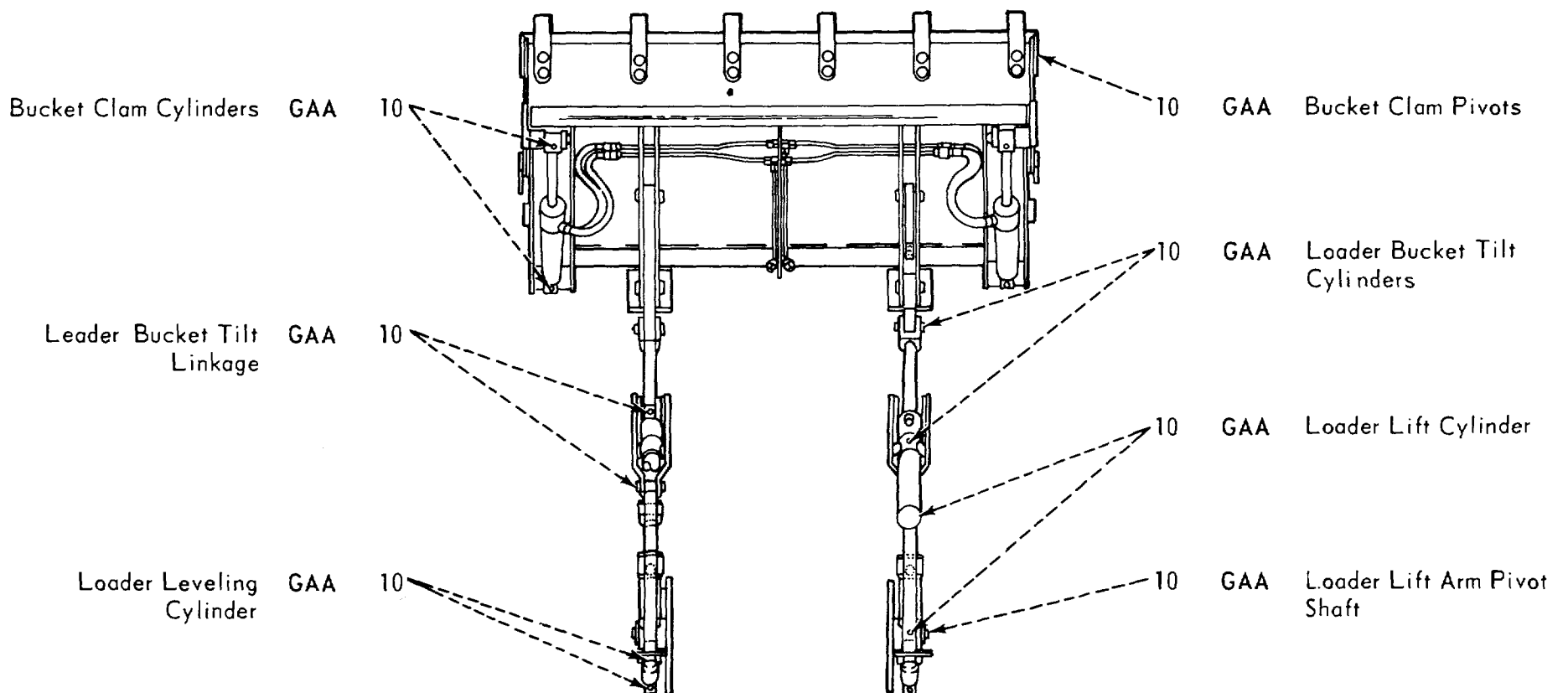

LOADER SCOOP TYPE

LUBRICANT ● INTERVAL

INTERVAL ● LUBRICANT

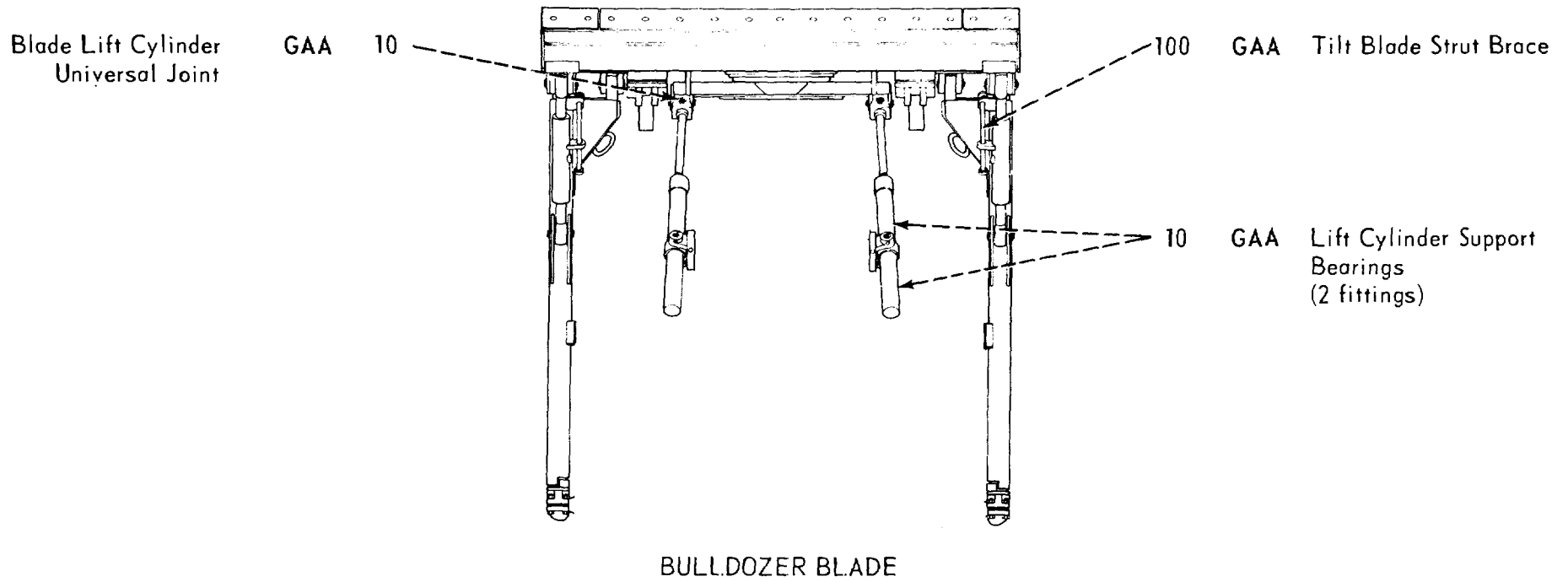

FOLD

FOLD

-KEY-

LUBRICANTS	CAPACITY	ALL TEMPERATURES	INTERVALS
OE-OIL, Engine, heavy Duty		HDO 30	Intervals given are in hours of normal operation.
Oil Can Points			
GAA-GREASE, Automotive and Artillery		GAA	

- NOTES:
- FOR OPERATION OF EQUIPMENT IN PROTRACTED COLD TEMPERATURES BELOW 10°F. Remove lubricants prescribed in the key for temperatures above -10°F. Relubricate with lubricants specified in the key for temperatures below -10°F.
 - OIL CAN POINTS. Every 50 hours lubricate control linkage, and all exposed adjusting threads with HDO.
 - LUBRICANTS. The following is a list of lubricants with the Military Symbols and applicable Specification numbers.

HDO MIL-L-45199	GAA MIL-G-10924
-----------------	-----------------
- Copy of this Lubrication Order will remain with the equipment at all times; instructions contained herein are mandatory.
- BY ORDER OF THE SECRETARY OF THE ARMY:
- W. C. WESTMORELAND
General, United States Army
Chief of Staff
- OFFICIAL:
- KENNETH G. WICKHAM,
Major General, United States Army,
The Adjutant General.

LO 5-2410-227-12-2 DISTRIBUTION: To be distributed in accordance with DA Form 12-25, Section II, (qty rqr block #474) organizational maintenance requirements for Tractors, Tracked, Light.

This fine document...

Was brought to you by me:



[Liberated Manuals -- free army and government manuals](#)

Why do I do it? I am tired of sleazy CD-ROM sellers, who take publicly available information, slap “watermarks” and other junk on it, and sell it. Those masters of search engine manipulation make sure that their sites that sell free information, come up first in search engines. They did not create it... They did not even scan it... Why should they get your money? Why are not letting you give those free manuals to your friends?

I am setting this document FREE. This document was made by the US Government and is NOT protected by Copyright. Feel free to share, republish, sell and so on.

I am not asking you for donations, fees or handouts. If you can, please provide a link to liberatedmanuals.com, so that free manuals come up first in search engines:

<A HREF=<http://www.liberatedmanuals.com/>>Free Military and Government Manuals

- Sincerely
Igor Chudov
<http://igor.chudov.com/>
- [Chicago Machinery Movers](#)