

LUBRICATION ORDER

LO 10 3930-624 12

12 March 1984

(Supersedes LO 10-3930-624-12-1, and -2; 24 FEBRUARY 1971)

TRUCK, LIFT, FORK; POWER SHIFT, GED,
6,000 LB CAPACITY, SRT, 180 INCH LIFT,
(ALLIS CHALMERS MODEL F60-24PS-180)
(ARMY MODEL MHE 212) (NSN 3930-00-489-0263)

Reference: TM 10-3930-624-12 and FEDERAL SUPPLY CATALOG C9100-IL.

Hard time intervals and the related man-hour times are based on normal operation. The man-hour time specified is the time you need to do all the services prescribed for a particular interval. Change the hard time interval if your lubricants are contaminated or if you are operating the equipment under adverse operating conditions, including longer than-usual operating hours. The hard time interval may be extended during periods of low activity. If extended, adequate preservation precautions must be taken.

WARNING

Dry cleaning fluid is flammable. Do not use near a flame or excessive heat. Use only with adequate ventilation. Avoid prolonged breathing of vapors and minimize skin contact.

Clean parts or fittings with dry cleaning solvent (SD), Type II or equivalent. Dry before lubricating. Dotted arrow shafts indicate lubrication on both sides of equipment. A dotted circle indicates a drain below. Relubricate all items found contaminated after fording or washing.

The lowest level of maintenance authorized to lubricate a point is indicated by one of the following symbols as appropriate: Operator/Crew (C); and Organizational Maintenance (O).

Reporting errors and recommending improvements.

You can help improve this manual. If you find any mistakes, or if you know of a way to improve the procedures, please let us know. Mail your letter or DA Form 2028 (Recommended Changes to Publications and Blank Forms) direct to: Commander, US Army Tank-Automotive Command, ATTN: DRSTA-MB, Warren, MI 48090. A reply will be furnished to you.

*The time specified is the time required to perform all services at the particular interval.

*TOTAL MAN-HOURS		*TOTAL MAN-HOURS	
INTERVAL	MAN-HOURS	INTERVAL	MAN-HOURS
10	0.3	500	1.0
50	0.3	1000	3.3
250	2.1		

TA 220164

LO 10-3930-624 12

CARD 1 OF 7

LUBRICANT • INTERVAL

INTERVAL • LUBRICANT

Transmission and Converter Oil Filter (O)
(See Note 8)

Distributor (O) **OE/HDO**
(See Note 7)

Crankcase Fill Cap (C) **OE/HDO**
(See Key)

Crankcase Level Gage (C)
(Check level)
CAUTION: When OEA Oil is used the level will be checked more often. (See Note 3)

Oil Filter (O)
(See Note 5)

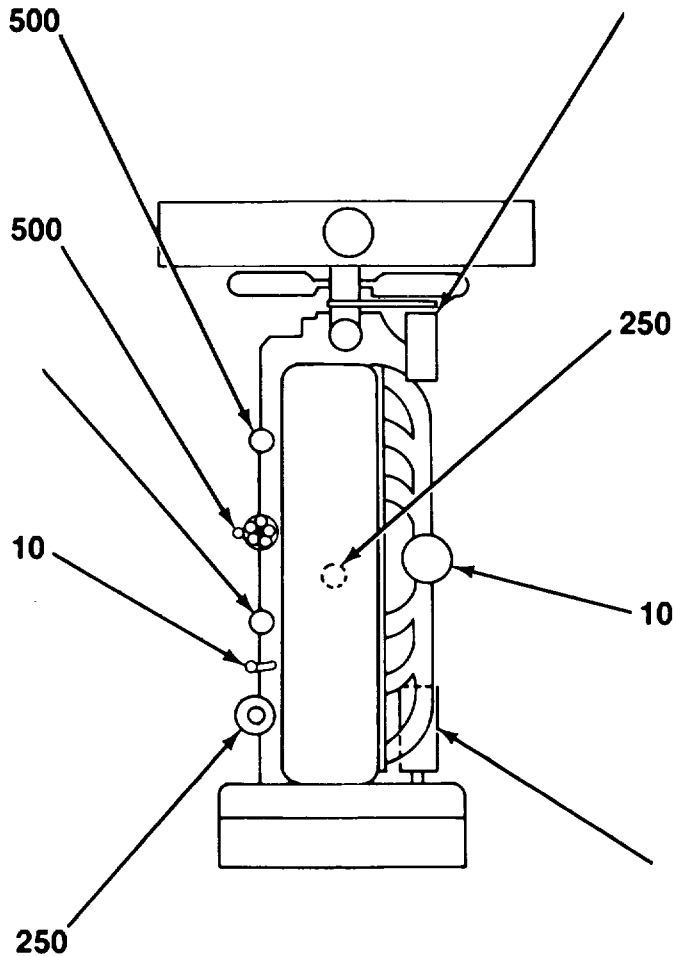

Engine Accessory Alternator (Sealed bearings, no lubrication required)

Crankcase Oil Drain Plug (O)
(Drain and refill)
(See Note 4)

10 OE/HDO Air Cleaner (C)
(See Key)
(See Note 6)

Starter (Sealed bearings, no lubrication required)

LUBRICANT • INTERVAL

INTERVAL • LUBRICANT

Carriage and Mast
Wear Plates (0)
(Clean and coat)

GAA 250

250 GAA Carriage Fork and
Latch (0)
(Clean and coat)

Differential
Drain Plug (0)
(Drain and refill)
(See Note 13)

C/MR

250 GO Differential Fill
and Level Plug (0)
(Check level and
fill) (See Key)

Hydraulic Steer
Cylinder (0)

GAA 250

1000 Hydraulic Reservoir
Filter (0)
(Remove cowl to
service) (See
Note 10)

Universal Joint (0)
(See Note 12)

GAA 500

1000 Hydraulic Reservoir
Drain Plug (0)
(Drain and refill)
(See Note 10)

King Pin (0)
(4 fittings)

GAA 250

**50 OE/
HDO** Hydraulic Reservoir
Fill and Level
Cap (C)
(Check level and
fill) (See Key)
(Remove plug in
floor plate to service)

Rear Drag Link (0)

GAA 250

250 GAA Tie Rods (0)

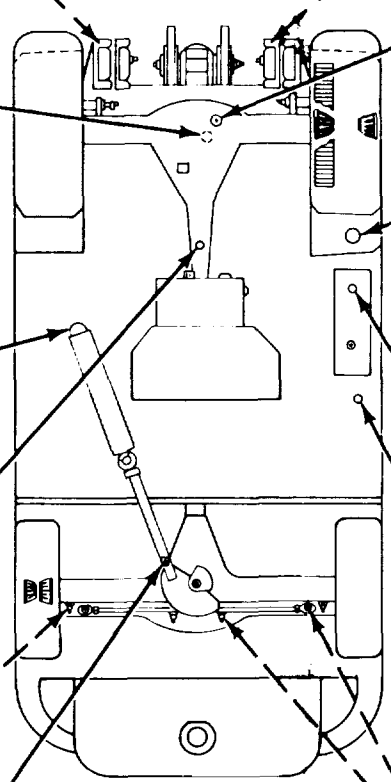

LUBRICANT • INTERVAL

INTERVAL • LUBRICANT

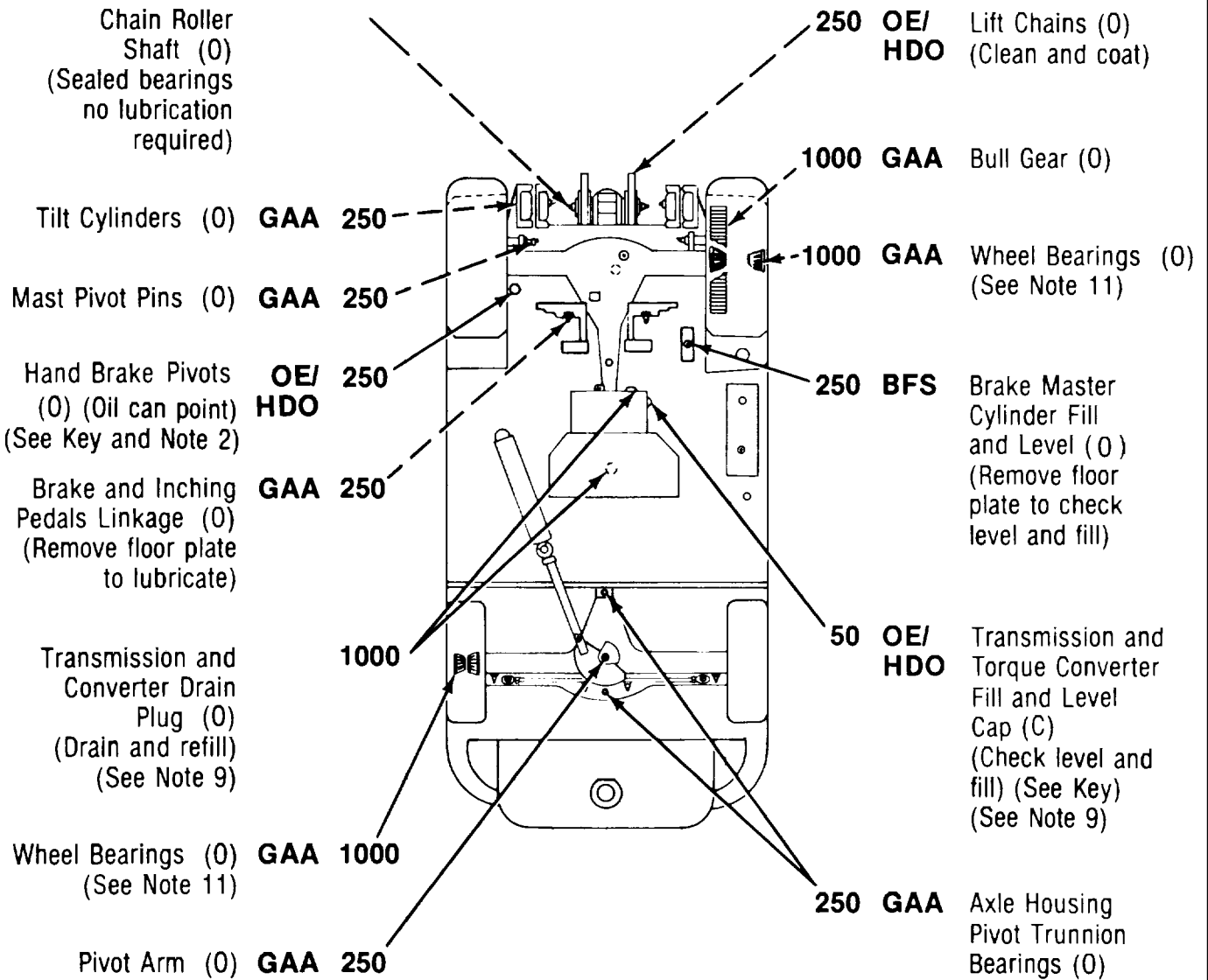

* KEY -

LUBRICANTS	CAPACITY	EXPECTED TEMPERATURES			INTERVALS
		Above + 15°F (Above -9°C)	+ 40° to -15°F (+ 4° to -26°C)	+ 40° to -65°F (+ 4° to -54°C)	
OE/ HDO - Lubricating Oil, Internal Combustion Engine, Tactical Service OEA - Lubricating Oil, Internal Combustion, Arctic - Engine Crankcase W/Filter - Oil Can Points (See Note 2)	7 qts. (6.62 L)	OE/HDO 30	OE/HDO 10	OEA (See Note 1)	C/MR Condition Monitor Intervals given are in hours of normal operation.
- Transmission and Converter	10 qts. (9.46 L)				
- Hydraulic Oil Reservoir W/Filters	38 qts. (35.94 L)				
- Air Cleaner	1/4 qt. (0.24 L)				
GO - Lubricating Oil, Gear, Multipurpose - Differential Axle	5 pts. (2.36 L)	GO 85W/145	GO 80W/90	GO 75W	For Arctic operation refer to FM 9-207
BFS - Brake Fluid, Silicone, Automotive - Brake Master Cylinder	5/16 qt. (0.3 L)	ALL TEMPERATURES			
GAA - Grease, Automotive and Artillery		ALL TEMPERATURES			

*See Note 14 for lubricant specification number.

NOTES:

1. FOR OPERATION OF EQUIPMENT IN PROTRACTED COLD TEMPERATURES BELOW -15°F (-260C). Remove lubricants prescribed in Key for temperatures above -150F (-260C). Relubricate with lubricants specified in Key for temperatures below -150F (-260C). If OEA lubricant is required to meet the temperature ranges prescribed in the Key, OEA lubricant is to be used in place of OE/HDO-10 lubricant for all temperature ranges where OE/HDO-10 is specified in the Key.

2. OIL CAN POINTS. Each 250 hours, lubricate shift linkage, control valve linkage, brake linkage, and all other oil can points with OE/HDO.

3. ENGINE OIL LEVEL HOT OR COLD CHECK. Cold engine, oil level should be at high mark on dipstick. Hot engine, oil level must be between high and low marks on dipstick (allow to set 5 minutes before checking).

4. ENGINE. Oil is to be changed each 250 hours. Drain when lubricant is warm.

5. ENGINE OIL FILTER. Each 250 hours, remove filter element, clean housing and install new filter element. After installing new filter element, fill crankcase, operate engine for 5 minutes, check housing for leaks, check crankcase oil level and bring to "FULL" mark.

6. AIR CLEANER. Each 10 hours, refill reservoir to level mark. Each 100 hours disassemble entire unit, clean, re-oil and assemble.

7. DISTRIBUTOR. Each 500 hours, lubricate rotor wick with 3 or 4 drops of OE/HDO. Apply very light coat of GAA to breaker cam.

8. TRANSMISSION AND CONVERTER OIL FILTER. Each 500 hours, remove filter element, clean filter housing, install new filter element and gasket. After replacement, with engine running at idle speed, oil at operating temperature and transmission in neutral, add oil to bring oil level to "FULL" mark. Operate for 5 minutes and check filter housing for leaks.

9. TRANSMISSION AND CONVERTER. Check level each 50 hours with engine running at idle speed, oil at operating temperature, and transmission in neutral. Maintain oil level at "FULL" mark. Each 1000 hours drain transmission and converter. Gain access to converter drain plug through timing gear opening on engine flywheel housing. Rotate flywheel until drain plug is in opening. Remove filter element, clean filter housing, install new filter element and gasket. Fill transmission to low mark. Run engine at idle speed to fill converter and lines. With engine running at idle speed, oil at operating temperature and transmission in neutral, add oil to bring oil level to "FULL" mark. Operate for 5 minutes and check for leaks.

10. HYDRAULIC SYSTEM AND HYDRAULIC RESERVOIR FILTER. Each 1000 hours, drain the hydraulic system, remove filter element, clean filter shell, install new filter element and gasket. Clean fill cap. Fill hydraulic reservoir, operate equipment for 5 minutes, check for leaks, check oil level and bring to "FULL" mark.

11. WHEEL BEARINGS. Each 1000 hours, remove wheels, clean and inspect all parts, replace damaged or worn parts, repack bearings, and assemble.

TA 220169

NOTES - CONTINUED:

12. UNIVERSAL JOINT. Each 500 hours, remove joint, disassemble, clean and inspect, replace damaged or worn parts, pack bearings, and assemble.

13. DIFFERENTIAL. Check level each 250 hours. Change gear lubricant only when required by maintenance repair action, contamination by water or other foreign material. After refill, operate for five minutes, check for leaks and bring oil level to fill and level plug opening.

14. LUBRICANTS. The following is a list of lubricants with military symbols and applicable specification numbers.

OE/HDO MIL-L-2104
GO MIL-L-2105
GAA MIL-G-10924
OEA MIL-L-46167
BFS MIL-B-46176
(SD), Type II P-D-680

Copy of this Lubrication Order will remain with the equipment at all times, instructions contained herein are mandatory.

By order of the Secretary of the Army:

JOHN A. WICKHAM, JR.
General, United States Army
Chief of Staff

OFFICIAL:

ROBERT M. JOYCE
Major General, United States Army
The Adjutant General

DISTRIBUTION:

To be distributed in accordance with DA Form 12-25A, Operator and Organizational maintenance requirements for Fork Lifts.

TA 220170

RECOMMENDED CHANGES TO EQUIPMENT TECHNICAL PUBLICATIONS



THEN... JOT DOWN THE DOPE ABOUT IT ON THIS FORM, CAREFULLY TEAR IT OUT, FOLD IT AND DROP IT IN THE MAIL!

SOMETHING WRONG WITH THIS PUBLICATION?

FROM: (PRINT YOUR UNIT'S COMPLETE ADDRESS)

DATE SENT

PUBLICATION NUMBER

PUBLICATION DATE

PUBLICATION TITLE

BE EXACT... PIN-POINT WHERE IT IS

PAGE NO.

PARA-GRAPH

FIGURE NO.

TABLE NO.

IN THIS SPACE TELL WHAT IS WRONG AND WHAT SHOULD BE DONE ABOUT IT:

TEAR ALONG PERFORATED LINE

PRINTED NAME, GRADE OR TITLE, AND TELEPHONE NUMBER

SIGN HERE:

This fine document...

Was brought to you by me:



[Liberated Manuals -- free army and government manuals](#)

Why do I do it? I am tired of sleazy CD-ROM sellers, who take publicly available information, slap “watermarks” and other junk on it, and sell it. Those masters of search engine manipulation make sure that their sites that sell free information, come up first in search engines. They did not create it... They did not even scan it... Why should they get your money? Why are not letting you give those free manuals to your friends?

I am setting this document FREE. This document was made by the US Government and is NOT protected by Copyright. Feel free to share, republish, sell and so on.

I am not asking you for donations, fees or handouts. If you can, please provide a link to liberatedmanuals.com, so that free manuals come up first in search engines:

<A HREF=<http://www.liberatedmanuals.com/>>Free Military and Government Manuals

- Sincerely
Igor Chudov
<http://igor.chudov.com/>
- [Chicago Machinery Movers](#)