

OPERATOR, ORGANIZATIONAL, FIELD,
AND DEPOT MAINTENANCE MANUAL

THEODOLITE; DIRECTIONAL
2/10 SEC, DEGREE GRADUATION
10.2-IN. LONG TELESCOPE
W / ACCESSORIES

(WILD HEERBRUGG MODEL T-3)

FSN 6675-382-9140

This copy is a reprint which includes
current pages from Change 4.

DEPARTMENTS OF THE ARMY AND THE AIR FORCE

JUNE 1963

Change }
No. 4 }

DEPARTMENTS OF THE ARMY
AND THE AIR FORCE
WASHINGTON, D.C., 15 August 1978

**Operator, Organizational, Field and Depot Maintenance Manual
THEODOLITE, SURVEYING, DIRECTIONAL, 2/10 SEC.
DEGREE GRADUATION; 10.2 INCH LONG TELESCOPE W / ACCESSORIES
(WILD HEERBRUGG MODEL T-3) NSN 6675-00-382-9140
(WILD HEERBRUGG MODEL T3-1969) NSN 6675-00-411-5446**

TM 5-6675-231-15/TO 49A8-10-1, 28 June 1963 is changes as follows:

Cover and table of contents page are changed as shown above.

Page 1. Immediately after title add the following:

Reporting Errors and Recommending Improvements

You can help improve this manual. If you find any mistake or if you know of a way to improve the procedures, please let us know. Mail your letter, DA Form 2028 (Recommended Changes to Publications and Blank Forms), or DA Form 2028-2 located in the back of this manual direct to Commander, US Army Troop Support and Aviation Materiel Readiness Command, ATTN: DRSTSMTPS, 4300 Goodfellow Blvd., St. Louis, Missouri 63120. A reply will be furnished directly to you.

Page 2. The appendices are changed as follows:

- Appendix I. Reference
- Appendix II. Component of End Item List
- Appendix III. Additional Authorization List
- Appendix IV. Maintenance Allocation Chart
- Appendix V. Expendable Supplies and Materials List

Page 3. Paragraph 1b is superseded as follows:

b. Appendix I contains a list of publications applicable to this manual. Appendix II contains a list of components of end item. Appendix III contains the additional authorization list. Appendix IV contains the maintenance allocation chart. Appendix V contains the expendable supplies and materials list. The organizational, field, and depot maintenance repair parts and special tools list are listed in TM 5-6675-231-25P.

Paragraph 1d is deleted in its entirety.

Paragraph 1e is changed to read paragraph 1d.

Page 92. Change "Appendix II, Maintenance Allocation Chart" to read "Appendix IV, Maintenance Allocation Chart" and add after Appendix III.

Appendix II. After Appendix I add "Appendix II, Components of End Item List".

*This change supersedes C3, 25 June 1973

APPENDIX II COMPONENTS OF END ITEMS LIST

Section I. INTRODUCTION

1. Scope

This appendix lists Integral Components of and Basic Issue Items (BII) for the Directional Theodolite to help you inventory items required for safe and efficient operation.

2. General

The components of end item list are divided into the following sections:

a. Section II. Integral Components of the End Item. These items, when assembled, comprise the Directional Theodolite and must accompany it whenever it is transferred or turned in. These illustrations will help you identify these items.

b. Section III. Basic Issue Items. These are minimum essential items required to place the Directional Theodolite in operation, to operate it and to perform emergency repairs. Although shipped separately packed, they must accompany the Directional Theodolite during operation and whenever it is transferred between accountable officers. The illustrations will assist you with hard-to-identify items. This manual is your authority to requisition replacement BII based on Table(s) of Organization and Equipment (TOE)/Modification Table of Organization and Equipment (MTOE) authorization of the end item.

3. Explanation of Columns

a. Illustration. This column is divided as follows.

- (1) *Figure Number.* Indicates the figure number of the illustration on which the item is shown (if applicable).

- (2) *Item Number.* The number used to identify item called out in the illustration.

b. National Stock Number (NSN). Indicates the national stock number assigned to the end item which will be used for requisitioning.

c. Part Number (P/N). Indicates the primary number used by the manufacturer which controls the design and characteristics of the item by means of its engineering drawings, specifications, standards and inspection requirements to identify an item or range of items.

d. Description. Indicates the federal item name and if required, a minimum description to identify the item.

e. Location. The physical location of each item listed is given in this column. The lists are designated to inventory all items in one area of the major item before moving on to an adjacent area.

f. Usable on Code. Not applicable.

g. Quantity Required (Qty Reqd). This column lists the quantity of each item required for a complete major item.

h. Quantity. This column is left blank for use during inventory. Under the received column, list the quantity you actually receive on your major item. The date columns are for use when you inventory the major item at a later date, such as for shipment to another site.

Section II. INTEGRAL COMPONENTS OF END ITEM

(1) ILLUSTRATION		(2)	(3)	(4)	(5)	(6)	(7)	(8) QUANTITY			
(a) FIG NO.	(b) ITEM NO.	NATIONAL STOCK NUMBER	PART NO.	DESCRIPTION	LOCA- TION	USABLE ON CODE	QTY REQ	RCV'D	DATE	DATE	DATE
		6675-00-472-7060	130348 (89905)	Cap. Dust			1				
		6675-01-014-3516	360473 (89905)	Mirror			2				
7			326747 (89905)	Case Assy, Consisting of:			1				
7			288983 (89905)	Hood Assy			1				
7		6675-00-963-6365	138656-74 (89905)	Base Assy			1				
13		6675-00-127-2857	316083 (89905)	Container Desiccant			1				
6		6675-00-020-9941	311737 (89905)	Case Assy, Shipping			1				
6		5340-00-682-1508	MS35647-3 (96906)	Padlock w/2 Keys			2				
				Case, Acces- sory Consisting of:							
10		6675-00-446-1765	NT3-260-492 (89905)	Sunglass Assembly			1				
10		6675-00-714-1336	216168 (89905)	Sunglass III Assembly			1				
10		6675-00-714-1337	236600 (89905)	Case Ac- cessory			1				
10		6675-00-560-5654	214077 (89905)	Cover In- strument			1				
10		6675-00-446-1768	XT16-116A (89905)	Sunglass Assembly			1				
10		6675-00-842-2124	NT2-381-382-383 (89905)	Prism As- sembly, Eyepiece Telescope			1				
10		6675-00-842-2123	NT2-312A (89905)	Eyepiece Prism, Microscope			1				
10		6675-00-714-1331	19907 (89905)	Diagonal Eyepiece, Prism			1				
10		6675-00-446-1764	T21-4GUS (89905)	Microscope Fitting			2				
10		6675-00-863-7471	316081 (89905)	Assy Lamp Fitting			2				
			No Part Number	Box Assembly, Battery, Consisting of:			1				

Section II. INTEGRAL COMPONENTS OF END ITEM (Cont'd)

(1) ILLUSTRATION		(2)	(3)	(4)	(5)	(6)	(7)	(8) QUANTITY			
(a) FIG NO.	(b) ITEM NO.	NATIONAL STOCK NUMBER	PART NO.	DESCRIPTION	LOCA- TION	USABLE ON CODE	QTY REQ	RCV'D	DATE	DATE	DATE
11		6675.00-490-9376	200819 (89905)	Box, Battery			1				
11		6150-00-378-9500	XT2-72 (89905)	Lead, Elec- trical			1				
11		6135-00-937-4118	EB329 (89905)	Battery, Dummy			2				
11		6675-00-714-1375	268034 (89905)	Light Assy, Hand			1				
				Tripod Assy Consisting of:			1				
9		6675-01-036-2227	21A00800066 (89905)	Tripod			1				
9		6675-00-378-9525	3A63 (89905)	Tripod Head Cover							
9		6675-00-026-2228	21A00700066 (89905)	Tool Kit Case			1				
14		5210-00-158-1353	243915 (89905)	Plumb bob Assy			1				
14		5120-00-169-2880	109153 (89905)	Wrench Tripod			1				
12		6675-00-560-5678	NT3-371 (89905)	Pack Rack			1				
		6675-00-838-0840	XT3-16 (89905)	Eyepiece Assy, 24X			1				
		Mounted on Theodolite	243358 (89905)	Eyepiece Assy, 30X			1				
13		6650-00-838-0842	NT3-305A (89905)	Eyepiece Assy, 40X			1				

Section III. BASIC ISSUE ITEMS

(1) ILLUSTRATION		(2) NATIONAL STOCK NUMBER	(3) PART NO.	(4) DESCRIPTION	(5) LOCA- TION	(6) USABLE ON CODE	(7) QTY REQ	(8) QUANTITY			
(a) FIG NO.	(b) ITEM NO.							RCV'D	DATE	DATE	DATE
10		7920-00-205-0565	MILB43363 (89905)	Brush, Dust			1				
10		8330-00-965-1722	KKC300 (81349)	Chamois, 2 in x 16 in			1				
10		6675-00-446-1762	167226 (89905)	Container, Lubricant			1				
10		6675-00-353-4103	109334 (89905)	Pin, Adjusting			2				
10		5120-00-446-2860	166794 (89905)	Screwdriver, Jeweler's			1				
11		6675-00-859-5936	166370 (89905)	Lamp, In- candescent			4				
				TM 5-6675-231-15, Oper- Organizational, Field and Depot Maintenance Manual							

Appendix III. After Appendix II add "Appendix III, Additional Authorization List".

**APPENDIX III
 ADDITIONAL AUTHORIZATION LIST**

Section I. INTRODUCTION

1. Scope

This appendix lists additional items you are authorized for the support of the Directional Theodolite.

have to be turned in with it. These items are authorized to you by CTA, MTOE, TDA or JTA.

2. General

This list identifies items that do not have to accompany the Directional Theodolite and that do not

3. Explanation of Listing

National stock number, descriptions and quantities are provided to help you identify and request the additional items you require to support this equipment. Usable On codes are not applicable.

Section II. ADDITIONAL AUTHORIZATION LIST

(1) National Stock Number	Part Number & FSCM	(2) Description	Usable on Code	(3) U/M	(4) Qty Auth
6135-00-120-1020		BA30 (81349) Battery, Dry, 1.5 Volts		EA	8

Appendix V. After Appendix IV add "Appendix V, Expendable Supplies and Materials List".

APPENDIX V
EXPENDABLE SUPPLIES AND MATERIALS LIST

Section I. INTRODUCTION

1. Scope

This appendix lists expendable supplies and materials you will need to operate and maintain the Directional Theodolite. These items are authorized to you by CTA50-970, Expendable Items (except Medical, Class V, Repair Parts and Heraldic Items).

2. Explanation of Columns

a. *Column 1 Item Number.* This number is assigned to the entry in the listing and is referenced in the narrative instructions to identify the material.

b. *Column 2 Level.* This column identifies the lowest level of maintenance that requires the listed item.

c. *Column 3 National Stock Number.* This is the national stock number assigned to the item; use it to request or requisition the item.

d. *Column 4 Description.* Indicates the federal item name and, if required, a description to identify the item. The last line for each item indicates the part number followed by the Federal Supply Code for Manufacturer (FSCM) in parenthesis, if applicable.

e. *Column 5 Unit of Measure (U/M).* Indicates the measure used in performing the actual maintenance function. This measure is expressed by a two-character alphabetical abbreviation (e.g., each (ea), inch (in), pair (pr), etc.). If the unit of measure differs from the unit of issue, requisition the lowest unit of issue that will satisfy your requirements.

Section II. EXPENDABLE SUPPLIES AND MATERIALS LIST

(1) Item Number	(2) Level	(3) National Stock Number	(4) Description	(5) U/M
1	C	7920-00-401-8034	Cloth, Lint free, non-abrasive, General Purpose, Part No. 1001	BX BX
2	C	9150-00-985-7244	Grease, Instrument and Aircraft (GIA) MIL-G-23827	TU
3	C	9150-00-252-6382	Oil, Clock and Watch OCW 5cc	BT
4	C	6810-00-223-2739	Acetone Technical 1 pt can; Fed Spec MMM-A-185	PT
5	C	6850-00-664-5683	Cleaning Solvent Fed Spec. P-D-680	QT
6	C	6640-00-597-6745	Lens Tissue NNNP40TYPEICLASS2 4 x 6 in (81349)	PK
7	C	5120-01-018-5908	Orange Sticks 13218E3063 (97403)	PK
8	C	6850-00-680-2233	Desiccant, Activated, 1.5 lb	LB

By Order of the Secretary of the Army:

Official:

J. C. PENNINGTON
Brigadier General, United States Army
The Adjutant General

BERNARD W. ROGERS
General, United States Army
Chief of Staff

Distribution:

To be distributed in accordance with DA Form 12-25A, Operator maintenance requirements for Surveying Equipment.

TECHNICAL MANUAL }
No. 5-6675-231-15 }
TECHNICAL ORDER }
No. 49A8-10-1 }

DEPARTMENTS OF THE ARMY
AND THE AIR FORCE
WASHINGTON 25, D.C., 28 June 1963

OPERATOR, ORGANIZATIONAL, FIELD AND DEPOT MAINTENANCE MANUAL

**THEODOLITE: DIRECTIONAL; 2/10-SEC. DEGREE GRADUATION; 10.2 IN.
LONG TELESCOPE W / ACCESSORIES (WILD HEERBRUGG MODEL T-3)
FSN 6675-382-9140**

	Paragraph	Page
CHAPTER 1. INTRODUCTION		
Section I. General	1, 2	3
II. Description and data	3-5	3
CHAPTER 2. INSTALLATION AND OPERATION INSTRUCTIONS		
Section I. Service upon receipt of equipment	6-10	9
II. Movement to a new worksite	11, 22	22
III. Controls and instruments	13, 14	22
IV. Operation of theodolite	15-22	25
CHAPTER 3. OPERATOR AND ORGANIZATIONAL MAINTENANCE INSTRUCTIONS		
Section I. Operator and organizational maintenance tools and equipment	23-25	32
II. Lubrication	26, 27	32
III. Preventive maintenance services	28-30	33
IV. Operator's maintenance	31, 32	38
V. Troubleshooting	33-45	38
VI. Carrying case and pack rack	46-48	39
VII. Eyepieces	49-52	41
VIII. Star plate	53, 54	43
IX. Illumination mirrors	55, 56	43
X. Tripod assembly, plumb bob, and tripod wrench	57-59	44
CHAPTER 4. DEMOLITION OF THEODOLITE TO PREVENT ENEMY USE	60-62	46
CHAPTER 5. SHIPMENT AND LIMITED STORAGE		
Section I. Shipment within zone of interior	63, 64	47
II. Limited storage	65, 66	47
CHAPTER 6. FIELD AND DEPOT MAINTENANCE INSTRUCTIONS		
Section I. General	67, 58	49
II. Description and data	69, 70	49
III. Special tools and equipment	71-73	51
IV. Troubleshooting	74-89	55
V. Illumination mirrors	90, 91	56
VI. Collimation level and lever assembly	92, 93	57
VII. Star plate	94, 95	61
VIII. Plate level, vertical circle illumination prism, micrometer circle illumination prism, and inverter prism	96-100	61
IX. Microscope, telescope, and reticle mirror	101-104	65
X. Micrometer	105, 106	69
XI. Horizontal, vertical, and collimation slow-motion screws	107, 108	71
XII. Horizontal circle illumination prism and housing cover, horizontal circle prism carrier, and illumination cable connector	109-112	73

	Paragraph	Page
XIII. Horizontal clamp, clamp ring, contact ring, outer vertical axis, and horizontal circle	113-115	76
XIV. Leveling screws, horizontal circle drive, illumination socket, and horizontal circle housing	116-120	79
XV. Right side axis bearing, vertical clamp, telescope axis, left side bearing, vertical circle, vertical circle housing, and vertical circle prism carrier	121-124	81
XVI. U-standard and inner vertical axis	125, 126	86
XVII. Illumination system	127-129	88
APPENDIX I. REFERENCES		91
II. MAINTENANCE ALLOCATION CHART		92
III. BASIC ISSUE ITEMS LIST		97
INDEX.....		100

AGO 5078A

CHAPTER 1

INTRODUCTION

Section I. GENERAL

1. Scope

a. These instructions are for the use of the personnel to whom the Wild Heerbrugg Model T-3 Theodolite is issued. Chapters 1 through 5 provide information on the operation, preventive maintenance services, and organizational maintenance of the equipment, accessories, components, and attachments. Chapter 6 provides information for field and depot maintenance (3d, 4th, and 5th echelons). This manual also provides descriptions of the main units and their functions in relationship to other components.

b. Appendix I contains a list of publications applicable to this manual. Appendix II contains the maintenance allocation chart. Appendix III contains the list of basic issue items authorized the operator of this equipment. The organizational, field, and depot maintenance repair parts and special tool lists are listed in TM 5-6675-231-25P.

c. Numbers in parentheses on illustrations indicate quantity. Numbers preceding nomenclature callouts on illustrations indicate the preferred maintenance sequence.

d. Report all deficiencies in this manual on DA Form 2028. Submit recommendations for changes, additions, or deletions to the Commanding Officer, U. S. Army Mobility Support Center, ATTN: SMOMS-MS P. O. Box 119, Columbus 16, Ohio. Direct communication is authorized.

e. Report all equipment improvement recommendations as prescribed by TM 38-750.

2. Record and Report Forms

For record and report forms applicable to the operator and organizational maintenance, refer to TM 38-750.

Note

Applicable forms, excluding Standard Form 46, which is carried by the operator, shall be kept in a canvas bag mounted on the equipment.

Section II. DESCRIPTION AND DATA

3. Description

The Wild Heerbrugg Model T-3 Theodolite (figs. 1 through 4) is a precision, directional type surveying and tracking instrument. It has both vertical and horizontal circle scales, calibrated in degrees for reading the value of angles. Such readings are observed through the microscope eyepiece (fig. 3). A micrometer circle (fig. 4) is provided for the interpolation of angle value readings to 2/10 second degree accuracy. The horizontal circle housing contains the 3 leveling screws (fig. 1) to which a star plate (fig. 1) for tripod mounting is attached.

Illumination of the vertical, horizontal, and micrometer circles during daylight operation is accomplished by adjusting the illumination mirrors (figs. 1 and 2). A battery-powered electrical illumination system is provided for night operation. Eyepiece prisms for attachment to the telescope and microscope eyepieces during high-angle and astronomical observations are contained in the accessory case. The telescope is equipped with a 30-power eyepiece, optional eyepieces of 24 and 40 power, which are stowed in the carrying case base, and may be installed when necessary.

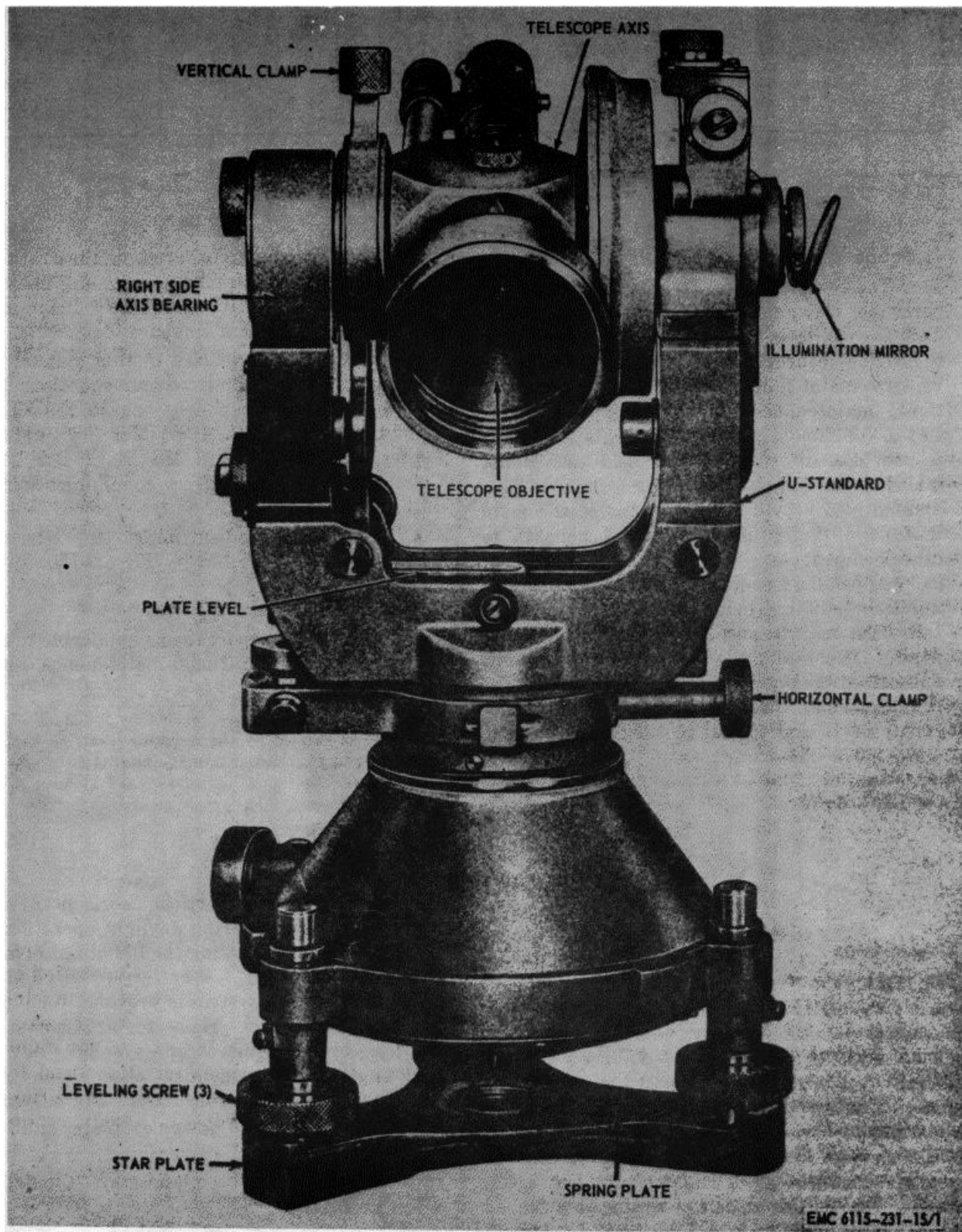

Figure 1. Theodolite, front view.

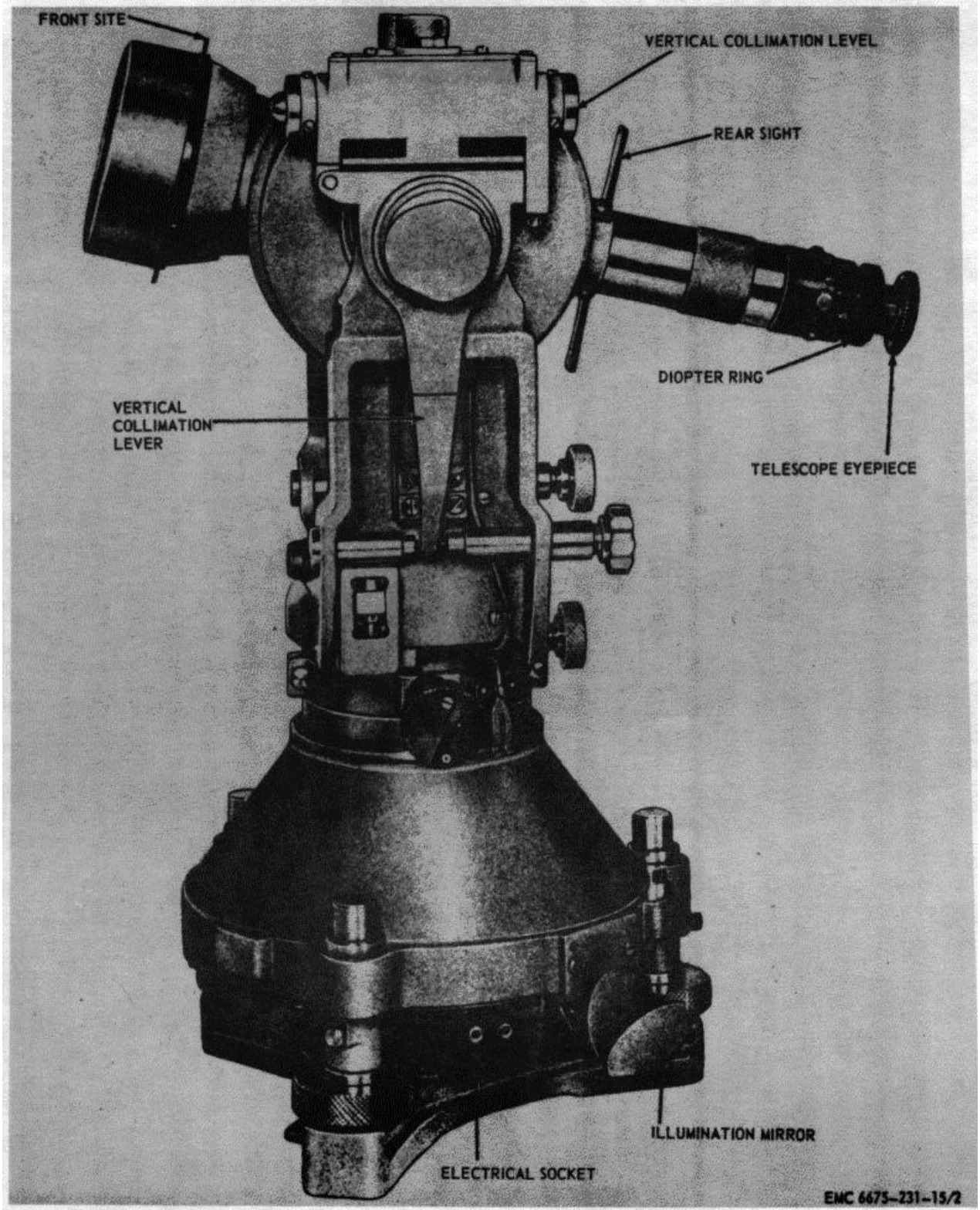

Figure 2. Theodolite, left side view.

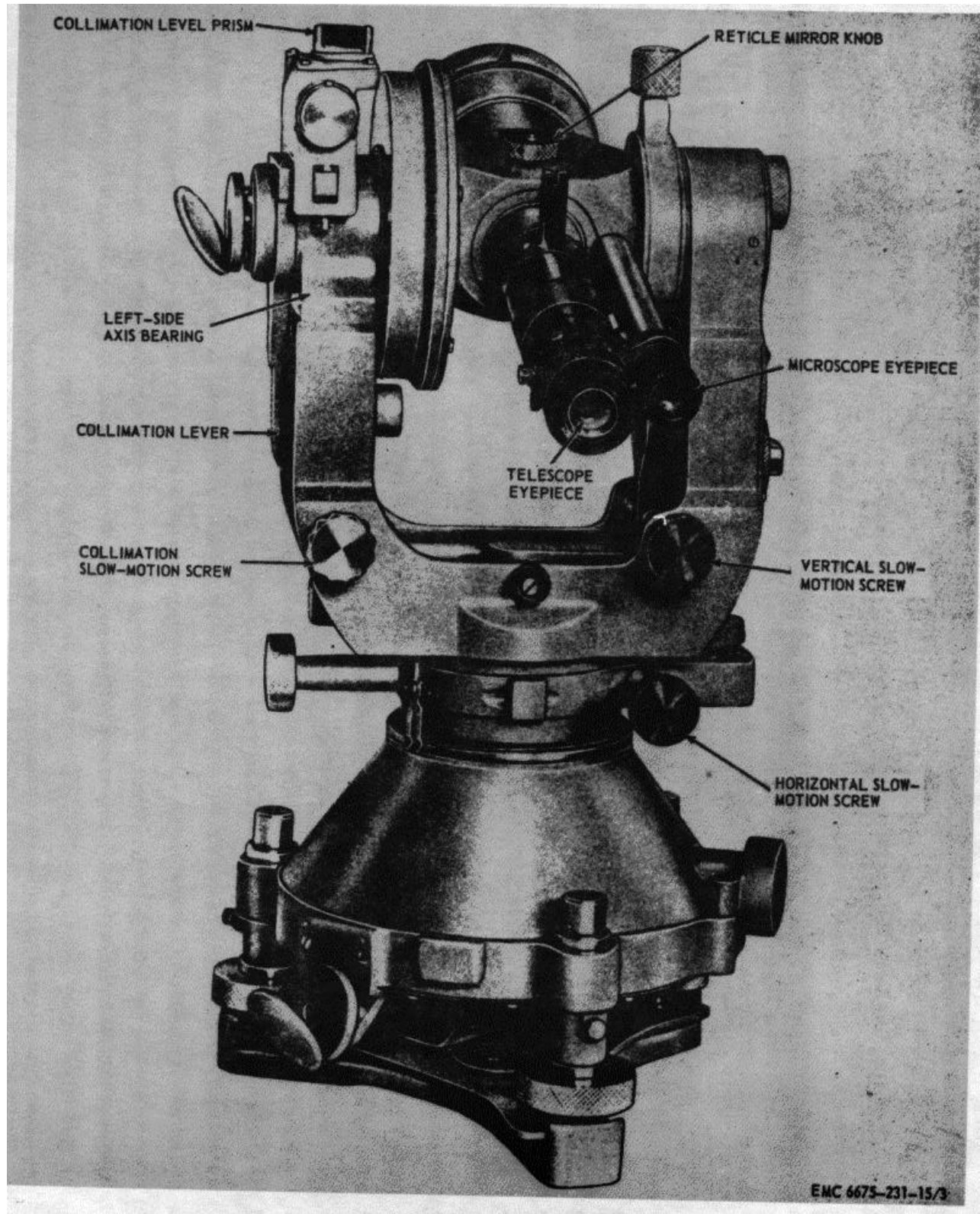

Figure 3. Theodolite, rear view.

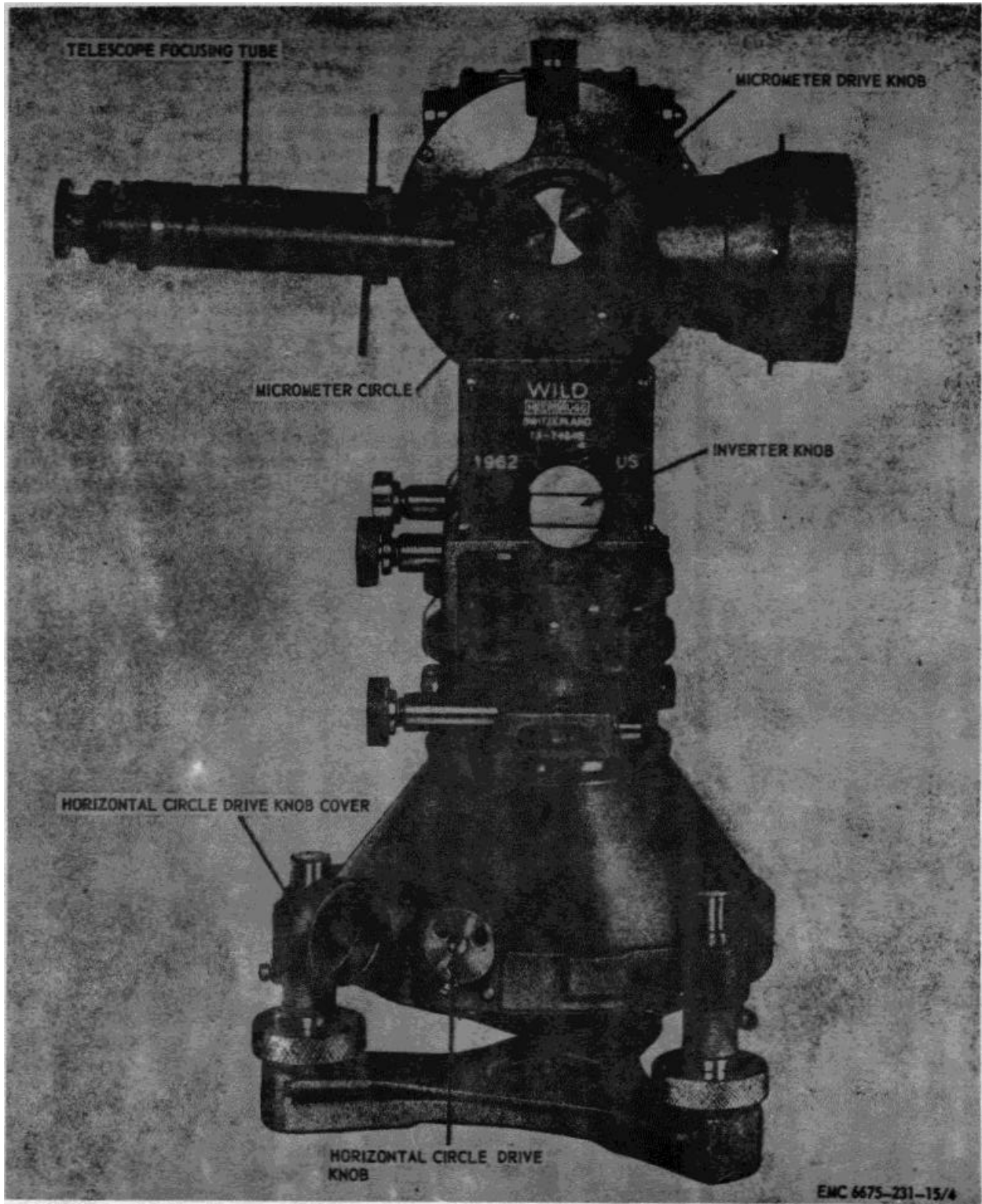

Figure 4. Theodolite, right side view.

4. Identification and Tabulated Data

a. *Identification.* The theodolite and carrying case have the following identification markings:

- (1) *Theodolite.* The manufacturer's name, model, and serial number are engraved on the inverter prism cover.
- (2) *Carrying case hood.* The manufacturer's name, model, and serial number are stenciled on the carrying case hood.

b. *Tabulated Data.*

(1) *General.*

Manufacturer.....	Wild Heerbrugg Ltd. Heerbrugg, Switzerland.
Model.....	T-3
Telescope	24, 30, 40X (power)
Telescope length	10.25 in. (inches)
Glass circles.....	360° (degrees)
Horizontal circle diameter.	5.5 in.
Horizontal circle graduation.	4 min. (minutes)

AGO 5078A

Vertical circle diameter	3.8 in.
Vertical circle graduation.	8 min.
Micrometer circle graduation.	0.2" (second)

Clear aperture of objective.....	2.4 in.
Plate level sensitivity.....	7" per m (millimeter)
Collimation level sensitivity	12" per 2 mm
Coincidence adjustment of	0.2" collimation level.
Microscope magnification.....	37X

(2) *Dimensions and weights.*

Tripod (nontelescopic).....	5 feet
Instrument	25 lb (pounds)
Carrying case.....	8 lb
Pack rack	4 lb
Tripod	16 lb

5. Difference in Models

This manual covers only the Wild Heerbrugg Model T-3 Theodolite. No known unit differences exist for the model covered by this manual.

CHAPTER 2

INSTALLATION AND OPERATION INSTRUCTIONS

Section I. SERVICE UPON RECEIPT OF EQUIPMENT

6. Unloading the Equipment

a. *Theodolite.* The theodolite is shipped in a shipping case (fig. 5). Unloading the instrument presents no problem since the loaded weight of the shipping case is only 68 pounds.

Caution

Exercise care while unloading to prevent damage to the theodolite.

b. *Tripod and Accessories.* The tripod and accessories used with the theodolite are shipped in a separate shipping container (fig. 5). The gross weight of the boxed tripod and accessories is 87 pounds. A handtruck or manpower may be used to unload the accessory container.

7. Unpacking the Equipment

a. *Theodolite and Carrying Case*

- (1) Remove the 2 locks, unfasten the 2 captive screws, and open the shipping case door (fig. 6).
- (2) Remove the theodolite carrying case from the shipping case.
- (3) Refer to figure 7 and remove the carrying case hood.
- (4) Refer to figure 8 and remove the carrying case base.

Caution

Do not grasp the left side axis bearing when lifting the theodolite. Failure to observe this caution will place undue pressure on the collimation lever and make readjustment necessary.

b. *Tripod.*

- (1) Remove the cover from the tripod and accessories shipping container (fig. 5).
- (2) Remove the tripod assembly (fig. 9) from the shipping container.

c. *Accessory Case.* Remove the accessory case (fig. 10) from the shipping container.

d. *Battery Box.* Remove the battery box (fig. 11) from the shipping container.

e. *Pack Rack.* Remove the pack rack (fig. 12) from the shipping container.

8. Inspecting and Servicing the Equipment

a. *General.* Perform the daily preventive maintenance services (par. 29).

b. *Carrying Case.*

- (1) Inspect the carrying case (fig. 6) for dents, cracks, rust, defective clamps, and carrying strap.
- (2) Inspect the telescope eyepieces (fig. 13) for scratched or cracked lens, and damaged threads.
- (3) Inspect the light housings (fig. 13) for broken glass and corroded or defective contacts.
- (4) Inspect the carrying case desiccant (fig. 13) for discoloration.

Note

Desiccant should be blue in color. Pink desiccant indicates moisture saturation and must be dehydrated or replaced.

c. *Theodolite.*

- (1) Visually inspect the theodolite for broken or missing parts, cracked or scratched lens and mirrors, loose or missing hardware, and other indications of damage.
- (2) Rotate the three leveling screws (fig. 1) and inspect for rough travel and instability.
- (3) Inspect the vertical clamp (fig. 1) and horizontal clamp (fig. 1) for improper operation.
- (4) Inspect the horizontal slow-motion screw (fig. 3), vertical slow-motion screw (fig. 3), and combination slow motion screw (fig. 3) for improper operation.

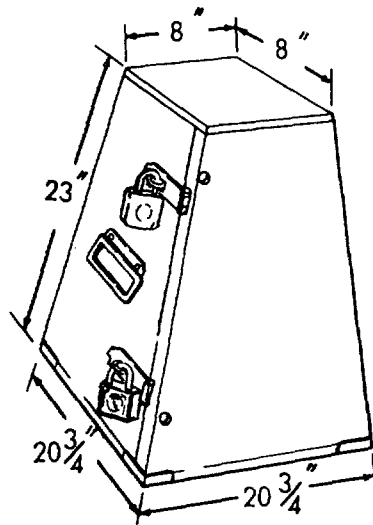

A. THEODOLITE SHIPPING CASE.

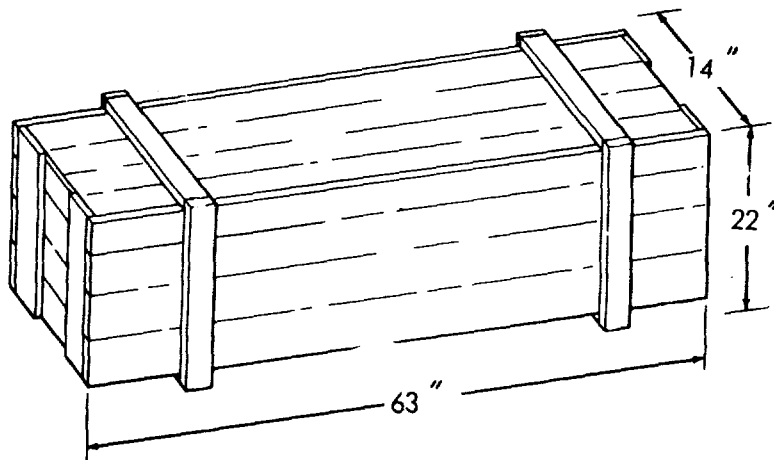

B. TRIPOD AND ACCESSORIES SHIPPING CRATE.

EMC 6675-231-15/5

Figure 5. Theodolite shipping case and accessory container with dimensions.

- (5) Inspect the reticle mirror knob (fig. 3), micrometer drive knob (fig. 4), and inverter knob (fig. 4) for smooth operation throughout their full travel.
- (6) Inspect the telescope focusing tube (fig. 4), telescope eyepiece (fig. 3), and microscope eyepiece (fig. 3) for smooth operation throughout their full travel.

d. Tripod Assembly.

- (1) Inspect the tripod assembly (fig. 9) for damaged or missing parts and loose or missing hardware.
- (2) Refer to figure 14 and inspect the tripod tool kit for damage. See that the plumb bob assembly, tripod wrench, and two adjusting pins are

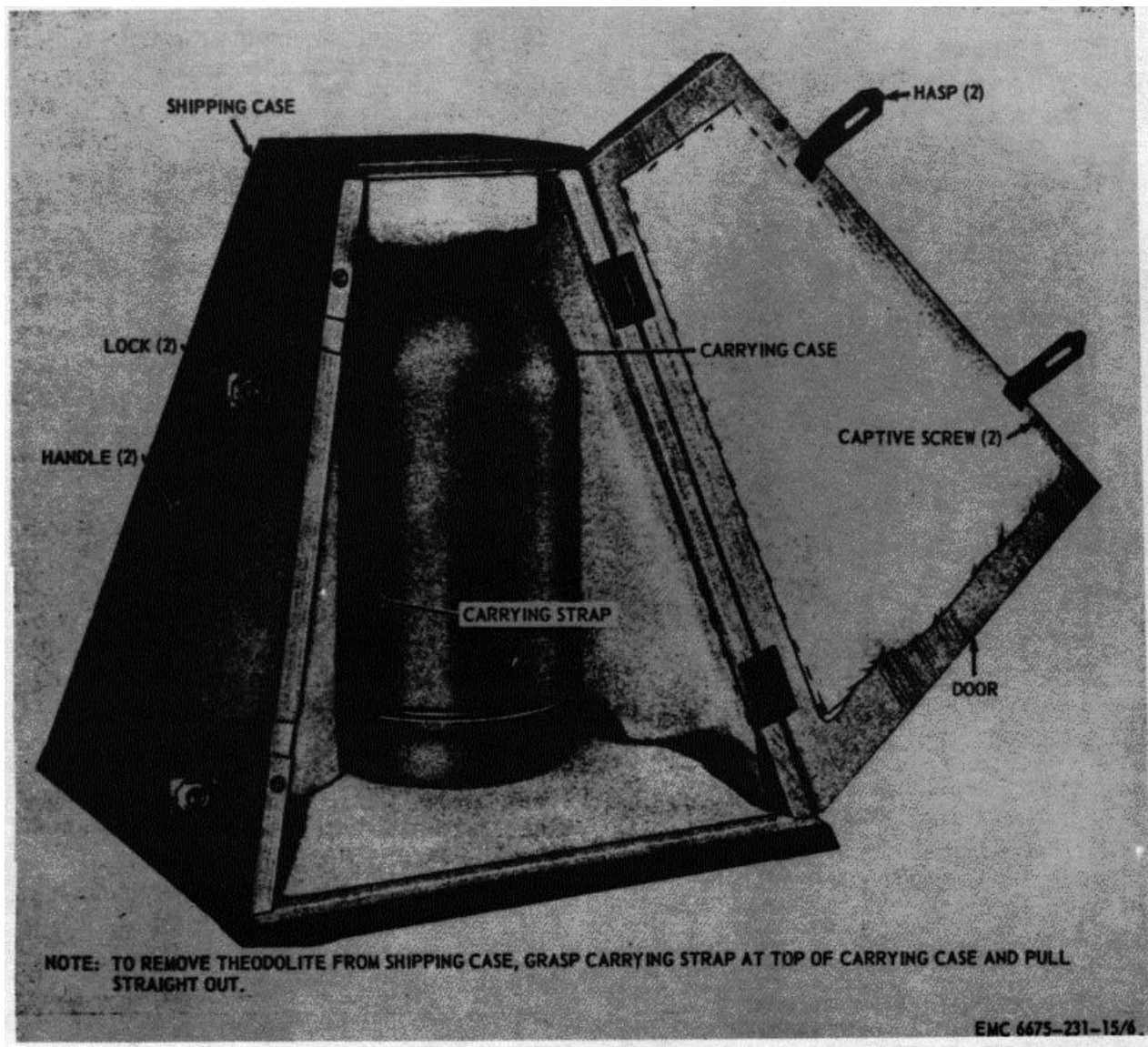

Figure 6. Theodolite carrying case, removal and installation.

contained in the case and are in serviceable condition.

e. Accessory Case.

- (1) Inspect the accessory case for damage and defective zipper and snaps. Make certain that the case contains the components shown by figure 10.
- (2) Inspect the telescope eyepiece prism, microscope eyepiece prism, and the telescope eyepiece sunglass for scratches, cracks, and damaged threads.

- (3) Inspect the light housings for broken glass and corroded or defective contacts.

f. Battery Box.

- (1) Inspect the battery box (fig. 11) for damage, rust, and defective clamps and carrying handle. Make certain the box contains all the components shown in figure 11.
- (2) Turn the rheostat knob (fig. 11) through its full travel. The movement should be smooth and free of binding.

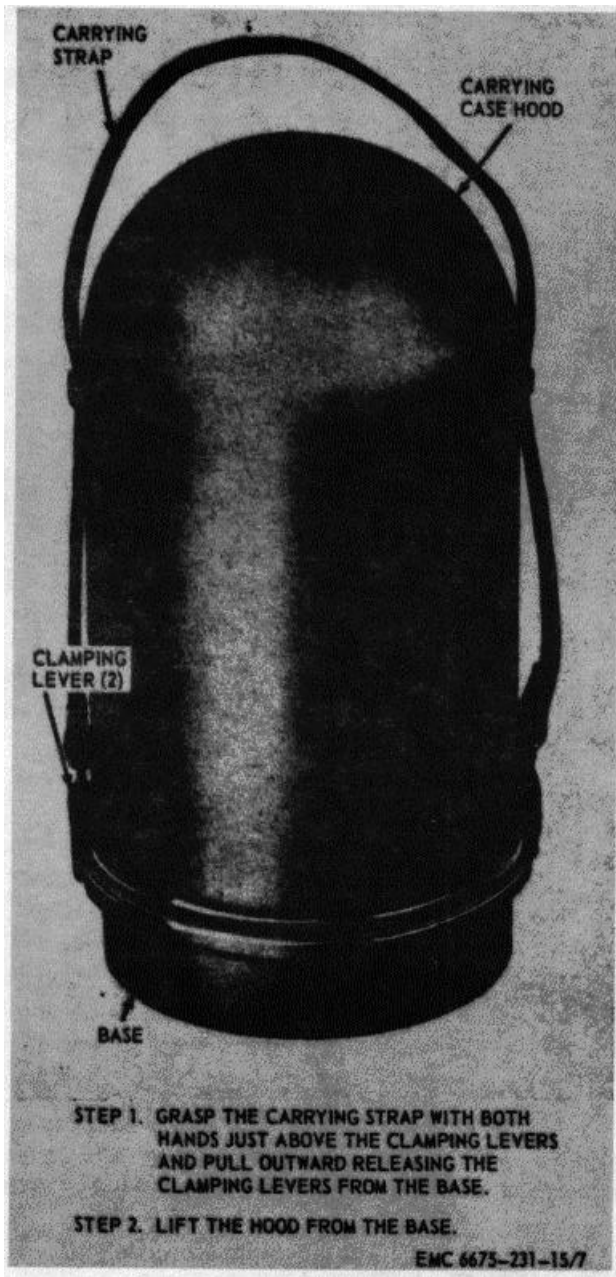

Figure 7. Carrying case hood, removal and installation.

- (3) Inspect all electrical contacts for loose connections and corrosion.
- (4) Inspect the hand light (fig. 11) for broken casing, defective switch, insecure or damaged plug, and frayed insulation.
- (5) Inspect the battery cable (fig. 11) for insecure or damaged plugs and frayed or cracked insulation.

g. Pack Rack. Inspect the pack rack (fig. 12) for damaged straps, insecure or defective buckles, torn padding, and bent or damaged frame.

9. Setting-Up Instructions

a. Tripod. Refer to figure 15 and set up the tripod.

b. Theodolite. Refer to figure 15 and set up the theodolite.

10. Equipment Conversion

a. General. During night or dark-day operation, the reading circles are illuminated by installing the illumination system which is contained in the battery box and the accessory case. For high-angle and celestial observations, the eyepiece prisms, contained in the accessory case, are installed on the telescope and microscope eyepieces.

b. Night or Dark-day Operations. Refer to figure 16 and install the illumination system.

c. High-angle Observations. Refer to figure 17 and install the eyepiece prisms and the telescope eyepiece prism sunglass.

Warning

Severe eye damage can result from performing observations against direct sunlight without utilizing the telescope eyepiece prism sunglass.

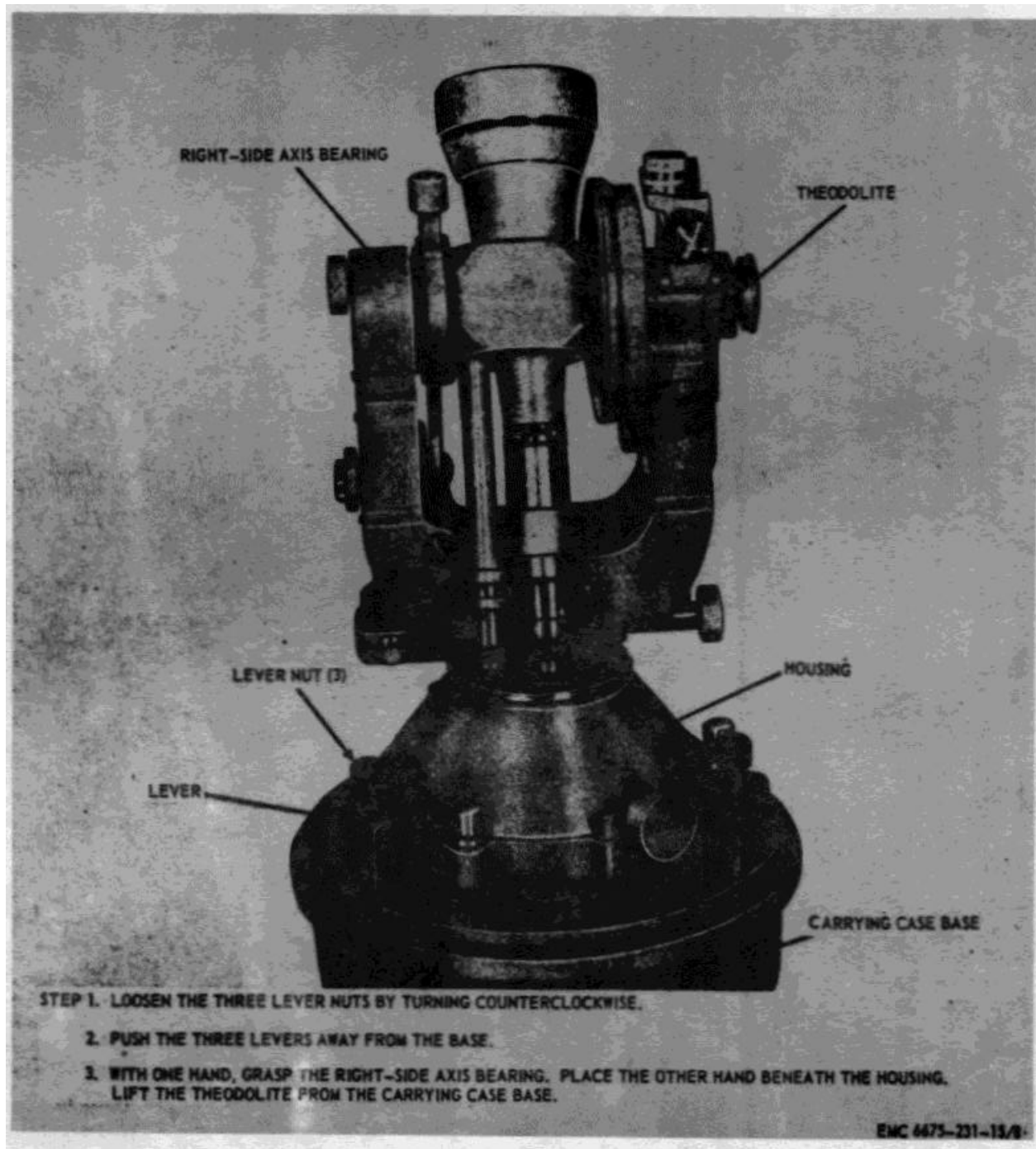

Figure 8. Carrying case base, removal and installation.

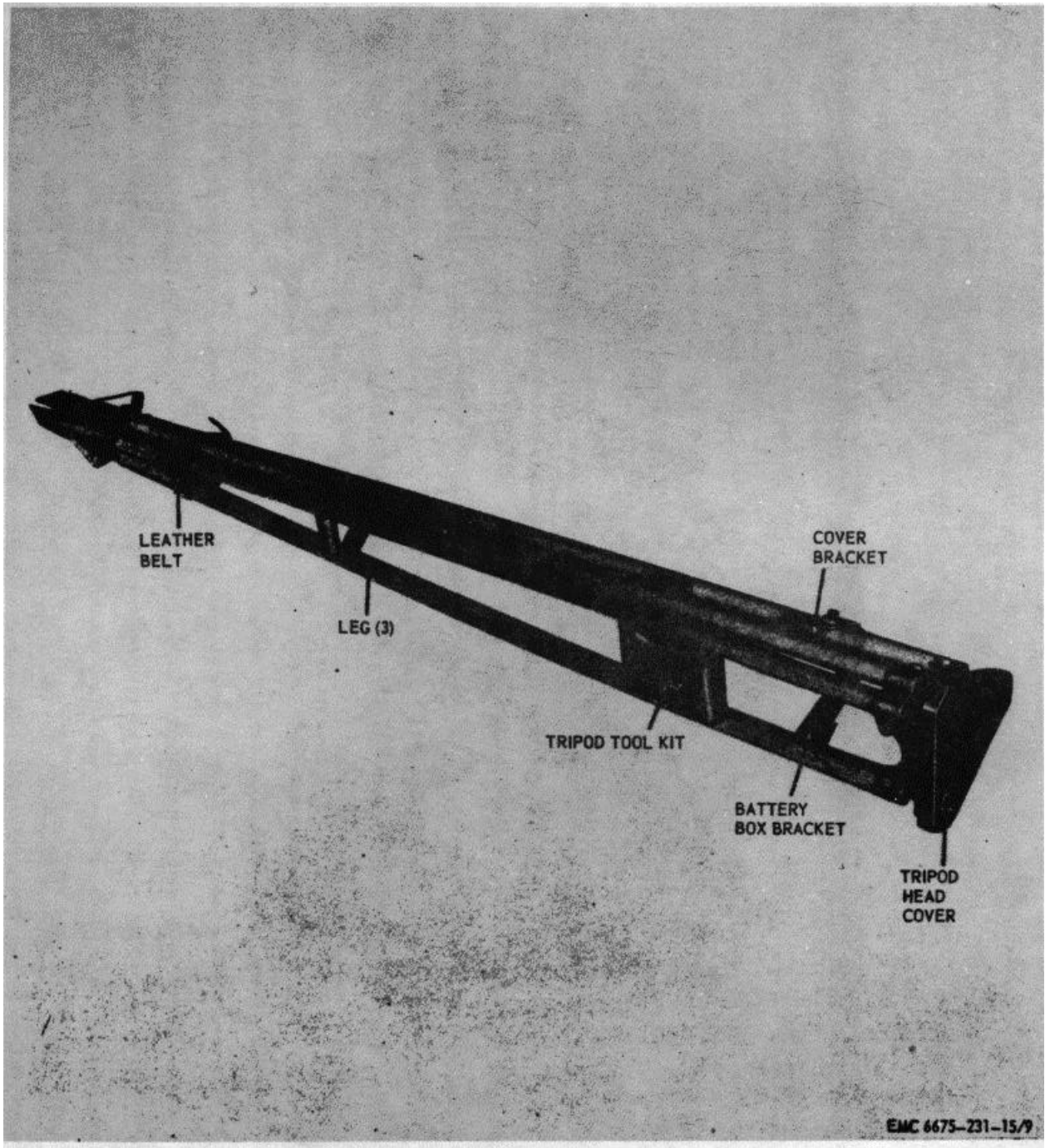
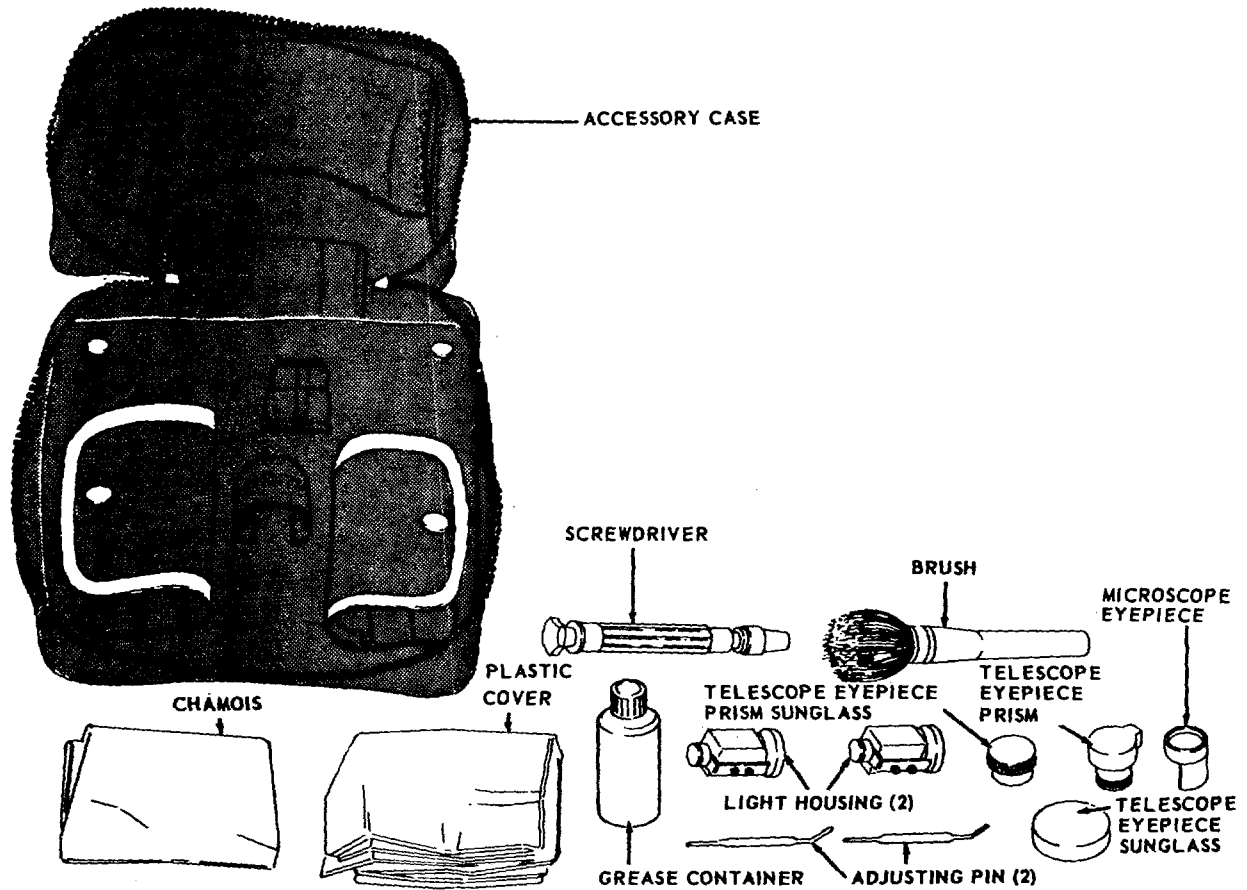
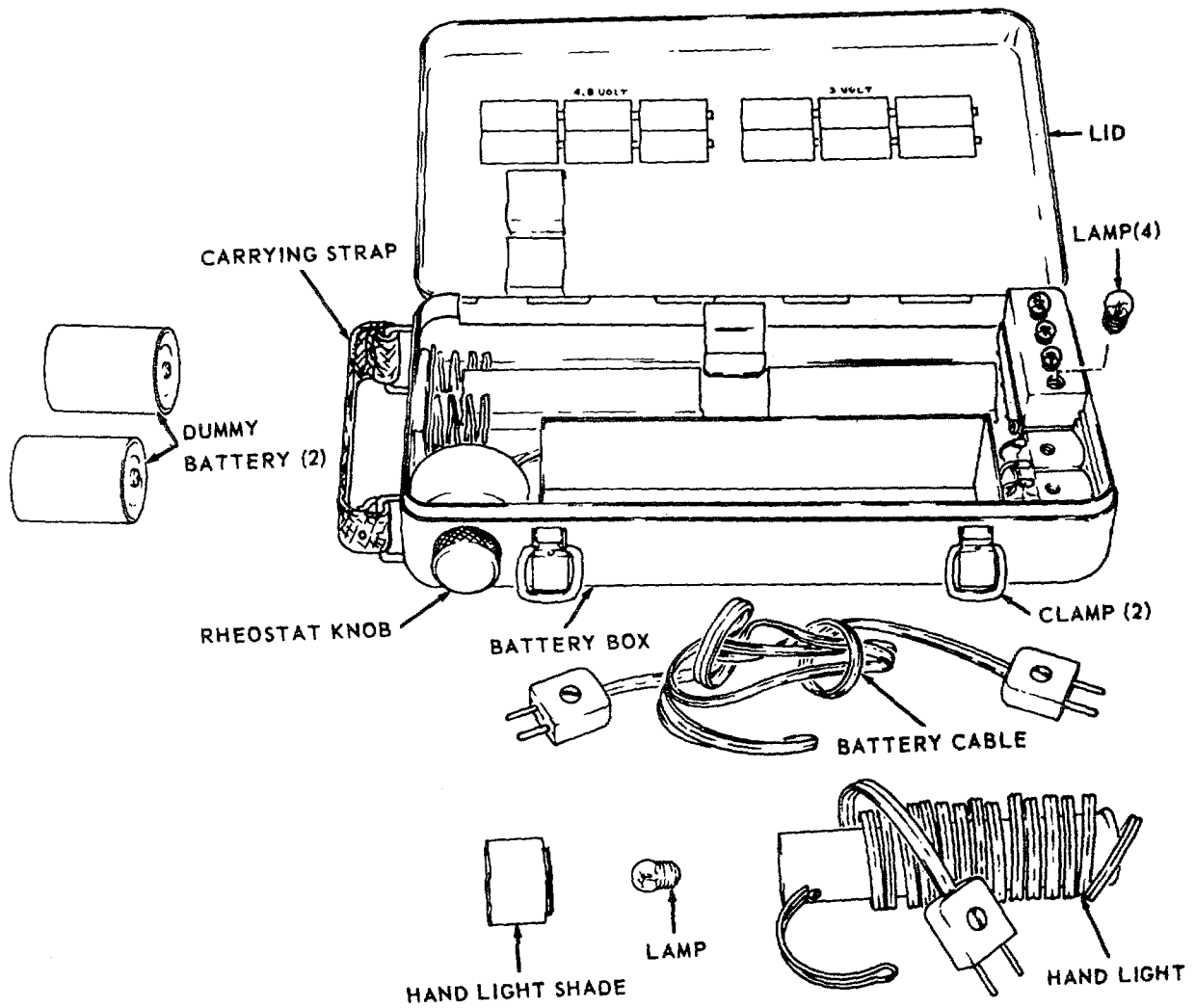

Figure 9. Tripod assembly.



EMC 6675-231-15/10

Figure 10. Accessory case, unpacked view.



EMC 6675-231-15/11

Figure 11. Battery box, unpacked view.

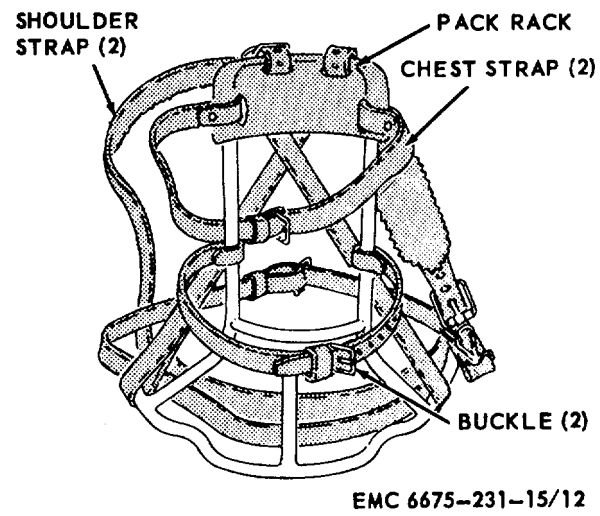

Figure 12. Pack rack.

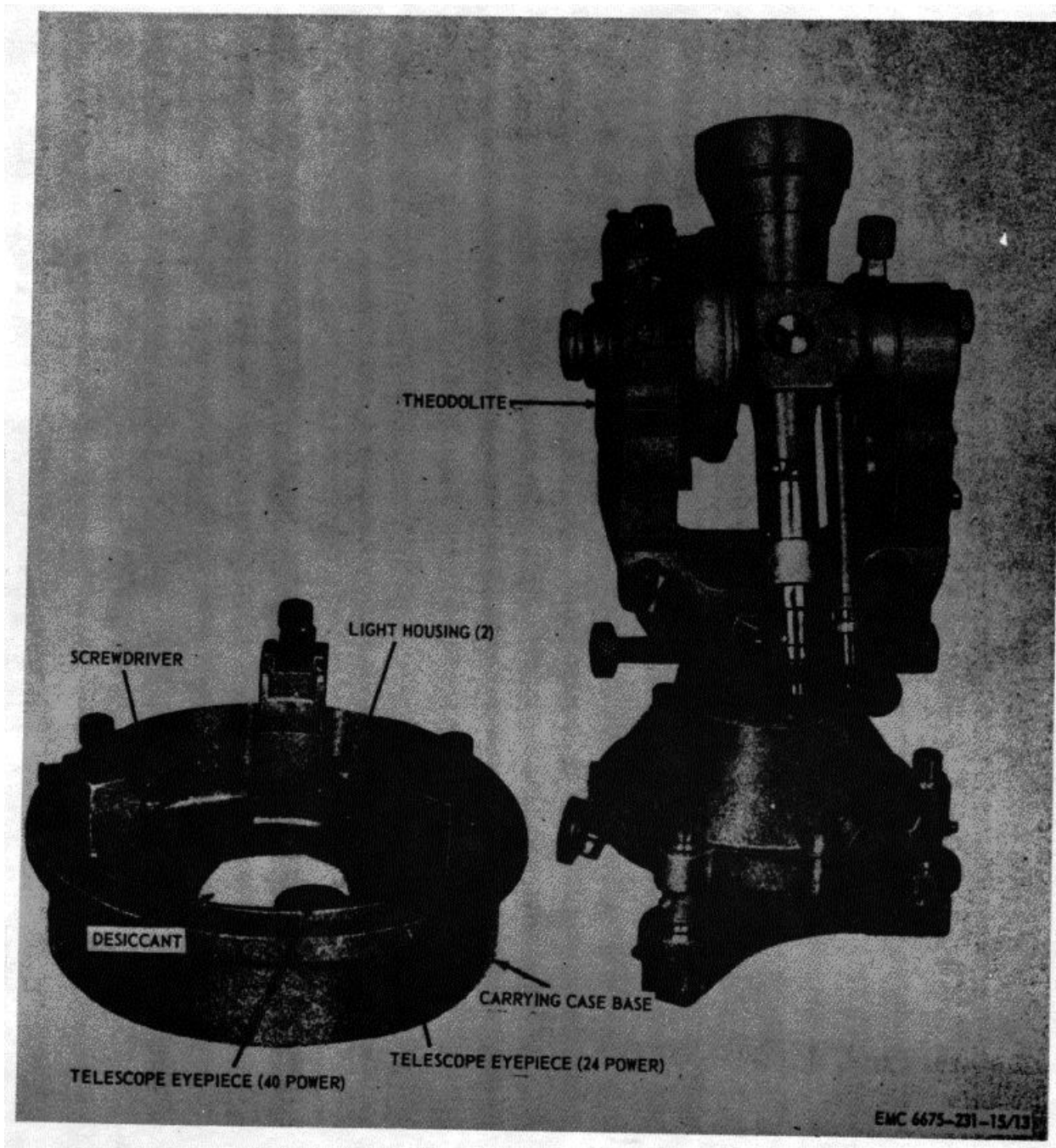

Figure 13. Carrying case base.

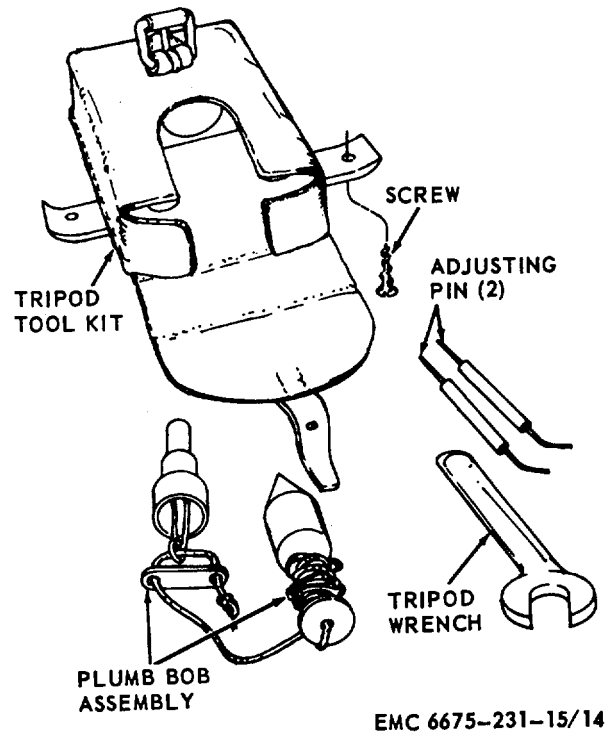

Figure 14. Tripod tool kit, unpacked view.

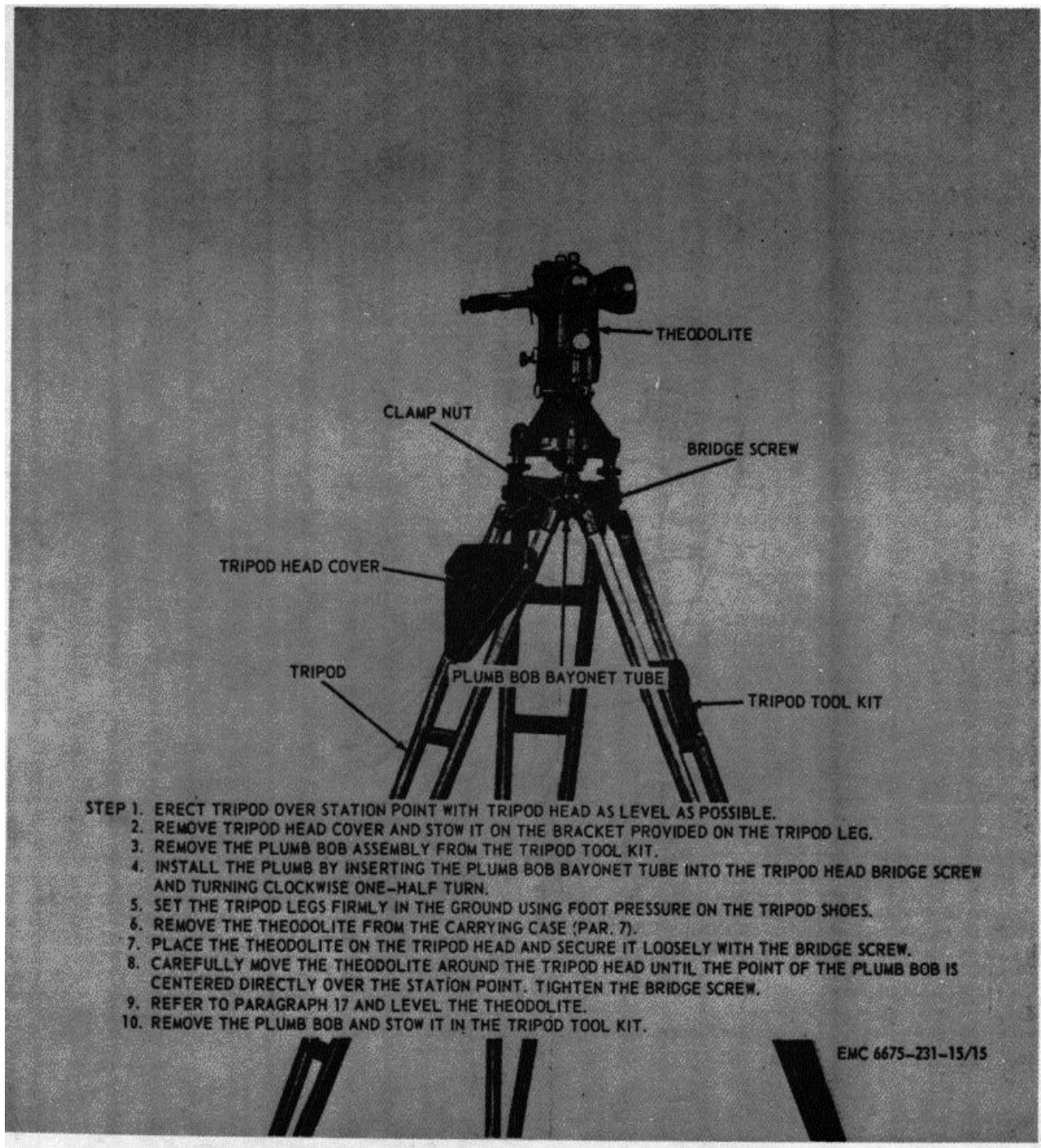

Figure 15. Tripod and theodolite, setting-up instructions.

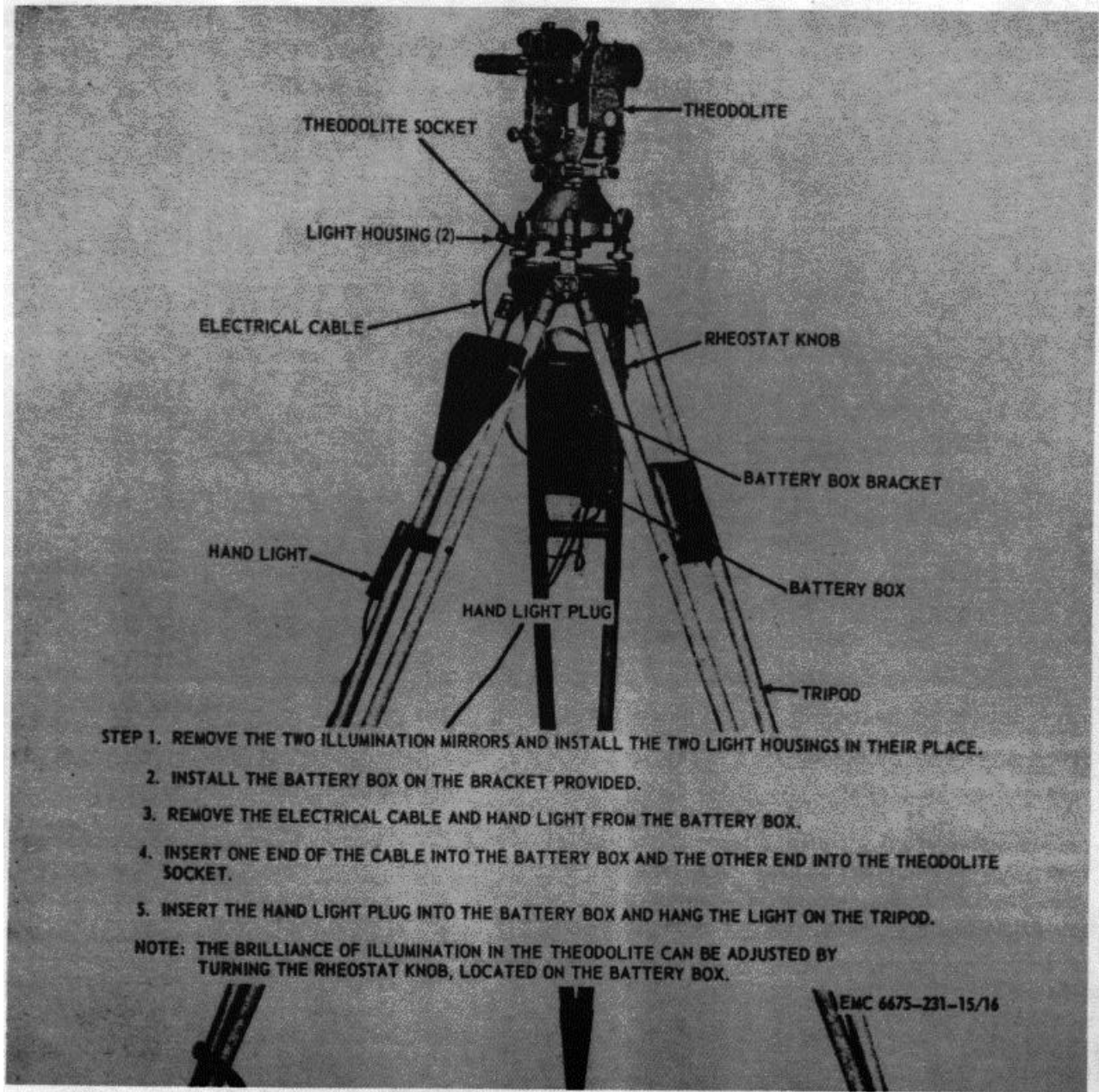

Figure 16. Illumination system, removal and installation

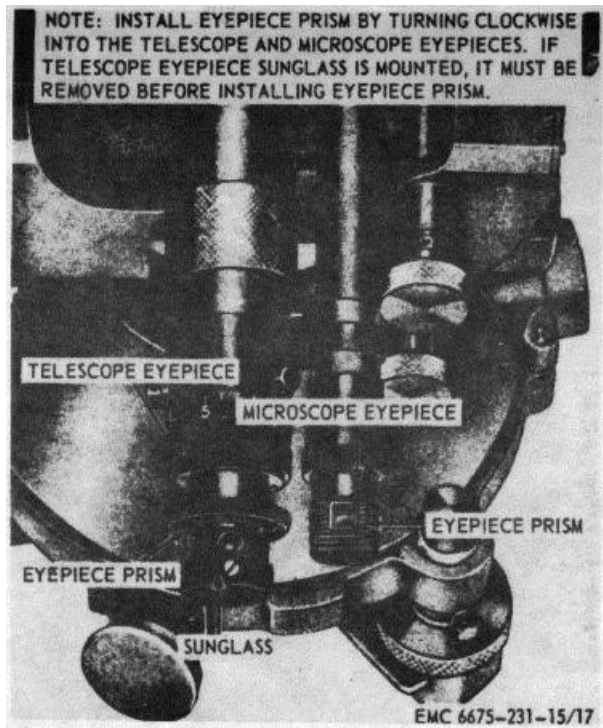

Figure 17. Theodolite eyepiece prisms and sunglass, removal and installation
Section II. MOVEMENT TO A NEW WORKSITE

11. Dismantling for Movement

a. *Short Distances.* For short distances in cleared, level areas, the operator may carry the instrument mounted on the tripod. If the instrument is carried while mounted on the tripod, the operator should not carry it in any position other than upright.

Caution

Exercise care when moving the theodolite mounted on tripod. Handle the instrument carefully. Never subject it to bumps, jars, or shocks. Never leave the instrument unattended for long periods of time unless it is returned to the carrying case. Never carry the instrument over the shoulder.

b. *Long Distances.*

- (1) When the theodolite must be moved for long distances or over rough terrain, the instrument should be transported in the carrying case (fig. 6).

- (2) Handle the carrying case carefully to avoid sudden jolts, continued vibration, or other shocks that might damage the delicate parts of the instrument.
- (3) Do not drop the carrying case into a vehicle or on the ground during transportation.

Note. If the carrying case is accidentally dropped, the instrument should be thoroughly inspected for damage.

- (4) If the theodolite is to be carried long distances by manpower, the pack rack (fig. 12) should be utilized.

12. Setting-Up Instructions After Movement

Refer to paragraph 9 for setting-up instructions after movement.

Section III. CONTROLS AND INSTRUMENTS

13. General

This section describes, locates, illustrates, and furnishes the operator or organizational maintenance personnel sufficient information about the various controls and instruments for proper operation of the theodolite.

14. Controls and Instruments

The purpose and normal settings of all controls and instruments will be found in figure 18.

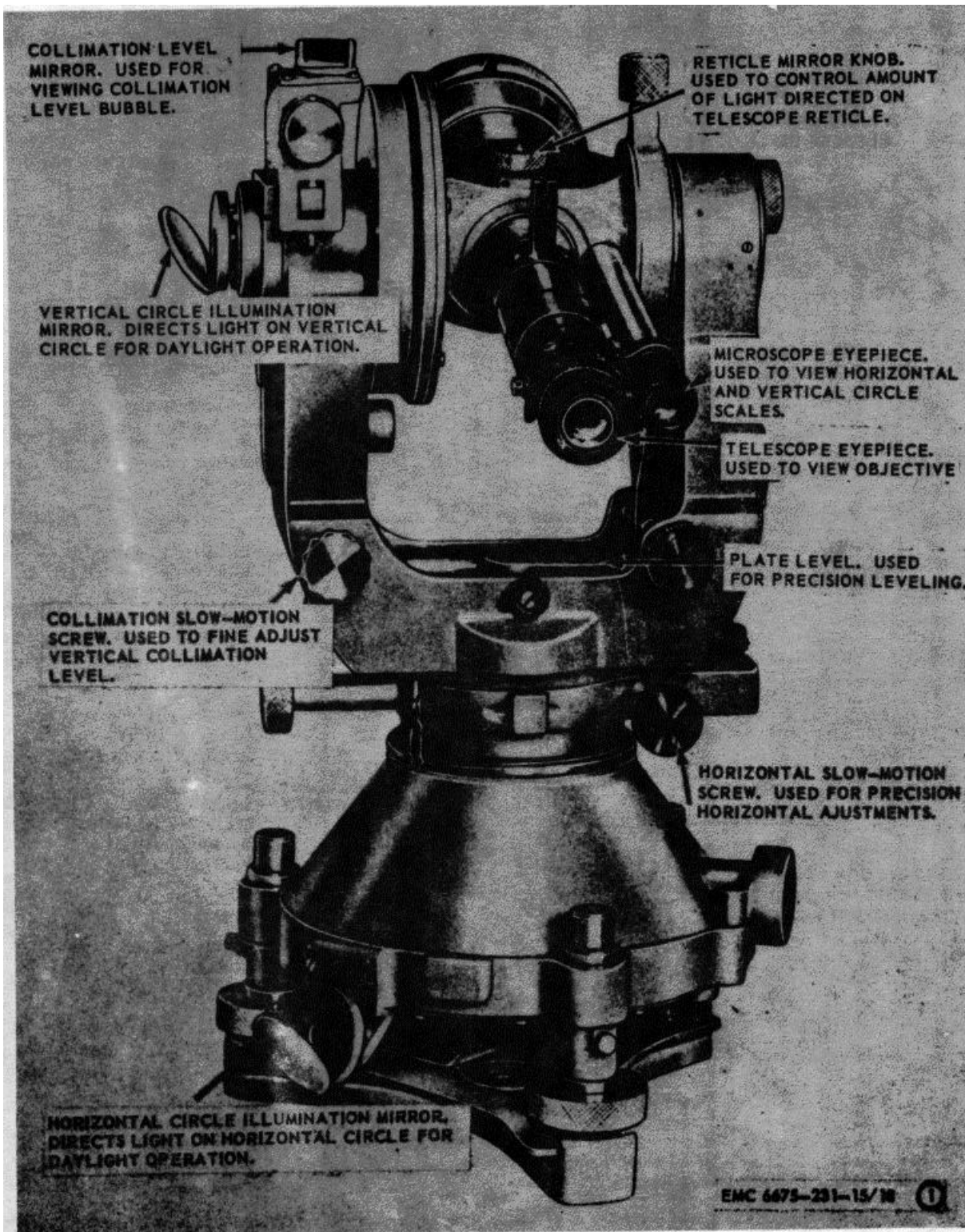

1 Reference A
 Figure 18. Controls and instruments.

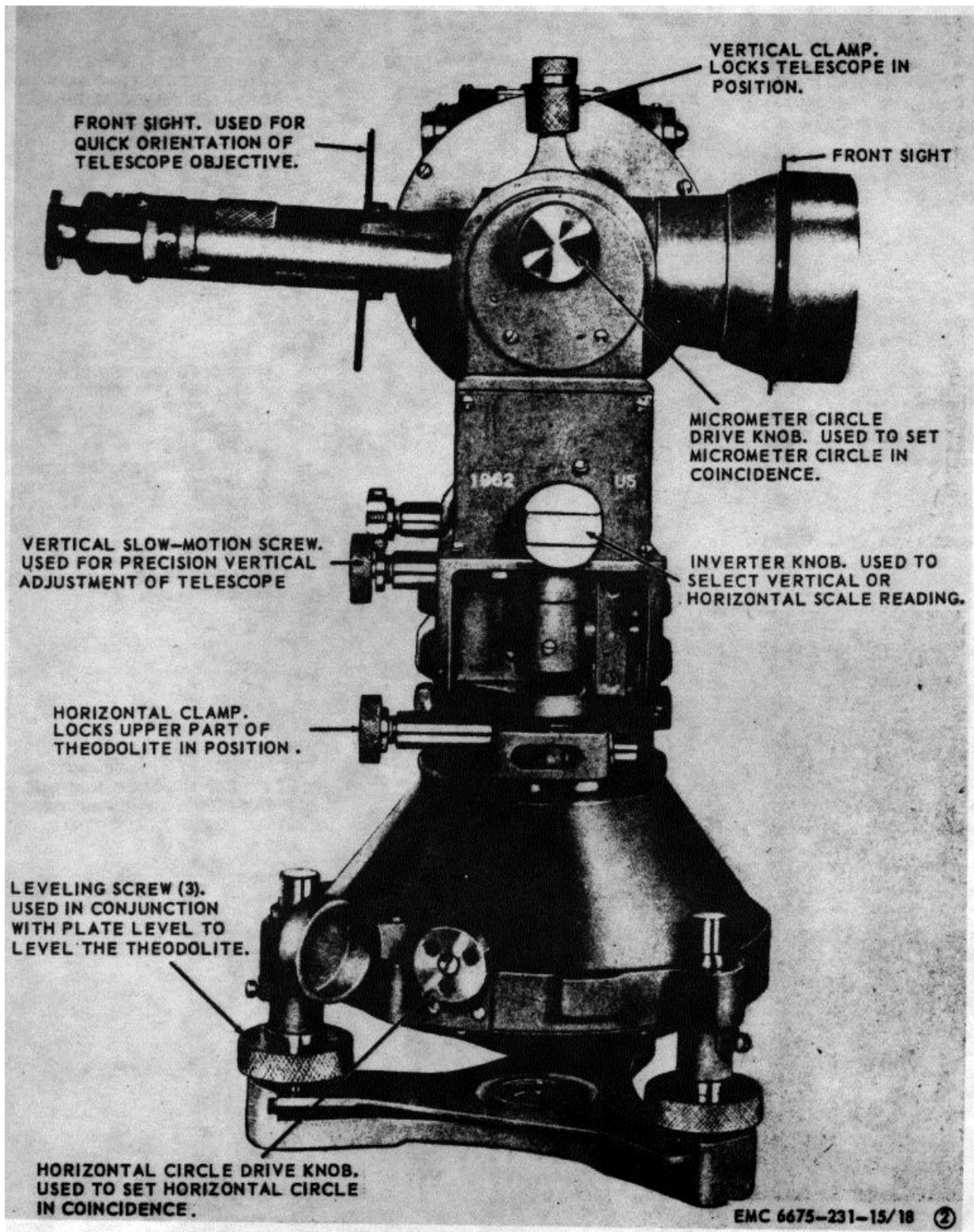

2 Reference B
Figure 18-Continued

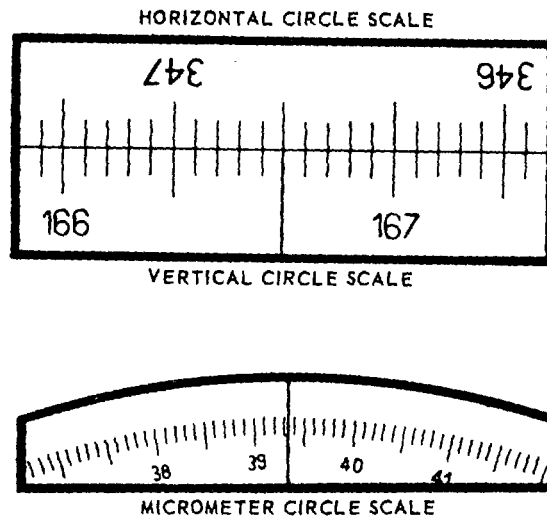

EMC 6675-231-15/18 (3)

3 Reference C
Figure 18-Continued.

Section IV. OPERATION OF THEODOLITE

15. General

a. The instructions in this section are for the information and guidance of the personnel responsible for the operation of the theodolite.

b. The operator must know how to perform every operation of which the theodolite is capable. This section gives instructions on handling and preparation for operation of the theodolite basic motions, adjustments, and on coordinating the basic motions to perform the specific tasks for which the equipment is designed. Since nearly every job presents a different problem, the operator may have to vary given procedures to fit the individual job.

16. Adjustments

a. *General.* There are two types of adjustments made on the theodolite: instrument and operational adjustments. Instrument adjustments bring the theodolite into proper operating condition with respect to the interrelationship of its parts and are not normally made in the field. Operational adjustments bring the theodolite into proper relationship with the terrain being surveyed, and are required each time

the theodolite is set up for actual surveying operations. This paragraph covers instrument adjustments.

b. *Plate Level.* Refer to figure 19 and adjust the plate level.

c. *Horizontal Slow-motion Screw.* Refer to figure 20 and adjust the horizontal slow-motion screw.

d. *Vertical Slow-motion Screw.* Refer to figure 20 and adjust the vertical slow-motion screw.

e. *Collimation Slow-motion Screw.* Refer to figure 20 and adjust the collimation slow-motion screw.

f. *Horizontal Circle Drive.* Refer to figure 21 and adjust the horizontal circle drive.

g. *Leveling Screws.* Refer to figure 22 and adjust the leveling screws.

h. *Horizontal Collimation Error Adjustment.* Refer to figure 23 and adjust the theodolite for horizontal collimation error.

i. *Collimation Level.* Refer to figure 24 and adjust the collimation level.

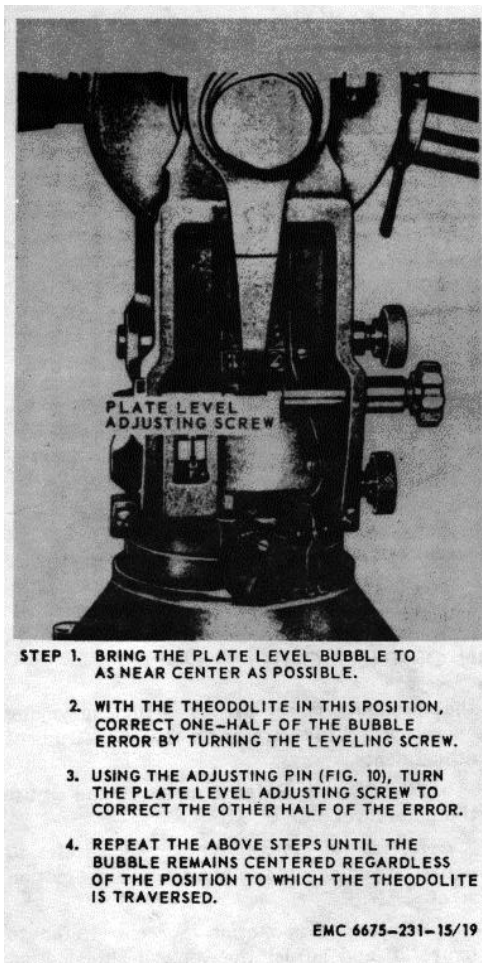

Figure 19. Plate level, adjustment.

17. Theodolite Operation

- Set up the theodolite on the tripod (par. 9).
- If necessary, install the illumination system (par. 10).

Note

To operate the illumination system, position the rheostat knob until desired brilliance is obtained. Place the hand light switch in the ON position.

- Install the eyepiece prisms as necessary (par. 10).
- Install the telescope eyepiece or telescope eyepiece prism sunglass as necessary (par. 49).

e. Perform the daily preventive maintenance services (par. 29).

f. Refer to figure 25 and level the theodolite.

Warning

Severe eye damage can result from performing observations against direct sunlight without utilizing the telescope sunglass.

g. Focus the telescope as follows:

(1) Direct the telescope toward a uniformly light background. Turn the diopter ring on the telescope eyepiece (fig. 2) until the crosslines are sharp and black.

Note

Observe the setting on the diopter ring (fig. 2). This setting will remain constant for the same observer but will vary for other observers.

(2) Turn the telescope focusing tube (fig. 4) to bring into view a clear image of the object being sighted.

h. The horizontal and vertical circle reading scales are both observed through the microscope eyepiece (fig. 3). When the rib of the inverter knob (fig 4) is in a horizontal position, the horizontal circle image appears in the upper window. When the inverter knob is turned with the rib in the vertical position, the vertical circle image appears in the lower window. Simultaneously with either of the circle images, the image of the seconds scale is always visible in the lower window.

18. Operation in Extreme Cold (Below 0°F.)

With proper precautions and servicing, the theodolite can be used in extreme cold. Its use is limited only by the endurance of operating personnel and conditions affecting visibility. The theodolite should be kept out-of-doors or in unheated buildings for short periods of nonuse. Extreme temperature changes will induce internal stresses affecting accuracy and lenses and prisms may become fogged. Theodolites to be used under conditions of extreme cold should be cleaned and all lubricants removed before being used. Snowfall, winds, and refraction of light are some of the conditions encountered at low temperatures.

Caution

Avoid subjecting the theodolite to sudden changes in temperature.

19. Operation in Extreme Heat

Operation of the theodolite in extreme heat and under the direct rays of the sun can cause

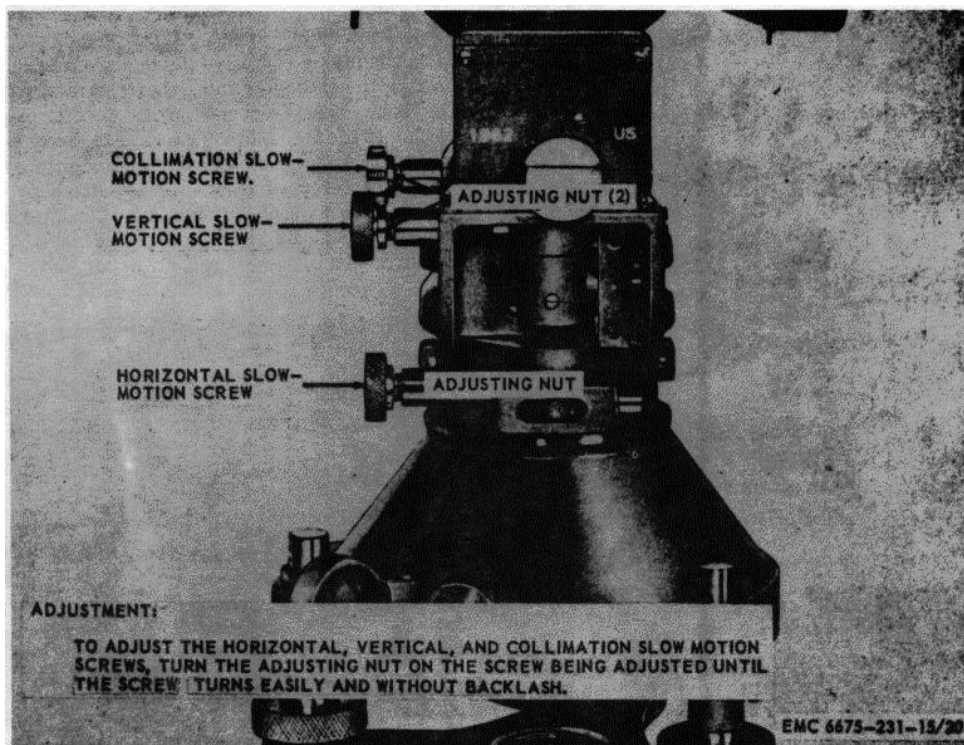

Figure 20. Horizontal, vertical, and collimation slow-motion screws, adjustment.

internal stresses and distortion in the instrument and produce poor sightings due to heat waves. If possible, the theodolite and the instrumentman should be protected from the direct sunlight by an umbrella or other suitable means. Under these conditions, shorter sightings will decrease the amount of sighting errors. Taking sightings during early morning and late evening will also minimize error magnitude. The use of suitable dark glasses by the instrumentman will reduce eyestrain and fatigue. If the theodolite is kept in a cool storage place, it should be removed from storage in sufficient time before use to allow the metal temperature to approach that of the outside air.

20. Operation in Dusty or Sandy Areas

Special care must be given instruments which are being used in dusty or sandy areas since both dust and sand are highly abrasive. If dust

and sand are allowed to remain on threaded or sliding surfaces, moving parts of the theodolite will soon bind and the instrument will become inaccurate or inoperable. The theodolite should be brushed frequently and carefully wiped clean. Be extremely careful not to scratch lens and prism surfaces during cleaning operations. Always protect the instrument from blowing dust and sand. Place a protective cover over the theodolite when it is not in use.

21. Operation Under Rainy or Humid Conditions

In humid areas, a slight lowering of the temperature will cause condensation of moisture and fogging of lenses and prisms. Internal fogging can usually be removed by placing the theodolite in a warm, dry place. Corrosion caused by high humidity can be partially eliminated by using warm, dry storage

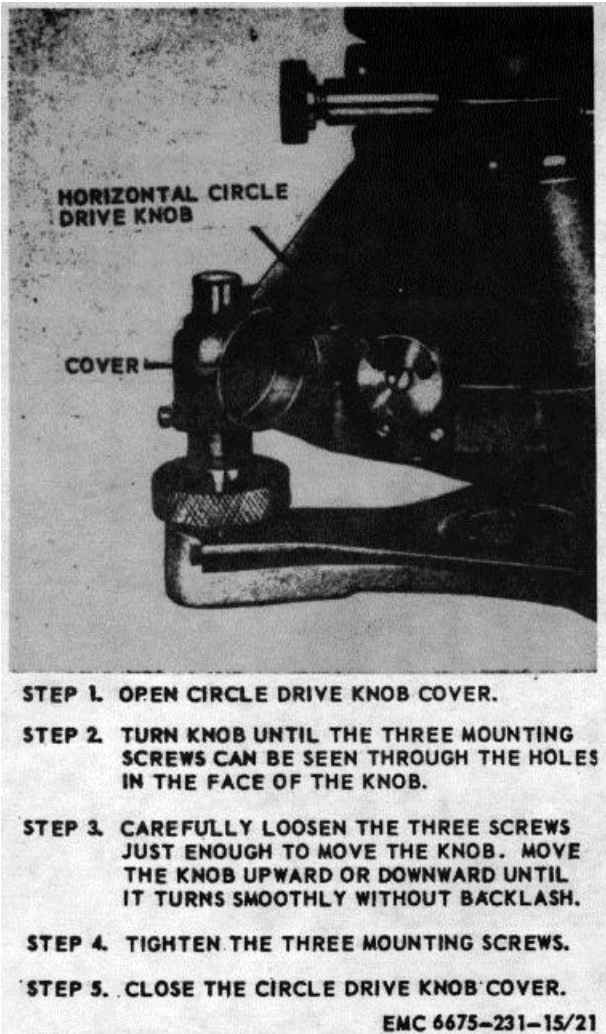

Figure 21. Horizontal circle drive, adjustment.

areas and desiccants. After use, dry the instrument thoroughly with a soft, lint-free cloth.

22. Operation in Salt Water Areas

Salt is highly corrosive to metals. When operating the theodolite in salt water areas, wipe the instrument frequently with a soft, clean cloth. If the theodolite is exposed to direct salt spray, it should be cleaned thoroughly and should be returned to an instrument shop for overhauling as soon as possible. Cleaning intervals should be shortened considerably for theodolites subjected to salt air exposure.

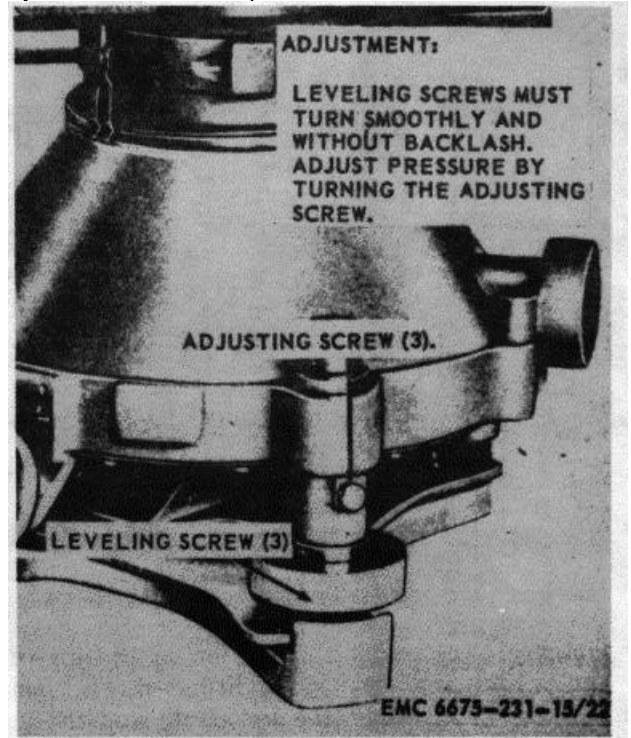
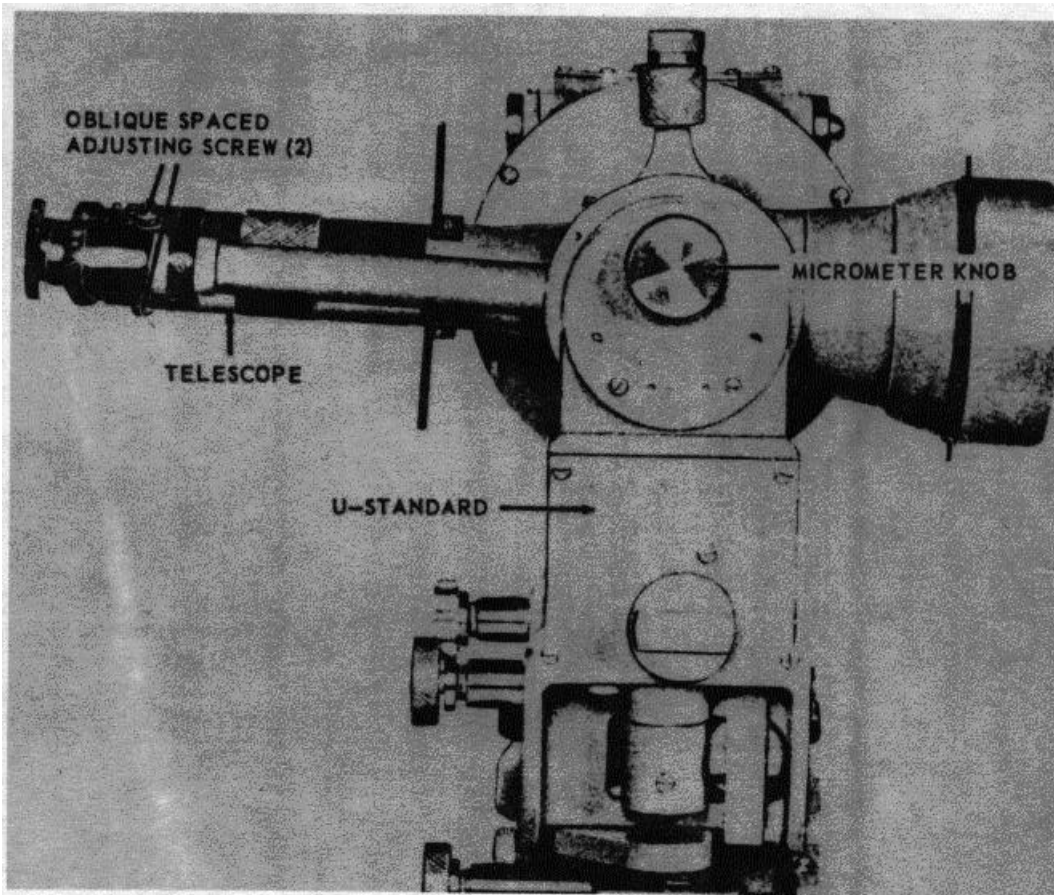

Figure 22. Leveling screws adjustment.



2. MAKE A HORIZONTAL OBSERVATION ON AN OBJECT AND RECORD THE AZIMUTH READING. REVERSE THE TELESCOPE AND ROTATE THE U-STANDARD UNTIL THE OBJECT IS AGAIN IN FOCUS. OBSERVE THE NEW AZIMUTH READING. SUBTRACT 180° FROM THE LARGER READING. IF THE VALUES ARE NOT EQUAL, A COLLIMATION ERROR IS INDICATED. THE TWO READINGS SHOULD NOW BE EQUAL. ANY DIFFERENCE BETWEEN READINGS IS EQUAL TO TWICE THE COLLIMATION ERROR.
3. TO CORRECT THE COLLIMATION ERROR, OBSERVE THE MICROMETER SCALE AND TURN THE MICROMETER KNOB UNTIL ONE-HALF THE DIFFERENCE FOUND IN STEP 2 IS COMPENSATED FOR ON THE MICROMETER SCALE. RESTORE THE COINCIDENCE OF THE SCALE GRADUATIONS BY TURNING THE HORIZONTAL SLOW-MOTION SCREW.
4. NOW THE TELESCOPE CROSSLINES MUST BE MOVED SIDWAYS UNTIL THEY ARE ON THE OBJECT AGAIN. TO MOVE THEM TO THE RIGHT, LOOSEN THE LEFT-SIDE ADJUSTING SCREW AND GENTLY TIGHTEN, BY EQUAL AMOUNTS, THE OTHER TWO OBLIQUELY SPACED ADJUSTING SCREWS. TO MOVE THE CROSSLINES TO THE LEFT, THE TWO OBLIQUELY SPACED ADJUSTING SCREWS MUST FIRST BE LOOSENED, BY EQUAL AMOUNTS, AND THE LEFT SIDE ADJUSTING SCREW TIGHTENED.

EMC 6675-231-15/23

Figure 23. Horizontal collimation error, adjustment.

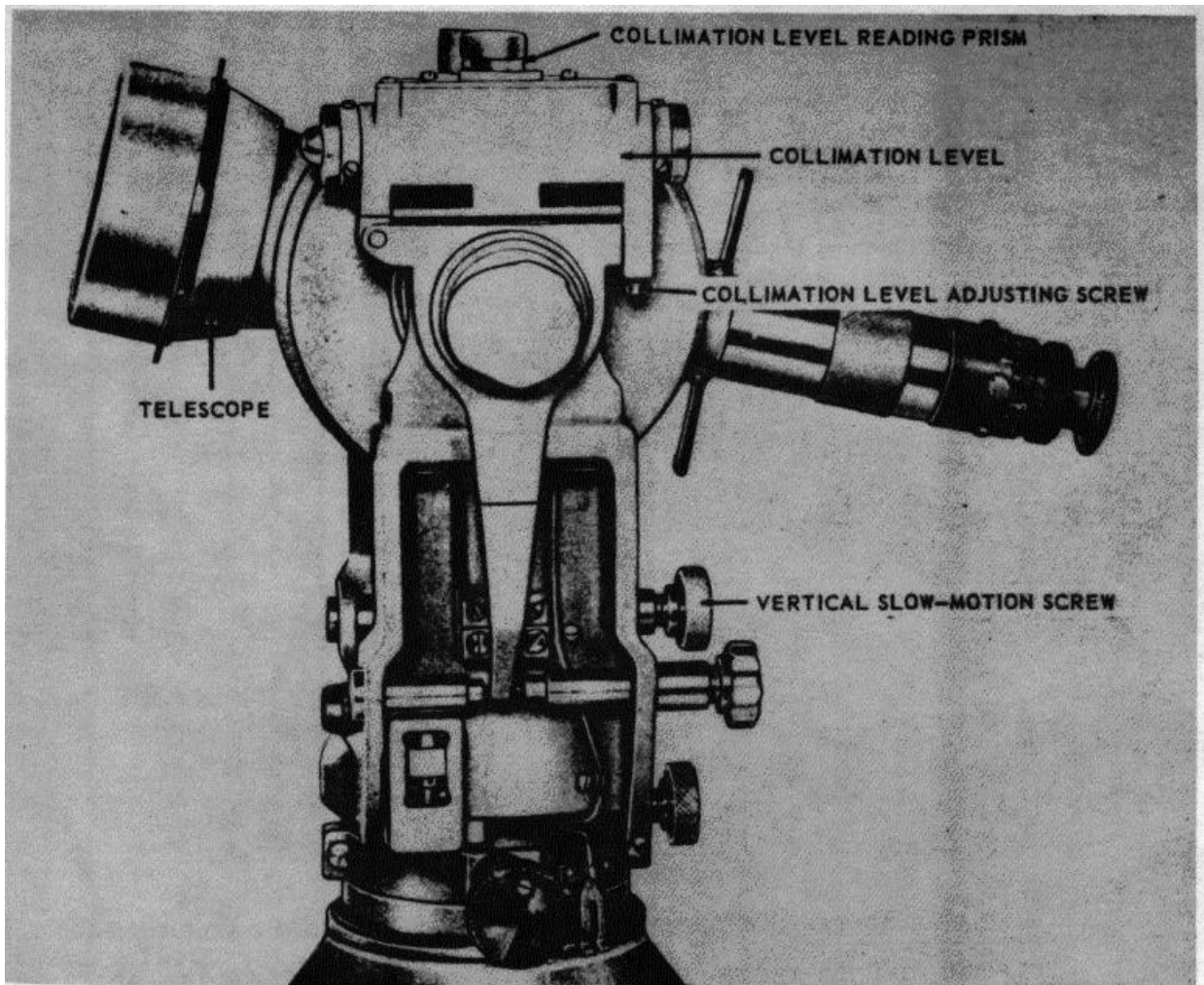

- STEP 1. REFER TO FIGURE 24 AND, IF NECESSARY, ADJUST THE THEODOLITE FOR PROPER HORIZONTAL COLLIMATION.**
- 2. TO TEST THE THEODOLITE FOR PROPER VERTICAL COLLIMATION, SIGHT THE VERTICAL ANGLE TO A WELL DEFINED OBJECT AND RECORD THE READING. REVERSE THE TELESCOPE AND RESIGHT THE OBJECT. RECORD THE READING. HALVE THE SECOND READING AND ADD 90° . THIS SHOULD GIVE EXACTLY THE READING OBTAINED IN THE FIRST POSITION.**
 - 3. TO ADJUST THE VERTICAL CIRCLE TO THE PROPER READING, PLACE THE TELESCOPE IN THE FIRST POSITION. SET THE MICROMETER SCALE TO THE PROPER SECONDS READING OBTAINED IN STEP 2. DIRECT THE TELESCOPE ON THE OBJECT. USE THE VERTICAL SLOW-MOTION SCREW AND BRING INTO COINCIDENCE THOSE GRADUATION LINES WHICH GIVE THE PROPER READING.**
 - 4. TURN THE COLLIMATION LEVEL ADJUSTING SCREW TO BRING THE LEVEL BUBBLE TO CENTER.**
 - 5. REPEAT THE MEASUREMENT OF THE VERTICAL ANGLE AS IN STEP 2. ADD THE TWO READINGS. THE SUM OF THE TWO READINGS SHOULD NOW BE WITHIN 6 SECONDS OF 180° . IF NECESSARY REPEAT STEPS 2 THROUGH 4.**

EMC 6675-231-15/24

Figure 24. Collimation level, adjustment.

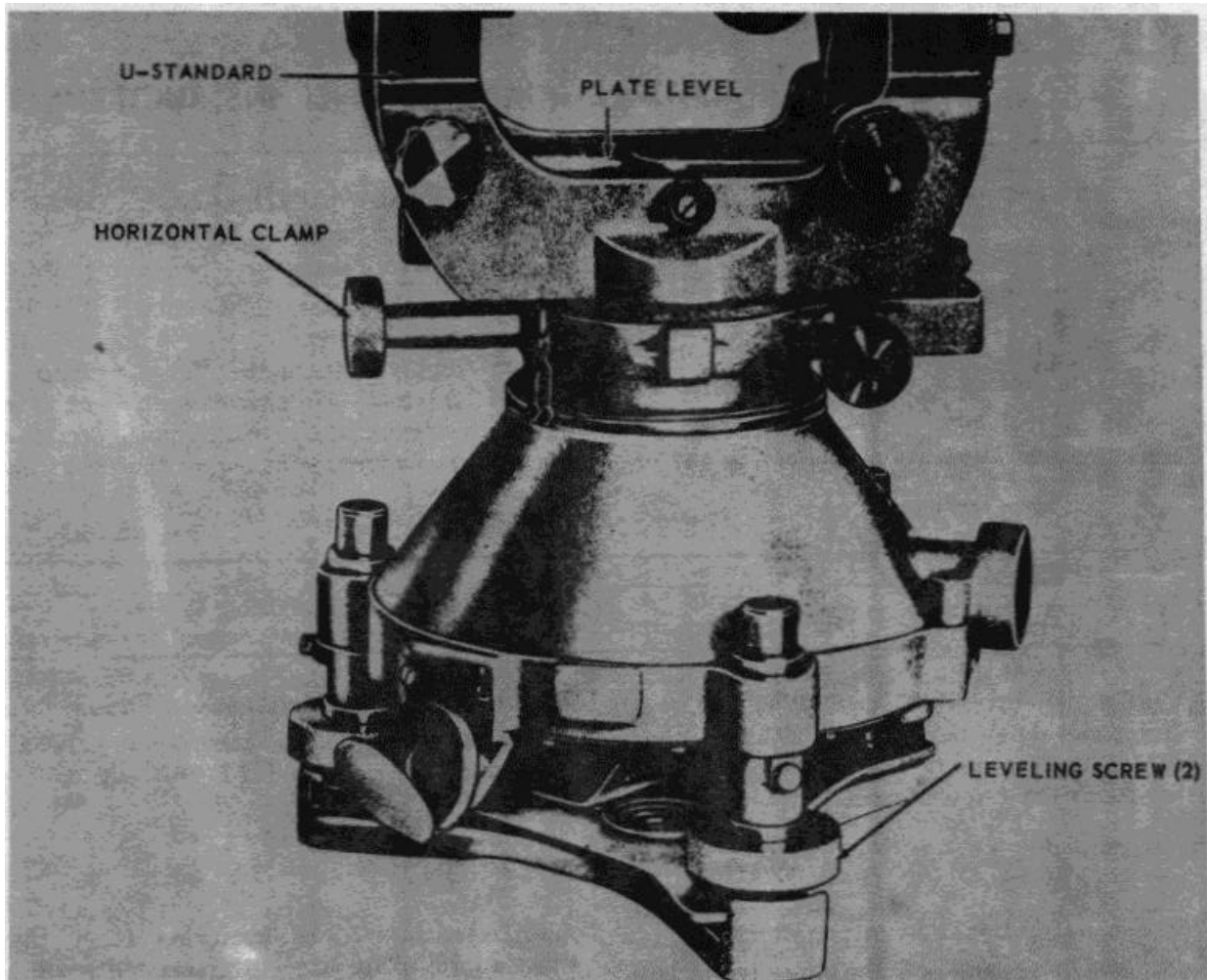

- STEP 1.** UNLOCK THE HORIZONTAL CLAMP. ROTATE THE U-STANDARD UNTIL THE PLATE LEVEL IS PARALLEL TO A LINE JOINING ANY TWO LEVELING SCREWS. LOCK THE CLAMP.
- 2.** TURN THE TWO LEVELING SCREWS THAT ARE PARALLEL WITH THE PLATE LEVEL SIMULTANEOUSLY BUT IN OPPOSITE DIRECTIONS UNTIL THE LEVEL BUBBLE IS CENTERED.
- 3.** UNLOCK THE CLAMP. ROTATE THE U-STANDARD 90° . LOCK THE CLAMP. TURN THE THIRD LEVELING SCREW UNTIL THE BUBBLE IS CENTERED AGAIN.
- 4.** UNLOCK THE CLAMP. ROTATE THE U-STANDARD 180° . LOCK THE CLAMP. TURN THE SAME LEVELING SCREWS AS IN STEP 3 AND REMOVE ONE-HALF OF ANY BUBBLE DISPLACEMENT THAT MAY EXIST.
- NOTE:** IF AFTER STEP 4, THE BUBBLE IS MORE THAN 3 OR 4 DIVISIONS FROM CENTRALITY, THE CORRECTION IS MADE BY MEANS OF THE PLATE LEVEL ADJUSTING SCREW. REFER TO PARAGRAPH 16.

EMC 6115-231-15/25

Figure 25. Theodolite, leveling.

CHAPTER 3
OPERATOR AND ORGANIZATIONAL MAINTENANCE INSTRUCTIONS

Section I. OPERATOR AND ORGANIZATIONAL MAINTENANCE TOOLS AND EQUIPMENT

23. Special Tools and Equipment

The special tools required to perform organizational maintenance on the theodolite are listed in table I and in TM 5-6675-231-25P. References and illustrations indicating the use of these tools are listed in the table.

The five-digit code preceding the stock number is the Federal supply code number for the manufacturer of the tool. No special equipment is required by organizational maintenance personnel for performing maintenance on the theodolite.

Table I. Special Tools

Item	FSN or part No.	Figure No.	Use
Pin, adjusting	6675-353-4103	10	Adjust theodolite adjusting screws.
Wrench, tripod	5120-429-2949	14	Tripod leg adjustment, removal and installation.

24. Basic Issue Tools and Equipment

Tools and repair parts issued with or authorized for the theodolite are listed in the basic issue items list (Appendix III).

25. Organizational Maintenance Repair Parts

Organizational maintenance repair parts are listed and illustrated in TM 5-6675-231-25P.

Section II. LUBRICATION

26. General Lubrication Information

All moving parts of the theodolite, both smooth and threaded surfaces, are fitted within extremely fine tolerances. For this reason, most parts of the theodolite are cleaned prior to lubrication. Any attempt to lubricate the theodolite without first cleaning it may result in damage to the instrument. Only those lubricants approved for use on the theodolite will be used. No lubrication will be performed in the field unless specifically called for.

Approved lubricants are non-corrosive, highly refined, and must be free from all paint removing ingredients. Ordinary machine oil is not an approved lubricant. The following lubricants are approved for use on this theodolite:

- (1) OCW; oil, clock and watch.
- (2) GL; grease, aircraft and instrument.

c. *Components Requiring Lubrication.*

- (1) *Telescope axle bearing.* Clean the area between the right side axis bearing (fig. 1), vertical clamp, and telescope axis. Apply 1 drop of oil at the top of each crack. Turn the telescope 180° and apply 1 drop of oil in the same cracks. Rotate the telescope and simultaneously press down and release the vertical clamp to work the oil into the telescope axis. When the axis is

27. Detailed Lubrication Information

a. *Care of Lubricants.* Special care should be taken to see that all surveying-instrument lubricants are kept absolutely free from contamination by any foreign substance. Containers must be stored in a clean, dry place and wiped free of dirt or dust before they are opened. All lids or bottle tops must be airtight.

b. *Lubricants.* No lubricants other than those approved for use on the theodolite will be stocked.

thoroughly lubricated, wipe off the excess oil with a clean, lint-free cloth.

- (2) *Collimation lever bearing.* Place 1 drop of oil at the top of the crack between the collimation lever (fig. 3) and the left side axis bearing (fig. 3). Work the oil into the crack by alternately pushing and releasing the lower part of the collimation lever against the spring of the collimation slow-motion screw (fig. 3). Wipe off all the excess oil with a clean, lint-free cloth.
- (3) *Leveling screws.* Turn the leveling screw (fig. 1) outward to the extreme length of its travel. Clean it thoroughly with a clean, lint-free cloth. Lubricate sparingly and run the screw through its travel several times to distribute the lubricant evenly. Wipe off all excess lubricant. Lubricate the other two leveling screws in a similar manner.
- (4) *Spring plate.* The sloped sides of the spring plate (fig. 1), which contact the leveling screws to hold them securely against the star plate (fig. 1), should be

lubricated sparingly as required. Remove the star plate (par. 54). Apply lubricant sparingly to the sloped edges of the openings in the spring plate (fig. 1). Install the star plate (par. 54).

- (5) *Horizontal circle drive knob cover hinge.* Apply 1 drop of oil to the hinge pin in the hinge of the horizontal circle drive knob cover (fig. 4). Carefully work the cover forward, backward, up, and down to distribute the oil over the working surfaces. Wipe off all excess oil with a clean, lint-free cloth.

d. Lubrication Procedure. Cleaning and lubrication services, which require partial or complete disassembly of the instrument, must be performed in the dust-free atmosphere of an instrument repair shop and only by qualified personnel. Disassembling the instrument under other conditions, especially where dust might filter into recesses, will do more harm than good. Since the lubricants must be applied sparingly, never use a container with a spout, such as an oil can, to squirt oil on parts or into assemblies.

Section III. PREVENTIVE MAINTENANCE SERVICES

28. General

To insure that the theodolite is ready for operation at all times, it must be inspected systematically, so that defects may be discovered and corrected before they result in serious damage or failure. The necessary preventive maintenance services to be performed are listed in paragraphs 29 and 30. The item numbers indicate the sequence of minimum inspection requirements. Defects discovered during operation of the unit shall be noted for future correction, to be made as soon as operation has ceased. Stop operation immediately if a deficiency is noted during operation, which would damage the equipment if operation were continued. All deficiencies and shortcomings will be recorded together with the corrective action taken on DA Form 2404 (Equipment Inspection and Maintenance Worksheet) at the earliest possible opportunity.

29. Daily Preventive Maintenance Services

This paragraph contains an illustrated tabulated listing of preventive maintenance services which must be performed by the operator. The item numbers are listed consecutively and indicate the sequence of minimum requirements. Refer to Figure 26 for the daily preventive maintenance services.

30. Quarterly Preventive Maintenance Services

a. This paragraph contains an illustrated tabulated listing of preventive maintenance services which must be performed by organizational maintenance personnel at quarterly intervals. A quarterly interval is equal to 3 calendar months, or 250 hours of operation, whichever occurs first.

b. The item numbers are listed consecutively and indicate the sequence of minimum requirements. Refer to figure 27 for quarterly preventive maintenance services

PREVENTIVE MAINTENANCE SERVICES

DAILY

TM5 6675-231-15

WILD HEERBRUGG MODEL T-3

THEODOLITE

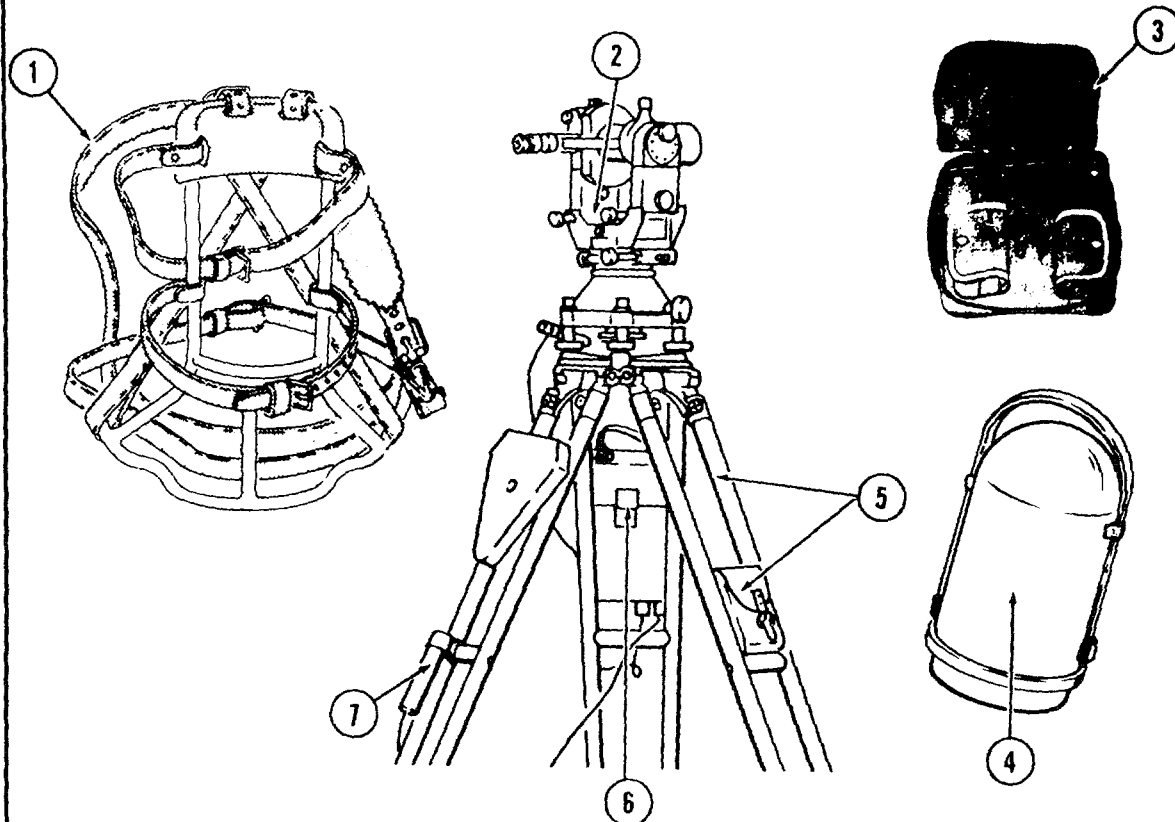

ITEM		PAR REF
1	<u>PACK RACK.</u> Inspect rack for serviceable condition	48
2	<u>THEODOLITE.</u> Inspect eyepieces, adjusting and clamping knobs, and adjusting screws for proper operation. Inspect lenses, level vials, and mirrors for dryness, cleanliness, and serviceable condition. Clean lenses, vials, and mirrors.	
3	<u>ACCESSORY CASE.</u> Inspect case for serviceability and presence of components.	
4	<u>CARRYING CASE.</u> Inspect case for serviceability. Inspect desiccant for proper color (blue). Dehydrate or replace desiccant of any other color. Inspect base recess for presence of components.	47

Figure 26. Daily preventive maintenance services.

ITEM		PAR REF
5	<u>TRIPOD.</u> Inspect tripod for serviceable condition. Inspect pouch for serviceable condition and presence of components.	57 thru 59
6	<u>BATTERY BOX.</u> Inspect box for presence of components. Inspect batteries and wiring for serviceable condition. Inspect rheostat for tight and clean connections and proper operation.	127
7	<u>HAND LIGHT.</u> Inspect light for serviceable condition and proper operation.	129

MSC 6675-231-15/25.1

Figure 26-Continued.

PREVENTIVE MAINTENANCE SERVICES

QUARTERLY

TMS 6675-231-15

WILD HEERBRUGG MODEL T-3

THEODOLITE.

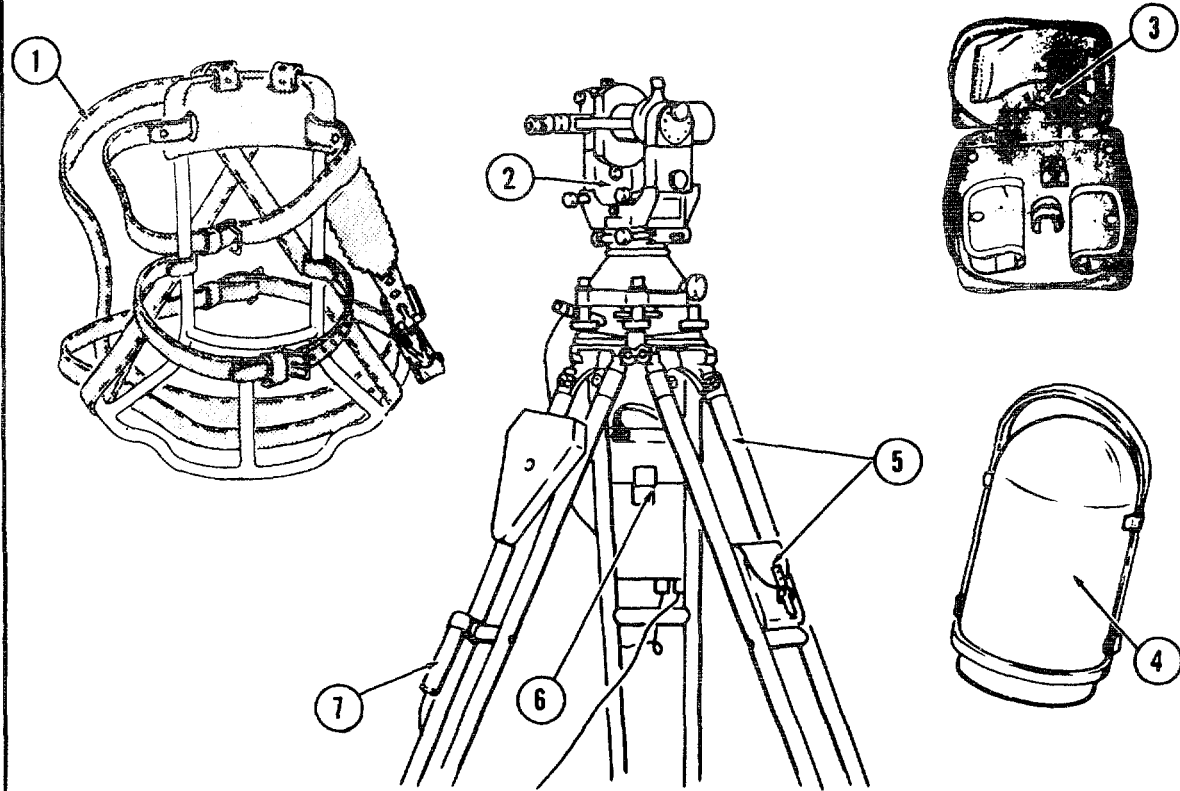

ITEM		PAR REF
1	PACK RACK. Inspect rack for serviceable condition.	48
2	THEODOLITE. Inspect eyepieces, adjusting and clamping knobs, and adjusting screws for proper operation. Inspect lenses, level vials, and mirrors for dryness, cleanliness, and serviceable condition. Clean lenses, vials, and mirrors.	
3	ACCESSORY CASE. Inspect case for serviceability and presence of components.	
4	CARRYING CASE. Inspect case for serviceability. Inspect desiccant for proper color (blue). Dehydrate or replace desiccant of any other color. Inspect base recess for presence of components.	47

Figure 27. Quarterly preventive maintenance services.

ITEM		PAR REF
5	<u>TRIPOD.</u> Inspect tripod for serviceable condition. Inspect pouch for serviceable condition and presence of components.	57 thru 59
6	<u>BATTERY BOX.</u> Inspect box for presence of components. Inspect batteries and wiring for serviceable condition. Inspect rheostat for tight and clean connections and proper operation.	127
7	<u>HAND LIGHT.</u> Inspect light for serviceable condition and proper operation.	129

MSC 6675-231-15/25.2

Figure 27-Continued.

Section IV. OPERATOR'S MAINTENANCE

31. Lamp Replacement

Refer to figure 28 and replace the lamps.

32. Battery Replacement

Refer to figure 28 and replace the batteries.

Section V. TROUBLESHOOTING

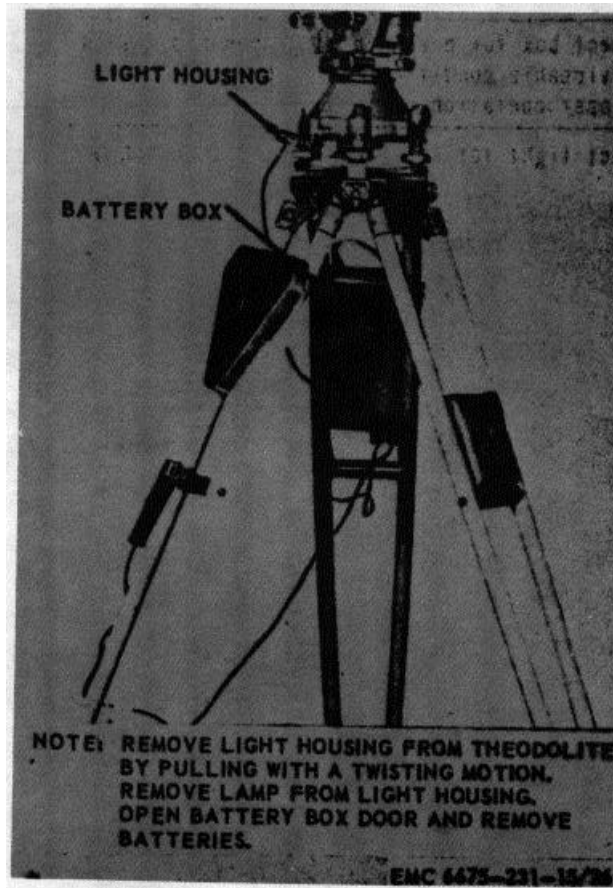

Figure 28. Lamp and battery, removal and installation.

33. General

This section provides information useful in diagnosing and correcting unsatisfactory operation or failure of the theodolite and its components. Each trouble symptom stated is followed by a list of probable causes of the trouble. The possible remedy recommended is described opposite the probable cause. Any trouble beyond the scope of organizational maintenance will be reported to field maintenance, 3d echelon.

34. Theodolite Will Not Seat Properly on Tripod Head

<i>Probable cause</i>	<i>Probable remedy</i>
Bridge screw improperly started.	Restart the bridge screw (par. 9).
Star plate defective	Replace star plate (par. 54).
Tripod head defective	Replace head (par. 58).

35. Theodolite Will Not Stay on Line

<i>Probable cause</i>	<i>Probable remedy</i>
Theodolite out of level.....	Level the theodolite (par. 17).
Horizontal collimation or collimation level out of adjustment.	Adjust horizontal collimation or collimation level (par. 16).

36. Plate Level Bubble Does Not Stay in Center

Probable cause *Possible remedy*
Plate level out of adjust- Adjust the level (par. 16).
ment.

37. Collimation Level Bubble Does Not Stay in Center

Probable cause *Possible remedy*
Collimation level out of Adjust the level (par. 16).
adjustment.

38. Telescope Crosslines Will Not Focus

Probable cause *Possible remedy*
Telescope eyepiece defec- Replace the eyepiece (par.
tive. 50).

39. Circle and Micrometer Images Will Not Focus

Probable cause *Possible remedy*
Microscope eyepiece de- Replace the eyepiece (par.
fective. 50).

40. Lights on Vertical and Horizontal Circles Unequal or Absent

Probable cause *Possible remedy*
Horizontal circle or Replace the mirror (par.
vertical circle illuminat- 56).
ing mirror defective.

Probable cause *Possible remedy*
Illumination lamp defec- Replace lamp (par. 31).
tive.

41. Illumination System Faulty or Fails To Function

Probable cause *Possible remedy*
Batteries defectiveReplace the batteries (par.
32).

42. Tripod Legs Will Not Lock in Position

Probable cause *Possible remedy*
Leg clamping screws Tighten or replace screws
loose or defective. (par. 58).

43. Horizontal Circle Hard To Move

Probable cause *Possible remedy*
Circle drive setting pinion Adjust circle drive (par.
out of adjustment. 16).

44. Leveling Screws Too Tight or Too Loose

Probable cause *Possible remedy*
Leveling screws too tight Adjust the screws (par. 16).
or too loose.

45. Telescope Turns Too Hard or Too Easily

Probable cause *Possible remedy*
Vertical clamp screw Loosen clamp screw.
improperly set.

Section VI. CARRYING CASE AND PACK RACK

46. General

The carrying case for the theodolite is composed of the metal hood and base. The carrying case provides a convenient means of carrying the theodolite in the field and serves as a dustproof and moistureproof container for the instrument when it is in storage. The base has a recess in the bottom which houses the desiccant container and provides storage for the screwdriver, 24and 40-power telescope eyepiece assemblies, and illumination light housings. The pack rack is used to carry the theodolite, in its carrying case, when use of the carrying case alone is impractical.

47. Carrying Case

a. Hood.

- (1) *Removal.* Remove the hood (par. 7).
- (2) *Disassembly.* Refer to figure 29 and disassemble the hood.

(3) *Cleaning, inspection, and repair.*

- (a) Clean all metal parts with an approved cleaning solvent and dry thoroughly.
- (b) Clean the strap with saddle soap.
- (c) Inspect the straps for cracks, breaks, and cuts. Inspect for worn mounting holes and deterioration due to age.
- (d) Inspect the lever pins for burs and wear. Inspect the locking levers and lever springs for burs, bends, and cracks. Inspect for enlarged mounting holes.
- (e) Inspect the hood for dents, cracks, and holes. Inspect the bottom rim for out-of-round.
- (f) Remove all burs from the lever pins, locking levers, and lever springs. Straighten minor dents. Remove all

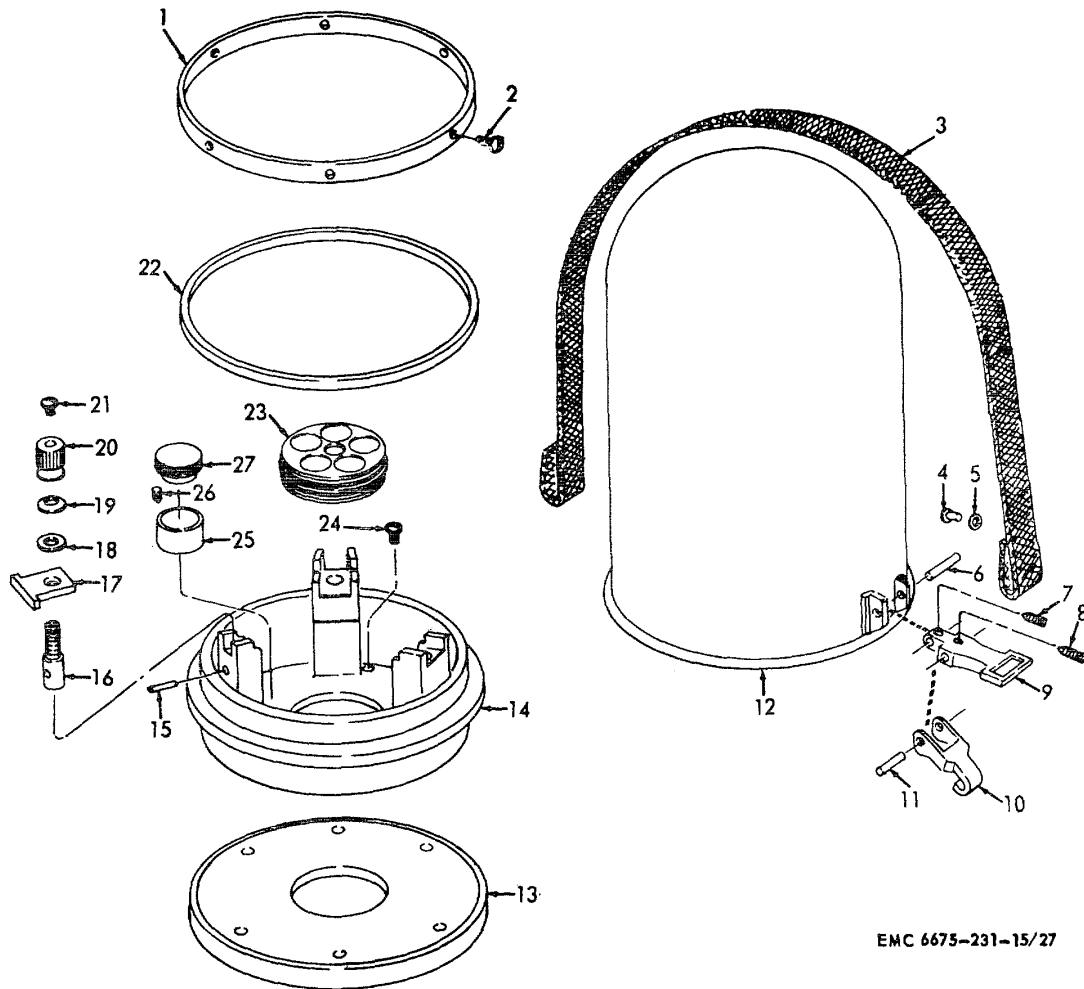

Figure 29. Carrying case, disassembly and reassembly.

- | | | |
|--------------------|----------------------|-------------------------------|
| 1 Collar | 10 Hook (2 rqr) | 19 Washer (3 rqr) |
| 2 Screw (6 rqr) | 11 Pin (2 rqr) | 20 Knob (3 rqr) |
| 3 Belt | 12 Hook | 21 Screw (spec) (3 rqr) |
| 4 Rivet (6 rqr) | 13 Plate | 22 Rubber gasket |
| 5 Washer (6 rqr) | 14 Base | 23 Desiccant container |
| 6 Pin (2 rqr) | 15 Pin (3 rqr) | 24 Screw (6 rqr) |
| 7 Setscrew (2 rqr) | 16 Screw pin (3 rqr) | 25 Eyepiece container (2 rqr) |
| 8 Setscrew (2 rqr) | 17 Lever (3 rqr) | 26 Screw (2 rqr) |
| 9 Lever (2 rqr) | 18 Washer (3 rqr) | 27 Cover |

traces of rust and repaint where necessary.

(g) Straighten minor dents or bends in the hood. Seal all cuts or holes in the hood. Repaint where necessary.

(h) Replace all defective parts that cannot be repaired.

(4) *Reassembly.* Refer to figure 29 and reassemble the hood.

(5) *Installation.* Install the hood (par. 7).

b. *Base.*

(1) *Removal.* Remove the base (par. 7).

(2) *Disassembly.* Refer to figure 29 and disassemble the base.

(3) *Cleaning, inspection, and repair.*

(a) Clean all metal parts with an approved cleaning solvent and dry thoroughly. Brush threaded surfaces free of any foreign matter.

Wipe the rubber washer clean with a soft cloth.

- (b) Inspect all threaded surfaces for worn or damaged threads. Inspect the lever nuts, slide levers, and washers for burrs and worn surfaces.
- (c) Inspect the base for cracks and a broken casting. Inspect the collar for bends, breaks, and out-of-round.
- (d) Inspect the rubber washer for damage or hardening because of age or excessive heat.
- (e) Remove all burrs from the base, bolts, slide levers, lever nuts, and collar. Straighten minor bends in the collar and washers. Replace all defective parts.

(4) *Reassembly.* Refer to figure 29 and reassemble the base.

(5) *Installation.* Install the base (par. 7).

c. *Desiccant and Container.*

(1) *Removal.* Remove the desiccant container (b above).

(2) *Disassembly.* Refer to figure 30 and disassemble the desiccant container.

(3) *Cleaning and inspection.*

(a) Clean all metal parts with an approved cleaning solvent and dry thoroughly.

(b) Inspect the sections of the container for bends, breaks, and damaged threads.

(c) Inspect the desiccant for color. Serviceable desiccant is blue in color. Pink desiccant indicates moisture saturation and the desiccant must be dehydrated or replaced.

(d) Replace the desiccant or container as necessary.

(4) *Reassembly.* Refer to figure 30 and reassemble the desiccant container.

(5) *Installation.* Install the desiccant container (b above).

48. Pack Rack

a. *General.*

The pack rack (fig. 12) is used for carrying the theodolite in its carrying case. The theodolite, in its carrying case, is strapped in the pack rack which in turn is carried on the operator's back.

b. *Cleaning and Inspection.*

(1) Clean all metal parts with an approved cleaning solvent and dry thoroughly. Clean the straps with saddle soap.

(2) Inspect the pack rack for damage and defects that would render it unserviceable. Repair or replace a defective pack rack.

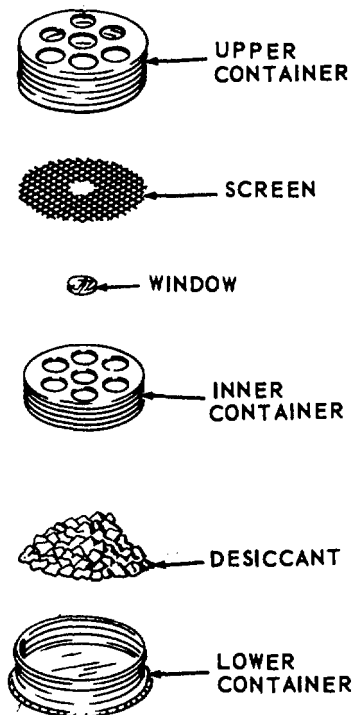

EMC 6675-231-15/28

Figure 30. Desiccant container, disassembly and reassembly.

Section VII. EYEPIECES

49. General

a. *Telescope and Microscope Eyepieces.* The telescope eyepiece is used to focus the crosslines and the objective point. Three telescope eyepieces of 24, 30, and 40 power are provided for this purpose. The

microscope eyepiece is used to bring the circle images into focus.

b. *Eyepiece Prisms.* The microscope eyepiece prism and the telescope eyepiece prism perform the functions of the conventional eyepieces

listed in a above. In addition, they enable the instrumentman to take sightings and readings up to the zenith.

c. *Sunglasses.* Two sunglasses are furnished with the theodolite. One is a triangular, three-color sunglass that may be installed over the telescope eyepiece prism. The other is a single-color sunglass that may be installed over the telescope eyepiece. The function of the sunglasses is to reduce glare when sightings or observations are made against direct sunlight. When not in use, the telescope eyepiece prism sunglass and the telescope eyepiece sunglass are stowed in the accessory case.

50. Telescope and Microscope Eyepieces

a. *Removal.* Refer to figure 31 and remove the telescope and microscope eyepieces.

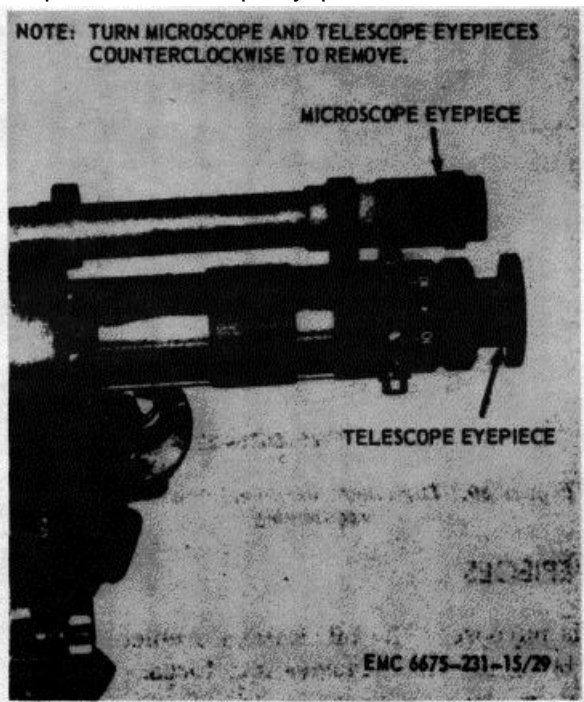

Figure 31. Telescope and microscope eyepieces, removal and installation.

b. *Cleaning and Inspection.*

- (1) Carefully clean the metal parts of the telescope and microscope eyepieces with a clean, dry cloth.
- (2) Remove dust or dirt from the lenses with a soft brush, lense tissue, or an approved cleaning solvent.
- (3) Inspect the eyepieces for worn or damaged threads, bent or broken metal parts, and chipped, cracked, or etched lenses. Replace defective eyepieces.

c. *Installation.* Refer to figure 31 and install the telescope and microscope eyepieces.

51. Eyepiece Prisms

a. *Removal.* Refer to figure 17 and remove the eyepiece prisms.

b. *Cleaning and Inspection.*

- (1) Clean all parts except the lenses with a cloth dampened with an approved cleaning solvent.
- (2) Clean the external part of the lenses with a soft brush, lens tissue, or an approved cleaning solvent.
- (3) Inspect the lenses for chips, cracks, and fungus etching. Inspect the metal parts for bends, breaks, and worn or damaged threads.
- (4) Replace all defective parts.

c. *Installation.* Refer to figure 17 and install the eyepiece prisms.

52. Sunglasses

a. *General.* The telescope eyepiece sunglass and the telescope eyepiece sunglass (fig. 10) are push-fit on the telescope. When not installed, they are stowed in the accessory case.

b. *Cleaning and Inspection.*

- (1) Clean the metal part of the sunglass with a cloth moistened with an approved cleaning solvent.
- (2) Clean the external parts of the lens with a soft brush, lens tissue, or an approved cleaning solvent.
- (3) Inspect the eyepiece for bent or cracked metal parts. Inspect the lens for chips, cracks, and fungus etching.
- (4) Replace a defective sunglass.

Section VIII. STAR PLATE

53. General

The star plate enables the operator to quickly and accurately secure the theodolite to, and remove it from, the tripod. This enables the operator to quickly move the instrument from one station to another when closing a traverse, or making measurements where speed and extreme accuracy are required.

54. Star Plate

a. *Removal.* Refer to figure 32 and remove the star plate.

b. *Cleaning and Inspection.*

- (1) Clean all metal parts with an approved cleaning solvent and dry thoroughly. Clean the footscrews with a soft brush dipped in an approved cleaning solvent.
- (2) Inspect the star plate for burs, cracks, breaks, or other defects.
- (3) Correct all -deficiencies or report them to field maintenance.

c. *Installation.* Refer to figure 32 and install the star plate.



Figure 32. Star plate, removal and installation.

Section IX. ILLUMINATION MIRRORS

55. General

The horizontal circle illumination mirror and the vertical circle illumination mirror are identical assemblies used to reflect light inside the theodolite to illuminate the vertical and horizontal circles.

56. Illumination Mirrors

a. *Removal.* Refer to figure 33 and remove the illumination mirrors.

b. *Cleaning and Inspection.*

- (1) Clean all metal parts with an approved cleaning solvent and dry thoroughly. Clean the mirror with a camel's-hair brush, if dusty; clean with a chamois, if foggy.
- (2) Inspect the hinge action for stiff or loose movement. Oil sparingly, if necessary, and wipe off all excess oil.
- (3) Inspect for a cracked or broken mirror. Inspect the metal mount for bends, cracks, and breaks.
- (4) Replace a damaged or defective mirror assembly.

c. *Installation.* Refer to figure 33 and install the illumination mirrors.

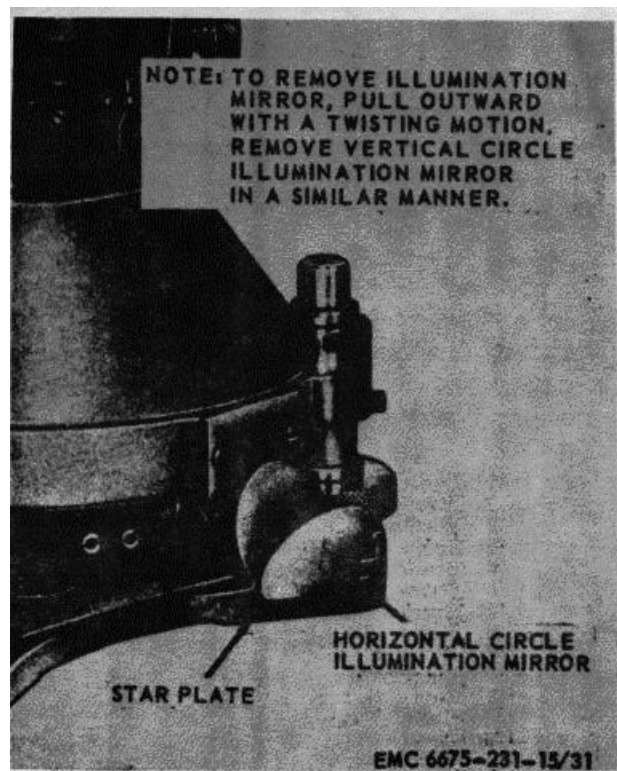

Figure 33. Illumination mirrors, removal and installation.

Section X. TRIPOD ASSEMBLY, PLUMB BOB, AND TRIPOD WRENCH

57. General

The tripod assembly is of the rigid-leg type which consists of the tripod head, tripod leg assemblies, and the cover plate. When the theodolite is being used for surveying work and other precision measuring, it is mounted on the tripod head. The plumb bob and tripod wrench are kept in the tripod tool kit mounted on one of the tripod legs. When the plumb bob is installed on the tripod, it is possible to center the

instrument exactly over the station point. The tripod wrench is used to tighten or loosen the clamping screws under the tripod head to hold the tripod legs in position.

58. Tripod Assembly

a. Disassembly.

- (1) Remove the tripod tool kit (fig. 15).
- (2) Refer to figure 34 and disassemble the tripod assembly.

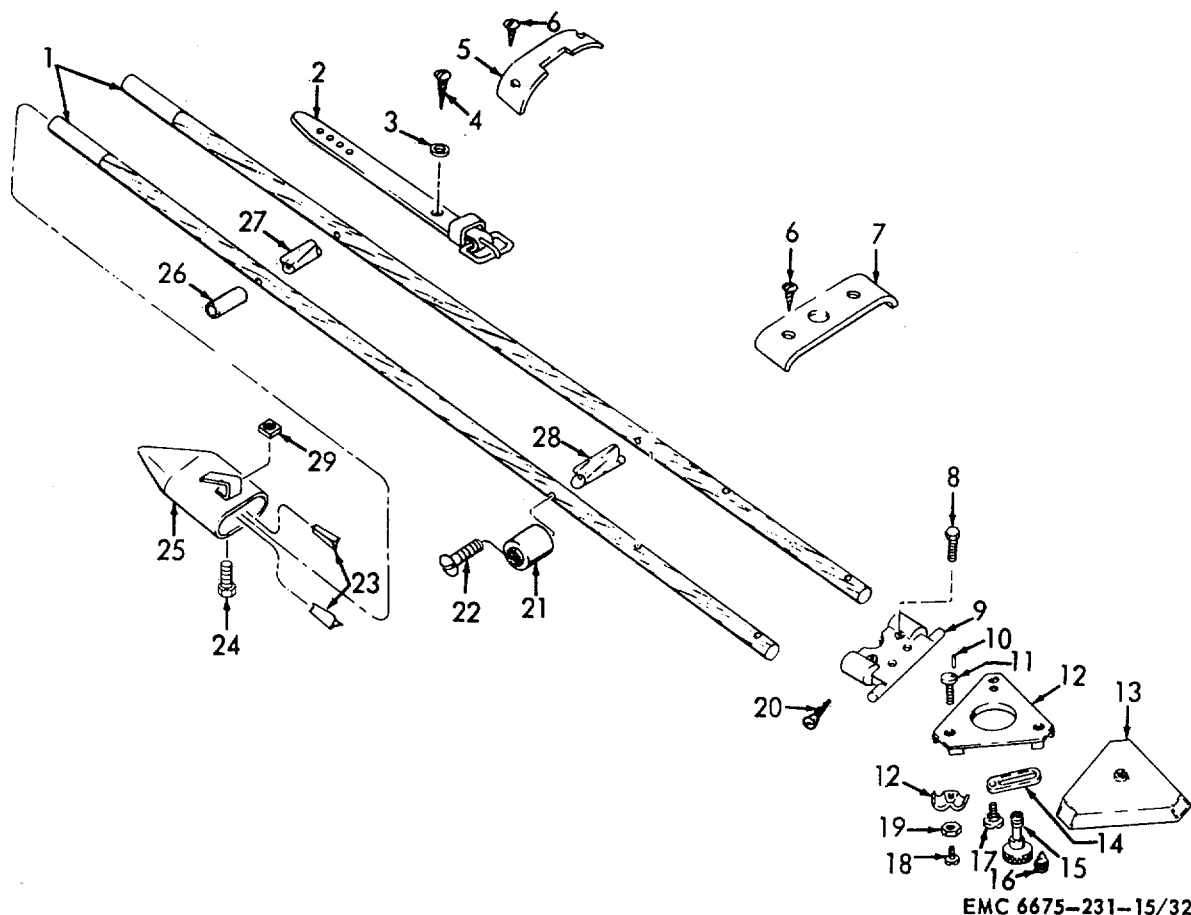

EMC 6675-231-15/32

- | | |
|------------------|--------------------|
| 1 Leg (6 rqr) | 16 Setscrew |
| 2 Strap | 17 Screw |
| 3 Washer (2 rqr) | 18 Screw |
| 4 Screw (2 rqr) | 19 Nut |
| 5 Bracket | 20 Screw (6 rqr) |
| 6 Screw (4 rqr) | 21 Bushing (3 rqr) |
| 7 Bracket | 22 Screw (6 rqr) |
| 8 Screw (6 rqr) | 23 Wedge (6 rqr) |
| 9 Housing | 24 Screw (3 rqr) |
| 10 Pin (3 rqr) | 25 Shoe (3 rqr) |
| 11 Screw (3 rqr) | 26 Bushing (3 rqr) |
| 12 Head | 27 Spacer (3 rqr) |
| 13 Cover | 28 Spacer (3 rqr) |
| 14 Washer | 29 Nut (3 rqr) |
| 15 Bridge screw | |

Figure 34. Tripod assembly, disassembly and reassembly.

b. *Cleaning and Inspection.*

- (1) Clean all metal parts with an approved cleaning solvent and dry thoroughly. Clean the wood parts with a soft cloth moistened with water and dry thoroughly. Clean the strap with a suitable cleaner.
- (2) Inspect the tripod leg housings and cover for burs, cracks, and wear. Inspect the head and cover for burs, scratches, cracks, and breaks. Inspect the bridge for bends, burs, wear, and damage. Inspect the clamps, shoes, and battery box bracket for cracks, breaks, and wear.
- (3) Inspect the strap for cuts, wear, and damage. Inspect the wood legs for cracks, splits, wear, and warping.
- (4) Remove all burs and minor scratches. Straighten minor dents and bends. Varnish the wood legs if the protective coating is worn or damaged.
- (5) Replace all defective parts that cannot be repaired.

c. *Reassembly.*

- (1) Refer to figure 34 and reassemble the tripod assembly.
- (2) Install the tripod tool kit (fig. 15).

59. Plumb Bob and Tripod Wrench

a. *Plumb Bob.*

- (1) *Disassembly.* Refer to figure 35 and disassemble the plumb bob.
- (2) *Cleaning, inspection, and repair.*
 - (a) Clean all metal parts with an approved cleaning solvent and dry thoroughly.
 - (b) Inspect the bayonet tube, ring, slide, and plumb bob for signs of wear, cracks, or breaks. Inspect the lugs on the bayonet tube for burs. Inspect the cords for wear.

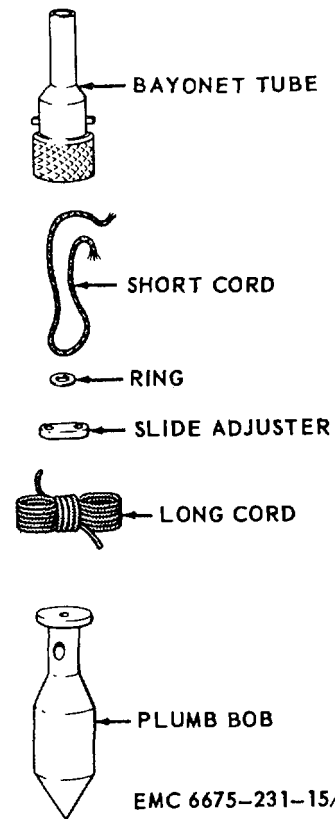

EMC 6675-231-15/33

Figure 35. Plumb bob, disassembly and reassembly

- (c) Remove all burs and replace damaged or defective parts. Use new cords when reassembling the plumb bob.

- (3) *Reassembly.* Refer to figure 35 and reassemble the plumb bob.

b. *Tripod Wrench.* Remove the tripod wrench from the tripod tool kit (fig. 14). Clean the wrench with an approved cleaning solvent and dry thoroughly. Inspect the wrench for wear, burs, cracks, or breaks. Remove minor burs from the wrench. Check to see if the wrench engages the bolts on the tripod head in a satisfactory manner. Replace a damaged or defective tripod wrench. Stow the wrench in the tripod tool kit.

CHAPTER 4
DEMOLITION OF THEODOLITE TO PREVENT ENEMY USE

60. General

When capture or abandonment of the theodolite to an enemy is imminent, the responsible unit commander must make the decision either to destroy the equipment or to render it inoperative. Based on this decision, orders are issued which cover the desired extent of destruction. Whatever method of demolition is employed, it is essential to destroy the same vital parts of all theodolites and all corresponding repair parts.

61. Demolition To Render the Theodolite Inoperative

a. Demolition by Mechanical Means. Using a hammer, bar, or other suitable tool, break all lenses, level vials, telescope, microscope, U-standard, tripod base, ground plate, and metal hood. Destroy the tripod, battery box, and accessory case. Rip the field pack apart.

b. Demolition by Burning. Pack oil-soaked rags, canvas, or other flammable material around the theodolite, leveling base, ground plate, metal hood, tripod, battery box, field pack, and accessory case and

set fire to the pile. Be sure the burning is thorough and complete before leaving.

c. Demolition by Submersion. Remove the theodolite from the carrying case. Submerge the instrument and all of its accessories in a body of water to insure water damage and provide concealment. Salt water will do the greatest damage to the metal parts.

62. Training

All operators should receive thorough training in the destruction of the theodolite. Simulated destruction, using all of the methods listed above, should be included in the operator training program. It must be emphasized in training that demolition operations are usually necessitated by critical situations when time available for carrying out destruction is limited. For this reason, it is necessary that operators be thoroughly familiar with all methods of destruction of equipment, and be able to carry out demolition instructions without reference to this or any other manual.

CHAPTER 5 SHIPMENT AND LIMITED STORAGE

Section I. SHIPMENT WITHIN ZONE OF INTERIOR

63. Preparation of Theodolite for Shipment

a. General. Detailed instructions for the preparation of Engineer equipment for domestic shipment are outlined within this paragraph.

b. Inspection. Perform a complete inspection as outlined in paragraph 8.

c. Cleaning and Drying. Remove dust and dirt from the theodolite and dry thoroughly. Refer to TM 38-230 for selection and application of cleaning and drying methods. EXCEPTION: clean all lenses and external prisms, using the camel's-hair brush provided with the equipment.

d. Painting. Paint all surfaces where the paint has been removed or damaged. Refer to TB ENG 60 for detailed cleaning and painting instructions.

e. Lubrication. Refer to paragraphs 26, 27, and 28 for selection and application of lubricants and areas to be lubricated.

f. Exterior Surfaces. When the instrument is to be placed in its carrying case and shipping case, it is not necessary to coat the machined ferrous metal surfaces with preservative. If the cases have become damaged or are not available, immediately after cleaning, exposed threads and unpainted machined ferrous metal surfaces of parts and accessories will be coated with lubricants specifically approved for use on the instrument.

g. Marking. Marking will conform to MILSTD-129 and fragile labels (DA LABEL 3, 4, or 5) will be affixed to at least three surfaces of the theodolite shipping case.

h. Batteries and Cables. Batteries will be removed from the battery box and packed in a suitable container. Cables will be disconnected, holes and openings sealed, and all terminals and connections wrapped and secured with type II, class 1, pressure-sensitive tape conforming to Specification PPP-T-60.

i. Disassembly and Packing.

(1) Disassemble and pack the accessories (reverse the instructions in paragraphs 7b through e) in the accessory container.

(2) Refer to paragraph 47c and inspect the desiccant. Replace desiccant if necessary. Reverse the instructions in paragraph 7a and pack the theodolite in the carrying case.

Note

Refer to TM 38-230 for guidance in selecting, fabricating, and packing a suitable accessory container.

64. Loading the Theodolite for Shipment

a. Loading. Loading the instrument for shipment can be accomplished by one man.

b. Shipping. Air transport is the best means of shipping the theodolite, as such travel subjects the instrument to a minimum of vibration, jolts, and stress caused by abrupt starts and stops. The shipping cases should be tied down securely and provision made against the possibility of the instrument shipping case being struck by loose objects or shifting freight.

Section II. LIMITED STORAGE

65. Preparation of Theodolite for Storage

a. General. Prepare the theodolite for limited storage in the same manner as outlined in

paragraph 63. Limited storage is defined as storage not to exceed 6 months. Refer to AR 743-505.

b. Storage. Store the theodolite, tripod, and accessories; in a dry, dust-free location where there is a minimum of vibration.

66. Inspection and Maintenance of Theodolite in Storage

Frequent inspection must be made to assure the equipment is ready for immediate use. Frequency of inspections will be prescribed by the

unit commander, taking into consideration such factors as the physical condition of the storage area, weatherproofing, vibrations, security from tampering or pilferage, humidity, and temperature conditions. The tripod and accessories must be inspected frequently unless they are in hermetically sealed packages containing adequate desiccants.

**CHAPTER 6
FIELD AND DEPOT MAINTENANCE INSTRUCTIONS**

Section I. GENERAL

67. Scope

a. The following instructions are for field and depot maintenance personnel. They contain information on equipment maintenance that is beyond the scope of the tools, equipment, personnel, or supplies normally available to organizational maintenance.

b. Appendix I includes the publications applicable to field and depot maintenance. Appendix II contains the maintenance allocation chart. The field and depot maintenance repair parts and special tool lists are listed in TM 5-6675-231-25P.

68. Record and Report Forms

For record and report forms applicable to field and depot maintenance, refer to TM 38 750.

Note

Applicable forms, excluding Standard Form 46 which is carried by the operator, shall be kept in a canvas bag mounted on the equipment.

Section II. DESCRIPTION AND DATA

69. Description

For a complete description of the theodolite, see paragraph 3.

70. Tabulated Data

a. *General.* This paragraph contains overhaul data pertinent to field and depot maintenance personnel.

b. *Time Standards.* Table II lists the number of man-hours required under normal conditions to perform the indicated maintenance and repair for the theodolite. Components are listed under the appropriate functional index. The times listed are not intended to be rigid standards. Under adverse conditions, the operations will take longer; but under ideal conditions with highly skilled instrument repairmen, most of the operations can be accomplished in considerably less time.

Table II. Time Standards

	Hours
(1) Lubrication and Service	
67 PRECISION INSTRUMENTS	
6700 THEODOLITE	
Theodolite	
Clean (general)	
(Use soft cloth free from dirt and oil, only on ex-	

Table II. Time Stands-Continued

	Hours
terior parts, not to include lens and mirrors. Do not use water, oil, or liquids when cleaning)...	0.3
Clean (special) (Use lens cloth to clean mirrors and lens. Use saddle soap on tripod accessory case when leather becomes hard or dry. Use linseed oil on tripod legs. Use a very stiff brush when cleaning canvas accessory case.)	0.4
(2) Remove and Replace	
17 HOOD	
1708 CARRYING CASES	
Case assembly, carrying	0.1
Pack rack	0.1
Case, shipping: Theodolite	0.1
26 ACCESSORIES, PUBLICATIONS, TEST EQUIPMENT AND TOOLS	
2602 ACCESSORIES	
Case, accessory	0.2
Socket assembly, plumb bob	0.1
Cover, plastic	0.1
Kit, tool: tripod	0.1
2604 SPECIAL TOOLS	
Wrench, tripod	0.1

Table II. Time Standards-Continued

	Hours
67 PRECISION INSTRUMENTS	
6700 THEODOLITE	
Theodolite	
(includes adjustment)	1.3
6701 TELESCOPE ASSEMBLY	
Axis, telescope	
(includes removal and installation of reticle mirror, vertical clamp, and telescope tube.)	6.0
Tube, telescope	
(includes removal and installation of eyepiece assembly and objective assembly).....	2.7
Bearing, right side	
(includes removal and installation of micrometer assembly)	1.2
Bearing, left side	
(includes removal and installation of vertical circle) ..	3.0
6702 OPTICS	
Objective assembly, telescope	0.7
Lens assembly, focus	
(includes removal and installation of the reticle assembly)	1.4
Reticle assembly, telescope	
(includes removal and installation of microscope, and telescope eyepieces).....	0.8
Eyepiece assembly, telescope,	
(includes removal and installation of microscope)	1.5
Eyepiece, telescope	0.2
Microscope assembly	0.3
Objective assembly, microscope	0.6
Eyepiece, prisms, microscope and telescope.....	0.1
Eyepiece, microscope	0.2
Mirror assembly, illumination.....	0.1
Prisms, micrometer and vertical circle	3.2
Mirror assembly, reticle	0.8
Lens assembly, vertical circle (includes removal and installation of left side bearing).....	4.0
Circle, horizontal	
(includes removal and installation of U-standard)	6.8
Vertical circle assembly	
(includes removal and installation of left side bearing)	3.0

Table II. Time Standards-Continued

	Hours
Circle, micrometer	2.0
Sunglass, telescope eyepiece ...	0.1
Micrometer assembly	0.4
Gunsight (front).....	0.4
Cap, dust, telescope.....	0.1
6703 MECHANICAL, STRUCTURAL, AND PRECISION PARTS	
Clamp assembly, vertical	
(includes removal and installation of right side telescope axis bearing)	1.6
Star plate	0.3
U-standard assembly	
(includes removal and installation of horizontal circle prism housing)	6.0
Screw, leveling	
(includes adjustment and removal and installation of star plate).....	1.2
Clamp assembly, horizontal	
(includes removal and installation of horizontal slow-motion screw)	0.8
Screw assemblies, slow-motion (includes adjustment).....	1.1
Base, housing assembly	
(includes removal and installation of the horizontal circle and circle drive).....	8.0
Circle drive assembly, horizontal	
(includes adjustment).....	0.8
Housing, prism, horizontal circle	
(includes removal and installation of base housing cover and leveling screws) ..	3.2
6708 BATTERIES	
Battery, dry cell	0.2
6709 LAMPS	
Fitting, lamp	0.1
Lamp (bulb)	0.1
Light, hand 0.1	
6718 MOUNTED CONNECTING DEVICES	
Socket, illumination	0.4
Contact ring	
(includes removal and installation of U-standard)	6.8
6719 MISCELLANEOUS WIRING AND FITTINGS	
Cable, electrical (internal) (includes removal and installation of horizontal circle)	7.2

Table II. Time Standards-Continued

	Hours
6723 POWER SUPPLY	
Battery box assembly	0.2
Cable, electrical	0.1
6724 LEVELS	
Plate level assembly	0.7
Collimation level assembly	1.2
Collimation lever assembly	1.2

Table II. Time Standards-Continued

	Hours
6725 TRIPODS	
Tripod	0.2
Head assembly, tripod	0.5
Leg assembly, tripod	0.5
Cover, tripod	0.1
82 MINERALS AND CHEMICALS	
Container, desiccant	0.2

Section III. SPECIAL TOOLS AND EQUIPMENT

71. Special Tools and Equipment

No special tools or equipment are required by field and depot maintenance personnel for performing maintenance on the theodolite.

72. Field and Depot Maintenance Repair Parts

Field and depot maintenance repair parts are listed and illustrated in TM 5-6675-231-25P.

73. Specially Designed Tools and Equipment

The specially designed tools and equipment illustrated in figure 36 and listed in table III are for field and depot maintenance personnel performing major overhaul work on the theodolite. The tools and equipment listed in table III are not available for issue, but must be fabricated by qualified field and depot maintenance personnel.

Table III. Specially Designed Tools

Item	References		Use
	Figure	Paragraph	
Puller, horizontal circle.....	36A	115	To remove and install the horizontal circle.
Tool, rotating prism mount.....	36B	111	To remove and install the horizontal circle prism carrier.
Wrench, tripod base.....	36C	54	To remove and install the star plate nut.
Tool, adjusting and assembly	36D	104	To hold reticle mirror axis in position.
Tool, adjusting and assembly.....	36E	102-103	To remove and install the eyepiece lens locking.
Wrench, adjustable spanner.....	36F	108	To remove and install slow-motion screw spring housings.

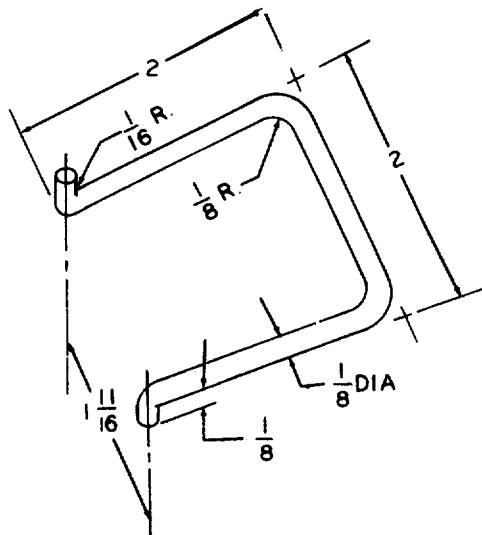

HORIZONTAL CIRCLE PULLER

HARD BRASS OR STEEL

A

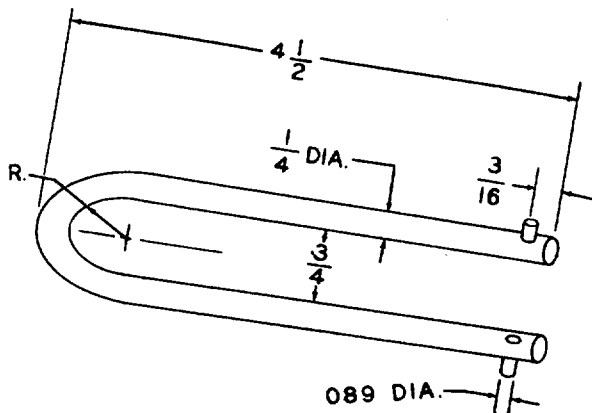

ROTATING PRISM
MOUNT TOOL

BODY - STEEL
PINS - STEEL

B

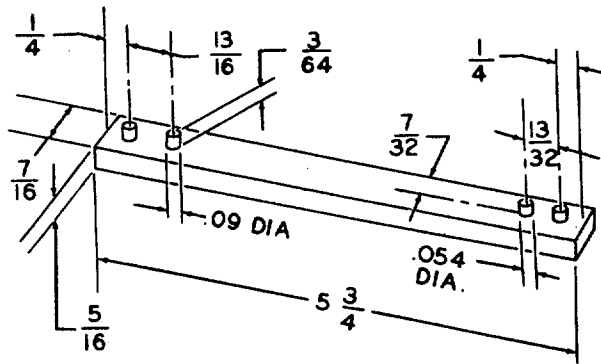

TRIPOD BASE WRENCH

BODY - STEEL
PINS - STEEL

C EMC 6675-205-15/26 ①

1 References A through C
Figure 36. Specially designed tools.

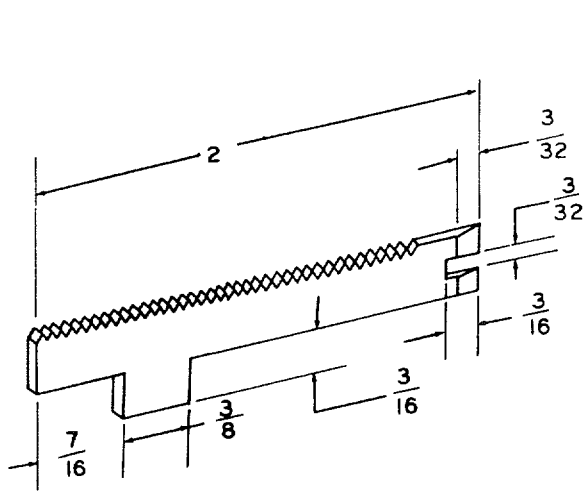

ADJUSTING & ASSEMBLY TOOL

MAKE FROM HACKSAW BLADE

D

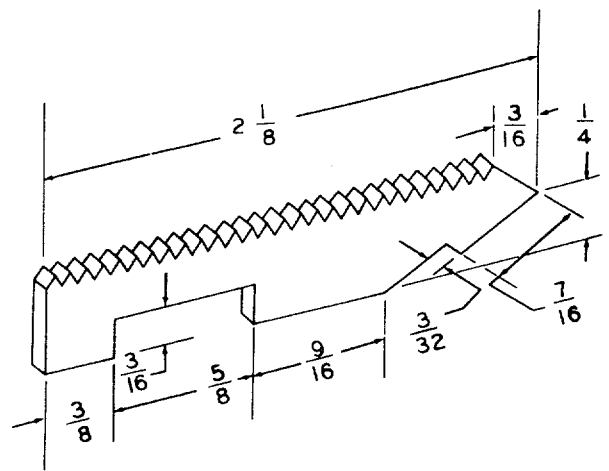

ADJUSTING & ASSEMBLY TOOL

MAKE FROM HACKSAW BLADE

E

EMC 6675-205-15/26 (2)

2 References D and E
Figure 36-Continued

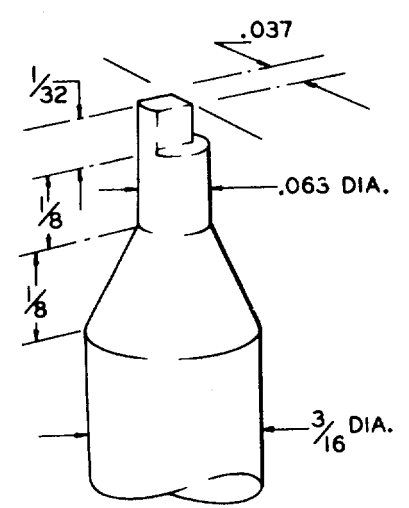
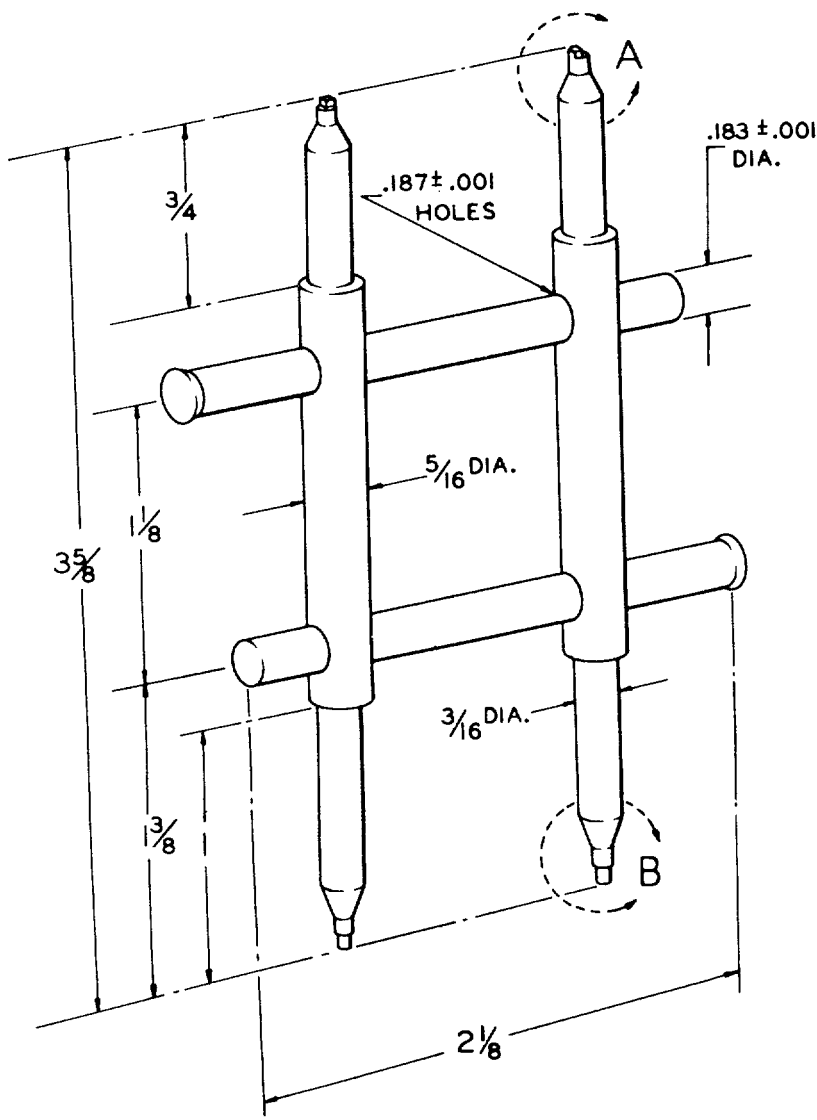

DETAIL A
ENLARGED

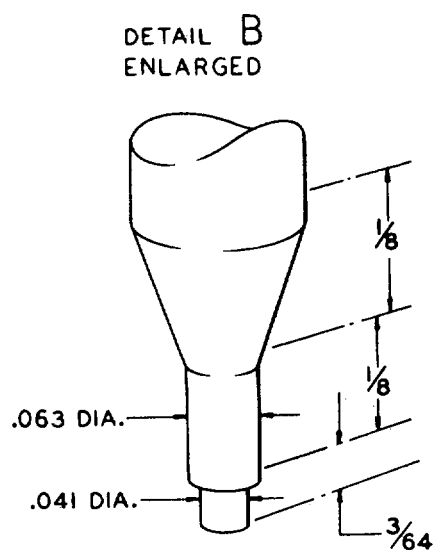

DETAIL B
ENLARGED

ADJUSTABLE SPANNER WRENCH
 MATERIAL: STEEL DRILL ROD

F EMC 6675-205-15/26 ③

3 Reference F
 Figure 36-Continued

Section IV. TROUBLESHOOTING

74. General

This section provides information useful in diagnosing and correcting unsatisfactory operation or failure of the theodolite and its components. Each trouble symptom stated is followed by a list of probable causes of trouble. The possible remedy recommended is described opposite the probable cause.

75. Theodolite Will Not Seat Properly on Tripod Head

<i>Probable cause</i>	<i>Possible remedy</i>
Star plate defective	Replace or repair the star plate (par. 95).

76. Theodolite Will Not Stay on Line

<i>Probable cause</i>	<i>Possible remedy</i>
Vertical travel off line	Line up right side axis bearing (par. 122).
Excessive right side axis bearing side play.	Align or replace axis bearing (par. 122).
Star plate loose or defective.	Tighten, replace, or repair star plate (par. 95).

77. Leveling Screws Too Tight or Too Loose

<i>Probable cause</i>	<i>Possible remedy</i>
Leveling screws dirty or worn.	Clean, repair, or replace leveling screws (par. 117).
Leveling screws out of adjustment.	Adjust leveling screws (par. 117).

78. Telescope Turns Too Hard or Too Easily

<i>Probable cause</i>	<i>Possible remedy</i>
Right side axis bearing defective.	Replace axis bearing (par. 122).
Telescope axis worn.....	Replace axis (par. 123).

79. Horizontal Circle Hard To Move

<i>Probable cause</i>	<i>Possible remedy</i>
Horizontal circle drive defective or out of adjustment.	Repair, replace, or adjust circle drive (par. 118).
Circle drive teeth dirty or worn.	Clean, repair, or replace circle drive teeth (pars. 115 and 118).

80. Plate Level Vial Defective

<i>Probable cause</i>	<i>Possible remedy</i>
Defective bubble	Replace vial (par. 97).
Level vial broken	Replace vial (par. 97).

81. Plate Level Bubble Does Not Stay in Center

<i>Probable cause</i>	<i>Possible remedy</i>
Leveling screws loose or worn.	Adjust or replace screws (par. 117).
Plate level bubble jumps	Replace level vial (par. 97).

82. Collimation Level Bubble Does Not Stay in Center

<i>Probable cause</i>	<i>Possible remedy</i>
Level mounting loose	Tighten screws (par. 93).
Level bearing binds	Clean bearing (par. 93).
Level bubble jumps	Replace level vial (par. 93).

83. Illumination System Fails To Function

<i>Probable cause</i>	<i>Possible remedy</i>
Wiring defective	Repair or replace wiring (pars. 128 and 129).
Faulty contact between U-standard contact and contact ring due to bent or dirty points and ring.	Clean ring or clean and straighten points (par. 115).
Illumination socket defective.	Replace socket (par. 119).
Battery box rheostat defective.	Replace rheostat (par. 128).
Battery box defective	Repair or replace battery box (par. 128).

84. Horizontal Circle Has Unequal Light or No Light

<i>Probable cause</i>	<i>Possible remedy</i>
Illumination system defective.	Refer to paragraph 83.
Illumination prism dirty, fogged, etched, or loose.	Clean, tighten, or replace prism (par. 110).

85. Vertical Circle Has Unequal Light or No Light

<i>Probable cause</i>	<i>Possible remedy</i>
Illumination system defective.	Refer to paragraph 83.
Inverter prism dirty, loose, or etched.	Clean, tighten, or replace prism (par. 100).

86. Horizontal Circle Graduations Unequal

<i>Probable cause</i>	<i>Possible remedy</i>
Illumination prism improperly installed or defective.	Reinstall or replace prism (par. 110).

87. Horizontal Circle Graduations Not at Right Angles to Line Dividing the Two Images

<i>Probable cause</i>	<i>Possible remedy</i>
Horizontal circle prism carrier too loose or too tight.	Adjust horizontal prism carrier (par. 111).

88. Vertical Circle Images Have Moved in Relation to the Line Dividing the Two Images and to the Reference Mark

Probable cause
Vertical circle prism im
properly installed or
defective.

Possible remedy
Reinstall or replace prism
(par. 98).

89. Micrometer Circle Has Unequal Light or No Light

Probable cause
Micrometer circle prism
dirty or defective.
Defect in illumination
system.

Possible remedy
Clean or replace prism
(par. 99).
Refer to paragraph 83.

Section V. ILLUMINATION MIRRORS

90. General

Two identical illumination mirrors are supplied with the theodolite. The vertical circle illumination mirror mounts on the vertical circle collar and the horizontal circle illumination mirror mounts on the socket on the horizontal base. The mirrors illuminate the vertical, horizontal, and micrometer circles.

91. Illumination Mirrors

a. *Removal.* Refer to paragraph 56 and remove the illumination mirrors.

b. *Disassembly.* Refer to figure 37 and disassemble the illumination mirrors.

c. *Cleaning, Inspection, and Repair.*

- (1) Clean all metal parts with an approved cleaning solvent and dry thoroughly.

Clean the mirror with an approved cleaning solvent and polish it with lens tissue or a lens cloth.

- (2) Inspect the mirror for cracks, breaks, and loose backing.
- (3) Inspect the sleeve and mount for bends, cracks, and burs. Inspect the pins for burs, bends, and wear.
- (4) Remove minor burs and straighten all slightly bent parts. Replace a damaged mirror. Cement the mirror firmly in place and let it dry thoroughly. Remove all excess adhesive.

d. *Reassembly.* Refer to figure 37 and reassemble the illumination mirrors.

e. *Installation.* Refer to paragraph 56 and install the illumination mirrors.

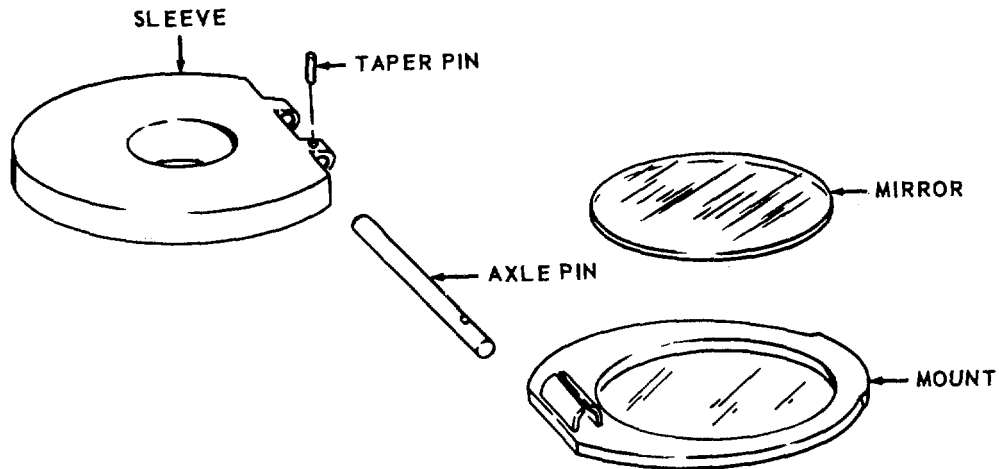

EMC 6675-231-15/35

Figure 37. Illumination mirrors, disassembly and reassembly.

Section VI. COLLIMATION LEVEL AND LEVER ASSEMBLY

92. General

The collimation level and lever assembly is provided to enable the operator to establish an exact horizontal plane and to make precise measurements relative to that plane.

93. Collimation Level and Lever Assembly

a. Removal.

- (1) Remove the illumination mirror (par. 56).
- (2) Refer to figure 38 and remove the collimation level and lever assembly.

b. *Disassembly.* Refer to figure 39 and disassemble the collimation level and lever assembly.

c. *Cleaning, Inspection, and Repair.*

- (1) Clean all metal parts with an approved cleaning solvent and dry thoroughly. Brush out all threaded surfaces with a brush dipped in an approved cleaning solvent. Polish the prism with lens tissue or with a lens cloth.

- (2) Inspect all threaded surfaces for worn or damaged threads. Inspect the prisms for chips, scratches, and etchings. Inspect the collimation lever, prism housing, carrier, level vial housing, cover, level cover, and sleeve for cracks, bends, dents, burs, and wear.

- (3) Remove all burs and straighten all dents and bends. Replace defective parts that cannot be repaired.

d. *Reassembly.* Refer to figure 39 and reassemble the collimation level and lever assembly.

e. *Installation.*

- (1) Refer to figure 38 and install the collimation level and lever assembly.

- (2) Install the illumination mirror (par. 56).

f. *Adjustment.* Refer to figure 24 and adjust the collimation level.

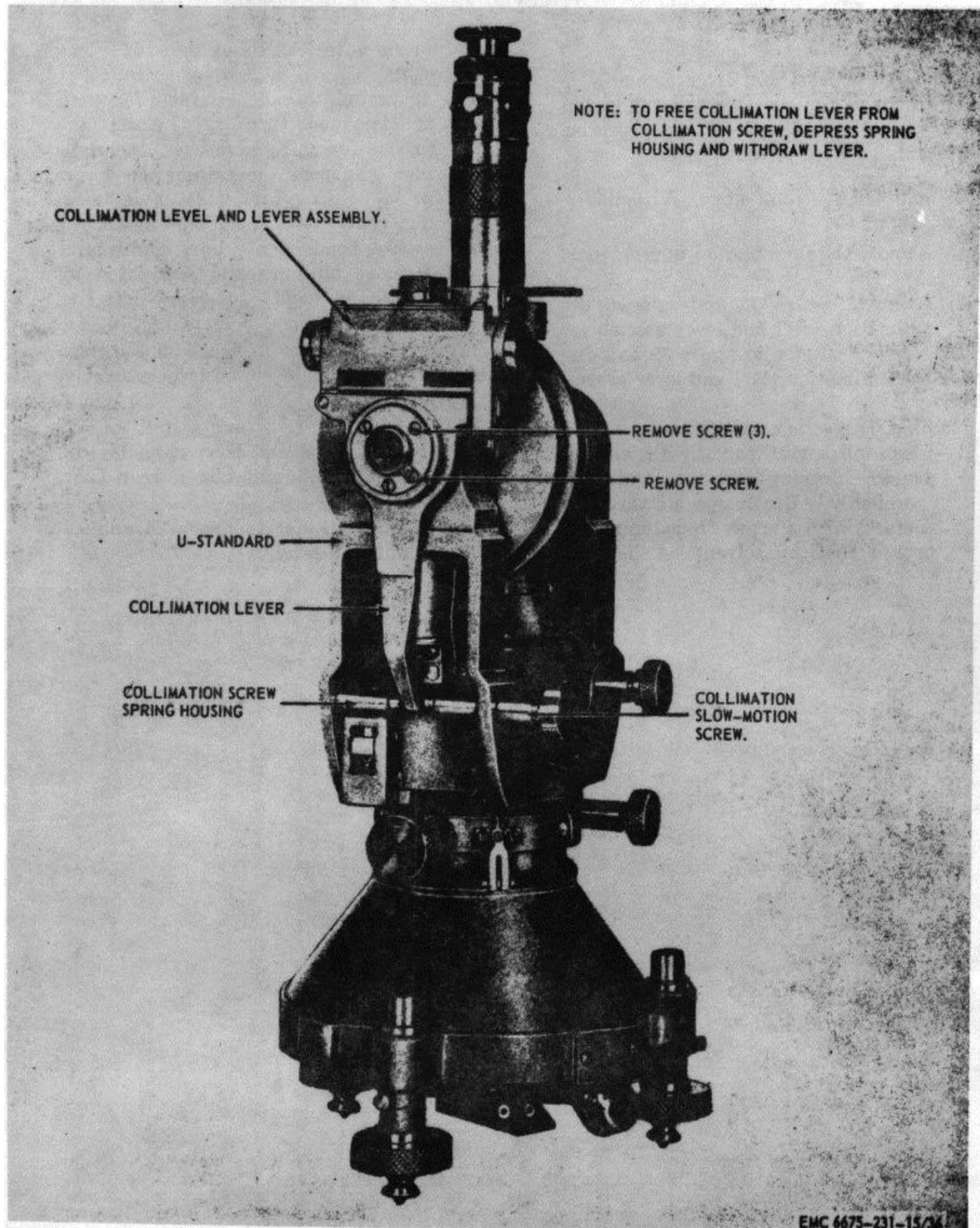
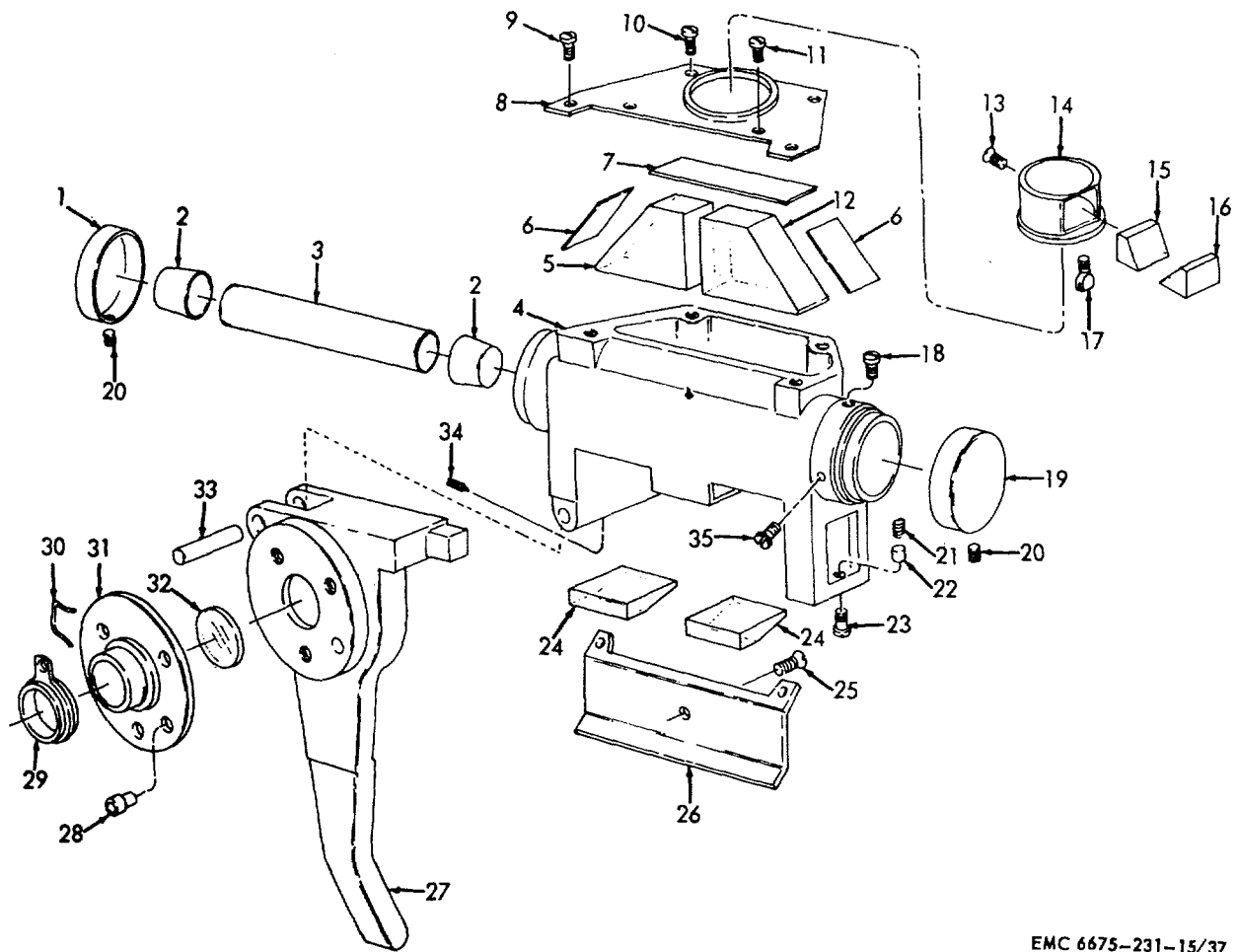

Figure 38. Collimation level and lever assembly, removal and installation.



EMC 6675-231-15/37

- | | | | |
|----|---------------------|----|-------------------|
| 1 | Cap | 19 | Cap |
| 2 | Vial cap (2 rqr) | 20 | Screw (2 rqr) |
| 3 | Vial | 21 | Spring |
| 4 | Housing | 22 | Spring housing |
| 5 | Prism | 23 | Adjusting screw |
| 6 | Brass strip (2 rqr) | 24 | Prism (2 rqr) |
| 7 | Brass strip | 25 | Screw |
| 8 | Cover | 26 | Cover |
| 9 | Screw (2 rqr) | 27 | Lever |
| 10 | Screw (2 rqr) | 28 | Insulator bushing |
| 11 | Screw (2 rqr) | 29 | Contact |
| 12 | Prism | 30 | Clip |
| 13 | Screw | 31 | Sleeve |
| 14 | Housing | 32 | Window |
| 15 | Prism | 33 | Pin |
| 16 | Prism | 34 | Setscrew |
| 17 | Stop screw | 35 | Screw (4 rqr) |
| 18 | Screw (2 rqr) | | |

Figure 39. Collimation level assembly, disassembly and reassembly.

Section VII. STAR PLATE

94. General

The star plate provides the means for quickly attaching the theodolite to the tripod. It is equipped with a spring plate which furnishes the proper tension on the three leveling screws.

95. Star Plate

a. *Removal.* Refer to paragraph 54 and remove the star plate.

b. *Disassembly.* Refer to figure 40 and disassemble the star plate.

c. *Cleaning, Inspection, and Repair.*

- (1) Clean all metal parts with an approved cleaning solvent and dry thoroughly.
- (2) Inspect all threaded surfaces for worn or damaged threads.
- (3) Inspect the star plate nut, spring plate, and star plate for bends, cracks, burs, breaks, and worn or damaged bearing surfaces.
- (4) Straighten minor dents and remove burs. Refinish and polish scratched or scored bearing surfaces.
- (5) Replace all defective parts that cannot be repaired.

d. *Reassembly.* Refer to figure 40 and reassemble the star plate.

e. *Installation.* Refer to paragraph 54 and install the star plate.

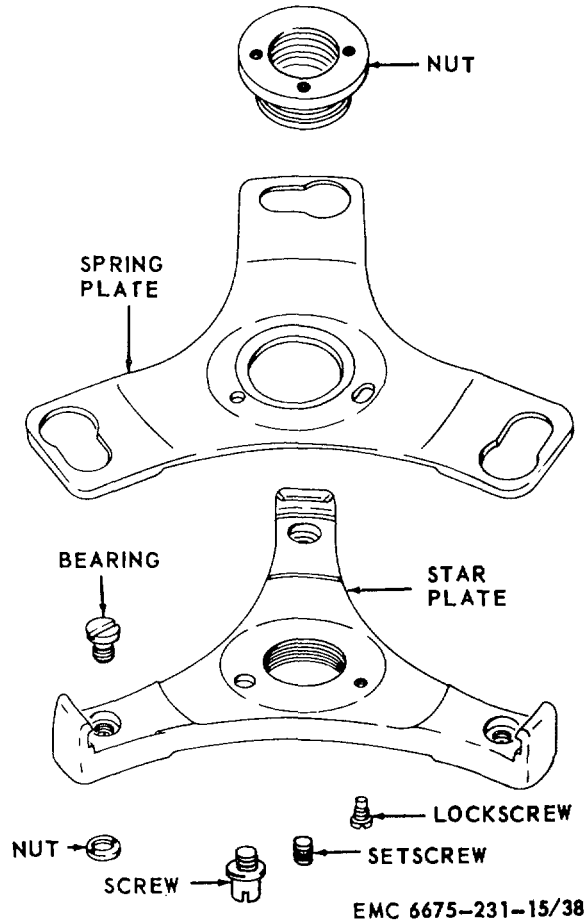

Figure 40. Star plate, disassembly and reassembly.

Section VIII. PLATE LEVEL, VERTICAL CIRCLE ILLUMINATION PRISM, MICROMETER CIRCLE ILLUMINATION PRISM, AND INVERTER PRISM

96. General

The plate level is used in conjunction with the leveling screws for precision leveling of the instrument. The vertical circle illumination prism and micrometer circle illumination prism direct the light to their respective circles to permit their images to be viewed through the microscope eyepiece. The inverter prism is used to project either the horizontal or vertical circle images or the microscope scale.

97. Plate Level

a. *Removal.* Refer to figure 41 and remove the plate level.

b. *Disassembly.* Refer to figure 42 and disassemble the plate level.

c. *Cleaning, Inspection, and Repair.*

- (1) Clean all metal parts with an approved cleaning solvent and dry thoroughly. Wipe off the vial and vial cover with a soft cloth moistened with

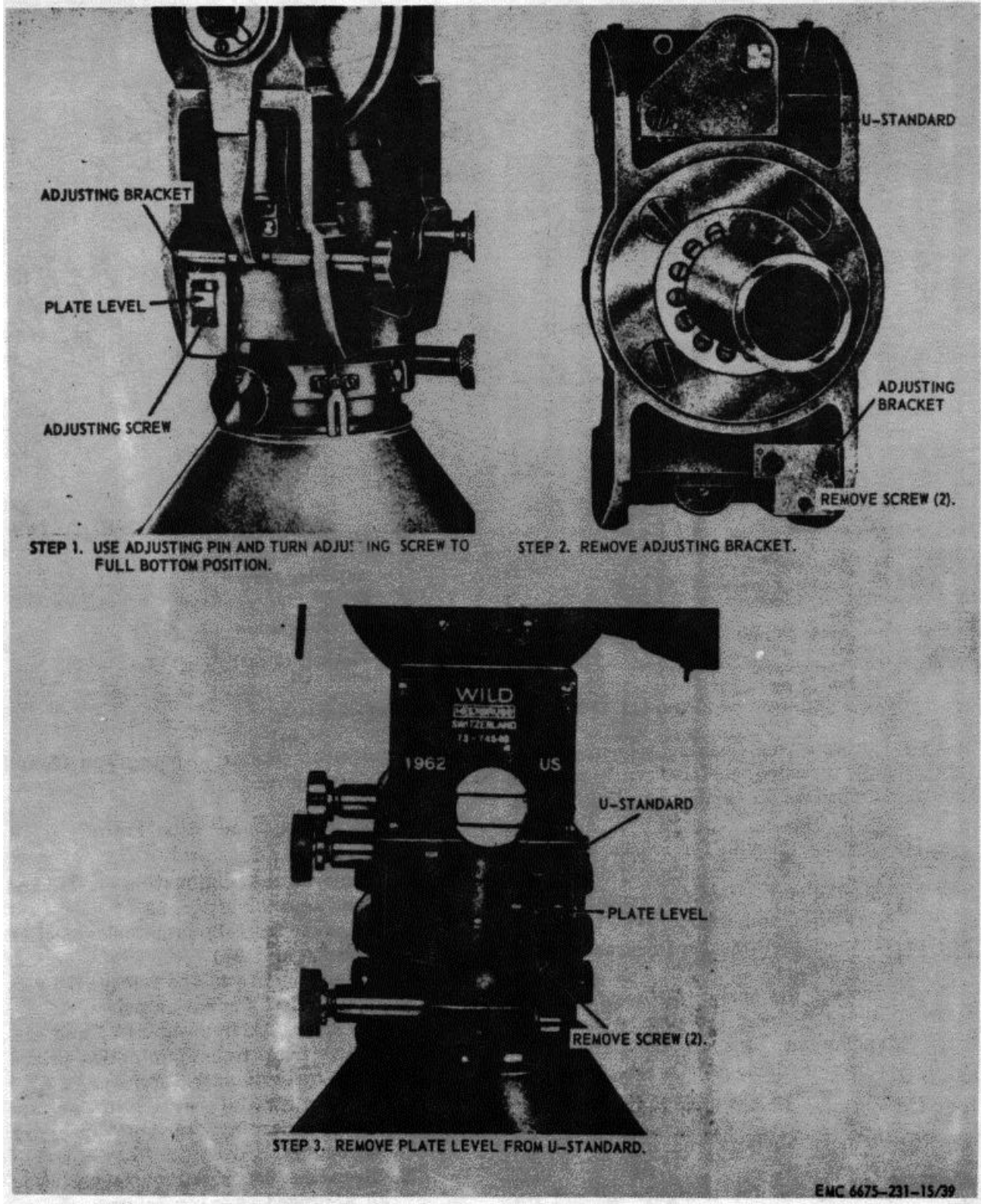
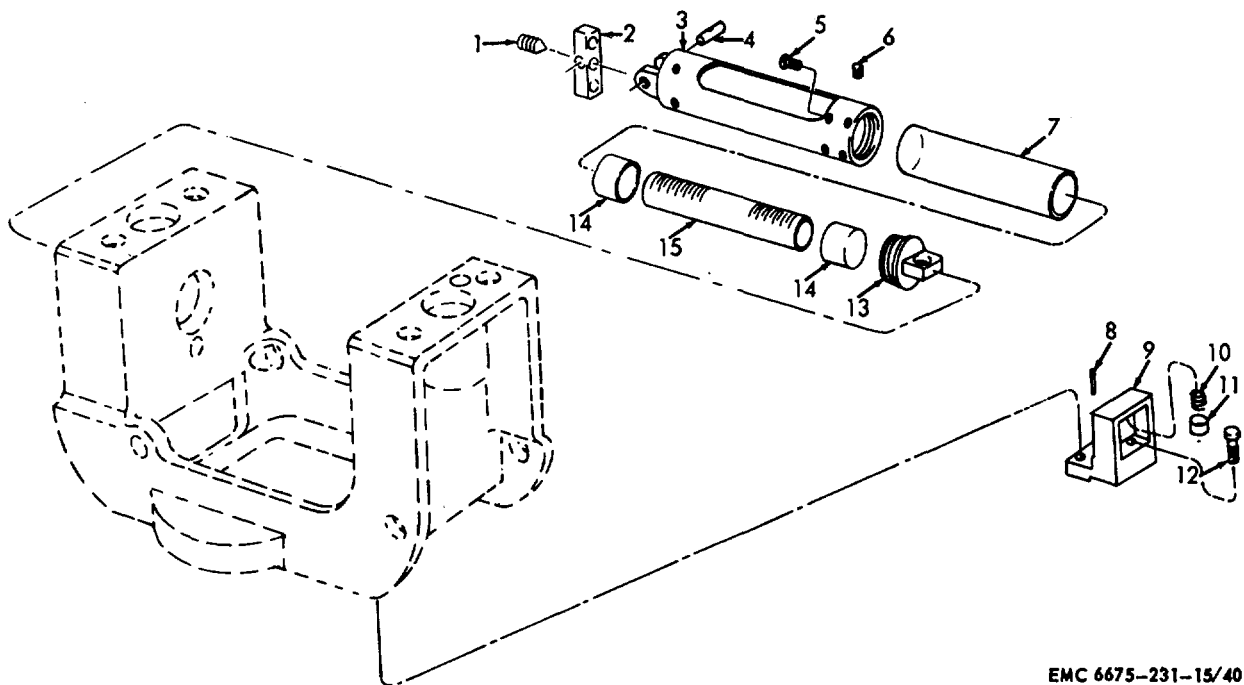

Figure 41. Plate level, removal and installation.



EMC 6675-231-15/40

- | | |
|--------------------|---------------------|
| 1 Setscrew | 9 Adjusting bracket |
| 2 Mounting bracket | 10 Spring |
| 3 Level housing | 11 Plunger |
| 4 Pin | 12 Adjusting screw |
| 5 Screw (6 rqr) | 13 End cap |
| 6 Setscrew | 14 Vial cap (2 rqr) |
| 7 Plastic cover | 15 Level vial |
| 8 Pin (2 rqr) | |

Figure 42. Plate level, disassembly and reassembly.

an approved cleaning solvent. Clean all threaded surfaces with a brush dipped in an approved cleaning solvent.

- (2) Inspect the vial for cracks, etchings, and defective bubble. Inspect the plastic vial cover for cracks, splits, scratches, and wear.
- (3) Inspect the brackets for cracks, burs, and breaks.
- (4) Inspect the spring for wear and fatigue. Inspect the plunger for burs and wear. Inspect the screws for worn or damaged threads. Inspect the housing for cracks or other defects.
- (5) Remove all burs and replace all defective parts.

d. Reassembly. Refer to figure 42 and reassemble the plate level.

e. Installation. Refer to figure 41 and install the plate level.

f. Adjustment. Refer to paragraph 16 and adjust the plate level.

98. Vertical Circle Illumination Prism

a. Removal.

- (1) Remove the collimation level and lever assembly (par. 93).
- (2) Remove the collimation slow-motion screw (par. 108).
- (3) Refer to figure 43 and remove the vertical circle illumination prism.

b. Disassembly. Refer to figure 44 and disassemble the vertical circle illumination prism.

c. Cleaning, Inspection, and Repair.

- (1) Clean all metal parts with an approved cleaning solvent and dry thoroughly.
- (2) Clean the prism with lens tissue or an approved cleaning solvent.
- (3) Inspect the prism for chips, cracks, scratches, and etching.
- (4) Replace damaged or defective parts.

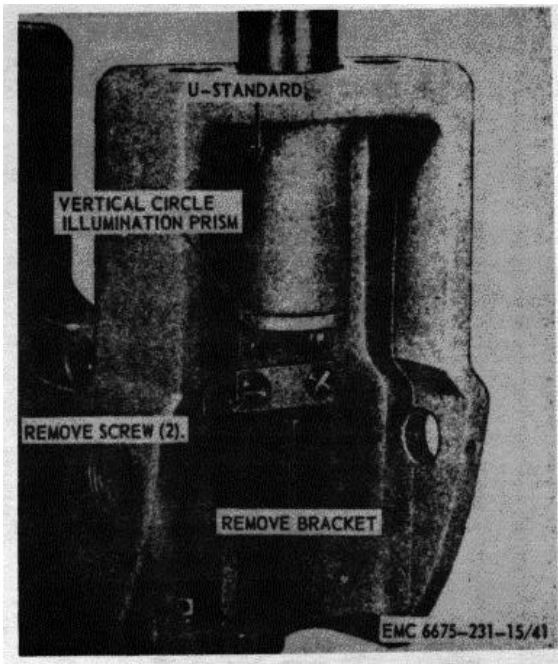

Figure 43. Vertical circle illumination prism, removal and installation.

d. *Reassembly.* Refer to figure 44 and reassemble the vertical circle illumination prism.

e. *Installation.*

- (1) Refer to figure 43 and install the vertical circle illumination prism assembly.
- (2) Install the collimation slow-motion screw (par. 108).
- (3) Refer to paragraph 93 and install the collimation level and lever assembly.

99. Micrometer Circle Illumination Prism

a. *Removal.* Refer to figure 45 and remove the micrometer circle illumination prism.

b. *Disassembly.* Refer to figure 46 and disassemble the micrometer circle illumination prism.

c. *Cleaning, Inspection, and Repair.*

- (1) Clean all metal parts with an approved cleaning solvent and dry thoroughly.
- (2) Clean the glass prism with lens tissue or a lens cloth.
- (3) Inspect the prism for chips, cracks, scratches, and etching.

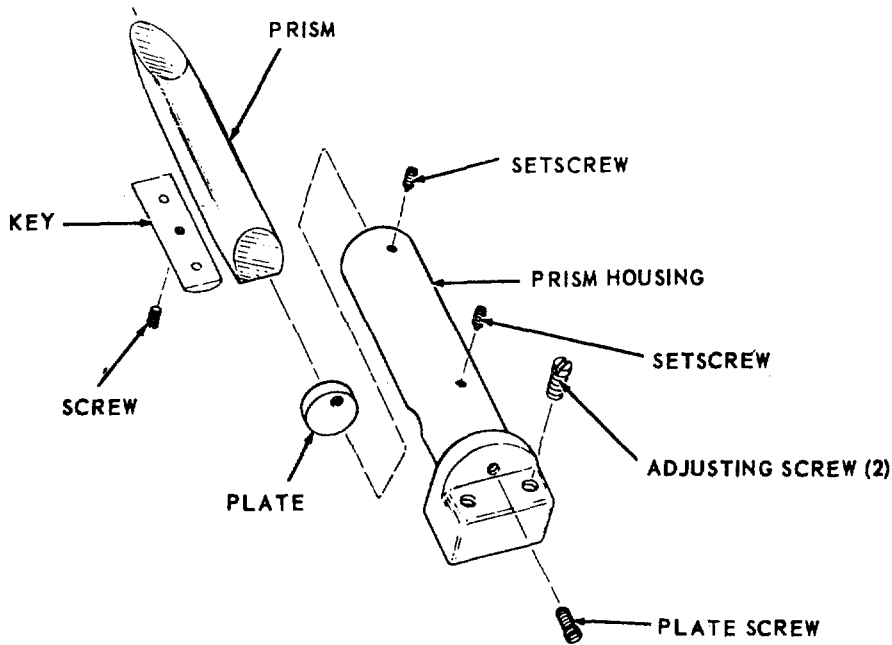

EMC 6675-231-15/42

Figure 44. Vertical circle illumination prism, disassembly and reassembly.

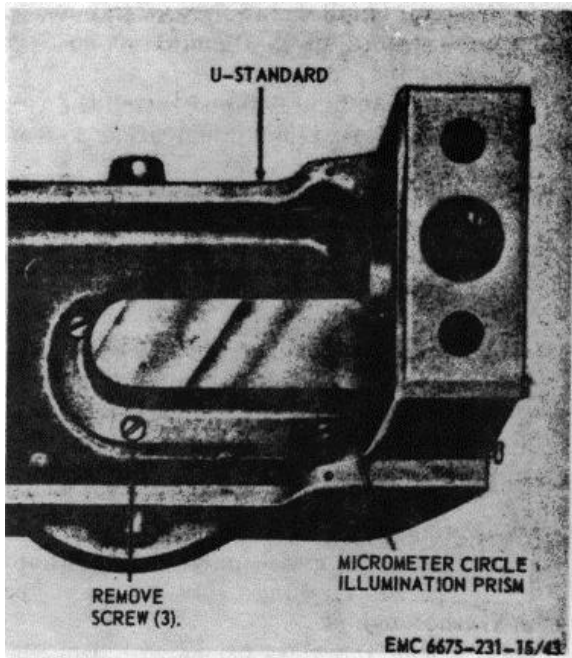

Figure 45. Micrometer circle illumination prism, removal and installation.

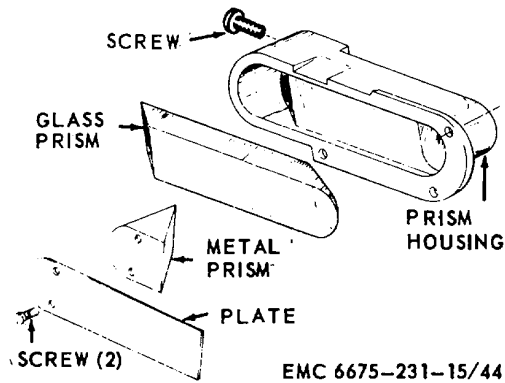

Figure 46. Micrometer circle illumination prism, disassembly and reassembly.

(4) Replace all damaged or defective parts.

d. *Reassembly.* Refer to figure 46 and reassemble the micrometer circle illumination.

e. *Installation.* Refer to figure 45 and install the micrometer circle illumination prism.

100. Inverter Prism

a. *General.* The inverter prism is used to shift the circle images seen in the microscope window from the vertical to the horizontal.

When the rib of the inverter knob is in a vertical position, the vertical circle image will be seen in the microscope window. When the rib is in a horizontal position, the horizontal circle image will appear in the microscope window.

b. *Removal.* Refer to figure 47 and remove the inverter prism.

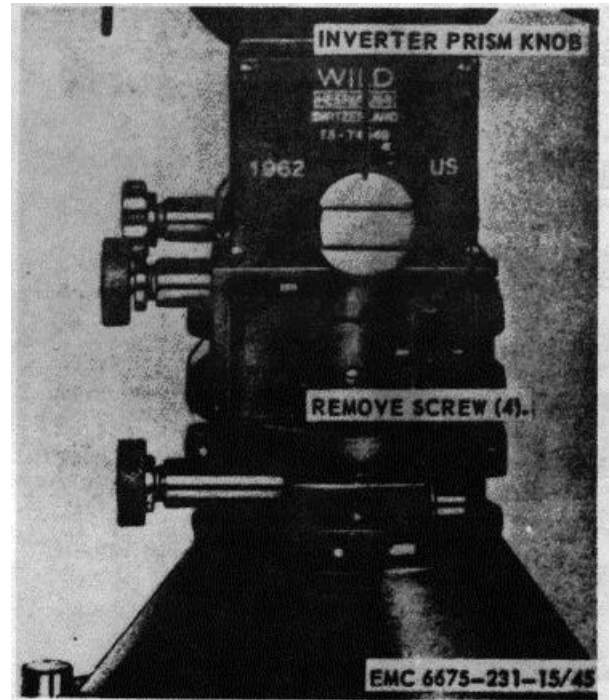
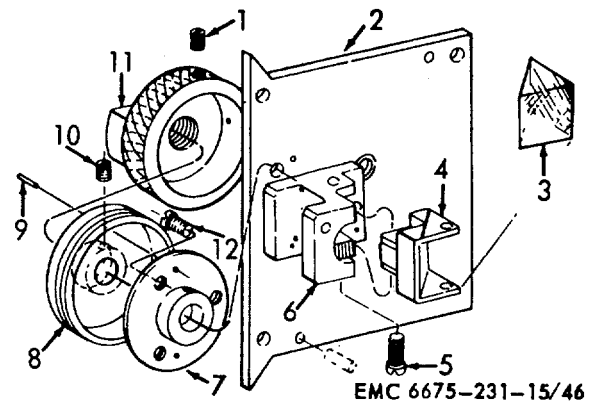

Figure 47. Inverter prism, removal and installation.

c. *Disassembly.* Refer to figure 48 and disassemble the inverter prism.



- | | |
|-----------------|------------------------|
| 1 Setscrew | 7 Bearing |
| 2 Plate | 8 Bracket |
| 3 Prism | 9 Locating pin (2 rqr) |
| 4 Prism housing | 10 Setscrew |
| 5 Screw | 11 Knob |
| 6 Axis | 12 Screw |

Figure 48. Inverter prism, disassembly and reassembly.

d. *Cleaning, Inspection, and Repair.*

- (1) Clean all metal parts with an approved cleaning solvent and dry thoroughly. Carefully clean the inverter prism with a lens cloth or with lens tissue.
- (2) Inspect the plate, bracket, and housing for burs, dents, bends, cracks, and other damage. Inspect the bearing and axis for burs, scratches, cracks, and wear.

- (3) Inspect the inverter prism for chips, scratches, cracks, and etching.
- (4) Straighten minor dents and bends. Remove all burs.
- (5) Replace all damaged or defective parts.

e. *Reassembly.* Refer to figure 48 and reassemble the inverter prism.

f. *Installation.* Refer to figure 47 and install the inverter prism.

Section IX. MICROSCOPE, TELESCOPE, AND RETICLE MIRROR

101. General

The microscope is used to bring the horizontal, vertical, and micrometer circle scales into proper focus. The microscope eyepiece is knurled to assist the operator in making this adjustment. The telescope provides a means of sighting and bringing into focus the objective or target. The eyepiece is used to bring the reticle crosslines into view. The focusing tube is used to bring the objective into focus. The reticle mirror, located in the telescope tube, is provided to illuminate the reticle crosslines when the electrical illumination system is utilized.

102. Microscope

a. *Removal.* Refer to figure 49 and remove the microscope.

b. *Disassembly.*

- (1) Remove the microscope eyepiece (par. 50).
- (2) Refer to figure 50 and disassemble the microscope.

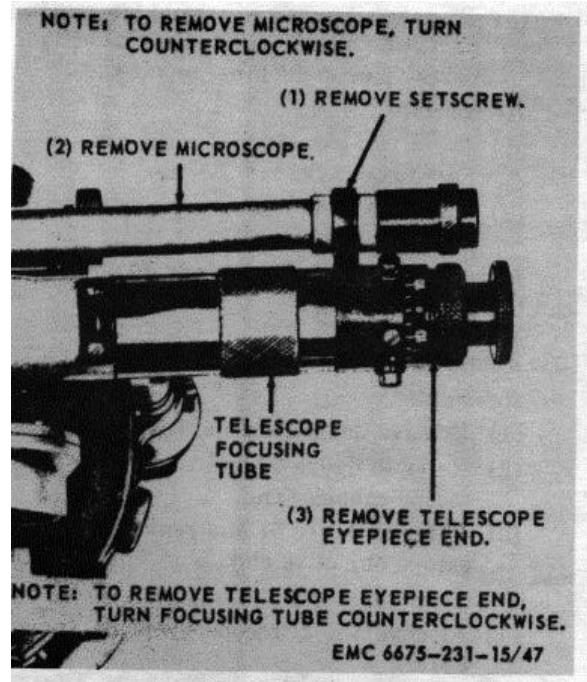

Figure 49. Microscope and telescope eyepiece end, removal and installation.

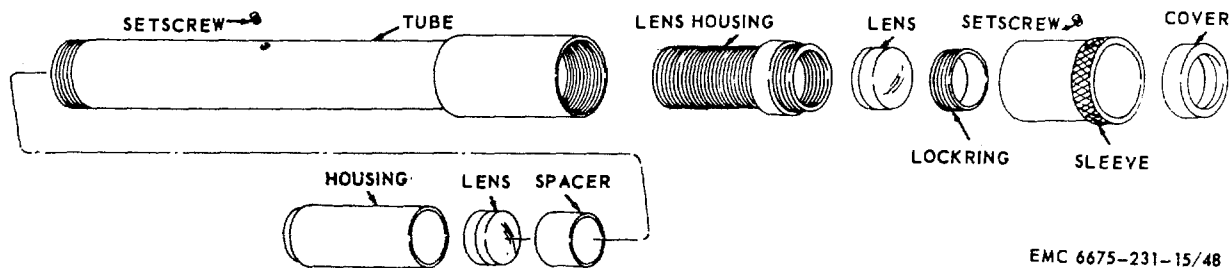

Figure 50. Microscope, disassembly and reassembly.

c. *Cleaning, Inspection, and Repair.*

- (1) Clean all; metal parts with an approved cleaning solvent and dry thoroughly. Clean the lenses with lens tissue or a lens cloth. Take care not to touch the lens surfaces with the fingers. Clean threaded parts with a small brush dipped in an approved cleaning solvent and dry with a clean, soft cloth.
- (2) Inspect the lens, housings, and tube for bends, dents, and burrs. Inspect the lenses for scratches, chips, cracks, and etchings. Inspect all threaded surfaces for worn or damaged threads.
- (3) Remove all burrs and straighten minor dents and bends. Replace all defective parts that cannot be repaired.

d. *Reassembly.*

- (1) Refer to figure 50 and reassemble the microscope.
- (2) Install the microscope eyepiece (par. 50).

e. *Installation.* Refer to figure 49 and install the microscope.

103. Telescope

a. *Removal.*

- (1) Remove the microscope (par. 102).
- (2) Refer to figure 49 and remove the telescope eyepiece end.
- (3) Refer to figure 51 and remove the telescope objective end.

b. *Disassembly.*

- (1) Remove the telescope eyepiece (par. 50).
- (2) Refer to figure 52 and disassemble the telescope eyepiece end.
- (3) Refer to figure 53 and disassemble the telescope objective end.

c. *Cleaning, Inspection, and Repair.*

- (1) Clean all metal parts with an approved cleaning solvent and dry thoroughly. Clean the lenses with lens tissue or a lens cloth, taking care not to touch lens surfaces with the fingers. Clean threaded parts with a small brush dipped in an approved cleaning solvent and dry with a clean, lint-free cloth.

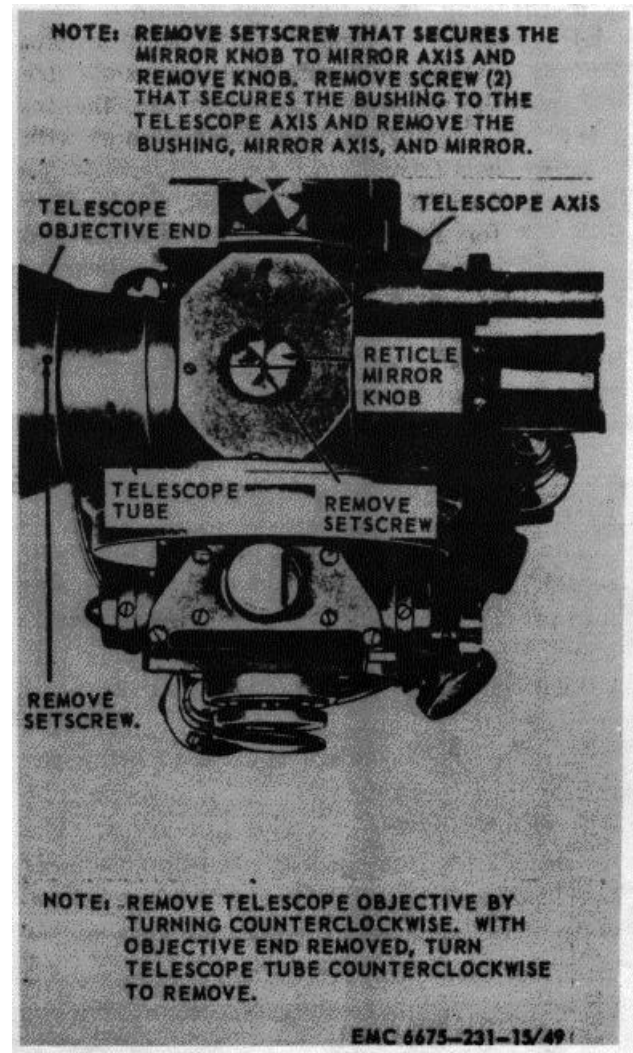
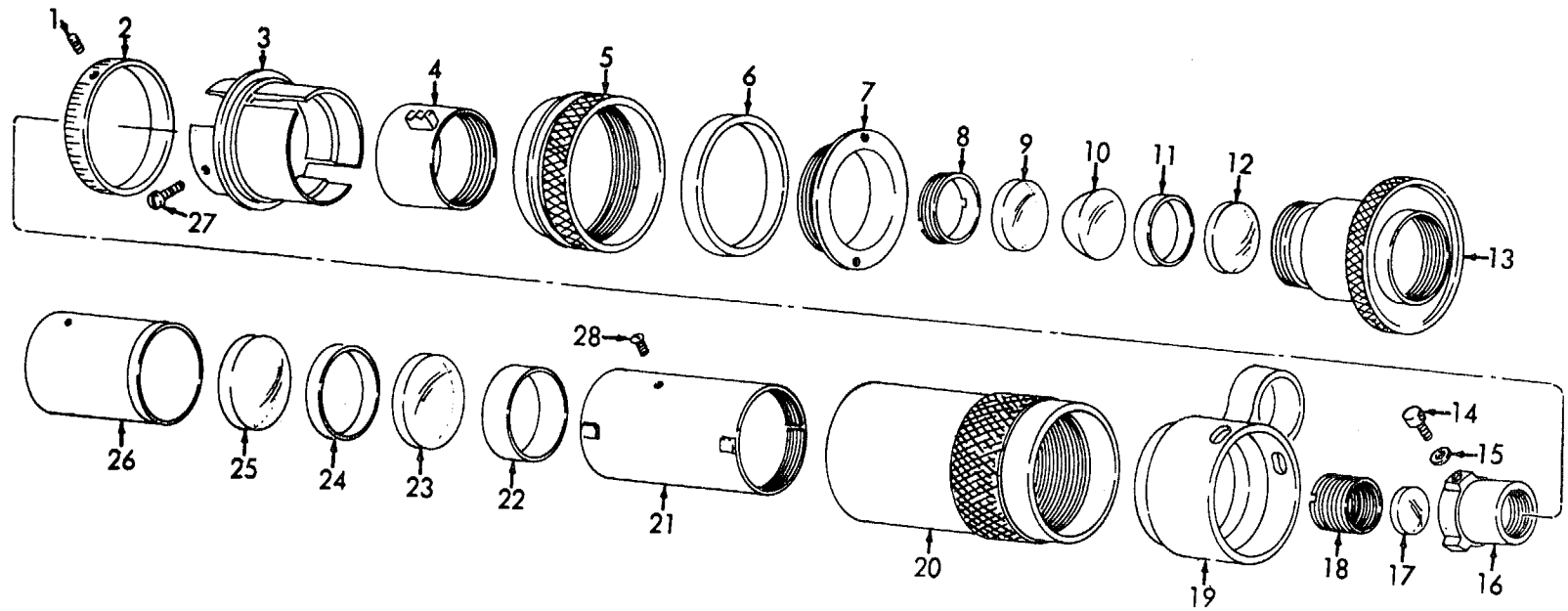

Figure 51. Telescope objective end and reticle mirror, removal and installation.

- (2) Inspect the mounts and housing for bends, dents, and cracks. Inspect the rings for cracks, burrs, and other damage. Inspect the reticle for scratches, chips, and damaged crosslines. Inspect the tubes for dents, cracks, and breaks. Inspect all threaded surfaces for worn or damaged threads.
- (3) Remove all burrs and straighten minor dents and bends.
- (4) Replace all worn, damaged, or defective parts as necessary.

d. *Reassembly.*

- (1) Refer to figure 53 and reassemble the telescope objective end.



EMC 6675-231-15/50

- | | | | |
|----|-------------------------|----|-----------------------|
| 1 | Setscrew | 15 | Washer (spec) (3 rqr) |
| 2 | Ring | 16 | Reticle mount |
| 3 | Sleeve | 17 | Reticle |
| 4 | Bracket | 18 | Lockring |
| 5 | Knob | 19 | Sleeve |
| 6 | Spacer | 20 | Knob |
| 7 | Lockring | 21 | Lens housing |
| 8 | Lockring | 22 | Spacer |
| 9 | Lens | 23 | Lens |
| 10 | Lens | 24 | Washer |
| 11 | Washer | 25 | Lens |
| 12 | Lens | 26 | Lens mount |
| 13 | Mount | 27 | Screw (3 rqr) |
| 14 | Adjusting screw (8 rqr) | 28 | Setscrew |

Figure 52. Telescope eyepiece end, disassembly and reassembly

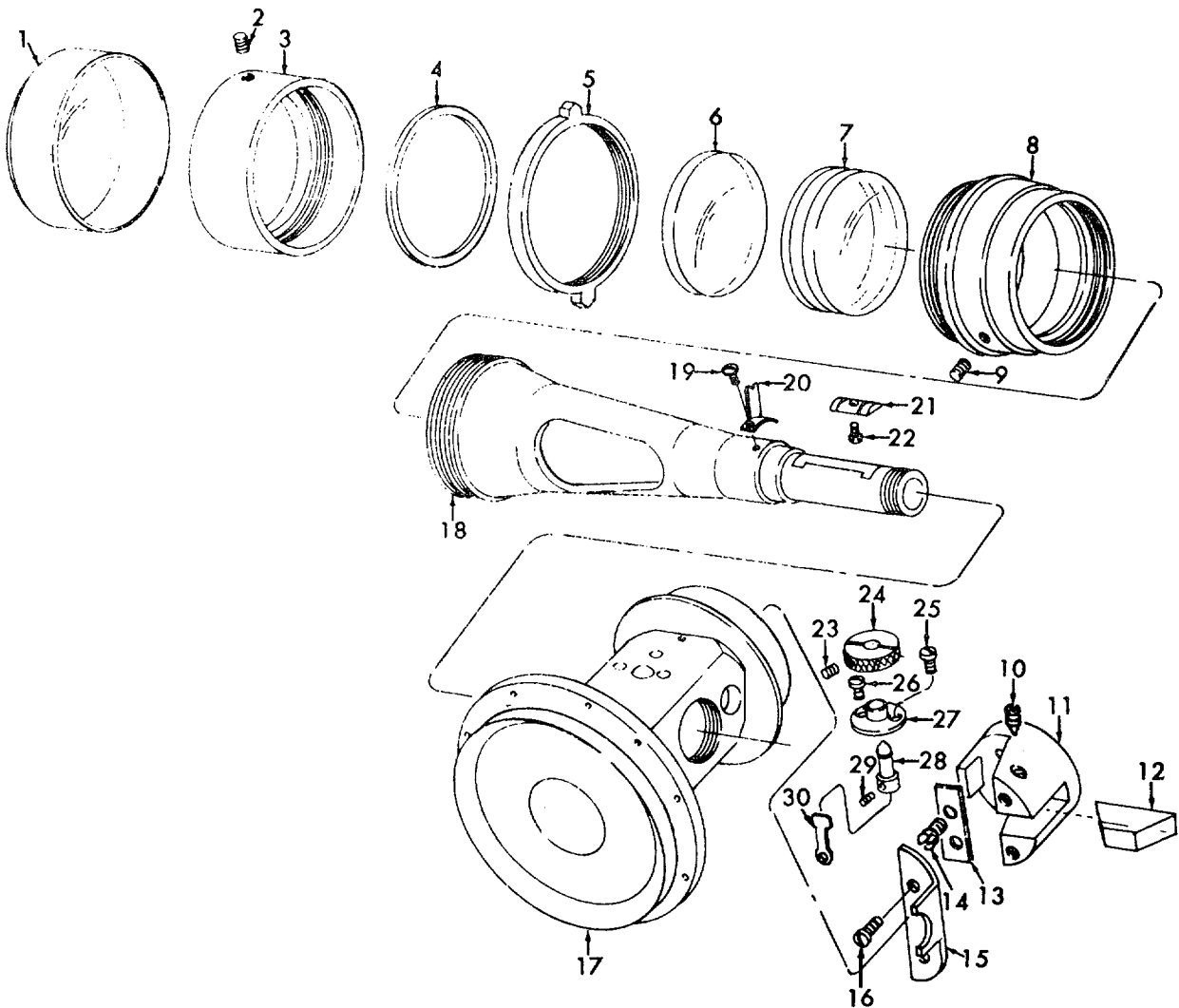

EMC 6675-231-15/51

- | | |
|---------------------|-----------------------|
| 1 Objective cap | 16 Screw (2 rqr) |
| 2 Setscrew | 17 Telescope axis |
| 3 Lock cap | 18 Telescope tube |
| 4 Rubber washer | 19 Screw (4 rqr) |
| 5 Front sight | 20 Rear sight (2 rqr) |
| 6 Lens | 21 Segment |
| 7 Lens | 22 Stopscrew |
| 8 Mount | 23 Setscrew |
| 9 Setscrew | 24 Knob |
| 10 Setscrew (2 rqr) | 25 Screw |
| 11 Housing | 26 Screw |
| 12 Prism | 27 Bushing |
| 13 Plate | 28 Axis |
| 14 Screw (2 rqr) | 29 Setscrew (2 rqr) |
| 15 Bracket | 30 Reticle mirror |

Figure 53. Telescope objective end, reticle mirror, telescope tube and telescope axis, disassembly and reassembly.

- (2) Refer to figure 52 and reassemble the telescope eyepiece end.
- (3) Install the telescope eyepiece (par. 50).

e. Installation.

- (1) Refer to figure 51 and install the telescope objective end.
- (2) Refer to figure 49 and install the telescope eyepiece end.
- (3) Install the microscope (par. 102).

104. Reticle Mirror

a. General. The reticle mirror assembly is located in the top of the telescope axis and provides illumination of the reticle assembly when the electric illumination system is used.

b. Removal. Refer to figure 51 and remove the reticle mirror.

c. Disassembly. Refer to figure 53 and disassemble the reticle mirror.

d. Cleaning, Inspection, and Repair.

- (1) Clean all metal parts with an approved cleaning solvent and dry thoroughly. Clean the reticle mirror with a soft cloth moistened with an approved cleaning solvent.
- (2) Inspect the objective telescope washer, objective lens housing, objective lens ring, and sunshade for dents, burs, cracks, and breaks. Inspect the reticle mirror for scratches or damage. Inspect the lens and lens assembly for scratches, chips, cracks, and etchings.
- (3) Remove all burs. Replace all defective parts which cannot be repaired.

e. Reassembly. Refer to figure 53 and reassemble the reticle mirror.

f. Installation. Refer to figure 51 and install the reticle mirror.

Section X. MICROMETER

105. General

The micrometer functions with both the vertical circle and the horizontal circle. The vertical and horizontal circles cover the degrees and minutes down to 10-minute readings. The micrometer refines these readings, through a 4-minute interval down to and including 0.2-second readings.

106. Micrometer

a. Removal. Refer to figure 54 and remove the micrometer.

b. Disassembly. Refer to figure 55 and disassemble the micrometer.

c. Cleaning, Inspection, and Repair.

- (1) Clean all metal parts with an approved cleaning solvent and dry thoroughly. Clean the lens, glass plates, and prisms with a lens tissue or lens cloth.
- (2) Clean the micrometer circle with a lens tissue or lens cloth, making sure that no lint is left on the face of the circle after cleaning.
- (3) Inspect the prisms, lens, and glass plates for chips, cracks, scratches, and etching. Inspect the micrometer cover for burs, cracks, and wear.

- (4) Inspect the bearing bracket, retaining mount, levers, axis, and cam wheel for bends, burs, and cracks. Inspect the springs for distortion, breaks,

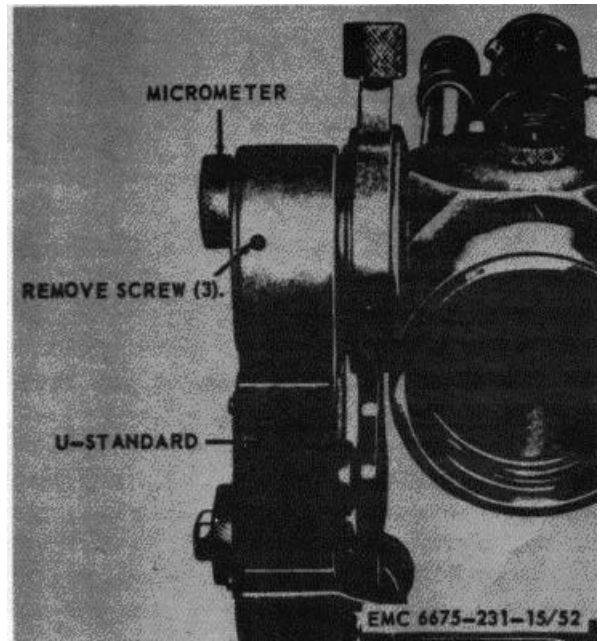
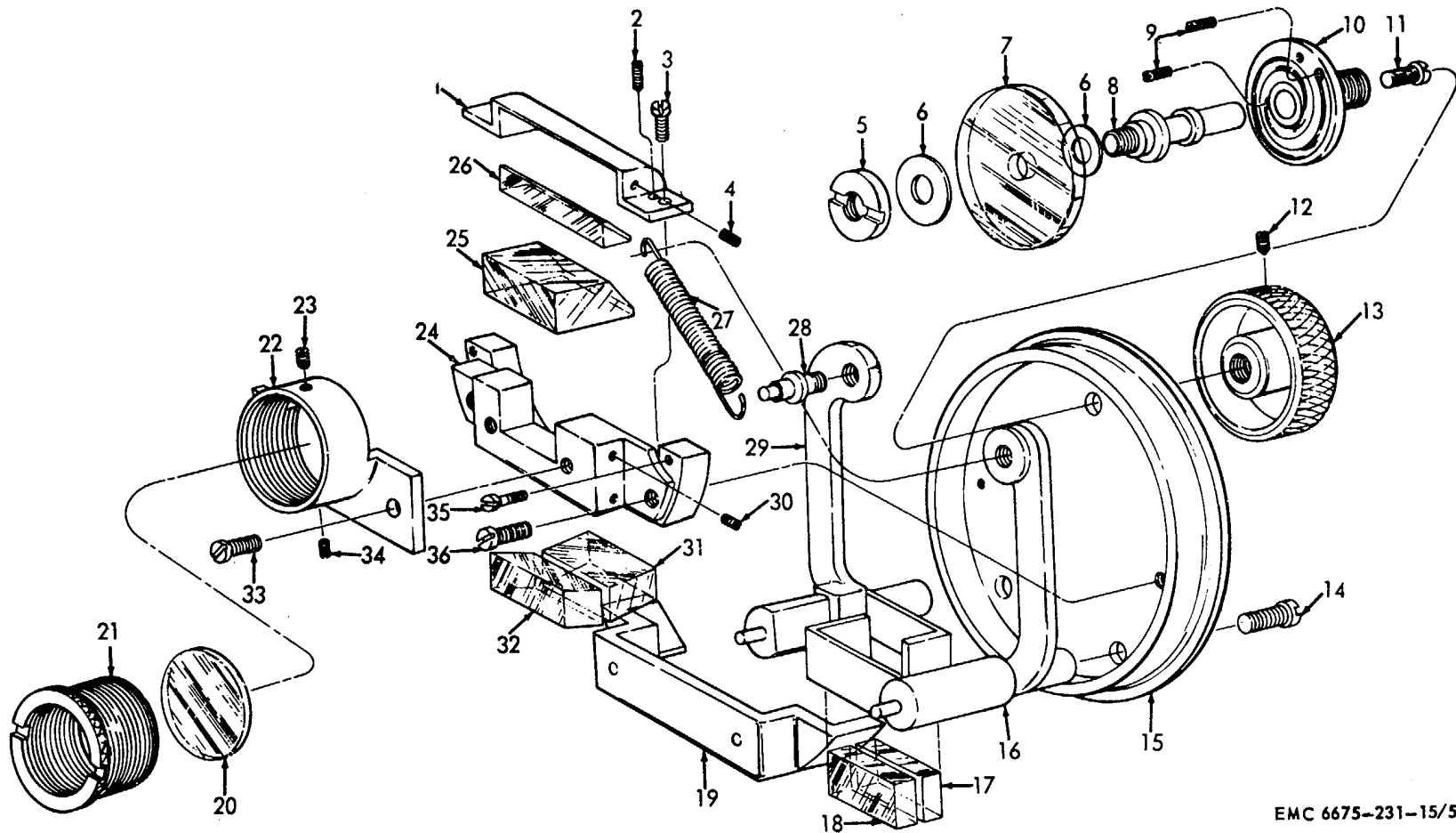

Figure 54. Micrometer, removal and installation.



EMC 6675-231-15/53

- | | | | |
|---------------------|------------------|--------------------|-------------------------|
| 1 Mount | 10 Wheel | 19 Bearing bracket | 28 Screw (spec) (2 rqr) |
| 2 Setscrew (2 rqr) | 11 Screw | 20 Lens | 29 Lever |
| 3 Screw (2 rqr) | 12 Setscrew | 21 Ring | 30 Setscrew (4 rqr) |
| 4 Setscrew (2 rqr) | 13 Knob | 22 Mount | 31 Prism |
| 5 Nut (spec) | 14 Screw (2 rqr) | 23 Setscrew | 32 Prism |
| 6 Washer | 15 Cover | 24 Mount | 33 Screw (2 rqr) |
| 7 Micrometer circle | 16 Lever | 25 Prism | 34 Setscrew |
| 8 Axis | 17 Glass plate | 26 Prism | 35 Screw (2 rqr) |
| 9 Setscrew (2 rqr) | 18 Glass plate | 27 Spring (2 rqr) | 36 Screw (2 rqr) |

Figure 55. Micrometer, disassembly and reassembly.

and fatigue. Inspect all threaded surfaces for worn or damaged threads.

- (5) Remove all burs and straighten minor dents and bends. Replace the springs if they are defective. Replace all worn or

damaged parts that cannot be repaired.

d. *Reassembly.* Refer to figure 55 and reassemble the micrometer.

e. *Installation.* Refer to figure 54 and install the micrometer.

Section XI. HORIZONTAL, VERTICAL, AND COLLIMATION SLOW-MOTION SCREWS

107. General

The horizontal slow-motion screw is mounted on the horizontal clamp and located on the right side of the theodolite. It is used for precise pointing of the instrument in a horizontal plane. The vertical slow-motion screw is located on the right side of the theodolite. It is used to accurately point the instrument in a vertical plane. The collimation slow-motion screw is located on the left side of the theodolite and is used to determine the horizontal line of sight by bringing the two ends of the collimation level bubble to coincidence.

108. Horizontal, Vertical, and Collimation Slow-Motion Screws

a. *Removal.* Refer to figure 56 and remove the horizontal, vertical, and collimation slowmotion screws.

b. *Disassembly.* Refer to figure 57 and disassemble the horizontal, vertical, and collimation slow-motion screws.

c. *Cleaning, Inspection, and Repair.*

- (1) Clean all parts with an approved cleaning solvent and dry thoroughly. Clean all threaded surfaces thoroughly with a small brush dipped in an approved cleaning solvent. Remove all grease and foreign matter from the inside of the housing and sleeves.
- (2) Thoroughly clean the inside of the adjusting knobs, split nuts, stop nuts, and screw housings.
- (3) Inspect all threaded surfaces for worn or damaged threads. Inspect the springs for wear, breaks, and fatigue. Inspect the adjusting knobs for burs and wear.
- (4) Inspect the pins, housings, and adjusting screws for wear, bends, burs, and other damage.
- (5) Remove all burs. Replace all defective parts that cannot be repaired.

d. *Reassembly.* Refer to figure 57 and reassemble the horizontal, vertical, and collimation slow-motion screws.

e. *Installation.* Refer to figure 56 and install the horizontal, vertical, and collimation slowmotion screws.

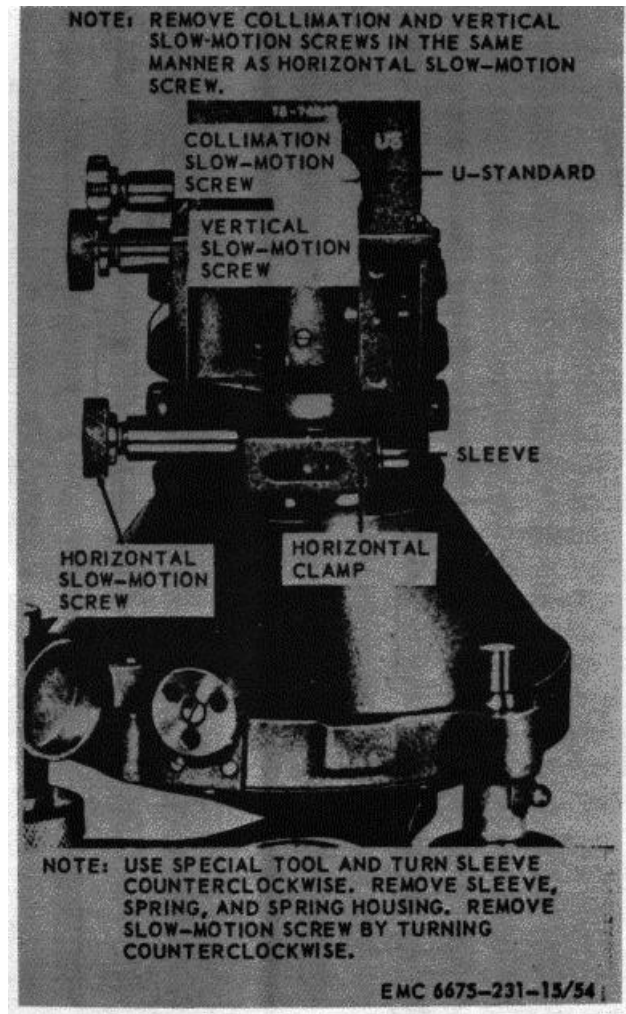
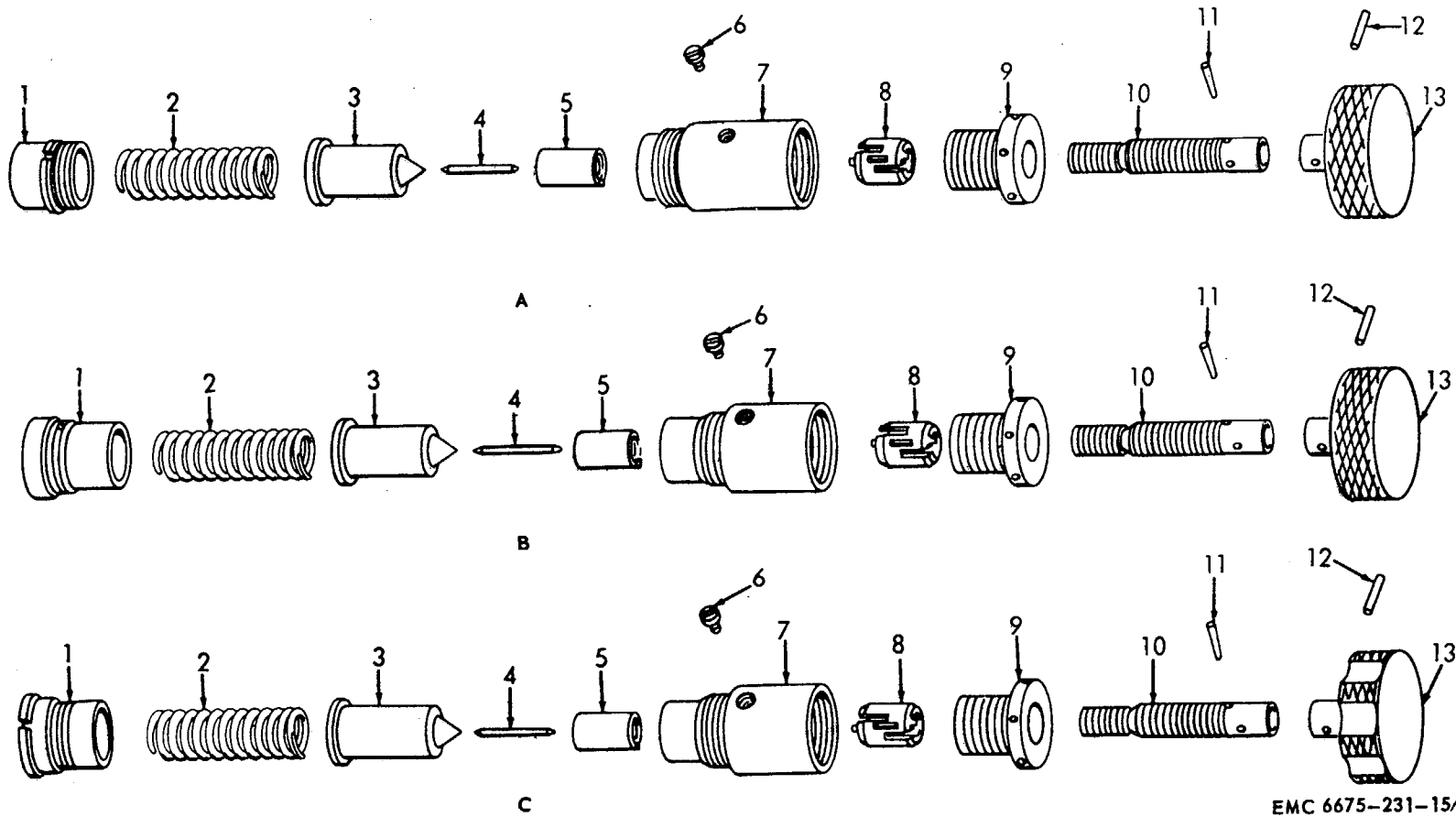

Figure 56. Horizontal, vertical, and collimation slow-motion screws, removal and installation.



EMC 6675-231-15/55

A—Horizontal slow-motion screw

- 1 Sleeve
- 2 Spring
- 3 Housing
- 4 Pin
- 5 Stop nut
- 6 Screw
- 7 Screw housing
- 8 Split nut
- 9 Adjusting screw
- 10 Screw
- 11 Stop pin
- 12 Dowel pin
- 13 Knob

B—Vertical slow-motion screw

- 1 Sleeve
- 2 Spring
- 3 Housing
- 4 Pin
- 5 Stop nut
- 6 Screw
- 7 Screw housing
- 8 Split nut
- 9 Adjusting screw
- 10 Screw
- 11 Stop pin
- 12 Dowel pin
- 13 Knob

C—Collimation slow-motion screw

- 1 Sleeve
- 2 Spring
- 3 Housing
- 4 Pin
- 5 Stop nut
- 6 Screw
- 7 Screw housing
- 8 Split nut
- 9 Adjusting screw
- 10 Screw
- 11 Stop pin
- 12 Dowel pin
- 13 Knob

Figure 57. Horizontal, vertical, and collimation slow-motion screws, disassembly and reassembly.

Section XII. HORIZONTAL CIRCLE ILLUMINATION PRISM AND HOUSING COVER, HORIZONTAL CIRCLE PRISM CARRIER, AND ILLUMINATION CABLE CONNECTOR

109. General

The horizontal circle housing cover encloses the bottom of the horizontal circle housing and serves as a mount for the horizontal circle illumination prism. The illumination prism directs light to the horizontal circle prisms. The horizontal circle prisms transmit the circle image to the microscope window and also provides light for reading the micrometer circle. The cable connector provides a means for connecting the electrical cable from the contact ring to the socket.

110. Horizontal Circle Housing Cover and Horizontal Circle Illumination Prism

a. Removal.

- (1) Remove the leveling screws (par. 117).
- (2) Refer to figure 58 and remove the horizontal circle housing cover and horizontal circle illumination prism.

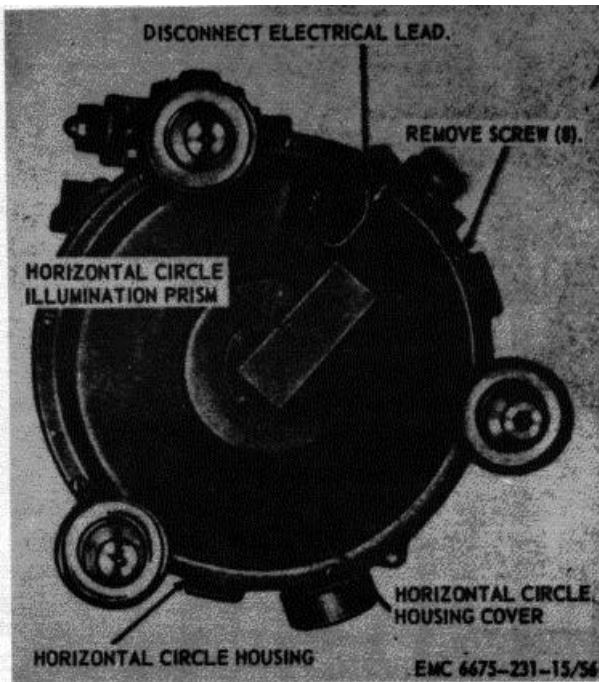

Figure 58. Horizontal circle housing cover and horizontal circle illumination prism, removal and installation.

b. *Disassembly.* Refer to figure 59 and disassemble the horizontal circle housing cover and horizontal circle illumination prism.

c. *Cleaning, Inspection, and Repair.*

- (1) Clean all metal parts with an approved cleaning solvent and dry thoroughly.
- (2) Clean the prism and lens with a lens cloth or lens tissue.
- (3) Inspect the horizontal circle housing cover for dents, cracks, or other defects. Inspect all threaded parts for damaged or worn threads.
- (4) Inspect the prism and lens for cracks, chips, etchings, and other damage.
- (5) Replace all damaged or worn parts.

d. *Reassembly.* Refer to figure 59 and reassemble the horizontal circle housing cover and horizontal circle illumination prism.

e. *Installation.*

- (1) Refer to figure 58 and install the horizontal circle housing cover.
- (2) Install the leveling screws (par. 117).

111. Horizontal Circle Prism Carrier

a. *Removal.*

- (1) Remove the horizontal circle housing cover (par. 110).
- (2) Refer to figure 60 and remove the horizontal circle prism carrier.

b. *Disassembly.* Refer to figure 61 and disassemble the horizontal circle prism carrier.

c. *Cleaning, Inspection, and Repair.*

- (1) Clean all metal parts with an approved cleaning solvent and dry thoroughly.
- (2) Clean the lenses and prisms with a lens cloth or lens tissue. Inspect the lenses and prisms for cracks, chips, etchings, and other damage.
- (3) Inspect all lens, mounts, and the prism carrier for bends, wear, and other damage.
- (4) Clean all threaded surfaces with a brush dipped in an approved cleaning solvent.

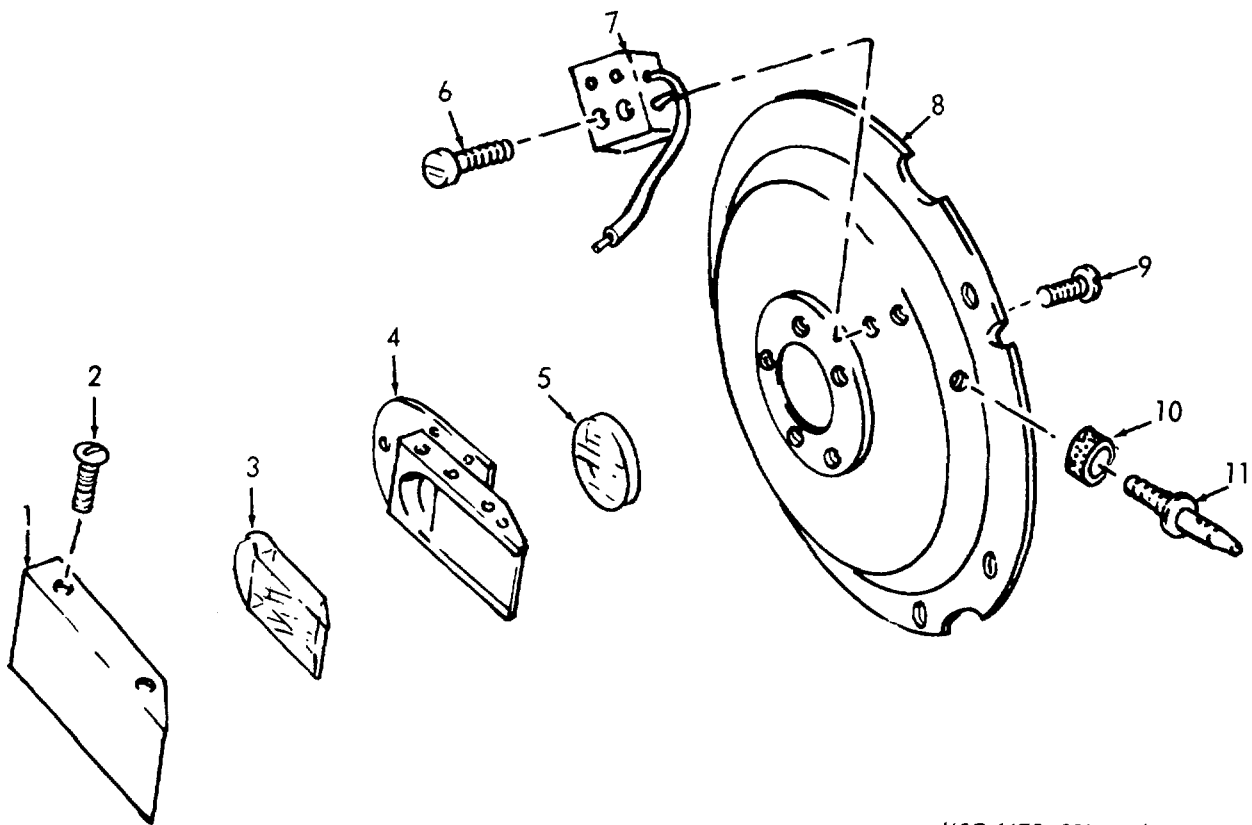

MSC 6675-231-15/57

- 1 Prism cover
- 2 Screw (4 rqr)
- 3 Illumination prism
- 4 Prism housing
- 5 Lens
- 6 Screw (2 rqr)

- 7 Socket
- 8 Circle housing cover
- 9 Screw (5 rqr)
- 10 Nut
- 11 Cable connector

Figure 59. Horizontal circle housing cover, horizontal circle illumination prism, and illumination cable connector, disassembly and reassembly.

(5) Remove all burrs and straighten bent or dented parts. Replace all damaged or worn parts that are not repairable.

d. Reassembly. Refer to figure 61 and reassemble the horizontal circle prism carrier.

e. Installation.

(1) Refer to figure 60 and install the horizontal circle prism carrier.

(2) Install the horizontal circle housing cover (par. 110).

112. Illumination Cable Connector

a. Removal and Disassembly.

(1) Disconnect the electrical lead (fig. 58).

(2) Refer to figure 59 and remove and disassemble the illumination cable connector.

b. Cleaning, Inspection, and Repair.

(1) Clean the connector with a dry, lintfree cloth.

(2) Inspect the connector for cracks and other damage.

(3) Inspect the threads for wear or other damage.

(4) Replace a damaged or defective connector.

c. Reassembly and Installation.

(1) Refer to figure 59 and reassemble and install the illumination cable connector.

(2) Connect the electrical lead (fig. 58).

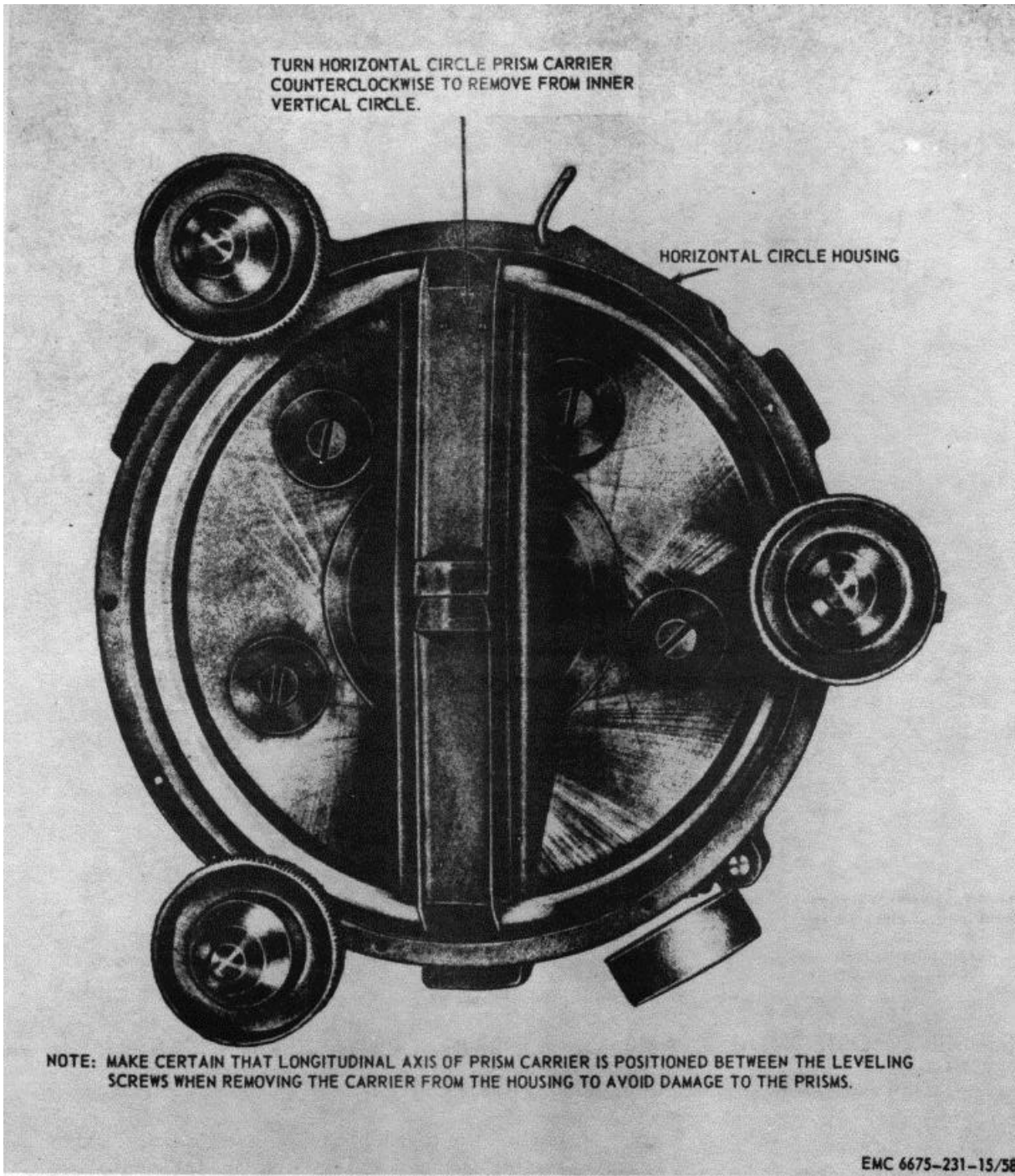
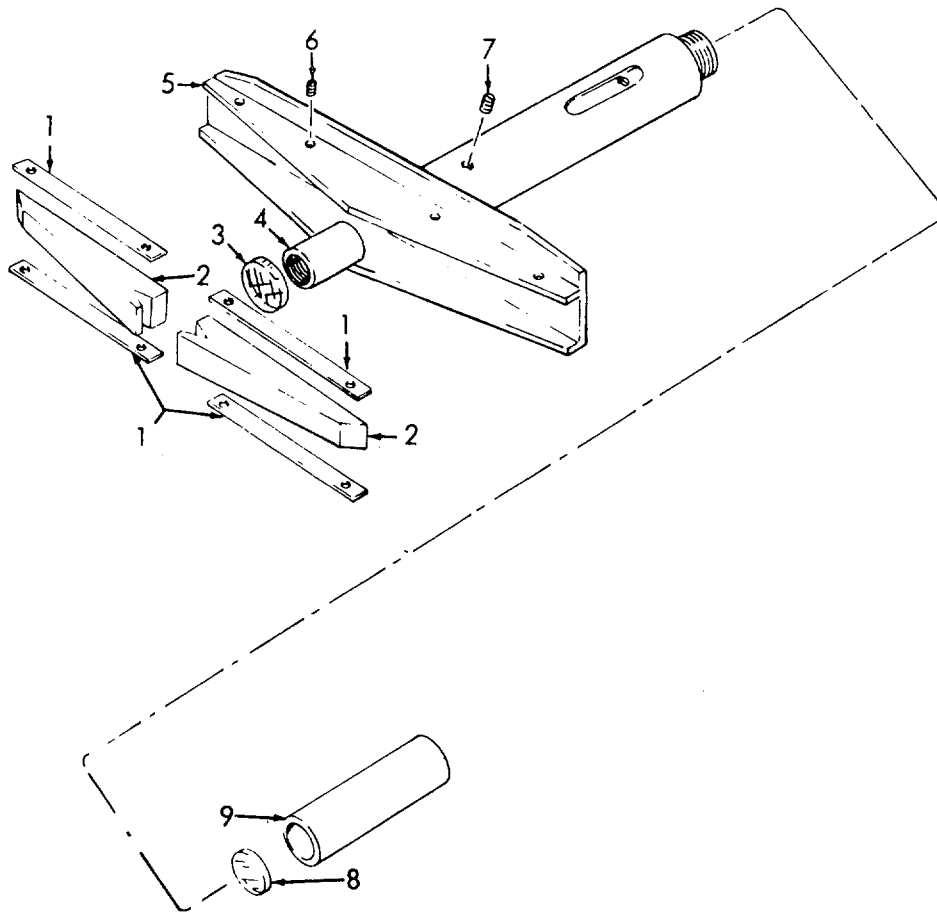

Figure 60. Horizontal circle prism carrier, removal and installation.



EMC 6675-231-15/59

- | | |
|------------------------|---------------------|
| 1 Brass strip (4 rqr) | 6 Setscrew (12 rqr) |
| 2 Pickup prism (2 rqr) | 7 Setscrew |
| 3 Lens | 8 Lens |
| 4 Lens mount | 9 Lens mount |
| 5 Pickup prism carrier | |

Figure 61. Horizontal circle prism carrier, disassembly and reassembly.

Section XIII. HORIZONTAL CLAMP, CLAMP RING, CONTACT RING, OUTER VERTICAL AXIS, AND HORIZONTAL

113. General

The horizontal clamp is used to lock the upper part of the theodolite in any desired position. The horizontal slow-motion screw is incorporated in the clamp to provide precise horizontal sighting. The clamp ring, mounted on the top of the horizontal circle housing, provides a locking surface for the clamp. The contact ring provides a means for transferring electrical current from the base to the upper part of the theodolite. The outer vertical axis retains the horizontal circle mount

and provides a seat for the bearings on which the U-standard rotates.

114. Horizontal Clamp

a. Removal.

- (1) Remove the horizontal slow-motion screw (par. 108).
- (2) Refer to figure 62 and remove the horizontal clamp.

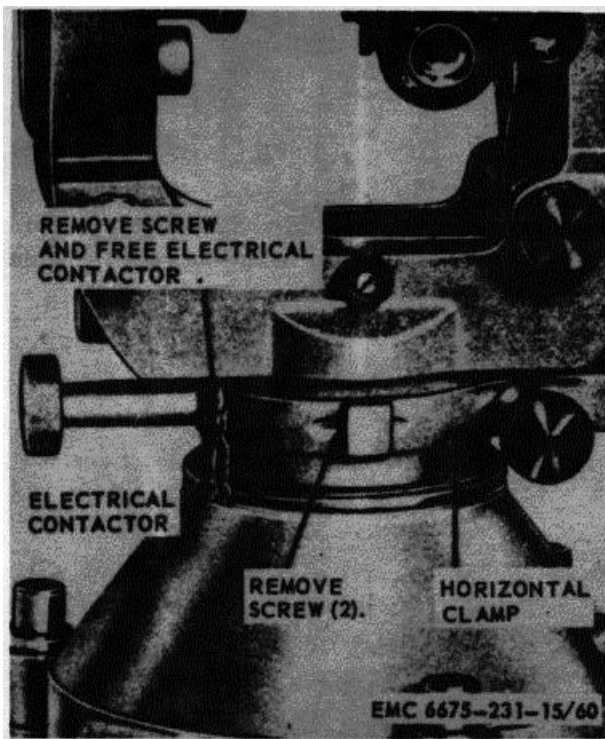

Figure 62. Horizontal clamp, removal and installation.

b. *Disassembly.* Refer to figure 63 and disassemble the horizontal clamp.

c. *Cleaning, Inspection, and Repair.*

- (1) Clean all metal parts with a cloth dampened with an approved cleaning solvent and dry thoroughly.
- (2) Inspect the clamp for burrs, cracks, breaks, and worn or damaged threads.
- (3) Inspect the pins and jaw for scoring, burrs, and wear. Inspect the lever for wear, cracks, and damage. Inspect the knob for burrs and damaged threaded surfaces.
- (4) Remove all burrs and minor scoring and scratches from polished surfaces.
- (5) Repair or replace all damaged or defective parts.

d. *Reassembly.* Refer to figure 63 and reassemble the horizontal clamp.

e. *Installation.*

- (1) Refer to figure 62 and install the horizontal clamp.
- (2) Install the horizontal slow-motion screw (par. 108).

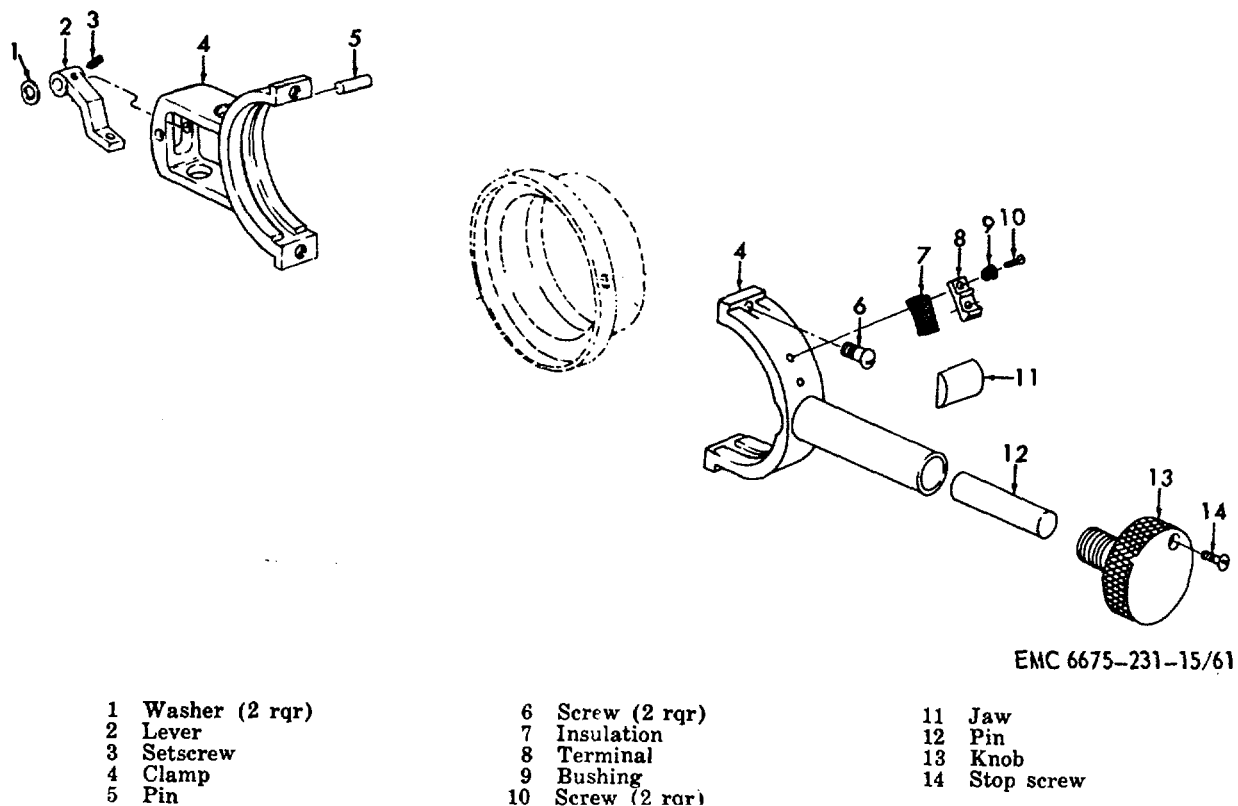

Figure 63. Horizontal clamp, disassembly and reassembly

115. Clamp Ring, Contact Ring, Outer Vertical Axis, and Horizontal Circle

a. Removal.

- (1) Remove the inner vertical axis (par. 126).
- (2) Remove the horizontal clamp (par. 114).
- (3) Refer to figure 64 and remove the clamp ring, contact ring, outer vertical axis, and horizontal circle.

b. *Disassembly.* Refer to figure 65 and disassemble the horizontal circle.

c. *Cleaning, Inspection, and Repair.*

- (1) Clean all metal parts with an approved cleaning solvent and dry thoroughly.
- (2) Clean all threaded surfaces with a brush dipped in an approved cleaning solvent

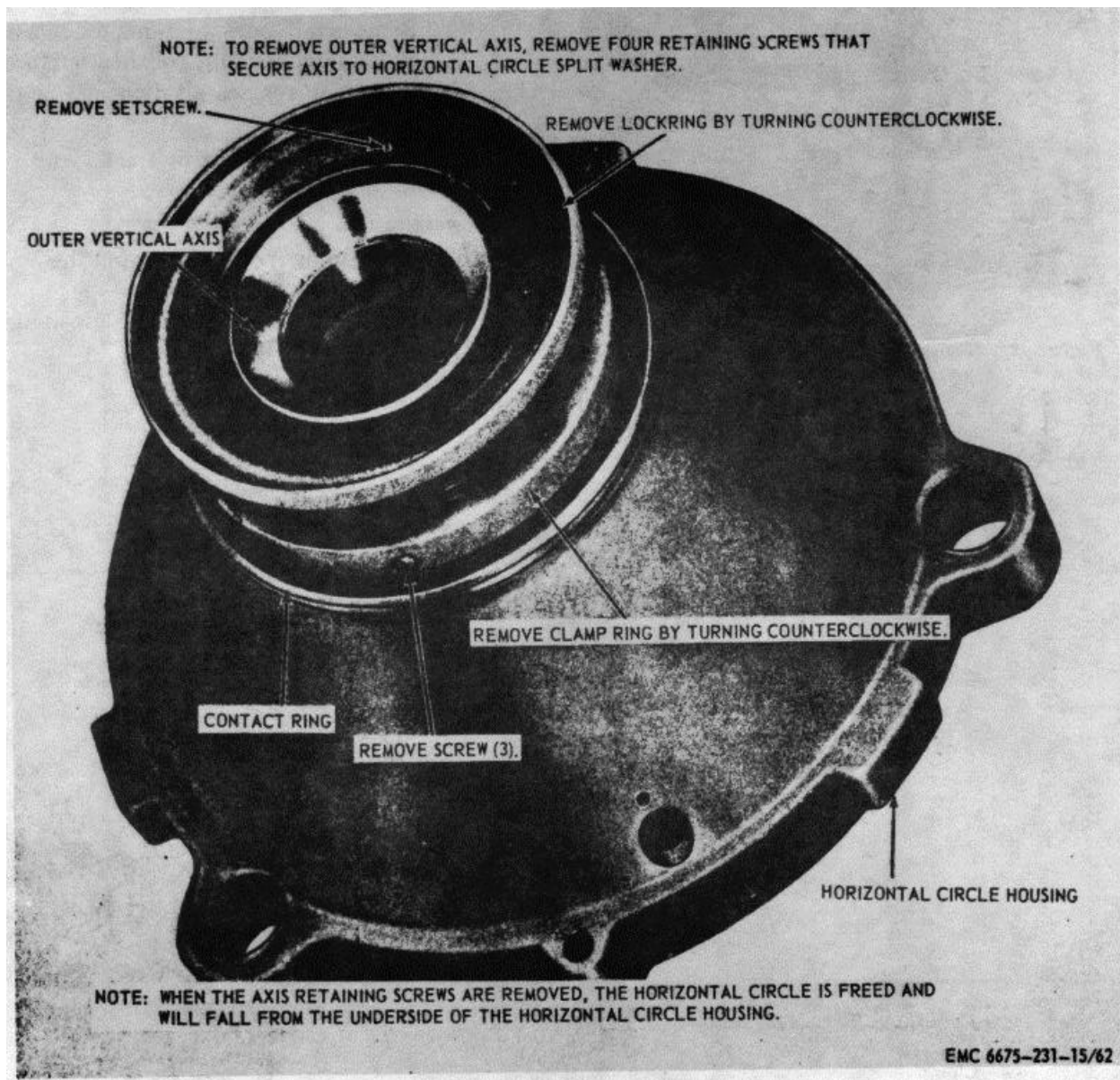
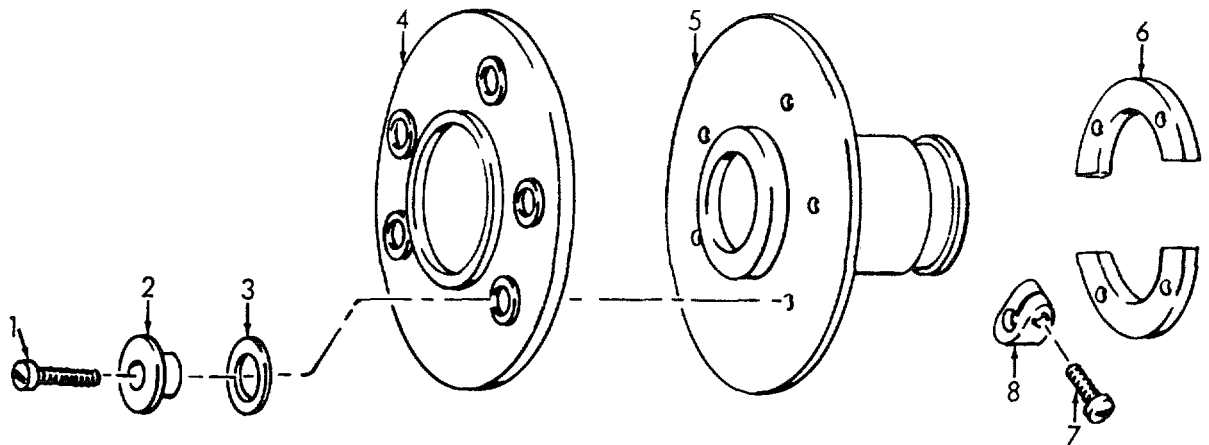

Figure 64. Clamp ring, contact ring, outer vertical axis, and horizontal circle, removal and installation.



EMC 6675-231-15/63

- | | |
|--------------------------|-------------------|
| 1 Screw (5 rqr) | 5 Circle mount |
| 2 Washer (spec) (5 rqr) | 6 Washer (spec) |
| 3 Plastic washer (5 rqr) | 7 Screw (5 rqr) |
| 4 Horizontal circle | 8 Locknut (5 rqr) |

Figure 65. Horizontal circle, disassembly and reassembly.

- (3) Clean the horizontal circle with a lens cloth or lens tissue. Inspect the circle for chips, cracks, or other damage. Inspect the teeth of the circle mount for wear, burs, and damage.
- (4) Inspect the clamp ring, contact ring, and outer vertical axis for dents, cracks, and other defects.
- (5) Inspect the ball bearings for wear, scratches, rust, and other defects.

- (6) Straighten all dents and replace all damaged parts that cannot be repaired.
- d. *Reassembly.* Refer to figure 65 and reassemble the horizontal circle.
- e. *Installation.*
 - (1) Refer to figure 64 and install the outer vertical axis, contact ring, clamp ring, and horizontal circle.
 - (2) Install the horizontal clamp (par. 114).
 - (3) Install the inner vertical axis (par. 126).

Section XIV. LEVELING SCREWS, HORIZONTAL CIRCLE DRIVE, ILLUMINATION SOCKET, AND HORIZONTAL CIRCLE HOUSING

116. General

The leveling screws are the means by which the theodolite is precisely leveled as indicated by the plate level. The horizontal circle drive is used to rotate the horizontal circle to any desired position without rotating the U-standard. The illumination socket, located on the circle housing, provides a mount for the horizontal circle illumination mirror and for the light housing when the electrical illumination system is utilized. The horizontal circle housing comprises the lower part of the theodolite to which the leveling screws and star plate are mounted.

It also supports the U-standard and contains the horizontal circle and vertical axis.

117. Leveling Screws

- a. *Removal and Disassembly.*
 - (1) Remove the star plate (par. 54).
 - (2) Refer to figure 66 and remove and disassemble the leveling screws.
- b. *Cleaning, Inspection, and Repair.*
 - (1) Clean all parts with an approved cleaning solvent and dry thoroughly.
 - (2) Inspect the threaded surfaces on the point screw, knob, and nut for wear

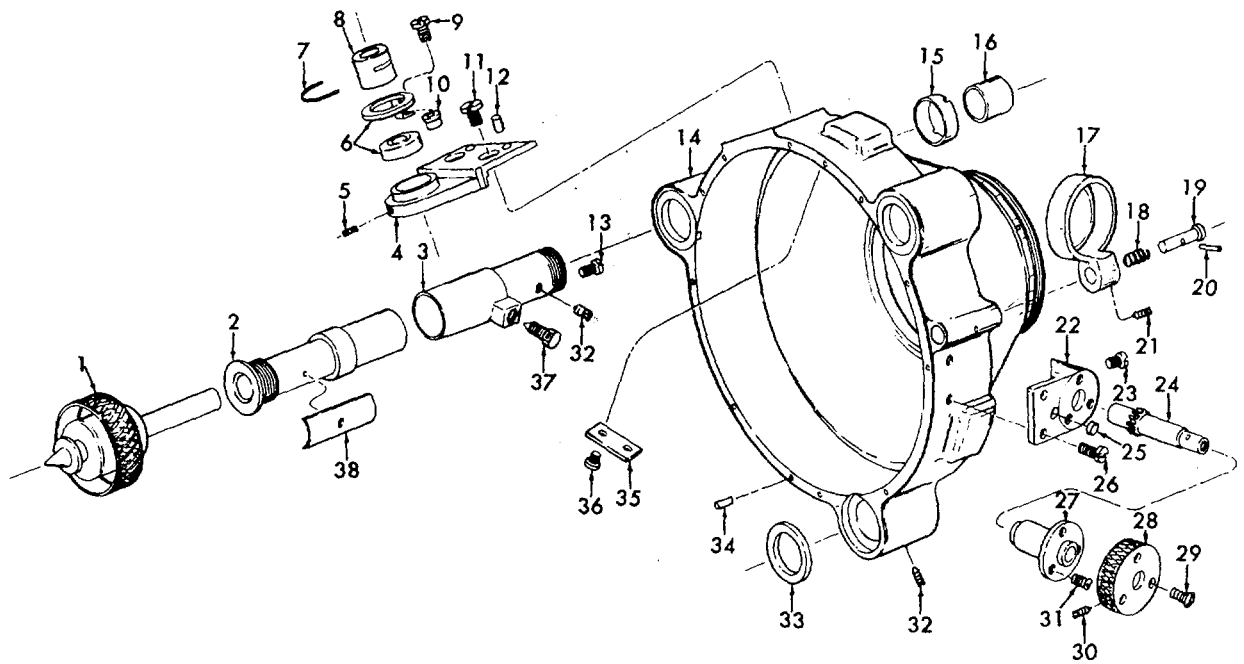

EMC 6675-231-15/64

- | | | | |
|----|------------------------|----|--------------------|
| 1 | Leveling screw (3 rqr) | 20 | Pin |
| 2 | Nut (3 rqr) | 21 | Setscrew |
| 3 | Bushing (3 rqr) | 22 | Bracket |
| 4 | Bracket | 23 | Screw |
| 5 | Setscrew | 24 | Drive |
| 6 | Insulation | 25 | Rubber stop |
| 7 | Clip | 26 | Screw (2 rgr) |
| 8 | Sleeve | 27 | Bushing |
| 9 | Screw | 28 | Knob |
| 10 | Bushing | 29 | Screw |
| 11 | Screw (2 rqr) | 30 | Setscrew |
| 12 | Locating pin (2 rqr) | 31 | Screw |
| 13 | Screw (3 rqr) | 32 | Setscrew (2 rqr) |
| 14 | Housing | 33 | Washer (3 rqr) |
| 15 | Locknut | 34 | Pin (2 rqr) |
| 16 | Cap | 35 | Clip |
| 17 | Cover | 36 | Screw (2 rqr) |
| 18 | Spring | 37 | Adjusting screw |
| 19 | Cover axis | 38 | Shoe clamp (3 rqr) |

Figure 66. Leveling screws, horizontal circle drive, illumination socket, and horizontal circle housing, removal, disassembly, reassembly, and installation.

and damage. Inspect the point screw, knob, nut, and cover for burs, bends, and cracks. Inspect the screws for worn or damaged threads and heads.

- (3) Remove all burs and replace defective parts.

c. Reassembly and Installation.

- (1) Refer to figure 66 and reassemble and install the leveling screws.
- (2) Install the star plate (par. 54).

- d. *Adjustment.* Adjust the leveling screws (par. 16).

118. Horizontal Circle Drive

- a. *Removal and Disassembly.* Refer to figure 66 and remove and disassemble the horizontal circle drive.

b. *Cleaning, Inspection, and Repair.*

- (1) Clean all metal parts with an approved cleaning solvent and dry thoroughly.
- (2) Inspect the drive and sleeve for wear, burs, rust, and damage. Inspect the two washers for wear and defects.

(3) Remove all burrs and minor scratches.
Replace all damaged parts.

c. Reassembly and Installation. Refer to figure 66 and reassemble and install the horizontal circle drive.

d. Adjustment. Refer to paragraph 16 and adjust the horizontal circle drive.

119. Illumination Socket

a. Removal and Disassembly. Refer to figure 66 and remove and disassemble the illumination socket.

b. Cleaning, Inspection, and Repair.

(1) Clean all metal parts with an approved cleaning solvent and dry thoroughly.

(2) Inspect the insulation for cracks and other defects. Inspect the mounting hardware for worn or damaged threads.

(3) Replace all worn or defective parts.

c. Reassembly and Installation. Refer to figure 66 and reassemble and install the illumination socket.

120. Horizontal Circle Housing

a. Removal.

(1) Remove the outer vertical axis (par. 115).

(2) Remove the horizontal circle drive (par. 118).

(3) Remove the illumination cable connector (par. 112).

(4) Remove the leveling screws (par. 117).

b. Cleaning, Inspection, and Repair.

(1) Clean all metal parts with an approved cleaning solvent and dry thoroughly.

(2) Inspect the housing for cracks, burrs, and other defects. Inspect the threaded portions for worn or damaged threads.

(3) Remove all burrs. Replace a defective horizontal circle housing.

c. Installation.

(1) Install the leveling screws (par. 117).

(2) Install the illumination cable connector (par. 112).

(3) Install the horizontal circle drive (par. 118).

(4) Install the outer vertical axis (par. 115).

Section XV. RIGHT SIDE AXIS BEARING, VERTICAL CLAMP, TELESCOPE AXIS, LEFT SIDE AXIS BEARING, VERTICAL CIRCLE, VERTICAL CIRCLE HOUSING, AND VERTICAL CIRCLE PRISM CARRIER

121. General

The right side axis bearing serves as a support for the right end of the telescope axis and houses the micrometer circle assembly. The vertical clamp assembly is mounted on the telescope axis and is used to clamp the telescope in position at any point in the vertical plane. The vertical clamp assembly works in conjunction with the vertical slow-motion screw to make slow and precise adjustments of the telescope in the vertical plane.

122. Right Side Axis Bearing and Vertical Clamp

a. Removal.

(1) Remove the micrometer (par. 106).

(2) Remove the vertical slow-motion screw (par. 108).

(3) Remove the inverter prism (par. 100).

(4) Refer to figure 67 and remove the right side axis bearing and vertical clamp.

b. Disassembly. Refer to figure 68 and disassemble the right side axis bearing and vertical clamp.

c. Cleaning, Inspection, and Repair.

(1) Clean all metal parts with an approved cleaning solvent and dry thoroughly.

(2) Inspect the right side axis bearing for burrs and cracked or broken casting. Inspect the vertical clamp and

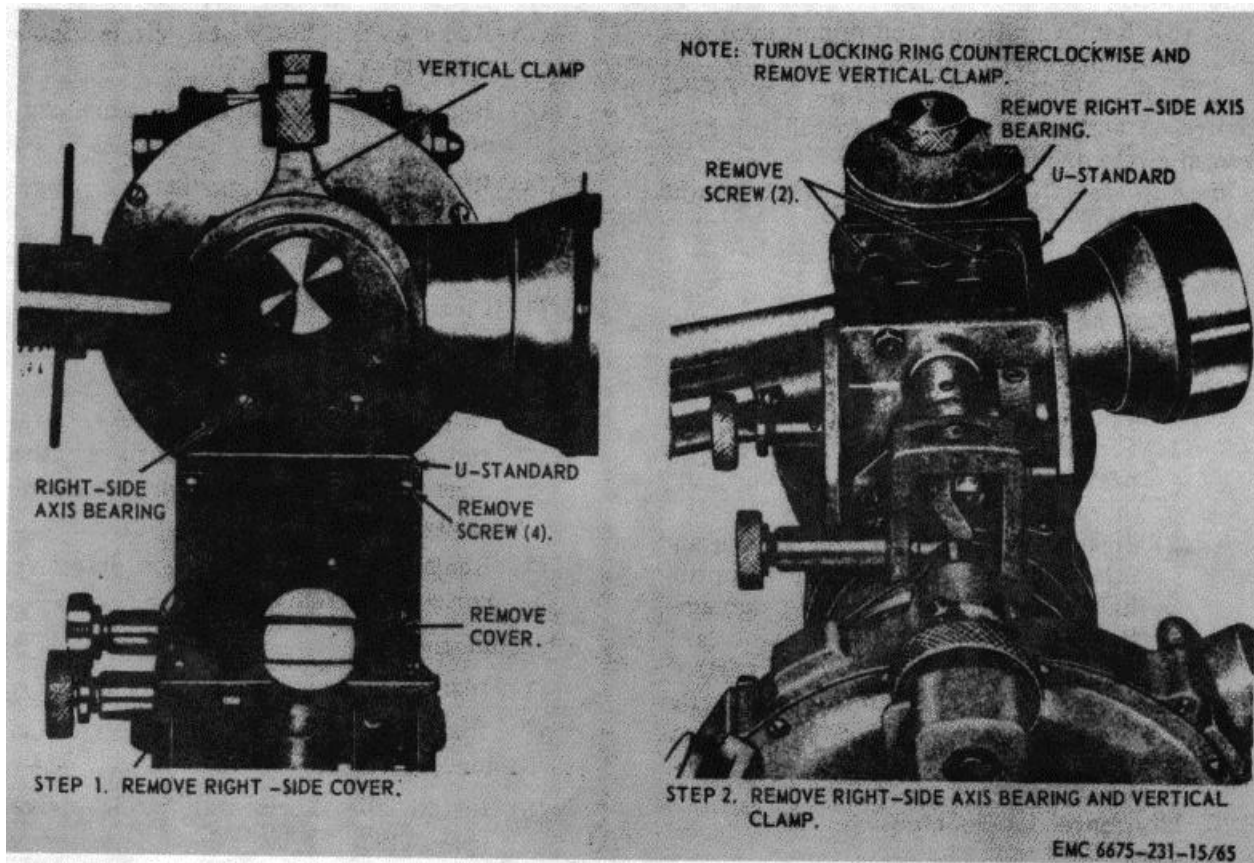

Figure 67. Right side axis bearing and vertical clamp, removal and installation.

lever for cracks, breaks, dents, and excessive wear. Inspect all threaded surfaces for worn or damaged threads.

- (3) Remove all burrs and straighten minor dents and bends. Replace all defective parts that cannot be repaired.

d. Reassembly. Refer to figure 68 and reassemble the vertical clamp and right side axis bearing.

e. Installation.

- (1) Refer to figure 67 and install the right side axis bearing and vertical clamp.
- (2) Install the inverter prism (par. 100).
- (3) Install the vertical slow-motion screw (par. 108).
- (4) Install the micrometer (par. 106).

123. Telescope Axis

a. Removal.

- (1) Remove the telescope (par. 103).

- (2) Remove the vertical clamp (par. 122).

- (3) Refer to figure 69 and remove the telescope axis.

b. Cleaning, Inspection, and Repair.

- (1) Clean all metal parts with an approved cleaning solvent and dry thoroughly.
- (2) Inspect the telescope axis for cracks, breaks, burrs, and damaged threads.
- (3) Remove all burrs and straighten all dents and bends. Replace all defective parts that cannot be repaired.

c. Installation

- (1) Refer to figure 69 and install the telescope axis.
- (2) Install the vertical clamp (par. 122).
- (3) Install the telescope objective end (par. 103).

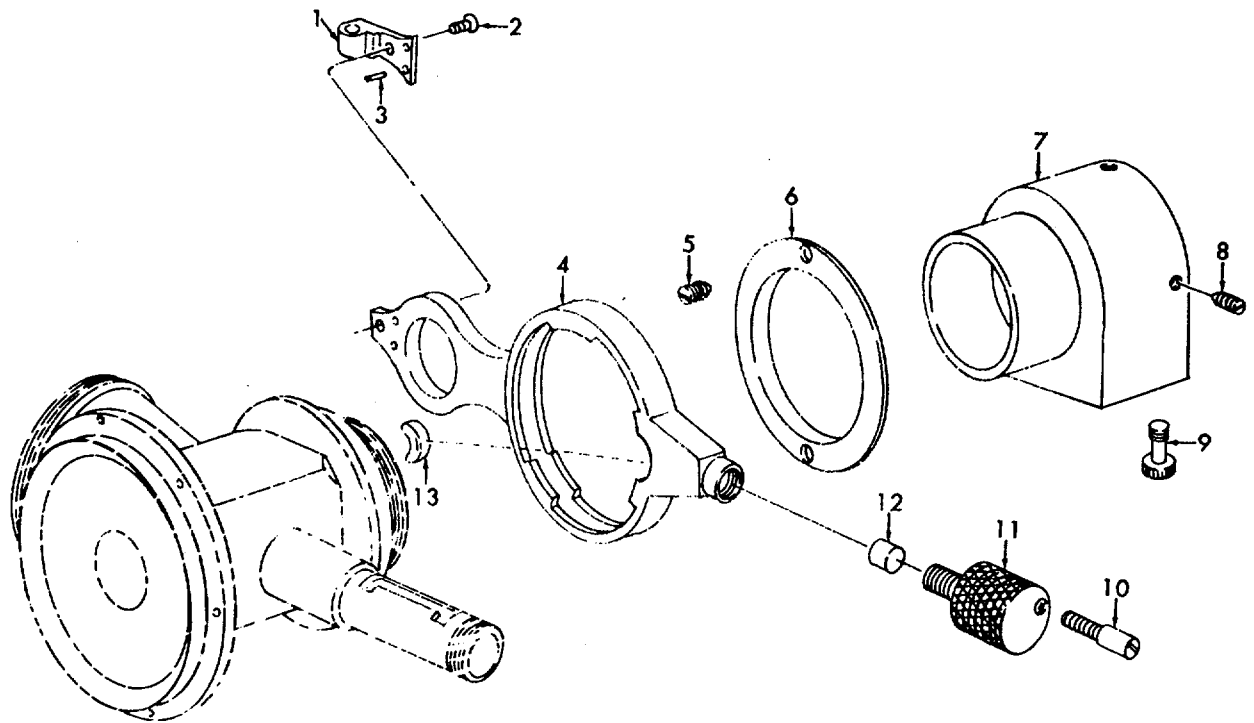

EMC 6675-231-15/66

- | | |
|---------------|--------------------|
| 1 Lever | 8 Setscrew (3 rqr) |
| 2 Screw | 9 Screw (2 rqr) |
| 3 Pin (2 rqr) | 10 Stop screw |
| 4 Clamp | 11 Knob |
| 5 Screw | 12 Pin |
| 6 Lockring | 13 Jaw |
| 7 Bearing | |

Figure 68. Right side axis bearing and vertical clamp, disassembly and reassembly.

124. Left Side Axis Bearing, Vertical Circle, Vertical Circle Housing, and Vertical Circle Prism Carrier a. Removal.

- (1) Remove the collimation level and lever assembly (par. 93).
- (2) Remove the vertical circle illumination prism (par. 98).
- (3) Remove the telescope axis (par. 123).
- (4) Refer to figure 70 and remove the left side axis bearing, vertical circle, vertical circle housing, and vertical circle prism carrier.

b. Disassembly. Refer to figure 71 and disassemble the left side axis bearing, vertical circle, vertical circle housing, and vertical circle prism carrier.

c. Cleaning, Inspection, and Repair.

- (1) Clean all metal parts with an approved cleaning solvent and dry thoroughly.

Clean all threaded parts with a brush dipped in an approved cleaning solvent.

- (2) Clean the lenses, and vertical circle prisms with lens tissue or a lens cloth. Be sure no lint remains on the vertical circle after cleaning.
- (3) Inspect the lenses and prisms for chips, cracks, scratches, and etching. Inspect the left side axis bearing and vertical circle prism carrier for cracks, burs, and wear.
- (4) Inspect the circle holding spring plate, prism mounts, vertical circle housing, and lens mounts for bends, dents, burs, cracks, and other damage.
- (5) Remove all burs and straighten minor dents and bends. Replace all damaged parts that cannot be repaired.

d. Reassembly. Refer to figure 71 and reassemble the vertical circle prism carrier, vertical

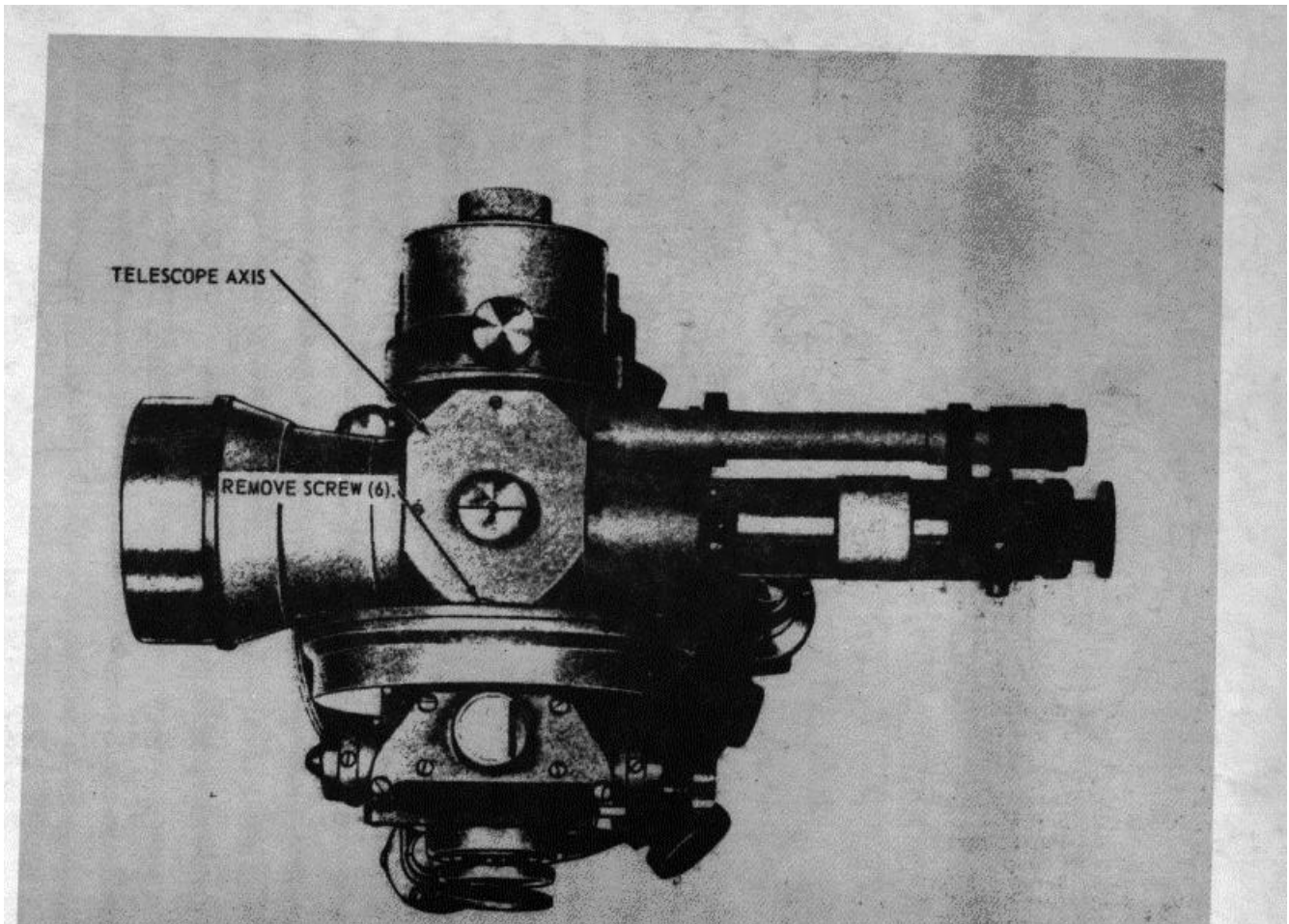

CAUTION: MAKE CERTAIN THE AXIS AND TELESCOPE TUBE ARE WELL SUPPORTED BEFORE REMOVING SCREWS.

EMC 6675-231-15/67

Figure 69. Telescope axis, removal and installation.

housing, vertical circle, and left side axis bearing.

e. Installation.

- (1) Refer to figure 70 and install the vertical circle prism carrier, vertical circle housing, vertical circle, and left side axis bearing.

- (2) Install the telescope axis (par. 123).
- (3) Install the vertical circle illumination prism (par. 98).
- (4) Install the collimation level and lever assembly (par. 93).

AGO 6078A

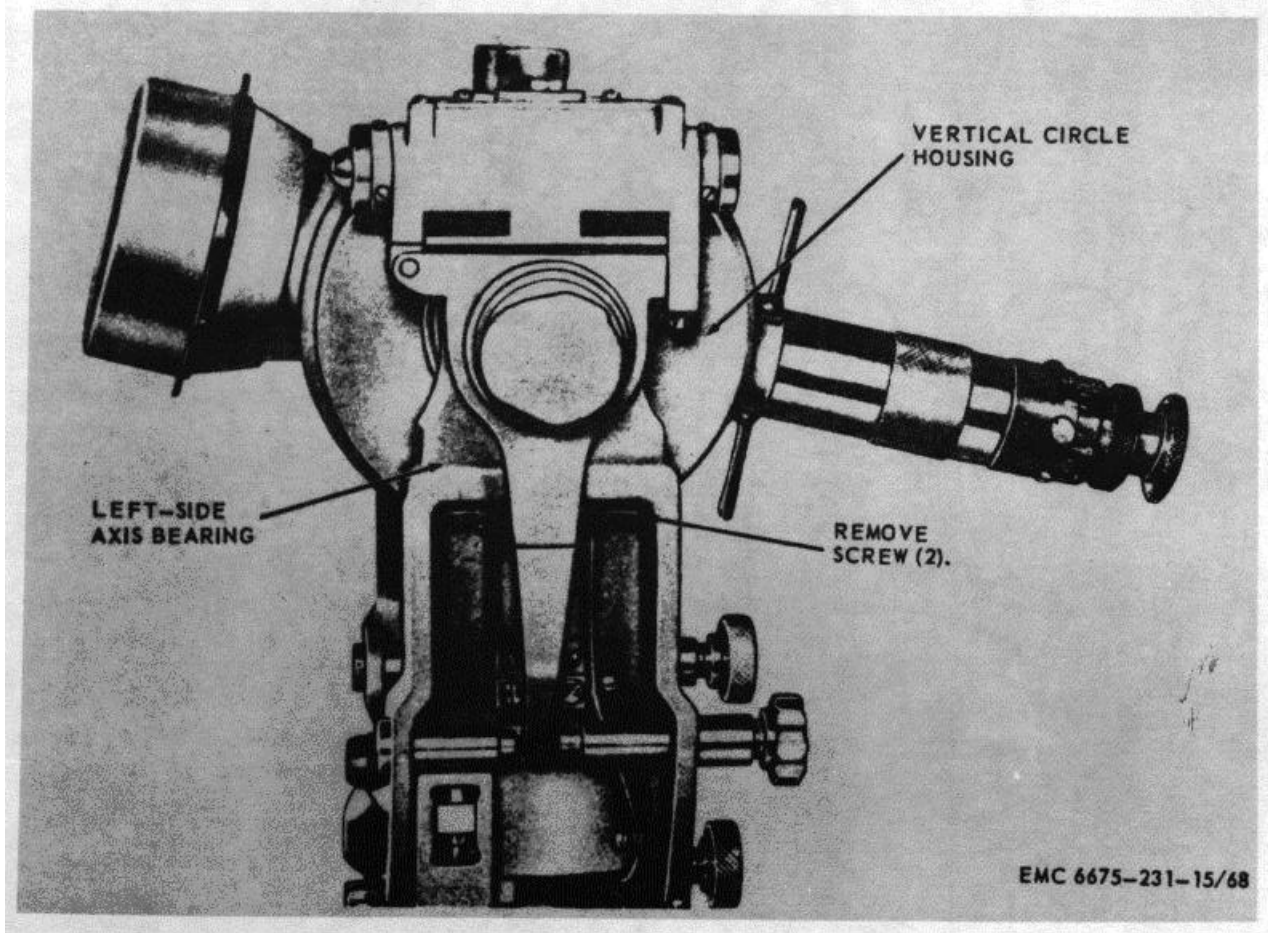
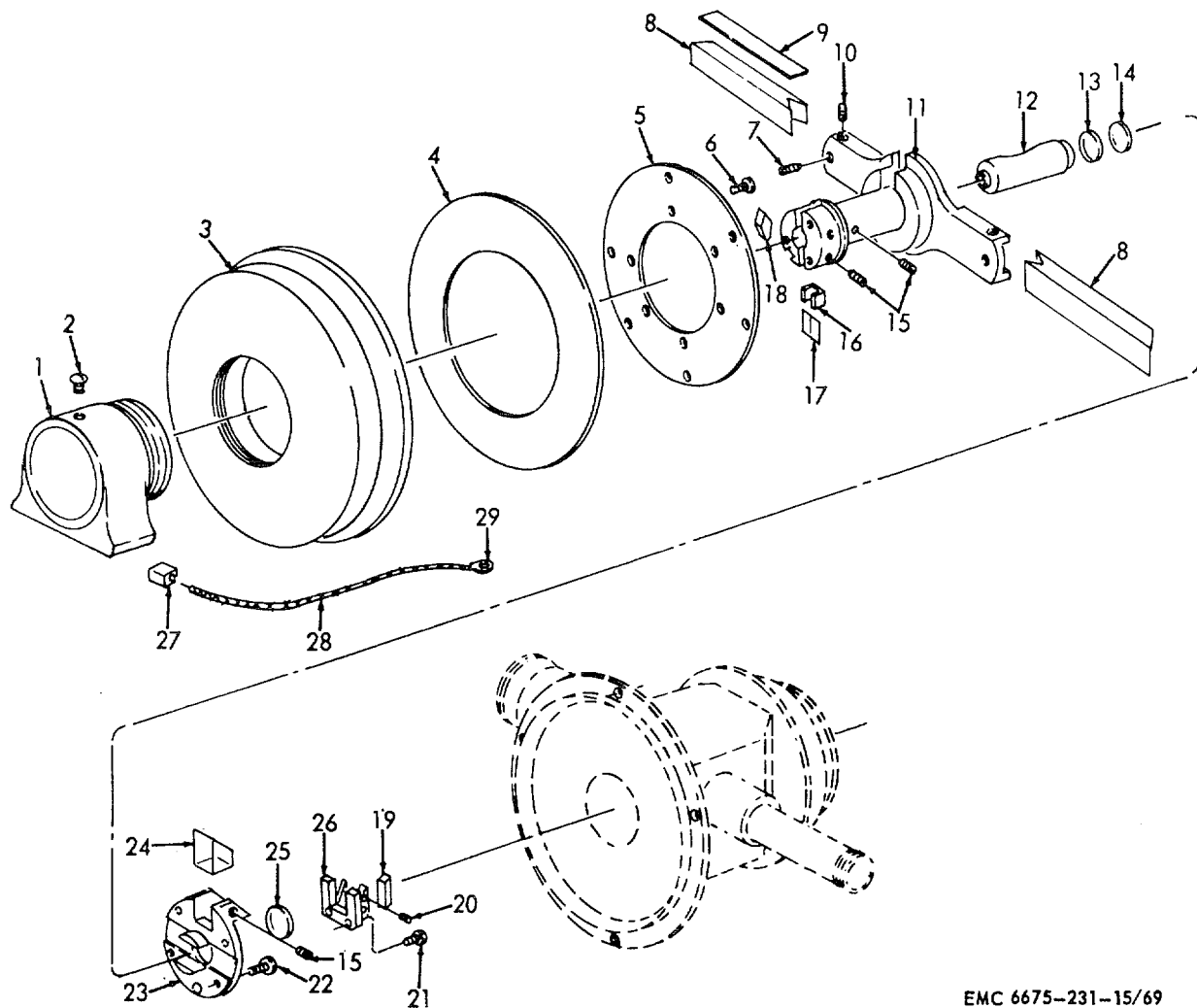

Figure 70. Left side axis bearing, vertical circle, vertical circle housing, and vertical circle prism carrier, removal and installation.



EMC 6675-231-15/69

- | | | | |
|----|------------------|----|------------------|
| 1 | Bearing | 16 | Housing |
| 2 | Screw | 17 | Prism |
| 3 | Circle housing | 18 | Prism |
| 4 | Vertical circle | 19 | Prism |
| 5 | Spring plate | 20 | Setscrew (2 rqr) |
| 6 | Screw (6 rqr) | 21 | Screw (2 rqr) |
| 7 | Setscrew (2 rqr) | 22 | Screw (2 rqr) |
| 8 | Prism (2 rqr) | 23 | Housing |
| 9 | Band (4 rqr) | 24 | Prism |
| 10 | Setscrew (8 rqr) | 25 | Lens |
| 11 | Prism carrier | 26 | Housing |
| 12 | Lens housing | 27 | Lug |
| 13 | Lens | 28 | Electrical cable |
| 14 | Lens | 29 | Lug |
| 15 | Setscrew (6 rqr) | | |

Figure 71. Left side axis bearing, vertical circle, vertical circle housing, and vertical circle prism carrier, disassembly and reassembly.

Section XVI. U-STANDARD AND INNER VERTICAL AXIS

125. General

The U-standard is the upper part of the theodolite which rotates on the inner vertical axis and is secured to

the horizontal circle housing by means of the horizontal circle prism carrier. The U-standard supports the

telescope, and contains the vertical circle, micrometer circle, collimation level, slow-motion screws, plate level, and prism. It permits revolving and aiming the telescope in any azimuthal or vertical direction.

126. U-Standard and Inner Vertical Axis

a. Removal and Disassembly.

- (1) Remove the telescope axis bearings (pars. 122 and 124).
- (2) Remove the horizontal, vertical, and collimation slow-motion screws (par. 108).
- (3) Remove the horizontal circle housing (par. 120).
- (4) Remove the plate level (par. 97).

- (5) Remove the micrometer circle illumination prism (par. 99).
- (6) Remove the vertical circle illumination prism (par. 98).
- (7) Refer to figure 72 and remove and disassemble the U-standard and inner vertical axis.

b. Cleaning, Inspection, and Repair.

- (1) Clean all metal parts with an approved cleaning solvent and dry thoroughly. Clean the window and lens with lens tissue or lens cloth.
- (2) Inspect the U-standard for cracks, damaged bearing surfaces, and worn or damaged threads. Inspect the win

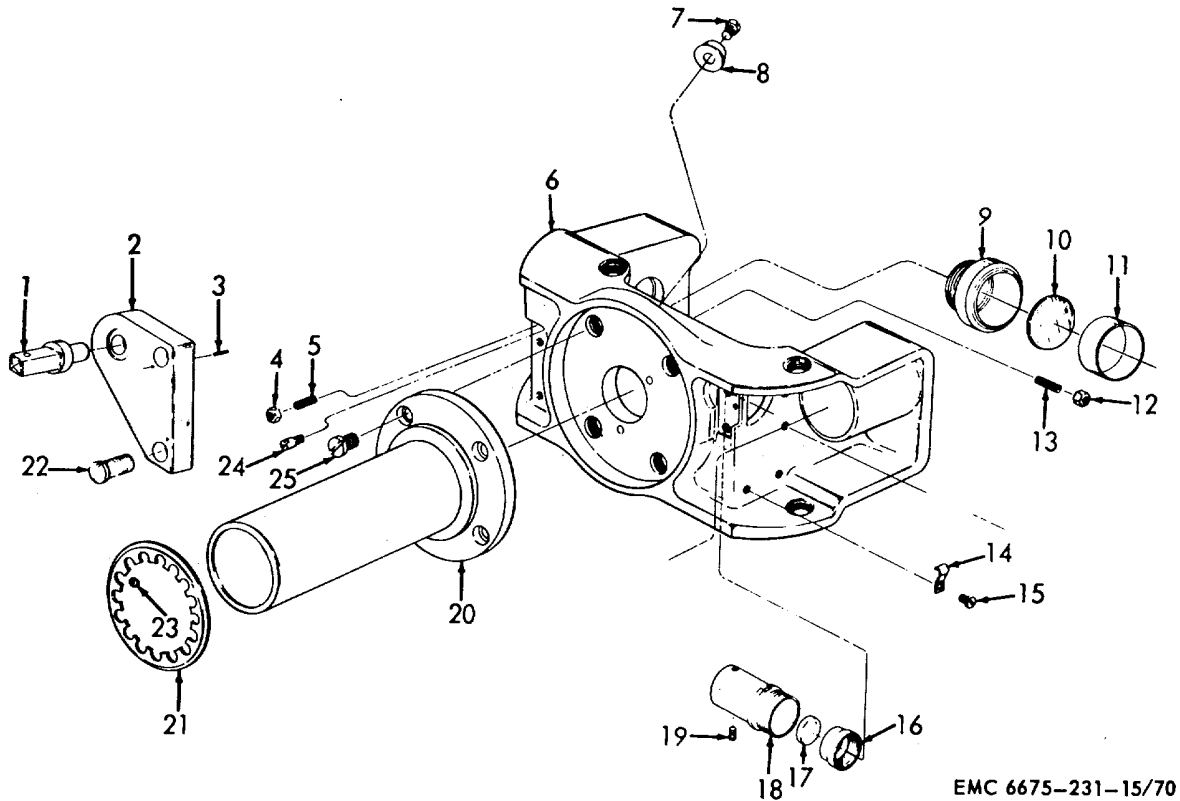

- 1 Pilot connection pin
- 2 Pilot connection
- 3 Locating pin (2 rqr)
- 4 Locknut
- 5 Stop screw
- 6 U-standard
- 7 Screw (2 rqr)
- 8 Rubber stop (2 rqr)
- 9 Window housing
- 10 Window
- 11 Washer
- 12 Locknut
- 13 Setscrew

- 14 Clip (2 rqr)
- 15 Screw (2 rqr)
- 16 Lens housing
- 17 Lens
- 18 Sleeve
- 19 Screw
- 20 Inner vertical axis
- 21 Separator
- 22 Screw (2 rqr)
- 23 Ball bearing (24 rqr)
- 24 Stop screw
- 25 Screw (4 rqr)

EMC 6675-231-15/70

Figure 72. U-standard and inner vertical axis, removal, disassembly, reassembly, and installation.

dow and lens for chips, cracks, and etchings.

- (3) Inspect the inner vertical axis for excessive wear, burs, and damaged threads.
- (4) Remove all burs. Replace all defective parts that cannot be repaired.

c. Reassembly and Installation.

- (1) Refer to figure 72 and reassemble and install the inner vertical axis and U-standard.
- (2) Install the vertical circle illumination prism (par. 98).

- (3) Install the micrometer circle illumination prism (par. 99).
- (4) Install the plate level (par. 97).
- (5) Install the horizontal circle housing (par. 120).
- (6) Install the horizontal, vertical, and collimation slow-motion screws (par. 108).
- (7) Install the telescope axis bearings (pars. 122 and 124).

Section XVII. ILLUMINATION SYSTEM

127. General

The illumination system consists of two light housings and a battery box with a rheostat to control the intensity of light illuminating the horizontal, vertical, and micrometer circles. A hand light that plugs into the battery box is also provided for general external lighting purposes.

128. Battery Box Assembly

a. Disassembly. Refer to figure 73 and disassemble the battery box assembly.

b. Cleaning, Inspection, and Repair.

- (1) Clean all metal parts with an approved cleaning solvent and dry thoroughly. Wipe all corrosion from terminals and contacts. Wipe dirt and other foreign matter from cables, lamp trunk, springs, washers, and rheostat.
- (2) Inspect the cables and contacts for cracked, swollen, or damaged insulation, broken wires, and defective terminals. Inspect the springs for bends, breaks, and fatigue.
- (3) Inspect the lamp trunk for cracks and other damage. Inspect the rheostat for improper operation and other damage. Inspect the sockets for cracks and wear. Inspect the springs for bends, breaks, and fatigue. Inspect the contacts and slide lever for wear, burs, and bends.
- (4) Inspect the battery box for dents, cracks, and defective mounting bracket, clamps, and carrying strap.
- (5) Remove all burs and straighten minor dents. Replace all defective parts that cannot be repaired.

c. Reassembly. Refer to figure 73 and reassemble the battery box assembly.

129. Light Housings, Connector Cable, and Hand Light

a. General. When not in use the light housings are stowed in the accessory case, and the hand light and connector cable are stowed in the battery box.

b. Disassembly. Refer to figure 74 and disassemble the light housings, connector cable, and hand light.

c. Cleaning, Inspection, and Repair.

- (1) Clean all metal parts with an approved cleaning solvent and dry thoroughly.
- (2) Inspect the lamps for defects. Inspect all electrical contacts for breaks, wear, and corrosion. Inspect the light housing glass filter for damage.
- (3) Inspect insulation for cracks, wear, and damage. Inspect the electrical cable for breaks and frayed insulation. Inspect the cable connectors for breaks and defective terminals.
- (4) Inspect the housings and tubes for dents, rust, burs, and other defects.
- (5) Remove all burs and straighten minor dents. Replace all defective parts that cannot be repaired.

d. Reassembly. Refer to figure 74 and reassemble the light housings, connector cable, and hand light.

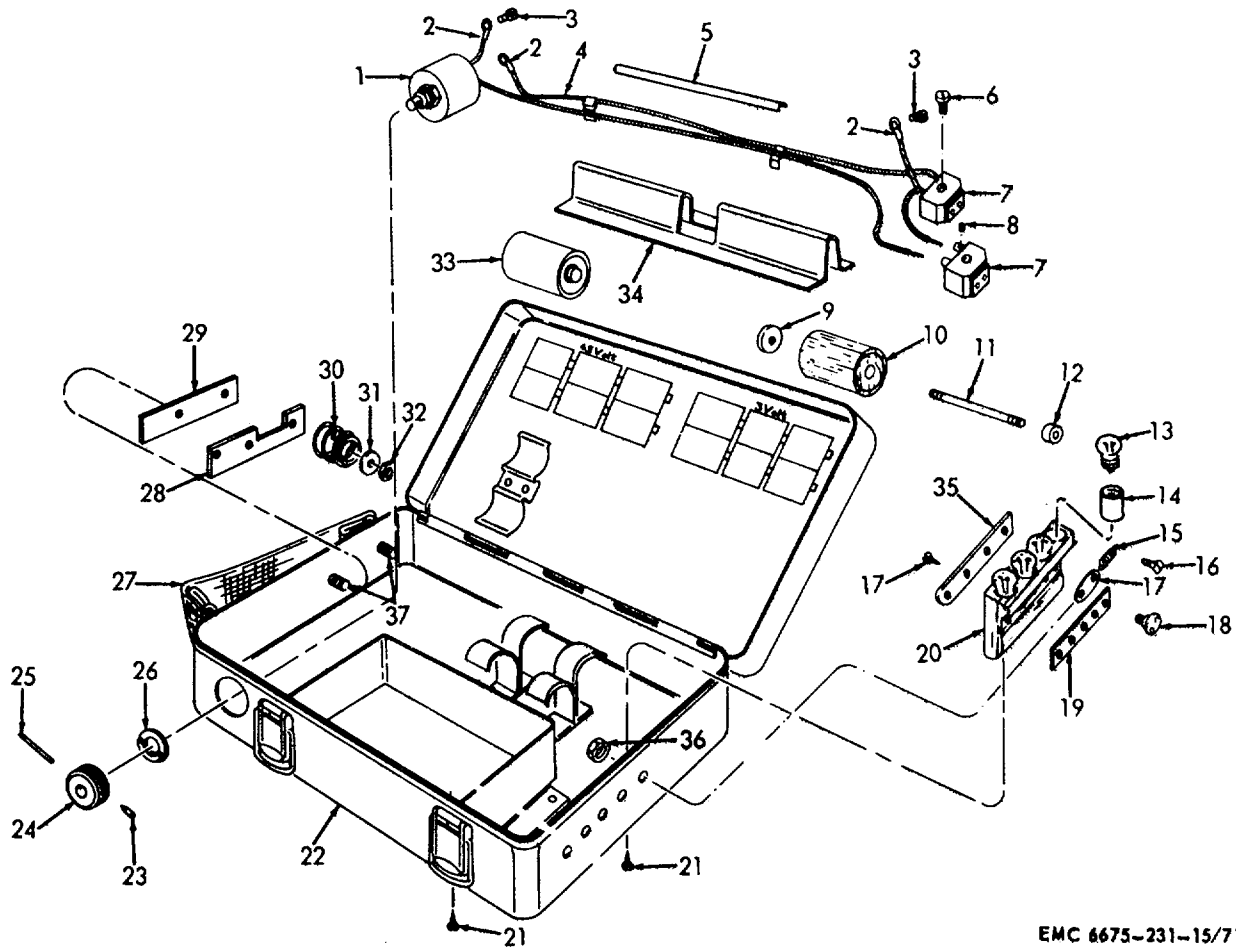

EMC 6675-231-15/71

- | | |
|--------------------------|-----------------------|
| 1 Rheostat | 20 Lamp trunk |
| 2 Terminal (3 rqr) | 21 Screw (2 rqr) |
| 3 Screw (2 rqr) | 22 Battery box |
| 4 Electrical cable | 23 Setscrew |
| 5 Insulation | 24 Rheostat knob |
| 6 Screw (2 rqr) | 25 Pin |
| 7 Socket (2 rqr) | 26 Washer |
| 8 Setscrew (4 rqr) | 27 Strap |
| 9 Washer (2 rqr) | 28 Electrical contact |
| 10 Dummy battery (2 rqr) | 29 Insulation |
| 11 Axle (2 rqr) | 30 Spring |
| 12 Nut (2 rqr) | 31 Washer |
| 13 Lamp | 32 Nut |
| 14 Lamp housing (4 rqr) | 33 Battery |
| 15 Spring | 34 Insulation |
| 16 Screw (2 rqr) | 35 Electrical contact |
| 17 Electrical contact | 36 Nut (2 rqr) |
| 18 Knob | 37 Rivet (2 rqr) |
| 19 Lever | |

Figure 73. Battery box assembly, disassembly and reassembly.

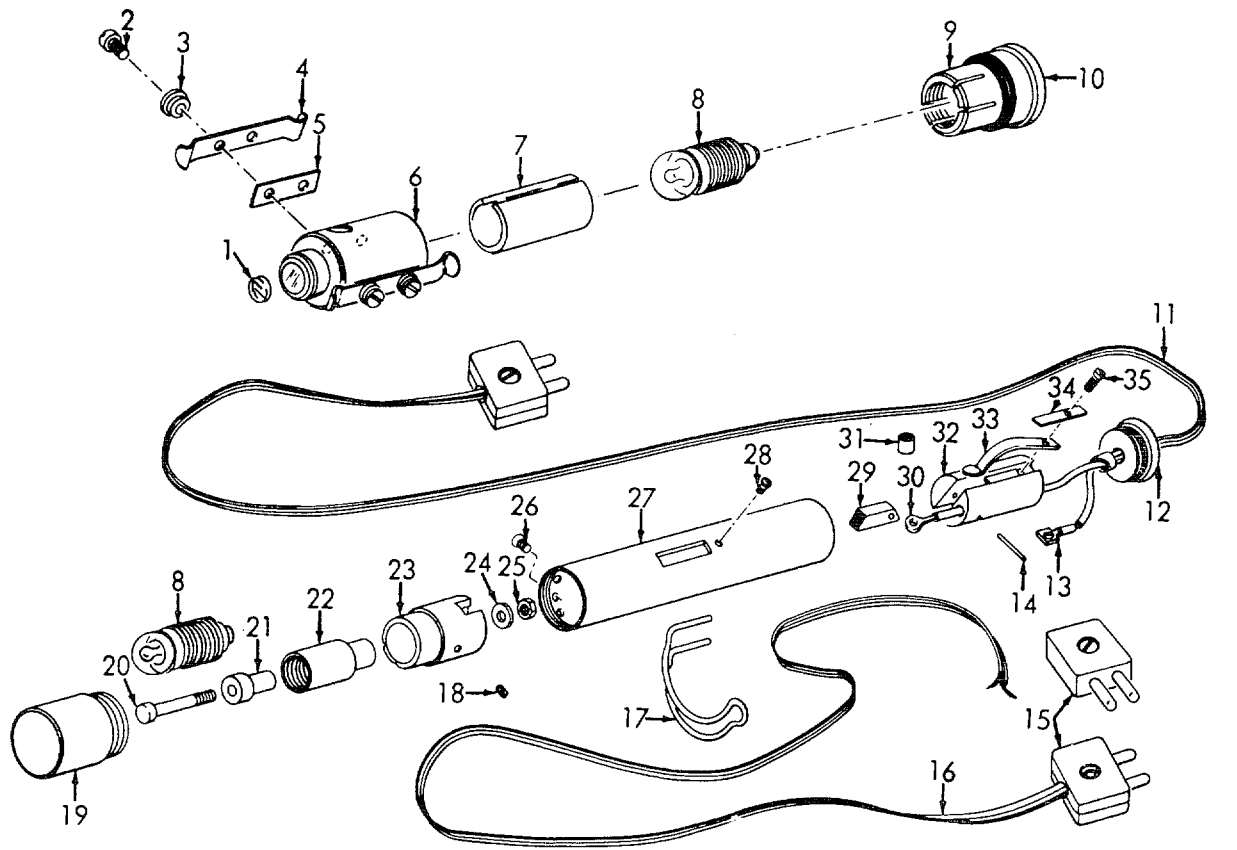

EMC 6675-231-15/72

- | | |
|------------------------------|------------------|
| 1 Glass filter | 19 Tube |
| 2 Screw (4 rqr) | 20 Contact screw |
| 3 Bushing (4 rqr) | 21 Tube |
| 4 Electrical contact (2 rqr) | 22 Housing |
| 5 Insulation (2 rqr) | 23 Adapter |
| 6 Housing | 24 Insulation |
| 7 Cover | 25 Nut |
| 8 Lamp (2 rqr) | 26 Screw |
| 9 Socket | 27 Tube |
| 10 Housing | 28 Screw |
| 11 Electrical cable | 29 Lever |
| 12 Cap | 30 Terminal |
| 13 Terminal | 31 Tube |
| 14 Pin | 32 Insulation |
| 15 Connector (2 rqr) | 33 Spring |
| 16 Electrical cable | 34 Spring |
| 17 Lever | 35 Screw |
| 18 Screw | |

Figure 74. Light housings, connector cable, and hand light, disassembly and reassembly.

AGO 5078A

APPENDIX I

REFERENCES

1. Dictionaries of Terms and Abbreviations

AR 320-5 Dictionary of United States Army Terms.
AR 320-50 Authorized Abbreviations and Brevity Codes.

2. Painting and Preservation

TB ENG 60 Preservation and Painting of Serviceable Corps of Engineer Equipment.

3. Preventive Maintenance

AR 750-5 Maintenance Responsibilities and Shop Operation.
TM 38.-750 The Army Equipment Record System and Procedures.

4. Publication Indexes

DA Pam 108-1 Index of Army Motion Pictures, Film Strips, Slides, and Phono-Recordings.
DA Pam 310-1 Index of Administrative Publications.
DA Pam 310-2 Index of Blank Forms.
DA Pam 310-3 Index of Training Publications.
DA Pam 810-4 Index of Technical Manuals, Technical Bulletins, Supply Bulletins, Lubrication Orders, and Modification Work Orders.
DA Pam 310-5 Index of Graphic Training Aids and Devices.
DA Pam 310-25 Index of Supply Manuals-Corps of Engineers.

5. Shipment and Limited Storage

AR 743-505 Storage of Supplies and Equipment, Limited Storage of Engineers Mechanical Equipment.
TM 38-230 Preservation, Packaging, and Packing of Military Supplies and Equipment.

6. Supply Publications

SM 10-C9100-SL Petroleum, Petroleum-Base Products, and Related Materiel.
TM 5-6675-231-25P Theodolite: Directional; 2/10 Sec. Degree Graduation; 10.2-In. Long Telescope W/Accessories (Wild Heerbrugg Model T-8) FSN 6675-882-9140.

7. Training Aids

FM 21-5 Military Training.
FM 21-6 Techniques of Military Instruction.
FM 21-380 Military Symbols.

APPENDIX II

MAINTENANCE ALLOCATION CHART

Section I. INTRODUCTION

1. General

This appendix contains explanations of all maintenance and repair functions authorized the various echelons. Section II contains the maintenance allocation chart.

2. Maintenance

Maintenance is any action taken to keep materiel in a serviceable condition or to restore it to serviceability when it is unserviceable. Maintenance of materiel includes the following:

a. Service. To clean, preserve, and replenish fuel and lubricants.

b. Adjust. To regulate periodically to prevent malfunction.

c. Inspect. To verify serviceability and detect incipient electrical or mechanical failure by scrutiny.

d. Test. To verify serviceability and detect incipient electrical or mechanical failure by use of special equipment such as gages, meters, and the like.

e. Replace. To substitute serviceable assemblies, subassemblies, and parts for unserviceable components.

f. Repair. To restore an item to serviceable condition through correction of a specific failure or unserviceable condition. This function includes, but is not limited to, inspecting, cleaning, preserving, adjusting, replacing, welding, riveting, and straightening.

g. Aline. To adjust two or more components of an electrical system so that their functions are properly synchronized.

h. Calibrate. To determine, check, or rectify the graduation of an instrument, weapon, or weapons system, or components of a weapons system.

i. Overhaul. To restore an item to completely serviceable condition as prescribed by published serviceability standards. This is accomplished through employment of the technique of "Inspect and Repair Only as Necessary" (IROAN). Maximum utilization of diagnostic and test equipment is combined with minimum disassembly of the item during the overhaul process.

3. Explanation of Columns

a. Functional Group. The functional group is a numerical group set up on a functional basis. The applicable functional grouping indexes (obtained from the Corps of Engineers functional grouping indexes) are listed on the MAC in the appropriate numerical sequence. These indexes are normally set up in accordance with their function and proximity to each other.

b. Components and Related Operation. This column contains the functional grouping index heading, subgroup headings, and a brief description of the part starting with the noun name. It also designates the operations to be performed such as service, adjust, inspect, test, replace, repair, and overhaul.

c. Echelons of Maintenance. This column contains the various echelons of maintenance by number designation. An X placed in the appropriate echelon column in line with an indicated maintenance function authorizes that echelon to perform the function. The X indicates the lowest echelon responsible for performing the function, but does not necessarily indicate repair parts stockage at that level. Higher echelons are authorized to perform the indicated functions of lower echelons.

d. Remarks. This column lists specific maintenance functions, special tools, cross-references, instructions, and the like pertinent to the operation being performed.

Section II. MAINTENANCE ALLOCATION CHART

Functional group	Components and related operation	Echelons of maintenance					Remarks
		1	2	3	4	5	
17	BODY; CAB; HOOD; HULL						
	1708 Carrying Cases						
	Case Assembly, Carrying						
	Replace	X					
	Repair		X				
	Pack Rack						
	Replace	X					
	Repair		X				
	Case, Shipping; Theodolite						
	Replace		X				
	Repair		X				
22	ACCESSORIES, PUBLICATIONS, TEST EQUIPMENT AND TOOLS						
	2602 Accessories						
	Case Assembly, Theodolite Accessory						
	Replace	X					
	Repair		X				
	Cover, Plastic						
	Replace	X					
	Kit, Tool						
	Replace	X					
	Socket Assembly, Plumb Bob						
	Replace	X					
	Repair	X					
	2604 Special Tools						
	Wrench, Tripod						
	Replace	X					
67	PRECISION INSTRUMENTS, MECHANICAL, OR ELECTRICAL						
	6700 Theodolite						
	Theodolite						
	Service	X					External
	Adjust	X					
	Replace		X				
	Repair			X			
	Overhaul					X	
	6701 Telescope Assembly						
	Axis, Telescope						
	Replace					X	
	Repair					X	
	Tube, Telescope						
	Replace					X	
	Bearing, Telescope Axis						
	Replace					X	
	6702 Optics						
	Objective Assembly, Telescope						
	Service	X					External
	Replace					X	
	Repair					X	
	Lens Assembly, Focus						
	Replace					X	
	Reticle Assembly, Telescope						
	Replace					X	
	Focusing Assembly, Telescope						
	Service	X					External
	Replace					X	
	Repair					X	
	Eyepiece, Telescope						
	Replace		X				

Section II. MAINTENANCE ALLOCATION CHART

Functional group	Components and related operation	Echelons of maintenance				Remarks
		1	2	3	4	
6703	Microscope Assembly					External
	Service	X				
	Replace				X	
	Repair				X	
	Objective Assembly, Microscope					
	Replace				X	
	Repair				X	
	Eyepiece Prism: Microscope and Telescope					
	Service	X				
	Replace	X				
	Repair				X	
	Eyepiece, Microscope					
	Replace		X			
	Mirror Assembly, Illumination					
	Service	X				
	Replace	X				
	Repair		X			
	Mirror Assembly, Telescope Illumination					
	Adjust	X				
	Replace				X	
	Repair				X	
	Prisms					
	Replace				X	
	Lens Assembly, Vertical Circle					
	Replace				X	
	Repair				X	
	Circle, Horizontal					
	Replace				X	
	Vertical Circle Assembly					
	Replace				X	
	Circle, Micrometer					
	Replace				X	
	Sunglass, Telescope Eyepiece					
	Replace	X				
	Micrometer Assembly					
	Replace				X	
	Repair				X	
	Gunsight					
	Replace				X	
	Cap, Dust					
Replace	X					
Mechanical, Structural, and Precision Parts						
Clamp Assembly, Vertical						
Replace				X		
Repair				X		
Base Plate, Starshaped						
Replace	X					
Repair				X		
U-Standard Assembly						
Replace				X		
Repair				X		
Screw, Leveling Assembly, Leveling						
Adjust	X					
Replace						
Repair		X				
Clamp Assembly						
Replace				X		
Repair				X		

Section II. MAINTENANCE ALLOCATION CHART

Functional group	Components and related operation	Echelons of maintenance					Remarks
		1	2	3	4	5	
	Screw Assemblies, Slow Motion, Horizontal, Vertical, and Collimation						External
	Adjust	X					
	Replace			X			
	Repair				X		
	Base, Housing Assembly						
	Replace					X	
	Repair					X	
	Circle Drive Assembly, Horizontal						
	Adjust		X				
	Replace			X			
	Repair			X			
	Housing, Prism, Horizontal Circle						
	Replace					X	
6708	Batteries						
	Battery, Dry Cell						
	Replace	X					
6709	Lamps						
	Fitting, Lamp						
	Service	X					
	Replace	X					
	Repair			X			
	Lamp, Battery Box						
	Replace	X					
	Light, Hand						
	Service	X					
	Replace	X					
	Repair			X			
6718	Mounted Connecting Devices						
	Socket, Optical Plumbing Device, Light						
	Replace					X	
	Contact Ring						
	Replace					X	
6719	Miscellaneous Wiring and Fittings						
	Cable, Electrical (Internal)						
	Replace					X	
6723	Power Supply						
	Battery Box Assembly						
	Service	X					
	Replace	X					
	Repair			X			
	Cable, Electrical						
	Replace	X					
	Repair			X			
6724	Levels						
	Plate, Level Assembly						
	Adjust	X					
	Replace					X	
	Repair					X	
	Collimation Assembly, Illumination						
	Adjust	X					
	Replace					X	
	Repair					X	
	Collimation Lever Assembly						
	Replace					X	
	Repair					X	

Section II. MAINTENANCE ALLOCATION CHART

Functional group	Components and related operation	Echelons of maintenance					Remarks
		1	2	3	4	5	
82	6725 Tripods						
	Tripod						
	Service	X					
	Replace		X				
	Repair		X				
	Head Assembly, Tripod						
	Replace		X				
	Repair		X				
	Leg Assembly						
	Replace		X				
	Repair		X				
	Cover Tripod						
	Replace		X				
	MINERALS AND CHEMICALS						
	Desslcant						
Service		X					
Replace		X					
Container, Ground Plate							
Service	X						
Replace	X						

APPENDIX III

BASIC ISSUE ITEMS LIST

Section I. INTRODUCTION

1. General

Section II lists the accessories, tools, and publications required in 1st echelon maintenance and operation, initially issued with, or authorized for the theodolite.

2. Explanation of Columns

a. *Source Codes.* The information provided in each column is as follows:

- (1) *Technical service.* This column lists the basic number (or symbol) of the technical service assigned supply responsibility for the part. Blank spaces denote Corps of Engineers supply responsibility. General Engineer supply parts are identified by the letters GE in parentheses, following the nomenclature in the description column. Other technical services basic numbers (or symbols) are 10-Quartermaster Corps 11-Signal Corps 12-Adjutant General's Corps
- (2) *Source.* The selection status and source of supply for each part are indicated by one of the following code symbols:
 - (a) P-applied to high-mortality repair parts which are stocked in or supplied from the technical service depot system, and authorized for use at indicated maintenance echelons.
 - (b) P1-applied to repair parts which are low-mortality parts, stocked in or supplied from technical service depots, and authorized for installation at indicated maintenance echelons.
 - (c) M-applied to repair parts which are not procured or stocked but are to be manufactured at indicated maintenance echelons.

(d) X2-applied to repair parts which are not stocked. The indicated maintenance echelon requiring such repair parts will attempt to obtain them through cannibalization; if not obtainable through cannibalization, such repair parts will be requisitioned with supporting justification through normal supply channels.

- (3) *Maintenance.* The lowest maintenance echelon authorized to use, stock, install, or manufacture the part is indicated by the following code symbol:

O-Organizational Maintenance
(1st and 2d Echelon)

- (4) *Recoverability.* Repair parts and/or tool and equipment items that are recoverable are indicated by one of the following code symbols:

(a) R-applied to repair parts and assemblies which are economically repairable at field maintenance facilities (3d and 4th echelons) and are normally furnished by supply on an exchange basis.

(b) T-applied to high-dollar value recoverable repair parts which are subject to special handling and are issued on an exchange basis. Such repair parts are normally repaired or overhauled at depot maintenance facilities.

(c) U-applied to repair parts specifically selected for salvage by reclamation units because of precious metal content, critical materials, high-dollar value reusable casings, castings, and the like.

Note

When no code is shown in the recoverability column, the part is considered expendable.

b. Federal Stock Numbers. When a Federal stock number is available for a part, it shall be shown in this column, and used for requisitioning purposes.

c. Description.

- (1) The item name and a brief description of the part are shown.
- (2) A five-digit Federal supply code for manufacturers and/or other technical services is shown in parentheses followed by the manufacturer's part number. This number shall be used for requisitioning purposes when no Federal stock number is indicated in the Federal stock number column. *Example:* (08645) 86453.
- (3) The letters GE, shown in parentheses immediately following the description, indicate General Engineer supply responsibility for the part.

d. Unit of Issue. Where no abbreviation is shown in this column, the unit of issue is "each".

e. Quantity Authorized. This column lists the quantities of repair parts, accessories, tools, or publications authorized for issue to the equipment operator or crew as required.

f. Quantity Issued with Equipment. This column lists the quantities of repair parts, accessories, tools, or publications that are initially issued with each item of equipment. Those indicated by an asterisk are to be requisitioned through normal supply channels as required.

3. Index to Federal Supply Code for Manufacturers

899005.....Wild Heerbrugg Instruments, Inc.

4. Comments and Suggestions

Suggestions and recommendations for changes to the basic issue items list will be submitted on DA Form 2028 to the Commanding Officer, U. S. Army Mobility Support Center, ATTN.: SMOMS-MS, P. O. Box 119, Columbus 16, Ohio. Direct communication is authorized.

Source codes				Federal stock No.	Description	Unit of issue	Expend-ability	Qty auth.	Qty. issued with equip.
Technical service	Source	Main-tenance	Recover-ability						
GROUP 17-HOOD									
1708-CARRYING CASE									
	P	O		6675-560-5678	PACK RACK (89905) NT3-1			1	1
	X2	O			METAL CARRYING CASE ASSEMBLY (89905) NT3-3116-US.			1	1
GROUP 26-ACCESSORIES, PUBLICATIONS, TEST EQUIPMENT, AND TOOLS									
2602-ACCESSORIES									
	P	O		6675-404-4406	CASE, TOOL (89905) 15014-51			1	1
	P	O		6675-560-5664	COVER, PLASTIC (89905) NT3-343			1	1
10	P	O		7920-378-9524	BRUSH, DUSTING (89905) 3A-59			1	1
P	O			6675-446-1762	CONTAINER, GREASE (89905) HDF3-4			1	1
M	O				CHAMOIS (89905) HDP3-7.				
					MANUFACTURE FROM:				
10	P	O		8330-257-2498	CHAMOIS, LEATHER: suede finish, 0.0234 to 0.0469 in. thk (71 x 71 in. required).			1	1
	P	O		5210-353-4130	PLUMB BOB SOCKET ASSEMBLY (89905) XT2-35A			1	1
	X2	O			PLUMB BOB ASSEMBLY (89905) 12B-27A-28			1	1
	X2	O			SLIDE, ADJUSTER (89905) 3A-39A			1	1
	M	O			STRING (89905) 3A-40			1	1
					MANUFACTURE FROM:				
10	P	O		4020-270-1659	CORD, LINEN: 1/20 in. dia, 25 yd block.				
	X2	O			BAYONET SOCKET (89905) 3A-540			1	1
	X2	O			RING (89905) 3A-56			1	1

Source codes				Federal stock No.	Description	Unit of issue	Expend-ability	Qty auth.	Qty. issued with equip.
Technical service	Source	Main-tenance	Recover-ability						
					2604-SPECIAL TOOLS				
	P	O		5120-429-2949	WRENCH, TRIPOD (89905) 4A-36			1	1
	P	O		6675-353-4103	PIN, ADJUSTING (89905) 3A-55			4	4
	P	O		5120-446-2860	SCREWDRIVER (89905) HDW1-10			2	2
					2605-PUBLICATIONS				
12					DEPARTMENT OF THE ARMY OPERATOR, ORGANIZA-TIONAL, FIELD, AND DEPOT MAINTENANCE MAN-UAL TM 5-6675-231-15.			2	2
12					DEPARTMENT OF THE ARMY ORGANIZATIONAL, FIELD, AND DEPOT MAINTENANCE REPAIR PARTS AND SPECIAL TOOL LISTS TM 5-6675-231-25P.			2	2
					GROUP 67-PRECISION INSTRUMENTS				
					6702-OPTICS				
	P	O		6675-446-1765	SUNGLASS, BLACK (89905) NT3-260-492			1	1
	P	O		6675-842-2124	EYEPIECE PRISM, TELESCOPE (89905) NT2-381-382-383			1	1
	P	O		6675-842-2128	EYEPIECE PRISM, MICROSCOPE (89905) NT2-3122			1	1
	P	O		6675-446-1768	SUNGLASS ASSEMBLY (89905) XT16-116A			1	1
	P	O		6650-838-0842	TELESCOPE EYEPIECE, 40X (89905) NT3-3052			1	1
	P	O		6650-838-0840	TELESCOPE EYEPIECE, 24X (89905) NT3-3032			1	1
					6709-LAMPS				
	P	O		6675-446-1764	LAMP FITTING (89905) T21-4G-US			4	4
	P	O		6675-378-9501	LIGHT, HAND (89905) XT2-73			1	1
	P	O		6675-859-5936	LAMP, BATTERY BOX, 2.5v (89905) HEG3-64			4	4
					6719-MISCELLANEOUS WIRING AND FITTINGS				
	P	O		6150-378-9500	LEAD, ELECTRICAL (89905) XT2-72			1	1
					6723-POWER SUPPLY				
	P	O		6675-378-9502	BATTERY BOX ASSEMBLY (89905) EB-319B			1	1
	X2	O			BATTERY, DUMMY ASSEMBLY (89905) EB-329			2	2
11	P	O		6135-120-1010	BATTERY, DRY: 1.5v			4	*

AGO 5078A

INDEX

	Paragraph	Page		Paragraph	Page
Adjustments:			Clamps:		
Collimation level	16i	25	Horizontal	114	76
Collimation slow-motion screw	16e	25	Ring	115	78
General	16a	25	Cold weather operations	18	26
Horizontal circle drive	16f	25	Collimation:		
Horizontal collimation error ..	16h	25	Error adjustment, horizontal	16h	25
Horizontal slow-motion screw	16c	25	Level and lever assembly	92, 93	58
Leveling screws	16g	25	Level adjustment	16i	25
Plate level	16b	25	Level bubble does not stay in		
Vertical slow-motion screw ..	16d	25	center	37, 82	39, 55
Axis:			Slow-motion screw	107, 108	71
Inner vertical	125, 126	86, 87	Adjustment	16e	25
Outer vertical	115	78	Connector cable	129	88
Telescope	123	82	Connector, illumination cable	112	74
Axis bearings:			Contact ring	115	78
Left side	124	83	Controls and instruments	13, 14	22
Right side	122	81	Cover, horizontal circle housing	110	73
Basic issue tools and equipment ...	24	32	Daily services, operator's	29	33
Battery box assembly	128	88	Data (See Tabulated data)		
Battery replacement	32	38	Demolition:		
Bearings:			General	60	46
Left side axis	124	83	To render the theodolite inopera-		
Right side axis	122	81	tive	61	46
Cable, connector	129	88	Training	62	46
Cable connector, illumination	112	74	Description	3, 69	3,41
Carrier: Dismantling for movement	11	22	Differences in models	5	8
Horizontal circle prism	111	73	Drive, horizontal circle	118	80
Vertical circle prism	124	83	Adjustment	16f	25
Carrying case	47	39	Dusty area operation	20	27
Carrying case and pack rack:			Equipment:		
Carrying case	47	39	Basic issue tools and	24	32
General	46	39	Conversion	10	12
Pack rack	48	41	Dismantling for movement	11	22
Case, carrying	47	39	Inspecting	8	9
Circle and micrometer images will not			Servicing	8	9
focus	39	39	Setting-up instructions after		
Circle drive, horizontal	118	80	movement	12	22
Adjustment	16f	25	Setting-up instructions	9	12
Circle housing:			Special tools and	23, 71	32, 51
Horizontal	120	81	Specially designed tools and	73	51
Vertical	124	83	Unloading	6	9
Circle illumination prisms:			Unpacking	7	9
Micrometer	99	63	Eyepiece prisms	51	42
Horizontal	110	73	Eyepieces:		
Vertical	98	62	Eyepiece prisms	51	42
Circle prism carrier:			General	49	41
Horizontal	111	73	Microscope	50	42
Vertical	124	83	Sunglasses	52	4
Circles:			Telescope	50	42
Horizontal	115	78	Field and depot maintenance repair		
Vertical	124	83	parts	72	51
Clamp, vertical	122	81	Forms, record and report	2, 68	3, 49

	Paragraph	Page		Paragraph	Page
Hand light	129	88	Inspection of theodolite in storage	66	48
Horizontal circle:			Instruments and controls	13, 14	22
Drive	118	80	Inverter prism	100	64
Adjustment	16f	25	Lamp replacement	31	38
Graduations:			Left side axis bearing	124	83
Not at right angles to line			Level and lever assembly, collimation ..	92, 93	58
dividing the two images87	55		Level adjustment	16i	25
Unequal	86	55	Level, plate	97	61
Hard to move	43, 79	39, 55	Adjustment	16	25
Has unequal light or no light	84	55	Horizontal collimation error ad-		
Horizontal circle	115	78	justment	16h	25
Housing	120	81	Leveling screws, horizontal circle		
Housing cover	110	73	drive, illumination socket, and hori-		
Illumination prism	110	73	zontal circle housing:		
Prism carrier	111	73	General	116	79
Horizontal circle illumination prism			Horizontal circle drive	118	80
and housing cover, horizontal circle			Adjustment	16f	25
prism carrier, and illumination cable			Horizontal circle housing	120	81
connector:			Illumination socket	119	81
General	109	72	Leveling screws	117	79
Horizontal circle housing cover .			Adjustment	16g	25
and illumination prism	110	73	Leveling screws too tight or too loose ...	44, 77	39, 55
Horizontal circle prism carrier ...	111	73	Lever assembly, collimation level and ..	92, 93	58
Illumination cable connector	112	74	Level adjustment	16i	25
Horizontal clamp, clamp ring, contact			Light, hand	129	88
ring, outer vertical axis, and hori-			Light housings	129	88
zontal circle:			Lights in vertical and horizontal		
Clamp ring, contact ring, outer..			circles unequal or absent	40	39
vertical axis, and horizontal .			Loading the theodolite for shipment.....	64	47
circle	115	78	Lubrication:		
General	113	76	Detailed information	27	32
Horizontal clamp	114	76	General information	26	32
Horizontal collimation error-adjust.			Maintenance:		
ment.....	16h	25	Of theodolite in storage	66	48
Horizontal, vertical, and collimation			Operator's:		
slow-motion screws	107,108	71	Battery replacement	32	38
Adjustment	16c, 16d, 16e	25	Lamp replacement.....	31	38
Hot weather operation	19	26	Repair parts:		
Humid conditions operation	21	27	Field and depot maintenance	72	51
Housing cover, horizontal circle	110	73	...Organizational maintenance	25	32
Housings:			Services (See Preventive main		
Light	129	88	tenance services)		
Horizontal circle	120	81	Micrometer	105, 106	69
Vertical circle	124	83	Micrometer circle:		
Identification and data.....	4	8	Has unequal light or no light	89	59
Illumination cable connector.....	112	74	Illumination prism	99	63
Illumination mirrors	55, 56, 90, 91	43, 56	Microscope eyepiece	50	42
Illumination prisms:			Microscope, telescope, and reticle		
Horizontal circle	110	73	mirror:		
Micrometer circle	99	63	General	101	65
Vertical circle	98	62	Microscope	102	65
Illumination socket	119	81	Reticle mirror	104	69
Illumination system:			Telescope	103	66
Battery box assembly	128	88	Mirrors:		
Fails to function	41, 83	39, 55	Illumination	55, 56, 90, 91	43, 56
Faulty or fails to function	41	39	Reticle	104	69
General	127	88	Models, difference in	5	8
Light housings, connector cable,			Movement to a new worksite:		
and hand light	129	88	Dismantling for	11	22
Inner vertical axis	125, 126	26,87	Setting-up instructions after.....	12	22
Inspecting and servicing equipment	8	9			

	Paragraph	Page		Paragraph	Page
Operation of theodolite:.....				Quarterly preventive maintenance services	30 33
Adjustments	16	25		Rack, pack	48 41
General	15	25		Rainy conditions operation	21 27
In dusty or sandy areas.....	20	27		Record and report forms.....	2, 68 3, 49
In extreme cold (Below 0° F.) ...	18	26		Repair parts:	
In extreme heat	19	26		Field and depot maintenance	72 51
In salt water areas	22	28		Organizational	25 32
In sandy areas	20	27		Replacement:	
Theodolite operation.....	17	26		Battery	32 38
Under humid conditions	21	27		Lamp	31 38
Under rainy or humid conditions	21	27		Report forms	2, 68 3,49
Operator's daily services	29	33		Right side axis bearing, vertical	
Operator's maintenance:				clamp, telescope axis, left side axis	
Battery replacement	32	38		bearing, vertical circle, vertical	
Lamp replacement	31	38		circle housing, arid vertical circle	
Organizational maintenance repair				prism carrier:	
parts	25	32		General	121 81
Outer vertical axis	115	78		Left side axis bearing, vertical	
Pack rack	48	41		circle, vertical circle housing,	
Parts (See Repair parts)				and vertical circle prism car-	
Plate level	97	60		rier	124 83
Adjustment	16b	25		Right side axis bearing and ver-	
Horizontal collimation error ad-				tical clamp	122 81
justment.....	16h1	25		Telescope axis	123 82
Plate level bubble does not stay in				Rings:	
center	36, 81	39, 55		Clamp	115 78
Plate level, vertical circle illumination				Contact	115 78
prism, micrometer circle illumina-	-	-		Salt water area operation	22 28
tion prism, and inverter prism:				Sandy area operation	20 27
General	96	60		Scope	1, 67 3, 49
Inverter prism	100	64		Screws:	
Micrometer circle illumination ...				Leveling	117 79
prism	99	63		Adjustment	16g 25
Plate level	97	60		Slow-motion:	
Adjustment	16b	25		Collimation	107, 108 71
Horizontal collimation error				Adjustment	16e 25
adjustment	16h	25		Horizontal	107, 108 71
Vertical circle illumination prism	98	62		Adjustment	16c 25
Plate level vial defective	80	55		Vertical	107,108 71
Plate, star	53,54,94 95	43,60		Adjustment	16d 25
Plumb bob.....	59	45		Services (See Preventive maintenance	
Preparation of theodolite:				services)	
For shipment	63	47		Setting-up instructions after move-	
For storage	65	47		ment	12 22
Preventive maintenance services:				Setting-up instructions	9 12
General	28	33		Shipment:	
Operator's daily services	29	33		Loading the theodolite for	64 47
(Also see Operator's mainte-				Preparation of theodolite for	63 47
nance)				Slow-motion screws:	
Quarterly	30	33		Collimation	107, 108 71
Prism carriers:				Adjustment	16e 25
Horizontal circle	111	73		Horizontal	107, 108 71
Vertical.....	124	83		Adjustment	16c 25
Prisms:				Vertical	107, 108 71
Eyepiece	51	42		Adjustment	16d 25
Horizontal circle illumination.....	110	73		Socket, illumination	119 81
Inverter	100	64		Special tools and equipment	23, 71 32, 51
Micrometer circle illumination ...	99	63		Specially designed tools and equip-	
Vertical circle illumination.....	98	62		ment	73 51
				Star plate	53, 54, 94, 95 43, 60

	Paragraph	Page		Paragraph	Page
Storage:			Plate level:		
Inspection of theodolite in	66	48	Bubble does not stay in		
Maintenance of theodolite in	66	48	center	81	55
Preparation of theodolite for	65	47	Vial defective	80	55
Sunglasses	52	42	Telescope turns too hard or too		
Tables:			easily	78	55
Special tools	23	2	Theodolite:		
Time standards	70b	49	Will not seat properly on tri-		
Specially designed tools	73	51	pod head	75	55
Tabulated data (Field and depot			Will not stay on line.....	76	55
maintenance):			Troubleshooting (Operator and or		
General	70a	49	organizational maintenance):		
Time standards	70b	49	Circle and micrometer images		
Tabulated data (Operator's and or-			will not focus.....	39	39
ganizational maintenance):			Collimation level bubble does not		
Dimensions and weights	4b(2)	8	stay in center.....	37	39
General	4b(1)	8	General	33	38
Telescope:Horizontal circle hard to move	43	39			
Axis	123	82	Illumination system faulty or		
Cross-lines will not focus	38	39	fails to function	41	39
Eyepiece	50	42	Leveling screws too tight or too		
Telescope	103	66	loose	44	39
Turns too hard or too easily	45, 78	39, 55	Lights on vertical and horizontal		
Theodolite:			circles unequal or absent	40	39
Operation (See Operation of			Plate level bubble does not stay in		
theodolite)			center	36	39
Will not seat properly on tripod					
head	34, 75	38,55	Telescope:		
Will not stay on line	35, 76	38, 55	Cross-lines will not focus	38	39
			Turns too hard or too easily ...	45	39
Tools and equipment:					
Basic issue	24	32	Theodolite:		
Special	23, 71	32, 51	Will not seat properly on tri-		
Specially designed	73	51	pod head	34	38
Training, demolition	62	46	Will not stay on line	35	38
Tripod assembly plumb bob, and tri-			Tripod legs will not lock in		
pod wrench:			position	42	39
General	57	44	Unloading the equipment	6	9
Plumb bob and tripod wrench ...	59	45	Unpacking the equipment.....	7	9
Tripod assembly	58	44	U-standard and inner vertical axis 125, 126		86, 87
Tripod legs will not lock in position	42	39			
Tripod wrench	59	45			
Troubleshooting			(Field and depotHas unequal light or no light	85	55
maintenance):			Images have moved in relation to		
Collimation level bubble does not			the line dividing the two images		
stay in center	82	55	and to the reference mark	88	56
General	74	55	Vertical axis, outer	115	78
Horizontal circle:			Vertical circle:		
Graduations not at right			Has unequal light or no light.....	85	55
angles to line dividing the			Housing	124	83
two images	87	55	Illumination prism	98	62
Graduations unequal.....	86	55	Images have moved in relation to		
Hard to move	79	55	the line dividing the two images		
Has unequal light or no light	84	55	and to the reference mark	88	56
Illumination system fails to func-			Prism carrier	124	83
tion	83	55	Vertical circle	124	83
Leveling screws too tight or too			Vertical clamp	122	81
loose.....	77	55	Vertical slow-motion screw .	107, 108	71
Micrometer circle has unequal ..			Adjustment	1	6d
light or no light	89	56	Wrench, tripod	59	45

By Order of the Secretaries of the Army and the Air Force:

EARLE G. WHEELER,
*General, United States Army,
Chief of Staff.*

Official:

J. C. LAMBERT,
*Major General, United States Army,
The Adjutant General.*

CURTIS E. LEMAY,
Chief of Staff, United States Air Force.

Official:

R. J. PUGH,
*Colonel, United States Air Force,
Director of Administrative Services.*

Distribution:

Active Army:

USASA (2)
DCSLOG (1)
CNGB (1)
TSG (1)
CofEngrs (3)
CSigO (1)
CofT (1)
USA Maint Bd (1)
 ARTYBD (2)
 ARMBD (2)
USAIB (2)
USAARADB (2)
USAAESWBD (2)
USAAVNBD (2)
USCONARC (3)
USAMC (5)
OS Maj Comd (5) except
 USARJ (10)
MDW (1)
Armies (2)
Corps (2)
USA Corps (1)
Div (2)
Engr Bde (1)
USMA (2)
Svc College (2)
Br Svc Sch (2) except
 USAES (100)
GENDEP (OS) (10)
Engr Dep (OS) (10)

Army Dep (2)
USA Trans Tml Comd (2)
Army Tml (1)
USAMOCOM (2)
USAOSA (2)
Div Engr (2)
Engr Dist (2)
Engr Fld Maint Shop (2)
USAERDL (3)
Engr Cen (5)
AMS (3)
Chicago Engr Proc Ofc (10)
USA Mbl Spt Cen (36)
ESCO (10)
Fld Comd, DASA (8)
USACOMZEUR (2)
USAREUR Engr Sup Con Agcy (10)
USAREUR Engr Proc Cen (2)
MAAG (1)
JBUSMC (1)
Units org under fol TOE:
 Two copies each UNOINDC:
 5-48
 5-167
 5-237 (5)
 5-262 (5)
 5-267 (1)
 5-278 (5)
 5-279
 5-327

NG: State AG (3).

USAR: Units same as Active Army except allowance is one copy to each unit.

For explanation of abbreviations used, see AR 320-50.

AGO 5078A

☆U. S GOVERNMENT PRINTING OFFICE : 1993 0 - 342-421 (80234)

RECOMMENDED CHANGES TO EQUIPMENT TECHNICAL PUBLICATIONS

 <p><i>THEN...JOT DOWN THE DOPE ABOUT IT ON THIS FORM. CAREFULLY TEAR IT OUT, FOLD IT AND DROP IT IN THE MAIL.</i></p>				SOMETHING WRONG WITH PUBLICATION	
				FROM: (PRINT YOUR UNIT'S COMPLETE ADDRESS)	
				DATE SENT	
PUBLICATION NUMBER			PUBLICATION DATE		PUBLICATION TITLE
BE EXACT PIN-POINT WHERE IT IS				IN THIS SPACE, TELL WHAT IS WRONG AND WHAT SHOULD BE DONE ABOUT IT.	
PAGE NO.	PARA-GRAPH	FIGURE NO.	TABLE NO.		
PRINTED NAME, GRADE OR TITLE AND TELEPHONE NUMBER				SIGN HERE	

The Metric System and Equivalents

Linear Measure

1 centimeter = 10 millimeters = .39 inch
 1 decimeter = 10 centimeters = 3.94 inches
 1 meter = 10 decimeters = 39.37 inches
 1 dekameter = 10 meters = 32.8 feet
 1 hectometer = 10 dekameters = 328.08 feet
 1 kilometer = 10 hectometers = 3,280.8 feet

Weights

1 centigram = 10 milligrams = .15 grain
 1 decigram = 10 centigrams = 1.54 grains
 1 gram = 10 decigrams = .035 ounce
 1 decagram = 10 grams = .35 ounce
 1 hectogram = 10 decagrams = 3.52 ounces
 1 kilogram = 10 hectograms = 2.2 pounds
 1 quintal = 100 kilograms = 220.46 pounds
 1 metric ton = 10 quintals = 1.1 short tons

Liquid Measure

1 centiliter = 10 milliliters = .34 fl. ounce
 1 deciliter = 10 centiliters = 3.38 fl. ounces
 1 liter = 10 deciliters = 33.81 fl. ounces
 1 dekaliter = 10 liters = 2.64 gallons
 1 hectoliter = 10 dekaliters = 26.42 gallons
 1 kiloliter = 10 hectoliters = 264.18 gallons

Square Measure

1 sq. centimeter = 100 sq. millimeters = .155 sq. inch
 1 sq. decimeter = 100 sq. centimeters = 15.5 sq. inches
 1 sq. meter (centare) = 100 sq. decimeters = 10.76 sq. feet
 1 sq. dekameter (are) = 100 sq. meters = 1,076.4 sq. feet
 1 sq. hectometer (hectare) = 100 sq. dekameters = 2.47 acres
 1 sq. kilometer = 100 sq. hectometers = .386 sq. mile

Cubic Measure

1 cu. centimeter = 1000 cu. millimeters = .06 cu. inch
 1 cu. decimeter = 1000 cu. centimeters = 61.02 cu. inches
 1 cu. meter = 1000 cu. decimeters = 35.31 cu. feet

Approximate Conversion Factors

<i>To change</i>	<i>To</i>	<i>Multiply by</i>	<i>To change</i>	<i>To</i>	<i>Multiply by</i>
inches	centimeters	2.540	ounce-inches	Newton-meters	.007062
feet	meters	.305	centimeters	inches	.394
yards	meters	.914	meters	feet	3.280
miles	kilometers	1.609	meters	yards	1.094
square inches	square centimeters	6.451	kilometers	miles	.621
square feet	square meters	.093	square centimeters	square inches	.155
square yards	square meters	.836	square meters	square feet	10.764
square miles	square kilometers	2.590	square meters	square yards	1.196
acres	square hectometers	.405	square kilometers	square miles	.386
cubic feet	cubic meters	.028	square hectometers	acres	2.471
cubic yards	cubic meters	.765	cubic meters	cubic feet	35.315
fluid ounces	milliliters	29.573	cubic meters	cubic yards	1.308
pints	liters	.473	milliliters	fluid ounces	.034
quarts	liters	.946	liters	pints	2.113
gallons	liters	3.785	liters	quarts	1.057
ounces	grams	28.349	liters	gallons	.264
pounds	kilograms	.454	grams	ounces	.035
short tons	metric tons	.907	kilograms	pounds	2.205
pound-feet	Newton-meters	1.356	metric tons	short tons	1.102
pound-inches	Newton-meters	.11296			

Temperature (Exact)

°F	Fahrenheit temperature	5/9 (after subtracting 32)	Celsius temperature	°C
----	------------------------	----------------------------	---------------------	----

PIN: 026291-000

This fine document...

Was brought to you by me:



[Liberated Manuals -- free army and government manuals](#)

Why do I do it? I am tired of sleazy CD-ROM sellers, who take publicly available information, slap “watermarks” and other junk on it, and sell it. Those masters of search engine manipulation make sure that their sites that sell free information, come up first in search engines. They did not create it... They did not even scan it... Why should they get your money? Why are not letting you give those free manuals to your friends?

I am setting this document FREE. This document was made by the US Government and is NOT protected by Copyright. Feel free to share, republish, sell and so on.

I am not asking you for donations, fees or handouts. If you can, please provide a link to liberatedmanuals.com, so that free manuals come up first in search engines:

<A HREF=<http://www.liberatedmanuals.com/>>Free Military and Government Manuals

- Sincerely
Igor Chudov
<http://igor.chudov.com/>
- [Chicago Machinery Movers](#)