

TM 32-5865-216-24&P

TECHNICAL MANUAL

**DIRECT SUPPORT AND GENERAL SUPPORT
(INTERMEDIATE SUPPORT) MAINTENANCE MANUAL
AND REPAIR PARTS AND SPECIAL TOOLS LIST
(INCLUDING DEPOT MAINTENANCE REPAIR
PARTS AND SPECIAL TOOLS)**

TUNABLE COUPLER

CU-2293/ALQ-151(V)

TRACOR AEROSPACE, INC.

DAAK 21-84-C-0099

This publication is not available through AQ Publications Center. Requisition through Commander, US Army Electronics Materiel Readiness Activity, Vint Hill Farms Station, Warrenton, Virginia 22186-5141.

HEADQUARTERS, DEPARTMENT OF THE ARMY

MAY 1989

WARNING

Adequate ventilation should be provided while using trichlorotrifluorethane. Prolonged breathing of vapor should be avoided. The solvent should not be used near heat or open flame; the products of decomposition are toxic and irritating. Since trichlorotrifluorethane dissolves natural oils, prolonged contact with skin should be avoided. When necessary, use gloves that the solvent cannot penetrate. If the solvent is taken internally, consult a physician immediately.

WARNING

Before performing any removal or replacement procedure, ensure that power is disconnected from the tunable coupler.

Technical Manual
 No. 32-5865-216-24&P

HEADQUARTERS
 DEPARTMENT OF THE ARMY
 WASHINGTON, DC, 15 MAY 1989

MAINTENANCE INSTRUCTIONS
 ORGANIZATIONAL, DIRECT SUPPORT AND
 GENERAL SUPPORT MAINTENANCE MANUAL
 FOR
 TUNABLE COUPLER
 CU-2293/ALQ-151(V)

REPORTING OF ERRORS

You can improve this manual by recommending improvements using DA Form 2028-2 located in the back of the manual. Simply tear out the self-addressed form, fill it out as shown on the sample, fold it where shown, and drop it in the mail.

If there are no blank DA Forms 2028-2 in the back of your manual, use the standard DA Form 2028 (Recommended Changes to Publications and Blank Forms) and forward to the Commander, U.S. Army Electronic Materiel Readiness Activity, Vint Hill Farms Station, Warrenton, Virginia 22186, Attn: SELEM-ME-E.

In either case a reply will be furnished directly to you.

TABLE OF CONTENTS

		Paragraph	Page
CHAPTER	1. INTRODUCTION		
SECTION	I. General		
	Scope	1-1	1-1
	Maintenance Forms Records and Reports.	1-2	1-2
	Destruction of Army Materiel		
	to Prevent Enemy Use	1-3	1-2
	Reporting of Errors	1-4	1-2
	Reporting Equipment Improvement		
	Recommendations (EIR)	1-5	1-2
SECTION	II. Description and Data		
	Description	1-6	1-2
	Tabulated Data	1-7	1-3
CHAPTER	2. ORGANIZATIONAL MAINTENANCE INSTRUCTIONS		
	Scope	2-1	2-1
CHAPTER	3. FUNCTIONAL DESCRIPTION OF EQUIPMENT		
SECTION	I. General		
	Scope	3-1	3-1

TABLE OF CONTENTS - Continued

		Paragraph	Page
	Organization	3-2	3-1
	Logic Terminology	3-3	3-1
SECTION	II. Functional Description		
	Tunable Coupler	3-4	3-1
	Control Circuit	3-5	3-3
	Status Circuit	3-6	3-10
	Power Distribution Circuit	3-7	3-12
	Extender CCA A5	3-8	3-14
CHAPTER	4. DIRECT SUPPORT MAINTENANCE INSTRUCTIONS		
SECTION	I. General		
	Scope	4-1	4-1
CHAPTER	5. GENERAL SUPPORT MAINTENANCE INSTRUCTIONS		
SECTION	I. General		
	Scope	5-1	5-1
	Organization	5-2	5-1
	Measurements and Data	5-3	5-1
SECTION	II. Tools and Equipment		
	General	5-4	5-1
	Tools and Equipment Required	5-5	5-1
SECTION	III. Troubleshooting		
	General	5-6	5-3
	Tunable Coupler Procedures	5-7	5-3
SECTION	IV. Maintenance of Tunable Coupler		
	General	5-8	5-3
	Maintenance Procedures	5-9	5-3
	Removal Procedures	5-10	5-25
	Replacement Procedures	5-11	5-30
	Circuit Card Assembly Repair Procedure	5-12	5-35
	Gasket Replacement	5-13	5-36
SECTION	V. General Support Test Procedures		
	General	5-14	5-36
	Test	5-15	5-36
APPENDIX	A. REFERENCES		
	Scope	A-1	A-1
	Technical Manuals	A-2	A-1
	Supply Bulletins	A-3	A-1
	Common Table of Allowances	A-4	A-2
	Pamphlets	A-5	A-2
	Army Regulations	A-6	A-2
	Forms	A-7	A-2
APPENDIX SECTION	B. MAINTENANCE ALLOCATION CHART		
	I. INTRODUCTION		
	General	B-1	B-1
	Maintenance Functions	B-2	B-1
	Column Entries Used in the MAC	B-3	B-2

TABLE OF CONTENTS - Continued

		Paragraph	Page
	Column Entries Used in Tool and Test Equipment Requirements (Section III)	B-4	B-3
	Explanation of Columns in Section IV	B-5	B-4
SECTION II	MAINTENANCE ALLOCATION CHART FOR TUNABLE COUPLER CU-2293/ALQ-151(V)		
SECTION III	TOOL AND TEST EQUIPMENT REQUIREMENTS FOR TUNABLE COUPLER CU-2293/ALQ-151(V)		
SECTION IV	REMARKS		
APPENDIX	C. REPAIR PARTS AND SPECIAL TOOLS LIST		
	Scope	C-1	C-3
	General	C-2	C-3
	Explanation of Columns	C-3	C-3
	Special Information	C-4	C-7
	How to Locate Repair Parts	C-5	C-7
	Abbreviations	C-6	C-8
APPENDIX SECTION	D. EXPENDABLE SUPPLIES AND MATERIALS LIST		
	I. Introduction		
	Scope	D-1	D-1
	Explanation of Columns	D-2	D-1
SECTION	II. Expendable Supplies and Materials List		
APPENDIX GLOSSARY INDEX	E.		E-1
		Glossary-1	
		Index-1	

LIST OF ILLUSTRATIONS

Figure	Title	Page
1-1	Tunable Coupler CU-2293/ALQ-151(V)	1-1
3-1	Tunable Coupler Block Diagram	3-2
3-2	Decoder CCA A4 Block Diagram	3-4
3-3	Control Logic CCA A3 Block Diagram	3-7
3-4	Motor Control CCA A2 Block Diagram	3-9
3-5	RF Switch Assembly S2 Block Diagram	3-11
3-6	Power Supply CCA A1 Block Diagram	3-13
5-1	Tunable Coupler CCA Locations	5-2
5-2	Power Supply CCA A1 Component Locations	5-8
5-3	Power Supply CCA A1 Test Setup	5-9
5-4	Motor Control CCA A2 Component Locations	5-20
5-5	Motor Control CCA A2 Test Setup	5-21
5-6	Tunable Coupler Component Locations	5-22
5-7	Tunable Coupler Cover Replacement	5-31
C-1	Tunable Coupler CU-2293/ALQ-151(V)	C-9
C-2	Power Supply CCA C5073889-1	C-18
C-3	Motor Control CCA C5073893-1	C-24
E-1	Gasket Dimensions	E-3
E-2	Bottom Cover Gasket Replacement	E-6
E-3	Chassis Gasket Replacement	E-7
FO-1	Tunable Coupler Interconnection Diagram	
FO-2	Decoder CAA A4 Schematic Diagram	
FO-3	Control Logic CCA A3 Schematic Diagram	
FO-4	Motor Control CCA A2 Schematic Diagram	
FO-5	RF Monitor CCA A6 and RF Switch Assembly S2 Schematic Diagram	
FO-6	Power Supply CCA A1 Schematic Diagram	

LIST OF TABLES

Table	Title	Page
1-1	Tunable Coupler Power and Signal Connections	1-3
3-1	Command Word Bit Functions	3-3
3-2	Decoder CCA A4 Test Point Signals	3-5
3-3	Control Logic CCA A3 Test Point Signals	3-8
3-4	Motor Control CCA A2 Test Point Signals	3-10
3-5	Power Supply CCA A1 Test Point Signals	3-14
3-6	Extender CCA A5 Test Point Signals	3-14
5-1	Power Supply CCA A1 Troubleshooting Procedure	5-4
5-2	Motor Control CCA A2 Troubleshooting Procedure	5-10

SAFETY SUMMARY

The following are general precautions that are not related to any specific procedures and, therefore, do not appear elsewhere in this publication. These are recommended precautions that personnel must understand and apply during many phases of operation and maintenance.

KEEP AWAY FROM LIVE CIRCUITS

Operating personnel must at all times observe all safety regulations. Do not replace components or make adjustments inside the equipment with the high-voltage supply turned on. Under certain conditions, dangerous potentials may exist when the power control is in the off position, due to charges retained by capacitors. To avoid casualties, always remove power and discharge and ground a circuit before touching it.

DO NOT SERVICE OR ADJUST ALONE

Under no circumstances should any person reach into or enter the enclosure for the purpose of servicing or adjusting the equipment except in the presence of someone who is capable of rendering aid.

WARNINGS AND CAUTIONS

The following warnings and cautions are used in the text of this volume and are repeated here for emphasis:

WARNING

Adequate ventilation should be provided while using trichlorotrifluoroethane. Prolonged breathing of vapor should be avoided. The solvent should not be used near heat or open flame; the products of decomposition are toxic and irritating. Since trichlorotrifluoroethane dissolves natural oils, prolonged contact with skin should be avoided. When necessary, use gloves that the solvent cannot penetrate. If the solvent is taken internally, consult a physician immediately. (Pages 5-25, 5-27)

WARNING

Before performing any removal or replacement procedure, ensure that power is disconnected from the tunable coupler. (Pages 5-26, 5-30)

CAUTION

Prolonged operation of the decade box with the output shorted may cause circuit damage. (Page 5-7)

CAUTION

Certain CCAS contain electrostatic discharge sensitive (ESDS) devices that can be damaged by static electricity. Special handling methods and materials must be used to prevent damage. Do not touch or remove any ESDS device or circuit without properly grounding your body, tools, and test equipment. Handle such CCAS on the edge only, and store such CCAS in conductive (antistatic) bags.
(Page 5-24)

CAUTION

Fitting the EMI\RFI gasket is critical to ensure an air-tight closure that meets the anti-sparking requirements of Tunable Coupler CU-2293/ALQ-151(V).
(Page 5-36)

CHAPTER 1

INTRODUCTION

Section I. General

1-1. SCOPE.

This manual provides organizational, direct support, and general support maintenance information, and repair parts and special tools list (RPSTL) for Tunable Coupler CU-2293\ALQ-151 (V) (figure 1-1), hereinafter referred to as the tunable coupler. In addition, the manual provides general information, tabulated data, and a functional description of the equipment. Refer to TM 32-5865-012-10 for organizational operating instructions for the tunable coupler.

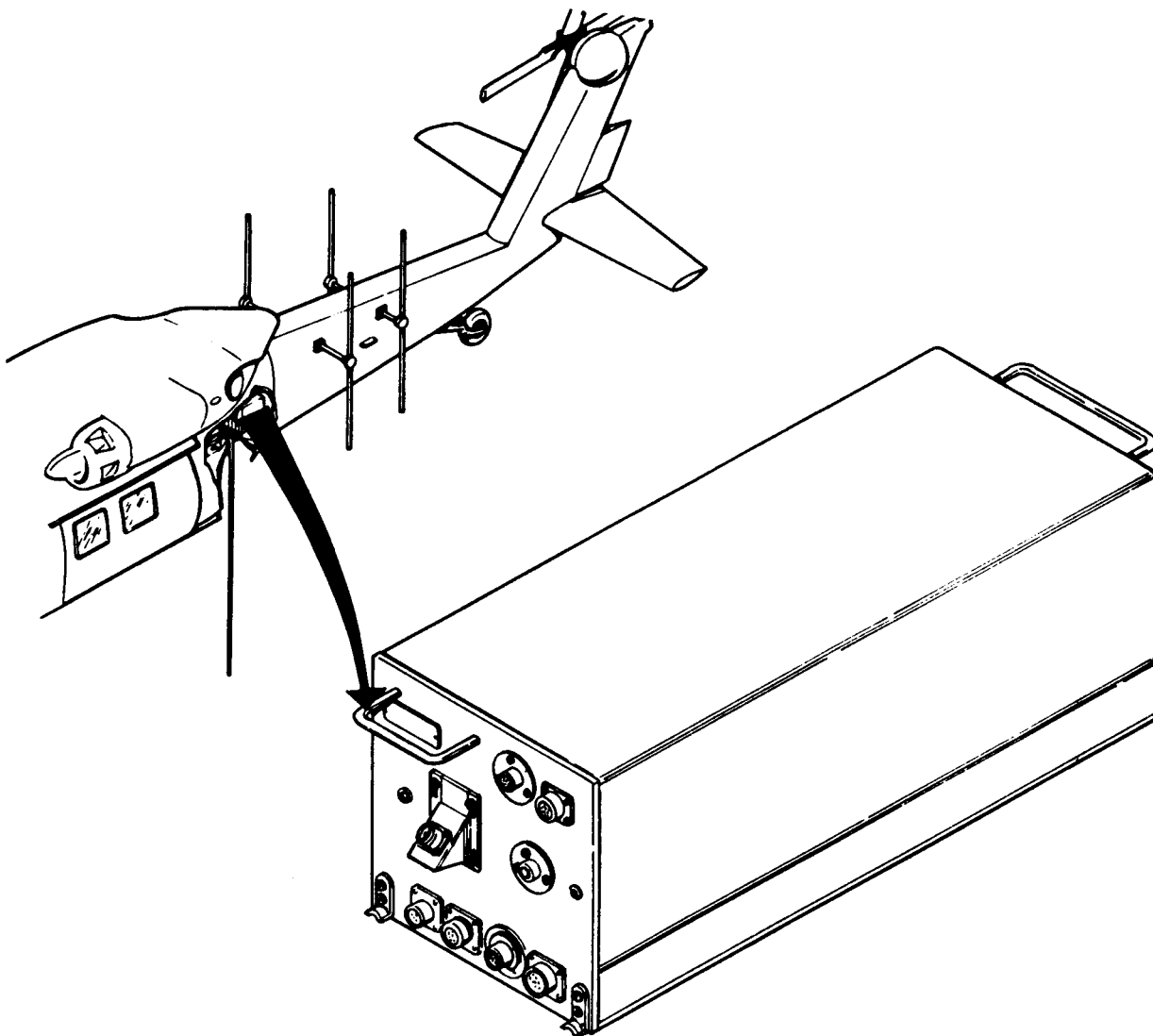

Figure 1-1. Tunable Coupler CU-2293/ALQ-151(V)

1-2. MAINTENANCE FORMS, RECORDS, AND REPORTS.

Department of the Army forms and procedures used for equipment maintenance will be those prescribed by DA PAM 738-750, The Army Maintenance Management System (TAMMS).

1-3. DESTRUCTION OF ARMY MATERIEL TO PREVENT ENEMY USE.

Procedures for the destruction of Army materiel are contained in TM 750-244-2, Procedures for Destruction of Electronics Materiel to Prevent Enemy Use (Electronics Command).

1-4. REPORTING OF ERRORS.

The reporting of errors, omissions, and recommendations for improving this publication by the individual user is encouraged. Reports should be submitted on DA Form 2028 (Recommended Changes to Publications) and forwarded directly to the Commander, U.S. Army Electronic-Materiel Readiness Activity, EMRA, Vint Hill Farms Station, Warrenton, Virginia 22186, Attn: SELEM-ME-E.

1-5. REPORTING EQUIPMENT IMPROVEMENT RECOMMENDATIONS (EIR).

If your tunable coupler needs improvement, let us know. Send us an EIR. You, the user, are the only one who can tell us what you don't like about your equipment. Let us know why you don't like the design or performance. Put it on an SF 368 (Quality Deficiency Report). Mail it to us at U.S. Army Electronic Materiel Readiness Activity, EMRA, Vint Hill Farms Station, Warrenton, Virginia 22186, Attn: SELEM-ME-E. We'll send you a reply.

SECTION II. DESCRIPTION AND DATA

1-6. DESCRIPTION.

In addition to the description provided herein, refer to TM 32-5865-012-10 for a general description and illustration of the tunable coupler. The tunable coupler is a metal enclosure that contains seven circuit card assemblies (CCAS), two RF relays, an RF switch assembly, a stepper motor, and four multipin connectors mounted on the front panel. The tunable coupler controls the RF path between external transmit and receive equipments and an external VHF antenna as commanded by digital data inputs. In addition, the tunable coupler receives antenna-deployed switch and DF inputs from external equipment in the system. The inputs are combined with other status signals generated in the tunable coupler and output to external equipment in the system. Tunable coupler power and input/output connections are made at the front panel (see table 1-1).

Table 1-1. Tunable Coupler Power and Signal Connections

Connector marking	Pin	Function/Remarks
J1		RF input
J2		RF output
J3	A	Antenna-deployed switch input (+)
J3	B	Antenna-deployed switch input (-)
J3	C	DF input (+)
J3	D	DF input (-)
J3	E	Transmit ready output (+)
J3	F	Transmit ready output (-)
J3	L	Cable shield
J3	M	DF input shield
J3	N	Transmit ready shield
J3	P	Antenna-deployed switch shield
J4	A	Digital output (+)
J4	C	Digital input (+)
J4	D	Digital input (-)
J4	E	Digital input shield
J4	G	Digital output shield
J4	H	Digital output (-)
J4	J	+28 V dc input shield
J4	K	+28 V dc input (-)
J4	L	Cable shield
J4	M	+28 V dc input (+)

1-7. TABULATED DATA.

Power:

Volts +28 V dc
 Tuning amperage 2.0 A while tuning for transmission
 Transmit amperage 0.3 A while in transmit mode
 Receive amperage 0.5 mA while in wideband receive mode

Dimensions:

Height 7.84 in.
 Depth 12.63 in.
 Width 5.12 in.

Weight 25 lb

Frequency Range:

Transmit 20 to 80 MHz
 Receive 1.5 to 80 MHz

Power Capability 550 W (continuous wave) maximum

Tuning Time:
Transmit 500 msec or less to any transmit band
Receive 100 msec or less from transmit frequency to wideband receive mode

Control Signals:
Input Transistor-transistor logic (TTL) serial command, Manchester-coded
Output TTL status bits

TTL Levels:
High (logic 1) 2.4 to 5.5 V dc
Low (logic 0) 0.0 to 0.4 V dc

Environmental:
Altitude
Operating 30,000 ft (maximum)
Nonoperating 40,000 ft (maximum)
Temperature
Operating -40°C (-40°F) to +55°C (+131°F)
Nonoperating -57°C (-71°F) to +85°C (+185°F)

Humidity 0 to 98%

CHAPTER 2

ORGANIZATIONAL MAINTENANCE INSTRUCTIONS

2-1. SCOPE.

Organizational support maintenance procedures are provided in TM 32-5865-012-20.

CHAPTER 3
FUNCTIONAL DESCRIPTION OF EQUIPMENT

Section I. GENERAL

3-1. SCOPE.

This chapter provides a functional description of the tunable coupler. The circuits are explained to the extent necessary for general support maintenance.

3-2. ORGANIZATION.

In addition to the functional description contained herein, refer to TM 32-5865-012-10 for operating instructions for the tunable coupler. The following description references block diagrams, an interconnection diagram, and schematic diagrams. Block diagrams are provided in the text or as foldout drawings. The interconnection diagram and schematic diagrams are provided as foldout drawings. Foldout drawings referenced in the text as FOs are located at the rear of the manual.

3-3. LOGIC TERMINOLOGY.

This paragraph provides information that applies to the following functional description.

3-3.1 Logic Levels. Logic input/output voltage levels are:

High (true) = +2.4 to 5.5 V dc
Low (false) = 0.0 to +0.4 V dc

3-3.2 Signal Names. Signal names describe the function performed by the signal. A signal name with an overbar is read with the prefix NOT. For example, $\overline{\text{RESET}}$ is read NOT RESET. If $\overline{\text{RESET}}$ is low (zero (0) or false), the opposite (RESET) is assumed to be high (one (1) or true).

Section II. FUNCTIONAL DESCRIPTION

3-4. TUNABLE COUPLER.

Refer to figure 3-1. The tunable coupler contains separate control, status, and power distribution circuits. As shown in figure FO-1, motherboard A7 provides interconnections between RF relays K1 and K2, RF switch assembly S2, stepper motor M1, and the following circuit card assemblies (CCAs):

Decoder CCA A4
Control logic CCA A3

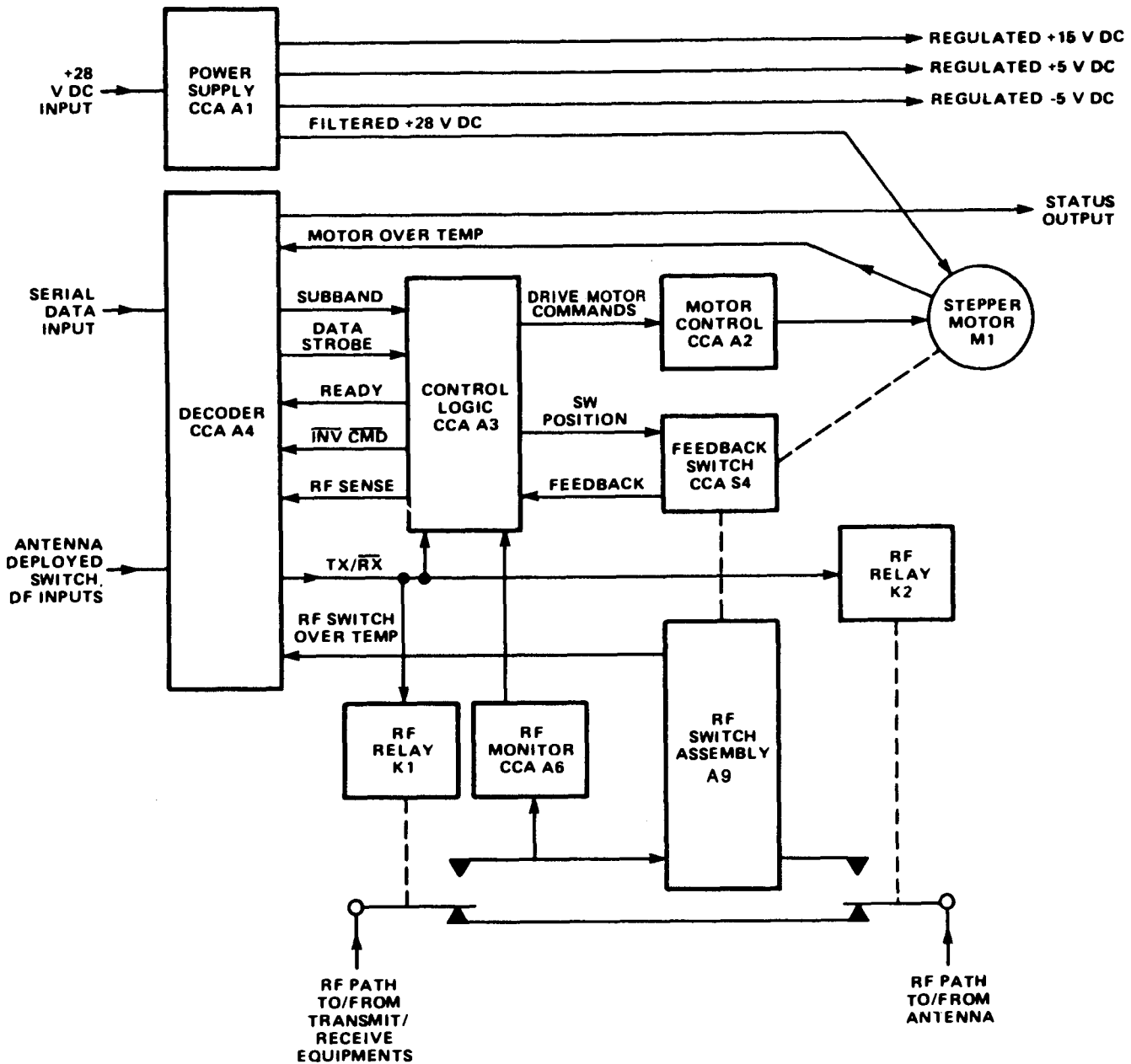

Figure 3-1. Tunable Coupler Block Diagram

Motor control CCA A2
 Feedback switch CCA S4
 RF monitor CCA A6
 Power supply CCA A1
 Extender CCA A5

3-5. CONTROL CIRCUIT.

The tunable coupler receives 16-bit, Manchester-coded command words as serial data input at connector pins J4-C and J4-D. The control circuit decodes each command word to select the transmit or receive operating mode and tune RF switch assembly S2 to a specified 100-kHz bandwidth. Table 3-1 lists the function of each bit in the command word.

3-5.1 Decoder CCA A4. Refer to figure 3-2. The decoder CCA control circuit converts the command word input into TX/RX, subband, and data strobe outputs to control logic CCA A3 and RF relays K1 and K2. Table 3-2 lists the control signal accessed from the decoder CCA test points. As shown in figure FO-2, the digital input passes through line receiver U18A and parity flip-flop U6A to command word detector and decoder U1 through U5 and U8 through U12. Three consecutive high bits indicate a command word follows and provide synchronization data to clock generator U14. The 1-MHz CLK, and RESET outputs of multi-vibrators U14A and U14B clock the command word into parity flip-flop and shift registers U1 and U2. If parity is correct (even), the Q output of U6 clocks the command word into flip-flops U8 through U10. The Q output of U6 also passes to the status circuit (U7) and control logic CCA A3 as the parity and data strobe signals, respectively. Flip-flops U8 through U10 convert the 16-bit command word into 12 frequency bits and (DB0 through B11) and TX/RX signal. Switch position decoder U15 and U16 converts the DB0 through DB11 signals into

Table 3-1. Command Word Bit Functions

Bit	Function
0	Frequency 100 kHz BCD 1
1	Frequency 100 kHz BCD 2
2	Frequency 100 kHz BCD 4
3	Frequency 100 kHz BCD 8
4	Not used
5	Parity (even for 16 bits)
6	Not used
7	Transmit/Receive (1=TX, 0=RX)
8	Frequency 1 MHz BCD 1
9	Frequency 1 MHz BCD 2
10	Frequency 1 MHz BCD 4
11	Frequency 1 MHz BCD 8
12	Frequency 10 MHz BCD 1
13	Frequency 10 MHz BCD 2
14	Frequency 10 MHz BCD 4
15	Frequency 10 MHz BCD 8

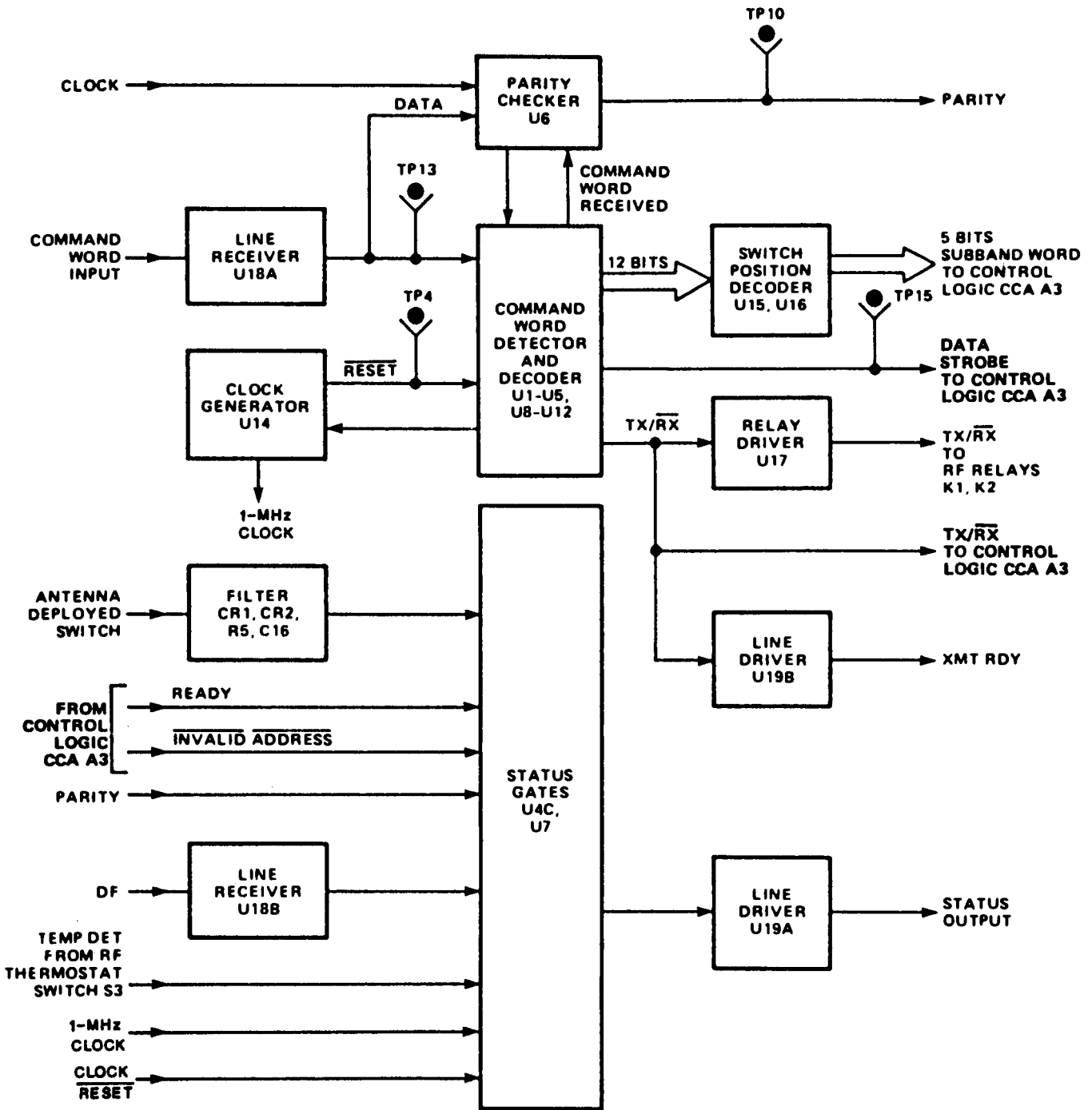

Figure 3-2. Decoder CCA A4 Block Diagram

Table 3-2. Decoder CCA A4 Test Point Signals

Test Point	Signal	From	To
TP1		U4B-6	U5A-1
TP2		U3A-6	U2-9
TP2		U3A-6	U1-9
TP3		U3B-8	U2-8
TP3		U3B-8	U1-8
TP4	<u>RESET</u>	U14A-13	U5A-13
TP4	<u>RESET</u>	U14A-13	U5B-10
TP4	<u>RESET</u>	U14A-13	U6-10
TP4	<u>RESET</u>	U14A-13	U8-1
TP4	<u>RESET</u>	U14A-13	U9-1
TP4	<u>RESET</u>	U14A-13	U10-1
TP5	NRZ DATA	U6A-3	U4B-4
TP5	NRZ DATA	U6A-3	U4D-12
TP5	NRZ DATA	U6A-3	U3C-1
TP5	NRZ DATA	U6A-3	U4A-1
TP5	NRZ DATA	U6A-3	U2-1
TP6	MANCON 1	U5A-3	U4D-13
TP6	MANCON 1	U5A-3	U3C-13
TP6	MANCON 1	U5A-3	U4A-2
TP6	<u>MANCON 2</u>	U5A-3	U3B-11
TP7	<u>MANCON 2</u>	U5B-6	U11A-1
TP7	<u>MANCON 2</u>	U5B-6	U4B-5
TP7	<u>MANCON 2</u>	U5B-6	U3A-4
TP8	<u>MANCON 1</u>	U5A-2	U5B-11
TP8	<u>MANCON 1</u>	U5A-2	U12A-5
TP9		U11C-8	U5A-4
TP10	PARITY	U6-5	U12A-4
TP10	PARITY	U6-5	U7-4
TP11		U4A-3	U6-11
TP12		U13F-12	U6-8
TP13	<u>DATA</u>	U13C-6	U6A-4
TP13	DATA	U13C-6	U11B-5
TP14	MANCON 2	U5B-5	U12A-2
TP14	MANCON 2	U5B-5	U3C-2
TP14	MANCON 2	U5B-5	U3B-9
TP15	LATCH DATA	U12A-6	U20A-1
TP15	LATCH DATA	U8-9	U20A-1
TP15	LATCH DATA	U9-9	U20A-1
TP15	LATCH DATA	U10-9	U20A-1

the B0 through B4 subband output to the control logic CCA. The $\overline{TR/RX}$ signal specifies the transmit-or receive operating-mode and passes to control logic CCA A3, relay driver U17, and line driver U19B.

For the transmit mode, $\overline{TX/RX}$ is high, and the driver U17 outputs operate RF relays K1 and K2 to connect the RF path through RF switch assembly S2. For the receive mode, $\overline{TX/RX}$ is low, the relays are normal, and the RF switch assembly is bypassed. Relay driver U19B applies the $\overline{TX/RX}$ signal to external system equipment as the XMT RDY signal.

3-5.2 Control Logic CCA A3. Refer to figure 3-3. The control logic CCA control circuit stores RF switch and stepper motor position data and converts the subband and TX/RX inputs from decoder CCA A4 into a 25-bit output to feedback CCA S4. In addition, the TX/RX, subband, and data strobe inputs from decoder CCA A4 are converted into drive pulse outputs to motor control CCA A2. Table 3-3 lists the control signals accessed from the control logic CCA test points.

3-5.2.1 RF Switch Decoder Circuit. As shown in figure FO-3, RF switch decoder circuit U16 through U19, U21B, and U22B converts the B0 through B4 data into a 32-bit word. The upper seven bits are applied to the status circuit (U9) and provide the INVALID ADDRESS output to decoder CCA A4. The lower 25 bits (Band 0 through Band 24) contain a single low bit that defines the required switch position. The Band 0 through Band 24 signals are applied to feedback CCA S4.

3-5.2.2 Motor Direction Decoder Circuit. Motor direction decoder circuit U1 and U8 compares the B0 through B4 input with data stored in present switch position latch U15. Comparison results determine the stepper motor M1 rotation direction. The motor direction control output of U1 passes to two-phase motor command generator U6, U13, and U20 and to extender CCA AS.

3-5.2.3 Motor Drive Circuit. In the motor drive circuit, each TX/RX signal specifies the transmit or receive operating mode and is accompanied by a data strobe signal. NAND gate U10B and OR gate U11A convert the data strobe input into a COUNTER RESET STB signal that resets counters U7 and U14. Motor control flip-flop U4B is cleared by the PWR ON RESET output of multivibrator U2B. The 200-Hz output of motor drive clock AR1A passes to the CLK input of U4B and the motor command generator. When clocking starts, the motor command generator provides drive pulse outputs (A1, A2, B1, B2) to motor control CCA A2, the Q output of U4B is NANDed by U22A with the TX/RX signal to provide a low READY output to the status circuit of decoder CCA A4, and counters U7 and U14 are triggered by the PARALLEL LOAD STB output of U12C. The low READY signal inhibits receipt of subsequent TX/RX inputs. If stepper motor M1 is not properly positioned when counters U7 and U14 are fully incremented, the U7 output sets MTR DRIVE TIMEOUT low to prevent continuous motor operation. When stepper motor M1 reaches the proper position, the low bit of the Band 0 through Band 24 output is applied through NAND gate U12B as the SW FDBK signal. The outputs of flip-flop U4B change states to set the MTR DRIVE TIMEOUT low, to inhibit the motor command generator, and to set the READY output high. As READY goes high, the MEM STB output of U3B triggers strobe generator U2. The Q output of U2A clocks present switch position latch U15 to store the B0 through B4 data.

3-5.3 Motor Control CCA A2. Refer to figure 3-4. The motor control CCA converts A1, A2, B1, and B2 drive pulses from control logic CCA A3 into power outputs to stepper motor M1. The pulses are two-phase, with A1 high when A2 is low and B1 high when B2 is low. Table 3-4 lists the signals accessed from the motor control CCA test points.

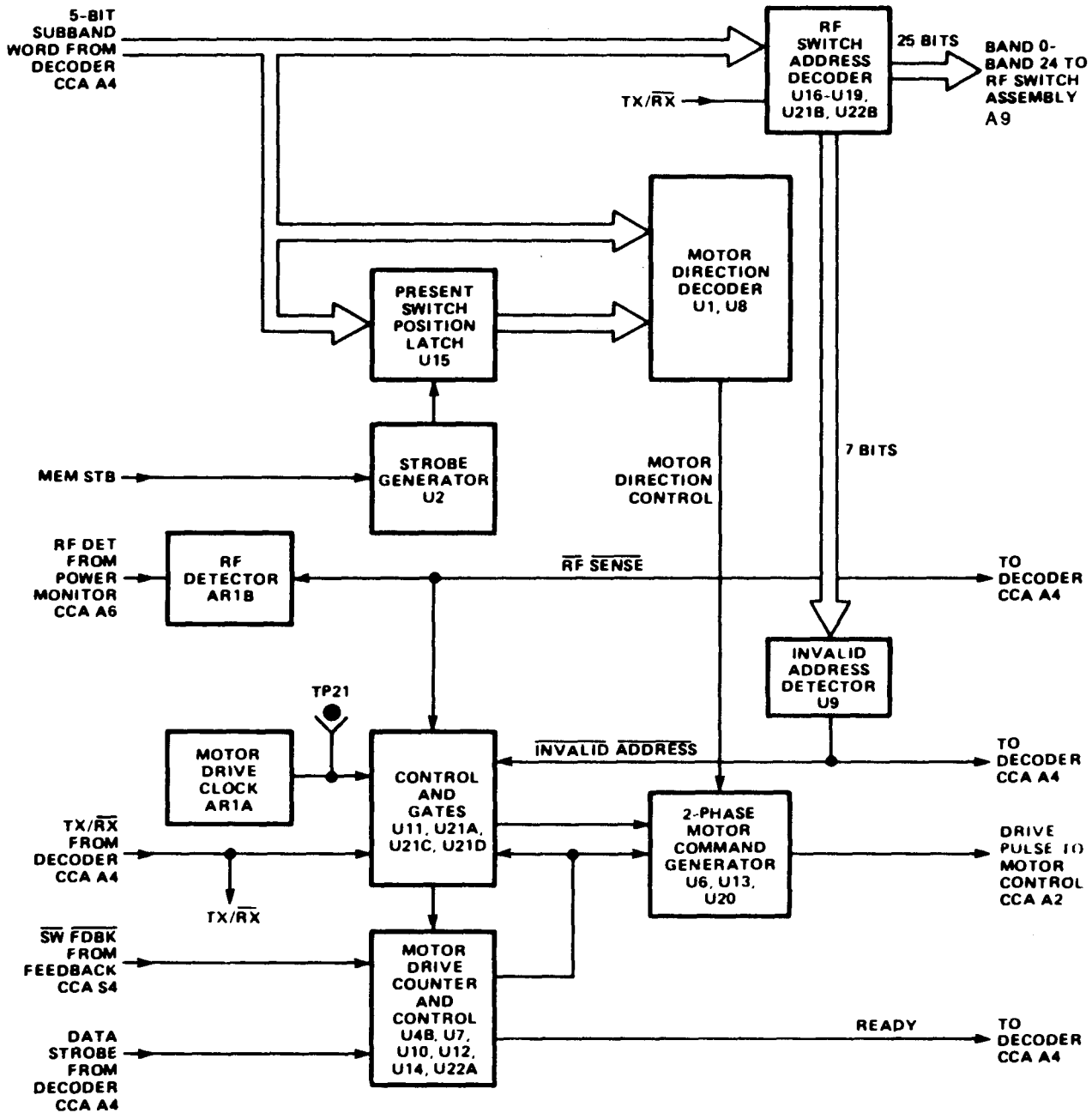

Figure 3-3. Control Logic CCA A3 Block Diagram

Table 3-3. Control Logic CCA A3 Test Point Signals

Test Point	Signal	From	To
TP1	MOTOR DIRECTION CONTROL	U1-7	P1-31
TP1	MOTOR DIRECTION CONTROL	U1-7	U3E-11
TP1	MOTOR DIRECTION CONTROL	U1-7	U13B-1
TP1	<u>MOTOR DIRECTION CONTROL</u>	U1-7	U13A-4
TP2	SHIFT REGISTER ENABLE	U2-4	U15-9
TP3	MEM STB	U3B-4	U2-2
TP3	MEM STB	U3B-4	U10A-2
TP4		U3F-12	U4B-4
TP4		U3F-12	U10C-9
TP5	MOTOR DRIVE CONTROL	U4B-3	U10D-12
TP5	MOTOR DRIVE CONTROL	U4B-3	U10C-10
TP5	MOTOR DRIVE CONTROL	U4B-3	U12A-2
TP5	MOTOR DRIVE CONTROL	U4B-3	P1-64
TP6	Motor drive counter reset B	U10A-3	U11A-3
TP7	<u>Motor drive counter reset C</u>	U10B-6	U11A-4
TP8	<u>PWR ON RESET</u>	U2B-12	U11A-5
TP8	<u>PWR ON RESET</u>	U2B-12	U15-1
TP8	PWR ON RESET	U2B-12	U4B-13
TP9		U5C-6	U12B-4
TP9		U5C-6	U11B-11
TP10	Motor drive counter clock	U5B-4	U11B-10
TP10	<u>Motor drive counter clock</u>	U5B-4	U14-5
TP11	<u>INVALID ADDRESS</u>	U5A-2	P1-38
TP11	INVALID ADDRESS	U5A-2	U11C-1
TP12		U6B-1	U5F-13
TP12		U13A-6	U5F-13
TP13		U6A-5	U13A-5
TP13		U6A-5	U20C-4
TP14		U6B-3	U20A-9
TP15	<u>DATA STB</u>	U13B-8	U5D-9
TP15	DATA STB	U13B-8	U6A-11
TP16	COUNTER RESET STB	U11A-6	U14-14
TP16	<u>COUNTER RESET STB</u>	U11A-6	U7-14
TP17	<u>PARALLEL LOAD STB</u>	U12C-8	U14-11
TP17	PARALLEL LOAD STB	U12C-8	U7-11
TP18	RF DET	ARIB-12	U11C-13
TP18	<u>RF DET</u>	ARIB-12	P1-3
TP19	<u>MTR DRIVE TIMEOUT</u>	U12D-11	U20A-10
TP19	<u>MTR DRIVE TIMEOUT</u>	U12D-11	U20B-12
TP19	<u>MTR DRIVE TIMEOUT</u>	U12D-11	U20C-5
TP19	<u>MTR DRIVE TIMEOUT</u>	U12D-11	U20D-2
TP19	<u>MTR DRIVE TIMEOUT</u>	U12D-11	U3D-9
TP19	<u>MTR DRIVE TIMEOUT</u>	U12D-11	U21A-2
TP20	B3 DATA	U21B-6	U16-5
TP21	MOTOR DRIVE CONTROL 200 Hz	AR1A-7	U21A-1

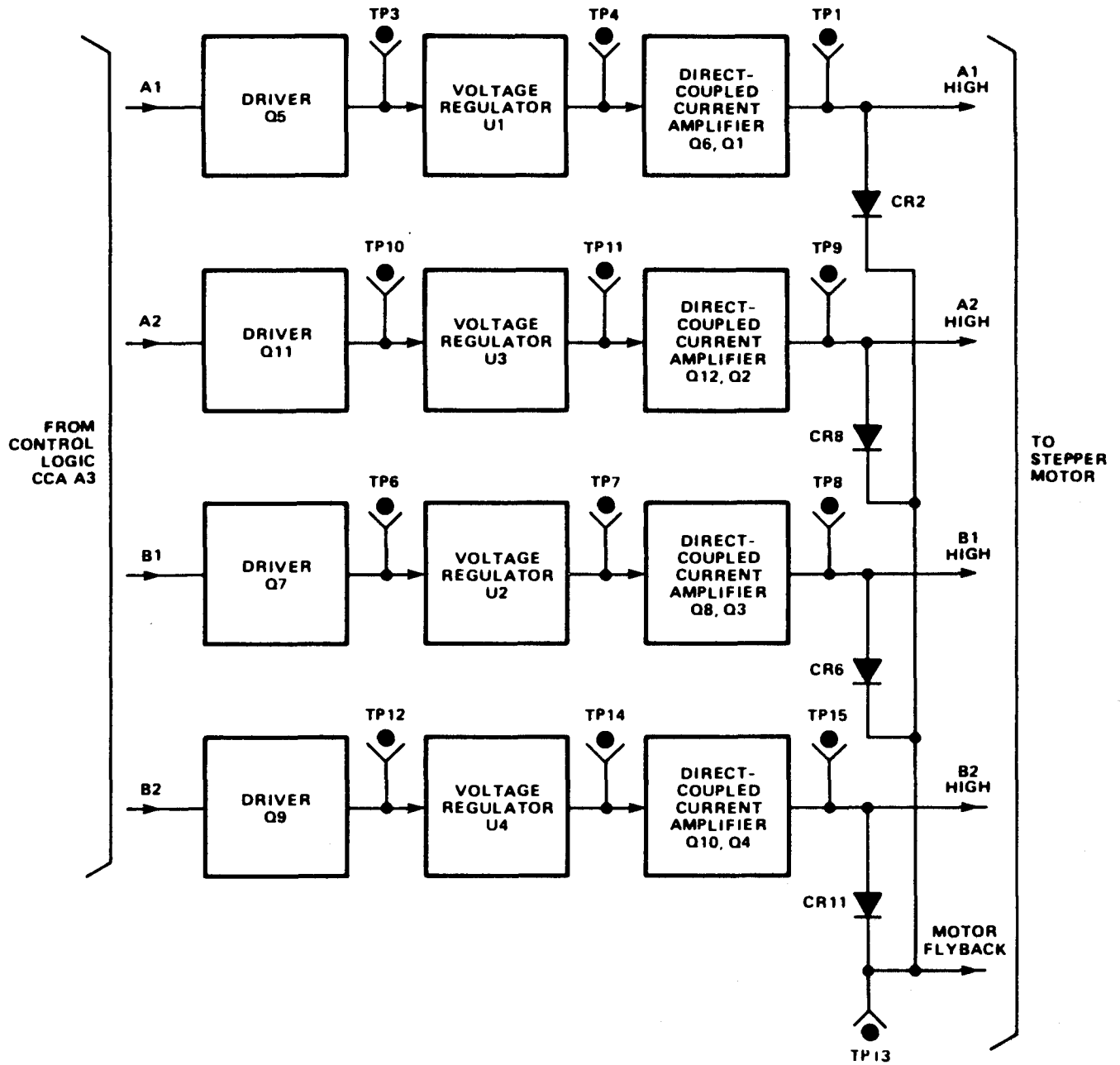

Figure 3-4. Motor Control CCA A2 Block Diagram

Table 3-4. Motor Control CCA A2 Test Point Signals

Test point	Signal
TP1	A1 high test
TP2	A low test
TP3	A1
TP4	A1
TP5	B low test
TP6	B1
TP7	B1
TP8	B1 high test
TP9	A2 high test
TP10	A2
TP11	A2
TP12	B2
TP13	MOTOR FLYBACK
TP14	B2
TP15	B2 high test

As shown in figure FO-4, input A1 is applied through driver Q5 to voltage regulator U1. Voltage regulator U1 provides a constant current source to current amplifiers Q6 and Q1. The resulting A1 high output is routed to the windings of stepper motor M1 and to extender CCA A5. Diode CR2 prevents excessive current surges to the motor windings and provides a MOTOR FLYBACK output to extender CCA AS.

3-5.4 RF Switch Assembly. Refer to figure 3-5. The RF switch assembly contains four rotary switch wafers and eight RF CCAS. Stepper motor M1 operates the switch wafers to select one of 20 tuned circuits through the CCAs. As shown in figure FO-5, RF relays K1 and K2 receive TX/RX inputs and control the RF path through the RF switch assembly. For the transmit mode, relays K1 and K2 operate. Relay K1 applies the RF input from connector J2 to the selected tuned circuit. Relay K2 applies the tuned circuit output through connector J1 to the external antenna. For the receive mode, relays K1 and K2 are de-energized and the RF switch assembly is bypassed.

3-5.5 Feedback Switch CCA S4. Refer to figure FO-1. The feedback switch CCA receives Band 0 through Band 24 signals from control logic CCA A3 that specifies the transmit mode operating frequency. The feedback switch CCA is operated by stepper motor M1, and provides an SW FDBK output to control logic CCA A3 when the stepper motor reaches the proper position.

3-6. STATUS CIRCUIT.

The tunable coupler status circuit receives antenna-deployed switch and DF input signals at connector pins J3-A through J3-D. The signals are combined with status signals from the tunable coupler CCAs and applied to external equipment in the system.

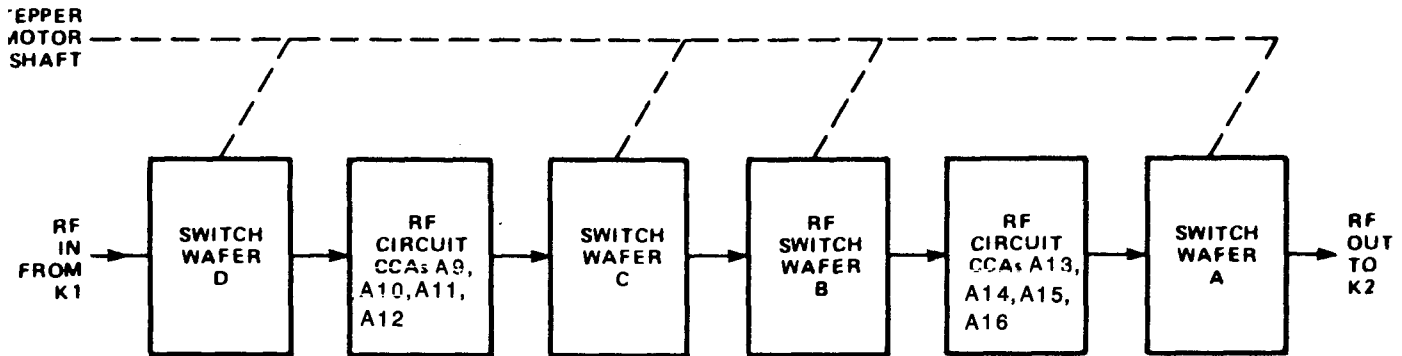

Figure 3-5. RF Switch Assembly S2 Block Diagram

3-6.1 Decoder CCA A4. Refer to figure 3-2. The decoder CCA status circuit consists of filters CR1, CR2, R5, and C16; line receiver U18B; AND gate U4C; NAND gate U7; and line driver U19. As shown in figure FO-2, the filter applies the antenna-deployed switch input to NAND gate U7-5. Line receiver U18B converts the DF input into a DF signal to NAND gate U7-3. The READY and INVALID ADDRESS inputs from control logic CCA A3 are applied to NAND gate U7-2 and NAND gate U7-6, respectively. AND gate U4C receives the BUF 1-MHz output of multivibrator U14B and the TEMP DET input from switch S3 in RF switch assembly S2. The U4C output is inverted and passes to NAND gate U7-12 as the CLOCK READY signal. The inverted U4C output also passes to extender CCA A5 as the TOL signal. In addition, NAND gate U7 receives PARITY, RESET, and MANCON 2 signals from flip-flop U6B, multivibrator UL4A, and flip-flop U5B, respectively. The U7-8 output through line driver U19A indicates status conditions as follows:

3-6.1.1 Not Ready for Commands. The digital output signal is a logic low when the tunable coupler is performing any operation that inhibits receipt of a command word.

3-6.1.2 Ready for Commands. The digital output signal is a logic high when all of the following conditions are met:

Data parity in the previous command is correct.
Tuning operation is correct.
Tunable coupler temperature is within limits.
The frequency band requested is valid.
The antenna is fully deployed.

3-6.1.3 Overtemperature. The parity line state alternates between a logic high and a logic low at a 1-MHz rate when an internal overtemperature condition is detected.

3-6.2 Control Logic CCA A3. Refer to figure 3-3. The control logic CCA status circuit consists of RF detector AR1B and invalid address detector U9. As shown in figure FO-3, detector AR1B receives RF DET inputs from RF monitor CCA A6 and provides an RF SENSE output to the control logic CCA A3 logic circuit (U11C) and to decoder CCA A4. The RF SENSE signal is low (logic 0) when the RF monitor CCA detects an RF input to RF switch assembly S2. Test point TP18 allows verification of the RF SENSE signal. Invalid address decoder U9 receives a seven-bit input from the control circuit (U16 through U19, U21B, and U22B). When all the bits are high, the output of U9 indicates the requested frequency band is valid. If any bit is low, the U9-8 output indicates the requested frequency band is out of range. The output of U9 passes to the decoder CCA status circuit.

3-6.3 RF Switch Assembly S2. Refer to figure FO-1. The RF switch assembly status circuit consists of RF thermostat switch S3, RF monitor CCA A6, and RFI filters FL1 through FL4. An overtemperature circuit connects motor temperature thermostat switch S1 and RF thermostat switch S3 to decoder CCA A4. Filters FL1 and FL2 reduce fluctuations in the TEMP DET input from switch S1 and the TEMP DET output to the decoder CCA, respectively. As shown in figure FO-5, filters FL3 and FL4 reduce fluctuation in the RF DET outputs from the RF monitor CCA sensing network to detector AR1B in control logic CCA A3.

3-7. POWER DISTRIBUTION CIRCUIT.

Refer to figure 3-6. Power supply CCA A1 converts the +28 V dc input into outputs of filtered +28 and regulated +15, +5, and -5 V dc. Table 3-5 lists the voltages accessed from the power supply CCA test points. As shown in figure FO-6, filter L1, L2, C1, C2, C13, and C14 provides a filtered +28 V dc output to RF relays K1 and K2, motor control CCA A2, extender CCA A5, and stepper motor M1. Voltage regulator AR3 and transistor Q6 convert the filter output into +15 V outputs to extender CCA A5 and motor control CCA A2. Chopper Q1 and Q5 and pulse transformer T1 comprise a dc-to-dc converter that provides +5 V outputs. Comparator AR1 monitors the voltage drop across resistor R1 and adjusts the chopper Q1 and Q2 duty cycle to maintain current. Filter C9 through C11 and C15 passes the +5 V output to decoder CCA A4 and control logic CCA A3. Diode CR4 and filter C6 through C8 pass the -5 V output to decoder CCA A4 and control logic CCA A3. Voltage divider network R21 and R22 divides the VREF output of AR3 and provides a precision reference to crowbar circuit Q2 through Q4 and AR2.

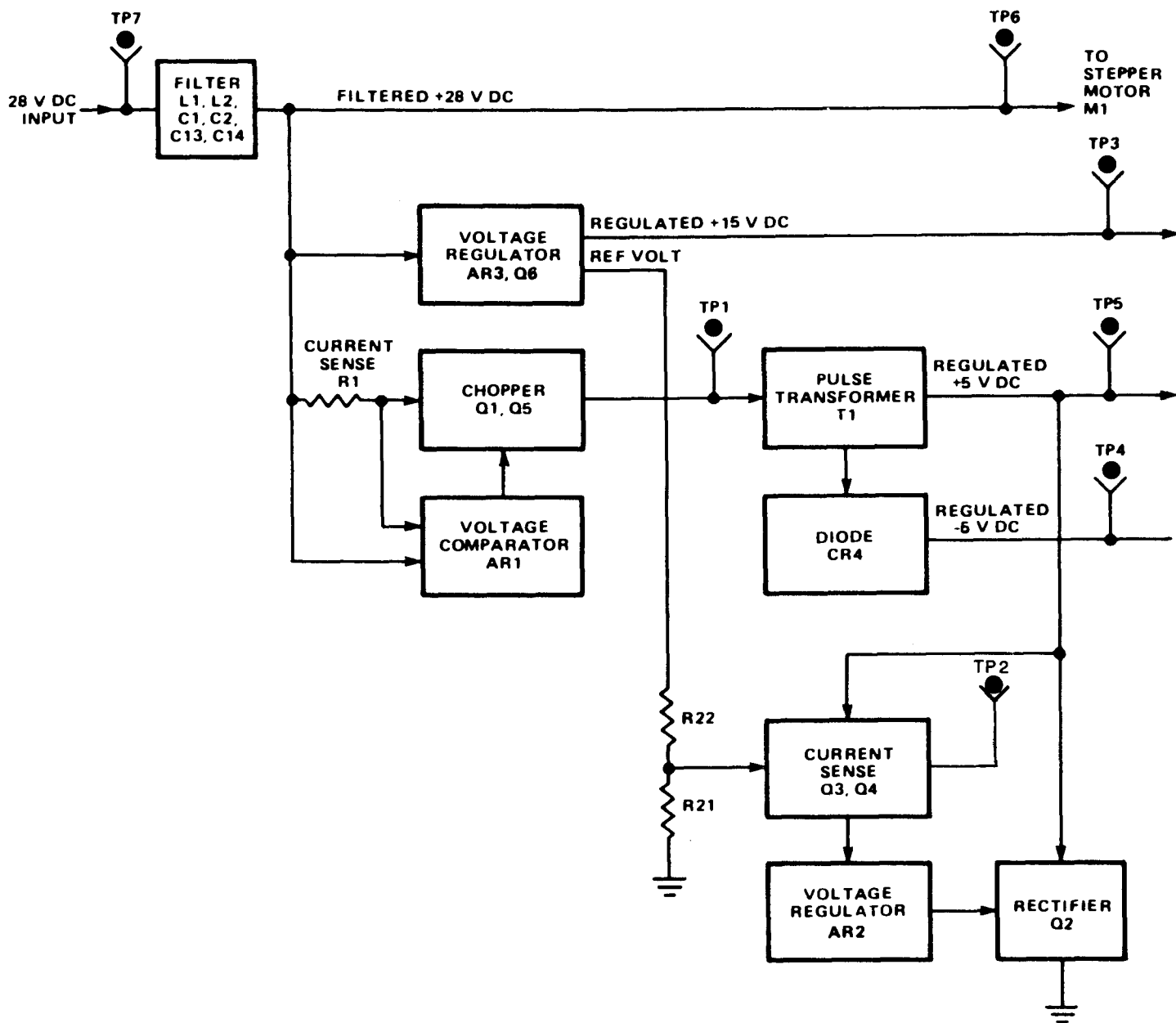

Figure 3-6. Power Supply CCA A1 Block Diagram

If the regulated +5 V rises to approximately +6 V, comparators Q3 and Q4 conduct and Q2 triggers to clamp the output of T1-2 to ground.

Table 3-5. Power Supply CCA A1 Test Point Signals

Test point	Signal
TP1	28 V (switched at 33 KHz)
TP2	+4.4 v
TP3	+15 v
TP4	-5 v
TP5	+5 v
TP6	+28 V

3-8. EXTENDER CCA A5.

The extender CCA is installed in slot XA5 of motherboard A7 and contains test points for access to critical tunable coupler signals and voltages. Table 3-6 lists the signal accessed from each extender CCA test point. The extender CCA can also be used to extend CCA A1 through A4 for CCA testing.

Table 3-6 Extender CCA A5 Test Point Signals

Test point	Signal	Signal Origin
1	B2 HIGH	Motor Control CCA A2
2	READY	Decoder CCA A4
3	B2	Motor Control CCA, A2
4	RF SENSE	Control Logic CCA A3
5	MTR FLYBACK	Motor Control CCA A2
6	+28 V	Power Supply CCA A1
7	A1	Motor Control CCA A2
8		
9	TDL	Decoder CCA A4
10	RESET	Decoder CCA A4
11	A2	Motor Control CCA A2
12	B1 HIGH	Motor Control CCA A2
13	B LOW	Motor Control CCA A2
14		
15		
16		
17	B1	Motor Control CCA A2
18	ANT DEPL	Decoder CCA A4

Table 3-6 Extender CCA A5 Test Point Signals - Continued

Test point	Signal	Signal Origin
19		
20	+15V	Power Supply CCA A1
21		
22	A LOW	Motor Control CCA A2
23		
24	A1 HIGH	Motor Control CCA A2
25	MANCON 2	Decoder CCA A4
26		
27	+5 v	Power Supply CCA A1
28	MTR DIR CNTRL	Control Logic CCA A3
29	BIT 3	Decoder CCA A4
30	BIT 0	Decoder CCA A4
31	A2 HIGH	Motor Control CCA A2
32	MTR DRIVE CNTRL	Control Logic CCA A3
33	+28 V FIL	Power Supply CCA A1
34		
35		
36		
37		
38		
39	INV ADDR	Decoder CCA A4
40		
41		
42		
43		
44		
45		
46		
47		
48		
49	PARITY	Decoder CCA A4
50		
51		
52		
53		
54		
55		
56		
57	TX/ $\overline{\text{RX}}$	Decoder CCA A4
58		
59		
60	BIT 4	Decoder CCA A4
61		
62		
63	BIT 1	Decoder CCA A4
64	BIT 2	Decoder CCA A4
65	-5 v	Power Supply CCA A1
66	GND	Decoder CCA A4

CHAPTER 4

DIRECT SUPPORT MAINTENANCE INSTRUCTIONS

Section I. GENERAL

4-1. SCOPE.

No direct support maintenance is required for this equipment. Units removed during organizational maintenance are forwarded to the general support level for maintenance as described in chapter 5.

CHAPTER 5

GENERAL SUPPORT MAINTENANCE INSTRUCTIONS

Section I. GENERAL

5-1. SCOPE.

This chapter provides general support maintenance instructions for the tunable coupler. The troubleshooting and test procedures in this chapter supplement the maintenance instructions provided in TM 32-5865-012-20 by the use of additional test equipment, tools, and materials available to general support maintenance.

5-2. ORGANIZATION.

This chapter contains reference data and measurements that are made on the tunable coupler to determine proper operation. This chapter also lists the tools and test equipment required and provides troubleshooting procedures. In addition, the chapter provides maintenance and test procedures to the component level for general support maintenance.

5-3. MEASUREMENTS AND DATA.

General support maintenance consists of removal, troubleshooting and repair of the power supply circuit card assembly (CCA) A1 and motor control CCA A2, and removal and replacement of certain chassis mounted components. Locations of the CCAs in the tunable coupler are shown in figure 5-1. The tunable coupler and the remainder of the coupler assemblies are tested using automatic test equipment (ATE). Instructions for using the ATE are provided in TM 32-5865-216-40&P.

Section II. TOOLS AND EQUIPMENT

5-4. GENERAL.

This section references lists of tools, test equipment, and materials required to perform general support maintenance.

5-5. TOOLS AND EQUIPMENT REQUIRED.

List of authorized common tools and equipment are provided as part of the Maintenance Allocation Chart (MAC) located in Appendix B of this manual. Appendix D of this manual is a list of expendable supplies and materials required.

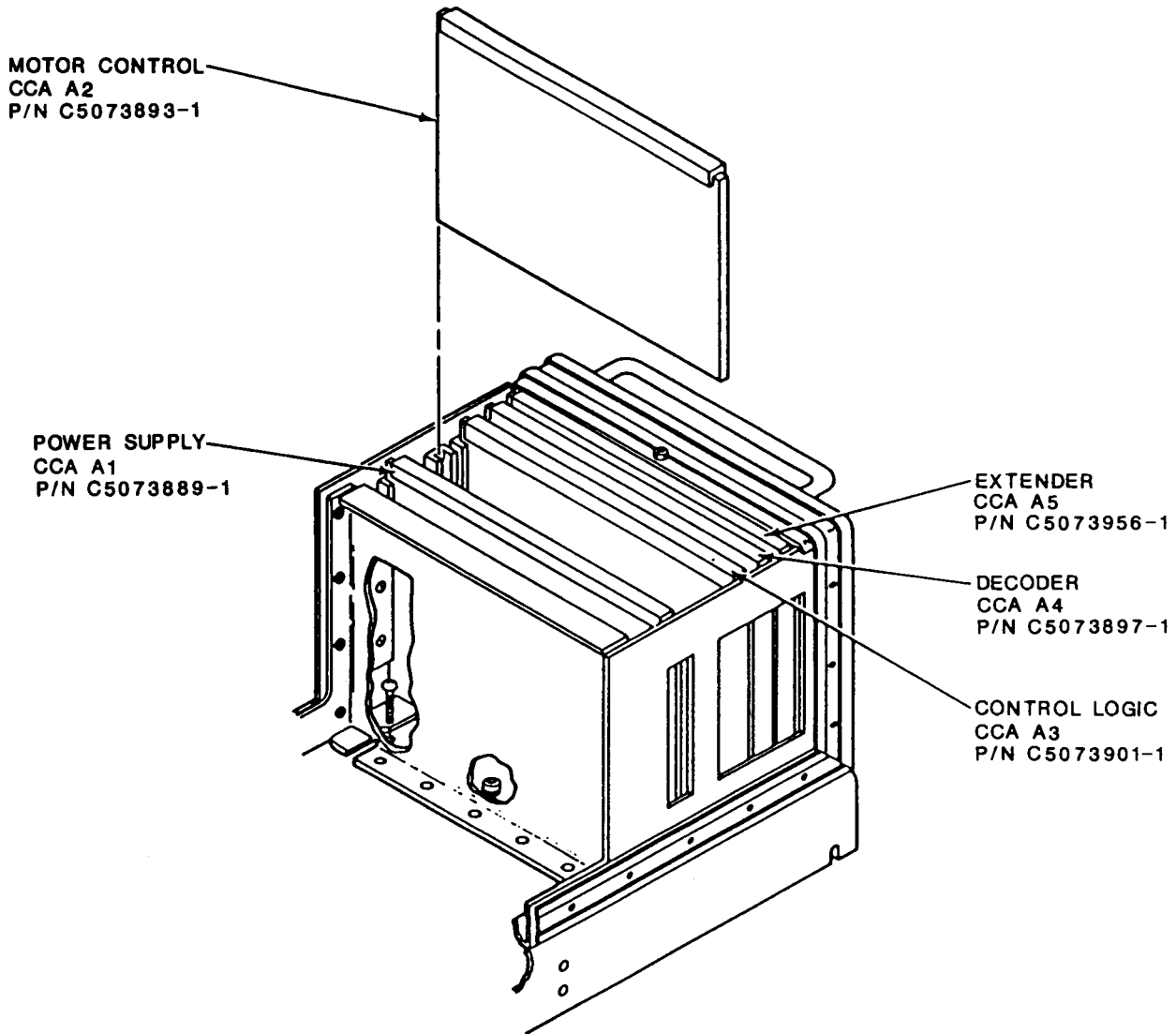

Figure 5-1. Tunable Coupler CCA Locations

Section III. TROUBLESHOOTING

5-6. GENERAL.

This section provides troubleshooting instructions for the tunable coupler.

5-7. TUNABLE COUPLER PROCEDURES.

Troubleshooting of the tunable coupler consists of a series of checks that verify that all components function properly. The procedures assume that system-level troubleshooting by organizational maintenance personnel has been performed as given in TM 32-5865-012-20 to isolate the problem to the tunable coupler. After performing the general inspection and cleaning procedures in section IV of this chapter, refer to paragraphs 5-7.1 and 5-7.2 for the troubleshooting procedures. After the problem is isolated, refer to section IV of this chapter for the appropriate maintenance procedures.

5-7.1 Power Supply CCA A1. Table 5-1 contains the troubleshooting procedure for power supply CCA A1. Figures 5-2 and 5-3 show component locations and the test equipment connections, respectively, referenced in the power supply CCA troubleshooting procedure.

5-7.2 Motor Control CCA A2. Table 5-2 contains the troubleshooting procedure for motor control CCA A2. Figures 5-4 and 5-5 show component locations and the test equipment connections, respectively, referenced in the motor control CCA troubleshooting procedure.

Section IV. MAINTENANCE OF TUNABLE COUPLER

5-8. GENERAL.

This section provides maintenance procedures that are the responsibility of general support maintenance personnel. Paragraph 5-9 contains general inspection and cleaning instructions for the tunable coupler. The subsequent paragraphs contain specific maintenance procedures applicable to the tunable coupler components shown in figure 5-6. The procedures reference the components by parenthetical numbers that are keyed to figure 5-6. Perform both the general procedures and the applicable specific procedures.

5-9. MAINTENANCE PROCEDURES.

Remove the top and bottom covers as given in paragraphs 5-10.1 and 5-10.2 and perform the following items.

Table 5-1. Power Supply CCA A1 Troubleshooting Procedure

Step	Test Point	Test Equipment	Procedure	Normal Indication	If Indication Is Normal	If Indication Is Abnormal
			<p style="text-align: center;">NOTE</p> <p>This procedure includes the major components that may be defective within the power supply CCA. The procedure does not test point-to-point wiring, resistors, capacitors, or inductors within the power supply CCA.</p> <p style="text-align: center;">NOTE</p> <p>Remove CCA A1 power supply board.</p> <p style="text-align: center;"><u>Test Setup</u></p>			
1		See figure 5-3.	<p>a. Turn power supply on and set for +28 V dc output.</p> <p>b. Use multimeter to verify power supply output.</p> <p>c. Establish test setup as shown in figure 5-3.</p> <p style="text-align: center;"><u>Input Power Test</u></p>	+28 V dc.	Proceed with step 2.	
2	TP6	Same as step 1.	Measure voltage between test point TP6 (+) and terminal stud E3 (-).	+27.5 (± 1.5) V dc.	Proceed with step 3.	Turn power supply off and check front-to-back

Table 5-1. Power Supply CCA A1 Troubleshooting Procedure - Continued

Step	Test Point	Test Equipment	Procedure	Normal Indication	If Indication Is Normal	If Indication Is Abnormal
2 Cont'd						resistance between terminal studs E7 and E6. If difference is less than ten times greater one way than the other, replace diode CR6.
3	TP3	Same as step 1	<p align="center"><u>+15 V Circuit Test</u></p> <p>Measure voltage between test point TP3 (+) and terminal stud E3 (-).</p>	+15 (± 0.5) V dc.	Proceed with step 4.	Remove jumper between terminal studs E4 and E5 and recheck. If still out of tolerance, replace transistor Q6 or voltage regulator AR3. If in tolerance, replace comparator AR1 or voltage regulator AR2. After repair, resolder jumper between terminal studs E4 and E5.
4	TP1	Same as step 1	<p align="center"><u>Switching Circuit Test</u></p> <p>Use oscilloscope to measure frequency between test point TP1 (+) and terminal stud E3 (-).</p>	33 to 40kHz Pulse wave shape	Proceed with step 5.	Replace the following in sequence and repeat check after each item is



Table 5-1. Power Supply CCA A1 Troubleshooting Procedure - Continued

Step	Test Point	Test Equipment	Procedure	Normal Indication	If Indication Is Normal	If Indication Is Abnormal
4 Cont'd						replaced: comparator AR1, transistor Q1, transistor Q5, diode CR1, diode CR2, capacitor C4, transformer T1.
			<u>+5 V Circuit Test</u>			
5	TP5	Same as step 1	Measure voltage between test point TP5 (+) and terminal stud E3 (-).	+5 (± 0.4) V dc.	Proceed with step 6.	Remove the following in sequence and repeat check after each item is replaced: transistor Q2, comparator AR1, transistor Q4, transistor Q3, voltage regulator AR2, diode CR5, diode CR3, transformer T1.
			<u>-5 V Circuit Test</u>			
6	TP4	Same as step 1	Measure voltage between test point TP4 (+) and terminal stud E3 (-).	-5 (± 0.5) V dc.	Proceed with step 7.	Replace diode CR4 and transformer T1 in sequence and repeat check after each item is replaced.

Table 5-1. Power Supply CCA A1 Troubleshooting Procedure - Continued

Step	Test Point	Test Equipment	Procedure	Normal Indication	If Indication Is Normal	If Indication Is Abnormal
6 Cont'd			<div style="border: 1px dashed black; padding: 5px; text-align: center; margin-bottom: 10px;">CAUTION</div> <p>The following steps must be performed quickly. Prolonged operation of the decade box with the output shorted may cause circuit damage.</p> <p style="text-align: center;"><u>Overload Protection</u> <u>Circuit Tests</u></p>			
7	AR3-2	Same as step 1	<p>a. Turn power supply off.</p> <p>b. Install jumper between terminal studs E3 and E4.</p> <p>c. Turn power supply on and measure voltage between voltage regulator pin AR3-2 (+) and ground (-).</p> <p>d. Remove jumper</p>	+0.7 (± 0.1) V dc.	Proceed with step 8.	Replace voltage regulator AR3.
8		Same as step 1	Decrease resistance of decade box DB1 in one-ohm increments while monitoring amperage and voltage between connector	Amperage reading increases to 2.6 A maximum. Voltage should hold at	Proceed with step 9.	If amperage goes higher than 2.6 A or if voltage does not drop when decade box

Table 5-1. Power Supply CCA A1 Troubleshooting Procedure - Continued

Step	Test Point	Test Equipment	Procedure	Normal Indication	If Indication Is Normal	If Indication Is Abnormal
8 Cont'd			pins P1-3 (+) and P1-4 (-).	5 V, then drop to 0 V as overload protection engages.		DB1 is set to zero, replace transistor Q2 or voltage regulator AR2.
9		Same as step 1	a. Turn power supply off. b. Disconnect test equipment and replace cover.		Test completed.	

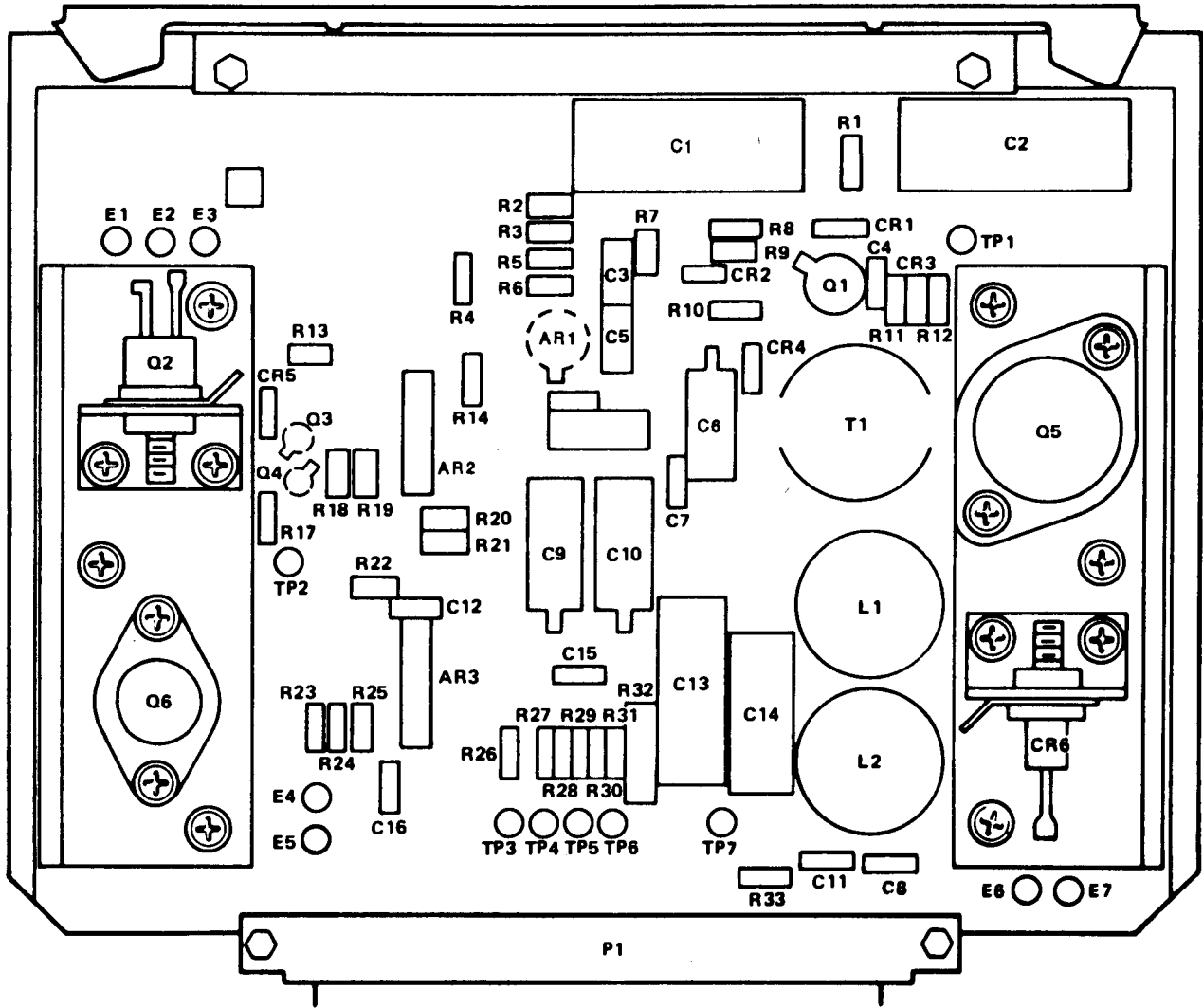

Figure 5-2. Power Supply CCA A1 Component Locations

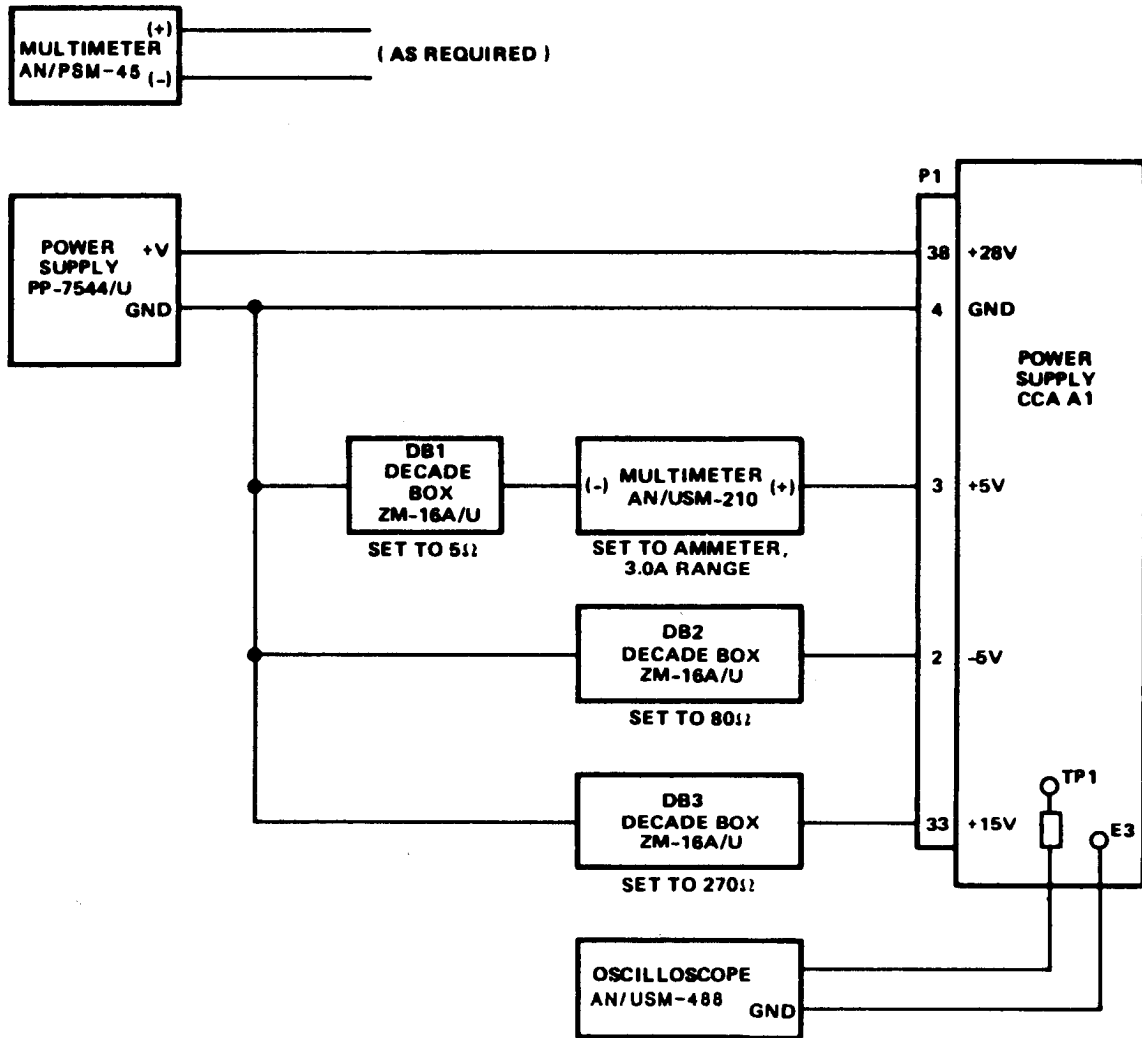

Figure 5-3. Power Supply CCA A1 Test Setup

Table 5-2. Motor Control CCA A2 Troubleshooting Procedure

Step	Test Point	Test Equipment	Procedure	Normal Indication	If Indication Is Normal	If Indication Is Abnormal
1		See figure 5-5.	<p style="text-align: center;">NOTE</p> <p>This procedure includes the major components that may be defective within the motor control CCA. The procedure does not test point-to-point wiring, resistors, and capacitors within the motor control CCA.</p> <p style="text-align: center;"><u>Test Setup</u></p> <p>a. Turn power supplies PS1 and PS2 on.</p> <p>b. Set power supply PS1 for +15 V dc output.</p> <p>c. Set power supply PS2 for +28 V dc output.</p> <p>d. Use multimeter to verify output of power supplies PS1 and PS2.</p> <p>e. Turn power supplies PS1 and PS2 off and establish test setup as shown in figure 5-5.</p>	<p>PS1 output: +15 V dc. PS2 output: +28 V dc.</p>	<p>Proceed with step 2.</p>	

Table 5-2. Motor Control CCA A2 Troubleshooting Procedure - Continued

Step	Test Point	Test Equipment	Procedure	Normal Indication	If Indication Is Normal	If Indication Is Abnormal
<u>A1 Signal Path Tests</u>						
2	P1-25, P1-33, TP3	Same as step 1.	<p>a. Turn power supplies PS1 and PS2 on.</p> <p>b. Observe AN/USM-210 multimeter.</p> <p>c. Connect power supply PS2 ground (-) to connector pin P1-21.</p> <p>d. Use AN/PSM-45 multi-meter to measure voltage between test point TP3(+) and ground (-).</p>	Imperceptible current for all three decade box settings (530, 30, and 5 ohms).	Proceed with step 3.	<p>Proceed with step 2c.</p> <p>If indication is less than 0.5 V dc, replace voltage regulator U1.</p> <p>If indication is greater than 0.5 V dc and less than 4 V dc, replace transistor Q5.</p> <p>If indication is greater than 4 V dc, replace diode CR1.</p>
3	U1 pin 3	Same as step 1	Turn power supplies off, remove all connection to CCA, and check front-to-back resistance of CR3.	Difference at least 10 times greater one way than the other.	Proceed with step 4.	Replace diode CR3.

Table 5-2. Motor Control CCA A2 Troubleshooting Procedure - Continued

Step	Test Point	Test Equipment	Procedure	Normal Indication	If Indication Is Normal	If Indication Is Abnormal
4	P1-33, P1-3	Same as step 1	Check front-to-back resistance between connector pins P1-33 and P1-3.	Difference at least 10 times greater one way than the other.	Proceed with step 5	Replace diode CR2.
5	P1-33, P1-25	Same as step 1	a. Reconnect test setup as established in step 1. Connect PS2 ground to P1-21. b. Turn power supplies PS1 and PS2 on. c. Set decade box to 30 ohms <u>only</u> long enough to obtain stable ampmeter reading, then switch back to 530 ohms.	Current is 150 ±20 ma.	Proceed with step 6.	Replace transistor Q6.
6	P1-33, P1-25	Same as step 1	a. Set decade box to 5 ohms <u>only</u> long enough to obtain stable ampmeter reading, then switch back to 530 ohms. <u>A2 Signal Path Tests</u>	Current is 0.9 ±0.1 amp.	Proceed with step 7.	Replace transistor Q1.
7	P1-25, P1-32, TP10	Same as step 1	a. Turn power supplies PS1 and PS2 off. b. Move AN/USM-210 multimeter connection from connector pin P1-33 to connector pin P1-32.			

Table 5-2. Motor Control CCA A2 Troubleshooting Procedure - Continued

Step	Test Point	Test Equipment	Procedure	Normal Indication	If Indication Is Normal	If Indication Is Abnormal
7 Cont'd			<p>c. Set decade box to 530 ohms.</p> <p>d. Turn power supplies PS1 and PS2 on.</p> <p>e. Observe AN/USM-210 multimeter.</p> <p>f. Connect power supply PS2 ground (-) to connector pin P1-26.</p> <p>g. Use AN/PSM-45 multimeter to measure voltage between test point TP10 (+) and ground (-).</p>	Imperceptible current for all three decade box settings (530, 30, and 5 ohms).	Proceed with step 8.	<p>Proceed with step f.</p> <p>If indication is less than 0.5 V dc, replace voltage regulator U3.</p> <p>If indication is greater than 0.5 V dc and less than 4 V dc, replace transistor Q11.</p> <p>If indication is greater than 4 V dc, replace diode CR7.</p>
8	U3 pin 3	Same as step 1	Turn power supplies off, remove all connections to CCA, and check front-to-back resistance.	Difference of at least 10 times greater one way than the other.	Proceed with step 9.	Replace diode CR9.

Table 5-2. Motor Control CCA A2 Troubleshooting Procedure - Continued

Step	Test Point	Test Equipment	Procedure	Normal Indication	If Indication Is Normal	If Indication Is Abnormal
9	P1-32, P1-3	Same as step 1	Check front-to-back resistance between connector pins P1-32 and P1-3.	Difference of at least 10 times greater one way than the other.	Proceed with step 10.	Replace diode CR8.
10			Reconnect test setup as established in step 1. Reconnect PS2 ground to P1-26. b. Turn power supplies PS1 and PS2 on. c. Set decade box to 30 ohms <u>only</u> long enough to obtain stable ammeter reading, then switch back to 530 ohms.	Current is 150 ± 20 ma Current is 150 ± 20 ma.	Proceed with step 11. Proceed with step 11.	Replace transistor Q12. Replace transistor Q12.
11			a. Set decade box to 5 ohms <u>only</u> long enough to obtain stable ammeter reading, then switch back to 530 ohms. <u>B1 Signal Path Tests</u>	Current is 0.9 ± 0.1 amp.	Proceed with step 12.	Replace transistor Q2.
12	P1-10, P1-12, TP6	Same as step 1	a. Turn power supplies PS1 and PS2 off. b. Move AN/USM-210 multimeter connection from connector pin P1-32 to connector pin P1-10.			

Table 5-2. Motor Control CCA A2 Troubleshooting Procedure - Continued

Step	Test Point	Test Equipment	Procedure	Normal Indication	If Indication Is Normal	If Indication Is Abnormal
12 Cont'd			<p>c. Move decade box connection from connector pin P1-25 to connector pin P1-12.</p> <p>d. Set decade box to 530 ohms.</p> <p>e. Turn power supplies PS1 and PS2 on.</p> <p>f. Observe AN/USM-210 multimeter.</p> <p>g. Connect power supply PS2 ground (-) to connector pin P1-16.</p> <p>h. Use AN/PSM-45 multimeter to measure voltage between test point TP6 (+) and ground (-).</p>	<p>Imperceptible current for all three decade box settings (530, 30, and 5 ohms).</p>	<p>Proceed with step 13.</p>	<p>Proceed with step g.</p> <p>If indication is less than 0.5 V dc, replace voltage regulator U2.</p> <p>If indication is greater than 0.5 V dc and less than 4 V dc, replace transistor Q7.</p> <p>If indication is greater than 4 V dc, replace diode CR4.</p>

Table 5-2. Motor Control CCA A2 Troubleshooting Procedure - Continued

Step	Test Point	Test Equipment	Procedure	Normal Indication	If Indication Is Normal	If Indication Is Abnormal
13	U2 pin 3	Same as step 1.	Turn power supplies off, remove all connections to CCA, and check front-to-back resistance between U2 pin 3 and ground.	Difference of at least 10 times greater one way than the other.	Proceed with step 14.	Replace diode CR5.
14	P1-10, P1-3	Same as step 1.	Check front-to-back resistance between connector pins P1-10 and P1-3.	Difference of at least 10 times greater one way than the other.	Proceed with step 15.	Replace diode CR6.
15	P1-10, P1-12	Same as step 1	<p>a. Reconnect test setup as established in step 1, then change connections per steps 12b and 12c and reconnect PS2 ground to P1-16.</p> <p>b. Turn power supplies PS1 and PS2 on.</p> <p>c. Set decade box to 30 ohms <u>only</u> long enough to obtain stable ammeter reading, then switch back to 530 ohms.</p>	Current is 150 ± 20 ma.	Proceed with step 16.	Replace transistor Q8.
16	P1-10, P1-12	Same as step 1	<p>a. Set decade box to 5 ohms <u>only</u> long enough to obtain stable ammeter reading, then switch back to 530 ohms.</p>	Current is 0.9 ± 0.1 amp.	Proceed with step 17.	Replace transistor Q3.

Table 5-2. Motor Control CCA A2 Troubleshooting Procedure - Continued

Step	Test Point	Test Equipment	Procedure	Normal Indication	If Indication Is Normal	If Indication Is Abnormal
17	P1-1, P1-12, TP12	Same as step 1	<p><u>B2 Signal Path Tests</u></p> <p>a. Turn power supplies PS1 and PS2 off.</p> <p>b. Move AN/USM-210 multimeter connection from connector pin P1-10 to connector pin P1-1.</p> <p>c. Set decade box to 530 ohms.</p> <p>d. Turn power supplies PS1 and PS2 on.</p> <p>e. Observe AN/USM-210 multimeter.</p> <p>f. Connect power supply PS2 ground (-) to connector pin P1-8.</p> <p>g. Use AN/PSM-45 multimeter to measure voltage between test point TP12 (+) and ground (-).</p>	Imperceptible current for all three decade box settings (530, 30, and 5 ohms).	Proceed with step 18.	<p>Proceed with step f.</p> <p>If indication is less than 0.5 V dc, replace voltage regulator U4.</p> <p>If indication is greater than 0.5 V dc and less than 4 Vdc, replace transistor Q9.</p>

Table 5-2. Motor Control CCA A2 Troubleshooting Procedure - Continued

Step	Test Point	Test Equipment	Procedure	Normal Indication	If Indication Is Normal	If Indication Is Abnormal
17 Cont'd						If indication is greater than 4 V dc, replace diode CR10.
18	U4 pin 3	Same as step 1	Turn power supplies off, remove all connections to CCA, and check front-to-back resistance between U4 pin 3 and ground.	Difference of at least 10 times greater one way than the other.	Proceed with step 19.	Replace diode CR12.
19	P1-1, P1-3	Same as step 1	Check front-to-back resistance between connector pins P1-1 and P1-3.	Difference of at least 10 times greater one way than the other.	Proceed with step 20.	Replace diode CR11.
20	P1-1, P1-12	Same as step 1	a. Reconnect test setup as established in step 1, then change connections per step 17b and reconnect PS2 ground to P1-8.			
	P1-1, P1-12	Same as step 1	b. Turn power supplies PS1 and PS2 on. c. Set decade box to 30 ohms <u>only</u> long enough to obtain stable ammeter reading, then switch back to 530 ohms. d. Set decade box to 5 ohms <u>only</u> long enough to obtain stable ammeter reading, then switch back to 530 ohms.	Current is 150 \pm 20 ma. Current is 0.9 \pm 0.1 amp.	Test complete.	Replace transistor Q10. Replace transistor Q4.

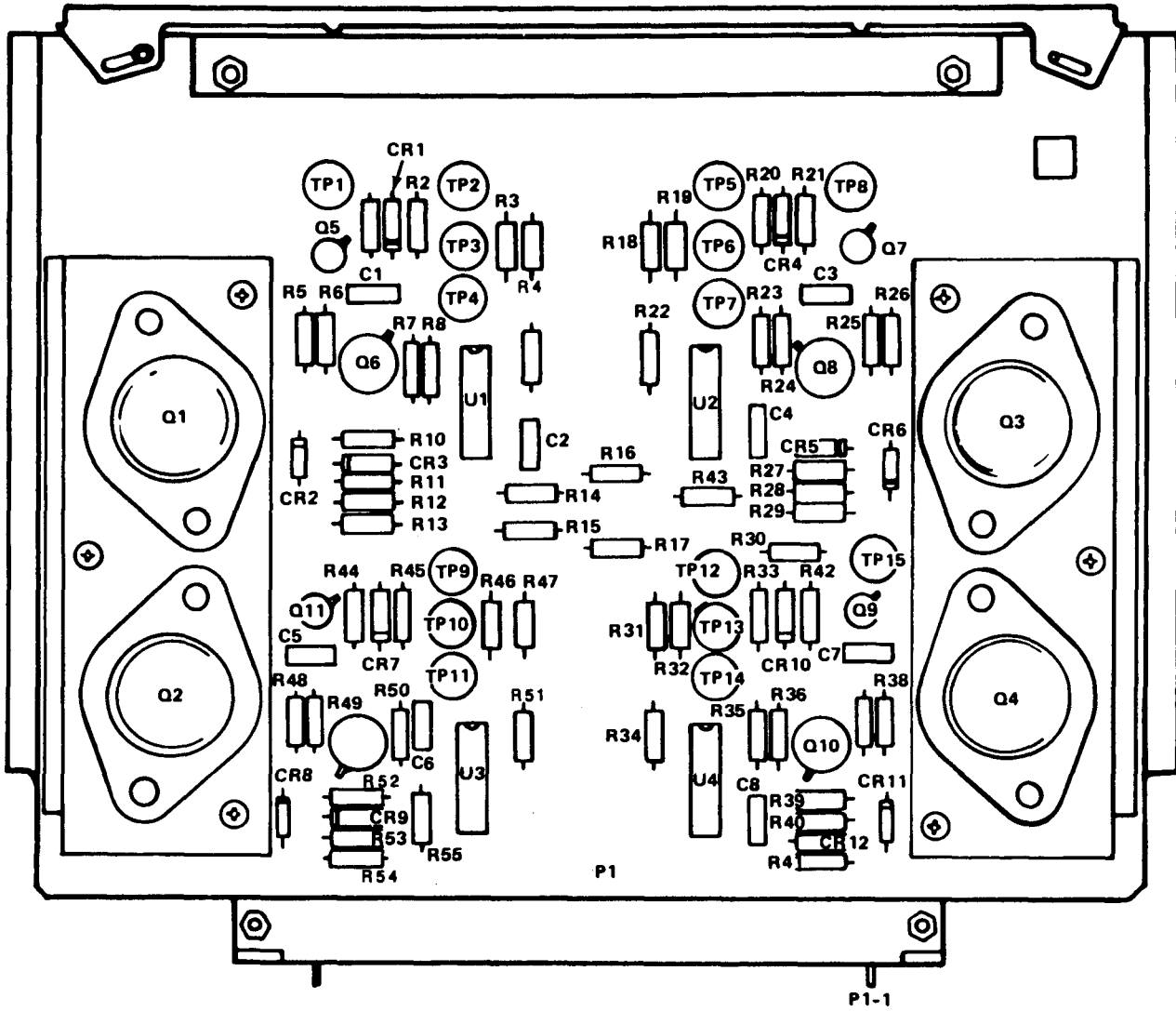
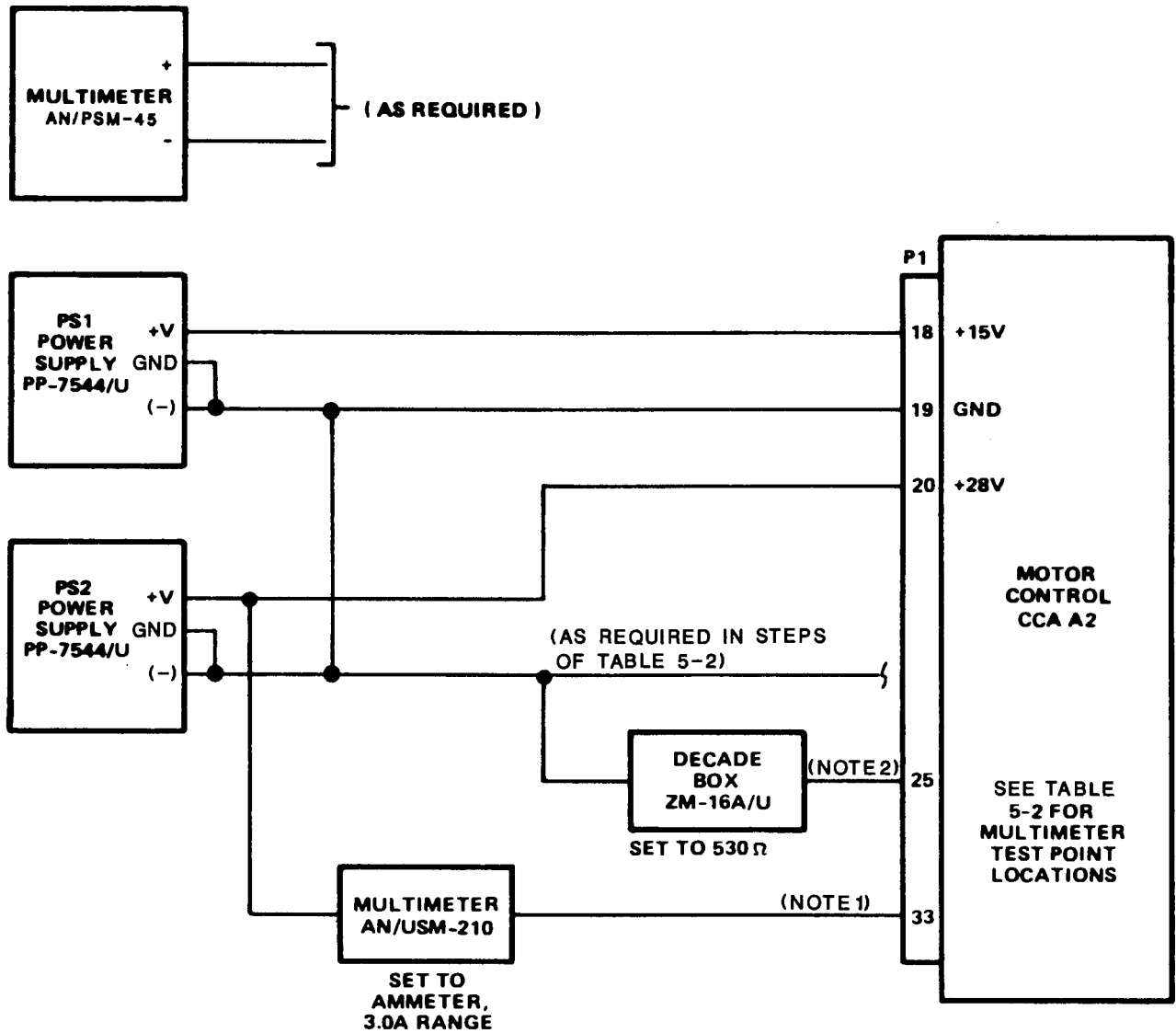

Figure 5-4. Motor Control CCA A2 Component Locations



NOTES:

1. Connect for tests as follows: Test A1 High, P1-33; A2 High, P1-32; B1 High, P1-10; and B2 High, P1-1.
2. Connect for tests as follows: Test A1 and A2 High, P1-25; B1 and B2 High, P1-12.

Figure 5-5. Motor Control CCA A2 Test Setup

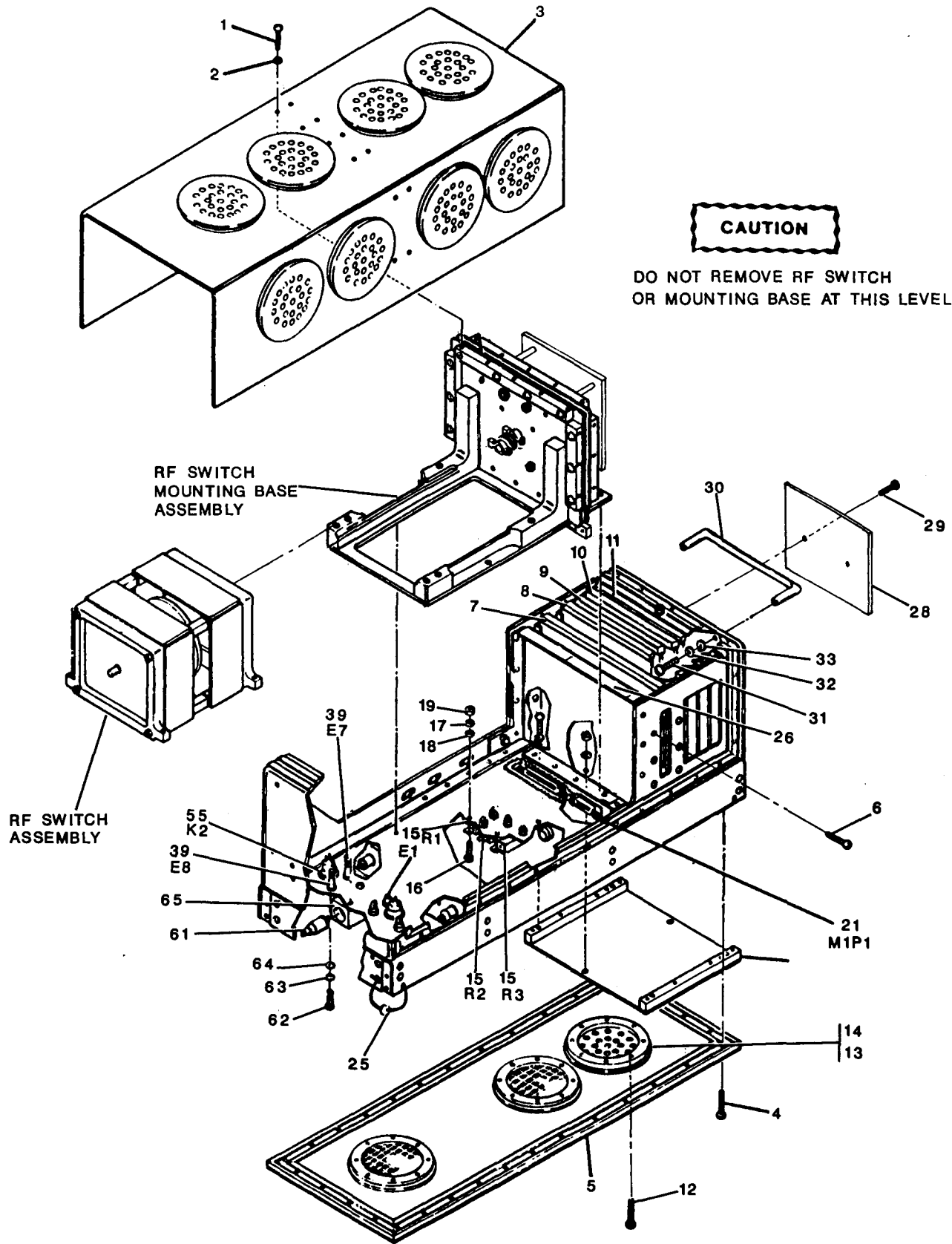

Figure 5-6. Tunable Coupler Component Locations
(Sheet 1 of 2)

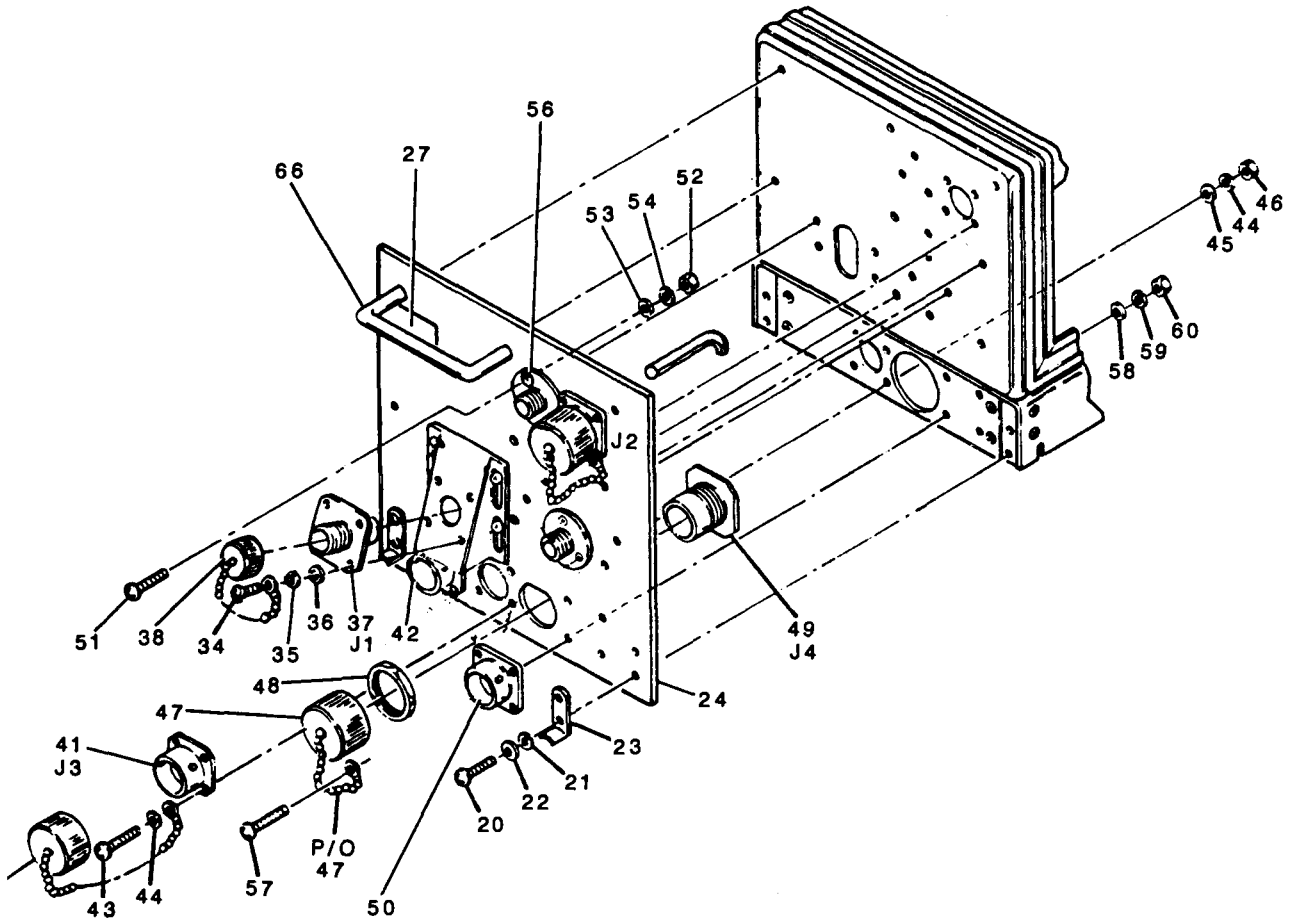

Figure 5-6. Tunable Coupler Component Locations
(Sheet 2 of 2)

5-9.1 Inspection of Chassis Items. To inspect the chassis and chassis-mounted components proceed as follows:

- a. Check for discolored, burned or cracked wire insulation, or broken wires or terminals. Also check for cracked heatshrink tubing.
- b. Check cable connectors for correct pin depth.
- c. Check for loose or broken tie wrap mounts, mounting clamps, tiedown straps or grommets.
- d. Check for discolored (cold), cracked, or loose solder connections.
- e. Check for leaking, bulging, or burned capacitors or filters.
- f. Check for discolored, burned, powdered, or cracked diodes, resistors, or other semiconductor devices.
- g. Check for damaged brackets, covers, housings, and plates. Check for loose or missing attaching hardware.
- h. Inspect exterior surfaces of the unit for dust, chipped paint, locations and corrosion. If necessary, spot paint surfaces as follows:
 1. Remove rust and corrosion from metal surfaces by lightly sanding them with No. 000 sandpaper (item 16, App. D).
 2. Brush two coats of light green semi-gloss enamel (item 5, App. D), MIL-E-15090 Class 2, type III, color number 24410, IAW Standard 595, on bare metal to protect it from further corrosion.
 3. Refer to the applicable cleaning and refinishing practices specified in TB 43-0118.

5-9.2 Inspection of CCAs. To inspect the CCAs proceed as follows:

CAUTION

Certain CCAs contain electrostatic discharge sensitive (ESDS) devices that can be damaged by static electricity. Special handling methods and materials must be used to prevent damage. Do not touch or remove any ESDS device or circuit without properly grounding your body, tools, and test equipment. Handle such CCAs on the edge only, and store such CCAs in conductive (antistatic) bags.

- a. Check for cracked circuit card.
- b. Check for loose or damaged shields or heatsinks.

- c. Check for printed wiring traces that are loose, broken, or otherwise damaged.
- d. Check for loose, burned, or broken connectors.
- e. Check for discolored, burned, or broken wiring.
- f. Check for cracked, discolored, or burned component insulator pads.
- g. Check for burned, powdered, or broken resistors, diodes, transistors, and ICs.
- h. Check for leaking, bulging, cracked, burned, or powdered capacitors or inductors.

5-9.3 Cleaning.

- a. Remove dust and loose dirt from exterior surfaces with a clean, soft cloth (item 3, Appendix D).
- b. Remove dust and dirt from cable and CCA connectors, internal wiring and other surfaces with a soft brush (item 2, Appendix D).

WARNING

Adequate ventilation should be provided while using trichlorotrifluoroethane. Prolonged breathing of vapor should be avoided. The solvent should not be used near heat or open flame; the products of decomposition are toxic and irritating. Since trichlorotrifluoroethane dissolves natural oils, prolonged contact with skin should be avoided. When necessary, use gloves (item 7, App. D) that the solvent cannot penetrate. If the solvent is taken internally, consult a physician immediately.

- c. Remove grease and/or ground-in dirt with a cloth dampened (not wet) with trichlorotrifluoroethane (item 19, Appendix D).

5-10 REMOVAL PROCEDURES.

Disassembly of the tunable coupler consists of removal of the top and bottom covers to gain access to interior subassemblies, and removal of subassemblies. Where removal procedures are obvious, no instructions are provided. Refer to figure 5-6 for the location of the components.

WARNING

Before performing any removal procedure, ensure that power is disconnected from the tunable coupler.

5-10.1. Top Cover Removal. Remove 68 screws (1) and flat washers (2) that secure top cover (3) to chassis. Lift cover straight up and off chassis.

5-10.2. Bottom Panel Removal.

- a. Place chassis in upside-down position.
- b. Remove 28 screws (4) that secure the bottom panel (5) to chassis.
- c. Remove panel from chassis.

5-10.3. Circuit Card Assembly A1 and A2 Removal.

- a. Remove top cover (3) in accordance with paragraph 5-10.1.
- b. Remove four screws (two on each side) (6) that secure CCA A1(7) or A2 (8) in chassis.
- c. Grasp CCA by top edge and pull out of chassis.

5-10.4. Circuit Card Assembly A3, A4, and A5 Removal.

- a. Remove top cover (3) in accordance with paragraph 5-10.1.
- b. Grasp the CCA A3 (9), A4 (10), or A5 (11) by top edge and pull out of chassis.

5-10.5. Vent Cover and Screen Assembly Removal.

- a. Remove the top cover (3) or bottom panel (5) in accordance with paragraph 5-10.1 or 5-10.2 as required to have access to the vent cover.
- b. Remove the eight rivets (12) securing vent cover (13) and screen assembly (14) in accordance with paragraph 5-10.19 and remove the vent cover and the screen assembly.

5-10.6. Resistor R1, R2 and R3 Removal.

- a. Remove top cover (3) in accordance with paragraph 5-10.1.
- b. Remove bottom panel (5) in accordance with paragraph 5-10.2.
- c. Tag and unsolder the two wires from resistor to be removed (15).

- d. Remove the two screws (16) , lock washers (17), flat washers (18), and nuts (19) that secure each resistor to the chassis and remove resistor.

5-10.7. Front Hook Removal. Remove the two screws (20), flat washers (21), and lock washers (22), that secure each hook (23) to the front panel (24). Remove each hook.

5-10.8. Diode CR1 Removal.

- a. Remove bottom panel (5) in accordance with paragraph 5-10.2.
- b. Tag and unsolder the two wires to the diode (25) from terminals E7 (39) and E8 (39). Remove the diode.

5-10.9. Decal Removal.

- a. Remove top cover (3) in accordance with paragraph 5-10.1.

WARNING

Adequate ventilation should be provided while using trichlorotrifluoroethane. Prolonged breathing of vapor should be avoided. The solvent should not be used near heat or open flame; the products of decomposition are toxic and irritating. Since trichlorotrifluoroethane dissolves natural oils, prolonged contact with skin should be avoided. When necessary, use gloves (item 7, App. D) that the solvent cannot penetrate. If the solvent is taken internally, consult a physician immediately.

- b. Remove the old adhesive securing old decal (26) using cloth dampened (not wet) with trichlorotrifluorethane (item 19, App. D), and pull away decal.

5-10.10. Warning Plate Removal.

WARNING

Adequate ventilation should be provided while using trichlorotrifluoroethane. Prolonged breathing of vapor should be avoided. The solvent should not be used near heat or open flame; the products of decomposition are toxic and irritating. Since trichlorotrifluoroethane dissolves natural oils, prolonged contact with skin should be avoided. When necessary, use gloves (item 7, App. D) that the solvent cannot penetrate. If the solvent is taken internally, consult a physician immediately.

Remove the old adhesive securing the warning plate (27) using a cloth dampened (not wet) with trichlorotrifluoroethane (item 19, App. D) and peel away warning plate.

5-10.11. Identification Plate Removal. Remove the two rivets (29) securing identification plate (28) to tunable coupler in accordance with paragraph 5-10.19. Remove identification plate.

5-10.12. Handle Removal.

- a. Remove the top cover (3) in accordance with paragraph 5-10.1.
- b. To gain access to the attaching hardware for the rear handle (30), remove circuit card assemblies A1 through A5 (7 through 11) in accordance with paragraph 5-10.3 and 5-10.4.
- c. To remove handle (30 or 66) remove the two screws (31), lock washers (32), and flat washers (33) securing each handle to the chassis.

5-10.13. Connector J1 Removal.

- a. Remove the top cover (3) in accordance with paragraph 5-10.1.
- b. Remove the four screws (34), lock washers (35) and flat washers (36) securing the connector J1 (37) and the connector cap (38) to the tunable coupler.
- c. Tag and unsolder wire to connector J1 and remove connector.
- d. Slowly pull connector J1 away from the mounting base, taking up the slack in the wire from J1 to relay K2 (55) to gain access to the back of the connector.

5-10.14. Connector J3 Removal.

- a. Remove bottom panel (5) in accordance with paragraph 5-10.2.
- b. Remove the connector cap (40) from connector J3 (41) and place on the blank connector (42).
- c. Remove the four screws (43), eight flat washers (44), four lock washers (45) and four nuts (46) securing connector J3 to the front panel (24). Remove connector J3.
- d. Tag all wires to J3 for proper reconnection, then use extractor tool to remove wires from connector.

5-10.15. Connector J4 Removal.

- a. Remove bottom panel (5) in accordance with paragraph 5-10.2.
- b. Remove the connector cap (47) from connector J4 (49) and place on the blank connector (50).
- c. Remove the jam nut (48) securing connector to front panel (24) and remove connector.
- d. Remove screws from FL-5 to allow access to rear of J4.

- e. Tag all wires to J4 for proper reconnection, then use extractor tool to remove wires from connector.

5-10.16. Blank Connector for J2 Removal.

- a. Remove top cover (3) in accordance with paragraph 5-10.1.
- b. Remove the three screws (51), nuts (52), and four lock washers (54) and flat washers (53) securing the blank connector (56) to the front panel (24). Remove the blank connector.

5-10.17. Blank Connectors for J3 and J4 Removal.

- a. Remove the bottom panel (5) in accordance with paragraph 5-10.2.
- b. Remove the four screws (57) , lock washers (58), flat washers (59) and nuts (60) securing the blank connector (42 and 50) with connector cap and chain (47 or 40).

5-10.18. Filter FL5 Removal.

- a. Remove bottom panel (5) in accordance with paragraph 5-10.2.
- b. Tag and unsolder the wires to filter FL5 (61).
- c. Remove the two screws (62), lock washers (63) and flat washers (64) securing filter shield (65) to the chassis.
- d. Remove the filter shield from the chassis and the filter from the filter shield.

5-10.19. Rivet Removal.

- a. File a flat area on the head of the rivets securing the vent cover or identification plate.
- b. Center punch on the flat surface of the rivet heads.
- c. Select a drill one size smaller than the rivet shank and drill out the rivet heads. Drill the rivet to the depth of its head, while holding the drill at a 90° angle. The rivet head will often break away and climb the drill, which is a good signal to withdraw the drill.
- d. If the rivet head does not come loose of its own accord, insert a drift punch into the hole and twist slightly to either side until the head comes off.
- e. Drive out the shank of the rivets with a drift punch slightly smaller than the diameter of the shank.

5-11. REPLACEMENT PROCEDURES.

Refer to figure 5-6 for the location of the components.

WARNING

Before performing any replacement procedure, ensure that power is disconnected from the tunable coupler.

5-11.1. Top Cover Replacement.

- a. Place cover (3) on chassis.
- b. Replace and tighten screws (1) and flat washers (2) in sequence shown in figure 5-7.

5-11.2. Bottom Panel Replacement.

- a. Place chassis in upside-down position.
- b. Replace 28 screws (4) that secure bottom panel (5) to chassis.

5-11.3. Circuit Card Assembly A1 and A2 Replacement (figure 5-1).

- a. Place CCA (7 or 8) in proper slot (see figure 5-2). Slide CCA evenly into chassis until CCA connector and motherboard connector engage.
- b. Press firmly on CCA to verify it is properly seated in motherboard connector.

NOTE

If a gap exists between CCA heatsink and chassis heatsink, install shims (item 8, Appendix D) between CCA heatsink and CCA as required.

- c. Install four screws (two on each side) (6) that secure CCA in chassis.
- d. Replace top cover (3) in accordance with paragraph 5-11.1.

5-11.4. Circuit Card Assembly A3, A4, and A5 Replacement.

- a. Place CCA (9, 10, or 11) in proper slot (see figure 5-2). Slide CCA evenly into the chassis until CCA connector and motherboard connector engage.
- b. Press firmly on CCA to verify it is properly seated in motherboard connector.
- c. Replace top cover (3) in accordance with paragraph 5-11.1

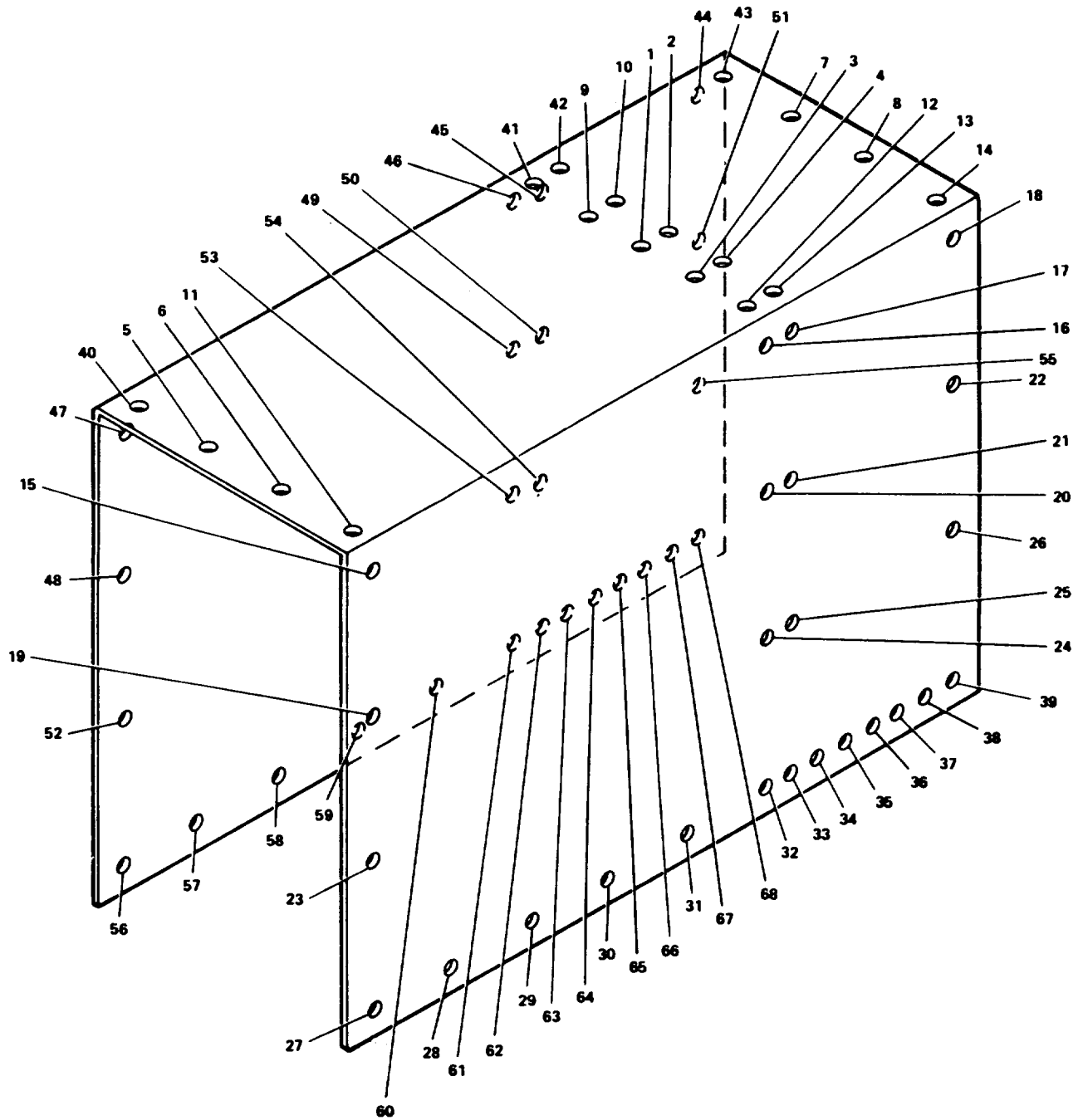

Figure 5-7. Tunable Coupler Cover Replacement

5-11.5. Vent Cover and Screen Assembly Replacement

- a. Position the vent cover (13) and screen assembly (14) in place and secure with eight 3/32 inch diameter x 1/4 inch long rivets (12) using the riveter kit.
- b. Replace the top cover (3) or bottom panel (5) in accordance with paragraph 5-11.1 or 5-11.2 as required.

5-11.6. Resistors R1, R2 and R3 Replacement.

- a. Secure each resistor to the chassis with two screws (16), lock washers (17), flat washers (18) and nuts (19).
- b. Solder the two wire to each resistor as previously tagged.
- c. Replace bottom panel (5) in accordance with paragraph 5-11.2.
- d. Replace top cover (1) in accordance with paragraph 5-11.1

5-11.7. Front Hook Replacement. Position each hook (23) in place on the front panel (24) and secure with two screws (20), flat washers (21), and lock washers (22).

5-11.8. Diode CR1 Replacement.

- a. Position diode CR1 (25) in place with cathode connected at terminal E8 (39) and anode at terminal E7 (39).
- b. Solder the two wires to the terminals and diode as previously marked.
- c. Replace bottom panel (5) in accordance with paragraph 5-11.2.

5-11.9. Decal Replacement.

- a. After surface has dried from the decal removal procedure, position the new decal (26) in place so that it is located symmetrically and can be read from the front of the unit.
- b. Peel away the decal protective backing and press firmly in place.
- c. Replace top cover (1) in accordance with paragraph 5-11.1.

5-11.10. Warning Plate Replacement.

- a. After surface has dried from the warning plate removal procedure, position the new warning plate (27) in place so that it can be read when facing the front panel with the tunable coupler top side up.
- b. Peel away the warning plate protective backing and press firmly in place.

5-11.11. Identification Plate Replacement.

NOTE

If identification plate is being replaced, ensure that correct tunable coupler serial number has been permanently marked on the identification plate.

Position the identification plate (28) in place and secure with two rivets (29) using the riveting kit.

5-11.12. Handle Replacement.

- a. Place each handle (30 or 66) in position and secure with two screws (31), lock washers (32) and flat washers (33).
- b. When the rear handle is replaced, replace circuit card assemblies A1 through A5 (7 through 11) in accordance with paragraphs 5-11.3 and 5-11.4.
- c. Replace the top cover (3) in accordance with paragraph 5-11.1.

5-11.13. Connector J1 Replacement.

- a. Solder the wire from relay K2 (55), to center terminal of connector J1 (37).
- b. Carefully push the wire back through the mounting hole and position the connector in place.
- c. Secure the connector and connector cap chain (38) to the tunable coupler with four screws (34), lock washers (35) and flat washers (36). The chain is secured at the lower right mounting hole.
- d. Replace the top cover (3) in accordance with paragraph 5-11.1.

5-11.14. Connector J3 Replacement.

- a. Position Connector J3 (41) in place with wide key slot oriented at 3 o'clock, i.e., toward J4 (49), and secure with four screws (43), eight flat washers (44), four lock washers (45), and four nuts (46). The chain attaching connector cap (40) is secured at lower right mounting hole.
- b. Use insertion tool to insert wires into connector as previously tagged.
- c. Remove the connector cap (40) from the blank connector (42) and secure on connector J3.
- d. Replace bottom panel (5) in accordance with paragraph 5-11.

5-11.15. Connector J4 Replacement.

- a. Use insertion tool to insert wires into connector as previously tagged.
- b. Position connector J4 (49) in place and secure with jam nut (48).
- c. Secure FL5 to chassis with screws and washers.
- d. Remove the connector cap (47) from the blank connector (50) and secure on connector J4.
- e. Replace the bottom panel (5) in accordance with paragraph 5-11.2.

5-11.16. Blank Connector for J2 Replacement.

- a. Position the blank connector (56) in place and secure with three screws (51) and nuts (52) and four lock washers (54) and flat washers (53).
- b. Replace top cover (3) in accordance with paragraph 5-11.1.

5-11.17. Blank Connectors for J3 and J4 Replacement.

- a. Position the blank connector (50 or 42) in place with the connector cap chain (47 or 40) and secure with four screws (57), lock washers (58), flat washers (59), and nuts (60). The chain for the connector cap is secured at the low corner nearest the connector it will cover.
- b. Replace the bottom panel (5) in accordance with paragraph 5-11.2.

5-11.18. Filter FL5 Replacement.

- a. Replace the filter FL5 (61) inside the filter shield (65).
- b. Position the filter shield (65) in place and secure with two screws (62), lock washers (63) and flat washers (64).
- c. Solder the wires to filter as previously tagged.
- d. Replace the bottom panel (5) in accordance with paragraph 5-11.2.

5-11.19. Riveting.

To replace a rivet(s) on a vent cover or the identification plate obtain and install appropriate size rivet from riveter kit (See MAC, App. B). Using the riveter and appropriate size head, install the replacement rivet.

5-12. CIRCUIT CARD ASSEMBLY REPAIR PROCEDURES.

Removal and replacement of a CCA component requires the use of a low-wattage (30 watts or less) soldering iron and appropriate heatsinks. Standard shop practices, along with general practices and precautions for CCA and microelectronic components, should be observed when performing these repairs.

5-12.1. Power Supply CCA A1 Repair Procedures. Refer to figure 5-3 for component locations.

- a. When replacing heatsink mounted components Q2, Q5, Q6, and CR6, lightly coat component and heatsink mating surfaces with thermal transfer compound (item 4, Appendix D).
- b. Apply adhesive (item 1, Appendix D) to capacitors C1, C2, C6, C9, C10, C13, and C14 to attach them to circuit board.
- c. Apply a continuous fillet of adhesive (item 1, Appendix D) to area behind plug P1.
- d. Determine type of conformal coating used on repaired CCA. Test a small area away from components with freon TFE, TE, or TME (item 6, Appendix I)). If freon strips away coating, coating is humiseal 1R31. If it does not strip away, coating is humiseal 1A33. Patch conformal coating with appropriate type of humiseal in test and repair areas. Humiseal 1A33 and 1B31 (items 10 & 11, Appendix D) are not compatible. Patch conformal coating only with type already present on CCA.

5-12.2. Motor Control CCA A2 Repair Procedures. Refer to figure 5-4 for component locations.

- a. When replacing heatsink mounted components Q1, Q2, Q3, and Q4, lightly coat component and heatsink mating surface with thermal transfer compound (item 4, Appendix D).
- b. Apply a continuous fillet of adhesive (item 1, Appendix D) to area behind plug P1.
- c. Determine type of conformal coating used on repaired CCA. Test a small area away from components with freon TFE, TE, or TME. If freon strips away coating, coating is humiseal 1B31. If it does not strip away, coating is humiseal 1A33. Patch conformal coating with appropriate type of humiseal in test and repair areas. Humiseal 1A33 and 1B31 (items 10 & 11, Appendix D) are not compatible. Patch conformal coating only with type already present on CCA.

5-13. GASKET REPLACEMENT.

CAUTION

Fitting the EMI/RFI gasket is critical to ensure an air-tight closure that meets the anti-sparking requirements of Tunable Coupler CU-2293/ALQ-151(V).

To replace the bottom cover or chassis gasket, refer to Appendix E.

Section V. GENERAL SUPPORT TEST PROCEDURES

5-14. GENERAL.

This section provides the test procedure that should be performed after any repair and alignment is completed to determine whether the performance of the repaired tunable coupler is satisfactory for return to the user.

5-15. TEST.

Perform all the steps in tables 5-1 and 5-2 to verify operation of power supply CCA A1 and motor control CCA A2. Perform each step in the sequence listed. Then, ensure that the ATE tests in TM 32-5865-216-40&P are performed to verify satisfactory performance of the tunable coupler.

APPENDIX A

REFERENCES

A-1. SCOPE.

This appendix lists all technical manuals, miscellaneous publications, regulations, and forms referenced in this manual or pertaining to Tunable Coupler CU-2293/ALQ-151(V).

A-2. TECHNICAL MANUALS.

<u>Publication Number</u>	<u>Title</u>
TM 32-5865-216-40&P	Maintenance Instructions, General Support, Tunable Coupler CU-2293/ALQ-151(V)
TM 32-5865-012-10	Operation Instructions, Special Purpose Countermeasures System AN/ALQ-151(V)2
TM 32-5865-012-20	Maintenance Instructions, Organizational, Special Purpose Countermeasures System AN/ALQ-151(V)2
TM 38-230-1	Packaging of Material: Preservation
TM 38-230-2	Packaging of Material: Packing
TM 38-260	Preparation of Industrial Plant Equipment for Storage or Shipment
TM 43-0139	Painting Instructions for Field Use
TM 740-90-1	Administrative Storage of Equipment
TM 750-244-2	Procedures for Destruction of Electronics Materiel to Prevent Enemy Use (Electronics Command)
TB 43-0118	Field Instructions for Painting and Preserving Electronics Command Equipment Including Camouflage Pattern Painting of Electrical Equipment Shelters

A-3. SUPPLY BULLETINS.

<u>Publication Number</u>	<u>Title</u>
SB 11-573	Painting and Preservation Supplies Available for Field Use for Electronics Command Equipment

<u>Publication Number</u>	<u>Title</u>
SB 38-100	Preservation, Packaging and Packing Materials, Supplies and Equipment Used by the Army
SB 708-41/42	Federal Supply Code for Manufacturers, United States and Canada, Code to Name, Cataloging Handbook H4-2.

A-4. COMMON TABLE OF ALLOWANCES.

<u>Publication Number</u>	<u>Title</u>
CTA 50-970	Expendable Items

A-5. PAMPHLETS.

<u>Publication Number</u>	<u>Title</u>
DA PAM 310-1	Index of Administrative Publications
DA PAM 310-2	Index of Blank Forms
DA PAM 310-4	Index of Technical Manuals; Technical Bulletins, Supply Manuals (Types 7, 8, 9), Supply Bulletins, and Lubrication Orders
DA PAM 738-750	The Army Maintenance Management System (TAMMS)

A-6. ARMY REGULATIONS.

<u>Publication Number</u>	<u>Title</u>
AR 310-25	Dictionary of United States Army Terms
AR 310-50	Catalog of Abbreviations and Brevity Codes
AR 55-38	Reporting of Transportation Discrepancies in Shipments

A-7. FORMS.

<u>Publication Number</u>	<u>Title</u>
DA Form 2028	Recommended Changes to Publications and Blank Forms
DA Form 2404	Equipment Inspection and Maintenance Work Sheets

<u>Publication Number</u>	<u>Title</u>
DA Form 2407	Maintenance Request
DA Form 2408	Equipment Log Assembly (Records)
DA Form 2408-1	Equipment Daily Log
DA Form 2408-5	Equipment Modification Record
SF 361	Discrepancy in Shipment Report
SF 364	Report of Discrepancy
SF 368	Quality Deficiency Report

APPENDIX B
MAINTENANCE ALLOCATION CHART

Section I. INTRODUCTION

B-1. GENERAL.

a. The Maintenance Allocation Chart identifies the maintenance operations that must be performed. It assigns each of those operations to the lowest level of maintenance authorized to perform the complete task, or any part of the task, in terms of availability of time, tools, test and support equipment, skills and employment of the subsystem.

b. The Maintenance Allocation Chart (MAC) in Section II designates overall responsibility for the performance of maintenance functions for the Tunable Coupler C-2293/ALQ-151(V).

c. Section III lists the special tools and test equipment required for each maintenance function as referenced from Section II.

d. Section IV contains supplemental instructions on explanatory notes for a particular maintenance function.

B-2. MAINTENANCE FUNCTIONS.

a. **Inspect.** To determine the serviceability of an item by comparing its physical, mechanical and /or electrical characteristics with established standards through examination.

b. **Test.** To verify serviceability and detect incipient failure by measuring the mechanical or electrical characteristics of an item and comparing those characteristics with prescribed standards.

c. **Service.** Operations required periodically to keep an item in proper operating condition; i.e., to clean (decontaminate), preserve, drain, paint or replenish fuel, lubricants, hydraulic fluids, or compressed air supplies.

d. **Adjust.** To maintain, within prescribed limits, by bringing into proper or exact position, or by setting the operating characteristics to specified parameters.

e. **Aline.** To adjust specified variable elements of an item to bring about optimum or desired performance.

f. **Calibrate.** To determine and cause corrections to be made or to be adjusted on instruments or test, measuring and diagnostic equipment used in precision measurement. Consists of comparisons of two instruments, one of which is a certified standard of known accuracy; to detect and adjust any discrepancy in the accuracy of the instrument being compared,

g. **Install.** The act of emplacing, seating, or fixing into position an item, part, or module/component/assembly in a manner to allow the proper functioning of an equipment or system,

h. **Replace.** The act of substituting a serviceable like type part, subassembly, or module/component/assembly for an unserviceable counterpart.

i. **Repair.** The application of maintenance services¹ or other maintenance actions² to restore serviceability to an item by correcting specific damage, fault, malfunction, or failure in a part, subassembly, module, component, assembly, of an item or system,

j. **Overhaul.** The maintenance effort (services/actions) necessary to restore an item to a completely serviceable/operational condition as prescribed by maintenance standards (i.e., DMWR) in appropriate technical publication. Overhaul is normally the highest degree of maintenance performed by the Army. Overhaul does not normally return an item to like new condition.

k. **Rebuild.** Consists of those services/actions necessary for the restoration of unserviceable equipment to a like new condition in accordance with original manufacturing standards, Rebuild is the highest degree of material maintenance applied to Army equipment. The rebuild operation includes the act of returning to zero those age measurements (hours/miles, etc.) considered in classifying Army equipments/components.

B-3 . COLUMN ENTRIES USED IN THE MAC.

a. **Column 1, Group Number.** Column 1 lists group numbers, the purpose of which is to identify components, assemblies, subassemblies, and modules with the next higher assembly.

b. **Column 2, Component/Assembly.** Column 2 contains the names of components, assemblies, subassemblies, and modules with the next higher assembly.

c. **Column 3, Maintenance Functions.** Column 3 lists the function to be performed on the item listed in column 2. (For detailed explanation of these function, see paragraph B-2.)

¹ Services-inspect, test, service, adjust, aline, calibrate, or replace.

²Action - welding, grinding, riveting, straightening, facing, remachining, or resurfacing.

d. **Column 4, Maintenance Category.**

(1) Column 4 specifies, by the listing of a "work time" figure in the appropriate subcolumn(s), the lowest level of maintenance authorized to perform the function listed in column 3. This figure represents the active time required to perform the maintenance function, at the indicated level of maintenance,

(2) If the number or complexity of the tasks within the listed maintenance function vary at different maintenance levels, appropriate "work time" figures will be shown for each level. The number of man-hours specified by the "work time" figure represents the average time required to restore an item (assembly/subassembly/component/module/end item/system) to a serviceable condition under typical field operating conditions. This time includes preparation time, troubleshooting time, and quality assurance/quality control time in addition to the time required to perform the specific tasks identified for the maintenance functions authorized in the Maintenance Allocation Chart. The symbol designations for the various maintenance levels are as follows:

- C - Operator or crew.
- O - Organizational maintenance.
- F - Direct support maintenance.
- H - General support maintenance.
- D - Depot maintenance.

e. **Column 5, Tools and Equipment.** Column 5 specifies, by code, those common tool sets (not individual tools), special tools and test equipment required to perform the designated function.

f. **Column 6, Remarks.** Column 6 contains a letter code in alphabetical order which is keyed to the remarks contained in Section IV. If no remarks were required, column 6 remains blank and Section IV is deleted.

B-4. COLUMN ENTRIES USED IN TOOL AND TEST EQUIPMENT REQUIREMENTS (SECTION III).

a. **Column 1, Tool or Test Equipment Reference Code.** The tool and test equipment reference code correlates with a maintenance function on the identified end item or component.

b. **Column 2, Maintenance Category.** The lowest level of maintenance authorized to use the tool or test equipment.

c. **Column 3, Nomenclature.** Name or identification of the tool or test equipment,

d. **Column 4, National/NATO Stock Number.** The National or NATO stock number of tool or test equipment.

e. **Column 5, Tool Number.** The manufacturer's part number.

B-5. EXPLANATION OF COLUMNS IN SECTION IV.

a. **Reference Code.** The code scheme recorded in Column 1, Section III.

b. **Remarks.** This column lists information pertinent to the maintenance function being performed as indicated on the MAC, Section II. If no remarks are required, column 6 in Section II remains blank and Section IV is deleted.

SECTION II. MAINTENANCE ALLOCATION CHART FOR
TUNABLE COUPLER CU-2293/ALQ-151(V)

(1) GROUP NUMBER	(2) COMPONENT/ASSEMBLY	(3) MAINTENANCE FUNCTION	(4) MAINTENANCE CATEGORY					(5) TOOLS AND EQUIPMENT	(6) REMARKS
			C	O	F	H	D		
0501	TUNABLE COUPLER	INSPECT						9	
		TEST				0.5		2,9	B
		ALINE				0.5		1,9	
		SERVICE				0.5			
		REPAIR				0.4		2,5,6,9	
0502	PRINTED CIRCUIT BOARD	REPAIR					X		A
		INSPECT				0.1			
		TEST				0.5		1,3,6,7,9,10	
		REPLACE				0.5		9	
0503	PRINTED WIRING BOARD	REPAIR				0.5		1,3,6,7,9,10	
		INSPECT				0.1			
		TEST				0.5		1,3,6,7,9	
		REPLACE				0.5			
0504	CHASSIS ASSEMBLY, CO	REPAIR					X		A
		REPLACE					X		A
0505	COVER ASSEMBLY, CHASSIS	REPLACE				0.1		9	
		REPAIR				0.5			
		REPAIR				0.3		4,8,9	
0507	COVER ASSEMBLY, LOWER	INSPECT				0.1			
		REPLACE				0.4			
		REPAIR				0.5		4,8,9	
0508	RADIO FREQUENCY SWITCH	REPLACE					X		A
		REPAIR					X		A
0508	MOUNTING BASE ASSEMBLY	REPLACE					X		A
		REPAIR					X		A

SECTION II. MAINTENANCE ALLOCATION CHART FOR
TUNABLE COUPLER CU-2293/ALQ-151(V) - CONT.

(1) GROUP NUMBER	(2) COMPONENT/ASSEMBLY	(3) MAINTENANCE FUNCTION	(4) MAINT CA					(5) TOOLS AND EQUIPMENT	(6) REMARKS
			C	O	F	H	D		
0510	PRINTED WIRING BOARD	INSPECT				0.1			
		TEST				0.5		1,6,7,9,10	
		REPLACE				0.5			
		REPAIR				0.5		1,6,7,9	
0511	PRINTED WIRING BOARD	REPLACE					X		A
		REPAIR					X		A
0512	PRINTED WIRING BOARD	REPLACE					X		A
		REPAIR					X		A
0514	MOTOR/SLEEVE ASSEMBLY	REPLACE					X		A
		REPAIR					X		A
0523	BASE ASSEMBLY, MOUNT	REPLACE					X		A
		REPAIR					X		A
0526	CONNECTOR CAP ASSEMBLY	INSPECT				0.1			
		REPLACE				0.3			
		REPAIR				0.3		4,8,9	

SECTION III. TOOL AND TEST EQUIPMENT REQUIREMENTS FOR
TUNABLE COUPLER CU-2293/ALQ-151(V)

TOOL OR TEST EQUIP REF CODE	MAINTENANCE CATEGORY	NOMENCLATURE	NATIONAL/NATO STOCK NUMBER	TOOL NUMBER
1	H	MULTIMETER, DIGITAL (QUANTITY: 2)	6625-01-139-2512	AN/PSM-45
2	H	TEST SET	6625-01-069-4223	AN/USM-410(V)2
3	H	OSCILLOSCOPE	6625-01-187-7847	AN/USM-488
4	H	RIVETER KIT	6665-01-022-4165	HP-200
5	H	MAINTENANCE KIT, ELECTRONIC	6625-01-068-1665	MK-1961/G
6	H	MAINTENANCE KIT, ELECTRONIC	6625-01-068-1666	MK-1962/G
7	H	POWER SUPPLY	- - -	PP-7544/U
8	H	TOOL KIT, ELECTRONIC EQUIPMENT	5180-00-605-0079	TK-100/G
9	H	TOOL KIT, ELECTRONIC EQUIPMENT	5180-00-610-8177	TK-105/G
10	H	RESISTOR DECADE (QUANTITY: 3)	- - -	ZM-16A/U

SECTION IV. REMARKS

<i>Reference Codes</i>	<i>Remarks</i>
A	Refer to DMWR 32-5865-216 for depot-level removal, replacement, and repair instructions, as necessary.
B	This LRU is tested using the AN/USM-410(V)2 Automatic Test Equipment.

APPENDIX C
 REPAIR PARTS AND SPECIAL TOOLS LIST
 FOR
 TUNABLE COUPLER CU-2293/ALQ-151(V)

TABLE OF CONTENTS

		Page	Illus Figure
Section	I	INTRODUCTION	C-3
	II	REPAIR PARTS LIST	C-9
Group	05	Tunable Coupler CU-2293	C-9
		ALQ-151(V)	C-1
	0501	Power Supply CCA A1 C5073889-1	C-18 C-2
	0502	Motor Control CCA A2 C5073893-1	C-24 C-3
	0503	Chassis Assembly	C-13 C-1
	0504	Cover Assembly, Chassis	C-13 C-1
	0505	Cover Assembly, Lower	C-13 C-1
	0506	Front Panel	C-13 C-1
	0507	RF Switch Assembly	C-13 C-1
	0508	Mounting Base Assembly	C-13 C-1
	0509	Feedback Mounting Post	C-13 C-1
	0510	Control Logic CCA A3 C5073901-1	C-30 C-4
	0511	Decoder CCA A4 C5073897-1	C-33 C-5
	0513	Motherboard CCA A7 C5073909	C-36 C-6
	0514	Motor/Sleeve Assembly	C-13 C-1
	0515	Heatsink Shim	C-13 C-1
	0516	Relay	C-13 C-1
	0517	Power Board Assembly A6	C-13 C-1
	0518	Stiffener	C-13 C-1
	0519	Thermal Clamp	C-13 C-1
	0520	Hub/Contact Assembly	C-13 C-1
	0521	Coupler	C-13 C-1
	0522	Mount T3ase Assembly	C-13 C-1
	0523	Filter	C-13 C-1
	0524	Connector, Receptacle	C-13 C-1
	0526	Connector Cap Assembly	C-13 C-1
	0527	Capacitor	C-13 C-1
	0528	Stiffener	C-13 C-1
Section	III	SPECIAL TOOLS LIST (not applicable)	C-41
	IV	NATIONAL STOCK NUMBER AND PART NUMBER	C-43
		INDEX	

Section I. INTRODUCTION

C-1. Scope. This appendix lists spares and repair parts; special tools; special test, measurement, and diagnostic equipment (TMDE); and other special support equipment required for performance of direct support maintenance of Tunable Coupler CU-2293/ALQ-151(V). It authorizes the requisitioning and issue of spares and repair parts as indicated by the source and maintenance codes.

C-2. General. This repair parts and special tools list is divided into the following sections:

a. Section II. Repair Parts List. A list of spares and repair parts authorized for use in the performance of maintenance. The list also includes parts which must be removed for replacement of the authorized parts. Parts lists are composed of functional groups in numerical sequence, with the parts in each group listed in figure and item number sequence.

b. Section III. Special Tools List. Not applicable.

c. Section IV. National Stock Number and Part Number Index. A list, in national item identification number (NIIN) sequence, of all national stock numbers (NSNs) appearing in the listings, followed by a list, in alphanumerical sequence, of all part numbers appearing in the listings. National stock numbers and part numbers are cross-referenced to each illustration figure and item number appearance.

C-3. Explanation of Columns.

a. Illustration. This column is divided as follows:

(1) Figure Number. Indicates the figure number of the illustration on which item is shown.

(2) Item Number. The number used to identify item called out in the illustration.

b. Source, Maintenance, and Recoverability (SMR) Codes.

(1) Source Code. Source codes indicate the manner of acquiring support items for maintenance, repair, or overhaul of end items. Source codes are entered in the first and second positions of the Uniform SMR Code format as follows:

<u>Code</u>	<u>Definition</u>
PA	- Item procured and stocked for anticipated or known usage.
PB	- Item procured and stocked for insurance purpose because essentiality dictates that a minimum quantity be available in the supply systems.
PC	- Item procured and stocked and which otherwise would be coded PA except that it is deteriorative in nature.
PD	- Support item, excluding support equipment, procured for initial issue or outfitting and stocked only for subsequent or additional initial issues or outfitting. Not subject to automatic replenishment.
PE	- Support equipment procured and stocked for initial issue or outfitting to specified maintenance repair activities.
PF	- Support equipment that will not be stocked but which will be centrally procured on demand.
PG	- Item procured and stocked to provide for sustained support for the life of the equipment. It is applied to an item peculiar to the equipment which, because of probable discontinuance or shutdown of production facilities, would prove uneconomical to produce at a later time.
KD	- An item of a depot overhaul/repair kit and not purchased separately. Depot kit defined as a kit that provides items required at the time of overhaul or repair.
KF	- An item of a maintenance kit and not purchased separately. Maintenance kit defined as a kit that provides an item that can be replaced at organizational or intermediate levels of maintenance.
KB	- Item included in both a depot overhaul/repair kit and a maintenance kit.
MO	- Item to be manufactured or fabricated at organizational level.
MF	- Item to be manufactured or fabricated at the direct support maintenance level.

<u>Code</u>	<u>Definition</u>
MH	- Item to be manufactured or fabricated at the general support maintenance level.
MD	- Item to be manufactured or fabricated at the depot maintenance level.
AO	- Item to be assembled at the organizational level.
AF	- Item to be assembled at the direct support maintenance level.
AH	- Item to be assembled at the general support maintenance level.
AD	- Item to be assembled at the depot maintenance level.
XA	- Item is not procured or stocked because the requirements for the item will result in the replacement of the next higher assembly.
XB	- Item is not procured or stocked. If not available through salvage, requisition.
xc	- Installation drawing, diagram, instruction sheet, or field service drawing that is identified by manufacturer's part number.
XD	- A support item that is not stocked. When required, item will be procured through normal supply channels.

NOTE

Cannibalization or salvage may be used as a source of supply for any items source coded above except those coded XA, and aircraft support items as restricted by AR 700-42.

(2) Maintenance Code. Maintenance codes are assigned to indicate the levels of maintenance authorized to USE and REPAIR support items. The maintenance codes are entered in the third and fourth positions of the Uniform SMR Code format as follows:

(a) The maintenance code entered in the third position will indicate the lowest maintenance level authorized to remove, replace, and use the support item. The maintenance code entered in the third position will indicate one of the following levels of maintenance:

<u>Code</u>	<u>Application/Explanation</u>
C	- Crew or operator maintenance performed within organizational maintenance.
O	- Support item is removed, replaced, used at the organizational level.
F	- Support item is removed, replaced, used at the direct support level.
H	- Support item is removed, replaced, used at the general support level.
D	- Support item is removed, replaced, used at depot, mobile depot, or specialized repair activity only.

(b) The maintenance code entered in the fourth position indicates whether the item is to be repaired and identifies the lowest maintenance level with the capability to perform complete repair (i.e., all authorized maintenance functions). This position will contain one of the following maintenance codes:

<u>Code</u>	<u>Application/Explanation</u>
O	- The lowest maintenance level capable of complete repair of the support item is the organizational level.
F	- The lowest maintenance level capable of complete repair of the support item is the direct support level.
H	- The lowest maintenance level capable of complete repair of the support item is the general support level.
D	- The lowest maintenance level capable of complete repair of the support item is the depot level.
L	- Repair restricted to (enter applicable designated specialized repair activity) designated specialized repair activity.
Z	- Nonreparable. No repair is authorized.
B	- No repair is authorized. The item may be reconditioned by adjusting, lubricating, etc., at the user level. No parts or special tools are procured for the maintenance of this item.

(3) Recoverability Code. Recoverability codes are assigned to support items to indicate the disposition action on unserviceable items. The recoverability code is entered in the fifth position of the Uniform SMR Code format as follows:

<u>Recoverabil-</u> <u>ity Codes</u>	<u>Definition</u>
Z -	Nonreparable item. When unserviceable, condemn and dispose at the level indicated in position 3.
O -	Reparable item. When uneconomically reparable, condemn and dispose at organizational level.
F -	Reparable item. When uneconomically reparable, condemn and dispose at the direct support level.
H -	Reparable item. When uneconomically reparable, condemn and dispose at the general support level.
D -	Reparable item. When beyond lower level repair capability, return to depot. Condemnation and disposal not authorized below depot level.
L -	Reparable item. Repair, condemnation, and disposal not authorized below depot/specialized repair activity level.
A -	Item requires special handling or condemnation procedures because of specific reasons (i.e., precious metal content, high dollar value, critical material or hazardous material). Refer to appropriate manuals/directives for specific instructions.

c. National Stock Number. Indicates the national stock number assigned to the item and will be used for requisitioning purposes.

d. Part Number. Indicates the primary number used by the manufacturer (individual company, firm, corporation, or government activity) which controls the design and characteristics of the item by means of its engineering drawings, specifications, standards, and inspection requirements to identify an item or range of items.

NOTE

When a stock-numbered item is requisitioned, the repair part received may have a different part number than the part being replaced.

e. Federal Supply Code for Manufacturer (FSCM). The FSCM is a five-digit numeric code listed in SB 708-42 which is used to identify the manufacturer, distributor, or government agency, etc.

f. Description. Indicates the Federal item name and, if required, a minimum description to identify the item.

g. Unit of Measure (U/M). Indicates the standard of the basic quantity of the listed item as used in performing the actual maintenance function. This measure is expressed by a two character alphabetical abbreviation (e.g., ea, in, pr, etc.). When the unit of measure differs from the unit of issue, the lowest unit of issue that will satisfy the required units of measure will be requisitioned.

h. Quantity Incorporated in Unit. Indicates the quantity of the item used in the breakout shown on the illustration figure, which is prepared for a functional group, subfunctional group, or an assembly.

C-4 . Special Information. Not applicable.

C-5. How to Locate Repair Parts.

a. When National Stock Number or Part Number is Unknown.

(1) First. Using the table of contents, determine the assembly or subassembly within which the repair part belongs. This is necessary since illustrations are prepared for assemblies or subassemblies, and listings are divided into the same groups.

(2) Second. Find the illustration covering the functional group to which the repair part belongs.

(3) Third. Identify the repair part on the illustration and note the illustration figure and item number of the repair part.

(4) Fourth. Using the repair parts listing, find the figure and item number noted on the illustration.

b. When National Stock Number or Part Number is Known.

(1) First. Using the index of NSNS and Part Numbers, find the pertinent national stock number or part number. This index is in NIIN sequence followed by a list of part numbers in alphanumerical sequence, cross-referenced to the illustration figure number and item number.

(2) Second. After finding the figure and item number, locate the figure and item number in the repair parts list.

C-6 . Abbreviations. Not applicable.

Section II. REPAIR PARTS LIST

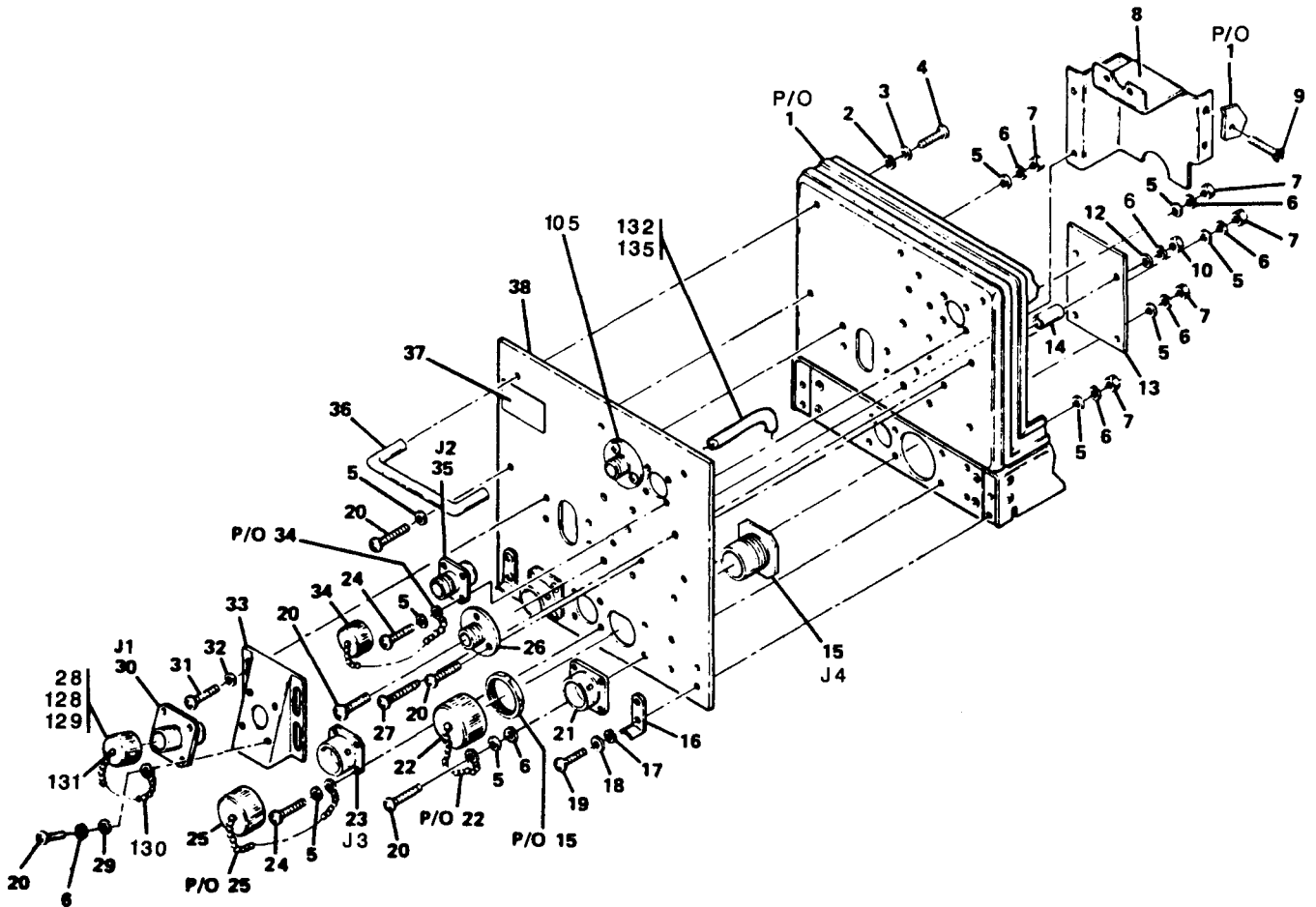

Figure C-1. Tunable Coupler CU-2293/ALQ-151(V)
(Sheet 1 of 4)

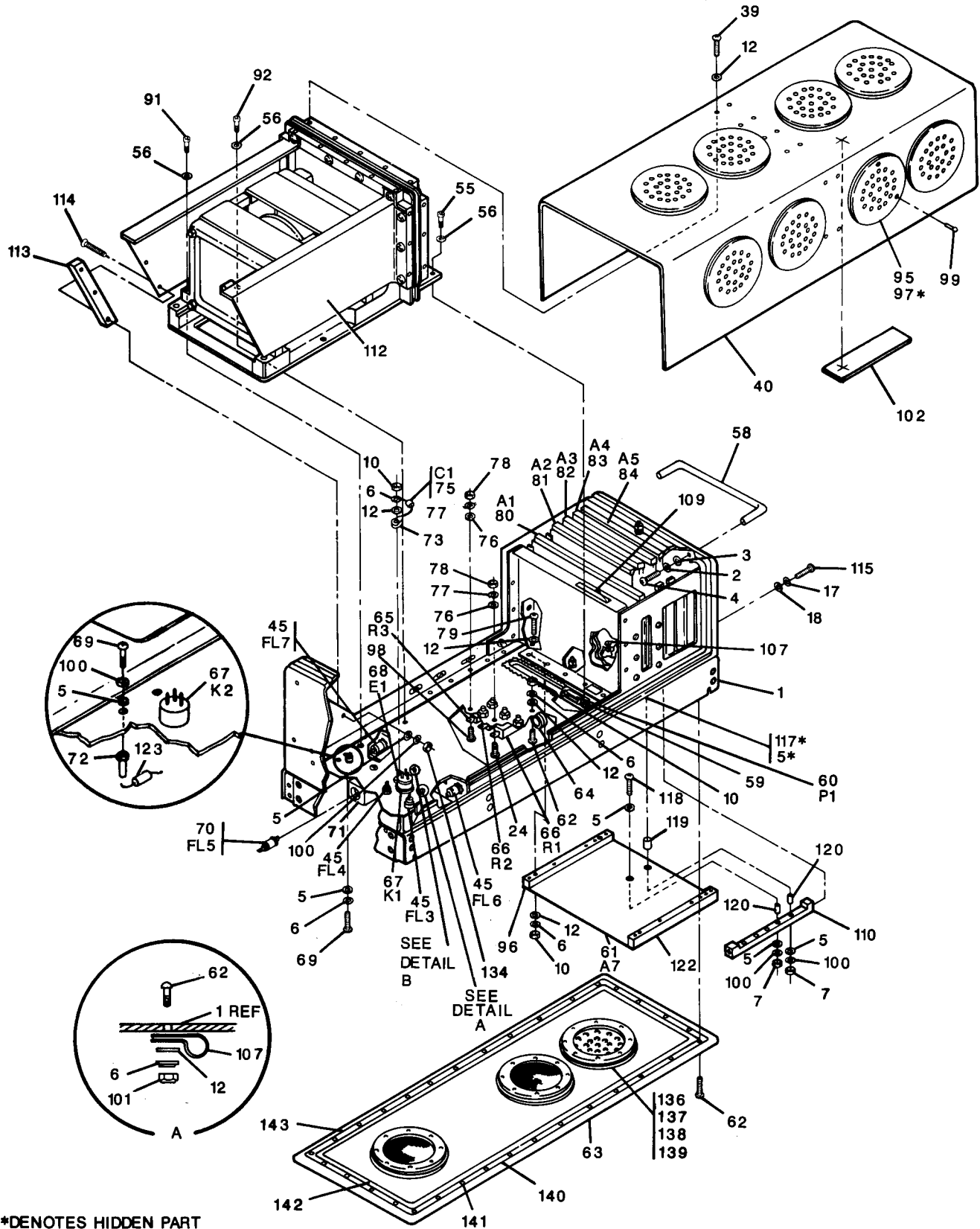

Figure C-1. Tunable Coupler CU-2293/ALQ-151(V)
(Sheet 2 of 4)

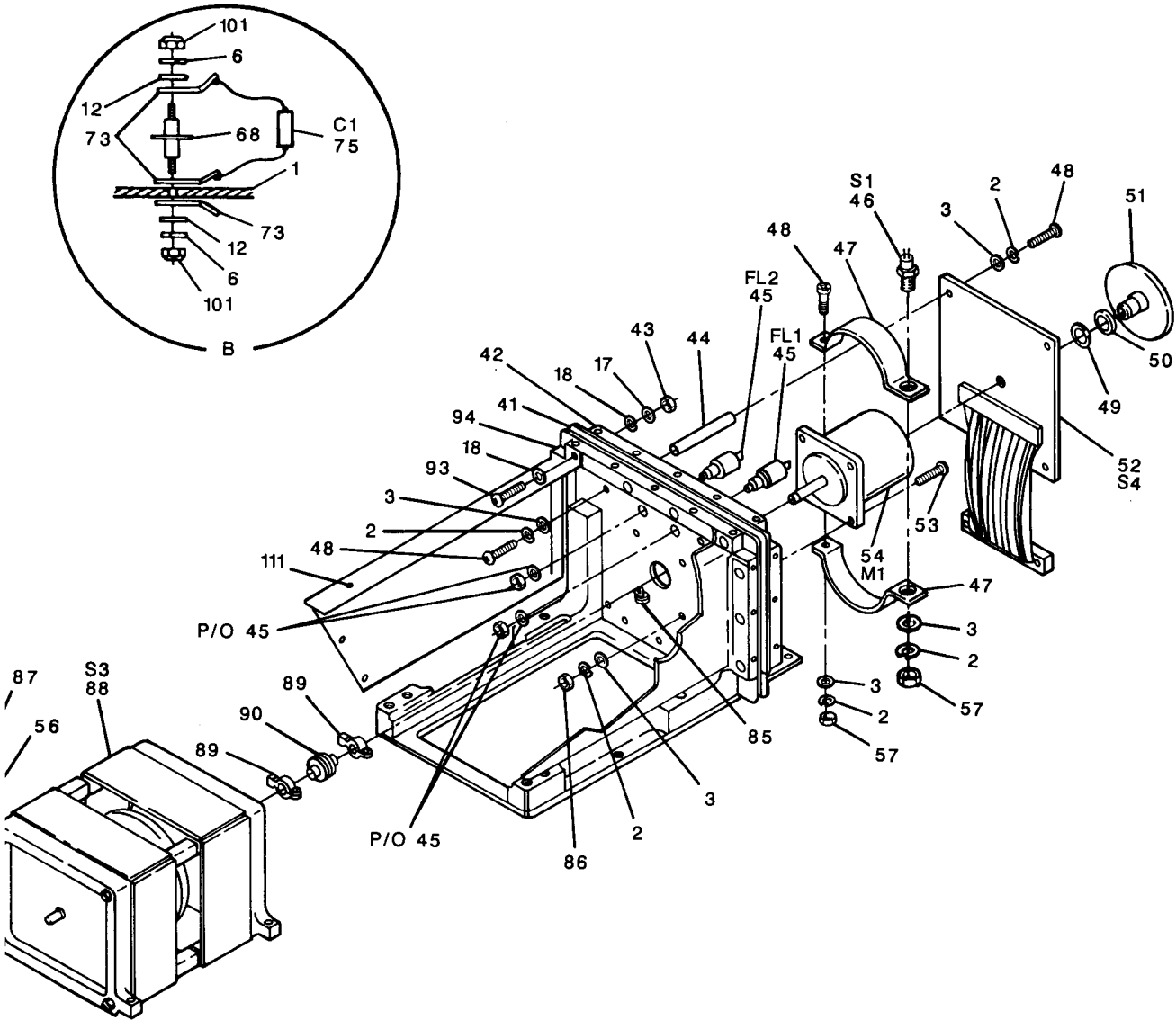

Figure C-1. Tunable Coupler CU-2293/ALQ-151(V)
(Sheet 3 of 4)

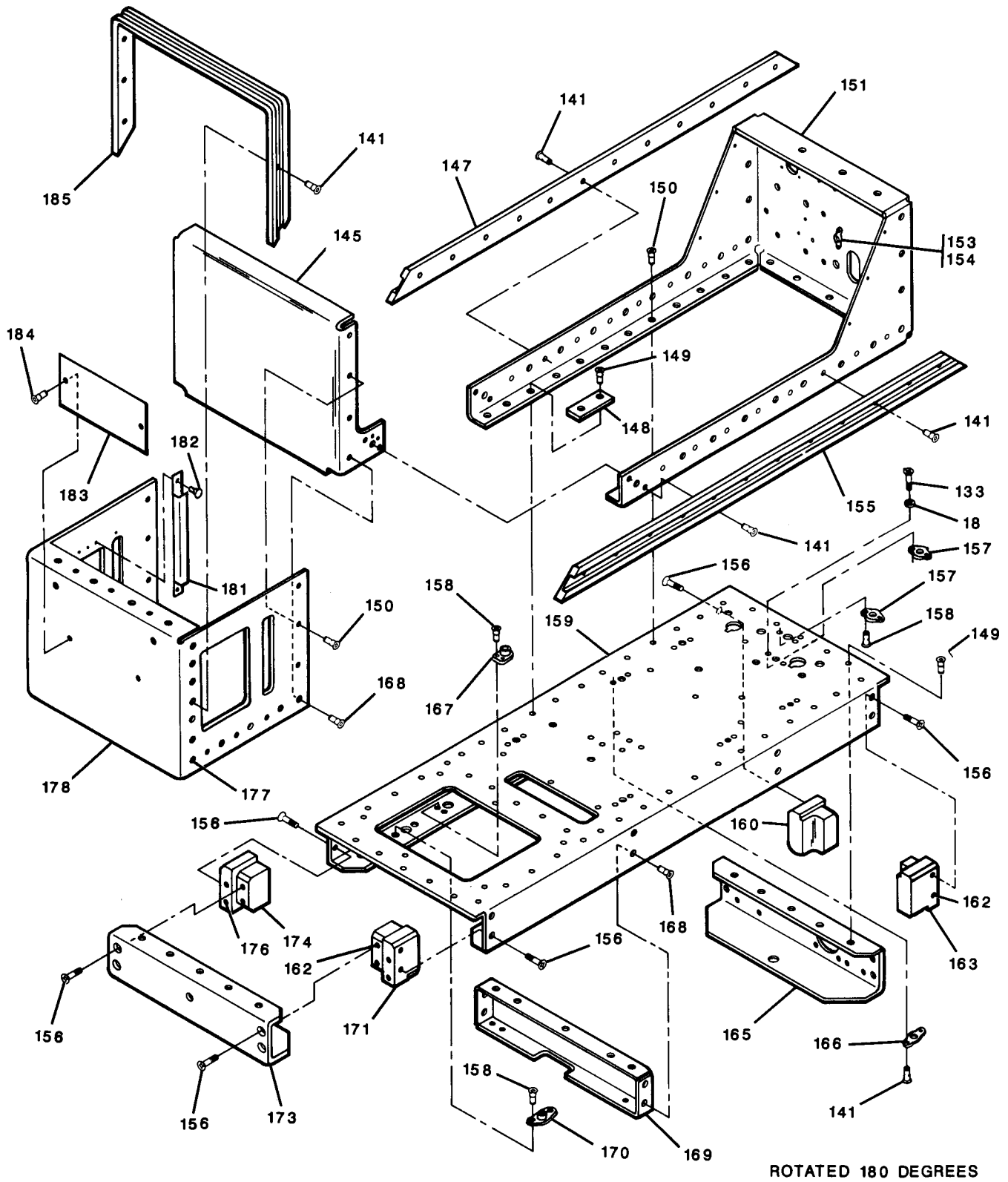

Figure C-1. Tunable Coupler CU-2293/ALQ-151(V)
(Sheet 4 of 4)

(1) ILLUSTRATION		(2)	(3)	(4)	(5)	(6)	(7)	(8)
FIG NO	ITEM NO	SMR CODE	NATIONAL STOCK NUMBER	PART NUMBER	FSCM	DESCRIPTION USABLE ON CODE	U/M	QTY INC IN UNIT
						GROUP 05-TUNABLE COUPLER C5073810-1 (57958)		
C-1	1	XDDDD		C5073834-1	57958	CHASSIS ASSY, CP LR	EA	1
C-1	2	XDDZZ	5310-00-933-8120	MS35338-138	96906	WASHER, LOCK, NO. 10	EA	18
C-1	3	XDDZZ	5310-00-883-9384	MS15795-842	96906	WASHER, FLAT	EA	19
C-1	4	XDHZZ	5305-00-059-3660	MS51958-64	96906	SCREW, MACHINE	EA	5
C-1	5	XDDZZ	5310-00-782-1349	MS15795-804	96906	WASHER, FLAT, NO. 4	EA	33
C-1	6	XDDZZ	5310-00-929-6395	MS35338-136	96906	WASHER, LOCK, NO. 6	EA	31
C-1	7	XDDZZ		MS35650-344	96906	NUT, PLAIN, HEX, NO. 4-40	EA	15
C-1	8	XDDZZ		C5073998-1	57958	COVER ASSY, RADIO FREQ MONITOR	EA	1
C-1	9	XDDZZ	5305-00-151-2084	MS24693-3	96906	SCREW, PFH	EA	2
C-1	10	XDDZZ		MS35650-364	96906	NUT, PLAIN, HEX, NO. 6-32	EA	10
	11					NOT USED		
C-1	12	XDDZZ	5310-00-722-5998	MS15795-805	96906	WASHER, FLAT, NO. 6	EA	83
C-1	13	PADZZ	5865-01-207-3438	C5073995-1	57958	BOARD ASSY, PWR MONITOR	EA	1
C-1	14	XDDZZ	5365-00-684-5982	NASA 3DD1-38	96906	SPACER	EA	4
C-1	15	XDHZZ	5935-01-222-3309	MS27476Y14D15P	96906	CONNECTOR, INTERLOCK	EA	1
C-1	16	XDHZZ	5340-00-917-4549	43-9507-01-901	13636	HOOK, FRONT	EA	2
C-1	17	XDDZZ	5310-01-067-9589	MS35338-137	96906	WASHER, LOCK, NO. 8	EA	8
C-1	18	XDDZZ	5310-00-225-5328	MS15795-841	96906	WASHER, FLAT, NO. 8	EA	24
C-1	19	XDHZZ	5305-00-054-6671	MS51957-46	96906	SCREW, MACHINE	EA	4
C-1	20	XDHZZ	5305-00-054-5651	MS51957-17	96906	SCREW, PPH	EA	16
C-1	21	XDHZZ	5935-00-947-1036	MS3115-14A	96906	CONNECTOR BLANK	EA	2
C-1	22	XDHZZ	5935-00-899-9361	MS3181-14C	96906	CAP/CHAIN	EA	1
C-1	23	XDHZZ	5935-00-902-7035	MS3114H14C12P	96906	CONNECTOR, CONTROL	EA	1
C-1	24	XDHZZ	5305-00-054-5649	MS51957-15	96906	SCREW, PPH	EA	12
C-1	25	XDHZZ		MS275-11-E-14-N	96906	CAP CONNECTOR	EA	1
C-1	26	XDHZZ		C5074018-1	57958	CONNECTOR BLANK	EA	1
C-1	27	XDDZZ	5305-01-081-8077	MS24693-34B	96906	SCREW, PFH	EA	4
C-1	28	XDHHH	5935-01-207-5591	C5074005-1	57958	CONNECTOR CAP ASSY	EA	1
C-1	29	XDHZZ	5310-00-595-6211	MS15795-803	96906	WASHER, FLAT	EA	4
C-1	30	PAHZZ	5935-01-028-5793	25-S3000	94375	CONNECTOR, COAX	EA	1
C-1	31	XDHZZ	5305-00-059-3662	MS51958-66	96906	SCREW, PPH	EA	4
C-1	32	PAHZZ	5310-00-595-6772	MS15795-808	96906	WASHER, FLAT	EA	4
C-1	33	XDDDD		C5073860-1	57958	BASE ASSY, MTG	EA	1
C-1	34	XDHZZ		MS25043-100	96906	CAP/CHAIN	EA	1
C-1	35	XDDZZ	5935-00-962-9848	M39012/02-0006	81349	CONN, COAXIAL	EA	1
C-1	36	XDHZZ	5340-00-060-5957	MS39087-5	96906	HANDLE	EA	1
C-1	37	XDHZZ		C5074020-1	57958	PLATE, WARNING	EA	1
C-1	38	XDDZZ		C5073839-1	57958	PANEL, FRONT	EA	1
C-1	39	XDHZZ	5305-00-054-6655	MS51957-31	96906	SCREW, MACHINE	EA	68
C-1	40	XDHHH		C5073842-1	57958	COVER ASSY, CHASSIS	EA	1
C-1	41	XDDDD		C5073835-1	57958	MTG BASE ASSY	EA	1

(1) ILLUSTRATION		(2)	(3)	(4)	(5)	(6)	(7)	(8)
FIG NO	ITEM NO	SMR CODE	NATIONAL STOCK NUMBER	PART NUMBER	FSCM	DESCRIPTION USABLE ON CODE	U/M	QTY INC IN UNIT
C-1	42	XDHZZ		C5074024-1	57958	BAR, MTG	EA	2
C-1	43	XDDZZ	5310-00-837-1381	NAS671C8	80205	NUT, PLAIN, HEX	EA	4
C-1	44	XDDZZ		C5073843-1	57958	MTG POST, FEEDBACK BD	EA	4
C-1	45	PADZZ	5915-01-043-6963	M15733/25-0002	81349	FILTER	EA	6
C-1	46	PADZZ		M554T179A194	81349	SWITCH, THERMO	EA	1
C-1	47	XDDZZ		C5073936-1	57958	CLAMP, THERMAL	EA	2
C-1	48	XDDZZ	5305-00-059-3657	MS51958-61	96906	SCREW, PPH	EA	8
C-1	49	XDDZZ	5365-00-804-7645	MS16624-4050	96906	RING, SNAP	EA	1
C-1	50	XDDZZ		C5073846-2	57958	SPACER	EA	1
C-1	51	PADZZ	5999-01-207-5584	C5073918-1	57958	HUB/CONTACT ASSY	EA	1
C-1	52	PADDD	5865-01-207-5595	C5073905-1	57958	PWB ASSY	EA	1
C-1	53	XDDZZ	5305-00-059-3661	MS51958-65	96906	SCREW, MACHINE	EA	4
C-1	54	XDDDD	6105-01-207-5572	C5073960-1	57958	MOTOR/SLEEVE ASSY	EA	1
C-1	55	XDDZZ	5305-00-225-7773	MS16996-22	96906	SCREW, SOCKET, HD	EA	2
C-1	56	XDDZZ	5310-00-952-0309	NAS620C416	80205	WASHER, FLAT	EA	10
C-1	57	XDDZZ	5310-00-934-9765	MS35650-304	96906	NUT, PLAIN, HEX, NO. 10-32	EA	2
C-1	58	XDHZZ	5340-00-060-5386	MS39087-3	96906	HANDLE	EA	1
C-1	59	XDDZZ	5307-01-130-6500	D110550	71468	JACKSCREW ASSY	EA	2
C-1	60	XDDZZ	5935-00-975-6265	M24308-3-2	81349	CONN, ROPT, ELEC	EA	1
C-1	61	PADDD	5865-01-207-0771	C5073909-1	57958	PWB, MOTHERBOARD (REFER TO FIGURE C-7)	EA	1
C-1	62	XDDZZ	5305-00-066-7328	MS24693-C27	96906	SCREW, PFH	EA	29
C-1	63	XDHHH		C5073825-1	57958	COVER ASSY, LOWER	EA	1
C-1	64	XDHZZ		NAS1397-7	80205	CLAMP, CABLE	EA	1
C-1	65	PAHZZ		RER60F1000R	57958	RES, 5W, 1%	EA	1
C-1	66	PAHZZ		RER65F7R50R	57958	RES, 10W, 1%	EA	2
C-1	67	PADZZ	5945-01-135-7710	M83725-5-001	81349	RELAY	EA	2
C-1	68	XDDZZ	5940-01-222-0502	352-4613-03-07-1	71279	TERMINAL, INSULATED	EA	1
C-1	69	XDDZZ	5305-00-054-5648	MS51957-14	96906	SCREW, PPH	EA	2
C-1	70	PAHZZ	5915-01-074-8413	M15733/27-0020	81349	FILTER	EA	1
C-1	71	XDHZZ		C5073873-1	57958	SHIELD, FILTER	EA	1
C-1	72	XDDZZ		SE20-5-D-01-S	88245	TERMINAL, INSULATED	EA	2
C-1	73	XDDZZ	5940-00-155-7686	MS77066-1	96906	TERMINAL LUG	EA	3
C-1	74	XDHZZ	5305-00-054-5656	MS51957-22	96906	SCREW, MACHINE	EA	2
C-1	75	PADZZ	5910-01-054-7379	2DHT54T100FAB	21052	CAP, CERAMIC RF	EA	1
C-1	76	XDDZZ	5310-00-595-6761	MS15795-802	96906	WASHER, FLAT, NO. 2	EA	6
C-1	77	XDDZZ	5310-00-928-2690	MS35338-134	96906	WASHER, LOCK, NO. 2	EA	6
C-1	78	XDDZZ		MS35650-324	96906	NUT, PLAIN, HEX, NO. 2-56	EA	6
C-1	79	XDDZZ	5305-00-054-6656	MS51957-32	96906	SCREW, MACHINE	EA	4
C-1	80	PAHHD	5865-01-207-3434	C5073889-1	57958	CKT CARD ASSY, PWR SPLY A1 (REFER TO FIG C-2)	EA	1
C-1	81	PAHHD	5865-01-207-3441	C5073893-1	57958	CKT CARD ASSY A2 (REFER TO FIG C-3)	EA	1
C-1	8?	PAHDD	5865-01-207-0774	C5073901-1	57958	CKT CARD ASSY, CONT LOGIC A3 (REFER TO FIG C-4)	EA	1

(1) ILLUSTRATION		(2)	(3)	(4)	(5)	(6)	(7)	(8)
FIG NO	ITEM NO	SMR CODE	NATIONAL STOCK NUMBER	PART NUMBER	FSCM	DESCRIPTION USABLE ON CODE	U/M	QTY INC IN UNIT
C-1	83	PAHDD	5865-01-207-0775	C5073897-1	57958	CKT CARD ASSY, DECODER DECODER A4 (REFER TO FIG C-5)	EA	1
C-1	84	PADZZ	5865-01-207-3437	C5073956-1	57958	PWB, EXTENDER BD A5 (REFER TO FIG C-6)	EA	1
C-1	85	XDHZZ		NAS1397-2	80205	CLAMP, CABLE	EA	1
C-1	86	XDDZZ	5310-00-934-9765	MS35650-304	96906	NUT, PLAIN, HEX	EA	3
C-1	87	XDDZZ	5305-00-992-6032	MS16996-24	96906	SCREW, SOCKET, HD	EA	4
C-1	88	PAHDD	5985-01-248-7471	C5073817-1	57958	RF SWITCH ASSY	EA	1
C-1	89	XDDZZ		GC-15-5-26063	07649	CLAMP	EA	2
C-1	90	XDDDD		R3-C5-26059	07649	COUPLER	EA	1
C-1	91	XDDZZ	5305-00-958-7667	MS16996-23	96906	SCREW, SOCKET, HD	EA	2
C-1	92	XDDZZ	5305-00-225-7775	MS16996-25	96906	SCREW, CAP, SOCKET	EA	2
C-1	93	XDDZZ	5305-00-054-6676	MS51957-51	96906	SCREW, PPH	EA	10
C-1	94	XDHZZ		C5074025-1	57958	BAR, MTG	EA	4
C-1	95	XDHZZ		C5073841-1	57958	VENT COVER	EA	12
C-1	96	XDDZZ		C5073845-1	57958	STIFFENER	EA	1
C-1	97	XDHHH		C5073871-1	57958	SCREEN ASSY	EA	12
C-1	98	XDDZZ	5305-00-054-5639	MS51957-5	96906	SCREW, PPH	EA	6
C-1	99	XDDZZ		MS20470AD3-4	96906	RIVET	EA	96
C-1	100	XDDZZ	5310-00-933-8118	MS35338-135	96906	WASHER, LOCK, NO. 4	EA	10
C-1	101	XDDZZ		MS35650-364	96906	NUT, PLAIN, HEX, NO. 6-32	EA	10
C-1	102	XDDZZ		C5074017-1	57958	GASKET	EA	2
C-1	103					NOT USED		
C-1	104					NOT USED		
C-1	105	XDHZZ		C5074019-1	57958	CONNECTOR BLANK	EA	1
C-1	106					NOT USED		
C-1	107	XDHZZ	5340-00-964-2555	NAS1397-6	80205	CLAMP, CABLE	EA	1
C-1	108					NOT USED		
C-1	109	XDHZZ		C5074026-1	57958	DECAL	EA	1
C-1	110	XDDZZ		C5074033-1	57958	STIFFENER	EA	1
C-1	111	XDHZZ		C5074034-1	57958	SUPPORT	EA	1
C-1	112	XDHZZ		C5074034-2	57958	SUPPORT	EA	1
C-1	113	XDHZZ		C5074035-1	57958	SPACER	EA	2
C-1	114	XDHZZ	5305-00-780-8454	MS24693-C7	96906	SCREW, FLH	EA	6
C-1	115	XDHZZ	5305-00-054-6670	MS51957-45	96906	SCREW, PPH	EA	2
C-1	116					NOT USED		
C-1	117	XDDZZ	5305-00-182-9270	MS51957-122	96906	SCREW, PPH	EA	2
C-1	118	XDDZZ	5305-00-054-5654	MS51957-20	96906	SCREW, PPH	EA	3
C-1	119	XDDZZ		8154-SS-0440	06540	STANDOFF	EA	2
C-1	120	XDDZZ		9223A115	06540	SPACER	EA	5
C-1	121					NOT USED		
C-1	122	XDDZZ		C5073845-2	57958	STIFFENER	EA	1
C-1	123	PAHZZ	5961-00-898-2101	JANTX1N645	81349	SEMI CONDUCTOR DEVICE, DIODE	EA	1

(1) ILLUSTRATION		(2)	(3)	(4)	(5)	(6)	(7)	(8)
FIG NO	ITEM NO	SMR CODE	NATIONAL STOCK NUMBER	PART NUMBER	FSCM	DESCRIPTION USABLE ON CODE	U/M	QTY INC IN UNIT
C-1	124	XDDZZ		D142-56	06090	FERRULE (NOT SHOWN)	EA	2
C-1	125	XDDZZ	5940-01-010-1571	D142-51	06090	FERRULE (NOT SHOWN)	EA	12
C-1	126	XDHZZ	5305-00-088-9665	MS24693C29	96906	SCREW,PFH (NOT SHOWN)	EA	8
C-1	127	XDDZZ	5305-01-049-9121	MS51957-12	96906	SCREW,PPH (NOT SHOWN)	EA	4
C-1	128	XDHZZ		C5074003-1	57958	CAP CONNECTOR	EA	1
C-1	129	XDHZZ		C5074002-1	57958	GASKET	EA	1
C-1	130	XDHZZ		C5074004-1	57958	CHAIN	EA	1
C-1	131	XDHZZ		MS20470A3-7	57958	RIVET	EA	1
C-1	132	XDDZZ		C5073850-1	57958	SLEEVE,COAX	EA	1
C-1	133	XDDZZ	5305-00-054-6669	MS51957-44	96906	SCREW,PPH	EA	2
C-1	134	XDHZZ	5310-00-934-9750	MS35650-384	96906	NUT,PLAIN,HEX	EA	6
C-1	135	XDDZZ		C5074015-1	57958	COAX	EA	1
C-1	136	XDHZZ		C5073826-1	57958	VENT RING	EA	3
C-1	137	XDDZZ		C5073871-1	57958	SCREEN ASSY	EA	3
C-1	138	XDHZZ		C5073841-1	57958	VENT COVER	EA	3
C-1	139	XDHZZ		MS20426AD3-4	96906	RIVET	EA	24
C-1	140	XDHZZ		C5073823-3	57958	GASKET	EA	1
C-1	141	XDDZZ	5320-00-584-0672	MS20426AD3-6	96906	RIVET	EA	98
C-1	142	XDHZZ		C5073823-5	57958	GASKET	EA	2
C-1	143	XDHZZ		C5073823-4	57958	GASKET	EA	1
C-1	144					NOT USED		
C-1	145	XDDDD		C5073833-1	57958	REAR WALL ASSY,PWB	EA	1
C-1	146					NOT USED		
C-1	147	XDDZZ		C5073823-2	57958	GASKET	EA	1
C-1	148	XDDZZ		C5073824-1	57958	SPACER,RF SWITCH	EA	2
C-1	149	XDDZZ	530-00-117-6830	MS20470AD4-8	96906	RIVET,UNIV HD	EA	15
C-1	150	XDDZZ	530-00-117-6828	MS20470AD4-6	96906	RIVET,UNIV HD	EA	41
C-1	151	XDDDD		C5073828-1	57958	ENCLOSURE ASSY,REAR	EA	1
C-1	152					NOT USED		
C-1	153	XDDZZ	5310-00-728-9458	MS21070L3	96906	NUT,PL,SLFLKG	EA	4
C-1	154	XDDZZ	5320-00-655-4757	MS20426A3-4	96906	RIVET,CSKH	EA	8
C-1	155	XDDZZ		C5073823-1	57958	GASKET	EA	1
C-1	156	XDDZZ	5305-00-056-9962	MS24693-C47	96906	SCREW,CSKH	EA	16
C-1	157	XDDZZ	5310-00-771-7360	MS21076-L04	96906	NUT,SLFLKG	EA	2
C-1	158	XDDZZ	5320-00-619-0497	MS20426A3-5	96906	RIVET,CSKH	EA	152
C-1	159	XDDZZ		C5073829-1	57958	CHASSIS ASSY,LWR	EA	1
C-1	160					NOT USED		
C-1	161	XA		C5073832-7	57958	BLOCK	EA	1
C-1	162	XDDZZ		C5074038-1	57958	BUSHING,MTG	EA	2
C-1	163	XDDDD		C5073832-6	57958	BLOCK,MTG	EA	1
C-1	164					NOT USED		
C-1	165	XDDZZ		C5073827-1	57958	BRACKET ASSY,CHASSIS	EA	1
C-1	166	XDDZZ	5310-00-771-7359	MS21076L4	96906	NUT,SLFLKG	EA	6
C-1	167	XDDZZ		NAS1789-C06M	80205	NUT,SLFLKG	EA	18
C-1	168	XDDZZ	530-00-117-6951	MS20426AD4-6	96906	RIVET,CSKH	EA	10

(1) ILLUSTRATION		(2)	(3)	(4)	(5)	(6)	(7)	(8)
FIG NO	ITEM NO	SMR CODE	NATIONAL STOCK NUMBER	PART NUMBER	FSCM	DESCRIPTION USABLE ON CODE	U/M	QTY INC IN UNIT
C-1	169	XDDZZ		C5073830-1	57958	STIFFENER, CHASSIS	EA	2
C-1	170	XDDZZ	5310-00-780-1049	MS21060-06	72962	NUT, SLFLKG	EA	50
C-1	171	XDDDD		C5073832-1	57958	BLOCK, MTG	EA	1
C-1	172					NOT USED		
C-1	173	XDDZZ		C5073827-2	57958	BRACKET ASSY, CHASSIS	EA	1
C-1	174	XDDDD		C5073832-2	57958	BLOCK, MTG	EA	1
C-1	175					NOT USED		
C-1	176	XDDZZ		MS35914-307	57958	INSERT	EA	20
C-1	177	XDDZZ		NAS1789-C06M	80205	NUT, SLFLKG	EA	6
C-1	178	XDDDD		C5073831-1	57958	ENCLOSURE ASSY, PWB	EA	1
C-1	179					NOT USED		
C-1	180					NOT USED		
C-1	181	XDDZZ	5999-00-249-1804	35-6B2-8-3	18915	RETAINER, PCB	EA	10
C-1	182	XDDZZ		MS20470AD2-4	96906	RIVET, UNIV HD	EA	20
C-1	183	XDHZZ		C5073816-1	57958	PLATE, ID	EA	1
C-1	184	XDHZZ	5320-00-117-6516	MS20470AD4-3	96906	RIVET, UNIV HD	EA	2
C-1	185	XDDZZ		C5074823-6	57958	GASKET	EA	2

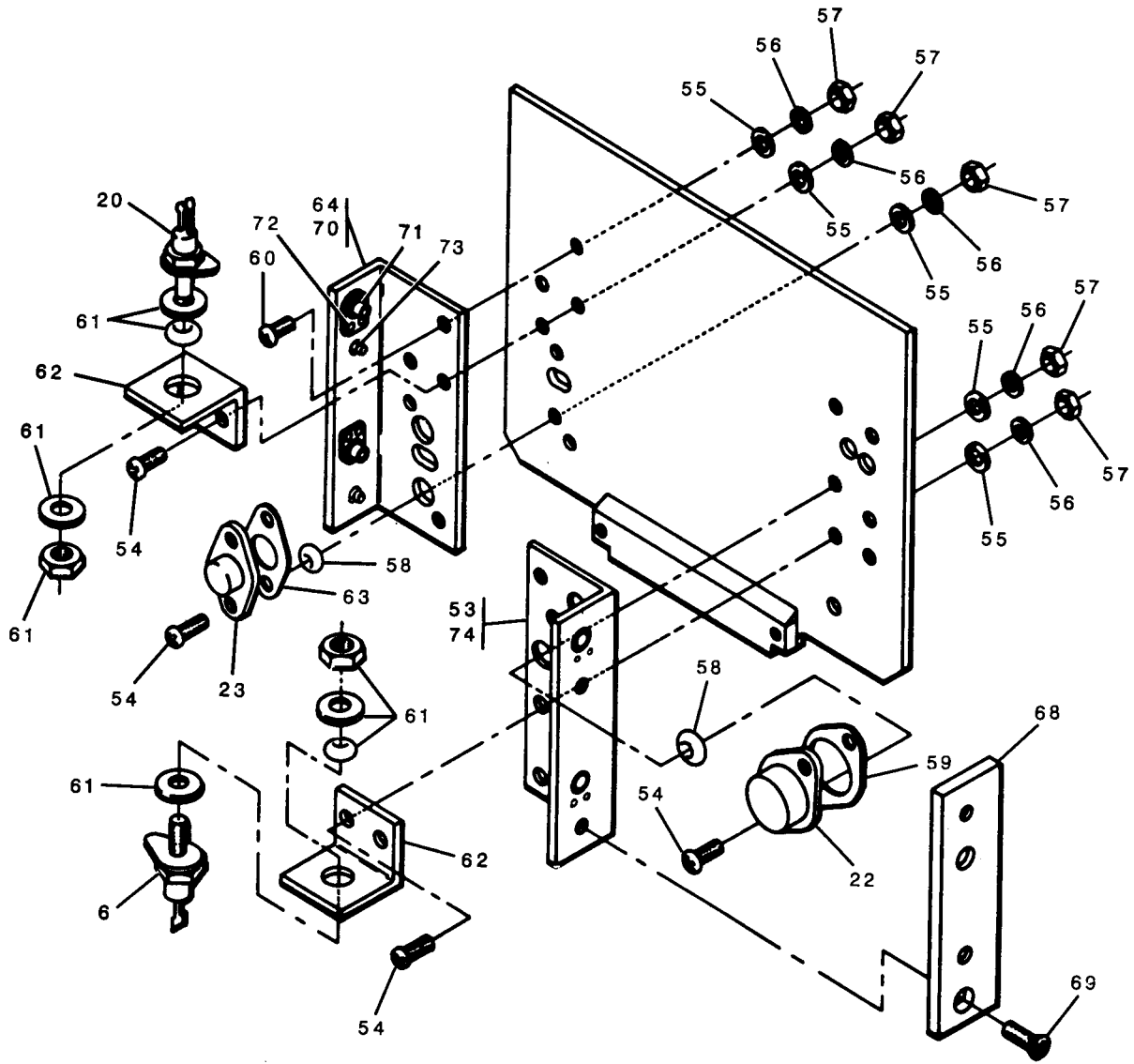

Figure C-2. Power Supply CCA C5073889-1
(Sheet 1 of 4)

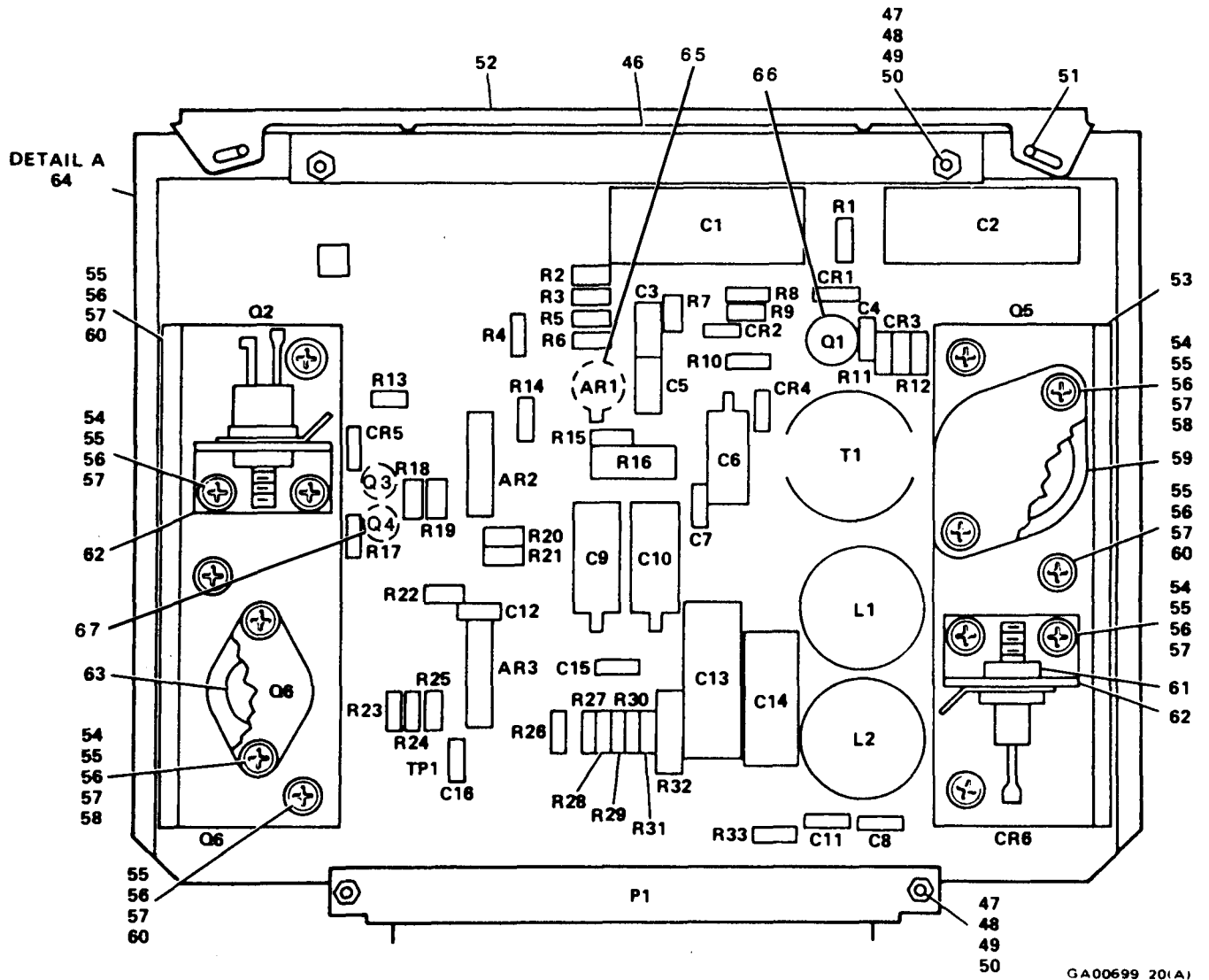
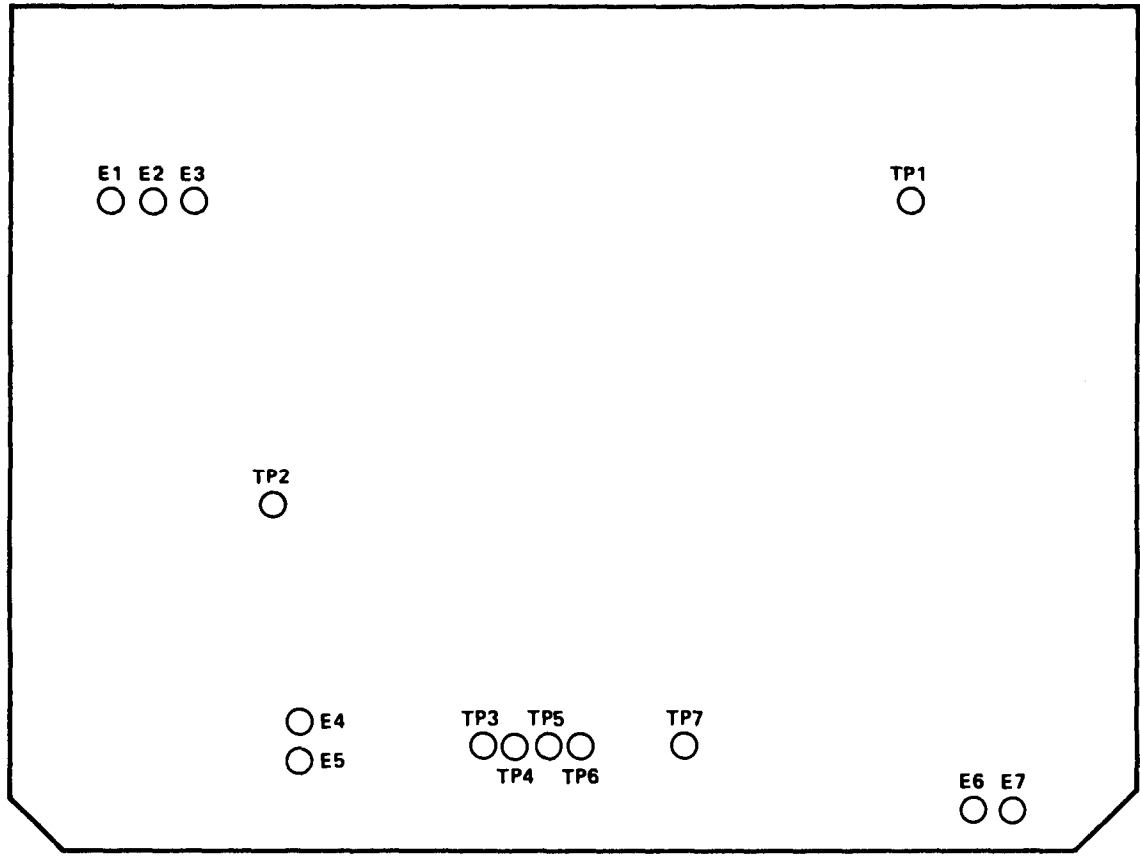

Figure C-2. Power Supply CCA C5073889-1
(Sheet 2 of 4)



DETAIL A

GA00699 21(A)

Figure C-2. Power Supply CCA C5073889-1
(Sheet 3 of 4)

REF DES	ITEM NO	REF DES	ITEM NO	REF DES	ITEM NO	REF DES	ITEM NO	REF DES	ITEM NO	REF DES	ITEM NO
AR1	1	C6	10	E4	16	R2	25	R16	36	R30	43
AR2	2	C7	11	E5	16	R3	26	R17	37	R31	31
AR3	2	C8	11	E6	16	R4	27	R18	38	R32	44
CR1	3	C9	12	E7	16	R5	28	R19	26	R33	31
CR2	3	C10	12	L1	17	R6	26	R20	39	TP1	16
CR3	4	C11	11	L2	17	R7	29	R21	38	TP2	16
CR4	5	C12	13	P1	18	R8	27	R22	40	TP3	16
CR5	3	C13	14	Q1	19	R9	30	R23	41	TP4	16
CR6	6	C14	15	Q2	20	R10	27	R24	26	TP5	16
C1	7	C15	11	Q3	21	R11	31	R25	42	TP6	16
C2	7	C16	11	Q4	21	R12	32	R26	31	TP7	16
C3	8	E1	16	Q5	22	R13	33	R27	31	T1	45
C4	9	E2	16	Q6	23	R14	34	R28	43		
C5	8	E3	16	R1	24	R15	35	R29	31		

Figure C-2. Power Supply CCA C5073889-1
(Sheet 4 of 4)

(1) ILLUSTRATION		(2)	(3)	(4)	(5)	(6)	(7)	(8)
FIG NO	ITEM NO	SMR CODE	NATIONAL STOCK NUMBER	PART NUMBER	FSCM	DESCRIPTION USABLE ON CODE	U/M	QTY INC IN UNIT
						GROUP 0501-POWER SUPPLY CCA C5073889-1 (57958)		
C-2	1	PAHZZ	5962-01-048-7767	M38510/10304BGB	81349	MICROCKT, LINEAR	EA	1
C-2	2	PAHZZ	5962-00-417-1080	M38510/10201BCB	81349	MICROCKT, D GTL	EA	2
C-2	3	PAHZZ	5961-00-938-1135	1N4148	81349	SCND DVC, D IODE	EA	3
C-2	4	PAHZZ		1N5807	81349	SCND DVC, D IODE	EA	1
C-2	5	PAHZZ		1N5802	81349	SCND DVC, D IODE	EA	1
C-2	6	PAHZZ		1N1206A	81349	SCND DVC, D IODE	EA	1
C-2	7	PAHZZ	5910-01-066-6274	M39022/10-C305JM	81349	CAP, FXD, CER, D IEL	EA	2
C-2	8	PAHZZ	5910-01-016-2400	CMR04C5R0DPDP	81349	CAP, FXD, CER, D IEL	EA	2
C-2	9	PAHZZ	5910-00-113-5277	M39014/01-1563	81349	CAP, FXD, CER, D IEL	EA	1
C-2	10	PAHZZ	5910-00-113-5689	M39003/01-3015	81349	CAP, FXD, CER, D IEL	EA	1
C-2	11	PAHZZ	5910-00-010-8717	M39014/01-1593	81349	CAP, FXD, CER, D IEL	EA	5
C-2	12	PAHZZ	5910-00-236-8745	M39003/01-3021	81349	CAP, FXD, CER, D IEL	EA	2
C-2	13	PAHZZ	5910-00-113-5276	M39014/01-1351	81349	CAP, FXD, CER, D IEL	EA	1
C-2	14	PAHZZ	5910-01-009-8502	M39006/09-9034	81349	CAP, FXD, CER, D IEL	EA	1
C-2	15	PAHZZ	5910-01-067-7879	M39022-10-C105J	81349	CAP, FXD, CER, D IEL	EA	1
C-2	16	XA		SE16-X-C-01-S	57958	TERMI NAL, TURRET	EA	14
C-2	17	PAHZZ	5865-01-207-3406	C5073971-2	57958	I NDUCTOR ASSY	EA	1
C-2	18	XDHZZ		M55302/57-B66Y-1	81349	CONNECTOR, P LUG, ELEC	EA	1
C-2	19	PAHZZ		2N3763	81349	TRANSISTOR	EA	1
C-2	20	PAHZZ	5961-00-689-1989	JANTX2N1774A	81349	TRANSISTOR	EA	1
C-2	21	PAHZZ	5961-00-951-8757	2N2222A	81349	TRANSISTOR	EA	2
C-2	22	PAHZZ	5961-00-359-5752	JANTX2N5038	81349	TRANSISTOR	EA	1
C-2	23	PAHZZ	5961-00-054-4141	2N3441	81349	TRANSISTOR	EA	1
C-2	24	PAHZZ		RWR81SR499FR	81349	RES, FXD, WW	EA	1
C-2	25	PAHZZ	5905-00-284-9477	RNC55J1001BS	81349	RES, FXD, FILM	EA	1
C-2	26	PAHZZ	5905-00-137-8563	RNC55J2552BS	81349	RES, FXD, FILM	EA	4
C-2	27	PAHZZ	5905-00-141-1183	RCR07G101JS	81349	RES, FXD, CMPSN	EA	3
C-2	28	PAHZZ	5905-01-078-1958	RNC55J4872BS	81349	RES, FXD, FILM	EA	1
C-2	29	PAHZZ	5905-00-721-0815	RNC55J5112BS	81349	RES, FXD, FILM	EA	1
C-2	30	PAHZZ	5905-00-009-1157	RNC55J3832BS	81349	RES, FXD, FILM	EA	1
C-2	31	PAHZZ	5905-00-106-3666	RCR07G103JS	81349	RES, FXD, CMPSN	EA	6
C-2	32	PAHZZ	5905-00-107-0656	RCR07G100JS	81349	RES, FXD, CMPSN	EA	1
C-2	33	PAHZZ	5905-00-196-5187	RNC55J3321BS	81349	RES, FXD, FILM	EA	1
C-2	34	PAHZZ	5905-00-133-0440	RCR07G560JS	81349	RES, FXD, CMPSN	EA	1
C-2	35	PAHZZ	5905-00-252-1671	RCR07G225JS	81349	RES, FXD, CMPSN	EA	1
C-2	36	PAHZZ	5905-00-121-9861	RCR32G102JS	81349	RES, FXD, CMPSN	EA	1
C-2	37	PAHZZ	5905-00-110-0388	RCR07G104JS	81349	RES, FXD, CMPSN	EA	1
C-2	38	PAHZZ	5905-00-233-7113	RNC55J4991BS	81349	RES, FXD, FILM	EA	2

(1) ILLUSTRATION		(2)	(3)	(4)	(5)	(6)	(7)	(8)
FIG NO	ITEM NO	SMR CODE	NATIONAL STOCK NUMBER	PART NUMBER	FSCM	DESCRIPTION USABLE ON CODE	U/M	QTY INC IN UNIT
C-2	39	PAHZZ	5905-00-151-4669	RNC55J2871BS	81349	RES,FXD,FILM	EA	1
C-2	40	PAHZZ	5905-00-273-9721	RNC55J2151BS	81349	RES,FXD,FILM	EA	1
C-2	41	PAHZZ	5905-00-128-6237	RCR07G3R3JS	81349	RES,FXD,CMP SN	EA	1
C-2	42	PAHZZ	5905-00-466-1011	RNC55J2322BS	81349	RES,FXD,FILM	EA	1
C-2	43	PAHZZ	5905-00-110-7620	RCR07G102JS	81349	RES,FXD,CMP SN	EA	2
C-2	44	PAHZZ	5905-00-576-5705	RWR89S1OR0BR	81349	RES,FXD,WW	EA	1
C-2	45	PAHZZ	5950-01-207-6151	C5073971-1	57958	XMFR	EA	1
C-2	46	XDHZZ		C5073844-1	57958	STIFFENER,PWB	EA	1
C-2	47	XDHZZ	5305-00-054-5649	MS51957-15	96906	SCREW,PPH	EA	47
C-2	48	XDHZZ	5310-00-595-6211	MS15795-803	96906	WASHER	EA	4
C-2	49	XDHZZ	5310-00-933-8118	MS35338-135	96906	WASHER,LOCK	EA	4
C-2	50	XDHZZ	5310-00-208-3786	NAS671C4	80205	NUT,PLAIN,HEX	EA	4
C-2	51			NOT USED				
C-2	52			NOT USED				
C-2	53	XDHHH		C5073838-2	57958	HEATSINK ASSY,CB	EA	1
C-2	54	XDHZZ	5305-00-054-6654	MS51957-30	96906	SCREW,PPH	EA	12
C-2	55	XDHZZ	5310-00-722-5998	MS15795-805	96906	WASHER	EA	18
C-2	56	XDHZZ	5310-00-929-6395	MS35338-136	96906	WASHER,LOCK	EA	18
C-2	57	PAHZZ	5310-00-616-8660	NAS671C6	80205	NUT	EA	18
C-2	58	XDHZZ	5970-01-164-9157	5612-25-50	86928	WASHER	EA	4
C-2	59	PAHZZ	5970-01-080-6291	56-03-2	18725	INSULATOR	EA	1
C-2	60	XDHZZ	5305-00-054-6653	MS51957-29	96906	SCREW,PPH	EA	6
C-2	61	XDHZZ		138B8021GR1OP	09214	MOUNTING KIT	EA	2
C-2	62	XDHZZ		C5073821-1	57958	BRACKET	EA	2
C-2	63	PAHZZ	5970-00-023-6246	DF31A	02735	INSULATOR	EA	1
C-2	64	XDHHH		C5073838-1	57958	HEATSINK,ASSY CB	EA	2
C-2	65	PAHZZ	5999-00-442-9434	7717-38N	13103	PAD,MTG	EA	1
C-2	66	PAHZZ	5999-01-086-6658	7717-86N	13103	PAD,MTG	EA	1
C-2	67	PAHZZ	5999-01-029-9866	7717-89-N	13103	PAD,MTG	EA	1
C-2	68	XDHZZ		C5073837-1	57958	HEATSINK,CHASSIS	EA	2
C-2	69	XDHZZ	5305-00-088-9665	MS24693-C29	96906	SCREW,PPH	EA	4
C-2	70	XA		C5073838-3	57958	HEATSINK	EA	1
C-2	71	XDHZZ		NAS1789-C06M	80205	NUT,SLF-LKG	EA	4
C-2	72	XDHZZ	5320-00-619-0497	MS20426A3-5	96906	RIVET,CSK HD	EA	8
C-2	73	XDHZZ	5310-00-878-7111	F-632-1	46384	NUT,CL INCH	EA	4
C-2	74	XA		C5073838-4	57958	HEATSINK	EA	1

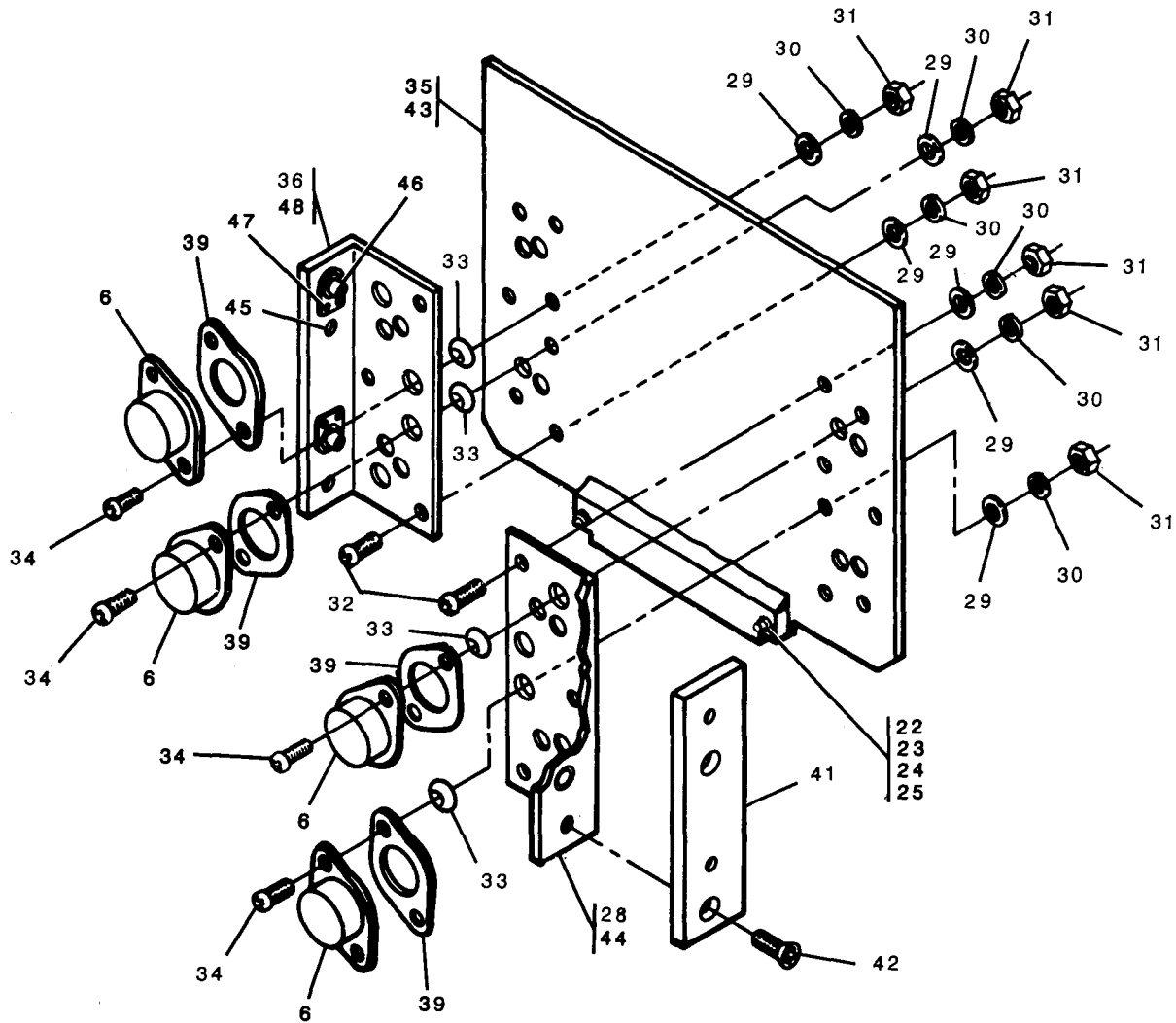
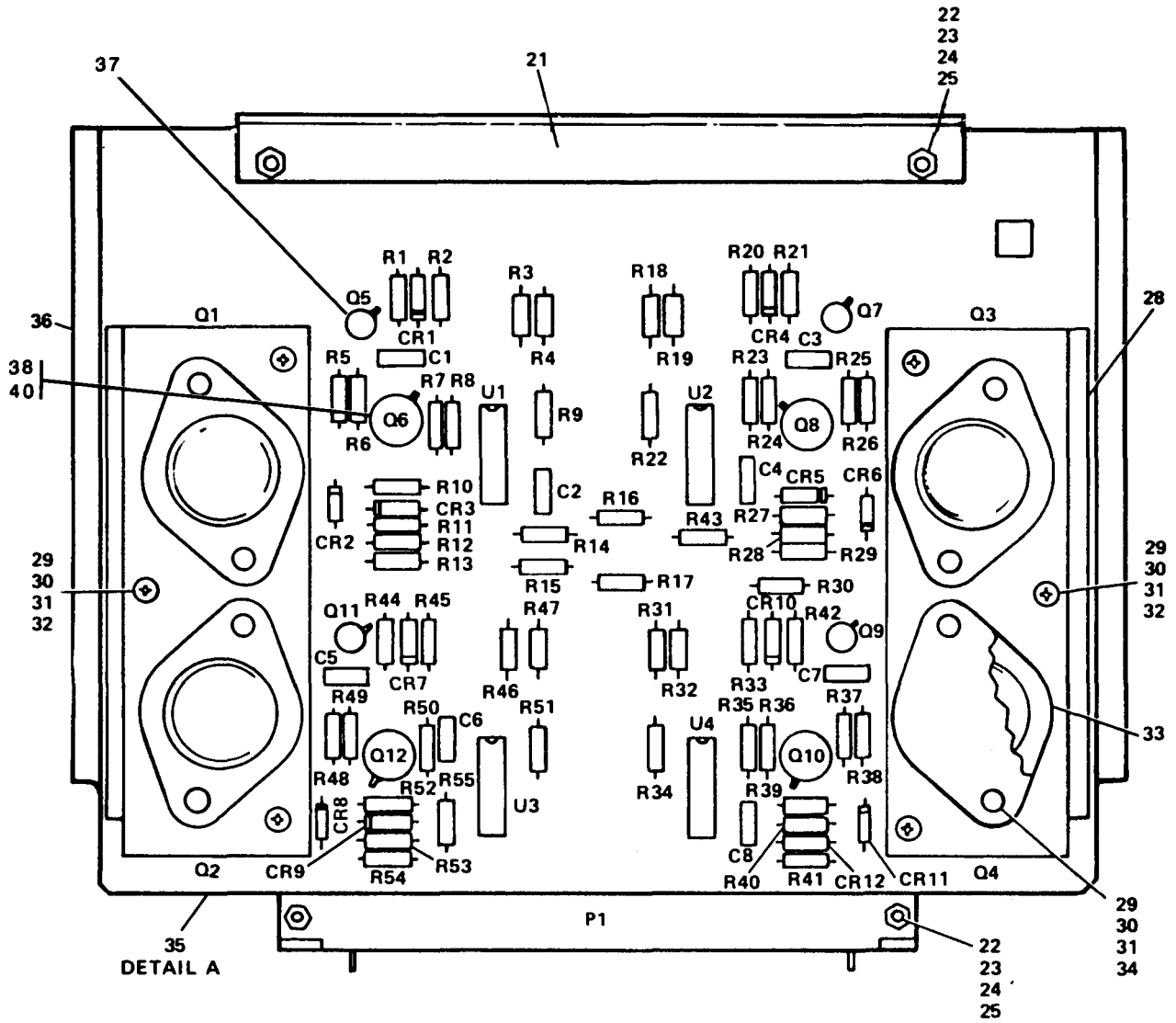
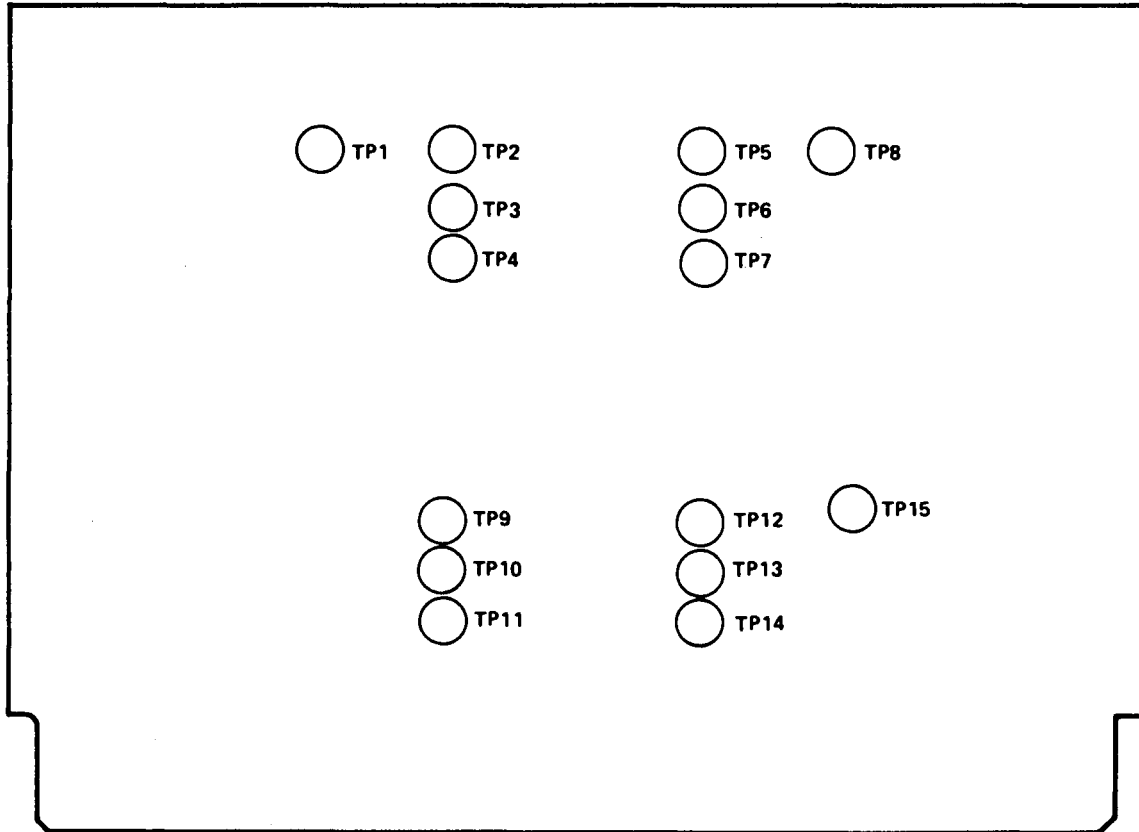

Figure C-3. Motor Control CCA C5073893-1
(Sheet 1 of 4)



GA00699-22 (A)

Figure C-3. Motor Control CCA C5073893-1
(Sheet 2 of 4)



DETAIL A

GA00699 231A1

Figure C-3. Motor Control CCA C5073893-1
(Sheet 3 of 4)

	ITEM NO	REF DES	ITEM NO	REF DES	ITEM NO	REF DES	ITEM	REF DES	ITEM NO	REF DES	ITEM NO
CR1	1	C7	3	R4	12	R22	10	R40	10	TP3	19
CR2	2	C8	4	R5	13	R23	14	R41	10	TP4	19
CR3	1	P1	5	R6	10	R24	15	R42	9	TP5	19
CR4	1	Q1	6	R7	14	R25	10	R43	17	TP6	19
CR5	1	Q2	6	R8	15	R26	13	R44	9	TP7	19
CR6	2	Q3	6	R9	10	R27	16	R45	10	TP8	19
CR7	1	Q4	6	R10	16	R28	10	R46	11	TP9	19
CR8	2	Q5	7	R11	17	R29	10	R47	12	TP10	19
CR9	1	Q6	8	R12	10	R30	17	R48	13	TP11	19
CR10	1	Q7	7	R13	10	R31	12	R49	10	TP12	19
CR11	2	Q8	8	R14	18	R32	11	R50	14	TP13	19
CR12	1	Q9	7	R15	18	R33	10	R51	10	TP14	19
C1	3	Q10	8	R16	18	R34	10	R52	16	TP15	19
C2	4	Q11	7	R17	18	R35	14	R53	10	U1	20
C3	3	Q12	8	R18	11	R36	15	R54	17	U2	20
C4	4	R1	9	R19	12	R37	10	R55	15	U3	20
C5	3	R2	10	R20	10	R38	13	TP1	19	U4	20
C6	4	R3	11	R21	9	R39	16	TP2	19		

Figure C-3. Motor Control CCA C5073893-1
(Sheet 4 of 4)

(1) ILLUSTRATION		(2)	(3)	(4)	(5)	(6)	(7)	(8)
FIG NO	ITEM NO	SMR CODE	NATIONAL STOCK NUMBER	PART NUMBER	FSCM	DESCRIPTION USABLE ON CODE	U/M	QTY INC IN UNIT
						GROUP 0502-MOTOR CONTROL CCA C5073893-1 (57958)		
C-3	1	PAHZZ	5961-00-494-4915	JANTX 1N4 148	81349	SCND DVC, D IODE	EA	8
C-3	2	PAHZZ	5961-00-458-5813	JANTX 1N4 245	81349	SCND DVC, D IODE	EA	4
C-3	3	PAHZZ	5910-00-113-5445	M39014-01-1339	81349	CAP, FXD, CER, D IEL	EA	4
C-3	4	PAHZZ	5910-00-010-8666	M39014-01-1357	81349	CAP, FXD, CER	EA	4
C-3	5	XDHZZ		M5 5302-57-B66Y-6	81349	CONNECTOR	EA	1
C-3	6	PAHZZ	5961-00-359-5752	JANTX 2N50 38	81349	TRANSISTOR	EA	4
C-3	7	PAHZZ	5961-00-858-3826	JANTX 2N2222A	81349	TRANSISTOR	EA	4
C-3	8	PAHZZ	5961-01-053-7166	JANTX 2N5 662	81349	TRANSISTOR	EA	4
C-3	9	PAHZZ	5905-00-111-4727	RCR0 7G272JS	81349	RES, FXD, CMPSN	EA	4
C-3	10	PAHZZ	5905-00-106-3666	RCR0 7G103JS	81349	RES, FXD, CMPSN	EA	19
C-3	11	PAHZZ	5905-00-759-8722	RNR5 5E1 582DS	81349	RES, FXD, FILM	EA	4
C-3	12	PAHZZ	5905-00-429-7018	RNR5 5E2 742BS	81349	RES, FXD, FILM	EA	4
C-3	13	PAHZZ	5905-00-104-8363	RCR0 7G820JS	81349	RES, FXD, CMPSN	EA	4
C-3	14	PAHZZ	5905-00-114-0708	RCR07G202JS	81349	RES, FXD, CMPSN	EA	4
C-3	15	PAHZZ	5905-00-133-0440	RCR0 7G560JS	81349	RES, FXD, CMPSN	EA	4
C-3	16	PAHZZ	5905-00-136-3891	RCR0 7G621JS	81349	RES, FXD, CMPSN	EA	4
C-3	17	PAHZZ	5905-00-119-3504	RCR07G273JS	81349	RES, FXD, CMPSN	EA	4
C-3	18	PAHZZ	5905-00-116-8556	RCR0 7G223JS	81349	RES, FXD, CMPSN	EA	4
C-3	19	XDHZZ		SE16-X-C-01-S	81349	TERMI NAL, TURRET	EA	15
C-3	20	PAHZZ	5962-00-417-1080	M38510/10201BCB	81349	MICROCKT	EA	4
C-3	21	XDHZZ		C5073844-1	57958	STIFFENER, PWB	EA	1
C-3	22	XDHZZ	5310-00-208-3786	NAS671C4	80205	NUT, PLAIN, HEX	EA	4
C-3	23	XDHZZ	5310-00-933-8118	MS3 5338-135	96906	WASHER, LOCK	EA	4
C-3	24	XDHZZ	5310-00-595-6211	MS1 5795-803	96906	WASHER, FLAT	EA	4
C-3	25	XDHZZ	5305-00-054-5649	MS51957-15	96906	SCREW, PPH	EA	4
C-3	26			NOT USED				
C-3	27			NOT USED				
C-3	28	XDHHH		C5073911-2	57958	HEAT SINK ASSY	EA	1
C-3	29	XDHZZ	5310-00-722-5998	MS15795-805	96906	WASHER, FLAT	EA	6
C-3	30	XDHZZ	5310-00-929-6395	MS3 5338-136	96906	WASHER, LOCK	EA	6
C-3	31	PAHZZ	5310-00-616-8660	NA S67 1C6	80205	NUT, PLAIN, HEX	EA	6
C-3	32	XDHZZ	5305-00-054-6653	MS5 1957-29	96906	SCREW, PPH	EA	6
C-3	33	XDHZZ	5970-01-164-9157	5612-25-50	86928	WASHER, FLAT	EA	8
C-3	34	XDHZZ	5305-00-054-6654	MS5 1957-30	96906	SCREW, PPH	EA	8
C-3	35	XDHHD		C5073892-1	57958	PC BOARD, MOTOR CONT	EA	1
C-3	36	XDHHH		C5073911-1	57958	HEAT SINK ASSY	EA	4
C-3	37	PAHZZ	5999-01-029-9866	7717-89-N	13103	MOUNTING PAD	EA	4
C-3	38	PAHZZ	5999-01-086-6658	7717-86N	13103	MOUNTING PAD	EA	4
C-3	39	PAHZZ	5970-01-080-6291	56-03-2	13103	INSULATOR	EA	4

(1) ILLUSTRATION		(2)	(3)	(4)	(5)	(6)	(7)	(8)
FIG NO	ITEM NO	SMR CODE	NATIONAL STOCK NUMBER	PART NUMBER	FSCM	DESCRIPTION USABLE ON CODE	U/M	QTY INC IN UNIT
C-3	40	PAHZZ	5999-00-147-9775	2226B	13103	HEAT SINK	EA	4
C-3	41	XDHZZ		C5073837-1	57958	HEAT SINK, CHAS	EA	2
C-3	42	XDHZZ	5305-00-088-9665	MS24693-C29	96906	SCREW, PPH	EA	4
C-3	43	XA		C5073892-2	57958	PCB	EA	1
C-3	44	XA		C5073911-4	57958	HEAT SINK	EA	1
C-3	45	XDHZZ	5310-00-338-2256	M45938-4-5	81349	NUT CL INCH	EA	4
C-3	46	XDHZZ		NAS1789-C06M	80205	NUT, SELF-LKG	EA	4
C-3	47	XDHZZ	5320-00-619-0497	MS20426A3-5	96906	RIVET, CSK	EA	8
C-3	48	XA		C5073911-3	57958	HEAT SINK	EA	1

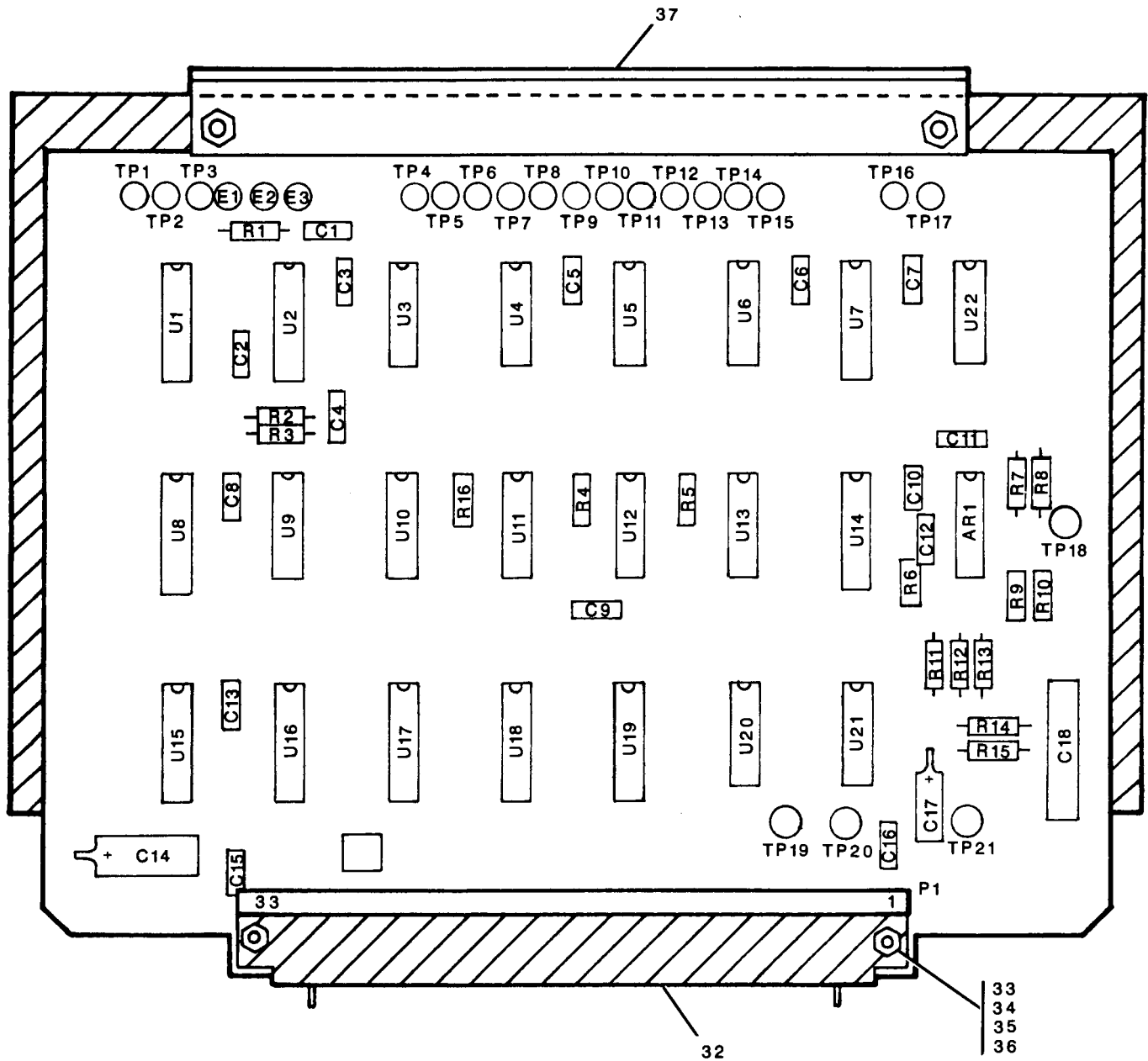

Figure C-4. Control Logic CCA A3 C5073901-1
(Sheet 1 of 2)

LEGEND

REF DES	ITEM NO	REF DES	ITEM NO	REF DES	ITEM NO	REF DES	ITEM NO	REF DES	ITEM NO	REF DES	ITEM NO
C1	1	R8	11	TP20	REF						
C2	1	R9	13	TP21	REF						
C3	2	R10	13	U1	17						
C4	3	R11	14	U2	18						
C5	2	R12	15	U3	19						
C6	2	R13	11	U4	20						
C7	2	R14	16	U5	19						
C8	2	R15	11	U6	20						
C9	4	R16	12	U7	21						
C10	2	TP1	REF	U8	22						
C11	3	TP2	REF	U9	23						
C12	2	TP3	REF	U10	24						
C13	2	TP4	REF	U11	25						
C14	6	TP5	REF	U12	24						
C15	2	TP6	REF	U13	26						
C16	3	TP7	REF	U14	21						
C17	5	TP8	REF	U15	27						
C18	7	TP9	REF	U16	28						
E1	REF	TP10	REF	U17	28						
E2	REF	TP11	REF	U18	28						
E3	REF	TP12	REF	U19	28						
R1	8	TP13	REF	U20	29						
R2	8	TP14	REF	U21	24						
R3	9	TP15	REF	U22	30						
R4	10	TP16	REF	AR1	31						
R5	10	TP17									
R6	11	TP18									
R7	12	TP19									

Figure C-4. Control Logic CCA A3 C5073901-1
(Sheet 2 of 2)

(1) ILLUSTRATION		(2)	(3)	(4)	(5)	(6)	(7)	(8)
FIG NO	ITEM NO	SMR CODE	NATIONAL STOCK NUMBER	PART NUMBER	FSCM	DESCRIPTION USABLE ON CODE	U/M	QTY INC IN UNIT
						GROUP 0510-CONTROL LOGIC CCA A3 C5073901-1 (57958)		
C-4	1	PAHZZ	5910-00-113-5445	M39014/01-1339	81349	CAPACITOR	EA	2
C-4	2	PAHZZ	5910-00-124-0659	M39014/01-1575	81349	CAPACITOR	EA	9
C-4	3	PAHZZ	5910-00-010-8717	M39014/01-1593	81349	CAPACITOR	EA	3
C-4	4	PAHZZ	5910-00-113-5278	M39014/01-1587	81349	CAPACITOR	EA	1
C-4	5	PAHZZ	5910-00-360-2333	M39003/01-5631	81349	CAPACITOR	EA	1
C-4	6	PAHZZ	5910-01-077-9390	M39003/01-5635	81349	CAPACITOR	EA	1
C-4	7	PAHZZ	5910-01-034-2597	M83421/01-1169R	81349	CAPACITOR	EA	1
C-4	8	PAHZZ	5905-00-116-8555	RCR07G153JS	81349	RESISTOR	EA	2
C-4	9	PAHZZ	5905-00-110-0388	RCR07G104JS	81349	RESISTOR	EA	1
C-4	10	PAHZZ	5905-00-106-3666	RCR07G103JS	81349	RESISTOR	EA	2
C-4	11	PAHZZ	5905-00-627-0282	RNC55J1503BS	81349	RESISTOR	EA	4
C-4	12	PAHZZ	5905-00-114-0711	RCR07G472JS	81349	RESISTOR	EA	2
C-4	13	PAHZZ	5905-00-152-8454	RNC55J7501BS	81349	RESISTOR	EA	2
C-4	14	PAHZZ	5905-00-557-3201	RNC55J2943FS	81349	RESISTOR	EA	1
C-4	15	PAHZZ	5905-00-167-0624	RNC55J5622BS	81349	RESISTOR	EA	1
C-4	16	PAHZZ	5905-00-110-7620	RCR07G102JS	81349	RESISTOR	EA	1
C-4	17	PAHZZ	5962-01-050-0919	SNJ54LS153J	01295	MICROCIRCUIT	EA	1
C-4	18	PAHZZ	5962-01-084-0321	SNJ54LS221J	01295	MICROCIRCUIT	EA	1
C-4	19	PAHZZ	5962-00-390-7970	M38510/02005BCB	81349	MICROCIRCUIT	EA	2
C-4	20	PAHZZ	5962-01-049-2604	SNJ54LS107AJ	01295	MICROCIRCUIT	EA	2
C-4	21	PAHZZ	5962-01-066-1153	54LS193DMQB	07263	MICROCIRCUIT	EA	2
C-4	22	PAHZZ		C5074011-1	57958	MICROCIRCUIT	EA	1
C-4	23	PAHZZ		M38510/30009BCX	81349	MICROCIRCUIT	EA	1
C-4	24	PAHZZ	5962-01-031-7030	M38510/30001BCB	81349	MICROCIRCUIT	EA	4
C-4	25	PAHZZ	5962-00-396-2262	M38510/02003BCB	81349	MICROCIRCUIT	EA	1
C-4	26	PAHZZ	5962-01-035-7479	M38510/30401BCB	81349	MICROCIRCUIT	EA	1
C-4	27	PAHZZ	5962-01-043-3940	M38510/30106BEB	81349	MICROCIRCUIT	EA	1
C-4	28	PAHZZ	5962-01-084-0322	SNJ54LS138J	01295	MICROCIRCUIT	EA	4
C-4	29	PAHZZ	5962-01-054-3674	M38510/32102BCB	81349	MICROCIRCUIT	EA	1
C-4	30					NOT USED		
C-4	31	PADZZ		LM119DB	34335	MICROCIRCUIT	EA	1
C-4	32	XDHZZ		M55302/57-B66Y-11	81349	CONNECTOR	EA	1
C-4	33	XDHZZ	5305-00-054-5649	MS51957-15	98906	SCREW	EA	4
C-4	34	XDHZZ	5310-00-595-6211	MS15795-803	96906	WASHER	EA	4
C-4	35	XDHZZ	5310-00-933-8118	MS35338-135	96906	WASHER	EA	4
C-4	36	PAHZZ	5310-00-208-3786	NAS671C4	80205	NUT	EA	4
C-4	37	XDHZZ		C5073844-1	57958	STIFFENER, PWB	EA	1

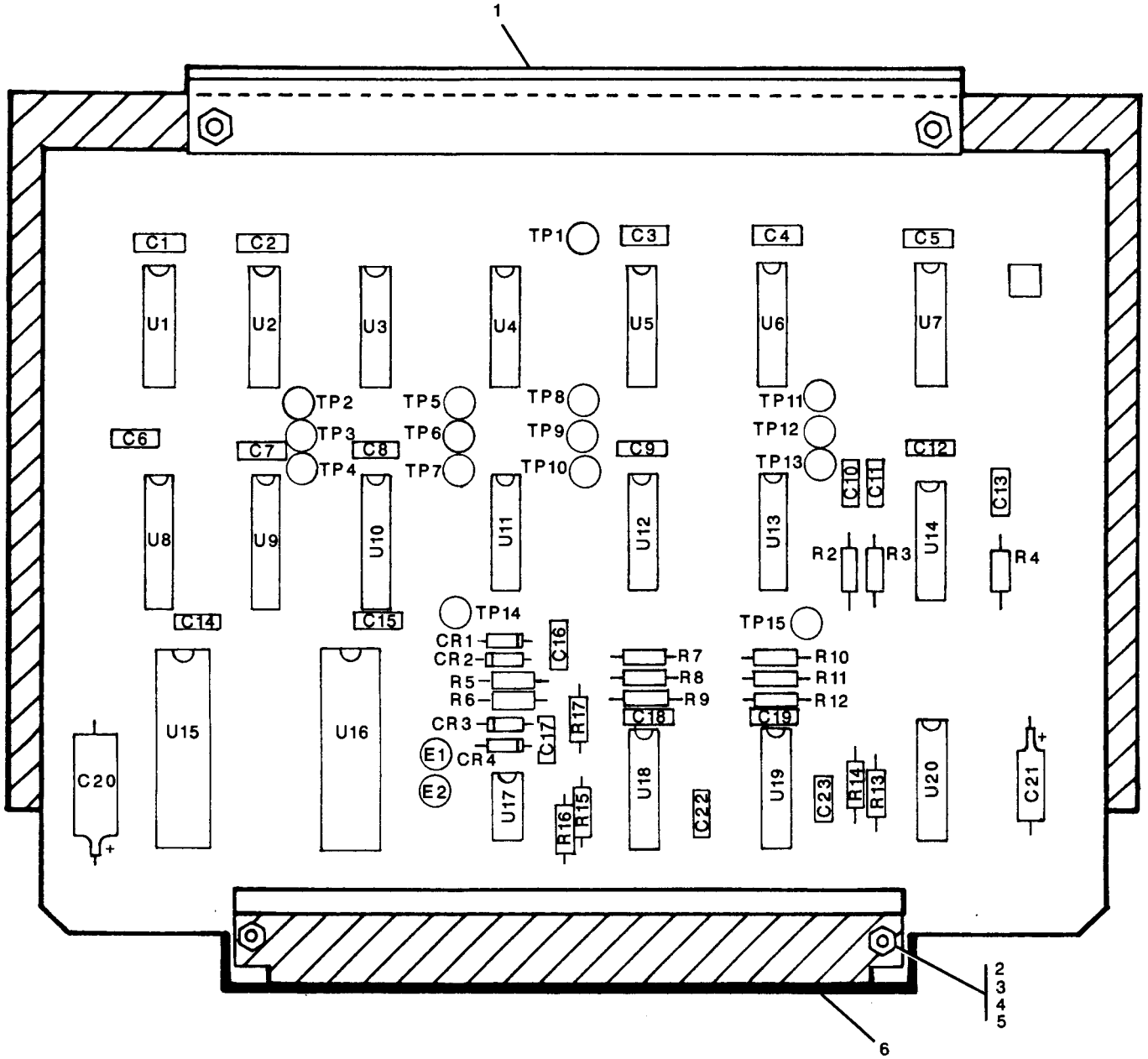

Figure C-5. Decoder Circuit Card Assy A4 C5073897-1
(Sheet 1 of 2)

LEGEND

REF DES	ITEM NO	REF DES	ITEM NO	REF DES	ITEM NO	REF DES	ITEM NO	REF DES	ITEM NO	REF DES	ITEM NO
R1	-	TP1	REF	U10	26						
R2	11	TP2	REF	U11	27						
R3	7	TP3	REF	U12	28						
R4	7	TP4	REF	U13	29						
R5	8	TP5	REF	U14	30						
R6	8	TP6	REF	U15	31						
R7	12	TP7	REF	U16	35						
R8	12	TP8	REF	U17	32						
R9	10	TP9	REF	U18	33						
R10	12	TP10	REF	U19	34						
R11	12	TP11	REF	U20	29						
R12	9	TP12	REF								
R13	13	TP13	REF								
R14	14	TP14	REF								
R15	12	TP15	REF								
R16	12										
R17	10										
C1	17										
C2	17	CR1	20								
C3	17	CR2	20								
C4	17	CR3	20								
C5	17	CR4	20								
C6	17										
C7	17										
C8	17	E1	45								
C9	17	E2	45								
C10	17										
C11	16	U1	21								
C12	17	U2	21								
C13	15	U3	22								
C14	17	U5	23								
C15	17	U5	24								
C16	17	U6	24								
c17	17	U7	25								
C18	17	U8	26								
C19	17	U9	26								
C20	18										
C21	19										
C22	17										
C23	17										

Figure C-5. Decoder Circuit Card Assy A4 C5073897-1
(Sheet 2 of 2)

(1) ILLUSTRATION		(2)	(3)	(4)	(5)	(6)	(7)	(8)
FIG NO	ITEM NO	SMR CODE	NATIONAL STOCK NUMBER	PART NUMBER	FSCM	DESCRIPTION USABLE ON CODE	U/ M	QTY INC IN UNIT
						GROUP 0511- DECODER CCA A4 C5073897-1 (57958)		
C-5	1	XDHZZ		C5073844-1	57958	STIFFENER	EA	1
C-5	2	XDHZZ	5305-00-054-5649	MS51957-15	96906	SCREW	EA	4
C-5	3	XDHZZ	5310-00-595-6211	MS15795-803	96906	WASHER	EA	4
C-5	4	XDHZZ	5310-00-933-8118	MS35338-135	96906	WASHER	EA	4
C-5	5	PAHZZ	5310-00-208-3786	NAS671C4	80205	NUT	EA	4
C-5	6	XDHZZ		M55302/57-B66Y-16	81349	CONNECTOR	EA	1
C-5	7	PAHZZ	5905-00-233-7104	RNC55J1002BS	81349	RESISTOR	EA	2
C-5	8	PAHZZ	5905-00-106-3666	RCR07G103JS	81349	RESISTOR	EA	2
C-5	9	PAHZZ	5905-00-110-7620	RCR07G102JS	81349	RESISTOR	EA	1
C-5	10	PAHZZ	5905-00-111-1679	RCR07G512JS	81349	RESISTOR	EA	2
C-5	11	PAHZZ	5905-00-116-8555	RCR07G153JS	81349	RESISTOR	EA	1
C-5	12	PAHZZ	5905-00-106-1249	RCR07G510JS	81349	RESISTOR	EA	6
C-5	13	PAHZZ	5905-00-105-7768	RCR07G561JS	81349	RESISTOR	EA	1
C-5	14	PAHZZ	5905-00-110-7622	RCR07G682JS	81349	RESISTOR	EA	1
C-5	15	PAHZZ	5910-00-098-9242	M39014/01-1566	81349	CAPACITOR	EA	1
C-5	16	PAHZZ		CMR04F131FODP	81349	CAPACITOR	EA	1
C-5	17	PAHZZ	5910-00-010-8717	M39014/01-1593	81349	CAPACITOR	EA	1
C-5	18	PAHZZ	5910-01-077-9390	M39003/01-5635	81349	CAPACITOR	EA	1
C-5	19	PAHZZ	5910-00-360-2333	M39003/01-5631	81349	CAPACITOR	EA	1
C-5	20	PAHZZ	5961-00-335-8934	JANTX1N5712	81349	SCND DVC, DIODE	EA	4
C-5	21	PAHZZ	5962-01-085-4705	SNJ54LS164J	01295	MICROCIRCUIT	EA	2
C-5	22	PAHZZ	5962-01-030-6352	M38510/30005BCB	81349	MICROCIRCUIT	EA	1
C-5	23	PAHZZ	5962-01-034-9832	M38510/31004BCB	81349	MICROCIRCUIT	EA	1
C-5	24	PAHZZ	5962-01-049-2604	SNJ54LS107AJ	01295	MICROCIRCUIT	EA	2
C-5	25	PAHZZ		M38510/30009BCX	81349	MICROCIRCUIT	EA	1
C-5	26	PAHZZ	5962-01-043-3940	M38510/30106BEB	81349	MICROCIRCUIT	EA	3
C-5	27	PAHZZ	5962-01-031-7030	M38510/30001BCB	81349	MICROCIRCUIT	EA	1
C-5	28	PAHZZ	5962-01-026-2493	M38510/30007BCB	81349	MICROCIRCUIT	EA	1
C-5	29	PAHZZ	5962-01-027-6863	M38510/30003BCB	81349	MICROCIRCUIT	EA	2
C-5	30	PAHZZ	5962-01-113-4267	SNJ54LS123J	01295	MICROCIRCUIT	EA	1
C-5	31	PAHZZ	5962-01-250-8532	C5074010-1	81349	MICROCIRCUIT	EA	1
C-5	32	PAHZZ	5962-01-100-6043	SN55462JG	01295	MICROCIRCUIT	EA	1
C-5	33	PAHZZ	5962-00-621-7201	M38510/10401BCB	81349	MICROCIRCUIT	EA	1
C-5	34	PAHZZ	5962-00-534-7290	SN55110AJ	01295	MICROCIRCUIT	EA	1
C-5	35	PAHZZ	5962-01-250-8533	C5074010-2	57958	MICROCIRCUIT	EA	1
C-5	36	XDHZZ		M55155/16-1	81349	TERMINAL	EA	2
C-5	37	XA		C507389-1	81349	PRINTED WIRING BOARD	EA	1

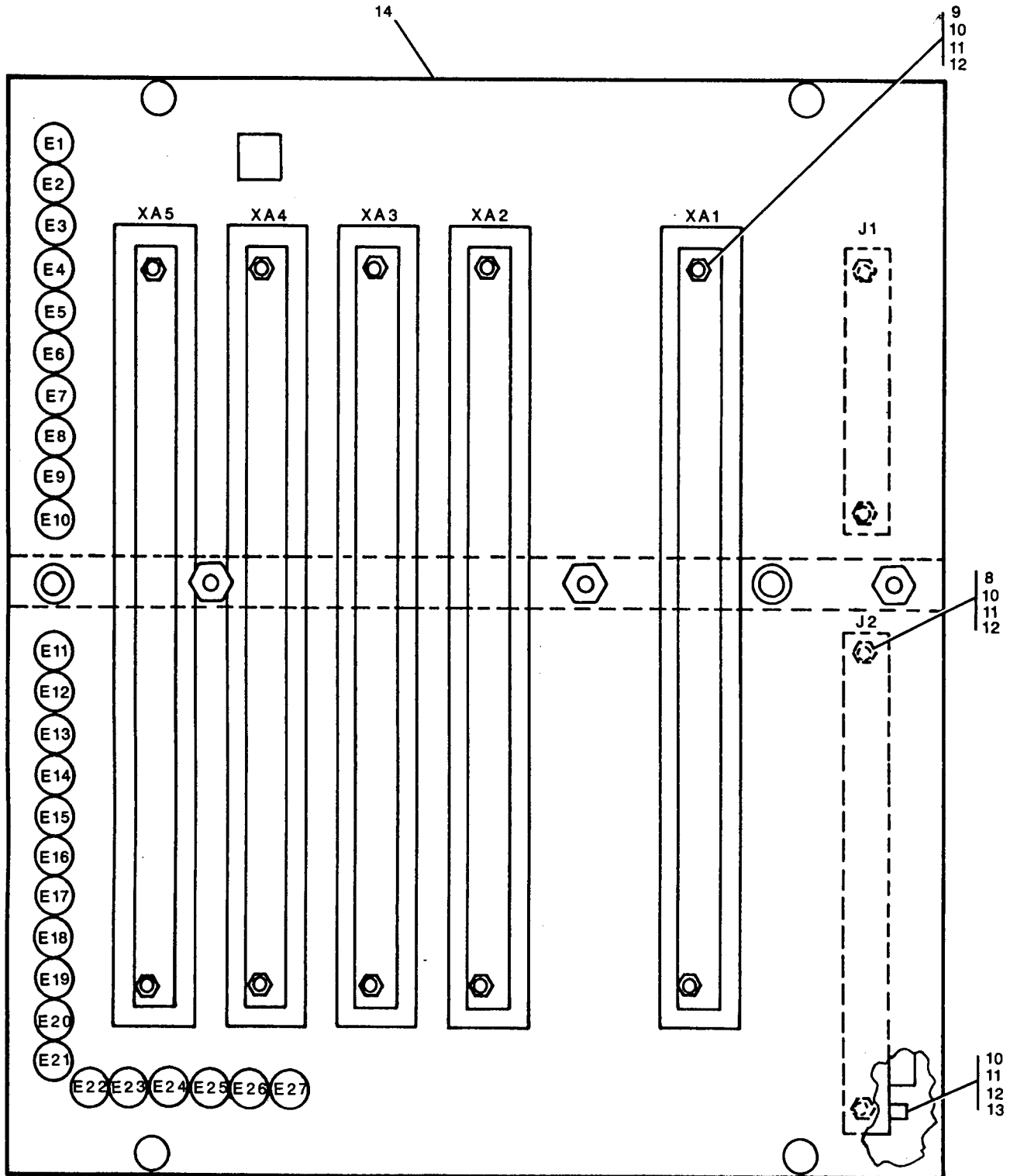

Figure C-6. Motherboard CCA A7 C5073909-1
(Sheet 1 of 2)

LEGEND

REF DES	ITEM NO	REF DES	ITEM NO	REF DES	ITEM NO	REF DES	ITEM NO	REF DES	ITEM NO	REF DES	ITEM NO
E1	REF	J1	6								
E2	REF	J2	5								
E3	REF										
E4	REF	XA1	1								
E5	REF	XA2	2								
E6	REF	XA3	3								
E7	REF	XA4	4								
E8	REF	XA5	7								
E9	REF										
E10	REF										
E11	REF										
E12	REF										
E13	REF										
E14	REF										
E15	REF										
E16	REF										
E17	REF										
E18	REF										
E19	REF										
E20	REF										
E21	REF										
E22	REF										
E23	REF										
E24	REF										
E25	REF										
E26	REF										
E27	REF										

Figure C-6. Motherboard CCA A7 C5973909-1
(Sheet 2 of 2)

(1) ILLUSTRATION		(2)	(3)	(4)	(5)	(6)	(7)	(8)
FIG NO	ITEM NO	SMR CODE	NATIONAL STOCK NUMBER	PART NUMBER	FSCM	DESCRIPTION USABLE ON CODE	U/M	QTY INC IN UNIT
						GROUP 0513 - MOTHER-BOARD CCA A7 C5073909-1 (57958)		
C-6	1	XDHZZ	5935-01-110-7081	M55302/58-C66Y-1	81349	CONNECTOR	EA	1
C-6	2	XDHZZ		M55302/58-C66Y-6	81349	CONNECTOR	EA	1
C-6	3	XDHZZ		M55302/58-C66Y-11	81349	CONNECTOR	EA	1
C-6	4	XDHZZ		M55302/58-C66Y-16	81349	CONNECTOR	EA	1
C-6	5	XDHZZ	5935-01-017-6546	M24308/24-40	81349	CONNECTOR	EA	1
C-6	6	XDHZZ	5935-01-073-0797	M24308/24-38	81349	CONNECTOR	EA	1
C-6	7	XDHZZ		WTB66SED1 ISY-2	10400	CONNECTOR	EA	1
C-6	8	XDHZZ	5305-00-054-5650	MS51957-16	96906	SCREW	EA	4
C-6	9	XDHZZ	5305-00-054-5651	MS51957-17	96906	SCREW	EA	10
C-6	10	XDHZZ	5310-00-595-6211	MS15795-803	96906	WASHER	EA	22
C-6	11	XDHZZ	5310-00-933-8118	MS35338-135	96906	WASHER	EA	22
C-6	12	XDHZZ	5310-00-934-9748	MS35649-244	96906	NUT	EA	22
C-6	13	XDHZZ	5307-00-449-3100	D110551	71468	JACKPOST ASSY	EA	4
C-6	14	XA		C5073908-1	57958	PRINTED WIRING BOARD	EA	1

Section III. SPECIAL TOOLS LIST

(Not Applicable)

Section III. SPECIAL TOOLS LIST

(Not Applicable)

NATIONAL STOCK NUMBERS

NATL STOCK NUM	FIGURE	ITEM	NATL STOCK NUM	FIGURE	ITEM
5310-00-595-6211	C-4	34	5865-01-207-3406	C-2	17
5310-00-595-6211	C-5	3	5865-01-207-3434	C-1	80
5310-00-595-6211	C-6	10	5865-01-207-3437	C-1	84
5310-00-595-6761	C-1	76	5865-01-207-3438	C-1	13
5310-00-595-6772	C-1	32	5865-01-207-3441	C-1	81
5310-00-616-8660	C-2	57	5865-01-207-5595	C-1	52
5310-00-616-8660	C-3	31	5905-00-009-1157	C-2	30
5310-00-722-5998	C-1	12	5905-00-104-8363	C-3	13
5310-00-722-5998	C-2	55	5905-00-105-7768	C-5	13
5310-00-722-5998	C-3	29	5905-00-106-1249	C-5	12
5310-00-728-9458	C-1	153	5905-00-106-3666	C-2	31
5310-00-771-7359	C-1	166	5905-00-106-3666	C-3	10
5310-00-771-7360	C-1	157	5905-00-106-3666	C-4	10
5310-00-780-1049	C-1	170	5905-00-106-3666	C-5	8
5310-00-782-1349	C-1	5	5905-00-107-0656	C-2	32
5310-00-837-1381	C-1	43	5905-00-110-0388	C-2	37
5310-00-878-7111	C-2	73	5905-00-110-0388	C-4	9
5310-00-883-9384	C-1	3	5905-00-110-7620	C-2	43
5310-00-928-2690	C-1	77	5905-00-110-7620	C-4	16
5310-00-929-6395	C-1	6	5905-00-110-7620	C-5	9
5310-00-929-6395	C-2	56	5905-00-110-7622	C-5	14
5310-00-929-6395	C-3	30	5905-00-111-1679	C-5	10
5310-00-933-8118	C-1	100	5905-00-111-4727	C-3	9
5310-00-933-8118	C-2	49	5905-00-114-0708	C-3	14
5310-00-933-8118	C-3	23	5905-00-114-0711	C-4	12
5310-00-933-8118	C-4	35	5905-00-116-8555	C-4	8
5310-00-933-8118	C-5	4	5905-00-116-8555	C-5	11
5310-00-933-8118	C-6	11	5905-00-116-8556	C-3	18
5310-00-933-8120	C-1	2	5905-00-119-3504	C-3	17
5310-00-934-9748	C-6	12	5905-00-121-9861	C-2	36
5310-00-934-9750	C-1	134	5905-00-128-6237	C-2	41
5310-00-934-9765	C-1	57	5905-00-133-0440	C-2	34
5310-00-934-9765	C-1	86	5905-00-133-0440	C-3	15
5310-00-952-0309	C-1	56	5905-00-136-3891	C-3	16
5310-01-067-9589	C-1	17	5905-00-137-8563	C-2	26
5320-00-117-6516	C-1	184	5905-00-141-1183	C-2	27
5320-00-584-0672	C-1	141	5905-00-151-4669	C-2	39
5320-00-619-0497	C-1	158	5905-00-152-8454	C-4	13
5320-00-619-0497	C-2	72	5905-00-167-0624	C-4	15
5320-00-619-0497	C-3	47	5905-00-196-5187	C-2	33
5320-00-655-4757	C-1	154	5905-00-233-7104	C-5	7
5340-00-060-5386	C-1	58	5905-00-233-7113	C-2	38
5340-00-060-5957	C-1	36	5905-00-252-1671	C-2	35
5340-00-917-4549	C-1	16	5905-00-273-9721	C-2	40
5340-00-964-2555	C-1	107	5905-00-284-9477	C-2	25
5365-00-684-5982	C-1	14	5905-00-429-7018	C-3	12
5365-00-804-7645	C-1	49	5905-00-466-1011	C-2	42
5865-01-207-0771	C-1	61	5905-00-557-3201	C-4	14
5865-01-207-0774	C-1	82	5905-00-576-5705	C-2	44
5865-01-207-0775	C-1	83	5905-00-627-0282	C-4	11

NATIONAL STOCK NUMBERS

NATL STOCK NUM	FIGURE	ITEM	NATL STOCK NUM	FIGURE	ITEM
5905-00-721-0815	C-2	29	5961-00-689-1989	C-2	20
5905-00-759-8722	C-3	11	5961-00-858-3826	C-3	7
5905-01-078-1958	C-2	28	5961-00-898-2101	C-1	123
5910-00-010-8666	C-3	4	5961-00-938-1135	C-2	3
5910-00-010-8717	C-2	11	5961-00-951-8757	C-2	21
5910-00-010-8717	C-4	3	5961-01-053-7166	C-3	8
5910-00-010-8717	C-5	17	5962-00-390-7970	C-4	19
5910-00-098-9242	C-5	15	5962-00-396-2262	C-4	25
5910-00-113-5276	C-2	13	5962-00-417-1080	C-2	2
5910-00-113-5277	C-2	9	5962-00-417-1080	C-3	20
5910-00-113-5278	C-4	4	5962-00-534-7290	C-5	34
5910-00-113-5445	C-3	3	5962-00-621-7201	C-5	33
5910-00-113-5445	C-4	1	5962-01-026-2493	C-5	28
5910-00-113-5689	C-2	10	5962-01-027-6863	C-5	29
5910-00-124-0659	C-4	2	5962-01-030-6352	C-5	22
5910-00-236-8745	C-2	12	5962-01-031-7030	C-4	24
5910-00-360-2333	C-4	5	5962-01-031-7030	C-5	27
5910-00-360-2333	C-5	19	5962-01-034-9832	C-5	23
5910-01-009-8502	C-2	14	5962-01-035-7479	C-4	26
5910-01-016-2400	C-2	8	5962-01-043-3940	C-4	27
5910-01-034-2597	C-4	7	5962-01-043-3940	C-5	26
5910-01-054-7379	C-1	75	5962-01-048-7767	C-2	1
5910-01-066-6274	C-2	7	5962-01-049-2604	C-4	20
5910-01-067-7879	C-2	15	5962-01-049-2604	C-5	24
5910-01-077-9390	C-4	6	5962-01-050-0919	C-4	17
5910-01-077-9390	C-5	18	5962-01-054-3674	C-4	29
5915-01-043-6963	C-1	45	5962-01-066-1153	C-4	21
5915-01-074-8413	C-1	70	5962-01-084-0321	C-4	18
5935-00-899-9361	C-1	22	5962-01-084-0322	C-4	28
5935-00-902-7035	C-1	23	5962-01-085-4705	C-5	21
5935-00-947-1036	C-1	21	5962-01-100-6043	C-5	32
5935-00-962-9848	C-1	35	5962-01-113-4267	C-5	30
5935-00-975-6265	C-1	60	5962-01-250-8532	C-5	31
5935-01-017-6546	C-6	5	5962-01-250-8533	C-5	35
5935-01-028-5793	C-1	30	5970-00-023-6246	C-2	63
5935-01-073-0797	C-6	6	5970-01-080-6291	C-2	59
5935-01-110-7081	C-6	1	5970-01-080-6291	C-3	39
5935-01-207-5591	C-1	28	5970-01-164-9157	C-2	58
5935-01-222-3309	C-1	15	5970-01-164-9157	C-3	33
5940-00-155-7686	C-1	73	5985-01-248-7471	C-1	88
5940-01-010-1571	C-1	125	5999-00-147-9775	C-3	40
5940-01-222-0502	C-1	68	5999-00-249-1804	C-1	181
5945-01-135-7710	C-1	67	5999-00-442-9434	C-2	65
5950-01-207-6151	C-2	45	5999-01-029-9866	C-2	67
5961-00-054-4141	C-2	23	5999-01-029-9866	C-3	37
5961-00-335-8934	C-5	20	5999-01-086-6658	C-2	66
5961-00-359-5752	C-2	22	5999-01-086-6658	C-3	38
5961-00-359-5752	C-3	6	5999-01-207-5584	C-1	51
5961-00-458-5813	C-3	2	6105-01-207-5572	C-1	54
5961-00-494-4915	C-3	1			

PART NUMBERS

PART NUMBER	FSCM	FIGURE	ITEM	PART NUMBER	FSCM	FIGURE	ITEM
CMR04F131FODP	81349	C-5	16	C507389-1	81349	C-5	37
CMR04C5R0DPDP	81349	C-2	8	C5073892-1	57958	C-3	35
C5073816-1	57958	C-1	183	C5073892-2	57958	C-3	43
C5073817-1	57958	C-1	88	C5073893-1	57958	C-1	81
C5073821-1	57958	C-2	62	C5073897-1	57958	C-1	83
C5073823-1	57958	C-1	155	C5073901-1	57958	C-1	82
C5073823-2	57958	C-1	147	C5073905-1	57958	C-1	52
C5073823-3	57958	C-1	140	C5073908-1	57958	C-6	14
C5073823-4	57958	C-1	143	C5073909-1	57958	C-1	61
C5073823-5	57958	C-1	142	C5073911-1	57958	C-3	36
C5073824-1	57958	C-1	148	C5073911-2	57958	C-3	28
C5073825-1	57958	C-1	63	C5073911-3	57958	C-3	48
C5073826-1	57958	C-1	136	C5073911-4	57958	C-3	44
C5073827-1	57958	C-1	165	C5073918-1	57958	C-1	51
C5073827-2	57958	C-1	173	C5073936-1	57958	C-1	47
C5073828-1	57958	C-1	151	C5073956-1	57958	C-1	84
C5073829-1	57958	C-1	159	C5073960-1	57958	C-1	54
C5073830-1	57958	C-1	169	C5073971-1	57958	C-2	45
C5073831-1	57958	C-1	178	C5073971-2	57958	C-2	17
C5073832-1	57958	C-1	171	C5073995-1	57958	C-1	13
C5073832-2	57958	C-1	174	C5073998-1	57958	C-1	8
C5073832-6	57958	C-1	163	C5074002-1	57958	C-1	129
C5073832-7	57958	C-1	161	C5074003-1	57958	C-1	128
C5073833-1	57958	C-1	145	C5074004-1	57958	C-1	130
C5073834-1	57958	C-1	1	C5074005-1	57958	C-1	28
C5073835-1	57958	C-1	41	C5074010-1	81349	C-5	31
C5073837-1	57958	C-2	68	C5074010-2	57958	C-5	35
C5073837-1	57958	C-3	41	C5074011-1	57958	C-4	22
C5073838-1	57958	C-2	64	C5074015-1	57958	C-1	135
C5073838-2	57958	C-2	53	C5074017-1	57958	C-1	102
C5073838-3	57958	C-2	70	C5074018-1	57958	C-1	26
C5073838-4	57958	C-2	74	C5074019-1	57958	C-1	105
C5073839-1	57958	C-1	38	C5074020-1	57958	C-1	37
C5073841-1	57958	C-1	95	C5074024-1	57958	C-1	42
C5073841-1	57958	C-1	138	C5074025-1	57958	C-1	94
C5073842-1	57958	C-1	40	C5074026-1	57958	C-1	109
C5073843-1	57958	C-1	44	C5074033-1	57958	C-1	110
C5073844-1	57958	C-2	46	C5074034-1	57958	C-1	111
C5073844-1	57958	C-3	21	C5074034-2	57958	C-1	112
C5073844-1	57958	C-4	37	C5074035-1	57958	C-1	113
C5073844-1	57958	C-5	1	C5074038-1	57958	C-1	162
C5073845-1	57958	C-1	96	C5074823-6	57958	C-1	185
C5073845-2	57958	C-1	122	DF31A	02735	C-2	63
C5073846-2	57958	C-1	50	D110550	71468	C-1	59
C5073850-1	57958	C-1	132	D110551	71468	C-6	13
C5073860-1	57958	C-1	33	D142-51	06090	C-1	125
C5073871-1	57958	C-1	97	D142-56	06090	C-1	124
C5073871-1	57958	C-1	137	F-632-1	46384	C-2	73
C5073873-1	57958	C-1	71	GC-15-5-26063	07649	C-1	89
C5073889-1	57958	C-1	80	JANTX1N4148	81349	C-3	1

PART NUMBERS

PART NUMBER	FSCM	FIGURE	ITEM	PART NUMBER	FSCM	FIGURE	ITEM
JANTX 1N4245	81349	C-3	2	MS24693-3	96906	C-1	9
JANTX 1N5712	81349	C-5	20	MS24693-34B	96906	C-1	27
JANTX 1N645	81349	C-1	123	MS24693C29	96906	C-1	126
JANTX 2N1774A	81349	C-2	20	MS25043-100	96906	C-1	34
JANTX 2N2222A	81349	C-3	7	MS27476Y14D15P	96906	C-1	15
JANTX 2N5038	81349	C-2	22	MS275-11-E-14-N	96906	C-1	25
JANTX 2N5038	81349	C-3	6	MS3114H14C12P	96906	C-1	23
JANTX 2N5662	81349	C-3	8	MS3115-14A	96906	C-1	21
LM119DB	34335	C-4	31	MS3181-14C	96906	C-1	22
MS15795-802	96906	C-1	76	MS35338-134	96906	C-1	77
MS15795-803	96906	C-1	29	MS35338-135	96906	C-2	49
MS15795-803	96906	C-2	48	MS35338-135	96906	C-3	23
MS15795-803	96906	C-3	24	MS35338-135	96906	C-1	100
MS15795-803	96906	C-4	34	MS35338-135	96906	C-4	35
MS15795-803	96906	C-5	3	MS35338-135	96906	C-5	4
MS15795-803	96906	C-6	10	MS35338-135	96906	C-6	11
MS15795-804	96906	C-1	5	MS35338-136	96906	C-1	6
MS15795-805	96906	C-1	12	MS35338-136	96906	C-2	56
MS15795-805	96906	C-2	55	MS35338-136	96906	C-3	30
MS15795-805	96906	C-3	29	MS35338-137	96906	C-1	17
MS15795-808	96906	C-1	32	MS35338-138	96906	C-1	2
MS15795-841	96906	C-1	18	MS35649-244	96906	C-6	12
MS15795-842	96906	C-1	3	MS35650-304	96906	C-1	57
MS16624-4050	96906	C-1	49	MS35650-304	96906	C-1	86
MS16996-22	96906	C-1	55	MS35650-324	96906	C-1	78
MS16996-23	96906	C-1	91	MS35650-344	96906	C-1	7
MS16996-24	96906	C-1	87	MS35650-364	96906	C-1	10
MS16996-25	96906	C-1	92	MS35650-364	96906	C-1	101
MS20426AD3-4	96906	C-1	139	MS35650-384	96906	C-1	134
MS20426AD3-6	96906	C-1	141	MS35914-307	57958	C-1	176
MS20426AD4-6	96906	C-1	168	MS39087-3	96906	C-1	58
MS20426A3-4	96906	C-1	154	MS39087-5	96906	C-1	36
MS20426A3-5	96906	C-1	158	MS51957-12	96906	C-1	127
MS20426A3-5	96906	C-2	72	MS51957-122	96906	C-1	117
MS20426A3-5	96906	C-3	47	MS51957-14	96906	C-1	69
MS20470AD2-4	96906	C-1	182	MS51957-15	96906	C-1	24
MS20470AD3-4	96906	C-1	99	MS51957-15	96906	C-2	47
MS20470AD4-3	96906	C-1	184	MS51957-15	96906	C-3	25
MS20470AD4-6	96906	C-1	150	MS51957-15	98906	C-4	33
MS20470AD4-8	96906	C-1	149	MS51957-15	96906	C-5	2
MS20470A3-7	57958	C-1	131	MS51957-16	96906	C-6	8
MS21060-06	72962	C-1	170	MS51957-17	96906	C-1	20
MS21070L3	96906	C-1	153	MS51957-17	96906	C-6	9
MS21076-L04	96906	C-1	157	MS51957-20	96906	C-1	118
MS21076L4	96906	C-1	166	MS51957-22	96906	C-1	74
MS24693-C27	96906	C-1	62	MS51957-29	96906	C-2	60
MS24693-C29	96906	C-2	69	MS51957-29	96906	C-3	32
MS24693-C29	96906	C-3	42	MS51957-30	96906	C-2	54
MS24693-C47	96906	C-1	156	MS51957-30	96906	C-3	34
MS24693-C7	96906	C-1	114	MS51957-31	96906	C-1	39

PART NUMBERS

PART NUMBER	FSCM	FIGURE	ITEM	PART NUMBER	FSCM	FIGURE	ITEM
MS51957-32	96906	C-1	79	M39014/01-1593	81349	C-2	11
MS51957-44	96906	C-1	133	M39014/01-1593	81349	C-4	3
MS51957-45	96906	C-1	115	M39014/01-1593	81349	C-5	17
MS51957-46	96906	C-1	19	M39022-10-C105J	81349	C-2	15
MS51957-5	96906	C-1	98	M39022/10-C305JM	81349	C-2	7
MS51957-51	96906	C-1	93	M45938-4-5	81349	C-3	45
MS51958-61	96906	C-1	48	M55155/16-1	81349	C-5	36
MS51958-64	96906	C-1	4	M55302-57-B66Y-6	81349	C-3	5
MS51958-65	96906	C-1	53	M55302/57-B66Y-1	81349	C-2	18
MS51958-66	96906	C-1	31	M55302/57-B66Y-11	81349	C-4	32
MS77066-1	96906	C-1	73	M55302/57-B66Y-16	81349	C-5	6
M15733/25-0002	81349	C-1	45	M55302/58-C66Y-1	81349	C-6	1
M15733/27-0020	81349	C-1	70	M55302/58-C66Y-11	81349	C-6	3
M24308-3-2	81349	C-1	60	M55302/58-C66Y-16	81349	C-6	4
M24308/24-38	81349	C-6	6	M55302/58-C66Y-6	81349	C-6	2
M24308/24-40	81349	C-6	5	M554T179A194	81349	C-1	46
M38510/02003BCB	81349	C-4	25	M83421/01-1169R	81349	C-4	7
M38510/02005BCB	81349	C-4	19	M83725-5-001	81349	C-1	67
M38510/10201BCB	81349	C-2	2	NAS1397-2	80205	C-1	85
M38510/10201BCB	81349	C-3	20	NAS1397-6	80205	C-1	107
M38510/10304BGB	81349	C-2	1	NAS1397-7	80205	C-1	64
M38510/10401BCB	81349	C-5	33	NAS1789-C06M	80205	C-1	167
M38510/30001BCB	81349	C-4	24	NAS1789-C06M	80205	C-1	177
M38510/30001BCB	81349	C-5	27	NAS1789-C06M	80205	C-2	71
M38510/30003BCB	81349	C-5	29	NAS1789-C06M	80205	C-3	46
M38510/30005BCB	81349	C-5	22	NAS43DD1-38	96906	C-1	14
M38510/30007BCB	81349	C-5	28	NAS620C416	80205	C-1	56
M38510/30009BCX	81349	C-4	23	NAS671C4	80205	C-2	50
M38510/30009BCX	81349	C-5	25	NAS671C4	80205	C-3	22
M38510/30106BEB	81349	C-4	27	NAS671C4	80205	C-4	36
M38510/30106BEB	81349	C-5	26	NAS671C4	80205	C-5	5
M38510/30401BCB	81349	C-4	26	NAS671C6	80205	C-2	57
M38510/31004BCB	81349	C-5	23	NAS671C6	80205	C-3	31
M38510/32102BCB	81349	C-4	29	NAS671C8	80205	C-1	43
M39003/01-3015	81349	C-2	10	NOT USED		C-1	11
M39003/01-3021	81349	C-2	12	NOT USED		C-1	103
M39003/01-5631	81349	C-4	5	NOT USED		C-1	104
M39003/01-5631	81349	C-5	19	NOT USED		C-1	106
M39003/01-5635	81349	C-4	6	NOT USED		C-1	108
M39003/01-5635	81349	C-5	18	NOT USED		C-1	116
M39006/09-9034	81349	C-2	14	NOT USED		C-1	121
M39012/02-0006	81349	C-1	35	NOT USED		C-1	144
M39014-01-1339	81349	C-3	3	NOT USED		C-1	146
M39014-01-1357	81349	C-3	4	NOT USED		C-1	152
M39014/01-1339	81349	C-4	1	NOT USED		C-1	160
M39014/01-1351	81349	C-2	13	NOT USED		C-1	164
M39014/01-1563	81349	C-2	9	NOT USED		C-1	172
M39014/01-1566	81349	C-5	15	NOT USED		C-1	175
M39014/01-1575	81349	C-4	2	NOT USED		C-1	179
M39014/01-1587	81349	C-4	4	NOT USED		C-1	180

PART NUMBERS

PART NUMBER	FSCM	FIGURE	ITEM	PART NUMBER	FSCM	FIGURE	ITEM
NOT USED		C-2	51	RNC55J7501BS	81349	C-4	13
NOT USED		C-2	52	RNR55E1582DS	81349	C-3	11
NOT USED		C-3	26	RNR55E2742BS	81349	C-3	12
NOT USED		C-3	27	RWR81SR499FR	81349	C-2	24
NOT USED		C-4	30	RWR89S10R0BR	81349	C-2	44
RCR07G102JS	81349	C-4	16	R3-C5-26059	07649	C-1	90
RCR07G102JS	81349	C-5	9	SE16-X-C-01-S	57958	C-2	16
RCR07G103JS	81349	C-4	10	SE16-X-C-01-S	81349	C-3	19
RCR07G103JS	81349	C-5	8	SE20-5-D-01-S	88245	C-1	72
RCR07G104JS	81349	C-4	9	SNJ54LS107AJ	01295	C-4	20
RCR07G153JS	81349	C-4	8	SNJ54LS107AJ	01295	C-5	24
RCR07G153JS	81349	C-5	11	SNJ54LS123J	01295	C-5	30
RCR07G472JS	81349	C-4	12	SNJ54LS138J	01295	C-4	28
RCR07G510JS	81349	C-5	12	SNJ54LS153J	01295	C-4	17
RCR07G512JS	81349	C-5	10	SNJ54LS164J	01295	C-5	21
RCR07G561JS	81349	C-5	13	SNJ54LS221J	01295	C-4	18
RCR07G682JS	81349	C-5	14	SN55110AJ	01295	C-5	34
RCR07G100JS	81349	C-2	32	SN55462JG	01295	C-5	32
RCR07G101JS	81349	C-2	27	WTB66SED11SY-2	10400	C-6	7
RCR07G102JS	81349	C-2	43	1N1206A	81349	C-2	6
RCR07G103JS	81349	C-2	31	1N4148	81349	C-2	3
RCR07G103JS	81349	C-3	10	1N5802	81349	C-2	5
RCR07G104JS	81349	C-2	37	1N5807	81349	C-2	4
RCR07G202JS	81349	C-3	14	138B8021GR10P	09214	C-2	61
RCR07G223JS	81349	C-3	18	2DHT54T100FAB	21052	C-1	75
RCR07G225JS	81349	C-2	35	2N2222A	81349	C-2	21
RCR07G272JS	81349	C-3	9	2N3441	81349	C-2	23
RCR07G273JS	81349	C-3	17	2N3763	81349	C-2	19
RCR07G3R3JS	81349	C-2	41	2226B	13103	C-3	40
RCR07G560JS	81349	C-2	34	25-S3000	94375	C-1	30
RCR07G560JS	81349	C-3	15	35-6B2-8-3	18915	C-1	181
RCR07G621JS	81349	C-3	16	352-4613-03-07-1	71279	C-1	68
RCR07G820JS	81349	C-3	13	43-9507-01-901	13636	C-1	16
RCR32G102JS	81349	C-2	36	54LS193DMQB	07263	C-4	21
REER60F1000R	57958	C-1	65	56-03-2	18725	C-2	59
REER65F7R50R	57958	C-1	66	56-03-2	13103	C-3	39
RNC55J1001BS	81349	C-2	25	5612-25-50	86928	C-2	58
RNC55J1002BS	81349	C-5	7	5612-25-50	86928	C-3	33
RNC55J1503BS	81349	C-4	11	7717-38N	13103	C-2	65
RNC55J2151BS	81349	C-2	40	7717-86N	13103	C-2	66
RNC55J2322BS	81349	C-2	42	7717-86N	13103	C-3	38
RNC55J2552BS	81349	C-2	26	7717-89-N	13103	C-2	67
RNC55J2871BS	81349	C-2	39	7717-89-N	13103	C-3	37
RNC55J2943FS	81349	C-4	14	8154-SS-0440	06540	C-1	119
RNC55J3321BS	81349	C-2	33	9223A115	06540	C-1	120
RNC55J3832BS	81349	C-2	30				
RNC55J4872BS	81349	C-2	28				
RNC55J4991BS	81349	C-2	38				
RNC55J5112BS	81349	C-2	29				
RNC55J5622BS	81349	C-4	15				

PART NUMBERS

PART NUMBER	FSCM	FIGURE	ITEM	PART NUMBER	FSCM	FIGURE	ITEM
M38510-10201BCB	81349	3	20	RCR07G103JS	81349	2	31
M38510-10304BGB	81349	2	1	RCR07G103JS	81349	3	10
M39003-01-3015	81349	2	10	RCR07G104JS	81349	2	37
M39003-01-3021	81349	2	12	RCR07G202JS	81349	3	14
M39006-09-9034	81349	2	14	RCR07G223JS	81349	3	18
M39012-02-0006	81349	1	35	RCR07G225JS	81349	2	35
M39014-01-1339	81349	3	3	RCR07G272JS	81349	3	9
M39014-01-1351	81349	2	13	RCR07G273JS	81349	3	17
M39014-01-1357	81349	3	4	RCR07G3R3JS	81349	2	41
M39014-01-1563	81349	2	9	RCR07G560JS	81349	2	34
M39014-01-1593	81349	2	11	RCR07G560JS	81349	3	15
M39022-10-C-105J	81349	2	15	RCR07G621JS	81349	3	16
M39022-10-C305JM	81349	2	7	RCR07G820JS	81349	3	13
M45938/4-5	81349	3	45	RCR32G102JS	81349	2	36
M55302-57-B66Y-6	81349	3	5	RER60F1000R	57958	1	65
M55302-57-866Y-1	81349	2	18	RER65F7R50R	57958	1	66
M554T179A194	81349	1	46	RNC55J1001BS	81349	2	25
M83725-5-001	81349	1	67	RNC55J2151BS	81349	2	40
NAS1397-2	80205	1	85	RNC55J2322BS	81349	2	42
NAS1397-6	80205	1	107	RNC55J2552BS	81349	2	26
NAS1397-7	80205	1	64	RNC55J2871BS	81349	2	39
NAS1789-C06M	80205	1	167	RNC55J3832BS	81349	2	30
NAS1789-C06M	80205	2	71	RNC55J4872BS	81349	2	28
NAS1789-C06M	80205	3	46	RNC55J4991BS	81349	2	38
NAS1789-006M	80205	1	177	RNC55J5112BS	81349	2	29
NAS43DD1-38	96906	1	14	RNR55E1582DS	81349	3	11
NAS620C416	80205	1	56	RNR55E2742BS	81349	3	12
NAS671C4	80205	2	50	RWR81SR499FR	81349	2	24
NAS671C4	80205	3	22	RWR89S10ROBR	81349	2	44
NAS671C6	80205	2	57	R3-C5-26059	07649	1	90
NAS671C6	80205	3	31	SE16-X-C-01-S	57958	2	16
NAS671C8	80205	1	43	SE16-X-C-01-S	81349	3	19
NOT USED			11	SE20-5-D-01-S	88245	1	72
NOT USED		1	95	1N1206A	81349	2	6
NOT USED		1	97	1N4148	81349	2	3
NOT USED		1	99	1N5802	81349	2	5
NOT USED		1	102	1N5807	81349	2	4
NOT USED		1	103	138B8021GR10P	09214	2	61
NOT USED		1	104	2DHT54T100FAB	21052	1	75
NOT USED		1	106	2N2222A	81349	2	21
NOT USED		1	108	2N3441	81349	2	23
NOT USED		1	116	2N3763	81349	2	19
NOT USED		1	121	2226B	13103	3	40
NOT USED		1	180	25-S3000	94375	1	30
NOT USED		2	51	35-6B-2-8-3	18915	1	181
NOT USED		2	52	352-4613-03-07-1	71279	1	68
RCR07G100JS	81349	2	32	43-9507-01-901	13636	1	16
RCR07G101JS	81349	2	27	56-03-2	18725	2	59
RCR07G102JS	81349	2	43	56-03-2	13103	3	39

PART NUMBERS

PART NUMBER	FSCM	FIGURE	ITEM	PART NUMBER	FSCM	FIGURE	ITEM
5612-25-50	86928	2	58				
5612-25-50	86928	3	33				
7717-38N	13103	2	65				
7717-86N	13103	2	66				
7717-86N	13103	3	38				
7717-89N	13103	2	67				
7717-89N	13103	3	37				
8154-SS-0440	06540	1	119				
9223A115	06540	1	120				

APPENDIX D

EXPENDABLE SUPPLIES AND MATERIALS LIST

Section I. Introduction

D-1. SCOPE.

This appendix lists expendable supplies and materials you will need to operate and maintain the tunable coupler. These items are authorized to you by CTA 50-970, Expendable Items (Except Medical, Class V, Repair Parts, and Heraldic Items).

D-2. EXPLANATION OF COLUMNS.

a. Column (1) - Item number. This number is assigned to the entry in the listing and is referenced in the narrative instructions to identify the material (e.g., "Use cleaning compound, item 5, Appendix D").

b. Column (2) - Level. This column identifies the lowest level of maintenance that requires the listed item.

C - Operator/Crew
O - Organizational Maintenance
F - Direct Support Maintenance
H - General Support Maintenance

c. Column (3) - National Stock Number. This is the National stock number assigned to the item. Use it to request or requisition the item.

d. Column (4) - Description. Indicates the Federal item name and, if required, a description to identify the item. The last line for each item indicates the Federal Supply Code for Manufacturer (FSCM) in parentheses followed by the part number.

e. Column (5) - Unit of Measure (U/M). Indicates the measure used in performing the actual maintenance function. This measure is expressed by a two-character alphabetical abbreviation (e.g., ea. in. pr.). If the unit of measure differs from the unit of issue, requisition the lowest unit of issue that will satisfy your requirements.

Section II. EXPENDABLE SUPPLIES AND MATERIALS LIST

(1)	(2)	(3)	(4)	(5)
<u>ITEM NO.</u>	<u>LEVEL</u>	<u>NSN</u>	<u>DESCRIPTION</u>	<u>U/M</u>
1	H	8040-00-225-4568	Adhesive FSCM 96717, RTV732	
2	H	8020-00-246-8806	Brush, Soft	ea
3	H	8305-00-267-5015	Cloth, Lint-free	ro
4	H	6850-00-281-4033	Compound, Thermal Transfer	
5	H		Enamel, semigloss, MIL-E-15090, Class 2, Type III, color No. 24410, IAW FED standard 595.	qt
6	H		Freon TFE, TE, or TME	
7	H	8415-00-200-7013	Gloves, rubber, heavy duty	pr
8	H		Grommet, Plastic, MS21266-3	
9	H		Heatsink Shim, C5073822	ea
10	H		Humiseal 1A33	
11	H		Humiseal 13B1	
12	H		Polyurethane Resin, MIL-I-46058, Type UR	
13	H		RFI Gasket FSCM 12881; 06-0120-6044-13	
14	H		RFI Gasket FSCM 12881; 02-0104-0433-07	
15	H		RFI Gasket FSCM 12881; 01-0501-1854	
16	H		Sandpaper, No. 000	sht
17	H		Sponge, Strip-N-Stick Self- adhesive Silicone	
18	H		Tape, Rubber 1" x 4" FSCM 71643	in
19	H	6850-00-984-5853	Trichlorotrifluoroethane, MIL-C-18718	gl

APPENDIX E

INTEGRATED LIST OF MANUFACTURED ITEMS

E-1. GENERAL. This appendix provides the replacement procedure for the EMI/RFI gasket on the bottom cover and chassis of Tunable Coupler CU-2293/ALQ-151(V). This appendix can be used to facilitate repair and maintenance in the field.



Fitting is critical to ensure an airtight closure that meets the anti-sparking requirements of Tunable Coupler CU-2293/ALQ-151(V).

E-2. PARTS LIST.

<u>Item Description</u>	<u>Quantity</u>
EMI/RFI Gasket, FSCM 12881, P/N 06-0120-6044-13	7.5 ft (2286 cm)
Adhesive, FSCM 96717, RTV733	1 tube

E-3. GASKET REPLACEMENT.

To replace the bottom cover or chassis gasket, proceed as follows:

- a. Use the riveter kit (see maintenance allocation chart) to remove the gasket to be replaced.
- b. Refer to figure E-1 for the required dimensions of the replacement gasket. Figures E-2 and E-3 show locations for the bottom cover and chassis gasket.

NOTE

During the following step, cut the gasket and weather seal separately to the required length, before cutting the aluminum center strip.

- c. Measure and cut the gasket, weather seal, and aluminum center strip to the required lengths (see figure E-1).
- d. Drill the required number and size of holes in the aluminum center strip at the specified locations.
- e. Clean all old adhesive from the surface where the gasket is to be installed.
- f. Apply a continuous bead of adhesive to the surface where the gasket is to be installed.
- g. Place the replacement gasket in position by alining the holes in the gasket with the holes in the bottom cover or chassis.

- h. Use the riveter kit to secure the replacement gasket. The aluminum center strip must be flush with the bottom cover or chassis.

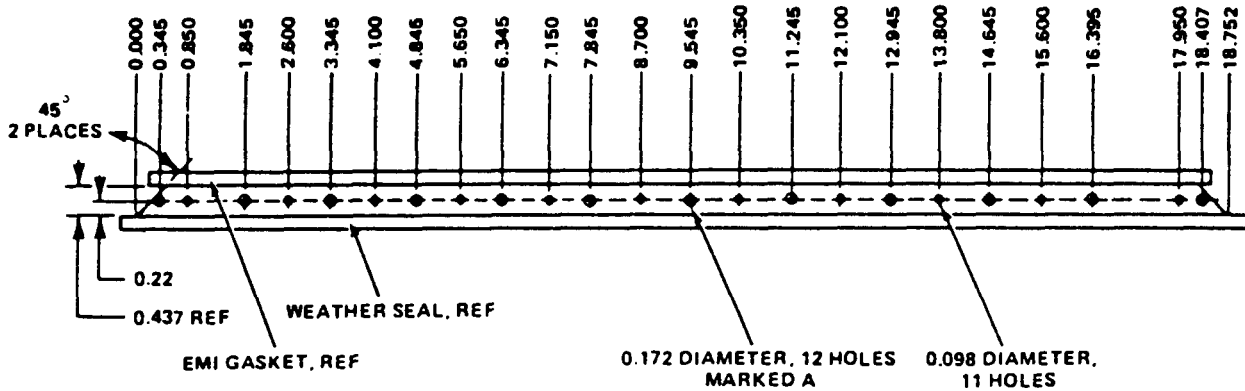

A. BOTTOM COVER SIDES (SEE FIGURE 5-9)

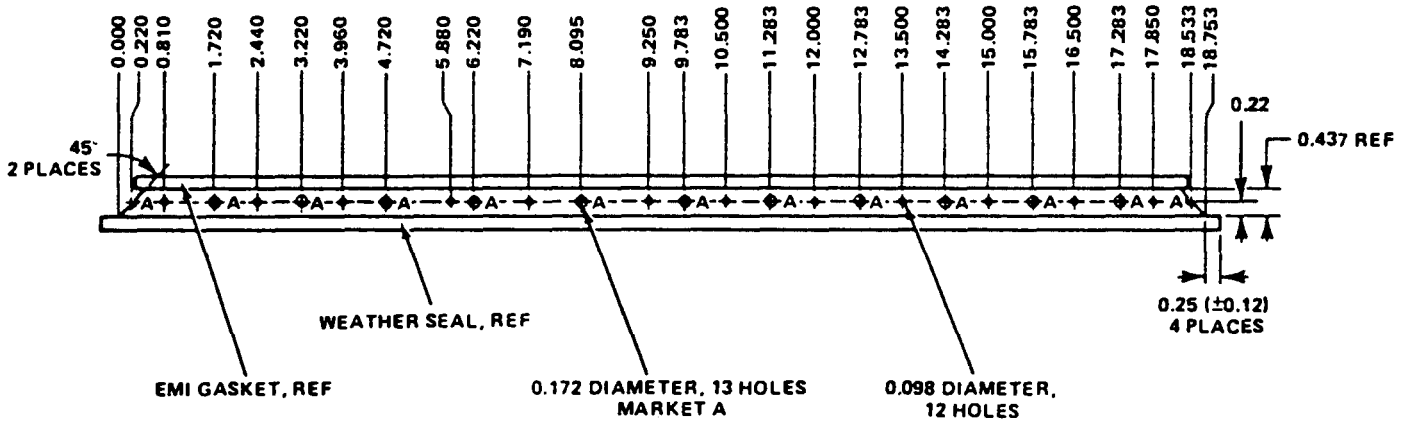

B. CHASSIS SIDES (SEE FIGURE 5-10A)

- NOTES: 1. BEFORE CUTTING ALUMINUM CENTER STRIP TO DESIGNATED LENGTH, CUT GASKET AND WEATHER SEAL AS SHOWN.
2. ALL DIMENSIONS GIVEN IN INCHES.

Figure E-1. Gasket Dimensions (Sheet 1 of 3)

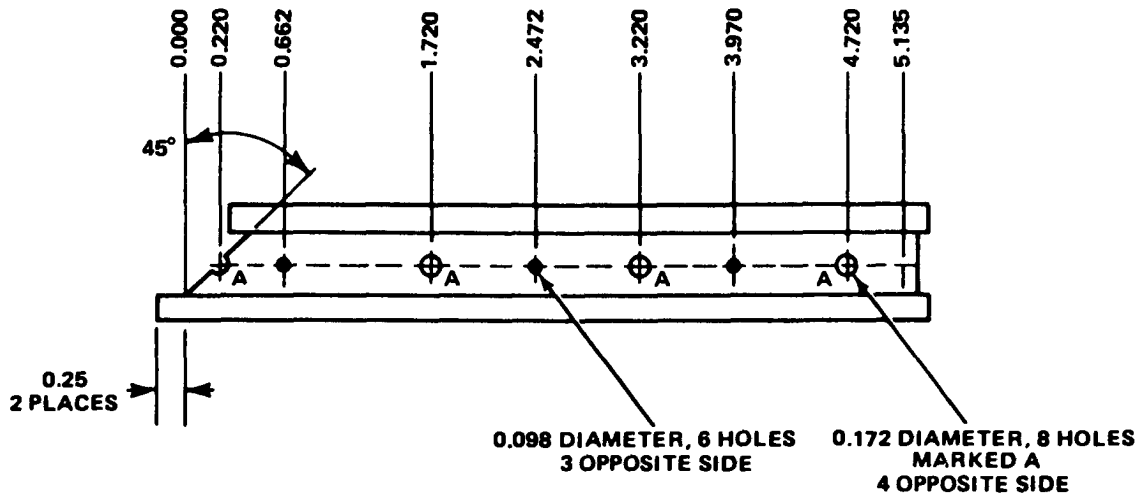

C. CHASSIS ENDS (SEE FIGURE 5-10A)

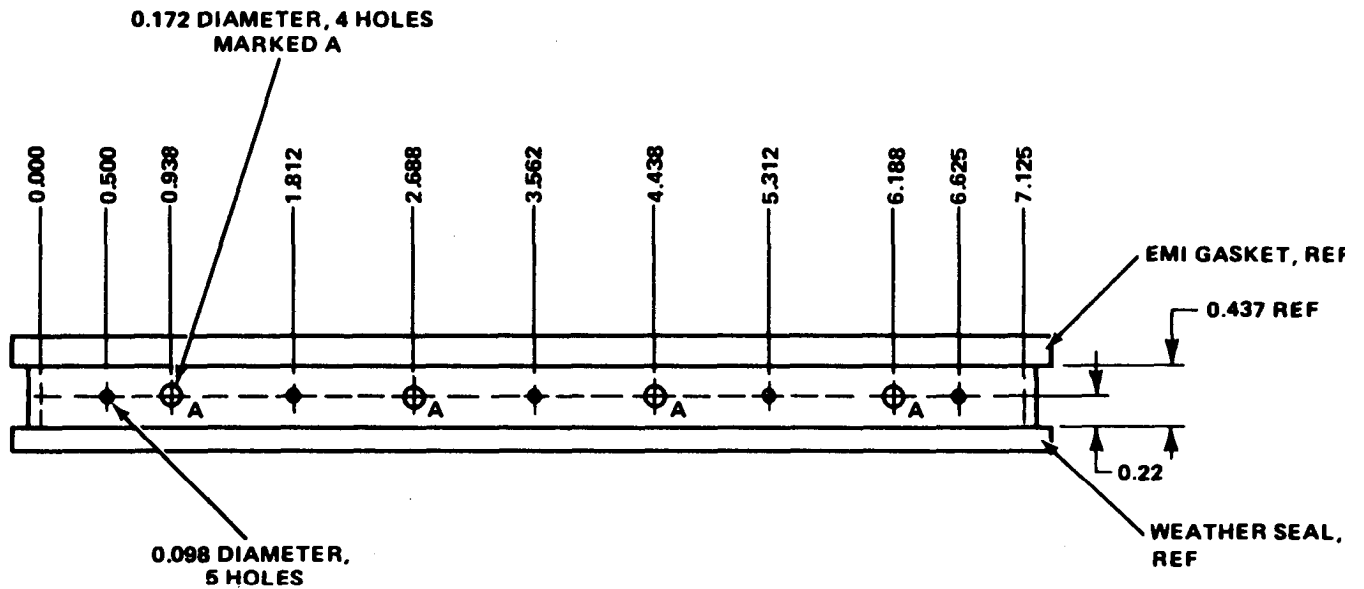

D. CHASSIS TOP (SEE FIGURE 5-10B)

NOTES: 1. BEFORE CUTTING ALUMINUM CENTER STRIP TO DESIGNATED LENGTH, CUT GASKET AND WEATHER SEAL AS SHOWN.

2. ALL DIMENSIONS GIVEN IN INCHES.

Figure E-1. Gasket Dimensions (Sheet 2 of 3)

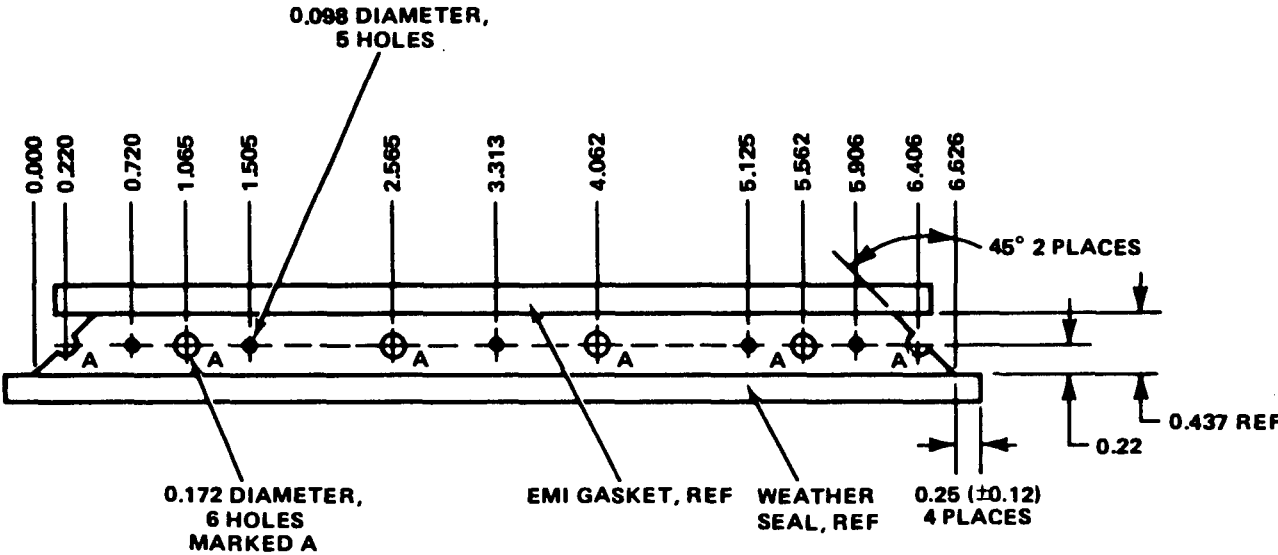

E. BOTTOM COVER ENDS (SEE FIGURE 5-9)

- NOTES: 1. BEFORE CUTTING ALUMINUM CENTER STRIP TO DESIGNATED LENGTH, CUT GASKET AND WEATHER SEAL AS SHOWN.
- 2. ALL DIMENSIONS GIVEN IN INCHES.

Figure E-1 . Gasket Dimensions (Sheet 3 of 3)

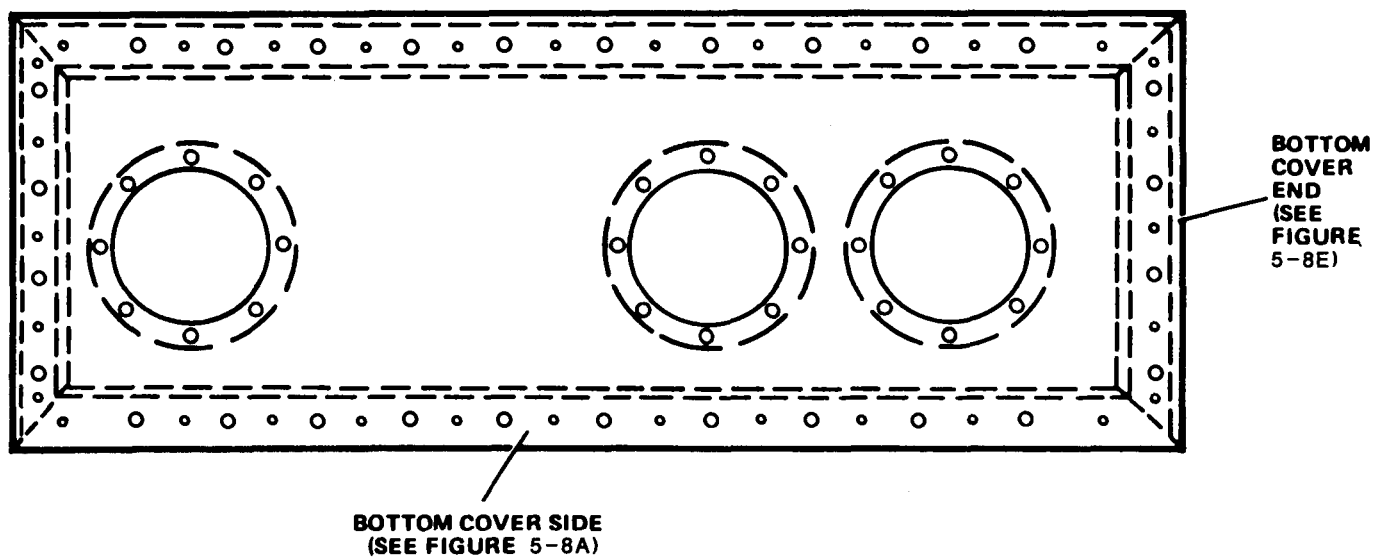

NOTES: 1. PLACE GASKET IN POSITION AS SHOWN BY ALINING HOLES IN GASKET WITH HOLES IN COVER.

2. ALUMINUM STRIP IN CENTER OF GASKET MUST BE RIVETED FLUSH AGAINST COVER.

3. ALL DIMENSIONS GIVEN IN INCHES.

Figure E-2. Bottom Cover Gasket Replacement

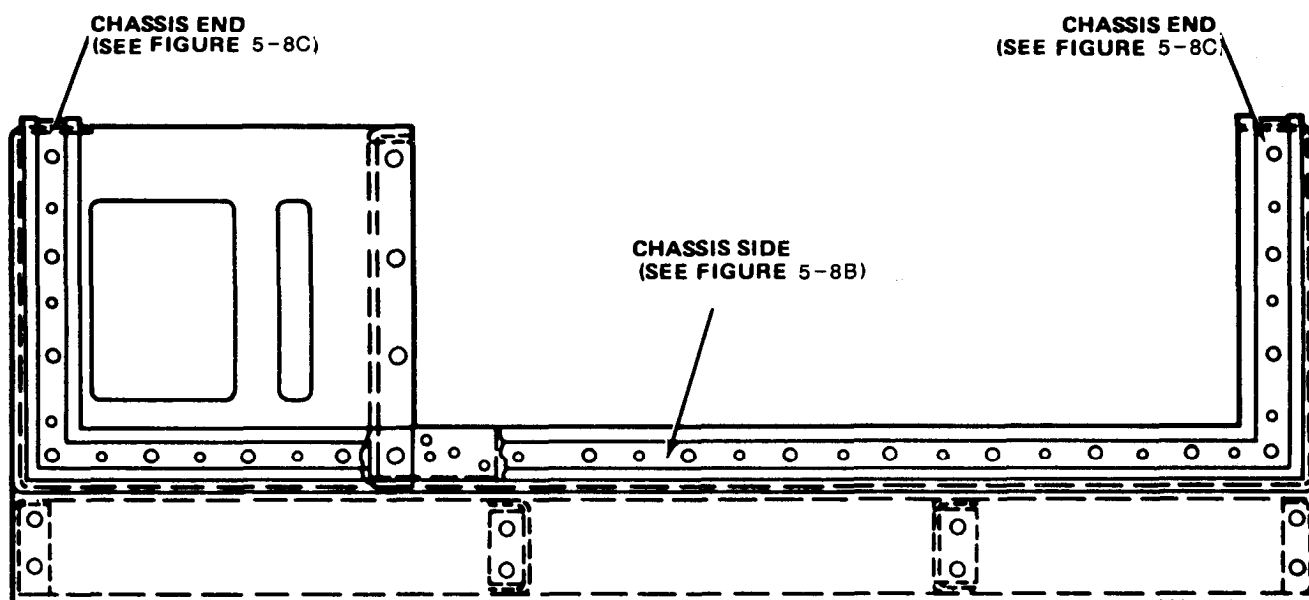

A. SIDE VIEW

- NOTES:**
- 1. PLACE GASKET IN POSITION AS SHOWN BY ALINING HOLES IN GASKET WITH HOLES IN CHASSIS.**
 - 2. ALUMINUM STRIP IN CENTER OF GASKET MUST BE RIVETED FLUSH AGAINST CHASSIS.**

Figure E-3. Chassis Gasket Replacement (Sheet 1 of 2)

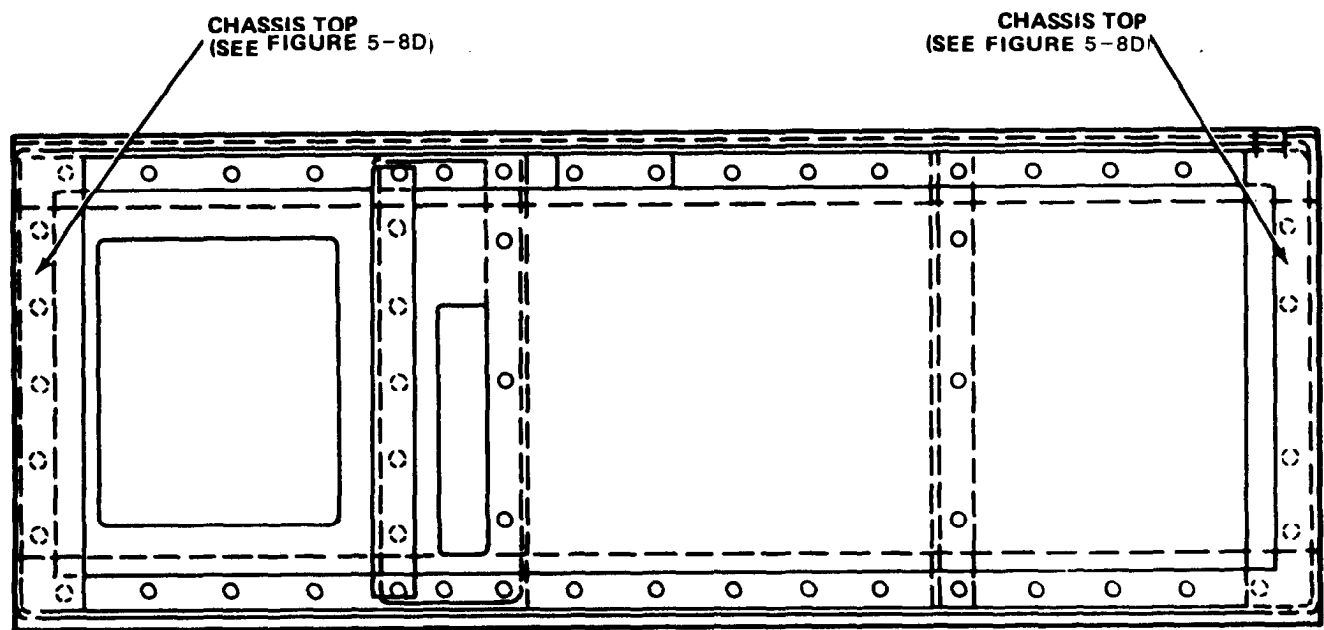

B. TOP VIEW

- NOTES: 1. PLACE GASKET IN POSITION ASS OWN BY ALINING HOLES IN GASKET WITH HOLES IN CHASSIS.
2. ALUMINUM STRIP IN CENTER OF GASKET MUST BE RIVETED FLUSH AGAINST CHASSIS. RIVET HEAD SHOULD BE ON TOP (4 PLACES MARKED F) AND FLUSH ON FAR SIDE.

Figure E - 7 . Chassis Gasket Replacement (Sheet 2 of 2)

GLOSSARY

Abbreviated terms used in this manual and their spelled-out equivalents are listed below.

<u>Term</u>	<u>Equivalent</u>
EIR	Equipment Improvement Recommendations
TAMMS	The Army Maintenance Management System
Tunable Coupler	Tunable Coupler CU-2293/ALQ-151(V)

INDEX

Subject	Paragraph Figure/Table	Page
A		
Administrative Storage	1-4	1-2
Army Regulations	A-6	A-2
Assemblies		
RF Switch	3-5.4, 3-6.3, FO-5	3-10, 3-12,
B		
Blank Connector for J2		
Removal5-10.16	5-25
Replacement5-11.16	5-30
Blank Connectors for J3 and J4		
Removal5-10.17	5-25
Replacement5-11.17	5-30
Bottom Cover Gasket Replacement	FE-2, E-3	E-6, E-1
Bottom Panel		
Removal5-10.2	5-22
Replacement5-11.2	5-26
C		
CCAS		
Control Logic A3	F3-3, T3-3, 3-5.2, 3-6.2, FO-3	3-7, 3-8, 3-6, 3-12
Decoder A4.	F3-2, T3-2, 3-5.1 3-6.1 FO-2	3-4, 3-5, 3-3, 3-11
Extender A5	3.8, T3-6	3-14, 3-14
Feedback S4	3-5.5,	3-10
Motor Control A2	3-5.3, F3-4, F5-4, F5-5, 5-7.2, T5-2, FC-3, FO-4	3-6, 3-9, 3-10, 5-17, 5-18, 5-3, 5-10, C-20

INDEX - Continued

Subject	Paragraph Figure/Table	Page
CCAS (continued)		
Power Supply A1	T3-5, F3-6, 5-7.1, T5-1, F5-2, F5-3, FC-2, FO-6	3-14, 3-13, 5-3, 5-4, 5-8, 5-9, C-14
RF Monitor A6	FO-5	
CCAs, Removal of	5-10.3,	5-22
C	5-10.4,	5-22
CCAs, Replacement of	5-11.3, 5-11.4	5-26 5-26
CCAs, Repair of	5-12	5-31
Chassis Gasket Replacement	E-3, FE-3	E-1, E-7
Circuits		
Control	3-5.2	3-6
Motor Direction Decoder	3-5.2.2	3-6
Motor Drive	3-5.2.3	3-6
Power Distribution	3-7	3-12
RF Switch Decoder	3-5.2.1	3-6
Status.	3-6	3-10
Cleaning the Tunable Coupler	5-9.3	5-21
Command-Word Bit Functions	T3-1	3-3
Common Table of Allowances	A-4	A-2
Connector J1		
Removal	5-10.13	5-24
Replacement	5-11.13	5-29
Connector J3		
Removal	5-10.14	5-24
Replacement	5-11.14	5-29
Connector J4		
Removal	5-10.15	5-24
Replacement	5-11.15	5-30
Control Circuit	3-5	3-3
Control Logic CCA A3		
Block Diagram	F3-3	3-7
Functional Description	3-5.2, 3-6.2	3-6, 3-12
Schematic Diagram	FO-3	
Test Point Signals	T3-3	3-8
Cover-Top		
Removal	5-10.1	5-22
Replacement	5-11.1, F5-7	5-26 5-27

INDEX - Continued

Subject	Paragraph Figure/Table	Page
D		
Decal		
Removal	5-10.9	5-23
Replacement	5-11.9	5-29
Decoder CCA A4		
Block Diagram	F3-2	3-4
Functional Description	3-5.1, 3-6.1	3-3, 3-11
Schematic Diagram	FO-2	
Test Point Signals	T3-2	3-5
Description	1-6	1-2
Destruction of Army Materiel to Prevent Enemy Use	1-3	1-2
Diode CR1		
Removal	5-10.8	5-23
Replacement	5-11.8	5-28
Direct Support Maintenance Instructions, Scope . . .	4-1	4-1
E		
EMI/RFI Gasket Replacement		
Errors, Reporting of	1-5	1-2
Extender CCA A5		
Functional Description	3-8	3-14
Test Point Signals	T3-6	3-14
F		
Federal Supply Code for Manufacturer (FSCM)	C-3.5	C-7
Feedback CCA S4		
Functional Description	3-5.5	3-10
Filter FL5		
Removal	5-10.18	5-25
Replacement	5-11.18	5-30
Forms	A-7	A-2
Front Hook		
Removal	5-10.7	5-23
Replacement	5-11.7	5-28
Functional Description, Tunable Coupler and Circuits.	3-4	3-1
Functioning of Equipment, Scope	3-1	3-1
G		
Gasket Dimensions	FE-1	E-3
Gasket Replacement	5-13	5-32
Bottom Cover	E-3, FE-2	E-1, E-6
Chassis	E-3, FE-3	E-1, E-7

INDEX - Continued

Subject	Paragraph Figure/Table	Page
General Support Maintenance Instructions, Scope	5-1	5-1
General Support Test Procedures	5-14	5-32
H		
Handles		
Removal	5-10.12	5-24
Replacement	5-11.12	5-29
I		
Identification Plate		
Removal	5-10.11	5-24
Replacement	5-11.11	5-29
Inspection of CCAS	5-9.2	5-20
Inspection of Chassis Items	5-9.1	5-20
L		
Logic Levels	3-3.1	3-1
Logic Terminology	3-3	3-1
M		
Maintenance		
Cleaning	5-9.3	5-21
Code	C-3.2.2	C-5
Direct Support Instructions	4-1	4-1
Forms and Records	1-2	1-2
Functions	B-2	B-1
General	5-8	5-3
General Support Instructions, Scope	5-1	5-1
Inspection-of Chassis Items	5-9.1	5-20
Organizational Instructions	2-1	2-1
Procedures	5-9	5-3
Maintenance Allocation Chart for		
Tunable Coupler	App. B	B-1
Measurements and Data	5-3	5-1
Motor Control CCA A2		
Block Diagram	F3-4	3-9
Component Locations	F5-4	5-17
Functional Description	3-5.3	3-6
Repair Parts List	FC-3	C-20
Schematic Diagram	FO-4	
Test Point Signals	T3-4	3-10
Test Setup	F5-5	5-18
Troubleshooting Procedure	5-7.2, T5-2	5-3, 5-10

INDEX - Continued

Subject	Paragraph Figure/Table	Page
N		
National Stock Number and Part Number Index	C-2.3	C-3
O		
Organizational Maintenance Instructions, Scope	2-1	2-1
P		
Power and Signal Connections	T1-1	1-3
Power Distribution Circuit	3-7	3-12
Power Supply CCA A1		
Block Diagram	F3-6	3-13
Component Locations	F5-2	5-8
Repair Parts List	FC-2	C-14
Schematic Diagram	FO-6	
Test Point Signals	T3-5	3-14
Test Setup	F5-3	5-9
Troubleshooting Procedure	5-7.1, T5-1	5-3 5-4
Procedures		
CCA Repair	5-12	5-31
Maintenance	5-9	5-3
Removal	5-10	5-21
Replacement	5-11	5-26
Troubleshooting	5-7	5-3
R		
Recoverability Code	C-3.2.3	C-6
References		
Army Regulations	A-6	A-2
Common Table of Allowances	A-4	A-2
Forms	A-7	A-2
Pamphlets	A-5	A-2
Supply Bulletins	A-3	A-2
Technical Manuals	A-2	A-1
Removal of		
Blank Connect for J1	5-10.16	5-25
Blank Connect for J3 and J4	5-10.17	5-25
Bottom Panel	5-10.2	5-22
CCAs A1 and A2	5-10.3	5-22
CCAs A3, A4, and A5		5-22
Connector J1	5-10.4	5-24
Connector J3	5-10.14	5-24
Connector J4	5-10.15	5-24
Cover, Top	5-10.1	5-22
Decal	5-10.9	5-23

INDEX - Continued

Subject	Paragraph Figure/Table	Page
Removal of (continued)		
Diode CR1	5-10.8	5-23
Filter FL5	5-10.18	5-25
Front Hook	5-10.7	5-23
Handles	5-10.12	5-24
Identification Plate	5-10.11	5-24
Resistors R1, R2 and R3.	5-10.6	5-22
Rivet	5-10.19	5-25
Screen Assembly	5-10.5	5-22
Vent Cover	5-10.5	5-22
Warning Plate	5-10.10	5-23
Repair of CCAs	5-12	5-31
Repair Parts List		
Description	C-2.1	C-3
Tunable Coupler	FC-1	C-9
Power Supply CCA A1	FC-2	C-14
Motor Control CCA A2	FC-3	C-20
Replacement of		
Blank Connect for J2	5-11.16	5-30
Blank Connectors for J3 and J4	5-11.17	5-30
Bottom Panel	5-11.2	5-26
CCAs A1 and A2	5-11.3	5-26
CCAs A3, A4, and AS	5-11.4	5-26
Connector J1	5-11.13	5-29
Connector J3	5-11.14	5-29
Connector J4	5-11.15	5-30
Cover, Top	5-11.1	5-26
Decal	5-11.9	5-28
Diode CR1	5-11.8	5-28
Filter FL5	5-11.18	5-30
Front Hook	5-11.7	5-28
Gasket	5-13,	5-32
	App. E	E-1
Handles	5-11.12	5-29
Identification Plate	5-11.11	5-29
Resistors R1, R2 and R 3	5-11.6	5-28
Rivets	5-11.19	5-30
Screen Assembly	5-11.5	5-28
Vent Cover	5-11.5	5-28
Warning Plate	5-11.10	5-28
Resistors R1, R2 and R3		
Removal	5-10.6	5-23
Replacement	5-11.6	5-28
Reporting Equipment Improvement		
Recommendations (EIR)	1-5	1-2
Reporting of Errors	1-4	1-2
Riveting Removal	5-10.19	5-25
Replacement	5-11.19	5-30

INDEX - Continued

Subject	Paragraph Figure/Table	Page
RF Monitor CCA A6 Schematic Diagram	FO-5	
RF Switch Assembly 52		
Block Diagram	F3-5	3-11
Functional Description	3-5.4 3-6.3	3-10, 3-12
Schematic Diagram	FO-5	
S		
Screen Assembly		
Removal	5-10.5	5-22
Replacement	5-11.5	5-28
Signal Names	3-3.2	3-1
Source, Maintenance, and Recoverability (SMR) Codes	C-3.2	C-3
Special Tools List	C-2.2	C-3
Status Circuit	3-6	3-11
Supply Bulletins	A-3	A-2
T		
Tabulated Data	1-7	1-3
Technical Manuals	A-2	A-1
Test Equipment	5-5	5-1
Test Point Signals		
Control Logic CCA A3	T3-3	3-8
Decoder CCA A4	T3-2	3-5
Extender CCA A5	T3-6	3-14
Motor Control CCA A2	T3-4	3-10
Power Supply CCA A1	T3-5	3-14
Test Procedures, General Support	5-14	5-32
Tool and Test Equipment Requirements for Tunable Coupler	App.B	B-4
Tools and Equipment, General	5-4	5-1
Tools and Equipment, Required	5-5	5-1
Troubleshooting		
General	5-6	5-3
Tunable Coupler	5-7	5-3
Troubleshooting Procedures		
Motor Control CCA A2	5-7.2, T5-2	5-3, 5-10
Power Supply CCA A1	5-7.1, T5-1	5-3, 5-4
Tunable Coupler		
Block Diagram	F3-1	3-2
CCA Locations	F5-1	5-2
Cleaning	5-9.3	5-21
Component Locations	F5-6	5-19
Control Circuit	3-5	3-3
Description	1-6	1-2
Extender CCA A5	3-8	3-14

INDEX - Continued

Subject	Paragraph Figure/Table	Page
Tunable Coupler (continued)		
Front View	F1-1	1-1
Functional Description	3-4	3-1
Gasket Replacement	5-13	5-32
Inspection	5-9.1	5-20
Interconnection Diagram	FO-1	
Maintenance Allocation Chart	App.B	B-5
Maintenance Procedures	5-9	5-3
Measurements and Data	5-3	5-1
Power Distribution Circuit	3-7	3-12
Power and Signal Connections	T1-1	1-3
Repair Parts List	C-2.1, FC-1	C-3, C-9
Special Tools List	C-2.2	C-3
Status Circuit	3-6	3-10
Tabulated Data	1-7	1-3
Test	5-15	5-32
Troubleshooting Procedures	5-7	5-3

V

Vent Cover		
Removal	5-10.5	5-22
Replacement	5-11.5	5-28

W

Warning Plate		
Removal	5-10.10	5-23
Replacement	5-11.10	5-30

By Order of the Secretary of the Army:

CARL E. VUONO
General, United States Army
Chief of Staff

Official:

WILLIAM J. MEEHAN II
Brigadier General, United States Army
The Adjutant General

RECOMMENDED CHANGES TO EQUIPMENT TECHNICAL PUBLICATIONS



THEN... JOT DOWN THE DOPE ABOUT IT ON THIS FORM, CAREFULLY TEAR IT OUT, FOLD IT AND DROP IT IN THE MAIL!

SOMETHING WRONG WITH THIS PUBLICATION?

FROM: (PRINT YOUR UNIT'S COMPLETE ADDRESS)

DATE SENT

PUBLICATION NUMBER

TM 32-5865-216-24&P

PUBLICATION DATE

9 Nov 87

PUBLICATION TITLE

Tunable Coupler CU-2293/ALQ-151(V)

BE EXACT... PIN-POINT WHERE IT IS

PAGE NO.

PARA-GRAPH

FIGURE NO.

TABLE NO.

IN THIS SPACE TELL WHAT IS WRONG AND WHAT SHOULD BE DONE ABOUT IT:

TEAR ALONG PERFORATED LINE

PRINTED NAME, GRADE OR TITLE, AND TELEPHONE NUMBER

SIGN HERE:

FILL IN YOUR
UNIT'S ADDRESS

FOLD BACK

TEAR ALONG PERFORATED LINE

DEPARTMENT OF THE ARMY

POSTAGE AND FEES PAID
DEPARTMENT OF THE ARMY
DOD 314



OFFICIAL BUSINESS
PENALTY FOR PRIVATE USE \$300

Commander
U.S. Army Communications Electronics Activity-Vint Hill
ATTN: SELCE-MR-E-P
Vint Hill Farms Station
Warrenton, Virginia 22186

RECOMMENDED CHANGES TO EQUIPMENT TECHNICAL PUBLICATIONS



THEN... JOT DOWN THE DOPE ABOUT IT ON THIS FORM, CAREFULLY TEAR IT OUT, FOLD IT AND DROP IT IN THE MAIL!

SOMETHING WRONG WITH THIS PUBLICATION?

FROM: (PRINT YOUR UNIT'S COMPLETE ADDRESS)

DATE SENT

PUBLICATION NUMBER

TM 32-5865-216-24&P

PUBLICATION DATE

9 Nov 87

PUBLICATION TITLE

Tunable Coupler CU-2293/ALQ-151(V)

BE EXACT... PIN-POINT WHERE IT IS

PAGE NO.

PARA-GRAPH

FIGURE NO.

TABLE NO.

IN THIS SPACE TELL WHAT IS WRONG AND WHAT SHOULD BE DONE ABOUT IT:

TEAR ALONG PERFORATED LINE

PRINTED NAME, GRADE OR TITLE, AND TELEPHONE NUMBER

SIGN HERE:

FILL IN YOUR
UNIT'S ADDRESS

FOLD BACK

TEAR ALONG PERFORATED LINE

DEPARTMENT OF THE ARMY

POSTAGE AND FEES PAID
DEPARTMENT OF THE ARMY
DOD 314



OFFICIAL BUSINESS
PENALTY FOR PRIVATE USE \$300

Commander
U.S. Army Communications Electronics Activity-Vint Hill
ATTN: SELCE-MR-E-P
Vint Hill Farms Station
Warrenton, Virginia 22186

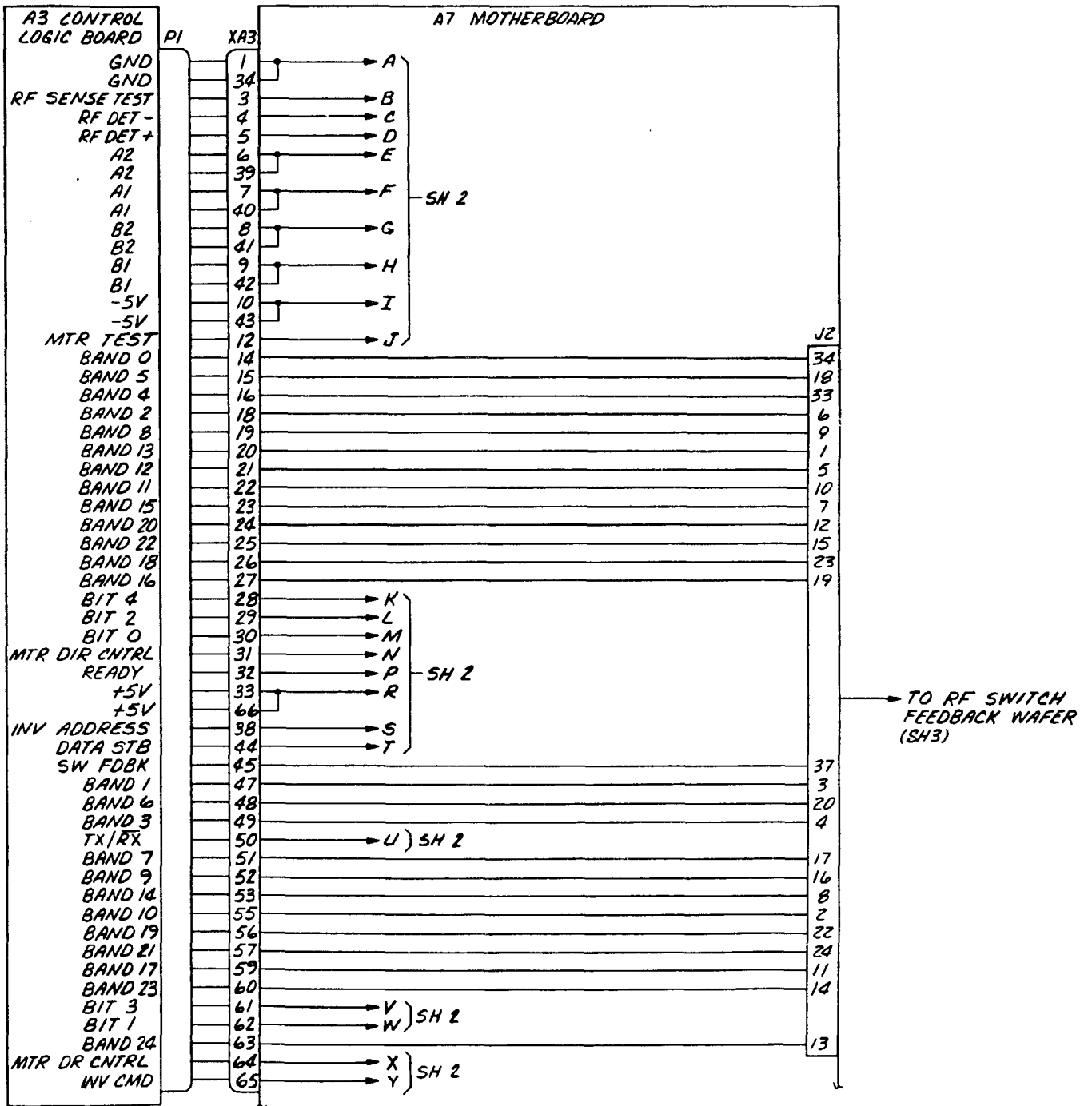

Figure FO-1. Tunable Coupler Interconnection Diagram (Sheet 1 of 4)

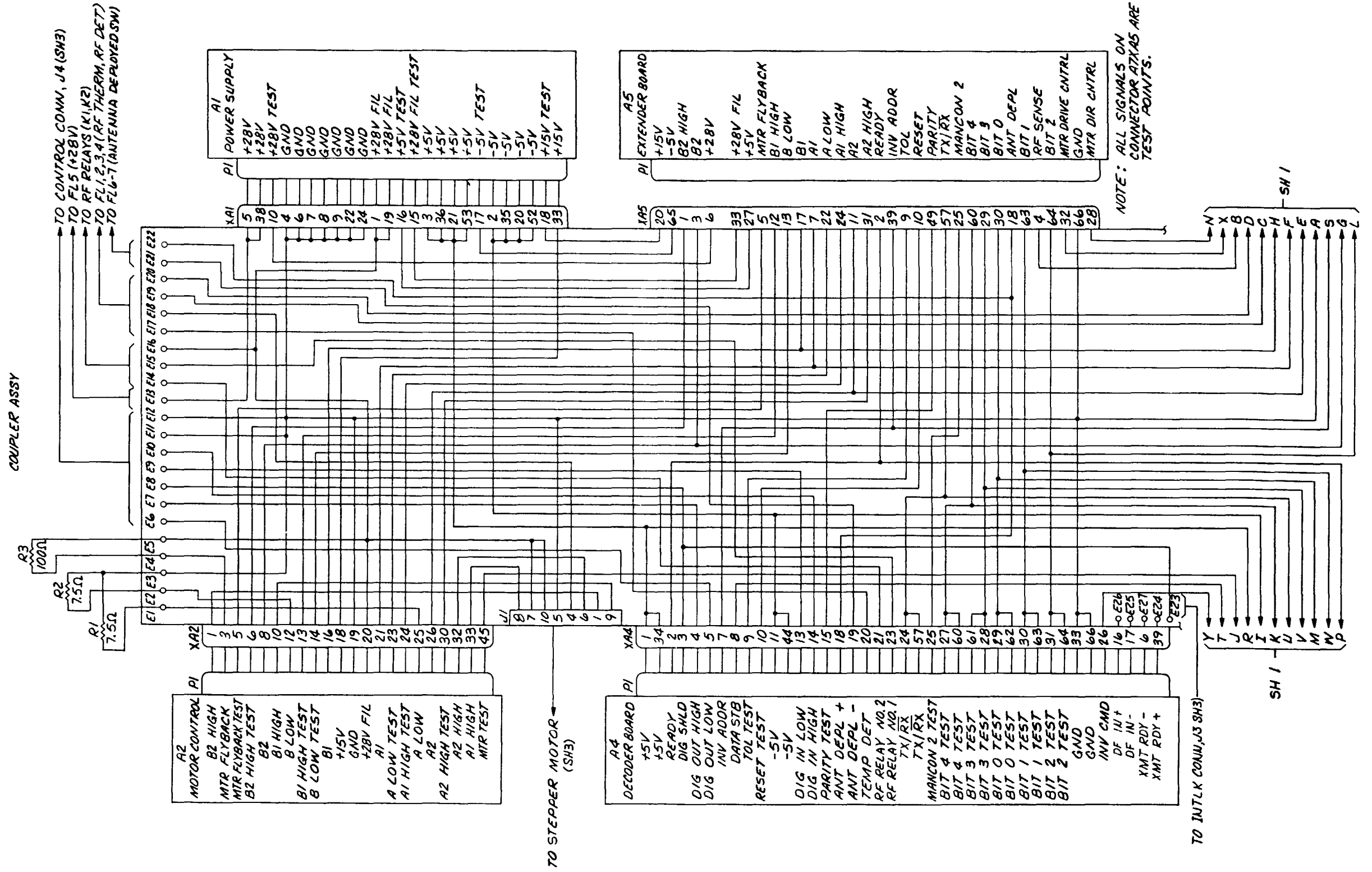

Figure FO-1. Tunable Coupler Interconnection Diagram (Sheet 2 of 4)

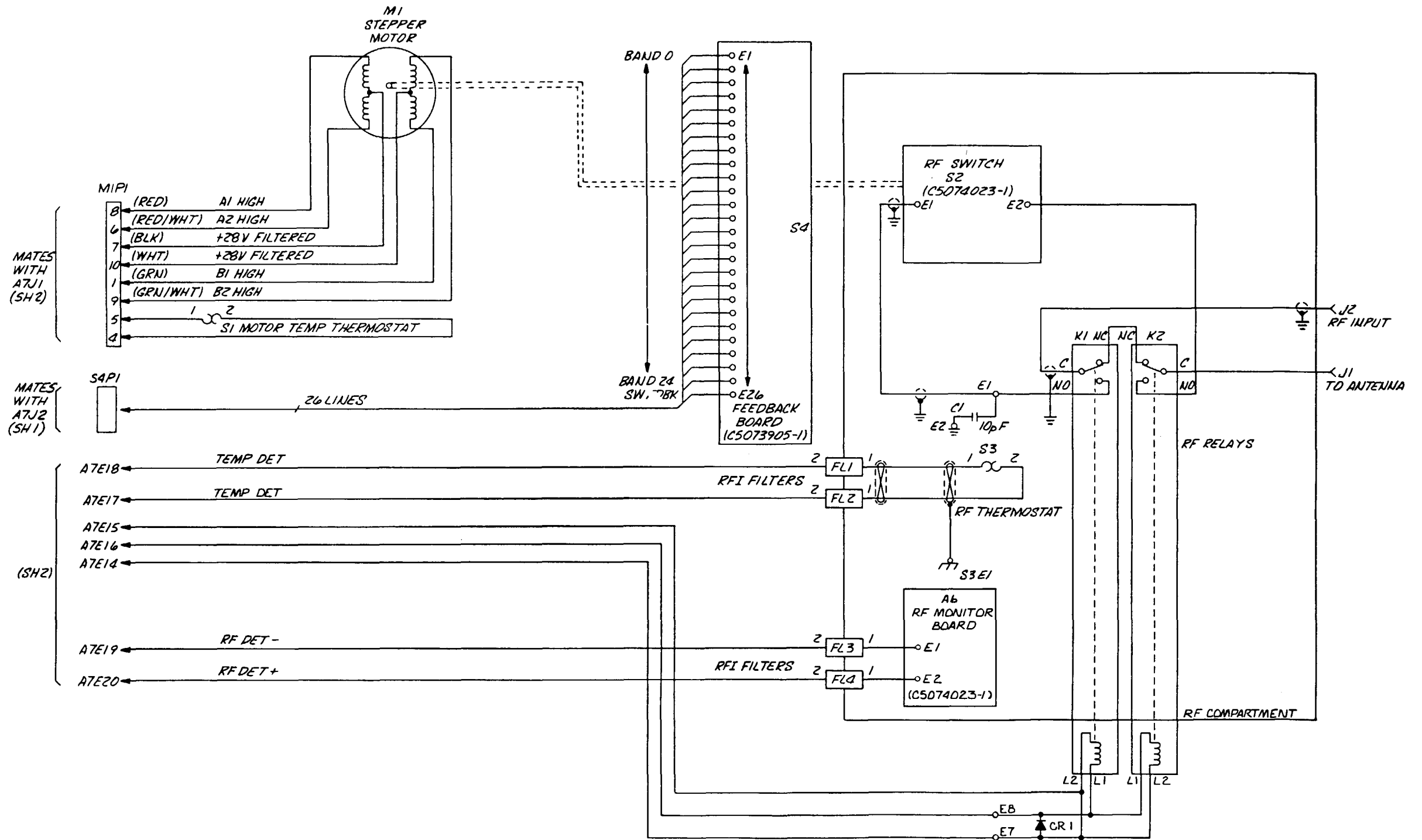

Figure FO-1. Tunable Coupler Interconnection Diagram (Sheet 3 of 4)

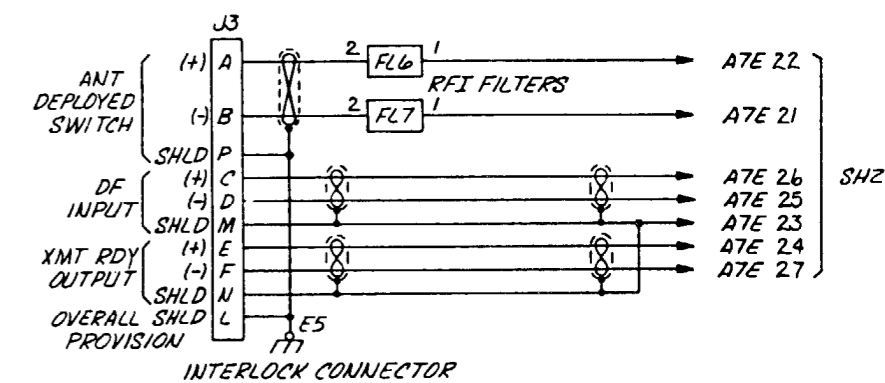
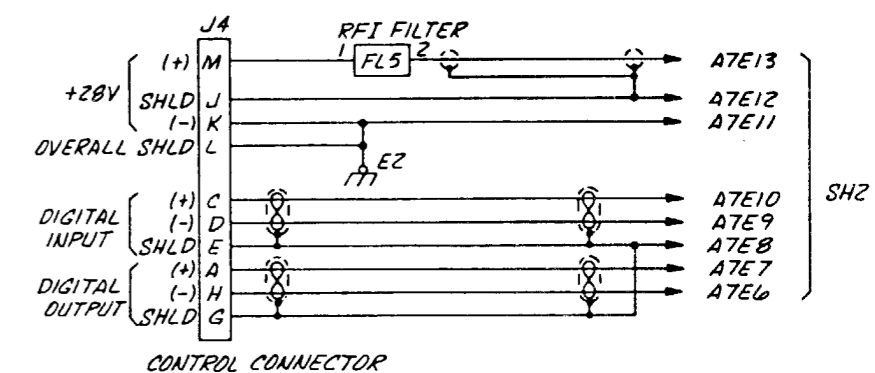

Figure FO-1. Tunable Coupler Interconnection Diagram (Sheet 4 of 4)

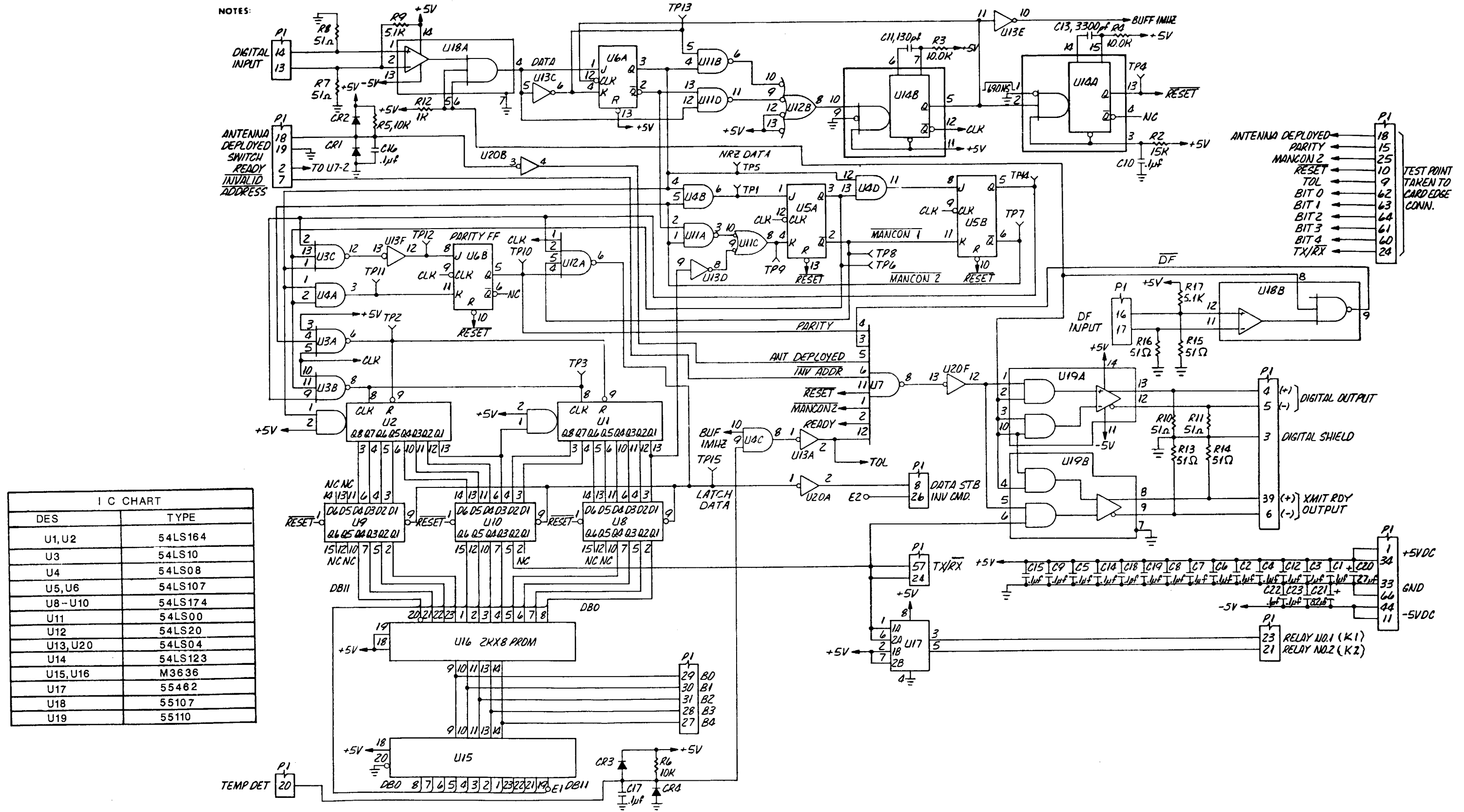

Figure FO-2. Decoder CCA A4 Schematic Diagram

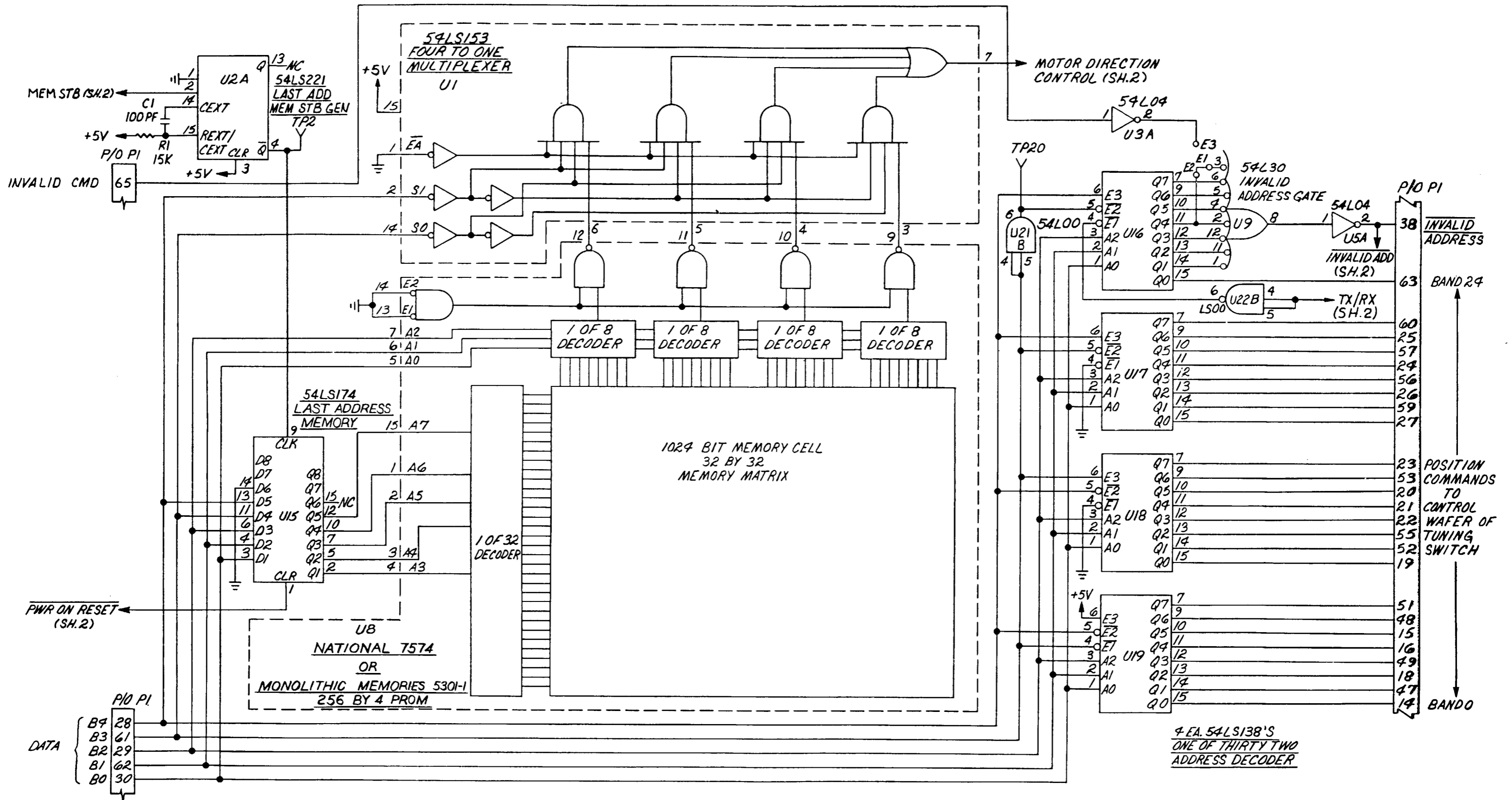

Figure FO-3. Control Logic CCA A3 Schematic Diagram (Sheet 1 of 2)

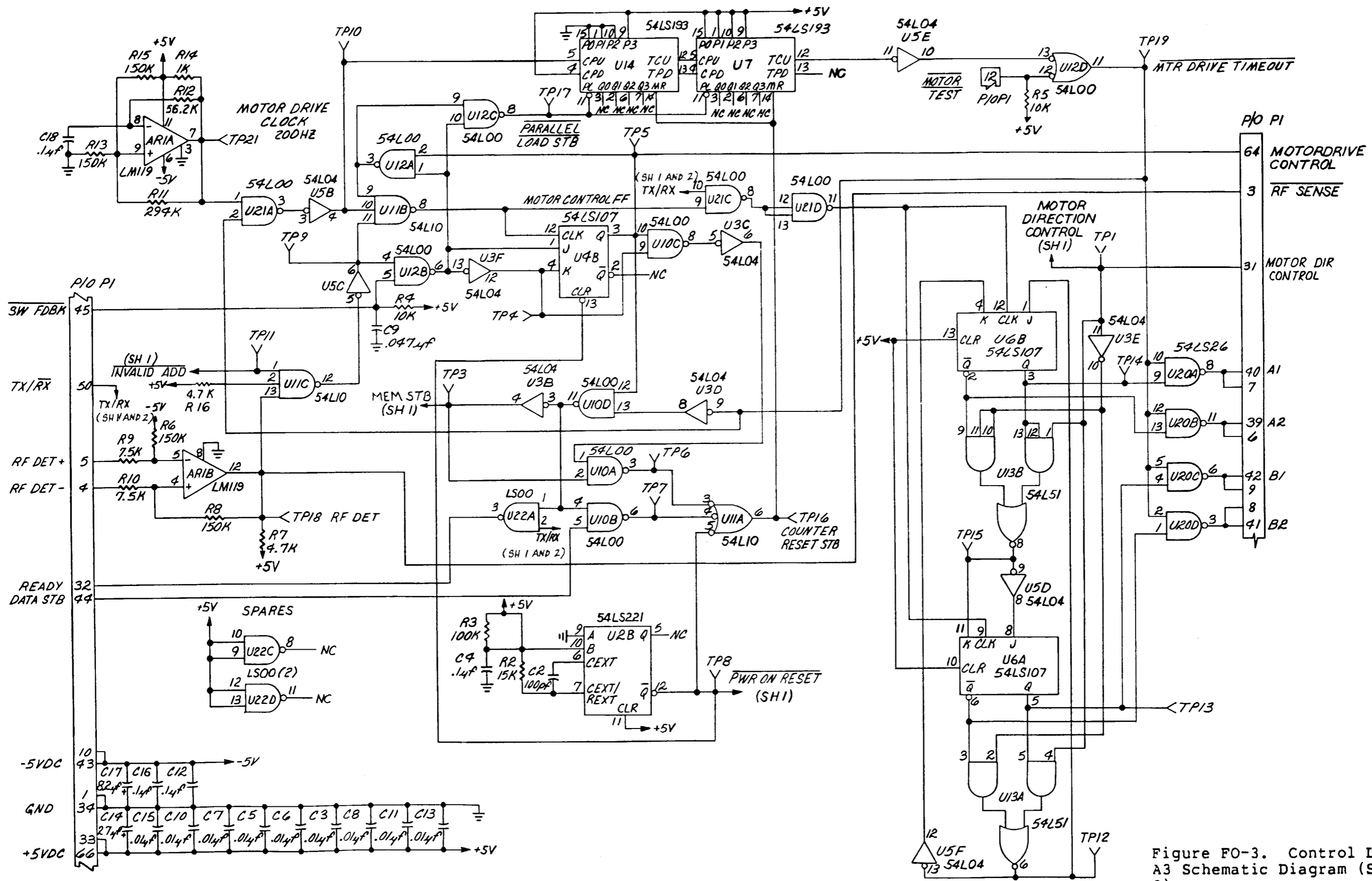

Figure FO-3. Control Logic CCA A3 Schematic Diagram (Sheet 2 of 2)

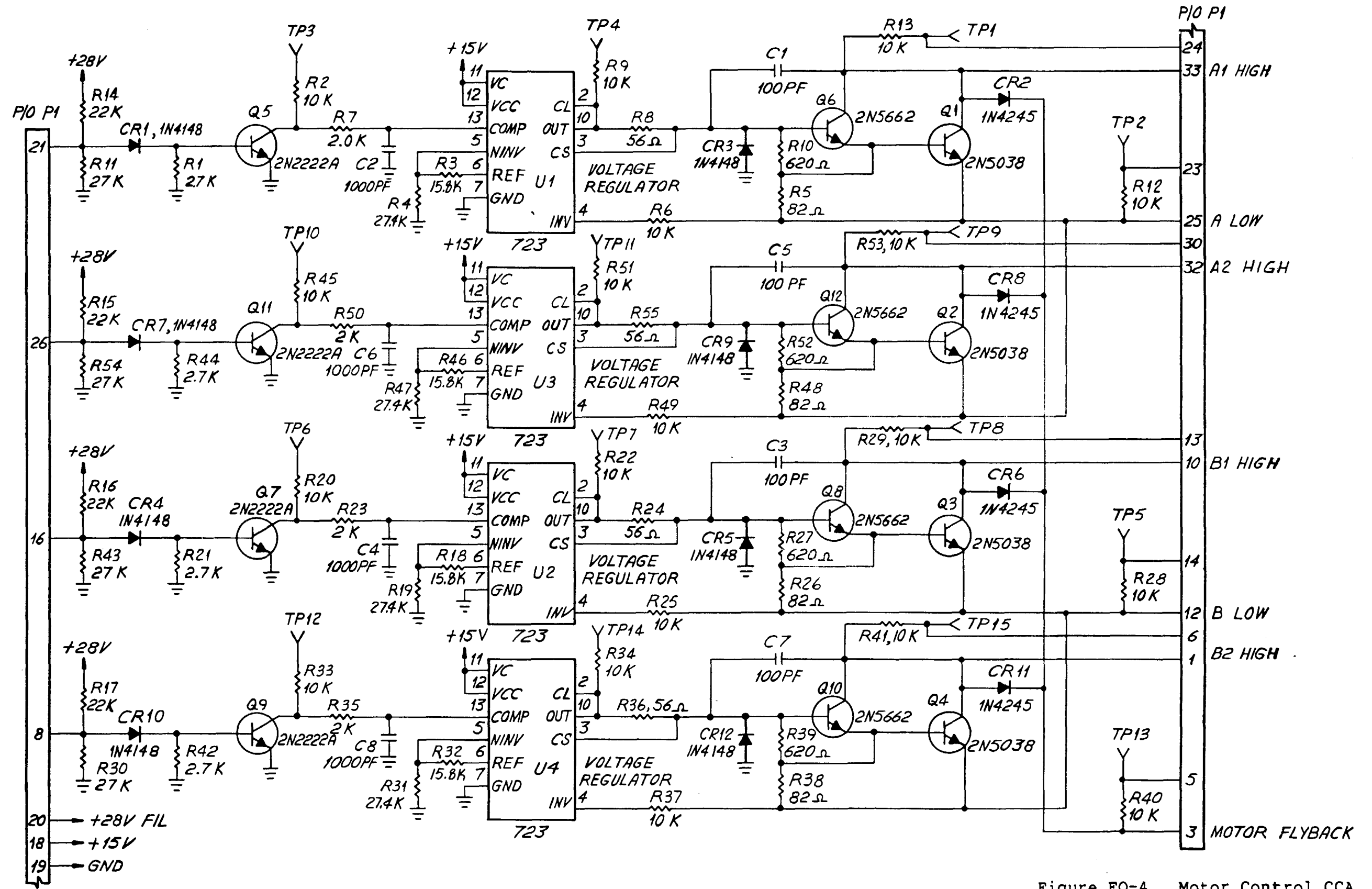

Figure FO-4. Motor Control CCA A2 Schematic Diagram

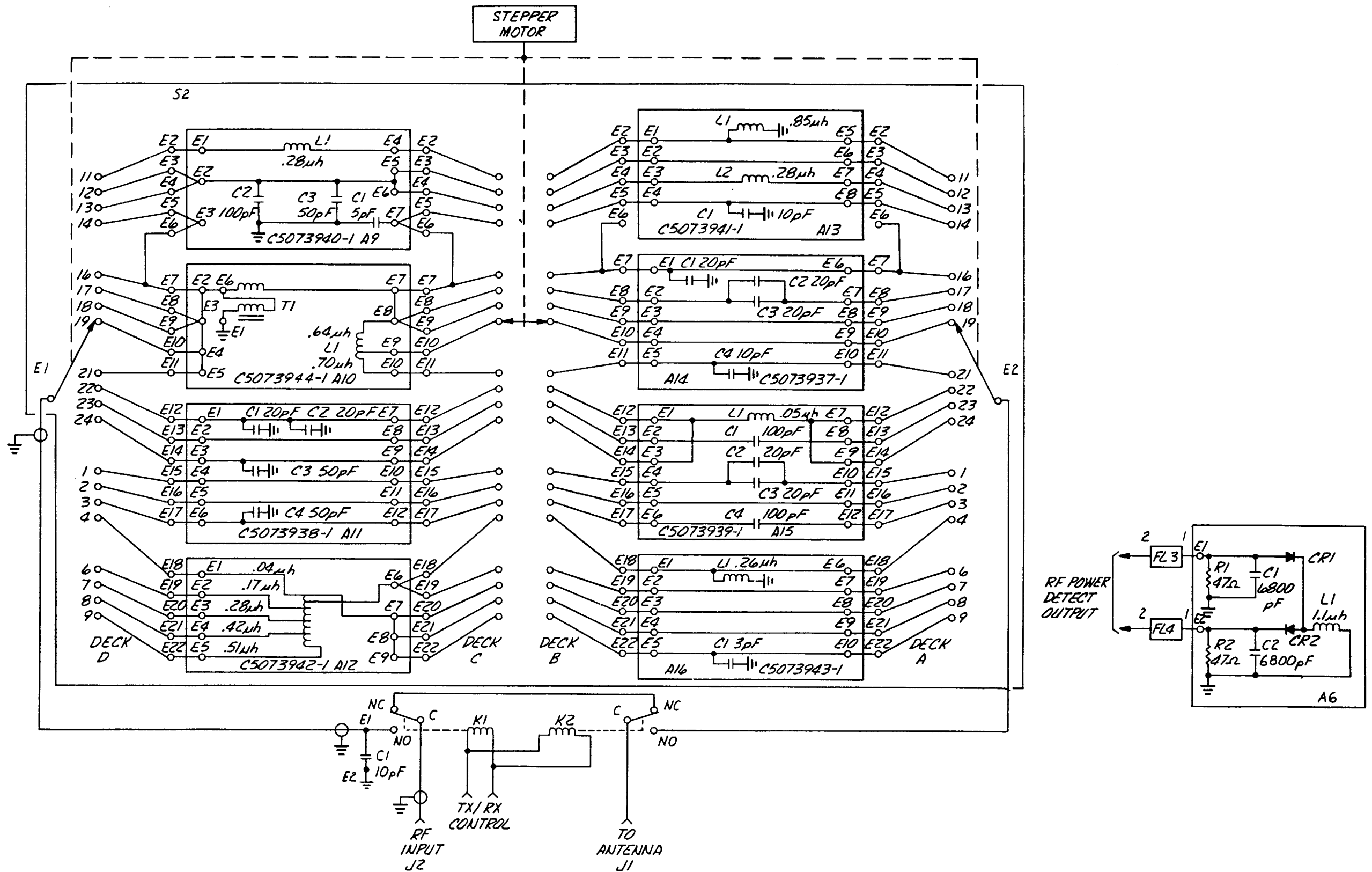
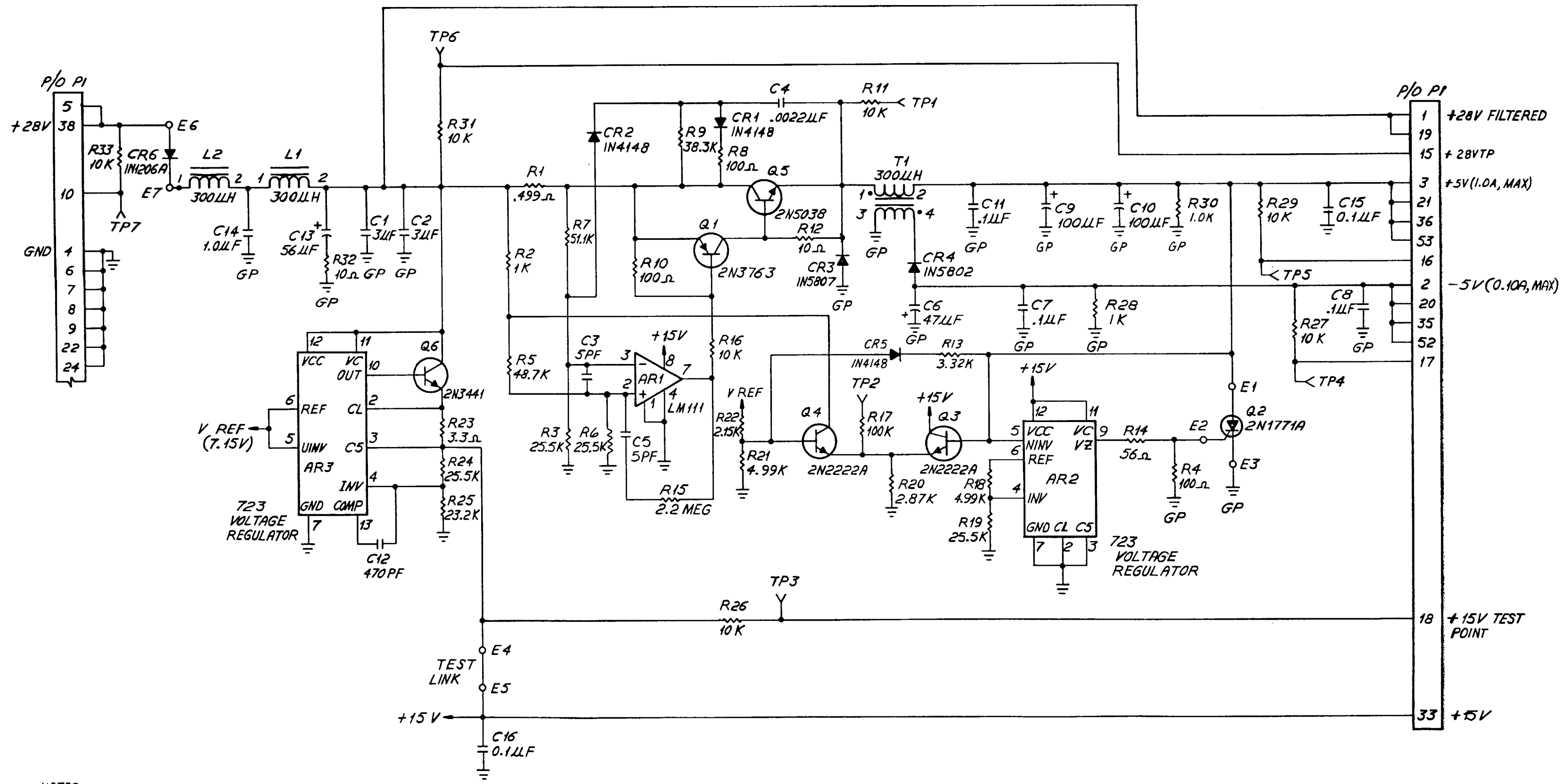

Figure FO-5. RF Monitor CCA A6 and RF Switch Assembly S2 Schematic Diagram



NOTES
 1. GP INDICATES CONNECTION TO GROUND PLANE

Figure FO-6. Power Supply CCA A1 Schematic Diagram

This fine document...

Was brought to you by me:



[Liberated Manuals -- free army and government manuals](#)

Why do I do it? I am tired of sleazy CD-ROM sellers, who take publicly available information, slap “watermarks” and other junk on it, and sell it. Those masters of search engine manipulation make sure that their sites that sell free information, come up first in search engines. They did not create it... They did not even scan it... Why should they get your money? Why are not letting you give those free manuals to your friends?

I am setting this document FREE. This document was made by the US Government and is NOT protected by Copyright. Feel free to share, republish, sell and so on.

I am not asking you for donations, fees or handouts. If you can, please provide a link to liberatedmanuals.com, so that free manuals come up first in search engines:

<A HREF=<http://www.liberatedmanuals.com/>>Free Military and Government Manuals

- Sincerely
Igor Chudov
<http://igor.chudov.com/>
- [Chicago Machinery Movers](#)