

# TM 11-6625-1635-12

DEPARTMENT OF THE ARMY TECHNICAL MANUAL

---

## OPERATOR AND ORGANIZATIONAL MAINTENANCE MANUAL INCLUDING REPAIR PARTS AND SPECIAL TOOL LISTS MAINTENANCE KIT, ELECTRONIC EQUIPMENT MK-1004/ARC

This copy is a reprint which includes current  
pages from Changes 1 and 2.

---

HEADQUARTERS, DEPARTMENT OF THE ARMY  
MARCH 1968

## **WARNING**

DEATH OR SERIOUS INJURY may result from hazards in this equipment unless proper safety measures are observed when operating and maintaining the equipment. 27.5V DC exists when the equipment is energized.

Technical Manual

No. 11-6625-1635-12

HEADQUARTERS  
DEPARTMENT OF THE ARMY  
Washington, D. C., 25 March 1968

**Operator and Organizational Maintenance Manual Including  
Repair Parts and Special Tool Lists  
MAINTENANCE KIT, ELECTRONIC EQUIPMENT MK-1004/ARC**

	Paragraph	Page
Chapter 1.	INTRODUCTION	
Section I.	General	1-1-1-3 1-1
II.	Description and data	1-4-112 1-1
Chapter 2.	OPERATION	
Section I.	Service upon receipt of equipment	2-1,2-2 2-1
II.	Operator's switches, controls, indicators, and jacks	2-3-2-7 2-3
Chapter 3.	ORGANIZATIONAL MAINTENANCE INSTRUCTIONS	3-1-3-13 3-1
4.	SHIPMENT, LIMITED STORAGE, AND DEMOLITION TO PREVENT ENEMY USE	
Section I.	Disassembly and repackaging	4-1,4-2 4-1
II.	Demolition of materiel to prevent enemy use	4-3,4-4 4-2
Appendix A.	REFERENCES	A-1
B.	BASIC ISSUE ITEMS LIST (BIIL) AND ITEMS TROOP INSTALLED OR AUTHORIZED LIST (ITIAL) (Not Applicable)	
C.	MAINTENANCE ALLOCATION	C-1
D.	ORGANIZATIONAL REPAIR PARTS	D-1

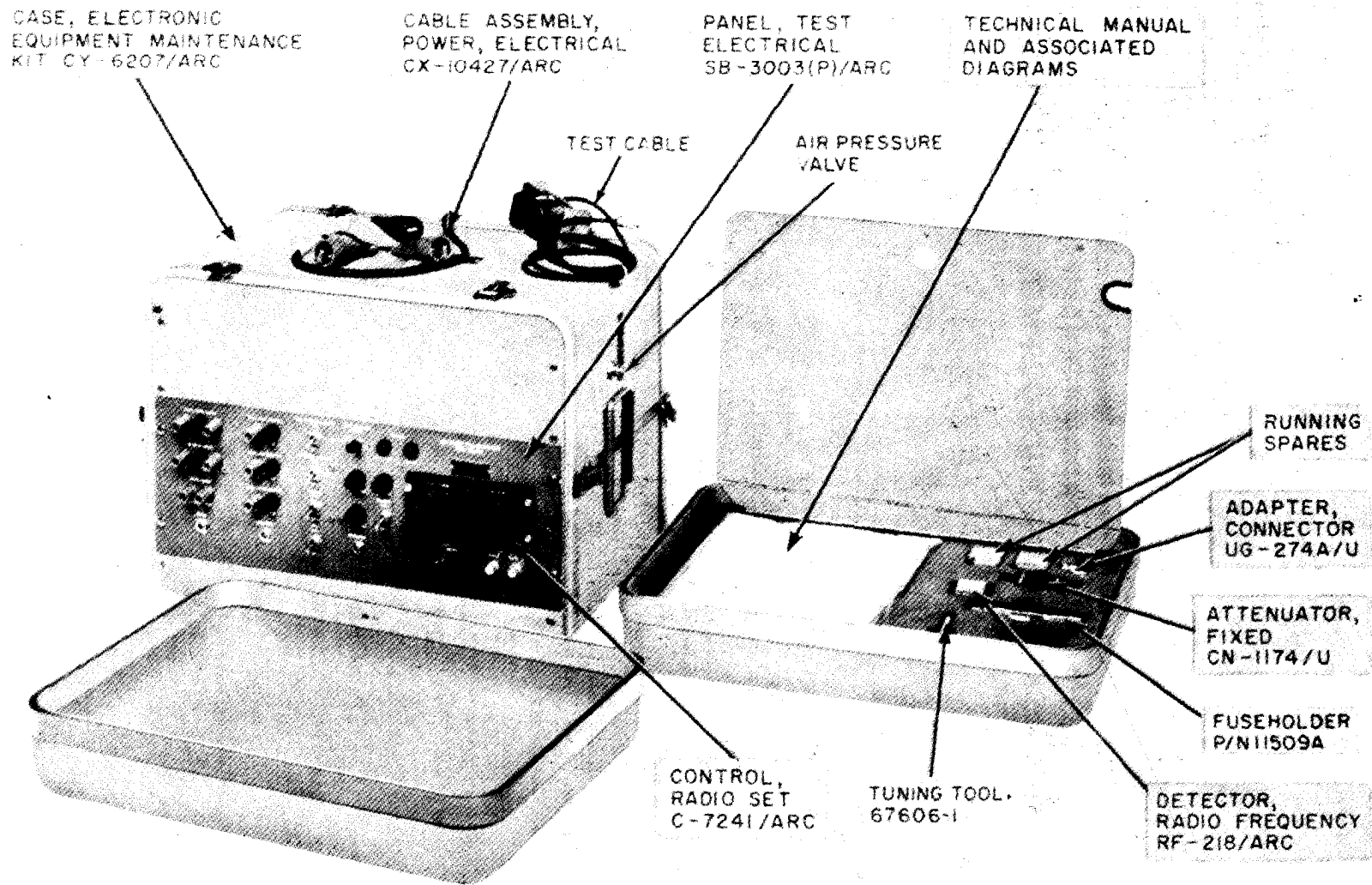

TM6625-1635-2-12

Figure 1-1. Maintenance kit, electronics equipment MK-1004/ARC.

## CHAPTER 1

### INTRODUCTION

---

#### Section 1. GENERAL

##### 1-1. Scope

a. This manual describes Maintenance Kit, Electronic Equipment MK-1004/ARC (fig. 1-1 and 1-1.1 ) and provides instruction for operation and organizational maintenance. It

includes instructions for cleaning and inspection of the equipment, and troubleshooting and replacement of parts available to the organizational maintenance repairman.

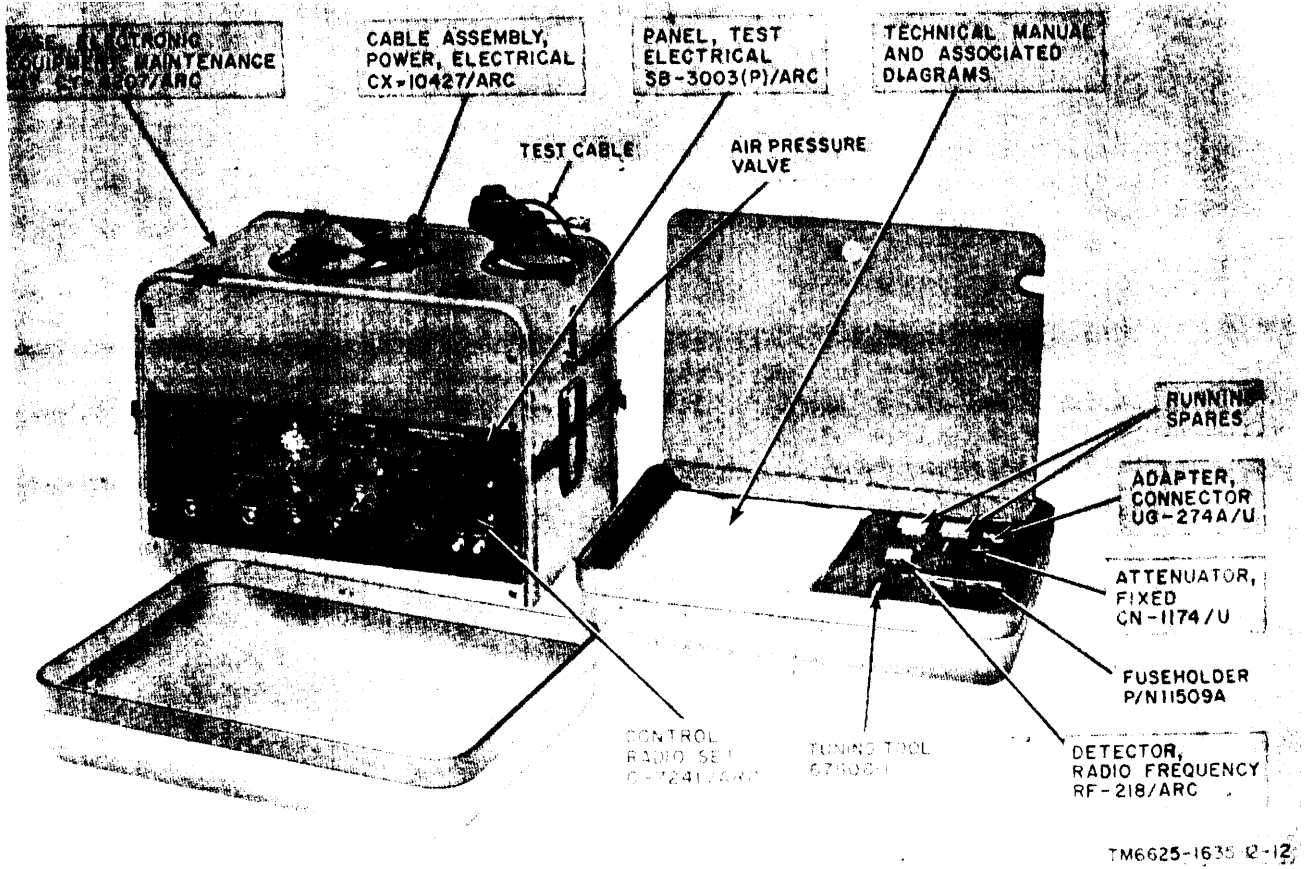

Figur 1-1. Maintenance kit, electronic equipment MK-1004/ARC, unmodified.

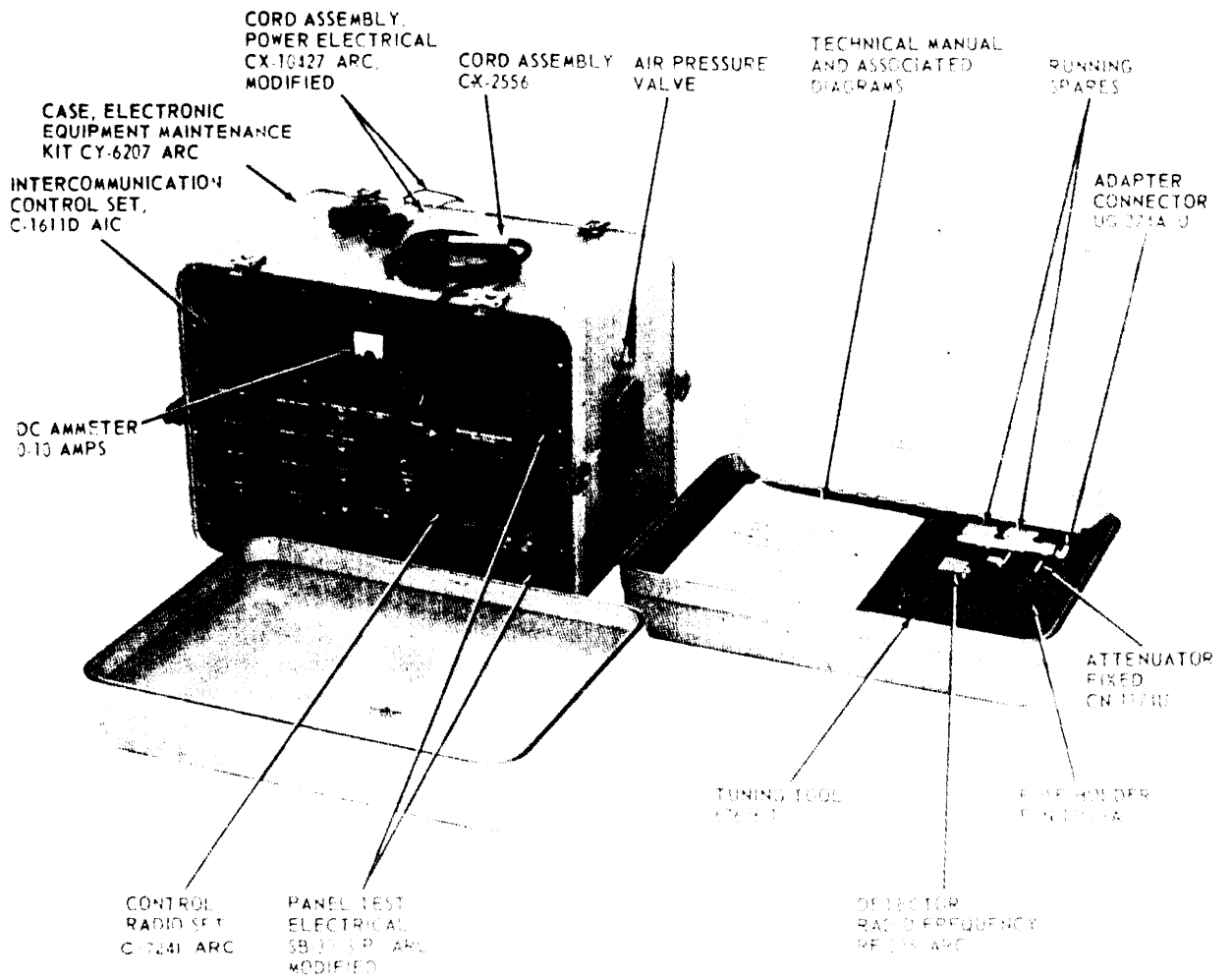

FIGURE 1-1. MK-100/ARC, modified.

Figure 1-1.1 Maintenance kit, electronic equipment MK-100/ARC, modified.

b. This manual covers both the unmodified equipment and that modified by installation of MWO 11-6625-1635-40/1. When instructions apply to only one of these models, the nomenclature or common name will specify unmodified or modified (as an example, modified maintenance kit). References not specified as modified or unmodified apply to both models.

c. The maintenance allocation chart (MAC) appears in appendix C.

## 1-2. Indexes of Publications

a. *DA Pam 310-4*. Refer to the latest issue of DA Pam 310-4 to determine whether there are new editions, changes, or additional publications pertaining to the equipment.

b. *DA Pam 310-7*. Refer to DA Pam 310-7 to determine whether there are modification work orders (MWO's) pertaining to the equipment.

## 1-3. Forms and Records

a. *Reports of Maintenance and Unsatisfactory Equipment*. Maintenance forms, records, and reports which are to be used by maintenance

personnel at all maintenance levels are listed in and prescribed by TM 38-750.

b. *Report of Packaging and Handling Deficiencies*. Fill out and forward DD Form 6 (Report of Packaging and Handling Deficiencies) as prescribed in AR 700-58 (Army)/NAVSUP PUB 378 (Navy)/AFR 71-4 (Air Force)/and MCO P4030.29 (Marine Corps).

c. *Discrepancy in Shipment Report (DISREP) (SF 361)*. Fill out and forward Discrepancy in Shipment Report (DISREP) (SF 361) as prescribed in AR 55-38 (Army)/NAVSUP PUB 459 (Navy)/AFM 75-34 (Air Force)/and MCO P4610.19 (Marine Corps).

### 1-3.1. Reporting of Equipment Publication Improvements

The reporting of errors, omissions, and recommendations for improving this publication by the individual user is encouraged. Reports should be submitted on DA Form 2028 (Recommended Changes to Publications) and forwarded direct to Commander, US Army Electronics Command, ATTN: AMSEL-MA-A Fort Monmouth, NJ 07703.

## Section II. DESCRIPTION AND DATA

### 1-4. Purpose and Use

a. Maintenance Kit, Electronic Equipment MK-1004/ARC is a portable equipment used in field testing and adjusting Radio Set AN/ARC-134.

b. The MK-1004/ARC includes Panel, Test, Electrical SB-3003(P)/ARC mounted on the front of the equipment. The SB-3003(P)/ARC houses a Control, Radio Set C-7241/ARC, various input and output jacks, switches, indicators, and controls that are used to check, and adjust for, the proper operation of the AN/ARC-134.

c. The LMK-1004/ARC modified includes Intercommunication Control Set C-1611D/AIC which

is used to verify proper performance of the intercommunication control set in the VHF communication network under test.

d. The radio control is used to provide power control, receiver volume control, and channel selection for the AN/ARC-134 under test. A COMM TEST switch on the radio control provides a means of checking the operation of the AN/ARC-134 with the receiver squelch circuit disabled.

e. Figure 1-2 is a simplified block diagram illustrating the relationship between the MK-1004/ARC, the required external test equipment, and the AN/ARC-134.



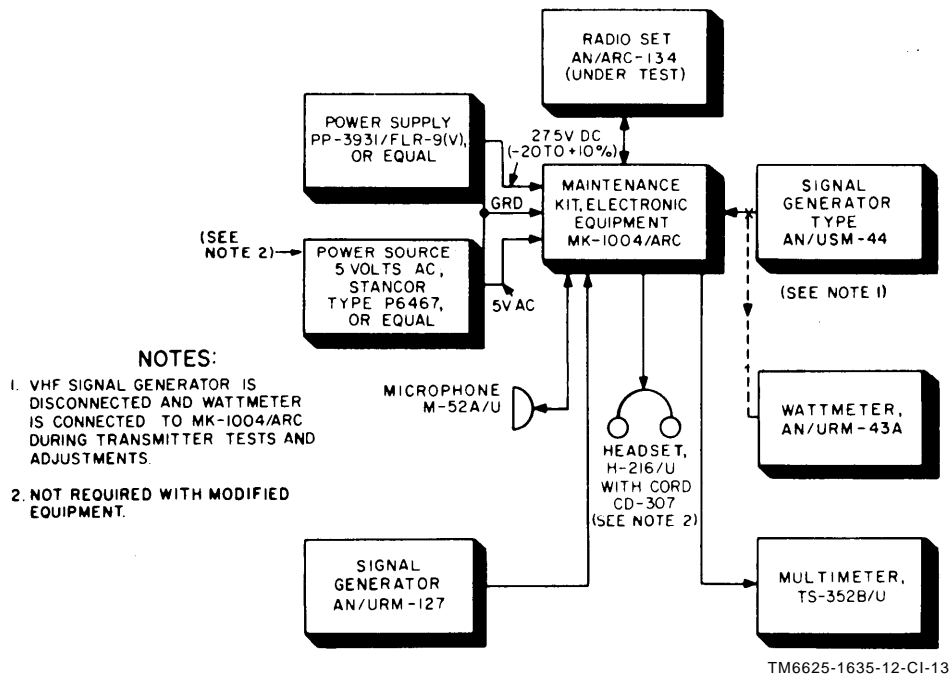

Figure 1-2. Maintenance kit, electronic equipment MK-1004/ARC, and associated equipment.

### 1-5. Technical Characteristics

Technical characteristics of the MK-1004/ARC are provided below. The differences in models are the result of MWO 11-6625-1635-40/1 which has been installed on some units.

Frequency range	116.000 to 149.975 MHz
Channel spacing	25 kHz
Control Radio Set	
MK-1004/ARC unmodified	C-7241/ARC
Intercommunications Control Set	
MK-1004/ARC unmodified	None
MK-1004/ARC modified	C-1611D/AIC

DC Power Input Requirement		
MK-1004/ARC unmodified		27.5 volts-20 + 10 percent at 11.5 amperes
MK-1004/ARC modified		28.7 volts
AC Power Input Requirement		
MK-1004/ARC unmodified		5 volts ± 10 percent at 1.0 ampere
MK-1004/ARC modified		None
Power Consumption		
MK-1004/ARC unmodified		6.20 watts (lighting circuit only)
MK-1004/ARC modified		approximately 7 Watts
Weight		40 pounds

## 1-6. Components and Dimensions of Maintenance Kit, Electronic Equipment MK-1004/ARC

Qty	Item	Dimensions(in.)				weight (lb.)	Fig. No.
		Height	Depth	Width			
1	Panel, Test Electrical SB-3003(P)/ARC unmodified (used in MK-1004/ARC unmodified)	7.0	7.0	19.0		8.0	1-1
1	Panel, Test Electrical SB-3003(P)/ARC modified (used in MK-1004/ARC modified)	12.50	7.0	19.0		10.0	1-1.1
1	Control, Radio Set C-7241/ARC (used in MK-1004/ARC unmodified) or Control, Radio Set C-7241/ARC (used in MK-1004/ARC modified)	2.625	6.0	5.750		2.1	1-1
1	Intercommunications Control Set C-1611D/AIC (used in MK-1004/ARC modified)	2.625	6.0	5.750		2.1	1-1.1
1	Intercommunications Control Set C-1611D/AIC (used in MK-1004/ARC modified)	2.937		5.750		2.0	1-1.1
1	Case, Electronic Equipment Maintenance Kit CY-6207/ARC	16.04	19.0	21.20		22.75	1-1
1	Detector, Radio Frequency RF-218/ARC <sup>a</sup>	0.75	0.4375	0.8125		0.0156	1-3
1	Attenuator, Fixed CN-1174/U	1.25	1.125	3.0		5.0156	1-3
1	Adapter, Connector UG-274A/U	0.5	1.0625	1.25		0.0312	1-3
1	Fuse holder 7000061-0001 <sup>b</sup>	0.75	4.625	0.75		0.375	1-3
1	Tuning tool 67606-1	0.5	0.3125	3.875		0.5	1-3
1	Cable Assembly, Power Electrical CX-10427/ARC unmodified (used in MK-1004/ARC unmodified) or Cable Assembly, Power Electrical CX-10427/ARC modified (used in MK-1004/ARC modified)		N/A				1-3
1	Technical manual		N/A				1-3
1	Running spares ( <i>b</i> below)	1.625	0.875	1.375		1.125	1-4

<sup>a</sup> Contained in plastic box, 083442-0001.

<sup>b</sup> Ten (10) fuses (P/N700061-0002) for fuse holder in plastic box 083448-0001.

### 1-6.1. Items Comprising an Operable Equipment

FSN	QTY	Nomenclature, part No., and mfr code	Fig. No.	Usable on code
		<b>NOTE</b> The part number is followed by the applicable 5-digit Federal supply code for manufacturers (FSCM) identified in SB 708-42 and used to identify manufacturer, distributor, or Government agency, etc.		
		<b>NOTE</b> Number 1 in the usable on code column refers to items comprising an operable MK-1004/ARC unmodified number 2 refers to items comprising an operable MK-1004/ARC modified.		
5821-926-7292		Maintenance Kit, Electronic Equipment MK-1004/ARC unmodified consisting of:	1-1	1
		Maintenance Kit, Electronic Equipment MK-1004/ARC modified.	1-1.1	2
5935-201-2411	1	Adapter, Connector UG-274A/U: 81349	1-3	
5120-949-6692	1	Alignment Tool: 67606-1; 65597	1-3	
5905-073-8220	1	Attenuator, Fixed CN-1174/U: 80058	1-3	

FSN	QTY	Nomenclature, part No., and mfr code	Fig. No.	Usable on code
	1	Box, Plastic, Small Parts (M334474)001; 65597	1-4	
	1	Box, Plastic, Small Parts 0834484001; 65597	1-4	
	1	Box, Plastic: ICA; 28307	1-3	
6150-933-9805	1	Cable Assembly, Power, Electrical CX-10427/ARC: 80058	1-3	1
	1	Cable Assembly, Power, Electrical CX-10427/ARC Modified: 80058	1-3	2
5821-933-9606	1	Detector, Radiofrequency RF-218/ARC: 80058	1-3	



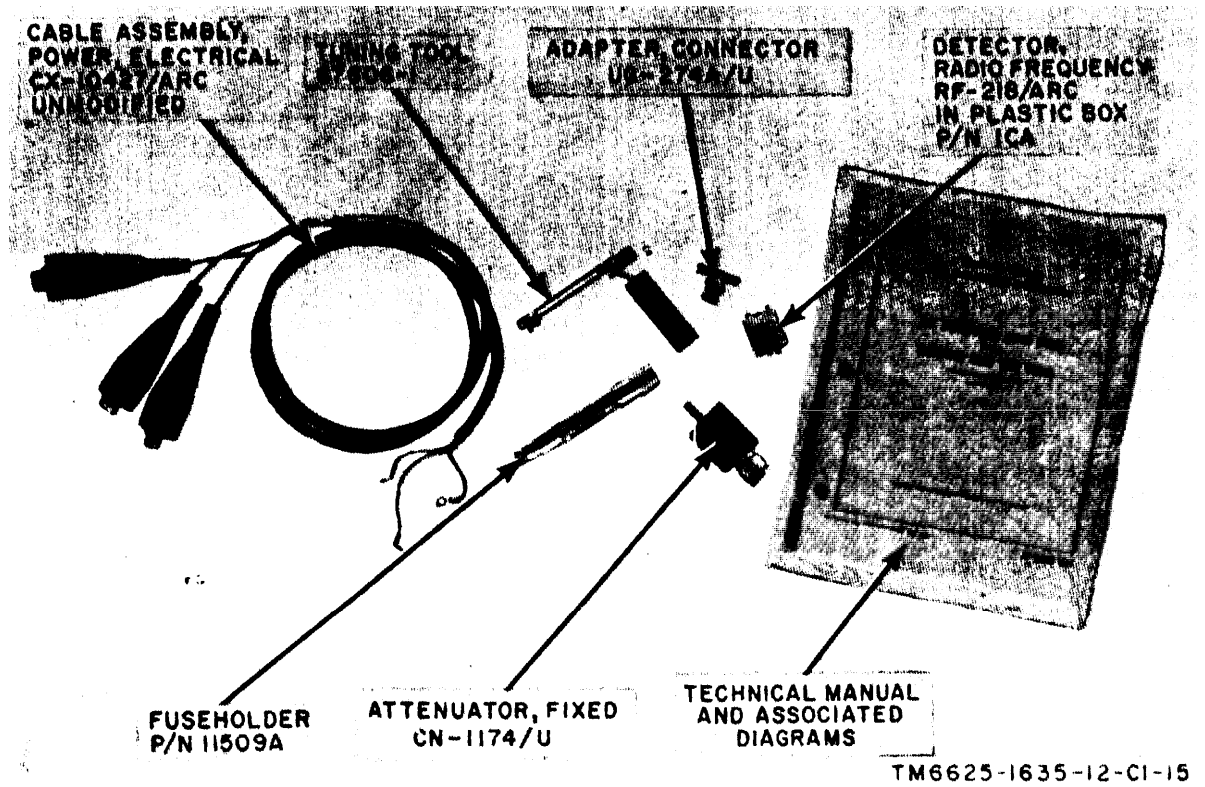
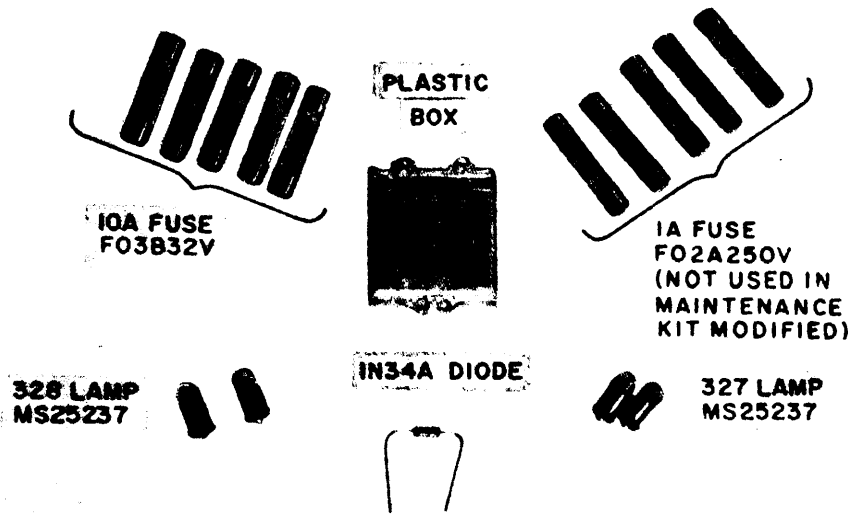

Figure 1-3. Minor components of maintenance kit, electronic equipment WK-1004/ARC.



TM6625-1635-12-C1-16

Figure 1-4. Maintenance kit, electronic equipment MK-1004/ARC, running spares.

1-7. Nomenclature and Common Names

A list of the nomenclature assignments for Maintenance Kit, Electronic Equipment MK-1004/ARC and its components is given below. A common name used throughout the remainder of the manual is indicated after each item.

<i>Nomenclature</i>	<i>Common name</i>
Maintenance Kit, Electronic Equipment MK-1004 / ARC	Maintenance kit
Panel, Test, Electrical	
SB-3003(P) / ARC	Test panel
Control, Radio Set C-7241 / ARC	Radio control
Case, Electronic Equipment Maintenance Kit CY-6207 / ARC	Equipment case
Detector, Radio Frequency	
RF-218 / ARC	RF detector
Attenuator, Fixed CN-1174 / U	Attenuator
Adapter, Connector UG-274A / U	Adapter
Tuning Tool 67601-1	Tuning tool
Cable Assembly, Power Electrical CX-10427 / ARC	Power cable assembly
Intercommunications Control Set C-1611D / AIC	Intercom control

1-8. Description of Equipment

a. *General.* The maintenance kit (fig. 1-1 or 1-1.1) is a portable unit designed to facilitate

resting and adjustment of Radio Set AN/ARC-134 in the field. All electrical components are within the equipment case. There is an air pressure valve, for use in air shipment, on the equipment case. All operating controls and test jacks are on the test panel, which is accessible by removing the front cover of the equipment case. Minor assemblies and running spares are mounted in partitions in the removable rear cover. Test cable plugs for the AN/ARC-134 main connector and antenna connector are accessible at the rear of the equipment case when the rear cover is removed. The power cable assembly is also at the rear of the equipment case. Alligator clip insulators (P / O power cable assembly ) are marked to indicate the required input voltage connections.

b. *Equipment Case* (fig. 1-1 ). The equipment case is a lightweight, ruggedized inclosure with removable front and rear covers, and four rubber legs on the bottom. Six clamps around the front of the main housing are used for locking the front cover to the housing. An additional six clamps around the rear of the equipment case are

for locking the rear cover in place. Minor assemblies and running spares are in partitions on the inside of the removable rear cover and are held in place by a metal panel which is secured with three quarter-turn fasteners.

c. *Test Panel* (fig. 1-5 or 1-5.1). The test panel contains various signal input and output jacks, switches, controls, and indicators. A cutout is provided for mounting the radio

control. On the modified unit a cutout is provided to mount the intercom control. All electrical connections to the test panel are completed through cable connectors at the rear. A test cable plug and antenna connector provide all required connections to the AN/ARC-134. Power is supplied to the unit by means of the power cable assembly.

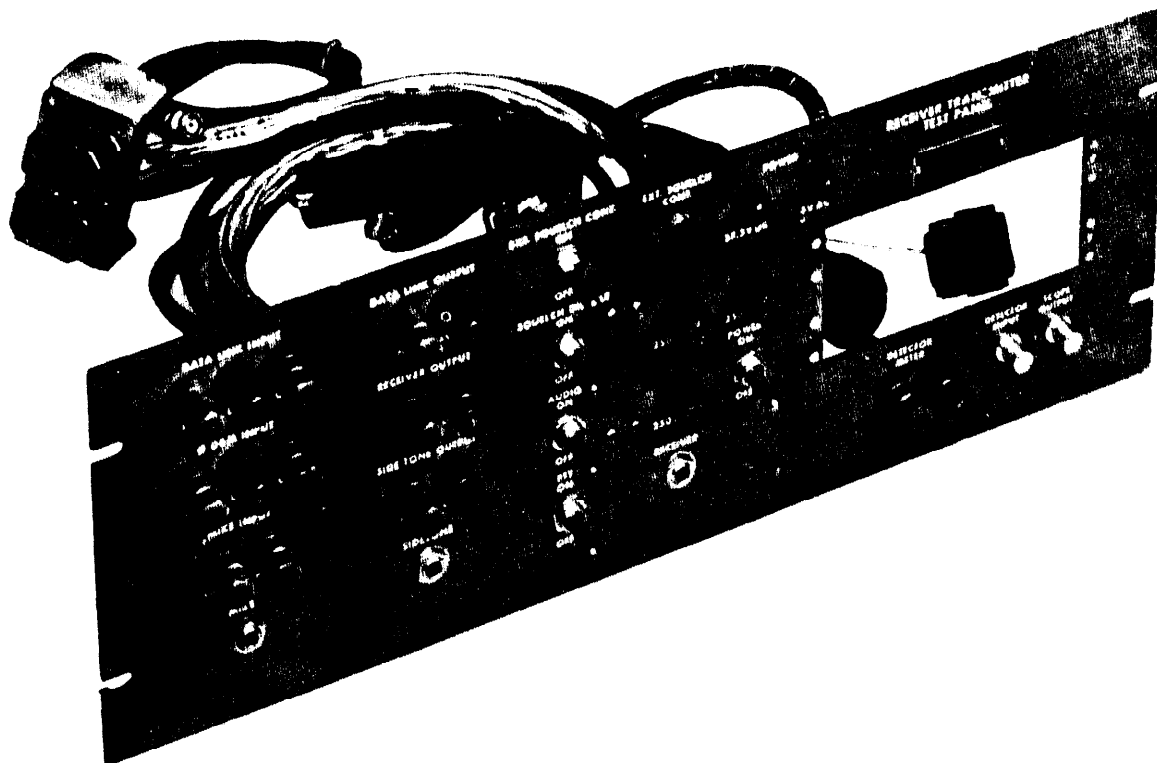

TM6625-1635-2-18

Figure 1-5. Test panel, unmodified, front oblique view.

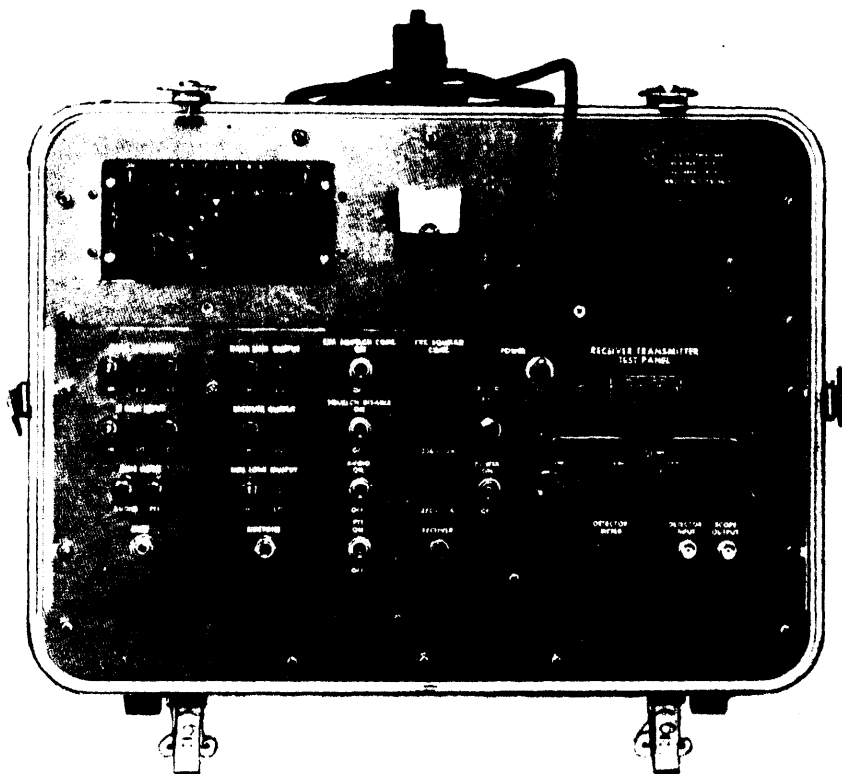

TM6625-1635-12-4

Figure 1-5.1 Test Panel, modified, front oblique view.

*d. Radio Control* (fig. 1-1 or 1-1.1). The radio control provides power, receiver volume, and channel-selection control functions for the AN/ARC-134. A COMM TEST switch is used for disabling the receiver squelch circuit during test procedures. All controls are on an edge-lighted plastic front panel, and the selected channel frequency is indicated on an illuminated digital counter dial. The radio control is completely inclosed except for the front panel. All electrical connections are completed through rear-mounted connectors. The unit is mounted in a cutout on the test panel front panel and is held in place by four quick-release fasteners (fig. 3-2).

*e. Intercom Control* (fig. 1-1.1) The intercom control, included in the MK-1004/ARC modified, is used to verify proper performance of

the aircraft intercommunications control set. It includes a chassis, front and rear mounting plates, and a front panel. The controls and two panel lights are mounted on the front mounting plate and extend through cutouts in the front panel. The translucent front panel is edge-lighted by the panel lights. A pin receptacle on the rear mounting plate is provided for connection of the headset-microphone. Eight DZUS fasteners on the front mounting plate are used to secure the intercom control to the test panel.

*f. Power Cable Assembly* (fig. 1-3). The power cable assembly provides all power connections to the maintenance kit. The assembly, approximately 5-feet long, consists of individually insulated cables inclosed by a 48-inch length of sleeving. Each individual conductor is



terminated with an insulated alligator clip at one end and a solderless terminal lug at the other end. The alligator clip insulators are appropriately marked to indicate the required input voltage connection. In the unmodified equipment, the third alligator clip insulator (black) is used as a ground connection and is unmarked. In the MK-1004/ARC modified, a protective diode has been added to prevent damage from reverse polarity hook-up.

**1-9. Description of Minor Assemblies**

Special features of some of the minor assemblies are given below (fig. 1 -3).

*a. Fuse Holder 700061-0001.* The fuse holder, with self-contained fuse, is used whenever an external signal generator is connected to the maintenance kit antenna connector. The fuse holder prevents possible damage to the signal generator through accidental keying of the AN/ARC-134 transmitter.

*b. Radio Frequency Detector.* The radio frequency (RF) detector is used to observe modulation during adjustments to the RF exciter/amplifier or driver stages in the AN/ARC-134 transmitter circuits.

*c. Attenuator.* The attenuator is connected to the external signal generator output to provide a proper signal input level to the AN/ARC-134 during test procedures.

*d. Tuning Tool.* The tuning tool is used whenever it is necessary to adjust the power amplifier grid and plate coils in the AN/ARC-134 transmitter circuits.

*e. Adapter.* The adapter is used to connect the external signal generator, oscilloscope, and load wattmeter during transmitter test or adjustment procedures.

**1-10. Additional Equipment Required**

The following equipment is not supplied as part of the maintenance kit, but is required for use with it.

*a. Power Supply PP-3931/FLR-9(V).* The PP-3931/FLR-9(V), or equal, is required to supply the dc power to the AN/ARC-134 under test.

*b. 5-Volt. Alternating Current Source* (maintenance kit unmodified only). An alternating current (ac) power source providing 5 volts ( $\pm 10$  percent) at 1.0 ampere is required for the lighting circuits of the test panel and the radio control.

*c. Radio Set AN/ARC-134.* The AN/ARC-134 is required for use with the maintenance kit.

*d. Other Equipment.* Additional equipment required for use with the maintenance kit is listed below.

- (1) Signal Generator AN/USM-44.
- (2) Wattmeter, Radiofrequency AN/URM-43A.
- (3) Signal Generator AN/URM-127.
- (4) Multimeter TS-352B/U.
- (5) Microphone M-52A/U (maintenance kit unmodified only).
- (6) Headset, Electrical H-216/U with Cord CD-307 (maintenance kit unmodified only).
- (7) Coaxial Adapter UG-201/U.
- (8) Capacitor, 50 microfarads ( $\mu\text{f}$ ). 25 volts direct current (dc), Sprague Type TL-1200, or equal.
- (9) Coaxial Connector UG-88/U (two required).
- (10) RG-58 coaxial cable (as required).

**1-11. Use of Term Hertz**

The National Bureau of Standards has officially adopted the term Hertz (Hz) to replace cycles per second (cps). The chart below provides the equivalents of the unit/quality terms and the list of approved abbreviations that are used throughout the manual.

<i>Unit/quantity</i>	<i>Old term</i>	<i>Old abbreviation</i>	<i>New term</i>	<i>New abbreviation</i>
Frequency	Cycles per second	cps	Hertz	Hz
$10^3$ cycles per second	Millicycles per second	mc	Millihertz	mHz
$10^3$ cycles per second	Kilocycles per second	Kc	Kilohertz	kHz
$10^6$ cycles per second	Megacycles per second	Mc	Megahertz	MHz
$10^9$ cycles per second	Gigacycles per second	Gc	Gigahertz	GHz

**1-12. Differences in Models**

Specific differences in the unmodified and modified maintenance kit, as a result of MWO 11-6625-1635-40/1, are given in table 1-1. MWO 11-6625-1635-40/1 is a field

modification that improves utilization of the maintenance kit in testing the complete VHF communications network of which the AN/ARC-134 Radio Set is a part.

Table 1-1. Differences in Models

Item	MK-1004 / ARC unmodified	MK-1004 / ARC modified
Control Radio Set	C7241 / ARC	C7241 / ARC
Intercommunications Control Set	None	C-1611D / AIC
DC Ammeter	None	0-10 Amps. Used to monitor input current to the radio set under test.
Reverse Current Diode	None	1N3890. Prevents damage to the Radio Set due to reverse polarity hook-up.
Headset-Microphone	M-52 A / U Microphone and H-216U Headset required as additional equipment	Cord Assembly CX-2556 and Headset-Microphone H-101A / U included as integral part of maintenance kit.
AC power supply	5-volt power source STANCOR type P6467 or equal required	None

## CHAPTER 2

### OPERATION

---

#### Section 1. SERVICE UPON RECEIPT OF EQUIPMENT

##### 2-1. Unpacking

*a. Packaging Data.* When packed for shipment, the units of the maintenance kit are sealed in a single shipping carton. The shipping

carton and its contents are shown in figure 2-1. The dimensions are 22 by 16¾ by 21 inches, the volume is 4.5 cubic feet, and the weight is 42.5 pounds.

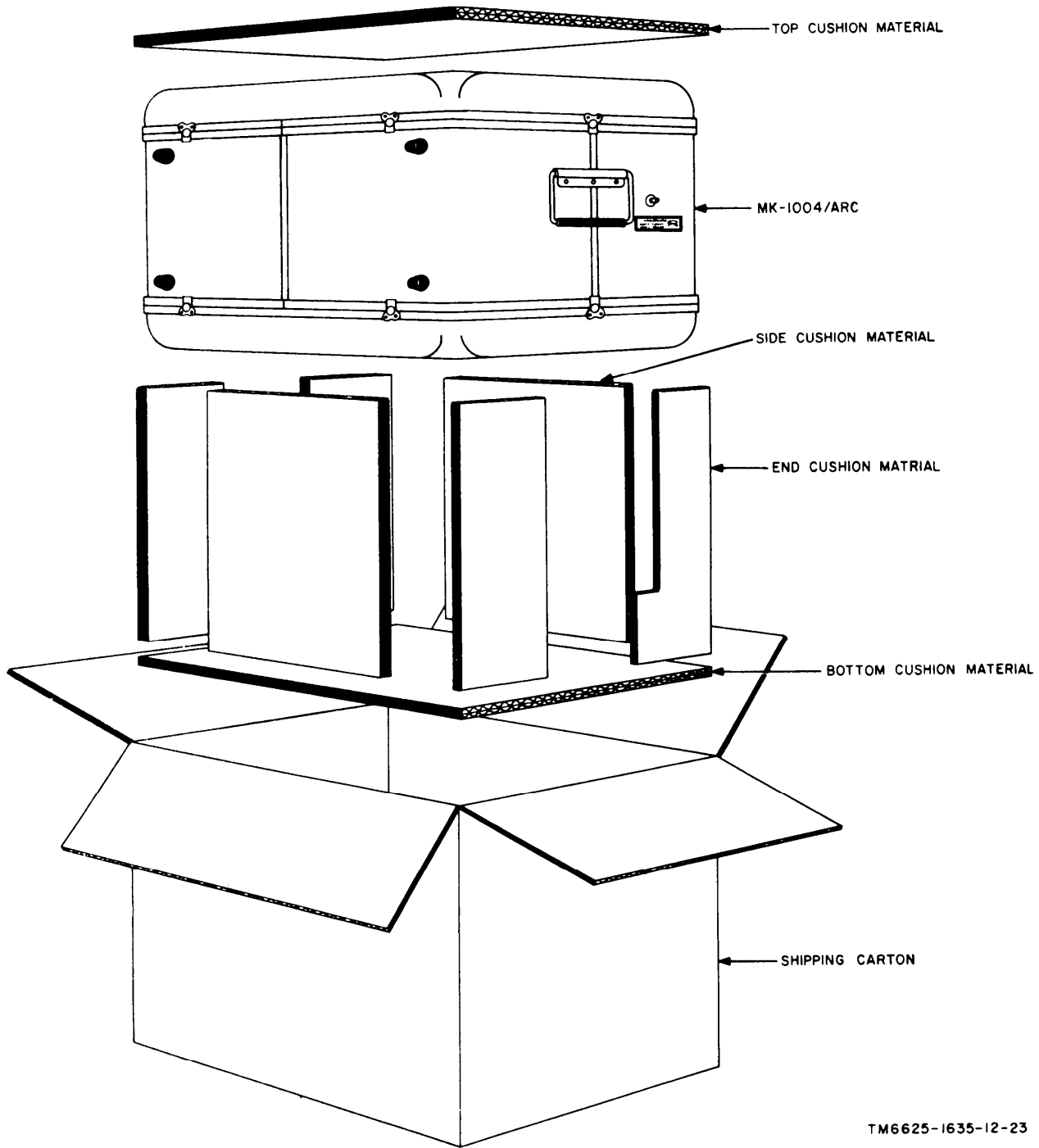

TM6625-1635-12-23

Figure 2-1. Maintenance kit packaging diagram.

- b. Removing Contents.*
- (1) Cut the tape and open the top of the shipping carton.
  - (2) Remove the cushioning material from the carton.
  - (3) Remove the equipment from the carton.
  - (4) Remove front and rear covers from the maintenance kit.
  - (5) Release the three fasteners on the inner panel of the rear cover, lift the panel, and remove the envelopes containing the manual and diagrams.
  - (6) Remove the nylon tape that secures the test cables at the rear of the unit.
  - (7) Place all cushioning material in the shipping container and save for storage or reshipment.

## 2-2. Checking Unpacked Equipment

- a.* Inspect the equipment for damage incurred during shipment. If the equipment has been damaged report the damage on DD Form 6.
- b.* See that the equipment is complete as listed

in the packing slip. Report all discrepancies in accordance with TM 38-750. Shortage of a minor assembly or part that does not affect proper functioning of the equipment should not prevent use of the equipment.

*c.* If the equipment has been used or reconditioned, see whether it has been changed by a modification work order (MWO). If the equipment has been modified, the MWO number will appear on the front panel near the nomenclature plate. If modified, see that any operational instruction changes resulting from the modification have been entered in the equipment manual.

### NOTE

Current MWO's applicable to the equipment are listed in DA Pam 310-7.

*d.* Check the latest issue of DA Pam 310-4 and its latest changes to see whether the latest editions of all applicable maintenance literature are available. (Equipment issued by depots may have been in stock for some time and may contain superseded manuals.)

## Section II. OPERATOR'S SWITCHES, CONTROLS, INDICATORS, AND JACKS

### 2-3. Maintenance Kit Operating Switches, Controls, Indicators, and Jacks

(Fig. 2-2 or fig. 2-2.1)

Switch, control, indicator, jack, or fuse	Function
POWER switch (maintenance kit unmodified)	In the ON position, applies the primary operating voltages to the radio control and lights the test panel 27.5-Vdc and 5-Vac POWER indicator lamps and the radio control panel lamps.
(maintenance kit modified)	In the ON position, applies the primary operating voltage to the radio control and the intercom control. Lights the POWER indicator lamp and the panel lamps on the radio control and the intercom control.
VHF COMM OFF-PWR switch	In the PWR position, applies primary operating voltage to the AN/ARC-134 and lights the radio control VHF COMM frequency counter dial indicator lamps.
VMH COMM MHz frequency selector switch	Tunes the AN/ARC-134 to the desired frequency (116 to 149 MHz).
VHF COMM fractional MHz frequency selector switch	Tunes the AN/ARC-134 to the desired fractional megahertz frequency (116.000 to 149.975 MHz).
VHF COMM VOL control	Adjusts the AN/ARC-134 volume level.
COMM TEST switch	Disables the AN/ARC-134 squelch circuit.
VHF COMM frequency counter dial	Indicates channel frequency to which the AN/ARC-134 is tuned.

**NOTE.** VHF NAV portion of Radio Set Control C-7241/ARC is not wired in, and is not used with the maintenance kit at this time.

## TM 11-6625-1635-12

Switch, control, indicator, jack or fuse	Function
AUDIO switch	Turns the AN/ARC-134 audio output on and off.
SQUELCH DISABLE switch	In the ON position, the AN/ARC-134 squelch circuit is disabled, permitting signal levels below the squelch threshold to be heard.
EXT SQUELCH CONT switch	In the ON position, the AN/ARC-134 squelch can be adjusted by means of the test panel EXT SQUELCH CONT
EXT SQUELCH CONT	Adjusts the AN/ARC-134 squelch when the EXT SQUELCH CONT switch is set on ON.
Indicator Lamps	
27.5 Vdc (maintenance kit modified)	Lights when 27.5 Vdc power is applied to the maintenance kit and the POWER switch is set to ON.
28.7 Vdc B + (maintenance kit unmodified)	Lights when 28.7 Vdc power is applied to the maintenance kit and the POWER switch is set to ON.
5 Vac (maintenance kit unmodified)	Lights when 5-volts ac power is applied to the maintenance kit and the POWER switch is set to ON.
250 V 10A fuses	Powerline fuses. Protect the dc circuits in the maintenance kit and AN/ARC-134.
250 V 1A fuse (maintenance kit unmodified)	Powerline fuse. Protects the ac circuits in maintenance kit.
PTT switch	Keys the AN/ARC-134 when set to ON.
MIKE jack	Provides circuit connections for keying and modulating the AN/ARC-134 with an external carbon microphone.
MIKE INPUT jacks	Provide connections to a 100-ohm input circuit for modulating the AN/ARC-134 with an external audio test signal.
Ø DBM INPUT jacks	Provide connections to a 500-ohm center-tapped microphone input circuit for modulating the AN/ARC-134 with an external audio test signal.
DATA LINK INPUT jacks	Provide connections to the ATCSS <sup>a</sup> input circuit for modulating the AN/ARC-134 with an external audio test signal.
RECEIVER OUTPUT jack	Provides a headset connection.
RECEIVER OUTPUT jacks	Provide connections for an audio voltmeter.
DATA LINK OUTPUT jacks	Provide connections to the ATCSS <sup>a</sup> output circuit in the AN/ARC-134.
SIDETONE jack	Provides a headset connection.
SIDTONE OUTPUT jacks	Provide connections for an audio voltmeter.
DETECTOR INPUT jack	Used to connect the AN/ARC-134 output to the input of a detector circuit in the maintenance kit.
DETECTOR METER jacks	Provide connections from the output of a detector circuit in the maintenance kit to an audio voltmeter, permitting measurement of the AN/ARC-134 modulation level.
SCOPE OUTPUT jack	Provides a connection from the output of a detector circuit in maintenance kit to an oscilloscope, permitting the AN/ARC-134 modulation to be observed.
AVC GROUNDED switch (maintenance kit modified)	When set to AVC GROUNDED, disables the AVC circuit of the AN/ARC-134.
0-10 A ammeter (maintenance kit modified)	Used to monitor the input current to the AN/ARC-134 under test.
Transmit-interphone selector, a six-position rotary switch (maintenance kit modified)	When set to position 3 and PTT switch on U-94A/U connector is depressed, applies audio from the H-101A/U microphone through the preamplifier and amplifier of the intercom control to the transmitter of the AN/ARC-134 under test. Also receiver audio to amps and headset.
VOL control, intercom control (maintenance kit modified)	Adjusts volume of the intercom control amplifier
Plug, connector, U-94A/U (maintenance kit modified)	Provides connection for Headset-Microphone H-101A/U. Provides PTT switch for keying the transmitter of the AN/ARC-134.

<sup>a</sup> Air Traffic Control Signaling System

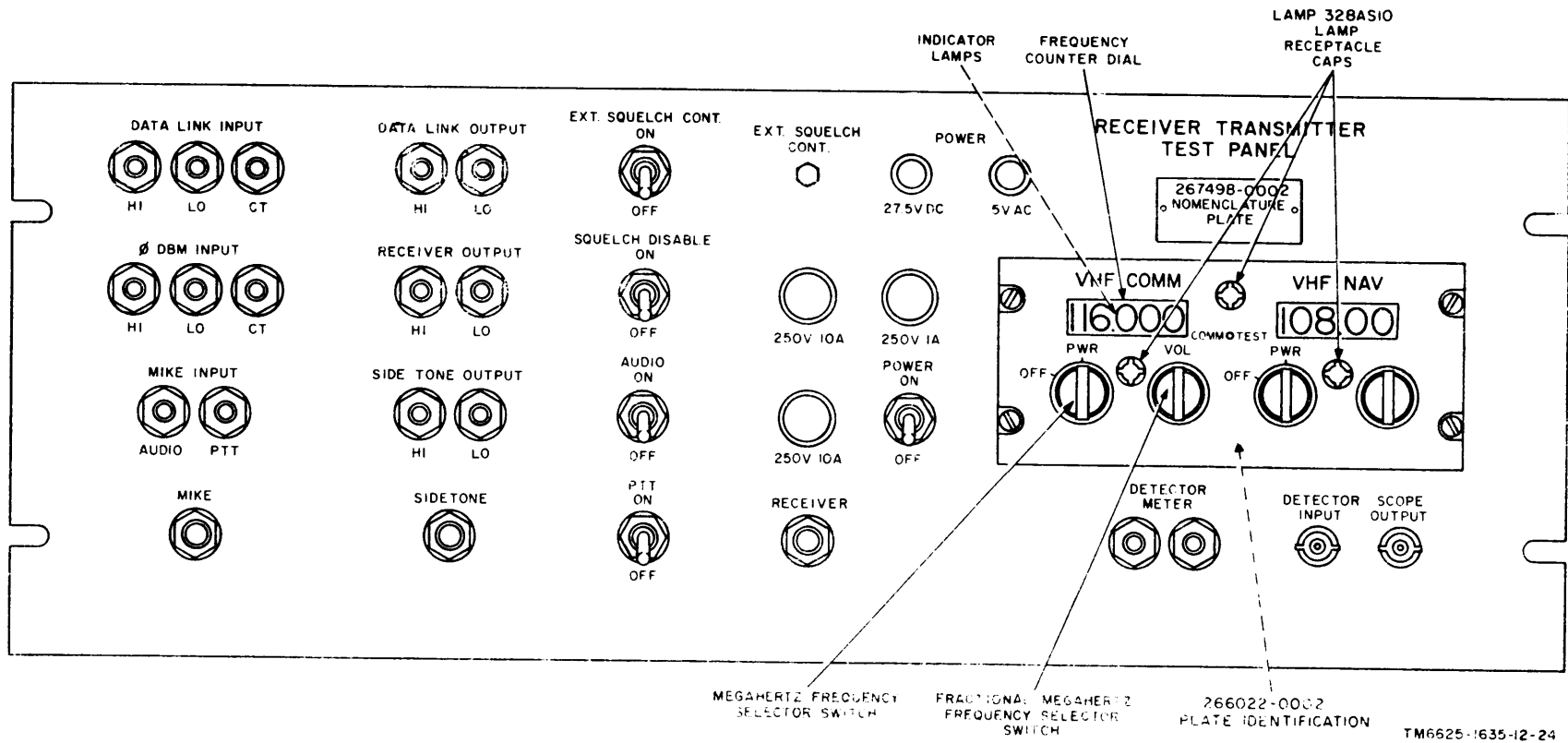

Figure 2-2. Maintenance kit, unmodified, switches, controls, indicators, and jacks.

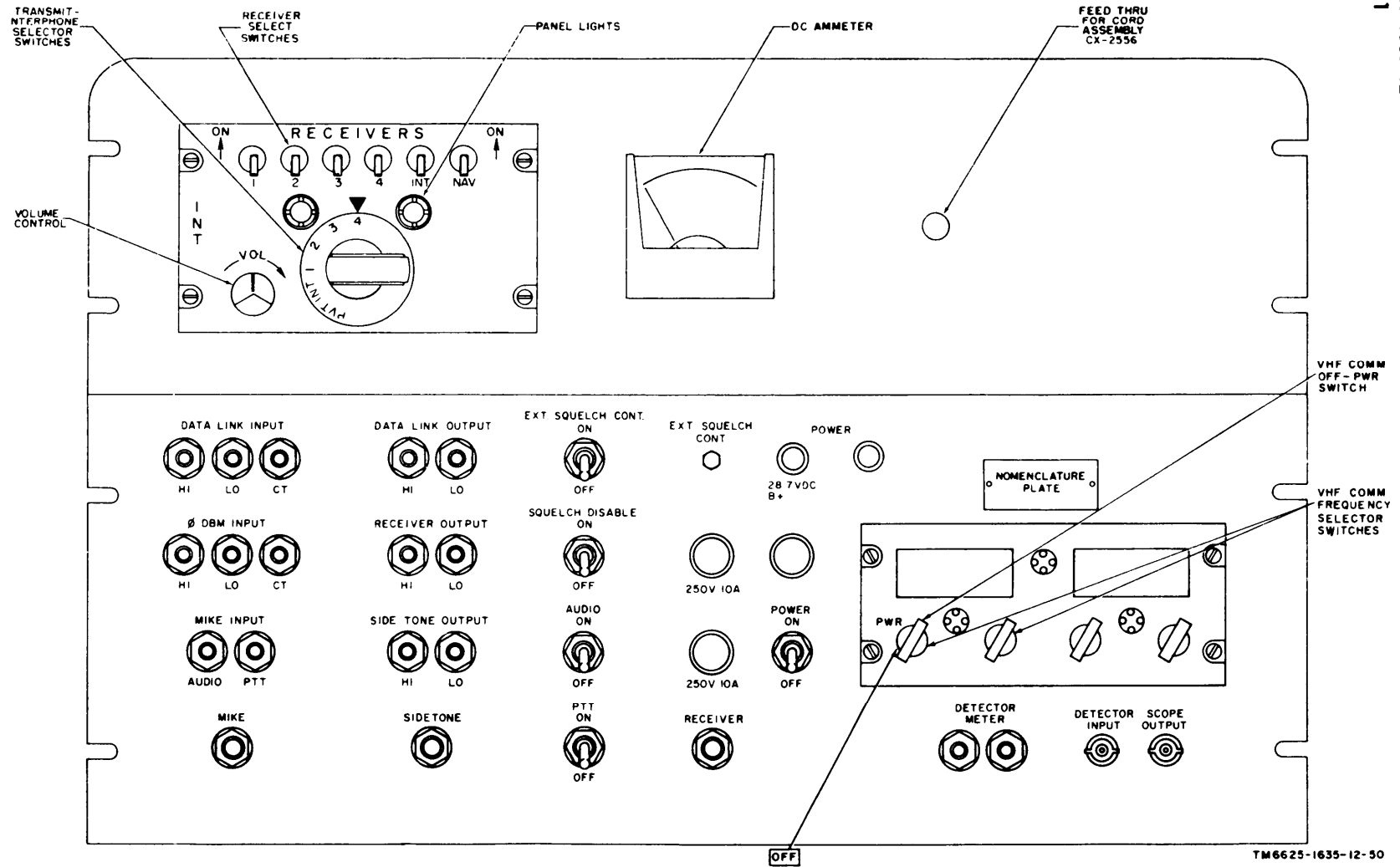

Figure 2-2.1 Maintenance kit, modified, switches, control, indicators, and jacks.



### 2-4. Preliminary Starting Procedure

Perform the operations listed below before starting the equipment.

- a. On the maintenance kit unmodified, set all switches to OFF.
- b. On the maintenance kit modified, set the transmit-interphone selector switch to position 3, the RECEIVERS switch 3 to ON and the AVC GROUNDED switch to the up position. Set all other switches on the maintenance kit to OFF.
- c. Set the EXT SQUELCH CONT to off.
- d. Set the VHF COMM VOL control fully clockwise.
- e. Apply primary operating power (para 1-5) to the maintenance kit.

### 2-5. Starting Procedure

*Note. If an abnormal indication is obtained during the starting procedure, refer to the monthly preventive maintenance checks and service chart (para 3-6) for corrective measures.*

To start the equipment, make sure the controls are set as required by the preliminary starting procedure (para 2-4). Perform the procedure given below.

- a. Set the POWER switch to ON. On the maintenance kit unmodified, the test panel indicator lamps and the panel lamps on the radio control should light. On the maintenance kit modified, the POWER 28.7 Vdc B+ lamp, and the panel lamps on the radio control and intercom control should light.

6. Connect the AN / maintenance kit as shown

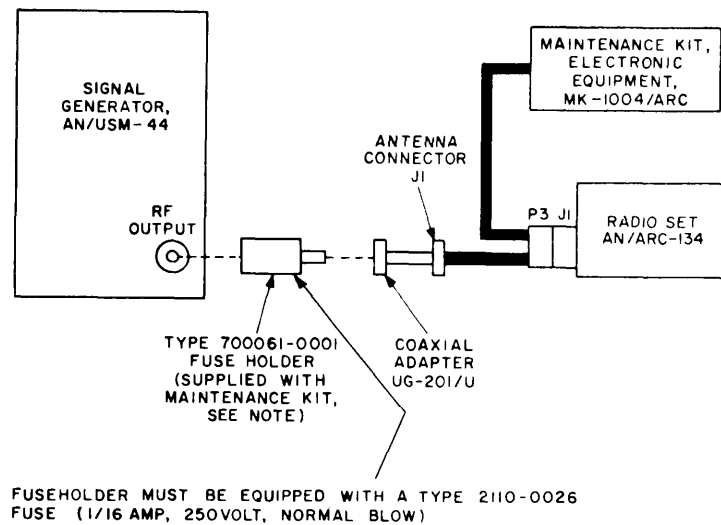
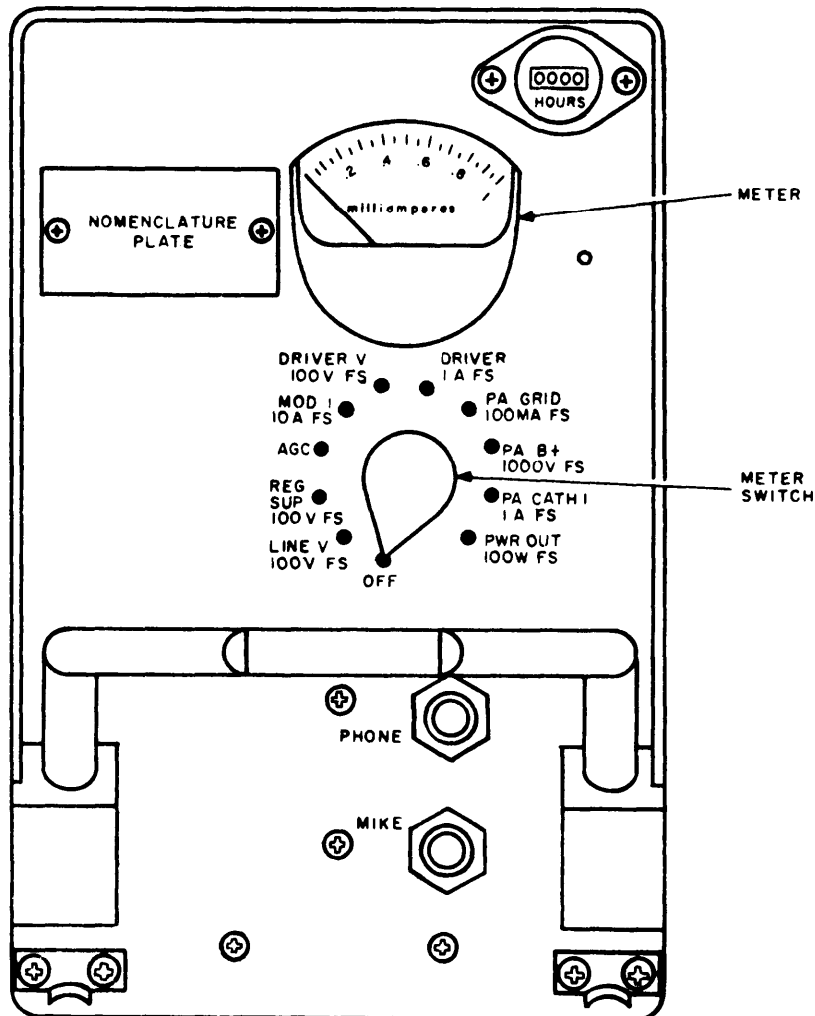

Figure 2-3. Radio Set AN/ARC-134 connected to maintenance kit.

- c. Set the VHF COMM OFF-PWR switch to PWR. The indicator lamps behind the VHF COMM frequency counter dials should light. On the maintenance kit modified, the DC ammeter should indicate between 2 and 3 amps.

- d. Set the meter switch (fig. 2-4) on the AN/ARC-134 front panel to LINE V 100 V FS; the AN/ARC-134 meter (fig. 2-4) should indicate 27.5 volts dc (—20 + 10 percent).



TM 6625-1635-12-25

Figure 2-4. Radio Set AN/ARC-134, front panel view.

## 2-6. Operational Checks

The operational checks in *a* through *h* below are given to familiarize the operator with the use of the maintenance kit. For the complete AN/ARC-134 test procedures, refer to TM 11-5821-277-35.

*a. Receiver Control Circuit Check at 132.5 MHZ.* Start the equipment as instructed in paragraph 2-5 and proceed as follows:

(1) Set Multimeter TS-352B/U to read alternating current (ac) volts and connect to RECEIVER OUTPUT jacks on the maintenance kit.

*Caution.* In (2) below, be sure to connect the 70061-0001 fuse holder between the output receptacle of the AN/USM-44 and antenna connector J1 (fig. 2-3) on the maintenance kit. The fuse holder should be equipped with a 70061-0002 fuse. Do not press the PTT switch on the microphone or the test panel when the very high frequency (vhf) signal generator is connected to connector J1.

(2) Connect the AN/USM-44 to antenna connector J1 on the maintenance kit (fig. 2-3). Set the AN/USM-44 for a 132.500-MHz

signal, modulated 90 percent at 1,000 Hz, and set the output attenuator for a 6-microvolt output.

(3) Set the VHF COMM frequency selector switches to 132.500 MHz. An output indication should be obtained on the TS-352B/U.

(4) Connect the TS-352B/U to the DATA LINK OUTPUT jacks. The indicated voltage should be considerably lower than that obtained in (3) above.

*b. Receiver Audio Output Checks.* Start the equipment as instructed in paragraph 2-5 and proceed as follows:

(1) Leave the AN/USM-44 connected and adjusted as described in *a* above.

(2) On the maintenance kit unmodified, connect the H-216/U to the test panel RECEIVER jack. On the maintenance kit modified, connect the H-101A/U to the U-94A/U connector on the CX-2556 Cord Assembly.

(3) Set the AUDIO switch to ON. A signal should be heard in the headset.

(4) On the maintenance kit modified, place the AVC GROUNDED switch in the down (grounded) position. The signal heard in the headset should increase in volume, indicating that the AN/ARC-134 AVC circuit is disabled. Return the AVC GROUNDED switch to the up position.

(5) On the maintenance kit modified, set RECEIVERS switch 3 to OFF. The signal heard in the headset should disappear. In sequence, set RECEIVERS switches 1, 2, 4, INT, and NAV to ON. No signal should be heard in the headset. Return RECEIVERS switches 1, 2, 4, INT, and NAV to the OFF position. Return RECEIVERS switch 3 to the ON position. The signal should again be heard in the headset.

(6) Set the EXT SQUELCH CONT switch to ON, and adjust the EXT SQUELCH CONT until the signal just disappears.

(7) Press the radio control COMM TEST switch. The signal heard in the headset should increase in volume, indicating that the AN/ARC-134 squelch circuit is disabled. Release the COMM TEST switch.

*c. Squelch Control Circuit Checks.* Start the

equipment as instructed in paragraph 2-5 and proceed as follows:

(1) Leave the equipment connected as described in *a* and *b* above.

(2) Leave switches in position set at the conclusion of *b* above.

(3) Set the EXT SQUELCH CONT SWITCH TO ON.

(4) Adjust the AN/USM-44 output attenuator for a 0-microvolt output.

(5) Slowly increase the AN—USM-44 output level until the squelch opens as indicated by the presence of a tone in the headset. The AN/USM-44 level should not be greater than 1 microvolt.

(6) Set the AN/USM-44 output level to 0) microvolt. Set the EXT SQUELCH CONT fully clockwise. Slowly increase the AN/USM-44 output level until the squelch opens. The AN/USM-44 level should not be greater than 100 microvolts.

*d. Channel Selection Checks.* Start the equipment as instructed in paragraph 2-5 and proceed as follows:

(1) Leave the AN/USM-44 connected and adjusted as described in *a* above. Leave the headset connected as described in *b* above.

(2) Set the AUDIO switch to ON.

(3) Set the EXT SQUELCH CONT switch to OFF. Adjust the AN/USM-44 output attenuator for a 3-microvolt output.

(4) Set the AN/USM-44 and the radio control VHF COMM frequency selector switches to each of the following frequencies and check for proper frequency selection as denoted by a tone in the headset: 116.00 MHz, 126.00 MHz, 136.00 MHz, 146.00 MHz, 147.00 MHz, 148.00 MHz, 149.00 MHz, 140.00 MHz, 111.00 MHz, 142.00 MHz, 143.00 MHz, 144.00 MHz, 145.00 MHz, 145.10 MHz, 145.20 MHz, 145.30 MHz, 145.40 MHz, 145.50 MHz, 145.60 MHz, 145.70 MHz, 145.80 MHz, 145.90 MHz, and 145.95 MHz.

(5) Disconnect the AN/USM-44 and TS-352B/U from the maintenance kit and on the maintenance kit unmodified, disconnect the headset.

*e. Transmitter Output and Control Circuit*

C1

*Check.* Start the equipment as instructed in paragraph 2-5 and proceed as follows:

(1) Connect Wattmeter, Radio Frequency AN/URM-43A (fig. 2-5) to antenna connector J1 on the maintenance kit.

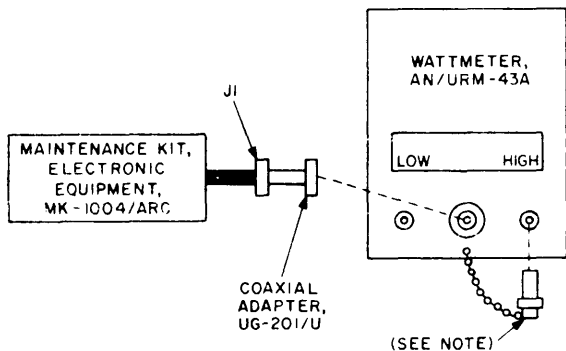

**NOTE:**

CONNECT DIODE FOR 'HIGH' WATTMETER OPERATION.  
TM6625-1635-12-27

Figure 2-5. Wattmeter, Radio Frequency AN/URM-43A, connected to maintenance kit.

(2) Set the VHF COMM frequency selector switches (fig. 2-2) to 132.500 MHz.

(3) Set the test panel PTT switch to ON. A power output indication should be observed on the AN/URM-43A and, on the maintenance kit modified, the dc ammeter should indicate between 6 and 9 amps.

*f. Sidetone Check, Unmodified Maintenance Kit.* Start the equipment as instructed in paragraph 2-5 and proceed as follows:

(1) Leave the AN/URM-43A connected as described in *e* above.

(2) Connect microphone M-52A/U to the test panel MIKE jack.

(3) Connect the H-216/U to the SIDETONE jack.

(4) Key the AN/ARC-134 with the M-52A/U switch and talk into the M-52A/U. The AN/ARC-134 sidetone should be heard in the headset. Release the M-52A/U switch.

*g. Sidetone Check, Modified Maintenance Kit.* Start the equipment as instructed in paragraph 2-5 and proceed as follows:

(1) Leave the AN/URM-43A connected as described in *e* above.

(2) Set the selector switch to PVT.

(3) Key the AN/ARC-134 with the U-94A/U and talk into the microphone. Sidetone should be present in the headset and no power output should be indicated on the AN/URM-43A.

(4) Set the selector switch to position 1.

(5) Repeat step 3. There should be no sidetone and no power indication on the AN/URM-43A.

(6) Set the selector switch to position 2.

(7) Repeat step 3. There should be no sidetone or power indication.

(8) Set the selector switch to position 3.

(9) Repeat step 3. Sidetone should be present, power should be indicated on the AN/URM-43A, and the meter on the maintenance kit should indicate changing current levels.

(10) Set the selector switch to position 4.

(11) Repeat step 3. There should be no sidetone or power indication.

(12) Set the selector switch to position 3.

*h. Modulation Checks.* Start the equipment as instructed in paragraph 2-5 and proceed as follows:

(1) Leave the AN/URM-43A connected as described in *e* above. On the maintenance kit unmodified, leave the M-52A/U connected to the MIKE jack.

(2) Set the AN/ARC-134 meter switch (fig. 2-4) to MOD 1 10A FS.

(3) On the maintenance kit unmodified, key the AN/ARC-134 with the M-52A/U switch. On the maintenance kit modified, key the AN/ARC-134 with the U-94A/U. Talk into the microphone and observe the AN/ARC-134 meter. The meter should fluctuate with modulation.

(4) Disconnect the H-216/U and M-52A/U from the test panel of the maintenance kit unmodified.

(5) Connect Signal Generator AN/URM-127 through a 50- $\mu$ f blocking capacitor (fig. 2-6) to the test panel MIKE INPUT jacks (fig. 2-2).

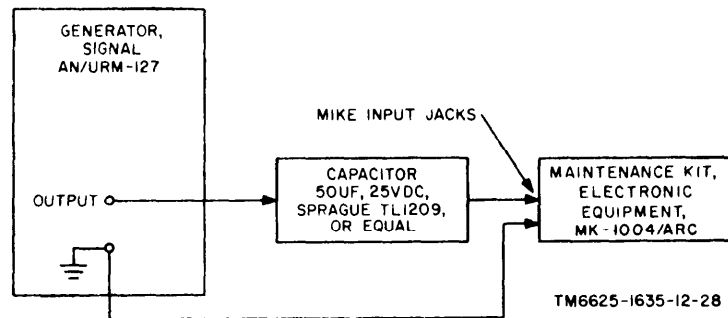

Figure 2-6. Signal Generator AN/URM-127, connected to maintenance kit.

(6) Set the AN/URM-127 to a frequency of 1,000 Hz.

(7) Set the test panel PTT switch to ON and increase the AN/URM-127 output level. A modulation indication should be observed on the AN/ARC-134.

(8) Repeat the procedure given in (5), (6), and (7) above with the AN/URM-127 connected first to the test panel 0 DBM INPUT jacks and then to the data link input jacks.

i. *Detector Circuit Checks.* Start the equipment as instructed in paragraph 2-5 and proceed as follows:

(1) Reconnect the AN/URM-127 through a 50-µf blocking capacitor to the test panel MIKE INPUT jacks.

(2) Connect the TS-352B/U to the test panel DETECTOR METER jacks. Set the TS-352B/U to the 10-volt range on the OUTPUT scale.

(3) Disconnect antenna connector J 1 on the maintenance kit from the AN/URM-43A, and connect J1 to the test panel DETECTOR INPUT receptacle.

(4) Connect the AN/URM-43A (fig. 2-7) to the test panel SCOPE OUTPUT receptacle.

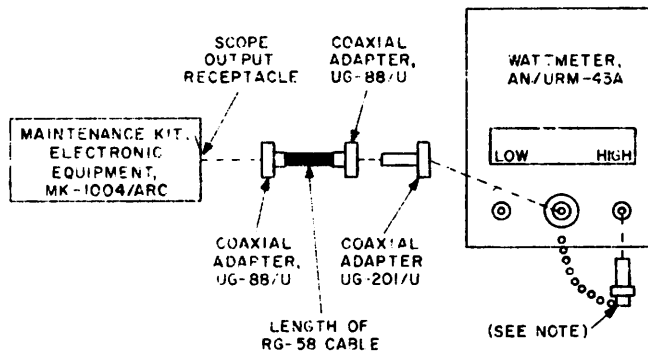

**NOTE:**  
CONNECT DIODE FOR 'HIGH' WATTMETER OPERATION.  
TM6625-1635-12-29

Figure 2-7. Wattmeter, Radio Frequency AN/URM-43A, connected to maintenance kit detector.

(5) Set the test panel PTT switch to ON and increase the AN/URM-127 output level. Modulation should be indicated by a meter deflection on the TS-352R/U and by an increase in the AN/URM-43A indication.

### 2-7. Stopping Procedure

a. To remove operating power from the

AN/ARC-134, set the VHF COMM OFF-PWR switch (fig. 2-2) to OFF. The indicator lamps behind the VHF COMM frequency counter dials should extinguish.

b. To remove all power from the maintenance kit, set the test panel POWER switch (fig. 2-2) to OFF. The test panel POWER indicator lamps should extinguish.

## CHAPTER 3

### ORGANIZATIONAL MAINTENANCE INSTRUCTIONS

#### 3-1. Scope of Organizational Maintenance

The maintenance duties assigned to the operator and organizational personnel of the maintenance kit are listed below, together with a reference to the paragraphs covering the specific maintenance function.

- a. Preventive maintenance checks and services (para 3-5, 3-6, and 3-7).
- b. Cleaning (para 3-8).
- c. Repainting (para 3-9).
- d. Troubleshooting (para 3-11).
- e. Repairs (para 3-13).

(1) Replacement of indicator lamps (para 3-13).

(2) Replacement of fuses (para 3-13).

#### 3-2. Special Equipment Required for Maintenance

Special tools, parts, and special equipment sets supplied for use with the maintenance kit are listed in appendix B.

#### 3-3. Organizational Preventive Maintenance

Preventive maintenance is the systematic care, servicing, and inspection of equipment to prevent the occurrence of trouble, to reduce downtime, and to insure that the equipment is serviceable.

a. *Systematic Care.* The procedures given in paragraphs 3-8, 3-9, and 3-10 cover routine systematic care and cleaning essential for proper upkeep and operation of the equipment.

b. *Preventive Maintenance Checks and*

*Services.* The preventive maintenance checks and services charts (para 3-5, 3-6, and 3-7) outline functions to be performed at specific intervals. These checks and services are to maintain Army electronic equipment in a combat serviceable condition. To assist operators in maintaining combat serviceability, the charts indicate what to check, how to check, and the normal conditions; the *References* column lists the illustrations, paragraphs, or manuals that contain detailed repair or replacement procedures. If the defect cannot be remedied by performing the corrective action indicated, higher category maintenance or repair is required. Records or reports of these checks and services must be made in accordance with the requirements set forth in TM 38-750.

#### 3-4. Preventive Maintenance Checks and Services Periods

Preventive maintenance checks and services for the maintenance kit are required daily, monthly, and quarterly.

a. Paragraph 3-5 specifies checks and services that must be accomplished daily.

b. Paragraph 3-7 specifies additional checks and services that must be performed quarterly. When quarterly preventive maintenance is performed, monthly preventive maintenance (para 3-6) must also be performed.

#### 3-5. Daily Preventive Maintenance Checks and Services Chart

<i>Sequence No.</i>	<i>Item to be inspected</i>	<i>Procedure</i>	<i>References</i>
1	Completeness	See that the equipment is complete	App B
2	C o n n e c t o r s	Check the tightness of all connectors.	
3	Switches, controls, and indicators.	While making the operating checks, observe that the mechanical action of each switch and knob is smooth and free of external or internal binding and that no excessive looseness is apparent.	

### 3-6. Monthly Preventive Maintenance Checks and Services Chart

Sequence No.	Item to be inspected	Procedure	References
1	Indicators	Check all inculcators for proper operation and indication.	
2	Cables	Inspect cords, cables, and wires for chafed, cracked, or frayed insulation. Replace connectors that are broken, stripped, worn excessively, or show evidence of arcing.	
3	Handles and latches	Inspect handles, latches, and hinges for looseness. Replace or tighten as necessary.	
4	Metal surfaces	Inspect exposed metal surfaces for rust and corrosion. Clean and touch up paint as required.	Para. 3-8 and 3-9.
5	Jacks	Inspect jacks for snug fit and good contact.	
6	Terminal blocks	Inspect terminal blocks for loose connections and cracked or broken insulation.	
7	Preliminary	Set all switches and controls as indicated in paragraph 2-4.	
8	AN/ARC-134 meter, POWER indicator lamps, and indicator lamps behind VHF COMM frequency counter dials and intercom control panel	Perform procedure given in paragraph 2-5. Note the following: <i>a.</i> The AN/ARC-134 meter reads 27.5 volts dc ( $-20 +10\%$ ). <i>b.</i> The POWER indicator lamps light. <i>c.</i> The indicator lamp behind VHF COMM frequency counter dials light. <i>d.</i> On the maintenance kit modified, the panel lamps on the intercom control light.	Para 3-12.
9	RECEIVER OUTPUT jacks	Perform the procedure given in paragraph 2-6 <i>a</i> (1), (2), and (3). An output indication should be obtained on the TS-352B/U.	
10	DATA LINK OUTPUT jacks	Perform the procedure given in paragraph 2-6 <i>a</i> (4). An output indication considerably lower than that obtained in sequence No. 9 should be obtained on the TS-352B/U.	
11	RECEIVER jack	Perform the procedure given in paragraph 2-6 <i>b</i> (1), (2), and (3). A signal should be heard in the headset.	
12	AVC GROUNDED switch (maintenance kit modified only)	Perform the procedure given in paragraph 2-6 <i>b</i> (4). The signal heard in the headset should increase in volume when switch is in the up position.	
13	RECEIVERS switches (maintenance kit modified only)	Perform the procedure given in paragraph 2-6 <i>b</i> (5). A signal should be heard in the headset only when RECEIVERS switch 3 is in the ON position.	
14	COMM TEST switch	Perform the procedure -given in paragraph 2-6 <i>b</i> (6) and (7). The signal should again be heard in the headset.	
15	EXT SQUELCH CONT switch	Perform the procedure given in paragraph 2-6 <i>c</i> (1) through (5). Squelch threshold should be 1 microvolt or less.	
16	EXT SQUELCH CONT	Perform the procedure given in paragraph 2-6 <i>c</i> (6). Squelch threshold should be 100 microvolts or less.	
17	VHF COMM frequency selector switches.	Perform the procedure given in paragraph 2-6 <i>d</i> (1) through (4). Tone should be heard in the headset on each channel checked.	



<i>Sequence No.</i>	<i>Item to be inspected</i>	<i>Procedure</i>	<i>References</i>
18	VHF COMM VOL control. . . . .	Leave equipment adjusted as described in sequence No. 17. Vary VHF COMM VOL control from minimum to maximum. Signal in the headset should increase as control is turned maximum clockwise.	
19	Intercom control VOL control (maintenance kit modified only)	Leave equipment adjusted as described in sequence 17. Vary VOL control from minimum to maximum. Signal in H-101A/U should increase as control is turned clockwise.	
20	PTT switch. . . . .	Perform the procedure given in paragraph 2-6d (5) and then the procedure in paragraph 2-6e. A power output indication should be observed on the AN/URM-43A and, on the maintenance kit modified, the dc ammeter should indicate between 6 and 9 amps.	
21	MIKE jack (maintenance kit unmodified)	Perform the procedure given in paragraph 2-6f. The AN/ARC-134 sidetone should be heard in the H-216/U.	
22	SIDETONE jack (maintenance kit unmodified)	Perform the procedure given in paragraph 2-6f (1) through (4). The AN/ARC-134 sidetone should be heard in the headset.	
23	MIKE INPUT jack (maintenance kit unmodified)	Perform the procedure given in paragraph 2-6h (1) through (7). A modulation indication should be observed in the AN/ARC-134.	
24	Transmit-Interphone Selector Switch (maintenance kit modified only)	Perform the procedure given in paragraph 2-6g. Sidetone should be heard when transmit-interphone selector switch is in Position INT.PVT. and 3. Power output should be observed on the AN/URM-43A only when the selector switch is in position 3.	
25	Ø DBM INPUT jacks. . . . .	Perform the procedure given in paragraph 2-6h. A modulation indication should be observed on the AN/AQRC-134 meter.	
26	DATA LINK INPUT jacks . . . . .	Perform the procedure given in paragraph 2-6h. A modulation indication should be obtained on the AN/ARC-134 meter.	
27	DETECTOR METER DETECTOR INPUT and SCOPE OUTPUT jacks	See paragraph 6i. Modulation should be indicated by a meter deflection on the TS-352/B/U and by an increase in the AN/URM-43A indication.	

**3-7. Quarterly Preventive Maintenance Checks and Services Chart**

<i>Sequence No.</i>	<i>Item to be inspected</i>	<i>Procedure</i>	<i>References</i>
1	Publications . . . . .	See that all publications are complete, serviceable, and current.	DA Pam 310-4.
2	Modifications . . . . .	Check DA Pam 310-7 to determine if new applicable MWO's have been published. All URGENT MWO's must be applied immediately. All NORMAL MWO's must be scheduled.	DA Pam 310-7.
3	Spare parts . . . . .	Check all spare parts (operator and organization) for general condition and method of storage. No overstock should be evident and all shortages must be on valid requisitions.	App B.

**3-8. Cleaning**

inspect the exterior surfaces of the maintenance kit. The exterior surface should be free of dust, dirt, grease, and fungus.

**Caution. Do not use any cleaning solvent on the front panel or where silkscreening is present.**

a. Remove dust and loose dirt with a clean soft cloth.

**Warning. Cleaning compound is toxic and flammable. Provide adequate ventilation. DO NOT use near a flame.**

b. Remove grease, fungus, and ground-in dirt with a cloth dampened (not wet) with cleaning compound.

c. Remove, with a brush, dust or dirt from plugs, receptacle, and jacks.

d. Use a soft, clean cloth to clean the front panel and control knobs. If dirt is difficult to remove, dampen the cloth with water and use mild soap if necessary.

**3-9. Touchup Painting Instructions**

Remove rust and corrosion from metal surfaces by lightly sanding them with fine sandpaper. Brush two thin coats of paint on the bare metal to protect it from further corrosion. Refer to applicable cleaning and refinishing practices specified in TB SIG 364.

**3-10. Lubrication**

The following parts in the radio control have been lubricated by the manufacturer and require no further lubrication except as noted in the *Remarks* column below :

<i>Part</i>	<i>Lubricant</i>	<i>Remarks</i>
Detent arm subassembly rollers.	Lubricating Oil, Instrument (OAI) (FSN) 9150-664-6518).	Add lubricant sparingly during installation of new part(s).
Detent plate ball bearings.	Grease, Aircraft and Instrument (GI) (FSN)9150-664-6518).	Add lubricant sparingly during installation of new part(s).
Metal bearing surfaces of COMM switch assembly.	Lubricating oil, Instrument (OAI) (FSN 9150-664-6518).	Add lubricant sparingly during installation of new part(s).
Metal bearing surfaces of COMM-NAV switch assembly.	Lubricating Oil, Instrument (OAI) (FSN 9150-664-6518).	Add lubricant sparingly during installation of new part(s).
COMM counter dial indicator shafts.	Lubricating Oil, Instrument (OAI) (FSN 9150-664-6518).	Add lubricant sparingly during installation of new part(s).

**3-11. General Troubleshooting Information**

Troubleshooting this equipment at the operator or organizational category is based on the operational checks contained in the monthly preventive maintenance checks and services chart, To troubleshoot the equipment, perform all functions indicated in sequence number 8 in the monthly preventive maintenance checks and services chart (para 3-6) and proceed through the functions until an abnormal condition or

result is observed. When an abnormal condition is observed, refer to the troubleshooting chart (para 3-12) and perform the checks and corrective actions indicated. If the corrective measures indicated do not result in correction of the trouble, higher category maintenance is required.

**3-12. Troubleshooting Chart**

a. Maintenance kit unmodified.

<i>Trouble symptom</i>	<i>Probable trouble</i>	<i>Checks and corrective measures</i>
■ (1) Test panel 5 Vac power indicator lamp fails to light.	POWER switch set to OFF Defective lamp. . . . .	Set POWER switch to ON. Replace lamp (para 3-13a).
■ (2) Test panel 27.5 Vdc POWER indicator lamp fails to light.	Defective 250 V 1A fuse Defective 250 V 10A fuse Defective lamp. . . . .	Replace fuse (para 3-13b). Replace fuse (para 3-13b). Replace lamp (para 3-13a).
■ (3) AN/ARC-134 meter does not indicate 27.5 volts dc (-20 +10%).	VHF COMM OFF-PWR switch is at OFF. AN/ARC-134 meter switch not set to LINE V.	Set VHF COMM OFF PWR switch to PWR. Set meter switch to LINE V.
■ (4) Radio control panel lamps do not light.	Radio control panel lamps defective.	Replace lamps (para 3-13c).
■ (5) VHF COMM frequency counter dials not illuminated.	Defective frequency counter dial lamps.	Replace lamps (para 3-13d).

*b. Maintenance kit modified.*

<i>Trouble symptom</i>	<i>Probable trouble</i>	<i>Checks and corrective measures</i>
■ (1) Test panel 28.7 Vdc B+ POWER indicator lamp fails to light.	Defective 250 V 10A fuse	Replace fuse (para 3-13b).
■ (2) AN/ARC-134 meter does not indicate 27.5-volts dc (-20 +10%).	Defective lamp VHF COMM OFF-PWR switch is OFF. AN/ARC-134 meter switch not set to LINE V.	Replace lamp (para 3-13a). Set VHF COMM OFF-PWR switch to PWR. Set meter switch to LINE V.
■ (3) Radio control or intercom control panel lamps do not light.	Defective panel lamps.	Replace lamps (para 3-13c).
■ (4) VHF COMM frequency counter dials do not illuminate.	Defective frequency counter dial lamps.	Replace lamps (para 3-13d).

3-13. Repairs

*a. Replacement of Test Panel POWER Indicator Lamps.*

- (1) Rotate lampholder (fig. 3-1) counterclockwise until it separates from the test panel.

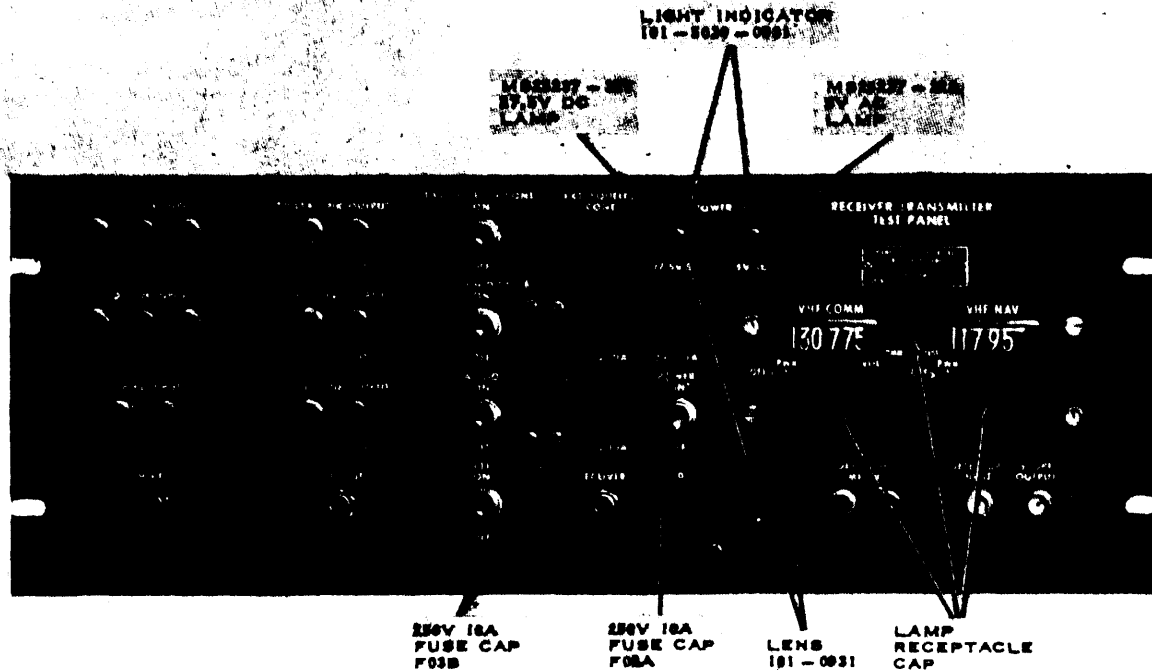

TM 6625-1635-12-30

Figure 3-1. Test panel, unmodified, indicator lamps and fuse locations.

(2) Extract the defective lamp from the lampholder; use a knife blade or small screwdriver as a pry if the bulb is difficult to remove.

(3) Install a new lamp and rotate the lampholder clockwise until it is secure.

*b. Replacement of Test Panel Fuses.*

(1) Turn the fuse cap (fig. 3-1) counterclockwise until it separates from the fuse holder on the test panel.

(2) Extract the defective fuse from the fuse holder.

(3) Install a new fuse in the fuse holder.

(4) Replace the fuse cap on the fuse holder and rotate the cap clockwise until it is secure.

*c. Replacement of Radio Control and Intercom Control Panel Lamps.*

(1) Rotate lamp receptacle caps (fig. 3-1) counterclockwise and remove them from the front panel.

(2) Insert a new lamp into the lamp receptacle cap and rotate the cap clockwise until it is secure.

*d. Replacement of Frequency Counter Dial Indicator Lamps.*

(1) Rotate the quick-release fasteners (fig. 3-3) one-quarter turn counterclockwise.

(2) Slide the radio control forward and out of the test panel.

(3) Remove the cover attaching screws (fig. 3-3) and lift the cover from the radio control.

(4) Remove the lamp cover (fig. 3-2) from the dial indicator lamp.

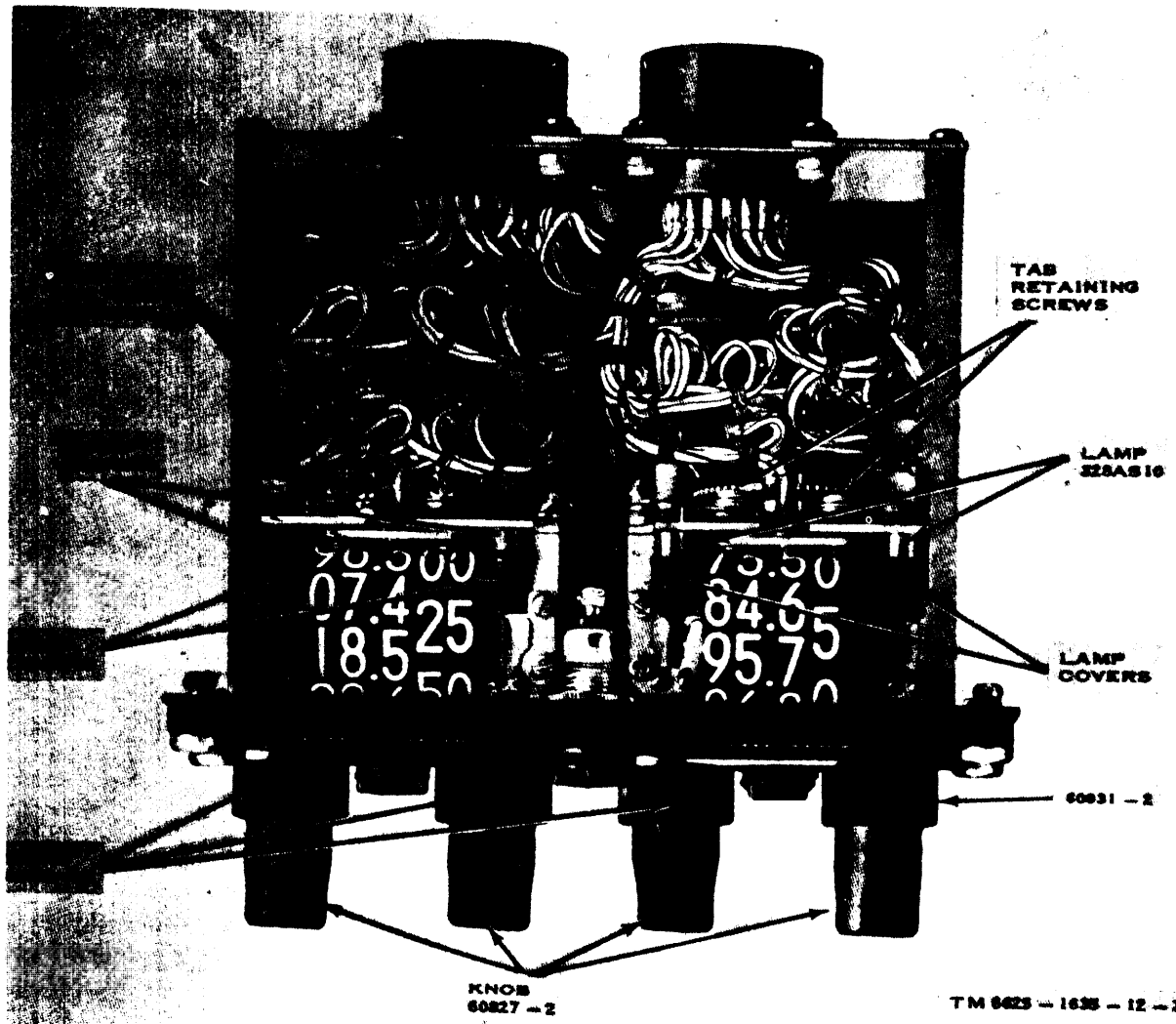
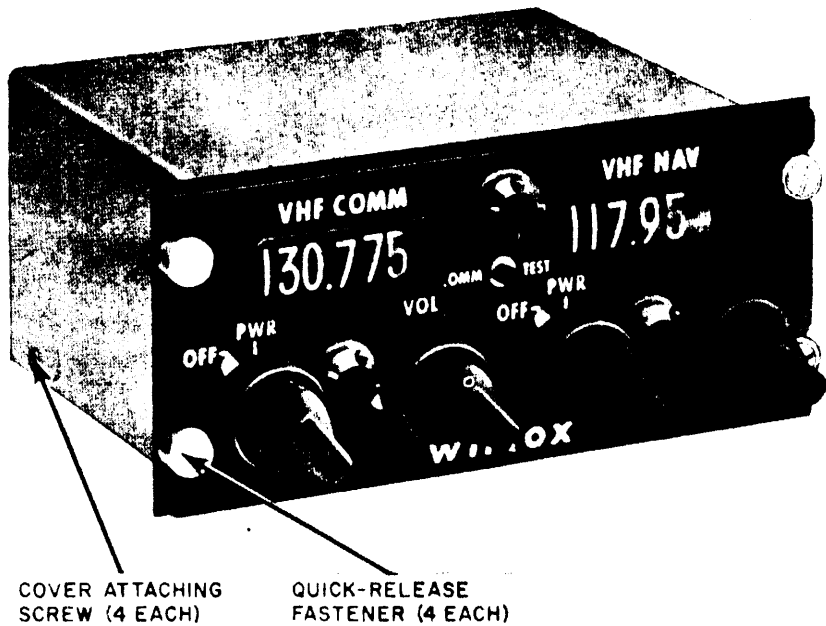

Figure 3-2. Radio control dial indicator lamp locations.



TM 6625 - 1635 - 12 - 47

Figure 3-3. Radio control disassembly.

(5) Loosen the tab retaining screw (fig. 3-2) near the lamp base.

(6) Turn the retaining tab away from the lamp base.

(7) Push the lamp backward through the hole in the gear plate and remove the lamp.

(8) Insert a new lamp in the gear plate.  
(9) Position the retaining tab over the base of the lamp and tighten the retaining screw.

(10) Replace the lamp cover over the lamp.

## CHAPTER 4

### SHIPMENT, LIMITED STORAGE, AND DEMOLITION TO PREVENT ENEMY USE

---

#### Section 1. DISASSEMBLY AND REPACKAGING

##### 4-1. Disassembly of Equipment

Prepare the maintenance kit for shipment and storage as follows:

- a. Disconnect all control, antenna, and power cables.
- b. Replace all minor assemblies, running

spares, the pendent cable plug, and technical manual and associated diagrams in the proper positions inside the rear cover of the equipment case.

- c. Close the metal panel inside the rear cover of the equipment case and secure the panel with the three fasteners (fig. 4-1).

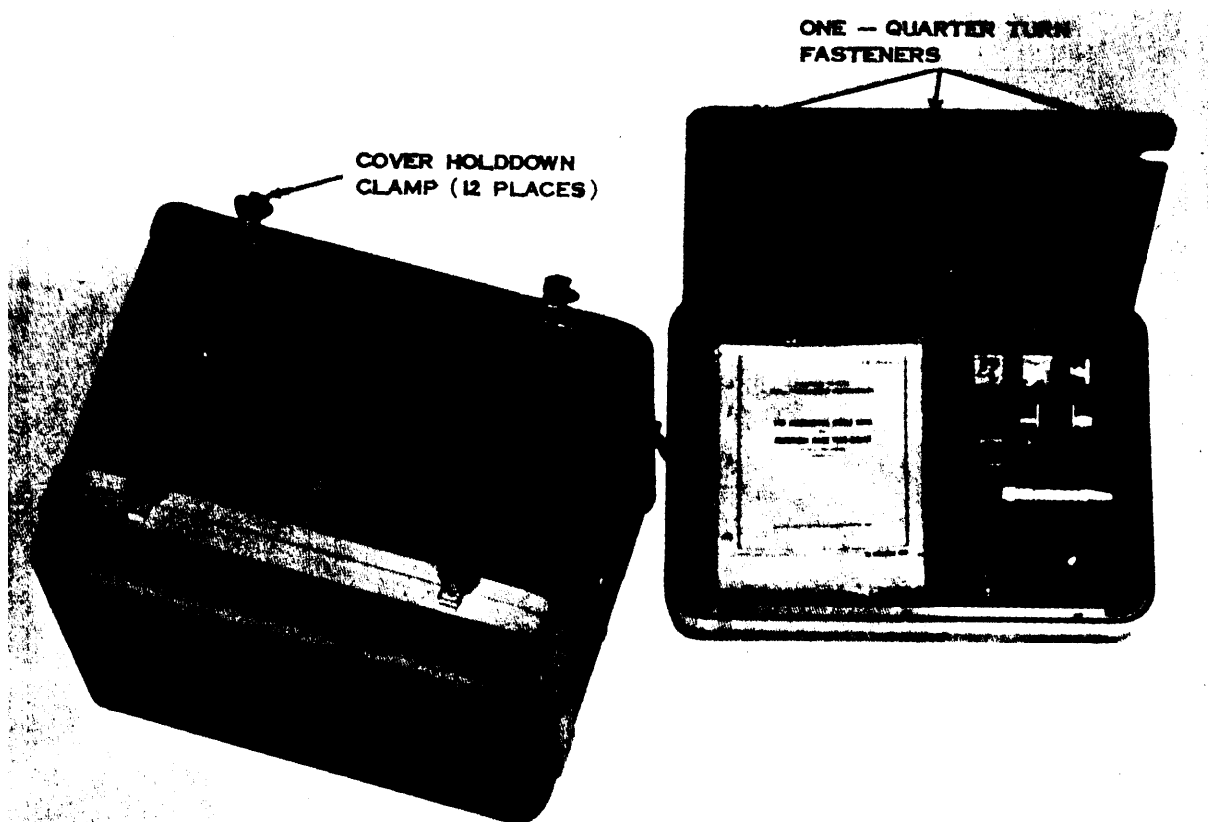

TM 6625-1635-12-34

Figure 4-1. Equipment case, location of minor assemblies.

d. Coil the power cables at the rear of the test panel, and secure the cables with a length of nylon tape.

e. Replace the rear cover on the equipment case and secure the cover with six holddown clamps (fig. 4-1).

f. Replace the front cover on the equipment case (fig. 4-1) and secure the cover with six holddown clamps.

#### 4-2. Repackaging for Shipment or Limited Storage

The exact procedure for repackaging depends on the material available and the conditions under which the equipment is to be shipped or stored. Adapt the procedures outlined below whenever circumstances permit. The information concerning unpackaging (para 2-1) will also be helpful.

a. *Material Requirements.* The following materials are required for packaging the maintenance kit. For stock numbers of materials, consult SB 38-100.

<i>Material</i>	<i>Quantity</i>
Carton -----	1 (22 X 16¾ X 21)
Tape, cloth backing, waterproof ---	6 ft
Tape, nylon -----	1 ft
Cushioning material (¾" thick- ness).	21 sq ft

b. *Packaging.* Package the items of the maintenance kit as outlined below.

(1) Place cushioning material in the bottom of the shipping carton.

**Caution 1: If the maintenance kit is being prepared for storage, close the air pressure valve (fig. 1-1) to prevent moisture and dust accumulation inside the equipment case.**

**Caution 2: If the maintenance kit is being prepared for air shipment, open the air pressure valve (fig. 1-1) to prevent possible rupture of the equipment case at high altitudes.**

(2) Place the maintenance kit in the shipping carton and insert cushioning material around the equipment case.

(3) Secure the top of the shipping carton with the cloth-backed waterproof tape.

## Section II. DEMOLITION OF MATERIEL TO PREVENT ENEMY USE

#### 4-3. Authority for Demolition

The demolition procedures given in paragraph 4-4 will be used to prevent the enemy from using or salvaging this equipment. Demolition of the equipment will be accomplished only upon the order of the commander.

#### 4-4. Methods of Destruction

The tactical situation and time available will determine the method to be used when destruction of equipment is ordered. In most cases, it is preferable to completely demolish some portions of the equipment rather than partially destroy all the equipment units.

a. *Smash.* Use sledges, axes, hammers, crowbars, and any other heavy tools available to smash the interior units of the maintenance kit.

(1) Use the heaviest tool on hand to smash the connectors, dials, knobs, and switches.

(2) Remove the covers from the unit and smash as many of the parts as possible.

b. *Cut.* Use axes, machetes, and similar tools to cut cabling, cording, and wiring. Cut all cords and cables in a number of places.

**Warning: Be extremely careful with explosives and incendiary devices. Use these items only when the need is urgent.**

c. *Burn.* Burn technical manuals and diagrams first. Burn as much of the equipment as is flammable; use gasoline, oil, flamethrowers, and similar materials. Pour gasoline on the cut cables and internal wiring and ignite it. Use a flamethrower to burn spare parts, or pour gasoline on the spares and ignite them.

d. *Dispose.* Bury or scatter destroyed parts or throw them into nearby waterways. This is particularly important if a number of parts have not been completely destroyed.



## APPENDIX A

### REFERENCES

---

Following is a list of applicable references available to the operator and organizational repairman of the MK-1004/ARC.

DA Pam 310-4	Index of Technical Manuals, Technical Bulletins, Supply Manuals (Types 7, 8, and 9), Supply Bulletins, and Lubrication Orders
DA Pam 310-7	U.S. Army Equipment Index of Modification Work Orders
SB 38-100	Preservation, Packaging and Packing Materials, Supplies, and Equipment Used by the Army
TM 11-5133	Radio Frequency Wattmeters AN/URM-43A and AN/URM-43B
TM 11-5821-277-25-1	Organizational, DS, GS, and Depot Maintenance Manual: Receiver-Transmitter RT-857/ARC-134 and Mounting MT-3791/ARC-134 (Part of Radio Set AN/ARC-134)
TM 11-6625-366-15	Organizational, DS, GS, and Depot Maintenance Manual: Multirmeter TS-352B/U
TM 11-6625-508-10	Operator's Manual: Signal Generators AN/USM-44 and AN/USM44A
TM 11-6625-1635-20P	Organizational Maintenance Repair Parts and Special Tools List for Maintenance Kit, Electronic Equipment MK-1004/ARC
TM 38-750	Army Equipment Record Procedures



## APPENDIX C

### MAINTENANCE ALLOCATION

---

#### Section I. INTRODUCTION

##### C-1. General

This appendix provides a summary of the maintenance operations covered in the equipment literature for Maintenance Kit, Electronic Equipment MK-1004/ARC. It authorizes categories of maintenance for specific maintenance functions on repairable items and components and the tools and equipment required to perform each function. This appendix may be used as an aid in planning maintenance operations.

<i>Code</i>	<i>Maintenance category</i>
C - - - - -	Operator/crew
O - - - - -	Organizational maintenance
F - - - - -	Direct support maintenance
H - - - - -	General support maintenance
D - - - - -	Depot maintenance

*d. Tools and Equipment.* The numbers appearing in this column refer to specific tools and equipment which are identified by these numbers in section III.

*e. Remarks.* Self-explanatory.

##### C-2. Explanation of Format for Maintenance Allocation Chart

*a. Group Number.* Group numbers correspond to the reference designation prefix assigned in accordance with ASA Y32.16, Electrical and Electronics Reference Designations, They indicate the relation of listed items to the next higher assembly.

*b. Component Assembly Nomenclature.* This column lists the item names of component units, assemblies, subassemblies, and modules on which maintenance is authorized.

*c. Maintenance Function.* This column indicates the maintenance category at which performance of the specific maintenance function is authorized. Authorization to perform a function at any category also includes authorization to perform that function at higher categories. The codes used represent the various maintenance categories as follows:

##### C-3. Explanation of Format for Tool and Test Equipment Requirements

The columns in the tool and test equipment requirements chart are as follows:

*a. Tools and Equipment.* The numbers in this column coincide with the numbers used in the tools and equipment column of the MAC. The numbers indicate the applicable tool for the maintenance function.

*b. Maintenance Category.* The codes in this column indicate the maintenance category normally allocated the facility.

*c. Nomenclature.* This column lists tools, test and maintenance equipment required to perform the maintenance functions.

*d. Federal Stock Number.* This column lists the Federal stock number.

*e. Tool Number.* Not used.

## SECTION II. MAINTENANCE ALOCATION CHART

GROUP NUMBER	COMPONENT ASSEMBLY NOMENCLATURE	MAINTENANCE FUNCTIONS										TOOLS AND EQUIPMENT	REMARKS	
		INSPECT	TEST	SERVICE	ADJUST	ALIGN	CALIBRATE	INSTALL	REPLACE	REPAIR	OVERHAUL			REBUILD
1	MAINTENANCE KIT, ELECTRONIC EQUIPMENT MK-1004/ARC	F	F	F				F	F	F			1 thru 8	Verify operation, perform preliminary tests, replace components, repair cables, connectors etc. General purpose tools normally available for assigned task
2	PANEL, TEST ELECTRICAL SB-3003(P)/ARC	F	H	F	H			F	F	F	H	H	D	1 thru 8 See note in Section III
3	CONTROL, RADIO SET C-7241/ARC	F	F	F				F	F	F	H	D	1 thru 8	See note Section III General purpose tools normally available for assigned task

## SECTION III. TOOL AND TEST EQUIPMENT REQUIREMENTS

TOOLS AND EQUIPMENT	MAINTENANCE CATEGORY	NOMENCLATURE	FEDERAL STOCK NUMBER	TOOL NUMBER
		MK-1004/ARC (continued)		
1	F,H,D	GENERATOR, SIGNAL AN/URM-127	6625-783-5965	
2	F,H,D	GENERATOR, SIGNAL AN/USM-44	6625-669-4031	
3	F,H,D	WATTMETER, RADIOFREQUENCY AN/URM-43A	6625-635-9186	
4	F,H,D	MULTIMETER TS-352B/U	6625-242-5023	
5	F,H,D	TOOL KIT, ELECTRONIC EQUIPMENT TK-100/G	5180-505-0079	
6	F,H,D	TRANSFORMER, VARIABLE POWER CN-16/U	5950-235-2086	
7	F,H,D	MICROPHONE M-52A/U	5965-546-4678	
8	F,H,D	HEADSET, ELECTRICAL H-216/U (WITH CORD CD-307, FCN 5995-553-1056)	5965-892-3353	
		NOTE: One each Receiver-Transmitter, Radio RT-857/ARC-134 (FSN 5821-072-6108) required for final testing.		



## APPENDIX D

### ORGANIZATIONAL REPAIR PARTS

---

#### Section I. INTRODUCTION

##### D-1. Scope

This appendix contains a list of repair parts required for the performance of organizational maintenance for Maintenance Kit, Electronic Equipment MK-1004/ARC.

*Note.* No special tools, test and support equipment are required.

##### D-2. General

The repair parts list is divided into the following sections:

*a. Prescribed Load Allowance (PLA), Section II.* The PLA is a consolidated listing of repair parts allocated for initial stockage at the organizational maintenance category. This is a mandatory minimum stockage allowance.

*b. Repair Parts for Organizational Maintenance, Section III.* Repair parts authorized for organizational maintenance are included in this section.

*Note.* The index noted below is cross-referenced to index numbers. The index numbers appear in ascending sequence in column 1 of the repair parts list (para D-3a). The index number for the particular item will be the same for the item in all sections of this appendix.

*c. Federal Stock Number Cross-Reference to Index Number, Section IV.* This is a cross-reference index of Federal stock numbers and manufacturer's part numbers to index numbers.

##### D-3. Explanation of Columns

*a. Source, Maintenance, and Recoverability Codes (SMR) and Index Numbers Column.* The first line in this column lists the applicable SMR codes for the part. Listen in ascending

order directly below the SMR codes is the index number assigned to the repair part.

(1) *Source code (S).* The selection status and source for the listed item is noted here. Source codes and their explanations are as follows:

<i>Code</i>	<i>Explanation</i>
P	Applies to repair parts that are stocked in or supplied from the GSA/DSA, or Army supply system, and authorized for use at indicated maintenance categories.
M	Applies to repair parts that are riot procured or stocked but are to be manufactured at indicated maintenance categories.
A	Applies to assemblies that are not procured or stocked as such but are made up of two or more units, each of which carries an individual stock number and description and is procured and stocked and can be assembled by units at indicated maintenance categories.
X2	Applies to repair parts that are not stocked. The indicated maintenance category requiring such repair parts will attempt to obtain them through cannibalization; if not obtained through cannibalization, such repair parts will be requisitioned with supporting justification through normal supply channels.
C	Applies to repair parts authorized for local procurement. If not obtainable from local procurement, such repair parts will be requisitioned through normal supply channels with a supporting statement of nonavailability from local procurement.

(2) *Maintenance code (M)*. The lowest category of maintenance authorized to install the listed item is noted here.

<i>Code</i>	<i>Explanation</i>
O - - - - -	Organizational maintenance
F - - - - -	Direct support maintenance

(3) *Recoverability code (R)*. The information in this column indicates whether un-serviceable items should be returned for recovery or salvage. Recoverability code and its explanation is as follows:

*Note.* When no code is indicated in the recoverability column, the part will be considered expendable.

<i>Code</i>	<i>Explanation</i>
R--	Applies to repair parts and assemblies which are economically repairable at DSU and GSU activities and normally are furnished by supply on an exchange basis.

*b. Federal Stock Number Column.* The Federal stock number for the item is listed in this column.

*c. Description Column.* This column includes the Federal item name and any additional description of the item required, the manufacturer's part number (reference number), and the applicable five-digit Federal Supply Code for Manufacturers (para D-5). For subsequent appearances of the same item, the manufacturer's code and part number (reference number) are omitted. The words "same as" followed by the index number assigned to the item when it first appeared in the list will follow the item name, e.g., "RESISTOR, FIXED, COMPOSITION: SAME AS A298." Usable on code column is not used.

*d. Unit of Issue Column.* The unit used as a basis of issue (e.g., ea, pr, ft, yd, etc.) is indicated in this column.

*e. Quantity Incorporated in Unit Pack Column.* Not used.

*f. Quantity Incorporated in Unit Column.* The quantity of repair parts in an assembly is given in this column. Subsequent appearances of the same item in the same assembly are indicated by the letters "REF."

*g. Maintenance Allowances Column.*

(1) The maintenance allowance column is divided into subcolumns. Indicated in each

subcolumn opposite the first appearance of the item is the total quantity of items authorized for the number of equipments supported. Subsequent appearances of the same item will have no entry in the allowance columns, but will have a reference in the description column to the first appearance of the item. Items authorized for use as required, but not for initial stockage, are identified with an asterisk in the allowance column.

(2) The quantitative allowances for organizational category of maintenance represents one initial prescribed load for a 15-day period for the number of equipments supported. Units and organizations authorized additional prescribed loads will multiply the number of prescribed loads authorized by the quantity of repair parts reflected in the appropriate density column to obtain the total quantity of repair parts authorized.

(3) Subsequent changes to organizational allowances will be limited as follows: No change in the range of items is authorized. If additional items are considered necessary, recommendation should be forwarded to Commanding General, U.S. Army Electronics Command, ATTN: AMSEL-ME-NMP-AC, Fort Monmouth, N.J., 07703, for exception or revision to the allowance list. Revisions to the range of items authorized will be made by the USA ECOM National Maintenance Point based upon engineering experience, demand data, or TAERS information.

*h. Illustrations Column.*

(1) *Figure number (a)*. The number of the illustration in which the item is shown is indicated in this column.

(2) *Item No. or reference designation (b)*. Not used.

#### D-4. Location of Repair Parts

*a.* This appendix contains one cross-reference index (sec. IV), to be used to locate a repair part when the Federal stock number or reference number (manufacturer's part number) is known. The first column in the cross-reference index is prepared in numerical sequence. The second column of the cross-ref-



erence index lists the index number assigned to the part.

b. Refer to the cross-reference index (para D-2c) and note the index number in the second column; then refer to the repair parts list to locate the index number which is listed in ascending order in column 1 of the repair parts list.

**D-5. Federal Supply Codes**

This paragraph lists the Federal supply code with the associated manufacturer's name.

<i>Code</i>	<i>Explanation</i>
28307	Bradley Industries, Inc.
28480	Hewlett-Packard Co.
65597	Wiicox Electric Co., Inc.
71744	Chicago Miniature Lamp Works
72619	Dialight Corp.
80058	Joint Electronic Type Designation System
81349	Military Specifications
93332	Sylvania Electric Products, Inc., Semiconductor Products Div.
96906	Military Standards

SECTION II. PRESCRIBED LOAD ALLOWANCE

(1) FEDERAL STOCK NUMBER	(2) DESCRIPTION  USABLE ON CODE	(3) QTY INC IN UN PK	(4) 15-DAY ORG. MAINT. ALLOWANCE			
			(a)	(b)	(c)	(d)
			1-5	6-20	21-50	51-100
5920-287-8342	FUSE, CARTRIDGE: F02A250V1A; 81349		*	*	2	2
5920-727-1452	FUSE, CARTRIDGE: F03B32V10A; 81349		*	*	2	2
5920-874-5028	FUSE, CARTRIDGE: 2110-0025; 18480		*	2	2	3
6240-155-7836	LAMP, INCANDESCENT: MS25237-327; 96906		*	2	3	5
6240-155-7857	LAMP, INCANDESCENT: MS25237-328; 96906		*	2	3	5
6240-801-5941	LAMP, INCANDESCENT: 328AS10; 71741		*	2	4	8
	LIGHT, INDICATOR: 101-5030-0931; 72619		*	*	*	2

SECTION III. REPAIR PARTS FOR ORGANIZATIONAL MAINTENANCE (CONTINUED)

(1) SMR CODE	(2) FEDERAL STOCK NUMBER	(3) DESCRIPTION	(4) UNIT OF ISSUE	(5) QTY INC IN UNIT PACK	(6) QTY INC IN UNIT	(7) 15-DAY ORGANIZATIONAL MAINTENANCE ALLOW				(8) ILLUSTRATIONS	
						(a) 1-5	(b) 6-20	(c) 21-50	(d) 51-100	(a) FIG NO.	(b) ITEM NO. OR REFERENCE DESIGNATION
A-F-R A001	5821-926-7292	MAINTENANCE KIT ELECTRONIC EQUIPMENT, MK-1004/ARC: (This item is nonexpendable.)									
X2-O A022		TAG, CAUTION: 104826-0001; 65597	ea								
C-O A023		TWINE, NYLON: MILF713; type D, class 2, waxed; 81349	lb		2						
P-O A156	5355-913-9601	KNOB: 60825-2; 65597	ea		3	*	*	*	*		3-2
P-O A163	5355-728-6448	KNOB: 60827-2; 65597	ea		4	*	*	*	*		3-2
P-O A164	5355-727-4064	KNOB: 60831-2; 65597	ea		1	*	*	*	*		3-2
P-O A169	6240-801-5941	LAMP, INCANDESCENT: 328AS10; 71744	ea		3	2	2	4	8		2-1
P-O A170	6240-801-5941	LAMP, INCANDESCENT: SAME AS A169	ea		REF						2-2
P-O A171	6240-801-5941	LAMP, INCANDESCENT: SAME AS A169	ea		REF						2-2
P-O A256	6240-801-5941	LAMP, INCANDESCENT: SAME AS A169	ea		2						3-2
P-O A257	6240-801-5941	LAMP, INCANDESCENT: SAME AS A169	ea		REF						3-2
P-O A370	6240-801-5941	LAMP, INCANDESCENT: SAME AS A169	ea		2						3-2
P-O A371	6240-801-5941	LAMP, INCANDESCENT: SAME AS A169	ea		REF						3-2
P-O A439	5920-280-8342	FUSE, CARTRIDGE: F02A250V1A; 81349	ea		5	*	*	2	2		3-1
P-O A440	5920-727-1452	FUSE, CARTRIDGE: F03E32V10A; 81349	ea		5	*	*	2	2		3-1
P-O A442	5920-804-5028	FUSE, CARTRIDGE: 2110-0026; 28486	ea		10	*	2	4	3		3-1
P-O A443	6240-155-7836	LAMP, INCANDESCENT: MS25237-327; 96906	ea		1	*	2	3	5		3-1
P-O A444	6240-155-7857	LAMP, INCANDESCENT: MS25237-328; 96906	ea		1	*	2	3	5		3-1
P-O A446	5920-280-8342	FUSE, CARTRIDGE: SAME AS A439	ea		1						3-1
P-O A467	5920-727-1452	FUSE, CARTRIDGE: SAME AS A440	ea		2						3-1
P-O A468	5920-727-1452	FUSE, CARTRIDGE: SAME AS A440	ea		REF						3-1
P-O A477	5355-914-1974	KNOB: 60848-1; 65597	ea		1	*	*	*	*		
P-O A480		LIGHT, INDICATOR: 101-5030-0931; 72619	ea		2	*	*	*	2		3-1
P-O A481		LIGHT, INDICATOR: SAME AS A480	ea		REF						3-1
P-O A482	6210-842-1679	LENS, INDICATOR LIGHT: 101-0931; 72619	ea		2	*	*	*	2		3-1
M-O A490		PLATE, IDENTIFICATION: 266022-0002; 65597	ea		1	*	*	*	*		3-1
M-O A562		PLATE, IDENTIFICATION: 267498-002; 65597	ea		1	*	*	*	*		3-1

SECTION IV. INDEX-FEDERAL STOCK NUMBER CROSS REFERENCE  
TO INDEX NUMBER

FEDERAL STOCK NUMBER	INDEX NO.	FEDERAL STOCK NUMBER	INDEX NO.	FEDERAL STOCK NUMBER	INDEX NO.
5355-727-4064	A164				
5355-728-6448	A163				
5355-913-9601	A158				
5355-914-1974	A477				
5821-926-7292	A001				
5920-280-8342	A439				
5920-727-1452	A440				
5920-804-5028	A442				
6210-842-1679	A482				
6240-155-7836	A443				
6240-155-7857	A444				
6240-801-5941	A169				
<u>REF NUMBER</u>	<u>INDEX NUMBER</u>				
101-5930-0931	A480				
266022-0002	A490				
2674 20-0002	A562				

**TM 11-6625-1635-12**

**C1**

By Order of the Secretary of the Army :

Official :

**W. C. WESTMORELAND,**  
*General, United States Army,*  
*Chief of Staff.*

**VERNE L. BOWERS,**  
*Major General, United States Army,*  
*The Adjutant General.*

Distribution :

To be distributed in accordance with DA Form 12-36, Direct and General Support maintenance requirements for O-1A, O-1E, OV-1A, OV-1B, OV-1C, U-1A, U-6A, U-8D, CH-21C, CH-34A, CH-34C, CH-47A, UH-1B, UH-1D, UH-19C, UH-19D, AH-1G and CH-54 aircrafts.

GPO: 1973—527-495





DEPARTMENT OF THE ARMY  
US ARMY AG PUBLICATIONS CENTER  
1655 WOODSON ROAD  
ST. LOUIS, MISSOURI 63114

OFFICIAL BUSINESS  
PENALTY FOR PRIVATE USE, \$300

POSTAGE AND FEES PAID  
DEPARTMENT OF THE ARMY  
DOD 314

**FOURTH CLASS**





This fine document...

Was brought to you by me:



## [Liberated Manuals -- free army and government manuals](#)

Why do I do it? I am tired of sleazy CD-ROM sellers, who take publicly available information, slap “watermarks” and other junk on it, and sell it. Those masters of search engine manipulation make sure that their sites that sell free information, come up first in search engines. They did not create it... They did not even scan it... Why should they get your money? Why are not letting you give those free manuals to your friends?

I am setting this document FREE. This document was made by the US Government and is NOT protected by Copyright. Feel free to share, republish, sell and so on.

I am not asking you for donations, fees or handouts. If you can, please provide a link to [liberatedmanuals.com](http://liberatedmanuals.com), so that free manuals come up first in search engines:

<A HREF=<http://www.liberatedmanuals.com/>>Free Military and Government Manuals</A>

- Sincerely  
Igor Chudov  
<http://igor.chudov.com/>
- [Chicago Machinery Movers](#)