

DEPARTMENT OF THE ARMY TECHNICAL MANUAL

---

OPERATOR, ORGANIZATIONAL, DIRECT SUPPORT,  
GENERAL SUPPORT AND DEPOT MAINTENANCE MANUAL  
ANTENNA SYSTEM,  
QRC-280 (A)

This publication is not available through AG Publication Channels. Requisition through Commander, US Army Security Agency, Materiel Support Command, Vint Hill Farms, Warrenton, VA 22186.



HEADQUARTERS, DEPARTMENT OF THE ARMY

JANUARY 1968

**HANDBOOK OF OPERATING  
AND  
MAINTENANCE INSTRUCTIONS  
FOR  
QRC-280(A) ANTENNA SYSTEM**

**September 1, 1967**

**(Revised January 22, 1968)**

**Contract F30602-67-C-0155**

<b>LIST OF EFFECTIVE PAGES</b>
--------------------------------

TOTAL NUMBER OF PAGES IS 232, AS FOLLOWS:

<i>Page No.</i>	<i>Issue</i>	<i>Page No.</i>	<i>Issue</i>
* Title	22 January 1968	5-48 through 5-60	Original
* A	22 January 1968	* 5-61	22 January 1968
± through v	Original	5-62 through 5-111	Original
* vi	22 January 1968	APPENDIX I	(To be published later)
vii through viii	Original		
1-0	Original		
* 1-1	22 January 1968		
1-2 through 1-3	Original		
* 1-4 through 1-5	22 January 1968		
1-6	Original		
* 1-7 through 1-8	22 January 1968		
1-9	Original		
* 1-10	22 January 1968		
1-11 through 1-15	Original		
* 1-16	22 January 1968		
1-17 through 1-26	Original		
* 1-27	22 January 1968		
1-28 through 1-35	Original		
* 2-1 through 2-2	22 January 1968		
2-3	Original		
* 2-4	22 January 1968		
2-5 through 2-52	Original		
3-1 through 3-2	Original		
* 3-3	22 January 1968		
3-4 through 3-13	Original		
* 4-1	22 January 1968		
4-2 through 4-11	Original		
5-1 through 5-11	Original		
* 5-12	22 January 1968		
5-13 through 5-40	Original		
* 5-41	22 January 1968		
5-42 through 5-43	Original		
Blank			
* 5-45 through 5-47	22 January 1968		

\*The asterisk indicates pages revised, added or deleted by the current change.

## TABLE OF CONTENTS

	Page
<b>SECTION I. GENERAL DESCRIPTION</b>	
1. GENERAL.....	1-1
A. Purpose and Scope of the Manual .....	1-1
B. Purpose of the Equipment .....	1-1
C. Equipment Supplied.....	1-1
(1) Antenna System .....	1-3
(2) Antenna Pedestal .....	1-4
(3) Elevation Drive Assembly .....	1-4
(4) Type I Radome-Platform .....	1-4
(5) Antenna Control Power Supply.....	1-5
(6) Antenna Position Control Indicator .....	1-5
(7) Scope.....	1-5
D. Special Tools and Test Equipment.....	1-6
E. Condensed Data .....	1-6
(1) Equipment Specifications and Operating Characteristics.....	1-6
(2) Special Design Features.....	1-6
2. SYSTEM THEORY OF OPERATION .....	1-10
A. General .....	1-10
B. Antenna Positioning and Drive Circuits .....	1-12
(1) Antenna System Drive Circuits.....	1-12
(2) Manual Mode of Operation .....	1-12
(3) Slave Mode of Operation.....	1-15
(4) Scan Mode of Operation.....	1-16
C. Cable-Wrap Circuits .....	1-19
D. Polarization Diversity Control Circuits .....	1-21
E. Electromechanical Linear Actuator (Beam Broadener) and Indicator Circuits .....	1-21
F. Radome-Platform Circuits.....	1-27
(1) Blower and Control Circuits .....	1-27
(2) Pressure Safety Switches and Indicator Circuits .....	1-27
(3) Deicer Circuits.....	1-31
(4) Utility Circuits .....	1-31
(5) Intercom Circuit.....	1-31

TABLE OF CONTENTS (Cont)

	Page
<b>SECTION II. INSTALLATION</b>	
1. GENERAL .....	2-1
2. INSTALLATION TOOLS AND EQUIPMENT .....	2-1
3. INSTALLATION CONSIDERATIONS AND GENERAL PROCEDURES.....	2-1
A. General .....	3-1
B. Location of the Antenna System .....	2-1
C. Site Preparation and Equipment Unloading.....	2-1
(1) Equipment Unloading and Placement.....	2-3
4. ANTENNA SYSTEM SITE INSTALLATION PROCEDURES .....	2-3
A. General .....	2-3
B. Removal of Transit Cover.....	2-4
C. 80-Foot Tower Installation.....	2-4
D. Portable Stand and Hoisting Unit Installation .....	2-5
E. Assembling the System Inside the Radome .....	2-7
5. CONTROL UNIT INSTALLATION PROCEDURES .....	2-10
A. Antenna Control Power Supply .....	2-10
B. Antenna Position Control Indicator .....	2-10
C. Scope .....	2-10
D. Installation .....	2-10
6. ANTENNA PEDESTAL LEVELING PROCEDURES .....	2-10
7. 80-FOOT TOWER ERECTION PROCEDURES .....	2-12
A. Assembled Tower .....	2-12
B. Erection Equipment .....	2-12
C. Erection Procedure .....	2-12
D. Disassembly of Tower.....	2-39
8. SYSTEM INTERCONNECTIONS.....	2-39
9. BORESIGHTING PROCEDURE.....	2-39
A. Target Installation .....	2-39
B. Check and Adjustment.....	2-45
10. EQUIPMENT RELOCATION .....	2-45

TABLE OF CONTENTS (Cont)

	Page
<b>SECTION III. OPERATION AND ADJUSTMENT</b>	
1. GENERAL .....	3-1
2. RADOME INFLATION .....	3-1
3. ACTIVATING THE EQUIPMENT .....	3-3
A. Initial Switch and Control Settings.....	3-3
(1) Antenna Control Power Supply .....	3-3
(2) Antenna Position Control Indicator .....	3-3
(3) Antenna Pedestal .....	3-3
4. PRE-OPERATIONAL TEST CHECK LIST .....	3-4
A. Initial Turn-On Procedure.....	3-4
(1) Antenna Control Power Supply .....	3-4
(2) Antenna Position Control Indicator .....	3-4
B. Static Accuracy Check.....	3-5
C. Limit Stop Check .....	3-6
D. Sector Scan Check .....	3-7
E. Polarization Control Check .....	3-7
F. Electromechanical Linear Actuator Check.....	3-7
G. Safety Circuit Check .....	3-8
5. SYSTEM ALIGNMENT AND ADJUSTMENT .....	3-8
A. General .....	3-8
B. +24-Volt DC Regulated Adjustment .....	3-8
C. Beam Width Meter Adjustment .....	3-8
D. Cable Wrap Adjustment.....	3-9
E. Sector Scan Adjustment. ....	3-9
6. OPERATING PRECAUTIONS.....	3-10
7. SYSTEM OPERATING PROCEDURES .....	3-11
A. General .....	3-11
B. Manual Mode of Operation .....	3-11
C. Slave Mode of Operation.....	3-11
D. Scan Mode of Operation.....	3-11
E. Polarization Control .....	3-12
F. Beam Width Change .....	3-12
8. STOPPING PROCEDURES .....	3-12

## TABLE OF CONTENTS (Cont)

	Page
<b>SECTION IV. MAINTENANCE</b>	
1. GENERAL .....	4-1
2. PERIODIC INSPECTION AND PREVENTIVE MAINTENANCE.....	4-1
3. TOOL REQUIREMENT .....	4-3
4. TROUBLE ANALYSIS .....	4-3
<b>SECTION V. DESCRIPTION OF COMPONENTS</b>	
1. SYSTEMS DESCRIPTION .....	5-1
A. General .....	5-1
B. Antenna System .....	5-1
(1) Description .....	5-1
(2) Parts List .....	5-6
2. DESCRIPTION OF SYNCHROS .....	5-6
A. General .....	5-6
B. Types of Synchros Used.....	5-6
(1) Synchro Transmitters .....	5-6
(2) Control Transformers .....	5-6
(3) Differential Control Transmitters.....	5-7
C. Synchro Zeroing Procedures.....	5-7
(1) Control and Torque Transmitter.....	5-7
(2) Control Transformer .....	5-8
(3) Differential Control Transmitter .....	5-9
3. ANTENNA .....	5-10
4. ANTENNA VSWR TESTS AND TROUBLESHOOTING.....	5-11
A. VSWR Tests.....	5-11
B. Troubleshooting .....	5-11
5. POLARIZATION UNIT .....	5-11
A. General Description and Theory of Operation .....	5-11
B. Schematic Diagram and Parts List .....	5-15
6. ELECTROMECHANICAL LINEAR ACTUATOR.....	5-15
A. General Description and Theory of Operation .....	5-15
B. Adjustments.....	5-15
C. Wiring Diagram and Parts List .....	5-17

TABLE OF CONTENTS (Cont)

	Page
<b>SECTION V. DESCRIPTION OF COMPONENTS (coat)</b>	
7. ANTENNA PEDESTAL.....	5-17
A. General Description and Theory of Operation .....	5-17
B. Adjustments and Repair.....	5-21
(1) Limit Switch Adjustment .....	5-21
(2) Cable Wrap Adjustment .....	5-25
(3) Electric Brake, Installation and Adjustment.....	5-25
C. Schematic Diagram and Parts List .....	5-27
8. ELEVATION DRIVE ASSEMBLY.....	5-27
A. General Description and Theory of Operation .....	5-27
B. Adjustment and Repair .....	5-27
(1) Limit Switch Adjustment .....	5-27
C. Schematic Diagram and Parts List .....	5-32
9. RADOME-PLATFORM .....	5-32
10. PORTABLE STAND AND HOISTING UNIT.....	5-32
A. Description .....	5-32
B. Parts List .....	5-37
11. ELEVATION DRIVE ASSEMBLY HOIST .....	5-37
A. Description .....	5-37
B. Parts List .....	5-37
12. 80-FOOT TOWER.....	5-37
A. Description .....	5-37
B. Parts List .....	5-37
13. ANTENNA POSITION CONTROL INDICATOR.....	5-37
A. General .....	5-37
B. Theory of Operation.....	5-38
(1) Function of Operating Controls and Indicators.....	5-38
(2) Location and Function of Test Points and Adjustments.....	5-41
(3) Scan Generator Theory of Operation.....	5-41
(4) Control Indicator Transmission Assembly .....	5-47
C. Alignment and Adjustment Procedures .....	5-47
(1) Scan Clutch and Limit Switch Adjustment.....	5-47
D. Schematic Diagram and Parts List .....	5-49



TABLE OF CONTENTS (Cont)

	Page
<b>SECTION V. DESCRIPTION OF COMPONENTS (cont)</b>	
14. ANTENNA CONTROL POWER SUPPLY .....	5-49
A. General .....	5-49
B. Theory of Operation.....	5-49
(1) Function of Operating Controls and Indicators .....	5-53
(2) Location and Function of Test Points and Adjustments.....	5-53
C. Alignment and Adjustment Procedures .....	5-53
D. Schematic Diagram and Parts List .....	5-56
15. DIRECTION FINDING DISPLAY SCOPE .....	5-56
A. General .....	5-56
B. Description of Modifications.....	5-56
C. Modulator Circuit Board .....	5-61
D. Demodulator Circuit Board.....	5-61
E. Writing Gun Relay Driver.....	5-61

APPENDIX I

LIST OF ILLUSTRATIONS

Figure No.	Title	
1-1	Antenna System QRC-280(A), Equipment Supplied.....	1-0
1-2	Antenna System, PS-135-1, Overall Block Diagram .....	1-11
1-3	Antenna Positioning and Drive Circuits, Simplified Schematic Diagram .....	1-13
1-4	Scan Generator, Simplified Block Diagram .....	1-17
1-5	Cable Wrap Circuit, Simplified Schematic Diagram .....	1-20
1-6	Polarization Diversity Circuits, Simplified Schematic Diagram .....	1-23
1-7	Beam Width Control and Indicating Circuits, Simplified Schematic Diagram.....	1-25
1-8	Radome-Platform Blower and Control Circuits, Simplified Schematic Diagram.....	1-28
1-9	Radome-Platform Pressure Safety Switch and Indicator Circuits, Simplified Schematic Diagram .	1-29
1-10	Radome-Platform Deicer Circuit, Simplified Schematic Diagram .....	1-33
1-11	Frequency vs. Feed Position, Typical Chart.....	1-35

## LIST OF ILLUSTRATIONS (Cont)

Figure No.	Title	Page
2-1	Base Plate Installation, Portable Stand and Hoisting Unit.....	2-2
2-2	Portable Stand and Hoisting Unit .....	2-6
2-3	Use of Elevation Hoist .....	2-9
2-4	80-Foot Tower Assembly .....	2-13
2-5	80-Foot Tower Erection Equipment.....	2-20
2-6	80-Foot Tower Erection .....	2-21
2-7	80-Foot Tower Disassembly.....	2-40
2-8	System Interconnection Cabling Diagram .....	2-43
2-9	Antenna System, Stowed Position .....	2-46
5-1	Antenna System, Major Components Location.....	5-2
5-2	Antenna System Assembly, Exploded View .....	5-4
5-3	VSWR Test Setup .....	5-12
5-4	Polarization Diversity Mechanism, Schematic Diagram .....	5-13
5-5	Electromechanical Linear Actuator, Wiring Diagram .....	5-16
5-6	Antenna Pedestal, Major Components Location.....	5-18
5-7	Electric Brake Details.....	5-20
5-8	Schematic, AC Servo Amplifier .....	5-23
5-9	Schematic, Antenna Pedestal .....	5-29
5-10	Elevation Drive Assembly, Major Components Location .....	5-31
5-11	Schematic, Elevation Drive Assembly .....	5-33
5-12	Radome Box, Schematic Diagram .....	5-35
5-13	Control Indicator, Antenna Position, Operating Controls and Indicators.....	5-39
5-14	Control Indicator, Antenna Position, Top View, Location of Adjustments and Test Points.....	5-42
5-15	Control Indicator, Antenna Position, Bottom View, Location of Adjustments and Test Points.....	5-43
5-16	Schematic, Scan Generator.....	5-45
5-17	Antenna Position Control Indicator, Gearing Diagram .....	5-48
5-18	Schematic, Antenna Position Control Indicator .....	5-51
5-19	Power Supply - Antenna Control, Front Panel Controls and Indicators .....	5-54
5-20	Power Supply, Antenna Control, Location of Adjustments and Test Points.....	5-55
5-21	Schematic, Power Supply - Antenna Control.....	5-57
5-22	Scope Modifications Block Diagram.....	5-59
5-23	Scope Wiring Modifications .....	5-60
5-24	Modulator Schematic Diagram.....	5-62
5-25	Demodulator Schematic Diagram .....	5-63
5-26	Writing Gun Relay Driver Schematic Diagram .....	5-65

## LIST OF TABLES

Table No.	Title	Page
1-1	Tabulated List of Equipment Supplied.....	1-1
1-2	Special Tools and Test Equipment.....	1-6
1-3	Equipment Specifications and Operating Characteristics .....	1-8
2-1	80-Foot Tower Erection Equipment.....	2-12
2-2	Cabling Chart.....	2-47
4-1	Periodic Inspection and Preventive Maintenance Schedule .....	4-1
4-2	Trouble Analysis Chart.....	4-4
5-1	Antenna System, Major Components Parts List .....	5-68
5-2	Antenna System, Parts List.....	5-70
5-3	Antenna Pedestal, Parts List.....	5-75
5-4	Azimuth Drive Assembly, Parts List .....	5-81
5-5	Polarization Diversity Mechanism .....	5-84
5-6	Electromechanical Linear Actuator, Parts List .....	5-85
5-7	Elevation Drive Assembly, Parts List .....	5-86
5-8	Portable Stand and Hoist, Parts List.....	5-88
5-9	Elevation Drive Assembly Hoist, Parts List .....	5-89
5-10	80-Foot Tower, Parts List.....	5-91
5-11	Antenna Position Control Indicator, Location and Function of Test Points and Adjustments .....	5-93
5-12	Control Indicator, Antenna Position, Parts List .....	5-94
5-13	Antenna Control Power Supply, Location and Function of Test Points and Adjustments.....	5-103
5-14	Power Supply - Antenna Control, Parts List.....	5-104
5-15	Modulator, Parts List.....	5-106
5-16	Demodulator, Parts List .....	5-108
5-17	Writing Gun Relay Driver, Parts List .....	5-110

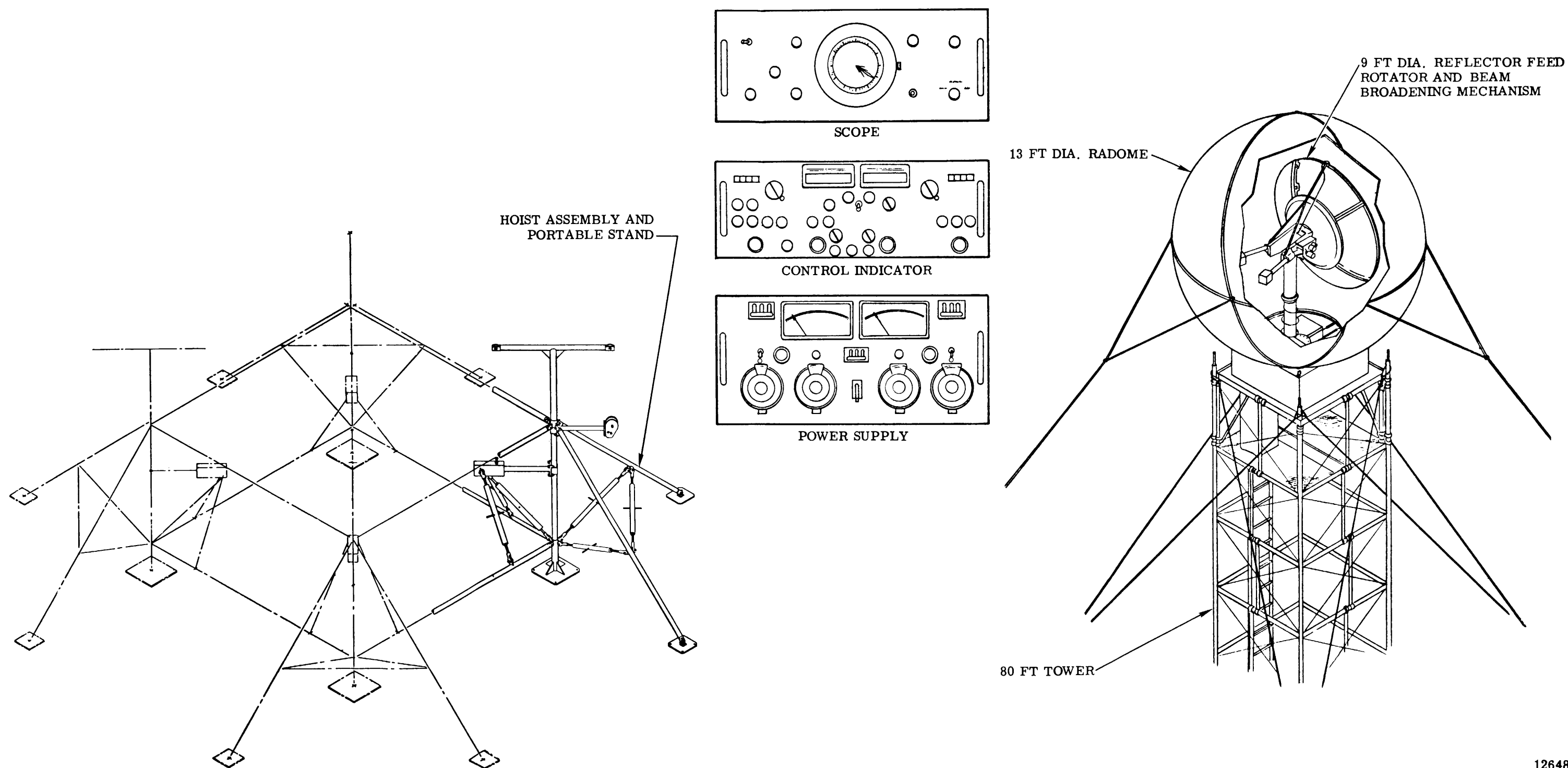

Figure 1-1. Antenna System QRC-280(A), Equipment Supplied.

**SECTION I**  
**GENERAL DESCRIPTION**

**1. GENERAL**

A. **PURPOSE AND SCOPE: OF THE MANUAL** -This handbook contains information concerning the Model QRC-280(A) Antenna System (Figure 1-1), designed and fabricated by the Temec Division of the Systems Group, Canoga Electronics Corporation, Canoga Park, California. Included herein is information relative to description and theory of operation of the Antenna System and complete, concise procedures for system operation, maintenance, installation, and adjustment. The theory and procedures are supplemented by the necessary schematic diagrams, drawings and illustrations, and parts lists.

B. **PURPOSE OF THE EQUIPMENT** - The Antenna System, which consists of a fixed-position communications antenna with azimuth and elevation rotation capabilities, allows an area in space to be searched for a point or points of uhf and microwave radiation. Searching may be accomplished by local manual (operator) control, slave, or automatic sector scanning.

C. **EQUIPMENT SUPPLIED** - The equipment supplied and required for operation of the Antenna System is listed in Table 1-1 and the Antenna System is illustrated in Figure 1-1. A brief description of the Antenna System and the major components therein is contained in the succeeding paragraphs. Major components comprising the Antenna System are discussed in detail in Section V.

**TABLE 1-1. TABULATED LIST OF EQUIPMENT SUPPLIED.**

Nomenclature	Part Number	Qty	Weight (Pounds)	Dimensions (Inches)		
				Height	Width (Dia)	Depth
Reflector, Parabolic 9 - Foot	728901	2	*	---	(108)	---
Antenna, Log-Periodic Dipole Feed	728967	1	*	---	---	---
Polarization Unit	728531-1	2	*	---	---	---
Actuator Electromechanical, Linear	728542	1	*	3.5	17.5	3.5

TABLE 1-1. TABULATED LIST OF EQUIPMENT SUPPLIED (CONT).

Nomenclature	Part Number	Qty	Weight (Pounds)	Dimensions (Inches)		
				Height	Width (Dia)	Depth
Antenna Pedestal	728733-5	1	*	20	(36)	---
Elevation Drive	728910-1	1	*	32	28	18
Support Casting	728599	2	*	---	---	---
Extension, Support Elevation Drive	728574	2	*	---	---	---
Support, Elevation Drive	728619	1	*	---	---	---
Radome-Platform	980200	2	*	---	---	---
Tower, Antenna, 80-Foot	L1686	1	700 (est)	960	86	86
Control Indicator, Antenna Position	728922	1	41	7	19	20.5
Power Supply, Antenna Control	728917	1	51	10.5	19	18
Lightning Rod	728678-3 1		10 (est)	---	---	---
Lightning Rod	728698	1	10 (est)	---	---	---
Hoisting Unit and Stand, Portable	728952	1	300 (est)	---	---	---
Hoist, Elevation	728833	1	25 (est)	72	32	8
Wire Rope Assembly	728680	3	10 (est)	---	---	---
Guy, Radome, 80-Foot Tower	728753	4	300 (est)	---	---	---
Guy, Radome, Ground Installation	728663-3 4		80 (est)	---	---	---
Drive Tool	728685	1	12 (est)	---	---	---

TABLE 1-1. TABULATED LIST OF EQUIPMENT SUPPLIED (CONT).

Nomenclature	Part Number	Qty	Weight (Pounds)	Dimensions (Inches)		
				Height	Width (Dia)	Depth
Ground Rod Assembly	728701	1	10 (est)	---	---	---
Transmitter	Model 122	1	12 (est)	24	(18)	---
DF Display Oscilloscope	728930	1	60	8.71	19	23

\*Total weight 1700 lbs

(1) ANTENNA SYSTEM (See Figure 5-1) - The Antenna System is housed in a 16-foot inflatable radome on a type I platform. It is designed for installation on an 80-foot tower or a portable hoisting stand. The Antenna System consists of a 9-foot fiberglass parabolic reflector fed by a log-periodic dipole feed, an elevation drive assembly with elevation capabilities of from -18 to +98 degrees, an elevation drive support casting, an elevation drive support extension, an antenna pedestal with rotation capabilities of  $\pm 300$  degrees, two level bubbles, an elevation data cable assembly, and r-f cable assemblies.

a. The antenna has a very narrow beam width and requires both azimuth and elevation rotation capabilities in order to scan for, locate and receive r-f radiation from a point, or points, in space. The antenna operates over the frequency range of from 1 to 12 GHz. The antenna is also provided with an electromechanical linear actuator (beam broadener) with a motor-driven mechanism which provides remotely selectable actuation of the linear movement of the feed support shaft relative to the focal point of the reflector. The primary effect of defocusing the feed toward the reflector from the focal point is to increase the phase error across the reflector, broadening the main lobe by several degrees and reducing the gain of the antenna. The antenna is capable of any one of four modes of remotely selected linear polarization: horizontal, vertical, left-hand 45 degrees, or right-hand 45 degrees. Polarization and beam-broadening is controlled from the remotely-located Antenna Position Control Indicator via cabling to the antenna pedestal, the elevation data cable assembly, from the antenna pedestal to the elevation drive, and a cable from the elevation drive to the antenna.

(2) ANTENNA PEDESTAL (See Figure 5-6) - The antenna pedestal used with the Antenna System consists of a cylindrical riser base which houses the azimuth servo drive mechanism, azimuth synchro assembly, azimuth, electric pressure brake, and part of the antenna polarization control unit. The azimuth servo drive mechanism consists of a servoamplifier, an a-c servo motor, and a gear train connected to a vertical tubular shaft, mounted in a precision bearing assembly, which has a mounting flange on top for mounting the antenna mast. An angle scale, graduated from 0 to 360 degrees, attached to the vertical tubular shaft, and an index marker attached to the stable part of the riser base provide a visual indication of the pedestal azimuth rotation, and during installation they allow orientation of the pedestal either to true north or to a selected reference point. A safety switch on the riser base controls operating power to the servo drive. The azimuth synchro assembly contains two synchros which provide control and data outputs for the azimuth axis, a cable-wrap potentiometer, and two electric limit switches. Two mechanical stops in the azimuth drive limit rotation of the pedestal to  $\pm 300$  degrees. The electrical limit switch, which acts as a buffer for the mechanical stops, makes contact approximately 30 degrees before the mechanical stops. The electric brake, which is released only when power is applied to the system, prevents movement of the antenna in azimuth when the system is not operating. A detailed description and theory of operation of the antenna pedestal are contained in Section V of this manual.

(3) ELEVATION DRIVE ASSEMBLY (See Figure 5-10) - The elevation drive assembly, which consists essentially of a yoke assembly, a housing, and a drive motor, supports the antenna and tilts it in elevation. The yoke assembly, a non-rotatable assembly with a stationary drive gear, is bolted to an elevation drive support casting which couples the azimuth drive to the elevation drive. The elevation housing, a U-shaped casting which is bolted to and supports the antenna, is supported through roller bearings in the yoke assembly. The drive motor, when powered, drives the elevation housing around the yoke assembly. An angle scale, graduated from 0 to 360 degrees, affixed to the movable housing, and an index marker affixed to the stable elevation yoke provide a visual indication of the elevation angle of the antenna, and during installation they allow orientation of the antenna to zero-degree elevation. Two mechanical limit stop assemblies prevent movement of the elevation housing below -18 degrees and above +98 degrees. An electrical limit switch, which acts as a buffer for the mechanical stops, makes contact approximately 3 degrees before the mechanical stops. Two synchros provide control and data outputs for the elevation axis. An electric pressure brake, which is released only when power is applied to the system, prevents movement of the antenna in elevation when the system is not operating.

(4) TYPE I RADOME-PLATFORM -

a. The type I radome-platform used with the Antenna System consists of an inflatable radome and a box-type metal construction which serves as the radome base and houses the radome blowers and pressure switches and the Antenna System. The type I platform measures 6 by 6 by 2.58 feet. The radome, when inflated, has a maximum diameter of 16 feet.



b. The radome-platform contains an electric motor-driven blower to inflate the radome, automatic pressure controls to maintain radome pressure within defined limits, pressure limit switches, and deicers. The pressure limit switches interrupt servo drive power to the Antenna System when the radome pressure is below the defined safe limit.

(5) ANTENNA CONTROL POWER SUPPLY (See Figure 5-19) - The Antenna Control Power Supply provided with the Antenna System is capable of supplying power, servo excitation, and azimuth orient correction factors. In addition, the unit provides the controls necessary to control power, pressure, and deicing of the radome-platform. A detailed description of the Antenna Control Power Supply and the controls and indicators thereon is contained in Section V of this manual, paragraph 14.

(6) ANTENNA POSITION CONTROL INDICATOR (See Figure 5-13) -- The Antenna Position Control Indicator is provided with the Antenna System. It contains the controls necessary to control the Antenna System simultaneously in azimuth and elevation and to provide a decimal display of the true azimuth and elevation position of the antenna. Additional controls allow selection of the mode of system operation - scan, manual, or slave. In the scan mode of operation, a scan generator in the unit allows the antenna to scan a predetermined sector in azimuth, within a maximum sector of  $\pm 270$  degrees around the true azimuth zero references. In this mode, the antenna elevation angle is controlled as in the manual mode. In the manual mode, synchros driven by manually operated handwheels on the front panel of the unit provide the control voltages required to position the antenna in azimuth and elevation. In the slave mode, control voltages from a radar or remote antenna system supply the azimuth and elevation positioning control voltages through switches in the unit.

a. Additional controls are provided which allow the polarization of the antenna to be changed and the beam width of the Antenna System to be increased or decreased. A meter is provided which indicates the beam width by percentage of increase from the fixed focal point of the reflector. To attain proper beam-broadening, the meter reading must be set according to the Frequency vs. Feed Position chart provided with the Control Indicator. A typical chart is shown in Figure 1-11. A cable-wrap meter with an "O" center and two red limit markings affords a visual indication of the azimuth cable wrap in the antenna pedestal. A detailed description of the Antenna Position Control Indicator and the controls and indicators thereon is contained in Section V of this manual, paragraph 13.

(7) SCOPE --- The Direction Finding Display Scope is provided with the Antenna System. It is a plotting storage oscilloscope which produces a visible output on the viewing screen corresponding to the antenna pattern signals. The scope is used for determining the azimuth direction of a received signal. A detailed description of the scope is contained in Section V of this manual, paragraph 15, and in Appendix I.

D. SPECIAL TOOLS AND TEST EQUIPMENT - Table 1-2 lists the special tools and test equipment required to install, check out, operate, and maintain the Antenna System.

E. CONDENSED DATA

(1) EQUIPMENT SPECIFICATIONS AND OPERATING CHARACTERISTICS Equipment specifications and operating characteristics are contained in Table 1-3.

(2) SPECIAL DESIGN FEATURES - The special features of the Antenna System are contained in the following paragraphs.

a. Antenna and antenna feeds are designed to provide maximum usable signals that the present state of the art permits. Small sector scanning, about 10 degrees, followed by manual heading of the antenna provides quick, precise location of a source of uhf radiation in space.

b. Use of a-c motors and synchros reduces possibility of generating r-f interference and obviates use of heavy rectifiers.

**TABLE 1-2. SPECIAL TOOLS AND TEST EQUIPMENT.**

Qty	Description	Manufacturer	Part Number
1	Box, Tool	Furnished with System	
1	Hammer, Plastic Head	Furnished with System	
1	Pliers	Furnished with System	
1	Wrench, Adjustable	Furnished with System	
1	Wrench, Open-End, 1-1/8" x 1-1/16"	Furnished with System	
1	Screwdriver, Phillips Head, 8"	Furnished with System	
1	Screwdriver, Slot	Furnished with System	
2	1/2" Drive Extension, 10"	Furnished with System	
1	Wrench Set, Allen, 14-Piece	Furnished with System	
1	Wrench, Open-End, 3/4" x 7/8"	Furnished with System	
1	Wrench, Open-End, 9/16" x 1/2"	Furnished with System	
1	Wrench, Open-End, 5/8" x 3/4"	Furnished with System	

TABLE 1-2. SPECIAL TOOLS AND TEST EQUIPMENT (CONT).

Qty	Description	Manufacturer	Part Number
1	Wrench, Open-End, 3/8" x 7/16"	Furnished with System	
1	Universal Joint, 1/2" Drive	Furnished with System	
1	1-1/8" Socket, 1/2" Drive	Furnished with System	
1	3/4" Socket, 1/2" Drive	Furnished with System	
1	9/16" Socket, 1/2" Drive	Furnished with System	
1	Hammer, Sledge	Furnished with System	
1	Wrench, Allen, 3/8"	Furnished with System	
1	Transit (Surveyors, with Azimuth and Elevation Scales)		
1	Axe, 3-pound (Michigan or Connecticut Pattern)		
2	Shovel, No. 3, Long Handle		
1	Bar, Crow (6-foot approx.)		
1	Bar, Digging and Tamp		
1	Level, Plumb and (carpenter's, 28")		
1	Line, Chalk - Mason's braided, 1000 feet		
2	Bundle (24) Stakes, Locating 1" x 2" x 20" (Pine wood) No.1)		
1	Bundle (24) Stakes, Locating 1" x 2" x 40" (Pine wood) No.1)		
1	Oscilloscope	Tektronix	535
1	Vacuum Tube Voltmeter	Hewlett-Packard or equal	HP-410
1	Signal Generator 450-1230 mc	Hewlett-Packard or equal	HP-612A
1	Signal Generator 1.8-4.0 kmc	Hewlett-Packard or equal	HP-616A
1	Signal Generator 3.8-7.6 kmc	Hewlett-Packard or equal	HP-618B
1	Signal Generator 7.0-11.0 kmc	Hewlett-Packard or equal	HP-620A
1	Signal Generator 10.0-15.5 kmc	Hewlett-Packard or equal	HP-626A

**TABLE 1-2. SPECIAL TOOLS AND TEST EQUIPMENT (CONT).**

Qty	Description	Manufacturer	Part Number
1	VSWR Meter	Hewlett-Packard or equal	HP-415B
1	Coax Slotted Line	Hewlett-Packard or equal	HP-806B
1	Probe Carriage	Hewlett-Packard or equal	HP-809B
1	Slotted Line	Hewlett-Packard or equal	HP-805A
1	Standing Wave Detector	Polytechnic Research and Development	PRD219
1	Calibrated Susceptance	Polytechnic Research and Development	3302-L
1	Detector Mount	Hewlett-Packard or equal	HP-440A
1	Broadband Probe	Hewlett-Packard or equal	HP-442B

**TABLE 1-3. EQUIPMENT SPECIFICATIONS AND OPERATING CHARACTERISTICS.**

<p><u>POWER REQUIREMENTS</u></p> <p>Source: Voltage: Phase: Frequency: Maximum Current:</p> <p><u>Current Required by Major Components</u></p> <p>Antenna System Power Servo Excitation Radome Power Utilities</p>	<p>Commercial or Diesel Generator 120/208 ±10% 3-Phase, 4-Wire, Wye Connected 48 to 62 cps 80 AMP per Phase at 115V</p> <p>20 AMP MAX per phase (3 phase) 10 AMP MAX (single phase) 40 AMP MAX per phase (3 phase) 20 AMP MAX (single phase)</p>
--	--

**TABLE 1-3. EQUIPMENT SPECIFICATIONS AND OPERATING CHARACTERISTICS (CONT)**

<p><u>Wattage Ratings of Major Components</u></p> <p>Service Outlets in Radome Shelter          Azimuth Drive Motor          Elevation Drive Motor          Polarization Unit Motor          Linear Actuator Motor</p> <p><u>Wattage - Heat Dissipation of Major Components</u></p> <p>Power Supply - Antenna Control          Control Indicator - Antenna Position</p> <p><u>ANTENNA CHARACTERISTICS</u></p> <p><u>Antenna</u></p> <p>Operating Frequency Range          Polarization          VSWR</p> <p><u>PEDESTAL AND SERVO SYSTEM CHARACTERISTICS</u></p> <p><u>Servo</u></p> <p><u>Azimuth Travel</u></p> <p><u>Elevation Travel</u></p> <p><u>Angular Rate</u>  <u>Angular Acceleration</u>  <u>Angular Accuracy</u>  <u>Data Output</u></p>	<p>100W Output          25W Output          15W (Estimated)          15W (Estimated)</p> <p>260W (Estimated)          200W (Estimated)</p> <p>1 to 12 GHz          HORIZ, VERT, RH 45°, LH 45°          3:1</p> <p>Type I          ± 270° to Electrical Stops          ± 300° to Mechanical Stops          -15° to +95° to Electrical Stops          -18° to +98° to Mechanical Stops          21° per second          13° to 15° per second per second          ±½° RMS either axis          Azimuth and Elevation, 1-Speed Synchro</p>
---	--

c. Use of one cable-wrap meter for indicating cable wrap on the antenna reduces cable conductor requirements, permits mounting the meter on the same panel with the antenna indicators, and simplifies operator functions.

#### NOTE

**Reference phase current for all synchros must be supplied from a common phase source.**

## 2. SYSTEM THEORY OF OPERATION

A. GENERAL (See Figure 1-2) - The Antenna System is installed in an inflatable radome and has azimuth and elevation rotation capabilities. The Antenna System and associated control units allow an area in space to be searched for a point or points of UHF or microwave radiation throughout the frequency range of from 1 to 12 GHz.

(1) Operation of the Antenna System is possible in three modes - manual, slave or scan. In either of the three modes, positioning of the antenna is controlled by two identical channels, an azimuth channel and an elevation channel, each of which is capable of receiving control voltages from a local or remote source and converting these voltages into azimuth and elevation positioning data. In addition, the azimuth channel may be controlled by voltages originating in a scan generator in the Control Indicator. In the manual mode of operation, the antenna is positioned by a 60-cps control voltage generated by handwheel-driven synchros. In the slave mode of operation, the antenna and counters on the Control Indicator are positioned by a 60-cps control voltage from a remote source. In the scan mode of operation, the antenna scans a predetermined sector in azimuth in response to control voltages generated by the scan generator. In this mode, the elevation positioning circuit functions as in the manual mode.

(2) Synchro outputs, which are proportional to the azimuth and elevation angles of the antenna, with respect to zero-degree azimuth and elevation reference points, are provided by the Antenna System.

(3) The direction of true heading is relative to a furnished reference line and earth stable coordinates. The azimuth orient controls on the Antenna Position Power Supply allow a compensation factor to be set into the system for misorientation of a system to the established references.

(4) Figure 1-2 is an overall block diagram of the QRC-280(A) Antenna System which indicates the major functional components of the Antenna System and the relationship of these components to the control units. The Antenna Control Power Supply provides operating power, servo excitation, and azimuth

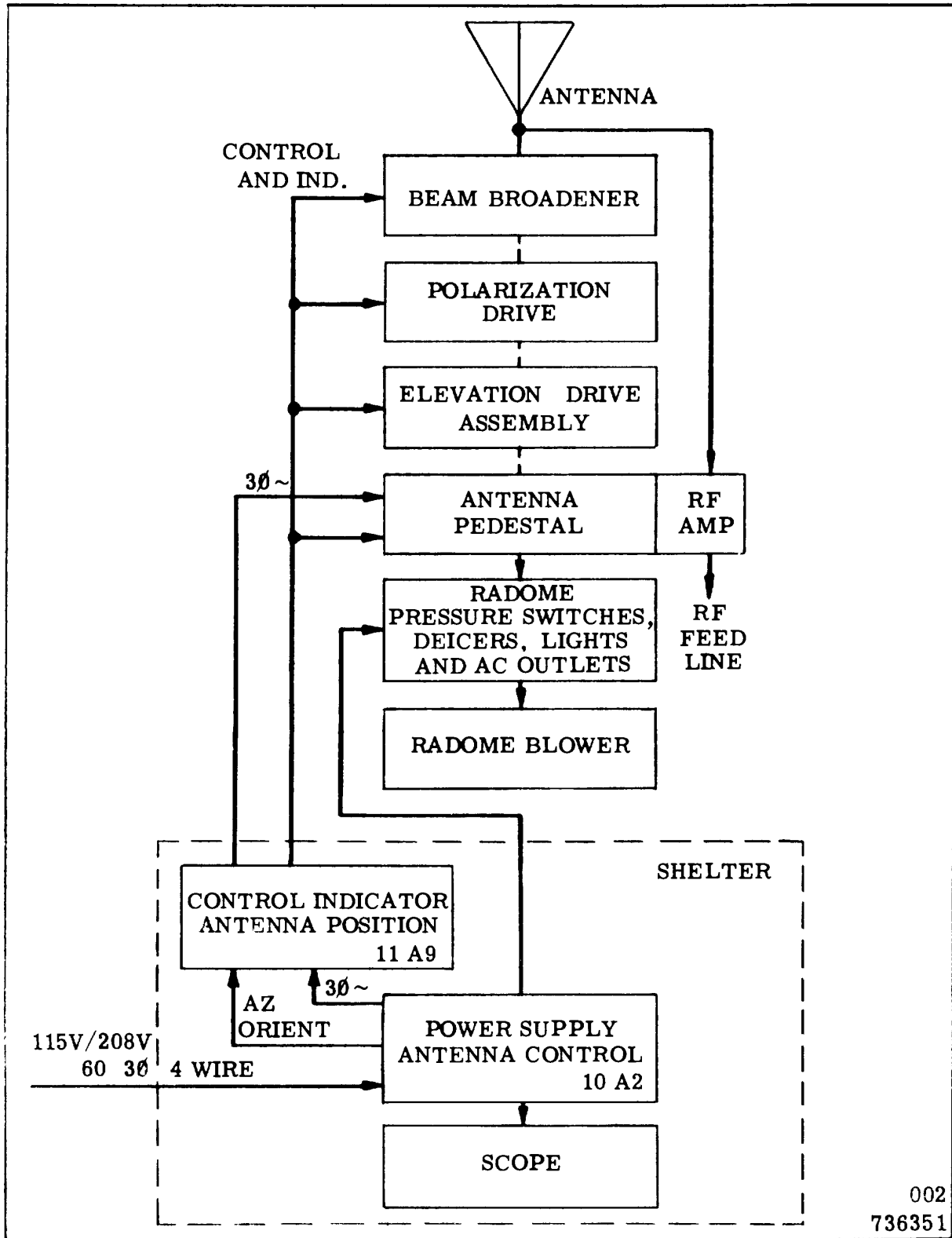

002  
736351

Figure 1-2. Antenna System, PS-135-1, Overall Block Diagram.

orient control for the Antenna Position Control Indicator. The configuration illustrated in Figure 1-2 is the normal operating configuration.

(5) The major functional circuits in the Antenna System are discussed in the succeeding paragraphs. These circuits are the antenna drive and positioning circuits, the cable-wrap circuit, the polarization selection circuits, the beam-broadener circuit, the radome blower, deicer, and safety circuits.

B. ANTENNA POSITIONING AND DRIVE CIRCUITS (See Figure 1-3) - The simplified schematic diagram of Figure 1-3 illustrates the antenna drive and positioning circuits for the Antenna Position Control Indicator with both azimuth and elevation positioning capability, and the power and azimuth orient circuits on the associated Antenna Control Power Supply.

(1) ANTENNA SYSTEM DRIVE CIRCUITS - Drive power is interlocked with a SAFE-RUN switch S1 on the antenna pedestal, the SERVO DRIVE switch S1 on the Control Indicator, and a SAFE PRESSURE switch in the radome. When the switches are in the positions indicated on Figure 1-3 (i. e., the SAFERUN switch in the RUN position and the SERVO DRIVE switch in the ON position), 28-volt DC is applied through the closed circuit to energize relays K2 and K3 in the Power Supply. With K2 and K3 energized, 115-volts AC is applied through the mated contacts of the relays to energize the azimuth and elevation servo amplifiers in the antenna pedestal.

(2) MANUAL MODE OF OPERATION

#### NOTE

**Since the azimuth and elevation channels function the same in the manual mode of operation, only the azimuth channel is discussed herein.**

In the manual mode of operation, the azimuth positioning voltage is generated by rotation of the azimuth handwheel, located on the front panel of the Control Indicator. Mode selection is accomplished by placing the MODE SELECT switch S2 to the MANUAL position. This allows 28-volts DC to be applied to the azimuth handwheel clutch, L1, energizing the clutch and connecting the azimuth handwheel to the manual/scan control transmitter synchro, B3, in the Control Indicator. The stator leads of B3 are connected through other contacts of MODE SELECT switch S2 to the azimuth orient differential control transmitter synchros B1 and B2 in the Power Supply. The differential control transmitters allow a preset factor, which compensates for misorientation of the antenna pedestal to true north or a selected reference point, to be added to the error voltage generated by the manual/scan control transmitter synchro in the Control Indicator. The stator leads of the differential control transmitters are



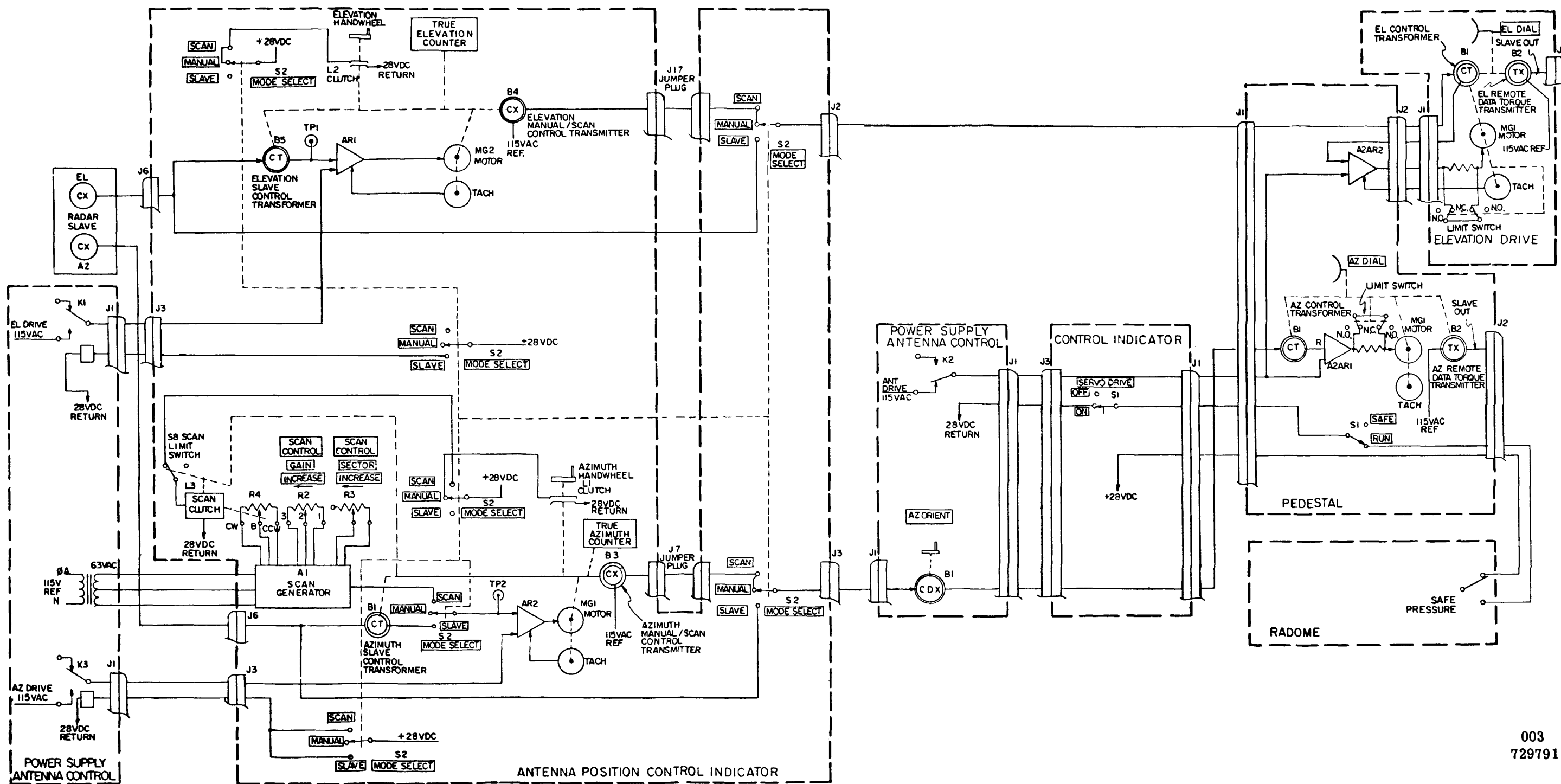

003  
729791

Figure 1-3. Antenna Positioning and Drive Circuits, Simplified Schematic Diagram.

connected to the stator leads of control transformer synchro B1, one in each of the antenna pedestals, which are geared in a 1:1 ratio with the respective azimuth drive assembly. The output of the control transformer is an error voltage, the amplitude of which is proportional to the rotational displacement and the phase of which is a function of the direction of displacement between the shafts of the differential controlled transmitter in the Power Supply and the control transformer in the antenna pedestal. This error voltage is applied to a solid-state servoamplifier in the antenna pedestal. The output of the servoamplifier is an AC voltage which drives servo motor MG1 to reposition the antenna through a gear train, which is also coupled to the rotor of control transformer synchro B1 and remote data torque transmitter synchro B2. Thus, the antenna, and subsequently control transformer B1, is driven in a direction which reduces the error voltage from the control transformer to zero. The limit switch on the output of the azimuth servoamplifier limits the azimuth rotation capabilities of the antenna to  $\pm 270$  degrees. When a limit is engaged, the limit switch opens, causing the current from the servoamplifier to flow through the large load resistor, reducing the amount of drive voltage to MG1. This switch opens 30 degrees before the mechanical stops are engaged and acts as a buffer for the mechanical stops. In elevation, the limit switch functions the same, limiting the elevation capability of the antenna from -15 to +95 degrees, and engages 3 degrees before the mechanical stops.

### (3) SLAVE MODE OF OPERATION

#### NOTE

**Since the azimuth and elevation channels function the same in the slave mode of operation, only the azimuth channel is discussed herein.**

In the slave mode of operation, a 60-cps slave input voltage from a control transmitter synchro in a remote antenna or radar system is applied to the stator leads of the slave control transformer synchro B1 in the Control Indicator and, through contacts of MODE SELECT switch S2, which in this mode is in the SLAVE position, to the azimuth orient differential control transmitter synchros in the power supply. The function of the system from the differential control transmitter synchros through repositioning of the antenna is the same in the slave mode of operation as in the manual mode of operation; however, the slave input from the remote system which is applied to slave control transformer B1 in the Control Indicator is used to drive the true azimuth counter to indicate the position of the antenna pedestal. This is accomplished as follows: The output of slave control transformer B1 in the Control Indicator is an error voltage, the amplitude of which is proportional to the rotational displacement and the phase of which is a function of the direction of displacement between the shaft of the remote master control transmitter synchro in the radar or antenna system and the shaft of control transformer synchro B1 in the Control Indicator.

This output is applied to a servoamplifier AR2 in the Control Indicator which is identical to the servoamplifier in the antenna pedestal. The output of the servoamplifier drives motor MG1 in the Control Indicator, which is coupled through a gear train to the true azimuth counter and to slave control transformer B1. Thus, the slave control transformer B1 is driven to null the error output on its stator leads and the true azimuth counter is driven to indicate the azimuth position of the antenna. Servoamplifier AR2 receives 115-volts AC from relay K3 in the Power Supply, which is energized by 28-volts DC through contacts of the MODE SELECT switch on the Control Indicator.

(4) SCAN MODE OF OPERATION - In the scan mode of operation, the antenna is automatically repositioned in azimuth by a positioning voltage from a scan generator in the Control Indicator. This mode of operation allows any preset sector in azimuth within a maximum sector of  $\pm 270$  degrees, with reference to the system's zero reference point, to be automatically scanned. In this mode, the elevation channel is controlled by the manually operated handwheel on the front panel of the Control Indicator in the same manner as the manual mode of operation.

a. The scan generator circuitry (see Figure 1-4) consists of the scan generator circuit card, the SCAN CONTROL SECTOR potentiometer, R2, and the SCAN CONTROL GAIN potentiometer, R3, on the front panel of the Control Indicator and the antenna position potentiometer, R4, which is coupled through a magnetic clutch to the gear train driven by the azimuth drive motor. Potentiometer R2 controls the width of the sector to be scanned. Potentiometer R3 controls the gain of the error output and, subsequently, the rate at which the sector is scanned. Potentiometer R4 is a continuous rotation potentiometer which is spring loaded to its center position. This potentiometer is connected through a magnetic clutch, L3, when the clutch is energized, to the azimuth gear train in the Control Indicator driven by the drive motor MG1 and follows the gear train from its position when the clutch was energized. When the scan clutch is deenergized, potentiometer R4 returns to its center position through the spring loading action. The output of R4 is, therefore, an analog voltage which is proportional to the azimuth angle of the antenna, relative to the position of the antenna prior to scan clutch engagement. Operation of this circuit is as follows:

b. With the MODE SELECT switch, S2, in the SCAN position, 28-volts DC is applied through scan limit switch S8 to energize scan clutch, L3, connecting potentiometer R4 to the azimuth gear train. The output of R4 is an analog voltage which is proportional to the antenna position around the angle to be scanned. A 2: 1 voltage divider, formed by R6, R9, R11 and R12, is connected between the arm of the potentiometer R4 and SCAN CONTROL SECTOR width potentiometer R2. Differential amplifier A1 senses the voltage difference between the voltage divider and the arm of potentiometer R2. The outputs of A1 are applied to two emitter-follower amplifiers, A2 and A3, which act as a buffer to prevent differential amplifier A4 from loading A1. The outputs of A4

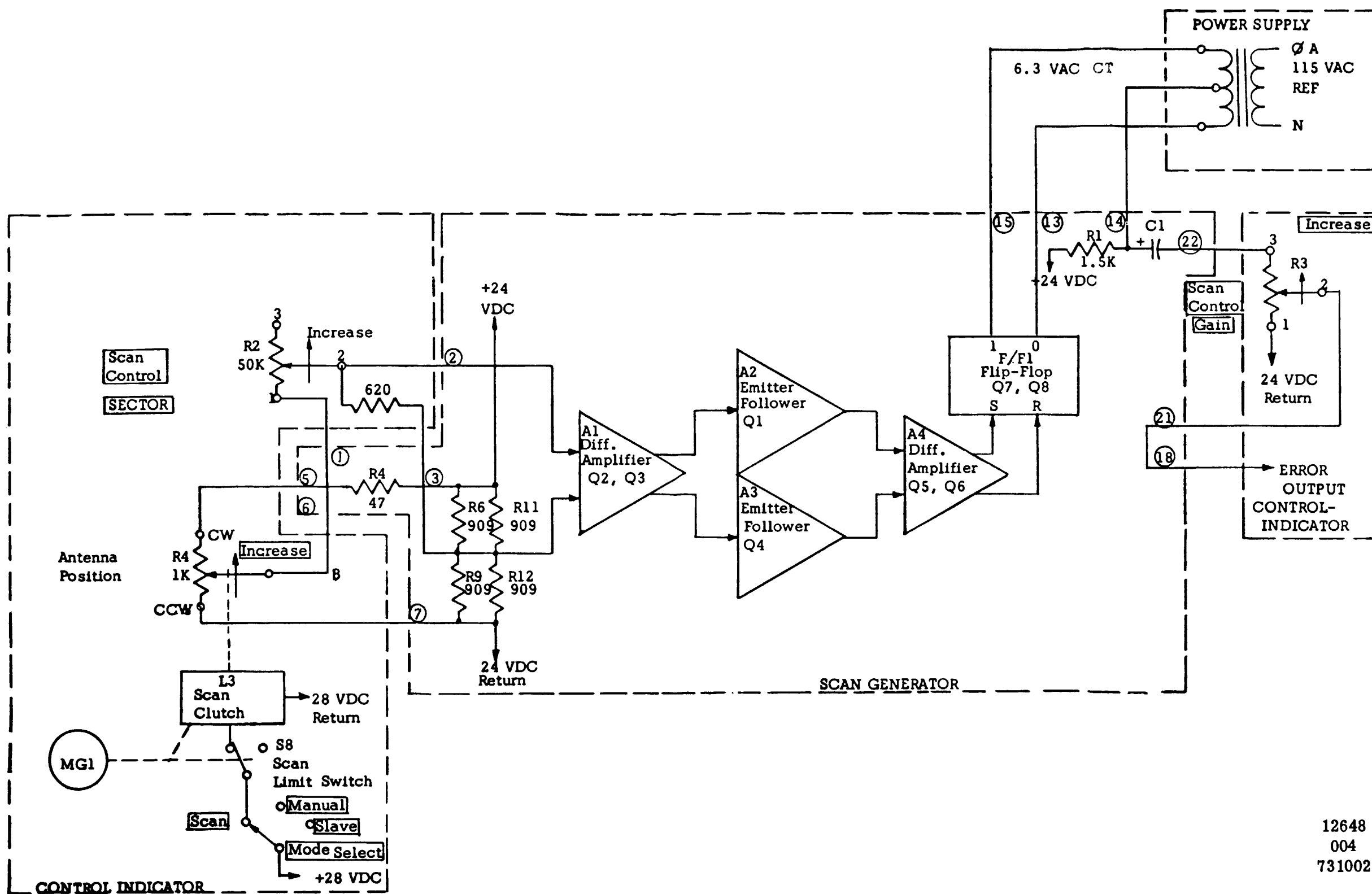
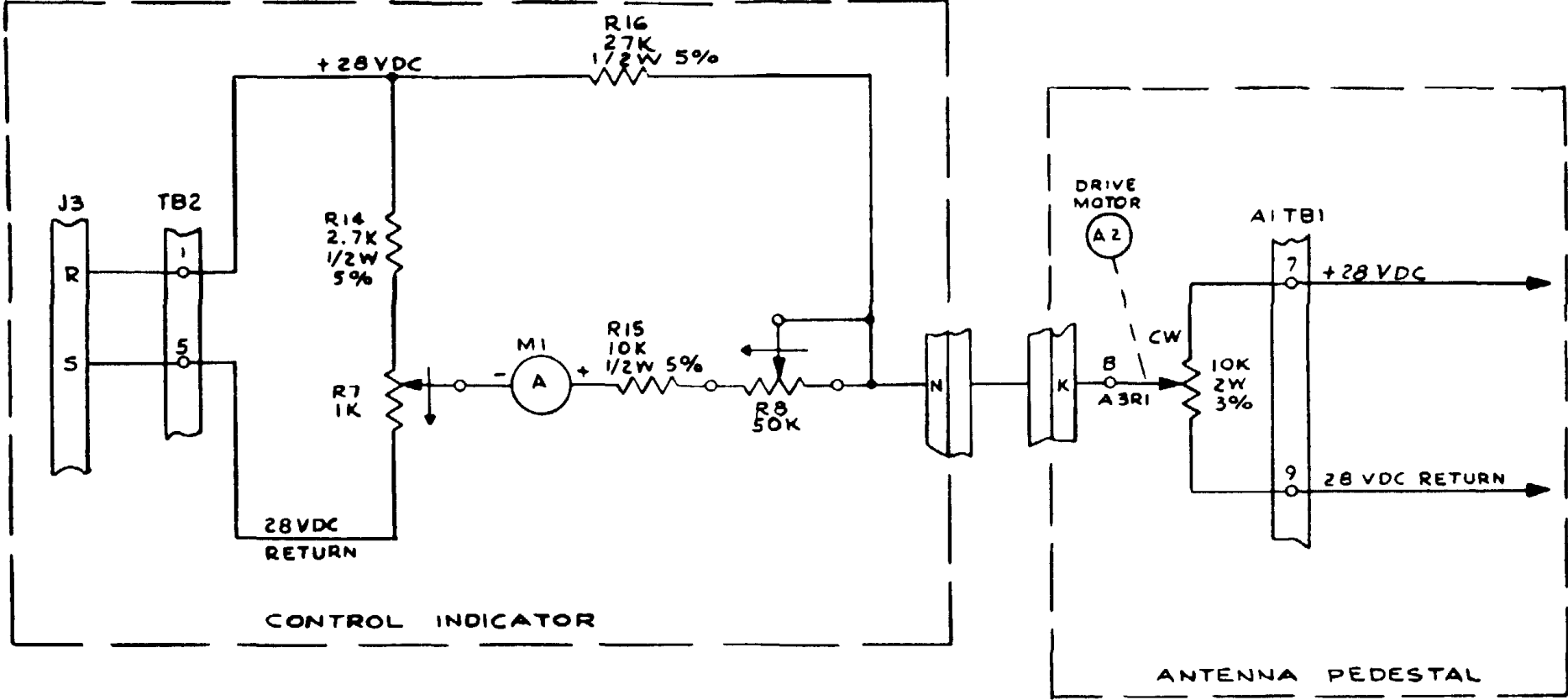

Figure 1-4. Scan Generator, Simplified Block Diagram.

are used to set or reset a flip-flop, depending upon the direction of antenna rotation. When the output is from the ONE side of the flip-flop, one side of a 6. 3-volt transformer winding is connected to ground. When the output is from the ZERO side of the flip-flop, the other winding of the 6. 3-volt transformer is connected to ground. Thus, the voltage at the center tap of the 6. 3-volt transformer will reverse phase when the flip-flop is alternately switched on and off. The voltage from the 6. 3-volt transformer's center tap is AC-coupled by a capacitor C1 to SCAN CONTROL GAIN potentiometer R3. The movable arm of R3 determines the amount of error voltage which is applied to the servoamplifier and, subsequently, the rate at which the antenna scans the predetermined sector. The servoamplifier drives azimuth drive motor MG1 which, in turn, through a gear train, drives the manual/scan control transmitter synchro B3, repositioning the rotor of B3 so that a voltage appears on the stator leads. The system functioning from this point through repositioning of the antenna is essentially the same as in the manual mode of operation. Drive motor MG1 also drives potentiometer R4, through the gear train, in an increasing or decreasing direction depending upon the direction of antenna rotation. When R4 is positioned such that it corresponds to the maximum sector to be scanned, either clockwise or counterclockwise, the flip-flop in the scan generator is either set or reset, depending upon its previous condition, and drives the antenna in the opposite direction. When SCAN CONTROL SECTOR width potentiometer R2 is rotated fully counterclockwise, only a few degrees of movement of potentiometer R4 is required to set or reset the flip-flop. When the potentiometer R2 is rotated clockwise, it requires proportionally larger angles of rotation of the potentiometer R4 to set or reset the flip-flop. Therefore, with potentiometer R2 rotated full counterclockwise, the angle scanned will be small; that is, approximately 10 degrees. With potentiometer R2 rotated full clockwise, the width of the angle scanned increases to the full  $\pm 270$  degrees. The function of scan limit switch S8 is to deenergize the clutch when the scanned angle exceeds  $\pm 270$  degrees to avoid damaging the center positioning spring of potentiometer R4.

C. CABLE-WRAP CIRCUITS (See Figure 1-5) - The cable-wrap circuit consists of: potentiometer A3R1 in the antenna pedestal which is ganged to the azimuth limit switch and geared to the azimuth drive assembly, meter M1, and resistors R8, R15, R7, R14 and R16 in the Control Indicator. The function of this circuit is to indicate the limits of the azimuth cable wrap in either a CW or CCW direction. The cable-wrap meter M1 is essentially a 0- to 50-millimeter with a zero center-scale marking and red markings which indicate the limits of the cable wrap in either a CW or CCW direction at either end. With the antenna positioned at 0 degree, the movable arm of A3R1 is positioned so that the current through M1 is such that the meter is balanced (at zero center scale). As the antenna travels in a CW direction, the current through meter M1 increases, causing the deflection of the meter to increase. As the antenna travels in a CCW direction, the current through meter M1 decreases, causing the deflection of the meter to decrease. CABLE WRAP indicator M1 will indicate the position of the antenna. The cable-wrap meter is adjusted by potentiometers R8 and R7 so



005  
736353

Figure 1-5. Cable Wrap Circuit, Simplified Schematic Diagram.

that the needle of the cable-wrap meter M1 goes into the red area of the scale whenever an electrical limit of  $\pm 270$  is reached.

#### D. POLARIZATION DIVERSITY CONTROL CIRCUITS (See Figure 1-6)

(1) The Antenna System is capable of any one of four modes of linear polarization: left-hand, right-hand, left-hand 45 degrees, or right-hand 45 degrees. The mode is selected by operation of POLARIZATION SELECT switch S6. Refer to Figure 1-6. When the desired mode is reached, all lights except the one for the selected mode will go out.

a. The antenna polarization is selected by a motor-driven Polarization Diversity Mechanism which is mounted by struts on the reflector and supports the antenna feed. This mechanism is controlled by a detent relay in the antenna pedestal which is, in turn, controlled in the aforementioned manner by the controls on the Control Indicator. The motor-driven Polarization Diversity Mechanism shaft, which supports the antenna, has four positions and will drive through 135 degrees of actual rotation. It has stops in positions that are one fourth of this total rotation. There is a dual function of movement which indicates a coarse position of the polarizer, and an indexing movement which operates at four times the polarizer speed and determines a precise motor stop position. When the polarizer motor reaches the limit of travel, a switch controlled by the Geneva mechanism causes a reversing relay to be actuated or deenergized, depending on the direction of rotation. The antenna polarization control then causes the motor to drive in the opposite direction. For example, if the antenna is directed in a horizontal position and the operator desires to drive it to vertical position, the motor will then be driving out of one stop into another stop position. If it is desired to turn it in the reverse direction (for example, to the right-hand circular), the motor drive will drive forward to the limit stop, reverse its direction of rotation, and then return to the newly selected position, which is between vertical and horizontal polarization. Due to the time interval between the fine and the coarse indexing switches on the motor-driven polarizer, it is necessary that the detent relay be operated which, in turn, prevents the reversing relays and the Control Indicator from operating until the motor itself has come to a complete index stop in either direction of rotation. This sequence assures that the polarizer will stop only in the correct polarizing position.

E. ELECTROMECHANICAL LINEAR ACTUATOR (BEAM BROADENER) AND INDICATOR CIRCUITS (See Figure 1-7) - The Antenna System is provided with an electromechanical linear actuator (beam broadener) which consists of a motor-driven mechanism to provide remotely selectable actuation of the linear movement of the antenna feed support shaft relative to the focal point of the reflector. The primary effect of defocusing the antenna feed toward the reflector from the focal point is to increase the phase error across the reflector, broadening the main lobe by several degrees and reducing the gain of the antenna.

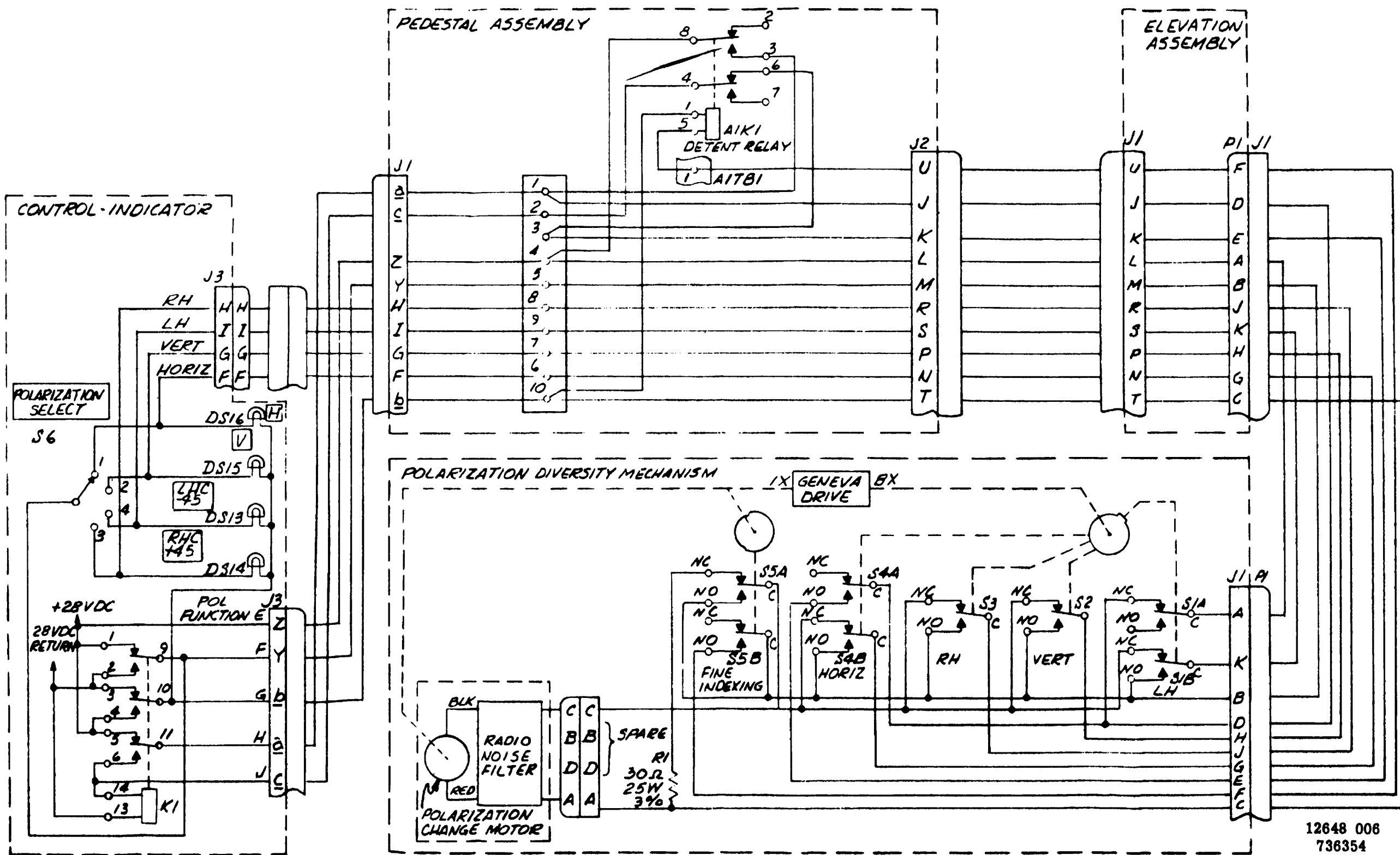

12648 006  
736354

Figure 1-6. Polarization Diversity Circuits, Simplified Schematic Diagram.



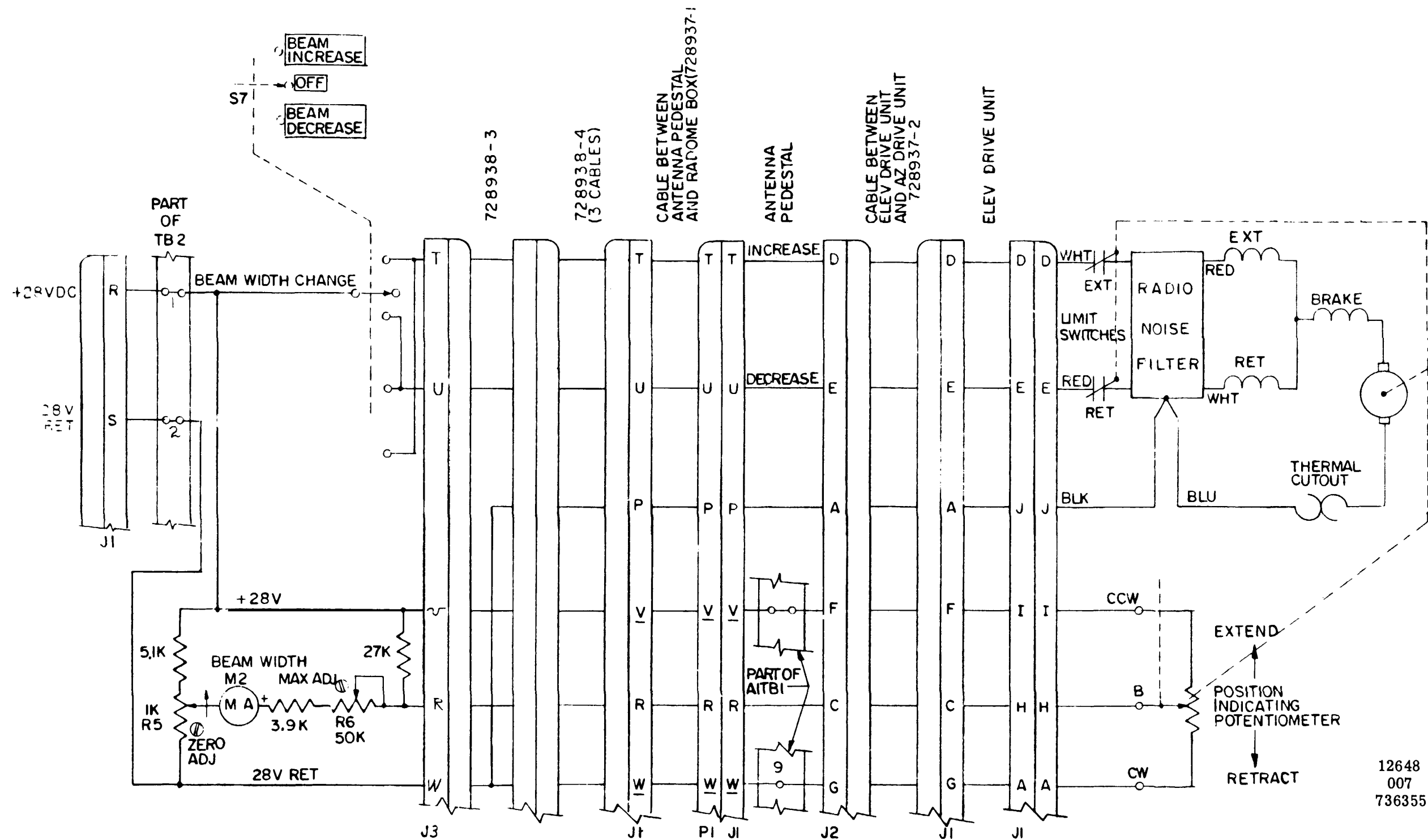

Figure 1-7. Beam Width Control and Indicating Circuits, Simplified Schematic Diagram.

Operation of this defocusing process is controlled by the BEAM INCREASE-BEAM DECREASE switch, S7, on the Control Indicator. Switch S7 is a DPDT switch which applies 28-volts DC to one of the fields of a reversible actuator motor in the electromechanical linear actuator on the antenna. This drives a shaft on the actuator which extends or retracts, depending upon the positioning of S7, the feed on the antenna. Reversing the position of switch S7 reverses the direction of shaft movement.

(1) BEAM WIDTH meter M2 on the Control Indicator, which is essentially a 0- to 50-millimeter graduated from 0 to 100, indicates the position of the antenna feed as a percentage of increase relative to the focal point of the antenna. The position of the pointer on the meter is controlled by a position-indicating potentiometer on the electromechanical linear actuator which is mechanically ganged to the actuator drive motor and adjusting resistors R4 and R6 on the Control Indicator. The normal focal point of the antenna is obtained when the actuator is completely retracted; in this position, the indicating potentiometer is at its further clockwise point and the beam width meter on the Control Indicator indicates zero. As the beam width is defocused, the position-indicating potentiometer rotates in a counterclockwise direction, increasing the current flow through the beam width meter and thus the position of the pointer. Maximum defocusing is obtained when the beam width meter is at 100.

#### F. RADOME-PLATFORM CIRCUITS

(1) BLOWER AND CONTROL CIRCUITS (See Figure 1-8) - The radome-platform blower and control circuits consist of the RADOME POWER circuit breaker, CB1, and the BLOWER switch, S2, on the Antenna Control Power Supply and blower B1, relay K1 and pressure switch S1 in the radome-platform. When the RADOME POWER circuit breaker is operated to the ON position, three-phase AC power is made available to the open contacts of relay K1. When the BLOWER switch is placed to the ON position, relay K1 is energized, allowing the blower to operate.

(2) PRESSURE SAFETY SWITCHES AND INDICATOR CIRCUITS (See Figure 1-9) - The radome-platform pressure safety switch circuits consist of pressure switch S1 in the junction box in the radome-platform, which is in series with the SAFE-RUN switch on the antenna pedestal. This provides two interlocks for the azimuth drive circuit and if either one is inoperative, the antenna will not drive in azimuth or elevation. The pressure switch closes when radome pressure falls below 6 inches of water (approximately 0.22 PSI). Indicator light DS2 on the junction box in the radome-platform indicates when the pressure switch is closed if antenna system power is available in the pedestal. Another indicator light, DS1, also on the junction box, indicates when the pressure switch is open or when any one of the SAFE-RUN switches is in the SAFE position. When pressure switch S1 is operated, +28-volts DC is applied to the PRESSURE SAFE indicator light on the Antenna Control Power Supply.

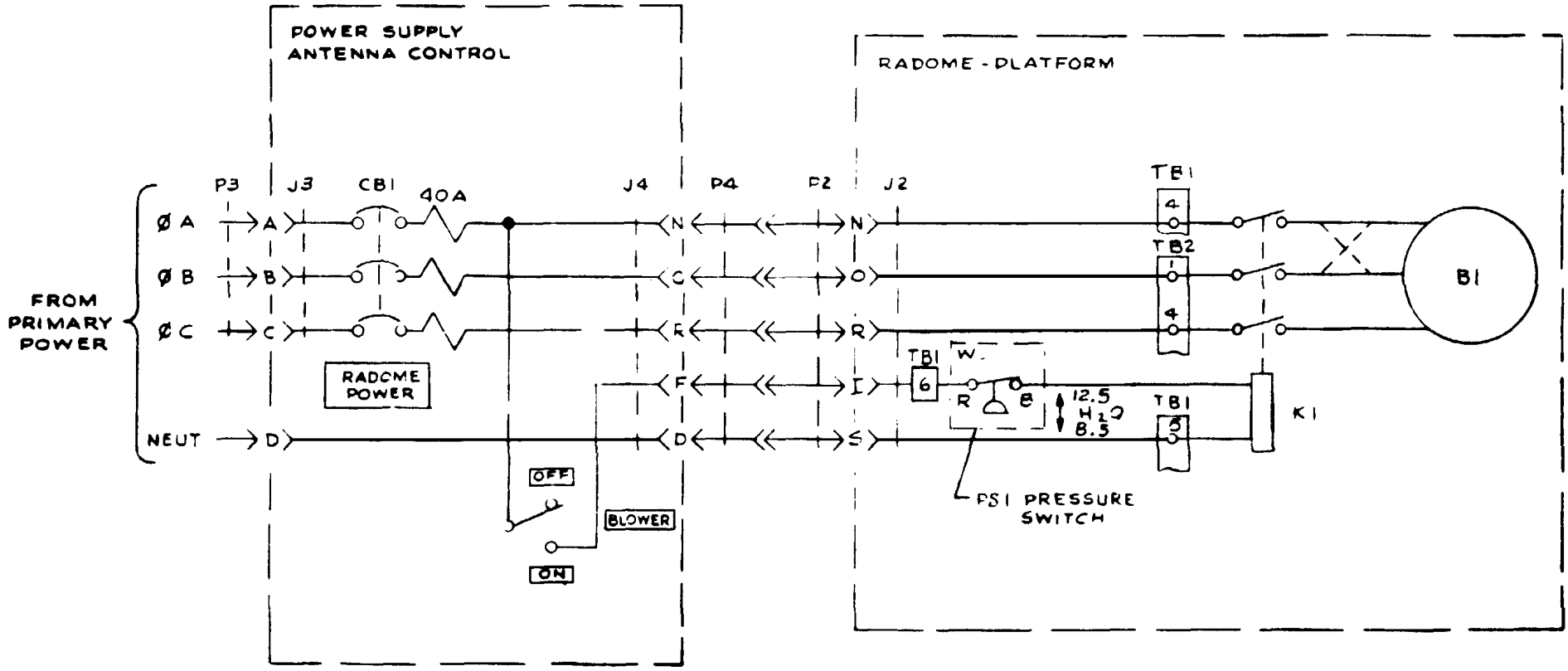

Figure 1-8. Radome-Platform Blower and Control Circuits, Simplified Schematic Diagram.

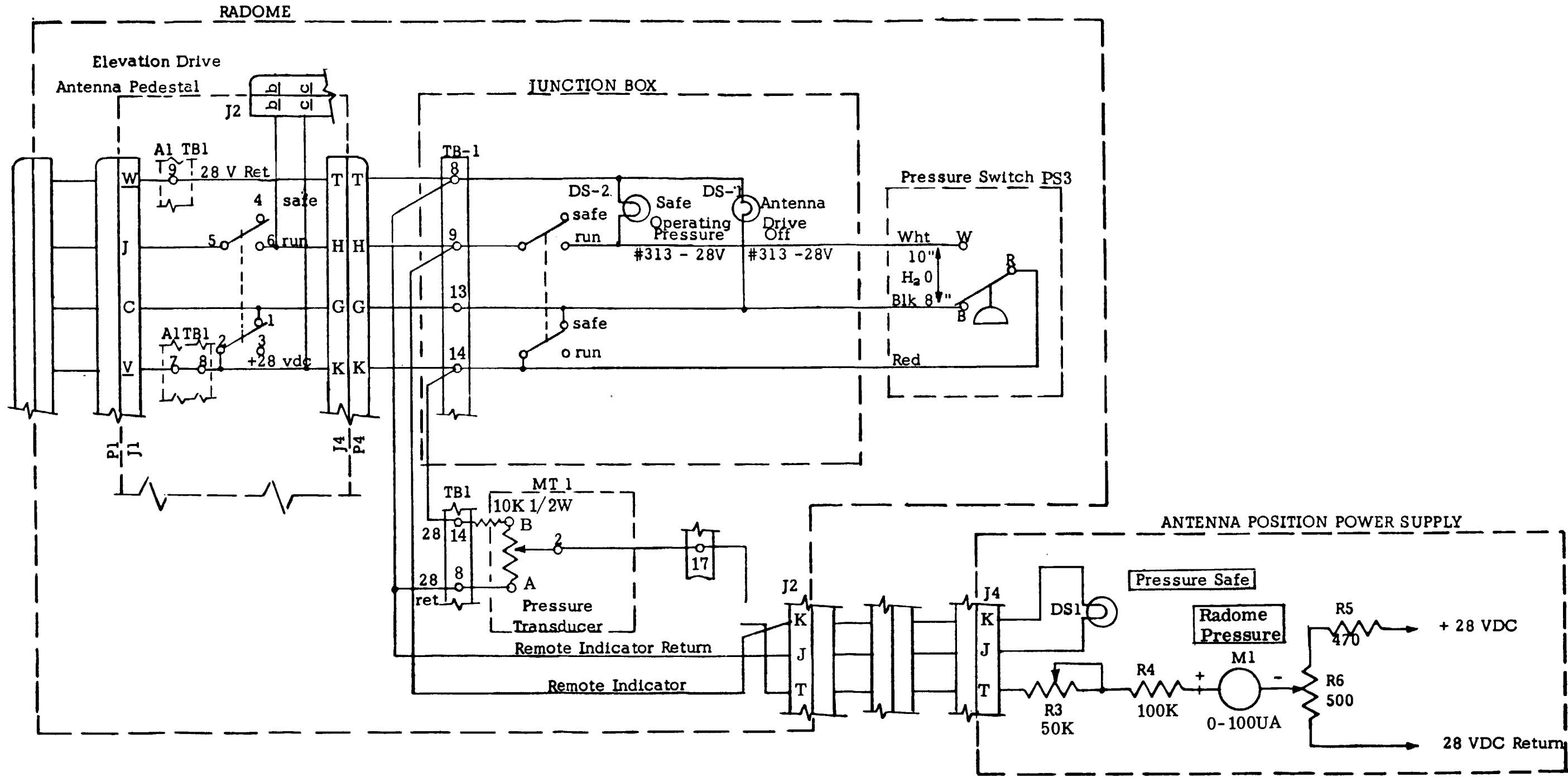

Figure 1-9. Radome-Platform Pressure Safety Switch and Indicator Circuits, Simplified Schematic Diagram.

Illumination of this light indicates that the radome is inflated to a safe pressure. A pressure transducer, MT1, in the radome-platform, which is essentially a variable potentiometer, has its wiper connected through resistors R3 and R4 to a pressure gauge on the Antenna Control Power Supply. The function of this circuit is to indicate the radome pressure in pounds per square inch. The pressure transducer varies its resistance with radome pressure. The pressure gauge is essentially a 0- to 100-microampere, graduated from 0 to 1, representing pounds per square inch from 0 to 1. With zero radome pressure, the movable arm of the pressure transducer is positioned so that there is no current flow through the meter and the needle on the meter is at 0. As radome pressure increases, the current through the meter increases, causing the deflection of the needle on the meter to increase. The pressure gauge is adjusted by potentiometers R3 and R6 so that when radome pressure is zero, the needle is at 0 and when radome pressure is 1 PSI, the needle is at 1.

(3) DEICER CIRCUITS (See Figure 1-10) - The radome-platform deicer circuits consist of RADOME POWER circuit breaker CB1 and the DEICER switch on the Antenna Control Power Supply. When the radome circuit breaker is in the ON position, three-phase AC power is made available to contacts of relay K3 in the radome-platform. The deicer switch on the Power Supply controls operation of relay K3. This switch is in series with pressure switch S4 and temperature switch S5 in the radome-platform. Should radome pressure fall below 9 inches of water (approximately 0.35 PSI) or the temperature in the radome increase to 38 degrees Fahrenheit, the switches will open, automatically shutting off the deicers. Assuming sufficient operating pressure at a temperature below 38 degrees Fahrenheit with the deicer control switch on the Power Supply in the ON position, phase A from the primary power source energizes relay K3, supplying one phase of the primary power source to a bank of three heat lamps.

(4) UTILITY CIRCUITS - The utility circuits in the radome-platform consist of two convenience outlets and a power switch on panel A1 and two work lights. Primary operating power for the utility circuits is obtained through the UTILITIES circuit breaker, CB2, on the Antenna Control Power Supply.

(5) INTERCOM CIRCUIT - The radome-platform intercom circuit consists of head and chest set jack, J14, on the junction box in the radome platform. This jack is connected through the antenna pedestal to a PHONE jack J6 on the Power Supply.

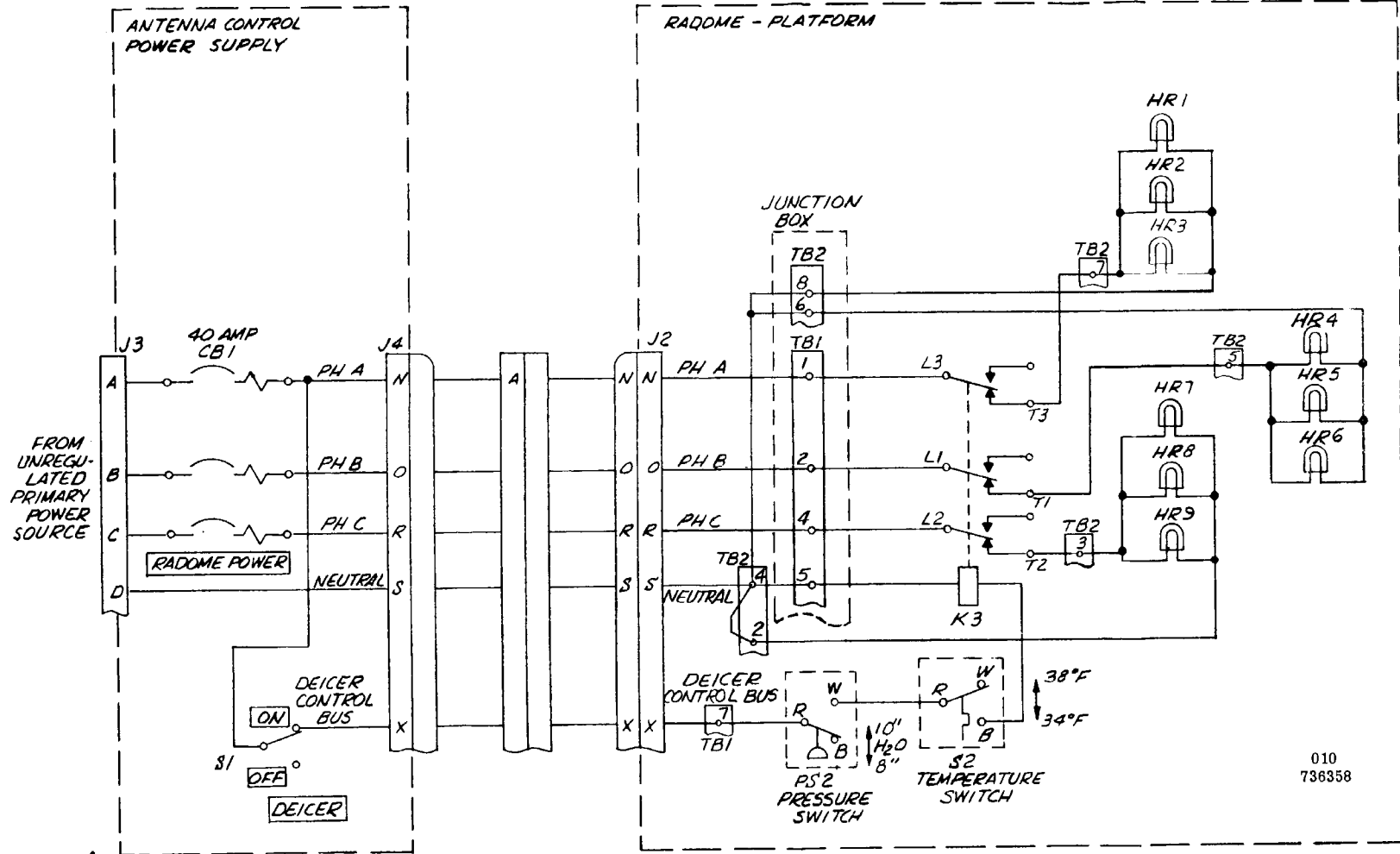

Figure 1-10. Rando-Platform Deicer Circuit, Simplified Schematic diagram

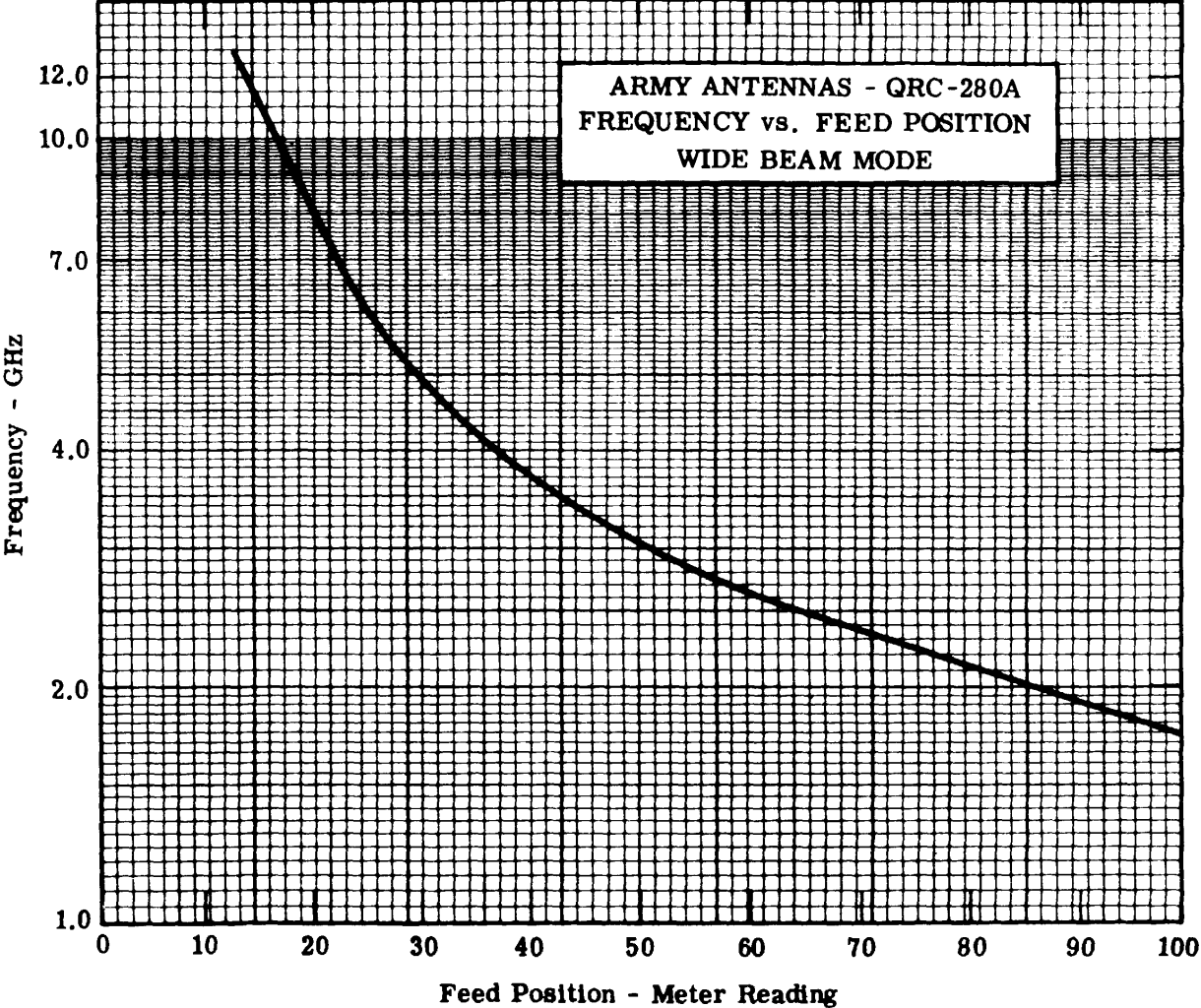

Figure 1-11. Frequency vs. Feed Position (Typical Chart)

## SECTION II

### INSTALLATION

#### 1. GENERAL

This section contains the procedures necessary to assemble the Antenna System into an operating configuration and to install the system at an operating site. Prior to installing the system at an operating site, the siting requirements should be reviewed, an appropriate site chosen, and the details of system layout planned.

#### 2. INSTALLATION TOOLS AND EQUIPMENT

The tools and equipment required for installation of the Antenna System are listed in Table 1-3.

#### 3. INSTALLATION CONSIDERATIONS AND GENERAL PROCEDURES

**A. GENERAL** - Installation of the QRC-280(A) Antenna System requires handling, positioning, and aligning and interconnecting the major components of the Antenna System listed in Table 1-1.

#### NOTE

**Do not remove the radome at any time unless absolutely necessary for maintenance or repair.**

**B. LOCATION OF THE ANTENNA SYSTEM** - Location of the Antenna System is determined by the terrain at the individual site, the chosen arrangement of the Antenna System, and a restricting cable length of 125 feet. The method of installation of the Antenna System is as follows:

- (1) On Top of an 80-Foot Tower
- (2) On a Portable Stand and Hoist Unit

**C. SITE PREPARATION AND EQUIPMENT UNLOADING** - The first prerequisite for unloading the Antenna System is a flat, relatively level area for parking the loaded cargo trailers, with a level area, or area that can be leveled, around them. A 20-foot square area, or 12 small pad areas, should be leveled to accommodate the baseplates and outrigger support tie rod baseplates of the portable stand and hoist assemblies. Figure 2-1 illustrates the layout and the



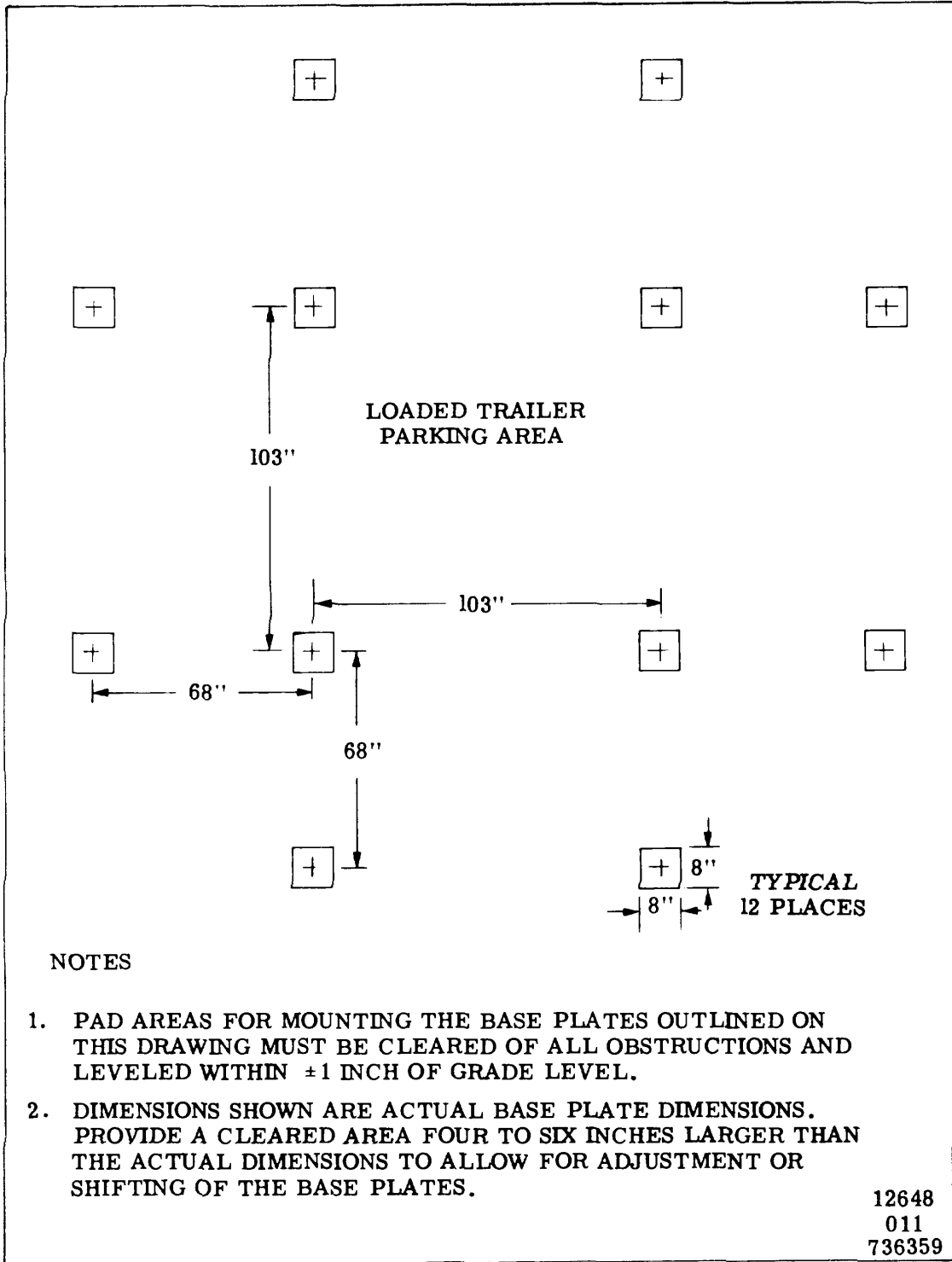

New Figure 2-1. Base Plate Installation, Portable Stand and Hoisting Unit

relative baseplate dimensions. The baseplate areas must be leveled to within one inch relative to each other.

#### NOTE

**Leveling screws are located on each corner of the portable stand which provide approximately one inch of adjustment for each corner of the Radome-Platform mounted thereon. The purpose of these adjustments can be defeated if the Portable Stand baseplate areas are not leveled to within one inch relative to each other prior to assembling the stand.**

**(1) EQUIPMENT UNLOADING AND PLACEMENT** -When the site has been properly staked out and the area leveled for the portable stand and hoisting unit, unload the equipment in accordance with the following procedures.

a. Unload the 80-foot towers and associated equipment.

b. Unload the portable stand and hoisting unit near the point where it will first be used.

c. If the Antenna System is to be installed on the 80-foot tower, park the trailer containing the system near the base of the tower, leaving room to assemble and operate the portable hoisting unit between the trailer and the tower. Position the trailer, relative to the four corners of the tower, so that the Antenna System is approximately oriented to true north or the selected zero reference point.

1. If the Antenna System is to be installed on the portable stand and hoisting unit, park the trailer at the installation site. Position the trailer so that the Antenna System is approximately oriented to true north or the selected zero reference point.

#### **4. ANTENNA SYSTEM SITE INSTALLATION PROCEDURES (See Figure 5-1)**

A. GENERAL - When the Antenna System is shipped from the factory, the antenna pedestal, elevation drive support casting, elevation drive assembly, and the center section of the reflector are installed in the radome-platform. The reflector is stowed in the zenith position and the radome deflated and tucked into the platform. A portable transit cover is installed over the Antenna System while the system is in transit or storage. If, upon receipt of the Antenna System, it is not so assembled, the antenna pedestal, elevation drive support casting, elevation drive assembly, reflector center section, and radome should be installed in accordance with Figure 5-2.

**NOTE**

**When the mounting location for the Antenna System is established, but before the Antenna System is installed, locate the boresight target and survey the boresight azimuth as described in Paragraph 9 of this section.**

**B. REMOVAL OF TRANSIT COVER** - Prior to unloading the Antenna System from the trailer, the transit cover should be removed in accordance with the following procedures. To perform this procedure, the trailer should be approximately level.

- (1) Unsnap top of transit cover and remove.
- (2) Unsnap transit cover sides from radome-platform and remove.
- (3) Install eye bolts in corners of radome-platform.

**CAUTION**

**Care should be exercised when removing the transit cover from the Antenna System to avoid snagging, chafing, or otherwise damaging the radome.**

**C. 80-FOOT TOWER INSTALLATION** - Install the tower as described in paragraph 7 of this section, then proceed as follows:

(1) Park the trailer containing the Antenna System near the base of the tower, leaving room to assemble and operate the portable hoisting unit between the trailer and the tower. Position the trailer relative to the four corners of the selected zero reference point.

(2) Assemble the portable stand and hoisting unit around the Antenna System and lift the system off the trailer in accordance with the procedures set forth in paragraph 4D of this section.

(3) Lower the Antenna System to the ground.

(4) Using rollers, if available, slide the Antenna System under the 80-foot tower to facilitate fastening the 80-foot tower hoist cables to the corner eye bolts on the radome-platform.

(5) Interconnect the Antenna System to the control units as shown in Figure 2-8.

(6) Hoist the Antenna System to the top of the 80-foot tower in accordance with the procedures set forth in paragraph 7 of this section.

(7) Drive the ground rod assembly into the ground with a sledge hammer about 3-1/2 feet from a tower leg until ground wire clamp is just above the ground.

(8) Fasten the ground fitting to the tower leg.

(9) Attach the armored ground wire to the fitting on the tower leg and to the ground rod.

#### NOTE

**When attaching (armored) bare ground wire to a ground rod, remove sufficient armor to double the end of the wire through the ground clamp. Insert the doubled end of the wire through the clamp against the ground rod on the side opposite the clamp set screw. Tighten the ground clamp firmly. After the clamp and wire have set a half hour or more, retighten the set screw.**

(10) Assemble the Antenna System inside the radome in accordance with the procedures set forth in paragraph 4E of this section.

(11) Level the antenna pedestal in accordance with the procedures set forth in paragraph 6 of this section.

**D. PORTABLE STAND AND HOISTING UNIT INSTALLATION** (See Figure 2-2) - The portable hoisting unit should be assembled while the system is still on the trailer. Pad areas should be leveled for the hoisting unit support and outrigger support tie rod baseplates prior to assembly. Then proceed as follows:

(1) Position each winch support leg in a hoisting unit support baseplate and place one assembly at each corner of the type I radome-platform.

(2) Insert the cable assembly on each winch in the hole on the radome platform and adjust the winches until the cable is taut.

(3) Assemble the eight white end tensioning tie rods to the winch support legs.

(4) Assemble the two red end tensioning tie rods to the winch support legs.

(5) Assemble the eight outrigger support tie rods to the winch support legs.

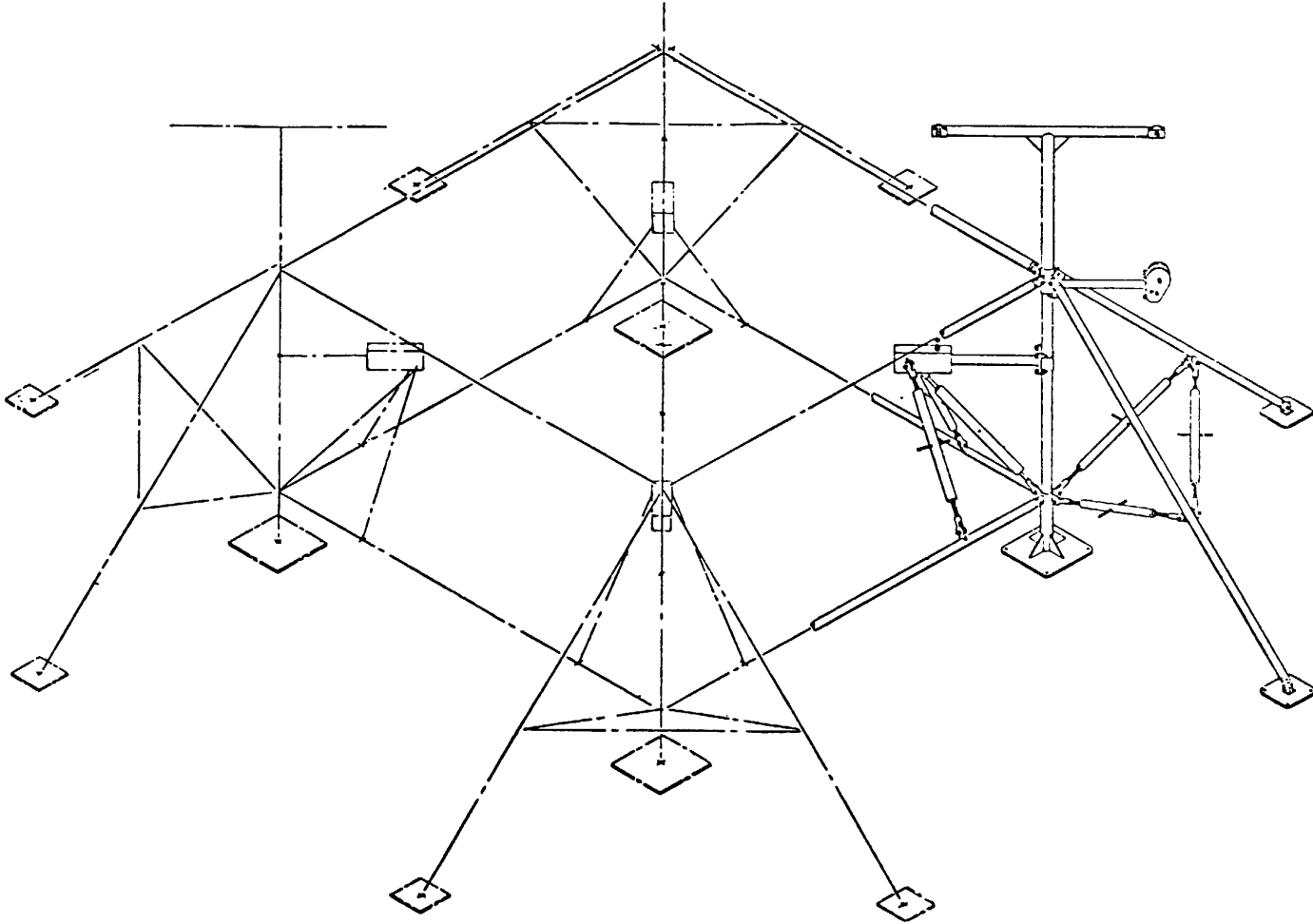

Figure 2-2. Portable Stand and Hoisting Unit

- (6) Assemble the yellow end tensioning tie rods to the two outrigger support tie rods at each corner of the structure.
- (7) Assemble one blue/white end tensioning tie rod between the winch support leg and each outrigger support tie rod.
- (8) Adjust each of the tensioning and outrigger support tie rods until the structure is rigid and level.
- (9) With one man stationed at each of the winches, operate the winches to lift the Antenna System out of the trailer to a height approximately five feet from the ground.
- (10) Remove one of the white end tensioning tie rods and pull the trailer out from under the Antenna System. Replace the tensioning tie rod.
- (11) Lower the Antenna System onto the box supports.
- (12) Fasten the radome-platform to the box supports with the special screws.
- (13) Free that part of the radome that is tucked in the platform.
- (14) Place the radome web strapping over the radome and attach the guy cables (Figure 5-1) to the strapping.
- (15) Interconnect the Antenna System to the control units as shown in Figure 2-7.
- (16) Inflate and guy the radome in accordance with the procedures contained in Section III, paragraph 2, of this manual.
- (17) Assemble the Antenna System inside the radome in accordance with the procedures set forth in paragraph 4E of this section.
- (18) Level the pedestal in accordance with the procedures set forth in paragraph 6 of this section.

**E. ASSEMBLING THE SYSTEM INSIDE THE RADOME (Figure 5-2)**

- (1) When the radome has inflated to a safe pressure, enter the radome.
- (2) Place the SAFE-RUN switch on the antenna pedestal to the SAFE position.
- (3) Move the four outer reflector sections from their stored position on the floor of the platform. Carefully place the section against the side of the radome so that no rough edges are against the radome.

- (4) Remove the counterweights from the elevation drive assembly and place them out of the assembly area.
- (5) Remove the reflector center section from the elevation drive assembly and place it out of the assembly area.
- (6) Install the elevation hoist to the elevation drive support coating in accordance with Figure 2-3, step 2.
- (7) Remove the socket-head cap screws holding the elevation drive assembly in place.
- (8) Raise the elevation drive assembly as illustrated in step 3, Figure 2-3, and install the elevation drive support extension between the drive assembly and the support casting, aligning the red marks as indicated.
- (9) Remove the elevation hoist and reinstall the counterweights and center section of the reflector.
- (10) Assemble the four outer reflector sections to the center section. Orient the sections by mating the numbers on the sections with corresponding numbers on the center section. The sections are fastened to the center section by tee-handle, quick-release pins on the inside flanged edges of the outer sections. The outer sections are fastened together by quarter-turn clasp hook fasteners around the outer rim.
- (11) Attach the three feed support assemblies to the polarization unit. Orient the polarization unit so that the numbers on the unit correspond to the same numbered feed support. Secure the unit in position with the hardware called out on Figure 5-2.
- (12) Prior to installing the log-periodic dipole feed, install the electromechanical linear actuator by mating the guide pin on the polarization unit with the corresponding hole on the actuator and securing in place with the hardware called for in Figure 5-2. Install the feed and cabling in accordance with the procedures contained in steps (14) through (16), mating the guide pin on the actuator with the corresponding hole in the polarization unit.
- (13) Mate the guide pin on the polarization unit with the corresponding hole on the log-periodic dipole feed. Secure the feed to the polarization unit with the hardware called out on Figure 5-2.
- (14) Install the completed assembly to the reflector in accordance with Figure 5-2, orienting the assembly so that the numbers on the support correspond with the numbers on the back of the reflector.

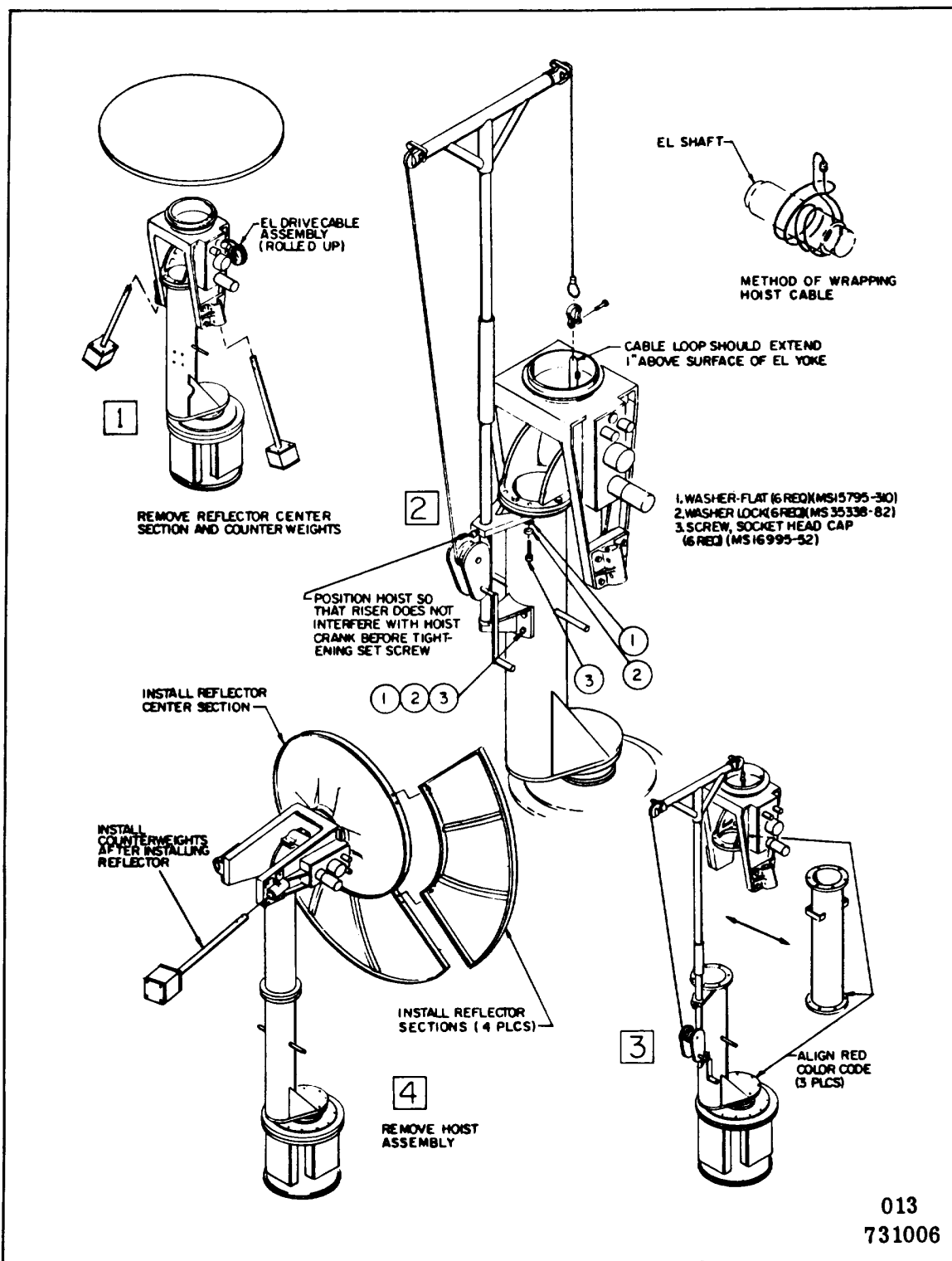

Figure 2-3. Use of Elevation Hoist



(15) Install the elevation data cable from receptacle connector J2 on the antenna pedestal to the connector on the elevation drive assembly. Wrap the cable around the elevation drive support casting and extension as illustrated in Figure 5-2. Secure the cable to the support casting with a cable clamp and associated hardware.

(16) Install the cable from the elevation drive assembly to the polarization unit. Secure the cable to the feed support assembly with the furnished spiral wrap.

(17) Install the rf cables to the log-periodic dipole feed. Secure the cable to feed support assembly with the furnished spiral wrap.

## 5. CONTROL UNIT INSTALLATION PROCEDURES

**A. ANTENNA CONTROL POWER SUPPLY** - The Antenna Control Power Supply is a 10-1/2-inch high, standard 19-inch wide, panel-mounted unit. The chassis extends 19 inches behind the panels and is slide mounted. The slides extend 22-5/16 inches behind the panel so that overall depth of the assembly is 24 inches. The Antenna Control Power Supply weighs about 65 pounds.

**B. ANTENNA POSITION CONTROL INDICATOR** - The Antenna Position Control Indicator is a seven-inch high, standard 19-inch wide, panel-mounted unit. The chassis extends about 22 inches behind the panels and is slide mounted. The control indicator slides extend 22-5/16 inches behind the panel so the overall depth is 24 inches. The Antenna Position Control Indicator weighs about 40 pounds.

**C. SCOPE** - (Data to be supplied later) **D. INSTALLATION** - Installation of the units consists of engaging the slides, in the proper position, with the chassis tracks in the furnished racks and sliding them into place. The panel and chassis assemblies are held in place with standard type, number 10-32 thread, knurled and slotted head captive screws.

Interconnect the units to the systems as shown in Figure 2-7.

## 6. ANTENNA PEDESTAL LEVELING PROCEDURES

A. When the antenna pedestal is completely installed, level the pedestal in accordance with the following procedures:

### NOTE

Unless otherwise specified, the figure references contained in the following steps are in reference to Figure 5-7.

- (1) Loosen the pedestal-to-riser base mounting bolts (four required).
- (2) Observe the position of the bubble in one of the level bubbles located on top of the antenna mast mounting flange on the elevation drive support assembly.
- (3) Rotate the antenna mast mounting plate 180 degrees in azimuth and again observe the position of the bubble.
- (3). (4) Adjust one pair of opposing leveling screws to take out half of the error observed between steps (2) and (3).
- (5) Rotate the antenna mast mounting plate 180 degrees in azimuth and repeat step (4).
- (6) Repeat step (4) until the level bubble indicates that the pedestal is level at these two positions.
- (7) Observe the position of the bubble in the second level bubble.
- (8) Repeat steps (3) through (6) for the second level.
- (9) When the second level bubble indicates that the pedestal is level at these two positions, observe the first level bubble. Minor adjustments of the leveling screws for each level bubble may be necessary to assure that the pedestal is level at any position on the azimuth axis.
- (10) When leveling is complete, tighten the pedestal-to-riser base bolts loosened in step (1).
- (11) Pedestal Alignment - The servoamplifier has two potentiometers found by removing amplifier cover. After entire system is aligned, set these two potentiometers (tach feedback and servo gain) at mid-range and turn on servo drive. Then proceed as follows:
  - a. Push antenna off null and observe as it returns to null.
  - b. Increase servo gain until antenna hunts, then reduce gain until antenna returns to null without excessive hunting.
  - c. If antenna responds sluggishly, increase gain and stop hunting by increasing tach feedback.
  - d. If when handwheel control is moved smoothly, antenna follows raggedly, reduce tach feedback and servo gain to stop hunting.

**NOTE**

**Servo gain and tach feedback are interactive controls. Many adjustment settings will work, but there is only one optimum setting, which can be found only after experimentation in the above mentioned manner.**

(12) Boresighting - Complete boresighting procedure as described in paragraph 9 of this section.

**7. 80-FOOT TOWER ERECTION PROCEDURES**

**A. ASSEMBLED TOWER** - The assembled 80-foot tower is shown in Figure 2-4. Table 5-10 identifies the component parts of the 80-foot tower.

**B. ERECTION EQUIPMENT** - An erection davit, platform, and associated tackle is required for erection of the 80-foot tower. This equipment is illustrated in Figure 2-5 and listed in Table 2-1.

**TABLE 2-1. 80-FOOT TOWER ERECTION EQUIPMENT**

Part NO.	Description	Qty Required
L-1686-20	Erection Davit	1
L-1686-21	Hoist Line, 380-Foot	1
L-1686-22	Erection Platform	2
2123	Tag Line, 140-Foot	2
651	Ratchet Wrench With Socket	2
2150	Tensiometer	4
2163	Tensiometer Case	4
2234	Digging Bar	1

**C. ERECTION PROCEDURE** - Refer to Figure 2-6, sheets 1 through 18, for detailed illustrated procedures for erection of the 80-foot tower.

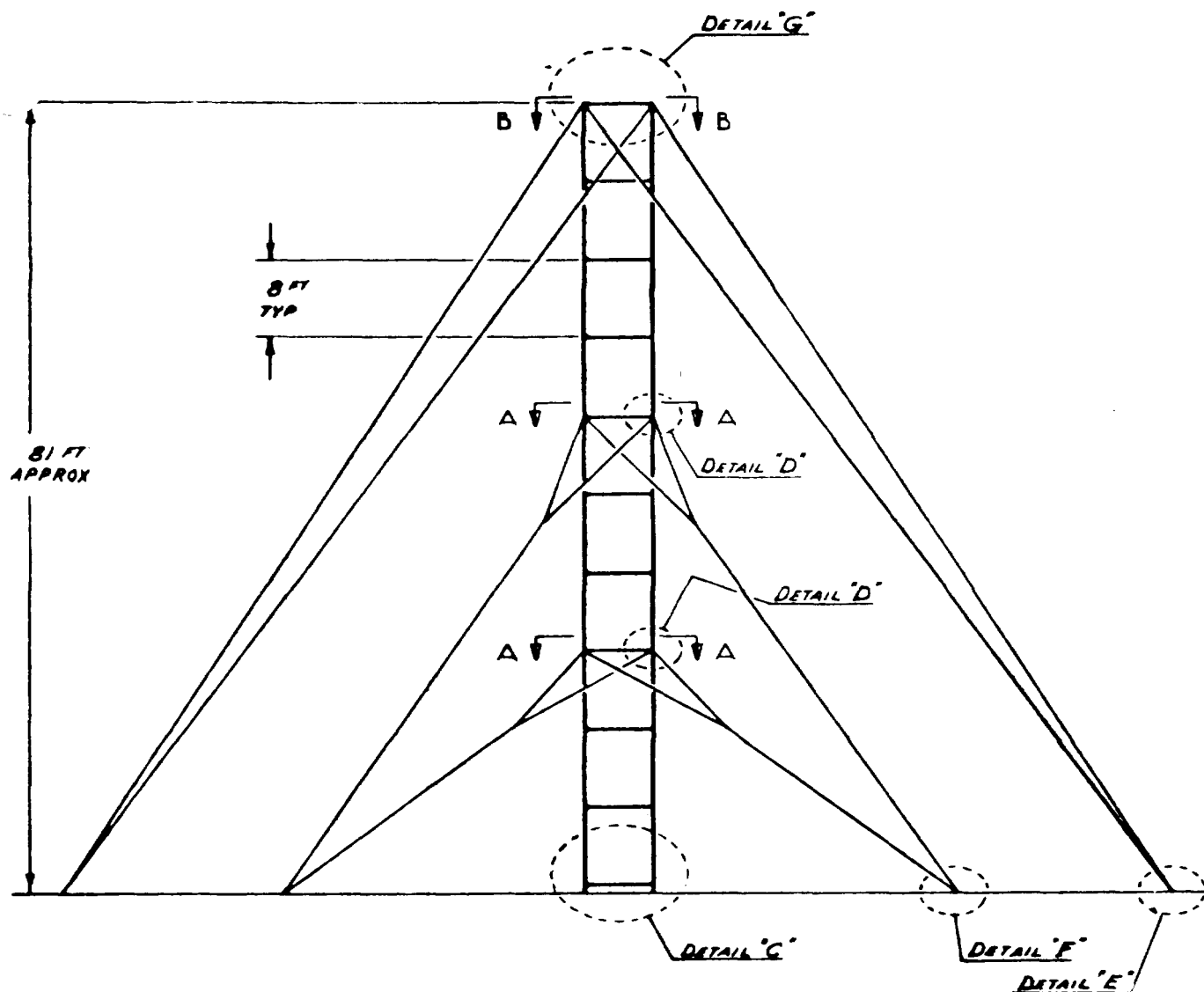

FOLLOWING PARTS ARE ALSO REQUIRED BUT ARE NOT SHOWN.

PART NO.	DESCRIPTION	REQD
2150	TENSIOMETER	4
2234	DIGGING BAR	1
L-1686-18	NYLON ROPE ASSY	1
L-1686-19	NYLON ROPE ASSY	1
L-1686-7	HORIZ CABLE BRACE	18

Figure 2-4. 80-Foot Tower Assembly, Sheet 1 of 7

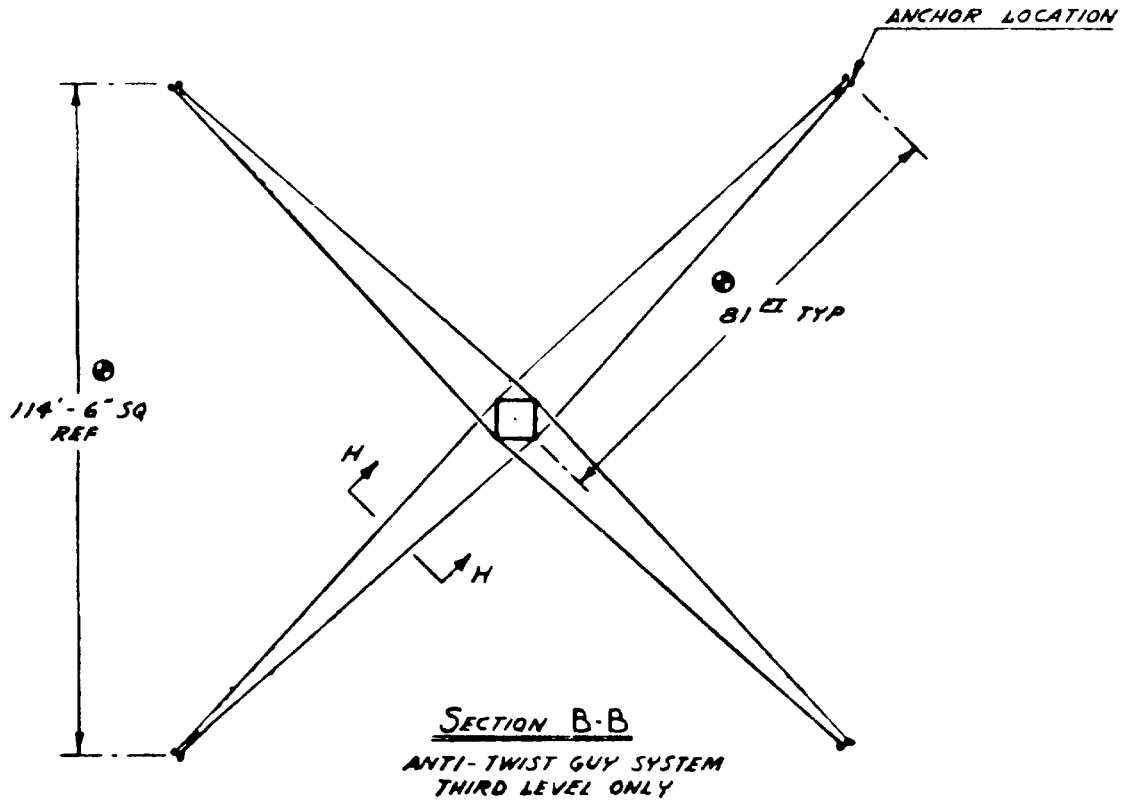
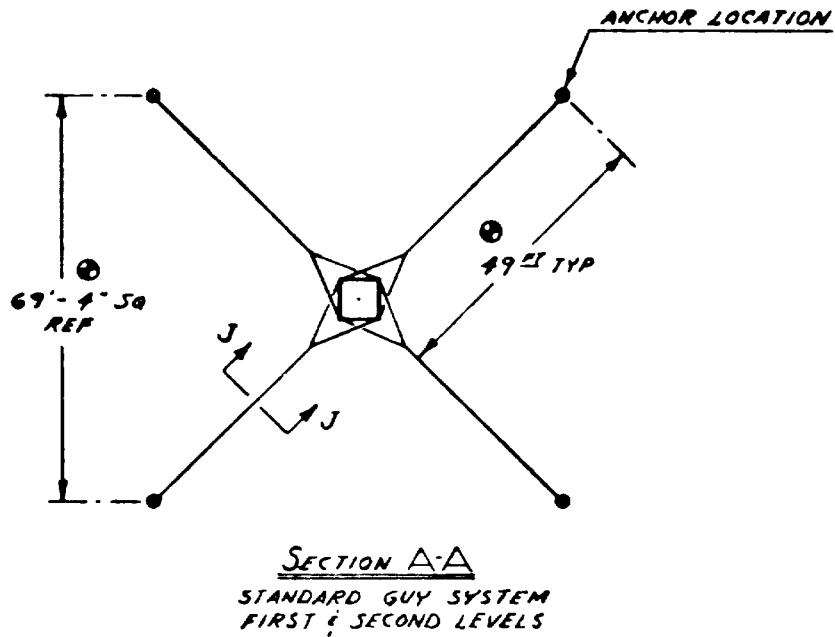

⊕ DIMENSIONS MARKED AS SHOWN ARE TRUE ONLY IF TOWER IS LOCATED ON A LEVEL SITE, OTHERWISE THE ANGLES SHOWN IN VIEWS J AND H WILL DETERMINE THE ANCHOR LOCATIONS.

Figure 2-4. 80-Foot Tower Assembly, Sheet 2 of 7

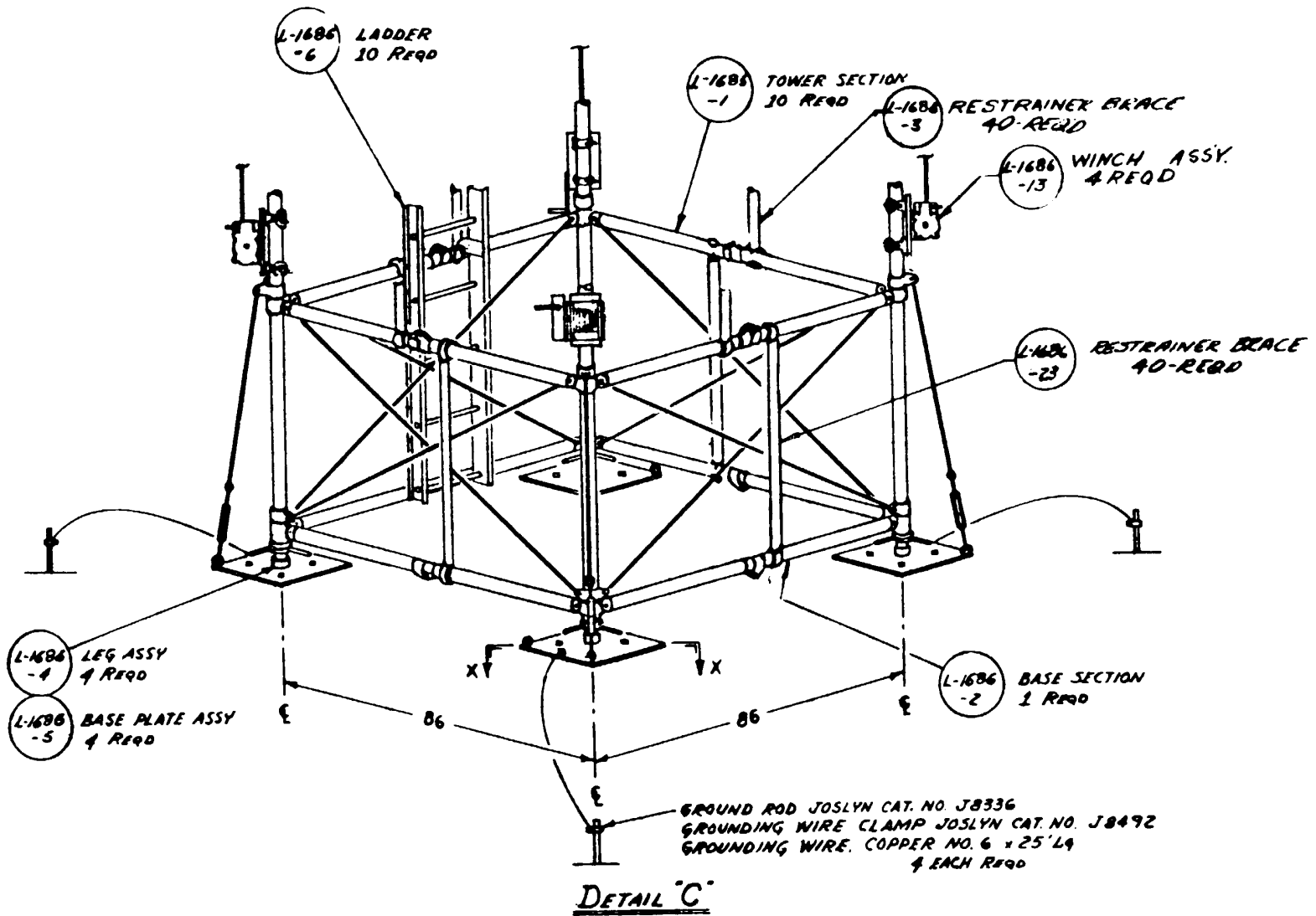
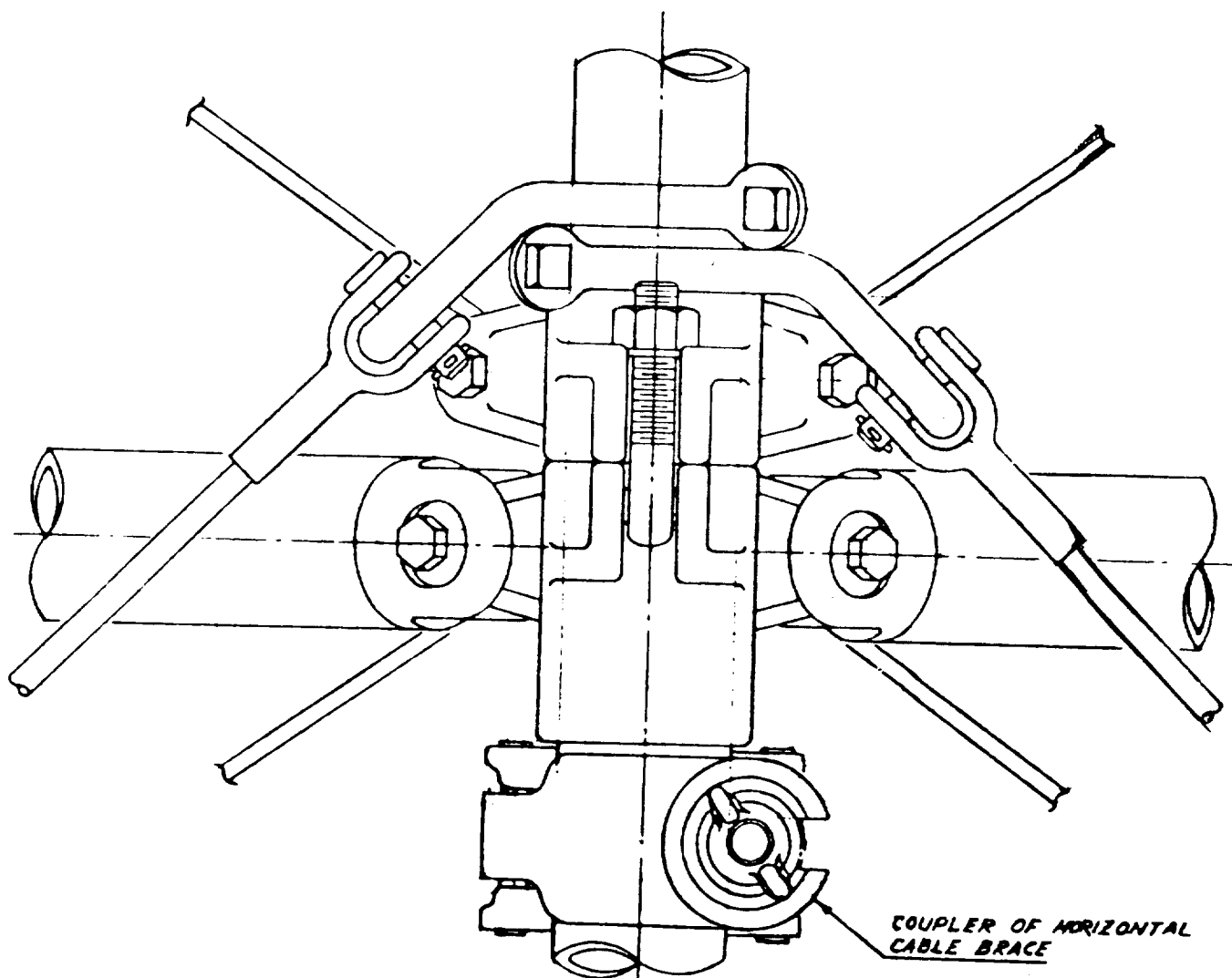

Figure 2-4. 80-Foot Tower Assembly, Sheet 3 of 7



DETAIL D  
TYPICAL GUY ATTACHMENT

Figure 2-4. 80-Foot Tower Assembly, Sheet 4 of 7

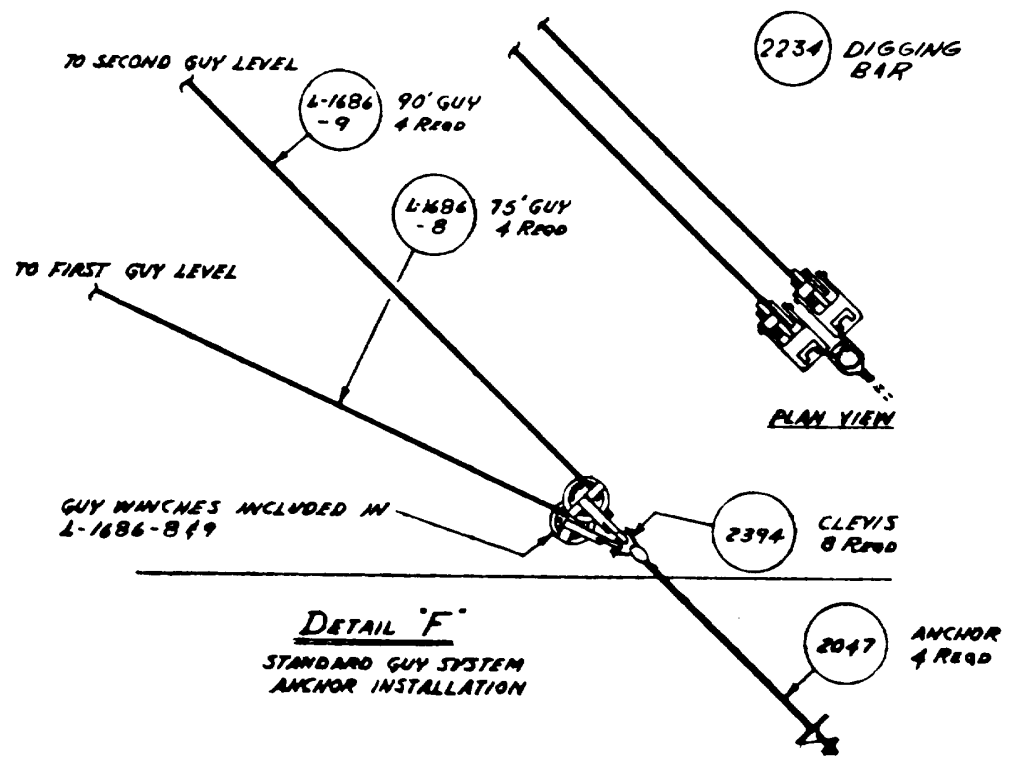
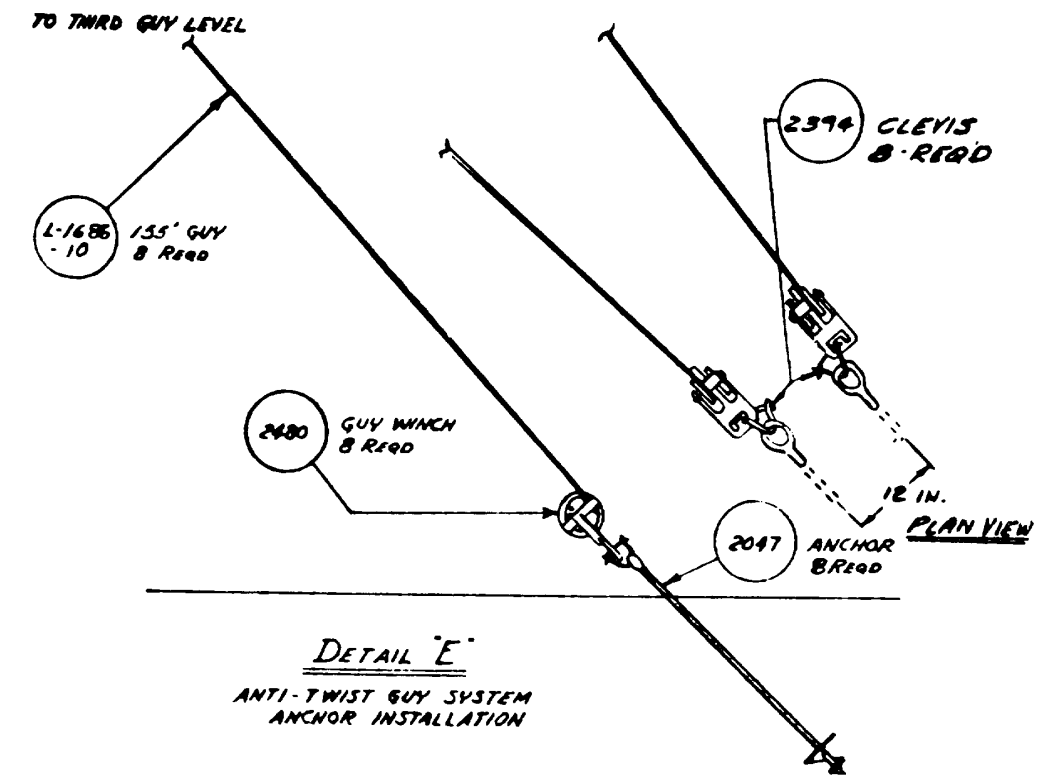

Figure 2-4. 80-Foot Tower Assembly, Sheet 5 of 7



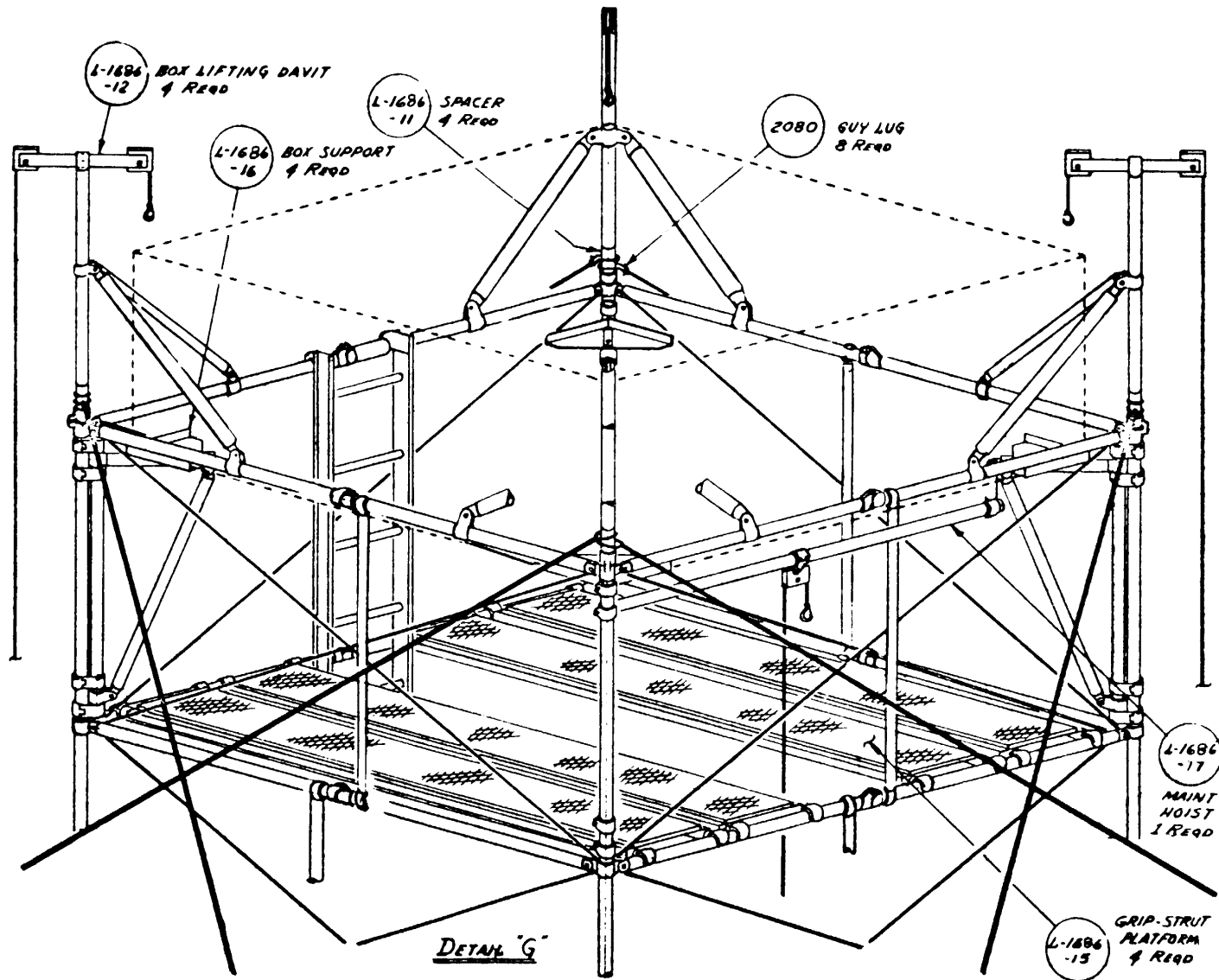

Figure 2-4. 80-Foot Tower Assembly, Sheet 6 of 7

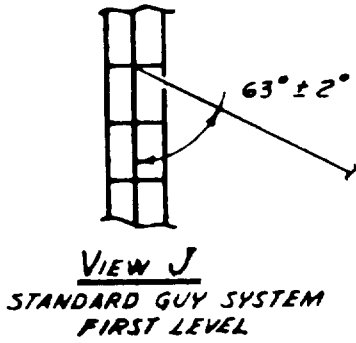
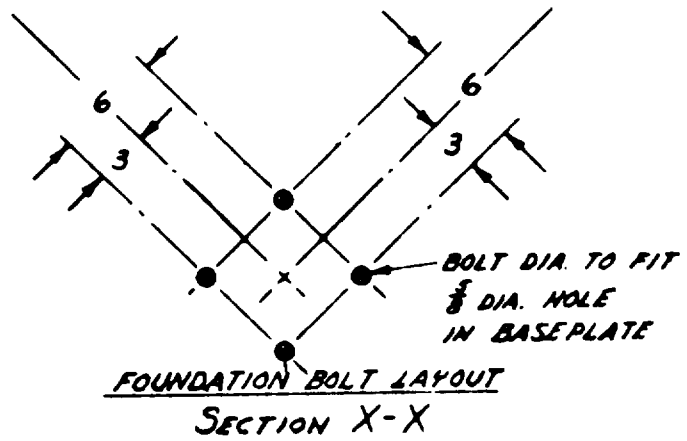
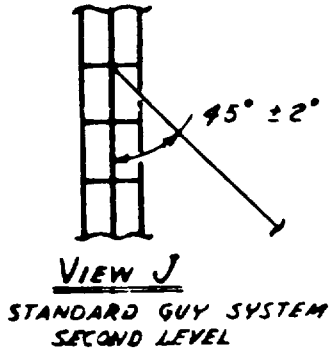
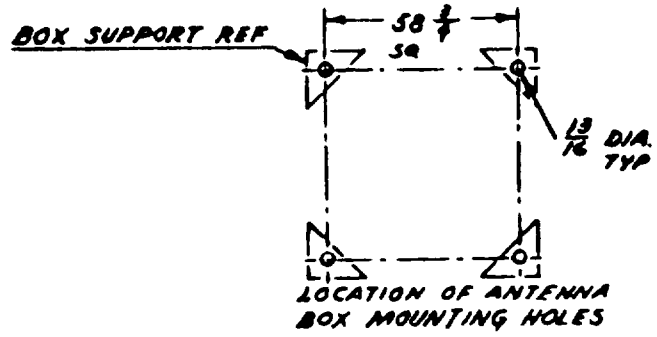
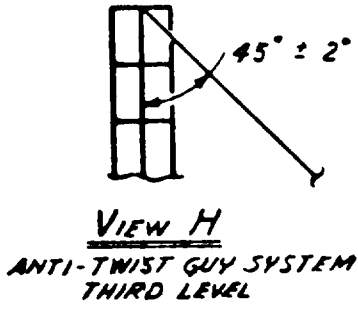

Figure 2-4. 80-Foot Tower Assembly, Sheet 7 of 7

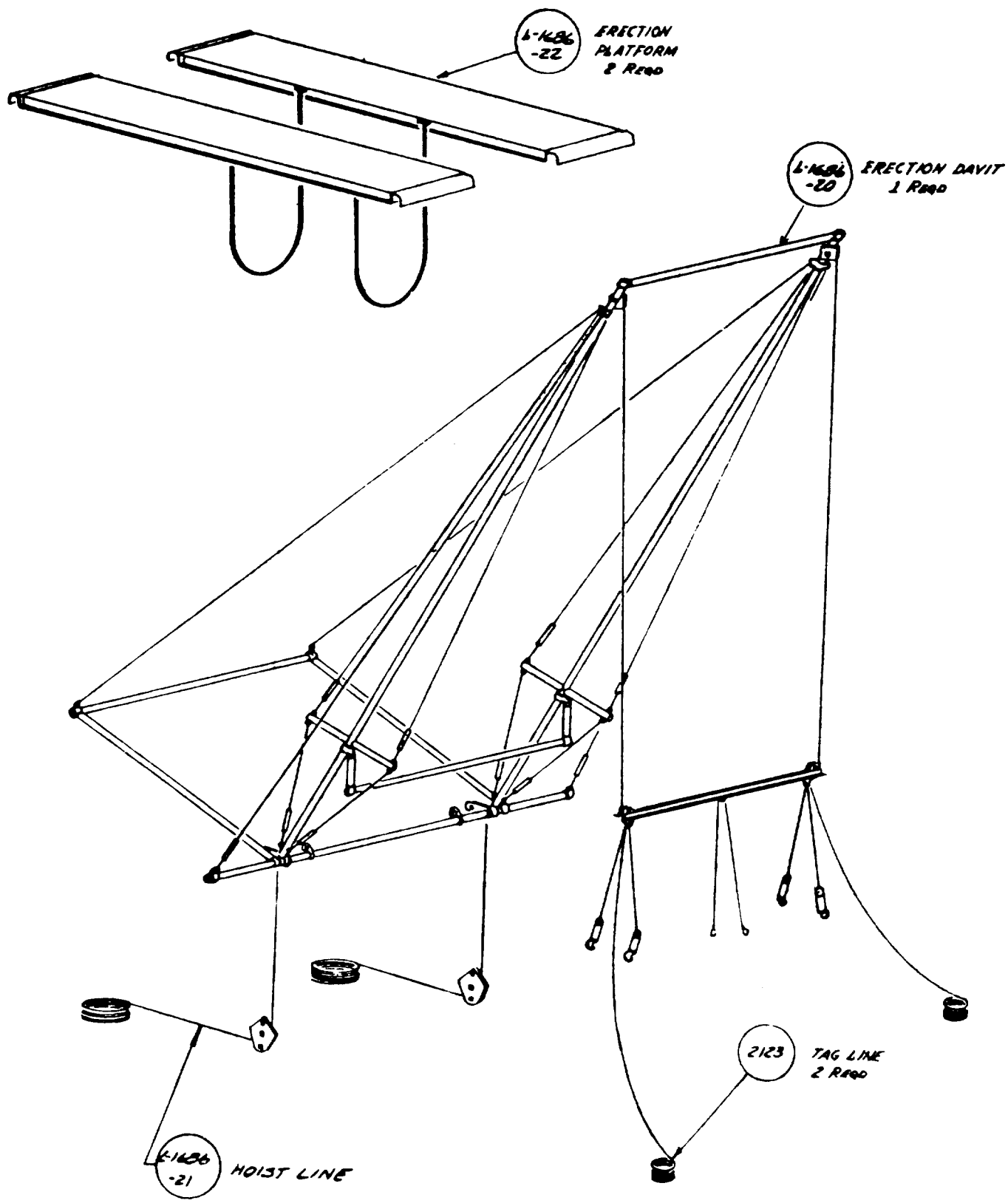
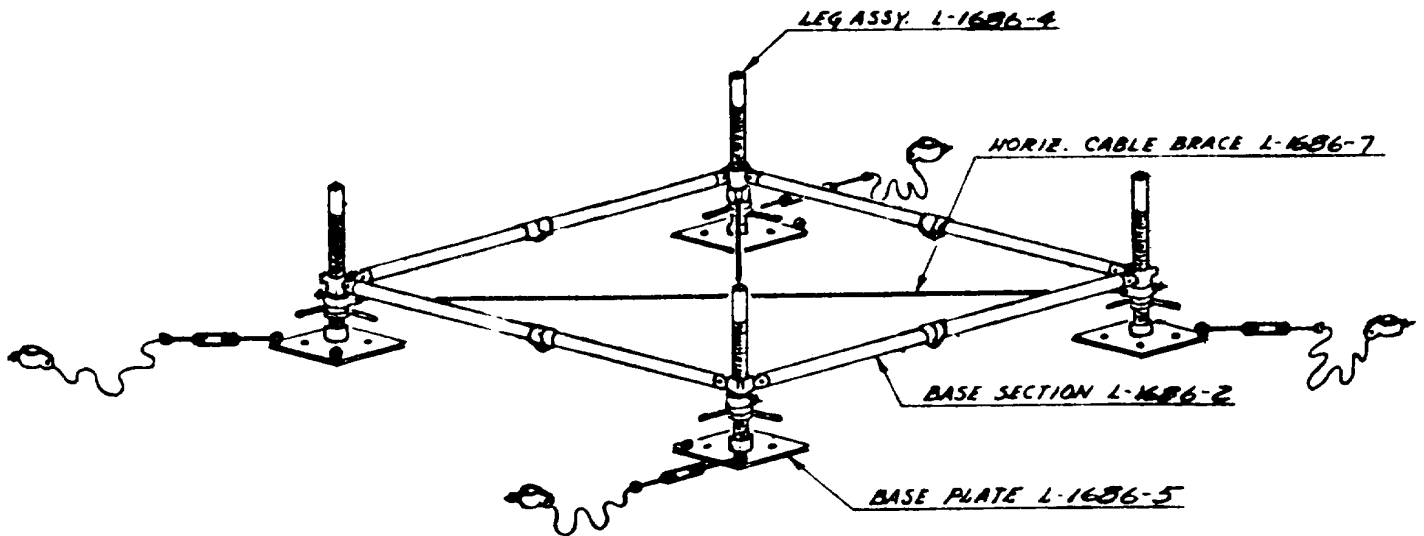
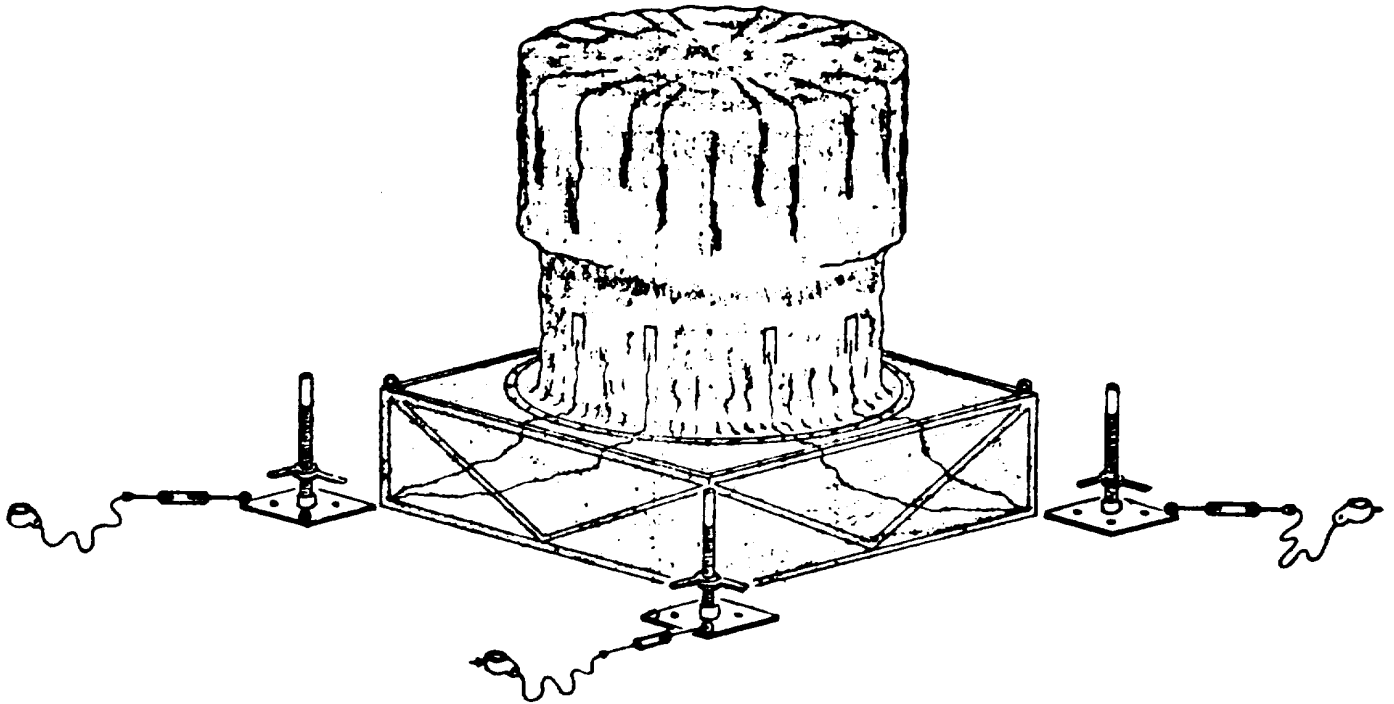

Figure 2-5. 80-Foot Tower Erection Equipment



- A. Insert adjustable legs into sockets of base plates.
- B. Expand and lock base section and place over adjustable legs.
- C. Install horizontal cable braces to be sure that the base section is square, then use the base section assembly as a template to locate holes in foundation.
- D. Secure base plates to foundation.

Figure 2-6. 80-Foot Tower Erection, Sheet 1 of 18



- A. Remove base section.
- B. Locate antenna set box in center of base plates.

Figure 2-6. 80-Foot Tower Erection, Sheet 2 of 18

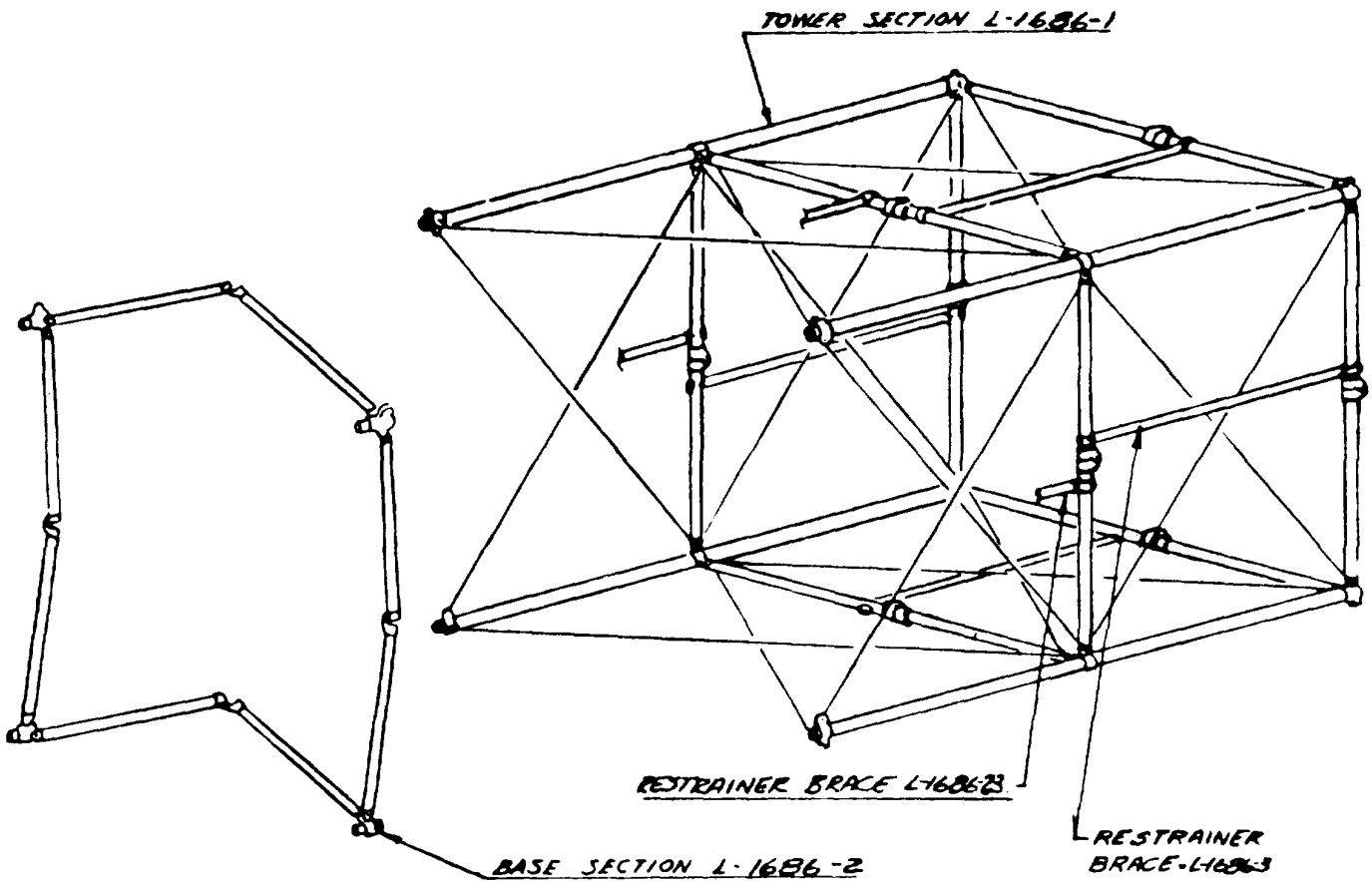

- A. Expand and lock tower section while lying on its side.
- B. Expand but do not lock base section until it is engaged with tower section.
- C. Engage swing bolts and make fingertight.
- D. Lock base section.
- E. Install restrainer braces.

Figure 2-6. 80-Foot Tower Erection, Sheet 3 of 18

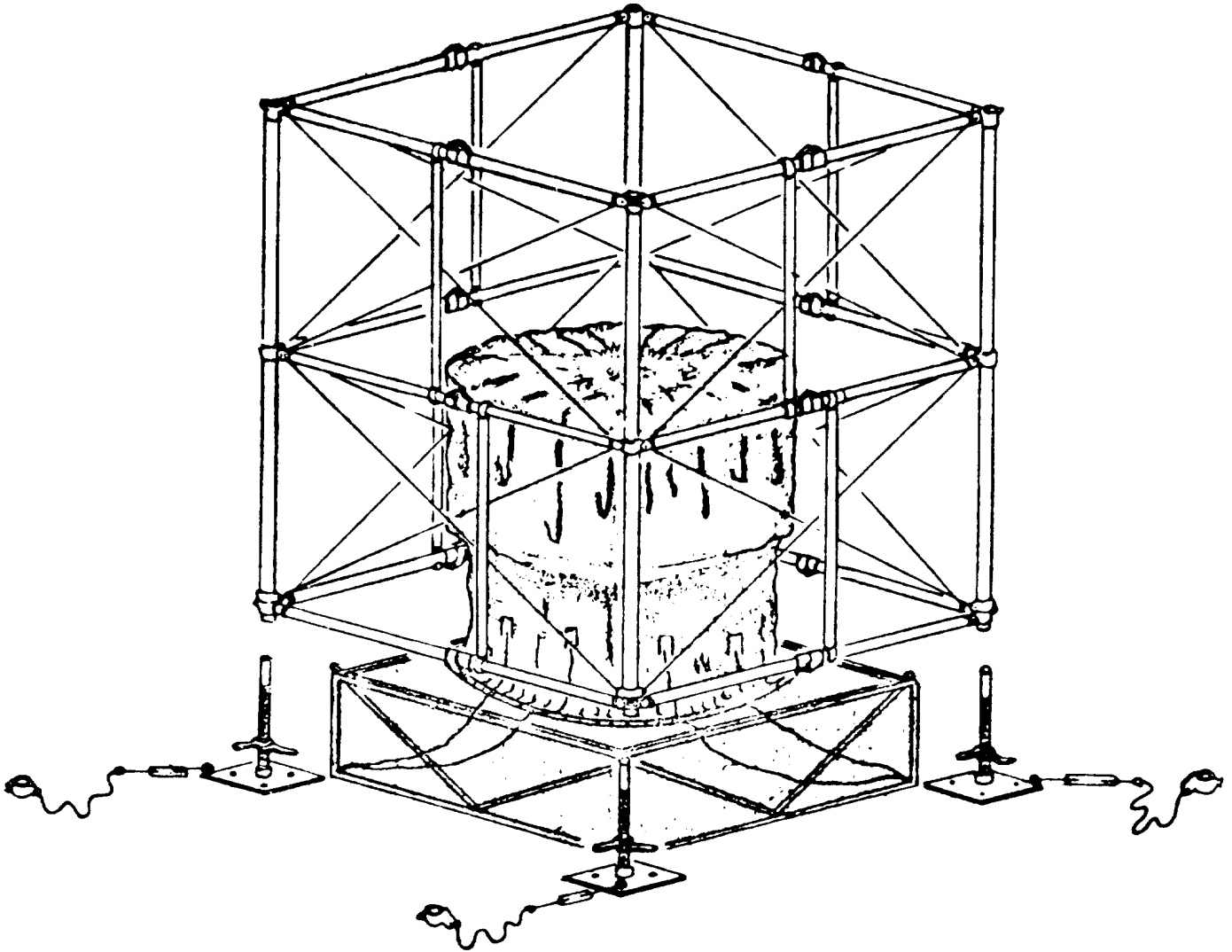

- A. Tip assembled section to the upright position.
- B. Lift section over antenna box and set down on adjustable legs of base plates.
- C. Level section by using adjusting hand nuts.

**Figure 2-6. 80-Foot Tower Erection, Sheet 4 of 18**

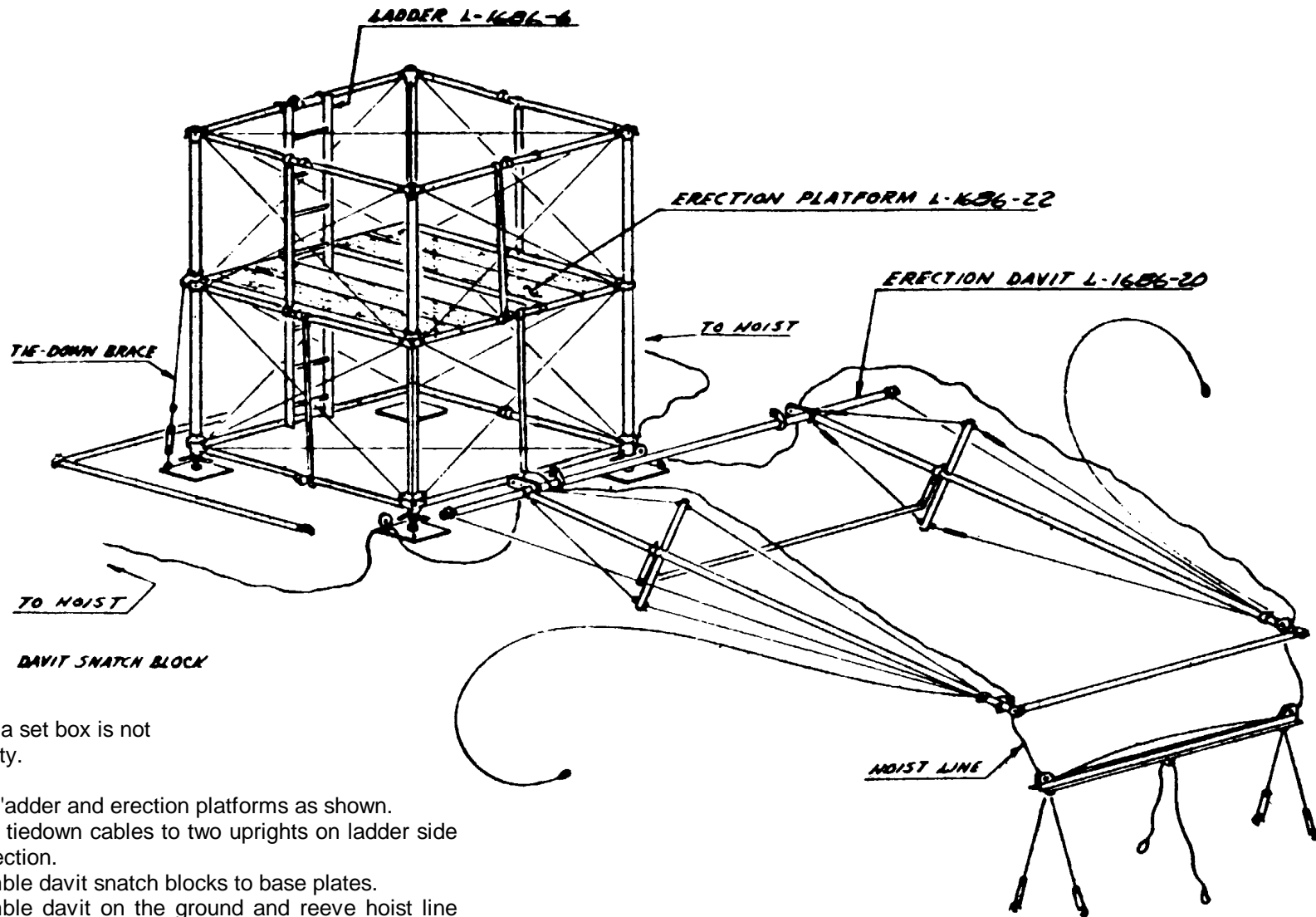

NOTE: Antenna set box is not shown for clarity.

- A. Install ladder and erection platforms as shown.
- B. Attach tiedown cables to two uprights on ladder side of tower section.
- C. Assemble davit snatch blocks to base plates.
- D. Assemble davit on the ground and reeve hoist line as shown.

Figure 2-6. 80-Foot Tower Erection, Sheet 5 of 18



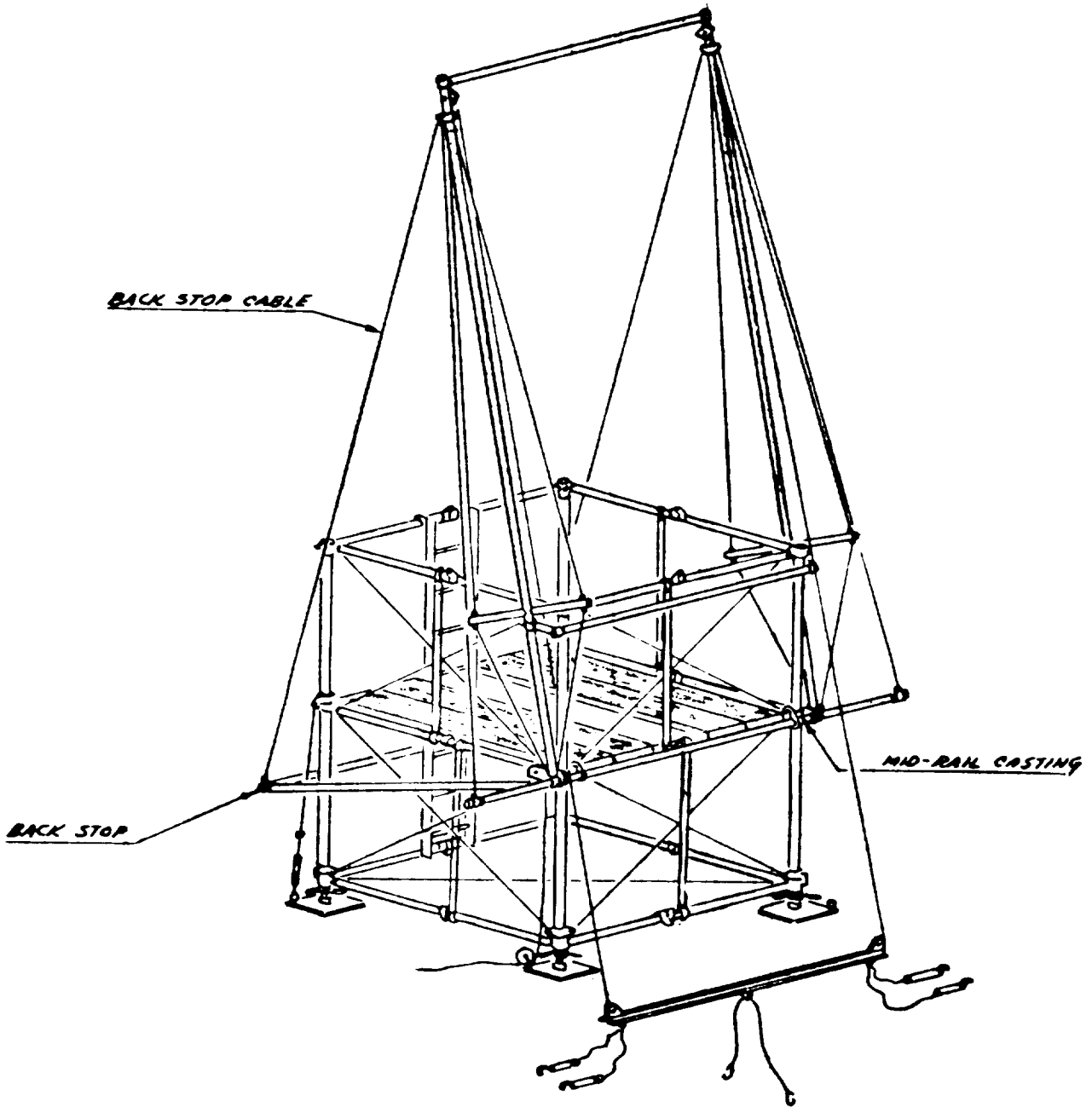

- A. Install davit by raising to vertical position and hooking on to mid-rail castings as shown.
- B. Tip davit and install backstop and backstop cables.

Figure 2-6. 80-Foot Tower Erection, Sheet 6 of 18

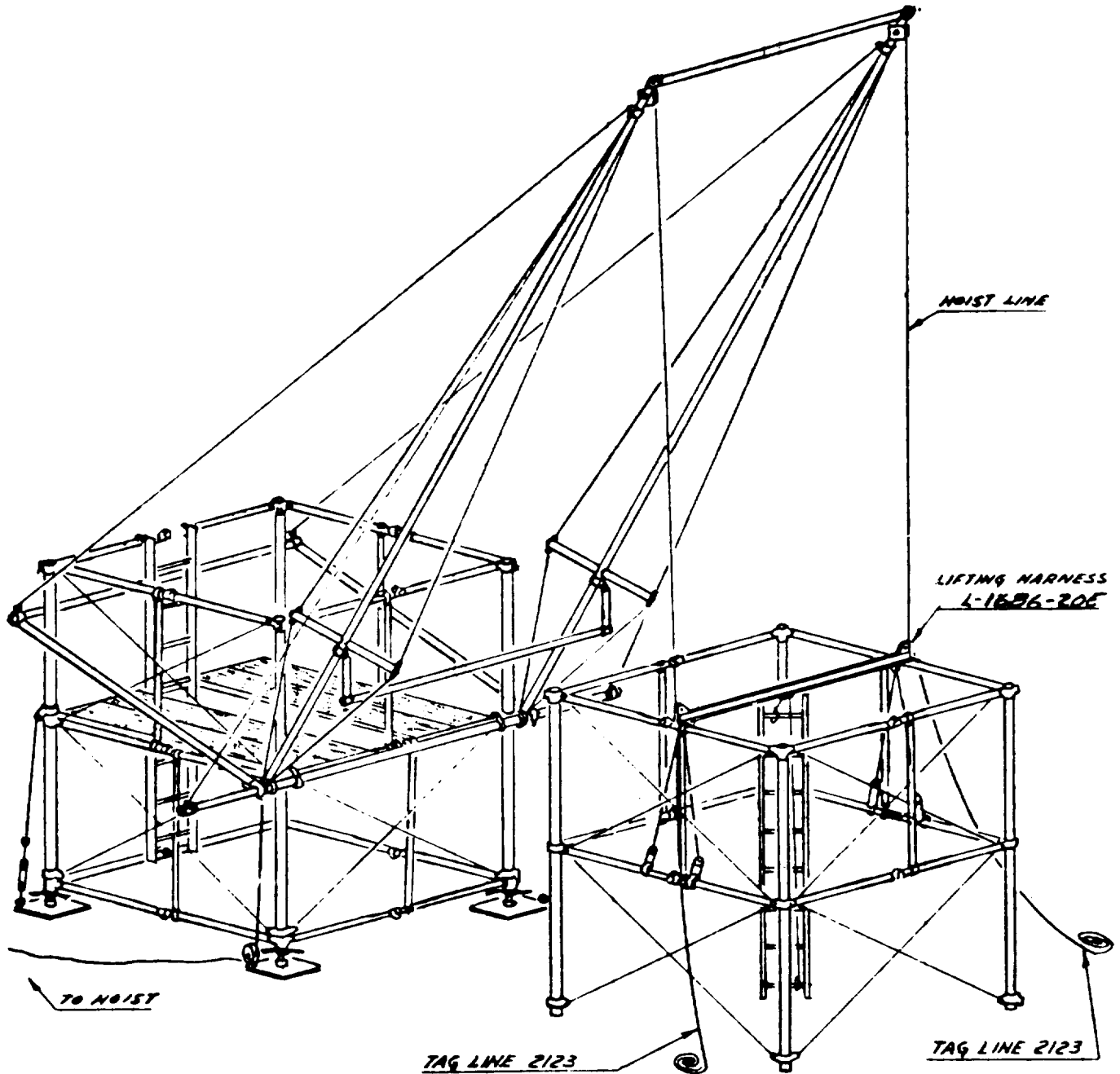

- A. Tip davit to lifting position.
- B. Assemble next section and attach lifting harness and ladder as shown.
- C. Hook two tag lines to eyebolts on lifting harness.

Figure 2-6. 80-Foot Tower Erection, Sheet 7 of 18

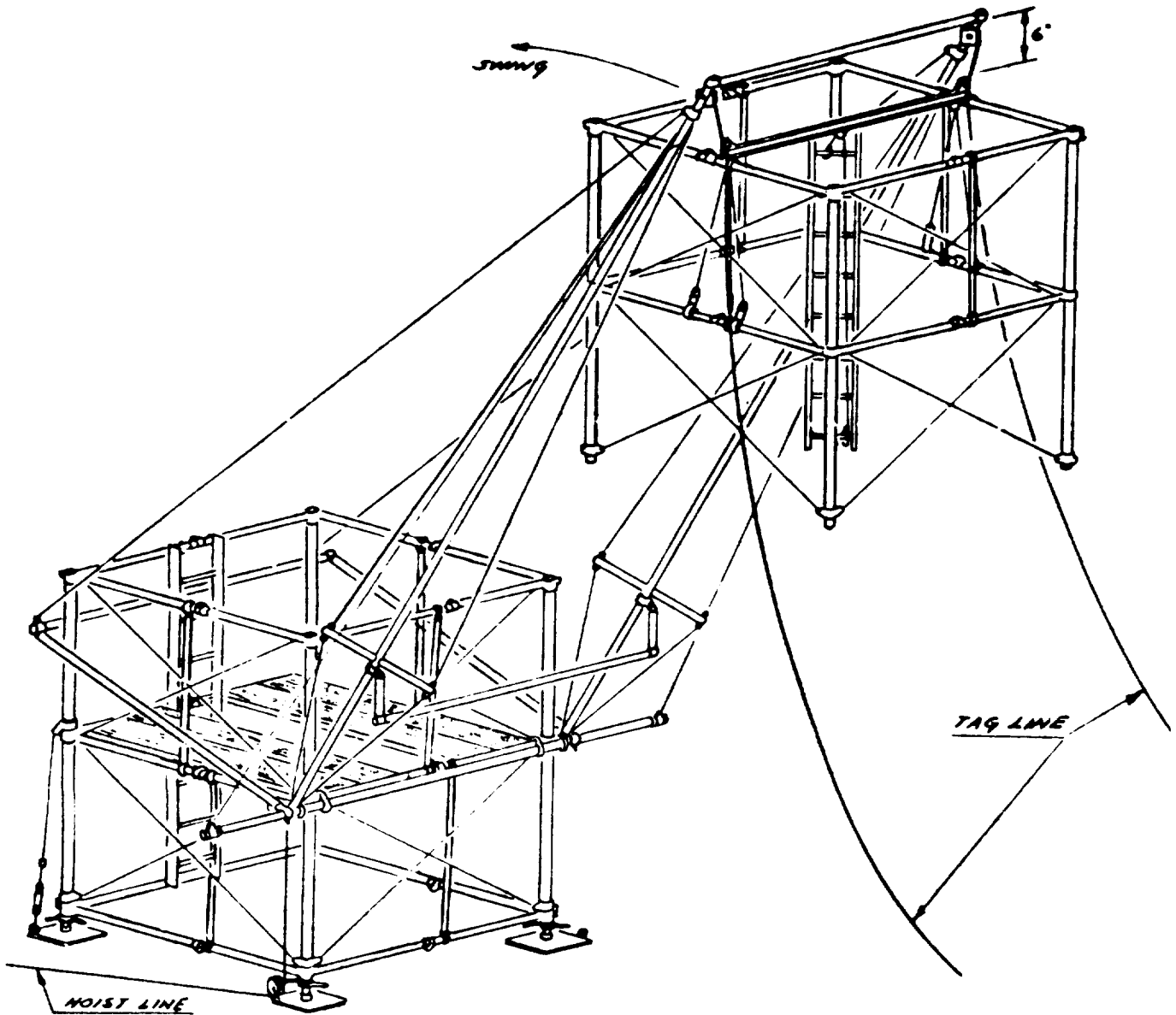

- A. Lift section until it is approximately six inches under the top cross bar of davit. (Section must be carefully guided with tag lines during the lifting operation. )
- B. Swing davit and section over base section.

Figure 2-6. 80-Foot Tower Erection, Sheet 8 of 18

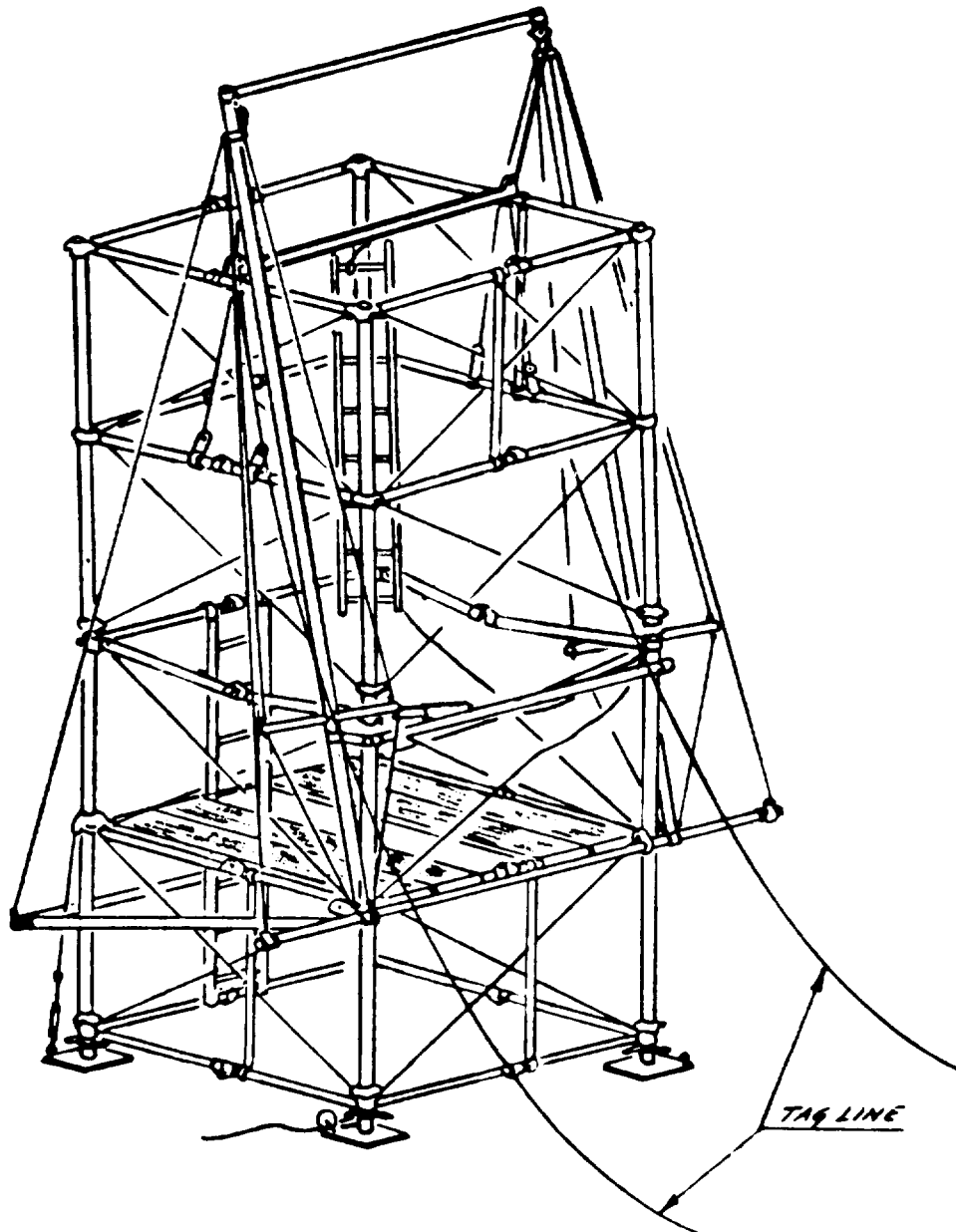

- A. Lower section until one upright member can be inserted and bolted.
- B. Unlock slide tube while lifting and holding ladder clear.
- C. Insert and bolt second upright member.
- D. Replace ladder.
- E. Unlock three remaining hinge braces, insert and bolt remaining upright members.
- F. Lock all hinge braces.
- G. Unhook ladder from lifting harness and install on section.
- H. Install restrainer braces.

**Figure 2-6. 80-Foot Tower Erection, Sheet 9 of 18**

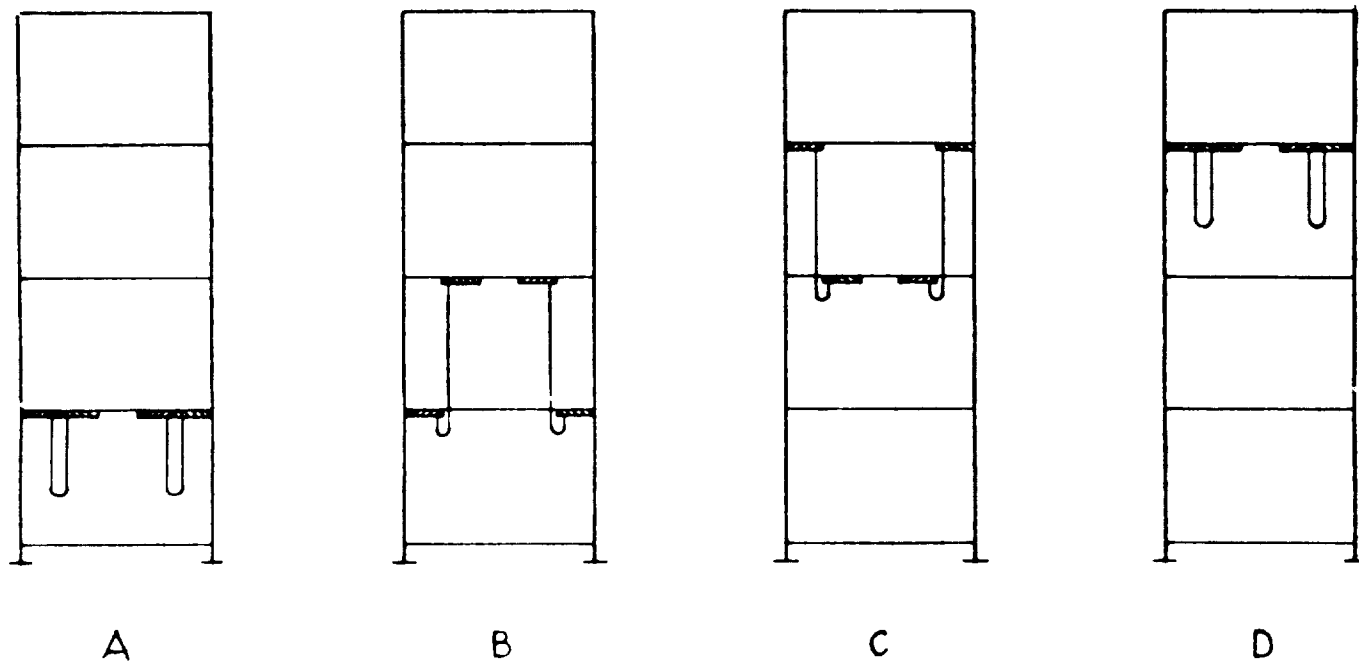

A. Move erection platforms to next higher position by following sequence shown above.

Figure 2-6. 80-Foot Tower Erection, Sheet 10 of 18

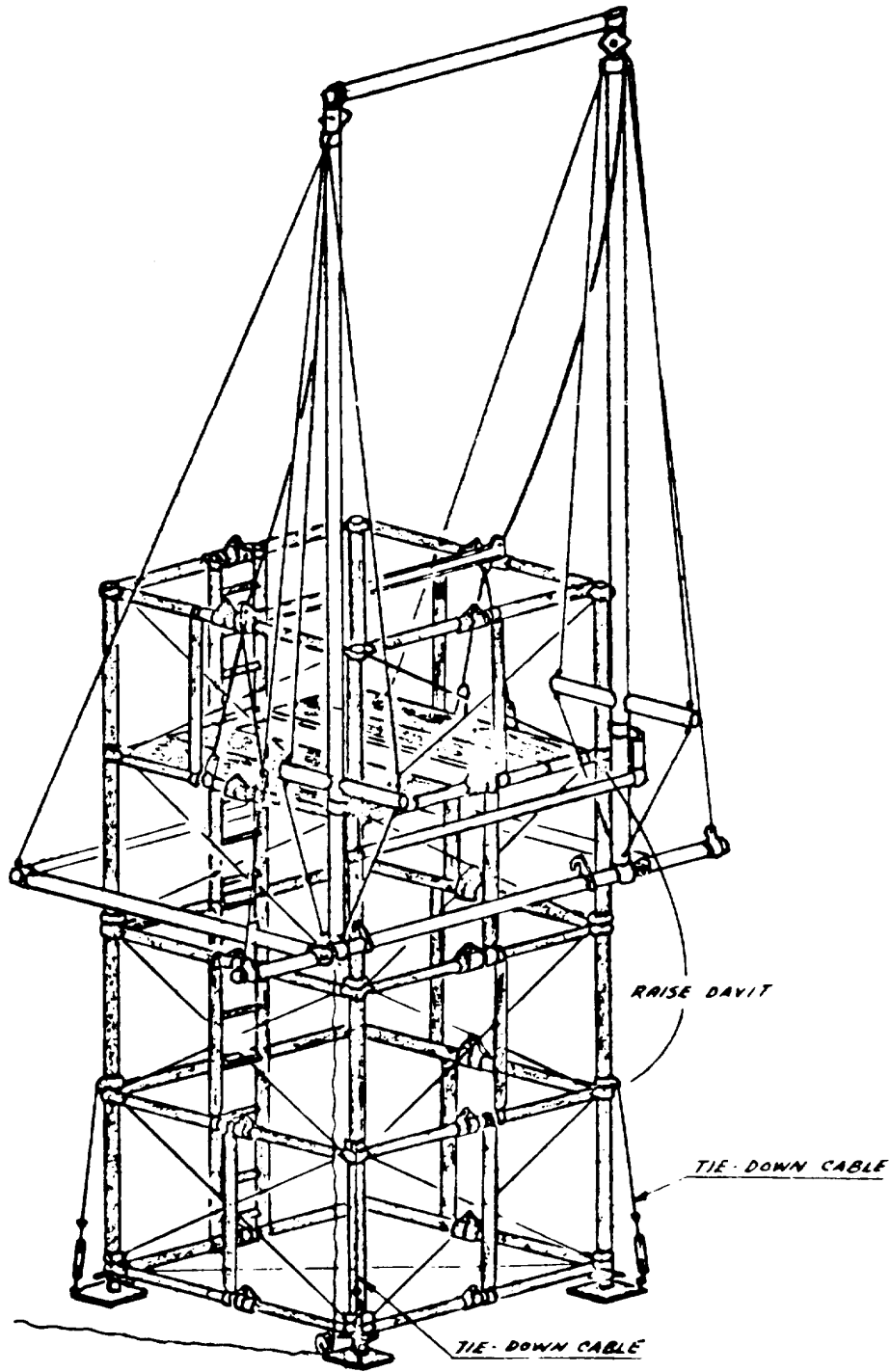

- A. Leave lifting harness installed on section.
- B. Pull up enough slack in hoist line and tie off to a vertical member clear of davit.
- C. Tip davit to a vertical position and lift hooks clear.
- D. Use hand-over-hand method and raise davit to next position.
- E. Install remaining tiedown cables to base section.

Figure 2-6. 80-Foot Tower Erection, Sheet 11 of 18

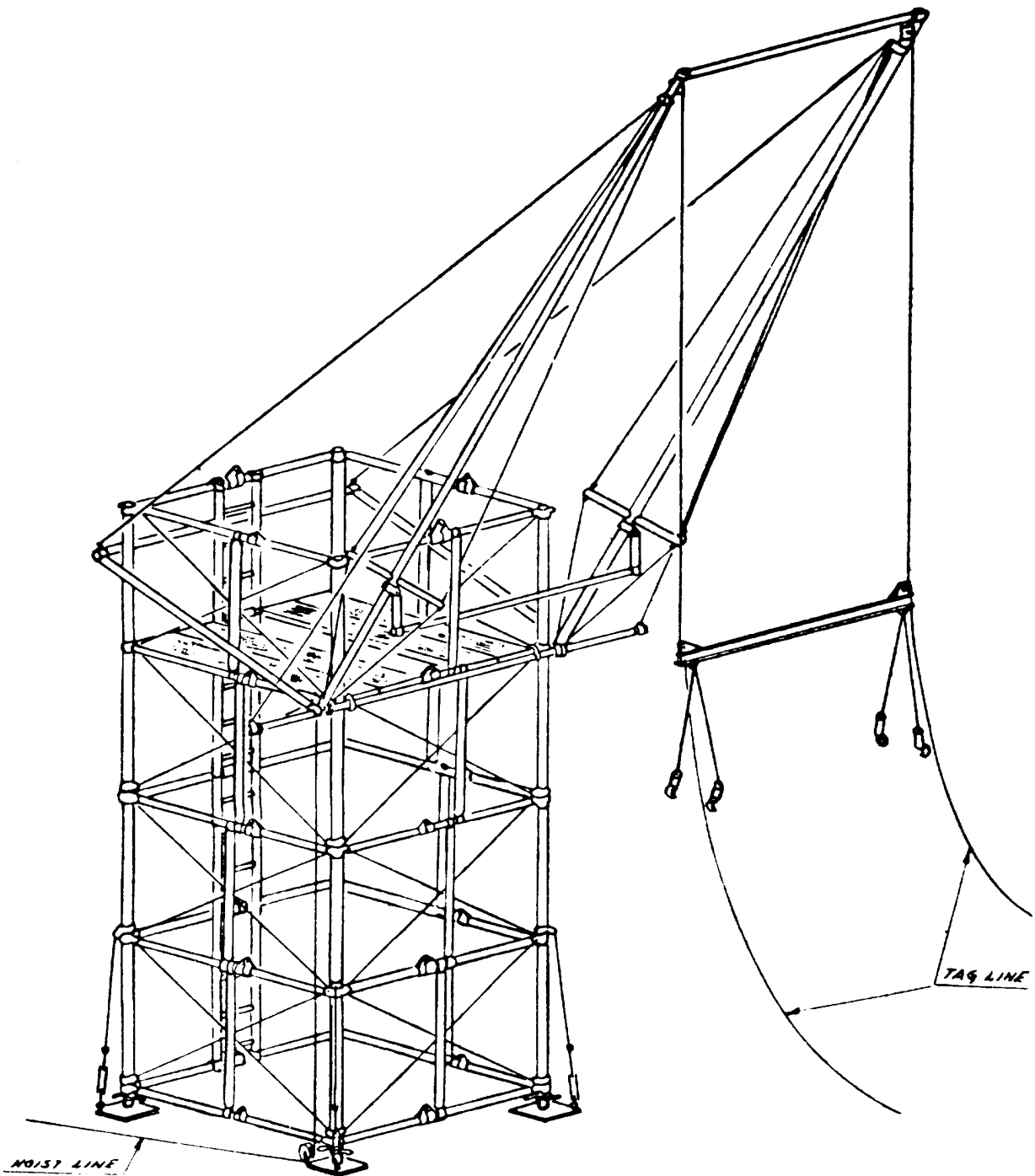

- A. Swing davit to lifting position.
- B. Prepare next section for lifting and continue operations until tower is completed.
- C. As each guy level is reached, attach guys.
- D. Apply 600 lbs tension equally to each guy.

Figure 2-6. 80-Foot Tower Erection, Sheet 12 of 18

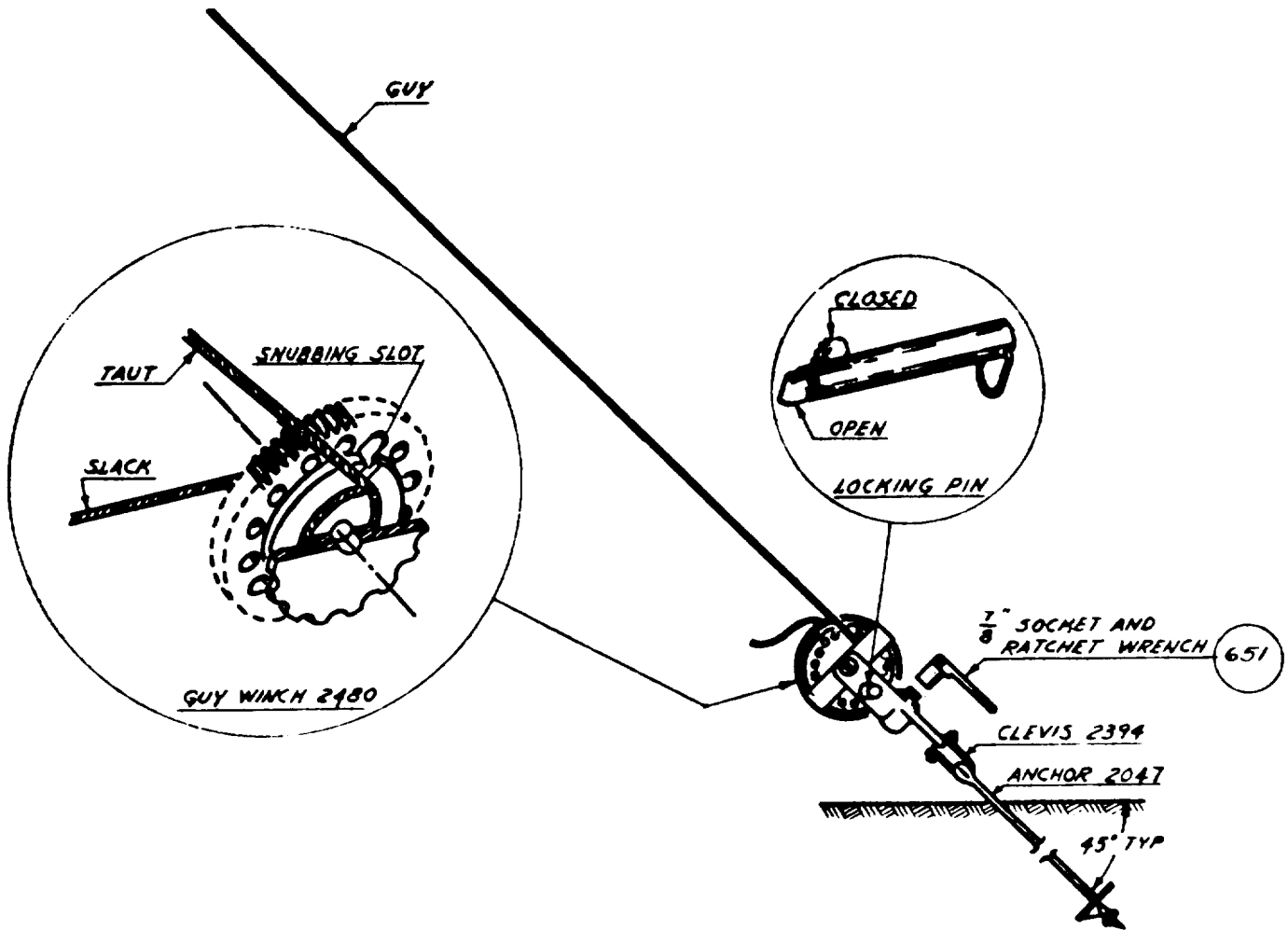

- A. When first guy level is reached, install two horizontal cable braces on the tower just below guy level (see detail D on figure 2-4).
- B. Determine the location of the guy anchor as shown on figure 2-4, sheet 2.
- C. With the digging bar or a shovel, dig a pilot hole about 6" deep x 12" dia to aid in starting the anchor.
- D. Screw anchor into the ground at a 45-degree angle until the top of the eye is not more than 4" above the ground surface.
- E. Attach guy winch to the anchor with clevis or guy spacer (figure 2-4, sheet 5).
- F. Pass the slack end of the guy through the snubbing slot of the winch.
- G. Leave enough slack in the guy cable to allow at least 1-1/2 turns to be wound on the winch before tensioning guy.
- H. Do not place the guy under too much tension until all four guys of a given set are attached to their winches.
- I. Guys should be tensioned simultaneously while checking the tower for plumb.
- J. Use the tensiometer as shown in figure 2-6, sheet 14, and tension each guy to 800 lbs. The locking pin must be installed in the guy winch after each takeup.
- K. When proper tension has been reached, continue erecting tower as shown on sheet 12.

Figure 2-6. 80-Foot Tower Erection, Sheet 13 of 18



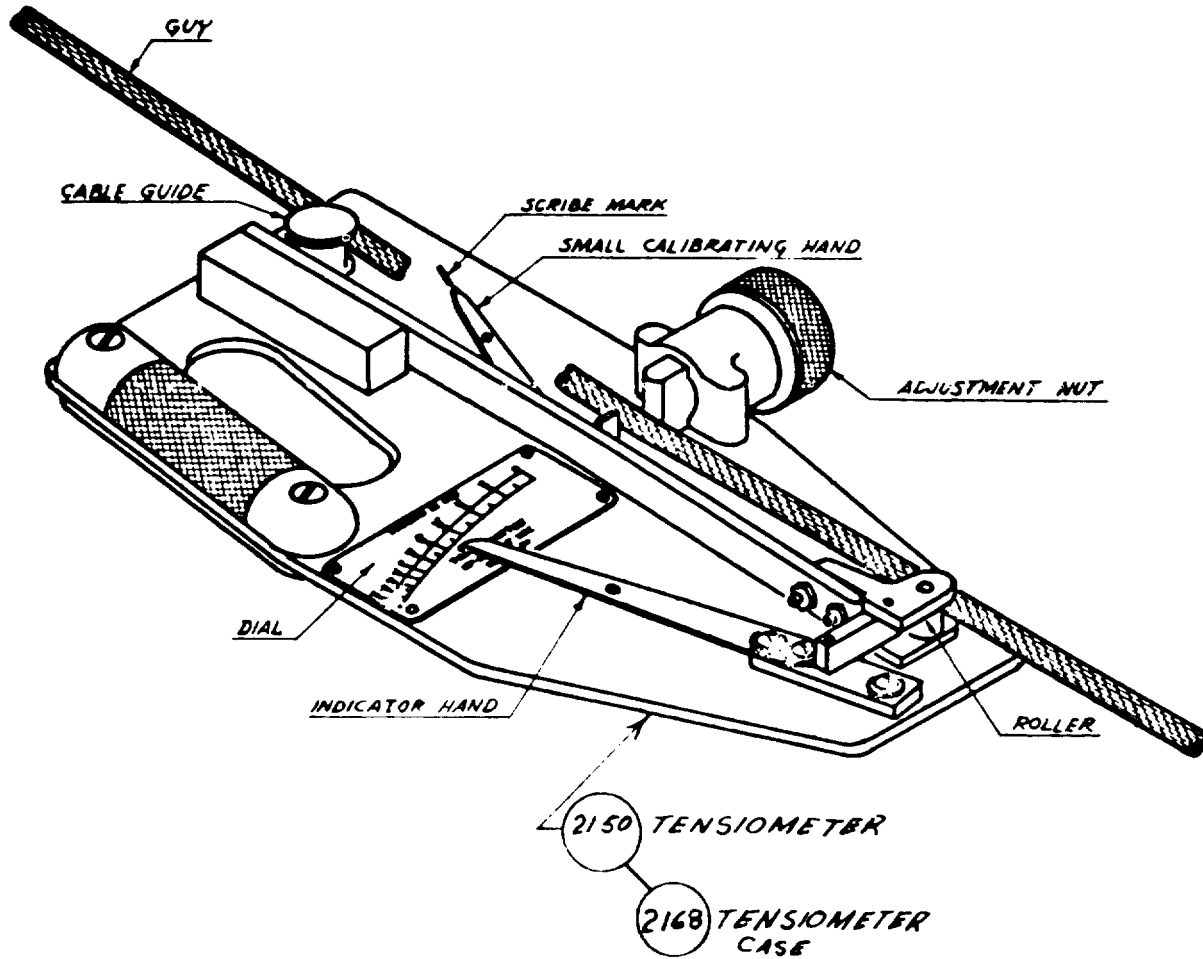

- A. The tensiometer, supplied in its case, is used to check the tension of the guys.
- B. Use the tensiometer on guy cables as shown above.
- C. Turn the knurled adjustment nut until the small calibrating hand moves in line with the mark scribed on the tensiometer frame.
- D. Then read the tension directly from the large indicating hand on the dial.

Figure 2-6. 80-Foot Tower Erection, Sheet 14 of 18

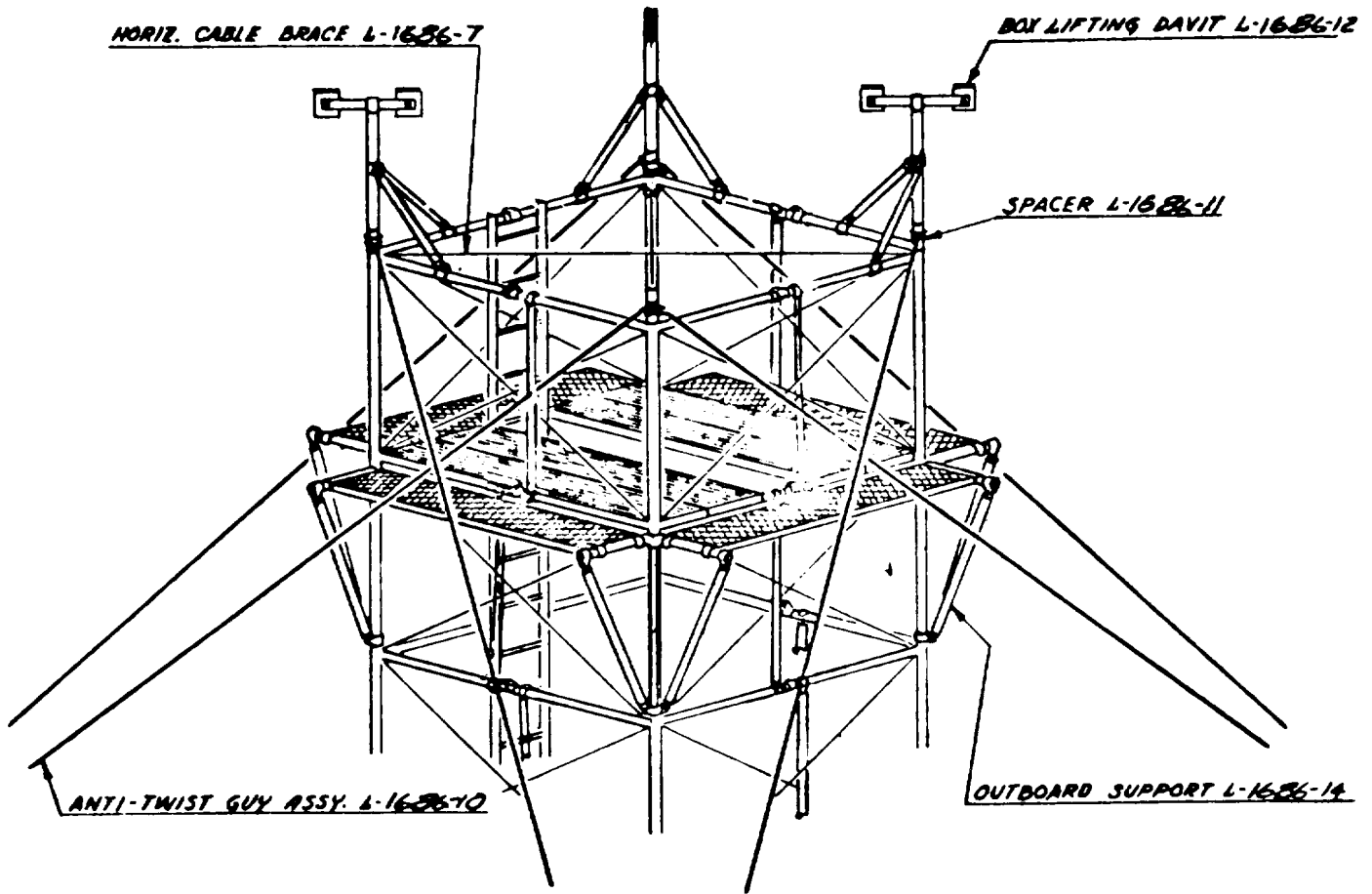

- A. After tower has been fully erected, remove erection davit and lower it to the ground.
- B. Use tab line to lift the following parts and install on the tower in the order listed:
  1. Horizontal cable brace (2)
  2. Spacer (4)
  3. Anti-twist guy assy (8)
  4. Box - lifting davit (4)
  5. Outboard support (4)
  6. Grip-strut platform (4)
- C. Remove horizontal cable braces after guys have been installed and properly tensioned.

Figure 2-6. 80-Foot Tower Erection, Sheet 15 of 18

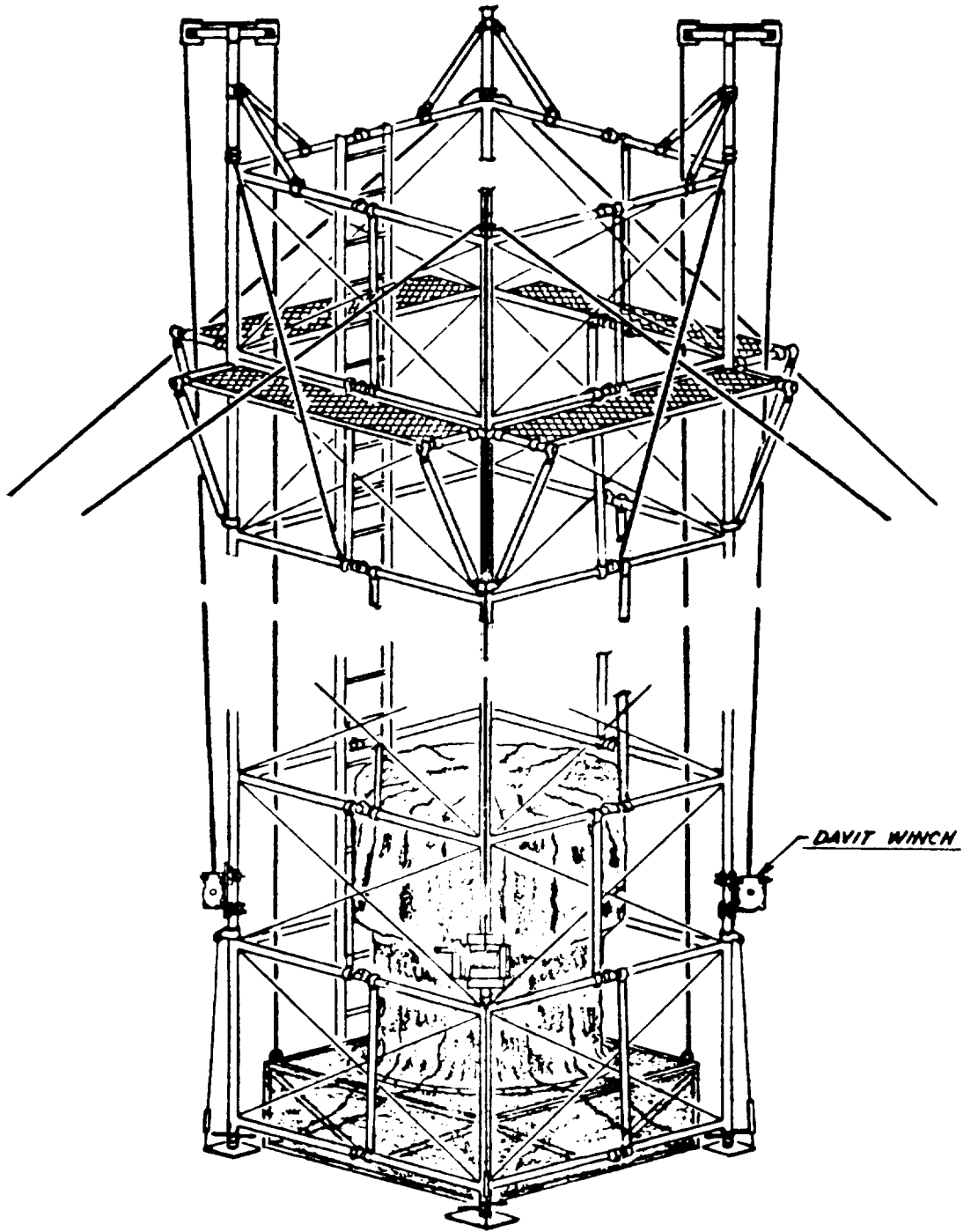

- A. Remove erection platforms from the tower.
- B. Install davit winches (4) on the vertical members of the first tower section.
- C. Reeve hoist line over the davit sheaves and attach hoisting hooks to antenna set box.

Figure 2-6. 80-Foot Tower Erection, Sheet 16 of 18

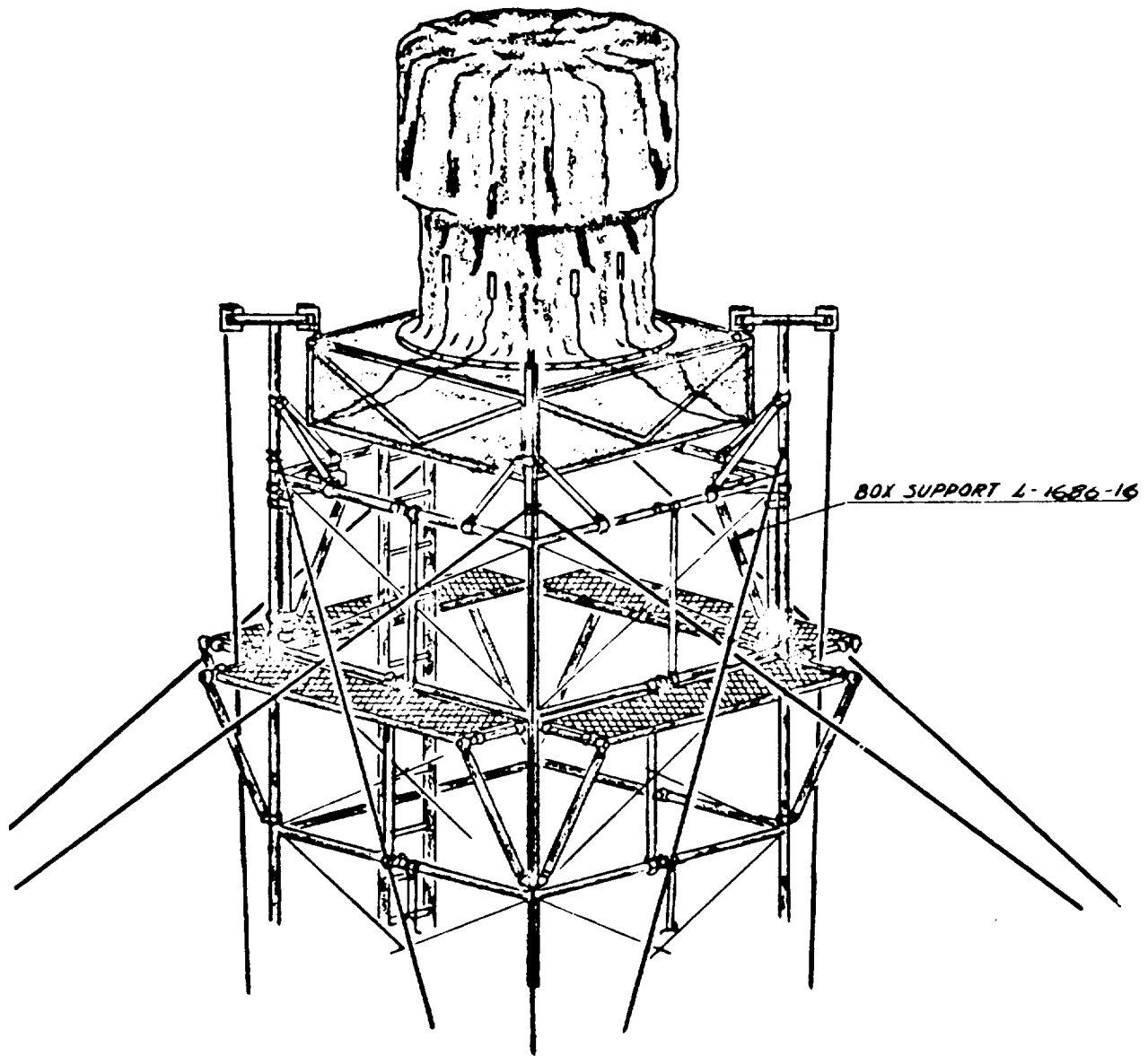
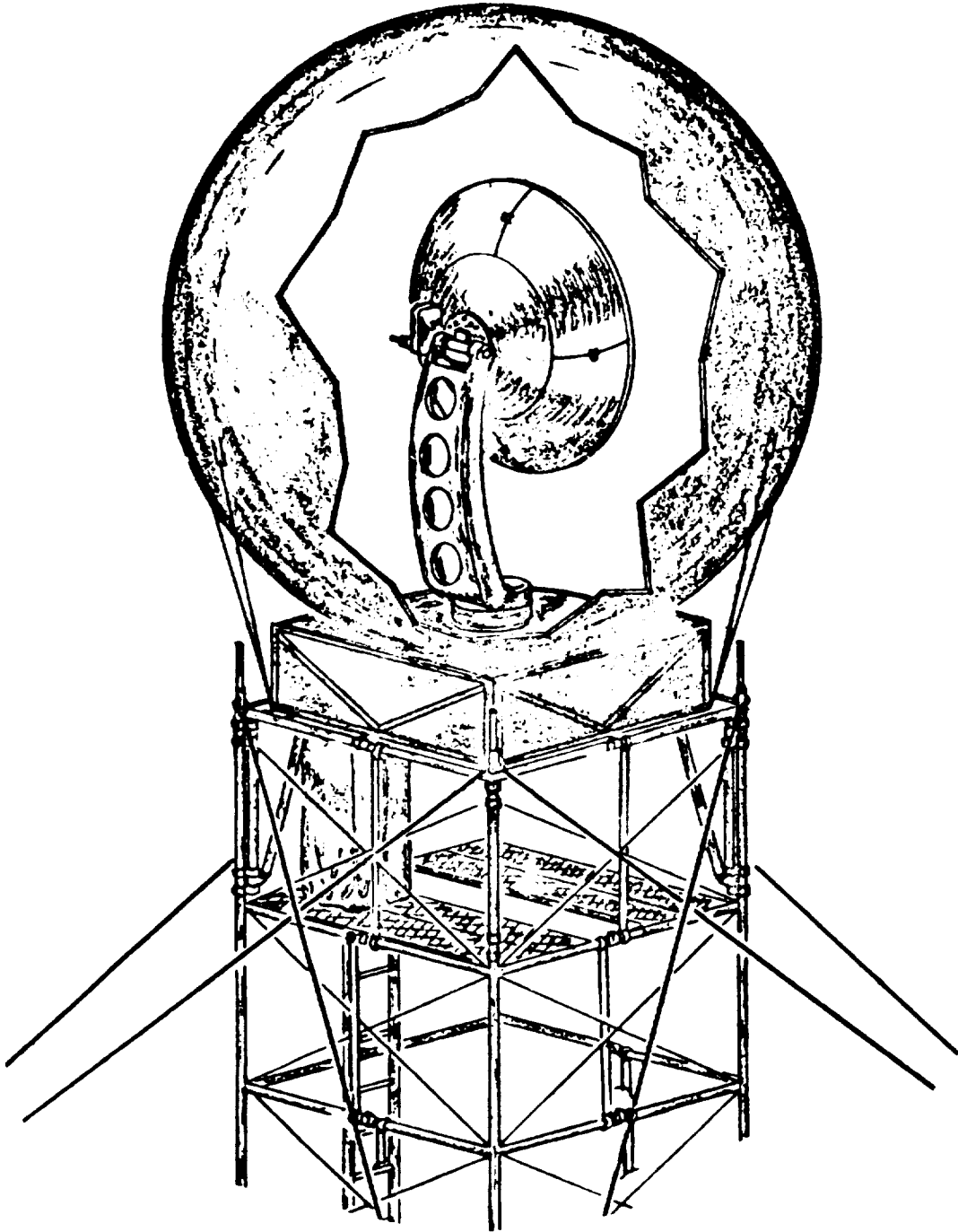

Figure 2-6. 80-Foot Tower Erection. Sheet 17 of 18.

- A. Make sure guys have been properly tensioned at each guy level, then remove all horizontal cable braces and platforms from inside tower.
- B. Carefully hoist box to top of tower by operating all four winches at equal speed.
- C. Install box supports (4), then slowly lower the box until it rests firmly on supports.



**Figure 2-6. 80-Foot Tower Erection, Sheet 18 of 18.**

- A. Relocate the grip-strut platforms from the outboard supports to the inside of the tower.
- B. Remove the outboard supports and the box-lifting davits.
- C. Install two horizontal cable braces in each tower section except top section and base section (see detail D on figure 2-4, sheet 4).
- D. Use erection platforms as shown in figure 2-6, sheet 10.
- E. Inflate the radome.
- F. Install maintenance hoist.
- G. Install grounding system at base of the tower as shown in detail C on figure 2-4, sheet 3.

D. DISASSEMBLY OF TOWER - Disassembly of the 80-foot tower is essentially the reverse of the procedure described in Figure 2-6; however, in order to have an orderly cable arrangement inside the folded section, use the two nylon rope assemblies, part No. L-1686-18 and -19, during the folding operation as described below.

- (1) Position the section laying on its side (see Figure 2-7).
- (2) Attach the snap hooks of -19 to the four cable crossings in the lower half of the section after threading the nylon ropes through the section as shown in view 1. Always snap on the hook as shown. The hook axis has to be in line with the direction of pull.
- (3) Attach the snap hooks of -18 to the four cable crossings in the upper half of the section as shown in view 2.
- (4) While two men pull on -18 and -19, have all 8 brace joints unlocked.
- (5) Slowly push the 4 uprights together until section is folded. During this operation, see that all cable thimbles pivot into the pull direction of -18 and -19.
- (6) Gather cables together in two locations and attach 2 hose clamps as shown in view 4.
- (7) Remove all hooks and pull out -18 and -19 rope assemblies.

## 8. SYSTEM INTERCONNECTIONS

A. System interconnection cabling is shown in Figure 2-8. Table 2-2 lists the signals applied to each connector pin.

## 9. BORESIGHTING PROCEDURE

A. TARGET INSTALLATION - After the mounting location for the Antenna System has been established, but before the Antenna System has been installed, determine the azimuth of the boresight target as follows:

- (1) Locate an r-f signal generator with boresight target at a distance of approximately one-half mile from the Antenna System.
- (2) Set up a transit or similar instrument on the Antenna System mounting location.
- (3) Determine the true azimuth of the boresight target from the Antenna System. Record this position.

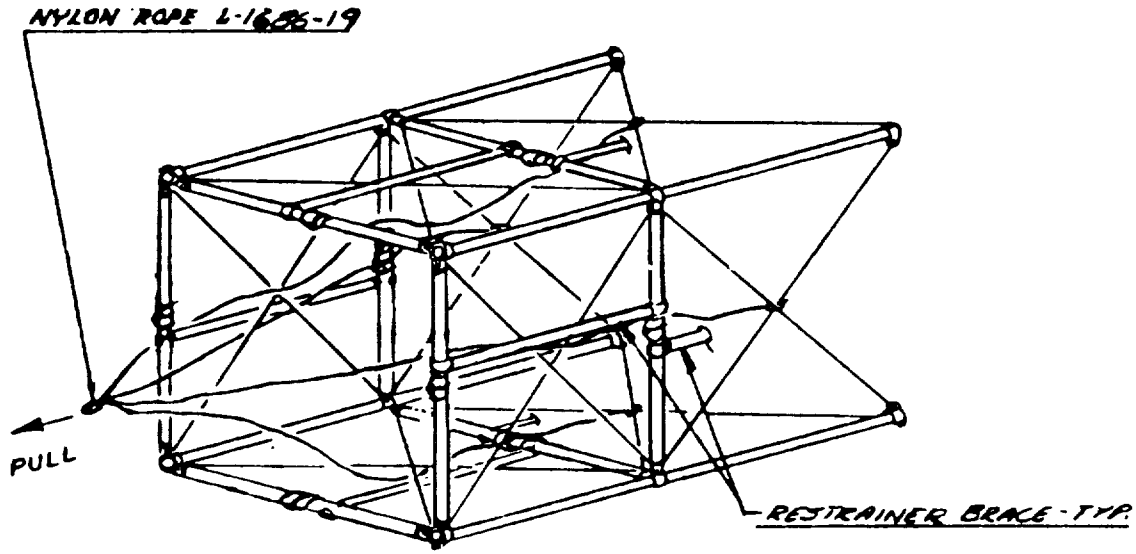

VIEW No 1

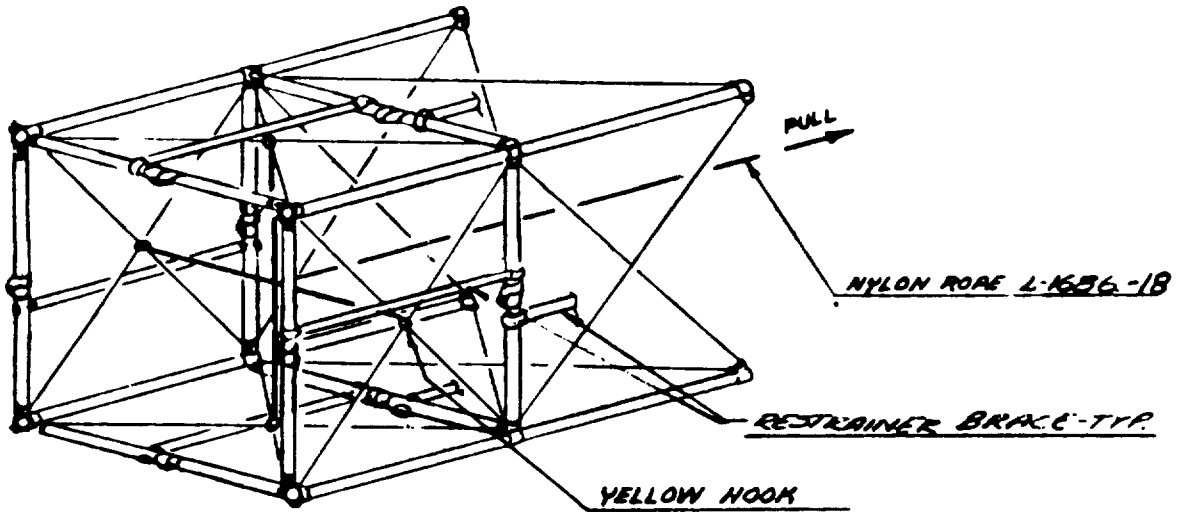

VIEW No 2

Figure 2-7. 80-Foot Tower Disassembly, Sheet 1 of 2.

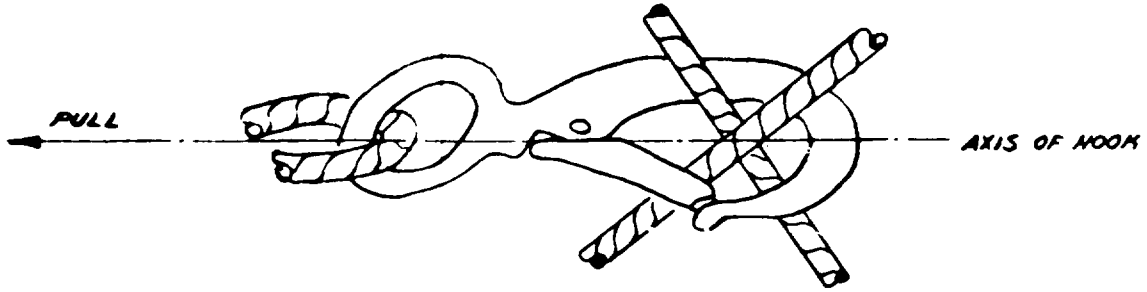

VIEW NO. 3

GATHER CABLES TOGETHER AND  
FASTEN WITH HOSE CLAMP

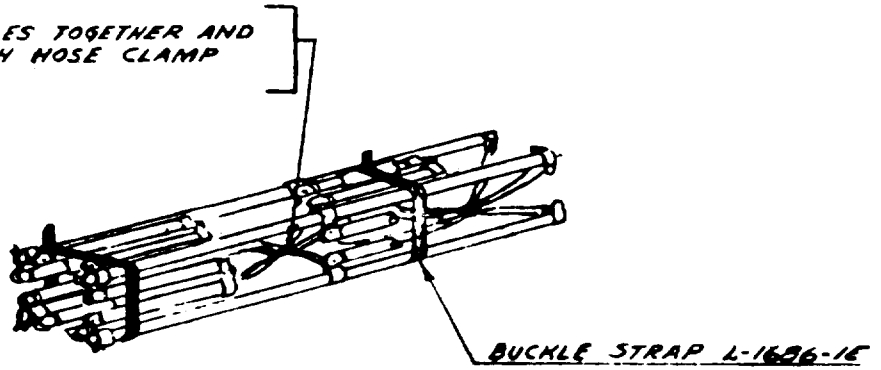

VIEW NO. 4

Figure 2-7. 80-Foot Tower Disassembly, Sheet 2 of 2.



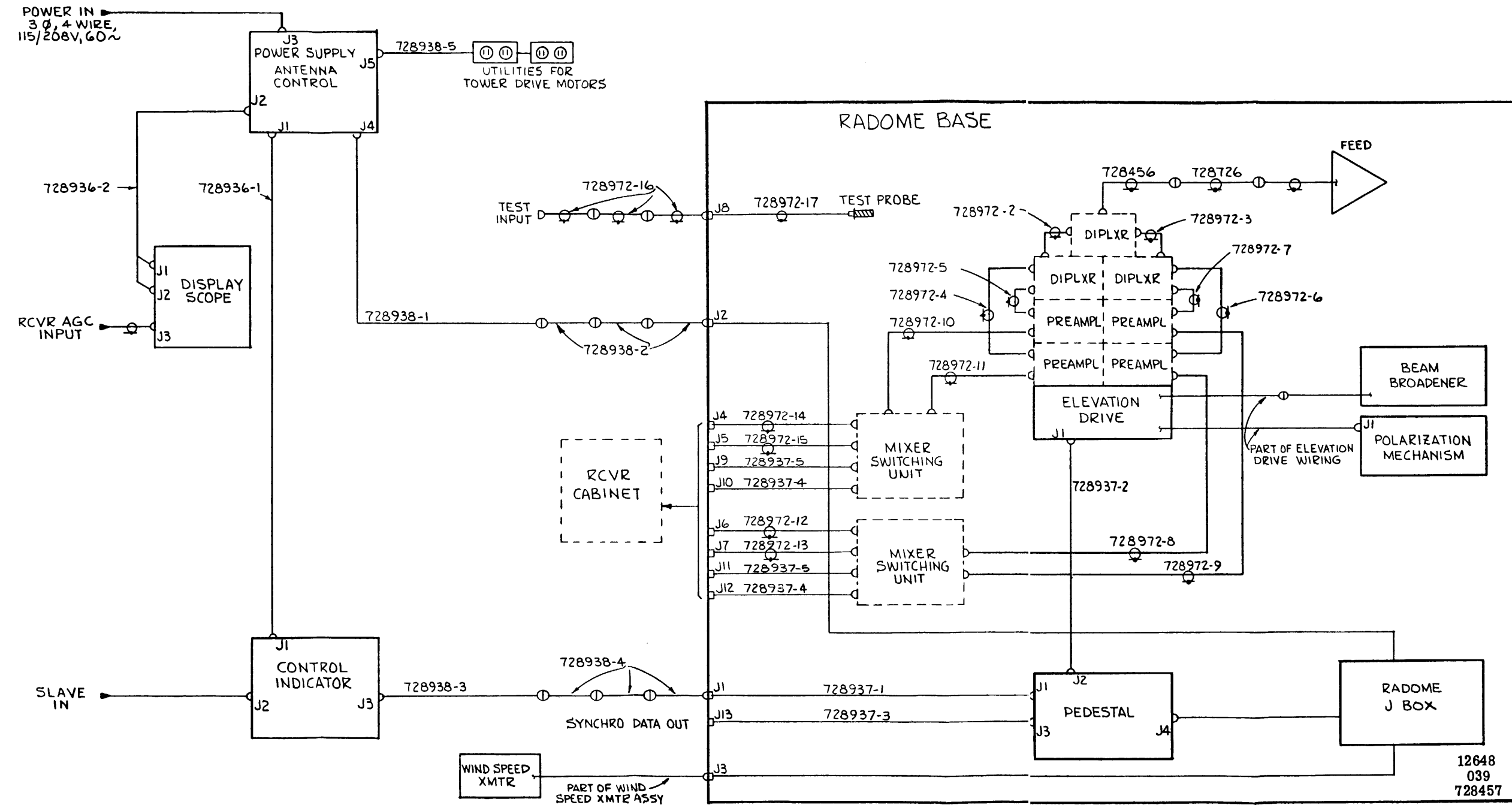

Figure 2-8. System Interconnection Cabling Diagram

B. CHECK AND ADJUSTMENT - When the Antenna System is installed and operating, check the boresight as follows:

- (1) Turn on the r-f signal generator.
- (2) Acquire the r-f signal generator with the Antenna System and note the azimuth indication on the Control Indicator.
- (3) Subtract the indicated azimuth from the azimuth surveyed in step A(3).
- (4) Set the AZ ORIENT control on the Antenna Control Power Supply to the algebraic difference determined in step B(3).
- (5) Repeat steps B(2) and B(3) to check boresight.

#### 10. EQUIPMENT RELOCATION

- A. Procedures for stowing and relocating the Antenna System are essentially the reverse of installation procedures given in this section.
- B. See paragraph 7 for special procedures applicable to stowing the 80-foot tower.
- C. See Figure 2-9 for configuration of the Antenna System in the stowed position.

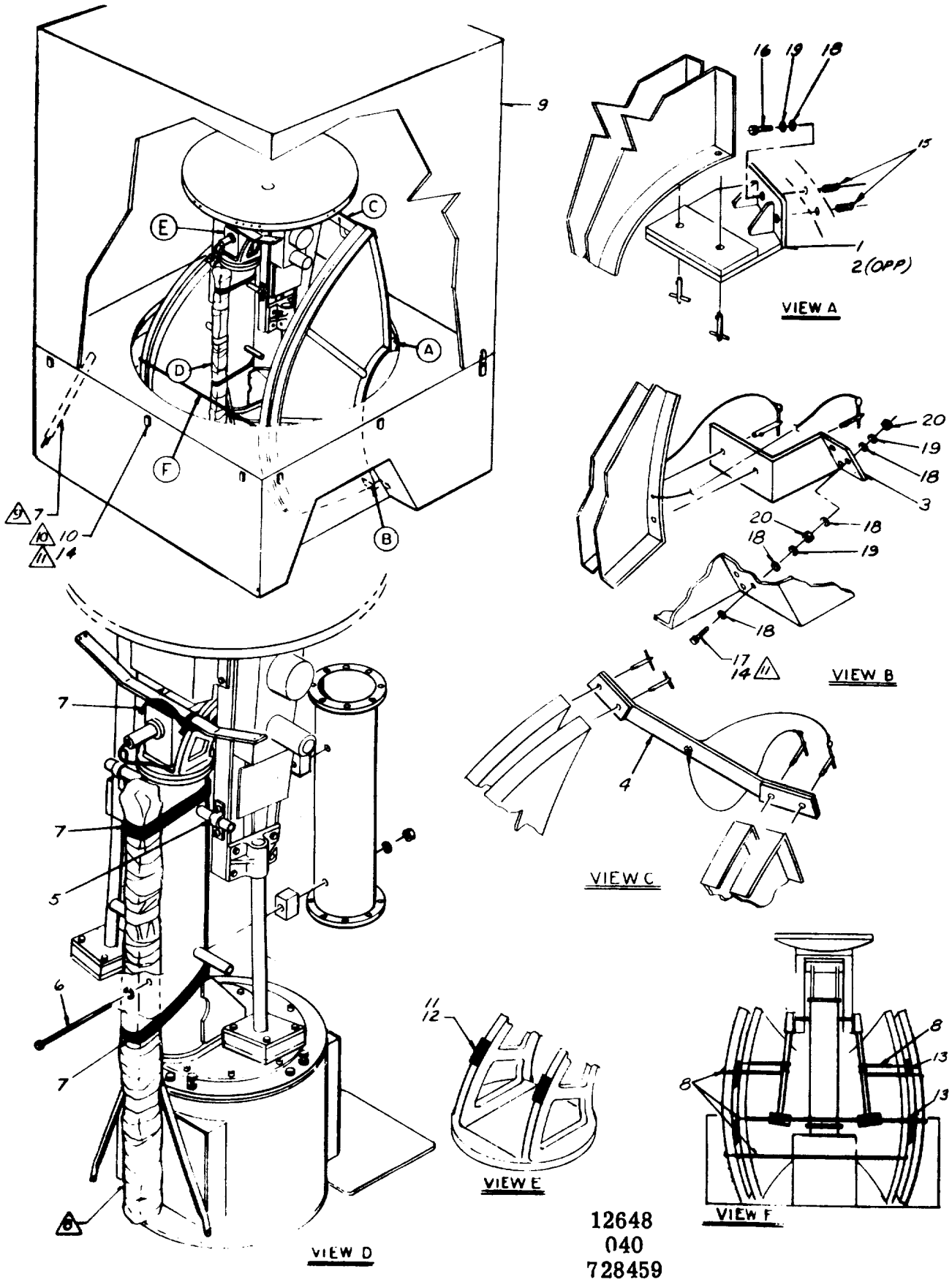

12648  
040  
728459

Figure 2-9. Antenna System, Stowed Position.  
2-46

Item	Qty	Part Number	Nomenclature and Description
1	1	728451	BRACKET, Stow, L. H.
2	1	728449	BRACKET, Stow, R. H.
3	2	728448	BRACKET, Stow, lower
4	1	728450	BRACKET, Stow, top
5	2	728452	CLAMP, Stow, elevation
6	2	728446	BOLT ASSEMBLY, Stow, Elevator Drive supports
7	5		STRAP, Canvas
8	4		BUNGEE CORD, 3/8 in. dia x 18 in. long
9	1	728976	HARD COVER ASSEMBLY
10	12	51L1-1X1AA	LATCH, Tension, adjust.
11	2	728459-11	PAD, Rubber, solid, 1/16 in. thick
12	A/R	1357	CEMENT, Contact
13	A/R	728459-13	RUBBER, Foam, 1/2 in. thick
14	A/R	RTV-731	SEALANT, Rubber
15	4	HS-25020-50	INSERT-TAPLOCK, 1/4-20 I.D.
16	4	MS35307-306	SCREW, Cap, hex. head, 1/4-20 x 3/4 lg.
17	6	MS51957.-87	SCREW, Pan head, 1/4-20 x 2.0 lg.
18	28	MS15795-810	WASHER, Flat, 1/4 in
19	16	MS35338-82	WASHER, Lock, split, 1/4 in
20	12	MS35690-410	NUT, Hex., plain, 1/4-20

**Figure 2-9. Antenna System, Stowed Portion, Index.**

TABLE 2-2. CABLING CHART

Plug & Pin	Signal	Plug & Pin	Signal
<u>J1, Antenna Pedestal</u>			
	<u>MS3102E36-7P</u>	<u>p</u>	B4R2
A	Servo Reference Hi	<u>r</u>	B4R1
B	Servo Reference Lo	<u>s</u>	B4R3
C	Safety On Light	<u>t</u>	AC Power in Hi
D	Spare	<u>u</u>	AC Power in Lo
E	Spare	<u>v</u>	+28-Volts DC
F	Horizontal Polarization	<u>w</u>	28-Volts DC Return
G	Vertical Polarization	<u>x</u>	Spare
H	RHC/45° Polarization	<u>y</u>	Spare
I	LHC/45° Polarization	<u>z</u>	Spare
J	Pressure & Manual Disable	<u>J2, Antenna Pedestal</u>	
K	Cable Wrap Out		<u>MS3112E22-55S</u>
L	Frame Ground	A	28V Return
M	B1S1	B	R1 E1 TX Synchro
N	B1S2	C	Beam Width Meter
O	B1S3	D	Beam Width Increase
P	Spare	E	Beam Width Decrease
R	Beam Width Meter	F	28-Volts DC
S	Spare	G	28-Volt Return
T	Beam Width Increase	H	Frame Ground
U	Beam Width Decrease	J	Limit Reversing Switch N.C. Contact
V	S1 E1 Ckt	K	Detent Relay A1K1-6
W	S2 E1 Ckt	L	Limit Reversing Switch ±28V
X	S3 E1 Ckt	M	Polarization Activate
Y	Polarization Activate	N	Horizontal Polarization
Z	Limit Reversing Switch i28V	P	Vertical Polarization
<u>a</u>	Limit Reversing Switch N.C. Contact	R	RHC/45° Polarization
<u>b</u>	Motor Common	S	LHC/45° Polarization
<u>c</u>	Limit Reversing Switch N. O. Contact	T	Motor Common
<u>d</u>	Spare	U	Detent Relay A1K1-5
<u>e</u>	Spare	V	Frame Ground
<u>f</u>	Spare	W	R2 E1 TX Synchro
<u>g</u>	Spare	X	Spare
<u>h</u>	B4S 1	Y	Spare
<u>i</u>	Pressure & Manual Disable	Z	E1 Drive Jumper A
<u>k</u>	Shield for h & j	<u>a</u>	E1 Drive Jumper B
<u>m</u>	Spare	<u>b</u>	Spare
<u>n</u>	Spare		

TABLE 2-2. CABLING CHART (CONT)

Plug & Pin	Signal	Plug & Pin	Signal
c	Spare	J	R1 E1 TX
d	Limit Switch	K	R2 E1 TX
e	S1 E1 Ckt	L	Spare
f	S2 E1 Ckt	<u>J4, Antenna Pedestal</u>	
g	S3 E1 Ckt	<u>MS3112E20-16S</u>	
h	Blower 01	A	Spare
i	Blower Common	B	Spare
k	Limit Switch	C	Spare
m	R2 E1 Ckt	D	Spare
n	R1 E1 Ckt	E	Spare
p	E1 Motor Hot	F	Frame Ground
q	Spare	G	Low Pressure Safety On
r	E1 Motor Common	H	Pressure Switch Interlock
s	E1 Motor Hot	J	28V Return
t	E1 Tach Lo	K	+28 VDC
u	E1 Tach Hi	L	Spare
v	Tach Ext.	M	Spare
w	S1 E1 TX	N	Spare
y	S2 E1 TX	P	Spare
z	S3 E1 TX	R	Spare
AA	Frame Ground	S	Spare
BB	Blower 02	<u>J1, Control Indicator</u>	
CC	Spare	<u>MS3112E-20-41P</u>	
DD	Spare	A	Servo Reference Hi
EE	Spare	B	Servo Reference Lo
FF	Spare	C	Frame Ground
GG	Spare	D	E1 Indicator Drive OA
HH	Spare	E	E1 Indicator Drive Neutral
<u>J3, Antenna Pedestal</u>		F	E1 Indicator Servo Power Relay
<u>MS3112E18-11S</u>		G	Ant. 1 Drive Power 0C Hi
A	Angle Data TX-S1	H	Ant. 1 Drive Power 0C Lo
B	Angle Data TX-S2	J	Spare
C	Angle Data TX-S3	K	Spare
D	S1 E1 TX	L	Ant. 1 Drive Power Relay
E	S2 E1 TX		
F	S3 E1 TX		
G	Angle Data TX-R1		
H	Angle Data TX-R2		

TABLE 2-2. CABLING CHART (CONT)

Plug & Pin	Signal	Plug & Pin	Signal
M	Az Ind. Servo Power Relay	E	S2 Az. Input
N	Spare	F	S1 Az. Input
P	Az. Ind. Drive Hi 0 A	G	R2 Synchro TX Excitation
R	+28 VDC	H	R1 Synchro TX Excitation
S	28 VDC Return		
T	Spare	<u>J3, Control Indicator</u>	
U	+24 VDC		<u>MS3112E-36-7S</u>
V	Spare		
W	Spare	A	Servo Ref. 0 A
X	R2 Synchro TX Excitation	B	Servo Ref. Neutral
Y	R1 Synchro TX Excitation	C	Safety On Lamp
Z	24 VDC Return	D	Spare
<u>a</u>	S1 Az. Ant. Position	E	Spare
<u>b</u>	S2 Az. Ant. Position	F	Horizontal Polarization
<u>c</u>	S3 Az. Ant. Position	G	Vertical Polarization
<u>d</u>	Oriented RSUR R1	H	LH Polarization
<u>e</u>	Oriented RSUR R3	I	Manual Disable Pressure
<u>f</u>	Shield		Safety Interlock
<u>g</u>	S3 Oriented Az. Ant. Pos. Ant. 1	K	Cable Wrap Pot Wiper
<u>h</u>	S2 Oriented Az. Ant. Pos. Ant. 1	L	Frame Ground
<u>i</u>	S1 Oriented Az. Ant. Pos. Ant. 1	M	AZ CT S1
<u>k</u>	6.3 VAC CT	N	AZ CT S2
<u>m</u>	6.3 VAC CT	O	AZ CT S3
<u>n</u>	Spare	P	Spare
<u>p</u>	Resolver Excitation	R	Beam Width Pot Wiper
<u>q</u>	Resolver Excitation	S	Spare
<u>r</u>	Shield	T	Beam Increase
<u>s</u>	Spare	U	Beam Decrease
<u>t</u>	6.3 VAC CT	V	EL PED CT S1
		W	EL PED CT S2
		X	EL PED CT S3
		Y	Polarizer Function F
		Z	+28V Polarizer Function E
		<u>a</u>	Polarizer Function H
		<u>b</u>	Polarizer Function G
		<u>c</u>	Polarizer Function J
		<u>d</u>	Spare
		<u>e</u>	Spare
		<u>f</u>	Spare
		<u>g</u>	Spare
<u>J2, Control Indicator</u>			
	<u>MS3112E-12-10S</u>		
A	S3 E1 Input		
B	S2 E1 Input		
C	S1 E1 Input		
D	S3 Az. Input		

TABLE 2-2. CABLING CHART (CONT)

Plug & Pin	Signal	Plug & Pin	Signal
<u>h</u>	RSUR Excitation	X	Remote Ref. Neutral
<u>i</u>	RSUR Excitation	Y	Remote Ref. Hot
<u>k</u>	Shield	Z	24 VDC Return
<u>m</u>	Spare	<u>a</u>	CDX Input 1
<u>n</u>	Spare	<u>b</u>	CDX Input 2
<u>p</u>	Shield	<u>c</u>	CDX Input 3
<u>q</u>		<u>d</u>	Orient Resolver R1
<u>r</u>	Ped Rsvr R1	<u>e</u>	Orient Resolver R3
<u>s</u>	Ped Rsvr R3	<u>f</u>	Resolver Shield
<u>t</u>	Ant. Drive Power	<u>g</u>	CDX Output 3
<u>u</u>	Ant. Drive Neutral	<u>h</u>	CDX Output 2
<u>v</u>	+28V	<u>i</u>	CDX Output 1
<u>w</u>	28V Return	<u>k</u>	Scan Ref.
<u>x</u>	Spare	<u>m</u>	Scan Ref.
<u>Y</u>	Spare	<u>n</u>	Spare
<u>z</u>	Spare	<u>p</u>	Resolver Excitation
		<u>q</u>	Resolver Excitation
		<u>s</u>	Spare
		<u>t</u>	Scan Ref. CT
<u>J1. Power Supply</u>		<u>J2. Power Supply</u>	
	<u>MS3112E-20-41S</u>		<u>PT02SE14-18S</u>
A	Servo Ref. 0 A	A	Resolver Excitation
B	Servo Ref. Neutral	B	Resolver Excitation
C	Chassis Ground	C	Resolver Shield
D	E1 Ind. Drive 0 A	D	Spare
E	E1 Ind. Drive Neutral	E	Spare
F	E1 Ind. Servo & Ref.	F	Spare
	Drive Relay	G	Spare
G	Ant. Drive 0 C	H	Spare
H	Neutral	J	Spare
J	Spare	K	Resolver Ref.
K	Spare	L	Resolver Ref.
L	Ant. Drive Relay	M	Resolver Shield
M	Az. Ind. Servo Relay	N	Resolver S1
N	Neutral	P	Resolver S2
P	Az. Ind. Drive 0 A	R	Ground
R	+28 VDC Unregulated	S	Neutral
S	28 VDC Return	T	Phase B to Scope
T	Spare	U	Phase A Ref.
U	+24 VDC Regulated		
V	Spare		
W	Spare		



TABLE 2-2. CABLING CHART (CONT)

Plug & Pin	Signal	Plug & Pin	Signal
<u>J3, Power Supply</u>			
	<u>MS3102E-18-10P</u>	O	Phase B
A	115/208 VAC 0 A	P	Radome Util. 0 B
B	115/208 VAC 0 B	R	Phase C
C	115/208 VAC 0 C	S	Neutral
D	Neutral	T	Pressure Gauge
		U	Anemometer
		V	Phone
		W	Phone
		X	Deicers On
		Y	Spare
		Y	Spare
		Z	Spare
		<u>a</u>	Spare
		<u>b</u>	Spare
		<u>c</u>	Spare
		<u>d</u>	Spare
		<u>e</u>	Spare
<u>J4, Power Supply</u>		<u>J5, Power Supply</u>	
	<u>MS3102E-32-8S</u>		<u>MS3102E- 16-10S</u>
A	Spare	A	Phase B
B	Spare	B	Neutral
C	Spare	C	Chassis Ground
D	Spare		
E	Spare		
F	Spare		
G	Spare		
H	Spare		
J	Safe Pressure Light		
K	Safe Pressure Light		
L	Spare		
M	Frame Ground		
N	Phase A		

**SECTION III**  
**OPERATION AND ADJUSTMENT**

1. GENERAL

This section contains the procedures necessary for proper operation and adjustment of the Antenna System and is written with the presupposition that operating personnel are thoroughly familiar with the content of the system and its operating controls. If not, it is recommended that Section V of this manual and the appendix to this manual be reviewed in detail prior to operation. Prior to system operation, the following cautions and notes should be observed.

**CAUTION**

- **When the input power cable is attached to the Antenna Control Power Supply and is energized from an external power source, approximately 208-volts AC should be present in the power supply at the line side terminals of the ANTENNA SYSTEM POWER circuit breaker, CB3, and the RADOME POWER circuit breaker, CB1. Before these circuit breakers are turned on, ensure that the electrical power is within the 208-volt  $\pm 10$  percent AC limit across any two of the three line side terminals of any of the circuit breakers by testing the voltage with a portable meter before placing the circuit breakers to the ON position.**
- **Check the AC power source to ensure that the line frequency is within the 48- to 62-CPS limit.**

**NOTE**

**Ensure that all switches and circuit breakers on the Antenna Position Control Indicator and Antenna Control Power Supply are off.**

2. RADOME INFLATION

A. After installation, and prior to system operation, the radome should be inflated in accordance with the following procedures.

**NOTE**

**It is assumed that during installation the radome guy straps have been positioned at the four corners of the radome platform and smoothed out so that there are no kinks or twists in the guy straps.**

- (1) Station one man at each of the four radome guy cables to stabilize the radome during inflation.
- (2) Position the RADOME POWER circuit breaker, CB1, on the Antenna Control Power Supply controlling the Antenna System to the ON position.
- (3) Position the BLOWER switch S3 on the Antenna Control Power Supply to the ON position.
- (4) Position the ANTENNA SYSTEM POWER circuit breaker to the ON position.
- (5) Observe that the pressure gauge on the Antenna Control Power Supply indicates an increasing pressure. When the radome is fully inflated, the pressure gauge should indicate approximately 0.5 PSI and the PRESSURE SAFE indicator light, DS1, should illuminate.
- (6) When the radome is fully inflated, secure the radome guy cables, maintaining an equal tension on each guy cable.

**CAUTION**

- **After installation, the radome control circuit breakers should be left on and the blower switch maintained in the ON position until the system is disassembled for reshipment. Leaving the radome inflated prevents the possibility of damaging the radome or the antenna feed and allows instantaneous system operation.**
- **Do not operate the DEICER power switch S1 on the Antenna Control Power Supply until the radome inflates to a safe pressure to avoid damage to the radome, should the automatic pressure switches in the radome fail. These pressure switches are in series with the deicer switches. When a safe pressure is reached, the deicer switches should be operated accordingly to prevent ice from forming on the radome and adversely affecting the antenna pattern.**

### 3. ACTIVATING THE EQUIPMENT

A. INITIAL SWITCH AND CONTROL SETTINGS - Prior to performing the procedures contained in paragraph 4 of this section, the switches and controls on the Antenna Control Power Supply, Antenna Position Control Indicator and antenna pedestal should be positioned as follows:

(1) ANTENNA CONTROL POWER SUPPLY (See Figure 5-19)

a. CB3, ANTENNA SYSTEMS POWER circuit breaker -ON, for operation of the radome pressure meters.

b. CB4, SERVO EXCITATION circuit breaker - OFF.

c. AZ ORIENT-O.

(2) ANTENNA POSITION CONTROL INDICATOR (See Figure 5-13)

a. S1, SERVO DRIVE switch - OFF.

b. S2, MODE SELECT switch - MANUAL.

c. R2, SCAN GAIN adjustment - full CCW.

d. R3, SCAN SECTOR adjustment - full CCW.

(3) ANTENNA PEDESTAL

a. SAFE-RUN switch - RUN.

#### CAUTION

To avoid injury to personnel, the SAFE-RUN switch should be in the SAFE position while personnel are working in the vicinity of the antenna. Placing SAFE-RUN switch in RUN position will cause the antenna to rotate, aligning itself in accordance with the commands from the Control Indicator.

#### NOTE

Due to the interlock of the SAFE-RUN switch on the antenna pedestal with the SERVO DRIVE switch, S1, on the Control Indicator, the system will not operate if the SAFE-RUN switch is in the SAFE position.

Revised January 22, 1968

**CAUTION**

The **SAFE** position of the **SAFE-RUN** switch assures the servo drive cannot be activated; however, voltage is still present inside the pedestal.

## 4. PREOPERATIONAL TEST CHECK LIST

**NOTE**

Prior to performing the procedures contained in this paragraph, ensure that the procedures contained in paragraphs 2 and 3 of this section have been performed.

## A. INITIAL TURN-ON PROCEDURE

## (1) ANTENNA CONTROL POWER SUPPLY (See Figure 5-19)

a. Set CB3, the ANTENNA SYSTEMS POWER circuit breaker, to the ON position. On the Antenna Position Control Indicator, observe illumination of DS7, AZIMUTH MODE MANUAL indicator light. On the Antenna Control Power Supply, observe that the RADOME PRESSURE meter is indicating radome pressure, and that the PRESSURE SAFE indicator light is illuminated.

b. Set CB4, the SERVO EXCITATION circuit breaker, to the ON position.

## (2) ANTENNA POSITION CONTROL INDICATOR (See Figure 5-13)

a. Set the S1 SERVO DRIVE switch to the ON position. Observe illumination of DS4 SERVO DRIVE on indicator and DS21, ELEVATION MODE MANUAL indicator.

**NOTE**

If DS4 does not illuminate but DS18, the SAFETY ON indicator light illuminates, the **SAFE-RUN** switch on the antenna pedestal is in the **SAFE** position or there is insufficient pressure in the radome.

b. Rotate the azimuth handwheel CW. Observe that the TRUE AZIMUTH digital counter indicates an increasing azimuth angle and the cable-wrap meter deflects toward its right red limit marking.

c. Rotate the azimuth handwheel CCW. Observe that the TRUE AZIMUTH digital counter indicates a decreasing azimuth angle and the cable-wrap meter deflects toward its left red limit marking.

d. Rotate the LAMP INTENSITY control CW and CCW. Observe that CW rotation brightens and CCW rotation dims the lights over the TRUE AZIMUTH and TRUE ELEVATION digital counters.

## B. STATIC ACCURACY CHECK

### NOTE

**Prior to performing this check, the AZ ORIENT control on the Antenna Position Power Supply should be set to zero.**

(1) Rotate the azimuth handwheel CW to position the antenna to 120. 0240.0 degrees and to three intermediate arbitrary positions as indicated on the TRUE AZIMUTH digital counter. Observe and record the antenna position on the antenna pedestal vernier for each setting of the counter dial. The actual antenna heading should be within  $\pm 0.5$  degree of the azimuth angle indicated on the TRUE AZIMUTH digital counter. Note and record the antenna position deviation for each of the selected settings.

(2) Repeat step (1) by rotating the azimuth handwheel CCW so that the same positions are approached from the opposite direction. Record the antenna positions and note that the positions are within  $\pm 0.5$  degree of the selected position.

(3) Rotate the azimuth handwheel to position the TRUE AZIMUTH digital counter to 000.0.

(4) Position the AZ ORIENT control on the Antenna Control Power Supply to 5, 10, and 20 degrees. The antenna should go to the complement of these settings, i.e., 355 degrees, 350 degrees, and 340 degrees, respectively. Record the actual antenna position, as indicated on the vernier, for each setting.

(5) Return the AZ ORIENT dial knob to zero.

(6) Rotate the elevation handwheel to 000.0, 045.0, 090.0 degree and to three intermediate, arbitrary positions as indicated on the TRUE ELEVATION digital counter. Record the actual antenna position as indicated on the vernier on the elevation drive assembly for each setting.

- (7) Rotate the elevation handwheel to position the TRUE ELEVATION digital counter to 000.9 degree.

### C. LIMIT STOP CHECK

- (1) Position the MODE SELECT switch, S2, to the MANUAL position.

(2) Rotate the azimuth handwheel CW to +270 degrees, the CW electrical limit. Prior to engaging the mechanical stop, observe that antenna rotation slows up, as indicated by the cable-wrap meter. When the antenna is in its CW limit, the needle in the cable-wrap meter should be fully in the right red limit marking.

(3) Rotate the azimuth handwheel CCW to -270 degrees, the CCW electrical limit. Prior to engaging the mechanical stop, observe that antenna rotation slows up, as indicated by the cable-wrap meter. When the antenna is in its CCW limit, the needle on the cable-wrap meter should be fully in the left red limit marking.

- (4) Rotate the azimuth handwheel CW until the TRUE AZIMUTH digital counter indicates 000.0 degree.

### NOTE

**If a correction factor is set into the AZ ORIENT control, this factor should be added to the limit to obtain the actual position in degrees at which the limit stops will be engaged (i.e., if 20 degrees is set into the AZ ORIENT control, the electrical limit will be engaged at 290 degrees and the mechanical limit at 310 degrees, as indicated by the azimuth vernier on the counter on the Control Indicator.**

(5) Slowly lower the antenna in elevation, by rotating the elevation handwheel CCW, until the lower electrical limit is engaged at approximately -15 degrees. Prior to engaging the mechanical stop, observe that antenna rotation slows up.

- a. Repeat step (3), rotating the elevation handwheel CW to the upper electrical limit of +95 degrees.
- b. Rotate the elevation handwheel CCW until the TRUE ELEVATION digital counter indicates 000.0.

D. SECTOR SCAN CHECK (1) With the MODE SELECT switch, S2, in the MANUAL position, rotate the azimuth and elevation handwheels to position the TRUE ELEVATION to 000. 0.

(2) Rotate the SCAN CONTROL GAIN adjustment, R2, full CCW.

(3) Rotate the SCAN CONTROL SECTOR adjustment, R3, full CCW.

(4) Set the MODE SELECT switch, S2, to the SCAN position. Observe illumination of DS8, the AZIMUTH MODE SCAN light.

(5) Slowly rotate the SCAN CONTROL SECTOR and GAIN adjustments, R3 and R2, a few degrees CW. Observe on the TRUE AZIMUTH digital counter that the antenna scans a small angle around 000. 0 degree azimuth at a slow speed.

(6) Rotate R3 and R2 to various positions and observe that the sector scanned can be increased from approximately  $\pm 5$  to  $\pm 270$  degrees around 000. 0 degree azimuth. The rate at which the sector is scanned should increase with CW rotation of R2. With R3 full CW, the sector scanned should be approximately  $\pm 270$  degrees, which are the electrical limits of the antenna pedestal in azimuth.

(7) During sector scan operation, rotate the elevation handwheel and observe on the TRUE ELEVATION digital counter that the antenna follows in elevation.

(8) Rotate R3 and R2 full CCW.

#### E. POLARIZATION CONTROL CHECK

(1) Set the POLARIZATION SELECT switch, S6, to the H position.

(2) Observe that when the antenna is horizontally polarized, all indicator lights, except the horizontal (H) light, go off.

#### F. ELECTROMECHANICAL LINEAR ACTUATOR CHECK

(1) On the Control Indicator, set and hold the beam width change switch, S7, to the BEAM INCREASE position. Observe that the needle on the BEAM WIDTH meter deflects in an increasing direction.

(2) Reposition S7 to the BEAM DECREASE position. Observe that the needle on the BEAM WIDTH meter deflects in a decreasing direction.



## G. SAFETY CIRCUIT CHECK

(1) Set the SAFE-RUN switch on the antenna pedestal to the SAFE position. Observe, on the Control Indicator, that the SAFETY ON indicator light illuminates and that the antenna will not drive, regardless of what mode of operation is selected.

(2) Reposition the SAFE-RUN switch on the antenna pedestal to the RUN position.

### NOTE

**An automatic pressure safe switch in the radome-platform is also in series with the safety switches on the antenna pedestal and/or radome junction box. The pressure safe switch opens when radome pressure falls below approximately 0.3 PSI.**

## 5. SYSTEM ALIGNMENT AND ADJUSTMENT

A. GENERAL - The contents of this subsection are presented with the presupposition that each unit has been aligned individually in accordance with the procedures contained in Section V.

### B. +24-VOLT DC REGULATED ADJUSTMENT

(1) Operate the equipment in accordance with the procedures contained in paragraph 4. A of this section.

(2) Connect a DC voltmeter between TP3 (+) and TP2 (ground) on the Power Supply.

(3) With a screwdriver, rotate potentiometer R1 (Figure 5-20) to obtain a 24-volt reading on the DC voltmeter.

### C. BEAM WIDTH METER ADJUSTMENT

(1) Operate the equipment in accordance with the procedures contained in paragraph 4. A of this section.

(2) Position and hold the beam width change switch, S7, to the BEAM DECREASE position until the feed is fully retracted (as reported by personnel in the radome).

(3) Adjust potentiometer R5 on the Control Indicator until the needle on the BEAM WIDTH meter is at zero.

(4) Position and hold the beam width change switch, S7, to the BEAM INCREASE position until the feed is fully extended (as reported by personnel in the radome).

(5) Adjust potentiometer R6 on the Control Indicator until the needle on the BEAM WIDTH meter is at 100.

(6) Repeat steps (2) through (5) until optimum deflection of the needle on the BEAM WIDTH meter is obtained in either direction.

#### D. CABLE WRAP ADJUSTMENT

(1) Operate the equipment in accordance with the procedures contained in paragraph 4.A of this section.

(2) Rotate the azimuth handwheel CCW to 90 degrees (-270 degrees limit). The needle on the CABLE WRAP meter, M1, should deflect in a decreasing direction toward its left red limit marking.

(3) Adjust potentiometer R7 on the Control Indicator until the needle on the CABLE WRAP meter just enters the left red limit marking.

(4) Rotate the azimuth handwheel CW to 270 degrees. The needle on the CABLE WRAP meter, M1, should deflect in an increasing direction toward its right red limit marking.

(5) Adjust potentiometer R8 on the Control Indicator until the needle on the CABLE WRAP meter first enters the right red limit marking.

(6) Repeat steps (2) through (5) until optimum deflection of the needle on the CABLE WRAP meter is obtained in either direction.

#### E. SECTOR SCAN ADJUSTMENT

(1) Operate the equipment in accordance with the procedures contained in paragraph 4.A of this section.

(2) Perform the sector scan procedures contained in paragraph 4.D of this section.

(3) If, when scanning a sector, the angle scanned is not equal on either side of 000. 0 degree, within  $\pm 5$  degrees, deenergize the equipment and perform the following procedures:

a. Remove the handwheels, four screws holding the meter panel to the gear box, and the six screws securing the front panel to the chassis. Lower the front panel.

b. Reenergize the equipment and while scanning a small sector at a slow rate, loosen the three allen-head screws holding the antenna position potentiometer, R4, in position. Slowly rotate R4 on the Control Indicator until the sector scanned is equal on either side of 000.0 degree within  $\pm 5$  degrees.

c. Tighten the allen-head screws loosened in step b. Care should be taken when tightening these screws to keep the potentiometer from slipping.

d. Reinstall the hardware removed in step a.

(4) If, when scanning, the minimum sector scanned is not approximately  $\pm 5$  degrees, rotate potentiometer A1R8 on the Control Indicator until the minimum sector scanned reaches these limits.

## 6. OPERATING PRECAUTIONS

A. No special precautions are to be observed during operation of the Antenna System. Operating procedures which are essential to highlight are supplemented by notes in the operating procedures contained in paragraph 7 of this section. The following CAUTION is to be observed prior to operation:

### CAUTION

**Do not operate the system until the green PRESSURE SAFE indicator light on the Antenna Control Power Supply illuminates when the ANTENNA SYSTEMS POWER circuit breaker, CB3, is in the ON position. The radome pressure meter should indicate approximately 0.5 PSI.**

### NOTE

**During operation, the AZ ORIENT control should be in the position recorded in paragraph 3.A of this section.**

## 7. SYSTEM OPERATING PROCEDURES

A. GENERAL - This subsection presents the procedures required to operate the equipment in each of its three modes of operation and accomplish each unique operation feature. The AZ ORIENT control on the Antenna Control Power Supply should be set as follows prior to actual system operation.

(1) AZ ORIENT -Position to compensate for any misalignment of the Antenna System to true north or a selected reference point. Record the position of this control.

### B. MANUAL MODE OF OPERATION

(1) Perform the initial turn-on procedures contained in paragraph 4.A of this section.

(2) Rotate the azimuth and/or elevation handwheels to the desired position.

### C. SLAVE MODE OF OPERATION

(1) Perform the initial turn-on procedure contained in paragraph 4.A of this section.

(2) Position the antenna in the approximate azimuth and/or elevation direction of the slaving source with the azimuth and/or elevation handwheels.

(3) Set the MODE SELECT switch, S2, to the SLAVE position. Observe illumination of DS6, the AZIMUTH MODE SLAVE indicator light. The slaving source should now have full command of the system.

### D. SCAN MODE OF OPERATION

(1) Perform the initial turn-on procedures contained in paragraph 4.A of this section.

(2) With the MODE SELECT switch, S2, in the MANUAL position, rotate the azimuth and elevation handwheels to position the antenna to the azimuth angle about which it is desired to scan, as indicated on the TRUE AZIMUTH and TRUE ELEVATION digital counters.

(3) Rotate the SCAN CONTROL GAIN adjustment, R2, full CCW.

(4) Rotate the SCAN CONTROL SECTOR adjustment, R3, full CCW.

(5) Set the MODE SELECT switch, S2, to the SCAN position. Observe illumination of DS8, the AZIMUTH MODE SCAN indicator light.

(6) Slowly rotate the SCAN CONTROL GAIN adjustment, R2, a minimum CW.

(7) Slowly rotate the SCAN CONTROL SECTOR adjustment, R3, CW until the antenna is scanning the required sector.

(8) Slowly rotate the SCAN CONTROL GAIN adjustment, R2, CW to obtain the desired scanning rate. The antenna will now automatically scan the preset sector at the desired rate.

(9) Rotate the elevation handwheel, on systems with elevation capabilities, as required to increase or decrease the elevation angle of the antenna.

#### E. POLARIZATION CONTROL

(1) Set the POLARIZATION SELECT switch, S6, to the desired mode of polarization - H, V, LHC -45, or RHC +45.

(2) Observe that when the antenna repolarizes as selected, all indicator lights, except the one for the selected polarization, go off.

#### F. BEAM WIDTH CHANGE

(1) If it is desired to change the beam width of the antenna while the system is operating in any one of the three possible modes of operation, set the beam width change switch, S7, to the BEAM INCREASE or BEAM DECREASE position, as desired.

(2) Hold S7 in the selected position and observe an increase or decrease, depending on the position of S7, on the BEAM WIDTH meter. Release S7 when the antenna beam, as indicated on the meter, reaches the desired width.

### 8. STOPPING PROCEDURES

A. When operation of the Antenna System is complete, the system should be shut down in accordance with the following procedures:

(1) Set the SERVO DRIVE switch, S1, on the Antenna Position Control Indicator, to the OFF position.

(2) Set the SERVO EXCITATION circuit breaker, CB4, on the Antenna Control Power Supply, to the OFF position.

(3) Set the ANTENNA SYSTEMS POWER circuit breaker, CB3, on the Antenna Control Power Supply to the OFF position.

- (4) Set the DEICER power switch, S1, on the Antenna Control Power Supply to the OFF position.

**CAUTION**

**The RADOME POWER circuit breaker on the Antenna Control Power Supply should be left on and the BLOWER switch on the Antenna Control Power Supply maintained in the ON position to keep the radome inflated. Leaving the radome inflated prevents the possibility of damaging the radome or the antenna feeds and allows instantaneous operation.**

**SECTION IV  
MAINTENANCE**

1. GENERAL

A. This section and the appendix to this manual provide the instructions necessary for inspection and preventive and corrective maintenance of the Antenna System. The contents of this section presupposes that maintenance personnel are thoroughly familiar with the physical makeup of the equipment, the installation and operating procedures, and detailed theory of operation contained in other sections of this manual. The wiring and schematic diagrams necessary for troubleshooting the system are contained in Section V of this manual. The simplified schematic diagrams contained in Section I of this manual simplify system and component troubleshooting.

2. PERIODIC INSPECTION AND PREVENTIVE MAINTENANCE

A. Adherence to the inspection and preventive maintenance procedures and recommendations contained in Table 4-1 and in the appendix to this manual will increase the life of the equipment, assure continuity of service, and maintain the equipment in peak operation condition.

**NOTE**

**Do not remove radome at any time unless absolutely necessary for maintenance or repair.**

**TABLE 4-1. PERIODIC INSPECTION AND PREVENTIVE MAINTENANCE SCHEDULE**

Component	Check	Schedule
All	a. Visually inspect cables, connectors, and all exposed components for signs of wear. b. Perform a complete operational check. c. Check the radome, tower, and antenna.	Weekly

**CAUTION**

**To avoid injury to personnel, the Antenna Pedestal SAFE-RUN switch should be in the SAFE position while personnel are working in the vicinity of the antenna. Placing SAFE-RUN switch in RUN position will cause antenna to rotate, aligning itself to the commands from the Control Indicator.**

Revised January 22, 1968

TABLE 4-1. PERIODIC INSPECTION AND PREVENTIVE MAINTENANCE SCHEDULE (CONT)

Component	Check	Schedule
All	<ul style="list-style-type: none"> <li>a. Check for loose or damaged cables and connectors.</li> <li>b. Check fuses, switches, and relays. Clean and burnish contacts.</li> <li>c. Check the radome, tower, and antenna.</li> </ul>	Monthly
All	<ul style="list-style-type: none"> <li>a. Disconnect all cables and inspect and clean all receptacles and plugs.</li> <li>b. Blow the dust out of the interior of all components.</li> <li>c. Check for loose mounting screws or other mounting hardware. Do not exert sufficient force to damage threads when tightening.</li> <li>d. Check for corrosion. If present, remove with sandpaper, polish, apply zinc chromate, and repaint with matching color.</li> <li>e. Inspect antenna pedestal and elevation drive assembly drive motors for moisture and water seepage. Examine brushes and replace as required.</li> <li>f. Check all gear assemblies for dirt, wear, or looseness.</li> <li>g. Check level of pedestal.</li> <li>h. Check each unit for signs of excessive heating, indicated by burned resistors or melted wax.</li> <li>i. Check all potentiometers for wear, poor contact, or noise.</li> <li>j. Inspect each unit for loose or broken connections, damaged parts, dirt, or signs of excessive wear.</li> <li>k. Clean all slides on the electrical units and apply a thin coating of vaseline or equivalent.</li> <li>l. Check the radome, tower, and antenna.</li> </ul>	Quarterly



**TABLE 4-1. PERIODIC INSPECTION AND PREVENTIVE MAINTENANCE SCHEDULE (CONT)**

Component	Check	Schedule
All	a. Visually inspect all component parts. Replace if any component shows evidence of damage. b. Lubricate the azimuth and elevation drive gear train with a thin coat of MIL-G-3278A grease. c. Check the radome, tower, and antenna.	Yearly

**3. TOOL REQUIREMENT**

A. No special tools, other than those listed in Table 1-3, are required for inspection and routine maintenance of the equipment. It is assumed that a set of standard hand tools are available on site.

**4. TROUBLE ANALYSIS**

A. The trouble analysis chart, Table 4-2, is designed to enable maintenance personnel to rapidly isolate the cause of trouble to a specific circuit. Once located, normal troubleshooting procedures may be used to isolate the faulty component. The most important step in the rapid location of trouble is the application of common sense. Prior to starting a troubleshooting procedure to locate a trouble, all fuses and switch and control settings should be checked.

B. Since the equipment is primarily electromechanical, most major troubles may be isolated rapidly by observing the following:

(1) If the system will operate in the local and slave mode, but not in the sector scan mode, the trouble is probably in the scan generator circuit card. This should be replaced if this trouble occurs.

(2) If the system will not slew in azimuth, the trouble is probably servo-amplifier AR1 in the pedestal.

(3) If the system will not slew in elevation, the trouble is probably in elevation servo-amplifier AR2 in the pedestal.

TABLE 4-2. TROUBLE ANALYSIS CHART

Step No.	Procedure	Normal Indication	Corrective Step
1	All circuit breakers are turned off and all switches are turned off. One man is stationed at each of the four radome guy cables to stabilize radome during inflation and the blower inlets are open.		
2	Position the RADOME POWER circuit breaker, CB1, on the Antenna Control Power Supply to the ON position.	Power will be applied to the open contacts of all contactors in the radome box.	<ul style="list-style-type: none"> <li>a) Check input power</li> <li>b) Check interconnecting cables</li> </ul>
3	Position the BLOWER selector switch, S2, on the Antenna Control Power Supply to the ON position.	K1 in radome box closes, blower rotates.	<ul style="list-style-type: none"> <li>a) Check pressure switch S3 and K1 if B1 fails to operate</li> <li>b) Check rotation of the blower; if it rotates in the wrong direction, reverse phase A and B, phase A and C, or phase B and C. Reversal of any two phases will reverse the direction of the motor. Check interconnecting cable.</li> </ul>
<p><b>NOTE</b></p> <p><b>The blower will operate in either direction; however, it is more efficient in one direction than the other. Radome inflation time should be approximately 5 minutes. If it is much longer, blower is probably running in wrong direction.</b></p>			

TABLE 4-2. TROUBLE ANALYSIS CHART (CONT)

Step No.	Procedure	Normal Indication	Corrective Step
4	Position the ANTENNA SYSTEMS POWER circuit breaker, CB3, to the ON position.	The RADOME PRESSURE meter on the Power Supply should show an increasing reading as the radome becomes inflated.	a) If meter is inoperative, check TP1 in the Power Supply for +28 volts. Check fuse F4.
5	Observe that the RADOME PRESSURE gauge on the Antenna Control Power Supply reaches approximately 0.5 PSI when the radome is inflated and that the PRESSURE SAFE indicator light, DS1, on the power supply illuminates.		a) Check the light bulbs. b) Check pressure switch S1 in the radome. c) Check pressure transducer MT1 in radome box.
6	Set CB4, the SERVO EXCITATION circuit breaker, on the Power Supply, to the ON position.	Illumination of DS4, the drive indicator light.	
7	Set S1, the SERVO DRIVE switch on the Control Indicator, to the ON position.		a) Check radome pressure. b) Check SAFE-RUN switch in radome boxes. c) Check SAFE-RUN switch on the pedestal.

TABLE 4-2. TROUBLE ANALYSIS CHART (CONT)

Step No.	Procedure	Normal Indication	Corrective Step
8	Rotate the azimuth handwheel clockwise.	The TRUE AZIMUTH digital counter will read an increasing azimuth angle and the CABLE WRAP meter will deflect toward the right red limit marking.	<ul style="list-style-type: none"> <li>a) If, when the handwheel is rotated, the gear train and the associated digital counter do not move, check the azimuth handwheel clutch.</li> <li>b) If the counter moves but the cable-wrap meter does not deflect toward the right red marking, check to see that the pedestal is not in a limit.</li> <li>c) Check the azimuth servo amplifier in pedestal.</li> <li>d) Check servo excitation to the pedestal.</li> <li>e) If the antenna moves, but the CABLE WRAP meter gives no indication, check the cable-wrap potentiometer in the antenna pedestal.</li> </ul>
9	Rotate the azimuth handwheel counterclockwise.	Reverse of step 8.	Same as step 8.

TABLE 4-2. TROUBLE ANALYSIS CHART (CONT)

Step No.	Procedure	Normal Indication	Corrective Step
10	Rotate the lamp intensity control on the Control Indicator clockwise and counterclockwise.	The lights over the TRUE AZIMUTH and TRUE ELEVATION digital counters, the lights for the BEAM WIDTH meter, and CABLE WRAP meter will change intensity.  <p style="text-align: center;"><b>NOTE</b></p> <p style="text-align: center;"><b>The AZ ORIENT control on the Power Supply should be set to zero for the following checks.</b></p>	a) Check lamp intensity potentiometer. b) Check light bulbs.
11	Rotate the azimuth handwheel to position the antenna to 120°, 240°, and to three arbitrary positions.	The azimuth angle scale on the antenna pedestal will read whatever the TRUE AZIMUTH digital counter reads, within ± 1/2°.	a) Check the zero of the CT in the pedestal. b) Check the zero of the Power Supply CDX. c) Check the zero of the azimuth CX in the Control Indicator. d) If the pedestal does not move, or moves sluggishly or erratically, check the azimuth servo amplifier in the pedestal.

TABLE 4-2. TROUBLE ANALYSIS CHART (CONT)

Step No.	Procedure	Normal Indication	Corrective Step
12	Position the AZ ORIENT control to 5, 10 and 20 degrees with the TRUE AZIMUTH counter on the Control Indicator set to zero.	The antenna should follow the complement of these settings within $\pm 1/2^\circ$ .	<ul style="list-style-type: none"> <li>a) Check zero of the CDX being rotated.</li> <li>b) Check zero of the CT in the pedestal.</li> <li>c) Check zero of the azimuth CX in the Control Indicator.</li> </ul>
13	Rotate the elevation handwheel to 0, 45 and 90 degrees and to three intermediate arbitrary positions.	The antenna in elevation should follow within $\pm 1/2^\circ$ .	<ul style="list-style-type: none"> <li>a) If elevation does not move or moves sluggishly or erratically, check the elevation servo amplifier in the pedestal.</li> <li>b) If elevation moves normally but does not follow within <math>\pm 1/2^\circ</math>, check the zero of the CT in the elevation assembly.</li> <li>c) Check the zero of the elevation CX in the Control Indicator.</li> </ul>
14	Run the antenna into an azimuth electrical limit.	The antenna's servo action will become sluggish $30^\circ$ prior to contacting the mechanical stop.	<ul style="list-style-type: none"> <li>a) Check the setting of the limit switches.</li> <li>b) Check the azimuth limit resistor.</li> </ul>
15	Repeat step 14 for the opposite limit.		

TABLE 4-2. TROUBLE ANALYSIS CHART (CONT)

Step No.	Procedure	Normal Indication	Corrective Step
16	Run the elevation into an electrical limit.	Servo action becomes sluggish approximately 3° before contacting a mechanical stop.	<ul style="list-style-type: none"> <li>a) Check setting of the elevation limit switches.</li> <li>b) Check the elevation limit resistor.</li> </ul>
17	With the TRUE AZIMUTH counter set at zero and SCAN CONTROL SECTOR and SCAN CONTROL GAIN controls fully counterclockwise, set the MODE SELECT switch, S2, to the SCAN position.	The antenna will not move; the AZIMUTH MODE SCAN indicator light will illuminate.	Check the light bulb.
18	Rotate the SCAN CONTROL GAIN control to increase the rate of the sector scanned.	The TRUE AZIMUTH counter on the Control Indicator will begin to slowly sector scan back and forth about zero. The antenna will follow.	<ul style="list-style-type: none"> <li>a) Check the scan generator card.</li> <li>b) Check the azimuth servo amplifier in the Control Indicator.</li> <li>c) Check the 6.3 -volts AC scan reference voltage.</li> <li>d) Check the position of the cam on S8 in the gear train in the Control Indicator.</li> <li>e) Check the +24 volts on sector scan potentiometer.</li> </ul>

TABLE 4-2. TROUBLE ANALYSIS CHART (CONT)

Step No.	Procedure	Normal Indication	Corrective Step
19	Rotate R3 and R2 to various positions.	Scan speed should increase and decrease as R2 is varied. The area sectored should increase from an approximate total of 10° up to an approximate total of more than 180°.	<ul style="list-style-type: none"> <li>a) Check the associated pots.</li> <li>b) Check the position of the cam that operates S8.</li> <li>c) Check the adjustment of the scan generator card if the area scanned is not correct.</li> </ul>
20	During scan operation, rotate the elevation handwheel.	The TRUE ELEVATION counter will change and the antenna will follow.	Repeat troubleshooting in step 13.
21	Set the POLARIZATION SELECT switch, S6, to the H position.	All four polarization lights, H, V, RH and LH, should light. Three of the four will go out; the one that remains lighted will be the H light.	<ul style="list-style-type: none"> <li>a) Check the light bulbs.</li> <li>b) Check the polarization relays in the Control Indicator.</li> <li>c) Check the detent relay in the antenna pedestal.</li> <li>d) Check the polarization diversity mechanism. Repeat above procedure for all four polarization modes.</li> </ul>
22	Repeat step 21 in turn for the for the V, LH, and RH positions.	Same as step 21.	Same as step 21.



TABLE 4-2. TROUBLE ANALYSIS CHART (CONT)

Step No.	Procedure	Normal Indication	Corrective Step
23	Switch the beam width change switch, S7, to the BEAM INCREASE position.	The beam broadener will extend. The BEAM WIDTH meter will move from left to right.	<ul style="list-style-type: none"> <li>a) Check the beam broadener.</li> <li>b) Check for 28 volts at the beam width change switch, S7.</li> <li>c) If the beam broadener operates but the BEAM WIDTH meter does not operate, check the potentiometer on the beam broadener.</li> <li>d) Check for 28 volts at this beam broadener potentiometer.</li> <li>e) Check the BEAM WIDTH meter.</li> </ul>
24	Set the beam width change switch, S7, to the BEAM DECREASE position.	Reverse action of the beam increase.	Same as step 23.
25	Set the SAFE-RUN switch on each pedestal to the SAFE position.	The SAFETY ON lights on the Control Indicator will illuminate; the antenna will not drive.	<ul style="list-style-type: none"> <li>a) Check the light bulb.</li> <li>b) Check the switch.</li> </ul>

## SECTION V

### DESCRIPTION OF COMPONENTS

#### 1. SYSTEMS DESCRIPTION

A. GENERAL - This subsection contains a description of the Antenna System and describes the components therein. The description is referenced to a major component location diagram and to exploded views which clearly illustrate all of the major components comprising the system. Appendix I, which contains detailed information on the scope, supplements the information provided in this section.

#### B. ANTENNA SYSTEM (See Figure 5-1)

(1) DESCRIPTION - The Antenna System, which is housed in a 16-foot inflatable radome-platform, is designed for installation on an 80-foot tower, on a portable hoisting unit or on a portable stand. Two guying structures, one for the portable stand installation and one for the 80-foot tower installation, are provided. Two lightning rod mounts and one lightning rod are provided. For system shipment and storage, a transit cover with removable panels is provided. This cover fits over the disassembled Antenna System and is held in position by snap-lock fasteners.

a. The Antenna System (Figure 5-2) consists of a 9-foot fiberglass paraboloidal reflector fed by a log-periodic dipole feed (item 5), an elevation drive assembly with elevation capabilities of from -15 to +95 degrees, an elevation drive support casting (item 8), an elevation drive support extension (item 7), an antenna pedestal (item 10) with rotation capabilities of + 300 degrees, two level bubbles (item 24), an elevation data cable assembly (item 2), three rf cable assemblies (items 67, 68 and 69), and one portable stand.

b. The antenna has a very narrow beam width and requires both azimuth and elevation rotation capabilities in order to search for, locate, and receive rf radiation from a point, or points, in space. The antenna operates over the frequency range of from 1 to 12 MHz. The antenna is also provided with an electromechanical linear actuator (beam broadener) with a motor-driven mechanism which provides remotely selectable actuation of the linear movement of the feed support shaft, relative to the focal point of the reflector. The primary effect of defocusing the feed toward the reflector from the focal point is to increase the phase error across the reflector, broadening the main lobe by several degrees and reducing the gain of the antenna. The antenna is capable of generating linear polarization only. Each feed is mounted on a polarization mechanism which rotates it to any one of four orientations to provide horizontal, vertical, +45-degree or -45-degree linear polarization. Polarization and beam

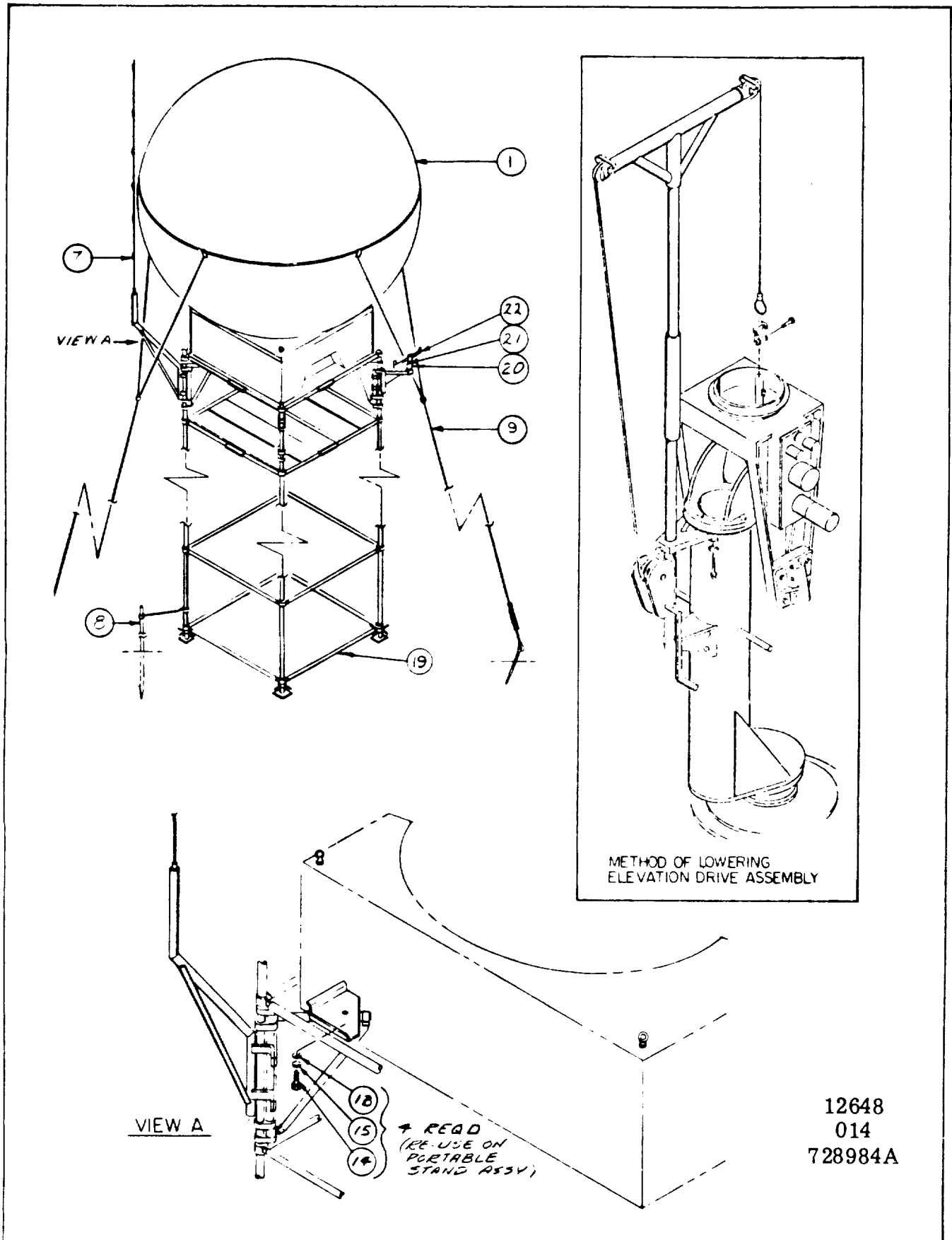

Figure 5-1. Antenna System, Major Components Location (Sheet 1 of 2).

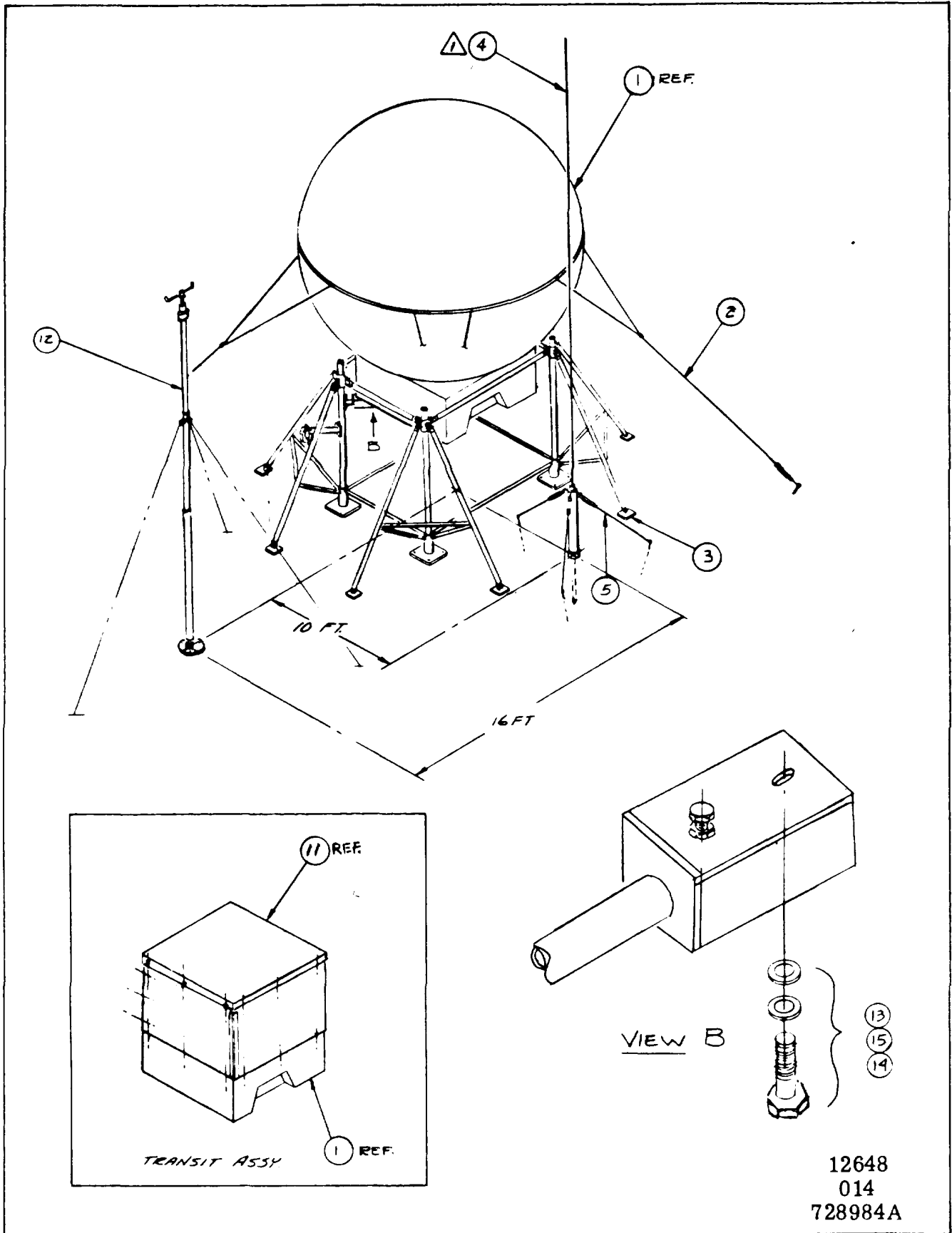
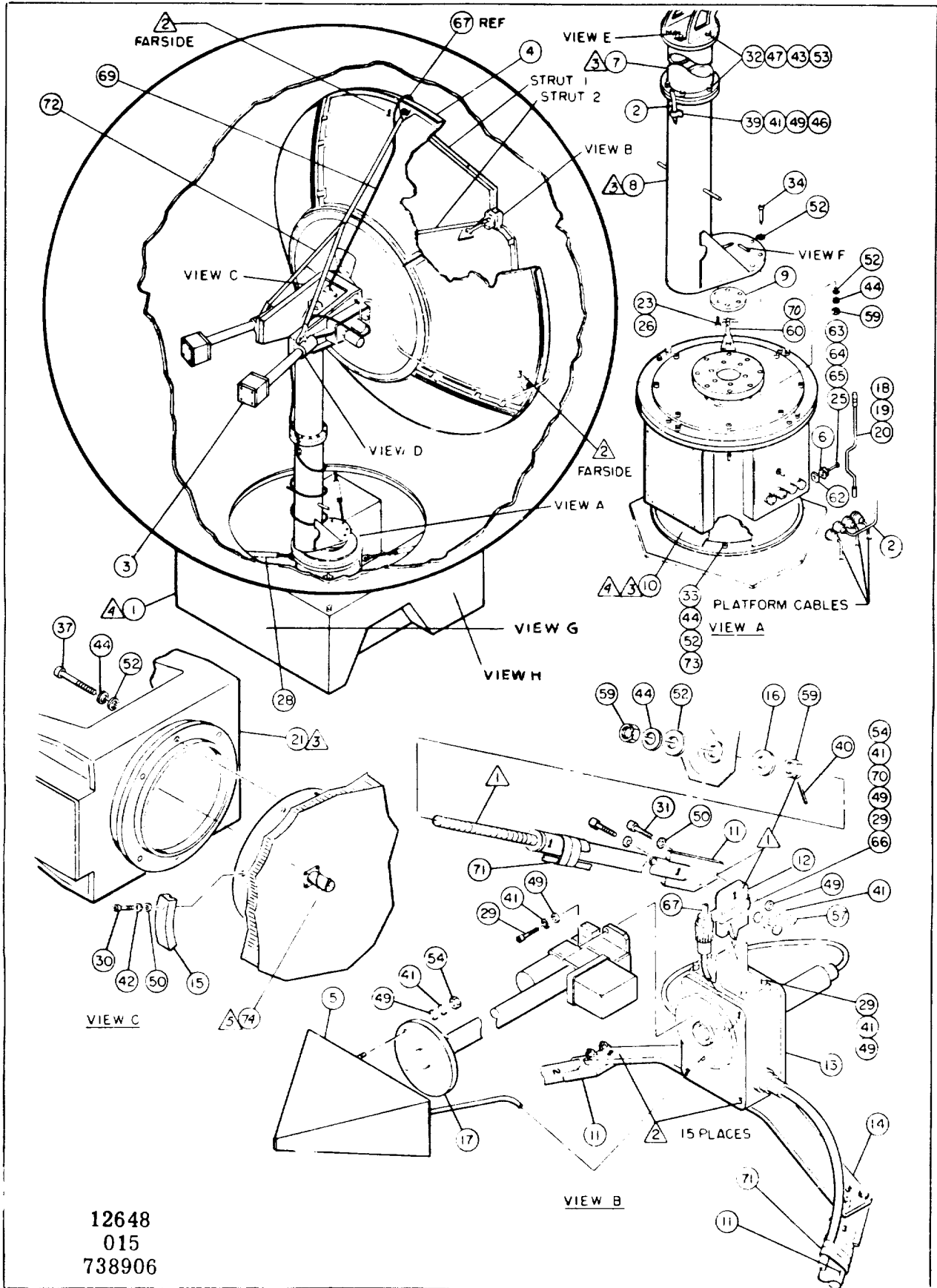
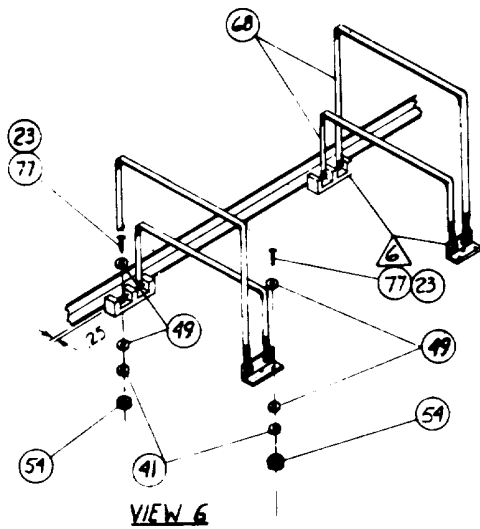
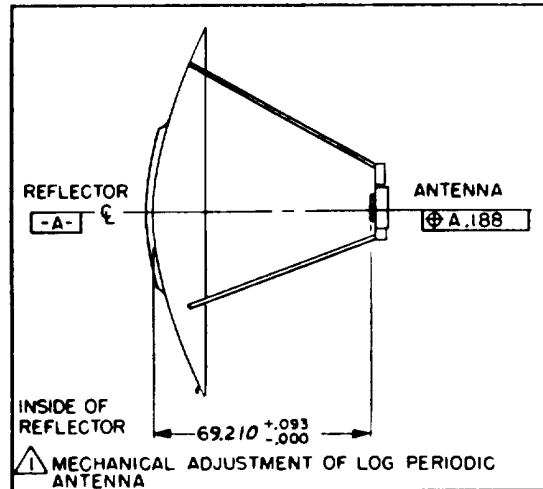
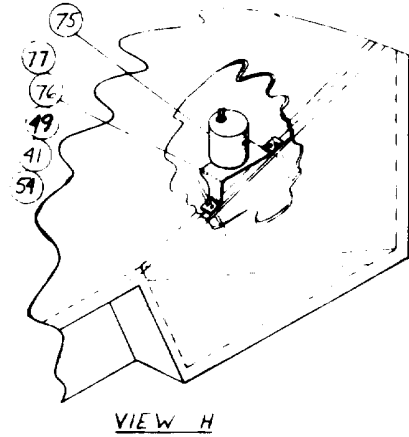
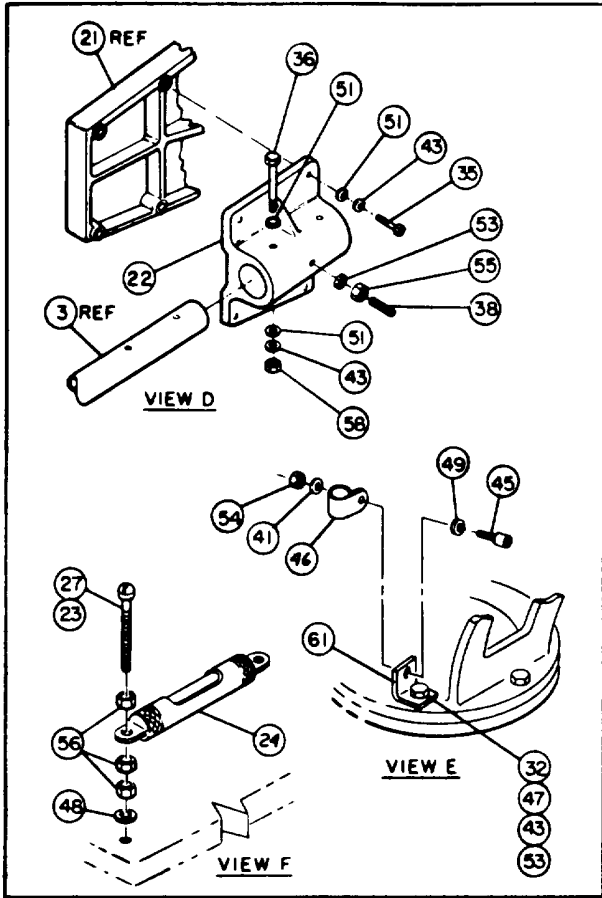

Figure 5-1. Antenna System, Major Components Location (Sheet 2 of 2).



12648  
015  
738906

Figure 5-2. Antenna System Assembly, Exploded View (Sheet 1 of 2).



- 6 Apply item 23 to item 77 (externally) and to the bottom of pin block and angle.
- 5 See Dwg. #728454 for installation instructions.
- 4 Align item 10 with item 1 so that connector door (on item 10) is 90° and to the right from trap door (on item 1) blank side of item 10 will be on the left.
- 3 Align items 7 8 8 to items 10 & 21 according to red arrows on respective parts.
- 2 After 1 rubber stamp appropriate strut numbers 12 point high black alt gothic on items 4, 11, 12, 13, 8, 14 as shown. Cover with clear lacquer.
- 1 After mechanical assy (see diagram for mechanical adjustment of log periodic antenna) and electrical adjustments, drill #D (.246) dia thru items 11, 12 and 11, 14 (3 places) drill 1/16 (.062) dia thru item 11 and 50 for item 40 (3 places).

Notes: Unless otherwise specified.

12648  
015  
728906

Figure 5-2. Antenna System Assembly, Exploded View (Sheet 2 of 2).

broadening is controlled from the remotely located Control Indicator via cabling to the antenna pedestal, the elevation data cable assembly from the antenna pedestal to the elevation drive, and a cable from the elevation drive to the antenna.

(2) PARTS LIST - Table 5-1 is a major component parts list for the Antenna System and is referenced to Figure 5-1. Table 5-2 is a parts list for the Antenna System and is referenced to Figure 5-2.

## 2. DESCRIPTION OF SYNCHROS

A. GENERAL - The Antenna System employs synchro devices throughout the positioning and drive circuits (Control Indicator and Azimuth and Elevation drives) to transmit and receive local and remote antenna position data. Detailed synchro theory is not included in this handbook; however, a general description of each type of synchro used is presented.

B. TYPES OF SYNCHROS USED - Synchro devices used in the Antenna System consist of synchro control transmitters, control transformers, and differential control transmitters. A brief description of these devices is presented in the following paragraphs to assist in a better understanding of the system.

(1) SYNCHRO TRANSMITTERS - Synchro control transmitters (CX) are used in the antenna system. The control transmitter can drive only a relatively small load. In the Antenna System, the synchro transmitters are used to drive control transformers (CT). The rotor winding of these synchros consists of a single machine-wound coil with the axis perpendicular to the shaft. The rotor functions as the excitation for the primary winding of the synchro. The stator is a cylindrical structure of slotted laminations on which Y-connected coils are wound with their axes 120 degrees apart. The stator acts as a secondary winding and its excitation is supplied by the rotor through transformer action.

(2) CONTROL TRANSFORMERS - The control transformer is used as a companion unit with a control transmitter to comprise a synchro control system. This type of control transformer is designed to supply an AC voltage from its rotor terminals with a magnitude and phase determined by its angular position relative to that of the control transmitter and the signal applied to the stator winding. The control transformer differs from the synchro units previously discussed in several important respects. The rotor winding is never connected to the AC supply voltage, it induces no voltage in the stator winding, and stator currents are determined only by the voltage supplied to the high impedance windings. Also, rotor position has very little effect on stator current. There is no appreciable current flowing in the rotor winding because its output voltage is always applied to a high-impedance load. In the Antenna System, the high-impedance load is the servoamplifier in the Antenna Position Control Indicator or in the antenna pedestal. The rotor is not attracted to a particular position when voltage is applied to the stator winding. The rotor shaft is turned by an

external source and produces varying output voltages from the rotor winding. The output voltage of the control transformer can be varied either by displacement of the rotor or by varying the input data signal applied to the stator input from the associated control transformer.

(3) DIFFERENTIAL CONTROL TRANSMITTERS - The differential control transmitters used in the Antenna System connect the stators of control transmitters to the stators of control transformers so that the rotation of any one shaft is either the sum of or the difference between the rotation of the other two. Both the rotor and stator winding of the differential control transmitters consist of three Y-connected coils. The stator of the differential receives its excitation from the stator of a control transmitter. The voltages appearing across the rotor terminals of the differential are determined by the magnetic field produced by the stator currents and the physical position of the rotor. The magnetic field created by the stator currents assumes an angle corresponding to that of the magnetic field in the transmitter supplying the excitation. If the rotor position changes, the voltage present at the rotor terminals changes.

C. SYNCHRO ZEROING PROCEDURES - Synchros are factory adjusted to electrical zero at zero-degree azimuth and elevation. The following procedure should be followed to rezero the synchros if the factory adjustments have been altered.

#### NOTE

**Before zeroing the synchros on the elevation drive assembly and antenna pedestal, set the elevation and azimuth angles to zero as read on their respective angle dials. This will place the azimuth angle in the center of its travel, midway between the limit stops, and the elevation angle will correspond to horizon pointing.**

#### (1) CONTROL AND TORQUE TRANSMITTER

- a. Loosen the clamps holding the synchro transmitter in place sufficiently to permit rotating the synchro by hand with moderate force. Disconnect the external wiring to the stator terminals.
- b. Connect a jumper between rotor terminal R2 and stator terminal S3.
- c. Connect a voltmeter between rotor terminal R1 and stator terminal S2. Set the voltmeter to its 0- to 250-volt scale.
- d. Energize the rotor of the synchro transmitter from a 115-volt, 60-cycle a-c source.



- e. Carefully rotate the synchro transmitter until the voltmeter indicates approximately 37 volts.
- f. Remove the 115-volt a-c source from the rotor.
- g. Remove the jumper from between R2 and S3 and connect the voltmeter across stator terminals S1 and S3.
- h. Reconnect the 115-volt a-c source to R1 and R2.
- i. Carefully rotate the synchro transmitter to obtain minimum voltmeter indication and secure the clamps loosened in step a without moving the synchro transmitter.
- j. Remove the test connections and replace the original wiring.

(2) CONTROL TRANSFORMER

**CAUTION**

**When 115-volts AC is connected to the control transformer, it may overheat and cause permanent damage if left connected over 2 minutes. If the zeroing procedure cannot be accomplished within that time, use 78-volts AC.**

- a. Loosen the clamps holding the control transformer in place sufficiently to permit rotating the transformer by hand with moderate force. Disconnect the external wiring to the stator terminals.
- b. Connect a jumper between stator terminal S1 and rotor terminal R1.
- c. Connect an a-c voltmeter across stator terminal S3 and rotor terminal R2. Set the voltmeter to its 0- to 250-volt scale.
- d. Apply 115-volt, 60-cycle a-c power from a local source to control stator terminals S1 and S3.
- e. Carefully rotate the control transformer to obtain minimum voltmeter indication.
- f. Remove the 115-volt a-c power source from the rotor.
- g. Remove the jumper from between terminals R1 and S1 and connect between terminals S1 and S3.

scale.

- h. Connect an a-c voltmeter across rotor terminals R1 and R2. Set the voltmeter to its 0- to 5-volt

- i. Apply 115-volt, 60-cycle a-c power from a local source to stator terminals S1 and S2.

- j. Carefully rotate the control transformer to obtain minimum voltmeter indication and secure the clamps loosened in step a without moving the control transformer.

- k. Remove the test connections and replace the original.

### (3) DIFFERENTIAL CONTROL TRANSMITTER

- a. Position the orient control on the front panel of the Antenna Control Power Supply for the differential to be zeroed to 0 degree.

- b. Loosen the clamps holding the differential control transmitting synchro in place sufficiently to permit rotating the differential by hand.

- c. Remove all rotor and stator connections from the differential.

- d. Connect a jumper between rotor terminals R1 and R3.

- e. Connect a jumper between stator terminals R1 and S3.

- f. Connect a 115-volt, 60-cycle, a-c source between stator terminals S2 and S3.

- g. Connect a 0- to 250-volt a-c voltmeter, using the 0-to-250 scale, between the R2 and S2 terminals of the differential. Rotate the differential until the voltmeter indicates minimum.

- h. Remove the 115-volt a-c source from terminals S2 and S3.

- i. Disconnect the voltmeter from between terminals R2 and S2.

- j. Remove the jumper from between rotor terminals R1 and R3.

- k. Connect the 115-volt a-c source between rotor terminals S2 and S3.

- l. Set the voltmeter to the 0- to 5-volt scale and connect across rotor terminals R1 and R3.

- m. Rotate the differential until a null reading is obtained on the voltmeter and carefully secure the clamps loosened in step b without moving the differential.

- n. Remove the test connections and replace the original wiring.

### CAUTION

**The differential control transmitter will overheat if connected to the 115-volt AC for any length of time. If the zeroing procedure cannot be accomplished quickly, use an autotransformer and 70-volts AC.**

### 3. ANTENNA

A. The antenna consists of a 9-foot fibreglas paraboloidal reflector fed by a log-periodic dipole feed. The antenna is capable of generating any one of four modes of polarization: horizontal, vertical, right-hand 45 degrees, or left-hand 45 degrees linear. Polarization selection is controlled from the remotely located Control Indicator and implemented by a polarization unit (refer to paragraph 5, this section) which rotates to place the feed at the correct angle for the polarization selected. An electromechanical linear actuator is installed between the polarization unit and the dipole feed. The actuator contains a motor-driven shaft which displaces the feed in respect to the focal point of the reflector, broadening the secondary radiation pattern and reducing the gain of the antenna. Beam broadening is also remotely controlled by the Antenna Position Control Indicator.

B. The 9-foot diameter antenna reflector is constructed of 1/8-inch thick fiberglass which contains a metallic coating to provide the required reflectivity. It is formed with a circular center section about 40 inches in diameter and four equal segments which fit around the perimeter of the center section. The five parts of the dish are fastened together by quarter-turn, tee-handle, quick-release pins on the inside flanged edges and quarter-turn clasp hook fasteners around the outer rim. The four outer segments are easily fastened to the center section and adjacent sections by inserting the quick release pins which are captive or short lengths of flexible cable adjacent to the attaching holes. The outside segments are clamped together at the perimeter by four three-quarter inch, hex-head, eccentric cam fasteners. The dipole feed is mounted on the electromechanical actuator which, in turn, is mounted on the polarization unit and is correctly oriented on the polarization unit by key pin-hole arrangement. The feed-polarization unit is held in place at the focal point of the reflector by three supports secured to the outer rim of the reflector. These supports and the attaching hardware have been predrilled for key pins to assure that the feed is installed at the reflector focal point during assembly.

#### 4. ANTENNA VSWR TESTS AND TROUBLESHOOTING

A. VSWR TESTS - Figure 5-3 illustrates the test setup required to perform VSWR tests on the antenna. To obtain true VSWR of the antenna under test, the VSWR as indicated should be corrected for the loss due to the length of RG-87/U cable used.

B. TROUBLESHOOTING - Troubleshooting of the antenna is performed by measuring the VSWR at the input (back) of a parabola. A VSWR of 3: 1 or less indicates proper operation. If VSWR exceeds 3: 1, move along the feed line, measuring wherever a connector permits a break in the line, until an acceptable reading (less than 3: 1) is obtained. The component measured just prior to the acceptable measurement should be the faulty component.

#### 5. POLARIZATION UNIT (See Figure 5-4)

A. GENERAL DESCRIPTION AND THEORY OF OPERATION - The polarization unit for the antenna consists of a 28-volt DC drive motor, a Geneva drive mechanism, four high-speed cam-operated switches, S1 through S4, and an indexing switch, S5. The motor actuates the Geneva drive mechanism which, in turn, operates the polarizing device through 135 degrees of rotation to obtain horizontal, vertical, +45-degree or -45-degree linear polarization. In order that the motor will stop at a precise point, the indexing or zero-seeking action consists of two parts to provide the accurate polarization control. The first is through the Geneva drive mechanism (an 8-position-per-revolution control), which provides a coarse control for the polarization movement, and the second is through an indexing control which deenergizes the motor at a precise position and at the same time applies an electric braking action to the motor.

(1) One set of contacts on the high-speed cam-operated, fine-indexing switch, S5, provides a cycling action of a detent relay in the antenna pedestal. This cycling action operates the detent relay to interrupt the 28-volt DC supply to the drive motor at each detent position. Therefore, when the motor-driven polarizer reaches either limit of travel (or one of the intermediate stop positions), the voltage to the motor is cut off so that the motor stops. Then reversed polarity of 28-volts DC can be supplied to reverse the motor and permit the polarizer to progress to the selected position.

(2) The cam which operates the indexing switch turns one full revolution in progressing to each polarization control position. There are four control positions marked H, V, RHC, or +45°, and LHC, or -45°. These positions represent horizontal, vertical, right-hand 45 degrees, and left-hand 45 degrees linear polarization, respectively.

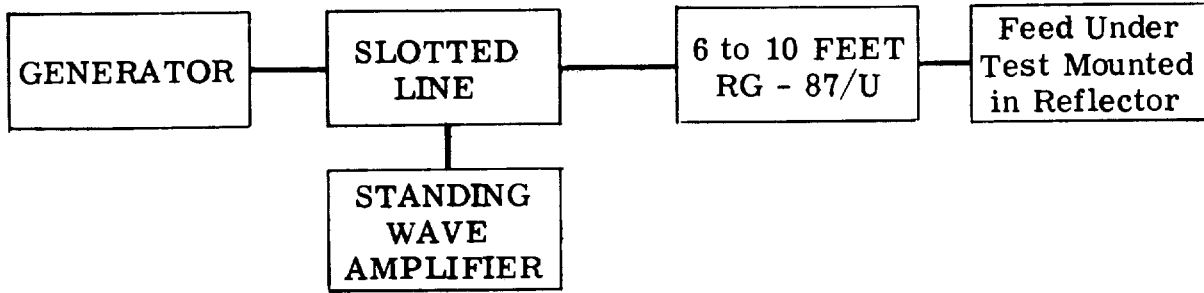

Standing Wave Amplifier:

Hewlett-Packard 415B

Generator:

Hewlett-Packard 614A (800-2100 MCS),  
 Hewlett-Packard 616B (1800-4200 MCS)  
 Hewlett-Packard 618B (3.2-7.6 MCS)  
 Hewlett-Packard 620A (7-11 KMC)  
 Hewlett-Packard 626A (10-0-15.5 KMC)

Slotted Line:

Hewlett-Packard 805C (500-4000 MCS)  
 Hewlett-Packard 809B Universal  
 Probe Carriage  
 Hewlett-Packard 442B Broad Band Probe  
 Hewlett-Packard 440A Detector Mount  
 (2.6-12.4 KMC)  
 Hewlett-Packard Slotted Section 806B  
 (3.0-12.0 KMC)

— HIGH FREQUENCY, 9-FOOT REFLECTOR —

12648  
 017  
 736360

Figure 5-3. VSWR Test Setup



(3) When the system is energized and ready for operation, the POLARIZATION MODE select switch on the Control Indicator may be set to the desired mode; for example, RHC +45°. The motor then starts and runs until it reaches the right-hand 45-degree position. At this time, the normally closed contacts on the RH switch, S3, open and then the normally open contacts close. Also in the circuit is an index switch which physically supports the feed element in the unit. Due to the fine action of this switch, its contacts remain closed until the polarizer reaches a precise position, at which time its closed contacts open and its open contacts close, resulting in two important functions: connecting a resistive load across the motor, providing an effective electromagnetic braking action to the motor, and at the same time reversing the polarity of the 28-volts DC which was received through the reversing switch contacts. This leaves the circuit in a ready condition for the next actuation.

B. SCHEMATIC DIAGRAM AND PARTS LIST - Figure 5-4 is the schematic diagram for the polarization unit. The parts list is contained in Table 5-5.

## 6. ELECTROMECHANICAL LINEAR ACTUATOR (See Figure 5-5)

A. GENERAL DESCRIPTION AND THEORY OF OPERATION - The electromechanical linear actuator consists essentially of a reversible DC motor geared to a movable shaft, two electrical limit switches, and a position indicator potentiometer. The DC drive motor is controlled by a DPDT BEAM INCREASE BEAM DECREASE switch on the Antenna Position Control Indicator which, when operated, applies 28-volts DC to one or the other fields of the motor, causing the geared shaft to extend or retract, depending upon the direction of rotation of the drive motor. The length of the actuator in its fully retracted position is 17.375 inches and in its fully extended position 29.375 inches. Mechanical stops are provided at these points. Two electrical limit switches are provided which limit extension and retraction of the actuator shaft to 29.250 and 17.500 inches, respectively. The position indicating potentiometer, which is also geared to the actuator drive motor, provides a voltage which is proportional to amount of extension of the actuator shaft to drive the BEAM WIDTH meter on the Antenna Position Control Indicator.

(1) The electromechanical actuator is installed between the dipole feed and the polarization unit. The primary purpose of this unit is to provide remotely selectable actuation of the linear movement of the dipole feed relative to the focal point of the reflector. The primary effect of defocusing the antenna feed toward the reflector from the focal point is to increase the phase error across the reflector, broadening the main lobe by several degrees and reducing the gain of the antenna.

B. ADJUSTMENTS - The only adjustment possible on the electromechanical linear actuator is the position indicator potentiometer. This potentiometer should be adjusted as follows:

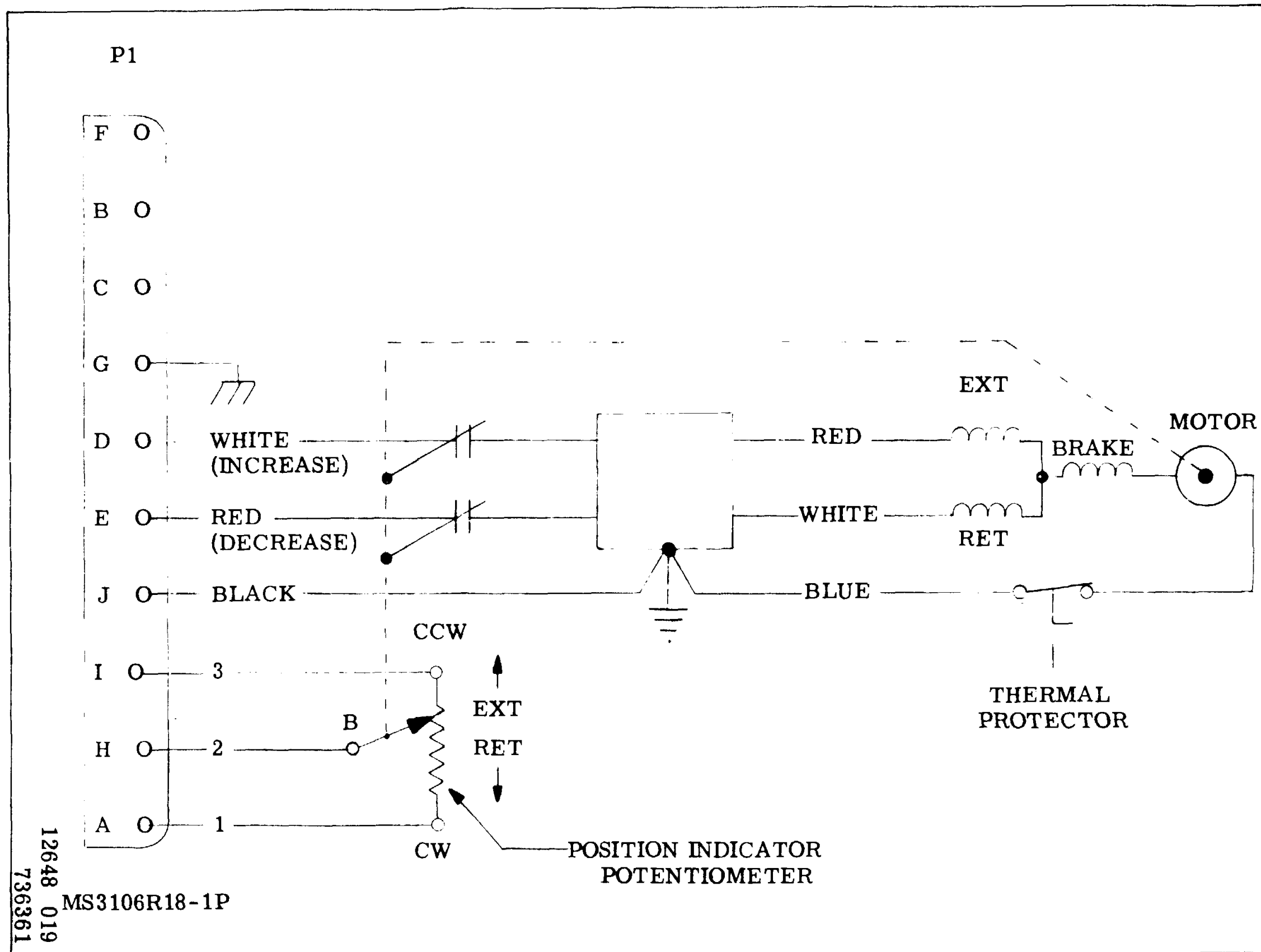

Figure 5-5. Electromechanical Linear Actuator, Wiring Diagram.



- (1) Position the actuator to its center position.
- (2) Connect an ohmmeter from pin H to pin A on connector P1.
- (3) Loosen the screws holding the potentiometer in position and rotate the potentiometer until the ohmmeter indicates one-half the total resistance of the potentiometer.
- (4) Tighten the screws loosened in step (3).

C. WIRING DIAGRAM AND PARTS LIST - Figure 5-5 is a wiring diagram of the electromechanical linear actuator. The parts list is contained in Table 5-6.

7. ANTENNA PEDESTAL (See Figure 5-6) A. GENERAL DESCRIPTION AND THEORY OF OPERATION - The antenna pedestal used with the Antenna System consists of a cylindrical riser base (item 7) which houses the azimuth servo drive assembly (item 1), azimuth electric pressure brake, and motor control units (items 10 and 11).

(1) The azimuth servo drive assembly consists of an AC servo motor and a gear train connected to a vertical tubular shaft mounted in a precision bearing assembly. This assembly has a mounting flange on top for mounting the antenna mast. An angle scale, which is graduated from 0 to 360 degrees and attached to the vertical tubular shaft and two index markers, one at zero and one 180 degrees, attached to the stable part of the riser base, provides a visual indication of the pedestal's azimuth rotation. An azimuth synchro assembly which contains two synchros, two rotary electrical limit switches, a resolver, and a cable-wrap potentiometer is also geared to the azimuth drive motor. The synchros provide control and data signals for the azimuth axis. The resolver provides position information to the display scope. The electrical limit switches limit rotation of the azimuth axis to  $\pm 270$  degrees. The limit switches engage 30 degrees before mechanical stops in the azimuth drive assembly and act as a buffer for the mechanical stops. The detailed theory of operation for the synchros is contained in paragraph 2 of this section. The theory of synchros, cable-wrap potentiometer and limit switches as used in the Antenna System is contained in Section I. The azimuth electric pressure brake in the azimuth drive assembly is a solenoid-operated brake which engages any time power is removed from the antenna pedestal. With the pedestal deenergized, the brake may be manually released by rotating the release knob in a clockwise direction as shown on Figure 5-7.

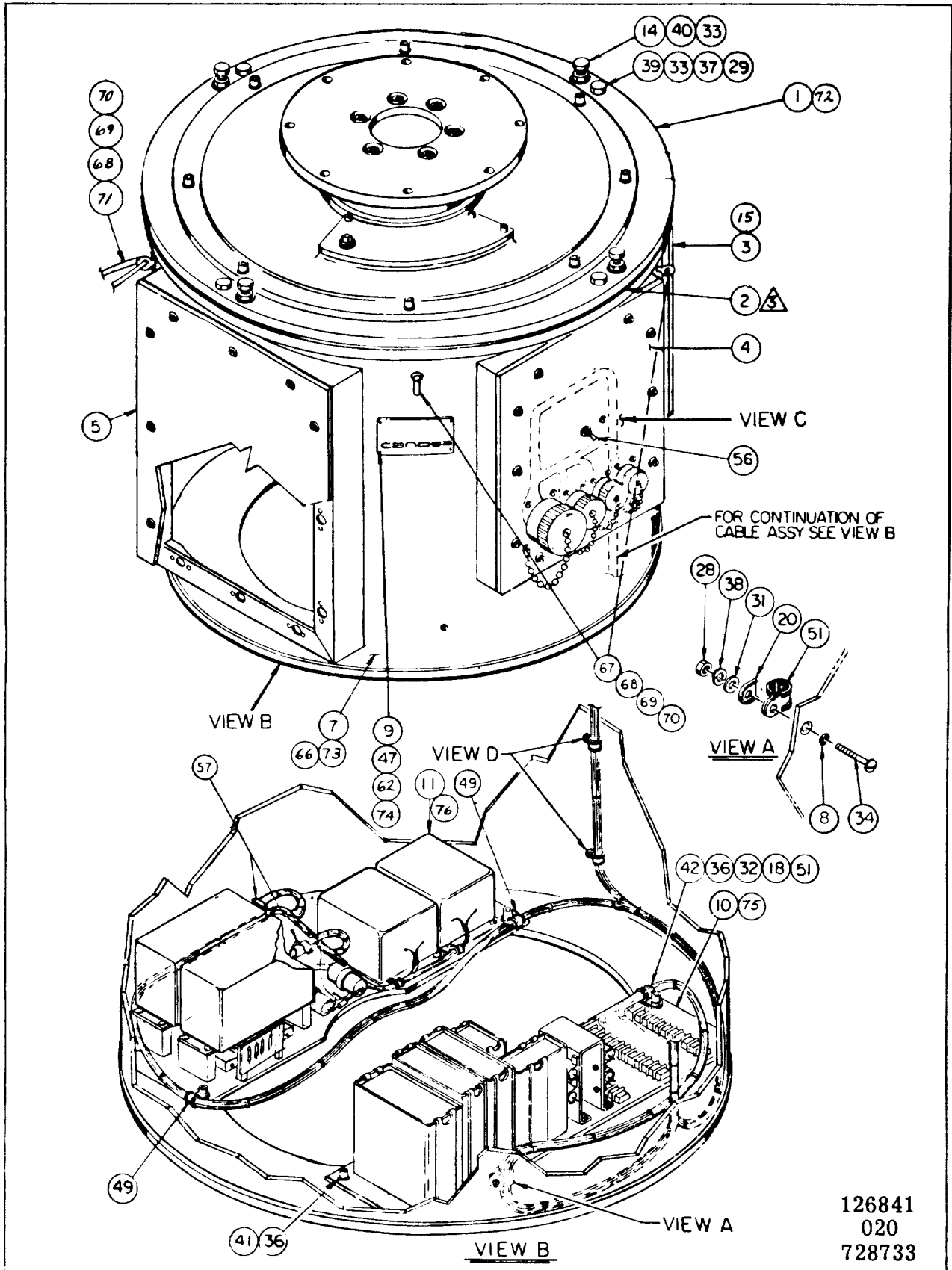
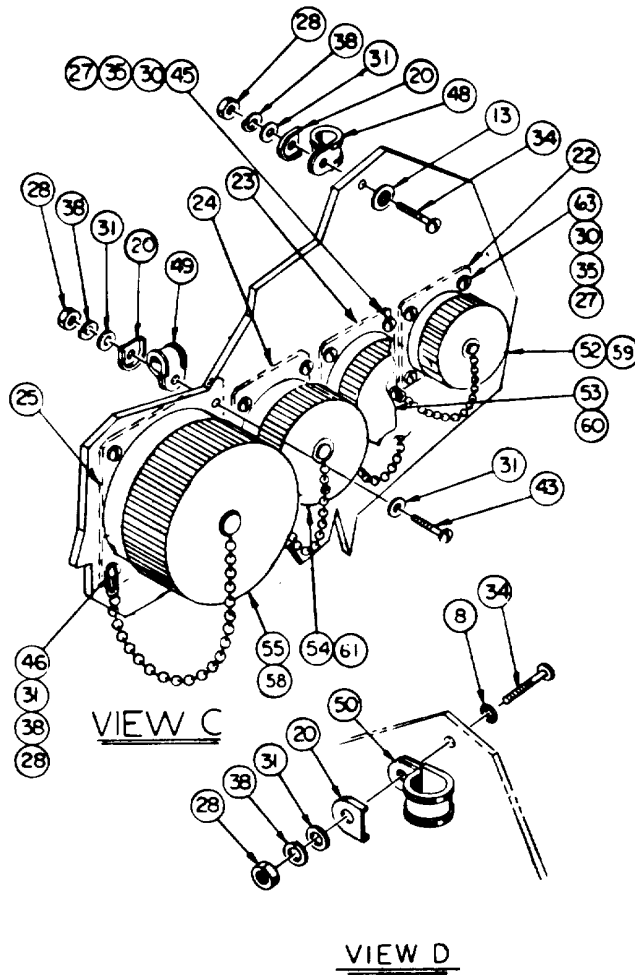
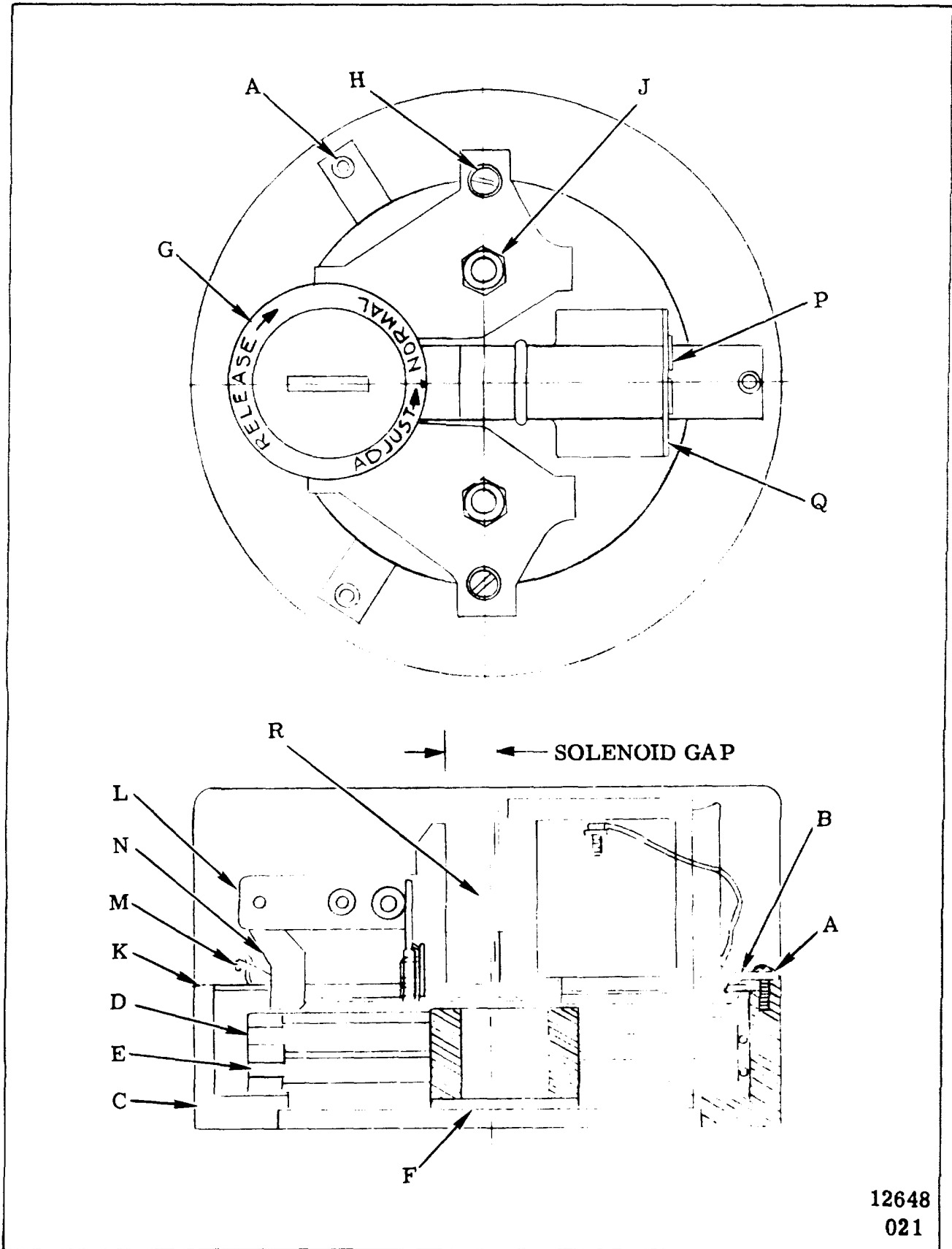

Figure 5-6. Antenna Pedestal, Major Components Location (Sheet 1 of 2).



12648  
020  
728733

Figure 5-6. Antenna Pedestal, Major Components Location (Sheet 2 of 2).



12648  
021

Figure 5-7. Electric Brake Details.

(2) Two motor control units are used in each antenna pedestal. These units are designated motor control No. 1 and No. 2. Motor control No. 2, which is designated unit A1, consists essentially of terminal strips A1TB1 through A1TB3, resistors A1R1 through A1R4, and capacitors A1C1 through A1C3. Motor control No. 1, which is designated unit A2, contains servoamplifier A2AR1 (see Figure 5-8), radio interference filters A2FL1 through A2FL2, capacitors A2C1 through A2C4, resistors A2R1 and A2R2, and terminal boards A2TB1 and A2TB2. The detailed theory of operation of the pedestal electrical components is contained in Section I.

(3) A safety switch (item 56) on the riser base, with the positions SAFE and RUN, controls operating power to the pedestal servo drive. When in the SAFE position, the servo drive is disabled.

### CAUTION

**When the servo drive is disabled, voltages are still present inside the riser base.**

B. ADJUSTMENTS AND REPAIR - The components requiring adjustment on the antenna pedestal are: synchros, cable-wrap potentiometer, limit switches, and the electric pressure brake. The synchro adjustment procedures are contained in paragraph 2 of this section. Procedures for adjustment of the cable-wrap potentiometer, limit switches, and electric pressure brake are contained in subsequent paragraphs as are procedures for repair of the pressure brake.

#### (1) LIMIT SWITCH ADJUSTMENT

- a. Release the electric brake.
- b. Connect an ohmmeter across the azimuth limit resistor.
- c. Rotate the pedestal CW to 270 degrees, as indicated on the azimuth vernier.
- d. Loosen the three allen-head screws holding the upper section of the limit switch in position. Slowly rotate the switch until the ohmmeter just indicates zero.
- e. Tighten the retaining screws on the limit switch.
- f. Rotate the pedestal CCW through 0 to 90 degrees, as indicated on the azimuth vernier.

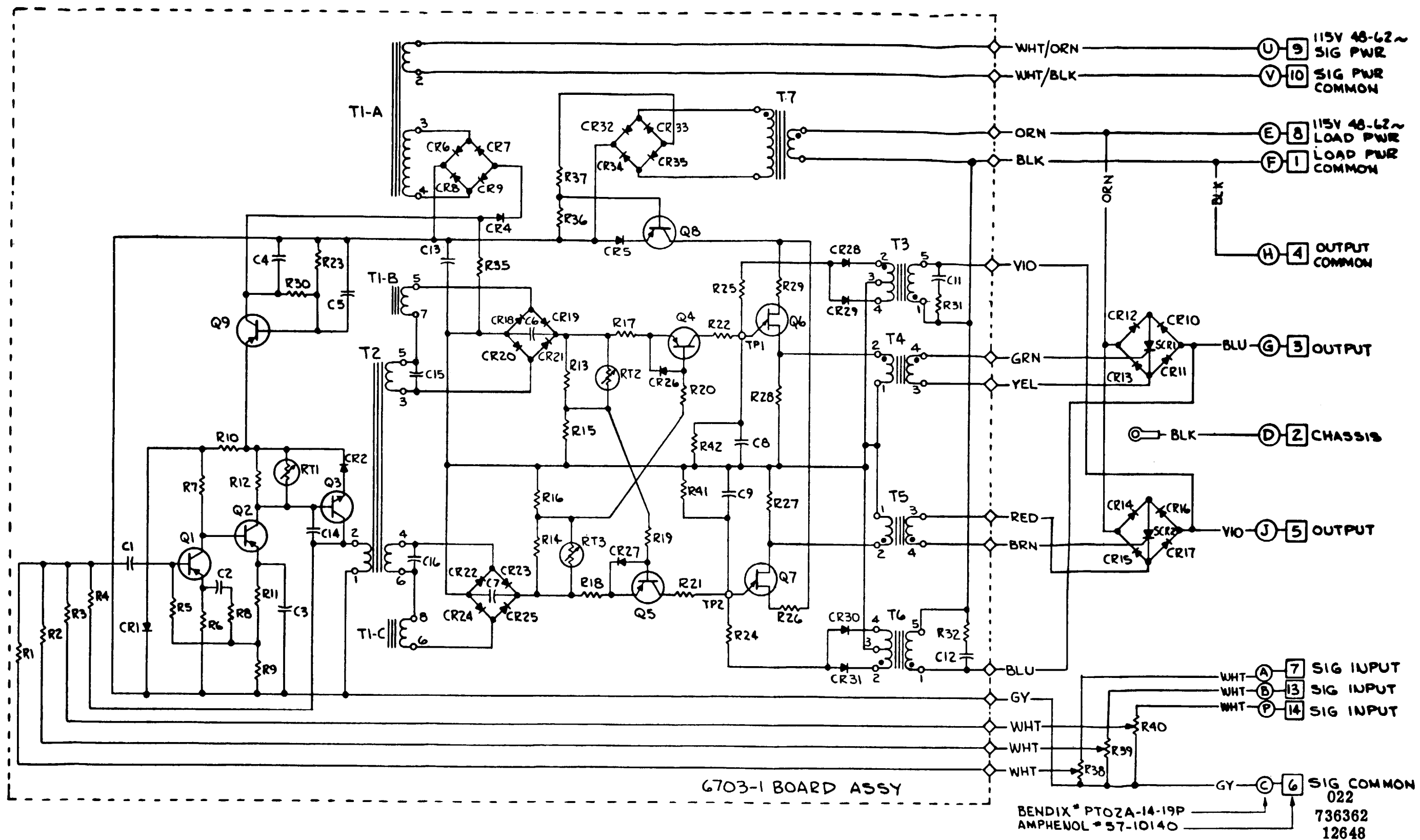

Figure 5-8. Schematic - AC Servo Amplifier

g. Loosen the three allen-head screws holding the lower section of the limit switch in position. Slowly rotate the switch until the ohmmeter just indicates zero.

h. Tighten the retaining screws, remove the ohmmeter, and release the pressure brake.

(2) CABLE WRAP ADJUSTMENT

a. Release the electric brake and position the pedestal to the 0-degree position as indicated on the azimuth vernier.

b. Connect an ohmmeter across A1TB1-7 (CW) and J1-K.

c. Loosen the three screws holding the cable-wrap potentiometer, A3R1, in the antenna pedestal and slowly rotate the potentiometer until the ohmmeter indicates the center of the total resistance.

d. Tighten the retaining screws, remove the ohmmeter and reengage the electric brake.

(3) ELECTRIC BRAKE, INSTALLATION AND ADJUSTMENT (See Figure 5-7)

a. INSTALLATION PROCEDURE

1. Locate the hub (part F) on the motor shaft 5/16 inch from the mounting face and set the screw securely.

2. Remove the housing, support plate assembly, stationary ring and friction lining.

3. Attach the endplate to the motor endbell.

4. Reassemble the items removed in step (2).

b. ADJUSTMENT FOR LINING WEAR

1. With the power off and the indicator knob (part G) at NORMAL position, indicates the brake is in proper adjustment.

2. When the indicator knob is at the ADJUST position, or if marked increase in stopping time is noted, lining wear adjustment is necessary.

3. To adjust the lining.

clockwise.

(a) Rotate the wear adjustment screws (part M) approximately one-eighth turn

(b) The solenoid gap should be 7/16 inch when in proper adjustment.

(c) Maximum torque may be obtained after operating the brake several times and then rotating either wear adjustment screw very slightly either way and noting which position of fine adjustment provides satisfactory stopping without changing the solenoid gap.

c. REPLACEMENT OF FRICTION LININGS

1. To replace the friction linings.

(a) After the housing has been removed, remove the 3 screws (part A) holding the support plate assembly (part B) to the endplate (part C) and lift the support plate assembly from the endplate.

(b) Remove the stationary ring (part D) and lining (part E).

(c) Reassemble with new lining.

(d) With the coil deenergized, rotate both wear adjustment screws (part H) counterclockwise until the brake lining is free to rotate or until the solenoid gap is not increased by further rotation of the wear adjustment screws.

(e) Rotate one wear adjustment screw clockwise until the solenoid plunger moves downward slightly. Repeat utilizing the other wear adjustment screws. The initial movement of the plunger occurs when the wear adjustment screw contacts the stationary ring (part D).

d. REPLACEMENT OF SOLENOID COIL

1. Disconnect the solenoid from circuit.

2. Insert a screwdriver between the support plate (part K) and the lever arm (part L).

3. Wedge apart and remove the bearing and pin (part N) and solenoid lever (part M) with the solenoid link and plunger.

4. Remove the coil clamp screw and washer (part P), coil clamp (part Q), and coil holder and plunger guides (part R).

5. Remove old coil and insert new coil. Reassemble and connect leads.



C. SCHEMATIC DIAGRAM AND PARTS LIST - The schematic diagram for the antenna pedestal is contained in Figure 5-9. The parts list for the antenna pedestal is contained in Table 5-3 and referenced to Figure 5-6 for component location. The parts list for the azimuth drive assembly is contained in Table 5-4.

## 8. ELEVATION DRIVE ASSEMBLY (See Figure 5-10)

A. GENERAL DESCRIPTION AND THEORY OF OPERATION - The elevation drive assembly, which consists essentially of a yoke assembly (item 8), a housing (item 2), and a drive motor (item 3), supports the antenna and tilts it in elevation. The yoke assembly, a nonrotatable assembly with a stationary drive gear, is bolted to an elevation drive support casting which couples the azimuth drives to the elevation drive. The elevation housing, a U-shaped casting which is bolted to and supports the antenna, is supported through roller bearings in the yoke assembly. The drive motor, when powered, drives the elevation housing around the yoke assembly. An angle scale, graduated from 0 to 360 degrees, affixed to the movable housing and an index marker affixed to the stable elevation yoke, provides a visual indication of the elevation angle of the antenna and, during installation, allows orientation of the antenna to 0-degree elevation. Two mechanical limit stop assemblies (item 9) prevent movement of the elevation housing below -18 degrees and above +98 degrees. An electrical limit switch (item 7), which acts as a buffer for the mechanical stops, makes contact 3 degrees before the mechanical stops. Two synchros (items 4 and 5) provide control and data signals for the elevation axis. An electric pressure brake (item 6), which is released when power is applied to the system, prevents movement of the antenna in elevation when the system is not operating. The detail theory of operation of the circuits in the elevation drive assembly is contained in Section I.

B. ADJUSTMENT AND REPAIR - The components requiring adjustment on the antenna pedestal are the synchros, electrical limit switch, and the electric brake. The synchro adjustment procedures are contained in paragraph 2, this section, and the electric brake adjustment procedures in paragraph 7.B(3), this section. Procedures for adjustment of the electrical limit switch are contained in the following paragraph.

### (1) LIMIT SWITCH ADJUSTMENT

- a. Release the electric brake.
- b. Connect an ohmmeter between pins k and d on receptacle connector J1 on the elevation drive assembly.
- c. Position the elevation housing to 345 (-15) degrees, as indicated on the elevation vernier.

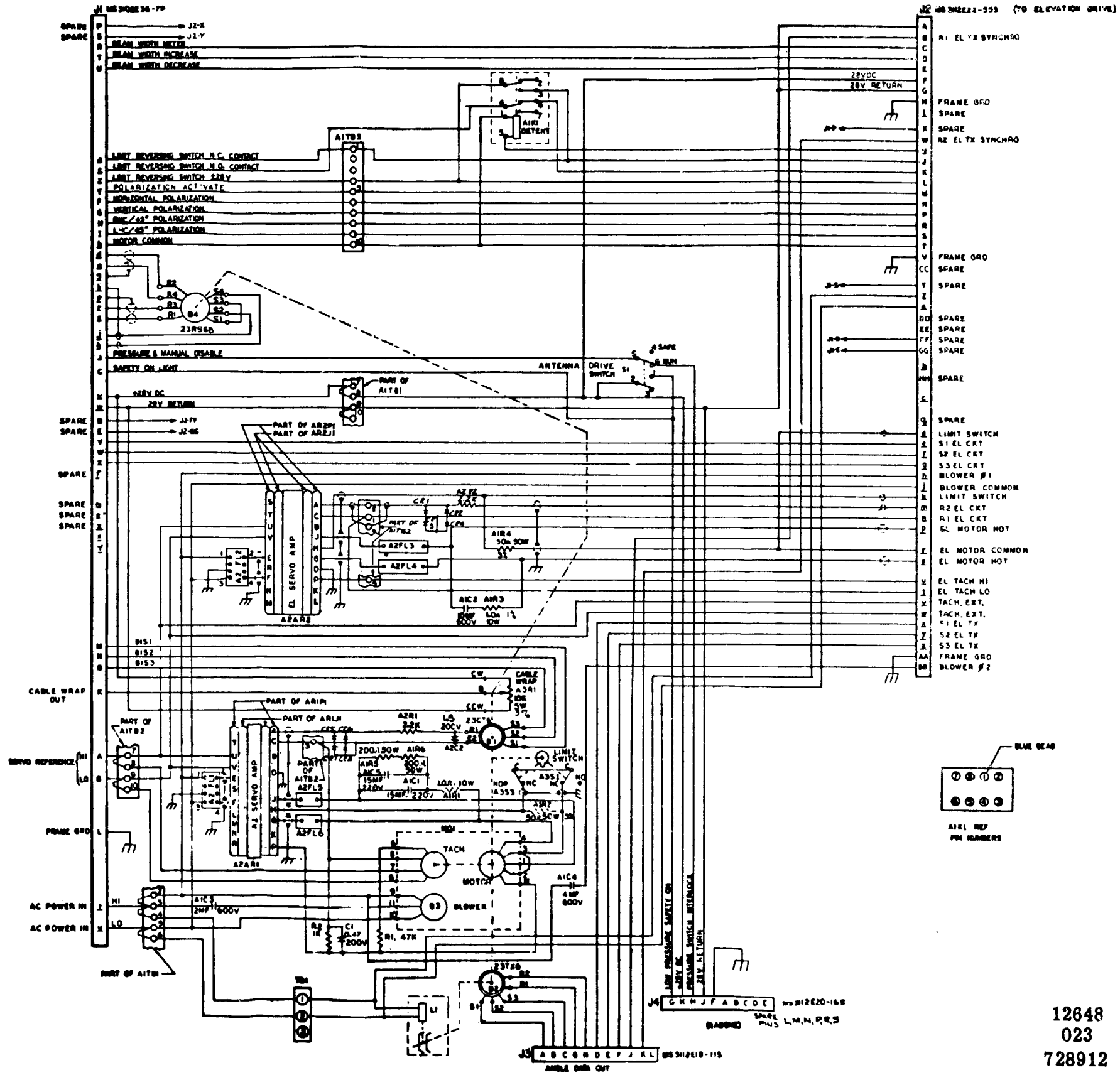

Figure 5-9. Schematic, Antenna Pedestal.

12648  
023  
728912

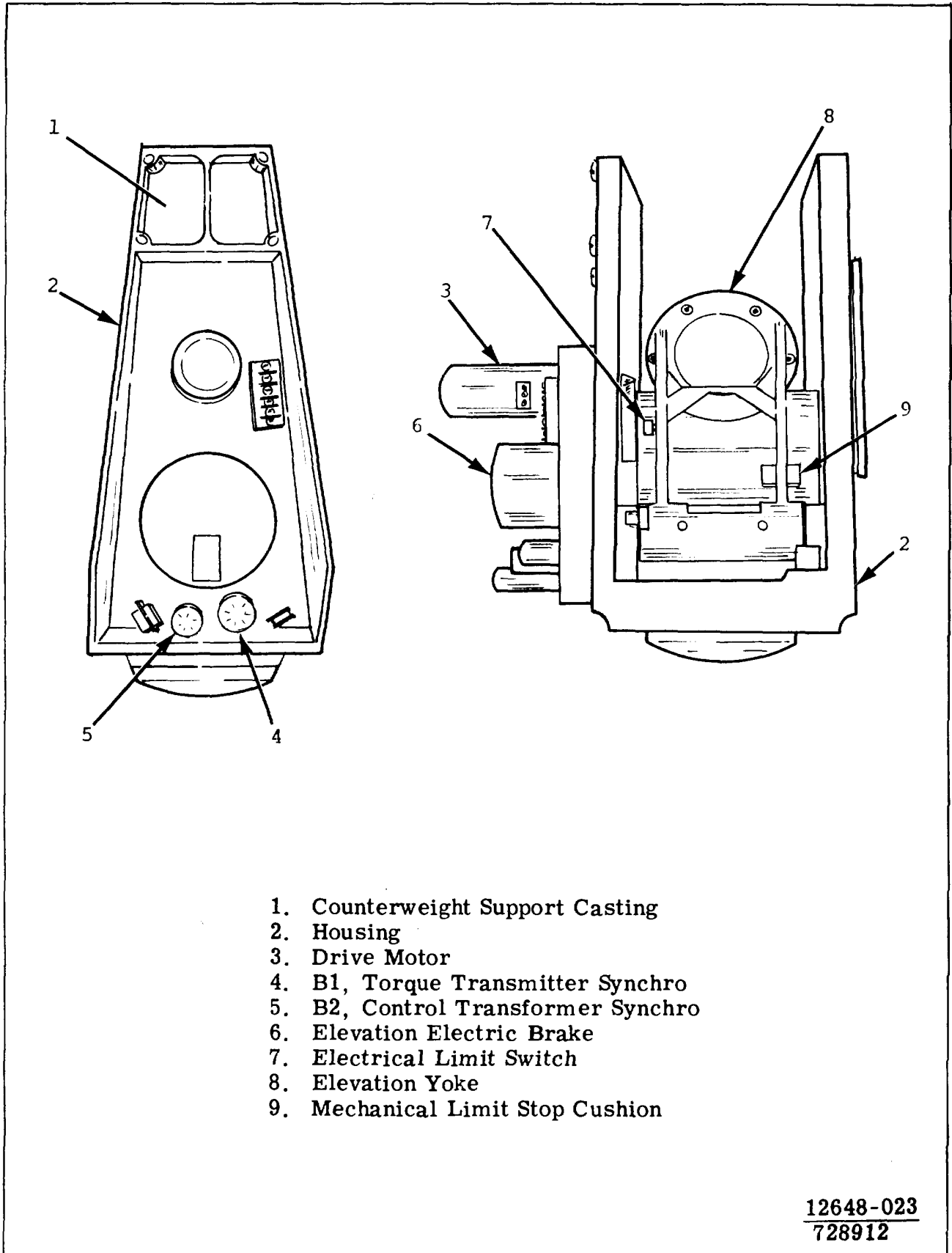

Figure 5-10. Elevation Drive Assembly, Major Components Location.

d. Loosen the two screws holding the switch actuator block on the elevation yoke and position the block until the ohmmeter just indicates zero.

e. Tighten the screws loosened in step d.

f. Position the elevation housing to +95 degrees, as indicated on the elevation vernier, and repeat steps d and e for the other switch actuator.

C. SCHEMATIC DIAGRAM AND PARTS LIST - The schematic diagram for the elevation drive assembly is contained in Figure 5-11. The parts list for the elevation drive assembly is contained in Table 5-7 and referenced to Figure 5-10 for component location.

## 9. RADOME-PLATFORM

A. Section I of this manual contains information concerning the radome-platform circuits which are interconnected with other circuits in the Antenna System. The schematic diagram for the radome box is shown in Figure 5-12.

## 10. PORTABLE STAND AND HOISTING UNIT (See Figure 2-2)

A. DESCRIPTION - The portable stand and hoisting unit consists of four tubular aluminum alloy winch support legs approximately six feet high; four hoisting unit baseplates 14 inches square; four pairs (eight identical) of tubular aluminum outrigger support tie rods which form the braces for the wind support legs; eight blue/white end tensioning tie rods; four winches, four T-bar assemblies, four red end tensioning tie rods; eight adjustable tie rods, four horizontal bottom braces, four horizontal top braces, and four box supports. The winch support legs are spaced and braced in place by the tensioning tie rods, which have threaded clevis bolts at the ends. The clevis bolts have right-hand and left-hand threads which permit tightening each corner assembly into a rigid structure. The tensioning tie rods and corner outrigger support tie rods are attached with bolts to mating pads welded to the winch support legs, hoisting unit support baseplate, and outrigger support tie rods. A hand-operated winch is mounted on each vertical support. A cable from the winch passes over two pulleys mounted on the T-bar and is attached to the radome-platform base. When the hand crank on the winch is turned, it raises or lowers the radome. Holes in the corners of each hoisting unit support and outrigger support tie rod baseplate are provided for securing the baseplates in place with ground stakes. The portable hoisting unit is used for lifting a radome-platform out of the transporting trailers for lowering them to the ground. This is done when the radome-platform is installed on an 80-foot tower. The same hoisting procedure is used for lifting the radome-platform to mount it on the portable stand so that the radome-platform can be operated while it is supported by the portable hoisting unit. Box supports bolt to the radome base to hold it securely in operating position.

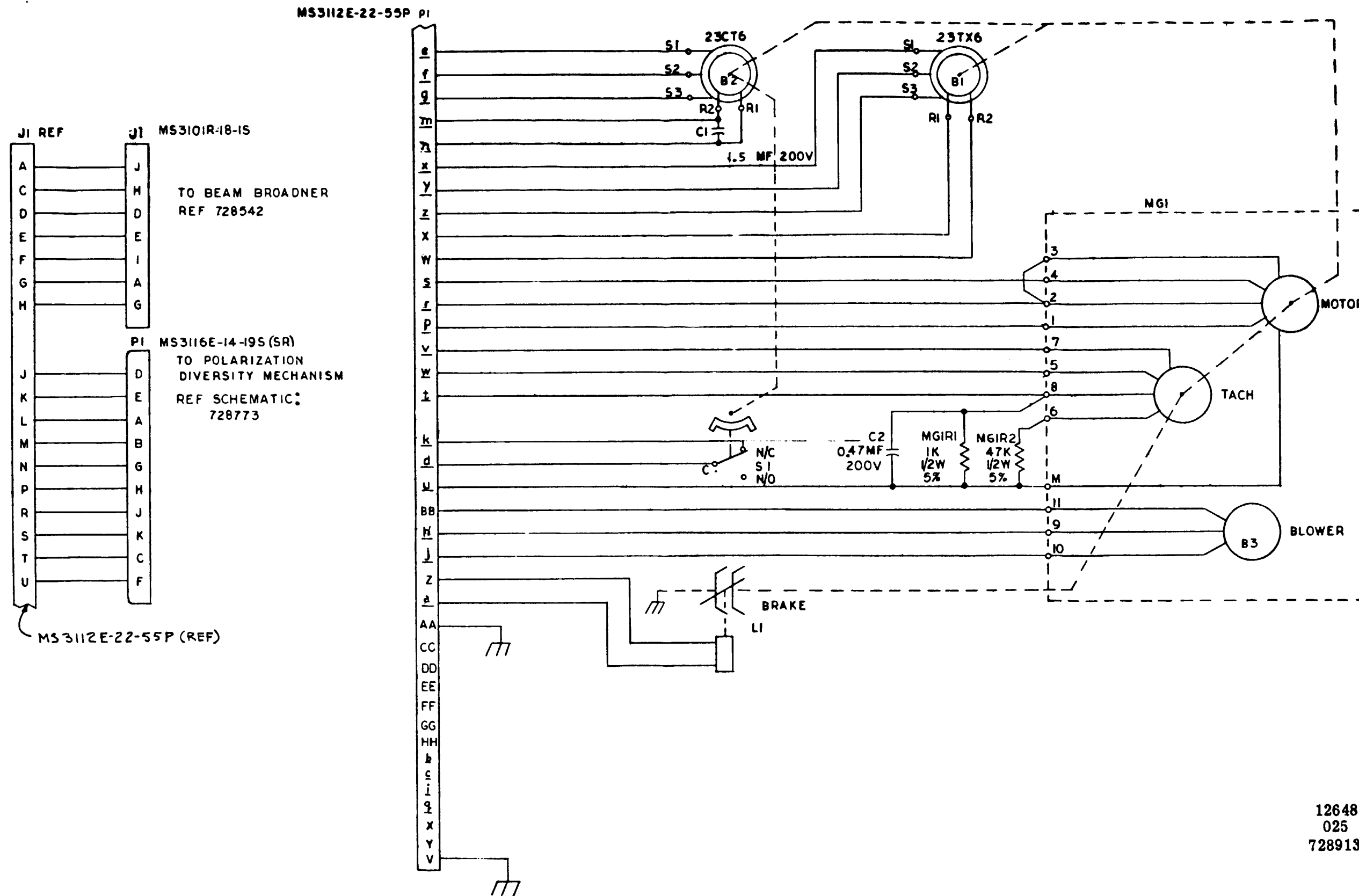

12648  
025  
728913

Figure 5-11. Schematic, Elevation Drive Assembly.

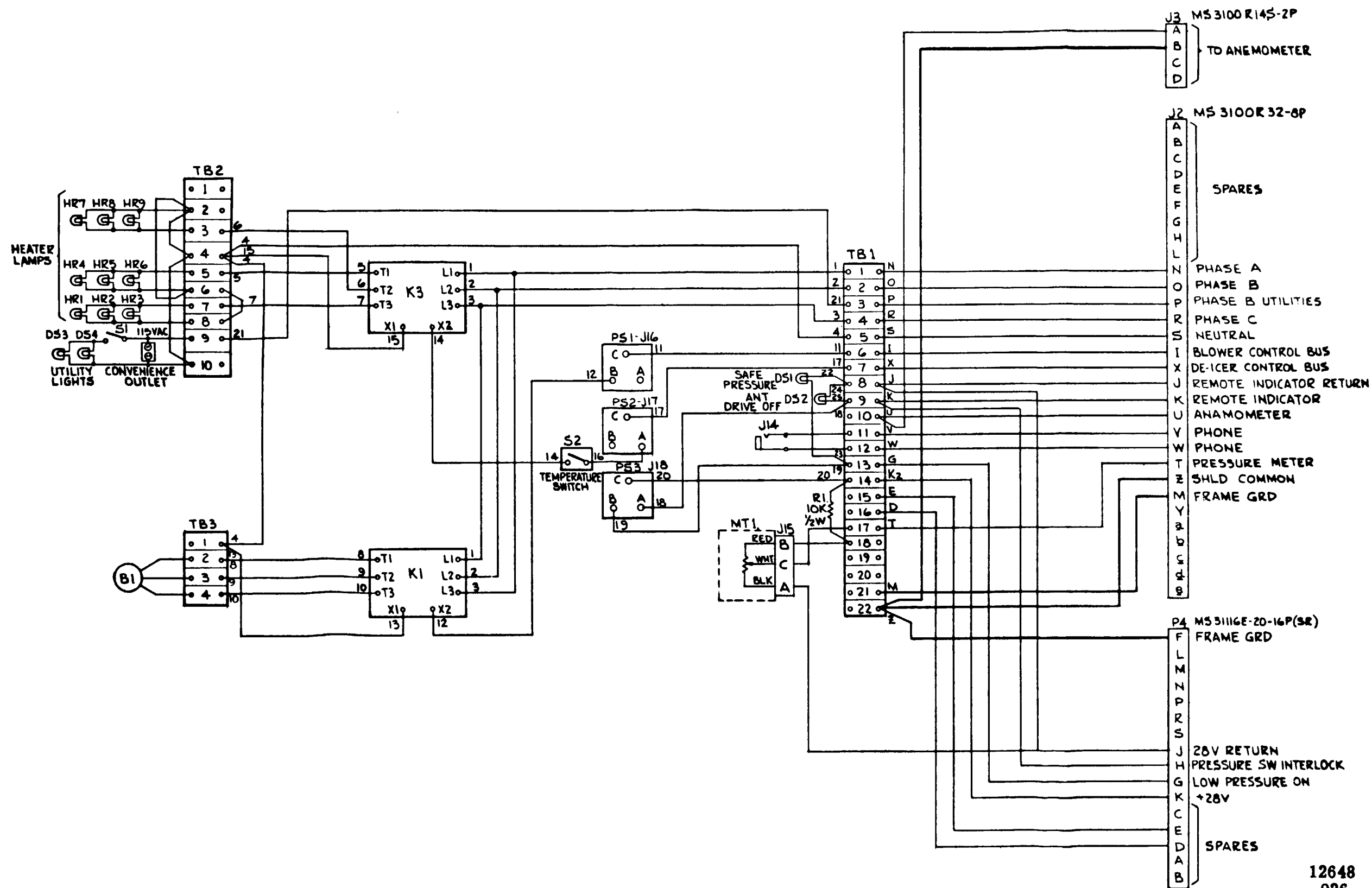

12648  
026  
728916

Figure 5-12. Radome Box, Schematic Diagram.

## NOTE

- **Careful leveling of the areas for locating the baseplates for the portable hoisting unit will greatly facilitate installation.**
- **Four installers can assemble the portable hoisting unit to a ready condition in approximately a half hour.**

B. PARTS LIST - The parts list for the portable hoisting unit is contained in Table 5-8 and referenced to Figure 2-2.

#### 11. ELEVATION DRIVE ASSEMBLY HOIST (See Figure 2-3)

A. DESCRIPTION - The elevation hoist consists of three sections: a lower section which contains the winch drum and bolts to the elevation drive support casting when used to install the elevation assembly, a tubular middle section, and a top T-shaped support with two pulleys. Use of the elevation hoist is illustrated in Figure 2-3 and discussed in Section II of this manual. The hardware for attaching the hoist to the elevation drive support casting is also included as a part of the elevation hoist.

B. PARTS LIST - The parts list for the elevation hoist is contained in Table 5-9.

#### 12. 80-FOOT TOWER

A. DESCRIPTION - An 80-foot tower is provided for mounting the antenna system well above any nearby interference such as hills or buildings. The tower (Figure 2-4) consists of a base section, ten tower sections, and associated braces, guys, anchors, ladders, etc. Davits and winches are provided with the tower for lifting the antenna assembly and other supplies to the top of the tower.

B. PARTS LIST - The parts list for the tower is contained in Table 5-10.

#### 13. ANTENNA POSITION CONTROL INDICATOR

A. GENERAL - An Antenna Position Control Indicator is provided with the QRC-280(A) Antenna System. It contains the controls necessary to operate the Antenna System simultaneously in azimuth and elevation and provide a decimal display of the true azimuth and elevation position of the antennas, relative to the E and H planes. The azimuth and elevation controls allow selection of the mode of system operation - scan, manual, or slave. In the scan mode of operation, a scan generator in the unit allows the antenna to scan a predetermined

sector in azimuth, within a maximum sector of  $\pm 270$  degrees around the true azimuth zero reference. In this mode, the antenna elevation angle is controlled as in the manual mode. In the manual mode, synchros, driven by manually operated handwheels on the front panel of the unit, provide the control voltages required to position the antenna in azimuth and elevation. In the slave mode, control voltages from a radar or remote antenna system supply the azimuth and elevation positioning control voltages through switches in the unit.

(1) Additional controls are provided which allow the polarization of the antenna to be changed and the beam width of the Antenna System to be increased or decreased. A meter is provided which visually indicates the beam width by percentage of increase from the fixed focal point of the reflector. A cablewrap meter with a "0" center and two red limit markings affords a visual indication of the azimuth cable wrap in the antenna pedestal.

B. THEORY OF OPERATION - This subsection contains the theory of operation for the components within the Control Indicator. A detailed description of these components, as used in the system, is contained in paragraph 2, Section I, of this manual. The theory of operation of the synchro devices used on the Control Indicator is contained in paragraph 2 of this section.

(1) FUNCTION OF OPERATING CONTROLS AND INDICATORS (See Figure 5-13)

a. SERVO DRIVE SWITCH AND INDICATORS - The SERVO DRIVE switch (item 8), S1, which is interlocked with the SAFE-RUN switch on the antenna pedestal, provides 28-volts DC to operate relays K2 and/or relay K3 on the Power Supply, depending on the position of switch S3. The indicator light, D64 (item 7), illuminates when the switch S1 is in the ON position and power is being applied to the servo drive. The SAFETY ON indicator light, DS18 (item 18), illuminates if the SAFE-RUN switch on the antenna pedestal is in the SAFE position.

b. ANTENNA OPERATION CONTROLS AND INDICATORS - The antenna operation controls and indicators consist of the MODE SELECT switch (item 16), S2; the AZIMUTH MODE SCAN (item 13), MANUAL (item 14), and SLAVE (item 15) indicator lights, DS8, DS7 and DS6, respectively; the ELEVATION MODE MANUAL (item 25) and SLAVE (item 26) indicator lights DS21 and DS20, respectively; and the azimuth and elevation handwheels (items 10 and 3, respectively).

1. The MODE SELECT switch, S2, with SCAN MANUAL and SLAVE positions, provides selection of the desired mode of system operation. The selected mode of operation is indicated by illumination of the associated AZIMUTH MODE and ELEVATION MODE indicator lights. DS8, DS7 or DS6, and DS20 or DS21.



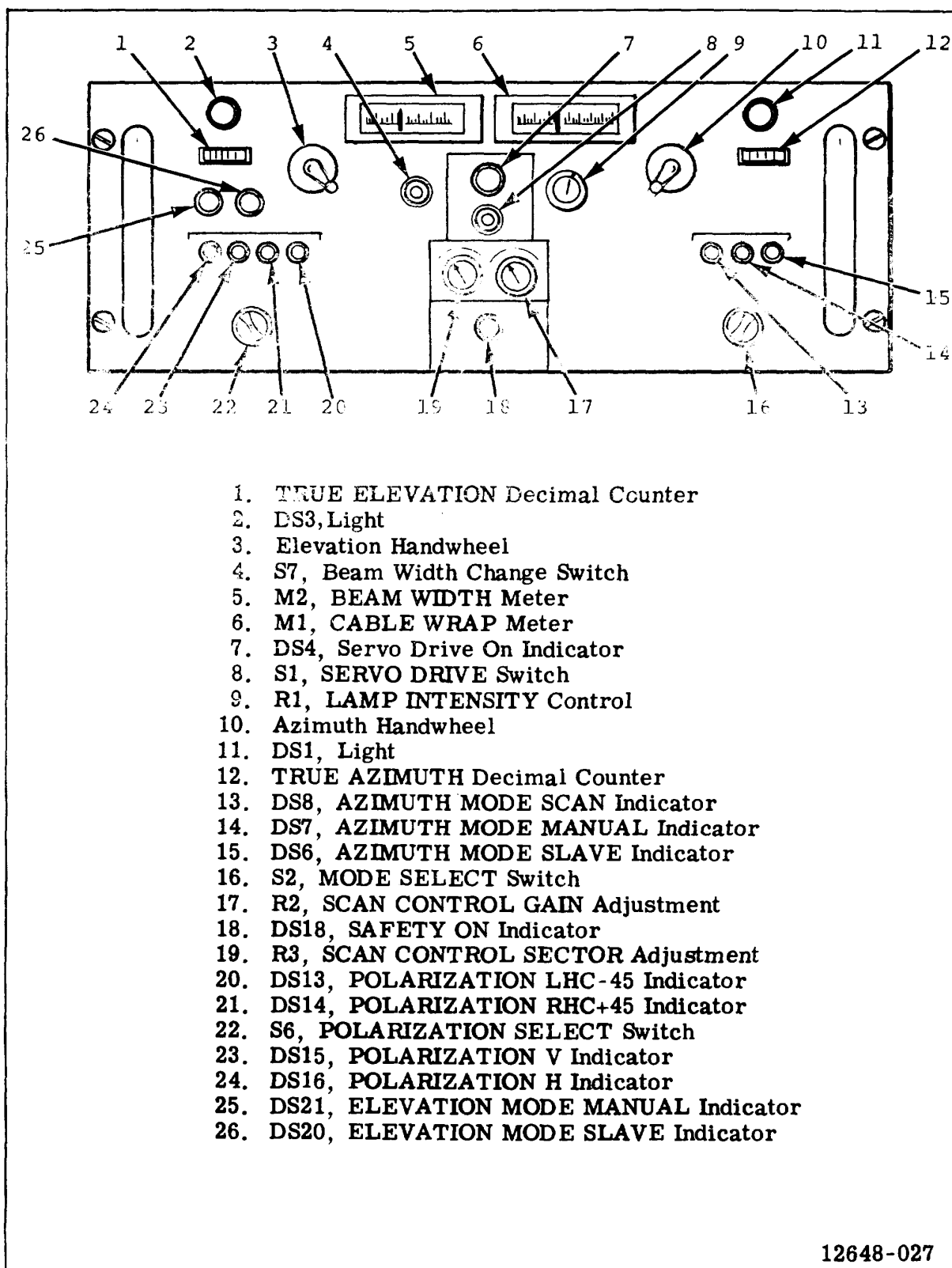

12648-027

Figure 5-13. Control Indicator, Antenna Position, Operating Controls and Indicators

2. The azimuth and elevation handwheels are connected through magnetic clutches (L1 for azimuth, L2 for elevation) to control transmitter synchros B1 and B5, respectively. When the system is energized and placed in the manual mode of operation, 28-volts DC is applied through contacts of switch S2 to energize the magnetic clutches, connecting the handwheels to their respective synchros. Rotation of the handwheel causes the respective synchro to generate an error voltage which is used to reposition the antenna.

c. POLARIZATION CONTROLS AND INDICATORS - The polarization controls and indicators consist of the POLARIZATION SELECT switch (item 22), S6; and the POLARIZATION V (item 23), H (item 24), RHC/+45 (item 21), and LHC/-45 (item 20) indicator lights, DS15, DS16, DS14, and DS13, respectively.

1. The POLARIZATION SELECT switch, S6, allows selection of the desired mode of polarization. The OPERATE pushbutton switch, S5, when depressed, implements the polarization change. When the antenna is repolarized to the selected position, all indicator lights except the one associated with that position will go off.

d. BEAM WIDTH CONTROLS AND INDICATORS - These controls and indicators consist of the BEAM WIDTH meter (item 5), M2, and the BEAM INCREASE BEAM DECREASE switch (item 4), S7.

1. The BEAM WIDTH meter, M2, which is graduated from 0 to 100, is electrically connected to a potentiometer on the electromechanical linear actuator and indicates the position of the antenna feed as a percentage of increase relative to the focal point of the antenna.

2. The BEAM INCREASE BEAM DECREASE switch, S7, is electrically connected to a reversible DC drive motor on the electromechanical linear actuator on the antenna. Operation of switch S7 to the BEAM INCREASE position energizes the DC drive motor, which is geared to a shaft supporting the antenna feed, driving the shaft toward the antenna (i.e., extending the shaft). Operation of S7 to the BEAM DECREASE position causes the shaft to retract.

e. DIGITAL COUNTERS - Two digital counters, a TRUE ELEVATION counter (item 1) and a TRUE AZIMUTH counter (item 12), are provided to indicate the azimuth and elevation angles of the antenna in degrees and tenths of degrees.

f. CABLE WRAP. METER - The CABLE WRAP meter (item 6), M1, is essentially a 0- to 50-millimeter with a zero center-scale marking and red markings, which indicate the limits of the cable wrap in either a CW or CCW direction at either end.

(2) LOCATION AND FUNCTION OF TEST POINTS AND ADJUSTMENTS (See Figures 5-14 and 5-15) - The location and function of the test points and adjustments on the Antenna Position Control Indicator are contained in Table 5-11.

(3) SCAN GENERATOR THEORY OF OPERATION (See Figure 5-16) The scan generator circuitry consists of a scan generator circuit card, potentiometers R2, R3, and R4 on the Control Indicator, and a 6.3-volt AC transformer on the Antenna Position Power Supply. These components control the antenna for sector scanning. The scan generator circuit card contains the circuitry which senses the antenna position as indicated by antenna position potentiometer R4, amplifies the positioning voltage and allows reversing the direction of rotation of the azimuth servo drive while the antenna is scanning.

a. Antenna position potentiometer R4 is coupled by magnetic clutch L3 to the shaft which rotates R4. Rotation of R4 varies a voltage representing the antenna position. When the clutch is deenergized, the wiper of R4 is centered by a spring. With the clutch deenergized, the antenna is pointed in the direction to be scanned. To scan, the clutch is energized and as the antenna turns, the voltage on the wiper of R4 is proportional to antenna position. Twenty-four volts DC is applied to one side of R4 and to a two-to-one voltage divider formed by resistors R6, R11, R9 and R12. These resistors form a bridge circuit on the scan generator circuit card. Sector width potentiometer R3 is connected between the wiper of R4 and the center of the divider. A differential amplifier on the scan generator circuit card, consisting of transistors Q2 and Q3, senses the voltage difference between the voltage divider and the wiper of R3. Transistors Q1 and Q4 comprise two emitter-follower amplifiers which act as buffers for the differential amplifier formed by transistors Q2 and Q3 against the loading of the differential amplifier formed by transistors Q5 and Q6.

b. Approximately 0.15-volt difference between the bases of Q2 and Q3 drives the collectors of Q5 and Q6 to either set or reset a flip-flop formed by transistors Q7 and Q8. When sector width potentiometer R3 is turned fully counterclockwise, only a few degrees of movement of R4 is sufficient to develop the 0.15-volt difference between the bases of Q2 and Q3. When the wiper of R3 is rotated clockwise, it requires proportionately larger angles of rotation of R4 to develop the 0.15-volt difference between the bases of Q2 and Q3. Therefore, with R3 rotated fully counterclockwise, the angle scanned will be small; that is, approximately 10 degrees. With the R3 rotated almost fully clockwise, the width of the angle scanned is approximately +270 degrees.

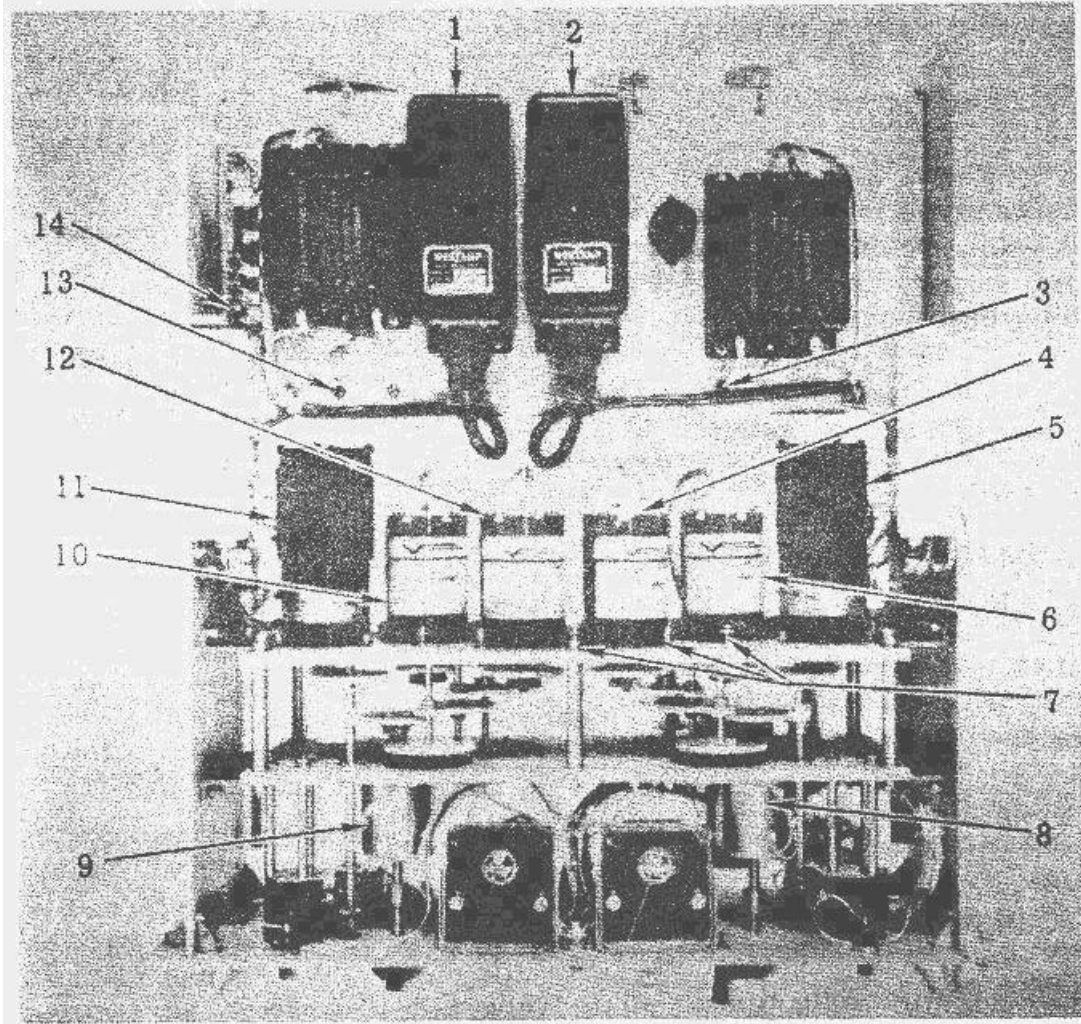

1. AR1, Elevation Servo Amplifier
2. AR2, Azimuth Servo Amplifier
3. P2, Azimuth Error Input Test Point
4. 5, Elevation Slave/Follow-Up
5. G2, Elevation AC Servomotor
6. 4, Elevation Manual/Scan Control Transmitter
7. Synchro Clamp (Typical, 3 per Synchro)
8. 1, Azimuth Handwheel Clutch
9. 2, Elevation Handwheel Clutch
10. 3, Azimuth Manual/Scan Control Transmitter
11. G1, Azimuth AC Servomotor
12. 1, Azimuth Slave/Follow-Up Control Transformer
13. P1, Elevation Error Input Test Point
14. AIR 8, Scan Generator Level Set Potentiometer

12648-028

**Figure 5-14. Control Indicator, Antenna Position, Top View,  
Location of Adjustments and Test Points**

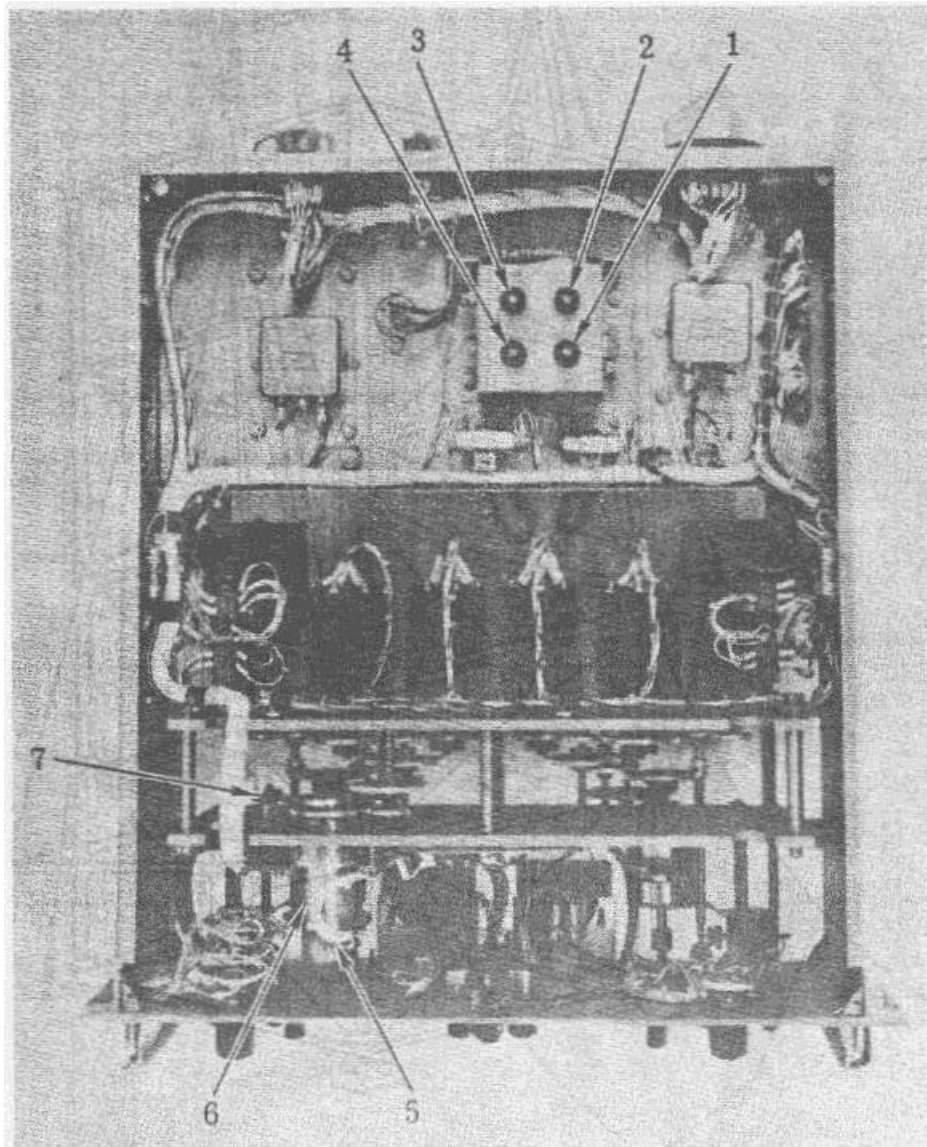

1. R8, Cable 'Wrap Meter Max. Adj. Pot.
2. R7, Cable Wrap Meter Min. Adj. Pot.
3. R5, Beam Width Meter Min. Adj. Pot.
4. R6, Beam Width Meter Max. Adj. Pot.
5. R4, Antenna Position Potentiometer
6. L3, Scan Generator Clutch
7. S8, Sector Scan Limit Switch

12648-029

**Figure 5-15. Control Indicator, Antenna Position, Bottom View, Location of Adjustments and Test Points**

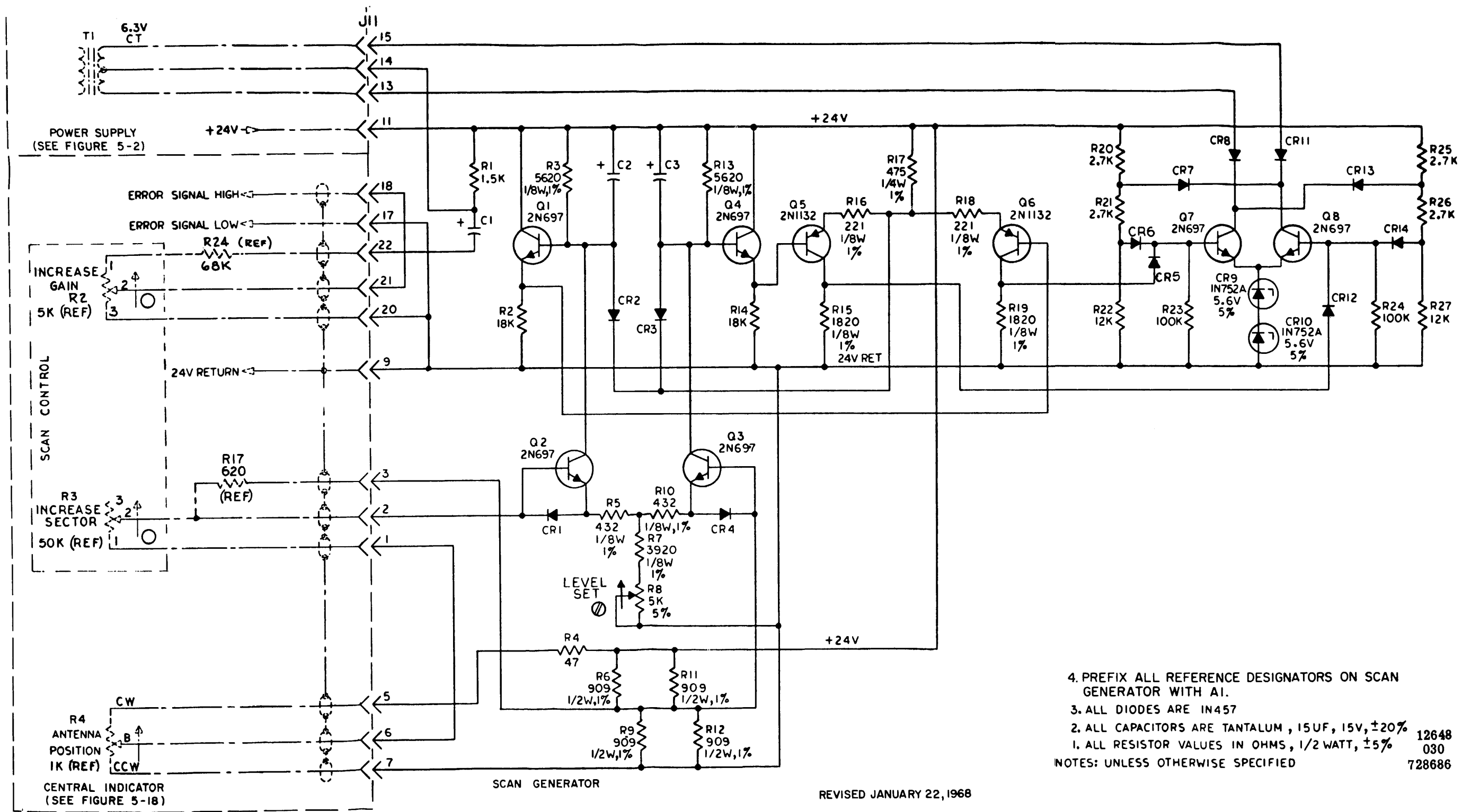

- 4. PREFIX ALL REFERENCE DESIGNATORS ON SCAN GENERATOR WITH A1.
  - 3. ALL DIODES ARE IN457
  - 2. ALL CAPACITORS ARE TANTALUM, 15UF, 15V, ±20%
  - 1. ALL RESISTOR VALUES IN OHMS, 1/2 WATT, ±5%
- NOTES: UNLESS OTHERWISE SPECIFIED

12648  
030  
728686

Figure 5-16. Schematic, Scan Generator

c. Diode switching is used to select one phase or the other from a 6. 3-volt center-tapped transformer winding. Diodes CR8 and CR11 perform this function. When transistor Q7 is turned on, one side of the 6. 3-volt transformer winding is connected to ground by diode CR8. When transistor Q8 is turned on, the other side of the 6. 3-volt transformer winding is connected to ground by diode CR11. Thus, the voltage at the centertap of the 6. 3-volt transformer will reverse phase when Q7 and Q8 are alternately switched on. The voltage from the 6. 3-volt transformer center tap is AC coupled by a capacitor C1 to scan control gain potentiometer R2.

d. The voltage picked up by the wiper of R2 is applied to azimuth servo amplifier AR2, as shown in Figure 5-18, to control the speed at which a sector is scanned. The phase of this voltage controls the direction of the servo motor rotation. A level-set potentiometer, A1R8, is provided on the scan generator circuit card for initial alignment of the circuits to set the voltage level of the collectors of transistors Q5 and Q6 at approximately 8.5 volts. The voltage on the collectors of transistors Q5 and Q6 should be balanced for zero volt difference. Balancing can be accomplished by adjusting the voltage from R4 to set the voltage on the collector of Q6 to the same level as the voltage on the collector of Q5. When this is done, the sector width can be selected by adjusting R3. When scan control gain potentiometer R2 is set to scan at the desired speed, the antenna will scan the preset arc at the desired speed.

(4) CONTROL INDICATOR TRANSMISSION ASSEMBLY - Figure 5-17 illustrates the gearing ratios and arrangement for the synchros, drive motors, handwheels, digital counters, and, in the case of azimuth, scan clutch L3, sector scan limit switch S8, and antenna position potentiometer R4. This diagram is self-explanatory.

C. ALIGNMENT AND ADJUSTMENT PROCEDURES - The only alignment and adjustment procedures which are to be performed on the Control Indicator when not connected into the system is adjusting the sector scan clutch and limit switch and zeroing the synchros. Synchro zeroing procedures are contained in paragraph 2 of this section. Additional in-system adjustment procedures for the Control Indicator are contained in Section III of this manual.

#### (1) SCAN CLUTCH AND LIMIT SWITCH ADJUSTMENT

a. Manually rotate the azimuth and elevation gear trains until the TRUE AZIMUTH and TRUE ELEVATION digital counters are at 0000.

b. Zero all synchros in accordance with the procedures set forth in paragraph 2 of this section.

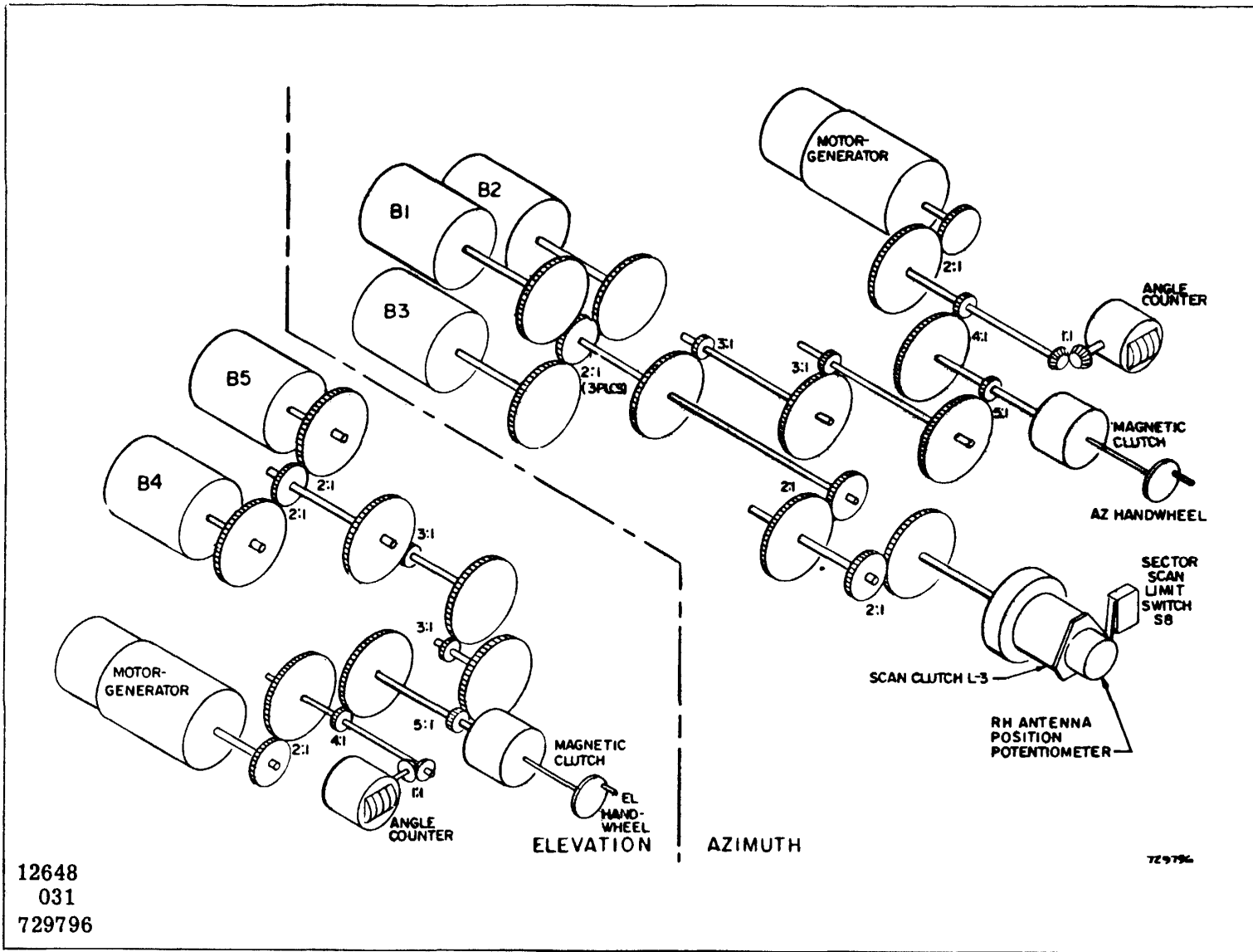

Figure 5-17. Antenna Position Control Indicator, Gearing Diagram



c. Remove the allen-head screws holding the sector scan clutch and potentiometer in position -and move the assembly far enough to disengage the gears. Position the cam so that sector scan limit switch S8 is aligned with the center of the cam lobe. Reengage the gears and secure the assembly to the transmission housing.

d. Connect an ohmmeter between the B and CW terminals of potentiometer R4.

e. Loosen the screws holding R4 in position and slowly rotate R4 until the ohmmeter indicates approximately 500 ohms. Secure R4 in position and remove the ohmmeter.

#### NOTE

**R4 should be readjusted in accordance with the procedures set forth in Section m of this manual, paragraph 5. A(4), when the system is operating.**

f. Manually rotate the azimuth gear train CW (TRUE AZIMUTH counter increasing) 630 degrees. The counter should indicate 270. 0.

g. Loosen sector scan limit stop switch S8 and rotate the gear train CCW 540 degrees. Observe that the contacts of switch S8 again make between 90 and 60 degrees.

D. SCHEMATIC DIAGRAM AND PARTS LIST - The schematic diagram for the Antenna Position Control Indicator is contained in Figure 5-18. The parts list for the Antenna Position Control Indicator is contained in Table 5-12.

#### 14. ANTENNA CONTROL POWER SUPPLY

A. GENERAL - The unit is capable of supplying power, servo excitation, and azimuth orient correction factors for the Antenna System. In addition, the unit provides the controls necessary to control power, pressure, and driving of the radome-platform.

B. THEORY OF OPERATION - This subsection contains the theory of operation for the components within the Power Supply. A detailed description of these components, as used in the system, is contained in paragraph 2, Section I, of this manual. The theory of operation of the synchro devices used in the Power Supply is contained in paragraph 2 of this section.

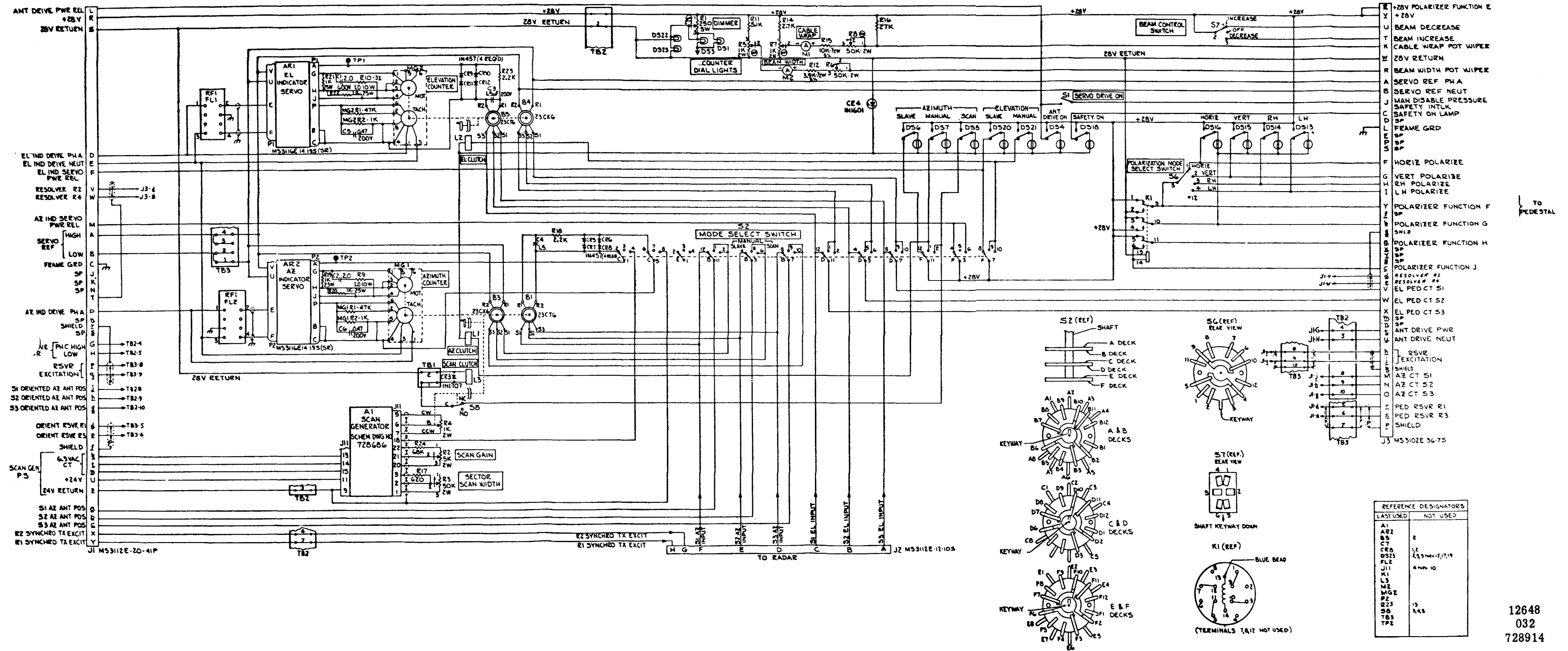

Figure 5-18. Schematic, Antenna Position Control Indicator

5-51/5-52

12648  
032  
728914

## (1) FUNCTION OF OPERATING CONTROLS AND INDICATORS (See Figure 5-19)

a. ANTENNA SYSTEM POWER CIRCUIT BREAKER - The ANTENNA SYSTEMS-POWER circuit breaker, CB3, controls application of the 120/208volt AC power to the Antenna System.

b. RADOME CONTROLS AND CIRCUIT BREAKERS - The radome controls and circuit breakers consist of:

CB1, RADOME POWER Circuit Breaker  
 M1, RADOME PRESSURE Meter  
 S1, DEICER Power Switch  
 S2, BLOWER Power Switch  
 DS1, PRESSURE SAFE Indicator Light

RADOME POWER (CB1) circuit breaker controls power application to the radome when the BLOWER (S2) power switch is in the appropriate position. The DEICER (S1) power switch controls power to the deicers in the radome. When the deicer is in operation, should radome pressure fall below 9 inches of water (approximately 0.35 psi) or the temperature in the radome increase to 38 degrees Fahrenheit, pressure switches in the radome open, rendering the deicers inoperative.

c. SERVO EXCITATION CIRCUIT BREAKER- The SERVO EXCITATION circuit breaker (CB4) applies primary power to the servo circuits in the Control Indicator and antenna pedestals.

d. WIND SPEED METER - The WIND SPEED meter (M2) indicates the local wind speed in mph. It is connected to an anemometer mounted on a mast adjacent to the radome.

e. UTILITIES POWER - The UTILITIES circuit breaker (CB2) controls 115-vac power available at convenience receptacles in the radome and on the tower.

f. AZIMUTH ORIENTATION - The AZ ORIENT control is used to set the true azimuth of the antenna installation so that the TRUE AZIMUTH indicator on the Control Indicator unit will be correctly oriented for the site.

(2) LOCATION AND FUNCTION OF TEST POINTS AND ADJUSTMENTS (See Figure 5-20) - The location and function of the test points and adjustments on the Antenna Control Power Supply are contained in Table 5-13.

C. ALIGNMENT AND ADJUSTMENT PROCEDURES - The only alignment and adjustment procedures which are to be performed on the Power Supply when not connected into the system is zeroing the azimuth differential control

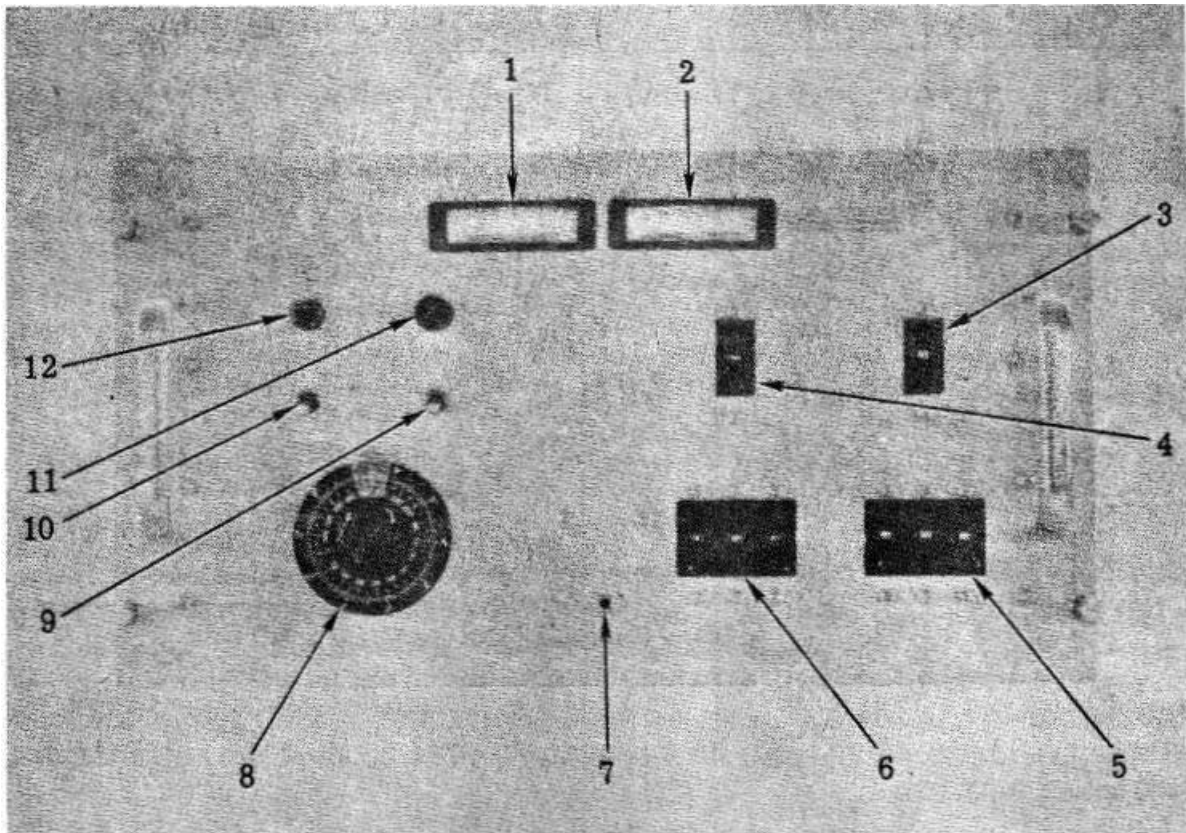

1. M1, Radome Pressure Meter
2. M2, Wind Speed Meter
3. CB4, Servo Excitation Circuit Breaker
4. CB2, Utilities Circuit Breaker
5. CB3, Antenna Systems Power Circuit Breaker
6. CB1, Radome Power Circuit Breaker
7. J6, Phone Jack
8. B1, B2, AZ Orient Control
9. S1, Deicer Switch
10. S2, Blower Switch
11. R7, Dimmer Control
12. DS1, Radome Indicator

12648-033

**Figure 5-19. Power Supply - Antenna Control, Front Panel Controls and Indicators**

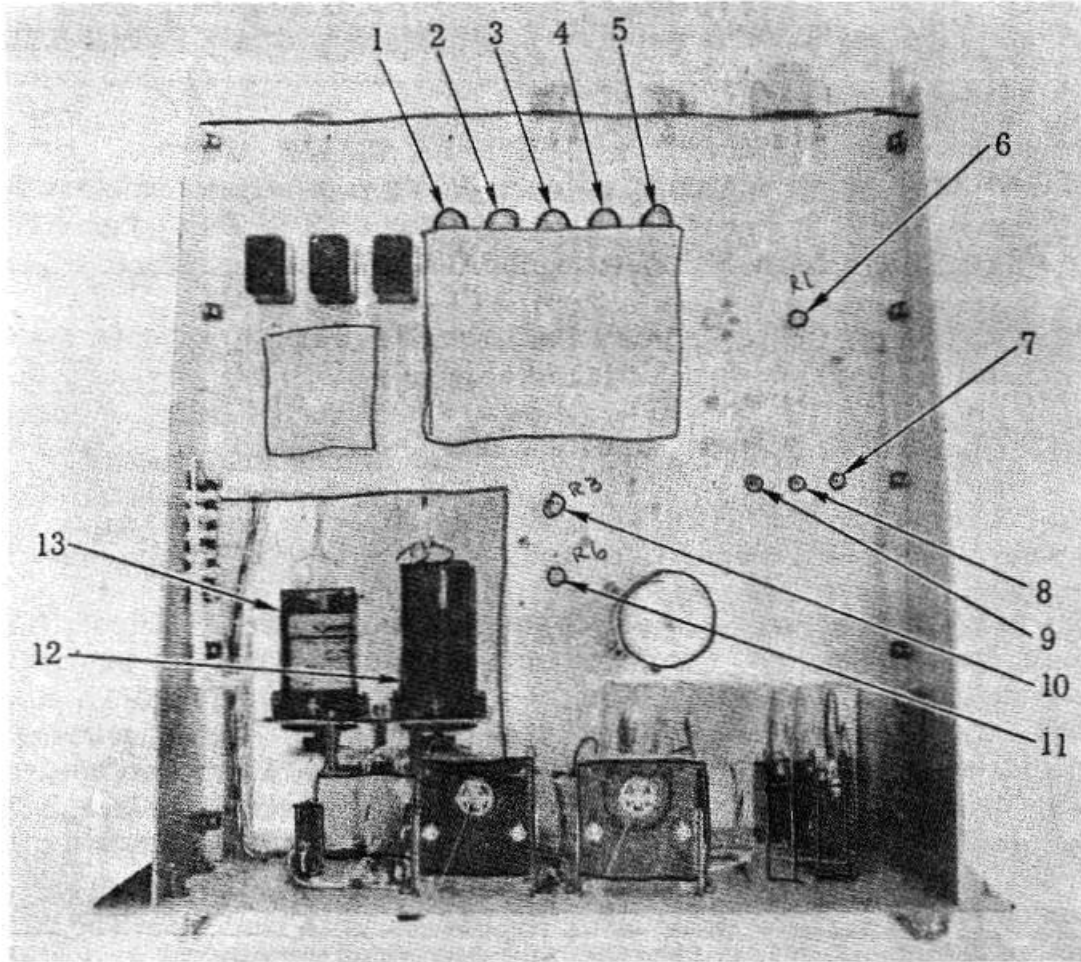

1. F1, 5A Fuse (L8V Unregulated)
2. F2, 3A Fuse (Remote Reference)
3. F3, 3A Fuse (Primary Power  $\text{ØA}$ )
4. F4, 3A Fuse (Primary Power  $\text{ØB}$ )
5. F5, 10A Fuse (Primary Power  $\text{ØC}$ )
6. R1, +24 VDC Regulated Adjustment
7. TP3, +24 VDC Regulated Test Point
8. TP2, Ground Test Point
9. TPI, +28 VDC Unregulated Test Point
10. R3, Pressure Gauge M1 Min. Adj. Pot.
11. R6, Pressure Gauge M1 Max. Adj. Pot.
12. Synchro Clamps (Typical, 3 per Synchro)
13. B1, Differential Control Transmitter

12648-034

**Figure 5-20. Power Supply, Antenna Control, Location of Adjustments and Test Points**

transmitter synchros and resolver. These synchros should be zeroed in accordance with the procedures set forth in paragraph 2 of this section.

D. SCHEMATIC DIAGRAM AND PARTS LIST - The schematic diagram for the Antenna Control Power Supply is contained in Figure 5-21. The parts list is contained in Table 5-14.

#### 15. DIRECTION FINDING DISPLAY SCOPE

A. GENERAL - The scope displays the antenna pattern in azimuth and is used for indicating the azimuth direction of a received signal. Append I contains complete instructions applicable to the basic scope. Some modifications have been added to the scope; they are described below.

B. DESCRIPTION OF MODIFICATIONS -The modifications added to the basic scope are shown in Figure 5-22. This consists of the addition of four circuit cards and some interconnection wiring. The circuit cards are a modulator, two demodulators, and a writing gun relay driver.

(1) Inputs to the scope are the AGC signal from the associated receiver and the resolver reference voltage. The modulator produces a square wave output with amplitude proportional to the magnitude of the AGC signal (which in turn is proportional to signal strength) and in phase with the resolver reference voltage.

(2) The resolver block is actually two resolvers, one in the Pedestal and one in the Antenna Control Power Supply. The resolver in the pedestal is geared to antenna azimuth direction and is corrected for boresighting errors by the AZ ORIENT resolver in the power supply. The two resolver outputs are proportional to the sine and cosine of the true azimuth angle. These AC signals are demodulated to DC and applied to the X and Y deflection amplifiers of the scope.

(3) To avoid damaging the scope face with a spot burn when no signal is present, the writing gun is kept off until a signal is present. The writing gun relay driver is adjusted to energize the WRITE-DON'T WRITE relay at an AGC level just above zero signal level. When the relay is energized, the writing gun is enabled.

(4) Interconnection wiring changes are shown in Figure 5-23. The circuit boards are described in greater detail in the following paragraphs.

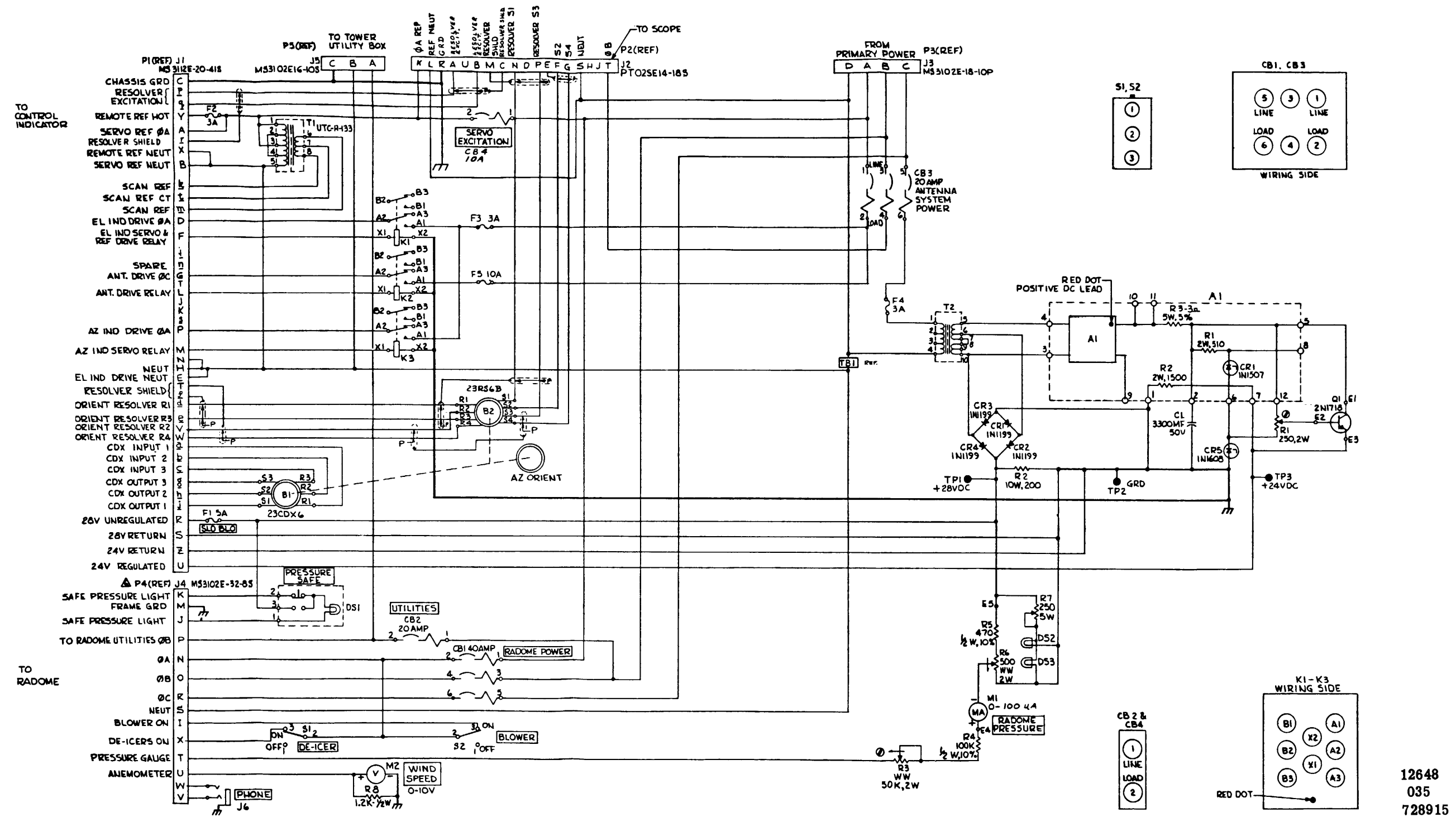
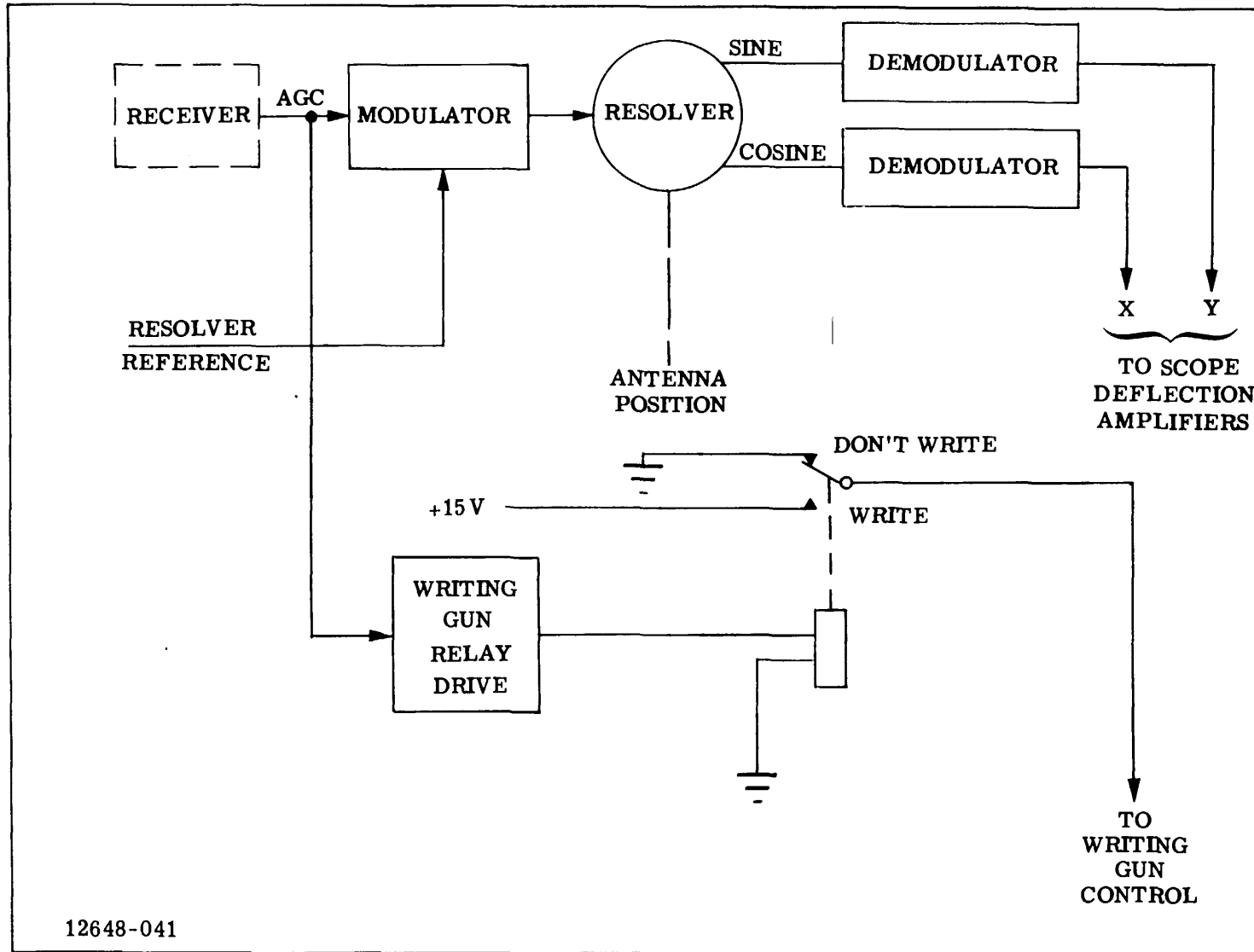

Figure 5-21. Schematic, Power Supply - Antenna Control



12648-041

Figure 5-22. Scope Modifications Block Diagram



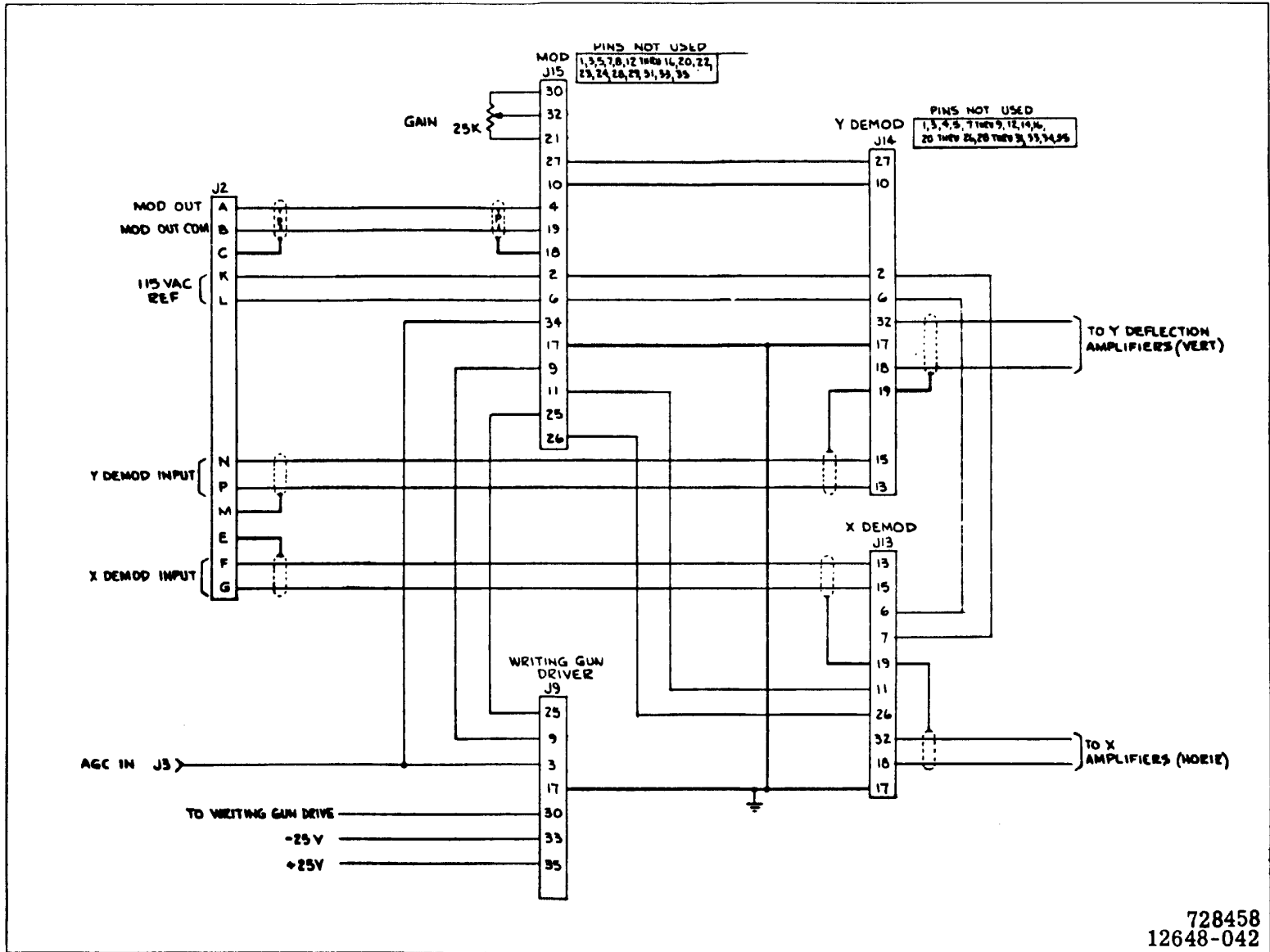

Figure 5-23. Scope Wiring Modifications

### C. MODULATOR CIRCUIT BOARD See Figure 5-24)

(1) The modulator produces a square wave output signal whose amplitude is proportional to the magnitude of the receiver AGC signal. It consists of two operational amplifiers, a 60-cps reference generator, and an output amplifier.

(2) The AGC signal is applied through pin 34 to operational amplifier A1. A 115-volt, 60-cps resolver reference signal is applied through pins 2 and 6 to transformer T1. The output winding of T1 controls transistors Q2 and Q4 which in turn switch Q1 and Q3 at a 400-cps rate. Thus the output of A1 is a 60-cps square wave proportional to the AGC signal in amplitude. This signal is further amplified by operational amplifier A2 and output amplifiers Q5 and Q6.

(3) PARTS LIST AND SCHEMATIC - The parts list for the modulator is contained in Table 5-15. The schematic diagram is shown in Figure 5-24.

### D. DEMODULATOR CIRCUIT BOARD (See Figure 5-25)

(1) The demodulator is a dual-purpose card. It provides a full-wave phase sensitive demodulator and an operational amplifier for compensation. The demodulator consists of two transistor switches Q1 and Q2. Q1 and Q2 switch the inputs alternately to ground. Q1 and Q2 are caused to switch by the reference generator Q3 and Q4. A1 is a high gain operational amplifier which provides an integration. Amplifier current balance is provided by BAL control R10.

(2) PARTS LIST AND SCHEMATIC - The parts list for the demodulator is contained in Table 5-16. The schematic diagram is shown in Figure 5-25.

### E. WRITING GUN RELAY DRIVER (See Figure 5-26)

(1) The writing gun relay driver controls operation of the scope writing gun so that a scope display will be present only when a signal is being received. The circuit card consists of an operational amplifier, a transistorized relay driver and a relay.

(2) The AGC signal from the receiver is applied to pin 3 and TP2. This signal is amplified by amplifier A1 and, when of sufficient magnitude, triggers relay driver Q1 to the ON condition. When Q1 is on, a ground path is completed for the coil of relay K1 which is energized, applying +15V to pin 30 and enabling the writing gun in the scope to operate. When K1 is deenergized, a ground is applied to pin 30 and the writing gun is disabled.

(3) ADJUSTMENTS - Set LEVEL control R8 so that relay K1 is energized at an AGC voltage just above zero signal level. This control setting will vary

Revised January 22, 1968

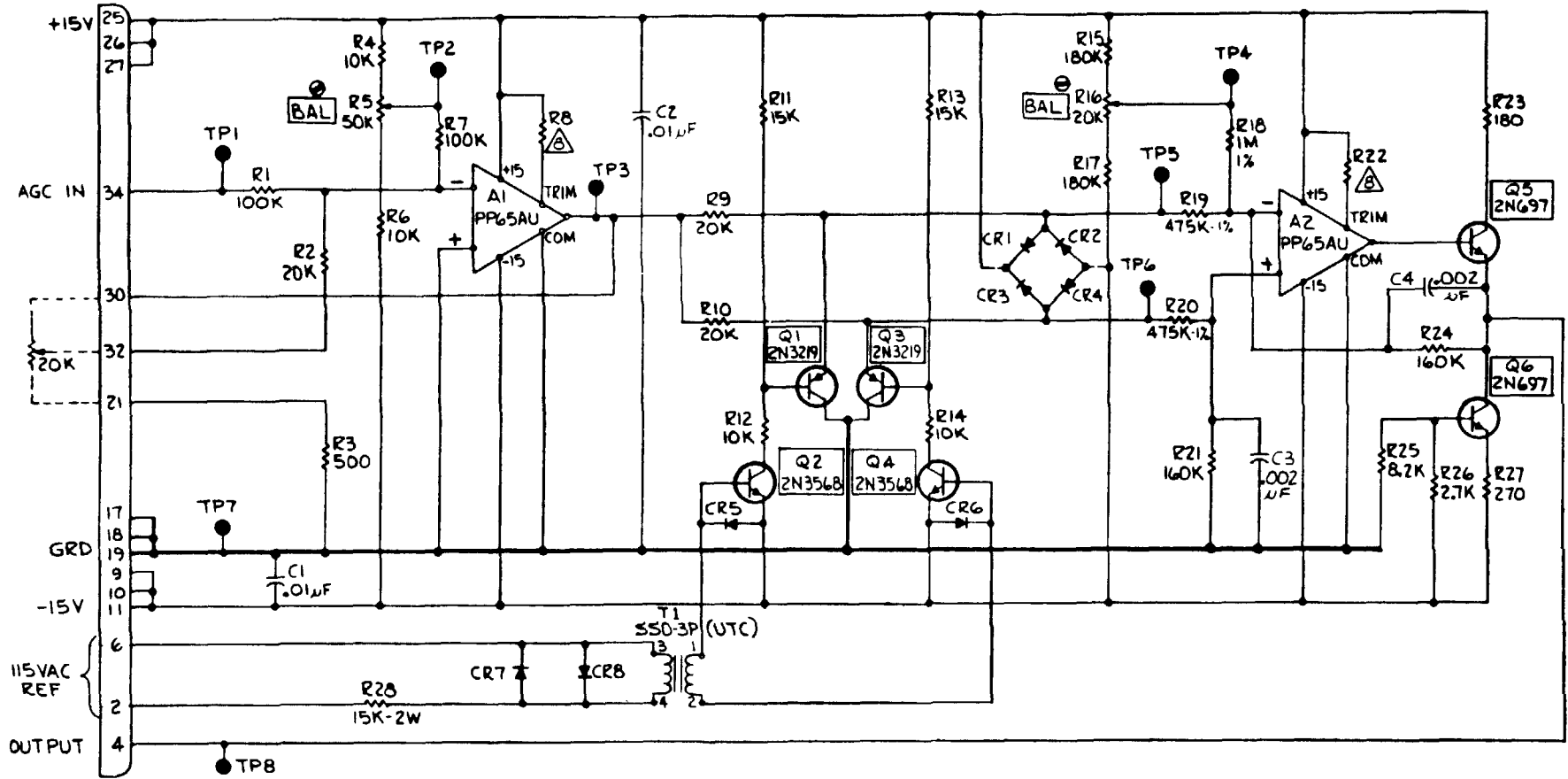

728438  
12648-043

Figure 5-24. Modulator Schematic Diagram

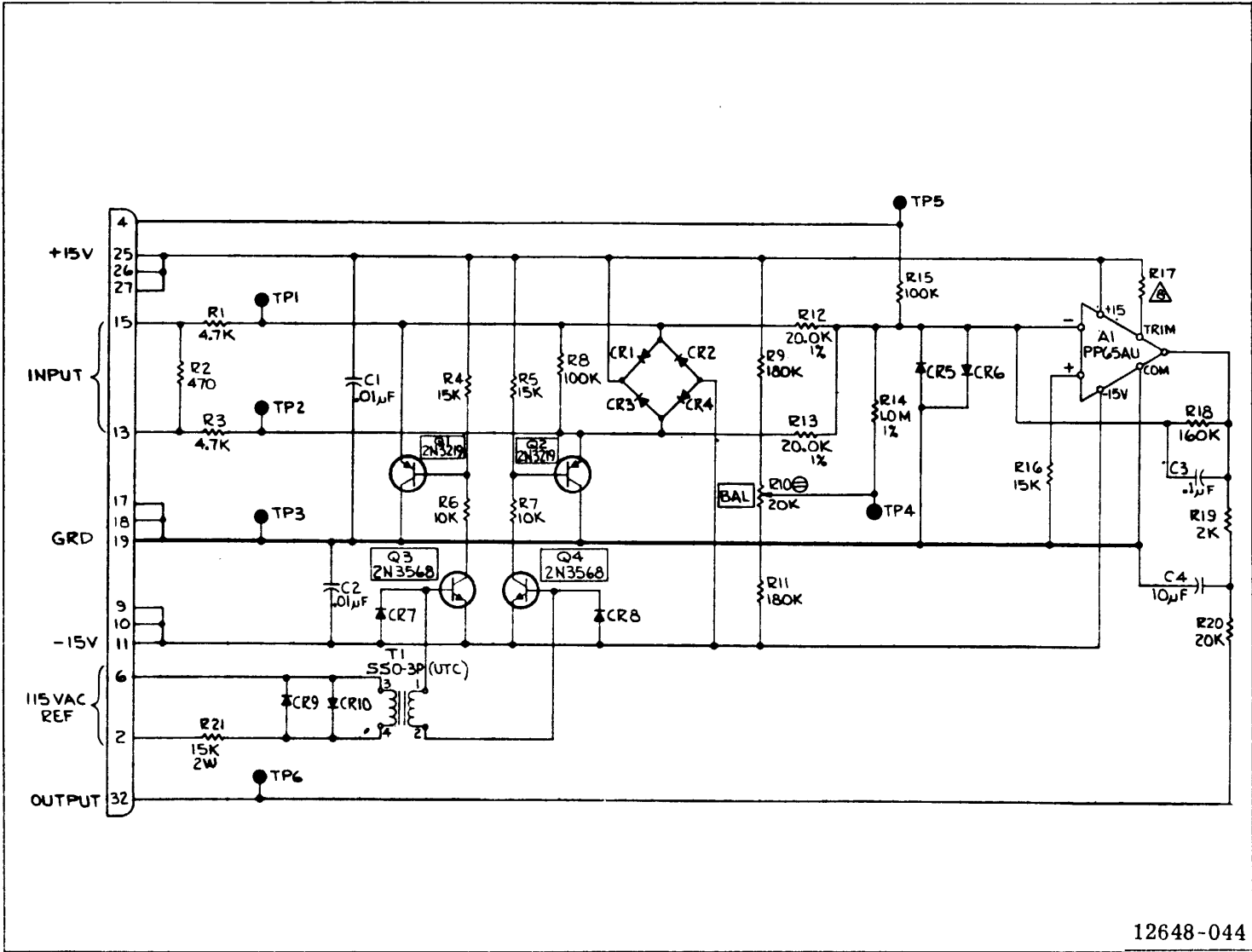

Figure 5-25. Demodulator Schematic Diagram

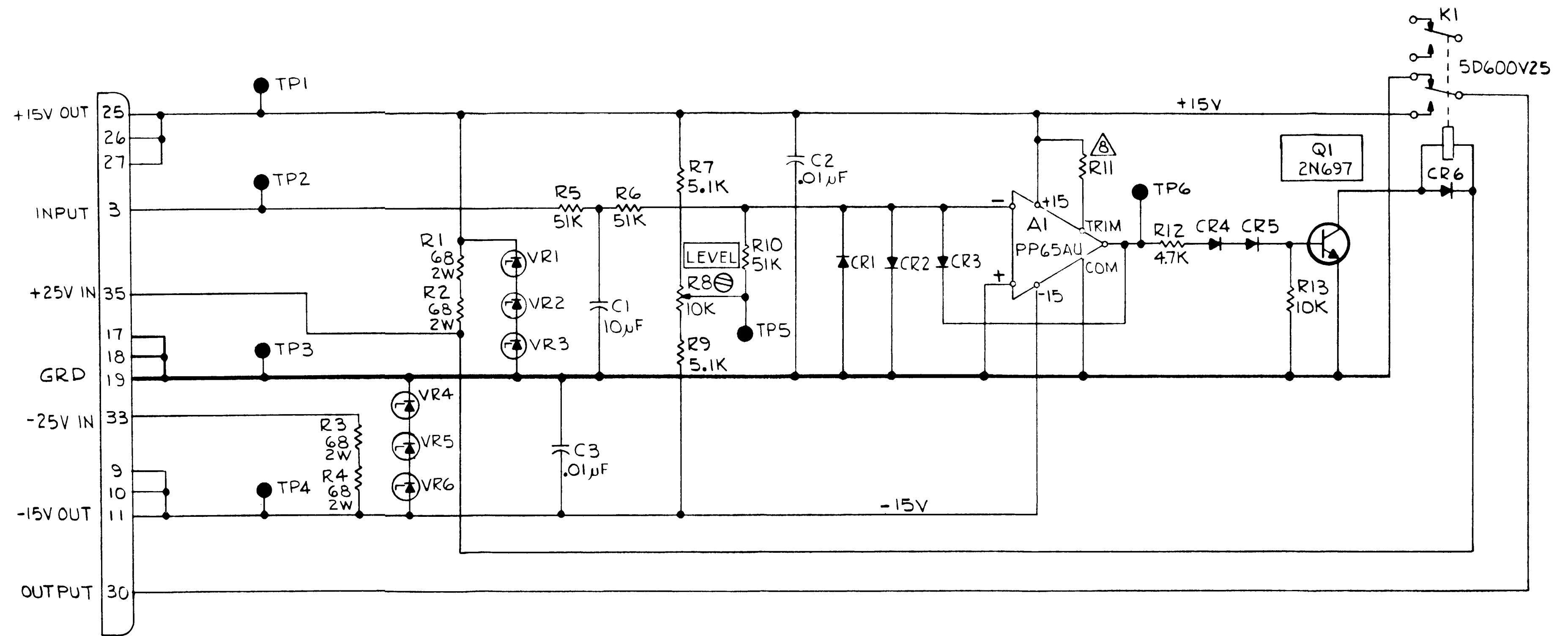

Figure 5-26. Writing Gun Relay Driver Schematic Diagram

with the receiver in use. The circuit card will operate over a wide range of AGC voltage; however, the object is to have the writing gun operate only when a signal is present.

(4) PARTS LIST AND SCHEMATIC - The parts list for the Writing Gun Relay Driver is contained in Table 5-17. The schematic diagram is shown in Figure 5-26.

TABLE 5-1. ANTENNA SYSTEM, MAJOR COMPONENTS PARTS LIST

Figure Ref.	Ref. Desig.	Description	Air Force Part Number	Fed. Standard Part Number	Commercial Part Number	Mfr.	Qty Per Unit
5-1							
-1		Antenna System (See Table 5-2)			728906	98825	1
-2		Guy, Radome Ground Installation			728663-3	98825	4
-3		Stand, Portable (See Table 5-8)			728952	98825	1
-4		Lightning Rod, Ground Rod			728673-3	98825	1
		Rod			MS-54	97540	1
		Rod			MS-53	97540	4
		Rod			MS-52	97540	1
		Rod			MS-51	97540	1
		Rod			MS-50	97540	1
		Rod			MS-49	97540	1
-5		Wire Rope Assembly			728680	98825	3
-6		Drive Tool			728685	98825	1
-7		Lightning Rod, Tower Rod			728698	98825	1
		Rod			MS-54	97540	1
		Rod			MS-53	97540	4
		Rod			MS-52	97540	1
		Rod			MS-51	97540	1
		Rod			MS-50	97540	1
		Rod			MS-49	97540	1
-8		Ground Rod Assembly			728701	98825	1
-9		Guy, Radome, 80-Foot Tower Installation			728753	98825	4
-10		Hoist, Elevation Drive (See Table 5-9)			728833	98825 1	
-11		Cover Assembly, Hard			728976	98825 1	

TABLE 5-1. ANTENNA SYSTEM, MAJOR COMPONENTS PARTS LIST (CONT)

Figure Ref.	Ref. Desig.	Description	Air Force Part Number	Fed. Standard Part Number	Commercial Part Number	Mfr.	Qty Per Unit
5-1 - 12		Mounting Assembly, Anemometer			728977	98825	1
-13		Washer, Flat; CRES, 3/4-Inch		MS15795-322			4
-14		Screw, Cap, Hex Head; CRES, 3/4- 1(x4. 00 Inch Lg		MS35307-495			4
-15		Washer, Lock, Split; CRES, 3/4-Inch		MS35338-89			4
-16		Washer, Flat; CRES, 1/4		MS15795-810			6
-17		Washer, Lock, Split; CRES, 1/4		MS35338-52			6
-18		Screw, Cap, Socket Head; 1/4- 20x 1. 00 Inch Lg		MS16995-52			6
-19		Tower Assembly, 80-Foot			L-1686	88900	1
-20		Anemometer Mounting Assembly, Tower			728988	98825	1
-21		Adapter, Mast			515333	23667	1
-22		Transmitter, Wind Speed			Model 122	23667	1



TABLE 5-2. ANTENNA SYSTEM, PARTS LIST

Figure Ref.	Ref. Desig.	Description	Air Force Part Number	Fed. Standard Part Number	Commercial Part Number	Mfr.	Qty Per Unit
5-2							
-1		Radome-Platform, Type I					1
-2		Cable Assy, Elevation Data			728937-2	98825	1
-3		Counterweight			728794	98825	2
-4		Reflector, 9-Foot Diameter			728901	98825	1
-5		Antenna, Log-Periodic				72171	1
-6		Clip			6009-18A	91506	2
-7		Extension, Support			728574	98825	1
-8		Support, Elevation Drive Assembly			728599	98825	1
-9		Adapter			728603	98825	1
-10		Pedestal, Antenna (See Table 5-3)			728733-5	98825	1
-11		Support Assembly			728710	98825	3
-12		Bracket			728600	98825	1
-13		Polarization Diversity Mechanism (See Table 5-5)			728920	98825	1
-14		Bracket			728605	98825	1
-15		Clamp, 9-Foot Antenna			728624	98825	4
-16		Washer, Tapered			728650	98825	3
-17		Actuator, Electromechanical Linear (See Table 5-6)			728542-1	98825	1
-18		Socket, 8-Point, 1/4-Inch, 1/4 Drive			4708-S	93389	1
-19		Extension Bar, 1/4 Drive			TM-2	55719	1
-20		Wrench, Speeder, 1/4 Drive			TM-4A	55719	1

TABLE 5-2. ANTENNA SYSTEM, PARTS LIST (CONT)

Figure Ref.	Ref. Desig.	Description	Air Force Part Number	Fed. Standard Part Number	Commercial Part Number	Mfr.	Qty Per Unit
5-2							
-21		Drive Assembly, Elevation (See Table 5-7)			728910	98825	1
-22		Support, Counterweight			728622	98825	2
-23		Sealant, Rubber, Silicone			RTV-731	71984	AR
-24		Level Bubble			1986G	57163	2
-25		Screw, Machine, Pan Head; CRES, #2-56x3/4 Inch Lg		MS35233-9			4
-26		Screw, Machine, Flat Head; CRES #10-32x1/2 Inch Lg		MS35250-72			6
-27		Screw, Machine, Fillister Head; CRES #6-32x1-1/4 Inch Lg		MS35275-35			4
-28		Auxiliary Pedestal Support			728888-1		2
-29		Screw, Cap, Socket Head; CRES # 10-32x3/4 Inch Lg		MS16996-12			13
-30		Screw, Cap, Socket Head; CRES 1/4-20x1/4 Inch Lg		MS16995-53			8
-31		Screw, Shoulder, Socket Head; (E 10-24) Steel Cad Plate, 1/4x3/4 Inch Lg		MS16638-4			6
-32		Screw, Cap, Socket Head, CRES, 3/8-16x2-1/4 Inch Lg		MS16995-86			12

TABLE 5-2. ANTENNA SYSTEM, PARTS LIST (CONT)

Figure Ref.	Ref. Desig.	Description	Air Force Part Number	Fed. Standard Part Number	Commercial Part Number	Mfr.	Qty Per Unit
5-2							
-33		Screw, Cap. Socket Head; CRES, 1/2-13x 1-1/4 Inch Lg		MS16995-95			12
-34		Screw, Cap, Socket Head; CRES, 1/2-13x2-1/4 Inch Lg		MS16995-99			7
-35		Screw, Cap, Hex Head; CRES, 3/8-16x 1-1/4 Inch Lg		MS35307-62			8
-36		Screw, Cap, Hex Head; CRES, 3/8-16x4-1/2 Inch Lg		MS35307-76			4
-37		Screw, Cap, Hex Head; CRES, 1/2-20x2-1/4 Inch Lg		MS35308-116			6
-38		Setscrew, Cup Point, Steel, Cad Plate, 5/16-18-1/4 Inch Lg		MS51017-90			2
-39		Screw, Cap,.. Socket Head; CRES, #10-32x1/2 Inch Lg		MS16996-10			2
-40		Pin, Spring, CRES 1/16 Dia x 3/4 Inch Lg		MS16562-198			3
-41		Washer, Lock, Split, CRES #10		MS35338-81			38
-42		Washer, Lock, Split, CRES 1/4		MS35338-82			8
-43		Washer, Lock, Split		MS35338-84			24
-44		Washer, Lock, Split, CRES 1/2		MS35338-86			28
-45		Screw, Cap, Socket Head, CRES # 10-32x7/8 Inch Lg		MS16996-13			1

TABLE 5-2. ANTENNA SYSTEM, PARTS LIST (CONT)

Figure Ref.	Ref. Desig.	Description	Air Force Part Number	Fed. Standard Part Number	Commercial Part Number	Mfr.	Qty Per Unit
5-2		Cable Clamp			728821	98825	1
-46		Washer, Flat; CRES 3/8		AN960C616			24
-47		Washer, Flat; CRES #6		MS15795-305			4
-48		Washer, Flat; CRES #10		MS15795-308			52
-49		Washer, Flat; CRES 1/4		MS15795-310			14
-51		Washer, Flat; CRES 3/8		MS15795-314			16
-52		Washer, Flat; CRES 1/2		MS15795-318			35
-53		Washer, Flat; CRES 5/16		MS15795-312			2
-54		Nut, Plain, Hex; CRES #10-32		MS35650-104			18
-55		Nut, Plain, Hex (JAM); CRES 5/16-18		MS35691-510			2
-56		Nut, Plain, Hex; CRES #6-32		MS35649-64			12
-57		Nut, Plain, Hex; CRES #10-24		MS35649-104			6
-58		Nut .t, Plain, Hex; CRES 3/8-16		MS35690-610			16
-59		Nut, Plain, Hex; CRES 1/2-13		MS35690-810			13
-60		Support, Cable Clamp Assembly			728965	98825	1
-61		Bracket, Cable Clamp			728834-1	98825	1
-62		Spacer Clip, Mounting			728817	98825	2
-63		Nut., Plain, Hex; CRES #2-56	1	MS35649- 24			4

TABLE 5-2. ANTENNA SYSTEM, PARTS LIST (CONT)

Figure Ref.	Ref. Desig.	Description	Air Force Part Number	Fed. Standard Part Number	Commercial Part Number	Mfr.	Qty Per Unit
5-2 -64		Washer, Lock, Split; CRES #2		MS35338-77			4
-65		Washer, Flat: CRES # 2		MS15795-302			4
-66		Bracket, Cable Clamp			728863	98825	1
-67		Cable Assembly, Radio Frequency, 9-Foot Dish			728726	98825	1
-68		Cable Assembly, Mixer Switching Units			728453	98825	2
-69		Cable Assembly, Radio Frequency, 9-Foot Dish			728727	98825	1
-70		Cable Clamp				84971	1
-71		Spiral Wrap			SWN-3/8	05593	AR
-72		Support, Split -Washer, Sealing			2230-8	98159	1
-73		Test Probe Assembly			728454	98825	1
-74		Pressure Transducer, 0-1 PSID Range			2010-1PD-10	27151	1
-75		Pressure Transducer			728997	98825	1
-76		Screw Machine, Pan Head; #10-32x 7/8 in. lg		MS51958-66			14

TABLE 5-3. ANTENNA PEDESTAL, PARTS LIST

Figure Ref.	Ref. Desig.	Description	Air Force Part Number	Fed. Standard Part Number	Commercial Part Number	Mfr.	Qty Per Unit
5-6							
-1		Drive Assembly, Azimuth See Table 5-4)			728615-1	98825	1
-2		Gasket Azimuth Drive			728702	98825	1
-3		Cover Access, Synchro			728690-5	98825	1
-4		Cover, Access, Motor Control			728690-1	98825	1
-5		Cover, Access, Motor			728691	98825	1
-6		Deleted					
-7		Base, Riser, Azimuth Drive			728675-7	98825	1
-8		Packing "O" Ring		AN6227-3			3
-9		Plate, Unit Identification			728919-7	98825	1
-10		Control, Motor, No. 2			728739-1	98825	1
	C1	Capacitor, 15 µf, 600 VDC			331P3U	96733	3
	C3	Capacitor, 2 µf, 600 VDC, MIL-C- 25/7		CP70BIEF- 205K1			1
	C4	Capacitor, 4 µf, 600 VDC, MIL -C-25/7		CP70BIEF- 405K1			
	K1	Relay				09026	1
	R1	Resistor, 10Ω, 10W, MIL-R- 18546/1		RE65G1R00			2
	R2	Resistor, WW, 50W				91637 2	1
	R3	Same as R1					
	R4	Same as R2					

TABLE 5-3. ANTENNA PEDESTAL, PARTS LIST (CONT)

Figure Ref.	Ref. Desig.	Description	Air Force Part Number	Fed. Standard Part Number	Commercial Part Number	Mfr.	Qty Per Unit
5-6	R5	Resistor, WW, 50W			RH-50, 200 ±3%g	91637	2
-10	R6	Same as R5					
	TB1	Terminal Strip 10- Terminal			10-140	71785	3
	TB2	Same as TB1					
-11	TB3	Same as TB1					
		Control, Motor, No. 1 Amplifier			728741-1 A539-250C- 13B6-A	98825	1
		Filter, Radio Interference			GF-2967	07294	2
		Capacitor, 0. 47 µf, 200 VDC			12M2474-DG	96733	2
		RF Filter			GF-3410	07294	4
		Resistor, 2.2K, 1/2W, 5%. MIL-R-11/3		RC20GF222J			1
		Capacitor, 1.5 if, 200 VDC			44M2155-DG	96733	1
-12		Clip			6008-2A	91506	1
-13		Stat-O-Seal #8			600-001-8	83259	1
-14		Screw, Leveling			728793	98825	4
-15		Label, Pressure Sensitive			728765	98825	3
-16		Ratchet Wrench, 1/4-Inch Drive			4749	93389	1
-17		Socket, 8-Point, 1/4-Inch			4708-S	93389	1
-18		"D" Washer		3	D-191	95987	3
-19		Deleted					

TABLE 5-3. ANTENNA PEDESTAL, PARTS LIST (CONT)

Figure Ref.	Ref. Desig.	Description	Air Force Part Number	Fed. Standard Part Number	Commercial Part Number	Mfr.	Qty Per Unit
5-6		"D" Washer			D- 167	95987	5
-20		Solder, QQ-S-571		SN60WARP2			AR
-21		Gasket			10-101949-18	77820	1
-22		Gasket			10-101949-20	77820	1
-23		Gasket			10-101949-22	77820	1
-24		Gasket			10-40450-36	77820	1
-25		Gasket					1
-26		Sealing Compound, Ret, MIL-S-22473 CL30		E Grade			AR
-27		Nut, Plain, Hex; CRES #4-40 UNC		MS35649-44			12
-28		Nut, Plain, Hex; CRES #8-32 UNC		MS35649-84			8
-29		Nut, Plain, Hex; CRES 5/8-11 UNC		MS35690-1010			4
-30		Washer, Flat; CRES #4		MS15795-303			24
-31		Washer, Flat; CRES #8		MS15795-307			12
-32		Washer, Flat; CRES #10		MS15795-308			3
-33		Washer, Flat; CRES 5/8		MS15795-320			12
-34		Screw, Machine, Pan Head, CRES #8-32 UNC x 3/4 Inch Lg		MS35233-47			4
-35		Washer, Lock, Split; CRES #4		MS35338-78			12



TABLE 5-3. ANTENNA PEDESTAL, PARTS LIST (CONT)

Figure Ref.	Ref. Desig.	Description	Air Force Part Number	Fed. Standard Part Number	Commercial Part Number	Mfr.	Qty Per Unit
5-6							
-36		Washer, Lock, Split, CRES # 10		MS35338-8 1			8
-37		Washer, Lock, Split. CRES 5/8		MS35338-88			4
-38		Washer, Lock, Split, CRES #8		MS35338-80			8
-39		Screw, Cap, Hex Head, CRES 5/8-11 UNC x 3-1/4 Inch Lg		MS35307-169			4
-40		Nut, Plain, Hex (JAM), CRES 5/8-11 UNC		MS35691-1010			4
-41		Screw, Cap, Socket Head, CRES # 10-32 UNF x 5//8 Inch Lg		MS16996-11			5
-42		Screw, Cap, Socket Head, CRES #10-32 UNF x 5/8 Inch Lg		MS16996-12			3
-43		Screw, Machine, Pan Head, CRES #8-32 UNC x 7-1/8 inch Lg		MS35233-48			1
-44		Screw, Machine, Pan Head, CRES #2-56 UNC x 3/16 inch Lg		MS35233-2			2
-45		Screw, Machine, Pan Head, CRES #4-40 UNC x 1/2 Inch Lg		MS35233-17			8

TABLE 5-3. ANTENNA PEDESTAL, PARTS LIST (CONT)

Figure Ref.	Ref. Desig.	Description	Air Force Part Number	Fed. Standard Part Number	Commercial Part Number	Mfr.	Qty Per Unit
5-6							
-46		Screw, Machine, Pan Head, CRES #8-32 UNC x 5/8 Inch Lg		MS35233-46			3
-47		Screw, Drive #4 x 3/16 Inch Lg Steel Cad Plate		MS21318-20			4
-48		Cable Clamp			3/4-6	95987	1
-49		Cable Clamp			7/16-6	95987	2
-50		Cable Clamp			1/2-6	95987	2
-51		Cable Clamp			7/8-6	95987	2
-52		Receptacle		MS3112E18- 11S			1
-53		Receptacle		MS3112E20- 16S			1
-54		Receptacle		MS3112E22- 55S			1
-55		Receptacle		MS3102R36- 7P			1
-56		Switch		MS24524-23			1
-57		Plug			PT06E-14- 19S(SR)	77820	2
-58		Dust Cap		MS25D43-36C			1
-59		Protection Cap			10-101960- 183	77820	1
-60		Protection Cap			10-101960- 203	77820	1

TABLE 5-3. ANTENNA PEDESTAL, PARTS LIST (CONT)

Figure Ref.	Ref. Desig.	Description	Air Force Part Number	Fed. Standard Part Number	Commercial Part Number	Mfr.	Qty Per Unit
5-6							
-61		Protection Cap			10-101960-223	77820	1
-62		Deleted					
-63		Screw, Round Head, Sit CRES 4-40 UNC x 1/2 Inch Lg		4N515-4-8			4
-64		Deleted					
-65		Deleted					
-66		Base, Riser, Azimuth Drive			728675-7	98825	1
-67		Bolt, Eye, Special			728889	98825	4
-68		Washer, Split Lock, CRES 1/2		MS35338-86			4
-69		Washer, Flat, CRES 1/2		AN960C816			4
-70		Nut, Hex, Plain, CRES 1/2-13 UNC		MS35690-810			4
-71		Guy, Pedestal Support			728905	98825	2

TABLE 5-4. AZIMUTH DRIVE ASSEMBLY, PARTS LIST

Figure Ref.	Ref. Desig.	Description	Air Force Part Number	Fed. Standard Part Number	Commercial Part Number	Mfr.	Qty Per Unit
		Housing			728597	98825	1
		Shaft			728596	98825	1
		Cone, Class 3			29675	60038	1
		Cup, Class 3			29620	60038	2
		Ring			728638	98825	2
		Spring			9-1004-31	15840	10
		Cone, Class 3			29680	60038	1
		Spacer, Azimuth			728786	98825	1
		Bearing, ABEC-1			303SZZG	38443	2
		Gearshaft			728582	98825	1
		Gear			728583	98825	1
		Gear, Spur			728579	98825	1
		Limit Stop Assembly			728652	98825	1
		Ring, Collector			728618	98825	1
		Ring, Collector			728617	98825	1
		Seal			53X3355	08479	1
		Dial			728674	98825	1
		Gasket			728704	98825	1
		Sealing Grip			DB-3516	49367	1
		Brake, NEMA C Flange, 7/16 Bore, 3/32 Sq Key			728941	05805	1
		Motor			728762	98825	1
		Gearshaft			728581	98825	1
		Bearing, ABEC-1.			201SZZG	38443	4
		Gearshaft			728580	98825	1

TABLE 5-4. AZIMUTH DRIVE ASSEMBLY, PARTS LIST (CONT)

Figure Ref.	Ref. Desig.	Description	Air Force Part Number	Fed. Standard Part Number	Commercial Part Number	Mfr.	Qty Per Unit
		Synchro Assembly			728639-1	98825	1
		Synchro., Control Transformer -			23CT6	97497	1
		Synchro, Torque Transmitter -			23TX6	97497	1
		Overtravel Switch			727235	98825	1
		Gear Cluster			728671	98825	1
		Clam-Synchro			C 12	00328	8
		Clamp-Cable			1/2-3	95987	1
		Shaft			728641	98825	1
		Bearing, ABEC-5			SFR4SS	70854	1
		Retaining Ring		MS16624-4025			1
		Retaining Ring		MS16624-4037			1
		Bearing, ABEC-5			SFR6FF	70854	1
		Shaft Extension			AU-3	00141	1
		Gear			251-195/ SHA. 2500	01351	1
		Gear			AB150-231/ CT. 250	01351	1
		Gear			AB250-126/ CT. 250	01351	2
		Clamp-Gear			SC-313	01351	5
		Pin, Spring, CRES, 1/16 Dia x 1/8 Inch Lg			79-012-062- 125		3
		Set Screw, CRES, 6-32 x 3/16		MS51029-17			1

TABLE 5-4. AZIMUTH DRIVE ASSEMBLY, PARTS LIST (CONT)

Figure Ref.	Ref. Desig.	Description	Air Force Part Number	Fed. Standard Part Number	Commercial Part Number	Mfr.	Qty Per Unit
		Pin, Spring, CRES, 1/16 Dia x 9/16 Inch Lg		MS16562-195			1
		Resolver			VRE23-6H2	97497	1
		Capacitor, 0.47 $\mu$ f, 200 VDC			12M2474-DG	96733	1
		Indicator, Azimuth +180°			728846	98825	1

TABLE 5-5. POLARIZATION DIVERSITY MECHANISM

Figure Ref.	Ref. Desig.	Description	Air Force Part Number	Fed. Standard Part Number	Commercial Part Number	Mfr.	Qty Per Unit
		Spacer, Stepped			728566	98825	1
		Drive, Polarizer			728543	98825	1
		Shaft, Polarizer			728584	98825	1
		Washer, Flat			728570	98825	1
		Cam. Control			728569	98825	1
		Spacer, Sleeve			728567	98825	1
		Washer, Laminated			728585	98825	2 max
		Connector		MS3114E-14-19P			1
		Connector		MS3114E-8-4S			1
		Bearing			200-SZZ	38443	1
		Bearing			202-SZZ	38443	1
		Switch, Sub Min			1SM1-T	91929	8
		Roller Leaf			JS-51	91929	1
		Resistor, 25W			RHM-25 30Ω, 3%	91637	1

TABLE 5-6. ELECTROMECHANICAL LINEAR ACTUATOR, PARTS LIST

Figure Ref.	Ref. Desig.	Description	Air Force Part Number	Fed. Standard Part Number	Commercial Part Number	Mfr.	Qty Per Unit
		Actuator, Linear			728542-1	98825	1
		Connector		MS3106R-18-1P			1
		Flange, Mounting			728542-3	98825	1
		Flange, Mounting			728542-5	98825	1
		Connector		MS3106R-18-1P			1
		Pin, Straight		MS16555-32			1
		Pin, Straight		MS16555-650			1
		Label, Unit Identification			728918-1		1



TABLE 5-7. ELEVATION DRIVE ASSEMBLY, PARTS LIST

Figure Ref.	Ref. Desig.	Description	Air Force Part Number	Fed. Standard Part Number	Commercial Part Number	Mfr.	Qty Per Unit	
5-11	B1	Motor, Synchro			23TX6	97497	1	
	B2	Motor, Synchro			23CT6	97497	1	
	B3	Motor, Elevation Drive			728761	98825	1	
	C1	Capacitor, 1.5 $\mu$ f, 200 VDC			44M2155-DG	96733	1	
	C2	Capacitor, 0 47 $\mu$ f, 200 VDC			12M2474-DG	96733	1	
	L1	Brake, NEMA "C" Flange			728940	98825	1	
	MG1	Same as B3						
	S1	Switch				BZE6-2RN2	74059	1
		Shaft, Elevation Drive				728627	98825	1
		Dial. Index Pointer				728637	98825	1
		Bumper, Limit Stop				728662	98825	2
		Gearshaft, Spur				728634	98825	1
		Gearshaft, Spur				728632	98825	1
		Gearshaft, Spur				728629	98825	1
		Clamp, Synchro				C 12	10123	6
		Clamp, Synchro				C2	10123	3
		Bearing, ABEC-5				SFR6FF	70854	2
		Bearing, ABEC-1				201SZZG	38443	2
		Bearing, ABEC- 1				203SZZG	38443	2
		Cone, Bearing, Class 3				29680	60038	1
		Cup, Bearing, Class 3				29620	60038	2
		Cone, Bearing, Class 3				29675	60038	1
		Dial				65DRR14CC	08674	1
		Seal				63X 1471	08479	1
		Seal				71X6304	08479	2
		Clamp, Gear				YC21A-1S	12444	a

TABLE 5-7. ELEVATION DRIVE ASSEMBLY, PARTS LIST (CONT)

Figure Ref.	Ref. Desig.	Description	Air Force Part Number	Fed. Standard Part Number	Commercial Part Number	Mfr.	Qty Per Unit
5-11		Gear, Antibacklash			ACM2405-84	12444	2
		Limit Stop Assembly			728657	98825	2
		Pin, Spring, CRES, 1/16 Dia x 1/8 Inch Lg			79-012-062-125	72962	2
		Cable Clamp, 3/8-6			3/8-6	95987	1
		Cable Clamp, 9/16-6			9/16-6	96987	1
		Plug			PT06E 14-19S(SR)	77820	1
		Plug		MS3101R- 18-1S			1
		Connector		MS3112E22-55P			1
	Clamp, Cable, CRES			TA716SS13	84971	1	

TABLE 5-8. PORTABLE STAND AND HOIST, PARTS LIST

Figure Ref.	Ref. Desig.	Description	Air Force Part Number	Fed. Standard Part Number	Commercial Part Number	Mfr.	Qty Per Unit
		Screw, Special			728667	98825	4
		Tie Rod, Adjustable			728957-11	98825	8
		Tie Rod, Outrigger Support			728950	98825	8
		Tie Rod, Adjustable			728957-12	98825	4
		Plate, Base			728943	98825	4
		Brace, Horizontal, Bottom			728960	98823	4
		Support, Vertical			728947	98825	1
		Brace, Horizontal, Top			728961	98825	1
		Winch Assembly			728959	98825	4
		T-Bar Assembly			728946	98825	4
		Box Support			728951	98825	4
		Knee, Box Support			728962	98825	4
		Tie Rod, Adjustable			728957-13	98825	8
		Cable Assembly			728963	98825	1

TABLE 5-9. ELEVATION DRIVE ASSEMBLY HOIST, PARTS LIST

Figure Ref.	Ref. Desig.	Description	Air Force Part Number	Fed. Standard Part Number	Commercial Part Number	Mfr.	Qty Per Unit
		Winch, Drum			728646	98825	1
		Hoist, Section			728826	98825	1
		Tube, Hoist			728887	98825	1
		Support			728828	98825	1
		Bracket, Pulley			728829	98825	2
		Clamp			728830	98825	2
		Wire Rope Assembly			728835	98825	1
		Support Arm			729890	98825	1
		Washer, Lock, Split; CRES, 5/16 Nom.		MS35338-83			2
		Screw, Cap, Hex Head; CRES, 1/4-20 NC x 2-1/2		MS35307-16			4
		Washer, Flat, Round; CRES, 1/4 Nom.		MS15795-310			6
		Washer, Lock, Split; CRES, 1/4 Nom.		MS35338-82			4
		Nut, Plain, Hex (Jam); CRES, 1/4-20 NC		MS35691-410			6
		Washer, Flat, Round; CRES, 1/4 Nom.		MS15795-311			2
		Screw, Shoulder; Steel(5/16), 1/4-20x2-7/6 Inch Lg		MS16638-15			2
		Washer, Flat; CRES, 5/16 Norm.		MS15799-312			4
		Sheave; Steel			2011		2

TABLE 5-9. ELEVATION DRIVE ASSEMBLY HOIST, PARTS LIST (CONT)

Figure Ref.	Ref. Desig.	Description	Air Force Part Number	Fed. Standard Part Number	Commercial Part Number	Mfr.	Qty Per Unit
		Clamp, Wire Rope: Steel Cad Plate, 1/8 Dia x1-3/4 Lg			1/8 Dia	75535	1
		Wire Rope Thimble; Steel Galv. 1/8 Dia x 1-3/4 Lg			#323 1/8 Dia	79577	1
		Anchor Shackle; Steel Galv, 1/2 Dia Pin			#290, Size 7/16	79577	1

TABLE 5-10. 80-FOOT TOWER, PARTS LIST

Figure Ref.	Ref. Desig.	Description	Air Force Part Number	Fed. Standard Part Number	Commercial Part Number	Mfr.	Qty Per Unit
2-4		Tower Section			L-1686-1	88900	10
		Base Section			L-1686-2	88900	1
		Restrainer Brace			L-1686-3	88900	40
		Leg Assembly			L- 1686-4	88900	4
		Base Plate Assembly			L-1686-5	88900	4
		Ladder			L-1686-6	88900	10
		Horizontal Cable Brace			L-1686-7	88900	18
		75-Foot Guy Assembly			L-1686-8	88900	4
		90-Foot Guy Assembly			L-1686-9	88900	4
		155-Foot Wire Rope Assembly (Anti-twist)			L-1686-10	88900	8
		Spacer			L-1686-11	88900	4
		Box Lifting Davit			L-1686-12	88900	4
		Box Lifting Winch Assembly			L-1686-13	88900	4
		Outboard Support			L-1686-14	88900	4
		Grip-Strut Platform			L-1686-15	88900	4
		Box Support			L-1686-16	88900	4
		Maintenance Hoist			L-1686-17	88900	1
		Nylon Rope Assembly			L-1686-18	88900	1
		Nylon Rope Assembly			L-1686-19	88900	1
		Restrainer Brace			L-1686-23	88900	40
		Anchor			2047	88900	12
		Guy Lug			2080	88900	8
		Clevis			2394	88900	16
		Guy Winch			2480	88900	8
	Ground Rod			J8336	91824	4	

TABLE 5-10. 80-FOOT TOWER, PARTS LIST (CONT)

Figure Ref.	Ref. Desig.	Description	Air Force Part Number	Fed. Standard Part Number	Commercial Part Number	Mfr.	Qty Per Unit
2-4		Grounding Wire, Copper NO. 6 x 25 ft lg Grounding Wire Clamp			J8492	91824	4

**TABLE 5-11. ANTENNA POSITION CONTROL INDICATOR, LOCATION  
AND FUNCTION OF TEST POINTS AND ADJUSTMENTS**

Figure Ref.	Test Point or Adjustment	Function
	TP2, Azimuth Error Input  TP1, Elevation Error Input  A1R8, Scan Generator Level Set Potentiometer  R8, Cable Wrap Meter Max. Adj. Pot.  R7, Cable Wrap Meter Min. Adj. Pot.  R5, Beam Width Meter Min. Adj. Pot.  R6, Beam Width Meter Max. Adj. Pot.  R4, Antenna Position Potentiometer  S8, Sector Scan Limit Switch	Test point for checking the azimuth slave or manual error input to azimuth servo amplifier AR2.  Test point for checking the elevation error input to elevation servo amplifier AR1.  Adjustment for setting the range around which the antenna will sector scan.  Allows adjustment of the maximum deflection of the needle on CABLE WRAP meter M1.  Allows adjustment of the minimum deflection of the needle on CABLE WRAP meter M1.  Allows adjustment of the minimum deflection of the needle on the BEAM WIDTH meter M2.  Allows adjustment of the maximum deflection of the needle on BEAM WIDTH meter M2.  Establishes the center position of the angle to be scanned during sector scan operation.  Limits sector scan to $\pm 270$ degrees.



TABLE 5-12. CONTROL INDICATOR, ANTENNA POSITION, PARTS LIST

Figure Ref.	Ref. Desig.	Description	Air Force Part Number	Fed. Standard Part Number	Commercial Part Number	Mfr.	Qty Per Unit
		Transmission Assembly			728925	98825	1
		Clamp			728551	98825	3
		Shaft, Ctr DR (R.H.)			728553	98825	1
		Shaft, Intermediate			728554	98825	7
		Control			728594	98825	1
		Shaft Extension			728613	98825	1
		Coupling			728608	98825	1
		Spring, Helical Torque			728595	98825	1
		Gear, Hubless			728616	98825	1
		Setscrew, Special; CRES #6-32			728601	98825	1
		Cam			728815	98825	1
		Clamp			YC5- IS	12444	3
		Clamp			YC 12-1S	12444	3
		Clutch			C-28-1	06315	1
	R4	Potentiometer, 1000			Model 100	02111	1
		Terminal Strip			2-141	71735	1
		Angle Counter			1503	99479	2
		Magnetic Clutch			F-24	08699	2
		Motor-Generator			728778	98825	2
		Synchro, Control Transmitter			23CX6	97497	2
		Synchro, Control Transformer			23CT6	97497	2
		Bearing			SFR4SS	70854	4
		Bearing			SFR3SS	70854	14
		Ring, Retaining, 1/4 x 0.025		MS16624-4025			2

TABLE 5-12. CONTROL INDICATOR, ANTENNA POSITION, PARTS LIST (CONT)

Figure Ref.	Ref. Desig.	Description	Air Force Part Number	Fed. Standard Part Number	Commercial Part Number	Mfr.	Qty Per Unit
		Ring, Retaining, 3/16 x 0.015		MS16624-1018			14
		Clamp			YC5-2S	12444	12
		Clamp			C75	57533	4
		Clamp			YC20A- 1S	12444	2
		Clamp			YC21A- 1S	12444	8
		Clamp			YC5-4S	12444	11
		Ring, Retaining, Bowed 1/4 x 0.025		MS16628-4025			2
		Gear, Bevel (Set)			N1-1-S-C	12139	2
		Gear, Spur			H28-60	12139	2
		Gear, Spur			G14-120	12139	2
		Gear, Spur			G14-30	12139	2
		Gear, Spur			G12-130	12139	2
		Gear, Spur			G12-40	12139	4
		Gear, Spur			G12-120	12139	3
		Gear, Spur			G12-60	12139	4
		Gear, Spur			251-120SHA 2498	01351	2
		Gear, Spur			N48A-26	12444	2
		Gear, Spur AB			ACD6-120	12444	2
		Gear, Spur AB			ACN2405-120	12444	4
		Pin, Spring, CRES 1/16 Dia x 3/8		MS16562-192			13
		Pin, Spring, CRES 1/16 Dia x 1/2		MS16562-194			6
		Switch, Subminiature			1SM1-T	91929	1
		Roller Leaf			JS-5	91929	1
	CR3	Diode			IN1707	Coml	1

TABLE 5-12. CONTROL INDICATOR, ANTENNA POSITION, PARTS LIST (CONT)

Figure Ref.	Ref. Desig.	Description	Air Force Part Number	Fed. Standard Part Number	Commercial Part Number	Mfr.	Qty Per Unit
	M1	Meter, Cablewrap			728298-1	98825	1
	M2	Meter, Beamwidth			727298-3	98825	1
		Resistor Assembly			728718	98825	1
		Resistor Subassembly			728720	98825	1
		Resistor, MIL-R-11/3		RC20GF512J			1
		Resistor, MIL-R- 11/3		RC20GF103J			1
		Resistor, MIL-R-11/3		RC20GF392J			1
		Resistor, MIL-R- 11/3		RC20GF272J			1
	A1	Card, Scan Generator			728688	98825	1
	R1	Resistor, 1500Ω, 1/2W, 5%, MIL-R-11/3		RC20GF152J			1
	R2	Resistor, 18K, 1/2W, 5%, MIL-R-11/3		RC20GF183J			2
	R3	Resistor, 5620Ω, 1/8W, 1%, MIL-R-10509/1		RN60B5621F			2
	R4	Resistor, 47Ω, 1/2W, 5%, MIL-R-11/3		RC20GF470J			1
	R5	Resistor, 432Ω, 1/8W, 1%, MIL-R-10509/1		RN60B4320F			2
	R6	Resistor, 909Ω, 1/2W, 1%, MIL-R-10509/3		RN70B909OF			4
	R7	Resistor, 3920Ω, 1/8W, 1%, MIL-R-10509/1		RN60B3921F			1
	R8	Potentiometer, 5K, 1W, 5%,			224P-1-502	80294	1
	R9	Same as R6					
	R10	Same as R5					
	R11	Same as R6					

TABLE 5-12. CONTROL INDICATOR, ANTENNA POSITION, PARTS LIST (CONT)

Figure Ref.	Ref. Desig.	Description	Air Force Part Number	Fed. Standard Part Number	Commercial Part Number	Mfr.	Qty Per Unit
	R12	Same as R6					
	R13	Same as R3					
	R14	Same as R2					
	R 15	Resistor, 1820Ω, 1/8W, 1%, MIL-R-10509/1		RN60B1821F			2
	R16	Resistor, 221Ω, 1/8W, 1%, MIL-R-10509/1		RN60B2210F			2
	R 17	Resistor, 475Ω, 1/4W, 1%, MIL-R-10509/2		RN65B4750F			1
	R18	Same as R16					
	R19	Same as R15					
	R20	Resistor, 2700Ω, 1/2W, 5%, MIL-R-11/3		RC20GF272J			4
	R21	Same as R20					
	R22	Resistor, 12K, 1/2W, 5%, MIL-R- 11/3		RC20GF123J			2
	R23	Resistor, 100K, 1/2W, 5%, MIL-R-11/3		RC20GF104J			2
	R24	Same as R23					
	R25	Same as R20					
	R26	Same as R20					
	R27	Same, as R22					
	C1	Capacitor, 15 μf, 15V, 10%			SCM156BP-015D2	06228	3
	C2	Same as C1					
	C3	Same as C1					

TABLE 5-12. CONTROL INDICATOR, ANTENNA POSITION, PARTS LIST (CONT)

Figure Ref.	Ref. Desig.	Description	Air Force Part Number	Fed. Standard Part Number	Commercial Part Number	Mfr.	Qty Per Unit
	Q1	Transistor, MIL-T-19500A/99		USA/2N697			6
	Q2	Same as Q1					
	Q3	Same as Q1					
	Q4	Same as Q1					
	Q5	Transistor, MIL-T-19500/177		USN/2N 1132			2
	Q6	Same as Q5					
	Q7	Same as Q1					
	Q8	Same as Q1					
		Nylon Transipad			A-10095	07047	8
	CR1	Diode, MIL-F-1/1026		JAN/ 1N457			12
	CR2	Same as CR1					
	CR3	Same as CR1					
	CR4	Same as CR1					
	CR5	Same as CR1					
	CR6	Same as CR1					
	CR7	Same as CR1					
	CR8	Same as CR1					
	CR9	Diode, Zener, MIL-S-19500/127		USN/1N752A			
	CR10	Same as CR9					
	CR11	Same as CR1					
	CR12	Same as CR1					
	CR13	Same as CR1					
	CR14	Same as CR1					

TABLE 5-12. CONTROL INDICATOR, ANTENNA POSITION, PARTS LIST (CONT)

Figure Ref.	Ref. Desig.	Description	Air Force Part Number	Fed. Standard Part Number	Commercial Part Number	Mfr.	Qty Per Unit
		Bracket, Cable			728768	98825	2
		Grommet			G51H-C	0329 6	AR
		Shaft, Extension			S025-11	57533	2
	J1	Receptacle		MS3112E-20-41P			1
	J2	Receptacle		MS3112E-12-10S			1
	J3	Receptacle		MS3112E-37-37S			1
	J4	Not used					
	J5	Not used					
	J6	Not used					
	J7	Not used					
	J8	Not used					
	J9	Not used					
	J10	Not used					
	J11	Connector			K1-1500-22	05712	1
	TP1	Test Point		MS16108-2			2
	TP2	Same as TP1					
	TB2	Terminal Strip			10-140	75173	2
	TB3	Same as TB2					
	R1	Resistor, Variable, 250Ω, 5W			WN251	71590	1
	R2	Resistor, Variable, 5K, MIL-R-94 15		RV4NAYSD-502A		1	
	R3	Resistor, Variable, 50K, MIL-R-94/5		RV4NAYSD-503A		1	

TABLE 5-12. CONTROL INDICATOR, ANTENNA POSITION, PARTS LIST (CONT)

Figure Ref.	Ref. Desig.	Description	Air Force Part Number	Fed. Standard Part Number	Commercial Part Number	Mfr.	Qty Per Unit
	R17	Resistor, 620, $\pm 5\%$ , 1/2W. MIL-R- 11/3		RC20GF621J			1
	R18	Resistor, 2.2K, $\pm 5\%$ , 1/2W. MIL-R-11/3		RC20GF222J			1
	S1	Switch		MS35039-22			1
	S2	Switch			PA-2039	71590	1
	S3	Not used					
	S4	Not used					
	S5	Not used					
	S6	Switch			PA-6003	71590	1
	S7	Switch		MS35059-27			1
	FL1	Filter			GF-2967	07294	2
	FL2	Same as FL1					
	K1	Relay			MHJ- 12D- 265V	70309	1
	A2	Amplifier, Model A539			A539-250C- L3B6-A	12745	2
	A3	Same as A2					
	C1	Capacitor, MIL-C-25/4		CP53BIEF- 205KI			2
	C2	Same as C1					
	C3	Capacitor, 1.5 $\mu$ f, 200 VDC			44M2155-DG	96733	2
	C4	Same as C3					
	C5	Capacitor, 0.47 $\mu$ f, 200 VDC			12M2474-DG	96733	2
	C6	Same as C5					
	CR4	Diode			IN1601	Comrl	1

TABLE 5-12. CONTROL INDICATOR, ANTENNA POSITION, PARTS LIST (CONT)

Figure Ref.	Ref. Desig.	Description	Air Force Part Number	Fed. Standard Part Number	Commercial Part Number	Mfr.	Qty Per Unit
	P1	Connector		MS3116E-14-19S(SR)			2
	P2	Same as P1					
		Knob Crank			125-6-2G	49956	2
		Knob, Dial			90-3-2G	49956	2
		Knob, Control			70-2-2G	49956	3
		Light Shield Assembly			4-1930	72619	2
		Light, Indicator		MS2504 1-3			1
		Lampholder		MS90282-1			2
		Lamp, 28V, 0.04A		MS25237-327			13
		Lamp, 28V, 0.04A		MS15571-6			2
		Light, Indicator		MS2504 1-2			1
		Light, Indicator		MS2504 1-4			9
		Resistor Assembly			728718	98825	1
	R5, R7	Resistor, Variable, 1K, 2W, 10%		RV4LAYS-102A			2
	R6, R8	Resistor, Variable, 50K, 2W, 10%		RV4LAYS-			2
	R9, R10	Resistor, Fixed, 1 $\Omega$ , 2W, 10%			RH-10	91637 2	
		Resistor Subassembly			728720	98825	1
	R11	Resistor, Fixed, 5.1K, 1/2W, 5%		RC20GF512J			1
	R12	Resistor, Fixed, 3.9K, 1/2W, 5%		RC20GF392J			1
	R13, R16	Resistor, Fixed, 2.7K, 1/2W, 5%		RC20GF273J			2



TABLE 5-12. CONTROL INDICATOR, ANTENNA POSITION, PARTS LIST (CONT)

Figure Ref.	Ref. Desig.	Description	Air Force Part Number	Fed. Standard Part Number	Commercial Part Number	Mfr.	Qty Per Unit
	R14	Resistor, Fixed, 2.7K, 1/2W, 5%		RC20GF272J			1
	R15	Resistor, Fixed. 10K, 1/2W. 5%		RC20GF103J			1

**TABLE 5-13. ANTENNA CONTROL POWER SUPPLY, LOCATION AND  
FUNCTION OF TEST POINTS AND ADJUSTMENTS**

Figure Ref.	Test Point or Adjustment	Function
1. 5-20	TP1, +28 VDC Unregulated	Test point for checking the voltage level of the +28 volts in unregulated DC.
2. 5-20	TP2, Chassis Ground Test Point	Test point for ground connection.
14. 5-29	R6, Radome Pressure Gauge M1, Max. Adj. Pot.	Allows adjustment of the maximum deflection of the needle on pressure gauge M1.
15. 5-20	R3, Radome Pressure Gauge M1, Min. Adj. Pot.	Allows adjustment of the minimum deflection of the needle on pressure gauge M1.
23. 5-20	TP3, +24 VDC Regulated	Test point for checking the voltage level of the +24 volts regulated DC.
25. 5-20	R1, +24 VDC Regulated Adjustment	Allows adjustment of the level of the regulated DC voltage.

TABLE 5-14. POWER SUPPLY - ANTENNA CONTROL, PARTS LIST

Figure Ref.	Ref. Desig.	Description	Air Force Part Number	Fed. Standard Part Number	Commercial Part Number	Mfr.	Qty Per Unit
	M1	Meter, Pressure			728928-3	98825	1
	M2	Meter, mph			728428-1	98825	1
	B1	Control, Synchro			23CDX6	75298	1
	B2	Resolver			23RS6B	75298	1
		Drive, Dual Speed			DSD-3	80134	1
	T1	Transformer			H-133	80223	1
	T2	Transformer			H-96	80223	1
	K1, K2, K3	Relay, 10 Amp, 2 PDT, Class B8, Sealed		MS25273-D1			3
	CR1 thru CR4	Diode, Semiconductor Device with insulating hardware			1N1199	81483	4
	CR5	Diode, Semiconductor Device with insulating hardware			1N1608	81483	1
	CB4	Circuit Breaker			225-290-101	79405	1
	CB1	Circuit Breaker			225-220-101	79405	1
	CB2	Circuit Breaker			124-210-101	79405	1
	CB3	Circuit Breaker			124-220-101	79405	1
		Switch, Toggle		MS24523-22			2
		Light, Indicator		MS2504 1-3-327			1
		Fuseholder			HKL	74100	5
	F1	Fuse			313005	75915	1
	F2, F3, F4	Fuse		MS90078-12			3
	F5	Fuse		MS90080-2			1

TABLE 5-14. POWER SUPPLY - ANTENNA CONTROL, PARTS LIST (CONT)

Figure Ref.	Ref. Desig.	Description	Air Force Part Number	Fed. Standard Part Number	Commercial Part Number	Mfr.	Qty Per Unit
	TP1	Jack, Tip, White		MS16108-1			1
	TP2	Jack, Tip, Black		MS16108-3			1
	TP3	Jack, Tip, Red		MS16108-2			1
	J1	Connector, Recp, Elec		MS3112E-20-41S			1
	J2	Connector, Recp, Elec		PT02SE-14-18S			1
	J3	Connector, Recp, Elec		MS3102R-18-10P			1
	J4	Connector, Recp, Elec		MS3112E-32-8S			1
	J5	Connector, Recp, Elec		MS3112E-16-10S			1
	A1	Resistor, Rect. Assembly			728758	98825	1
	C1	Capacitor, 3300 , $\mu$ f, 50 VDC			CET1C-332G	05571	1
	R1	Resistor, Variable, 250Q, 2W		RV4LAYS-251A			1
	R2	Resistor, 200 $\Omega$ , 10W, 3%					
	R3	Resistor, Variable		RA20LASB-502A			1
	R4	Resistor, 1K, 1/2W, 5%		RC20GF102K			1
	R5	Resistor, 470 $\Omega$ , 1/2W, 5%		RC20GF47 1K			1
	R6	Resistor, Variable		RA20LASB-501A			1
	R7	Resistor, Variable, 250 $\Omega$ 5%			WN251	71590	1
	R8	Resistor, 1.2K, 1/2W, 5%		RC20GF122J	1		
	Q1	Transistor			2N 1718	01295	1

TABLE 5-15. MODULATOR, PARTS LIST

Figure Ref.	Ref. Desig.	Description	Air Force Part Number	Fed. Standard Part Number	Commercial Part Number	Mfr.	Qty Per Unit
	A1, A2	Integrated Circuit, Operational Amplifier			PP65AU	95023	2
	C1, C2	Capacitor, CER Disc, 0.01 $\mu$ f, 1K V, $\pm$ 10%		CK63AW103K			2
	C3, C4	Capacitor, CER Disc, 0.002 $\mu$ f, 1K V, $\pm$ 20%			CCD202	04062	2
	CR1 thru CR8	Diode, General Purpose		1N457			8
	Q1, Q3	Transistor, PNP		2N3219			2
	Q2, Q4	Transistor, NPN		2N3568			2
	Q5, Q6	Transistor, NPN		2N697			2
	R1, R7	Resistor, Fixed Carbon, 100K, 1/2W, $\pm$ 5%		RC20GF104J			2
	R2, R9, R10	Resistor, Fixed Carbon, 20K, 1/2W, $\pm$ 5%		RC20GF203J			3
	R3	Resistor, Fixed Carbon, 500K 1/2W, $\pm$ 5%		RC20GF501J			1
	R4, R6, R12, R14	Resistor, Fixed Carbon, 10K, 1/2W, $\pm$ 5%		RC20GF103J			4
	R8, R22	Resistor, Fixed Carbon, Select, 1/2W, $\pm$ 5%					2
	R11, R13	Resistor, Fixed Carbon, 15K, 1/2W, $\pm$ 5%		RC20GF153J			2
	R15, R17	Resistor, Fixed Carbon, 180K, 1/2W, $\pm$ 5%		RC20GF184J			2

TABLE 5-15. MODULATOR, PARTS LIST (CONT)

Figure Ref.	Ref. Desig.	Description	Air Force Part Number	Fed. Standard Part Number	Commercial Part Number	Mfr.	Qty Per Unit
	R18	Resistor, Metal Film, 1 meg, $\pm 1\%$		RN65C1004F			1
	R19, R20	Resistor, Metal Film, 475K, $\pm 1\%$		RN65C4753F			2
	R21, R24	Resistor, Fixed Carbon, 160K, 1/2W, $\pm 5\%$		RC20GF164J			2
	R23	Resistor, Fixed Carbon, 180 $\Omega$ , 1/2W, $\pm 5\%$		RC20GF 181J			1
	R25	Resistor, Fixed Carbon, 8.2K, 1/2W, $\pm 5\%$		RC20GF822J			1
	R26	Resistor, Fixed Carbon, 2.7K, 1/2W, $\pm 5\%$		RC20GF272J			1
	R27	Resistor, Fixed Carbon, 270 $\Omega$ , 1/2W, $\pm 5\%$		RC20GF272J			1
	R28	Resistor, Fixed Carbon, 15K, 2W, $\pm 5\%$		RC42GF153J			1
	R5	Resistor, Variable, 50K, 1W, $\pm 10\%$			56PR50K	80740	1
	R16	Resistor, Variable, 20K, 1W, $\pm 10\%$			56PR20K	80740	1
	T1	Transformer			SSO-3P	80223	1
	TP1 thru TP8	Terminal, Turret			2010B	15849	8
		PC Board			728439	98825 1	

TABLE 5-16. DEMODULATOR, PARTS LIST

Figure Ref.	Ref. Desig.	Description	Air Force Part Number	Fed. Standard Part Number	Commercial Part Number	Mfr.	Qty Per Unit
	A1	Integrated Circuit, Operational Amplifier			PP65AU	95023	1
	C1, C2	Capacitor, CER Disc, 0.01, $\mu$ f, 1 KV, $\pm$ 10%		CK63AW103K		05162	2
	C3	Capacitor, Mylar, 0.1, $\mu$ f, 100V, $\pm$ 10%			210B1B106M	14752	1
	C4	Capacitor, Mylar, 10 $\mu$ f, 100V, $\pm$ 20%			210B1B106M	14752	1
	CR1 thru CR10	Diode, General Purpose		1N457			10
	R1, R3	Resistor, Fixed Carbon, 4.7K, 1/2W, $\pm$ 5%		RC20GF472J			2
	R4, R5, R16	Resistor, Fixed Carbon, 15K, 1/2W, $\pm$ 5%		RC20GF153J			3
	R6, R7	Resistor, Fixed Carbon, 10K, 1/2W, $\pm$ 5%		RC20GF103J			2
	R8, R15	Resistor, Fixed Carbon, 100K, 1/2W, $\pm$ 5%		RC20GF104J			2
	R9, R11	Resistor, Fixed Carbon, 180K, 1/2W, $\pm$ 5%		RC20GF184J			2
	R12, R13	Resistor, Metal Film, 20.0K, 1/2W, $\pm$ 1%		RN65C2002F			2
	R14	Resistor, Metal Film, 1 meg, 1/2W, $\pm$ 1%		RN65C1004F			1

TABLE 5-16. DEMODULATOR, PARTS LIST (CONT)

Figure Ref.	Ref. Desig.	Description	Air Force Part Number	Fed. Standard Part Number	Commercial Part Number	Mfr.	Qty Per Unit
	R17	Resistor, Fixed Carbon, Select, 1/2 $\pm$ , $\pm$ 5%		RC20GF			1
	R18	Resistor, Fixed Carbon, 160K, 1/2W, $\pm$ 5%		RC20GF164J			1
	R19	Resistor, Fixed Carbon, 2K, 1/2W, $\pm$ 5%		RC20GF202J			1
	R20	Resistor, Fixed Carbon, 20K, 1/2W, $\pm$ 5%		RC20GF203J			1
	R21	Resistor, Fixed Carbon, 15K, 2W, $\pm$ 5%		RC42GF153J			1
	R10	Resistor, Variable, 20K, 20K, 1W, 10%			56PR20K	80740	1
	R2	Resistor, Fixed Carbon, 470 $\Omega$ , 1/2W, 5%		RC20GF47 1K			1
	T1	Transformer			SSO-3P	80223	1
	TP1 thru TP6	Terminal-Turret			2010B	15849	6
	Q1, Q2	Transistor, PNP		2N3219			2
	Q3, Q4	Transistor, NPN		2N3568			2
		PC Board			728443	98825	1



TABLE 5-17. WRITING GUN RELAY DRIVER, PARTS LIST

Figure Ref.	Ref. Desig.	Description	Air Force Part Number	Fed. Standard Part Number	Commercial Part Number	Mfr.	Qty Per Unit
	A1	Integrated Circuit, Operational Amplifier			PP65AU	95023	1
	C1	Capacitor, Mylar, 10 $\mu$ f, 100V, $\pm$ 20%			210B1B106M	14752	1
	C2, C3	Capacitor, Ceramic Disc, 0.01 $\mu$ f, 1 KV, $\pm$ 10%		CK63AW103K		05162	2
	CR1 thru CR6	Diode, General Purpose		1N457			6
	K1	Relay, 25V, DPDT			5D600V25		1
	Q1	Transistor, NPN		2N697			1
	R1, R2, R3, R4	Resistor, Fixed Carbon. 68Q, 2W, $\pm$ 5%		RC42GF680J			4
	R5, R6, R10	Resistor, Fixed Carbon, 51K, 1/2W, $\pm$ 5%		RC20GF513J			3
	R7, R9	Resistor, Fixed Carbon, 5.1K, 1/2W, $\pm$ 5%		RC20GF512J			2
	R11	Resistor, Fixed Carbon, Select, 1/2W, $\pm$ 5%		RC20GF			1
	R12	Resistor, Fixed Carbon, 4.7K, 1/2W, $\pm$ 5%		RC20GF472J			1
	R13	Resistor, Fixed Carbon, 10K, 1/2W, $\pm$ 5%		RC20GF103J			1
	R8	Resistor, Variable, 10K, 1W, $\pm$ 10%			56PR100K	80740	1
	TP1 thru TP6	Terminal-Turret			2010B	15849	6

TABLE 5-17. WRITING GUN RELAY DRIVER, PARTS LIST (CONT)

Figure Ref.	Ref. Desig.	Description	Air Force Part Number	Fed. Standard Part Number	Commercial Part Number	Mfr.	Qty Per Unit
	VR1 thru VR6	Diode, Zener		1N4733A			6
		PC Board			728435	98825	1

By Order of the Secretary of the Army:

Official:

KENNETH G. WICKHAM,  
*Major General, United States Army,  
The Adjutant General.*

HAROLD K. JOHNSON,  
*General, United States Army,  
Chief of Staff.*

RECOMMENDED CHANGES TO EQUIPMENT TECHNICAL PUBLICATIONS

 <p style="text-align: center;"><i>THEN...JOT DOWN THE DOPE ABOUT IT ON THIS FORM. CAREFULLY TEAR IT OUT, FOLD IT AND DROP IT IN THE MAIL.</i></p>		SOMETHING WRONG WITH PUBLICATION		
		FROM: (PRINT YOUR UNIT'S COMPLETE ADDRESS)		
PUBLICATION NUMBER		DATE SENT		
PUBLICATION DATE		PUBLICATION TITLE		
BE EXACT PIN-POINT WHERE IT IS				
PAGE NO.	PARA-GRAPH	FIGURE NO.	TABLE NO.	<p style="text-align: center; font-weight: bold;">IN THIS SPACE, TELL WHAT IS WRONG AND WHAT SHOULD BE DONE ABOUT IT.</p>
PRINTED NAME, GRADE OR TITLE AND TELEPHONE NUMBER			SIGN HERE	

## The Metric System and Equivalents

### Linear Measure

1 centimeter = 10 millimeters = .39 inch  
 1 decimeter = 10 centimeters = 3.94 inches  
 1 meter = 10 decimeters = 39.37 inches  
 1 dekameter = 10 meters = 32.8 feet  
 1 hectometer = 10 dekameters = 328.08 feet  
 1 kilometer = 10 hectometers = 3,280.8 feet

### Weights

1 centigram = 10 milligrams = .15 grain  
 1 decigram = 10 centigrams = 1.54 grains  
 1 gram = 10 decigrams = .035 ounce  
 1 decagram = 10 grams = .35 ounce  
 1 hectogram = 10 decagrams = 3.52 ounces  
 1 kilogram = 10 hectograms = 2.2 pounds  
 1 quintal = 100 kilograms = 220.46 pounds  
 1 metric ton = 10 quintals = 1.1 short tons

### Liquid Measure

1 centiliter = 10 milliliters = .34 fl. ounce  
 1 deciliter = 10 centiliters = 3.38 fl. ounces  
 1 liter = 10 deciliters = 33.81 fl. ounces  
 1 dekaliter = 10 liters = 2.64 gallons  
 1 hectoliter = 10 dekaliters = 26.42 gallons  
 1 kiloliter = 10 hectoliters = 264.18 gallons

### Square Measure

1 sq. centimeter = 100 sq. millimeters = .155 sq. inch  
 1 sq. decimeter = 100 sq. centimeters = 15.5 sq. inches  
 1 sq. meter (centare) = 100 sq. decimeters = 10.76 sq. feet  
 1 sq. dekameter (are) = 100 sq. meters = 1,076.4 sq. feet  
 1 sq. hectometer (hectare) = 100 sq. dekameters = 2.47 acres  
 1 sq. kilometer = 100 sq. hectometers = .386 sq. mile

### Cubic Measure

1 cu. centimeter = 1000 cu. millimeters = .06 cu. inch  
 1 cu. decimeter = 1000 cu. centimeters = 61.02 cu. inches  
 1 cu. meter = 1000 cu. decimeters = 35.31 cu. feet

## Approximate Conversion Factors

<i>To change</i>	<i>To</i>	<i>Multiply by</i>	<i>To change</i>	<i>To</i>	<i>Multiply by</i>
inches	centimeters	2.540	ounce-inches	Newton-meters	.007062
feet	meters	.305	centimeters	inches	.394
yards	meters	.914	meters	feet	3.280
miles	kilometers	1.609	meters	yards	1.094
square inches	square centimeters	6.451	kilometers	miles	.621
square feet	square meters	.093	square centimeters	square inches	.155
square yards	square meters	.836	square meters	square feet	10.764
square miles	square kilometers	2.590	square meters	square yards	1.196
acres	square hectometers	.405	square kilometers	square miles	.386
cubic feet	cubic meters	.028	square hectometers	acres	2.471
cubic yards	cubic meters	.765	cubic meters	cubic feet	35.315
fluid ounces	milliliters	29.573	cubic meters	cubic yards	1.308
pints	liters	.473	milliliters	fluid ounces	.034
quarts	liters	.946	liters	pints	2.113
gallons	liters	3.785	liters	quarts	1.057
ounces	grams	28.349	liters	gallons	.264
pounds	kilograms	.454	grams	ounces	.035
short tons	metric tons	.907	kilograms	pounds	2.205
pound-feet	Newton-meters	1.356	metric tons	short tons	1.102
pound-inches	Newton-meters	.11296			

## Temperature (Exact)

°F	Fahrenheit temperature	5/9 (after subtracting 32)	Celsius temperature	°C
----	---------------------------	-------------------------------	------------------------	----



This fine document...

Was brought to you by me:



## [Liberated Manuals -- free army and government manuals](#)

Why do I do it? I am tired of sleazy CD-ROM sellers, who take publicly available information, slap “watermarks” and other junk on it, and sell it. Those masters of search engine manipulation make sure that their sites that sell free information, come up first in search engines. They did not create it... They did not even scan it... Why should they get your money? Why are not letting you give those free manuals to your friends?

I am setting this document FREE. This document was made by the US Government and is NOT protected by Copyright. Feel free to share, republish, sell and so on.

I am not asking you for donations, fees or handouts. If you can, please provide a link to [liberatedmanuals.com](http://liberatedmanuals.com), so that free manuals come up first in search engines:

<A HREF=<http://www.liberatedmanuals.com/>>Free Military and Government Manuals</A>

- Sincerely  
Igor Chudov  
<http://igor.chudov.com/>
- [Chicago Machinery Movers](#)