

TM 32-5865-218-24&P

TECHNICAL MANUAL

**MAINTENANCE INSTRUCTIONS
ORGANIZATIONAL,
DIRECT SUPPORT AND GENERAL SUPPORT
(INCLUDING REPAIR PARTS
AND SPECIAL TOOLS LIST)
COUNTERMEASURES PANEL INDICATOR
ID-2300/ALQ-151(V)
AND
COUNTERMEASURES CONTROL
C-11124/ALQ-151(V)**

**ESL I
DAAK20-80-C-0521**

This copy is a reprint which includes current
pages from Changes 1.

This publication is not available through AG Publications. Requisition through U.S. Army Electronics Materiel Readiness Activity, Vint Hill Farms, Warrenton, VA 22186.

HEADQUARTERS, DEPARTMENT OF THE ARMY

20 NOVEMBER 1983

WARNING

High voltage is used in the operation of this equipment. Avoid contacting high-voltage connections when installing or repairing this equipment. Injury or death may result if personnel fail to observe safety precautions.

WARNING

Adequate ventilation should be provided while using trichlorotrifluoroethane. Prolonged breathing of vapor should be avoided. The solvent should not be used near heat or open flame; the products of decomposition are toxic and irritating. Since trichlorotrifluoroethane dissolves natural oils, prolonged contact with skin should be avoided. When necessary, use gloves that the solvent cannot penetrate. If the solvent is taken internally, consult a physician immediately.

Technical Manual
 NO. 32-5865-218-24&P

HEADQUARTERS
 DEPARTMENT OF THE ARMY
 Washington, DC, 20 November 1983

MAINTENANCE INSTRUCTIONS
 ORGANIZATIONAL, DIRECT SUPPORT AND
 GENERAL SUPPORT
 FOR
 COUNTERMEASURES PANEL INDICATOR
 ID-2300/ALQ-151(V) AND COUNTERMEASURES
 CONTROL C-11124/ALQ-151(V)

REPORTING OF ERRORS

You can improve this manual by recommending improvements using DA Form 2028-2 located in the back of the manual. Simply tear out the self-addressed form, fill it out as shown on the sample, fold it where shown, and drop it in the mail.

If there are no blank DA Forms 2028-2 in the back of your manual, use the standard DA Form 2028 (Recommended Changes to Publications and Blank Forms) and forward to the Commander, U.S. Army Electronic Materiel Readiness Activity, Vint Hill Farms Station, Warrenton, Virginia, 22186, Attn: SELEM-ME-E.

In either case, a reply will be furnished directly to you.

TABLE OF CONTENTS

		Paragraph	Page
CHAPTER	1. INTRODUCTION		
SECTION	I. General		
	Scope	1-1	1-1
	Maintenance Forms and Records	1-2	1-2
	Destruction of Army Materiel to Prevent Enemy Use	1-3	1-2
	Administrative Storage	1-4	1-2
	Reporting of Errors	1-5	1-3
	Reporting Equipment Improvement Recommendations (EIR)	1-6	1-3
SECTION	II. Description and Data		
	ECM Panel Indicator	1-7	1-3
	Tabulated Data	1-8	1-4
	Countermeasures Control	1-9	1-5
	Tabulated Data	1-10	1-9

TABLE OF CONTENTS - Continued

			Paragraph	Page
CHAPTER	2.	ORGANIZATIONAL MAINTENANCE INSTRUCTIONS		
		Scope	2-1	2-1
CHAPTER	3.	FUNCTIONING OF EQUIPMENT		
SECTION	I.	General		
		Scope	3-1	3-1
		Organization	3-2	3-1
SECTION	II.	Functional Description		
		ECM Panel Indicator	3-3	3-1
		Countermeasures Control	3-4	3-2
CHAPTER	4.	DIRECT SUPPORT MAINTENANCE INSTRUCTIONS		
SECTION	I.	General		
		Scope	4-1	4-1
CHAPTER	5.	GENERAL SUPPORT MAINTENANCE INSTRUCTIONS		
SECTION	I.	General		
		Scope	5-1	5-1
		Organization	5-2	5-1
		Countermeasures Control		
		Measurements and Data	5-3	5-1
SECTION	II.	Tools and Equipment		
		General	5-4	5-1
		Tools and Equipment Required	5-5	5-1
SECTION	III.	Troubleshooting		
		General	5-6	5-2
		ECM Panel Indicator Procedure	5-7	5-2
		Countermeasures Control Procedures	5-8	5-6
SECTION	IV.	Maintenance		
		General	5-9	5-6
		Maintenance Procedures	5-10	5-25
		ECM Panel Indicator Procedures	5-11	5-27
		Countermeasures Control Procedures	5-12	5-37
SECTION	V.	General Support Test Procedures		
		General	5-13	5-61
		ECM Panel Indicator Test	5-14	5-61
		Countermeasures Control Test	5-15	5-61
APPENDIX	A.	REFERENCES		
		Scope	A-1	A-1
		Technical Manuals	A-2	A-1
		Supply Bulletins	A-3	A-2
		Common Table of Allowances	A-4	A-2
		Pamphlets	A-5	A-2
		Army Regulations	A-6	A-2
		Forms	A-7	A-3
APPENDIX	B.	MAINTENANCE ALLOCATION CHART		
		General	B-1	B-1
		Maintenance Functions	B-2	B-1
		Column Entries Used in the MAC	B-3	B-2
		Column Entries Used in Tool and Test		
		Equipment Requirements		
		(Section III)		B-3
		Explanation of Columns in Section IV	B-5	B-4

TABLE OF CONTENTS - Continued

		Paragraph	Page
APPENDIX C.	REPAIR PARTS AND SPECIAL TOOLS LIST		
	Scope	C-1	C-3
	General	C-2	C-3
	Explanation of Columns	C-3	C-3
	Special Information	C-4	C-8
	How to Locate Repair Parts \ \ \ \ \	C-5	C-8
	Abbreviations	C-6	C-8
APPENDIX D.	EXPENDABLE SUPPLIES AND MATERIALS LIST		
	Scope	D-1	D-1
	Explanation of Columns \ \ \ \ \	D- 2	D-1
GLOSSARY			
INDEX			

LIST OF ILLUSTRATIONS

Figure	Title	Page
1-1	Countermeasures Panel Indicator ID-2300/ALQ-151(v)...	1-1
1-2	Countermeasures Control C-11124/ALQ-151(V)	1-2
3-1	Countermeasures Control Audio Circuits Simplified Schematic Diagram	3-4
3-2	Countermeasures Control Intercom Control Circuit Simplified Schematic Diagram	3-6
3-3	Countermeasures Control Monitor Circuits Simplified Schematic Diagram	3-7
3-4	Countermeasures Control Lamp Control Circuit Simplified Schematic Diagram	3-8
5-1	Countermeasures Control Mission Power Test Setup	5-10
5-2	Countermeasures Control Lamp Adjust Test Setup	5-10
5-3	Countermeasures Control Lamp Control Circuit Test Setup....	5-22
5-4	Countermeasures Control Transistor Q1 Test Setup	5-22
5-5	Countermeasures Control ICS Power Test Setup	5-23
5-6	Countermeasures Control Audio Test Setup	5-23
5-7	Countermeasures Control Flasher Test Setup	5-24
5-8	Countermeasures Control FL1 Test Setup	5-24
5-9	ECM Panel Indicator Component Locations	5-28
5-10	Switch/Indicator Replacement	5-30
5-11	Indicator Replacement.	5-32
5-12	Fastener Removal and Installation	5-36
5-13	Countermeasures Control Component Locations	5-38
5-14	Indicator CCA A3 Component Locations	5-41
5-15	Voltage Regulator A1 Component Locations	5-44
5-16	Terminal Board TB1 Component Locations	5-48
5-17	Terminal Board TB2 Component Locations	5-49
5-18	Circuit Breaker Replacement.	5-53
C-1	Countermeasures Control C-11124/ALQ-151 (V).....	C-9
C-2	Countermeasures Panel Indicator ID-2300/ALQ-151(V)	C-20
FO-1	ECM Panel Indicator Schematic Diagram	
FO-2	Countermeasures Control Schematic Diagram	
FO-3	Indicator CCA A3 Schematic Diagram	
FO-4	Voltage Regulator A1 Schematic Diagram	

LIST OF TABLES

Table	Title	Page
1-1	ECM Panel Indicator Power and Signal Connections	1-3
1-2	Countermeasures Control Power and Signal Connections	1-5
3-1	Countermeasures Control Audio and Control Through-Wiring	3-3
5-1	ECM Panel Indicator Troubleshooting Procedure	5-3
5-2	Countermeasures Control Voltage Regulator AI Troubleshooting Procedure	5-7
5-3	Countermeasures Control Troubleshooting Procedure	5-11
5-4	Countermeasures Control Audio Test Connections and Display Data	5-25

SAFETY SUMMARY

The following are general precautions that are not related to any specific procedures and, therefore, do not appear elsewhere in this publication. These are recommended precautions that personnel must understand and apply during many phases of operation and maintenance.

KEEP AWAY FROM LIVE CIRCUITS

Operating personnel must at all times observe all safety regulations. Do not replace components or make adjustments inside the equipment with the high-voltage supply turned on. Under certain conditions, dangerous potentials may exist when the power control is in the off position, due to charges retained by capacitors. To avoid casualties, always remove power and discharge and ground a circuit before touching it.

DO NOT SERVICE OR ADJUST ALONE

Under no circumstances should any person reach into or enter the enclosure for the purpose of servicing or adjusting the equipment except in the presence of someone who is capable of rendering aid.

WARNINGS AND CAUTIONS

The following warnings and cautions are used in the text of this volume and are repeated here for emphasis:

WARNING

High voltage is used in the operation of this equipment. Avoid contacting high-voltage connections when installing or repairing this equipment. Injury or death may result if personnel fail to observe safety precautions.

WARNING

Adequate ventilation should be provided while using trichlorotrifluoroethane. Prolonged breathing of vapor should be avoided. The solvent should not be used near heat or open flame; the products of decomposition are toxic and irritating. Since trichlorotrifluoroethane dissolves natural oils, prolonged contact with skin should be avoided. When necessary, use gloves that the solvent cannot penetrate. If the solvent is taken internally, consult a physician immediately. (Page 5-26, 5-35, and 5-58)

WARNING

Before performing repair procedures, ensure that power is disconnected from the ECM indicator panel or countermeasures control. (Pages 5-27 and 5-37)

CAUTION

Use a soldering pencil to solder all necessary points on the CCA. A soldering gun may cause overheating of CCA traces, lead pads, or laminations. Overheating may cause either pads or traces to lift from the CCA. Subsequent breakage is probable. (Page 5-40)

CAUTION

Certain CCAS contain electrostatic discharge sensitive (ESDS) devices that can be damaged by static electricity. Special handling methods and materials must be used to prevent damage. Do not touch or remove any ESDS device or circuit without properly grounding your body, tools, and test equipment. Handle such CCAs on the edges only, and store such CCAs in conductive (antistatic) bags. (Page 5-39, 5-40)

CAUTION

When replacing a rivet, use caution to avoid damage to other components while drilling or using a punch and hammer. (Page 5-55)

LIST OF EFFECTIVE PAGES

INSERT LATEST CHANGED PAGES. DESTROY SUPERSEDED PAGES.

NOTE The portion of the text affected by the changes is indicated by a vertical line in the outer margin of the page. Changes to illustrations are indicated by mini pointing hands. Changes to wiring diagrams are indicated by shaded areas.

Dates of issue for original and changed pages are:

Original... 20 November 1983 Change... 3 February 1986

TOTAL NUMBER OF PAGES IN THIS PUBLICATION IS 158 CONSISTING OF THE FOLLOWING:

Page No.	Change No.	Page No.	Change No.
Title	1	5-61	0
A	1	5-62 blank	0
i - ii	0	A-1 - A-2	1
iii - iv	1	A-3	0
v - vii	0	A-4 blank	0
viii blank	0	B-1 - B-4	0
1-1	0	B-5 - B-7	1
1-2 - 1-10	1	B-8 blank	1
1-11	0	C-1	0
1-12 blank	0	C-2 blank	0
2-1	0	C-3 - C-7	0
2-2 blank	0	C-8 - C-1	1
3-1-3-9	1	C-12	0
3-10 blank	1	C-13 - C-21	1
4-1	0	C-22	0
4-2 blank	0	C-23 - C-28	1
5-1-5-2	0	D-1 - D-2	1
5-3- 5-5	1	Glossary 1	0
5-5.1	1	Glossary 2 blank	0
5-5.2 blank	1	Index 1-8	1
5-6-5-27	1	FO-1 - FO-2 (Sht 1)	0
5-28- 5-43	0	FO-2 (Sht 2)	1
5-44	0	FO-3 - FO-4	0
5-45-5-60	1		

Upon receipt of these and subsequent changes to this document, personnel responsible for maintaining this publication in current status will ascertain that all previous changes have been received and incorporated. Action should be taken promptly if the publication is incomplete.

*Zero in this column indicates an original page.

CHAPTER 1

INTRODUCTION

Section I. GENERAL

1-1. Scope. This manual provides organizational, direct support, and general support maintenance information, and repair parts and special tools list (RPSTL) for Countermeasures Panel Indicator ID-2300/ALQ-151(V) and Countermeasures Control C-11124/ALQ-151(V). Countermeasures Panel Indicator ID-2300/ALQ-151(V) (figure 1-1) is hereinafter referred to as the ECM panel indicator, and Countermeasures Control C-11124/ALQ-151(V) (figure 1-2) is hereinafter referred to as the countermeasures control. In addition, the manual provides general information, tabulated data, and a functional description of the equipment. Refer to TM 32-5865-012-10 for organizational operating instructions for the ECM panel indicator.

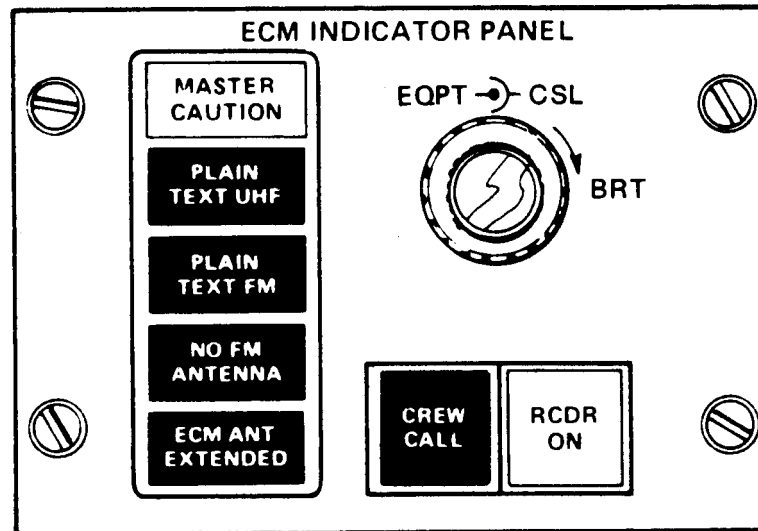

Figure 1-1. Countermeasures Panel Indicator ID-2300/ALQ-151(V)

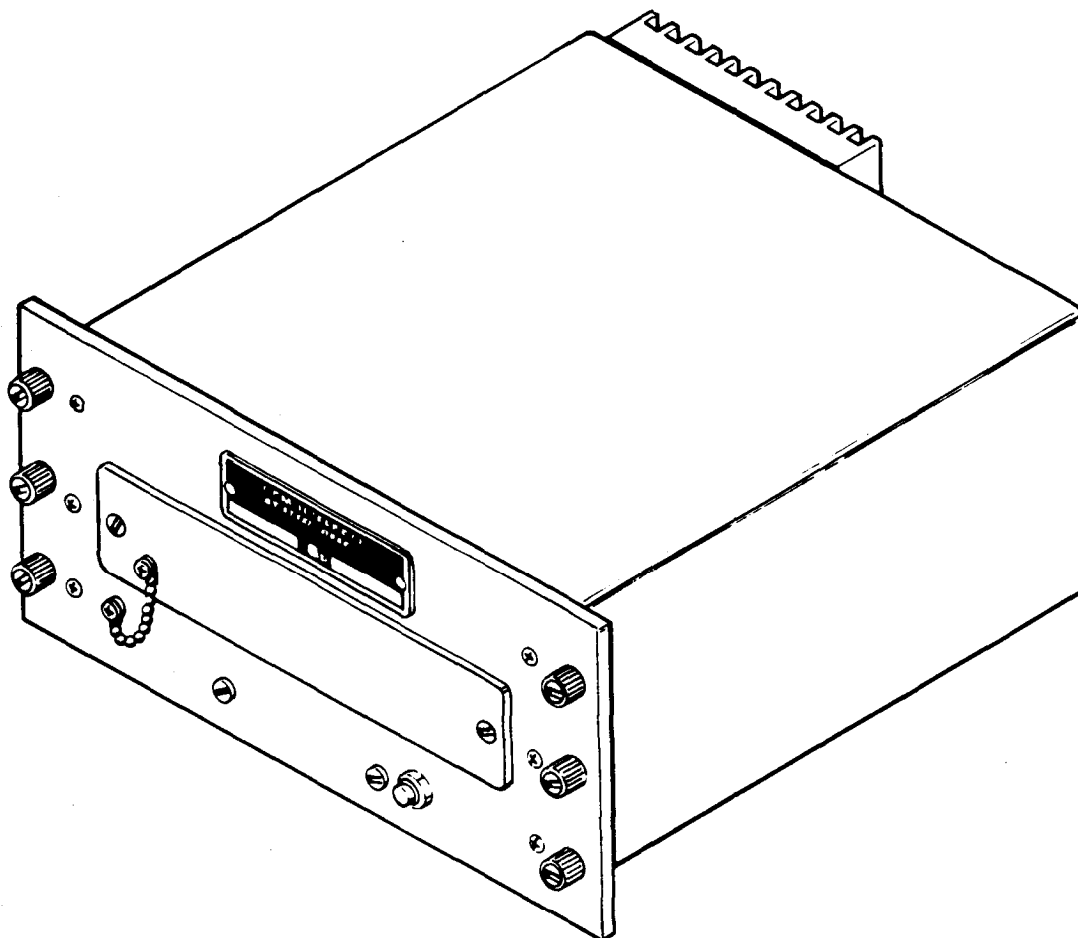

Figure 1-2. Countermeasures Control C-11124/ALQ-151(V)

1-2. Maintenance Forms and Records. Department of the Army forms and procedures used for equipment maintenance will be those prescribed by DA PAM 738-750, The Army Maintenance Management System (TAMMS).

1-3. Destruction of Army Materiel to Prevent Enemy Use. Procedures for the destruction of Army materiel are contained in TM 750-244-2, Procedures for Destruction of Electronics Materiel to Prevent Enemy Use (Electronics Command).

1-4. Administrative Storage. Refer to TM 740-90-1, Administrative Storage of Equipment, for test procedures, forms and records, and inspections required during administrative storage of this equipment.

1-5. Reporting Errors. The reporting of errors, omissions, and recommendations for improving this publication by the individual user is encouraged. Reports should be submitted on DA Form 2028 (Recommended Changes to Publications) and forwarded directly to the Commander, U.S. Army Electronic Materiel Readiness Activity, EMRA, Vint Hill Farms Station, Warrenton, Virginia 22186, Attn: SELEM-ME-E.

1-6. Reporting Equipment Improvement Recommendations (EIR). EIRs will be prepared using SF 368, Quality Deficiency Report. Instructions for preparing EIRs are provided in DA PAM 738-750, The Army Maintenance Management System (TAMMS). EIRs should be mailed directly to the Commander, U.S. Army Electronic Materiel Readiness Activity, EMRA, Vint Hill Farms Station, Warrenton, Virginia 22186, Attn: SELEM-ME-F. A reply will be furnished directly to you.

Section II. DESCRIPTIONS AND DATA

1-7. ECM Panel Indicator. The following paragraphs provide description and data for general support maintenance of the ECM panel indicator.

a. Description. In addition to the description contained herein, refer to TM 32-5865-012-10 for a general description and illustration of the ECM panel indicator. The ECM panel indicator is a metal enclosure that contains five lamps, two switches, and a dual illumination control. The lamps indicate system caution and operation conditions. The switches control external system equipment. The illumination control provides two variable outputs that adjust the brightness of lamps on external system equipments. ECM panel indicator power and input/output connections are made at the rear panel (see table 1-1).

Table 1-1. ECM Panel Indicator Power and Signal Connections

Connector marking	Pin	Function/Remark
J1	A	115V ac 400 Hz in
J1	B	115V ac 400 Hz neutral in
J1	C	115V ac 400 Hz ground in
J1	D	115V ac 400 Hz out
J1	E	115V ac 400 Hz neutral out
J1	F	115V ac 400 Hz ground out
J1	G	PLAIN TEST FM indicator
J1	H	NO FM ANTENNA indicator
J1	J	Lamp dimmer power input
J1	K	MASTER CAUTION indicator

Table 1-1. ECM Panel Indicator Power and Signal Connections - Continued

Connector marking	Pin	Function/Remark
J1	L	PLAIN TEXT UHF indicator
J1	M	ECM ANT EXTENDED indicator
J1	N	Mission power ground
J1	P	CREW CALL flasher
J1	R	CREW CALL Indicator trigger
J1	S	ECM panel dimmer high
J1	T	ECM panel dimmer wiper
J1	U	ECM panel dimmer low
J1	V	ECM console dimmer high
J1	W	Spare
J1	X	ECM console dimmer low
J1	Y	ICS power +28 V dc in
J1	Z	ICS +28 V dc power return
J1	a	Spare
J1	b	Spare
J1	c	Spare

1-8. Tabulated Data.

Input power (dc) +28 V dc

Input/Output Power (ac) 115 V ac, 400 Hz

Input Voltages:

CREW CALL FLASHER Open (inactive) and ground (active)

MASTER CAUTION, PLAIN TEXT
UHF, PLAIN TEXT FM, NO FM
ANTENNA, ECM ANT EXTENDED Open (inactive) and ground (active)

LAMP DIM - PWR +7 to +26 V dc

ECM PANEL DIM (HI) +23 V dc

ECM CONSOLE DIM (HI) +23 V dc

ECM PANEL DIM WIPER Ground

Output Voltages:

CREW CALL FLASHER Open (inactive) and ground (active)

ECM PANEL DIM (LOW) +1 V dc

ECM CONSOLE DIM (LOW) +1 V dc

Dimensions:

Height 3.00 in. (7.62 cm)

Depth 3.67 in. (9.32 cm)

Width 4.31 in. (10.97 cm)

Weight 2.5 lb (1.13 kg)

Environmental:

Altitude

Operating 30,000 ft (maximum)

Nonoperating 40,000 ft (maximum)

Temperature

Operating -40°C (-40°F) to
+55°C (+131°F)

Nonoperating -57°C (-71°C) to
+85°C (+185°F)

Humidity 0 to 98%

1-9. Countermeasures Control. The following paragraphs provide description and data for general support maintenance of the countermeasures control.

a. Description. The countermeasures control is a metal enclosure that contains one circuit card assembly, one voltage regulator two relays, one RF switch, and one front panel circuit breaker. The countermeasures control conditions, distributes, and controls system audio signals between external equipments. The countermeasures control also monitors system caution sensors. Countermeasures control power and input/output connections are made at the rear panel (see table 1-2).

Table 1-2. Countermeasures Control Power and Signal Connections

Connector marking	Pin	Function/Remark
J1		Radiated BITE signal
J2	A	Transmitter audio no. 2 (recorder)
J2	B	Receiver no. 2 audio (recorder)
J2	C	Nav audio (voice recorder)
J2	D	Receiver no. 1 audio
J2	E	Receiver no. 1 audio return
J2	F	Transmitter no. 1 audio
J2	G	Recorder no. 3 audio (FM)
J2	H	Transmitter no. 3 audio (FM)
J2	J	Transmitter no. 4 audio (PVT)
J2	K	Receiver no. 4 audio (PVT)
J2	L	Interphone
J2	M	Override audio
J2	N	Receiver audio no. 5 (DF/ITC)
J2	P	AUX audio (TLQ-17A)
J2	R	MIC HI
J2	S	MIC LO
J2	T	Shield
J2	U	HSDT HI

Table 1-2. Countermeasures Control Power and Signal Connections - Continued

Connector marking	Pin	Function/Remark
J2	V	HSDT LO
J2	W	PTT common
J2	X	PTT FT SW
J2	Z	Transmitter no. 1 control UHF
J2	a	Transmitter no. 3 control UHF FM
J2	<u>c</u>	+27.5 V dc in
J2	<u>d</u>	Battery ground
J2	e	Chassis ground
J2	f	Lamp ground
J2	g	Lamp dimmer
J3	A	Crew call
J3	C	Crew call trigger
J3	D	Master caution
J3	E	FM antenna control
J3	F	+28 V dc mission in
J3	G	+28 V dc mission in return
J3	H	+28 V dc ICS
J3	J	+28 V dc ICS return
J3	K	MIC HI
J3	L	MIC LO
J3	M	Shield
J3	N	HDST HI
J3	P	HDST LO
J3	R	PTT HDST
J3	S	PTT HDST
J3	T	PTT HDST return
J3	U	PTT HDST return
J3	V	ECM antenna extend
J3	W	+28 V dc mission return
J3	X	+28 V dc unfiltered mission in
J3	Y	Mission return
J4		FM troop antenna
J5		ARC-186 antenna
J6	A	Channel no. 2 DEMUX OUT
J6	B	Channel no. 2 DEMUX OUT return
J6	C	UNH-16A no. 2 channel 2 P.B.
J6	D	UNH-16A no. 2 channel 2 P.B. return
J6	E	UNH-16A no. 2 MIC no. 2
J6	F	UNH-16A no. 2 MIC no. 2 return
J6	G	Channel no. 2 MUX in

Table 1-2. Countermeasures Control Power and Signal Connections - Continued

Connector marking	Pin	Function/Remark
J6	H	Channel no. 2 MUX in return
J6	J	Transmitter no. 4 audio PVT
J6	K	Transmitter no. 4 audio PVT return
J6	L	Receiver no. 4 audio PVT
J6	M	Receiver no. 4 audio PVT return
J6	N	Receiver audio no. 5 DF/ITC
J6	P	Receiver audio no. 5 DF/ITC return
J6	R	TLQ-17A receiver audio
J6	S	TLQ-17A receiver audio return
J6	T	Transmitter no. 3 COM FM (KY-58)
J6	U	Transmitter no. 1 control
J6	V	Power supply PP-7294A +5 V dc
J6	W	Receiver no. 1 audio
J6	X	Receiver no. 1 audio return
J6	Y	Transmitter no. 1 audio
J6	Z	Transmitter no. 1 audio return
J6	a	ARC-186(V) receiver audio
J6	b	Audio out COM no. 1
J6	c	ARC-186(V) transmitter audio
J6	d	ARC-186(V) transmitter audio return
J6	e	Interphone audio
J6	f	Interphone audio return
J6	g	Override audio
J6	h	Override audio return
J6	j	TLQ-17A audio HI
J6	k	TLQ-17A audio LO
J6	m	186(V) PTT
J6	n	Shield ground
J6	p	Audio out from KY-58
J6	q	Audio out from KY-58 return
J6	r	KY-58/ARC-186(V) MIC
J6	s	KY-58/ARC-186(V) MIC return
J6	t	Transmitter no. 3 control
J7	A	Flasher lamp control
J7	B	Flasher lamp control return
J7	C	Cockpit crew call trigger
J7	D	Crew call return
J7	F	Zeroize
J7	G	Plain text FM
J7	H	Plain text UHF
J7	J	Interphone audio

Table 1-2. Countermeasures Control Power and Signal Connections - Continued

Connector marking	Pin	Function/Remark
J7	R	+28 V dc ICS in
J7	s	+28 V dc ICS in return
J7	U	Plain text FM
J7	V	Zeroize
J7	W	Dimming out (KY-58)
J7	X	Lamp dim out (ARC-186(V))
J7	Y	+28 V dc mission (KY-58)
J7	Z	+28 V dc mission return (KY-58)
J7	a	+28 V dc mission (ARC-186(V))
J7	b	+28 V dc mission return (ARC-186(V))
J8	A	+28 V dc mission (ARC-186(V))
J8	B	+28 V dc mission (ARC-186(V)) return
J8	C	+28 V dc mission (KY-58)
J8	D	+28 V dc mission return (KY-58)
J8	G	Plain text FM
J8	H	No FM antenna (BITE LIGHT)
J8	J	Lamp dim
J8	K	Master caution
J8	L	Plain text UHF
J8	M	ECM antenna extend
J8	N	+28 V dc mission return
J8	P	Crew call flasher
J8	R	Crew call trigger
J8	S	Lamp dimmer control
J8	T	Lamp dimmer control
J8	U	Lamp dimmer control
J8	V	Lamp dimmer control
J8	X	Lamp dimmer control
J8	Y	Console lamp no. 1
J8	X	Console lamp return
J8	a	Console lamp no. 2
J8	b	+28 V dc ICS return
J8	c	+28 V dc ICS

1-10. Tabulated Data.

Input Power (dc)	+5, +28 V dc
Output Power (dc)	+28 V dc
Input Voltages:	
CH2 DEMUX OUT, RTN.....	5 V p-p
UNH-16A NO. 2 CH2 P.B., RTN	5 V p-p nominal, 20 V p-p maximum
ARC-186(V) XMTR AUDIO, RTN	4 V p-p nominal
TLQ-17A AUDIO HI, LO	5 V p-p maximum
AUDIO OUT FROM KY-58, RTN	5 V p-p nominal
PWR SPLY PP-7294A	+5 (± 13.5) V dc
XMTR AUDIO NO. 2 (RCDR)	3 V p-p
XMTR NO. 3 AUDIO (FM)	2 V p-p
PLAIN TEXT FM	Open (inactive) and ground (active)
PLAIN TEXT UHF	Open (inactive) and ground (active)
COCKPIT CREW CALL TRIGGER	Open (inactive) and ground (active)
FLASHER LAMP CONT, RTN	Open (inactive) and ground (active)
FM ANTENNA CONT	Open (inactive) and ground (active)
CREW CALL	Open (inactive) and ground (active)
MASTER CAUTION	Open (inactive) and +28 V dc (active)
ECM ANT EXTENDED	Open (inactive) and ground (active)
ZEROIZE	Open (inactive) and +28 V dc (active)
XMTR NO. 1 AUDIO	4 V p-p
XMTR NO. 4 AUDIO PVT	3 V p-p
XMTR NO. 3 CONT UHF FM	+1.2 (± 0.6) V dc (active)
XMTR NO. 1 CONT UHF	10 mA maximum
XMTR NO. 3 COM FM (KY-58)	+28 V dc (inactive) and ground (active)
RCVR NO. 1 AUDIO, RTN	4 V p-p
RCVR NO. 4 AUDIO PVT, RTN	4 V p-p maximum
RCVR AUDIO NO. 5 DF/ITC, RTN	4 V p-p
XMTR NO. 1 AUDIO, RTN	4 V p-p
Output Voltages:	
OVERRIDE AUDIO	2 V p-p
UNH-16A NO. 2 MIC NO. 2, RTN	5 V p-p nominal
ARC-186(V) RCVR AUDIO, COM NO.	4 V p-p nominal

Output Voltages: (Continued)

CHAN NO. 2 MUX IN, RTN	5 V p-p nominal
TLQ-17A RCVR AUDIO, RTN	5 V p-p nominal
KY-58/ARC-186(V) MIC, RTN	4 V p-p nominal
RCVR NO. 2 AUDIO (RCDR)	4 V p-p nominal
NAV AUDIO (VOICE RCDR)	4 V p-p nominal
RCDR NO. 3 AUDIO (FM)	4 V p-p nominal
AUX, AUDIO (TLQ-17A)	4 V p-p
PLAIN TEXT FM	Open (inactive) and ground (active)
PLAIN TEXT UHF	Open (inactive) and ground (active)
CREW CALL FLASHER	Open (inactive) and ground (active)
CREW CALL TRIG	Open (inactive) and ground (active)
INTERPHONE AUDIO, RTN (J6)	5 V p-p nominal
OVERRIDE AUDIO, RTN.	5 V p-p nominal
FLASHER LAMP CONT	Open (inactive) and ground (active)
NO FM ANT (BITE LIGHT)	Open (inactive) and ground (active)
MASTER CAUTION	Open (inactive) and +28 V dc (active)
ECM ANT EXTENDED	Open (inactive) and ground (active)
CONSOLE LAMP NO. 1, 2, 3	+4 to +23 V dc
LAMP DIM OUT (ARC-186(V))	+1 to +23 V dc
DIMMING OUT (KY-58)	+1 to +23 V dc
ZEROIZE	Open (inactive) and +28 V dc (active)
XMTR NO. 1 AUDIO, RTN	4 V p-p
XMTR NO. 4 AUDIO PVT, RTN	4 V p-p maximum
XMTR NO. 3 CONT	4 V p-p
XMTR NO. 1 CONT	4 V p-p
186(V) PTT	Open (inactive) and +1.2 (± 0.6) V dc (active)
RCVR NO. 1 AUDIO, RTN	4 V p-p
RCVR NO. 4 AUDIO PVT	3 V p-p
RCVR NO. 5 DF/ITC	2 V p-p
LAMP DIM	+1 to +28 V dc

Input/Output Voltages:

INTERPHONE	4 V p-p
INTERPHONE AUDIO, RTN (J6)	5 V p-p

Input/Output Impedance

(J1, J4, J5)	50 ohms
------------------------	---------

TTL Levels:

High (logic 1)	+2.4 to 5.5 V dc
Low (logic 0)	+0.0 to 0.4 V dc

Dimensions:

Height 4.88 in. (12.40 cm)
 Depth 11.37 in. (28.88 cm)
 Width 10 in. (25.4 cm)

Weight 7.251b (3.29 kg)

Environmental:

Altitude

Operating 30,000 ft (maximum)
 Nonoperating 40,000 ft (maximum)

Temperature

Operating -40°C (-40°F) to +55°C
 (+131°F)
 Nonoperating -57°C (-71°C) to +85°C
 (+185°F)

Humidity 0 to 98%

CHAPTER 2

ORGANIZATIONAL MAINTENANCE INSTRUCTIONS

2-1. Scope. Organizational support maintenance procedures are provided in TM 36-5865-012-20.

CHAPTER 3

FUNCTIONING OF EQUIPMENT

Section I. GENERAL

3-1. Scope. This chapter provides a functional description of the ECM panel indicator and the countermeasures control. The circuits are described to the extent necessary for general support maintenance.

3-2. Organization. In addition to the functional description contained herein, refer to TM 32-5865-012-10 for operating instructions for the ECM panel indicator. The following description references simplified schematic diagrams and schematic diagrams. The simplified schematic diagrams are provided in text. The schematic diagrams are provided as foldout drawings. Foldout drawings referenced in the text as FOs are located at the rear of the manual.

Section II. FUNCTIONAL DESCRIPTION

3-3. ECM PANEL INDICATOR. Refer to figure FO-1. The ECM panel indicator contains lamps DS1 thru DS5, switches S1 and S2, and potentiometer R1. Safety features are provided in the form of interlock jumpers on the rear panel connector.

a. Indicator Circuits. MASTER CAUTION lamp DS1 lights when external system equipment provides an input at connector pin J1-K. The lamp dimmer power at connector pin J1-J passes to terminal stud E1. The power is distributed to lamps DS2 thru DS5 and switch S2. External equipment provides ground at connector pins J1-L, J1-G, J1-H, and J1-M to light lamps DS2 thru DS5, respectively.

b. CREW CALL Switch S1. The +28 V dc ICS power and return inputs at connector pins J1-Y and J1-Z pass to CREW CALL switch S1 contacts 2 and 4, the common (C) contact of A, and the normally open (NO) contact of B. The crew call flasher input at connector pin J1-P passes to the lamp and B common contacts. Switch S1 is a momentary-action, pushbutton switch indicator. When switch S1 is pressed and held, the C and NO contacts of B close to light the CREW CALL lamp. The C and NO contacts of A close to connect the ICS power return to external equipment at connector pin J1-R. If switch S1 is restored when external equipment provides an input at connector pin J1-P, the CREW CALL lamp flashes.

c. RCDR ON Switch S2. The 115 V ac, 400 Hz input at connector pin J1-A passes to the B common contact of RCDR ON switch S2.

Contacts 2 and 4 receive lamp voltage from terminal stud E1. Switch S2 is an alternate-action, pushbutton switch/indicator. When switch S2 is pressed, the C and NO contacts of A close to connect ground from connector pin J1-N to the lamp C contact. The RCDR ON lamp lights and the C and NO contacts of A close to connect the 115 V ac to external system equipment at connector pin J1-D. When switch S2 is restored, the C and NO contacts are open and the lamp is off.

d. CSL BRT Potentiometer R1A. External system equipment applies lamp voltage to connector pin J1-V. CSL BRT potentiometer R1A varies the output to external equipment at connector pin J1-X.

e. EQPT BRT Potentiometer R1B. External system equipment applies lamp voltage and ground to connector pins J1-S and J1-U. EQPT BRT potentiometer R1B varies the output to external equipment at connector pin J1-T.

f. Interlock Jumpers. The interlock circuit originates at the external ac line. The 115 V ac ground and 115 V ac neutral potentials are routed through the ECM panel indicator and external equipments in the system. The ECM panel indicator interlock circuit consists of jumpers between connector pins J1-C and J1-F, J1-B and J1-E. The ground interlock jumper also connects to the cable shield. If connector J1 is removed, the interlock circuit is opened, and the external units cannot operate.

3-4. Countermeasures Control. Refer to figure FO-2. The countermeasures control contains indicator circuit card assembly (CCA) A3, voltage regulator A1, RF coaxial switch S1, and circuit breaker CB1. In addition, through-wiring connections are provided between external system equipments. These connections (see table 3-1) pass audio and control signals that perform no function within the countermeasures control.

a. Indicator CCA A3. Refer to figure FO-3. The indicator CCA conditions system audio signals and monitors plain text and radio control signals. It also provides control outputs to external system equipment. In addition, the indicator CCA contains a control circuit that adjusts the brightness of front panel lamps on external system equipment.

(1) Audio Signal Conditioning Circuits. As shown in figure 3-1, the XMTR AUDIO No. 2 (RCDR) input at connector pin J2-A passes to the primary winding of transformer T1. The primary winding also receives the audio return inputs at connector pins J6-P and J6-X through terminal board connections TB1-17 and TB1-19. The secondary winding of transformer T1 passes the audio signal through connector pins J6-G and J6-H to external system equipment.

Table 3-1. Countermeasures Control Audio and Control Through-Wiring

From Connector marking	Pin	To Connector marking	Pin	Function/Remarks
J2	F	J6	Y	XMTR NO. 1 AUDIO
J2	U	J3	N	HDST HI
J2	V	J3	P	HDST LO
J2	Z	J6	U	XMTR NO. 1 CONT UHF
J2	a	J6	t	XMTR NO. 3 CONT UHF FM
J3	D	J8	K	MASTER CAUTION
J3	K	J2	R	MIC HI
J3	L	J2	S	MIC LO
J3	R	J2	X	PTT HDST
J3	S	J2	X	PTT HDST
J3	V	J8	M	ECM ANT EXTEND
J6	N	J2	N	RCVR AUDIO NO. 5 DF/ITC
J6	W	J2	D	RCVR NO. 1 AUDIO
J6	X	J2	E	RCVR NO. 1 AUDIO RTN
J7	F	J7	V	ZEROIZE
J8	A	J7	a	+28 V dc MISSION (ARC-186(V))
J8	B	J7	b	+28 V dc MISSION (ARC-186(V)) RTN
J8	C	J7	Y	+28 V dc MISSION (KY-58)
J8	D	J7	z	+28 V dc MISSION (KY-58) RTN

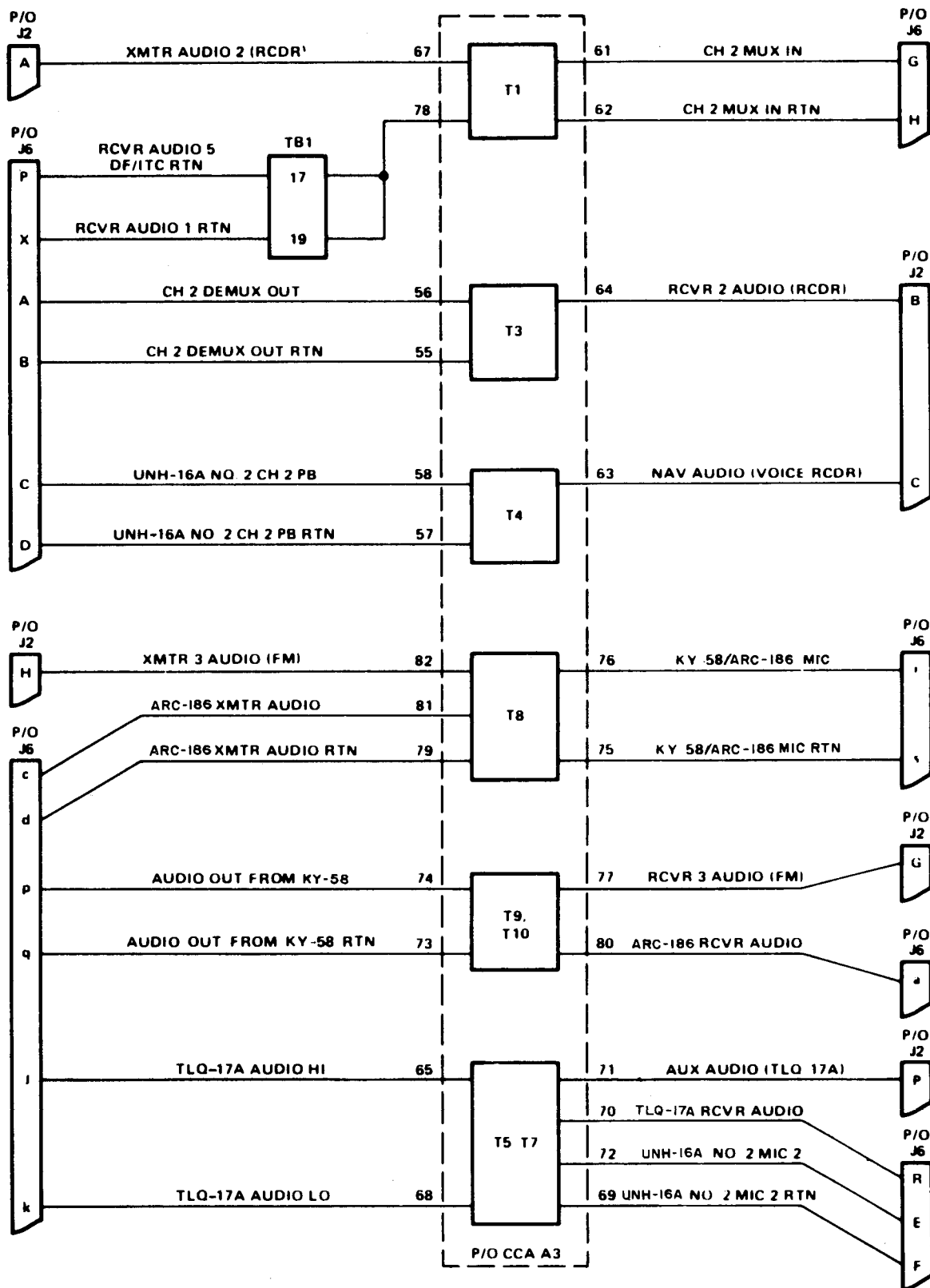

Figure 3-1. Countermeasure Control Audio Circuits Simplified Schematic Diagram

(2) Intercom Control Circuit. As shown in figure 3-2, the intercom circuit receives CREW CALL control inputs at connector pins J7-C, J8-R, and J3-A. When any input is a low (logic 0) signal, current flows through diode TB1CR1 or TB1CR2 to provide a low to external system equipment at connector pin J3-C. In addition, the following functions occur:

(a) Relay K1 operates when the COCKPIT CREW CALL TRIGGER input goes low. Contacts K1-A2 and K1-A1 close to connect the interphone audio signal at connector pin J7-J to contact B2 of relay K2. Contacts K1-B2 and K1-B1 close to activate relay K3. Contacts K3-A2 and K3-A1 connect the flasher lamp control return input at connector pin J7-B to external system equipment at connector pin J7-A.

(b) Relay K2 operates when the CREW CALL TRIG or CREW CALL input is low. Contacts K2-A2 and K2-A3 open, and contacts K2-A2 and K2-A1 close. This connects the interphone audio signal at connector pin J7-J to external system equipment at connector pins J6-e and J2-L and removes the terminating resistor TB1R1 from the signal line. Contacts K2-B2 and K2-B3 open to break the override audio signal path between contact K1-A1 and connector pins J2-M and J6-g.

(c) On indicator CCA A3, the output of timer U1A goes high (logic 1) when any CREW CALL input goes low. The output of timer U1A resets multivibrator U1B. The 5 (1) Hz output pulse of multivibrator (U1B) is applied through transistor Q8 to operate relay K3. Contacts K3-A2 and K3-A1 close to provide the flasher lamp control output to external system equipment at connector pin J7-A. The 5 (1) Hz pulse also passes to external system equipment at connector pin J8-P. After five to seven seconds, the timer output goes low, multivibrator U1B is inhibited, and relay K3 restores.

(3) Monitor Circuits. As shown in figure 3-3, terminal board TB2 and diodes CR5 and CR6 receive transmitter control and plain text inputs. Relay TB2K1 is operated by a logic 0 transmitter control input from external system equipment at connector pin J6-T. The logic 0 input also causes a low signal through diode TB2CR2 and connector pin J6-m to external system equipment. When relay TB2K1 operates, contacts A2 and A1 close to connect the PLAIN TEXT FM signal at connector pin J7-U to diode A3CR5 and to external system equipment at connector pin J7-G. When the PLAIN TEXT FM signal is a logic 0, the PLAIN TEXT FM outputs are also low at connector pins J8-G and J7-G. The PLAIN TEXT UHF monitor circuit is a direct link to the system with no separate controls such as relay K1 to affect its operation. When a logic 0 is input to connector pin J7-H, diode CR6 is forward biased placing the logic 0 on connector pin J8-L. When a logic 1 is placed on connector pin J7-H, diode CR6 is reverse biased and connector pin J8-L becomes a logic 1.

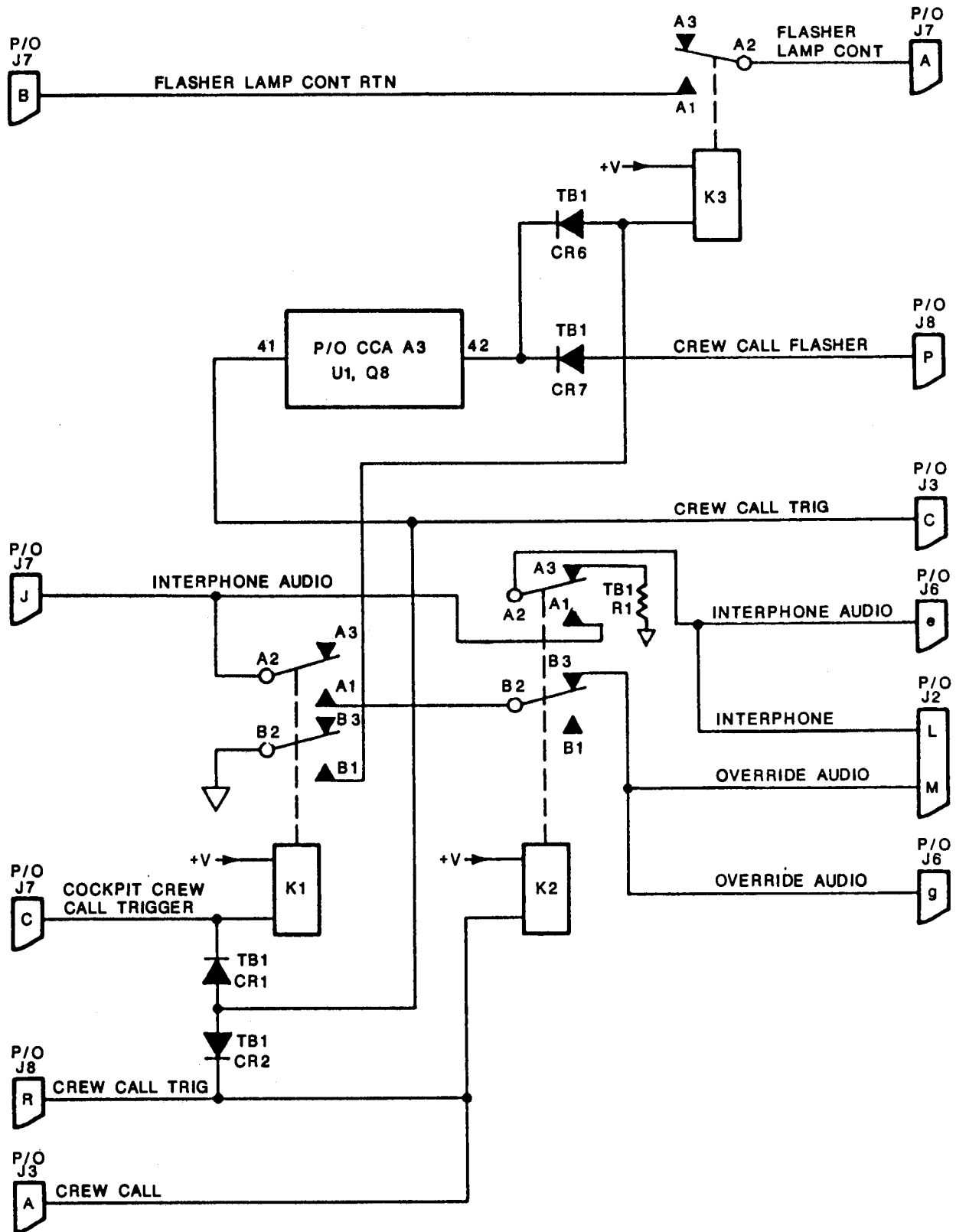

Figure 3-2. Countermeasures Control Intercom Control Circuit Simplified Schematic Diagram

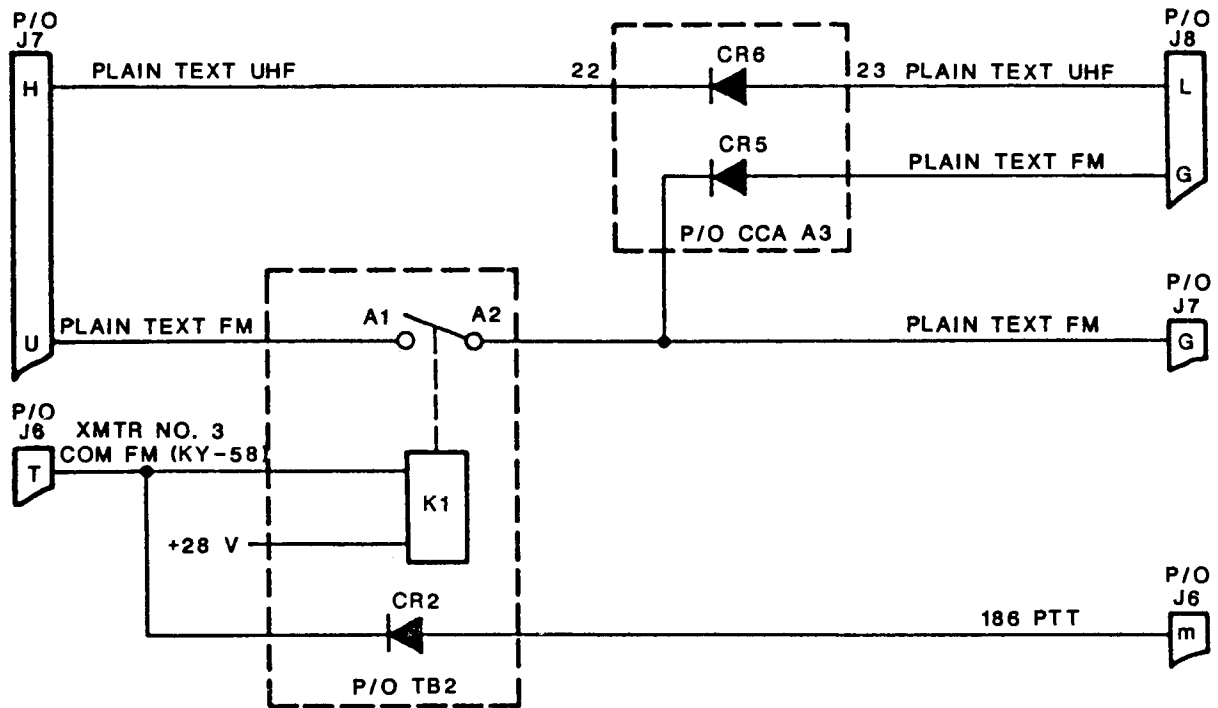

Figure 3-3. Countermeasures Control Monitor Circuits Simplified Schematic Diagram

(4) Lamp Control Circuit. As shown in figure 3-4, resistors R20 thru R27, zener diodes VR2 and VR3, amplifier U2, and transistor Q7 comprise a current-limiting circuit. The lamp control potentiometer in the external system equipment is connected to pins J8-S, J8-T, and J8-U. The LAMP DIMMER CONTROL input at pin J8-T varies the transistor Q7 output to power transistor Q1 on the countermeasures control chassis. The output of transistor Q1 is applied to terminal stud E2 for distribution to external system equipment at connector pins J2-g, J7-W, J7-X, and J8-J.

b. RF Coaxial Switch S1. Refer to figure FO-2, sheet 1. Switch S1 controls RF input/output signals between external system equipments at connectors J4 and J5. During normal operation, the FM antenna control input from external system equipment is high (logic 1). When the control input goes low, the switch operates to connect the BITE input from external system equipment at connector J1 to the

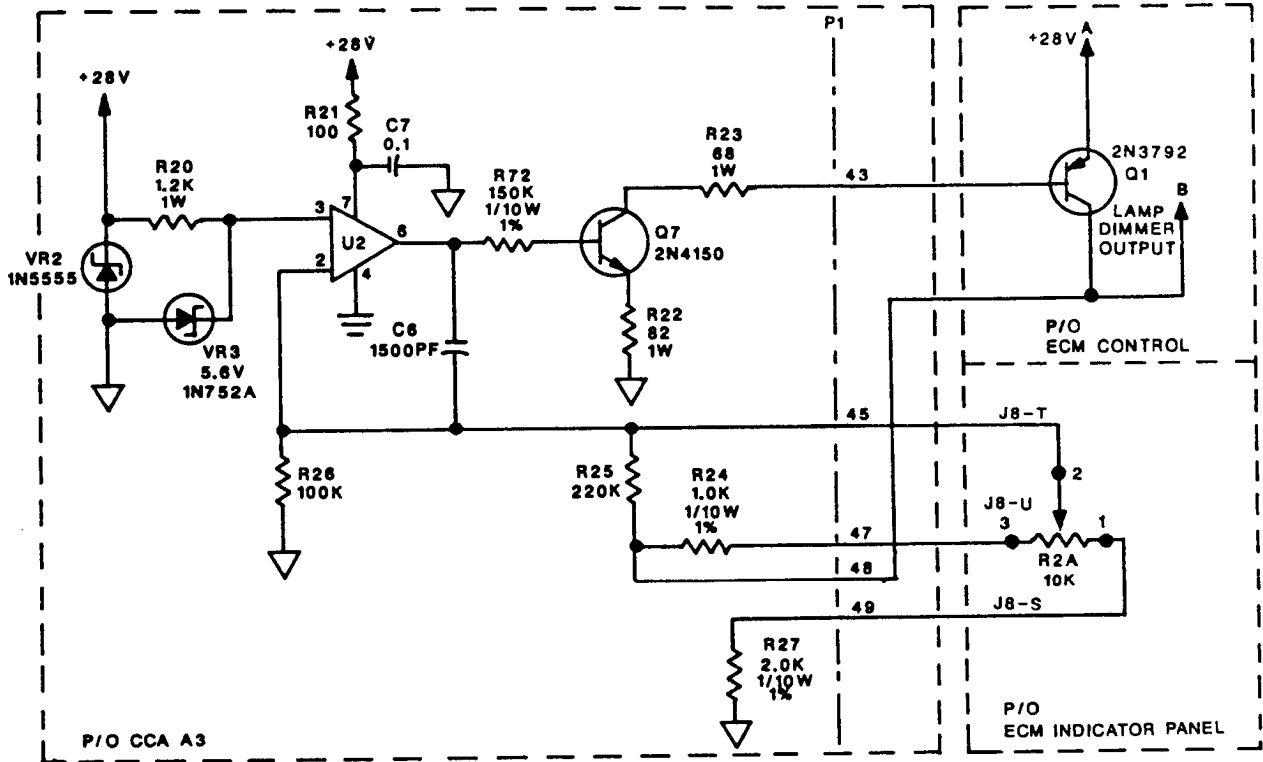

Figure 3-4. Countermeasures Control Lamp Control Circuits Simplified Schematic Diagram

external system equipment at connector J4. Contacts 2 and 3 close to provide ground to external system equipment at connector pin J8-H. When the FM antenna control input goes high, the switch restores, and contacts 2 and 3 open.

c. Voltage Regulator A1. Refer to figure FO-2, sheet 2. Front panel circuit breaker CB1 protects the +28 V dc unfiltered mission power input to voltage regulator A1. When DC POWER circuit breaker CB1 is set to the on (in) position, the +28 V dc input at connector pin J3-X passes through connector pin A1P1-1 to voltage regulator assembly A1. The lamp adjust inputs from external system equipment at connector pins J8-V and J8-X pass through connector pins A1P1-4 and A1P1-5, respectively, to control voltage regulators VR1 and VR2 (figure FO-4). The outputs of voltage regulators VR1 and VR2 pass through connector pins A1P1-2, A1P1-3, J8-Y, and J8-a to external system equipment.

Lamp return passes to external system equipment through connector pins A1P1-9 and J8-Z.

d. Power Distribution. The countermeasures control receives +5 and +28 V dc power inputs. Separate circuits distribute the inputs as follows:

- (1) The +5 V dc input at connector pin J6-V (figure FO-2, sheet 1) passes through connector pin XA3-1 to the indicator CCA.
- (2) The +28 V dc mission power at connector pins J3-F, J3-G, and J3-Y (figure FO-2, sheet 2) passes to terminal studs E1 and E3. Mission power is distributed to indicator CCA A3, power transistor Q1 (figure FO-2, sheet 1), relay TB2K1, and voltage regulator A1.
- (3) Through-wiring connections pass the +28 V dc mission (ARC-186(V)) and (KY-58) inputs at connector pins J8-A thru J8-D to external system equipment at connector pins J7-a, J7-b, J7-Y, and J7-Z.
- (4) The +28 V dc ICS power input at connector pin J7-R passes through filter FL1 to terminal stud E4. ICS power return at connector pin J7-S passes to terminal studs E5 and E7. Filtered ICS power is distributed to diodes TB1CR3 thru TB1CR5 and to external system equipment at connect pins J8-b, J8-c, J3-H, and J3-J. ICS power return is also distributed to external equipment at connector pins J7-D, J2-T, J2-W, J2-d, and J2-e.

CHAPTER 4

DIRECT SUPPORT MAINTENANCE INSTRUCTIONS

Section I. GENERAL

4-1. Scope. No direct support maintenance is required for this equipment. Units removed during organizational maintenance are forwarded to the general level for maintenance as described in chapter 5.

CHAPTER 5

GENERAL SUPPORT MAINTENANCE INSTRUCTIONS

Section I. GENERAL

5-1. Scope. This chapter provides general support maintenance instructions for the ECM panel indicator and the countermeasures control. Troubleshooting and test procedures in this chapter supplement maintenance instructions provided in TM 32-5865-012-20 by using additional test equipment, tools, and materials available to general support maintenance.

5-2. Organization. This chapter contains reference data for and measurements made on the ECM panel indicator and countermeasures control to determine proper operation. This chapter also lists tools and test equipment required and provides troubleshooting procedures. In addition, the chapter provides maintenance and test procedures to the component level for general support maintenance.

5-3. Countermeasures Control Measurements and Data. The ECM Control contains resistor R2, a 620 ohm isolation resistor which isolates the audio line for transmitter No. 4 from the other audio circuits. This resistor prevents crosstalk between channels. If R2 should open, other audio channels will override channel 4. If R2 should short, Channel 4 will override all other channels. Whenever the ECM Control is reported failed due to crosstalk, R2 should be checked before any other troubleshooting procedures is attempted. To verify resistor R2, refer to FO-2, and measure the resistance between connector pins J2-J and J6-K. The measurement should be 62 ($\pm 5\%$) ohms. Replace R2 if any other reading is obtained.

Section II. TOOLS AND EQUIPMENT

5-4. General. This section lists tools, test equipment, and materials required to perform general support maintenance.

5-5. Tools and Equipment Required. Lists of authorized common tools and equipment are provided as part of the Maintenance Allocation Chart (MAC) located in Appendix B of this manual. Appendix D of this manual is a list of expendable supplies and materials required.

Section III. TROUBLESHOOTING

5-6. General. This section provides troubleshooting instructions for the ECM panel indicator and the countermeasures control.

5-7. ECM Panel Indicator Procedure. Troubleshooting of the ECM panel indicator consists of performing a series of checks to isolate a fault. The procedure assumes that system-level troubleshooting by organizational maintenance personnel has been performed as given in TM 32-5865-012-20 to isolate the problem to the ECM panel indicator. After performing general inspection and cleaning procedures in section IV of this chapter, refer to table 5-1 for the troubleshooting procedure. After isolating the problem refer to section IV of this chapter for the appropriate maintenance procedure.

Table 5-1. ECM Panel Indicator Troubleshooting Procedure

Step	Test Point	Test Equipment	Procedure	Normal Indication	If Indication is Normal	If Indication is Abnormal
			NOTE			
			This procedure includes the major components that may be defective within the ECM panel indicator. The procedure does not test point-to-point wiring within the ECM panel indicator. Remove enclosure before beginning procedures.			
			<u>EQPT Control Test</u>			
1	J1-S, J1-U, J1-T	Multimeter	a. Measure resistance between connector pins J1-S and J1-U.	10k ($\pm 10\%$) ohms.		Replace potentiometer R1.
			b. Slowly turn EQPT control fully clockwise (CW) and measure resistance between connector pins J1-S and J1-T.	Less than 1 ohm.		Replace potentiometer R1.
			c. Slowly turn EQPT control fully counterclockwise (CCW) while observing multimeter indication.	Resistance increase to 10k ($\pm 10\%$) ohms.	Proceed with step 2.	Replace potentiometer R1.
			<u>CONSOLE Control Test</u>			
2	J1-V, J1-X	Same as step 1.	a. Slowly turn CONSOLE control fully CCW and measure resistance between connector pins J1-V and J1-X.	Less than 1 ohm.		Replace potentiometer R1.

Table 5-1. ECM Panel Indicator Troubleshooting Procedure - Continued

Step	Test Point	Test Equipment	Procedure	Normal Indication	If Indication is Normal	If Indication is Abnormal
2 Cont			b. Slowly turn CONSOLE control fully CW while observing multimeter indication.	Resistance increase to 5k (+500) ohms.		Replace potentiometer R1.
			<u>RCDR ON Switch Test</u>			
3	J1-N, J1-J, J1-A, J1-P	Same as step 1.	a. Measure resistance between connector pins J1-N and J1-J.	Less than 50 ohms or open circuit.		
			b. Press RCDR ON switch.	If step 3a indication was less than 50 ohms, multimeter indicates open circuit.		Replace switch S2.
				If step 3a indication was open circuit, multimeter indicates less than 50 ohms.		
			c. Measure resistance between connector pins J1-A and J1-D.	Open/short circuit.		Replace switch S2.
			d. Press RCDR ON switch.	Open/short circuit	Proceed with step 4.	Replace switch S2.

Table 5-1. ECM Panel Indicator Troubleshooting Procedure - Continued

Step	Test Point	Test Equipment	Procedure	Normal Indication	If Indication is Normal	If Indication is Abnormal	
4	J1-Z, J1-R, J1-P	Same as step 1.	<u>CREW CALL Switch Test</u>				
			a. Measure resistance between connector pins J1-Z and J1-R.	Short circuit or open circuit.			
			b. Press CREW CALL switch.	If step 4a indication was short circuit, multimeter indicates open circuit.		Replace switch S2.	
				If step 4a indication was open circuit, multimeter indicates short circuit.			
			c. Measure resistance between connector pins J1-Z and J1-P.	Open/Short circuit.		Replace switch S1.	
			d. Press CREW CALL switch.	Open/Short circuit.	Proceed with step 5.	Replace switch S1.	

Table 5-1. ECM Panel Indicator Troubleshooting Procedure - Continued

Step	Test Point	Test Equipment	Procedure	Normal Indication	If Indication is Normal	If Indication is Abnormal
5	J1-J	Same as step 1.	a. Be sure RCDR ON switch S2 is not depressed. Measure resistance between J1-J and J1-M, J1-J and J1-H, J1-J and J1-G, and J1-J and J1-L.	Short circuit		Replace DS5, DS4, DS3, or DS2, respectively
	J1-M					
	J1-H					
	J1-G					
5	J1-L		b. Measure resistance between J1-L and J1-K.	Short circuit		Replace DS-1
	J1-K					
	J1-N					
	J1-P					
5	J1-Y		c. Depress RCDR ON switch S2. Measure resistance between J1-J and J1-N. Reset S2 to non-selected position.	Short circuit		Replace one or more lamps in S2
6			d. Depress CREW switch S1. Measure resistance between J1-P and J1-Y. Reset S1 to non-selected position.	Short circuit		
6			a. Disconnect test equipment		Test completed.	

5-8. Countermeasures Control Procedures. Troubleshooting of the countermeasures control consists of performing a series of checks on specific items to isolate a fault. Separate instructions are provided for voltage regulator A1 and the remaining components in the countermeasures control. The instructions assume that system-level troubleshooting by organizational maintenance personnel has been performed as given in TM 32-5865-012-20 to isolate the problem to the countermeasures control. After performing general inspection and cleaning procedures in section IV of this chapter, refer to the following paragraphs for troubleshooting instructions.

a. Voltage Regulator A1 Troubleshooting. The voltage regulator troubleshooting procedure (table 5-2) checks operation of circuit breaker CB1 and voltage regulator A1. After performing general inspection and cleaning procedures in section IV of this chapter, refer to table 5-2 and perform each step in sequence. Figures 5-1 and 5-2 show test equipment connections referenced in table 5-2. After isolating the problem, refer to section IV of this chapter for the appropriate maintenance procedure.

b. Countermeasures Control Troubleshooting. The countermeasures control troubleshooting procedure (table 5-3) consists of a series of tests that verify operations of all components except circuit breaker CB1 and voltage regulator A1 (see paragraph 5-8a). The procedure also checks the circuits on indicator CCA A3. After performing the general inspection and cleaning procedures in section IV of this chapter, refer to table 5-3. The steps in table 5-3 may be performed in sequence or independently to verify a specific component. If the problem listed on the maintenance form indicates the crew call flasher circuit (connector pins J7-C, J8-R, and/or J3-C), replace indicator CCA A3 as given in paragraph 5-12f. Figure 5-3 thru 5-6 and table 5-4 contain test equipment connections referenced in table 5-3. After isolating the problem, refer to section IV of this chapter for the appropriate maintenance procedure.

Section IV. MAINTENANCE

5-9. General. This section provides maintenance procedures that are the responsibility of general support maintenance personnel. Paragraph 5-10 contains general inspection and cleaning instructions for the ECM panel indicator and the countermeasures control. Subsequent paragraphs contain specific maintenance procedures for individual equipment items. Perform both general procedures and applicable specific procedures.

Table 5-2. Countermeasures Control Voltage Regulator A1 Troubleshooting Procedure

Step	Test Point	Test Equipment	Procedure	Normal Indication	If Indication is Normal	If Indication is Abnormal
1	J3-X, J3-W	Power supply, Multimeter	<p style="text-align: center;">NOTE</p> <p>This procedure includes major components that may be defective within the countermeasures control. The procedure does not test point-to-point wiring within the countermeasures control.</p> <p style="text-align: center;"><u>Test Setup</u></p> <p>a. Turn power supply on and set for +28 V dc output.</p> <p>b. Use multimeter to verify power supply output.</p> <p>c. Turn power supply off and establish test setup shown in figure 5-1.</p> <p>d. Remove voltage regulator A1 IAW para 5-12i.</p> <p>e. Disconnect connector A1P1 from voltage regulator A1.</p> <p>f. Turn power supply on.</p>	+28 (±2.8) V dc.	Proceed with step 2.	

Table 5-2. Countermeasures Control Voltage Regulator A1
Troubleshooting Procedure - Continued

Step	Test Point	Test Equipment	Procedure	Normal Indication	If Indication is Normal	If Indication is Abnormal	
2	A1P1-1, A1P1-6	Same as step 1	<u>Circuit Breaker CB1 Test</u>				
			a. Set DC POWER circuit breaker CB1 to off (out) position.				
			b. Measure voltage between connector pins A1P1-1 (+) and A1P1-6 (-).	0 V dc.		Replace circuit breaker CB1.	
			c. Set DC POWER circuit breaker CB1 to on (in) position.	+28 (± 2.8) V dc.		Replace circuit breaker CB1.	
			d. Turn power supply off and reconnect connector A1P1 to voltage regulator A1.				
			e. Install voltage regulator A1 IAW para 5-12i.		Proceed with step 3.		
3	J8-Y, J8-Z, J8-a	Power supply, Multimeter, Decade box	<u>Lamp Adjust Test</u>				
			a. Establish test setup shown in figure 5-2.				
			b. Turn power supply on.				

Table 5-2. Countermeasures Control Voltage Regulator A1
Troubleshooting Procedure - Continued

Step	Test Point	Test Equipment	Procedure	Normal Indication	If Indication is Normal	If Indication is Abnormal
3 Cont			c. Measure voltage at connector pins J8-Y (+) and J8-Z (-).	22.74 (± 1.0) V dc.		Replace voltage regulator VR1 or resistor R1 or R2.
			d. Measure voltage at connector pins J8-a (+) and J8-Z (-).	27.4 (± 1.0) V dc.		Replace voltage regulator VR2.
			e. Slowly decrease decade box resistance to 0 ohm.	Voltage decreases to 11.27 (± 1.0) V dc.		Replace voltage regulator VR2.
			f. Measure voltage at connector pins J8-Y (+) and J8-Z (-).	1.5 (± 0.5) V dc.	Proceed with step 4.	Replace voltage regulator VR1.
			g. Turn power supply off.			
4			Disconnect test equipment.		Test completed.	

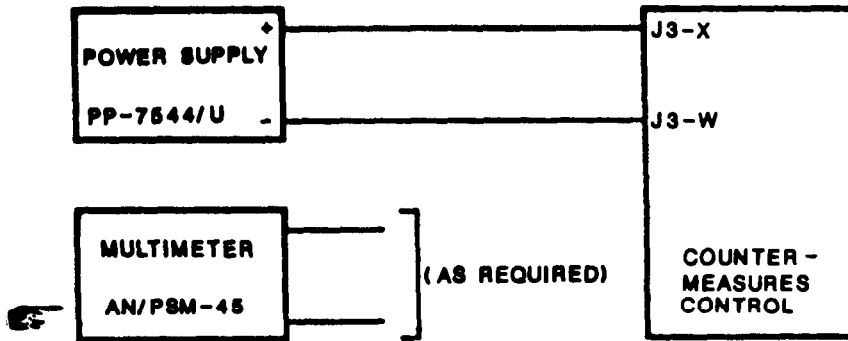

Figure 5-1. Countermeasures Control Mission Power Test Setup

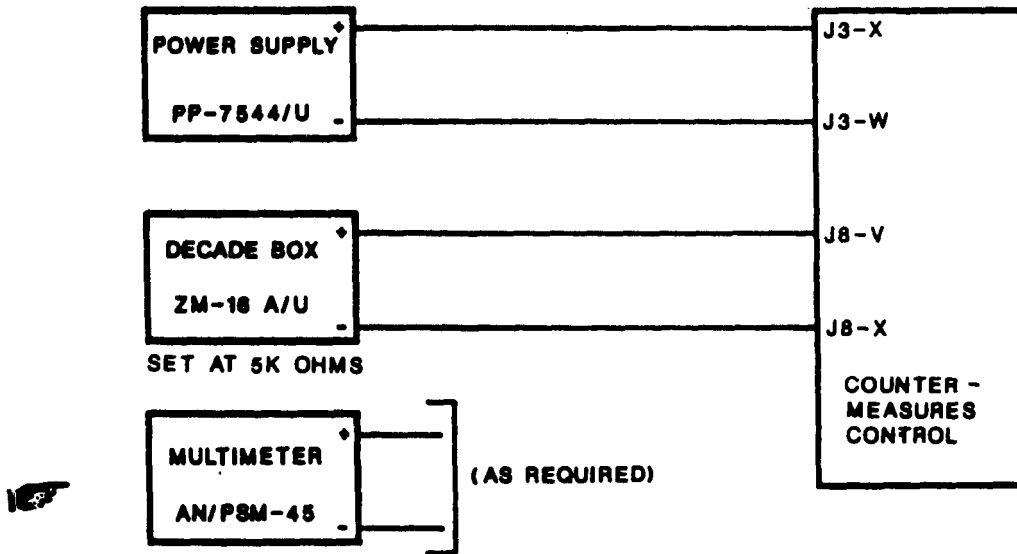

Figure 5-2. Countermeasures Control Lamp Adjust Test Setup

Table 5-3. Countermeasures Control Troubleshooting Procedure

Step	Test Point	Test Equipment	Procedure	Normal Indication	If Indication is Normal	If Indication is Abnormal
			<p>NOTE</p> <p>This procedure includes major components that may be defective within the ECM indicator panel. The procedure does not test point-to-point wiring within the ECM indicator panel. Remove top cover before conducting procedures.</p> <p style="text-align: center;"><u>Test Setup</u></p> <p>a. Turn power supply on and set for +28 V dc output.</p> <p>b. Use multimeter to verify power supply output.</p> <p>c. Turn power supply off and establish test setup shown in figure 5-3.</p> <p>d. Turn power supply on.</p> <p style="text-align: center;"><u>Lamp Control Test</u></p>			
1	J3-F, J3-G, J8-U, J8-T, J8-S	Power supply, Multi-meter, Decade box (2)		+28 (±2.8) V dc.	Proceed with step 2.	
2	Q1 collector, E3	Power supply, Multi-meter, Decade box	Measure voltage between terminal stud E2 (transistor Q1 collector (+)) and terminal stud E3 (-).	28 (±2.8) V dc.	Proceed with step 4.	Proceed with step 3.

Table 5-3. Countermeasures Control Troubleshooting Procedure - Continued

Step	Test Point	Test Equipment	Procedure	Normal Indication	If Indication is Normal	If Indication is Abnormal
3	Q1 collector, Q1 base, E3, E5	Power supply, Multimeter, Decade box (2)	<u>Transistor Q1 Test</u> a. Turn power supply off. b. Remove indicator CCA A3. c. Establish test setup shown in figure 5-4 and turn power supply on. d. Measure voltage at terminal stud E2 (transistor Q1 collector (+)) and terminal stud E3 (-). e. Slowly decrease decade box DB2 resistance to 70k ohms and repeat step 3d. f. Turn power supply off and disconnect test equipment.	Less than 5 V dc.	Replace indicator CCA A3.	Replace transistor Q1.
			<u>Switch S1 Test</u> a. If only switch S1 is being tested, connect the power supply as shown in figure 5-3. Leave power supply turned off. b. Measure resistance between connectors J4 and J5.	Short circuit.		

Table 5-3. Countermeasures Control Troubleshooting Procedure - Continued

Step	Test Point	Test Equipment	Procedure	Normal Indication	If Indication is Normal	If Indication is Abnormal
4 Cont			c. Measure resistance between connectors J4 and J1.	Open circuit.		Replace switch S1.
			d. Measure resistance between connector pins J3-W and J8-H.	Open circuit.		Replace switch S1.
			e. Install jumper between connector pins J8-N and J3-E, turn power supply on and repeat step d.	Short circuit.		Replace switch S1.
			f. Turn power supply on.			
			g. Measure resistance between connectors J4 and J1.	Short circuit.		Replace switch S1.
			h. Measure resistance between connectors J4 and J5.	Open circuit.		Proceed with step 5.
			i. Turn power supply off.			
			<u>Intercom Control Test</u>			
5	J3-A, J3-C, J7-C	Multimeter	a. Measure and record resistance between connector pins J3-A (-) and J3-C (+).			
			b. Measure resistance between connector pins J3-A (+) and J3-C (-).	Resistance at least 10 times greater than value recorded in step 5a.		

Table 5-3. Countermeasures Control Troubleshooting Procedure - Continued

Step	Test Point	Test Equipment	Procedure	Normal Indication	If Indication is Normal	If Indication is Abnormal
5 Cont			<p>c. Measure and record resistance between connector pins J3-C (+) and J7-C (-).</p> <p>d. Measure resistance between connector pins J-3C (-) and J7-C(+).</p> <p style="text-align: center;"><u>Relay TB2K1 Test</u></p>			
6	J7-U, J7-G	Power supply, Multi-meter	<p>a. If only relay TB2K1 is being tested, connect the power supply as shown in figure 5-3. Leave power supply turned off.</p> <p>b. Measure resistance between connector pins J7-U and J7-G.</p> <p>c. Install jumper between connector pins J8-N and J6-T.</p> <p>d. Turn power supply on and repeat step 6b.</p> <p>e. Turn power supply off.</p> <p>f. Measure and record resistance between connector pins J6-T (-) and J6-<u>m</u> (+).</p>	<p>Resistance at least 10 times greater than value recorded in step 5c.</p> <p>Open circuit.</p> <p>Short circuit.</p>	<p>Proceed with step 6.</p>	<p>Replace diode TB1CR1.</p> <p>Replace relay TB2K1.</p> <p>Replace relay TB2K1, resistor TB2R1, capacitor C1, or diode TB2CR1.</p>

Table 5-3. Countermeasures Control Troubleshooting Procedure - Continued

Step	Test Point	Test Equipment	Procedure	Normal Indication	If Indication is Normal	If Indication is Abnormal		
7	J7-L, J7-J, J6-e, J6-M, J2-M, J2-L, J7-J, J7-A, J7-B	Same as step 5.	g. Measure resistance between connector pins J6-T (+) and J6-m (-).	Resistance at least 10 time greater than value recorded in step 6f.	Proceed with step 7.	Replace diode TB2CR2.		
			h. Disconnect test equipment.					
			<u>Relays K1 thru K3 Tests</u>					
			a. Establish test setup as shown in figure 5-5.					
			b. Turn power supply on.	+28 (± 2.8) V dc				
			c. Measure resistance between connector pins J2-L and J7-J.	Open circuit.		Replace relay K2.		
			d. Measure resistance between connector pins J6-e and J6-M.	150 ohms, minimum.	Proceed with step 7e.	Proceed with step 7d(1).		
			(1) Measure resistance between TB1-16 and TB1-20	150 ohms, minimum	Replace relay K2 and proceed with step 7e.	Replace resistor R1 and proceed with step 7e.		

Table 5-3. Countermeasures Control Troubleshooting Procedure - Continued

Step	Test Point	Test Equipment	Procedure	Normal Indication	If Indication is Normal	If Indication is Abnormal
7 Cont			<p>e. Turn power supply off and install jumper between connector pins J3-J and J8-R.</p> <p>f. Turn power supply on and repeat step 7d.</p> <p>g. Measure resistance between connector pins J2-L and J7-J.</p> <p>h. Remove jumper.</p> <p>i. Measure resistance between connector pins J2-M and J7-J.</p> <p>j. Turn power supply off and install jumper between connector pins J3-J and J7-C.</p> <p>k. Turn power supply on and repeat step 7i.</p> <p>l. Turn power supply off and install jumper between connector pins J7-D and J3-A.</p> <p>m. Turn power supply on and repeat step 7i.</p> <p>n. Measure resistance between connector pins J7-A and J7-B.</p>	<p>Open circuit.</p> <p>Short circuit.</p> <p>Open circuit.</p> <p>Short circuit.</p> <p>Open circuit.</p> <p>Short circuit.</p>		<p>Replace relay K2.</p> <p>Replace relay K2.</p> <p>Replace relay K1 or K2.</p> <p>Replace relay K2.</p> <p>Replace relay K2.</p> <p>Replace relay K3.</p>

Table 5-3. Countermeasures Control Troubleshooting Procedure - Continued

Step	Test Point	Test Equipment	Procedure	Normal Indication	If Indication is Normal	If Indication is Abnormal
7 Cont			<p>o. Turn power supply off and remove jumpers.</p> <p>p. Turn power supply on and repeat step 7n.</p> <p>q. Turn power supply off and disconnect test equipment.</p> <p style="text-align: center;"><u>PLAIN TEXT Test</u></p>	Open circuit.	Proceed with step 8.	Replace relay K3.
8	J7-G, J8-G, J7-H, J8-L	Multimeter	<p>a. Measure and record resistance between connector pins J7-G (-) and J8-G (+).</p> <p>b. Measure resistance between connector pins J7-G (+) and J8-G (-).</p> <p>c. Measure and record resistance between connector pins J7-H (-) and J8-L (+).</p> <p>d. Measure resistance between connector pins J7-H (+) and J8-L (-).</p>	<p>Resistance at least 10 times greater than value recorded in step 8a.</p> <p>Resistance at least 10 times greater than value recorded in step 8c.</p>	<p>Proceed with step 9.</p>	<p>Replace diode A3CR5.</p> <p>Replace diode A3CR6.</p>

Table 5-3. Countermeasures Control Troubleshooting Procedure - Continued

Step	Test Point	Test Equipment	Procedure	Normal Indication	If Indication is Normal	If Indication is Abnormal
9	J6-G, J6-H	Test oscillator, Oscilloscope	<p><u>XMTR AUDIO 2 (RCDR) Test</u></p> <p>a. Connect test oscillator and oscilloscope to connector pins J2-A (+) and J2-E (-).</p> <p>b. Set test oscillator for 1 kHz, sine wave, to 3 V p-p output.</p> <p>c. Connect oscilloscope to connector pins J6-G (+) and J6-H (-).</p> <p><u>CH2 DEMUX OUT, UNH-16A</u> <u>NO. 2 CH2 PB, AUDIO OUT</u> <u>From KY-58, and TLQ-17A</u> <u>AUDIO Tests</u></p>	2.6 (± 0.3)V p-p.	Proceed with step 10.	Replace A3T1.
10	J2-B, J2-E, J2-C, J2-G, J6-a, J6-b, J6-R, J6-S, J2-P, J6-E, J6-F		<p>a. Connect test oscillator and oscilloscope to connector pins J6-A (+) and J6-B (-).</p> <p>b. Set test oscillator for 1 kHz, sine wave, 5 V p-p output.</p> <p>c. Connect oscilloscope to connector pins J2-B (+) and J2-E (-).</p> <p>NOTE</p> <p>Leave test oscillator set for 1 kHz, sine wave, output at 5 V p-p.</p>	4.7 (± 0.5)V p-p.		Replace A3T3.

Table 5-3. Countermeasures Control Troubleshooting Procedure - Continued

Step	Test Point	Test Equipment	Procedure	Normal Indication	If Indication is Normal	If Indication is Abnormal
10 Cont			d. Connect test oscillator and oscilloscope to each set of connector pins listed in table 5-4.	See table 5-4 for each measurement.	Proceed with step 11.	Replace defective component listed in table 5-4.
			<u>ARC-186 XMTR AUDIO and XMTR 3 AUDIO (FM) Tests</u>			
11	J6-r, J6-s, J2-H, H2-E, J6-c, J6-d	Same as step 9.	a. Establish test setup shown in figure 5-6. b. Connect test oscillator and oscilloscope to connector pins J2-H (+) and J2-E (-). c. Set test oscillator for 1 kHz, sine wave, 4 V p-p output.			
			<u>Lamp Control Test</u>			
12	Q1 collector, E3	Power supply, Multi-meter, Decade Box	a. Turn power supply on. b. Measure voltage between transistor Q1 collector (+) and terminal stud E3 (-).	18(±2.0) V dc.	Proceed with step 14.	Proceed with step 13.
			<u>Transistor Q1 Test</u>			
13	Q1 collector, Q1 base E3, E5	Power Supply, Multi-meter, Decade Box (2)	a. Turn power supply off. b. Remove indicator CCA A3. c. Establish test setup shown in figure 5-4 and turn power supply on.			

Table 5-3. Countermeasures Control Troubleshooting Procedure - Continued

Step	Test Point	Test Equipment	Procedure	Normal Indication	If Indication is Normal	If Indication is Abnormal
13 Cont			<p>d. Measure voltage at transistor Q1 collector (+) and terminal stud E3(-).</p> <p>e. Slowly decrease Decade Box DB2 resistance to 70k ohms and repeat step 3d.</p> <p>f. Turn power supply off and disconnect test equipment.</p> <p><u>Crew Call Flasher Test</u></p>	<p>Less than 5 V dc.</p> <p>Voltage increases to 27 (± 1.0) V dc.</p>	<p>Replace transistor A3Q7 or microcircuit A3U2.</p>	<p>Replace transistor Q1.</p>
14	J7-X J8-P J7-A J3-X J3-W J3-G	Power Supply, Multimeter, Decade Box, Oscilloscope	<p>a. Turn power supply on and set for +28 V dc output.</p> <p>b. Use multimeter to verify power supply output.</p> <p>c. Turn power supply off and establish test setup shown in figure 5-7.</p> <p>d. Turn power supply on.</p> <p>e. Connect oscilloscope to measure signal at J8-P.</p> <p>f. Turn power supply off and disconnect test equipment.</p>	<p>+28 (± 2.8) V dc</p> <p>5 (± 1 Hz) squarewave</p>		<p>Replace microcircuit A3U1 or transistor A3Q8.</p>

Table 5-3. Countermeasures Control Troubleshooting Procedure - Continued

Step	Test Point	Test Equipment	Procedure	Normal Indication	If Indication is Normal	If Indication is Abnormal
15	J3-H J3-J	Power Supply, Multimeter	<p><u>FL1 Test</u></p> <p>a. Turn power supply on and set for +28 V dc output.</p> <p>b. Use multimeter to verify power supply output.</p> <p>c. Turn power supply off and establish test setup shown in figure 5-8.</p> <p>d. Turn power supply on.</p> <p>e. Measure voltage at J3-H (+) and J3-J(-).</p>	+28 V dc		
16			<p>a. Disconnect test equipment.</p> <p>b. Replace top cover.</p>	28(±2.8) V dc	Test Completed	Replace FL1.

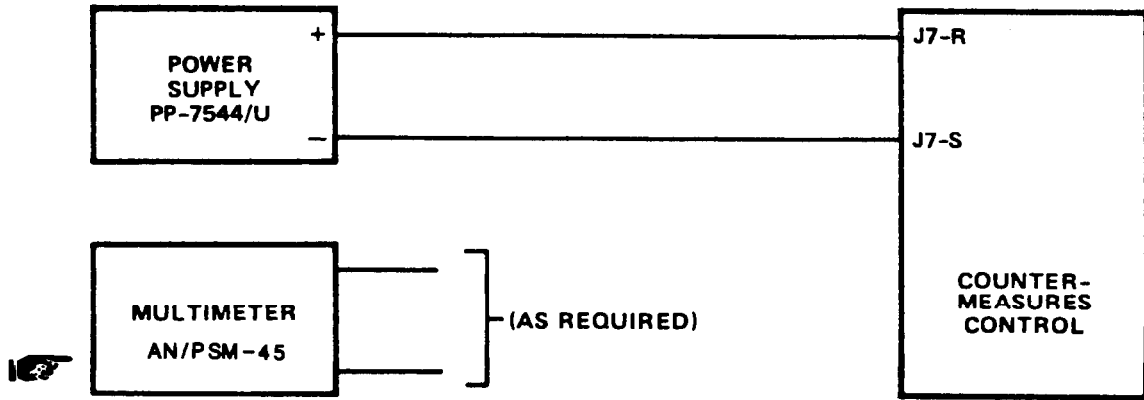

Figure 5-5. Countermeasures Control ICS Power Test Setup

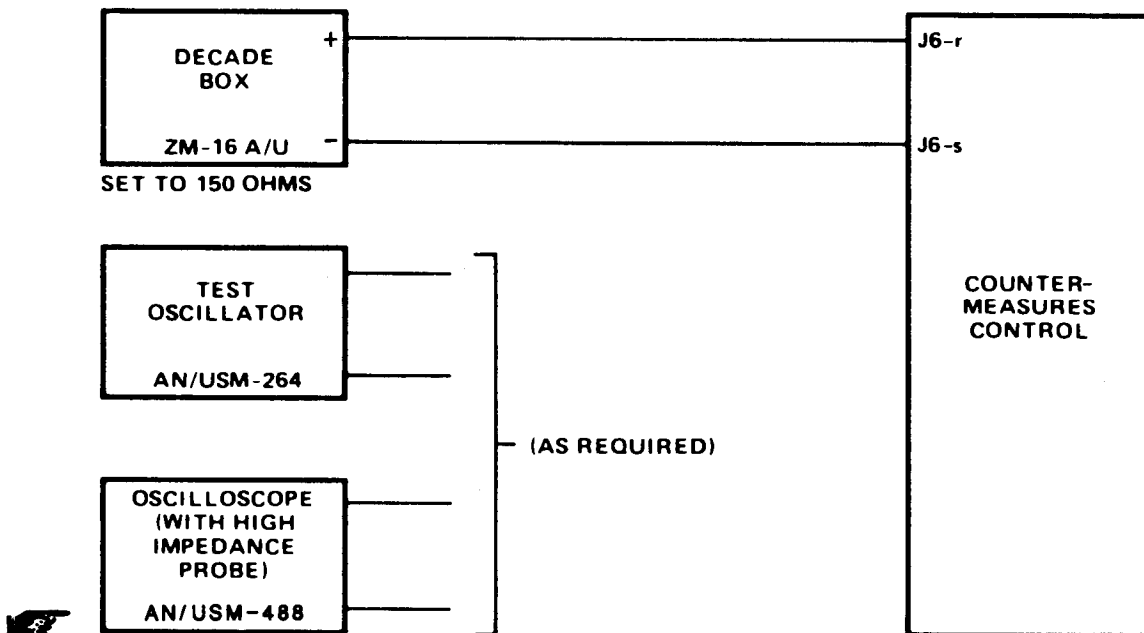

Figure 5-6. Countermeasures Control Audio Test Setup

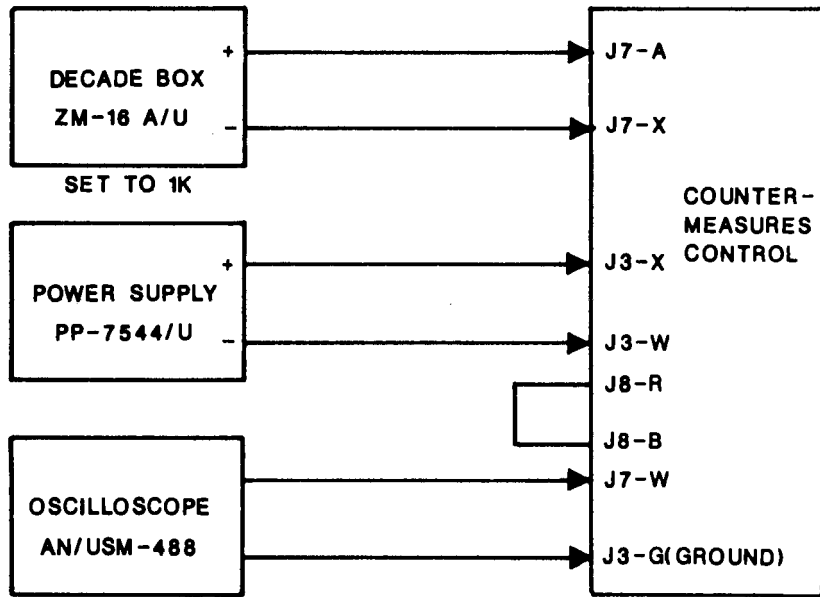

Figure 5-7. Countermeasures Control Flasher Test Setup

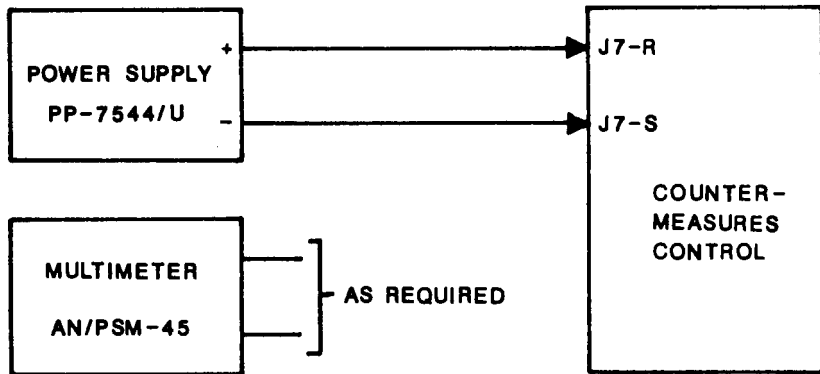

Figure 5-8. Countermeasures Control FL1 Test Setup

Table 5-4. Countermeasures Control Audio Test Connections and Display Data

Test oscillator (+) (-)		Oscilloscope (+) (-)		Normal indication	Defective component
J6-C	J6-D	J2-C	J2-E	4.7 (± 0.5) Vp-p	T4
J6-p	J6-q	J2-G	J2-E	2.5 (± 0.5) Vp-p	T9
J6-p	J6-q	J6-a	J6-b	2.5 (± 0.5) Vp-p	T10
J6-j	J6-k	J6-R	J6-S	0.85 (± 0.3) Vp-p	T6
J6-j	J6-k	J2-P	J2-E	0.85 (± 0.3) Vp-p	T5
J6-j	J6-k	J6-E	J6-F	2.3 (± 0.5) Vp-p	T7

5-10. Maintenance Procedures. This paragraph contains general maintenance procedures that are common to the ECM panel indicator and the countermeasures control. For the ECM panel indicator, remove the enclosure as given in paragraph 5-11a and perform the following items. For the countermeasures control, remove the top and bottom covers as given in paragraphs 5-12a and 5-12c, then perform the following items.

a. Chassis Inspection. To inspect the ECM panel indicator or the countermeasures control chassis mounted components, proceed as follows:

- (1) Check for discolored, burned or cracked wire insulation, or broken wires or terminals. Also check for damaged heat shrink tubing.
- (2) Check cables for correct pin depths.
- (3) Check for loose or broken tie wrap mounts, mounting clamps, or tiedown straps.
- (4) Check for cracked circuit breaker casings and for damaged terminal boards.
- (5) Check for discolored (cold) , cracked, or loose solder connections.
- (6) Check for leaking, bulging, or burned transformers, capacitors, or filters.
- (7) Check for discolored, burned or cracked diodes, resistors or other semiconductor devices.
- (8) Check for damaged brackets, covers, housing, and plates. Check for loose or missing attaching hardware.

- (9) Replace enclosure in accordance with paragraph 5-11, step 1.
- (10) Replace top and bottom covers of countermeasures control in accordance with paragraphs 5-12z and 5-12ab.
- (11) Inspect exterior surfaces of the unit for dust, chipped, paint, and corrosion. If necessary, spot paint surfaces as follows:
 - (a) Remove rust and corrosion from metal surfaces by lightly sanding them with No. 000 sandpaper (item 10, App. D).
 - (b) Brush two coats of light green semi-gloss enamel (item 7, App. D), MIL-E-15090 class 2 type III color number 24410 IAW FED Standard 595, on bare metal to protect it from further corrosion.
 - (c) Refer to the applicable cleaning and refinishing practices specified in TB 43-0118.

b. Cleaning.

- (1) Remove dust and loose dirt from exterior surfaces with a clean, soft cloth (item 4, App. D).
- (2) Remove dust and dirt from connector, internal wiring, and other surfaces with a soft brush (item 2, App. D).

WARNING

Adequate ventilation should be provided while using trichlorotrifluoroethane. Prolonged breathing of vapor should be avoided. The solvent should not be used near heat or open flame; the products of decomposition are toxic and irritating. Since trichlorotrifluoroethane dissolves natural oils, prolonged contact with skin should be avoided. When necessary, use gloves (item 8, App. D) that the solvent cannot penetrate. If the solvent is taken internally, consult a physician immediately.

- (3) Remove grease and/or ground-in dirt with a cloth dampened (not wet) with trichlorotrifluoroethane (item 18, App. D).

c. CCA/ECA Inspection. To inspect CCA within the countermeasures control, remove it in accordance with paragraph 5-12f, then proceed as follows:

CAUTION,

Certain CCAS contain electrostatic discharge sensitive (ESDS) devices that can be damaged by static electricity. Special handling methods and materials must be used to prevent damage. Do not touch or remove any ESDS device or circuit without properly grounding your body, tools, and test equipment. Handle such CCAS on the edges only, and store such CCAS in conductive (antistatic) bags.

- (1) Check for cracked or broken ejectors.
- (2) Check for cracked circuit card.
- (3) Check for loose or damaged shields or heat sinks.
- (4) Check for loose, broken, or damaged printed wiring traces
- (5) Check for loose or damaged connectors
- (6) Check for discolored, burned, or broken wiring straps.
- (7) Check for cracked, discolored, or burned component insulator pads.
- (8) Check for burned or broken resistors, diodes, transistors, and ICS.
- (9) Check for leaking, bulging, cracked or burned capacitors or inductors.
- (10) Replace CCA in accordance with paragraph 5-12g.

5-11. ECM Panel Indicator Procedures. ECM panel indicator maintenance consists of removing the enclosure and, if required, repairing the unit using the following procedures. Figure 5-9 shows ECM panel indicator component locations. Procedures reference components by parenthetical numbers keyed to figure 5-9.

WARNING

Before performing the repair procedure, ensure that power is disconnected from the ECM panel indicator.

- a. Enclosure Removal. Refer to figure 5-9 and proceed as follows:
 - (1) At the rear of the unit, remove the nut (1) from terminal stud E3 (2).

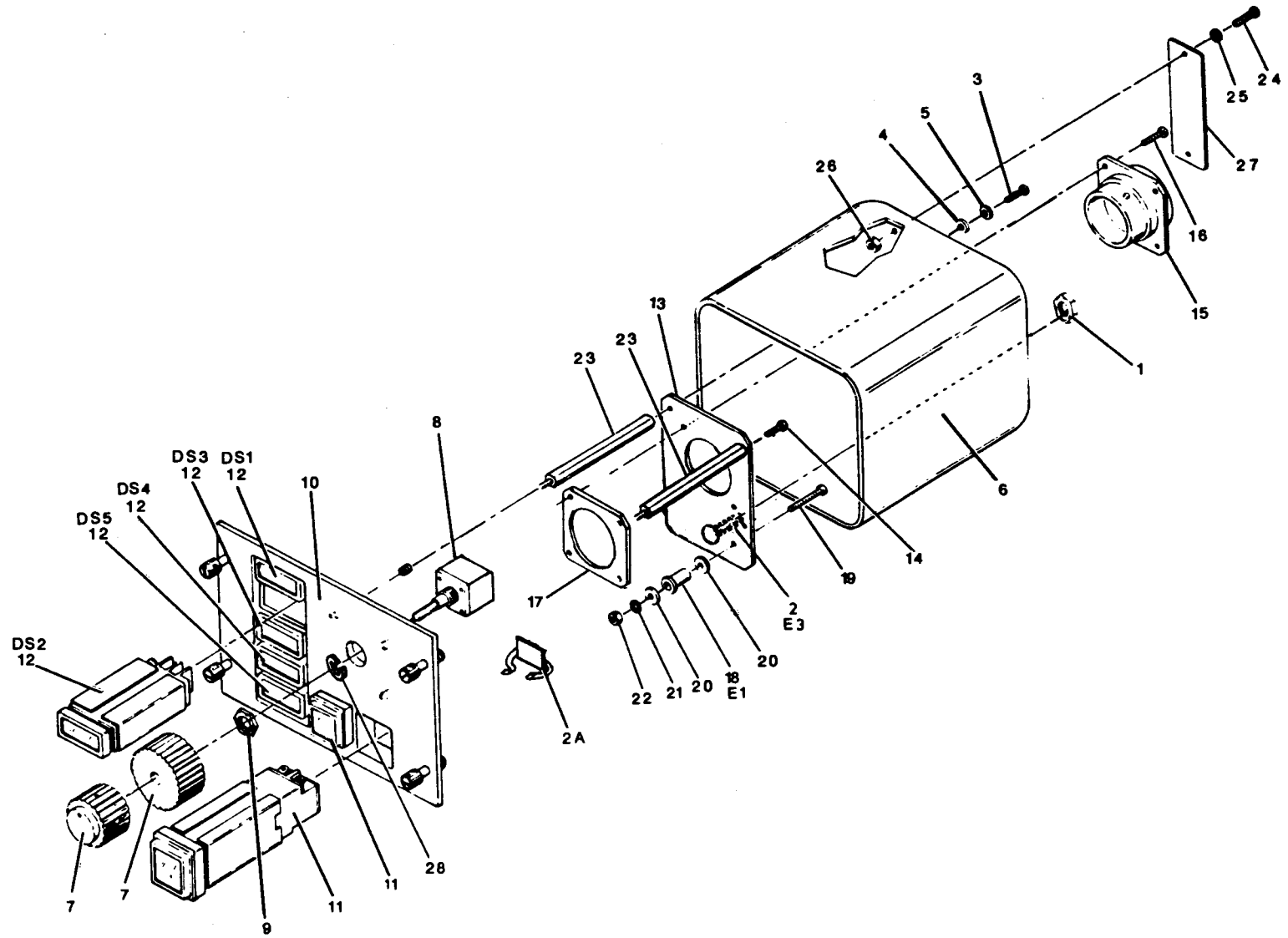

Figure 5-9. ECM Panel Indicator Component Locations

(2) Remove the two screws (3), flat washers (4), and lock washers (5) that secure the enclosure (6) to the chassis stand off (23).

(3) Slide the enclosure (6) backward, off the chassis.

b. Potentiometer Removal and Replacement. Refer to figure 5-9 and proceed as follows:

(1) Remove enclosure (6) in accordance with paragraph 5-11a.

(2) Loosen the setscrews and remove both knobs (7) from the potentiometer (8).

(3) Remove the collar nut (9) and lock washer (28) that secure the potentiometer (8) to the front panel (10). Remove the potentiometer.

(4) Tag the wires to identify potentiometer (8) connections.

(5) Unsolder the wires from the potentiometer (8).

(6) Solder the wires to the replacement potentiometer (8) as tagged.

(7) Remove the collar nut (9) and lock washer (28) from the replacement potentiometer. Slide the replacement potentiometer into the front panel (10) and secure with the collar nut (9) and lock washer (28).

(8) With the potentiometer in the fully counterclockwise position install both knobs (7) and secure the indicator with the setscrews.

(9) Replace enclosure (6) in accordance with paragraph 5-11, step 1.

(10) Refer to section V of this chapter.

c. Switch/Indicator Removal and Replacement. Refer to figure 5-9 and figure 5-10, and proceed as follows:

(1) Remove enclosure (6) in accordance with paragraph 5-11a.

(2) Grasp the edges of the lens assembly of the switch/indicator (11) to be replaced and pull forward about one inch (see figure 5-10). Allow the lens assembly to hang down on the front panel to expose the locking cam adjustment screws.

(3) Use a screwdriver to turn the two locking cam adjustment screws counterclockwise (CCW).

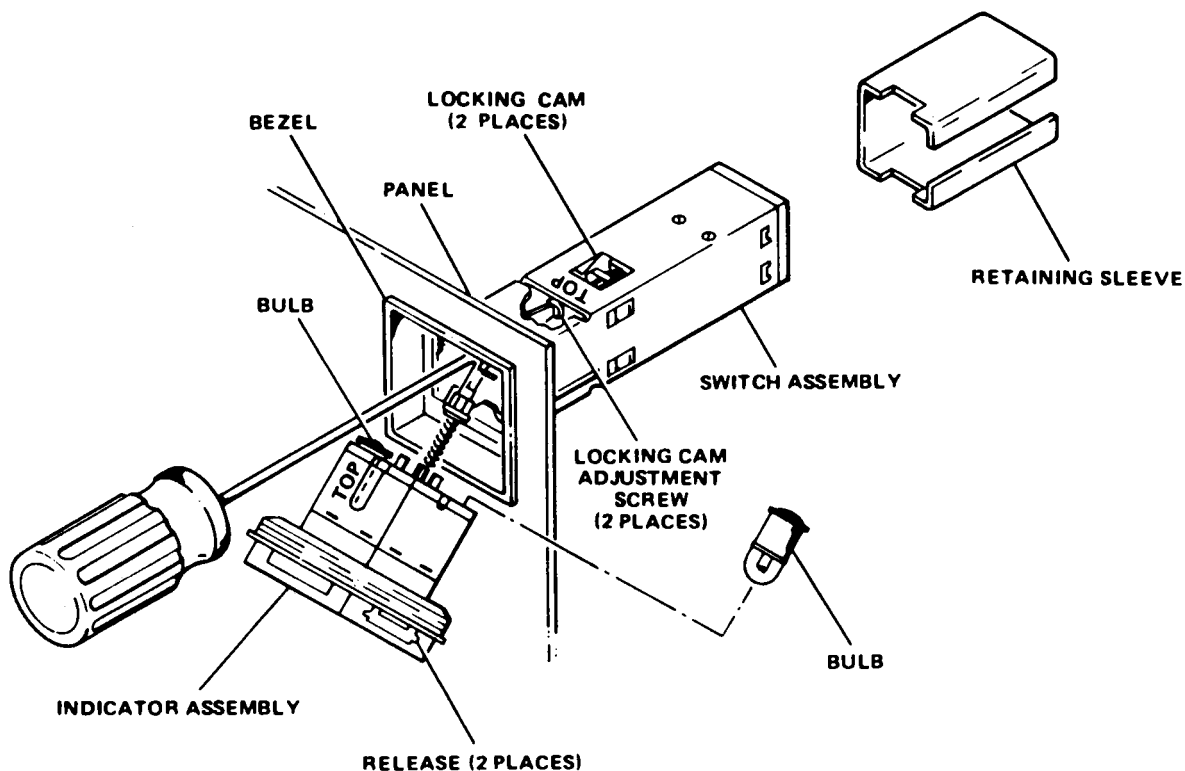

Figure 5-10. Switch/Indicator Replacement

- (4) Slowly pull the switch/indicator forward until the wires are exposed.
- (5) Tag the wires to identify terminal connections.
- (6) Unsolder wires from indicator/switch.
- (7) On the replacement switch/indicator, grasp the lens assembly and pull forward about one inch.
- (8) Verify that the replacement switch/indicator contains two lamps.
- (9) Use a screwdriver to turn the two locking cam adjustment screws fully CCW.
- (10) Solder the wires to the switch/indicator as tagged.

- (11) Verify that the TOP label on the switch assembly faces up and install the replacement switch/indicator.
- (12) Use a screwdriver to turn the two locking cam adjustment screws fully clockwise (CW).
- (13) Verify that the indicator label is facing up and install the lens assembly.
- (14) Replace enclosure in accordance with paragraph 5-11, step 1.
- (15) Refer to section V of this chapter.

d. Indicator Removal and Replacement. Refer to figure 5-9 and figure 5-11, and proceed as follows:

- (1) Remove enclosure (6) in accordance with paragraph 5-11a.
- (2) Press and release the indicator (12) to be replaced.
- (3) Grasp the edges of the lens assembly and pull forward approximately one inch. (See figure 5-11.) Allow lens assembly to hang down on the front panel.
- (4) At the rear of the indicator being replaced, tag each wire for proper reconnection, then remove wires from indicator terminal lugs.
- (5) Loosen the two retaining clip screws at the rear of the indicator and pivot the two clips so that the retaining sleeve can be removed. Remove the retaining sleeve.
- (6) Pull the indicator through the front panel and remove.
- (7) Insert replacement indicator through the front panel and verify that it is positioned correctly.
- (8) From rear of indicator, place the retaining sleeve over the indicator and pivot the two retaining clips over the sleeve. Tighten the two retaining clip screws to secure the indicator and retaining sleeve to the front panel.
- (9) Reconnect wires as tagged during removal.
- (10) Verify that the replacement indicator contains two lamps, then carefully push indicator lens into body and verify proper operation.

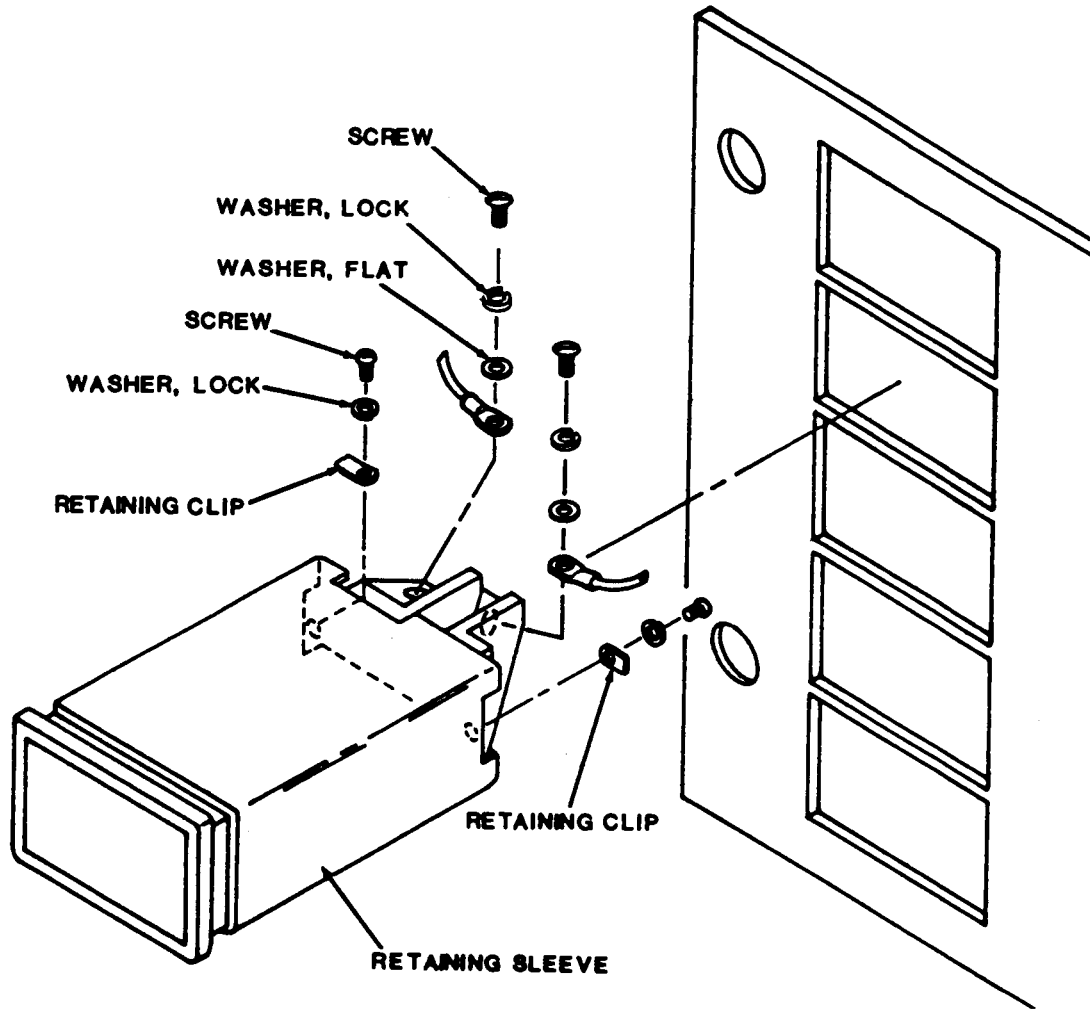

Figure 5-11. Indicator Replacement

(11) Replace enclosure in accordance with paragraph 5-11, step 1.

(12) Refer to section V of this chapter.

e. Connector Panel Removal and Replacement. Refer to figure 5-9 and proceed as follows:

(1) Remove enclosure (6) in accordance with paragraph 5-11a.

(2) Remove two screws (14) that secure connector panel (13) to standoffs (23).

(3) Cut lacing that secures connector wiring to cable mount (2A) secured to back side of connector panel (13).

(4) Remove connector J1 (15) in accordance with paragraph 5-11f.

(5) Remove terminal stud E1 (18) in accordance with paragraph 5-11g.

(6) To replace connector panel (13), install terminal stud E1 in accordance with paragraph 5-11g, then install connector J1 in accordance with paragraph 5-11f.

(7) Use lacing tape (item 17, App. D) to secure connector wiring to cable mount (2A). Apply locking compound (item 6, App. D) to threads of screws (14), then use screws to secure connector panel (13) to standoffs (23).

(8) Replace enclosure (6) in accordance with paragraph 5-11, step 1.

(8) Refer to section V of this chapter.

f. Connector J1 Removal and Replacement. Refer to figure 5-9 and proceed as follows:

(1) Remove enclosure (6) in accordance with paragraph 5-11a.

(2) Remove four screws (16) and nutring (17) that secure connector (15) to connector panel (13).

(3) Tag and remove wires from connector.

(4) To replace connector, attach wires as tagged during removal, then secure connector to connector panel with four screws (16) and nutring (17).

(5) Replace enclosure in accordance with paragraph 5-11, step 1.

(6) Refer to section V of this chapter.

g. Terminal Stud E1 Removal and Replacement. Refer to figure 5-9 and proceed as follows:

- (1) Remove enclosure (6) in accordance with paragraph 5-11a.
- (2) Remove screw (19), two nylon sleeves (20), flat washer (21), and nut (22) that secure terminal stud E1 (18) to connector panel.
- (3) Tag and unsolder all wiring to terminal stud.
- (4) To replace terminal stud E1, solder wires as tagged during removal, then secure stud (18) to connector panel (13) with screw (19), two nylon sleeves (20), flat washer (21), and nut (22).
- (5) Replace enclosure (6) in accordance with paragraph 5-11, step 1.
- (6) Refer to section V of this chapter.

h. Front Panel Removal and Replacement. Refer to figure 5-9 and proceed as follows:

- (1) Remove enclosure (6) in accordance with paragraph 5-11a.
- (2) Remove connector panel (13) in accordance with step (2) of paragraph 5-11e.
- (3) Unscrew four standoffs (23) from front panel (10).
- (4) Remove EQPT-CSL control (7) in accordance with paragraph 5-11b.
- (5) Remove CREW CALL and RCDR ON switches (11) in accordance with paragraph 5-11c.
- (6) Remove indicators (12) in accordance with paragraph 5-11d.
- (7) To replace front panel, install indicators (12) into front panel in accordance with paragraphs 5-11d.
- (8) Install CREW CALL and RCDR ON switches (11) in accordance with paragraph 5-11c.
- (9) Install EQPT-CSL control (7) in accordance with paragraph 5-11b.
- (10) Secure four standoffs (23) to front panel (10), then secure connector panel (13) to standoffs in accordance with paragraph 5-11e.

- (11) Replace enclosure in accordance with paragraph 5-11, step 1.
- (12) Refer to section V of this chapter.

i. Cable Mount Replacement. Refer to figure 5-9 and proceed as follows:

- (1) Remove enclosure (6) in accordance with paragraph 5-11a.
- (2) Cut lacing that secures connector wiring to cable mount.

WARNING

Adequate ventilation should be provided while using trichlorotrifluoroethane. Prolonged breathing of vapor should be avoided. The solvent should not be used near heat or open flame; the products of decomposition are toxic and irritating. Since trichlorotrifluoroethane dissolves natural oils, prolonged contact with skin should be avoided. When necessary, use gloves (item 8, App. D) that the solvent cannot penetrate. If the solvent is taken internally, consult a physician immediately.

- (3) Remove old adhesive using cloth dampened (not wet) with trichlorotrifluoroethane (item 18, App. D).
- (4) After one minute drying time, apply coating of clear adhesive, type 608 (item 1, App. D) to surface where part is to be mounted, then press part into adhesive and allow to dry for one minute.

j. Front Panel Fastener Assembly Removal and Replacement. Refer to figure 5-9 and proceed as follows:

- (1) Remove front panel (10) in accordance with paragraph 5-11h.
- (2) Use tool set no. PT 3 1/2 to remove defective fasteners from front panel. Place head of defective fastener into block as shown in figure 5-12. Place tool against locking head of fastener and strike tool with hammer to drive defective fastener out of panel.
- (3) Insert replacement fastener through opening in panel, then insert fastener into flaring hand tool PT 3 1/2A as shown in figure 5-12 and flare fastener tight to front panel.
- (4) Replace front panel in accordance with paragraph 5-11h.

k. Screw Thread Insert Removal and Replacement. Refer to figure 5-9 and proceed as follows:

- (1) Remove the front panel in accordance with paragraph 5-11h.
- (2) Remove and replace the defective screw thread insert in accordance with the procedures in paragraph 5-12ah.
- (3) Replace front panel in accordance with paragraph 5-11h.

l. Enclosure Replacement. Refer to figure 5-9 and proceed as follows:

- (1) Slide the enclosure (6) forward, over the chassis.
- (2) Replace the two screws (3), flat washers (4), and lock washers (5) that secure the enclosure (6) to the chassis.
- (3) Replace the nut (1) on terminal stud E3 (2).

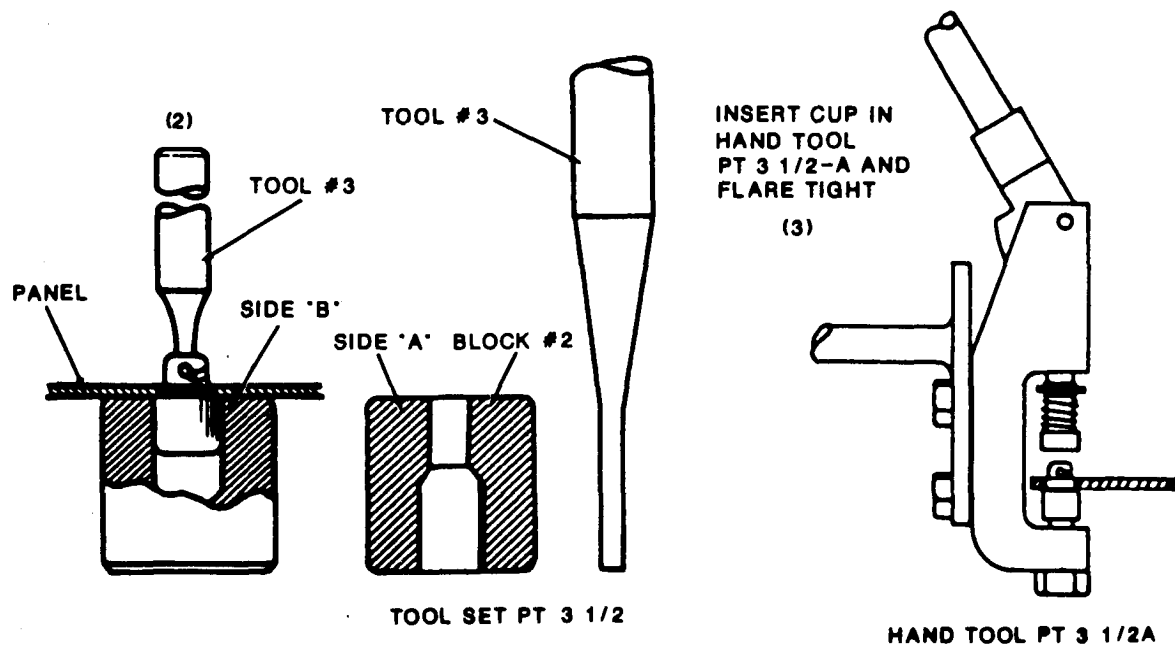

Figure 5-12. Fastener Removal and Installation

m. Identification Plate Removal and Replacement. Refer to figure 5-9 and proceed as follows:

- (1) Remove enclosure (6) in accordance with paragraph 5-11a.
- (2) Remove two screws (24), washers (25) and nuts (26) that secure the identification plate (27) to the enclosure (6).
- (3) To replace, secure identification plate (27) using two screws (24), washers (25) and nuts (26).

5-12. Countermeasures Control Procedures. Countermeasures control maintenance consists of removing the top cover and, if required, repairing the unit using the following procedures. Figure 5-13 shows countermeasures control component locations. Procedures reference components by numbers keyed to figure 5-13.

WARNING

Before performing the repair procedure, ensure that power is disconnected from the countermeasures control.

a. Top Cover Removal and Replacement.

- (1) Refer to figure 5-13. Remove the 10 screws (1) and top cover (2) .
- (2) To replace top cover (2), align cover with the mounting holes on chassis (52) and install the 10 screws (1).

b. Front Panel Removal and Replacement. Refer to figure 5-13 and proceed as follows:

- (1) Remove six screws (6) and flat washers (7) that secure front panel (3) to chassis (52).
- (2) Remove top cover in accordance with paragraph 5-12a.
- (3) Remove two screws (8) that secure bottom cover (9) to front panel (3), then pull front panel out of the chassis (52).
- (4) On front panel (3), remove outer collar nut (4) and lock washer (44) from circuit breaker (5).
- (5) To replace front panel (3), place the circuit breaker (5) in the front panel (3) and install the outer collar nut (4) and lock washer (44) on the circuit breaker.
- (6) Align the front panel (3) with the mounting holes and install the six mounting screws (6) and flat washers (7) that secure the front panel to the chassis (52).

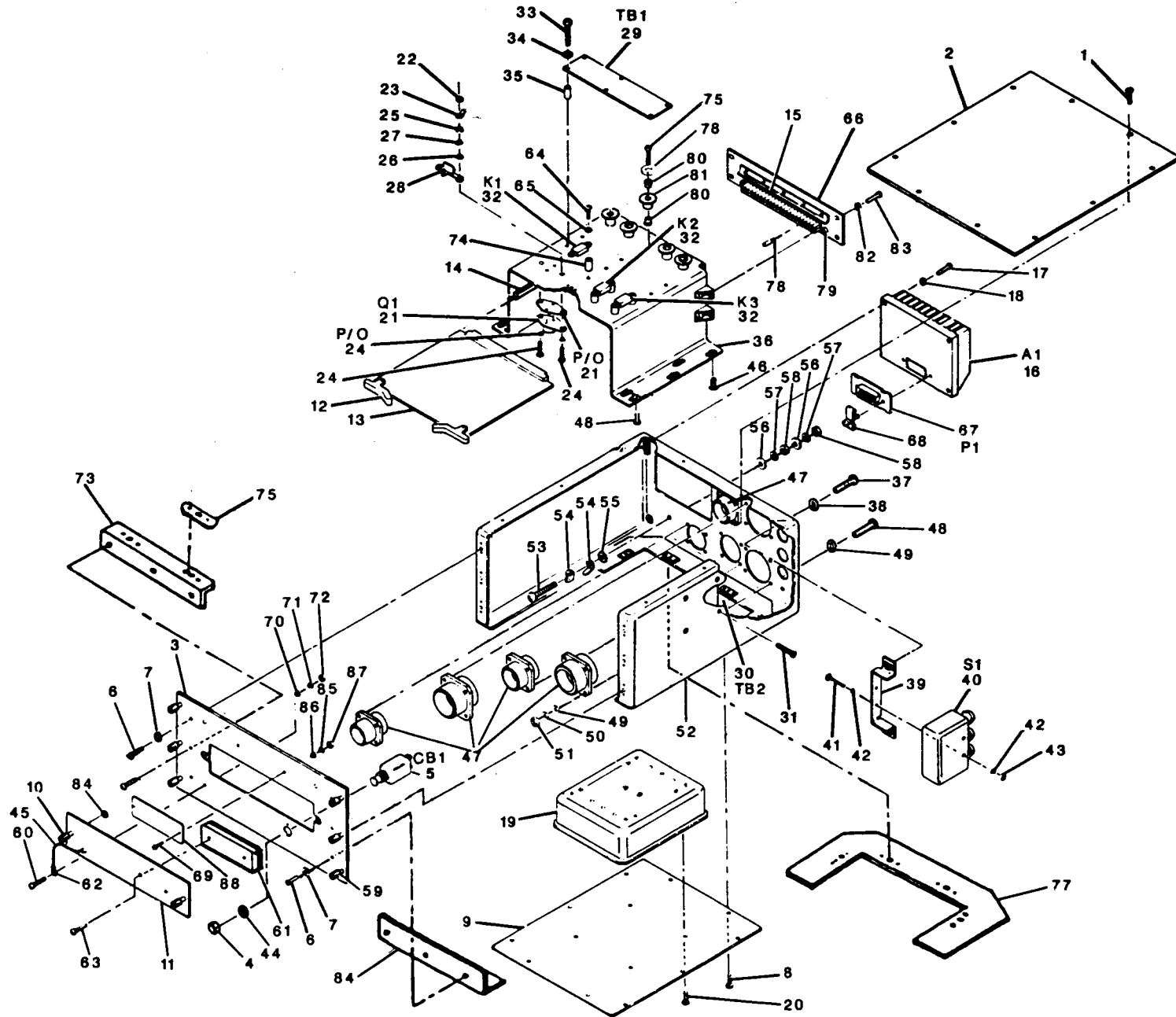

Figure 5-13. Countermeasures Control Component Locations

- (7) Install the two screws (8) that secure the bottom cover (9) to the front panel (3).
- (8) Install the top cover in accordance with paragraph 5-12b.

c. Bottom Cover Removal and Replacement. Refer to figure 5-13 and proceed as follows:

- (1) Place unit bottom-side up and remove 10 screws (8) that secure cover (9) to ECM bracket (36), chassis (52), and front panel (3).
- (2) Remove four screws (20) that secure FL1 (19) to bottom cover (9), then remove cover.
- (3) To replace the bottom cover (9), secure FL1 (19) to the bottom cover (9) with four screws (20).
- (4) Place the unit bottom-side up and align the bottom cover (9) with the mounting holes on the chassis (52) and install the 10 screws (8).

d. Front Panel Plate Removal and Replacement. Refer to figure 5-13 and proceed as follows:

- (1) Release two turnlock studs (10) that secure front panel plate (11) to front panel (3).
- (2) Remove screw (60), washer (62), washer (70), lock washer (71), and nut (72) that secure chain (45) to plate (11).
- (3) To replace front cover plate (11), secure chain (45) to plate (11) with screw (60), washer (62), washer (70), lock washer (71), and nut (72), then secure plate (11) to front panel (3) with two turnlock studs (10).
- (4) Refer to section V of this chapter.

e. PCB Retainer Removal and Replacement. Refer to figure 5-13 and proceed as follows:

- (1) Remove front panel plate (11) in accordance with paragraph 5-12d.
- (2) Remove two screws (63) that secure PCB retainer (61) to front panel plate (11).
- (3) Replace PCB retainer (61) to front panel plate (11), using two screws (63).
- (4) Replace front panel plate (11) in accordance with paragraph 5-12d.
- (5) Refer to section V of this chapter.

f. Indicator CCA A3 Removal. Refer to figure 5-13 and proceed as follows:

- (1) Turn the two turnlock studs (10) CCW and remove the front panel plate (11) in accordance with paragraph 5-12d.
- (2) Lift both card ejectors (12) pull the indicator CCA (13) forward, out of the holder (14) and chassis (52).

g. Indicator CCA A3 Replacement. Refer to figure 5-13 and proceed as follows:

- (1) Place the indicator CCA (13) into the holder (14) and slide the CCA evenly into the ECM bracket (36) until it engages connector XA3 (15).
- (2) Press the indicator CCA (13) firmly into connector XA3 (15).
- (3) Aline the front panel plate (11) with the mounting holes and turn the two turnlock studs (10) fully CW.

h. Circuit Card Assembly Repair. Removal and replacement of an indicator CCA A3 component (see figure 5-14) requires use of a low-wattage (30 W or less) soldering iron and appropriate heat sinks. Observe standard shop practices as well as general practices and precautions for CCA and microelectronic components while performing the following steps:

CAUTION

Use a soldering pencil to solder all necessary points on the CCA. A soldering gun may cause overheating of CCA traces, lead pads, or laminations. Overheating may cause either pads or traces to lift from the CCA. Subsequent breakage is probable.

- (1) Assemble the following soldering materials: soldering pencil, rosin core solder, small stiff brush (item 3, App. D), cotton swabs (item 16, App. D), solder sucker or resoldering wick, orangewood sticks (item 31, App. D), humiseal (1A33 or 1B31) (item 9, App. D), and freon/alcohol cleaning solution (freon TFE, TE, or TMS) (item 14, App. D).
- (2) Saturate a cotton swab (item 16, App. D) with AP-20 Kester Resin Remover Solvent (item 15, App. D).
- (3) Wipe area to be repaired with saturated swab until conformal coating is dissolved.
- (4) Clean up excess solvent, using a clean cotton swab. Allow CCA to air dry at ambient temperature at least 15 minutes prior to beginning further repair work.

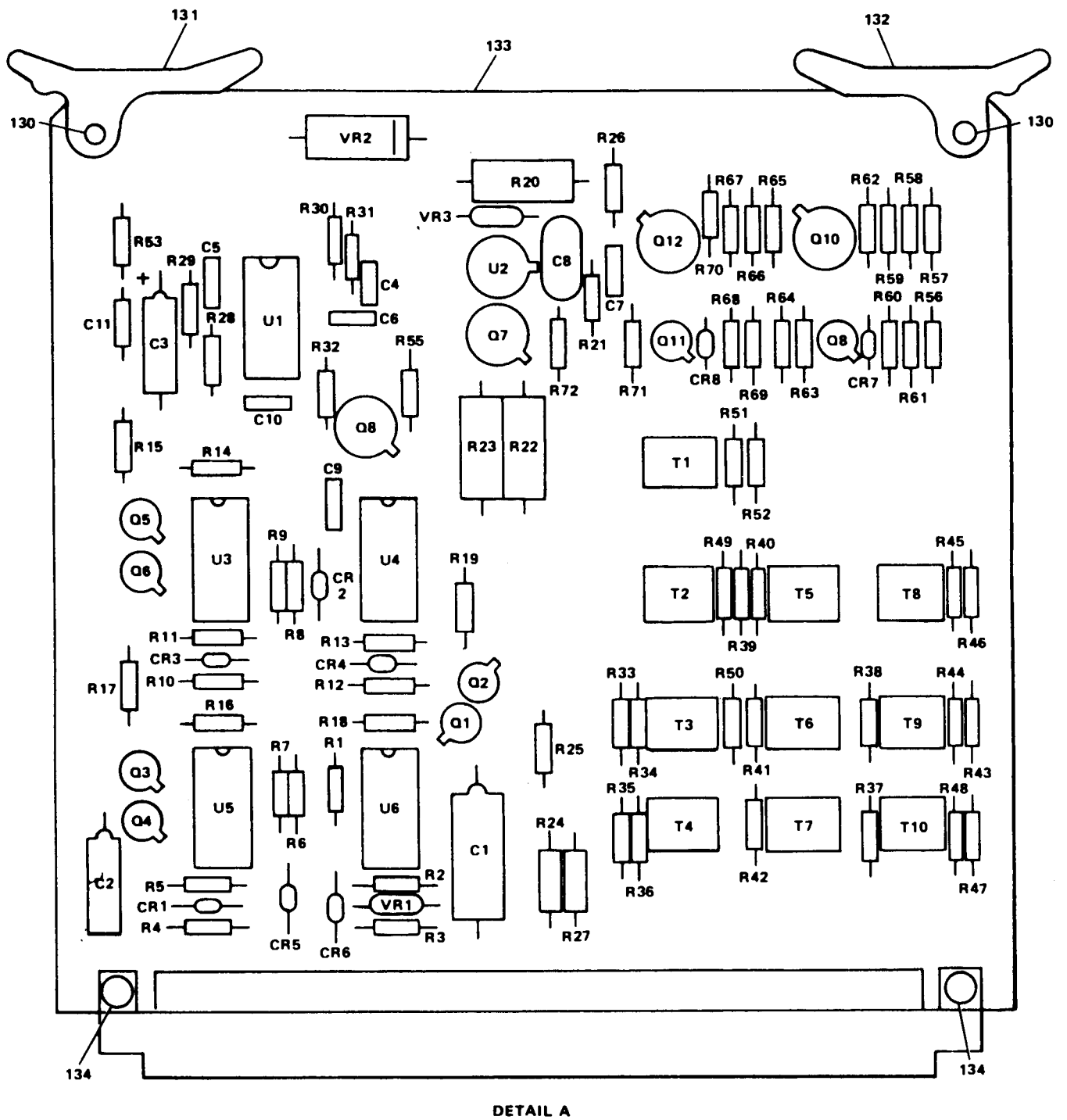

Figure 5-14. Indicator CCA A3 Component Locations

- (5) Unsolder and remove component. Clean pads.
- (6) Use the orangewood stick to remove any burned conformal coating residue from the area. Use care to avoid damage to traces or pads.
- (7) Clean the area around the top and bottom component lead pads with cotton swabs (item 16, App. D) and the cleaning solution (item 14, App. D).
- (8) Insert the new component in the CCA and trim leads to the proper length.
- (9) Solder the new component in place.
- (10) After soldering all leads, clean the connections with the stiff brush (item 3, App. D) and cleaning solution (item 14, App. D).
- (11) Retest the CCA to verify successful repair and proper operation.
- (12) Determine the type of conformal coating used on the repaired CCA. Test a small area away from components with freon TFE, TE, or TMS (item 14, App. D). If the freon strips away from the coating, the coating is humiseal 1B31 (item 9, App. D); if it does not strip away, the coating is humiseal 1A33 (item 9, App. D).

NOTE

Humiseal 1A33 and 1B31 are not compatible. Patch the conformal coating only with the type already present.

- (13) Patch the conformal coating with the appropriate type of humiseal in the test and repair areas.
- (14) Refer to section V of this chapter.

i. Voltage Regulator A1 Replacement. Refer to figure 5-13 and proceed as follows:

- (1) Remove the four screws (17) and flat washers (18) that secure the heat sink and voltage regulator (16) to the chassis, then remove the heat sink and voltage regulator.
- (2) Disconnect connector A1P1 (67) from voltage regulator (16) by unscrewing screws in screw lock assemblies (68).
- (3) Attach connector A1P1 (67) to voltage regulator A1 (16).
- (4) Aline voltage regulator A1 (16) with the mounting holes and secure with the four screws (17) and flat washers (18) .

(5) Refer to section V of this chapter.

j. Voltage Regulator A1 Component Removal and Replacement. Refer to figure 5-15 and proceed as follows:

- (1) Remove voltage regulator A1 in accordance with paragraph 5-12i.
- (2) Remove screw lock assembly (1) on J1 (2). Tag wires on J1, cut heatshrink (3), and desolder wires. Remove standoffs (4) from A1.
- (3) To remove C1 (27), C2 (28), C3 (29), C4 (30), R1 (31), or R2(32), tag location and connection and desolder.
- (4) Tag and desolder all wiring connected to the terminal stud(s) to be removed.
- (5) Remove terminals E3 (5), E5 (6) E6 (7)F or E7 (8) by unscrewing terminal.
- (6) Remove terminals E1 (9), E2 (10), or E4 (11) by unscrewing terminal and removing washer (12).
- (7) Remove terminal E11 (13) by unscrewing and removing terminal E6 (7), then removing terminal E11.
- (8) Remove terminal E8 (20) by removing screw (21), flat washer (22), and two nylon sleeves (23) that secure E8 to voltage regulator A1, then removing E8.
- (9) Remove terminal E9 (14) or E10 (15) by removing nut (16) on screw (17) holding terminal E9 to VR1 (18) or E10 to VR2 (19), then removing E9 or E10.
- (10) Remove VR1 (18) or VR2 (19) by removing E9 (on VR1) or E10 (on VR2) in accordance with the previous step. Remove screw (17), two flat washers (24), lock washer (25), and nut (26) securing each end of VR1 or VR2 to A1. Remove VR1 or VR2.
- (11) To reassemble voltage regulator A1 install VR1 (18) or VR2 (19) by securing components to A1 with a screw (17), two flat washers (24), lock washer (25), and nut (26) at each end.
- (12) Replace terminal E9 (14) or E10 (15) by placing E9 or E10 on screw (17) holding terminal E9 to VR1 (18) or E10 to VR2 (19), then replacing nut (16).
- (13) Replace terminal E8 (20) by assembling screw (21), flat washer (22), two nylon sleeves (23), and terminal E8 and secure to voltage regulator A1.

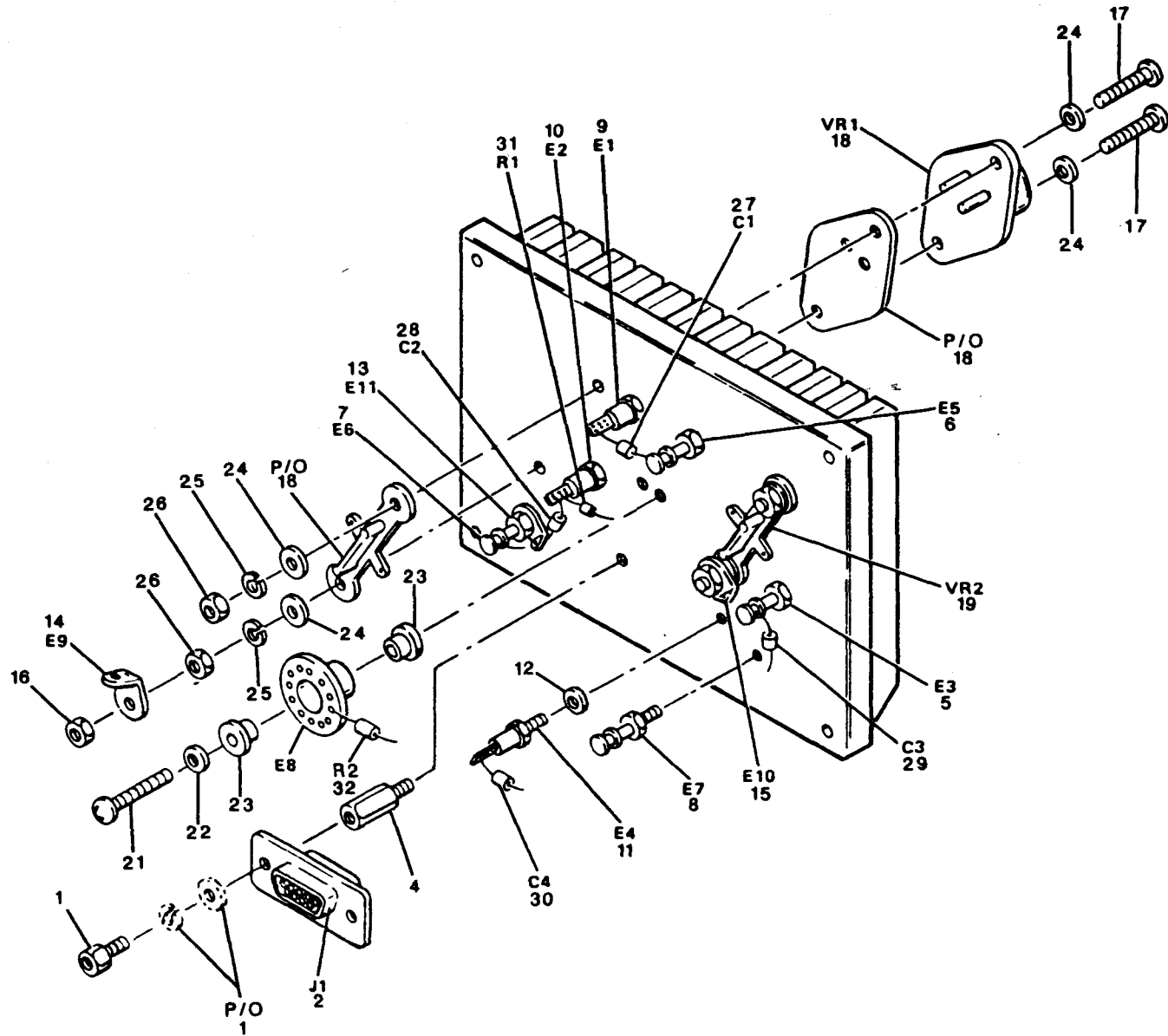

Figure 5-15. Voltage Regulator A1 Component Locations

- (14) Replace terminal E11 (13) by installing on terminal E6 (7), then securing to voltage regulator A1 with terminal E6.
- (15) Replace terminals E1 (9), E2 (10), or E4 (11) by installing washer (12) on terminal and securing terminal to voltage regulator A1.
- (16) Replace terminals E3 (5), E5 (6), E6 (7), or E7 (8) by securing terminal to voltage regulator A1.
- (17) Solder all wiring to terminals as tagged during removal.
- (18) Replace C2 (27), C2 (28), C3 (29), C4 (30), R1 (31), or R2 (32) by soldering in place as tagged during removal.
- (19) Replace standoffs (4) by screwing into A1. Slide 1\2-inch piece of heatshrink (3) over tagged wires and solder wires as tagged to J1 (2). Shrink heatshrink. Install screw lock assembly (1) on J1.
- (20) Replace voltage regulator A1 in accordance with paragraph 5-12i.

k. Filter FL1 Removal and Replacement. Refer to figure 5-13 and proceed as follows:

- (1) Remove the bottom cover (9) as given in paragraph 5-12c.
- (2) Tag the wires to identify filter (19) connections.
- (3) Unsolder the wires from the filter (19) and remove filter.
- (4) Solder the wires to the replacement filter (19) as tagged.
- (5) Aline the replacement filter with the mounting holes and secure to bottom cover (9) with the four screws (20).
- (6) Replace bottom cover (9) in accordance with paragraph 5-12c.
- (7) Refer to section V of this chapter.

l. Transistor Q1 Removal and Replacement. Refer to figure 5-13 and proceed as follows:

- (1) Remove front panel plate (11) in accordance with paragraph 5-12d.
- (2) Remove the indicator CCA (13) as given in paragraph 5-12f.

- (3) Remove the top cover (2) in accordance with paragraph 5-12a.
- (4) Remove the bottom cover (9) as given in paragraph 5-12c.
- (5) Tag the wires to identify transistor (21) connections.
- (6) Remove the nut (22) that secure the wires and terminal lugs (23) to the transistor (21). Tag and unsolder other wire connections.
- (7) Remove the two screws (24), nuts (25), flat washers (26), lock washers (27), and insulators (28) that secure the transistor (21) to the ECM bracket (36) above the indicator CCA. Remove the transistor (21).
- (8) To replace, aline the replacement transistor with the mounting holes and secure with the two screws (24), flat washers (26), lock washers (27), insulators (28), and nuts (25).
- (9) Attach the terminal lugs (23) to the transistor (21) as tagged during removal with the nuts (22). Solder other wires to the transistor as tagged during removal.
- (10) Replace the bottom cover (9) as given in paragraph 5-12c.
- (11) Replace the top cover in accordance with paragraph 5-12a.
- (12) Replace the indicator CCA (13) as given in paragraph 5-12g.
- (13) Replace front panel plate (11) in accordance with paragraph 5-12d.
- (14) Refer to section V of this chapter.

m. Terminal Board TB1 Removal and Replacement. Refer to figure 5-13 and proceed as follows:

CAUTION

Use a heatsink when resoldering components on TB1 to prevent damage to heat-sensitive components.

- (1) Remove top cover (2) in accordance with paragraph 5-12a.
- (2) Tag all wiring connected to TB1 (29), then unsolder wiring.
- (3) Remove six screws (33), flat washers (34), and spacers (35) that secure TB1 to ECM bracket (36), then remove TB1.

- (4) To replace TB1, secure it to ECM bracket (36) with six screws (33), flat washers (34), and spacers (35), then solder wiring to terminals as tagged during removal.
 - (5) Replace top cover in accordance with paragraph 5-12a.
- n. Terminal Board TB1 Component Replacement. Refer to figure 5-16 unless otherwise indicated and proceed as follows:

CAUTION

Use a heatsink when resoldering components on TB1 to prevent damage to heat-sensitive components.

- (1) Refer to figure 5-13. Remove top cover (2) in accordance with paragraph 5-12a.
 - (2) Tag and remove the wires from the terminal board (29) component to be replaced.
 - (3) Replace the defective component.
 - (4) Attach the wires to the terminal board (29) component as tagged.
 - (5) Replace top cover in accordance with paragraph 5-12a.
- o. Terminal Board TB2 Removal and Replacement. Refer to figure 5-17 unless otherwise indicated and proceed as follows:
- (1) Refer to figure 5-13. Remove top cover (2) in accordance with paragraph 5-12a. Support the terminal board (30) while removing the four screws (31) that attach the terminal board to the side of the chassis.
 - (2) Refer to figure 5-17. Support the terminal board (6) while removing the four screws (7) and flat washers (8) that attach the terminal board to the spacers (9).
 - (3) Tag and remove wires from terminal board components.
 - (4) Remove the terminal board (6) from the chassis.
 - (5) To replace TB2, solder all wires to components as tagged during removal. Aline the terminal board (6) and spacers (9) with the mounting holes and secure to the spacers with four screws (7) and flat washers (8).
 - (6) Refer to figure 5-13. Support to terminal board (30) while securing it to the side of the chassis with four screws (31).

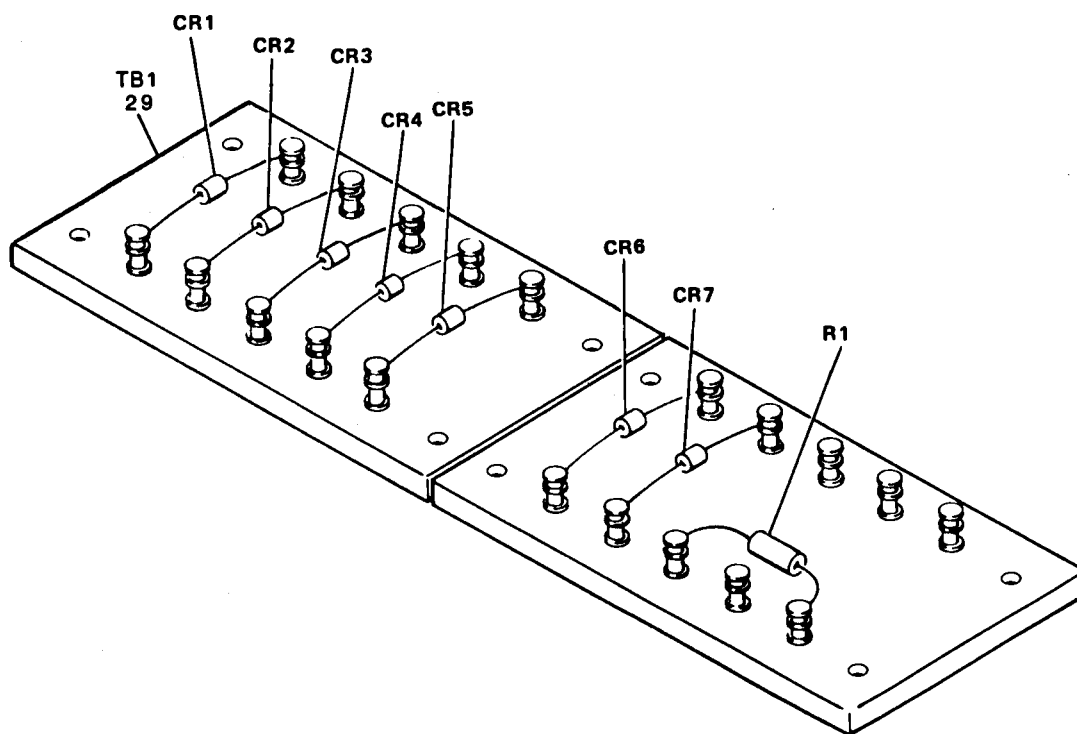

Figure 5-16. Terminal Board TB1 Component Locations

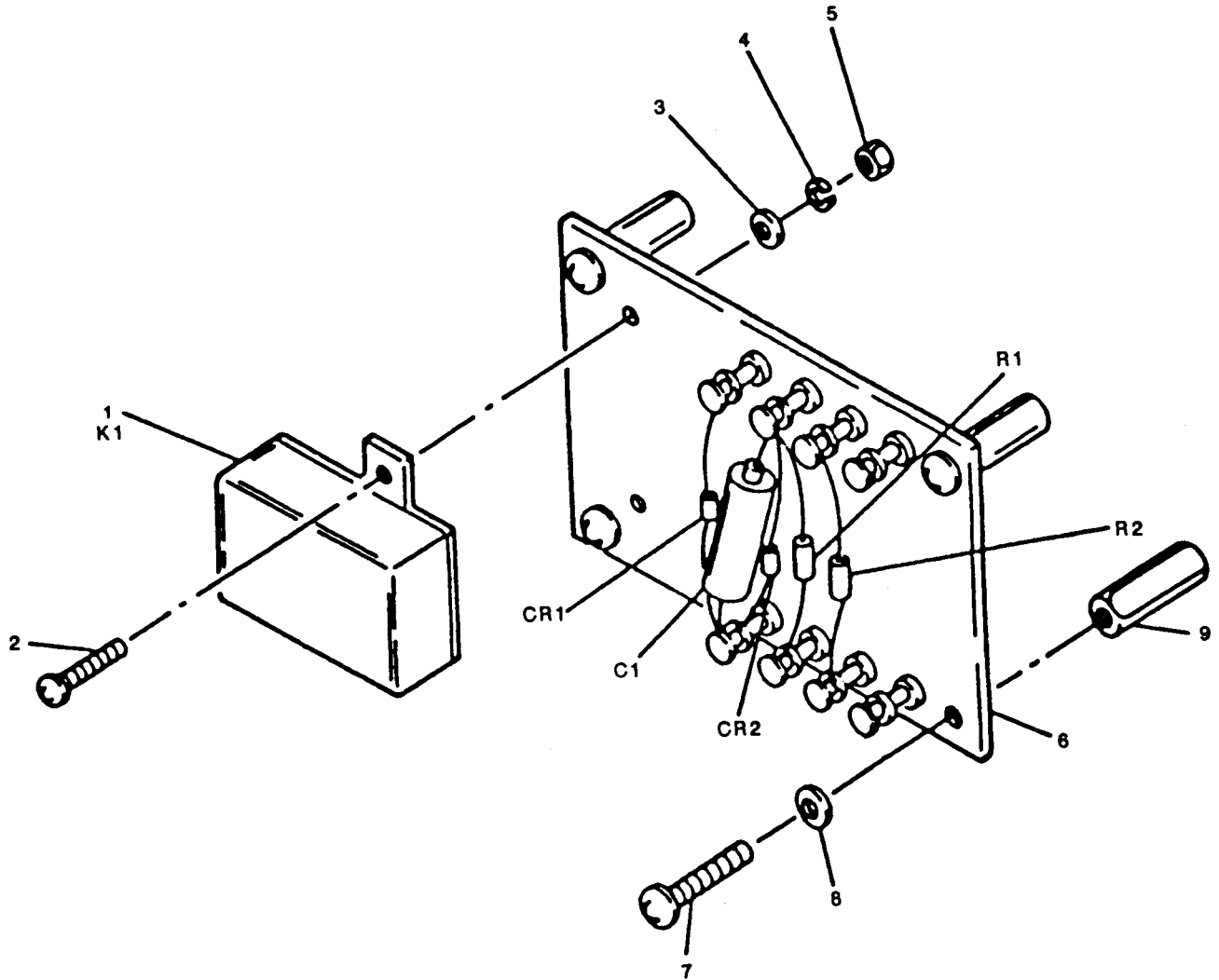

Figure 5-17. Terminal Board TB2 Component Locations

(7) Replace top cover in accordance with paragraph 5-12a.

p. Terminal Board TB2 Component Replacement. Refer to figure 5-17 unless otherwise indicated and proceed as follows:

- (1) Refer to figure 5-13. Remove top cover in accordance with paragraph 5-12a.
- (2) Refer to figure 5-13. Remove TB2 (30) in accordance with paragraph 5-12o. Do not remove wiring to terminal board.
- (3) Remove and replace defective component.
- (4) Replace TB2 in accordance with paragraph 5-12o.
- (5) Replace top cover in accordance with paragraph 5-12a.
- (6) Refer to section V of this chapter.

q. Relay TB2K1 Removal and Replacement. Refer to figure 5-13 and figure 5-17, and proceed as follows:

- (1) Remove top cover (2) in accordance with paragraph 5-12a.
- (2) Remove terminal board TB2 (30) from side of chassis in accordance with paragraph 5-12o. Do not remove wiring from terminal board.
- (3) Remove heatshrink tubing, then tag and remove wires connected to TB2K1.
- (4) Remove two screws (2), flat washers (3), lock washers (4), and nuts (5) (see figure 5-10C, items 2 thru 5) that secure relay K1 (1) to terminal board TB2.
- (5) To replace relay K1, secure K1 to TB2 with two screws (2), flat washers (3), lock washers (4), and nuts (figure 5-17, items 2 thru 5).
- (6) Place length of 0.125 ID black heatshrink tubing (item 12, App. D) over each wire, then solder wires to relay terminals as tagged during removal. Slide heatshrink tubing over connection and shrink.
- (7) Replace terminal board TB2 to side of chassis in accordance with paragraph 5-12o, and top cover in accordance with paragraph 5-12a.
- (8) Refer to section V of this chapter.

r. Relay K1, K2, or K3 Removal and Replacement. Refer to figure 5-13 and proceed as follows:

- (1) Remove top cover (2) in accordance with paragraph 5-12a.

- (2) Identify relay to be replaced (32).
- (3) Tag wiring for proper reconnection, then remove heatshrink tubing and unsolder wires from relay terminals.
- (4) Remove two screws (64), flat washers (65), and spacers (74) that secure relay to ECM bracket (36) and remove relay (32).
- (5) To replace relay, mount relay in place on ECM bracket (36) and secure with two screws (64), flat washers (65), and spacers (74).
- (6) Place length of 0.125 ID black heatshrink tubing (item 12, App. D) over each wire, solder wires to relay terminals as tagged during removal. Slide heatshrink tubing over connection and shrink.
- (7) Replace top cover in accordance with paragraph 5-12a.
- (8) Refer to section V of this chapter.

s. Terminal Stud E1 through E5 Removal and Replacement. Refer to figure 5-13 and proceed as follows:

- (1) Remove top cover (2) in accordance with paragraph 5-12a.
- (2) Tag all wiring connected to terminal stud (56) then unsolder wiring.
- (3) Remove screw (75), flat washer (76), and two nylon sleeves (80) that secure stud to ECM bracket (36) , then remove stud. Note that if terminal stud is used as a ground (black wiring), nylon sleeves are not used.
- (4) To replace terminal stud, secure it to ECM bracket with two nylon sleeves (80), flat washer (76) and screw (75), then solder wiring as tagged during removal.
- (5) Replace top cover in accordance with paragraph 5-12a.
- (6) Refer to section V of this chapter.

t. ECM Bracket Removal and Replacement. Refer to figure 5-13 and proceed as follows:

- (1) Remove top cover (2) in accordance with paragraph 5-12a.
- (2) Remove terminal studs (81) in accordance with paragraph 5-12s. Do not unsolder wiring.
- (3) Remove terminal board TB1 (29) in accordance with paragraph 5-12m. Do not unsolder wiring.

- (4) Remove two screws (64), flat washers (65), and spacers (74) that secure K1, K2, and K3 (32) to top of ECM bracket. Do not unsolder wiring to relays.
- (5) Remove transistor Q1 (21) in accordance with paragraph 5-121.

CAUTION

Perform steps (7) and (10) carefully to avoid damaging ECM chassis-wiring.

- (6) Lay components and wiring removed from top of ECM bracket (36) out of the way.
- (7) Remove bottom cover (9) in accordance with paragraph 5-12c. Place box on right side and lay bottom cover on left.
- (8) From bottom side of chassis, remove six screws (46) that secure ECM bracket to bottom of chassis, then lift bracket out of chassis.
- (9) Remove four screws (82) and flat washers (83) that secure connector bracket (66) to ECM bracket (36).
- (10) To replace ECM bracket (36) into chassis, secure connector bracket (66) to ECM bracket with four screws (82) and flat washers (83), then position ECM bracket over mounting holes in bottom of chassis and secure with six screws (46). Replace bottom cover in accordance with paragraph 5-12c.
- (11) Replace transistor Q1 in accordance with paragraph 5-12, step 1. Also replace terminal board TB1 in accordance with paragraph 5-12m. Replace bottom cover in accordance with paragraph 5-12c.
- (12) Secure relays K1 (32), K2 (32) and K3 (32) to top of ECM bracket in accordance with paragraph 5-12r.
- (13) Replace terminal studs (81) in accordance with paragraph 5-12s.
- (14) Replace top cover in accordance with paragraph 5-12a.
- (15) Refer to section V of this chapter.

u. Connector Bracket Removal and Replacement. Refer to figure 5-13 and proceed as follows:

- (1) Remove ECM bracket (36) in accordance with paragraph 5-12t.

- (2) Remove four screws (82) and flat washers (83) that secure connector bracket (66) to ECM bracket (36).
- (3) Tag and remove wires to connector, then remove connector bracket from chassis.
- (4) To replace connector bracket, solder wires to connector a marked during removal, then secure connector bracket (66) to ECM bracket (36) with four screws (82) and flat washers (83) . Replace ECM bracket (36) in accordance with paragraph 5-12t. Be careful not to damage connector bracket wiring or ECM bracket wiring.
- (5) Refer to section V of this chapter.

v. Switch S1 Removal and Replacement. Refer to figure 5-13 and proceed as follows:

- (1) Remove top cover (2) in accordance with paragraph 5-12a.
- (2) Tag the wires to identify switch (40) connections.
- (3) Remove the wires from the switch (40).
- (4) Remove the two screws (37) and lock washers (38) that secure the switch bracket (39) to the rear of the chassis. Remove the switch (40) and bracket (39) from the chassis.
- (5) Remove the two screws (41), four flat washers (42), and two nuts (43) that secure the switch (40) to the bracket (39).
- (6) To replace, aline the replacement switch with the bracket (39) mounting holes and install the two screws (41), four flat washers (42), and two nuts (43).
- (7) Aline the bracket (39) with the mounting holes on the rear of the chassis (52) and install the two screws (37) and lock washers (38) .
- (8) Attach the wires to the replacement switch as tagged.
- (9) Replace top cover in accordance with paragraph 5-12a.
- (10) Refer to section V of this chapter.

w. Coax Switch Bracket Removal and Replacement. Refer to figure 5-13. To remove replace the coax switch bracket (39), remove top cover (2) in accordance with paragraph 5-12a, then follow the procedures listed in paragraph 5-12v, steps 4 and 5.

x. Circuit Breaker CB1 Removal and Replacement. Refer to figure 5-18 and proceed as follows:

- (1) Remove front panel in accordance with paragraph 5-12b.
- (2) Tag the wires to identify circuit breaker (5) connections.
- (3) Remove the wires from the circuit breaker.
- (4) To replace, remove the outer collar nut (4) from the replacement circuit breaker.
- (5) Attach the wires to the circuit breaker (5) as tagged.
- (6) Replace front panel in accordance with paragraph 5-12b.
- (7) Refer to section V of this chapter.

y. Connectors J2, J3, J6 thru J8 Removal and Replacement. Refer to figure 5-13 and proceed as follows for each connector:

- (1) Remove top cover (2) in accordance with paragraph 5-12a.
- (2) Remove four screws (48), eight flat washers (49), four lock washers (50), and four nuts (51) that secure connector (47) to ECM chassis (52) and remove connector.
- (3) Tag each wire, then use removal tool to remove each wire from connector.
- (4) To replace connector (47), use insertion tool to attach wires as marked during removal, insert connector through opening in chassis, and secure with four screws (48), eight flat washers (49), four lock washers (50), and four nuts (51).
- (5) Replace top cover in accordance with paragraph 5-12a.
- (6) Refer to section V of this chapter.

z. Ground Stud Removal and Replacement. Refer to figure 5-13 and proceed as follows:

- (1) Remove top cover in accordance with paragraph 5-12a.
- (2) Remove two flat washers (56), lock washers (57) and nut (58) that secure ground stud (53) to chassis (52).
- (3) Remove stud from chassis, then remove two lugs (54) and lockwasher (55). It is not necessary to unsolder wiring from lugs.

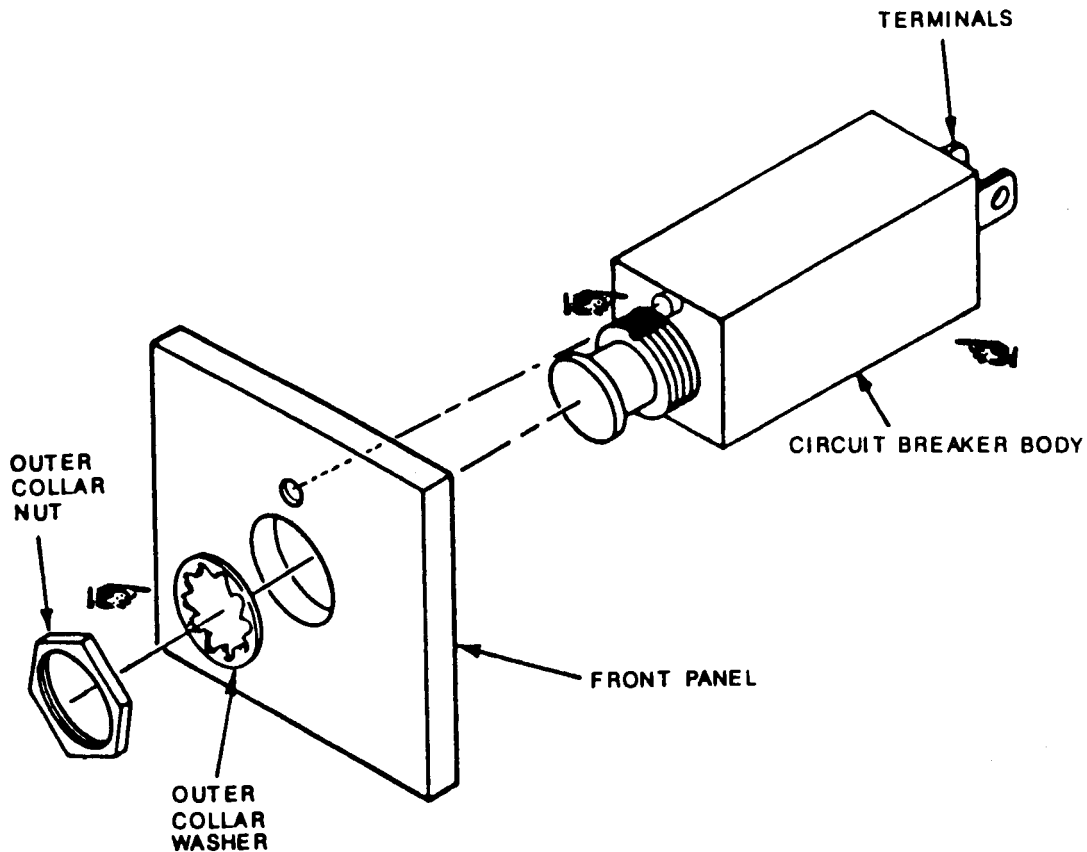

Figure 5-18. Circuit Breaker Replacement

- (4) To replace ground stud, place two lugs (54) and lock washer (55) over stud, then insert stud (53) through opening in chassis from inside unit.
- (5) Secure stud to chassis with two flat washers (56), lock washers (57) and nuts (58), alternately placed.
- (6) Replace top cover in accordance with paragraph 5-12a.
- (7) Refer to section V of this chapter.

aa. Front Panel Fastener Assembly Removal and Replacement. Refer to figure 5-13, item (59) and figure 5-12, and proceed as follows:

- (1) Remove front panel in accordance with paragraph 5-12b.
- (2) Use tool set no. PT 31/2 to remove defective fasteners from front panel (3). Place head of defective fastener into block as shown in figure 5-12. Place tool against locking head of fastener and strike tool with hammer to drive defective fastener out of panel.
- (3) Insert replacement fastener through opening in panel, then insert fastener into flaring hand tool PT 3 1/2A as shown in figure 5-12 and flare fastener tight to front panel.

- (4) Replace front panel in accordance with paragraph 5-12b.

ab. Riveting. To replace a rivet(s) on the unit, proceed as follows:

CAUTION

When replacing a rivet, use caution to avoid damage to other components while drilling or using a punch and hammer.

- (1) Remove covers and components as required to gain access to rivet(s) to be replaced. (Refer to paragraph 5-12 for removal procedures).
- (2) Center punch the rivet head of rivet to be replaced.
- (3) Place cloth under rivet being drilled to prevent metal shavings from falling into chassis.
- (4) Using a drill smaller than the diameter of the rivet, drill out the center of rivet head to be replaced.
- (5) Increase the size of the drill to rivet size or a size slightly smaller than rivet size, and again drill out rivet head. Rivet head should fall off at this point. If not, position a punch or similar tool against the rivet head and carefully drive it out with a hammer.
- (6) Using a punch and a hammer, punch out the remainder of the rivet to be replaced.
- (7) Obtain and install appropriate size rivet. Using the riveter and appropriate size head, install the replacement rivet.

ac. Front Panel Repair.

- (1) Remove front panel (3) in accordance with paragraph 12b.
- (2) Remove and replace or repair a defective top (73) or bottom (84) angle in accordance with paragraph 5-12ab.
- (3) Remove and replace a self-locking nut plate (75) on a top (73) or bottom (84) angle in accordance with paragraph 5-12ab.
- (4) Replace front panel (3) in accordance with paragraph 5-12b.

ad. Chassis Repair.

- (1) Remove chassis (52) components in accordance with the appropriate sections of paragraph 5-12.
- (2) Remove and replace a defective bottom cover bracket (77) in accordance with paragraph 5-12ab.
- (3) Replace chassis (52) components in accordance with paragraph 5-12b.

ae. Voltage Regulator A1 Heat Sink Repair. Voltage regulator A1 heat sink is repairable by removing and replacing a defective threaded insert. To repair the heat sink, proceed as follows:

- (1) Remove voltage regulator A1 in accordance with paragraph 5-12i.
- (2) Remove voltage regulator A1 components in accordance with paragraph 5-12j.
- (3) Insert blade of extracting tool into insert so that flat side of blade faces top of insert (blade is perpendicular to tang break-off point. See figure 5-19(a)).
- (4) Strike head of extracting tool with a light blow to cause the blade to cut into insert slightly.
- (5) Maintain steady pressure between blade and insert while unscrewing insert out of heat sink.
- (6) Thread replacement insert onto mandril of installation tool. Screw insert into hole to depth of one-half turn below surface of heat sink.
- (7) Insert end of tang break-off tool into insert and apply pressure. The spring-loaded punch mechanism within tang break-off tool will provide sharp blow to break tang.
- (8) Remove tang from hole.
- (9) Replace voltage regulator A1 components in accordance with paragraph 5-12j.
- (10) Replace voltage regulator A1 in accordance with paragraph 5-12i.

af. Front Panel Plate Repair. Refer to figure 5-13. The front panel plate (11) is repairable by removing and replacing the turnlock studs (figure 5-13, item 10). To replace a turnlock stud, proceed as follows:

- (1) Remove front panel plate (11) in accordance with paragraph 5-12d.
- (2) Use small needle-nose pliers to remove split-ring washers (84).
- (3) Remove damaged stud (10).
- (4) Insert replacement stud (10) through hole in plate (11) and press on split-ring washer (84).
- (5) Replace front panel plate (11) in accordance with paragraph 5-12d.

ag. PCB Retainer Repair. To PCB retainer (61) is repairable by removing and replacing the silicone rubber pad. To replace the rubber strip, proceed as follows:

- (1) Remove the PCB retainer. (Refer to paragraph 5-12e.)
- (2) Use knife or other sharp tool to remove damaged silicone rubber.



Adequate ventilation should be provided while using trichlorotrifluoroethane. Prolonged breathing of vapor should be avoided. The solvent should not be used near heat or open flame; the products of decomposition are toxic and irritating. Since trichlorotrifluoroethane dissolves natural oils, prolonged contact with skin should be avoided. When necessary, use gloves that the solvent cannot penetrate. If the solvent is taken internally, consult a physician immediately.

- (3) Remove old adhesive using cloth dampened (not wet) with trichlorotrifluoroethane (item 18, App. D).
- (4) Cut new piece of silicone rubber (item 38, App. D).
- (5) Apply coating of clear adhesive, type 608 (item 1, App. D) to top surface of PCB retainer, then place silicone rubber on PCB retainer and allow one minute to dry.

ah. Identification Plate Removal and Replacement. Refer to figure 5-13 and proceed as follows:

- (1) Remove front panel (3) in accordance with paragraph 5-12d.
- (2) Remove two screws (69), lock washers (85), flat washers (86) and nuts (87) that secure the identification plate (88) to the front panel (3).
- (3) To replace, secure identification plate (88) to the front panel (3) using two screws (69), lock washers (85), flat washers (86) and nuts (87).
- (4) Replace front panel (3) in accordance with paragraph 5-12d.

ai. Connector Bracket Electrical Contact Removal and Replacement. Refer to figure 5-13 and proceed as follows:

- (1) Remove connector bracket (66) in accordance with paragraph 5-12u.
- (2) Cut and remove heatshrink from pin (78) to be replaced.
- (3) Tag and desolder wire(s) connected to electrical contact (78).
- (4) Use extraction tool (Teradyne 600-0001-000) from the solder side of the connector bracket to push the electrical contact (78) through and out of the plate.
- (5) Use insertion tool (Teradyne 600-0004-000) to press the new electrical contact (78) through and out of the plate.
- (6) Solder wire to electrical contact.
- (7) Slide a 1/2-inch piece of insulated heatshrink (App. D, Item 12) over the contact and wire and heatshrink into place.
- (8) Replace connector bracket (66) in accordance with paragraph 5-12u.

aj. Connector Bracket Polarizing Key Removal and Replacement. Refer to figure 5-13 and proceed as follows:

- (1) Remove connector bracket (66) in accordance with paragraph 5-12u.
- (2) Push polarizing pin (79) out from electrical contact pin (78) solder side of connector bracket (66).
- (3) Push in a replacement polarizing pin (79).

- (4) Replace connector bracket (66) in accordance with paragraph 5-12u.

ak. Connector A1P1 and J1 Removal and Replacement. Refer to figure 5-14 and proceed as follows:

- (1) Remove screws in screw locking assembly holding connectors A1P1 and J1 (figure 5-14, item 3) together and disconnect connectors. Remove screw locking plates and replace, if damaged.
- (2) Tag wires on A1P1 (67), cut heatshrink, and desolder wires. Replace connector A1P1, if damaged.
- (3) Remove screw lock assembly on J1 (figure 5-13, item 68). Replace screw lock assembly, if damaged. Tag wires on J1, cut heatshrink, and desolder wires. Replace connector J1, if damaged.

al. Voltage Regulator A1 Terminal Stud E1 thru E8 Removal and Replacement. Refer to figure 5-13 and proceed as follows:

- (1) Remove voltage regulator A1 (16) in accordance with paragraph 5-12h.
- (2) Tag and desolder all wiring connected to the terminal stud(s) to be removed/replaced.
- (3) Remove terminals E3, E5, E6, or E7 by unscrewing terminal.
- (4) Remove terminals E1, E2, or E4 by unscrewing terminal and removing washer (3).
- (5) Remove terminal E11 by first unscrewing and removing terminal E6.
- (6) Remove terminal E9 or E10 by removing nut on screw holding the terminal to VR1 or VR2.
- (7) Remove terminal E8 by removing screw, flat washer, and two nylon sleeves that secure stud to voltage regulator A1, then remove stud.
- (8) To replace terminal stud E8, secure it to voltage regulator A1 with two nylon sleeves, flat washer, and-screw.
- (9) Solder wiring as tagged during removal.
- (10) Replace voltage regulator A1 in accordance with paragraph 5-12h.

Section V. GENERAL SUPPORT TEST PROCEDURES

5-13. General. This section provides general support test instructions to determine whether the performance of the repaired ECM indicator panel or countermeasures control is satisfactory for return to the user.

5-14. ECM Indicator Panel Test. Perform all the steps in table 5-1 to verify operation of the ECM indicator panel. Perform each step in table 5-1 in the sequence listed.

5-15. Countermeasures Control Test. Perform all the steps in tables 5-2 and 5-3 to verify operation of the countermeasures control. Perform each step in tables 5-3 and 5-3 in the sequence listed.

APPENDIX A**REFERENCES****A-1. Scope.**

This appendix lists all technical manuals, miscellaneous publications, regulations, and forms referenced in this manual or pertaining to Countermeasures Panel Indicator ID-2300/ALQ-151(V) and Countermeasures Control C-11124/ALQ-151(V).

A-2. Technical Manuals.

<u>Publication number</u>	<u>Title</u>
TM 11-5821-262-20	Organizational Maintenance Manual; Control, Communications System C-6533/ARC
TM 32-5865-012-10	Operation Instructions, Special Purpose Countermeasures System AN/ALQ-151(V)2
TM 32-5865-012-20	Maintenance Instructions, Organizational, Special Purpose Countermeasures System AN/ALQ-151(V)2
TM 32-5865-012-20P	Repair Parts and Special Tools List, AN/ALQ-151(V)2
TM 38-230-1	Packaging of Material: Preservation
TM 38-230-2	Packaging of Material: Packaging
TM 38-260	Preparation of Industrial Plant Equipment for Storage or Shipment
TM 43-0139	Painting Instructions for Field Use
TM 740-90-1	Administrative Storage of Equipment
TM 750-244-2	Procedures for Destruction of Electronics Materiel to Prevent Enemy Use (Electronics Command)
TM 43-0118	Field Instructions for Painting and Preserving Electronics Command Equipment Including Camouflage Pattern Painting of Electrical Equipment Shelters

A-3. Supply Bulletins.

<u>Publication number</u>	<u>Title</u>
SB 11-573	Painting and Preservation Supplies Available for Field Use for Electronics Command Equipment
SB 38-100	Preservation, Packaging and Packing Materials, Supplies and Equipment Used by the Army

A-4. Common Table of Allowances.

<u>Publication number</u>	<u>Title</u>
CA 50-970	Expendable Items

A-5. Pamphlets.

<u>Publication number</u>	<u>Title</u>
DA PAM 310-1	Index of Administrative Publications
DA PAM 310-2	Index of Blank Forms
DA PAM 310-4	Index of Technical Manuals; Technical Bulletins, Supply Manuals (Types 7, 8, 9), Supply-Bulletins, and Lubrication Orders
DA PAM 738-750	The Army Maintenance Management System (TAMMS).

A-6. Army Regulations.

<u>Publication number</u>	<u>Title</u>
AR 310-25	Dictionary of United States Army Terms
AR 310-50	Catalog of Abbreviations and Brevity Codes
AR 55-38	Reporting of Transportation Discrepancies in Shipments

A-7. Forms.

<u>Publication number</u>	<u>Title</u>
DA Form 2028	Recommended Changes to Publications and Blank Forms
DA Form 2404	Equipment Inspection and Maintenance Work Sheets
DA Form 2407	Maintenance Request
DA Form 2408	Equipment Log Assembly (Records)
DA Form 2408-1	Equipment Daily Log
DA Form 2408-5	Equipment Modification Record
SF 361	Discrepancy in Shipment Report
SF 364	Report of Discrepancy
SF 368	Quality Deficiency Report

APPENDIX B
MAINTENANCE ALLOCATION CHART

Section I. INTRODUCTION

B-1. General.

a. The maintenance allocation chart identifies the maintenance operations that must be performed. It assigns each of those operations to the lowest level of maintenance authorized to perform the complete task, or any part of the task, in terms of availability of time, tools, test and support equipment, skills and employment of the subsystem.

b. The Maintenance Allocation Chart (MAC) in Section II designates overall responsibility for the performance of maintenance functions for the Countermeasures Panel Indicator ID-2300/ALQ-151(V) and Countermeasures Control C-11124/ALQ-151(V).

c. Section III lists the special tools and test equipment required for each maintenance function as referenced from Section II.

d. Section IV contains supplemental instructions on explanatory notes for a particular maintenance function.

B-2. Maintenance Functions.

a. Inspect. To determine the serviceability of an item by comparing its physical, mechanical and/or electrical characteristics with established standards through examination.

b. Test. To verify serviceability and detect incipient failure by measuring the mechanical or electrical characteristics of an item and comparing those characteristics with prescribed standards.

c. Service. Operations required periodically to keep an item in proper operating condition; i.e., to clean (decontaminate), preserve, drain, paint or replenish fuel, lubricants, hydraulic fluids, or compressed air supplied.

d. Adjust. To maintain, within prescribed limits, by bringing into proper or exact position, or by setting the operating characteristics to specified parameters.

e. Align. To adjust specified variable elements of an item to bring about optimum or desired performance.

f. Calibrate. To determine and cause corrections to be made or to be adjusted on instruments or test, measuring and diagnostic equipments used in precision measurement. Consists of comparisons of two instruments, one of which is a certified standard of known accuracy: to detect and adjust any discrepancy in the accuracy of the instrument being compared.

g. Install. The act of emplacing, seating, or fixing into position an item, part, or module (component or assembly) in a manner to allow the proper functioning of an equipment or system.

h. Replace. The act of substituting a serviceable like type part, subassembly, or module (component or assembly) for an unserviceable counterpart.

i. Repair. The application of maintenance services¹ or other maintenance actions² to restore serviceability to an item by correcting specific damage, fault, malfunction, or failure in a part, subassembly, module (component or assembly), and items, or system.

j. Overhaul. The maintenance effort (services/actions) necessary to restore an item to a completely serviceable/operational condition as prescribed by maintenance standards (i.e., DMWR) in appropriate technical publication. Overhaul is normally the highest degree of maintenance performed by the Army. Overhaul does not normally return an item to like new condition.

k. Rebuild. Consists of those services/actions necessary for the restoration of unserviceable equipment to a like new condition in accordance with original manufacturing standards. Rebuild is the highest degree of material maintenance applied to Army equipment. The rebuild operation includes the act of returning to zero those age measurements (hours/miles, etc.) considered in classifying Army equipments/components.

B-3. Column Entries Used in the MAC.

a. Column 1, Group Number. Column 1 list group numbers, the purpose of which is to identify components, assemblies, subassemblies and modules with the next higher assembly.

b. Column 2, Component/Assembly. Column 2 contains the names of components, assemblies, subassemblies, and modules for which maintenance is authorized.

c. Column 3, Maintenance Functions. Column 3 lists the functions to be performed on the item listed in column 2. (For detailed explanation of these functions, see para. B-2).

d. Column 4, Maintenance Category.

(1) Column 4 specifies, by the listing of a "work time" figure in the appropriate sub-column(s), the lowest level of

¹Services - inspect, test, service, adjust, align, calibrate, or replace.

²Action - welding, grinding, riveting, straightening, facing, remachining, or resurfacing.

maintenance authorized to perform the function listed in column 3. This figure represents the active time required to perform the maintenance function, at the indicated level of maintenance.

(2) If the number or complexity of the tasks within the listed maintenance function vary at different maintenance, appropriate "work time" figures will be shown for each level. The number of man-hours specified by the "work time" figure represents the average time required to restore an item (assembly, subassembly, component, module, end item, or system) to a serviceable condition under typical field operating conditions. This time includes preparation time, troubleshooting time, and quality assurance/quality control time in addition to the time required to perform the specific tasks identified for the maintenance functions authorized in the maintenance allocation chart. The symbol designations for the various maintenance levels are as follows:

- C - Operator or crew.
- O - Organizational maintenance.
- F - Direct support maintenance.
- H - General support maintenance.
- D - Depot maintenance.

e. Column 5, Tools and Equipment. Column 5 specifies, by code, those common tool sets (not individual tools) and special tools, test, and support equipment required to perform the designated function.

f. Column 6, Remarks. Column 6 contains a letter code in alphabetical order which is keyed to the remarks contained in Section IV.

B-4. Column Entries Used in Tool and Test Equipment Requirements (Section III).

a. Column 1, Tool or Test Equipment Reference Code. The tool and test equipment reference code correlates with a maintenance function on the identified end item or component.

b. Column 2, Maintenance Category. The lowest level of maintenance authorized to use the tool or test equipment.

c. Column 3, Nomenclature. Name or identification of the tool or test equipment.

d. Column 4, National/NATO Stock Number. The National or NATO stock number of tool or test equipment.

e. Column 5, Tool Number. The manufacturer's part number.

B-5. Explanation of Columns in Section IV.

a. Reference Code. The code scheme recorded in Column 1, Section III.

b. Remarks. This column lists information pertinent to the maintenance function being performed as indicated on the MAC, Section II. If no remarks were indicated in the MAC, Section IV will be deleted.

SECTION II. MAINTENANCE ALLOCATION CHART
FOR
COUNTERMEASURES PANEL INDICATOR ID-2300/ALQ-151 (V)
COUNTERMEASURES CONTROL C-11124/ALQ-151(V)

(1) GROUP NUMBER	(2) COMPONENT/ASSEMBLY	(3) MAINTENANCE FUNCTION	(4) MAINTENANCE CATEGORY					(5) TOOLS AND EQUIPMENT	(6) REMARKS
			C	O	F	H	D		
09	PANEL INDICATOR, 00U	Inspect Test Service Repair				0.1 0.2 0.2 0.2		6 1 6 1,2,6	
0901	FRONT PANEL ASSEMBLY	Inspect Replace Repair				0.1 0.7 0.4		6 6 3,4,5,6	
13	CONTROL, ELECTRONIC	Inspect Test Service Repair				0.1 0.3 0.4 0.4		9,14 4,5,6,9,10, 14,15 14 4,5,6,7,9, 10,14,15	
1301	VOLTAGE REGULATOR	Inspect Test Replace Repair				0.1 0.2 0.1 0.3		14 4,9,10,14,15 14 4,9,10,14,15	
1302	CIRCUIT CARD ASSEMBLY	Inspect Test Replace Repair				001 0.2 0.1 0.2		14 4,5,6,9,10 14,15 4,5,6,9,10, 14,15,16	
1303	PANEL ASSEMBLY, FRONT	Inspect Replace Repair				0.1 0.3 0.4		14 14 7,11,12,13,14	
1304	PLATE, FRONT PANEL	Inspect Replace Repair				0.1 0.1 0.2		14 14 3,14	
1305	CHASSIS, ELECTRONIC	Inspect Replace Repair				0.1 1.3 0.4		14 7,9,14 7,13,14	
1306	BRACKET ASSEMBLY, ELECTRONIC	Inspect Replace Repair				0.1 0.7 0.4		14 9,14 7,13,14	

SECTION II. MAINTENANCE ALLOCATION CHART
FOR

COUNTERMEASURES PANEL INDICATOR ID-2300/ALQ-151(V)
COUNTERMEASURES CONTROL C-11124/ALQ-151(V) - Continued

(1) GROUP NUMBER	(2) COMPONENT/ASSEMBLY	(3) MAINTENANCE FUNCTION	(4) MAINTENANCE CATEGORY					(5) TOOLS AND EQUIPMENT	(6) REMARKS
			C	O	F	H	D		
1307	BRACKET, CONNECTOR	Inspect				0.1		14	
		Replace				0.4		14	
		Repair				0.3		1,2,7,13,14	
1308	TERMINAL BOARD ASSEMBLY	Inspect				0.0		14	
		Test				0.2		4,9,10,14	
		Replace				0.3		9,14	
		Repair				0.2		4,8,9,10,14	
1309	TERMINAL WARD ASSEMBLY	Inspect				0.1		14	
		Test				0.2		4,9,10,14	
		Replace				0.3		9,14	
		Repair				0.2		4,9,10,14	

SECTION III. TOOL AND TEST EQUIPMENT REQUIREMENTS FOR
 COUNTERMEASURES PANEL INDICATOR ID-2300/ALQ-151(V)
 COUNTERMEASURES CONTROL C-11124/ALQ-151(V)

TOOL OR TEST EQUIPMENT REF CODE	MAINTENANCE CATEGORY	NOMENCLATURE	NATIONAL/NATO STOCK NUMBER	TOOL NUMBER
1	H	REMOVAL TOOL	TBA	600-001-000
2	H	INSERTION TOOL	TBA	600-004-000
3	H	RETAINING RING TOOL	TBA	82-0-7595-11
4	H	MULTIMETER, DIGITAL	6625-01-139-2512	AN/PSM-45
5	H	GEN SIGNAL TEST OSC	6625-00-935-4214	AN/USM-264
6	H	OSCILLOSCOPE	6625-01-187-7847	AN/USM-488
7	H	RIVETER KIT	6665-01-022-4165	HP-200
8	H	MAINT KIT ELECTRONIC	6625-01-068-1665	MK-1961/G
9	H	MAINT KIT ELECTRONIC	6625-01-068-1666	MK-1962/G
10	H	POWER SUPPLY	TBA	PP-7544/U
11	H	TOOL SET	TBA	PT 3 1/2
12	H	TOOL	TBA	PT 3 1/2A
13	H	TOOL KIT, ELEC EQUIP	5180-00-605-0079	TK-100/G
14	H	TOOL KIT, ELEC EQUIP	5180-00-610-8177	TK-105/G
15	H	RESISTOR DECADE	TBA	ZM-16A/U
*16	H	92-PIN CARD EXTENDER	TBA	12-001343

* TENTATIVE. AWAITING DCN CONCURRENCE/APPROVAL.

APPENDIX C
REPAIR PARTS AND SPECIAL TOOLS LIST
FOR
COUNTERMEASURES CONTROL C-11124/ALQ-151(V)
AND
COUNTERMEASURES INDICATOR PANEL ID-2300/ALQ-151(V)

TABLE OF CONTENTS

			Page	Illus Figure
Section	I	Introduction	C-3	
	II	Repair Parts List	C-9	
Group	13	Countermeasures Control C-11124/ALQ-151(V)	C-9	C-1
	1301	Voltage Regulator Al C5074621-1	C-13	C-1
	1302	Indicator Circuit Card Assembly A3 1951-1-4546-2	C-10	C-1
	09	Countermeasures Indicator Panel ID-2300/ALQ-151(V)	C-20	C-2
Section	III	Special Tools List (not applicable)	C-22	
	IV	National Stock Number and Part Number Index	C-23	

Section I. INTRODUCTION

C-1. Scope. This appendix lists spares and repair parts; special tools; special test, measurement, and diagnostic equipment (TMDE); and other special support equipment required for performance of direct support maintenance of Countermeasures Control C-11124/ALQ-151(V) and Countermeasures Indicator Panel ID-2300/ALQ-151(V) . It authorizes the requisitioning and issue of spares and repair parts as indicated by the source and maintenance codes.

C-2. General. This repair parts and special tools list is divided into the following sections.

a. Section II. Repair Parts List. A list of spares and repair parts authorized for use in the performance of maintenance. The list also includes parts that must be removed for replacement of the authorized parts. Parts lists are composed of functional groups in numerical sequence, with the parts in each group listed in figure and item number sequence.

b. Section III. Special Tools List. Not applicable.

Section IV. National Stock Number and Part Number Index. A list, in national item identification number (NIIN) sequence, of all national stock numbers (NSNs) appearing in the listings, followed by a list, in alphanumerical sequence, of all part numbers appearing in the listings. National stock numbers and part numbers are cross-referenced to each illustration figure and item number appearance.

C-3. Explanation of Columns.

a. Illustration. This column is divided as follows:

(1) *Figure Number.* Indicates the figure number of the illustration on which item is shown.

(2) *Item Number.* The number used to identify item called out in the illustration.

b. Source, Maintenance, and Recoverability (SMR) Codes.

(1) *Source Code.* Source codes indicate the manner of acquiring support items for maintenance, repair, or overhaul of end items. Source codes are entered in the first and second positions of the Uniform SMR Code format as follows:

<u>Code</u>	<u>Definition</u>
PA	Item procured and stocked for anticipated or known usage.
PB	Item procured and stocked for insurance purpose because essentiality dictates that a minimum quantity be available in the supply system.
PC	Item procured and stocked and which otherwise would be coded PA except that it is deteriorative in nature.
PD	Support item, excluding support equipment, procured for initial issue or outfitting and stocked only for subsequent or additional initial issues of outfitting. Not subject to automatic replenishment.
PE	Support equipment procured and stocked for initial issue or outfitting to specified maintenance repair activities.
PF	Support equipment that will not be stocked but will be centrally procured on demand.
PG	Item procured and stocked to provide for sustained support for the life of the equipment. It is applied to an item peculiar to the equipment which, because of probable discontinuance or shutdown of production facilities, would prove uneconomical to produce at a later time.
KD	An item of a depot overhaul/repair kit and not purchased separately. Depot kit defined as a kit that provides items required at the time of overhaul or repair.
KF	An item of a maintenance kit and not purchased separately. Maintenance kit defined as a kit that provides an item that can be replaced at organizational or intermediate levels of maintenance.
KB	Item included in both a depot overhaul/repair kit and a maintenance kit.
MO	Item to be manufactured or fabricated at organizational level.
MF	Item to be manufactured or fabricated at the direct support maintenance level.
MH	Item to be manufactured or fabricated at the general support maintenance level.

<u>Code</u>	<u>Definition</u>
MD	- Item to be manufactured or fabricated at the depot maintenance level.
AO	- Item to be assembled at the organizational level.
AF	- Item to be assembled at the direct support maintenance level.
AH	- Item to be assembled at the general support maintenance level.
AD	- Item to be assembled at the depot maintenance level.
XA	- Item is not procured or stocked because the requirements for the item will result in the replacement of the next higher assembly.
XB	- Item is not procured or stocked. If not available through salvage, requisition.
XC	- Installation drawing, diagram, instruction sheet, or field service drawing that is identified by manufacturer's part number.
XD	- A support item that is not stocked. When required, item will be procured through normal supply channels.

NOTE

Cannibalization or salvage may be used as a source of supply for any items coded above except those coded XA and aircraft support items as restricted by AR 700-42.

(2) *Maintenance Code.* Maintenance codes are assigned to indicate the levels of maintenance authorized to USE and REPAIR support items. The maintenance codes are entered in the third and fourth positions of the Uniform SMR Code format as follows:

(a) The maintenance code entered in the third position will indicate the lowest maintenance level authorized to remove, replace, and use the support item. The maintenance code entered in the third position will indicate one of the following levels of maintenance:

<u>Code</u>	<u>Application/Explanation</u>
C	- Crew or operator maintenance performed within organizational maintenance.
O	- Support item is removed, replaced, used at the organizational level.
F	- Support item is removed, replaced, used at the direct support level.
H	- Support item is removed, replace, used at the general support level.
D	- Support item is removed, replaced, used at depot, mobile depot, or specialized repair activity only.

(b) The maintenance code entered in the fourth position indicates whether the item is to be repaired and identifies the lowest maintenance level with the capability to perform complete repair (i.e., all authorized maintenance functions). This position will contain one of the following maintenance codes:

<u>Code</u>	<u>Application/Explanation</u>
O	The lowest maintenance level capable of complete repair of the support item is the organizational level.
F	The lowest maintenance level capable of complete repair of the support item is the direct support level.
H	The lowest maintenance level capable of complete repair of the support item is the general support level.
D	The lowest maintenance level capable of complete repair of the support item is the depot level.
L	Repair restricted to (enter applicable designated specialized repair activity) specialized repair activity.
Z	Nonreparable. No repair is authorized.
B	No repair is authorized. The item may be reconditioned by adjusting, lubricating, etc., at the user level. No parts or special tools are procured for the maintenance of this item.

(3) *Recoverability Code.* Recoverability codes are assigned to support items to indicate the disposition action on unserviceable

items. The recoverability code is entered in the fifth position of the Uniform SMR Code format as follows:

<u>Recoverability Codes</u>	<u>Definition</u>
Z -	Nonreparable item. When unserviceable, condemn and dispose at the level indicated in position 3.
O -	Reparable item. When uneconomically reparable, condemn and dispose at organizational level.
F -	Reparable item. When uneconomically reparable, condemn and dispose at the direct support level.
H -	Reparable item. When uneconomically reparable, condemn and dispose at the general support level.
D -	Reparable item. When beyond lower level repair capability, return to depot. Condemnation and disposal not authorized below depot level.
L -	Reparable item. Repair, condemnation, and disposal not authorized below depot/specialized repair activity level.
A -	Item requires special handling or condemnation procedures because of specific reasons (i.e., precious metal content, high dollar value, critical material or hazardous material). Refer to appropriate manuals/directives for specific instructions.

c. National Stock Number. Indicates the national stock number assigned to the item and will be used for requisitioning.

d. Part Number. Indicates the primary number used by the manufacturer (individual, company, firm, corporation, or government activity), which controls the design and characteristics of the item by means of its engineering drawings, specifications, standards, and inspection requirements to identify an item or range of items.

NOTE

When a stock-numbered item is requisitioned, the item received may have a different part number than the part being replaced.

e. Federal Supply Code for Manufacturer (FSCM). The FSCM is a five-digit numeric code listed in SB 708-42 which is used to identify the manufacturer, distributor, or government agency, etc.

f. Description. Indicates the Federal item name and, if required, a minimum description to identify the item.

g. Unit of Measure (U/M). Indicates the standard of the basic quantity of the listed item as used in performing the actual maintenance function. This measure is expressed by a two-character alphabetical abbreviation (e.g., ea, in, pr, etc.). When the unit of measure differs from the unit of issue, the lowest unit of issue that will satisfy the required units of measure will be requisitioned.

h. Quantity Incorporated in Unit. Indicates the quantity of the item used in the breakout shown on the illustration figure, which is prepared for a functional group, subfunctional group, or an assembly.

C-4. Special Information.

a. Action change codes indicated in the left-hand margins of the listing page denote the following:

- N - Indicates an added item
- C - Indicates a change in data
- R - Indicates a change in NSN only

b. Missing NSN's have been applied for, they will be added to this TM by future change or revision.

C-5. How to Locate Repair Parts.

a. When National Stock Number or Part Number is Unknown.

(1) First. Using the table of contents, determine the functional group within which the item belongs. This is necessary since illustrations are prepared for functional groups and listings are divided into the same groups.

(2) Second. Find the illustration covering the functional group to which the item belongs.

(3) Third. Identify the item on the illustration and note the illustration figure and item number of the item.

(4) Fourth. Using the repair parts list, find the figure and item number noted on the illustration.

b. When National Stock Number or Part Number is Known.

(1) First. Using the index of NSNs and Part Numbers, find the pertinent national stock number or part number. This index is in NIIN sequence followed by a list of part numbers in alphabetical sequence, cross-referenced to the illustration figure number and item number.

(2) Second. After finding the figure and item number, locate the figure and item number in the repair parts list.

C-6. Abbreviations . Not applicable.

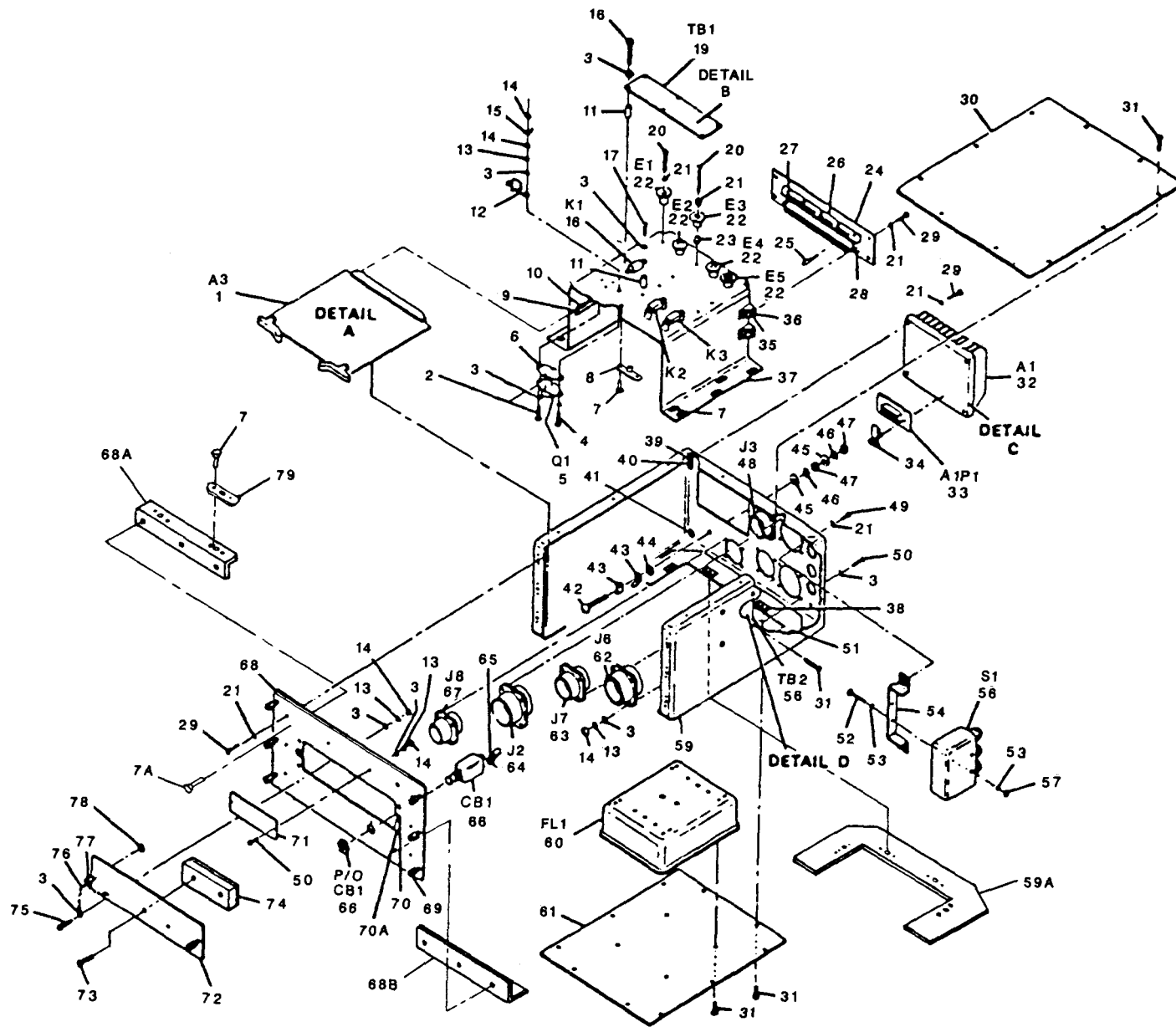
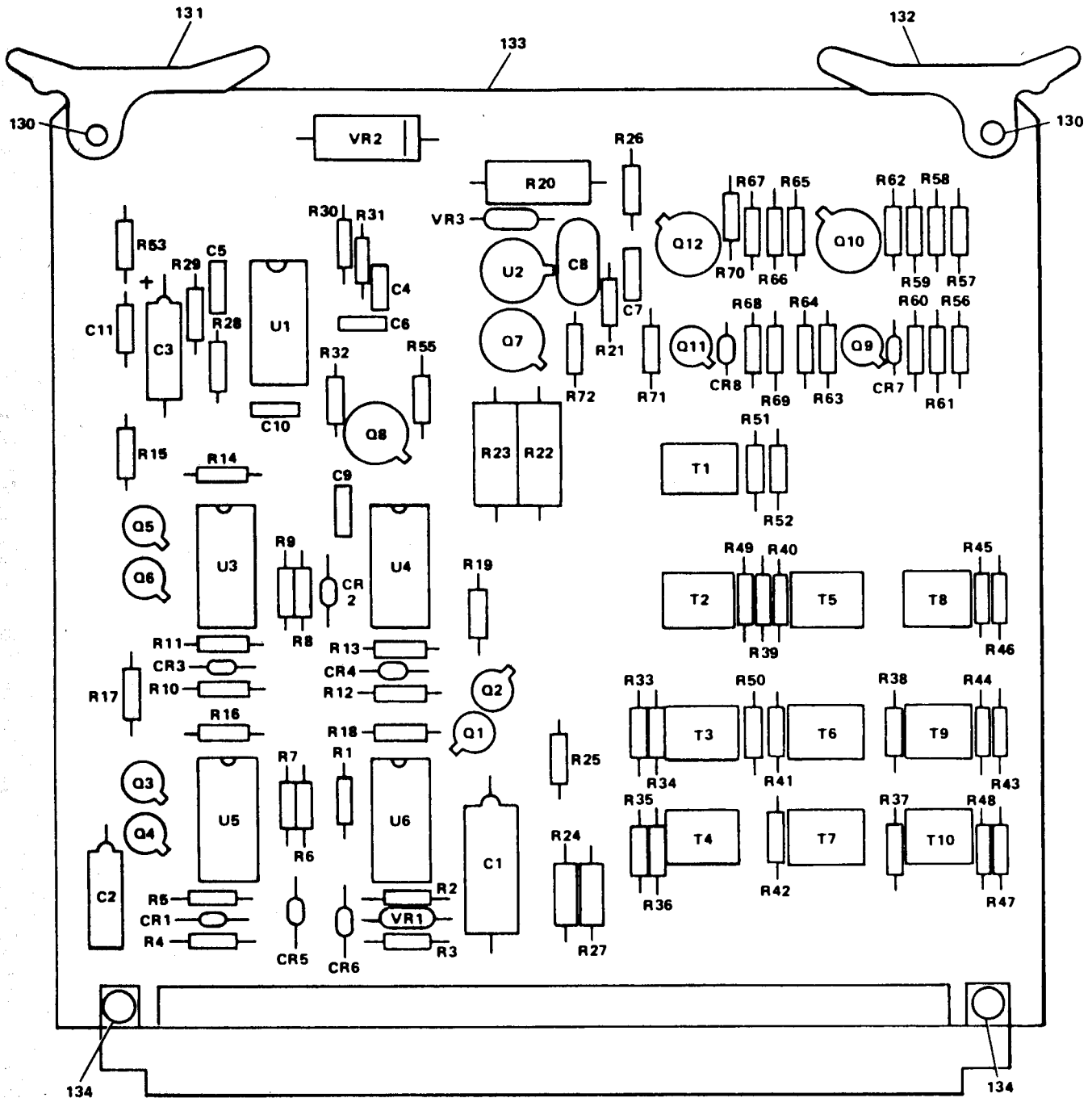

Figure C-1. Countermeasures Control C-11124/ALO-151(V)
(Sheet 1 of 6)



DETAIL A

Figure C-1. Countermeasures Control C-11124/ALQ-151(V)
(Sheet 2 of 6)

REF DES	ITEM NO	REF DES	ITEM NO	REF DES	ITEM NO	REF DES	ITEM NO	REF DES	ITEM NO	REF DES	ITEM NO
CR1	80	Q2	89	R11	96	R31	110	R51	113	R72	122
CR2	80	Q3	89	R12	97	R32	111	R52	112	T1	123
CR3	80	Q4	89	R13	96	R33	112	R53	118	T2	123
CR4	80	Q5	89	R14	98	R34	113	R55	95	T3	123
CR5	80	Q6	89	R15	99	R35	112	R56	115	T4	123
CR6	80	Q7	90	R16	98	R36	113	R57	106	T5	123
CR7	80	Q8	91	R17	99	R37	114	R58	95	T6	123
CR8	80	Q9	89	R18	98	R38	114A	R59	109	T7	123
C1	81	Q10	91	R19	99	R39	115	R60	119	T8	123
C2	82	Q11	89	R20	100	R40	114	R61	120	T9	123
C3	83	Q12	91	R21	101	R41	116	R62	95	T10	123
C4	84	R1	92	R22	102	R42	116	R63	121	U1	124
C5	85	R2	93	R23	103	R43	117	R64	115	U2	125
C6	85	R3	94	R24	104	R44	117	R65	106	U3	126
C7	86	R4	95	R25	105	R45	115	R66	95	U4	126
C8	87	R5	96	R26	106	R46	112	R67	109	U5	126
C9	85	R6	95	R27	107	R47	117	R68	119	U6	126
C10	86	R7	95	R28	95	R48	117	R69	120	VR1	12-9
C11	86	R8	97	R29	108	R49	113	R70	95	VR2	128
P1	88	R9	96	R30	109	R50	112	R71	121	VR3	129
Q1	89	R10	95								

Figure C-1. Countermeasures Control C-11124/ALQ-151(V)
(Sheet 3 of 6)

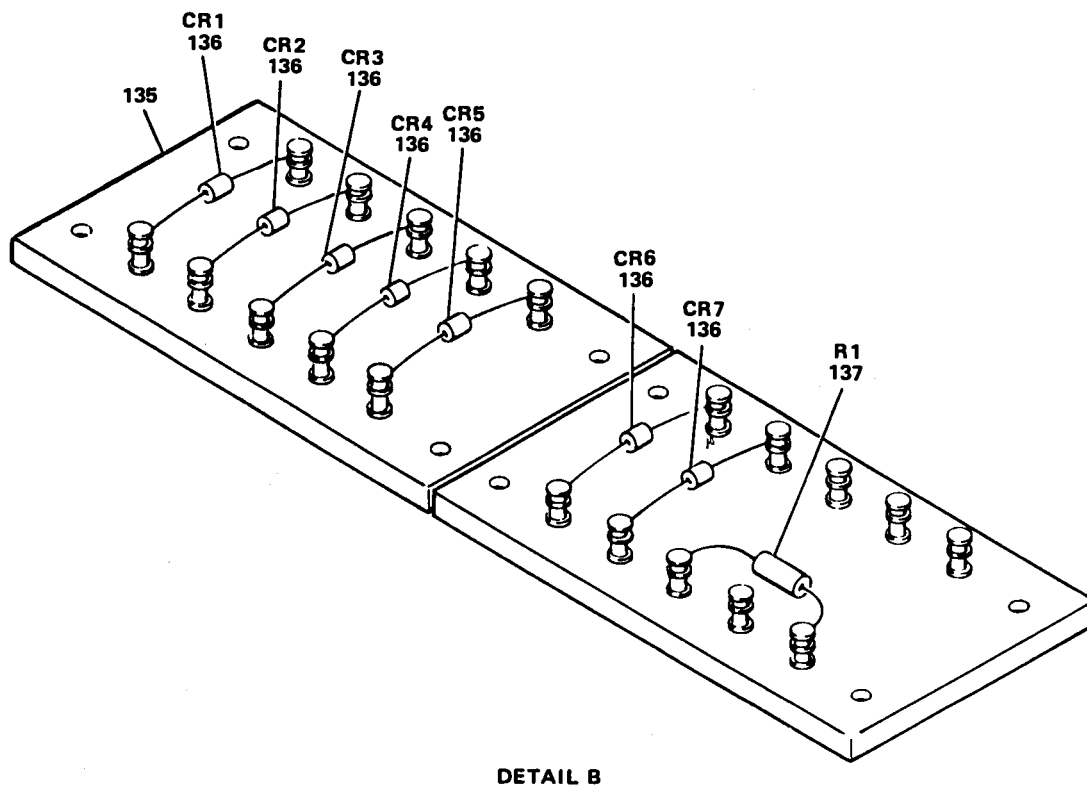

Figure C-1. Countermeasures Control C-11124/ALQ-151(V)
(Sheet 4 of 6)

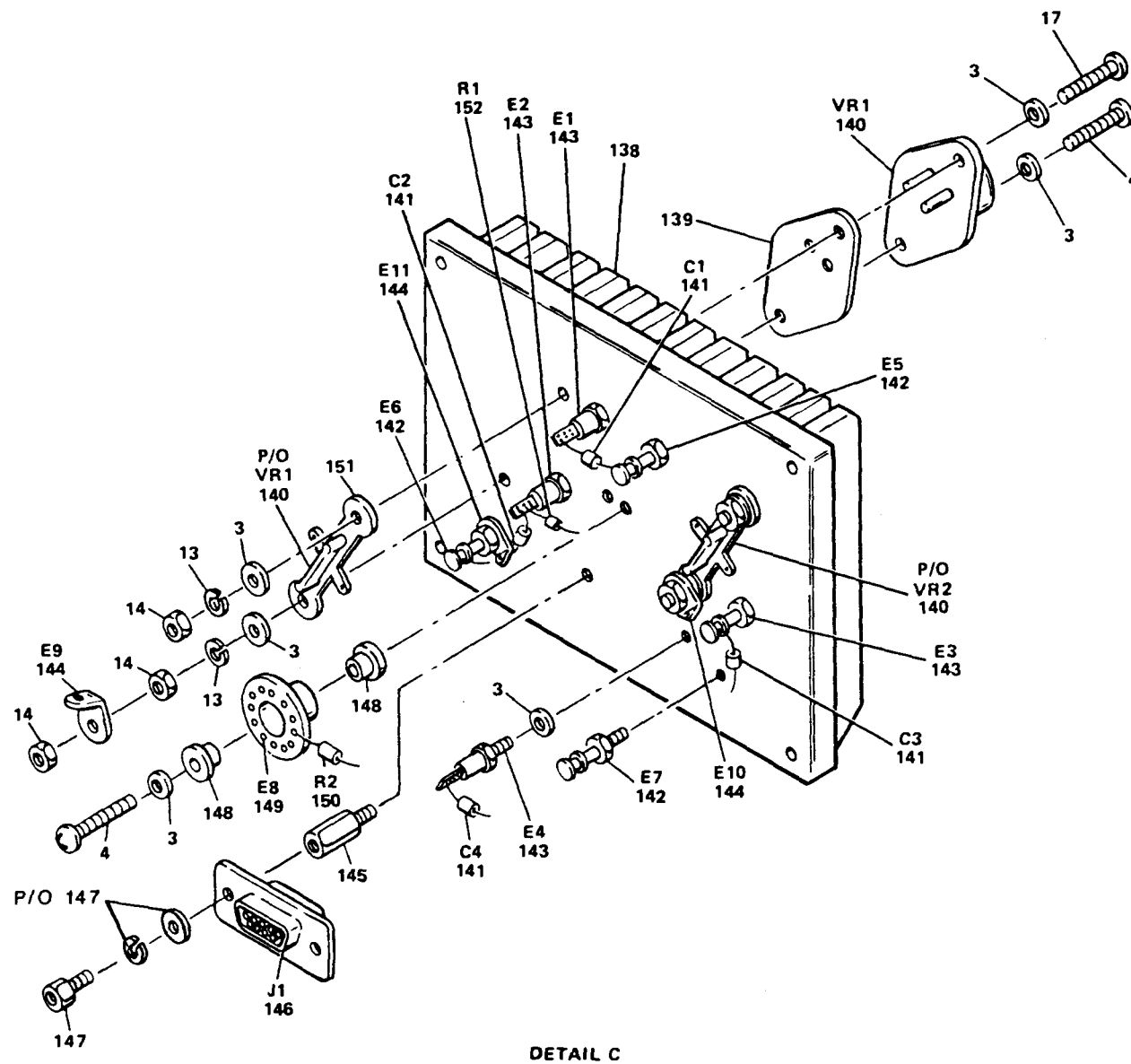
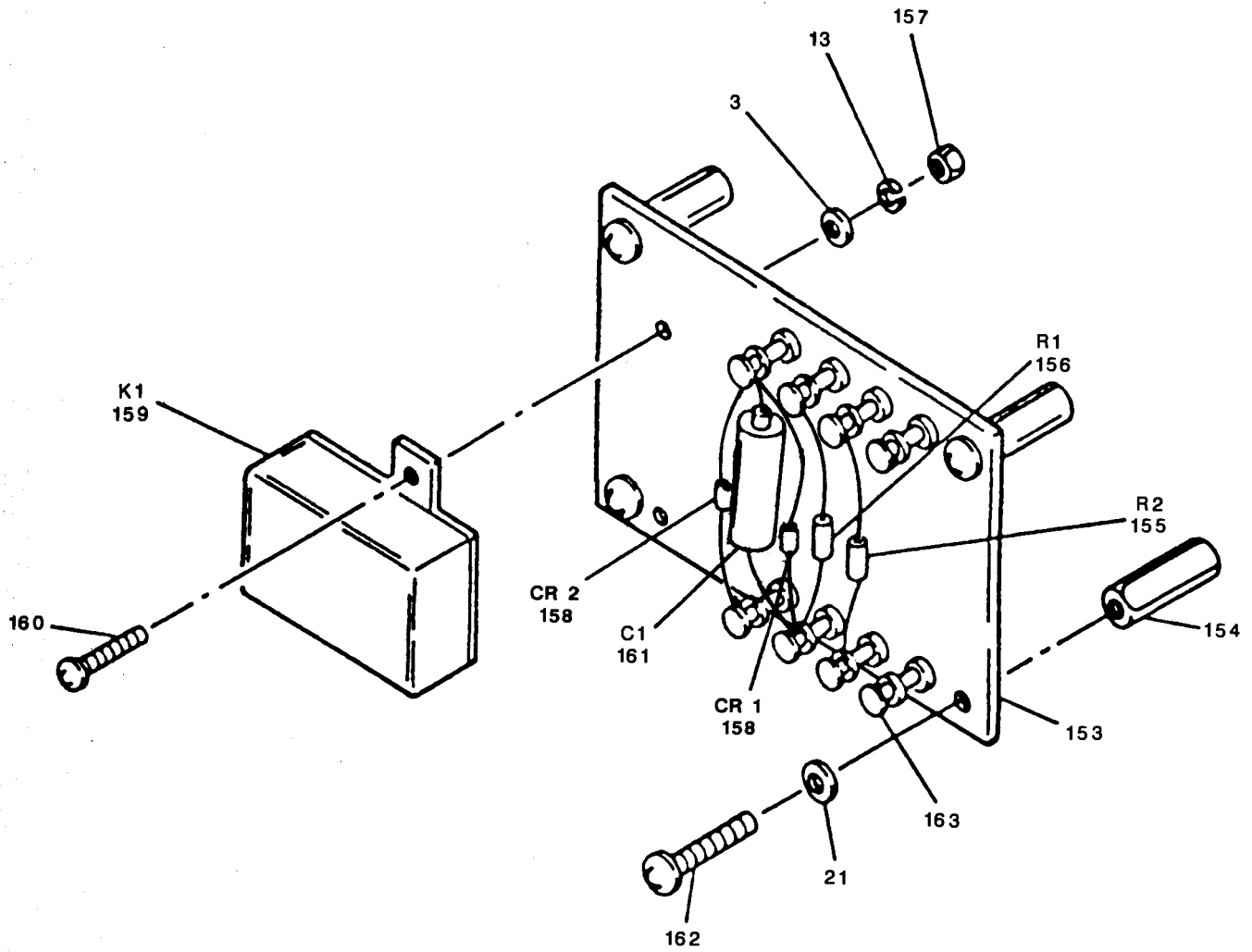

Figure C-1. Countermeasures Control C-11124/ALO-151(V)
 (Sheet 5 of 6)



DETAIL D

Figure C-1. Countermeasures Control C-11124/ALQ-151(V)
(Sheet 6 of 6)

SECTION II. REPAIR PARTS LIST

ILLUSTRATION		(2)	(3)	(4)	(5)	(6)	(7)	(8)
FIG NO	ITEM NO	SMR CODE	NATIONAL STOCK NUMBER	PART NUMBER	FSCM	DESCRIPTION USABLE ON CODE	U/M	QTY INC IN UNIT
						GROUP 13 - COUNTER - MEASURES CONTROL C-11124/ALQ-151(V) C5074239		
1	1	PAHHD	5811-01-206-4672	1951-1-4546-2	15942	CKT CARD ASSY	EA	1
1	2	XDHZZ	5305-00-054-5651	MS51957-17	96906	SCREW,MACHINE	EA	5
1	3	XDHZZ	5310-00-595-6211	MS15795-803	96906	WASHER,FLAT	EA	83
1	4	XDHZZ	5305-00-054-5652	MS51957-18	96906	SCREW,MACHINE	EA	4
1	5	PAHZZ	5961-00-627-0275	JANTX2N3792	81349	TRANSISTOR	EA	1
1	6	XDHZZ	5970-01-081-4666	7403-09FR-05	55285	INSULATOR	EA	1
1	7	XDHZZ	5320-00-584-0672	MS20426AD3-6	96906	RIVET,SOLID	EA	68
1	7A	XDHZZ	5320-00-117-6941	MS20426AD3-7	96906	RIVET,SOLID	EA	6
1	8	XDHZZ	5310-00-771-7360	MS21076L04	96906	NUT,SLFLKG,PLATE	EA	12
1	9	XDHZZ	5320-00-119-6754	MS20470AD2-3	96906	RIVET,SOLID	EA	4
1	10	XDHZZ		35-7B-2-10-1	18915	HOLDER,ELEC	EA	2
1	11	XDHZZ		9211-SS-115-7	06540	SPACER,SLEEVE	EA	12
1	12	XDHZZ	5970-00-007-0112	TM-1	95987	INSULATOR	EA	1
1	13	XDHZZ	5310-00-933-8118	MS35338-135	96906	WASHER,LOCK	EA	32
1	14	XDHZZ	5310-00-934-9748	MS35649-244	96906	NUT,PLAIN,HEX	EA	29
1	15	XDHZZ	5940-00-820-6235	1416-4	83330	TERMINAL,LUG	EA	1
1	16	PAHZZ	5945-01-057-2646	M39016/6-104M	81349	RELAY,EM	EA	3
1	17	XDHZZ	5305-00-054-5653	MS51957-19	96906	SCREW,MACHINE	EA	8
1	18	XDHZZ	5305-00-054-5654	MS51957-20	96906	SCREW,MACHINE	EA	6
1	19	PAHHH	5811-01-206-4673	C5074653-1	57958	TERMINAL BD ASSY	EA	1
1	20	XDHZZ	5305-00-054-6656	MS51957-32	96906	SCREW,MACHINE	EA	5
1	21	XDHZZ	5310-00-722-5998	MS15795-805	96906	WASHER,FLAT	EA	19
1	22	XDHZZ	5940-00-839-0828	SE26XF01	81349	TERMINAL,STUD	EA	5
1	23	XDHZZ	5970-01-043-5759	N276	08863	BEARING,SLV	EA	5
1	24	XDHZZ	5935-01-210-0121	5065757-1	57958	BRKT CONN	EA	1
1	25	XDHZZ	5999-01-051-3735	010-8509-502	31413	CONTACT,ELEC	EA	92
1	26	XDHZZ	5935-01-129-7630	302-0002-002	31413	INSUL SLVG,ELEC	EA	92
1	27	XDHZZ	5320-00-754-0822	MS20470AD4-5	96906	RIVET,SOLID	EA	5
1	28	XDHZZ	5970-00-464-0465	516-0018-000	31413	KEY,POLARIZING	EA	2
1	29	XDHZZ	5305-00-054-6652	MS51957-28	96906	SCREW,MACHINE	EA	4
1	30	XDHZZ		C5074492-1	57958	COVER,CHASSIS	EA	1
1	31	XDHZZ	5305-00-763-6962	MS51959-27	96906	SCREW,MACHINE	EA	37
1	32	PAHHD	6110-01-209-2417	C5074621-1	57958	VOLTAGE REG ASSY	EA	1
1	33	PAHZZ	5935-00-410-9251	M24308/3-1	81349	CONN,PLUG,ELEC	EA	1
1	34	XDHZZ	5935-00-956-2935	D20419	71468	SCREW LOCK ASSY	EA	2
1	35	XDHZZ	5310-00-843-7635	MF6001-06	15653	NUT,SLFLKG,PL	EA	4
1	36	XDHZZ	5320-00-117-6815	MS20470AD3-4	96906	RIVET,SOLID	EA	8

SECTION II. REPAIR PARTS LIST

(1) ILLUSTRATION		(2)	(3)	(4)	(5)	(6)	(7)	(8)
FIG NO	ITEM NO	SMR CODE	NATIONAL STOCK NUMBER	PART NUMBER	NSM	DESCRIPTION USABLE ON CODE	J/M	QTY INC IN JNIT
1	37	⟨DHHH		C5074467-1	57958	BRACKET ECM	EA	1
1	38	⟨DHZZ	5310-00-771-7369	MS21076L06	96906	NUT, SLFLKG, PL	EA	33
1	39	⟨DHZZ	5320-00-117-6938	MS20426AD3-4	96906	RIVET, SOL ID	EA	44
1	40	⟨DHZZ	5310-00-685-2318	MK2001-04	15653	NUT, SLFLKG, PL	EA	4
1	41	⟨DHZZ	5310-00-893-7355	F-032-1	46384	NUT, SLFLKG, CL	EA	2
1	42	⟨DHZZ	5305-00-059-3661	MS51958-65	96906	SCREW, MACHINE	EA	1
1	43	⟨DHZZ	5940-00-583-7741	MS77068-4	96906	TERMINAL LUG	EA	2
1	44	⟨DHZZ	5310-00-209-1239	MS35335-60	96906	WASHER, LOCK	EA	1
1	45	⟨DHZZ	5310-00-595-6772	MS15795-808	96906	WASHER, FLAT	EA	2
1	46	⟨DHZZ	5310-00-933-812C	MS35338-138	96906	WASHER, LOCK	EA	2
1	47	⟨DHZZ	5310-00-934-976E	MS35650-304	96906	NUT, PLAIN, HEX	EA	2
1	48	PAHZZ	5935-01-056-3587	MS27508E18F32S	96906	CONN, RCPT, ELEC	EA	1
1	49	⟨DHZZ	5305-00-054-665E	MS51957-29	96906	SCREW, MACHINE	EA	8
1	50	⟨DHZZ	5305-00-054-564E	MS51957-15	96906	SCREW, MACHINE	EA	24
1	51	⟨DHZZ	5320-00-117-695C	MS20426AD4-5	96906	RIVET, SOL ID	EA	7
1	52	⟨DHZZ	5305-00-054-667E	MS51957-50	96906	SCREW, MACHINE	EA	2
1	53	⟨DHZZ	5310-00-880-597E	MS15795-807	96906	WASHER, FLAT	EA	4
1	54	⟨DHZZ	5985-01-222-093E	C5074487-1	57958	BRACKET, COAX	EA	1
1	55		DELETED					
1	56	PAHZZ	5985-01-222-093E	D4-313Q1	50667	SWITCH, COAX	EA	1
1	57	⟨DHZZ	5310-00-939-085C	MS21083C08	96906	NUT, SLFLKG, HEX	EA	2
1	58	PAHHH	5811-01-206-467C	C5074707-2	57958	TERMINAL BD ASSY	EA	1
1	59	⟨DHHH		C5074687-1	57958	CHASSIS, ECM	EA	1
1	59A	⟨DHZZ		C5074687-502	57958	BRACKET, COVER, BOTTOM	EA	1
1	60	PAHZZ	5915-01-089-405C	1951-1-4876-1	15942	FILTER ASSY	EA	1
1	61	⟨DHZZ		C5074618-1	57958	COVER, CHASSIS	EA	1
1	62	PAHZZ	5935-01-114-3441	MS27508E22F55S	96906	CONN, RCPT, ELEC	EA	1
1	63	PAHZZ	5935-01-056-3585	MS27508E18F32P	96906	CONN, RCPT, ELEC	EA	1
1	64	PAHZZ	5935-01-064-9203	MS27508E16F26P	96906	CONN, RCPT, ELEC	EA	1
1	65	⟨DHZZ	5940-01-010-2898	MS25036-149	96906	TERMINAL LUG	EA	2
1	66	PAHZZ	5925-00-224-7425	MS3320-2	96906	CIRCUIT BREAKER	EA	1
1	67	PAHZZ	5935-01-097-4859	MS27508E20F41S	96906	CONN, RCPT, ELEC	EA	1
1	68	⟨DHHH		C5074134-1	57958	PANEL ASSY, FRONT	EA	1
1	68A	⟨DHZZ		C5074134-502	57958	ANGLE, TOP	EA	1
1	68B	⟨DHZZ		C5074134-503	57958	ANGLE, BOTTOM	EA	1
1	69	⟨DHHH		PFSC31/2-38ASS	72794	FASTENER, ASSY	EA	6
1	70	⟨DHZZ	5325-00-788-5635	82-35-302-15	94222	RCPT, TURNLOCK	EA	2
1	70A	⟨DHZZ	5320-00-117-6939	MS20426AD3-5	96906	RIVET, SOL ID	EA	4
1	71	⟨DHZZ		C5074128-11	57958	PLATE, IDENT	EA	1
1	72	⟨DHHH		C5074499-1	57958	PLATE, FR PANEL	EA	1

SECTION II. REPAIR PARTS LIST

(1) ILLUSTRATION		(2)	(3)	(4)	(5)	(6)	(7)	(8)
FIG NO	ITEM NO	SMR CODE	NATIONAL STOCK NUMBER	PART NUMBER	FSCM	DESCRIPTION USABLE ON CODE	U/M	QTY INC IN UNIT
1	73	XDHZZ	5305-00-993-9189	MS24693-C2	96906	SCREW,MACHINE	EA	2
1	74	XDHZZ	5999-01-209-2429	C5074763-2	57958	RETAINER,PCB	EA	2
1	75	XDHZZ	5305-00-054-5648	MS51957-41	96906	SCREW,MACHINE	EA	4
1	76	XDHZZ	4010-01-006-3001	NAS1201C6B5B	80205	CHAIN-BEAD	EA	1
1	77	XDHZZ		82-19-120-20	94222	STUD,TURNLOCK	EA	2
1	78	XDHZZ	5310-00-949-6139	82-32-101-20	94222	RING,RETAINING	EA	2
1	79	XDHZZ	5310-00-771-7369	MS21076L06	96906	NUT,SLFLKG,PL	EA	15
1	80	PAHZZ	5961-00-494-4915	JANTX1N4148	81349	SCND DVC,DIODE	EA	8
1	81	PAHZZ	5910-00-996-2238	M39003/01-2617	81349	CAP,FXD,ELCTLT	EA	1
1	82	PAHZZ	5910-00-464-9812	M39003/01-2497	81349	CAP,FXD,ELCTLT	EA	1
1	83	PAHZZ	5910-00-996-2236	M39003/01-2578	81349	CAP,FXD,ELCTLT	EA	1
1	84	PAHZZ	5910-00-113-9453	M39014/02-1409	81349	CAP,FXD,CER	EA	1
1	85	PAHZZ	5910-00-010-8718	M39014/02-1258	81349	CAP,FXD,CER	EA	3
1	86	PAHZZ	5910-01-047-8498	M39014/02-1270	81349	CAP,FXD,CER	EA	3
1	87	PAHZZ	5910-00-932-0402	M23269/10-3312	81349	CAP,FXD,GLASS	EA	1
1	88	PAHZZ	5935-01-076-4499	M1001-00844-AA	28815	CONN,RCPT,ELEC	EA	1
1	89	PAHZZ	5961-00-858-3826	JANTX2N2222A	81349	TRANSISTOR	EA	8
1	90	PAHZZ	5961-00-504-5134	JANTX2N4150	81349	TRANSISTOR	EA	1
1	91	PAHZZ	5961-01-047-1828	JANTX2N6350	81349	TRANSISTOR	EA	3
1	92	PAHZZ	5905-00-131-1255	RCR07G122JP	81349	RES,FXD,CMPSN	EA	1
1	93	PAHZZ	5905-00-110-7622	RCR07G682JP	81349	RES,FXD,CMPSN	EA	1
1	94	PAHZZ	5905-00-141-0743	RCR07G392JP	81349	RES,FXD,CMPSN	EA	1
1	95	PAHZZ	5905-00-106-3666	RCR07G103JP	81349	RES,FXD,CMPSN	EA	10
1	96	PAHZZ	5905-00-228-5506	RCR07G622JP	81349	RES,FXD,CMPSN	EA	4
1	97	PAHZZ	5905-00-116-8555	RCR07G153JP	81349	RES,FXD,CMPSN	EA	2
1	98	PAHZZ	5905-00-114-0711	RCR07G472JP	81349	RES,FXD,CMPSN	EA	3
1	99	PAHZZ	5905-00-105-7764	RCR07G222JP	81349	RES,FXD,CMPSN	EA	3
1	100	PAHZZ	5905-00-369-6916	RCR32G122JP	81349	RES,FXD,FILM	EA	1
1	101	PAHZZ	5905-00-141-1183	RCR07G101JP	81349	RES,FXD,CMPSN	EA	1
1	102	PAHZZ	5905-00-131-1256	RCR32G820JP	81349	RES,FXD,CMPSN	EA	1
1	103	PAHZZ		RCR32G680JP	81349	RES,FXD,CMPSN	EA	1
1	104	PAHZZ	5905-00-138-3376	RN55H1001FP	81349	RES,FXD,FILM	EA	1
1	105	PAHZZ	5905-00-105-7765	RCR07G224JP	81349	RES,FXD,CMPSN	EA	1
1	106	PAHZZ	5905-00-110-0388	RCR07G104JP	81349	RES,FXD,CMPSN	EA	3
1	107	PAHZZ		RNC55C2001FP	81349	RES,FXD,FILM	EA	1

SECTION II. REPAIR PARTS LIST

(1) ILLUSTRATION		(2)	(3)	(4)	(5)	(6)	(7)	(8)
FIG NO	ITEM NO	SMR CODE	NATIONAL STOCK NUMBER	PART NUMBER	FSCM	DESCRIPTION USABLE ON CODE	U/M	QTY INC IN UNIT
1	108	PAHZZ	5905-00-116-8554	RCR07G105JP	81349	RES,FXD,CMPSN	EA	1
1	109	PAHZZ	5905-00-119-3505	RCR07G683JP	81349	RES,FXD,CMPSN	EA	3
1	110	PAHZZ	5905-00-485-4545	RCR07G334JP	81349	RES,FXD,CMPSN	EA	1
1	111	PAHZZ	5905-00-119-8811	RCR07G151JP	81349	RES,FXD,CMPSN	EA	1
1	112	PAHZZ	5905-00-113-4861	RCR07G390JP	81349	RES,FXD,CMPSN	EA	5
1	113	PAHZZ	5905-00-105-7768	RCR07G561JP	81349	RES,FXD,CMPSN	EA	4
1	114	PAHZZ	5905-00-135-3973	RCR07G221JP	81349	RES,FXD,CMPSN	EA	3
1	114A	PAHZZ	5905-00-104-8368	RCR07G470JP	81349	RES,FXD,CMPSN	EA	1
1	115	PAHZZ	5905-00-110-7620	RCR07G102JP	81349	RES,FXD,CMPSN	EA	4
1	116	PAHZZ	5905-00-119-8768	RCR07G821JP	81349	RES,FXD,CMPSN	EA	2
1	117	PAHZZ	5905-00-106-9357	RCR07G750JP	81349	RES,FXD,CMPSN	EA	4
1	118	PAHZZ	5905-00-141-2313	RCR07G563JP	81349	RES,FXD,CMPSN	EA	1
1	119	PAHZZ	5905-00-141-0717	RCR07G473JP	81349	RES,FXD,CMPSN	EA	2
1	120	PAHZZ	5905-00-106-9356	RCR07G203JP	81349	RES,FXD,CMPSN	EA	2
1	121	PAHZZ	5905-00-131-9729	RCR07G302JP	81349	RES,FXD,CMPSN	EA	2
1	122	PAHZZ	5905-00-419-2843	RNC55H1503FP	81349	RES,FXD,FILM	EA	1
1	123	PAHZZ	5950-00-320-7338	SP-67	81095	TRANSFORMER,AF	EA	10
1	124	PAHZZ	5962-01-068-9585	SE556FB	34335	MICROCKT,LIN	EA	1
1	125	PAHZZ	5962-00-167-6330	M38510/10101BGC	81349	MICROCKT,DGTL	EA	1
1	126	PAHZZ	5962-01-144-9009	LM139D/883B	27014	MICROCKT,LIN	EA	4
1	127	PAHZZ	5961-01-009-2234	JANTX1N4104	81349	SCND DVC,DIODE	EA	1
1	128	PAHZZ	5961-00-172-4970	JANTX1N5555	81349	SCND DVC,DIODE	EA	1
1	129	PAHZZ	5961-00-105-5730	JANTX1N752A	81349	SCND DVC,DIODE	EA	1
1	130	XDHZZ	5999-01-068-9564	14007-1P4	91506	PIN,SPRING	EA	2
1	131	XDHZZ	5999-01-028-6070	14009-1P14	91506	RTNR-EJCTR,CARD	EA	1
1	132	XDHZZ	5999-00-605-7936	14009-1P12	91506	RTNR-EJCTR,CARD	EA	1
1	133	XBHZZ		1951-1-4547-2	15942	PRINTED WRG BD	EA	1
1	134	XDHZZ	5320-00-243-8357	MS20470AD2-5	96906	RIVET,SOLID	EA	2
1	135	PAHZZ	5940-01-159-5225	MS27249-2B2	96906	TERMINAL BOARD	EA	1
1	136	PAHZZ	5961-00-494-4915	JANTX1N4148	81349	SCND DVC,DIODE	EA	8
1	137	PAHZZ	5905-00-108-6922	RCR20G151JS	81349	RES,FXD,CMPSN	EA	1
1	138	XDHZZ		C5074622-1	57958	HEAT SINK	EA	1
1	139	PAHZZ	5970-01-081-4666	7403-09FR-05	55285	INSULATOR	EA	2
1	140	PAHZZ		M38510/11704BZA	14933	MICROCKT,LINER	EA	2
1	141	PAHZZ	5910-01-047-8498	M39014/02-1270	81349	CAP,FXD,CER	EA	4
1	142	PAHZZ	5940-00-950-5756	2009	83330	TERMINAL,STUD	EA	3
1	143	PAHZZ	5940-01-150-5902	572-4898-01-05-16	71279	TERMINAL,STUD	EA	4
1	144	PAHZZ	5940-00-682-2477	MS77068-1	96906	TERMINAL,LUG	EA	3
1	145	XDHZZ		164-09SS4-40E	57177	STUD,EXTENSION	EA	2

SECTION II. REPAIR PARTS LIST

ILLUSTRATION		(2)	(3)	(4)	(5)	(6)	(7)	(8)
FIG NO	ITEM NO	SMR CODE	NATIONAL STOCK NUMBER	PART NUMBER	FSCM	DESCRIPTION USABLE ON CODE	U/M	QTY INC IN UNIT
1	146	PAHZZ	5935-00-490-5219	M24308/2-1	81349	CONN,RCPT,ELEC	EA	1
1	147	XDHZZ	5935-01-069-7285	D20418-2	71468	SCREW LOCK ASSY	EA	2
1	148	PAHZZ	5970-01-043-5759	N276	08863	BEARING,SLV	EA	2
1	149	PAHZZ	5940-00-839-0828	SE26XF01	81349	TERMINAL,STUD	EA	1
1	150	PAHZZ	5905-00-116-8555	RCR07G153JS	81349	RES,FXD,CMPSN	EA	1
1	151	PAHZZ	5970-00-004-0112	TM-1	95987	INSULATOR	EA	2
1	152	PAHZZ	5905-00-135-3973	RCR07G221JS	81349	RES,FXD,CMPSN	EA	1
1	153	XDHZZ	5811-01-206-4675	C5074705-1	57958	TERMINAL BOARD	EA	1
1	154	XDHZZ		8215-4-0632-10A	06540	POST,ELEC-MECH	EA	4
1	155	PAHZZ	5905-00-141-0723	RCR20G621JS	81349	RES,FXD,CMPSN	EA	1
1	156	PAHZZ	5905-00-110-0196	RCR20G102KS	81349	RES,FXD,CMPSN	EA	1
1	157	XDHZZ	5310-00-934-9748	MS35649-244	96906	NUT,PLAIN,HEX	EA	6
1	158	PAHZZ	5961-00-458-5813	JANTX1N4245	81349	SCND DVC,DIODE	EA	2
1	159	PAHZZ	5945-01-108-8023	MS5757/13-079	81349	RELAY,EM	EA	1
1	160	XDHZZ	5305-00-054-5648	MS51957-14	96906	SCREW,MACHINE	EA	2
1	161	PAHZZ	5910-00-069-1799	M39003/01-2614	81349	CAP,FXD,ELCTLT	EA	1
1	162	XDHZZ	5305-00-054-6651	MS51957-27	96906	SCREW,MACHINE	EA	4
1	163	XDHZZ		SE12XC07S	81349	TERMINAL,STUD	EA	1

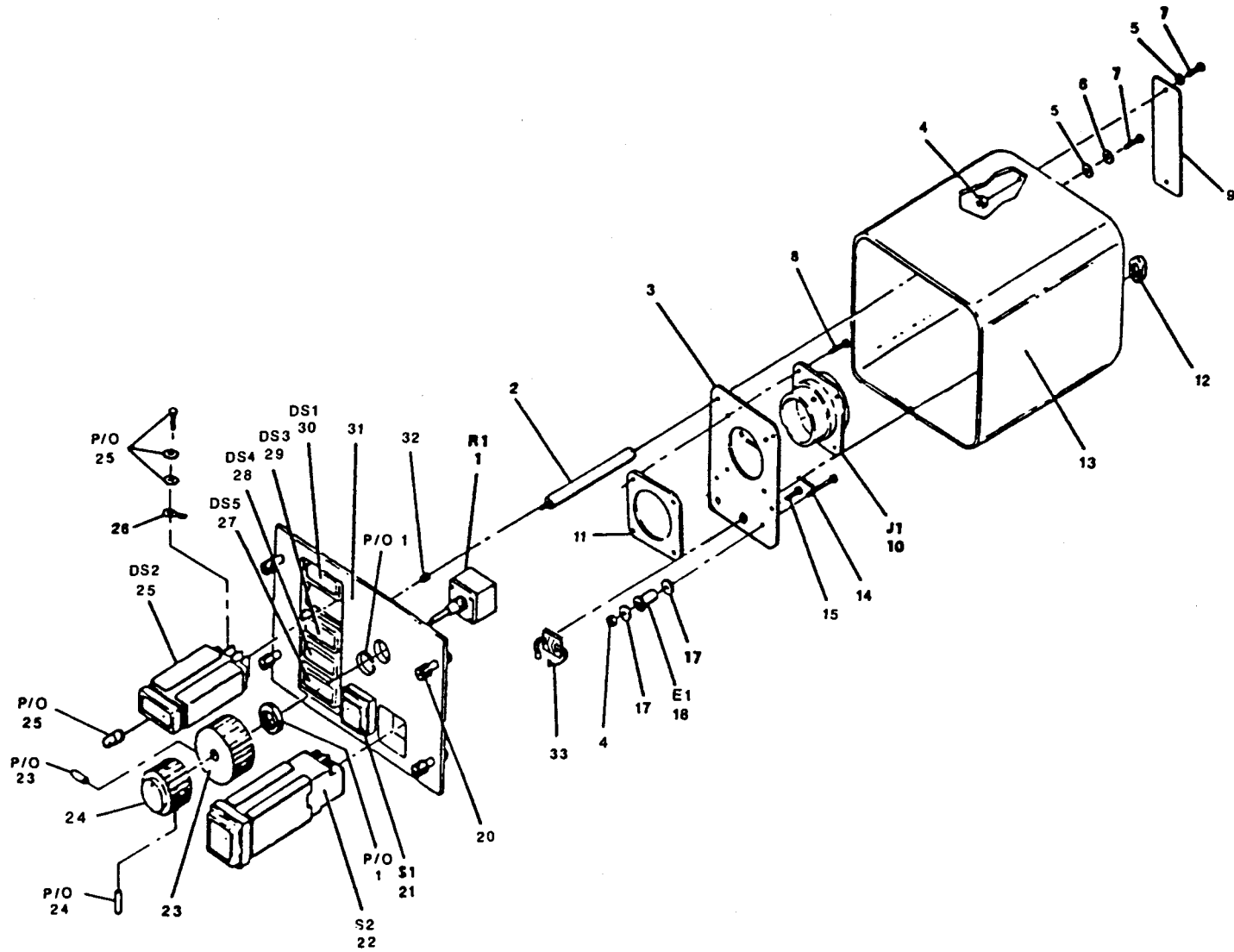

Figure C-2. Countermeasures Indicator Panel ID-2300/ALQ-151(V)

SECTION II. REPAIR PARTS LIST

(1) ILLUSTRATION		(2)	(3)	(4)	(5)	(6)	(7)	(8)
FIG NO	ITEM NO	SMR CODE	NATIONAL STOCK NUMBER	PART NUMBER	FSCM	DESCRIPTION USABLE ON CODE	U/M	QTY INC IN UNIT
						GROUP 09-PANEL INDICATOR COUNTERMEASURE S ID-2300/ALQ-151(V) C5074159-1 (57958)		
2	1	PAHZZ		22M340	01121	RES, VAF, NON WW	EA	1
2	2	XDHZZ		164-38-SS-4-40-E	57177	STUD, EXTENSION	EA	4
2	3	XDHZZ		C5074639-1	57958	CONN PANEL ASSY, ECM	EA	1
2	4	XDHZZ	5310-00-982-5000	MS21045-C04	96906	NUT, SLFLKG, HEX	EA	4
2	5	XDHZZ	5310-01-110-2458	NAS620C-4L	80205	WASHER, FLAT	EA	6
2	6	XDHZZ	5310-00-933-8118	MS35338-135	96906	WASHER, LOCK	EA	2
2	7	XDHZZ	5305-00-054-5648	MS51957-14	96906	SCREW, MACHINE	EA	4
2	8	XDHZZ	5305-00-054-5649	MS51957-15	96906	SCREW, MACHINE	EA	4
2	9	XDHZZ		C5074135-6	57958	PLATE, IDENT	EA	1
2	10	XDHZZ	5935-01-066-1945	MS27508E16F26P	96906	CONN, RCPT, ELEC	EA	1
2	11	XDHZZ		S915-16	19904	NUT RING	EA	1
2	12	XDHZZ	5310-00-934-9765	MS35650-304	96906	NUT, PLAIN, HEX	EA	1
2	13	XDHZZ		C5074152-1	57958	ENCLOSURE	EA	1
2	14	XDHZZ	5305-00-780-8454	MS24693-C7	96906	SCREW, MACHINE	EA	2
2	15	XDHZZ	5305-00-225-6400	MS24693-C3	96906	SCREW, MACHINE	EA	2
2	16		DELETED					
2	17	XDHZZ	5970-00-893-5804	N5228	08863	WASHER, FLAT NYL	EA	2
2	18	XDHZZ	5940-00-939-7825	SE26XF03S	81349	TERMINAL, STUD	EA	2
2	19		DELETED				EA	
2	20	XDHZZ	5325-00-351-4597	PFSC31/2-38A	72794	FASTENER ASSY	EA	1
2	21	PAHZZ	5930-01-221-8163	10620EL1-1	08719	SWITCH, PUSH	EA	1
2	22	PAHZZ	5930-01-221-2358	10620FL1-2	08719	SWITCH, PUSH	EA	1
2	23	PAHZZ	5355-00-071-8739	MS91528-2N2BC	96906	KNOB, CONTROL	EA	1
2	24	PAHZZ	5355-00-057-7794	MS91528-OC1B	96906	KNOB	EA	1
2	25	PAHZZ	6210-01-221-1336	30288EL-2	18719	LIGHT, INDICATOR	EA	1
2	26	XDHZZ	5940-00-577-3807	MS25036-145	96906	TERMINAL, LUG	EA	10
2	27	PAHZZ	6210-01-221-1339	30288EL-5	08719	LIGHT, INDICATOR	EA	1
2	28	PAHZZ	6210-01-221-1338	30288EL-4	08719	LIGHT, INDICATOR	EA	1
2	29	PAHZZ	6210-01-221-1337	30288EL-3	08719	LIGHT, INDICATOR	EA	1
2	30	PAHZZ	6210-01-220-7144	30288EL-1	08719	LIGHT, INDICATOR	EA	1
2	31	XBHHH		C5074151-1	57958	PANEL, FRONT	EA	1
2	32	XDHZZ	5340-00-827-4024	MS21209C0420	96906	INSERT, SCR THD	EA	4
2	33	XDHZZ	4920-00-110-5317	TC817	59730	MOUNT, CABLE		AR

Section III. SPECIAL TOOLS LIST

(Not Applicable)

Section IV. NATIONAL STOCK NUMBER AND PART NUMBER INDEX

NATIONAL STOCK NUMBER INDEX

NATL STOCK NUM	F	ITEM	NATL STOCK NUM	F	ITEM
	1	10	5305-00-059-3661	1	42
	1	11	5305-00-225-6400	2	15
	1	30	5305-00-763-6962	1	31
	1	37	5305-00-780-8454	2	14
	1	56	5305-00-993-9189	1	73
	1	59	5310-00-209-1239	1	44
	1	59A	5310-00-595-6211	1	3
	1	61	5310-00-595-6772	1	45
	1	68	5310-00-685-2318	1	40
	1	68A	5310-00-722-5998	1	21
	1	68B	5310-00-771-7360	1	8
	1	69	5310-00-771-7369	1	38
	1	71	5310-00-771-7369	1	79
	1	72	5310-00-843-7635	1	35
	1	77	5310-00-880-5978	1	53
	1	103	5310-00-893-7355	1	41
	1	107	5310-00-933-8118	1	13
	1	133	5310-00-933-8118	2	6
	1	138	5310-00-933-8120	1	46
	1	140	5310-00-934-9748	1	14
	1	145	5310-00-934-9748	1	157
	1	154	5310-00-934-9765	1	47
	1	163	5310-00-934-9765	2	12
	2	1	5310-00-939-0850	1	57
	2	2	5310-00-949-6139	1	78
	2	3	5310-00-982-5000	2	4
	2	9	5310-01-110-2458	2	5
	2	11	5320-00-117-6815	1	36
	2	13	5320-00-117-6938	1	39
	2	31	5320-00-117-6939	1	70A
4010-01-006-3001	1	76	5320-00-117-6941	1	7A
4920-00-110-5317	2	33	5320-00-117-6950	1	51
5305-00-054-5648	1	75	5320-00-119-6754	1	9
5305-00-054-5648	1	160	5320-00-243-8357	1	1
5305-00-054-5648	2	7	5320-00-584-0672	1	7
5305-00-054-5649	1	50	5320-00-754-0822	1	27
5305-00-054-5649	2	8	5325-00-351-4597	2	20
5305-00-054-5651	1	2	5325-00-788-5635	1	70
5305-00-054-5652	1	4	5340-00-827-4024	2	32
5305-00-054-5653	1	17	5355-00-057-7794	2	24
5305-00-054-5654	1	18	5355-00-071-8739	2	23
5305-00-054-6651	1	162	5811-01-206-4670	1	58
5305-00-054-6652	1	29	5811-01-206-4672	1	1
5305-00-054-6653	1	49	5811-01-206-4673	1	19
5305-00-054-6656	1	20	5811-01-206-4675	1	153
5305-00-054-6675	1	52	5905-00-104-8368	1	114A

NATIONAL STOCK NUMBER AND PART NUMBER INDEX

NATL STOCK NUM	FIGURE	ITEM	NATL STOCK NUM	FIGURE	ITEM
5905-00-105-7764	1	99	5935-00-956-2935	1	34
5905-00-105-7765	1	105	5935-01-056-3585	1	63
5905-00-105-7768	1	113	5935-01-056-3587	1	48
5905-00-106-3666	1	95	5935-01-064-9203	1	64
5905-00-106-9356	1	120	5935-01-066-1945	2	10
5905-00-106-9357	1	117	5935-01-069-7285	1	147
5905-00-108-6922	1	137	5935-01-076-4499	1	88
5905-00-110-0196	1	156	5935-01-097-4859	1	67
5905-00-110-0388	1	106	5935-01-114-3441	1	62
5905-00-110-7620	1	115	5935-01-129-7630	1	26
5905-00-110-7622	1	93	5935-01-210-0121	1	24
5905-00-113-4861	1	112	5940-00-577-3807	2	26
5905-00-114-0711	1	98	5940-00-583-7741	1	43
5905-00-116-8554	1	108	5940-00-682-2477	1	144
5905-00-116-8555	1	97	5940-00-820-6235	1	15
5905-00-116-8555	1	150	5940-00-839-0828	1	22
5905-00-119-3505	1	109	5940-00-839-0828	1	149
5905-00-119-8768	1	116	5940-00-939-7825	2	18
5905-00-119-8811	1	111	5940-00-950-5756	1	142
5905-00-131-1255	1	92	5940-01-010-2898	1	65
5905-00-131-1256	1	102	5940-01-150-5902	1	143
5905-00-131-9729	1	121	5940-01-159-5225	1	135
5905-00-135-3973	1	114	5945-01-057-2646	1	16
5905-00-135-3973	1	152	5945-01-108-8023	1	159
5905-00-138-3376	1	104	5950-00-320-7338	1	123
5905-00-141-0717	1	119	5961-00-105-5730	1	129
5905-00-141-0723	1	155	5961-00-172-4970	1	128
5905-00-141-0743	1	94	5961-00-458-5813	1	158
5905-00-141-1183	1	101	5961-00-494-4915	1	80
5905-00-141-2313	1	118	5961-00-494-4915	1	136
5905-00-228-5506	1	96	5961-00-504-5134	1	90
5905-00-369-6916	1	100	5961-00-627-0275	1	5
5905-00-419-2843	1	122	5961-00-858-3826	1	89
5905-00-485-4545	1	110	5961-01-009-2234	1	127
5910-00-010-8718	1	85	5961-01-047-1828	1	91
5910-00-069-1799	1	161	5962-00-167-6330	1	125
5910-00-113-9453	1	84	5962-01-068-9585	1	124
5910-00-464-9812	1	82	5962-01-144-9009	1	126
5910-00-932-0402	1	87	5970-00-004-0112	1	151
5910-00-996-2236	1	83	5970-00-007-0112	1	12
5910-00-996-2238	1	81	5970-00-464-0465	1	28
5910-01-047-8498	1	86	5970-00-893-5804	2	17
5910-01-047-8498	1	141	5970-01-043-5759	1	23
5915-01-089-4050	1	60	5970-01-043-5759	1	148
5925-00-224-7425	1	66	5970-01-081-4666	1	6
5930-01-221-2358	2	22	5970-01-081-4666	1	139
5930-01-221-8163	2	21	5985-01-222-0938	1	54
5935-00-410-9251	1	33	5985-01-222-0938	1	56
5935-00-490-5219	1	146	5999-00-605-7936	1	132

NATIONAL STOCK NUMBER AND PART NUMBER INDEX

NATL STOCK NUM	F	ITEM	NATL STOCK NUM	F	ITEM
5999-01-028-6070	1	131			
5999-01-051-3735	1	25			
5999-01-068-9564	1	130			
5999-01-209-2429	1	74			
6110-01-209-2417	1	32			
6210-01-220-7144	2	30			
6210-01-221-1336	2	25			
6210-01-221-1337	2	29			
6210-01-221-1338	2	28			
6210-01-221-1339	2	27			

PART NUMBER INDEX

PART NUMBER	FSCM	FIGURE	ITEM	PART NUMBER	FSCM	F	ITEM
		1	55	MS20426AD4-5	96906	1	51
		2	16	MS2047OAD2-3	96906	1	9
C5074128-11	57958	1	71	MS2047OAD2-5	96906	1	134
C5074134-1	57958	1	68	MS2047OAD3-4	96906	1	36
C5074134-502	57958	1	68A	MS2047OAD4-5	96906	1	27
C5074134-503	57958	1	68B	MS21045-C04	96906	2	4
C5074135-6	57958	2	9	MS21076L04	96906	1	8
C5074151-1	57958	2	31	MS21076L06	96906	1	38
C5074152-1	57958	2	13	MS21076L06	96906	1	79
C5074467-1	57958	1	37	MS21083C08	96906	1	57
C5074487-1	57958	1	54	MS21209C0420	96906	2	32
C5074492-1	57958	1	30	MS24693-C2	96906	1	73
C5074499-1	57958	1	72	MS24693-C3	96906	2	15
C5074618-1	57958	1	61	MS24693-C7	96906	2	14
C5074621-1	57958	1	32	MS25036-145	96906	2	26
C5074622-1	57958	1	138	MS25036-149	96906	1	65
C5074639-1	57958	2	3	MS27249-2B2	96906	1	135
C5074653-1	57958	1	19	MS27508E16F26P	96906	1	64
C5074687-1	57958	1	59	MS27508E16F26P	96906	2	10
C5074687-502	57958	1	59A	MS27508E18F32P	96906	1	63
C5074705-1	57958	1	153	MS27508E18F32S	96906	1	48
C5074707-2	57958	1	58	MS27508E20F41S	96906	1	67
C5074763-2	57958	1	74	MS27508E22F55S	96906	1	62
DELETED		2	19	MS3320-2	96906	1	66
D20418-2	71468	1	147	MS35335-60	96906	1	44
D20419	71468	1	34	MS35338-135	96906	1	13
D4-313Q1	50667	1	56	MS35338-135	96906	2	6
F-032-	46384	1	41	MS35338-138	96906	1	46
JANTX1N4104	81349	1	127	MS35649-244	96906	1	14
JANTX1N4148	81349	1	80	MS35649-244	96906	1	157
JANTX1N4148	81349	1	136	MS35650-304	96906	1	47
JANTX1N4245	81349	1	158	MS35650-304	96906	2	12
JANTX1N5555	81349	1	128	MS51957-14	96906	1	160
JANTX1N752A	81349	1	129	MS51957-14	96906	2	7
JANTX2N2222A	81349	1	89	MS51957-15	96906	1	50
JANTX2N3792	81349	1	5	MS51957-15	96906	2	8
JANTX2N4150	81349	1	90	MS51957-17	96906	1	2
JANTX2N6350	81349	1	91	MS51957-18	96906	1	4
LM139D/883B	27014	1	126	MS51957-19	96906	1	17
MF6001-06	15653	1	35	MS51957-20	96906	1	18
MK2001-04	15653	1	40	MS51957-27	96906	1	162
MS15795-803	96906	1	3	MS51957-28	96906	1	29
MS15795-805	96906	1	21	MS51957-29	96906	1	49
MS15795-807	96906	1	53	MS51957-32	96906	1	20
MS15795-808	96906	1	45	MS51957-41	96906	1	75
MS20426AD3-4	96906	1	39	MS51957-50	96906	1	52
MS20426AD3-5	96906	1	70A	MS51958-65	96906	1	42
MS20426AD3-6	96906	1	7	MS51959-27	96906	1	31
MS20426AD3-7	96906	1	7A	MS5757/13-079	81349	1	159

PART NUMBER INDEX

PART NUMBER	FSCM	F	ITEM	PART NUMBER	FSCM	FIGURE	ITEM
MS77068-1	96906	1	144	RCR07G622JP	81349	1	96
MS77068-4	96906	1	43	RCR07G682JP	81349	1	93
MS91528-0C1B	96906	2	24	RCR07G683JP	81349	1	109
MS91528-2N2BC	96906	2	23	RCR07G750JP	81349	1	117
M1001-00844-AA	28815	1	88	RCR07G821JP	81349	1	116
M23269/10-3312	81349	1	87	RCR20G102KS	81349	1	156
M24308/2-1	81349	1	146	RCR20G151JS	81349	1	1
M24308/3-1	81349	1	33	RCR20G621JS	81349	1	155
M38510/10101BGC	81349	1	125	RCR32G122JP	81349	1	100
M38510/11704BZA	14933	1	140	RCR32G680JP	81349	1	103
M39003/01-2497	81349	1	82	RCR32G820JP	81349	1	102
M39003/01-2578	81349	1	83	RNC55C2001FP	81349	1	107
M39003/01-2614	81349	1	161	RNC55H1503FP	81349	1	1
M39003/01-2617	81349	1	81	RN55H1001FP	81349	1	104
M39014/02-1258	81	1	85	SE12XC07S	81349	1	163
M39014/02-1270	81349	1	86	SE26XF01	81349	1	22
M39014/02-1270	81349	1	141	SE26XF01	81349	1	149
M39014/02-1409	81349	1	84	SE26XF03S	81349	2	18
M39016/6-104M	81	1	16	SE556FB	34335	1	124
NAS1201C6B5B	80205	1	76	SP-67	81095	1	123
NAS620C-4L	80205	2	5	S915-16	19904	2	11
N276	08863	1	23	TC81	59730	2	33
N276	08863	1	148	TM-	95987	1	12
N5228	08863	2	17	TM-1	95987	1	151
PFSC31/2-38A	72794	2	20	010-8509-502	31413	1	25
PFSC31/2-38ASS	72794	1	69	10620EL1-1	08719	2	21
RCR07G101JP	81349	1	101	10620FL1-2	08719	2	22
RCR07G102JP	81349	1	115	14007-1P4	91506	1	130
RCR07G103JP	81349	1	95	14009-1P12	91506	1	132
RCR07G104JP	81349	1	106	14009-1P14	91506	1	131
RCR07G105JP	81349	1	108	1416-4	83330	1	15
RCR07G122JP	81349	1	92	164-09SS4-40E	57177	1	145
RCR07G151JP	81349	1	111	164-38-SS-4-40-E	57177	2	2
RCR07G153JP	81349	1	97	1951-1-4546-2	15942	1	1
RCR07G153JS	81349	1	150	1951-1-4547-2	15942	1	133
RCR07G203JP	81349	1	120	1951-1-4876-1	15942	1	60
RCR07G221JP	81349	1	114	2009	83330	1	142
RCR07G221JS	81349	1	152	22M340	01121	2	1
RCR07G222JP	81349	1	99	302-0002-002	31413	1	26
RCR07G224JP	81349	1	105	30288EL-1	08719	2	30
RCR07G302JP	81349	1	121	30288EL-2	18719	2	25
RCR07G334JP	81349	1	110	30288EL-3	08719	2	29
RCR07G390JP	81349	1	112	30288EL-4	08719	2	28
RCR07G392JP	81349	1	94	30288EL-5	08719	2	27
RCR07G470JP	81349	1	114A	35-7B-2-10-1	18915	1	10
RCR07G472JP	81349	1	98	5065757-1	57958	1	24
RCR07G473JP	81349	1	119	516-0018-000	31413	1	28
RCR07G561JP	81349	1	113	572-4898-01-05-16	71279	1	143
RCR07G563JP	81349	1	118	7403-09FR-05	55285	1	6

PART NUMBER INDEX

PART NUMBER	FSCM	F	ITEM	PART NUMBER	FSCM	F	ITEM
7403-09FR-05	55285	1	139				
82-19-120-20	94222	1	77				
82-32-101-20	94222	1	78				
82-35-302-15	94222	.1	70				
8215-4-0632-10A	06540	1	154				
9211-SS-115-7	06540	1	11				

APPENDIX D
EXPENDABLE SUPPLIES AND MATERIALS LIST

Section I. INTRODUCTION

D-1. SCOPE

This appendix lists expendable supplies and materials you will need to operate and maintain the ECM panel indicator and countermeasures control. These items are authorized to you by CTA 50-970. Expendable Items (Except Medical, Class V, Repair Parts, and Heraldic Items).

D-2. EXPLANATION OF COLUMNS

a. Column(1)- Item number. This number is assigned to the entry in the listing and is referenced in the narrative instructions to identify the material (e.g., "Use cleaning compound, item 5, App. D").

b. Column(2)- Level. This column identifies the lowest level of maintenance that requires the listed item.

(enter as applicable)

- C - Operator/Crew
- O - Organizational Maintenance
- F - Direct Support Maintenance
- H - General Support Maintenance

c. Column(3)- National Stock Number. This is the National stock number assigned to the item; use it to request or requisition the item.

d. Column(4)- Description. Indicates the Federal item name and, if required, a description to identify the item. The last line for each item indicates the Federal Supply Code for Manufacturer (FSCM) in parentheses followed by the part number.

e. Column(5)- Unit of Measure (U/M). Indicates the measure used in performing the actual maintenance function. This measure is expressed by a two-character alphabetical abbreviation (e.g., ea, in, pr). If the unit of measure differs from the unit of issue, requisition the lowest unit of issue that will satisfy your requirements.

Section II. EXPENDABLE SUPPLIES AND MATERIALS LIST

(1) ITEM NO.	(2) LEVEL	(3) NSN	(4) DESCRIPTION	(5) U/M
1	H	TBS	Adhesive, clear, type 608	TBS
2	H	8029-00-246-8806	Brush, soft	ea
3	H	TBS	Brush, stiff	ea
4	H	8305-00-267-3015	Cloth, lint-free	ro
5	H	TBS	Coating, primer, MIL-S-22473	TBS
6	H	TBS	Compound, locking, MIL-S-22473	TBS
7	H	TBS	Enamel, semi-gloss, MIL-E-15090, color no. 24410	pt
8	H	TBS	Gloves, rubber heavy duty	pr
9	H	TBS	Humiseal, 1A33 or 1B31	TBS
10	H	TBS	Sandpaper, No. 000	sht
11	H	*	Sleeving, insulated, heatshrink, 0.187 ID black	in
12	H	*	Sleeving, insulated, heatshrink, 0.125 ID black	in
13	H	TBS	Solder, SN60WRAP3	ro
14	H	TBS	Solution, cleaning (freon TFE, TE, or TMS)	TBS
15	H	TBS	Solvent, Resin Remover, Type AP-20	pt
16	H	TBS	Swabs, cotton	TBS
17	H	TBS	Tape, Lacing, size 5, black	ro
18	H	6850-00-984-5853	Trichlorotrifluoroethane	gl
19	H	TBS	Wire, electrical, 20 AWG	in
20	H	TBS	Wire, electrical, 20 AWG, black	in
21	H	TBS	Wire, electrical, 20 AWG, blue	in
22	H	TBS	Wire, electrical, 20 AWG, red	in
23	H	TBS	Wire, electrical, 22 AWG, black	in
24	H	TBS	Wire, electrical, 22 AWG, red	in
25	H	TBS	Wire, electrical, 22 AWG, white	in
26	H	6145-00-0595602	Wire, electrical, 24 AWG, black	in
27	H	6145-01-2266718	Wire, electrical, 24 AWG, blue	in
28	H	6145-01-0099902	Wire, electrical, 24 AWG, red	in
29	H	6145-00-8455205	Wire, electrical, 24 AWG, white	in
30	H	TBS	Wire, electrical, 24 AWG, blk/wht	in
31	H	5120-00-293-3112	Description of orangewood sticks to be provided	

* Obtain applicable size length from kit, Heatshrink Tubing,
Fit 221MSI, NSN 5970-01-026-1877.

GLOSSARY

Abbreviated terms used in this manual and their spelled-out equivalents are listed below.

<u>Term</u>	<u>Equivalent</u>
Countermeasures control	Countermeasures Control C-11124/ ALQ-151(V)
ECM panel indicator	Countermeasures Panel Indicator ID-2300/ALQ-151(V)
EIR	Equipment Improvement Recommendations
TAMMS	The Army Maintenance Management System

INDEX

Subject	Paragraph, figure, table	Page
A		
Administrative Storage	1-4	1-2
Army Regulations	A-6	A-2
Audio and Control Through-Wiring	T3-1	3-3
Audio Signal Conditioning Circuits		
Description	3-4a(1)	3-2
Simplified Schematic Diagram	F3-1	3-4
Audio Test		
Connections and Display Data	T5-4	5-25
Setup	F5-6	5-23
B		
Bottom Cover		
Removal	5-12c	5-39
Replacement	5-12c	5-39
C		
CCA, Indicator A3		
Description	3-4a	3-2
Removal	5-12f	5-40
Replacement	5-12g	5-40
CCA/ECA Inspection	5-10c	5-26
CCAs, Repair of	5-12h	5-40
Chassis Inspection	5-10a	5-25
Chassis Repair	5-12ad	5-57
Circuits		
Indicator	3-3a	3-1
Intercom Control	3-4a(2)	3-5
Interlock	3-3f	3-2
Lamp Control	3-4a(4)	3-7
Monitor	3-4a(3)	3-5
Power Distribution	3-4d	3-9
Circuit Breaker CB1 Removal and Replacement	5-12x	5-54
Cleaning the ECM Panel Indicator and Countermeasures Control	5-10b	5-26
Coax Switch Bracket Removal and Replacement	5-12w	5-54
Common Table of Allowances	A-4	A-2
Connector Bracket Removal and Replacement	5-12u	5-52
Connector J1 Removal and Replacement	5-11f	5-33
Connectors J2, J3, J6 through J8 Removal and Replacement	5-12y	5-54
Connector Panel Removal and Replacement	5-11e	5-33
CONSOLE BRT Potentiometer R1A	3-3d	3-2
Countermeasures Control		
Audio and Control Through-Wiring	T3-1	3-3
Audio Circuits Simplified Schematic Diagram	F3-1	3-4

INDEX -- Continued

Subject	Paragraph, figure, table	Page
Countermeasures Control (continued)		
Audio Test Connections and Display Data	T5-4	5-25
Audio Test Setup	F5-6	5-23
Component Locations	F5-9	5-28
Countermeasures Control Troubleshooting		
Procedure.	T5-3	5-11
Equipment Description	1-9a	1-5
Flasher Test Setup	F5-7	5-24
FL1 Test Setup	F5-8	5-24
Front View	F1-2	1-2
Functional Description	3-4	3-2
ICS Power Test Setup	F5-5	5-23
Intercom Control Circuit Simplified Schematic		
Diagram	F3-2	3-6
Lamp Adjust Test Setup	F5-2	5-10
Lamp Control Circuit Test Setup	F5-3	5-22
Lamp Control Circuit Simplified Schematic		
Diagram	F3-4	3-8
Maintenance Procedures	5-12	5-37
Measurements and Data	5-3	5-1
Mission Power Test Setup	F5-1	5-10
Monitor Circuits Simplified Schematic		
Diagram	F3-3	3-7
Power and Signal Connections	T1-2	1-5
Repair Parts List	C-2a	C-3
	FC-1	C-9
Schematic Diagram	FO-2	
Tabulated Data	1-10	1-9
Test	5-15	5-62
Transistor Q1 Test Setup	F5-4	5-22
Troubleshooting	5-8b	5-6
Voltage Regulator A1 Troubleshooting		
Procedure.	T5-2	5-7
Cover, Bottom		
Removal of	5-12c	5-39
Replacement of	5-12c	5-39
Cover, Top		
Removal of	5-12a	5-37
Replacement of	5-12a	5-37
CREW CALL Switch S1	3-3b	3-1

D

Destruction of Army Material to Prevent		
Enemy Use	1-3	1-2
Direct Support Maintenance Instructions, Scope	4-1	4-1

INDEX -- Continued

Subject	Paragraph, figure, table	Page
E		
ECM Bracket, Removal and Replacement	5-12t	5-51
ECM Panel Indicator		
Component Locations	F5-9	5-28
Equipment Description	1-7a	1-3
Front View	F1-1	1-1
Functional Description	3-3	3-1
Maintenance Procedures	5-11	5-27
Power and Signal Connections	T1-1	1-3
Repair Parts List	C-2a, FC-2	C-3, C-20
Schematic Diagram	FO-1	
Tabulated Data	1-8	1-4
Test	5-14	5-62
Troubleshooting Procedure	5-7, T5-1	5-2 5-3
Enclosure		
Removal.	5-11a	5-27
Replacement.	5-111	5-36
EQPT BRT Potentiometer RIB	3-3e	3-2
Errors, Reporting of	1-5	1-3
F		
Federal Supply Code for Manufacturer (FSCM)	C-3e	C-7
Filter FLI, Removal and Replacement	5-12K	5-45
Front Panel		
Removal.	5-12b	5-37
Replacement.	5-12b	5-37
Fastner Assembly Removal and Replacement	5-12a	5-55
Plate Removal and Replacement	5-12d	5-39
Removal and Replacement	5-11h	5-34
Repair	5-12ac	5-56
Functioning of Equipment, Scope	3-1	3-1
G		
General Support Maintenance Instructions, Scope	5-1	5-1
General Support Test Procedures	5-13	5-62
Ground Stud Removal and Replacement	5-12az	5-55
I		
ICS Power Test Setup	F5-5	5-23
Indicator CCA A3		
Description.	3-4a	3-2
Removal.	5-12f	5-40

INDEX -- Continued

Subject	Paragraph, figure, table	Page
Indicator CCA A3 (continued)		
Replacement	5-12g	5-40
Schematic Diagram	F0-3	
Indicator Circuits	3-3a	3-1
Indicator Removal and Replacement	5-11d	5-31
Indicator Replacement	F5-11	5-32
Inspection of ECM Panel Indicator and Countermeasures Control	5-10a	5-25
Intercom Control Circuit		
Description	3-4a(2)	3-5
Simplified Schematic Diagram	F3-2	3-6
Interlock Jumpers	3-3F	3-2
J		
Jumpers, Interlock.	3-3f	3-2
L		
Lamp Adjust Test Setup	F5-2	5-10
Lamp Control Circuit		
Description	3-4a(4)	3-7
Simplified Schematic Diagram	F3-4	3-8
Test Setup	F5-3	5-22
M		
Maintenance		
Code	C-3b(2)	C-5
Countermeasures Control Procedures	5-12	5-37
Direct Support Instructions	4-1	4-1
ECM Indicator Panel Procedures	5-11	5-27
Forms and Records	1-2	1-2
Functions	B-2	B-1
General Support Instructions	5-1	5-1
Organizational Instructions	2-1	2-1
Procedures	5-10	5-25
Maintenance Allocation Chart for ECM Panel		
Indicator and Countermeasures Control		B-5
Measurements and Data, Countermeasures Control	5-3	5-1
Mission Power Test Setup	F5-1	5-10
Monitor Circuits		
Description	3-4a(3)	3-5
Simplified Schematic Diagram	F3-3	3-7
N		
National Stock Number and Part Number Index	C-2C	C-3

INDEX -- Continued

Subject	Paragraph, figure, table	Page
O		
Organizational Maintenance Instructions, Scope . . .	2-1	2-1
P		
PCB Retainer Removal and Replacement	5-12e	5-39
Potentiometer Removal and Replacement	5-11b	5-29
Potentiometers		
CONSOLE BRT R1A.	3-3d	3-2
EQPT BRT R1B	3-3e	3-2
Removal and Replacement	5-11b	5-29
Power and Signal Connections		
Countermeasures Control	T1-2	1-5
ECM Panel Indicator	T1-1	1-3
Power Distribution	3-4d	3-9
R		
RCDR ON Switch S2	3-3C	3-1
Recoverability Code	C-3b(3)	C-6
References		
Army Regulations	A-6	A-2
Common Table of Allowances	A-4	A-2
Forms.	A-7	A-3
Pamphlets.	A-5	A-2
Supply Bulletins	A-3	A-2
Technical Manuals	A-2	A-1
Relay K1, K2 or K3 Removal and Replacement	5-12r	5-50
Relay TB2K1 Removal and Replacement	5-12q	5-50
Removal and Replacement		
Circuit Breaker.	5-12x	5-54
Coax Switch Bracket	5-12w	5-54
Connector Bracket	5-12u	5-52
Connector J1	5-11f	5-33
Connectors J2, J3, J6 through J8	5-12y	5-54
Connector Panel	5-11e	5-33
ECM Bracket.	5-12t	5-51
Filter FL1	5-12k	5-45
Front Panel.	5-11h	5-34
Front Panel Fastener Assembly	5-12aa	5-55
Front Panel Plate	5-12d	5-39
Ground Stud.	5-12az	5-55
Indicator.	5-11d	5-31
PCB Retainer	5-12e	5-39
Potentiometer:	5-11b	5-29
Relay K1, K2, or K3	5-12r	5-50
Relay TB2K1.	5-12q	5-50

INDEX -- Continued

Subject	Paragraph, figure, table	Page
Removal and Replacement (continued)		
Switch S1.	5-12v	5-53
Switch/Indicator	5-11C	5-29
Terminal Board TBI	5-12m	5-46
Terminal Board TB2	5-120	5-47
Terminal Stud.	5-11q	5-34
	5-12s	5-51
Transistor Q1.	5-121	5-45
Removal of		
Cover, Bottom.	5-12c	5-39
Cover, Top	5-12a	5-37
Enclosure.	5-11a	5-27
Front Panel.	5-12b	5-37
Indicator CCA A3	5-12f	5-40
Voltage Regulator A1	5-12j	5-43
Repair of CCAs.	5-12h	5-40
Repair Parts, How to Locate	C-5	C-8
Repair Parts List		
Countermeasures Control	FC-1	C-9
Description.	C-2a	C-3
ECM Panel Indicator	FC-2	C-20
Replacement of		
Cover, Bottom.	5-12c	5-39
Cover, Top	5-12a	5-37
Enclosure.	5-111	5-36
Front Panel.	5-12b	5-37
Indicator.	F5-8a	5-28
Indicator CCA A3	5-12g	5-40
Terminal Board TB1 Components	5-12n	5-46
Terminal Board TB2 Components	5-12p	5-50
Voltage Regulator A1	5-12j	5-43
Reporting Equipment Improvement		
Recommendations (EIR)	1-6	1-3
Reporting of Errors	1-5	1-3
RF Switch S1.	3-4b	3-7
Riveting.	5-12ad	5-56

S

Source, Maintenance, and Recoverability		
(SMR) Codes	C-3b	c-3
Special Tools List	C-2b	C-3
Storage, Administrative	1-4	1-2
Supply Bulletins.	A-3	A-2
Switches		
CREW CALL S1	3-3b	3-1
RCDR ON S2	3-3C	3-1
RF S1.	3-4b	3-7

INDEX -- Continued

Subject	Paragraph, figure, table	Page
Switch S1 Removal and Replacement	5-12v	5-53
Switch/Indicator Removal and Replacement	5-11c	5-29
T		
Tabulated Data		
Countermeasures Control	1-10	1-9
ECM Panel Indicator	1-8	1-4
Technical Manuals	A-2	A-1
Terminal Board TB1 Component Replacement	5-12n	5-47
Terminal Board TB2 Component Replacement	5-12p	5-50
Terminal Board TB1 Removal and Replacement	5-12m	5-46
Terminal Board TB2 Removal and Replacement	5-12o	5-47
Test Equipment.	5-5	5-1
Test Procedures, General Support	5-13	5-61
Tests		
Audio.	F5-6	5-23
	T5-4	5-25
Countermeasures Control	5-15	5-62
ECM Panel Indicator	5-14	5-62
ICS Power.	F5-5	5-23
Lamp Adjust.	F5-2	5-10
Lamp Control Circuit	F5-3	5-22
Mission Power.	F5-1	5-10
Transistor Q1.	F5-4	5-22
Tool and Test Equipment Requirements for ECM		
Panel Indicator and Countermeasures Control		B-7
Tools and Equipment Required	5-5	5-1
Top Cover		
Removal.	5-12a	5-37
Replacement.	5-12a	5-37
Transistor Q1 Test Setup	F5-4	5-22
Transistor Q1 Removal and Replacement	5-121	5-45
Troubleshooting Procedures		
Countermeasures Control	5-8b	5-6
	T5-3	5-11
ECM Panel Indicator	5-7	5-2
	T5-1	5-3
Voltage Regulator A1	5-8a	5-6
	T5-2	5-7
v		
Voltage Regulator A1		
Component Locations	F5-15	5-44
Description.	3-4C	3-8
Removal.	5-12j	5-43

INDEX -- Continued

Subject	paragraph, figure, table	Page
Voltage Regulator A1 (continued)		
Replacement	5-12j	5-43
Schematic Diagram	FO-4	
Troubleshooting Procedure	5-8a	5-6
	T5-2	5-7

By Order of the Secretary of the Army:

CARL E. VUONO
General, United States, Army
Chief of Staff

Official:

R. L. DILWORTH
Brigadier General, United States Army
The Adjutant General



SOMETHING WRONG WITH THIS MANUAL?

THEN... JOT DOWN THE DOPE ABOUT IT ON THIS FORM, TEAR IT OUT, FOLD IT AND DROP IT IN THE MAIL!

FROM: (YOUR UNIT'S COMPLETE ADDRESS)

Commander
Stateside Army Depot
ATTN: AMSTA-US
Stateside, N.J. 07703

DATE 10 July 1975

PUBLICATION NUMBER

TM 11-5840-340-12

DATE

23 Jan 74

TITLE

Radar Set AN/PSC-76

BE EXACT... PIN-POINT WHERE IT IS

IN THIS SPACE TELL WHAT IS WRONG AND WHAT SHOULD BE DONE ABOUT IT:

PAGE NO.	PARA-GRAPH	FIGURE NO.	TABLE NO.
----------	------------	------------	-----------

2-25	2-28		
3-10	3-3		3-1
5-6	5-8		

FO3

Recommend that the installation antenna alignment procedure be changed through to specify a 2° IFF antenna lag rather than 1°.

REASON: Experience has shown that with only a 1° lag, the antenna servo system is too sensitive to wind gusting in excess of 20 knots, and has a tendency to rapidly accelerate and decelerate as it hunts, causing strain to the drive train. Hunting is minimized by adjusting the lag to 2° without degradation of operation.

Item 5, Functions column. Change "2 db" to "3db."

REASON: The adjustment procedure for the TRANS POWER FAULT indicator calls for a 3 db (500 watts) adjustment to light the TRANS POWER FAULT indicator.

Add new step f.1 to read, "Replace cover plate removed in step e.1, above."

REASON: To replace the cover plate.

Zone C 3. On J1-2, change "+24 VDC to "+5 VDC."

REASON: This is the output line of the 5 VDC power supply. + 24 VDC is the input voltage.

TYPED NAME, GRADE OR TITLE, AND TELEPHONE NUMBER

SSG I. M. DeSpirito 999-1776

SIGN HERE:

SSG I. M. DeSpirito

TEAR ALONG DOTTED LINE

NOTES (UNLESS OTHERWISE SPECIFIED):

1. PARTIAL REFERENCE DESIGNATIONS ARE SHOWN. FOR COMPLETE REFERENCE DESIGNATIONS, PREFIX WITH APPLICABLE UNIT AND ASSEMBLY DESIGNATIONS.
2. INDICATES EQUIPMENT MARKING.
3. ALL UNDERLINED LETTERS INDICATE LOWER CASE.

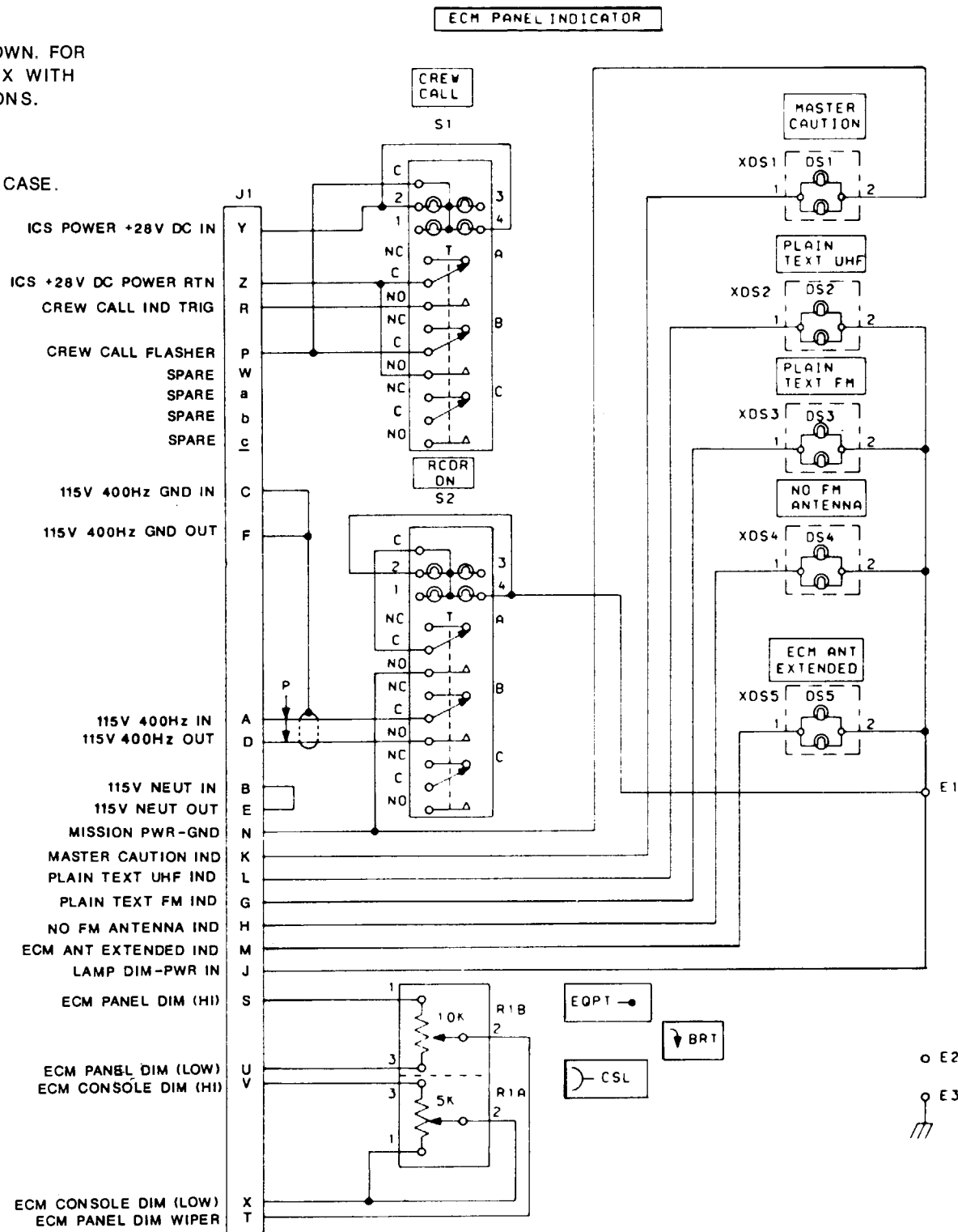
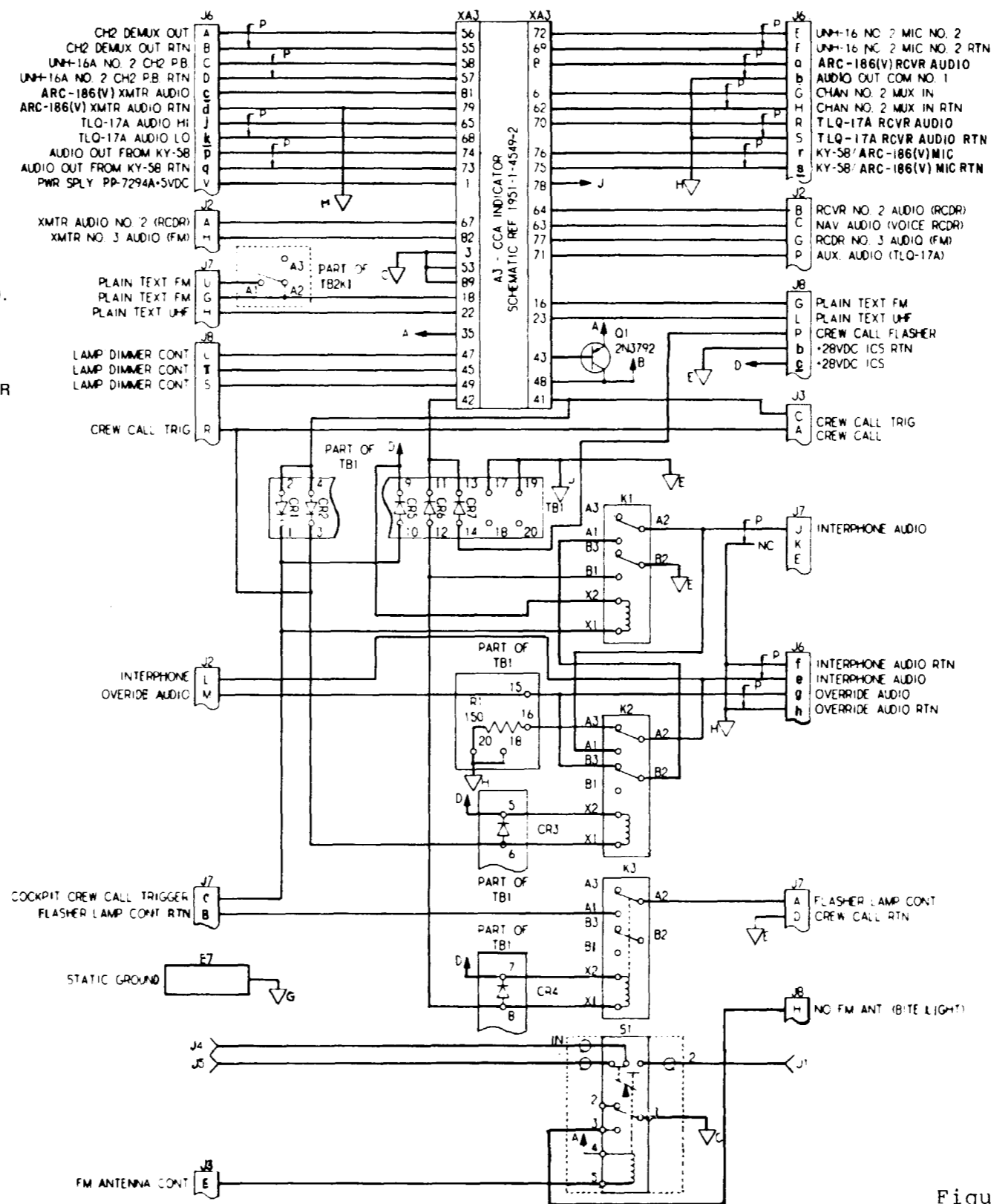

Figure FO-1. ECM Panel Indicator Schematic Diagram

NOTES (UNLESS OTHERWISE SPECIFIED):

- PARTIAL REFERENCE DESIGNATIONS ARE SHOWN, FOR COMPLETE REFERENCE DESIGNATION PREFIX WITH APPLICABLE UNIT ASSEMBLY DESIGNATIONS.
- ALL CAPACITANCE VALUES ARE IN MICROFARADS (μ F).
- ALL DIODES ARE JANTXIN4245.
- ALL RESISTANCE VALUES ARE IN OHMS (Ω).
- J7-A TO K3-A2 & J7-B TO K3-1A ARE TWISTED PAIR (SYMBOL NOT SHOWN).
- J2-C TO E4 & J2-D TO E5 ARE TWISTED PAIR (SYMBOL NOT SHOWN).

POWER AND GROUND		
SYMBOL	TIE POINT	POWER OR GROUND DEFINITION
\uparrow A	E1	MISSION POWER
\uparrow B	E2	LAMP DIMMER PWR
∇ C	E3	MISSION PWR RETURN
\uparrow D	E4	ICS PWR
∇ E	E5	ICS PWR RETURN
\uparrow F	E6	NOT USED
∇ G	E7	REAR PANEL GROUND
∇ H	TB1-18,20	AUDIO COMMON NO 1
∇ J	TB1-17,19	AUDIO COMMON NO 2
NC		NO CONNECTION



CONNECTOR SPARE PINS	
CONN DESIG	PIN DESIGNATIONS
J2	Y B H J K M N P Q R S I
J3	B Y Z A B C D E F G H J
J6	L U V W X Y Z AA BB CC DD EE FF GG HH
J7	L M N P C D E F G H J K T
J8	E F W

REFERENCE DESIGNATIONS			
LAST USED		NOT USED	
AJ	CB1	TB1CR7	A2
FL1	K4	Q1	XA1, XA2
TB2	E7	XA3	
J8	TB2C1	TB2CR2	
TB1R1	TB2K1	TB2R3	

Figure FO-2. Countermeasures Control Schematic Diagram (Sheet 1 of 2)

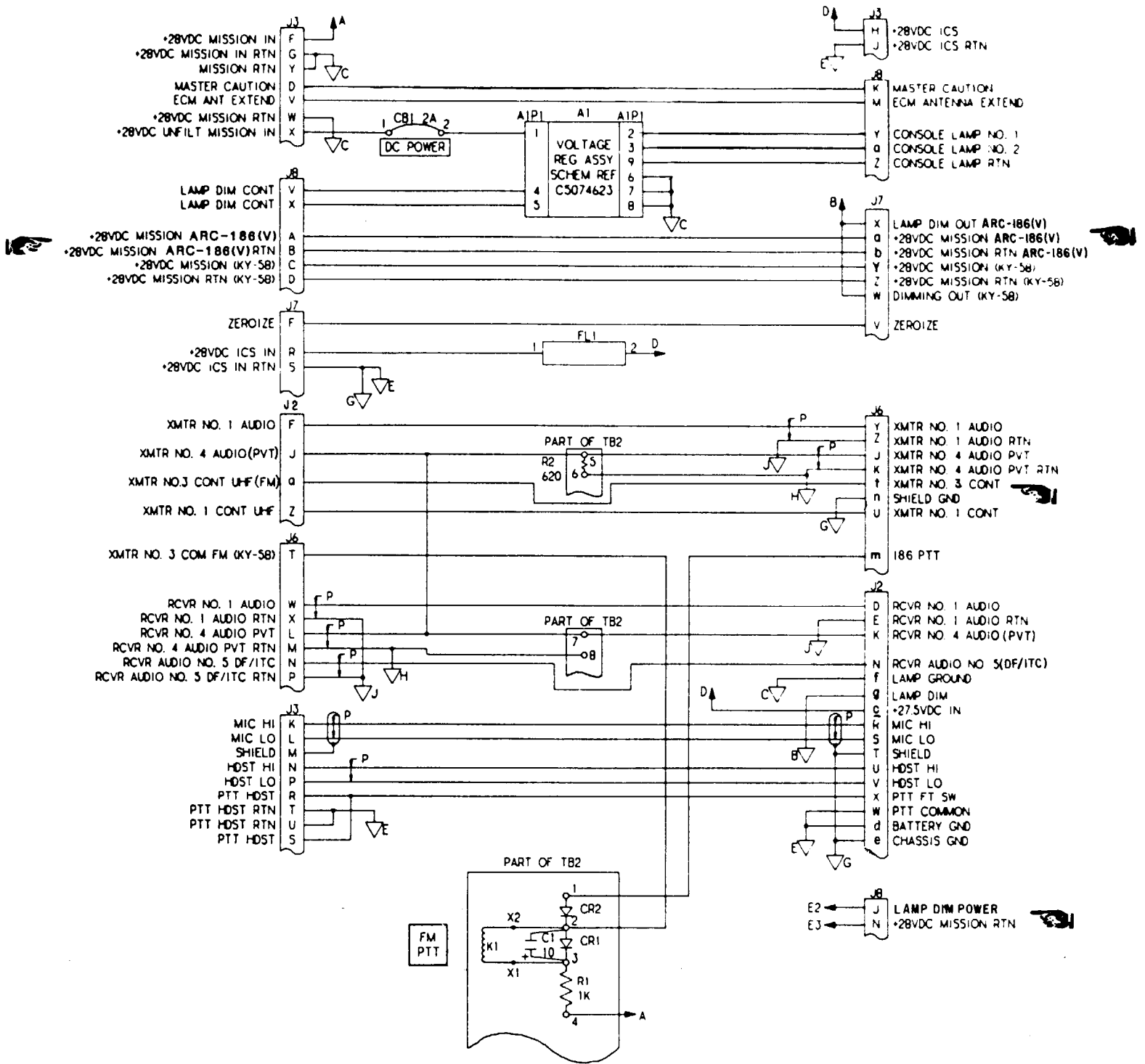

Figure FO-2. Countermeasures Control Schematic Diagram (Sheet 2 of 2)

HIGHEST REFERENCE DESIGNATIONS							
C11	CR8	Q12	P1	R72	T10	U6	VR3
REFERENCE DESIGNATIONS NOT USED							
R54	VR4						

MICROCIRCUIT IDENT					
REF DES	TYPE	VCC	GND	+V	-V
U1	556	14	7	—	—
U2	LM741H	—	4	7	—
U3-6	LM139	—	12	3	—

NOTES: UNLESS OTHERWISE SPECIFIED

1. RESISTANCE VALUES ARE IN OHMS
± 5% IN WATT.
2. CAPACITANCE VALUES ARE IN UF.
3. TRANSISTORS ARE 2N2222A.
4. DIODES ARE IN4148.
5. DELETED

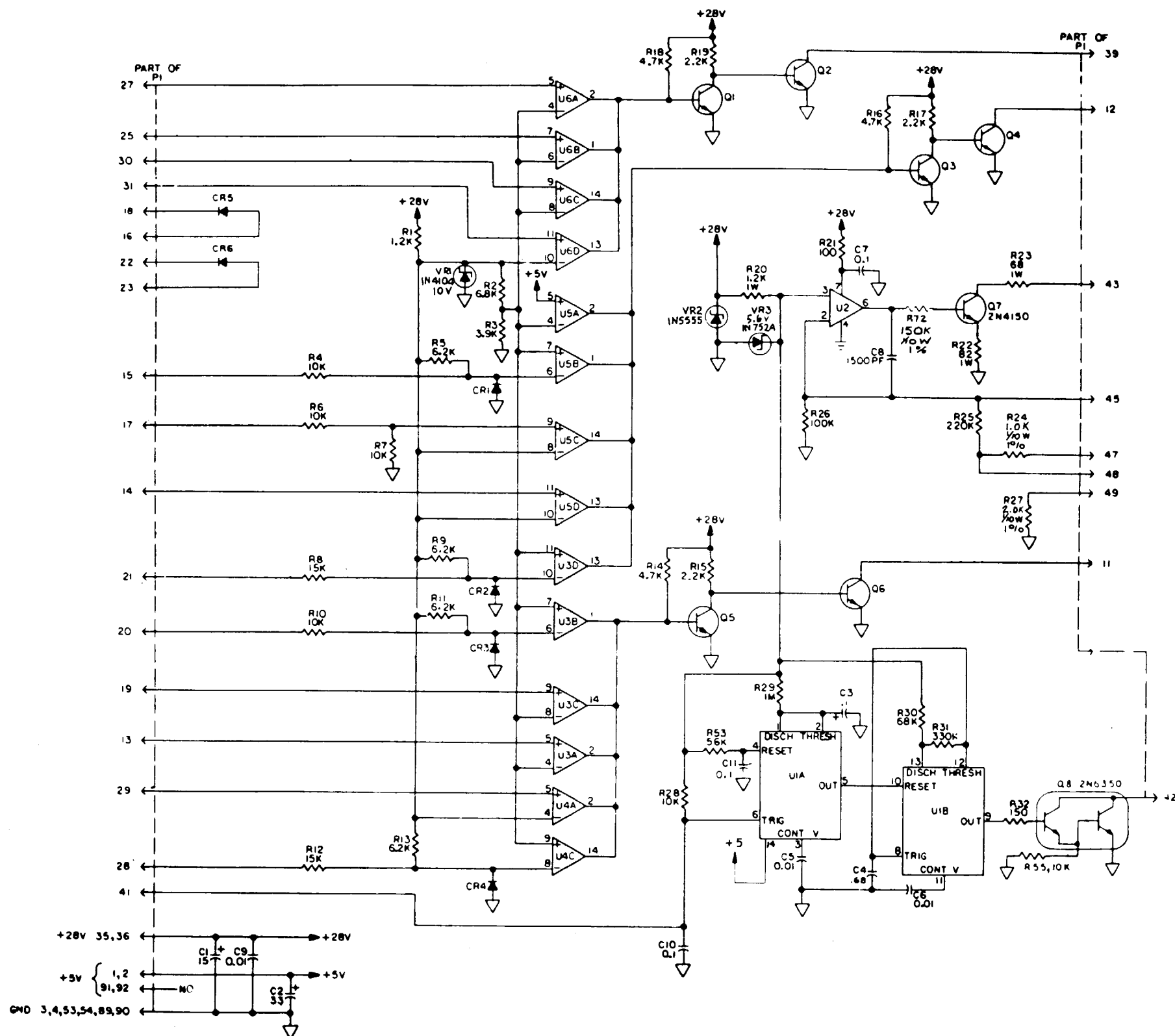

Figure FO-3. Indicator CCA A3
Schematic Diagram (Sheet 1 of 2)

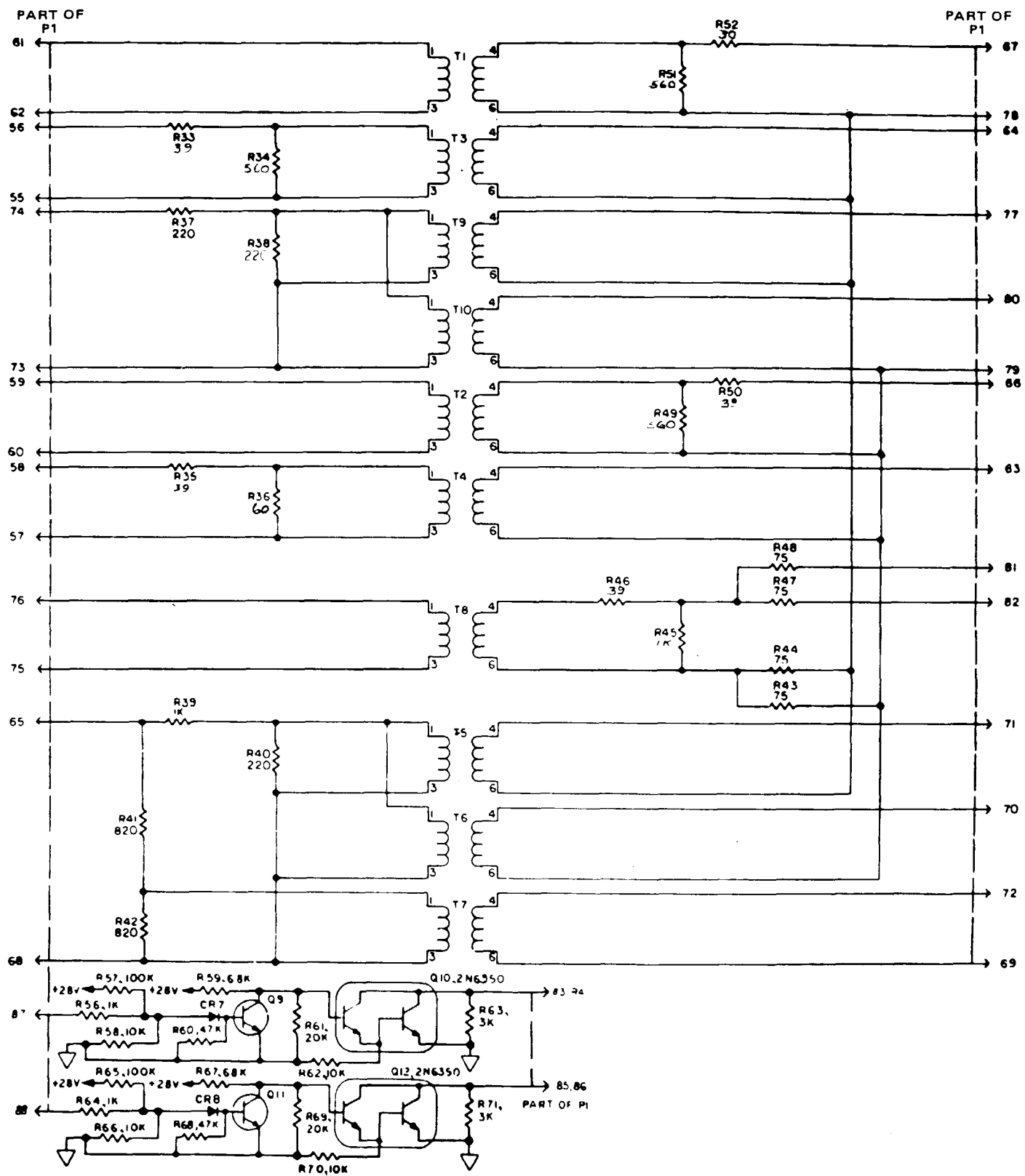

Figure FO-3. Indicator CCA A3
Schematic Diagram (Sheet 2 of 2)

NOTES (UNLESS OTHERWISE SPECIFIED):

1. PARTIAL REFERENCE DESIGNATIONS ARE SHOWN. FOR COMPLETE DESIGNATION, PREFIX WITH APPLICABLE UNIT AND ASSEMBLY DESIGNATIONS.
2. RESISTANCE VALUES IN OHMS, 1/4W, $\pm 5\%$.
3. CAPACITANCE VALUES IN F, $\pm 10\%$.

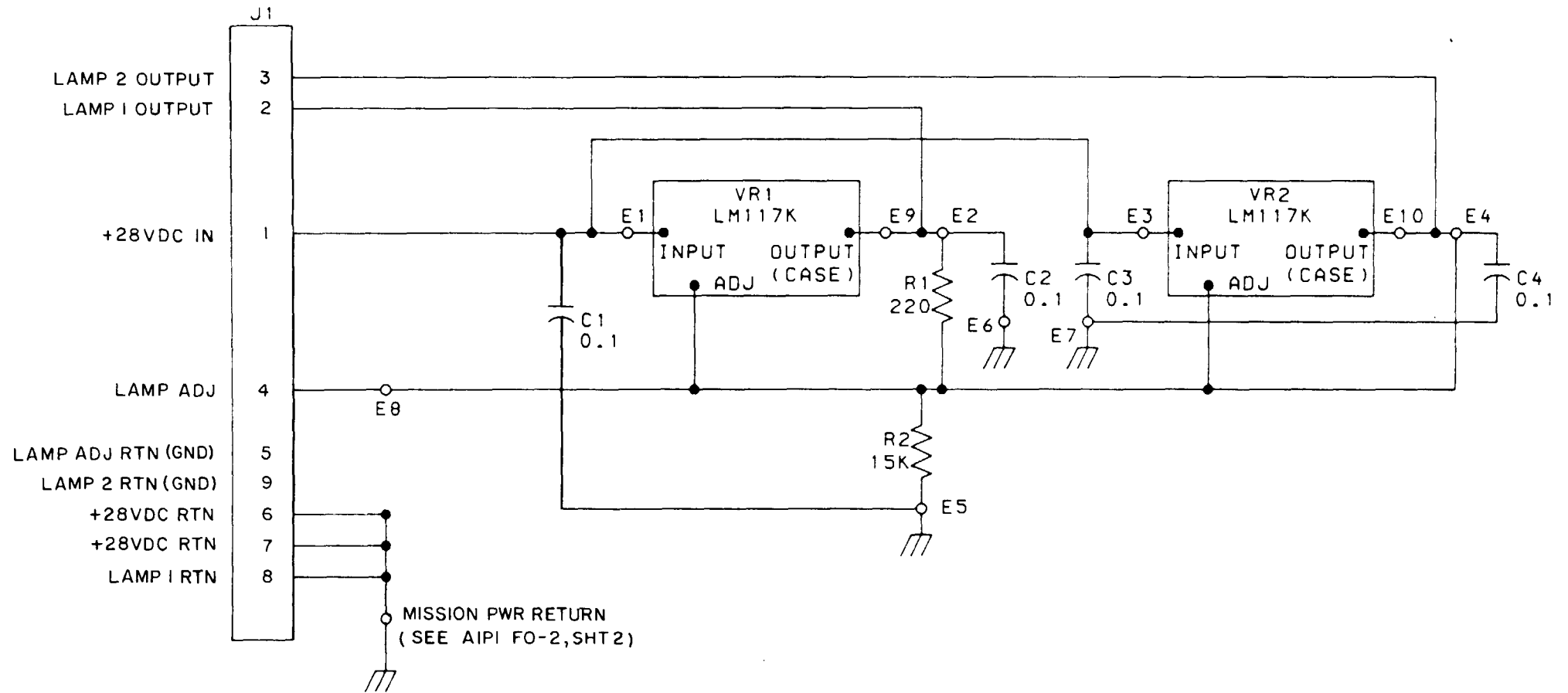

Figure FO-4. Voltage Regulator A1 Schematic Diagram

This fine document...

Was brought to you by me:



[Liberated Manuals -- free army and government manuals](#)

Why do I do it? I am tired of sleazy CD-ROM sellers, who take publicly available information, slap “watermarks” and other junk on it, and sell it. Those masters of search engine manipulation make sure that their sites that sell free information, come up first in search engines. They did not create it... They did not even scan it... Why should they get your money? Why are not letting you give those free manuals to your friends?

I am setting this document FREE. This document was made by the US Government and is NOT protected by Copyright. Feel free to share, republish, sell and so on.

I am not asking you for donations, fees or handouts. If you can, please provide a link to liberatedmanuals.com, so that free manuals come up first in search engines:

<A HREF=<http://www.liberatedmanuals.com/>>Free Military and Government Manuals

- Sincerely
Igor Chudov
<http://igor.chudov.com/>
- [Chicago Machinery Movers](#)