

TECHNICAL MANUAL

---

OPERATOR'S MANUAL  
FOR  
NIGHT VISION SIGHT,  
INDIVIDUAL SERVED WEAPON AN/PVS-2  
(5855-087-2947), ANIPVS-2A  
(5855-179-3708), AND ANIPVS-2B  
(5855-760-3869)

This reprint includes all changes in effect at the time of publication; changes 1 and 2.

---

HEADQUARTERS, DEPARTMENT OF THE ARMY

AUGUST 1974

**WARNING**

**RADIATION HAZARD**

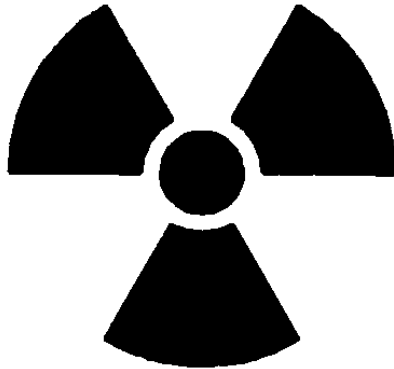

**RADIOACTIVE MATERIAL**

**THORIUM-232**

**THE OPTICAL GLASS IN THE NIGHT VISION SIGHT MAY CONTAIN THORIUM AND PRESENT A POSSIBLE EYE HAZARD. A GREEN KNURLED RING, JUST FORWARD OF THE EYESHIELD INDICATES THAT THE NIGHT VISION SIGHT IS SAFE TO USE.**

CHANGE

NO 1

HEADQUARTERS  
DEPARTMENT OF THE ARMY  
WASHINGTON DC 13 *April 1976*

**Operator's Manual  
For  
NIGHT VISION SIGHT,  
INDIVIDUAL SERVED WEAPON  
AN/PVS-2 (5855-087-2947),  
AN/PVS-2A (5855-179-3708), AND  
AN/PVS-2B (5855-760-3869)**

TM 11-5855-203-10, 29 August 1974, is changed as follows:

*Page 4*, paragraph 1-3, line 1. Change "AMSEL-MA-S" to read "DRSEL-MA-Q"

*Page 16*. paragraph 2-4 After paragraph 2-4. and paragraph 2-4.1.

**2-4.1. Installation on M60 Machine Gun**

(fig. 2-4.1)

- a. Refer to figure 2-4.1 for installation of the M60 adapter assembly on the M60 machine gun

- b.* Rotate the lock knobs of the boresight mount assembly forward (toward objective lens) until they come to a stop on the pins on the assembly.
- c.* Slide the boresight mount assembly onto the guide rail of the M60 adapter assembly from the rear until it is positioned against the pin stop of the guide rail.
- d.* Lock the night vision sight on the M60 adapter assembly by rotating the two locking knobs of the boresight mount assembly in a rearward direction.

## INSTALLATION INSTRUCTIONS FOR M60 MACHINEGUN ADAPTER ASSEMBLY

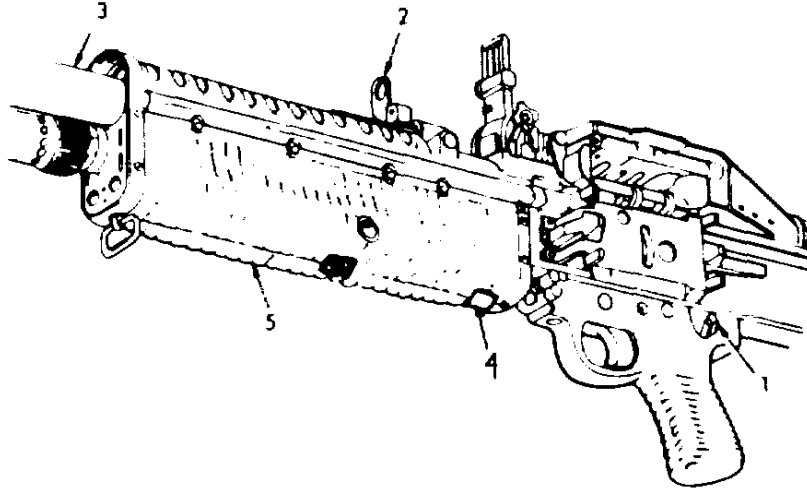

### BARREL AND HEAT SHIELD REMOVAL

- STEP 1. PLACE SAFETY (I) ON SAFE.
- STEP 2. RAISE BARREL LOCK LEVER (1).
- STEP 3. PULL BARREL (3) STRAIGHT FORWARD TO REMOVE.
- STEP 4. INSERT HOSE OF CARTRIDGE INTO HOLE (4) AND DEPRESS HEAT SHIELD LATCH.
- STEP 5. WITHDRAW AND REMOVE HEAT SHIELD

EL855 -203 -10-C -TM-10①

*Figure 2-4.1 1. Installation of M60 adapter assembly (sheet (1) of 4).*

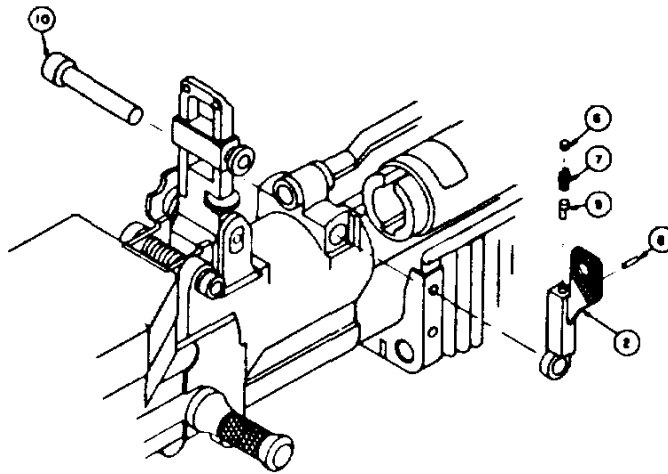

RELEASE LEVER AND SHAFT REMOVAL

CAUTION

THE DETENT PLUNGER (6) AND DETENT SPRING(7) ARE SPRING TENSION LOADED BEFORE REUOVING LOCK PIN (8) PLACE AND OVER TOP OF BARREL RELEASE LEVER (2) SO THAT PARTS WILL NOT BE LOST UPON REMOVAL OF LOCK PIN

STEP 6

REMOVE LOCK PIN (8) DETENT PLUNGER (6). DETENT SPRING (7) AND DETENT PIN (9) FROM BARREL RELEASE LEVER (2)

STEP 7-

REMOVE BARREL RELEASE LEVER (2) AND WITHDRAW BRARREL LOCK SHAFT (10)

NOTE

THE BARREL LOCK SHAFT (10) AND THE BARREL RELASE LEVER (2) INCLUDING LOCK PIN (8). DETENT PLUNGER (6), DETENT SPRING (7), AND DETENT PIN (9) ARE REPLACED WITH A COMBINATION BARREL LOCK SHAFT AND RELEASE LEVER (15) THAT IS SUPPLIED WITH THE WEAPON ADAPTER BRACKET ASSEMBLY

EL5855-203-10-CI-TM-10(2)

Figure 24.1 (2). Installation of M60 adapter assembly (sheet 2 of 4).

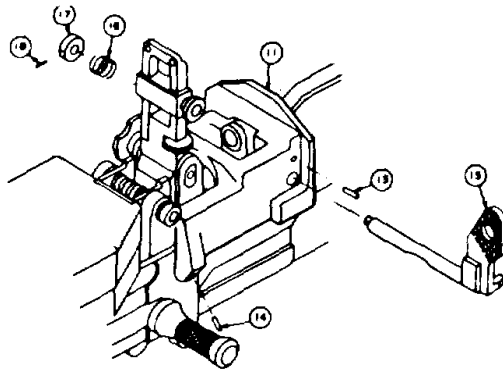

SADDLE BLOCK INSTALLATION

NOTE: BEFORE INSTALLING SADDLE BLOCK (II) ON GUN REMOVE ADAPTER BRACKET (12) LOOSEN FOUR SET SCREWS (13) AND (14) (TWO SET SCREWS ARE LOCATED ON EACH SIDE OF SADDLE BLOCK) AND REMOVE BARREL LOCK SHAFT (15) FROM SADDLE BLOCK

STEP 8 PLACE SADDLE BLOCK (II) DOWN INTO POSITION ON GUN

STEP 9 INSTALL BARREL LOCK SHAFT (15) INTO SADDLE BLOCK PLACE COMPRESSION SPRING (16) WITH RETAINING COLLAR (17) OVER END OF SHAFT AND INSTALL SPRING PIN (18) THROUGH COLLAR AND SHAFT. PUT RELEASE LEVER END OF BARREL LOCK (15) IN VERTICAL POSITION TO RECEIVE BARREL

STEP 10 REPLACE BARREL ON GUN BY INSERTING STRAIGHT BACK INTO RECEIVER WITH GAS CYLINDER NUT IN ALINEMENT WITH OPERATING ROD TUBE

STEP 11 LOWER BARREL LOCK RELEASE LEVER TO HORIZONTAL POSITION LOKCING BARREL IN PLACE

STEP 12 SNUG UP EVENLY BY ALTERNATE GRADUAL TIGHTENING THE TWO SET SCREWS (13). DURING THIS PROCEDURE CHECK FREE MOVEMENT OF BARREL LOCK SHAFT BY RAISING AND LOWERING BARREL RELEASE LEVER TO INSURE THAT SHAFT IS NOT BINDING. THEN SNUG UP EVENLY IN SIMLAR MANNER THE REMAINING TWO SET SCREWS (14)

STEP 11 RAISE BARREL LOCK RELEASE LEVER TO VERTICAL POSITION AND REMOVE BARREL

NOTE THE SADDLE BLOCK SHOULD BE LEFT ON THE GUN ONCE IT IS INSTALLED. INSTALL THE WEAPON ADAPTER BRACKET ON THE SADDLE BLOCK WHENEVER THE STARLIGHT SCOPE IS TO BE USED

ELS855-203-10-CI-TM-10(3)

Figure 2-4.1 (3). Installation of M60 adapter assembly (sheet 3 of 4).

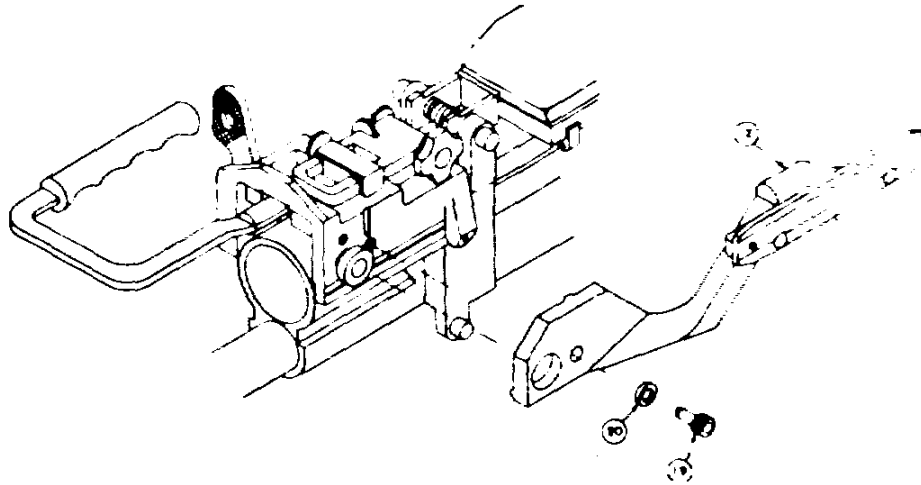

WEAPON ADAPTER BRACKET INSTALATION

- STEP 14 PLACE WEAPON ADAPTER BRACKET (12) IN PLACE AGAINST SADDLE BLOCK (11) AND TIGHTEN SCREW (19) THROUGH BLOCK WASHER (20) AND ADAPTER BRACKET INTO SADDLE BLOCK
- STEP 15 REPLACE HEAT SHEILD ON GUN BY GUIDING THE ASSEMBLY OVER THE OPERATING ROD TUBE TO INSURE THAT THE OPERATING ROD DOES NOT STRIKE THE BAFFLES INSIDE THE ASSEMBLY. ALINE THE RECESS IN THE HEAT SHIELD ASSEMBLY WITH THE END OF THE OPERATING ROD TUBE. TAP BOTTOM REAR OF THE ASSEMBLY FIRMLY WITH THE PALM OF THE HAND TO LOCK IT IN POSITON.
- STEP 16 REPLACE BARREL ON GUN FOLLOWING PROCEDURE GIVEN IN STEP 10 AND 11.

EL5855-203-10-CI-TM-10(4)

Figure 2-4.1 (4). Installation of M60 adapter assembly (sheet 4 of 4).

Page 35, Section III. Add the following in the appropriate column:

(1)	(2)	(3)	(4)
5855-405-0407	ADAPTER ASSEMBLY, M60 SSC645740 (80063)	EA	1



By Order of the Secretary of the Army:

FRED C WEYAND  
*General, United States Army*  
*Chief of Staff*

Official:

PAUL T. SMITH  
*Major General, United States Army*  
*The Adjutant General*

DISTRIBUTION:

Active Army

USASA (2)  
COE (1)  
TSG (1)  
USAARENBD (1)  
AMC (1)  
TRADOC (2)  
ARADCOM (2)  
ARADCOM Rgn (2)  
OS Maj Comds (4)  
MICOM (2)  
TECOM (2)  
USACC (4)  
MDW (1)  
Armies (2)  
Corps (2)  
HISA (Ft Monmouth) (33)  
Svc Colleges (1)  
USASESS (5)  
USAADS (2)  
USAFAS (2)  
USAARMS (2)  
USAIS (2)

USAES (2)  
USAINTCS (3)  
MAAG (1)  
USARMIS (1)  
Instl [2] except  
    Fort Gillem (10)  
    Fort Gordon (10)  
    Fort Huachuca (10)  
    Fort Carson (5)  
    Ft Richardson (ECOM Ofc) (2)  
    LBAD (14)  
    SAAD (30)  
    TOAD (14)  
    SHAD (3)  
Sig FLDMS (1)  
USAERDAA (1)  
USAERDAW ! 1  
Units org under fol TOE  
    (1 copy each unit  
    11-500 (AA-AC)  
    29-134  
    29-136

NG: State AG (3)

USAR: None

For explanation of abbreviations used, see AR 310-50.

Changes in force: C1 and C2

**TM-11-5855-203-10**

C2

CHANGES }  
No. 2 }

HEADQUARTERS  
DEPARTMENT OF THE ARMY  
WASHINGTON, DC, 26 August 1977

**Operator's Manual for Night Vision Sight  
INDIVIDUAL SERVED WEAPON AN/PVS-2  
(NSN 5855087-2947), AN/PVS-2A  
(NSN 5855-00-179-3708), AND AN/  
PVS-2B (NSN 5855-00-760-3869)**

TM 11-5855-203-10, 29 August 1974, is changed as follows:

Title of manual is changed as shown above.

*Page preceding page 1. Add radiation warning.*

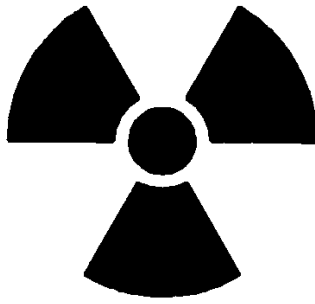

**STD-RW-2**

Image intensifier	Th 232	Less than 30%
		5585-00-051-2792
Eye Piece Assembly	Th 232	Less than 30%
		5585-00-941-3037

Radiation Warning Information: The following radiation hazard information must be read and understood by all personnel before operating or repairing the Night Vision Sight AN/PVS-2, AN/PVS-2A, and the AN/PVS-2B. Hazardous radioactive materials are present in the above listed components of the Night Vision Sight AN/PVS-2, AN/PVS-2A, and AN/PVS-2B. The components are potentially hazardous when broken. See qualified medical personnel and the

local Radiological Protection Officer (RPO) immediately if you are exposed to or cut by broken components. First aid instructions are contained in TB 43-0122, and AR 755-15.

NEVER place radioactive components in your pocket. Use extreme care NOT to break radioactive components while handling them.

NEVER remove radioactive components from cartons until you are ready to use them.

If any of these components are broken, notify the local RPO immediately. The RPO will survey the immediate area for radiological contamination and will supervise the removal of broken components. The above listed radioactive components *will not* be repaired or disassembled.

Disposal of broken, unserviceable, or unwanted radioactive components will be accomplished in accordance with the instructions in AR 755-15.

By Order of the Secretary of the Army:

BERNARD W. ROGERS  
*General, United States Army*  
Chief of Staff

Official:

PAUL T. SMITH  
*Major General, United States Army*  
*The Adjutant General*

Distribution:

Active Army:

USASA (2)	USAARMS (2)
COE (1)	USAIS (2)
TSG (1)	USAES (2)
USAARENBD (1)	IIIS.A (Ft Monmouth) (33)
DARCOM (1)	AD (1) except
TECOM (2)	SAAD (30)
USACC (4)	LBAD (14)
TRADOC (2)	TOAD (14)
OS Maj Comd (4)	SHAD (3)
MDW (1)	USA Dep (2)
Armies (2)	Sig Sec USA Dep (2)
Corps (2)	Sig Dep (2)
Ft Gillem (10)	MAAG (1)
Ft Gordon (10)	USARMIS (1)
Ft Huachuca (10)	USAERDAA (1)
Ft Carson (5)	USAERDAW (1)
Ft Richardson (ECOM Ofc) (2)	Sig FLDMS (Less Europe) (1)
Svc Colleges (11)	Units org under fol TOE:
USAIC- (3)	11-500(AA AC) (1)
USAADS (2)	29-134 (1)
USAFAS (2)	29-136 (1)

ARNG: State AG (3); Units - Same as- Active Army except allowance is one (1) copy per unit.  
USAR: None  
For explanation of abbreviations used, see AR 310-50.

**Operator's Manual  
for  
NIGHT VISION SIGHT,  
INDIVIDUAL SERVED WEAPON  
AN/PVS-2, AN/PVS-2A, and AN/PVS-2B**

		Paragraph	Page
<b>CHAPTER</b>	1.	INTRODUCTION .....	3
<b>Section</b>	I.	General .....	3
		Purpose and Scope.....	1-1 3
		Maintenance Forms and Records.....	1-2 3
		Recommending Improvements .....	1-3 3
	II.	Description and Data.....	5
		Description .....	1-4 5
		Items Comprising an Operable	
		End Items .....	1-5 7
		Expendable Consumable Items .....	1-6 8
		Tabulated Data.....	1-7 9
<b>CHAPTER</b>	2.	OPERATING INSTRUCTIONS.....	10
<b>Section</b>	I.	Installation .....	10
		Installation of Battery.....	2-1 10
		Installation on M14 Rifle.....	2-2 10
		Installation on M16 Rifle .....	2-3 13
		Installation on M67 Rifle .....	2-4 13
		Dismounting Night Vision	
		Sight .....	2-5 16

		<b>Paragraph</b>	<b>Page</b>
	Transporting .....	2-6	16
	Storage .....	2-7	17
Section	II. Operation .....		19
	Function and Location of Controls.....	2-8	20
	Operating Procedures .....	2-9	21
	Zeroing Procedures .....	2-10	22
	III. Operation Under Unusual Conditions .....		24
	Operation in Extreme Cold .....	2-11	24
	Operation in Dusty or Sandy Areas .....	2-12	24
	Operation in Rainy or Humid Conditions .....	2-13	25
	Operation in Salt Water Areas.....	2-14	26
<b>CHAPTER</b>	3. MAINTENANCE INSTRUCTIONS .....		24
	Preventive Maintenance Checks and Services .....	3-1	27
	Troubleshooting .....	3-2	30
<b>APPENDIX</b>	A. REFERENCES		31
	B. BASIC ISSUE ITEMS LIST		32

\*This manual supersedes so much of TM 11-5855 203-13, 10 April 1967, including all changes, that pertains to operation and operator's maintenance.



**CHAPTER 1**  
**INTRODUCTION**  
**Section I. GENERAL**

**1-1. Purpose and Scope**  
**(fig. 1-1)**

This manual is for your use in operating and maintaining Night Vision Sight, Individual Served Weapon AN, PVS-2, AN/PVS-2A, and AN, PVS-2B. All asterisk in parenthesis (\*) after the nomenclature is used to indicate all models of the equipment. Hereafter the AN/PVS-2 (\*) will be referred to as the night vision sight.

**1-2. Maintenance Forms and Records**

Maintenance forms and records that you are required to use are explained in TM 38-750.

**1-3. Reporting of Equipment Publication Improvements**

The reporting of errors, omissions, and recommendations for improving this manual by the individual user is encouraged. Reports should be submitted on DA Form 2028 (Recommended Changes to DA Publications and Blank Forms) and forwarded direct to Commander, U. S.-Army Elec-

tronics Command, ATTN: AMSEL-MA-S, Fort Monmouth, NJ 07703.

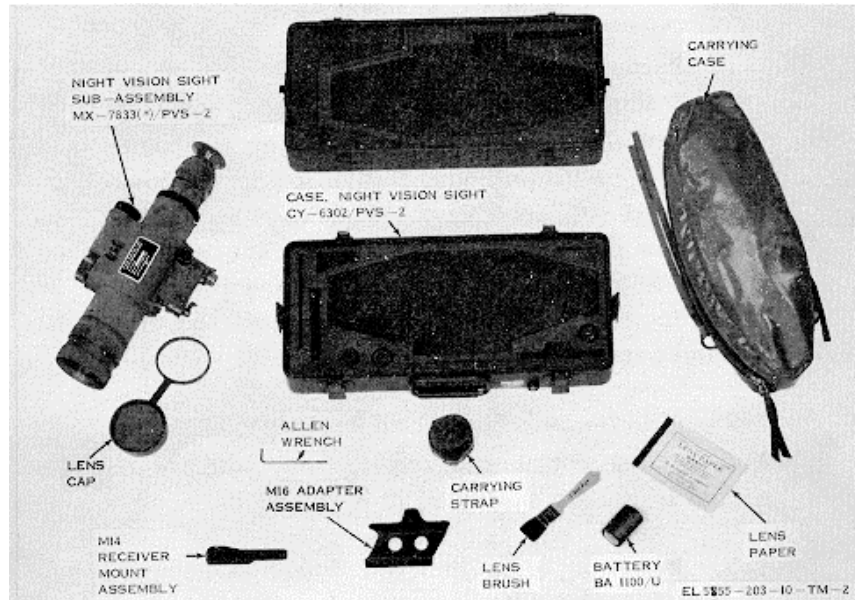

Figure 1-1. AN/PVS-2(\*) and accessories.

## Section II. DESCRIPTION AND DATA

### 1-4. Description (fig. 1-2)

a. *Night Vision Sight.* The night vision sight is a portable, battery powered, electro-optical instrument used for passive visual observation and aimed fire of weapons at night. It uses the natural light (moonlight and/or starlight) of the night sky for target illumination. Since the night vision sight does not project a visible or infrared light, it is free from the possibility of enemy detection. The night vision sight consists of the main housing, objective lens assembly, power supply, eyepiece with rubber eyeshield, boresight mount assembly, image intensifier assembly, and lens cap. It is designed for use on the M14, M14A2, and XM16E1 rifles, and the 90-millimeter recoilless rifle Mi67.

b. *Basic Functioning.* When the power switch is turned on, the battery energizes the image intensifier assembly. The objective lens assembly, using the surrounding light of the night sky, focuses an image of the scene being viewed onto the front face of the image intensifier assembly. The image intensifier assembly receives the dim image from the objective lens assembly and amplifies it to such a

degree that it can be seen with the naked eye. The eyepiece assembly magnifies and focuses the image so that you can see the image displayed on the image intensifier assembly.

c. *Differences in Models.* An automatic bright-ness control (ABC) is included in the AN/PVS-2B.

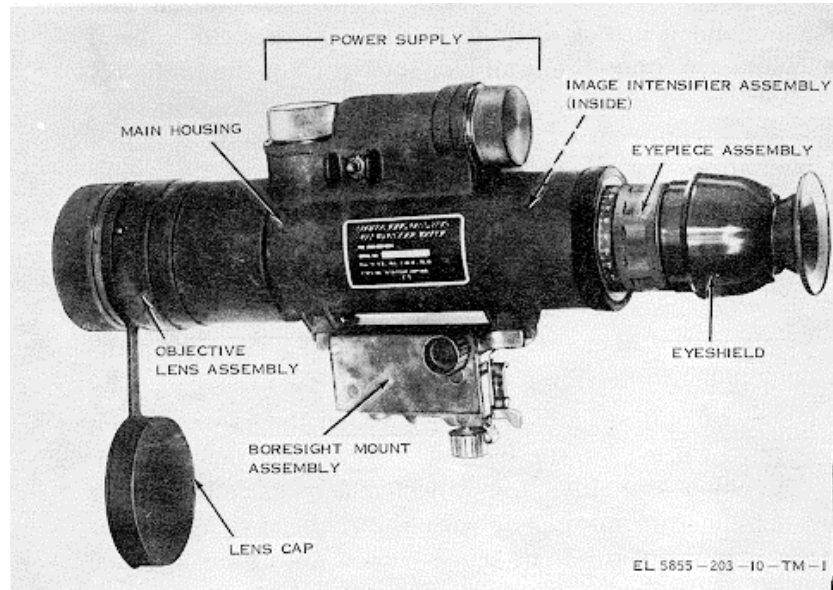

Figure 1-2. Night vision sight.

This feature automatically varies the brightness of the image intensifier assembly for varying levels of light. The AN/PVS-2 and AN/PVS-2A do not have this feature but the image intensifier assembly will cut off completely if the surrounding light level is too bright.

d. Additional Information. If you need a de-tailed description of the night vision sight, ask your supervisor to see TM 11-5855-203-13.

**1-5. Items Comprising an Operable End Item**

**(fig. 1-1)**

a. The items listed in table 1-1 make tip an operable Night Vision Sight, Individual Served Weapon AN/PVS-2 (FSN 5855-087-2947i), ANP'PVS-2A (FSN 5855-179-3708) or AN/PVS-2B (FSN 5855-760-3869).

*Table 1-1. Items Comprising an Operable End Item*

<b>Federal Stock Number</b>	<b>Name</b>	<b>Quantity</b>
5855-832-9224	Night Vision Sight Subassembly MX-7833/PVS-2	1
5855-400-2619	or Night Vision Sight Subassembly MX-7833A/PVS-2	1
5122-198-5392	Allen Wrench	1
5855-782-7546	Lens Cap	1
5855-924-9994	Carrying Strap	1

*Table 1-1. Items Comprising an Operable End Item  
(Continued)*

Federal Stock Number	Name	Quantity
6135-926-0827	<p><b>NOTE</b>                      Battery, BA-1100/U                      Dry batteries shown are used with the equipment but are not considered part of the equipment. They will not be preshipped automatically but are to be requisitioned in quantities necessary for the particular organization in accordance , with SB 11-6.</p>	1

- b. Refer to appendix B, Section 11 for information on the cases.
- c. Refer to appendix B, Section III for information on MI14, M16, and IM67 adapter assemblies.

**1-6. Expendable Consumable Items**

The items listed in table 1-2 are required for operation and are authorized to be requisitioned by SB 700-50.

*Table 1-2. Expendable Consumable Items*

Federal Stock Number	Item	Quantity
7920-205-0565	Lens brush	1
6640-592-6745	Lens tissue	1 package

**1-7. Tabulated Data**

Magnification	4 power
Field of View	10.7 degrees
Eyepiece Focus	+4 to -4 diopters
Objective lens Focus	4 meters to infinity
Weight	6 pounds
Length	15 <sup>7</sup> / <sub>8</sub> inches
Width	3 <sup>1</sup> / <sub>2</sub> inches
Height	7 <sup>3</sup> / <sub>4</sub> inches
Range	Dependent on surrounding light level.
Operating Temperature	-60° to +125° F at humidity ranging from 0 to 100 percent
Battery Life	Approximately 100 hours.

**CHAPTER 2**  
**OPERATING INSTRUCTIONS**  
**Section I. INSTALLATION**

**CAUTION**

DO NOT ALLOW DIRECT RAYS FROM THE SUN OR ANY OTHER BRIGHT LIGHT SOURCE TO ENTER THE OBJECTIVE LENS: THIS MAY DAMAGE THE IMAGE INTENSIFIER ASSEMBLY

**2-1. Installation of Battery**

**CAUTION**

EXAMINE THE POSITION OF THE POWER SWITCH. MAKE SURE THAT THE SWITCH IS IN THE OFF POSITION (DOWN POSITION) BEFORE INSTALLING THE BATTERY.

Install the battery as shown in figure 2-1.

**2-2. Installation on M14 Rifle**

- a. Refer to figure 2-2 for installation of the receiver mount assembly on the M14 rifle.
- b. Rotate the lock knobs of the boresight mount assembly forward toward objective lens) until they come to a stop on the pins located on the assembly.
- c. Slide the boresight mount assembly onto the guide rail of the receiver mount assembly from the rear until it is positioned against the pin stop of the guide rail.



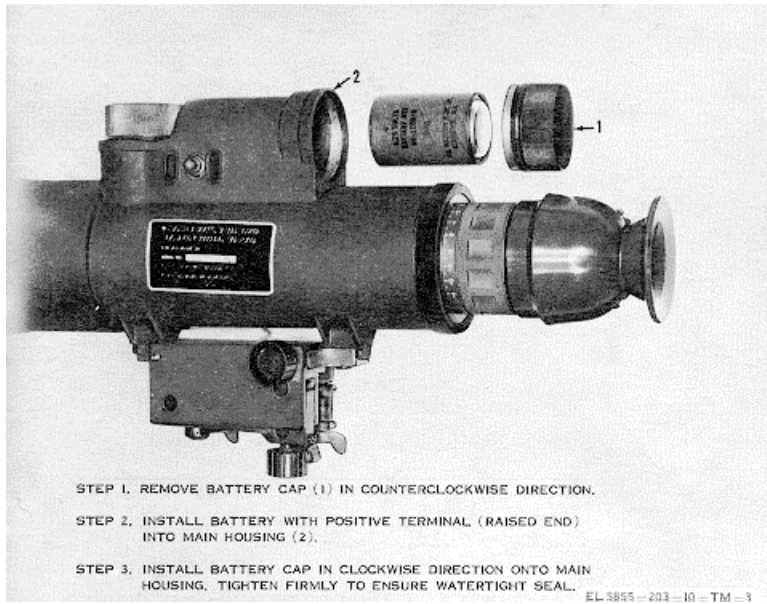

*Figure 2-1. Installation of battery.*

d. Lock the night vision sight to the receiver mount assembly by rotating the two locking knobs the boresight mount assembly in a rearward direction.

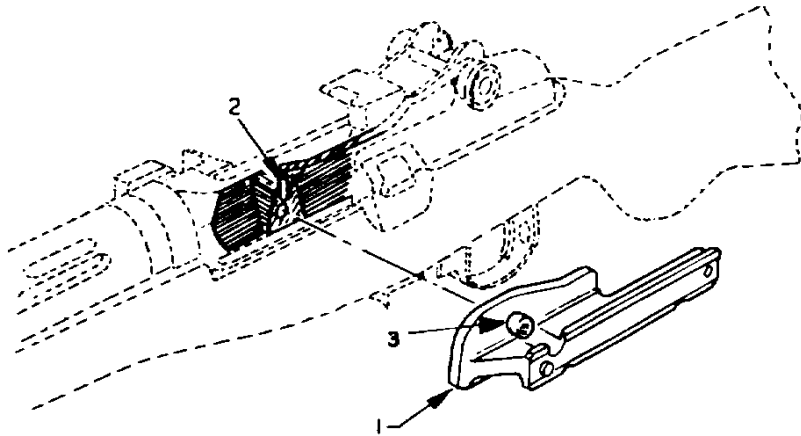

STEP 1,

ALINE RECEIVER MOUNT ASSEMBLY (1) WITH THE GROOVE (2) AND SCREW RECESS ON LEFTSIDE OF RECEIVER,

STEP 2.

TIGHTEN SCREW (3) SECURELY WITH ALLEN WRENCH.

EL5S55-203-10-TM-4

*Figure 2-2. Installation of M14 receiver mount assembly.*

**2-3. Installation on M16 Rifle**

- a. Refer to figure 2-3 for installation of the NMI(6 adapter assembly on the M16 rifle.
- b. Rotate the lock knobs of the boresight mount assembly forward (toward objective lens) until they come to a stop on the pins located on the assembly.
- c. Slide the boresight mount assembly onto the glide rail of the 1116 adapter assembly from the rear until it is positioned against the pin stop of the guide rail.
- d. Lock the night vision sight to the 5116 adapter assembly by rotating the two locking knobs of the boresight mount assembly in a rearward direction.

**2-4. Installation on M67 Rifle**

- a. Refer to figure 2-4 for installation of the M167 adapter assembly on the M67 rifle.
- b. Rotate the lock knobs of the boresight mount assembly forward (toward objective lens) until they come to a stop on the pins located on the assembly.
- c. Slide the boresight mount assembly onto the guide rail of the M67 adapter assembly front the rear until it is positioned against the pin stop of the guide rail.

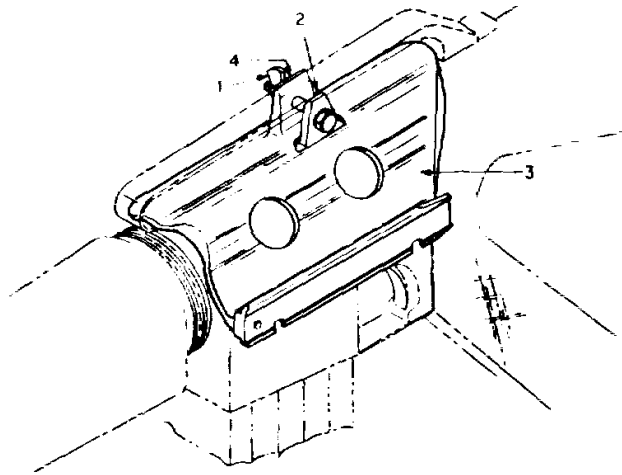

- STEP 1. UNTHREAD WING NUT (1) TO THREAD STOP ON SCREW,  
STEP 2. PULL TAB (2) AWAY FROM WEAPON ADAPTER ASSEMBLY (3).  
STEP 3. SLIDE MOUNTING EAR (4) UNDER HANDLE AND POSITION WEAPON ADAPTER ASSEMBLY FLAT AGAINST TOP OF RECEIVER AND ALL THE WAY FORWARD.  
STEP 4. FIRMLY TIGHTEN WING NUT (1) UNTIL TAB (2) IS PULLED TIGHTLY AGAINST HANDLE AND WEAPON ADAPTER ASSEMBLY.

EL5855- 203-10-TM -6

*Figure 2-3. Installation of M16 adapter assembly*

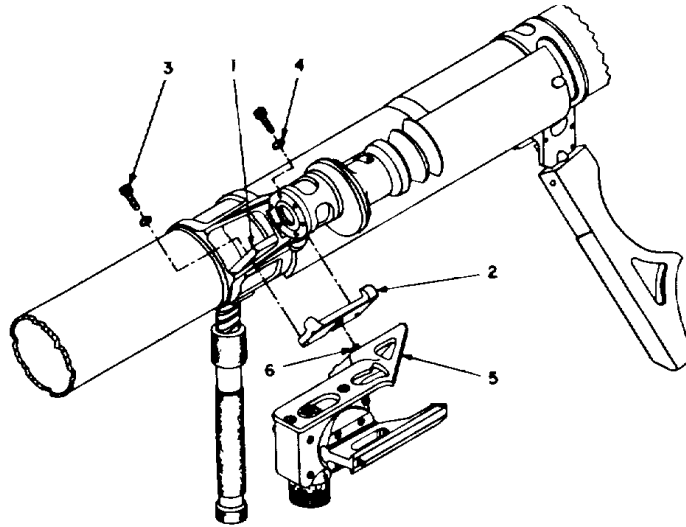

- STEP 1. POSITION CLAMP (ION INSIDE OF WEAPON FRONT BRACKET AS SHOWN.
- STEP 2. PLACE HOLDER ( ON OUTSIDE OF WEAPON FRONT BRACKET SO THAT THE TWO THREADED HOLES IN THE HOLDER LINE UP WITH THE TWO CLEARANCE HOLES IN THE CLAMP.
- STEP 3. INSTALL TWO SCREWS ( WITH LOCK WASHERS ) AS SHOWN. DO NOT TIGHTEN.
- STEP 4. WHILE PUSHING HOLDER ( DOWN AND TO THE REAR OF THE WEAPON, TIGHTEN TWO SCREWS.
- STEP 5. ATTACH ADAPTER ASSEMBLY) TO HOLDER BY INSERTING AND TIGHTENING CAPTIVE SCREW INTO THREADED HOLE OF HOLDER.

**EL5855-203-10-TM-5**

*Figure 2-4. Installation of M67 adapter assembly.*

d. Lock the night vision sight to the 5P, 7 adapter assembly by rotating the two locking knobs of the boresight mount assembly in a rearward direction.

## **2-5. Dismounting Night Vision Sight**

Under conditions of foot mobility, the night vision sight may be kept mounted or it may be removed from the weapon and placed in the carrying case.

- a. Loosen the lock knobs on the boresight mount assembly.
- b. Remove the night vision sight from the weapon by sliding the night vision sight away with one hand while holding the weapon with the other hand.
- c. Check to be sure that the power switch is in the off position. Do not remove the battery.
- d. Open the carrying case, place the night vision sight inside, and close the case.

## **2-6. Transporting**

a. *Shipping Case.* When packed in the shipping case, the night vision sight can be transported by one man by means of the carrying handle, or in any vehicle.

- b. *Carrying Case.* The night vision sight may be carried in the carrying case by attaching the metal belt loops on the carrying case to your cartridge belt.
- c. *Carrying Straps.* The night vision sight may also be carried by the carrying straps (fig. 2-5).
- d. *Weapon Mounted.* When immediate use is apparent, the night vision sight may be left mounted on the weapon.

## **2-7. Storage**

Under conditions where the night vision sight is not to be used for long periods of time, it should be stored in the shipping case.

### **CAUTION**

THE BATTERY MUST BE REMOVED BEFORE STORING THE NIGHT VISION SIGHT.

- a. Before removing the battery from the night vision sight, make sure that the power switch is in the off position.
- b. Remove the battery by reversing the procedure shown in figure 2-1.
- c. Place the night vision sight in the carrying case, and repack it in the shipping case.
- d. Place the battery back in the shipping case.

- e. Replace the upper lid on the shipping case, and latch all latches.

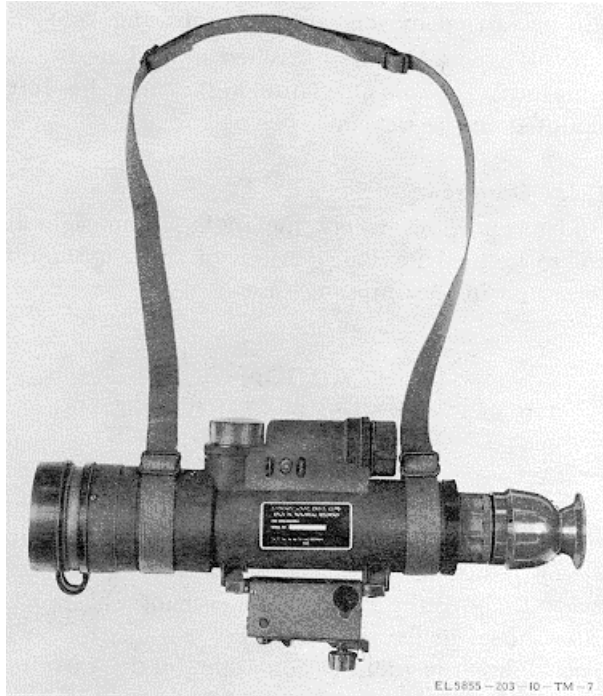

*Figure 2-5. Carrying straps attached to night vision sight.*



## Section II. OPERATION

### 2-8. Function and Location of Controls

The location of the night vision sight controls are shown in figure 2-6. The function of the controls are given in the chart below.

Control	Function
Power switch	a. In the down position, all power is off. b. In the up position, power is on for operation.  NOTE POWER IS AUTOMATICALLY REMOVED IF EXCESSIVE LIGHT ENTERS THE OBJECTIVE LENS. FOR DAYLIGHT USE, LENS CAP MUST BE USED.
Focus ring	Adjusts focusing eyepiece assembly.
Diopter scale	Permits presetting focus ring if operator's diopter factor is known.
Range focus ring	Adjusts focusing objective lens assembly.
Elevation adjustment knob.	a. Clockwise rotation moves night vision sight up.

Control	Function
Azimuth adjustment knob.	b. Counterclockwise rotation moves night vision sight down. a. Clockwise rotation moves night Vision sight to right. b. Counterclockwise rotation moves night vision sight to left.

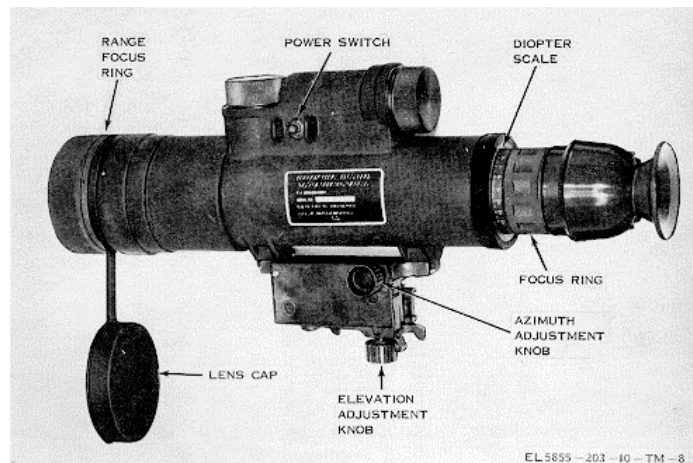

Figure 2-6. Location of controls.

## 2-9. Operating Procedure

The operating procedure is given on figure 2-7.

### NOTE

TO AVOID DETECTION DUE TO LIGHT REFLECTING FROM THE INSIDE SURFACE OF THE LENS CAP, THE LENS CAP SHOULD BE REMOVED AND REPLACED IN THE POCKET BEFORE USING THE NIGHT VISION SIGHT.

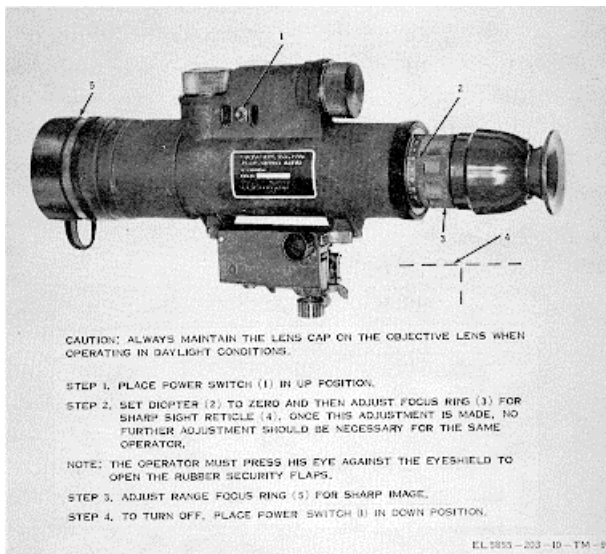

Figure 2-7. Operating procedure.

## **2-10. Zeroing Procedures**

a. The night vision sight may be zeroed during daylight hours or during hours of darkness. However, you may experience some difficulty in attempting to zero the AN/PVS-2 and AN/PVS-2A just before darkness (dusk). The light level is too low at dusk to permit you to resolve your zero target with the lens cap in place, but the light level at dusk is still intense enough to cause the night vision sight to automatically cut off unless the lens cap is positioned over the objective lens. You should not have any difficulty with the AN/PVS-2B as it has the automatic brightness control. The recommended nominal distance for zeroing the night vision sight, in daylight or at night, is 150 meters when mounted on the M14, and NM16 rifles.

b. The night vision sight is zeroed to the M14 and M16 rifles as follows:

- (1) Place or select a target at the desired zeroing range. Assume a comfortable prone position and support the weapon and night vision sight combination with sand-bags, stakes, or any other available equipment that will afford maximum stability.
- (2) Carry out operating instructions as given in figure 2-7.

- (3) Place the reference aiming point on the center of mass of the target, and fire enough rounds to obtain a good shot group on the target. Check the target to determine the location of the center of the shot group in relation to the point of aim.
- (4) Adjust the night vision sight to move the aim reference point to the center of the shot group. When making adjustments for errors in elevation or azimuth, the night vision sight must be moved in the direction of the error. For example, if the shot group is high and to the left of the point of aim, compensate for this error by moving the night vision sight to the left and raising it.

**NOTE**

EACH CLICK OF THE AZIMUTH OR ELEVATION KNOB WILL MOVE THE STRIKE OF THE ROUND 3 INCHES AT 150 METERS.

- (5) Repeat the procedures given in (3) and (4) above until the point of aim is aligned with the center of the shot group.
  - c. To engage targets at ranges other than the zero range, the operator must compensate for the rise and fall in the trajectory of the round.

---

**Section III. OPERATION  
UNDER UNUSUAL CONDITIONS**

**2-11. Operation in Extreme Cold.**

**The night vision sight will operate in temperatures as low as -65°F.**

a. Battery Switching. A method of operation in temperatures below -20°F to extend battery life is to periodically switch batteries.

(1) Keep one battery in an inner pocket as close to the body as possible for warmth.

(2) After approximately 1 hour of operation, remove the battery from the night vision sight and install the warm battery from the pocket.

(3) Place the removed battery in an inner pocket, and reinstall it after approximately 1 hour.

b. Lens Frosting. The lenses may have a tendency to fog and frost up in cold weather and will require more frequent cleaning.

**2-12. Operation in Dusty or Sandy Areas**

Operation of the night vision sight in dusty or sandy areas is not recommended; however, if such operation becomes necessary, the following precautions should be observed:

- a. Avoid pointing the objective lens into the wind. Dust and sand will scratch and pit the optical glass surfaces.
- b. Cover as much of the night vision sight as possible to prevent damage to the external surfaces.
- c. Keep the shipping case closed and the carrying case sealed when not removing or replacing equipment.
- d. The eyepiece lens and objective lens will require frequent cleaning. To remove dust and sediment from lenses, use a lens brush. Finish cleaning with lens paper.

### **2-13. Operation in Rainy or Humid Conditions**

The night vision sight is designed for satisfactory operation without damage under rainy or humid conditions.

#### **CAUTION**

TO PREVENT CORROSION OR DETERIORATION, THOROUGHLY DRY ALL PARTS OF THE NIGHT VISION SIGHT AFTER EXPOSURE TO RAIN OR HIGH HUMIDITY. CLEAN THE LENSES WITH LENS PAPER. KEEP THE SHIPPING CASE CLOSED TO MAINTAIN DRY LINERS. KEEP THE CARRYING CASE DRY. DO NOT STORE THE NIGHT VISION SIGHT IN A WET CARRYING CASE OR SHIPPING CASE.

**2-14. Operation in Salt Water Areas**

The night vision sight is designed for satisfactory operation without damage under salt-spray conditions. Thoroughly clean and dry all parts after exposure to salt-spray conditions. The night vision sight may be immersed in fresh water to eliminate all traces of salt spray.



---

## CHAPTER 3 MAINTENANCE INSTRUCTIONS

---

### 3-1. Preventive Maintenance Checks and Services

Preventive maintenance checks and services (PMCS) is the systematic care, services, and inspection of equipment to insure that the equipment is service-able and to prevent the occurrence of trouble.

a. *PMICS Periods.* Preventive maintenance checks and services, Table 3-1, lists checks to be performed daily. If the night vision sight is not used daily, it should be checked and serviced immediately before going on a mission and as soon after completion of a mission as possible. Do not allow the night vision sight to go beyond one week without performing the daily preventive maintenance checks and services.

b. *PAFCS Reporting.* If you cannot correct the defect, a higher category of maintenance is required. Record all checks in accordance with TM 38-750.

c. *Table 3-1 Column Heading Explanation.* The first column lists the interval and sequence that a particular check or service is required. This column is subdivided into three columns: B (Before Operation), D (During Operation), and A (After Operation). The second column lists the item to be

inspected and the procedure. The third column (Worktime (MH)) lists the man-hours it should take to perform the check or service. This time is expressed in tenths of an hour.

*Table 3-1. Operator's Daily Preventive Maintenance Checks and Services*

B-Before  
Operation  
Time required: .3

D-During  
Operation  
Time required: .1

A-After  
Operation  
Time required: .1

INTERVAL			Item to be inspected procedure	Worktime (M/H)
B	D	A		
1			<p><b>NIGHT SIGHT</b> Check for dirt and moisture on external surfaces and parts. Clean the exposed glass surfaces of the objective lens assembly and eyepiece assembly by removing loose dirt with a lens brush, and then clean the glass surfaces with lens paper. Saturate the lens paper with water to remove stubborn dirt. (Use distilled water, if available.) Dry and polish the lenses with dry lens paper. Clean all exposed metal surfaces with a lint-free cloth. If necessary, dampen the cloth with water. Allow these surfaces to dry thoroughly before storing the night vision sight. Clean the rubber eyeshield with a wet cloth.</p>	0 1

Table 3 1. Operator's Daily Preventive Maintenance Checks and Services (Continued)

INTERVAL			Item to be inspected procedure	Worktime (M/H)
B	D	A		
2			<p>BATTERY Inspect and replace if any corrosion is found.</p>	0.1
3			<p>CARRYING CASE Check for dirt, moisture, and mildew. Wipe the inside and outside of the carrying case with a damp cloth.</p>	0.1
4			<p>CONTROLS While making the operating checks (items a. through e.), see that the mechanical action of each knob, switch, and control is smooth and free of external or internal binding.</p> <p>a. Power switch Place in on position. Look for characteristic green glow.</p> <p>b. Focus ring Adjust for sharp sight reticle.</p> <p>c. Range focus ring Adjust for sharp image.</p> <p>NOTE IF THE NIGHT VISION SIGHT IS ZEROED TO A PARTICULAR WEAPON, COUNT THE NUMBER OF CLICKS, AND RETURN THE</p>	0.1

Table 3-1. Operator's Daily Preventive Maintenance Checks and Services (Continued)

INTERVAL			Item to be inspected procedure	Worktime (M/H)
B	D	A		
		5	KNOB TO ITS ORIGINAL SETTING. d. Azimuth adjustment knob Rotate azimuth adjustment knob, and see that boresight assembly is adjustable. e. Elevation adjustment knob Rotate elevation adjustment knob, and see that boresight assembly is adjustable. CONDITION OF EQUIPMENT After completion of a mission: a. Perform sequence 1 and 3 again. b. Remove the battery from the night vision sight.	0.1

**3-2. Troubleshooting**

Troubleshooting by the operator is limited to re-placement of the battery (fig. 2-1). Replace the battery if the sight image is weak, blurred, or not illuminated. If battery replacement does not correct the trouble, higher category of maintenance is required. No repairs or maintenance adjustments by the operator are authorized.

**APPENDIX A  
REFERENCES**

---

SB 11-6	Dry Battery Supply Data
SB 700-50	Expendable Items
TM I 11-5855-203-13	Operators, Organizational and Direct Support Maintenance Manual, including Repair Parts and Special Tools Lists for Night Vision Sight, Individual Served Weapon AN/PVS-2 and AN/PVS-2A.
TM 38-750	The Army Maintenance Management Systems (TAMMS)

**APPENDIX B  
BASIC ISSUE ITEMS LIST  
(BIIL) AND ITEMS TROOP  
INSTALLED OR AUTHORIZED LIST (ITIAL)**

---

**Section I. INTRODUCTION**

**1. Scope**

This appendix lists basic issue items and items troop installed or authorized required by the crew/ operator for installation, operation, and maintenance of Individual Served 1WTeapon AN/PVS-2, AN /PVS-2A, and AN/PVS-2B.

**2. General**

This Basic Issue Items and Items Troop Installed or Authorized List is divided into the following sections:

*a.* Basic Issue Items List-Section II. A list, in alphabetical sequence, of items which are furnished with, and which must be turned in with the end item.

*b.* Items Troop Installed or Authorized List-Section III. A list, in alphabetical sequence of items which, at the discretion of the unit commander may accompany the end item, but are not subject to be turned in with the end item.

---

### **3. Explanation of Columns**

The following provides an explanation of columns found in the tabular listings:

- a. Illustration. This column is divided as follows:
  - (1) Figure number. Indicates the figure number of the illustration in which the item is shown.
  - (2) Item number. Not applicable.
- b. Federal Stock Number. Indicates the Federal Stock Number assigned to the item and will be used for requisitioning purposes.
- c. Part Number. Indicates the primary number used by the manufacturer (individual, company, firm, corporation, or Government activity), which controls the design and characteristics of the item by means of its engineering drawings, specifications standards, and inspection requirements, to identify an item or range of items.
- d. Federal Supply Code for Manufacturer (FSCM). The FSCM is a 5-digit numeric code used to identify the manufacturer, distributor, or Government agency, etc., and is identified in SB 708-42.

e. *Description*. Indicates the Federal item name and a minimum description required to identify the item.

f. *Unit of Measure (U/M)*. Indicates the standard of basic quantity of the listed item as used in performing the actual maintenance function. This measure is expressed by a two-character alphabetical abbreviation, (e.g., ea., in., pr., etc.). When the unit of measure differs from the unit of issue, the lowest unit of issue that will satisfy the required units of measure will be requisitioned.

g. *Quantity Furnished with Equipment (Basic Issue Items Only)*. Indicates the quantity of the basic issue item furnished with the equipment.

h. *Quantity Authorized (Items Troop Installed or Authorized Only)*. Indicates the quantity of the item authorized to be used with the equipment.

#### **4. Special Information**

Usable on codes are shown in the description column. Uncoded items are applicable to all models. Identification of the usable on codes used in this publication are:

<u>Code</u>	<u>Used On</u>
CNW	AN/PVS-2
BDH	AN/PVS-2A
CFE	AN/PVS-2B



*Section II. BASIC ISSUE ITEMS LIST*

(1) ILLUSTRATION		(2) FEDERAL STOCK NUMBER	(3) DESCRIPTION PART NUMBER & FSCM USABLE ON CODE	(4) QTY FURN WITH EQUIP
(A) FIG. NO.	(B) ITEM NO.			
1-1		5855-832-6525		1
1-1		5855-832-6523		1

**Section III. ITEMS TROOP INSTALLED OR  
AUTHORIZED LIST**

(1) FEDERAL STOCK NUMBER	(2) DESCRIPTION PART NUMBER AND FSCM USABLE ON CODE	(3) U/M	(4) QTY AUTH
5855-912-3885	ADAPTER ASSEMBLY, SIGHT, M16 SCC607230 (80063)	EA	1
5855-405-0409	MOUNT FOR M67 SCC647550 (80063)	EA	1
5855-941-3036	RECEIVER MOUNT ASSEMBLY M14 SSC607130 (80063)	EA	1

By Order of the Secretary of the Army:

CREIGHTON W. ABRAMS  
General, United States Army  
Chief of Staff

Official:

VERNE L. BOWERS  
Major General, United States Army  
The Adjutant General

Distribution:

Active Army:

USASA (2)  
CNGB (1)  
Dir of Trans (1)  
COE (1)  
TSG (1)  
USAARENBD ()  
AMC (1)  
TRADOC (2)  
ARADCOM (2)  
ARADCOM Rgn (2)  
OS Maj Comd (4)  
LOCCOMDS (3)  
MICOM (2)  
TECOM (2)  
USACC (4)  
MDW (1)  
Armies (2)  
Corps (2)  
HISA Ft Monmouth (18)

USAINTCS (3)  
WRAMC (1)  
ATS (1)  
Fort Gordon (10)  
Fort Huachuca (10)  
WSMR (1 )  
Fort Carson (5)  
Ft Richardson  
(ECOM Ofc) (2)  
Army Dep (1) except  
LBAD (14)  
SAAD (30)  
TOAD (14)  
ATAD (10)  
USA Dep (2)  
Sig Sec USA Dep (2)  
Sig Dep (2)  
Sig FLDMS (1)  
USAERDAA (1)

SVC Colleges (1)  
USASESS (5)  
USAADS (2)  
USAFAS (3)  
USAARMS (2)  
USAIS (2)  
USAES (2)

USAERDANV (1)  
MAAG (1)  
USARMIS (1)  
Units org under fol  
TOE:  
(1 copy each)  
11-500 AA-AC  
29-134  
29-136

*NG*: State AG (3)

*USAR*: None

For explanation of abbreviations used, see AR 310-50.

GPO : 1993 0 - 342-421 (80932)

RECOMMENDED CHANGES TO EQUIPMENT TECHNICAL PUBLICATIONS



## SOMETHING WRONG WITH THIS PUBLICATION?

THEN... JOT DOWN THE DOPE ABOUT IT ON THIS FORM, CAREFULLY TEAR IT OUT, FOLD IT AND DROP IT IN THE MAIL!

FROM: (PRINT YOUR UNIT'S COMPLETE ADDRESS)

---

DATE SENT

PUBLICATION NUMBER

PUBLICATION DATE

PUBLICATION TITLE

BE EXACT... PIN-POINT WHERE IT IS				IN THIS SPACE TELL WHAT IS WRONG AND WHAT SHOULD BE DONE ABOUT IT:
PAGE NO	PARA-GRAPH	FIGURE NO	TABLE NO	

PRINTED NAME, GRADE OR TITLE, AND TELEPHONE NUMBER

SIGN HERE:

TEAR ALONG PERFORATED LINE

DA FORM 2028-2  
1 JUL 79

PREVIOUS EDITIONS  
• ARE OBSOLETE.

P.S.—IF YOUR OUTFIT WANTS TO KNOW ABOUT YOUR RECOMMENDATION MAKE A CARBON COPY OF THIS AND GIVE IT TO YOUR HEADQUARTERS.

**PIN: 018614-000**

This fine document...

Was brought to you by me:



## [Liberated Manuals -- free army and government manuals](#)

Why do I do it? I am tired of sleazy CD-ROM sellers, who take publicly available information, slap “watermarks” and other junk on it, and sell it. Those masters of search engine manipulation make sure that their sites that sell free information, come up first in search engines. They did not create it... They did not even scan it... Why should they get your money? Why are not letting you give those free manuals to your friends?

I am setting this document FREE. This document was made by the US Government and is NOT protected by Copyright. Feel free to share, republish, sell and so on.

I am not asking you for donations, fees or handouts. If you can, please provide a link to [liberatedmanuals.com](http://liberatedmanuals.com), so that free manuals come up first in search engines:

<A HREF=<http://www.liberatedmanuals.com/>>Free Military and Government Manuals</A>

- Sincerely  
Igor Chudov  
<http://igor.chudov.com/>
- [Chicago Machinery Movers](#)