

TECHNICAL MANUAL
DIRECT SUPPORT
MAINTENANCE
MANUAL



PRINCIPLES OF
OPERATION 1-4

SERVICE UPON
RECEIPT 2-2

TROUBLESHOOTING 2-6

MAINTENANCE
PROCEDURES 2-23

PREPARATION FOR
STORAGE
OR SHIPMENT 2-52

TELEPHONE SET
TA-341 B/TT
(NSN 5805-01-039-3499)

HEADQUARTERS, DEPARTMENT OF THE ARMY
JANUARY 1983

WARNING

OBSERVE POLARITY MARKED ON
ELECTROLYTIC CAPACITOR. FAILURE
TO DO SO CAN RESULT IN
PERSONAL INJURY.



5

SAFETY STEPS TO FOLLOW IF SOMEONE IS THE VICTIM OF ELECTRICAL SHOCK

1

DO NOT TRY TO PULL OR GRAB THE INDIVIDUAL

2

IF POSSIBLE, TURN OFF THE ELECTRICAL POWER

3

IF YOU CANNOT TURN OFF THE ELECTRICAL POWER, PULL, PUSH, OR LIFT THE PERSON TO SAFETY USING A DRY WOODEN POLE OR A DRY ROPE OR SOME OTHER INSULATING MATERIAL

4

SEND FOR HELP AS SOON AS POSSIBLE

5

AFTER THE INJURED PERSON IS FREE OF CONTACT WITH THE SOURCE OF ELECTRICAL SHOCK, MOVE THE PERSON A SHORT DISTANCE AWAY AND IMMEDIATELY START ARTIFICIAL RESUSCITATION

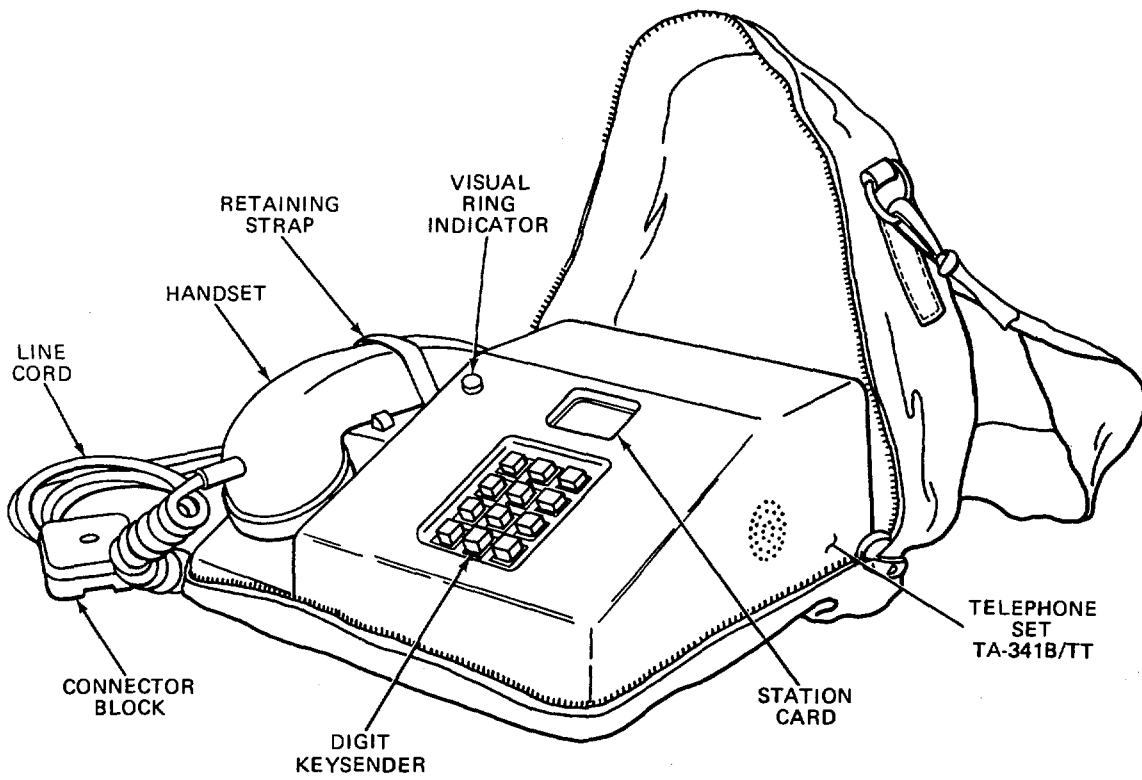
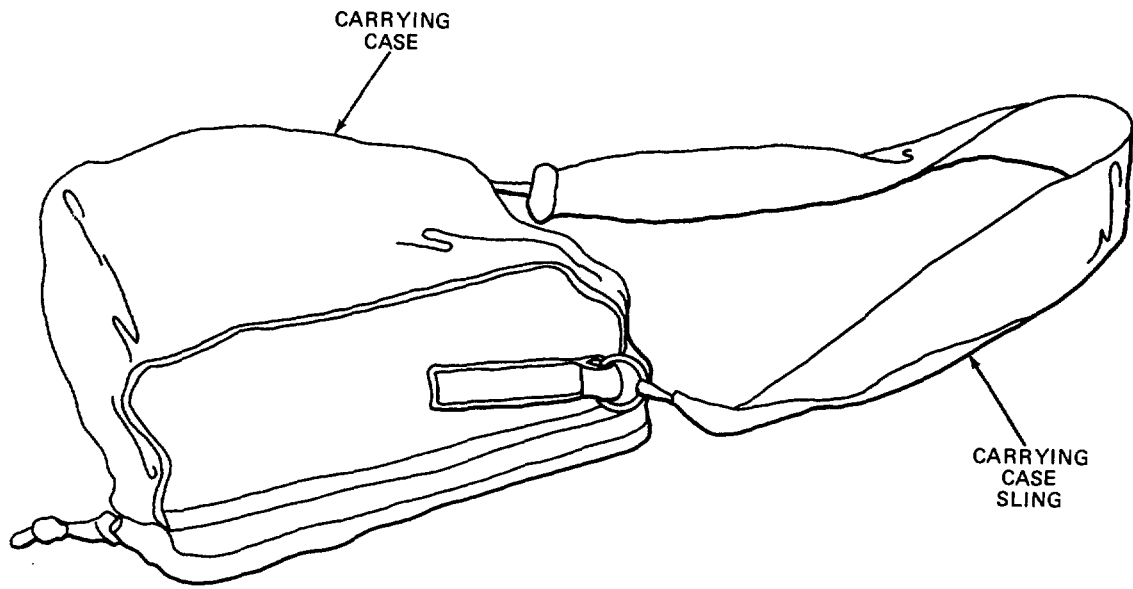

TELEPHONE SET TA-341 B/TT WITH CARRYING CASE

**DIRECT SUPPORT
MAINTENANCE MANUAL**

**TELEPHONE SET TA-341B/TT
(NSN 5805-01-039-3499)**

REPORTING ERRORS AND RECOMMENDING IMPROVEMENTS

You can help improve this manual. If you find any mistakes, or if you know of a way to improve the procedures, please let us know. Mail your letter, DA Form 2028 (Recommended Changes to Publications and Blank Forms), or DA Form 2028-2, located in the back of this manual, direct to: Commander, US Army Communications-Electronics Command and Fort Monmouth. ATTN: DRSEL-ME-MP, Fort Monmouth, New Jersey 07703. A reply will be furnished to you.

Page

| | | | |
|---------|-------------|--|------|
| | | HOW TO USE THIS MANUAL | ii |
| CHAPTER | 1 | INTRODUCTION | 1-1 |
| | Section I | General Information | 1-1 |
| | Section II | Equipment Description and Data | 1-4 |
| | Section III | Technical Principles of Operation | 1-4 |
| CHAPTER | 2 | DIRECT SUPPORT MAINTENANCE | 2-1 |
| | Section I | Repair Parts, Special Tools, TMDE, and Support Equipment | 2-1 |
| | Section II | Service Upon Receipt | 2-2 |
| | Section III | Troubleshooting | 2-6 |
| | Section IV | Maintenance Procedures | 2-23 |
| | Section V | Preparation for Storage or Shipment | 2-52 |

***THIS MANUAL SUPERSEDES TM 11-5805-384-34, 29 NOV 74, INCLUDING ALL CHANGES**

| | | |
|------------|--|------------|
| APPENDIX A | REFERENCES | A-1 |
| APPENDIX B | EXPENDABLE SUPPLIES AND MATERIALS LIST | B-1 |
| GLOSSARY | | Glossary 1 |
| INDEX | | Index 1 |

HOW TO USE THIS MANUAL

In this manual, paragraphs are numbered by chapter and the order in which they appear in each chapter. To find the paragraph you need, locate your subject in the table of contents. Turn to the page shown and read the paragraph headings until you find what you're looking for. If you find a word or term you don't understand, refer to the glossary in the back of this manual.

**CHAPTER 1
INTRODUCTION**

| Subject | Section | Page |
|---|---------|------|
| General Information..... | I | 1-1 |
| Equipment Description | II | 1-4 |
| Technical Principles of Operation | III | 1-4 |

OVERVIEW

This chapter contains general information (type of manual, purpose of equipment, maintenance forms and records), equipment description (characteristics, capabilities, features, safety, care and handling), and principles of operation (block diagram presentation) of the Telephone Set TA-341B/TT.

Section I GENERAL INFORMATION

| Subject | Section | Page |
|--|---------|------|
| Scope | 1-1 | 1-1 |
| Maintenance Forms, Records, and Reports | 1-2 | 1-2 |
| Destruction of Army Electronics Materiel..... | 1-3 | 1-2 |
| Preparation for Storage or Shipment..... | 1-4 | 1-2 |
| Reporting Equipment Improvement Recommendations..... | 1-5 | 1-2 |
| Nomenclature Cross-Reference List | 1-6 | 1-3 |
| List of Abbreviations..... | 1-7 | 1-3 |

1-1. SCOPE.

Type of Manual: Direct Support Maintenance

Equipment Name and Model Number: Telephone Set TA-341 B/TT

Purpose of Equipment: The purpose of Telephone Set TA-341 B/TT is for sending and receiving telephone calls through a switching facility or, when connected to another Telephone Set TA-341B/TT, for point-to-point communication.

1-2. MAINTENANCE FORMS, RECORDS, AND REPORTS.

REPORTS OF MAINTENANCE AND UNSATISFACTORY EQUIPMENT

Department of the Army forms and procedures used for equipment maintenance will be those prescribed by TM 38-750, The Army Maintenance Management System (TAMMS).

REPORT OF PACKAGING AND HANDLING DEFICIENCIES

Fill out and forward SF-364 (Report of Discrepancy (ROD)) as prescribed in AR 735-11-2/DLAR 4140.55.

DISCREPANCY IN SHIPMENT REPORT (DISREP) (SF 361)

Fill out and forward Discrepancy in Shipment Report (DISREP) (SF 361) as prescribed in AR 55-38.

1-3. DESTRUCTION OF ARMY ELECTRONICS MATERIEL.

Destruction of Army electronics materiel to prevent enemy use shall be in accordance with TM 750-244-2.

1-4. PREPARATION FOR STORAGE OR SHIPMENT.

Administrative storage of equipment issued to and used by Army activities will have preventive maintenance performed in accordance with the PMCS charts before storing. When removing the equipment from administrative storage, the PMCS should be performed to assure operational readiness. Disassembly and repacking of equipment for shipment or limited storage are covered in chapter 2, section V.

1-5. REPORTING EQUIPMENT IMPROVEMENT RECOMMENDATIONS (EIR).

If your Telephone Set TA-341 B/TT needs improvement, let us know. Send us an EIR. You, the user, are the only one who can tell us what you don't like about your equipment. Let us know why you don't like the design or performance. Put it on an SF 368 (Quality Deficiency Report). Mail it to: Commander, US Army Communications-Electronics Command and Fort Monmouth. ATTN: DRSEL-ME-MP, Fort Monmouth, New Jersey 07703. A reply will be sent to you.

1-6. NOMENCLATURE CROSS-REFERENCE LIST.

| Common Name | Official Nomenclature |
|--------------------|--|
| telephone set | Telephone Set TA-341 B/TT |
| switching facility | Automatic Telephone Control Offices AN/TCC48(V)1 and AN/TCC38(V)2, AN/TCC-25 |
| batteries | Local Batteries BA-42, BA 2042 |
| handset | H-60 Handset |
| microphone | Microphone Element TA-235(*)/TT |
| receiver | Receiver Element TA-235(*)/TT |
| LB/CB switch | local battery/common battery switch |

1-7. LIST OF ABBREVIATIONS.

The following abbreviations are used in this manual.

| Abbreviation | Word or Term |
|--------------|---|
| ac | alternating current |
| AC Supv. | alternating current supervision |
| CB | common battery |
| cm | centimeter |
| dB | decibels |
| dBm | decibels referenced to one milliwatt |
| dc | direct current |
| DTMF | dual tone multi-frequency |
| Hz | Hertz |
| LB | local battery |
| LB/CB | local battery/common battery |
| ma | milliamps |
| ms | milliseconds |
| RPSTL | repair parts and special tools list |
| TAMMS | The Army Maintenance Management System |
| TMDE | test, measurement, and diagnostic equipment |

Section II EQUIPMENT DESCRIPTION AND DATA

See TM 11-5805-384-12 for a complete description of Telephone Set TS-341B/TT equipment.

Section III TECHNICAL PRINCIPLES OF OPERATION

| Subject | Para | Page |
|--------------------------------------|------|------|
| Block Diagram Presentation | 1-8 | 1-4 |
| Operational Modes and Controls | 1-9 | 1-11 |

1-8. BLOCK DIAGRAM PRESENTATION.

This section gives a block diagram presentation of Telephone Set TA-341 B/TT. Below the diagram is the name and description of the major circuits of the telephone set.

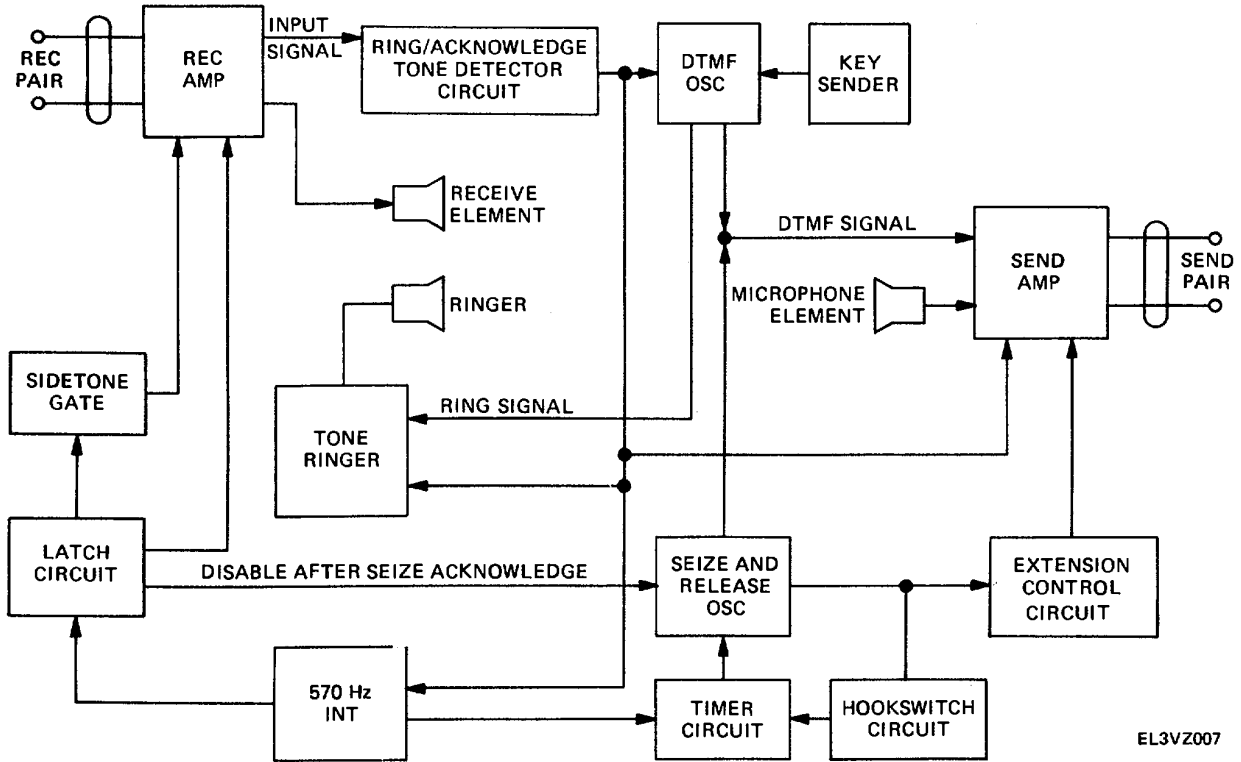

RECEIVE AMPLIFIER CIRCUIT

A transistorized amplifier which controls the amplitude of voice and supervision signals sent to the receive element in the handset. The circuit also controls the off hook impedance of the telephone set.

1-8. BLOCK DIAGRAM PRESENTATION. (CONT)

SEND AMPLIFIER CIRCUIT

The send amplifier is a transistorized amplifier which amplifies voice signals from the microphone element and signals generated by the telephone set. This circuit also matches output impedance to the switching facility.

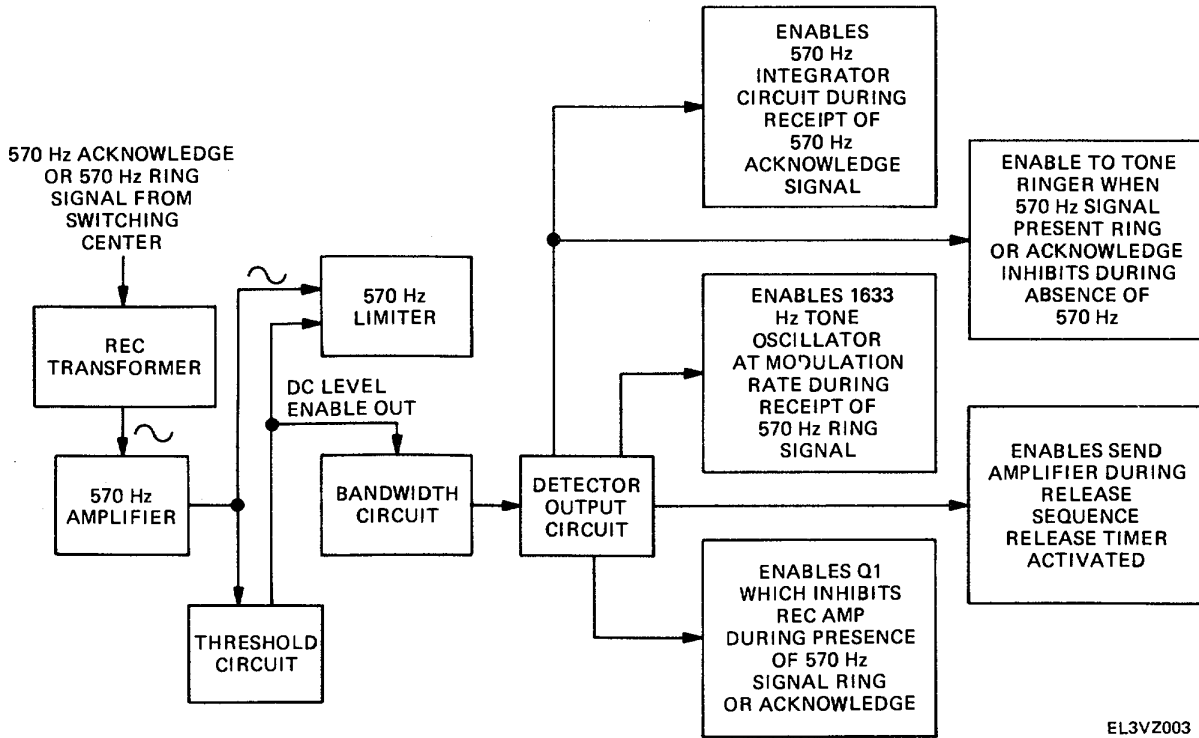

RING ACKNOWLEDGE TONE DETECTOR CIRCUIT

The ring acknowledge tone detector circuit is made up of five subcircuits. The five circuits and their functions are explained below:

570 Hz Amplifier

The 570 Hz amplifier amplifies the 570 Hz ring and acknowledge signals. The amplifier also controls the on-hook impedance of the Telephone Set.

Threshold Control Circuit

This circuit produces a dc output from the 570 Hz amplifier output signal which controls the threshold of 570 Hz limiter circuit and bandwidth circuit.

1-8. BLOCK DIAGRAM PRESENTATION. (CONT)

RING ACKNOWLEDGE TONE DETECTOR CIRCUIT (CONT)

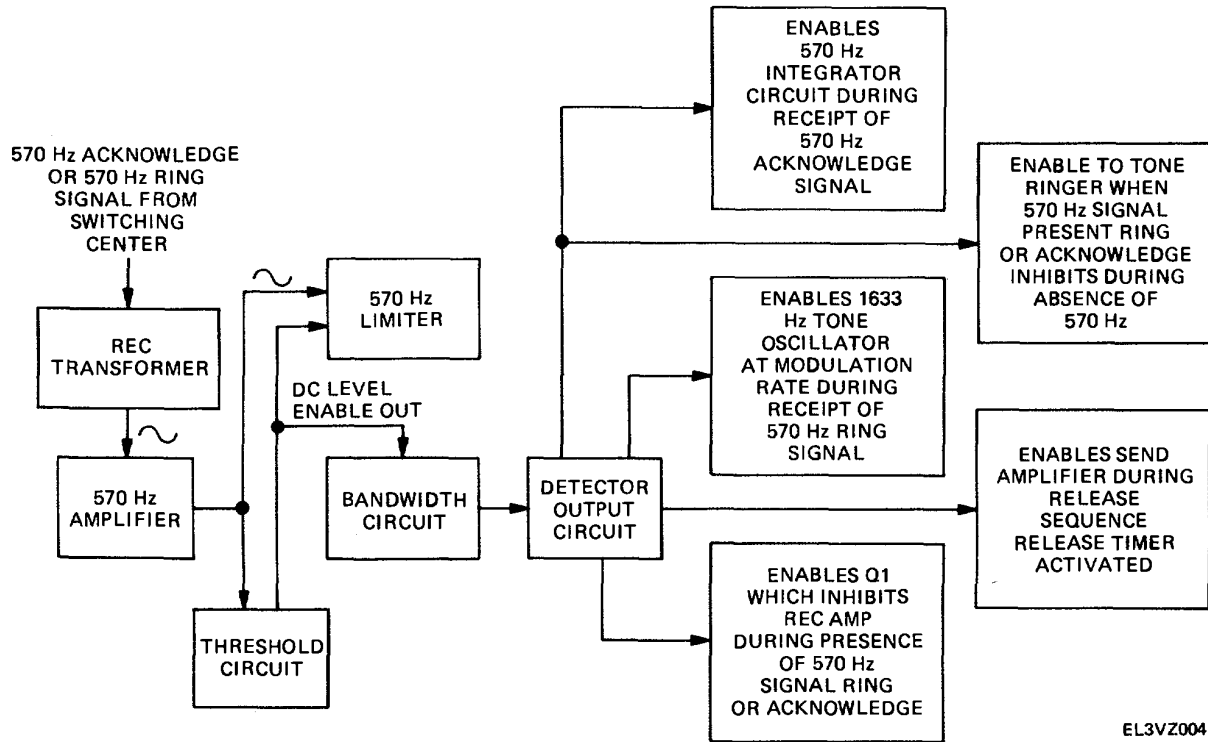

EL3VZ004

570 Hz Limiter Circuit

This circuit produces a square wave output form the 570 HZ amplifier output signal.

Bandwidth Circuit

The output signal of this circuit controls the bandwidth of the detector output circuit. It is designed to conduct at the 2 dB point on the positive part of the signal.

DETECTOR OUTPUT CIRCUIT

The detector output circuit is made up of five switching stages designed to perform the following functions:

Energize the 570 HZ integrator when acknowledge signals are received.

Energize the tone ringer when 570 HZ signal is present and stop he tone ringer during sending of dual tone multifrequency (DTMF) signals.

1-8. BLOCK DIAGRAM PRESENTATION. (CONT)

DETECTOR OUTPUT CIRCUIT (CONT)

Energize the 1633 Hz tone oscillator during ring sequence.

Energize the send amplifier during release sequence.

Energize the control transistor Q1 during the ring or acknowledge sequence.

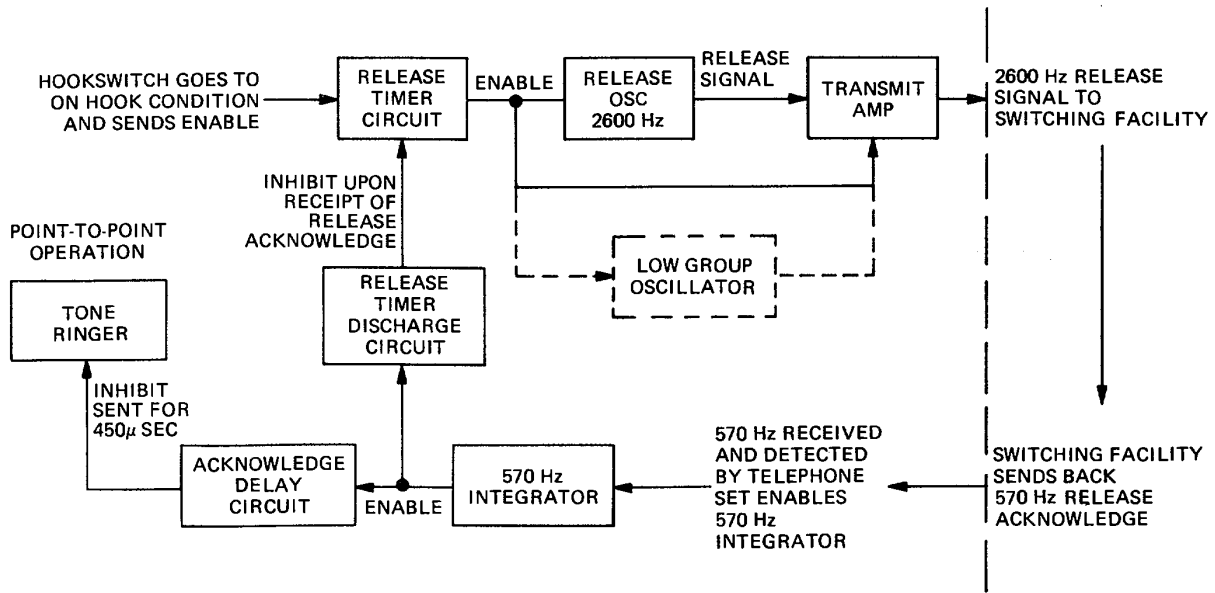

EL3V2005

TIMER CIRCUIT

The timer circuit is made up of three subcircuits. The three circuits and their functions are described below:

Release Timer Circuit

The release timer circuit is controlled by the hookswitch and is designed to produce a low voltage output when the handset is placed in the cradle.

1-8. BLOCK DIAGRAM PRESENTATION. (CONT)

TIMER CIRCUIT (CONT)

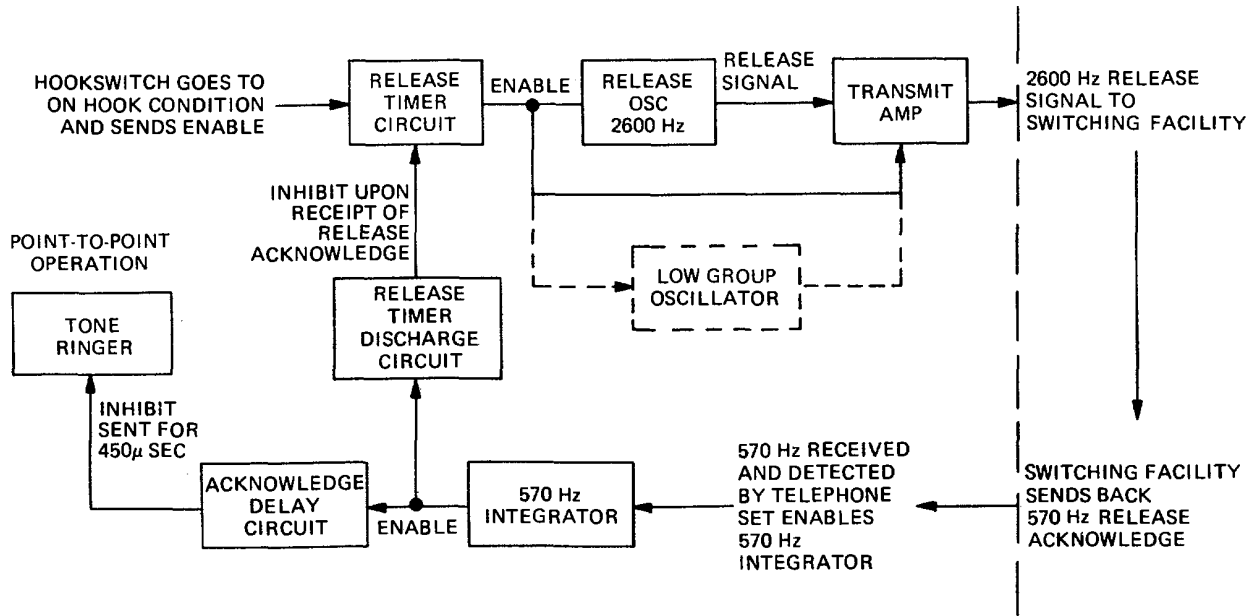

EL3VZ006

The low voltage output from the release timer performs three functions:

- Energizes the 2600 Hz release oscillator.
- Energizes the send amplifier for transmission of release tone.
- Energizes the low group oscillator when in point-to-point mode.

Release Timer Discharge Circuit

This is the second subcircuit making up the timer circuit. It is designed not to function while the release acknowledge signal is being received by the telephone set.

Acknowledge Delay Circuit

This is the third subcircuit making up the timer circuit. It is designed to stop the tone ringer circuit for a minimum of 450 milliseconds after release sequence.

1-8. BLOCK DIAGRAM PRESENTATION. (CONT)

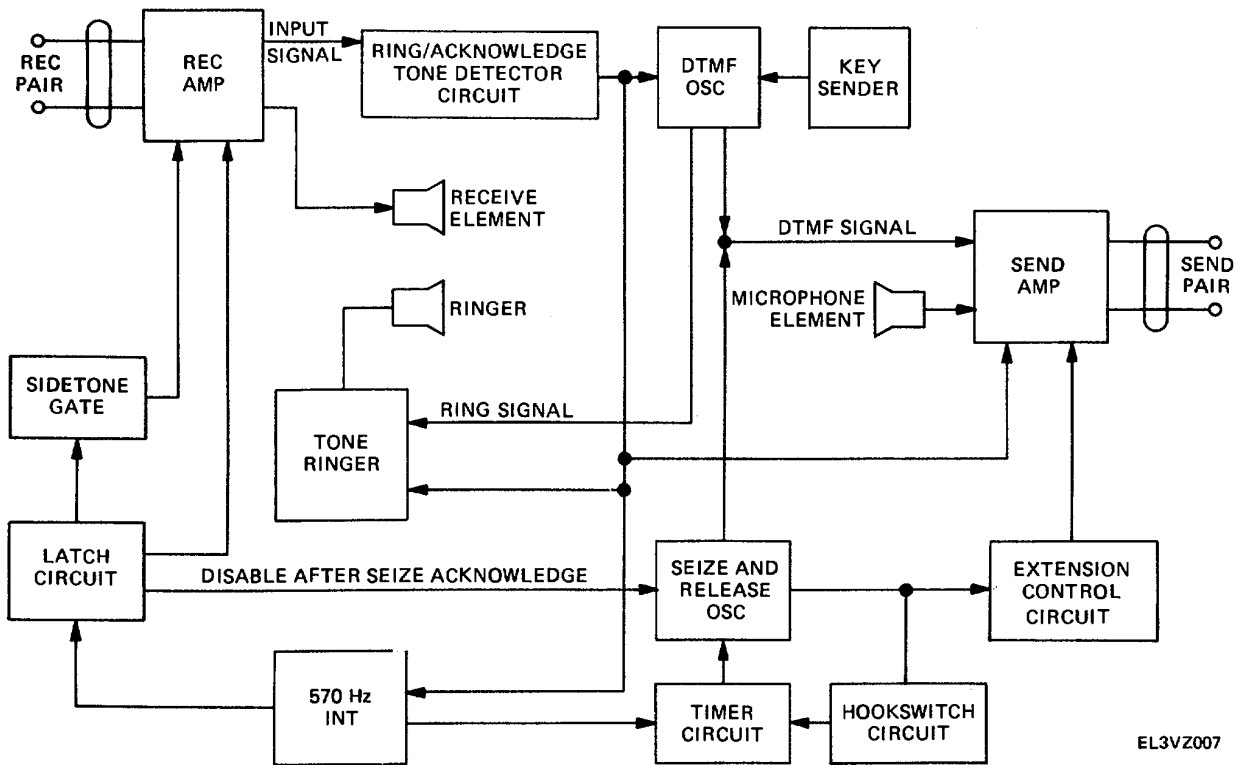

DUAL TONE MULTIFREQUENCY (DTMF) OSCILLATOR AND KEYSENDER CIRCUIT

This circuit is made up of two transformer-coupled transistor oscillators which are controlled by the contacts of the digit keysender push button switches. The DTMF oscillator and keysender circuit produces the following outputs:

A burst of 570 Hz ring tone in point-to-point mode.

Dual tone frequencies for digit information, establishing priority, conference, or recall signaling to the switching facility.

EXTENSION CONTROL CIRCUIT

The extension control circuit controls the signals of extension telephones. Its functions include stopping the ring tone in an extension telephone when the handset of any other extension is lifted from its cradle during the ring cycle. It also stops the release timer in an extension telephone until the last extension telephone handset is placed in its cradle.

1-8. BLOCK DIAGRAM PRESENTATION. (CONT)

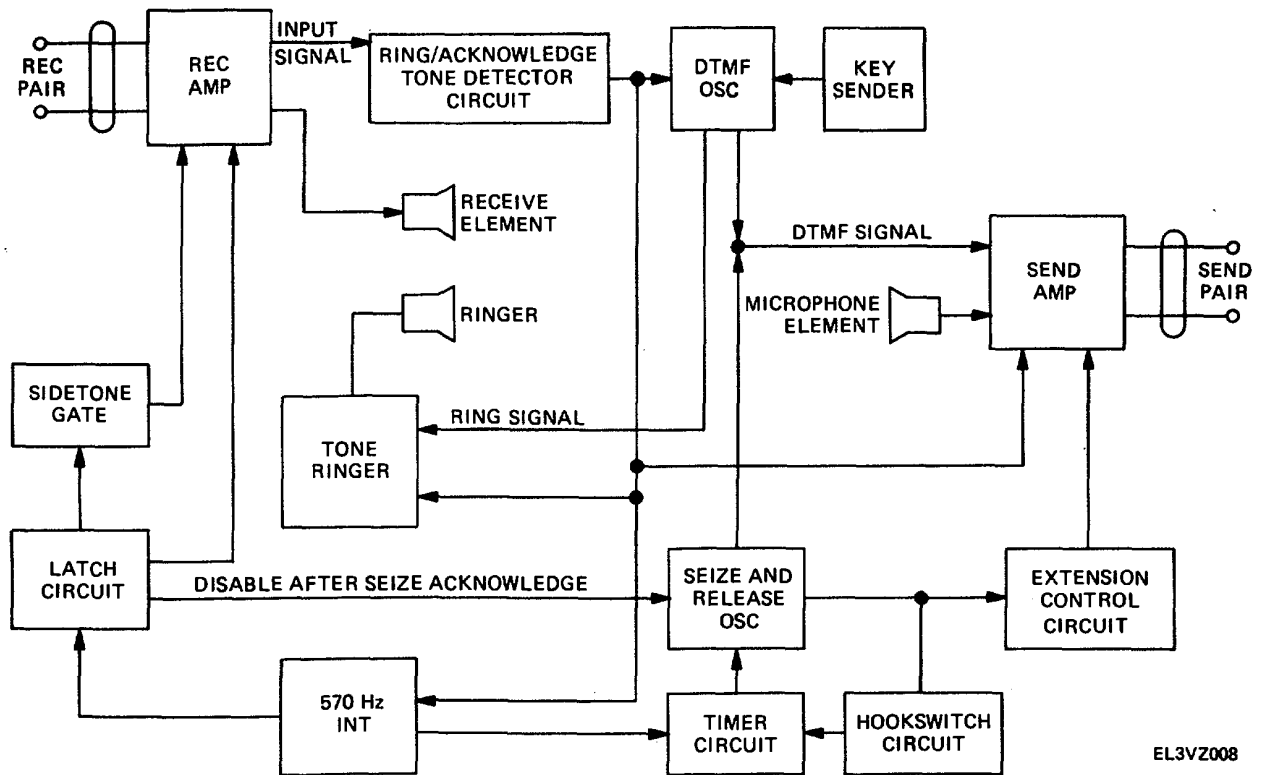

570 Hz INTEGRATOR CIRCUIT

This circuit functions only when a 570 Hz seize or release acknowledge signal is received from a switching facility. The circuit performs the five following functions:

When acknowledge signals are received, the circuit provides a delay to allow time for seize or release tones to be transmitted to a switching facility.

Stops the tone ringer circuit while an acknowledge signal is being received.

Energizes the latch circuit while the seize acknowledge signal is being received.

Energizes the release timer discharge circuit 800 milliseconds after a release acknowledge signal is received from the switching facility.

Energizes the acknowledge delay timer circuit which stops the tone ringer circuit for 450 milliseconds after the acknowledge sequence.

1-8. BLOCK DIAGRAM PRESENTATION. (CONT)

SIDETONE GATE CIRCUIT

The sidetone circuit provides current for the receive amplifier after the latch circuit is energized. With the digit key sender, it also provides proper voice and digit side tones.

LATCH CIRCUIT

The latch circuit energizes the seize oscillator when the handset is lifted from the cradle. It also energizes the receive amplifier and sidetone gate circuit needed to establish a voice and sidetone path after the seize acknowledge signal is received from a switching facility. It also stops the seize oscillator after a seize acknowledge signal is received.

1-9. OPERATIONAL MODES AND CONTROLS.

KEYSENDER

The digit key sender contains digit keys 0 through 9 and the letters R and C. Key C sets up conferencing capabilities in three modes:

Broadcast Mode

All members of the conference number are automatically called at the same time.

Progressive Mode

Key C and the numbers of each conference number are pressed on the digit keys one at a time.

Meet-Me-Mode

Each person of the conference presses Key C and an agreed upon number on the digit keys at an agreed upon time to speak in conference.

KEY R

Key R, when used with the digit keys, can set up priority and precedence calls. Priority and precedence rating allows the caller to break into calls of a lower precedence level or priority rating.

1-9. OPERATIONAL MODES AND CONTROLS. (CONT)

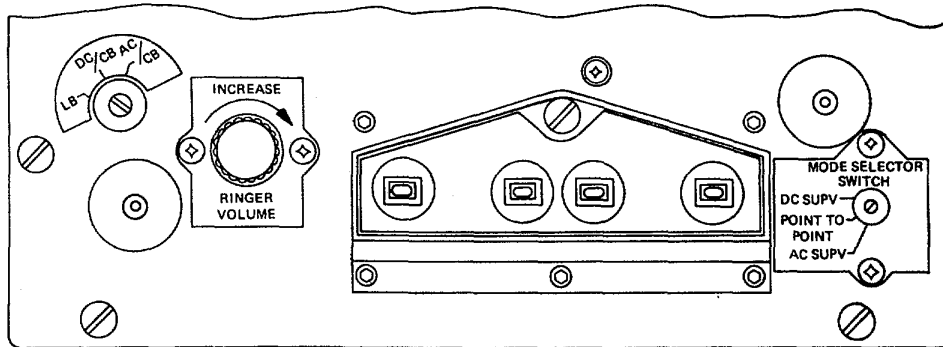
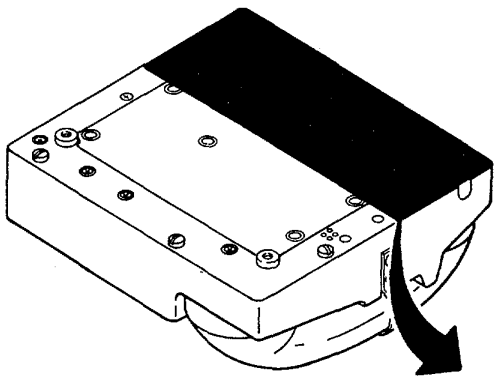

LOCAL BATTERY/COMMON BATTERY SWITCH

This switch allows the telephone set to operate on internal or switching facility power. Local battery (LB) position allows the telephone to operate on four batteries (BA-42). Switching facility power will consist of ac or dc current. If the facility is using ac current the switch should be set to AC/CB. If dc current is used, the switch should be set to DC/CB. The ac and dc settings must be the same as those of the MODE SELECTOR SWITCH.

MODE SELECTOR SWITCH

The MODE SELECTOR SWITCH will allow you to adjust the telephone set to work with switching facilities which use either ac or dc current. If ac current is used, the switch will be in the AC SUPV position; if dc current is used, the switch will be in the DC SUPV position. The POINT TO POINT position is used when two telephone sets are connected directly to each other without a switching facility.

1-9. OPERATIONAL MODES AND CONTROLS. (CONT)

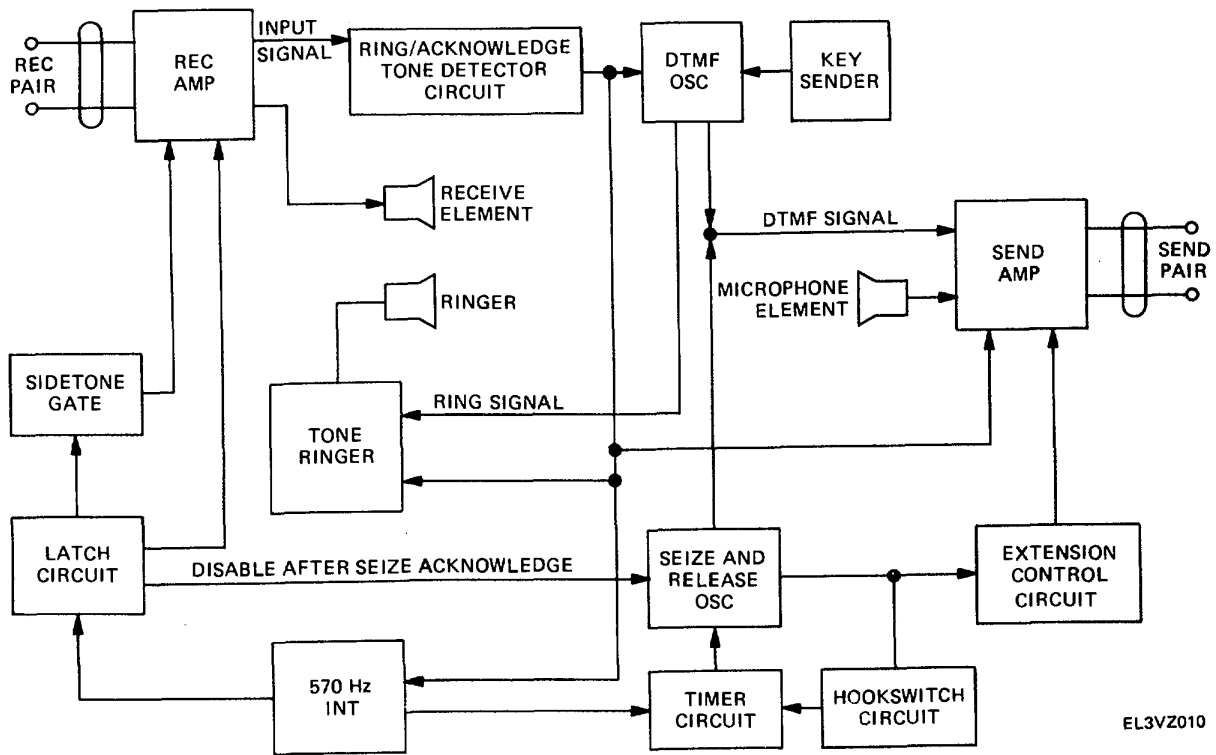

EL3V2010

OUTGOING CALL WITH MODE SELECTOR SWITCH IN AC SUPV POSITION

When the telephone set is installed for operation with a switching facility and the MODE SELECTOR SWITCH is in AC SUPV position, a request for service is transmitted to the switching facility by the hookswitch contacts when the handset is lifted from its cradle. The hookswitch performs the following functions in the order given below:

Tunes the seize and release oscillator to 2250 Hz for oscillation at the seize tone frequency.

Applies negative battery dc current to the send amplifier, preparing it for sending the seize tone to the switching facility.

Changes the input impedance of the telephone set to about 600 ohms.

Energizes the receiver element in the receive amplifier circuit.

Applies positive battery dc current to the dual tone multifrequency (DTMF) oscillator.

Opens the path to the latch circuit when the handset is lifted from its cradle.

1-9. OPERATIONAL MODES AND CONTROLS. (CONT)

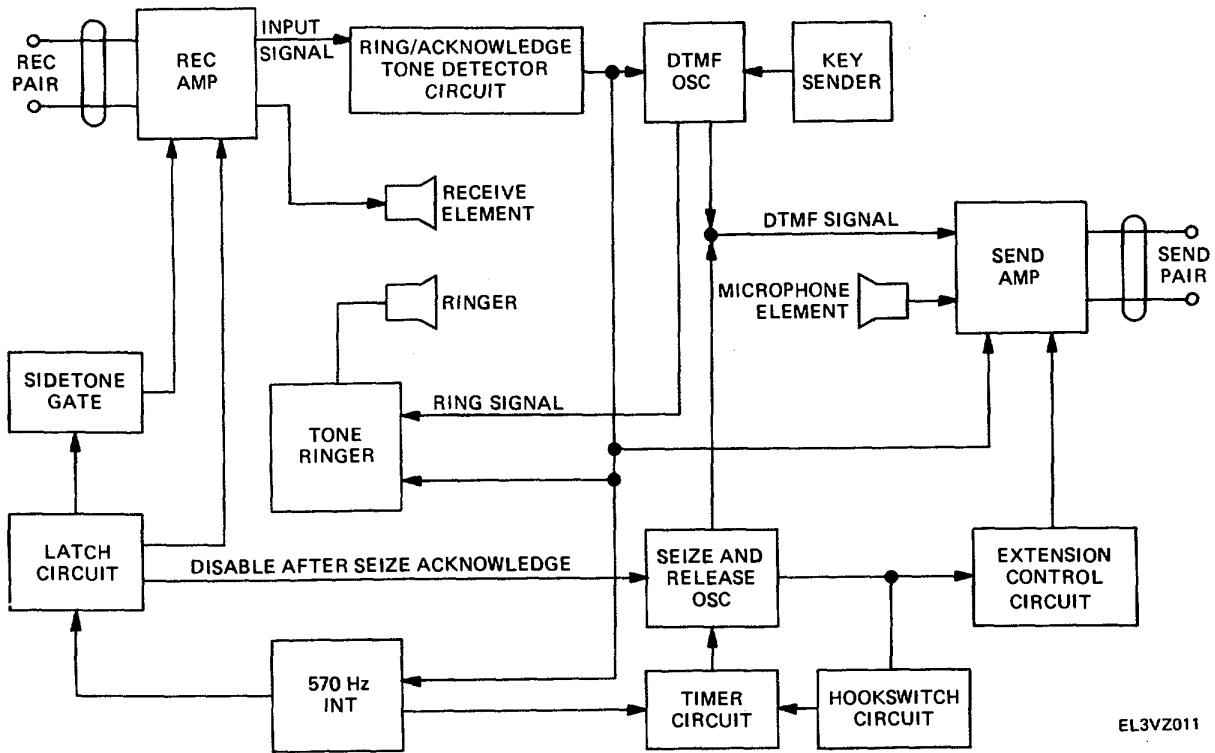

OUTGOING CALL WITH MODE SELECTOR SWITCH IN AC SUPV POSITION (CONT)

Once the 2250 Hz seize oscillator is energized, the signal is coupled to the send amplifier, amplified, and sent to the switching facility. The switching facility acknowledges the request for service and the following functions occur in the order given.

A seize acknowledge signal (570 Hz) is sent to the receive terminals of the telephone set and is inductively coupled to the input of the 570 Hz amplifier in the ring acknowledge tone detector circuit.

The acknowledge signal is amplified and the output of the detector energizes the integrator circuit. The integrator circuit provides a dc output which energizes the latch circuit.

The latch circuit, when energized, stops the seize oscillator and energizes the receive amplifier and sidetone gate circuit.

1-9. OPERATIONAL MODES AND CONTROLS. (CONT)

OUTGOING CALL WITH MODE SELECTOR SWITCH IN AC SUPV POSITION (CONT)

After the latch circuit stops the 2250 Hz seize tone, the switching facility stops sending the 570 Hz acknowledge signal. This energizes the receive amplifier in the telephone set. The switching facility starts to send a dial tone signal (425 Hz). Once the dial tone is sent, the following functions occur in the order given below:

The dial tone is received on the receive terminals of the telephone set and is sent to the receive amplifier where it is amplified and then sent to the receiver element.

The calling party hears the dial tone, and presses the push button on the keysender for the first digit of the number he is dialing. Pressing the push button energizes the dual tone multifrequency oscillator and tunes each oscillator (low and high group) for the frequency of that digit.

The dual tone frequency is sent to the send amplifier which sends a signal to the switching facility. The switching facility acknowledges the first digit dialed and stops the dial tone to the Telephone Set.

The calling party dials the rest of the numbers and the switching facility either processes the call or returns a busy signal. If a busy signal is returned, it goes to the receive element of the calling party's telephone. If the called party is not busy, the call is connected and a voice path is established.

When the call is completed, the handset is placed back in its cradle. At this time the hookswitch performs the following functions in the order given below:

When the handset is placed in the cradle, the hookswitch contacts change the polarity of the input to the release timer circuit. This energizes the release timer, the output of which goes to the release oscillator circuit and the send amplifier.

The oscillator is tuned to the 2600 Hz release frequency. The release signal is sent to the send amplifier.

The send amplifier sends the 2600 Hz signal to the switching facility. The switching facility acknowledges the 2600 Hz signal as a signal for release and returns a 570 Hz acknowledge signal to the telephone set.

The release signal is received on the receive terminals which are coupled to the 570 Hz amplifier. Here the signal is amplified and detected.

1-9. OPERATIONAL MODES AND CONTROLS. (CONT)

OUTGOING CALL WITH MODE SELECTOR SWITCH IN AC SUPV POSITION (CONT)

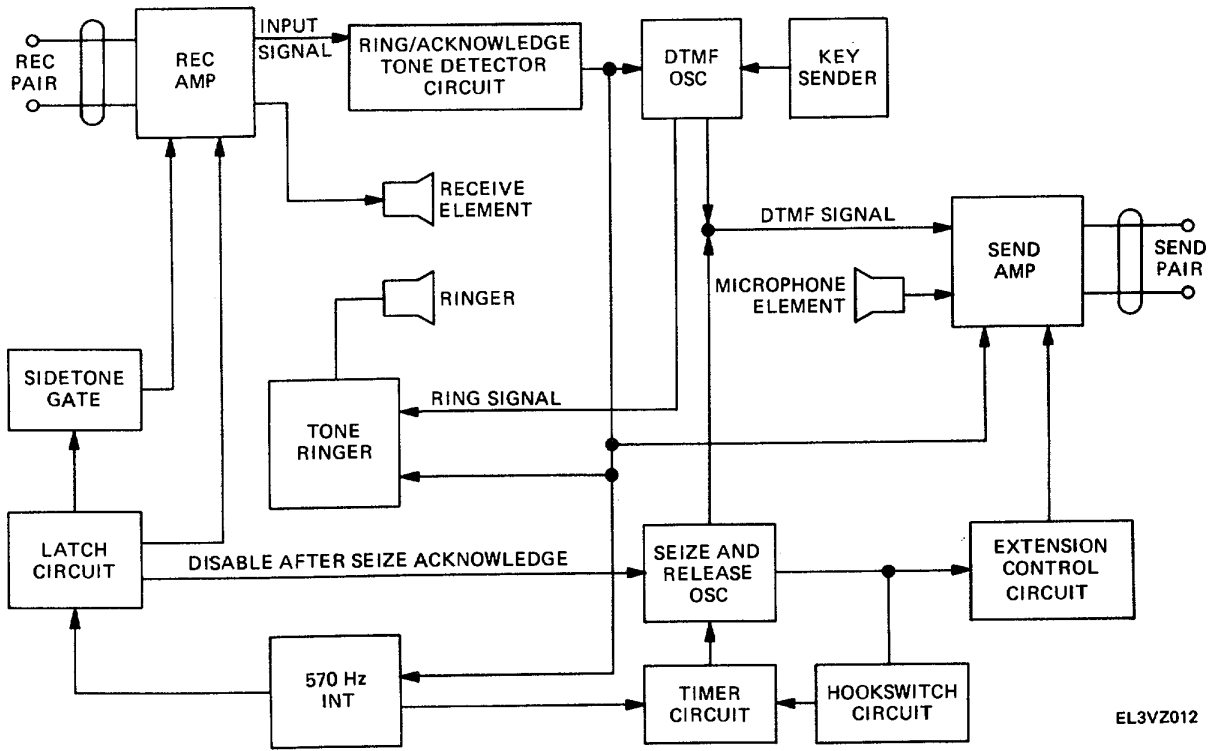

EL3VZ012

After the signal passes through ring acknowledge tone detector circuit, the output energizes the 570 Hz integrator circuit. The output of this circuit is coupled to the timer circuit, which removes the release signal from the send amplifier.

The switching facility which is not receiving a release signal stops sending the 570 Hz release acknowledge signal to the telephone set. This allows the integrator to return to its normal off condition.

When the integrator switches off, the acknowledge delay circuit also switches off. The acknowledge delay circuit is a transistor in the timer circuit which is normally conducting. The output of the acknowledge delay circuit supplies the positive voltage necessary for the tone ringer circuit to function. However, when the integrator and acknowledge delay are off, the tone ringer cannot function for at least 450 milliseconds. After this period of time the telephone set is ready to accept incoming calls.

1.9. OPERATIONAL MODES AND CONTROLS. (CONT)

INCOMING CALL WITH MODE SELECTOR SWITCH IN AC SUPV POSITION

When the telephone set is installed for operation with a switching facility and the MODE SELECTOR SWITCH is in AC SUPV position, the called telephone set is signaled by a 570 Hz ring signal. The following functions occur in the order given below:

The 570 Hz signal is received on the receive terminals of the telephone set. The receive terminals are inductively coupled to the input of the 570 Hz amplifier in the ring acknowledge tone detector circuit. However, the output of the circuit does not energize the integrator circuit because the 570 Hz signal is modulated.

The capacitor on the input to the integrator acts as a short circuit to the modulation frequency. The detector output is used to energize the 1633 Hz oscillator.

The 1633 Hz oscillator switches on and off at modulation frequency. The output of the oscillator is coupled to the tone ringer circuit receive element. The telephone set rings at a frequency of 1633 Hz and the ringing signal is stopped at the modulation rate of the incoming ring signal.

The call is answered by lifting the handset from its cradle. When the handset is lifted from its cradle, the hookswitch contacts change the polarity of the input to the release timer circuit. This energizes the release timer, the output of which goes to the release oscillator circuit and the send amplifier.

The send amplifier sends the 2550 Hz ring-trip-tone to the switching facility. The switching facility acknowledges the ring-trip-tone, stops sending a ringtone, and sends a steady 570 Hz ring-trip-tone to the telephone set.

The ring-trip-tone is received on the receive terminals of the telephone set which are coupled to the 570 Hz amplifier. Here the signal is amplified and detected.

The ring-trip-tone is amplified and the output of the detector energizes the integrator circuit. The integrator circuit provides a dc output which energizes the latch circuit. The latch circuit, when energized, stops the ring-trip-tone and energizes the receive amplifier and the sidetone gate circuit.

The receive amplifier is now active and a voice path is established between the telephone set and the switching facility.

When the handset is placed in its cradle at the end of a call, a release tone is sent to the switching facility.

1-9. OPERATIONAL MODES AND CONTROLS. (CONT)

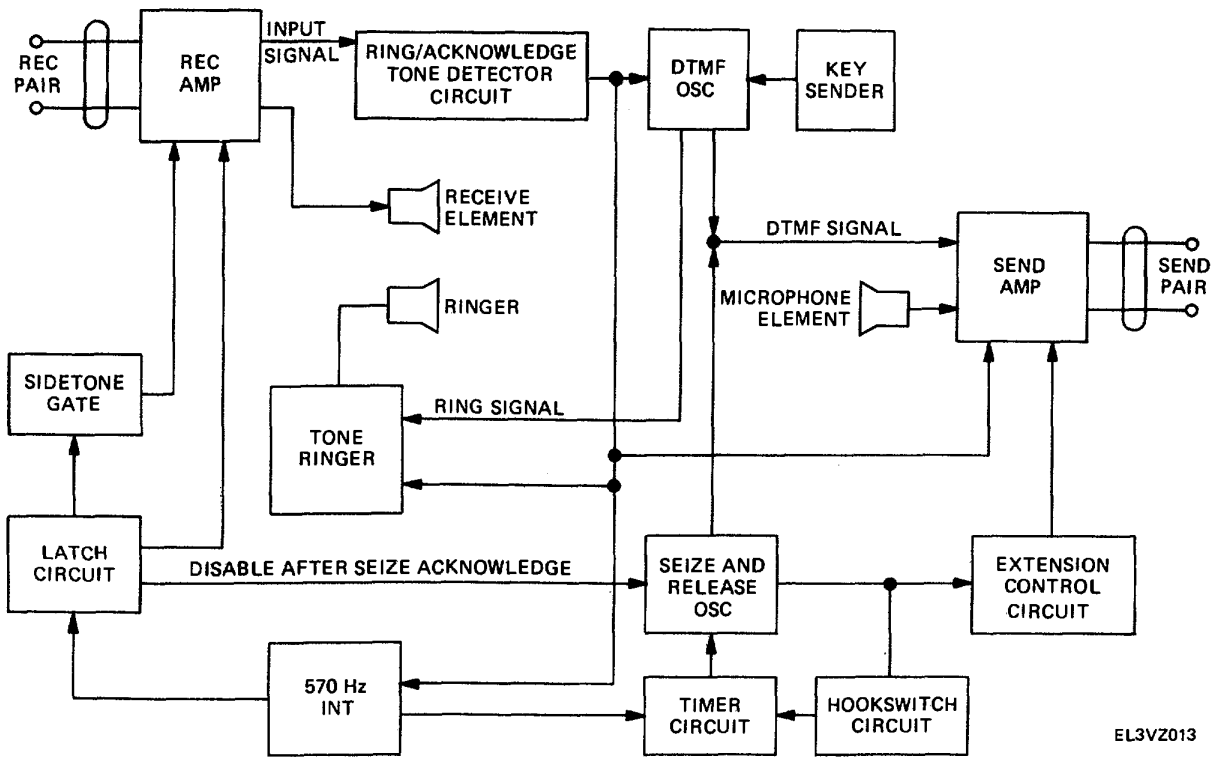

INCOMING CALLS WITH MODE SELECTOR SWITCH IN AC SUPV POSITION (CONT)

The tone is sent when the hookswitch contacts change the polarity of the input to the release timer circuit. This energizes the release timer, the output of which goes to the release oscillator circuit and the send amplifier.

The oscillator is tuned to the 2600 Hz release frequency. The release signal is sent to the send amplifier. Here the signal is amplified and detected.

After the signal passes through the ring acknowledge tone detector circuit, the output energizes the 570 Hz integrator circuit. The output of this circuit is coupled to the timer circuit, which removes the release signal from the send amplifier.

The switching facility which is not receiving a release signal stops sending the 570 Hz release acknowledge signal to the telephone set. This allows the integrator to return to its normal off condition.

1-9. OPERATIONAL MODES AND CONTROLS. (CONT)**INCOMING CALLS WITH MODE SELECTOR SWITCH IN AC SUPV POSITION (CONT)**

When the integrator switches off, the acknowledge delay circuit also switches off. The acknowledge delay circuit is a transistor in the timer circuit which is normally conducting. The output of the acknowledge delay circuit supplies the positive voltage necessary for the tone ringer circuit to function. However, when the integrator and acknowledge delay are off, the tone ringer cannot function for at least 450 milliseconds. After this period of time the telephone set is ready to accept incoming calls.

POINT-TO-POINT MODE

When two telephone sets are connected for point-to-point operation, a switching facility is not used. When the MODE SELECTOR SWITCH is set to POINT TO POINT, lifting the handset of the calling telephone set will cause the following functions in the order given:

The calling telephone sends a 570 Hz signal burst for about two seconds.

The 570 Hz signal is received on the receive terminals of the called telephone set. The receive terminals are inductively coupled to the input of the 570 Hz amplifier in the ring acknowledge tone detector circuit. However, the output of the circuit does not energize the integrator circuit because the 570 Hz signal is modulated.

The capacitor on the input to the integrator acts as a short circuit to the modulation frequency. The detector output is used to energize the 1633 Hz oscillator.

The 1633 Hz oscillator switches on and off at modulation frequency. The output of the oscillator is coupled to the tone ringer circuit receive element. The telephone set rings at a frequency of 1633 Hz and the ringing signal is stopped at the modulation rate of the incoming ring signal.

When the called telephone answers, a voice path is established between the two telephone sets. If the called telephone set does not answer, the calling party must replace the handset in the cradle and lift it again.

DC SUPERVISION MODE

When two telephone sets are connected for DC SUPV operation, the MODE SELECTOR SWITCH is set to DC SUPV position and the telephone is connected to a switching facility which uses dc current. In this mode, seize and release tones are prevented.

1-9. OPERATIONAL MODES AND CONTROLS. (CONT)

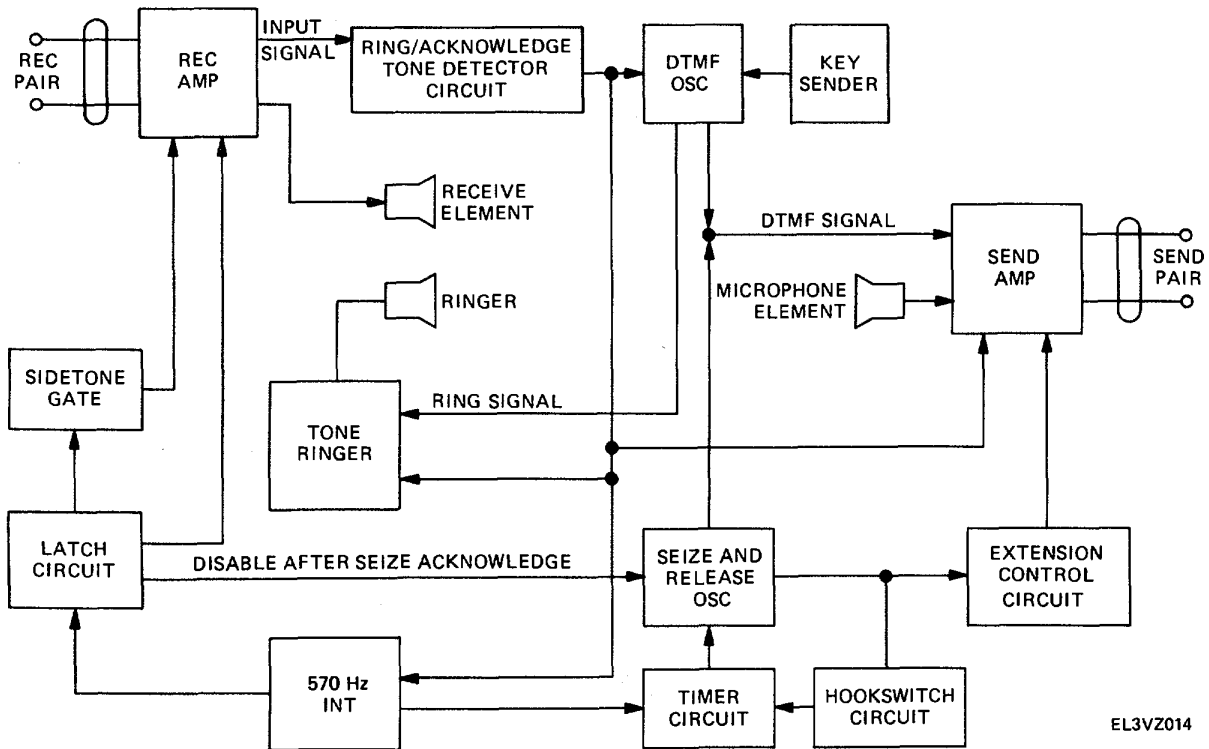

EL3VZ014

DC SUPERVISION MODE (CONT)

The seize tone is stopped by the MODE SELECTOR SWITCH which sets the latch circuit when the handset is lifted from the cradle. The MODE SELECTOR SWITCH is open when in the DC SUPV position, and this removes the input of the timer from hookswitch.

An off cradle indication is given to the switching facility when a load resistor is inserted between the send and receive transformers at the switching facility. This causes a current drain of 14 ma on the power supply at the switching facility. This current drain is seen as a request for service or an answer, depending upon whether it is an incoming call to the telephone set or coming from the telephone set itself.

When the handset is replaced on the cradle, the load resistor is removed by way of the hookswitch and the switching facility sees the on-hook condition due to the reduced current drain.

1-9. OPERATIONAL MODES AND CONTROLS. (CONT)

EXTENSION CONTROL MODE

The functions of the extension control circuit depend upon whether the telephone set is the controlled or controlling telephone. The controlling telephone is the first of a set of extension telephones to be lifted from the cradle and the last to be replaced in the cradle.

The first telephone lifted from the cradle stops the ringing and the seize tones of the other telephones. When a number of telephones have their handsets removed from their cradles at the same instant, multiple seize tones are sent.

If there is no control signal from any extension telephone, any telephone will send seize tones and release tones for each off-cradle and on-cradle condition, no matter what the previous circuit condition was.

Battery ground is common between extension telephones by way of the receive pair of wires.

When a number of telephone handsets are lifted from their cradles, any one telephone can send digit selection frequencies.

**CHAPTER 2
DIRECT SUPPORT MAINTENANCE**

| Subject | Section | Page |
|--|---------|------|
| Repair Parts, Special Tools, TMDE, and Support Equipment | I | 2-1 |
| Service Upon Receipt..... | II | 2-2 |
| Troubleshooting..... | III | 2-6 |
| Maintenance Procedures..... | IV | 2-23 |
| Preparation for Storage or Shipment..... | V | 2-52 |

OVERVIEW

This chapter contains service, troubleshooting, and maintenance procedures for the telephone set at the direct support maintenance level.

Section I REPAIR PARTS, SPECIAL TOOLS, TMDE, AND SUPPORT EQUIPMENT

| Subject | Para | Page |
|---|------|------|
| Common Tools and Equipment..... | 2-1 | 2-1 |
| Special Tools, TMDE, and Support Equipment..... | 2-2 | 2-1 |
| Repair Parts..... | 2-3 | 2-1 |

2-1. COMMON TOOLS AND EQUIPMENT.

The common tools and equipment needed for maintenance procedures at the direct support maintenance level can be found in the Maintenance Allocation Chart (Appendix B) in TM 11-5805-384-12.

2-2. SPECIAL TOOLS, TMDE, AND SUPPORT EQUIPMENT.

The special tools, TMDE, and support equipment needed for maintenance procedures at the direct support maintenance level can be found in the Maintenance Allocation Chart (Appendix B) in TM 11-5805-384-12.

2-3. REPAIR PARTS.

The repair parts needed for maintenance procedures at the direct support maintenance level can be found in the repair parts and special tools list. See TM 11-5805-384-24P.

Section II SERVICE UPON RECEIPT

| | | |
|---------------------------------|------|------|
| Subject | Para | Page |
| Unpacking..... | 2-4 | 2-2 |
| Checking Unpacked Material..... | 2-5 | 2-4 |

2-4. UNPACKING.

This task covers:

Unpacking

INITIAL SETUP

| | |
|---|-----------------------------|
| Tools | Personnel Required |
| Tool Kit, Electronic Equipment TK-100/G | One technician |
| Materials/Parts | Equipment Condition |
| None | Packing box on a workbench. |

| LOCATION ITEM | REMARKS | ACTION |
|---------------|----------------------|--|
| 1. Box | Box (1) and tape (2) | Using knife, cut tape. Do not allow knife to enter carton. |
| 2. | Flaps (3) | Open and fold back. |
| 3. | Manuals (4) | Remove. |
| 4. | Fiberboard pads (5) | Remove. |
| 5. | Telephone set (6) | Lift out. |

NOTE

If unit is packed in wooden crate, see TM 11-5805-384-12.

2-4. UNPACKING. (CONT)

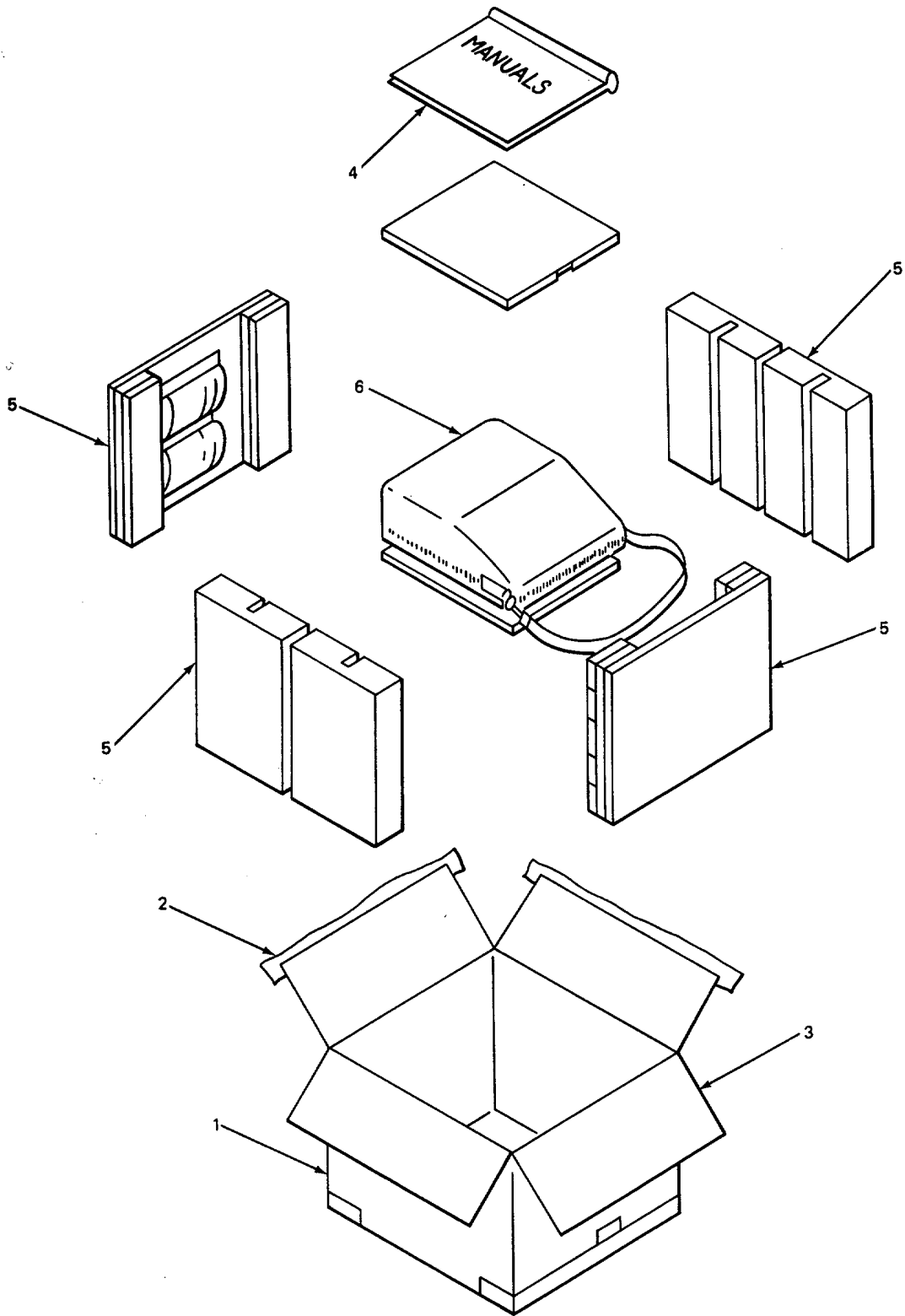

EL3VZ015

2-5. CHECKING UNPACKED EQUIPMENT.

This task covers:

Checking unpacked equipment

INITIAL SETUP

Tools

None

Materials/Parts

None

Personnel Required

One technician

Equipment Condition

Equipment removed from packing box.

| | LOCATION | ITEM | ACTION REMARKS |
|-----|----------------------------|------------------------------------|---|
| 1. | Telephone set | Carrying case (1) and sling (2) | Check for rips. |
| 2. | | Carrying case zipper (3) | Check for free operation. |
| 3. | | Shell assembly (4) | Check for cracks. |
| 4. | | Keysender (5) | Press keys to check for proper movement. |
| 5. | | Handset (6) | Check for cracks. |
| 6. | | Handset elements (7) | Unscrew covers and check elements for cracks. |
| 7. | | Handset cord (8) | Check for cuts. |
| 8. | | Line cord (9) | Check for cuts. |
| 9. | Bottom of telephone set | Batteries(10) | Open battery compartment cover and check quantity (4). |
| 10. | Telephone set | Connector block (11) | Check for cracks. |

NOTE

If problems are found, see TM 11-5805-384-12.

2-5. CHECKING UNPACKED EQUIPMENT. (CONT)

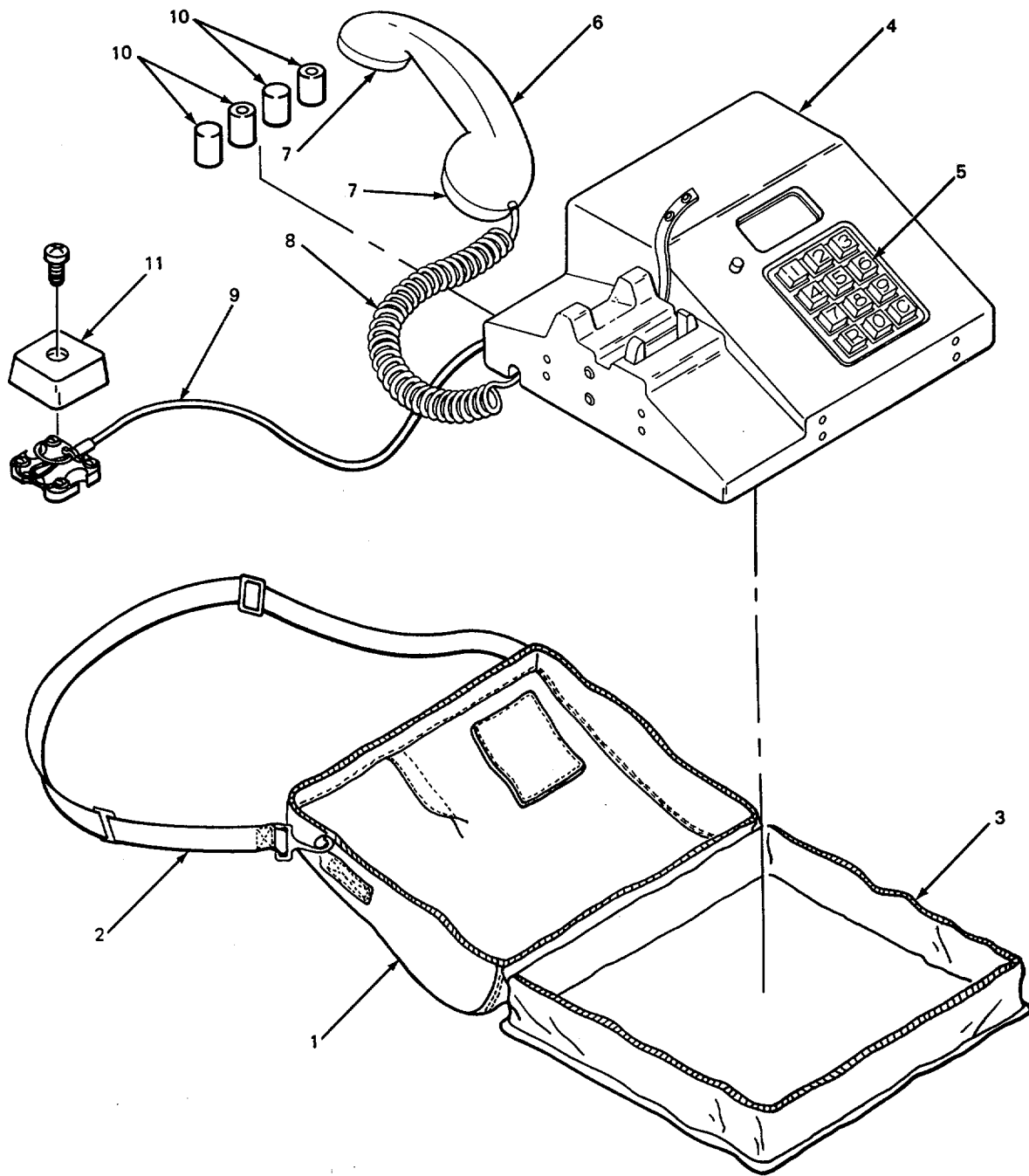

Section III TROUBLESHOOTING

| Subject | Para | Page |
|----------------------|------|------|
| Overview..... | 2-6 | 2-6 |
| Symptom Index..... | | 2-7 |
| Troubleshooting..... | | 2-8 |

2-6. OVERVIEW.

When trouble occurs, look for simple causes such as oxidation of hookswitch contacts and loose terminal screws. Do not perform major disassembly of parts until simple malfunctions are eliminated.

This manual does not list all malfunctions that may happen. If a malfunction is not listed, or if a malfunction is not corrected by a listed corrective action, report it to a higher level of maintenance.

To use the troubleshooting procedures, find your problem in the symptom index. The symptom index will give you a page number where you will find your problem listed with its corrective actions.

CAUTION

Use care when handling telephone set chassis. Damage or misadjustment of hookswitch assembly will result from improper handling.

SYMPTOM INDEX

| | Page |
|--|------|
| DIAL TONE | |
| No dial tone from switching facility | 2-8 |
| DIGIT TONE | |
| No digit tone or signal frequency tone when pressing the keys on the keysender | 2-19 |
| RELEASE TONE | |
| No release tone | 2-20 |
| RINGBACK | |
| Repeated wrong numbers and/or ringback tone..... | 2-9 |
| SEIZE TONE | |
| Seize tone does not stop after dial tone is received | 2-12 |
| Seize tone or release tone not inhibited by another off-hook telephone..... | 2-15 |
| No seize tone and side tone high when handset is lifted from cradle..... | 2-21 |
| SIDE TONE | |
| No side tone when voice transmission is normal..... | 2-11 |
| No voice and side tone received | 2-13 |
| TRANSMISSION | |
| Telephone does not inhibit seize or release from extension phone..... | 2-14 |
| Telephone does not ring or ring properly | 2-10 |
| Ring signal is not cutoff after one burst in point-to-point operation | 2-16 |
| Voice transmission low or no voice transmission | 2-17 |
| No output or low output..... | 2-18 |

TROUBLESHOOTING

| MALFUNCTION | TEST OR INSPECTION | CORRECTIVE ACTION |
|-------------|--------------------|-------------------|
|-------------|--------------------|-------------------|

1. No dial tone from switching facility.

Step 1. Replace hookswitch assembly. See paragraph 2-10.

If malfunction continues, go to step 2.

Step 2. Replace circuit card assembly. See paragraph 2-11.

If malfunction continues, report to a higher level of maintenance.

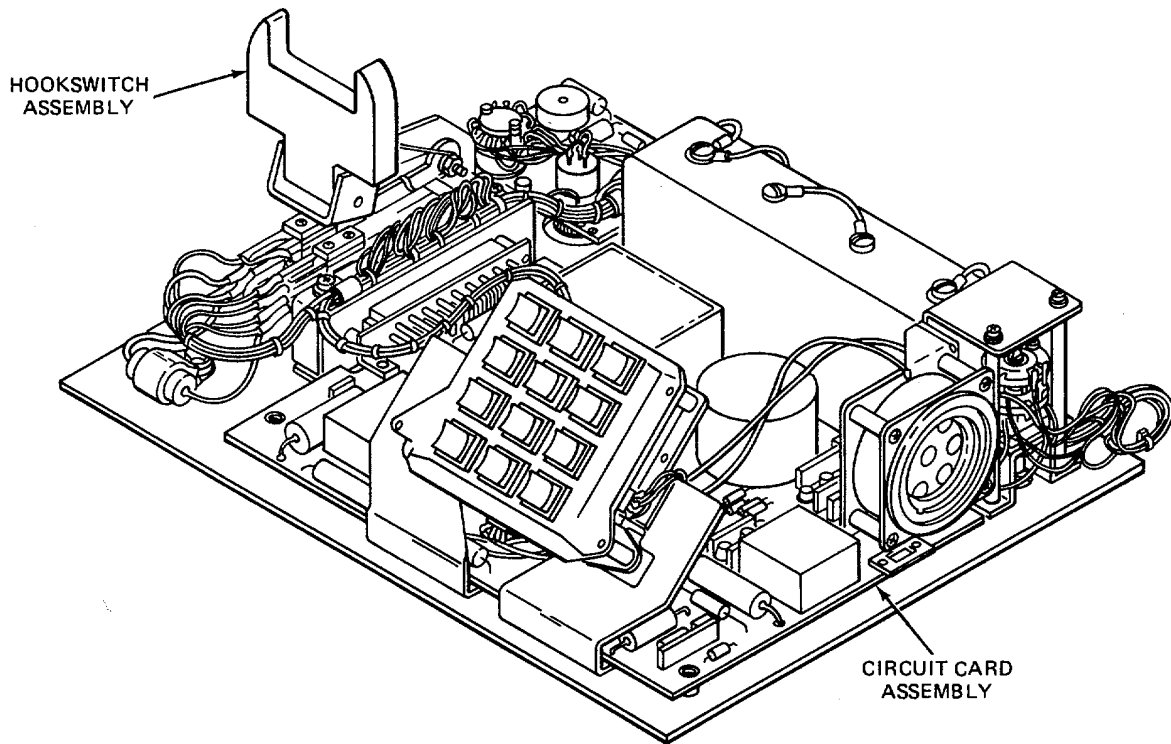

EL3VZ017

TROUBLESHOOTING (CONT)

| MALFUNCTION | TEST OR INSPECTION | CORRECTIVE ACTION |
|-------------|--------------------|-------------------|
|-------------|--------------------|-------------------|

2. Repeated wrong numbers and/or ringback tone.

Step 1. Replace circuit card assembly. See paragraph 2-11.

If malfunction continues, go to step 2.

Step 2. Replace keysender assembly. See paragraph 2-12.

If malfunction continues, report to a higher level of maintenance.

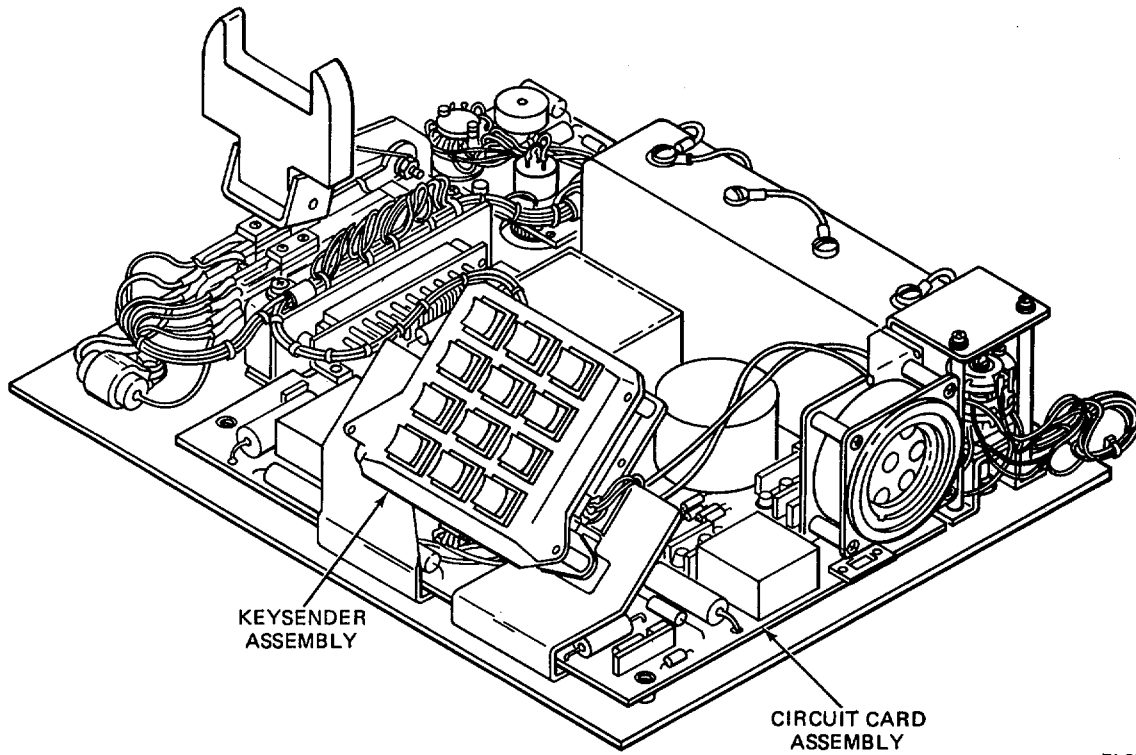

EL3VZ018

TROUBLESHOOTING (CONT)

| MALFUNCTION | TEST OR INSPECTION | CORRECTIVE ACTION |
|-------------|--------------------|-------------------|
|-------------|--------------------|-------------------|

3. Telephone does not ring or ring properly.

Step 1. Check RINGER VOLUME control. See paragraph 2-15.

Replace RINGER VOLUME control. See paragraph 2-15.

Step 2. Replace hookswitch assembly. See paragraph 2-10.

If malfunction continues, go to step 3.

Step 3. Replace circuit card assembly. See paragraph 2-11.

If malfunction continues, report to a higher level of maintenance.

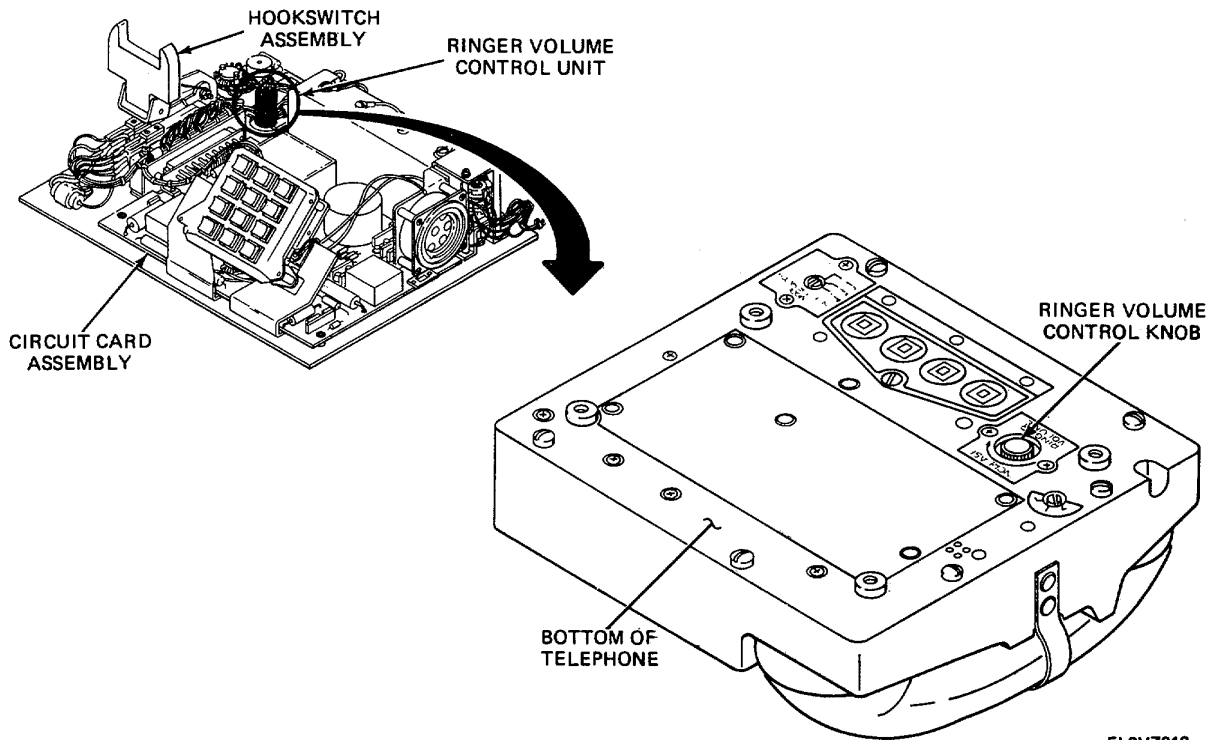

EL3VZ019

TROUBLESHOOTING (CONT)

| MALFUNCTION | TEST OR INSPECTION | CORRECTIVE ACTION |
|-------------|--------------------|-------------------|
|-------------|--------------------|-------------------|

4. No sidetone when voice transmission is normal.

Replace circuit card assembly. See paragraph 2-11.

If malfunction continues, report to a higher level of maintenance.

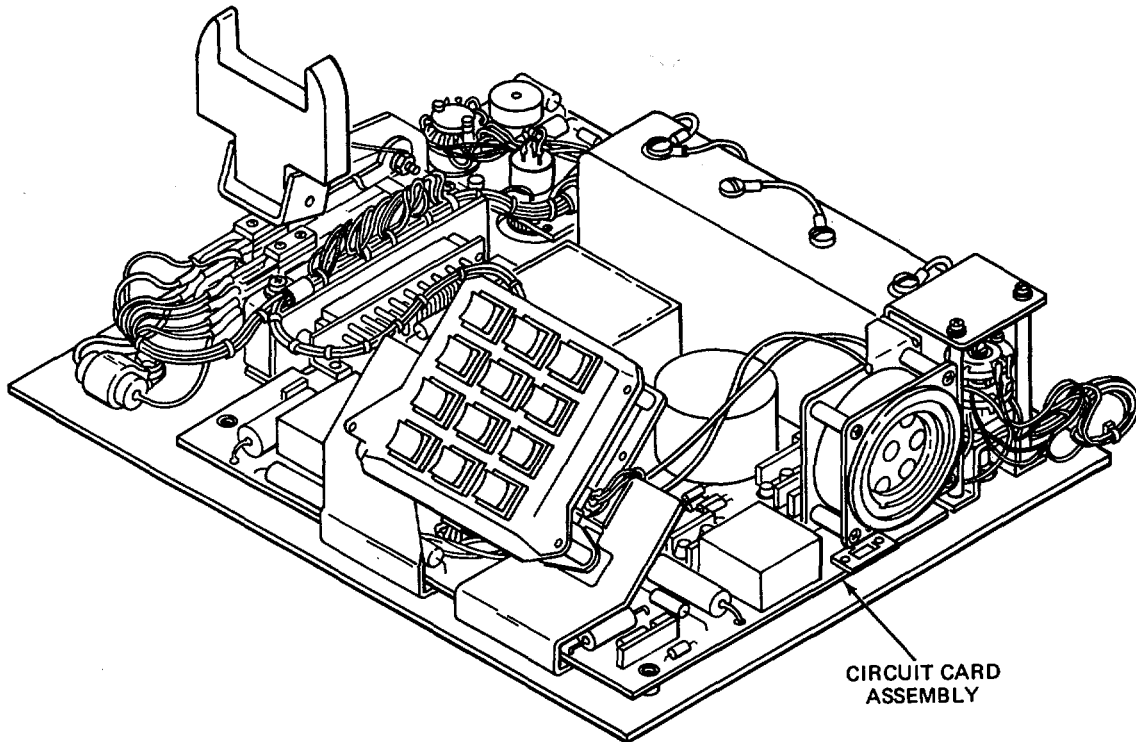

EL3VZ020

TROUBLESHOOTING (CONT)

| MALFUNCTION | TEST OR INSPECTION | CORRECTIVE ACTION |
|-------------|--------------------|-------------------|
|-------------|--------------------|-------------------|

5. Seize tone does not stop after dial tone is received.

Replace circuit card assembly. See paragraph 2-11.

If malfunction continues, report to a higher level of maintenance.

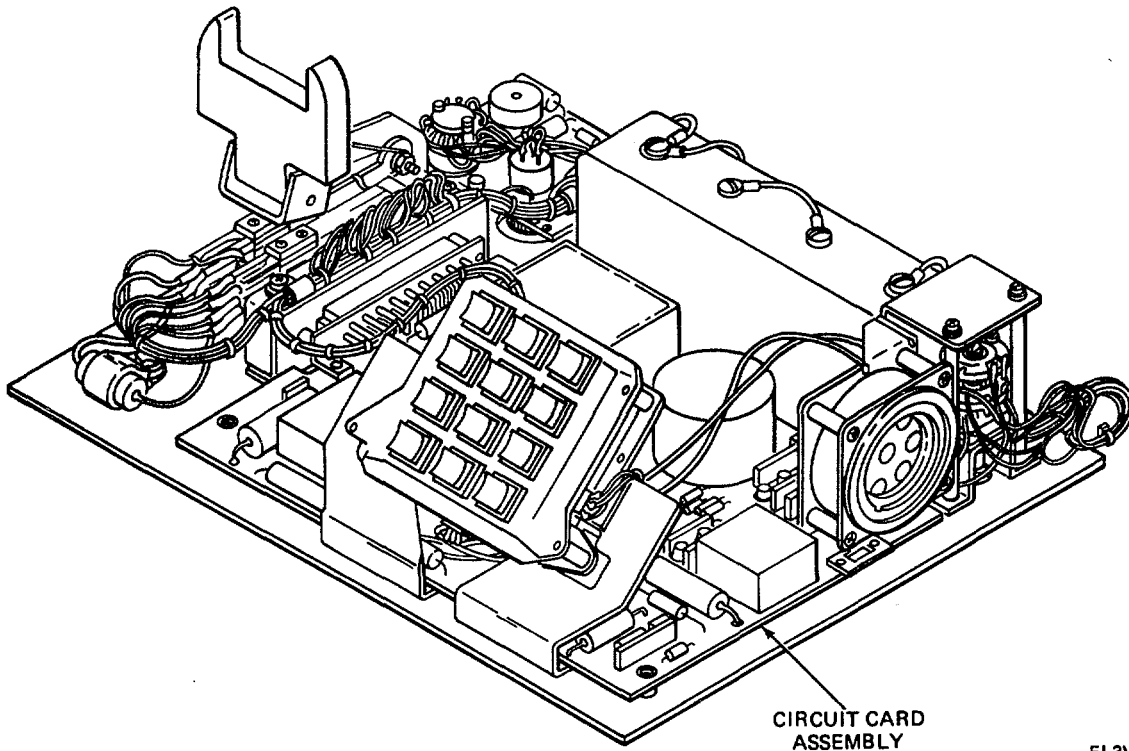

EL3VZ021

TROUBLESHOOTING (CONT)

| MALFUNCTION | TEST OR INSPECTION | CORRECTIVE ACTION |
|-------------|--------------------|-------------------|
|-------------|--------------------|-------------------|

6. No voice and sidetone received.

Step 1. Replace hookswitch assembly. See paragraph 2-10.

If malfunction continues, go to step 2.

Step 2. Replace circuit card assembly. See paragraph 2-11.

If malfunction continues, report to a higher level of maintenance.

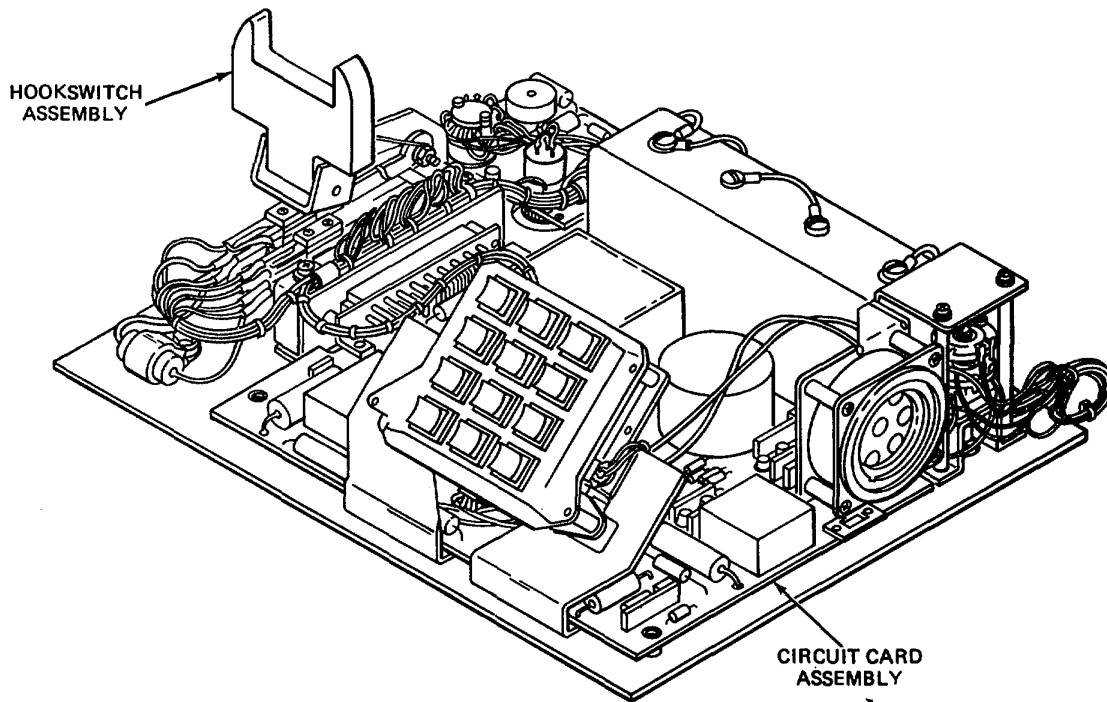

EL3V2022

TROUBLESHOOTING (CONT)

| MALFUNCTION | TEST OR INSPECTION | CORRECTIVE ACTION |
|-------------|--------------------|-------------------|
|-------------|--------------------|-------------------|

7. Telephone does not inhibit seize or release tone from extension telephone.

Step 1. Replace hookswitch assembly. See paragraph 2-10.

If malfunction continues, go to step 2.

Step 2. Replace circuit card assembly. See paragraph 2-11.

If malfunction continues, report to a higher level of maintenance.

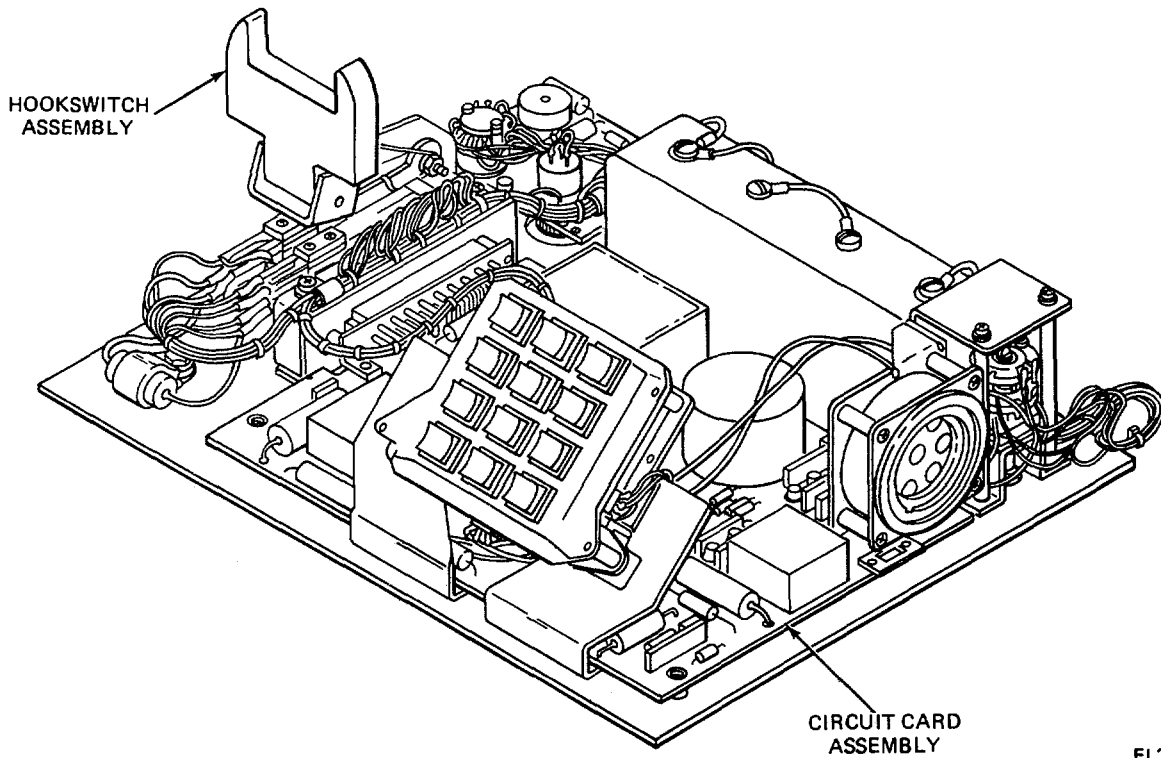

EL3VZ023

TROUBLESHOOTING (CONT)

| MALFUNCTION | TEST OR INSPECTION | CORRECTIVE ACTION |
|-------------|--------------------|-------------------|
|-------------|--------------------|-------------------|

8. Seize or release tone not inhibited by another off-hook telephone.

Step 1. Replace hookswitch assembly. See paragraph 2-10.

If malfunction continues, go to step 2.

Step 2. Replace circuit card assembly. See paragraph 2-11.

If malfunction continues, report to a higher level of maintenance.

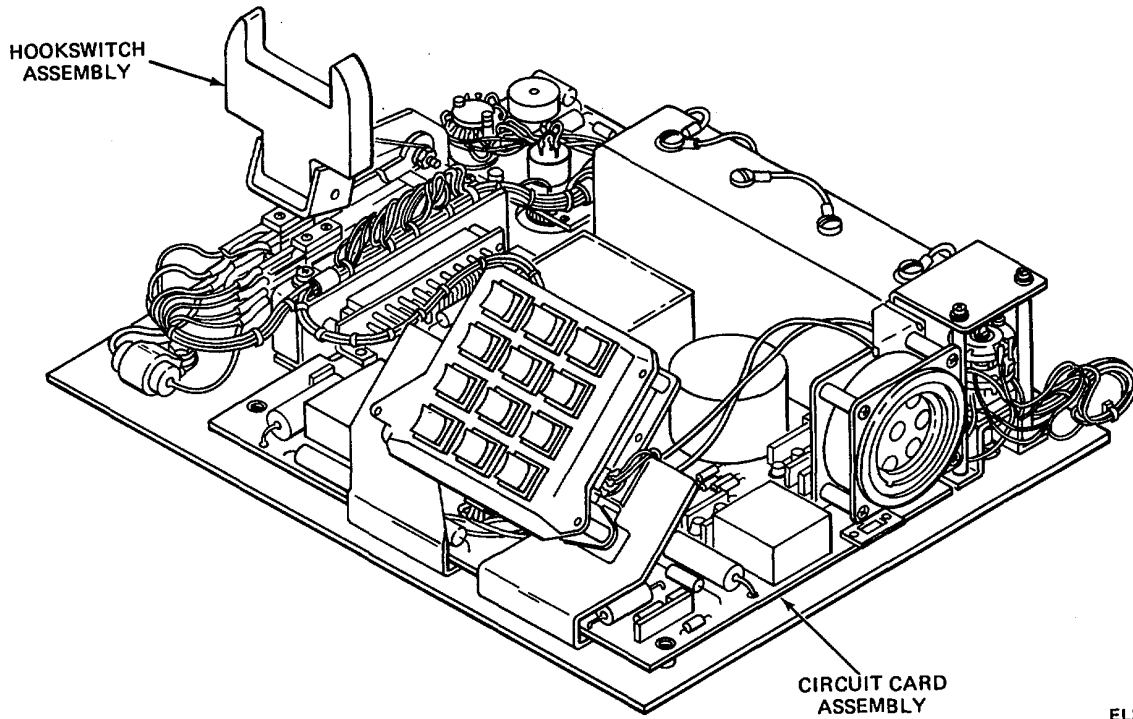

EL3VZ024

TROUBLESHOOTING (CONT)

| MALFUNCTION | TEST OR INSPECTION | CORRECTIVE ACTION |
|-------------|--------------------|-------------------|
|-------------|--------------------|-------------------|

9. Ring signal does not cut off after one burst in point-to-point operation.

Step 1. Replace circuit card assembly. See paragraph 2-11.

If malfunction continues, go to step 2.

Step 2. Replace keysender assembly. See paragraph 2-12.

If malfunction continues, report to a higher level of maintenance.

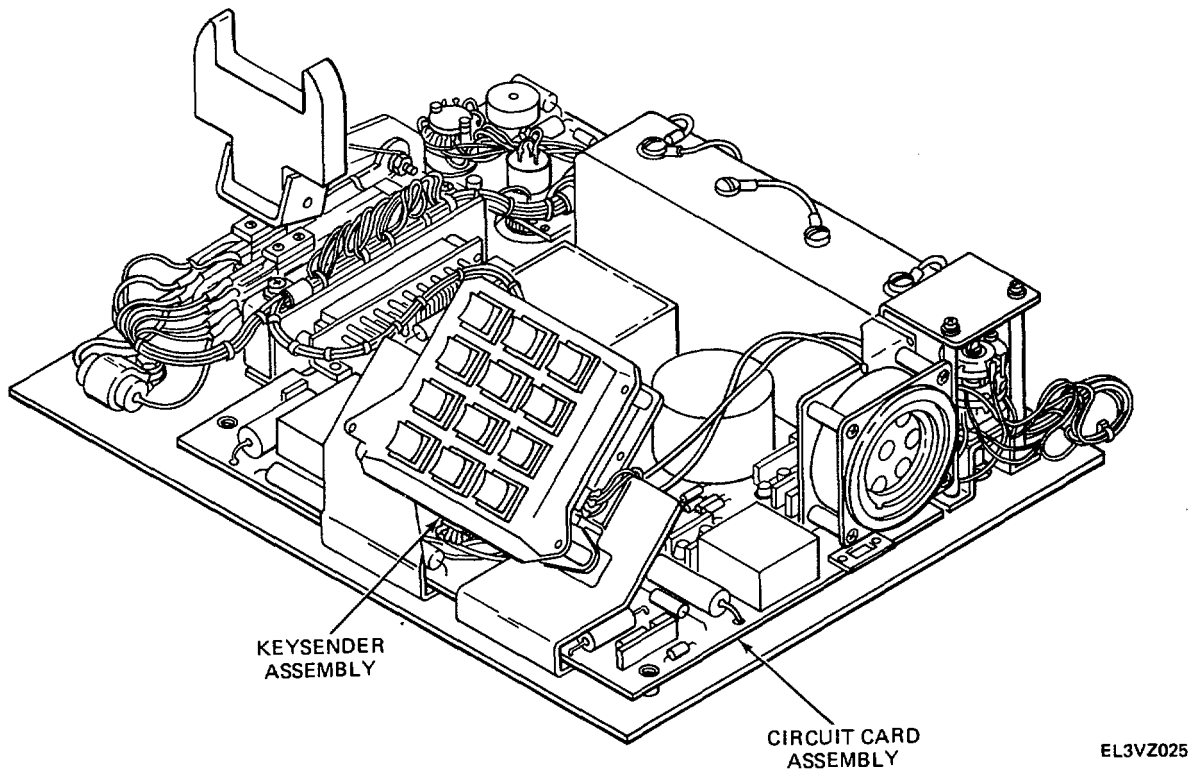

TROUBLESHOOTING (CONT)

| MALFUNCTION | TEST OR INSPECTION | CORRECTIVE ACTION |
|-------------|--------------------|-------------------|
|-------------|--------------------|-------------------|

10. Voice volume low or no voice transmission at all.

Step 1. Check for bad microphone element.

Replace microphone element. See paragraph 2-16.

Step 2. Replace keysender assembly. See paragraph 2-12.

If malfunction continues, report to a higher level of maintenance.

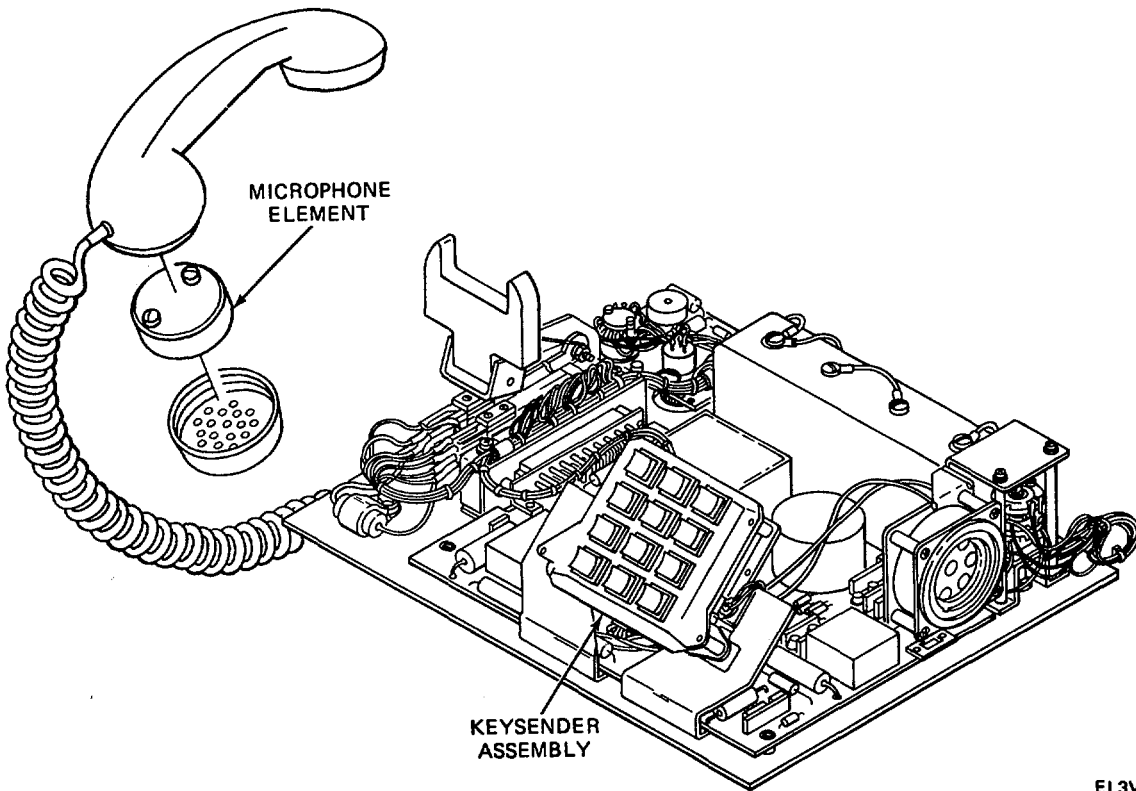

EL3VZ026

TROUBLESHOOTING (CONT)

| MALFUNCTION | TEST OR INSPECTION | CORRECTIVE ACTION |
|-------------|--------------------|-------------------|
|-------------|--------------------|-------------------|

11. No output or low output.

Step 1. Replace circuit card assembly. See paragraph 2-11.

If malfunction continues, go to step 2.

Step 2. Replace hookswitch assembly. See paragraph 2-10.

If malfunction continues, report to a higher level of maintenance.

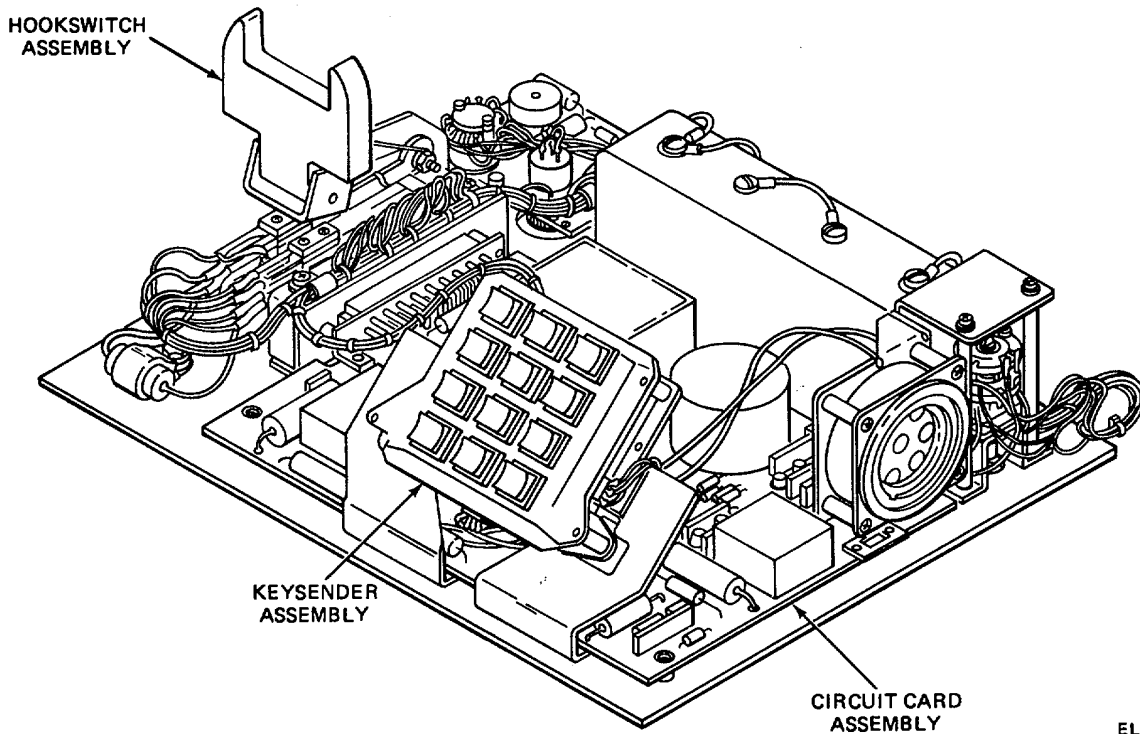

EL3VZ028

TROUBLESHOOTING (CONT)

| MALFUNCTION | TEST OR INSPECTION | CORRECTIVE ACTION |
|-------------|--------------------|-------------------|
|-------------|--------------------|-------------------|

12. No digit tone or signal frequency tone when pressing the keys on the keysender.

Step 1. Replace circuit card assembly. See paragraph 2-11.

If malfunction continues, go on to step 2.

Step 2. Replace keysender assembly. See paragraph 2-12.

If malfunction continues, go on to step 3.

Step 3. Replace hookswitch assembly. See paragraph 2-10.

If malfunction continues, report to a higher level of maintenance.

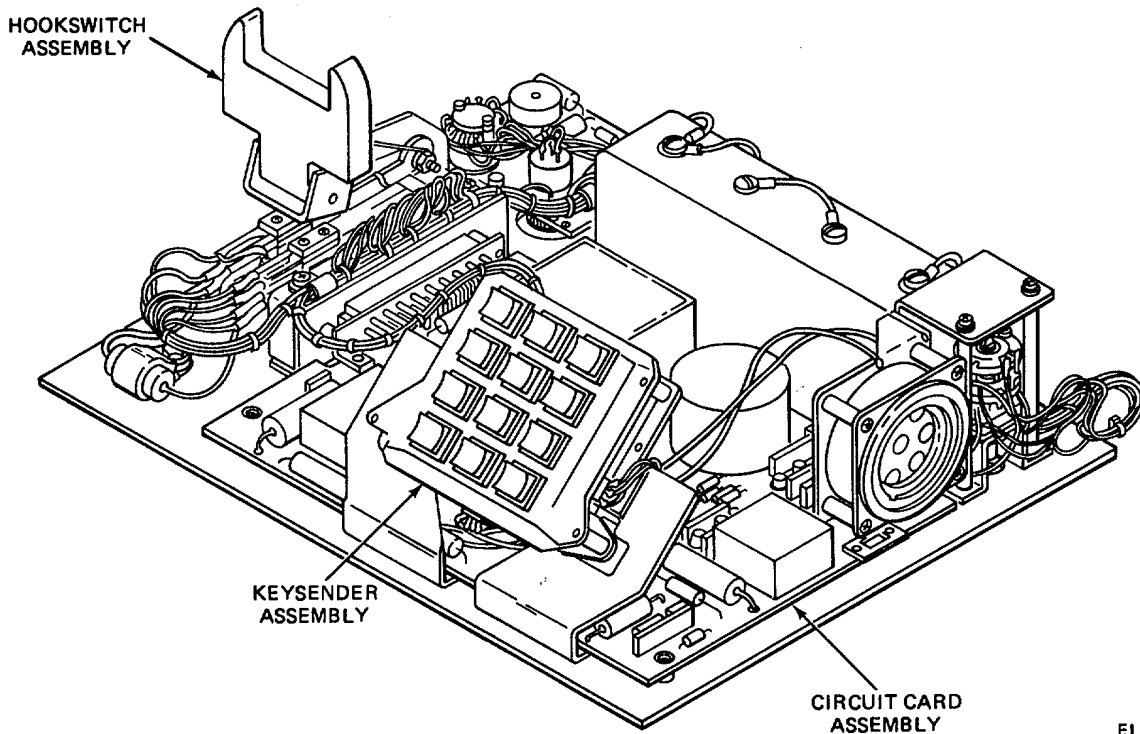

EL3VZ028

TROUBLESHOOTING (CONT)

| MALFUNCTION | TEST OR INSPECTION | CORRECTIVE ACTION |
|-------------|--------------------|-------------------|
|-------------|--------------------|-------------------|

13. No release tone.

Step 1. Check that all wires are not broken or frayed, and are connected to terminals.

Solder wires if disconnected.

Step 2. Replace circuit card assembly. See paragraph 2-11.

If malfunction continues, go to step 3.

Step 3. Replace hookswitch assembly. See paragraph 2-10.

If malfunction continues, refer to a higher level of maintenance.

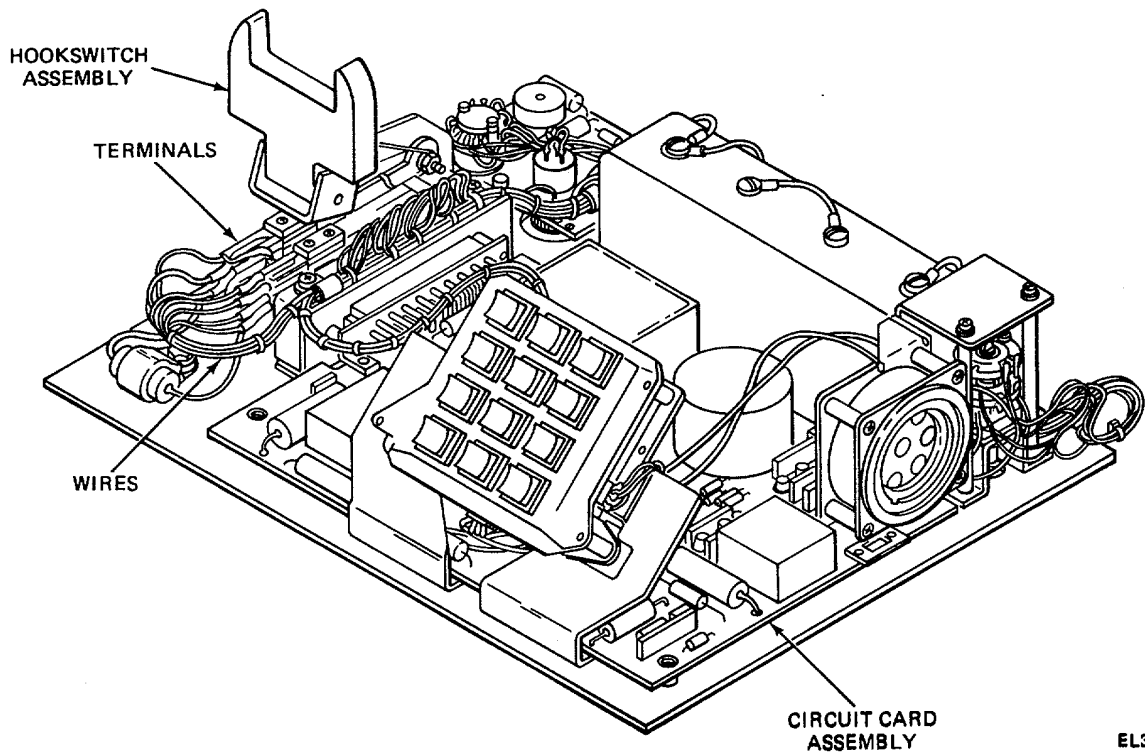

EL3VZ029

TROUBLESHOOTING (CONT)

| MALFUNCTION | TEST OR INSPECTION | CORRECTIVE ACTION |
|-------------|--------------------|-------------------|
|-------------|--------------------|-------------------|

14. No seize tone. Side tone level high when handset is lifted from cradle.

Step 1. Replace hookswitch assembly. See paragraph 2-10.

If malfunction continues, go to step 2.

Step 2. Replace circuit card assembly. See paragraph 2-11.

If malfunction continues, report to a higher level of maintenance.

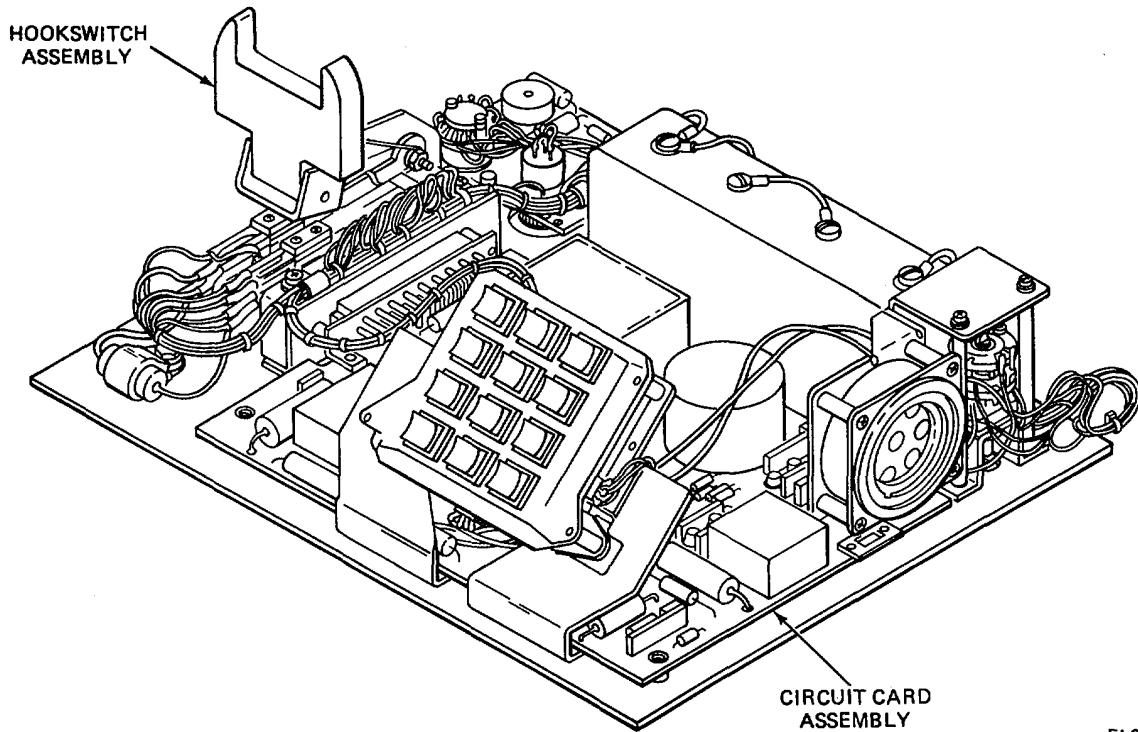

EL3VZ030

Section IV MAINTENANCE PROCEDURES

| Subject | Para | Page |
|--|------|------|
| Overview..... | 2-7 | 2-23 |
| Replacement of Ringer Element..... | 2-8 | 2-24 |
| Replacement of Telephone Shell..... | 2-9 | 2-26 |
| Replacement of Hookswitch Assembly..... | 2-10 | 2-28 |
| Replacement of Circuit Card Assembly..... | 2-11 | 2-30 |
| Replacement of Keysender Assembly..... | 2-12 | 2-32 |
| Replacement of Station Card..... | 2-13 | 2-34 |
| Replacement of MODE SELECTOR SWITCH..... | 2-14 | 2-36 |
| Replacement of RINGER VOLUME Control..... | 2-15 | 2-38 |
| Handset Element Maintenance..... | 2-16 | 2-40 |
| Replacement of Battery Compartment..... | 2-17 | 2-42 |
| Replacement of Fixed Electrolytic Capacitor..... | 2-18 | 2-44 |
| Replacement of Handset Cord..... | 2-19 | 2-46 |
| Replacement of LCICB Switch..... | 2-20 | 2-48 |
| Line Cord Maintenance..... | 2-21 | 2-50 |

2-7. OVERVIEW.

This chapter contains instructions for maintenance and replacement of items at direct support level for Telephone Set TA-341 B/TT.

2-8. REPLACEMENT OF RINGER ELEMENT.

This task covers:

1. Removal
 2. Installation
-

INITIAL SETUP

Tools

Tool Kit, Electronic Equipment TK-100/G

Personnel Required

One technician

Materials/Parts

Ringer Element
paragraph 2-9.

Equipment Condition

Telephone shell assembly removed. See

| LOCATION | ITEM | ACTION REMARKS |
|----------|------|-------------------|
|----------|------|-------------------|

REMOVAL

| | | |
|---------------------------|---|--------------------------------------|
| 1. Ringer element | Four screws, spacers, and ringer element retainer (1) | Using cross-tip screwdriver, remove. |
| 2. | Gasket (2) | Remove. |
| 3. | Wires (3) | Using flat-tip screwdriver, remove. |
| 4. Ringer element bracket | Ringer element (4) | Remove. |

INSTALLATION

| | | |
|---------------------------|---|---------------------------------------|
| 1. Ringer element bracket | Ringer element (4) | Install. |
| 2. Ringer element | Wires (3) | Using flat-tip screwdriver, install. |
| 3. | Gasket (2) | Install. |
| 4. | Four screws, spacers, and ringer element retainer (1) | Using cross-tip screwdriver, install. |

2-8. REPLACEMENT OF RINGER ELEMENT. (CONT)

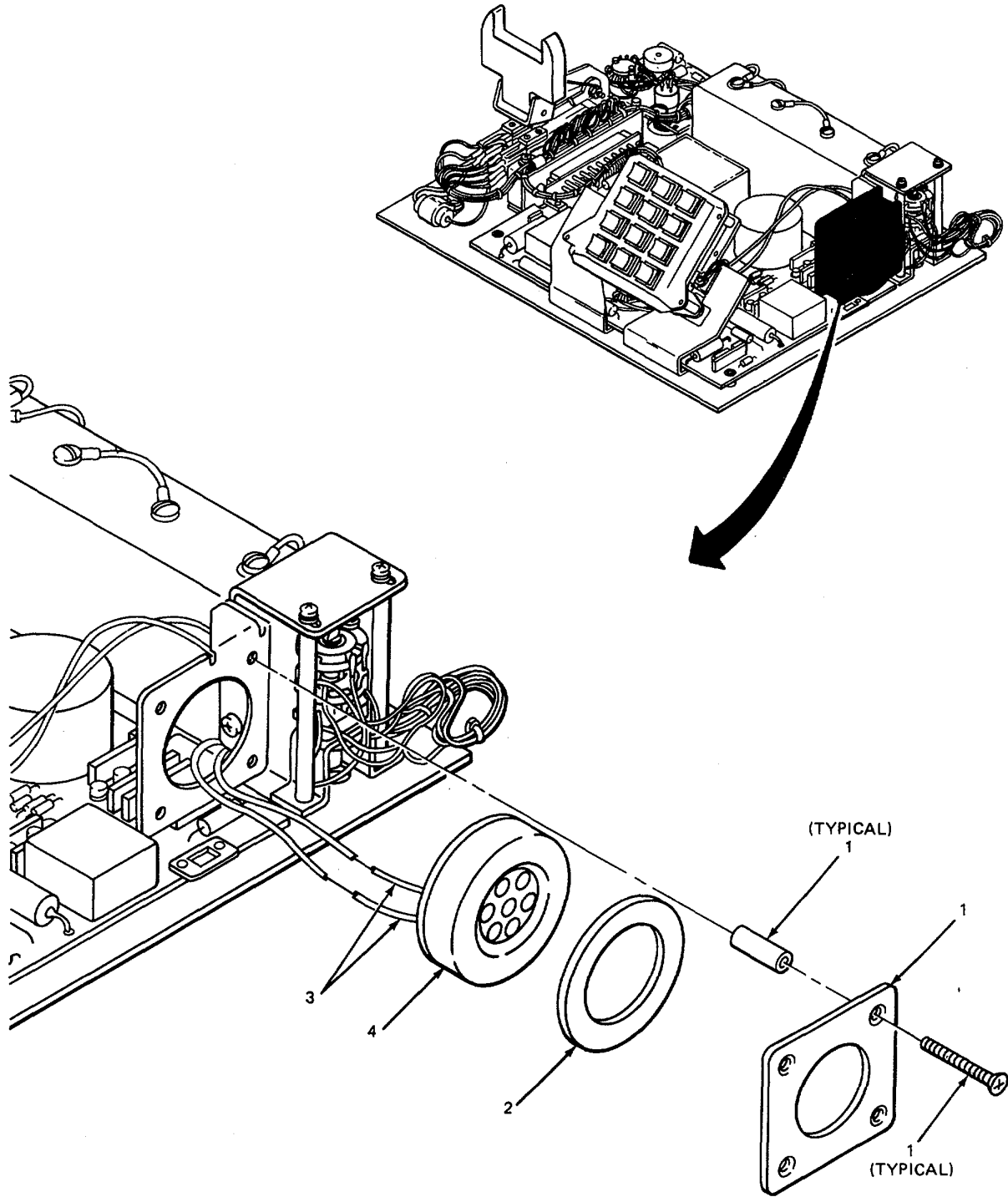

EL3VZ031

2-9. REPLACEMENT OF TELEPHONE SHELL.

This task covers:

1. Removal
2. Installation

INITIAL SETUP

| | |
|---|-------------------------|
| Tools | Personnel Required |
| Tool Kit, Electronic Equipment TK-100/G | One technician |
| Materials/Parts | Equipment Condition |
| Shell, telephone set | Telephone disconnected. |

| LOCATION | ITEM | ACTION REMARKS |
|----------|------|-------------------|
|----------|------|-------------------|

REMOVAL

| | | |
|----------------------------------|---------------------------------------|---|
| 1. Telephone set (1) handset (2) | Retaining strap cradle and cradle (3) | Unsnap retaining strap and lift handset from |
| 2. Telephone set base | Screws (4) | Using flat-tip screwdriver, remove. There are six screws. All screws must be removed to remove telephone shell. |
| 3. Telephone set | Telephone shell (5) | Remove. If telephone shell must be replaced, see paragraph 2-13 to replace station card. |

INSTALLATION

| | | |
|-----------------------|---|---|
| 1. Telephone set | Telephone shell (5) | Install. |
| 2. Telephone set base | Screws (4) | Using flat-tip screwdriver, install. There are six screws. All screws must be installed to install telephone shell. |
| 3. Telephone set | Cradle (3), handset (2) and Retaining strap (1) | Place handset on cradle and snap on retaining strap. |

2-9. REPLACEMENT OF TELEPHONE SHELL. (CONT)

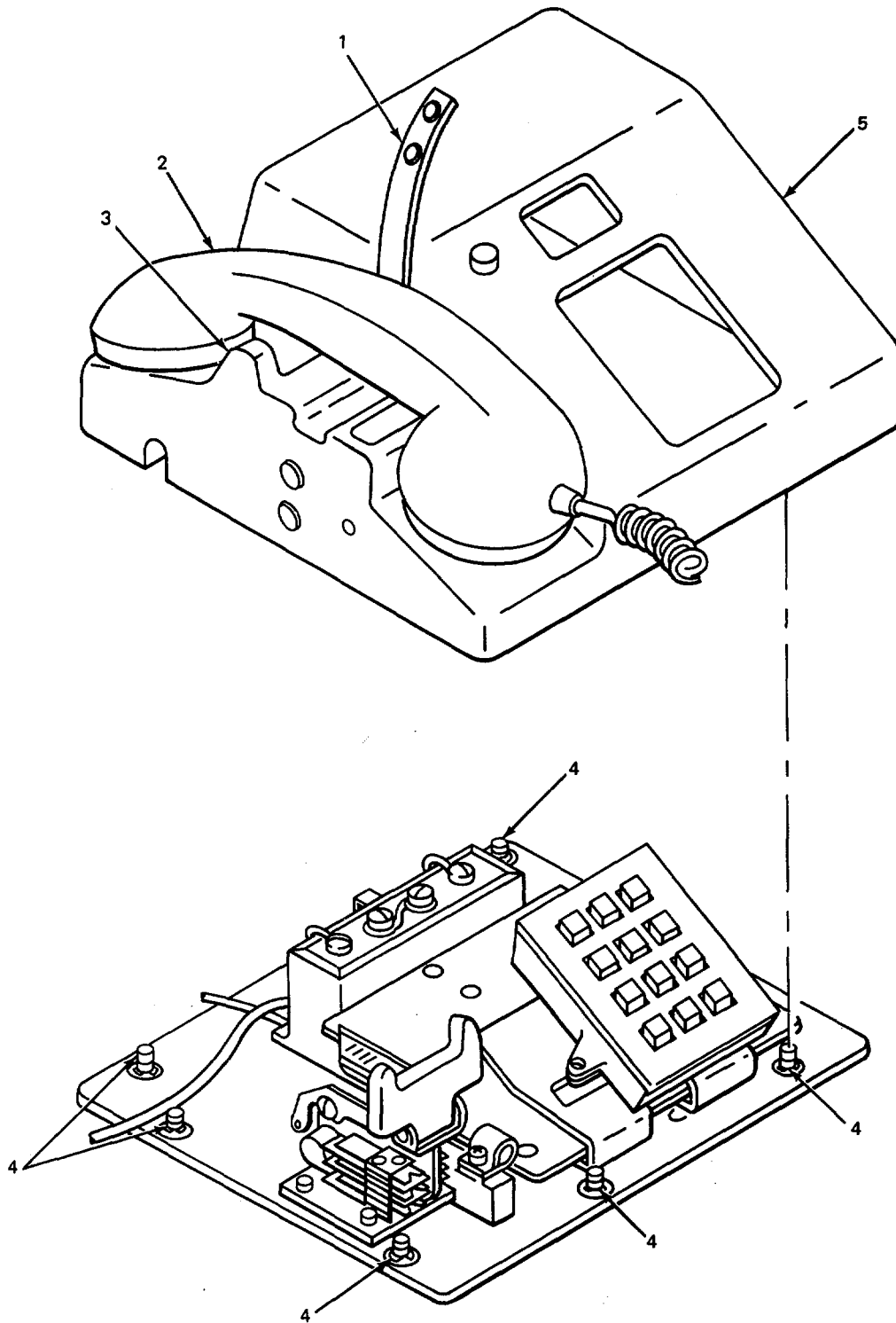

EL3VZ032

2-10. REPLACEMENT OF HOOKSWITCH ASSEMBLY.

This task covers:

Replacement

INITIAL SETUP

Tools

Tool Kit, Electronic Equipment TK-100G

Materials/Parts

Hookswitch Assembly

Personnel Required

One technician

Equipment Condition

Telephone shell assembly removed.
See paragraph 2-9.

| LOCATION | ITEM | ACTION | REMARKS |
|----------|------|--------|---------|
|----------|------|--------|---------|

REPLACEMENT

CAUTION

Handle hookswitch assembly with care so that the spring pile up adjustment will not be changed.

NOTE

Unsolder and connect wires one at a time to proper location on new assembly.

| | | | |
|----|-----------------------|--|---|
| 1. | Hookswitch assembly 1 | Wires (1) | Using soldering iron, unsolder. |
| 2. | Hookswitch assembly 2 | Wires (1) | Using soldering iron, solder. |
| 3. | | Wires (1) | Repeat steps 1 and 2 until all wires are connected. |
| 4. | Telephone set base | Hookswitch assembly 1 and two screws (2) | Using cross-tip screwdriver, remove. Set aside. |
| 5. | | Hookswitch assembly 2 and two screws (2) | Using cross-tip screwdriver, install. |

2-10. REPLACEMENT OF HOOKSWITCH ASSEMBLY. (CONT)

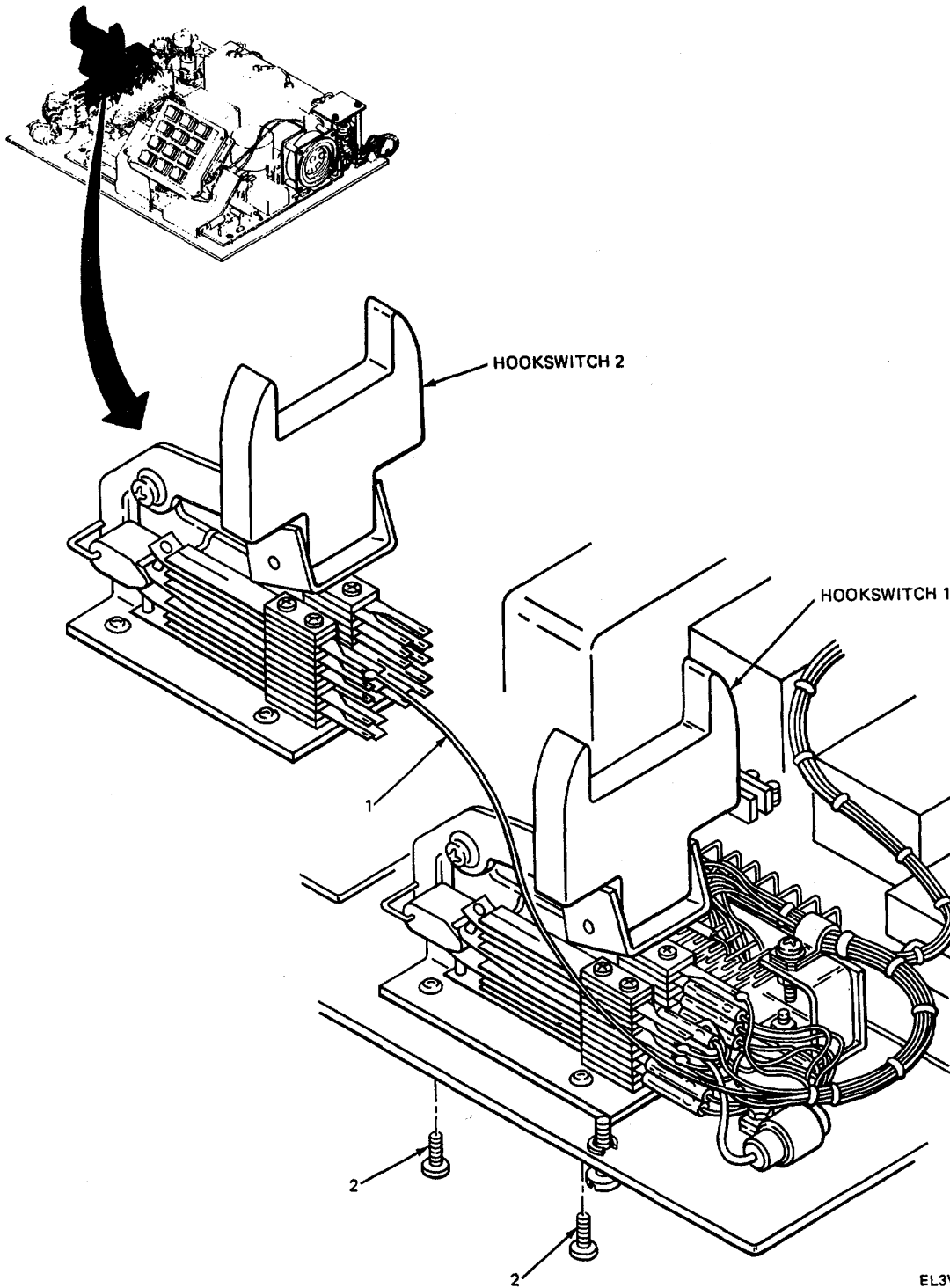

EL3VZ033

2-11. REPLACEMENT OF CIRCUIT CARD ASSEMBLY.

This task covers:

1. Removal
 2. Installation
-

INITIAL SETUP

| | |
|---|---|
| Tools | Personnel Required |
| Tool Kit, Electronic Equipment TK-100/G | One technician |
| Materials/Parts | Equipment Condition |
| Circuit Card Assembly | Telephone shell assembly removed. See paragraph 2-9. Batteries removed. See TM 11-5805-384-12. |

| LOCATION | ITEM | ACTION REMARKS |
|-----------------------|--|--|
| REMOVAL | | |
| 1. Telephone set base | Five screws (1) | Using cross-tip screwdriver, remove. |
| 2. | Slot (2) pry circuit card assembly forward. | Using flat-tip screwdriver, insert into slot and |
| 3. | Circuit card assembly (3) | Slide out. |

CAUTION

Be careful not to damage circuit card components when sliding circuit card assembly under keyset brackets.

INSTALLATION

| | | |
|-----------------------|---|---|
| 1. Telephone set base | Circuit card assembly (3) | Slide in. Observe caution. |
| 2. | Slot (2) pry circuit card assembly backward to connect | Using flat-tip screwdriver, insert into slot and it. |

2-11. REPLACEMENT OF CIRCUIT CARD ASSEMBLY. (CONT)

| LOCATION | ITEM | ACTION | REMARKS |
|----------|------|--------|---------|
|----------|------|--------|---------|

INSTALLATION (CONT)

NOTE

Check that connector of circuit card is a lined with guide pins of back plane assembly.

| | | | |
|-----------------------|-----------------|---------------------------------------|--|
| 3. Telephone set base | Five screws (1) | Using cross-tip screwdriver, install. | |
|-----------------------|-----------------|---------------------------------------|--|

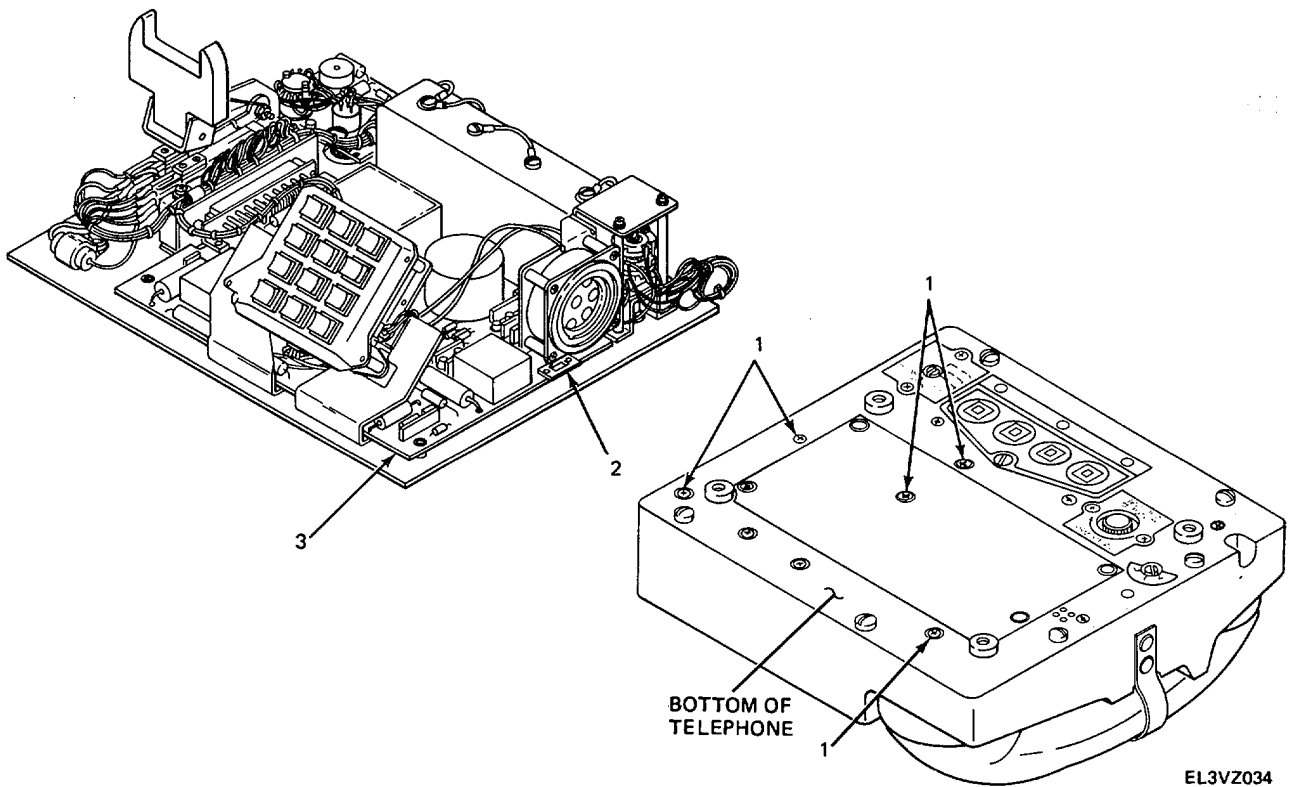

2-12. REPLACEMENT OF KEYSENDER ASSEMBLY.

This task covers:

1. Removal
2. Installation

| | |
|-------------------------------|---------------------|
| INITIAL SETUP | Personnel Required |
| Tools | One technician |
| Tool Kit, | Equipment Condition |
| Electronic Equipment TK-100/G | Equipment off. |
| Materials/Parts | |
| Keysender | |

| LOCATION | ITEM | ACTION | REMARKS |
|-----------------------|------------------------------|--|--------------------|
| REMOVAL | | | |
| 1. Telephone set | Telephone assembly (1) | Remove. | See paragraph 2-9. |
| 2. Keysender bracket | Screws (2) | Using cross-tip screwdriver, remove. | |
| <u>CAUTION</u> | | | |
| 3. Keysender. | Wires (3) | Be careful not to upset the spring pile up adjustment. Tag wires. Using soldering iron, unsolder | |
| INSTALLATION | | | |
| 1. Keysender. | Wires (3) | Note tags. Using soldering iron, solder | |
| 2. Keysender bracket | Screws (2) | Using cross-tip screwdriver, install. | |
| 3. Telephone set. | Telephone shell assembly (1) | Install. | See paragraph 2-9 |

1-12. REPLACEMENT OF KEYSENDER ASSEMBLY. (CONT)

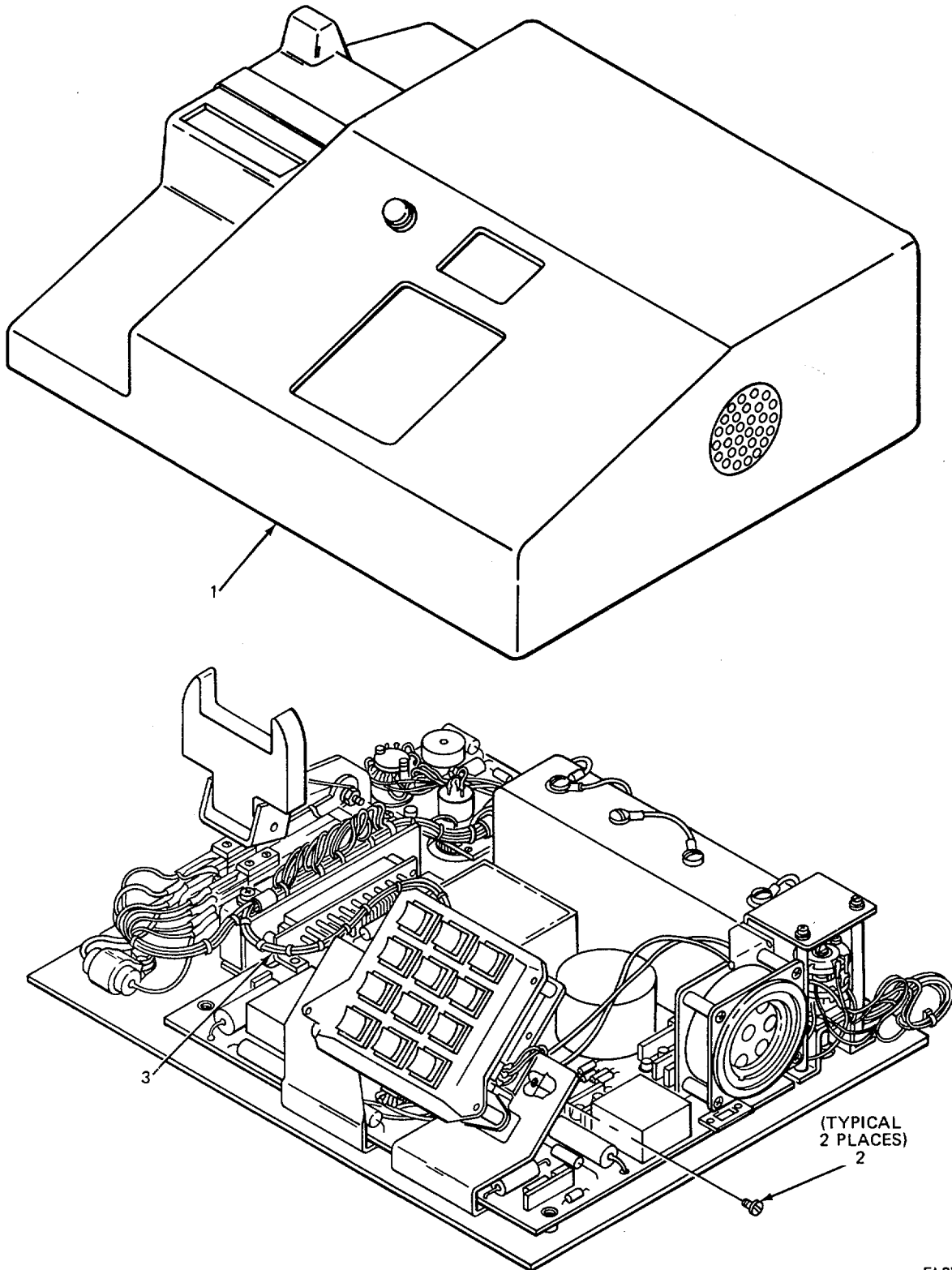

EL3VZ035

2-13. REPLACEMENT OF STATION CARD.

This task covers:

1. Removal
2. Installation

| | |
|----------------------|----------------------------|
| INITIAL SETUP | Personnel Required |
| Tools | One technician |
| Flat-tip screwdriver | Equipment Condition |
| Materials/Parts | Telephone set in operation |
| Station card | |

| LOCATION | ITEM | ACTION REMARKS |
|------------------------------|------------------------------------|--|
| REMOVAL | | |
| 1. Telephone shell assembly. | Station card retaining bracket (1) | Using screwdriver, pry off |
| 2. | Station card (2) | Remove. |
| INSTALLATION | | |
| 1. Telephone shell assembly | Station card (2) | Install. |
| 2. | Station card retaining bracket (1) | Using screwdriver, pry bracket and insert into slot. |

2-13. REPLACEMENT OF STATION CARD. (CONT)

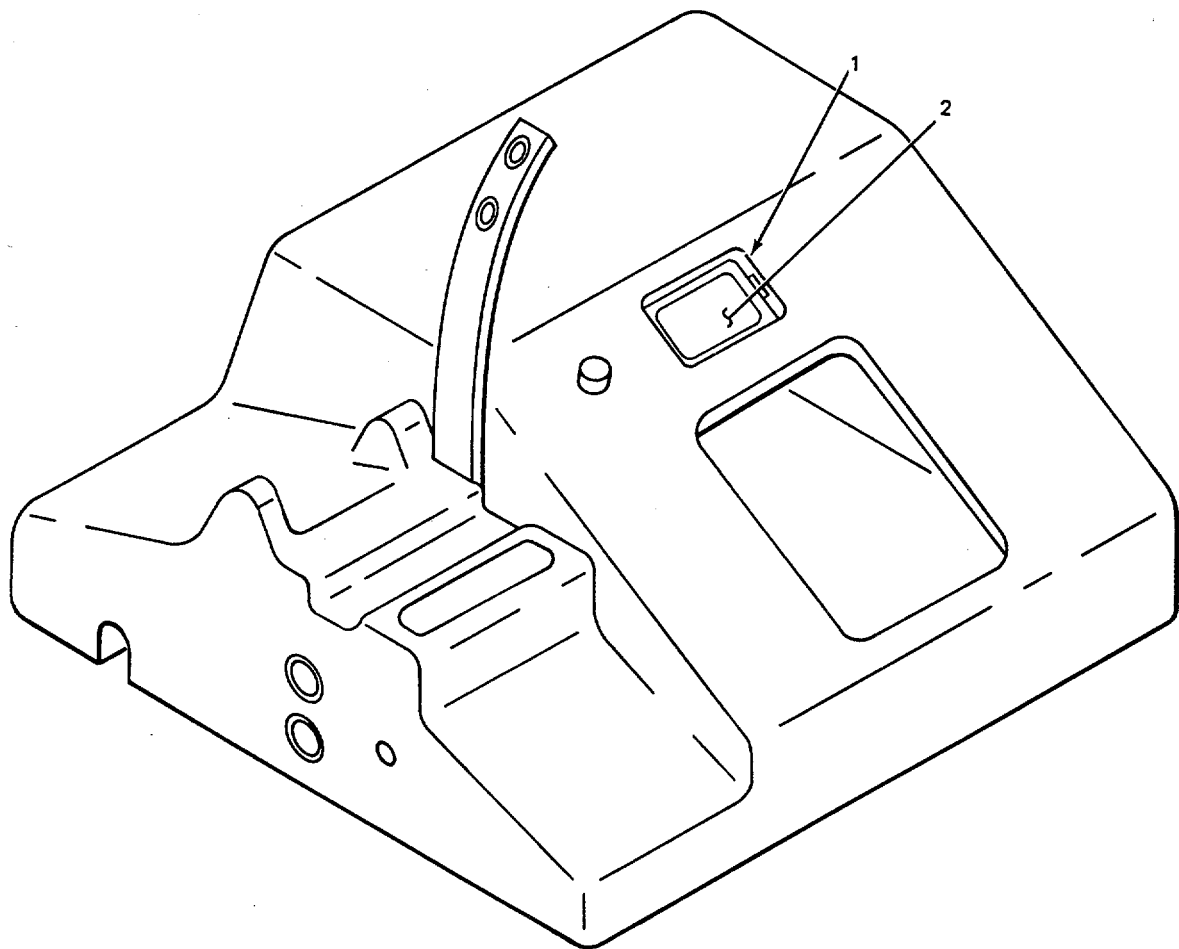

EL3VZ036

2-14. REPLACEMENT OF MODE SELECTOR SWITCH.

This task covers:

Replacement

INITIAL SETUP

Tools

Tool Kit, Electronic Equipment TK-100/G

Personnel Required

One technician

Materials/Parts

MODE SELECTOR SWITCH

Equipment Condition

Telephone shell assembly removed. See paragraph 2-9

| LOCATION | ITEM | ACTION | REMARKS |
|----------|------|--------|---------|
|----------|------|--------|---------|

NOTE

Unsolder and connect wires one at a time to proper location on new assembly.

| | | | |
|-------------------------------------|---|-------------------------------------|---|
| 1. Telephone set base. | Two screws (1) and MODE SELECTOR SWITCH plate (2) | Using cross-tip screwdriver, remove | |
| 2. MODE SELECTOR SWITCH assembly 1. | Bracket (3) | | Remove from base plate |
| 3. | Nut and washer (4) | | Using 9/16-inch wrench, remove |
| 4. | Wires (5) | | Using soldering iron, unsolder |
| 5. MODE SELECTOR SWITCH assembly 2. | Wires (5) | | Using soldering iron, solder |
| 6. | Wires (5) | | Repeat steps 4 and 5 until all wires are connected. |

2-14. REPLACEMENT OF MODE SELECTOR SWITCH. (CONT)

| LOCATION | ITEM | ACTION REMARKS |
|--------------------------------------|---|---------------------------------------|
| REPLACEMENT (CONT) | | |
| 7. MODE SELECTOR SWITCH assembly (2) | Nut and washer (4) | Using 9/16-inch wrench, install |
| 8. | Bracket (3) | Install on base plate. |
| 9. | MODE SELECTOR SWITCH plate (2) and two screws (1) | Using cross-tip screwdriver, install. |

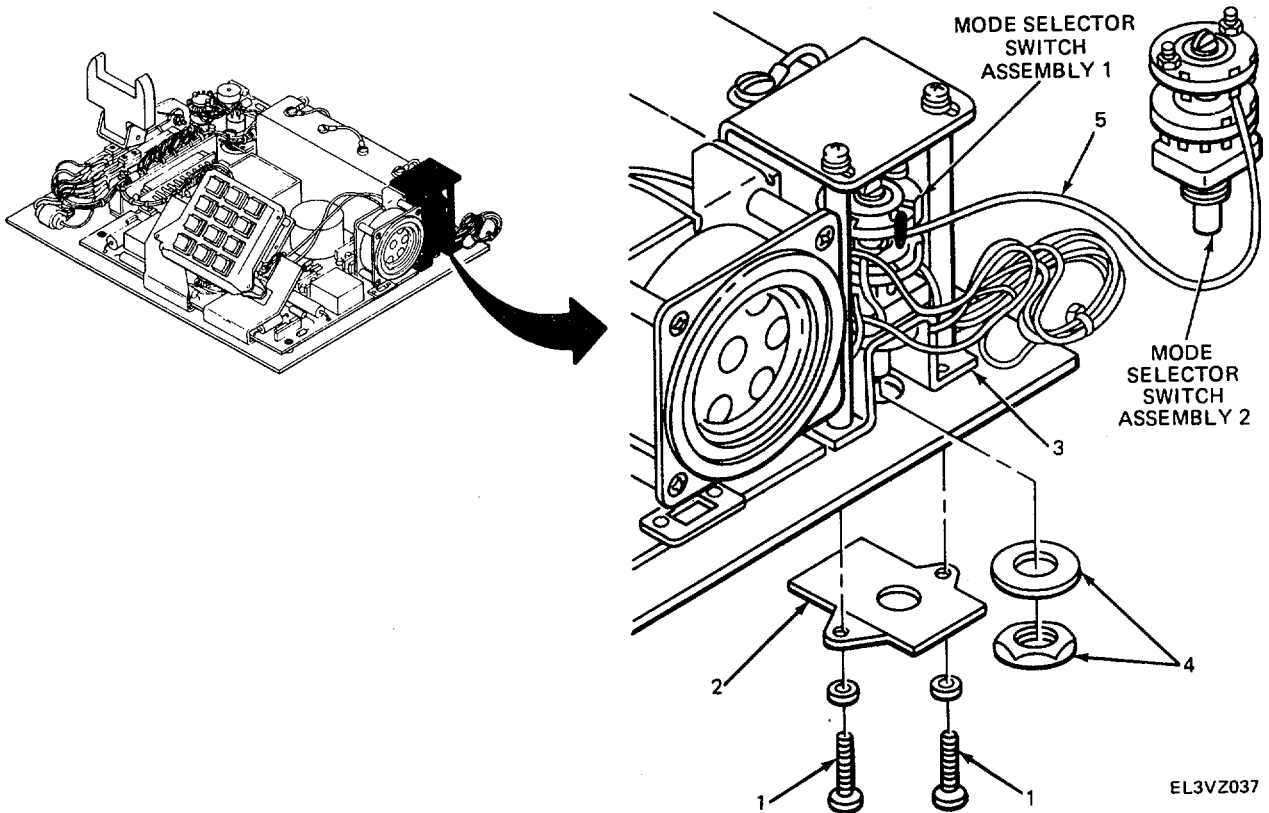

2-15. REPLACEMENT OF RINGER VOLUME CONTROL.

This task covers:

1. Removal
2. Testing
2. Installation

INITIAL SETUP

Personnel Required

Tools

One technician

Multimeter TS352/U

Equipment Condition

Tool Kit, Electronic Equipment TK-100/G

Telephone shell assembly removed. See paragraph 2-9

Materials/Parts

RINGER VOLUME Control

| LOCATION | ITEM | ACTION | REMARKS |
|---------------------------|--|--|---------|
| REMOVAL | | | |
| 1. Telephone set base | Two screws (1) and RINGER VOLUME control plate (2) and spacers (3) | Using cross-tip screwdriver, remove | |
| 2. RINGER VOLUME control. | Knob (4) | Using allen key, remove | |
| 3. | Nut and washer (5) | Using 3/8-inch wrench, remove. | |
| 4. | Wires (6) | Tag. Using soldering iron, unsolder | |
| TESTING | | | |
| 1. | White wire (7) | Using soldering iron, unsolder | |
| 2. Multimeter. | Leads (8) | Connect leads | |
| 3. RINGER VOLUME control. | Shaft (9) | Using needle nose pliers, rotate | |
| 4. Multimeter | Gage (10) | As shaft is rotated, reading should vary from 0 to 4 ohms. | |

2-15. REPLACEMENT OF RINGER VOLUME CONTROL. (CONT)

| LOCATION | ITEM | ACTION REMARKS |
|--------------------------|--|---|
| TESTING (CONT) | | |
| 5. RINGER VOLUME control | White wire (7) | Using soldering iron, solder. |
| INSTALLATION | | |
| 1. RINGER VOLUME control | Wires (6) | Note tags. Using soldering iron, solder |
| 2. | Nut and washer (5) | Using 3/8-inch wrench, install. |
| 3. | Knob (4) | Using alien key, install. |
| 4. Telephone set base | RINGER VOLUME control plate (2) spacers (3) and screws (1) | Using cross-tip screwdriver, install |

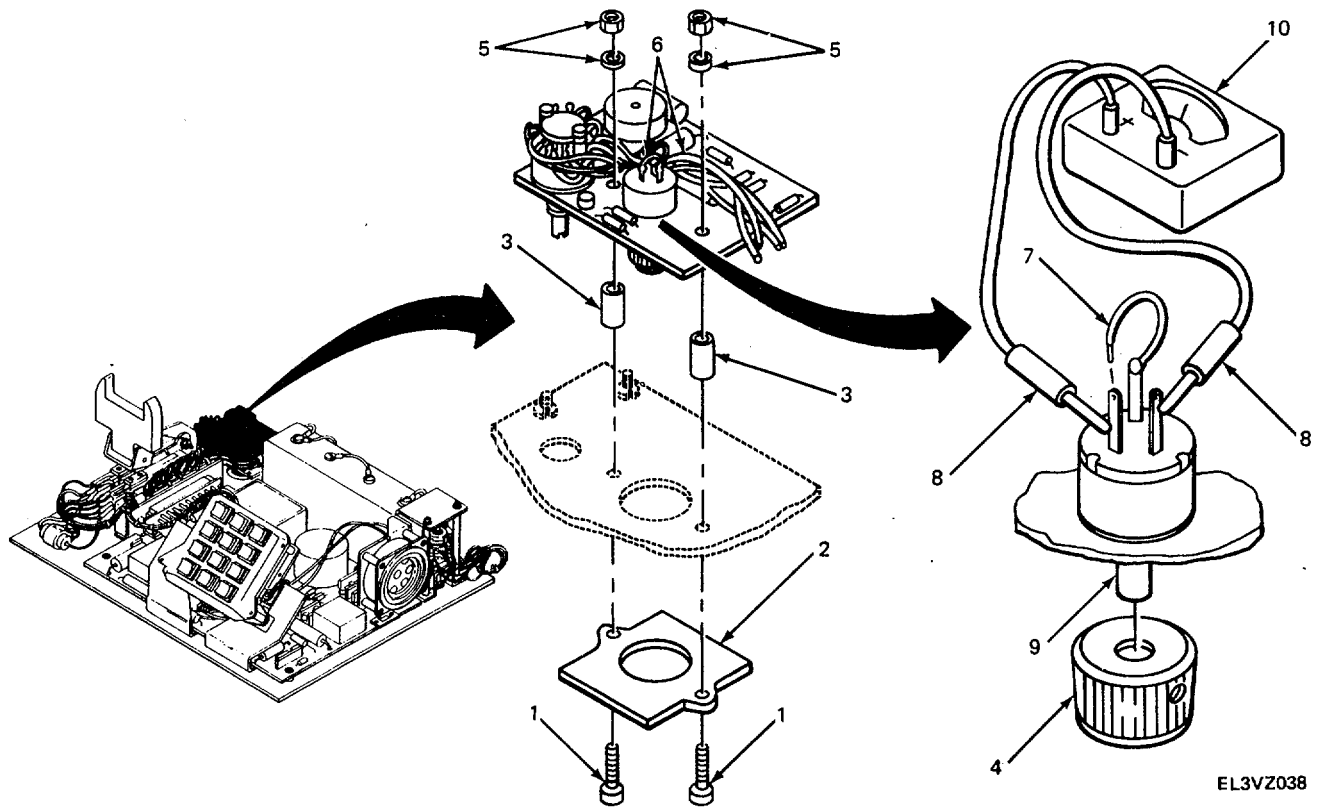

EL3VZ038

2-16. HANDSET ELEMENT MAINTENANCE.

This task covers:

1. Removal
2. Testing
3. Installation

| | |
|-----------------------|---------------------------|
| INITIAL SETUP | Personnel Required |
| Tools | One technician |
| Flat-tip screwdriver | Equipment Condition |
| Multimeter AN/URM-105 | Equipment on a workbench. |
| Materials/Parts | |

Handset Elements

| LOCATION | ITEM | ACTION REMARKS |
|----------|------|-------------------|
|----------|------|-------------------|

NOTE

Removal and replacement procedures are only for one element since both are done in the same way.

REMOVAL

| | | |
|------------------|--------------------|--|
| 1. Handset. | Element cover (1) | Unscrew to remove Set aside. |
| 2. | Element gasket (2) | Remove. Set side. |
| 3. Handset cord. | Leads (3) | Using screwdriver, remove Test element. |

TESTING

| | | |
|---------|--------------|--|
| Element | Contacts (4) | Check continuity. Receiver should be 37 +10 ohms. Microphone should be 37 □ 10 ohms. |
|---------|--------------|--|

2-16. HANDSET ELEMENT MAINTENANCE. (CONT)

| LOCATION | ITEM | ACTION | REMARKS |
|------------------|--------------------|----------------------------|---------|
| INSTALLATION | | | |
| 1. Handset cord. | Leads (3) | Using screwdriver, replace | |
| 2. Handset | Element gasket (2) | Replace. | |
| 3. | Elements (5) | Replace. | |
| 4.. | Element cover (1) | Screw on to handset | |

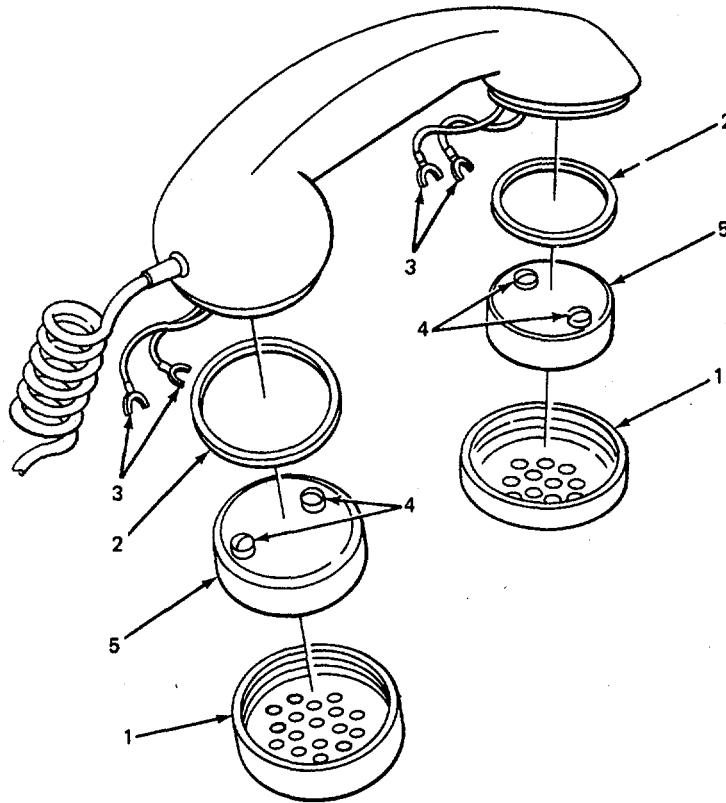

EL3VZ039

2-17. REPLACEMENT OF BATTERY COMPARTMENT.

This task covers:

1. Removal
2. Testing
2. Installation

| | |
|---|--|
| INITIAL SETUP | Personnel Required |
| Tools | One technician |
| Tool Kit, Electronic Equipment TK-100/G | Equipment Condition |
| Materials/Parts | Telephone set shell assembly removed. (para 2-9) |
| Battery compartment | |

| LOCATION | ITEM | ACTION REMARKS |
|----------|------|-------------------|
|----------|------|-------------------|

REMOVAL

| | | | |
|----|---------------------|------------------------------------|--|
| 1. | Battery compartment | Screws and nuts (1) | Using flat-tip screwdriver, remove. |
| 2. | Telephone set | Battery cover (2) | Using flat-tip screwdriver, open. |
| 3. | Battery compartment | Batteries (3) | Remove. |
| 4. | | Screws (4) | Using flat-tip screwdriver, remove. |
| 5. | | Cable guard and screw (5) | Using cross-tip screwdriver, remove. Set aside. |
| 6. | Telephone set | Handset cord (6) and line cord (7) | Remove. |
| | | Battery compartment (8) | Remove. |

INSTALLATION

| | | | |
|----|---------------------|------------------------------------|---------------------------------------|
| 1. | Telephone set | Battery compartment (8) | Install. |
| 2. | Battery compartment | Line cord (7) and handset cord (6) | Install. |
| 3. | | Cable guard and screw (5) | Using cross-tip screwdriver, install. |

2-17. REPLACEMENT OF BATTERY COMPARTMENT. (CONT)

INSTALLATION (CONT)

| LOCATION | ITEM | ACTION REMARKS |
|------------------------|---------------------|-------------------------------------|
| 4. Battery compartment | Screws (4). | Using flat-tip screwdriver, install |
| 5. | Batteries (3) | Install |
| 6. | Battery cover (2) | Using flat-tip screwdriver, close |
| 7. | Screws and nuts (1) | Using flat-tip screwdriver, install |

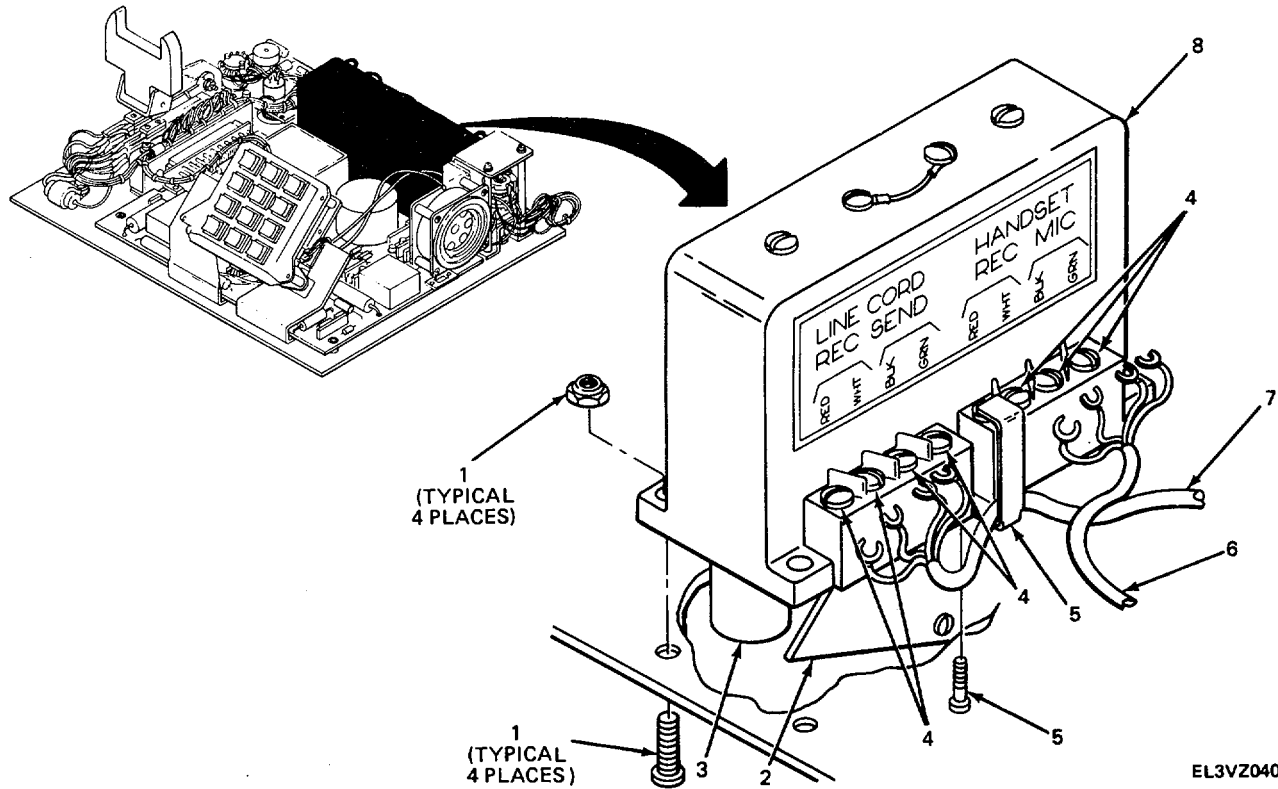

EL3VZ040

2-18. REPLACEMENT OF FIXED ELECTROLYTIC CAPACITOR.

This task covers:

1. Removal
2. Installation

| | |
|---|--|
| INITIAL SETUP | Personnel Required |
| Tools | One technician |
| Tool Kit, Electronic Equipment TK-100/G | Equipment Condition |
| Materials/Parts | Telephone set shell assembly removed. (para 2-9) |
| Capacitor, fixed, electrolytic NSN 5910-00-010-2855 | |

| LOCATION | ITEM | ACTION REMARKS |
|----------|------|-------------------|
|----------|------|-------------------|

REMOVAL

| | | |
|------------------------|--|--|
| 1. Baseplate assembly. | Nut (1) | Using 114-inch wrench, remove |
| 2. Capacitor | Positive lead (2) and plastic sleeving (3) | Using needle nose pliers, slide sleeving away from terminal. |

NOTE

The positive lead is closest to positive sign (+).

WARNING

Observe polarity marked on capacitor. Failure to do so can cause injury.

| | | |
|---------------|-------------------|--|
| 3. Hookswitch | Terminal (4) | Using soldering iron, unsolder positive lead. Tag terminal. |
| 4. Capacitor | Negative lead (5) | Using soldering iron, unsolder. Tag terminal. |

INSTALLATION

| | | |
|--------------|-------------------|---|
| 1. Capacitor | Negative lead (5) | Using soldering iron, solder to terminal. |
|--------------|-------------------|---|

2-18. REPLACEMENT OF FIXED ELECTROLYTIC CAPACITOR. (CONT)

| LOCATION | ITEM | ACTION REMARKS |
|-------------------------|--|---|
| INSTALLATION (CONT) | | |
| 2. | Plastic sleeving(3) and positive lead (2) | Using needle nose pliers, slide plastic sleeving on lead. |
| 3. Hookswitch | Terminal (4) | Using soldering iron, solder positive lead. Observe polarity. |
| 4. Capacitor | Positive lead (2) and plastic sleeving (3) | Using needle nose pliers, slide sleeving onto terminal. |
| 5. Baseplate assembly . | Nut (1) | Using 1/4-inch wrench, install |

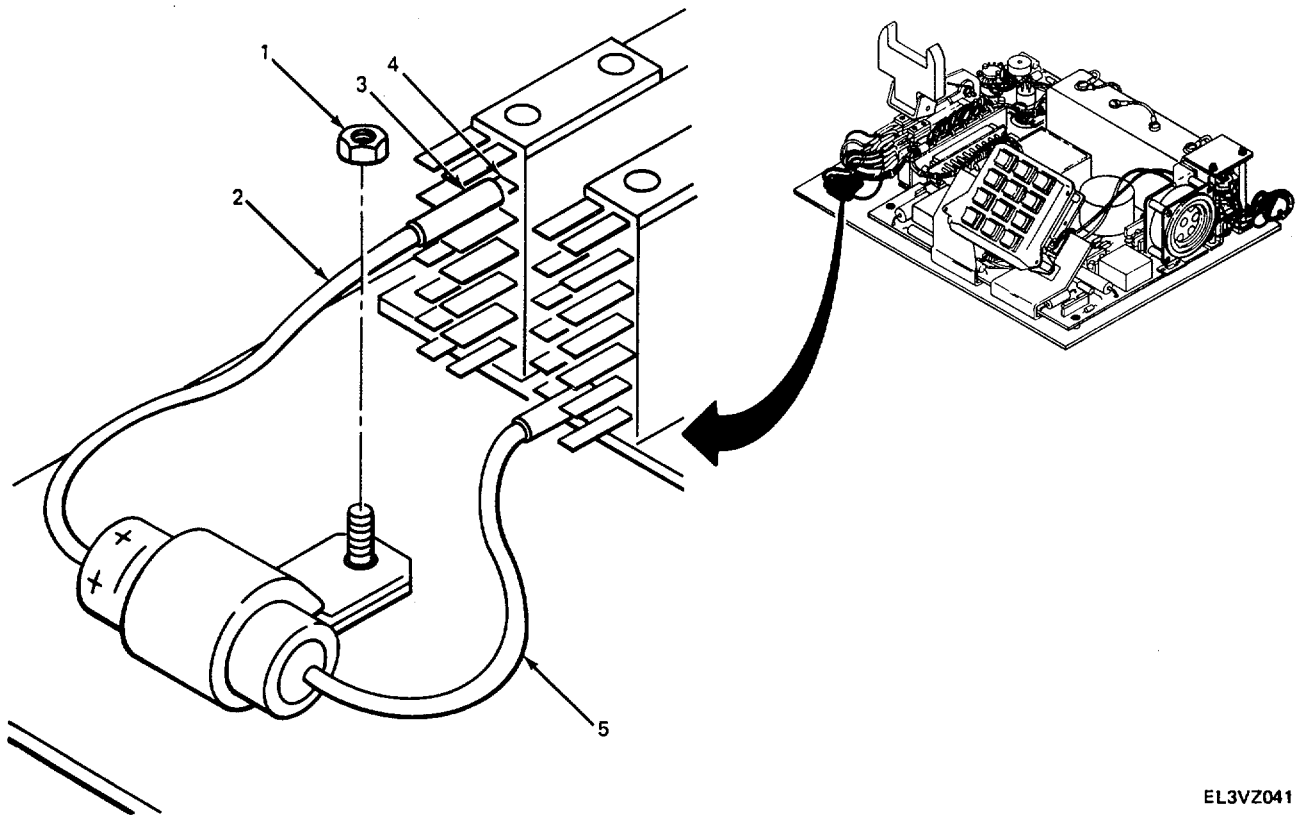

EL3VZ041

2-19. REPLACEMENT OF HANDSET CORD.

This task covers:

1. Removal
2. Installation

INITIAL SETUP

Tools

Cross-tip screwdriver

Flat-tip screwdriver

Materials/Parts

Handset cord
NSN 5805-00-348-3851

Personnel Required

One technician

Equipment Condition

Telephone set shell assembly removed (para 2-9).

| LOCATION | ITEM | ACTION REMARKS |
|------------------|---------------------------|---------------------------------------|
| REMOVAL | | |
| 1. Handset | Element covers (1) | Unscrew to remove. |
| 2. Elements | Screws (2) | Using flat-tip screwdriver, remove. |
| 3. Handset | Handset cord (3) | Remove. |
| 4. Telephone set | Cable guard and screw (4) | Using cross-tip screwdriver, remove. |
| 5. | Screws (5) | Using flat-tip screwdriver, remove. |
| 6. | Handset cord (3) | Remove. |
| INSTALLATION | | |
| 1. Telephone set | Handset cord (3) | Install. Follow color code. |
| 2. | Screws (5) | Using flat-tip screwdriver, install |
| 3. | Cable guard and screw (4) | Using cross-tip screwdriver, install. |
| 4. Handset | Handset cord (3) | Install. |

2-19. REPLACEMENT OF HANDSET CORD. (CONT)

| LOCATION | ITEM | ACTION REMARKS |
|----------|------|-------------------|
|----------|------|-------------------|

INSTALLATION (CONT)

- | | | |
|-------------|--------------------|--------------------------------------|
| 5. Elements | Screws (2) | Using flat-tip screwdriver, install. |
| 6. Handset | Element covers (1) | Screw on to install. |

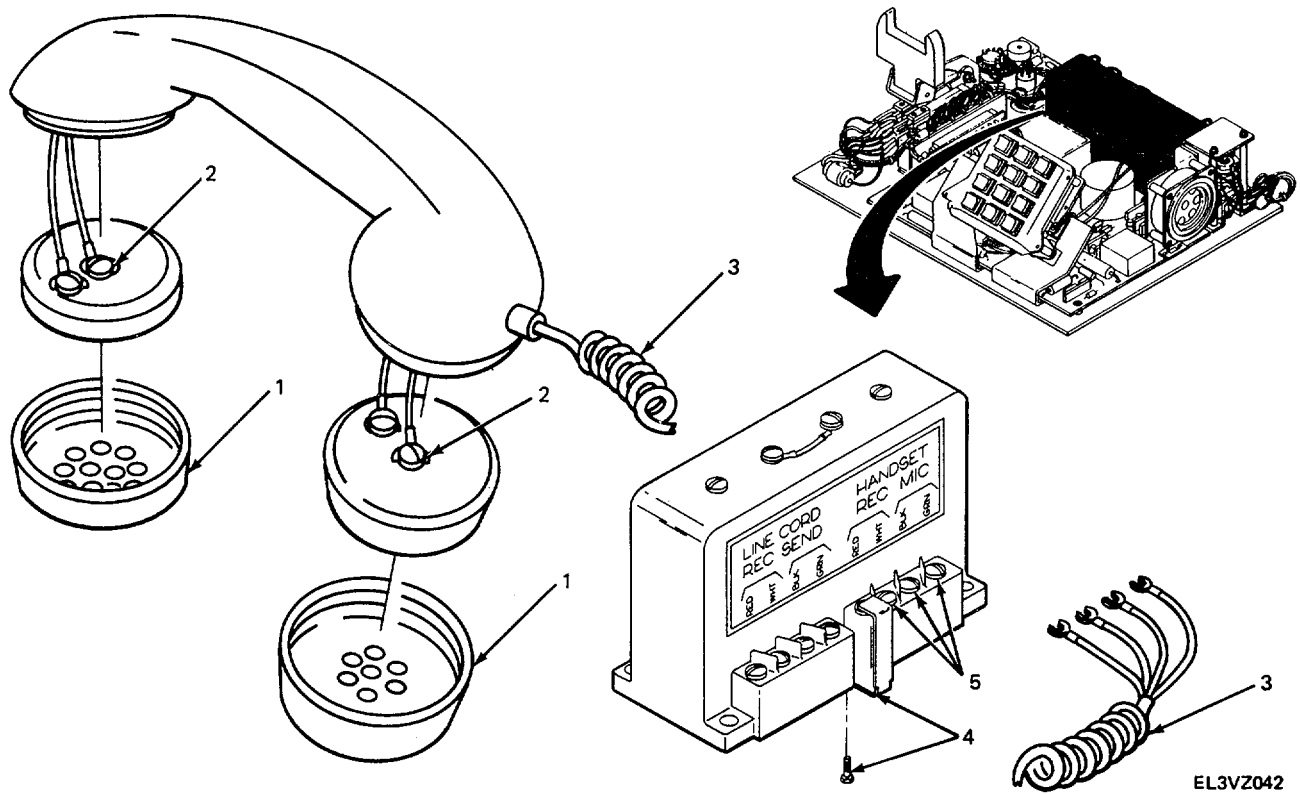

2-20. REPLACEMENT OF LBICB SWITCH.

This task covers:

Replacement

| | |
|---|--|
| INITIAL SETUP | Personnel Required |
| Tools | One technician |
| Tool Kit, Electronic Equipment TK-100/G | Equipment Condition |
| Materials/Parts | Telephone set shell assembly removed (para 2-9). |
| LBICB Switch | |

| LOCATION | ITEM | ACTION REMARKS |
|----------|------|-------------------|
|----------|------|-------------------|

NOTE

Unsolder and connect wires one at a time to proper location on new assembly.

| | | | |
|----|------------------|------------------------|---|
| 1. | LBICB switch (1) | Nut (1) and washer (2) | Using 1/2-inch wrench, remove. |
| 2. | | Wires (3) | Using soldering iron, unsolder |
| 3. | LB/CB switch (2) | Wires (3) | Using soldering iron, solder |
| 4. | | Wires (3) | Repeat steps 2 and 3 until all wires are connected. |
| 5. | | Nut (1) and washer (2) | Using 1/2-inch wrench, install. |

2-20. REPLACEMENT OF LB/CB SWITCH. (CONT)

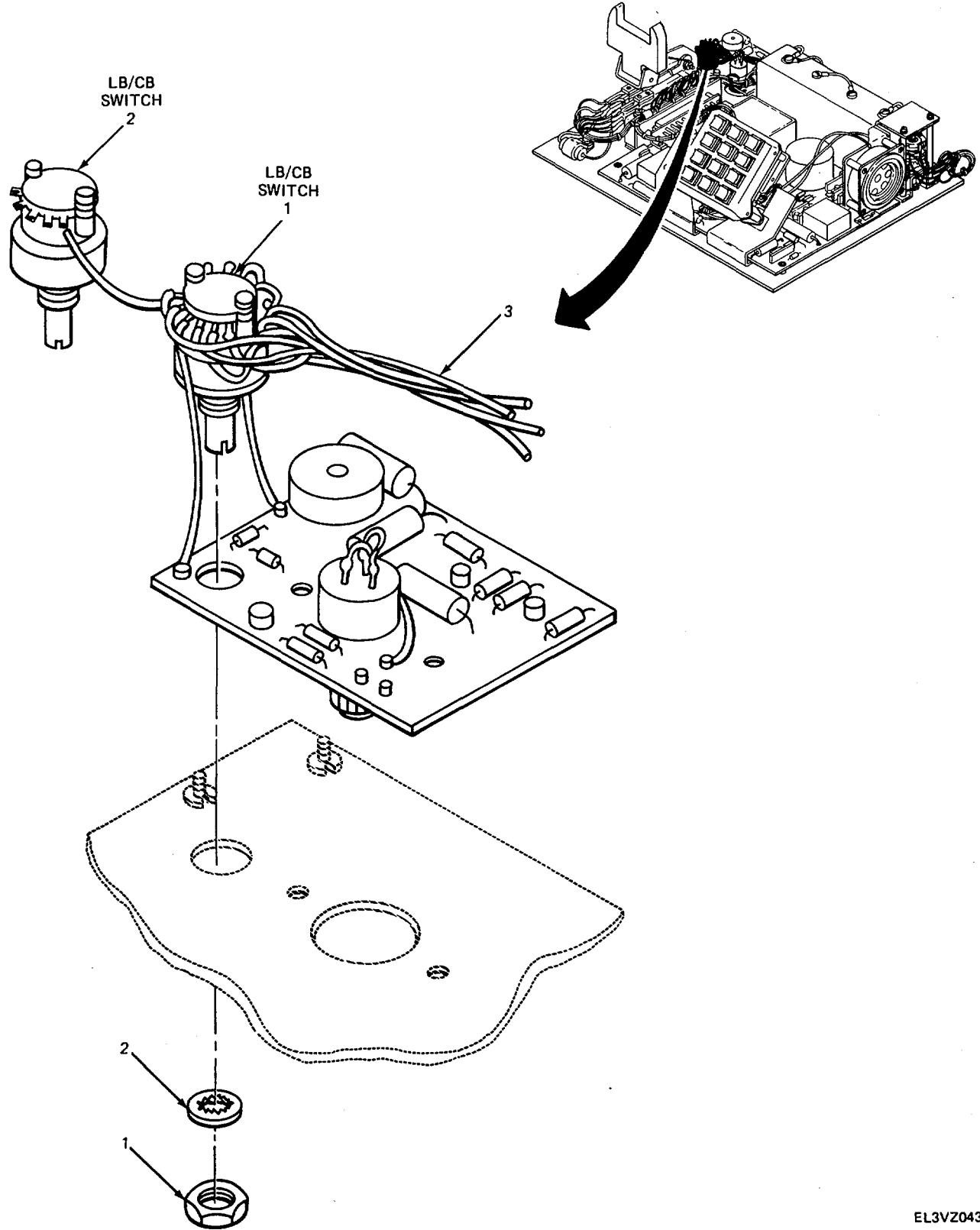

EL3V2043

2-21. LINE CORD MAINTENANCE.

This task covers:

1. Removal
2. Testing
3. Installation

| | |
|---|--|
| INITIAL SETUP | Personnel Required |
| Tools Tool Kit, Electronic Equipment TK-105/G Multimeter AN-URM-105 | One technician |
| Materials/Parts | Equipment Condition |
| Line cord | Telephone set shell assembly removed (para 2-9). |

| LOCATION | ITEM | ACTION REMARKS | |
|--------------|---------------|---------------------------|--|
| REMOVAL | | | |
| 1. | Telephone set | Screws (1) | Using flat-tip screwdriver, remove. |
| 2. | | Cable guard and screw (2) | Using cross-tip screwdriver, remove |
| 3. | | Line cord (3) | Remove. |
| TESTING | | | |
| 1. | Line cord. | Leads (4) | Test for continuity of each lead Meter should indicate 0 ohms. |
| 2. | | | Test for shorts between leads. Meter should indicate infinite ohms. |
| INSTALLATION | | | |
| 1. | Line cord | Leads (4) | Replace as shown |
| 2. | Telephone set | Screws (1) | Using flat-tip screwdriver, install. |
| | | Cable guard and screw (2) | Using cross-tip screwdriver, install. |

2-21. LINE CORD MAINTENANCE. (CONT)

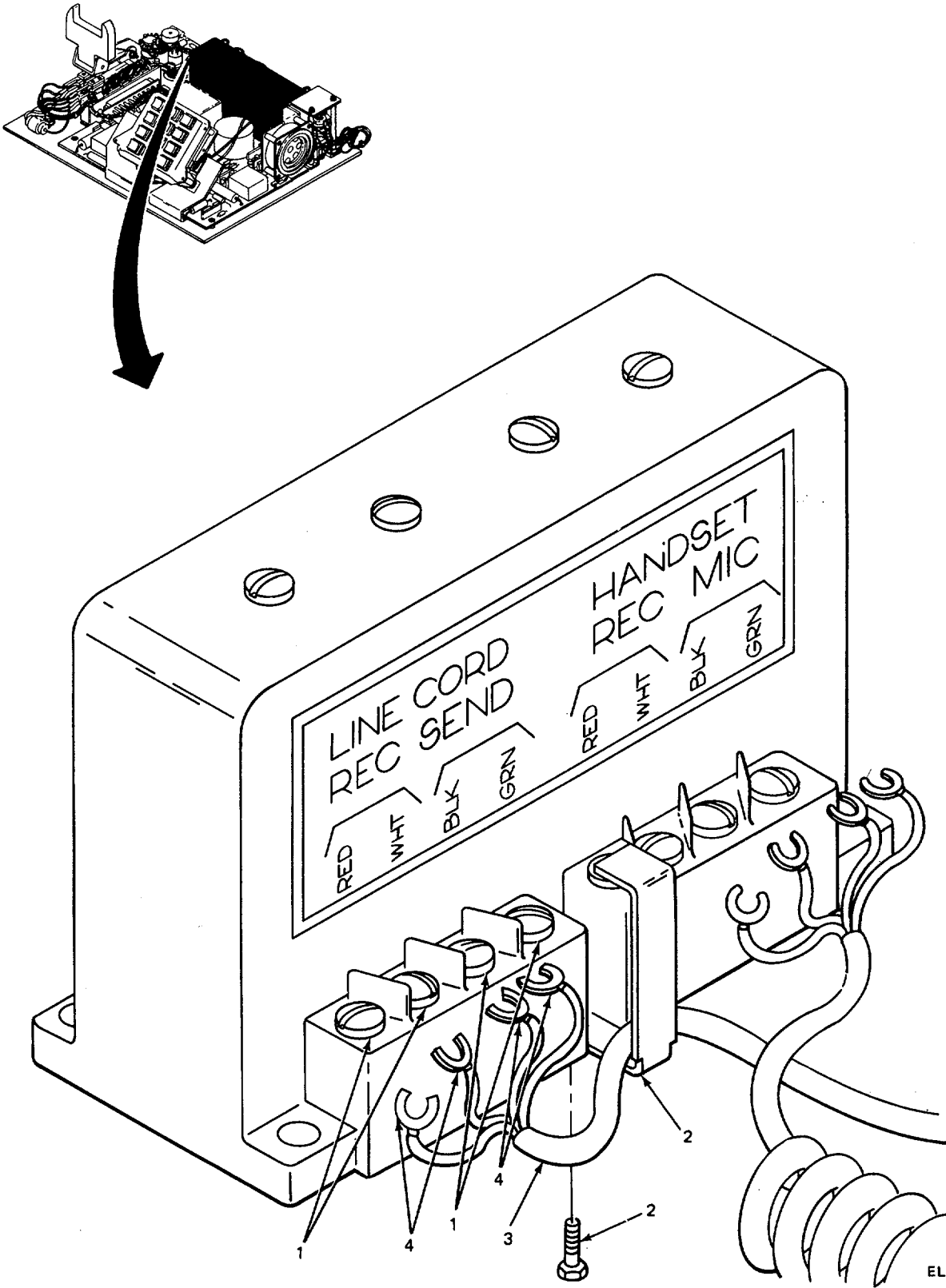

Section V PREPARATION FOR STORAGE OR SHIPMENT

This section provides procedures for repacking the telephone set. Before repacking, the next scheduled preventive maintenance checks and services should be performed, all known problems corrected, and all current modification work orders applied.

2-22. ADMINISTRATIVE STORAGE.

Administrative or short term storage refers to storage of equipment from 1 to 45 days.

This task covers:

Removal from service

INITIAL SETUP

Tools

Cross-tip screwdriver
Flat-tip screwdriver

Materials/Parts

Carrying case
Carrying case sling

Personnel Required

One technician

Equipment Condition

Telephone set in service.

| LOCATION | ITEM | ACTION REMARKS |
|--------------------|-------------------------|---------------------------------------|
| 1. Connector block | Screw (1) and cover (2) | Using cross-tip screwdriver, remove |
| 2.. | External wiring (3) | Using flat-tip screwdriver, remove |
| 3. Telephone set. | Connector block (4) | Using flat-tip screwdriver, remove |
| 4. Connector block | Cover (2) and screw (1) | Using cross-tip screwdriver, replace. |
| 5. Telephone set | Batteries (5) | Remove. See paragraph |

2-22. ADMINISTRATIVE STORAGE. (CONT)

| LOCATION | ITEM | ACTION REMARKS |
|-------------------|-------------------------------------|--|
| 6. Cradle | Handset (6) and retaining strap (7) | Secure. |
| 7. Carrying case. | Telephone set (8) | Place in case Place wires in an orderly manner. |
| 8. | Carrying case sling (9) | Attach. |
| 9.. | Batteries (5) | Store in case |
| 10.. | Cover (10) | Close Place In storage area. |

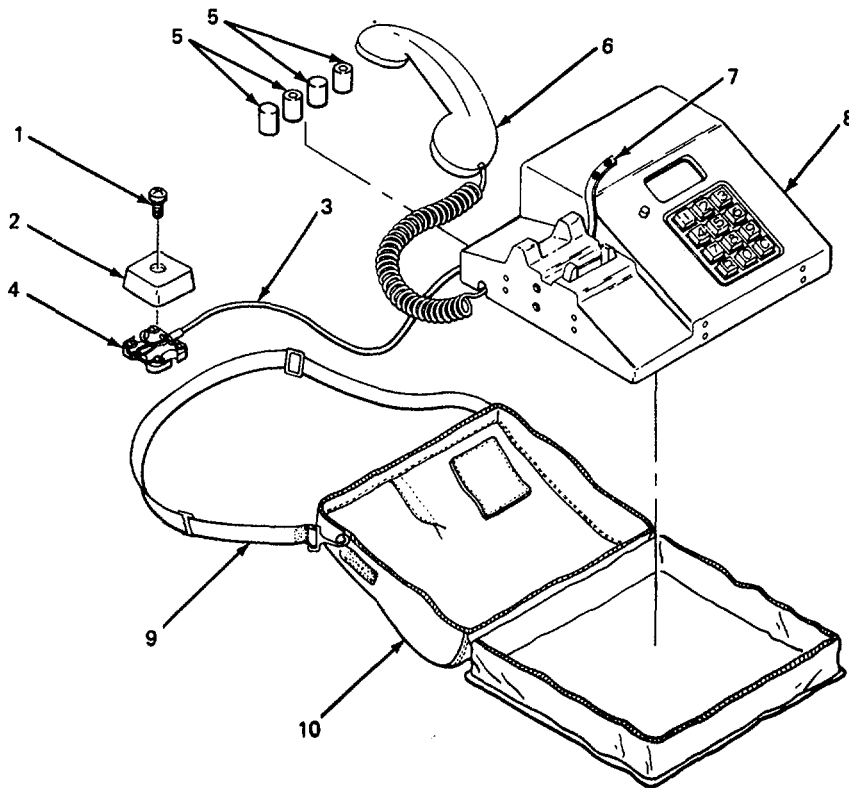

EL3VZ045

APPENDIX A
REFERENCES

A-1. SCOPE.

This appendix lists all forms, field manuals, technical manuals, and miscellaneous publications referenced in this manual.

A-2. FORMS.

Quality Deficiency Report SF 368

Recommended Changes to DA Publications DA Form 2028

A-3. TECHNICAL MANUALS.

Administrative Storage of Equipment TM 740-90-1

Operator's and Organizational Maintenance Manual for Telephone Sets TA-341/TT, TA-341A/TT (NSN 5805-00-910-8844) and TA-341 B/TT (NSN 5805-01-039-3499) TM 11-5805-384-12

Direct Support Maintenance Repair Parts and Special Tools Lists (Including Depot Maintenance Repair Parts and Special Tools for Telephone Set TS-341B/TT (NSN 5805-01-039-3499)) TM 11-5805-384-30P

Procedures for Destruction of Electronics Materiel to Prevent Enemy Use (Electronics Command) TM 750-244-2

The Army Maintenance Management System (TAMMS) TM 38-750

A-4. MISCELLANEOUS PUBLICATIONS.

Consolidated Index of Army Publications and Blank Forms DA PAM 310-1

APPENDIX B
EXPENDABLE SUPPLIES AND MATERIALS LIST

Section I INTRODUCTION

B-1. SCOPE.

This appendix lists expendable supplies and materials you will need to operate and maintain Telephone Set TA-341 B/TT. These items are authorized to you by CTS 50-970, Expendable Items (Except Medical, Class A, Repair Parts, and Heraldic Items).

B-2. EXPLANATION OF COLUMNS.

a. Column 1, Item number. This number is assigned to the entry in the listing and is referenced in the narrative instructions to identify the material (e.g., Use Cleaning Compound, Item 2, App. B).

b. Column 2, Level. This column identifies the lowest level of maintenance that requires the listed item.

C - Operator/Crew

O - Organizational Maintenance/Aviation Unit Maintenance

F - Direct Support Maintenance/Aviation Intermediate Maintenance

H - General Support Maintenance

c. Column 3, National Stock Number. This is the National stock number assigned to the item; use it to request or requisition the item.

d. Column 4, Description. Indicates the Federal item name and, if required, a description to identify the item. The last line for each item indicates the Federal Supply Code for Manufacturer (FSCM) in parentheses followed by a part number.

e. Column 5, U/M (Unit of Measure). Indicates the measure used in performing the actual maintenance function. This measure is expressed by a two-character alphabetical abbreviation (e.g., ea, in, pr). If the unit of measure differs from the unit of issue, requisition the lowest unit of issue that will satisfy your requirements.

Section II EXPENDABLE SUPPLIES AND MATERIALS LIST

| (1) ITEM NUMBER | (2) LEVEL | (3) NATIONAL NUMBER STOCK | (4) DESCRIPTION FSCM | (5) U/M |
|-----------------------|--------------|---------------------------------|--------------------------|------------|
| 1 | 0 | 6135-00-120-1010 | Batteries (80063) BA-42 | ea. |
| 2 | 0 | 6850-00-105-3084 | Trichlorotrifluoroethane | oz. |
| 3 | 0 | 7920-00-924-5700 | Cleaning cloth | ea. |

GLOSSARY

AC. An abbreviation for alternating current.

ALTERNATING CURRENT. Electric current that continually changes in magnitude and direction.

AMPLIFICATION. The process of increasing the voltage, current, or power of a signal.

AMPLIFIER. A device consisting of one or more components used to increase a signal.

BANDWIDTH. A range of frequencies which fall within set limits. These limits are established by the number of cycles per second of the frequency.

BUSY SIGNAL. A series of short tones sent to the telephone set by the switching facility to indicate when the telephone set being called is busy.

CONFERENCE. A telephone conversation between three or more people.

CURRENT. The movement of electrons through a conductor.

DC. An abbreviation for direct current.

DIAL TONE. A continuous tone sent to the telephone set by the switching facility to indicate that the switching facility is ready to accept the telephone number of a distant phone.

DIRECT CURRENT. Electric current that flows in only one direction and remains constant in magnitude.

EXTENSION TELEPHONE. A telephone which is connected directly to another telephone.

FREQUENCY. The number of cycles of a signal in a given time, usually per second.

GROUND. The zero reference point in electronic equipment regarding voltage.

HERTZ. A term meaning cycle per second, abbreviated Hz.

IMPEDANCE. The opposition of a circuit to the flow of current. This resistance is measured in ohms.

GLOSSARY (CONT)

INPUT. The driving force applied to a circuit. Input can also be terminals or other connections where this force is applied.

INTEGRATOR CIRCUIT. This circuit is used to separate two frequencies or functions.

MODULATION. The process of changing the amplitude, frequency, phase of a signal in such a way that it will convey information.

NEGATIVE. A point from which electrons will flow toward a positive point in the circuit.

OHM. The unit of measurement for resistance in a circuit.

OSCILLATOR. A device which produces alternating voltage and current when direct current is applied. The frequency is determined by components in the circuit.

OUTPUT. The driving force delivered by a device or circuit. Output can also be terminals or other connections where this force is delivered.

POLARITY. The condition which determines the direction of current flow in a circuit. Charges are either positive or negative.

PRECEDENCE. Having importance. There are four levels of precedence which determine which call is more important than another call.

PREEMPTION. A higher precedence call interrupting a lower precedence call.

RESISTANCE. The property of a conductor which causes it to oppose the flow of current.

RESISTOR. A component which opposes the flow of current in a circuit.

SIDETONE. In a telephone receiver, the system which allows you to hear your own voice.

SIGNAL. A means by which information is passed on over a communication system.

SUBSCRIBER. Someone who has been assigned a telephone set and a number.

SWITCHING FACILITY. A central location able to connect many telephone sets together by their assigned telephone numbers.

THRESHOLD. A minimum level needed to cause a response.

TRANSFORMER. A device which consists of primary and secondary windings used to either decrease or increase current.

tone. A sound wave that is in the audible range.

VOLTAGE. Electromotive force or pressure which causes current to flow.

INDEX

| Subject | Page |
|--|------------|
| A | |
| Acknowledge delay circuit | 1-8 |
| AC SUPV. | 1-12 |
| Administrative storage. | 2-52 |
| B | |
| Bandwidth circuit | 1-6 |
| Battery compartment, replacement | 2-42 |
| Block diagram presentation | 1-4 |
| Broadcast mode | 1-11 |
| C | |
| Capacitor, function. | 2-44 |
| Checking unpacked equipment..... | 2-4 |
| Circuit card assembly | 2-30 |
| Common tools and equipment | 2-1 |
| Cord, handset, replacement | 2-46 |
| D | |
| DC SUPV | 1-19 |
| Destruction of Army electronics materiel | 1-2 |
| Detector output circuit | 1-6 |
| Dial tone | 2-8 |
| Digit tone | 2-19 |
| Dual tone multifrequency oscillator | 1-9 |
| E | |
| Equipment description | 1-4 |
| Extension control circuit..... | 1-9 |
| Extension control mode | 1-21 |
| F | |
| G | |
| General information..... | 1-1 |
| Glossary | Glossary 1 |
| H | |
| Handset cord, replacement | 2-46 |
| Handset maintenance | 2-40 |
| Hookswitch assembly, replacement | 2-28 |
| How to use this manual | ii |

INDEX (CONT)

| Subject | Page |
|--|------|
| I | |
| Incoming call | 1-17 |
| Integrator circuit | 1-10 |
| Introduction | 1-1 |
| J | |
| K | |
| Keysender | 1-11 |
| Keysender, replacement..... | 2-32 |
| Key R | 1-11 |
| L | |
| Latch circuit | 1-11 |
| Line cord, maintenance | 2-50 |
| List of abbreviations | 1-3 |
| Local battery common battery switch | 1-12 |
| Local battery common battery switch, replacement | 2-48 |
| M | |
| Maintenance forms, records, reports..... | 1-2 |
| Maintenance, overview..... | 2-23 |
| Mode selector switch | 1-12 |
| Mode selector switch, replacement | 2-36 |
| Meet-me-mode..... | 1-11 |
| N | |
| Nomenclature cross reference list | 1-3 |
| O | |
| Outgoing call | 1-13 |
| Overview, maintenance | 2-23 |
| P | |
| Point to point mode | 1-19 |
| Preparation for storage or shipment | 2-52 |
| Principles of operation | 1-4 |
| Progressive mode | 1-11 |
| Purpose of equipment | 1-1 |

INDEX (CONT)

| Subject | Page |
|---|------|
| Q | |
| R | |
| Receive amplifier circuit..... | 1-4 |
| Release timer..... | 1-7 |
| Release timer discharge circuit..... | 1-8 |
| Repair parts | 2-1 |
| Replacement | |
| Ringer element | 2-24 |
| Telephone shell assembly | 2-26 |
| Hookswitch assembly | 2-28 |
| Circuit card assembly..... | 2-30 |
| Keysender assembly..... | 2-32 |
| Station card | 2-34 |
| Mode selector switch | 2-36 |
| Ringer volume control..... | 2-38 |
| Battery compartment..... | 2-42 |
| Fixed electrolytic capacitor | 2-44 |
| Handset cord..... | 2-46 |
| Local battery, common battery switch | 2-48 |
| Reporting equipment improvement recommendations | 1-2 |
| Ring acknowledge tone detector circuit | 1-5 |
| Ringing | 2-10 |
| S | |
| Send amplifier circuit..... | 1-5 |
| Service upon receipt | 2-2 |
| Sidetone | 2-11 |
| Sidetone gate circuit..... | 1-11 |
| Special tools, TMDE, and support equipment | 2-1 |
| Station card, replacement | 2-34 |
| Storage administrative | 2-52 |
| Symptom index | 2-7 |
| T | |
| Table of contents | i |
| Telephone shell assembly | 2-26 |
| Threshold control circuit..... | 1-5 |
| Timer circuit | 1-7 |
| Troubleshooting | 2-6 |
| U | |
| Unpacking..... | 2-2 |

INDEX (CONT)

| Subject | Page |
|--------------------------|-------------|
| V | |
| Voice transmission | 2-17 |
| W | |
| Warning, general..... | front cover |
| Warning, summary | front cover |
| Wrong numbers | 2-29 |

X,Y,Z

By Order of the Secretary of the Army:

E. C. MEYER
General, United States Army
Chief of Staff

Official:

ROBERT M. JOYCE
Major General, United States Army
The Adjutant General

PIN: 052296

This fine document...

Was brought to you by me:



[Liberated Manuals -- free army and government manuals](#)

Why do I do it? I am tired of sleazy CD-ROM sellers, who take publicly available information, slap “watermarks” and other junk on it, and sell it. Those masters of search engine manipulation make sure that their sites that sell free information, come up first in search engines. They did not create it... They did not even scan it... Why should they get your money? Why are not letting you give those free manuals to your friends?

I am setting this document FREE. This document was made by the US Government and is NOT protected by Copyright. Feel free to share, republish, sell and so on.

I am not asking you for donations, fees or handouts. If you can, please provide a link to liberatedmanuals.com, so that free manuals come up first in search engines:

<A HREF=<http://www.liberatedmanuals.com/>>Free Military and Government Manuals

- Sincerely
Igor Chudov
<http://igor.chudov.com/>
- [Chicago Machinery Movers](#)