

DEPARTMENT OF THE ARMY TECHNICAL MANUAL

Operator, Organizational, DS, GS,
and Depot Maintenance Manual
INSTRUCTIONS FOR INSTALLING RADIO SET
AN/VRC-46, AN/VRC-53, OR AN/GRC-125,
AND INTERCOMMUNICATION SET AN/VIC-1(V)
INSTALLATION UNITS, IN ARMORED VEHICLE LAUNCHER
BRIDGE (M48A2 HULL)

Headquarters, Department of the Army, Washington, D. C.
6 September 1966

		Paragraph	Page
CHAPTER	1. INTRODUCTION		
	Scope -----	1-1	3
	Index of publications -----	1-2	3
	Forms and records -----	1-3	3
CHAPTER	2. INSTALLATION		
SECTION	I. Service upon receipt of equipment		
	Unpacking -----	2-1	5
	Checking unpacked equipment -----	2-2	5
	II. Equipment installation		
	Tools required for installation -----	2-3	5
	Installation instructions -----	2-4	5
APPENDIX.	REFERENCES -----		9

CHAPTER 1

INTRODUCTION

1-1. Scope

This manual provides instructions for mounting the installation units (FSN 5820082-4046 and FSN 5830-082-4047) that permit mounting Radio Set AN/VRC46, AN/VRC53, our AN/GRC-125, and Intercommunication Set AN/VIC-1 (V) in Armored Vehicle Launcher Bridge (M48A2 Hull).

1-2. Index of Publications

Refer to the latest issue of DA Pam 310-4 to determine whether they are new editions, changes, or additional publications pertaining to this equipment. DA Pam 310-4 is an index of current technical manuals, technical bulletins, supply manuals, supply bulletins, lubrication orders, and modification work orders available through publications supply channels.

The index lists the individual parts (-10, -20, -35P, etc) and the latest changes to and revisions of each publication.

1-3. Forms and Records

a. Reports of Maintenance and Unsatisfactory Equipment. Use equipment forms and records in accordance with instructions in TM 38-750.

b. Report of Damaged or Improper Shipment. Fill out and forward DD Form 6 (Report of Damaged or Improper Shipment) as prescribed in AR 700-58 (Army), NAVSANDA Publication 378 (Navy), and AFR 71-4 (Air Force).

c. Reporting of Equipment Manual Improvements. The direct reporting by the individual user of errors, omissions, and recommendations for improving this manual is authorized and encouraged. DA Form 2028 (Recommended Changes to DA Publications) will be used for reporting these improvement recommendations.

This form will be completed using pencil, pen, or typewriter and forwarded direct to Commanding General, U. S. Army Electronics Command, ATTN: AMSELMR-NMP-AD, Fort Monmouth, N. J., 07703.

CHAPTER 2

INSTALLATION

Section I. SERVICE UPON RECEIPT OF EQUIPMENT**2-1. Unpacking**

Move the packing boxes close to the location where the installation is to take place and unpack the parts of the installation unit. Be careful not to lose any of the parts.

2-2. Checking Unpacked Equipment

a. Inspect the equipment for damage incurred during shipment. If the equipment has been damaged, report the damage on DD Form 6 (para 1-3).

b. See that the equipment is complete as listed in the packing slip. If a packing slip is not available, the completeness of the installation unit can be determined

by comparing the parts received with the items listed on the installation drawings (Figs. 2-4 and fig. 2-5).

Report all discrepancies in accordance with TM 38-750. Shortage of a minor assembly or part that does not affect proper installation or functioning of the equipment should not prevent the installation units from being installed.

c. When vehicles with radio sets are to be turned in or transferred, communication equipment will be removed and reinstalled in new replacement vehicles. Additional items which are required to complete installations should be requisitioned as individual items. To determine the Federal stock number of authorized items in the installation unit, refer to SB 11-131.

Section II. EQUIPMENT INSTALLATION**2-3. Tools Required for Installation**

The tools required for installation of Radio Set AN/VRC-46 and Intercommunication Set AN/VIC-1(V) in Armored Vehicle Launcher Bridge (M48A2 Hull) are a part of Tool Kit, Radar and Radio Repairman TK-87/U and Tool Kit, Supplementary, Radar and Radio Repair TK-88/U. The following additional items are needed:

- a. 1 electric drill (3/8 inch).
- b. 1 set of drill bits (1/16 inch to 3/8 inch).

2-4. Installation Instructions

a. To accomplish the installation, follow the instructions given below on those shown on figures 2-1 through 2-5.

Caution: Vehicle master control switch should be at OFF.

- (1) Identify all major parts and components in Radio Set AN/VRC-46 and Intercommunication Set AN/VIC-1 (V) in basic and installation units with the items as shown on figure 2-5.
- (2) Assemble and wire power plug and accessory assembly to the CX-4720/ VRC (fig. 2-5).
- (3) Refer to cording detail (fig. 2-5) to determine how the various components connect into the complete communication system. For drilling and welding, refer to figure 2-3.
- (4) Secure equipment in place (fig. 2-5).
- (5) Secure the cable assemblies in place by fastening the cable clamps to the tapping pads provided in the vehicle. Engage all connectors in their proper receptacles.

b. The following additional information is provided:

(1) To drill the correct size holes for the sheet metal screws, select a drill bit that is slightly smaller in diameter than the screw.

(2) When the installation is complete, check the tightness of all bolts and screws.

(3) Read the technical manuals supplied with the equipment before operating the communication system.

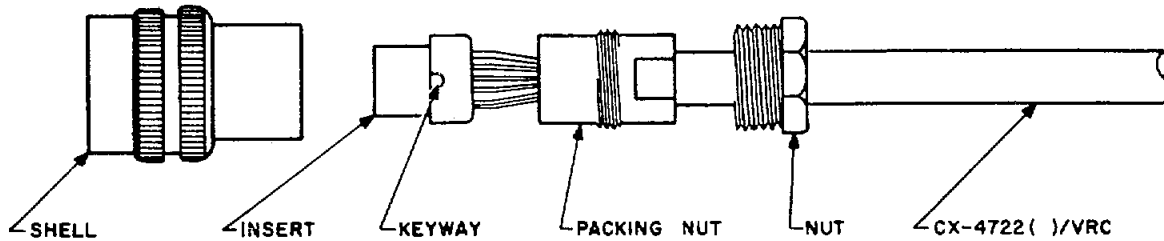

NOTES:

1. DISASSEMBLY PROCEDURE: LOOSEN NUT AND PACKING NUT. PULL INSERT FROM SHELL.

2. ASSEMBLY PROCEDURE: ALIGN KEYWAY TO SHELL PROPERLY AND PUSH INSERT INTO SHELL. TIGHTEN PACKING NUT AND NUT.

TM2300-364-15-1-1

Figure 2-1. Cable Assembly, Special Purpose, Electrical CX-4722/VRC connector disassembly.

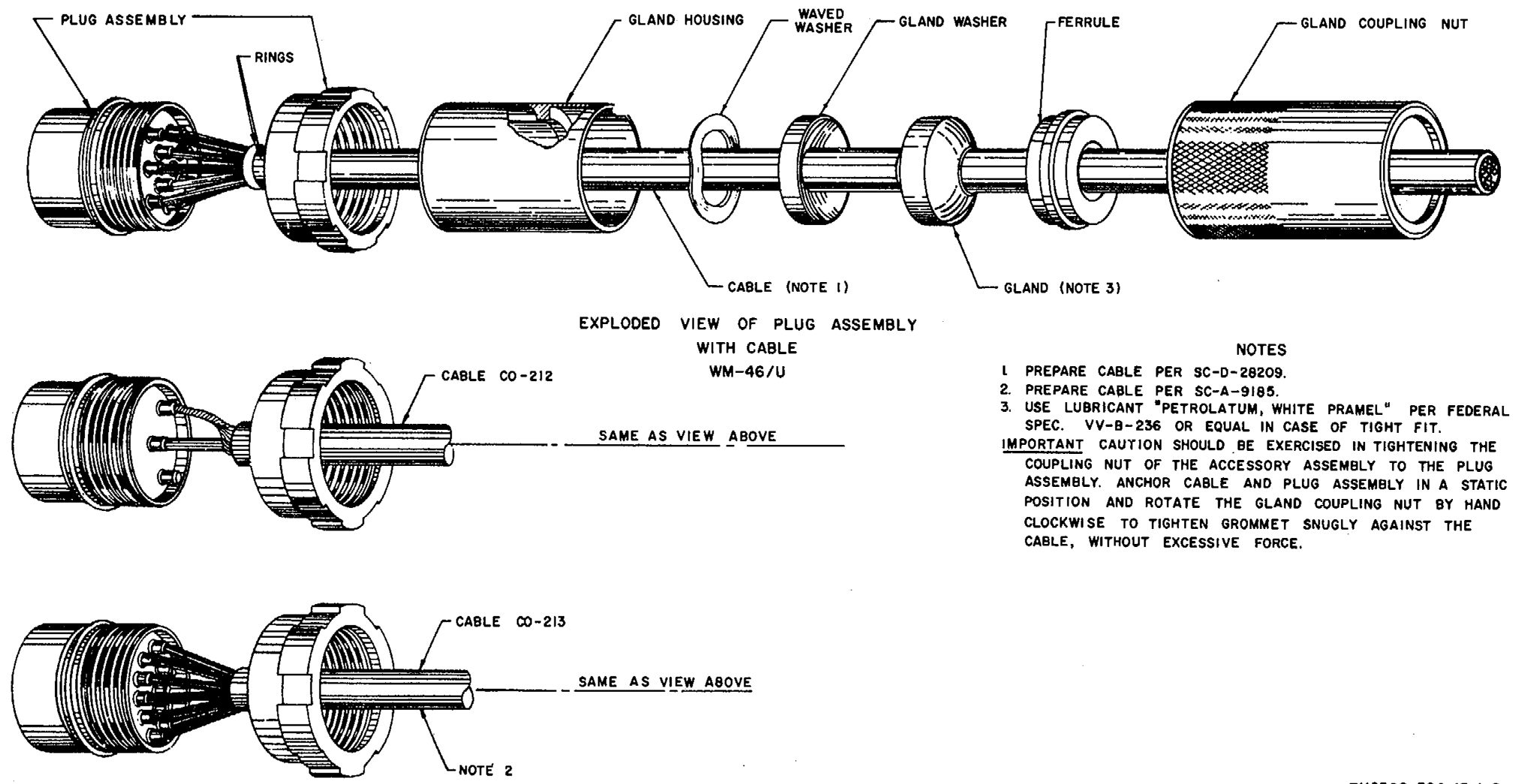

TM2300-364-15-1-2

Figure 2-2. Assembly of waterproof vehicle terminal box: plugs.

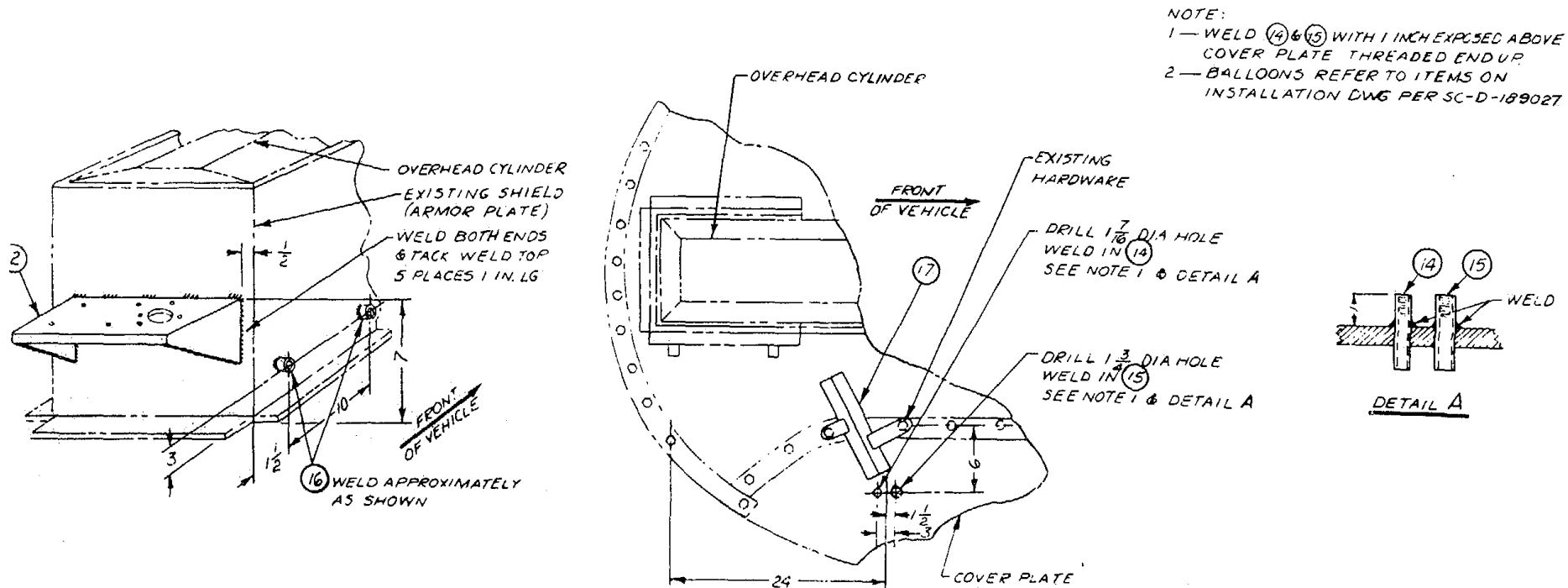

TM2300-364-15-1-3

Figure 2-3. Drilling and welding.

APPENDIX

REFERENCES

DA Pam 310-4	Index of Technical Manuals, Technical Bulletins, Supply Manuals (types 7, 8, and 9), Supply Bulletins, Lubrication Orders, and Modification Work Orders.
SB 11-131	Vehicular Radio Sets and Authorized Installations.
SB 38-100	Preservation, Packaging, and Packing Materials, Supplies, and Equipment Used by the Army.
TB SIG 364	Field Instructions for Painting and Preserving Electronics Command Equipment.
TM 11-5820-401-10	Operator's Manual: Radio Sets AN/VRC-12, and AN/VRC-43, -44, -45, -46, -47, -48, and -49.
TM 11-5820-401-20	Organizational Maintenance Manual (Including Repair Parts and Special: Tool Lists): Radio Sets AN/VRC-12, and AN/VRC-43,-44, -45, -46, -47, -48, and -49.
TM 11-5820-401-35	Field and Depot Maintenance Manual: Radio Set AN/VRC-12 and AN/VRCL43, -44, -45, -46, -47, -48, and -49.
TM 11-5820-498-10	Operator's Manual: Radio Sets AN/VRC-53 and AN/GRC-125 and Amplifier-Power Supply Group OA-3633/GRC.
TM 11-5820-498-20	Organizational Maintenance Manual: Radio Sets AN/VRC-53 and AN/GRC-125 and Amplifier-Power Supply Group OA-3633/GRC.
TM 11-5820-498-35	DS, GS, and Depot Maintenance Manual: Radio Sets AN/VRC-53 and AN/GRC-125 and Amplifier Power Supply Group OA-3633/GRC
TM 38-750	Army Equipment Record Procedures.

By Order of the Secretary of the Army:

HAROLD K. JOHNSON,
General, United States

Army,
Official:

Chief of Staff.

KENNETH G. WICKHAM,
Major General, United States Army,
The Adjutant General.

Distribution:

Active Army:

USASA (2)	MDW (1)	Army Pic Cen (2)
CNGB (1)	Armies (2) except	USACDCEC (10)
CO-E (7)	Seventh (5)	Instls (2) except
Dir of Trans (1)	Corps (2)	Ft Monmouth (70)
Cofengrs (1)	USAC (3)	Ft Gordon (10)
TSG (1)	Div (2)	Ft Huachuca (10)
CofSptS (1)	Div Arty (2)	Ft Carson (25)
USAIB (5)	Corps Arty (2)	Ft Knox (12)
USACDCEA (1)	Bde (2)	WSMR (5)
USACDCCBRA (1)	Regt/Gp/BG (2)	DPG (5)
USACDCCEA (1)	Bn (2)	USAEPG (5)
USACDCCEA:	Co/Btry (2)	GENDEP (2)
Ft Huachuca (1)	Det/Team (2)	Sig Sec GENDEP (5)
USACDCOA (1)	1st GM Bde (5)	Sig Dep (12)
USACDCQMA (1)	1st FA Bde (5)	A Dep (2) except
USACDCTA (1)	9th USASA Fld Sta (5)	LBAD (14)
USACDCADA (1)	12th USASA Fld Sta (5)	SAAD (30)
USACDCARMA (1)	Svc Colleges (2)	TOAD (14)
USACDCAVNA (1)	USASCS (30)	LEAD (10)
USACDCARTYA (1)	USMA (5)	SHAD (3)
USACDCSWA (1)	USAQMS (5)	NAAD (5)
USAMC (5)	USAMPS (5)	SVAD (5)
USCONARC (5)	MFSS (5)	CHAD (3)
ARADCOM (5)	USATSCH (5)	ATAD (10)
ARADCOM Rgn (2)	USAARMS (30)	Sig FLDMS (2)
OS Maj Comd (4) except	USASESCS (60)	AMS (1)
USARAL (10)	USAAMS (30)	USAERDAA (2)
USEUCOM (10)	USAIS (30)	USAERDAW (13)
USARYIS (5)	USASTC (2)	USACRREL (2)
USAREUR (10)	USATC Armor (2)	Edgewood Arsenal (5)
LOGCOMD (2)	USATC Engr (2)	USARSG (5)
USAMICOM (4)	USATC Inf (2)	
USASTRATCOM (4)	USATC FA (5)	
USASTRATCOM-	USAATC (5)	
EUROPE (5)	WRAMC (1)	

NG: None.

USAR: None.

For explanation of abbreviations used, see AR 320-50.

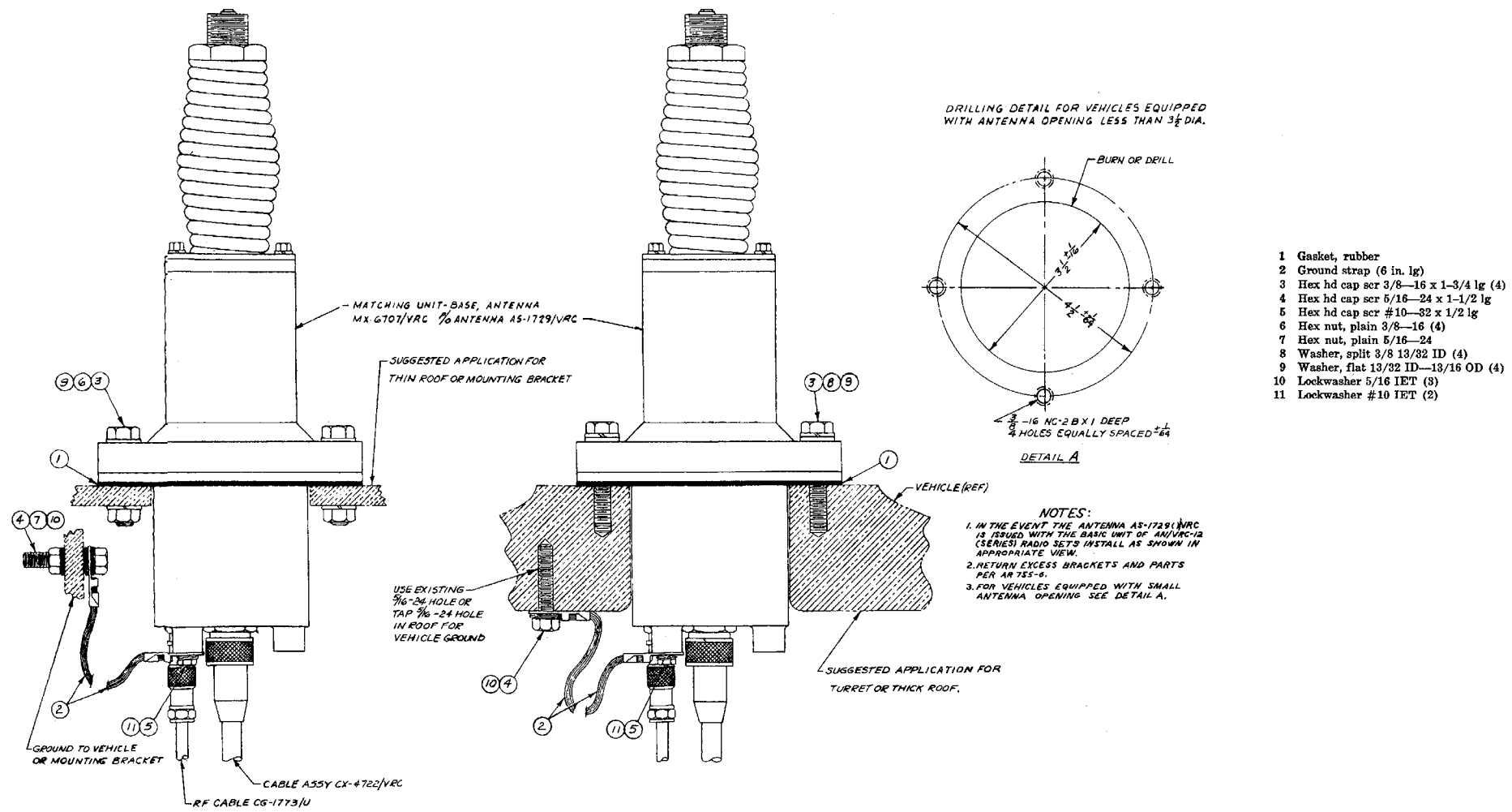

Figure 2-4. Drilling detail for Antenna AS-1729(../VRG).

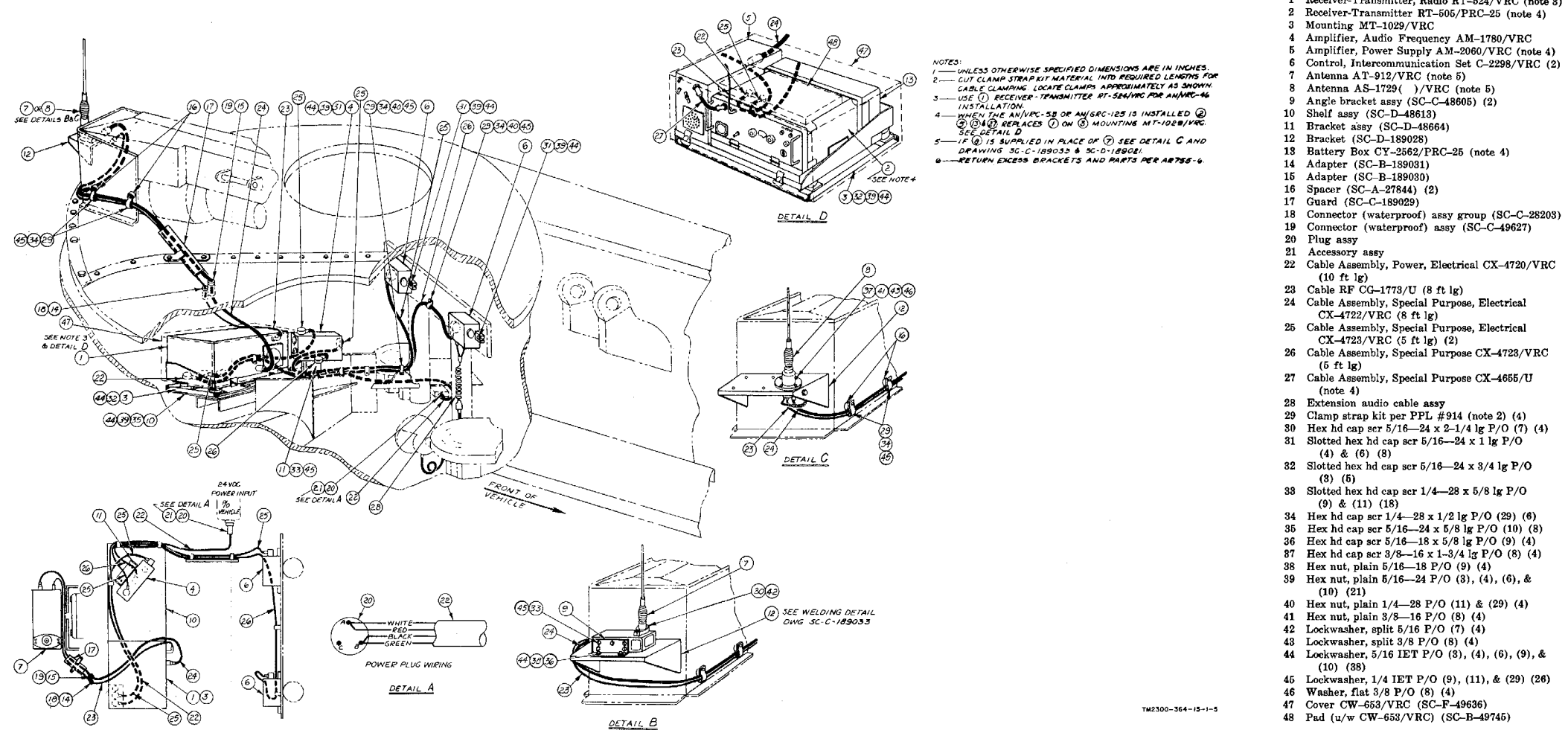

Figure 2-5. Installation of Radio Set AN/VRC-46, AN/VRC-53, or AN/GRC-125, and Intercommunication Set AN/VIC-1(V) in Armored Vehicle Launcher Bridge (M48A2 Hull).

RECOMMENDED CHANGES TO EQUIPMENT TECHNICAL PUBLICATIONS



THEN... JOT DOWN THE DOPE ABOUT IT ON THIS FORM, CAREFULLY TEAR IT OUT, FOLD IT AND DROP IT IN THE MAIL!

SOMETHING WRONG WITH THIS PUBLICATION?

FROM: (PRINT YOUR UNIT'S COMPLETE ADDRESS)

DATE SENT

PUBLICATION NUMBER

PUBLICATION DATE

PUBLICATION TITLE

BE EXACT... PIN-POINT WHERE IT IS

PAGE NO.

PARA-GRAPH

FIGURE NO.

TABLE NO.

IN THIS SPACE TELL WHAT IS WRONG AND WHAT SHOULD BE DONE ABOUT IT:

TEAR ALONG PERFORATED LINE

PRINTED NAME, GRADE OR TITLE, AND TELEPHONE NUMBER

SIGN HERE:

DA FORM 2028-2
1 JUL 78

PREVIOUS EDITIONS ARE OBSOLETE.

P.S.—IF YOUR OUTFIT WANTS TO KNOW ABOUT YOUR RECOMMENDATION MAKE A CARBON COPY OF THIS AND GIVE IT TO YOUR HEADQUARTERS.

PIN: 016045-000

This fine document...

Was brought to you by me:



[Liberated Manuals -- free army and government manuals](#)

Why do I do it? I am tired of sleazy CD-ROM sellers, who take publicly available information, slap “watermarks” and other junk on it, and sell it. Those masters of search engine manipulation make sure that their sites that sell free information, come up first in search engines. They did not create it... They did not even scan it... Why should they get your money? Why are not letting you give those free manuals to your friends?

I am setting this document FREE. This document was made by the US Government and is NOT protected by Copyright. Feel free to share, republish, sell and so on.

I am not asking you for donations, fees or handouts. If you can, please provide a link to liberatedmanuals.com, so that free manuals come up first in search engines:

<A HREF=<http://www.liberatedmanuals.com/>>Free Military and Government Manuals

- Sincerely
Igor Chudov
<http://igor.chudov.com/>
- [Chicago Machinery Movers](#)