

---

**TECHNICAL MANUAL**  
**OPERATOR, UNIT AND DIRECT SUPPORT**  
**MAINTENANCE MANUAL**  
**INCLUDING REPAIR PARTS**  
**AND SPECIAL TOOLS LIST**

**FOR**  
**TENT, KITCHEN,**  
**FLYPROOF, M1948**  
**NSN 8340-00-470-2341**

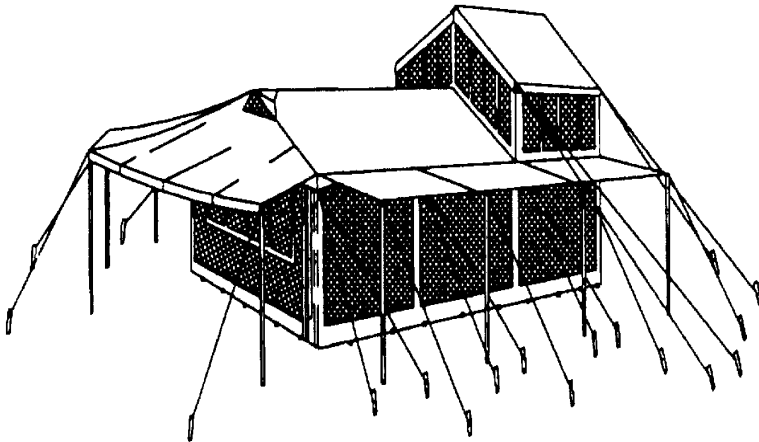

<b>OPERATING INSTRUCTIONS</b>	<b>2-1</b>
-----------------------------------	------------

<b>OPERATOR PREVENTATIVE MAINTENANCE CHECKS AND SERVICES (PMCS)</b>	<b>2-3</b>
---	------------

<b>UNIT MAINTENANCE INSTRUCTIONS</b>	<b>4-1</b>
--	------------

<b>UNIT TROUBLESHOOTING</b>	<b>4-5</b>
---------------------------------	------------

<b>DIRECT SUPPORT MAINTENANCE INSTRUCTIONS</b>	<b>5-1</b>
--	------------

<b>REPAIR PARTS AND SPECIAL TOOLS LIST</b>	<b>C-1</b>
--	------------

**DISTRIBUTION STATEMENT A: Approved for public release; distribution is unlimited.**

**\*This manual supersedes TM 10-8340-205-13 dated 2 August 1972 including all changes, and  
TM 10-8340-205-23P dated 27 August 1970 including all changes.**

---

**HEADQUARTERS, DEPARTMENT OF THE ARMY**  
**3 OCTOBER 1995**



**WARNING**

**DEATH or serious Injury may result if personnel fail to observe the following safety precautions.**

**WARNING**

**FLAMMABLE SUBSTANCES  
AND  
DANGEROUS CHEMICALS**

**CLEANING SOLVENT and COATING COMPOUND are both flammable and toxic. Do not use these materials near an open flame and keep the liquids away from the skin and clothing. Wear a respirator when a spray gun is used, and apply substances only in a well ventilated or open area.**

**If contact on bare skin is made with either of these liquids, wash exposed areas of the skin immediately with warm soapy water and rinse with clear, warm water**

**FIRST AID Instructions are given in FM 21-11, First Aid For Soldiers.**

**a/(b blank)**



TM 10-8340-205-13&P

CHANGE  
NO. 1

HEADQUARTERS  
DEPARTMENT OF THE ARMY  
WASHINGTON, DC, 30 SEPTEMBER 2005

TECHNICAL MANUAL

OPERATOR, UNIT AND DIRECT SUPPORT MAINTENANCE MANUAL  
INCLUDING REPAIR PARTS AND SPECIAL TOOLS LIST

FOR  
TENT, KITCHEN, FLYPROOF, M1948

(NSN: 8340-00-470-2341)

**DISTRIBUTION STATEMENT A:** Approved for public release; distribution is unlimited.

TM 10-8340-205-13&P, dated 3 October 1995, is changed as follows:

1. File this sheet in front of the manual for reference.
2. This change implements Army Maintenance Transformation and changes the Maintenance Allocation Chart (MAC) to support Field and Sustainment Maintenance.
3. New or updated text is indicated by a vertical bar in the outer margin of the page.
4. Added illustrations are indicated by a vertical bar adjacent to the figure number. Changed illustrations are indicated by a miniature hand adjacent to the updated area and a vertical bar adjacent to the figure number.
5. Remove old pages and insert new pages as indicated below:

**Remove Pages**

B-1 – B5/(B6 blank)

2028

**Insert Pages**

A/(B blank)

B-1 – B-6

Electronic 2028 Instructions/blank

Sample 2028 - Front/Back

2028 Front/Back

2028 Front/Back

2028 Front/Back

TM 10-8340-205-13&P  
C1

By Order of the Secretary of the Army:

PETER J. SCHOOMAKER  
General, United States Army  
*Chief of Staff*

Official:

  
SANDRA R. RILEY  
*Administrative Assistant to the  
Secretary of the Army*  
0525008

Distribution: To be distributed in accordance with initial distribution number (IDN) 251762 requirements for TM 10-8340-205-13&P.

INSERT LATEST CHANGED PAGES. DESTROY SUPERSEDED PAGES.

**LIST OF EFFECTIVE PAGES**

NOTE: The portion of text affected by the change is indicated by a vertical line in the outer margins of the page. Changes to illustrations are indicated by shaded or screened areas, or by miniature pointing hands. Zero in the "Change No." column indicates an original page.

Dates of issue for original and changed pages are:

Original .. 0 .. 3 October 1995

Change .. 1 .. 30 September 2005

**TOTAL NUMBER OF PAGES IN THIS PUBLICATION IS 132, CONSISTING OF THE FOLLOWING:**

Page No.	Change No.	Page No.	Change No.
Cover	0		
a/(b blank)	0		
i - iv	0		
1-0 - 1-4	0		
2-1 - 2-22	0		
3-1 - 3-4	0		
4-1 - 4-17/(4-18 blank)	0		
5-1 - 5-5(5-6 blank)	0		
A-1/(A-2 blank)	0		
B-1 - B-6	1		
C-1 - C-28	0		
D-1 - D-6	0		
E-1/(E-2 blank)	0		
F-1 - F-2	0		
G-1 - G-2	0		
Index-1 - Index-4	0		
Back Cover	0		





TECHNICAL MANUAL  
NO. 10-8340-205-13&P

HEADQUARTERS  
DEPARTMENT OF THE ARMY  
WASHINGTON, D.C., 3 OCTOBER 1995

TECHNICAL MANUAL  
OPERATOR, UNIT AND DIRECT SUPPORT  
MAINTENANCE MANUAL  
INCLUDING REPAIR PARTS  
AND SPECIAL TOOLS LIST

FOR

TENT, KITCHEN,  
FLYPROOF, M1948  
NSN 8340-00-470-2341

**REPORTING ERRORS AND RECOMMENDING IMPROVEMENTS**

You can help improve this manual If you find any mistakes or if you know of a way to improve these procedures, please let us know. Mail your letter, DA Form 2028 (Recommended Changes to Publications and Blank Forms) or DA Form 2028-2 located In the back of this manual directly to Commander, US Army Aviation and Troop Command, ATTN- AMSAT-I-MP, 4300 Goodfellow Blvd., St. Louis, MO 63120-1798 You may also submit your recommended changes by E-mail directly to <daf2028@st-louis-emh7.army.mil> A reply will be furnished directly to you.

**DISTRIBUTION STATEMENT A:** Approved for public release; distribution is unlimited.

**TABLE OF CONTENTS**

		<b>Page</b>
<b>CHAPTER 1</b>	<b>INTRODUCTION</b> .....	<b>1-1</b>
Section I.	General Information .....	1-1
Section II.	Equipment Description and Data .....	1-2
Section III.	Principles of Operation.....	1-4
<b>CHAPTER 2</b>	<b>OPERATING INSTRUCTIONS</b> .....	<b>2-1</b>
Section I.	Description and Use of Operator's Controls and Indicators ....	2-1
Section II.	Operator Preventive Maintenance Checks and Services (PMCS)....	2-3
Section III.	Operation Under Usual Conditions .....	2-7
Section IV.	Operation Under Unusual Conditions .....	2-19
<b>CHAPTER 3</b>	<b>OPERATOR MAINTENANCE INSTRUCTIONS</b> .....	<b>3-1</b>
Section I.	Lubrication Instructions .....	3-1
Section II.	Operator Troubleshooting Procedures .....	3-1
Section III.	Operator Maintenance Procedures .....	3-4

\*This manual supersedes TM 10-8340-205-13 dated 2 August 1972 including all changes, and TM 10-8340-205-23P dated 27 August 1970 including all changes.

**TABLE OF CONTENTS (Continued)**

		<b>Page</b>	<b>Figure</b>
<b>CHAPTER 4</b>	<b>UNIT MAINTENANCE INSTRUCTIONS .....</b>	<b>4-1</b>	
Section I.	Repair Parts; Tools; Special Tools; Test, Measurement, and Diagnostic Equipment (TMDE); and Support Equipment.	4-1	
Section II	Service Upon Receipt .....	4-2	
Section III.	Unit Preventive Maintenance Checks and Services (PMCS).	4-3	
Section IV.	Unit Troubleshooting .....	4-5	
Section V.	Unit Maintenance Procedures .....	4-8	
Section VI.	Preparation for Storage and Shipment .....	4-15	
<b>CHAPTER 5</b>	<b>DIRECT SUPPORT MAINTENANCE INSTRUCTIONS .....</b>	<b>5-1</b>	
Section I.	Direct Support Troubleshooting .....	5-1	
Section II.	Direct Support Maintenance Procedures .....	5-2	
<b>APPENDIX A</b>	<b>REFERENCES .....</b>	<b>A-1</b>	
<b>APPENDIX B</b>	<b>MAINTENANCE ALLOCATION CHART .....</b>	<b>B-1</b>	
<b>APPENDIX C</b>	<b>REPAIR PARTS AND SPECIAL TOOLS LIST .....</b>	<b>C-1</b>	
Section I.	Introduction .....	C-1	
Section II.	Repair Parts List .....	C-8	
Group 00	Tent, Kitchen, Flyproof, M1948 .....	C-9	C-1
Group 01	Tent Body		
	Tent Jumper Lines .....	C-11	C-2
	Tent Hardware .....	C-13	C-3
	Tent, Body, Exterior .... ..	C-15	C-4
Group 02	Screen Wall, Tent		
	Screen Wall, Tent .....	C-17	C-5
Group 03	Tent Support and Anchoring		
	Tent Support and Anchoring .....	C-19	C-6
Group 04	Tent Cover		
	Tent Cover .....	C-21	C-7
Group 05	Bulk Items .....	C-22	
Section III.	Special Tools List (Not Applicable) .....	C-23	
Section IV.	Cross-Reference Indexes .....	C-24	
	National Stock Number Index .....	C-24	
	Part Number Index .....	C-25	
	Figure and Item Number Index .....	C-27	

TABLE OF CONTENTS (Continued)

		Page	Figure
APPENDIX D	COMPONENTS OF END ITEM (COEI) AND BASIC ISSUE ITEMS (BII) .....	D-1	
APPENDIX E	ADDITIONAL AUTHORIZATION LIST (AAL).....	E-1	
APPENDIX F	EXPENDABLE AND DURABLE ITEMS LIST .....	F-1	
APPENDIX G	ILLUSTRATED LIST OF MANUFACTURED ITEMS .....	G-1	
ALPHABETICAL INDEX .....		INDEX 1	

## HOW TO USE THIS MANUAL

Be sure to read all WARNINGS before using your equipment.

This manual incorporates a quick reference tab feature that allows you to quickly locate the most often referenced subjects and topics appearing in this manual. The reference tab feature consists of the following components:

### Cover Page Index

Index boxes are located in the right-hand edge of the cover page. Each index contains a subject title, page number, and black index tab.

### Table of Contents

The Table of Contents lists all the major subjects contained in this manual. Subjects that are surrounded by a black box correspond to those that appear on the cover page index.

### Page Numbers and Index Tabs

Each page of this manual is identified with a page number. Pages that contain the subjects identified on the cover page index also contain a black tab on the right edge of the page that aligns with the cover index tab. To use the quick reference tab features, select the title of the subject you are trying to find from the cover page index. You can either turn to the indicated page or bend back the pages and thumb to the page tab that aligns with the cover index tab.

If the cover page is lost or badly worn, page numbers and index tabs can be located by referring to the Table of Contents.



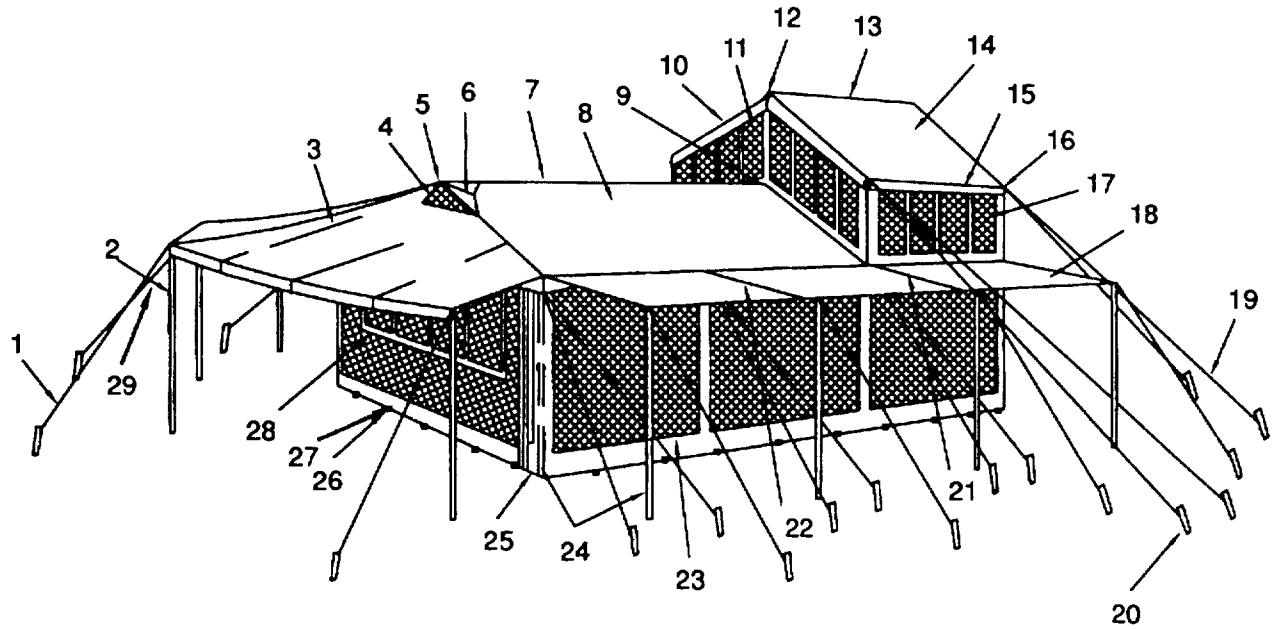

- |   |  |
|---|--|
| 1. Line, tent eave guy line                         | 16. Fairlead, tent line                          |
| 2. Pole, upright; 7-foot (2.135-meters)             | 17. Screen, stack, side                          |
| 3. Wall (awning), front                             | 18. Flap, ventilator, side                       |
| 4. Screen ventilator, front                         | 19. Line, stack guy line                         |
| 5. Pole, upright; 9-foot (2.745-meters)             | 20. Pin, tent; 24-inch (61.000-cm)               |
| 6. Flap, ventilator, front                          | 21. Wall (awning), side                          |
| 7. Pole, ridge; 11-foot, 10-inch (3.590-meters)     | 22. Fastener, slide, side wall                   |
| 8. Section, service                                 | 23. Wall, screen                                 |
| 9. Spindle, ridge pole                              | 24. Poles, upright; 6-foot 2-inch (1.950-meters) |
| 10. Flap, stack, front                              | 25. Fastener, slide, entrance                    |
| 11. Screen, stack front                             | 26. Pin; 16-inch (40.600-cm)                     |
| 12. Pole, upright; 12-foot, 3-inch (3.720-meters)   | 27. Line, footstop, tent screen                  |
| 13. Pole, ridge; 5-foot, 11 1/4-inch (1.830-meters) | 28. Screen, serving window                       |
| 14. Section, stack                                  | 29. Slip, tent line                              |
| 15. Flap, stack, side                               |  |

Figure 1-1. Tent, Kitchen, Flyproof, M1948.

**CHAPTER 1**  
**INTRODUCTION**

		<b>PAGE</b>
Section I	General Information .....	1-1
	1.1 Scope.....	1-1
	1.2 Maintenance Forms, Records and Reports .....	1-1
	1.3 Destruction of Army Materiel to Prevent Enemy Use .....	1-1
	1.4 Preparation for Storage and Shipment.....	1-2
	1.5 Quality Assurance (QA) Procedures .....	1-2
	1.6 Reporting Equipment Improvement Recommendations (EIR).....	1-2
	1.7 Nomenclature Cross-Reference List .....	1-2
	1.8 Corrosion Prevention and Control (CPC).....	1-2
Section II	Equipment Description and Data .....	1-2
	1.9 Equipment Characteristics, Capabilities and Features .....	1-2
	1.10 Location and Description of Major Components.....	1-3
	1.11 Equipment Data .....	1-4
Section III	Principles of Operation.....	1-4
	1.12 General .....	1-4

**SECTION I. GENERAL INFORMATION**

**1.1 SCOPE.**

a. Type of Manual. Operator, Unit and Direct Support Maintenance Manual Including Repair Parts and Special Tools List.

b. Model Number and Equipment Name. M1948 Tent, Kitchen, Flyproof.

c. Purpose of Equipment. The flyproof kitchen tent is a screened shelter designed for cooling and serving food in areas where flies and other insects are numerous.

**1.2 MAINTENANCE FORMS, RECORDS AND REPORTS.**

Department of the Army forms and procedures used for equipment maintenance will be those prescribed by DA Pam 738-750, The Army Maintenance Management System (TAMMS), as contained in the Maintenance Management Update.

**1.3 DESTRUCTION OF ARMY MATERIEL TO PREVENT ENEMY USE**

Destruction of Army equipment to prevent enemy use shall be in accordance with TM 750-244-3.

**1.4 PREPARATION FOR STORAGE AND SHIPMENT.**

Refer to Section VI, Chapter 4, Unit Maintenance Instructions.

**1.5 QUALITY ASSURANCE (QA) PROCEDURES.**

Any critical procedure or parts of procedures in this TM which require quality assurance inspections are identified by "(QA)" written after the applicable step.

**1.6 REPORTING EQUIPMENT IMPROVEMENT RECOMMENDATIONS (EIR).**

If your kitchen tent needs improvement, let us know. Send us an EIR. You, the user, are the only one who can tell us what you don't like about your equipment. Let us know why you don't like the design or performance. Put it on an SF 368 (Product Quality Deficiency Report) Mail it to us at: Commander, U S. Army Aviation and Troop Command, ATTN: AMSAT-I-MDO, 4300 Goodfellow Boulevard, St. Louis, MO 63120-1798. We will send you a reply

**1.7 NOMENCLATURE CROSS-REFERENCE LIST.**

<b>Common Name</b>	<b>Official Nomenclature</b>
Front Section	Service Section

**1.8 CORROSION PREVENTION AND CONTROL (CPC).**

a. Corrosion Prevention and Control (CPC) of Army manual is a continuing concern. It is important that any corrosion problems with this item be reported so that the problem can be corrected and improvements made to prevent the problem In future items.

b. While corrosion is typically associated with rusting of metal products, it can also include deterioration of other materials, such as rubber, plastic or treated canvas. Unusual cracking, softening, swelling or breaking of the materials may be a corrosion problem.

c. If a corrosion problem is identified, it can be reported using Standard Form 368, (Product Quality Deficiency Report). Using key words such as "corrosion," "rust," "deterioration" or "cracking" will ensure that the information is identified as a CPC problem.

d. The form should be submitted to the address specified in DA Pam 738-750.

**SECTION II. EQUIPMENT DESCRIPTION AND DATA.**

**1.9 EQUIPMENT CHARACTERISTICS, CAPABILITIES AND FEATURES.**

a. The M1948 Kitchen Tent (Figure 1-1) is a screened shelter for cooking and serving food in areas where flies and other insects are numerous. The stack section of the tent rises 3 feet higher than the service section. This allows adequate exhausting of hot air from field ranges through the stack screens. Small ventilator openings have flaps which can be lowered to dose the openings when a blackout condition exists or to keep dust, rain, and snow from inside the tent. A small ventilator screen in the front wall of the service section remains open when the tent is dosed for a blackout to provide a draft for proper ventilation of the interior. Each side wall and the front wall can be guyed out to form awnings. A screen wall, which snaps to the tent body, provides an insect proof enclosure when the walls are raised. The screen wall has a serving window screen in the front of the tent which can be opened and rolled up so that food can be transferred from a serving table to individual servings.



b. The tent body and cover are made of cotton duck material which is coated with a weather, water, and mildew resistant compound. The cover is provided for use when the tent is being transported or in storage (Section VI, Chapter 4). The tent body is supported by 13 upright poles and 2 ridge poles. When the side and front walls are raised to form awnings, 11 additional poles are used. The walls are equipped with 8 slide fasteners, but when the screen wall is installed, the slide fastener near the service window provides the only entrance to the tent.

**1.10 LOCATION AND DESCRIPTION OF MAJOR COMPONENTS.**

Figure 1-2 shows the general feature and major components of the kitchen tent.

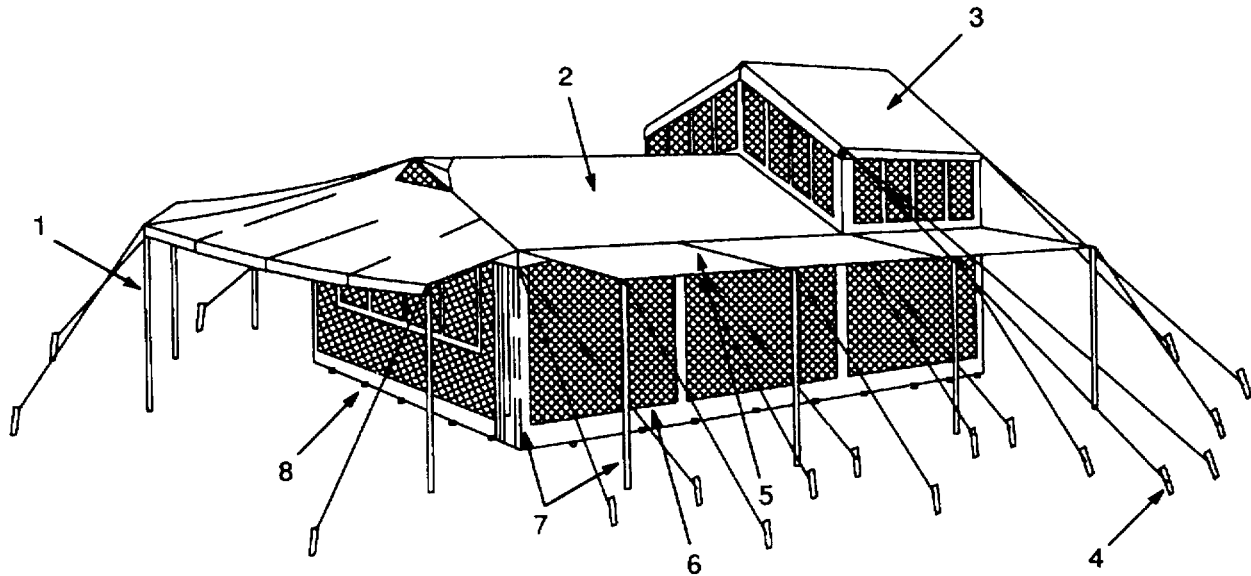

- 1. Pole, upright, 7 ft. lg. (2.135-meters)
- 2. Tent Body, front section
- 3. Tent Body, stack section
- 4. Pin, tent, 24 in (61.000-cm)
- 5. Fastener, slide
- 6. Screen Wall
- 7. Pole, upright, 6 ft 2 in (1.950-meters)
- 8. Pin, tent, 16 in. (40.600-cm)

*Figure 1-2. Exterior View of Tent Major Components.*

**1.11 EQUIPMENT DATA.**

a. Dimensions.

Width .....	12 feet (3.660-meters)
Length .....	18 feet (5.490-meters)
Height:	
Service section ridge .....	9 feet (2.745-meters)
Stack section ridge .....	12 feet, 3 inches (3.800-meters)
Slope of roof .....	57 degrees
Floor space .....	216 square feet (20.080 square meters)

b. Weights.

Tent body and screen wall .....	202.5 pounds (91.935 kg)
Tent poles .....	171.5 pounds (77.861 kg)
Tent pins .....	45.0 pounds (20 430 kg)

c. Cubage.

Tent body and screen (folded) .....	14.2 cubic feet (1.320 cubic meters)
Tent poles .....	9.0 cubic feet (0.837 cubic meters)
Tent pins .....	3.0 cubic feet (0.279 cubic meters)

**SECTION III. PRINCIPLES OF OPERATION.**

**1.12 GENERAL**

The M1948 Kitchen Tent is a screened shelter used for cooking and serving food in areas where flies and other insects are numerous. Ventilation flaps can be opened to allow air to freely circulate within the tent. The walls may also be raised to form awnings for additional ventilation. The tent can be dosed to meet blackout conditions.

**CHAPTER 2**  
**OPERATING INSTRUCTIONS**

		<b>PAGE</b>
Section I	Description and Use of Operator's Controls and Indicators .....	2-1
	2.1 General .....	2-1
	2.2 Operator Controls.....	2-2
Section II	Operator Preventive Maintenance Checks and Services (PMCS).	2-3
	2.3 General .....	2-3
	2.4 PMCS Procedures.....	2-4
	2.5 Cleaning Agents .....	2-4
	2.6 Leakage Definitions for Operator PMCS.....	2-5
Section III	Operation Under Usual Conditions.....	2-7
	2.7 Assembly and Preparation for Use .....	2-7
	2.8 Operating Procedures.....	2-16
	2.9 Preparation for Movement.....	2-17
Section IV	Operation Under Unusual Conditions.....	2-20
	2.10 Unusual Environment/Weather.....	2-20

**SECTION I. DESCRIPTION AND USE OF OPERATOR'S CONTROLS AND INDICATORS**

**2.1 GENERAL**

- a. The Instructions in this section are for the information and guidance of personnel responsible for the operation of the kitchen tent.
- b. The operator must know how to perform every operation of which the tent is capable. This section contains information on controls, or controllable tent components needed to operate the tent. These include stack screens, ventilator flaps, ventilator screen, awnings, screen wall, serving window screen, and slide fasteners.
- c. There are no indicators associated with this equipment.

**2.2 OPERATOR CONTROLS.** Figure 2-1 below provides the description and use of operator controls associated with the kitchen tent.

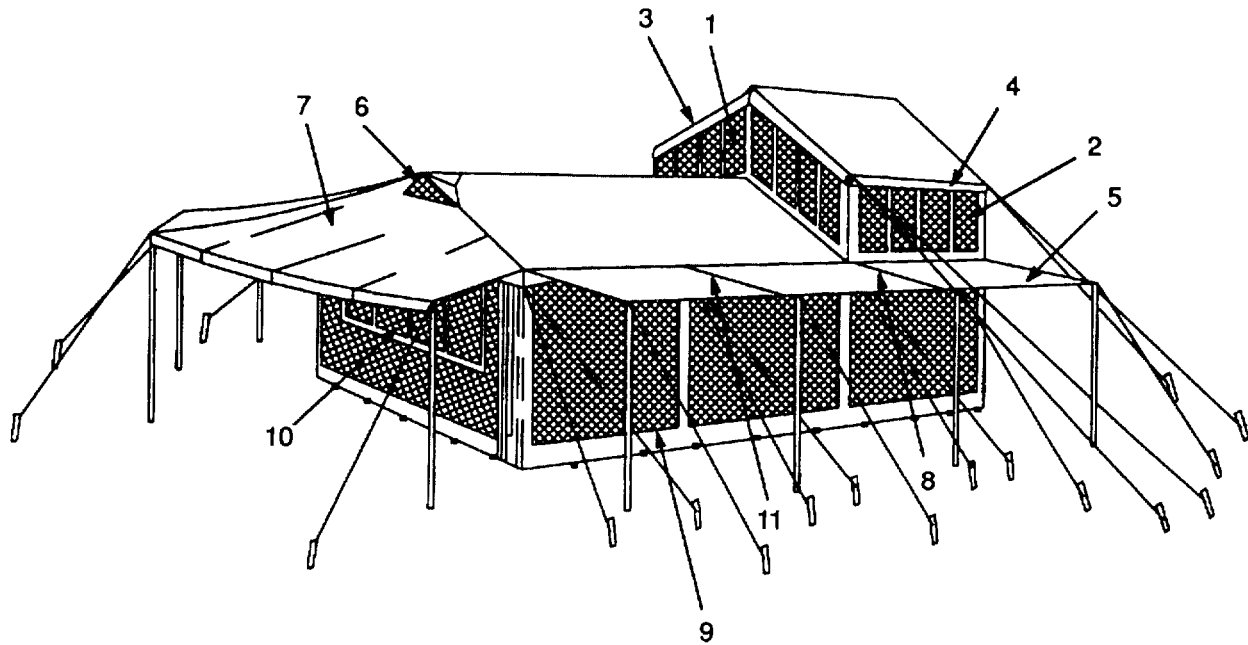

1. Screen, stack, front
2. Screen, stack, side
3. Flap, stack, front
4. Flap, stack side
5. Flap, ventilator, side
6. Screen, ventilator, front
7. Wall, (awning), front
8. Wall, (awning), side
9. Wall, screen
10. Screen, serving window
11. Fastener, slide

*Figure 2-1. Kitchen Tent Operator Controls.*

- a. Stack screens. The rear section of the tent is 3 feet higher than the front section. This allows adequate exhausting of hot air from field ranges, during operation, through the stack screens (1 and 2).
- b. Stack flaps. Small ventilation flaps (3, 4, and 5) are used for ventilation of the tent when in the open position. The flaps may be lowered to close the openings when a blackout condition is being observed or to keep dust, rain, and snow from inside the tent.
- c. Small ventilator screens. Located in the front wall of the service section, the ventilator screen (6), remains open when the tent is closed for a blackout condition to provide a draft for proper ventilation of the interior.
- d. Wall (awnings), front. The front and side walls (7 and 8) can be guyed out to form awnings for additional ventilation during hot weather conditions.
- e. Wall screen. The wall screen (9) snaps to the tent body and provides an insect proof enclosure when the walls are raised to form awnings.
- f. Screen and serving window. The serving window screen (10) can be opened and rolled up so that food can be transferred from a serving table to individual servings.
- g. Slide fasteners. The walls are equipped with eight slide fasteners (11), but when the screen wall is in place, the slide fastener near the service window provides the only entrance to the tent.

## SECTION II. OPERATOR PREVENTIVE MAINTENANCE CHECKS AND SERVICES (PMCS)

**2.3 GENERAL.** Preventive Maintenance Checks and Services (PMCS) means systematic caring, inspecting, and servicing of equipment to keep it in good condition and to prevent breakdowns. As the tent operator, your mission is:

- a. Be sure to perform your PMCS each time you use the tent. Always do your PMCS in the same order, so it gets to be a habit. Once you've had some practice, you'll quickly spot anything wrong.
- b. Do your BEFORE (B) PMCS just before you use the tent. Pay attention to WARNINGS, CAUTIONS, and NOTES.
- c. Do your DURING (D) PMCS while you use the tent. During operation means to check the tent and its related components while it is being used. Pay attention to WARNINGS, CAUTIONS, and NOTES.
- d. Do your AFTER (A) PMCS right after using the tent. Pay attention to WARNINGS, CAUTIONS, and NOTES.
- e. Do your WEEKLY (W) PMCS once a week.
- f. Do your MONTHLY (M) PMCS once a month.
- g. Use DA Form 2404 (Equipment Inspection and Maintenance Worksheet) to record any faults that you discover before, during, or after operation, unless you can fix them. You DO NOT need to record faults that you fix.
- h. Be prepared to assist unit maintenance when they lubricate the tent slide fasteners. Perform any other service when required by unit maintenance.

## 2.4 PMCS PROCEDURES.

- a. Your Preventive Maintenance Checks and Services, Table 2-1, lists inspections and care required to keep your tent in good operating condition. It is set up so you can make your BEFORE (B) OPERATION checks as you walk around the tent.
- b. The "ITEM NO." column is used to record the results of checks/services on DA Form 2404.
- c. The "INTERVAL" column of Table 2-1 tells you when to do a certain check or service.
- d. The "PROCEDURE" column of Table 2-1 tells you how to do required checks and services. Carefully follow these instructions. If you do not have tools, or if the procedure tells you to, notify your supervisor.

### NOTE

Terms "ready/available" and "mission capable" refer to same status: Equipment is on hand and ready to perform its combat missions. (See DA Pam 738-750)

- e. The "NOT FULLY MISSION CAPABLE IF:" column in Table 2-1 tells you when your tent is nonmission capable and why the tent cannot be used.
- f. If the tent does not perform as required, refer to Chapter 3, Section II, Operator Troubleshooting.
- g. If anything looks wrong and you can't fix it, write it on your DA Form 2404 IMMEDIATELY and report it to your supervisor.
- h. When you check for "operating condition," you look at the component to see if its serviceable.

## 2.5 CLEANING AGENTS.

### WARNING

- DO NOT use diesel fuel, gasoline, or benzene (benzol) for cleaning
- DO NOT SMOKE when using cleaning solvent. NEVER USE IT NEAR AN OPEN FLAME. Be sure there is a fire extinguisher nearby and use cleaning solvent only in well ventilated places. Flash point of solvent is 138°F (60°C).
- USE CAUTION when using cleaning solvents. Cleaning solvents evaporate quickly and can irritate exposed skin If solvents contact skin. In cold weather, contact of exposed skin with cleaning solvents can cause frostbite.

### CAUTION

When cleaning tentage, DO NOT use a high pressure water supply system. Damage to tent materials or other components may result.

### NOTE

Only use those authorized cleaning solvents or agents listed in Appendix F.

a. Cleaning the tent.

(1) When using soap and water to clean the tent, always rinse with clean, clear water. Use water pressure and volume similar to a standard household type water system (45-70 psi, 6.5-10.2 kPa).

(2) After cleaning, allow tent to completely air dry. Do not use compressed air to dry your tent.

b. Treating Mildewed Areas. Canvas that has mildewed can be cleaned by scrubbing with a dry, stiff brush. If it is necessary to use soap and water to remove dirt, it should not be used until mildew has been removed. After remove mildew, examine fabric. Look for evidence of deterioration. If canvas has deteriorated, it should be repaired or replaced

**CAUTION**

Keep cleaning solvents, gasoline, and lubricants away from plastic material. They will cause rapid deterioration of the material.

c. Cleaning Rust. When cleaning rusty metal parts, use a cleaning solvent. Then apply a thin coat of lubricating to the affected areas.

**2.6 LEAKAGE DEFINITIONS FOR OPERATOR PMCS.**

a. General. It is necessary for you to know how rain leakage affects the use of your tent. Following are types/classes of leakage an operator needs to know to be able to determine the status of the tent. Learn these leakage definitions and remember - when in doubt, notify your supervisor.

**CAUTION**

- Equipment operation is allowable with minor leakages (Class I or II). Of course, consideration must be given to how much water leakage is allowable and still keep your tent in operation. When in doubt, notify your supervisor.
- When operating with Class I or II leaks, only do so until proper repair can be affected.
- Class III leaks should be immediately reported to your supervisor.

b. Class I. Seepage of fluid (as indicated by wetness or discoloration) not great enough to form drops.

c. Class II. Leakage of fluid great enough to form drops, but not enough to cause drops to drip from area being checked/inspected.

d. Class III. Leakage of fluid great enough to form drops that fall from item being checked/inspected.

Table 2-1. Operator Preventive Maintenance Checks and Services

Item No.	Interval	Location of Item to Check/Service	Procedure	Not Fully Mission Capable if:
1	Before	Tent Body	<p style="text-align: center;"><b>NOTE</b></p> <p>If the equipment must be kept in continuous operation, do only the procedures that can be done without disturbing operation. Make complete checks and services when the equipment is shut down.</p>	
2	Before	Tent, Screen, Wall	<p>Inspect tent body for rips, tears, broken stitching, and damaged or missing hardware</p> <p>Check to be sure that the coating compound is intact on all parts of the tent body. Inspect ventilator screens for rips, tears and excessive grease accumulation</p> <p>Check for broken or missing jumper lines and ventilator hoisting lines.</p>	<p>Large tears or rips in roof portion of tent causing Class III leaks when raining.</p> <p>Coating compound cracked or deteriorated. Large tears, rips and excessive grease.</p> <p>Lines are cut, frayed or excessively worn.</p>
3	Before	Tent, Screen, Wall	<p>Inspect screen mesh for tears and holes. Check for missing or damaged snap fasteners, slide fasteners, footstops, tie tapes, and grommets.</p>	<p>Screen mesh ripped or torn. Snap fasteners damaged or missing. Slide fasteners binds, does not open, close or is torn away from fabric. Footstops missing or damaged. Tie tapes ripped or torn away from fabric. Grommets are missing or torn away from material causing fabric to tear.</p>
4	Before	Tent Support and Anchoring	<p>Inspect tent ridge poles, sectionalized upright poles, and remaining poles for cracks and breaks that would weaken the poles.</p> <p>Check for bent or loose spindles on pole ends.</p> <p>Check for corrosion or rust on metal parts of poles.</p>	<p>Broken ridge or sectionalized upright poles.</p> <p>Bent, broken or loose spindles.</p> <p>Excessive corrosion or rust.</p>
4	Before	Tent Cover	<p>Inspect cover for tears, broken stitches, damaged grommets, frayed or broken lines.</p> <p>Inspect for deterioration of the coating compound.</p>	<p>Large tears or rips, missing stitches, grommets are missing or torn away from material causing fabric to tear. Lines are cut, frayed or excessively worn</p> <p>Coating compound is cracked or deteriorated.</p>



**Table 2-1. Operator Preventive Maintenance Checks and Services - continued**

<b>Item No.</b>	<b>Interval</b>	<b>Location of Item to Check/Service</b>	<b>Procedure</b>	<b>Not Fully Mission Capable if:</b>
5	Weekly	Slide Fastener	Service slide fasteners by applying a stick lubricant (Item 7, Appendix F).	
6	Monthly	Tent Fabric	Service tent fabric by removing accumulated dirt, oil, and grease. Use a mild solution of soap (Item 3, Appendix F) and warm water.  Rinse thoroughly with clear, cold, water.	

### SECTION III. OPERATION UNDER USUAL CONDITIONS

#### 2.7 ASSEMBLY AND PREPARATION FOR USE.

##### a. Site Selection.

(1) The ground should be level and free from projecting roots and rocks. When such a spot is not available, a place can often be leveled and cleared. In woods, loose soil and rocks can be used to level the ground.

#### NOTE

Drainage can be improved by trenching around the tent and digging an outlet ditch to divert water in the desired direction. Refer to paragraph 2.10c.

(2) The ground should be high enough for good drainage. See paragraph 2.10c(a) for additional information.

(3) The site should be protected from wind as much as possible.

(4) Selecting an area with a ground cover of tough top grass is desirable.

#### NOTE

Do not select a site near dead grass and/or pine needles. These materials present a fire hazard.

(5) During hot weather, when possible, select a site that will provide ample shade.

(6) The tent should be placed far enough from rivers and lakes so that it will be above the high water mark.

(7) Locate tent away from dead trees or trees with large dead branches.

(8) In mountainous terrain, do not place tent in canyons or next to dry creek beds. Such areas can quickly flood with rushing torrents of water in a very short time.

(9) Avoid locating tent at the base of a cliff or steep mountainside. There may be danger from avalanches or falling rocks.

b. Pitching the Tent.

(1) Remove the tent body and screen wall from the tent cover. Remove the poles and pins from their containers. Be sure that all items are present and in serviceable condition. See Appendix D for complete listing of components.

(2) Select site for tent and follow instructions in paragraph 2.7a above.

**NOTE**

The tent can be pitched by five soldiers in approximately 60 minutes. When conditions permit, the tent should be pitched away from natural elevations or tall equipment that might obstruct a draft through the tent stack.

(3) Spread tent out according to ground plan (Figure 2-2) with four 9-foot (2.745-meters) and six 6-foot, 2-inch (1.950-meters) side poles and twenty 24-inch (61.000-cm) pins in proper position (Figure 2-3).

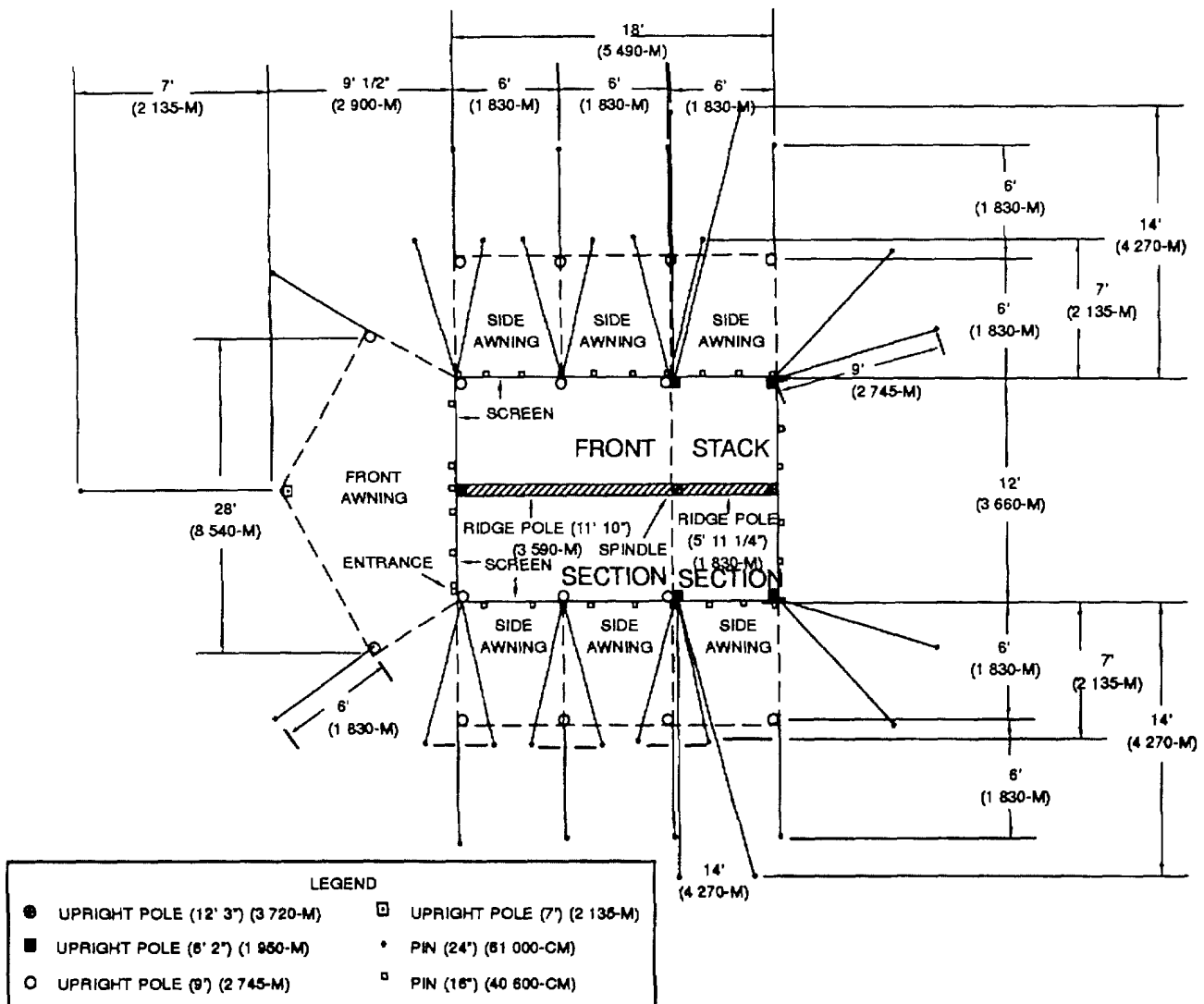

Figure 2-2. Tent Ground Plan

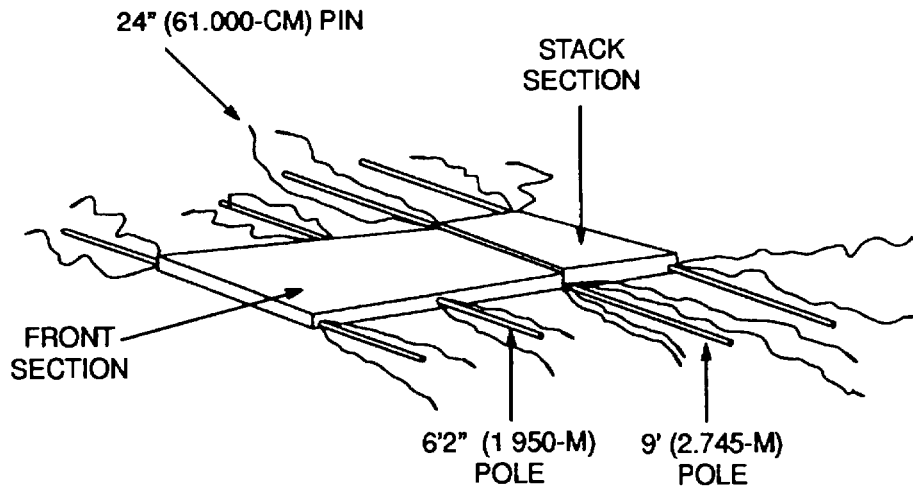

Figure 2-3. Spreading Tent

- (4) Open slide fasteners on tent walls and fold side and front walls over roof area of tent.
- (5) Drive 24-inch (61.000-cm) pins into the ground at locations shown in Figure 2-2.

**NOTE**

The 5-foot, 11 1/4-inch ridge pole for the stack section is over twelve feet from the ground and the 11-foot, 10-inch ridge pole for the service section is nine feet from the ground.

- The service section ridge pole must be connected to the front 12-foot, 3-inch upright pole supporting the stack section ridge pole. Additionally, the jumper line located at the inside top of the tent where the front 12-foot, 3-inch upright joins the 5-foot, 11 1/4-inch ridge pole must be used to secure the junction of the service and stack section ridge poles (See Figure 2-9).
- The front peak of the service section is approximately nine feet from the ground and the screen wall must be attached at this point BEFORE the tent is raised.
- If you do not have access to a ladder or other means to make these connections, perform the following steps. If a ladder is available, proceed to step (13).

- (6) Assemble ridge poles and uprights flat on the ground as shown in Figure 2-4.

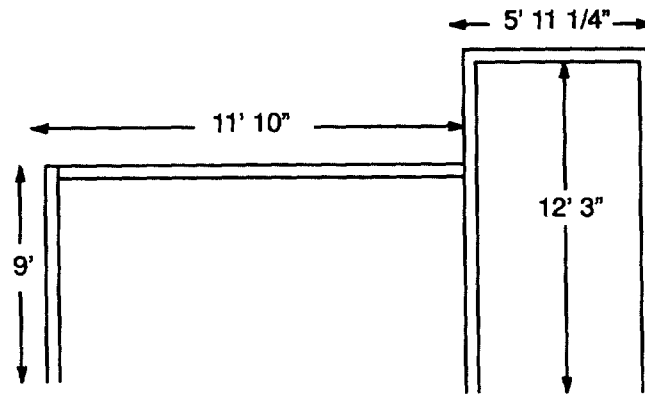

Figure 2-4. Assembled Framework.

(7) As you are facing the spread out tent from the front, fold tent in half to expose the jumper line, inside surfaces of the ridge pole grommets, and the front peak of the service section.

(8) Position assembled ridge and upright pole framework and make connections for screen wall and ridge poles and secure with jumper line as shown in Figure 2-9.

(9) Return tent to original ground plan position.

(10) Position soldiers at each 9-foot upright pole and at each 6-foot, 2-inch pole on side of tent opposite of ridge and upright pole framework.

(11) Insert spindles of two 9-foot upright poles and three 6-foot, 2-inch poles through grommets in eave at side of tent stack and service sections. Raise stack and service section sides and run guy lines from tent to pins in the ground (Figure 2-5).

(12) With one soldier at each upright and two soldiers assisting, raise entire ridge and upright framework until uprights are vertical.

(13) Position a soldier at each 9-foot (2.745-m) upright pole and at each 6-foot, 2-inch (1.950-m) pole on one side of the tent.

(14) Insert spindles of two 9-foot (2.745-m) and three 6'2" upright poles through grommets in eave at one side of tent stack and service sections. Raise stack and service section sides and run guy lines from poles to pins in the ground (Figure 2-5).

**NOTE**

When raising the side, the poles should be pointed slightly toward the inside.

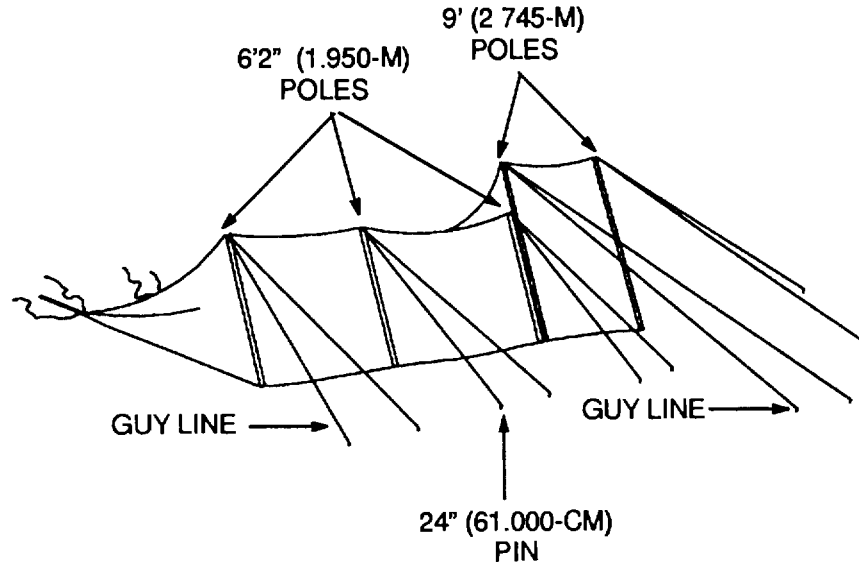

Figure 2-5. Raising Tent Side.

- (15) Raise other side of tent, straighten poles, close slide fasteners, drive thirty-two 16-inch (40.600-cm) pins into ground, and attach footstop lines to pins (Figure 2-6).

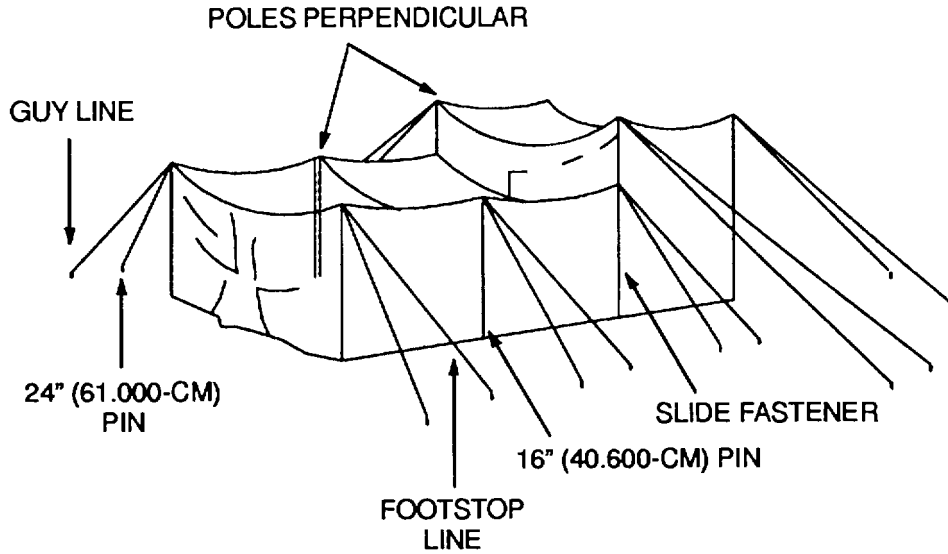

Figure 2-6. Raising Complete Tent

(16) Insert spindles of the two 12-foot, 3-inch (3.720-m) upright center poles into the holes on the 5-foot, 11 1/4-inch (1.830-m) ridge pole. Raise the two upright poles and the ridge pole in the center of the stack section area until the pole spindles extend through the ridge plates and grommets of the stack section. Raise the poles and stack roof until the upright poles are vertical (Figure 2-7).

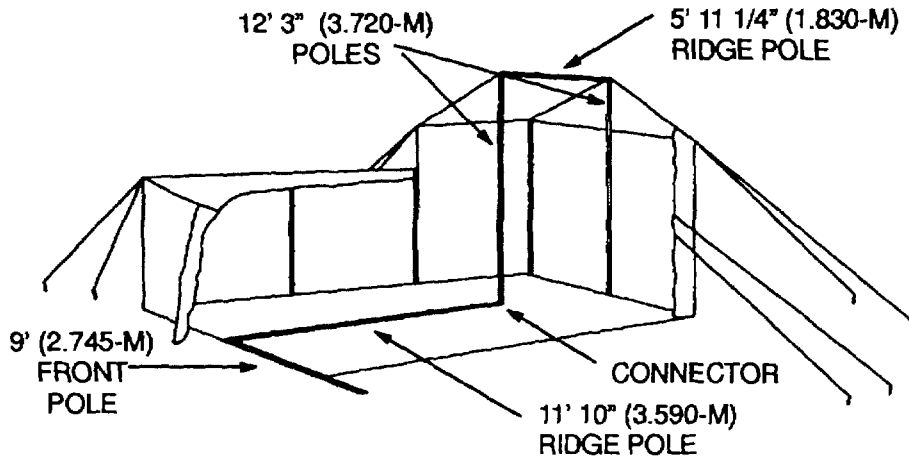

Figure 2-7. Fastening Short Ridge and Upright Poles.

**NOTE**

The 12-foot, 3-inch (3.720-m) upright poles should be at the front and rear center of the stack section, six feet from each side, and vertically straight.

(17) Position one soldier at each end of the long ridge pole. Raise pole to a position where a third soldier can insert the spindle of the 9-foot (2.745-m) front upright pole through the hole in the front end of the ridge pole and into the grommet in the service section ridge of the tent. Set upright pole vertically in place (Figure 2-8).

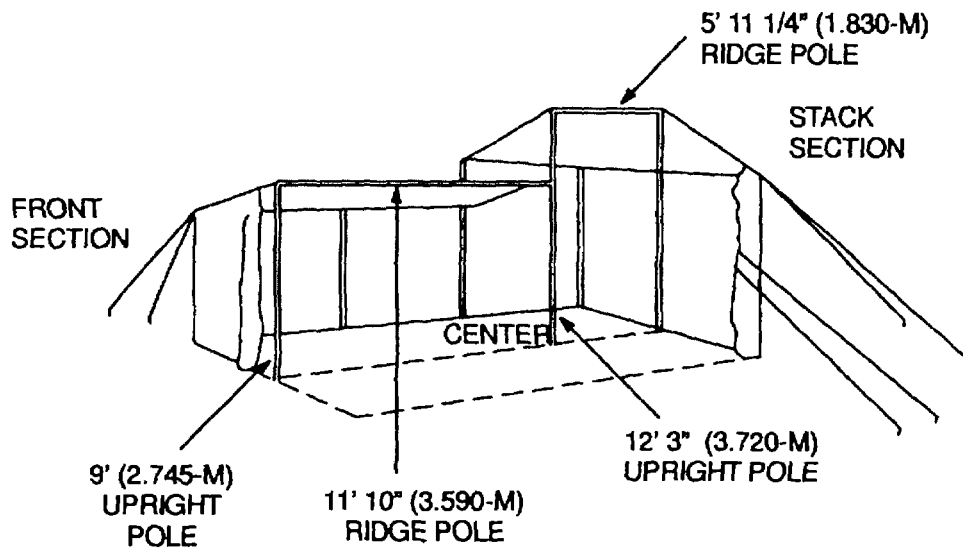

Figure 2-8. Raising Ridge Poles

(18) Fasten connector end of long ridge pole to the 12-foot, 3-inch (3.720-m) upright front center pole (Figure 2-9) about three feet from the top of the stack so that the long ridge pole is level with the ground. This is done by placing the connector of the ridge pole around the upright pole, swinging the swivel plate into position on one side of the upright pole, and tightening the nuts with an 8-inch adjustable wrench (Appendix B, Section III, Item 2).

(19) Attach jumper line at front stack ridge around short ridge pole with a half hitch knot. Secure it to metal loop of connector with a round and two half hitches (Refer to FM 10-16).

(20) Insert spindle of connector through grommet at rear ridge of tent service section (Figure 2-9).

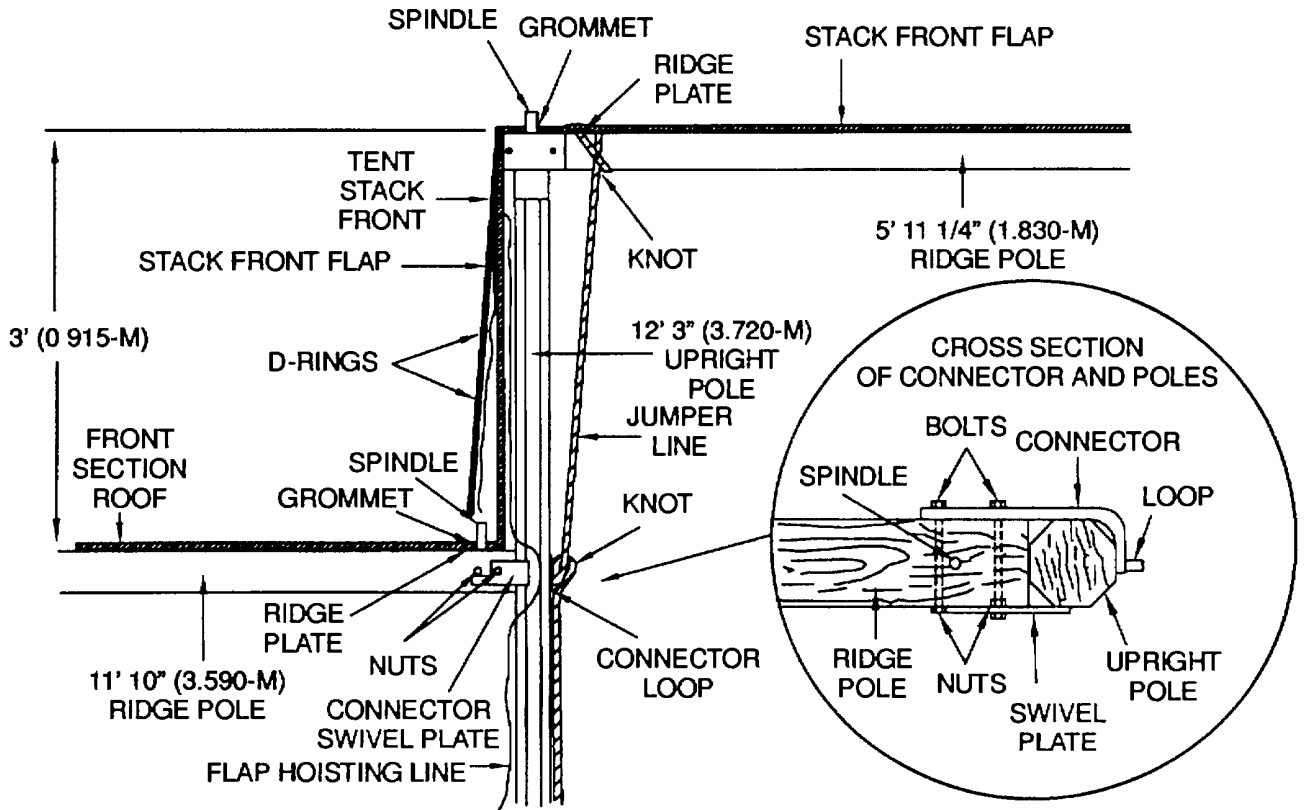

Figure 2-9. Center Ridge Pole Installed In Tent.

(21) Attaching Screen Wall.

- (a) Unfasten slide fasteners at front and rear corners of side walls, detach footsteps and pins.
- (b) Extend side walls outward with eight 6-foot, 2-inch (1.950-m) poles
- (c) Extend front wall with two 6-foot, 2-inch (1.950-m) poles and one 7-foot (2.135-m) pole to form awnings (Figure 2-10).

**NOTE**

If water collects in awnings, move base of each pole toward tent so that awning will slope enough to drain the water.

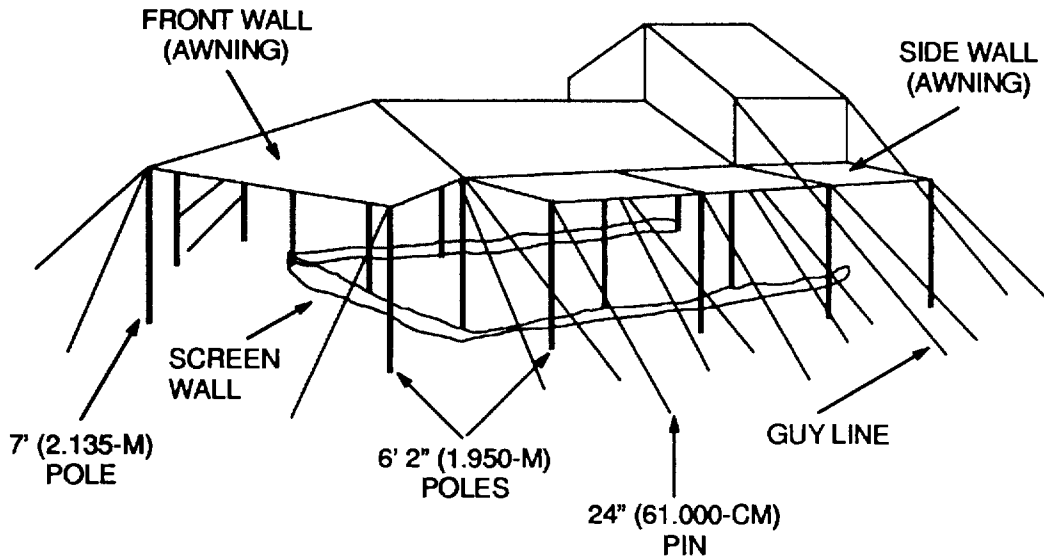

Figure 2-10. Extending Tent Walls to Form Awnings.

- (d) Drive pins and attach guy lines as shown in Figures 2-2 and 2-10.

**NOTE**

The slide fasteners on the side wall awnings at the front end of the stack section can be unfastened, and the long guy lines from the 9-foot (2.745-m) front side stack poles can go through the openings

- (e) Lay the rolled screen wall in front of the two 9-foot (2.745-m) poles at the front of the service section.
- (f) Unroll the screen wall around the tent as shown in Figure 2-10.

**NOTE**

Be sure that the peak of the screen wall is located at the center of the tent.

- (g) Attach screen wall to snap fasteners located along the tent eave line (Figure 2-11).



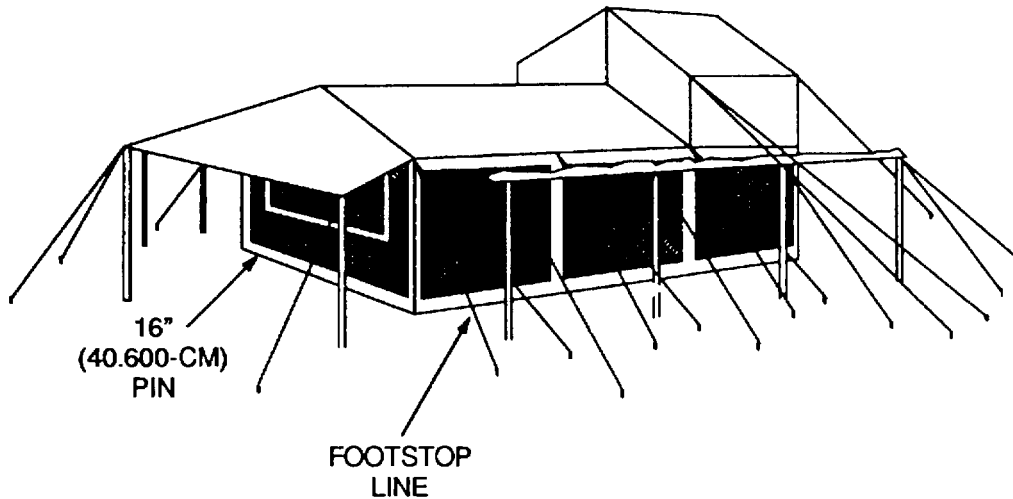

Figure 2-11. Attaching Screen Wall.

(h) Remove spindles of eave line poles from eave line grommets. Insert the spindles into screen tabs and then replace spindles in grommets.

**NOTE**

The peak of the screen wall is approximately 9-feet high and a ladder or other means must be used to perform the next step (see paragraphs (6) thru (12)).

(i) Tie the front peak of screen wall to the ridge pole with screen wall tie line.

(j) Drive thirty-two 16-inch (40.600-cm) tent pins through footstops at bottom of screen wall.

(22) Tying jumper lines, adjusting hoisting lines, and ventilator screen flaps (Figures 2-9 and 2-12).

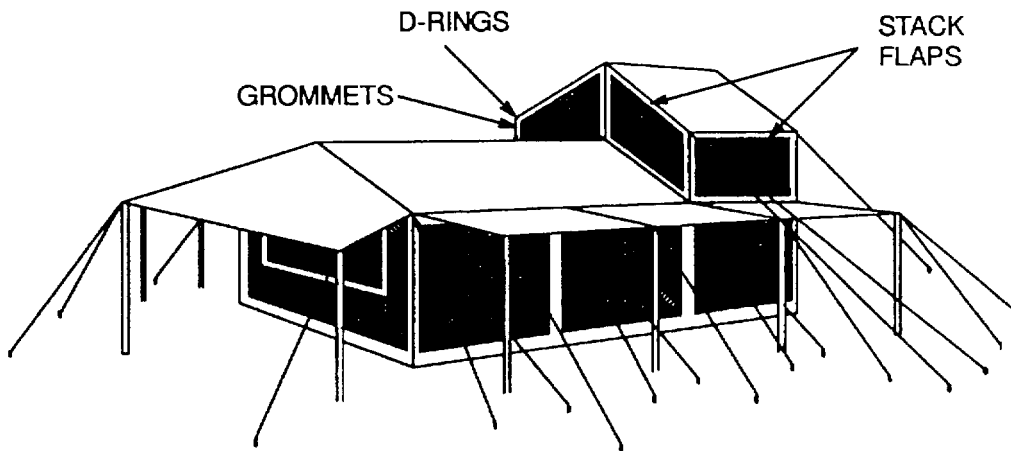

Figure 2-12. Tying Jumper Lines and Adjusting Hoisting Lines

- (a) Tie all jumper lines to eave line poles.

**NOTE**

Hoisting lines are located on each stack upright pole inside the tent.

- (b) Adjust hoisting lines which go through D-rings on stack ventilator flaps and grommets on screen panel. Raise flaps and be hoisting lines around stack upright poles (Figure 2-12).

- (23) Perform your BEFORE preventive maintenance checks and services (PMCS) (Table 2-1).

**2.8 OPERATING PROCEDURES.**

a. Preparing Tent For Blackout Conditions.

- (1) Remove the 11 poles that support the awnings and loop the footstops over the pins that hold the screen wall to the ground (Figure 2-13)

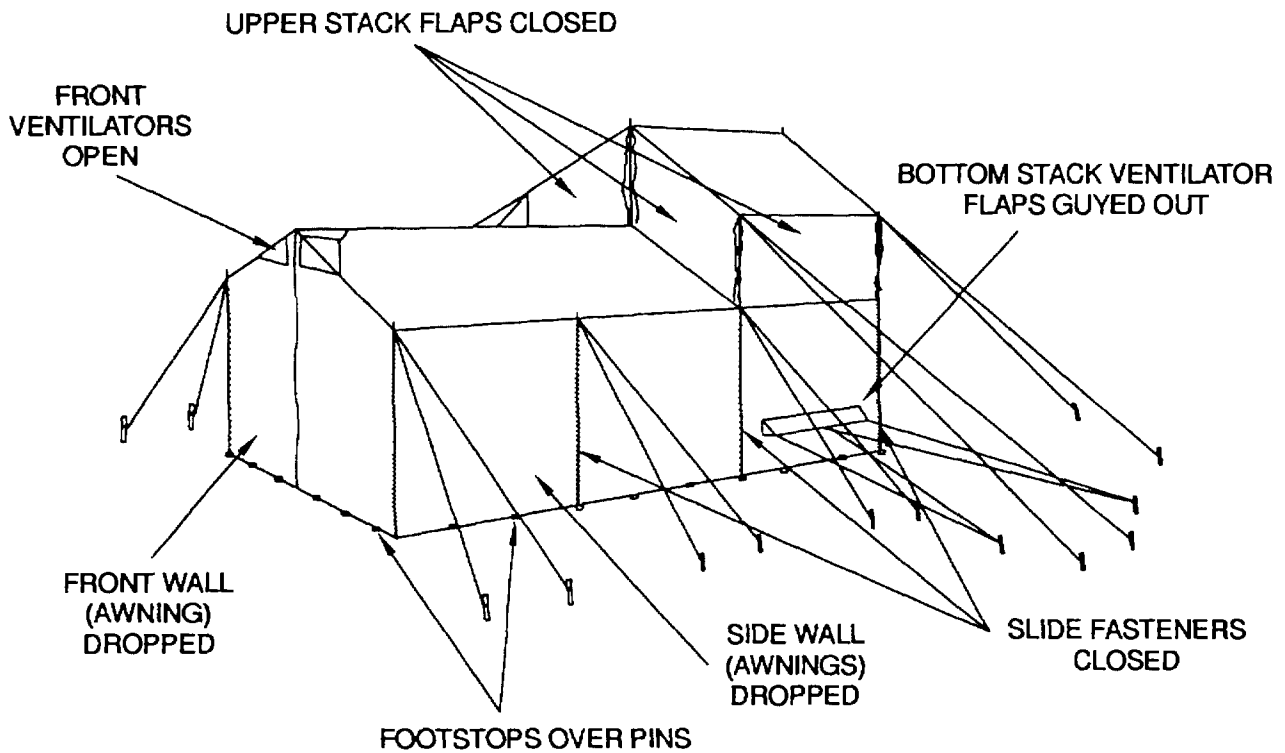

Figure 2-13. Tent in Blackout Condition.

- (2) Close all slide fasteners.
- (3) Close the stack section flaps.
- (4) Check that ventilators on the front wall of the service section are open.
- (5) Use tent lines to hold bottom stack ventilator flaps open.

**b. Preparing Tent for Cooking and Serving Food****NOTE**

During favorable weather conditions, the side and front walls may be raised to form awnings as described in paragraph 2.7.b(21).

- (1) To assure maximum ventilation through the stack section, raise the upper end lower ventilator flaps with the hoisting lines at each pole in the stack section.
- (2) When the walls are raised, make certain the serving window in the screen wall is kept closed until food is served to keep the tent free of insects.
- (3) When food is ready to be served, open the slide fasteners on the serving window. Roll up the screen serving window and then tie the rolled window open with the tie tapes located at the top of the window. Drop the window and dose the slide fasteners when the serving line is dosed.
- (4) During inclement weather, the side awnings may be dropped as described in paragraph 2.8.a above. To prevent the entrance of water into the tent during this condition, close the stack and front ventilators.

**2.9 PREPARATION FOR MOVEMENT.****a. Striking the Tent.**

- (1) Perform your WEEKLY and MONTHLY preventive maintenance checks and services (PMCS) (Table 2-1).

**WARNING**

Before allowing the tent to collapse during striking of the tent, be sure that all personnel are clear from the inside and outside of the tent. Serious personal injury could result.

- (2) Remove jumper lines and hoisting lines (Figure 2-9).
  - (a) Untie hoisting lines from around stack upright poles and dose ventilator flaps.
  - (b) Untie hoisting lines from D-rings on stack ventilator flaps and grommets on screen panel.
  - (c) Untie jumper lines from eave line poles
- (3) Removing screen wall (Figures 2-10 and 2-11).
  - (a) Remove thirty-two 16-inch (40.600-cm) tent pins from footstops at bottom of screen wall
  - (b) Untie screen wall tie lines from ridge pole, and remove front peak of screen wall from ridge pole.
  - (c) Remove spindles from eave line grommets on eave line poles. Remove screen tabs from spindles and replace spindles into eave line grommets.
  - (d) Unsnap screen wall from snap fasteners located along the tent eave lines
  - (e) Roll up screen wall and remove from tent.

- (f) Remove all guy lines and tent pins (Figure 2-2)
- (g) Remove one 7-foot (2.135-m) pole and two 6-foot, 2-inch (1.950-m) poles allowing front wall (awning) to return to its original position.
- (h) Remove eight 6-foot, 2-Inch (1.950-m) poles allowing side walls (awnings) to return to their original position.
- (i) Close slide fasteners.

- (4) Remove connector spindle from grommet at rear ridge in tent service section.
- (5) Remove jumper line from metal loop of connector and then remove jumper line from around short ridge pole and detach from front stack ridge.
- (6) Loosen nuts on long nudge pole connector and swing swivel plate out of way. Unfasten connector end of long ridge pole from upright pole (Figure 2-9).
- (7) Remove and disassemble 9-foot (2.745-m) front upright pole and 11'10" ridge pole from the front section of the tent (Figure 2-8).
- (8) Remove and disassemble the two 12-foot, 3-inch (3.720-m) upright center poles and the 5-foot, 11 1/4-inch (1.830-m) nudge pole from the stack section of the tent (Figure 2-8).
- (9) Remove footstop lines from pins and remove pins. Open slide fasteners (Figure 2-6).
- (10) Remove guy lines from pins and remove pins. Then remove spindles of two 9-foot (2.745-m) upright poles from grommets in eave at one side of tent (Figure 2-5).
- (11) Remove thirty-one 24-inch (61.000-cm) pins (Figure 2-2).
- (12) Spread out tent.
- (13) Position side poles and tent pins for easy access (Figure 2-3).

b. Folding and Packing Instructions.

- (1) Screen wall.
  - (a) Spread screen wall on ground as shown in Figure 2-14 and close the entrance and service window slide fasteners.

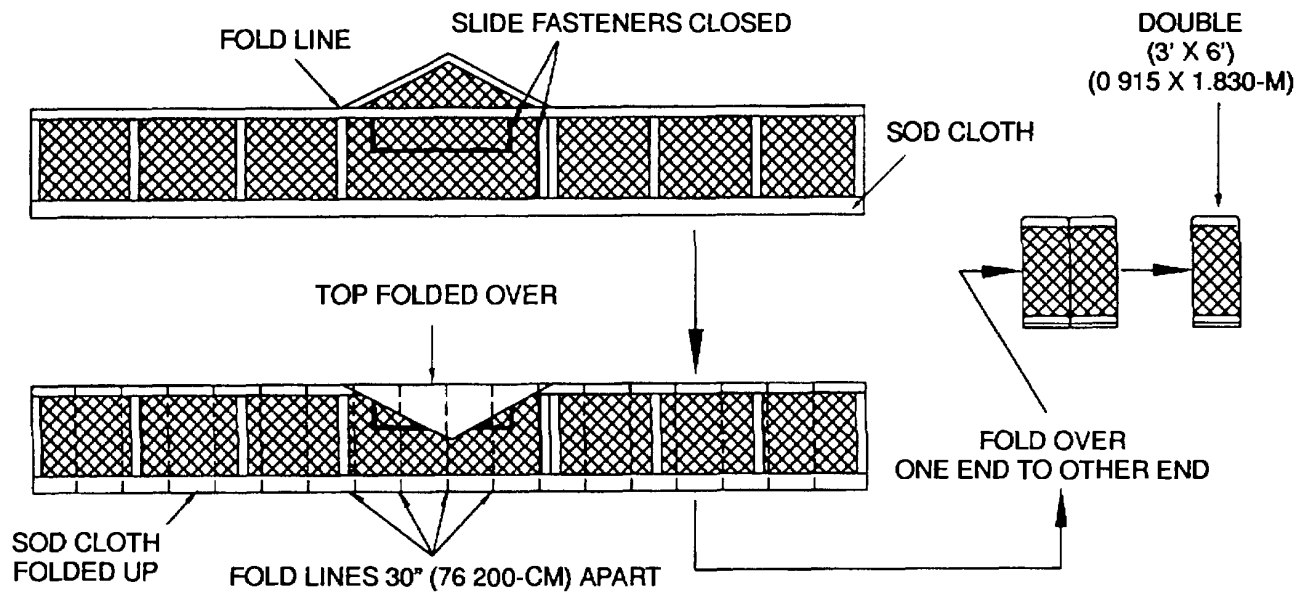

Figure 2-14. Screen Wall Prepared for Folding.

- (b) Fold the sod cloth and triangular portion of the screen over the screen wall.
  - (c) Fold ends of wall toward center with 30-inch (76 200-cm) folds
  - (d) Fold screen on center line to form a 3-by-6-foot (0.915 x 1.830-m) bundle.
- (2) Tent body
- (a) Spread tent flat on ground as shown in Figure 2-15 .

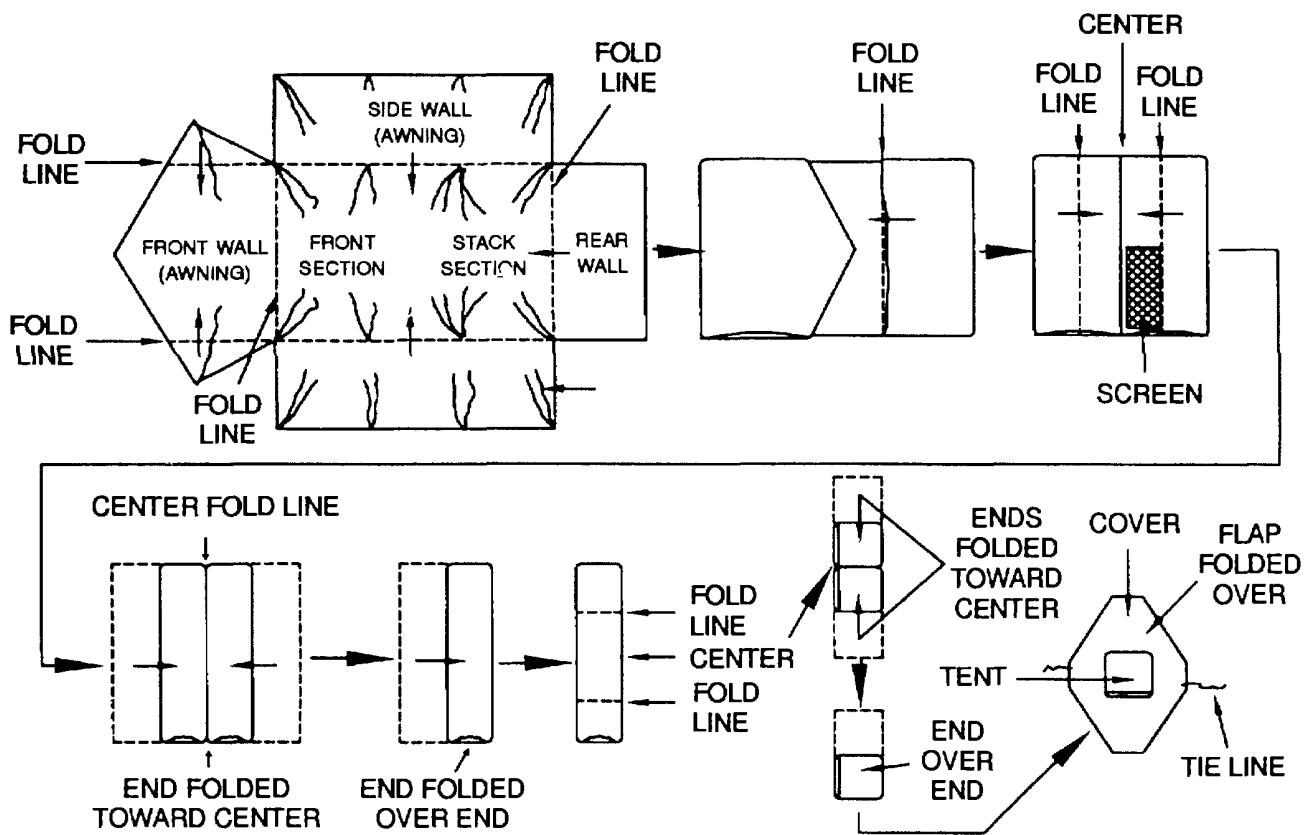

Figure 2-15. Tent Body Prepared for Folding.

- (b) Throw all tent lines toward center of tent.
- (c) Fold side and end walls toward center of tent body.
- (d) Fold the stack and rear walls over roof of service section. The tent body should now form a 12-foot (3.660-m) square.
- (e) Establish a center line and place the folded screen wall on the right side of this line as shown.
- (f) Fold ends of tent so they meet at the center line.
- (g) Fold tent body on center line.
- (h) Establish a center line across the short width of the tent and fold the two ends so the ends will meet on center line
- (i) Fold tent on the center line to form a bundle with a base that is approximately 3-feet (0.915-m) square.
- (j) Place tent body and screen wall on the tent cover.
- (k) Fold the long flaps of the cover over the bundle and then fold the short flaps over the bundle. Close cover by lacing cover tie lines through grommets on the short flaps and tying the lines with two half hitches (FM 10-16). Figure 2-16 shows how your tent should look when packing is finished.

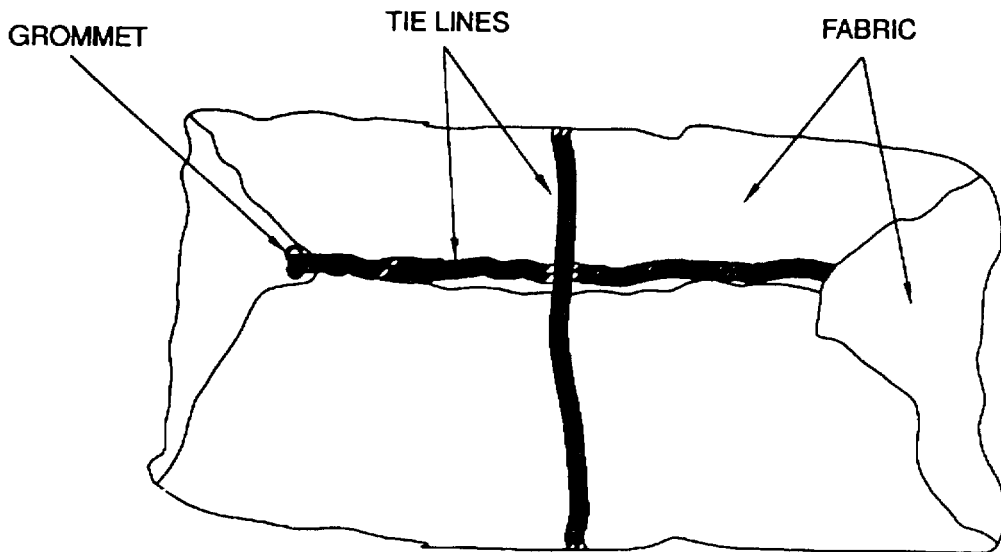

Figure 2-16. Tent Bundled In Tent Cover.

#### SECTION IV. OPERATION UNDER UNUSUAL CONDITIONS

##### 2.10 UNUSUAL ENVIRONMENT/WEATHER.

###### a. Operation in Extreme Heat.

- (1) Ventilate with all available ventilations.
- (2) Raise tent walls to awning position opposite direct rays of the sun. Change to other side after midday. Raise all walls after sundown.

###### b. Operation in Extreme Cold.

- (1) Before selecting a site on snow covered ground, prod surface with a satisfactory tool to see whether or not snow conceals any crevices. It may be impossible to find an area entirely without crevices, but it is possible to avoid accidents by knowing where they are.
- (2) When an adequate site on snow has been found, pack snow hard by stamping on it, or better still, shovel top snow off until firm snow is found below.
- (3) Pitch tent so that entrance is not directly downwind. If the tent is pitched on snow with the entrance directly downwind, the entrance may become blocked, since snow tends to pile up in the lee of any object.
- (4) If site is not temporary, dig tent into snow. This will provide better protection from the wind. In open terrain with a strong wind, it may be necessary to build a snow wall on the windward side of the tent to protect it from the wind; thus the tent is easier to heat and is less likely to blow down. Leave some space between sides tent and snow wall to have room to shovel out snow that may drift into tent.

- (5) When a tent is pitched on a slope, a horizontal platform should be formed. The snow which is removed may be packed around the outer edge of the platform to widen the space for the tent.
- (6) High winds, common in cold regions, requires that tents be anchored securely and that tent pins may not provide sufficient anchorage. Place snow, blocks of snow or ice, stones, logs, or other heavy objects on the cloths to help anchor the tent.

**NOTE**

Use Pin, steel, 12-inches (30.480-cm) long or Pin, steel, 9-inches (22.860-cm) long for hard or frozen ground. (Refer to Appendix E, AAL).

- (7) Do not attempt to drive wooden tent pins into hard, frozen ground if the force required is excessive. Instead, chop small holes into the ground, insert tent pins into holes, and fill holes with slush or water; in a short time the tent pins will be firmly anchored. When removing pins from the frozen ground, always chop them out; never hammer them sideways to break them loose.

c. Operation in Wet Climate.

- (1) The following instructions supplement the instructions contained in paragraph 2.7.

- (a) When possible, erect the tent on a mound which slopes in all directions.
- (b) If the tent is erected on flat terrain composed of heavy soil or clay, dig a trench around the tent To carry water from the trench, dig an outlet ditch from the trench to the lowest point in the area.

**NOTE**

- When the tent is set up on very sandy soil, which quickly absorbs water, or when it is located on a mound which slopes in all directions, a trench may not be necessary.
  - There should be enough slope in the trench so that the water will flow freely toward the outlet and not back up.
- (c) When digging the trench, throw the dirt away from the tent. Never throw it against the tent because it will quickly rot the tent fabric In most cases, do not dig the trench more than 4 or 5 inches (10 or 1 2-cm) deep.
  - (d) When there is a possibility that water may flow to the trench from high ground, dig a ditch that will divert the water before it can reach the tent.
  - (e) Before the tent lines become water soaked, loosen them sufficiently so that when they shrink they will not pull the tent pins from the ground nor tear the tent fabric. However, the lines must remain slightly taut.



**CHAPTER 3**

**OPERATOR MAINTENANCE INSTRUCTIONS**

		<b>PAGE</b>
Section I	Lubrication Instructions.....	3-1
Section II	Operator Troubleshooting Procedures .....	3-1
3.1	Introduction .....	3-1
3.2	Troubleshooting.....	3-1
Section III	Operator's Maintenance Procedures.....	3-4
3.3	General .....	3-4

**SECTION I. LUBRICATION INSTRUCTIONS**

Lubrication is not required.

**SECTION II. OPERATOR TROUBLESHOOTING PROCEDURES**

**3.1 INTRODUCTION.**

a. This table lists common malfunctions that you may find with your equipment. Perform the inspections and corrective actions in the order they appear in the table.

b. This table cannot list all the malfunctions that may occur, all the inspections needed to find the fault, or all of the corrective actions needed to correct the fault. If the equipment malfunction is not listed or actions not listed to correct the fault, notify your supervisor.

**3.2 TROUBLESHOOTING.**

Troubleshooting procedures are provided in Table 3-1. Notify Unit Maintenance for other malfunctions observed.

Table 3-1. Operator Troubleshooting Table

MALFUNCTION 1. Slide Fastener Won't Open, Close, or is Difficult to Operate.

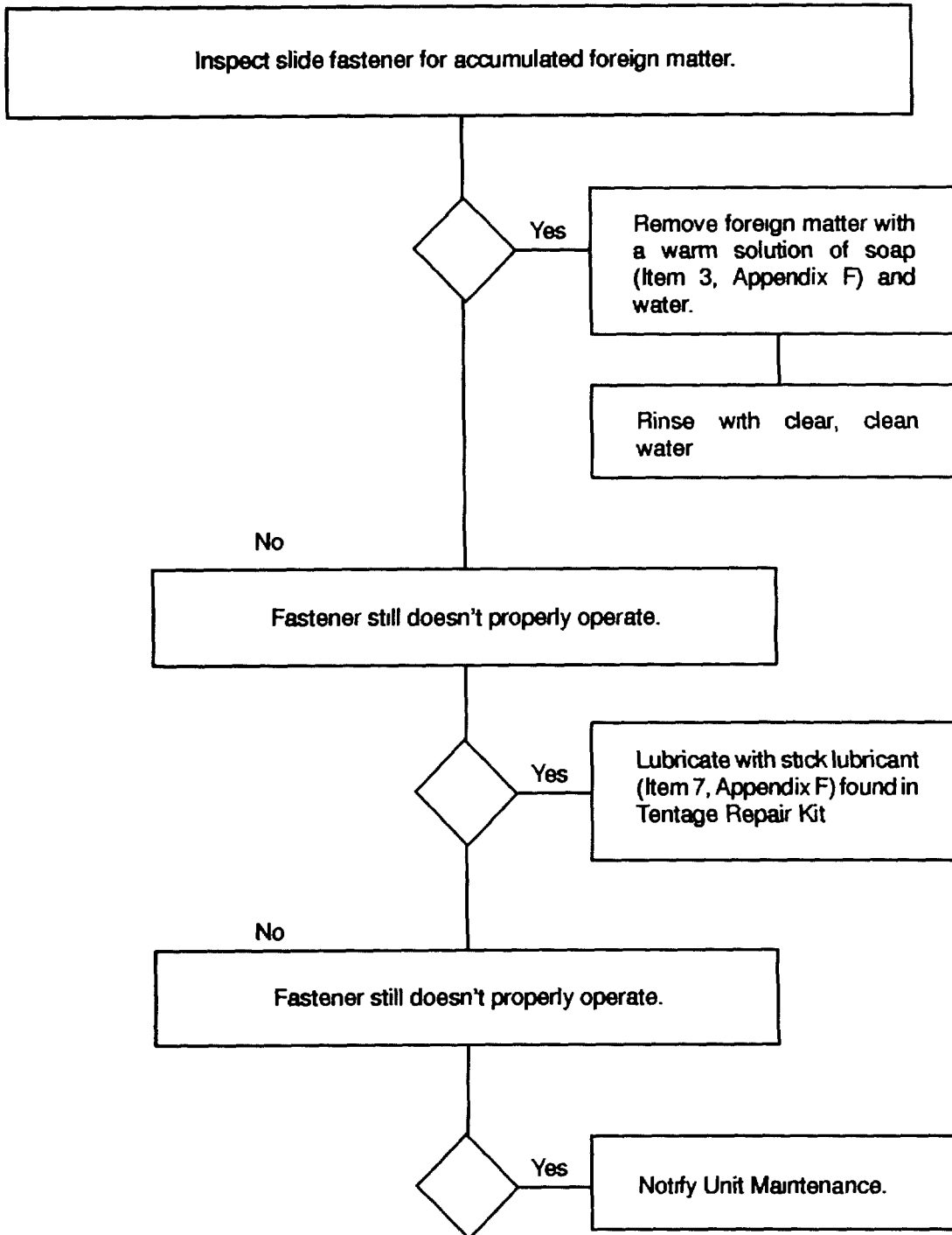
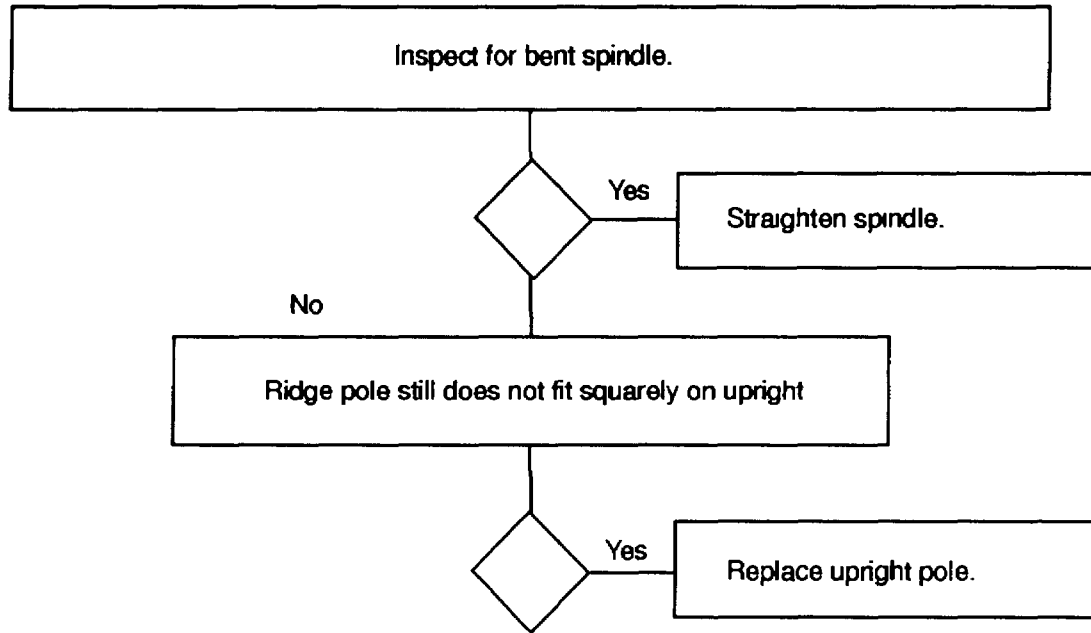

Table 3-1. Operator Troubleshooting Table - continued

**MALFUNCTION 2. Ridge Pole Does Not Fit Squarely On Upright.**



**MALFUNCTION 3. Grommets Ripping Out With Regularity.**

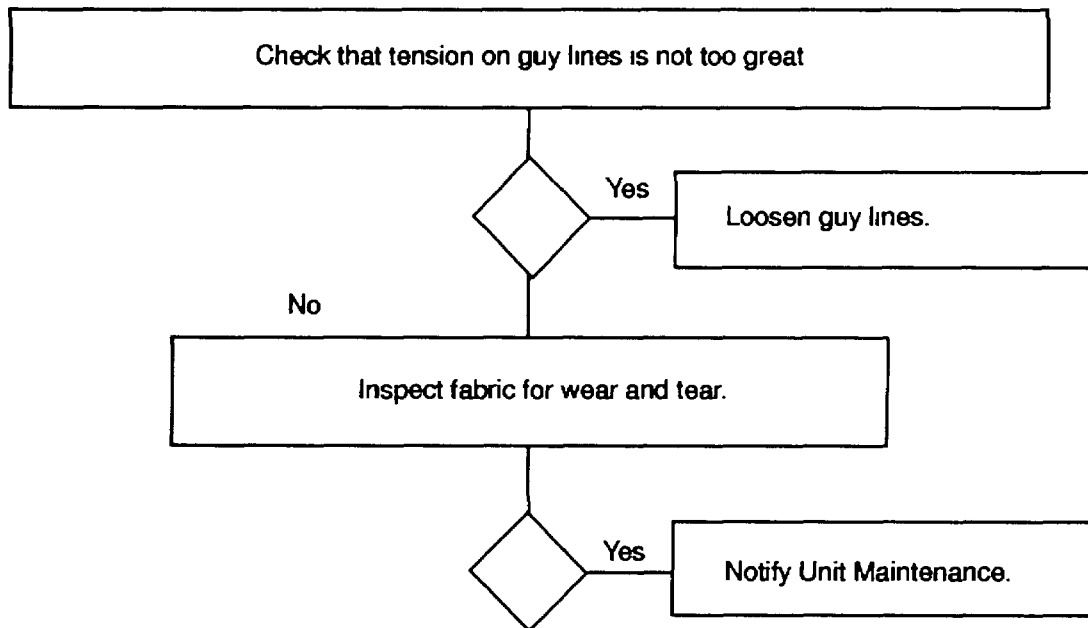
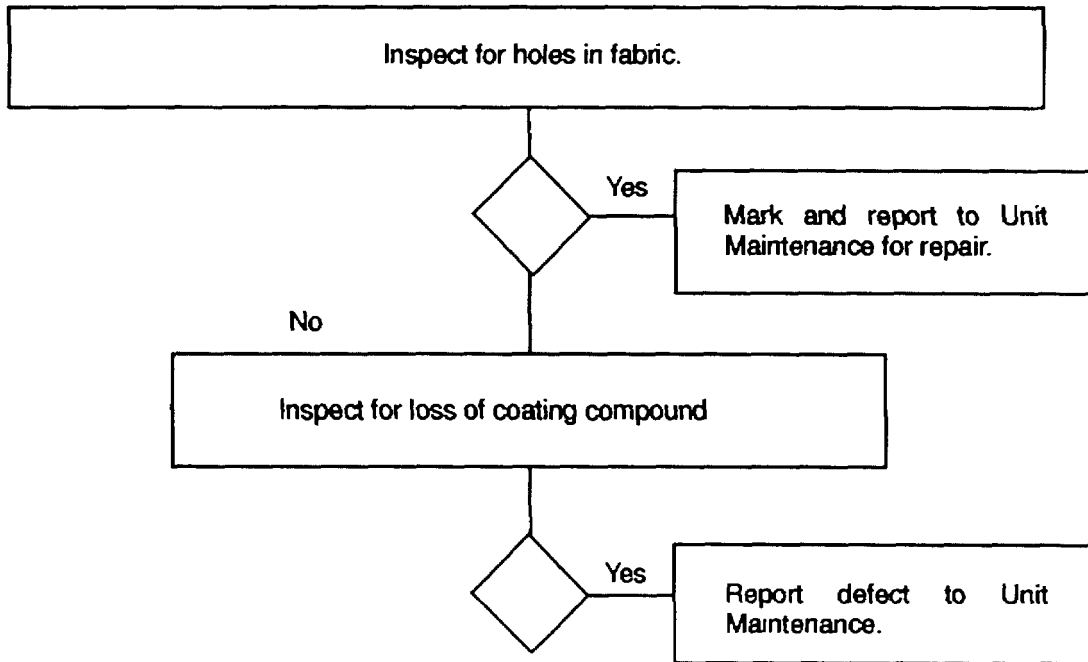

Table 3-1. Operator Troubleshooting Table - continued

MALFUNCTION 4. Tent Leaks.



SECTION III. OPERATOR'S MAINTENANCE PROCEDURES

3.3 GENERAL

The maintenance Allocation Chart does not authorize repair functions at the operator level.

CHAPTER 4

UNIT MAINTENANCE INSTRUCTIONS

		<b>PAGE</b>
Section I	Repair Parts, Tools; Special Tools; Test, Measurement and Diagnostic Equipment (TMDE), and Support Equipment.....	4-1
4.1	Common Tools and Equipment .....	4-1
4.2	Special Tools, TMDE, and Support Equipment .....	4-2
4.3	Repair Parts .....	4-2
Section II	Service Upon Receipt.....	4-2
4.4	Site and Shelter Requirements .....	4-2
4.5	Service Upon Receipt of Materiel .....	4-2
4.6	Installation Instructions .....	4-3
4.7	Preliminary Servicing and Adjustment of Equipment .....	4-3
Section III	Unit Preventive Maintenance Checks and Services (PMCS).....	4-3
4.8	General .....	4-3
Section IV	Unit Troubleshooting.....	4-5
4.9	General .....	4-5
Section V	Unit Maintenance Procedures.....	4-8
4.10	General .....	4-8
4.11	Tent Body.....	4-8
4.12	Screen Wall, Tent.....	4-11
4.13	Tent Support and Anchoring .....	4-12
4.14	Tent Cover .....	4-14
Section VI	Preparation for Storage and Shipment.....	4-15
4.15	Protection Against Mildew.....	4-15
4.16	Protection of Tent Against Damage .....	4-16
4.17	Protection of Pins, Poles, and Lines Against Damage.....	4-17
4.18	Administrative Storage .....	4-17

**SECTION I. REPAIR PARTS; TOOLS; SPECIAL TOOLS; TEST, MEASUREMENT, AND DIAGNOSTIC EQUIPMENT (TMDE); AND SUPPORT EQUIPMENT**

**4.1 COMMON TOOLS AND EQUIPMENT.**

For authorized common tools and equipment, refer to the Modified Table of Organization and Equipment (MTOE), CTA 50-970, or CTA 8-100, as applicable to your unit.

**4.2 SPECIAL TOOLS, TMDE, AND SUPPORT EQUIPMENT.**

No special tools or equipment are required for maintenance of the kitchen tent.

**4.3 REPAIR PARTS.**

Repair parts are listed and illustrated in Appendix C of this manual.

**SECTION II. SERVICE UPON RECEIPT****4.4 SITE AND SHELTER REQUIREMENTS.**

Refer to paragraph 2.7.a for site selection and requirements. There are no shelter requirements for this equipment.

**4.5 SERVICE UPON RECEIPT OF MATERIEL.**

- a. Unpacking. When either a new or used tent is received, it must be uncrated and inspected to make certain all items are accounted for and in serviceable condition. Five soldiers can erect the tent in approximately 60 minutes.
- b. Checking Unpacked Equipment
  - (1) Inspect the equipment for damage incurred during shipment. If the equipment has been damaged, report the damage on Standard Form 364, Report of Deficiency.
  - (2) Check the equipment against the packing slip to see. If the tent is complete. Report all discrepancies in accordance with the instructions contained in DA Pam 738-750.
- c. Processing Unpacked Equipment. The greatest amount of damage to tentage is caused by carelessness, such as forgetting to loosen the lines when it starts to rain, adjusting lines carelessly, driving pins in a slipshod manner, or dragging tents over rough ground. To prolong the life and usefulness of the tent, observe the following rules:
  - (1) Pitch, strike, and fold the tent in the manner described in this manual. See paragraphs 2.7 and 2.9. Do not try to take shortcuts unless you are sure no damage will be done. To protect the top of the tent during handling and in storage, fold the tent so that the side walls rather than the top of the tent will be exposed.
  - (2) Observe the utmost care when pitching and striking the tent, making sure the material does not tear on protruding pins, over-hanging branches, or other objects.
  - (3) Never drag your tent on the ground or floor.
  - (4) Use all the necessary parts and accessories for the tent and use them for their intended purpose.
  - (5) Pack the tent carefully for shipment. The tent is issued complete with cover. Carry tent in cover.
  - (6) Pack pins and poles separately from the tent.
  - (7) Inspect tentage to make sure that it is in serviceable condition. Particular attention should be given to seams, bindings, lines, and all places where strain is exerted. Be constantly on the lookout for:
    - (a) Any evidence of mildew.
    - (b) Any foreign matter which may have collected on tent.

(c) Small rips and holes, splitting of seams, lines which are beginning to rot, or anything else which does not appear to be in a normal condition.

**4.6 INSTALLATION INSTRUCTIONS.**

a. Tools, Test Equipment, and Materials Required for Installation.

Mallet, Wooden (Appendix E)  
 Repair Kit, Tentage (Appendix E)

b. Assembly of Equipment. Refer to paragraph 2.7.

**4.7 PRELIMINARY SERVICING AND ADJUSTMENT OF EQUIPMENT .**

Perform the PMCS shown in Table 2-1.

**SECTION III. UNIT PREVENTIVE MAINTENANCE CHECKS AND SERVICE (PMCS)**

**4.8 GENERAL**

To ensure that the tent is ready for use at all times, it must be periodically inspected and serviced so that defects may be discovered and corrected before they result in serious damage or equipment failure. The PMCS to be perform are listed and described in Table 4-1. The numbers in the Item No. column show the order in which the check or service should be done. These numbers should be used when recording deficiencies and shortcomings on DA Form 2404, Equipment Inspection and Maintenance Worksheet.

**NOTE**

Tents which are in administrative storage should be inspected semiannually; however, the inspection should be limited to removing the cover to look for mildew, insects, or rodent damage.

**Table 4-1. Unit Preventive Maintenance Checks and Services**

Item No.	Interval	Location of Item to Check/Service	Procedure	Not Fully Mission Capable if:
1	Quarterly	Tent Body a. Fabric	<p><b>NOTE</b>                      If the equipment must be kept in continuous operation, do only the procedures that can be done without disturbing operation Make complete checks and services when the equipment is shut down.</p> <p>Inspect for abrasions, mildew, holes, poor condition of previous repairs, broken stitches, evidence of leaks, low tensile strength, and missing or damaged grommets.</p>	Excessive abrasions, excessive mildew, large tears or holes Previous repairs are in poor condition. Missing stitches, evidence of leakage, fabric tears easily and grommets are missing or torn away from material causing fabric to tear

**Table 4-1. Unit Preventive Maintenance Checks and Services - continued**

Item No.	Interval	Location of Item to Check/Service	Procedure	Not Fully Mission Capable if:
1	Quarterly	Tent Body (Continued)  b. Tent Lines  c. Footstop Lines  d. Slide Fasteners	Check lines for frayed or raveled ends and for broken strands.  Check for missing or broken footstop lines  Inspect for damage and freedom of movement.  Service with stick lubricant from tentage repair kit (Appendix E).	Lines are cut, frayed or excessively worn.  Footstop lines missing or damaged.  Slide fasteners binds, does not open, dose or is tom away from fabric.
2	Quarterly	Screen Wall Tent  a. Fabric  b. Slide Fastener	Inspect the screen mesh and fabric for tears, missing or damaged slide fasteners and missing or damaged snap fasteners.  Service with stick lubricant from tentage repair kit (Appendix E).	Screen mesh ripped or torn. Slide fasteners binds, does not open, dose or is tom away from fabric. Snap fasteners damaged or missing
3	Quarterly	Tent Support and Anchoring a. Poles  b. Pins c. Hardware	Check poles for cracks, splinters, and dam-aged metal parts. Check pins for breaks and cracks. Inspect all metal parts for corrosion, looseness, damage, and missing parts.	Broken ridge or sectionalized upright poles. Pins are cracked or broken Excessive rust or corrosion, loose, missing or damaged parts.
4	Quarterly	Tent Cover	Inspect cover for rips, mildew, broken stitching, frayed tie lines, and loose or missing grommets.	Large tears or holes, excessive mildew, missing stitches. Lines are cut, frayed or excessively worn Grommets are missing or tom away from material causing fabric to tear.



SECTION IV. UNIT TROUBLESHOOTING

4.9 GENERAL

This section provides troubleshooting information for the kitchen tent at the unit maintenance level. Table 4-2, Troubleshooting Table is presented as flow diagrams for each malfunction listed. Each diagram provides the troubleshooting procedures and corrective actions to return the tent to mission capable readiness.

Table 4-2. Unit Troubleshooting Table

MALFUNCTION 1. Tent Leaking.

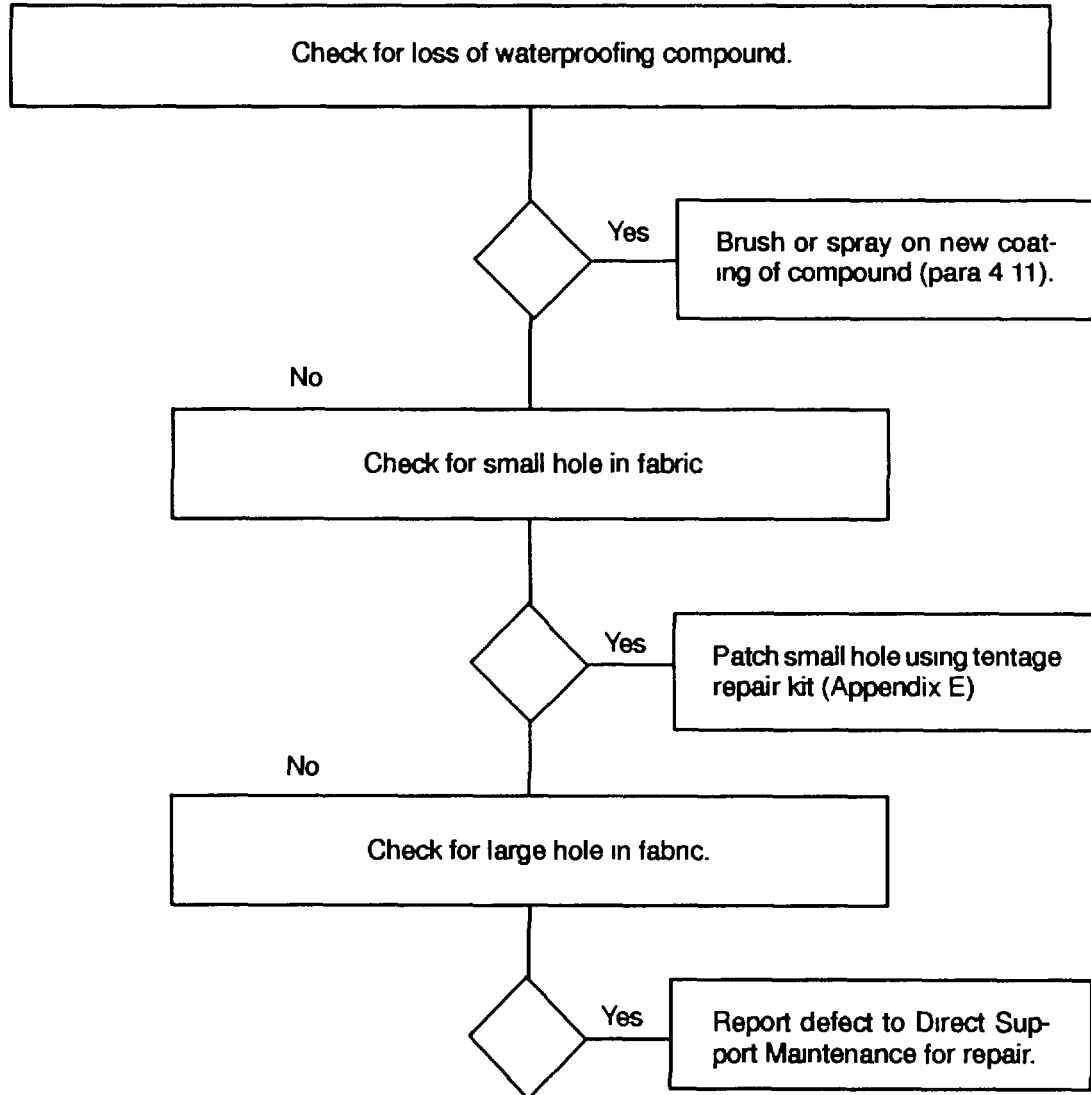

Table 4-2. Unit Troubleshooting Table - continued

MALFUNCTION 2. Tent Will Not Stay Taut.

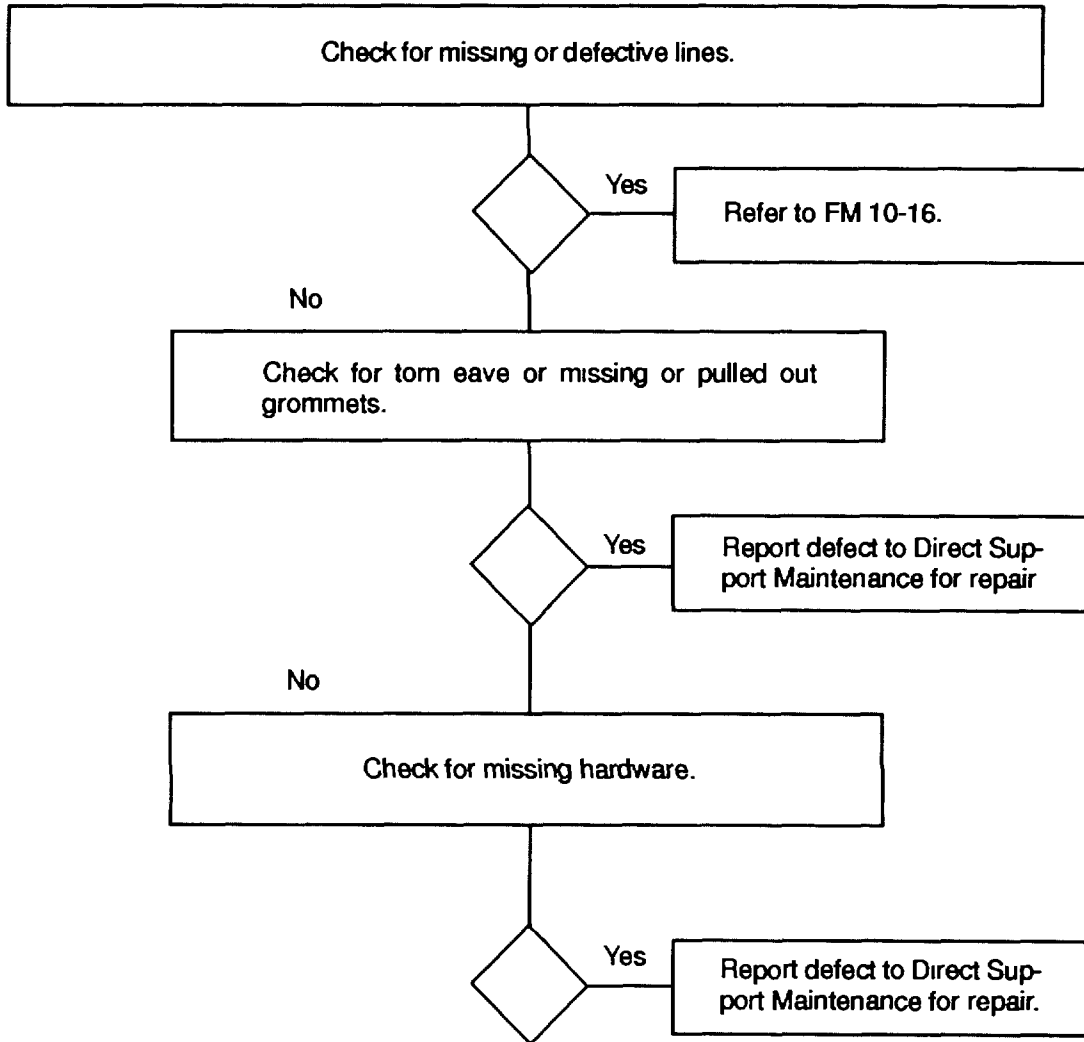
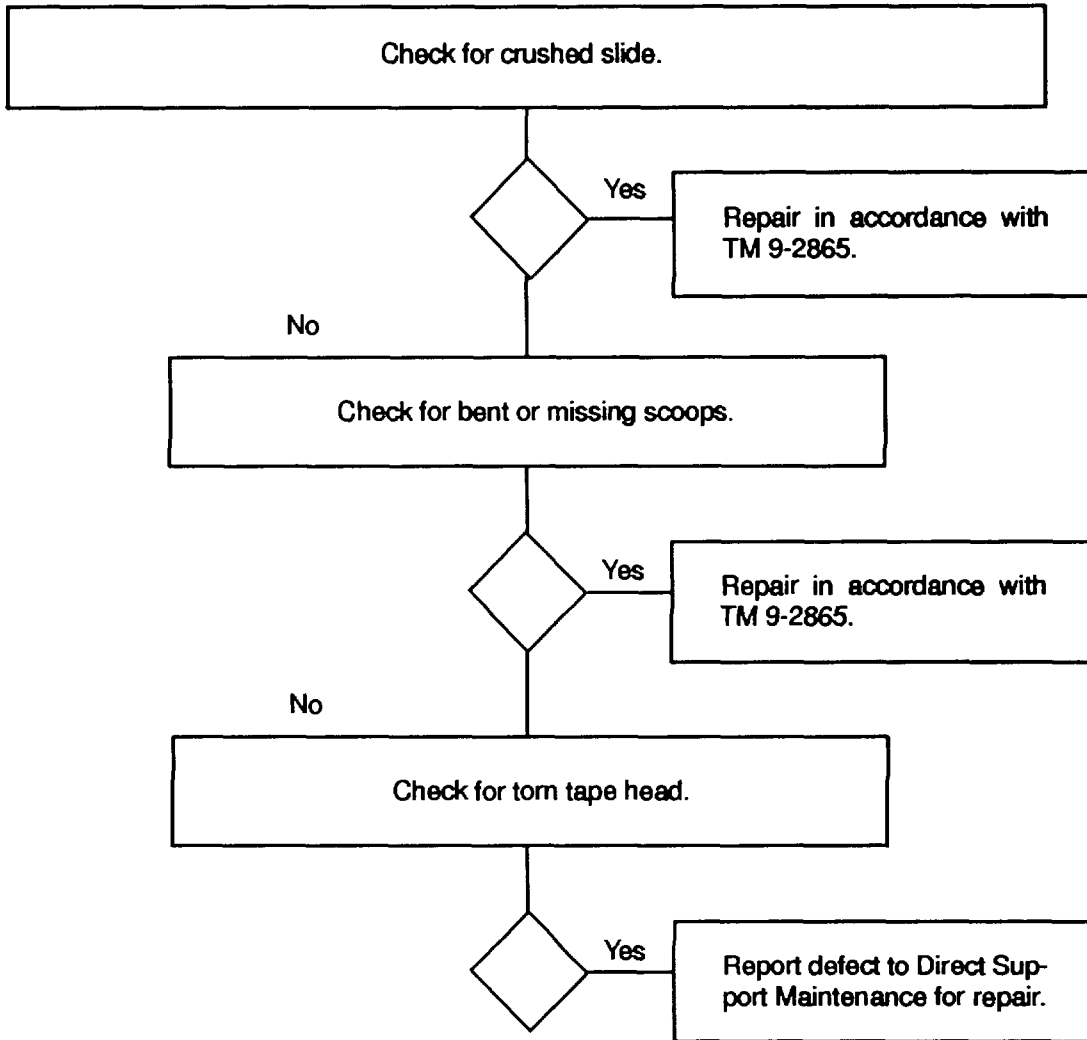

Table 4-2. Unit Troubleshooting Table - continued

MALFUNCTION 3. Slide Fasteners Locked or Defective.



**SECTION V. UNIT MAINTENANCE PROCEDURES**

**4.10 GENERAL**

Unit maintenance personnel shall perform the maintenance functions described in this section as authorized by the Maintenance Allocation Chart.

**MAINTENANCE OF TENT, KITCHEN**

**4.11 TENT BODY.**

This task covers:

a. Inspect

b. Service

c. Repair

**INITIAL SETUP:**

**Tools**

Tentage Repair Kit (Appendix E, AAL)

**Materials/Parts**

Nylon Cord (Item 5, Appendix F)  
 Compound Coating  
 (Item 1, Appendix F)  
 Fairlead (Appendix C)  
 Soap (Item 3, Appendix F)  
 Solvent (Item 2, Appendix F)

**Equipment Condition**

Tent erected

**Reference**

FM 10-16  
 TM 9-2865

**General Safety Instructions**

**WARNING**

CLEANING SOLVENT and COATING COMPOUND are both flammable and toxic. Do not use these materials near an open flame and keep the liquids away from the skin and clothing. Wear a respirator when a spray gun is used, and apply substances only in a well ventilated or open area.

If contact on bare skin is made with either of these liquids, wash exposed areas of the skin immediately with warm, soapy water Rinse with clean, clear water. Refer to FM 21-11 for first aid.

**INSPECT**

- a. Test the tensile strength of the fabric around damaged areas by grasping a small fold of fabric between the thumb and forefinger of each hand.
- b. Grip the fabric so that the tips of the forefingers touch, then tug on the fabric several times.
- c. If the fabric does not tear, the damaged area can be repaired with a patch slightly larger than the damaged area. Refer to FM 10-16.
- d. If the fabric tears, test additional areas around the damaged area to determine the extent of deterioration and the size of the patch needed. Repair as required. Refer to FM 10-16.

- e. Extensive damage should be reported to Direct Support Maintenance.

## **SERVICE**

### APPLYING COATING COMPOUND TO FABRIC

- a. Clean the fabric with a brush. Use a mild solution of soap (Item 3, Appendix F) and water to remove grease and oil stains. Rinse with clean water.
- b. Thoroughly dry tent before compound application.

### **CAUTION**

Do not apply compound on a tent that is wet, dirty, mildewed, or has oil and grease spots on the fabric.

- c. Mix 40% of the compound with 60% cleaning solvent for either spraying or brushing.

### **NOTE**

Be sure the seams and patches receive a generous amount of compound because these areas are more susceptible to mildew.

- d. Apply compound to outer surfaces of fabric. Treated fabric will dry to the touch in 30 minutes, but if tent is to be folded, it must be left to dry for 24 hours in a well ventilated area.

## **REPAIR**

- a. Grommets.
  - (1) For loose or missing grommets, install new grommets as described in FM 10-16.
  - (2) For grommets torn out, refer to Direct Support Maintenance for machine repair of damaged area, then install grommets per FM 10-16.
- b. Fairleads.
  - (1) Remove eave guy lines.
  - (2) Open eye of hook and remove fairlead.
  - (3) Insert eye of replacement fairlead in hook, then close hook eye.
  - (4) Thread eave guy lines through fairlead.
- c. Line, Tent, Jumper, 6-feet (1.830-m).

Refer to FM 10-16.

d. Line, Tent Jumper, 10 feet, 6 inches (3.200-m).

Refer to FM 10-16.

e. Line, Tent, Ventilator Flap.

- (1) Cut flap line where it passes through grommet and remove defective line.
- (2) Cut nylon cord of same length as removed line.
- (3) Tie a bowline knot (FM 10-16) so that it forms an 8-inch (20 320-cm) loop at one end of line. Pass opposite end through flap grommets and then through eye of bowline knot.
- (4) Pull the end of line tight. Secure end of line to spindle of proper eave pole.

f. Slide Fastener Thongs.

- (1) Cut defective thong from wire stirrup of slider.
- (2) Using 10-inch (25.400-cm) length of nylon cord, fold in half.
- (3) Insert folded end through ring of slider, then put both ends through loop and draw tight.
- (4) Tie ends with an overhand knot. Refer to FM 10-16.

g. Cloth, Cotton Duck and Plastic Screening.

**NOTE**

Unit maintenance is authorized repair of tent fabrics within the limitations of the tentage repair kit. Major fabric repairs require maintenance at the Direct Support level.

- (1) Determine if patching is to be applied with cement or will require hand sewing.
- (2) Cut and apply patch per instructions contained in FM 10-16.

---

**4.12 SCREEN WALL, TENT**

---

This task covers:

a. Inspect

b. Service

c. Repair

---

**INITIAL SETUP:****Tools**

Tentage Repair Kit (Item 1, Section III, Appendix B)

**Reference**

FM 10-16  
TM 9-2865

**Materials/Parts**

Slide Fastener (Appendix C)  
Snap Fastener (Appendix C)

**Equipment Condition**

Tent erected.

---

**INSPECT**

Inspect the wall screen for tears, missing or damaged slide fasteners, or snap fasteners.

**SERVICE**

Lubricate slide fasteners with stick lubricant from the tentage repair kit.

**REPAIR**

a. Cloth, Cotton Duck and Plastic Screening.

Refer to FM 10-16 for repair procedures.

b. Grommets, Snap Fasteners, and Reinforcements.

Refer to FM 10-16 for replacement procedures.

c. Slide Fasteners.

Refer to TM 9-2865 for replacement procedures.

---

**4.13 TENT SUPPORT AND ANCHORING.**

---

This task covers:

a. **Inspect**

b. **Repair**

---

**INITIAL SETUP:****Tools**

Tentage Repair Kit (Item 1, Section III, Appendix B)  
Adjustable Wrench, 8 inches  
(Item 2, Section III, Appendix B)  
Hammer, Hand (Item 3, Section III, Appendix B)

**Materials/Parts**

Sandpaper (Item 6, Appendix F)  
Pipe, 3/4 inch, 15 inches long  
Nylon Cord (Item 5, Appendix F)  
Lubricating Oil (Item 4, Appendix F)

**Equipment Condition**

Tent erected.

---

**INSPECT**

- a. Inspect poles for cracks and splinters.
- b. Check pins for cracks or breaks.
- c. Check end whipping on loose ends of lines.
- d. Inspect all metal parts for corrosion, rust, looseness, damage, and missing parts.

**REPAIR**

- a. Poles.
  - (1) Remove any splinters or splinters from poles.
  - (2) Sandpaper the areas to obtain a smooth finish.
  - (3) Remove corrosion and rust from metal connectors and lubricate with light oil.
- b. Pins.

Replace damaged pins.



c. Lines.

Replace damaged lines and footstops with nylon cord lines of the same length. Refer to FM 10-16

d. Eave Lines.

End whip or eye splice eave lines. Refer to FM 10-16.

e. Tent Slips.

Remove sharp edges from tent slips with sandpaper.

f. Hardware.

(1) Use 15-inch (38.100-cm) length of 3/4-inch (1.900-cm) pipe to straighten bent pole spindles.

(2) Tighten nuts on ridge pole connectors with 8 inch adjustable wrench when they become loose.

(3) Straighten bent ferrules with a hammer.

---

**4.14 TENT COVER.**

---

This task covers:

a. **Inspect**

b. **Service**

c. **Repair**

---

**INITIAL SETUP:****Tools**

Tentage Repair Kit (Item 1, Section III, Appendix B)

**Reference**

FM 10-16

**Equipment Condition**

Tent erected. Cover not being used.

---

**INSPECT**

- a. Check the tensile strength of the fabric around damaged areas (paragraph 4.11).
- b. Inspect for missing or damaged grommets.
- c. Examine for condition of coating compound.

**SERVICE**

Refer to paragraph 4.11 for application of coating compound.

**REPAIR**

Refer to FM 10-16.

## SECTION VI. PREPARATION FOR STORAGE AND SHIPMENT .

4.15 PROTECTION AGAINST MILDEW.

- a. General. Most tents are mildew resistant. This does not mean that they are not subject to mildew. Under war and damp conditions, especially in tropical and jungle areas, tents may be ruined by mildew in a few days if proper care is not taken.
- b. Preventing Mildew.
  - (1) Never fold or roll tent when wet. Even if it is only damp from dew, it will mildew when stored. Make sure the seams and edges of the tent, especially the bottom edge, and the sod cloth are dry and dean.
  - (2) When storing or transporting the tent, keep poles and pins separate from the tent. Make sure the pins and poles are cleaned and dried before being stored.
  - (3) Keep tent clean at all times. The growth of fungi and mold is caused, to some extent, by tree drippings, oils greases, and starches, which accumulate on tentage.
  - (4) Before storing, dry tent by hanging it off the ground in bright sunlight. A tent dried on the ground or left hanging outdoors after sundown, may absorb enough moisture for mildew to start. When necessary, tent can be dried indoors. When drying indoors, hang the tent in a well ventilated place, high enough to permit the tent to be suspended off the floor or ground.

**NOTE**

Only lumber that has been thoroughly cured should be used for dunnage. The moisture contained in green lumber will promote the growth of mildew.

- (5) When storing the tent, stack it on dunnage supported by 2-by-4-inch (5.080-by-10.160-cm) lumber. If the floor is hard surfaced or wooden, the tentage should be at least 4-inches (10.160-cm) from the floor. If the floor is earthen, the tentage should be at least 8-inches (20.320-cm) from the ground.
- (6) When moisture (high humidity) is in the air, dunnage should be used between each course to permit circulation of air between the blocks. The blocks should be separated and reduced to a minimum number of course to allow passage of air on all four sides.
- (7) If the tent is stacked near ventilators or other openings that may admit moisture, protect the tent by packing in waterproof covering.
- (8) Do not place tentage received from the field in bags until tent is thoroughly dried and all dirt removed with stiff brushes. If any visible signs of mildew are present; hang tent in the open air, preferably in the sun.
- (9) Give priority of issue to tentage that has been in storage the longest. To prevent issue of newly stored tentage before older stocks are exhausted, blocks should be marked according to length of time tentage has been in storage.
- (10) When tentage is stored in open sheds or in tents, it should be stacked well away from the sides and ends of the shelter (about 2-feet) (0.610-m) Items not affected by moisture should be stacked between tentage am outer edges of shelter.
- (11) During routine inspections, any tentage found to have mildew, immediately remove from storage. Remove mildew from contaminated areas with a stiff brush, allow to dry thoroughly, and issue on a priority basis. If the tent cannot be issued immediately, segregate from good tentage to prevent contamination from spreading. Tents containing extensive damage should be evacuated to direct support maintenance for repair.

**4.16 PROTECTION OF TENT AGAINST DAMAGE.**

- a. General. Damage is often caused by carelessness, such as forgetting to loosen the lines when it starts to rain, adjusting lines carelessly, driving pins in a slipshod manner, or dragging tents over rough ground. To prolong the life and usefulness of tentage, observe the following:
- (1) Pitch, strike, and fold the tent as shown in paragraph 2.7. Do not try to take shortcuts unless you are sure no damage will result. To protect the top of the tent during handling and in storage, fold the tent so that the side walls rather than the top of the tent will be exposed.
  - (2) Observe the utmost care when pitching and striking the tent, making sure the material does not tear on protruding pins, over-hanging branches, or other objects
  - (3) Never drag tent along the ground or floor
  - (4) Use all the necessary parts and accessories for the tent and use them for their intended purpose.
  - (5) Pack tent carefully for shipment. The tent is issued complete with cover. Carry tent in cover.
  - (6) Pack pins and poles separately from the tent.
  - (7) Inspect tentage at frequent intervals to make sure that it is in serviceable condition. Particular attention should be given to seams, bindings, lines, and all places where strain is exerted. Be constantly on the lookout for:
    - (a). Any evidence of mildew.
    - (b). Any foreign matter which may have collected on the tent.
    - (c). Small rips and holes, splitting of seams, grommets which have become loose, lines which are beginning to rot, or anything else which does not appear to be in a normal condition.
  - (8) Withdraw from storage any tent found to be infected with mildew. Brush with a stiff brush, allow to thoroughly dry, and issue immediately to units where dry atmospheric conditions prevail. If there is no opportunity for immediate issue, segregate infected tent from sound tents to prevent contamination. Tents which have become unserviceable and cannot be repaired at the unit level of maintenance, shall be evacuated to direct support maintenance for repair and return to the user. If items are uneconomically repairable in accordance with TB 43-0002-27, they should be salvaged.

**4.17 PROTECTION OF PINS, POLES, AND LINES AGAINST DAMAGE.**

- a. Pins. All wooden tent pins currently Issued receive a wood preservative treatment. Care should be taken in handling pins to see that they are not broken or otherwise damaged. In determining serviceability of pins, look for cracks, splits, distorted ends, and broken or flattened points.
- b. Poles. Care should be taken In handling tent poles to see that they are not broken or otherwise damaged. In determining serviceability of poles, look for cracks, splits, condition of metal parts, and missing or bent spindles.
- c. Lines. Lines require periodic inspection. The stability and safety of the tent may depend on the condition of the various lines used. Deterioration may be either physical or chemical in nature. Physical damage is caused by surface wear or from internal function between the fibers. Chemical damage is caused by exposure to weather conditions and acids. To prevent damage to tent lines, observe the following rules.
  - (1) Store lines properly in a dry, unheated building or a room with good air circulation. Place lines in loose coils off the floor on wooden grating, or hang them on wooden pegs. It is best to hang small lines In loose coils and to coil large sizes loosely on a grating or platform raised from the floor to insure necessary circulation of air. Never store lines in a small confined space without good air circulation Clean thoroughly before storing. Continuous exposure to sunlight is damaging to lines. Improper storage conditions frequently causes dry rot.
  - (2) Dry line properly after exposure to moisture. Lines are best dried when hung loosely between two trees or other objects so that they do not come is contact with the ground
  - (3) Keep lines clean. If lines become dirty, they should be washed In dean water and thoroughly dried. Grit from sand, mud, or other materials, if allowed to remain and work into the lines, will grind and wear the fibers
  - (4) Protect lines from chemicals. Keep lines away from chemicals or their fumes, especially acids or alkaline substances. Drying oils, such as linseed oil and paint will also damage lines.
  - (5) Reverse lines when possible, end for end, periodically, so that all sections of the lines will receive equal wear. When wear is localized in a short section, periodically shortening will present a new wearing surface
  - (6) If line becomes damaged, causing loss of more than 10% of its breaking strength, replace the line with new one.
  - (7) Whip ends of lines to prevent raveling (see FM 10-16).

**4.18 ADMINISTRATIVE STORAGE.**

- a. Placement of equipment in administrative storage should be for short periods of time when a shortage of maintenance effort exists. Items should be in mission readiness within 24-hours or within the time factors as determined by the directing authority. During the storage period, appropriate maintenance records will be kept.
- b. Before placing equipment in administrative storage, current maintenance services and Equipment Serviceable Criteria (ESC) evaluations should be completed, shortcomings and deficiencies should be corrected, and all Modification Work Orders (MWOs) should be applied.
- c. Storage Site Selection. Inside storage is preferred for items selected for administrative storage. If Inside storage is not available, trucks, vans, conex containers, and other containers may be used.
- d. In addition, the instructions contained in TM 740-90-1 and TM 38-230-1 apply.



**CHAPTER 5**

**DIRECT SUPPORT MAINTENANCE INSTRUCTIONS**

		<b>PAGE</b>
Section I	Direct Support Troubleshooting .....	5-1
	5.1 Direct Support Troubleshooting Procedures .....	5-1
Section II	Maintenance Procedures.....	5-2
	5.2 General.....	5-2
	5.3 Tent Body .....	5-3
	5.4 Screen Wall, Tent .....	5-4
	5.5 Tent Support and Anchoring.....	5-5
	5.6 Tent Cover.....	5-5

**SECTION I. DIRECT SUPPORT TROUBLESHOOTING**

**5.1 TROUBLESHOOTING PROCEDURES.**

There is no troubleshooting at direct support maintenance For unit maintenance troubleshooting, refer to Chapter 4 Section IV of this manual.

**SECTION II. DIRECT SUPPORT MAINTENANCE PROCEDURES**

**5.2 GENERAL**

Direct support maintenance provides more extensive tentage repair than is authorized at the unit maintenance level. Repairs of tent fabric greater than 4-inches in length or diameter and major repairs to other tent components are done at this level of maintenance. Repair is usually accomplished by industrial machine sewing and stitching of large patches over damaged areas or cloth panel replacement on the tent. Table 5-1 lists the most commonly used sewing machines.

**Table 5-1. Industrial Sewing Machines**

SEWING MACHINE TYPE	DESCRIPTION
SEWING MACHINE, INDUSTRIAL (Heavy duty)	General sewing; power driven; lock stitch; single needle; flat bed; w/rigid table stand; 7-33 or any equivalent model
SEWING MACHINE, INDUSTRIAL (Medium duty)	General sewing; power driven; lock stitch; single needle; flat bed; w/rigid table stand; 111W155 or any equivalent model.
SEWING MACHINE, INDUSTRIAL (Darning, light to medium)	Darning; power driven; lock stitch; single needle; 6 7/8-inches depth of throat; cylinder bed; w/rigid table stand; 47W70 or any equivalent model.
SEWING MACHINE, INDUSTRIAL (Very heavy duty)	Heavy leather or webbing sewing; power driven; lock stitch; single needle; 12-inches depth of throat; cylinder bed; nonadjustable pedestal mounted; 97-10 or any equivalent model.
SEWING MACHINE, INDUSTRIAL (Medium duty zigzag)	Double-throw zigzag sewing for rope tacking, power-driven; lock stitch; single needle; 10 7/8-inches depth of throat; flat bed; w/rigid table stand, 17W15 or any equivalent model
SEWING MACHINE, INDUSTRIAL (Light duty)	General sewing; power driven; lock stitch; single needle, flat bed; w/rigid table stand; 10- to 13-inches depth of throat; 31-15 or any equivalent model.



---

### 5.3 TENT BODY

---

**This task covers:    Repair**

---

#### INITIAL SETUP:

##### Tools

Industrial Sewing Machine (Table 5-1)

##### References

FM 10-16  
TM 9-2865

##### Materials/Parts

Cloth, Cotton Duck (Appendix C)  
Webbing, Cotton/nylon (Appendix C)  
Thread, nylon/cotton (Appendix C)

##### Equipment Condition

Tent folded.

---

### REPAIR

#### **NOTE**

Fabric repairs will consist of panel replacement, large patches, machine sewing of seams, webbing, and chapes for necessary reinforcement.

- a. Fabric Repairs.
  - (1) Prepare the tent body for repair as directed in FM 10-16.
  - (2) Methodically inspect essential points of tent as shown in FM 10-16.
  - (3) Follow all standards in FM 10-16 for fabric repairs.
  - (4) After repairs are completed, make a final inspection paying particular attention to quality and thoroughness of repair actions. Check all points outlined in FM 10-16.

- b. Hardware Replacement.

**NOTE**

Hardware and slide fasteners should be obtained from salvaged tent bodies when possible.

- (1) Slide fastener. Repair or replace slide fasteners as directed in TM 9-2865.
- (2) Hardware. Grommets, D-rings, snap fasteners, and other hardware should be replaced in accordance with FM 10-16.

**5.4 SCREEN WALL, TENT.**

**This task covers: Repair**

**INITIAL SETUP:**

**Tools**

Tentage Repair Kit (Item 1, Section III, Appendix B)

**References**

FM 10-16  
TM 9-2865

**Materials/Parts**

Screening (Appendix C)

**Equipment Condition**

Tent folded.

**REPAIR**

**NOTE**

Maintenance consists of repairing damaged areas of both the fabric and screen mesh, and replacement of damaged or missing hardware.

- a. Screen Wall Fabric. Repair as directed in FM 10-16
- b. Slide Fasteners. Repair as directed in TM 9-2865.
- c. Hardware. Repair as directed in FM 10-16

**5.5 TENT SUPPORT AND ANCHORING.**

**This task covers:**

- a. **Repair**

**INITIAL SETUP:**

**Equipment Condition**

Tent folded

**References**

FM 10-16

**REPAIR**

Repair consists of replacing missing or damaged metal parts of tent poles Refer to FM 10-16 for instructions

**5.6 TENT COVER.**

**This task covers:    Repair**

**INITIAL SETUP:**

**Tools**

Industrial Sewing Machine (Table 5-1)

**References**

FM 10-16

**Materials/Parts**

Cloth, Cotton, Duck (Appendix C)  
 Webbing (Appendix C)  
 Thread (Appendix C)

**Equipment Condition**

Tent cover separated from tent.

**REPAIR**

**NOTE**

Fabric repairs will consist of panel replacement, large patches, and machine sewing of seams, webbing, and chapes for necessary reinforcement

Refer to paragraph 5.3 and conduct tent cover repair in the same manner as tent body fabric repair.



**APPENDIX A**

**REFERENCES**

**A.1 SCOPE.**

This appendix lists all forms, field manuals, technical manuals, and miscellaneous publications referenced in this manual.

**A.2 FORMS AND RECORDS.**

Recommended Changes to Publications and Blank Forms .....	DA Form 2028
Recommended Changes to Equipment Technical Publications.....	DA Form 2028-2
Equipment Inspection and Maintenance Worksheet.....	DA Form 2404
The Army Maintenance Management System (TAMMS).....	DA Pam 738-750
Product Quality Deficiency Report .....	SF 368
Report of Deficiency .....	SF 364

**A.3 FIELD MANUALS.**

General Repair of Tent Canvas and Webbing.....	FM 10-16
First Aid for Soldiers .....	FM 21-11

**A.4 TECHNICAL MANUALS AND BULLETINS .**

Destruction of Army Materiel to Prevent Enemy Use .....	TM 750-244-3
Administrative Storage .....	TM 740-90-1
Preservation, Packaging, and Packing of Military Supplies and Equipment	TM 38-230-1
Repair of Slide Fasteners .....	TM 9-2865
Hand Portable Fire Extinguisher for Army Users.....	TB 5-4200-200-10
Maintenance Expenditure Limits for F&C Groups 72, 83, 84, F&C Classes 7210, 8340 and 8400.....	TB 43-0002-27

**A.5 MISCELLANEOUS PUBLICATIONS.**

Army Materiel Maintenance Policy and Retail Maintenance Operations... Expendable/Durable Items (Except Medical, Class V, Repair Parts, and Heraldic Items).....	AR 750-1 CTA 50-970
Abbreviations for Use on Drawings, Standards, Specifications & Technical Operations.....	MIL-STD-12



## APPENDIX B

---

**MAINTENANCE ALLOCATION CHART (MAC)**

---

**Section I. INTRODUCTION****B-1. The Army Maintenance System MAC**

This introduction provides a general explanation of all maintenance and repair functions authorized at the two maintenance levels under the Two-Level Maintenance System concept.

This MAC (immediately following the introduction) designates overall authority and responsibility for the performance of maintenance functions on the identified end item or component. The application of the maintenance functions to the end item or component shall be consistent with the capacities and capabilities of the designated maintenance levels, which are shown on the MAC in column (4) as:

Field - includes two columns, Unit maintenance and Direct Support maintenance. The Unit maintenance column is divided again into two more subcolumns, C for Operator or Crew and O for Unit maintenance.

Sustainment – includes two subcolumns, General Support (H) and Depot (D).

The tools and test equipment requirements (immediately following the MAC) list the tools and test equipment (both special tools and common tool sets) required for each maintenance function as referenced from the MAC.

The remarks (immediately following the tools and test equipment requirements) contain supplemental instructions and explanatory notes for a particular maintenance function.

**B-2. Maintenance Functions**

Maintenance functions will be limited to and are defined as follows:

1. Inspect. To determine the serviceability of an item by comparing its physical, mechanical, and/or electrical characteristics with established standards through examination (e.g., by sight, sound, or feel.) This includes scheduled inspection and gagings and evaluation of cannon tubes.
2. Test. To verify serviceability by measuring the mechanical, pneumatic, hydraulic, or electrical characteristics of an item and comparing those characteristics with prescribed standards on a scheduled basis, i.e., load testing of lift devices and hydrostatic testing of pressure hoses.
3. Service. Operations required periodically to keep an item in proper operating condition; e.g., to clean (includes decontaminate, when required), to preserve, to drain, to paint, or to replenish fuel, lubricants, chemical fluids, or gases. This includes scheduled exercising and purging of recoil mechanisms. The following are examples of service functions:
  - a. Unpack. To remove from packing box for service or when required for the performance of maintenance operations.
  - b. Repack. To return item to packing box after service and other maintenance operations.
  - c. Clean. To rid the item of contamination.

- d. Touch up. To spot paint scratched or blistered surfaces.
  - e. Mark. To restore obliterated identification.
4. Adjust. To maintain or regulate, within prescribed limits, by bringing into proper position, or by setting the operating characteristics to specified parameters.
  5. Align. To adjust specified variable elements of an item to bring about optimum or desired performance
  6. Calibrate. To determine and cause corrections to be made or to be adjusted on instruments of test, measuring, and diagnostic equipment used in precision measurement. Consists of comparisons of two instruments, one of which is a certified standard of known accuracy, to detect and adjust any discrepancy in the accuracy of the instrument being compared.
  7. Remove/Install. To remove and install the same item when required to perform service or other maintenance functions. Install may be the act of emplacing, seating, or fixing into position a spare, repair part, or module (component or assembly) in a manner to allow the proper functioning of an equipment or system.
  8. Paint. To prepare and spray color coats of paint so that the ammunition can be identified and protected. The color indicating primary use is applied, preferably, to the entire exterior surface as the background color of the item. Other markings are to be repainted as original so as to retain proper ammunition identification.
  9. Replace. To remove an unserviceable item and install a serviceable counterpart in its place. "Replace" is authorized by the MAC and assigned maintenance level is shown as the third position code of the Source, Maintenance and Recoverability (SMR) code.
  10. Repair. The application of maintenance services, including fault location/troubleshooting, removal/installation, disassembly/assembly procedures and maintenance actions to identify troubles and restore serviceability to an item by correcting specific damage, fault, malfunction, or failure in a part, subassembly, module (component or assembly), end item, or system.

### NOTE

The following definitions are applicable to the "repair" maintenance function:

**Services.** Inspect, test, service, adjust, align, calibrate, and/or replace.

**Fault location/troubleshooting.** The process of investigating and detecting the cause of equipment malfunctioning; the act of isolating a fault within a system or Unit Under Test (UUT).

**Disassembly/assembly.** The step-by-step breakdown (taking apart) of a spare/functional group coded item to the level of its least component, that is assigned an SMR code for the level of maintenance under consideration (i.e., identified as maintenance significant).

**Actions.** Welding, grinding, riveting, straightening, facing, machining, and/or resurfacing.



11. Overhaul. That maintenance effort (service/action) prescribed to restore an item to a completely serviceable/operational condition as required by maintenance standards in appropriate technical publications. Overhaul is normally the highest degree of maintenance performed by the Army. Overhaul does not normally return an item to like new condition.
12. Rebuild. Consists of those services/actions necessary for the restoration of unserviceable equipment to a like new condition in accordance with original manufacturing standards. Rebuild is the highest degree of material maintenance applied to Army equipment. The rebuild operation includes the act of returning to zero those age measurements (e.g., hours/miles.) considered in classifying Army equipment/components.

**B-3. Explanation of Columns in the MAC, Section II**

Column (1) Group Number. Column (1) lists Functional Group Code (FGC) numbers, the purpose of which is to identify maintenance significant components, assemblies, subassemblies, and modules with the Next Higher Assembly (NHA).

Column (2) Component/Assembly. Column (2) contains the names of components, assemblies, subassemblies, and modules for which maintenance is authorized.

Column (3) Maintenance Function. Column (3) lists the functions to be performed on the item listed in column (2). (For a detailed explanation of these functions refer to "Maintenance Functions" outlined above).

Column (4) Maintenance Level. Column (4) specifies each level of maintenance authorized to perform each function listed in column (3), by indicating work time required (expressed as manhours in whole hours or decimals) in the appropriate subcolumn. This work time figure represents the active time required to perform that maintenance function at the indicated level of maintenance. If the number or complexity of the tasks within the listed maintenance function varies at different maintenance levels, appropriate work time figures are to be shown for each level. The work time figure represents the average time required to restore an item (assembly, subassembly, component, module, end item, or system) to a serviceable condition under typical field operating conditions. This time includes preparation time (including any necessary disassembly/assembly time), troubleshooting/fault location time, and quality assurance time in addition to the time required to perform the specific tasks identified for the maintenance functions authorized in the MAC. The system designations for the various maintenance levels are as follows:

Field:

- C Operator or Crew maintenance
- O Unit maintenance
- F Direct Support maintenance

Sustainment:

- L Specialized Repair Activity
- H General Support maintenance
- D Depot maintenance

## NOTE

The "L" maintenance level is not included in column (4) of the MAC. Functions to this level of maintenance are identified by work time figure in the "H" column of column (4), and an associated reference code is used in the REMARKS column (6). This code is keyed to the remarks and the SRA complete repair application is explained there.

Column (5) Tools and Equipment Reference Code. Column (5) specifies, by code, those common tool sets (not individual tools), common Test, Measurement and Diagnostic Equipment (TMDE), and special tools, special TMDE and special support equipment required to perform the designated function. Codes are keyed to the entries in the tools and test equipment table.

Column (6) Remarks Code. When applicable, this column contains a letter code, in alphabetic order, which is keyed to the remarks table entries.

### **B-4. Explanation of Columns in the Tools and Test Equipment Requirements, Section III**

Column (1) - Tool or Test Equipment Reference Code. The tool or test equipment reference code correlates with a code used in column (5) of the MAC.

Column (2) - Maintenance Level. The lowest level of maintenance authorized to use the tool or test equipment.

Column (3) - Nomenclature. Name or identification of tool or test equipment.

Column (4) - National Stock Number (NSN). The NSN of the tool or test equipment.

Column (5) - Tool Number. The manufacturer's part number.

### **B-5. Explanation of Columns in Remarks, Section IV**

Column (1) - Remarks Code. The code recorded in column (6) of the MAC.

Column (2) - Remarks. This column lists information pertinent to the maintenance function being performed as indicated in the MAC.

**SECTION II. MAINTENANCE ALLOCATION CHART FOR  
TENT, KITCHEN, FLYPROOF, M1948**

(1) GROUP NUMBER	(2) COMPONENT/ ASSEMBLY	(3) MAINTENANCE FUNCTION	(4) MAINTENANCE LEVEL					(5) TOOLS AND EQUIPMENT REFERENCE CODE	(6) REMARKS CODE
			FIELD		SUSTAINMENT				
			UNIT		DIRECT SUPPORT	GENERAL SUPPORT	DEPOT		
			C	O	F	H	D		
00	TENT,KITCHEN FLYROOF, M1948								
01	TENT BODY	Inspect Service Repair	0.5 0.5	0.5 0.5	1.5				
02	SCREEN WALL, TENT	Inspect Service Repair	0.1 0.2	0.1 0.2	0.5		1	A,B	
03	TENT SUPPORT AND ANCHORING	Inspect Service Repair	0.1 2.0	0.1 0.2	0.5		1,2,3	A,B	
04	TENT COVER	Inspect Service Repair	0.1 0.2	0.1 0.2	1.5		1	A,B	

**Section III. TOOLS AND TEST EQUIPMENT FOR  
TENT, KITCHEN, FLYPROOF, M1948**

(1) TOOL OR TEST EQUIPMENT REFERENCE CODE	(2) MAINTENANCE LEVEL	(3) NOMENCLATURE	(4) NATIONAL STOCK NUMBER	(5) TOOL NUMBER
1 2 3	O, F O O	Repair Kit, Tentage Adjustable Wrench, 8 inch Hammer, Hand	8340-00-262-5767 5120-00-244-9147 5120-00-474-3249	

**Section IV. REMARKS FOR  
TENT, KITCHEN, FLYPROOF, M1948**

(1) REMARKS CODE	(2) REMARKS
A	Repair consists of materials contained in the Tentage Repair Kit authorized at the Unit level of maintenance.
B	Direct Support maintenance consists of repairs that require industrial sewing machine, which is not authorized at the Unit maintenance level. Direct Support is the lowest level of maintenance for machine repair.

APPENDIX C

REPAIR PARTS AND SPECIAL TOOLS LIST

SECTION I. INTRODUCTION

**C.1 SCOPE.** This RPSTL lists and authorizes spares and repair parts, special tools, special test, measurement and diagnostic equipment (TMDE); and other special support equipment required for performance of unit and direct support maintenance of the Tent, Kitchen, Flyproof, M1948 It authorizes the requisitioning, issue, and disposition spares, repair parts and special tools as indicated by the source, maintenance and recoverability (SMR) codes.

**C.2 GENERAL** In addition to this section, Introduction, this Repair Parts and Special Tools List is divided into following sections:

a. **Section II. Repair Parts List.** A list of spares and repair parts authorized by this RPSTL for use in the performance of maintenance This list also includes parts which must be removed for replacement of the authorized parts. Parts lists are composed of functional groups in ascending alphanumeric sequence, with the parts in each group listen ascending figure and Item number sequence Bulk materials are listed in item name sequence. Items are shown in associated illustration(s)/figure(s).

b. **Section III. Special Tools List.** A list of special tools, special TMDE, and other special support equipment authorized by this RPSTL (as indicated by Basis of Issue (BOI) information in DESCRIPTION AND USABLE ON CC column) for the performance of maintenance.

c. **Section IV. Cross-Reference Index.** A list, in National Item Identification Number (NIIN) sequence, of all National stock numbered items appearing in the listing, followed by a list In alphanumeric sequence of all part numbers appearing in the listings National stock numbers and part numbers are cross referenced to each illustration figure item number appearance. The figure and item number index lists figure and Item numbers In alphanumeric sequence and cross references NSN, CAGEC and part number.

**C.3 EXPLANATION OF COLUMNS (SECTIONS II AND III).**

a. **ITEM NO. Column (1).** Indicates the number used to Identify Items called out in the illustration.

b. **SMR Code (Column (2)).** The Source, Maintenance, and Recoverability (SMR) code is a 5-position o containing supply/requisitioning information, maintenance category authorization criteria, and disposition instruct as shown in the following breakout:

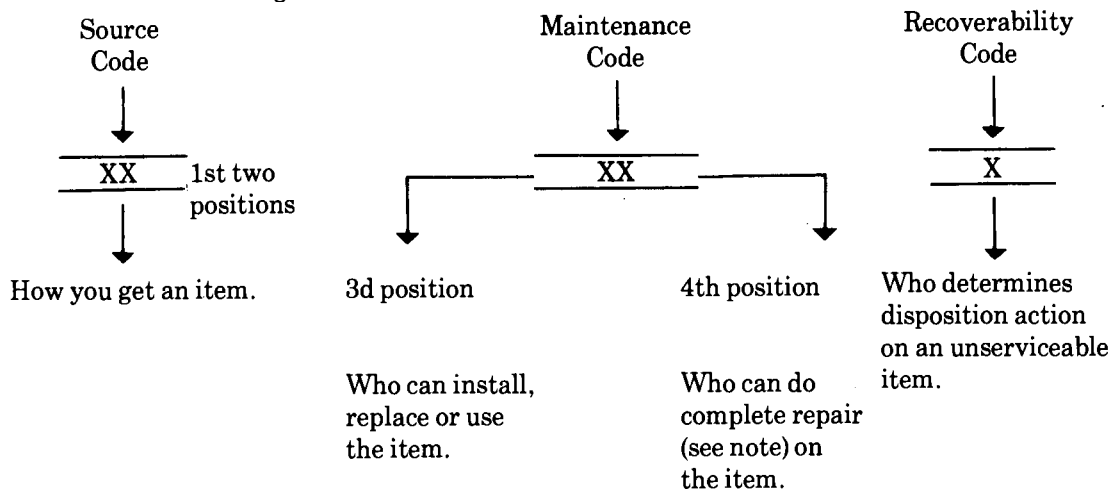

\* Complete Repair: Maintenance capacity, capability, and authority to perform all corrective maintenance tasks of the "Repair" function In a use/user environment in order to restore serviceability to a failed item.

(1) Source Code. The source code tells you how you get an item needed for maintenance, repair, or overhaul of an end item/equipment. Explanations of source codes follow.

**Source Code**

**Explanation**

PA	}	Stocked items; use the applicable NSN to request/requisition items with these source codes. They are authorized to the category indicated by the code entered in the 3rd position of the SMR code.
PB		
PC**		
PD		
PE		
PF		
PG		**NOTE : Items coded PC are subject to deterioration.

KD	}	Items with these codes are not to be requested/requisitioned individually. They are part of a kit which is authorized to the maintenance category indicated in the 3rd position of the SMR code. The complete kit must be requisitioned and applied.
KF		
KB		

MO- (Made at UNIT/AVUM level)	}	Items with these codes are not to be requested/requisitioned individually. They must be made from bulk material which is identified by the part number in the DESCRIPTION and USABLE ON CODE (UOC) column and listed in the Bulk Material group of the repair parts list in the RPSTL. If the item is authorized to you by the 3rd position code of the SMR code, but the source code indicates it is made at a higher level, order the item from the higher level of maintenance.
MF- (Made at DS/AVUM level)		
MH- (Made at GS level)		
ML- (Made at Specialized Repair Activity (SRA))		
MD- (Made at Depot)		

AO- (Assembled by Unit/AVUM Level)	}	Items with these codes are not to be requested/requisitioned individually. The parts that make up the assembled item must be requisitioned or fabricated and assembled at the level of maintenance indicated by the source code. If the 3rd position of the SMR code, authorizes you to replace the item, but the source code indicates the items are assembled at a higher level, order the item from the higher level of maintenance.
AF- (Assembled by DS/AVUM code Level)		
AH- (Assembled by GS Category)		
AL- (Assembled by SRA)		
AD- (Assembled by Depot)		

XA - Do not requisition an "XA"-coded item. Order its next higher assembly. (Refer to the NOTE below.)

XB - If an "XB" item is not available from salvage, order it using the CAGEC and part number given.

XC - Installation drawing, diagram, instruction sheet, field service drawing, that is identified by manufacturer's part number.

XD - Item is not stocked. Order an "XD"-coded item through normal supply channels using the CAGEC and part number given, if no NSN is available.

**NOTE**

Cannibalization or controlled exchange, when authorized, may be used as a source of supply for items with the above source codes, except for those source coded "XA" or those aircraft support items restricted by requirements of AR 750-1.

(2) Maintenance Code. Maintenance codes tell you the level(s) of maintenance authorized to USE and REPAIR support items. The maintenance codes are entered in the third and fourth positions of the SMR code as follows:

(a) The maintenance code entered in the third position tells you the lowest maintenance level authorized to remove, replace, and use an item. The maintenance code entered in the third position will indicate authorization to the following levels of maintenance.

<b>Maintenance Code</b>	<b>Application/Explanation</b>
C - Crew or operator maintenance done within unit/AVUM maintenance.	
O - Unit level VAVUM maintenance can remove, replace, and use the item.	
F - Direct support/AVIM maintenance can remove, replace, and use the item.	
H - General support maintenance can remove, replace, and use the item.	
L - Specialized repair activity can remove, replace, and use the item.	
D - Depot can remove, replace, and use the item.	

(b) The maintenance code entered in the fourth position tells whether or not the item is to be repaired and identifies the lowest maintenance level with the capability to do complete repair (i.e., perform all authorized repair functions). This position will contain one of the following maintenance codes.

**NOTE**

Some limited repair may be done on an item at a lower level of maintenance, if authorized by the Maintenance Allocation Chart (MAC) and SMR codes.

<b>Maintenance Code</b>	<b>Application/Explanation</b>
O - Unit /AVUM is the lowest level that can do complete repair of the item.	
F - Direct support /AVIM is the lowest level that can do complete repair of the item.	
H - General Support is the lowest level that can do complete repair of the item.	
L - Specialized repair activity is the lowest level that can do complete repair of the item.	
D - Depot is the lowest level that can do complete repair of the item.	
Z - Nonreparable. No repair is authorized.	
B - No repair is authorized. No parts or special tools are authorized for the maintenance of a "B" coded item. However, the item may be reconditioned by adjusting, lubricating, etc., at the user level.	

(3) Recoverability. Recoverability codes are assigned to items to indicate the disposition action on unserviceable items. The recoverability code is entered in the fifth position of the SMR Code as follows:

**Recoverability  
Codes**

**Application/Explanation**

- Z - Nonreparable item. When unserviceable, condemn and dispose of the item at the level of maintenance shown in 3rd position of SMR Code.
- O - Reparable item. When not economically reparable, condemn and dispose of the item at unit or AVUM level.
- F - Reparable item. When uneconomically reparable, condemn and dispose of the item at the direct support or AVIM level.
- H - Reparable item. When uneconomically reparable, condemn and dispose of the item at the general support level.
- D - Reparable item. When beyond lower level repair capability, return to depot. Condemnation and disposal of item not authorized below depot level.
- L - Reparable item. Condemnation and disposal not authorized below specialized repair activity (SRA).
- A - Item requires special handling or condemnation procedures because of specific reasons (e.g., precious metal content, high dollar value, critical material, or hazardous material). Refer to appropriate manuals/directives for specific instructions.

c. CAGEC (Column (3)). The Commercial and Government Entity Code (CAGEC) is a 5-digit numeric code which is used to identify the manufacturer, distributor, or Government agency/activity that supplies the item.

d. PART NUMBER (Column (4)). Indicates the primary number used by the manufacturer, (individual, company, firm, corporation, or Government activity), which controls the design and characteristics of the item by means of its engineering drawings, specifications, standards, and inspection requirements to identify an item or range of items.

**NOTE**

When you use an NSN to requisition an item, the item you receive may have a different part number from the number listed.

e. DESCRIPTION AND USABLE ON CODE (UOC) (Column (5)). This column includes the following information:

- (1) The Federal item name and, when required, a minimum description to identify the item.
- (2) Part numbers of bulk materials are referenced in this column in the line entry for the item to be manufactured/fabricated.
- (3) The statement "END OF FIGURE" appears just below the last item description in Column (5) for a given figure in both Section II and Section III..
- (4) Items that are included in kits and sets are listed below the name of the kit or set.
- (5) Spare/repair parts that make up an assembled item are listed immediately following the assembled item line entry.
- (6) Part numbers for bulk materials are referenced in this column in the line item entry for the item to be manufactured/fabricated.
- (7) The indenture, shown as dots appearing before the repair part, indicates that the item is a repair part of the next higher assembly.



f. QTY (Column (6)) The QTY (quantity per figure) column indicates the quantity of the item used in the breakout shown on the illustration/figure, which is prepared for a functional group, subfunctional group, or an assembly. A "V" appearing in this column instead of a quantity indicates that the quantity is variable and may vary from application 1 application.

**C.4 EXPLANATION OF INDEX FORMAT AND COLUMNS (SECTION IV).**

a. NATIONAL STOCK NUMBER (NSN) INDEX.

(1) STOCK NUMBER Column. This column lists the NSN in national item identification number (NIIN) sequence. The NIIN consists of the last nine digits of the NSN, i.e.

NSN
5305-01-574-1467
NIIN

When using this column to locate an item, ignore the first four digits of the NSN. Use the complete NSN (13 digits) when requisitioning items by stock number.

(2) FIG. Column. This column lists the number of the figure where the item is identified/located. The figures are in numerical order in Section II and Section III.

(3) ITEM Column. The item number identifies the item associated with the figure listed in the adjacent FIG. column. This item is also identified by the NSN listed on the same line.

b. PART NUMBER INDEX. Part numbers in this index are listed in ascending alphanumeric sequence (i.e., vertical arrangement of letter and number combinations which place the first letter or digit of each group in order A through Z, followed by the numbers 0 through 9, and each following letter or digit in like order).

(1) CAGEC Column. The Commercial and Government Entity Code (CAGEC) is a 5-digit numeric code used to identify the manufacturer, distributor, or Government agency/activity that supplies the item.

(2) PART NUMBER Column. Indicates the primary number used by the manufacturer (individual, firm, corporation, or Government activity), which controls the design and characteristics of the item by means of its engineering drawings, specifications, standards, and inspection requirements to identify an item or range of items.

(3) STOCK NUMBER Column. This column lists the NSN for the associated part number and manufacturer identified in the PART NUMBER and CAGEC columns to the left.

(4) FIG. Column. This column lists the number of the figure where the item is identified/located in Section II and Section III.

(5) ITEM Column. The item number is that number assigned to the item as it appears in the figure referenced in the adjacent figure number column.

c. FIGURE AND ITEM NUMBER INDEX.

(1) FIG. Column. This column lists the number of the figure where the item is identified/located in Section II and Section III.

(2) ITEM Column. The item number is that number assigned to the item as it appears in the figure referenced in the adjacent figure number column.

(3) STOCK NUMBER Column. This column lists the NSN for the item.

(4) CAGEC Column. The Commercial and Government Entity Code (CAGEC) is a 5-digit numeric code used to identify the manufacturer, distributor, or Government agency/activity that supplies the item.

(5) PART NUMBER Column. Indicates the primary number used by the manufacturer (individual, firm, corporation, or Government activity), which controls the design and characteristics of the item by means of its engineering drawings, specifications, standards, and inspection requirements to identify an item or range of items.

### **C.5 SPECIAL INFORMATION.**

a. FABRICATION INSTRUCTIONS. Bulk materials required to manufacture items are listed in the Bulk Material Functional Group of this RPSTL. Part numbers for bulk materials are also referenced in the description column of the line entry for the item to be manufactured/fabricated. Detailed fabrication instructions for items source coded to be manufactured or fabricated are found in this manual.

b. INDEX NUMBERS. Items which have the word BULK in the figure column will have an index number shown in the item number column. This index number is a cross-reference between the National Stock Number/Part Number Index and the bulk material list in Section II.

### **C.6 HOW TO LOCATE REPAIR PARTS.**

a. When National Stock Numbers or Part Numbers are NOT Known.

(1) First. Using the table of contents, determine the assembly or subassembly group to which the item belongs. This is necessary since figures are prepared for assembly groups and subassembly groups, and listings are divided into the same groups.

(2) Second. Find the figure covering the assembly group or subassembly group to which the item belongs.

(3) Third. Identify the item on the figure and use the Figure and Item Number Index to find the NSN.

b. When National Stock Number or Part Number is Known.

(1) First. Using the of National Stock Number and Part Number Indexes find the pertinent National Stock Number or Part Number. The NSN index is in National Item Identification Number (NIIN) sequence (see paragraph C.4.a). The part numbers in the Part Number index are listed in ascending alphanumeric sequence (see paragraph C.4.b.). Both indexes cross-reference you to the illustration/figure and item number of the item you are looking for

(2) Second. Turn to the figure and item number, verify that the item is the one you are looking for, then locate the item number in the repair parts list for the figure

**C.7 ABBREVIATIONS.** Abbreviations used in this manual are listed in MIL-STD-12.



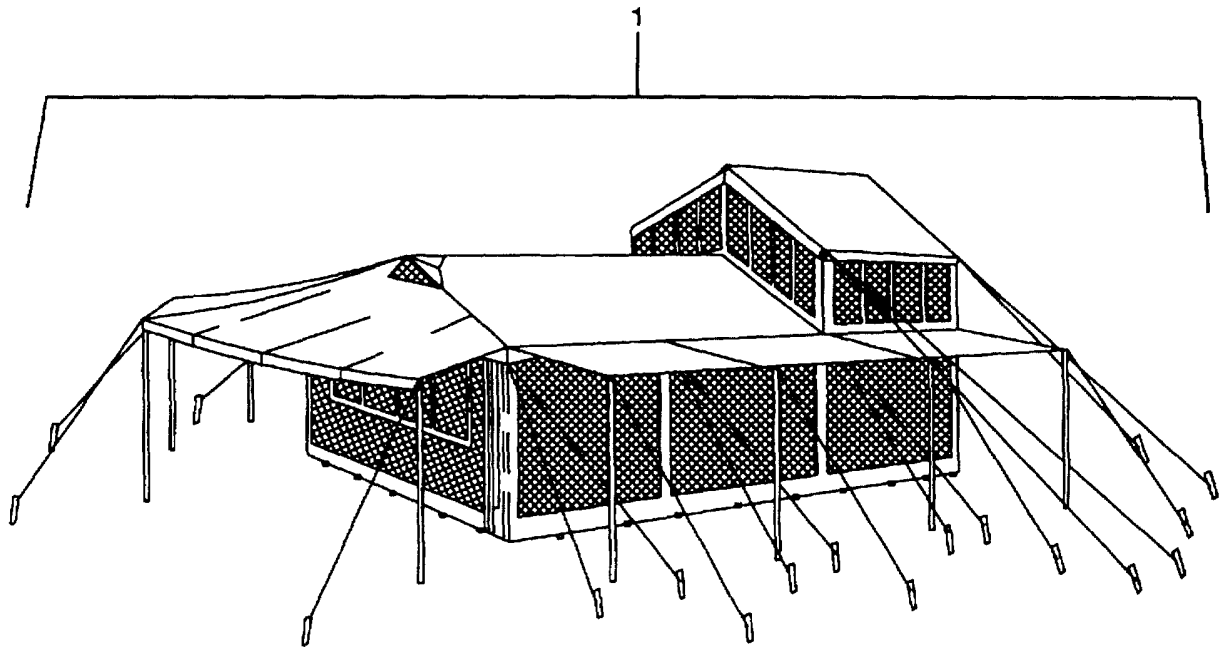

Figure C-1. Tent, Kitchen, Flyproof, M1948

(C-7 blank)/C-8

SECTION II.

TM 10-8340-205-13&P

(1) ITEM NO	(2) SMR CODE	(3) CAGEC	(4) PART NUMBER	(5) DESCRIPTION AND USABLE ON CODES(UOC)	(6) QTY
1	PAOFF	81349	MIL-T-10009	GROUP 00 TENT KITCHEN, FLYPROOF, M1948 FIG. C-1 TENT, KITCHEN, FLYPROOF TENT, KITCHEN, FLYPROOF ..... END OF FIGURE	1

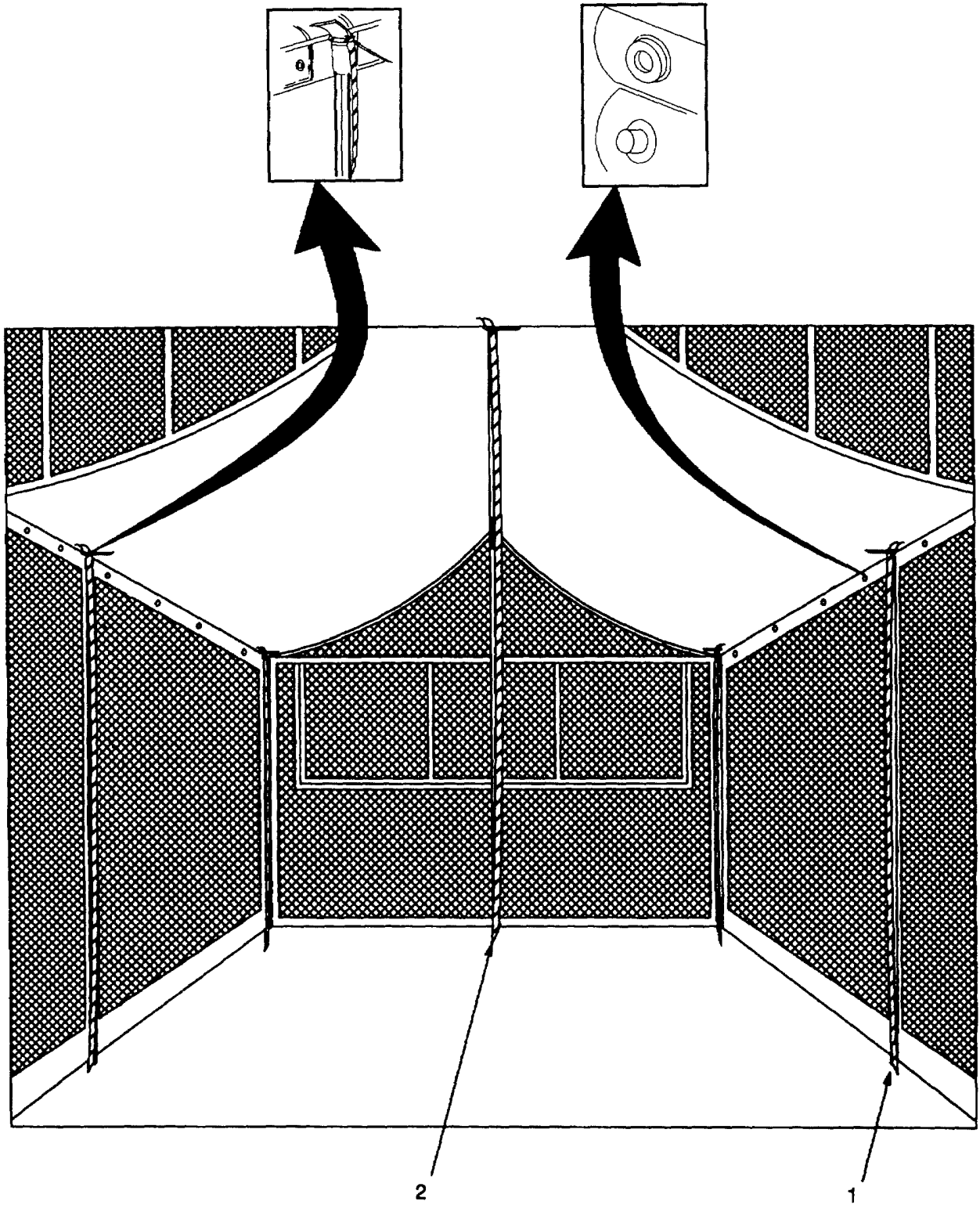

Figure C-2. Tent Jumper Lines

SECTION II.

TM 10-8340-205-13&P

(1) ITEM NO	(2) SMR CODE	(3) CAGEC	(4) PART NUMBER	(5) DESCRIPTION AND USABLE ON CODES(UOC)	(6) QTY
				GROUP 01 TENT BODY	
				FIG. C-2 TENT JUMPER LINES	
1	PAOZZ	81349	MIL-L-1709	LINE, TENT, JUMPER, 6 FT. LG., (1 830-M) MIL-SPEC L-1709 (CA) .....	10
2	PAOZZ	64067	8340-00-252-2282	LINE, TENT, JUMPER, 10 FT, 6 IN. LG, (3.200-M) MIL-SPEC L-1709 (CA) .....	4
				END OF FIGURE	

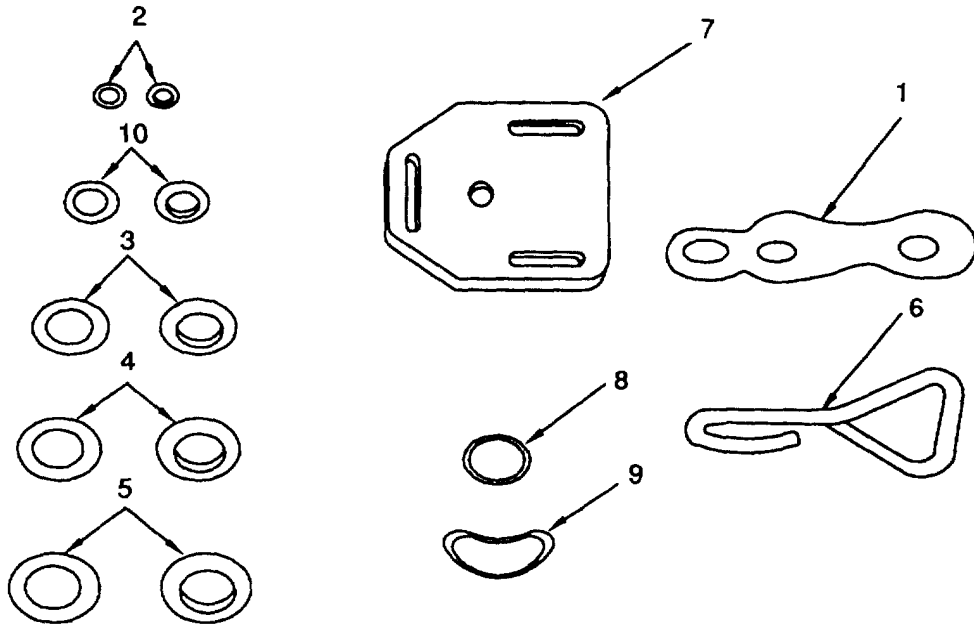

Figure C-3. Tent Hardware



## SECTION II.

TM 10-8340-205-13&amp;P

(1) ITEM NO	(2) SMR CODE	(3) CAGEC	(4) PART NUMBER	(5) DESCRIPTION AND USABLE ON CODES(UOC)	(6) QTY
				GROUP 01 TENT BODY	
				FIG. C-3 TENT HARDWARE	
1	PAOZZ	81349	MIL-F-1611	SLIP, TENT LINE, MAGNESIUM, 3 1/4 IN., MIL SPEC 5-1734 .....	31
2	PAFZZ	81349	G16491TYPE3 CLASS3SIZE0	GROMMET, METALLIC, NO. 0, VENTILATOR FLAP, FRONT, STACK OPENING, MIL SPEC G-16491.....	30
3	PAOZZ	81349	MILG16491TYPE3 CLASS3SIZE4	GROMMET, METALLIC, NO. 4, FOOTSTOPS, TENT EAVE .....	36
4	PAOZZ	81349	MILG16491TYPE3 CLASS3SIZE5	GROMMET, METALLIC, NO. 5, FOOTSTOPS, TENT EAVE .....	25
5	PAFZZ	81349	MILG16491BTYPE 3CLASS3SIZE6	GROMMET, METALLIC, NO. 6, TENT RIDGE, MIL SPEC G-16491.....	4
6	PAFZZ	81349	MILH1608AMEND2	HOOD, TENT, STEEL, TENT EAVE, MIL SPEC H-1608 (CA).....	10
7	PAFZZ	81349	MILP500	PLATE, RIDGE, TENT, ROOF, MIL SPEC P-500 (CA).....	4
8	PAFZZ	81349	MIL-R-2327 CLASS2SIZE4	RING, CONNECTOR, ROUND, FRONT VENTILATOR FLAP TIE LINE, MIL SPEC R-1482.....	2
9	PAFZZ	81349	MILR3390	RING, DEE, STACK VENTILATOR FLAP, MIL SPEC R-3390.....	68
10	PAFZZ			GROMMET, METALLIC: VENTILATOR FLAP STACK OPENING, REAR, BRASS NO. 1, TYPE 3, CLASS 3, MIL SPEC G-16491 .....	10
				END OF FIGURE	

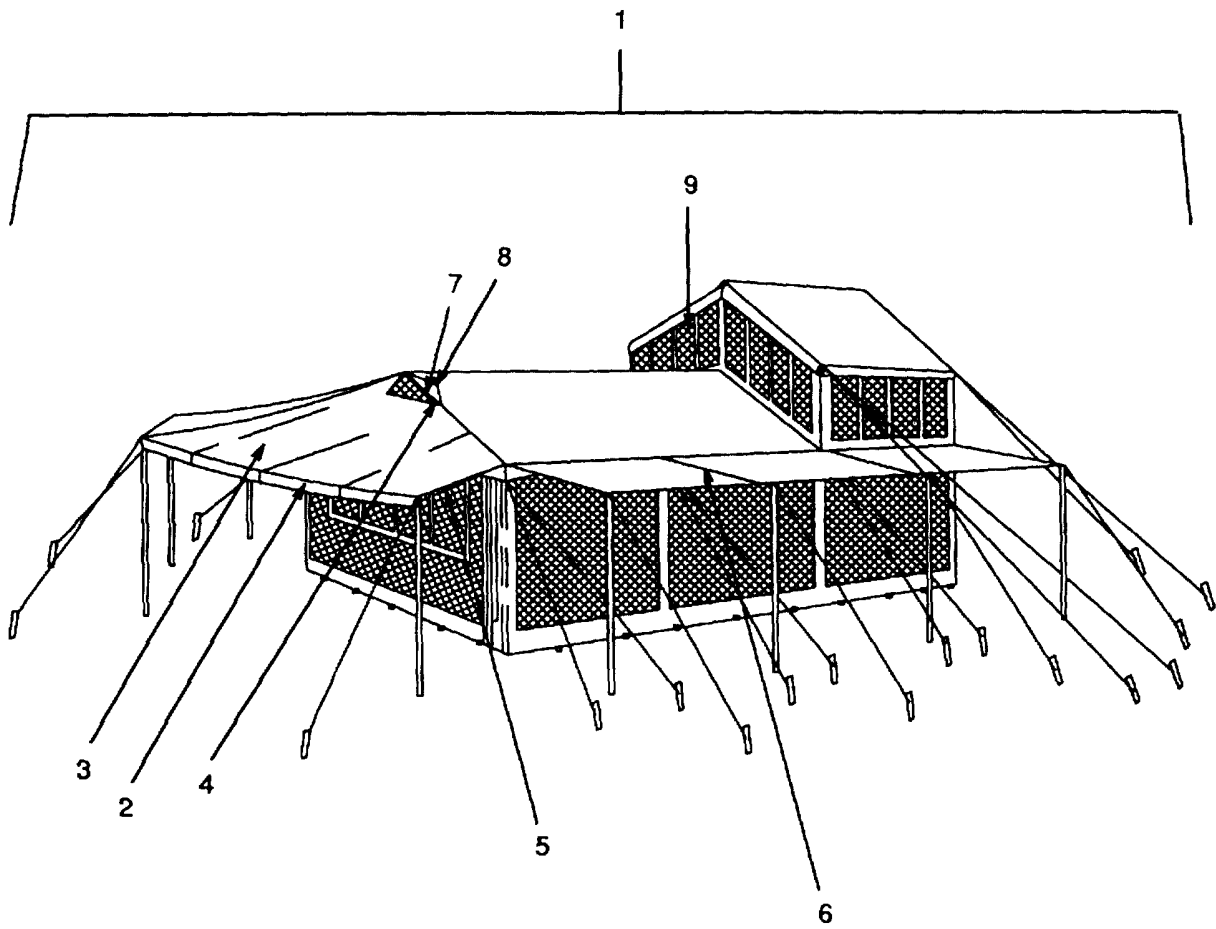

Figure C-4. Tent Body, Exterior

## SECTION II.

TM 10-8340-205-13&amp;P

(1) ITEM NO	(2) SMR CODE	(3) CAGEC	(4) PART NUMBER	(5) DESCRIPTION AND USABLE ON CODES(UOC)	(6) QTY
				GROUP 01 TENT BODY	
				FIG. C-4 TENT BODY, EXTERIOR	
1	PAOFF	81349	MIL-T-10009	TENT, KITCHEN, FLYPROOF .....	1
2	MFFZZ	81349	MIL-T-43566	BINDING, COTTON, SOD CLOTH, FRONT AND REAR WALLS, MAKE FROM TAPE, MIL-T-43566 .....	V
3	MFFZZ	81349	MIL-C-43627	TENT, CLOTH PANELS, MAKE FROM CLOTH, COTTON, DUCK, OLIVE DRAB, MIL-C-43627.....	V
4	MFFZZ	81349	MIL-T-43566	FACING, COTTON, VENTILATOR SCREENS, MAKE FROM TAPE, MIL-T43566 .....	V
5	PAFZZ	81348	VF106TYPE3 STYLE1 SIZEH	FASTENER, SLIDE, INTERLOCKING, CORNER 70 IN. LG .....	4
6	PAFZZ	81348	VF106TYPE5 STYLE3SIZEH	FASTENER, SLIDE, INTERLOCKING, SIDEWALL, 70 IN LG., FED SPEC V-F-106.....	4
7	PAFZZ	81349	MILF10884	FASTENER, SNAP, INTERLOCKING .....	68
8	MFFZZ	81349	MIL-C-43627	FLAP, VENTILATOR SCREENS, MAKE FROM CLOTH, MIL-C-43627 .....	9
9	PAFZZ	96906	MS20230BS1	GROMMET, METALLIC, NO. 1, MIL SPEC G16491 .....	2
				<b>NOTE</b>	
				The remaining items are not illustrated.	
10	MFFZZ		FED SPEC DDD-L-20	LABEL, CLOTH, ERECTION INSTRUCTIONS, FED SPEC DDD-L-20 .....	1
11	MFFZZ		FED SPEC DDD-L-20	LABEL, CLOTH, IDENTIFICATION, FED SPEC DDD-L-20 .....	1
12	PAOZZ	81349	MIL-L-1709	LINE, TENT, HOOD AND VENTILATOR FLAP HOISTING, MIL SPEC L-1709 (CA) .....	18
13	PAOZZ	81349	MIL-L-1709	LINE, TENT, STACK FRONT VENTILATOR FLAP, HOISTING.....	4
14	MFFZZ	81349	MIL-T-43566	REINFORCEMENT, COTTON, SOD CLOTH, SIDE WALL, MAKE FROM TAPE, MIL-T-43566 .....	V
15	MFFZZ	81349	MIL-T-43566	REINFORCEMENT, COTTON, 1 1/2 IN. (3.810-CM) W., MAKE FROM TAPE, MIL-T-43566 .....	V
16	MFFZZ	81349	MIL-W-43638	REINFORCEMENT, COTTON, 1 1/2 IN. (3 810-CM) W, MAKE FROM WEBBING, MIL-W-43638 .....	V
17	MFFZZ	02106	890340-97	TENT SCREENING, NONMETALLIC, MAKE FROM SCREENING, 890340-97 .....	V
18	PAFZZ	88044	AN227-19BL	STUD, SNAP FASTENER, SCREEN LUG, MIL SPEC F-10884 .....	68
19	PAFZZ	96906	MS27977-8N	STUD, SNAP FASTENER, SCREEN LUG, REAR WALL, MIL SPEC F-10884.....	18
				END OF FIGURE	

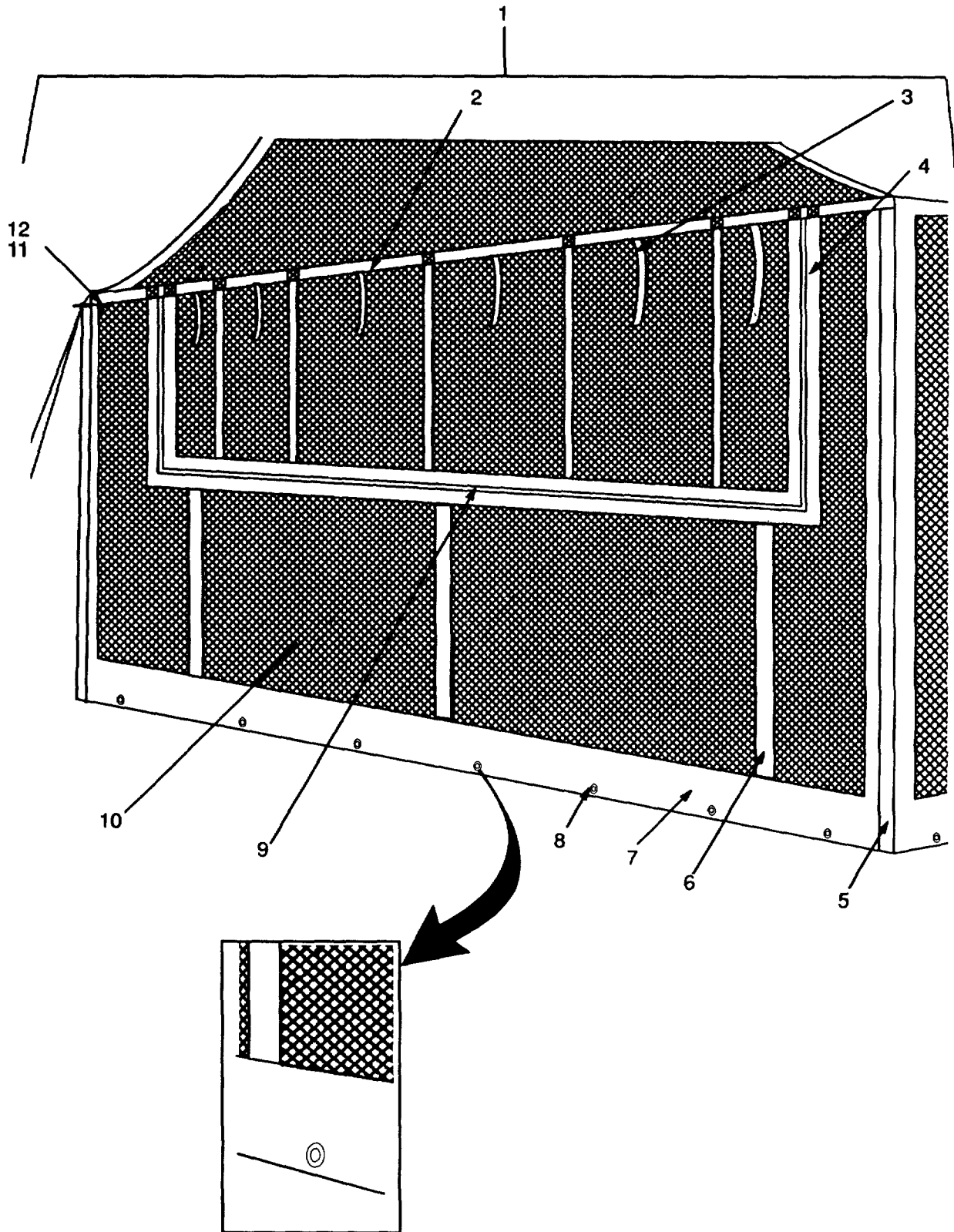

Figure C-5. Screen Wall, Tent  
C-16

## SECTION II.

TM 10-8340-205-13&amp;P

(1) ITEM NO	(2) SMR CODE	(3) CAGEC	(4) PART NUMBER	(5) DESCRIPTION AND USABLE ON CODES(UOC)	(6) QTY
				GROUP 02 SCREEN WALL, TENT	
				FIG. C-5 SCREEN WALL, TENT	
1	PAOFF	81349	MIL-T-10009	SCREEN WALL, TENT .....	1
2	MFFZZ	81349	MIL-T-43566	REINFORCEMENT, COTTON, 2 IN (5.080-CM) W., SCREEN WALL, TOP, SERVING WINDOW, SLIDE FASTENERS, MAKE FROM TAPE MIL-T-43566.....	V
3	MFFZZ	81349	MIL-T-43566	TIE TAPE, COTTON, SERVING WINDOW SCREEN, 3/4 IN. (1 900-CM) W, MAKE FROM MIL-T-43566.....	10
4	PAFZZ	81348	VF106TYPE3 STYLE1 SIZEH	FASTENER, SLIDE, INTERLOCKING, SERVING WINDOW, 30 IN. (76 200-CM) LG., FED SPEC V-F-106 .....	2
5	PAFZZ	81348	VF106TYPE3 STYLE1 SIZEH	FASTENER, SLIDE, INTERLOCKING, ENTRANCE, 70 IN. (177.800-CM) LG.....	1
6	MFFZZ	81349	MIL-T-43566	STRAP, SUPPORT, COTTON, FRONT WALL, LOWER PANEL, 1 1/2 IN. (3 810-CM) W., MAKE FROM TAPE, MIL-T-43566 .....	3
7	MFFZZ	81349	MIL-T-43566	BINDING, COTTON, SOD CLOTH, SCREEN WALL, 3/4 IN. (1 900-CM) W, MAKE FROM TAPE, MIL-T-43566 .....	V
8	PAOZZ	81349	MILG16491TYPE 3CLASS3SIZE4	GROMMET, METALLIC, FOOTSTOP, NO 4 .....	26
9	PAFZZ	81348	VF106TYPE5 STYLE3SIZEH	FASTENER, SLIDE, INTERLOCKING, SERVING WINDOW, 120 IN (304.800-CM) LG., FED SPEC V-F-106 .....	1
10	PAOZZ	02106	890340-97	TENT, SCREENING, NONMETALLIC, MAKE FROM SCREENING, 890340-97 .....	V
11	MFFZZ	81349	MILG16491TYPE 2CLASS3SIZE2	TAB, COTTON, SCREEN WALL, 2 IN (5 080-CM) W, MAKE FROM GROMMET, MILG16491TYPE2CLASS3SIZE2 AND TAPE, MIL-T-43566.....	6
12	PAOZZ	81349	MILG16491TYPE 3CLASS3SIZE5	GROMMET, METALLIC, SCREEN WALL TAB, NO 5 .....	6
				<b>NOTE</b>	
				The below listed items are not illustrated	
13	PAFZZ	19207	549252	GROMMET, METALLIC, WALL REINFORCEMENT, NO 3, MIL SPEC G-1 6491 .....	68
14	PAOZZ	81349	MIL-L-1709	LINE, TENT, COTTON, SCREEN WALL TIE LINE, 1/4 IN (0.640-CM) DIA., 3 FT 4 IN (O 915-M, 10 160-CM) LG MIL SPEC L-1709 (CA) .....	1
15	PAFZZ	81349	MILF10884	FASTENER, SNAP, SCREEN END .....	18
				END OF FIGURE	

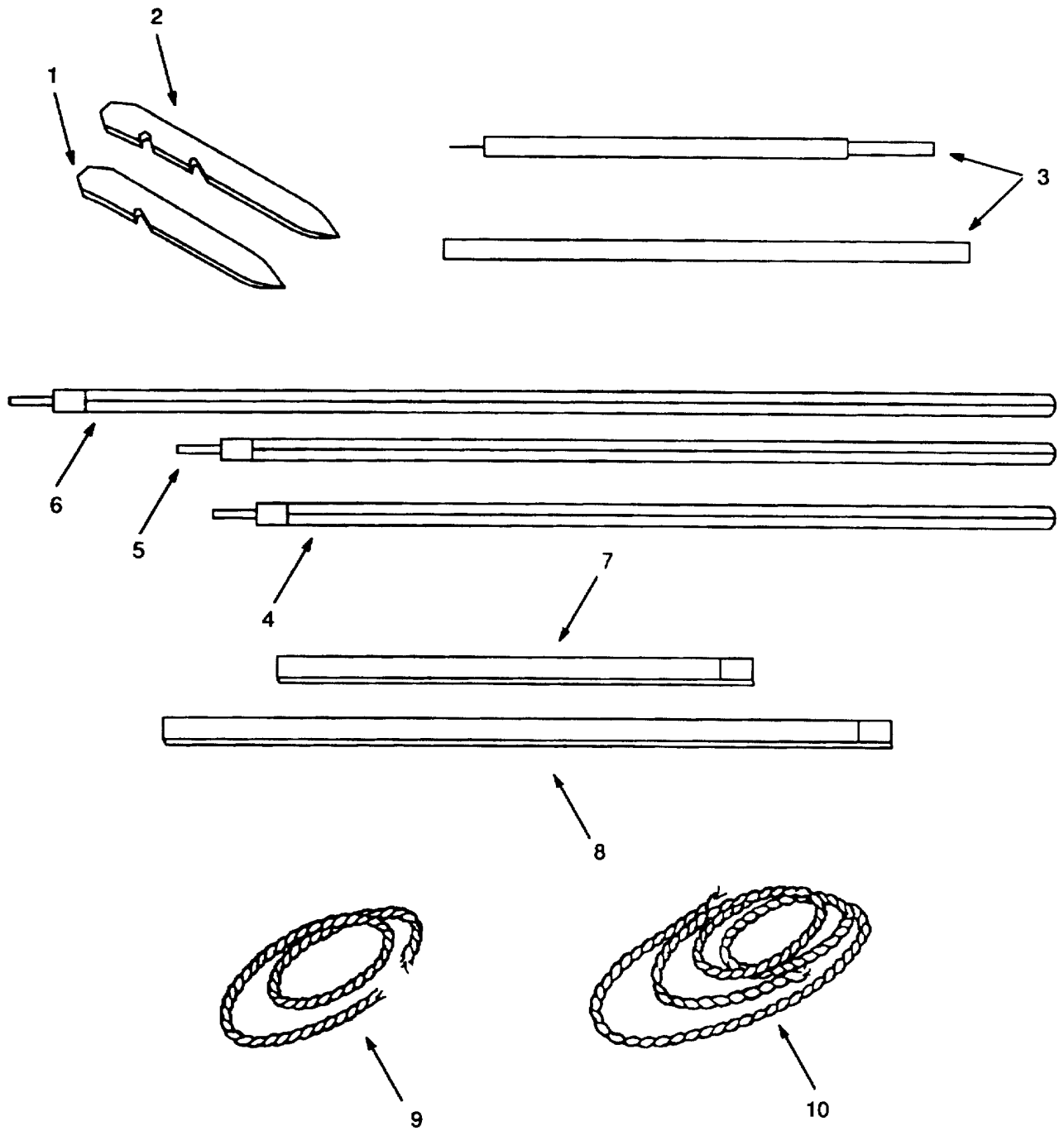

Figure C-6. Tent Support and Anchoring

(1) ITEM NO	(2) SMR CODE	(3) CAGEC	(4) PART NUMBER	(5) DESCRIPTION AND USABLE ON CODES(UOC)	(6) QTY
<b>GROUP 03 TENT SUPPORT AND ANCHORING</b>					
<b>FIG. C-6 TENT SUPPORT AND ANCHORING</b>					
1	PAOZZ	81349	8340-00-261-9750	PIN, TENT WOOD, 16 IN. (40.600-CM) LG, MIL SPEC P-2383 (CA).....	32
2	PAOZZ	64067	8340-00-261-9751	PIN, TENT, WOOD, 24 IN. (61.000-CM) LG., MIL SPEC P-2383 (CA).....	31
3	PAOZZ	64067	MILP549	POLE, TENT, CENTER, UPRIGHT, JOINTED, 12 FT., 3 IN. (3.720-M), MIL SPEC P-549 (CA) .....	2
4	PAOZZ	81349	MILP549	POLE, TENT, WOOD, UPRIGHT, SOLID, 6 FT. 2 IN. (1.950-M) LG., MIL SPEC P-549 (CA) .....	16
5	PAOZZ	81349	MILP549	POLE, TENT, WOOD, UPRIGHT, SOLID, 7 FT. (2.135-M) LG., MIL SPEC P-549 (CA).....	1
6	PAOZZ	81349	MILP549	POLE, TENT, WOOD, UPRIGHT, SOLID, 9 FT (2.745-M) LG., MIL SPEC P-549 (CA).....	5
7	PAOZZ	81349	MILP549	POLE, TENT, WOOD, RIDGE, WITH HARDWARE, WITHOUT CLEATS, 5 FT. 11 1/4 IN. (1.830-M) LG., MIL SPEC P-549 (CA) .....	1
8	PAOZZ	81349	MILP549	POLE, TENT, WOOD, RIDGE, SOLID, WITH HARDWARE, WITHOUT CLEATS, 11 FT. 10 IN. (3.590-M) LG., MIL SPEC P-549 (CA).....	1
9	MFFZZ	81349	MIL-L-1709	LINE, TENT, COTTON, FOOTSTOP, 1/4 IN. (0.635-CM) DIA., 19 IN. (48.260-CM) LG., MIL SPEC L-1709 (CA) .....	67
10	MFFZZ	81349	8340-00-252-2273	LINE, TENT, MANILA, STACK GUY LINE, 5/16 IN. (0.794-CM) DIA., 19 FT. (48.260-CM) LG., MIL SPEC L-1709 (CA) .....	8
END OF FIGURE					

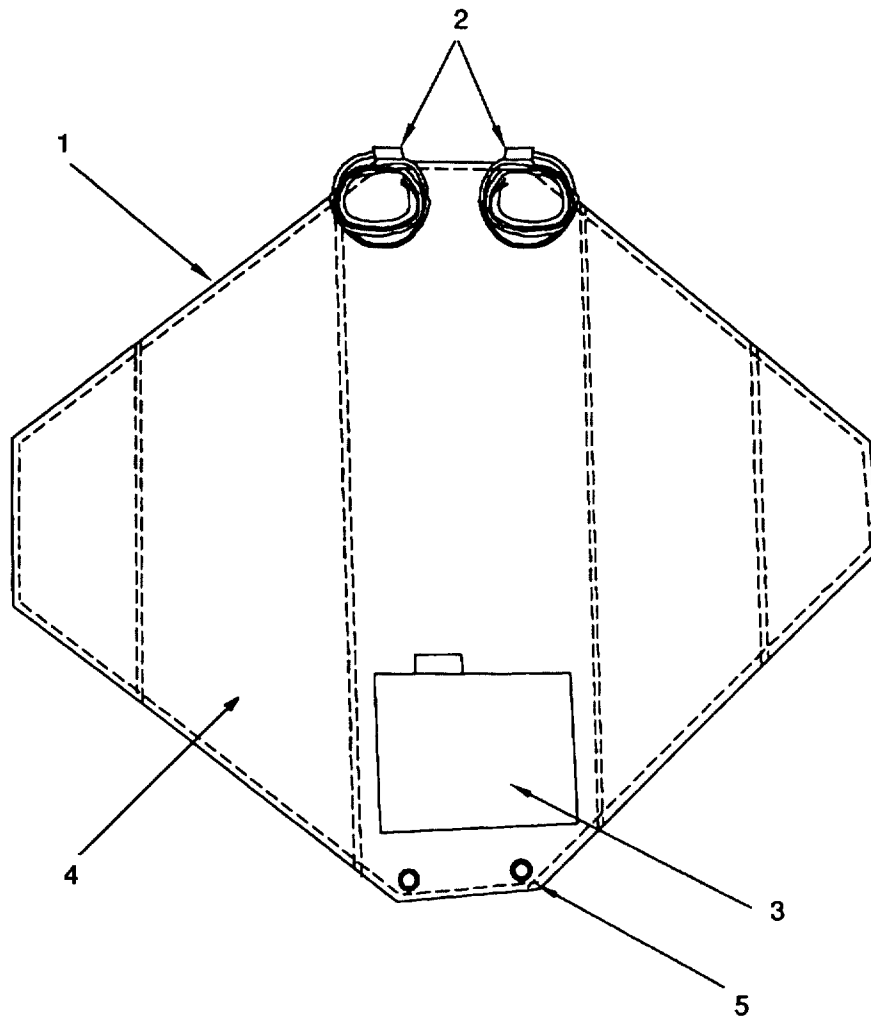

Figure C-7. Tent Cover



SECTION II.

TM 10-8340-205-13&P

(1) ITEM NO	(2) SMR CODE	(3) CAGEC	(4) PART NUMBER	(5) DESCRIPTION AND USABLE ON CODES(UOC)	(6) QTY
<p><b>GROUP 04 TENT COVER</b></p> <p><b>FIG. C-7 TENT COVER</b></p>					
1	PAOFF	64067	8340-00-262-2397	COVER, TENT, COTTON DUCK, OD, MIL SPEC T-1712 (CA).....	1
2	PAOZZ	64067	8340-00-252-2271	LINE, TENT, TIE LINE, ONE END WITH EYE, ONE END SEWN, 5/16 IN. (0.794-CM) DIA., 13 FT. (3.965-M) LG., MIL SPEC L-1709 .....	2
3	MFFZZ		FED SPEC DDD-L-20	LABEL, CLOTH, TYPE IV, CLASS 8, MAKE FROM FED SPEC DDD-L-20, ERECTION INSTRUCTIONS, IDENTIFICATION .....	2
4	PAOZZ	81349	MILG16491TYPE3 CLASS3SIZE4	GROMMET, METALLIC, NO. 4.....	4
5	MFFZZ	81349	MIL-C-43627	PANEL CLOTH, COTTON, DUCK, BASIC FABRIC OF COVER, OD. MAKE FROM CLOTH, COTTON DUCK, MIL-C-43627.....	V
<p>END OF FIGURE</p>					

## SECTION II.

TM 10-8340-205-13&amp;P

(1) ITEM NO	(2) SMR CODE	(3) CAGEC	(4) PART NUMBER	(5) DESCRIPTION AND USABLE ON CODES(UOC)	(6) QTY
<b>GROUP 05 BULK MATERIALS</b>					
<b>FIG. BULK</b>					
1	PAFZZ	81349	MIL-T-43566	TAPE, TEXTILE, COTTON, OD, 3/4 IN (1.905-CM) W .....	V
2	PAFZZ	81349	MIL-T-43566	TAPE, TEXTILE, COTTON, OD, 1 1/2 IN. (3.810-CM) W. ....	V
3	PAFZZ	81349	MIL-C-43627	CLOTH, COTTON, DUCK, BASIC FABRIC OF TENT, OD, 12.29 OZ. (348.400-GR), 29 1/2 IN. (74.930-CM) W .....	V
4	PAFZZ	81349	MIL-W-43638	WEBBING, TEXTILE, COTTON, OD, 1 1/2 IN (3.810-CM) W .....	V
5	PAFZZ	02106	890340-97	SCREEN PLASTIC, OG, 22 MESH, STACK, FRONT, REAR AND SIDE, VENTILATOR, FRONT AND SIDE .....	V
6	PAFZZ	80244	V-T-285TY1CL15S A&B	THREAD, POLYESTER, OD, TICKET NO. E .....	V
7	PAFZZ	70167	23B28030-4	THREAD, POLYESTER, OD, TICKET NO. F .....	V
8	PAOZZ	70167	23B28030-3	THREAD, POLYESTER, OD, TICKET NO. FF .....	V
9	PAFZZ	81349	MIL-T-43566	TAPE, TEXTILE, COTTON, OD, 2 IN. (5.080-CM), W .....	V
10	PAFZZ	81349	G16491TYPE3	GROMMET, SIZE 0 .....	V
11	PAFZZ	96906	MS20230BS1	GROMMET, SIZE 1 .....	V
12	PAFZZ	81349	MILG16491TYPE3	GROMMET, SIZE 2 .....	V
13	PAFZZ	19207	549252	GROMMET, SIZE 3 .....	V
14	PAFZZ	81349	MILG16491TYPE3	GROMMET, SIZE 4 .....	V
15	PAFZZ	81349	MILG16491TYPE3	GROMMET, SIZE 5 .....	V
16	PAFZZ	81349	MILG16491TYPE3	GROMMET, SIZE 6 .....	V
END OF FIGURE					

**SECTION III. SPECIAL TOOLS LIST**

**(Not Applicable)**

SECTION IV. CROSS-REFERENCE INDEXES

CROSS-REFERENCE INDEXES

NATIONAL STOCK NUMBER INDEX

STOCK NUMBER	FIG.	ITEM	STOCK NUMBER	FIG.	ITEM
8340-00-082-2167	C-6	6	8315-00-253-6289	C-4	14
5325-00-174-2926	C-4	19		C-5	4
5325-00-174-9067	C-5	5		C-5	10
8340-00-188-8392	C-6	7	8315-00-253-6292	C-4	2
8340-00-188-8396	C-6	8		C-4	4
8340-00-188-8406	C-6	4		C-4	15
8340-00-188-8407	C-6	5		C-5	8
8340-00-188-8411	C-6	3	8315-00-253-6293	C-5	9
5325-00-202-2053	C-3	4		C-5	15
	C-5	12	8340-00-254-8997	C-5	1
8340-00-205-2753	C-3	6	5340-00-260-1412	C-3	9
8340-00-205-2759	C-3	1	8340-00-261-9750	C-6	1
5325-00-222-1522	C-4	5	8340-00-261-9751	C-6	2
	C-5	6	8340-00-262-2397	C-7	1
5325-00-222-1529	C-5	7	5340-00-264-1222	C-3	8
5325-00-222-1530	C-4	6	5325-00-276-4273	C-4	18
5325-00-231-6622	C-3	3	5325-00-286-9554	C-4	7
	C-5	11		C-5	3
	C-7	5	8340-00-470-2341	C-1	1
5325-00-231-6624	C-3	5		C-4	1
8340-00-247-4396	C-3	7	8305-00-634-5048	C-4	16
8340-00-252-2271	C-7	2	5325-00-639-8109	C-4	9
8340-00-252-2273	C-6	10	5325-00-641-0404	C-5	15
8340-00-252-2282	C-2	2	5325-00-641-1278	C-3	2
8340-00-252-2286	C-2	1	5325-00-641-3430	C-5	2
8340-00-252-2299	C-6	9	8305-00-926-1613	C-5	14
8340-00-252-2301	C-4	12	8305-00-926-6171	C-4	3
8340-00-252-2303	C-4	13		C-4	8
8340-00-252-2305	C-5	13		C-7	4

CROSS-REFERENCE INDEXES

CAGEC	PART NUMBER	PART NUMBER INDEX		FIG.	ITEM
			STOCK NUMBER		
88044	AN227-19BL FED SPEC DDD-L-20		5325-00-276-4273	C-4	18
				C-4	10
				C-4	11
				C-7	3
81349	G16491TYPE3CLASS3SIZE0		5325-00641-1278	C-3	2
				BULK	10
81349	MIL-C-43627		8305-00-926-6171	C-4	3
				C-4	8
				C-7	4
				BULK	3
81349	MILF10884		5325-00-286-9554	C-4	7
81349	MILG16491TYPE3CLASS3SIZE2		5325-00-641-0404	C-5	3
				C-5	15
81349	MILG16491TYPE3CLASS3SIZE4		5325-00-231-6622	BULK	12
				C-3	3
81349	MILG16491TYPE3CLASS3SIZE5		5325-00-202-2053	C-5	11
				BULK	14
				C-3	4
				C-5	12
81349	MILG16491BTYPE3CLASS3SIZE6		5325-00-231-6624	BULK	15
				C-3	5
81349	MILH1608AMEND2		8340-00-205-2753	BULK	16
81349	MIL-L-1709		8340-00-252-2286	C-3	6
			8340-00-252-2286	C-2	1
			8340-00-252-2301	C-4	12
			8340-00-252-2303	C-4	13
			8340-00-252-2305	C-5	13
			8340-00-252-2289	C-6	9
			8340-00-247-4396	C-3	7
81349	MILP500		8340-00-188-8411	C-6	3
64067	MILP549		8340-00-188-8406	C-6	4
81349	MILP549		8340-00-188-8407	C-6	5
81349	MILP549		8340-00-082-2167	C-6	6
81349	MILP549		8340-00-188-8392	C-6	7
81349	MILP549		8340-00-188-8396	C-6	8
81349	MILP2327CLASS2SIZE4		5365-00-264-1222	C-6	8
81349	MILR3390		5365-00-260-1412	C-3	9
81349	MIL-T-10009		8340-00-470-2341	C-1	1
			8340-00-470-2341	C-4	1
			8340-00-470-2341	C-4	1
			8340-00-254-8997	C-5	1
			8315-00-253-6292	C-4	2
			8315-00-253-6289	C-4	4
			8315-00-253-6289	C-4	14
81349	MIL-T43566		8315-00-253-6292	C-4	15
			8315-00-253-6289	C-5	4
			8315-00-253-6292	C-5	8

CROSS-REFERENCE INDEXES

CAGEC	PART NUMBER	PART NUMBER INDEX		FIG.	ITEM
			STOCK NUMBER		
			8315-00-253-6293	C-5	9
			8315-00-253-6289	C-5	10
			8315-00-253-6293	C-5	15
			8315-00-253-6289	BULK	1
			8315-00-253-6292	BULK	2
			8315-00-253-6293	BULK	9
81349	MIL-W-43638		8305-00-634-5048	C-4	16
				BULK	4
96906	MS20230BS1		5325-00-639-8109	C-4	9
				BULK	11
96906	MS27977-8N		5325-00-174-2926	C-4	19
81348	VF106TYPE3STYLE1SIZEH		5325-00-222-1522	C-4	5
				C-5	6
			5325-00-174-9067	C-5	5
81348	VF106TYPE5STYLE3SIZEH		5325-00-222-1530	C-4	6
			5325-00-222-1529	C-5	7
80244	V-T-285-TY1CL1SSA&B		8310-00-988-1298	BULK	6
70167	23B28030-3		8310-00-988-1301	BULK	8
70167	23B28030-4		8310-00-988-1300	BULK	7
70167	23B28045-1		8340-00-205-2759	C-3	1
19207	549252		5325-00-641-3430	C-5	2
				BULK	13
64067	8340-00-252-2271		8340-00-252-2271	C-7	2
81349	8340-00-252-2273		8340-00-252-2273	C-6	10
64067	8340-00-252-2282		8340-00-252-2282	C-2	2
81349	8340-00-261-9750		8340-00-261-9750	C-6	1
64067	8340-00-261-9751		8340-00-261-9751	C-6	2
64067	8340-00-262-2397		8340-00-262-2397	C-7	1
02106	890340-97		8305-00-926-1613	C-4	17
				C-5	14
				BULK	5

**CROSS-REFERENCE INDEXES**  
**FIGURE AND ITEM NUMBER INDEX**

FIG.	ITEM	STOCK NUMBER	CAGEC	PART NUMBER
C-1	1	8340-00-470-2341	81349	MIL-T-10009
C-2	1	8340-00-252-2286	81349	MIL-L-1709
C-2	2	8340-00-252-2282	64067	8340-00-252-2282
C-3	1	8340-00-205-2759	70167	23B28045-1
C-3	2	5325-00-641-1278	81349	G16491TYPE3CLASS3SIZE0
C-3	3	5325-00-231-6622	81349	MILG16491TYPE3CLASS3SIZE4
C-3	4	5325-00-202-2053	81349	MILG16491TYPE3CLASS3SIZE5
C-3	5	5325-00-231-6624	81349	MILG16491TYPE3CLASS3SIZE6
C-3	6	8340-00-205-2753	81349	MILH1608AMEND2
C-3	7	8340-00-247-4396	81349	MILP500
C-3	8	5365-00-264-1222	81349	MIL-R-2327 CLASS 2 SIZE 4
C-3	9	5365-00-260-1412	81349	MILR3390
C-4	1	8340-00-470-2341	81349	MIL-T-10009
C-4	2	8315-00-253-6292	81349	MIL-T-43566
C-4	3	8305-00-926-6171	81349	MIL-C-43627
C-4	4	8315-00-253-6292	81349	MIL-T-43566
C-4	5	5325-00-222-1522	81348	VF106TYPE3STYLE1SIZEH
C-4	6	5325-00-222-1530	81348	VF106TYPE5STYLE3SIZEH
C-4	7	5325-00-286-9554	81349	MILF10884
C-4	8	8305-00-926-6171	81349	MIL-C-43627
C-4	9	5325-00-639-8109	96906	MS20230BS1
C-4	10			FED SPEC DDD-L-20
C-4	11			FED SPEC DDD-L-20
C-4	12	8340-00-252-2301	81349	MIL-L-1709
C-4	13	8340-00-252-2303	81349	MIL-L-1709
C-4	14	8315-00-253-6289	81349	MIL-T-43566
C-4	15	8315-00-253-6292	81349	MIL-T-43566
C-4	16	8305-00-634-5048	81349	MIL-W-43638
C-4	17	8305-00-926-1613	02106	890340-97
C-4	18	5325-00-276-4273	88044	AN227-19BL
C-4	19	5325-00-174-2926	96906	MS27977-8N
C-5	1	8340-00-254-8997	81349	MIL-T-10009
C-5	2	5325-00-641-3430	19207	549252
C-5	3	5325-00-286-9554	81349	MILF10884
C-5	4	8315-00-253-6289	81349	MIL-T-43566
C-5	5	5325-00-174-9067	81348	VF106TYPE3STYLE1SIZEH
C-5	6	5325-00-222-1522	81348	VF106TYPE3STYLE1SIZEH
C-5	7	5325-00-222-1529	81348	VF106TYPE5STYLE3SIZEH
C-5	8	8315-00-253-6292	81349	MIL-T-43566
C-5	9	8315-00-253-6293	81349	MIL-T-43566
C-5	10	8315-00-253-6289	81349	MIL-T-43566
C-5	11	5325-00-231-6622	81349	MILG16491TYPE3CLASS3SIZE4
C-5	12	5325-00-202-2053	81349	MILG16491TYPE3CLASS3SIZE5
C-5	13	8340-00-252-2305	81349	MIL-L-1709
C-5	14	8305-00-926-1613	02106	890340-97
C-5	15	5325-00-541-0404	81349	MILG16491TYPE2CLASS3SIZE2

## CROSS-REFERENCE INDEXES

## FIGURE AND ITEM NUMBER INDEX

FIG.	ITEM	STOCK NUMBER	CAGEC	PART NUMBER
C-5	15	8315-00-253-6293	81349	MIL-T-43566
C-6	1	8340-00-261-9750	81349	8340-00-261-9750
C-6	2	8340-00-261-9751	64067	8340-00-261-9751
C-6	3	8340-00-188-8411	64067	MILP549
C-6	4	8340-00-188-8406	81349	MILP549
C-6	5	8340-00-188-8407	81349	MILP549
C-6	6	8340-00-082-2167	81349	MILP549
C-6	7	8340-00-188-8392	81349	MILP549
C-6	8	8340-00-188-8396	81349	MILP549
C-6	9	8340-00-252-2299	81349	MIL-L-1709
C-6	10	8340-00-252-2273	81349	8340-00-252-2273
C-7	1	8340-00-262-2397	64067	8340-00-262-2397
C-7	2	8340-00-252-2271	64067	8340-00-252-2271
C-7	3			FED SPEC DDD-L-20
C-7	5	5325-00-231-6622	81349	MIL-C-43627



## APPENDIX D

## COMPONENTS OF END ITEM (COEI) AND BASIC ISSUE ITEMS (BII) LISTS

## SECTION I. INTRODUCTION

**D.1 SCOPE** This appendix lists components of the end item and basic issue items for the Tent, Kitchen, Flyproof M1948 to help you inventory the items for safe and efficient operation of the equipment.

**D.2 GENERAL** The Components of End Item and Basic Issue Items (BII) Lists are divided into the following sections:

**a. Section II. Component of End Item**. This listing is for information purposes only, and is not authority to requisition replacements. These items are part of the Tent, Kitchen, Flyproof, M1948, but they are to be removed and separate packaged for transportation or shipment. As part of the end item, these items must be with the end item whenever is issued or transferred between property accounts. Illustrations are furnished to help you find and identify the item.

**b. Section III. Basic Issue Items**. These essential items are required to place the Tent, Kitchen, Flyproof, M194 in operation, operate it, and to do emergency repairs. Although shipped separately packaged, BII must be with the Tent during operation and when it is transferred between property accounts. Listing items is your authority to request/requisition them for replacement based on authorization of the end item by the TOE/MTOE. Illustrations are furnished to help you find and identify the items.

**D.3 EXPLANATION OF COLUMNS**.

a. Column (1), Illustration Number, gives you the number of the item illustrated.

b. Column (2), National Stock Number, identifies the stock number of the item to be used for requisitioning purpose.

c. Column (3), Description and Usable On Code, identifies the Federal item name (in all capital letters) followed t a minimum description when needed. The last line below the description is the CAGEC (Commercial and Government Entity Code) (in parenthesis) and the part number.

d. Column (4), U/I (Unit of Issue), indicates how the item is issued for the National Stock Number shown in column two.

e. Column (5), Qty Rqr, indicates the quantity required.

SECTION II. COMPONENTS OF END ITEM

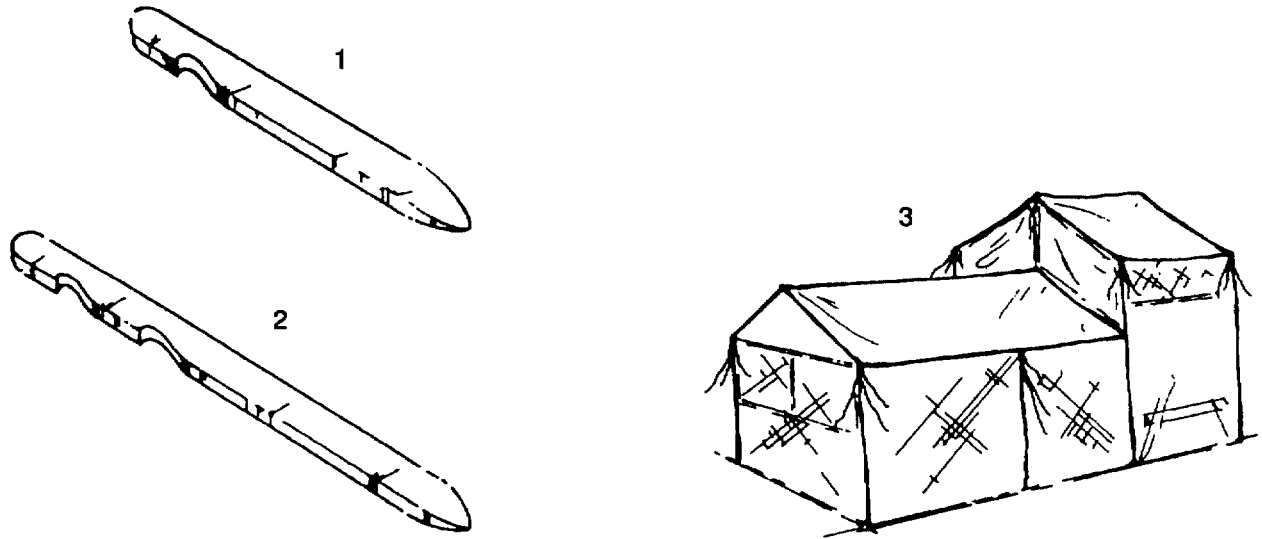

(1) ILLUS NO.	(2) NATIONAL STOCK NUMBER	(3) DESCRIPTION CAGEC AND PART NUMBER	USABLE ON CODE	(4) U/I	(5) QTY RQR
1	8340-00-261-9750	PIN, TENT, WOOD 16 inches (40.600 cm) (81349) MIL-P-2383	AVG	EA	32
2	8340-00-261-9751	PIN, TENT, WOOD 24 inches (61.000 cm) (81349) MIL-P-2383	AVG	EA	31
3	8340-00-257-2560	TENT, KITCHEN, FLYPROOF M-1948 with screen and cover (81349) MIL-T-10009	AVG	EA	1

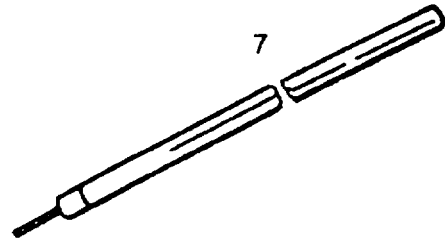
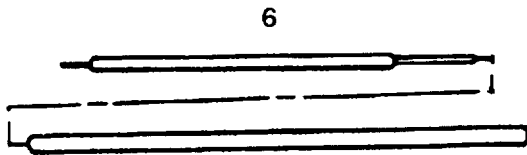
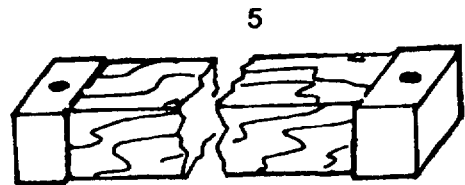
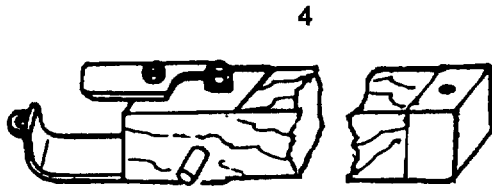

(1) ILLUS NO.	(2) NATIONAL STOCK NUMBER	(3) DESCRIPTION CAGEC AND PART NUMBER	USABLE ON CODE	(4) U/I	(5) QTY RQR
4	8340-00-188-8396	POLE, TENT, RIDGE, Jointed metal sleeve 11 ft 10 in (3.590 m) (81349) MIL-P-549	AVG	EA	1
5	8340-00-188-8392	POLE, TENT, RIDGE, Jointed metal sleeve 5 ft 11 1/4 in (1.830 m) (81349) MIL-P-549	AVG	EA	1
6	8340-00-188-8411	POLE, TENT, UPRIGHT, Jointed metal sleeve 12 ft 3 in. (3.720 m) (81349) MIL-P-549	AVG	EA	2
7	8340-00-082-2167	POLE, TENT, UPRIGHT, Solid, 9 ft (2.745 m) (81349) MIL-P-549	AVG	EA	5

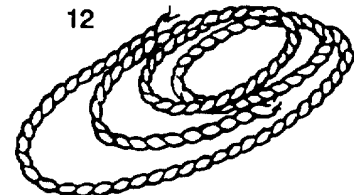
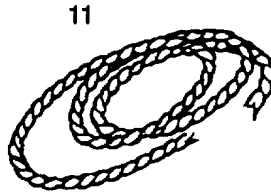
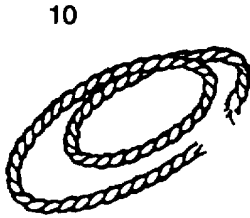
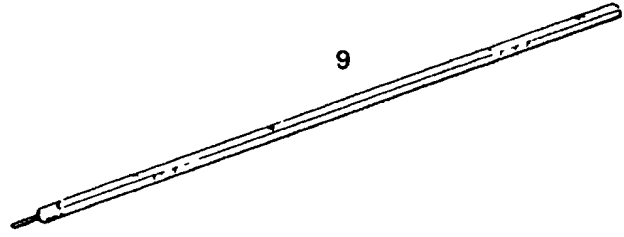
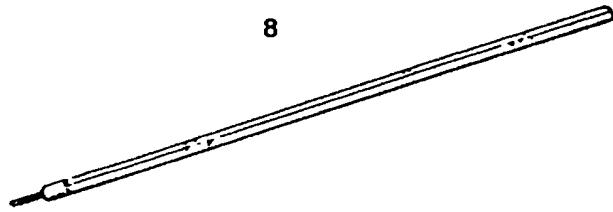

(1) ILLUS NO.	(2) NATIONAL STOCK NUMBER	(3) DESCRIPTION CAGEC AND PART NUMBER	USABLE ON CODE	(4) U/I	(5) QTY RQR
8	8430-00-188-8407	POLE, TENT, UPRIGHT, Solid, 7 ft (2.135 m) (81349) MIL-P-549	AVG	EA	1
9	8340-00-188-8406	POLE, TENT, UPRIGHT, Solid, 6 ft 2 in (1 950 m) (81349) MIL-P-549	AVG	EA	16
10	8340-00-252-2299	LINE, TENT, 19 in. (48.260 cm) (81349) MIL-L-1709	AVG	EA	67
11	8340-00-252-2301	LINE, TENT, 9 ft (2.745 m) (81349) MIL-L-1709	AVG	EA	18
12	8340-00-252-2303	LINE, TENT, 14 ft (4.270 m) (81349) MIL-L-1709	AVG	EA	4

13

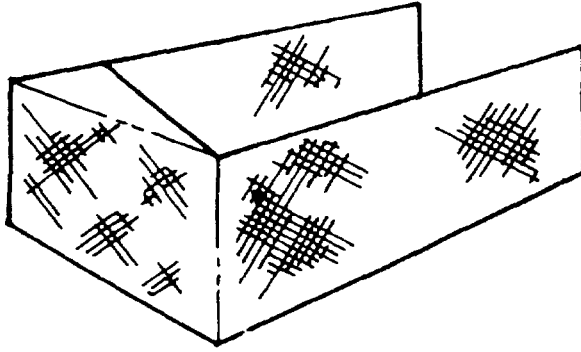

14

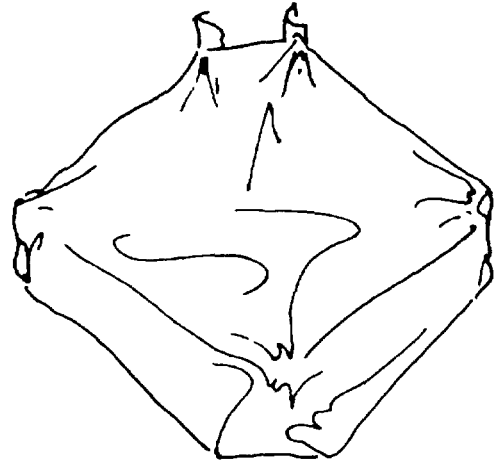

(1) ILLUS NO.	(2) NATIONAL STOCK NUMBER	(3) DESCRIPTION CAGEC AND PART NUMBER	(3) USABLE ON CODE	(4) U/I	(5) QTY RQR
13	8340-00-254-8997	WALL, SCREEN, TENT (81349) MIL-T-10009	AVG	EA	
14	8340-00-262-2397	COVER, TENT (81349) MIL-T-1712 (81349) 5-43359	AVG	EA	



APPENDIX E

ADDITIONAL AUTHORIZATION LIST (AAL)

SECTION I. INTRODUCTION

**E.1 SCOPE.**

This appendix lists additional items you are authorized for the support of the Tent, Kitchen, Flyproof, M1948.

**E.2 GENERAL.**

This list identifies items that do not have to accompany the Tent, Kitchen, Flyproof, M1948 and that do have to be turn in with it. These items are all authorized to you by CTA, MTOE, TDA, or JTA.

**E.3 EXPLANATION OF LISTING.**

National stock numbers, descriptions, and quantities are provided to help you identify and request the additional item you require to support this equipment. The items are listed in alphabetical sequence by item name. If the item you required differs between serial numbers of the same model, effective serial numbers are shown in the last line of the description. If item required differs for different models of this equipment, the model is shown under the "Usable on" heading in the description column.

<u>Usable on Code</u>	<u>Model</u>
AVG	M1948

SECTION II. ADDITIONAL AUTHORIZATION ITEMS LIST

(1) NATIONAL STOCK NUMBER	(2) DESCRIPTION CAGEC and Part Number	Usable On Code	(3) U/I	(4) Qty rqr
5120-00-474-3249	Hammer, hand	AVG	EA	1
5120-00-926-7116	Mallet, wood	AVG	EA	1
8340-00-261-9749	Pin, steel, 9 inches lg.	AVG	EA	32
8340-00-823-7451	Pin, steel, 12 inches lg.	AVG	EA	31
8340-00-262-5767	Repair kit, tentage	AVG	KT	1
5120-00-244-9147	Wrench, adjustable, 8 inch	AVG	EA	1





## APPENDIX F

## EXPENDABLE/DURABLE SUPPLIES LIST

## SECTION I. INTRODUCTION

**F.1 SCOPE**

This appendix lists expendable/durable supplies that you will need to operate and maintain the Tent Kitchen, Flyproof, M1948. This listing is for information only and is not authority to requisition the listed items. These items are authorized to you by CTA 50-790, Expendable/Durable Items (except medical, class V repair parts, and heraldic items), or CTA 8-100, Army Medical Department Expendable/Durable Items.

**F.2 EXPLANATION OF COLUMNS.**

a. Column 1. Item number This number is assigned to the entry in the listing and is referenced in the narrative instructions to identify the item (e.g. "Use cleaning compound, item 5, Appendix F".)

b. Column 2. Level. This column identifies the lowest level of maintenance that requires the item.

- C - Operator/crew
- O - Unit maintenance
- F - Direct support maintenance
- H - General support maintenance

c. Column 3. National stock number. This is the national stock number assigned to the item which you can use to requisition it.

d. Column 4. Item name, description, Commercial and Government Entity Code (CAGEC), and part number. This provides the other information you need to identify the item.

e. Column 5. Unit of measure. This code shows the physical measurement or count of an item, such as gallon, dozen, gross, etc.

SECTION II. EXPENDABLE/DURABLE SUPPLIES AND REQUIREMENTS LIST

(1) ITEM NUMBER	(2) LEVEL	(3) NATIONAL STOCK NUMBER	(4) ITEM NAME, DESCRIPTION CAGEC, PART NUMBER	(5) U/M
1	O	8030-00-261-2346	COMPOUND COATING, Mildew, Water, and Fire Resistant, 5 gal., TT-P-595	CN
2	O	6850-00-264-9038	DRY CLEANING SOLVENT, 5 gal., P-D-680	CN
3	C	7930-00-965-4868	SOAP	EA
4	C	9150-00-458-0075	OIL, Lubricating	EA
5	O	4020-00-262-2019	NYLON CORD	FT
6	O	5350-00-192-9330	SANDPAPER	SH
7	C	9150-00-999-7548	STICK LUBRICANT	EA

APPENDIX G

ILLUSTRATED LIST OF MANUFACTURED ITEMS

SECTION I. INTRODUCTION

**GENERAL.** Table G-1 is a listing of all items authorized for manufacture at the direct support level of maintenance. Illustrations and instructions for the manufacture of these items are shown in FM 10-16.

*Table G-1. Manufactured Items*

Item	Make From	Part Number of Specification
BINDING, cotton, sod cloth, front and rear walls 3/4 in (1.900 cm) W.	TAPE 8315-00-253-6289	
FACING, cotton, ventilator screen, 1 1/2 in. (3.810 cm) W.	TAPE 8315-00-253-6292	
FLAP, ventilator screens.	CLOTH 8305-00-926-6171	
LABEL, cloth, erection instructions, Type VI, Class 7.		FED SPEC DDD-L-20
LABEL, cloth, identification, Type VI, Class 6.		FED SPEC DDD-L-20
REINFORCEMENT, cotton, sod cloth, side wall, 3/4 in. (1 900 cm) W., 101/2 In (26.670 cm) lg.	TAPE 8315-253-6289	
REINFORCEMENT, cotton, 1 1/2 in. (3.810 cm) W., comer and side wall fasteners, front wall, ventilator front and rear screen, top, ventilator rear screen bottom, ventilator side screen, bottom and top.	TAPE 8315-00-253-6292	
REINFORCEMENT, cotton, 1 1/2 in. (3.810 cm) W., roof low elongation, roof ndge low elongation.	WEBBING 8305-00-634-5048	
SCREEN, plastic, OG, 22 mesh, stack, front, rear, and side, ventilator, front and side.	SCREENING 8305-00-926-1613	
TIE TAPE, cotton, serving window screen, 3/4 in. (1.900 cm) W.	TAPE 8315-00-253-6289	
STRAP, SUPPORT, cotton, front wall lower panel, 11/2 in. (3.810 cm) W.	TAPE 8315-00-253-6292	

**Table G-1. Manufactured Items - continued**

Item	Make From	Part Number of Specification
REINFORCEMENT, cotton, 2 in. (5.080 cm) W., screen wall, top, serving window, slide fasteners.	TAPE 8315-00-253-6293	
BINDING, cotton, sod cloth, screen wall, 3/4 in. (1.900 cm) W.	TAPE 8315-00-253-6289	
TAB, cotton, screen wall, 2 in. (5.080 cm) W.	GROMMET 5325-00-231-6623	
LABEL, cloth, TYPE IV, Class 8, erection instructions, identification.	TAPE 8315-00-253-6293	FED SPEC DDD-L-20

INDEX

**Subject, Page**

**A**

Abbreviations, C-6  
 Additional Authorization Items List, E-1  
 Additional Authorization List (AAL)  
     General, E-1  
     Scope, E-1  
 Adjustment of Equipment, Preliminary Servicing and,  
 4-3  
 Army Maintenance System MAC, The, B-1  
 Assembly and Preparation for Use, 2-7  
 Authorization Items List, Additional, E-1

**B**

Basic Issue Items, D-1, D-6  
 Bulletins, Technical Manuals and, A-1

**C**

Capabilities and Features, Equipment Characteristics,  
 1-2  
 Characteristics, Capabilities and Features, Equipment,  
 1-2  
 Cleaning Agents, 2-4  
 Columns in the MAC, Section II, Explanation of, B-2  
 Common Tools and Equipment, 4-1  
 Components of End Item, D-2  
 Components of End Item (COEI) and Basic Issue  
 Items (BII)  
     General, D-1  
     Scope, D-1  
 Components of End Item (COEI) and Basic Issue  
 Items (BII) Lists, D-1  
 Controls and Indicators, Description and Use of  
 Operator's, 2-1  
 Corrosion Prevention and Control (CPC), 1-2

**Subject, Page**

Cover, Tent, 4-14, 5-5  
 Cross-Reference Indexes  
     Figure and Item Number, C-27  
     National Stock Number, C-24  
     Part Number, C-25  
 Cross-Reference List, Nomenclature, 1-2

**D**

Damage, Protection of Tent Against, 4-16  
 Data, Equipment, 1-4  
 Data, Equipment Description and, 1-2  
 Description and Data, Equipment, 1-2  
 Description and Use of Operator's Controls and  
 Indicators, 2-1  
     General, 2-1  
 Description of Major Components, Location and, 1-3  
 Destruction of Army Materiel to Prevent Enemy Use  
 1-1  
 Direct Support  
     Maintenance Procedures, 5-2  
     General, 5-2  
 Troubleshooting, 5-1  
 Direct Support Maintenance Instructions, 5-1

**E**

End Item, Components of, D-1  
 Enemy Use, Destruction of Army Materiel to Prevent  
 1-1  
 Environment/Weather, Unusual, 2-20  
 Equipment Characteristics, Capabilities and Feature  
 1-2  
 Equipment Data, 1-4  
 Equipment Description and Data, 1-2  
 Equipment Improvement Recommendations (EIR),  
 Reporting, 1-2  
 Expensible/Durable Supplies and Requirements  
 List, F-2

## INDEX (CONTINUED)

**Subject, Page**

Expendable/Durable Supplies List, F-1  
 Scope, F-1  
 Explanation of  
   Column in Remarks, Section IV, B-3  
   Columns, F-1  
   Columns (Sections II and III), C-1  
   Columns in the MAC, Section II, B-2  
   Columns in Tools and Test Equipment  
     Requirements, Section III, B-3  
   Columns, COEI and BII, D-1  
 Index Format and Columns (Section IV), C-5  
 Listing, E-1

**F**

Features, Equipment Characteristics, Capabilities and,  
 1-2  
 Field Manuals, A-1  
 Forms and Records, A-1  
 Forms, Records and Reports, Maintenance, 1-1  
 Functions, Maintenance, B-1

**G**

General, 1-4, 2-1, 2-3, 3-4, 4-3, 4-5, 4-8, 5-2, C-1,  
 D-1, E-1, G-1  
 General Information, 1-1  
 Scope, 1-1

**H**

How to Locate Repair Parts, C-6  
 How to Use This Manual, iv

**I**

Illustrated List of Manufactured Items, G-1  
 General, G-1  
 Installation Instructions, 4-3

**Subject, Page**

Instructions, Operating, 2-1  
 Instructions, Installation, 4-3  
 Introduction, 1-1  
   Additional Authorization List (AAL), E-1  
   COEI and BII, D-1  
   Expendable/Durable Supplies List, F-1  
   Illustrated List of Manufactured Items, G-1  
   Maintenance Allocation Chart, B-1  
   Repair Parts and Special Tools List, C-1  
   Troubleshooting Procedures, 3-1

**L**

Leakage Definitions for Operator PMCS, 2-5  
 Lines Against Damage, Protection of Pins, Poles, and,  
 4-17  
 List, Nomenclature Cross-Reference, 1-2  
 Locate Repair Parts, How to, C-6  
 Location and Description of Major Components, 1-3  
 Lubrication Instructions, Operator, 3-1

**M**

Maintenance Allocation Chart, B-1, B-4  
 Maintenance Forms, Records and Reports, 1-1  
 Maintenance Functions, B-1  
 Maintenance Instructions  
   Direct Support, 5-1  
   Operator, 3-1  
   Unit, 4-1  
 Maintenance Procedures  
   Direct Support, 5-2  
   General, 5-2  
   General, Unit, 4-8  
   Unit, 4-8

Maintenance Procedures, Operator's, 3-4  
 Major Components, Location and Description of, 1-3  
 Manual, How to Use This, iv  
 Manufactured Items, Illustrated List of, G-1

## INDEX (CONTINUED)

**Subject, Page**

Mildew, Protection Against, 4-15  
 Miscellaneous Publications, A-1  
 Movement, Preparation for, 2-17  
 N  
 Nomenclature Cross-Reference List, 1-2  
 O  
 Operating Instructions, 2-1  
 Operating Procedures, 2-16  
 Operation Under Unusual Conditions, 2-20  
 Operation Under Usual Conditions, 2-7  
 Operator, Troubleshooting, 3-1  
 Operator Controls, 2-2  
 Operator Maintenance Instructions, 3-1  
 Operator PMCS, 2-3  
   Cleaning Agents, 2-4  
   General, 2-3  
   Leakage Definitions for, 2-5  
   Procedures, 2-4  
 Operator's Maintenance Procedures, 3-4  
   General, 3-4

**P**

Parts and Special Tools List, Repair, C-1  
 Parts, Repair, Unit, 4-1  
 Pins, Poles, and Lines Against Damage, Protection of,  
   4-17  
 PMCS Procedures, 2-4  
 Poles, and Lines Against Damage, Protection of Pins,  
   4-17  
 Preliminary Servicing and Adjustment of Equipment,  
   4-3

**Subject, Page**

Preparation for Movement, 2-17  
 Preparation for Storage and Shipment, 1-2, 4-15  
 Preparation for Use, Assembly and, 2-7  
 Prevention and Control (CPC), Corrosion, 1-2  
 Preventive Maintenance Checks and Services (PMCS)  
   Operator, 2-3  
   Unit, 4-3  
 Principles of Operation, 1-4  
   General, 1-4  
 Procedures, Quality Assurance (QA), 1-2  
 Procedures, Operating, 2-16  
 Procedures, Troubleshooting, 5-1  
 Protection Against  
 Mildew, 4-15  
   Pins, Poles, and Lines Damage, 4-17  
   Tent Damage, 4-16  
 Protection Against Mildew, 4-15  
 Protection of  
   Pins, Poles, and Lines Against Damage, 4-17  
   Tent Against Damage, 4-16

**Q**

Quality Assurance (QA) Procedures, 1-2

**R**

Receipt, Service Upon, 4-2  
 Records and Reports, Maintenance Forms, 1-1  
 Records, Forms and, A-1  
 References, A-1  
   Scope, A-1  
 Remarks, B-5  
 Remarks, Section IV, Explanation of Columns in, B-3  
 Repair Parts, 4-2  
 Repair Parts and Special Tools List, C-1  
   General, C-1  
   Scope, C-1  
 Repair Parts; Tools; Special Tools; Test, Measurement  
 and Diagnostic Equipment (TMDE); and Support  
 Equipment, 4-1

INDEX (CONTINUED)

**Subject, Page**

Reporting Equipment Improvement Recommendations (EIR), 1-2  
 Reports, Maintenance Forms, Records and, 1-1  
 Requirements List, Expendable/Durable Supplies and, F-2

**S**

Scope, 1-1, A-1, C-1, D-1, E-1, F-1  
 Screen Wall, Tent, 4-11, 5-4  
 Service Upon Receipt, 4-2  
  
 Service Upon Receipt of Materiel, 4-2  
  
 Servicing and Adjustment of Equipment, Preliminary, 4-3  
 Shelter Requirements, Site and, 4-2  
 Shipment, Preparation for Storage and, 1-2, 4-15  
  
 Site and Shelter Requirements, 4-2  
 Special Information, C-6  
 Special Tools, Unit, 4-1  
  
 Special Tools List, C-23  
  
 Special Tools, TMDE, and Support Equipment, 4-2  
  
 Storage and Shipment, Preparation for, 1-2, 4-15  
 Support and Anchoring, Tent, 4-12, 5-5  
 Support Equipment, Unit, 4-1  
 Support Equipment, Special Tools, TMDE, and, 4-2

**T**

Technical Manuals and Bulletins, A-1  
 Tent  
     Body, 4-8, 5-3  
     Cover, 4-14, 5-5  
     Screen Wall, 4-11, 5-4  
     Support and Anchoring, 4-12, 5-5

**Subject, Page**

Tent Body, 4-8, 5-3  
 TMDE, Unit, 4-1  
  
 TMDE, and Support Equipment, Special Tools, 4-2  
  
 Tools, Unit, 4-1  
 Tools and Equipment, Common, 4-1  
 Tools and Test Equipment Requirements, B-5  
 Tools and Test Equipment Requirements, Section III, Explanation of Columns in, B-3  
 Troubleshooting, 3-1  
     Direct Support, 5-1  
     Operator, 3-1  
  
 Troubleshooting Procedures, 5-1

**U**

Unit  
     Maintenance Procedures, 4-8  
     General, 4-8  
 Troubleshooting, 4-5  
     General, 4-5  
  
 Unit Maintenance Instructions, 4-1  
  
 Unit PMCS, 4-3  
     General, 4-3  
 Unit Troubleshooting 45  
     General, 4-5  
 Unusual Condition, Operation Under, Environment/Weather, 2-20  
 Unusual Conditions, Operations Under, 2-20  
 Unusual Environment/Weather, 2-20  
 Usual Conditions, Operation Under, 2-7

**W**

Weather, Unusual Environment/, 2-20



By Order of the Secretary of the Army:

Official:   
*Acting Administrative Assistant to the  
Secretary of the Army*  
00676

DENNIS J. REIMER  
*General, United States Army*  
*Chief of Staff*

DISTRIBUTION:

To be distributed in accordance with DA Form 12-25-E, block no. 1762, requirements for TM 10-8340-205-13&P.



## ***These are the instructions for sending an electronic 2028***

The following format must be used if submitting an electronic 2028. The subject line must be exactly the same and all fields must be included; however only the following fields are mandatory: 1, 3, 4, 5, 6, 7, 8, 9, 10, 13, 15, 16, 17, and 27.

From: "Whomever" <whomever@avma27.army.mil>

To: amssbriml@natick.army.mil

Subject: DA Form 2028

1. From: Joe Smith
2. Unit: home
3. Address: 4300 Park
4. City: Hometown
5. St: MO
6. Zip: 77777
7. Date Sent: 19-OCT-93
8. Pub no: 55-2840-229-23
9. Pub Title: TM
10. Publication Date: 04-JUL-85
11. Change Number: 7
12. Submitter Rank: MSG
13. Submitter FName: Joe
14. Submitter MName: T
15. Submitter LName: Smith
16. Submitter Phone: 123-123-1234
17. Problem: 1
18. Page: 2
19. Paragraph: 3
20. Line: 4
21. NSN: 5
22. Reference: 6
23. Figure: 7
24. Table: 8
25. Item: 9
26. Total: 123
27. Text:

This is the text for the problem below line 27.



<b>RECOMMENDED CHANGES TO PUBLICATIONS AND BLANK FORMS</b> For use of this form, see AR 25-30; the proponent agency is ODISC4.						Use Part II (reverse) for Repair Parts and Special Tool Lists (RPSTL) and Supply Catalogs/Supply Manuals (SC/SM).	<b>DATE</b> 21 October 2003
<b>TO:</b> (Forward to proponent of publication or form) (Include ZIP Code) COMMANDER U.S. ARMY TANK-AUTOMOTIVE AND ARMAMENT COMMAND ATTN: AMSTA-LC-CECT 15 KANSAS STREET NATICK, MA 01760-5052						<b>FROM:</b> (Activity and location) (Include ZIP Code)  <i>PFC Jane Doe</i> <i>CO A 3<sup>rd</sup> Engineer BR</i> <i>Ft. Leonardwood, MO 63108</i>	
<b>PART I – ALL PUBLICATIONS (EXCEPT RPSTL AND SC/SM) AND BLANK FORMS</b>							
<b>PUBLICATION/FORM NUMBER</b> TM 10-1670-296-23&P				<b>DATE</b> 30 October 2002	<b>TITLE</b> Unit Manual for Ancillary Equipment for Low Velocity Air Drop Systems		
<b>ITEM NO.</b>	<b>PAGE NO.</b>	<b>PARA-GRAPH</b>	<b>LINE NO. *</b>	<b>FIGURE NO.</b>	<b>TABLE NO.</b>	<b>RECOMMENDED CHANGES AND REASON</b> (Provide exact wording of recommended changes, if possible).	
	0036 00-2				1	<p><i>In table 1, Sewing Machine Code Symbols, the second sewing machine code symbol should be MD ZZ not MD 22.</i></p> <p><i>Change the manual to show Sewing Machine, Industrial: Zig-Zag; 308 stitch; medium-duty; NSN 3530-01-181-1421 as a MD ZZ code symbol.</i></p>	
*Reference to line numbers within the paragraph or subparagraph.							
<b>TYPED NAME, GRADE OR TITLE</b>  Jane Doe, PFC				<b>TELEPHONE EXCHANGE/AUTOVON, PLUS EXTENSION</b>  508-233-4141		<b>SIGNATURE</b>  Jane Doe <i>Jane Doe</i>	

<b>TO:</b> <i>(Forward direct to addressee listed in publication)</i> COMMANDER U.S. ARMY TANK-AUTOMOTIVE AND ARMAMENT COMMAND ATTN: AMSTA-LC-CECT 15 KANSAS STREET NATICK, MA 01760-5052	<b>FROM:</b> <i>(Activity and location) (Include ZIP Code)</i> <i>PFC Jane Doe</i> <i>CO A 3<sup>rd</sup> Engineer BR</i> <i>Ft. Leonardwood, MO 63108</i>	<b>DATE</b> 21 October 2003
--	---	--------------------------------

**PART II – REPAIR PARTS AND SPECIAL TOOL LISTS AND SUPPLY CATALOGS/SUPPLY MANUALS**

<b>PUBLICATION NUMBER</b> TM 10-1670-296-23&P	<b>DATE</b> 30 October 2002	<b>TITLE</b> Unit Manual for Ancillary Equipment for Low Velocity Air Drop Systems
--	--------------------------------	---

PAGE NO.	COLM NO.	LINE NO.	NATIONAL STOCK NUMBER	REFERENCE NO.	FIGURE NO.	ITEM NO.	TOTAL NO. OF MAJOR ITEMS SUPPORTED	RECOMMENDED ACTION
0066 00-1					4			<i>Callout 16 in figure 4 is pointed to a <u>D-Ring</u>. In the Repair Parts List key for figure 4, item 16 is called a <u>Snap Hook</u>. Please correct one or the other.</i>

SAMPLE

**PART III – REMARKS** *(Any general remarks or recommendations, or suggestions for improvement of publications and blank forms. Additional blank sheets may be used if more space is needed.)*

TYPED NAME, GRADE OR TITLE	TELEPHONE EXCHANGE/AUTOVON, PLUS EXTENSION	SIGNATURE
----------------------------	--	-----------

<p align="center"><b>RECOMMENDED CHANGES TO PUBLICATIONS AND BLANK FORMS</b></p> <p>For use of this form, see AR 25-30; the proponent agency is ODISC4.</p>						Use Part II (reverse) for Repair Parts and Special Tool Lists (RPSTL) and Supply Catalogs/Supply Manuals (SC/SM).	DATE
<b>TO:</b> (Forward to proponent of publication or form) (Include ZIP Code) COMMANDER U.S. ARMY TANK-AUTOMOTIVE AND ARMAMENT COMMAND ATTN: AMSTA-LC-CECT 15 KANSAS STREET NATICK, MA 01760-5052						<b>FROM:</b> (Activity and location) (Include ZIP Code)	
<b>PART I – ALL PUBLICATIONS (EXCEPT RPSTL AND SC/SM) AND BLANK FORMS</b>							
PUBLICATION/FORM NUMBER TM 10-8340-205-13&P				DATE 3 October 1995	TITLE Operator, Unit and Direct Support Maintenance Manual Including Repair Parts and Special Tools List for Tent, Kitchen, Flyproof, M1948		
ITEM NO.	PAGE NO.	PARA-GRAPH	LINE NO. *	FIGURE NO.	TABLE NO.	RECOMMENDED CHANGES AND REASON <i>(Provide exact wording of recommended changes, if possible).</i>	
*Reference to line numbers within the paragraph or subparagraph.							
TYPED NAME, GRADE OR TITLE				TELEPHONE EXCHANGE/AUTOVON, PLUS EXTENSION		SIGNATURE	

<b>TO:</b> (Forward direct to addressee listed in publication) COMMANDER U.S. ARMY TANK-AUTOMOTIVE AND ARMAMENT COMMAND ATTN: AMSTA-LC-CECT 15 KANSAS STREET NATICK, MA 01760-5052	<b>FROM:</b> (Activity and location) (Include ZIP Code)	<b>DATE</b>
---	---	-------------

**PART II – REPAIR PARTS AND SPECIAL TOOL LISTS AND SUPPLY CATALOGS/SUPPLY MANUALS**

PUBLICATION NUMBER TM 10-8340-205-13&P	DATE 3 October 1995	TITLE Operator, Unit and Direct Support Maintenance Manual Including Repair Parts and Special Tools List for Tent, Kitchen, Flyproof, M1948
---	------------------------	---

PAGE NO.	COLM NO.	LINE NO.	NATIONAL STOCK NUMBER	REFERENCE NO.	FIGURE NO.	ITEM NO.	TOTAL NO. OF MAJOR ITEMS SUPPORTED	RECOMMENDED ACTION

**PART III – REMARKS** (Any general remarks or recommendations, or suggestions for improvement of publications and blank forms. Additional blank sheets may be used if more space is needed.)

TYPED NAME, GRADE OR TITLE	TELEPHONE EXCHANGE/AUTOVON, PLUS EXTENSION	SIGNATURE
----------------------------	--	-----------



<p align="center"><b>RECOMMENDED CHANGES TO PUBLICATIONS AND BLANK FORMS</b></p> <p>For use of this form, see AR 25-30; the proponent agency is ODISC4.</p>						Use Part II (reverse) for Repair Parts and Special Tool Lists (RPSTL) and Supply Catalogs/Supply Manuals (SC/SM).	DATE
<b>TO:</b> (Forward to proponent of publication or form) (Include ZIP Code) COMMANDER U.S. ARMY TANK-AUTOMOTIVE AND ARMAMENT COMMAND ATTN: AMSTA-LC-CECT 15 KANSAS STREET NATICK, MA 01760-5052						<b>FROM:</b> (Activity and location) (Include ZIP Code)	
<b>PART I – ALL PUBLICATIONS (EXCEPT RPSTL AND SC/SM) AND BLANK FORMS</b>							
PUBLICATION/FORM NUMBER TM 10-8340-205-13&P				DATE 3 October 1995	TITLE Operator, Unit and Direct Support Maintenance Manual Including Repair Parts and Special Tools List for Tent, Kitchen, Flyproof, M1948		
ITEM NO.	PAGE NO.	PARA-GRAPH	LINE NO. *	FIGURE NO.	TABLE NO.	RECOMMENDED CHANGES AND REASON <i>(Provide exact wording of recommended changes, if possible).</i>	
*Reference to line numbers within the paragraph or subparagraph.							
TYPED NAME, GRADE OR TITLE				TELEPHONE EXCHANGE/AUTOVON, PLUS EXTENSION		SIGNATURE	

<b>TO:</b> (Forward direct to addressee listed in publication) COMMANDER U.S. ARMY TANK-AUTOMOTIVE AND ARMAMENT COMMAND ATTN: AMSTA-LC-CECT 15 KANSAS STREET NATICK, MA 01760-5052	<b>FROM:</b> (Activity and location) (Include ZIP Code)	<b>DATE</b>
---	---	-------------

**PART II – REPAIR PARTS AND SPECIAL TOOL LISTS AND SUPPLY CATALOGS/SUPPLY MANUALS**

PUBLICATION NUMBER TM 10-8340-205-13&P	DATE 3 October 1995	TITLE Operator, Unit and Direct Support Maintenance Manual Including Repair Parts and Special Tools List for Tent, Kitchen, Flyproof, M1948
---	------------------------	---

PAGE NO.	COLM NO.	LINE NO.	NATIONAL STOCK NUMBER	REFERENCE NO.	FIGURE NO.	ITEM NO.	TOTAL NO. OF MAJOR ITEMS SUPPORTED	RECOMMENDED ACTION

**PART III – REMARKS** (Any general remarks or recommendations, or suggestions for improvement of publications and blank forms. Additional blank sheets may be used if more space is needed.)

TYPED NAME, GRADE OR TITLE	TELEPHONE EXCHANGE/AUTOVON, PLUS EXTENSION	SIGNATURE
----------------------------	--	-----------

# The Metric System and Equivalents

## Linear Measure

1 centimeter = 10 millimeters = .39 inch  
 1 decimeter = 10 centimeters = 3.94 inches  
 1 meter = 10 decimeters = 39.37 inches  
 1 dekameter = 10 meters = 32.8 feet  
 1 hectometer = 10 dekameters = 328.08 feet  
 1 kilometer = 10 hectometers = 3,280.8 feet

## Weights

1 centigram = 10 milligrams = .15 grain  
 1 decigram = 10 centigrams = 1.54 grains  
 1 gram = 10 decigrams = .035 ounce  
 1 dekagram = 10 grams = .35 ounce  
 1 hectogram = 10 dekagrams = 3.52 ounces  
 1 kilogram = 10 hectograms = 2.2 pounds  
 1 quintal = 100 kilograms = 220.46 pounds  
 1 metric ton = 10 quintals = 1.1 short tons

## Liquid Measure

1 centiliter = 10 milliliters = .34 fl. ounce  
 1 deciliter = 10 centiliters = 3.38 fl. ounces  
 1 liter = 10 deciliters = 33.81 fl. ounces  
 1 dekaliter = 10 liters = 2.64 gallons  
 1 hectoliter = 10 dekaliters = 26.42 gallons  
 1 kiloliter = 10 hectoliters = 264.18 gallons

## Square Measure

1 sq. centimeter = 100 sq. millimeters = .155 sq. inch  
 1 sq. decimeter = 100 sq. centimeters = 15.5 sq. inches  
 1 sq. meter (centare) = 100 sq. decimeters = 10.76 sq. feet  
 1 sq. dekameter (are) = 100 sq. meters = 1,076.4 sq. feet  
 1 sq. hectometer (hectare) = 100 sq. dekameters = 2.47 acres  
 1 sq. kilometer = 100 sq. hectometers = .386 sq. mile

## Cubic Measure

1 cu. centimeter = 1000 cu. millimeters = .06 cu. inch  
 1 cu. decimeter = 1000 cu. centimeters = 61.02 cu. inches  
 1 cu. meter = 1000 cu. decimeters = 35.31 cu. feet

## Approximate Conversion Factors

To change	To	Multiply by	To change	To	Multiply by
inches	centimeters	2.540	ounce-inches	newton-meters	.007062
feet	meters	.305	centimeters	inches	.394
yards	meters	.914	meters	feet	3.280
miles	kilometers	1.609	meters	yards	1.094
square inches	square centimeters	6.451	kilometers	miles	.621
square feet	square meters	.093	square centimeters	square inches	.155
square yards	square meters	.836	square meters	square feet	10.764
square miles	square kilometers	2.590	square meters	square yards	1.196
acres	square hectometers	.405	square kilometers	square miles	.386
cubic feet	cubic meters	.028	square hectometers	acres	2.471
cubic yards	cubic meters	.765	cubic meters	cubic feet	35.315
fluid ounces	milliliters	29.573	cubic meters	cubic yards	1.308
pints	liters	.473	milliliters	fluid ounces	.034
quarts	liters	.946	liters	pints	2.113
gallons	liters	3.785	liters	quarts	1.057
ounces	grams	28.349	liters	gallons	.264
pounds	kilograms	.454	grams	ounces	.035
short tons	metric tons	.907	kilograms	pounds	2.205
pound-feet	newton-meters	1.356	metric tons	short tons	1.102
pound-inches	newton-meters	.11296			

## Temperature (Exact)

°F	Fahrenheit	5/9 (after	Celsius	°C
	temperature	subtracting 32)	temperature	

**PIN: 074038-000**

This fine document...

Was brought to you by me:



## [Liberated Manuals -- free army and government manuals](#)

Why do I do it? I am tired of sleazy CD-ROM sellers, who take publicly available information, slap “watermarks” and other junk on it, and sell it. Those masters of search engine manipulation make sure that their sites that sell free information, come up first in search engines. They did not create it... They did not even scan it... Why should they get your money? Why are not letting you give those free manuals to your friends?

I am setting this document FREE. This document was made by the US Government and is NOT protected by Copyright. Feel free to share, republish, sell and so on.

I am not asking you for donations, fees or handouts. If you can, please provide a link to [liberatedmanuals.com](http://liberatedmanuals.com), so that free manuals come up first in search engines:

<A HREF=<http://www.liberatedmanuals.com/>>Free Military and Government Manuals</A>

- Sincerely  
Igor Chudov  
<http://igor.chudov.com/>
- [Chicago Machinery Movers](#)