

TECHNICAL MANUAL

OPERATOR'S, UNIT AND

DIRECT SUPPORT MAINTENANCE MANUAL

(INCLUDING REPAIR PARTS AND SPECIAL TOOLS LIST)

FOR

OHAUS HARVARD TRIP BALANCE

NSN 6670-00-436-9857

This technical manual is an authentication of the manufacturer's commercial literature and does not conform with the format and the content requirements normally associated with Army technical manuals. This technical manual does, however, contain all essential information required to operate and maintain the equipment.

Approved for public release; distribution is unlimited.

HEADQUARTERS, DEPARTMENT OF THE ARMY

28 SEPTEMBER 1990

This technical manual is an authentication of the manufacturer's commercial literature and does not conform with the format and the content requirements normally associated with Army technical manuals. This technical manual does, however, contain all essential information required to operate and maintain the equipment.

Approved for public release; distribution is unlimited.

SUPPLEMENTARY INTRODUCTORY MATERIAL

1-1. Maintenance Forms and Records.

Department of the Army forms and procedures used for equipment maintenance will be those described by DA Pam 738-750, The Army Maintenance Management System.

1-2. Reporting Errors and Recommending Improvements.

You can help improve this manual. If you find any mistakes or if you know of a way to improve the procedures, please let us know. Mail your letters, DA Form 2028 (Recommended Changes to Publications and Blank Forms), or DA Form 2028-2 located in the back of this manual, directly to: Commander, U.S. Army Troop Support Command, ATTN: AMSTR-MCTS, 4300 Goodfellow Blvd., St. Louis, MO 63120-1798. A reply will be furnished to you.

1-3. Destruction of Army Material to Prevent Enemy Use.

Refer to TM 750-244-3 for instructions covering the destruction of Army Material to prevent enemy use.

1-4. Administrative Storage of Equipment.

a. Placement of equipment in administrative storage should be for short periods of time when a shortage of maintenance effort exists. Items should be in mission readiness within 24 hours or within the time factors as determined by the directing authority. During the storage period appropriate maintenance records will be kept.

b. Before placing equipment in administrative storage, current preventive maintenance checks and services should be completed. Shortcomings and deficiencies should be corrected, and all modification work orders (MWO's) should be applied.

c. Storage site selection. Inside storage is preferred for items selected for administrative storage. If inside storage is not available, trucks, vans, conex containers and other containers may be used.

OHAUS[®] HARVARD TRIP BALANCE

Directions for Use and Maintenance

Please read this manual before unpacking, setting up, and using your balance.

Your new precision balance has been packed in a carton specifically designed to protect it during shipment.

Follow these instructions and your balance will be operational in just a few minutes.

1. Remove the balance from the carton.
2. Remove the two round rubber beam retainers from the balance. These should be saved if you anticipate any future shipment of the balance.

Set-Up Instructions

Select a reasonably flat, level surface and move the beam poises (and the tare poise on appropriate models) all the way to the left. This will result in the scale being very nearly at zero balance.

Zeroing the Balance

To balance the scale exactly at zero, adjust the knurled zero adjust knob which is located at the right end of the beam. It is advisable to check the zero balance periodically because foreign material may accumulate on the platforms or the beams. This can produce a slight change in the zero balance position. In addition, whenever the scale is moved the zero balance must be rechecked. Any appreciable change in the inclination of the working surface will affect it.

The base of each balance is leveled on a surface plate at the factory and will rest evenly on any perfectly flat surface. The balance may rock slightly if the working surface selected is not absolutely flat. This should be eliminated by shimming under the base. Be sure to adjust the zero balance after leveling.

Weighing

Once the zero balance has been checked, proceed as follows:

1. Place the unknown mass on the left hand platform.
2. Move the large poise on the lower beam to the right until it reaches the first notch which will cause the right hand platform to drop.
3. Move the large poise back one notch, which will allow the right hand platform to rise again.
4. Move the small poise on the upper beam to the right until the scale is brought into balance.
5. To determine the weight of the unknown mass, add the amounts indicated on the two beams. The capacity of the balance exceeds the beam capacity and additional weights are necessary to take advantage of the full capacity.

Ohaus recommends the Sto-A-Weigh[®] weight sets, part numbers 213-00 (1000 gram x 1 gram) or 277-00 (2 pound x 1/16 ounce) as applicable.

To weigh masses which exceed the beam capacity:

1. Place additional weights on the right hand platform to compensate for the excess weight of the unknown mass.

2. Adjust the poises on the beams to bring the scale into balance.
3. To determine the weight of the unknown mass, add the weight(s) on the right hand platform to the amounts indicated on the two beams.

Use of the Tare Poise

(Models 1510-DT and 1560-SD)

For those models which are equipped with the Tare Beam Assembly a patented tare poise can be used to tare off containers which weigh less than 200 grams.

With the container on the left hand platform slide the tare poise to a position on the tare beam which indicates approximate balance. Rotate the poise in either direction to position it precisely on the tare beam.

When not in use, the tare poise is to be moved all the way to the left to the tare beam.

Specific Gravity Determination

A Clamp and Rod Support Ohaus part number 183-00, is an accessory used to elevate the balance for suspending a specimen in water. The rod is inserted into the 1/2 inch recess on the underside of the base. By means of a fine wire or thread, the specimen is attached to the check pin which connects the platform loop to the check rod. The procedure for weighing a suspended specimen is the same as that for weighing an unknown mass on the platform.

Care and Maintenance

The following practices will assure that your balance will give you years of satisfactory and trouble-free service.

When the balance is not in use, remove any mass or weights from the platform(s). Move one of the poises away from zero so that the balance is not in equilibrium. This will stop the balance from oscillating and prevent unnecessary wear.

Use and store the balance in places free of vibration.

Never lubricate the scale bearings. The bearings in these balances are high grade polished agate V-blocks and the knife edges are hardened, precision-ground steel. This type of bearing works most efficiently when clean and dry.

Keep the balance clean at all times, being particularly careful not to let dirt accumulate in the vicinity of the bearings. If the bearings should become dirty, first try to clean them by using an air syringe. If this is not satisfactory, the bearing covers will have to be removed. When the bearing covers are returned, it is essential that the hardened blue steel friction plates are replaced in the recesses provided.

Cleaning Magnet Faces

In general, most foreign matter may be easily removed by an air syringe. If the damper vane still does not move freely, proceed as follows:

1. CAREFULLY turn the balance on its side.
2. Remove the four (4) screws that mount the magnet case to the underside of the base.
3. Remove the magnet case.
4. Clean the magnet faces by pressing a piece of adhesive-backed tape against them.
5. Reinstall the magnet case.

Accessories

PART NO.	PART NAME
107-00	Polypropylene footed scoop, 12" x 6" x 2-3/4" deep
107-SO	Stainless steel footed scoop, 12" x 6" x 2-3/4" deep
183-00	Specific gravity rod and clamp
213-00	Weight set, Metric, 1000 gram x 1 gram
277-00	Weight set, Avoirdupois, 2 lb x 1/16 oz

Replacement Parts List

PART NO.	PART NAME	REQUIRED PER BALANCE
All Models		
1008-23	Agate Bearing	6
1023-00	Balance Cup	2
1034-00	Friction Plate	4
1247-00	Friction Plate with Tab (See on open side of parallel loop) 2	
1035-03	Bearing Cover	5
1221-00	Side Beam Lug (if required)	2
9701-01	Balance Compensator Assembly	1
9725-00	Pointer Assy Compl.	1
1371-01	Dial Bracket Assembly	1

TABULATION A

Part No.	Side Beam Assemblies with Poise	Model No.
1217-00	Single Beam Metric (10 x 0.1g)	1450-SD
1332-00	Double Beam Metric (200 x 10g & 10 x 0.1g)	1510-DO, 1520-DO, 1520-SD, 1550-SD, 1560-SD, 1510-DT
1293-00	Single Beam Combination-Metric & Avoirdupois	1454-SD
9705-00	Tare Beam Assembly	1510-DT, 1560-SD

TABULATION B

Plate, Pan or Scoop Combinations		Model No.
Pan Set with Cross	1071-01 (2) 1064-30 (2)	1510-DO, 1510-DT
Plate Assembly	1450-SD, 1454-SD, 3045-00 (2)	1550-SD, 1560-SD
Scale Scoop (stainless steel) with 4069-10 Fork 2555-03 Fork Stud 3045-00 Plate Assembly	1077-03	1520-SD

Scale Scoop 1101-20
 (polypropylene) with
 4069-10 Fork
 2555-03 Fork Stud
 3045-00 Plate Assembly

1520-DO

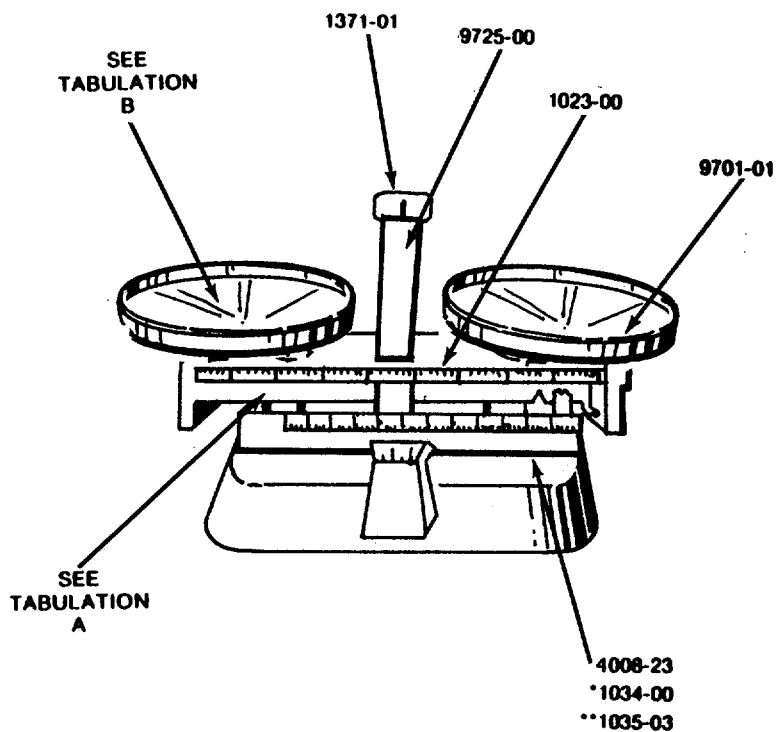

*1247-00 on open side

**Not required behind pointer assembly

OHAUS LIMITED WARRANTY

Your balance is warranted against defects in materials and workmanship for ninety (90) days from the date of delivery. During that period, Ohaus will repair, or at its option, replace at no charge, parts that prove to be defective, provided that the balance is returned to Ohaus Scale Corporation. No other expressed or implied warranty is given by Ohaus Scale Corporation and it shall not be liable for any consequential damages.

For further warranty information, please contact Ohaus Scale Corporation. Please fill in your registration card and mail within ten (10) days.

OHAUS is the registered trademark of Ohaus Scale Corporation as are the following trademarks: AUTOGRAM®, DRAINWEIGH®, CENT-O-GRAM®, CHECK-O-GRAM®, CUBE-O-GRAM®, DEC-O-GRAM®, DIAL-O-GRAIN®, DU-O-MEASURE®, GALAXY®, LUME-O-GRAM®, PORT-O-COUNT®, PORT-O-GRAM®, PRACT-O-GRAM®, PRIMER®, STO-A-WEIGH®, TOUCH-N-WEIGH®, 50-5®, and 10-10®.

OHAUS SCALE CORP.
 29 Hanover Road
 Florham Park, N.J. 07932
 Tel: 201-377-9000
 Telex: 6853191 OSCALE

OHAUS SCALE EUROPE, LTD.
 Broad Lane, Cottenham
 Cambridge CB4 4SW
 ENGLAND
 Tel: 0954-51343

APPENDIX A

REFERENCES

A-1. **Scope.** This appendix contains all forms, pamphlets and technical manuals referenced in both the Air mobile and Semi-trailer mounted Laboratories.

A-2. **Forms.**

Recommended Changes to Publications	DA Form 2028
	DA Form 2028-2
Quality Deficiency Report	SF 368
Equipment Inspection and Maintenance Work Sheet	DA Form 2404
Hand Receipts	DA Form 2062

A-3. **Field Manuals.**

Petroleum Testing Facilities:	
Laboratories and Kits	FM 10-72
Inspecting and Testing Petroleum Products	FM 10-70
ASTM Test Method Supplement to	FM 10-92C1/C2

A-4. **Technical Manuals.**

Atlas-Copco Compressor	TM 10-4310-392-13&P
Alcor Jet Fuel Thermal Oxidation Tester Operating and Maintenance Manual	TM 10-6635-210-13&P
Bacharach Gas Alarm and Calibration Data	TM 10-6665-297-13&P
Brother Portable Typewriter	TM 10-7430-218-13&P
Chemtrix Field Ph Meter	TM 10-6630-237-13&P
Elkay Manufacturing 30 GPH Cooler	TM 10-4130-240-13&P
Emcee Micro-Separometer	TM 10-6640-222-13&P
Foxboro Pressure Recording Gauge	TM 10-6685-365-13&P
Gammon Aqua Glo Water Detector	TM 10-6640-221-13&P
Gammon Mini Monitor Fuel Sampling Kit	TM 10-6630-230-13&P
Jelrus Burn-Out Furnace	TM 10-6640-231-13&P
Koehler Cleveland Open Tester	TM 10-6630-236-13&P
Koehler Cloud and Pour Point Chamber	TM 10-6630-238-13&P
Koehler Copper Strip Corrosion Bomb Bath	TM 10-6640-220-13&P
Koehler Distillation Apparatus	TM 10-6630-233-13&P
Koehler Dropping Point Apparatus	TM 10-6635-211-13&P
Koehler Electric Pensky-Martins Tester	TM 10-6630-231-13&P
Koehler Foaming Characteristics Determination Apparatus	TM 10-6640-228-13&P
Koehler Kinematic Viscosity Bath	TM 10-6630-239-13&P
Koehler Tag Closed Cup Flash Tester	TM 10-6630-235-13&P
Lab-Line Explosion Proof Refrigerator	TM 10-6640-219-13&P
Lily Freezer	TM 10-6640-234-13&P
Millipore OM 39 Filter Holder	TM 10-6640-225-13&P
Millipore Vacuum Pump	TM 10-6640-217-13&P
Ohaus Harvard Trip Balance	TM 10-6670-278-13&P
Precision Gas-Oil Distillation Test Equipment	TM 10-6630-219-13&P
Precision General Purpose Water Bath	TM 10-6640-229-13&P

Precision High Temperature Bronze Block Gum Bath	TM 10-6630-234-13&P
Precision General Purpose Ovens	TM 10-6640-218-13&P
Precision Heater Instruction Manual and Parts List	TM 10-6640-223-13&P
Precision Oxidation Stability Bath	TM 10-6640-232-13&P
Precision Pensky-Martens Flash Testers	TM 10-6630-231-13&P
Precision Reid Vapor Pressure Bath	TM 10-6640-226-13&P
Precision Slo-Speed Stirrer	TM 10-6640-224-13&P
Precision Universal Centrifuge	TM 10-6640-230-13&P
Precision Universal Penetrometer	TM 10-6640-228-13&P
Sargent-Welch Vacuum Pump	TM 10-4310-391-13&P
Sartorius Analytical Balance	TM 10-6670-277-13&P
Scotsman Cuber	TM 10-6640-227-13&P
Soltec VOM-Multimeter	TM 10-6625-3127-13&P
Teel Self-Priming Centrifugal Pump	TM 10-6640-217-13&P
Teel Submersible Pump	TM 10-4320-320-13&P
Texas Instrument TI-503011 Calculator	TM 10-7420-210-13&P

A-5. Pamphlets.

The Army Maintenance Management System (TAMMS)	DA Pam 738-750
--	----------------

A-6. Miscellaneous Publications.

The Army Integrated Publishing and Printing Program	AR 25-30
Laboratory, Airmobile, Aviation Fuel	MIL-L-52733A(ME)
Apparatus, Instruments, Chemicals, Furniture, and Supplies for Industrial, Clinical, College and Government Laboratories	Fisher Scientific Laboratories Catalog
Petroleum-Petrochemical Testing Equipment	Precision Scientific Catalog

APPENDIX B

MAINTENANCE ALLOCATION CHART

Section I. INTRODUCTION

B-1. General.

a. This section provides a general explanation of all maintenance and repair functions authorized at various maintenance categories.

b. The Maintenance Allocation Chart (MAC) in Section II designates overall authority and responsibility for the performance of maintenance functions on the identified end item or component. The application of the maintenance functions to the end item or component will be consistent with the capacities and capabilities of the designated maintenance categories.

c. Section III lists the tools and test equipment (both special tools and common tool sets) required for each maintenance function as referenced from Section II.

d. Section IV contains supplemental instructions and explanatory notes for a particular maintenance function.

B-2. Maintenance Functions. Maintenance functions will be limited to and defined as follows:

a. Inspect. To determine the serviceability of an item by comparing its physical, mechanical, and/or electrical characteristics with established standards through examination (e.g., by sight, sound, or feel).

b. Test. To verify serviceability by measuring the mechanical, pneumatic, hydraulic, or electrical characteristics of an item and comparing those characteristics with prescribed standards.

c. Service. Operations required periodically to keep an item in proper operating condition, i.e., to clean (includes decontaminate, when required), to preserve, to drain, to paint, or to replenish fuel, lubricants, chemical fluids, or gases.

d. Adjust. To maintain or regulate, within prescribed limits, by bringing into proper or exact position, or by setting the operating characteristics to specified parameters.

e. Align. To adjust specified variable elements of an item to bring about optimum or desired performance.

f. Calibrate. To determine and cause corrections to be made or to be adjusted on instruments or test, measuring, and diagnostic equipments used in precision measurement. Consists of comparisons of two instruments, one of which is a certified standard of knob accuracy, to detect and adjust any discrepancy in the accuracy of the instrument being compared.

g. Remove/install. To remove and install the same item when required to perform service or other maintenance functions. Install may be the act of emplacing, seating, or fixing into position a spare, repair part, or module (component or assembly) in a manner to allow the proper functioning of an equipment or system.

h. Replace. To remove an unserviceable item and install a serviceable counterpart in its place. "Replace" is authorized by the MAC and is shown as the third position code of the SMR code.

i. Repair. The application of maintenance services, including fault location/troubleshooting,² removal/installation, and disassembly/assembly procedures³ and maintenance actions⁴ to identify troubles and restore serviceability to an item by correcting specific damage, fault, malfunction, or failure in a part, subassembly, module (component or assembly), end item, or system.

j. Overhaul. That maintenance effort (service/action) prescribed to restore an item to a completely serviceable/operational condition as required by maintenance standards in appropriate technical publications (i.e., DMWR). Overhaul is normally the highest degree of maintenance performed by the Army. Overhaul does not normally return an item to like-new condition.

k. Rebuild. Consists of those services/actions necessary for the restoration of unserviceable equipment to a like-new condition in accordance with original manufacturing standards. Rebuild is the highest degree of materiel maintenance applied to Army equipment. The rebuild operation includes the act of returning to zero those age measurements (hours/miles, etc.) considered in classifying Army equipment/components.

B-3. Explanation Of Columns In The MAC, Section II.

a. Column I. Group Number. Column 1 lists functional group code numbers, the purpose of which is to identify maintenance significant components, assemblies, subassemblies, and modules with the next higher assembly. End item group number shall be "00."

b. Column 2. Component/Assembly. Column 2 contains the names of components, assemblies, subassemblies, and modules for which maintenance is authorized.

c. Column 3. Maintenance Function. Column 3 lists the functions to be performed on the item listed in column 2. (For a detailed explanation of these functions, see paragraph B-2.)

d. Column 4. Maintenance Category. Column 4 specifies, by the listing of a work time figure in the appropriate subcolumn(s), the category of maintenance authorized to perform the function listed in column 3. This figure represents the active time required to perform that maintenance function at the indicated category of maintenance. If the number or complexity of the tasks within the listed maintenance function vary at different maintenance categories, appropriate work time figures will be shown for each category. The work time figure represents the average time required to restore an item (assembly, subassembly, component, module, end item, or system) to a serviceable condition under typical field operating conditions. This time includes preparation time (including any necessary disassembly/ assembly time), troubleshooting/fault location time, and quality assurance/quality control time in addition to the time required to perform the specific tasks identified for the maintenance functions authorized in the maintenance allocation chart. The symbol designations for the various maintenance categories are as follows:

- 1 Services inspect, test, service, adjust, align, calibrate, and/or replace.
- 2 Fault locate/troubleshoot the process of investigating and detecting the cause of equipment malfunctioning; the act of isolating a fault within a system or unit under test (UUT).
- 3 Disassemble/assemble encompasses the step-by-step taking apart (or breakdown) of a spare/functional group coded item to the level of its least componency identified as maintenance significant (i.e., assigned an SMR code) for the category of maintenance under consideration.
- 4 Actions welding, grinding, riveting, straightening, facing, remachining, and/or resurfacing.

- C Operator/Crew
- O Unit Maintenance
- F Direct Support Maintenance
- H General Support Maintenance
- D Depot Maintenance

e. Column 5. Tools and Equipment. Column 5 specifies, by code, those common tool sets (not individual tools) and special tools, TMDE, and support equipment required to perform the designated function.

f. Column 6. Remarks. This column shall, when applicable, contain a letter code, in alphabetic order, which shall be keyed to the remarks contained in section IV.

B-4. Explanation Of Columns In Tool And Test Equipment Requirements, Section III.

a. Column I. Reference Code. The tool and test equipment reference code correlates with a code used in the MAC, section II, column 5.

b. Column 2. Maintenance Category. The lowest category of maintenance authorized to use the tool or test equipment.

c. Column 3. Nomenclature. Name or identification of the tool or test equipment.

d. Column 4. National Stock Number. The National stock number of the tool or test equipment.

e. Column 5. Tool Number. The manufacturer's part number.

B-5. Explanation Of Columns In Remarks, Section IV.

a. Column I. Reference Code. The code recorded in column 6, Section II.

b. Column 2. Remarks. This column lists information pertinent to the maintenance function being performed as indicated in the MAC, section II.

Section II. MAINTENANCE ALLOCATION CHART

(1) GROUP NUMBER	(2) COMPONENT/ ASSEMBLY	(3) MAINTENANCE FUNCTION	(4) MAINTENANCE LEVEL				(5) TOOLS AND EQUIPMENT	(6) REMARKS	
			UNIT		DS	GS			DEPOT
			C	O	F	H			D
01	BALANCE, DOUBLE BEAM	INSPECT REPLACE REPAIR	0.1	0.1 1.0				1	

**Section III. TOOL AND TEST EQUIPMENT REQUIREMENTS
FOR
MAINTENANCE ALLOCATION CHART**

(1) TOOL/TEST EQUIP. REF CODE	(2) MAINTENANCE CATEGORY	(3) NOMENCLATURE	(4) NSN	(5) TOOL NUMBER
1	O	TOOL KIT, GENERAL AUTOMOTIVE	5180-00-177-7033	(50980) SC 51 80-90- CL-N26

Section IV. REMARKS

NOT APPLICABLE

APPENDIX C

COMPONENTS OF END ITEM AND BASIC ISSUE ITEMS LISTS

NOT APPLICABLE

C-1/ (C-2 Blank)

APPENDIX D

ADDITIONAL AUTHORIZATION LIST

(1) National Stock Number	(2) Description CAGEC And Part Number	Usable On Code	(3) U/M	(4) Qty
6670-00-803-9680	WEIGHT SET BALANCE (BRASS) (81348) AAA-W-20L		EA	1
6670-00-351-2356	WEIGHT SET BALANCE W/I BOX AND FORCEPS (22527) 2-214A		EA	2

D-1/(D-2 Blank)

APPENDIX E

EXPENDABLE/DURABLE SUPPLIES AND MATERIALS LIST

NOT APPLICABLE

E-1/(E-2 Blank)

By Order of the Secretary of the Army:

CARL E. VUONO
General, United States Army
Chief of Staff

Official:

THOMAS F. SIKORA
Brigadier General, United States Army
The Adjutant General

DISTRIBUTION:

To be distributed in accordance with DA Form 12-21A, Operator, Unit and Direct Support Maintenance requirements for Laboratory, Petroleum, MTD

* U.S. GOVERNMENT PRINTING OFFICE: 1991 554-123/20080

RECOMMENDED CHANGES TO EQUIPMENT TECHNICAL PUBLICATIONS

 <div style="border: 1px solid black; border-radius: 15px; padding: 5px; display: inline-block; margin-left: 10px;"> <p style="margin: 0;"><i>THEN...JOT DOWN THE DOPE ABOUT IT ON THIS FORM. CAREFULLY TEAR IT OUT, FOLD IT AND DROP IT IN THE MAIL.</i></p> </div>		SOMETHING WRONG WITH PUBLICATION		
		FROM: (PRINT YOUR UNIT'S COMPLETE ADDRESS)		
PUBLICATION NUMBER		DATE SENT		
PUBLICATION DATE		PUBLICATION TITLE		
BE EXACT PIN-POINT WHERE IT IS				
PAGE NO.	PARA-GRAPH	FIGURE NO.	TABLE NO.	<p style="text-align: center; font-weight: bold;">IN THIS SPACE, TELL WHAT IS WRONG AND WHAT SHOULD BE DONE ABOUT IT.</p>
PRINTED NAME, GRADE OR TITLE AND TELEPHONE NUMBER			SIGN HERE	

The Metric System and Equivalents

Linear Measure

1 centimeter = 10 millimeters = .39 inch
 1 decimeter = 10 centimeters = 3.94 inches
 1 meter = 10 decimeters = 39.37 inches
 1 decameter = 10 meters = 32.8 feet
 1 hectometer = 10 decameters = 328.08 feet
 1 kilometer = 10 hectometers = 3,280.8 feet

Weights

1 centigram = 10 milligrams = .15 grain
 1 decigram = 10 centigrams = 1.54 grains
 1 gram = 10 decigram = .035 ounce
 1 decagram = 10 grams = .35 ounce
 1 hectogram = 10 decagrams = 3.52 ounces
 1 kilogram = 10 hectograms = 2.2 pounds
 1 quintal = 100 kilograms = 220.46 pounds
 1 metric ton = 10 quintals = 1.1 short tons

Liquid Measure

1 centiliter = 10 milliliters = .34 fl. ounce
 1 deciliter = 10 centiliters = 3.38 fl. ounces
 1 liter = 10 deciliters = 33.81 fl. ounces
 1 dekaliter = 10 liters = 2.64 gallons
 1 hectoliter = 10 dekaliters = 26.42 gallons
 1 kiloliter = 10 hectoliters = 264.18 gallons

Square Measure

1 sq. centimeter = 100 sq. millimeters = .155 sq. inch
 1 sq. decimeter = 100 sq. centimeters = 15.5 sq. inches
 1 sq. meter (centare) = 100 sq. decimeters = 10.76 sq. feet
 1 sq. decameter (are) = 100 sq. meters = 1,076.4 sq. feet
 1 sq. hectometer (hectare) = 100 sq. decameters = 2.47 acres
 1 sq. kilometer = 100 sq. hectometers = .386 sq. mile

Cubic Measure

1 cu. centimeter = 1000 cu. millimeters = .06 cu. inch
 1 cu. decimeter = 1000 cu. centimeters = 61.02 cu. inches
 1 cu. meter = 1000 cu. decimeters = 35.31 cu. feet

Approximate Conversion Factors

<i>To change</i>	<i>To</i>	<i>Multiply by</i>	<i>To change</i>	<i>To</i>	<i>Multiply by</i>
inches	centimeters	2.540	ounce-inches	Newton-meters	.007062
feet	meters	.305	centimeters	inches	.394
yards	meters	.914	meters	feet	3.280
miles	kilometers	1.609	meters	yards	1.094
square inches	square centimeters	6.451	kilometers	miles	.621
square feet	square meters	.093	square centimeters	square inches	.155
square yards	square meters	.836	square meters	square feet	10.764
square miles	square kilometers	2.590	square meters	square yards	1.196
acres	square hectometers	.405	square kilometers	square miles	.386
cubic feet	cubic meters	.028	square hectometers	acres	2.471
cubic yards	cubic meters	.765	cubic meters	cubic feet	35.315
fluid ounces	milliliters	29,573	cubic meters	cubic yards	1.308
pints	liters	.473	milliliters	fluid ounces	.034
quarts	liters	.946	liters	pints	2.113
gallons	liters	3.785	liters	quarts	1.057
ounces	grams	28.349	liters	gallons	.264
pounds	kilograms	.454	grams	ounces	.035
short tons	metric tons	.907	kilograms	pounds	2.205
pound-feet	Newton-meters	1.356	metric tons	short tons	1.102
pound-inches	Newton-meters	.11296			

Temperature (Exact)

°F	Fahrenheit temperature	5/9 (after subtracting 32)	Celsius temperature	°C
----	------------------------	----------------------------	---------------------	----

This fine document...

Was brought to you by me:



[Liberated Manuals -- free army and government manuals](#)

Why do I do it? I am tired of sleazy CD-ROM sellers, who take publicly available information, slap “watermarks” and other junk on it, and sell it. Those masters of search engine manipulation make sure that their sites that sell free information, come up first in search engines. They did not create it... They did not even scan it... Why should they get your money? Why are not letting you give those free manuals to your friends?

I am setting this document FREE. This document was made by the US Government and is NOT protected by Copyright. Feel free to share, republish, sell and so on.

I am not asking you for donations, fees or handouts. If you can, please provide a link to liberatedmanuals.com, so that free manuals come up first in search engines:

<A HREF=<http://www.liberatedmanuals.com/>>Free Military and Government Manuals

- Sincerely
Igor Chudov
<http://igor.chudov.com/>
- [Chicago Machinery Movers](#)