

TECHNICAL MANUAL

OPERATOR'S, UNIT AND

DIRECT SUPPORT MAINTENANCE MANUAL

(INCLUDING REPAIR PARTS AND SPECIAL TOOLS LIST)

FOR

PRECISION OXIDATION STABILITY BATH

MODEL TS 75042 AR-5

NSN 6640-00-290-6693

This technical manual is an authentication of the manufacturer's commercial literature and does not conform with the format and the content requirements normally associated with Army technical manuals. This technical manual does, however, contain all essential information required to operate and maintain the equipment.

Approved for public release; distribution is unlimited.

HEADQUARTERS, DEPARTMENT OF THE ARMY

15 OCTOBER 1990

This technical manual is an authentication of the manufacturer's commercial literature and does not conform with the format and the content requirements normally associated with Army technical manuals. This technical manual does, however, contain all essential information required to operate and maintain the equipment.

Approved for public release; distribution is unlimited.

SUPPLEMENTARY INTRODUCTORY MATERIAL

1-1. Maintenance Forms and Records.

Department of the Army forms and procedures used for equipment maintenance will be those described by DA Pam 738-750, The Army Maintenance Management System.

1-2. Reporting Errors and Recommending Improvements.

You can help improve this manual. If you find any mistakes or if you know of a way to improve the procedures, please let us know. Mail your letters, DA Form 2028 (Recommended Changes to Publications and Blank Forms), or DA Form 2028-2 located in the back of this manual, directly to: Commander, U.S. Army Troop Support Command, ATTN: AMSTR-MCTS, 4300 Goodfellow Blvd., St. Louis, MO 63120-1798. A reply will be furnished to you.

1-3. Destruction of Army Material to Prevent Enemy Use.

Refer to TM 750-244-3 for instructions covering the destruction of Army Material to prevent enemy use.

1-4. Administrative Storage of Equipment.

a. Placement of equipment in administrative storage should be for short periods of time when a shortage of maintenance effort exists. Items should be in mission readiness within 24 hours or within the time factors as determined by the directing authority. During the storage period appropriate maintenance records will be kept.

b. Before placing equipment in administrative storage, current preventive maintenance checks and services should be completed. Shortcomings and deficiencies should be corrected, and all modification work orders (MWO's) should be applied.

c. Storage site selection. Inside storage is preferred for items selected for administrative storage. If inside storage is not available, trucks, vans, conex containers and other containers may be used.

i/(ii Blank)

PrecisionTM

Instruction Manual TS-75042 AR-5

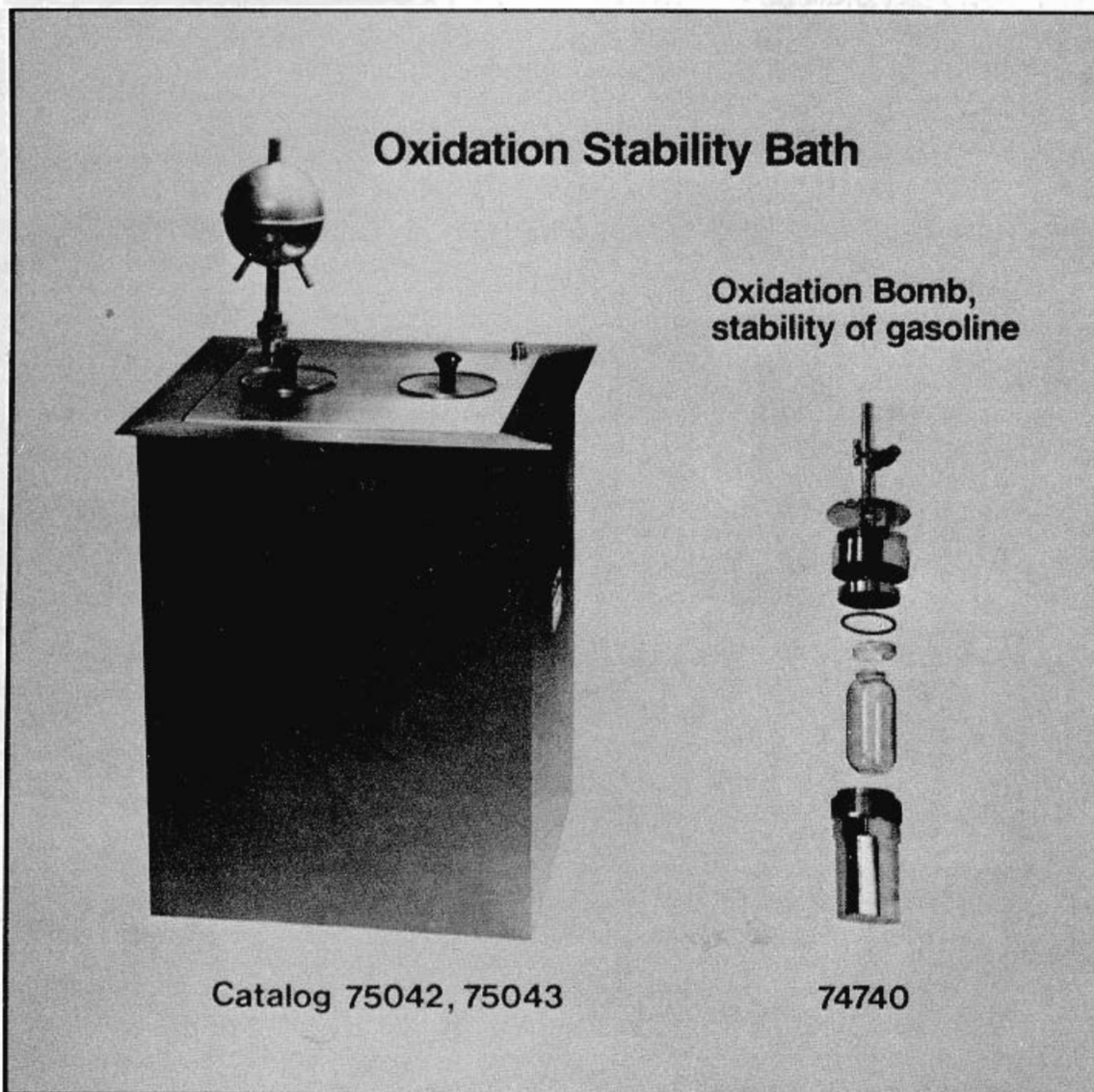

GCA[®]



GCA CORPORATION
Precision Scientific Group
3737 West Cortland Street
Chicago, Illinois 60647
Telephone 312-227-2660
Telex 25-4028

Oxidation Stability Bath

Introduction

Your satisfaction and safety are important to GCA/PRECISION SCIENTIFIC, and a complete understanding of this unit is necessary to attain these objectives.

As the ultimate user of this apparatus, it is your responsibility to understand its proper function and operational characteristics. This instruction manual should be thoroughly read and all operators given adequate training before attempting to place this unit in service. Awareness of the stated cautions and warnings, and compliance with recommended operating parameters-together with maintenance requirements-are important for safe and satisfactory operation. The unit should be used for its intended application; alterations or modifications will void the Warranty.

WARNING:

As a routine laboratory precaution, always wear safety glasses when working with this apparatus.

This apparatus is not designed for use in Class I, II, or III locations as defined by the National Electrical Code.

Unpacking and damage

Save all packing material if apparatus is received damaged. This merchandise was carefully packed and thoroughly inspected before leaving our factory.

Responsibility for its safe delivery was assumed by the carrier upon acceptance of the shipment; therefore, claims for loss or damage sustained in transit must be made upon the carrier by the recipient as follows:

Visible Loss or Damage: Note any external evidence of loss or damage on the freight bill, or express receipt, and have it signed by the carrier's agent. Failure to adequately describe such external evidence of loss or damage may result in the carrier's refusing to honor your damage claim. The form required to file such a claim will be supplied by the carrier.

Concealed Loss or Damage: Concealed loss or damage means loss or damage which does not become apparent until the merchandise has been unpacked and inspected. Should either occur, make a written request for inspection by the carrier's agent within 15 days of the delivery date; then file a claim with the carrier since the damage is the carrier's responsibility.

By following these instructions carefully, we guarantee our full support of your claim to be compensated for loss from concealed damage.

DO NOT -FOR ANY REASON -RETURN THIS UNIT WITHOUT FIRST OBTAINING AUTHORIZATION. In any correspondence to GCA/PRECISION SCIENTIFIC, please supply the nameplate data, including catalog number and serial number.



General information

These instructions encompass the Oxidation Stability Baths listed below with their specific electrical characteristics:

Cat.	No.	Volts	Hertz	Watts	Amps
	75042	120	50/60	2000	17.3
	75043	240	50/60	2000	8.7

These Baths and Oxidation Stability of Gasoline Bombs (see accessories) are designed to determine the stability of gasoline in accordance with ASTM D-525 and the determination of the tendency of aviation, reciprocating, turbine and jet fuels to form gum and deposits under accelerated aging conditions in conformance with ASTM D-873.

WARNING:

Gasoline and other test fuels are extremely flammable and adequate ventilation should be provided during the test. See PRECAUTIONARY STATEMENTS in ASTM D-525 & D-873 for Additional Caution, Warning, and Danger Explanations.

SAFETY CONSIDERATIONS AND WARNINGS: The following guidelines are presented to supplement the existing safety rules enforced by your company:

- 1) Safety glasses should be worn by the operator and by anyone in the vicinity who could be struck by glass fragments caused by glass sample container or cover breakage or by splashing from handling liquid samples.
- 2) It is recommended that a fire extinguisher of Halon 1211 or CO₂ (at least a 5-lb. tank size) be placed conveniently in reach of the operator of the unit to protect against sample fires which might accidentally occur.
- 3) Service or circuit testing should be attempted only by a qualified person who has been trained with regard to the potential danger of working with live electrical circuitry.

WARNING:

Disconnect the unit from the power source whenever replacing electrical components.

- 4) Insulated gloves should be used when handling hot oxidation bomb or sample container.

TECHNICAL SPECIFICATIONS

Test method conformance:	ASTM D-525, IP-40, DIN 51780 ASTM D-873, IP-138, DIN 51799 Fed. Test Method Std. No.791a(Method 33545).
Max. rated temperature	100C
Time to reach max. temp.....	1/2 hours
Bomb capacity	2
Liquid capacity	2 gallons(7.6 liters)
Wattage	500,1000,2000
Cabinet dimensions	14"(355.6mm)W 14"(355.6mm)D, 19"(4826 mm)H
Condenser length	814"(209.6mm)L

Installation

Location: The most uniform operating conditions and results will be obtained by placing the unit in an area remote from drafts, ventilating outlets, radiators, and other rapidly changing ambient conditions.

Recess Mounting:

The bath contains a flange on 4 sides which can be used to support the bath in a bench top opening.

TABLE OPENING FOR RECESS MOUNTING

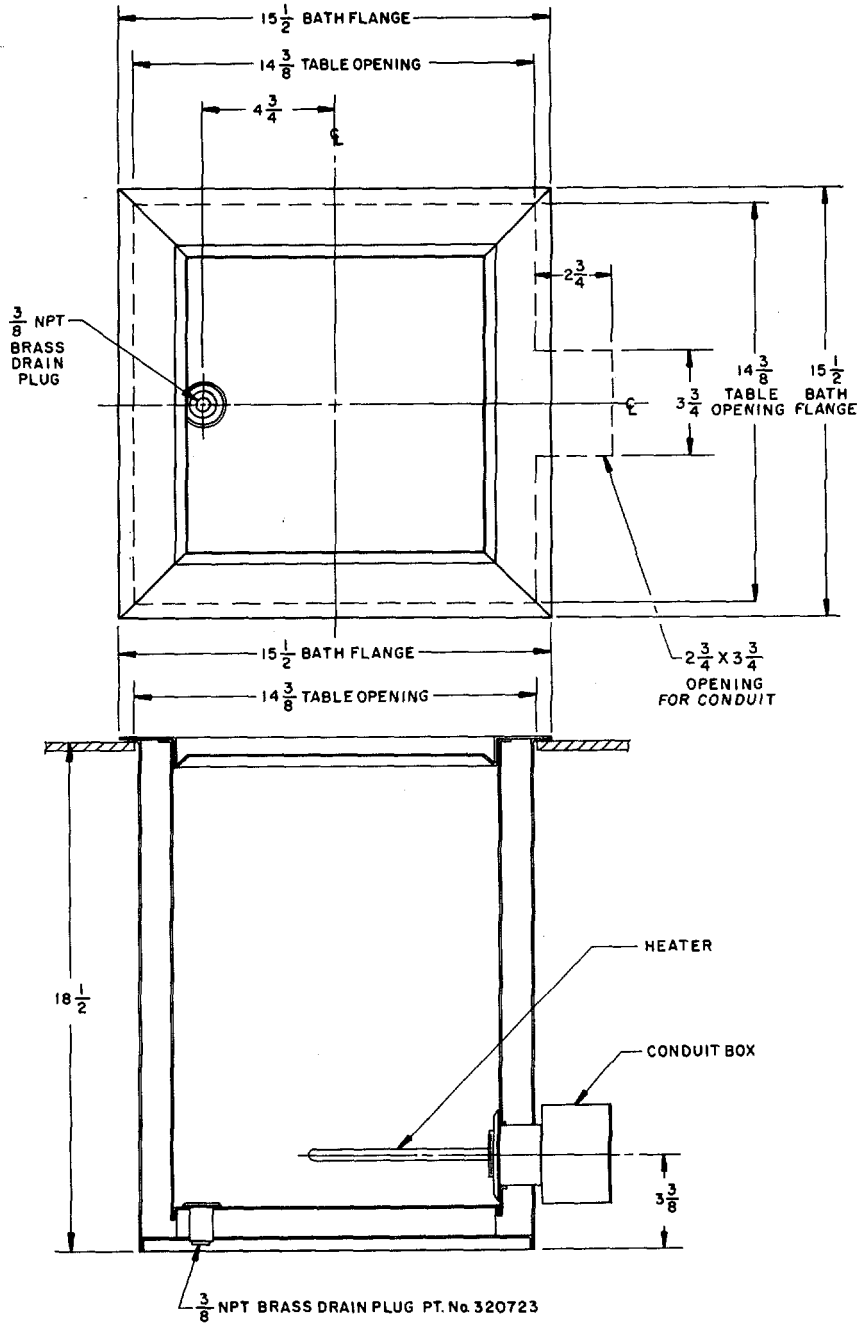



Electrical Connections: Important (Please read carefully.)

CAUTION:

The bath contains an immersion heater. The unit **must not** be connected to a power source unless it is filled with liquid and the switch is in the "Off" position. This will prevent the heater from burning out.

Determine the total amount of current presently being used by other apparatus connected to the circuit that will be used for this unit. It is critical that the added current demand and other equipment on the circuit not exceed the rating of the fuse or circuit breaker in use.

CAUTION:

Be sure the power supply is of the same voltage as specified on the nameplate.

A conduit box is supplied on the side of the bath and it contains the heater terminals.

The three heat switch provided should be mounted in an acceptable location to the conduit box and accessible to the operator.

WARNING:

National Electrical Code should be observed for proper fusing and the size of the service wires. For personal safety, this apparatus **must** be properly grounded.

All wiring should be completed by a qualified electrician. See "Heater and Three Heat Switch Connections."

HEATER AND 3 HEAT SWITCH CONNECTIONS

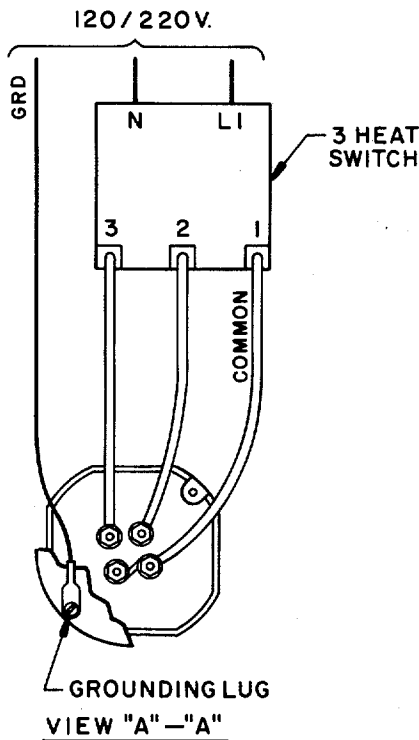

SWITCH CIRCUIT	
HIGH HEAT	1 & LI 2 & N 3 & N
MEDIUM HEAT	1 & LI 3 & N
LOW HEAT	2 & LI 3 & N
OFF	ALL OPEN

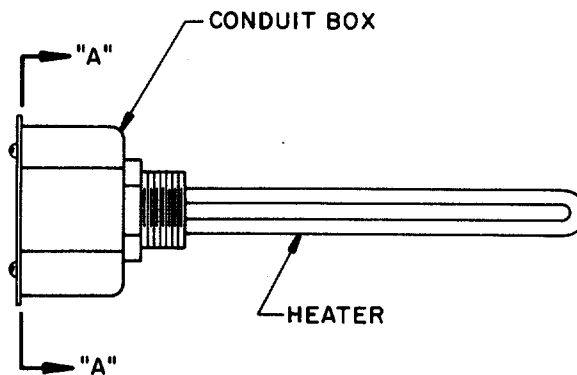



Reflux Condenser

A condenser is provided to reduce evaporation of the bath water and should be fastened to the coupling located on the top of the bath.

Two serrated hose connectors located on the bottom of the condenser are an integral part of the reflux condenser.

Attach 1/4" I. D. tygon or rubber tubing from a cool water source to the serrated hose connector marked "In", and attach another piece of 1/4" I. D. tubing from the other hose connector to the drain. Adjust the flow of cool water to maintain a minimum of water vapor from escaping the condenser outlet tube.

Thermometer:

A thermometer well is provided on top of the bath and is designed to accept a thermometer (not supplied) conforming to the requirements as prescribed in ASTM E1 or in the specifications for IP Standard thermometers.

<u>Temperature Range</u>	<u>Thermometer ASTM</u>	<u>Number IP</u>
204 to 218°F	22F	24F
95 to 103C	22C	24C

Operation

Preparation of the apparatus, preparation of the sample, test procedure, calculations and reporting, and appropriate tables are supplied in the ASTM Methods D-525 and D-873.

ASTM test methods can be obtained from:

American Society for Testing Materials 1916 Race Street
Philadelphia, Pennsylvania 19103

Place the three heat switch in the "High" position for quick heat up; then adjust to a lower position, if necessary, to maintain test temperature.



Parts list

<u>ITEM NO.</u>	<u>DESCRIPTION</u>	<u>QTY.</u>	<u>PART NO.</u>
1	Cover With Knob (Bomb Opening)	2	516713
2	Condenser, Soxhlet	1	67847
3	Thermometer Coupling	1	501357
4	Thermometer Well	1	501356
5	Locknut, Thermometer Well	1	501030
6	Leather Washer, Thermometer Well	2	218031
7	Switch, 3 Heat	1	240178
8	Wall Plate	1	264016
9	Heater, 120V, 2000W	1	247175
	Heater, 240V, 2000W	1	247176

Accessories

<u>CATALOG NUMBER</u>	<u>DESCRIPTION</u>
74740Oxidation Bomb, stability of gasoline
74739	Flexible helical bronze tubing, 1/8"(3.1mm) 1. D. .5'(1524.0mm)L with protective armor braid. One end has 1/8"NPT thread to fit bomb, the other end 1/4" IPS thread to fit pressure recorder.
74741 Wrench for 74740
74744	Recording pressure gauge, single pen. With 12" chart range 0-200 lbs. ,in 2-lb. divisions, with 24-hour spring
74748Table flange grips lower half of 74740 bomb for easy removal or tightening
74743Bomb Gaskets, Part Number 232240, pkg. of 100

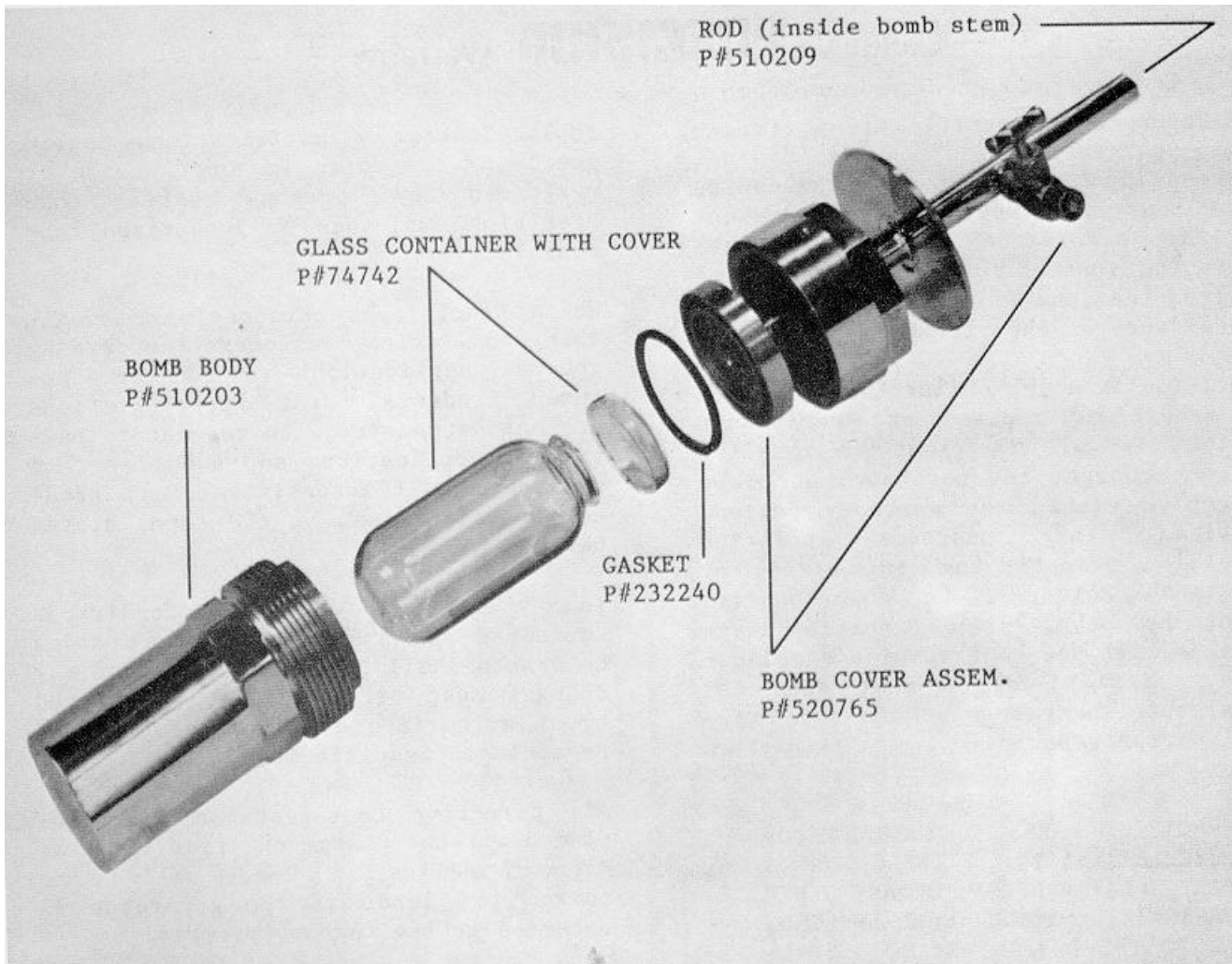

**OXIDATION BOMB, STABILITY
OF GASOLINE, CAT. NO.74740**



GCA/Precision Scientific Group (Precision) warrants its products against defects in material or in workmanship, when used under appropriate conditions and in accordance with appropriate operating instructions for a period of no less than one (1) year from the date of delivery of the products.

Precision's sole obligation shall be to repair or replace at Precision's option, F. O. B. its plant or locally, without charge, any part(s) that prove defective within the warranty period, provided the customer notifies Precision promptly and in writing of any such defect. Compensation for labor by other than Precision's employees will not be Precision's obligation. Part(s) replacement does not constitute an extension of the original warranty period.

PRECISION MAKES NO WARRANTY OF MERCHANTABILITY, FITNESS FOR A PARTICULAR PURPOSE, OR ANY OTHER WARRANTY, EXPRESSED OR IMPLIED, AS TO THE DESIGN, SALE, INSTALLATION, OR USE OF ITS PRODUCTS, AND SHALL NOT BE LIABLE FOR CONSEQUENTIAL DAMAGES RESULTING FROM THE USE OF ITS PRODUCTS.

Precision will not assume responsibility for unauthorized repairs or failure as a result of unauthorized product modifications, or for repairs,

replacements, or modifications negligently or otherwise improperly made or performed by persons other than Precision employees or authorized representatives.

While Precision's personnel are available to advise customers concerning general applications of all manufactured products, oral representations are not warranties with respect to particular applications and should not be relied upon if inconsistent with product specifications or the terms stated herein.

In any event, the terms and conditions contained in Precision's formal sales contracts shall be controlling; and any changes must be in writing and signed by an authorized executive of the GCA/Precision Scientific Group.

All defective components will be replaced without charge one year from the date of delivery. There will be no charge for labor if the apparatus is returned to the factory prepaid.

Conditions and qualifications of the warranty statement shall prevail at all times.

APPENDIX A

REFERENCES

A-1. **Scope.** This appendix contains all forms, pamphlets and technical manuals referenced in both the Air mobile and Semitrailer mounted Laboratories.

A-2. **Forms.**

Recommended Changes to Publications DA Form 2028
 DA Form 2028-2
 Quality Deficiency Report SF 368
 Equipment Inspection and Maintenance Work Sheet DA Form 2404
 Hand Receipts DA Form 2062

A-3. **Field Manuals.**

Petroleum Testing Facilities:
 Laboratories and Kits FM 10-72
 Inspecting and Testing Petroleum Products FM 10-70
 ASTM Test Method Supplement to FM 10-92C1/C2

A-4. **Technical Manuals.**

Atlas-Copco Compressor TM 10-4310-392-13&P
 Alcor Jet Fuel Thermal Oxidation Tester Operating
 and Maintenance Manual TM 10-6635-210-13&P
 Bacharach Gas Alarm and Calibration Data TM 10-6665-297-13&P
 Brother Portable Typewriter TM 10-7430-218-13&P
 Chemtrix Field Ph Meter TM 10-6630-237-13&P
 Elkay Manufacturing 30 GPH Cooler TM 10-4130-240-13&P
 Emcee Micro-Separometer TM 10-6640-222-13&P
 Foxboro Pressure Recording Gauge TM 10-6685-365-13&P
 Gammon Aqua Glo Water Detector TM 10-6640-221-13&P
 Gammon Mini Monitor Fuel Sampling Kit TM 10-6630-230-13&P
 Jelrus Burn-Out Furnace TM 10-6640-231-13&P
 Koehler Cleveland Open Tester TM 10-6630-236-13&P
 Koehler Cloud and Pour Point Chamber TM 10-6630-238-13&P
 Koehler Copper Strip Corrosion Bomb Bath TM 10-6640-220-13&P
 Koehler Distillation Apparatus TM 10-6630-233-13&P
 Koehler Dropping Point Apparatus TM 10-6635-211-13&P
 Koehler Electric Pensky-Martins Tester TM 10-6630-231-13&P
 Koehler Foaming Characteristics Determination Apparatus TM 10-6640-228-13&P
 Koehler Kinematic Viscosity Bath TM 10-6630-239-13&P
 Koehler Tag Closed Cup Flash Tester TM 10-6630-235-13&P
 Lab-Line Explosion Proof Refrigerator TM 10-6640-219-13&P
 Lily Freezer TM 10-6640-234-13&P
 Millipore OM 39 Filter Holder TM 10-6640-225-13&P
 Millipore Vacuum Pump TM 10-6640-217-13&P
 Ohaus Harvard Trip Balance TM 10-6670-278-13&P
 Precision Gas-Oil Distillation Test Equipment TM 10-6630-219-13&P
 Precision General Purpose Water Bath TM 10-6640-229-13&P

Precision High Temperature Bronze Block Gum Bath	TM 10-6630-234-13&P
Precision General Purpose Ovens	TM 10-6640-218-13&P
Precision Heater Instruction Manual and Parts List	TM 10-6640-223-13&P
Precision Oxidation Stability Bath	TM 10-6640-232-13&P
Precision Pensky-Martens Flash Testers	TM 10-6630-231-13&P
Precision Reid Vapor Pressure Bath	TM 10-6640-226-13&P
Precision Slo-Speed Stirrer	TM 10-6640-224-13&P
Precision Universal Centrifuge	TM 10-6640-230-13&P
Precision Universal Penetrometer	TM 10-6640-228-13&P
Sargent-Welch Vacuum Pump	TM 10-4310-391-13&P
Sartorius Analytical Balance	TM 10-6670-277-13&P
Scotsman Cuber	TM 10-6640-227-13&P
Soltec VOM-Multimeter	TM 10-6625-3127-13&P
Teel Self-Priming Centrifugal Pump	TM 10-6640-217-13&P
Teel Submersible Pump	TM 10-4320-320-13&P
Texas Instrument TI-503011 Calculator	TM 10-7420-210-13&P

A-5. Pamphlets.

The Army Maintenance Management System (TAMMS)	DA Pam 738-750
--	----------------

A-6. Miscellaneous Publications.

The Army Integrated Publishing and Printing Program	AR 25-30
Laboratory, Airmobile, Aviation Fuel	MIL-L-52733A(ME)
Apparatus, Instruments, Chemicals, Furniture, and Supplies for Industrial, Clinical, College and Government Laboratories	Fisher Scientific Laboratories Catalog
Petroleum-Petrochemical Testing Equipment	Precision Scientific Catalog

APPENDIX B

MAINTENANCE ALLOCATION CHART

Section I. INTRODUCTION

B-1. General.

a. This section provides a general explanation of all maintenance and repair functions authorized at various maintenance categories.

b. The Maintenance Allocation Chart (MAC) in Section II designates overall authority and responsibility for the performance of maintenance functions on the identified end item or component. The application of the maintenance functions to the end item or component will be consistent with the capacities and capabilities of the designated maintenance categories.

c. Section III lists the tools and test equipment (both special tools and common tool sets) required for each maintenance function as referenced from Section II.

d. Section IV contains supplemental instructions and explanatory notes for a particular maintenance function.

B-2. **Maintenance Functions.** Maintenance functions will be limited to and defined as follows:

a. Inspect. To determine the serviceability of an item by comparing its physical, mechanical, and/or electrical characteristics with established standards through examination (e. g. , by sight, sound, or feel).

b. Test. To verify serviceability by measuring the mechanical, pneumatic, hydraulic, or electrical characteristics of an item and comparing those characteristics with prescribed standards.

c. Service. Operations required periodically to keep an item in proper operating condition, i. e. , to clean (includes decontaminate, when required), to preserve, to drain, to paint, or to replenish fuel, lubricants, chemical fluids, or gases.

d. Adjust. To maintain or regulate, within prescribed limits, by bringing into proper or exact position, or by setting the operating characteristics to specified parameters.

e. Align. To adjust specified variable elements of an item to bring about optimum or desired performance.

f. Calibrate. To determine and cause corrections to be made or to be adjusted on instruments or test, measuring, and diagnostic equipments used in precision measurement. Consists of comparisons of two instruments, one of which is a certified standard of knob accuracy, to detect and adjust any discrepancy in the accuracy of the instrument being compared.

g. Remove/Install. To remove and install the same item when required to perform service or other maintenance functions. Install may be the act of emplacing, seating, or fixing into position a spare, repair part, or module (component or assembly) in a manner to allow the proper functioning of an equipment or system.

h. Replace. To remove an unserviceable item and install a serviceable counterpart in its place. "Replace" is authorized by the MAC and is shown as the third position code of the SMR code.

i. Repair. The application of maintenance services,¹ including fault location/troubleshooting,² removal/installation, and disassembly/assembly procedures³ and maintenance actions⁴ to identify troubles and restore serviceability to an item by correcting specific damage, fault, malfunction, or failure in a part, subassembly, module (component or assembly), end item, or system.

j. Overhaul. That maintenance effort (service/action) prescribed to restore an item to a completely serviceable/operational condition as required by maintenance standards in appropriate technical publications (i. e, DMWR). Overhaul is normally the highest degree of maintenance performed by the Army. Overhaul does not normally return an item to like-new condition.

k. Rebuild. Consists of those services/actions necessary for the restoration of unserviceable equipment to a like-new condition in accordance with original manufacturing standards. Rebuild is the highest degree of materiel maintenance applied to Army equipment. The rebuild operation includes the act of returning to zero those age measurements (hours/miles, etc.) considered in classifying Army equipment/components.

B-3. Explanation Of Columns In The MAC, Section II.

a. Column 1. Group Number. Column 1 lists functional group code numbers, the purpose of which is to identify maintenance significant components, assemblies, subassemblies, and modules with the next higher assembly. End item group number shall be "00. "

b. Column 2. Component/Assembly. Column 2 contains the names of components, assemblies, subassemblies, and modules for which maintenance is authorized.

c. Column 3. Maintenance Function. Column 3 lists the functions to be performed on the item listed in column 2. (For a detailed explanation of these functions, see paragraph B-2.)

d. Column 4. Maintenance Category. Column 4 specifies, by the listing of a work time figure in the appropriate subcolumn(s), the category of maintenance authorized to perform the function listed in column 3. This figure represents the active time required to perform that maintenance function at the indicated category of maintenance. If the number or complexity of the tasks within the listed maintenance function vary at different maintenance categories, appropriate work time figures will be shown for each category. The work time figure represents the average time required to restore an item (assembly, subassembly, component, module, end item, or system) to a serviceable condition under typical field operating conditions. This time includes preparation time (including any necessary disassembly/ assembly time), troubleshooting/fault location time, and quality assurance/quality control time in addition to the time required to perform the specific tasks identified for the maintenance functions authorized in the maintenance allocation chart. The symbol designations for the various maintenance categories are as follows:

-
- 1 Services inspect, test, service, adjust, align, calibrate, and/or replace.
 - 2 Fault locate/troubleshoot the process of investigating and detecting the cause of equipment malfunctioning; the act of isolating a fault within a system or unit under test (UUT).
 - 3 Disassemble/assemble encompasses the step-by-step taking apart (or breakdown) of a spare/functional group coded item to the level of its least componency identified as maintenance significant (i.e., assigned an SMR code) for the category of maintenance under consideration.
 - 4 Actions - welding, grinding, riveting, straightening, facing, remachining, and/or resurfacing.

- C..... Operator/Crew
- O Unit Maintenance
- F Direct Support Maintenance
- H General Support Maintenance
- D Depot Maintenance

e. Column 5. Tools and Equipment. Column 5 specifies, by code, those common tool sets (not individual tools) and special tools, TMDE, and support equipment required to perform the designated function.

f. Column 6. Remarks. This column shall, when applicable, contain a letter code, in alphabetic order, which shall be keyed to the remarks contained in section IV.

B-4. Explanation Of Columns In Tool And Test Equipment Requirements, Section III.

a. Column 1. Reference Code. The tool and test equipment reference code correlates with a code used in the MAC, section II, column 5.

b. Column 2. Maintenance Category. The lowest category of maintenance authorized to use the tool or test equipment.

c. Column 3. Nomenclature. Name or identification of the tool or test equipment.

d. Column 4. National Stock Number. The National stock number of the tool or test equipment.

e. Column 5. Tool Number. The manufacturer's part number.

B-5. Explanation Of Columns In Remarks, Section IV.

a. Column 1. Reference Code. The code recorded in column 6, Section II.

b. Column P. Remarks. This column lists information pertinent to the maintenance function being performed as indicated in the MAC, section II.

Section II. MAINTENANCE ALLOCATION CHART

(1) GROUP NUMBER	(2) COMPONENT/ ASSEMBLY	(3) MAINTENANCE FUNCTION	(4) MAINTENANCE LEVEL					(5) TOOLS AND EQUIPMENT	(6) REMARKS
			UNIT		DS	GS	DEPOT		
			C	O	F	H	D		
00	OXIDATION STABILITY BATH	INSPECT REPLACE REPAIR	0.2					1,2	
				0.3 2.0					
01	BOMB, OXIDATION	INSPECT REPLACE REPAIR	0.1						
				0.2 0.2					

**Section III. TOOL AND TEST EQUIPMENT REQUIREMENTS
FOR
MAINTENANCE ALLOCATION CHART**

(1) TOOL/TEST EQUIP. REF CODE	(2) MAINTENANCE CATEGORY	(3) NOMENCLATURE	(4) NSN	(5) TOOL NUMBER
1	0	TOOL KIT, GENERAL AUTOMOTIVE	5180-00-177-7033	(50980) SC 5180-90- CL-N26
2	0	MULTIMETER, 0-500V	6625-00-691-2453	

Section IV. REMARKS

NOT APPLICABLE

APPENDIX C

COMPONENTS OF END ITEM AND BASIC ISSUE ITEMS LISTS

Section I. INTRODUCTION

C-1. **Scope.**

This appendix lists components of end item and basic issue items for the Oxidation Stability Bath to help you inventory items required for safe and efficient operation.

C-2. **General.**

The Components of End Item and Basic Issue Items Lists are divided into the following sections:

a. Section II Components of End Item. This listing is for informational purposes only, and is not authority to requisition replacements. These items are part of the end item, but are removed and separately packaged for transportation or shipment. As part of the end item, these items must be with the end item whenever it is issued or transferred between property accounts. Illustrations are furnished to assist you in identifying the items.

b. Section III. Basic Issue Items. These are the minimum essential items required to place the Oxidation Stability Bath in operation, to operate it, and to perform emergency repairs. Although shipped separately packaged, BII must be with the shelter during operation and whenever it is transferred between property accounts. The illustrations will assist you with hard-to-identify items. This manual is your authority to request/requisition replacement BII, based on TOE/MTOE authorization of the end item.

C-3. **Explanation of Columns.**

The following provides an explanation of columns found in the tabular listings:

a. Column (1) Illustration Number (Illus Number). This column indicates the number of the illustration in which the item is shown.

b. Column (2) National Stock Number. Indicates the National stock number assigned to the item and will be used for requisitioning purposes.

c. Column (3) Description. Indicates the Federal item name and, if required, a minimum description to identify and locate the item. The last line for each item indicates the CAGEC (in parentheses) followed by the part number.

d. Column (4) Unit of Measure (U/M). Indicates the measure used in performing the actual operational/maintenance function. This measure is expressed by a two-character alphabetical abbreviation (e.g., ea, in, pr).

e. Column (5) Quantity required (QTY RQR). Indicates the quantity of the item authorized to be used with/on the equipment.

Section II. COMPONENTS OF END ITEM

(1) Illus	(2) National Stock Number	(3) Description Usable CAGEC And Part Number On Code	(4) U/M	(5) Qty
	6685-00-242-3763	OXIDATION BOMB, STABILITY OF GASOLINE(48619) 74740 THERMOMETER, SELF INDICATING, LIQUID IN GLASS207.5 TO 215.50F (22527) 13-618J THERMOMETER, SELF INDICATING, LIQUID IN GLASS95 TO 1030C WITH CASE (22527) 13-575F	EA	1 2 2

Section III. BASIC ISSUE ITEMS

NOT APPLICABLE

APPENDIX D

ADDITIONAL AUTHORIZATION LIST

SECTION I. INTRODUCTION

D-1. SCOPE

This appendix lists additional items you are authorized for the support of the Precision Oxidation Stability Bath.

D-2. GENERAL

This list identifies items that do not have to accompany the Precision Oxidation Stability Bath and that do not have to be turned in with it. These items are authorized to you by CTA, MTOE, TDA or JTA.

D-3. EXPLANATION OF LISTING

National stock numbers, descriptions and quantities are provided to help you identify and request the additional items you require to support this equipment. The items are listed in alphabetical sequence by item name under the type document (i.e., CTA, MTOE, TDA or JTA) which authorizes the item(s) to you.

(1) National Stock Number	(2) Description CAGEC And Part Number	Usable On Code	(3) U/M	(4) Qty
	RECORDING PRESSURE GAUGE (48619) 74744		EA	1

D-1/(D-2 Blank)

APPENDIX E

EXPENDABLE/DURABLE SUPPLIES AND MATERIALS LIST

Section I. INTRODUCTION

E-1. **Scope.** This listing is for informational purposes only and is not authority to requisition the listed items. These items are authorized to you by CTA 50-970, Expendable/Durable Items (except medical, class V, repair parts, and heraldic items).

E-2. **Explanation of Columns.**

a. Column (1) - Item Number. This number is assigned to the entry in the listing and is referenced in the narrative instructions to identify the material (e.g., Use cleaning compound, item 5, appendix C).

b. Column (2) - Level. This column identifies the lowest level of maintenance that requires the listed item.

- C - Operator/Crew
- O - Unit Maintenance
- F - Direct Support Maintenance
- H - General Support Maintenance

c. Column (3) - National Stock Number. This is the National stock number assigned to the item; use it to request or requisition the item.

d. Column (4) - Description. Indicates the Federal item name, and, if required, a description to identify the item. The last line for each item indicates the Commercial and Government Entity Code (CAGEC) in parentheses followed by the part number.

e. Column (5) - Unit of Measure (U/M). Indicates the measure used in performing the actual maintenance function. This measure is expressed by a two-character alphabetical abbreviation (e.g., EA, IN, PR). If the unit of measure differs from the unit of issue, requisition the lowest unit of issue that will satisfy your requirements.

Section II. EXPENDABLE/DURABLE SUPPLIES AND MATERIALS LIST

(1) Item Number	(2) Level	(3) National Stock Number	(4) Description	(5) U/M
1	C		OXIDATION BOMB WITH GLASS CONTAINER AND COVER (48619) 74742	
	C		GASKET COVER ASSEMBLY (48619) 520765	
	C		GASKET, BOMB (48619) 74743	PKG.

E-1/(E-2 Blank)

By Order of the Secretary of the Army:

CARL E. VUONO
General, United States Army
Chief of Staff

Official:

THOMAS F. SIKORA
Brigadier General, United States Army
The Adjutant General

DISTRIBUTION:

To be distributed in accordance with DA Form 12-21A, Operator, Unit and Direct Support Maintenance requirements for Laboratory, Petroleum, MTD

☆U.S. GOVERNMENT PRINTING OFFICE 1990: 554-123/20055

RECOMMENDED CHANGES TO EQUIPMENT TECHNICAL PUBLICATIONS



THEN...JOT DOWN THE
DOPE ABOUT IT ON THIS FORM.
CAREFULLY TEAR IT OUT, FOLD IT
AND DROP IT IN THE MAIL.

SOMETHING WRONG WITH PUBLICATION

FROM: (PRINT YOUR UNIT'S COMPLETE ADDRESS)

DATE SENT

PUBLICATION NUMBER

PUBLICATION DATE

PUBLICATION TITLE

BE EXACT PIN-POINT WHERE IT IS

PAGE
NO.

PARA-
GRAPH

FIGURE
NO.

TABLE
NO.

IN THIS SPACE, TELL WHAT IS WRONG
AND WHAT SHOULD BE DONE ABOUT IT.

TEAR ALONG PERFORATED LINE

PRINTED NAME, GRADE OR TITLE AND TELEPHONE NUMBER

SIGN HERE

THE METRIC SYSTEM AND EQUIVALENTS

Linear Measure

1 centimeter = 10 millimeters = .39 inch
 1 decimeter = 10 centimeters = 3.94 inches
 1 meter = 10 decimeters = 39.37 inches
 1 dekameter = 10 meters = 32.8 feet
 1 hectometer = 10 dekameters = 328.08 feet
 1 kilometer = 10 hectometers = 3,280.8 feet

Weights

1 centigram = 10 milligrams = .15 grain
 1 decigram = 10 centigrams = 1.54 grains
 1 gram = 10 decigram = .035 ounce
 1 dekagram = 10 grams = .35 ounce
 1 hectogram = 10 dekagrams = 3.52 ounces
 1 kilogram = 10 hectograms = 2.2 pounds
 1 quintal = 100 kilograms = 220.46 pounds
 1 metric ton = 10 quintals = 1.1 short tons

Cubic Measure

1 cu. centimeter = 1000 cu. millimeters = .06 cu. inch
 1 cu. decimeter = 1000 cu. centimeters = 61.02 cu. in.
 1 cu. meter = 1000 cu. decimeters = 35.31 cu. feet

Square measure

1 sq. centimeter = 100 sq. millimeters = .155 sq. in.
 1 sq. decimeter = 100 sq. centimeters = 15.5 inches
 1 sq. meter (centare) = 100 sq. decimeters = 10.76 feet
 1 sq. dekameter (are) = 100 sq. meters = 1,076.4 sq. ft.
 1 sq. hectometer (hectare) = 100 sq. dekameters = 2.47 acres
 1 sq. kilometer = 100 hectometers = .386 sq. miles

Liquid Measure

1 dekaliter = 10 liters = 2.64 gallons
 1 hectoliter = 10 dekaliters = 26.42 gallons
 1 kiloliter = 10 hectoliters = 264.18 gallons
 1 liter = 10 deciliters = 33.81 fl. ounces
 1 centiliter = 10 milliliters = .34 fl. ounce
 1 deciliter = 10 centiliters = 3.38 fl. ounces
 1 metric ton = 10 quintals = 1.1 short tons

Approximate Conversion Factors

To change	To	Multiply by	To change	To	Multiply by
inches	centimeters	2.540	ounce inches	newton-meters	.0070062
feet	meters	.305	centimeters	inches	.394
yards	meters	.914	meters	feet	3.280
miles	kilometers	1.609	meters	yards	1.094
sq. inches	sq. centimeters	6.451	kilometers	miles	.621
sq. feet	sq. meters	.093	sq. centimeters	sq. inches	.155
sq. yards	sq. meters	.836	sq. meters	sq. yards	10.764
sq. miles	sq. kilometers	2.590	sq. kilometers	sq. miles	1.196
acres	sq. hectometers	.405	sq. hectometers	acres	2.471
cubic feet	cubic meters	.028	cubic meters	cubic feet	35.315
cubic yards	cubic meters	.765	milliliters	fluid ounces	.034
fluid ounces	milliliters	29.573	liters	pints	2.113
pints	liters	.472	liters	quarts	1.057
quarts	liters	.946	grams	ounces	.035
gallons	liters	3.785	kilograms	pounds	2.205
ounces	grams	28.349	metric tons	short tons	1.102
pounds	kilograms	.454	pound-feet	newton-meters	1.356
short tons	metric tons	.907			
pound inches	newton-meters	.11296			

Temperature (Exact)

°F Fahrenheit temperature

5/9 (after subtracting 32)

Celsius Temperature °C

This fine document...

Was brought to you by me:



[Liberated Manuals -- free army and government manuals](#)

Why do I do it? I am tired of sleazy CD-ROM sellers, who take publicly available information, slap “watermarks” and other junk on it, and sell it. Those masters of search engine manipulation make sure that their sites that sell free information, come up first in search engines. They did not create it... They did not even scan it... Why should they get your money? Why are not letting you give those free manuals to your friends?

I am setting this document FREE. This document was made by the US Government and is NOT protected by Copyright. Feel free to share, republish, sell and so on.

I am not asking you for donations, fees or handouts. If you can, please provide a link to liberatedmanuals.com, so that free manuals come up first in search engines:

<A HREF=<http://www.liberatedmanuals.com/>>Free Military and Government Manuals

- Sincerely
Igor Chudov
<http://igor.chudov.com/>
- [Chicago Machinery Movers](#)