

**TECHNICAL MANUAL
OPERATOR'S, UNIT AND
DIRECT SUPPORT MAINTENANCE MANUAL
(INCLUDING REPAIR PARTS AND SPECIAL TOOLS LIST)
FOR
KOEHLER FOAMING CHARACTERISTICS
DETERMINATION APPARATUS
MODEL K43000**

This technical manual is an authentication of the manufacturer's commercial literature and does not conform with the format and the content requirements normally associated with Army technical manuals. This technical manual does, however, contain all essential information required to operate and maintain the equipment.

Approved for public release; distribution is unlimited.

This technical manual is an authentication of the manufacturer's commercial literature and does not conform with the format and the content requirements normally associated with Army technical manuals. This technical manual does, however, contain all essential information required to operate and maintain the equipment.

Approved for public release; distribution is unlimited.

SUPPLEMENTARY INTRODUCTORY MATERIAL

1-1. Maintenance Forms and Records.

Department of the Army forms and procedures used for equipment maintenance will be those described by DA Pam 738-750, The Army Maintenance Management System.

1-2 Reporting Errors and Recommending Improvements.

You can help improve this manual. If you find any mistakes or if you know of a way to improve the procedures, please let us know. Mail your letters, DA Form 2028 (Recommended Changes to Publications and Blank Forms), or DA Form 2028-2 located in the back of this manual, directly to: Commander, U.S. Army Troop Support Command, ATTN: AMSTR- MCTS, 4300 Goodfellow Blvd., St. Louis, MO 63120-1798. A reply will be furnished to you.

1-3. Destruction of Army Material to Prevent Enemy Use.

Refer to TM 750-244-3 for instructions covering the destruction of Army Material to prevent enemy use.

1-4. Administrative Storage of Equipment.

a. Placement of equipment in administrative storage should be for short periods of time when a shortage of maintenance effort exists. Items should be in mission readiness within 24 hours or within the time factors as determined by the directing authority. During the storage period appropriate maintenance records will be kept.

b. Before placing equipment in administrative storage, current preventive maintenance checks and services should be completed. Shortcomings and deficiencies should be corrected, and all modification work orders (MWO's) should be applied.

c. Storage site selection. Inside storage is preferred for items selected for administrative storage. If inside storage is not available, trucks, vans, conex containers and other containers may be used.



K43000 & K43090
FOAM TEST APPARATUS
ASTM D892
FOAMING CHARACTERISTICS
OF
LUBRICATING OILS

1595 SYCAMORE AVE.
BOHEMIA, N Y 11716
(516) 589-3800
TELEX 4973677 "KOEHLER"
FAX (516) 589-3815

KOEHLER

K43000 & K43090

FOAM TEST APPARATUS

ASTM D892

TABLE OF CONTENTS

SECTION:

- (A) **GENERAL INSTRUCTIONS:**
- (1) UNPACKING INSTRUCTIONS
 - (2) ASSEMBLY INSTRUCTIONS
 - (3) OPERATING INSTRUCTIONS
 - (4) SERVICE INSTRUCTIONS
- (B) WIRING DIAGRAMS
- (C) FLOW GAUGE AND VALVE ASSEMBLY DRAWING
- (D) SPARE PARTS LIST

NOTE: The K43090 Foam Test Apparatus is the same as the K43000, except the voltage is 230V., 50/60 Hz.

SAFETY AND HAZARD WARNING

THIS EQUIPMENT MAY INVOLVE HAZARDOUS MATERIAL AND OPERATIONS. THIS MANUAL DOES NOT PURPORT TO ADDRESS ALL OF THE SAFETY PROBLEMS ASSOCIATED WITH THE USE OF THE EQUIPMENT. IT IS THE RESPONSIBILITY OF WHOEVER USES THIS EQUIPMENT TO CONSULT AND ESTABLISH APPROPRIATE SAFETY AND HEALTH PRACTICES, AND DETERMINE THE APPLICABILITY OF REGULATORY LIMITATIONS PRIOR TO USE.



PLEASE NOTE

Due to the difficulty in obtaining Certified Norton Diffuser Stones we are currently supplying as an alternate the Mott 5 Micron Stainless Steel Diffuser. This improved Diffuser is currently under evaluation by ASTM and has produced consistent comparative results to the Norton Diffuser Stone. It is expected to be incorporated into the method as an alternate in the near future. Please call or write if you have a problem using this Diffuser.

1595 SYCAMORE AVE.
BOHEMIA, N Y 11716
(516) 589-3800
TELEX 4973677 "KOEHLER"
FAX (516) 589-3815

SECTION A

(1) UNPACKING INSTRUCTIONS: (See Shipping Diagram)

The K430 Bath comes packed in one carton. Remove the bath top, 1000ML jar and the air delivery tube assembly and place in a safe location. Remove the inner boxes next and unpack the pyrex jar. Inside the jar are the flow gauge, shelf and lead collar, packed separately. Remove the base from the carton and take away the packing from around the components and carefully proceed to assemble the instrument.

(2) ASSEMBLY INSTRUCTIONS:

NOTE: The Foam Test Bath should be assembled and placed on a firm level table in a room free of excessive drafts.

- (A) Place the base on a firm level table, and install the pyrex jar with the shelf installed.
- (B) Fill the jar with clean water or clear oil to the level prescribed in ASTM D892. Capacity 8.8 Gals.
- (C) Place the bath top assembly on the jar and plug the control cable into the receptacle on the top of the control unit.
- (D) Install the thermistor probe in the top with cork provided.
- (E) Plug the control unit line cord into a properly fused and grounded receptacle of the correct voltage as marked on the rear plate of the control unit.
- (F) Install the flow gauge assembly and connect the air supply to the flow gauge, as shown in assembly drawing.
- (G) Connect the cooling coils to a cold water line for use when running low temperature tests.

SECTION A

(3) OPERATING INSTRUCTIONS:

(A) Bath is now ready for operation. Make sure all switches are OFF.

(B) Turn all switches to ON, and adjust the Ten-Turn Potentiometer clockwise all the way.

(C) When the bath is about 100 below the desired temperature, turn the continuous heater OFF and adjust the Ten-Turn Potentiometer until the pilot light blinks ON and OFF.

(D) Allow the bath temperature to stabilize. Adjust the Ten-Turn Potentiometer to bring bath temperature to exact set point.

(E) Clean the 1000ML Graduated Cylinder as per instructions in ASTM D892 and pour the test sample into the cylinder to the recommended level as per ASTM D892.

(F) Clean and flush the air delivery tube assembly (diffusion stone) as per ASTM D892.

(G) Place the 1000ML Cylinder with the lead collar on the shelf in the bath, and proceed with the test as per ASTM D892.

(H) Read and record the test results in accordance with the ASTM Method.

SECTION A

(4) SERVICE INSTRUCTIONS:

Under normal conditions service is not required. However, any service problems can often be resolved quickly and inexpensively by phone or letter. Please contact our office at:

KOEHLER INSTRUMENT
COMPANY, INC.
1595 SYCAMORE AVENUE
BOHEMIA, NEW YORK 11716

TELEPHONE: (516) 589-3800

TELEX: 4973677 KOEHLER

FOAM TEST BATH K430
FLOW GAGE & VALVE ASS'Y

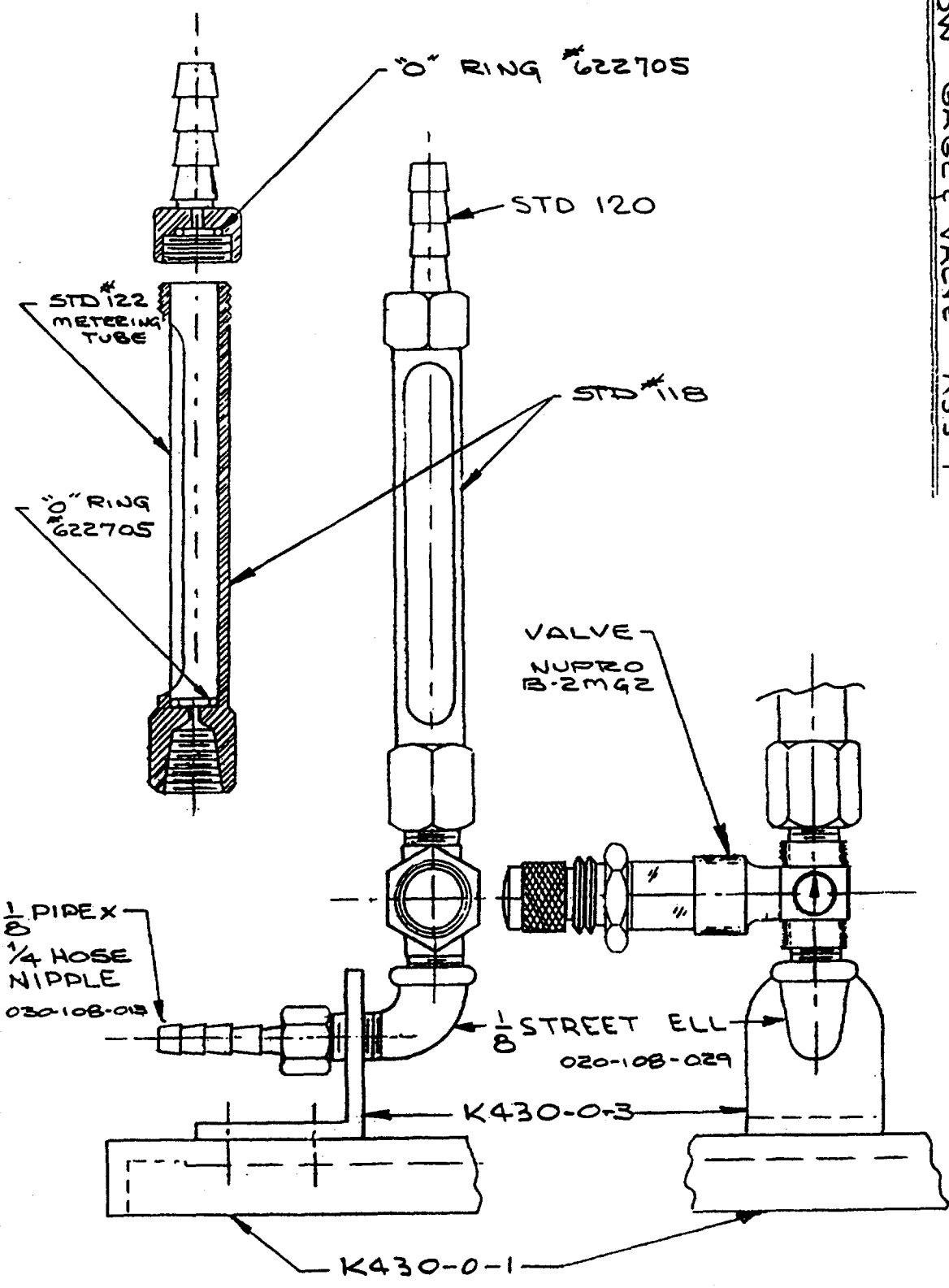

K430-2
FULL SCALE

7-30-85

EFFECTIVE FROM JUNE 16, 77 TO DATE

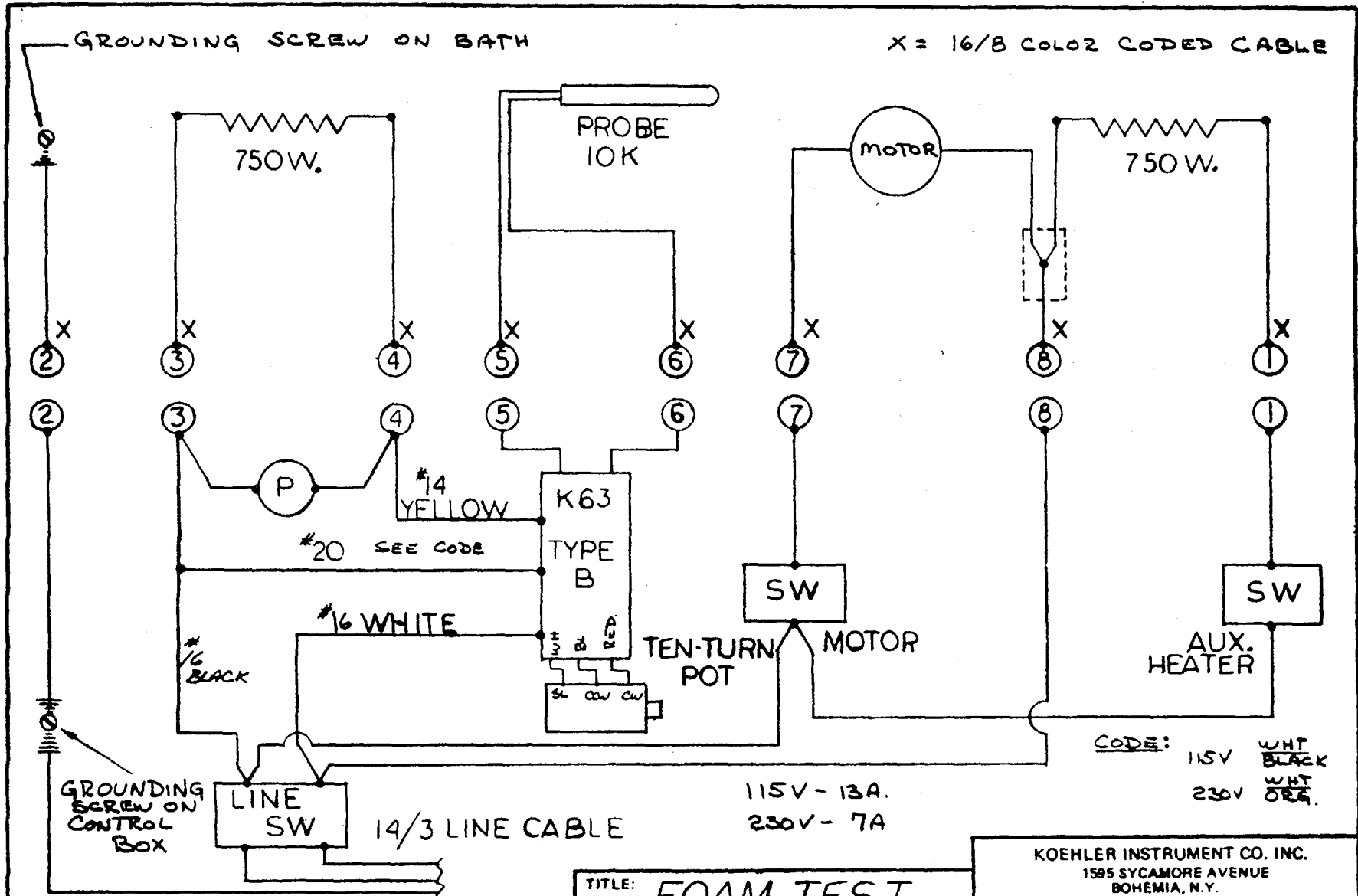

INSTRUMENT: K430		NO. REQD. 1		TITLE: FOAM TEST BATH		KOEHLER INSTRUMENT CO. INC. 1595 SYCAMORE AVENUE BOHEMIA, N.Y.	
MAT. //		DWG. SIZE A		SCALE //		PART NO. WIRING DIAGRAM	
FINISH //		SHEET 1 OF 1		REV.			

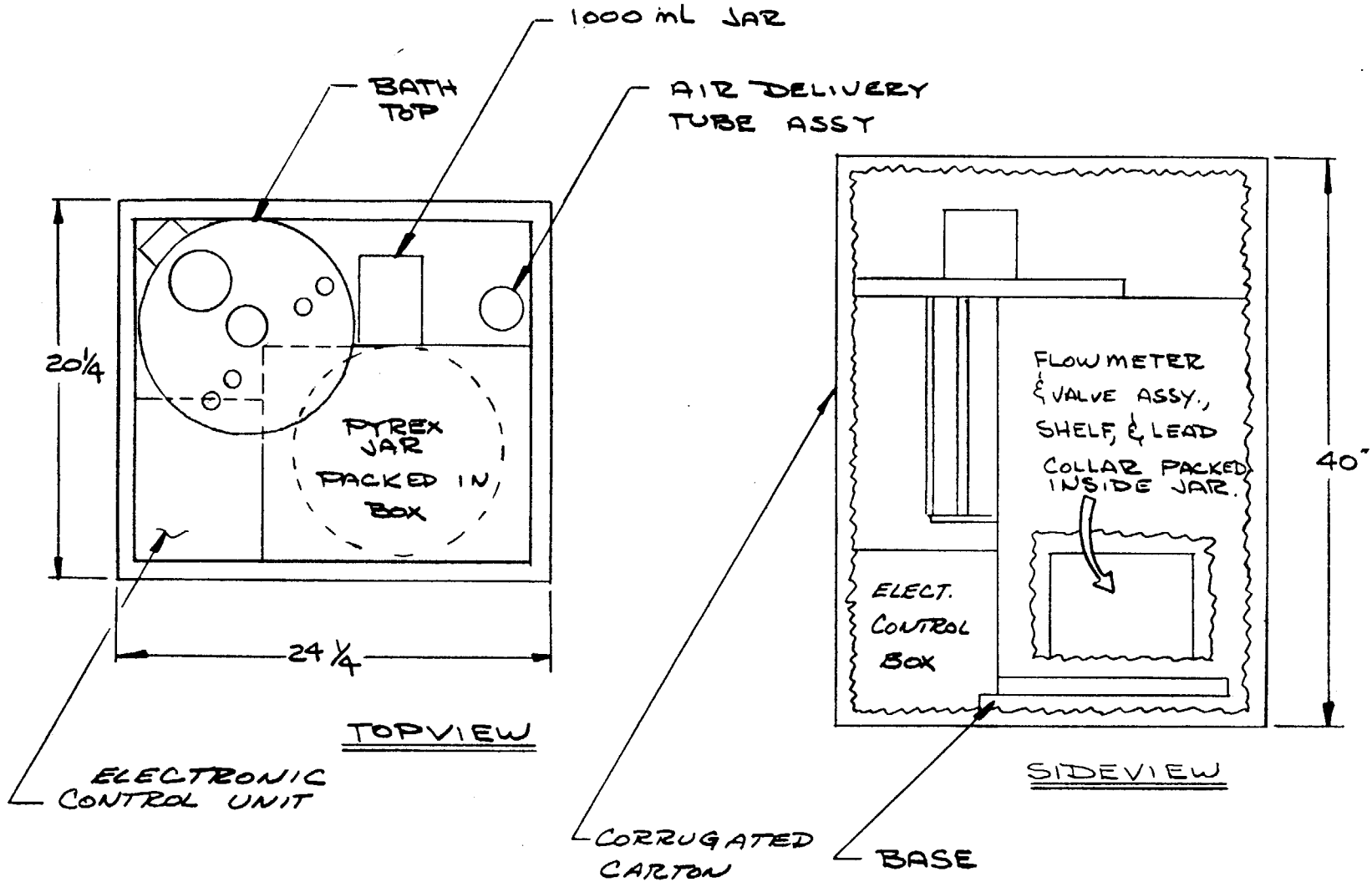

INSTRUMENT: K430 Foam TEST		NO. REQD. 1	TITLE: SHIPPING ARRANGEMENT		KOEHLER INSTRUMENT CO. INC. 1595 SYCAMORE AVENUE BOHEMIA, N.Y.	
MAT. 44	FINISH 44	DWG. SIZE A			SCALE NONE	SHEET 1 OF 1

K43000 & K43090FOAM TEST APPARATUS

<u>Part No.</u>	<u>Description</u>	<u>Quantity</u>
K233-0-5	Base	1 each
332-001-003	Pyrex Jar	1 each
K430-0-12	1000ML Pyrex Cylinder	1 each
K430-0-8	Rubber Stopper	1 each
K430-3C	Air Delivery Tube W/Certified Ball	1 each
K430-3B	Air Delivery Tube W/Mott Diffuser	1 each
010-115-002	Type B Controller with 10K	1 each
010-103-001	Probe, 12" long	
045-115-001	Pilot Light, Neon 115V.	1 each
045-230-001	Pilot Light, Neon 230V.	1 each
288-115-004	Motor, 115V. 230V.	1 each
010-010-001	10 Turn Dial	1 each
010-010-002	10 Turn Pot	1 each
050-001-001	Toggle Switches	2 each
050-002-004	Line Switch	1 each
K430-2	Flow Gauge and Valve	1 each
170-000-001	Metering Tube only	1 each
344-100-01C	Certified Porous Ball Only	1 each
344-005-001	Mott Diffuser	1 each
K430-0-2A	Control Heater (115V)	1 each
K430-0-2B	Continuous Heater (115V) 1 each	
K430A-0-2A	Control Heater (230V)	1 each
K430A-0-2B	Continuous Heater (230V) 1 each	
K430-0-13	Air Outlet Elbow	1 each



WARRANTY POLICY

Any product* manufactured by Koehler Instrument Co., Inc. (hereinafter referred to as the company) is sold on the following basis and none other. ALL IMPLIED WARRANTIES OF MERCHANTABILITY AND OF FITNESS FOR A PARTICULAR PURPOSE ARE HEREBY EXPRESSLY EXCLUDED.

The following warranty shall apply, and no other warranty, express or implied, shall apply.

If within one year from date of shipment the product fails because of defective material or poor workmanship, the company will repair or replace, without charge, any product that has failed provided:

- a) the product has been properly installed, operated and maintained.
- b) the company is advised in writing of the malfunction and authorizes the return of the product to the factory.
- c) All transportation charges for the return to the factory are prepaid. (Products will be returned freight collect.)
- d) A complete description of the reason for return must accompany the unit.

NOTE: A nominal handling charge for inspection will be made on units for which a claimed defect cannot be confirmed.

THE COMPANY'S SOLE LIABILITY HEREUNDER SHALL BE TO REPAIR OR REPLACE ANY PRODUCT WHICH HAS NOT COMPLIED WITH THIS WARRANTY.

In no event shall the company be liable for:

- 1) Prospective profits or special, indirect or consequential damages caused by failure of its product.
- 2) Any charges for labor or materials for work done on its products by others.

*Wherever used in this Warranty Policy the term "product" shall mean any items manufactured and/or sold by Koehler Instrument Co., Inc.

1595 SYCAMORE AVE.
BOHEMIA. N Y 11716
(516) 589-3800
TELEX 4973677 "KOEHLER"
FAX (516) 589-3815

PRODUCT: Foaming Characteristics of Lubricating Oils

Foaming Characteristics Determination Apparatus

- Conforms to ASTM D892, FTM 791-3211, 3213* and related specifications
- Calibrated and certified air diffuser stone
- Sensitive solid state temperature controller with thermistor sensor probe
- Highly accurate direct reading flowmeter

Fully equipped constant temperature bath tests foaming characteristics of lubricating oils to determine their suitability for high speed gearing, splash lubrication, high volume pumping and other applications. Aerates sample through diffuser stone at 94 ± 5 ml/min. and maintains sample temperature at $24.5 \pm 93.5 \pm 0.5^{\circ}\text{C}$ (75 and $200 \pm 1^{\circ}\text{F}$) for three-sequence testing.

Features precise solid state temperature control with thermistor sensor probe for convenient reliable operation. A silent 1/20 hp ball bearing stirrer provides complete circulation to assure temperature uniformity.

Chrome plated cooling coil with serrated hose connections allows for accurate control at 24.5°C (75°F). Bath components are mounted in a sturdy machined 1/2" (1.27 cm) composition top plate, which rests on A 12 x 18" (30.5 x 46 cm) Pyrex jar.

Certified diffuser stone meets ASTM specifications, eliminating the need for calibration by the operator. A sensitive direct reading 0-200 ml/min. flowmeter and needle valve assembly controls air flow to the air diffuser at the specified rate.

SPECIFICATIONS

Conforms to the specifications of:

ASTM D892, FTM 791-3211,
3213*, IP 146, DIN 51566

Temperature Range: Ambient to 275°F
(134°C)

Controller Sensitivity: $\pm 1^\circ\text{F}$
($\pm 0.5^\circ\text{C}$)

Heater Range: 0-1500W
Bath Capacity/Medium: 9 gal (38.5 l)
water or white
technical oil

DIMENSIONS

Bath Interior: 12" dia x 18" h
(30 x 46 cm)

Overall:
Bath: 14 5/8" dia x 28" h
(37 x 71 cm)

Control Housing: 9 1/8" w x 6 1/2" h
(23 x 20 x 17 cm)

SHIPPING INFORMATION

Net Weight: 57 lbs (25.8 kg)
Shipping Weight: 100 lbs (45.4 kg)
Dimensions: 28 x 24 x 43"
(71 x 61 x 109 cm)

ORDERING INFORMATION

Includes Pyrex TM1000 ml graduated sample cylinder with lead ring and stainless steel support tripod, cast aluminum bath support, control cabinet with multiconductor connector cable and diffuser stone with calibration certificate. Order thermometer separately.

Catalog No.	Description
K43000	Foaming Characteristics Test Apparatus 115V 50/60 Hz
K43090	Foaming Characteristics Test Apparatus 220-240V 50/60 Hz

*For FTM 791-3213 operation (Foaming Characteristics of Aircraft Turbine Lubricating Oils), flowrator to deliver 1000 cc air/min. and 500 ml sample cylinder are supplied in place of standard equipment. 'Specify when ordering.

Accessories and Replacements

K43010	Certified Diffuser Stone Calibrated and certified for compliance with ASTM specifications K43020 Diffuser Stone Non-calibrated
K43030	Stainless Steel Diffuser
K43025	Diffuser Stone Apparatus For maximum pore diameter and permeability tests on non-calibrated diffuser stones. Consists of 90 cm flowmeter, 500 ml flask, and control valve. Mounted on a steel base.
355-001-001	White Technical Oil
250-000-12F	ASTM 12F Thermometer Range: -5 to 215°F Graduations: 0.5°C
250-000-12C	ASTM 12C Thermometer Range: -20 to 102°C Graduations: 0.2°C

K430-0-12 1000 ML PYREX CYLINDER
K430-0-8 RUBBER STOPPER

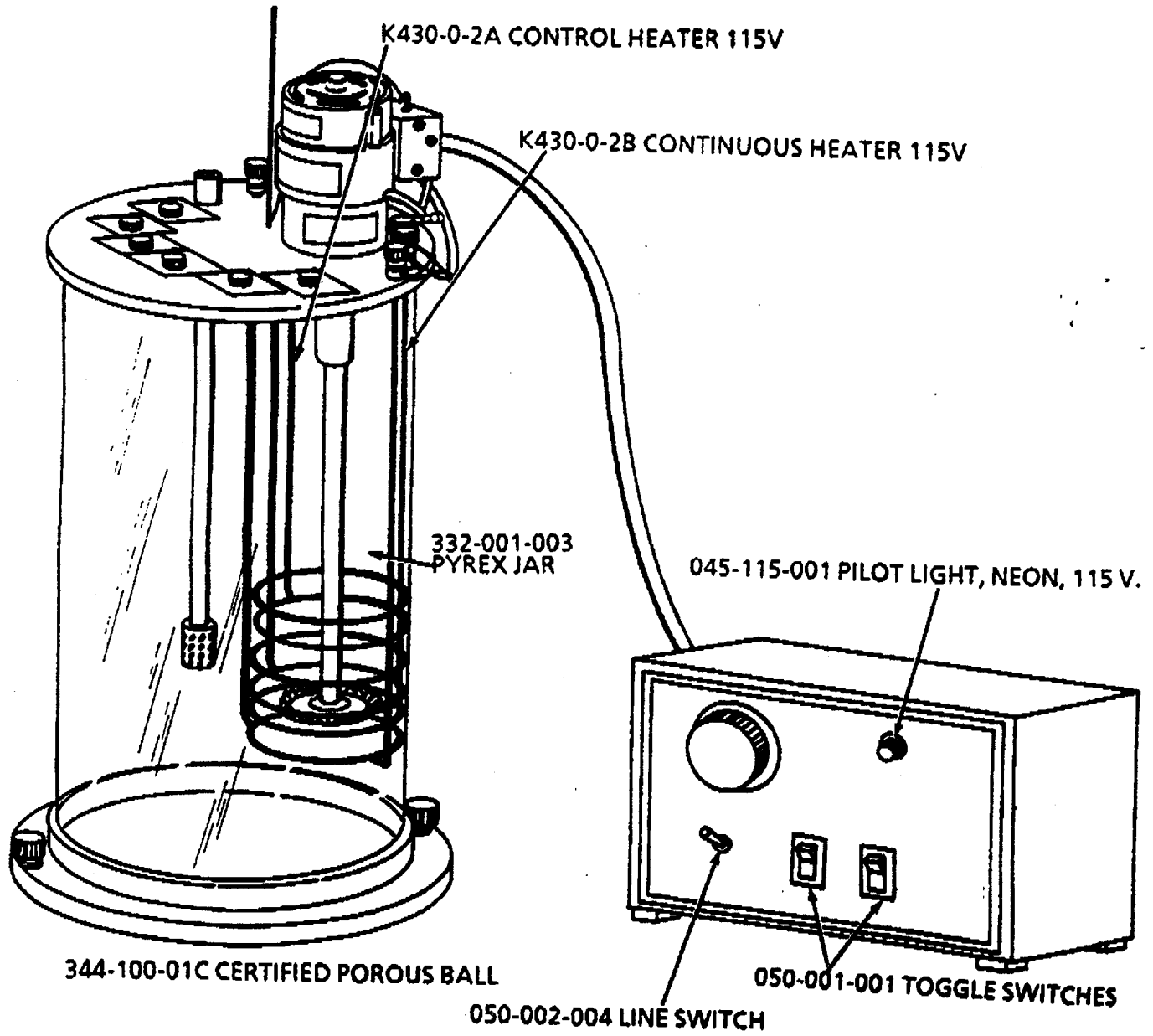

KOEHLER K43000 FOAM TEST APPARATUS

APPENDIX A

REFERENCES

A-1. Scope. This appendix contains all forms, pamphlets and technical manuals referenced in both the Air mobile and Semitrailer mounted Laboratories.

A-2. Forms.

Recommended Changes to Publications DA Form 2028
 DA Form 2028-2
 Quality Deficiency Report SF 368
 Equipment Inspection and Maintenance Work Sheet DA Form 2404
 Hand Receipts DA Form 2062

A-3 Field Manuals.

Petroleum Testing Facilities:
 Laboratories and Kits FM 10-72
 Inspecting and Testing Petroleum Products FM 10-70
 ASTM Test Method Supplement to FM 10-92C1/C2

A-4 Technical Manuals.

Atlas-Copco Compressor TM 10-4310-392-13&P
 Alcor Jet Fuel Thermal Oxidation Tester Operating
 and Maintenance Manual TM 10-6635-210-13&P
 Bacharach Gas Alarm and Calibration Data TM 10-6665-297-13&P
 Brother Portable Typewriter TM 10-7430-218-13&P
 Chemtrix Field Ph Meter TM 10-6630-237-13&P
 Elkay Manufacturing 30 GPH Cooler TM 10-4130-240-13&P
 Emcee Micro-Separometer TM 10-6640-222-13&P
 Foxboro Pressure Recording Gauge TM 10-6685-365-13&P
 Gammon Aqua Glo Water Detector TM 10-6640-221-13&P
 Gammon Mini Monitor Fuel Sampling Kit TM 10-6630-230-13&P
 Jelrus Burn-Out Furnace TM 10-6640-231-13&P
 Koehler Cleveland Open Tester TM 10-6630-236-13&P
 Koehler Cloud and Pour Point Chamber TM 10-6630-238-13&P
 Koehler Copper Strip Corrosion Bomb Bath TM 10-6640-220-13&P
 Koehler Distillation Apparatus TM 10-6630-233-13&P
 Koehler Dropping Point Apparatus TM 10-6635-211-13&P
 Koehler Electric Pensky-Martins Tester TM 10-6630-231-13&P
 Koehler Foaming Characteristics Determination Apparatus TM 10-6640-228-13&P
 Koehler Kinematic Viscosity Bath TM 10-6630-239-13&P
 Koehler Tag Closed Cup Flash Tester TM 10-6630-235-13&P
 Lab-Line Explosion Proof Refrigerator TM 10-6640-219-13&P
 Lily Freezer TM 10-6640-234-13&P
 Millipore OM 39 Filter Holder TM 10-6640-225-13&P
 Millipore Vacuum Pump TM 10-6640-217-13&P
 Ohaus Harvard Trip Balance TM 10-6670-278-13&P
 Precision Gas-Oil Distillation Test Equipment TM 10-6630-219-13&P
 Precision General Purpose Water Bath TM 10-6640-229-13&P

Precision High Temperature Bronze Block Gum Bath	TM 10-6630-234-13&P
Precision General Purpose Ovens	TM 10-6640-218-13&P
Precision Heater Instruction Manual and Parts List	TM 10-6640-223-13&P
Precision Oxidation Stability Bath	TM 10-6640-232-13&P
Precision Pensky-Martens Flash Testers	TM 10-6630-231-13&P
Precision Reid Vapor Pressure Bath	TM 10-6640-226-13&P
Precision Slo-Speed Stirrer	TM 10-6640-224-13&P
Precision Universal Centrifuge	TM 10-6640-230-13&P
Precision Universal Penetrometer	TM 10-6640-228-13&P
Sargent-Welch Vacuum Pump	TM 10-4310-391-13&P
Sartorius Analytical Balance	TM 10-6670-277-13&P
Scotsman Cuber	TM 10-6640-227-13&P
Soltec VOM-Multimeter	TM 10-6625-3127-13&P
Teel Self-Priming Centrifugal Pump	TM 10-6640-217-13&P
Teel Submersible Pump	TM 10-4320-320-13&P
Texas Instrument TI-503011 Calculator	TM 10-7420-210-13&P

A-5. Pamphlets.

The Army Maintenance Management System (TAMMS)	DA Pam 738-750
--	----------------

A-6. Miscellaneous Publications.

The Army Integrated Publishing and Printing Program	AR 25-30
Laboratory, Airmobile, Aviation Fuel	MIL-L-52733A(ME)
Apparatus, Instruments, Chemicals, Furniture, and Supplies for Industrial, Clinical, College and Government Laboratories	Fisher Scientific Laboratories Catalog
Petroleum-Petrochemical Testing Equipment	Precision Scientific Catalog

APPENDIX B

MAINTENANCE ALLOCATION CHART

Section I. INTRODUCTION

B-1. General.

a. This section provides a general explanation of all maintenance and repair functions authorized at various maintenance categories.

b. The Maintenance Allocation Chart (MAC) in Section II designates overall authority and responsibility for the performance of maintenance functions on the identified end item or component. The application of the maintenance functions to the end item or component will be consistent with the capacities and capabilities of the designated maintenance categories.

c. Section III lists the tools and test equipment (both special tools and common tool sets) required for each maintenance function as referenced from Section II.

d. Section IV contains supplemental instructions and explanatory notes for a particular maintenance function.

B-2. Maintenance Functions. Maintenance functions will be limited to and defined as follows:

a. Inspect. To determine the serviceability of an item by comparing its physical, mechanical, and/or electrical characteristics with established standards through examination (e.g., by sight, sound, or feel).

b. Test. To verify serviceability by measuring the mechanical, pneumatic, hydraulic, or electrical characteristics of an item and comparing those characteristics with prescribed standards.

c. Service. Operations required periodically to keep an item in proper operating condition, i.e., to clean (includes decontaminate, when required), to preserve, to drain, to paint, or to replenish fuel, lubricants, chemical fluids, or gases.

d. Adjust. To maintain or regulate, within prescribed limits, by bringing into proper or exact position, or by setting the operating characteristics to specified parameters.

e. Align. To adjust specified variable elements of an item to bring about optimum or desired performance.

f. Calibrate. To determine and cause corrections to be made or to be adjusted on instruments or test, measuring, and diagnostic equipment used in precision measurement. Consists of comparisons of two instruments, one of which is a certified standard of knob accuracy, to detect and adjust any discrepancy in the accuracy of the instrument being compared.

g. Remove/Install. To remove and install the same item when required to perform service or other maintenance functions. Install may be the act of emplacing, seating, or fixing into position a spare, repair part, or module (component or assembly) in a manner to allow the proper functioning of an equipment or system.

h. Replace. To remove an unserviceable item and install a serviceable counterpart in its place. "Replace" is authorized by the MAC and is shown as the third position code of the SMR code.

i. Repair. The application of maintenance services, including fault location/troubleshooting,² removal/installation, and disassembly/assembly procedures³ and maintenance actions⁴ to identify troubles and restore serviceability to an item by correcting specific damage, fault, malfunction, or failure in a part, subassembly, module (component or assembly), end item, or system.

j. Overhaul. That maintenance effort (service/action) prescribed to restore an item to a completely serviceable/operational condition as required by maintenance standards in appropriate technical publications (i.e., DMWR). Overhaul is normally the highest degree of maintenance performed by the Army. Overhaul does not normally return an item to like-new condition.

k. Rebuild. Consists of those services/actions necessary for the restoration of unserviceable equipment to a like-new condition in accordance with original manufacturing standards. Rebuild is the highest degree of materiel maintenance applied to Army equipment. The rebuild operation includes the act of returning to zero those age measurements (hours/miles, etc.) considered in classifying Army equipment/components.

B-3. Explanation Of Columns In The MAC, Section II.

a. Column 1 Group Number. Column 1 lists functional group code numbers, the purpose of which is to identify maintenance significant components, assemblies, subassemblies, and modules with the next higher assembly. End item group number shall be "00."

b. Column 2. Component/Assembly. Column 2 contains the names of components, assemblies, subassemblies, and modules for which maintenance is authorized.

c. Column 3. Maintenance Function. Column 3 lists the functions to be performed on the item listed in column 2. (For a detailed explanation of these functions, see paragraph B-2.)

d. Column 4. Maintenance Category. Column 4 specifies, by the listing of a work time figure in the appropriate subcolumn(s), the category of maintenance authorized to perform the function listed in column 3. This figure represents the active time required to perform that maintenance function at the indicated category of maintenance. If the number or complexity of the tasks within the listed maintenance function vary at different maintenance categories, appropriate work time figures will be shown for each category. The work time figure represents the average time required to restore an item (assembly, subassembly, component, module, end item, or system) to a serviceable condition under typical field operating conditions. This time includes preparation time (including any necessary disassembly/ assembly time), troubleshooting/fault location time, and quality assurance/quality control time in addition to the time required to perform the specific tasks identified for the maintenance functions authorized in the maintenance allocation chart. The symbol designations for the various maintenance categories are as follows:

¹ Services - inspect, test, service, adjust, align, calibrate, and/or replace.

² Fault locate/troubleshoot- the process of investigating and detecting the cause of equipment malfunctioning; the act of isolating a fault within a system or unit under test (UUT).

³ Disassemble/assemble - encompasses the step-by-step taking apart (or breakdown) of a spare/functional group coded item to the level of its least commonality identified as maintenance significant (i.e., assigned an SMR code) for the category of maintenance under consideration.

⁴ Actions - welding, grinding, riveting, straightening, facing, remachining, and/or resurfacing.

- COperator/Crew
- OUnit Maintenance
- FDirect Support Maintenance
- HGeneral Support Maintenance
- DDepot Maintenance

e. Column 5. Tools and Equipment. Column 5 specifies, by code, those common tool sets (not individual tools) and special tools, TMDE, and support equipment required to perform the designated function.

f. Column 6. Remarks. This column shall, when applicable, contain a letter code, in alphabetic order, which shall be keyed to the remarks contained in section IV.

B-4. Explanation Of Columns In Tool And Test Equipment Requirements, Section III.

a. Column 1. Reference Code. The tool and test equipment reference code correlates with a code used in the MAC, section II, column 5.

b. Column 2. Maintenance Category. The lowest category of maintenance authorized to use the tool or test equipment.

c. Column 3. Nomenclature. Name or identification of the tool or test equipment.

d. Column 4. National Stock Number. The National stock number of the tool or test equipment.

e. Column 5. Tool Number. The manufacturer's part number.

B-5. Explanation Of Columns In Remarks, Section IV.

a. Column 1. Reference Code. The code recorded in Column 6, Section II.

b. Column 2. Remarks. This column lists information pertinent to the maintenance function being performed as indicated in the MAC, section II.

Section II. MAINTENANCE ALLOCATION CHART

(1) GROUP NUMBER	(2) COMPONENT/ ASSEMBLY	(3) MAINTENANCE FUNCTION	(4) MAINTENANCE LEVEL					(5) TOOLS AND EQUIPMENT	(6) REMARKS
			UNIT		DS	GS	DEPOT		
			C	O	F	H	D		
01	APPARATUS, FOAMING CHARACTERISTICS DETERMINATION	INSPECT REPLACE REPAIR	0.2	0.3	1.0			1	

Section III. TOOL AND TEST EQUIPMENT REQUIREMENTS
FOR
MAINTENANCE ALLOCATION CHART

(1) TOOL/TEST EQUIP. REF CODE	(2) MAINTENANCE CATEGORY	(3) NOMENCLATURE	(4) NSN NUMBER	(5) TOOL
1	0	TOOL SET, GENERAL AUTOMOTIVE	5180-00-177-7033	(50980) SC 5180-90- CL-N26

Section IV. REMARKS

NOT APPLICABLE

APPENDIX C

COMPONENTS OF END ITEM AND BASIC ISSUE ITEMS LISTS

Section I. INTRODUCTION

C-1. Scope.

This appendix lists components of end item and basic issue items for the Foaming Characteristics Determination Apparatus to help you inventory items required for safe and efficient operation.

C-2. General.

The Components of End Item and Basic Issue Items Lists are divided into the following sections:

a. Section II. Components of End Item. This listing is for informational purposes only, and is not authority to requisition replacements. These items are part of the end item, but are removed and separately packaged for transportation or shipment. As part of the end item, these items must be with the end item whenever it is issued or transferred between property accounts. Illustrations are furnished to assist you in identifying the items.

b. Section III. Basic Issue Items. These are the minimum essential items required to place the Foaming Characteristics Determination Apparatus in operation, to operate it, and to perform emergency repairs. Although shipped separately packaged, BII must be with the shelter during operation and whenever it is transferred between property accounts. The illustrations will assist you with hard-to-identify items. This manual is your authority to request/requisition replacement BII, based on TOE/MTOE authorization of the end item.

C-3. Explanation of Columns.

The following provides an explanation of columns found in the tabular listings:

a. Column (1) - Illustration Number (Illus. Number). This column indicates the number of the illustration in which the item is shown.

b. Column (2) - National Stock Number. Indicates the National stock number assigned to the item and will be used for requisitioning purposes.

c. Column (3) - Description. Indicates the Federal item name and, if required, a minimum description to identify and locate the item. The last line for each item indicates the CAGEC (in parentheses) followed by the part number.

d. Column (4) - Unit of Measure (U/M). Indicates the measure used in performing the actual operational/maintenance function. This measure is expressed by a two-character alphabetical abbreviation (e.g., ea., in, pr).

e. Column (5) - Quantity required (QTY RQR). Indicates the quantity of the item authorized to be used with/on the equipment.

Section II. COMPONENTS OF END ITEM

(1) ILLUS NUMBER	(2) NATIONAL STOCK NUMBER	(3) DESCRIPTION CAGEC AND PART NUMBER	(4) USABLE ON CODE U/M	(5) QTY
		THERMOMETER RANGE: -5 TO 215°F W/ GRADUATIONS: 0.5°F ASTM 12F (23035) 250-000-12 F THERMOMETER RANGE: -20 TO 102°C W/ GRADUATIONS: 0.2°C ASTM 12C (23035) 250-000-12 C	EA EA	1 1

Section III. BASIC ISSUE ITEMS

NOT APPLICABLE

APPENDIX D
ADDITIONAL AUTHORIZATION LIST
NOT APPLICABLE

D-1/(D-2 Blank)

APPENDIX E

EXPENDABLE/DURABLE SUPPLIES AND MATERIALS LIST

Section I. INTRODUCTION

E-1. **Scope.** This listing is for informational purposes only and is not authority to requisition the listed items. These items are authorized to you by CTA 50-970, Expendable/Durable Items (except medical, class V, repair parts, and heraldic items).

E-2. **Explanation of Columns.**

a. Column (1) - Item Number. This number is assigned to the entry in the listing and is referenced in the narrative instructions to identify the material (e.g., Use cleaning compound, item 5, appendix C).

b. Column (2) - Level. This column identifies the lowest level of maintenance that requires the listed item.

- C - Operator/Crew
- O - Unit Maintenance
- F - Direct Support Maintenance
- H - General Support Maintenance

c. Column (3) - National Stock Number. This is the National stock number assigned to the item; use it to request or requisition the item.

d. Column (4) - Description. Indicates the Federal item name, and, if required, a description to identify the item. The last line for each item indicates the Commercial and Government Entity Code (CAGEC) in parentheses followed by the part number.

e. Column (5) - Unit of Measure (U/M). Indicates the measure used in performing the actual maintenance function. This measure is expressed by a two-character alphabetical abbreviation (e.g., EA, IN, PR). If the unit of measure differs from the unit of issue, requisition the lowest unit of issue that will satisfy your requirements.

Section II. EXPENDABLE/DURABLE SUPPLIES AND MATERIALS LIST

(1) Item Number	(2) Level	(3) National Stock Number	(4) Description	(5) U/M
	C		TECHNICAL OIL, WHITE (23035)355-001-001	CN

By Order of the Secretary of the Army:

CARL E. VUONO
General, United States Army
Chief of Staff

Official:

THOMAS F. SIKORA
Brigadier General, United States Army
The Adjutant General

DISTRIBUTION:

To be distributed in accordance with DA Form 12-21A, Operator, Unit and Direct Support Maintenance requirements for Laboratory, Petroleum, MTD

The Metric System and Equivalents

Linear Measure

1 centimeter = 10 millimeters = .39 inch
 1 decimeter = 10 centimeters = 3.94 inches
 1 meter = 10 decimeters = 39.37 inches
 1 dekameter = 10 meters = 32.8 feet
 1 hectometer = 10 dekameters = 328.08 feet
 1 kilometer = 10 hectometers = 3,280.8 feet

Weights

1 centigram = 10 milligrams = .15 grain
 1 decigram = 10 centigrams = 1.54 grains
 1 gram = 10 decigram = .035 ounce
 1 decagram = 10 grams = .35 ounce
 acres
 1 hectogram = 10 decagrams = 3.52 ounces
 1 kilogram = 10 hectograms = 2.2 pounds
 1 quintal = 100 kilograms = 220.46 pounds
 1 metric ton = 10 quintals = 1.1 short tons

Liquid Measure

1 centiliter = 10 milliliters = .34 fl. ounce
 1 deciliter = 10 centiliters = 3.38 fl. ounces
 1 liter = 10 deciliters = 33.81 fl. ounces
 1 dekaliter = 10 liters = 2.64 gallons
 1 hectoliter = 10 dekaliters = 26.42 gallons
 1 kiloliter = 10 hectoliters = 264.18 gallons

Square Measure

1 sq. centimeter = 100 sq. millimeters = .155 sq. inch
 1 sq. decimeter = 100 sq. centimeters = 15.5 sq. inches
 1 sq. meter (centare) = 100 sq. decimeters = 10.76 sq. feet
 1 sq. dekameter (are) = 100 sq. meters = 1,076.4 sq. feet
 1 sq. hectometer (hectare) = 100 sq. dekameters = 2.47
 1 sq. kilometer = 100 sq. hectometers = .386 sq. mile

Cubic Measure

1 cu. centimeter = 1000 cu. millimeters = .06 cu. inch
 1 cu. decimeter = 1000 cu. centimeters = 61.02 cu. inches
 1 cu. meter = 1000 cu. decimeters = 35.31 cu. feet

Approximate Conversion Factors

<i>To change</i>	<i>To</i>	<i>Multiply by</i>	<i>To change</i>	<i>To</i>	<i>Multiply by</i>
inches	centimeters	2.540	ounce-inches	Newton-meters	.007062
feet	meters	.305	centimeters	inches	.394
yards	meters	.914	meters	feet	3.280
miles	kilometers	1.609	meters	yards	1.094
square inches	square centimeters	6.451	kilometers	miles	.621
square feet	square meters	.093	square centimeters	square inches	.155
square yards	square meters	.836	square meters	square feet	10.764
square miles	square kilometers	2.590	square meters	square yards	1.196
acres	square hectometers	.405	square kilometers	square miles	.386
cubic feet	cubic meters	.028	square hectometers	acres	2.471
cubic yards	cubic meters	.765	cubic meters	cubic feet	35.315
fluid ounces	milliliters	29,573	cubic meters	cubic yards	1.308
pints	liters	.473	milliliters	fluid ounces	.034
quarts	liters	.946	liters	pints	2.113
gallons	liters	3.785	liters	quarts	1.057
ounces	grams	28.349	liters	gallons	.264
pounds	kilograms	.454	grams	ounces	.035
short tons	metric tons	.907	kilograms	pounds	2.205
pound-feet	Newton-meters	1.356	metric tons	short tons	1.102
pound-inches	Newton-meters	.11296			

Temperature (Exact)

°F	Fahrenheit	5/9 (after	Celsius	°C
	temperature	subtracting 32)	temperature	

PIN: 046068-000

This fine document...

Was brought to you by me:



[Liberated Manuals -- free army and government manuals](#)

Why do I do it? I am tired of sleazy CD-ROM sellers, who take publicly available information, slap “watermarks” and other junk on it, and sell it. Those masters of search engine manipulation make sure that their sites that sell free information, come up first in search engines. They did not create it... They did not even scan it... Why should they get your money? Why are not letting you give those free manuals to your friends?

I am setting this document FREE. This document was made by the US Government and is NOT protected by Copyright. Feel free to share, republish, sell and so on.

I am not asking you for donations, fees or handouts. If you can, please provide a link to liberatedmanuals.com, so that free manuals come up first in search engines:

<A HREF=<http://www.liberatedmanuals.com/>>Free Military and Government Manuals

- Sincerely
Igor Chudov
<http://igor.chudov.com/>
- [Chicago Machinery Movers](#)